

VOLUME 21

FEBRUARY, 1933

NUMBER 2

PROCEEDINGS
of
The Institute of Radio
Engineers



Walter J. Malone
WJAM

Form for Change of Mailing Address or Business Title on Page XVII

Institute of Radio Engineers Forthcoming Meetings

NEW YORK MEETING

February 1, 1933

March 1, 1933

PHILADELPHIA SECTION

February 2, 1933

March 2, 1933

PROCEEDINGS OF

The Institute of Radio Engineers

Volume 21

February, 1933

Number 2

Board of Editors

ALFRED N. GOLDSMITH, *Chairman*

R. R. BATCHER
H. H. BEVERAGE
F. W. GROVER
G. W. PICKARD

L. P. WHEELER
L. E. WHITTEMORE
WILLIAM WILSON
K. S. VAN DYKE

CONTENTS

PART I

Frontispiece.....	174
Institute News and Radio Notes.....	175
January Meeting of the Board of Directors.....	175
Institute Meetings.....	177
Personal Mention.....	187

PART II

Technical Papers

The Required Minimum Frequency Separation Between Carrier Waves of Broadcast Stations.....	193
..... P. P. ECKERSLEY	
Low Power Radio Transmitters for Broadcasting.....	212
..... A. W. KISHPAUGH AND R. E. CORAM	
Supervisory and Control Equipment for Audio-Frequency Amplifiers.....	228
..... HARRY SOHON	
General Theory on the Propagation of Radio Waves in the Ionized Layer of the Upper Atmosphere.....	238
..... SHOGO NAMBA	
Some Long-Distance Transmission Phenomena of Low-Frequency Waves.....	263
..... EITARO YOKOYAMA AND ISAO TANIMURA	
A Practical Analysis of Parallel Resonance.....	271
..... REUBEN LEE	
Relations Between the Parameters of Coupled-Circuit Theory and Transducer Theory with Some Applications.....	282
..... J. G. BRAINERD	
Graphical Methods for Problems Involving Radio-Frequency Transmission Lines.....	290
..... HANS RODER	
Ellipse Diagram of a Lecher Wire System.....	303
..... ATAKA HIKOSABURO	
Discussion on "On the Amplitude of Driven Loud Speaker Cones," by M. J. O. Strutt.....	312
..... N. W. MCLACHLAN AND M. J. O. STRUTT	
Discussion on "Historical Review of Ultra-Short-Wave Progress," by William H. Wenstrom.....	315
..... H. M. DOWSETT AND WILLIAM H. WENSTROM	
Book Reviews: "Thermionic Vacuum Tubes," by E. V. Appleton.....	317
..... B. E. SHACKELFORD	
"Servicing Receivers by Means of Resistance Measurement," by John F. Rider.....	317
..... S. S. KIRBY	
Booklets, Catalogs, and Pamphlets Received.....	318
Radio Abstracts and References.....	319
Contributors to this Issue.....	326

The Institute of Radio Engineers

GENERAL INFORMATION

INSTITUTE. The Institute of Radio Engineers was formed in 1912 through the amalgamation of the Society of Wireless Telegraph Engineers and the Wireless Institute. Its headquarters were established in New York City and the membership has grown from less than fifty members at the start to almost six thousand by the end of 1932.

AIMS AND OBJECTS. The Institute functions solely to advance the theory and practice of radio and allied branches of engineering and of the related arts and sciences, their application to human needs, and the maintenance of a high professional standing among its members. Among the methods of accomplishing this need is the publication of papers, discussions, and communications of interest to the membership.

PROCEEDINGS. The PROCEEDINGS is the official publication of the Institute and in it are published all of the papers, discussions, and communications received from the membership which are accepted for publication by the Board of Editors. Copies are sent without additional charge to all members of the Institute. The subscription price to nonmembers is \$10.00 per year, with an additional charge for postage where such is necessary.

RESPONSIBILITY. It is understood that the statements and opinions given in the PROCEEDINGS are views of the individual members to whom they are credited, and are not binding on the membership of the Institute as a whole. Papers submitted to the Institute for publication shall be regarded as no longer confidential.

REPRINTING PROCEEDINGS MATERIAL. The right to reprint portions or abstracts of the papers, discussions, or editorial notes in the PROCEEDINGS is granted on the express condition that specific reference shall be made to the source of such material. Diagrams and photographs published in the PROCEEDINGS may not be reproduced without making specific arrangements with the Institute through the Secretary.

MANUSCRIPTS. All manuscripts should be addressed to the Institute of Radio Engineers, 33 West 39th Street, New York City. They will be examined by the Papers Committee and the Board of Editors to determine their suitability for publication in the PROCEEDINGS. Authors are advised as promptly as possible of the action taken, usually within two or three months. Manuscripts and illustrations will be destroyed immediately after publication of the paper unless the author requests their return. Information on the mechanical form in which manuscripts should be prepared may be obtained by addressing the secretary.

MAILING. Entered as second-class matter at the post office at Menasha, Wisconsin. Acceptance for mailing at special rate of postage is provided for in the act of February 28, 1925, embodied in Paragraph 4, Section 412, P. L. and R., and authorization was granted on October 26, 1927.

Published monthly by

THE INSTITUTE OF RADIO ENGINEERS, INC.

Publication office, 450-454 Ahnaip St., Menasha, Wis.

BUSINESS, EDITORIAL, AND ADVERTISING OFFICES

Harold P. Westman, *Secretary*

33 West 39th Street, New York, N. Y.

INSTITUTE SECTIONS

- ATLANTA—Chairman, H. L. Wills; Secretary, Philip C. Bangs, 23 Kensington Road, Avondale Estates, Ga.
- BOSTON—Chairman, E. L. Chaffee; Secretary, G. W. Kenrick, Tufts College, Mass.
- BUFFALO-NIAGARA—Chairman, L. Grant Hector; Secretary, E. C. Waud, 235 Huntington Avenue, Buffalo, N. Y.
- CHICAGO—Chairman, R. M. Arnold; Secretary, Donald H. Miller, McGraw-Hill Publishing Co., 520 N. Michigan Ave., Chicago, Ill.
- CINCINNATI—Chairman, C. E. Kilgour; Secretary, H. G. Boyle, Crosley Radio Corp., Cincinnati, Ohio.
- CLEVELAND—Chairman, P. A. Marsal; Secretary, R. P. Worden, Radio Editor, *Cleveland News*, Cleveland, Ohio.
- CONNECTICUT VALLEY—Chairman, H. W. Holt; Secretary, C. B. De Soto, American Radio Relay League, 38 La Salle Rd., W. Hartford, Conn.
- DETROIT—Chairman, G. W. Carter; Secretary, E. C. Denstaedt, Detroit Police Department, Detroit, Mich.
- LOS ANGELES—Chairman, E. H. Schreiber; Secretary, H. W. Andersen, 2332 Lake View Ave., Los Angeles, Calif.
- NEW ORLEANS—Chairman, Pendleton E. Lehde; Secretary, Anton A. Schiele, 1812 Masonic Temple, New Orleans, La.
- PHILADELPHIA—Chairman, H. W. Byler; Secretary, G. C. Blackwood, 243 E. Upsal St., Mt. Airy, Philadelphia, Pa.
- PITTSBURGH—Chairman, R. T. Griffith; Secretary, C. K. Krause, 1541 Princess Ave., Pittsburgh, Pa.
- ROCHESTER—Chairman, A. E. Soderholm; Secretary, John J. Long, Radio Station WHAM, Sagamore Hotel, Rochester, N. Y.
- SAN FRANCISCO—Chairman, C. V. Litton; Secretary, K. G. Clark, Department of Commerce, 328 Custom House, San Francisco, Calif.
- SEATTLE—Chairman, H. H. Bouson; Secretary, Howard Mason, 2709-4th West, Seattle, Wash.
- TORONTO—Chairman, R. A. Hackbusch; Secretary, G. E. Pipe, Rogers-Majestic Corporation, Toronto, Ont, Canada.
- WASHINGTON—Chairman, H. G. Dorsey; Secretary, C. L. Davis, Patent Department, Radio Corporation of America, 1227-1233 National Press Building, Washington, D. C.

**GEOGRAPHICAL LOCATION OF MEMBERS ELECTED
JANUARY 4, 1933**

Transferred to the Fellow Grade

Massachusetts Arlington Heights, 72 Oakland Ave..... Lamson, H. W.
Auburndale, 21 Lasell St..... Clapp, J. K.

Transferred to the Member Grade

Illinois La Grange, 229 N. Kensington Ave..... Knouf, R. J.

Elected to the Member Grade

New Jersey Deal, c/o Bell Telephone Laboratories..... Hunt, L. E.
New York Buffalo, 978 Amherst St..... Gates, H. A.

Elected to the Associate Grade

California Long Beach, Marine Detachment, U.S.S. Arkansas..... Handel, A. J.
Los Angeles, 353 E. 74th St..... Delacourt, F. H.
Los Angeles, 3745 S. Grand Ave..... Haralson, B. J.
Los Angeles, 1217 W. 10th St..... Lillyblad, G. F.
Pasadena, Box 649..... Bacon, W. L.
San Anselmo, 1 Santa Cruz Ave..... Cherry, C. E.

Dist. of Columbia Washington, Radio Materiel School, Naval Research Lab. Daigle, A. A.
Washington, 3382 Stephenson Pl., N.W. McClurg, G. H.

Illinois Chicago, 4521 N. Malden Ave..... Mitchell, C. A.
Chicago, 6139 S. Sangamon St..... O'Pink, B.
Chicago, 3738 Monticello Ave..... Sparks, D. E.
Tinley Park..... Von Ohlen, F. D.

Indiana Wilmette, 412 Central Ave..... Klapperich, A. J.
Notre Dame, Box 85..... Coomes, E. A.

Michigan Highland Park, 216 Florence Ave..... Stephenson, R. J.

Missouri Overland, 2315 Gaebler Ave..... Sattgast, J. K.
St. Louis, 3662 Robert Ave..... Lachnit, W. S.

New Jersey Montclair, 42 Christopher St..... Hinck, A. J., Jr.
New York Brooklyn, 2131 Dean St..... Niccolls, W.
New York City, 421 Canal St..... Donovan, W. E.
New York City, c/o Popowitz, 2210 Lyon Ave..... Temler, H. H.

Ohio Ashtabula, 222 W. 53rd St..... Straw, F. D.

Pennsylvania Philadelphia, Moore School of E.E., 200 S. 33rd St..... Hart, H. C.
Philadelphia, Arrott Arms Apts. E-9, Arrott and Leiper Sts. Johnston, E. R.
Philadelphia, 5231 Heston St..... Morrow, J.
Amarillo, 800 W. 6th St..... Gooch, C. S.

Texas Houston, 215 B Humble Bldg..... Gardner, D. H.
Salt Lake City, Station KSL..... Groves, W. E.

Utah Vancouver, 1109 Broadway..... Sharon, R. W.

Washington Elkhorn, 11 S. Wright St..... Wilkinson, J. D.

Wisconsin Canberra, Broadcast Station 2CA..... Ryan, A. J.

Australia Beckenham, Kent, 17 Westfield Rd..... Partridge, N.
England Cullercoats, Northumberland, 13, Marden Ter..... Swanson, J.
Darlington, Co. Durham, 43 Bondgate..... Reeves, J. C.
Grimsby, Lincolnshire, 28 Mangle St..... Laverack, H.
London, N.W. 6, 113 Goldhust Ter., South Hampstead..... Boyd, W. J. T.
Muncastergate, York, "Ravensdene"..... Hardy, C.
Shrewsbury, 15 Clarendon St..... Mitchell, A. R.

New Zealand Christchurch, N.Z. Broadcasting Board, Station 3YA,
Gloucester St..... Penton, W. A.

North Wales Waipu, North Auckland, "Bird-Grove"..... McLean, C.
Llanwnda, Caernarvonshire, Wood Cottage, Glynllifon
Park..... Williams, W.

Elected to the Junior Grade

Kansas Topeka, 113 W. 2nd St..... Burns, L. V.

Elected to the Student Grade

California Berkeley, International House..... Emanuel, V.

Indiana Lafayette, 1418 Center St..... Alford, H. W.
Lafayette, Elec. Eng. Bldg., Purdue University..... Booth, R. M., Jr.

Kansas Lawrence, 1344 Kentucky St..... Omer, C. L.
Lawrence, 308 W. 16th St..... Porter, R.

Massachusetts Boston, 37 Bay State Rd..... Kline, F. S.
Boston, 523 Newbury St..... Krim, N. B.
Boston, 532 Beacon St..... Snyder, G. H.

Cambridge, 12 Trowbridge St..... Graham, M. L.

Cambridge, Box 113, M.I.T. Dormitory..... Warsher, A. I.

Chelsea, 154 Shawmut St..... Goodman, L.

New York Brooklyn, 74 Osborn St..... Sussman, H.

Pennsylvania Bethlehem, P.O. Box 18..... Jones, C. B.
Mt. Airy, Philadelphia, 645 W. Sedgwick St..... Flack, S. G.

Reading, 346 N. 6th St..... Fritz, J. R.

Washington Seattle, 4023 Corliss Ave..... Woodyard, J.

APPLICATIONS FOR MEMBERSHIP

Applications for transfer or election to the various grades of membership have been received from the persons listed below, and have been approved by the Committee on Admissions. Members objecting to transfer or election of any of these applicants should communicate with the Secretary on or before February 28, 1933. These applicants will be considered by the Board of Directors at its meeting on March 1, 1933.

For Election to the Associate Grade

California	Huntington Park, 2321 Mortimer St.....	Weissmantel, F. A.
	Los Angeles, 1117 Venice Blvd.....	Stern, M. M.
Connecticut	Hartford, 71 Brownell Ave.....	Chase, A. E.
Illinois	Oak Park, 1133 S. Scoville Ave.....	Linell, C. S.
	Rockford, 710 Sunset Ave.....	White, C. E.
Kentucky	Louisville, 655 S. 28th St.....	DeWitt, A. G.
Massachusetts	Springfield, 27 Sunapee St.....	Johnson, P. K.
Michigan	Detroit, 529 Congress St., W.....	Marmorstein, B.
	Grand Rapids, Minsky-Trendle Broadcasting Corp., 501 Young Bldg.....	Bergeron, L. A.
	Pontiac, c/o E. Campbell, R.F.D. No. 4.....	Poole, L. C.
Missouri	Moberly, 515 Reed St.....	Winn, G. L.
New Jersey	Allendale, 89 Powell Rd.....	Aston, W. P., Jr.
	Glen Gardens.....	Degnan, W. A.
New York	Schenectady, 1330 Union St.....	Caldwell, P. G.
Ohio	Shaker Heights, 14316 Ashwood Rd.....	Abell, H. W.
Oklahoma	Enid, University Station.....	McKinney, E. G.
Pennsylvania	Coatesville, 116 S. 11th Ave.....	Spratt, G. G.
	St. Marys, c/o Stackpole Carbon Co.....	Williams, H. A.
China	Shanghai, Shanghai Radio Central Station, 565 Mingkoh Rd.....	Hsu, J.
England	Bournemouth, Hants., 27 Livingstone Rd., Pokesdown.....	Granfield, C. C.
	London E. C. 4, Siemens Schuckert (Gt. Brit.) Ltd., 30-34 New Bridge St.....	Tunncliffe, E. J.
	London, c/o Philco Radio & Television Corp., Argyll St.....	Williams, G.
	Norwich, Norfolk, 18 Bridewell Alley.....	Fisher, C. C.
Hungary	Budapest, Muegytem.....	Babits, V.
India	Jhansi, U. P., G.I.P. Railway.....	Mulleneux, H. J.
Sweden	Stocksund, Berstigen 6.....	Lofgren, E. O.

For Election to the Junior Grade

New York	New York City, 314 W. 94th St.....	Stevens, E. F.
----------	------------------------------------	----------------

For Election to the Student Grade

California	Los Angeles, 134 S. Occidental.....	Campbell, A. N.
	Los Angeles, 211 N. Dillon St.....	Simmons, E., Jr.
	San Mateo, 216 E. Bellevue Ave.....	Roake, W. C.
Georgia	Atlanta, Box 139, Georgia School of Technology.....	Smith, L. C.
Kansas	Cawker City, 10-6th Ave.....	Miller, H. A.
	Overland Park, 6204 W. 79th St.....	Files, C. O.
	Topeka, 612 Tyler St.....	Wright, G. W.
Massachusetts	Cambridge, C-43 Dunster House.....	Hastings, T. M., Jr.
	Dorchester, 50 Southern Ave.....	White, M.
	Wakefield, 115 Pleasant St.....	Turner, R.
Minnesota	Minneapolis, 1515 University Ave., S.E.....	Cowperthwait, H. S.
	Minneapolis, 1519-7th St., S.E.....	Lowell, P.
	Minneapolis, E.E. Bldg., University of Minnesota.....	Shidel, F. C.
Wisconsin	Madison, 28 E. Gilman St.....	Ensmann, B.
	Madison, 233 Lake Lawn Pl.....	Moe, R. E.
Canada	Edmonton, Alta., c/o Dr. John MacDonald, University of Alberta.....	Simons, F.



OFFICERS AND BOARD OF DIRECTORS, 1933

(Terms expire January 1, 1934, except as otherwise noted)

President

L. M. HULL

Vice President

JONATHAN ZENNECK

Treasurer

MELVILLE EASTHAM

Secretary

HAROLD P. WESTMAN

Editor

ALFRED N. GOLDSMITH

Directors

M. C. BATSEL

J. V. L. HOGAN

C. M. JANSKY, JR.

R. H. MANSON, *Junior Past President*

E. R. SHUTE

A. F. VAN DYCK

WILLIAM WILSON

Serving until January 1, 1935

W. G. CADY, *Junior Past President*

O. H. CALDWELL

C. W. HORN

E. L. NELSON

Serving until January 1, 1936

R. A. HEISING

H. M. TURNER

F. A. KOLSTER

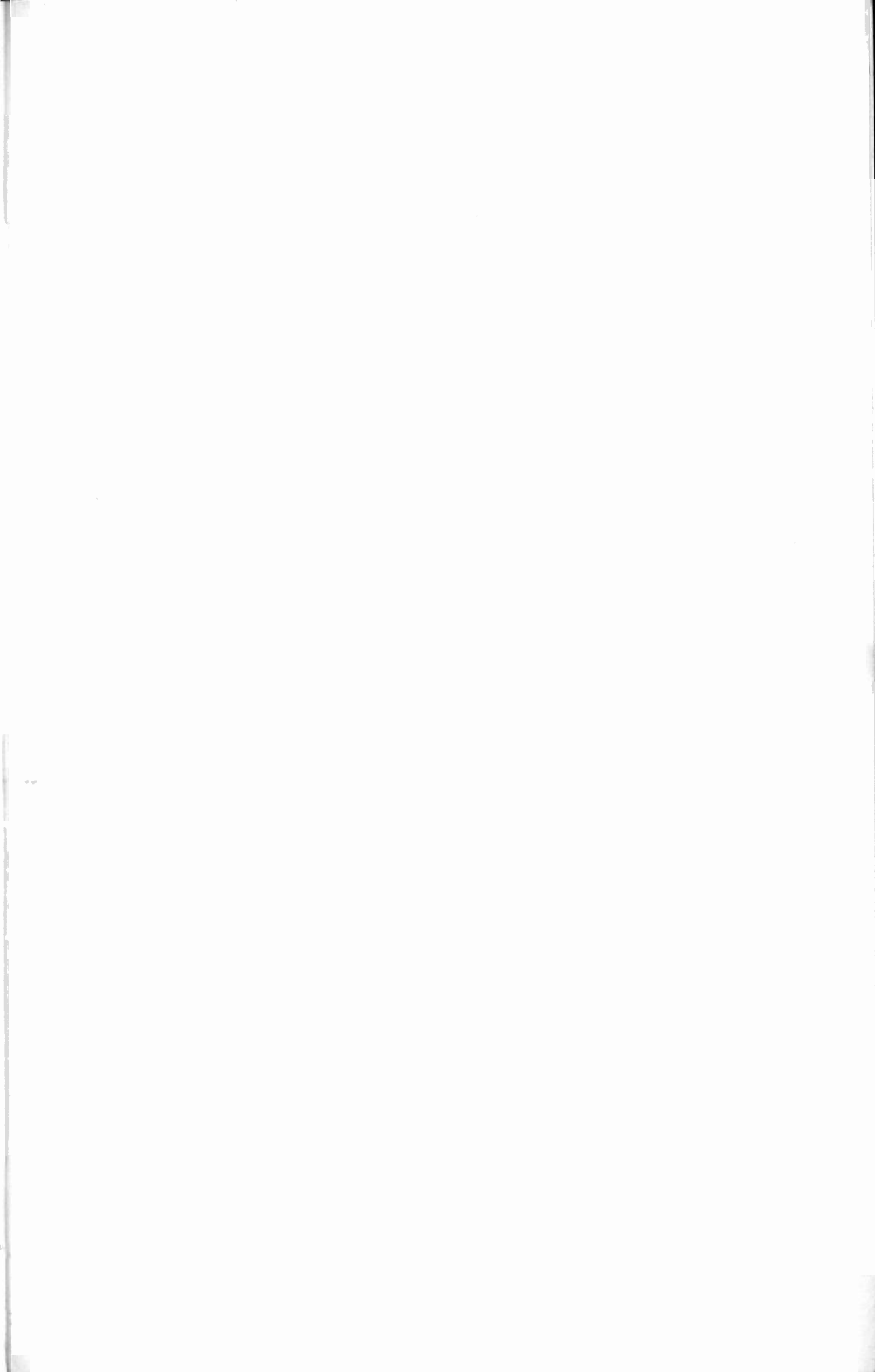



CHARLES WILLIAM HORN, DIRECTOR, 1933

Charles William Horn was born in New York City on July 9, 1894. His interest in radio dates back to 1908 when he operated his own amateur station. At this time licenses for either operators or stations were unknown.

After finishing high school at an early age, he began the study of electrical engineering which, however, was broken by the spirit of wanderlust which prompted him to take his first job as a marine wireless operator at the age of sixteen. For some years he was employed by the United Wireless Telegraph Company and also the United Fruit Company.

During the war he served in the United States Navy as an officer in the Naval Communication Service and still holds the rank of Lieutenant Commander in the Naval Reserve Force.

In 1929 he joined the staff of the Westinghouse Electric and Manufacturing Company where he began his pioneer work in broadcasting. He became manager of operations for that organization and had charge of all its radio stations. He pioneered in the field of short-wave transmission, being associated with Dr. Conrad to whom he gives credit for much of the early developments. His work, however, is responsible to a great extent for the recent successful interchange of programs between America and other continents. Much of his work found application in the allied arts of sound pictures and television.

In 1929 he became general engineer of the National Broadcasting Company and made a survey of radio conditions in Europe which has led to the interchange of programs between that continent and America. He has contributed many devices to the radio industry among the more recent of which is the parabolic microphone which received much publicity through its use at the political conventions held in Chicago in 1932.

He became an Associate member of the Institute in 1914, a Member in 1928, and was transferred to the Fellow grade in 1930.

INSTITUTE NEWS AND RADIO NOTES

Annual Meeting of the Board of Directors

The annual meeting of the Board of Directors was held at the Institute office on Wednesday, January 4, 1933. Those in attendance were, L. M. Hull, president; Melville Eastham, treasurer; Arthur Batcheller, Alfred N. Goldsmith, R. A. Heising, C. W. Horn, F. A. Kolster, R. H. Marriott, E. L. Nelson, H. M. Turner, A. F. Van Dyck, William Wilson, and H. P. Westman, secretary.

After approving the minutes of the previous meeting, all Board members whose terms were expiring left the room and a quorum of the new Board being present, the appointment of the chairman of the Board of Editors, secretary, treasurer, and five directors to serve for 1933 was proceeded with. The following appointments were made:

Alfred N. Goldsmith, Chairman of the Board of Editors

H. P. Westman, Secretary

Melville Eastham, Treasurer

The names of the five appointed directors are:

Alfred N. Goldsmith

J. V. L. Hogan

C. M. Jansky, Jr.

E. R. Shute

William Wilson

President Hull presented to the Board his recommendations on the personnel of committees to serve during his term of office. With but slight modifications, these appointments were approved, and the complete list of committees will appear in the April issue of the PROCEEDINGS.

It was felt that it would be desirable for the present to restrict the personnel of the Standards Committee to not more than five members whose duty it shall be to make an analysis of the Institute's position in the field of standardization and report to the Board its recommendations of policies to govern the future operation of the Standards Committee and the Institute's other standards activities. It is assumed that after these policies have been formulated, the complete personnel of the Standards Committee will be named.

J. K. Clapp of Auburndale, Mass., and H. W. Lamson of Arlington Heights, Mass., were transferred to the grade of Fellow, R. J. Knouf of La Grange, Ill., was transferred to the Member grade, and H. A. Gates of Buffalo, N. Y., and L. E. Hunt of Deal, N. J., were elected to the grade of Member.

Forty-one Associates, one Junior, and sixteen Students were elected to membership.

The proposed budget for 1933 which was revised at the December meeting of the 1932 Board was considered and approved.

Because the Institute by-laws specify that an annual list of the membership shall be published and that at least ten meetings shall be held in New York each year, the Board members will be notified that the waiving of these by-laws for 1933 will be considered at the March meeting of the Board. Thirty days advance notice is required before such modifications of the by-laws can be considered.

In order to assist in advancing the work of the Engineering Societies Library, a small contribution to that organization was approved. All Institute members may have access to the library, and works that they may desire to obtain on loan will be made available to them. The library holds the Institute responsible for all loans made to its members.

Continuance of the Institute as a member body of the American Standards Association was approved.

Mr. Marriott, chairman of the Emergency Employment Committee, reported on the activities of his committee during the past year. The committee was established at the January, 1932, meeting of the Board of Directors.

Registered Members of the Institute

Unemployed	350
Temporarily employed	25
Permanently employed	45
Total	420

Registered Nonmembers of the Institute

Unemployed	66
Temporarily employed	1
Permanently employed	4
Total	71

During the past year, approximately 120 members and a few non-members of the Institute were placed in jobs through the efforts of the Emergency Employment Committee. Many of these jobs were of a permanent nature although some were known to be temporary and others proved to be temporary because of further declines in general business.

Surveys were conducted in thirty-four of the United States and 105 Institute members participated in this work. It has been reported that in a number of instances, members have located either temporary or permanent work through their contacts resulting from survey work.

Over \$5,500 has been contributed to this work by members of the Institute. All of this has gone to the aid of the unemployed as all administrative costs have been defrayed from the national treasury.

The total number of members in good standing as of December 31, 1932, was 6403 compared with 6734 as of December 31, 1931.

International Scientific Radio Union

A. E. Kennelly, Professor Emeritus of Electrical Engineering of Harvard University, has recently been elected President of the International Scientific Radio Union (Union Radio Scientifique Internationale) to succeed the late General Ferrié. The unfortunate death of Dr. Louis W. Austin in July, 1932, prevented his assuming the presidency as was originally proposed.

Proceedings Binders

Binders for the PROCEEDINGS, which may be used as permanent covers or for temporary transfer purposes, are available from the Institute office. These binders are of handsome Spanish grain fabrikoid, in blue and gold. Wire fasteners hold each copy in place, and permit removal of any issue from the binder in a few seconds. All issues lie flat when the binder is open. Each binder will accommodate a full year's supply of the PROCEEDINGS, and they are available at one dollar and seventy five cents (\$1.75) each. Your name, or PROCEEDINGS volume number, will be stamped in gold for fifty cents (50c) additional.

Institute Meetings

BOSTON SECTION

The Boston Section held a meeting on November 18 at Harvard University, E. L. Chaffee, chairman, presiding.

The paper of the evening "Radiation Characteristics of a Vertical Half-Wave Antenna," by J. A. Stratton and H. A. Chinn of Massachusetts Institute of Technology, was published in the December, 1932, issue of the PROCEEDINGS. The attendance at the meeting totaled 100 and an interesting discussion followed the presentation of the paper.

The December meeting of the Boston Section was held on the 9th at Harvard University with G. W. Kenrick presiding in the absence of Dr. Chaffee.

A paper on "An Optically Controlled Quartz-Crystal Oscillator," by W. G. Cady, of Wesleyan University and president of the Institute. Dr. Cady described a piezo-electric oscillator in which the quartz plate is driven from an amplifier, the input to which is obtained from a photo-electric cell. The cell is actuated by periodic fluctuations in a beam of light passing through the quartz crystal which is situated between two Nicol prisms. An auxiliary quartz plate is used as an optical compensator.

By suitable control of the amplifier impedances, the phase of the output voltage is given proper value for driving the crystal at such a frequency as to insure greatest stability. This is the frequency at which the velocity of motion in the crystal is approximately in phase with the driving force. The phase relations were discussed by reference to the admittance circle of the resonator, due attention being paid to the effect of the air gap and other series impedances. The possible use of the device as a frequency standard was mentioned.

The discussion which followed the presentation of the paper was participated in by Messrs. Ballou, Browning, Clapp, Eastham, Field, Kennelly and a number of others of the 125 members and guests who attended the meeting.

CHICAGO SECTION

The Chicago Section held its November 18 meeting jointly with the Chicago Section of the American Institute of Electrical Engineers and the Western Society of Engineers in the main auditorium of the Engineering Building in Chicago. R. M. Arnold, vice chairman, presided in the absence of Dr. Hoag.

"Electric Eyes in Industry" was the subject of the paper by O. H. Caldwell, Editor of *Electronics* and *Radio Retailing*. The paper was profusely illustrated and the subject matter treated broadly. New applications of photo-sensitive devices and radio principles in controlling operations and processes were discussed, and the revolutionizing effects which these have had upon all branches of engineering considered.

A local manufacturer installed photocell counting equipment at the door of the auditorium to give a practical example of the effectiveness of such devices in accurately counting the number of persons passing into a room. Following the paper, a demonstration of electronic and photocell equipment was given by a number of manufacturers of these devices.

A short address was made by Captain Gorby who outlined the progress being made in preparation for the Chicago World's Fair which will open in June, 1933. This Fair will be of substantial interest to those attending the Institute's Annual Convention which will be held in Chicago late in June.

The Annual Meeting of the Chicago Section was held on December 16 at the Engineering Building. The officers elected for 1933 were: Chairman, R. M. Arnold; Vice Chairman, J. F. Church, Jensen Radio Manufacturing Company; and Secretary-Treasurer, D. H. Miller, McGraw-Hill Publishing Company.

"Practical Difficulties of Aviation Radio Systems" was the subject of an open forum led by Messrs. M. M. Eells of the National Air Transport and R. H. Freeman of United Air Lines. The discussion was confined principally to service failures encountered in the operation of aircraft radio equipment together with their causes.

At the conclusion of the above discussion, a paper on "Recent Trends in Receiver Design" was presented by David Grimes of the RCA License Engineering Department. The speaker discussed new development trends including a system of automatic tone control in which the fidelity characteristic of the receiver is varied in relationship to the field strength of the signal being received. This permits high fidelity with signals of sufficient intensity to override local noise while the high-frequency cut-off point of the audio-frequency amplifier is lowered when receiving weak signals to make the interference less apparent.

The discussion which was participated in by Messrs. Arnold, Church, Clough, Crosley, Freeman, Silver, and Wunderlich was confined to the characteristic impedances of the input circuit of a vacuum tube as affected by the plate load, the principle upon which the automatic tone control is based and the various considerations in the commercial application of the circuit. The attendance totaled 110.

CLEVELAND SECTION

A meeting of the Cleveland Section was held on October 21 at the Case School of Applied Science, E. L. Gove, chairman, presiding.

W. L. Everitt, associate professor of electrical engineering of Ohio State University presented a paper on "Impedance Matching." In it he pointed out that while in most cases it is desirable to equalize impedances, there are times when such is not advisable. In general, maximum power transfer, high efficiency, minimum distortion, and a discrimination between waves moving in opposite directions in a common

circuit are the result of proper matching of impedances of connecting networks.

In long wire lines which are a combination of resistance, inductance, and capacity, a proper transformer is required to obtain maximum power at the end of the circuit. The endeavor is to make the terminating impedance equal to that of the line itself. The input impedance varies with frequency when the line is improperly terminated, and distortion may result. Lines operated at high frequencies must be properly terminated if radiation is not to occur. In filters there will be distortion if all the power in the initial wave is not absorbed at the load by proper impedance matching.

A number of general formulas were given and their applications to practical problems in the design of tube equipment outlined.

The meeting was attended by sixty members and guests.

E. L. Gove, chairman, presided at the November meeting of the Cleveland Section held at the Case School of Applied Science on the 18th. The attendance was forty-five.

"Report of Radio Tests Made During the Recent Total Solar Eclipse" was the subject of J. R. Martin, Professor of Electrical Engineering of Case School of Applied Science.

The paper described experiments at Case School to determine the effects of the total solar eclipse upon short-wave radio transmission. Tests were made by means of controlled transmissions from a location in Maine in the path of totality, to special receiving and recording equipment in the electrical laboratory of Case School. A continuous graph showed a gradual increase in signal strength from first contact at 2 P.M. on August 31 until the pen went off the upper edge of the paper just before the second contact. At that contact the signals disappeared abruptly and did not again become audible until about midway between the third and fourth contact. The gradual up-building was then repeated with another abrupt fading out at the fourth contact or at the end of the eclipse. At early twilight transmission had returned to normal as determined by recordings for the past week.

Assuming the existence of a Kennelly-Heaviside layer capable of reflecting and refracting radio waves, the endeavor was to determine whether this layer was electronic in composition or of ultra-violet wave formation.

An ultra-violet Kennelly-Heaviside layer would theoretically tend to disappear entirely during the brief artificial night of the total solar eclipse whereas an electronic layer would probably persist. Wide fluctuations in the observed test, however, might have resulted from the

shifting, thinning, or warping of an ultra-violet wave with corresponding changes in the skip distance between Maine and Cleveland. The spectacular variations which were recorded are of such character as to make them difficult to interpret. However, Professor Martin indicated he was inclined toward the theory of an ultra-violet layer having varying density and height at different times of day and night and at different seasons of the year.

As this was the annual meeting, officers for 1933 were elected. These are: Chairman, P. A. Marsal, National Carbon Company; Vice Chairman, E. B. Snyder, consulting engineer; Secretary-Treasurer, R. P. Worden, Radio Editor of the *Cleveland News*.

CONNECTICUT VALLEY SECTION

The Connecticut Valley Section held a meeting on June 23 at the Hotel Garde, Hartford, H. W. Holt, vice-chairman, presiding.

As a change from the ordinary routine of technical papers, this last meeting before the closing for the summer months was known as "Old-Timer's Night." Practically all of the eighteen in attendance had some experiences in the more or less early days of radio to relate, and an enjoyable evening resulted.

The October meeting of the Connecticut Valley Section was held on the 20th in Springfield, Mass., at the Hotel Charles, H. W. Holt, vice chairman, presiding.

"Cathode Ray Tube Operation" was the subject of a paper by R. R. Batcher, consulting engineer.

His paper covered the use of cathode ray tubes in industry, and several practical applications were given. The operation of a number of types of tubes was demonstrated. Various patterns resulting from the application of different frequencies to the deflector plates were shown and their interpretation discussed.

The attendance totaled forty-eight.

The annual meeting of the Connecticut Valley Section was held on December 15 at the Hotel Garde in Hartford, Conn., L. F. Curtis, chairman, presiding.

"Automatic Volume Control" was the subject of an open forum discussion which was opened by L. W. Hatry who described several simple types and outlined their operating characteristics. The discussion was continued by L. F. Curtis, M. W. Bond, B. V. K. French and others who outlined recent developments in this field, in each case involving diode demodulators. Suggested causes and remedies for some of the more common faults were discussed.

As this was the annual meeting, officers for 1933 were elected and are as follows: Chairman, H. W. Holt, chief engineer, WMAS, Springfield, Mass.; Vice Chairman, George Grammer, American Radio Relay League, West Hartford, Conn.; Secretary-Treasurer, Clinton B. De Soto, American Radio Relay League, West Hartford, Conn.

The attendance at the meeting totaled twenty-four.

DETROIT SECTION

H. L. Byerly, chairman, presided at the December 16 meeting of the Detroit Section which was held in the Detroit News Conference Room and attended by fifty members and guests.

F. D. Bentley of the RCA Victor Company presented a paper on "Application of Radio Receivers to Automobiles." His paper discussed, in general, methods of installing and operating radio receivers in automobiles, and, in particular, antenna installations and the suppression of ignition and static interference.

The speaker pointed out that the average automobile antenna could be improved considerably and that the lead-in generally used was unsatisfactory. It was his opinion that an antenna of bright copper screen cut so that the edges were not closer than four inches to the metal sides of the top was usually best. The lead-in recommended was an insulated wire covered with loom over which a shield was placed.

After outlining the known causes of ignition and static trouble, some methods employed in particularly stubborn cases were described. In one case, static charges built up on the car were discharged as the wheels of the car passed over steel reinforced expansion joints in a concrete pavement. The remedy for this lies in having a tire which allows these charges to leak to ground. It was found that tires in which the tread is well worn give more trouble of this nature than new tires.

A general discussion followed the presentation of the paper. As this was the annual meeting, the following officers were elected: Chairman, G. W. Carter, Professor at the Detroit City College; Vice Chairman, L. M. Augustus, Michigan Bell Telephone Company; and Secretary-Treasurer, E. C. Denstaedt of the Detroit Police Department.

NEW YORK MEETING

The annual meeting of the Institute was held in New York in the auditorium of the Engineering Societies Building and was presided over by President Hull. A paper on "New Developments in Filamentless Tubes" was presented by August Hund, a member of the research staff of Wired Radio.

Dr. Hund described the construction and characteristics of some

gaseous tubes developed for operation without the use of a heated filament. A few hundred volts of direct current supplies the power for their operation. These tubes comprise a number of unusually-shaped electrodes and could be operated with almost any gas including air at reduced pressure. It was possible with them to obtain modulation, demodulation, amplification, and oscillation. Oscillations could be produced by means of tubes having negative resistance characteristics, by automatic relaxation effects operating in synchronism with impressed input voltages which may be of speech or music frequencies, as well as by self-excited variations due to the tube and its associated circuit. Oscillations could also be obtained by tubes designed to provide a separation of positive and negative ions.

The use of the tubes as detectors of broadcast transmissions was demonstrated by a single tube set-up as well as by a receiver employing one tube as a detector followed by a two-stage audio-frequency amplifier, the output stage of which operated two tubes in a push-pull connection. Another tube was operated as a feed-back oscillator generating frequencies in the broadcast band, its ability to oscillate in this type of circuit being definite proof of its capabilities as a radio-frequency amplifier. A high-frequency receiver capable of operating on frequencies up to thirty megacycles was displayed.

At the conclusion of the presentation of the paper and the demonstrations, a lengthy discussion ensued which was participated in by a number of those in attendance.

Approximately 600 members and guests were present at the meeting.

PHILADELPHIA SECTION

"Aircraft Radio, Its Growth and Future" was the subject of the paper Harry Diamond of the Bureau of Standards presented before the December 1 meeting of the Philadelphia Section held at the Engineers Club in Philadelphia. H. W. Byler, chairman, presided, and the attendance totaled ninety-eight.

Mr. Diamond's paper dealt with developments in aircraft radio, and was given from the viewpoint of both the development engineer and the aircraft pilot. He discussed radio range beacon systems, and outlined the solution of the problem of night effects which caused errors in the operation of these beacons. An extensive discussion followed this presentation.

PITTSBURGH SECTION

The December meeting of the Pittsburgh Section was held at the Fort Pitt Hotel on the 20th, and was presided over by R. T. Griffith,

chairman. L. O. Grondahl of the Union Switch and Signal Company presented a paper on "Copper Oxide Rectifiers and Photocells."

Dr. Grondahl opened his paper with the history of the discovery of the rectifying property of copper and cuprous oxide twelve years ago. He then discussed developments in the design and operation of these devices describing the characteristics, uses, and manufacturing processes of present-day rectifiers of this type. Next he covered an interesting development of these rectifiers for the rectification of radio-frequency signals so as to obtain the necessary direct currents for automatic volume control. The primary characteristic claimed for such a demodulator is the absence of harmonic distortion.

At the close of the paper an interesting discussion ensued which was participated in by Messrs. Allen, Griffith, Krause, Place, Reardon, Wallace, and Wyckoff of the thirty-one members and guests in attendance. The discussion also covered distortion in diode detectors, crystal band-pass filters, and photovoltaic properties of metals.

SAN FRANCISCO SECTION

A meeting of the San Francisco Section was held on December 7, and was presided over by George T. Royden. The attendance totaled twenty-six.

A paper on the "Use of Diamond-Shaped Antennas on Ultra-High Frequencies" was presented by D. R. Hall. The paper was illustrated by diagrams showing the radiation patterns of various antennas. The methods of design and operation of diamond-shaped antennas were outlined and their characteristics discussed. A number of the members present participated in its discussion.

Following the presentation of the paper, two papers which have appeared in the PROCEEDINGS were reviewed and discussed generally. The first of these, "Copper-Oxide Rectifier Used for Radio Detector and Automatic Volume Control," by L. O. Grondahl and W. P. Place was reviewed by E. W. Morris. The second paper was on "Radio Guidance" by J. E. Miller and was reviewed by Henry Wolff. In the review of these papers, a general discussion in which most of those present participated ensued.

SEATTLE SECTION

A meeting of the Seattle Section was held on October 28 at the University of Washington with L. C. Austin, chairman, presiding. "Electronic Emission from Cold Metals" was the subject of a paper presented by Professor Henderson of the University of Washington.

The paper covered a method devised to permit determining the electronic properties of a metal under ordinary temperature conditions rather than at the abnormally high temperatures which give rise to thermionic emission. This is done by a study of the velocity distribution of electrons emitted by a cold metal under the action of an intense electrical field. The velocity distribution shows that the electron condition within a metal is very different than ordinarily supposed. Electrons within the metal tested, which was tungsten, must be regarded as having energies ranging effectively up to forty electron volts rather than a few hundredths of a volt which they would have if in kinetic equilibrium with the molecules of the metal. In addition, the most probable value of the energy is very close to the maximum energy observed. These facts considered in connection with the probability of transmission of electrons through the potential barrier at the surface of the metal are consistent with the predictions of the Fermi-Dirac statistics as applied to metals by Sommerfeld and Pauli. Preliminary results of the change in distribution produced when a current is flowing in the metal was shown.

The meeting was attended by thirty-eight members and guests.

The November meeting of the Seattle Section was held on the 25th at the University of Washington with L. C. Austin, chairman, presiding. The attendance totaled thirty-five.

Fred S. Eastman, an instructor in aeronautical engineering at the University of Washington, presented a paper on "Automatic Weighing with Vacuum Tubes." In it he described a balance built at the university for use in the laboratory wind tunnels employed in measuring air-plane stresses. The conventional type of automatic balance used for this purpose is motor-operated, the motor being controlled by metallic contacts located on the end of the balance arm. These contacts have always given considerable trouble due to arcing and pitting. Thyatron tubes were applied to this circuit to control the speed and direction of rotation of the motor. The grids of these tubes were controlled by a magnetic device which eliminated all contacts. This contact trouble being eliminated, an increased accuracy in the results of the experimental work was obtained.

A new type of balance was then demonstrated, wherein balance was obtained by means of a small solenoid instead of the conventional sliding weights. This solenoid consisted of a moving coil and a field magnet similar to a dynamic speaker. The current through the moving coil was controlled by a thyatron tube under the control of the same magnetic device used for the motor-driven balance. The solenoid field was

maintained constant, and the force acting on the balance was directly proportional to the current through the moving coil, as read by a meter in the circuit. This type of balance has the advantage of being almost instantaneous in action, may be used with a recording instrument to give a continuous record of forces, and its scale may be adjusted to almost any range at will by means of a shunt across the moving coil. A demonstration of weighing a few grams, and several hundred grams with equal accuracy with this balance was made.

On the 16th of December the annual meeting of the Seattle Section was held at the University of Washington, and the following officers elected for 1933. Chairman, H. H. Bouson, consulting engineer; Vice Chairman, R. C. Fisher; and Secretary-Treasurer, Howard Mason.

A paper on "Petroleum Geophysics" was presented by R. C. Fisher who outlined various methods developed for locating underground deposits of specific materials and particularly that type of material associated with the presence of petroleum.

Twenty-one members and guests attended the meeting.

TORONTO SECTION

A meeting of the Toronto Section was held at the University of Toronto on November 17 with Chairman Hackbusch presiding.

"Dual Speakers" was the subject of the paper by H. S. Knowles, superintending engineer of the Jensen Manufacturing Company. Mr. Knowles first discussed single speaker operation and then dual speaker operation, giving a number of interesting mathematical comparisons. His talk was well illustrated with slides, and was discussed by Messrs. Bayly, Hackbusch, Leslie, Meredith, Ocley, and Robb.

The attendance totaled sixty-four.

WASHINGTON SECTION

The annual meeting of the Washington Section was held on December 8 at the Kennedy-Warren Apartments at Washington, and was presided over by J. H. Dellinger, chairman. Officers elected for the following year are: Chairman, H. G. Dorsey, Coast and Geodetic Survey; Vice Chairman, T. McL. Davis of the Naval Research Laboratory; and Secretary-Treasurer, C. L. Davis, of the Radio Corporation of America.

A "Review of Ultra-Short-Wave Literature" was presented by W. F. Curtis, a junior physicist of the Naval Research Laboratory.

The author defined ultra-short waves as radiation having wavelengths of less than one meter, and gave a brief history of the work done in this region. A number of circuits such as the Barkhausen-Kurz, Gill-

Morell, grid-spiral, Pierret, and magnetron were given and discussed under such headings as operation, range of wavelengths covered, typical circuit constants, and the order of magnitude of the power produced. The more outstanding of recent practical accomplishments in this field were discussed.

The attendance totaled fifty-three.

Personal Mention

Raymond Asserson formerly with Radio Frequency Laboratories is now in the engineering division of the Federal Radio Commission.

Formerly with Operadio Manufacturing Company, R. E. Baird has become equipment engineer for Hawley Products Company of St. Charles, Ill.

Zolmon Benin has joined the staff of Aeradio Corporation of Jersey City, having previously been connected with the Ergon Corporation.

Formerly with the Insuline Corporation of America, J. L. Cassell has become chief engineer of Myers Electrical Research Corporation in New York City.

E. G. Chadder has been transferred from the British Broadcasting Corporation station in Aberdeen, Scotland, to the West Regional Transmitter at Minehead, Somerset, England.

Previously with the Arcturus Radio Company, P. W. Charton has joined the research and development staff of National Union Radio Corporation in Newark, N. J.

L. M. Clement has left the Federal Telegraph Company to become chief engineer for broadcast receivers for Europe for Standard Telephones and Cables of Billancourt, France.

Kendall Clough formerly with Silver-Marshall has become chief engineer for the Clough-Brengle Company.

Captain H. D. Clough has been transferred from Camp Borden, Ontario to Winnipeg, Man.

A. H. Edgerly, Jr., has joined the radio engineering department of the United American Bosch Corporation.

Previously with the Hazeltine Corporation, N. V. Fedotoff has become a development engineer for the National District Telegraph Company in New York City.

Formerly with RCA Victor Company, E. D. A. Geoghegan has joined the staff of Sprague Specialties Company at North Adams, Mass.

J. K. Hilliard previously with United Artists Studio is now transmission engineer for the Fox Film Corporation.

E. S. Heiser has been transferred from Chicago to Denver, Colo. to become acting inspector in charge of District 15 of the Federal Radio Commission.

L. W. Hermes formerly with Messrs. Siemens has become technical director of Ideal Radio and Gramophone Company of Surbiton, England.

F. A. Holborn has joined the engineering staff of the Western Union Telegraph Company having previously been with the International Communications Laboratories.

Lieutenant Commander C. F. Holden, U.S.N., has been transferred from the U.S.S. Tennessee to the U.S.S. Tarbell.

Lieutenant C. M. Johnson, U.S.N., has been transferred from the Naval Air Station at Lakehurst to the U.S.S. Bushnell.

Previously with the Thordarsen Electric Manufacturing Company, P. M. Komm has become an electrical engineer for the Grigsby-Grunow Company in Chicago.

A. G. Manke has joined the staff of Pilot Radio and Tube Company at Lawrence, Mass., having formerly been an engineer for Leeds and Northrup Company of Philadelphia.

A. C. Matthews has become chief engineer of Brunswick Engineers, Inc., of Long Island City, N. Y. He was formerly connected with the Freed Radio and Television Corporation.

Previously with A. H. Grebe and Company, A. P. Montgomery has become an engineer for Philco Radio and Television Corporation in Philadelphia.

F. J. Novotny, Jr., formerly with International Telephone and Telegraph Company has established a practice as patent attorney with headquarters in New York City.

C. A. Petry has left the Bell Telephone Laboratories to join the radio engineering staff of United Air Lines with headquarters at Chicago.

Previously with the Paramount Publix Corporation, H. I. Reiskind has become a recording engineer for the Eastern Service Studios, Inc., in New York City.

F. T. Reynolds formerly with Reynolds Microphone Laboratories has become a sound technician for Commercial Film Enterprise of San Francisco.

Previously with Vitaphone Corporation, V. A. Schlenker has become a consulting acoustical engineer with headquarters in New York City.

Formerly with WEAN, Harold Thomas has been appointed chief engineer of WSAR at Fall River, Mass.

Previously with the Jenkins Laboratories, R. H. Thomsen has become a radio engineer for Radio Research Company of Silver Spring, Md.

Formerly with Lang Radio Company, Barnet Trott, has joined the engineering staff of Freed Radio and Television Corporation of Long Island City, N. Y.

E. N. Wendell has left the International Telephone and Telegraph Company to become a radio engineer for the Compania Telefonica Nacional de Espana at Madrid, Spain.

Previously with the Radio Corporation of America, J. C. Whitehead has joined the staff of Philco Radio and Television Company in Philadelphia.

W. P. Wilson formerly with Marconi's Wireless Telegraph Company has joined the Research Department of the British Broadcasting Corporation in London, England.

L. J. Wolf has been transferred from the Westinghouse Company at Chicopee Falls, Mass., to the Engineering Department of the Westinghouse X-Ray Company at Long Island City, N. Y.

D. J. Yenoli formerly with F.A.D. Andrea is now in the Long Lines Department of the American Telephone and Telegraph Company in New York City.

Formerly in the Electrotechnical Laboratory of the Ministry of Communications Eitaro Yokoyama has become chief engineer of the Japan Wireless Telegraph Company of Tokyo, Japan.



Harry Shoemaker

Radio engineering and radio engineers owe a great deal to Harry Shoemaker. Many members of this Institute probably never heard of him and probably but few of those who knew of him have learned that he died last summer.

Word of his death was brought to the Board of Directors of the Institute at its September meeting but the files of the Institute did not contain sufficient data to make a statement in keeping with the history of his activities. The writer searched his personal files and recollection and found they too were inadequate. Further information was obtained from Mr. Greenleaf Whittier Pickard who, with the writer, was closely associated with Mr. Shoemaker in 1901, and frequently in close touch with him for the fifteen years following. Information regarding Mr. Shoemaker's more recent activities was obtained from Mr. P. R. Mallory.

Harry Shoemaker was a radio pioneer and was nationally and internationally prominent in early radio engineering. He was granted a large number of patents for devices in radio and allied arts. At one time there probably were more United States radio patents issued to him than had been issued to any other inventor. The variable air condensers designed and made by Shoemaker about a quarter of a century ago were mechanically like the variable air condensers made for standards purposes to-day; some of them were still in use at least within the last few years. What Shoemaker called the "link circuit," now known as a radio transmission line, was a favorite device with him about 1910. In the companies with which Shoemaker was connected he occupied an executive position or a position of leadership, however, he personally worked out details in design, construction, operation, and research. He was a Member of The Wireless Institute, a parent society of this Institute and a Fellow of this Institute for many years. He contributed to both Institutes in their early difficult days. In later years he retired

more and more to his own work and from contact with the extensive personnel that constitutes the radio engineering world of to-day. The writer, who used to pal around with him many years ago, had not seen him during recent years.

Harry Shoemaker was born near Millville, Pennsylvania, May 11, 1879. He was educated at the Greenwood Seminary in Millville, the Normal School in Muncy, Pa., and Pennsylvania State College.

In October, 1899, he became associated with G. P. Gehring of Philadelphia in wireless work; in 1900 they, with others, organized the American Wireless Telephone and Telegraph Company, the first radio incorporation in the United States. The patent basis for this corporation included the Dolbear wireless patent issued in 1886 and Shoemaker applications. Mr. Shoemaker was Chief Engineer. In 1901 that company built experimental stations in New Jersey and reported the Columbia vs. the Shamrock yacht races by wireless.

From 1902 to 1904 he was Chief Engineer of the Consolidated Wireless Telephone and Telegraph Company; 1904-1908 he was principle owner of the International Telegraph Construction Company building radio apparatus for the U. S. Government and others; 1908-1912 he was a prominent engineer with the United Wireless Telegraph Company; 1913-1918 he was a member of the engineering staff of the Marconi Wireless Telegraph Company of America; 1918-1921 he was Chief Engineer of the Liberty Electric Corporation manufacturing radio transmitters and receivers; 1921-1929 he was Chief Engineer of P. R. Mallory and Company. When the P. R. Mallory Company moved their manufacturing activities to Indiana Mr. Shoemaker resigned to remain in the east on independent work. In May, 1932 he was again employed by P. R. Mallory and Company on research work on dry plate rectifiers at the laboratory of Samuel Ruben in New Rochelle, New York. On August 23, 1932, while conducting this research in that laboratory he suddenly suffered a cerebral hemorrhage and fell dead. A wife and two children survive him.

ROBERT HENRY MARRIOTT



TECHNICAL PAPERS

THE REQUIRED MINIMUM FREQUENCY SEPARATION
BETWEEN CARRIER WAVES OF BROADCAST STATIONS*

By

P. P. ECKERSLEY

(Consulting Engineer, London, England)

SPECTRUM OF FREQUENCIES RADIATED BY
BROADCAST STATIONS

Summary— The general problem of interference between adjacent broadcast channels is discussed in relation to the average distribution of power over the frequency range of typical broadcast signals, the response characteristics of the ear, and the frequency characteristics of transmitters and receivers. The discussion includes a consideration of what may be accomplished by modifying the characteristics of transmitters and receivers, and the extent to which the required modifications depend upon relative field intensity of desired and interfering signals. The conclusions suggest that some rather extensive changes in the frequency allocation of broadcast channels will be necessary in order to provide at least one clear channel capable of high quality program transmission to all receivers.

IN ORDER to convey intelligence by space waves the amplitude of the carrier is successively increased and decreased, or, as we say, modulated. This modulation takes the form, either of successions of full and zero energy as in Morse signaling, or, as in broadcast practice, by modulating from the output of the microphone. The microphone is energized by the varying sound field created by the instruments, voices, etc., which it is desired to be broadcast. For the sake of completeness we shall begin by a statement of first principles.

It is well known that if f_c is the frequency of the carrier wave and f_m a single low frequency of modulation, then the resulting disturbance sent out from the radiating aerial is composed of three frequencies:

$$f_c, f_c + f_m, f_c - f_m.$$

In broadcasting the spectrum of modulation frequencies should consist of all or any of the frequencies between 20 cycles per second and 20,000 cycles per second. Not all ears can appreciate frequencies as high as 20,000 cycles per second, but many can hear up to 15,000 cycles per

* Decimal classification: R430. Original manuscript received by the Institute, August 31, 1932. Presented before New York Meeting of the Institute, September 28, 1932.

second provided the intensity is great enough. The quantities involved in broadcast technique are, however, too cumbersome to allow us to fix our ideals higher than to expect a transmission, and therefore a reproduction, of any modulation of frequency higher than 10,000 cycles per second. There is no doubt that this makes quality worse than it would be if the 10,000 to 20,000 cycles per second band were present, but the upper limit of 10,000 cycles is, in the circumstances, inevitable.

The reader will appreciate, therefore, that in what follows the as-

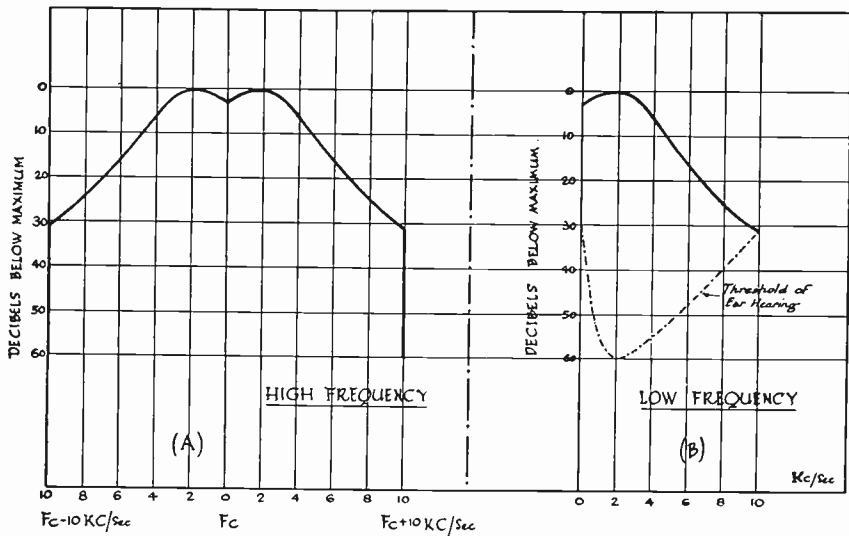

Fig. 1

sumption of the 10,000 cycles per second upper frequency limit is made for the sake of expediency; it is realized that a higher upper limit would be desirable.

It will be seen from the above that a broadcast station sends out a spectrum of frequencies, the width of which is equal to twice the highest modulation frequency. In broadcast practice this will be $2 \times 10,000 = 20,000$ cycles per second.

It is the function of the high-frequency circuits of the receiver to give an equal response over the whole spectrum, but, for perfection, not to respond appreciably to any frequencies outside this spectrum.

It will be obvious, however, that if the separation of the carrier-wave frequencies of two similarly modulated stations creating signals of comparable strength at a given point is less than twice the highest modulation frequency, then the spectra of the two stations must overlap. This will create mutual interference at points where the fields of the two stations are of comparable strength.

For the sake of clarity let us say that we wish the receiver to select

a station called the "wanted station" (creating a "wanted spectrum") and reject a station called the "unwanted station" (creating an "unwanted spectrum"). Let us also assume that the two stations are contiguous in a wavelength distribution plan. The selectivity of a receiver is generally expressed in terms of its ability to reject unwanted and accept the wanted station. But if the spectra of the two stations overlap, and if the field of the wanted station is of a strength comparable to the field of the unwanted station, then the receiver will have to be responsive over a band width of frequencies which is less than the whole width of the wanted spectrum. It will in fact have to cut off that part of the wanted spectrum which is spoiled by the fringes of the unwanted spectrum, and so quality of reproduction will not be so good as if the unwanted station were less powerful or further separated in frequency from the wanted station.

QUANTITATIVE ANALYSIS CONCERNING OVERLAP OF SPECTRA

Although the above facts concerning the problems of selectivity are well known, they have never, so far as the writer is aware, been subjected to a quantitative analysis.

The first requirement of a quantitative analysis is to know what is the relative intensity of the several component frequencies of the spectrum created by a broadcast transmission.

The writer has made measurements, first, of the peak voltage in the spectrum, and second, in coöperation with F. Davey¹ of the energy in the spectrum. The two methods give results which are in substantial agreement. Details of the latter method are given in Appendix I.

Suffice it to say here, that the average of many different types of programs gives a spectrum which is completely defined in Fig. 1 (A), and the effect of perfect rectification, amplification, and reproduction is to produce an air wave or sound spectrum as shown in Fig. 1 (B). The crosshatched line is drawn to represent the threshold of hearing value of a typical human ear. That is to say, intensities of value below those indicated by the threshold of hearing curve will be inaudible to the average human ear. The threshold of hearing curve is drawn in Fig. 1 (B) to meet the spectrum curve at 10,000 cycles per second. This is equivalent to saying that we do not expect reproduction above 10,000 cycles per second. To represent "perfection" the threshold of hearing curve would be drawn lower down in the diagram of Fig. 1 (B), and the curve of average energy would extend to meet the threshold of hearing curve at a frequency value of from 15,000 to 20,000 cycles per

¹ Member research staff Wireless Music, Limited, London.

second. This would represent both a greater contrast of light and shade and more faithful quality in the reproduction.

Now consider the effect of another station producing an overlap of spectra. (Fig. 2 (A)). The effect of the unwanted spectrum, provided both transmitter and receiver exhibit a sharp cut at 10,000 cycles per second, and provided there is complete "demodulation" of the unwanted spectrum,² is to produce a sound or air-wave spectrum as shown in Fig. 2 (B).

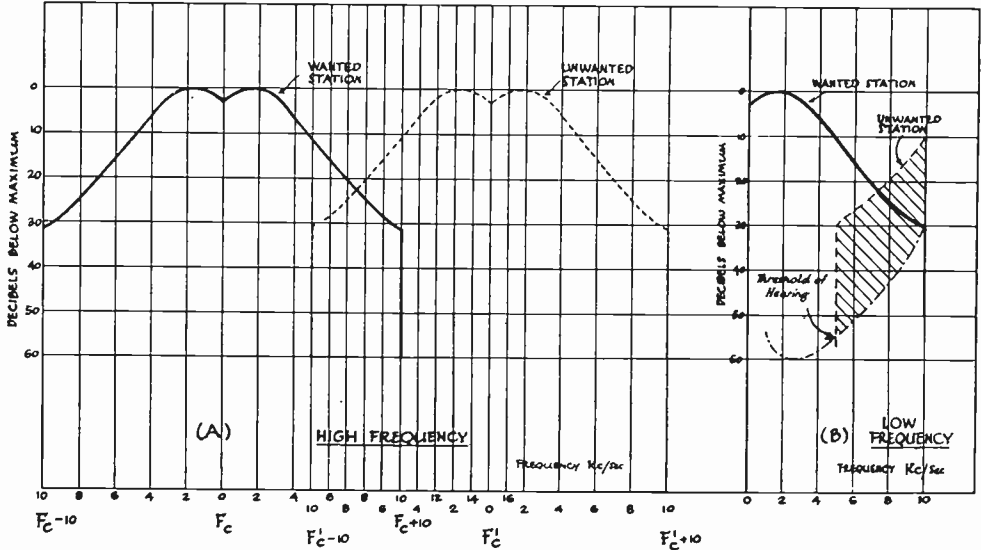

Fig. 2

Elimination of Interference

There are in general two methods by which the unwanted station interference may be eliminated from the reproduction, as:

- (a) In the receiver
- (b) In the transmitter.

Considering (a), elimination in the receiver, it will be seen from Fig. 3 (A) that the receiver can be adjusted to eliminate the interference by:

- (a) 1. Reducing the output power from the loud speaker. This is shown in the diagram (Fig. 3 (A)) by moving the threshold of hearing curve upwards so that all the interference lies below the threshold of hearing curve and is thus inaudible.
- (a) 2. Reducing the band width of frequency response. This is shown in Fig. 3 (B).
- (b) Interference can be eliminated by altering the conditions of transmission, as:

² See Appendix II.

- (b) 1. Arranging for a sufficiently large frequency separation between the carrier wavelengths. Fig. 4 (A).

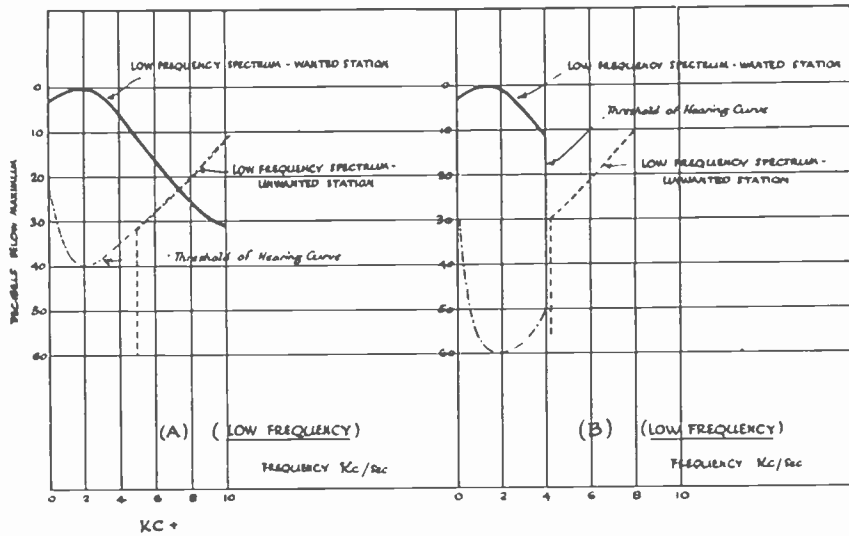

Fig. 3

- (b) 2. By sufficiently reducing the power of the interfering station, whatever the frequency separation. Fig. 4 (B).

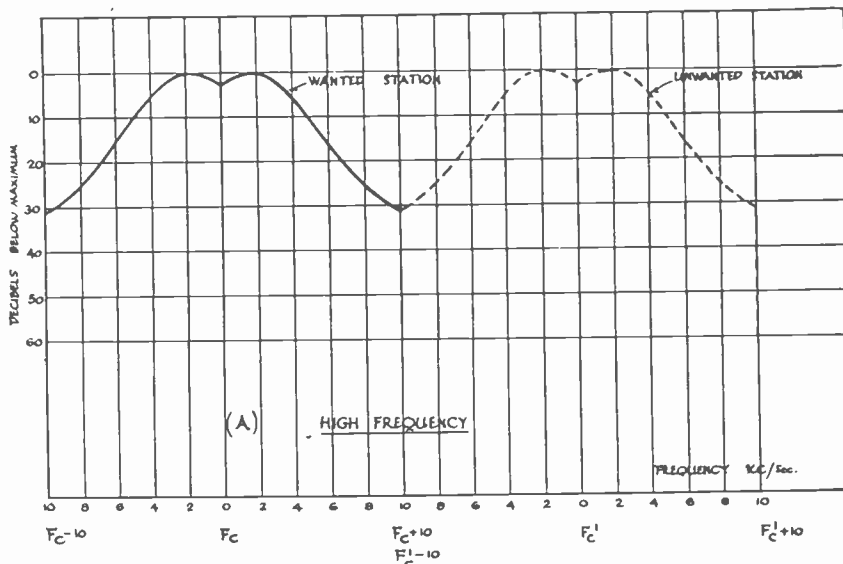

Fig. 4(A)

- (b) 3. By "cutting off" the outer fringes of the transmission spectrum and assuming a similar cut be made in the receiver. Fig. 4 (C).

Note that all methods except (b)1 and (b)2 involve "cutting off" the upper fringes of the wanted spectrum, and thus produce a poorer quality than that specified as a practical ideal.

Receiver Selectivity

It is particularly interesting to note that receiver selectivity is a meaningless term unless both the quality of reproduction and the vol-

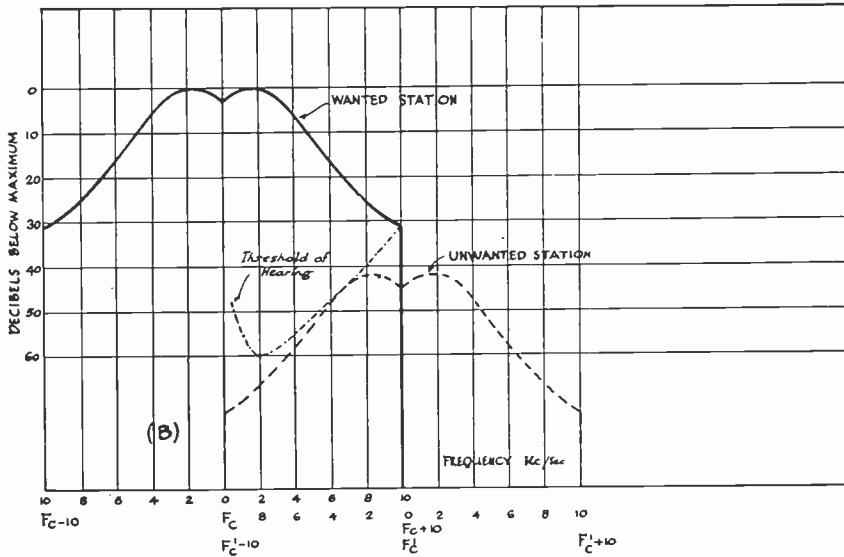

Fig. 4(B)

ume of sound output required are defined. Furthermore, the volume output of a receiver is a measure of its selectivity and its ability to give

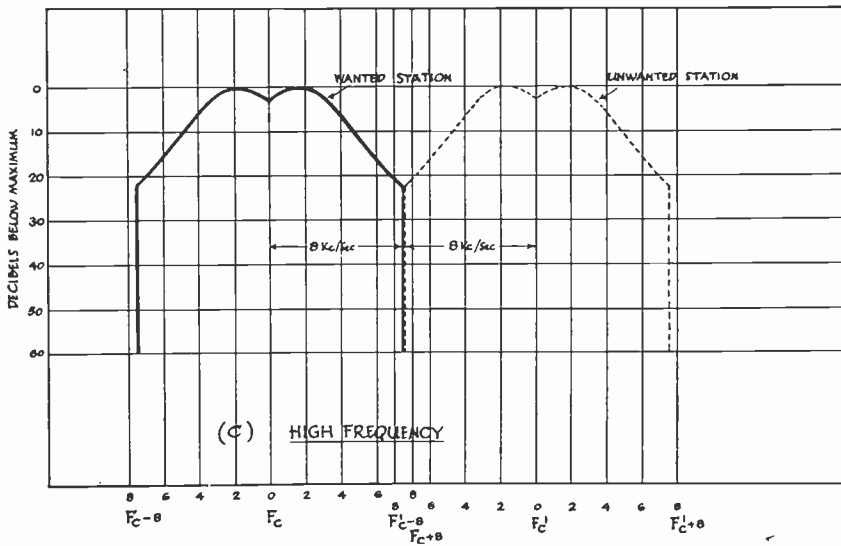

Fig. 4(C)

good quality. Thus an unselective and low power receiver in a wanted station field strong enough to push all the interfering stations below the ideal threshold of hearing curve is a very selective receiver (if we

mean by that that it functions without experiencing interference from other stations), whereas a very sensitive multivalve receiver, with an elaborate filter circuit system by means of which one attempts to select a weak signal, interfered with by powerful neighboring-frequency stations, may not seem to be selective. A multivalve receiver so conditioned can only be made selective by reducing the output level and/or its over-all width of (loud speaker reproduced) frequency response (Figs. 3A and 3B). A receiver which is not able to give reproduction above ear threshold intensity up to a frequency of 10,000 cycles per second; however perfect its frequency-response curve, and however relatively strong the signal, exhibits, what is, in fact, a cut-off, (Fig. 3A) which occurs at the frequency where the ear threshold curve cuts the spectrum energy curve.

*Quantities Involved and Assumptions Made to Draw Graphs of
Figs. 5, 6, 7.*

It will be obvious from the quasi quantitative analysis given above that it is not always necessary for the elimination of interstation interference, to make the minimum separation between carrier waves equal to twice the highest modulation frequency. Method (b)² above is in fact available if the geographical separation of stations is great enough.

The next step in the analysis is, therefore, to calculate the relationship between ratio of fields of wanted and unwanted stations and required frequency of separation for a 10,000-cycle-per-second upper frequency reproduction in a "perfect" receiver as defined below.

In order to discover this relationship we make certain assumptions as follows:

- (1) Assume that every receiver can be made to give the effects of demodulation² so that the lower modulation frequencies of the carrier wave of the unwanted station become upper-frequency interferences to the wanted station.
- (2) Assume that the receiver, either in its high- or low-frequency circuits, exhibits an abrupt cut-off just below 10,000 cycles per second, as indicated in the relevant diagrams. This eliminates any question of bothering about heterodyne interference. It is not an impracticable assumption since abrupt low-pass audio-frequency filters can be manufactured perfectly satisfactorily.
- (3) Assume the modulation characteristics of each station to be identical.

Now draw a diagram of the assumed spectrum. Lay a piece of tracing paper over this diagram and make a copy of the spectrum on

the tracing paper. Next reverse the tracing paper and lay it so that it makes a picture of wanted (drawn on the diagram) and unwanted (drawn on the tracing paper) spectra. By sliding the tracing paper left or right or up or down a position can always be found where the tracing paper diagram lies under the threshold hearing curve of the fixed diagram drawn on ordinary paper.

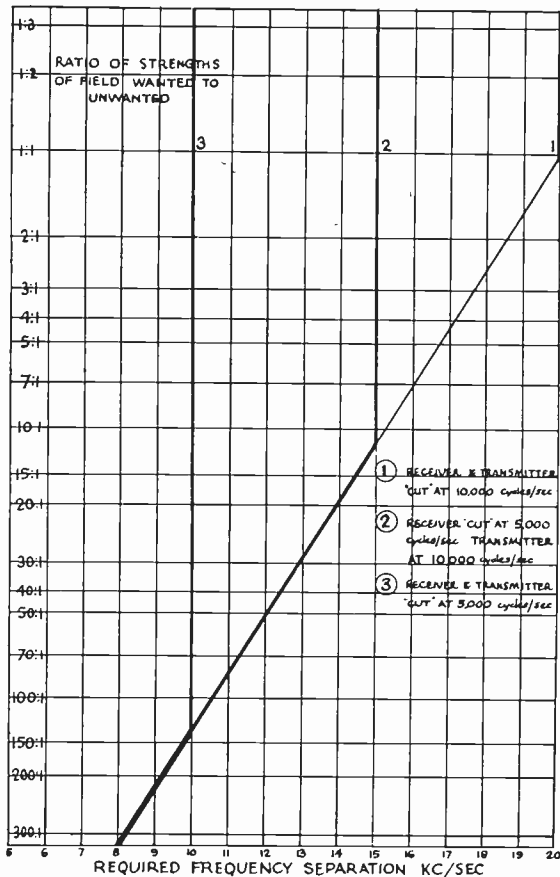

Fig. 5

It is possible by this method to find out the required frequency separation of carrier waves of stations to prevent interference (all tracing paper diagram underneath threshold of hearing curve) with different ratio of fields of interfering and wanted stations when we assume:

1. The necessity for a 10,000-cycle-per-second upper frequency of reproduction.
2. That the receiver low-frequency circuits "cut" at 5000 cycles per second.
3. That both receiver and transmitter cut at 5000 cycles per second.

The information derived by this method is given in Fig. 5, curves 1, 2, and 3.

It is possible to express the curves of Fig. 5 in terms of the power of the interfering or unwanted station. To do this we make the following assumptions:

1. Following the writer's previous papers and one in particular,³

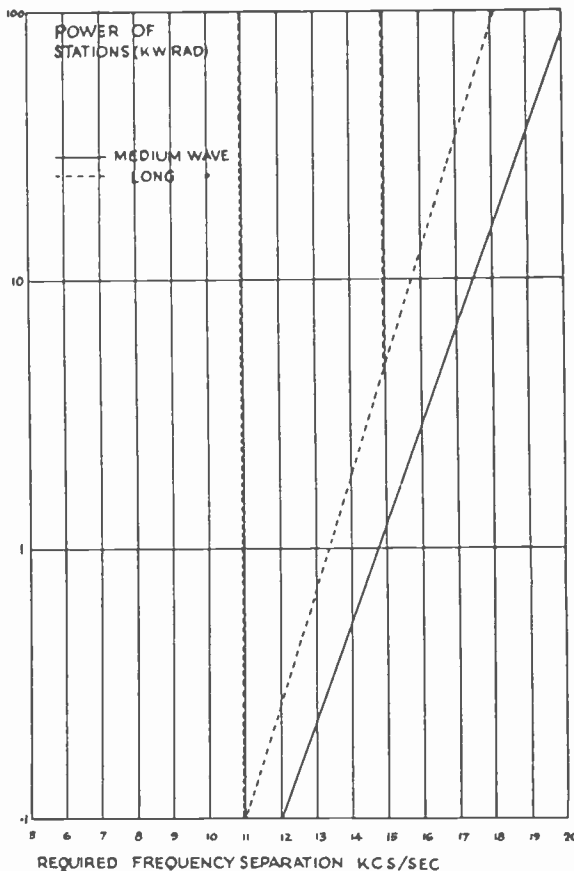

Fig. 6

assume a field of 2.5 microvolts per meter as a minimum signal strength for a worth-while broadcast service.

2. Assume that the geographical separation between stations contiguous on a wavelength plan which are likely to be in the same zone of darkness during normal hours of broadcasting to be of the order of 1000 kilometers.
3. From 2 it will be clear that we may assume that the interfering field will be created almost entirely by the indirect or space ray.

³ "The calculation of the service area of broadcast stations," Proc. I.R.E., vol. 18, pp. 1160-1194; July, (1930).

Assume that this, for long waves is of the order of 0.15 microvolt per meter per kilowatt radiated, and that for medium waves it is of the order of 0.3 microvolt per meter per kilowatt radiated. This assumption is justified as shown in previous papers.

These assumptions give us all the required data for calculating Fig. 6.

"Free Area of Reception" Against Ratio of Strength of Wanted and Unwanted Stations.

It is now interesting to calculate what precautions must be taken in the design of receiver circuits to prevent interstation interference when the minimum frequency separation between stations, creating signals of comparable strength, is less than that shown to be necessary in Figs. 5 and 6. This is a far-from-academic calculation since in Europe today the average power of broadcast stations is of the order of 12 kilowatts and the thirty or more regional stations have powers between 50 and 100 kilowatts. Furthermore, the frequency separation is only 9000 cycles per second. The geographical separation between stations contiguous in the European wavelength repartition plan, averages 600 to 1000 kilometers, and all stations are fully modulated to frequencies as high as 8000 cycles per second and many to 10,000 cycles per second frequency.

We can express the requirements of receiver design for interstation interference elimination in terms of methods (a)1 and (a)2 given above. This shows us that both receiver output level and the total low-frequency band width of response may be reduced to reduce the overlapping spectrum interference (Figs. 3A and 3B). But the method of Fig. 3B (low-frequency cut-off but retention of a large volume output over the remaining lower band of frequencies) results, when the interfering station is strong, in such a low value of upper-(audio-) frequency cut-off, that it is advisable to express the results only in terms of Fig. 3(A); i.e., making the receiver volume output smaller and *in consequence* cutting off some of the upper parts of the (audio) spectrum.

We can in fact find a number which we shall call "the free area of reception coefficient" and express this coefficient in terms of decibels, depth, and frequency width. This is perhaps a somewhat astonishing conception; we do not normally multiply such quantities together. It seems justifiable, however, to use this number and plot it against ratio of fields of wanted and unwanted stations, but at successive points on the curve itself, write a figure to indicate the required upper limit of frequency to assure interference-free reception.

The curve expressing the free area of reception coefficient against ratio of fields of the wanted and unwanted stations is given in Fig. 7.

CONCLUSIONS DRAWN FROM THE ANALYSIS

It is quite obvious that we may conclude from the calculations that broadcast technique, as it is quantitatively practiced today, does not,

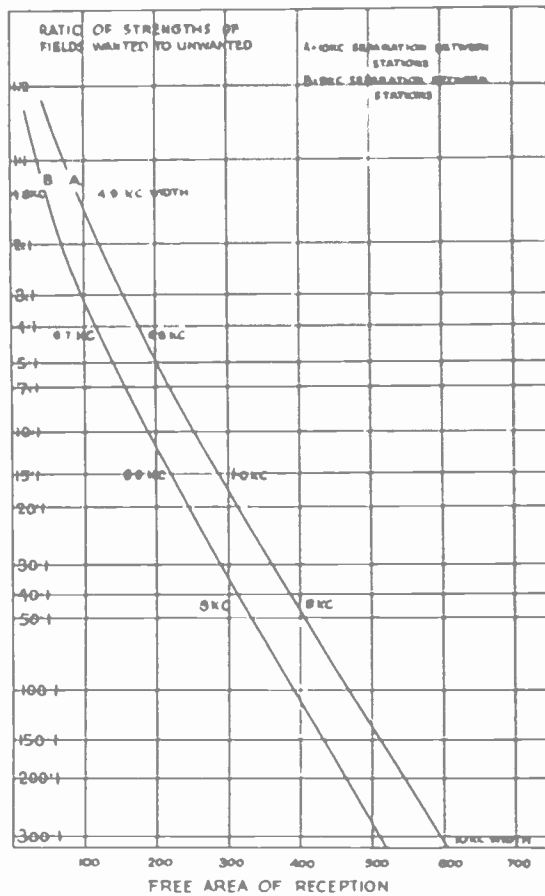

Fig. 7

and cannot, give the typical user of a receiving apparatus that quality of reproduction which satisfies the really exacting ear.

The writer has, for the past eight years, tried to induce responsible technicians to plan broadcast transmission systems so that *every* listener wherever he may be shall have facilities for the clear, uninterrupted, steady reception of at least one program. In some countries this is achieved; in others there is a good service of many programs in the towns and no worth while service in the country.

The writer believes it to be the paramount duty of the authorities to ensure first that every listener, urban or rural, shall be assured a

service of at least one program whereafter, if there are surplus channels available, alternatives may be given.

The manifest unsuitability of the wavelengths allocated by governments for the use of the broadcast service has forced those who try to give a real nation-wide urban and rural service to use very large station power, and an altogether too small frequency separation between the carrier waves of stations likely to interfere one with another.

DIFFERENT METHODS TO OVERCOME PRESENT DIFFICULTIES

There are three possible methods of attack to subdue the unwieldy quantities which prevent good service today, as:

Method (a)

To separate stations by 9 or 10 kilocycles frequency difference and cut off all transmission modulations above a value equal to half the minimum frequency separation but, because of government regulations, use medium wavelengths (550–200 meters).

Method (b)

To separate stations by 20 kilocycles frequency difference and cut off all transmission modulations above 10 kilocycles but, because of government regulations, use medium wavelengths (550–200 meters).

Method (c)

To separate stations by 20 kilocycles and cut off all transmission modulations above 10 kilocycles, and, postulating wise regulations, permitting such a scheme, use wavelengths between 300 and 2000 meters.

Obviously method (a) suffers from the disadvantage that the resulting quality of reproduction in the receiver will be poorer than with other methods. Some may argue that a reproduction up to 4500 or 5000 cycles per second is adequate. It may be adequate for those who argue that it is adequate, but there are those others who like to listen to music.

Method (b) suffers from the disadvantage that the total geographical area served, using the same station power as with method (a), is half that covered by method (a).

Method (c) suffers from the disadvantage that it allows only 42 different programs to be radiated simultaneously in a given zone, whereas method (a) allows the radiation of 100 different programs in the same zone. Furthermore, it is argued that the receiving set design

for a 300-2000-meter wave range is complicated by the fact that one condenser, associated with one inductance, cannot be used to cover the full gamut and that, therefore, a second inductance must be inserted for part of the tuning range.

Quantitative Comparisons Between Methods to Give Better Service

It is, however, interesting to calculate the degree to which such quantitative comparisons have meaning.

TABLE I

Calculations comparing transmission schemes				Relevant information	
Method	Σ (Service area of stations)	No. of different programs (approx.)	Cut-off frequency	Areas of continents	
				Continental area	Area square kilometers
	Square kilometers		Kilocycles		
(a)	2.6×10^6	100	5		
(b)	1.2×10^6	50	10	Europe (inc. Russia in Europe)	10×10^6 (approx.)
(c)	10.0×10^6	42	10	United States of America and Canada in same zone of darkness during winter broadcast hours	10×10^6 (approx.)

It has been pointed out in previous papers⁴ that the service area of a station cannot be increased beyond a certain amount whatever the power of the sending station. At a certain determinable distance from the station the indirect or space ray is always equal to the direct service-area-making ground ray, and increasing the power does not alter this one-to-one ratio. Thus we can calculate a certain ground ray attenuation, and associate with every wavelength a maximum possible service area independent of station power.

Thus to compare methods (a), (b), and (c) above we can calculate Σ (maximum possible service area of stations) and take the result as one part of a figure of merit for the scheme, the other parts being variety of program and quality of reproduction.

In order not to burden the paper with a redundancy of printed matter, only the result of these calculations is given, and it is hoped that the reader will accept the findings. The calculations are based upon the author's previous and many times practically justified assumptions on the calculation of the service area of broadcast stations.⁵ The table shows the result of such calculations.

This approximate numerical comparison shows that method (c)

⁴ Notably P. P. Eckersley, "Service area of broadcast stations," *loc. cit.*

⁵ See pamphlet with above title published by B.B.C., pp. 17 and 18.

would cover the continental areas satisfactorily *with one program* and would allow really good quality reproduction. But the number of separate programs available is fewer than with method (a). Obviously the whole population of Europe or Northern America would only be given an alternative program if a 5-kilocycle upper limit of frequency were accepted and a long-wave technique adopted.

The disadvantage of method (c)—that the receiver design is complicated if the band of frequencies to be tuned through is more than can be handled by one inductance associated with one condenser—has been unduly exaggerated because, after all, every European receiver is successfully designed to cover two bands of frequency.

CONCLUSION

The writer believes (and the above-cited figures abundantly prove the justification for that belief), that a good service of broadcasting cannot be expected so long as the present wavelengths continue to be used for broadcasting. It is true that method (c) does not give that highly desirable range of alternative programs which can be more easily given as the number of separate wavelengths available is increased.

The sociological influence of broadcasting must be limited so long as the technical system is limited as it is today.

It appears impossible, with a wireless broadcast technique, to expect a wide distribution of service simultaneously with a proper service of alternative programs. It becomes, therefore, more and more necessary to investigate the technical and economic possibilities of wired as opposed to wireless broadcasting. The physical network has the advantage that it allows a service of many alternative programs in, at any rate, the densely populated areas. The future may, therefore, see a *wireless* broadcast system based upon the use of adequate station frequency separation and, so-called, long waves with a station power and geographical distribution designed for service for the rural population, while a wired system will give a choice between many alternative programs for the urban populations. The ultra-short-wave technique of wireless broadcasting for urban service deserves, moreover, further investigation. One fact, apart from these speculations, remains, and that fact—the lack of available other channels and the unsuitability of the wavelengths used in wireless broadcasting—continually demonstrates the poverty of the resources of a wireless broadcast technique to give all and sundry true entertainment.

In only one continent, where broadcasting is in any measure developed, does this not apply; thus Australia, thanks to its geographical

isolation, could have a planned system which could largely neglect these difficult problems and could thus be concentrated upon true service to both rural and urban populations.

APPENDIX I

METHOD TO MEASURE FREQUENCY SPECTRUM OF A BROADCAST STATION

It was the intention of the experiment to be described to measure the relative average energies of each part of the spectrum (50–10,000 cycles per second) radiated by a broadcast station with different typical broadcast items. It was not, therefore, the object to measure

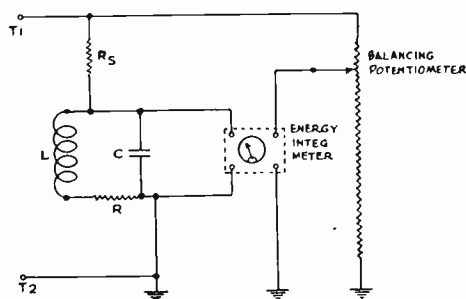

Fig. 8

the momentary energy in any component part of a particular spectrum, as, for instance, an "S" sound in speech or the upper harmonics of a violin played to give, for instance, a fundamental of 1000 cycles per second, as has been done previously, but rather to measure, over a long period of time, the average energy in a particular frequency produced by a typical speaker or a typical kind of musical combination.

The basis of the method is to use a frequency selective voltmeter connected across the output terminals of an "irreproachable" receiver which is energized from a strong signal created by an "irreproachable" transmitter modulated from a high class but typical microphone.

The diagram of connections of the circuit is shown in Fig. 8.

The impedance Z_{pr} of the "tuned" circuit L , R , C at resonance is well known to be given by

$$Z_{pr} = \frac{\omega_r^2 L^2}{R} \quad (1)$$

where,

$$\omega_r = \frac{1}{\sqrt{LC}} = 2\pi f_r$$

where f_r is the frequency at which resonance occurs.

Also Z_{pr} behaves as a pure resistance so that

$$V_n = \frac{\frac{\omega_r^2 L^2}{R}}{\frac{\omega_r^2 L^2}{R} + R_s} \cdot V_0 \quad (2)$$

where V_n is the voltage developed across the closed circuit and V_0 is the voltage applied across R_s and tuned circuit in series.

If,
$$R_s \gg \frac{\omega_r^2 L^2}{R}$$

then,

$$V_n = \frac{\omega_r^2 L^2}{R} \cdot \frac{1}{R_s} \cdot V_0 \quad (3)$$

or, from (1) and (3),

$$V_0 = \frac{1}{Z_{pr}} \cdot R_s \cdot V_n. \quad (4)$$

Obviously the measurable response of the circuit extends over a narrow width of frequencies; we cannot say that the circuit responds to only one frequency. It is important to arrange quantities, however, so that the appreciable response occurs over a very narrow band width of frequencies.

In general we may write

$$Z_p = \frac{\omega^2 L^2}{\sqrt{R^2 + \left[\omega^2 L^2 \left(\omega L - \frac{1}{\omega C} \right) \right]^2}} \quad (5)$$

We are interested in the value of Z_p at frequencies $\omega_r \pm \Delta\omega$ where $\Delta\omega \ll \omega_p$.

Thus from (5) we may write

$$Z_{p\Delta\omega} = \frac{(\omega_r \pm \Delta\omega)^2}{\sqrt{R^2 + \left[(\omega_r \pm \Delta\omega)^2 L^2 \left((\omega_r \pm \Delta\omega)L - \frac{1}{(\omega_r \pm \Delta\omega)C} \right) \right]^2}}$$

Obviously the expression varies only appreciably with

$$\{(\omega_r \pm \Delta\omega)^2 L^2\} \left\{ (\omega_r \pm \Delta\omega)L - \frac{1}{(\omega_r \pm \Delta\omega)C} \right\}.$$

Remembering that $\omega_r L = 1/\omega_r C$ we can prove that as a first approximation

$$Z_{p\Delta\omega} = \frac{\omega_r^2 L^2}{L \sqrt{\left(\frac{R}{L}\right)^2 + (2\Delta\omega)^2}} \quad (6)$$

also evidently

$$\frac{dZ_{p\Delta\omega}}{d(\Delta\omega)} \propto \frac{2\Delta\omega}{\sqrt{\left(\frac{R}{L}\right)^2 + (2\Delta\omega)^2}}. \quad (7)$$

Thus if R/L is very large the rate of change of Z_p is proportional to $\Delta\omega$ while, if small, the rate of change is greater. Furthermore the rate of change of impedance will only be concerned with the value of R/L and not with any other quantity.

Thus if the R/L value of the coil is small and the same at all values of ω_r and if $R_1 \gg Z_p$ then V_n will represent the same quantity over the full range of frequencies 50–10,000 cycles per second. Thus V_0 will be determined as the value of the voltage produced in the same very narrow band width of frequencies within the spectrum. By using an air-cored stranded wire inductance we may say that the R value at any frequency is equal to the direct-current value of resistance.

Referring now to Fig. 8 and assuming we have a coil of very low R/L ratio we see that if we connect the output of the tuned circuit to an energy integrating meter⁶ then this will deflect at a rate depending upon the energy in the spectrum and the multiplier $R_s \cdot 1/Z_p$. (See (4).) But if means are arranged so that a part of the full energy of the spectrum taken as in the figure from an aperiodic source is made to energize the meter in a sense opposite to that of the energy applied from the closed circuit, then an adjustment of the balancing potentiometer may be found at which the meter needle does not budge.

It is then a matter for simple calculation to find out the relative amount of energy in the narrow band width of frequencies to that in the total spectrum.

From these we may average out an approximate mean spectrum

⁶ A grassop flux meter was actually used.

and say that this is the spectrum of a typical broadcast station. (Fig. 1(A).)

APPENDIX II

DEMODULATION

This paper does not greatly concern the question of receiver design, and the "perfect" receiver is thus assumed. It is insisted, however, throughout the paper, that the effects of demodulation are present, and it might be advisable briefly to describe an experiment wherein certain relevant quantities were measured.

It is well known that the demodulation effect can only take place when the detector circuit is arranged so that the value of the output rectified component is strictly proportional to the modulated high-frequency input (straight-line detection) and when the strength of the carrier wave of the station tuned in (wanted station) greatly exceeds the strength of the carrier wave of the station it is required to eliminate (unwanted station). While certain theoretical calculations exist as to the ratio of wanted-to-unwanted carrier which must exist if the effects are to take place, the author of this paper was not sufficiently impressed with their completeness to trust the arithmetical answer which might have been derived from the equations given.

Thus a simple experiment⁷ was arranged wherein the input high-frequency circuits of a receiver were specially damped to give effectively the same response over a 40-kilocycle band width of "high" frequencies. The high-frequency circuits were arranged to be energized from a 20 microvolts per meter signal from the London broadcast station. A small local oscillator was set at a frequency difference of 10 kilocycles from the frequency of the London station. This local oscillator was modulated. The strength of the currents induced in the high-frequency circuits of the receiving set was gradually increased until a value of setting was found at which the modulations of the local oscillator just became intelligible as music and below which they appeared as what has been called "monkey chatter" or a demodulated signal. Obviously this strength of interference on the London station was that which was just sufficient to prevent the demodulation effects occurring in the (straight-line) detector circuit. It was then an easy matter to switch off the London station and measure the strength of the oscillations representing the interfering station and, vice versa, switch off the interfering station and measure the strength of the London station signal.

One can say, as a result of these experiments, that the carrier

⁷ Thanks to R. E. H. Carpenter of R.M. Radio, Limited, England, using one of his "perfect quality" receivers.

strength of the wanted station at the detector must be at least 10 decibels greater than the strength of the interfering station carrier at the detector if demodulation effects are to be sufficiently produced.

It is thus interesting to note that, even if the modulation of the transmitting station is cut off above 5000 cycles, then, if there are several stations located *at different points* in the same city or town, the high-frequency filter circuits may have to have a response of 20, or more, decibels less, at the carrier-wave frequency plus or minus 10,000 cycles per second, than at the carrier-wave frequency. It is difficult to see how this can be achieved without a severe cut-down of receiver over-all frequency response between, say, 3000 and 5000 cycles per second and so the 10-kilocycle separation of carrier waves is seen to be too small if good quality reproduction is required. Of course if the transmission system is planned instead of allowed to grow haphazard, this disability does not arise because all transmissions will be radiated from practically the same geographical position somewhere on the boundary of the town or city to be served. In this case service areas are coincident and in no case does the field from one station enormously exceed that from another.

The author's British regional scheme of broadcasting is successfully based upon a system whereby each transmitting center is equipped with two transmitters, thus making receiver design simple and receiver performance adequate if not ideal.



LOW POWER RADIO TRANSMITTERS FOR BROADCASTING*

BY

A. W. KISHPAUGH AND R. E. CORAM

(Bell Telephone Laboratories, New York City)

Summary—This paper discusses the place of low powered installations in the existing radio broadcast system, and the importance of apparatus for such stations meeting the present-day requirements pertaining to frequency stability, modulation capability, fidelity, and radio-frequency harmonics. The characteristics and more interesting features of a new line of transmitters covering the range of output from 100 to 1000 watts are described. The basic unit is a 100-watt transmitter employing grid-bias modulation which is novel in so far as American broadcast practice is concerned. Outputs of 250, 500, and 1000 watts are obtained through the use of a supplementary amplifier unit equipped with tubes of appropriate capacity. Radiation-cooled tubes are used throughout, and both units are self-contained, being operated direct from an alternating-current supply without the use of rotating machinery. Mechanically the units are novel in that the housings are of a cabinet form with doors which allow complete access from the front for adjustment and maintenance.

RADIO broadcasting began with the use of transmitters of what we would now term low power. That these were not ineffective is evidenced by the immediate response given by the public and the rapid growth of the new industry.

However, to extend the distances over which programs could be satisfactorily transmitted and to reach receiving points unfavorably located, the necessity for powers greater than the few hundred watts first employed was soon recognized and the development of equipment rated at five kilowatts and upward followed. This development has been characterized by important technical advances in equipment and paralleled by a great growth in the broadcast industry with its own important advances in technique. Not a little of the growth and increased effectiveness of broadcasting is due to the capabilities of this so-called high power equipment and its performance in rendering service not otherwise possible.

Recognition of what has been accomplished with relatively high powered transmitters, and of the fact that they offer the only satisfactory means of broadcasting over large areas, has tended to divert attention from low powered equipment and has possibly prevented a general appreciation of its capabilities in the field for which it is adapted, that is, in the serving of relatively small areas. The terms

* Decimal classification: R355.21. Original manuscript received by the Institute, September 23, 1932. Presented before New York Meeting, December 2, 1931.

“low power” and “small area” are both indefinite, and while we may arbitrarily define “low power” as covering transmitters rated at one kilowatt or less, the “area” which one of these transmitters may be capable of serving cannot be defined in such an arbitrary manner as it is dependent upon many factors. Important among these are the class of service required, the nature of the territory over which the transmission takes place, and the receiving conditions encountered.¹

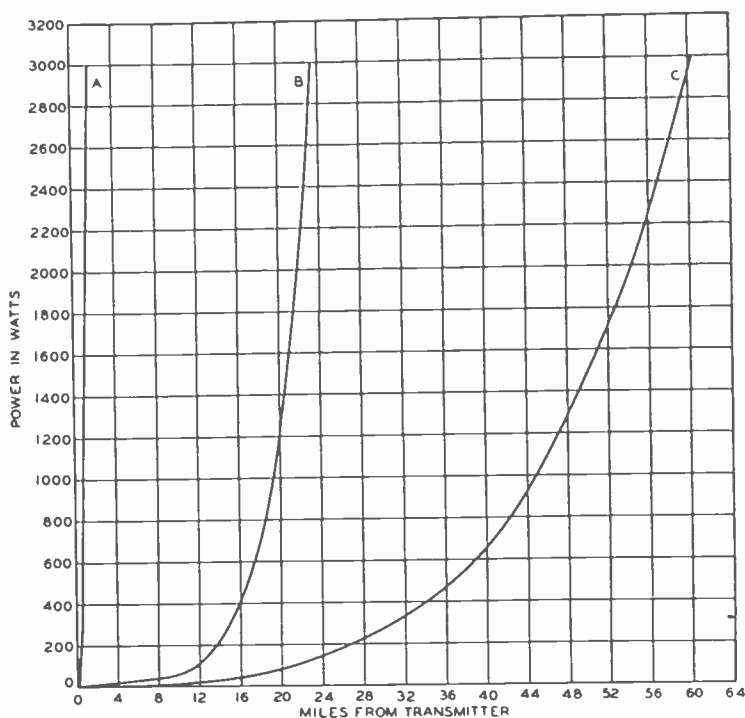

Fig. 1

Simply to indicate in a general way the comparative results which may be expected with the radiation of different amounts of power, there have been plotted on Fig. 1 a number of curves to show the distances from a broadcast station at which, under the conditions assumed, certain field strengths will be obtained. Three curves are shown. Curve A indicates the approximate distances at which the field strength is 200 millivolts per meter. Curves B and C indicate the approximate distances at which the field strength is 2 millivolts under unfavorable and favorable conditions of frequency and attenuation. It will be seen that with 100 watts radiated field strengths between 200 and 2 millivolts may be expected over distances between one-fourth

¹ C. M. Jansky, Jr. and S. L. Bailey, "On the use of field intensity measurements for the determination of broadcast station coverage," *Proc. I.R.E.*, vol. 20, no. 1, pp. 62-76; January, (1932).

and 12 to 21 miles from the station, and with 3000 watts radiated the same range of field strengths may be had over distances between 2 and 24 to 60 miles.

While these curves and figures are only typical, they do illustrate the extent to which power must be increased to extend materially the region of high daytime field strengths and the effectiveness of small amounts of power in producing these field strengths over appreciable though relatively short distances. With full realization that the larger areas must of necessity be served with high power equipment, and that closely grouped smaller areas may well be taken care of in the same manner to advantage, it is evident that small isolated areas can be adequately served with rather small amounts of power. Thus where a program has only community interest and it is not desired to cover more than the local area, a single small station will probably do all that is required. Also, where it is wished to distribute a program to a number of limited areas around separate centers of population, the provision of a number of low power transmitters, one centrally located in each area, is an efficient and economical arrangement. In this connection, it may be noted that centrally locating small transmitters is not a serious problem as the points of very high field strength which might cause troublesome interference do not extend far from the transmitter. This feature is advantageous as it facilitates useful employment of the radiation in all directions from the transmitter location.

The importance which has been attached to the possibility of serving the smaller communities at relatively low cost through the use of low power equipment is indicated by the facts that nearly half of the total number of broadcast channels are given over to stations of one kilowatt and less in power, and that there are some 500 of these stations.

Compared with a larger station, the sphere of influence of one of these may be relatively small, and apparatus failure or irregularity at a single station may be relatively unimportant; nevertheless they represent in the aggregate a great many listeners who are entitled to receive satisfactory service. Poor service and poor quality are distasteful to the individual whether he is one of a few listeners or one of thousands.

For these reasons, regulations covering the performance of equipment as it affects the service given or the general broadcast scheme apply equally to transmitting equipment of all powers. As these regulations are made more rigorous to gain the advantages of progress in the art, increasing attention must be given to the equipment which is employed, and to the details of design which enable it to meet the exacting requirements placed upon it. In the case of low power equip-

ment particularly it is important that both operation and maintenance of the high performance standards required be had at reasonable expense.

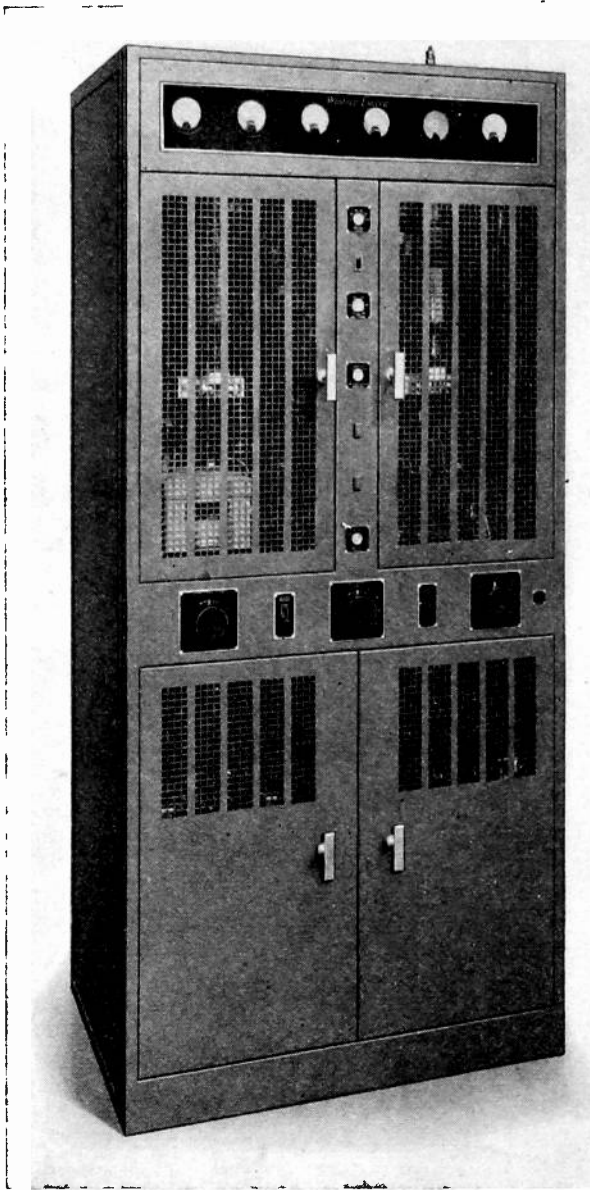

Fig. 2—Western Electric No. 12-A (100-watt) radio transmitter.

To illustrate how the various demands upon it are met in a modern radio broadcast transmitter, a line of low powered equipment will be described in which a number of novel features have been incorporated.

The basic unit is the self-contained 100-watt radio transmitter

shown in Figs. 2 and 3. It occupies a floor space 36 by 25 inches and stands 6 feet 6 inches high. The housing marks a departure from what

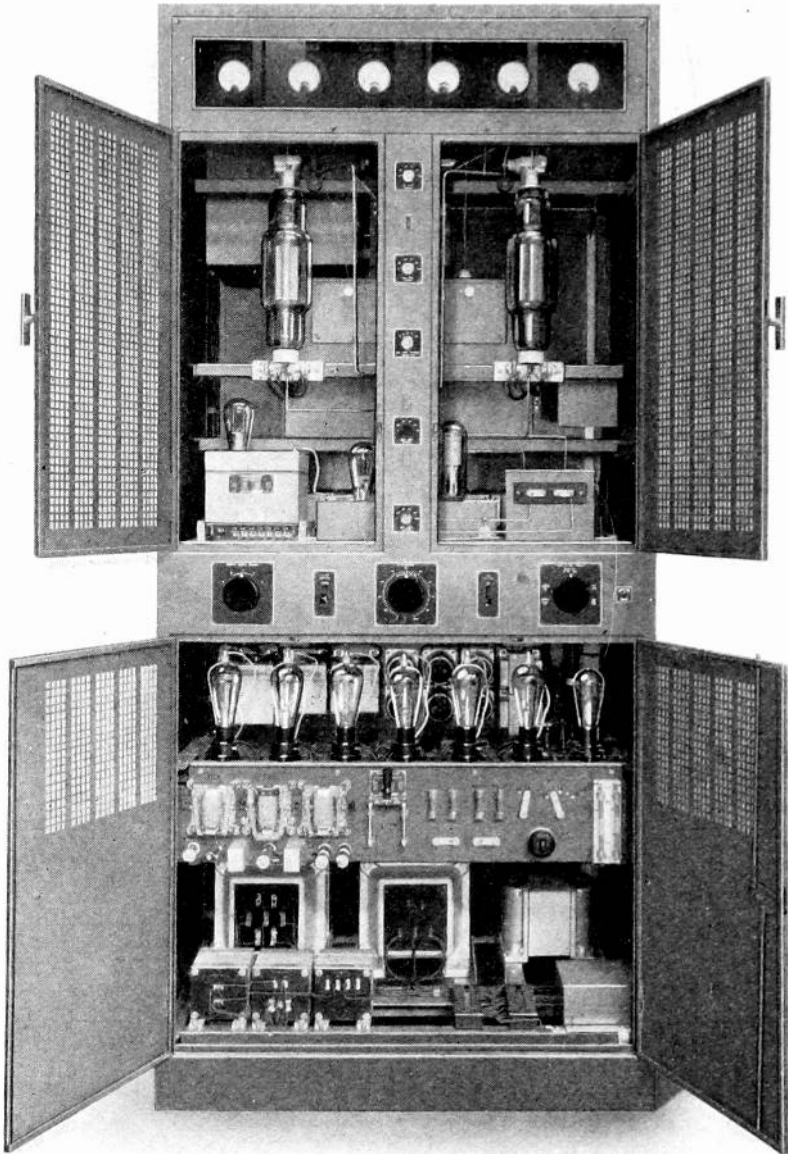

Fig. 3—Western Electric No. 12-A (100-watt) radio transmitter (doors open).

has been common in this type of equipment. It is in the form of a substantial steel cabinet designed and finished to present a pleasing appearance. The meters and controls are conveniently grouped to allow

large doors in the front which permit access for all ordinary adjustment and maintenance.

The circuit of this unit, somewhat simplified, is shown in Fig. 4. The quartz controlled oscillator at the left provides frequency stability well within the present 50-cycle requirement with practically no maintenance. No adjustment of thermostat or circuit is required of the operator, and as the crystal is not handled after calibration, the fre-

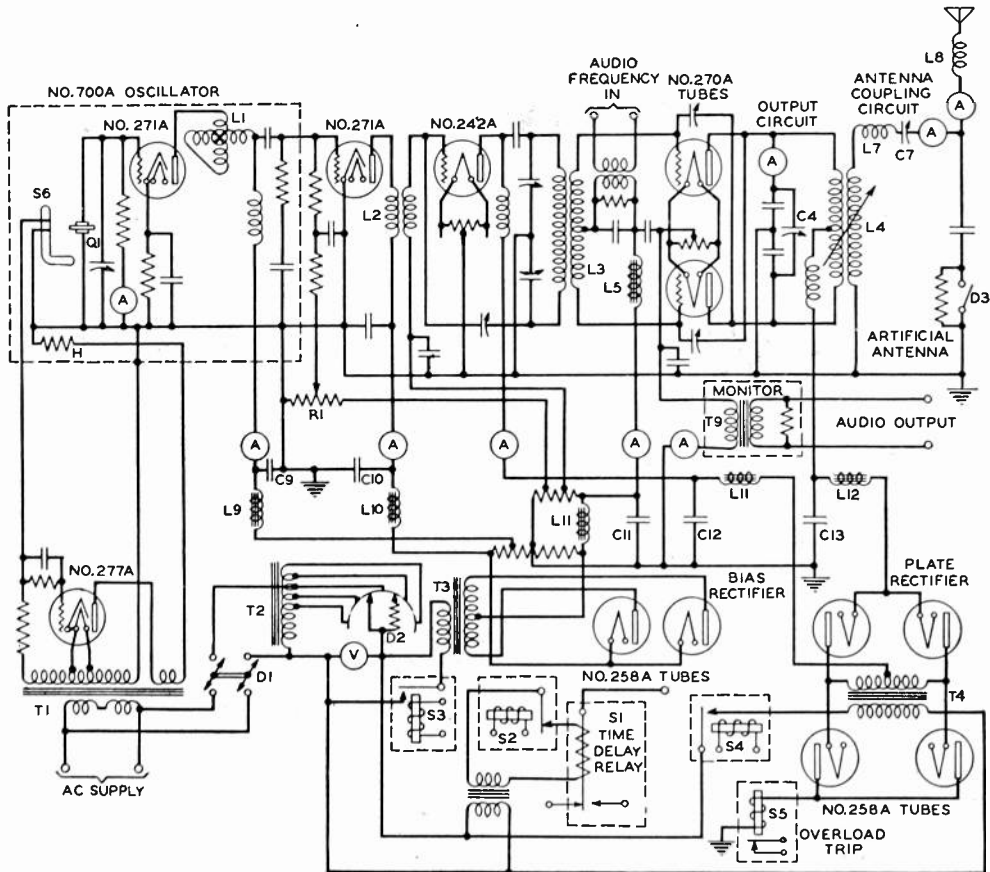

Fig. 4—Simplified circuit of the No. 12-A (100-watt) radio transmitter.

quency control may be said to be truly automatic, and the hazards of careless handling or maintenance are minimized. The entire oscillator circuit is housed and calibrated as a unit which may be readily removed or replaced in the transmitter. Fig. 5 shows how this oscillator unit is placed in position in the transmitter. The control element in the crystal heater circuit is a three-element gaseous tube rectifier. When the contact in the thermostat is open, this rectifier is allowed to pass current to the heater as the grid of the tube is effectively positive in respect to the filament. When the correct operating temperature is

reached and the contacts of the thermostat close, the grid of the tube is connected in such a way that it is always out of phase with the plate voltage, and no current can flow through the tube into the heater. This method of heat control eliminates the usual relay and reduces the



Fig. 5—Placing crystal oscillator unit in the transmitter.

amount of current that the thermostat contact is required to carry to a negligible amount.

The second tube is of the same type as the oscillator and is resistance coupled to it. Grid bias is obtained from a potentiometer and is always of sufficient amount to insure that this tube will not draw grid current. This potentiometer is used to control the output of the

transmitter as the output of this buffer tube is smoothly varied from nothing to full output by merely changing the bias from a value so far beyond cut-off that no output is obtained to a value that will give the desired output.

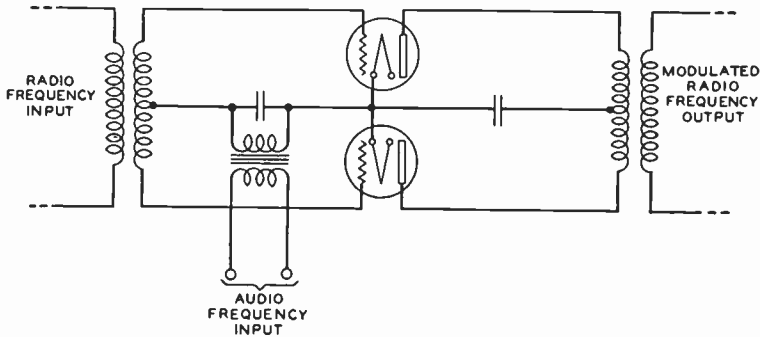

Fig. 6

This stage is transformer coupled to the second stage which in turn is coupled to the final stage by means of a tuned circuit and neutralized by the conventional Rice circuit.

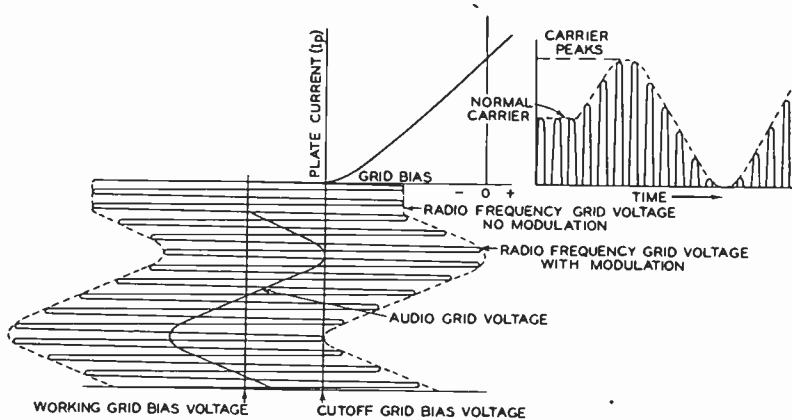

Fig. 7

The final amplifier stage employs two tubes in a push-pull circuit and it is here that modulation takes place. It is effected by what is known as grid-bias modulation. While it is believed to be entirely new to radio broadcasting, this type of modulation has been used in commercial carrier telephone systems for a number of years and is by no means untried. The type of modulation most desirable for a particular purpose is dependent upon a great many factors. The type employed in this transmitter is advantageous here in involving a minimum number of vacuum tubes, and in contributing to the simplicity and economy of operation. The fundamental circuit and the mechanism of its operation are illustrated in Figs. 6 and 7. The grids of the tubes are biased

to considerably below cut-off, and the radio-frequency grid voltage is applied to the two grids out of phase as in any push-pull amplifier. The audio frequency or modulating voltage is applied to the two grids in parallel effectively in series with the grid biasing voltage. Thus the effective grid-bias voltage is varied in accordance with the audio frequency or other modulating voltage which accounts for the name "grid-bias modulation." Referring to Fig. 7, the direct grid-bias voltage is shown adjusted to approximately one and one-half times the value required to reduce the plate current to zero, and to this is added the radio-frequency input voltage sufficient to produce a radio-frequency output. If by changing the bias or otherwise the peak radio-frequency grid voltage is varied between cut-off, where no output is had, and some greater value, a completely modulated radio-frequency output is obtained. This transmitter is arranged so that when enough radio-frequency voltage is applied to the grids to just reach the point where they become positive, causing grid current to flow, the output is something over 400 watts which is the peak required for complete symmetrical modulation of 100 watts. The output is adjusted to 100 watts of carrier by adjusting the output of the first amplifier stage. The audio frequency, applied to the grids in parallel, is then adjusted so that the maximum swings of it, which are to effect complete modulation, cause the radio-frequency grid voltage to vary between cut-off and the point near where the grids become positive and the output is about 400 watts. As the tubes are operated so that the relation between input and output voltages is essentially linear, the audio-frequency distortion experienced is slight as is indicated by Fig. 8.

It will be noted that the transmitter contains no speech amplifier as the input transformer which connects to the grids of the modulating amplifier is fed directly from the speech input equipment. This is another step in separating the radio- and audio-frequency circuits in a radio broadcast system, a trend which began with the inauguration of low level modulation. The speech level required is +10 decibels, a value considerably higher than commonly required at the input of a radio transmitter, but one that any amplifier capable of operating a loud speaker can supply.

The output of the final and modulating stage is transferred through the output and antenna coupling circuits to the antenna. The coupling circuit, which includes the secondary of the output transformer L_4 , the inductance L_7 , condenser C_7 , and the antenna coupling condenser C_8 is arranged to be very effective in the suppression of the radio-frequency harmonics. This simple network is not difficult to adjust, and increases in effectiveness with the order of the harmonics. L_7 is made so that its

reactance is high at the fundamental frequency, and the circuit is tuned by adjustment of C_7 . As the antenna coupling reactance is relatively small, the reactance of L_7 is practically annulled by the negative reactance of C_7 , so that for the fundamental frequency the reactance of L_7 and C_7 together is very small. At harmonic frequencies the reactance of L_7 increases while that of C_7 decreases, and the resultant reactance of the combination is relatively very large, thereby greatly discrimi-

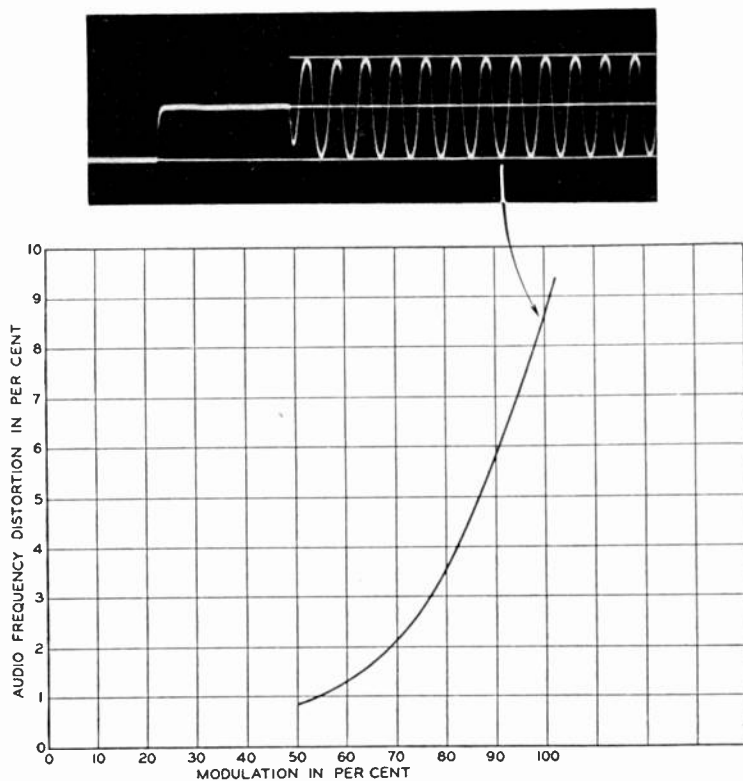

Fig. 8—Oscillogram of rectified output of the No. 12-A radio transmitter at 100 per cent modulation, and curve showing variation in audio-frequency distortion with percentage modulation.

nating against harmonic currents. Further discrimination is had by the effect of the negative reactance of the antenna coupling condenser. By the means employed, the harmonic radiation is kept well below 0.05 per cent of the fundamental, thus anticipating any requirement which may reasonably be expected.

The antenna is tuned by adjusting the antenna loading inductance L_8 for maximum current in the usual manner. An artificial antenna resistance is provided so that the transmitter may be energized without radiating a signal, should this be desired for test purposes.

A monitoring output is provided by means of a transformer which

is connected in the plate circuit of the final stage. This type of monitor is new and does not require a tube or other type of rectifier. It is obvi-



Fig. 9—Western Electric No. 71-A amplifier equipped for 1000-watt operation.

ous that the audio-frequency currents flowing in this circuit result from the modulation of the output of the amplifier, and therefore give a faithful indication of it.

The entire power for the transmitter is obtained from alternating-current supply without the use of rotating machinery. Two rectifiers supply 3000 volts for the last stage and lower voltages for plate and grid-bias circuits. Wherever voltage reduction is required, potentiometers are employed in order to provide stability of the derived voltage.

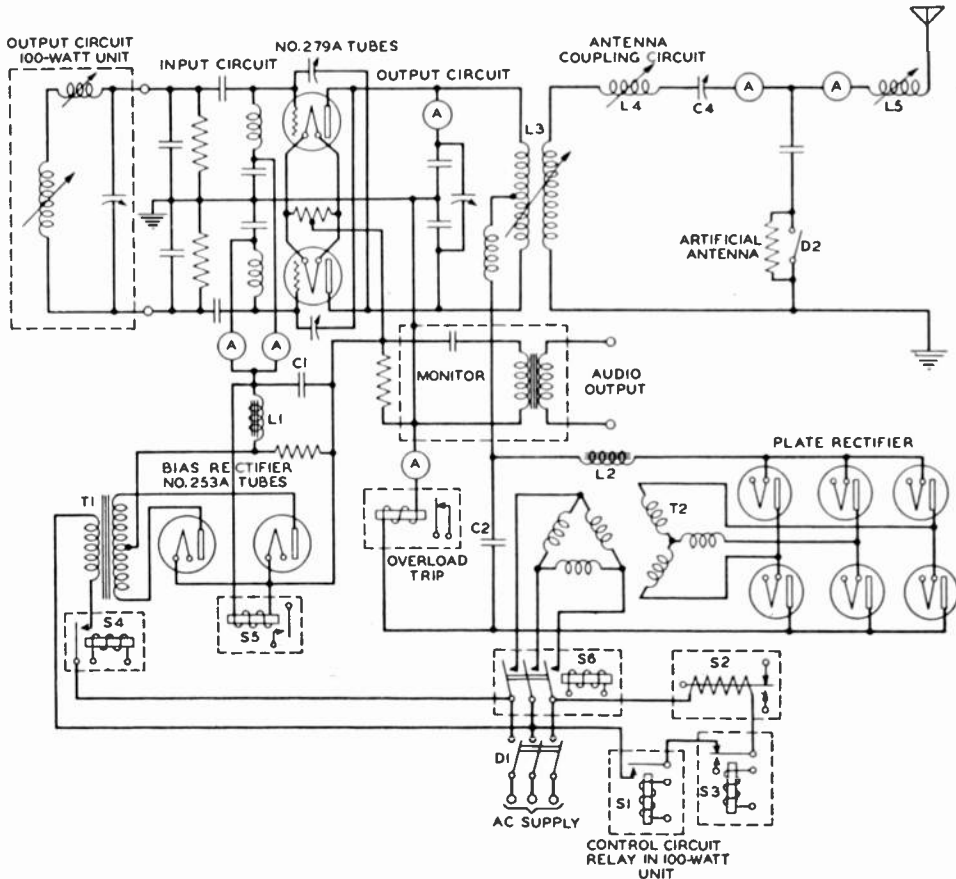

Fig. 10—Simplified circuit of the No. 71-A amplifier.

The circuits are controlled simply, and relays are provided to introduce the time delays necessary in energizing the mercury-vapor rectifier tubes. When the "START" switch is operated, closing D_1 , the filaments are all lighted, and thermal relay S_1 begins to operate closing its front contacts after the proper interval. This operates the relay S_3 which locks itself up and, in addition to starting the low voltage rectifier that supplies all grid potentials and low plate voltages, operates relay S_2 opening the circuit through the thermal relay. This allows the relay to cool and remake its back contact which through S_4 , operated by the grid-bias rectifier, energizes the 3000-volt rectifier. This sequence allows the rectifiers to come into operation properly and

prevents application of plate voltage without grid bias. The overload relay in the high voltage rectifier operates to remove only the high voltage.

The power required for operation of the transmitter is approximately 1500 watts single phase.

The amplifier which is attached to the 100-watt unit to provide outputs of 250, 500, or 1000 watts is similar in appearance to the transmitter and occupies the same amount of space. It is designed for readily mounting the tubes required for any of the three-powers. It

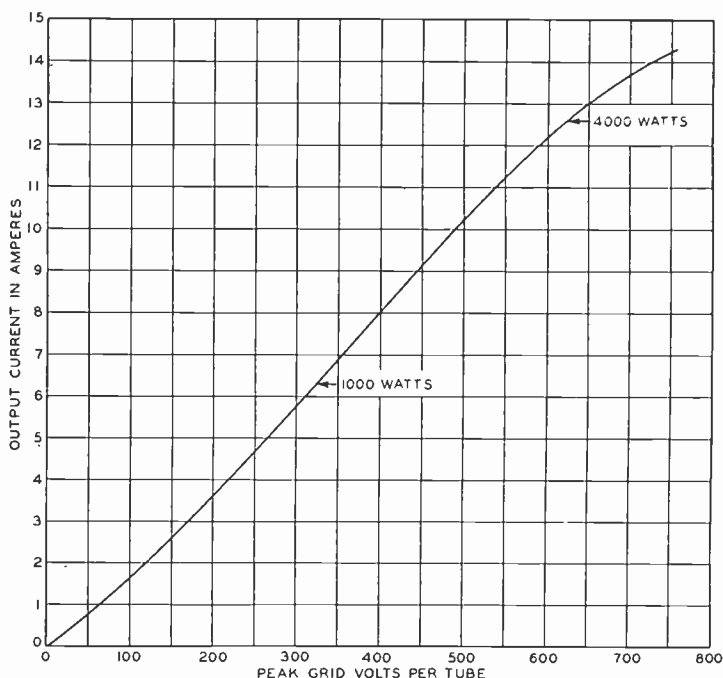

Fig. 11—Dynamic characteristics of the No. 71-A (1000-watt) amplifier.

also is a self-contained unit and operates directly from a three-phase alternating-current power supply. Fig. 9 is a view, with the doors open, of this unit equipped for 1000 watts output. It will be noted that all circuit elements likely to radiate are completely shielded. The box in the center contains the output circuit coupling coil, and the antenna loading coil is directly above it. The interior is divided horizontally into two main divisions with the power apparatus located in the lower section and the radio-frequency apparatus above.

A simplified circuit of the amplifier is shown in Fig. 10.

The amplifier input is connected to the terminals of condenser C_7 in the 100-watt unit. The resistances connected from grid to grid form the load for the driving unit and in them is dissipated the power out-

put of the modulated stage. The remainder of the circuit is similar to that of the 100-watt unit with the natural exception that the circuit elements are designed for the larger currents they must carry. Here

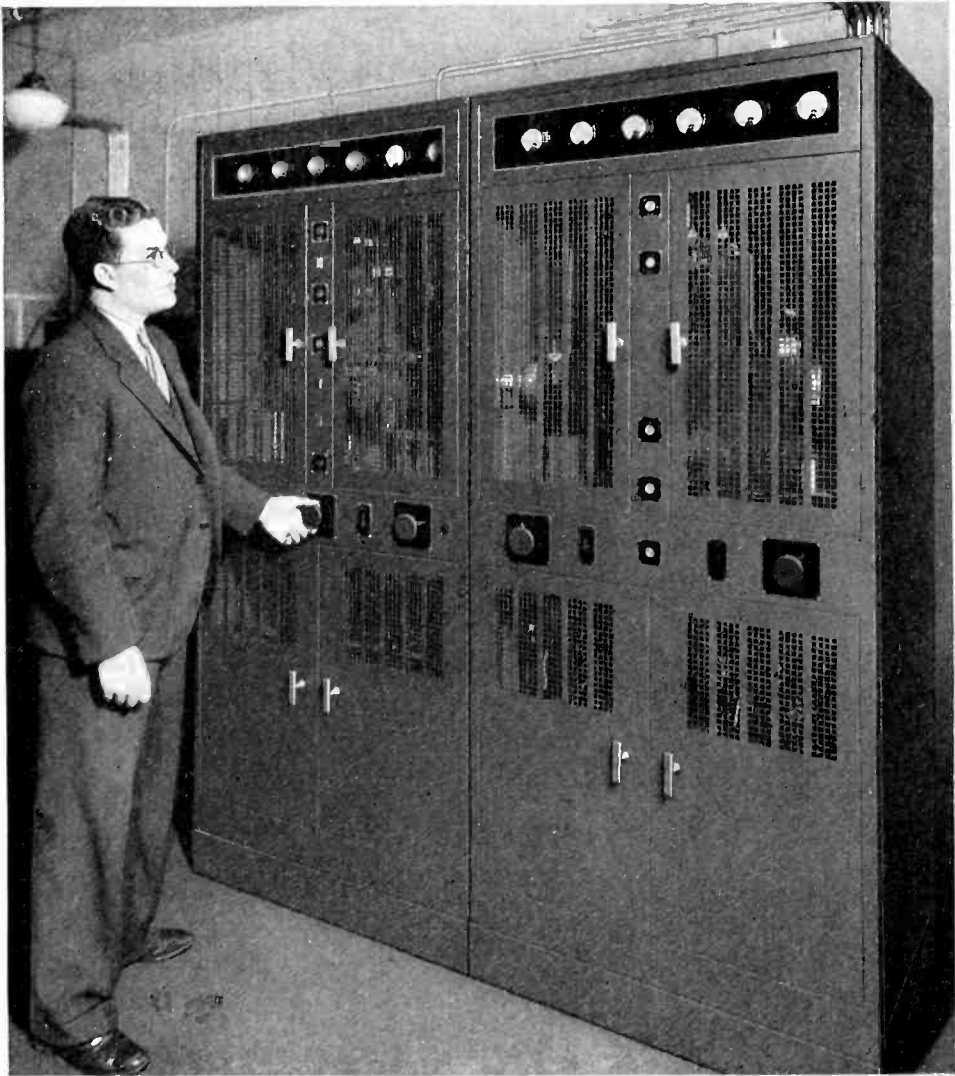

Fig. 12—Western Electric No. 304-A (1000-watt) radio transmitting equipment consisting of the No. 12-A radio transmitter and the No. 71-A amplifier.

again it will be seen that an artificial antenna resistance is provided to enable the transmitter to be operated for test purposes without radiating, and a monitoring arrangement similar to that in the 100-watt unit is provided.

Two radiation-cooled tubes of a new design are employed in a push-pull circuit. The dynamic characteristic of the amplifier shown

in Fig. 11 indicates ample tube capacity to permit 1000-watt operation with complete modulation which entails a peak power of four kilowatts.

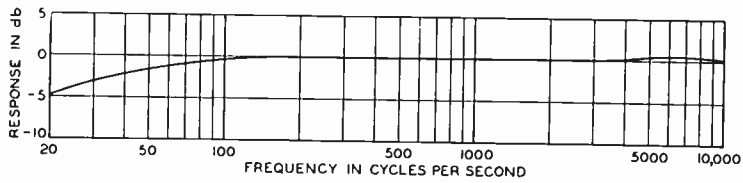

Fig. 13—Audio-frequency characteristic of the No. 304-A (1000-watt) radio transmitting equipment.

This unit requires about 4000 watts of three-phase power. The bias voltage is obtained from a full-wave single-phase rectifier which employs mercury-vapor tubes, and the 3000-volt plate potential is ob-

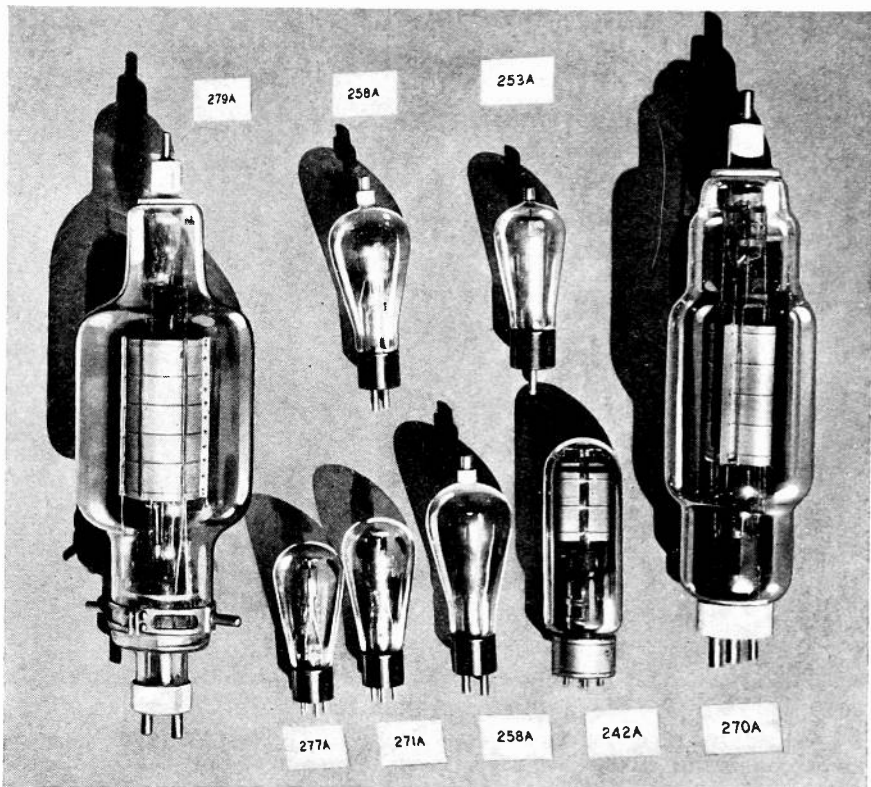

Fig. 14—Types of tubes employed in the No. 304-A (1000-watt) radio transmitting equipment (designations are Western Electric code numbers).

tained from a full-wave three-phase rectifier also employing mercury-vapor rectifier tubes. A thermal delay circuit provides the necessary time interval for the filaments of the tubes to reach operating temperature before the high voltage is applied. An overload trip is pro-

vided to prevent operation at heavy overloads, and a relay in the grid-bias circuit is used to control the application of high voltage, thus preventing the operation of the amplifier tubes without grid bias.

Fig. 12 is a photograph of a complete 1000-watt radio transmitter made up of the 100-watt unit and the amplifier just described. The entire equipment stands 6 feet 6 inches high and occupies a floor space 72 by 25 inches. All apparatus is accessible from the front for maintenance and adjustment. The sides and back panels are, however, readily removable should occasion require it. All of the meters are mounted under glass at the top of the units, and the controls are of the spanner wrench type, a feature that will be appreciated by those who may have had an adjustment changed by some curious visitor to the transmitter room.

The safety and control circuits of the two units are interlocked. Opening any one of the doors on either unit removes all high voltages from both units. While switches are provided so that starting may be sectionalized if desired, the entire transmitter may be controlled by the master switch in the 100-watt unit. When this switch is operated, all of the various circuits are energized in proper sequence, and the transmitter may be put "on the air" from a cold condition in less than a minute.

The audio-frequency characteristic of a complete 1000-watt transmitter is shown on Fig. 13.

Fig. 14 is a photograph of the various types of tubes used in the 1000-watt transmitter. The 271-A, 242-A, and 270-A are employed in the radio-frequency circuits of the 100-watt unit. The 258-A tube is used in the rectifier, and the 277-A controls the temperature of the quartz oscillator. The 1000-watt amplifier employs the 253-A and 258-A rectifier tubes and the 279-A amplifier tube.



SUPERVISORY AND CONTROL EQUIPMENT FOR AUDIO-FREQUENCY AMPLIFIERS*

BY

HARRY SOHON

(Instructor in Electrical Engineering, Cornell University, Ithaca, N. Y.)

Summary—This paper is divided into two parts: In the first part a new type of level indicator is presented, and in the second a device for controlling the output signal of an amplifier is described.

Part I: Two types of level indicators in use at the present time on audio-frequency amplifiers are the r-m-s voltmeter and the average voltmeter. Neither of these will tell the operator how near the signal is to the overload point of the amplifier. A new type peak voltmeter is described that makes continuous measurements of the highest peak values attained by the signal.

Part II: An automatic control circuit is described which reduces the amplification of a special amplifier when the output voltage reaches a certain amount, thereby keeping the subsequent equipment from being overloaded.

PART I. A NEW PEAK VOLTMETER

THE maximum undistorted power that an amplifier can deliver is not a fixed figure for a particular amplifier. The peak value of the signal voltage is the factor that influences the allowable output. If the peak value becomes too great, distortion will be introduced due to undesirable grid rectification or due to the fact that the action is carried too far into the curved portion of the plate-current grid-voltage characteristic. More undistorted power can be obtained from an input signal having a flat top than from a sharply peaked one. In giving the power rating of an amplifier it is assumed that the wave form is sinusoidal.

When monitoring a program it is essential that we know how near we are to the overload point of the amplifier. The practice at the present time is to use either an r-m-s voltmeter or an average value voltmeter. Either of these meters can be calibrated so that the operator knows how near he is to the overload point if the signal is sinusoidal. For any other signal the voltmeter readings are merely approximations.

As a numerical example to show what is likely to be met with, refer to Fig. 1. It shows three different wave forms with their respective equations. Let us assume that the peak value in each case is such that it is just within the allowable value for the amplifier. Supposé we have

* Decimal classification: R243.1×R363. Original manuscript received by the Institute, June 17, 1932. Revised manuscript received by the Institute, November 3, 1932. This paper is part of a thesis submitted to the Faculty of the Graduate School of Cornell University for the degree of Doctor of Philosophy, June, 1932.

two level indicators, one giving the average voltage, and the other giving the r-m-s voltage. We have both indicators calibrated to read unity at the overload point for a sinusoidal input signal. If we measure

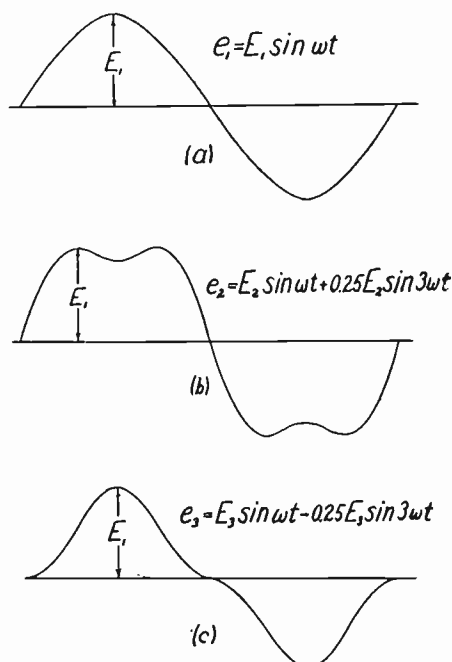

Fig. 1—Types of signals.

the three signals of Fig. 1, the meter readings will be as indicated in Table I.

TABLE I

Signal	R-M-S	Average
e_1	1.00	1.00
e_2	1.16	1.21
e_3	0.825	0.733

For the second signal the meter readings would indicate that the amplifier was being considerably overloaded, while for the third signal the readings would indicate quite a margin of safety.

Fig. 2 shows a circuit diagram for a meter that will actually indicate the peak value of the signal voltage. The principle of operation is that the condenser is charged to the peak value of the voltage to be measured, and the charge leaks off slowly enough to allow an indication to be given by the galvanometer in the plate circuit of the triode. The meter will show how high the peak value becomes during any time interval.

The purpose of the resistances between the plates of the rectifier tubes is keep the impedance of the meter as nearly constant as possible. The equivalent circuit looking from the transformer is as shown in Fig. 3. When the condenser is uncharged its reaction on the circuit is

greatest, and when it is charged to a voltage at least half the value of the applied voltage its reaction is nil. The values of the resistances and capacitance are chosen so that the impedance of the circuit shown in Fig. 3 is practically equal to the resistances alone for the highest frequency to be measured. The value of the grid leak is then chosen so that the galvanometer will have time to indicate the peak value of the voltage to be measured.

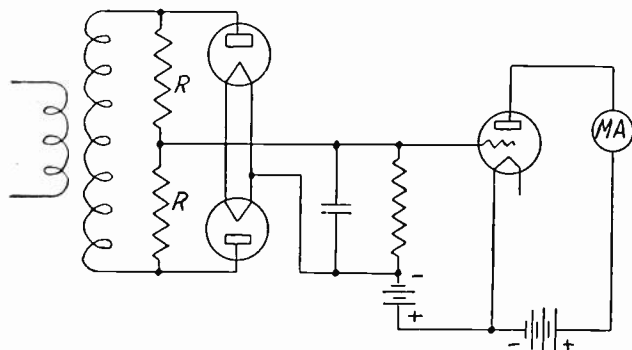

Fig. 2—Peak voltmeter circuit.

The operation of the peak voltmeter is illustrated in Fig. 4. Fig. 4a shows the galvanometer current with the condenser removed from the circuit. The signal applied is sinusoidal, and the curve shows the current for one cycle of the input signal. Fig. 4b shows the galvanometer current with the condenser in the circuit for the same applied signal

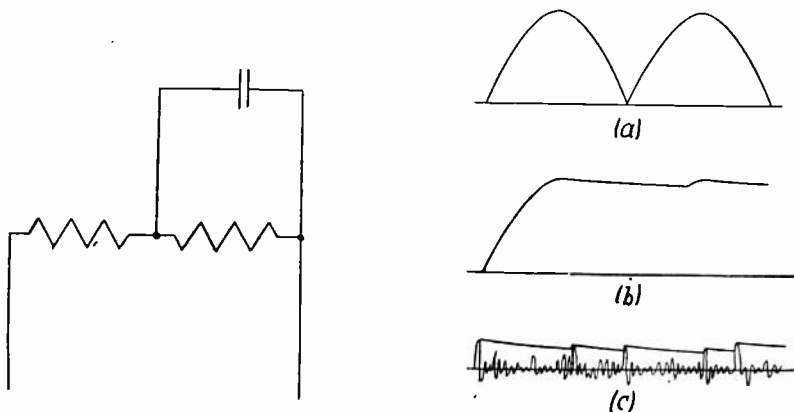

Fig. 3—Equivalent circuit.

Fig. 4—Galvanometer current.

as in the case of Fig. 4a. It is assumed in Fig. 4b that the signal is actually applied at the beginning of the cycle so that the build-up of the current can be shown. Fig. 4c shows the galvanometer current when a nonperiodic wave is impressed, as speech or music. The complex wave is shown in Fig. 4c so that the way the galvanometer current is related to the peak value of the impressed wave can be brought out clearly.

Fig. 4c shows how the peak voltmeter indicates the highest peaks. We would need an oscillograph to measure every peak, but we are interested only in the greatest ones because if they do not exceed the overload point of the equipment the lesser peaks will not. Since it is direct reading, without requiring adjustments for each measurement, the meter will be found simpler than the usual type of peak voltmeter for making other measurements as in finding the form factor of periodic waves.

PART II. AUTOMATIC CONTROL

In Part I of this article a peak voltmeter was described which can be used so that the operator will know how close the signal is to the overload point of an amplifier, and can reduce the input signal intensity to prevent distortion in the output. The apparatus about to be de-

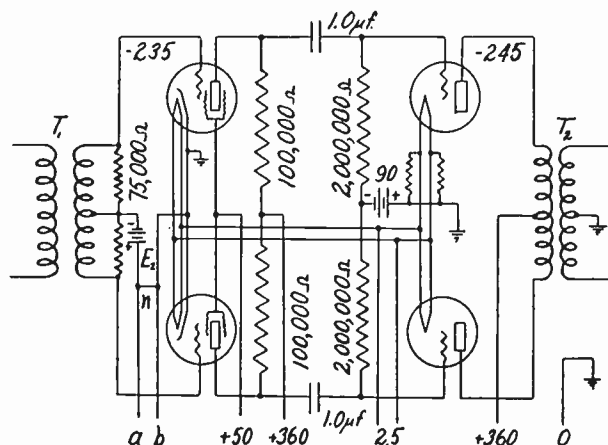

Fig. 5—Amplifier wiring diagram.

scribed will automatically reduce the amplification of a special amplifier when the output voltage approaches a value that might overload succeeding apparatus. There is a lapse of time before the amplification returns to the previous value after the signal intensity decreases; this allows the hearers to know that there was a change in level.

The amplifier on which the control circuit works is shown in Fig. 5. It consists of two stages, each connected in push-pull. The first stage contains variable- μ tubes, the second contains power tubes of the UX-245 type. The over-all amplification of the amplifier can be varied by changing the average voltage on the grids of the variable- μ tubes, that is, by changing the value of E_z in Fig. 5. The manner in which the amplification varies with E_z is shown in Fig. 6. It was found that as the amplification was reduced by increasing E_z the allowable input signal increased. This variation is in the desired direction since the amplification is to be reduced as the input signal increases.

The control circuit is shown in Fig. 7. The two condensers marked C_y pick off the output voltage of the amplifier. The wires marked a and b , in Fig. 7 are connected to the wires marked a and b , respectively, in Fig. 5, and the connecting link marked n in Fig. 5 is removed. The

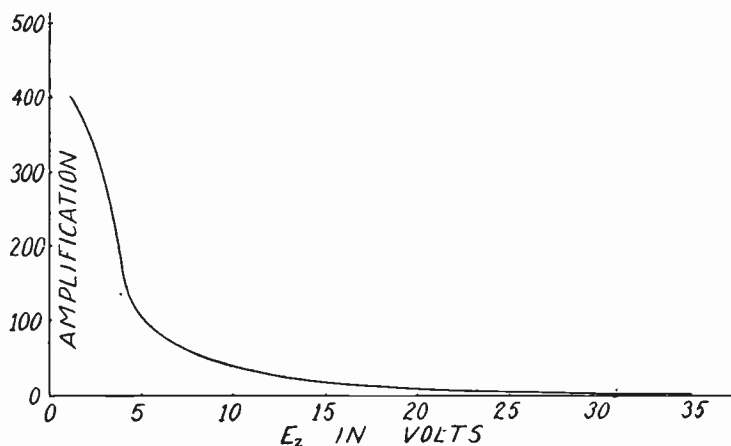

Fig. 6

circuit consists of two UY-227 vacuum tubes with their plates connected together, and with the resistance R_x connected in series with the plate battery E_x . If a plate current flows in the UY-227 circuit the voltage drop across R_x is applied to the grids of the variable-mu tubes in series with the potential supplied by E_z , Fig. 5.

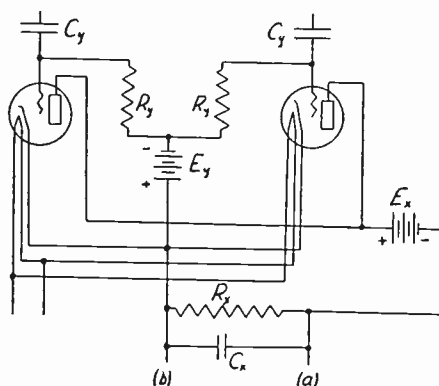

Fig. 7—Control circuit.

The battery E_y normally biases the 227's beyond cut-off through the grid resistances R_y . The condensers marked C_y apply the output voltage of the amplifier to the grids of the 227's, and when the output voltage becomes great enough to overcome the effect of E_y , there will be a flow of current in the plate circuit of the 227's. This current causes a voltage drop in R_x as explained above and reduces the amplification

of the amplifier. If the action of the control circuit is great for a small increase in output voltage, the output voltage will be held practically constant.

The use of E_v makes it possible to obtain a strong action in the control and gives a regulation of practically zero per cent in the output voltage. The principle of operation is illustrated in Fig. 8. Fig. 8 shows the plate-current grid-voltage characteristic of the 227, and has the point of plate-current cut-off indicated on the horizontal axis. The value of E_v is indicated, and a vertical line drawn at this value of grid voltage. Three sine waves of varying amplitudes are drawn with this vertical line as a time axis. The amplitude of one is not great enough

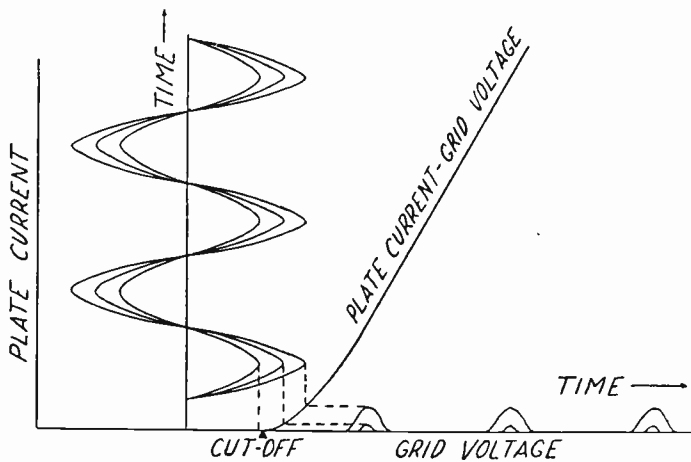

Fig. 8—Static and dynamic characteristics.

to carry it beyond cut-off in a positive direction so no plate current will flow and the amplifier has its maximum amplification. The second voltage wave extends slightly beyond cut-off and a plate current will flow during the part of the cycle in which the instantaneous value of grid voltage exceeds the cut-off value. The plate-current wave is indicated along the horizontal axis as a time axis. The third signal is only slightly greater than the second, but the plate current that flows with the third signal applied is considerably more than that for the second signal. We can see then that only a slight increase in output voltage will cause a great drop in amplification, and this is what is needed to keep the output voltage constant.

Condenser C_x , Fig. 7, acts as a filter to keep the voltage across R_x from varying at the signal frequency. The product of C_x and R_x determines the time required for the amplification to increase to its original value when the signal intensity is decreased. This time must be great enough so that there will be no distortion at the lowest frequency encountered. It is desirable to increase the time constant $C_x R_x$ to a

value greater than that required to prevent distortion. Music is written to have passages played at different intensities; a speaker raises his voice for emphasis; these variations in level must not be hidden from the hearers. Although a great increase in level may be partly masked by the control equipment, the decreases in level are more in evidence and keep the program from becoming monotonous.

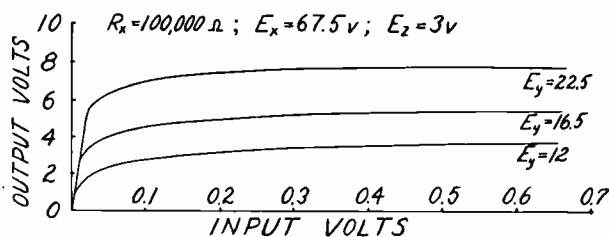

Fig. 9

C_x is charged through the plates of the two 227's so the charging time can be made different from the discharging time. The value of C_x is chosen such that it will charge quickly enough to pass only one or two cycles before the amplification is reduced.

Let us now consider the test curves. In Figs. 9 and 10 E_x was kept at 67.5 volts and R_x at 100,000 ohms. The output voltage was picked off the primary of the output transformer T_2 , Fig. 5, and the frequency of the test signal was 100 cycles per second. Fig. 9 shows output volts plotted against input volts with E_z kept at 3 volts. The three curves are for the three values of E_y : 12 volts, 16.5 volts, and 22.5 volts. The

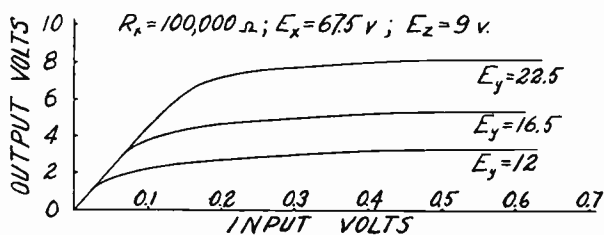

Fig. 10

three curves start along the same line, and when the output voltage is great enough to allow a plate current to flow in the 227's the curve branches off and becomes very nearly constant. The maximum output voltage is determined by E_y when the remaining circuit variables are held constant, as would be expected from the explanation of Fig. 8. Fig. 10 shows a set of curves similar to those in Fig. 9 except that E_z was 9 volts for the curves in Fig. 10. The chief difference between the curves in Fig. 9 and Fig. 10 is in the slope of the initial line. For values

of E_z between 3 and 9 volts the slopes of the initial lines have values between those of Figs. 9 and 10.

The curves of Fig. 11 were made under similar conditions to the curves of Fig. 9 except that E_z was kept at 45 volts. There is a noticeable difference in the maximum output voltages of the curves in Fig. 9 and Fig. 11. E_z is a factor in fixing the maximum output as well as E_y .

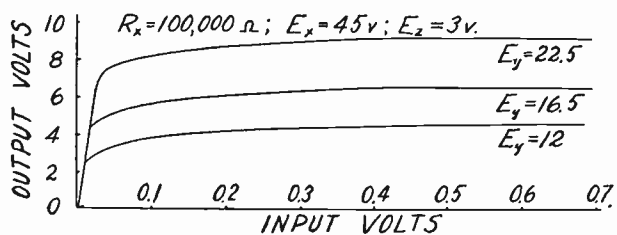

Fig. 11

This is to be expected since reducing E_z reduces the point of cut-off of the 227's which amounts to the same as reducing E_y .

In order to investigate the effect of changing R_x the following test was made. The input voltage was held at 0.5 volt, 100 cycles, and E_z was held at 3 volts, E_x at 67.5 volts, E_y at 12 volts. The value of R_x

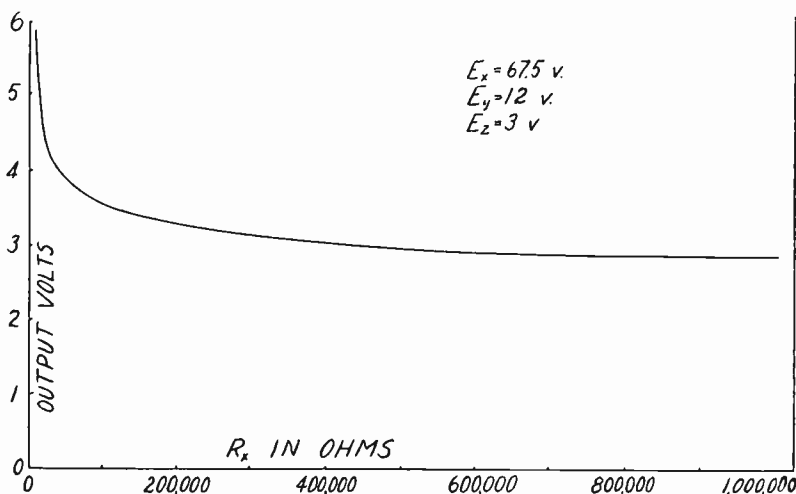

Fig. 12

was varied from 8000 to 1,000,000 ohms and the output voltage was recorded to give the curve of Fig. 12. The shape of this curve is readily explained since the control is not working when R_x is zero, and as R_x becomes large, the output voltage should decrease to the value at which the plate current just ceases to flow in the 227's. At very high values of R_x the output voltage becomes unstable.

Fig. 13 shows the effect of varying E_x with R_x kept at 100,000 ohms, E_y at 12 volts, and E_z at 4.5 volts. The way in which the output voltage can be controlled by varying E_x is shown very nicely in the curves for E_x equal to 67.5 volts and 45 volts. When E_x is 22.5 volts the control fails. This is explained by reference to Fig. 6. The additional bias supplied by the control circuit to the grids of the variable-mu tubes cannot be greater than E_x , and with E_x equal to 22.5 volts there is not sufficient range in amplification. The most economical method of varying the output is to keep E_x at 45 volts and vary E_y till the maximum output voltage obtained has the desired value.

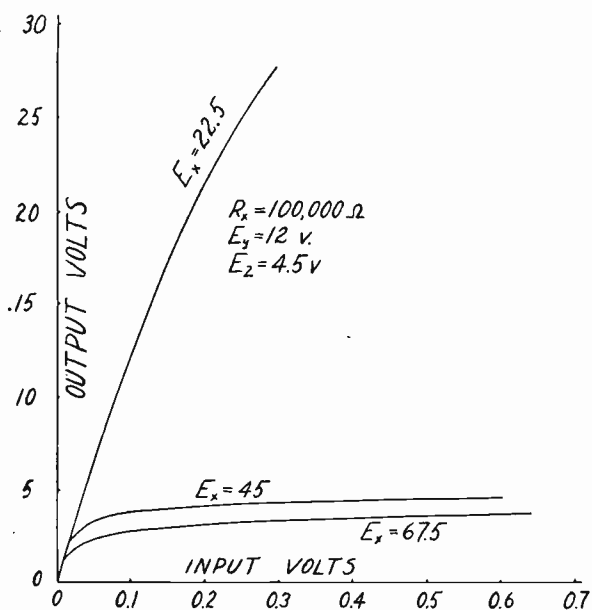

Fig. 13

The frequency characteristic of the amplifier is shown by curve A of Fig. 14. It gives the output voltage with E_z equal to 3 volts, R_x shorted, and an input signal of 0.01 volt for a frequency range from 100 to 10,000 cycles. The amplification at each frequency is altered by the same factor if E_z is changed.

Curve C, Fig. 14, was taken with E_x kept at 45 volts, E_y at 16.5 volts, E_z at 3 volts, and R_x at 100,000 ohms. The input voltage was 0.24 volt and the condensers C_y picked the output voltage from the secondary of the output transformer. The curve gives output voltage plotted against frequency. Curve C shows that the control is essentially independent of frequency.

Curve B in Fig. 14 is similar to curve C except that the output signal was picked off the primary of the output transformer by con-

densers C_v , and the input signal was increased to 0.4 volt. The curve gives output volts (measured across secondary of output transformer) plotted against frequency. Curve C suggests that the voltage across the primary of the output transformer was constant when curve B was being made, in which case a comparison of curves B and C will give an idea of the effect of the output transformer on the frequency characteristic of the amplifier.

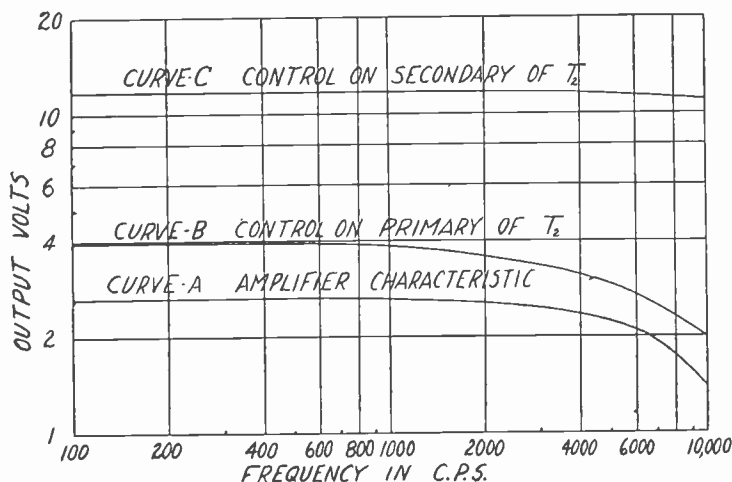

Fig. 14

This control circuit can be put to many uses. In all cases where a constant voltage is required it can be used as described above. If a constant current is desired, a slight change in the equipment can be made so that the control circuit keeps a constant voltage across a resistance.

Bibliography

1. M. von Ardenne, "Ein empfindliches Röhrenvoltmeter für Hochfrequenz," *Electrotech. Zeit.*, vol. 49, pp. 565-67, (1928).
2. S. C. Hoare, "A new thermionic instrument," *Trans. A.I.E.E.*, vol. 46, pp. 541-544, (1927).
3. C. M. Jansky, Jr. and C. B. Feldman, "A two range vacuum tube voltmeter," *Trans. A.I.E.E.*, vol. 47, pp. 307-313, (1928).
4. C. B. Jolliffe, "The use of the electron tube peak voltmeter for the measurement of modulation" *Proc. I.R.E.*, vol. 17, pp. 660-663, (1929).
5. E. B. Moullin, "Some developments of the thermionic voltmeter," *Jour. I.E.E. (London)*, vol. 68, no. 404, pp. 1039-1051, (1930).
6. W. F. Powers and G. W. Alderman, "A useful design of tube voltmeter," *Jour. Opt. Soc. Amer.*, vol. 17, pp. 379-801, (1928).
7. H. J. Reich, G. S. Marvin, and K. A. Stoll, "Vacuum tube voltmeter of high sensitivity," *Electronics*, vol. 3, no. 3, pp. 109-111; September, (1931).
8. S. Strauss, "Das Röhren-Elektrometer 'Mekapion' für selbsttätige Einzel- und Dauermessungen sowie Registrierungen," *Electrotech. und Maschinenbau*, vol. 46, pp. 1083-1086; November 11, (1928).

GENERAL THEORY ON THE PROPAGATION OF RADIO WAVES IN THE IONIZED LAYER OF THE UPPER ATMOSPHERE*

BY

SHOGO NAMBA

(Electrotechnical Laboratory, Ministry of Communications, Tokyo, Japan)

Summary—1. Theories on the propagation of radio waves in the entire range of frequencies used in communications are treated together with discussions on the applicable limit of the theory of geometrical optics to wave propagation.

2. Definitions of the "low-frequency," "medium-frequency," "medium-high-frequency," and "high-frequency" waves are given from the theoretical points of view.

3. A new term, "step reflection," is introduced to explain the propagation of medium-frequency waves, and its characteristics are explained.

4. Attenuation of a wave traveling through the ionized layer is calculated for various kinds of wave paths and electronic distributions.

5. The "metallic reflection theory" is applied to the investigations of the low-frequency transmission and a number of low-frequency phenomena; especially the sunset and sunrise drop of field intensity and polarization errors (or night errors) in direction finding are explained by applying the present theory.

6. Propagation of medium-frequency waves is treated by using the "step reflection method."

7. Medium-high-frequency and high-frequency transmissions are treated by applying the theory of geometrical optics, giving reasons why waves of 100-meter band in daylight and those of 500-meter band during the night have bad transmission characteristics. Propagation characteristics of the waves in the entire range of frequencies used in radio communications are seen in Table I and Fig. 9.

8. Transmission characteristics of the waves of various frequencies during the magnetic storm are theoretically considered by comparing them with our experiences hitherto known.

PRINCIPAL SYMBOLS ADOPTED

e = charge of electron

m = mass of electron

$$k = \frac{4\pi e^2}{m}$$

ω = angular frequency of wave = $2\pi f$

f = frequency of wave

λ = wavelength

λ' = critical wavelength

λ'' = limiting wavelength

* Decimal classification: R113. Original manuscript received by the Institute, August 25, 1932. Abbreviated translation from the original paper in Japanese, *Jour. I.E.E.* (Japan), September, (1932).

- c = velocity of light
 V = phase velocity
 ν = collision frequency per second
 σ = conductivity of ionized layer
 ϵ = dielectric constant of ionized layer
 n = refractive index of ionized layer
 N = number of electrons per unit volume
 N_0 = number of electrons at the apex of ray path
 N_{\max} = maximum value of N
 N_D, N_N = day and night values of N respectively
 N_E, N_F = values of N in the E and F layers respectively
 (Example: $N_{ED\max}$ represents maximum electron density in the E layer during daytime.)
 i = angle of incidence at the ionized layer
 i_0 = angle of incidence at the earth
 z = height above the ground
 z_0 = height above the lowest boundary of ionized layer
 r_0 = radius of the earth
 R_1 = reflection ratio (reflection coefficient) of electric force vibrating in the plane of incidence
 R_2 = reflection ratio (reflection coefficient) of electric force vibrating in the direction perpendicular to the plane of incidence
 γ = attenuation coefficient
 Γ = total attenuation = $\int \gamma ds$
 E_{i1}, E_{i2} = amplitude of the incident electric forces vibrating in the plane of incidence and in the direction perpendicular to it, respectively
 E_{r1}, E_{r2} = amplitude of the reflected electric forces vibrating in the plane of incidence and in the direction perpendicular to it, respectively

I. INTRODUCTION

NUMEROUS papers have hitherto been published regarding the theory of propagation of radio waves, but almost all of them are confined to those cases in which the range of wavelength is not widely considered. For example, some of them deal with low-frequency waves alone, while the others treat with high-frequency waves only. When theories on low- and high-frequency waves are treated separately as heretofore done, there is a natural tendency of making assumptions in each case independently without any close connection between them; this brings considerable difficulty to the investigation

when the propagation of medium-frequency waves is to be taken into account. The writer believes that this is the reason why theoretical works on medium-frequency transmission have not yet been developed as they ought to be. It is the main purpose of the present paper, therefore, to discuss the propagation of low-, medium-, and high-frequency waves simultaneously under a general equation and to introduce a theory which may be applied to the propagation of medium-frequency waves.

In the present paper, however, the phenomena of polarization of waves are not taken into account, because of the great difficulty involved in solving the problem of the propagation of radio waves in an anisotropic medium.

II. RÉSUMÉ OF PROGRESS IN THE STUDY OF THE IONIZED LAYER

During the last several years there have been some noticeable advancements in the study of the ionized layer of the upper atmosphere made by many investigators. Among them Appleton's experimental works^{2,3} and Chapman's theoretical calculations are the most noteworthy. They pointed out that there are two ionized layers of the maximum electron density in the upper atmosphere, one at the height of about 100 kilometers and the other at the height of more than 200 kilometers above the ground. Appleton has named the former the "E layer" and the latter the "F layer." According to the investigations made by Chapman,^{1,†} the F layer is probably constituted by atomic oxygen ionized by the ultra-violet radiation of the sun, and the E layer by nitrogen ionized by the nonwavy radiation of the neutral corpuscles shot out from the sun. Rough estimations given by Appleton, Eckersley and other investigators show that the maximum electron density is appreciably greater in the F layer than that in the E layer as shown in Fig. 1.

III. APPLICABLE LIMIT OF THE THEORY OF GEOMETRICAL OPTICS TO RADIO WAVE PROPAGATION

Usually the theory of geometrical optics is applied to the study of radio transmission, but its applicable limit must first be discussed when the range of wavelength covers the entire range of radio waves as in the present case. The discussion on the applicable limit of geometrical optics has been treated formerly by Rayleigh and Gans,¹² in the theory of optics, and recently by de Broglie,⁶ de Groot,⁷ Eckersley,⁸ etc., in the study of wave mechanics.

^{2, 3} Refer to Bibliography.

† As for the origin of ionization in these two layers there are somewhat different discussions given by Nagaoka⁵ and Förstering and Lassen.⁴

Assume,

$$\psi = Ae^{2\pi if t} \cdot e^{2\pi i\varphi} \tag{1}$$

where φ is to be measured in the unit of the wavelength λ .

Substituting (1) into the general equation of a wave:

$$\Delta\psi - \frac{n^2}{c^2} \frac{\partial^2\psi}{\partial t^2} = 0, \tag{2}$$

we obtain,

$$-4\pi^2 \sum \left(\frac{\partial\varphi}{\partial x} \right)^2 + 2\pi j\Delta\varphi + \frac{4\pi^2 f^2 n^2}{c^2} = 0. \tag{3}$$

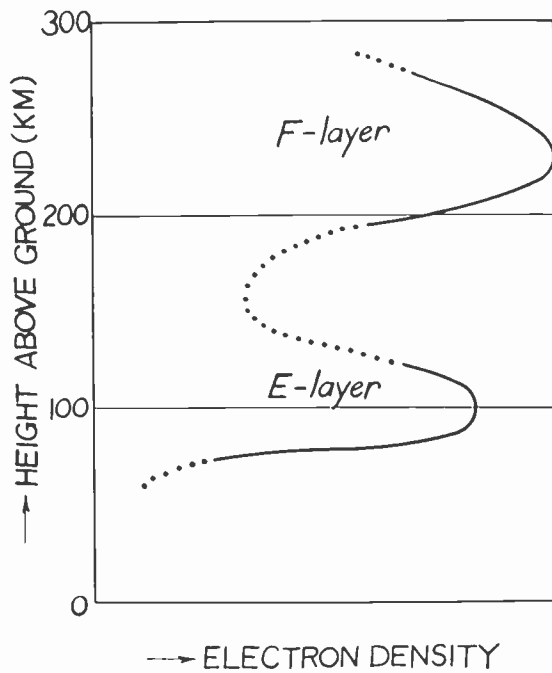

Fig. 1

If,

$$2\pi j\Delta\varphi \ll 4\pi^2 \sum \left(\frac{\partial\varphi}{\partial x} \right)^2, \tag{4}$$

then (3) becomes,

$$\sum \left(\frac{\partial\varphi}{\partial x} \right)^2 = \frac{f^2 n^2}{c^2} = \frac{1}{\lambda^2}, \tag{5}$$

which is the well-known "iconal-equation" of geometrical optics. The condition expressed by (4) determines the limit of applicability of the theory and has already been shown by various investigators in similar forms. Denoting l the direction of the maximum gradient of phase velocity V , and θ the angle between l and the direction of wave propagation, de Broglie expressed (4) by the following equation:

$$\cos \theta \cdot \frac{1}{V} \frac{dV}{dl} \lambda \ll 1. \quad (6)$$

Equation (6) shows that the change of the phase velocity within the course of a wavelength must be very small, in order that the theory of geometrical optics might be applied to the study of wave propagation. Accordingly, Fermat's principle of the minimum optical path holds in the case when (6) is valid.

IV. ATTENUATION OF WAVES

1. General formula

It is well known that in a homogeneous semiconducting medium there exist the following relations:

$$\left. \begin{aligned} n &= \sqrt{\epsilon - j \frac{4\pi\sigma c^2}{\omega}} \\ \sigma &= \frac{Ne^2}{m} \frac{v}{\omega^2 + v^2} \text{ (e.m.u.)} \\ \epsilon &= 1 - \frac{4\pi Ne^2}{m} \frac{1}{\omega^2 + v^2} \text{ (e.s.u.)} \end{aligned} \right\} \quad (7)$$

Attenuation coefficient γ is also given by

$$\gamma = \frac{2\pi\sigma}{cn}. \quad (8)$$

By using (7), we have,

$$\gamma = \frac{2\pi Ne^2}{mcn} \frac{v}{\omega^2 + v^2}. \quad (9)$$

When $\omega \gg v$, (9) becomes,

$$\gamma = \frac{2\pi Ne^2}{mcn} \frac{v}{\omega^2}. \quad (10)$$

Equation (10) represents the fact that the amplitude E of a wave is attenuated by the amount

$$dE = \gamma \cdot E \cdot ds \quad (11)$$

after traveling a distance ds .

The attenuation coefficient thus obtained will be used for the calculation of the total attenuation of a wave traveling in the ionized medium.

Let r_0 be the radius of the earth as shown in Figs. 2 and 3, then the optical invariants become

$$r_0 n_0 \sin i_0 = (r_0 + z) \cdot n \cdot \sin i, \tag{12}$$

in which n_0 becomes unity.

Also in Fig. 3,

$$ds = \frac{dz}{\cos i}.$$

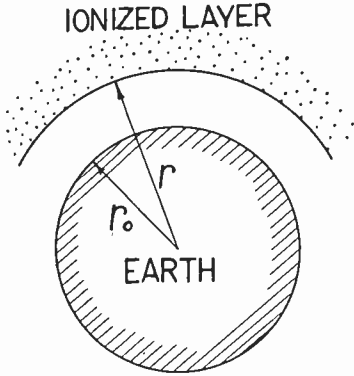

Fig. 2

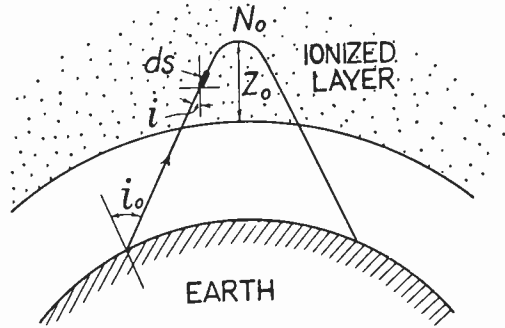

Fig. 3

Substituting the value of $\cos i$, which may be calculated from (12), we have,

$$ds = \frac{n \left(1 + \frac{z}{r_0} \right)^2 \cdot dz}{\sqrt{\cos^2 i_0 + \frac{2z}{r_0}} \sqrt{1 - \frac{N}{N_c}}}, \tag{13}$$

where,

$$N_c = \frac{m\omega^2}{4\pi e^2} \cdot \frac{\cos^2 i_0 + \frac{2z}{r_0}}{\left(1 + \frac{z}{r_0} \right)^2}.$$

Denoting Γ the total attenuation along a ray path in the ionized layer, we obtain the following equation as a general equation of attenuation:

$$\begin{aligned} \Gamma &= \int \gamma ds \\ &= \frac{2\pi e^2}{mc\omega^2} \cdot \frac{1}{\sqrt{\cos^2 i_0 + \frac{2z}{r_0}}} \int \frac{N \cdot v \cdot dz}{\sqrt{1 - \frac{N}{N_c}}}. \end{aligned} \tag{14}$$

2. Attenuation of the first kind

If $N_c > N$ in (14), the total attenuation becomes

$$\Gamma_1 \cong \frac{2\pi e^2}{mc\omega^2} \cdot \frac{1}{\sqrt{\cos^2 i_0 + \frac{2z}{r_0}}} \int_{z_{Emin}}^{z_{Emax}} Nvdz. \quad (15)$$

The attenuation as expressed in (15) is called the *attenuation of the first kind*, and its principal characteristics are found in the facts that the attenuation is inversely proportional to the square of the frequency and also to the angle of incidence.

3. Attenuation of the second kind

The total attenuation along a curved path in the ionized layer, when the wave, after being refracted, again comes back to the surface of the earth, next will be calculated.

The wave is assumed to travel in the ionized medium always satisfying the condition as expressed in (6), then the index of refraction n shown in (7) will be simplified as follows,

$$n = \sqrt{\epsilon} = \sqrt{1 - \frac{4\pi N e^2}{m\omega^2}}. \quad (16)$$

Denoting the electron density at the apex of the ray path by N_0 , we have from (12) and (16),

$$N_0 = \frac{m\omega^2}{4\pi e^2} \frac{\cos^2 i_0 + \frac{2z}{r_0}}{\left(1 + \frac{z}{r_0}\right)^2} \quad (17)$$

as i becomes $\pi/2$ at the apex. Then the total attenuation becomes:

$$\begin{aligned} \Gamma_2 &= \int \gamma ds \\ &= 2 \int_0^{z_0} \gamma \frac{dz}{\cos i} \\ &= \frac{4\pi e^2}{mc\omega^2} \frac{1}{\sqrt{\cos^2 i_0 + \frac{2z}{r_0}}} \int_0^{N_0} \frac{N \cdot v \cdot dN}{\frac{dN}{dz} \sqrt{1 - \frac{N}{N_c}}} \\ &= \frac{m\omega^2}{4\pi e^2} \left[\cos^2 i_0 + \frac{2z}{r_0} \right]^{3/2} \cdot \int_0^1 \frac{v \cdot \xi \cdot d\xi}{\frac{dN}{dz} \sqrt{1 - \xi}} \end{aligned} \quad (18)$$

in which,

$$\xi = \frac{N}{N_c}$$

Equation (18) represents that the attenuation Γ_2 is directly proportional to a certain power of the frequency and $\cos i_0$, and inversely proportional to the electronic gradient dN/dz . As Γ_2 has quite opposite characteristics, when compared with Γ_1 , with respect to the frequency and $\cos i_0$, we shall call this kind of attenuation as the *attenuation of the second kind*.

Next, Γ_2 will be calculated for several cases in which electron distributions are simple, where v is assumed to be constant for simplicity.

Denoting,

$$k = \frac{4\pi e^2}{m}$$

(1) $N = az$ (linear distribution)

$$\Gamma_2 = \frac{4}{3} \frac{\omega^2 v \left[\cos^2 i_0 + \frac{2z}{r_0} \right]^{3/2}}{cka} \quad (19)$$

(2) $N = bz^2$ (parabolic distribution)

$$\Gamma_2 = \frac{\omega v \pi \left[\cos^2 i_0 + \frac{2z}{r_0} \right]}{2c\sqrt{kb}} \quad (20)$$

(3) $N = pe^{az}$ (exponential distribution)

$$\Gamma_2 = \frac{2v}{cq} \left[\cos i_0 + \frac{2z}{r_0} \right] \quad (21)$$

Or (19), (20), and (21) may be represented in terms of the electronic gradient at the apex of the ray path $(dN/dz)_0$,

$$\Gamma_2 = A \frac{\omega^2 \left[\cos^2 i_0 + \frac{2z}{r_0} \right]^{3/2}}{\left(\frac{dN}{dz} \right)_0} \quad (22)$$

where A is a constant which depends on the form of the electronic distribution. It is a very important and interesting fact that the attenuation of the second kind is represented in the form shown in (22) whatever the electronic gradient may be.

V. PROPAGATION IN CASE WHEN THE THEORY OF GEOMETRICAL OPTICS IS NOT APPLICABLE

In Section III it is pointed out that the condition as expressed in (4) or (6) must be satisfied in order that Fermat's principle might be applied to the study of the propagation of radio waves. We shall next consider a case in which the wavelength of the wave under consideration is increased, namely, in such a case when the law of geometrical optics is not any longer applicable.

Let the ionized layer be divided into a number of horizontally stratified layers lying one upon another as shown in Fig. 4. Each layer is assumed to have a thickness appreciably smaller than the wave-

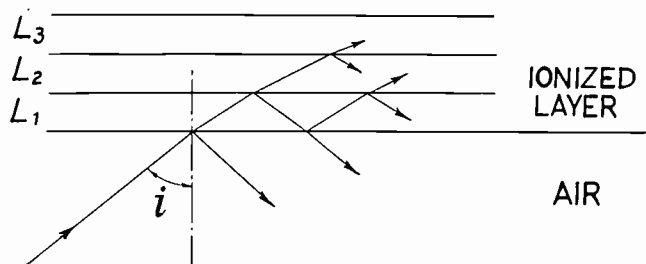

Fig. 4

length and an optical property homogeneous throughout the layer. It is also assumed that at a surface of the stratum between two consecutive layers, there is an abrupt change in the index of refraction, namely from n to $n + \Delta n$. The wave propagates through one layer and reaches a surface of the above-mentioned stratum, when one part of the energy of the wave penetrates into the adjacent layer, while the other part of the energy is reflected back from the surface of the stratum. The former reaches the other surface of the stratum and there take place again refraction and reflection, and so on. The useful energy must be the total sum of the energy reflected from the surfaces of the stratum and returned back again to the medium of air. The ionized layer being thus modified, the propagation may be treated in accordance with the law of geometrical optics, which is not otherwise directly applicable. This "step reflection method" is, of course, an approximate means of solution, and it is shown without difficulty that this treatment is mathematically rigorous only when the ratio of the thickness of the elementary layer to the wavelength becomes infinitely small, although the mathematical proof is omitted in this paper.

The amount of reflection of a single ray, which is called the "reflection ratio" in this paper, at the surface of the stratum between the two layers having the indexes of refraction n and $n + \Delta n$ is:

$$\left. \begin{aligned} R_1 &= -\frac{E_{r1}}{E_{i1}} = |R_1| \cdot e^{i\theta_1} \\ R_2 &= \frac{E_{r2}}{E_{i2}} = |R_2| \cdot e^{i\theta_2} \end{aligned} \right\} \quad (23)$$

where R_1 corresponds to an electric force vibrating in the plane of incidence, R_2 to that vibrating in a direction perpendicular to the plane of incidence, θ_1 and θ_2 are the phase changes at reflection. After several calculations they are given by;

$$\left. \begin{aligned} |R_1| &= \left| \frac{n\sqrt{(n + \Delta n)^2 - n^2 \sin^2 i} - (n + \Delta n)^2 \cos i}{n\sqrt{(n + \Delta n)^2 - n^2 \sin^2 i} + (n + \Delta n)^2 \cos i} \right| \\ |R_2| &= \left| \frac{n \cdot \cos i - \sqrt{(n + \Delta n)^2 - n^2 \sin^2 i}}{n \cdot \cos i + \sqrt{(n + \Delta n)^2 - n^2 \sin^2 i}} \right| \end{aligned} \right\} \quad (24)$$

where n is given by the following general equation, which may be calculated from (7) by arranging the real part of it.

$$n = \sqrt{\frac{\epsilon}{2}} + \sqrt{\frac{\epsilon^2}{4} + \left(\frac{2\pi\sigma c}{\omega}\right)^2}. \quad (25)$$

Thus to begin with a practical calculation of reflection, a numerical estimation of Δn is necessary.

VI. DEFINITIONS OF THE "HIGH-FREQUENCY," "MEDIUM-FREQUENCY," AND "LOW-FREQUENCY" WAVES

The author is of the opinion that the low-, medium-, and high-frequency waves should rigorously be defined as follows:

1. *The high-frequency wave (short wave)* is such a wave that its propagation can be treated with the theory of geometrical optics.

2. *The medium-frequency wave (medium wave)* is such a wave that its propagation cannot be treated directly by the law of geometrical optics; whereas, it may only be solved approximately by a special way, such as the "step reflection" method.

3. *The low-frequency wave (long wave)* is such a wave that its propagation can be dealt with the theory of step reflection as the limiting case. The usual law of reflection is sufficiently applicable, as the change of the optical property within a course of one wavelength is so great.

In solving practical problems, however, there are no such distinct boundaries between them, because of the existence of the various factors affecting, such as season, time, angle of incidence of a wave, etc., and rough classifications will be shown in Section XI.

VII. PROPAGATION OF LOW-FREQUENCY WAVES

Theories on the propagation of low-frequency waves have already been published in a paper⁹ by Mr. Yokoyama and the present author, and here only an abbreviated account will be given of the typical characteristics.

For a low-frequency wave of about 100 kilocycles or below, the electronic gradient of the ionized layer within a course of one wave-

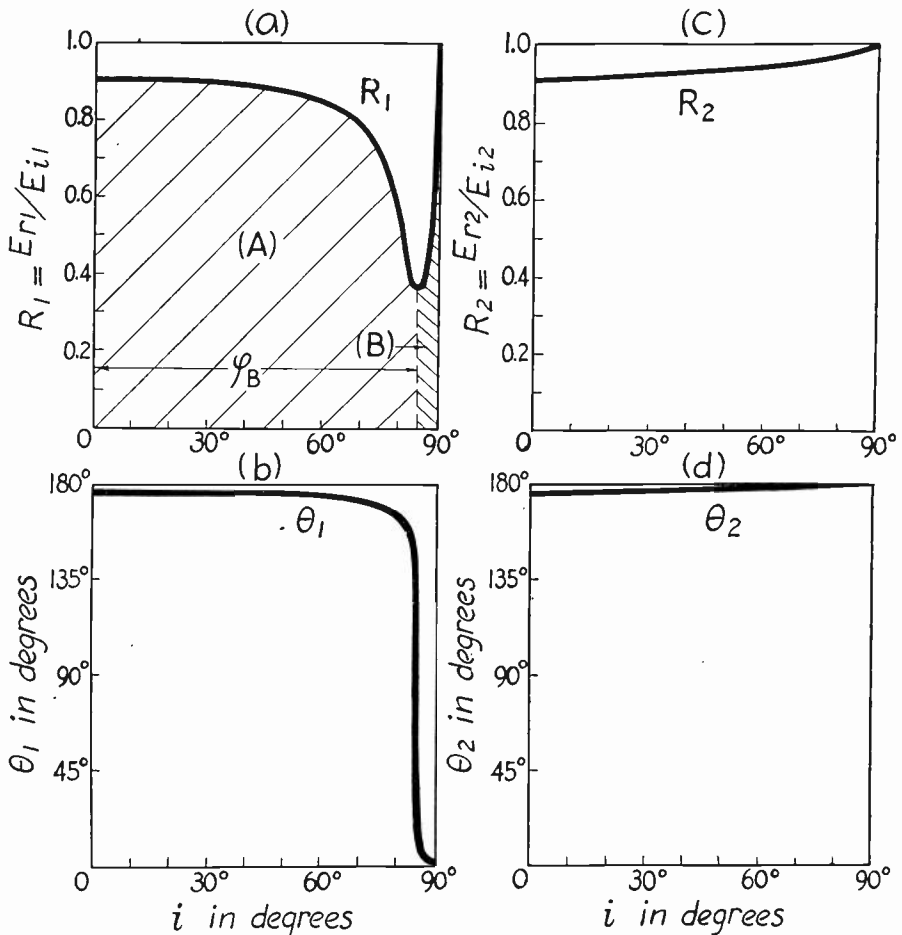

Fig. 5—Reflection characteristics of low-frequency wave (daytime).

length is so great that the layer behaves as a good reflecting surface. After careful calculations it is shown that there takes place the metallic reflection during daytime and the dielectric reflection during nighttime. The reflection ratios, R_1 and R_2 , of a wave at the reflecting surface are calculated for various conditions of the layer, together with the phase changes θ_1 and θ_2 at reflection. Figs. 5 and 6 show, respectively, the typical day and night reflection characteristics of low-frequency

waves. As shown in these figures the reflection ratio R_1 , which is an important factor in low-frequency communications, is usually better at night than during daytime for practical values of the angle of incidence, say $i = 70 \sim 80$ degrees, corresponding to a case of fairly long-distance transmission. During daytime, the longer the wavelength the better the reflection, as the conductivity is greater for a longer wave; while at night, the reflection is almost equally good for all the wavelengths.

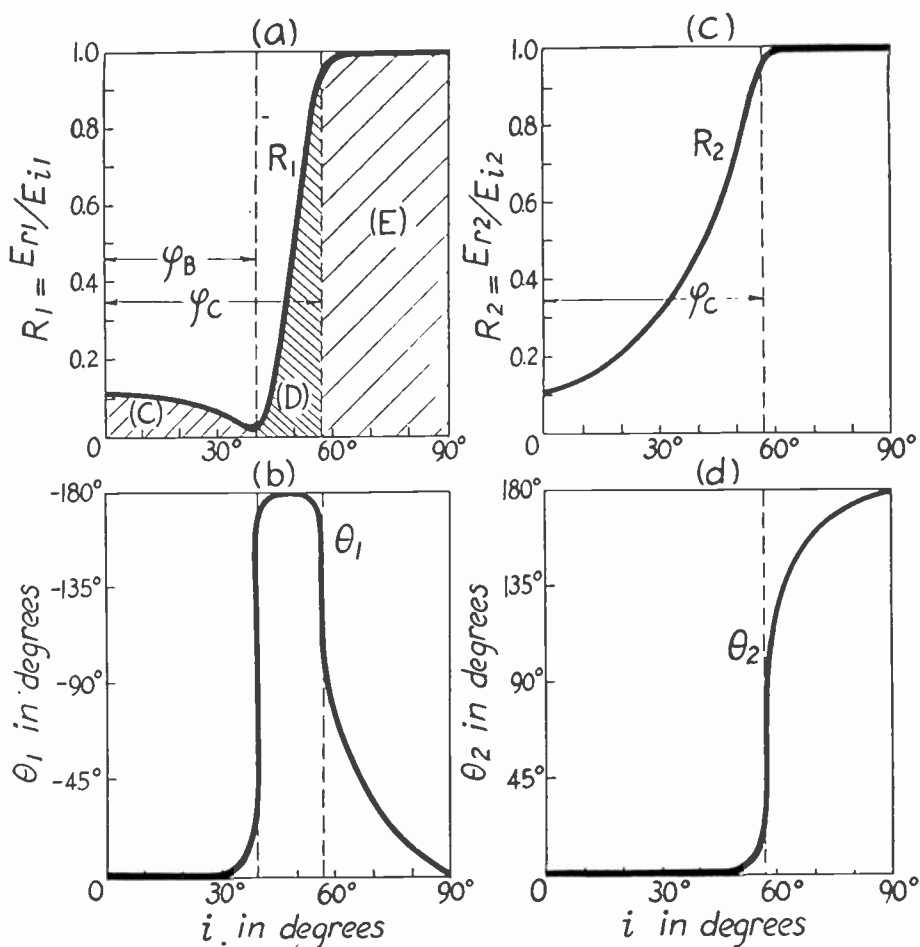

Fig. 6—Reflection characteristics of low-frequency wave (nighttime).

These results are in good agreement with experience. The effects of the season and the latitude where the transmission takes place upon the propagation characteristics of low-frequency waves are fully explained.

The reflection characteristics at the layer change gradually from a daylight state as shown in Fig. 5 to a night state as shown in Fig. 6 at the time of sunset; that is, the reflection passes from metallic to dielec-

tric. At a certain instant, when the angle of incidence of the waves just coincides with the Brewster's angle of reflecting layer, the reflection ratio and the phase change at reflection vary markedly. At the instant of coincidence, the electric force vibrating in the plane of incidence can hardly be reflected. Then the received signal intensity curve shows a pronounced crevasse at the sunset period. This phenomenon has long been experienced and known as the *sunset phenomenon*, although no one has ever published the probable explanation concerning it. At the sunrise period, the process is reversed and another crevasse is observed at the transition period from the dielectric reflection to the metallic. The phase angle between an electric force vibrating in the plane of incidence and that in the perpendicular direction also changes markedly at the transition period. These phenomena have been observed by using a cathode ray oscillograph, and the results of this oscillographic study are very useful in explaining the mechanism of the *polarization errors* (being usually called *night errors*) in direction finding.

VIII. PROPAGATION OF MEDIUM-FREQUENCY WAVES

It is shown in Section V, that the question of the propagation of medium-frequency waves may approximately be solved by using the "step reflection method." In the following the value of Δn , which is required for the calculation of the "step reflection," will roughly be estimated.

From (7),

$$\frac{dn}{dz} \cong - \frac{2\pi e^2}{m} \cdot \frac{1}{\omega^2 + v^2} \cdot \frac{dN}{dz} \quad (26)$$

where, for simplicity of calculation, a relation $\epsilon \gg (4\pi\sigma c^2/\omega)$ is assumed. Assuming, for example, $\omega = \pi \times 10^6$ ($\lambda = 600$ meters) and $v = 5 \times 10^5$,

$$\begin{aligned} \frac{dn}{dz} &\cong - 1.6 \times 10^{-4} \cdot \frac{dN}{dz} \\ \Delta n &= \frac{dn}{dz} \Delta z = - 1.6 \times 10^{-4} \cdot \frac{dN}{dz} \Delta z \end{aligned}$$

also if we assume $\Delta N = 3 \times 10^2$ for $\Delta z = \lambda/3 = 200$ meters in the following equation;

$$\Delta N = - \frac{dN}{dz} \Delta z$$

then we obtain

$$\Delta n \cong - 0.048.$$

Substituting the numerical values of $n=1$ and $\Delta n = -0.048$ into (24), we have a relation between the reflection ratio and the angle of incidence of a wave. The relation is clearly shown in Fig. 7. As shown in this figure no appreciable amount of reflection takes place at the ionized layer in the case of medium-frequency waves for the entire practical values of the angle of incidence (the value of i cannot exceed about 80 degrees at the ionized layer on account of the curvature of the earth),

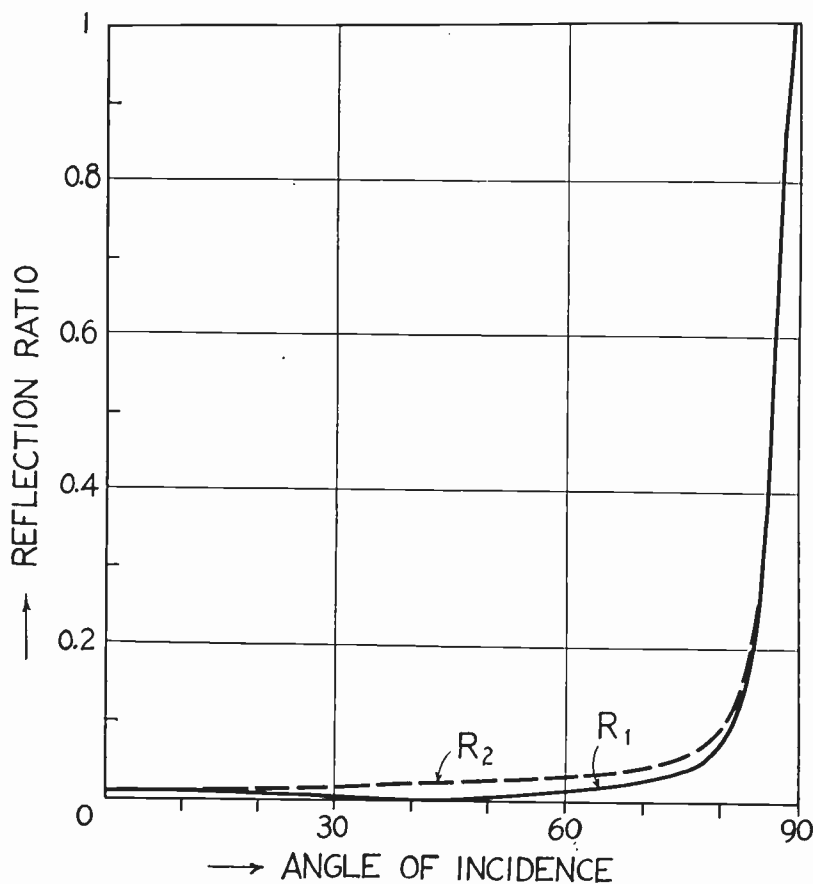

Fig. 7—Daylight reflection characteristics of medium waves.

and the major part of the energy will penetrate into the adjacent layer. The penetrating energy suffers absorption in the layer, and the attenuation can roughly be estimated from (10),

$$\gamma = \frac{2\pi e^2 N}{mcn} \cdot \frac{v}{\omega^2} \cong 5 \times 10^{-6} [\text{cm}^{-1}]$$

assuming $N = 3 \times 10^3$, $v = 10^6$ (hence $n \cong 0.36$). The result shows that, when the medium-frequency wave of 600 meters in wavelength travels a distance of one wavelength through the ionized medium, the ampli-

tude will be attenuated in the ratio of about $1/e^3$; and the value is so great that the part of energy penetrating into the layer without being reflected back at the first surface of the stratum is almost completely absorbed while propagating in the layer, and can scarcely be utilized in practical communication. As the reflection ratio depends on the magnitude of Δn within a course of a certain fraction of wavelength, it is understood that the higher the frequency, the worse the transmission characteristic.

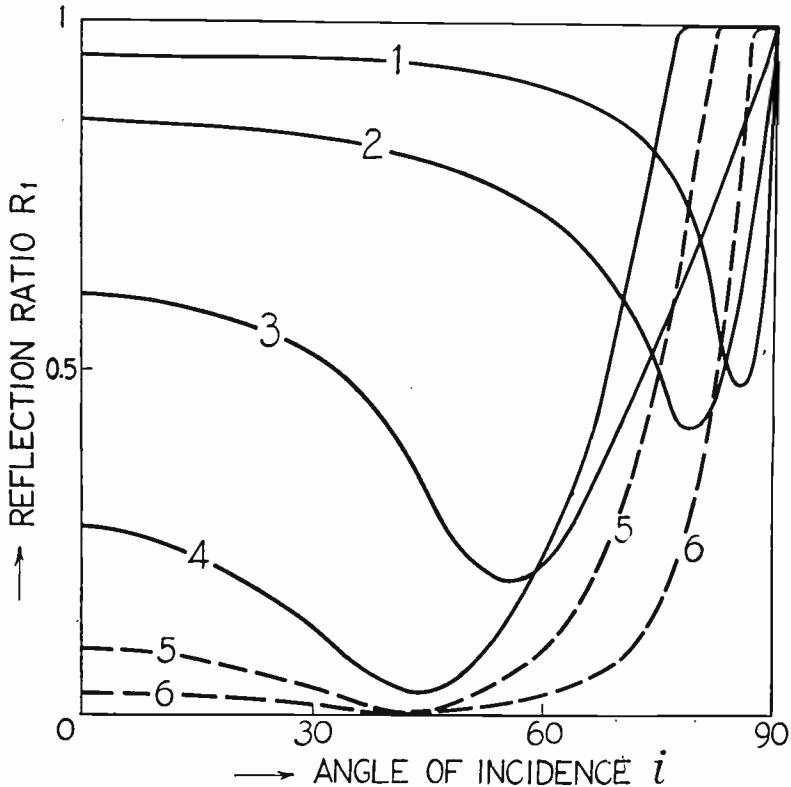

Fig. 8—Daylight reflection characteristics.

Daylight reflection characteristics of low- and medium-frequency waves are summarily shown in Fig. 8.

As the long-distance transmission usually takes place at a large value of the angle of incidence, say $i = 75$ degrees at the layer (which corresponds to $i_0 = 80 \sim 90$ degrees on the surface of the earth), the reflection ratio is fairly large in the case of the low-frequency transmission as shown by curve 1 in the figure; while, if the wavelength is gradually decreased, the reflection becomes worse and takes a very small value under a particular condition at which the Brewster angle of the reflecting surface just coincides with the angle of incidence of the wave as marked by curve 2 in Fig. 8. For shorter wavelengths the

reflection becomes dielectric, and at first it may look as if the reflection ratio again were increasing according to the decrease of wavelength, but the matter is entirely opposite. When the wavelength is further decreased, the value of the electronic gradient $(\Delta N/\Delta z)\lambda$ becomes insufficient for the wave to be reflected in the usual dielectric manner. Then a step reflection takes place, and the value of reflection ratio becomes worse and worse as the wavelength decreases. Curves 5 and 6 in Fig. 8 show these bad reflection characteristics of medium-frequency waves.

The night transmission phenomenon is quite similar to that of the daylight, but in the former case, the decrease of attenuation is noticeable. As the path of rays is fairly elevated during nighttime on account of the recombinations of electrons and positive ions, the reflection, of either the normal or the step type, takes place at a higher level than during daytime, when the mean collisional frequency is small ($\nu = 10^3 \sim 10^4$ approximately). The attenuation coefficient then decreases to an order of about 1/100 of the day value, and the wave scarcely suffers from absorption; for example, the amplitude of the 600-meter wave decreases only in a ratio of $1/e^{0.03}$ after traveling one wavelength. The path of ray is branched into a number of paths as shown in Fig. 4, as in the case of the propagation under the daylight condition, but the waves traveling over these paths are almost free from absorption, and almost all of them come back again to the surface of the earth. It is thus shown that, during nighttime, there is practically no absorption in the transmission of a medium-frequency wave although the mode is "step reflection," as in daytime. On the other hand, there appears a phenomenon of "fading," as the energy is carried by many component rays which have traveled on different paths almost free from absorption.

IX. PROPAGATION OF MEDIUM-HIGH-FREQUENCY WAVES

It is pointed out, in the previous paragraph, that the propagation of a medium-frequency wave can be treated by an approximate solution called "step reflection method." When the frequency of the wave is further increased, the "step reflection method" can no longer be used, and the general law of geometrical optics may directly be applied.

Here, the relation between the attenuation and the frequency of waves is very important. As described in Section II, there are at least two ionized layers of maximum electron density, namely the E and F layers. It is also shown in Section IV that the necessary value of electron density has been estimated, in order that a wave radiated with an angle of i_0 at the surface of the ground, may be refracted in the

ionized layer back again to the earth, and it is expressed as follows,

$$N_0 = \frac{m\omega^2}{4\pi e^2} \cdot \frac{\cos^2 i_0 + \frac{2z}{r_0}}{(1 + z/r_0)^2} \quad (27)$$

It is easily seen from this equation that if $N_0 > N_{E_{\max}}$, the wave cannot completely be refracted in the E layer, but the wave reaches the F layer, and sufficient refraction will take place at this upper layer where the electron density is richer than in the lower layer. The absorption in the E layer thus becomes maximum at the instant when the wave just comes out through the lower layer, because the attenuation of the second kind is inversely proportional to $(dN/dz)_0$, the electronic gradient at the apex of the path of a ray, as shown by the equations given in Section IV. The value of $(dN/dz)_0$ becomes infinitely small at the moment when the wave just leaves the E layer, namely the case $N_0 = N_{E_{\max}}$. The frequency under this critical condition will be called the "critical frequency."

Now, we have arrived at an important result that, when the frequency of the wave is below the critical frequency, the wave is sufficiently refracted in the E layer and is subjected to the attenuation of the second kind in proportion to a certain power of the frequency. While if the frequency of the wave is above the critical frequency, the wave is scarcely refracted in the E layer, but passes through it and reaches the F layer where it is refracted. The total absorption, then, is regarded as being composed of two parts—the absorption of the first kind by the E layer and the absorption of the second kind by the F layer—the latter is negligibly small compared with the former, as the collisional frequency is the order of $10^3 \sim 10^4$ at a height above 200 kilometers. It is thus shown that there is a frequency at which the wave suffers the greatest absorption in the ionized layer, and the waves above or below this critical frequency will suffer less absorption.

The author then intends to classify the short radio waves into the following two kinds: (a) the *medium-high-frequency wave*, which is defined as a wave having such characteristics as, "the law of geometrical optics can be applied to its propagation, and its attenuation is proportional to a certain power of the frequency"; (b) the *high-frequency wave*, which is defined as a wave having such characteristics as, "the law of geometrical optics can be applied to its propagation, and its attenuation is inversely proportional to the square of the frequency."

Although the above discussion is mainly confined to daylight transmission, a quite similar treatment may be used for night transmission. When the transmission takes place during nighttime, the absorption

in the E layer becomes much less for the reason that the wave is refracted at a higher level than during daytime on account of the recombination of electrons and positive ions. The critical wavelength during nighttime is of course shifted to a longer one as shown in the following equation;

$$\frac{\lambda_{N'}}{\lambda_{D'}} = \sqrt{\frac{N_{ED}}{N_{EN}}} \quad (28)$$

where N_{ED} and N_{EN} denote the electron density of the E layer during daytime and nighttime, respectively. The numerical value of the ratio of N_{ED} to N_{EN} may roughly be estimated at about 25 as it has been known from the results of various experiments that the wavelength for the maximum absorption is shifted to a value about five times longer than that of the day value, that is to say, waves of about 100-meter wavelength suffer the maximum attenuation during daytime, and about 500-meter waves during nighttime, though the amount of the maximum attenuation will be much smaller at night than in daylight.

X. PROPAGATION OF HIGH-FREQUENCY WAVES

High-frequency waves, which are of higher frequencies than the critical frequency as explained in the preceding paragraph, penetrate into the E layer, generally reaching the upper ionized layer, and they are refracted in the F layer, where the electron density is richer than in the E layer, so long as the maximum electron density of the F layer is great enough for the bending of the ray. While, if the value of N_0 calculated from (27) is greater than the maximum electron density of the F layer, the wave cannot be refracted back again to the earth. The wave which just escapes from the F layer will be called the "wave of limiting frequency or limiting wavelength."

As for the attenuation of the high-frequency transmission, the major part is caused in the E layer when the wave passes through it. The attenuation in the E layer is approximately of the first kind, which is inversely proportional to the square of the frequency; so that, the higher the frequency, the smaller the attenuation.

Although the part of attenuation occurring in the F layer, when the wave is slowly refracted in it, is generally very small compared with that in the E layer, yet it must be remembered that this kind of attenuation must be taken into account for the transmission of very high-frequency, say waves of 8- to 15-meter range. As the attenuation in the F layer is of the second type, which is not only directly proportional to a certain power of the frequency, but also inversely proportional to $(dN/dz)_0$, the higher the frequency, the greater becomes the attenuation.

We can summarize what we have so far discussed on the high-frequency transmission as follows: High-frequency waves are generally refracted from the F layer, their attenuation being caused mainly in the E layer. The higher the frequency, the smaller the attenuation; but, there is a frequency at which the minimum attenuation occurs. If the frequency is further increased, the attenuation in the F layer becomes one of the important factors and, at the limiting frequency, the wave propagates to the outer atmosphere of the earth. In practical communication, the frequency for the minimum attenuation must be selected under given conditions, such as season, distance, etc. Generally, the wave having the minimum attenuation during daytime lies between 14 and 20 meters in wavelength. Below 14 meters the signal strength is gradually lowered and becomes inaudible at the limiting wave, say 8 meters in wavelength.

During nighttime the limiting wavelength is shifted to the longer side, and from (27) it is easily shown that

$$\frac{\lambda_N''}{\lambda_D''} = \sqrt{\frac{N_{FD}}{N_{FN}}} \quad (29)$$

where λ_D'' and λ_N'' are limiting wavelengths, N_{FD} and N_{FN} are the electron density of the F layer during day and night, respectively. As the limiting wavelengths are considered to be about 8 meters during daytime and about 24 meters during nighttime, we know that the electron density of the F layer decreases at night to about one-tenth of the day value.

Above the critical frequency the waves pass through the F layer and escape from the earth's atmosphere. They are commonly called "*ultra-high-frequency waves.*"

XI. PRACTICAL CASES

1. In the previous discussion, the author classified the radio waves into low-, medium-, medium-high-, and high-frequency waves from theoretical points of view, yet the waves used in practical communications are not so rigorously classified, not only because the boundary frequency is not sharply defined, but also it is liable to be affected by various conditions, especially by the state of ionization and the angle of incidence.

It is known from the results of various experiments that a number of rays arrive at a receiving point, each having a different value of the angle of incidence. We shall consider, at present, a general case of the long-distance transmission, in which the total energy is assumed to be carried by a resultant ray having a mean value of $i_0 = 70$ degrees.

2. As pointed out by Taylor¹⁰ and others,* the waves of 100 meters in wavelength during daytime and those of about 500 meters during nighttime have the worst transmission characteristics as shown in Fig. 9. According to the author's present theory, the maximum attenuation occurs when the wave just escapes from the ionized layer. Then we may roughly estimate the values of the electron density of

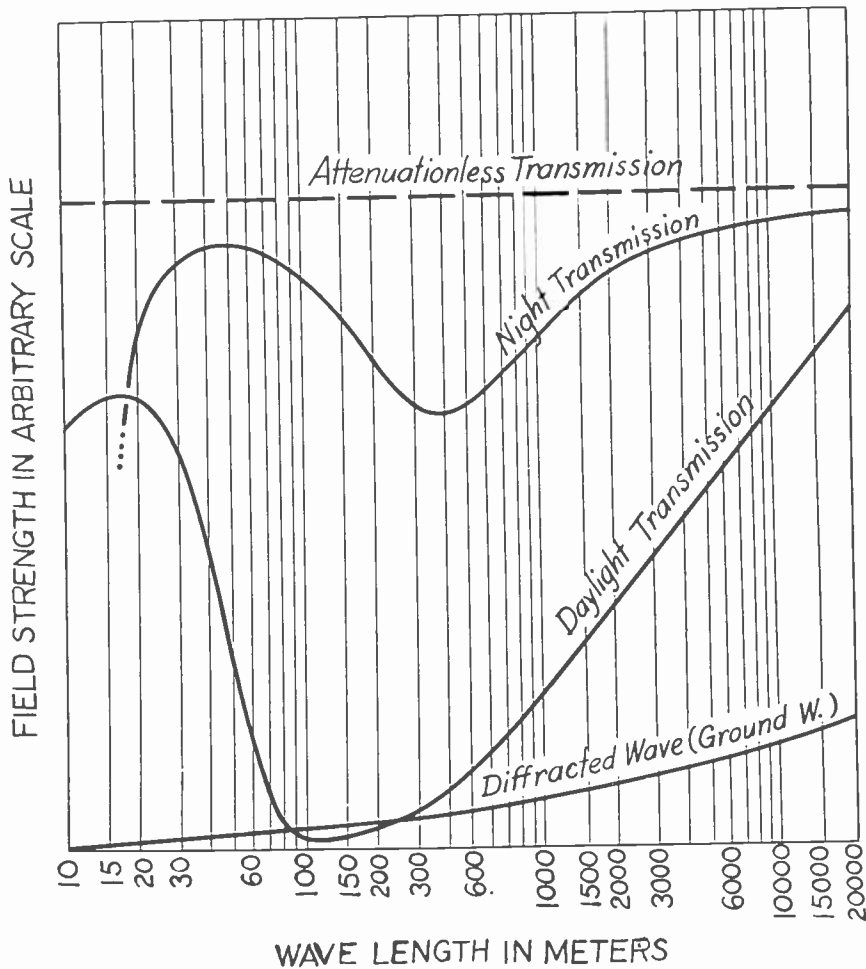

Fig. 9—Propagation characteristics of radio waves. $\lambda = 10$ to 20,000 meters.

the E and F layers by experimentally determining the critical and limiting wavelengths, and by assuming the proper values of z and i_0 .

By substituting probable values† of $z = 120$ kilometers, $i_0 = 45$ de-

* For example, Bureau of Standards, Letter Circular, No 317.

† When the frequency of the wave is in the neighborhood of the critical frequency, there arrive at the receiver not only waves refracted from the E layer but those refracted back from the F layer having smaller angle of incidence than the former. Thus when the electron density of the E layer alone is to be determined from the experimental result on the frequency of minimum transmission range, the value of i_0 must be selected to be an appreciably low value, say 45 degrees.

grees, and $\lambda = 100$ meters into (27), we have approximately,

$$N_{ED} \cong 5.6 \times 10^4 \text{ (mean value).}$$

Under the same condition the critical wavelength becomes about 30 meters when the wave is radiated from the transmitter tangentially to the surface of the earth, and about 140 meters when radiated vertically upward; that is to say, the waves longer than 140 meters never escape from the E layer even when radiated vertically upward.

As the wavelength of maximum absorption is increased to about 500 meters during nighttime, the electron density must be decreased at night as shown in the following formula;

$$N_{EN} = N_{ED} \times \left(\frac{100}{500}\right)^2 \cong 2.2 \times 10^3 \text{ (mean value).}$$

This value corresponds to the value of i_0 similar to the previous case. For the vertical incidence the critical wavelength becomes about 700 meters, and for the tangential incidence about 135 meters.

Next, as for the electron density of the F layer, we know that the limiting wavelength is about 8 meters at about noon and about 24 meters during nighttime of intense darkness, (these values correspond to $i_0 \cong 90$ degrees); then, by using (27), the average values of electron density in the F layer during daytime and nighttime may approximately be determined as,

$$N_{FD\max} \cong 1.5 \times 10^6$$

$$N_{FN\min} \cong 1.6 \times 10^5.$$

These results show that the day maximum value of the electron density in the F layer is about 10 times greater than the night minimum value, while with regard to the E layer, the day value is from about 20 to 30 times greater than the corresponding night value. The reason why the night value of the electron density in the E layer is so low, is no doubt due to the fact that the recombination constant between an electron and a positive ion is much greater in the E layer than in the F layer, because the atmospheric pressure which is approximately proportional to the recombination constant is much greater in the lower layer than in the upper layer.

3. The author then tried to classify the radio waves from the practical points of view as shown in Table I, assuming the mean value of the angle of incidence at 70 degrees. As shown in the table, the waves shorter than 20 meters during daytime and those shorter than 60 meters during nighttime do not come back again to the surface of the

earth, so long as they are radiated from the transmitter with an angle of incidence smaller than 70 degrees.

TABLE I
(ASSUMED $i_0 = 70$ DEGREES)

	Day Transmission	Night Transmission
Low-frequency wave	$f < 100$ kc Metallic reflection at the E layer	$f < 100$ kc Dielectric reflection at the E layer
Medium-frequency wave	$100 \text{ kc} < f < 1000$ kc Step reflection at the E layer	$100 \text{ kc} < f < 200$ kc Step reflection at the E layer
Medium-high-frequency wave	$1000 \text{ kc} < f < 6000$ kc Refracted back from the E layer	$200 \text{ kc} < f < 1200$ kc Refracted back from the E layer
High-frequency wave	$6000 \text{ kc} < f < 15,000$ kc Refracted back from the F layer	$1200 \text{ kc} < f < 5000$ kc Refracted back from the F layer
Ultra-high-frequency wave	$15,000 \text{ kc} < f$ Passes through the F layer	$5000 \text{ kc} < f$ Passes through the F layer

Remark 1: The table is prepared with regard to a single ray radiated with $i_0 = 70$ degrees. When i_0 is greater than 70 degrees, say $80 \sim 90$ degrees, as in the case of beam transmission, the boundary frequency between the high-frequency and the ultra-high-frequency waves will be increased to about 30,000 kilocycles during daytime and 12,000 kilocycles during nighttime.

Remark 2: According to the theory described in Section IX and the figures in this table, it is understood that a wave of $i_0 = 70$ degrees suffers greatest attenuation when its frequency is 6000 kilocycles (day) and 1200 kilocycles (night). While in the case of a practical communication there are additional waves which are refracted from the F layer having smaller value of i_0 . When the contributions of those waves are taken into account the frequency of the wave of the minimum transmission range is lowered, say, to approximately 3000 kilocycles (100 meters) during daytime and 600 kilocycles (500 meters) during night as shown in Fig. 9.

4. It must be remembered that, in the above discussion, the disturbance due to atmospherics is not taken into consideration. Although high- and low-frequency waves are almost equally efficient in their ability of propagation as shown in Fig. 9, yet as to the net communication ability, which is defined by the value of the ratio of signal-to-static intensity, the former is much more efficient than the latter.

5. With regard to the reason why the waves of 100~200 meters in wavelength have bad transmission characteristics under the daylight condition, there seems to be some apparent misunderstanding in the opinions of several investigators who have attributed the phenomenon to the effect of the earth's magnetic field. This is readily and clearly explained from the present theory.

6. In the case of long-distance transmission the energy is carried by sky waves for the entire range of wavelengths as shown in Fig. 9. Even for low-frequency waves, in which the amount of diffraction is most prominent, energy is almost completely carried by sky waves when the transmission takes place over a distance greater than a few hundred kilometers. The complete discussion has been given in a previous paper⁹ by Mr. Yokoyama and the present author.

XII. PROPAGATION UNDER MAGNETICALLY DISTURBED CONDITIONS

It has been well known that low- and high-frequency radio transmissions are markedly affected by magnetic storms. Explanations of propagation characteristics under such disturbed conditions based on the present transmission theory will be attempted here.

The up-to-date theory on the nature of magnetic disturbances is settled on the fact that it is caused by a number of charged corpuscles which are shot out from the sun due to the abnormal radiation pressure. After the corpuscles are deflected in the earth's magnetic field, they impinge upon the upper atmosphere of the earth and generate the abnormal ionization. According to the theory of Chapman, the ioniza-

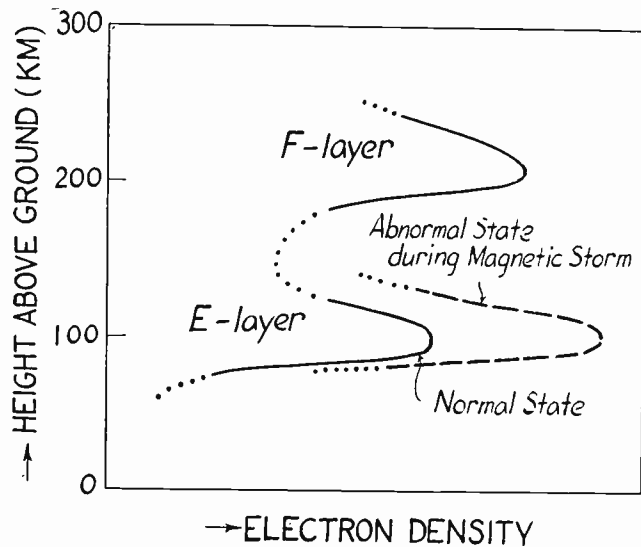

Fig. 10

tion of the E layer is closely associated with magnetic storms; therefore, it may safely be imagined that, under a magnetically disturbed state, the electron density in the E layer becomes abnormally great as shown in Fig. 10, and exceeds the normal value of the maximum density in the F layer on a magnetically calm day.

Low-frequency waves, as explained in Section VII, are usually reflected in a metallic manner during daytime and in a dielectric manner during nighttime. While under a magnetically disturbed state the ionized layer behaves as a better metallic reflector than usual during daytime due to the increase of conductivity σ . It acts, however, as a worse dielectric reflector than usual during nighttime, because the value of ϵ/σ is so small that a sufficient dielectric reflection can hardly take place. Accordingly the effect of a magnetic storm on the low-fre-

quency radio transmission is to increase daylight field strength slightly and reduce night intensity appreciably.

Transmission of high-frequency waves will be taken up next. These waves usually penetrate through the E-layer region, and reach the F layer where they are refracted back. While during magnetic disturbances the matter is quite different; the waves cannot get through the E-layer region, but are returned back from it, because the maximum electron density of the E layer during magnetic storms exceeds the normal maximum density of the F-layer region. Under this abnormal state of the ionized layer, the characteristic of high-frequency propagation is not altered in its principal feature that the propagation can be treated with the theory of geometrical optics, while there occurs a considerable change with respect to attenuation.

Let N_E and $N_{E'}$ be the electron density of the E layer on a quiet day and on a disturbed day, respectively, then the transmission characteristic of a wave of wavelength λ_1 in the F layer on a quiet day is easily proved to be equivalent* to that of a wave of wavelength λ_2 in the E layer on a magnetically disturbed day. Between λ_1 and λ_2 there is approximately the following relation:

$$\frac{\lambda_2}{\lambda_1} = \sqrt{\frac{N_{E'}}{N_E}}. \quad (30)$$

If we take, for example, $N_{E'} = 100 \cdot N_E$, and $\lambda_1 = 20$ meters, then λ_2 becomes 200 meters. Thus it may roughly be imagined that the propagation of high-frequency waves under the magnetically disturbed condition is equivalent to that of medium-high-frequency waves under the normal condition. As already explained in the previous paragraph, the attenuation of the medium-high-frequency wave is so great that we can easily understand the reason why high-frequency waves are heavily attenuated during magnetic storms. Another important characteristic is the relation of the attenuation to the frequency. Usually the attenuation of high-frequency waves is of the first kind; namely, it is directly proportional to the square of the wavelength. During magnetic disturbances, the attenuation becomes that of the second kind, namely it is inversely proportional to a certain power of the wavelength, as waves are refracted back from the E layer. Accordingly, shorter waves suffer the heavier attenuation during magnetic storms; for example, a 20-meter wave suffers heavier attenuation than a 30-meter wave; whereas, the matter is quite opposite under the normal

* The principle of the equivalent substitution is valid within the range in which the law of geometrical optics is applicable.

condition. Then the frequency band used for the high-frequency communication must be shifted to the longer side during magnetic disturbances as commonly done in practice.

As for the medium- and medium-high-frequency waves, the data available are very scarce, but it may safely be predicted from the present transmission theory that the daylight strength remains practically unchanged while the night intensity suffers considerable attenuation.

ACKNOWLEDGMENT

The writer is deeply indebted to Dr. H. Nagaoka for his valuable directions. He would also like to acknowledge his thanks to Mr. T. Tsukada who gave him many useful suggestions in connection with the present study.

Bibliography

1. S. Chapman, *Proc. Roy. Soc., A*, vol. 132, p. 353; August, (1931).
2. E. V. Appleton and J. A. Ratcliffe, *Proc. Roy. Soc., A*, vol. 128, p. 133, (1930).
3. E. V. Appleton and A. L. Green, *Proc. Roy. Soc., A*, vol. 128, p. 159, (1930).
4. K. Foersterling and H. Lassen, *Zeit. für tech. Phys.*, vol. 12, nos. 10 and 11, (1931).
5. H. Nagaoka, *Sci. Papers of Phys. and Chem. Researches (Tokyo)*, vol. 15, no. 297; April, (1931).
6. L. de Broglie, *Jour. de Phys. et le Radium*, series 6, tome 7, p. 321, (1926).
7. W. de Groot, *Phil. Mag.*, vol. 10, no. 65, p. 521, (1930).
8. T. L. Eckersley, *Proc. Roy. Soc., A*, vol. 132, no. 819, p. 83; July, (1931).
9. E. Yokoyama and S. Namba, *Jour. I. E. E. (Japan)*, February, (1932). (English translation published in the *Report of Radio Researches and Works in Japan*, vol. 2, no. 2, August, (1932).)
10. A. H. Taylor and E. O. Hulbert, *Phys. Rev.*, vol. 27, p. 189, (1926).
11. S. Namba and D. Hiraga, *Jour. Inst. of Teleg. and Teleph. Eng. of Japan*, February, (1932).
12. R. Gans, *Ann. d. Phys.*, bd. 47, s. 709, (1915).



SOME LONG-DISTANCE TRANSMISSION PHENOMENA OF LOW-FREQUENCY WAVES*

By

EITARO YOKOYAMA AND ISAO TANIMURA
(Electrotechnical Laboratory, Ministry of Communications, Tokyo, Japan)

Summary—From the results of a series of twenty-four-hour receiving measurements conducted here for more than two and a half years, some interesting phenomena are picked out and discussed. The main points of the conclusions reached are: (1) the daylight signal strength of Kahuku is greater than the night signal strength; (2) several successive crevasses of about a two hours' period are observed regularly in the signal strengths of Bolinas and Kahuku during the partial daylight hours.

I. INTRODUCTION

IN order to explore some phases of low-frequency wave transmission phenomena, a series of twenty-four-hour receiving measurements were conducted monthly over a period extending from May, 1928, to January, 1931, at the Isohama Radio Laboratory near Tokyo, on the following seven transmitting stations: Bolinas, Bordeaux, Kahuku, Malabar, Nauen, Saigon, and Warsaw.^{1,2}

It is the object of this paper to pick out and describe some important points obtained from the results of the above-mentioned measurements, giving explanations to each of the particular cases by applying the theory³ of low-frequency transmission developed by one of the authors and his coworker, Namba.

Each series of measurements was carried out once a month, and each measurement at an interval of thirty minutes during a greater part of a day, but at smaller intervals at such a particular time of a day as the strength of signals received was subjected to a rapid variation. The principal data of the transmitting stations, with respect to which the discussions are to be made in the present paper, are given in Table I.

A T-shaped antenna supported by two wooden poles, thirty-eight meters in height, was used for reception. The strength of signals was

* Decimal classification: R113.2. Original manuscript received by the Institute, October 31, 1932.

Revised form of the original manuscript presented before the 1931 Joint Annual Convention of the Three Electrical Institutes of Japan and the International Electrical Congress, Paris, 1932.

¹ E. Yokoyama and I. Tanimura, Researches Electrotech. Lab., No. 297; January, (1931). (In English.)

² E. Yokoyama and I. Tanimura, Researches Electrotech. Lab., No. 311; June, (1931). (In English.)

³ E. Yokoyama and S. Namba, "Theory on the propagation of low-frequency waves." *Jour. I.E.E.* (Japan), February, (1932); Rep. Radio Res. and Works in Japan, vol. 2, no. 2; August, (1932). (English translation.)

measured by the substitution method initiated by Beverage and Peterson⁴ with a little modification. The further details of measuring ar-

TABLE I

Name of Stations	Wave Frequency in Kilocycles	Direction* (Degrees)	Distance in Kilometers	Percentage of Seas on the Path
Bolinas (KET)	22.9	55	8,150	100
Bordeaux (FYL)	15.7	332	10,200	12
Kahuku (KIE)	17.7	88	6,100	100
Nauen (DFY)	16.5	331	8,920	7
Warsaw (SPL)	16.4	327	8,580	7

* Measured clockwise from the true North.

rangement and method were already given in a paper written by Nakai.⁵

As Bordeaux, Nauen, and Warsaw were only the stations among those named above transmitting continuously throughout nearly twenty-four hours, and the remaining stations shut down their transmitters for certain times of a day, the authors asked those stations not transmitting continuously to make special arrangements for transmissions in the latter part of the present measurements.

The following two transmission phenomena are pointed out and discussed principally:

(a) On the observations of Kahuku, the daylight signal strength was always greater than the darkness one, whereas the relations were of the reverse nature in the measurements with all the other stations observed.

(b) On the observations of Bolinas and Kahuku, which give oversea and east-westerly transmissions, three or four successive crevasses of very long periods were regularly noticed in the signal strength of Bolinas during the partial daylight hours, while two or three occurred in that of Kahuku.

II. COMPARISON BETWEEN DAY AND NIGHT SIGNAL STRENGTHS OF KAHUKU

1. *Results of Measurements*

As an example, a result of observations for Kahuku made on September 3 and 4, 1929, is given in Fig. 1. In view of making comparison, a similar one for Bolinas is also given in Fig. 2 as an example showing a normal variation in the signal strength. It will be seen that the daylight signal strength of Kahuku is greater than the darkness one, whereas the reverse is true for Bolinas.

⁴ "Radio transmission measurements on long wave lengths," Proc. I.R.E., vol. 11, p. 661; December, (1923).

⁵ T. Nakai, Researches Electrotech. Lab., No. 217, November, (1927).

In Figs. 3 and 4 are shown the monthly average curves of day and night signal strengths over the entire period of measurements, where

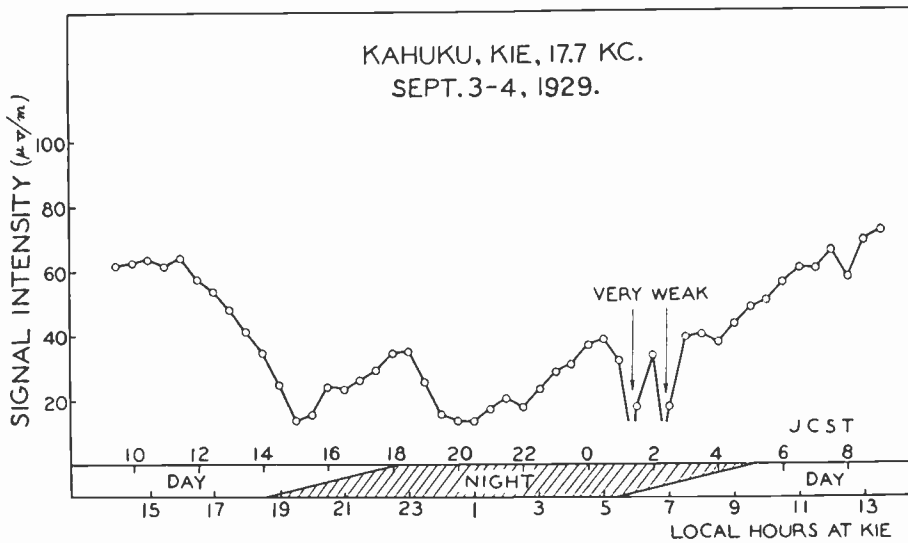

Fig. 1

day and night signal strengths mean that, when both the transmitting and receiving stations come entirely in either the daylight or darkness region. It will also be seen from the figures that the daylight signal

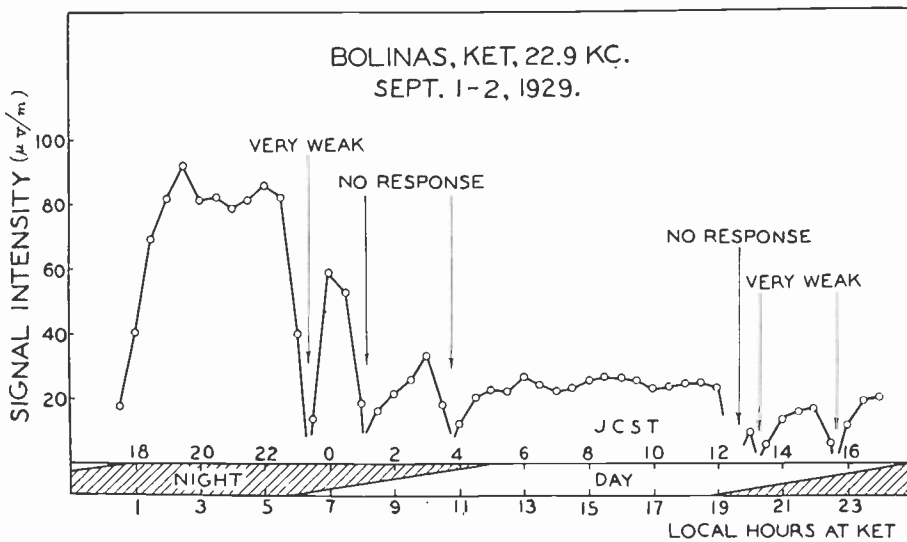

Fig. 2

strength of Kahuku was greater than the night one, through all the seasons, whereas the relation was always of the reverse nature for Bolinas and all other stations observed.

2. Explanation of the Result

It has been pointed out in the previous paper³ that the daylight intensity is generally smaller than the night intensity as the reflection ratio at the lower boundary of the ionized medium is greater at night than in daytime. It is, however, seen that the authors' results given above with Kahuku are contradictory to those in general cases.

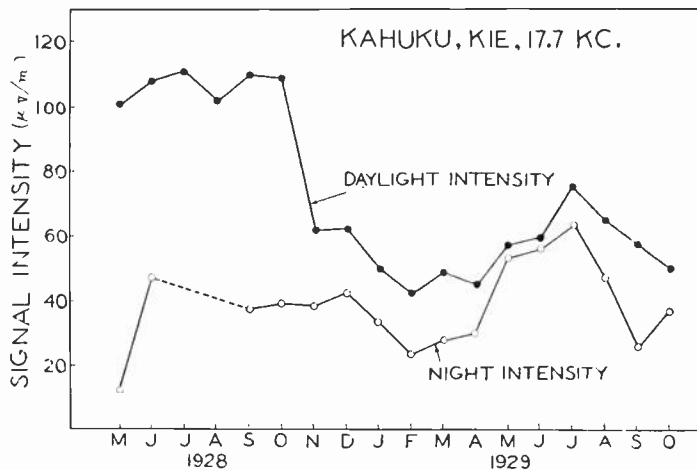

Fig. 3

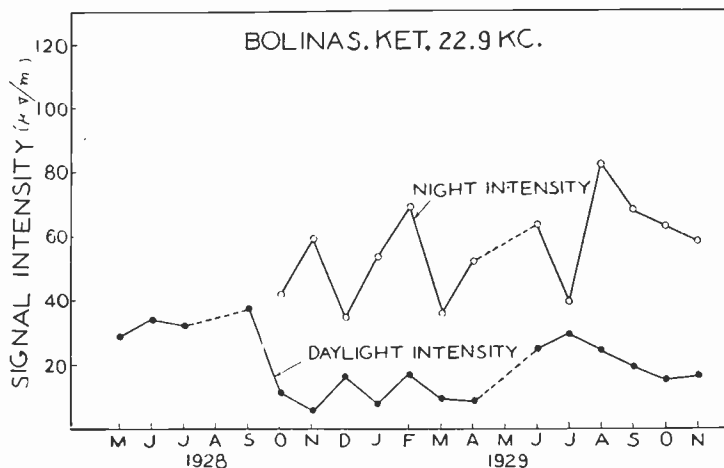

Fig. 4

This phenomenon may be explained by the following reason that the transmission between Hawaii and Japan follows the *skip-type* propagation because of 100 per cent oversea transmission. The radiated energy traveling through the medium bounded by the ionized layer and the earth, propagates with multiple hops and not diffusively, as fully explained in the previous paper. Thus the field strength does not always decrease when the distance of transmission is elongated.

With regards to the abnormal relation between day and night intensities observed on the transmission of Kahuku, it is understood that the main beam of the radiated energy has just exactly the downcoming

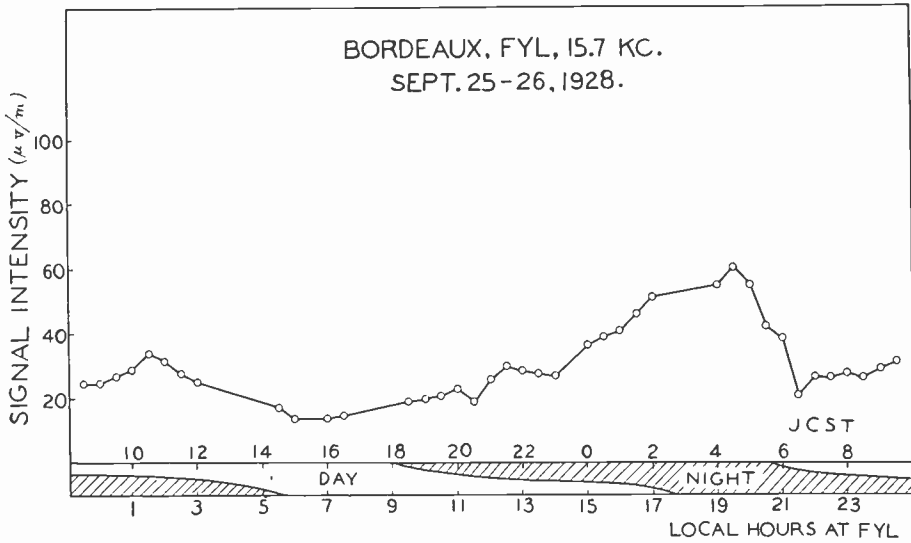

Fig. 5

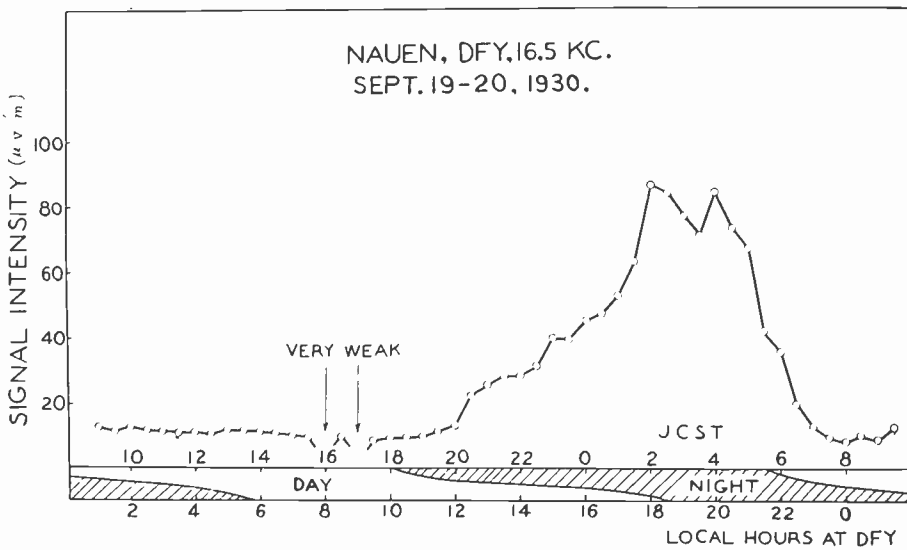

Fig. 6

nature within the receiving area, while during nighttime it comes down at a more distant region from the transmitter as the reflection at the Heaviside layer takes place at a higher level at night than during daytime. Thus, at the receiver, less energy is received at night than in daytime in contrast to the normal condition.

The inverse relation between day and night intensities described above is never met in the case of the overland transmission, because the transmission follows, in this case, the *diffused type* as shown in Figs. 5, 6, and 7.

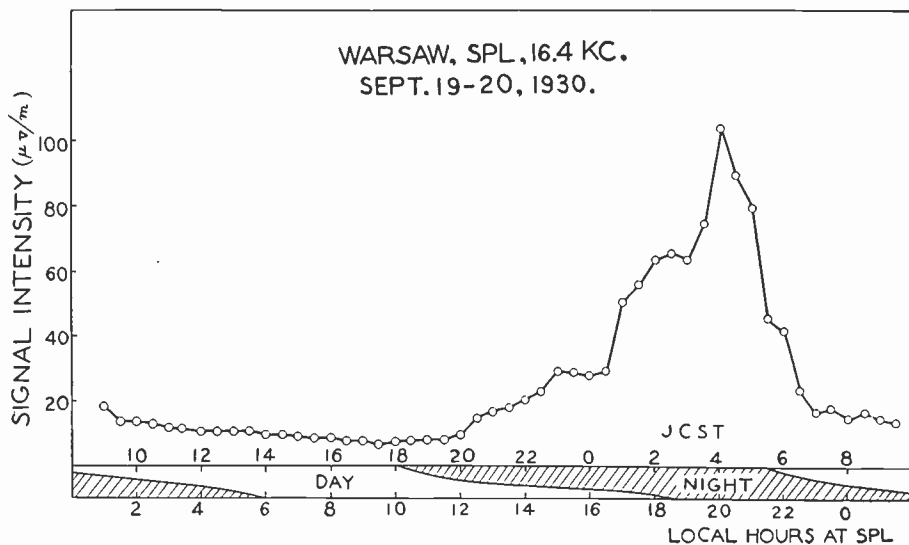

Fig. 7

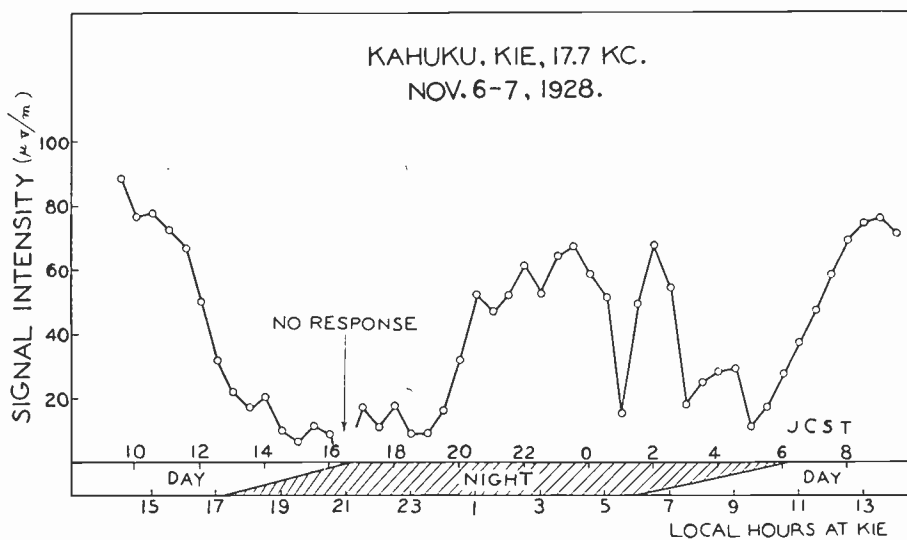

Fig. 8

III. SUNRISE AND SUNSET CREVASSES OBSERVED WITH KAHUKU AND BOLINAS

1. Results of Observations

In Fig. 8 is given another result of observations made for Kahuku on November 6 and 7, 1928, while in Fig. 9 that for Bolinas on October

16 and 17 in the same season of the year. It will be noticed that successive crevasses were regularly observed with the period of nearly one hour and a half in the signal strength of Kahuku in the partial daylight hours, while four successive crevasses with intervals of nearly two hours appeared in that of Bolinas.

Through the entire period of observations, similar diurnal variations were mostly repeated on the field strength, though the occurrence of crevasses was sometimes not observable. It was, however, particularly noticeable that the crevasses are generally less clear at sunset than those at sunrise.

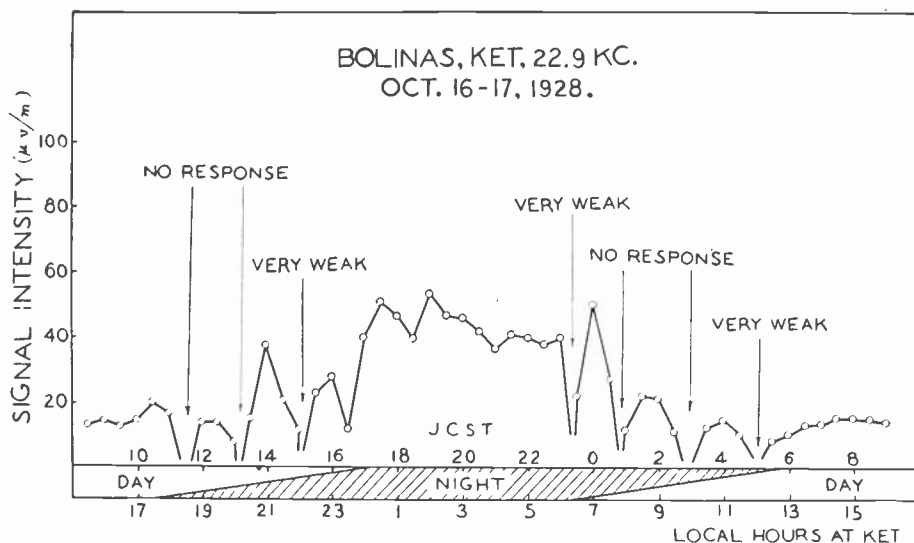

Fig. 9

2. Explanatory Notes of the Results

It may be considered that low-frequency waves are most strongly emitted approximately in the direction along the surface of the earth, and reach the receiving station after repeated reflections between the earth's surface and the Heaviside layer. Assuming the probable height of the layer for the low-frequency waves as about eighty kilometers, the waves transmitted from Kahuku are to be reflected three times, and those from Bolinas four times, by the layer to reach the receiving station.

The reason why the wave can scarcely be reflected from the layer when the layer is just under the twilight conditions was theoretically explained in the previous paper,³ the principal conclusion of which may briefly be stated as follows:

During daylight hours the wave is reflected from the ionized layer in the metallic manner, while at night in the dielectric manner. At a

certain instant between, when the reflection passes from metallic to dielectric or vice versa, that is to say, when the angle of incidence of the waves at the ionized layer just coincides with the Brewster angle of the reflecting layer, there scarcely takes place any amount of reflection of the electric force vibrating in the plane of incidence.

As there exist three apexes for the transmission path between Kahuku and Tokyo and four apexes for that between Bolinas and Tokyo, it may easily be understood that there appear three crevasses in the diurnal field intensity curve of the former and four in the latter.

The phenomena of multiple crevasses mentioned above are never observable in the case of the overland transmission for the reason similar to that explained in the previous chapter.

ACKNOWLEDGMENT

The authors wish to acknowledge their indebtedness to the staffs of the radio stations as well as the administrations and companies to which the stations belong, for their kindness in transmitting the signals specially for the experimental purpose, and in supplying them with the data of wavelengths, antenna currents, and radiation heights.



A PRACTICAL ANALYSIS OF PARALLEL RESONANCE*

BY

REUBEN LEE

(Westinghouse Electric and Manufacturing Company, Chicopee Falls, Massachusetts)

Summary—Vector diagrams are developed for various conditions of tuning parallel circuits, and from the geometry of the diagrams mathematical relations are derived. These relations are then plotted for use in tuning operations. Two examples are given of the practical application of the analysis.

THE parallel resonant circuit has been in continual use since the early days of radio, and has been analyzed by several writers. Usually the circuit was treated in the most general manner, and then the condition of resonance was imposed as a special case. The results were thus derived more or less in complex form, and the physical factors present in the tuning process were not emphasized to a great extent. It is the purpose of this paper to show that the results may be obtained in a simpler manner vectorially, by solving directly for the resonant condition, with perhaps a better indication of the physical phenomena involved.

The circuit will be considered to have a sinusoidal voltage of con-

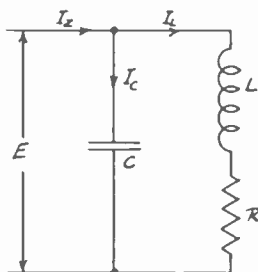

Fig. 1

stant frequency and amplitude applied as shown in Fig. 1. This circuit is an important special case of parallel tuned circuits.

If the condenser branch contains series resistance comparable with R the tuning relations for unity power factor and for maximum impedance will require further treatment.

In Fig. 2 is shown a vector diagram in full lines for the resonant condition of unity power factor. The total current I_z entering the circuit is in phase with the applied voltage E , the condenser current I_c leads E by 90 degrees, and the coil current I_L lags E by some angle θ .

* Decimal classification: R141.2. Original manuscript received by the Institute, October 28, 1932.

This angle is determined by the relation between R and X_L , where X_L is the coil reactance at the impressed frequency, or $2\pi fL$. In Fig. 3 is a diagram of this relationship, the two voltage drops $I_L R$ and $I_L X_L$ adding in quadrature to equal E . These vectors may also represent R , X_L , and Z_L , respectively, where $Z_L =$ impedance of the vector sum

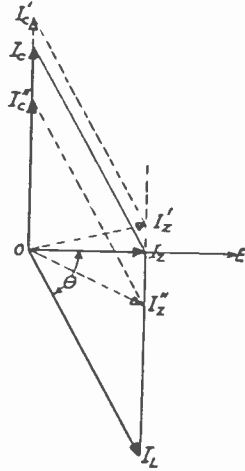

Fig. 2

$R + jX_L$. Since I_L always is in phase with $I_L R$, the current I_L makes the same angle θ with E as does $I_L R$. From Figs. 2 and 3 we can write:

$$\begin{aligned}
 I_z &= \frac{E}{Z}, \quad (Z = \text{total circuit impedance}) \\
 &= I_L \cos \theta \\
 &= \frac{I_L R}{\sqrt{R^2 + X_L^2}} \\
 I_c &= \frac{E}{X_c}, \quad \left(X_c = \text{condenser reactance} = \frac{1}{2\pi fC} \right) \\
 &= I_L \sin \theta \\
 &= \frac{I_L X_L}{\sqrt{R^2 + X_L^2}} \\
 I_L &= \frac{E}{\sqrt{R^2 + X_L^2}}.
 \end{aligned}$$

Hence,

$$X_c = \frac{R^2 + X_L^2}{X_L} \quad (1)$$

and,

$$Z = \frac{R^2 + X_L^2}{R} = \frac{L}{RC} \quad (2)$$

These are the mathematical relations between Z , X_c , X_L , and R for unity power factor resonance.

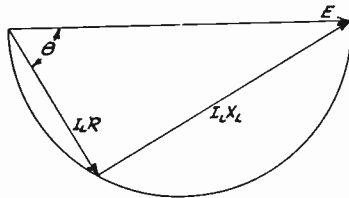

Fig. 3

If the capacity of C now can be varied from the condition of unity power factor, and E is assumed to be constant, I_c varies accordingly, and I_L is not affected. Increasing I_c to the value I_c' , shown dotted, results in an increase of I_z to the value I_z' . Decreasing I_c to some lower value I_c'' also results in an increase of I_z . Since varying C either way from its unity power factor value produces an increase in I_z , we see that tuning the circuit for unity power factor is accompanied by minimum I_z or maximum impedance. The two conditions of resonance, i.e., maximum impedance and unity power factor, are thus satisfied with the same setting of the condenser, provided the tuning is accomplished by varying C alone.

This property of condenser tuning contrasts with inductance tuning, in that in the latter case the circuit relations may be widely different for the unity power factor and maximum impedance conditions. In order to determine the circuit relations for maximum impedance when L is varied instead of C , it must first be known whether or not R stays constant in value as L is varied. The locus of the vector $I_L R$, Fig. 3, is a circle, for the vector sum of $I_L R$ and $I_L X_L$ must always equal E . Supposing R to remain constant, the vector I_L likewise follows a circle as its locus.

Referring to Fig. 4, the full lines indicate the unity power factor condition, as before. A line B drawn perpendicular to I_L intercepts the extension of E and thereby determines the diameter of the locus circle of I_L .

Let the circle be shifted vertically so that it passes through I_z , and becomes the circle with center A . Now as L is varied, I_L follows the lower circle and I_z follows the upper one. The point of minimum I_z is evidently where I_z becomes perpendicular to a tangent of the upper

circle. At this point I_z becomes I_z' , which is coincident with a line drawn from A to the origin O .

Remembering that the circle of Fig. 4 is the same as that of Fig. 3, with I_L taking the place of $I_L R$, and B taking the place of $I_L X_L$, we can find the circuit relations for maximum impedance, ($I_z = I_z'$). The circle diameter in Fig. 4 is

$$D = \sqrt{I_L^2 + B^2}$$

and,

$$\frac{B}{I_L} = \frac{X_L}{R}$$

whence,

$$D = \frac{I_L}{R} \sqrt{R^2 + X_L^2} = \frac{E}{R}.$$

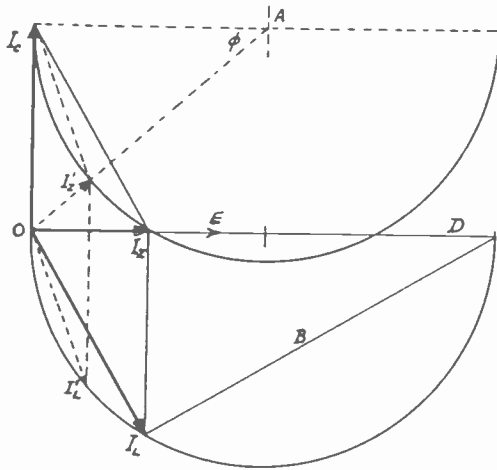

Fig. 4

Now,

$$I_z' = \sqrt{I_c^2 + (D/2)^2} - D/2 = E[\sqrt{1/X_c^2 + 1/4R^2} - 1/2R].$$

Also,

$$I_z' = \frac{E}{Z}$$

so that,

$$Z = \frac{2X_c R}{\sqrt{X_c^2 + 4R^2} - X_c}. \quad (3)$$

In triangle $A - I_c - I_s'$, line $I_c - I_s'$ is I_L' , or,

$$I_L' = \sqrt{\frac{D^2}{2} - \frac{D^2}{2} \cos \phi}$$

$$\cos \phi = \frac{D/2}{\sqrt{I_c^2 + D^2/4}} = \frac{X_c}{\sqrt{X_c^2 + 4R^2}}$$

Also,

$$I_L' = \frac{E}{\sqrt{X_L^2 + R^2}}$$

Therefore,

$$X_L = R \cdot \sqrt{\frac{2\sqrt{X_c^2 + 4R^2}}{\sqrt{X_c^2 + 4R^2} - X_c} - 1}. \tag{4}$$

Equations (3) and (4) are the circuit relations for the maximum impedance condition when R stays fixed and L is varied. They are more complex than the relations for unity power factor, and consequently it is much easier to visualize the tuning by constructing the vector diagram. The diagram also furnishes an easy method of solving for the currents I_c , I_L' , and I_s' .

Cases also occur in practice where R varies when L is varied, the most common example being the inductive coupling circuit shown in

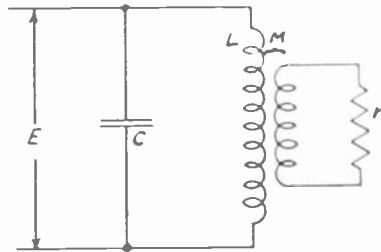

Fig. 5

Fig. 5. If this circuit be replaced by that shown in Fig. 1, the equivalent parallel resonant circuit is obtained. In the latter, R is the equivalent or reflected resistance of the coupled circuit; this R varies as L is varied because of the variation in coupling.

Fig. 6 shows the relationship between R and L for a typical coil. This curve was obtained by noting L , M , and R for the entire coil, and then stripping off a few turns and again finding L , M , and R . This process was continued until sufficient points were found for the curve. Although L usually is not varied in this manner, nevertheless some idea of the possible constancy of the ratio X_L/R is furnished by Fig. 6. The ratio X_L/R stays nearly constant for small changes in X_L , especially in certain regions of the curve. Therefore, an investigation of

the resonant circuit under this condition is of interest owing to the widespread use of the circuit of Fig. 5.

The unity power factor condition is shown again in Fig. 7 in full lines. Considering X_L/R as a constant, the angle θ remains constant also, and I_L merely increases or decreases in scalar value as X_L is varied. Let I_L be decreased until I_z is a minimum. This occurs at the

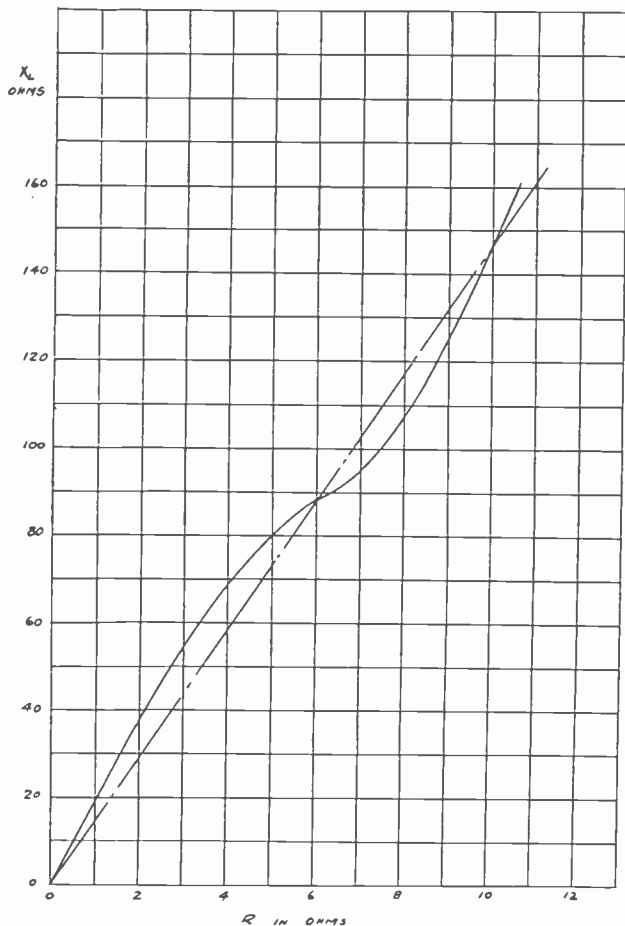

Fig. 6—Variation of R with X_L in coupling coil.

value I_z' , the current vector I_z' being perpendicular to I_L and making the angle θ with I_c . At this point, I_L becomes I_L' .

Solving for the circuit relations, we have

$$\begin{aligned} I_z' &= \frac{E}{Z} \\ &= I_c \cos \theta = I_c \cdot \frac{R}{\sqrt{R^2 + X_L^2}}, \end{aligned}$$

since θ has the same value as in Fig. 3.

Also,

$$\begin{aligned} I_L' &= \frac{E}{\sqrt{R^2 + X_L^2}} \\ &= I_c \sin \theta = \frac{I_c \cdot X_L}{\sqrt{R^2 + X_L^2}}, \end{aligned}$$

whence,

$$X_c = X_L \quad (5)$$

and,

$$Z = \frac{X_L}{R} \sqrt{R^2 + X_L^2} \quad (6)$$

Equations (5) and (6) are the relations for maximum impedance when X_L/R is a constant and L is varied. They are simple enough for general use, although a better conception of the tuning operation is still obtained from the vector diagram.

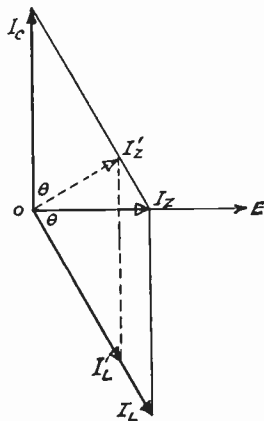

Fig. 7

Using vector diagrams similar to Figs. 4 and 7, a series of values were formed and plotted in Figs. 8 and 9. These curves show the respective I_L/I_c , X_L , and X_c values at different values of Z and a given value of R (25 ohms) for unity power factor and maximum impedance; Fig. 8 is for the case where R remains constant, and Fig. 9 where X_L/R remains constant. For any other value of R , say R' , the abscissas and the reactance ordinates should be multiplied by $R'/25$ in order to make the curves applicable. The ratio I_L/I_c requires no scale alteration when these multiplications are made.

It will be noted that, as Z , X_L and X_c increase in value with respect to R , the ratio I_L/I_c becomes more nearly the same for the unity power

factor and maximum impedance conditions in both Fig. 8 and Fig. 9, especially in the latter. This also may be seen by referring to Figs. 10(a) and 10(b), the difference in the currents, resistance, and imped-

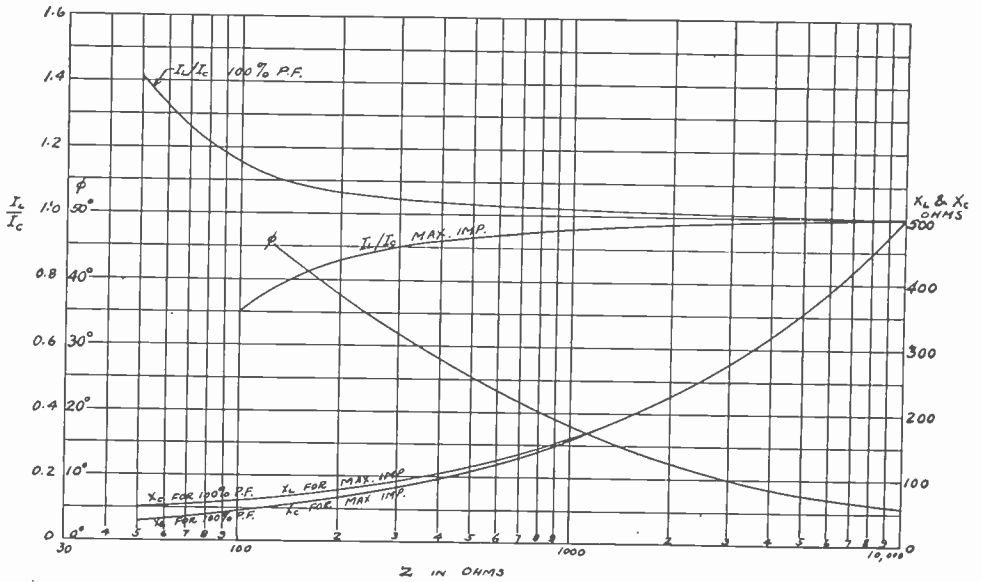

Fig. 8—Parallel resonance curves. $R = \text{constant}$.

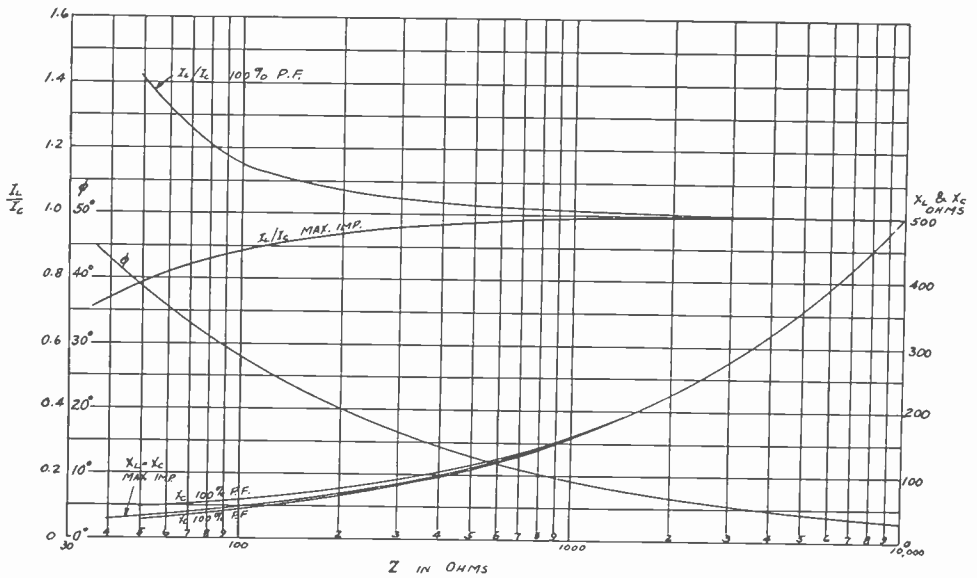
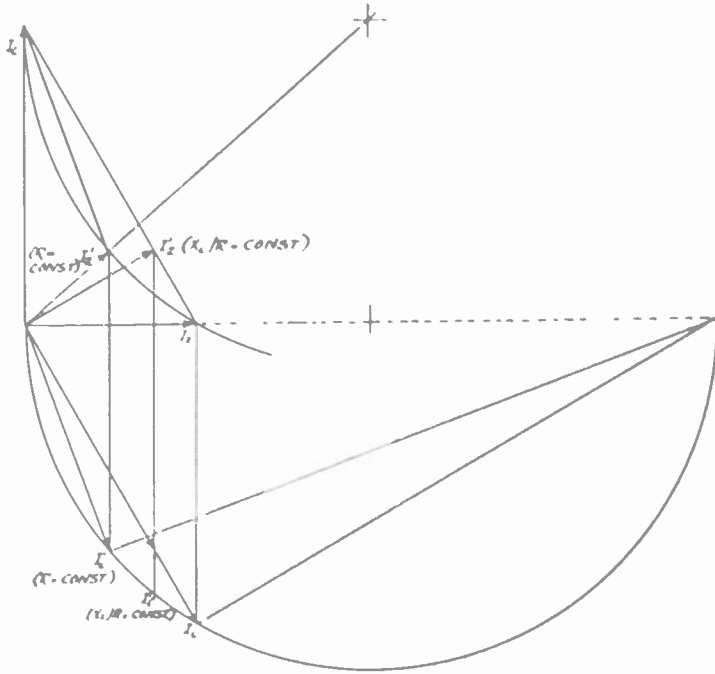
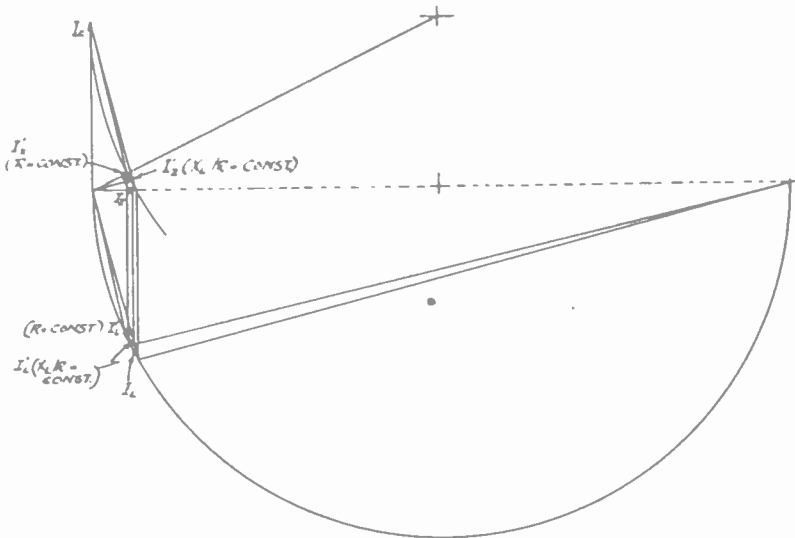

Fig. 9—Parallel resonance curves $(X_L/R) = \text{constant}$.

ance being noted on the figures. The maximum impedance conditions for both constant R and constant X_L/R are shown for comparison. As these conditions approach each other, the vector diagrams become less and less accurate, so that the algebraic relations become necessary for



	Z	I_L/I_c	R
Fig. 10(a)—Unity P. F.	100	1.15	25
Max. imp. ($R = \text{constant}$)	150	0.81	25
Max. imp. ($X_L/R = \text{constant}$)	115	0.87	33



	Z	I_L/I_c	R
Fig. 10(b)—Unity P. F.	400	1.03	25
Max. imp. ($R = \text{constant}$)	440	0.93	25
Max. imp. ($X_L/R = \text{constant}$)	416	0.965	27

accurate calculations. The curves of I_L/I_c may be useful in tuning circuits to unity power factor at low values of Z , but are useless at higher values, owing to the impossibility of obtaining sufficiently accurate meter readings. The higher Z is relative to R , the higher is the ratio of volt-amperes in the circuit to the watts consumed in R . Therefore we can state that at high volt-amperes/watt ratios, tuning for unity power factor becomes practically the same as for maximum impedance in all cases.

APPLICATIONS

The deductions and curves just discussed have direct bearing on the adjustment of present-day radio apparatus. For example, the difference between the values of Z for unity power factor and maximum impedance has puzzled many an operator. Although it is customary to tune an amplifier for minimum plate current, it is often found that full output cannot be obtained unless the tuning is slightly off this point. The conclusion is then drawn that the amplifier must be "detuned" in order to deliver full output, whereas it actually is changed from the maximum impedance to the unity power factor condition (just the reverse of the process used in constructing Figs. 4 and 7). This situation is avoided if the amplifier is condenser-tuned, so that the latter method has an advantage in simplicity of adjustment.

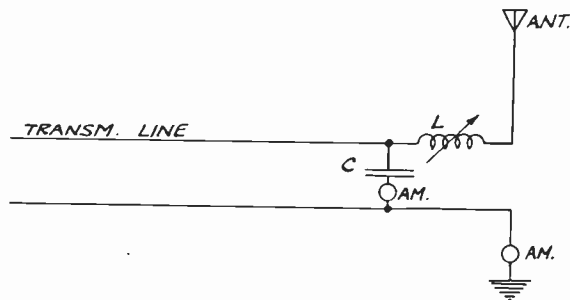

Fig. 11

In the termination of transmission lines, circuits are sometimes used which must be adjusted for unity power factor, a difficult matter unless the relations set forth above are used. In Fig. 11, the antenna and loading inductance form the inductive branch of a parallel resonant circuit as represented by Fig. 1. Here R is of constant value. Suppose the transmission line surge impedance is 400 ohms and the coil resistance plus the antenna resistance is 50 ohms. Referring to Fig. 8, the scale of abscissas must be multiplied by 2, or the point for reference on the present scale is $Z = 200$ ohms. The upper reactance curve shows X_c for unity power factor to be 75×2 or 150 ohms. Hence, C is known,

and usually the value as calculated can be held to very closely. The same cannot be said of L , and this is where the curve is of value.

With two ammeters located as shown in Fig. 11, the inductance of L can be varied until the ratio of currents I_L/I_c is 1.06. The transmission line is then terminated properly and delivers all the power into the antenna. The meters should be checked carefully to insure accurate readings, and the accuracy is further increased if they are of the current-squared type. Also, the terminating condenser must be of relatively low volt-ampere content. For instance, with the same surge impedance Z and a 5-ohm antenna, the reference abscissa is 2000 ohms. Here the ratio I_L/I_c is so near to unity that using the curves for adjustment would be scarcely feasible.

The I_L/I_c curve for maximum impedance is useful in obtaining a second point to check on the meter readings. In the examples just given, it may be possible to connect L , C , and R in series and tune them to resonance. Under this condition, $X_L = X_c$, and when the three elements are reconnected as shown in Fig. 11, the lower I_L/I_c curve of Fig. 9 applies to the two ammeter readings; that is, their ratio is 0.95 for a 50-ohm antenna. A change of 11 per cent is thus obtained in the inductance meter reading as the circuit is tuned to unity power factor. It should be noted that Z for the circuit is 480 ohms when $X_L = X_c = 150$ ohms, and this Z divided by 2, (240 ohms), is the reference point on Fig. 9 for finding $I_L/I_c = 0.95$.

When the circuit to be tuned is that of Fig. 5 it should be remembered that R decreases as the circuit is changed from maximum impedance to unity power factor condition.

The condition $X_L = X_c$ also can be made useful when the current in the two branches is too large to measure with the ammeters available. To illustrate, after the elements L , C , and R are tuned in series and then reconnected according to Fig. 11, a small meter may be loosely coupled to each branch. The coupling may be adjusted until the ratio of the readings is correct for $X_L = X_c$, or 0.95 in the case just outlined. The circuit may then be tuned for unity power factor as before. It is possible in this way to measure antenna currents of any magnitude with small meters, the only requirement being that proper shielding precautions be taken. Probably other uses of the curves will suggest themselves to field engineers and others who adjust such circuits frequently.



RELATIONS BETWEEN THE PARAMETERS OF COUPLED-CIRCUIT THEORY AND TRANSDUCER THEORY WITH SOME APPLICATIONS*

BY

J. G. BRAINERD

(Moore School of Electrical Engineering, University of Pennsylvania, Philadelphia, Pa.)

Summary—Relations between the impedance parameters usually used in coupled-circuit theory and those of transducer theory are derived. These indicate some useful methods of attacking certain problems—the determination of resonance conditions in a chain of coupled circuits, for example.

AN electrical network which has two pairs of terminals and contains no electromotive forces is a passive transducer.¹ The general study of transducers leads to many of the laws of steady state circuit theory. The applications of transducer theory have in general been in connection with equivalent circuits (with respect to two pairs of terminals), filters, characteristic impedances, transfer factors, etc. The fundamental equations of a passive transducer (Fig. 1) are

$$I_1 = \frac{E_1}{z_{1s}} + \frac{E_2}{z_{ts}} \quad (1)$$

and,

$$I_2 = \frac{E_1}{z_{ts}} + \frac{E_2}{z_{2s}}$$

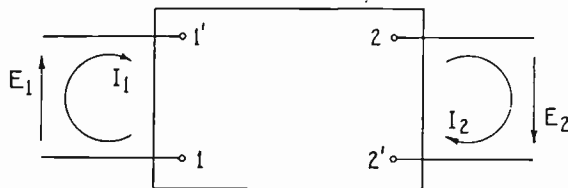

Fig. 1—Transducer.

where E 's and I 's are electromotive forces and currents, respectively, as shown on Fig. 1, and z_{1s} is the input impedance at 11' terminals when 22' are short-circuited ($E_2=0$), z_{2s} the input impedance at 22' terminals when $E_1=0$, and z_{ts} the transfer impedance E_1/I_2 when $E_2=0$, or E_2/I_1 when $E_1=0$. All quantities are complex. The impedances z_{1s} , z_{ts} , and z_{2s} are the so-called short-circuit impedances.

* Decimal classification: R140. Original manuscript received by the Institute, October 21, 1932.

¹ In this paper transducers with two pairs of terminals are the only ones considered.

Coupled-circuit theory, as we shall understand the term, has to do with the determination of currents, resonance conditions, etc., in networks of special but very important form. These networks may usually be classified as types of passive transducers. In a broad sense coupled-circuit theory states that the current-voltage equations of any passive network having two pairs of terminals may be reduced to the form

$$E_1 = z_{10}I_1 - z_m I_2 \quad (2)$$

and,

$$E_2 = -z_m I_1 + z_{20} I_2$$

where z_{10} is the input impedance at 11' (Fig. 1) when $I_2=0$; i.e., when 22' are open-circuited, z_{20} is similar (z_{10} and z_{20} are the so-called open-circuit impedances), and z_m is the generalized mutual impedance. The impedances z_{10} , z_m , and z_{20} may be called the coupled-circuit parameters and z_{1s} , z_{ts} , and z_{2s} the parameters of transducer theory, although z_{10} and z_{20} appear frequently in transducer theory.

Evidently the general forms of the two theories have little to distinguish them, and it is a matter of algebra to determine the relations existing between the two sets of parameters. These may be summarized by

$$\begin{aligned} z_m z_{ts} &= z_{10} z_{2s} = z_{20} z_{1s} = z_{10} z_{20} - z_m^2 = z_{10} z_{20} / k = k z_{1s} z_{2s} \\ &= z_{ts}^2 (k - 1) = k(k - 1)(z_{ts}^2 - z_{1s} z_{2s}) \end{aligned} \quad (3)$$

or,

$$\frac{z_{10}}{z_{1s}} = \frac{z_{20}}{z_{2s}} = \frac{z_m}{z_{ts}} + 1 = \frac{z_m z_{ts}}{z_{1s} z_{2s}} = \frac{z_{ts}^2}{z_{ts}^2 - z_{1s} z_{2s}} = \frac{z_{10} z_{20}}{z_{10} z_{20} - z_m^2} = k \quad (4)$$

where k is a factor the use of which is occasionally convenient. The derivations of (1) to (4) are given in Appendix A. The equality $z_{10} z_{2s} = z_{20} z_{1s}$ is well known in transducer theory, and (3) or (4) may be considered extensions of this. Equations (3) or (4) allow any one of the six impedance parameters to be expressed in terms of any three others, which is in accord with the law evident from (1) or (2) that any three independent impedance measurements at a given frequency completely determine at that frequency the reactions due to the transducer in the circuits external to its two pairs of terminals.

It may be noted that z_m appears in transducer theory since $z_m = z_b$ where z_b is the shunt arm (Fig. 2) of the equivalent T section. The two series arms z_a and z_c are equal to $z_{10} - z_m$ and $z_{20} - z_m$, respectively, showing, as was to be expected, that the coupled circuit parameters bear simple relations to those of the equivalent T section. An example is given in Appendix B.

The large number of expressions for any one impedance parameter which may be obtained from (3) or (4) renders these equations extremely useful in some problems. This is illustrated below, the fundamental formulas for determining resonance conditions in a chain of coupled circuits being written down. In this example the abundant variety of expressions for the parameters makes the determination of resonance conditions easy in comparison with methods previously used.

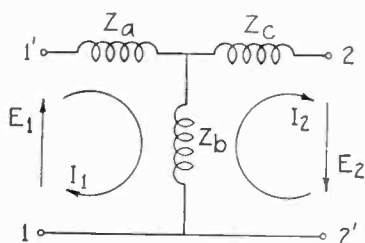

Fig. 2—T section.

The input impedance and transfer impedance under load are important factors in many problems. Let z_1 be the input impedance at 11' (Fig. 1) when an impedance z_r joins 22'. Substituting² $E_2 = -z_r I_2$ in (1) or (2), the simplest forms for z_1 are

$$z_1 = \frac{z_{10}(z_{2s} + z_r)}{z_{20} + z_r} = z_{10} - \frac{z_m^2}{z_{20} + z_r} \quad (5)$$

Likewise the transfer impedance z_{1t} ($= E_1/I_2$ when $E_2 = -z_r I_2$) is³

$$z_{1t} = \frac{z_{1s}}{z_{2s}}(z_{2s} + z_r) = \frac{z_{10}}{z_m}(z_{2s} + z_r) = \frac{z_{10}(z_{20} + z_r) - z_m^2}{z_m} \quad (6)$$

and,

$$\frac{z_1}{z_{1t}} = \frac{z_m}{z_{20} + z_r} = \frac{I_2}{I_1}, \quad (7)$$

which has important applications when transducers are joined in series.

² When z_r is considered an independent quantity it is most easily introduced by this substitution. When z_r is not of interest in itself, it may be considered part of the transducer, and E_2 may be taken zero in the absence of electromotive forces at 22'.

³ Equation (6) leads directly to several of the laws of steady state circuit theory, viz., (1) as far as conditions at the receiver (22') are concerned, there would be no change if the transducer and all the circuit external to 11' were replaced by an electromotive force $E_1 z_{2s}/z_{1s}$ in series with an impedance z_{2s} (Thevenin's theorem); (2) with a given transducer and E_1 (a) maximum receiver current will be obtained when $z_r = -jx_{2s}$ where jx_{2s} is the imaginary part of z_{2s} , (b) maximum power will be transferred to the receiver when z_r is the conjugate of z_{2s} , (c) the volt-amperes at the receiver will be maximum when $z_r = z_{2s}$ (matched impedances), (d) the voltage $-E_2$ across z_r will be maximum theoretically when $z_r = -z_{2s}$, and practically when z_r is such that the magnitude of $z_r/(z_{2s} + z_r)$ is maximum subject to the condition that the real part of z_r is positive.

If I_2/I_1 is fixed, a z_r may be obtained from (7) which, when used with a given transducer, will result in I_2/I_1 having the fixed value. Conversely if z_r is given, a transducer having the required current ratio when used with the given z_r may be obtained. More important, if the voltage ratio E_2/E_1 is given, then, since for any passive transducer

$$\frac{E_2}{E_1} = \frac{z_r}{z_{1t}}, \tag{8}$$

a value of z_r may be found which will give the required voltage ratio when used with the given transducer. Conversely, if z_r is specified a first condition for the design of a transducer to give the required voltage ratio when used with z_r is set. Equation (8) may be taken as the starting point for a study of transducers having predetermined voltage ratios (which may be greater than unity in magnitude) and not necessarily using mutual inductances. Equations (7) and (8) and one other independent condition can be satisfied simultaneously, so that not only the voltage ratio but the current ratio as well can be predetermined for a transducer the receiver impedance of which is fixed.

An interesting incidental result follows from (8) when $E_2/E_1 = 1$. Then,

$$z_r = \frac{z_{2s}z_{1s}}{z_{2s} + z_{1s}} \tag{9}$$

i.e., z_r must be equivalent to z_{2s} and z_{1s} in parallel for E_2/E_1 to be unity.

It is not proposed to do more than to present general formulas and methods in this paper; in consequence the applications following are not carried beyond the point of indicating procedures for particular problems.

EXAMPLES OF THE USE OF THE FORMULAS IN RESONANCE PROBLEMS

(1) As an illustration of the use of (3) we can indicate the well-known conditions which must be satisfied by the reactances of one and two meshes of the simple coupled circuit of Fig. 3 to obtain the maximum magnitude for I_2 when $E_2 = 0$ ($22'$ short-circuited).⁴ For I_2 maximum, z_{1s} must be a minimum. Choosing the equation

$$z_{1s} = \frac{z_{10}z_{20} - z_m^2}{z_m} \tag{10}$$

⁴ In this and the next two paragraphs complex quantities are printed bold face and the corresponding magnitudes in italics

it is seen from (18) that x_{11} appears in z_{10} only, and the adjustment of x_{11} to make z_{1s} minimum is easily shown to be $x_{11} = \omega^2 M^2 x_{22} / z_{22}^2$. Substituting this in z_{1s} the condition which x_{22} must satisfy, to give the minimum of all the subsidiary minima of z_{1s} obtained when x_{11} satisfies the equation above, may be found. The mesh equations have not been used in setting up the x_{11} and x_{22} conditions.

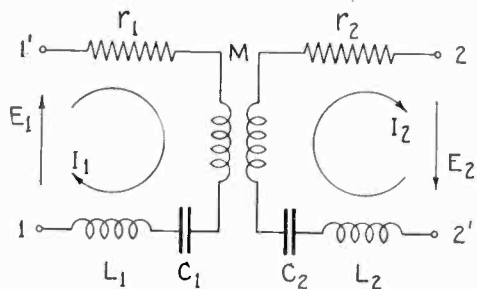

Fig. 3—Simple coupled circuits.

If the equations,

$$z_{1s} = \frac{z_{1s}z_{20}}{z_m} = \frac{z_{2s}z_{10}}{z_m} \tag{11}$$

had been chosen, x_{11} appears in z_{1s} only in the first and x_{22} appears in z_{2s} only in the second, hence the conditions for I_2 maximum are x_{11} such that z_{1s} is minimum and x_{22} such that z_{2s} is minimum, taken simultaneously.⁵

For the circuit of Fig. 3 the problem is relatively simple, and the use of (3) is not of particular importance. An example in which the present method is more evidently valuable follows.

(2) Consider the circuit shown in Fig. 4, which will be taken to be four subsidiary transducers in series forming one major transducer. The mutual impedances z_{12} , z_{23} , etc., are to be considered symbolically—they do not necessarily represent combinations of *conductive* elements (r , L , C) but may include mutual inductance as well. In the latter case the mutual impedance is not contained in whole in the self-impedance of either mesh to which it is common.

All z 's used below refer to the subsidiary transducers, a z with prime indicating an impedance facing 11', and a z without prime indicating an impedance facing 55'. Thus z_3 is the input impedance of 33'–44' when

⁵ Since $z_{1s} = I_2/E_1$ when $E_2 = 0$ and $z_{1s} = I_1/E_2$ when $E_1 = 0$, the appearance of z_{1s} twice in (1) is equivalent to the reciprocity theorem. G. W. Peirce in Chapter XIII of his "Electric Oscillations and Electric Waves" (McGraw-Hill Book Co., 1920) obtains (11) for the particular case of a two-mesh net by use of the reciprocity theorem. The application of this theorem is extremely cumbersome in any except the simplest cases, and usually involves solving the circuit equations many times.

the receiver impedance at 44' is z_4 , the input impedance of 44'-55'; z_{3s} is the input impedance of 33'-44' when 44' are short-circuited; z_{30}' is the input impedance of the transducer 22'-33' at 33' when 22' are open, etc.

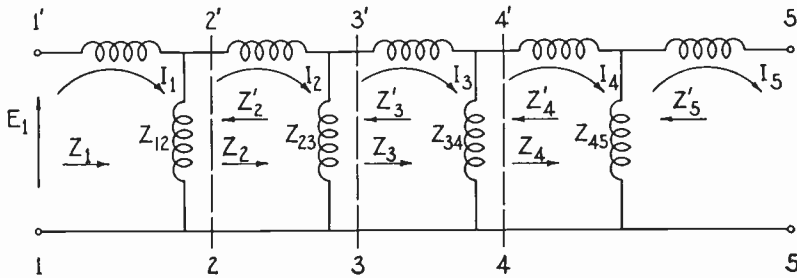

Fig. 4—Five-mesh chain.

Assume $E_5 = 0$ (55' short-circuited). Then by inspection,

$$\frac{E_4}{z_{4t}} = I_5 = \frac{z_4 I_4}{z_{4t}};$$

$$\frac{E_3}{z_{3t}} = I_4 = \frac{z_3 I_3}{z_{3t}}; \quad I_5 = \frac{z_4 z_3}{z_{4t} z_{3t}} I_3;$$

and, by the same process,

$$I_5 = \frac{z_2 z_3 z_4 E_1}{z_{1t} z_{2t} z_{3t} z_{4t}}, \tag{12}$$

the factor before E_1 being the reciprocal of the short-circuit transfer impedance between 11' and 55'. Substituting for z_{1t} from (6) and for the ratios z_2/z_{2t} , etc., from (7),

$$I_5 = \frac{z_{12} z_{23} z_{34} z_{45} E_1}{z_{10}(z_{2s}' + z_2)(z_{20}' + z_2)(z_{30}' + z_3)(z_{40}' + z_4)}, \tag{13}$$

which is one of the many possible forms for I_5 . This particular form would be of value if x_{11} ($z_{11} = z_{10} = r_{11} + jx_{11}$) were to be varied, since x_{11} appears only in z_{10} and z_{2s}' , two easily calculated impedances. I_5 is then maximum as far as x_{11} is concerned when x_{11} is such that the magnitude of $z_{10}(z_{2s}' + z_2)$ is a minimum. (In (12) x_{11} appears only in $z_{1t} = z_1(z_{20}' + z_2)/z_{12}$ by (6), so an equivalent condition is for x_{11} to be such that the magnitude of z_1 is a minimum.)

It is not worth while to carry the illustration beyond this point, as the conditions set by a given problem will dictate the details of the procedure in the specific case. In general, it can be said that for the

most part the attack will consist of a judicious choice of expressions for the given current, and a determination of various impedances, by the rules for combining impedances in series and in parallel.⁶ It is seen that the example, although using the net of Fig. 4, illustrates a general method of attack applicable to a chain of any number of meshes. Furthermore, the current in the final mesh need not be determined; any other, such as I_3 , could be written down by methods similar to those used above to obtain I_5 .

APPENDIX

A. Fundamental Equations

The fundamental equations relating the steady state alternating currents and voltages of any one frequency in a network of n meshes may be written

$$E_h = \sum_{k=1}^n z_{hk}' I_k \quad (h = 1, 2, \dots, n) \quad (14)$$

where $z_{kk}' = z_{kk}$ is the self-impedance of the k mesh, and $z_{hk}' = -z_{hk} = -z_{kh}$ ($h \neq k$) is the negative of the mutual impedance of the h and k meshes, E_h is the total electromotive force, and I_h the mesh current of the h mesh (E_h and I_h are taken positive in the same sense), and each E , z , and I appearing in (14) is complex. It is assumed that all circuit parameters (r , L , C , M) are constant at the given frequency and that the meshes are numbered from 1 to n .

Equations (14) may be solved for any I . For the case in which E_1 and E_2 are the only electromotive forces not zero, I_1 and I_2 are given by (1) where $z_{1s} = D/A_{11}$, $z_{ts} = D/A_{12} = D/A_{21}$, and $z_{2s} = D/A_{22}$, D being the determinant of the impedance coefficients in (14) and A_{hk} the cofactor corresponding to the element in h row and k column of D . Since D is symmetrical $A_{hk} = A_{kh}$.

Equations (1) can be solved for E_1 and E_2 and yield (2) provided

$$z_{10} = \frac{z_{1s}z_{ts}^2}{z_{ts}^2 - z_{1s}z_{2s}}; \quad z_m = \frac{z_{1s}z_{2s}z_{ts}}{z_{ts}^2 - z_{1s}z_{2s}}; \quad z_{20} = \frac{z_{2s}z_{ts}^2}{z_{ts}^2 - z_{1s}z_{2s}} \quad (15)$$

which give z_{10} , z_m , and z_{20} in terms of the short-circuit impedances, or indirectly in terms of D and A 's. Conversely,

⁶ G. W. Peirce, *loc. cit.*, Chapter XIV, has determined the resonance conditions for a particular case of a three-mesh chain, obtaining equations corresponding to (13) by the use of the reciprocity theorem.

No mesh equations need be used in the determination of the impedances appearing in (12) or (13) since (5), (6), and (7) can be used as recursion formulas. See also Appendix C.

$$z_{1s} = \frac{z_{10}z_{20} - z_m^2}{z_{20}}; \quad z_{1s} = \frac{z_{10}z_{20} - z_m^2}{z_m}; \quad z_{2s} = \frac{z_{10}z_{20} - z_m^2}{z_{10}}. \quad (16)$$

From (15) and (16) equations (3) and (4) are obtained.

B. Equivalent T of a Simple Coupled Circuit

Fig. 3 shows a simple coupled circuit. The circuit of Fig. 2 is exactly equivalent⁷ when,

$$z_b = z_m = j\omega M,$$

$$z_a = z_{10} - z_b = z_{11} - z_b = r_1 + j\omega(L_1 - M) + \frac{1}{j\omega C_1} \quad (17)$$

and,

$$z_c = z_{20} - z_b = z_{22} - z_b = r_2 + j\omega(L_2 - M) + \frac{1}{j\omega C_2}.$$

Here $\omega = 2\pi f$, f = frequency, $j = \sqrt{-1}$, and the meanings of undefined symbols are indicated on the figures. It should be noted that z_b represents a self-inductance of magnitude M and the term $j\omega(L_1 - M)$ represents a capacitance of magnitude $1/\omega^2(L_1 - M)$ when $M > L_1$ or a self-inductance of magnitude $L_1 - M$ when $M < L_1$.

All three impedances of the equivalent T depend on M whereas for the original circuit,

$$z_{10} = z_{11} = r_{11} + jx_{11} = r_1 + j\omega L_1 + \frac{1}{j\omega C_1},$$

$$z_m = j\omega M \quad (18)$$

and,

$$z_{20} = z_{22} = r_{22} + jx_{22} = r_2 + j\omega L_2 + \frac{1}{j\omega C_2}$$

and M appears in z_m only.

C. Note on Formulas for Combining Impedances

Although an equation such as (5) is well known, it is seldom noted that it represents a supplement to the usual rules for combining impedances in series or in parallel. The latter cannot be applied directly to portions of circuits containing mutual inductances, but (5) can be used to fill this gap in many cases.

⁷ This particular equivalent circuit, which is known, is of some importance since it is a true equivalent, with respect to the two pairs of terminals 11' and 22', of an ideal transformer. It should supersede the so-called equivalent circuit involving turn ratio which is now used. The latter is not a true equivalent in that it does not indicate voltage transformation.

GRAPHICAL METHODS FOR PROBLEMS INVOLVING RADIO-FREQUENCY TRANSMISSION LINES*

BY

HANS RODER

(Radio Engineering Department, General Electric Company, Schenectady, N. Y.)

Summary—When designing arrangements embodying radio-frequency transmission lines it is in most cases permissible to neglect resistance and leakage conductance of the line. The analysis, therefore, becomes considerably simplified as compared with the exact treatment.

Using the above assumption, in this paper graphical methods are given for the determination of currents, voltages, and impedances along a transmission line. A simplified elliptical diagram is developed for finding current or voltage distribution. The application of circle diagrams is explained, by means of which the line input impedance may be obtained under various conditions.

I. INTRODUCTION

THE exact theory of transmission lines becomes considerably simplified if applied to radio-frequency transmission. On account of the high frequency, the effects of distributed L and C become predominant to such an extent that in most cases line resistance and leakage conductance can be neglected with respect to inductance and capacitance. The simplicity of the theory can be further emphasized by employing graphical methods for the determination of currents, voltages, and impedances.

If we call (Fig. 1):

$E_1, I_1 \dots$ voltage and current at sending end,

$E_{x_0}, I_{x_0} \dots$ voltage and current at receiving end,

then the *exact theory* yields for steady state conditions:

$$\left. \begin{aligned} E_1 &= E_{x_0} \cosh mx_0 + I_{x_0} Z_0 \sinh mx_0 \\ I_1 &= I_{x_0} \cosh mx_0 + \frac{E_{x_0}}{Z_0} \sinh mx_0 \end{aligned} \right\} \quad (1)$$

where,

x_0 = distance between sending and receiving end

$m = \alpha + j\beta$

α = attenuation constant

β = wavelength constant.

* Decimal classification: 621.319.2×R116. Original manuscript received by the Institute, September 24, 1932.

α and β are given by the relations

$$\begin{aligned}\alpha^2 - \beta^2 &= RG - \omega^2 LC, \\ 2\alpha\beta &= \omega(LG + CR),\end{aligned}$$

while Z_0 (surge impedance) follows from

$$Z_0 = \sqrt{\frac{R + j\omega L}{G + j\omega C}}.$$

At radio frequencies, in most cases, the terms R (resistance) and G (leakage conductance) can be neglected versus ωL and ωC , thus yielding

$$Z_0 = \sqrt{\frac{L}{C}} \quad (2)$$

$$\alpha = 0$$

$$\beta = \sqrt{LC}. \quad (3)$$

In case the medium between the conductors is air, we have,

$$\beta = \frac{2\pi f}{c} = \frac{2\pi}{\lambda},$$

with,

f . . . frequency in cycles

λ . . . wavelength in centimeters

c . . . velocity of light waves = $3 \cdot 10^{10}$ cm/sec.

The expressions for current and voltage in (1) become

$$\left. \begin{aligned}E_1 &= E_{x_0} \cos \theta_0 + jI_{x_0}Z_0 \sin \theta_0 \\ I_1 &= I_{x_0} \cos \theta_0 + j\frac{E_{x_0}}{Z_0} \sin \theta_0\end{aligned} \right\} \quad (4)$$

where, for reasons of abbreviation

$$\theta_0 = 2\pi \frac{x_0}{\lambda}. \quad (5)$$

θ_0 measures the electrical length of the transmission line in degrees. x_0 and λ are to be measured in equal but arbitrary units.

II. ELLIPTICAL DIAGRAM FOR CURRENT AND VOLTAGE DISTRIBUTION

In order to compute current and voltage in any point of the line, we consider point Y to be the sending terminal. By replacing θ_0 by θ

$$\theta = 2\pi \frac{y}{\lambda} \quad (6)$$

we get from (4)

$$\left. \begin{aligned} E_y &= E_{x_0} \cos \theta + jI_{x_0}Z_0 \sin \theta \\ I_y &= I_{x_0} \cos \theta + j\frac{E_{x_0}}{Z_0} \sin \theta \end{aligned} \right\} \quad (7)$$

If E_{x_0} and I_{x_0} are given by magnitude and phase (Fig. 2a), E_y and I_y can be readily obtained either by calculation or graphically. If the equations (7) are represented by vector diagrams for various values of θ then it is found that the end-point of E_y and I_y respectively, traces

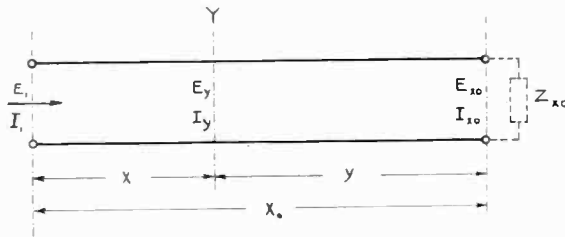

Fig. 1

an ellipse.¹ It can be easily shown by considering a differential increase or decrease of θ at $\theta=0$ or $\theta=90$ degrees that the vectors $2E_{x_0}$ and $j2I_{x_0}Z_0$ represent *conjugate diameters* of the voltage ellipse² (Fig. 2b). The same holds for the vectors $2I_{x_0}$ and $j2E_{x_0}/Z_0$ in the current ellipse (Fig. 2c). This fact may be used to construct the ellipses. For convenience, in the Appendix, a method of obtaining graphically the main axes of an ellipse from two known conjugate diameters is given. If the ellipses once are drawn, the values of E_y and I_y can be found for any value of electrical length θ . The procedure simply follows from the equations (7) as it is shown in Fig. 2.

However, this method of obtaining the ellipses is somewhat inconvenient. The following method proves to be simpler. If we call Z_{x_0} the impedance which is located at the end of the line then we have

$$Z_{x_0} = R_{x_0} + jX_{x_0} = E_{x_0}/I_{x_0}. \quad (8)$$

¹ If attenuation is taken into consideration, an elliptical spiral will result. (See bibliography No. 1.)

² Communicated to the author in 1928 by Messrs. W. Buschbeck and H. O. Roosenstein.

We refer Z_{x0} to the surge impedance, Z_0 , by putting

$$\frac{Z_{x0}}{Z_0} = \frac{R_{x0} + jX_{x0}}{Z_0} = \gamma + j\zeta. \tag{9}$$

γ and ζ are pure numbers. Then equations (7) take on the following form

$$\left. \begin{aligned} E_v &= E_{x0} \left(\cos \theta + j \frac{\gamma}{\gamma^2 + \zeta^2} \sin \theta + \frac{\zeta}{\gamma^2 + \zeta^2} \sin \theta \right) \\ I_v &= I_{x0} (\cos \theta + j\gamma \sin \theta - \zeta \sin \theta) \end{aligned} \right\} \tag{10}$$

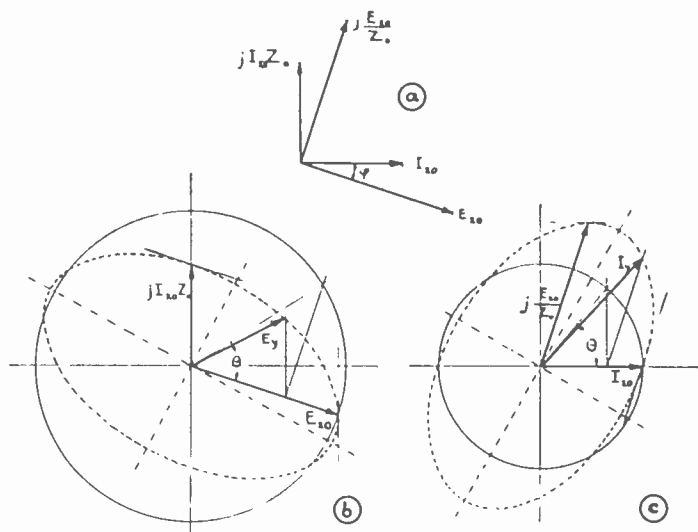

Fig. 2

A sinusoidally varying magnitude is best represented by the projection of a rotating vector of constant magnitude into a projection axis. This principle, if applied to the second equation in (10), yields Fig. 3a for the imaginary and Fig. 3b for the real term. Shifting Fig. 3b by -90 degrees and adding vectorially the projections obtained in Figs. 3a and 3b, we obtain the desired value of the bracketed term in the above equation. This procedure can be expressed in the following way by means of a formula. We put

$$\begin{aligned} \sin \theta &= +1 \\ \cos \theta &= +j \end{aligned}$$

and multiply the real term by $-j\mathcal{R}$ and the imaginary term by $+\mathcal{I}$. With these alterations, equation (10) becomes

$$\begin{aligned} E_v &= E_{x0} \left[\mathcal{R} \left(+1 - j \frac{\zeta}{\gamma^2 + \zeta^2} \right) + \mathcal{I} \left(\frac{\gamma}{\gamma^2 + \zeta^2} \right) \right] \\ I_v &= I_{x0} [\mathcal{R}(1 + j\zeta) + \mathcal{I}(\gamma)] \end{aligned} \tag{11}$$

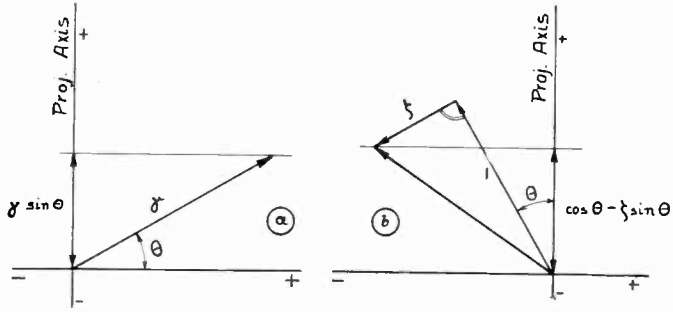

Fig. 3

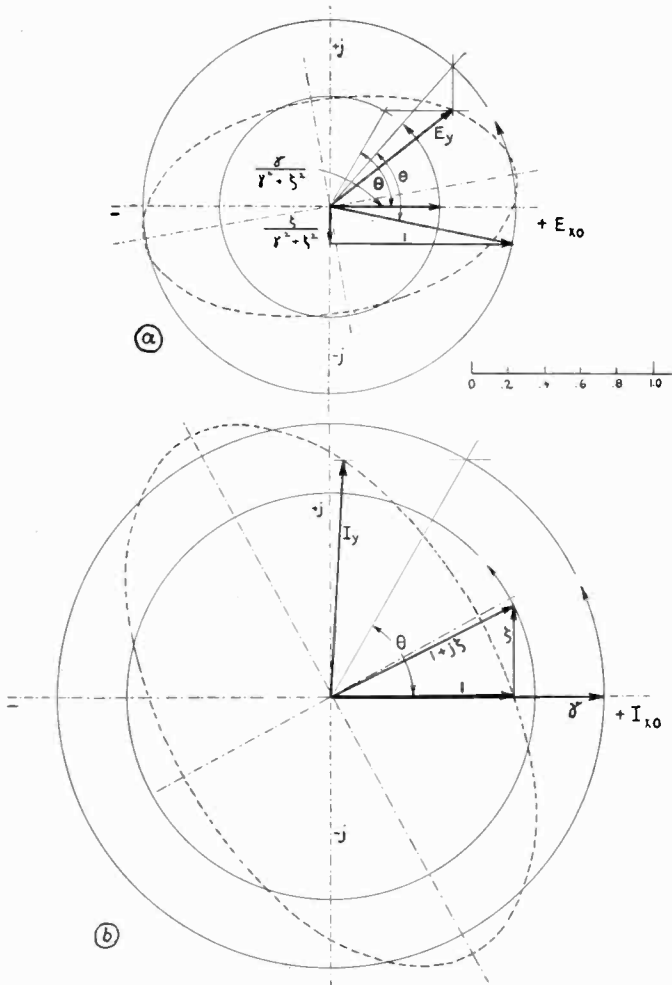

Fig. 4

where \mathcal{R} indicates that only the *real*, and \mathcal{I} indicates that only the *imaginary* component of the respective vector is to be used if the vectors are rotated from 0 to 360 degrees.

Briefly, the method is as follows: In order to obtain the current diagram (voltage diagram) draw the vectors $(1+j\zeta)$ and γ (the vectors $(1-j\zeta/(\gamma^2+\zeta^2))$ and $\gamma/(\gamma^2+\zeta^2)$). Rotate both vectors simultaneously through a full revolution and add in every instant the real component of the first and the j -component of the second vector. The resulting vector gives the desired current (desired voltage) in amplitude and

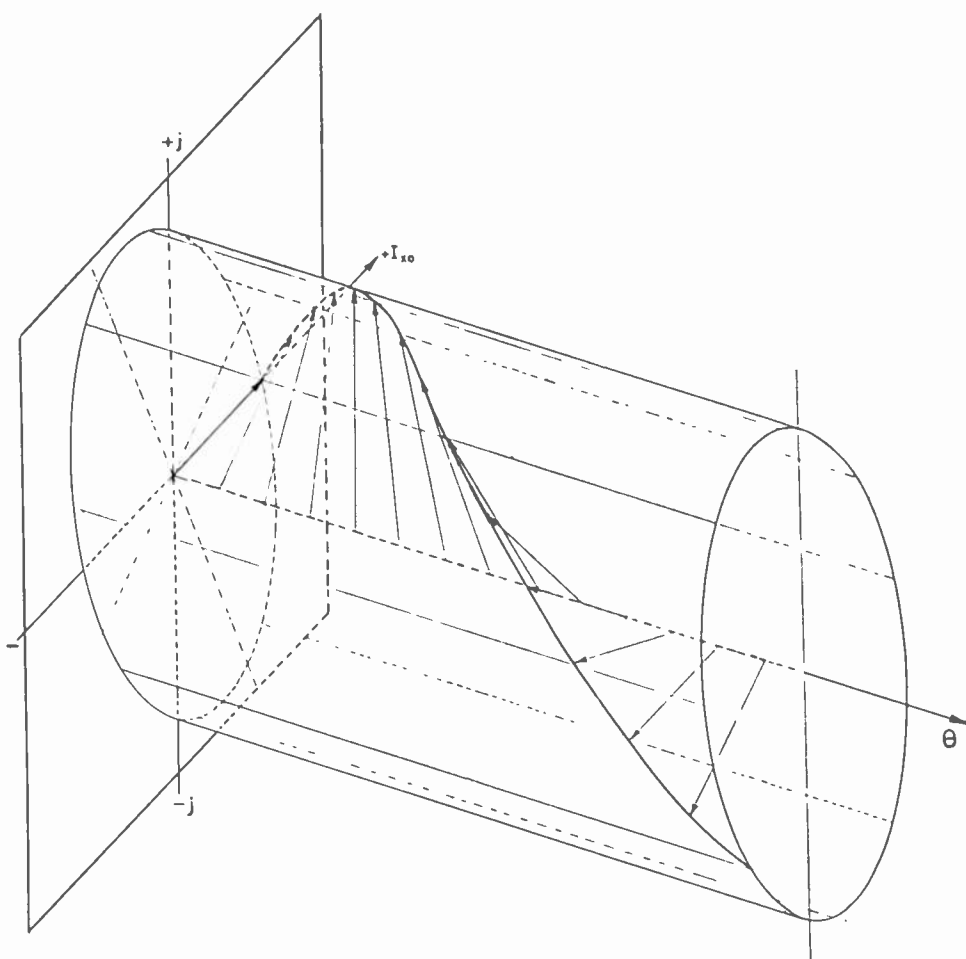

Fig. 5

phase. The angle by which the vectors have been shifted equals the electrical length of the line, at which the current (voltage) is to be measured.

Figs. 4(a) and 4(b) show the application of this method. As one can easily see the main axes of the ellipse will coincide with the axes of the coordinate system in case $\zeta=0$. If $\zeta=0$ and $\gamma=1$, then the ellipse degenerates into a circle, which represents the case of the perfectly matched line with uniform current and voltage distribution.

From the elliptical diagrams, a three-dimensional diagram can be derived, which gives a good representation of the voltage and current distribution. The ellipses form the basis area, the transmission line forms the axis of an elliptical cylinder. (Fig. 5.) The end-points of the current and voltage vectors describe helixes on the respective cylinders.

III. CIRCLE DIAGRAMS

When working with transmission lines, frequently the impedance is to be calculated which is seen when looking into the line from the sending end, if the line is loaded by a known impedance. Problems of this type, however, can be greatly simplified by graphical treatment by means of circle diagrams.

The use of circle diagrams³ is well established in electrical engineering, its most frequent application being that for the induction motor.⁴ It is known that for a complex function of the form

$$Z = \frac{A + xB}{C + xD} \quad (12)$$

where A , B , C , and D are *constant* complex terms, the complex number Z will be located on a *circle* (Fig. 6) for any real value of the variable x between $-\infty$ and $+\infty$. Equation (12) can be transferred into

$$Z = \frac{A + xB}{C + xD} = W + \frac{1}{T + xV}, \quad (13)$$

with,

$$W = Z_{x=\infty} = \frac{B}{D} = w_1 + jw_2$$

$$T = \frac{CD}{AD - BC} = t_1 + jt_2$$

$$V = \frac{D^2}{AD - BC} = v_1 + jv_2.$$

The center of the circle is given by⁵

$$W_0 = \frac{AD_c - BC_c}{CD_c - DC_c}, \quad (14)$$

³ For the theory of circle diagrams and locus curves see bibliographies nos. 3, 4, and 7.

⁴ For other applications see bibliography nos. 5 and 6.

⁵ See bibliography no. 7.

while the radius, as measured from the end-point of W to the center of the circle is

$$R_0 = \frac{1}{2} \left(\frac{v_2}{t_1 v_2 - t_2 v_1} + j \frac{v_1}{t_1 v_2 - t_2 v_1} \right). \quad (15)$$

The symbols C_c and D_c indicate the conjugate complex terms with respect to C and D , respectively. In order to find those points on the circle which correspond to various values of x we utilize the relation (Fig. 6)

$$\tan \alpha = \frac{-n - x}{m}, \quad (16)$$

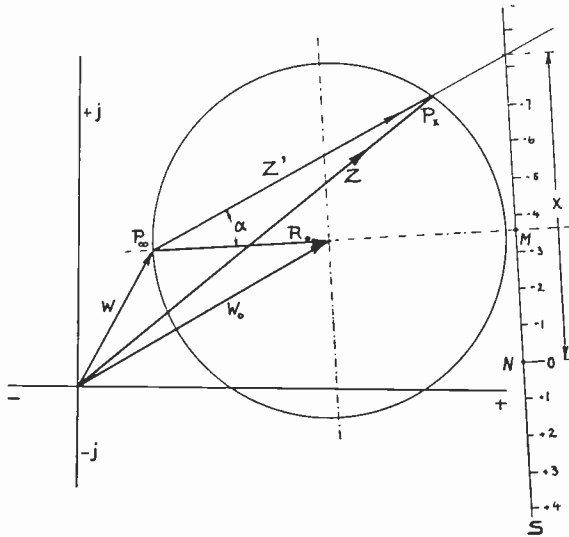

Fig. 6

α being the angle between Z' and R_0 . This angle can be readily determined graphically since its tangent is in linear relation with respect to the variable x . We have to make

$$m = \overline{P_\infty M} = \frac{t_1 v_2 - t_2 v_1}{v_1^2 + v_2^2} \quad (17)$$

$$n = \overline{MN} = \frac{t_1 v_1 + t_2 v_2}{v_1^2 + v_2^2}. \quad (18)$$

Equation (16) enables us to find graphically in the most simple manner the value of Z for any value of x , as shown in Fig. 6. m , n , and x must be drawn in equal, but arbitrary units. Extending MN , the "scale" S can be found by means of which every point on the circle is related to its corresponding value of x . In other words, we obtain Z immediately if we project the "scale" S upon the circle with P_∞ being the projection center.

For the proof of the relations given above, (13) to (18), reference is made to the original publications.⁶

Returning now to the transmission line, the following relation can be easily obtained from (7)

$$\frac{E_v}{I_v} = Z_v = Z_0 \frac{Z_{x_0} \cos \theta + jZ_0 \sin \theta}{Z_0 \cos \theta + jZ_{x_0} \sin \theta} \quad (19)$$

Substituting (9) it follows

$$Z_v = Z_0 \frac{(\gamma + j\zeta) \operatorname{ctg} \theta + j}{\operatorname{cgt} \theta - \zeta + j\gamma} \quad (20)$$

Comparing this expression with (12) we see that a circle diagram for Z_v is obtained in every one of the following cases:⁷

- 1— $\operatorname{ctg} \theta$ variable, γ and ζ fixed
- 2— $\gamma = \frac{R_{x_0}}{Z_0}$ variable, X_{x_0} and θ fixed
- 3— $\zeta = \frac{X_{x_0}}{Z_0}$ variable, R_{x_0} and θ fixed
- 4— γ or ζ variable; γ/ζ fixed, θ fixed

Case 1 gives the input impedance for variable length of the transmission line. It also allows to find the input impedance at variable frequency in case the load impedance is independent of frequency. Cases 2 and 3 deal with cases where the resistive or the reactive component, respectively, of the load is varied. In case 4, the load power factor is kept constant.

Example 1

Let us consider in more detail the first case which is the most interesting. With reference to (12) we find

$$\begin{aligned} x &\cdots \operatorname{ctg} \theta \\ A &\cdots + j \\ B &\cdots \gamma + j\zeta \\ C &\cdots - \zeta + j\gamma \\ D &\cdots 1. \end{aligned}$$

⁶ Bibliography nos. 3, 4, and 7.

⁷ See also bibliography nos. 2 and 8.

Thus, from (13) to (18)

$$W = \gamma + j\zeta$$

$$W_0 = \frac{1 + \gamma^2 + \zeta^2}{2\gamma}$$

$$R_0 = \frac{1 - \gamma^2 + \zeta^2}{2\gamma} - j\zeta$$

$$\tan \alpha = \frac{-\zeta + \operatorname{ctg} \theta}{\gamma}$$

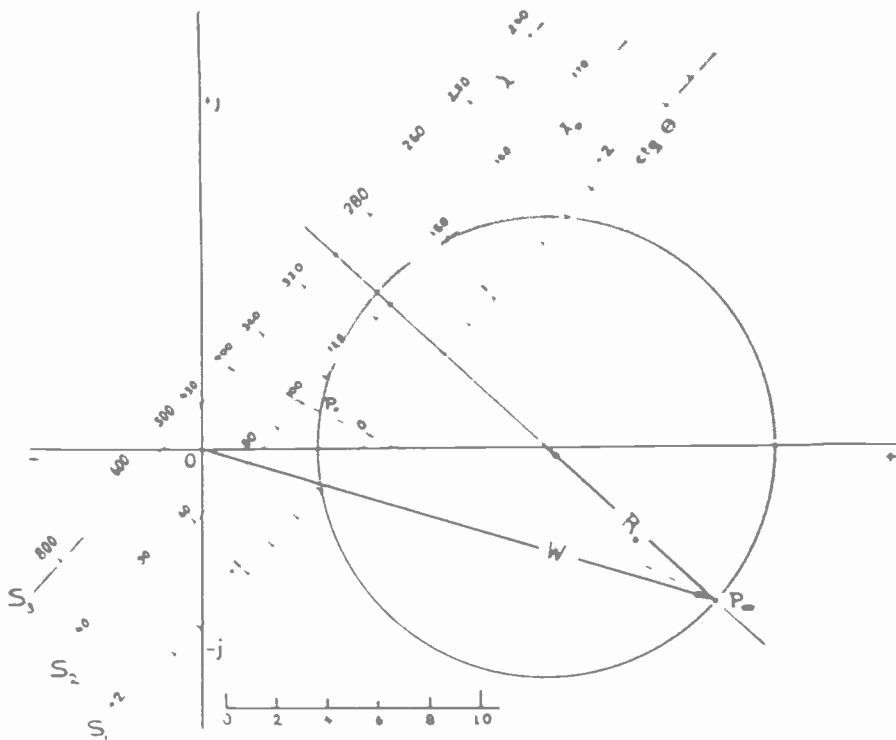

Fig. 7

With these data, the circle and "scale" S can be drawn. The "scale" is to be divided in linear progression in terms of $\operatorname{ctg} \theta$. It may, however, be more convenient to divide it in nonlinear progression with respect to the length of the line (frequency constant) or with respect to the frequency or wavelength (length of the line and load impedance constant) by means of (5).

Fig. 7 shows the application of the circle diagram in this case for a numerical example. The diagram gives the input impedance of a transmission line of variable electrical length which at its end is loaded by an impedance $Z_0(2 - j0.6)$. It is found that

$$\begin{aligned}
 W &= 2 - j 0.60 \\
 W_0 &= + 1.34 \\
 R_0 &= - 0.66 + j 0.60 \\
 n &= + 0.60 \\
 m &= 2 \\
 \tan \alpha &= \frac{1}{2}(0.6 + \text{ctg } \theta).
 \end{aligned}$$

The scale S_1 is linearly subdivided in terms of $\text{ctg } \theta$. Scale S_2 may be used to find Z_v in case the frequency is constant (wavelength 400 meters or 750 kilocycles, respectively), but the physical length of the line (measured in meters) is variable. To find Z_v at, say, 160 meters length of transmission line, connect P_∞ and point 160 on S_2 . The vector from the origin to the intersection point of that line with the circle after multiplication with Z_0 immediately gives the desired input impedance Z_v . In case the length of the above transmission line is kept constant at 100 meters but the operating frequency is varied, the scale S_3 is to be used. S_3 is ruled in terms of wavelength such that for any wavelength the corresponding input impedance can be found.

Example 2

As a second case, we assume the resistive component, R_{z0} , to be variable. We best rewrite (20) in the following manner:

$$Z_v = Z_0 \frac{j(1 + \zeta \text{ctg } \theta) + \gamma \text{ctg } \theta}{\text{ctg } \theta - \zeta + \gamma(+j)}.$$

Thus, with reference to (13) to (18)

$$\begin{aligned}
 x &\cdots \gamma \\
 A &\cdots + j(1 + \zeta \text{ctg } \theta) \\
 B &\cdots \text{ctg}^{-1} \theta \\
 C &\cdots \text{ctg}^{-1} \theta - \zeta \\
 D &\cdots + j(1).
 \end{aligned}$$

This yields

$$\begin{aligned}
 W &= - j \text{ctg } \theta \\
 W_0 &= j \frac{1 + 2\zeta \text{ctg } \theta - \text{ctg}^2 \theta}{2(\text{ctg } \theta - \zeta)} \\
 R_0 &= + j \frac{1 + \text{ctg}^2 \theta}{2(\text{ctg } \theta - \zeta)} \\
 n &= 0
 \end{aligned}$$

$$m = + (\text{ctg } \theta - \zeta)$$

$$\tan \alpha = \frac{-\gamma}{\text{ctg } \theta - \zeta}.$$

Fig. 8 shows a circle diagram for this case. It is assumed
 electrical length of transmission line = 45 degrees

$$R_{x_0} = \text{variable}$$

$$X_{x_0} = \frac{1}{2}Z_0.$$

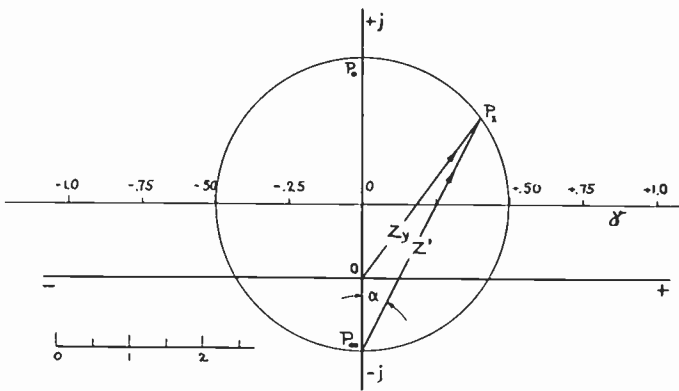

Fig. 8

With these data, we get

$$W = -j1$$

$$W_0 = +j1$$

$$R_0 = +j2$$

$$\tan \alpha = -2\gamma.$$

The diagram is drawn for positive and negative values of γ . Negative values of γ (i.e., R_{x_0}), however, have no physical meaning. For practical application, consequently, only that portion of the diagram is to be used which is located in the first and fourth quadrant.

The two remaining cases can, without much difficulty, be treated in an analogous manner.

APPENDIX

Construction of the main axes of an ellipse if two conjugate diameters are given.

With reference to Fig. 9, we call

$$\left. \begin{array}{l} a_1a_2 \\ b_1b_2 \end{array} \right\} \text{two given conjugate diameters}$$

$$\left. \begin{array}{l} A_1A_2 \\ B_1B_2 \end{array} \right\} \text{main axes, to be found.}$$

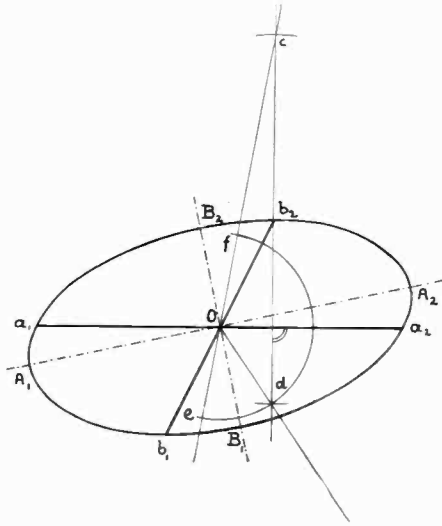

Fig. 9

Draw cb_2d perpendicular to a_1a_2 . Make $b_2c = b_2d = oa_1 = oa_2$. Obtain *direction* of main axes by bisecting the angle cOd . Draw circle edf . Then the *length* of the main axes is equal to the distances cf and ce respectively.

Bibliography

1. F. Breisig, *Theoretische Telegraphie* (Section 221). Published by Vieweg und Sohn, A. G., Braunschweig, (1924).
2. F. Creedy, "A proof that the induction motor circle diagram applies to the transmission line," *Jour. I.E.E.* (London), vol. 49, p. 381, (1930).
3. A. Fraenkel, *Theorie der Wechselstroeme* (Theory of Alternating Currents), Sections 12-15. Published by J. Springer, Berlin, (1930).
4. G. Hauffe, *Ortskurven der Starkstromtechnik* (Locus curves in Electrical Engineering). Published by J. Springer, Berlin, (1932).
5. F. Ollendorff, *Die Grundlagen der Hochfrequenztechnik* (Fundamentals of High-Frequency Alternating Currents), Chapters 136, 150, 151, 178. Published by J. Springer, Berlin, (1926).
6. N. M. Rust, "An application of the circle diagram to the design of attenuation and phase equalizers," *Marconi Review*, no. 33, 19, November, December, (1931). no. 34, 1, January, February, (1932).
7. W. O. Schumann, "Zur Theorie der Kreisdiagramme" (Note on the theory of circle diagrams), *Archiv fur Elektrotech.*, vol. 11, p. 140, (1922).
8. L. F. Woodruff, *Principles of Electric Power Transmission and Distribution*, Chapter XII. Published by John Wiley and Sons, New York, (1925).

ELLIPSE DIAGRAM OF A LECHER WIRE SYSTEM*

BY

ATAKA HIKOSABURO

(Meidi College of Technology, Tobata, Japan.)

Summary—According to theoretical investigation, the current through the end of a Lecher wire system has been found to be inversely proportional to the length of a radius vector drawn from a point to the boundary of an ellipse. Such a diagram is called an "ellipse diagram" of the Lecher wire system, and is analogous to the so-called circle diagram for the induction motor. The nature of this diagram is explained in detail in this paper. By the aid of this diagram, the effect of the length of the wires on the form of the current through the end of Lecher wire system is investigated.

INTRODUCTION

THE precision determination of short wavelengths is usually carried out by the principle of the standing waves on Lecher wire systems. The form of current in this method is, however, as some authors state, liable to be complex. Recently a very interesting paper along this line was published in this journal by A. Mohammed and S. R. Kantabet.¹ They studied the form of a resonance curve of current through the bridge on Lecher wires in great detail. According to one of their results, the form of current can be gradually varied from a double hump to a single hump, by the change of the length of Lecher wires. To explain this transition of the form of current, we propose the ellipse diagram of a Lecher wire system.

GENERAL EQUATION OF CURRENT THROUGH THE END

Fig. 1 represents the Lecher wire system of the wavelength determination. \dot{Z}_a is the impedance of the end AA' , \dot{Z}_b that of the end BB' and \dot{Y}_c the admittance of the bridge CC' . Assuming a sinusoidal e.m.f. \dot{E} is impressed in only the end AA' , the current through the end BB' has been found as follows: (The reader is referred to Appendix I for detailed calculations.)

$$\dot{I} = \dot{E} \frac{1}{\dot{P}} \quad (1)$$

where,

* Decimal classification: R140. Original manuscript received by the Institute, August 3, 1932.

¹ "Formation of standing waves on Lecher wires," Proc. I.R.E. vol. 19, p. 1983-1988; November, (1931).

$$\begin{aligned}
 \dot{P} = & \left\{ \frac{1}{2} \dot{Z} \dot{Y}_c (\dot{Z}_a + \dot{Z}_b) + \frac{\dot{Z}^2 + \dot{Z}_a \dot{Z}_b}{\dot{Z}} \right\} \sinh nl \\
 & + \left\{ (\dot{Z}_a + \dot{Z}_b) + \frac{\dot{Y}_c (\dot{Z}^2 + \dot{Z}_a \dot{Z}_b)}{2} \right\} \cosh nl \\
 & - \frac{\dot{Z} \dot{Y}_c}{2} (\dot{Z}_a - \dot{Z}_b) \sinh 2nx + \frac{\dot{Y}_c}{2} (\dot{Z}_a \dot{Z}_b - \dot{Z}^2) \cosh 2nx.
 \end{aligned} \tag{2}$$

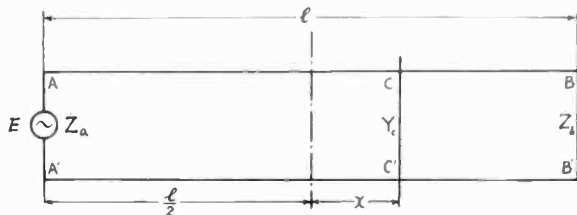

Fig. 1—Arrangement of Lecher wire system.

l is the length of Lecher wires, x the distance between the center of the wires and the bridge CC' , \dot{Z} the surge impedance, and n the vector attenuation constant of the system.

ELLIPSE DIAGRAM OF LECHER WIRE SYSTEM

For the actual Lecher wire system, the decrement of the wires must be fairly small, or else the distance between two adjacent current maxima can no longer be equal to a half wavelength. Hence to the first approximation, the decrement of the wires may be neglected. Then denoting the wavelength with λ ,

$$n = j \frac{2\pi}{\lambda} \tag{3}$$

and the hyperbolic functions in (2) can be expressed in the circular functions,

$$\dot{P} = \dot{Q} - j \frac{\dot{Z} \dot{Y}_c}{2} (\dot{Z}_a - \dot{Z}_b) \sin \frac{4\pi}{\lambda} x + \frac{\dot{Y}_c}{2} (\dot{Z}_a \dot{Z}_b - \dot{Z}^2) \cos \frac{4\pi}{\lambda} x$$

where,

$$\begin{aligned}
 \dot{Q} = & j \left\{ \frac{\dot{Z} \dot{Y}_c}{2} (\dot{Z}_a + \dot{Z}_b) + \frac{1}{\dot{Z}} (\dot{Z}_a \dot{Z}_b + \dot{Z}^2) \right\} \sin \frac{2\pi}{\lambda} l \\
 & + \left\{ (\dot{Z}_a + \dot{Z}_b) + \frac{\dot{Y}_c}{2} (\dot{Z}_a \dot{Z}_b + \dot{Z}^2) \right\} \cos \frac{2\pi}{\lambda} l.
 \end{aligned} \tag{4}$$

Now we put,

$$\dot{P} = \dot{Q} + \dot{P}' \tag{5}$$

then,

$$\dot{P}' = -j \frac{\dot{Z} \dot{Y}_c}{2} (\dot{Z}_a - \dot{Z}_b) \sin \frac{4\pi}{\lambda} x + \frac{\dot{Y}_c}{2} (\dot{Z}_a \dot{Z}_b - \dot{Z}^2) \cos \frac{4\pi}{\lambda} x$$

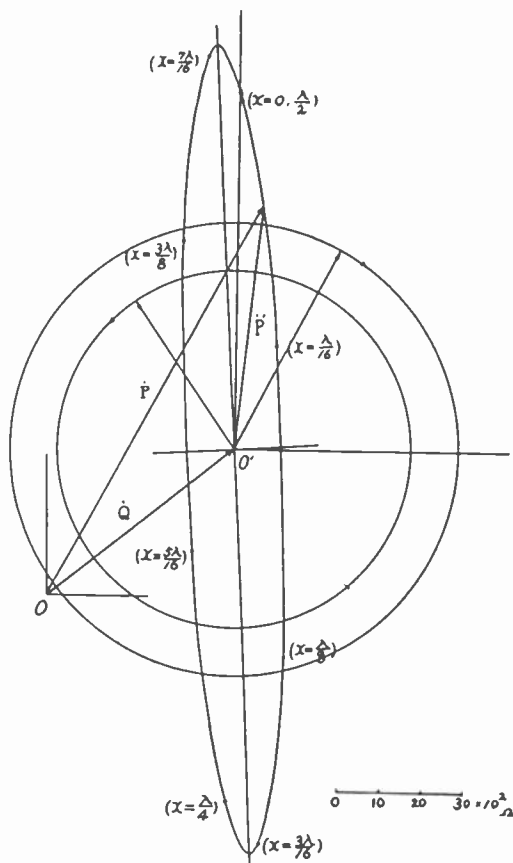

Fig. 2—Vectorial representation of fields in a Lecher system.

$$\begin{aligned} \text{Assume, } & \begin{cases} \dot{E} = 1 \text{ volt} \\ \dot{Z} = 4 \times 10^2 \text{ ohms} \\ \lambda = 10 \text{ meters} \end{cases} \\ \text{or, } & \begin{cases} \dot{Z}_a = (1 + j4) \cdot 10^2 \text{ ohms} \\ \dot{Z}_b = (1 + j1) \cdot 10^2 \text{ ohms} \\ \dot{Y}_c = (2 - j8) \cdot 10^{-2} \text{ mhs} \end{cases} \end{aligned}$$

or expressing the trigonometric functions with the exponential form,

$$\dot{P}' = \frac{\dot{Y}_c}{4} (\dot{Z}_a + \dot{Z}) (\dot{Z}_b - \dot{Z}) e^{j(4\pi/\lambda)x} + \frac{\dot{Y}_c}{4} (\dot{Z}_a - \dot{Z}) (\dot{Z}_b + \dot{Z}) e^{-j(4\pi/\lambda)x} \tag{6}$$

For tracing the variation of \dot{P}' with a variable x by means of (6), we

shall cite an analogy which is very familiar to electrical engineers. Suppose that x stands for the time and \dot{P}' for the intensity of the magnetic field, then the first term of the right-hand side of (6) is a circular rotary magnetic field with an angular velocity $4\pi/\lambda$ and the second term is the other circular rotary field with the same angular velocity. The resultant \dot{P}' of these two fields is well known to become an elliptical rotary magnetic field, and \dot{P}' describes the ellipse completely during the time $\lambda/2$. In Fig. 2 are shown these circular fields and the resultant elliptical field. The numerical values are given in Appendix II.

Now if the origin O' is transformed into such a point as $\vec{OO}' = \dot{Q}$, then the length of the radius vector drawn from the new origin O to the boundary of the ellipse is equal to P , the magnitude of the vector \dot{P} . According to the position of the new origin with respect to the ellipse, there can take place the following two cases:

- case (a) P has four extreme values, that is two maxima and two minima,
- case (b) P has only two extreme values, that is, one maximum and one minimum.

Since by (1) the current I is proportional to the reciprocal of P , I has also four extreme values in case (a) and only two extreme values in case (b) during the time $\lambda/2$. It will be clear that in case (a) there occurs a double-hump phenomenon in the form of the current I and in case (b) a single hump, as usually observed. Thus the diagram shown in Fig. 2 is very useful for investigating the variation of the current with x . On account of its form, we call it an ellipse diagram of Lecher wire system. It is of course analogous to the so-called circle diagram of the induction motor.

EFFECT OF LENGTH OF WIRES

We shall next consider the effect of the length of the wires on the form of current through the end. Since the length l of the wires is contained in the expression of \dot{Q} and the position of the new origin O in Fig. 2 is determined with \dot{Q} , the point O will describe a certain curve with the variation of l . In order to find this locus, (4) is transformed into:

$$\begin{aligned} \dot{Q} = & \frac{\dot{Z}\dot{Y}_c + 2}{4\dot{Z}}(\dot{Z}_a + \dot{Z})(\dot{Z}_b + \dot{Z})\epsilon^{j(2\pi/\lambda)l} \\ & + \frac{\dot{Z}\dot{Y}_c - 2}{4\dot{Z}}(\dot{Z}_a - \dot{Z})(\dot{Z}_b - \dot{Z})\epsilon^{-j(2\pi/\lambda)l} \end{aligned} \quad (7)$$

which is of the same form as (6). Therefore, the locus of the point O is also an ellipse having its center at the old origin O' . In Fig. 3 are shown this ellipse together with that of P' . \dot{Q} describes the ellipse completely during the interval λ . In Figs. 4a, 4b, 4c, and 4d are shown the relation between P and x , and that between I and x , for the cases

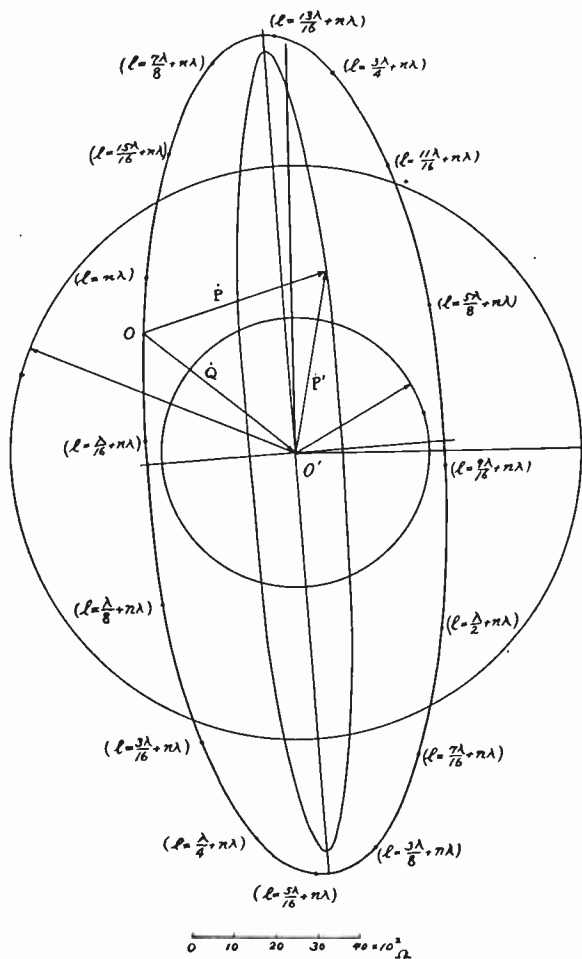

Fig. 3—Vectorial representation of fields in a Lecher system as influenced by the length.

$l = n\lambda, (\lambda/16) + n\lambda, (\lambda/8) + n\lambda, \dots (15\lambda/16) + n\lambda$ in the rectangular coordinates.

Viewing these figures in order from (1) to (16), we can observe a transition from a double hump to a single hump, and that from a single hump to a double hump. The wave form of the current for the case $l = \theta + n\lambda$ where $(\lambda/2) > \theta > 0$, is exactly equal to that for the case $l = \theta + (\lambda/2) + n\lambda$, but the latter leads the former by $\lambda/2$ in phase.

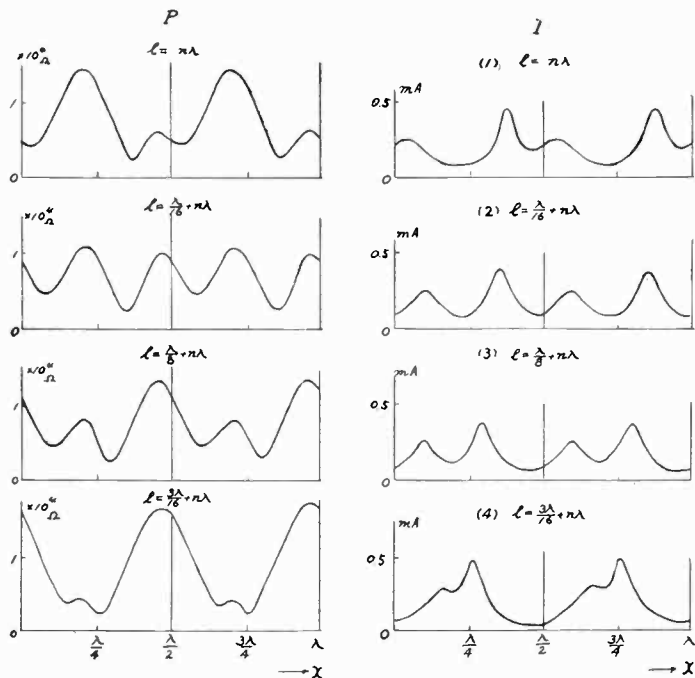

Fig. 4a

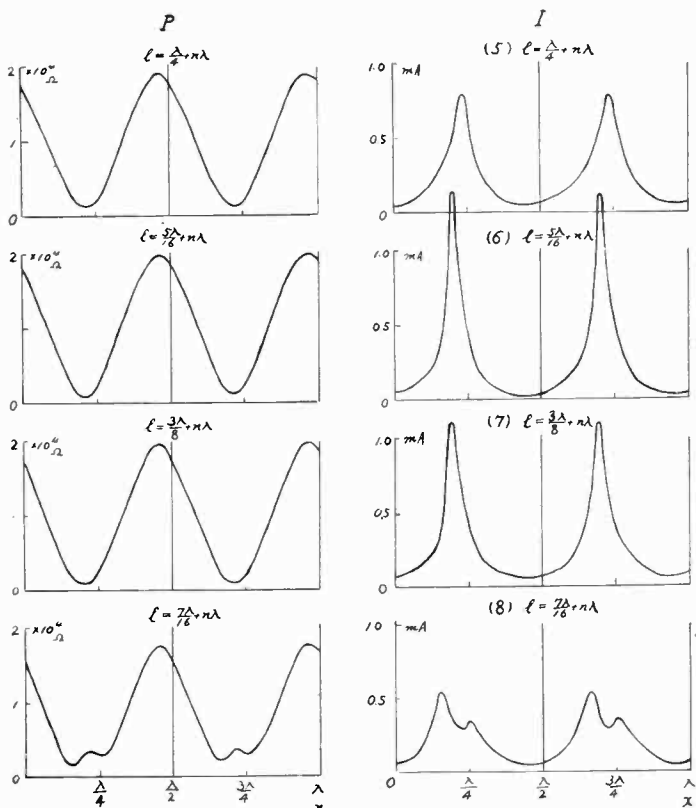

Fig. 4b

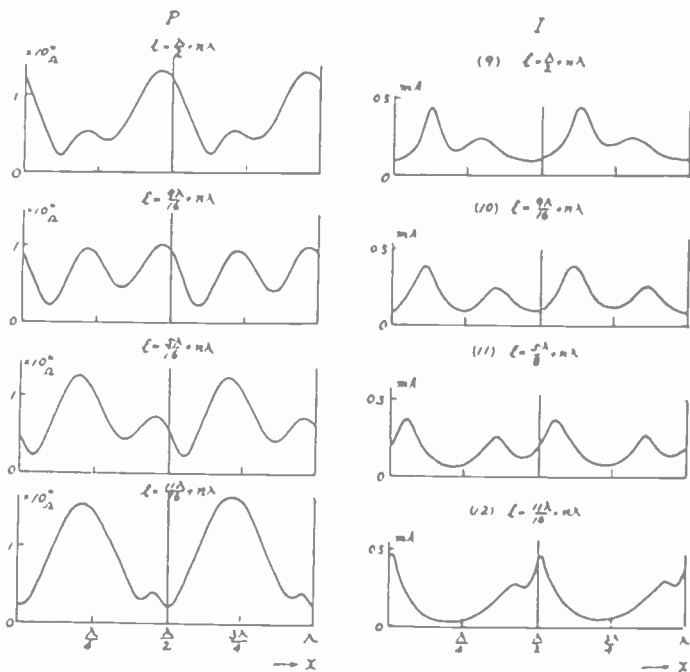

Fig. 4c.

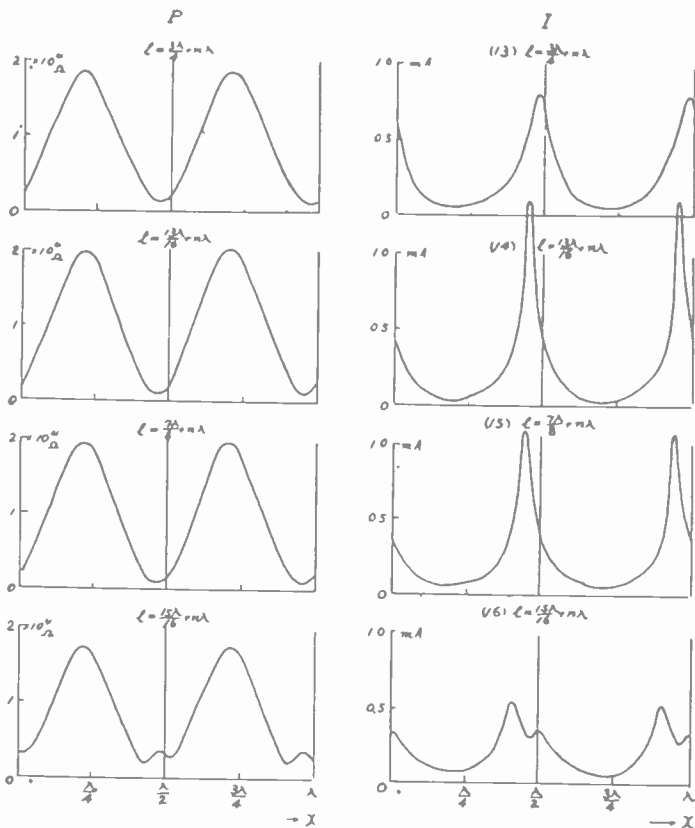

Fig. 4d

Figs. 4a, 4b, 4c, 4d, etc.—Typical double hump resonance phenomena resulting from various adjustments of Lecher wire lengths.

CONCLUSION

The current through the end of a Lecher wire system can be given by the reciprocal of a vector which describes an ellipse with the variation of x , the coördinate of the bridge. A double-hump phenomenon is a general form of current through the end, and the single-hump, which is usually observed, is its special form. The current through the bridge is slightly different from that through the end and the ellipse diagram for this current is more complicated than that for the current through the end. The general features are, however, similar for these two currents.

APPENDIX I

In Fig. 1 let \dot{I}_0 be the current through AA' and \dot{E}_l the difference of potential between the terminals of the end BB' . Then there are the following relations between \dot{E} , \dot{I}_0 , and \dot{E}_l , \dot{I} :

$$\left. \begin{aligned} \dot{E} &= \dot{A}\dot{E}_l + \dot{B}\dot{I} \\ \dot{I}_0 &= \dot{C}\dot{E}_l + \dot{D}\dot{I} \end{aligned} \right\}$$

$$\dot{A}\dot{D} - \dot{B}\dot{C} = 1.$$

where,

By the aid of the theory of a passive quadripole, it follows that,

$$\begin{aligned} \left. \begin{aligned} \left. \begin{array}{cc|cc} \dot{A} & \dot{B} & 1 & \dot{Z}_a \\ \dot{C} & \dot{D} & 0 & 1 \end{array} \right| &= & \left. \begin{array}{cc|cc} \cosh n\left(\frac{l}{2} + x\right), & \dot{Z} \sinh n\left(\frac{l}{2} + x\right) \\ \frac{1}{\dot{Z}} \sinh n\left(\frac{l}{2} + x\right), & \cosh n\left(\frac{l}{2} + x\right) \end{array} \right| \\ \left. \begin{array}{cc|cc} 1 & 0 \\ \dot{Y}_c & 1 \end{array} \right| &= & \left. \begin{array}{cc|cc} \cosh n\left(\frac{l}{2} - x\right), & \dot{Z} \sinh n\left(\frac{l}{2} - x\right) \\ \frac{1}{\dot{Z}} \sinh n\left(\frac{l}{2} - x\right), & \cosh n\left(\frac{l}{2} - x\right) \end{array} \right| \end{aligned} \right\} \end{aligned}$$

Hence we have,

$$\left. \begin{aligned} \dot{A} &= \left(1 + \frac{\dot{Y}_c \dot{Z}_a}{2}\right) \cosh nl + \left(\frac{\dot{Z}_a}{\dot{Z}} + \frac{\dot{Y}_c \dot{Z}}{2}\right) \sinh nl \\ &\quad + \frac{\dot{Y}_c \dot{Z}}{2} \sinh 2nx + \frac{\dot{Y}_c \dot{Z}_a}{2} \cosh 2nx \\ \dot{B} &= \left(\dot{Z}_a + \frac{\dot{Z}^2 \dot{Y}_c}{2}\right) \cosh nl + \left(\dot{Z} + \frac{\dot{Y}_c \dot{Z} \dot{Z}_a}{2}\right) \sinh nl \\ &\quad - \frac{\dot{Z} \dot{Y}_c \dot{Z}_a}{2} \sinh 2nx + \frac{\dot{Y}_c \dot{Z}^2}{2} \cosh 2nx \end{aligned} \right\}$$

At the end BB' , we have

$$\dot{E}_1 = \dot{I}Z_b$$

therefore,

$$\dot{I} = \frac{\dot{E}}{\dot{A}Z_b + \dot{B}}.$$

If we put,

$$\dot{P} = \dot{A}Z_b + \dot{B},$$

then (1) follows immediately.



DISCUSSION ON "ON THE AMPLITUDE OF DRIVEN LOUD
 SPEAKER CONES"*

M. J. O. STRUTT

N. W. McLachlan:¹ In the discussion on this paper Dr. Strutt attempts to evade the author's criticism by suggesting that our definitions of effective mass are different. It is easy to show, with the aid of his experimental results, that the two definitions are identical.

The impedance at the driving point of any mechanical system is $B + j\omega M_e$ where B is the mechanical resistance and M_e the effective mass which can be positive, zero, or negative. Dr. Strutt takes a rod and finds the mass which gives the same resonance frequency as that when a cone is attached. His system is driven, and the value of M_e conforms with that in the expression $B + j\omega M_e$. Thus our definitions are identical.

He defines efficiency as $\eta = M_e/M$. At 500 \sim , $\eta = 0.434$ whilst at 1740 \sim $\eta = 0.15$. Are we expected to believe that an operating efficiency of 43.4 per cent is obtained at 500 \sim ? The efficiency decreases with increase in frequency which is not in accordance with known results. G. A. V. Sowter and the author have shown recently² that the output from a 90° cone 12 cm radius is greatest between 2000 and 4000 \sim , since this is the region where resonances occur.

In citing an alternative definition of M_e Dr. Strutt seeks support from Crandall and Kennelly. We are told that M_e of a circular membrane at its first mode is 0.28 its natural mass. But neither Crandall nor Kennelly defined effective mass. They dealt with the mass coefficient³—a totally different quantity which arises as follows. The kinetic energy of the membrane is $T = m/2 \int_0^a 2\pi + v^2 dr$, where v is the velocity at radius t , and m the mass per unit area. Since v varies from a maximum at the center to zero at the periphery, T must be less than $\frac{1}{2}M\bar{V}^2$ where \bar{V} is the central velocity and M is the natural mass. T can be written $\frac{1}{2}M\bar{V}_m^2$ where \bar{V}_m is a mean square velocity over any radius. Alternatively it can be written $T = \frac{1}{2}kM\bar{V}^2$ where k is the mass coefficient. Since the square of the velocity is involved, k is always positive and >0 . This is in great contrast to M_e which can be positive, zero, or negative. We could, of course, define the effective mass as kM . Since kM refers to integration over the whole surface, but not to the driving point where the power is supplied, the writer thinks such a definition would lead to confusion. It would be rather embarrassing if we adopted this procedure in telephony. Input impedance would take a holiday and the effective inductance would be defined in the expression $\frac{1}{2}L_e I^2 = \frac{1}{2}kL I^2$. This quantity represents the electromagnetic energy stored throughout the length of the cable when the maximum input current is I ; and by virtue of I^2 it is always >0 . Moreover, we should banish capacity—by definition!

Dr. Strutt takes $fpds/PS = M_e/M$ but since $fpds$ involves the first power of the amplitude whereas kM involves the second power, it follows that the mass coefficient does not fit his argument. Consequently there is no possible doubt that his intended or unintended! value of M_e is defined in $B + j\omega M_e$.

Let us consider some of the consequences. For a certain annularly driven

* Proc. I.R.E., vol. 19, p. 839; May, (1931).

¹ Radio engineering consultant, London, England.

² Phil. Mag., vol. 12, pp. 771-814, (1931).

³ Crandall uses mass "coefficient," whilst Kennelly uses "equivalent" mass.

aluminium disk⁴ vibrating in air near its first center-stationary mode, M_e varies from +216 through zero to -127 grams. The natural mass of the disk is nearly 55 grams so that on Dr. Strutt's reckoning $\eta = M_e/M$ is successively 4.0 and 2.3. We have indeed defied the good old law of conservation of energy—if this still exists in an era of electrons, protons, cosmic rays, and expanding universes! Another consequence is that $f_p d_s$ takes no account of accession to inertia, although the latter appears in Dr. Strutt's experimental observations since these were not conducted in vacuo.

It is obvious, therefore, that M_e/M is not a criterion of the acoustic performance of a vibrating diaphragm.

Finally Dr. Strutt says the writer questioned the accuracy of and criticized his decay measurements. Actually I asked whether diaphragm loss was included in his results. I then proceeded to indicate how errors arose in a system of efficiency measurement which is entirely different from his own. There was no criticism.

M. J. O. Strutt:⁵ The writer fears that the present discussion does not bring forward the matter in hand, as it tends to become a mere fight over words and definitions. Fortunately I may this time be brief, as a paper, containing the most recent data available on this matter, has just appeared⁶.

In the first place I do not agree, that in the rod method for measuring the effective mass, as published in my paper in May, 1931, the cone is driven. In fact, the cone together with the rod and the valve circuit determines the free frequency of oscillation. Analysis shows that large mistakes may be made in assuming the cone driven in this method.

The criticism of my efficiency definition may be repudiated with the argument, already given in a previous discussion. I regret that Dr. McLachlan did not seem to notice it. It says that no damping and hence no sound radiation was taken into account in my theoretical interpretation of experimental results. They could not and still, (I am sorry to say) cannot be duly taken into account, as no sufficient theoretical and experimental material on this rather difficult, but very important question, is available. Hence, Dr. McLachlan's statements on acoustic radiation efficiency as compared with mine are beside the point.

For a full discussion of the various definitions in use on effective or equivalent mass, I refer to a paper in the *Annalen der Physik*.⁷ I shall not try here to discuss Dr. McLachlan's remarks on Prof. Kennelly's and the late Dr. Crandall's definitions.

I now come to the central point; i.e. the values of effective mass, measured by Dr. McLachlan, and brought forward by him in the previous and in the present discussion.

The difference between Dr. McLachlan's results and mine is, that he says: there is one equivalent mass of any specified cone at any specified frequency and that I contend: there are as many as you like. In fact it was shown a year ago,⁸ by experiments that the equivalent mass of loud speaker cones depends on the driving direction. As in the loud speaker cones, measured according to Kennelly's method by Dr. McLachlan, this driving direction will undoubtedly depend on

⁴ See reference 2, Fig. 4. Additional information on this subject is given in *Phil. Mag.*, vol. 12, p. 115, (1932).

⁵ Natuurkundig Laboratorium der N. V. Philips' Gloeilampenfabrieken, Eindhoven, Holland.

⁶ *Experimental Wireless*, March, (1932).

⁷ "Ueber die Admittanz linearer Schwingungssysteme," *Ann. der Physik*, vol. 10, pp. 244-256 (1931).

⁸ See *Experimental Wireless*, March, (1932).

the frequency, no special data on the *cones themselves* can be obtained by this method. I invite anyone, interested in this matter, to observe with a strong light an electromagnetic driving system, with a cone fastened to it, operating the system with a variable frequency generator, in order to see the strong vibrations, executed in different directions by the driving point at different frequencies. In the measurements, described in my paper under discussion, the motion of a cone was measured in a specified and *invariable* direction. Hence, I do not wonder that Dr. McLachlan's results differ from mine. For further details the reader may consult the recent paper cited above.



DISCUSSION ON "HISTORICAL REVIEW OF
ULTRA-SHORT-WAVE PROGRESS"*

WILLIAM H. WENSTROM

H. M. Dowsett:¹ We notice that in the above paper, the only reference made to work of the Marchese Marconi and his assistants in the ultra-short-wave field is that on page 97, in which it is stated that in "1896-1897, Marconi achieved radio communication over a distance of nearly two miles using waves of about one meter length . . . they were not again seriously considered as a means of communication for many years."

This statement is incomplete as it stands. In a paper read before the Institution of Civil Engineers on the 26th October, 1926, Marchese Marconi stated that ten years ago, during the War, "I began to consider the possible alternative which might be offered by an exploration of the capabilities for point-to-point communication of those electrical waves which had never yet been used for practical radiotelegraphy, that is, waves only a few meters in length. . . ."

"During some of my first experiments on these lines, carried out in Italy, and during subsequent tests, I was most valuably assisted by Mr. C. S. Franklin of the Marconi Co.

"These researches were continued by Mr. Franklin in consultation with me in Carnarvon, and in 1917 with a wavelength of three meters a range of over twenty miles was readily obtained when using a reflector at the transmitting end only."

Again, in a lecture delivered before a joint meeting of the American Institute of Electrical Engineers, and the Institute of Radio Engineers on June 20, 1922, Marchese Marconi makes brief reference to this ultra-short-wave research.²

The work performed by Mr. C. S. Franklin and referred to above by Marchese Marconi is described by the former in a paper read before the Institution of Electrical Engineers on the 3rd May, 1922, and published in the *Journal of the Institution of Electrical Engineers*, Volume 60, page 930, entitled "Short Wave Wireless Directional Telegraphy." All the above work was done with waves of the order of two to three meters, and is certainly important enough to justify reference in any article dealing with the history of ultra-short-wave research.

We should therefore be obliged if you would submit these notes to the author of the article in question and would allow them to appear in a future issue of your journal as comments on the paper in question.

The more recent work carried out by Marchese Marconi was made public in November of last year, the full details of which are, of course, known to you, but these researches would appear to have taken place subsequent to the period dealt with in the paper.

William H. Wenstrom:³ I can state at the outset that there was no intention in my paper of slighting the work of the Marchese Marconi, the importance of which is well known not only to every radio engineer, but to the entire public as well.

Mr. Dowsett states that the Marchese Marconi, after the early work in 1896-1897, again began to consider ultra-short waves in 1916. As the lapse of

* Proc. I.R.E., vol. 20, pp. 95-112; January, (1932).

¹ Research manager, Marconi's Wireless Telegraph Company, Ltd., London, England.

² Proc. I.R.E., vol. 10, no. 4, p. 225; August, (1922).

³ Signal Corps, U.S.A. Fort Monmouth, N. J.

time was apparently about nineteen years, I think that the relevant paragraph on page 97 of my paper is correct as it stands.

The remaining question, then, is whether the later (1916-1917) ultra-short-wave work of the Marchese Marconi and his assistants, carried out with spark transmitters, should have been accorded separate mention in its chronological place in the section of the review devoted to spark oscillators.

In a paper of this kind some selection is evidently necessary; it is manifestly impossible to include everything. The entire paper emphasizes original research, rather than practical application, because from a broad scientific viewpoint the former is more fundamental, and must precede the latter. This is particularly true in the section of the paper devoted to spark oscillators because it has long been apparent that the main future of practical radio communication lies in continuous waves. In the remainder of the section devoted to spark oscillators, therefore, my chief interest was the extension of the radio spectrum downward to the infra-red region, rather than any further practical application of spark transmitters to the needs of radio communication, the early demonstrations of the Marchese Marconi having shown such application to be possible.

The above statement sufficiently explains, I believe, the reasons for the scope of my paper as it stands. However, I would be glad to see Mr. Dowsett's letter, and any other interesting and relevant discussion which may develop from the original paper, published in the PROCEEDINGS or elsewhere.



BOOK REVIEWS

Thermionic Vacuum Tubes, by E. V. Appleton. Published by E. P. Dutton & Co., Inc., New York. 113 pages, 68 figures, price \$1.25.

This small book differs from many brief studies of vacuum tubes in that it is concerned with physical fundamentals rather than with descriptive items. It is written for the general physics student and for the technically inclined amateur. Features of the book are the considerable number of references to the literature, and a few references to other texts.

The treatment of the triode as an oscillator differs somewhat from that usually given, as does the discussion of amplification factor—both are refreshing in viewpoint.

The manufacturing procedure mentioned in the book differs from that of most firms in this country. The discussion of diode detectors is quite limited.

*B. E. SHACKELFORD

Servicing Receivers by Means of Resistance Measurement, by John F. Rider. Published by Radio Treatise Co. Inc., 1440 Broadway, New York. 203 pp. 94 figures.

This book urges the adoption and describes the methods of resistance measurement in place of voltage measurement in most radio receiver servicing. If the correct operating voltages are available from basic sources the application of these values to the tube elements is dependent upon the correct resistance in the various systems. It is also shown that a set may not function even when the correct voltages are indicated due to incorrect resistances in tube circuits. Resistance measurements may be made with the set inoperative and the tubes removed. The receiver may be fairly well examined without removing the chassis from the cabinet by working through the tube sockets. Resistance measurement allows individual unit measurement and stimulates systematic operation.

Since neither resistance nor voltage measurements are entirely satisfactory for condenser testing a condenser tester devised by the author is described.

The methods described are illustrated in detail by application to several types of radio receivers and power packs.

†S. S. KIRBY.

* RCA Radiotron Company, Inc., Harrison, N. J.

† Bureau of Standards, Washington, D. C.

- R113.5 A. M. Skellett. The ionizing effect of meteors in relation to radio propagation. *Proc. I.R.E.*, vol. 20, pp. 1933-1940; December, (1932).
 From a study of available meteor data it is concluded: (1) that meteors expend the larger part of their energy in the Kennelly-Heaviside regions; (2) that the major portion of a meteor's energy goes into ionization of the gases around its path; (3) that this ionization extends to a considerable distance from the actual path, and lasts for some minutes after the meteor has passed; (4) meteor trains are produced only in the lower Kennelly-Heaviside layer. A table of the various sources of ionization of the upper atmosphere is given with values for each in ergs cm^{-2} sec^{-1} .
- R113.5 J. P. Schafer and W. M. Goodall. Observations of Kennelly-Heaviside layer heights during the Leonid meteor shower of November, 1931. *Proc. I.R.E.*, vol. 20, pp. 1941-1945; December, (1932).
 X R113.61 This paper describes the results of radio measurements of the virtual heights of the Kennelly-Heaviside layer during the Leonid meteor shower of November, 1931. While the results are not conclusive, due to the fact that a moderate magnetic disturbance occurred during this same period, there is some reason to believe that the presence of meteors in unusual numbers causes increased ionization of an intermittent nature in the region of the lower layer.
- R113.55 R. W. Woodward. Amateur observations during the total eclipse of the sun. *QST*, vol. 17, pp. 32-38; January, (1933).
 A survey is given of the effects of the eclipse on radio reception as observed by amateurs on the amateur frequency bands. The findings indicate that the ionization is produced by ultra-violet light or some radiation traveling with the speed of light. There was no effect observed which would indicate the presence of a corpuscular eclipse.
- R113.6 P. Keck and J. Zenneck. Die magnetische Drehung der Polarisations-ebene von elektromagnetischen Wellen in ionisierten Gasen. (The magnetic rotation of the plane of polarization of electromagnetic waves in ionized gases.) *Hochfrequenz. und Elektroakustik*, vol. 40, pp. 153-158; November, (1932).
 Experiments are described by which the magnetic rotation of the plane of polarization in an ionized gas is detected and measured. The measured values of the rotation are compared with those calculated from the theory. The application of the theory requires the knowledge of the absorption coefficients and the index of refraction of the ionized gas for the frequency used. Both were measured, the last by an interference method.
- R113.6 H. Harbich and W. Hahnemann. Wirksame Bekämpfung des Nahschwundes im Rundfunk durch Sendeantennengebilde bestimmter Form. (Effective combating of the skip distance in broadcasting through building transmitting antennas of special shapes.) *Elek. Nach. Tech.*, vol. 9, pp. 361-377; October, (1932).
 A research on antenna construction is described which has led to the effective elimination of skip distance. Radiation diagrams representing various conditions and kinds of antennas are given. Pictures of antennas and fading records are given.
- R113.61 G. Builder. The existence of more than one ionized layer in the upper atmosphere. *Wireless Engineer & Experimental Wireless* (London), vol. 9, pp. 667-672; December, (1932).
 The chief wireless methods of investigating the electrical structure of the upper atmosphere are briefly described and compared. Evidence supports the hypothesis of at least two layers of ionization capable of reflecting wireless waves. The possibility of other layers is briefly discussed.
- R113.61 E. V. Appleton. Wireless studies of the ionosphere. *Jour. I.E.E.*, (London), vol. 71, pp. 642-650; October, (1932).
 The methods used in investigating the ionized region are described. Results of equivalent height measurements are given. The magneto-ionic theory of electric wave propagation is presented. A bibliography of 31 references is given.
- R114 K. G. Jansky. Directional studies of atmospherics at high frequencies. *Proc. I.R.E.*, vol. 20, pp. 1920-1932; December, (1932).

A system for recording the direction of arrival and intensity of static on short waves is described. The system consists of a rotating directional antenna array, a double detection receiver, and an energy-operated automatic recorder. The operation of the system is such that the output of the receiver is kept constant regardless of the intensity of the static. Data obtained with this system show the presence of three separate groups of static. Curves are given showing the direction of arrival and intensity of static.

- R120 J. A. Stratton and H. A. Chinn. The radiation characteristics of a vertical half-wave antenna. *PROC. I.R.E.*, vol. 20, pp. 1892-1913; December, (1932).

"Extensive measurements have been made of the field distribution about a vertical antenna operating at 29 megacycles over sea water. With the help of a small, nonrigid airship observations were made at various altitudes which permitted the plotting of the space characteristic and the determination of the attenuation as dependent on altitude. The experimental results are compared with field intensities computed for the given physical conditions from the theoretical expressions of Sommerfeld and Strutt. Details are given of the design of the apparatus required for carrying out the measurements."

- R133 G. Potapenko. On the generation of ultra-short electromagnetic waves using the scheme of H. Barkhausen and K. Kurz. *Phil. Mag.* (London), vol. 14, pp. 1126-1142; December, (1932).

An explanation of the phenomena of the generation of ultra-short waves is given.

- R134 G. Varret. La détection des oscillations modulées. (The detection of modulated oscillations.) *L'Onde Electrique*, vol. 11, pp. 315-328; September, (1932).

The author studies the problem of the detection of modulated waves in the conditions of use, that is, taking into account the presence of an impedance used in the plate circuit. The method, which consists of a study of a network of detection characteristics led the author to define the parameters in all points analogous to the usual coefficients of vacuum tubes: slope, amplification coefficient, and internal resistance.

- R140 Y. Rocard. Etude des régimes transitoires et des constantes de temps pour les principaux circuits utilisés en T.S.F. (Studies of transitory systems and time constants for the principal circuits used in radio telegraphy.) *L'Onde Electrique*, vol. 11, pp. 273-295, September; pp. 339-363; October, (1932).

In this article the application to simple electric circuit arrangements not permitting of propagation is regarded, by a method of calculation permitting the rapid obtaining of expressions for currents and voltages for certain types of electric perturbations. This method consists in principle of a particular case of Heaviside's operational calculus. The very simple generalities which extend to the method in the case of important identical circuits coupled by vacuum tubes without reaction, are given.

- R148 H. Roder. Some notes on demodulation. *PROC. I.R.E.*, vol. 20, pp. 1946-1961; December, (1932).

The audio output of a detector depends upon two magnitudes which are independent each from the other. These magnitudes are the radio-frequency envelope of the input and the rectification characteristic of the detector. A new method to find graphically the radio-frequency envelope for the "general modulated signal," is given. An analysis is made showing how to find the detector output if the input radio-frequency envelope and the rectification characteristic of the detector are known.

R200. RADIO MEASUREMENTS AND STANDARDIZATION

- R243.1 F. E. Rommel. Ein Röhrenvoltmeter mit logarithmischer Eichkurve. (An electron-tube voltmeter with logarithmic calibration curve.) *Hochfrequenz. und Elektroakustik*, vol. 40, pp. 124-127; October, (1932).

A simple circuit arrangement is described which makes it possible to draw sound pressure curves on logarithmic scale with photographic recorder. The dimensioning of the circuit constants as well as a suitable manner of application for wide measuring range are explained. The dependence of the working voltage on the alternating current supply voltage is given.

- R270 T. L. Eckersley. Note on the field strength of the Marconi broadcasting station erected at Warsaw. *Marconi Review*, No. 38, pp. 20-22; September-October, (1932).
"Results of a field intensity survey of the signal from the 120-kilowatt broadcast station at Warsaw are discussed from the point of view of their agreement with theoretical results."
- R270 W. W. Mutch. A note on an automatic field strength and static recorder. *PROC. I.R.E.*, vol. 20, pp. 1914-1919; December, (1932).
"A device for making a continuous record of the energy received from a signal or from static is described. Simple modifications are suggested by means of which peak or average voltage may be recorded."
- R282.1 LeRoy L. Barnes. The temperature variation of the positive ion emission from molybdenum. *Phys. Rev.*, vol. 42, pp. 492-497; November 15, (1932).
The values for the positive ion work function and for the reflection coefficient for molybdenum ions are found to be in better agreement with the theory of positive ion emission presented by L. P. Smith than were his experimental results on molybdenum ions.
- R282.1 LeRoy L. Barnes. The emission of positive ions from heated metals. *Phys. Rev.*, vol. 42, pp. 487-491; November 15, (1932).
"The positive ion emission from iron, nickel, copper, rhodium, columbium, platinum, uranium, and thorium has been studied. In addition to the emission of singly charged atoms of the alkalis, reported by others it is found that iron, nickel, copper, rhodium, and columbium emit singly charged atoms of their own metals."
- R282.1 J. B. Hoag and H. Jones. Permeability of iron at ultra-radio frequencies. *Phys. Rev.*, vol. 42, pp. 571-576; November 15, (1932).
Results are given of a study of the "initial" magnetic permeability of iron wire by the self inductance method at ultra-radio frequencies using the frequency determination method of Hoag.

R300. RADIO APPARATUS AND EQUIPMENT

- R325 R. M. Wilmotte. Directive antennae for broadcast stations. *Electronics*, vol. 5, pp. 362-64; December, (1932).
By use of a directive antenna WFLA was enabled to increase its power without producing interference in Milwaukee. Results of a survey of field intensity are given.
- R330 E. W. Herold. Triple grid-power amplifier tubes. *Radio Eng.*, vol. 12, pp. 7-9; December, (1932).
Characteristic curves and technical data on new types of tubes which provide large power output in class B operation.
- R330 A. W. Hull. New vacuum tubes and their applications. *Gen. Elec. Rev.*, vol. 35, pp. 622-629; December, (1932).
The latest products of the research laboratory of the General Electric Company are described. A pliotron FP-54 capable of detecting currents as small as 10^{-18} amperes; a pliotron PJ-11, a low noise tube designed for measuring small voltages; a cathode-ray tube for exciting characteristic spectra; some photo-electric and thyatron tubes are described.
- R330 L. Martin. New tube announcements. *Radio Craft*, vol. 4, pp. 398-399; January, (1933).
Four new tubes now available; 52, 15, 19, and KR-1. Characteristic curves and technical data on these tubes are given.
- R335 A power amplifier pentode tube. *Radio Eng.*, vol. 12, p. 15; November, (1932).
The uses and characteristics are given for the 48 type tube, a power amplifier tetrode capable of delivering large power output at low operating voltages.

- R355.5 Ultra-short wave technique in radio communication. *Nature* (London), vol. 130, p. 856; December 3, (1932).
A note on papers given by I. E. Mouromtseff and H. V. Noble, and I. E. Mouromtseff and G. R. Kilgore at the International Congress of Electricity in Paris last July.
- R355.6 R. E. Coram. A frequency monitoring unit for broadcast stations. *Bell Laboratories Record*, vol. 11, pp. 113-116; December, (1932).
A description of the Western Electric No. 1-A frequency monitoring unit.
- R355.9 Portable unmodulated radio-frequency generator and attenuator. *Marconi Review*, No. 38, pp. 8-19; September-October, (1932).
An instrument consisting of a radio-frequency generator and a radio-frequency attenuator is described. It enables control of known radio-frequency output voltages down to a fraction of a microvolt. It provides a means of measuring the sensitivity and selectivity or band width characteristics of a receiver. Methods of using the instrument are described.
- R355.9 H. J. Scott. A precise radio-frequency generator. *Bell Laboratories Record*, vol. 11, pp. 102-108; December, (1932).
A precise radio-frequency generator is described. It consists of a piezo-electric oscillator, various subharmonic generators and an audio oscillator. Frequencies can be combined in such a way as to produce the desired radio frequencies.
- R355.9 R. A. Heising. Generating high frequencies with precision. *Bell Laboratories Record*, vol. 11, pp. 100-101; December, (1932).
The method of producing a desired frequency through adding different available frequencies by modulation is described.
- R360 P. Shallcross. How to make a general purpose test meter. *Radio-Craft*, vol. 4, pp. 406-407; January, (1933).
Description of a test meter which measures inductance, capacity and resistance. Construction details and calibration data are given.
- R360 J. A. Myers, Jr. Useful equipment for receiver tests in shop and field. *Radio Eng.*, vol. 12, pp. 10-11; December, (1932).
Description of an analyzer which will make essential direct-current tests on a radio receiving set and which measures alternating-current filament and line voltage as well.
- R361 RadioCraft's list of trade names and model numbers. *RadioCraft*, vol. 4, pp. 404-405; January, (1933).
A compilation of trade names and model numbers of radio receiving sets is given.
- R361 H. F. Anderson. Ham band receivers from BC midgets. *QST*, vol. 16, pp. 11-15; December, (1932).
Converting a broadcast receiver to an all-wave superheterodyne for continuous-wave and 'phone operation.
- R363 L. G. A. Sims. Further note upon the pentode with capacitive
×R335 coupling. *Wireless Engineer & Experimental Wireless* (London), vol. 9, pp. 673-679; December, (1932).
An analysis of the load matching conditions which apply particularly to an output stage employing a pentode is given. Values of capacity are found for three cases; namely; (1) compensation of power response curve for uniform response to lowest possible frequency; (2) over compensation of power response curve at a particular low frequency; (3) maximum possible low-frequency power—the coincidence case.
- R381 G. F. Lampkin. Beat frequency oscillator control—determining proper plate shape. *Electronics*, vol. 5, p. 369; December, (1932).
A brief treatment of the shape of condenser plates.
- R384.5 L. Rohde and H. Schwarz. Interferenzwellenmesser mit grossem Wellenbereich für das Laboratorium. (Interference wave measurer

with large wavelength range for the laboratory.) *Hochfrequenz. und Elektroakustik*, vol. 40, pp. 117-120; October, (1932).

A wave measuring apparatus for laboratory use is described which consists of a "Grob" and a fine wavemeter. The accuracy of measurement which is attained in connection with a quartz plate with a fine wavemeter amounts to 0.01 per cent. The direct wavelength range of the "Grob" wavemeter is between 6 to 3600 meters and furnishes about 0.3 watt. The method of measurement and apparatus itself are described.

- R388 W. Heimann. Über die Empfindlichkeit der Braunschen Röhre mit Gaskonzentration bei verschiedenen Frequenzen. (On the sensitiveness of the Braun tube with gas concentration at various frequencies.) *Hochfrequenz. und Elektroakustik*, vol. 40, pp. 127-128; October, (1932).

The mean sensitivity is investigated for Braun tubes with gas focusing as a function of the plate voltage and for different gases in the frequency range of 0 to 10^6 cycles.

- R388 S. Bagno and S. Egert. Modulation and distortion measurements by means of the cathode-ray oscilloscope. *Radio Eng.*, vol. 12, pp. 7-9; November, (1932).

This article describes a set of experiments which were conducted at radio transmitting station WLTH. Photographic records and other data on the use and behavior of the cathode ray tube as a means of measuring modulation are given.

- R388 R. R. Batcher. Applications of the cathode ray oscillograph. *Proc. I.R.E.*, vol. 20, pp. 1878-1891; December, (1932).

"In the application of cathode ray tubes to oscillographic measurements, certain factors affect the accuracy of the results. The most important of these items are discussed and methods outlined whereby the effects of this distortion can be minimized or compensated for. A description is included of several oscillograph tubes and associated apparatus in which simplicity of operation is a feature."

- R388
×R583 A. B. DuMont. An investigation of various electrode structures of cathode ray tubes suitable for television reception. *Proc. I.R.E.*, vol. 20, pp. 1863-1877; December, (1932).

This paper takes up various constructions of cathode ray tubes for television reception and shows the characteristic curve of each as well as the behavior of the spot under various conditions. It was found that it was possible to design a tube which would operate with a negative bias on the focusing electrode and which required only a small input signal to modulate fully the intensity of the beam. Tubes made up with dual accelerating electrodes enabled higher intensities to be obtained and also permitted a separate adjustment of the size of the spot.

R400. RADIO COMMUNICATION SYSTEMS

- R400 F. Lüschen. Modern communication systems. *Jour. I.E.E.* (London), vol. 71, pp. 776-798; November, (1932).

Principles underlying modern communication engineering are discussed. Some characteristic examples of the multiple utilization of transmission systems, such as two-band systems and simultaneous telephony and telegraphy using short waves are dealt with.

- R423.3 One more step in universal communication. *Radio Eng.*, vol. 12, p. 18; December, (1932).

Description of RCA Victor Co., Inc., small two-way radiotelephone and telegraph receiver and transmitter in one unit for emergency and mobile communications over short distances.

- R423.4 R. A. Hull. An all-purpose 56 mc station. *QST*, vol. 16, pp. 16-19; December, (1932).

Construction details of class B equipped 56-megacycles outfit.

- R430 G. H. Browning. Reducing man-made static. *Electronics*, vol. 5, pp. 366-368; December, (1932); *RadioCraft*, vol. 4, p. 412; January, (1933).

The origin and elimination of man-made static are discussed.

- R430 E. T. Glas. Interference—Notes on methods for elimination of interference caused by non-radio devices. *Wireless Engineer & Experimental Wireless* (London), vol. 9, pp. 680-684; December, (1932).
The nature and methods of eliminating man-made static are discussed.
- R440 C. B. Feldman. Transmission lines for short-wave radio systems. *Bell Laboratories Record*, vol. 11, pp. 117-122; December, (1932).
Special concentric tube transmission lines are described.

R500. APPLICATIONS OF RADIO

- R522.1 W. M. Knott. Airport radio transmitter. *Radio Eng.*, vol. 12, pp. 13-14; November, (1932).
Western Electric radio equipment which is designed for communication between airplanes and ground stations is described.
- R522.1 J. B. Bishop. A radio transmitter for the itinerant flyer. *Radio Eng.*, vol. 12, pp. 12-13; December, (1932).
Transmitting set designed by Bell Laboratories to be used in connection with the Western Electric Company's 9D radio receiving set is described.

R600. RADIO STATIONS

- R610 Acoustic features of WCAU's new studios. *Electronics*, vol. 5, pp. 358-360; December, (1932).
These features are described.
- R616 T. W. Bennington. Speech from ship to shore. *Wireless World*, vol. 31, pp. 514-516; December 9, (1932).
A general description of the ship-to-shore system of telephone communication.

R800. NONRADIO SUBJECTS

- 535.3
×R330 W. P. Koechel. Radio tubes used as photo cells. *Electronics*, vol. 5, pp. 372-373; December, (1932).
This article describes methods whereby ordinary receiving tubes can be used as photoelectric cells. Vacuum tubes are light sensitive if the grids are floating and the cathode and anode voltages properly adjusted. Data are given on the sensitivity and current that may be obtained from such light sensitive units.
- 535.38 W. R. King. Photoelectric relays. *Radio Eng.*, vol. 12, pp. 10-12; November, (1932).
Equipment is described for usual types of applications. Alternating- and direct-current supply circuits.
- 537.7 C. F. J. Morgan. The resonance method of wave form analysis. *Jour. I.E.E.* (London), vol. 71, pp. 819-829; November, (1932).
The principles of the resonance method of wave form analysis are briefly described. A short account of the methods of analysis is included. A practical analyzer and results obtained with it are described. An extensive bibliography is given.
- 621.385.97 V. V. Gunsolly. Turntable design and operation. *Radio Eng.*, vol. 12, pp. 17-20; November, (1932).
An extensive study is made of phonograph type turntables.



CONTRIBUTORS TO THIS ISSUE

Brainerd, John Grist: Born 1904. Police reporter, staff of metropolitan newspaper, 1923-1925. Instructor, Moore School of Electrical Engineering, University of Pennsylvania, 1925 to date. Nonmember, Institute of Radio Engineers.

Coram, R. E.: Born May 21, 1889, at Lowell, Mass. Attended Massachusetts Institute of Technology, 1908-1910. New England Telephone and Telegraph Company, 1912-1919; engineering department, Western Electric Company, 1919-1925; radio development department, Bell Telephone Laboratories, Inc., 1925 to date. Nonmember, Institute of Radio Engineers.

Eckersley, P. P.: Born January 6, 1892, at La Puebla, Mexico. Educated at Bedales School and Manchester University. Apprenticed, Mather and Platt and Lancashire Dynamo and Motor Company. Royal Flying Corps, 1915; officer in charge of wireless training, Shouthern Brigade, 1916; brigade wireless officer, France; wireless experimental section, aircraft department, Marconi Company, 1919; head of experimental design department, 1921; chief engineer, British Broadcasting Corporation, 1923; His Master's Voice Gramophone and Marconi Company, 1929-1930; High-Frequency Engineering Company, Ltd., 1930-1931; visited Australia to advise Amalgamated Wireless Company on Australian broadcasting, 1932. Member, Institution of Electrical Engineers. Fellow, Institute of Radio Engineers, 1925.

Hikosaburo, Ataka: Born August 6, 1904, at Kanazawa, Japan. Graduated, electrical engineering department, Tokyo Imperial University, 1927. Instructor in electrical engineering, Meidi College of Technology, 1927 to date. Nonmember, Institute of Radio Engineers.

Kishpaugh, A. W.: Born November 5, 1891, at Newberry, Michigan. Received E. E. degree, University of North Dakota, 1912. General Electric Company, 1912-1914; Utah Power and Light Company, 1914-1916; engineering department, Western Electric Company, 1916-1925; radio development department, Bell Telephone Laboratories, Inc., 1925 to date. Associate member, Institute of Radio Engineers, 1920; Member, 1930.

Lee, Reuben: Born November 8, 1902, at Shirland, Derbyshire, England. Received B.S. degree in electrical engineering, West Virginia University, 1924. Westinghouse Electric and Manufacturing Company, 1924 to date. Student course, 1924; control engineering department, 1925-1928; radio engineering department, 1928 to date. Member, Tau Beta Pi. Associate member, Institute of Radio Engineers, 1932.

Namba, Shogo: Born July 14, 1904, at Kyoto, Japan. Studied electrical engineering, Kyoto Imperial University. Research engineer, radio section, Electrotechnical Laboratory, Ministry of Communications, 1927 to date. Engaged in wave propagation research, 1929 to date. Associate member, Institute of Radio Engineers, 1929.

Roder, Hans: Born September 27, 1899, at Mengersreuth, Bavaria, Germany. Institute of Technology, Munich, 1919-1923; received M.S. degree in electrical engineering, 1923. Development and research of transmitting apparatus, Telefunken Gesellschaft für drahtlose Telegraphie, 1923-1929; radio engineering department, General Electric Company, 1930 to date. Member, Institute of Radio Engineers, 1929.

Sohon, Harry: Born 1904 at New York City. Received E.E. degree in 1926; M.E.E. in 1930, and Ph.D. in 1932, Cornell University, Ithaca, N.Y. General Electric Company, September, 1926 to September, 1928; McMullen Research Scholar, Cornell University, September, 1928 to June, 1930; graduate student and instructor in electrical engineering, September, 1930, to June, 1931; McMullen Research Scholar and instructor in electrical engineering, September, 1931 to date. Member, Eta Kappa Nu, Phi Kappa Phi. Associate member, A.I.E.E. Associate member, Institute of Radio Engineers, 1928.

Tanimura, Isao: Born April 18, 1900, at Gohdo Town, Gifu Prefecture, Japan. Graduated, electrical department, Hiroshima Higher Technical School, 1924. Entered radio section, Electrotechnical Laboratory, Ministry of Communications, Japan, 1924; engaged in radio research, 1924 to date. Associate member, Institute of Radio Engineers, 1930.

Yokoyama, Eitaro: Born July 21, 1883, at Tukai City, Japan. Graduated, Engineering College, Tokyo Imperial University, 1908. Engaged in radio researches at the Electrotechnical Laboratory, Ministry of Communications, Japan. One of the inventors of the T. Y. K. oscillation gaps for radiotelephony. Chief of Radio Section, Laboratory, 1920. Member, Institute of Radio Engineers, 1917.



DEPENDABLE CONDENSERS

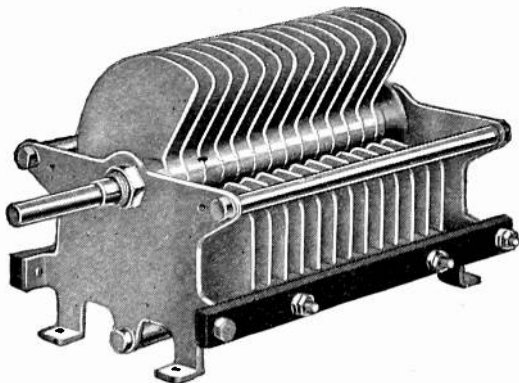

The CARDWELL line of condensers includes transmitting condensers for high, medium and low power, fixed oil dielectric condensers for induction furnaces and receiving condensers in infinite variety. The CARDWELL Midway Featherweight (all aluminum, none over 7 ounces in weight) for transmitting, receiving and neutralizing, is unequalled for aircraft and portable equipment.

CARDWELL made-to-order apparatus is well known for its excellence. We solicit your proposals. Our estimate on your requirements puts you under no obligations to us.

CARDWELL CONDENSERS and MANUFACTURING SERVICE

The Allen D. Cardwell Mfg. Corp'n

93 Prospect Street, Brooklyn, N.Y.

"THE STANDARD OF COMPARISON"

When writing to advertisers mention of the PROCEEDINGS will be mutually helpful.

SPECIAL ITEMS FOR RADIO MANUFACTURERS

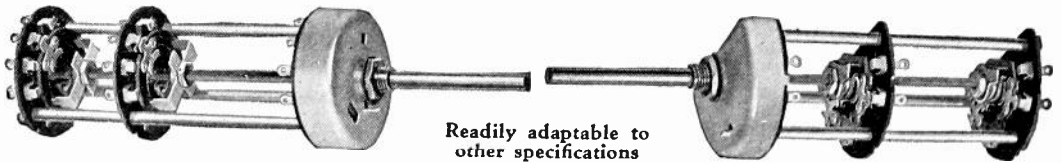

No. 7280A
3 gang, 4 positions
single circuit

Readily adaptable to
other specifications

No. 7260A
3 gang, 2 positions
2 circuits

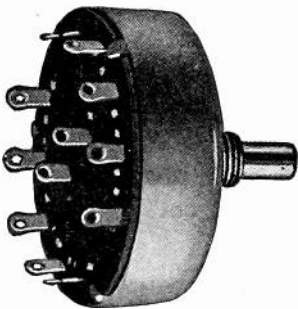

No. 7150A
5 positions, 2 circuits

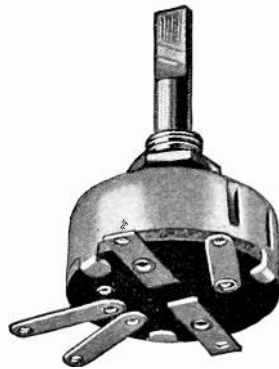

No. 7120A
Combined Acoustic and muting
switch 2 or 3 positions

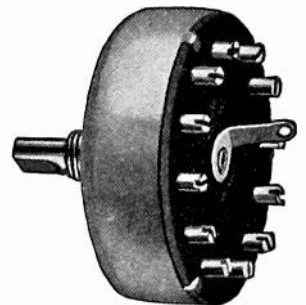

No. 7220A
12 positions, single circuit



Terminal Strip
5 Lugs No. 6880A, 4 lugs No. 6990A



Terminal Strip
4 Clips, No. 6830A

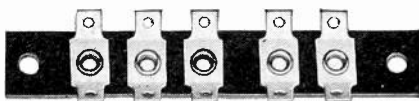

Terminal Strip
5 Lugs, No. 6950A

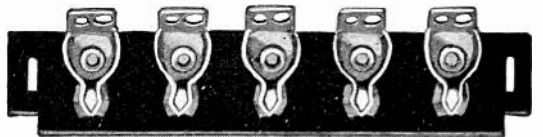

Terminal Strip
5 Clips, No. A6310AA, 4 Clips No. A6320AA

SORENG - MANEGOLD CO.

1901-9 Clybourn Avenue, CHICAGO, ILL.

1646 W. Adams St.
Los Angeles, Cal.

701 Stephenson Bldg.
Detroit, Mich.

245-5th Ave.
New York City

When writing to advertisers mention of the PROCEEDINGS will be mutually helpful.

Miracle Worker, AGE 8



His little hands hold the instrument tightly; his small, confident voice speaks eagerly into the mouthpiece. And as simply as that, he talks to his friend who lives around the corner, or to his Granny in a distant city . . . achievements which, not so many years ago, would have seemed miraculous.

These miracles he takes as a matter of course, in the stride of his carefree days. You yourself probably accept the telephone just as casually. Seldom do you realize what extraordinary powers it gives you.

You use it daily for a dozen different purposes. For friendly chats. For business calls. To save steps,

time and trouble. To be many places, do many things, visit many people, without so much as moving from the living room of your home or the desk in your office.

At this very moment, somewhere, your voice would be the most welcome music in the world. Some one would find happiness in knowing where you are and how you are. Some one would say gratefully, sincerely—"I was wishing you'd call."

Your telephone is the modern miracle which permits you to range where you will—talk with whom you will. It is yours to use at any hour of the day or night.

AMERICAN TELEPHONE AND TELEGRAPH COMPANY



When writing to advertisers mention of the PROCEEDINGS will be mutually helpful.

Piezo Electric Crystals

"Superior by Comparison"

Since 1925



COMMERCIAL and BROADCAST STATIONS

We are at your service to supply you with HIGH GRADE CRYSTALS for POWER USE, said crystals ground to an ACCURACY of BETTER than .03% fully mounted in our Standard Holder. TWO DAY DELIVERIES. Prices as follows:

Frequency Range

100 to 1500 Kilo-cycles	\$40.00
1501 to 3000 Kilo-cycles	45.00
3001 to 4000 Kilo-cycles	50.00
4001 to 6000 Kilo-cycles	60.00

Special Prices Quoted for Quantities of ten (10) or More Crystals

Amateur Band Crystals

Prices for grinding crystals in the Amateur Bands below are for a crystal ground to within 10 Kilo-cycles of your specified frequency unmounted. Mounted in our Standard Holder \$5.00 additional. Frequency calibration of the crystals are BETTER than .1%. Immediate delivery.

1715 to 2000 Kilo-cycles. .	\$12.00 each. <i>Two for \$20.00</i>
3500 to 4000 Kilo-cycles. .	\$15.00 each. <i>Two for \$25.00</i>

LOW FREQUENCY CRYSTALS

Low frequency crystals available to as low as 13,000 CYCLES. Prices upon receipt of specifications.

SCIENTIFIC RADIO SERVICE

"The Crystal specialists"

124 Jackson Avenue, University Park
HYATTSVILLE, MARYLAND

When writing to advertisers mention of the PROCEEDINGS will be mutually helpful.

The Institute of Radio Engineers

Incorporated

33 West 39th Street, New York, N. Y.

APPLICATION FOR ASSOCIATE MEMBERSHIP

(Application forms for other grades of membership are obtainable from the Institute)

To the Board of Direction

Gentlemen:

I hereby make application for Associate membership in the Institute of Radio Engineers on the basis of my training and professional experience given herewith, and refer to the members named below who are personally familiar with my work.

I certify that the statements made in the record of my training and professional experience are correct, and agree if elected, that I will be governed by the constitution of the Institute as long as I continue a member. Furthermore I agree to promote the objects of the Institute so far as shall be in my power, and if my membership shall be discontinued will return my membership badge.

.....
(Sign with pen)

.....
(Address for mail)

.....
(Date)

.....
(City and State)

References:

(Signature of references not required here)

Mr. Mr.

Address Address

City and State City and State

Mr.

Address

City and State

The following extracts from the Constitution govern applications for admission to the Institute in the Associate grade:

ARTICLE II—MEMBERSHIP

Sec. 1: The membership of the Institute shall consist of: * * * (c) Associates, who shall be entitled to all the rights and privileges of the Institute except the right to hold any elective office specified in Article V. * * *

Sec. 4: An Associate shall be not less than twenty-one years of age and shall be a person who is interested in and connected with the study or application of radio science or the radio arts.

ARTICLE III—ADMISSION AND EXPULSIONS

Sec. 2: * * * Applicants shall give references to members of the Institute as follows: * * * for the grade of Associate, to three Fellows, Members, or Associates; * * * Each application for admission * * * shall embody a full record of the general technical education of the applicant and of his professional career.

ENTRANCE FEE SHOULD ACCOMPANY APPLICATION

**Revolutionary developments in the design—
construction—and performance—of the**

ACRACON*
ELECTROLYTIC CONDENSER

*will be announced in
this magazine next month*

●
*Watch for our
advertisement*
●

**Patents Pending on all Acracon Features*

Condenser Corporation of America
259 Cornelison Ave., Jersey City, N.J.

Factory Representatives In:

Chicago Cincinnati St. Louis San Francisco Los Angeles Toronto

And Other Principal Cities

When writing to advertisers mention of the PROCEEDINGS will be mutually helpful.

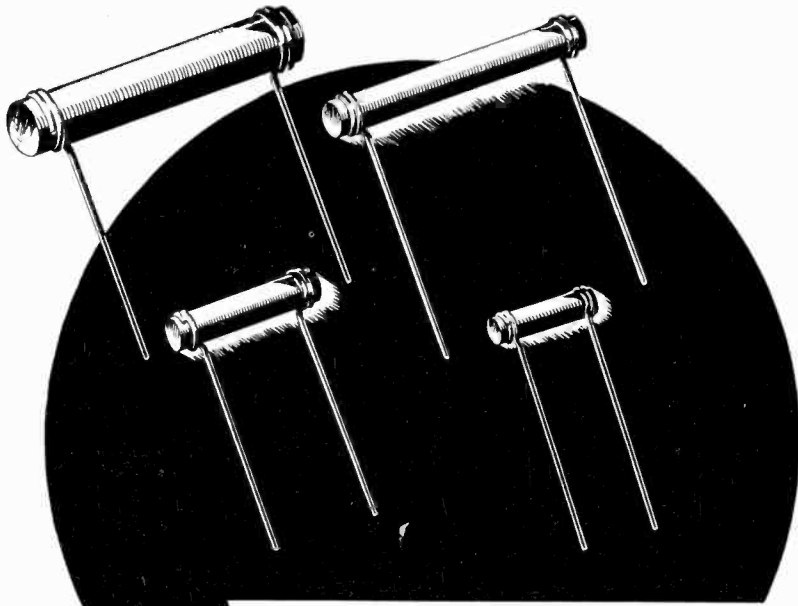

The change of resistance with voltage is very small in ERIE RESISTORS. In the majority of cases it is less than 2%. This means that regardless of what voltage the resistors are used at, the resistance value is constant.

ERIE RESISTORS are conservatively rated. 2,000 hours or more at loads 50% over the continuous rating have shown no failures, in repeated tests.

When you specify ERIE RESISTORS you are getting the very best moulded type resistor of fixed resistance value that the market affords.

Charts showing the small voltage effect and conservative rating of ERIE RESISTORS give the complete story and show the appreciable savings which set manufacturers may make by using them.

We will gladly send you our book of data sheets showing these and other charts which fully explain the technical data on Erie Resistor Corporation High Resistance Products.

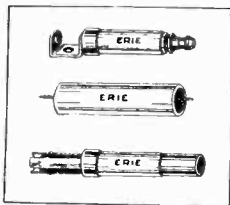

Erie Suppressor Resistors

are made in plug, screw and distributor types. They will not change more than 10% in resistance value in 50,000 miles use provided one suppressor resistor is used in each high tension lead.

Samples and additional information gladly given on request.

ERIE RESISTORS



ERIE RESISTOR CORPORATION, ERIE, PA.
Factories in Erie, Pa., Toronto Can., and London, Eng.

When writing to advertisers mention of the PROCEEDINGS will be mutually helpful.

PROFESSIONAL ENGINEERING DIRECTORY

For Consultants in Radio and Allied Engineering Fields

FOR ADVANCED TRAINING

in:

Practical Radio Engineering
Practical Television Engineering

write to

CAPITOL RADIO ENGI- NEERING INSTITUTE

Riggs Bank Bldg.
Washington, D.C.

Cathode Ray Tubes and Associated Equipment For All Purposes

Write for Complete
Technical Data

ALLEN B. DUMONT
LABORATORIES
UPPER MONTCLAIR, N.J.

FOR MANY YEARS

the Professional Engineering Directory has helped consulting engineers, designers, and laboratory men make the right contacts in the radio industry. Perhaps we can help you with your problems too. For further information write to

Advertising Department
INSTITUTE OF RADIO
ENGINEERS
33 West 39th St.
NEW YORK CITY, N.Y.

LITTLEFUSE LABORATORIES

Specialists in

Delicate Equipment Protection

INSTRUMENTS and METERS
RADIO RECEIVERS
RADIO AMPLIFIERS
RADIO TRANSMITTERS

1764 Wilson Ave., Chicago, Ill.

For the Engineering Consultant

who can handle a little extra business this year

For the Designer

who can manage some additional work

we suggest the Professional Engineering Directory of the I.R.E. PROCEEDINGS. Manufacturers who need services such as yours and organizations with special problems come to our Professional Engineering Directory for information. Your name and special services announced here will put you in line for their business. For further information and special rates for I.R.E. members write to the Institute of Radio Engineers.

When writing to advertisers mention of the PROCEEDINGS will be mutually helpful.

EMPLOYMENT PAGE

Advertisements on this page are available to members of the Institute of Radio Engineers and to manufacturing concerns who wish to secure trained men for positions. All material for publication on this page is subject to editing from the Institute office and must be sent in by the 15th of the month previous to the month of publication. (January 15th for February PROCEEDINGS IRE, etc.) Employment blanks and rates will be supplied by the Institute office. Address requests for such forms to the Institute of Radio Engineers, 33 West 39th Street, New York City, N.Y.

MANUFACTURERS and others seeking radio engineers are invited to address replies to these advertisements at the Box Number indicated, care the Institute of Radio Engineers. All replies will be forwarded direct to the advertiser.

COMMUNICATION ENGINEER with two years experience on military telephone and telegraph engineering problems. Six years with a large manufacturer on development of testing equipment for radio, telephone and sound picture apparatus. One year as consultant and designer of radio equipment. Desires placement in communication group, preferring field work or development of testing equipment. Age 32. Single. Will travel. Box 136.

GRADUATE of Capitol Radio Engineering Institute. Has had two years experience as chief operator on shipboard, nine months assistant to chief engineer on airport construction and operation. Four and one half years in tropical radio stations as plant engineer and manager handling traffic, technical and line work, and administrative problems. Desires radio engineering work in design, construction or maintenance. Laboratory work is preferred. Age 25. Married. Will travel. Box 138.

GRADUATE of University of Pennsylvania with B.S. and M.S. in electrical engineering. Has had three years experience with large manufacturer on design and development of modern broadcast receivers for both American and European short and long wave use. Desires employment in radio or associated fields including teaching in college or other schools. Age 25. Single. Will travel. Box 139.

When writing to advertisers mention of the PROCEEDINGS will be mutually helpful.

CHANGE IN MAILING ADDRESS OR BUSINESS TITLE

Members of the Institute are asked to use this form for notifying the Institute office of a change in their mailing address or the listing of their company affiliation or title in the Year Book.

The Secretary,
THE INSTITUTE OF RADIO ENGINEERS,
33 West 39th Street,
New York, N.Y.

Dear Sir:

Effective please note change in my address
(date)
for mail as follows:

FROM

.....
(Name)

.....
(Street Address)

.....
(City and State)

TO NEW ADDRESS

.....
(Street Address)

.....
(City and State)

Please note following change in my Year Book listing.

.....
(Title)

.....
(Company Name)

.....
(Company Address)

When writing to advertisers mention of the PROCEEDINGS will be mutually helpful.

Alphabetical Index to Advertisements

A

American Tel. & Tel. Co..... IX

C

Cardwell, Allen D., Mfg. Corp..... VII

Central Radio Laboratories..... XIX

Condenser Corp. of America..... XIII

Cornell Electric Mfg. Co..... XX

E

Eric Resistor Corp..... XIV

G

General Radio Co..... Outside Back Cover

I

I.R.E..... XI, XII, XVI, XVII, Inside Back Cover

P

Professional Eng. Directory..... XV

S

Scientific Radio Service..... X

Soreng-Manegold Co..... VIII

When writing to advertisers mention of the PROCEEDINGS will be mutually helpful.

don't PAY THE PENALTY OF A FEW PENNIES SAVED

Centralab Fixed Resistors cannot be built down to a price. The heritage of years of perfection cannot be sacrificed on the altar of "cheap," of "bargain" and of "just as good." And yet . . . in spite of their very obvious superiority they cost so little more that it is indeed poor economy not to specify CENTRALAB Fixed resistors on any radio that requires your unqualified approval and recommendation.

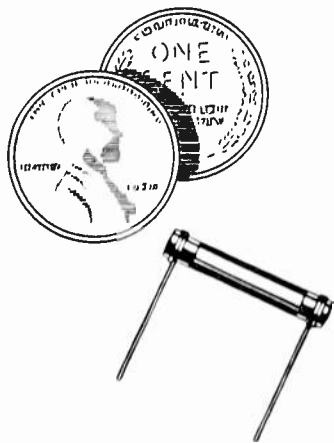

CENTRAL RADIO LABORATORIES
MILWAUKEE

Centralab

Resistors

When writing to advertisers mention of the Proceedings will be mutually helpful.

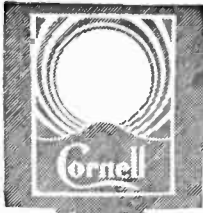

Cornell

TRADE MARK REG.

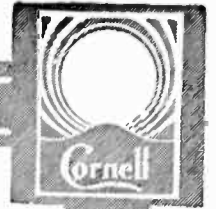

SINGLE AND DUAL SECTION ELECTROLYTICS

All Cornell Dry Electrolytic condensers both of the metal can and cardboard box type are made in strict accordance with the latest developments in the electrolytic condenser art. Every process is thoroughly checked and proved satisfactory by exacting laboratory work and life tests before being released for production uses.

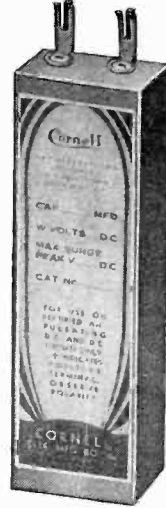

Every chemical and product that enters into a Cornell Dry Electrolytic condenser is tested and analyzed before use to prevent any possibility of variation from the strict standards that have been established. Cornell Dry Electrolytic units are all individually aged and tested. Extremely low power factor, low leakage and excellent shelf and active life are standard characteristics of these units.

WRITE FOR NEW CORNELL CATALOG

Our new catalog is just off the press. It illustrates and describes the complete Cornell line of Cub Condensers, Electrolytic Condensers, Paper Dielectric Capacitors for radio, television and ignition, and Resistors for radio and television.

CORNELL ELECTRIC MFG. CO., Inc.

Manufacturers of
CORNELL "CUB" CONDENSERS
Filter and By-Pass Condensers, Interference Filters and
All Types of Paper Dielectric Capacitors and Resistors

LONG ISLAND CITY, NEW YORK

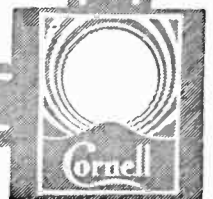
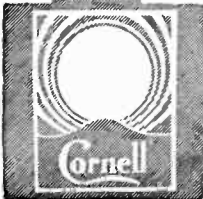

When writing to advertisers mention of the PROCEEDINGS will be mutually helpful.

Insure Yourself Against Disappointment . . . NOW!

Every day requests come into the Institute office for back issues of the PROCEEDINGS. We always fill these orders if we have copies of the issues desired—but frequently we do not have the particular copy wanted.

Then someone is disappointed—someone's bookshelf is incomplete and there are general growls and grumbles.

So why not insure yourself against any loss of your present or future copies of the PROCEEDINGS by keeping all of these copies in a

PROCEEDINGS BINDER



Binder of handsome Spanish Grain Fabrikoid in blue and gold. Can be used as temporary transfer binder or as a permanent cover. Wire fasteners hold each copy in place and permit removal of any issue from binder in a few seconds. All issues lie flat when binder is opened.

BINDER (holds complete 1931 or 1932 copies) \$1.75

(Name stamped on volume for \$.50 additional)

Send orders for binders, accompanied by remittance, to

INSTITUTE OF RADIO ENGINEERS

33 West 39th Street

New York City, New York



The TYPE 602 Decade-Resistance Boxes include a complete line of two-, three-, and four-dial standards of resistance suitable for use at audio and radio frequencies. Nine types are available whose resistance at maximum setting ranges from 11 ohms to 111,110 ohms.

Type 602-J
Decade-Resistance Box
0-11,100 ohms
\$50.00



Type 510
Decade-Resistance Unit
\$8.50—\$16.00

They are made up of combinations of the TYPE 510 Decade-Resistance Units. The most effective methods of winding non-inductive resistances are used in order that the error at radio frequencies be small. Each TYPE 510 Decade Resistance Unit is provided with an aluminum shield.

Insist on correct technical information. Catalog G discusses these resistance standards in detail.

GENERAL RADIO COMPANY
CAMBRIDGE MASSACHUSETTS