

VOLUME 19

DECEMBER, 1934

NUMBER 12

Walter J. Malone
W. J. Malone

PROCEEDINGS

of

The Institute of Radio
Engineers



Form for Change of Mailing Address or Business Title on Page XLIII

Institute of Radio Engineers

Forthcoming Meetings

CINCINNATI SECTION

December 15, 1931

NEW YORK MEETINGS

December 2, 1931

January 6, 1932

WASHINGTON SECTION

December 10, 1931

PROCEEDINGS OF

The Institute of Radio Engineers

Volume 19

December, 1931

Number 12

Board of Editors

ALFRED N. GOLDSMITH, *Chairman*

| | |
|-------------------|------------------|
| STUART BALLANTINE | G. W. PICKARD |
| RALPH BATCHER | L. E. WHITTEMORE |
| W. WILSON | |

CONTENTS

PART I

| | |
|---|------|
| Frontispiece, Harry Houck, Manager, 1931..... | 2048 |
| Institute News and Radio Notes..... | 2049 |
| November Meeting of the Board of Direction..... | 2049 |
| Radio Signal Transmissions of Standard Frequency..... | 2049 |
| Committee Work..... | 2051 |
| Institute Meetings..... | 2052 |
| Faraday Centenary Celebrations..... | 2056 |
| Personal Mention..... | 2057 |

PART II

Technical Papers

| | | |
|---|-----------------|------|
| Constant Frequency Oscillators..... | F. B. LLEWELLYN | 2063 |
| A Recent Development in Vacuum Tube Oscillator Circuits... J. B. DOW | | 2095 |
| A New Treatment of Electron Tube Oscillators with Feed-Back Coupling C. K. JEN | | 2109 |
| Amplitude, Phase, and Frequency Modulation..... HANS RÖDER | | 2145 |
| Application of Printing Telegraph to Long-Wave Radio Circuits..... AUSTIN BAILEY AND T. A. MCCANN | | 2177 |
| On Asymmetric Telegraphic Spectra..... C. R. BURCH | | 2191 |
| Second Meeting of the International Technical Consulting Committee on Radio Communication, Copenhagen, 1931..... | | 2219 |
| Book Review: "High Frequency Alternating Currents," by Knox McIl- wain and J. G. Brainerd..... S. S. KIRBY | | 2250 |
| Booklets, Catalogs, and Pamphlets Received..... | | 2251 |
| Radio Abstracts and References..... | | 2252 |
| Contributors to this Issue..... | | 2258 |

Copyright, 1931, by the Institute of Radio Engineers

The Institute of Radio Engineers

GENERAL INFORMATION

The PROCEEDINGS of the Institute is published monthly and contains papers and discussions thereon submitted for publication or for presentation before meetings of the Institute or its Sections. Payment of the annual dues by a member entitles him to one copy of each number of the PROCEEDINGS issued during the period of his membership.

Subscription rates to the PROCEEDINGS for the current year are received from nonmembers at the rate of \$1.00 per copy or \$10.00 per year. To foreign countries the rates are \$1.10 per copy or \$11.00 per year.

Back issues are available in unbound form for the years 1918, 1920, 1921, 1922, 1923, and 1926 at \$9.00 per volume (six issues) or \$1.50 per single issue. For the years 1913, 1914, 1915, 1916, 1917, 1919, 1923, 1924, and 1925 miscellaneous copies (incomplete unbound volumes) can be purchased for \$1.50 each; for 1927, 1928, and 1929 at \$1.00 each. The Secretary of the Institute should be addressed for a list of these.

Discount of twenty-five per cent is allowed on all unbound volumes or copies to members of the Institute, libraries, booksellers, and subscription agencies.

Bound volumes are available as follows: for the years 1922 and 1926 to members of the Institute, libraries, booksellers, and subscription agencies at \$8.75 per volume in blue buckram binding and \$10.25 in morocco leather binding; to all others the prices are \$11.00 and \$12.50 respectively. For the year 1929 the bound volumes prices are: to members of the Institute, libraries, booksellers, and subscription agencies, \$9.50 in blue buckram binding; to all others, \$12.00. Foreign postage on all bound volumes is one dollar, and on single copies is ten cents.

The 1931 YEAR BOOK, containing general information, the Constitution and By-Laws, Standards Report, Index to past issues of the PROCEEDINGS, Catalog of Membership, etc., is available to members at \$1.00; to nonmembers, \$1.50.

Contributors to the PROCEEDINGS are referred to the following page for suggestions as to approved methods of preparing manuscripts for publication in the PROCEEDINGS.

Advertising rates for the PROCEEDINGS will be supplied by the Institute's Advertising Department, Room 802, 33 West 39th Street, New York, N.Y.

Changes of address to affect a particular issue must be received at the Institute office not later than the 15th of the month preceding date of issue. That is, a change in mailing address to be effective with the October issue of the PROCEEDINGS must be received by not later than September 15th. Members of the Institute are requested to advise the Secretary of any change in their business connection or title irrespective of change in their mailing address, for the purpose of keeping the Year Book membership catalog up to date.

The right to reprint portions or abstracts of the papers, discussions, or editorial notes in the PROCEEDINGS is granted on the express condition that specific reference shall be made to the source of such material. Diagrams and photographs published in the PROCEEDINGS may not be reproduced without making special arrangements with the Institute through the Secretary.

It is understood that the statements and opinions given in the PROCEEDINGS are views of the individual members to whom they are credited, and are not binding on the membership of the Institute as a whole.

All correspondence should be addressed to the Institute of Radio Engineers, 33 West 39th Street, New York, N.Y., U.S.A.

Entered as second class matter at the Post Office at Menasha, Wisconsin.

Acceptance for mailing at special rate of postage provided for in the Act of February 28, 1925, embodied in paragraph 4, Section 412, P. L. and R. Authorized October 26, 1927.

Published monthly by

THE INSTITUTE OF RADIO ENGINEERS, INC.

Publication office, 450-454 Ahnaip Street, Menasha, Wis.

BUSINESS, EDITORIAL, AND ADVERTISING OFFICES,

Harold P. Westman, *Secretary*

33 West 39th St., New York, N.Y.

SUGGESTIONS FOR CONTRIBUTORS TO THE "PROCEEDINGS"

Preparation of Paper

Form—Manuscripts may be submitted by member and nonmember contributors from any country. To be acceptable for publication, manuscripts should be in English, in final form for publication, and accompanied by a summary of from 100 to 300 words. Papers should be typed double space with consecutive numbering of pages. Footnote references should be consecutively numbered and should appear at the foot of their respective pages. Each reference should contain author's name, title of article, name of journal, volume, page, month, and year. Generally, the sequence of presentation should be as follows: statement of problem; review of the subject in which the scope, object, and conclusions of previous investigations in the same field are covered; main body describing the apparatus, experiments, theoretical work, and results used in reaching the conclusions and their relation to present theory and practice; bibliography. The above pertains to the usual type of paper. To whatever type a contribution may belong, a close conformity to the spirit of these suggestions is recommended.

Illustrations—Use only jet black ink on white paper or tracing cloth. Cross-section paper used for graphs should not have more than four lines per inch. If finer ruled paper is used, the major division lines should be drawn in with black ink, omitting the finer divisions. In the latter case, only blue-lined paper can be accepted. Photographs must be very distinct, and must be printed on glossy white paper. Blueprinted illustrations of any kind cannot be used. All lettering should be $3/16$ in. high for an 8 x 10 in. figure. Legends for figures should be tabulated on a separate sheet, not lettered on the illustrations.

Mathematics—Fractions should be indicated by a slanting line. Use standard symbols. Decimals not preceded by whole numbers should be preceded by zero, as 0.016. Equations may be written in ink with subscript numbers, radicals, etc., in the desired proportion.

Abbreviations—Write a.c. and d.c. (a.c. and d.c. as adjectives), kc, μf , $\mu\mu f$, e m f., m h, μh henries, abscissas, antennas. Refer to figures as Fig. 1, Figs. 3 and 4, and to equations as (5). Number equations on the right in parentheses.

Summary—The summary should contain a statement of major conclusions reached, since summaries in many cases constitute the only source of information used in compiling scientific reference indexes. Abstracts printed in other journals, especially foreign, in most cases consist of summaries from published papers. The summary should explain as adequately as possible the major conclusions to a nonspecialist in the subject. The summary should contain from 100 to 300 words, depending on the length of the paper.

Publication of Paper

Disposition—All manuscripts should be addressed to the Institute of Radio Engineers, 33 West 39th Street, New York City. They will be examined by the Committee on Papers and by the Editor. Authors are advised as promptly as possible of the action taken, usually within one month.

Proofs—Galley proof is sent to the author. Only necessary corrections in typography should be made. *No new material is to be added.* Corrected proofs should be returned *promptly* to the Institute of Radio Engineers, 33 West 39th Street, New York City.

Reprints—With the galley proof a reprint order form is sent to the author. Orders for reprints must be forwarded promptly as type is not held after publication.

INSTITUTE SECTIONS

| <i>Chairmen</i> | <i>Secretaries</i> |
|--------------------|--|
| | ATLANTA |
| H. F. Dobbs | Philip C. Bangs, 23 Kensington Rd., Avondale Estates, Ga. |
| | BOSTON |
| George W. Pierce | Melville Eastham, 30 State St., Cambridge, Mass. |
| | BUFFALO-NIAGARA |
| Stanley W. Brown | E. C. Waud, 235 Huntington Ave., Buffalo, N. Y. |
| | CHICAGO |
| Byron B. Minnium | J. Barton Hoag, Ryerson Laboratory, University of Chicago, Chicago, Ill. |
| | CINCINNATI |
| D. D. Israel | H. G. Boyle, Crosley Radio Corp., Cincinnati, Ohio. |
| | CLEVELAND |
| G. B. Hammon | P. A. Marsal, National Carbon Co., Inc., P.O. Box No. 400, Cleveland, Ohio. |
| | CONNECTICUT VALLEY |
| R. S. Kruse | George Grammer, 334 South Quaker Lane, West Hartford, Conn. |
| | DETROIT |
| Lewis N. Holland | Samuel Firestone, Room 615, 2000 Second Ave., Detroit, Mich. |
| | LOS ANGELES |
| T. E. Nikirk | L. Elden Smith, 345 N. Painter Ave., Whittier, Calif. |
| | NEW ORLEANS |
| Pendleton E. Lehde | Anton A. Schiele, 1812 Masonic Temple, New Orleans, La. |
| | PHILADELPHIA |
| G. W. Carpenter | G. C. Blackwood, 243 E. Upsal St., Mt. Airy, Philadelphia, Pa. |
| | PITTSBURGH |
| J. G. Allen | J. G. McKinley, West Penn Electric Co., 14 Wood St., Pittsburgh, Pa. |
| | ROCHESTER |
| H. A. Brown | M. A. Wood, 175 Winbourne Ave., Rochester, N. Y. |
| | SAN FRANCISCO |
| Ralph M. Heintz | Frederick E. Terman, Stanford University, Calif. |
| | SEATTLE |
| Abner R. Willson | L. C. Austin, 540 N. 82nd St., Seattle, Wash. |
| | TORONTO |
| F. K. Dalton | W. F. Choat, 355 King, St., W., Toronto, Ont., Canada. |
| | WASHINGTON |
| L. P. Wheeler | Herbert G. Dorsey, U. S. Coast and Geodetic Survey, Washington, D. C. |

GEOGRAPHICAL LOCATION OF MEMBERS ELECTED NOVEMBER 4, 1931

Transferred to the Member grade

| | | |
|---------------|--|------------------|
| Massachusetts | Cambridge, Mass. Inst. of Tech. | Kear, F. G., Jr. |
| New York | Bayside, Hazeltine Service Corp., 209-71 26th Ave. | Case, N. P. |
| Pennsylvania | Avalon, 123 Harrison Ave. | Allen, J. G. |
| | Upper Darby, 255 Lamport Rd. | Frazier, H. S. |
| Canada | Toronto 2, Ont., Erie Resistor of Canada, Ltd., 47-49 Bathurst St. | Weese, R. |
| England | Manchester, College of Technology, Sackville St. | Jackson, W. |

Elected to the Member grade

| | | |
|----------------|--|------------------|
| Indiana | Fort Wayne, c/o Steinite Radio Co. | Victoreen, C. J. |
| New York | New York City, 195 Broadway | Gannett, D. K. |
| | New York City, Tropical Radio Telegraph Co., Pier 9, North River | Simon, W. C. |
| | Schenectady, 121 Woodland Ave. | Marvin, H. B. |
| Czechoslovakia | Prague, 5 Husova | Siegel, E. |
| Siam | Bangkok, General Post Office | Aram, Phra |

Elected to the Associate grade

| | | |
|---------------|--|---------------------|
| Alabama | Anniston, c/o The Radio Service Shop, Box No. 449 | Gray, J. M. |
| California | Berkeley, 2601 Durant Ave. | Hoag, L. J. |
| | Long Beach, 6132 California Ave. | Larsen, D. A. |
| | Los Angeles, 1225 W. 39th Pl. | Cutler, K. W. |
| | Los Angeles, 6565 Santa Monica Blvd. | Hooker, D. E. |
| | San Francisco, c/o KIFRC, 1000 Van Ness Ave. | Bensberg, C. B. |
| | San Francisco, 1466 40th Ave. | Cormack, A. N. |
| Colorado | Denver, 3922 W. 32nd Ave. | Needs, W. C. |
| Florida | Miami, 15 N. W. 12th Ave. | Gilbert, J. C. |
| Illinois | Chicago, 816 N. Kedzie Ave. | Bradshaw, E. |
| | Chicago, 2711 N. Sayre Ave. | Holm, E. A. |
| | Chicago, 449 N. Ridgeway Ave. | Mack, G. |
| | Chicago, 5424 W. 64th St. | Scheer, G. H., Jr. |
| Indiana | Evansville, 1735 S. Garvin St. | Travis, F. E. |
| | Fort Wayne, 1114 Crescent Ave. | Fischer, F. W. |
| | Fort Wayne, 1930 Oakland St. | Wise, C. E. |
| | Parker | Clark, L. B. |
| Massachusetts | Malden, 1257 Salem St. | Bacon, D. H. |
| | Weston, Old Road | Bent, A. E. |
| Michigan | Bessemer, Box No. 802 | Faehl, W. B. |
| Missouri | Clinton, 306 S. Main St. | Mitchem, F. M. |
| | Richmond, 321 S. Shaw St. | Basham, R. |
| | St. Louis, 1509 Hickory St. | Varney, H. |
| New Jersey | Ashland | Hamilton, E. T. |
| | Belleville, 199 Adelaide St. | Katzen, M. |
| | Bloomfield, 46 Heinrich's Pl. | Cox, A. |
| | Camden, 204 Evergreen Ave., Woodlynne | Gerber, P. |
| | East Orange, 44 Sunnyside Terrace | Laube, H. W. |
| | Newark, 61 Sunset Ave. | Rotolo, N. V. |
| | Waldwick, Box No. 436 | Chipp, R. W. |
| | West Orange, 24 Overlook Ave. | O'Neill, R. A., Jr. |
| New York | Brooklyn, P. O. Box No. 174, Times Plaza Station | Blanc, V. |
| | Brooklyn, 462 E. 28th St. | Christman, C. |
| | Brooklyn, 570 E. 26th St. | Gardner, L. H. |
| | Brooklyn, 239 Steuben St. | Garone, J. A. |
| | Elmira, 660 Cedar St. | Jenkins, H. F. |
| | New York City, 3834 Bailey Ave. | De Pasquale, R. H. |
| | New York City, 180 Varick St. | De Witt, J. H. |
| | New York City, Bell Tel. Labs., Rm. K-48, 463 West St. | Edwards, R. B. |
| | New York City, c/o Bell Tel. Labs., 180 Varick St. | Hight, S. C. |
| | New York City, 87 Barrow St. | Hooper, A. |
| | New York City, 179 Varick St. | Molyneux, C. |
| | New York City, Bell Tel. Labs., 463 West St. | Willard, G. W. |
| | Niagara Falls, 1509 Weston Ave. | Hehir, J. E. |
| | Oneonta, 14 Draper St. | Wendell, F. S. |
| | Rochester, University of Rochester, River Campus | Lawrence, H. E. |
| | Rome, 105 Francis St. | Fitch, J. A. |
| | Staten Island, Seaview Hospital | White, J. P. |
| North Dakota | Mandan, 506 1st Ave. N. W. | Richardson, O. H. |
| Ohio | Dayton, 1609 Detzen Ave. | Fleischer, E. F. |
| | Dayton, General Motors Radio Corp. | Hess, F. E. |
| | Dayton, 1816 Rosemont Blvd. | John, A. R. |
| | Toledo, 1249 Dorr St. | Oaks, N. |
| Pennsylvania | Monessen, 362 Park Way | Parenti, A. M. |
| | Philadelphia, 342 S. 2nd St. | Frederick, A. |
| | Tyrone, 1205 Logan Ave. | Kearney, H. B., Jr. |

Geographical Location of Members Elected November 4, 1931

| | | |
|-----------------------------|---|-----------------------|
| Tennessee | Nashville, 1704 Grand Ave., S. W. | Campbell, J. S. |
| Texas | Dallas, P. O. Box No. 2833 | Johnson, W. D. |
| Virginia | Richmond, 1720 Westwood Ave. | Havens, W. M. |
| | Richmond, 3109 Lamb Ave. | Stephenson, J. W. |
| West Virginia | Shinnston, Pike St. | Meek, G. L. |
| Australia | Melbourne, Victoria, 17 Inglisby Rd., Mont Albert E. 10 | McKenzie, A. J. |
| Canada | Hamilton, Ont., 15 Bold St., Apt. No. 15 | Madter, E. W. R. |
| | Quebec, P. Q., 141 des Franciscains St. | Guimond, A. |
| | Quebec, P. Q., 66 Sault au Matelot | Messier, J. L. |
| England | Burnley, 9 Carlton Rd. | Wade, A. |
| | Chesterton, Cambridge, 83 Hawthorne Way | Barnes, H. M. |
| | Heston, Middlesex, 34 Hogarth Gardens | Fayers, A. A. |
| | Kersal Bar, Manchester, Hope Bank | Garnett, S. A. |
| | London, Strand, Marconi Sounding Device Co., Marconi House | Shaxted, H. E. |
| | London E. 12, 350 Strone Rd., Manor Park | Snook, E. T. |
| | New Malden, Surrey, 63a Kingston Rd. | Dedman, E. A. |
| | Thornton Heath, Surrey, 184 Melfort Rd. | Smith, M. G. |
| | Wallington, Surrey, 18 West Ave. | Hodgson, A. D. |
| | Worcester, "Radio House," Vincent Rd. | Porter, W. J. |
| India | Multan Cautt, 412 Queen's Rd. | Prasad, J. |
| Japan | Ishikawa-ken, JOJK Nonoichi Sending Station, Nonoichi-machi | Tanaka, Y. |
| | Kyoto, 1, Koyama-Horiike, Kamikyoku | Yoshioka, T. |
| New Zealand | Christchurch, 447 Worcester St. | Beniams, W. |
| | Christchurch, 98 Office Rd. | Buckhurst, E. B., Jr. |
| | Dunedin, 12 Princes St., St. Kilda | Scott, T. |
| South Africa | Durban, Natal, Beach Grove Hotel, Beach Grove | King, C. L. |
| S. Australia | Adelaide, 60 Carlisle Rd., Westbourne Park | Elliott, H. R. |
| Elected to the Junior grade | | |
| New York | Hempstead, 2 Nassau Parkway | Fritzsche, E. H. |



APPLICATIONS FOR MEMBERSHIP

Applications for transfer or election to the various grades of membership have been received from the persons listed below and have been approved by the Committee on Admissions. Members objecting to transfer or election of any of these applicants should communicate with the Secretary on or before January 4, 1932. These applicants will be considered by the Board of Direction at its January 6 meeting.

For Admission to the Member grade

New York New York City, 244 W. 10th Street Eddy, M. F.

For Transfer to the Member grade

Massachusetts Belmont, 47 Berwick St. Gleason, H. H.
 Pennsylvania Emporium, 115 W. 6th St. Jones, W. R.

For Election to the Associate grade

| | | |
|---------------|---|----------------------|
| Arizona | Douglas, 954-9th St. | McGraw, E. |
| California | North Hollywood, 4918 Denny Ave. | Rauch, W. W. |
| | San Francisco, 500 Mills Bldg. | Harris, S. G. |
| | San Francisco, 333 Grant Ave. | Hutchinson, R. |
| Colorado | Denver, 831 Lincoln St. | McKinney, F. M. |
| Georgia | Decatur, 125 Wilton Dr. | Burns, C. S. |
| Idaho | Boise, Radio Station KIDO | Sanders, C. |
| | Gooding, Box No. 884 | Noll, E. T. |
| Illinois | Chicago, Magnavox Co., 155 E. Ohio St. | Beckman, C. A. |
| | Chicago, 9 S. Clinton St. | Boyd, W. W. |
| | Chicago, 2022-205 W. Wacker Dr. | Hansen, T. A. |
| | Chicago, 1109 Bryn Mawr Ave. | Hucke, D. R. |
| | Chicago, 7420 Dante Ave. | Turner, J., Jr. |
| Maine | Presque Isle, Radio Station WAGM | Fowler, R. H. |
| Maryland | Baltimore, 2424 Ellamont St. | Kreis, A. L. |
| Massachusetts | Everett, 42 Marlboro St. | Dagan, W. R. |
| | Springfield, 53 Eureka St. | Hodson, H. O. |
| Michigan | Ann Arbor, Arlington Blvd. | Kraus, J. D. |
| | Champion, Box No. 82 | Caron, J. H. |
| | Detroit, 1235 Chalmers Ave., Apt. No. 4 | Reynolds, C. B., Jr. |
| | Flint, 509 Ann Arbor St. | Leland, R. R. |
| | Pontiac, 7 Front St., Apt. No. 3 | Lasley, G. |
| Minnesota | Minneapolis, Pioneer Hall, University of Minn. | Gates, C. E. |
| | St. Paul, 1032 Hague Ave. | Walker, B. G. |
| Mississippi | Carrollton, Route 4, Box No. 98 | Carder, W. D. |
| Missouri | St. Louis, 4121 Potomac St. | Blansett, F. M. |
| | St. Louis, c/o S. W. Bell Tel. Co., 2656 Locust St. | Hillier, W. H. |
| | St. Louis, 3452a Utah St. | Keller, W. J. |
| | St. Louis, 3226 "A" Geyer Ave. | Mansfield, W. E. |
| | St. Louis, 5553 Devonshire Ave. | Plumb, W. C. |
| Nebraska | Lincoln, 545 N. 25th St. | Winkler, C. W. |
| New Jersey | East Orange, 38 Winans St. | Neuert, A. J. |
| | Oceanport, Box No. 333 | Bonham, W. E. |
| New York | West Collingswood, 138 White Horse Pike, Apt. No. B-7 | Burley, F. E. |
| | Bayside, Hazeltine Service Corp., 26th Ave. and 210th St. | Brook, J. E. |
| | Bellerose, 9305-241st St. | Peterman, W. G. |
| | Brooklyn, 1803 Beverley Rd. | Heins, J. L. |
| | Brooklyn, 1917-54th St. | Schumacker, A. L. |
| | Glen Cove, 6 Frost Pond Rd. | Peek, C. B. |
| | New York City, c/o R.C.A., 75 Varick St. | McCafferty, T. E. |
| | New York City, 3259 Cambridge Ave. | McGeorge, F. J. |
| | New York City, 72 W. 118th St. | Simon, P. R. |
| | New York City, 125 W. 45th St., Rm. No. 1019 | Van Etten, W. D. |
| | Valley Stream, 75 Munro Blvd. | Vollkommer, W. A. |
| Ohio | Athens, 84 Mill St. | He, Y. C. |
| | Cleveland, 1700 E. 21st St. | McIlyar, C. C. |
| | Dayton, 329 Cherry Dr. | Barton, J. P. |
| | Dayton, 637 Wyoming St. | Penney, A. C. |
| | Freemont, R.F.D. No. 2 | Witter, R. J. |
| | Lakewood, 2103 Mars Ave. | Morrow, L. A. |
| | Parma, 5489 State Rd. | Koebnitz, B. H. |
| | Waynesfield | Focht, C. |
| Oklahoma | Ponca City, P. O. Box No. 728 | Ehler, B. M. |
| Pennsylvania | Erie, 3831 Beech St. | Fryling, G. R. |
| | Perkasie, R.F.D. No. 1 | Moyer, L. K. |
| | Philadelphia, 4609 Marple St. | Stock, F. B. |
| Rhode Island | Providence, 129 Regent Ave. | Dandreta, W. |
| South Dakota | Rapid City, Box No. 505 | Newkirk, C. |
| Tennessee | Knoxville, 1409 Highland Ave. | Smith, R. T. |

Applications for Membership

| | | |
|-----------------|---|---------------------|
| Utah | Salt Lake City, 1707 S. 9th, E. | Frederickson, A. S. |
| Virginia | Lynchburg, 4216 Fort Ave. | Strange, O. O. |
| Washington | Pasco, P. O. Box No. 707 | Brown, F. L. |
| Wisconsin | Neenah, 321 Caroline St. | Thomas, W. A. |
| American Samoa | Tutuila, Naval Radio Station | Gay, J. E. |
| Argentina | Manuela Pedraza, c/o Standard Oil Co. of Bolivia, FCCNA | Powell, A. E. |
| Canada | Hamilton, Ont., 62 E. Bend Ave. N. | Horton, L. |
| | London, Ont., 486 Central Ave. | Armstrong, C. F. |
| | Pilot Butte, Sask. | Erickson, R. A. |
| | Rossland, B. C., Box No. 494 | Hings, D. L. |
| | Winnipeg, Man., 679 Beverley St. | Bjornson, B. |
| Ceylon | Matale, 113 King St. | Canagaratnam, B. |
| England | Hall Green, Birmingham, 87 Tixall Rd. | Parkinson, W. R. |
| | Hull, 86 Worthing St. | Arnold, R. |
| | Lancaster, Lancs., 18 Ashton Rd. | Leach, H. |
| | Liverpool, 100 Kingsley Rd. | Martin, A. W. |
| | Liverpool, 92 Kingsley Rd., Princes Park | Thompson, R. H. |
| | London N. 15, 33 Rowley Rd. | Evans, W. A. |
| | Uxbridge, Middlesex, 4 Derby Rd. | Bayley, C. J. |
| Hawaii | Hilo, P. O. Box 1121 | Holzman, L. O. |
| Japan | Aichiken, Okehazama, Hosojio, Arimatsucho | Ujiie, K. |
| | Kawasaki, c/o The Tokyo Electric Co. | Watanabe, T. |
| | Shizuokaken, c/o Yaizogyogyo Kumiai, Yaizu Machi | Tsukahara, S. |
| New South Wales | Willoughby, Nth Sydney, 11 Hollywood Crescent | Norville, C. H. |
| New Zealand | Auckland, 75 Dominion Rd. | Davies, M. A. |
| South Africa | Pretoria, 159 Potgieter St. | Megit, W. M. |
| Venezuela | Caracas, Radio Station Y.V.I.B.C. | Lopez, A. L. |

For Election to the Junior grade

| | | |
|-------------|--------------------------------------|-------------------|
| California | Coronado, 520 "C" Ave. | Jefferis, T. K. |
| Illinois | Chicago, 6635 S. Maplewood Ave. | Oehler, H. E. |
| Indiana | Parker | Walker, J. R. |
| N. Carolina | Raleigh, Box No. 3547, State College | Smith, C. M., Jr. |
| Ohio | Cleveland, 8333 Woodland Ave. | Mohl, J. |
| Wisconsin | Milwaukee, 797 N. Marshall St. | Eilenberg, I. C. |



OFFICERS AND BOARD OF DIRECTION, 1931

(Terms expire January 1, 1932, except as otherwise noted)

President

RAY H. MANSON

Vice President

C. P. EDWARDS

Treasurer

MELVILLE EASTHAM

Secretary

HAROLD P. WESTMAN

Editor

ALFRED N. GOLDSMITH

Managers

ARTHUR BATCHELLER

J. H. DELLINGER

LLOYD ESPENSCHIED

HARRY HOUCK

C. M. JANSKY, JR.

Serving until January 1, 1933

J. V. L. HOGAN

R. H. MARRIOTT

Serving until January 1, 1934

L. M. HULL

A. F. VAN DYCK

Junior Past Presidents

A. HOYT TAYLOR

LEE DE FOREST

BOARD OF EDITORS, 1931

ALFRED N. GOLDSMITH, *Chairman*

STUART BALLANTINE

RALPH BATCHER

G. W. PICKARD

L. E. WHITTEMORE

W. WILSON



HARRY W. HOUCK
Manager, 1931

Harry W. Houck was born in New Cumberland, Pennsylvania, on April 11, 1897.

He first became interested in radio communication as an amateur in 1910. When the United States entered the World War in 1917 he enlisted in the Signal Corps of the U. S. Army and served in France with the A. E. F. from 1917 to 1919.

In 1919 he joined the Engineering Department of the International Radio Telegraph Company and as an engineer assigned to special radio receiving set design problems. In 1921 he established a private practice as consulting engineer which he continued until 1923 when he became affiliated with the Dubilier Condenser Radio Corporation. He later became chief engineer of this organization. In 1931 he became assistant chief engineer of Kolster Radio, Inc.

Mr. Houck was associated with the original development of the superheterodyne method of reception and has done pioneer work on the development of alternating-current operated radio receivers. His contributions to the art are indicated by the many patents issued in his name.

Mr. Houck is a member of the American Institute of Electrical Engineers and is a Fellow of the Radio Club of America. He became an Associate member of the Institute of Radio Engineers in 1919, transferring to the grade of Member in 1928.

INSTITUTE NEWS AND RADIO NOTES

November Meeting of the Board of Direction

At the November 4 meeting of the Board of Direction the following were in attendance: Ray H. Manson, president; Melville Eastham, treasurer; Alfred N. Goldsmith, editor; Arthur Batcheller, Lloyd Espenschied, J. V. L. Hogan, Harry Houck, R. H. Marriott, A. F. Van Dyck, and H. P. Westman, secretary.

J. G. Allen, N. P. Case, H. S. Frazier, W. Jackson, F. G. Kear, and R. Weese were transferred to the Member grade, and Phyra Aram, D. K. Gannett, H. B. Marvin, E. Siegel, W. C. Simon, and C. J. Victoreen were elected to the Member grade.

Applications for the Associate grade of membership which were approved numbered eighty-four and one application for the Junior grade of membership was approved.

As the ballots cast by the membership on the vote for the new revised constitution showed an almost unanimous approval of it, the new constitution was declared to be in effect.

The resignation of Dr. Hull as chairman of the Committee on Broadcasting was accepted with regret and E. L. Nelson of the Bell Telephone Laboratories was appointed chairman.

Notices of New York meetings of the Institute will hereafter be forwarded to those members of the Institute who reside within approximately fifty miles of New York City. Those who will not receive notices under this new arrangement and who desire to receive notices may obtain them by specifically requesting that their names be included in this list. Such requests should be addressed to the secretary.

A report on the Faraday Centenary Celebrations which was sponsored by the Royal Society of Great Britain and the Institution of Electrical Engineers of London, England, and which was attended by F. W. Grover, as the representative of the Institute, was accepted with thanks. Portions of this report appear elsewhere in this section of the PROCEEDINGS.

In view of the necessity of early standardization in the field of television a Technical Committee on Electro Visual Devices was established to operate under the Standardization Committee. J. V. L. Hogan was appointed chairman of this newly established committee.

Radio Transmissions of Standard Frequency, December, 1931

The Bureau of Standards announces a new schedule of radio transmissions of standard frequencies. This service may be used by trans-

mitting stations in adjusting their transmitters to exact frequency, and by the public in calibrating frequency standards and transmitting and receiving apparatus. The signals are transmitted from the Bureau's station WWV, Washington, D.C., every Tuesday afternoon and evening. They can be heard and utilized by stations equipped for continuous-wave reception throughout the United States, although not with certainty in some places. The time schedules are different from those of previously announced transmissions. The only frequency utilized is 5000 kilocycles. The accuracy of the frequency is at all times much better than a part in a million.

The transmissions are by continuous-wave telegraphy at 5000 kilocycles. They are given continuously from 2:00 to 4:00 P.M., and from 8:00 to 10:00 P.M., Eastern Standard Time, every Tuesday throughout December (except December 29). The dates are December 1, 8, 15, 22.

The transmissions consist mainly of continuous, unkeyed carrier frequency, giving a continuous whistle in the receiving phones. The first five minutes of the transmission consist of the general call (CQ de WWV) and announcement of the frequency. The frequency and the call letters of the station (WWV) are given every ten minutes thereafter.

Information on how to receive and utilize the signals is given in Bureau of Standards Letter Circular No. 280, which may be obtained by addressing a request to the Bureau of Standards, Washington, D.C. From the 5000 kilocycles any apparatus may be given as complete a frequency calibration as desired by the method of harmonics.

Since the start of the 5000-kc transmissions at the beginning of this year the Bureau of Standards has been receiving reports regarding the reception of these transmissions and their use for frequency standardization, from nearly all parts of the United States, including the Pacific Coast and Alaska. The Bureau is desirous of receiving more reports on these transmissions, especially because radio transmission phenomena change with the season of the year.

The data desired are approximate field intensity, fading, and the suitability of the transmissions for frequency measurements. It is suggested that in reporting upon field intensities for these transmissions, the following designations be used where field intensity measurement apparatus is not at hand: (1) hardly perceptible, unreadable; (2) weak, readable now and then; (3) fairly good, readable with difficulty; (4) good, readable; (5) very good, perfectly readable. A statement as to whether fading is present or not is desired, and if so, its characteristics such as whether slow or rapid, and time between peaks of signal

intensity. Statements as to type of receiving set used in reporting on the transmissions and the type of antenna used are likewise desired. The Bureau would also appreciate reports on the use of the transmissions for purposes of frequency measurement or control.

The Bureau would also appreciate comment from all users of the service on the times of day when the transmissions are most useful. During July, August, and September, the evening transmissions were two hours later than in the schedule announced herein.

All reports and letters regarding the transmissions should be addressed Bureau of Standards, Washington, D.C.

Proceedings Binders

Binders for the PROCEEDINGS, which may be used as permanent covers or for temporary transfer purposes, are available from the Institute office. These binders are handsome Spanish grain fabrikoid, in blue and gold. Wire fasteners hold each copy in place and permit removal of any issue from the binder in a few seconds. All issues lie flat when the binder is open. Each binder will accommodate a full year's supply of the PROCEEDINGS and they are available at two (\$2.00) dollars each. Your name, or PROCEEDINGS volume number, will be stamped in gold for fifty cents (50¢) additional.

Bound Volumes

The twelve issues of the PROCEEDINGS published during 1930 are now available in blue buckram binding to members of the Institute at nine dollars and fifty cents (\$9.50) per volume. The price to nonmembers of the Institute is twelve (\$12.00) dollars per volume.

Incorrect Addresses

On pages 47, 48, 49 and 50 of the advertising section of this issue will be found the names of two hundred and seventy-six members of the Institute whose correct addresses are not known. It will be appreciated if anyone having information concerning the present addresses of any of the persons listed will communicate with the Secretary of the Institute.

Committee Work

COMMITTEE ON ADMISSIONS

A meeting of the Committee on Admissions was held in the office of the Institute on November 4 and was attended by R. A. Heising, act-

ing chairman; Arthur Batcheller, H. C. Gawler, R. H. Marriott, E. R. Shute, and H. P. Westman, secretary.

The committee tabled pending further information the application for transfer to the grade of Fellow presented to it. It approved none of the three applications for admission to the grade of Member and approved two of the three applications for transfer to the grade of Member which it considered.

COMMITTEE ON MEMBERSHIP

A meeting of the Committee on Membership was held in the office of the Institute on November 4. Those in attendance were A. M. Trogner, acting chairman; David Grimes and C. R. Rowe. The committee finished its final consideration of the new application blank for the student membership and also the application for the other grades of membership.

STANDARDIZATION

SUBCOMMITTEE ON METHODS OF MEASUREMENTS OF THE TECHNICAL COMMITTEE ON VACUUM TUBES—IRE

A meeting of the Subcommittee on Methods of Measurements operating under the Technical Committee on Vacuum Tubes of the Institute's Committee on Standardization was held on October 27 in the office of the Institute. Those members present were F. H. Engel, chairman; J. N. Hanley, H. A. Snow, K. S. Weaver, and B. Dudley, secretary.

The committee reviewed the minutes of its October 6 meeting and also the report on "Standard Methods of Testing Vacuum Tubes" which appeared in the 1931 Report of the Committee on Standardization and made a number of recommendations and suggestions regarding this material.

Inasmuch as the committee is recommending a substantial number of changes in the report already printed, it was decided to forward its complete recommendations in the matter to the Technical Committee on Vacuum Tubes. This will conclude the work of this subcommittee.

Institute Meetings

NEW YORK MEETING

The regular monthly New York meeting was held on November 4 in the Engineering Societies Building.

Two papers were delivered at this meeting. The first on "The Operation of Vacuum Tubes as Class B and Class C Amplifiers", by C. E. Fay of the Bell Telephone Laboratories of New York City is summarized below:

"A simple theoretical development of the action of a vacuum tube and its associated circuit when used as a class B or class C amplifier is given. An expression for the power output is obtained and the conditions for maximum output are indicated.

The way in which the tuned plate circuit filters out the harmonics in the pulsating plate-current wave is illustrated by an hypothetical example. A set of dynamic output current characteristics is developed graphically from a set of static characteristics. The class B dynamic curves are found to give a better approximation to a straight line than the class C curves because of a reversed curvature which appears at the lower ends. It is pointed out that the screen-grid tube should function similarly to a high- μ three-element tube in this type of operation. Experimental dynamic characteristics of a three-element tube, Western Electric 251-A, and of a screen-grid tube, Western Electric 278-A, of identical dimensions are shown which verify the theoretical results. The screen-grid tube gives about the same output and efficiency as the three-element tube but its dynamic characteristic tends to bend more rapidly at the upper end."

The second paper of the evening on the "Design and Characteristics of a New Power Radiotron for High-Frequency Operation", by M. A. Acheson of the General Electric Company and H. F. Dart of the Westinghouse Lamp Company was presented by Mr. Acheson. The summary of the paper is also given herewith:

"This paper indicates the need for high power vacuum tubes for high-frequency transmission, and discusses new factors most important in the design of a tube for this usage.

Older types of tubes were built with high efficiency, low-frequency use in view, with the result that when applied to high frequency they were severely limited by allowable operating voltage and by large internal capacitances and inductances. However, by operating class B amplifiers and thus dispensing with the power modulator, and by minor sacrifices in efficiency in class B or class C operation, it is possible to design a tube having greatly increased high-frequency rating, although it has no usual advantage at low frequency.

The actual design of such a high-frequency tube and the resulting characteristics and ratings are given for the UV-858 Radiotron. From these data some of its important uses are indicated and its possibilities in such uses may readily be estimated.

Results of special tests involving new phenomena, possible for the first time with this tube, are given."

Four hundred and fifty members and guests were present.

CINCINNATI SECTION

The October 13 meeting of the Cincinnati Section was held at the

Engineers Club at Dayton, Ohio, Dorman D. Israel, chairman, presiding.

The paper of the evening on "Effect of Geometrical Variation in Triodes with Plane, Parallel Electrodes" was presented by W. L. Krahl, chief engineer of Arcturus Radio Tube Company.

The author selected the type '45 tube as a specimen triode. Various curves were shown for normal tubes which could be expected to give quite normal operation throughout their life. The mathematical treatment was then given of the effects which might be expected if one or more of the elements of the tube was moved from its normal place and the facts of these variations were tabulated under the respective element headings. Both actual and theoretical curves were then shown for the various types of eccentricity which might and did occur in ordinary manufacture and a discussion of the possible benefits and objectional features given.

The paper was discussed by Messrs. Felix, Glessner, Israel, Loftis, and Nichols of the fifty-five members and guests who attended the meeting. Of those present, twenty-six attended the informal dinner which preceded the meeting.

In addition to the paper presented, a motion-picture film "The Story of Copper" was projected.

DETROIT SECTION

L. N. Holland, chairman of the Detroit Section, presided at the October 23 meeting of that section held in the Detroit News Auditorium.

Frank Duff of the Detroit Edison Company presented a paper on "The Cathode Ray Oscillograph as Used in the Study of Lightning Surges."

The speaker gave a very detailed description of the cathode ray oscillograph and associated equipment as used in the study of lightning surges on transmission lines of The Detroit Edison Company. The talk was illustrated with slides showing circuit diagrams, equipment used, and some oscillograms of surges, which were recorded. The equipment used by The Detroit Edison Company was developed by Professor George of Purdue University. Mr. Duff also spoke of the experiences encountered in the maintenance and operation of this equipment. A number of the sixty-two members and guests in attendance discussed the paper.

The Nominating Committee comprised of W. Hoffman, chairman; L. Augustus and T. Parkinson were appointed.

ROCHESTER SECTION

A meeting of the Rochester Section was held at the Sagamore Roof on October 1 and was presided over by Albert E. Schell, chairman of the Rochester Section of the American Society of Mechanical Engineers. This was a joint meeting.

The paper of the evening, "The Engineer as a Citizen", was presented by Roy V. Wright, president of the American Society of Mechanical Engineers.

Mr. Wright discussed in general some of the problems the railroads have to meet at the present time. Among the points brought up and discussed by those present was a question of the competition of the cross-country freight buses and what the railroads might do to protect themselves.

The meeting was attended by ninety, a number of whom took part in the discussion which succeeded the presentation of the paper.

SEATTLE SECTION

The members of the Seattle Section were the guests of the Charles D. Hopkins Chapter of the Telephone Pioneers of America at a meeting held September 24 at the Womens Century Club Building.

The meeting was devoted to an illustrated lecture entitled "Some Thoughts on Waves" which was presented by O. B. Blackwell, a transmission development engineer of the American Telephone and Telegraph Company. The paper gave an excellent program of the major projects including transoceanic radio, land, cables, and carrier current developments.

The meeting was attended by one hundred members and guests.

TORONTO SECTION

The September 30 meeting of the Toronto Section was held at the Electrical Building, University of Toronto, F. K. Dalton, chairman, presiding.

The speaker of the evening, Harold W. Parker, presented a paper on the "Output Characteristics of the Pentode."

The author started with a summary of the various types of tubes from the half-wave rectifier through to the pentode, taking into consideration all the possible arrangements of positive and negative potentials applied to various elements of different tubes and the effects produced thereby.

Curves explaining the action of the pentode under various conditions were presented together with a mathematical explanation of the results obtainable.

Relative merits of the UX-245 and UX-247, both singly and in push-pull arrangement, were discussed and the paper was concluded with the presentation of some interesting data on tube life test results.

The discussion which followed the talk was participated in by Messrs. Andre, Bayly, Fox, Hackbusch, Hepburn, Pipe, Pollock, and Smith of the sixty-two members and guests in attendance.

Faraday Centenary Celebrations

The celebrations of the centenary of the discovery of the electromagnetic induction by Michael Faraday in 1831 was held in London, September 21-25 under the auspices of the Royal Institution of Great Britain and the Institution of Electrical Engineers (London). About 300 delegates representing scientific societies and universities of some thirty different countries were represented. The Institute was represented by F. W. Grover of Union College at Schenectady.

The formal reception was held in the lecture room of the Royal Institution which had been treated so as to present an appearance essentially unchanged since the time of Faraday.

Lord Eustace Percy, President of the Royal Institution, opened the meeting with a short address of greeting and the individual delegates were then introduced.

Honorary membership in the Royal Institution was conferred upon a number of the visitors, those in the United States being Elihu Thomson, R. W. Wood, Howard McClenahan, and M. I. Pupin.

The special exercises on the same evening were held in Queen's Hall. Those who spoke at this meeting were Prime Minister MacDonald, duc de Broglie, Professor Elihu Thomson, Marchese Marconi, Professor Zeeman, Professor Debye, Lord Rutherford of Nelson, and Sir William Bragg.

On September 22 the Davy-Faraday laboratory was opened to visitors and interesting letters and personal relics of Faraday were shown. In the lecture room Sir William Bragg standing where Faraday had often addressed an audience and using some of Faraday's original apparatus, performed some of those experiments of Faraday which have proved of such profound importance.

On September 23 the delegates were afforded a private view of the Faraday Centenary Exhibition in advance of its formal opening. The exhibits were grouped about a statue of Faraday which occupied a position in the center of the large rotunda of the Royal Albert Hall in Kensington. A number of other exhibits were arranged and brought out

the many-sidedness of Faraday's genius and the great importance of his discoveries.

Among the many interesting objects preserved in the Royal Society and on exhibition September 24 were the mace presented by Charles II in 1663, the signatures of the founder, charter members, patrons, and fellows from 1662 to the present day, and early volumes of the minutes of the Council. Of peculiar interest was the original reflecting telescope made by Newton in 1671, a description of the instrument in his own handwriting, and the original manuscript of the *Principia*.

The closing event of the celebrations was a dinner given to the delegates by His Majesty's Government at the Dorchester Hotel on September 25.

Personal Mention

J. E. Bardino has been transferred from the East Pittsburgh plant of Westinghouse to WBZ in Boston, Mass.

J. L. Bonanno formerly with the Radio Corporation of America in New York is now manager of the C. B. Engineering Company of Irvington, N.J.

A. H. Brolly is now chief engineer of Television Laboratories, Ltd., San Francisco, Calif., having previously been in the radio engineering department of the Federal Telegraph Company of Palo Alto, Calif.

Formerly chief engineer of Radio Film Company, D. R. Canaday is now chief engineer of Canady Recording Equipment Company, Cleveland, Ohio.

Formerly an engineer for WSOA-WORD, J. M. Carment has become chief engineer of WCHI, Chicago.

R. E. H. Carpenter is now chief engineer of RM Radio, Ltd., of London.

Formerly a recording engineer for Pathé Sound News, R. W. Clark has become a studio engineer for the N.B.C. in San Francisco.

Lieutenant Commander Lowell Cooper has been transferred from the U.S.S. California to U.S. Naval Radio Station, Puget Sound Navy Yard, Bremerton, Wash.

P. H. Craig formerly a physicist for Harris Hammond has become vice president and technical director of the Invex Corporation, Cincinnati.

Previously sound director for Hughes-Franklin Theaters, Ltd., of Hollywood, Calif., Lodge Cunningham has become sound director for United Artists Studio in Hollywood.

B. L. Dolbear has become chief engineer of the Airplane and Marine Direction Finder Corporation of Lindenhurst, N.Y., having formerly

been in the engineering department of the RCA Victor Company at Jamaica Plain, Mass.

H. R. Dyson is now a radio transmitter engineer for RCA Victor at Camden having previously been with the Westinghouse Electrical and Manufacturing Company at Chicopee Falls, Mass.

F. E. Eldredge has been transferred from the New York to the Chicopee Falls, Mass., branch of the Westinghouse Electrical and Manufacturing Company.

Lieutenant C. F. Fielding has been transferred from the U.S.S. Whitney to the New York Navy Yard.

Formerly with Freshman Freed Eiseman Radio, Ltd., G. E. Foote has become a radio engineer for Colin B. Kennedy of Canada, Toronto.

T. L. Gottier has joined the radio engineering staff of Sparks Withington Company of Jackson, Mich., having previously been affiliated with the United Research Corporation.

N. C. Hall formerly with the Jenkins Television Corporation has joined the engineering staff of the Arcturus Radio Tube Company of Newark, N.J.

K. A. Kathaway formerly connected with the Chicago Daily News is now executive secretary of the Institute of Radio Servicemen of Chicago, Ill.

Previously with the General Motors Radio Corporation, L. E. Hayslett has become a radio engineer for the Rudolph Wurlitzer Company of North Tonawanda, N.Y.

A. P. Hill previously with the Southern California Telephone Company has become acoustic consulting superintendent of Electrical Research Products, Inc., of Hollywood.

F. E. Johnston is now chief engineer of the Crosley Radio Corporation of Cincinnati.

T. F. Johnston previously with the Bell Telephone Laboratories has become a U. S. Radio Inspector with headquarters in New York City.

Formerly chief research engineer of Federal Telegraph Company of Palo Alto, Calif., F. A. Kolster is now research engineer for the International Communications Laboratories of New York City.

Martin Devereaux previously of the Westinghouse Electrical and Manufacturing Company of Chicopee Falls, Mass., has become a radio engineer of the DeForest Radio Company of Passaic, N.J.

Daniel McDonald previously with the British Thomson Houston Company at Rugby is now associated with Birmingham Sound Reproducers of Birmingham, England.

S. R. Montcalm formerly with the International Standard Electric

Corporation is now a radio engineer for the International Communications Laboratories, Newark, N.J.

Lieutenant Commander M. C. Partello, U. S. N., has been transferred for duty on the U.S.S. Helena.

Lieutenant J. J. Pierrepoint has been transferred from the U.S.S. Omaha to the U.S.S. Concord.

Formerly with the Standard Electric Corporation, G. E. Pipe has joined the staff of Rogers Majestic Corporation of Toronto, Canada.

Formerly with the Short Wave and Television Laboratories, J. P. Putnam has become a radio engineer of the General Industries Corporation of Waltham, Mass.

R. E. Rice previously with the Western Electric Company has become chief engineer of the International Sound Recording Corporation of Chicago.

William Salt previously with the Edison Swan Electric Company has become a radio engineer for Pye Radio, Ltd., of Cambridge, England.

A. S. Santos has become an engineer for Kolster Radio of New York, having formerly been with the International Standards Corporation at Rio de Janeiro, Brazil.

R. E. Shaw has left Grigsby Grunow Company to join the radio engineering department of the Cinch Radio Corporation.

Melvin Van Sickle has left Canadian Brandes, Ltd., to become an engineer for Kolster Radio, Ltd., of Toronto, Canada.

R. M. Wilmotte previously with the Radio Frequency Laboratories is now doing consulting work in New York City.



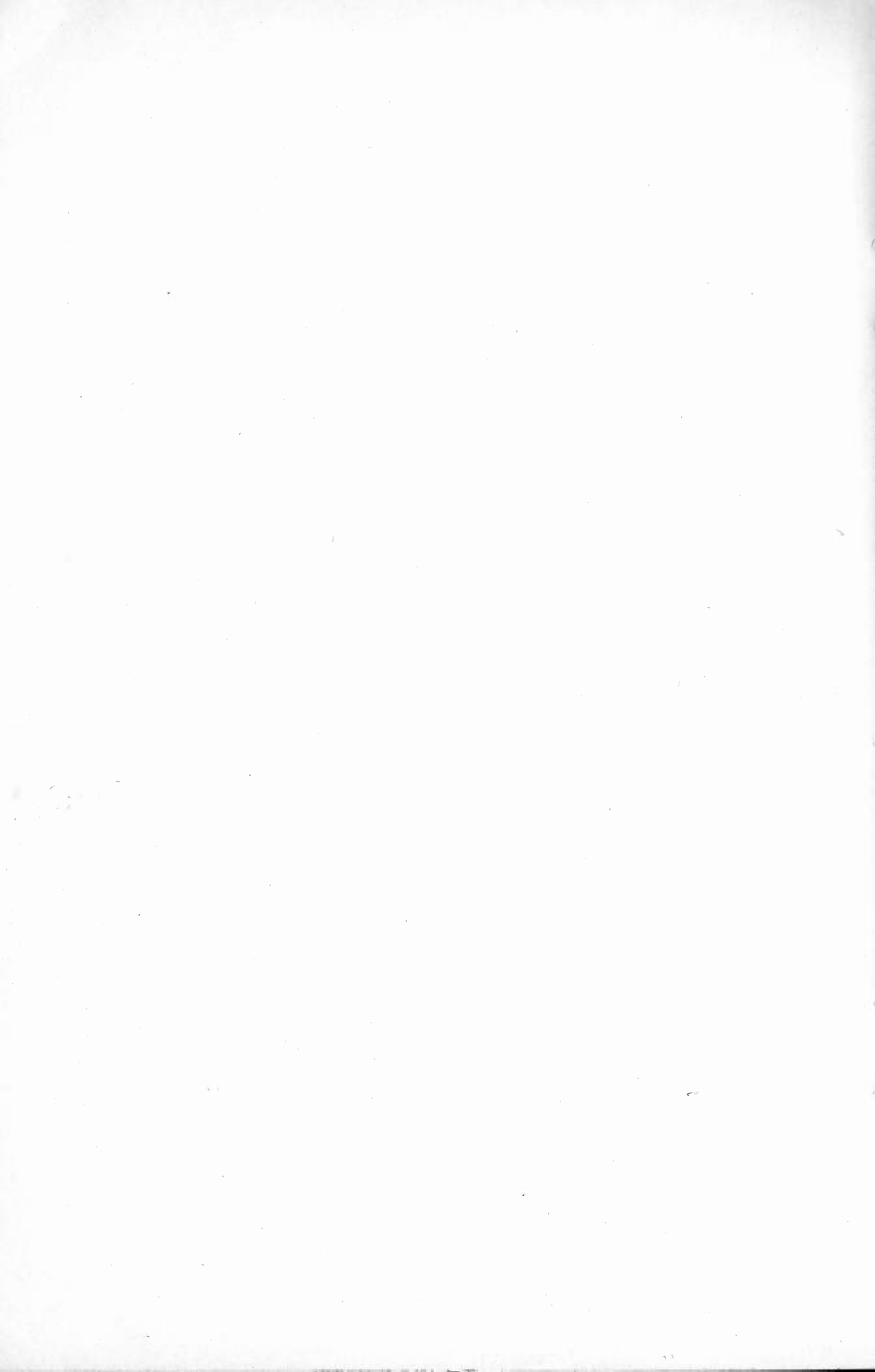

PART II
TECHNICAL PAPERS

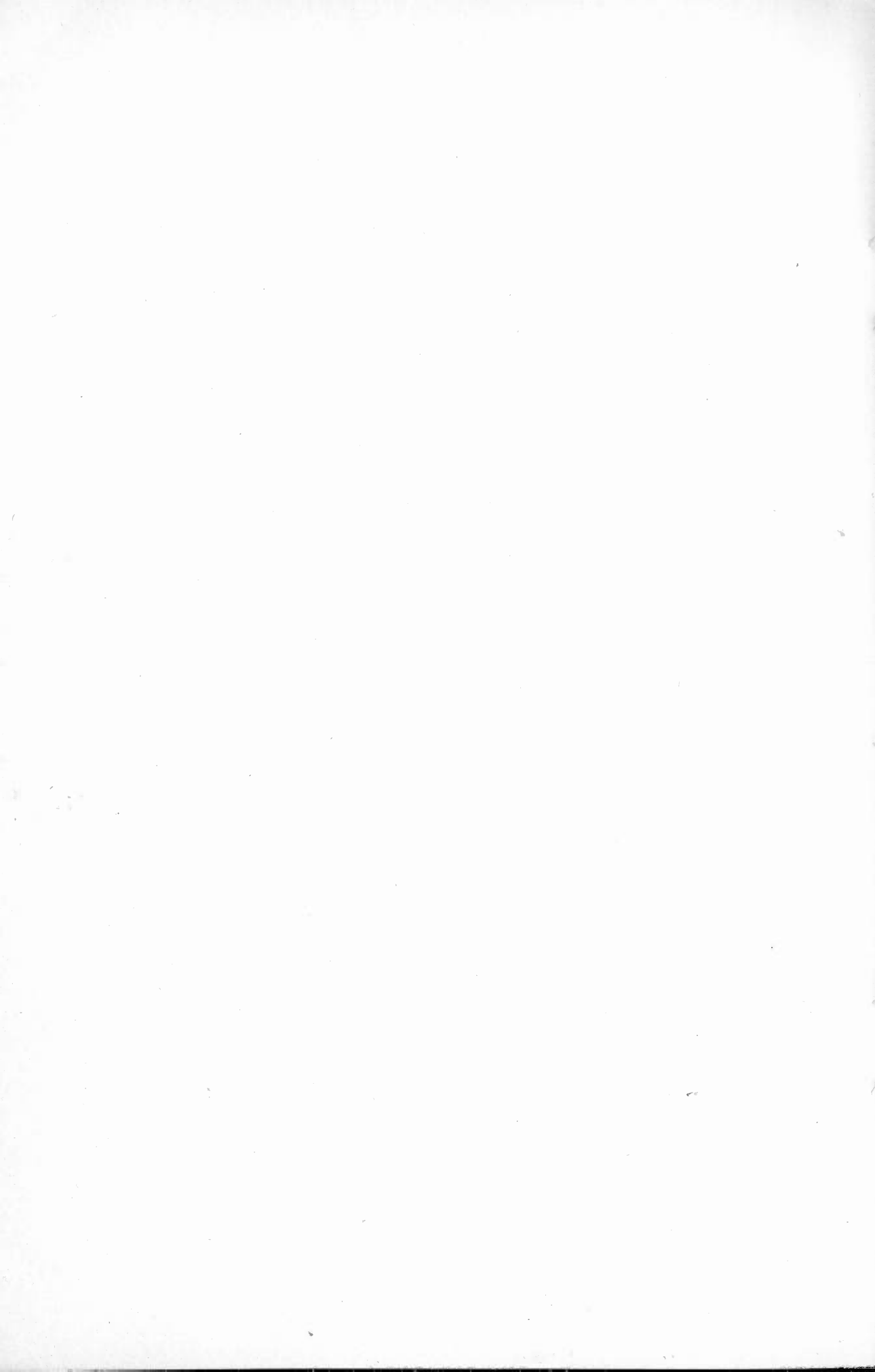

CONSTANT FREQUENCY OSCILLATORS*

BY

F. B. LLEWELLYN

(Bell Telephone Laboratories, New York City)

Summary—The manner in which the frequency of vacuum tube oscillators depends upon the operating voltages is discussed. The theory of the dependence is derived and is shown to indicate methods of causing the frequency to be independent of the operating voltages. These methods are applied in detail to the more commonly used oscillator circuits.

Experimental data are cited which show the degree of frequency stability which may be expected as a result of application of the methods outlined in the theory, and also show that the best adjustment is in substantial agreement with that predicted by theory. With a carefully built and adjusted oscillator the effects of normal variations in the operating voltages are negligible in comparison with the effects of temperature variations resulting from the changed operating currents. Methods of preventing these latter effects are not discussed in the present paper.

The appendix contains an analysis of the conditions under which the performance of an oscillator may be represented by the use of linear circuit equations.

INTRODUCTION

IN RECENT years the commercial requirements of vacuum tube oscillators have grown more rigid. The tremendous increase in the number of radio broadcast stations with the consequent narrowing of frequency band available to each, the analogous demands by the carrier telephone, and the tendency toward higher frequencies where a small percentage frequency change defeats the universal effort to secure better quality, all have united in creating a need for very constant frequencies. This need has led to a study of methods for holding the frequency constant. The most notable of these is the piezo-electric crystal. However, it has been known for some time that certain oscillator circuits have the inherent property of maintaining their frequency quite constant even though not crystal controlled. Some of these circuits have the additional advantage of combining constant frequency at a given wavelength with the ability to maintain this constancy at other wavelengths, thus giving a range of available frequencies, any one of which may be depended upon to stay constant.

The elements which cause the frequency of oscillators which are not crystal controlled to vary are such things as vibration, changing temperature, fluctuating voltage, and changing load. Vibration and temperature affect primarily the inductance and capacity in the circuit

* Decimal classification: R133. Original manuscript received by the Institute, March 31, 1931. Presented before Sixth Annual Convention of the Institute, June 6, 1931, Chicago, Illinois.

which naturally causes the frequency to change. Fluctuating voltages change the tube resistance, which in turn affects the frequency. Changing loads also change the frequency, since they take the form of variable resistance and reactance.

Considerable work has been done by various individuals to make the inductance and capacity of standard apparatus as free from the effects of vibration and temperature changes as possible. Work of that kind is not discussed here. Variable voltages occur in practically all installations and changing load impedance in many. These two things are the actual cause of the larger part of frequency variation in many installations.

Several vacuum tube circuits have been devised to surmount these difficulties. They may be divided roughly into two groups; first, those in which the attempt has been to minimize the change of frequency with battery voltage, and second, those in which the attempt has been to prevent the change. In the first group we have two types; first, circuits in which the effective resistance has been reduced to as low a figure as possible, and second, those in which a high impedance has been inserted between the tube and the tuned circuit in order to reduce the relative effect of changes in the tube. Considerable success has attended the efforts of a number of engineers led by J. W. Horton in these directions. More recently, circuits of the first type have been applied to the production of relatively high frequencies.¹

The second group in which the attempt has been to prevent the frequency change developed from the work of Messrs. J. F. Farrington and C. F. P. Rose. They found that a certain critical value of an impedance between the vacuum tube and the tuned circuit apparently produced a constant frequency over a limited range when the battery voltages were varied. They experimented with various forms of networks for this stabilizing impedance and developed several in which the output power was not reduced by stabilization.

THEORY

The writer attacked the problem from a theoretical standpoint and showed that in certain cases the mathematical procedure indicates means of making the oscillator frequency independent not only of a variable load resistance, but also of the battery voltages. The purpose of this paper is to develop the general theory and application of these circuits and to show how several circuits in particular may be made to produce practically constant frequency with customary variations of

¹ Ross Gunn, "A new frequency stabilized oscillator system," *Proc. I.R.E.*, 18, September, 1930.

voltage and load resistance. The relations necessary to maintain the frequency constant at any given setting when it is desirable that the oscillator be operative over a range of frequencies are also indicated.

Before proceeding with a detailed description of the various specific embodiments necessary to secure independence of frequency and battery voltage, it will be well to lay down the physical conditions upon which the frequency of any vacuum tube oscillator depends.

In general, all such oscillators consist of or may be resolved into, a tuned electrical circuit or network to which is attached a vacuum tube. Irrespective of any particular circuit, the frequency of the oscillator is completely determined by the following quantities, the designations used here being uniformly employed throughout the subsequent analysis:

- L , the self-inductance in the network
- M , the mutual inductance in the network
- C , the capacity in the network
- R , the resistance in the network
- r_p , the plate resistance of the vacuum tube
- r_g , the grid resistance of the vacuum tube
- μ , the amplification factor of the vacuum tube

Of these quantities, L , C , and M require little comment. They are merely symbolic of the elements of the electrical network. The quantity C includes the interelectrode capacities of the tube when they become of consequence. These three quantities are assumed to be constant, an assumption which has been found very reasonable in practice. The quantity R represents the resistance in the network. For the purpose of this discussion the oscillator is assumed to deliver only a small amount of power, being used most often in such a manner as to supply voltage to the grid of an amplifier tube. Consequently, the electrical network external to the vacuum tube may, and should, be constructed in such a manner as to include a minimum amount of resistance. Under these conditions the losses in the circuit have been found to be practically all the result of the internal resistances, r_p and r_g of the vacuum tube.

These two quantities, r_p and r_g , are very important, being principally responsible for changes in condition of the circuit as a whole. It should be realized that r_g has the same relation to the static values of grid current and potential that r_p has to the plate current and potential. The effect of varying the applied potential of the grid or plate, or of changing the filament current is directly to cause r_p and r_g to vary, usually in opposite directions. Further, when amplitude of oscillation

varies, for which variation of battery voltages (grid, plate, and filament) are again principally responsible, both r_g and r_p vary.²

The quantity μ is the amplification factor and is used with its usual significance. It varies with battery potential but this variation is ordinarily very small, though not to be neglected.

It eventuates, from the above considerations, that if the reactive elements of the frequency determining circuit are constant, a permissible assumption, the frequency may be stabilized if adequate account is taken of changes in battery voltages and load resistances. This it is the purpose of the present paper to discuss.

HARTLEY OSCILLATOR

Consider first the form of the Hartley oscillator shown in schematic form without indicating any special method of introducing the batteries, in Fig. 2. Fig. 1 shows the circuit equivalent of several of the oscillators in the following figures when the impedances are represented in generalized form, and, therefore, will be employed for an analysis of the conditions necessary to secure independence of frequency and battery or applied voltages, and the results of this analysis will then be interpreted in detail in terms of the special circuit of Fig. 2. In Fig. 1 the impedances, Z_4 and Z_5 , are inserted for the purpose of effecting the independence of frequency and battery voltages, and the values which they should have in order to accomplish this result are found by the following analysis:

From Fig. 1 we have the circuit equations when the assumed current conditions are as shown by the arrows:

$$\begin{aligned}\mu e &= I_1(r_p + Z_1 + Z_5) + I_2(Z_1 + Z_m) - I_3Z_m \\ 0 &= I_1(Z_1 + Z_m) + I_2Z_0 - I_3(Z_2 + Z_m) \\ 0 &= -I_1Z_m - I_2(Z_2 + Z_m) + I_3(r_g + Z_2 + Z_4) \\ e &= I_3r_g.\end{aligned}\tag{1}$$

These equations are expressions of Kirchkoff's Law regarding the sum of the potentials in a closed mesh. The equations (1) effectively comprise only three simultaneous equations because the network has only three meshes.

In the above equation Z_0 is symbolic of the series impedance of the tuned circuit. Using the symbolism of Fig. 1:

$$Z_0 = Z_1 + Z_2 + Z_3 + 2Z_m.\tag{2}$$

² The appendix to this paper contains a further discussion of the significance of r_p and r_g together with an analysis of the conditions under which oscillator networks may be treated by the use of linear circuit equations as is done in the following analysis.

Equations (1) may be rewritten in determinant form as follows:

$$\begin{vmatrix} (r_p + Z_1 + Z_5) & + (Z_1 + Z_m) & - (Z_m + \mu r_o) \\ + (Z_1 + Z_m) & Z_0 & - (Z_2 + Z_m) \\ - Z_m & - (Z_2 + Z_m) & (r_o + Z_2 + Z_4) \end{vmatrix} = 0 \quad (3)$$

This determinant form of (1) follows immediately from reducing (1) to three equations.

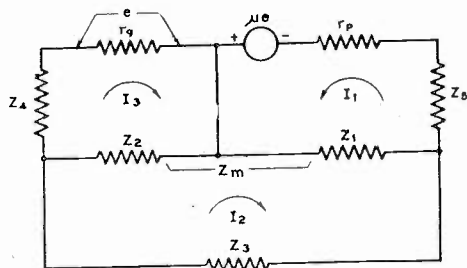

Fig. 1—Equivalent circuit network of Hartley- or Colpitts-type oscillator.

In accordance with the theory of the operation of oscillators, discussed in the appendix, both the conditions necessary for oscillation to exist and the frequency of oscillation may be found from (3). That is:

$$\begin{aligned} (r_p + Z_1 + Z_5)Z_0(r_o + Z_2 + Z_4) + (Z_1 + Z_m)(Z_2 + Z_m)(\mu r_o + 2Z_m) \\ = Z_0Z_m(\mu r_o + Z_m) + (Z_1 + Z_m)^2(r_o + Z_2 + Z_4) + (Z_2 + Z_m)^2 \\ (r_p + Z_1 + Z_5). \end{aligned} \quad (4)$$

The next step is to express each of the generalized Z 's in the equivalent form of $(R+iX)$ where i stands for the imaginary quantity, $\sqrt{-1}$, and both R and X are real, representing, respectively, resistance and reactance. A great simplification results when it is recalled that the circuits external to the vacuum tube are assumed to have very little resistance, and that practically all of the losses in the network are caused by the tube resistances, r_o and r_p , so that these two are the only resistances which need be retained in the analysis. With this understanding, (4) becomes:

$$\begin{aligned} [r_p + i(X_1 + X_5)]iX_0[r_o + i(X_2 + X_4)] - (X_1 + X_m)(X_2 + X_m) \\ [\mu r_o + 2iX_m] = -X_0X_m[\mu r_o + iX_m] - (X_1 + X_m)^2[r_o + i(X_2 + X_4)] \\ - (X_2 + X_m)^2[r_p + i(X_1 + X_5)]. \end{aligned} \quad (5)$$

In order for (5) to be true, both the real and the imaginary portions must separately be equal to zero. If (5) (which comes naturally from (3) with the given substitutions) is separated into its real and imaginary

parts, the resulting two equations must be simultaneous and between them express the frequency and relative values which r_p and r_g must assume in order for oscillations to exist. The particular aim in the present case is to find whether values of X_4 or X_5 exist which will enable the frequency to be expressed in terms of the constants of the circuit external to the vacuum tube so that if r_p , r_g , and μ should vary, the frequency, being dependent upon the external circuit, only, will remain constant.

From (5), then, the real and imaginary parts give the following two equations:

$$\begin{aligned} -X_0[r_p(X_2 + X_4) + r_g(X_1 + X_5)] - \mu r_g(X_1 + X_m)(X_2 + X_m) \\ = -X_0 X_m \mu r_g - (X_1 + X_m)^2 r_g - (X_2 + X_m)^2 r_p \end{aligned} \quad (6)$$

$$\begin{aligned} X_0[r_p r_g - (X_1 + X_5)(X_2 + X_4)] - 2X_m(X_1 + X_m)(X_2 + X_m) \\ = -X_0 X_m^2 - (X_1 + X_m)^2(X_2 + X_4) - (X_2 + X_m)^2(X_1 + X_5). \end{aligned} \quad (7)$$

There are certain mathematical rules for finding whether the desired constancy of frequency may be obtained from the conditions given by (6) and (7). Without, however, going into detail in regard to these, it is easy to see from (7) that if X_4 and X_5 have such values as to satisfy the equation:

$$\begin{aligned} 2X_m(X_1 + X_m)(X_2 + X_m) = (X_1 + X_m)^2(X_2 + X_4) \\ + (X_2 + X_m)^2(X_1 + X_5) \end{aligned} \quad (8)$$

(which is obtained by including all terms of (7) which do not contain X_0), then the frequency of oscillation is exactly that which will cause X_0 to become zero, and will remain so, no matter what values may be taken by r_p , r_g , and μ . In other words, the oscillation frequency is equal to the series resonant frequency of the tuned circuit.

It follows, then, that if the battery voltages were to vary, the frequency, being determined by the circuit elements external to the vacuum tube, only, would remain constant. In regard to a changing load resistance, it is evident that if this were connected in parallel either with r_p or r_g , then the combination of the two resistances could be considered as a single resistance. It therefore follows that the same adjustment which causes the frequency to be independent of battery voltage is also the correct one to render the frequency independent of a variable load impedance when this impedance is resistive, only; and is connected in parallel either with the plate or grid resistance of the tube.

In order to complete the general demonstration, it remains to show that the values imposed on (7) by the condition of (8) do not require physically impossible values of r_p , r_g , and μ in order to satisfy (6) and

thus maintain oscillation. To do this, assume that (8) is solved for either X_4 or X_5 and substitute in (6), remembering that X_0 is zero. The result is:

$$\frac{r_p}{r_o} = \mu \left(\frac{X_1 + X_m}{X_2 + X_m} \right) - \left(\frac{X_1 + X_m}{X_2 + X_m} \right)^2. \quad (9)$$

Inspection of this expression shows that the conditions required are physically possible, and it follows that the amplitude of oscillation increases or decreases until the effective values of r_p and of r_o , which are measures of the dissipation of energy on the plate and on the grid sides, take up the values specified by the conditions of (9). Thus, for instance, if X_1 and X_2 were approximately equal, then r_p would have to be $(\mu - 1)$ times as large as r_o before the oscillation amplitude settled down to a steady state value. To many who are accustomed to neglect the losses occurring on the grid side of a vacuum tube when dealing with oscillator problems, this low value of r_o will appear as somewhat unusual. In this connection, it may be pointed out that the low value of r_o is not in any way a special requirement imposed by the stabilizing reactances, X_4 and X_5 , but is inherent in vacuum tube oscillators in general, unless particular conditions are arranged to render it otherwise. For instance, it is a well-known experimental fact that resistances of the order of 4000 ohms may be placed across the grid filament terminals of an oscillator employing any of the more common types of three-element receiving amplifier tubes without stopping the oscillations, when a good low-loss tuned circuit is employed. In view of the fact that the amplitude of the oscillations is commonly limited by r_o , this is evidence that stable oscillations may be secured with values of r_o which are of the order of 2000 or 3000 ohms.

The demonstration may be made more rigid by the use of (6) and for the special case where $X_1 = X_2$ and $X_4 = X_5 = X_M = 0$, in which the stabilizing reactances have been omitted. For such a simplified circuit, it is found by elimination of X_0 between (6) and (7) that:

$$\frac{r_p}{r_o} = \mu \left[\frac{r_p r_o - X_1^2}{r_p r_o + X_1^2} \right] - 1.$$

Now, X_1 is of the order of 500 or 600 ohms at the most, while both r_p and r_o are at least enough larger than this in the case of the more commonly used vacuum tubes so that the expression for r_p/r_o is roughly equal to $(\mu - 1)$. Thus, in the simplest kind of vacuum tube circuit, it is seen that r_o is apt to be appreciably smaller than r_p , and by no means negligible in its effect.

To return to (8), which expresses the relation between X_4 , X_5 and other circuit reactances which are necessary to cause the frequency to be independent of battery voltages, we note that, although (8) is still in generalized form, and is yet to be applied to the particular case shown in Fig. 2, the very significant fact that the oscillation frequency for

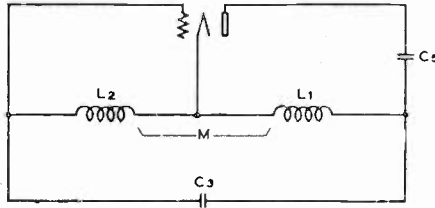

Fig. 2—Hartley oscillator, plate stabilization.

$$C_5 = C_3 \left[\frac{L_0}{L_1 + L_2 A^2 - 2MA} \right]$$

where,

$$L_0 = L_1 + L_2 + 2M \quad A = \frac{L_1 + M}{L_2 + M}$$

this type of stability must be the series resonant frequency of the tuned circuit is a direct consequence of the requirements of the equation.

For application to the Hartley type of oscillator, the various terms of (8) have the following significance:

$$X_1 = \omega L_1$$

$$X_2 = \omega L_2$$

$$X_m = \omega M$$

where $\omega = 2\pi \times$ frequency and X_4 or X_5 are to be determined. In the case of Fig. 2, where stabilization is accomplished on the plate side, we put X_4 equal to zero. Then solving (8) for X_5 , we find:

$$X_5 = 2\omega M \left(\frac{L_1 + M}{L_2 + M} \right) - \omega L_2 \left(\frac{L_1 + M}{L_2 + M} \right)^2 - \omega L_1.$$

X_5 is thus required to be negative, so that a capacitive reactance is necessary for plate stabilization of a Hartley-type oscillator. Thus putting

$$X_5 = -\frac{1}{\omega C_5}$$

and remembering that since $X_0 = 0$, the angular frequency is given by

$$\omega^2 = 1/C_3(L_1 + L_2 + 2M)$$

finally we get

$$C_5 = C_3 \frac{L_1 + L_2 + 2M}{L_1 + L_2 \left(\frac{L_1 + M}{L_2 + M} \right)^2 - 2M \left(\frac{L_1 + M}{L_2 + M} \right)} \quad (10)$$

which is the value of capacity which should be inserted between the plate and the tuned circuit of a Hartley-type oscillator in order to cause the frequency to remain constant when the battery voltages are varied, and there is no reactance between the grid and tuned circuit. Of course in actual practice, it is necessary to provide a d-c path for the space current of the tube, which can be accomplished by shunting the condenser, C_5 , with a high impedance choke.

It is often the case that a stopping condenser is desirable in the X_4 position, instead of a direct connection between grid and tuned circuit. This stopping condenser and the accompanying leak are advantageous

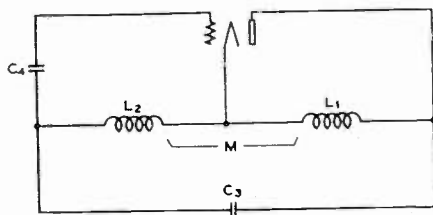

Fig. 3—Hartley oscillator, Grid stabilization.

$$C_4 = C_3 A^2 \left[\frac{L_0}{L_1 + L_2 A^2 - 2MA} \right]$$

where,

$$L_0 = L_1 + L_2 + 2M \quad A = \frac{L_1 + M}{L_2 + M}$$

inasmuch as it has been found by experience that an oscillator operating with a leak and condenser combination is inherently much more stable as regards change of frequency with change of battery voltage than an oscillator with a d-c low resistance path from grid to filament, even when a battery is employed to impose a negative bias on the grid. The explanation for this improved stability lies in the fact that the grid leak tends to keep the grid resistance, r_g , constant. It frequently happens, when the leak and condenser combination is used, that difficulty is experienced in avoiding "blocking" when a large enough condenser to have negligible reactance is employed. In such cases the required value of C_5 may be chosen in the manner discussed in connection with Fig. 4 below, which allows for a finite reactance between grid and tuned circuit, or else, as another alternative, the plate may be directly connected to the tuned circuit so that X_5 is zero, and stabilization may be accom-

plished by choosing the value of C_4 in accordance with the requirements then imposed by (8), which refer to Fig. 3 and necessitate the value of capacity shown on the figure. Another possible stabilizing arrangement is shown in Fig. 4, where either capacity or inductance

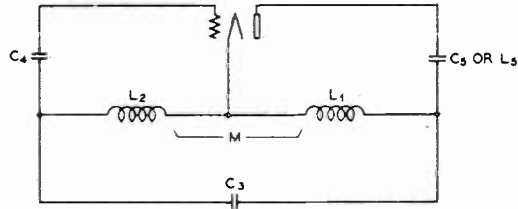

Fig. 4—Hartley oscillator, plate and grid stabilization.

$$\frac{1}{C_5} + \frac{A^2}{C_4} = \frac{1}{C_3} \left[\frac{L_1 + L_2 A^2 - 2MA}{L_0} \right]$$

$$L_5 = L_0 \frac{C_3}{C_4} A^2 - L_1 - L_2 A^2 + 2MA$$

where,

$$L_0 = L_1 + L_2 + 2M \qquad A = \frac{L_1 + M}{L_2 + M}$$

may be used on the plate side, depending on the value of capacity at C_4 on the grid side. Yet another possible modification of Fig. 4 would be to use an inductance on the grid side. This would require a very small capacity on the plate side, and probably is less convenient than the arrangement indicated in the figure.

In all three of the cases considered thus far, the equations show that the value of the stabilizing capacity or inductance depends upon the values of L_1 , L_2 , M , and C_3 so that if the frequency of the oscillator

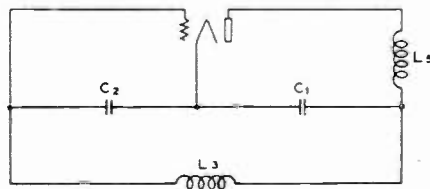

Fig. 5—Colpitts oscillator, plate stabilization.

$$L_5 = L_3 \frac{C_2}{C_1}$$

were varied intentionally, by changing L_1 , for instance, then a different value of stabilizing capacity or inductance would be required to secure independence of frequency and battery voltage at the new frequency. If, however, the circuit were so constructed that M were zero, and L_1 and L_2 were made so that they remained always equal to each other,

then the value of the stabilizing element would depend upon C_3 , only, and the frequency could be changed by varying L_1 and L_2 simultaneously without destroying the stabilizing adjustment.

COLPITTS OSCILLATOR

This property may be utilized to even greater advantage in connection with the Colpitts type of oscillator, which is illustrated in Figs. 5, 6, and 7 and will now be investigated with the aid of (8) in the same

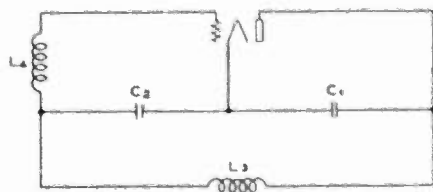

Fig. 6—Colpitts oscillator, grid stabilization.

$$L_4 = L_3 \frac{C_1}{C_2}$$

manner in which the relations necessary for stabilizing the Hartley oscillator were secured. Thus, for the Colpitts circuit:

$$X_1 = -\frac{1}{\omega C_1}$$

$$X_2 = -\frac{1}{\omega C_2}$$

$$X_m = 0$$

$$\omega^2 = \frac{1}{L_3} \left(\frac{1}{C_1} + \frac{1}{C_2} \right)$$

The values of the stabilizing elements required by (8) are given in Figs. 5, 6, and 7 which show several arrangements for the stabilizing

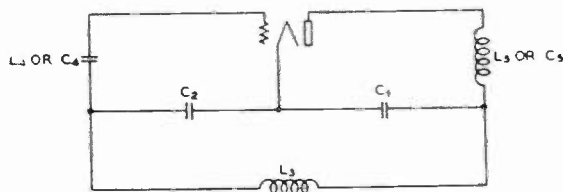

Fig. 7—Colpitts oscillator, plate and grid stabilization.

$$L_4 \left(\frac{C_2}{C_1} \right) + L_5 \left(\frac{C_1}{C_2} \right) = L_3$$

$$L_5 = L_3 \frac{C_2}{C_1} \left[1 + \frac{C_2}{C_4} \left(\frac{C_2}{C_1 + C_2} \right) \right]$$

impedance, as applied to the Colpitts-type oscillator. In particular, Fig. 7 shows a choice of either an inductance or a capacity on the grid side.

In Figs. 5 and 6 and in Fig. 7 when inductance is used on both plate and grid sides it is evident that if the condensers, C_1 and C_2 , are connected together in a "gang" mounting so that when they are varied, the ratio of their capacities remains constant, then the frequency of the oscillator may be changed by changing C_1 and C_2 without disturbing the stabilizing adjustment which causes the frequency to be independent of battery voltages.

FEED-BACK OSCILLATOR

Figs. 8, 9, and 10 shows conventional drawings of the type of oscillator circuit known as a "feed-back" or sometimes as a "tuned input"

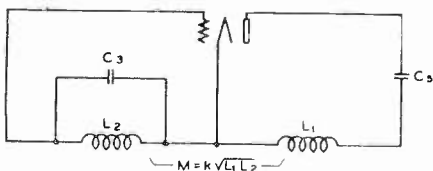

Fig. 8—Feed-back oscillator, plate stabilization.

$$C_5 = C_3 \frac{L_2}{L_1} \left(\frac{1}{1 - k^2} \right).$$

circuit. In Fig. 8 stabilizing is accomplished on the plate side; in Fig. 9 on the grid side; and in Fig. 10 on both sides. A mathematical analysis analogous to that which was described in detail in connection with Fig. 1

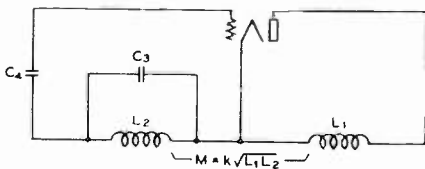

Fig. 9—Feed-back oscillator, grid stabilization.

$$C_4 = C_3 \left(\frac{k^2}{1 - k^2} \right).$$

gives the values of stabilizing impedances which are shown on the figures, and also indicates that the conditions for oscillation may be met when these values are employed.

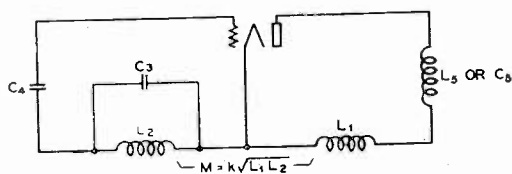

Fig. 10—Feed-back oscillator, plate and grid stabilization.

$$L_b = L_1 \left[k^2 \left(1 + \frac{C_3}{C_4} \right) - 1 \right]$$

$$C_b = C_3 \frac{L_2}{L_1} \left[\frac{1}{1 - k^2 \left(1 + \frac{C_3}{C_4} \right)} \right].$$

REVERSED FEED-BACK OSCILLATOR

Figs. 11, 12, and 13 show conventional drawings of the type of oscillator circuit known as a "reversed feed-back" or sometimes as a "tuned output" type of oscillator, with the application of stabilizing

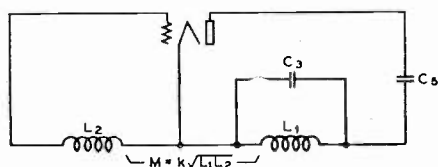

Fig. 11—Reversed feed-back oscillator, plate stabilization.

$$C_b = C_3 \left(\frac{k^2}{1 - k^2} \right).$$

impedances to cause the frequency to be independent of changes in battery voltages. In Fig. 11 the stabilizing impedance is placed between the plate and the tuned circuit; in Fig. 12 between the grid and coupling

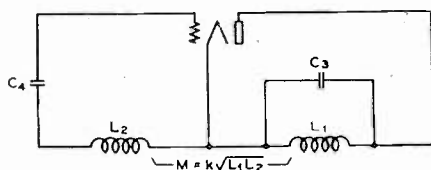

Fig. 12—Reversed feed-back oscillator, grid stabilization.

$$C_4 = C_3 \frac{L_1}{L_2} \left(\frac{1}{1 - k^2} \right).$$

coil; and in Fig. 13 stabilization is accomplished by impedances placed in both positions. Again, the mathematical analysis gives the values of the stabilizing impedances as shown on the figures and indicates that oscillation is possible when these values are used.

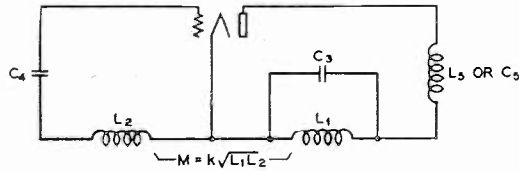

Fig. 13—Reversed feed-back oscillator, plate and grid stabilization.

$$L_5 = L_1 \left[1 + \frac{1}{k^2} \left(\frac{L_1 C_3}{L_2 C_4} - 1 \right) \right]$$

$$C_5 = \frac{C_3}{\frac{1}{k^2} \left(1 - \frac{L_1 C_3}{L_2 C_4} \right) - 1}$$

OTHER TYPES OF OSCILLATOR CIRCUITS

As an instance of the stabilizing of another general class of oscillator circuit which has wide application in a number of special cases, attention is drawn to the tuned-plate, tuned-grid circuit of Fig. 14. The

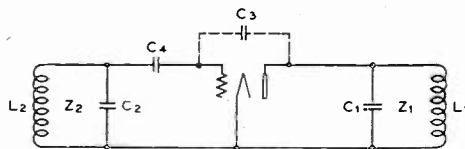

Fig. 14—Tuned-plate, tuned-grid oscillator with no magnetic coupling.

$$C_1 = \frac{L_2}{L_1} \left[C_2 + \frac{(1 + \mu) C_3 C_4}{C_4 + (1 + \mu) C_3} \right] - C_3$$

input and output circuits are shown in the drawing as consisting of condenser and inductance combinations connected in parallel. At any specified frequency, however, the parallel combination may be replaced by a series circuit, or, in fact, by any form of network which has the same impedance, and none of the currents or voltages in the remainder of the circuit will be altered. In particular, the inductance and capacity shown on the input side in Fig. 14 may be replaced by a

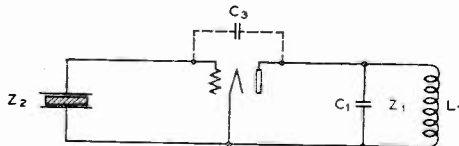

FIG. 14a

piezo-electric crystal, as shown in Fig. 14-a, having the same impedance at the operating frequency without affecting the currents and voltages in the remaining parts of the circuit.

It is well known that the frequency of such a piezo-electric oscillator is less affected by changes in battery voltages than is the frequency of the ordinary, nonstabilized electric oscillator. However, the battery voltages do influence the frequency of the piezo-electric oscillator to an extent which is undesirable for certain accurate types of work. It therefore becomes useful to apply stabilization to the piezo-electric oscillator. It will be shown that the stabilization may be accomplished by adjusting the size of the output tuning condenser to such a value that the impedance of the output circuit bears a certain critical relation to the impedance of the crystal, while at the same time, the circuit as a whole fulfills the conditions necessary for the existence of oscillations.

The same kind of stabilization is, of course, applicable to an electric oscillator having analogous relations between the input and output impedances. Thus, it is often possible to stabilize the Hartley oscillator by moving the connection between the filament and coil to different positions on the coil, until that one which gives the proper ratio of input to output impedances has been found. In the case of the Hartley and Colpitts oscillators, however, it is more often preferable to stabilize by the special circuit arrangements illustrated in Figs. 1 to 7, while, on the other hand, the tuned-grid, tuned-plate type of circuit lends itself readily to stabilization by adjustment of the output circuit.

Numerical expressions for the proper impedance relations may be obtained by noting that the circuit of Fig. 14 may be generalized into the circuit of Fig. 1 by regarding Z_4 and Z_5 as zero, while Z_2 comprises the whole input network which may consist of various arrangements of coils, condensers, grid leaks, and the like, and, in a similar fashion, Z_1 comprises the whole output network. The mathematical analysis given in connection with Fig. 1 may, therefore, be adapted to fit Fig. 14 immediately, and in place of (6) and (7) we have the two expressions:

$$X_0(r_p X_1 + r_p X_2) + \mu r_p X_1 X_2 = r_p X_2^2 + r_p X_1^2 \quad (11)$$

$$X_0(r_p r_p - X_1 X_2) = -X_1 X_2 (X_1 + X_2). \quad (12)$$

The requirements of (11) are:

$$r_p = r_p \frac{X_1}{X_2} \left[\frac{\mu X_2 + X_0 - X_1}{X_2 - X_0} \right] \quad (13)$$

which may be used to eliminate r_p in (12) and gives

$$X_0 r_p^2 (\mu X_2 + X_0 - X_1) = X_2^2 (X_0 - X_1 - X_2) (X_2 - X_0). \quad (14)$$

In order for the frequency to be independent of r_p , it is necessary for one of the factors on the left-hand side of the equation to be zero. This,

however, necessitates that one of the factors on the right-hand side of (14) also should be zero. Investigation shows that the only pair of factors of (14) that may both be zero, and still be consistent with (13) is the following:

$$\mu X_2 + X_0 - X_1 = 0 \quad (15)$$

$$X_2 - X_0 = 0. \quad (16)$$

Elimination of X_0 between these two expressions results in the following relation:

$$(1 + \mu)X_2 = X_1. \quad (17)$$

The frequency is then given by the expression:

$$X_1 + X_3 = 0. \quad (18)$$

Equation (17) expresses the relation which is required between the reactances of the input and the output network in order to provide for a constant frequency with varying battery voltages.

In the application of this stabilization to a piezo-electric oscillator such as is shown in Fig. 14-a it sometimes happens that stability improves with decrease in the value of the output tuning capacity but oscillations cease before complete stabilization is secured. The explanation for this and its remedy may be obtained from (17) and (18) by supposing that the reactance, X_2 , of the crystal may be represented by an antiresonant circuit, C_2 and L_2 , in series with a capacity, C_4 , while the output reactance, X_1 , consists of the antiresonant circuit, C_1 and L_1 . Thus, the value of C_1 which satisfies (17) and (18) is

$$C_1 = \frac{L_2}{L_1} \left[C_2 + \frac{(1 + \mu)C_3}{C_4 + (1 + \mu)C_3} C_4 \right] - C_3. \quad (19)$$

For discussion, the form which (19) takes in the absence of the stopping condenser, C_4 , is:

$$C_1 = \frac{L_2}{L_1} [C_2 + (1 + \mu)C_3] - C_3.$$

This shows that a fairly large value of C_1 may be required when C_4 is absent, which places the tuning of the plate antiresonant circuit in a rather critical portion of its reactance characteristic. In order to avoid this, the introduction of a fairly small condenser at C_4 is advantageous. Thus, if C_4 were made somewhat smaller than C_3 , then the value of C_1 required by (19) is roughly:

$$C_1 = \frac{L_2}{L_1} [C_2 + C_4] - C_3$$

which gives an appreciably smaller value of C_1 and results in stabilization with a much less critical adjustment than is the case when the stopping condenser is absent

In all of the above analyses, the requirement of a capacity or an inductance is indicated by the fact that the signs come out right in the final equations. If the wrong type of reactive element were used, it would result, for example, that a negative inductance apparently would be required, which of course would indicate the requirements of a capacitance.

ANOTHER TYPE OF STABILIZATION

A third general type of stabilization may be illustrated by considering a hypothetical oscillator having its plate circuit coupled back to its grid circuit by means of a transformer coil with a coefficient of coupling equal to unity. Methods of obtaining the equivalent effect of such a coil under practical operating conditions will be described later, so that for the present it will be assumed that a unity coupled coil is on hand. The equivalent circuit diagram of the oscillator is shown on Fig. 15, where the primary and secondary windings of the coil are indicated at X_1 and X_2 respectively.

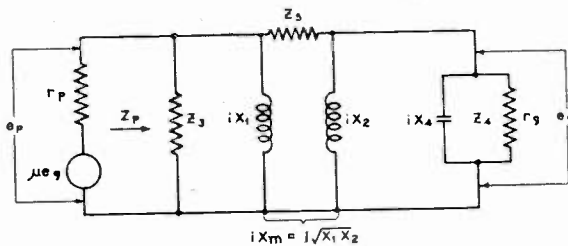

Fig. 15—Equivalent circuit of oscillator with unity coupling.

From the properties of unity coupled coils it follows that, no matter what impedances are hung across the coil, or connected between windings, the ratio of the voltage across the secondary to the voltage across the primary depends upon the coil reactances only, and not at all upon the attached impedances. In the circuit of Fig. 15 this ratio is given by the expression:

$$\frac{e_g}{E_p} = - \sqrt{\frac{X_2}{X_1}} \quad (20)$$

In general, the voltage E_p may be expressed in terms of the impedance looking out of the plate-filament terminals of the tube. Thus

$$E_p = - \frac{\mu e_0 Z_p}{r_p + Z_p} \quad (21)$$

where Z_p is the aforementioned impedance.

From (20) and (21) there results:

$$\frac{1}{Z_p} = \frac{1}{r_p} \left[\mu \sqrt{\frac{\bar{X}_2}{X_1}} - 1 \right]. \quad (22)$$

This equation completely expresses the operation of the oscillator in so far as impedance relations for the fundamental current component are concerned. From Fig. 15 ordinary circuit analysis shows that Z_p may be written

$$\frac{1}{Z_p} = \frac{1}{Z_3} + \frac{1}{Z_4} \left(\frac{X_2}{X_1} \right) + \frac{1}{iX_1} + \frac{1}{Z_5} \left(1 + \sqrt{\frac{\bar{X}_2}{X_1}} \right)^2$$

so that (22) becomes:

$$\frac{1}{Z_3} + \frac{1}{Z_4} \left(\frac{X_2}{X_1} \right) + \frac{1}{iX_1} + \frac{1}{Z_5} \left(1 + \sqrt{\frac{\bar{X}_2}{X_1}} \right)^2 = \frac{1}{r_p} \left[\mu \sqrt{\frac{\bar{X}_2}{X_1}} - 1 \right]. \quad (23)$$

The next step is to separate this into its real and imaginary components. We stipulate, as in the previous analyses, that the losses in the external circuit elements are small compared with those occasioned by the grid resistance of the tube. With this understanding, Z_4 may be separated into two parts, the one iX_4 , in parallel with the other which constitutes the grid resistance r_g . Both Z_3 and Z_5 are taken as pure reactances. Thus the last expression yields the two equations:

$$\frac{1}{X_3} + \frac{1}{X_4} \left(\frac{X_2}{X_1} \right) + \frac{1}{X_1} + \frac{1}{X_5} \left(1 + \sqrt{\frac{\bar{X}_2}{X_1}} \right)^2 = 0 \quad (24)$$

$$\frac{1}{r_g} \left(\frac{X_2}{X_1} \right) = \frac{1}{r_p} \left[\mu \sqrt{\frac{\bar{X}_2}{X_1}} - 1 \right]. \quad (25)$$

Equation (24) contains neither r_p , r_g , nor μ , so that the important conclusion can be drawn that the frequency of an oscillator with unity coupling between the plate and grid circuits depends only upon the inductances and capacities in the circuit, and not at all upon the tube parameters, r_p , r_g , and μ ; provided, however, that the losses in the external circuit are small, and the harmonic voltages across the tube are

small enough to allow r_p and r_o to be considered as pure resistances. In this connection, the interelectrode capacities may be grouped with the external circuit elements forming X_3 , X_4 , and X_5 , so that no high-frequency difficulty is to be anticipated from them.

Equation (25) contains the relation between r_p , r_o , and μ necessary to insure the presence of oscillation. In practice, the amplitude of the oscillations builds up until this relation is satisfied.

The foregoing theory of the action of a unity coupled oscillator has led to an extremely useful and desirable result; namely, the independence of frequency and operating voltages. The point now remaining to be shown is how to get the unity coupling.

In attacking this question, the first thing to notice is that our theory does not require that the unity coupling condition,

$$M = \sqrt{L_1 L_2}$$

should be obtained. What actually is required is the much less rigid condition:

$$X_m = \sqrt{X_1 X_2} \quad (26)$$

where X_1 and X_2 are not limited to inductance alone.

Thus, imagine one of the impedances, say X_2 , to consist of a coil L_2 , in series with a condenser, C_2 . We have then, by (26):

$$\omega^2 M^2 = \omega L_1 \left(\omega L_2 - \frac{1}{\omega C_2} \right) \quad (27)$$

or, writing

$$M = k \sqrt{L_1 L_2}$$

where k may now be less than one, we have from (27)

$$C_2 = \frac{1}{\omega^2 L_2 (1 - k^2)} \quad (28)$$

which gives the value of C_2 necessary to provide "unity" coupling at the operating frequency.

The value of X_2/X_1 is thus

$$\frac{X_2}{X_1} = \frac{\omega L_2 - \frac{1}{\omega C_2}}{\omega L_1} = \frac{\omega L_2 - \omega L_2 (1 - k^2)}{\omega L_1} = k^2 \frac{L_2}{L_1} \quad (29)$$

In practice, X_3 , X_4 , and X_5 would usually be capacities, to correspond to the circuit of Fig. 17. With this arrangement, and the relation given by (29) we have the frequency from (24):

$$\omega^2 = \frac{1}{L_1 \left[C_3 + k^2 C_4 \frac{L_2}{L_1} + C_5 \left(1 + k \sqrt{\frac{L_2}{L_1}} \right)^2 \right]} \quad (30)$$

The value of C_2 is thus written from (28) and (29) as follows:

$$C_2 = \left(\frac{1}{L_2} \right) \left[\frac{C_3 + k^2 C_4 \frac{L_2}{L_1} + C_5 \left(1 + k \sqrt{\frac{L_2}{L_1}} \right)^2}{1 - k^2} \right] \quad (31)$$

This is the general value of C_2 needed to stabilize the oscillator, and applies to any grid-stabilized oscillator where the unity coupling concept can be employed. In the case where C_5 and C_4 are small enough to be neglected we have the equivalent circuit of the reversed feed-back oscillator of Fig. 12, and for the value of the stabilizing capacity:

$$C_2 = \frac{L_1}{L_2} \frac{C_3}{1 - k^2} \quad (32)$$

When the notation of Fig. 17 is reconciled with that of Fig. 12, this is in agreement with the conclusion reached for the reversed feed-back oscillator by the former method of analysis.

The present analysis has the twofold advantage of allowing the interelectrode capacities to be included, which results in (31) instead of (32); and of giving a more readily interpreted picture of the relation required for stability, namely the "unity coupling" condition of equation (26). Equation (31) is moreover applicable to the tuned-plate tuned-grid type of oscillator, when there is magnetic coupling between the input and output circuits. Thus, in the particular instance when L_1 and L_2 are equal, as also are C_3 and C_4 , we have from (31):

$$C_2 = C_3 \frac{(1 + k^2)}{(1 - k^2)} + C_5 \frac{(1 + k)}{(1 - k)} \quad (33)$$

Hence, if tuning is done by "ganging" C_3 and C_4 together and varying them simultaneously, the stability may be maintained for all frequencies by making C_2 to consist of two parts; the one a fixed capacity equal to

$$C_5 \frac{(1 + k)}{(1 - k)}$$

and the other a variable capacity "ganged" together with C_3 and equal to

$$C_3 \frac{(1 + k^2)}{(1 - k^2)}$$

In order to insure fulfillment of the requirements of this theory, it was mentioned above that the oscillator should be relatively free from harmonics, so that r_p and r_g may be taken as pure resistances. That this requirement can be successfully met may be demonstrated by reference to Fig. 15 and consideration of the means which would be employed if the circuit represented an amplifier with e_o impressed on the grid of a following tube instead of on the grid of the driving tube itself. In such an arrangement, it is well known that the distortion is least when the impedance looking out of the plate of the driving tube is made materially larger than the internal plate resistance of the tube itself; and, second, when the impedance looking back out of the grid of the driven tube is made materially smaller than the internal grid resistance of the tube itself. The conditions which determine how nearly these two requirements may be met in the oscillator tube are governed by (22). Thus

$$\frac{r_p}{Z_p} = \mu \sqrt{\frac{X_2}{X_1}} - 1 \quad (34)$$

This should be small in order that the first requirement mentioned above should be fulfilled. Hence $\mu k \sqrt{L_2/L_1}$ should exceed unity by as little as is consistent with reliable oscillation. When we come to consider the second of the requirements for decreasing harmonics we obtain an expression analogous to (34), namely:

$$\frac{Z_g}{r_g} = \mu \sqrt{\frac{X_2}{X_1}} - 1 \quad (35)$$

so that the requirement that the impedance looking back out of the grid should be less than the grid resistance is satisfied by the same condition as that required by (34); namely, that $\mu k \sqrt{L_2/L_1}$ should exceed unity by as little as is consistent with reliable oscillation.

From Fig. 17, by regarding C_3 and C_5 as zero, the feed-back type of oscillator is obtained. Again, when C_3 and C_4 are zero, the Hartley oscillator results. The stabilization both of the feed-back oscillator and the Hartley type by the method shown on the figures was not described in the analysis of Figs. 3 and 9 inasmuch as the present method places the stabilizing element directly in the tuned circuit, whereas the former method placed it between the tuned circuit and the vacuum tube.

Besides the general circuit of Fig. 17, where stabilization is accomplished by imposing a critical value on C_2 , there is the alternative shown on Fig. 16, where the stabilizing element is C_1 , a condenser lo-

cated in series with L_1 , and of such a size as to cancel the leakage reactance between L_1 and L_2 . The formula giving this size in terms of the other circuit constants is shown on the figure, and the condition that

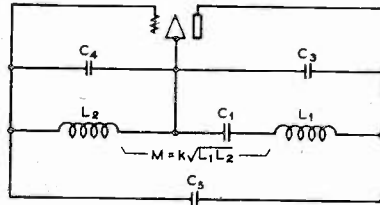

Fig. 16—General circuit of oscillator with unity coupling, plate stabilization.

$$C_1 = \frac{L_2}{L_1} \left[\frac{C_3 k^2 \frac{L_1}{L_2} + C_4 + C_5 \left(1 + k \sqrt{\frac{L_1}{L_2}} \right)^2}{1 - k^2} \right]$$

the harmonic content should be small for circuits of the general type of Fig. 16 is that $(\mu/k)\sqrt{L_2/L_1}$ should exceed unity by as little as is consistent with reliable oscillation.

From Fig. 16 the circuits of various types of oscillators may be derived in the manner which was described in connection with Fig. 17. Of these circuits, the reversed feed-back and the Hartley were not described in connection with Figs. 11 and 12.

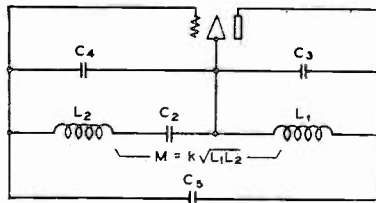

Fig. 17—General circuit of oscillator with unity coupling, grid stabilization.

$$C_2 = \left(\frac{L_1}{L_2} \right) \left[\frac{C_3 + k^2 C_4 \left(\frac{L_2}{L_1} \right) + C_5 \left(1 + k \sqrt{\frac{L_2}{L_1}} \right)^2}{1 - k^2} \right]$$

A combination of the features of Figs. 16 and 17 may be employed in the manner shown in Fig. 18 where condensers C_1 and C_2 are placed

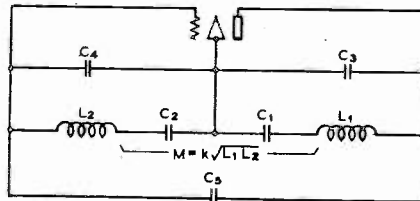

Fig. 18—General circuit of oscillator with unity coupling, plate and grid stabilization.

$$\omega^2 k^2 L_1 L_2 = \left(\omega L_1 - \frac{1}{\omega C_1} \right) \left(\omega L_2 - \frac{1}{\omega C_2} \right)$$

in series both with L_1 and L_2 , respectively. In this case, the formula for the required size of C_1 and C_2 becomes quite cumbersome when expressed in terms of the other circuit elements, only. Since, however, the frequency is usually known approximately, we may use the relation

$$X_m^2 = X_1 X_2$$

for finding C_1 and C_2 in terms of ω and get:

$$\omega^2 k^2 L_1 L_2 = \left(\omega L_1 - \frac{1}{\omega C_1} \right) \left(\omega L_2 - \frac{1}{\omega C_2} \right). \quad (36)$$

As in the case of Figs. 16 and 17, so also may the circuit of Fig. 18 be modified to correspond to the reversed feed-back, the feed-back and the Hartley types of oscillators where stabilization is accomplished both on the plate and on the grid sides.

EXPERIMENT

Of course, Figs. 1 to 18 are intended to represent only the fundamentals of the corresponding circuits. For practical operation these circuits would have to include the usual stopping condensers, leak resistances, sources, choke coils, and accessories. These circuit elements should be so valued and introduced into the oscillator circuit as a whole as not to interfere with the relations required by the analyses, in order to maintain the stabilizing effects of the stabilizing impedances. As to the choke coils, this means merely that they must be what the name implies, that is, a substantially infinite impedance. In the case of a Hartley-type oscillator, and where the reactance is chosen to be located in the grid leads instead of in the plate leads, a condenser must be used. This may replace the conventional stopping condenser. Where the reactance is in the plate lead for a similar type of oscillator, the stopping condenser in the plate lead should be large so as to have negligible impedance. Similar expedients are suggested for the impedances of the other types of oscillator circuits.

As typical of the general method whereby any of the simplified circuits of Figs. 1 to 18 may be elaborated into a conventional circuit of this kind, including the various adjunctive circuits, Fig. 19 should be referred to. This figure illustrates a complete wiring diagram of the oscillator of Fig. 7 and shows an example of stabilization by means of the inductance L_5 in the plate circuit and the inductance L_4 in the grid circuit. In addition to satisfying the relation shown on Fig. 7, it may be noticed that the value of L_5 is such as to tune with C_1 to the oscillation frequency, and, similarly, the value of L_4 is such as to tune with C_2 to the oscillation frequency. Under such conditions a resistance of ap-

preciable value may be introduced into the circuit of L_3 without affecting the frequency of the stabilization. The reason for this may be explained briefly as follows:

Consider a single series circuit formed of one of the three meshes of Fig. 19, for instance that composed of the elements, r_p , in parallel with the 8000-ohm leak, L_4 , and C_2 . This circuit is in series resonance at the frequency at which the circuit as a whole oscillates. Therefore it tends to introduce resistance impedance only into whatever circuits it is reactively coupled with. Thus, the effect of this circuit upon the adjacent circuit, L_3 , C_1 , C_2 , with which it is coupled is to introduce resistance only. Similarly, if this last circuit operates at series resonance, only re-

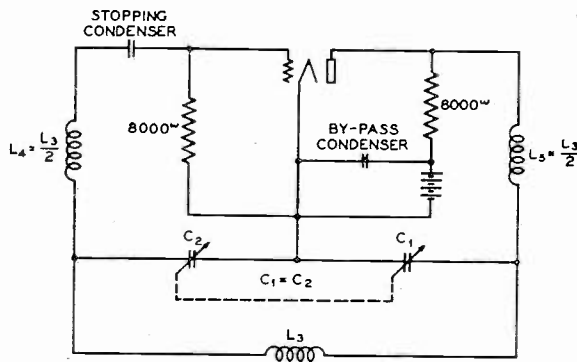
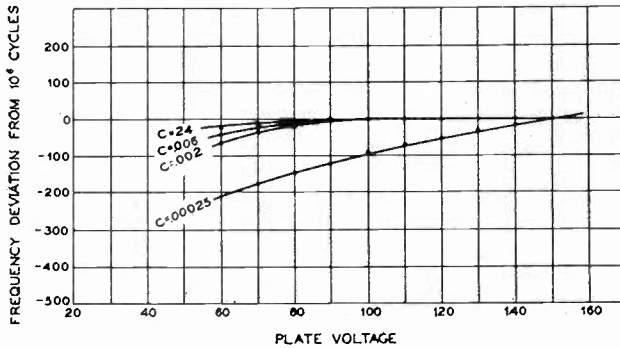

Fig. 19—Practical arrangement of oscillator with three series tuned coupled circuits.

sistance is introduced into the plate circuit, L_5 , C_1 , and r_p , in parallel with the d-c feed of 8000 ohms, with which it is coupled. Hence, if the plate circuit likewise operates at series resonance, a change in resistance of any part of the circuit will change only the resistance into which the tube works and therefore will leave the frequency unaltered.

In a more general sense, any of the oscillator forms discussed may be stabilized even when the resistance in the external circuit is not inappreciable, the effect of the external resistance manifesting itself in two ways: first, a value of stabilizing reactance slightly different from that given in the above formulas may be required, and second, the frequency, instead of being absolutely independent of battery voltage variations, goes through a maximum or a minimum as the battery voltages change, the voltage at which this maximum or minimum occurs depending upon the exact value of the stabilizing reactance. An exact mathematical analysis of this more general case yields formulas for the stabilizing reactances which involve r_o or r_p and hence are not as useful even in a case where the resistance in the external circuit is of importance as are the formulas presented above. The latter may be used as first approximations in any event.

In practice it has been found that when ordinary precautions are taken to insure a low-loss external circuit, the relations given above hold very accurately and any variations in frequency then existing as a result of varying battery voltages may be traced to either one of two causes, both of which may be guarded against: first, the interelectrode capacities of the tube may be sufficient to enter into the impedance relations. In this event, a change in the form of circuit, such as the use of the tuned-plate, tuned-grid arrangement of Fig. 17, where the inter-



(a)

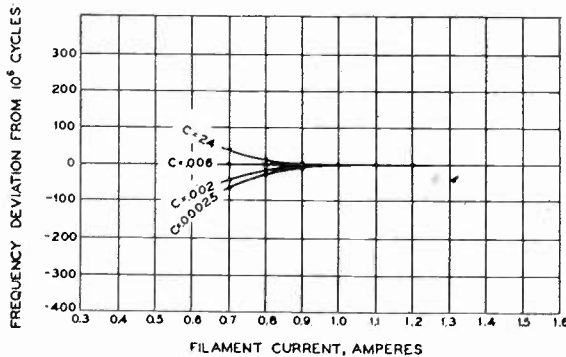

(b)

Fig. 20—Performance curves of reversed feed-back oscillator with tight coupling, grid stabilization.

(a) Variation of frequency with plate potential.

(b) Variation of frequency with filament current.

electrode capacities form a part of the external circuit, will eliminate the difficulty. Second, the harmonic currents caused by the nonlinear characteristics of the vacuum tube may introduce the effect of a reactive impedance back into the fundamental which may vary with battery voltage and so change the frequency. The remedy for this is to provide a low reactance path for the harmonics so that they have no opportunity to build up a reactive voltage across the tube, and also to use grid leaks and other such well-known devices for reducing the harmonic currents generated by the tube.

For the purpose of providing information as to the order of stability which may be expected from the several methods of stabilization outlined above, various quantitative experimental tests have been conducted. The general results of these tests may be summarized by saying that a close adherence to the theoretical requirements results in an oscillator whose frequency depends upon operating voltages to such a small extent that temperature effects become the predominating influence and special precautions must be taken in order to eliminate them before data showing the dependence of frequency on operating voltages can be obtained.

For instance, the data for the curves shown in the accompanying Figs. 20 and 21 were secured by the following procedure. A plate potential of 150 volts and a filament current of one ampere were selected as reference points. The frequency under these conditions was noted. A change to a different operating condition, say 140 volts plate potential and 1 ampere filament current, was made and the frequency measured as rapidly as possible, whereupon the operating voltages were returned immediately to their reference values and the frequency rechecked. Special care was taken to keep the room temperature very constant, but, even so, the heating of the parts of the oscillator circuit by the operating alternating and direct currents was sufficient to affect the frequency to an undesirable extent, requiring that the readings be taken with unusual rapidity in order to return the voltages to normal before the changed operating currents could appreciably affect the temperature of the coils, tube elements, and other parts of the circuit.

The final results, however, are consistent enough to be representative of what can be accomplished, and the two sets of curves shown in the figures bring out a result which was found to hold throughout the investigation; namely that the higher the coefficient of coupling in the coil used to secure feed-back, the less critical was the value of the stabilizing impedance. Thus, in Fig. 20 the coupling was as tight as it was possible to produce by winding the primary and secondary simultaneously upon a tube to form a single layer solenoid, while the coil used for Fig. 21 was made by removing about half the turns from the secondary of the same coil, thus providing for a step-down in voltage as well as a decrease in coupling. A possible explanation for the less critical adjustment required with tight coupling lies in the fact that the tightly coupled coil satisfies the condition for "unity coupling" as given by (26) over a range of frequencies whereas the loosely coupled coil satisfies the condition at only the frequency critically determined by the stabilizing capacity.

This would appear to indicate that the type of stabilization described in the theoretical part of the paper under the unity coupling concept offers certain practical advantages over those types where the stabilizing element is placed between the tuned circuit and the tube,

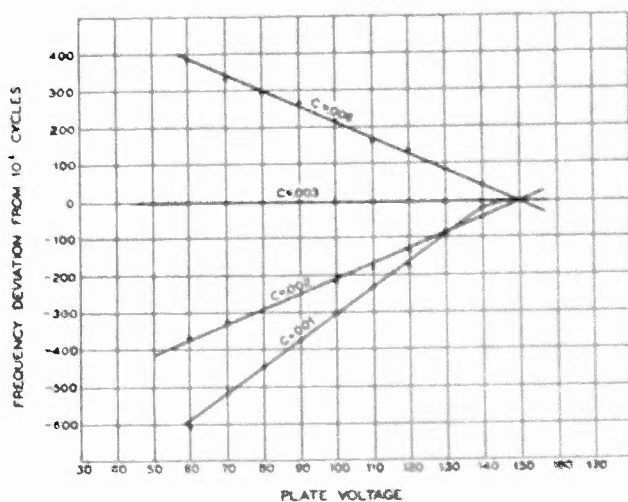

(a)

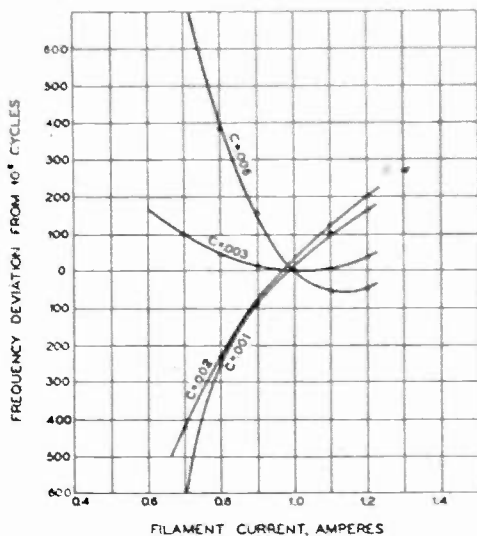

(b)

Fig. 21—Performance of reversed feed-back oscillator with loose coupling, grid stabilization.

(a) Variation of frequency with plate potential.

(b) Variation of frequency with filament current.

as in the Colpitts oscillator of Figs. 5, 6, and 7, for example, where no magnetic coupling whatever is employed. Experiments with the Colpitts circuit have shown, however, that when the capacities in the tuned circuit are made large relative to the inductance, a very satis-

factory degree of stabilization may be secured at the lower frequencies where interelectrode capacities may be neglected. A close inspection of the theory of stabilizing the frequency of the Colpitts oscillator shows an argument analogous to that of the coupled coils; namely that the smaller we make the inductance in the tuned circuit, and the larger we make the capacity, the frequency being kept constant, the greater will be the range of frequencies over which the condition, required by (8), that the series reactance of the tuned circuit be zero, is satisfied to an approximation sufficiently good for practical purposes, and hence the less critical will be the adjustment of the stabilizing impedance.

For the data in Figs. 20 and 21 a reversed feed-back type of oscillator was employed, having an elementary circuit similar to that of Fig. 12. A grid leak was placed in parallel with the stabilizing capacity, but care was taken to see that the resistance of the leak was always so high that its value did not affect the frequency. This was done by using a variable resistance and increasing its value until the frequency no longer changed. A large grid leak has always been found advantageous in securing constancy of frequency, but the size of the leak reaches a practical limitation determined by the time constant which produces the familiar "blocking."

The plate battery potential was fed through a choke in series with the plate inductance coil, the combination of choke and B battery being thoroughly by-passed with a large condenser.

For the purpose of checking the size of the stabilizing capacity to find its agreement with theory, an indirect method was used. The theory requires that

$$C_4 = C_3 \frac{L_1}{L_2} \left(\frac{1}{1 - k^2} \right)$$

as shown on Fig. 12. The operating frequency was one megacycle, which made a direct measurement of the coupling coefficient, k , somewhat awkward, so that a method based on the "unity coupling" concept was employed. Thus from (26)

$$k^2 \omega^2 L_1 L_2 = \omega L_1 \left(\omega L_2 - \frac{1}{\omega C_4} \right) \quad (37)$$

may also be used for determining C_4 . The primary, L_1 , of the coil was connected through an impedance to a source of e.m.f. of one megacycle, and a vacuum tube voltmeter was placed across it. The condenser, C_4 , was placed directly in parallel with the secondary, L_2 . With this arrangement the impedance looking into the primary is

$$Z = i\omega L_1 + \frac{\omega^2 k^2 L_1 L_2}{i\left(\omega L_2 - \frac{1}{\omega C_4}\right)}$$

unless points very near the resonance point are considered. This last equation may be written

$$iZ\left(\omega L_2 - \frac{1}{\omega C_4}\right) = -\omega L_1\left(\omega L_2 - \frac{1}{\omega C_4}\right) + \omega^2 k^2 L_1 L_2 \quad (38)$$

The condenser, C_4 , was varied until the reading of the vacuum tube voltmeter became zero. This means that Z was zero, and hence (38) gives the value of C_4 required by (37) which is in turn the value needed to stabilize the oscillator.

How well this checked the actual values needed for the case shown in Figs. 20 and 21 may be seen by the following: For Fig. 21 the value of C_4 measured as above, was 4000 $\mu\mu\text{f}$. The experimental value was 3000 $\mu\mu\text{f}$. For Fig. 20 the measurement gave a rather broad zero on the vacuum tube voltmeter, which was, however, estimated at 8400 $\mu\mu\text{f}$. For a check, a measurement was made at 7 megacycles which gave a sharper zero, and a value of 120 $\mu\mu\text{f}$. This must be reduced to its equivalent value of 1 megacycle by multiplying by 7^2 which gives 5880 $\mu\mu\text{f}$. The experimental curves of Fig. 20 show a noncritical value of 6000 $\mu\mu\text{f}$, which is nevertheless in good accord with the above measurements, while in Fig. 21 the agreement is somewhat more striking.

As an example of stabilization of oscillators in the altogether different frequency region from 7 to 40 kc, the following table was taken from data kindly supplied by F. J. Rasmussen:

TABLE I

| Frequency kc | L_1 mh | L_2 mh | Coupling k | Stabilizing Capacity $\mu\mu\text{f}$ | |
|-----------------|-------------|-------------|-----------------|--|-------------|
| | | | | Experimental | Theoretical |
| 12.5 | 3.176 | 6.891 | 0.131 | 0.0021 | 0.0022 |
| 40.0 | 3.210 | 7.010 | 0.134 | 0.0018 | 0.0023 |
| 12.5 | 3.178 | 6.974 | 0.129 | 0.0021 | 0.0022 |
| 40.0 | 3.211 | 7.094 | 0.133 | 0.0018 | 0.0023 |
| 7 | 2.498 | 0.500 | 0.720 | 0.4 to ∞ | 2.07 |
| 15 | 2.499 | 0.498 | 0.723 | 0.2 to ∞ | 0.46 |
| 15 | 1.409 | 0.161 | 0.695 | 0.2 to ∞ | 1.33 |
| 23 | 1.407 | 0.161 | 0.698 | 0.1 to ∞ | 0.58 |
| 23 | 0.665 | 0.093 | 0.677 | 0.1 to ∞ | 0.99 |
| 31 | 0.665 | 0.093 | 0.681 | 0.1 to ∞ | 0.57 |
| 31 | 0.487 | 0.076 | 0.663 | 0.1 to ∞ | 0.64 |

This table again emphasizes the less critical adjustment required when the coupling is tight, as in the last seven rows.

It is hoped that the foregoing data and comments will serve as a guide to design methods for constant frequency oscillators, in so far

as dependence of the frequency on operating voltages is concerned. Combinations and permutations of the various circuits dealt with will occur to the designer who requires special arrangements to fit special cases. The generalized circuit of Fig. 18 is suggested as being adaptable to meet the most widely varying conditions. This is particularly true at very high frequencies, since all the interelectrode capacities are included in the circuit of that figure.

The popular "push-pull" type of circuit may likewise be generalized to correspond to several of the fundamental circuits illustrated in the figures, and may be stabilized by the methods indicated. However, because of the nonuniformity of vacuum tubes and the added complication of the circuit, no advantage has been obtained by its use, so that the single tube circuits are to be preferred wherever special conditions do not require the push-pull type.

APPENDIX

The complete and rigorous mathematical relations for oscillation circuits containing vacuum tubes have seldom been discussed in connection with their practical application to useful circuits. In the case of the stabilization of oscillators against changes in battery voltages it is important to base the theory upon as strictly rigorous a mathematical foundation as possible, yet at the same time to be able to express the results in readily useful terms. It will be shown that this desirable result may be attained by a proper interpretation of the meaning of the internal impedances, r_p and r_o , of the vacuum tube.

To show this in the shortest and most obvious way, a simple series circuit will be considered. Let the circuit consist of a resistance, R , a condenser, C , and an inductance, L , all connected in a series with a vacuum tube which may be taken as having a "negative resistance" characteristic. In order to increase the generality of the demonstration, a sinusoidal driving voltage, E , of angular frequency, ω , is also allowed to act on the circuit. By Kirchhoff's Law, the current in the circuit is expressed by the equation

$$E = RI + L\frac{dI}{dt} + \frac{1}{C} \int Idt + V \quad (1)$$

where V is the drop across the vacuum tube. As a general expression for V in terms of the current the following expression may be used:

$$V = V_0 + A_1I + A_2I^2 + A_3I^3 + \dots \quad (2)$$

We are interested in the "steady state" solution, and accordingly a Fourier series will be the most general form which can be assumed for

the current. It is convenient to write the series in the following form:

$$I = \sum_{n=-\infty}^{\infty} \frac{b_n}{2} e^{in\omega t} \quad (3)$$

or, for brevity, in the symbolic form

$$I = \sum I(n\omega) \quad (4)$$

where the summation is understood to extend from minus infinity to plus infinity. Substitution of (4) and (2) into (1) gives:

$$\begin{aligned} E = R \sum I(n\omega) + L \sum in\omega I(n\omega) + \frac{1}{C} \sum \frac{I(n\omega)}{in\omega} \\ + V_0 + A_1 \sum I(n\omega) + A_2 \sum \sum I(n\omega) I(m\omega) \\ + A_3 \sum \sum \sum I(n\omega) I(m\omega) I(l\omega) + \dots \end{aligned} \quad (5)$$

For the component of fundamental frequency, ω , we get

$$\begin{aligned} E(\omega) = RI(\omega) + Li\omega I(\omega) + \frac{I(\omega)}{Ci\omega} + A_1 I(\omega) \\ + A_2 \sum_{n+m=1} I(n\omega) I(m\omega) + A_3 \sum_{n+m+l=1} I(n\omega) I(m\omega) I(l\omega) + \dots \end{aligned} \quad (6)$$

where the summation terms involve the products of all frequency components which beat together to give the fundamental, as indicated. In order to put the last expression in symmetrical form, it is convenient to multiply and divide each of the summation terms by $I(\omega)$ so that we may write

$$\begin{aligned} E(\omega) = I(\omega) \left[R + Li\omega + \frac{1}{Ci\omega} + A_1 + \frac{A_2}{I(\omega)} \sum I(n\omega) I(m\omega) \right. \\ \left. + \frac{A_3}{I(\omega)} \sum I(n\omega) I(m\omega) I(l\omega) + \dots \right] \end{aligned} \quad (7)$$

This expression exhibits the terms in square brackets in the form of an impedance, and shows that the vacuum tube may be treated as an ordinary linear circuit element if it is considered as having the impedance

$$Z = A_1 + \frac{A_2}{I(\omega)} \sum I(n\omega) I(m\omega) + \frac{A_3}{I(\omega)} \sum I(n\omega) I(m\omega) I(l\omega) + \dots \quad (8)$$

Of course, the numerical value of such an impedance cannot be found from this expression alone, but in oscillator analysis there is no

necessity for its numerical evaluation. The very important fact that the nonlinear elements in a circuit network may be replaced by equivalent impedances so that the ordinary circuit analysis can be employed has been demonstrated. It is possible to tell something about the form of the tube impedance from (8). Thus, the first term, namely A_1 , is a real quantity and contributes a part of the total effective resistance of the tube. All of the remaining terms are, in general, complex, depending upon the phases of the different harmonic currents. Thus, the conclusion is reached that a nonlinear resistance may be reduced to an equivalent linear impedance, but that this impedance has a reactive as well as a resistive component in the general case. There is at least one important instance where the equivalent linear impedance is resistive only. This occurs when the impedance in the circuit external to the vacuum tube contains resistance, only, to all of the harmonic currents.

With the general conception of the impedance of the vacuum tube, described above, the fundamental component of (1) becomes

$$E = \left[R + i\omega L + \frac{i}{i\omega C} + r + iX \right] I \quad (9)$$

where the tube impedance is represented by $r+iX$.

When the driving voltage, E , is zero, as in the case of oscillators, then for a finite current to exist the oscillation conditions are:

$$\begin{array}{l|l} R + r = 0 & \\ \omega L - \frac{1}{\omega C} + X = 0 & \end{array} \quad (10)$$

In the treatment of oscillator networks employed in the foregoing paper the quantities, r_p and r_o , are used in the sense of the resistance, r , in (9) and (10) of this appendix. The reactive component, X , of the tube impedance has been neglected in the paper, for the reason that all of the circuits discussed are of such character that the reactance of the external circuit to the harmonic currents may be made quite low, and the nonlinearity of the vacuum tube characteristics is not such as to cause excessive production of harmonics.

In the case of the dynatron type of oscillator, where the harmonic currents are especially strong, it has been found by experiment that the reactive component of the tube impedance cannot be neglected, but that it is, in fact, altogether responsible for the variation in frequency with battery voltages which is characteristic of the dynatron oscillator.

A RECENT DEVELOPMENT IN VACUUM TUBE OSCILLATOR CIRCUITS*

BY

J. B. Dow

(Bureau of Engineering, Navy Department, Washington, D. C.)

Summary—A constant frequency oscillator, which depends for its operation upon the use of electron coupling between the oscillation generating portion of the circuit and the work circuit, is described. This form of coupling is employed to isolate the work circuit from the frequency determining portion of the system. The oscillator is of the two-anode type (UX-865) and it is shown that by suitable choice of anode voltages, compensating effects may be obtained whereby changes in generator voltage may be made to have a negligible effect upon the frequency of oscillation.

THE circuit briefly described below is the result of an effort to develop a continuously variable source of radio-frequency energy which would meet a specification demanding (1) a high degree of frequency stability under such operating conditions as are usually imposed by variations in ambient temperature, supply voltages and loading conditions, and (2) the supply of a relatively large amount of radio-frequency energy.

Among the more important applications for such an oscillator are (1) as a master oscillator for radio transmitter control and (2) as a heterodyne oscillator.

After many experiments and observations involving the familiar circuits it was concluded that the following difficulties would have to be overcome or greatly minimized in the development of a circuit which would meet the specification.

- (a) Whenever capacitive, inductive or direct coupling were employed between known forms of oscillators and any terminal apparatus, changes in the latter were found to influence the frequency of oscillation so long as this coupling existed to such an extent as permitted appreciable amounts of energy to be derived from the oscillator. This influence of terminal apparatus upon frequency could of course be reduced appreciably by very loose coupling or by coupling to derive energy from the oscillator at some harmonic of the fundamental frequency, but even under these conditions the effect of terminal apparatus was found to be quite noticeable especially since it was desired to keep all possible accumulative sources of error to within 0.015 per cent.
- (b) Other well-known but less conventional forms of oscillator circuits such as those utilizing the dynatron principle were found to suffer from the influence of terminal apparatus quite as much as the more conventional types.

* Decimal classification: R133. Original manuscript received by the Institute, July 20, 1931.

- (c) All known forms of oscillators were found to suffer appreciably from changes in the electrical constants of the oscillator tube, these changes arising principally from temperature effects resulting either from a change in ambient temperature or to variations in anode dissipation which might be brought about as the direct result of changes in the electrical constants of terminal apparatus or variable loading conditions. Changes in ambient temperature could, of course, be reduced to a negligible value by temperature control of the oscillator tube and circuits,—this would not, however, care for temperature effects of short duration resulting from other causes.
- (d) Variations in the supply voltages of all known oscillators which were investigated were found to have a marked effect upon frequency. Changes in cathode voltage were found to have less effect upon frequency than proportional changes in the anode voltage.

Due consideration of the facts mentioned in subparagraphs (a) and (b) above led to the conclusion that a form of oscillator which would overcome the very real deficiencies due to the influence of terminal apparatus upon frequency should be made an initial goal.

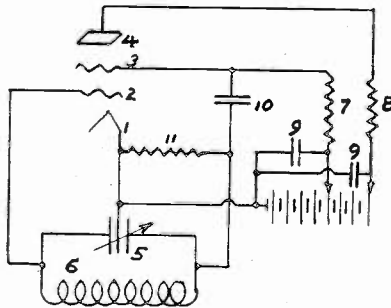

Fig. 1

Study of results obtained with the familiar oscillators suggested that a very real deficiency existed by virtue of the fact that the output circuit in each was an inherent part of the frequency determining portion. Such a condition obviously made any terminal apparatus an electrical part of the frequency determining portion. This fact having been recognized, it suggested that some arrangement of the circuit which would isolate the output circuit would appear to offer promise. Many experiments confirmed the desirability of utilizing a separate anode associated with the electron stream for deriving energy from the oscillator in lieu of coupling or connecting to the frequency determining portion of the circuit.

After many experiments, the basic circuit illustrated in Fig. 1 demonstrated the greatest freedom from external circuit reaction. This circuit comprises an electron tube having a cathode 1, a control grid 2, an inner anode 3, and an outer anode 4 connected as shown. The frequency of oscillation is substantially determined by the resonant

circuit made up of the capacity 5 and the inductance 6. 7 is a radio-frequency choke and 8 is a generic impedance representing the external portion of the output circuit which in this case becomes the work circuit. The circuit of Fig. 1, while constituting a step aimed to isolate the work circuit from the frequency determining portion, is not suitable for present purposes because of the electrostatic capacity existing between the inner and outer anodes. Electron coupling only is desired between the frequency determining portion of the circuit and the work circuit.

The particular arrangement of tube elements shown in Fig. 1 lends itself readily to neutralization of the effect of capacity which exists between those elements of the tube associated with the oscillation generating portion of the circuit and the work circuit anode. Neutral-

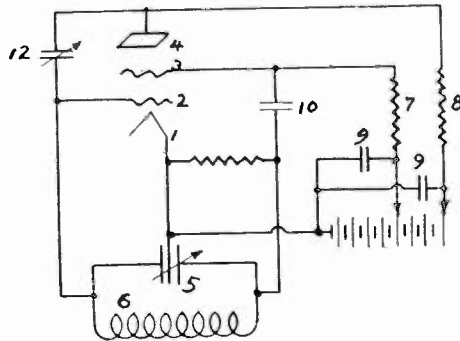

Fig. 2

ization is accomplished by connecting a capacity 12 between the control grid and outer anode as shown in Fig. 2. When this capacity is adjusted so that a potential is applied to the outer anode which is equal and opposite to that applied through the interelement capacity between the inner and outer anodes, then the oscillator is effectively neutralized. For ordinary tube structures, the following relation is approximately correct:

$$C_n/C_t = C_p/C_g$$

where,

C_n = neutralizing capacity.

C_t = interelement capacity between inner and outer anodes.

C_g = capacity of grid section of capacity 5 of Fig. 2.

C_p = capacity of plate section of capacity 5 of Fig. 2.

The neutralizing connection shown in Fig. 2 is independent of frequency. Capacity 12 may be readily adjusted to the correct value by disconnecting the outer anode potential, inserting a small thermomilliammeter in the work circuit 8, and adjusting the capacity 12

until the radio-frequency current indicated by the thermomilliammeter is of zero value.

While the circuit of Fig. 1 lends itself to the simple neutralizing scheme shown in Fig. 2 it will be recognized that other possible arrangements of the tube elements require somewhat different treatment in neutralizing. It is quite conceivable that if the output circuit anode 4 of Fig. 1 is so disposed as to have equal capacity with respect to elements 2 and 3, no neutralizing arrangement would be required, provided the circuit is so arranged that equal and opposite radio-frequency potentials are maintained upon elements 2 and 3.

In Fig. 3 the work circuit anode is screened electrostatically from those elements of the tube involved in oscillation generation so that neutralizing is unnecessary.

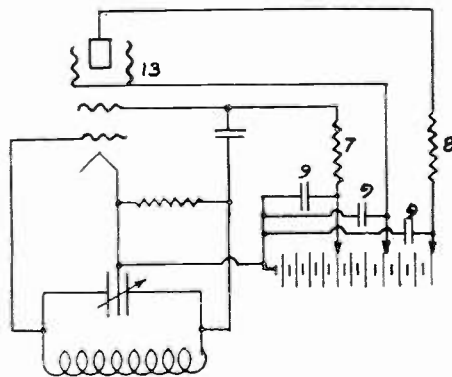

Fig. 3

The particular choice of fundamental circuit shown in Fig. 1 was made because those elements of the tube associated directly in oscillation generation are shunted by portions of the capacity 5 which may be made relatively large in comparison with the interelement capacities. Changes in the latter capacities due to temperature and vibration will, therefore, have a minimum effect on the frequency of oscillation.

In order that the resonance of circuit 5-6 of Fig. 1 shall be as sharply defined as possible, the grid-leak resistance 11 is placed in circuit as shown rather than in the more conventional place directly between the grid and cathode.

Nothing has been said thus far of the specific nature of impedance 8. This impedance may take the form of pure inductance, pure resistance, or any combination resulting in a sufficiently high impedance to fit the tube. The value is by no means critical except that a low value out of all proportion to the internal tube impedance between the outer anode and cathode is preferably to be avoided. It may be

desirable to make impedance 8 resonant to a harmonic frequency of the fundamental. For example, when a very high frequency is desired it has been found convenient to do this. In one case an output frequency of 38,000 kc was obtained by operating the circuit at a fundamental of 19,000 kc.

Study of the circuit will indicate that oscillations generated by the frequency determining portion of the circuit are not transmitted to the work circuit in the sense that alternating electromotive forces may be transmitted from one circuit to another by capacitive, inductive, or direct coupling. As has been pointed out any coupling of this nature has a deleterious effect and is purposely avoided to prevent reaction of the work circuit upon the frequency determining portion. The frequency determining portion of the

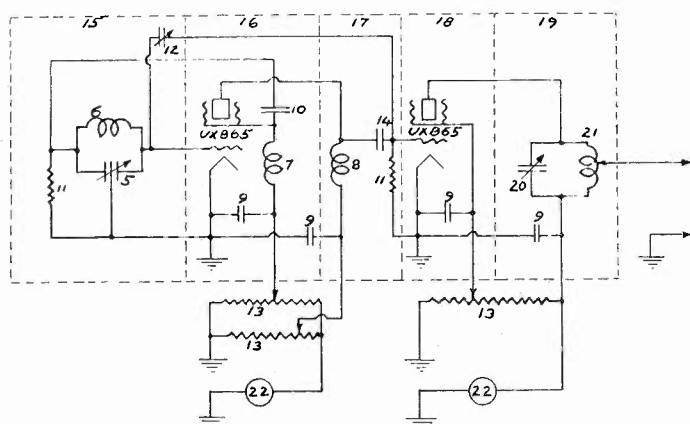

Fig. 4

- | | |
|------------------------------------|----------------------------|
| 5 = 0.00025 μ f each section | 14 = 0.00005 μ f |
| 6 = Single layer figure-eight coil | 15 = Constant temp. oven |
| 7 = R-F choke 425 μ h | 16 = Shielded compartments |
| 8 = R-F choke 425 μ h | 17 = " " |
| 9 = 0.01 μ f | 18 = " " |
| 10 = 0.002 μ f | 19 = " " |
| 11 = 0.1 meg. | 20 = 0.00066 μ f |
| 12 = 2 disks 1.2 inch diameter | 21 = Amp. tank inductance |
| 13 = Potentiometer | 22 = Anode energy source |

circuit serves merely to control electron flow to the separate anode associated with the work circuit thereby causing a pulsating direct current to flow in the work circuit impedance where an alternating electromotive force may be reincarnated at a frequency determined by the pulses of electrons which impinge upon that anode.

In the absence of a better term it is convenient to refer to this form of coupling as electron coupling.

Fig. 4 shows a master oscillator embodying the principles above described and employed to excite an amplifier stage. The impedances 7 and 8 in this case are radio-frequency choke coils. This choice of

circuit arrangement makes it necessary to provide only one master oscillator adjustment,—namely, that required to fix the frequency.

It will be recognized that neutralizing capacity 12 in Fig. 4 is not connected directly between the control grid and outer anode as shown in Fig. 2 but rather to the outer anode through coupling and blocking capacity 14. This particular arrangement results from the fact that the Type UX-865 tube which was used in the master oscillator stage of Fig. 4 does not lend itself well to neutralization by the connection shown in Fig. 2 when very high-frequency operation is desired. Doubtless some attention to the proper design of tubes for this purpose will permit the circuit of Fig. 2 to be generally adopted. Neutralizing of the circuit of Fig. 4 consists in applying to the grid of the amplifier tube a potential equal and opposite to that applied through the interelement capacities of the master oscillator tube. This is accomplished experimentally by disconnecting the outer anode potential to the master oscillator tube, inserting a small thermoammeter in the amplifier tank circuit 20–21, and adjusting neutralizing capacity 12 until no radio-frequency tank current exists.

The various circuit constants indicated in Fig. 4 are based upon operation at frequencies between 2000 and 5000 kc.

The observational data which follow are based upon the over-all performance of the circuit of Fig. 4 and indicate the degree of performance which may be expected when employing such a circuit for the control of radio transmitters. The model employed in collecting these data, while lacking certain mechanical and electrical refinements, was constructed with a view to meeting in a reasonable degree the following essential requirements.

- (1) Those items included in compartment 15 were maintained at substantially constant temperature by thermostatic control to avoid expansion and contraction effects due to temperature changes.
- (2) Magnetic coupling between coil 6 and other parts of the circuit was reduced to a minimum by making coil 6 of single layer figure-eight construction.
- (3) Displacement of capacity 5 due to external temperature effects was avoided by providing a suitable clutch to disengage the control shaft from the adjuster mechanism during idle periods.
- (4) Rigid electrostatic shielding was provided as indicated in Fig. 4.

Observational data covering the operation of the circuit of Fig. 4 are shown in Figs. 5 to 11 inclusive. Except where otherwise stated, the measurements indicated in these figures were each the average of two or more observations having an individual precision of measurement of 0.001 per cent. For reference, broken lines are drawn in each of these figures at a value 0.01 per cent above and below the basic frequency indicated in each figure.

EFFECT OF VARIATIONS IN ANODE VOLTAGE SUPPLY

Investigations pertaining to the present development led directly to the discovery that in oscillators having two or more anodes very useful frequency compensating effects could be produced by suitable manipulation of the relative potentials of the two anodes. It was found that the changes in frequency of an electron tube oscillator of the class described, due to a change in potential of one of the tube elements, as

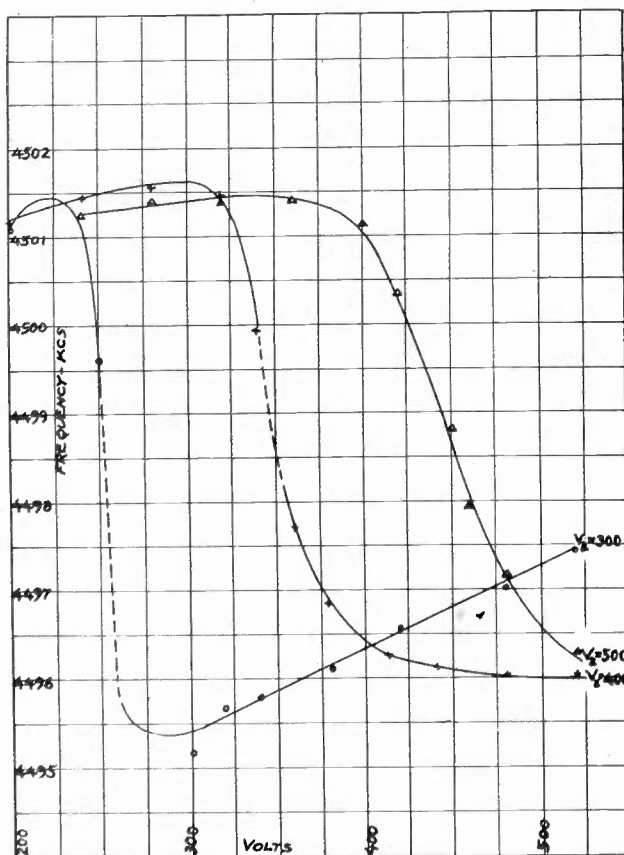

Fig. 5

well as the direction of such change in frequency, i.e., whether the frequency increased or decreased for a given change in this potential, — was dependent, among other things, upon (1) the potentials applied to the other elements of the tube, (2) the disposition with respect to the other elements of the tube of the element whose potential was being changed.

The curves of Fig. 5 show the change in frequency of the master oscillator circuit of Fig. 4 when the inner anode potential is varied throughout the range indicated meanwhile keeping the outer anode potential fixed at the value indicated for each curve.

The curves of Fig. 6 show the change in frequency of the master oscillator circuit of Fig. 4 when the outer anode potential is changed throughout the range indicated meanwhile keeping the inner anode potential fixed as stated for each curve.

The fact that the slopes of certain portions of the curves of Figs. 5 and 6 are equal and opposite suggests, as is clearly shown in Fig. 7, that great advantage readily can be taken of these characteristics to

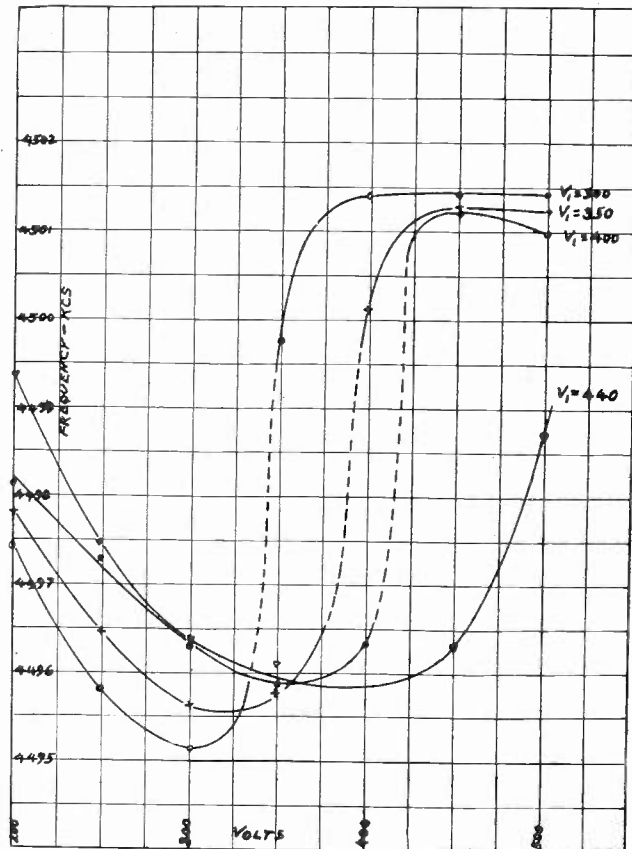

Fig. 6

compensate for changes in the frequency of oscillation arising from variations in the anode voltage supply. Curve I of Fig. 7 shows the variation in frequency of the master oscillator from 4500 kc as the inner anode voltage is varied meanwhile keeping the outer anode voltage constant at 440 volts. Curve II shows the variation in frequency as the outer anode voltage is varied meanwhile keeping the inner anode voltage constant at 330 volts. *If the supply to these two anodes is taken from the common source 22 in Fig. 4 and if such a choice of initially adjusted voltages is provided as to make the slopes of Curves I and II equal and opposite, no change in frequency would be expected to*

take place as a result of variations in the voltage of the common source. This is substantially the experimental result shown in Curve III of Fig. 7 wherein a change in frequency of only 10 cycles in 4,500,000 occurs for a 25 per cent change in the common anode voltage supply.

The measurements upon which Curve III of Fig. 7 are based, were made with a visual beat-frequency indicator and are accurate to 2 cycles. It is readily possible to adjust the master oscillator of Fig. 4

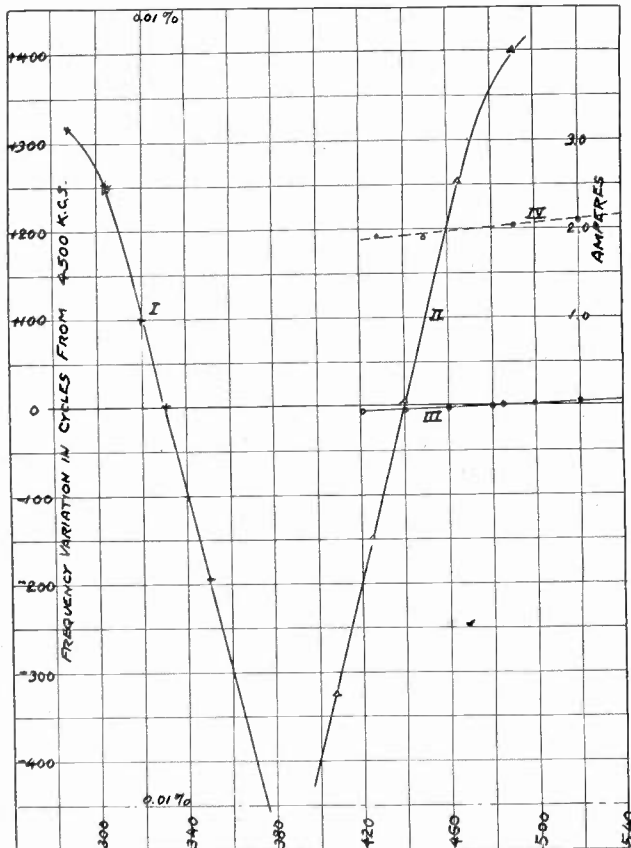

Fig. 7

such that the change in frequency for a momentary 25 per cent change in anode voltage is only 4 cycles in 4,500,000 so that the change in frequency indicated by Curve III of Fig. 4 may be considered somewhat exaggerated in so far as the effect of momentary voltage changes are concerned. The principles of compensation disclosed above may be utilized to correct for large permanent changes in voltage. However, it has been found that changes in such magnitude as cause appreciable changes in the interelement capacities due to temperature effects must be counteracted by overcompensation to such an extent as will care for the added situation resulting from the change in frequency due to

temperature change. This complication does not usually require treatment unless permanent changes in voltages of the order of 20 per cent or greater are to be encountered.

Curve IV of Fig. 7 shows the variation in amplifier tank current due to the change in amplifier excitation as the master oscillator anode voltage is varied.

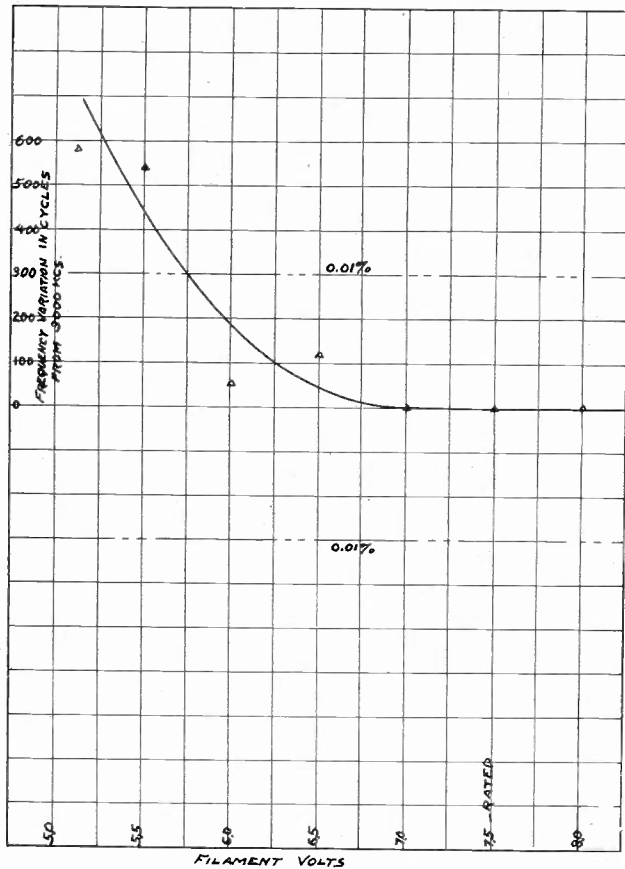

Fig. 8

EFFECT OF VARIATION IN FILAMENT VOLTAGE

Fig. 8 shows the variation in frequency of the master oscillator of Fig. 4 as the filament voltage is varied over the range indicated. It has been found that variation in filament voltage has practically a negligible effect upon frequency so long as the filament temperature is maintained above that required for saturation at the anode voltages used. It is conceivable that special situations requiring compensation for changes in filament voltage could be cared for by a suitable application of the principles explained in the preceding paragraph.

EFFECT OF VARIABLE LOADING CONDITIONS

The output or work circuit of the master oscillator of Fig. 4 is not adjustable so that any change in load upon the master oscillator must

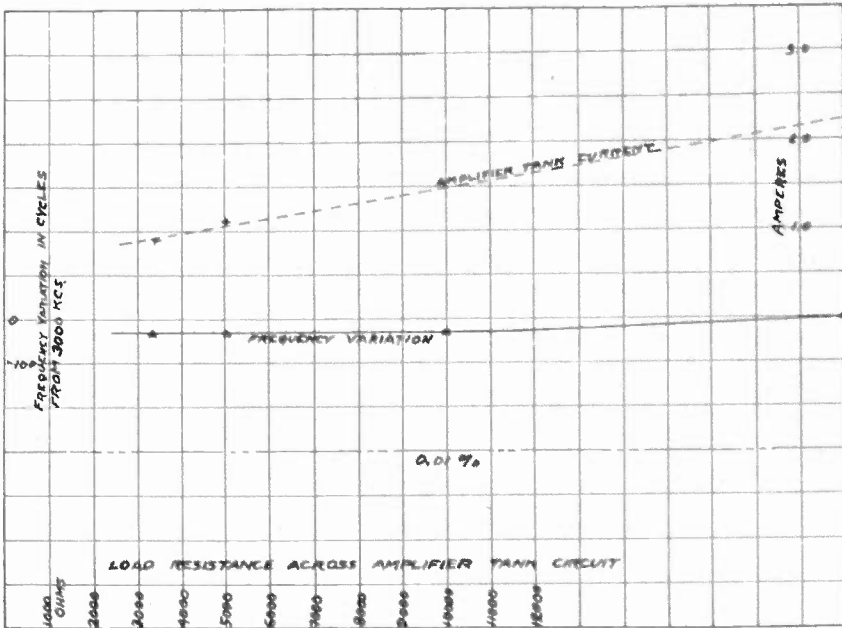

Fig. 9

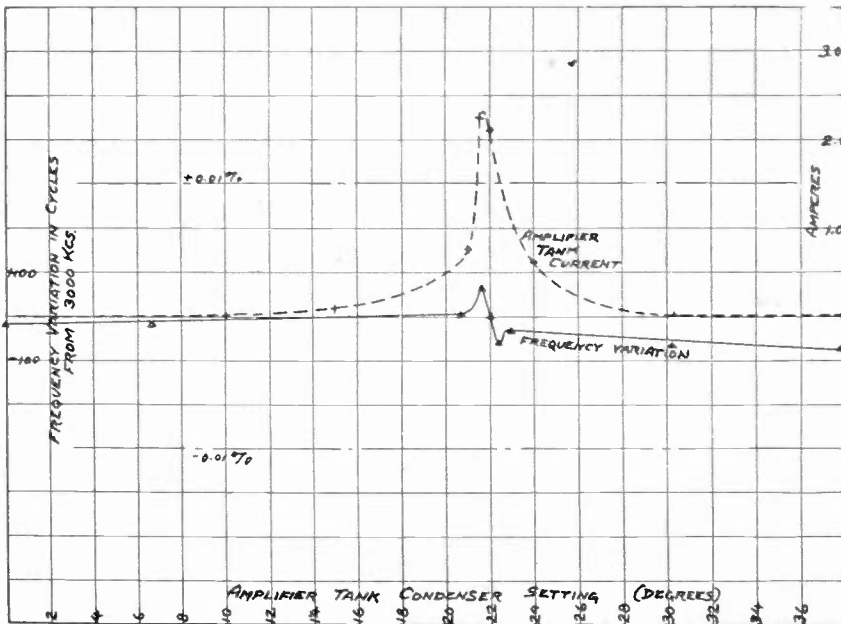

Fig. 10

be applied through the intermediary of the amplifier stage. Fig. 9 shows the effect of changing this load by shunting various resistances

across the amplifier tank circuit. The change in frequency resulting from varying the load upon the amplifier in this manner is only of the order of 0.001 per cent. The dotted curve in Fig. 9 shows the amplifier tank current corresponding to the various load resistances used. The solid curve of Fig. 10 shows the variation in frequency resulting from adjusting amplifier tank condenser 20 of Fig. 4 through the resonance region. The dotted curve of Fig. 10 shows the corresponding change in amplifier tank current. This severe treatment and the resulting maximum deviation in frequency of only slightly over 0.002 per cent shows not only the over-all effectiveness of the circuit but is indicative of the degree to which the frequency determining portion of the circuit is isolated from external effects. Freedom from this form of reaction is largely dependent upon the exactness of neutralizing, and with tubes permitting strict application of the neutralizing connection shown in Fig. 2, reaction is much less than that indicated in Fig. 10.

EFFECT OF VARIATION IN AMBIENT TEMPERATURE

Unless special precautions are taken in the selection of materials and in the design of the frequency determining portion of the circuit, a change in frequency of the order of 0.005 per cent per degree Centigrade change in temperature of the circuits will result. This corresponds approximately to the temperature coefficient of frequency of quartz crystal oscillators and therefore demands the same attention. It is quite essential then, to place the frequency determining circuit 5-6 of Fig. 4 and the neutralizing capacity 12 under temperature control to within 0.2 degree if relative advantage is to be taken of other features of the circuit. It also is desirable to place the master oscillator tube under temperature control when an especially high order of precision is required. For such an arrangement as that shown in Fig. 4, including a conventional aluminum plate variable condenser and copper inductance on a bakelite form, for the frequency determining circuit, and UX-865-type master oscillator tube, experimental data indicate the following:

- (1) Without temperature control of frequency determining portion of circuit or tube, a frequency drift of 0.005 per cent per degree change in ambient temperature may be expected.
- (2) With temperature control of circuit but without temperature control of tube, a frequency drift of 0.001 per cent per degree change in ambient temperature may be expected.
- (3) To avoid entirely the effect of changes in ambient temperature, it is essential to maintain both the tube and frequency determining portion of the circuit at a substantially constant temperature and at the same time to so arrange the mechanical construction by mounting the various parts of the master

oscillator circuit upon a suitable sub-base within the temperature controlled compartment, that mechanical strain caused by external temperature effects will not act to alter the adjustment of frequency. Other forms of construction to avoid this effect will be apparent.

Fig. 11 shows the results of a series of observations over a period of 5 hours upon the circuit of Fig. 4. During this run the various voltages as well as the loading condition were maintained constant. The ambient temperature varied approximately 5 degrees Centigrade to which the drift in frequency is attributed. The maximum change in

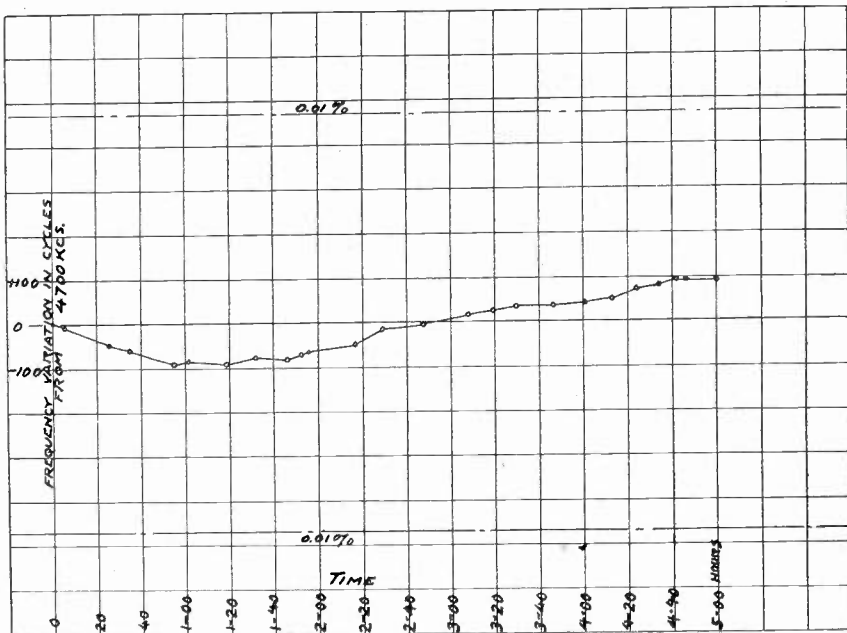

Fig. 11

frequency from the initially adjusted value of 4700 kc was 93 cycles. Observations in this case were accurate to two cycles per second in a million.

EFFECT OF VIBRATION

Experience has shown that reasonable freedom from the effects of vibration can be had only by giving special attention to the mechanical construction of the circuit elements. Vibration of the plates of capacity 5 of Fig. 4 and microphonic tendencies of the master oscillator tube are the most serious sources of trouble in this particular. Microphonic tendencies are greatly reduced by the use of a high C/L ratio in circuit 5-6 provided, of course, that the capacity is suitably constructed. This procedure, however, is usually attended by a reduction in output which may become objectionable under certain con-

ditions. The tube manufacturers must be looked to for such improvement as can be made to correct the microphonic tendencies of the tube and doubtless, suitable improvement in this direction will be made in due course of time.

The circuit of Fig. 4 has been used in the initial stages of a 500-watt radio transmitter for a sufficient time to demonstrate conclusively that for transmitter output frequencies up to 24,000 kc the degree of performance indicated by the experimental data included in this report may be attained. Reports of observations on the signals of this transmitter have been almost invariably reported as "pure d-c crystal control" for frequencies as high as 24,000 kc.

The use of many types of tubes has been investigated during this development. Of the more common tubes, the type 865 appears to be the most suitable. The type 224 is less microphonic than the 865 but has the disadvantage that the compensating effect indicated in Fig. 7 cannot be obtained simultaneously with high output. The type 860 tube cannot be neutralized in the manner disclosed in Fig. 2 for reasons which are not fully understood.

ACKNOWLEDGMENT

In conclusion, it is desired to express my appreciation to Mr. R. S. Baldwin and Mr. C. S. Robinson of the Naval Research Laboratory for their assistance in making the many precision measurements of frequency required in the preparation of this paper.

A NEW TREATMENT OF ELECTRON TUBE OSCILLATORS WITH FEED-BACK COUPLING*

BY

C. K. JEN

(Cruft Laboratory, Harvard University, Cambridge, Mass.)

Summary—In an electron tube oscillator with feed-back coupling, the ratio E_o/E_p may be expressed as $\epsilon|\Phi$, in which ϵ and Φ are respectively called "excitation" and "phase difference." For the maintenance of self-oscillation it is absolutely necessary to have a correct Φ , and for the optimum intensity of self-oscillation there is usually a most favorable ϵ for a given oscillator. The complex ratio E_o/E_p is a function entirely of the constants outside of the tube (i. e., independent of the tube characteristics), provided the grid current and the effect of resistances on the oscillation frequency are assumed negligible.

Expressions for E_o/E_p are given for several types of oscillators, which are derived from a general oscillator network containing three parallel resonant circuits connecting the plate, grid, and filament. All ordinary oscillators are subderivatives of these types and their expressions for E_o/E_p are easily obtained by applying special conditions. Numerical computations have been made for practically all special oscillators and the resulting values for ϵ and Φ are illustrated by curves from which considerable information concerning the operating behaviors of oscillators can be obtained.

In a two-mesh oscillator there are two frequencies, at either of which the oscillation may take place. It is shown that only the wave which gives the correct Φ can be excited.

Experimental check of the theory has been found quite satisfactory in most cases.

1. CLASSIFICATION OF ELECTRON TUBE OSCILLATORS

THERE are mainly two classes of electron tube oscillators: those with and those without a feed-back coupling between the grid and plate circuits outside the tube. In this paper we shall confine the treatment of oscillators to the first class. It is found possible to derive all the oscillators in this class from a prototype with three parallel-resonant circuits connecting the plate, grid, and filament of the oscillator. Thus, we can form from this prototype three main types of oscillators by removing the inductive element from each of the parallel-resonant circuits successively, and a fourth type by making one of the resonant circuits conductively separate from the remaining portion. From each type, one or more different kinds of oscillator circuits can be derived by further reduction of either inductive or capacitive elements. The scheme of this classification is shown in Fig. 1.

* Decimal classification: R133. Original manuscript received by the Institute, June 1, 1931.

2. CONSIDERATION OF EXCITATION AND PHASE DIFFERENCE

If E_g and E_p are respectively the r-m-s values of the alternating components of the grid and plate voltages in vector representation, then

$$E_g/E_p = \epsilon |\Phi|$$

wherein, we define $\epsilon = \hat{E}_g/\hat{E}_p$ and $\Phi = \Phi(E_g) - \Phi(E_p)$. Since the ratio of the amplitudes is a measure of the feed-back effect from the plate circuit to the grid circuit, it will be referred to simply as "excitation." E_p is here chosen to be along the positive direction of the x-axis, hence $\Phi(E_p) = 0$ and $\Phi = \Phi(E_g)$. It will be termed as "phase difference."

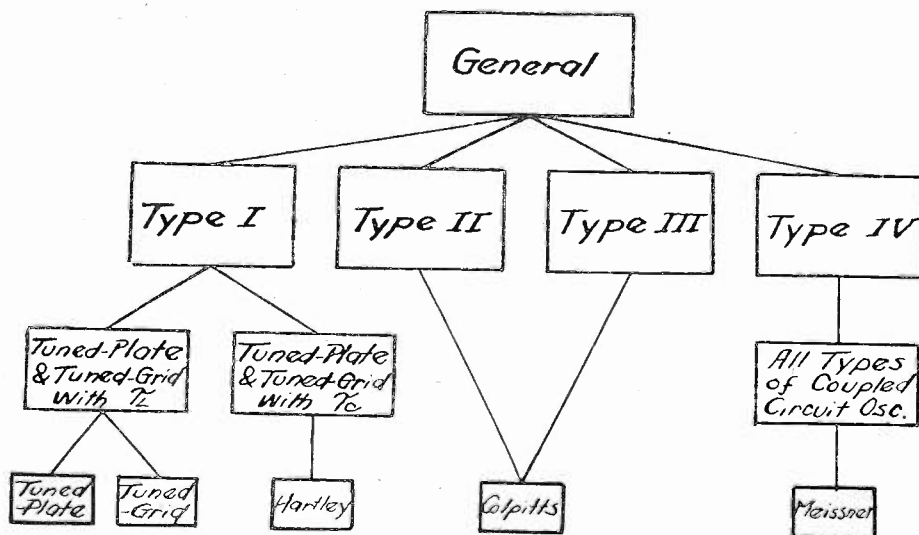

Fig. 1—Classification of electron tube oscillators with feed-back coupling.

3. CORRECT PHASE DIFFERENCE, $\Phi(E_g, E_p)$, AS A NECESSARY CONDITION FOR OSCILLATION

It can be readily proved¹ that in order to maintain self-oscillation with an electron tube, the following condition must be satisfied

$$\frac{1}{T} \int_0^T \dot{i}_p \ddot{e}_p dt < 0$$

where \dot{i}_p and \ddot{e}_p are respectively the instantaneous plate current and voltage measured from the average values. This condition requires that the phase angle (θ) between I_p and E_p (r-m-s vector representations for \dot{i}_p and \ddot{e}_p) must be

$$\frac{\pi}{2} < \theta < \frac{3\pi}{2}$$

¹ See Appendix II.

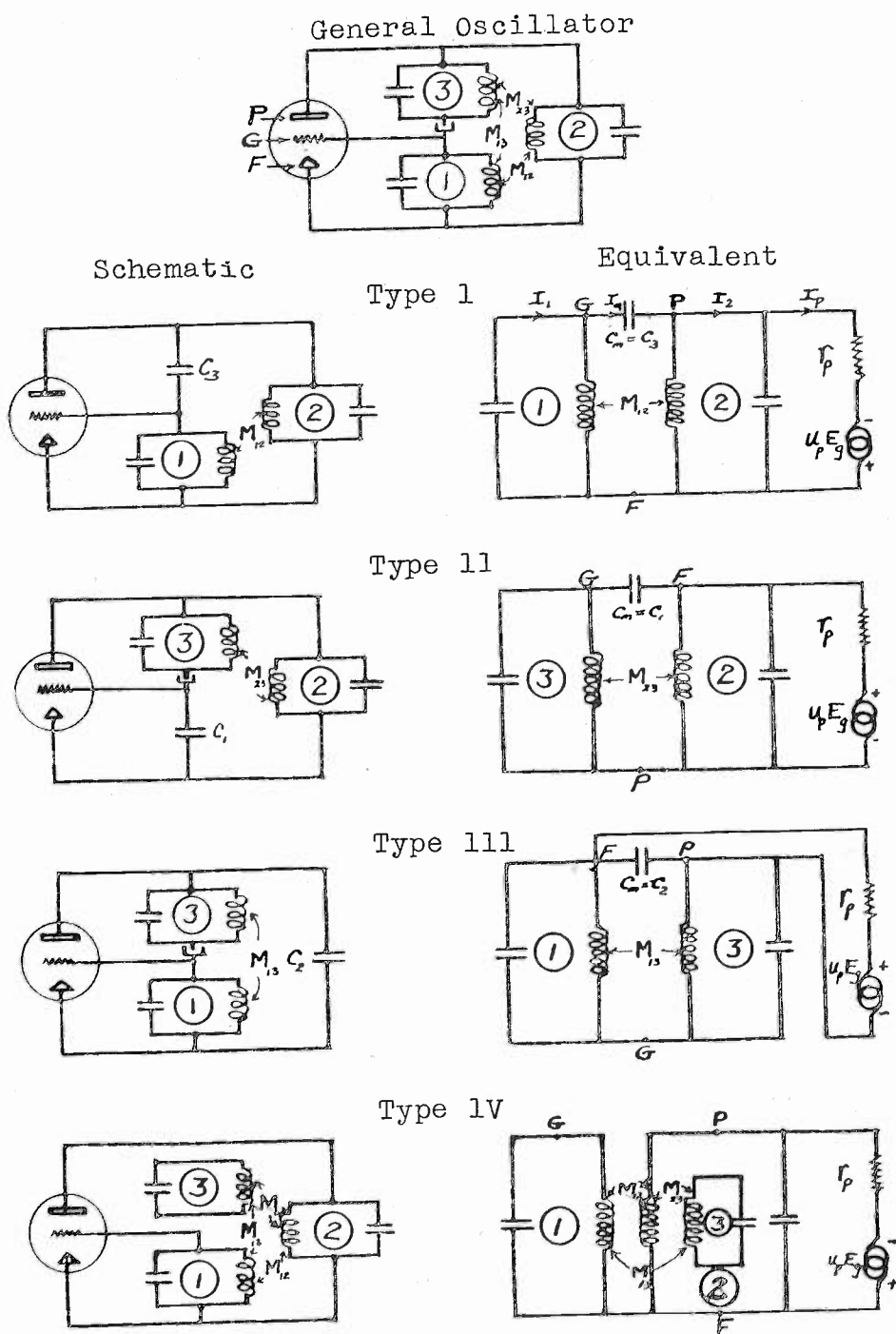

Fig. 2—Schematic and equivalent diagrams of four derived types from the general oscillator.

By taking a linear characteristic, it is shown in Appendix II that the phase difference (Φ) between the grid and plate voltages must obey the same law, namely,

$$\frac{\pi}{2} < \Phi < \frac{3\pi}{2}$$

This condition will be found useful in predicting whether an oscillation is possible or which one of the waves may be excited.

4. DERIVATION OF THE COMPLEX RATIO, E_o/E_p , FOR OSCILLATOR TYPE I

Abbreviations:

$$\begin{aligned} Z_1 &= R_1 + j\left(\omega L_1 - \frac{1}{\omega C_1}\right) & Z_2 &= R_2 + j\left(\omega L_2 - \frac{1}{\omega C_2}\right) \\ Z_{1m} &= R_1 + j\omega(L_1 + M) & Z_{2m} &= R_2 + j\omega(L_2 + M) \\ Z_m &= R_1 + R_2 + j\left\{\omega(L_1 + L_2 + 2M) - \frac{1}{\omega C_m}\right\}. \end{aligned} \quad (1)$$

With the aid of the above abbreviations and neglecting I_o , the equations for the equivalent circuit of a Type I oscillator (see Fig. 2) may be written as:

$$Z_1 I_1 - Z_{1m} I_m + j\omega M I_2 + 0 = 0 \quad (2)$$

$$-Z_{1m} I_1 + Z_m I_m - Z_{2m} I_2 + 0 = 0 \quad (3)$$

$$j\omega M I_1 - Z_{2m} I_m + Z_2 I_2 + \frac{j}{\omega C_2} I_p = E \quad (4)$$

$$-j\frac{\mu_p}{\omega C_1} I_1 + 0 + \frac{j}{\omega C_2} I_2 + \left(r_p - \frac{j}{\omega C_2}\right) I_p = 0. \quad (5)$$

In (4), E is a small voltage inserted in the bottom branch of circuit (2) to start a disturbance. If the condition of oscillation is satisfied, oscillation currents will continue to flow upon removal of the voltage. Further, the condition of oscillation is invariant of the point of application of the voltage.

By solving the above equations, we get

$$I_1 = \frac{(Z_{1m} Z_{2m} - j\omega M Z_m) \left(r_p - \frac{j}{\omega C_2}\right)}{\Delta} E \quad (6)$$

$$I_m = \frac{(Z_1 Z_{2m} - j\omega M Z_{1m}) \left(r_p - \frac{j}{\omega C_2}\right)}{\Delta} E \quad (7)$$

where Δ is the determinant formed by the coefficients of the currents on the left-hand side of (2), (3), (4), and (5).

But

$$E_o = \frac{j}{\omega C_1} I_1 \tag{8}$$

$$E_p = \frac{j}{\omega C_1} I_1 + \frac{j}{\omega C_m} I_m \tag{9}$$

Substituting (6) and (7) in (8) and (9) and taking the ratio, we have

$$\frac{E_o}{E_p} = \frac{Z_{1m}Z_{2m} - j\omega MZ_m}{\left(Z_{1m} + \frac{C_1}{C_m}Z_1\right)Z_{2m} - j\omega M\left(Z_m + \frac{C_1}{C_m}Z_{1m}\right)} \tag{10}$$

Equation (10) illustrates the significant result that the ratio E_o/E_p is entirely independent of the tube constants under the fore-mentioned limitation.

By using the equivalents for the abbreviations in (1), (10) becomes

$$\frac{E_o}{E_p} = \frac{C_m}{C_1 + C_m} \frac{\left\{R_1R_2 - \omega^2(L_1L_2 - M^2) - \frac{M}{C_m}\right\} + j\{R_1\omega L_2 + R_2\omega L_1\}}{\left\{R_1R_2 - \omega^2(L_1L_2 - M^2) + \frac{L_2}{C_1 + C_m}\right\} + j\left\{R_1\omega L_2 + R_2\omega L_1 - \frac{R_2}{\omega(C_1 + C_m)}\right\}} \tag{11}$$

Equation (11) represents the ratio, in complex form, of the alternating grid voltage to plate voltage of a Type I oscillator.

To put all quantities into ratio forms, let

$$\begin{aligned} \eta_1 &= \frac{R_1}{\omega L_1} & \eta_2 &= \frac{R_2}{\omega L_2} \\ \omega_1 &= \sqrt{(C_2 + C_m)/L_1(C_1C_2 + C_1C_m + C_2C_m)} & \omega_2 &= \sqrt{(C_1 + C_m)/L_2(C_1C_2 + C_1C_m + C_2C_m)} \\ \tau_L &= \frac{M}{\sqrt{L_1L_2}} & \tau_C &= \frac{C_m}{\sqrt{(C_1 + C_m)(C_2 + C_m)}} \end{aligned} \tag{12}$$

Equation (11) may be expressed in terms of the new constants in (12) as

$$\frac{E_o}{E_p} = \sqrt{\frac{L_1}{L_2}} \frac{\omega_1}{\omega_2} \frac{\left\{\tau_C(1 - \tau_L^2) + \tau_L \frac{\omega_1\omega_2}{\omega^2}(1 - \tau_C^2) - \tau_C\eta_1\eta_2\right\} - j\{\tau_C(\eta_1 + \eta_2)\}}{\left\{(1 - \tau_L^2) - \frac{\omega_1^2}{\omega^2}(1 - \tau_C^2) - \eta_1\eta_2\right\} - j\left\{\eta_1 + \eta_2 - \eta_2 \frac{\omega_1^2}{\omega^2}(1 - \tau_C^2)\right\}} \tag{13}$$

The complex ratio, E_o/E_p , may be expressed in the form

$$\frac{E_o}{E_p} = \epsilon \angle \phi \tag{14}$$

We get the expressions for ϵ and Φ as

$$\epsilon = \sqrt{\frac{L_1}{L_2}} \frac{\omega_1}{\omega_2} \sqrt{\frac{\left\{ \tau C(1 - \tau L^2) + \tau L \frac{\omega_1 \omega_2}{\omega^2} (1 - \tau C^2) - \tau C \eta_1 \eta_2 \right\}^2 + \left\{ \tau C(\eta_1 + \eta_2) \right\}^2}{\left\{ (1 - \tau L^2) - \frac{\omega_1^2}{\omega^2} (1 - \tau C^2) - \eta_1 \eta_2 \right\}^2 + \left\{ \eta_1 + \eta_2 - \eta_2 \frac{\omega_1^2}{\omega^2} (1 - \tau C^2) \right\}^2}} \quad (15)$$

$$\phi = \tan^{-1} \left\{ \frac{-\tau C(\eta_1 + \eta_2)}{\tau C(1 - \tau C^2) + \tau L \frac{\omega_1 \omega_2}{\omega^2} (1 - \tau C^2) - \tau C \eta_1 \eta_2} \right\} - \tan^{-1} \left\{ \frac{-\left(\eta_1 + \eta_2 - \eta_2 \frac{\omega_1^2}{\omega^2} (1 - \tau C^2) \right)}{\left((1 - \tau L^2) - \frac{\omega_1^2}{\omega^2} (1 - \tau C^2) - \eta_1 \eta_2 \right)} \right\} \quad (16)$$

Equations (15) and (16) represent the expressions for the excitation and phase difference obtained from the complex ratio of E_g/E_p in (13). Under the assumption that the grid current is negligible, the equations are exact.

5. EXPRESSIONS OF E_g/E_p FOR SPECIAL OSCILLATORS

It has been observed from the previous section that if the complex expression for E_g/E_p is known, the expressions for ϵ and Φ can be immediately obtained. We shall tabulate the results for all special oscillators in the order of their classification. For convenience, ratios of wavelengths are used in place of the corresponding ratios of angular velocities.

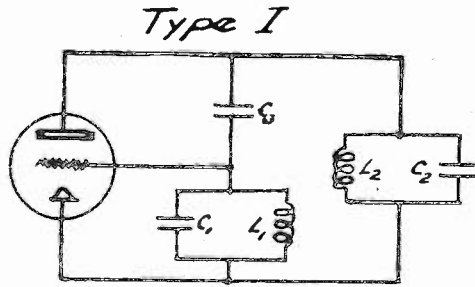

Fig. 3

$$\frac{E_g}{E_p} = \sqrt{\frac{L_1}{L_2}} \frac{\lambda_2}{\lambda_1} \frac{\left\{ \tau C(1 - \tau L^2) + \tau L \frac{\lambda^2}{\lambda_1 \lambda_2} (1 - \tau C^2) - \tau C \eta_1 \eta_2 \right\} - j \tau C(\eta_1 + \eta_2)}{\left\{ (1 - \tau L^2) - \frac{\lambda^2}{\lambda_1^2} (1 - \tau C^2) - \eta_1 \eta_2 \right\} - j \left\{ \eta_1 + \eta_2 - \eta_2 \frac{\lambda_2}{\lambda_1^2} (1 - \tau C^2) \right\}} \quad (17)$$

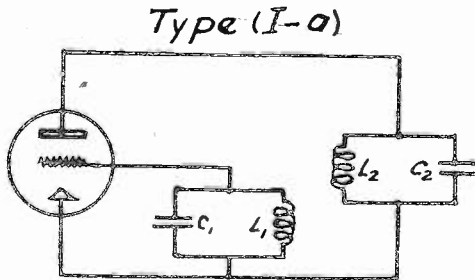

Fig. 4

$$\frac{E_o}{E_p} = - \sqrt{\frac{L_1}{L_2}} \frac{\tau L \frac{\lambda^2}{\lambda_1^2}}{\left\{ \eta_1 \eta_2 - (1 - \tau L^2) + \frac{\lambda^2}{\lambda_1^2} \right\} + j \left\{ \eta_1 + \eta_2 - \eta_2 \frac{\lambda^2}{\lambda_1^2} \right\}} \quad (18)$$

Type (I-b)

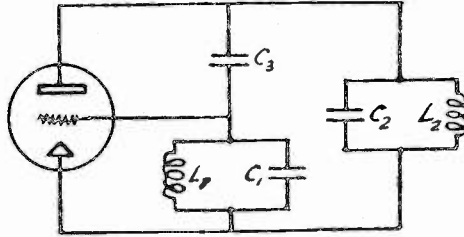

Fig. 5

$$\frac{E_o}{E_p} = \sqrt{\frac{L_1}{L_2}} \frac{\lambda_2}{\lambda_1} \tau C \frac{(1 - \eta_1 \eta_2) - j(\eta_1 + \eta_2)}{\left\{ 1 - \frac{\lambda^2}{\lambda_1^2} (1 - \tau C^2) - \eta_1 \eta_2 \right\} - j \left\{ \eta_1 + \eta_2 - \eta_2 \frac{\lambda^2}{\lambda_1^2} (1 - \tau C^2) \right\}} \quad (19)$$

Type (I-c)

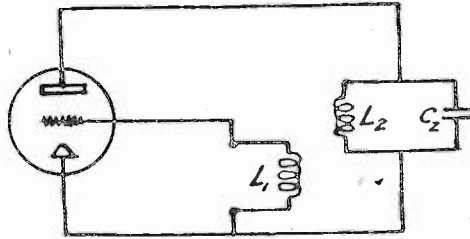

Fig. 6

$$\frac{E_o}{E_p} = - \sqrt{\frac{L_1}{L_2}} \frac{\tau L}{1 - j\eta_2} = \sqrt{\frac{L_1}{L_2}} \frac{\tau L}{\sqrt{1 + \eta_2^2}} \left| - \tan^{-1}(\eta_2) \right. \quad (20)$$

Type (I-d)

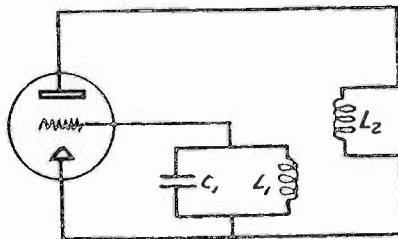

Fig. 7

$$\frac{E_o}{E_p} = - \sqrt{\frac{L_1}{L_2}} \frac{\tau L}{(\eta_1 \eta_2 + \tau L^2) + j\eta_1} = \sqrt{\frac{L_1}{L_2}} \frac{\tau L}{\sqrt{(\eta_1 \eta_2 + \tau L^2)^2 + \eta_1^2}} \left| \tan^{-1} \left\{ \frac{\eta_1}{-(\eta_1 \eta_2 + \tau L^2)} \right\} \right. \quad (21)$$

Type (I-e)

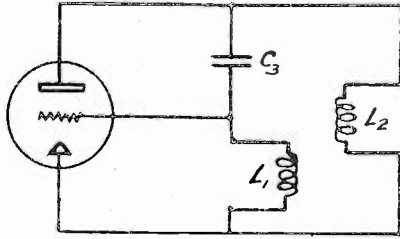

Fig. 8

$$\frac{E_o}{E_p} = \frac{\left\{ \eta_1 \eta_2 - (1 - \tau L^2) - \sqrt{\frac{L_1}{L_2}} \tau L \left(1 + 2\tau L \sqrt{\frac{L_2}{L_1} + \frac{L_2}{L_1}} \right) \right\} + j(\eta_1 + \eta_2)}{\left\{ \eta_1 \eta_2 - (1 - \tau L^2) + \left(1 + 2\tau L \sqrt{\frac{L_2}{L_1} + \frac{L_2}{L_1}} \right) \right\} + j \left\{ \eta_1 + \eta_2 - \eta_2 \left(1 + 2\tau L \sqrt{\frac{L_2}{L_1} + \frac{L_2}{L_1}} \right) \right\}} \quad (22)$$

Type II

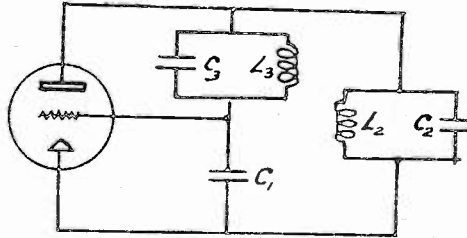

Fig. 9

$$\frac{E_o}{E_p} = \frac{C_3}{C_1 + C_3} \frac{\left\{ \eta_2 \eta_3 - (1 - \tau L^2) + \beta_3^2 + \frac{C_1}{C_3} \frac{\tau L}{\tau C} \frac{\lambda^2}{\lambda_1 \lambda_2} (1 - \tau C^2) \right\} + j \left\{ \eta_2 + \eta_3 - \eta_2 \beta_3^2 \right\}}{\left\{ \eta_2 \eta_3 - (1 - \tau L^2) + \frac{\lambda^2}{\lambda_3^2} (1 - \tau C^2) \right\} + j \left\{ \eta_2 + \eta_3 - \eta_2 \frac{\lambda^2}{\lambda_3^2} (1 - \tau C^2) \right\}} \quad (23)$$

where,

$$\beta_3^2 \equiv 1/\omega^2 L_3 C_3$$

Type (II-a)

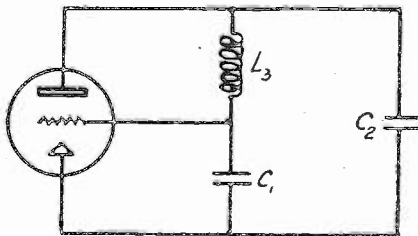

Fig. 10

$$\frac{E_o}{E_p} = \frac{C_2}{C_1} \frac{1}{1 - j \left(1 + \frac{C_2}{C_1} \eta_3 \right)} = \frac{C_2}{C_1} \frac{1}{\sqrt{1 + \left(1 + \frac{C_2}{C_1} \right)^2 \eta_3^2}} \left| -\tan^{-1} \left(1 + \frac{C_2}{C_1} \right) \eta_3 \right. \quad (24)$$

Type III

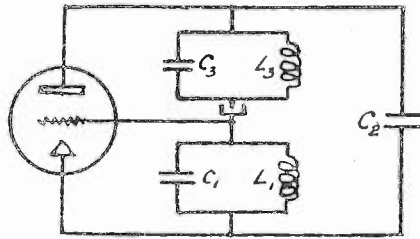

Fig. 11

$$\frac{E_g}{E_p} = \frac{C_3}{C_1 + C_3} \frac{\{ \eta_1(1 - \beta_3^2) + \eta_3 \} - j \{ \eta_1 \eta_3 - (1 - \tau L^2) + (1 + \sqrt{\frac{L_3}{L_1}} \tau L) \beta_3^2 \}}{\{ \eta_1 \left(1 - \frac{C_3}{C_1 + C_3} \beta_3^2 \right) + \eta_3 \left(1 - \frac{L_3}{L_1} \frac{C_3}{C_1 + C_3} \beta_3^2 \right) \} - j \{ \eta_1 \eta_3 - (1 - \tau L^2) + \frac{C_3}{C_1 + C_3} \beta_3^2 \left(1 + 2 \tau L \sqrt{\frac{L_3}{L_1} + \frac{L_3}{L_1}} \right) \}} \quad (25)$$

Type (IV-a)

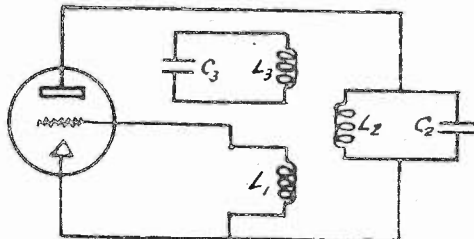

Fig. 12

$$\frac{E_g}{E_p} = \sqrt{\frac{L_1}{L_2}} \frac{\{ \tau_{12} \left(1 - \frac{\lambda^2}{\lambda_3^2} \right) + \tau_{13} \tau_{23} \} - j \eta_3 \tau_{12}}{\{ \tau_{23}^2 - \left(1 - \frac{\lambda^2}{\lambda_3^2} \right) + \eta_2 \eta_3 \} + j \{ \eta_2 + \eta_3 - \eta_2 \frac{\lambda^2}{\lambda_3^2} \}} \quad (26)$$

6. FREE OSCILLATION FREQUENCIES OF OSCILLATOR CIRCUITS WITH BOTH ELECTROSTATIC AND ELECTRO-MAGNETIC COUPLING

In the previous expressions for the excitation and phase difference, the angular velocity of oscillation, ω , is the only unknown quantity. To get ω , we can impose the condition of oscillation upon (6) or (7) such that²

$$\Delta = 0. \quad (27)$$

The resulting equation can be separated into two independent equations, real and imaginary. The expressions are generally very much involved, and also functions of λ of tube characteristics. Considerable

² P. S. Bauer: "The condition of self-oscillation of a general triode system," *Proc. Nat. Acad. Sci.*, 15, No. 1, January, 1929.

simplification may be made if all resistances are neglected and the results will naturally give the free oscillation frequencies of the coupled

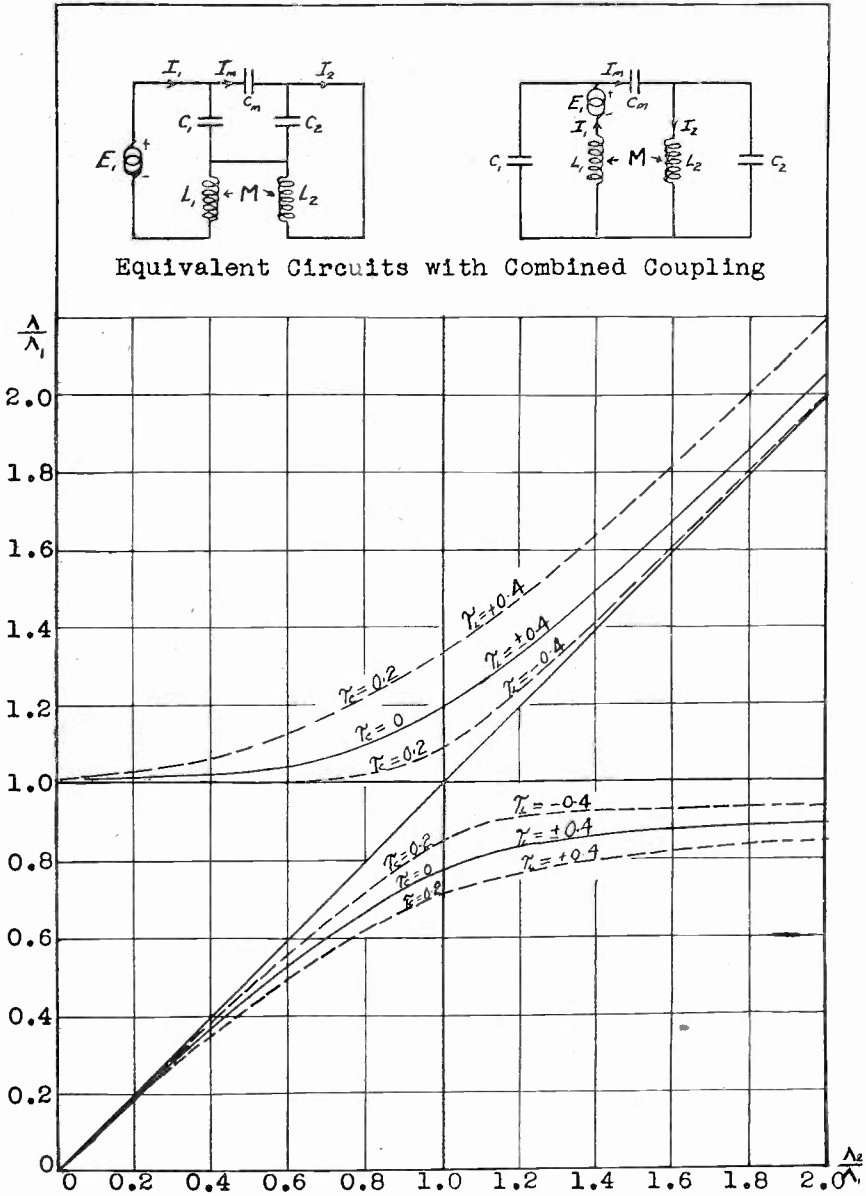

Fig. 13—Free oscillation wavelengths of a circuit with combined coupling.

circuits independent of the tube. Thus, if $\eta_1 = \eta_2 = 0$, the imaginary part of (27) gives

$$\left(1 - \frac{\omega_1^2}{\omega^2}\right)\left(1 - \frac{\omega_2^2}{\omega^2}\right) = \left(\tau_C \frac{\omega_1 \omega_2}{\omega^2} + \tau_L\right)^2 \tag{28}$$

Let ω' and ω'' be the roots of (28) corresponding to the higher and lower frequencies, then

$$\frac{\omega'}{\omega''} = \sqrt{\frac{\omega_1^2 + \omega_2^2 + 2\tau_L\tau_C\omega_1\omega_2 \text{ or } \sqrt{(\omega_1^2 + \omega_2^2 + 2\tau_L\tau_C\omega_1\omega_2)^2 - 4(1 - \tau_L^2)(1 - \tau_C^2)\omega_1^2\omega_2^2}}{2(1 - \tau_L^2)}} \tag{29}$$

Equation (29) may be expressed in terms of the ratios of wavelengths. Thus

$$\frac{\frac{\lambda''}{\lambda_1}}{\frac{\lambda'}{\lambda_1}} = \sqrt{\frac{1 + \left(\frac{\lambda_2}{\lambda_1}\right)^2 + 2\tau_L\tau_C\frac{\lambda_2}{\lambda_1} \text{ or } \sqrt{\left(1 + \left(\frac{\lambda_2}{\lambda_1}\right)^2 + 2\tau_L\tau_C\frac{\lambda_2}{\lambda_1}\right)^2 - 4(1 - \tau_L^2)(1 - \tau_C^2)\left(\frac{\lambda_2}{\lambda_1}\right)^2}}{2(1 - \tau_C^2)}} \tag{30}$$

Fig. 13 showing a sample plot of (30), illustrates very clearly the effect of the product term $2\tau_L\tau_C(\lambda_2\lambda_1)$, which may be either positive or negative, depending upon the sign of τ_L .

It is seen from (28) that we can define a combined coupling coefficient (for both electrostatic and electromagnetic couplings) as

$$\tau = \tau_C \frac{\omega_1\omega_2}{\omega^2} + \tau_L \doteq \tau_C + \tau_L. \tag{31}$$

The approximate relation is due to the fact that $\omega_1\omega_2/\omega^2 \doteq 1$ under normal conditions. If the use of (31) is justifiable, (28) gives an approximate expression

$$\text{or } \frac{\frac{\lambda''}{\lambda_1}}{\frac{\lambda'}{\lambda_1}} = \sqrt{\frac{\left(1 + \frac{\lambda_2^2}{\lambda_1^2}\right) \text{ or } \sqrt{\left(1 + \frac{\lambda_2^2}{\lambda_1^2}\right)^2 - 4(1 - \tau^2)\frac{\lambda_2^2}{\lambda_1^2}}}{2}} \tag{32}$$

7. GRAPHICAL REPRESENTATION OF THE COMPUTED RESULTS FOR THE EXCITATION AND PHASE DIFFERENCE FOR SPECIAL OSCILLATORS

Computations on the excitation and phase difference have been carried out in this paper for practically all special cases. The only assumption made in the computations is $\eta_1 = \eta_2 = 0.01$, which may be taken as a representative value for the usual oscillator coils. Otherwise, the results are perfectly general in their application, since all quantities are in ratio forms. In each case, a convenient independent variable is chosen, and values for the excitation and phase difference are computed while keeping all other quantities constant. We shall now consider individually the special cases and discuss the results with the aid of graphical representations.

Oscillator Type I

In Fig. 14-a, the phase relations are completely shown for both long and short waves. It is seen that the phase angle actually depends upon the combined coupling coefficient. If $\tau > 0$ the angle for the long wave is between 180 degrees and 270 degrees (second quadrant) while the angle for the short wave is between 0 and 90 degrees (first quadrant); hence

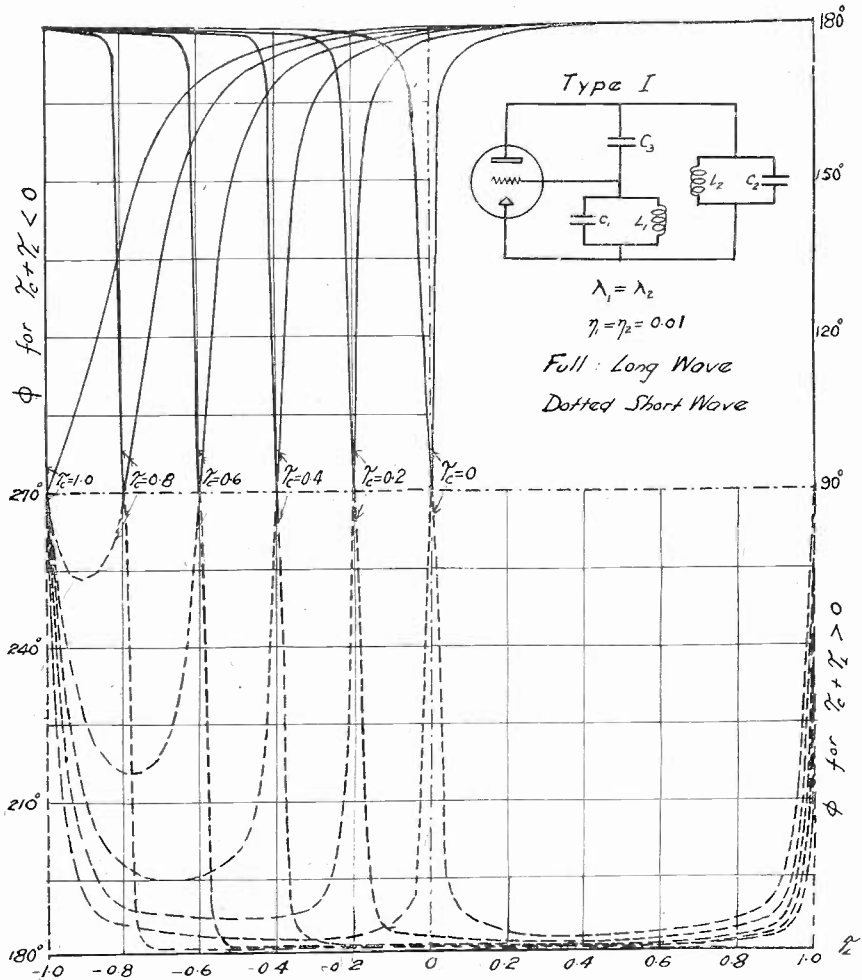

Fig. 14-a— Φ vs. τ_L at constant τ_C for Type I oscillator. Note that the phase relations are completely shown for the long and short waves.

only the long wave can be excited according to the condition of oscillation formulated in Section 3. If $\tau = 0$, the phase differences are 90 degrees and 270 degrees, respectively, for the long and short waves. No oscillation (unless it is of a totally different kind) can exist at this point, because there is no feed-back. If $\tau < 0$, the phase difference of the long wave is in the fourth quadrant, while that of the short wave is the third quadrant; consequently the short wave is now excited instead of

the long wave. We may conclude that if the combined coupling coefficient is positive, long wave is excited; if it is negative, short wave is excited; and if it is zero, no oscillation is possible.

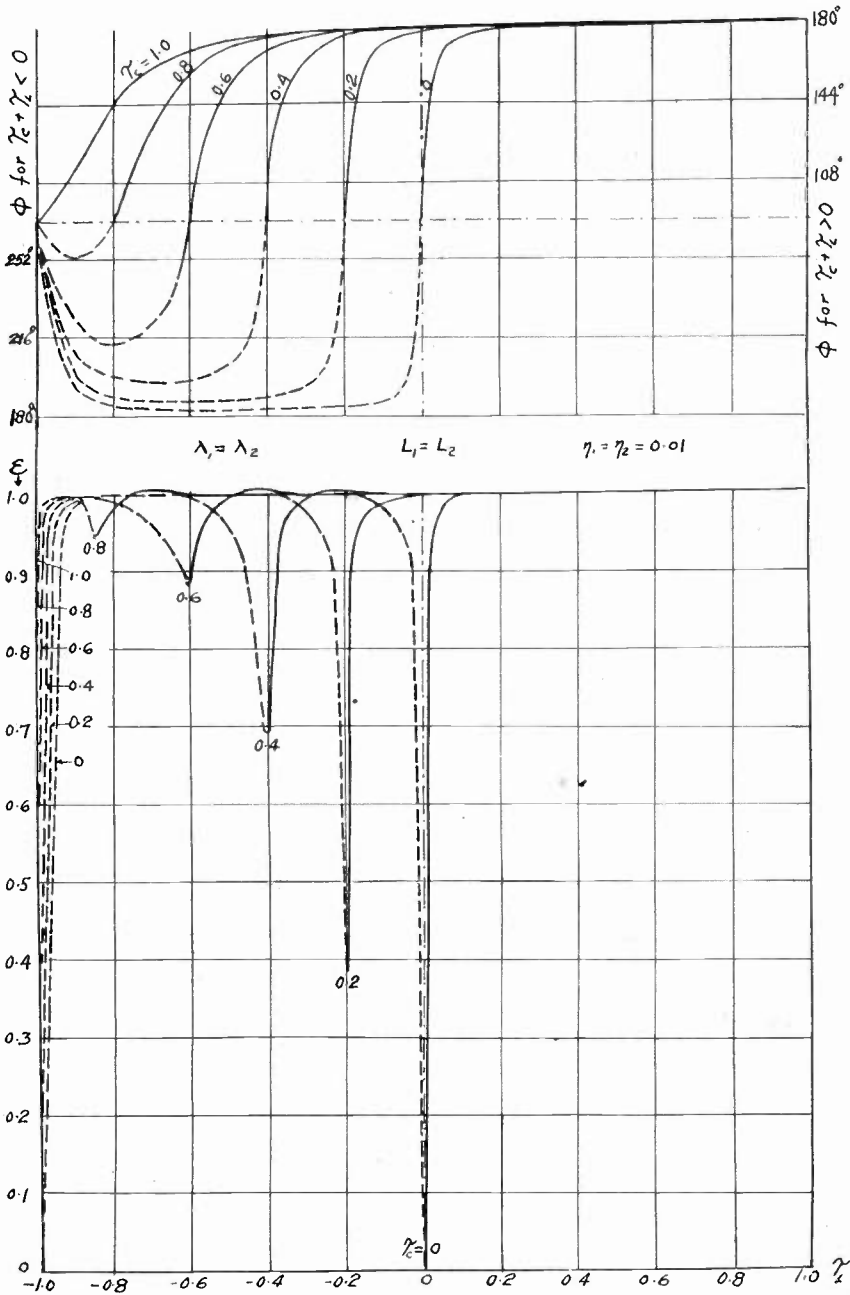

Fig. 14-b— Φ and ϵ vs. τ_L at constant τ_C for Type I oscillator.

Fig. 14-b shows the excitation as well as the phase difference for the same oscillator, except that the quantities forbidden by the condition of oscillation are omitted from the graph. It is noted that the excitation

is nearly constant for $|\tau| \gg 0$. It drops down very rapidly near $\tau \doteq 0$. The minimum is, however, different for different zero-coupling points.

Oscillator Type (I-a)

This circuit is known as the tuned-plate and tuned-grid oscillator

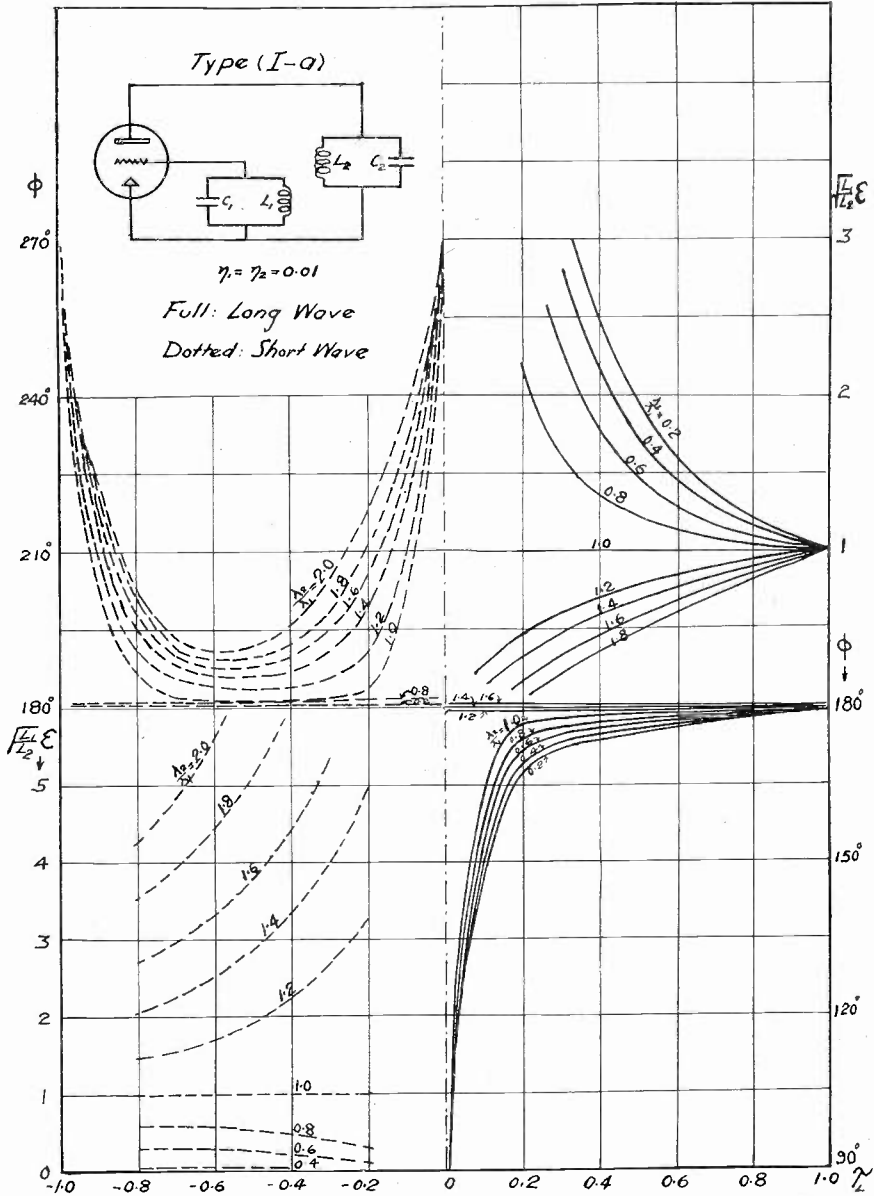

Fig. 15-a— Φ and ϵ vs. τ_L for Type I-a oscillator for different values of λ_2/λ_1 .

with inductive coupling. In Fig. 15-a it is readily seen that long wave is excited at positive values of τ_L and short wave at negative values. A better phase relation is secured by a large λ_2/λ_1 for the long wave, but by a small λ_2/λ_1 , for the short wave. Also, a large λ_2/λ_1 means small ex-

citation for the long wave and large excitation for the shorter wave; and vice versa.

In Fig. 15-b, we see even more clearly than before how the phase difference varies when the circuit is tuned at constant coupling. The

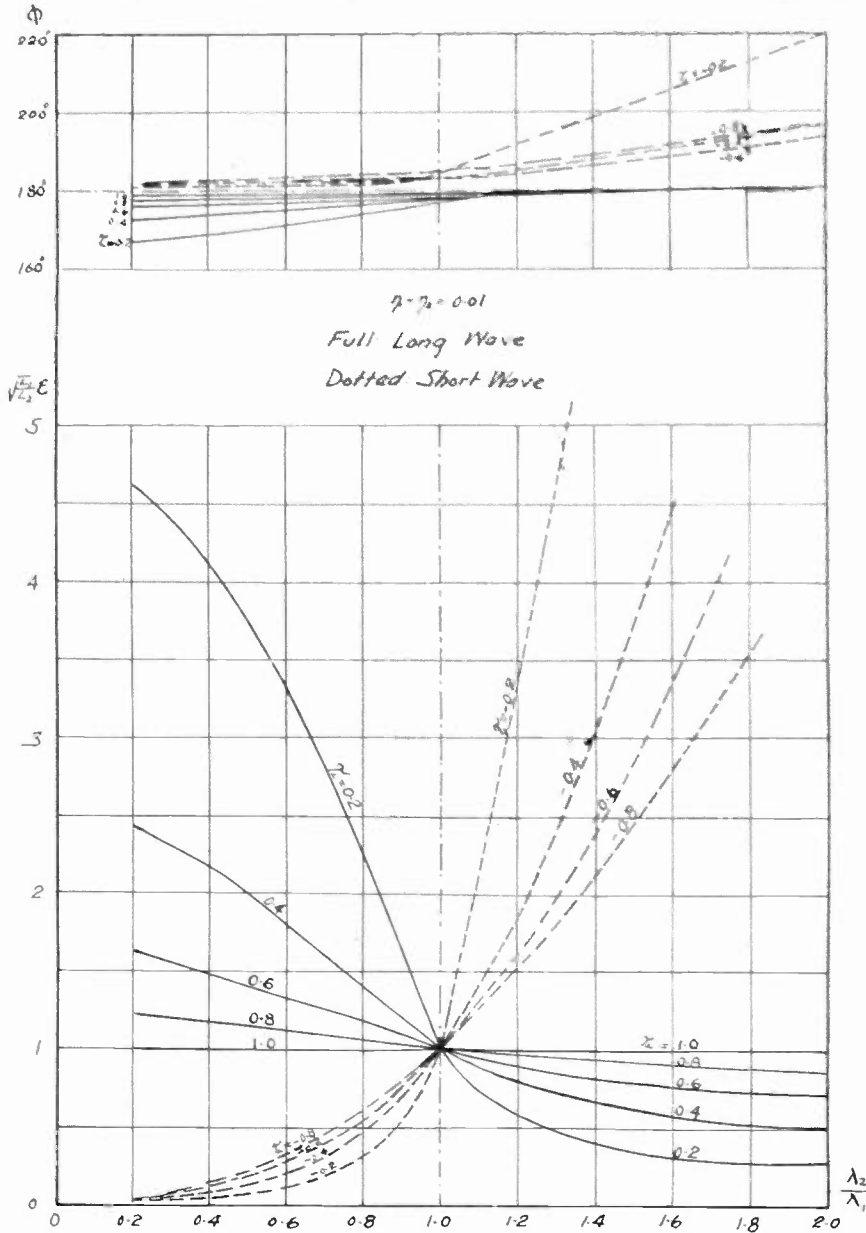

Fig. 15-b— Φ and ϵ vs. λ_2/λ_1 for Type I-a oscillator for different values of τ_L .

excitation curves for the long and short waves are oppositely directed; i.e., when one set is rising, the other is falling; and vice versa. The changes for excitation for the short wave are more rapid than those for the long wave in the same range of λ_2/λ_1 .

Oscillator Type (I-b)

If the coils in oscillator Type I are so placed that there is no inductive coupling between them, we obtain what may be called a tuned-plate and tuned-grid oscillator with capacitive coupling. τ_C is always

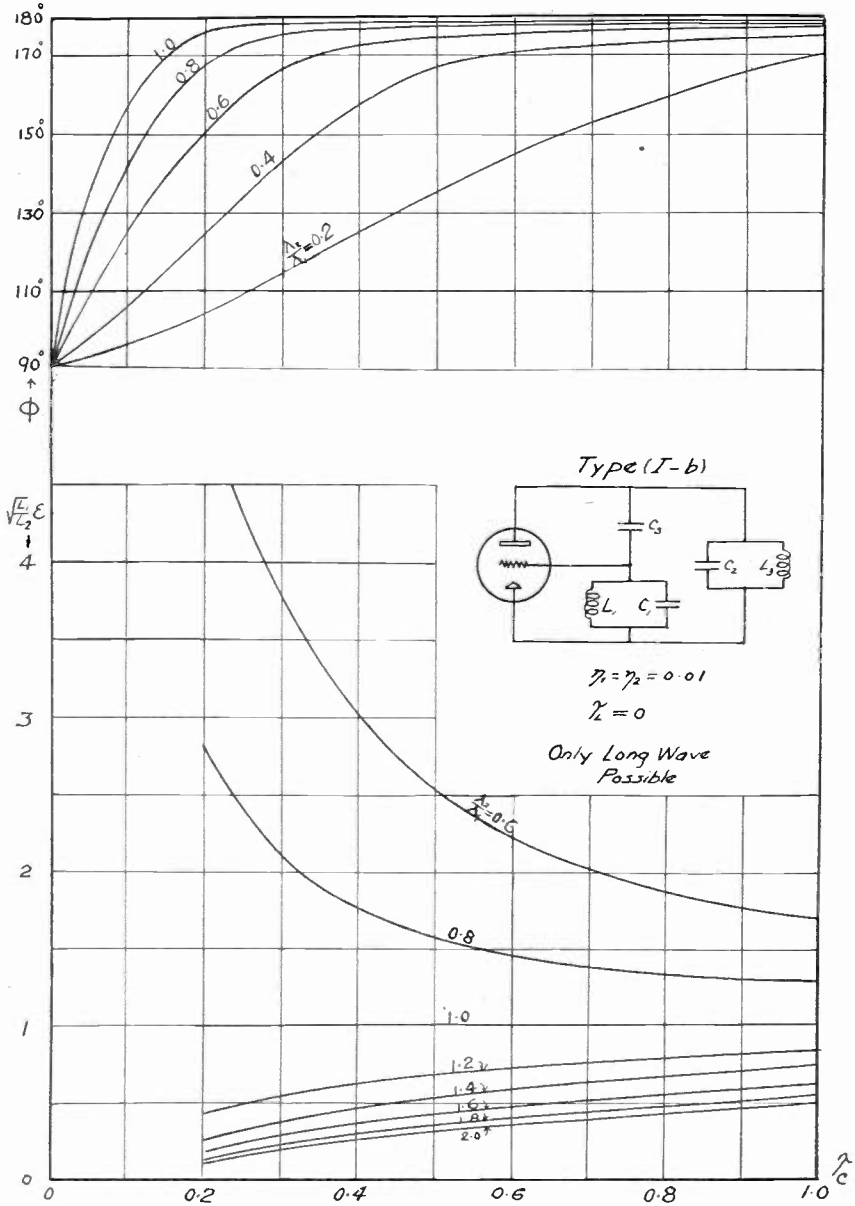

Fig: 16-a— Φ and ϵ vs. τ_C for Type I-b oscillator for different values of λ_2/λ_1 . Note that only the long wave can be excited.

positive and is equal to the combined coupling coefficient in this case, since τ_L is zero. It is noted that only the long wave can be excited in such oscillator circuits, because the short wave, having a calculated

phase difference (not shown) always in the first quadrant, can never be excited. The figures indicate that large value of τ_C and λ_2/λ_1 are generally favorable for oscillation.

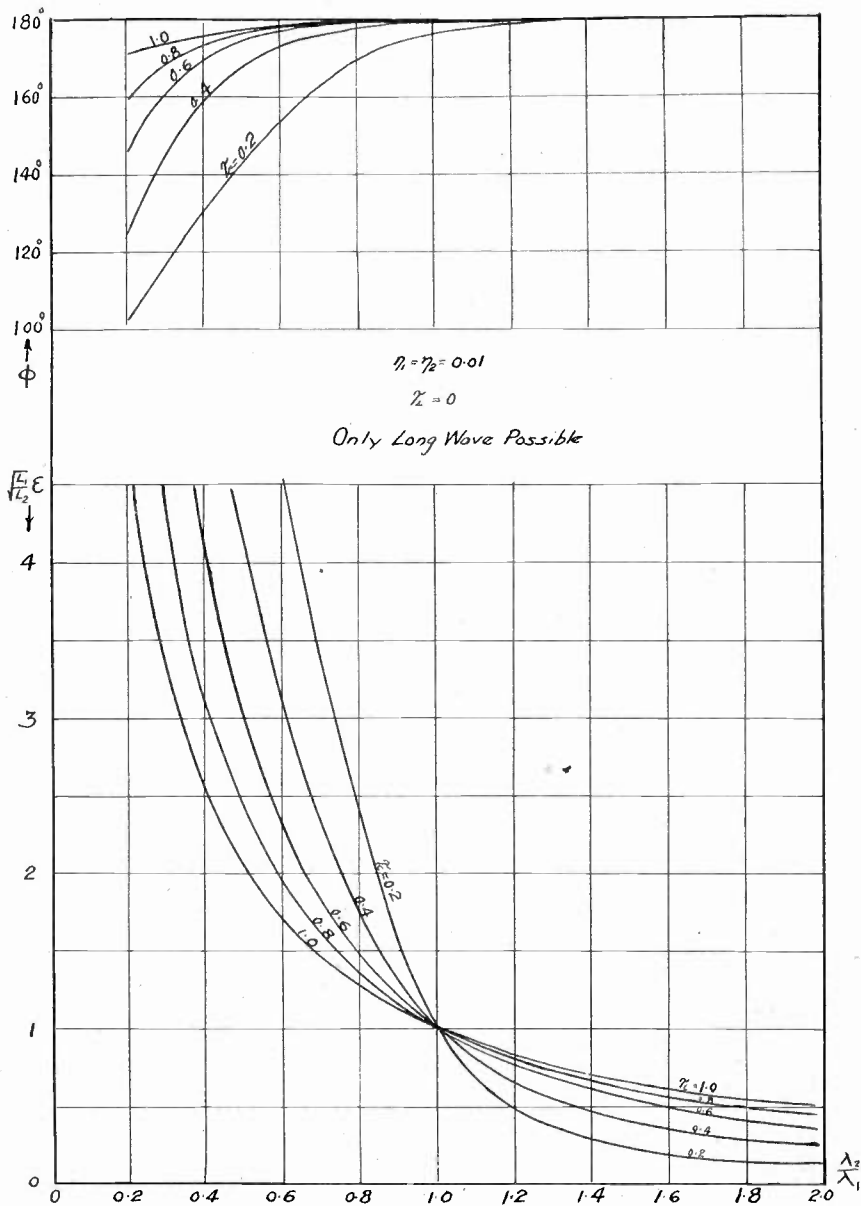

Fig. 16-b— Φ and ϵ vs. λ_2/λ_1 for Type I-b oscillator for different values of τ_C .

Oscillator Type (I-c)

The curves in Fig. 17 show the simple variations of ϵ and Φ for a tuned-plate oscillator. The oscillation angular velocity is very nearly $1/\sqrt{L_2 C_2}$. The phase difference is constant when τ_L is changed, because

it depends solely upon η_2 . As the excitation increases linearly from zero when $\tau_L = 0$, oscillation will not start until τ_L is large enough to give a favorable excitation.

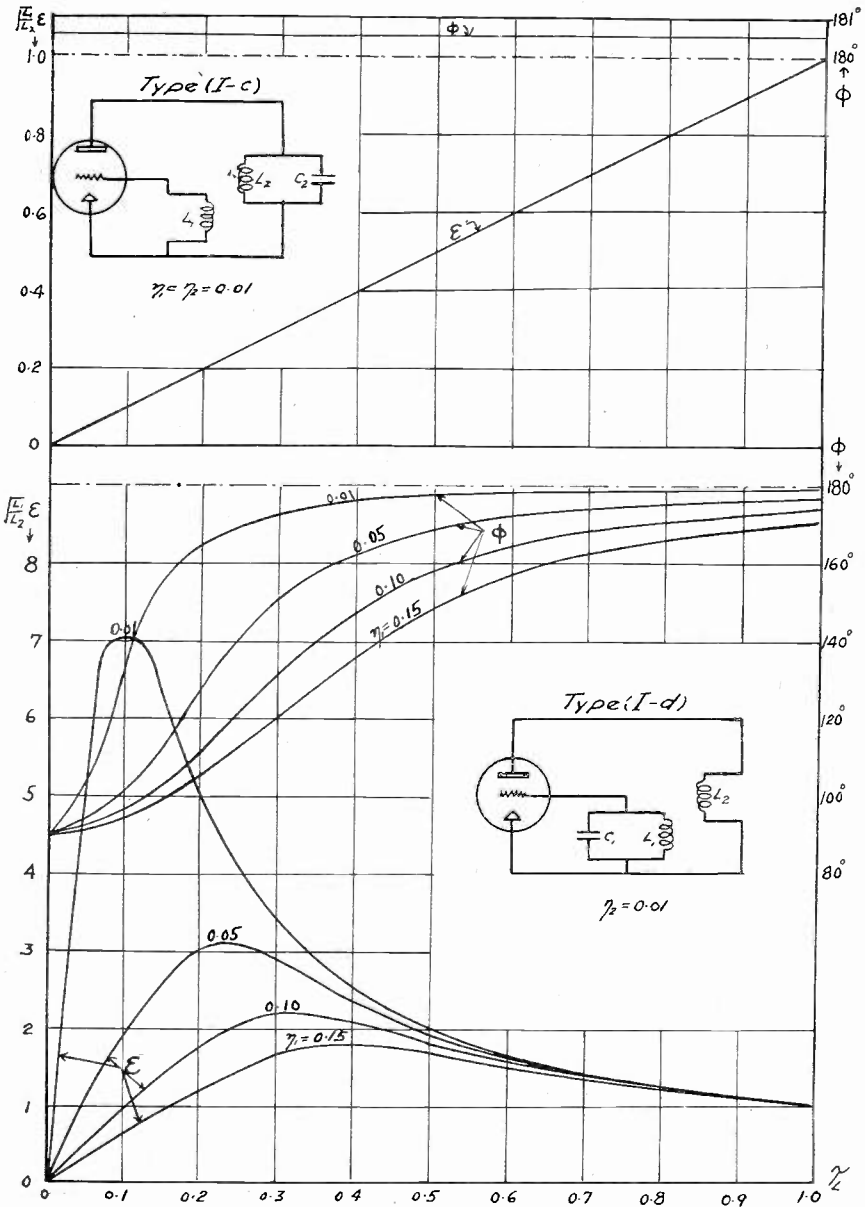

Fig. 17—(Above)— Φ and ϵ for Type I-c oscillator.

Fig. 18—(Below)— Φ and ϵ for Type I-d oscillator.

It is interesting to note that at positive τ_L , the phase difference is slightly greater than 180 degrees, thus satisfying the condition of oscillation. But if τ_L is made negative (not shown), the phase is slightly greater than 0 degrees (in the first quadrant). Therefore, no oscillation is possible for all negative values of τ_L .

Oscillator Type (I-d)

Fig. 18 shows the curves for the phase difference and excitation for a tuned-grid oscillator. The oscillation angular velocity is again roughly

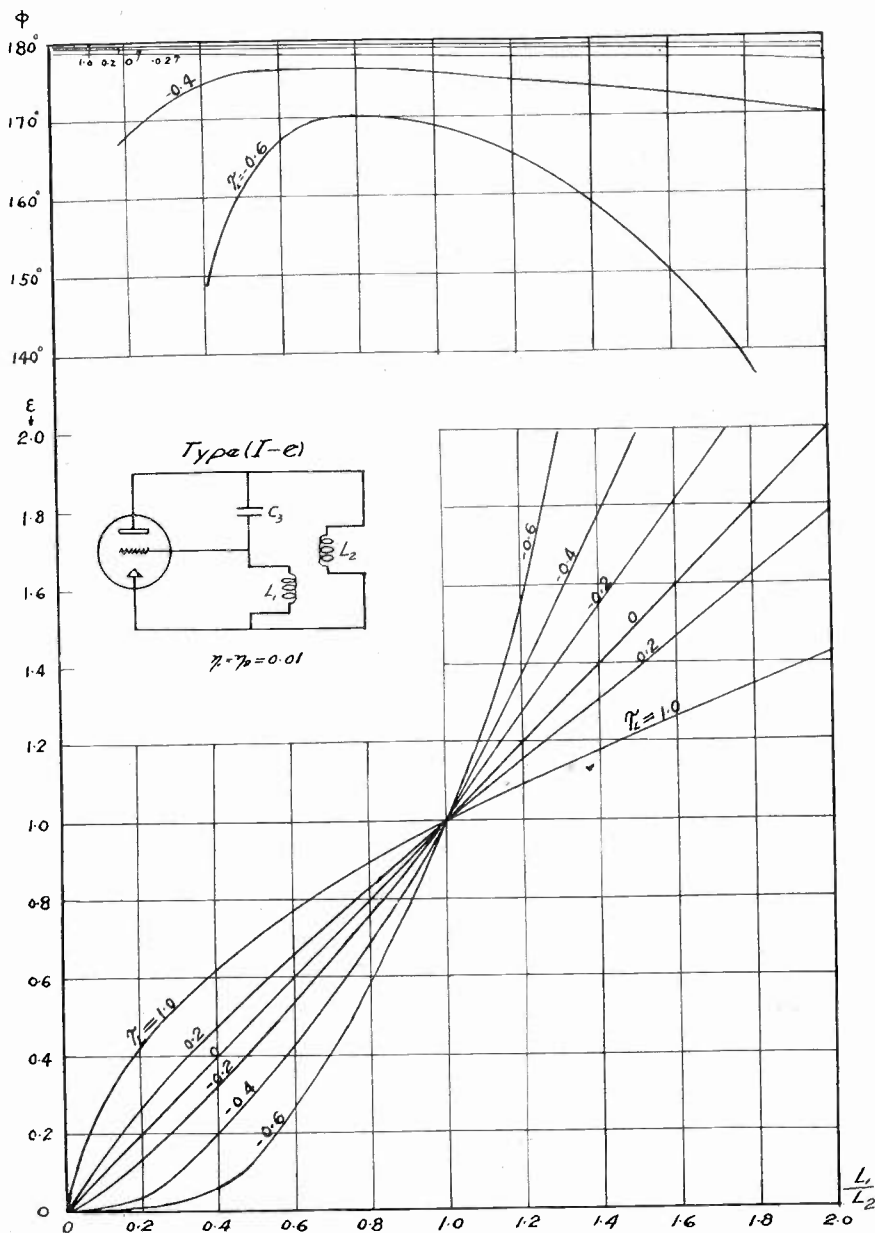

Fig. 19— Φ and ϵ vs. L_1/L_2 for Type I-e oscillator for different values of τ_L .

determined by $1/\sqrt{L_1 C_1}$. The phase difference starts at 90 degrees and rises to about 180 degrees as τ_L increases. The excitation curve for a constant η_1 starts from zero and rises to a maximum at $\tau_L = \sqrt{\eta_1}$, and gradually falls down to a limiting value $\sqrt{L_1/L_2}$. It is seen that oscilla-

tion cannot take place at very small values of τ_L , because of too small excitation combined with a poor phase difference. A negative τ_L will cause the phase difference to lie in the fourth quadrant. Oscillation is,

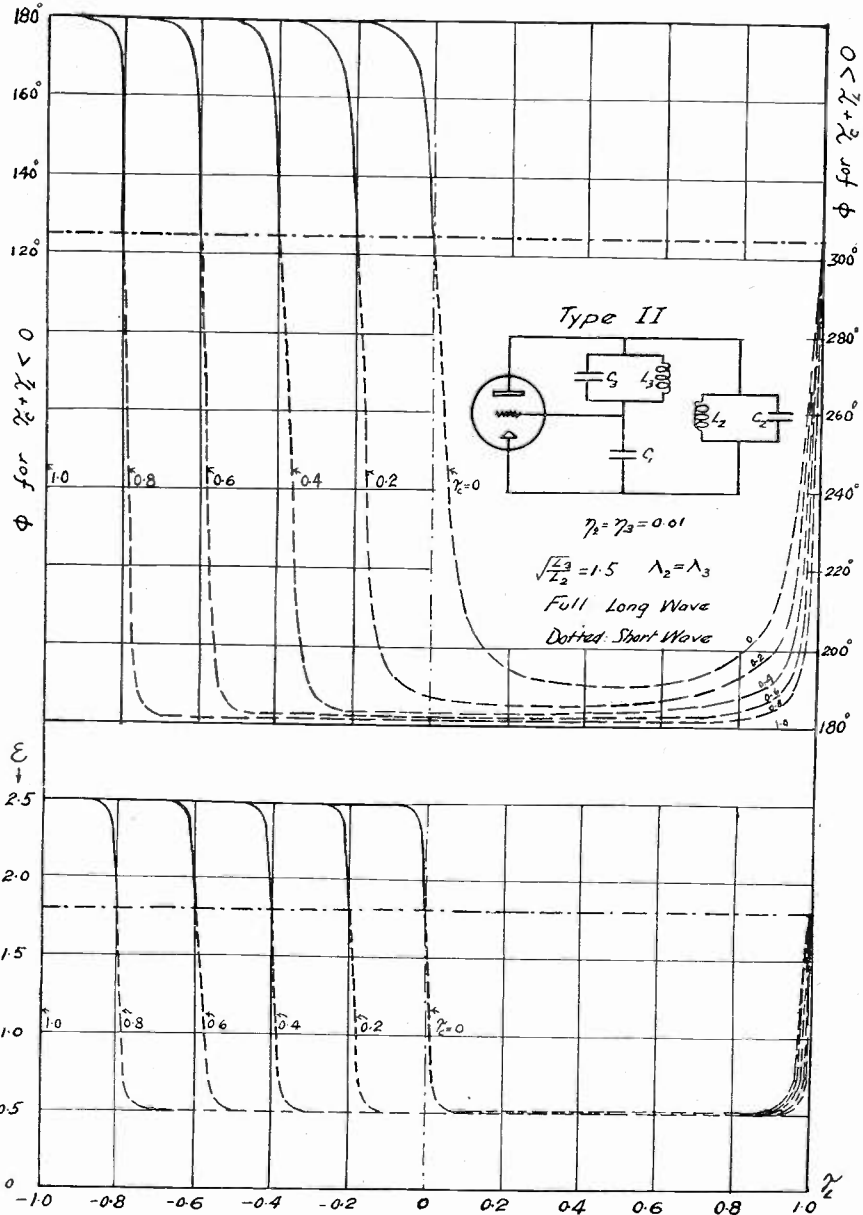

Fig. 20-a— Φ and ϵ vs. τ_L for Type II oscillator at $\lambda_2 = \lambda_3$ for different values of τ_C .

therefore, not possible with a reversed winding for a tuned-grid as well as for a tuned-plate oscillator.

Oscillator Type (I-e)

This circuit is known as the Hartley Oscillator. The angular velocity of oscillation is roughly $1/\sqrt{LC_3}$, where $L = L_1 + L_2 + 2M$ and M can be

either positive or negative. Usually a single coil is used with the grid and plate connected to the opposite ends and the filament to a center tap. τ_L is in this case positive by definition and its value depends upon

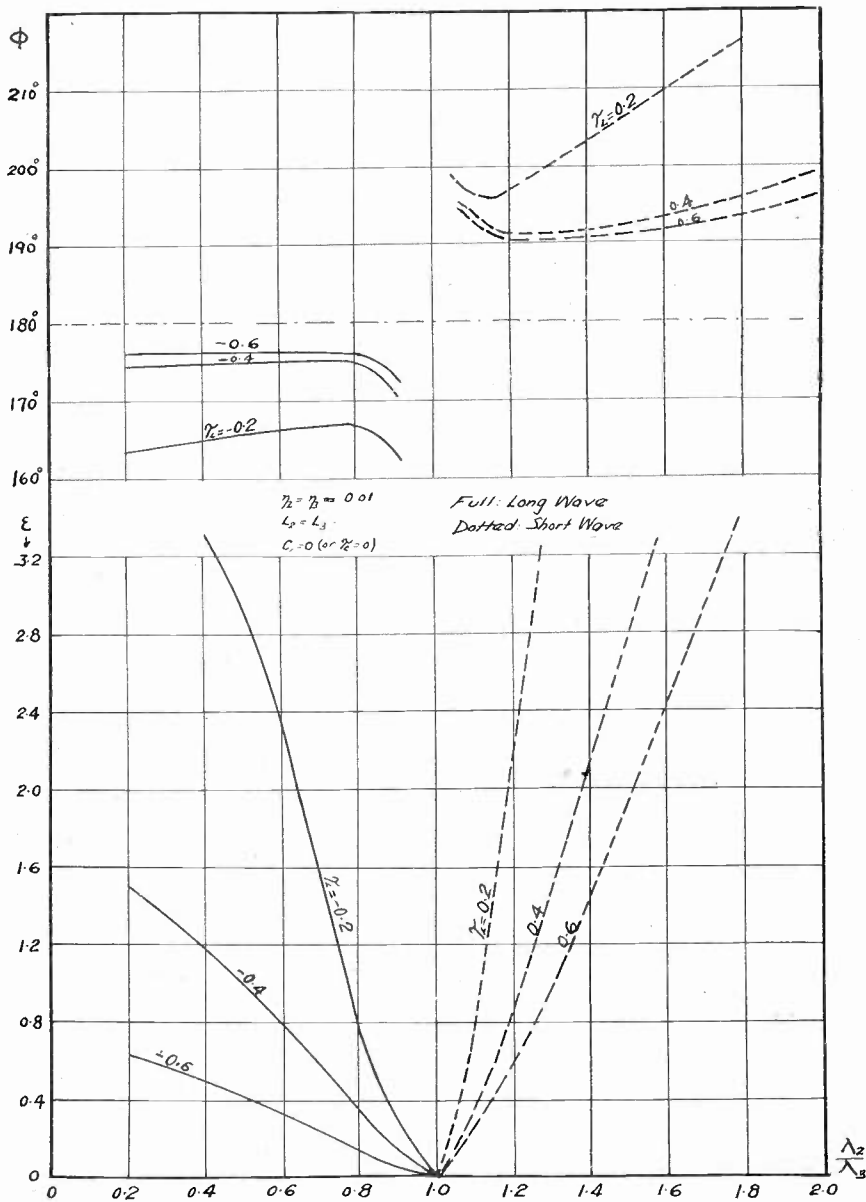

Fig. 20-b— Φ and ϵ vs. λ_2/λ_3 for Type II oscillator ($\tau_C = 0$) for different values of τ_L .

the compactness of winding, geometry of coil, etc. There are occasions when the coils with self-inductances L_1 and L_2 are placed to have a negative τ_L such as in a magnetostriction oscillator whose coils are reversed from the usual sense.

The form of the excitation curves depends upon the magnitude of τ_L . If $\tau_L = 1$, ϵ varies linearly as $\sqrt{L_1/L_2}$ as in the case of an iron-core transformer with a coupling coefficient very slightly less than unity.

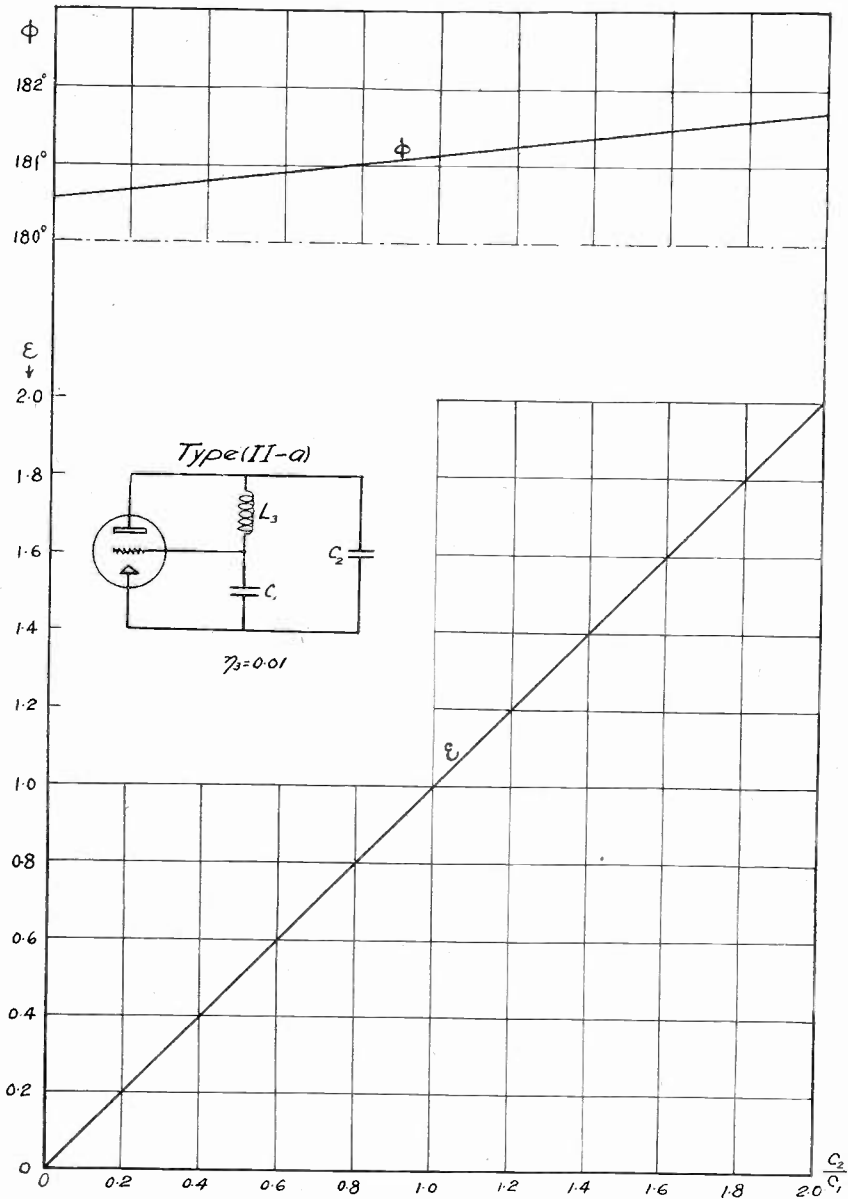

Fig. 21— Φ and ϵ vs. C_2/C_1 for Type II-a oscillator.

If $\tau_L = 0$, ϵ varies linearly as L_1/L_2 . If τ_L is negative, ϵ will vary as certain powers (larger than unity) of L_1/L_2 .

Φ remains nearly constant throughout the whole range of L_1/L_2 , if τ_L is positive, but it varies from slightly less than 180 degrees toward 0 degrees as τ_L increases in the negative direction. Ordinary oscillators

would not function very well under these circumstances, but it turns out to be an advantage for a magnetostriction oscillator.³

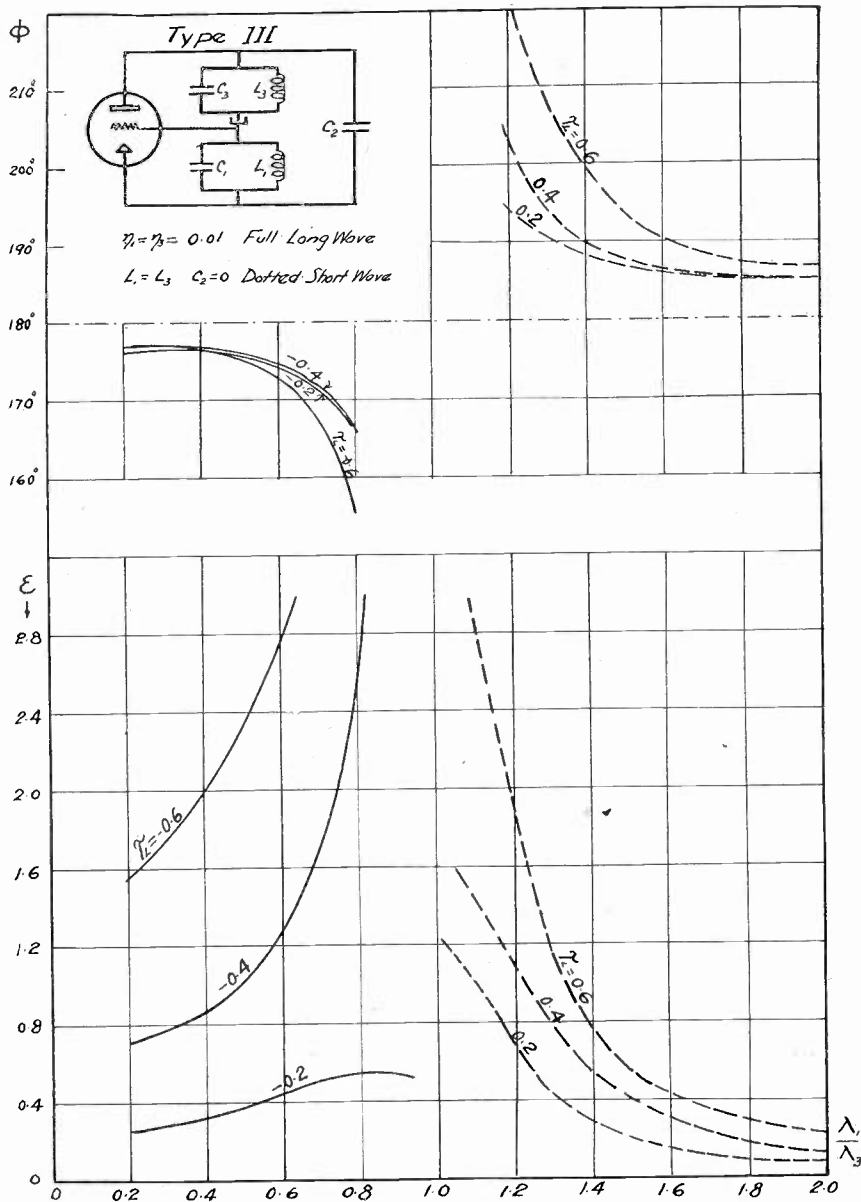

Fig. 22— Φ and ϵ vs. λ_1/λ_3 for Type III oscillator ($\tau_C = 0$) for different values of τ_L .

Oscillator Type II

In Fig. 20-a the phase difference for the short wave is slightly over 180 degrees at positive values of τ_L . It is just the opposite of the conditions in oscillator Type I. (See Fig. 14.) In fact, what was not excited

³ G. W. Pierce, "Magnetostriction oscillators," *Proc. Amer. Acad. Arts and Sci.*, 63, No. 1, 1928.

before can be excited now. Thus, at positive $\tau (\doteq \tau_C + \tau_L)$, short wave is excited, while at negative τ long wave is excited. Region of no oscillation again occurs near the zero combined coupling coefficient.

Fig. 20-b shows the effect of tuning (i.e., by changing λ_2/λ_3), at constant coupling, on the phase difference and excitation. For simplicity of calculation, C_1 is omitted and $L_2 = L_3$. It is seen that at positive τ_L short wave is excited only when $\lambda_2/\lambda_3 > 1$, long wave is not excited at all. At negative τ_L , long wave is excited only when $\lambda_2/\lambda_3 < 1$, short wave is not excited at all. Angular departure from 180 degrees and excitation become large as τ_L is made small in both cases.

Oscillator Type (II-a)

This circuit is known as the Colpitts Oscillator. The curves shown in Fig. 21 are exceedingly simple in that the phase difference changes but little from 180 degrees (always more than 180 degrees) and the excitation varies linearly with the ratio C_2/C_1 . The angular velocity of oscillation is roughly $1/\sqrt{L_3(C_1C_2/C_1 + C_2)}$. It is indeed a well-behaving circuit when both phase difference and excitation are considered.

Oscillator Type III

As in Type II, at positive τ_L short wave is excited for $\lambda_1/\lambda_3 > 1$, and at negative τ_L long wave is excited at $\lambda_1/\lambda_3 < 1$. But instead of dropping down toward $\lambda_1 = \lambda_3$, the curves climb up to exceedingly large values of excitation. Also, a large coupling gives large excitation, whereas the reverse is true for a Type II oscillator. As for the phase difference, short-wave angle lies in the third quadrant, while the long-wave angle lies in the second. The angular departure from 180 degrees tends to be very large when $\lambda_1 = \lambda_3$ is approached.

Oscillator Type (IV-a)

In Fig. 23-a, the phase differences for both long and short waves are in the third quadrant. At $\lambda_2/\lambda_3 > 1$, the phase difference for the long wave is more favorable for oscillation than that for the short wave; at $\lambda_2/\lambda_3 < 1$ the reverse is true. Therefore, we expect a jumping from one oscillation wavelength to the other as the ratio λ_2/λ_3 is changed. But the oscillation tends to stick to one wave until a jump is very imperative. Hence the breaking points will depend upon which way the tuning is accomplished. This gives rise to the so-called "drag-loop" phenomenon. It is noted from the figure that a larger τ_L would give a larger loop.

Oscillator Type (IV-b)

Similarly, the drag-loop phenomenon is present in a tuned-grid coupled circuit oscillator as shown in Fig. 23-b. The phase angles in

this case lie in the second instead of in the third quadrant. All curves intersect at the same point on the $\lambda_1/\lambda_3 = 1$ line.

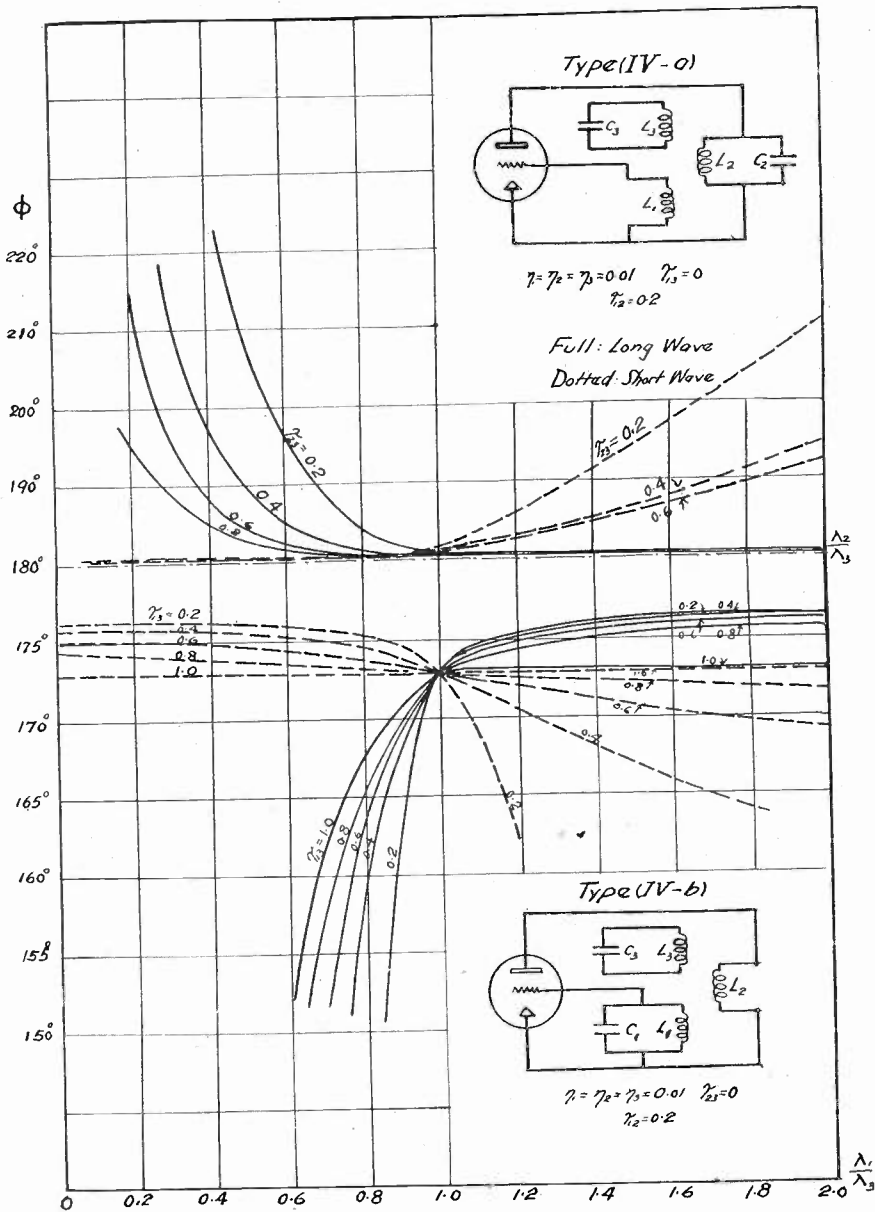

Fig. 23-a—(Above)— Φ vs. λ_2/λ_3 for Type IV-a oscillator.
 Fig. 23-b—(Below)— Φ vs. λ_1/λ_3 for Type IV-b oscillator.
 Note the difference in the angular scale.

8. SAMPLE EXPERIMENTAL RESULTS

To verify the theory previously deduced, we use a circuit similar to the most general oscillator network. Fig. 24 shows such a circuit when it is connected to an electron tube with all the measuring devices. The

circuit is formed and controlled in such a way that all quantities can be measured with satisfactory precision. In the present case we are chiefly concerned with the measurements on the excitation and phase difference. The oscillation wavelength is adjusted (by getting beats with a heterodyne wavemeter) to constant values in most experiments.

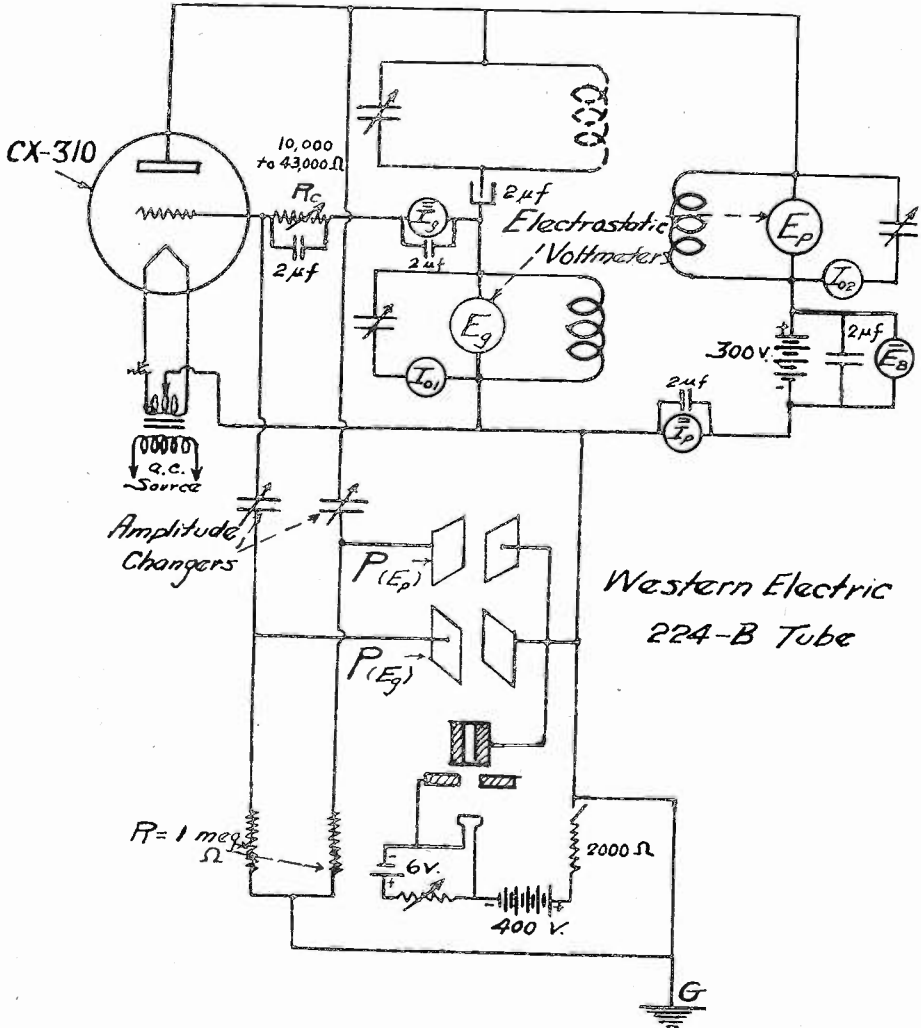
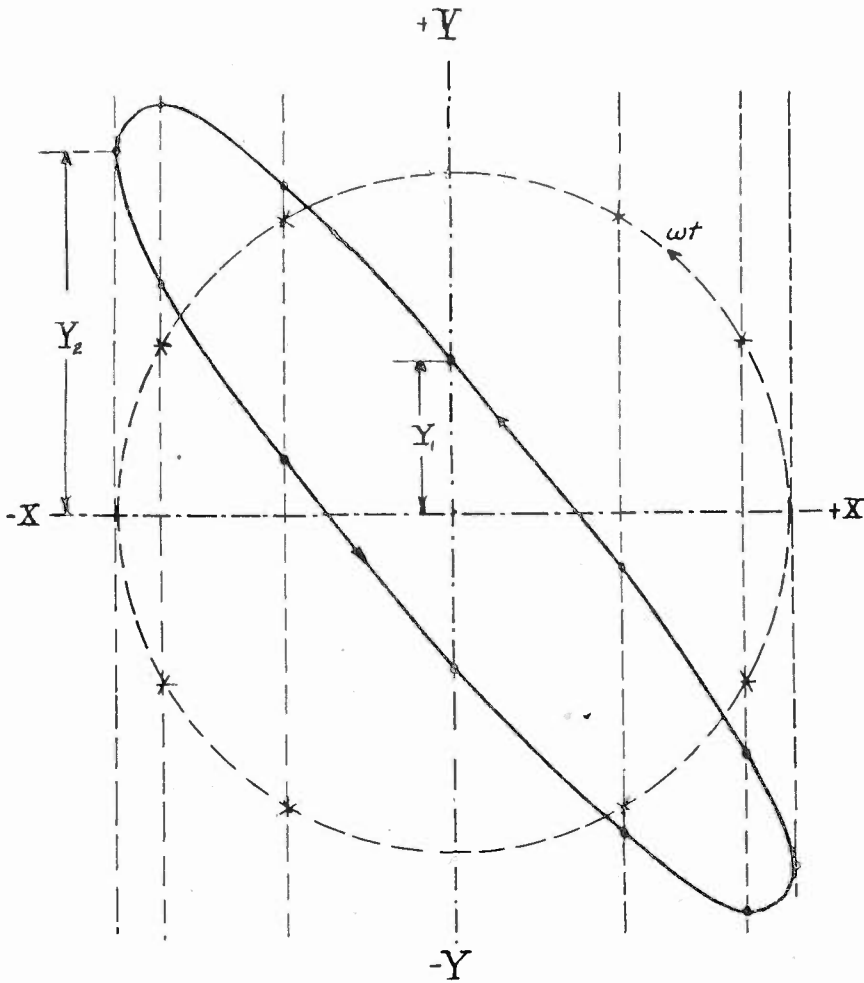

Fig. 24—Schematic diagram of the circuit connections used to measure the phase difference and excitation.

The alternating grid and plate voltages are measured by two electrostatic voltmeters. The ratio of the former to the latter gives directly the value for ϵ . The phase difference is measured from a Lissajous figure formed by the alternating grid and plate voltages when they are respectively impressed on two perpendicular plates in a Braun tube. The actual phase difference is calculated by the well-known formula

$$\phi = \tan^{-1} \left(\frac{Y_1}{Y_2} \right)$$

wherein the quantities Y_1 and Y_2 are indicated on a sample trace in Fig. 25.



$$\begin{aligned} X &= \hat{E}_p \cos \omega t \\ Y &= \hat{E}_o \cos (\omega t - \phi) \\ Y &= Y_1 \sin \omega t + Y_2 \cos \omega t \\ \phi &= \tan^{-1} \left(\frac{Y_1}{Y_2} \right) \end{aligned} \quad \left. \begin{array}{l} \text{Where } \phi \text{ is the phase} \\ \text{difference between } E_o \text{ and } E_p \end{array} \right\}$$

Fig. 25—Method of calculating phase difference from a Lissajous figure produced by two purely sinusoidal voltages.

Experiments have been done on practically all circuits treated in the preceding section. To save space, only a few sample curves representing the four different types will be shown.

Oscillator Type I

Compare with Fig. 14 for the calculated curves of the same oscillator. In the present arrangement, the highest τ_L attainable is slightly

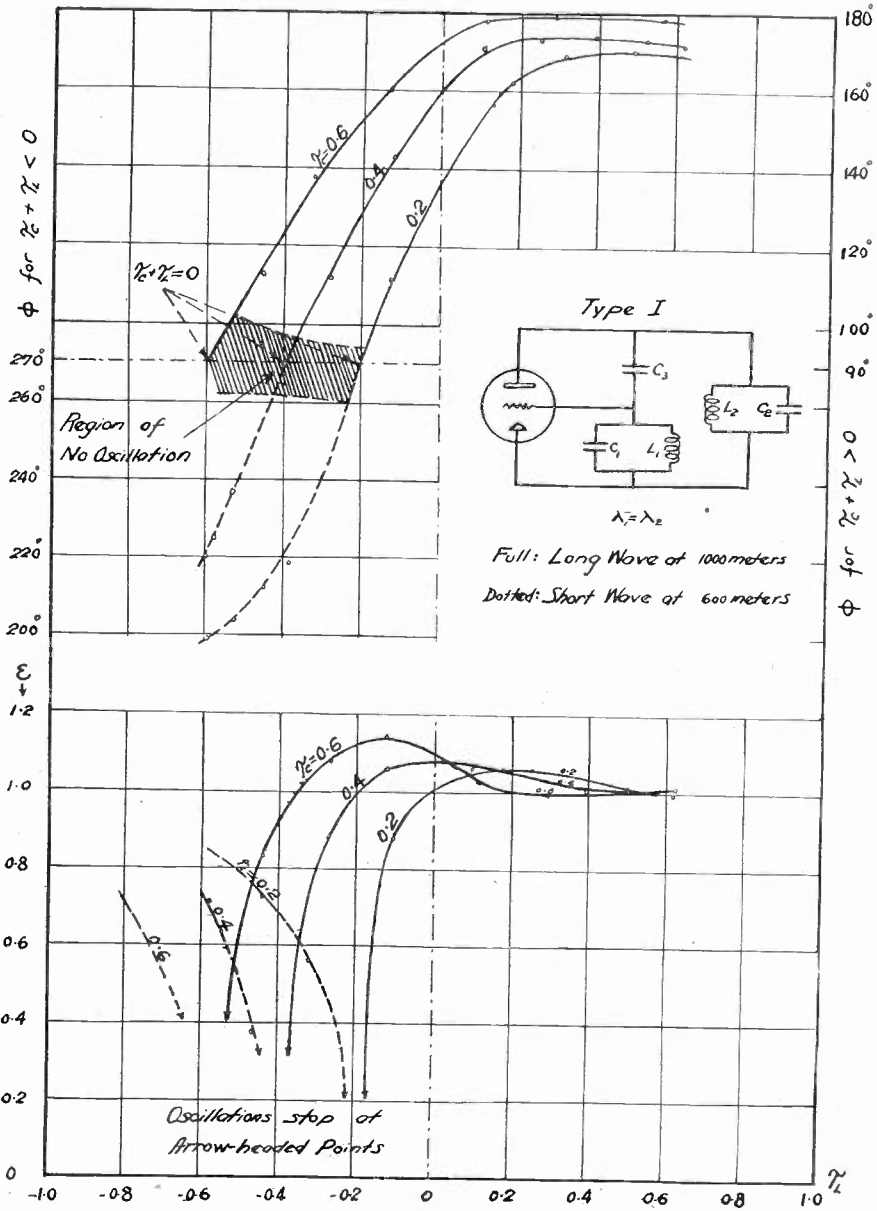
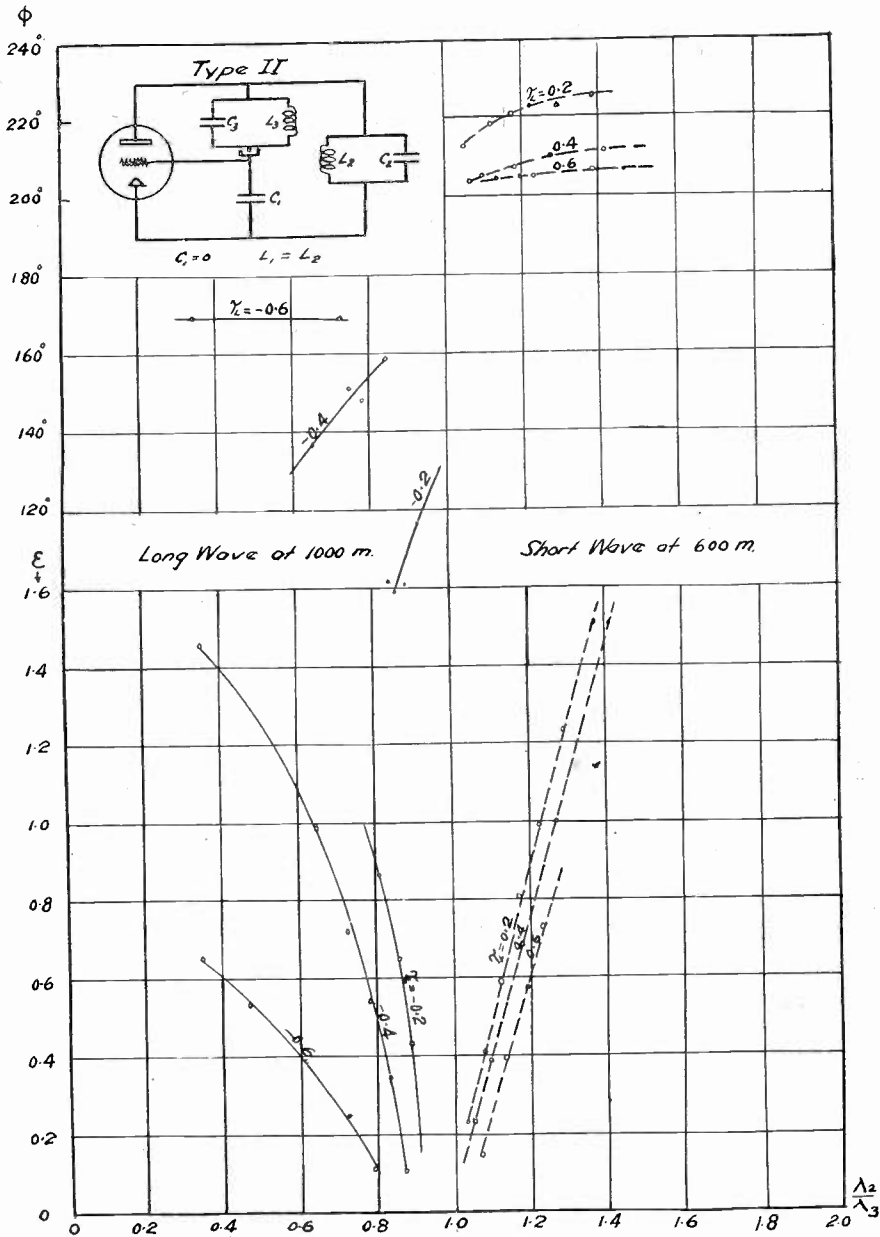

Fig. 26—Experimentally determined ϕ and ϵ vs. τ_L for Type I oscillator for different values of τ_C .

over 0.6 so that only three out of five coupling values can be checked. It was found that oscillations can be sustained till the angular departure from 180 degrees is somewhat less than 90 degrees in either direction. No oscillation is possible when it is at 90 degrees or 270 degrees,

thus proving the condition of oscillation outlined in Section 3. The shaded portion on the figure indicates the region of no oscillation. For positive $\tau (\doteq \tau_C + \tau_L)$ the long wave is excited, and for negative τ the



[Fig. 27—Experimentally determined Φ and ϵ vs. λ_2/λ_3 for Type II oscillator for different values of τ_L .

short wave is excited. Experimental curves for excitation differ slightly from the theoretical ones in showing a rise of excitation for the long wave before coming down.

Oscillator Type II

Compare Fig. 20. It is seen that the experimental and theoretical curves are in close agreement. No oscillation has been found possible

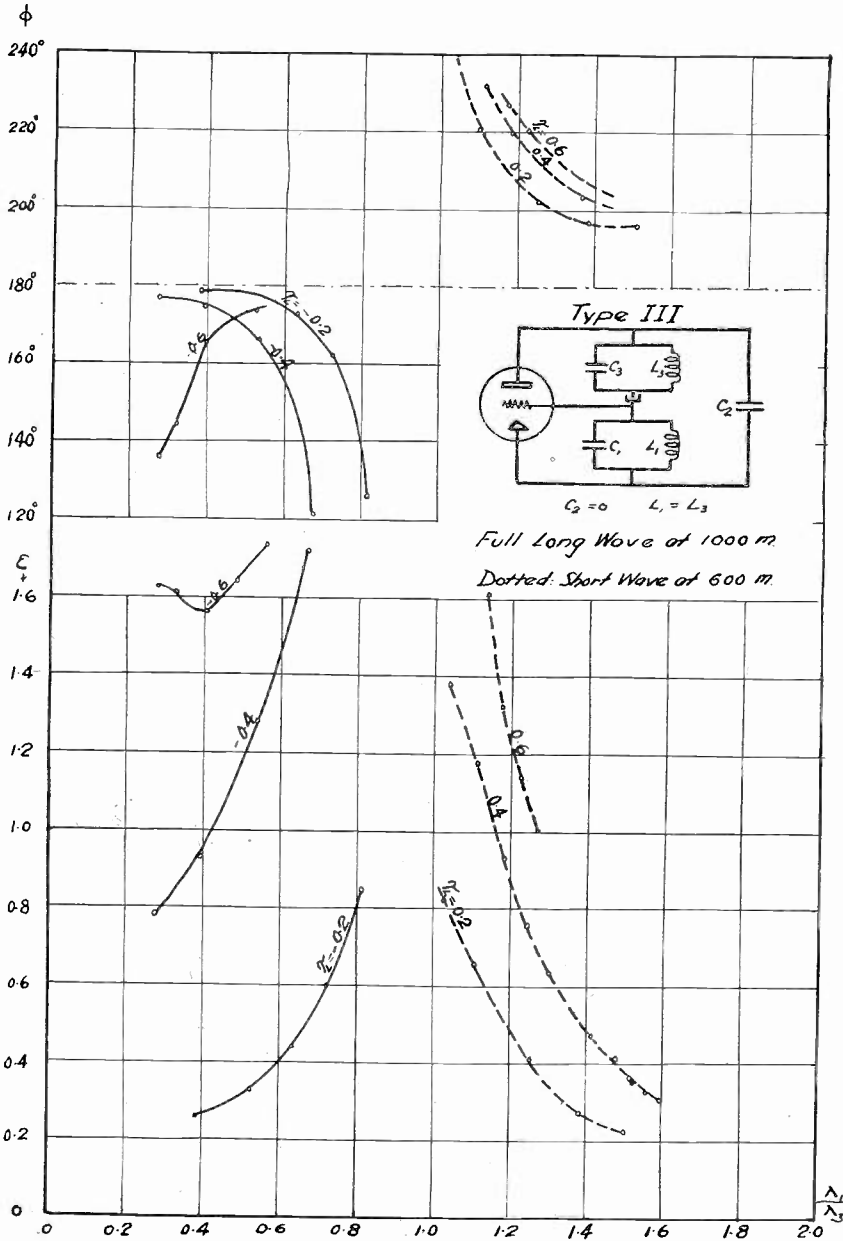

Fig. 28—Experimentally determined Φ and ϵ vs. λ_1/λ_3 for Type III oscillator for different values of τ_L .

when $\lambda_2/\lambda_3 = 1$. When τ_L is positive, short wave is excited at $\lambda_2/\lambda_3 > 1$, when it is negative, long wave is excited at $\lambda_2/\lambda_3 < 1$. Although we are at present not primarily interested in power outputs, it should be re-

marked that this oscillator gives for the short wave at least five times as much power output as for the long wave. The low output for the long wave is probably due to the large amount of harmonic oscillations present as indicated by the Lissajous figures (not shown in this paper).

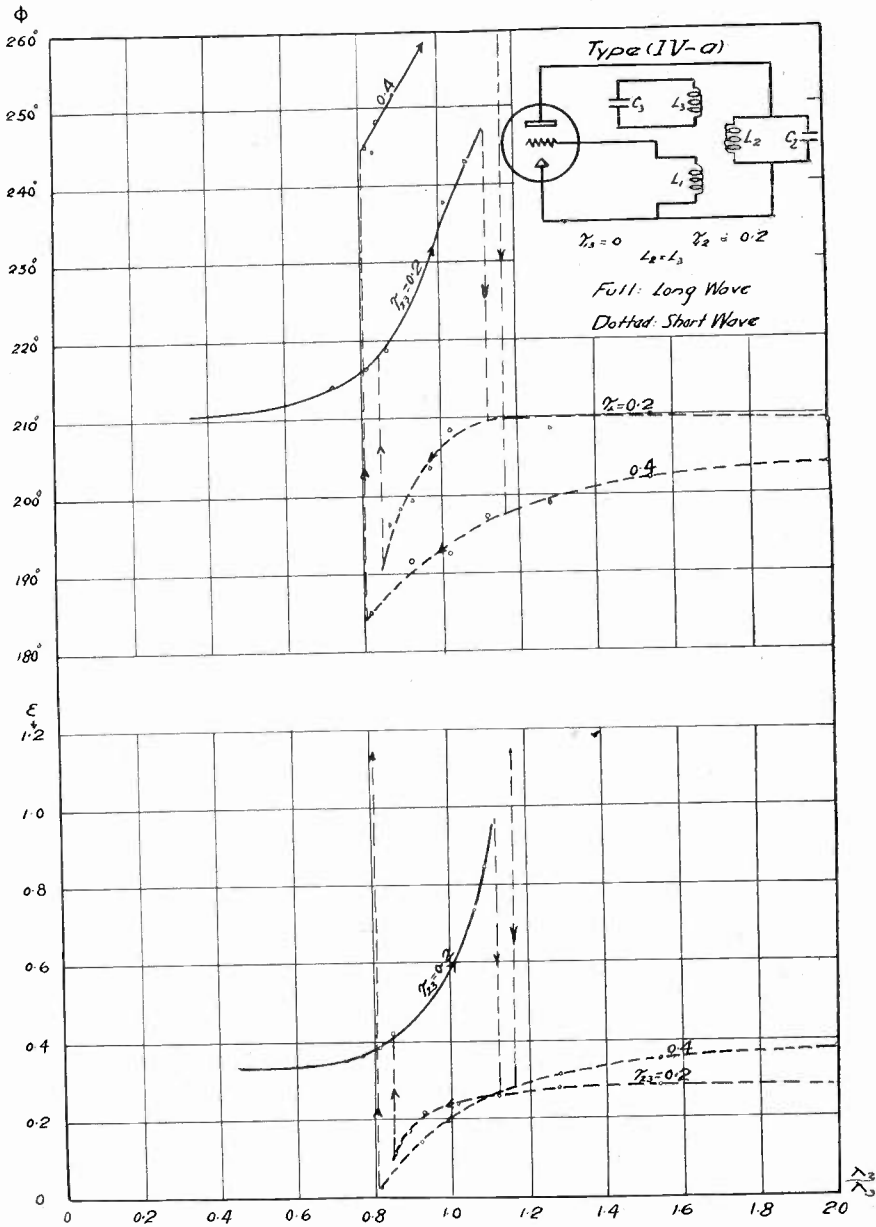

Fig. 29—Experimentally determined Φ and ϵ vs. λ_2/λ_3 for Type IV-a oscillator for two different values of τ_{23} .

Oscillator Type III

Compare Fig. 22. An oscillator of this type has proved to be both theoretically and experimentally quite different from an oscillator of

either Type I or Type II, as far as the appearance of their phase difference and excitation curves are concerned. Approaching the line $\lambda_1/\lambda_3 = 1$ from either direction, we find the values for excitation and the angular departure from 180 degrees are becoming larger and larger. The region of $\lambda_1/\lambda_3 > 1$ allows the excitation of short waves at positive τ_L and the region $\lambda_1/\lambda_3 < 1$ allows the excitation of long waves at negative τ_L .

Oscillator Type (IV-a)

Compare Fig. 23-a. Fig. 29 gives the experimental evidence of the drag-loop phenomenon for a tuned-plate coupled-circuit oscillator from the standpoint of the present treatment. The curves for the long-wave phase difference are seen to be similar to the theoretical ones. But the corresponding curves for the short wave do not check so well. It is noted that the drag-loop is larger at $\tau_{23} = 0.4$ than it is at $\tau_{23} = 0.2$, which is in agreement with the theoretical picture.

9. RECAPITULATION OF THE ESSENTIAL RESULTS OBTAINED

We have seen that the new treatment of electron tube oscillator by considering the ratio E_g/E_p turns out to be quite resourceful in forming working pictures for the performance of oscillators. The calculated values have been satisfactorily proved by experiments. The essential results obtained may be summarized as follows:

(a) If the grid current and the effect of resistances on oscillation frequency are negligible, the complex ratio E_g/E_p is entirely independent of the tube parameters.

(b) A necessary condition of oscillation requires that the phase difference between the alternating grid and plate voltages must lie between $\pi/2$ and $(3/2)\pi$.

(c) If an oscillator network possesses two natural angular velocities, the one whose phase difference satisfies the condition in (b) will be selected for excitation.

(d) In oscillator circuits with combined coupling, there exists a coupling coefficient, defined as $\tau = \tau_C(\omega_1\omega_2/\omega^2) + \tau_L \doteq \tau_C + \tau_L$ such that if it is positive, one wave is excited; and if it is negative, the other wave is excited; and if it is zero, no oscillation is possible.

(e) For oscillator circuits with a single natural angular velocity, the coupling coefficient must always be positive for oscillation.

ACKNOWLEDGMENT

The writer is very much indebted to Professor E. L. Chaffee for his able direction of this research.

APPENDIX I

Nomenclature

| Symbol | Definition | Meaning |
|--|--|--|
| 1. η | $\frac{R}{\omega L}$ | Power ratio of a coil (power ratio of an air condenser considered negligible). |
| 2. ω $\omega''\omega'$ $\omega_1\omega_2\omega_3$ | $2\pi f$ | Oscillation angular velocity (f in cycles per second); oscillation angular velocities, of lower and higher frequencies; natural angular velocities of circuits 1, 2, 3. |
| 3. λ $\lambda''\lambda'$ $\lambda_1, \lambda_2, \lambda_3$ | $\frac{V}{f}$ | Oscillation wavelength (V = velocity of light); long and short wavelengths; natural wavelengths of circuits 1, 2, 3. |
| 4. τ_L | $\frac{M^*}{\sqrt{L_1 L_2}}$ | Inductive coupling coefficient |
| τ_C | $C_m / \sqrt{(C_1 + C_m)(C_2 + C_m)}$ | |
| τ | $\tau_C \frac{\omega_1 \omega_2}{\omega^2} + \tau_L$ | |
| 5. \hat{E}_g E_g E_p E_p | $\frac{\hat{E}_g}{\sqrt{2}} \angle \Phi(E_g)$ $\frac{\hat{E}_p}{\sqrt{2}} \angle \Phi(E_p)$ | Combined coupling coefficient |
| | | Peak value of a-c grid voltage; r-m-s grid voltage in vector form. |
| | | Peak value of a-c plate voltage; r-m-s plate voltage in vector form. |
| ϵ | $\frac{\hat{E}_g}{\hat{E}_p}$ | Excitation: ratio of the amplitudes of a-c grid to plate voltage. |
| 6. Φ | $\Phi(E_g) - \Phi(E_p)$ | Phase angle difference between a-c grid and plate voltages. |
| θ | $\Phi(I_p) - \Phi(E_p)$ | Phase angle difference between plate current and voltage. |
| 7. e \ddot{e} \bar{E}_B | | Instantaneous voltage |
| | | Instantaneous voltage measured above average value |
| 8. i \ddot{i} I_p \bar{I}_p \bar{I}_p | | d-c battery voltage supplied to the plate |
| | | Instantaneous current |
| | | Instantaneous current measured above average value |
| | | r-m-s plate current in vector form |
| | $\frac{1}{T} \int_0^T i_p dt$ | d-c plate current |
| | | Average plate current |

* M is defined as positive when the coils are so wound and oriented that a steady current flowing from the plate to the filament through one coil and another steady current flowing from the filament to the grid through the other coil produce magnetic fields in the same direction. It is negative when the reverse is true.

APPENDIX II

Correct Phase Difference as a Necessary Condition for Oscillation

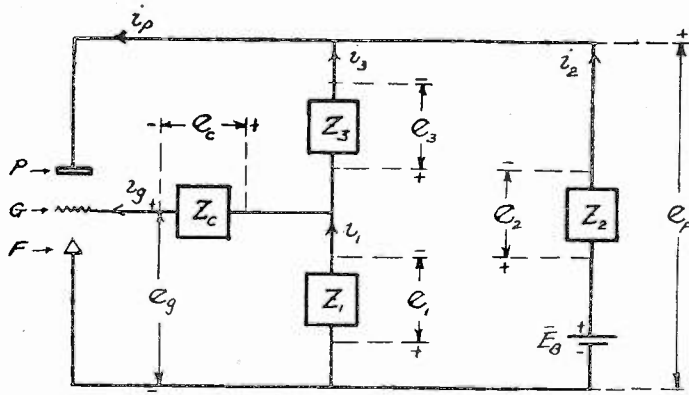

Fig. 30.

From the indicated quantities in Fig. 30, we have the following simple relations

$$\begin{aligned}
 i_p - i_2 - i_3 &= 0 & (a) \\
 i_g - i_1 + i_3 &= 0 & (b) \\
 e_p + e_1 + e_3 &= 0 & (c) \\
 e_p + e_2 - \bar{E}_B &= 0 & (d) \\
 e_g + e_1 + e_c &= 0. & (e)
 \end{aligned}
 \tag{1}$$

Multiplying (1-d) by i_p and taking the average over a period, we have

$$\frac{1}{T} \int_0^T i_p e_p dt + \frac{1}{T} \int_0^T i_p e_2 dt - \frac{1}{T} \int_0^T i_p \bar{E}_B dt = 0. \tag{2}$$

Substituting for i_p in the second and third terms in (2) by (1-a), there results

$$\frac{1}{T} \int_0^T i_p e_p dt + \frac{1}{T} \int_0^T i_2 e_2 dt - \frac{1}{T} \int_0^T i_2 \bar{E}_B dt + \frac{1}{T} \int_0^T i_3 e_2 dt - \frac{1}{T} \int_0^T i_3 \bar{E}_B dt = 0. \tag{3}$$

By (1-c) and (1-d) and (1-e)

$$e_2 = \bar{E}_B + e_3 - e_c - e_g. \tag{4}$$

Substituting (4) into the fourth term of (3), and using (1-b) and (1-e), we have

$$\begin{aligned}
 &\frac{1}{T} \int_0^T i_p e_p dt + \left(\frac{1}{T} \int_0^T i_1 e_1 dt + \frac{1}{T} \int_0^T i_2 e_2 dt + \frac{1}{T} \int_0^T i_3 e_3 dt \right) \\
 &+ \left(\frac{1}{T} \int_0^T i_g e_g dt + \frac{1}{T} \int_0^T i_g e_c dt \right) - \frac{1}{T} \int_0^T i_2 \bar{E}_B dt = 0.
 \end{aligned}
 \tag{5}$$

The instantaneous current and voltage are respectively (see Nomenclature)

$$\begin{aligned}
 i &= \bar{I} + \dot{i} \\
 e &= \bar{E} + \dot{e}.
 \end{aligned}$$

Therefore,

$$\frac{\pi}{2} < \theta < \frac{3\pi}{2}. \quad (13)$$

For illustration, we shall take the simple case of a linear tube characteristic

as

$$I_p = k_p(E_p + u_p E_g) \quad (14)$$

or,

$$\hat{I}_p |_{\theta} = k_p \hat{E}_p (1 + u_p \epsilon |_{\Phi}). \quad (15)$$

Equating the real and imaginary components, we have

$$\frac{\hat{I}_p}{k_p \hat{E}_p} \cos \theta = 1 + u_p \epsilon \cos \phi \quad (16-a)$$

$$\frac{\hat{I}_p}{k_p \hat{E}_p} \sin \theta = u_p \epsilon \sin \phi. \quad (16-b)$$

In order to satisfy (13), (16-a), and (16-b), we must have

$$\frac{\pi}{2} < \phi < \frac{3\pi}{2}. \quad (17)$$

Thus, a necessary condition of oscillation requires that the phase difference between the grid and plate voltages must lie between $3\pi/2$ and $\pi/2$ (i.e., in the second and third quadrants if E_p is taken as the reference vector).

AMPLITUDE, PHASE, AND FREQUENCY MODULATION*

BY

HANS RODER

(Radio Engineering Department, General Electric Company, Schenectady, New York)

Summary—This paper presents a comparative theoretical study of amplitude, phase, and frequency modulation.

In the first part, the fundamental mathematical expressions for the three types of modulation are derived. They are expressed in three different forms: as amplitude equations, side band equations and modulation vector equations. The amplitude equations indicate the envelope of the radio-frequency directly. The side band equations refer to the number, amplitude, and phase of the side bands produced by modulation. In the modulation vector equations, corresponding side bands are combined in pairs to form a "modulation vector." This is a r-f magnitude, rotating with the angular velocity of the carrier and its amplitude is simultaneously being changed at an audio rate. The main results derived from a discussion of these equations are:

In phase and frequency modulation an infinite number of side bands is produced. Amplitude modulation produces but one pair of side bands.

In amplitude modulation the modulation vector, representing the first pair of side bands is in phase with the carrier. In phase and frequency modulation, it is 90 degrees out of phase with respect to the carrier.

Frequency modulation is equivalent to a phase modulation in which the phase shift is inversely proportional to the audio frequency.

By means of the modulation vector, a new vector diagram of the phase modulation is given.

In the second part, amplitude modulation is considered in which undesired phase or frequency modulation or a combination of the two takes place simultaneously. Regarding distortion and interference with a signal in an adjacent frequency channel, it is found that additional frequency modulation has little effect, while phase modulation may give rise to either distortion or interference or both. The magnitudes of corresponding upper and lower side bands, which are equal in the case of pure amplitude modulation and in the case of amplitude modulation and additional phase modulation, are found to be different when additional frequency modulation is present. This provides a method of measuring additional phase or frequency modulation.

In the third part, a few cases of so-called "false phase modulation" are treated. These are obtained when in a normal amplitude modulated signal the amplitude or the phase of one or both side bands are changed. The results are applied to find the performance of two special sending systems, in which carrier and side bands are radiated from separated antennas.

INTRODUCTION

THE problem of modulation is inherently connected with every kind of radio communication. The constant radio signal is worthless: it is the *variations* of this signal which transmit the message. Telegraph communication uses keying as the only kind of modulation.

* Decimal classification: R148. Original manuscript received by the Institute, May 11, 1931. Delivered before Sixth Annual Convention of the Institute June 4, 1931, Chicago, Illinois.

“Keying” means that the radio signal is changed between two defined values, this change taking place in a more or less rapid transition. Two types of keying have been utilized since the earliest days of radio: The interruption of the signal (which is equivalent to amplitude modulation) and the “Keying by detuning” (which is equivalent to frequency modulation).

Modulation as we commonly understand it means the continuous and reversible change of r-f current or voltage from one state of conditions to another one. The vacuum tube provides an unexcelled means of producing this change. Amplitude modulation is more commonly used than the two other types.

Amplitude modulation by means of vacuum tubes can be effected in two different ways: as plate modulation or grid modulation. The efficiency of a power amplifier which is grid modulated—whether by means of bias voltage or r-f grid voltage change—is low (about 35 per cent). In plate modulation, however, the efficiency of the modulated radio stage is high (60–75 per cent), but this advantage is almost canceled when taking into account the very low efficiency of the plate modulator. In effect, both systems do not differ greatly as far as efficiency is concerned.

This low efficiency was rather unimportant as long as the transmitted power was small. But with the increased power rating of modern broadcast transmitters, the cost of input power becomes a considerable portion of the cost of operation, and in addition, the equipment for the dissipation of lost power grows to considerable magnitude in cost and dimensions. This condition has excited the interest of numerous inventors and engineers so that during the past few years a number of suggestions have been made for phase or frequency modulation. It is claimed that for these types of modulation the efficiency of the r-f amplifier can be as great as it is for telegraph service (70–80 per cent). Apparently, little practical success has been obtained.

But, simultaneously with the increase of broadcast stations in power and number, with the improved sensitivity and selectivity of radio receivers, and with the increased demand for better performance and fidelity in both transmission and reception it became necessary not only to keep each transmitter exactly at its assigned frequency and within its frequency channel, but also to reproduce the audio signal such that the distortion does not exceed a few per cent in the worst case. Observations showed that adjacent channel interference and distortion were due not only to nonlinearity of the amplitude characteristic of the transmitter but also to undesired frequency or phase modulation. Other observations made in connection with transoceanic

telephone communication¹ showed distortion in amplitude modulated signals, this distortion being due to additional frequency or phase modulation which was caused by selective fading or reflection in space. Experience with broadcast synchronization² and with certain types of alternator transmitters³ added further interest to the problem of frequency and phase modulation.

For these reasons, we see all over the world a new and vivid interest in the problems of modulation. R. A. Heising and J. R. Carson⁴ have shown that a modulated signal can be represented by a carrier and a number of side bands. For a more complete analysis it becomes necessary to consider not only the amplitude but also the phase of these components.

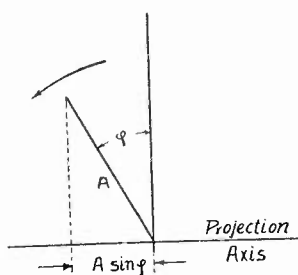

FIG. 1

In the present paper, an attempt is made to compare the three fundamental types of modulation and to show their physical differences.

PURE AMPLITUDE, PHASE, AND FREQUENCY MODULATION

A current, i , whose magnitude and direction are subjected to a sinusoidal change with respect to time, can be represented by the projection of the constant magnitude A in the x -axis (Fig. 1) if it is assumed that A rotates with constant angular velocity.

Thus:

$$i = A \sin \varphi. \quad (1)$$

The sense of rotation is commonly assumed to be counter-clock wise. φ is a function of time, t_1 . Since

$$\omega = \frac{d\varphi}{dt_1} \quad (2)$$

¹ See bibliography No. 15.

² See bibliography Nos. 7 and 9.

³ See bibliography No. 10.

⁴ See bibliography No. 5.

it follows for φ :

$$\varphi = \phi + \int \omega dt_1. \quad (3)$$

If ω is constant we find for i :

$$i = A \sin (\omega t_1 + \phi). \quad (4)$$

This equation represents a sinusoidal current of constant amplitude and frequency.

If any one of the three independent magnitudes:

A —Amplitude
 ϕ —Phase
 ω —Frequency

is subjected to a periodical change, the frequency of which is slow as compared with the "carrier" frequency ω , we call this procedure "modulation" and speak of amplitude, phase or frequency modulation for the three cases in the order named.

AMPLITUDE MODULATION

We put

$$A = A_0(1 + k_a \sin \mu t). \quad (5)$$

This equation indicates that the envelope of the amplitudes of the r-f current is represented by an average value, A_0 , and a superimposed low-frequency sine function of amplitude $k_a A_0$ and radian frequency μ . The current i becomes:

$$i = A_0(1 + k_a \sin \mu t) \sin (\omega t_1 + \phi) \quad (6)$$

ω and ϕ are constants in this case and since $(\omega t_1 + \phi) = \omega_0 t$ it follows for i :

$$i = A_0(\sin \omega_0 t + k_a \sin \omega_0 t \cdot \sin \mu t) \quad (7)$$

or,

$$i = A_0(\sin \omega_0 t + \frac{1}{2}k_a \cos (\omega_0 - \mu)t - \frac{1}{2}k_a \cos (\omega_0 + \mu)t). \quad (8)$$

PHASE MODULATION

A and ω are constant, but ϕ is assumed to change its value periodically:

$$\phi = \phi_0(1 + k_p \sin \mu t). \quad (9)$$

Substituting (9) into (3) and (4)

$$i = A_0 \sin (\omega_0 t + m_p \sin \mu t) \quad (10)$$

where,

$$m_p = k_p \phi_0. \quad (11)$$

From the theory of Bessel's functions the following relations are known:

$$\begin{aligned} \sin(x \sin r) = 2I_1(x) \sin r + 2I_3(x) \sin 3r \\ + 2I_5(x) \sin 5r \\ + \dots \end{aligned} \quad (12)$$

and,

$$\begin{aligned} \cos(x \sin r) = I_0(x) + 2I_2(x) \cos 2r \\ + 2I_4(x) \cos 4r \\ + \dots \end{aligned} \quad (13)$$

In these equations $I_n(x)$ means the Bessel function of the first kind⁵ and n^{th} order for the argument x . By means of (12) and (13), (10) can readily be transferred into

$$\begin{aligned} i = A_0 [I_0(m_p) \sin \omega_0 t + 2I_1(m_p) \sin \mu t \cos \omega_0 t \\ + 2I_2(m_p) \cos 2\mu t \sin \omega_0 t \\ + 2I_3(m_p) \sin 3\mu t \cos \omega_0 t \\ + \dots]. \end{aligned} \quad (14)$$

This equation may be written:

$$\begin{aligned} i = A_0 [I_0(m_p) \sin \omega_0 t + I_1(m_p) (\sin (\omega_0 + \mu)t - \sin (\omega_0 - \mu)t) \\ + I_2(m_p) (-\sin (\omega_0 + 2\mu)t + \sin (\omega_0 - 2\mu)t) \\ + I_3(m_p) (\sin (\omega_0 + 3\mu)t - \sin (\omega_0 - 3\mu)t) \\ + \dots]. \end{aligned} \quad (15)$$

FREQUENCY MODULATION

A and ϕ are constant, but while we may write for

$$\omega = \omega_0(1 + k_f \cos \mu t_1). \quad (16)$$

It would be a mistake to substitute (16) directly into (4) since (4) is correct for constant ω only. Substituting (16) into first (3) and then (1) and putting the arbitrary integration constant equal to zero, it is found

$$i = A_0 \sin (\omega_0 t + m_f \sin \mu t). \quad (17)$$

⁵ In Appendix (1), a numerical table of $I_n(x)$ is given. For more complete tables, see *Jahnke-Emde, Funktionentafeln und Kurven*, Leipzig 1928; *Gray and Mathews, A Treatise on Bessel Functions*, London.

In this expression

$$m_f = \frac{k_f \omega_0}{\mu} \quad (18)$$

Since (17) discriminates from (10) only by the constant term m_f (17) may be immediately replaced by:

$$\begin{aligned} i = A_0 [& I_0(m_f) \sin \omega_0 t + 2I_1(m_f) \sin \mu t \cdot \cos \omega_0 t \\ & + 2I_2(m_f) \cos 2\mu t \cdot \sin \omega_0 t \\ & + 2I_3(m_f) \sin 3\mu t \cdot \cos \omega_0 t \\ & + \dots] \quad (19) \end{aligned}$$

or,

$$\begin{aligned} i = A_0 [& I_0(m_f) \sin \omega_0 t + I_1(m_f) (\sin (\omega_0 + \mu)t - \sin (\omega_0 - \mu)t) \\ & + I_2(m_f) (-\sin (\omega_0 + 2\mu)t + \sin (\omega_0 - 2\mu)t) \\ & + I_3(m_f) (\sin (\omega_0 + 3\mu)t - \sin (\omega_0 - 3\mu)t) \\ & + \dots] \quad (20) \end{aligned}$$

If we call

f_0 — the radio frequency

f_{00} — the audio frequency

then,

$$2\pi f_0 = \omega_0$$

and,

$$2\pi f_{00} = \mu.$$

Thus,

$$m_f = \frac{k_f f_0}{f_{00}}.$$

Hence, m_f is given by the ratio between maximum frequency shift and audio frequency.

The equations (6), (7), (8), (10), (14), (15), (17), (19), and (20) represent the fundamental mathematical expressions for the three kinds of modulation.

Amplitude Equations:

(6), (10), and (17)

give the envelopes of the radio frequency.

Side Band Equations

(8), (15), and (20)

give the amplitudes of the side bands and the width of the band covered.

Modulation Vector Equations:

(7), (14), and (19)

combine two corresponding side bands to a modulation vector.

AMPLITUDES

It is a well-known fact that the rectified current which is delivered by a detector depends only upon the envelope of the r-f input and the detection characteristic of the detector. If this characteristic is a straight line (linear detection) the rectified current is a true reproduction of the r-f envelope; if it is curved, the rectified current contains audio harmonics not being present in the input envelope.

When using an aperiodic antenna the detector input voltage is proportional to the received field strength. Thus an ideal linear detector will deliver a rectified current i_r which, according to equations (6), (10), and (17) will be:

$$\text{For amplitude modulation: } i_r = K_1 A_0 (1 + k_a \sin \mu t)$$

$$\text{For phase modulation: } i_r = K_2 A_0$$

$$\text{For frequency modulation: } i_r = K_3 A_0.$$

(The K 's are proportionality constants.) It follows from the above that neither phase nor frequency modulation can produce any audio signal in a "pure detector." This statement holds equally for linear and curved detector characteristics. To make a phase or frequency modulated signal audible, it has to be converted into an amplitude modulated signal. This is achieved by inserting tuned circuits or filters between the receiving antenna and detector.

WIDTH OF THE FREQUENCY BAND

It follows from equations (8), (15), and (20) that each kind of modulation renders a carrier frequency and a set of side bands. The spacing between carrier frequency and the adjacent side frequency, or between two adjacent side frequencies is equal to the audio frequency.

Amplitude Modulation gives only *one* set of side bands and it covers a frequency band which is 2μ wide. The amplitudes of the side bands, are $1/2 A_0 k_a$. The side bands, therefore, are directly proportional to the amplitude of the applied audio signal.

Phase and Frequency Modulation. Equations (14) and (18) show that in these cases an *unlimited number of upper and lower side bands* is produced. The amplitudes of these side bands are given by Bessel Functions which have the arguments m_p and m_f , respectively.

B. van der Pol⁶ has introduced the expression "modulation index" for m_f . We shall use this term for both m_p and m_f . The magnitude of

⁶ See bibliography No. 14.

the modulation index defines the magnitudes of the Bessel's Functions and consequently the amplitudes of the carrier and the side bands.

Phase Modulation. In Fig. 2, the values of these amplitudes are plotted with respect to the modulation index m_p , the latter being expressed in degrees of phase angle. Inspection of these diagrams shows, that for small values of m_p (0 to 60 degrees) the carrier and the first side bands predominate, while all other side bands are negligibly small. However, when m_p is increased (60 degrees to 120 degrees) it is ob-

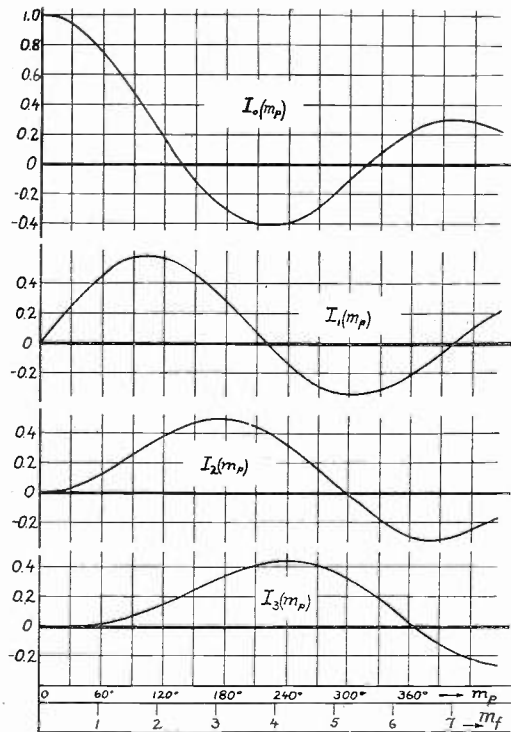

FIG. 2

served that the resulting higher side bands rapidly grow in amplitude while the carrier amplitude decreases. When m_p is increased beyond 120 degrees the amplitudes of the higher side bands are greatly increased. Simultaneously, the carrier and the lower side bands behave very differently than those of the amplitude modulation: for certain values of m_p the carrier or certain side bands disappear entirely, while the amplitude of other side bands may be considerably greater than that of the carrier. Consequently, an enlargement of the frequency band which is covered takes place. Theoretically, the band is infinitely wide, but the amplitudes of the remote side bands are rapidly converging versus zero. For the purpose of comparison with amplitude modulation, we shall arbitrarily neglect all those distant side bands having

an amplitude of less than 5 per cent or 10 per cent of that of the unmodulated carrier. The results thus obtained are plotted in Fig. 3. The ordinates in this diagram indicate the ratio between the width of the frequency channel required by a phase modulated signal compared with that of an amplitude modulated signal.

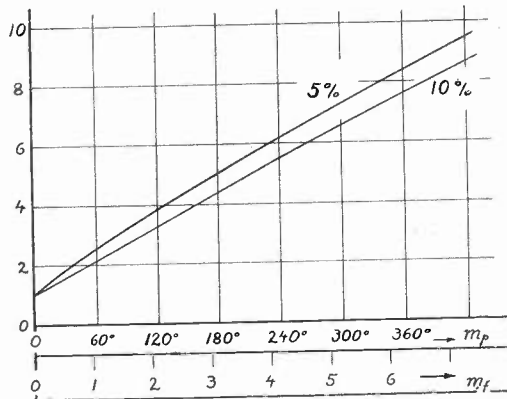

FIG. 3

It follows from this investigation that in phase modulation a phase shift of more than about ± 60 degrees involves great disadvantages. First, it produces a frequency band of considerably greater width than that of the amplitude modulation. Secondly, the amplitudes of the resulting side bands and of the carrier are in no way proportional to

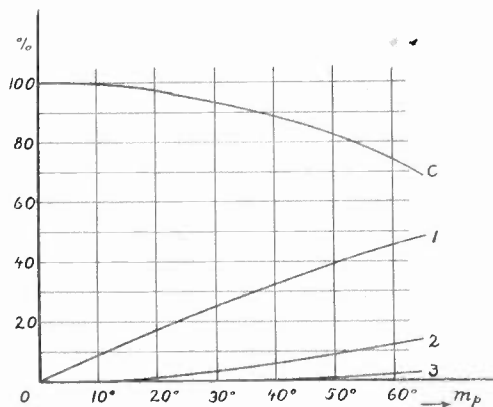

FIG. 4

the impressed audio signal (i.e., to m_p), thus giving rise to more or less audio distortion when the signal is received.

Phase modulation using less than ± 60 degree phase shift results differently. The undesired side bands are small, the carrier amplitude does not change very much and the amplitudes of the first side bands are nearly proportional to the impressed audio signal. The amplitudes of the adjacent side bands are small (Fig. 4). It proves convenient to

compare the conditions now obtained with the case of amplitude modulation. When plotting the ratio

$$M \text{ per cent} = \frac{2 \times \text{Amplitude of first side band}}{\text{Amplitude of carrier}} \cdot 100 \text{ per cent}$$

an almost straight line is obtained (Fig. 5). This ratio is chosen in analogy to amplitude modulation, in which it indicates the degree of percentage modulation. In amplitude modulation, the percentage modulation is proportional to the impressed audio signal. However, in phase modulation the percentage modulation is only approximately

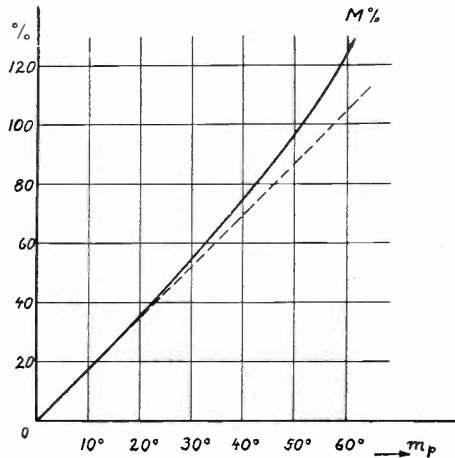

FIG. 5

proportional to the amplitude of this signal. The deviation from the straight line is as high as 10 per cent at 100 per cent modulation. The following table shows how a total energy of 1000 watts is distributed into carrier and side bands for different degrees of percentage modulation.

TABLE I

| M per cent | Carrier | Energy in watts in | | | Sum |
|------------|---------|--------------------|------|-----|--------|
| | | 1st | 2nd | 3rd | |
| | | Side band | | | |
| 0 | 1000 | — | — | — | 1000.0 |
| 20 | 980 | 20 | — | — | 1000.0 |
| 40 | 922 | 77 | 0.8 | — | 999.8 |
| 60 | 846 | 150 | 3.5 | — | 999.5 |
| 80 | 750 | 241 | 8.5 | — | 999.5 |
| 100 | 656 | 325 | 18.0 | 0.8 | 999.8 |

FREQUENCY MODULATION

If in (14) the modulation index of the phase modulation

$$m_p = k_p \phi_0$$

is replaced by the modulation index for frequency modulation

$$m_f = \frac{k_f f_0}{f_{00}}$$

equation (20) is obtained. Thus the results of the preceding chapter will hold for the frequency modulation as well. For this reason the Figs. 2 and 3 have two scales in the abscissa axis, one for phase, the other one for frequency modulation. Hence, these figures show the amplitudes of the carrier and of the side bands for the frequency modulation also.

But, from this fact it does not follow that phase and frequency modulation are identical. Frequency modulation differs much more from amplitude modulation than does phase modulation. The reason is that m_f , the modulation index of frequency modulation, contains not only the factor k_f which is proportional to the *amplitude* of the audio signal, but also the *frequency* of the audio signal. Therefore, in frequency modulation, the *amplitude* of the side bands not only depends upon the *amplitude* of the audio signal but also upon its *frequency*. This produces conditions which are hardly comparable with those obtained in amplitude modulation. A numerical example will illustrate this fact. Assume that a frequency modulated transmitter is modulated by an audio signal of constant amplitude, but of variable frequency. The r-f frequency f_0 may be 1000 kc. The amplitude of the audio signal may be such, that a frequency shift of ± 500 cycles is obtained ($k_f f_0 = 500$). Under these conditions, we obtain the following side bands for different audio frequencies:

TABLE A

| f_{00} | $\frac{k_f \cdot f_0}{f_{00}}$ | AMPLITUDES OF CARRIER AND SIDE BANDS IN PER CENT OF UNMODULATED CARRIER | | | | | | | | | | | | Width of the band | Corresponding phase shift in P-modul. | | |
|----------|--------------------------------|---|------|------|------|------|------|------|------|------|------|------|------|-------------------|---------------------------------------|--------|--------|
| | | C | 1 | 2 | 3 | 4 | 5 | 6 | 7 | 8 | 9 | 10 | 11 | | | 12 | |
| 10,000 | 0.05 | 100 | 2.5 | | | | | | | | | | | | | 20,000 | 2.9° |
| 5,000 | 0.10 | 100 | 5.0 | | | | | | | | | | | | | 10,000 | 5.7° |
| 2,500 | 0.20 | 99 | 9.9 | | | | | | | | | | | | | 5,000 | 11.5° |
| 1,000 | 0.50 | 93.8 | 24.2 | 3.1 | | | | | | | | | | | | 4,000 | 23.6° |
| 500 | 1.00 | 76.5 | 44.0 | 11.5 | 1.9 | | | | | | | | | | | 3,000 | 57.3° |
| 250 | 2.00 | 22.4 | 57.7 | 35.3 | 12.9 | 3.4 | | | | | | | | | | 2,000 | 114.6° |
| 100 | 5.00 | 17.7 | 32.7 | 4.6 | 36.5 | 39.1 | 26.1 | 13.1 | 5.3 | 1.8 | | | | | | 1,000 | 286° |
| 50 | 10.00 | 24.5 | 4.3 | 25.5 | 5.8 | 21.9 | 23.4 | 1.4 | 21.7 | 31.8 | 29.2 | 20.7 | 12.3 | 6.3 | | 1,200 | 573° |

This table shows that for high values of f_{00} ($f_{00} = 10,000$) almost no side bands are produced, while for the lower limit of audio frequencies ($f_{00} = 50$) an exceedingly large number of side bands is obtained. If $k_f f_0$ is made small, say 100 cycles, then for audio frequencies higher than 50 cycles only a very small percentage modulation is obtained,

while, if $k_f f_0$ is made say 5000, for audio frequencies below 5000 cycles prohibitive extending of the side bands would result.

The fundamental difference between phase and frequency modulation also follows from the above considerations. In phase modulation, if an *audio* signal of *constant* amplitude and *variable* frequency is applied, the amplitude of the side bands stays constant for any value of audio *frequency*. If the same signal is applied to a frequency modulated system, then the amplitudes of the side bands are different for different

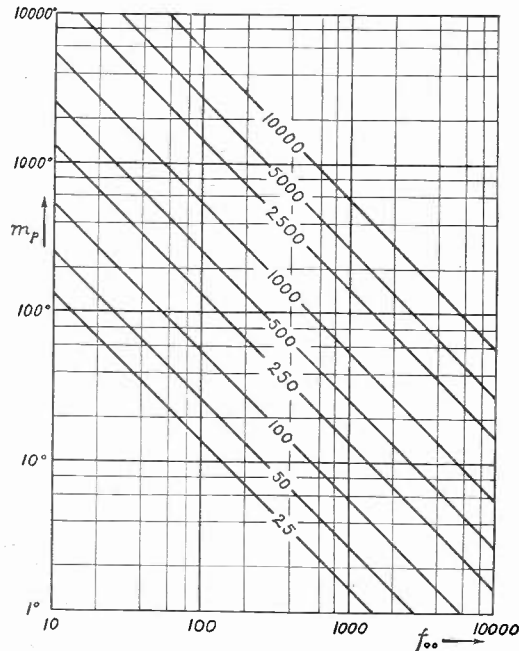

FIG. 6

audio frequencies. Thus, frequency modulation corresponds to a phase modulation where the *amplitude* of the audio signal is inversely proportional to the frequency of that signal. The last column in the above table gives the phase shift of the corresponding phase modulation. Fig. 6 shows this fact graphically.

MODULATION VECTORS

We shall now attempt to give a *vector diagram* of the three types of modulation. In electrical engineering it is conventional to replace a magnitude which varies with the time according to a sine function, by the projection of a counter-clock wise rotating vector of constant amplitude. We arbitrarily choose the horizontal axis as the projection axis and, thus, the magnitude

$$A \sin \omega t$$

would be represented by a vector "A" perpendicular to the projection axis (Fig. 1), while a magnitude

$$A \cos \omega t$$

would be given by a vector "A" parallel to this axis.

AMPLITUDE MODULATION

Equation (7) shows that an a-c current the amplitude of which is modulated consists of two components:

$$i = A_0[\sin \omega_0 t + k_a \sin \mu t \cdot \sin \omega_0 t]. \quad (7)$$

The first component has a constant amplitude, while the second one has an amplitude which is variable with audio frequency. Since both components are r-f terms we may plot them as vectors. Both components contain the term $\sin \omega_0 t$ and, thus, both have to be perpendicular

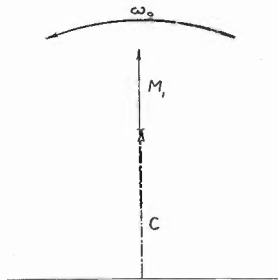

FIG. 7

with respect to the projection axis according to our above assumption (Fig. 7). The first component is the carrier, the second one is called the "modulation vector." Obviously, the modulation vector represents the combined side bands. The angular velocity of both carrier and modulation vector in Fig. 7 is ω_0 .

From a consideration of the above, it follows that:

In amplitude modulation, carrier and modulation vector are in phase.

PHASE AND FREQUENCY MODULATION

We shall first consider a case in which the modulation index is small. Then as Fig. 4 shows, the terms $I_2(m_p)$, $I_3(m_p)$. . . are small and can be neglected. Equation (14) when simplified becomes:

$$i = A_0[I_0(m_p) \sin \omega_0 t + 2I_1(m_p) \sin \mu t \cos \omega_0 t]. \quad (21)$$

This looks very similar to the expression for amplitude modulation (equation (7)); the only difference being the term " $\cos \omega_0 t$ " in the modulation vector. This indicates that the modulation vector should be

plotted in parallel to the projection axis (Fig. 8). Thus for small values of the modulation index:

In phase and frequency modulation, carrier and modulation vector are 90 degrees out of phase.

This means that an amplitude modulated signal can be transferred into a phase or frequency modulated signal, theoretically at least, by simply shifting its modulation vector by 90 degrees.

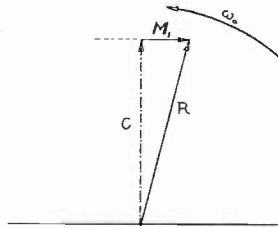

FIG. 8

However, these statements hold only for small values of m_p or m_f . With increasing modulation index, the second and third pair of side bands increase so that they can no longer be neglected. But it does not involve any difficulty to consider these terms. Returning to (14) or (19) we readily recognize, that we have to draw

- Carrier = $A_0 I_0(m_p)$ Perpendicular to the projection axis
- 1st mod. vector = $2A_0 I_1(m_p) \sin \mu t$ Parallel to the projection axis
- 2nd mod. vector = $2A_0 I_2(m_p) \cos 2\mu t$ Perpendicular to the projection axis
- 3rd mod. vector = $2A_0 I_3(m_p) \sin 3\mu t$ Parallel to the projection axis

and so on (Fig. 9).

Each of these vectors represents one pair of side bands. Each vector varies in amplitude at an audio rate as determined by the coefficients of μt in the above expressions. If we draw this vector diagram for subsequent values of μt we obtain Fig. 10. From this figure, we can see that the modulation vector is such in amplitude and direction that the vector sum

$$R = \text{Carrier} + (\text{sum of modulation vectors})$$

remains constant during the audio cycle. Thus, the diagram is in agreement with (10) and (17) which indicate that the *amplitude* of the radio frequency is constant.

The diagram also shows that a pure phase modulated signal necessarily *must* contain a great number of side bands, and that the number

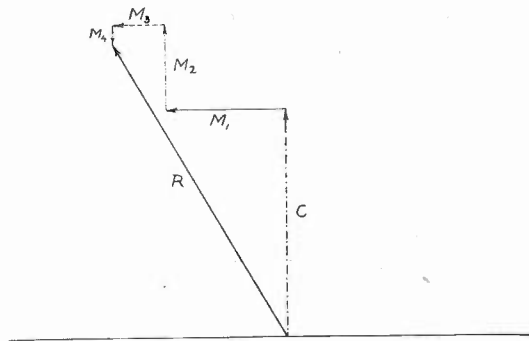

FIG. 9

and amplitude of these side bands must increase with increasing phase shift. Since the amplitude of the radio frequency has to stay constant during the audio cycle the endpoint of the vector *R* lies on a circle.

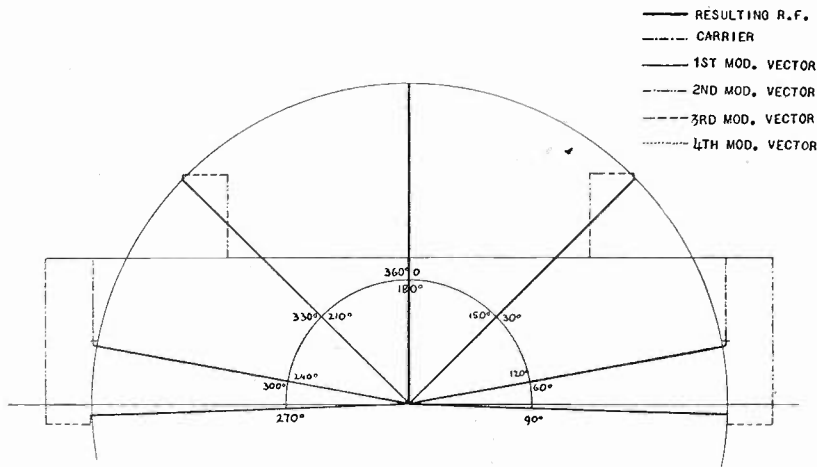

FIG. 10

Thus for small phase shift the modulation vector ought to contain only the term

$$2A_0I_1(m_p) \sin \mu t$$

which is parallel with the projection axis. This already renders a good approximation of the circle. If the shift is increased, this term alone no longer approximates the circle. We must add a term

$$2A_0I_2(m_p) \cos (2\mu t)$$

in order to approximate the circle. Consequently, the more the phase shift is increased, the more terms are necessary.

Since in phase and frequency modulation the amplitude of the radio frequency does not change, it is possible to operate the amplifier tubes at their full rated output and at good efficiency. This means that for a given tube in a phase or frequency modulated circuit the unmodulated carrier energy would be from 4 to 6 times as great as for the same tube amplitude modulated. This looks very advantageous for phase or frequency modulation, but represents only one portion of the analysis. Taking the receiver into account, we find that the signal has to be made audible, or in other words the modulation vector representing the set of first side band has to be shifted by 90 degrees. Apart from the distortion inherent to such an operation when applied to a wide range of audio frequencies, it is evident that simultaneously a considerable loss in percentage modulation must be encountered. Thus, the efficiency and output which is gained in the transmitter is partly or totally lost at the receiver.

To analyze this condition more exactly would necessitate the investigation of the distortions of a modulated signal when this signal passes through selective circuits. It is hoped to refer to this in some later publication.

SIMULTANEOUS AMPLITUDE, PHASE, AND FREQUENCY MODULATION

Up to the present there has been found no satisfactory modulation and receiving system for phase and frequency modulation. This fact, of course, has prevented the practical use of pure phase or frequency modulation.

But practical experience has shown that sometimes in amplitude modulated transmitters a certain undesired phase or frequency modulation takes place in addition to the amplitude modulation. Obviously with respect to our above results it can be expected that also in such cases a widening of the frequency band will be observed. Frequency modulation can be found in cases where either the oscillator itself is amplitude modulated or where the reaction from the modulated stage to the master oscillator is great enough as to produce a certain frequency shift. Various reasons for phase modulation may exist, such as regulation of the driving stage, the presence of a re- or degenerative voltage in the grid circuit which is due to tank or antenna current or poor tuning of the tank circuit. But we shall not be concerned in detail with the reasons which lead to these undesired modulations within the transmitter. We merely shall assume that an additional modulation exists and we shall study its effects.

SIMULTANEOUS AMPLITUDE AND PHASE MODULATION

In an amplitude modulated transmitter the antenna current is a linear function of the exciting voltage. (Fig. 11). Thus, if the antenna or tank current is liable to cause a certain r-f phase shift, this phase shift will be proportional to the current and consequently to the exciting voltage. If the exciting voltage varies sinusoidal, the antenna

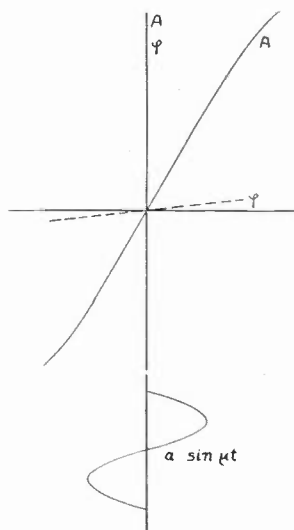

FIG. 11

current and phase shift will also be sine functions. Hence, we may state:

$$A = A_0(1 + k_a \sin \mu t).$$

$$\varphi = \varphi_0(1 + k_p \sin \mu t).$$

This gives for the resulting current:

$$i = A_0(1 + k_a \sin \mu t) \sin (\omega_0 t + m_p \sin \mu t). \quad (22)$$

Before discussing this result we shall set up the expressions for the modulation vectors as obtained from (22):

Carrier:⁷

$$A_0(I_0 \sin \omega_0 t + k_a I_1 \cos \omega_0 t). \quad (23)$$

Modulation vector of the first side bands:

$$A_0[\sin \omega_0 t(\sin \mu t \cdot k_a(I_0 - I_2)) + \cos \omega_0 t(\sin \mu t \cdot 2I_1)]. \quad (24)$$

Modulation vector for the second side bands:

$$A_0[\sin \omega_0 t(\cos 2\mu t \cdot 2I_2) + \cos \omega_0 t(-\cos 2\mu t \cdot k_a(I_1 - I_3))]. \quad (25)$$

⁷ Here, I_0 stands for $I_0(m_p)$, I_1 for $I_1(m_p)$. . . and so on.

Modulation vector for the third side bands:

$$A_0[\sin \omega_0 t (\sin 3\mu t \cdot k_a \cdot (I_2 - I_4)) + \cos \omega_0 t (\sin 3\mu t \cdot 2I_3)] \quad (26)$$

and so on.

For pure amplitude modulation the modulation vector of the first side bands was shown to be:

$$A_0 k_a \sin \mu t \cdot \sin \omega_0 t.$$

Comparing this expression with the above result, we see that there appears in the modulation vector an additional component which is due to undesired phase modulation. This component adds in quadrature to the component which is due to amplitude modulation. We also see that apart from the first side bands other side bands exist. The modulation vectors of these side bands also consist of two components

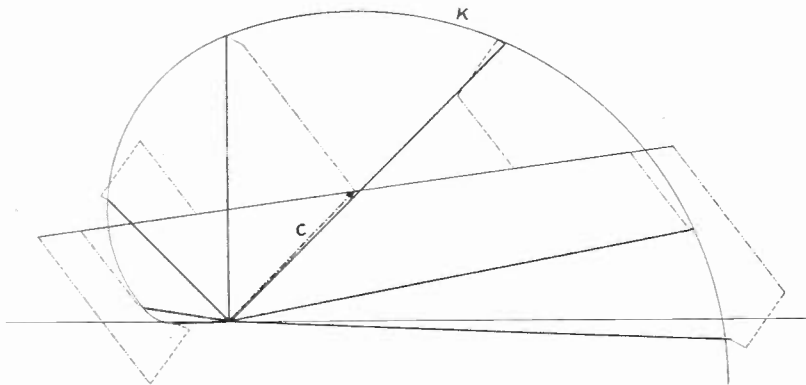

FIG. 12

which add in quadrature. Graphically, by combining carrier and modulation vectors for subsequent values of μt , we obtain the vector diagram Fig. 12. Comparing this diagram with the corresponding diagram for pure phase modulation (Fig. 10), it is seen that each modulation vector has been shifted by a certain angle. On account of the amplitude modulation the endpoint of the resulting r-f vector no longer traces a circle, but lies on a curve K (spiral), which when plotted in rectangular coördinates (Fig. 13) may be represented by the function

$$A_0(1 + k_a \sin \mu t).$$

This fact, of course, is self-evident from (22), since the term

$$\sin (\omega_0 t + m_f \sin \mu t)$$

cannot contribute to the *envelope* of the radio frequency. Thus it follows that undesired phase modulation does not distort the audio signal,

provided that the selectivity curve of the receiver is wide enough to pass *all* side bands. It is seen from Fig. 12 that each side band modulation vector contributes to the resulting vector, R . Therefore, if some of these side bands are cut off, the envelope of the r-f will not represent any longer a true reproduction of the audio signal. The dotted curve in Fig. 13 shows the envelope which is obtained if all side bands except the first are eliminated.

As we have seen, the second and third side bands due to undesired phase modulation do not affect the quality of the transmitter concerned, but they mean an extending of the assigned frequency band

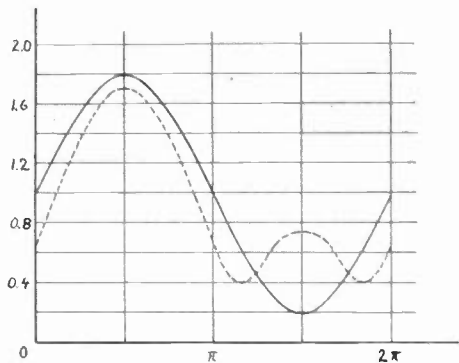

FIG. 13

and may prove very disturbing to the reception of an *adjacent* frequency band. The amplitudes of the side bands are given by evaluation of (24), (25), and (26) and are found to be:

for the first set of side bands:

$$\frac{1}{2}A_0 \sqrt{k_a^2(I_0 - I_2)^2 + \left(\frac{m_p}{1}\right)^2(I_0 + I_2)^2} \quad (27)$$

for the second set of side bands:

$$\frac{1}{2}A_0 \sqrt{k_a^2(I_1 - I_3)^2 + \left(\frac{m_p}{2}\right)^2(I_1 + I_3)^2} \quad (28)$$

for the third set of side bands:

$$\frac{1}{2}A_0 \sqrt{k_a^2(I_2 - I_4)^2 + \left(\frac{m_p}{3}\right)^2(I_2 + I_4)^2} \quad (29)$$

The amplitudes of corresponding upper and lower side bands are equal.

If we are in a position to *measure* the amplitudes of the individual side bands in the spectrum radiated by a modulated transmitter, we can readily find the magnitude of an additional phase modulation. For *small phase shift* we get approximately from (27) and (28):

Amplitude of the first side band

$$A_1 = \frac{1}{2}A_0k_a. \quad (27a)$$

Amplitude for the second side band

$$A_2 = \frac{1}{2}A_0 \cdot \frac{1}{2}m_p \cdot k_a. \quad (28a)$$

Thus, all we have to do is to measure in the spectrum, Fig. 14 the

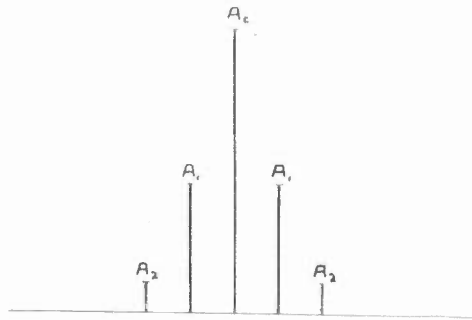

FIG. 14

side bands A_1 and A_2 . Then⁸

$$m_p = 2 \frac{A_2}{A_1}. \quad (30)$$

In making this measurement the observer must make sure, that the amplitude modulation does not involve second harmonics. This can be achieved by using a low percentage modulation in the linear portion of the excitation characteristic.

SIMULTANEOUS AMPLITUDE AND FREQUENCY MODULATION

If the frequency changes in accordance with the amplitude of the tank or antenna current (Fig. 15) we get:

$$A = A_0(1 + k_a \sin \mu t)$$

$$\omega = \omega_0(1 + k_f \sin \mu t).$$

From this we obtain:

$$i = A_0(1 + k_a \sin \mu t) \sin (\omega_0 t - m_f \cos \mu t) \quad (31)$$

⁸ This method should be used for a rough check only. The values obtained are smaller than the real value of m_p . The error is the larger the greater m_p is.

where,

$$m_f = \frac{k_f \omega_0}{\mu} = \frac{k_f \cdot f_0}{f_{00}}$$

This equation is equivalent to (22) except for the term $\cos \mu t$. Similarly, we may obtain for the modulation vectors:

Carrier:⁹

$$A_0 I_0 \sin \omega_0 t.$$

Modulation vector of the first side bands:

$$A_0 [\sin \omega_0 t (\sin \mu t \cdot k_a (I_0 + I_2)) + \cos \omega_0 t (-\cos \mu t \cdot 2I_1)]. \quad (32)$$

Modulation vector of the second side bands:

$$A_0 [\sin \omega_0 t (-\cos 2\mu t \cdot 2I_2) + \cos \omega_0 t (-\sin 2\mu t \cdot k_a (I_1 + I_3))]. \quad (33)$$

Modulation vector of the third side bands:

$$A_0 [\sin \omega_0 t (-\sin 3\mu t \cdot k_a (I_2 + I_4)) \cos \omega_0 t (+\cos 3\mu t \cdot I_3)] \quad (34)$$

and so on.

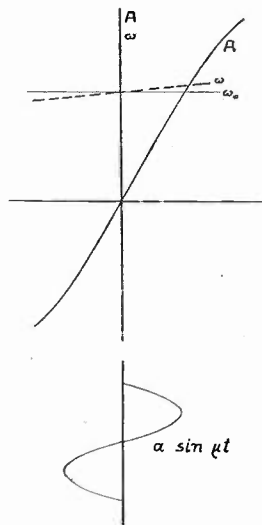

FIG. 15

We find that also in this case the modulation vectors consist of two components in quadrature. One component is amplitude modulated, while the other one depends solely on the magnitude of frequency modulation. The vector diagram can be found as in the preceding case.

Considering distortion and extension of the frequency band, this case presents a considerably more favorable result than additional phase modulation. Since the modulation index, m_f , is inversely propor-

⁹ $I_0, I_1 \dots$ have the argument m_f .

tional to the audio frequency, m_f will decrease for increasing audio frequency and consequently also the additional frequency modulation will decrease. If we assume for instance $k_f \cdot f_0$ to be, say ± 200 cycles, we obtain

$$\begin{array}{ll} \text{for } f_{00} = 50 & m_f = 4 \\ f_{00} = 500 & m_f = 0.4 \\ f_{00} = 5000 & m_f = 0.04. \end{array}$$

For the last audio frequency, 5000, the modulation vector representing the second side bands is about 2 per cent of the modulation vector of the first side bands. For higher audio frequencies, it is even less. In other words, for higher audio frequencies the undesired frequency modulation disappears automatically. However, several side bands are obtained for lower audio frequencies. For $f_{00} = 50$ in the above case, about 7 side bands would be noticeable. But all these side bands lie within the assigned frequency channel. Since the receiver passes all of them no audio distortion is obtained.

From this we may conclude that additional frequency modulation will do hardly any harm in a broadcast transmitter, provided that the frequency shift is not too great.

Additional frequency modulation can be measured statically by checking the frequency shift which is obtained when taking the excitation characteristic (Fig. 15).

Another method can be based on the following fact: In an amplitude modulated signal containing undesired frequency modulation, the amplitudes of corresponding upper and lower side bands are *not* equal. This can be readily understood if we compute the amplitudes of the side bands from (32), (33), and (34). We find by simple trigonometric transformation:

Amplitudes of the first side bands:

$$\begin{array}{ll} \text{Upper Side Band} & \text{Lower Side Band} \\ A_{10} = \frac{1}{2}A_0(I_0 + I_2)(k_a + m_f) & A_1 = \frac{1}{2}A_0(I_0 + I_2)(k_a - m_f). \end{array} \quad (35)$$

Amplitudes of the second side bands:

$$\begin{array}{ll} \text{Upper Side Band} & \text{Lower Side Band} \\ A_{20} = \frac{1}{2}A_0(I_1 + I_3)(k_a + \frac{1}{2}m_f) & A_2 = \frac{1}{2}A_0(I_1 + I_3)(k_a - \frac{1}{2}m_f) \end{array} \quad (36)$$

If, in the radiated spectrum, the amplitudes of the sidebands, for instance A_1 and A_{10} , can be measured directly, then it follows from (35):

$$m_f = k_a \frac{A_{10} - A_1}{A_{10} + A_1}. \quad (37)$$

This is an approximative formula only which holds the better the smaller m_f is.

A third method has been suggested by W. Runge.¹⁰ Since for decreasing audio frequency the modulation index, m_f , increases, the side band A_1 will disappear entirely if

$$m_f = k_a$$

which follows from (35). If the audio frequency, f_{00} is varied, the observed amplitudes of the upper and lower first side bands will vary as

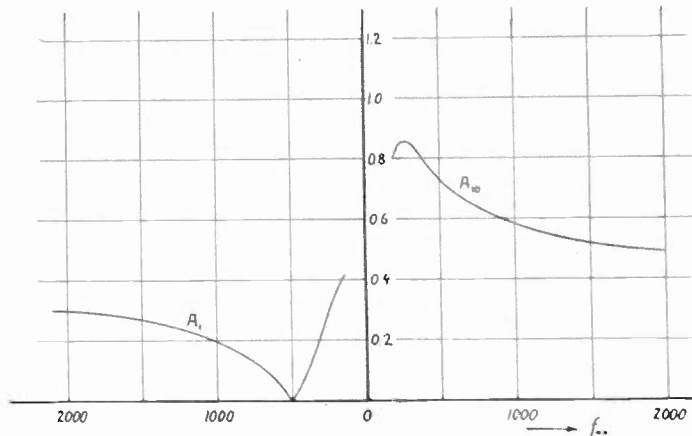

FIG. 16

Fig. 16 shows. For a certain audio frequency one of the side bands will be zero, which indicates that for this particular frequency $m_f = k_a$.

SIMULTANEOUS AMPLITUDE, PHASE, AND FREQUENCY MODULATION

We assume that the slight changes in phase and frequency which take place simultaneously with the change in amplitude are linear functions of the latter. Then

$$A = A_0(1 + k_a \sin \mu t)$$

$$\varphi = m_p \sin \mu t$$

$$\omega = \omega_0(1 + k_f \sin \mu t)$$

and we obtain

$$i = A_0(1 + k_a \sin \mu t) \sin(\omega_0 t + m_p \sin \mu t - m_f \cos \mu t). \quad (38)$$

Since m_f is inversely proportional to the audio radian frequency μ , the term $(m_f \cos \mu t)$ will disappear for high audio frequencies, while for low audio frequencies m_p can be neglected with respect to m_f . Thus, for the limit audio frequencies, (38) corresponds to the case of simultane-

¹⁰ See bibliography 19.

ous amplitude and phase modulation or amplitude and frequency modulation respectively.

The results found for that type of modulation, consequently, may be applied to this type of modulation also.

Due to the presence of frequency modulation, also in this case, the amplitudes of corresponding side bands above and below the carrier are *not* equal. This fact gives the possibility of determining whether an amplitude modulated signal contains additional phase or frequency modulation. If the amplitudes of the first side bands on both sides of the carrier are measured at different audio frequencies, the curve in Fig. 17 is obtained. The computation of these amplitudes gives:¹¹

$$\left. \begin{matrix} A_1 \\ A_{10} \end{matrix} \right\} = \frac{1}{2} A_0 \sqrt{(I_0 + I_2)^2 (m_p^2 + (k_a \pm m_f)^2) - 4 I_0 I_2 \frac{k_a^2 m_p^2}{m_p^2 + m_f^2}} \quad (39)$$

In this expression, the term

$$4 I_0 I_2 \frac{k_a^2 m_p^2}{m_p^2 + m_f^2}$$

is very small and can be neglected. Since, in general, m_p is considerably less than k_a , one of the side bands will assume a minimum at that audio frequency where $k_a = m_f$. It follows approximately for small values of m_p :

$$m_p = 2 \frac{A_p}{A_c}, \quad (40)$$

where A_p is the amplitude of the minimum (Fig. 17) and A_c the amplitude of that carrier which is obtained when no modulation is applied.

The superheterodyne principle may be used advantageously in an apparatus suitable for the measuring of individual side bands in a spectrum. The beat note, either before or after rectification, is passed through a highly selective circuit. A device, designed and built in the laboratories of the RCA-Victor Company, Camden, N.J., utilizes a radio-frequency beat note. Radio-frequency selection is accomplished by means of a crystal filter circuit. The band which is passed by this filter is about 200 cycles wide. Consequently, this device is applicable for measuring side bands due to audio frequencies of 500 cycles and more. W. Runge¹² has reported on another apparatus, employing a beat note as low as 15 cycles. The rectified radio frequency is applied to an audio amplifier which passes only frequencies between 8 and 20 cycles.

¹¹ I_0 and I_2 have the argument m_0 , where

$$m_0 = \sqrt{m_p^2 + m_f^2}.$$

¹² See bibliography 19.

This device can be used for measuring side bands spaced 50 cycles or more.

FALSE PHASE MODULATION

In the foregoing chapters, we considered "genuine phase or frequency modulation" assuming that the phase or frequency shift was proportional to the modulating audio current or voltage. In this case, numerous higher side bands were found. But there exists also the possibility of phase modulation in such cases where only the carrier and the first pair of side bands are present. This "false phase modulation," as we shall call it in opposition to the cases of phase modulation already considered, is important for amplitude modulation.

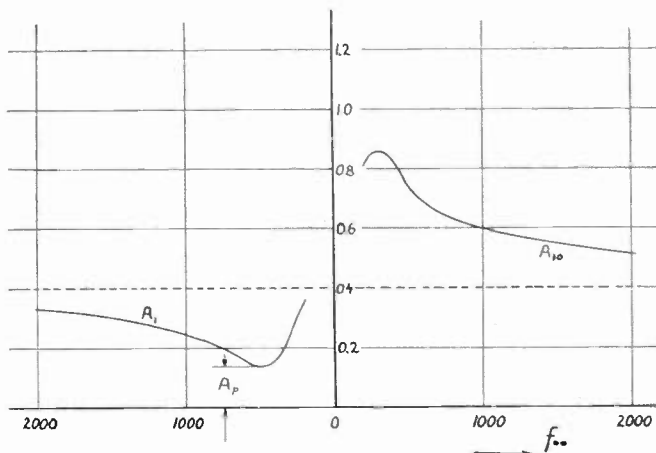

FIG. 17

We have seen that in pure amplitude modulation, the modulation vector always is in phase with the carrier. This is no longer the case if the amplitude or the phase of one or both of the side bands is changed.¹³ Since the carrier and the side bands have different frequencies, it is necessary to define this phase shift. We do this by relating it to the pure amplitude modulated signal. For this signal, we obtained previously (equation (8)).

$$i = A_0 \left[\sin \omega_0 t + \frac{k_a}{2} \cos (\omega_0 - \mu)t - \frac{k_a}{2} \cos (\omega_0 + \mu)t \right].$$

Thus for a change in amplitude:

$$i = A_0 [\sin \omega_0 t + a \cos (\omega_0 + \mu)t + b \cos (\omega_0 - \mu)t] \quad (41)$$

and for an additional change in phase:

$$i = A_0 [\sin \omega_0 t + a \cos ((\omega_0 + \mu)t + \alpha) + b \cos ((\omega_0 - \mu)t - \beta)]. \quad (42)$$

¹³ See bibliography 2.

Generally, in this expression, neither a and b nor α and β are equal.

We shall now consider a few cases important for a transmitter which is modulated by a pure audio-frequency sine wave.

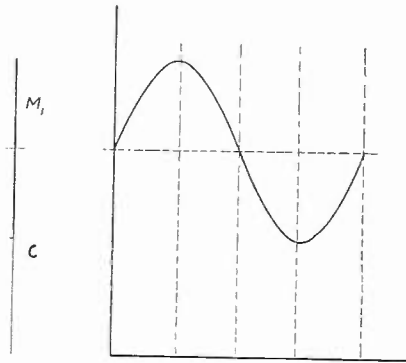

FIG. 18

Case (1). Pure amplitude modulation. (Fig. 18.) Carrier and Modulation vector are in phase. The r-f envelope is a pure sine function.

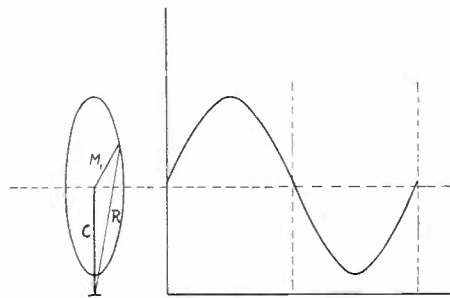

FIG. 19

Case (2). The same signal but one side band partly fading. (Fig. 19.) In this case the direction and magnitude of the modulation vector

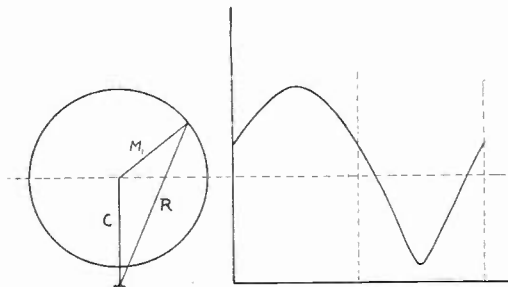

FIG. 20

varies so that during the audio cycle its end point lies on an ellipse. Consequently the resulting vector, R , is amplitude and phase modulated. The envelope of the radio-frequency is a slightly distorted sine wave.

Case (3). One side band totally fading (Fig. 20). The former ellipse has degenerated into a circle. The phase shift of R during the audio cycle has increased. The envelope of the radio frequency is considerably distorted.

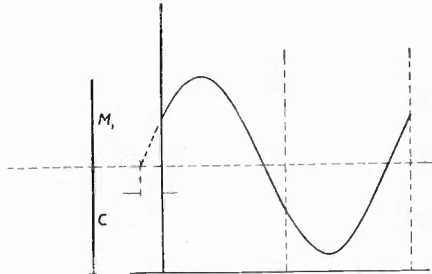

FIG. 21

Case (4). The amplitudes of both side bands are equal but their phases are changed with respect to the original pure amplitude modulated signal. Their phase shifts are of equal magnitude, but of opposite

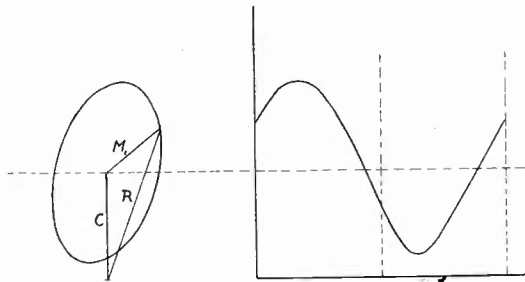

FIG. 22

sign. ($\alpha = \beta$; equation 42). In this case the modulation vector is in phase with the carrier. Neither audio distortion nor phase modulation is obtained. (Fig. 21).

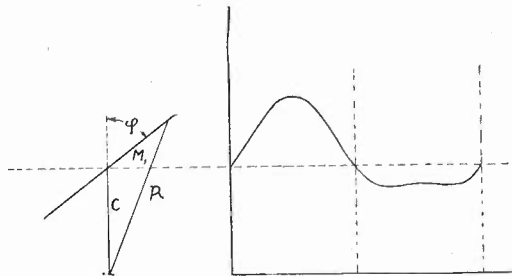

FIG. 23

Case (5). The same case as before, but the two side bands have unequal phase shift ($\alpha \neq \beta$). Then the end point of the modulation vector lies on an ellipse. The resulting vector, R , varies in phase. The r-f envelope shows a slightly distorted sine wave. (Fig. 22).

Case (6). The same as in (4), but the phase shift is of equal amplitude and equal sign for both side bands. ($\alpha = -\beta = \varphi$). The former ellipse has degenerated into a straight line, indicating that the modulation vector, M_1 , is lagging the carrier by the constant angle φ . Considerable phase modulation and audio distortion are found (Fig. 23).

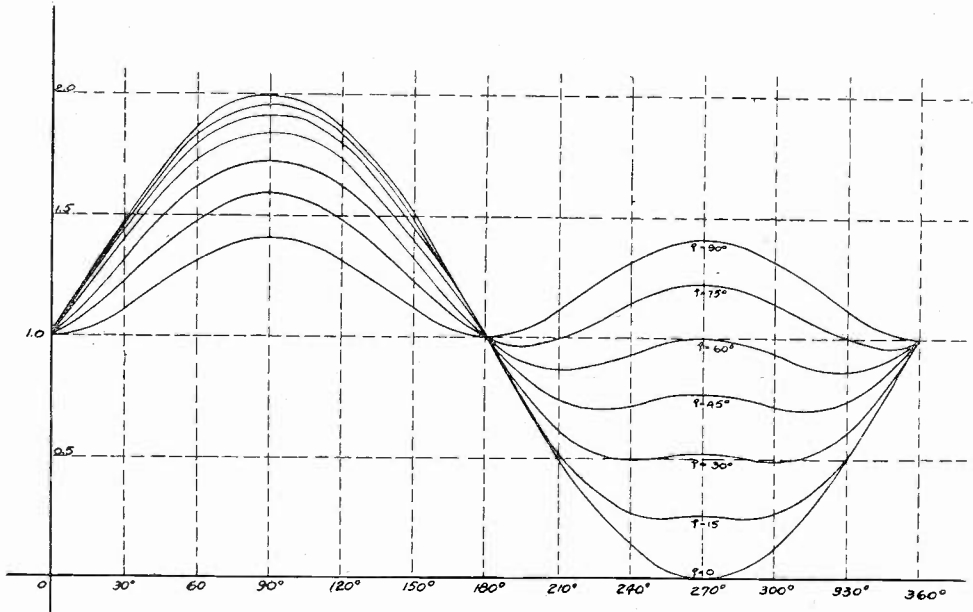

FIG. 24

The greater φ the greater the amplitude of the second harmonic in the r-f envelope. For $\varphi = 90^\circ$, the fundamental audio frequency has disappeared; the envelope contains only even harmonics of the audio frequency. Fig. 24 shows the shape of the envelope for different values of φ for a 100 percent amplitude modulated signal.

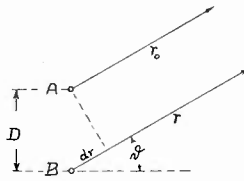

FIG. 25

Two Examples. Cases (4) and (6) have interesting practical applications. Let us consider case (6) first.

We assume two separate antennas and supply one, A , with the carrier and the other one, B , with both side bands from a balanced modulator (Fig. 25). Then antenna A will radiate in the horizontal plane a circular wave of the radian frequency ω_0 , which can be represented by

$$\sin \omega_0 \left(t - \frac{r_0}{c} \right) \quad (43)$$

where c is the velocity of light and r_0 is the distance of a far observer. Correspondingly, antenna B is the center of two circular waves:

$$\cos (\omega_0 + \mu) \left(t - \frac{r}{c} \right)$$

and,

$$\cos (\omega_0 - \mu) \left(t - \frac{r}{c} \right).$$

Since,

$$r = r_0 + D \sin \theta$$

with very good approximation these expressions may be transformed into

$$\cos \left((\omega_0 + \mu) \left(t - \frac{r_0}{c} \right) - 2\pi \cdot \frac{D}{\lambda} \sin \theta \right) \quad (44)$$

and,

$$\cos \left((\omega_0 - \mu) \left(t - \frac{r_0}{c} \right) - 2\pi \frac{D}{\lambda} \sin \theta \right). \quad (45)$$

Here,

$$\begin{aligned} D &= \text{distance between } A \text{ and } B \\ \lambda &= \text{wavelength of the carrier.} \end{aligned}$$

The signal which is received by the distant observer consists of the three portions given by (43), (44), and (45). Comparing these expressions with (42) and case (6) we find that

$$\alpha = -\beta = \varphi = 2\pi \frac{D}{\lambda} \sin \theta. \quad (46)$$

This indicates that in certain directions a badly distorted audio signal is received. For $D = \frac{3}{4}\lambda$, Fig. 26 shows the directions in which distorted r-f envelopes according to Fig. 24 are observed. Tests conducted at the General Electric Experimental Station at South Schenectady proved that for such a sending system "good" and "bad" directions do really exist. For this purpose an automobile was equipped with a receiver, a field intensity meter and an oscilloscope. A specially arranged

transmission schedule provided the possibility of measuring the field intensity of carrier and side bands separately and to check the quality of a sinusoidal 60-cycle modulation and of music. Observations were made in a sector of about 100 degrees. In a certain direction very good

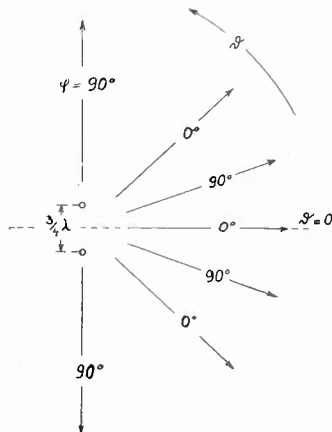

FIG. 26

quality of music and 60-cycle tone was found. In another direction, the quality of the music was bad; and the oscilloscope showed a very pronounced second harmonic in the 60-cycle modulation.

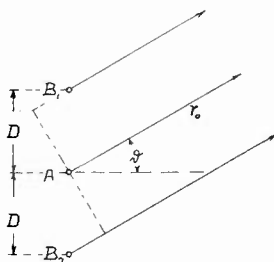

FIG. 27

It might be expected that a system consisting of three antennas (Fig. 27)—one for the carrier and one for each side band—will produce similar distortions. But this is not the case. If we supply the antenna *A* with the carrier and the antennas *B*₁ and *B*₂ with the upper and lower side band respectively, then we obtain:

Circular wave from *A*:

$$\sin \omega_0 \left(t - \frac{r_0}{c} \right).$$

Circular wave from *B*₁:

$$\cos \left((\omega_0 + \mu) \left(t - \frac{r_0}{c} \right) + 2\pi \frac{D}{\lambda} \sin \theta \right).$$

Circular wave from B_2 :

$$\cos \left((\omega_0 - \mu) \left(t - \frac{r_0}{c} \right) - 2\pi \frac{D}{\lambda} \sin \theta \right).$$

This indicates that the phases of the side bands are shifted by equal angles in opposite directions. Therefore, this arrangement corresponds to case (4) for which we have found that the modulation vector is always in phase with the carrier. Consequently, *no distortion* is obtained. Of course, it is required to keep this system free from any additional phase shifts between carrier and side bands, a condition which will not be met easily in practice.

APPENDIX I

TABLE FOR $I_n(x)$

| x | $I_0(x)$ | $I_1(x)$ | $I_2(x)$ | $I_3(x)$ | $I_4(x)$ |
|-----|----------|----------|----------|----------|-----------|
| 0. | 1.00000 | 0. | 0. | 0. | 0. |
| 0.1 | 0.9975 | 0.0499 | 0.00124 | | |
| 0.2 | 0.9900 | 0.0995 | 0.00498 | 0.000166 | 0.0000042 |
| 0.3 | 0.9776 | 0.1483 | 0.01117 | | |
| 0.4 | 0.9604 | 0.1960 | 0.0197 | 0.0013 | 0.000067 |
| 0.5 | 0.9385 | 0.2423 | 0.0306 | | |
| 0.6 | 0.9120 | 0.2867 | 0.0437 | 0.0044 | 0.000331 |
| 0.7 | 0.8812 | 0.3290 | 0.0589 | | |
| 0.8 | 0.8463 | 0.3688 | 0.0758 | 0.0102 | 0.001009 |
| 0.9 | 0.8075 | 0.4059 | 0.0946 | | |
| 1.0 | 0.7652 | 0.4401 | 0.1149 | 0.0196 | 0.002477 |
| 1.2 | 0.6711 | 0.4983 | 0.1679 | 0.0329 | 0.005023 |
| 1.4 | 0.5669 | 0.5419 | 0.2073 | 0.0505 | 0.009064 |
| 1.6 | 0.4554 | 0.5699 | 0.2570 | 0.0725 | 0.014995 |
| 2.0 | 0.2239 | 0.5767 | 0.3528 | 0.1289 | 0.03399 |
| 2.4 | +0.0025 | 0.5202 | 0.4311 | 0.1981 | 0.064307 |
| 2.8 | -0.2601 | 0.3391 | 0.4783 | 0.2728 | 0.10667 |

Bibliography

- (1) C. B. Aiken, "The detection of two modulated waves which differ slightly in carrier frequency," *Proc. I.R.E.*, 19, 120, 1931.
- (2) S. Ballentine, "Detection at high signal voltages," *Proc. I.R.E.*, 17, 1153, 1929.
- (3) R. Brown, DeLoss, K. Martin, and R. K. Potter, "Some studies in radio broadcast transmission," *Bell Sys. Tech. Jour.*, 5, 143, 1926.
- (4) J. R. Carson, *Proc. I.R.E.*, 7, 187, 1929.
- (5) J. R. Carson, "Notes on the theory of modulation," *Proc. I.R.E.*, 10, 57, 1922.
- (6) F. M. Coolebrook, "The physical reality of side bands," *Exp. Wireless and Wireless Eng.*, 8, 4, 1930.
- (7) P. P. Eckersley, "On the simultaneous operation of different broadcast stations on the same channel," *Proc. I.R.E.*, 19, 175, 1931.
- (8) T. L. Eckersley, "Frequency modulation and distortion," *Exp. Wireless and Wireless Eng.*, 7, 482, 1930.
- (9) F. Gerth and W. Hahnemann, "Einige Betrachtungen zum Problem des Gleichwellenrundfunks," *Elek. Nachr. Tech.*, 7, 226, 1930.

From the transmission standpoint, tape or automatic sending; i.e., sending from a tape perforated in accordance with a telegraphic code, is merely a matter of increasing speed and accuracy of the characters transmitted.³ Automatic tape recording of radio signals, such as by the syphon recorder or similar device, removes the advantage obtained from the tone character of the signal, so useful in ear reception, and substitutes for this tonal character the less acute ability of the eye to distinguish between signals and noise on the tape record.⁴ In sacrificing this ability to receive with greater accuracy in the presence of considerable noise there is, however, a gain in the speed of receiving radio signals. The tape record, which is in permanent form, makes it possible for several operators simultaneously to transcribe different parts of the received message at speeds much slower than the transmitting speed.

Printing telegraphy goes one step further in removing the human element from the process of receiving and substituting a mechanism which must be impelled to a definite act by each current element received. The printing mechanism inevitably records what it receives without using any judgment factor in the process other than the mechanical application of such fixed criteria as have been put into it by the designer. Unless the transmitted signal is received with such intensity and character as to be the controlling signal at the receiving end, errors will usually result. The use of printing telegraph equipment on radio circuits,⁵ therefore, makes the signal-to-noise ratio necessary for the receiving of satisfactory copy greater than would be required for either aural reception or tape signal recording.

It is of considerable interest to compare the approximate minimum values of signal-to-noise ratio required for satisfactory* transmission of intelligence by single side band long-wave radio using the customary double side band carrier telegraph. This has been done in the following table:

TABLE I

| Type of Facility | Speed of Transmission (Words per Minute) | Approximate Radio Band width Occupied (Cycles per Second) | Approximate Minimum Signal-to-Noise Ratio For Satisfactory Communication ($20 \log_{10} S/N$)* |
|--------------------------------------|--|---|--|
| Manual-sending, aural-receiving. cw | 20 | 35 | 10 |
| Manual-sending, aural-receiving. cw | 30 | 50 | 15 |
| Automatic-sending tape-recording. cw | 80 | 140 | 20 |
| Single-tone printer system. | 60 | 110 | 30 |
| Two-tone printer system. | 60 | 220 | 30 |
| Single side-band telephony. | 200 | 2700 | 40** |

* N is assumed to be measured in a constant band width of about 2200 cycles using the "warbler method"⁶ of noise measurement.

** S is assumed to be about 5 db above 1 milliwatt where speech is at reference volume.

* Obviously, "satisfactory" cannot have a definite quantitative meaning which is applicable to all modes of communication under all variations in the observed types of received noise. For example, "crashy static" would probably

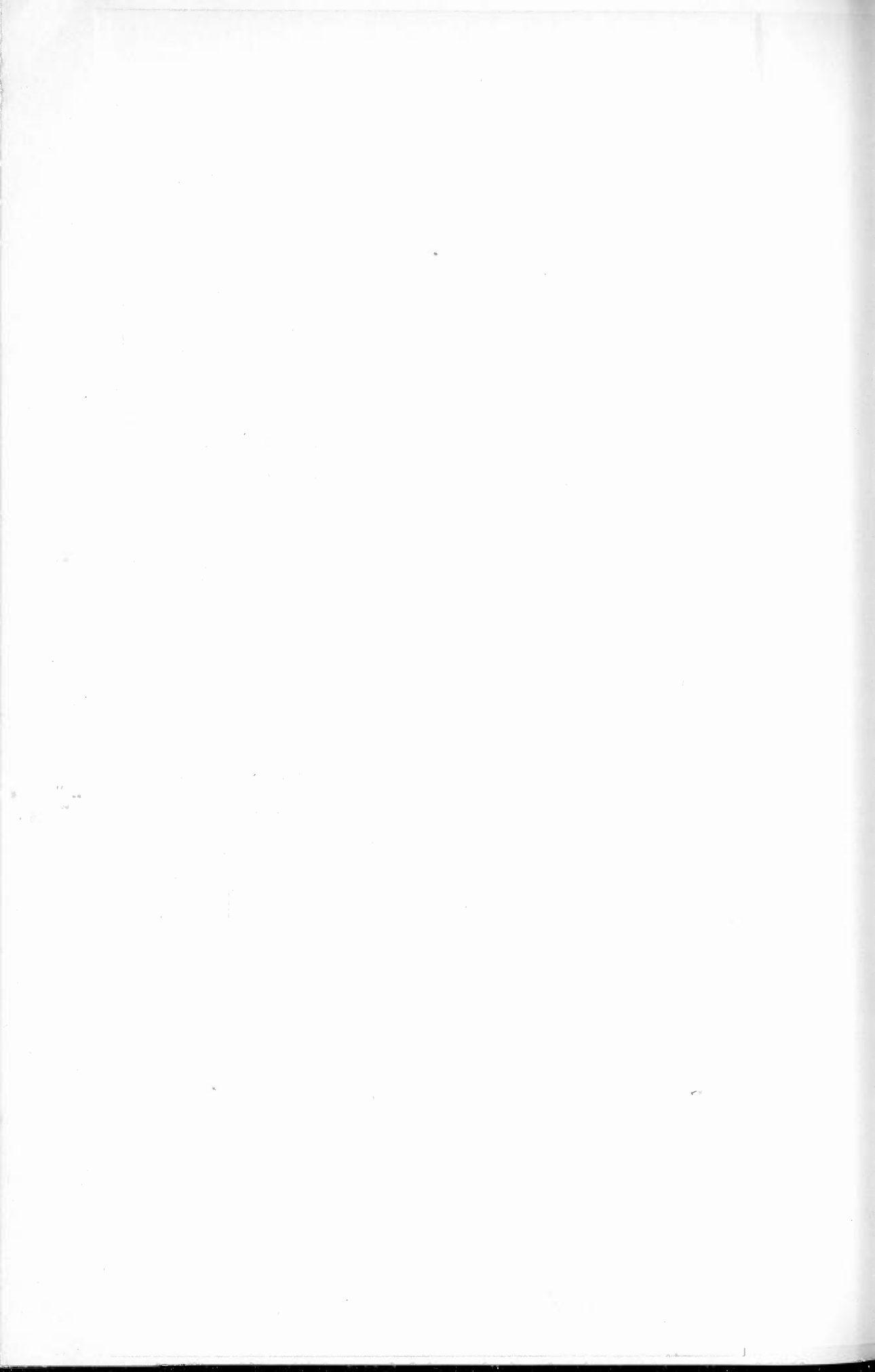

When automatic means for recording the signals are applied at the receiving end of a radio circuit it is desirable that considerable uniformity exist in the output level of the receiving equipment. This is even more important when printing equipment is used. Such a condition is rather to be expected inasmuch as ultimately in the system there must be a relay mechanism operated by the signals. This relay must with a certain degree of accuracy reproduce the length of the signal impulse. It is desirable to have the relay remain unbiased over a considerable range of variation in signal level. If a signal impulse is transmitted only for marking, the spacing signal becomes an interval of no current and the restoring force on the relay must be applied locally by either electrical or mechanical means. Then with signals of the usual rounded wave shape, if the relay operating force varies while the restoring force remains constant, the signals are either "heavy" or "light," that is, the marking intervals are either lengthened or shortened and the system becomes biased.^{7*}

The most obvious way of avoiding these difficulties is some arrangement in which the restoring force on the relay is varied in a manner similar to the operating force resulting from the received signal. One method of accomplishing this result which has been found quite effective is the two-tone method of transmission. As far as the radio circuit is concerned the signals consist of a marking and a spacing signal transmitted on slightly different frequencies. Since these two signals traverse the same transmission medium, they are, at least when there is no selective fading, subjected to similar variations in the equivalent of the transmission path. Therefore, if a polar receiving relay is operated by using one of these frequencies to produce the operating force and the other frequency to produce the restoring force, no bias results. The increase in magnitude of variations of the transmission circuit which can be tolerated by employing this two-tone method of transmission instead of the single-tone method with a fixed bias is shown by Fig. 1.

These curves show the relation between operating current and the limits of printer margin⁷ within which correct operation is secured for both the single interrupted tone method of signaling and for the two-

not be as serious in receiving by ear as it would be in receiving by other means. Then too, there is the personal judgment factor in determining just what constitutes "satisfactory" communication. The table is set up on a relative basis using quantitative values of signal-to-noise ratio which appear to represent the worst condition under which communication could be effected with only an occasional error. Of course, communication can be continued under much worse conditions, but with an increase in the number of errors.

* Details are given on this effect and methods for its measurement in reference 7.

tone method. The upper and lower limits of the printer margin are shown to meet at the lower levels of received current, indicating that the printer fails completely at these levels. As might be expected, increasing the received current level a few db does not affect the orientation range as seriously as a corresponding decrease. In each condition, however, the margin is less affected when signaling by the two-tone method. Were it not for the presence of noise on the radio circuit, it would be possible to establish the normal operating current at a higher

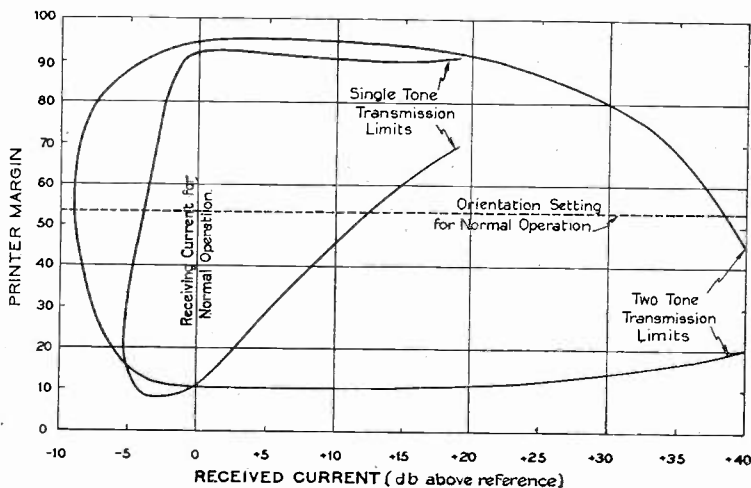

Fig. 1—Relation between received current and printer operating margin for the two-tone and single-interrupted tone methods of signaling.

value. The reason why this is not feasible is that the detectors in the voice-frequency telegraph receiving equipment are operated near the upper bend of their characteristics. Under this condition increasing the gain causes a relatively small increase in current from the rectifier that is receiving both noise and signal inputs while the current from the rectifier that is receiving noise only is increased.

Thus because of the desirability of operating through high noise levels on long-wave radio circuits, it is not advantageous to utilize all of the available protection against signal level changes. Rather, a compromise is sought which will afford satisfactory protection against reasonable signal level variations without making the receiving equipment unduly vulnerable to noise. This practical operating point has been selected at the zero indicated on this figure. The tolerance in received current level variations usually obtained is about ± 3 db in the case of single-tone signaling as compared to about ± 7 db for two-tone signaling. On the transatlantic long-wave radio circuits variations greater than those tolerated by the two-tone transmission method seldom occur with sufficient rapidity to escape manual correction.

With the two-tone system the amount of noise entering the receiving mechanism comes in through double the band width used in the single-tone system,⁸ and the intelligence transmitted is completely contained in both the marking and the spacing signals. It is, therefore, logical to expect that there will not be much difference between the two-tone and single-tone systems from the noise interference standpoint. If there were no received signal the noise through the marking and spacing filters probably would balance out to some extent but during operation either the mark or space signal is always present. The noise may effectively annul either signal by being approximately of equal intensity and opposite phase, but the noise through the other filter is received with the full intensity and, therefore, may operate the relay falsely.

Employing printing telegraph equipment on radio circuits is not new.^{5,9,10,11} There has, however, been comparatively little commercial use of such systems and there have been very few quantitative data published. Such practical information and quantitative data as have been obtained by the Bell System regarding the application of printing telegraph to radio circuits relate to long-distance overseas point-to-point communication and a short-distance point-to-point overland circuit. Both of these circuits were operated on long waves (about 60 kilocycles).

For the past three years printing telegraph has been employed on the long-wave radiotelephone circuit¹² between New York and London to exchange information pertaining to the operation of this telephone service. The printer is admirably suited to this kind of service since the information exchanged frequently consists of foreign names of places and people not familiar to the switchboard operators. By the use of the printer, these can be spelled out with speed and accuracy without the necessity of attempted pronunciation.

The printing telegraph arrangements provided at New York for use of the telephone traffic department on the transatlantic circuits are shown on Fig. 2. The instruments are installed on the table in the foreground. This table is located just behind the switchboard operators. As a large majority of the business transacted is of a question and answer nature, there are special arrangements in the printer to indicate whether the message printed originated with the New York or with the London operator. Messages transmitted from the local machine are typed in red while those received from the distant terminal are typed in black. This was accomplished by modifying the mechanism of the machine to automatically shift a half red and half black typing ribbon.

The voice-frequency telegraph terminal equipment² and its associated apparatus are shown in Fig. 3. The equipment comprises the voice-frequency terminal set for repeating between the local d-c printer loop circuit and the a-c line circuit. The printer switching circuits, testing arrangements, and monitoring equipment are, for convenience, included in the same assembly of apparatus. The installation includes



Fig. 2—Transatlantic telephone operator's position showing arrangement of printing telegraph equipment.

all the equipment necessary for one channel of a two-tone carrier telegraph system and sufficient equipment for adding another by providing suitable filters and a small amount of additional apparatus.

The connection of the printers to the telephone circuit is shown schematically in Fig. 4. The transmitting telegraph circuits are not connected permanently to the radio channel. When it is desired to establish the telegraph circuit, the connection is made through the operator's cord circuits into the transatlantic two-wire telephone circuit in a manner similar to that used to connect telephone subscribers. Audible monitoring arrangements are provided for the telephone operator, the technical operator, and the printer operator. The distant terminal

operator may interrupt the printer circuit with voice if such interruption seems expedient. In addition to the printer used by the printer operator, a printer at the technical operator's position, not shown in Fig. 4, is continuously connected to monitor on the system.

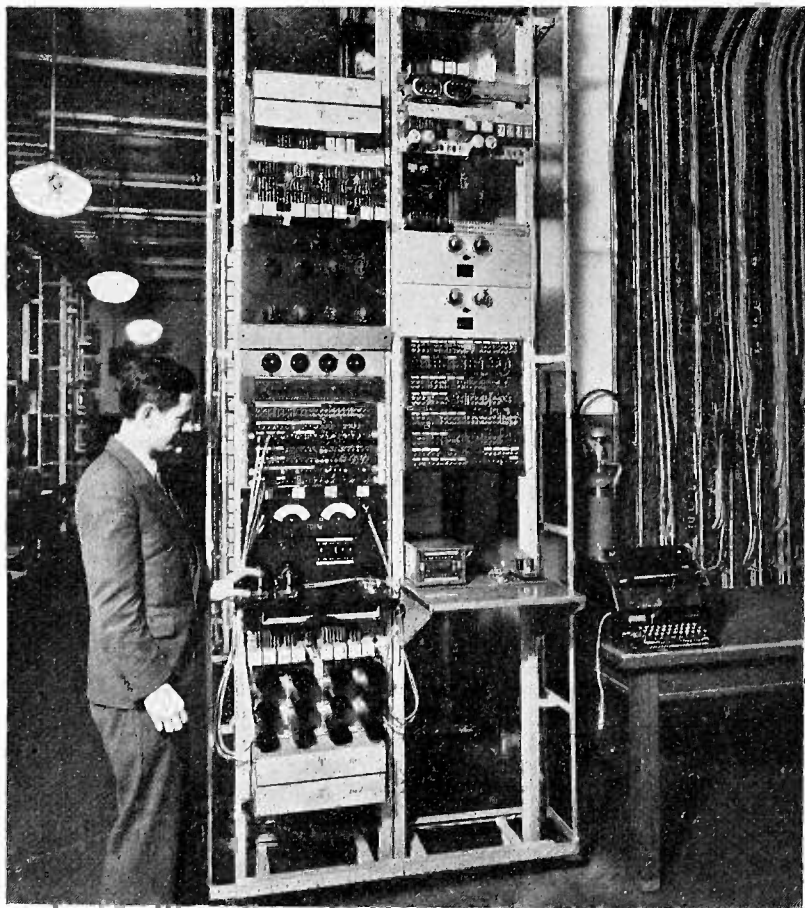

Fig. 3—Equipment for use in applying printing telegraph signals to the transatlantic radiotelephone circuit at the technical operator's position.

It should be noted that in the arrangement shown in Fig. 4 two different voice frequencies are used for transmission and two others for reception, thus giving the advantages of the two-tone method of transmission. The voice-frequency tones go out over wire circuits to the transmitting station at Rocky Point where, by means of the single side band suppressed-carrier method of radio transmission^{13,14} shown in Fig. 4, they are changed to radio frequencies of about 60 kilocycles and amplified. The equivalent radiated power for each frequency is about 50 kilowatts. For signals coming from England much the same process

is followed at the British end, the radiated frequencies, however, being different from those transmitted in the opposite direction.

The most serious handicap in the use of printing telegraph on the long-wave channel is noise. During the winter months little trouble is experienced, but interruptions are frequent and are occasionally of several hours duration during the summer months. At the radio receiving stations the directive antenna systems used for telephony¹⁵ greatly reduce the noise received.

Another important factor in reducing receiving interference is the frequency selectivity. The radio receiver itself restricts the received band sharply to that required for single side band telephony, passing a band about 3000 cycles wide. This is accomplished by the single side band carrier resupplied receiver¹⁴ shown in Fig. 4. The band admitted to each of the tone channel detectors beyond the receiver is narrowed down to about 110 cycles by a voice-frequency filter as indicated in Fig. 4. It is estimated that if the printer were used continuously on the long-wave transatlantic channel for the entire year, the per cent of errors would exceed 0.1 per cent less than 12 per cent of the time and 5.0 per cent less than 2 per cent of the time.

In order to obtain more accurate quantitative information regarding the effect of noise on the transmission of teletypewriter signals over radio circuits, a series of tests was carried out during 1930. For the purpose of these tests a radio circuit was established between the transmitting station at Rocky Point, L. I., and a temporary receiving station at Rochester, N. Y., a distance of 286 miles.

This one-way circuit utilized at New York the transatlantic transmitting facilities for printing telegraph described above with the exception that automatic transmission from a perforated tape for operating page teletypewriters was substituted for the manual keyboard method for operating tape printers ordinarily used.

At Rocky Point the power of the radio transmitter was greatly reduced for these tests. The average power radiated in the direction of Rochester was equivalent to 0.7 kilowatt radiated from a nondirectional antenna. The average deviation from this value was less than 1 db. Under these conditions the average field received in Rochester was 42.5 db above one microvolt per meter. The average deviation from this mean value was less than 2 db. A daily half-hour test was made in the afternoon or evening at a time so chosen as to avoid the sunset period of disturbed radio transmission.

At Rochester, laboratory type receiving equipment was employed for picking up the radio signals and demodulating them to voice frequencies. The voice-frequency signals were then used to operate stand-

ard voice-frequency carrier terminal equipment at Rochester. This was modified for two-tone operation in a manner similar to that shown for the transatlantic receiving terminal in Fig. 4.

The teletypewriter signals were sent out from New York at 60 words per minute from an automatic tape transmitter. The copy received over the radio circuit was subsequently compared with simultaneously recorded copy which was not sent over the radio circuit. Keyboard errors which occur occasionally in perforating the tape for automatic transmission appeared on both copies. Disregarding these

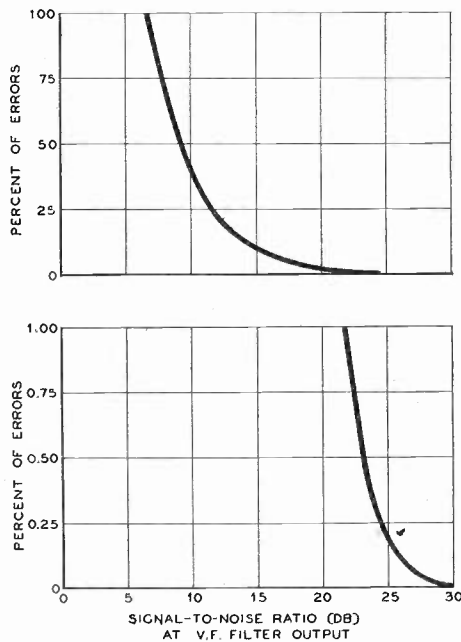

Fig. 5—Relation between printer errors and signal-to-noise ratio as determined from the Rocky Point-to-Rochester tests.

errors and counting all which did not appear on both copies, it was possible to obtain the per cent of errors caused by radio transmission. During the half-hour daily test period, about 10,000 characters were sent. It is apparent that rates of error which were less than about 0.1 per cent could not be determined accurately.

Before making the half-hour test each day to determine the per cent of errors received at Rochester, measurements were made of the amount of signal and of noise in the output of each voice-frequency filter. The signal-to-noise ratio thus measured was assumed to be the value obtaining over the succeeding half hour of test. The nature of these measurements was such that the data were somewhat scattered. However, by suitable smoothing procedures the approximate curve shown in Fig. 5 was plotted.

At Houlton, Maine, routine radio noise⁶ observations are made four times each day on a loop antenna and hourly on the wave-antenna system, as a part of the operating procedure in maintaining transatlantic telephone service.¹⁵ It seemed desirable to find out whether these data which extend over several years could be utilized to extrapolate the Rochester data into other months. An examination of the noise data observed on the loop antenna at Houlton along with the loop antenna received noise obtained at Rochester, New York, point by point during the period of these tests indicated a fairly constant differ-

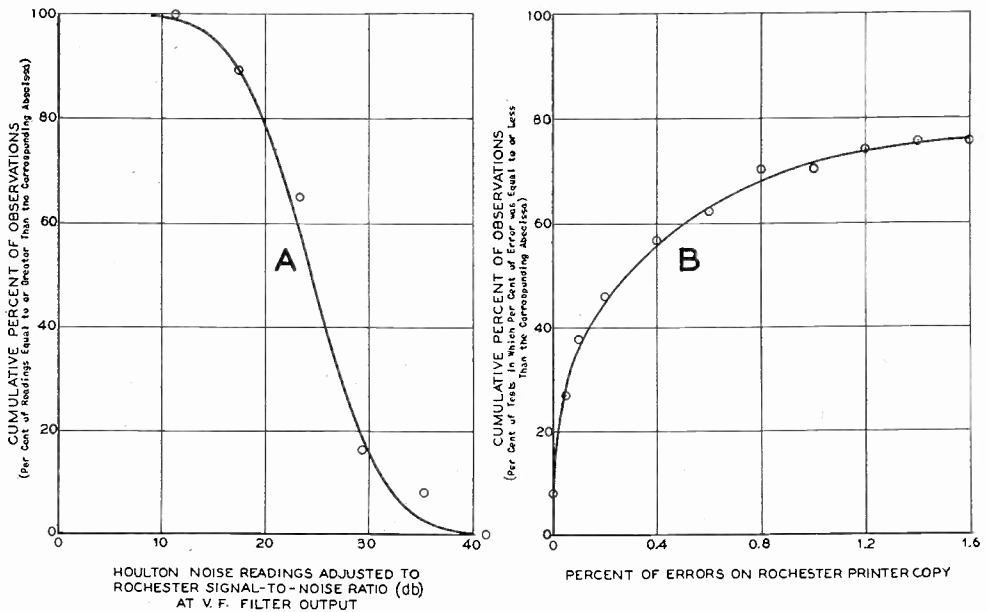

Fig. 6—Cumulative curves of signal-to-noise ratio derived from Houlton noise observations and of per cent of errors on the printer copy observed at Rochester.

ence between the noise at these two places. On 37 days during September, October, and November, 1930, observations of printer operation at Rochester and noise observations at Houlton were made within the same hour. Using the errors observed in the Rochester radio copy on these 37 days and the corresponding 37 values of loop noise at Houlton the cumulative curves shown in Fig. 6 were obtained. From these two curves the same relation as shown in Fig. 5 can again be obtained.*

Since such a good correlation had been observed between the Rochester and Houlton data over the period covered by the tests, it appeared that the Rochester data might be extrapolated to cover a greater time by use of the Houlton noise readings. The same general method as outlined in Appendix A has, therefore, been applied to the Houlton

* For detail of method see Appendix A.

loop noise data for the entire year of 1930 and the results are shown on Fig. 7. From this figure the great seasonal and diurnal variation in grade of transmission is at once apparent. It must be emphasized that the per cent of errors corresponding with the average noise condition is a much more significant figure than the average per cent of errors. For example, in the Rochester tests Fig. 6 indicates that the per cent of error corresponding to average noise condition is 0.28 per cent while the observed average of the daily per cents of errors is 6.44 per cent. It is more useful to know that half of the time the copy will be better than 0.28 per cent and half of the time worse, than to be unduly influenced by the effect on the average per cent of error of a few days in which the copy is almost all errors.

The results of the Rochester tests may be briefly summarized by giving a few figures which are based on the data obtained. A five-kilowatt station on long waves with a reasonable antenna, say 20 per cent efficient, would radiate one kilowatt. Assume that the local noise conditions are the same at the receiving station as those which have been used for the 9:00 P.M. values in Fig. 7 for Rochester, N. Y., variations. (These are obtained by applying a correction factor to the Houlton, Maine, noise observations for 1930.) Then the per cents of errors in the teletypewriter copy during the evening periods at different distances* from the transmitting station would be more than those given in the table for half of the time in each month.

TABLE II

| Distance Over- land from Sta- tion Radiating 1 kw at 60 kc (Statute Miles) | Errors in Printer Copy for Average Evening Noise Conditions for Each Month, Assuming Local Noise Conditions the Same as at Rochester, N. Y., and a Loop Receiving Antenna (Per Cent) | | | | | | | | | | | |
|--|---|------|------|------|------|------|------|------|-------|------|------|------|
| | Jan. | Feb. | Mar. | Apr. | May | June | July | Aug. | Sept. | Oct. | Nov. | Dec. |
| 50 | 0 | 0 | 0 | 0 | 0 | 0 | 0 | 0 | 0 | 0 | 0 | 0 |
| 100 | 0 | 0 | 0 | 0 | 0.01 | 0.03 | 0.15 | 0.01 | 0.01 | 0 | 0 | 0 |
| 200 | 0 | 0 | 0 | 0.03 | 1.60 | 3.6 | 9.5 | 1.7 | 1.7 | 0.04 | 0 | 0 |
| 400 | 3.5 | 0.23 | 0.10 | 13.0 | 100 | 100 | 100 | 100 | 100 | 14.3 | 3.1 | 0.29 |

* As the distance varies between transmitter and receiver with the radiated power a constant, there is a variation in received signal field. If the noise is assumed to be fixed, this variation in distance will result in a variation in signal-to-noise ratio. Many of the commonly used radio transmission formulas take the form:⁶

$$E = \sqrt{P} \frac{300 \times 10^3}{D} \epsilon^{-\alpha D/\lambda^x}$$

For these calculations we have assumed $x=1.25$ and from the field strength measurements at Rochester $\alpha=0.023$. P is measured in kilowatts radiated, D and λ in kilometers, and E in microvolts per meter.

The various signal-to-noise ratios can then be translated into rates of error by use of Fig. 5.

equivalent to the "per cent of time" for the period covered by the tests. Then if, as in the Rochester tests, the radio signal strength is substantially constant, the signal-to-noise ratio (expressed in db) becomes simply a constant minus the noise value (also expressed in db); and finally to get the signal-to-noise ratio at the voice-frequency filter output, a constant correction factor must be subtracted to take care of the band width, the difference in the methods used to measure noise and the difference in the absolute value of the noise observed at the two stations. Of course, if the Houlton loop noise is equal to or less than a given value for say 90 per cent of the time, the signal-to-noise ratio at the voice-frequency filter output derived from the Houlton noise will be equal to or less than its value for 10 per cent of the time.

Curve *B* of Fig. 6 is obtained directly from the observed errors on each test at Rochester and indicates in what per cent of the tests the per cent of errors observed was equal to or less than the value of "per cent of errors" given by the corresponding abscissa.

To combine the two curves of Fig. 6 it must be assumed that for each value of signal-to-noise ratio at the voice-frequency filter output there can be but one value for the observed per cent of errors, i.e., the variation in the per cent of errors depends only upon the signal-to-noise ratio received. If this is true, it is evident that a certain signal-to-noise ratio occurring a definite per cent of the time will always correspond to the per cent of errors which occurs the same per cent of the time. Hence, from the cumulative curves of Fig. 6 a curve relating signal-to-noise ratio with per cent of errors can be derived which is the same as Fig. 5. To do this a certain signal-to-noise ratio for which the corresponding per cent of errors on the Rochester printer copy is desired is selected. Curve *A* of Fig. 6 shows that this or some larger value of signal-to-noise ratio occurs *P* per cent of the time, but *P* per cent of the time, according to Curve *B* of Fig. 6, the per cent of errors on the Rochester printer copy was equal to or less than *E*. It is apparent, therefore, that *E* must be the value desired.

Assuming some constant received field strength at Rochester it is possible by this method to convert any individual Houlton loop noise observation into the corresponding per cent of errors on the Rochester teletypewriter copy.

BIBLIOGRAPHY

1. Paul M. Rainey, "A new printing telegraph system," *Elec. World*, 65, 848; April 3, 1915.
John H. Bell, "Printing telegraph systems," *Trans. A.I.E.E.*, 39, 167, 1920.
H. P. Clausen, "Morkrum-Kleinschmidt printing telegraph systems," *Elec. Communication*, 5, 216; January, 1927.

2. B. P. Hamilton, H. Nyquist, M. B. Long, and W. A. Phelps, "Voice-frequency carrier telegraph system for cables," *Jour. A.I.E.E.*, 44, 213; March, 1925. *Trans. A.I.E.E.*, 44, 327, 1925. *Elec. Communication*, 3, 288; April, 1925.
E. H. Colpitts and O. B. Blackwell, "Carrier current telephony and telegraphy," *Trans. A.I.E.E.*, 40, 205, 1921.
3. Fritz Van der Wonde and Alfred E. Seelig, "The high power Telefunken radio station at Sayville, Long Island," *Proc. I.R.E.*, 1, 23; July, 1913.
4. Julius Weinberger, "The recording of high speed signals in radio telegraphy," *Proc. I.R.E.*, 10, 176; June, 1922.
5. R. A. Heising, "Printing telegraph by radio," *Jour. Frank. Inst.*, 193, 97; January, 1922.
Henri Abraham and René Planiol, "La radiotelegraphie imprimee—emploi du telegraphe baudot en telegraphie sans fil," *Annal. des Postes, Telegraphes et Telephones*, 10, 193, 1921.
"The Baudot system and radio," *Electrician*, 93, 207; August 22, 1924.
Fritz Banneitz, "Über Versuche und Erfahrungen mit Drahtloser Schnelltelegraphie bei der Reichspost," *Elektrotech. Zeits.*, 42, 714; July 7, 1921.
6. Lloyd Espenschied, C. N. Anderson, and Austin Bailey, "Transatlantic radio telephone transmission," *Elec. Communication*, 4, 7; July, 1925. *Proc. I.R.E.*, 14, 7; February, 1926.
Ralph Bown, Carl R. Englund, and H. T. Friis, "Radio transmission measurements," *Proc. I.R.E.*, 11, 115; April, 1923.
7. H. Nyquist, R. B. Shanck, and S. I. Cory, "Measurement of telegraph transmission," *Jour. A.I.E.E.*, 46, 231; March, 1927.
8. John R. Carson, "Selective circuits and static interference," *Bell Sys. Tech. Jour.*, 4, 265; April, 1925.
9. "The Radio Corporation of America successfully tested printing telegraphy via their Chatham, Mass., radio station to the R.M.S. Majestic," *New York Times*, November 14, 1922.
10. "The Navy Department successfully tested printing telegraphy between an airplane and ground radio station," *New York Tribune*, August 10, 1922; *New York Times*, August 10, 1922.
11. G. S. Vernam, "Cipher printing telegraph systems for secret wire and radio telegraphic communications," *Trans. A.I.E.E.*, 45, 295, 1926.
12. S. B. Wright and H. C. Silent, "The New York-London telephone circuit," *Bell Sys. Tech. Jour.*, 6, 736; October, 1927.
13. R. A. Heising, "Production of single sideband for transatlantic radiotelephony," *Proc. I.R.E.*, 13, 291; June, 1925.
14. H. D. Arnold and Lloyd Espenschied, "Transatlantic radiotelephony," *Jour. A.I.E.E.*, 42, 815; August, 1923.
15. Austin Bailey, S. W. Dean, and W. T. Wintringham, "The receiving system for long-wave transatlantic radiotelephone," *Proc. I.R.E.*, 16, 1645; December, 1928.

ON ASYMMETRIC TELEGRAPHIC SPECTRA*

By

C. R. BURCH

(Metropolitan-Vickers Electrical Company, Limited, Manchester, England)

Summary—It is shown that single side band Morse transmission, if practicable, would relieve the present long-wave spectral congestion. Methods are developed whereby the wave shape of the single side band signals can be visualized when the original message envelope is given, and it is shown that the prolonged transmission of true single side band signals would in general necessitate the radiation of infinite amplitudes. Wave forms of approximations to single side band signals which evade this difficulty are determined: the wave form of the original message can be recovered without distortion from these "asymmetric side band" waves, the use of which, however, requires more power and also greater crest amplitudes than normal double side band transmission. The production and reception of asymmetric side band waves is discussed.

The subject is treated *de novo*, and the paper therefore overlaps considerably that of H. B. Nyquist† in which many of the present conclusions were obtained by slightly different analytical methods.

1. STARTING POINT OF THE INQUIRY

THE single side band transmission of speech has received adequate attention at the hands of previous thinkers: few accounts,‡ however, have been given of the problems involved in the transmission of single side band Morse signals, or of the properties enjoyed by the necessary wave forms. Since the principal, if not the only reason, for attempting single side band Morse transmission is the relief of spectral congestion, it is pertinent to inquire at once which factor contributes most to the width of the spectral band occupied (with appreciable amplitude) by an actual transmission—the unavoidable variations in the carrier frequency of a transmitter, or the finite width necessarily associated with the given speed of sending. Let us take an actual case—carrier frequency 16,000 cycles, sending speed 30 w.p.m. A dot, together with a space of equal duration, will occupy about 0.08 second. It is generally admitted that the effective band width of a (double side band) transmission is at least six times the fundamental frequency of a chain of "running dots"—i.e., the effective width of the above transmission is at least 75 cycles. It is said to be possible to maintain the carrier frequency of a transmitter correct to 1 in 10^5 for

* Decimal classification: R410. Original manuscript received by the Institute, March 13, 1931.

† See bibliography.

‡ When this paper was written the author was not aware of any account; he is indebted to the Editors for drawing his attention to the prior work of H. B. Nyquist.

fairly long periods. The added band width due to unavoidable frequency variations is thus in our case $\frac{1}{3}$ cycle—less than $\frac{1}{2}$ per cent of the band width necessarily associated with double side band transmission at the given speed.

Even if we consider hand sending, and suppose that the message consists solely of dashes, at 10 w.p.m., casual frequency variation only adds 4 per cent to the width of the spectral band occupied by the given double side band transmission. There is, therefore, a *prima facie* case for an inquiry into single side band Morse transmission.

2. THE ENVELOPE THEOREM

Let us establish a notation for spectral analysis. The spectral amplitude, at angular frequency q , is defined, for the signal $E=f(t)$, as the complex

$$X(q) = \int_{-\infty}^{\infty} f(t)\epsilon^{iqt}dt \quad (i^2 \equiv -1). \quad (1)$$

It will not be necessary to consider wave forms (forms of $f(t)$) for which, for general values of the parameter q , the integral (1) does not exist as the limit of a sum.

The "response function" of a quiescent circuit (i.e., a circuit having a finite positive damping exponent for every normal vibration) is defined as the complex $Y(q)$ such that the response at the "output terminals" of the circuit produced by the application at the "input terminals" of an amplitude given by the real part of ϵ^{-iqt} , approaches the real part of $Y(q)\epsilon^{-iqt}$, as t is increased indefinitely. Every quiescent circuit possesses a "response function."

We can write

$$f(t) = \text{real part of } \frac{1}{\pi} \int_0^{\infty} X(q) \cdot \epsilon^{-iqt} dq \quad (2)$$

and further, if $F(t)$ denotes the response produced at the "output terminals" of the above circuit by the application of $f(t)$ at its "input terminals,"

$$F(t) = \frac{1}{\pi} \int_0^{\infty} X(q) \cdot Y(q) \cdot \epsilon^{-iqt} dq \quad (\text{real part only}). \quad (3)$$

Finally we have,

$$\int_{-\infty}^{\infty} \{f(t)\}^2 dt = \frac{1}{\pi} \int_0^{\infty} |X(q)|^2 \cdot dq \quad (4)$$

and,

$$\int_{-\infty}^{\infty} \{F(t)\}^2 dt = \frac{1}{\pi} \int_0^{\infty} |X(q)|^2 \cdot |Y(q)|^2 \cdot dq. \quad (5)$$

The practical value of thinking in terms of $X(q)$ rather than $f(t)$ lies in the applicability of (3) and (5).

Let us now consider the spectrum of a typical Morse signal, which we shall represent by $\phi(t) \cdot \cos(pt + \eta)$. We shall suppose that the envelope, $\phi(t)$, is finite, save perhaps at one or more of the zeros of $\cos(pt + \eta)$, where it may be infinite in such a way that $f(t) = \phi(t) \cdot \cos(pt + \eta)$ is finite. Let us denote the spectrum of the envelope by $\chi(q)$, so that

$$\chi(q) = \int_{-\infty}^{\infty} \phi(t) \cdot e^{iqt} dt. \quad (6)$$

Applying (1) we obtain the envelope theorem,

$$X(q) = \frac{1}{2} \epsilon^{i\eta} \chi(q + p) + \frac{1}{2} \epsilon^{-i\eta} \chi(q - p). \quad (7)$$

Now, if the envelope, $\phi(t)$, does not vary rapidly in the time π/p , (except in a small number of places, widely separated—e.g., at the beginning and end of a rectangular envelope, of many times π/p seconds duration), for values of q near to p , but not at or very near to zeros of $\chi(q - p)$, $\chi(q + p)$ will be negligible compared with $\chi(q - p)$. For such an envelope, then, we have the approximation,

$$\text{and, } \left. \begin{array}{l} X(p \pm \zeta) \approx \frac{1}{2} \epsilon^{-i\eta} \chi(\pm \zeta) \\ |X(p \pm \zeta)| \approx \frac{1}{2} |\chi(\zeta)| \end{array} \right\} \begin{array}{l} \zeta \ll p \\ \zeta \text{ not near a zero of } \chi(\zeta) \end{array} \quad (8)$$

since $\chi(-\zeta) = \tilde{\chi}(\zeta)$ (conjugate complex of $\chi(\zeta)$), and $|\epsilon^{-i\eta}| = 1$. This approximate form of the envelope theorem shows that any signal capable of representation as the product of a sinusoidal wave with a simple envelope, possesses a spectrum approximately symmetrical in modulus on both sides of, and near to, $q = p$. Such a signal is necessarily a double side band transmission.

3. THE MANUFACTURE OF SINGLE SIDE BAND WAVES

Let us take a perfectly general wave, $f(t)$, and remove from it all frequencies above p , without changing the amplitude or phasing of the rest. We shall see that this, although mathematically possible, is physically impossible. The desired wave is given by the real part of

$$\frac{1}{\pi} \int_0^p \epsilon^{-i\tau q} \cdot \int_{-\infty}^{\infty} f(\tau) \epsilon^{i\tau r} d\tau \cdot dq. \quad (9)$$

We want to reverse the order of integration in (9). First, observe that since p is finite, and $\epsilon^{-i\tau q}$ is bounded in the range of integration, (9) is equal to

$$Lt_{\lambda \rightarrow \infty} \frac{1}{\pi} \int_0^p \epsilon^{-itq} \int_{-\lambda}^{\lambda} f(\tau) \epsilon^{iq\tau} d\tau \cdot dq \quad (10)$$

provided that the convergence of $Lt_{\lambda \rightarrow \infty} \int_{-\lambda}^{\lambda} f(\tau) \cdot \epsilon^{iq\tau} d\tau$ is uniform with respect to q , in the range $0 \leq q \leq p$.

Next, observe that the range of τ -integration in (9) and (10) need only extend over the range or ranges of τ for which $f(\tau) \neq 0$. If $f(\tau)$ is continuous throughout all ranges of τ for which it is not zero, it is therefore continuous in the ranges of τ -integration, and, further, the integrand of (10) is then a continuous function of both variables, τ , q , throughout the ranges of integration. We may then reverse the order of integration. Integrating first with respect to q gives:

Lower side band of $f(t) =$

$$\frac{1}{\pi} \int_{-\infty}^{\infty} \frac{f(\tau) \sin p(t - \tau)}{t - \tau} d\tau, = \frac{1}{\pi} \int_{-\infty}^{\infty} \frac{f(t - \tau) \cdot \sin p\tau}{\tau} \cdot d\tau \quad (11)$$

—subject to the restriction that $\int_{-\infty}^{\infty} f(\tau) \epsilon^{iq\tau} d\tau$ shall converge uniformly with respect to q in the range $0 \leq q \leq p$, and that $f(\tau)$ shall be continuous save for a finite number of ranges, throughout which it may be zero, and at the ends of which it may be discontinuous. A wave, continuous between two instants, and zero before and after, satisfies both these restrictions: it will be found that all types of wave which need be considered in signaling can be regarded as limiting cases of waves of this type.

The upper side band can be removed, then, from any wave, by the Duhamel operation, (11), the first derivate of the indicial admittance of the operating system being $\sin pt/t$ ($-\infty < t < \infty$). No physical system can have a finite indicial admittance in the range $-\infty < t < 0$, since the indicial admittance of a physical system can be identified with the response at time t to a wave of unit amplitude, which does not begin until $t=0$. Thus no physical system can perform the operation (11) for this operation necessitates a system possessing an anticipatory, as well as a retrospective memory. A physical system can, however, produce the approximation:

$$\text{Delayed lower side band of } f(t) = \frac{1}{\pi} \int_{-K}^K \frac{f(t - K - \tau)}{\tau} \sin p\tau d\tau \quad (12)$$

and the greater the K -second delay, the more closely does this wave approximate in shape, and therefore in $|X(q)|$, to the wave (11). It should be borne in mind, then, that the operations which we shall consider necessitate for their physical realization, an infinite delay.

Application of (11) to the special function $f(t) = \phi(t) \cdot \cos(pt + \eta)$, gives for the lower side band thereof the expression:

Lower side band of

$$\begin{aligned} \phi(t) \cdot \cos(pt + \eta) = & \frac{\cos(pt + \eta)}{2\pi} \int_{-\infty}^{\infty} \frac{\phi(t - \tau) \sin 2p\tau}{\tau} d\tau \\ & + \frac{\sin(pt + \eta)}{2\pi} \int_{-\infty}^{\infty} \frac{\phi(t - \tau) \cdot [1 - \cos 2p\tau]}{\tau} d\tau. \end{aligned} \quad (13)$$

Expression (13) enables us to form a picture of a normal (D.S.B.) Morse dot, when deprived of its upper side band. The first Duhamel operation we know simply abolishes frequencies in $\phi(t)$ above $2p$. But, as we have seen, $\phi(t)$ has $\chi(q)$ already very small for frequencies above $2p$. This operation has, therefore, little effect, save to smooth the discontinuities of the envelope. The effect of the second operation can also be simply ascertained. First, it may be verified directly that it abolishes frequencies in $\phi(t)$ above $2p$. Second, it can be seen that the term $\cos 2p\tau$ in the integrand contributes nothing to the integral from frequencies below $2p$. The operation (13) can thus be replaced by two cascaded operations: first produce

$$\phi_1(t) = \frac{1}{\pi} \int_{-\infty}^{\infty} \frac{\phi(t - \tau) \sin 2p\tau}{\tau} d\tau. \quad (14)$$

The effect of this may broadly be described as smoothing the discontinuities of ϕ in a special way.

Second, operate on $\phi_1(t)$ with the following operator, giving:

Lower side band of $\phi(t) \cos(pt + \eta) =$

$$\frac{1}{2} \cos(pt + \eta) \cdot \phi_1(t) + \frac{1}{2} \sin(pt + \eta) \cdot \frac{1}{\pi} \int_{-\infty}^{\infty} \frac{\phi_1(t - \tau) d\tau}{\tau}. \quad (15)$$

The second operation in (13) on ϕ is thus replaceable by the second operation in (15) on ϕ_1 , which is in effect a smoothed ϕ . The effect of the second operation can now be seen: it gives zero in the middle of a symmetrical ϕ , it increases towards the "ends" of ϕ , and dies away as t^{-1} , as t approaches infinity, if the average value of ϕ is not zero. As (14) removes discontinuities from ϕ , (15) produces a finite result everywhere. We can thus draw Fig. 1, in which curve (1) represents the envelope (ϕ) of an ordinary dot, and curves (2) ($\frac{1}{2}\phi_1$)

$$\text{and (3) } \frac{1}{2\pi} \int_{-\infty}^{\infty} \frac{\phi_1(t - \tau)}{\tau} d\tau$$

represent envelopes which if multiplied respectively by $\cos(pt+\eta)$ and $\sin(pt+\eta)$ and added, produce the lower side band of the dot formed by multiplying curve (1) by $\cos(pt+\eta)$. If the sign of curve (3) is changed, the upper side band is obtained (with frequencies above $2p$ abolished).

We obtain further insight into the operation (15) by choosing the special operand $\phi_1(t) = \cos(xt+\theta)$, without, however, making the restriction $0 < x < 2p$. We get

$$\begin{aligned} \frac{1}{2} \cos(pt + \eta) \cdot \cos(xt + \theta) + \frac{1}{2} \sin(pt + \eta) \sin(xt + \theta) \\ = \frac{1}{2} \cos[(p - x)t + \eta - \theta]. \end{aligned}$$

If $0 < x < 2p$, this is a wave of frequency $< p$, and so is included in the lower side band, for we have implicitly defined the lower side band as consisting of all constituent frequencies less than p .

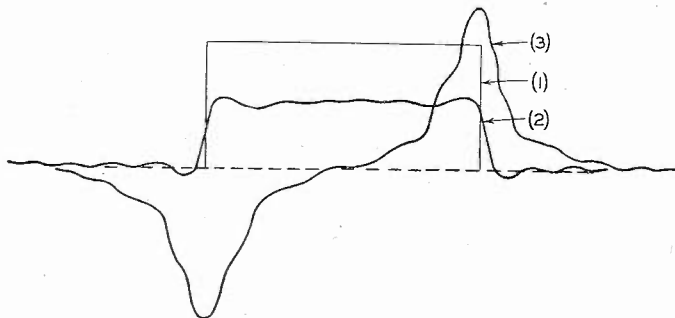

Fig. 1—Diagrammatic.

Now, this definition has the disadvantage that although the message to be transmitted defines the lower side band to be transmitted, the reverse is not uniquely true (even disregarding frequencies above $2p$), for the messages $\cos(xt+\theta)$ and $\cos[(2p-x)t+2\eta-\theta]$ both result in the transmission of the same wave, $\cos[(p-x)t+\eta-\theta]$. Since we are concerned with only a finite portion of the spectrum, it follows that we can even construct two different nonperiodic messages (neither containing frequencies above $2p$) which involve the transmission of the same wave, when the upper side band has been abolished. Further, the difference of these two messages is a nonperiodic message which involves the transmission of a lower side band wave which is identically zero. It is obviously essential to be able to determine the message uniquely in terms of the transmitted wave, and so we must lay down the restriction that messages to be transmitted on the lower side band must not contain any envelope frequency above p . Thus for unrestricted envelopes we distinguish between "the lower side band of $\phi(t) \cdot \cos(pt+\eta)$ " and "the lower side band signal corresponding to

envelope $\phi(t)$ and carrier $\cos(pt + \eta)$ " the former being given by cascading operations (14) and (15) and the latter by cascading the operation

$$\phi_2(t) = \frac{1}{\pi} \int_{-\infty}^{\infty} \frac{\phi(t - \tau) \sin a\tau}{\tau} d\tau \quad [0 < a < p] \quad (16)$$

and the operation (15), performed not on ϕ_1 , but on ϕ_2 . The equivalent single operation is: Lower side band signal corresponding to envelope $\phi(t)$ and carrier $\cos(pt + \eta) =$

$$\begin{aligned} & \frac{\cos(pt + \eta)}{2\pi} \int_{-\infty}^{\infty} \frac{\phi(t - \tau) \sin a\tau}{\tau} d\tau \\ & + \frac{\sin(pt + \eta)}{2\pi} \int_{-\infty}^{\infty} \frac{\phi(t - \tau) [1 - \cos a\tau]}{\tau} d\tau \quad [0 < a < p] \end{aligned} \quad (17)$$

The smoothed message $\phi_2(t)$, can be formally recovered from the L.S.B. signal (17), by multiplying by $\cos(pt + \eta)$ (a physically possible operation) and then removing frequencies above p . But it is not possible to recover the message ϕ_1 , without ambiguity, from the signal (15). In telegraphic practice, the limitation that one cannot convey message frequencies greater than p unambiguously by lower side band transmission is quite unimportant, for one does not attempt to convey with undiminished amplitude message frequencies higher than a very small fraction of p . Analytically, however, it is necessary to keep the point in mind.

If now we take an envelope, $\phi(t)$, discontinuities in which have been abolished (not necessarily by the abolition of frequencies exceeding some particular value; the derivate need not be continuous), and perform on it the operation described by

$$F(t) = \frac{1}{2} \cos(pt + \eta) \cdot \phi(t) - \frac{1}{2} \sin(pt + \eta) \cdot \frac{1}{\pi} \int_{-\infty}^{\infty} \frac{\phi(t - \tau)}{\tau} d\tau \quad (18)$$

we get a finite $F(t)$ which can properly be called the upper side band signal corresponding to $\phi(t)$ and carrier $\cos(pt + \eta)$, inasmuch as each constituent frequency, $\cos(xt + \theta)$, in ϕ , gives rise to one and only one term in $F(t)$, i.e., $\frac{1}{2} \cos[(p+x)t + \eta + \theta] \cdot (0 < x < \infty)$. We can recover the original ϕ by submitting $F(t)$ to the operation (15). It is thus possible to convey any continuous message as an upper side band signal. If we restrict ourselves, as in telegraphy we may, to the conveyance of messages smoothed by the abolition of frequencies above p , we can recover the smoothed message from the upper side band signal by the simpler process of multiplying by $\cos(pt + \eta)$ and then removing all frequencies above p .

As a check on the above analysis, notice that since the operation

$$\frac{1}{\pi} \int_{-\infty}^{\infty} \frac{\phi(t - \tau)}{\tau} d\tau$$

puts every frequency in ϕ in quadrature, two applications of this operator must reverse every frequency, and so we should have

$$\phi(t) = \frac{-1}{\pi^2} \int_{-\infty}^{\infty} \frac{d\tau}{\tau} \int_{-\infty}^{\infty} \frac{\phi(t - \tau - \tau')}{\tau'} d\tau'. \quad (19)$$

This can be checked by direct integration for the special function $\phi(t) = 0$ ($|t| > t_0$); $\phi(t) = 1$ ($-t_0 \leq t \leq t_0$). Hence it follows for every function for which the repeated integral exists.

4. THE CONVERGENCE OF THE MESSAGE

If we wish to convey intelligence by means of a series of electric waves of amplitude $E = E_n(t) = F(t + \tau_n)$, and to continue the process indefinitely, it will be in practice essential to use a wave form F , such that provided for every n , $\tau_n - \tau_{n-1} > K$, where K is some positive quantity, the message, i.e., the series

$$\sum_1^n E_n(t) \quad (20)$$

shall converge, when n is made infinite, for all values of t .

Now if we take a rectangular wave form for the dot or dash, and perform thereon the smoothing operation (16), depriving the envelope of frequencies above a , the resulting wave form will not give a convergent message, $\sum_1^n E_n(t)$, unless the frequency a happens to coincide with one of the zeros of the spectrum of the original envelope. For example, let the rectangular envelope be of unit amplitude, and last from $-t_1$ till t_1 . Deprived of frequencies above a , it becomes

$$E_0(t) = \frac{1}{\pi} Si[a(t + t_1)] - \frac{1}{\pi} Si[a(t - t_1)]$$

where $Si(z)$ denotes the sine integral,

$$\int_0^z \frac{\sin z}{z} dz.$$

$Si(z)$ possesses the asymptotic expansion

$$Si(z) \sim \frac{\pi}{2} - \frac{\cos z}{z} - \frac{\sin z}{z^2} + \frac{2 \cos z}{z^3} + \frac{2 \cdot 3 \cdot \sin z}{z^4} - \text{etc.} \quad (21)$$

(— the error not exceeding the fraction formed by substituting unity for $\sin z$ or $\cos z$ in the last term taken). Our signal, therefore, possesses the asymptotic expansion,

$$\begin{aligned}
 E_0(t) &\sim \frac{1}{\pi} \left[\frac{\cos a(t - t_1)}{a(t - t_1)} - \frac{\cos a(t + t_1)}{a(t + t_1)} \right] + 0(t^{-2}) \\
 &\sim \frac{1}{\pi} \frac{\sin at_1 \sin at}{at} + 0(t^{-2}) \tag{22}
 \end{aligned}$$

—and if $at_1 \neq m\pi$ (m integral) this is $0(t^{-1})$. Now, we cannot without justifying the process, assert that $\sum_1^n E_n(t)$ will be asymptotically represented by a series formed by summing with respect to n , term by term, the asymptotic expansion of $E_n(t)$. But, if we postulate $at_1 \neq m\pi$, and $a\tau_n = 2ns\pi$, where s is an integer, we can show that there is a range of values of t over which $\sum_1^\infty E_n(t)$ does not converge. For it is obviously possible to find values T and K such that whenever $t > T$, and $K \leq \sin at \leq 1$, the first term of the asymptotic expansion of $E_0(t)$ will lie between half and twice the actual value of $E_0(t)$. Now, for any value of t satisfying these conditions, $t + \tau_n$ will also satisfy them, and therefore, since for every n the first term of the asymptotic expansion will have the same sign, the sum of first terms, taken over all values of n , will lie between half and twice $\sum_1^\infty E_n(t)$. The sum of first terms is then

$$\frac{\sin at_0 \sin at_1}{\pi} \sum_{n=0}^\infty \frac{1}{at_0 + 2\pi ns},$$

—a series every term of which is greater than a corresponding term in the series $A \sum n^{-1}$, which is known to diverge.

If, therefore, we signal with the wave form obtained by depriving rectangular dots and dashes of frequencies above a , and $at_1 \neq m\pi$, then although each smoothed dot or dash is finite everywhere, the amplitude can be made at some time to exceed any given value, by sending a sufficiently long message. The production of terms in t^{-1} by the removal of frequencies above a is associated with the production of a spectral discontinuity; in fact it can be shown that if the spectrum $X(q)$ of a signal is such that (1) $\int_0^a X(q) dq$ exists, (2) the real and imaginary parts of $X(q)$ possess limited total fluctuation in the range $0 \leq q \leq a$, then the signal formed by removing frequencies above a is $0(t^{-1})$ as $t \rightarrow \infty$, and further, if $X(q)$ possesses a derivate at all parts of the range $0 \leq q \leq a$, and if the real and imaginary parts thereof also possess limited

total fluctuation in the range $0 \leq q \leq a$, and $X(a) = 0$, then the signal produced by removing frequencies above a is $O(t^{-2})$ as $t \rightarrow \infty$.

The formal difficulty of divergence of the message does not arise in practice, as no realizable filter can produce a spectral discontinuity. In our theoretical treatment, we do not wish to introduce the hypothesis that the cut-off is made at a zero of the spectrum of the original envelope ($at_1 = m\pi$ for a rectangular envelope, lasting from $-t_1$ to $+t_1$). We must, therefore, consider a gradual cut-off, and shall suppose that frequencies less than $a - a_1$ are unchanged; frequencies above a are abolished, and any frequency q in the range $a - a_1 \leq q \leq a$ is multiplied by a function $\mathfrak{F}(q, a, a_1)$, which is chosen to be 1 when $q = a - a_1$, and 0 when $q = a$, and to be continuous in the range $a - a_1 \leq q \leq a$. Analytically, this means that we must perform on the wave forms already derived (by operations (16) or (17), in which frequencies above a were removed), each of which can be written $F(t, a)$ the operation

$$F(t, a, a_1) = - \int_{a-a_1}^a F(t, \alpha) \cdot \frac{\partial \mathfrak{F}}{\partial \alpha}(\alpha, a, a_1) d\alpha. \quad (23)$$

Let us consider the effect of this operation on a wave form such as that derived by performing the operation (16) on a rectangular envelope lasting from $-t_1$ to t_1 . If $at_1 \gg 2\pi$, the result of the operation (16), $F(t, a)$, does not depend markedly on the precise value of a , for values of t lying in the range $-t_1 < t < t_1$, except very near $t = \pm t_1$. The operation (23) thus has little effect on $F(t, a)$ in the range $-t_1 < t < t_1$. But for large values of t , $F(t, a)$ does depend markedly on a (the expansion was given in (22)), and is a decreasing oscillating function of a , passing through one quasi cycle in the range $2\pi/a$. We may thus expect that $F(t, a, a_1)$ will start to obey the law $O(t^{-2})$, which we know it must obey for $t \gg$, for times of the order of, or greater than, $2\pi/a_1$.

Let us take as a simple form for the function \mathfrak{F} , $\mathfrak{F}(\alpha, a, a_1) = (a - \alpha)/a_1$ ($a - a_1 \leq \alpha \leq a$). (23) then becomes

$$F(t, a, a_1) = \frac{1}{a_1} \int_{a-a_1}^a F(t, \alpha) d\alpha. \quad (24)$$

Let us now apply operation (24) to the asymptotic expansion (22). It is legitimate to integrate any asymptotic expansion term by term, and so we have

$$F(t, a, a_1) \sim \frac{1}{\pi a_1} \int_{a-a_1}^a \left[\frac{\cos \alpha (t-t_1)}{\alpha(t-t_1)} - \frac{\cos \alpha (t+t_1)}{\alpha(t+t_1)} \right] + O(t^{-2}) d\alpha. \quad (25)$$

Consider

$$\frac{1}{\pi a_1} \int_{a-a_1}^a \frac{\cos \alpha x}{\alpha x} d\alpha,$$

where x may stand for $t \pm t_1$. It may be written

$$\frac{1}{\pi a_1 x} \int_{(a-a_1)x}^{ax} \frac{\cos \xi d\xi}{\xi},$$

which possesses the asymptotic expansion

$$\sim \frac{1}{\pi a_1 x} \left[\frac{\sin ax}{ax} - \frac{\sin (a - a_1)x}{(a - a_1)x} + 0(x^{-2}) \right]$$

i.e.,

$$\sim \frac{1}{\pi} \left[\frac{2 \cos (a - \frac{1}{2}a_1)x \cdot \sin \frac{1}{2}a_1x}{a_1x(a - a_1)x} - \frac{\sin ax}{ax \cdot (a - a_1)x} + 0(x^{-3}) \right]. \quad (26)$$

Substituting $t - t_1$, $t + t_1$, in turn for x , and subtracting, we see that the general effect of operation (24) is to divide the order of magnitude of $F(t, a)$ by $2/a_1 t$ for values of t such that $|t \pm t_1| \gg 2\pi/a_1$, while for the range $2\pi/a \ll |t \pm t_1| \ll 2\pi/a_1$, the order of magnitude of $F(t, a)$ is not altered, as is also the case in the range $-t_1 < t < t_1$.

It can be seen that the rectangular envelope message, originally convergent, and rendered divergent by operation (16) is rendered convergent again by the subsequent application of operation (23), or its special case, (24), for $E_n(t) = F(t + \tau_n, a, a_1) = 0(t + \tau_n)^{-2}$ as $|t + \tau_n| \rightarrow \infty$. That is, numbers t_0 and K exist, such that whenever $|t + \tau_n| > t_0$, $E_n(t) < K/(t + \tau_n)^2$, and so provided $\tau_n - \tau_{n-1} \neq 2t_1$, i.e., provided the original rectangular dots (and/or dashes) do not overlap, the message, though prolonged to $t = \pm \infty$ is absolutely convergent, by comparison with the series $\sum_{n=1}^{\infty} n^{-2}$.

We have now obtained analytical expressions which represent methods of abolishing frequencies above a , with a gradual cut-off, without making the message divergent thereby. But we have still to discuss the possible introduction of divergence by the operation (15) or (17), by which the unwanted side band is removed. As was pointed out on page 2195, the part of the S.S.B. dot which was represented by an enveloped quadrature carrier dies away as t^{-1} if the average value of the original dot envelope was not zero; this is of course due to the discontinuity produced in the spectrum by the removal of one side band of the dot. Let us consider the possibility of employing as envelopes for the original dots and dashes only such wave forms as have a zero average value. We must not curtail the duration of the positive part of a dot or dash, for this would increase the spectral spread of its envelope. There would be no point in eliminating one side band if this could only be done by doubling the breadth of the other. We may, however,

utilize the space of duration at least equal to that of a dot, which always follows each dot or dash, for the transmission of a negative wave of area numerically equal to that of the preceding (positive) dot or dash. If the duration of the dot be $2t_1$, the fraction of the total energy contributed by constituent frequencies considerably greater than π/t_1 is not increased by the addition of this negative wave; that is, in order to obtain a given legibility, it will not be necessary to increase the cut-off frequency; a , i.e., the width of the side band. This method, then, constitutes one way of avoiding the practical difficulties of a divergent message; the fact that it necessitates the use of a nonlinear operating system (an arrangement of relays to produce the negative waves at the right times) does not put it out of court.

Alternatively, we could argue that no physical system can produce a spectral discontinuity; an actual filter will either incompletely eliminate the unwanted side band, or will eliminate the unwanted side band substantially completely (but not identically), and eliminate an appreciable part of the wanted side band—thus reducing the amplitude of low constituent frequencies of the message, and nearly annulling zero frequency therein.

It is thus necessary to discuss the effect of eliminating zero frequency and reducing the amplitude of very low frequencies in the message, both as regards the wave form of the spectrally asymmetric (approximately, single side band) message actually transmitted, and in respect of the interpretation of this modified message at the receiver. Let us discuss, then, in a quite general way what wave form we must subtract from the original dot envelope, in order to eliminate zero frequency—the “cut-off” occupying the frequency range $0 \leq \zeta \leq b$. The wave, $\theta(t)$, which must be subtracted from the original envelope $\phi(t)$ is given by

$$\theta(t) = \text{real part of } \frac{1}{\pi} \int_0^b \mathcal{F}(\zeta) \epsilon^{-i\zeta t} \int_{-\infty}^{\infty} \phi(\tau) \epsilon^{i\zeta\tau} d\tau \cdot d\zeta \quad (27)$$

where $\mathcal{F}(\zeta) = 1$ when $\zeta = 0$; when $\zeta = 1$ and is a continuous function of ζ in that range. As in (9), page 2193, we may reverse the order of integration, and write

$$\theta(t) = \frac{1}{\pi} \int_{-\infty}^{\infty} \phi(t - \tau) \left\{ R \cdot \int_0^b \mathcal{F}(\zeta) \cdot \epsilon^{-i\zeta t} d\zeta \right\} \cdot d\tau \quad (28)$$

(R denoting real part only).

Let L be the bound of $|\phi(t - \tau)|$. Then we have the inequality

$$|\theta(t)| \leq \frac{L}{\pi} \int_{-\infty}^{\infty} \left| R \cdot \int_0^b \mathcal{F}(\zeta) \epsilon^{-i\zeta t} d\zeta \right| \cdot d\tau. \quad (29)$$

For many particular functions $\mathfrak{F}(\zeta)$ the repeated integral exists, and can be easily evaluated numerically. We can then see at once the extreme effect which the low-frequency suppression can have on the message. For example, let $\mathfrak{F}(\zeta) = \frac{1}{2}[1 + \cos(\pi\zeta)/b]$ ($0 \leq \zeta \leq b$). Then (28) becomes

$$\theta(t) = \frac{1}{2\pi} \int_{-\infty}^{\infty} \phi(t - \tau) \cdot \frac{\pi^2 \sin b\tau}{\tau(\pi^2 - (b\tau)^2)} d\tau \quad (30)$$

$\pi^2 \sin b\tau / \tau(\pi^2 - (b\tau)^2)$ is positive in the range $-2\pi/b < \tau < 2\pi/b$, and so

$$|\theta(t)| \leq \frac{L}{\pi} \int_0^{2\pi/b} \frac{\pi^2 \sin b\tau}{\tau(\pi^2 - (b\tau)^2)} d\tau + \frac{L}{\pi} \int_{2\pi/b}^{\infty} \left| \frac{\pi^2 \sin b\tau}{\tau(\pi^2 - (b\tau)^2)} \right| d\tau \quad (31)$$

$$< \frac{L}{\pi} [Si(2\pi) + \frac{1}{2}Si(\pi) + \frac{1}{2}Si(3\pi) + \frac{1}{2} \log 4/3]$$

i.e., $< 1.06 \dots L$. (32)

This holds whatever value we assign to b . If we make the restriction that $bt_1 \ll \pi$, where $2t_1$ is the time occupied by the original dot or dash, and denote by A the bound of the average, taken over a long time compared with t_1 , but short compared with $2\pi/b$, of the amplitude of the original envelope of the message, and neglect quantities of the order of bt_1 compared with A , we can replace L by A in (32).

Now the average amplitude of a Morse message does not exceed three-quarters of the crest amplitude, (since after each dash, of three dots' duration, there comes a space of at least one dot's duration). We can therefore write

$$|\theta(t)| < 1.06 \dots A + 0(bt_1)$$

or,
$$< 0.795 \dots L + 0(bt_1) \dots (bt_1 \ll \pi). \quad (33)$$

It is clear that there are many wave forms (e.g., rectangular) for the dots and dashes which, after the subtraction of $\theta(t)$ would still be recorded correctly by a suitably biased relay, no matter how long the message might be. Not all forms for the function $\mathfrak{F}(\zeta)$ will bring about a result such as (32) for any message, even though we make the restriction $|\mathfrak{F}(\zeta)| \geq 1$ —in fact, it would seem that a form in which $\mathfrak{F}(\zeta)$ oscillated between unity and some smaller value many times in the range $0 < \zeta < b$ (but being 1 at $\zeta = 0$ and 0 at $\zeta = b$) would fail for certain special messages. It is, however, clear that forms for $\mathfrak{F}(\zeta)$ other than $\frac{1}{2}[1 + \cos \pi\zeta/b]$ exist, which will satisfy a relation such as (32) or (33) for any message.

In any case, we need not be unduly distressed about the difficulty of recording $\phi(t) - \theta(t)$ by means of reasonably simple relays, for consider the practical alternatives:

If we wish to radiate a strictly single side band transmission, we radiate the wave given by substituting $\phi(t) - \theta(t)$ for $\phi(t)$ in operation (17) or (18), (followed by the "converging" operation (23)). It is then necessary to record dots and dashes from $\phi(t) - \theta(t)$ at the receiver. But if we are prepared to trespass on a frequency range b of the unwanted side band, it is sufficient to substitute $\phi(t) - \theta(t)$ for $\phi(t)$ only in the quadrature-envelope operation (the second operation of (17) or (18)). The receiver will then deliver to the recorder the wave form $\phi(t)$. The approximations to lower or upper side band signals produced in this way will be referred to as lower or upper asymmetric signals. From the practical point of view, the important thing is that the spectral range occupied by the transmission should be small. Now, the accuracy with which it is possible to assign a lower practical limit to a (for dots of given duration $2t_1$) is not sufficient to make the distinction appreciable between a and $a+b$. For practical purposes, then, the spectral breadth occupied by the asymmetric signal may be regarded as equal to that of a true single side band signal.

We now wish to know how the "equivalent quadrature envelope," $1/\pi \int_{-\infty}^{\infty} \phi(t-\tau) d\tau/\tau$ will be modified by the subtraction of $\theta(t)$ from $\phi(t)$. The difference wave which we seek is given by putting in quadrature every constituent frequency of $\theta(t)$; this may be done by choosing the real part of i times the integral in $\{ \}$ in (28) instead of the real part, there chosen. We then get

$$\frac{1}{\pi} \int_{-\infty}^{\infty} \frac{\theta(t-\tau)}{\tau} d\tau = \frac{1}{2\pi} \int_{-\infty}^{\infty} \phi(t-\tau) \left[\frac{2(b\tau)^2 + \pi^2 [\cos b\tau - 1]}{\tau [(b\tau)^2 - \pi^2]} d\tau \right] \quad (34)$$

and,

$$\begin{aligned} \psi(t) &= \frac{1}{\pi} \int_{-\infty}^{\infty} [\phi(t-\tau) - \theta(t-\tau)] \frac{d\tau}{\tau} \\ &= \frac{1}{\pi} \int_{-\infty}^{\infty} \frac{\phi(t-\tau) \cos^2 \frac{1}{2} b\tau}{\tau [1 - (b\tau)^2/\pi^2]} d\tau. \end{aligned} \quad (35)$$

We now seek for results analagous to that of (32). Divide (35) into

$$\begin{aligned} \psi_1(t) &= \frac{1}{\pi} \int_{-\infty}^{-\pi/b} ; \quad \psi_2(t) = \frac{1}{\pi} \int_{\pi/b}^{\infty} ; \\ \psi_3(t) &= \frac{1}{\pi} \int_{-\pi/b}^{\pi/b} \frac{\phi(t-\tau) \cos^2 \frac{1}{2} b\tau}{\tau [1 - (b\tau)^2/\pi^2]} d\tau. \end{aligned} \quad (36)$$

Then,

$$|\psi_1(t) + \psi_2(t)| \leq \frac{2L}{\pi} \int_{\pi/b}^{\infty} \frac{-\cos^2 \frac{1}{2}b\tau}{\tau[1 - (b\tau)^2/\pi^2]} \cdot d\tau \tag{37}$$

$$\begin{aligned} &\leq \frac{2L}{\pi} [\gamma + \log \pi - \frac{1}{2}Cs(\pi) - \frac{1}{4}Cs(2\pi)] \\ &\leq 0.183 \dots L \end{aligned} \tag{38}$$

γ denoting the Euler-Mascheroni constant, 0.5772157 . . . , and $Cs(x)$ the cosine integral

$$\int_0^x \frac{1 - \cos x}{x} \cdot dx, \sim \gamma + \log x - \frac{\sin x}{x} + \frac{\cos x}{x^2} + \frac{2 \sin x}{x^3} - \frac{2 \cdot 3 \cos x}{x^4} \text{ etc.} \tag{39}$$

Thus the part of any message envelope more remote in time than $\pm \pi/b$ seconds from the instant t , cannot contribute to the amplitude of the equivalent quadrature envelope at time t , an amount greater than 0.183 . . . times the bound of the original message envelope, provided zero frequency is removed in the specified way, before the construction of the quadrature envelope. The contribution from parts of the original message in the range $t - \pi/b$ to $t + \pi/b$ is given by $\psi_3(t)$, which can be written as $\psi_{31}(t) + \psi_{32}(t)$ where

$$\psi_{31}(t) = \frac{1}{\pi} \int_{-\pi/b}^{\pi/b} \phi(t - \tau) \left[\frac{1}{2\pi} \frac{\cos^2 \frac{1}{2}b\tau}{(1 - b\tau/\pi)} - \frac{1}{2\pi} \frac{\cos^2 \frac{1}{2}b\tau}{(1 + b\tau/\pi)} \right] \cdot d\tau \tag{40}$$

$$\psi_{32}(t) = \frac{1}{\pi} \int_{-\pi/b}^{\pi/b} \frac{\phi(t - \tau) \cos^2 \frac{1}{2}b\tau}{\tau} \cdot d\tau. \tag{41}$$

We have the inequality

$$|\psi_{31}(t)| \leq \frac{L}{\pi} [Cs(\pi) - \frac{1}{2}Cs(2\pi)], \leq 0.138 \dots L. \tag{42}$$

If $\phi(t)$ is always of the same sign (or zero) the contributions (38) and (42) may be halved.

There remains only $\psi_{32}(t)$. It is easiest to see the effect of the operation of (41) in the case of a message on which the smoothing operation (16) has not been employed. (It will be remembered that (16) need not be employed in the case of an upper side band, or upper asymmetric signal, provided that the original message envelope is free from discontinuities.) We consider then an envelope free from discontinuities; let each dot have a flat top, of amplitude L , duration $2t_1$, and straight sloping sides lasting $2\pi/\omega$ seconds.

The range $-\pi/\omega < \tau < \pi/\omega$ in the integral (41) can contribute to $\psi_{32}(t)$ an amount not exceeding

$$\frac{L}{2\pi} [1 + \epsilon^{-2}]; \text{ i.e. } \approx 0.181 \dots L. \quad (43)$$

This contribution is achieved when a certain part of the sloping side of a dot occurs at the instant t . The range $\pi/\omega < |\tau| < \pi/b$ can contribute not more than

$$\frac{L}{\pi} \int_{\pi/\omega}^{\pi/b} \frac{\cos^2 \frac{1}{2}b\tau}{\tau} d\tau. \quad (44)$$

(Since $\phi(t)$ has been chosen so as never to be negative, the inclusion in (44) of the range $-\pi/b < \tau < -\pi/\omega$ could only decrease (44)). (44) cannot exceed

$$\frac{L}{\pi} \left[\log \frac{\omega}{b} - \frac{1}{2}C_s(\pi) + \frac{1}{2}C_s\left(\frac{\pi b}{\omega}\right) \right]. \quad (45)$$

Adding all the contributions to the bound of $|\psi(t)|$; i.e. $\frac{1}{2}(38) + \frac{1}{2}(42) + (43) + (45)$, and neglecting $\pi b/\omega$ compared with unity, which will always be justifiable in practice, we obtain the remarkably simple result that for any message envelope, composed of dots and dashes of the type described, of bound L , when zero frequency has been removed in the prescribed manner during the construction of the equivalent quadrature envelope, the bound of the quadrature envelope satisfies the inequality

$$|\psi(t)| < L \left[\frac{1}{\pi} \log \frac{\omega}{b} + 0.079 \dots \right]. \quad (46)$$

Expression (46) is extremely important, for the difficulty of high power transmission depends not only on the average power, but on the crest amplitudes which it is necessary to transmit. It might be that although the power consumption was reasonable, the crest amplitudes associated with asymmetric transmissions would necessitate a fantastically large transmitter. We must therefore assign rough numerical values to ω and b . The shortest dot which we need consider occupies about 0.04 sec.: $2\pi/\omega = 0.004$ sec., therefore, seems not unreasonable. There does not seem to be any point in making $2\pi/b$ greater than the time taken by the transmitter to gain or lose one cycle, due to unavoidable variations of carrier frequency (the extent to which we encroach on the wanted or unwanted side band due to the suppression of low message frequencies in the quadrature envelope is then equal to the

practical uncertainty of the position of the edge of the side band). We have then $2\pi/b = \text{say } 3 \text{ sec.}$;

$$\frac{\omega}{b} = 750, \text{ and } |\psi(t)| < 2.11 \dots L. \tag{47}$$

Discussion of the precise practical significance of this figure will be deferred until corresponding expressions have been obtained for lower asymmetric transmission, for which it is necessary to employ the smoothing operation (16) on $\phi(t)$, together with some form of the convergence ensuring operation (23). We wish then to generalize (35) to include these operations. First, we must replace (35) by

$$\frac{1}{\pi} \int_{-\infty}^{\infty} [\phi(t - \tau) - \theta(t - \tau)] [1 - \cos \alpha\tau] \frac{d\tau}{\tau}, \tag{48}$$

or,

$$\frac{1}{\pi} \int_{-\infty}^{\infty} [\phi(t - \tau) \cdot [1 - \cos \alpha\tau] - \theta(\tau)] \frac{d\tau}{\tau}$$

—the two forms being equal, since $\theta(t)$ contains no frequency above b and $\cos \alpha\tau$, in the integrand, is without effect on frequencies lower than the lowest value $(a - a_1)$ which we shall give to α , and we shall assume that this value exceeds b .

We must then operate on (48) with (23). We shall set $\mathfrak{F}(\alpha) = \frac{1}{2} [1 + \cos \pi(\alpha - (a - a_1)/a_1)]$, $(a - a_1 < \alpha < a)$, a form which is not unreasonable, and has the merit of leading to convenient integrals. This gives for the smoothed quadrature envelope the expression

$$\frac{1}{\pi} \int_{-\infty}^{\infty} \left\{ \phi(t - \tau) \left[1 - \frac{1 \cos a\tau + \cos (a - a_1)\tau}{2 \cdot 1 - (a_1\tau)^2/\pi^2} \right] - \theta(t - \tau) \right\} \frac{d\tau}{\tau}. \tag{49}$$

The required generalization of (35) is thus that when all the smoothing operations in question have been performed, the smoothed quadrature envelope is given by, say $\sigma(t)$, =

$$\frac{1}{\pi} \int_{-\infty}^{\infty} \phi(t - \tau) \left[\frac{\cos^2 \frac{1}{2}b\tau}{1 - (b\tau)^2/\pi^2} - \frac{1}{2} \frac{\cos a\tau + \cos (a - a_1)\tau}{1 - (a_1\tau)^2/\pi^2} \right] \frac{d\tau}{\tau}. \tag{50}$$

We have,

$$\sigma(t) = \sigma_1(t) + \sigma_2(t) + \sigma_3(t) + \sigma_4(t) + \sigma_5(t) + \sigma_6(t) + \sigma_7(t)$$

where,

$$\sigma_1(t) = \frac{1}{\pi} \int_{\pi/b}^{\infty} + \frac{1}{\pi} \int_{-\infty}^{-\pi/b} \frac{\phi(t - \tau) \cos^2 \frac{1}{2}b\tau}{\tau(1 - (b\tau)^2/\pi^2)} \cdot d\tau \tag{51}$$

$$\sigma_2(t) = \frac{1}{\pi} \int_{\pi/a_1}^{\infty} + \frac{1}{\pi} \int_{-\infty}^{-\pi/a_1} \phi(t - \tau) \frac{[-\frac{1}{2} \cos a\tau - \frac{1}{2} \cos(a - a_1)\tau]}{\tau [1 - (a_1\tau)^2/\pi^2]} d\tau \quad (52)$$

$$\sigma_3(t) = \frac{1}{2\pi} \int_{-\pi/b}^{\pi/b} \phi(t - \tau) \left[\frac{b}{\pi} \frac{\cos^2 \frac{1}{2}b\tau}{(1 - b\tau/\pi)} - \frac{b}{\pi} \frac{\cos^2 \frac{1}{2}b\tau}{(1 + b\tau/\pi)} \right] d\tau \quad (53)$$

$$\sigma_4(t) = \frac{1}{2\pi} \int_{-\pi/a_1}^{\pi/a_1} \phi(t - \tau) \cdot \left[\frac{a_1 \cos a\tau + \cos(a - a_1)\tau}{2\pi [1 + a_1\tau/\pi]} - \frac{a_1 \cos a + \cos(a - a_1)\tau}{2\pi [1 - a_1\tau/\pi]} \right] d\tau \quad (54)$$

$$\sigma_5(t) = \frac{1}{\pi} \int_{\pi/a_1}^{\pi/b} + \frac{1}{\pi} \int_{-\pi/b}^{-\pi/a_1} \phi(t - \tau) \frac{\cos^2 \frac{1}{2}b\tau}{\tau} d\tau \quad (55)$$

$$\sigma_6(t) = \frac{1}{2\pi} \int_{-\pi a_1}^{\pi/a_1} \phi(t - \tau) \cdot \frac{\cos b\tau - 1}{\tau} d\tau \quad (56)$$

$$\sigma_7(t) = \frac{1}{2\pi} \int_{-\pi/a_1}^{\pi/a_1} \phi(t - \tau) \frac{(1 - \cos a\tau) + (1 - \cos(a - a_1)\tau)}{\tau} d\tau \quad (57)$$

We have the inequalities

$$|\sigma_1(t)| \geq \frac{2L}{\pi} [\gamma + \log \pi - \frac{1}{2}Cs(\pi) - \frac{1}{4}Cs(2\pi)]. \quad (58)$$

i.e., $\geq 0.183 \dots L$.

Substituting $|(1 + \cos a_1\tau)| + |\sin a_1\tau|$ in the range $2\pi/a_1$ to π/a_1 , and 2 in the range $\infty - 2\pi/a_1$, for $[(1 + \cos a_1\tau) \cdot \cos a\tau + \sin a_1\tau \sin a\tau]$ in (52) we get,

$$|\sigma_2(t)| < \frac{L}{\pi} [\frac{1}{2}(Cs(3\pi) + Cs(2\pi) - Cs(\pi)) + \frac{1}{2}(Si(3\pi) + Si(2\pi) - Si(\pi)) - \log 3] \quad (59)$$

i.e., $< 0.420 \dots L$

$$|\sigma_3(t)| \geq \frac{L}{\pi} [Cs(\pi) - \frac{1}{2}Cs(2\pi)] \quad (60)$$

i.e., $\geq 0.138 \dots L$.

By the same substitution as in (59) we get

$$|\sigma_4(t)| < \frac{L}{\pi} [Cs(\pi) + \frac{1}{2}Si(2\pi) - \frac{1}{2}Cs(2\pi)] \quad (61)$$

i.e., $< 0.363 \dots L$

$$|\sigma_5(t)| \cong \frac{L}{\pi} \left[2 \log \frac{a_1}{b} - Cs(\pi) + Cs \left(\frac{\pi b}{a_1} \right) \right] \quad (62)$$

$$|\sigma_6(t)| \cong \frac{L}{\pi} \left[Cs \left(\frac{\pi b}{a_1} \right) \right] \quad (63)$$

$$|\sigma_7(t)| \cong \frac{L}{\pi} \left[Cs \left(\frac{\pi a}{a_1} \right) + Cs \frac{(a - a_1)}{a_1} \right]. \quad (64)$$

Inequalities (58)–(64) hold for general values of b , a_1 , and a , and for any original envelope $\phi(t)$. Note that in the case of the inequalities (59) and (61), the L.H.S. can never attain the values given in the R.H.S. It has not proved practicable to determine the bounds of $|\sigma_2(t)|$ and $|\sigma_4(t)|$. In the special case when $\phi(t) \leq 0$, the right-hand sides of (58)–(64) may all be divided by 2.

We now want some information regarding the values which should be assigned to a_1 and a ; we shall, therefore, consider the effect of the smoothing operations (16) and the form of (23) already chosen, on the envelope $\phi(t)$, since the thus smoothed $\phi(t)$ —say $\xi(t)$ —forms the envelope of a part of the wave which we must radiate. It will readily be verified that operations (16) and (23) with

$$\mathcal{F}(\alpha) = \frac{1}{2} \left[1 + \cos \pi \left(\frac{\alpha - a - a_1}{a_1} \right) \right], \text{ on } \phi(t) \text{ give}$$

$$\xi(t) = \frac{1}{\pi} \int_{-\infty}^{\infty} \phi(t - \tau) \cdot \frac{1}{2} \left[\frac{\sin a\tau + \sin(a - a_1)\tau}{\tau(1 - (a_1\tau)^2/\pi^2)} \right] \cdot d\tau. \quad (65)$$

Set $\xi(t) = \xi_1(t) + \xi_2(t)$ where

$$\xi_1(t) = \frac{1}{\pi} \int_{2\pi/a_1}^{\infty} + \frac{1}{\pi} \int_{-\infty}^{-2\pi/a_1} \phi(t - \tau) \cdot \frac{1}{2} \left[\frac{\sin a\tau + \sin(a - a_1)\tau}{\tau(1 - (a_1\tau)^2/\pi^2)} \right] \cdot d\tau \quad (66)$$

$$\xi_2(t) = \frac{1}{\pi} \int_{-2\pi/a_1}^{2\pi/a_1} \phi(t - \tau) \cdot \frac{1}{2} \left[\frac{\sin a\tau + \sin(a - a_1)\tau}{\tau(1 - (a_1\tau)^2/\pi^2)} \right] \cdot d\tau. \quad (67)$$

We have the inequality

$$|\xi_1(t)| < \frac{L}{\pi} \log \frac{4}{3}, \text{ i.e., } < 0.0916 \dots L. \quad (68)$$

Both $\xi_1(t)$ and $\{\xi_2(t) - \phi(t)\}$ can be seen to become $0(a)^{-1}$ as a is increased without limit. It follows that whatever value we choose for a_1 it is possible to choose a value of a such that for any message $\xi_2(t) - \phi(t) \rightarrow 0$. But we are interested in securing a close resemblance be-

tween $\xi(t)$ and $\phi(t)$ —so that $\xi(t)$ may be recorded as $\phi(t)$ would be, by a simple relay,—with as small a value of a as is possible. It seems reasonable then so to choose a_1 that the time given by $2\pi/a_1$ is at least as long as the duration of a space ($2t_1$). Now choose a such that the smoothed wave, $\xi(t)$ corresponding to a single dot or dash, of any required duration, is not unduly distorted. The rest of the message—which may be infinite both ways—cannot add to the smoothed dot more than $\pm 0.0916 \dots L$. The shape of the smoothed single dot can be ascertained from (65) or, with error not exceeding $0.0916 \dots L$, from (67). If we assume a rectangular dot, lasting from $-t_1$ to $+t_1$, (65) gives a somewhat complicated expression, involving 12 sine integrals and 8 cosine integrals; we can however ascertain the general nature of the wave form in question, by mentally cascading operations (16) and (23) on the rectangular dot. That is, we think of

$$\xi(t) = \int_{a-a_1}^a L \sin \pi \frac{(\alpha - a + a_1)}{a_1} (Si(\alpha(t + t_1)) - Si(\alpha(t - t_1))) d\alpha \quad (69)$$

The shape of this wave, for values of $|t|$ not too great compared with t_1 is some sort of mean between $L/\pi Si\{a(t+t_1)\} - L/\pi Si\{a(t-t_1)\}$ and $L/\pi Si\{(a-a_1)(t+t_1)\} - L/\pi Si\{(a-a_1)(t-t_1)\}$; that is, if $(a-a_1)/a$ is nearly unity, the amplitude is small outside $\pm t_1$; approximately L inside $\pm t_1$, rises to not more than $2L/\pi Si(\pi) = 1.178 \dots L$, near $t_1 - t = +\pi/a$; $-t_1 - t = -\pi/a$, and falls not farther than $L/\pi [Si(3\pi) - Si(\pi)] = -0.0563 \dots L$ near $t_1 - t = -\pi/a$; $-t_1 - t = \pi/a$.

The shortest dot we need consider lasts about 0.04 sec., if we assume $2\pi/a = 0.004$ sec. our smoothed dot may for the purpose of recording, be considered undistorted. $2\pi/a_1$ we shall take equal to the duration of a space (0.04 sec.), and, as before, $2\pi/b = 3$ sec.

We can now return to inequalities (58)–(64), assuming $\phi(t) \leq 0$ (e.g., rectangular envelope, amplitude $+L$ or zero). We have then

$$|\sigma(t)| < 0.552 \dots L + \frac{L}{2\pi} \left[2 \log \frac{a_1}{b} + Cs\left(\pi \frac{a}{a_1}\right) + Cs\left(\pi \frac{a - a_1}{a_1}\right) - Cs(\pi) + 2Cs\left(\frac{\pi b}{a_1}\right) \right]. \quad (70)$$

Noting that $Cs(x) \sim \gamma + \log x + 0(x^{-1})$, and neglecting $a_1/\pi a$, and $\pi b/a_1$ in comparison with unity, we have

$$|\sigma(t)| < 0.552 \dots L + \frac{L}{\pi} \left[\frac{\gamma}{2} + \log \pi + \log \frac{\sqrt{a(a - a_1)}}{b} \right],$$

i.e., $< 2.052 \dots L$. (71)

We can now consider the crest amplitudes involved in the suggested forms of asymmetric signals. On the one hand we have the double side band wave, $\phi(t) \cos (pt + \eta)$, crest amplitude L ; on the other hand we have, in the case where we encroach to an extent b on the unwanted side band,

$$\phi(t) \frac{\cos (pt + \eta)}{2} - \psi(t) \frac{\sin (pt + \eta)}{2} \tag{72}$$

(upper asymmetric signal unsmoothed except to get convergence).

Or,

$$\xi(t) \frac{\cos (pt + \eta)}{2} + \sigma(t) \frac{\sin (pt + \eta)}{2} \tag{73}$$

(smoothed lower asymmetric signal).

Since ϕ, ψ, ξ, σ , maintain values near their bounds for periods long compared with $2\pi/p$, we must take as the crest amplitudes of the two transmissions the bound of

$$\left. \begin{array}{l} \frac{1}{2}\sqrt{[\phi(t)]^2 + [\psi(t)]^2} \text{ (upper asymmetric signal)} \\ \frac{1}{2}\sqrt{[\xi(t)]^2 + [\sigma(t)]^2} \text{ (lower asymmetric signal)} \end{array} \right\} \begin{array}{l} \text{each encroaching} \\ b \text{ radians/sec.} \\ \text{(say, } \frac{1}{3} \text{ cycle)} \\ \text{on the spectral} \\ \text{range of the} \\ \text{other.} \end{array} \tag{74}$$

$\phi(t)$ (original double side band transmission).

or,

$$\frac{L}{2}\sqrt{1 + 2.11^2} = 1.168 \dots L \text{ (u.s.b.)} \tag{a}$$

$$\frac{L}{2}\sqrt{1.178^2 + 2.052^2} = 1.183 \dots L \text{ (l.s.b.)} \tag{b} \tag{75}$$

$$\{\phi(t)\} = L. \tag{c}$$

It is necessary now to ascertain the respective merits of the asymmetrical and double side band transmissions as regards the signal: atmospheric ratio at the receiver. We shall consider an "ideal" homodyne receiver, in which the incoming wave is first subjected to a preliminary selective operation, in which constituent frequencies lying outside a certain range are removed, and the resulting amplitude is then multiplied by the amplitude of the cophased homodyne, $\cos(pt + \eta)$, after which frequencies exceeding a are removed from the product.

The principle of superposition holds for such a receiver. We wish to pass unchanged to the homodyne all constituent frequencies of the signal corresponding to message frequencies lower than a ; the receiver must, therefore, have uniform sensitivity over the range $p-b < q < p+a$, or $p-a < q < p+b$ for the asymmetrical signals (75a) or (75b), or over the range $p-a < q < p+a$ for the double side band signal (75c). We may not, however, assume that the sensitivity drops discontinuously to zero at the end of the required range, as this may, and in general would, render divergent the "message" of the atmospherics, since the atmospheric spectral amplitude will not in general be zero at $p \pm b$ or $p \pm a$. In fact, if atmospherics occur, on the average, at a steady rate, it is possible to specify a time such that there is a finite probability that the spectral amplitude, at a previously given frequency, of the totality of atmospherics that occur during the said time, will exceed any given value. When the given frequency is not zero, the time in question becomes proportional to the square of the given amplitude, as that is increased indefinitely. The range over which the receiver has finite sensitivity must therefore exceed the range over which it is desired to receive signal frequencies with uniform sensitivity. The phase difference between the two contributions to constituent frequency ζ in the final output of the receiver, due to constituent frequencies $p-\zeta$, $p+\zeta$, in the atmospheric, depends on the phasing of the homodyne at some part of the atmospheric wave which may be chosen as a time zero. Further, if, as is undoubtedly the case, all phasings of the homodyne may be considered equally probable, all phase differences between the two contributions to constituent output frequency ζ must be regarded as equally probable. If then we take the energy (time integral of square of amplitude) as a measure of the virulence of an atmospheric, and suppose that, on the average, the atmospheric spectral energy density is constant over the range of frequencies to which the receiver is sensitive, we may regard the area of the square of amplitude resonance curve of the receiver as a measure of the atmospheric interference. If then we made the frequency range over which the receiver sensitivity falls from its steady crest value, to zero, small compared with the range over which it is constant, we could say that if the atmospheric energy received by the double side band receiver is $2a$, that received by the single side band receiver is $a+b$, (we may neglect b in comparison with a). But it seems necessary to postulate that the receiver sensitivity should fall to zero in a frequency range of the order of a_1 , in order that the atmospheric amplitude, at time t , after the selective operation, but before multiplication by $\cos(pt+\eta)$, should exhibit a definitely limited dependence on the bound of atmospheric amplitude for times more re-

mote than $2\pi/a_1$. If we employ the particular cut-off $\mathcal{F}(q) = \frac{1}{2} [1 + \cos \pi q/a_1]$, over a range of q of extent a_1 , a result precisely analagous to (68) holds. It would seem fair, then, to assess the received atmospheric energies as proportional to

$$\left. \begin{aligned} 2a + \frac{3}{4}a_1 \text{ (double side band)} \\ a + b + \frac{3}{4}a_1 \text{ (asymmetrical signal)} \end{aligned} \right\} \quad (76)$$

– the factor $\frac{3}{4}$ being twice the average of $\left[\frac{1}{2} \left[1 + \cos \frac{\pi q}{a_1} \right] \right]^2$.

Regarding the relative energies expended in the two kinds of signal, it may be verified that the contributions associated with constituent frequencies lying in the range $b < |p - q| < a$, from the single side band wave $\frac{1}{2}\xi(t) \cdot \cos(pt + \eta) \pm \frac{1}{2}\sigma(t) \sin(pt + \eta)$ are exactly half the contribution, from the same range, to the energy of the double side band wave $\xi(t) \cos(pt + \eta)$. For a single dot (of duration essentially less than $2\pi/b$ seconds) these contributions constitute nearly the whole of the energy of the single side band wave. For a message of duration sufficiently long compared with $2\pi/b$ seconds, a fraction of the total energy given by the square of the average amplitude divided by the average of the square of the amplitude is associable with a very small frequency range, δ , infinitely close to p . For a rectangular Morse envelope, this fraction can rise to $\frac{3}{4}$ (message consisting of dashes alone, with dot spaces): it will normally be somewhat smaller, and we shall take it to be $\frac{1}{2}$. $\sigma(t)$ contributes nothing to the energy associated with frequencies infinitely close to p : this energy, for the given single side band wave is therefore one-quarter of the corresponding contribution for the D.S.B. wave; i.e., 1/8th of the whole energy of the double side band wave. The part of the total energy associable with the rest of the range $\delta < |p - q| < b$ will in general be small compared with that associable with the range $b < |p - q| < a$.

We may now compare messages (75 b) and (75 c). The units are arbitrary.

(75c) – D.S.B. (smoothed for $q > a$)

(75b) – asymmetrical
(smoothed)

| | | |
|---|-----------------------|--|
| Average Power | 1 | $\frac{5}{8}$ |
| Crest Amplitude | 1 | 1.183 |
| Amplitude of homo- dyned signal | 1 | $\frac{1}{2}$ |
| Average atmospheric received energy. | $2 + \frac{3a_1}{4a}$ | $1 + \frac{3a_1}{4a} + \frac{b}{a}$ (77) |

b/a we can neglect: the value previously assumed (0.1) for a_1/a is not unreasonable.

We conclude, then, that using the asymmetrical side band transmission in which we trespass to a small extent (say 1/3 cycle) on the unwanted side band, if we wish to achieve the same ratio of signal to atmospheric at the receiver, it will be necessary to use about 30 per cent more power than is used in double side band transmission, and the asymmetrical side band transmitter must be capable of handling crest amplitudes $\sqrt{1.3} \times \sqrt{2} \times 1.183$ times greater—say 90 per cent greater than the crest amplitude of the double side band transmission. We shall see, shortly, that it is desirable, if not essential, to radiate a small steady carrier with the asymmetric transmission: the above figures must therefore be increased to about 40 per cent more power and 100 per cent more crest amplitude than are used in the double side band case.

5. PRODUCTION OF THE QUADRATURE ENVELOPE

One way of realizing an approximation to an upper or lower asymmetric signal would be to modulate, with the desired message envelope, an oscillator of suitable low frequency, filter out the unwanted side band, and heterodyne the resulting asymmetric or single side band message to the desired final carrier frequency. It may be that this would be the best practical procedure. But it is natural to inquire whether a physical system can be devised which will perform an approximation to the quadrature operation, so that we could construct the asymmetric wave by modulating with the message envelope a carrier frequency oscillator, and adding to the output thereof that of a quadrature carrier frequency oscillator modulated by the equivalent quadrature envelope.

An approximation to the desired operation can be obtained with the aid of a cable, of low attenuation and sufficiently long transit time, suitably terminated, for we can thus obtain from $\phi(t)$, $\phi(t-n\tau)$, and picking out this response at various points on the cable, with suitable amplitude, we can get (disregarding a T -sec. delay)

$$\sum_{n=1}^{\lceil T/\tau} \frac{\phi(t-n\tau) - \phi(t+n\tau)}{n\tau}$$

that is, we can construct a circuit having a (delayed) response function

$$Y(q) = i \cdot 4/\pi \sum_{n \text{ odd}}^{\lceil T/\tau} (\sin(nq\tau))/n.$$

If we suppose that frequencies exceeding a have already been removed from the message envelope, we may set $\tau = \pi/a$, and $T = N\pi/a$: the approximation to the quadrature operation achieved by the system

is representable by the approximation to unity achieved by $4/\pi \sum_{n=1}^N$ ($\sin \pi nq/a$)/ n ($0 < q < a$). It would seem desirable to include values of n up to the integer nearest to a/b : the transit time of the cable would then be $2\pi/b$, (3 sec.), and the production of the quadrature envelope would be delayed $1\frac{1}{2}$ sec. It would of course be necessary to delay the message envelope by the same time before the modulating operation; this could be done on the same cable. The most disconcerting thought about this method of realizing the quadrature envelope is that the values previously assumed for a and b imply 1500 tapings on the propagating system! The quadrature operation might even be carried out on an elastic system, on which mechanical waves were propagated; possibly such a system could be more easily constructed to deal with the low frequencies in question.

Alternatively, the production of approximations to the quadrature envelope might be tackled by using nonlinear mechanism; if we are prepared to use dots and dashes of standard duration, it is clear that the problem can be reduced to that of cutting the wave forms of dots, dashes, and their approximate equivalent quadrature forms on the profiles of certain cams.

6. ON HETERODYNING BEFORE DETECTION

As was pointed out in Section 2, the smoothed wave shape of the original dot may be formally recovered by multiplying the single side band (or asymmetrical) wave by a homodyne cophased with the original carrier, and removing frequencies above p . If the homodyne is quadphased, the wave shape obtained is that of the quadrature envelope. Other phasings produce a linear compound of the original and quadrature envelopes. It was further pointed out, in expression (19), Section 3, that the original and equivalent quadrature envelopes were reciprocally related, and (with a change of sign) were formally interchangeable. It follows that a single side band wave does not uniquely determine its generating wave shape unless the carrier phasing is specified, and though it would appear that, excluding the case of an unbounded generating wave, an asymmetrical signal of the type described does uniquely determine its generating wave and carrier phasing, it does not seem practicable to effect the determination at the receiver. We must therefore lay down the restriction that the receiving homodyne shall be cophased, and the transmitter must therefore radiate a steady carrier of sufficient amplitude to "lock" in phase the receiving homodyne. This carrier may of course be received on a receiver having far greater selectivity than that used to receive the

signal. It would probably suffice if the carrier amplitude were 10 per cent of the r-m-s signal amplitude, involving an extra expenditure of power during "marking" of not more than 21 per cent and during spacing of not more than 1 per cent—say, on the average 10 per cent—of the power put into the signal itself.

Now it would be very desirable to heterodyne the signal before detection, and to perform some of the selection after heterodyning. But it is necessary to homodyne finally with exactly the right frequency and phasing. The only way to insure the maintenance of phasing of the final homodyne is to employ a scheme in which the homodyne frequency controls the heterodyne frequency, or vice versa. Thus, one receives the carrier, $\cos(pt + \eta)$ on an exceedingly selective receiver, and uses it to hold an oscillator in this phasing. The output of that oscillator is heterodyned with a second oscillator, $\cos(qt + \theta)$, and the result, $\cos(p - qt + \eta - \theta)$ is used to heterodyne the signal "to frequency q " in the ordinary meaning of the phrase. Selection is then performed "at intermediate frequency q " and the oscillator $\cos(qt + \theta)$, is used as final homodyne. It can readily be verified that provided q does not vary enough to influence the q -frequency selection, the frequency q and the phasing θ are without influence on the final result. Successive heterodyning and selection at several successive frequencies may be done by an extension of the method. It would, of course, be essential to have a phase shifter in the amplifier used to lock the p -frequency homodyne, but this adjustment would not depend on the adjustment of the q -frequency oscillator.

We have thus outlined a physically realizable system, by which messages smoothed by the abolition of frequencies above a may be conveyed in a spectral range of width $a + b$ (where b may be very small compared with a) in such a manner that the smoothed wave shape is recovered at the receiver after a delay T , with an error which can be made vanishingly small if T is sufficiently great. The method involves the use of perhaps 40 per cent more power, and 100 per cent higher crest amplitudes than normal double side band transmission; it also involves the difficulty of a cophased homodyne at the receiver; moreover, normal aural heterodyne reception would appear to be precluded.

These, or similar disadvantages, it would appear, are the price that we must pay for the relief of telegraphic spectral congestion.

It will be realized that the preceding discussion, in so far as it relates to the transmission and distortionless reception of an arbitrary "message" is applicable not only to Morse signaling, but also both to simple and kinematic facsimile transmission.

7. TWO MORSE MESSAGES ON ONE CARRIER

It is perhaps natural to inquire into the properties of a transmission scheme in which two double side band messages are radiated on the same carrier frequency and phasing, the one being a normal symmetrical double side band message, and the other being an antisymmetrical double side band message (i.e., having one side band reversed in sign). It will be clear from the preceding discussion that the "abnormal" double side band message is a normal double side band transmission of an "abnormal" envelope (equivalent quadrature envelope) on a quadphased carrier. It is possible to regard the differentiation between the two messages at the receiver as achievable by the $\pi/2$ difference in carrier phasing, or by the difference in envelope shape.

If we take the former view, it is not easy to see any reason for using the "abnormal" "equivalent quadrature shape" for the second message. If we use the same shape for the two messages, the scheme then reduces itself to the sending of two normal double side band messages in carrier quadrature (radiating also a small steady carrier to determine the homodyne phasing). This is, in fact, a transmission scheme worthy of trial. If, on the other hand, we feel that the difference in envelope shape, apart from carrier phasing, provides a basis for differentiation, there would seem to be no reason for sending the messages in carrier quadrature. And thus we are led to the question: Can a relay-system be devised which will distinguish between an envelope and its equivalent quadrature shape, and continue to make the distinction when these envelopes are repeated at irregular intervals?

Without further restriction, the mathematician would perhaps be tempted to answer "Yes". But for the question to be pertinent to the problem of signaling, it is necessary to lay down the restriction that the relays of the receiving system are capable of only a finite accuracy; that the scale (fading and receiver amplification) of the message may not remain absolutely constant, and that the envelope has been deprived of high frequencies to such an extent that the thus restricted receiver can only just record it correctly in any case. With these restrictions we are probably justified in a negative answer. The problem is also of direct interest to cable telegraphists, and we may safely leave it to them to say the final "No."

For one thing, they have more money at stake.

ACKNOWLEDGMENT

The author desires to thank the Metropolitan-Vickers Electrical Company Limited for permission to publish this analysis,

Bibliography

H. B. Nyquist, "Certain topics of telegraph transmission theory," presented before Winter Convention, A.I.E.E., February, 1928; in abridged form, *Jour. A.I.E.E.*, p. 214, March, 1928.

H. B. Nyquist, U. S. Patent, No. 1,748,186.

J. R. Carson, "Selective circuits and static interference," *Jour. A. I. E. E.*, 1145; December, 1924; *Bell Sys. Tech. Jour.*, IV, 265, 1925.

A. Koerts, "Atmosphaerische Störungen in der drahtlosen Nachrichtenübermittlung," *Hochfrequenz.*, I,

C. R. Burch and Ir. J. Bloemsma, "An application of the periodogram to wireless telegraphy," *Phil. Mag.*, 49, No. 290, February, 1925. and *T. S. F.*

E. T. Whittaker and G. N. Watson, *A Course of Modern Analysis*, 4th Ed. Cap. IV, VIII., IX, et al.



SECOND MEETING OF THE INTERNATIONAL TECHNICAL CONSULTING COMMITTEE ON RADIO COMMUNICATION, COPENHAGEN, 1931*

Summary—The twenty-one opinions which were unanimously approved at the 1931 C.C.I.R. meeting are given together with fourteen questions for consideration at the third meeting to be held in Lisbon, Portugal, at a time to be specified later. A list of the members of the U. S. delegation is included.

THE International Technical Consulting Committee on Radio (C.C.I.R.) was established by the International Radiotelegraph Convention, Washington, 1927, for the purpose of studying technical and related questions pertaining to radio communication. Its first meeting was held at The Hague in September, 1929.¹ At this meeting a number of recommendations were made² and certain questions to be studied and considered at the second meeting were proposed.

The second meeting was held in Copenhagen, Denmark, in June, 1931, and was attended by representatives³ of 38 governments and 38 operating companies.

* Decimal classification: R007.9 Manuscript originally received by the Institute, August 24, 1931.

¹ S. C. Hooper, "The Hague Conference," *Proc. I.R.E.* 18, 762; May, 1930.

² "Recommendations of the International Technical Consulting Committee on Radio Communication," *Proc. I.R.E.* 18, 775; May, 1930.

³ The delegation from the United States of America was comprised of the following members:

Delegates

Senator Wallace H. White, Jr., Chairman
Dr. J. H. Dellinger, Bureau of Standards, Department of Commerce
Dr. C. B. Jolliffe, Federal Radio Commission

Technical Assistants

Dr. Irvin Stewart, Department of State
Mr. Gerald C. Gross, Federal Radio Commission
Lieut. Comdr. E. M. Webster, U. S. Coast Guard, Treasury Department
Lieut. Comdr. J. R. Redman, U. S. Navy
Lieut. W. T. Guest, U. S. Army
Lieut. T. H. Maddocks, U. S. Army
Dr. C. G. Mellwraith, Bureau of Standards, Department of Commerce

Technical Adviser

Maj. K. B. Warner, American Radio Relay League

Secretary of Delegation

Mr. Vinton Chapin, Foreign Service Officer

Representatives of Private Operating Companies

Mr. Paul Goldsborough, Aeronautical Radio, Inc.
Mr. H. H. Buttner, All America Cables, Inc., and International Telephone and Telegraph Corporation.
Mr. Lloyd Espenschied, Mr. L. E. Whittemore, and Dr. William Wilson, American Telephone and Telegraph Company

The opinions, which were unanimously adopted, and the questions to be studied and considered at the third meeting to be held in Lisbon, Portugal, at a date to be announced later, are given below. For convenience they are preceded by an index listing the subjects covered in each item⁴:

OPINIONS ADOPTED

- 30 Time limit for submitting questions for meetings of the C.C.I.R.
- 31 Sendings of proposals and new questions, by May 1, 1932.
- 32 Time limit and procedure for submitting proposals for meetings of the C.C.I.R.
- 33 Publication of the opinions of the C.C.I.R. for the Madrid Conference.
- 34 Organization of commercial radiotelephony between mobile stations and the land network.
- 35 Coördination of fixed station radiotelephony with wire telephony.
- 36 Extension of radiotelephone connection under unfavorable radio conditions.
- 37 Frequency list to be published by International Bureau.
- 38 Precision of expression of frequency and wavelength.
- 39 Separate call signal for each frequency in fixed service.
- 40 Definition of power of a transmitter.
- 41 Station frequency tolerances.
- 42 Methods of comparing national frequency standards.
- 43 Accuracy of station frequency meters.
- 44 Reduction of interference in the bands of frequencies shared by fixed and mobile service.
- 45 Constancy of station frequency.
- 46 Limitation of nonessential emissions.
- 47 Side-band suppression.
- 48 Limitation of harmonics.
- 49 Limitation of overmodulation.
- 50 Suppression of spacing waves in arc transmitters.

QUESTIONS REMAINING FOR THIRD MEETING OF C.C.I.R.

- 1 Organization regulations of the C.C.I.R.
- 2 Participation of international organizations in the C.C.I.R.

Mr. Ralph M. Heintz, Globe Wireless, Ltd.

Mr. Haraden Pratt, International Telephone and Telegraph Corporation
 Colonel Samuel Reber and Mr. Loyd A. Briggs, Radio Corporation of America
 and Radiomarine Corporation of America

Mr. A. J. Costigan, Radiomarine Corporation of America

⁴ The numbers 1 to 29 inclusive were used to designate the opinions adopted at the first meeting of the C.C.I.R., held at The Hague, in 1929. *See Proc. I.R.E.*, 18, 775; May, 1930.

- 3 Working of a mobile station accurately on the frequency of a land station.
- 4 Allocation of bands of frequencies.
- 5 Study of harmonics.
- 6 Reduction of electrical interference.
- 7 Selectivity and frequency stability of radio receivers.
- 8 High-frequency calling frequencies.
- 9 Modulated telegraph transmission.
- 10 Key clicks.
- 11 Standard frequency transmissions.
- 12 Measurement of noise.
- 13 Radiotelephony between small ships and land stations.
- 14 Telephony with moving trains.

Opinions Adopted at the Second Meeting of the C.C.I.R.

OPINION NO. 30

*Time limit fixed for sending proposals for
the meetings of the C.C.I.R.*

The C.C.I.R.,

recognizing

the necessity of establishing definite time limits for the forwarding of proposals to be discussed in its meetings,

expresses the opinion

that no question may be included in the program of a meeting of the C.C.I.R. unless it has been forwarded to the organizing administration at least three months before the date of the meeting.

OPINION NO. 31

*Forwarding of proposals concerning questions
not solved and new questions*

The C.C.I.R.,

considering

1. that the next meeting of the C.C.I.R. will take place after the Madrid Conference, and
2. that all questions proposed should be submitted to the Madrid Conference,

expresses the opinion

that the questions recorded at the closing of this meeting, in the list of questions to be solved, should be handled as soon as possible by the centralizing administrations with the collaboration of the interested administrations and private enterprises. All the proposals which are ready before May 1, 1932, and all new questions which it is possible to

propose before that date, will be forwarded to the International Bureau to be communicated to all the interested administrations and private enterprises.

OPINION NO. 32

*Normal procedure for forwarding reports
on questions to be studied*

The C.C.I.R.,

recognizing

that it would be useful to provide rules for the exact determination as to whom reports must be sent concerning questions to be studied, expresses the opinion

that when the study of a question has been entrusted to a centralizing administration, it is to this administration that all administrations and organizations must directly send a copy of their report on this question, five months before the date of the meeting of the C.C.I.R., in order that the said administration may take them into account in its report and in its proposals. The administrations and organizations are free, of course, to send also a copy of their report to the International Bureau, if they wish these reports to be communicated immediately and separately to all interested administrations and companies.

OPINION NO. 33

*Proposals of the C.C.I.R. for the International
Radiotelegraph Conference of Madrid*

The C.C.I.R.,

not being able to reach an agreement as to whether it may itself present drafts of modifications to the International Radiotelegraph Regulations on the basis of opinions it has expressed,

suggests

that the opinions, expressed in the present meeting of the C.C.I.R., should be brought, before July, 1931, to the knowledge of all administrations and companies by the International Bureau. The said Bureau is requested to include the opinions issued by the two sessions of the C.C.I.R. (The Hague, 1929, and Copenhagen, 1931), as an appendix in the Book of Proposals for the World Conference of Madrid.

OPINION NO. 34

*Organization of a commercial radiotelephone service between
mobile stations and the land network*

The C.C.I.R.,

considering

that it is possible to organize a commercial radiotelephone service between mobile stations and the land network, and

that the data now available permit the indication with some accuracy of the technical and operating conditions necessary for the carrying on of this service,

expresses the opinion

that it is desirable that this service be established and operated in conformity with the recommendations contained in Annex I given hereafter.

ANNEX I

Recommendations relating to the organization of a commercial radio-telephone service between mobile stations and the land network

1. As a general rule, carrier waves between 3000 and 23,000 kc (100 to 13 m) will be used; in near-by zones, carrier waves between 1500 and 3000 kc (200 to 100 m) may also be used.

2. In cases where the ground wave is used rather than the reflected wave, it will generally be favorable to place the land station in the neighborhood of the sea.

3. Land transmitters should have as great a power as possible. On the other hand, for ship transmitters it is recommended not to exceed, in telephony, a power of the order of 2 kw, so as to maintain within permissible limits the action of the transmitter upon the ship station receivers.

4. On land, as far as possible, directive antennas will be used for transmission and reception. It is desirable that the beam angle of these antennas be as small as the service of the stations will allow. It will sometimes be possible to reduce the number of antennas necessary on board ships by selecting types which permit the use of several frequencies per antenna, for transmission as well as for reception (for instance, simple dipoles).

5. It is particularly important, in this service, to confine the frequency variations of the land station in conformity with Opinion No. 41. These limits also apply to ship stations.

6. The time necessary for making a change of wave in ship and land stations should be as short as possible; this time should not exceed 5 minutes.

7. Ship receivers should have great sensitivity and great selectivity, and they must be provided with devices to compensate for the phenomena of fading. In ship stations using an antenna of a simple type and for zones in which the intensity of the field received is of from 20 to 5000 microvolts per meter, it is necessary and possible to insure a suitable and sufficiently constant voice level. It is desirable that, for fre-

quencies between 250 and 2750 cycles, the receiver possess a practically horizontal characteristic.

8. In the present state of the art, it is necessary to place the receiving and the transmitting antennas as far apart as possible on board ships.

9. It is important to avoid, as much as possible, interference caused by the action of the transmitting carrier wave upon the receivers, as well as those resulting from electrical strays on board ships.

10. For a ship installation, it will often be sufficient to use an installation in which the phones and the microphone are separated; on the other hand, on land, it is recommended to apply all the means used in long-distance point-to-point radiotelephone service, the purpose of which is to prevent the generation of echo effects and the passing of noises from the receiver to the land transmitter. When the service is carried on in a near-by zone, it may in that case be possible to dispense with any voice-operated device.

11. In the case where two different carrier frequencies are used for the two directions of a connection, it is desirable that these frequencies be not too far separated from each other. At least three pairs of frequencies should, therefore, be assigned to each land station for communication with ship stations. In general, each ship station should have available, at a given time, a number of pairs of frequencies equal to the number of land stations with which it wishes to communicate. For the use of these various frequencies, a schedule must be established taking into account the distance, the hour, and the season.

12. The distribution of frequencies should be made in such a way that interference between telephony and telegraphy is minimized. For that purpose, it appears desirable to place, in a definite band (mobile band, band shared by fixed and mobile services, and, in the case where a mobile band is adjacent to such a shared band, these two adjacent bands taken together), the frequencies assigned to land stations for telegraph and telephone services in the center of this band, and the frequencies used on board ship at the extremities of this band, that is, the frequencies of the telegraph service at the low-frequency end, and the frequencies of the telephone service at the high-frequency end.

The minimum separation between frequencies should, as far as possible, be as follows:

| Services | Minimum separation between frequencies |
|--|--|
| Ship telephony to coast station telephony..... | 3 per cent |
| Ship telephony to ship telegraphy..... | 3 per cent |
| Ship telephony to coast station telegraphy..... | 3 per cent |
| Coast station telephony to ship telegraphy..... | 3 per cent |
| Coast station telegraphy to ship telegraphy..... | 1 per cent |
| Coast station telephony to coast station telegraphy..... | 0.5 per cent |
| Ship telegraphy to ship telegraphy..... | 0.4 per cent |

In the case where a single frequency is used for both directions of a radiotelephone connection, this frequency should be selected among the frequencies permissible for ship stations in accordance with the above indications.

13. The maximum band widths necessary per telephone channel to carry on an efficient service are approximately the following, for the different values of the carrier frequency:

| Carrier frequencies in kc | Maximum width of the communication band in kc | Maximum frequency tolerance in kc ¹ | Interference guard band in kc | Maximum total width of the telephone channel in kc ² |
|---------------------------|---|--|-------------------------------|---|
| 3000 | 6 | 2.4 | 2.0 | 10.4 |
| 4000 | 6 | 3.2 | 2.0 | 11.2 |
| 6000 | 6 | 4.8 | 3.0 | 13.8 |
| 8000 | 6 | 6.4 | 4.0 | 16.4 |
| 13000 | 6 | 10.4 | 6.0 | 22.4 |
| 17000 | 6 | 13.6 | 8.0 | 27.6 |
| 22000 | 6 | 17.6 | 10.0 | 33.6 |

¹ Tolerances have been fixed by Opinion No. 41 of the C.C.I.R., that is, for land stations in the range between 1500 and 23,000 kc, 0.04 per cent.

² It is desirable to work within narrower limits.

14. It must be understood that the above recommendations apply, in the intention of the C.C.I.R., to passenger vessels provided with installations that are sufficiently efficient so that the administrations or companies concerned may admit them to enter into communication with the stations of their public network.

ANNEX II⁵

Résumé Prepared by the German Administration Based on the Reports of the Other Administrations and the Experiences in Germany Concerning the Organization of a Commercial Radiotelephone Service Between the Mobile Stations and the Land Network.

1. This annex consists of a document set up by the German administration, centralizing the answers from various administrations and companies to Question 1 of the program for the second meeting of the C.C.I.R., and is not reproduced here because of its length.

⁵ This Annex, is given in full in the Book of Opinions of the Second Meeting of the C.C.I.R., Copenhagen, 1931, published by the International Bureau of the Telegraph Union, Berne, Switzerland. The recommendations of the C.C.I.R. given in Annex I have been based upon Paragraph F of this document. However, they have been given a more general and more flexible form in order to take into consideration certain technical possibilities which under certain circumstances might prove to be beneficial.

OPINION NO. 35⁶*Coördination of radiotelephony between fixed stations
with telephony over the land network*

The C.C.I.R.,

considering

1. that the question of coördination of radiotelephony between fixed stations with telephony over the land network has already been studied by the C.C.I. Telephone, which has already given it an answer in its plenary meeting of Brussels, 1930,
 2. that at present there is nothing to add to the opinion expressed by the C.C.I. Telephone,
- is in agreement with the following opinion⁷ expressed by the C.C.I. (Telephone), in its plenary meeting at Brussels (June, 1930).

OPINION NO. 36

*Extension of a radiotelephone connection in case of
unfavorable radio conditions*

The C.C.I.R.,

considering

1. that the annex to Opinion No. 29 of the C.C.I.R. on the subject of coördination of telephony by wire and radiotelephony contains the following phrase:

"It should be observed that in case of unfavorable radio conditions, it may be necessary to abandon the normally possible extension of radiophone connection by wire connections."

and that an administration proposed the modification of that phrase to the end that, in case of unfavorable radio conditions, it would be permissible to make extensions of the radiophone connection by four-wire circuits,

2. that the above-mentioned sentence already permits the interested administrations and companies to use in case of unfavorable radio conditions, not only the technique used by the said administration, but also any other type of connection which would be deemed desirable,
- expresses the opinion

that there is no need to modify the above sentence given in the annex to Opinion No. 29 of the C.C.I.R.

⁶ This opinion replaces opinion No. 29 of the C.C.I.R.

⁷ The opinion of the C.C.I. (Telephone) to which reference is made is given in full in the Book of Opinions of the Second Meeting of the C.C.I.R., Copenhagen, 1931, published by the International Bureau of the Telegraph Union, Berne, Switzerland.

OPINION NO. 37⁸*Frequency List*

The C.C.I.R.,

considering

that the International Radiotelegraph Convention (Washington, 1927) does not provide for the publication of a frequency list, that a frequency list would be very useful and of great practical value, that *this list* should include information on all frequencies provided for regular services or assigned to these services and capable of causing interference beyond the limits of the country in which they are used,

expresses the opinion,

1. that a frequency list should be established and published by the International Bureau of the Telegraph Union and should include the following indications, which should be forwarded without delay to that Bureau.

A. Frequency. The exact frequency should be indicated in kc. (See Opinion No. 38 of the C.C.I.R.)

In the case of a multiplex system, all the carrier frequencies will be indicated in Column 1, and with respect to each of these frequencies, in the remarks column, all the other carrier frequencies of the system will be repeated with the indication "multiplex system."

In the case of an emission in which the carrier frequency is suppressed, there should be given in Column 1 a frequency which, combined with the figure given in Column 9 (modulation frequency), will determine the frequency band employed. Column 14 (remarks) should indicate that the carrier frequency is suppressed and whether the transmission is conducted with single side band or otherwise.

B. Wavelength. The approximate wavelength should be expressed in meters. (See Opinion No. 38 of the C.C.I.R.)

C. Date of notification. This date will be that of the communication by which information pertaining to the frequency in question has been transmitted to the International Bureau.

D. Call signal.

E. Name of the station and country under the jurisdiction of which this station operates.

F. Type of emission. This will be indicated by A1, A2, A3, B, *special*. The indication *special* must apply to types of emission which are not included in the other designations (facsimile and television emissions).

⁸ This opinion replaces Opinion No. 19 of the C.C.I.R.

G. Power in the antenna.

- (1) The indications in this column should give the power of the carrier wave under normal service conditions.
- (2) Degree of modulation, per cent.

The figure appearing in this column should give the real maximum degree of modulation used in normal service. (See opinion No. 49 of the C.C.I.R.)

H. Directivity of antenna. When a directive antenna is used, it should be indicated by the letter "D" followed by the letter "T" in the case where the radiation system may be subject to rotation.

I. Frequency of modulation. The frequency of modulation to be inserted in this column should indicate the frequency band intended to modulate the carrier frequency, that is to say, for A1 and B types of emission, no figure, for A2, A3, and *special* types of emission, the maximum width in kilocycles of the band used. If the transmission is using only one side band, this will be indicated by placing before the figure the sign + (side band above carrier frequency) or—(side band below carrier frequency).J. Transmission speed in bauds.⁹ This speed should be the maximum speed of telegraph transmission normally used in the service.

K. Nature of service and countries with which communication is provided or established.

L. Date of putting into service of the frequency (anticipated date between parentheses).

M. Administration or operating company.

N. Remarks

2. that this list should be considered as a service document within the meaning of Article 13 of the General Regulations annexed to the International Radiotelegraph Convention of Washington.

OPINION NO. 38

*Precision in the indication of frequencies and
of wavelengths*

The C.C.I.R.,

considering

that Article 4, paragraph 1 (5) of the General Regulations of Washing-

⁹ The meeting of the C.C.I.T. at Berlin (1929) has expressed the opinion under A. I. a:

"that the transmission speed be expressed by the reciprocal of the value of the elementary interval measured in seconds, that the transmission speed of an interval per second be called "baud" to honor the memory of the great telegrapher, Emile Baudot."

ton, provides that waves shall be designated in the first place by their frequency in kilocycles per second (kc) and that following this designation shall be indicated, in parentheses, the approximate wavelength in meters, the latter being expressed by the quotient of the division of the number 300,000 by the frequency expressed in kilocycles per second,

express the opinion

1. that the frequency be expressed by a number of figures such that the uncertainty of approximation be equal to 1/10 of the tolerance allowed, and that the wavelength be computed with an approximation equal to the tolerance,
2. that the figure representing the frequency be always considered exact, even if the corresponding wavelength is expressed by a round number.

OPINION NO. 39

Assignment of a separate call signal to each frequency used in the fixed service

The C.C.I.R.,

considering

that the assignment of a separate call signal would facilitate the study of all cases of interference between fixed stations and could, therefore, enable one to reduce this interference,

express the opinion

1. that each frequency used by a station of the fixed service should be designated by a separate call signal used solely for that frequency,
2. that each call signal should be indicated in the corresponding column of the nomenclature of fixed and land stations opposite the frequency to which it is assigned.

In addition the call signal corresponding to each notified frequency should appear in the corresponding column of the frequency list.

OPINION NO. 40¹⁰

Definition of the power of a transmitter

The C.C.I.R.,

considering

that it is not practicable actually to measure correctly the power of a radio transmitter, that is to say, the power radiated by the antenna, that, on the other hand, the technique prescribes easy methods for the determination of the power absorbed or transformed by the different parts of a radio transmitter,

that, in the case of modulated emissions, for example that of radio-

¹⁰ This opinion replaces Opinion No. 5 of the C.C.I.R.

telephony, the definition of the power of a transmitter should be set up in a manner to give the information applying to the different types of modulation by indicating two numbers,

expresses the following opinion

The power of a radio transmitter is understood to mean the power in the antenna. By antenna is meant the radiating conductor or the entire assembly of radiating conductors.

The power in the antenna may be obtained either by direct measurement in the antenna itself or by measurements carried out on an equivalent dummy antenna or on other parts of the transmitter (e.g., at the input of the transmitter of a mobile station, if wished); in the case of indirect measurement, the power in the antenna will be estimated by taking account of the efficiency of the intermediate stages.

In the case of a radiotelegraph transmitter, by the power in the antenna is meant the power measured in a continuous dash.

In the case of a modulated wave transmitter, the power in the antenna is given by two numbers: the value of the power of the carrier wave supplied to the antenna, and, in addition, the actual maximum percentage of modulation used.

Consequently, the indication of the power of such a radio transmitter consists of the indication of the number of kilowatts, and, in addition, that of the figure representing the actual maximum percentage of modulation. It will be necessary in case one side band or the carrier frequency is suppressed, to mention that fact.

In the case of a modulated short-wave or very short-wave transmitter, the power in the antenna is calculated from the power leaving the last stage of the transmitter, taking into account the efficiency of the intermediate stages.

ANNEX TO OPINION No. 40

The percentage modulation, M , of a transmitter having two symmetrical side bands is defined, for example, by the relation

$$M = 2 \frac{I_1}{I_p} \cdot 100 \text{ per cent}$$

where I_1 is the amplitude of the current in the side band, and I_p the amplitude of the carrier current, the transmitter being modulated by a sinusoidal wave.

OPINION NO. 41¹¹*Tolerances*

The C.C.I.R.,

expresses the opinion

that the following considerations be taken into account:

1. Tolerance is the maximum admissible difference between the frequency which should be emitted by the station assuming it to be without any error and the frequency actually emitted under the most unfavorable condition in which all errors are additive.

2. This difference results from the combination of three errors:

- A. the error of the radio-frequency meter or frequency indicator used,
- B. the error made during the adjustment of the station,
- C. slow variations in the frequency of the transmitter (instability).

3. In the tolerance no account is taken of modulation.

4. The tolerances recommended in the several frequency bands and for the various services are given in the following table:

TOLERANCE TABLE

| | Tolerances recommended as being immediately applicable | Tolerances recommended as applicable in the future ¹ |
|--|--|---|
| | Plus or Minus | Plus or Minus |
| A—10 to 550 kc/s (30,000 to 545 m) | | |
| (a) Fixed stations | 0.1 per cent | 0.1 per cent |
| (b) Land stations | 0.1 per cent | 0.1 per cent |
| (c) Mobile stations using indicated frequencies | 0.5 per cent ² | 0.5 per cent ² |
| (d) Mobile stations using any wave within the band during a transmission | 0.5 per cent | 0.5 per cent |
| (e) Broadcast stations | 0.3 kc/s | 0.05 kc/s |
| B—550 to 1500 kc/s (545 to 200 m) | | |
| (a) Broadcast stations | 0.3 kc/s | 0.05 kc/s |
| (b) Land stations | 0.1 per cent | 0.1 per cent |
| (c) Mobile stations using any wave within the band during a transmission | 0.5 per cent | 0.5 per cent |
| C—1500 to 6000 kc/s (200 to 50 m) | | |
| (a) Fixed stations | 0.05 per cent | 0.03 per cent |
| (b) Land stations | 0.1 per cent | 0.04 per cent |
| (c) Mobile stations using indicated frequencies | 0.1 per cent | 0.1 per cent |
| (d) Mobile stations using any wave within the band during a transmission | 5 kc/s | 3 kc/s |
| (e) Fixed and land stations of low power (up to 250 antenna watts) working in bands common to fixed and mobile services, during a transmission | 5 kc/s | 3 kc/s |
| D—6000 to 23,000 kc/s (50 to 13 m) | | |
| (a) Fixed stations | 0.05 per cent | 0.02 per cent |
| (b) Land stations | 0.1 per cent | 0.04 per cent |
| (c) Mobile stations using indicated frequencies | 0.1 per cent | 0.1 per cent |
| (d) Mobile stations using any wave within the band during a transmission | 0.1 per cent | (0.04 per cent for frequencies in the shared bands) |
| (e) Broadcast stations | 0.03 per cent | 0.05 per cent |
| (f) Fixed and land stations of low power (up to 250 antenna watts) working in bands common to fixed and mobile services, during a transmission | 0.1 per cent | 0.01 per cent |
| | | 0.05 per cent |

¹ The C.C.I.R. means, by this expression, that the figures in this column should be generally applied to new transmitters only after 1933, and to all transmitters only after 1938.

² It is recognized that there are in this service a large number of spark transmitters and simple self-oscillating transmitters which will be unable, at all times, to meet this requirement.

¹¹ This opinion replaces Opinion No. 14 of the C.C.I.R.

OPINION NO. 42¹²*Definition of terms relating to frequency measurement methods
and comparison of frequency standards*

The C.C.I.R.,

expresses the opinion

that opinion No. 9 of the C.C.I.R. be replaced by the following:

1. The following definitions have been accepted to avoid any error of interpretation:

Frequency meter—Absolute standard of frequency: measuring apparatus which permits the evaluation of a frequency as a function of the second of mean solar time.¹³

Radio-frequency meter or wavemeter: commercial instrument which permits making the measurement of high frequencies included between two definite limits.

Heterodyne frequency meter or heterodyne wavemeter: apparatus permitting the measurement of high frequencies by the production of continuous radio oscillations of a frequency equal to that which is to be measured or which differs from it by a known quantity.

Frequency indicator: commercial device (oscillator or resonator) to verify a single frequency.

Secondary frequency standard: apparatus capable of producing a frequency with such a constancy that the absolute standard of frequency can discover no variation in it.

2. For comparing secondary standards; i.e., national frequency standards, various methods are technically available, for instance the following:

A. Methods involving transportation of the apparatus—

(1) Direct comparison of two wavemeters.

(2) Comparison of several wavemeters with a traveling apparatus; i.e., with an apparatus that would be transported from one country to another.

B. Methods not involving the transportation of apparatus.

(1) Transmission of standard frequencies, standardized either in high or in low frequency (modulated waves).

(2) Simultaneous measurements of the same transmitted wave, not standardized, but being sufficiently stable to permit of concurrent measurements.

¹² This opinion replaces Opinion No. 9 of the C.C.I.R.

¹³ The C.C.I.R. learned with satisfaction that the International Committee on Weights and Measures studied, at the request of the C.C.I.R., 1929, the organization of an International systematic comparison of frequency standards established by the national laboratories (see Annex hereafter).

3. The precision of one one-hundred thousandth ($1/100,000$) for a frequency meter absolute standard of frequency is considered satisfactory for existing radio services.

4. Since radio operating agencies have an interest in reducing frequency tolerances as rapidly as the technique makes available more accurate, convenient, and economical means, the C.C.I.R. recommends that scientific organizations in the different countries seek in the future, to attain a precision of one one-millionth ($1/1,000,000$) for absolute frequency meter standards.

5. Since all methods permitting the comparison of frequency standards are capable of giving very accurate results, it is advisable to leave to the persons charged with making the comparisons the task of determining, according to circumstances, the method to be used, drawing attention, however, to the importance which may be attached to the use, for this purpose, of sturdy and convenient portable standards, such as, for example, piezo-electric oscillators and resonators.

For the comparison of frequency standards at a distance, or even in the laboratory, it would be desirable to use frequencies which may be demultiplied to 1000 cycles per second with a precision of $1/10,000$

ANNEX TO OPINION No. 42

Decision unanimously adopted by the International Committee on Weights and Measures at its meeting of April 16, 1931

The International Committee on Weights and Measures has taken cognizance of Opinion No. 11 of the International Technical Consulting Committee on Radio Communications, supported by the Electrical Consulting Committee. The committee recalls that the normal unit of frequency is simply the reciprocal of the second, the measurement of which is above all of an astronomical nature. For that reason, while accepting in principle the work of coördination and comparison of radio-frequency standards, the committee considers that the acceptance of the principle will have to be confirmed by the General Conference on Weights and Measures, which will meet in 1933.

OPINION NO. 43¹⁴

Degree of precision of radio-frequency meters and frequency indicators

1. The following definitions have been accepted:

Partial precision or partial uncertainty of a radio-frequency meter: the absolute value of the maximum relative frequency error due to a given cause, that is to say, the relation between the absolute value

¹⁴ This opinion replaces Opinion No. 10 of the C.C.I.R.

of the maximum frequency error which can be produced by the cause in question, and the measured frequency.

Total precision or total uncertainty of a radio-frequency meter: the sum of the maximum values of the following partial precisions or uncertainties attained over the range of the wavemeter scale (these maximum values may correspond to different points).

A. *Mechanical precision or mechanical uncertainty:* the uncertainty due only to errors caused by defects or imperfections of construction.

The mechanical uncertainty consists of:

- (1) the uncertainty due to imperfection of construction of the movable parts of the wavemeter, or introduced by the existence of parts which are not rigid or solidly fixed,
- (2) the reading uncertainty with reference to errors caused by the impossibility of reading fractions of the scale below a certain limit,
- (3) the uncertainty due to irregularities of the calibration curve.

B. *Lack of constancy:* the uncertainty which refers only to errors due to different circumstances, such as variations of temperature, humidity, and atmospheric pressure, and for heterodyne wavemeters of the supply voltage and of tube characteristics.

C. *Independence of external influences:* the uncertainty due only to errors caused by the influence on the wavemeter of neighboring external objects.

D. *Indication precision or uncertainty:* the uncertainty due only to errors caused by the indicating system with which the wavemeter is equipped.

The inexactitude of calibration, that is to say, the uncertainty referring only to errors introduced by calibration defects, will be considered separately. It is to be noted that the inexactitude of calibration does not contribute to the total uncertainty of the wavemeter.

2. According to the present state of technique, radio-frequency meters may be classified, as follows:

A. *high precision wavemeters:* wavemeters having a total uncertainty equal to, or less than $1/10,000$,

B. *precision wavemeters:* wavemeters having a total uncertainty equal to or less than $1/1,000$ and greater than $1/10,000$,

C. *ordinary wavemeters:* wavemeters having an uncertainty equal to or less than $5/1,000$ and greater than $1/1,000$.

The inexactitude of calibration of each class of wavemeters must not exceed half of the limit of their total precision.

In the present state of technique, wavemeters having uncertainties greater than the limit fixed for ordinary wavemeters must be considered as unusable for the checking of a transmission.

3. With radio-frequency meters not equipped with special devices (thermostats, crystals, etc.) it is possible to measure a frequency with a precision of from 2/10,000 to 5/10,000.

By the use of special apparatus and by taking particular precautions, it is possible to make measurements with a precision of from 2/100,000 to 5/100,000.

With apparatus intended for mobile stations (ships and aircraft) as well as with that which must be used in unfavorable conditions of location and climate, as in the colonies, it is hardly possible, in the present state of technique, to make measurements with an uncertainty of less than 3/1,000 or 4/1,000.

4. The precision of the wavemeters used must in every case be such that it permits the station involved to keep within the tolerance limits indicated in the table given in Opinion No. 41.

To attain this result, it seems necessary that the uncertainty of the wavemeters used should be at the most equal to one-third of the tolerance. (See the study of the Italian Administration, centralizing the answers to Question 5 on the program of the second meeting of the C.C.I.R.¹⁵)

OPINION NO. 44

Reduction of interference in the shared bands, for frequencies above 6000 kc

The C.C.I.R.,

is of the opinion

that, in order to obtain a noticeable reduction of interference in the shared bands for frequencies above 6000 kc,

1. the tolerances recommended for fixed stations and land stations should be strictly observed by those stations using frequencies situated in these bands;

2. the tolerances recommended for land stations should also be observed, as soon as possible, by mobile stations when using frequencies situated in these bands;

3. the stations using type A2 waves situated in these shared bands and which occupy a total band of frequencies much wider than that indicated by Opinion No. 20 of the C.C.I.R., should endeavor to reduce this band width;

¹⁵ This is included in the Book of Documents of the Second Meeting of the C.C.I.R., Copenhagen, 1931, published by the International Bureau of the Telegraph Union at Berne, Switzerland.

4. the fixed service stations using frequencies included in the shared bands should use, when such use is compatible with the nature of the service carried on, and to the greatest possible extent, directive aerial systems having a narrow beam.

The land stations using frequencies included in the shared bands should also, when this use is compatible with the nature of the service carried on, and to the greatest possible extent, make use of directive aerial systems, even with very wide beams.

5(a). In the case of telegraph communication in the maritime mobile service carried out in a permanent manner on particular waves, some for coast stations and others for ships, the normal receiving waves of the coast stations should, in order to avoid conflict with paragraph 2 above, be situated outside the shared bands.

(b). Communications by alternate transmission and reception using frequencies situated in the shared bands should be made on the same frequency, in both directions, whenever the use of two frequencies is not justified by the increase in efficiency of communication which results.

6(a). The frequencies of these shared bands used by the same category of stations could advantageously be grouped;¹⁶

(b). The groups of frequencies assigned to the same service should as far as possible be in harmonic relation.

OPINION NO. 45

Technical methods of stabilization

The C.C.I.R.,

considering

1. that the frequency stability of the transmitter concerns only the variation of the transmitted frequency with reference to the frequency to which the transmitter is adjusted, whether or not the latter coincides with the nominal frequency.

When measurements repeated at a distance have been made at indeterminate times and for certain periods, it is convenient, in practice, to refer all measurements to the nominal frequency.

¹⁶ An example of the advantages of such grouping as is referred to in subparagraph 6 may be given by that of ships carrying on at the same time a radiotelegraph and a radiotelephone service. All frequencies used by them for radiotelephony may then be grouped, for example, in the high-frequency part of the band, and these used by them for radiotelegraphy as far away as possible from the first ones. Another example of the advantage of such grouping could be given by considering the difficulties of the aeronautic mobile services in relation to the maritime mobile services. The low power of aircraft stations and the particularly difficult conditions of reception on board aircraft expose them to interference which a rational grouping of the frequencies used by each of these services would likely decrease.

It follows that the figures thus obtained permit the determination not only of the stability with reference to the frequency of adjustment indicated above, but also of the accuracy of adjustment with reference to the nominal frequency.

The figures given hereafter refer only to the stability itself.

2. In the frequency band between 10 and 1500 kc/s, fixed and land stations use, among others, arc transmitters, high-frequency alternators, and tube transmitters. Experience has shown that the best transmitters working in this band, can easily be stabilized at 0.1 per cent.

3. A study of the various methods of stabilization, which may be used between 1500 and 23,000 kc/s shows that carefully built transmitters can be stabilized at about 0.1 per cent. Some transmitters, using modern devices, maintain their stability during long periods and under normal service conditions at 0.01 per cent.

4. Broadcast stations can easily use modern methods of automatic frequency stabilization and can, therefore, be maintained within the limit of a tolerance of 50 cycles per second, as proposed in Opinion No. 41 of the C.C.I.R.

5. The modern devices permitting the attainment of results of this kind are master oscillators, tuning forks, and quartz crystals, all these devices being placed under thermostat control.

6. Mobile stations and certain stations, the service of which involves frequent and quick changes of wavelength, are limited, due to special conditions under which they operate, to the use of relatively simple apparatus and service methods and cannot in practice attain such degrees of stability.

7. Opinion No. 15, of the C.C.I.R., indicates that with relatively complicated and expensive apparatus, a stability of 1/100,000 could be insured and that a far superior stability could be attained in the future. This opinion is reaffirmed; nevertheless, the present discussion is limited to results which have already been amply demonstrated in the normal service of stations.

8. The great number of fixed and broadcast stations operating on neighboring frequencies necessitates, for the latter, narrower tolerances. It is especially important that these stations should be equipped with the devices necessary to maintain them at all times, and with accuracy, on their normal frequencies.

For that purpose, each of these stations should have two independent devices. The first is the device of stabilization properly speaking, (for example, the master oscillator), the second being independent of the first, and, therefore, capable of being used as a check.

This device may be for example;

- A. a frequency indicator (piezo oscillator or other) or wavemeter located in the station,
- B. a spare master oscillator for checking purposes,
- C. a frequency standard from a checking station, directly connected with the transmitting station.

Ordinary measurements made by a checking station, are not considered sufficient, unless there is a direct connection with the transmitting station, permitting an immediate adjustment to be obtained.

recommends

as constituting a suitable technical basis to refer to, the detailed information relative to the available technical methods of stabilization given in the following documents by the various administrations and organizations as well as in the technical articles and magazines, mentioned therein.

*Documents Relating to Question 3 of the Program of the Second Meeting of the C.C.I.R.*¹⁷

International Broadcasting Union (Doc. 63), Group of French Companies (Doc. 79), United States of America (Docs. 105 and 164), Italy (Doc. 148), Japan (Doc. 163), and Union of Soviet Socialist Republics (Doc. 211).

OPINION NO. 46

Reduction of nonessential emissions

The C.C.I.R.,

considering

1. that the most important nonessential emissions likely to cause interference may be classified as follows:
 - A. radio-frequency harmonics.
 - B. emissions which may be produced in the neighborhood of the radio-frequency transmitted, when a high order of frequency multiplication is used.
 - C. parasitic components of modulation due to overmodulation.
 - D. compensation waves of arc transmitters.
 - E. compensation waves of transmitters other than arc transmitters using two waves (working wave and compensation wave) for a single communication.
 - F. parasitic components due to frequency modulation.

¹⁷ Included in the Book of Documents of the Second Meeting of the C.C.I.R., Copenhagen, 1931, published by the International Bureau of the Telegraph Union, Berne, Switzerland.

2. that emissions of classes A, C, and D are the subject of opinions 48, 49, and 50,

expresses the opinion

1. that emissions of class B outside the useful frequency band should comply with the same conditions as those which apply to emissions of class A.
2. the method of operation by means of a compensation wave should be discontinued for transmitters mentioned in E above, except in cases where both carrier frequencies always lie inside the tolerance limits specified for the frequency assigned to the station, or where the increased efficiency of communication would justify the use of two frequencies.
3. the amplitude of parasitic components due to frequency modulation outside the useful frequency band should be reduced to such a value that these components may not interfere with the normal reception of other stations using neighboring frequencies.

OPINION NO. 47

Reduction of the frequency band of a transmitter

The C.C.I.R.,

expresses the opinion

1. that for frequencies below about 100 kc/s, it is possible and desirable to suppress one side band, and, moreover, in certain cases, the carrier wave, in transmissions covering large bands of frequencies (radio-telephony, facsimile transmissions, etc.).
2. that for frequencies above about 100 kc/s such a suppression is also possible, at least for certain radio communications, but even for these radio communications experience does not yet permit one to state whether this suppression would procure a sufficient benefit, considering the technical and economic difficulties encountered.

Annex to Opinion No. 47

General report¹⁸ of the Austrian Administration relative to the reduction of the frequency band of a transmitter

This report is composed of the following documents:

1. A memorandum by the Centralizing Administration (Austria) outlining the method adopted for a systematic answer to question 7, (see Annex 1).

¹⁸ This report is given in full in the Book of Opinions of the Second Meeting of the C.C.I.R., Copenhagen, 1931, published by the International Bureau of the Telegraph Union, Berne, Switzerland.

2. Reports of collaborating administrations: United States (Annex 2) and Germany (Annex 3).
3. A study of the Japanese Administration, presented after the compilation of this general report (Annex 4).

OPINION NO. 48

Suppression of harmonics and permissible tolerance for their intensity

The C.C.I.R.,

considering

1. that when they are of good design, transmitting apparatus other than that of mobile stations, produce harmonics, the individual intensity of which at a distance of about 5 km of the limits of the transmitting antenna may attain the following percentage of the intensity of the fundamental wave:

| Frequency of Fundamental Wave | Percentage of Fundamental Wave Intensity |
|-------------------------------|--|
| 10- 100 kc | 0.1 per cent (tube transmitters) |
| 100- 550 kc | 0.1 per cent |
| 550-1500 kc | 0.05 per cent |

and that on the other hand it is difficult to determine the significance of harmonics of frequencies above 3000 kc on account of intervening factors such as the angle of radiation, the nature of propagation, and the difficulty of measuring the field intensity of such frequencies,

2. that it is possible to reduce harmonics of all transmitters by various methods such as those mentioned in the two annexes below,

expresses the opinion

1. that it is necessary to protect all services against interference caused by nonessential emissions, particularly harmonics of such intensity or character as to interfere with their normal reception, but it is not possible at present to fix maximum limits for the field intensity of those harmonics which would be applicable in all cases,
2. that it is, however, desirable to find a way of fixing such limits, independently of the power of the transmitter, and as a function only of the conditions of reception on the harmonic frequency.

Annex I¹⁹ to Opinion No. 48*Proposals of the German Administration relating to question 8 of the program of the second meeting of the C.C.I.R.*

¹⁹ This annex is given in full in the Book of Opinions of the Second Meeting of the C.C.I.R., Copenhagen, 1931, published by the International Bureau of the Telegraph Union, Berne, Switzerland.

Annex II²⁰ to Opinion No. 48

Response of the Japanese Administration to question 8 of the program of the second meeting of the C.C.I.R.

OPINION NO. 49

Tolerance of overmodulation of radiotelephone transmitters

The C.C.I.R.,

considering

1. that the overmodulation of radiotelephone transmitters produces parasitic components of modulation which have as a result, on the one hand, the enlargement of the frequency band transmitted and on the other hand, the reduction of the quality of reproduction of speech and music,

2. that it is possible to reduce these effects by various methods, such as those indicated in the following study by the United States of America,

expresses the opinion

1. that it is desirable that radiotelephone transmitters should be designed and adjusted in such a way that the amplitude of parasitic components of modulation outside the useful frequency band be reduced to such a value that they do not interfere with the normal reception of other stations using neighboring frequencies,

2. that it is desirable that the percentage of modulation of radiotelephone transmitters should be limited to such a value that, for the maximum power and for any frequency included in the frequency band to be transmitted, the total amplitude of all parasitic components of modulation should not exceed the following percentage of the fundamental modulating wave:

| | |
|-------------------------------|--|
| Radio broadcast stations | 4 per cent (corresponding to 3.2 nepers or 28 decibels down). |
| Other radiotelephone stations | 10 per cent (corresponding to 2.3 nepers or 20 decibels down). |

Annex²⁰ to Opinion No. 49

Study made by the United States of America in response to question 9 on the program of the second meeting of the C.C.I.R.

²⁰ This annex is given in full in the Book of Opinions of the Second Meeting of the C.C.I.R., Copenhagen, 1931, published by the International Bureau of the Telegraph Union, Berne, Switzerland.

OPINION NO. 50

Suppression of spacing waves in arc transmitters

The C.C.I.R.,

expresses the opinion that it is desirable that, in arc transmitters, all measures should be taken to suppress or at least to reduce as much as possible the radiation of a spacing wave, and that all arc transmitters should be modified accordingly within a time limit of about 2 years.

The C.C.I.R. indicates as an example, the following study of the Polish Administration.

Annex²¹ to Opinion No. 50*Study of the Polish Administration relative to question 12 of the program of the second meeting of the C.C.I.R.*

Questions Unanswered and New Questions

QUESTION 1

Organization Regulations for the C.C.I.R.

The C.C.I.R.,

expresses the opinion that it is necessary to make a study of its organization regulations with a view to improving and completing them, and that the Italian Administration as centralizing administration, will be kind enough to send, on or before May 1, 1932, its report to the International Bureau, to be forwarded to all interested administrations and companies.

Collaborating Administrations: Germany, United States of America, France, Great Britain, Japan, Portugal, Czechoslovakia, and the Union of Soviet Socialist Republics.

Note: The administrations which make this study will wish to examine also the following question which should be considered as being included in question 1:

In what measure are the recommendations of the C.C.I.R. put in practice by the administrations, the private enterprises, and the organizations which collaborate in the work of the C.C.I.R.?

QUESTION 2

Admission of representatives of International Organizations to the work of the C.C.I.R.

The C.C.I.R. not having reached an agreement on the question as to whether or not representatives of international organizations

²¹ This annex is given in full in the Book of Opinions of the Second Meeting of the C.C.I.R., Copenhagen, 1931, published by the International Bureau of the Telegraph Union, Berne, Switzerland.

should be allowed in the future to take part in its meetings, (Art. 2, pars. 1 and 2, and Art. 6, par. 5, of the Internal Regulations of the Copenhagen meeting, 1931) suggests that the participation of said organizations in its work—a participation which is not provided for in Article 33 of the General Regulations of Washington—be considered by the administrations before the Madrid Conference, to be the subject of discussions at the said conference.

Centralizing Administration: Italy.

Collaborating Administrations: Germany, United States of America, France, Great Britain, Netherlands, Czechoslovakia, and the Union of Soviet Socialist Republics.

QUESTION 3

Study of economic and technical means enabling a mobile station to operate with more accuracy on the frequency of any land station with which it wishes to correspond

Centralizing Administration: Great Britain.

Collaborating Administrations: Germany, United States of America, and Japan.

QUESTION 4

Allocation of frequency bands

The C.C.I.R.,

considering

that the allocation of frequency bands among the various radio services does not come within its competence, but must be dealt with at the next world conference at Madrid,

that, however, the constant development of all radio services is producing an increased overcrowding of the ether which is likely to limit the progress of these services or even to jeopardize their normal operation, that the C.C.I.R. has the duty of studying the technical methods or processes of all kinds enabling the insurance of a harmonious development of radio communications,

that a systematic study of the conditions of propagation of Hertzian waves in the various sections of the frequency spectrum, as well as the technical conditions of their use by the various services, is desirable and useful,

expresses the opinion

1. that such studies should be undertaken or continued, especially on the basis of the studies already submitted²² to the C.C.I.R. by the following administrations:

²² These are given in full in the Book of Documents of the Second Meeting of the C.C.I.R., Copenhagen, 1931, published by the International Bureau of the Telegraph Union, Berne, Switzerland.

Germany (Answer to question 11 of the program of the second meeting of the C.C.I.R.)

United States of America (Two documents: Answer to question 11, contribution to the study of question 11)

France (Three documents: Answer to question 8, answer to question 11)

Poland (See the second answer to question 11)

Union of Soviet Socialist Republics (Answer to question 11)

International Broadcasting Union (Two documents: Answer to question 11, Contribution to the study of the laws of propagation of Hertzian waves in the range from 150 to 1500 kc/s).

as well as on the basis of the program of studies contained in the following Annex;

2. that the data already compiled and the results of new studies undertaken by the various interested organizations should be entrusted to the Administration of Great Britain as centralizing administration with a view to their analysis and coördination.

3. that this administration should, as soon as possible, prepare a combined report and should send it to the International Bureau before May 1, 1932, to be forwarded to all interested administrations and operating companies, so that this report may be used in the preparation of the work for the Madrid Conference.

Centralizing Administration: Great Britain.

Collaborating Administrations: Germany, Belgian Congo, Denmark, Spain, United States of America, France, Dutch East Indies, Italy, Japan, Morocco, Mexico, Norway, Portugal, Czechoslovakia, and the Union of Soviet Socialist Republics.

Collaborating Organization: International Broadcasting Union.

Annex to Question 4

Program of studies

1. What are the characteristics of propagation of the waves belonging to the various parts of the frequency spectrum?

In particular, what is the influence of the following elements on the shape of the waves and on the field intensity:

- A. Special installation conditions of the transmitter and receiver
- B. The terrain over which propagation takes place (shape and nature)
- C. Distance
- D. Direction
- E. Atmospherics
- F. Magnetic storms

- G. Ionization
- H. Direct and indirect propagation
- I. Echoes
- J. Skip distance
- K. Fading?

What is the influence of these various elements in the daily, seasonal, annual variations, and also in the variations which appear over a period of several years?

2. What are the characteristics of various waves as regards radio direction finding?

3. What is the field intensity necessary for reception in the following different cases:

- Telegraphy type A1, aural reception
- Telegraphy type A1, automatic reception
- Telegraphy type A2, aural reception
- Telegraphy type A2, automatic reception
- Commercial telephony
- Broadcasting
- Radio direction finding
- Picture transmission and television?

What is the influence on reception of the different special conditions which may occur?

QUESTION 5

The fixing of permissible tolerances for the intensity of harmonics. Study of harmonics of various stations and their action on receivers of various services

Centralizing Administration: Germany.

Collaborating Administrations: United States of America, France, Japan, the Netherlands, Czechoslovakia, and the Union of Soviet Socialist Republics.

Collaborating Organization: International Broadcasting Union.

QUESTION 6

Reduction of parasitic currents in receivers

The C.C.I.R.,

recognizing the necessity of the immediate study of the question of the reduction of interference produced by industrial apparatus and electrical installations of all kinds,

expresses the opinion

that the administration of Denmark be good enough to take charge, as centralizing administration, of the study of the question concerning the

reduction of interference produced by industrial apparatus and electrical installations of all kinds, with the collaboration of the administrations and organizations which will be good enough to lend their assistance.

The Administration of Denmark is, moreover, requested to submit the results of these studies to the International Radiotelegraph Conference of Madrid, so that the latter may express itself concerning the necessity or not, of continuing the studies by a committee having the power to add to its membership representatives of any international organization interested in the question.

Centralizing Administration: Denmark.

Collaborating Administrations: Germany, Austria, Spain, United States of America, France, Great Britain, Italy, Norway, the Netherlands, Switzerland, and the Union of Soviet Socialist Republics.

Collaborating Organization: International Broadcasting Union.

QUESTION 7

Selectivity and stability of receiving apparatus

The C.C.I.R.,

considering

that the selectivity and stability of receivers has an essential bearing on the fixing of the spacing between the frequencies of stations operating on neighboring frequencies,

that some receivers now used do not have all the selectivity desirable, that the studies already made do not yet permit the completion by accurate indications, of Opinion No. 21 of the C.C.I.R.,

expresses the opinion

1. that the study of receivers should be continued on the basis of the documents already submitted to the second meeting of the C.C.I.R. by the group of French Companies, the United States of America, France, Japan, and Germany, in accordance with the program resulting from the attached Annex;
2. that the documents already compiled and the results of new studies undertaken by the various organizations concerned should be communicated to a centralizing administration with a view to their analysis and coördination.

Centralizing Administration: France.

Collaborating Administrations: Germany, United States of America, Italy, Japan, and the Netherlands.

Annex to Question 7

What is the relation between the selectivity and the frequency stability of radio receivers, used in the different services on the one

hand, and the frequency separation between transmitting stations on the other hand?

The study will touch on the following points:

1. Exact definition of the selectivity and of the stability of a receiver;
2. Methods to be used for measuring the selectivity and the stability of a receiver;
3. Conditions with which, from the point of view of selectivity and of stability, a receiver intended to receive a definite emission conforming to conditions fixed by the tolerance table, should comply, without interference from emissions of a neighboring frequency;
4. Results already obtained with the existing receiving systems;
5. Devices to be recommended for enabling a receiver to comply with the conditions required for the service to be carried on;
6. To what extent can the required selectivity in a receiver be adequately reconciled with the fidelity of reproduction of side bands of modulation (multiplex telegraphy, telephony, broadcasting, facsimile, television, etc.)?

QUESTION 8

Reduction of interference in the shared bands

The C.C.I.R.,

having recognized

that certain interference in the shared bands would undoubtedly be avoided if calling frequencies were used in the mobile services working on short waves, recommends this use even if it has only a regional character.

In this case, it calls attention to the following points:

1. such calling frequencies should be established both for the maritime mobile service and for the air mobile service;
2. they should be chosen in the bands especially reserved for mobile services and should be in harmonic relation with each other.

Consequently, the C.C.I.R.

expresses the opinion

that experiments should be continued in order to ascertain the advantages and disadvantages of such a system.

Centralizing Administration: Denmark.

Collaborating Administrations: Germany, Spain, United States of America, France, Great Britain, and Japan.

QUESTION 9

Modulated telegraph emissions

Study of the frequency band covered by such emissions. Maximum frequency to be admitted for an aural reception. Determination of their parasitic components of modulation and maximum permissible value for these components.

Centralizing Administration: Italy.

Collaborating Administrations: Germany, United States of America, and France.

QUESTION 10

Key Clicks

Study of interference produced by key clicks from radio transmitters. Methods for reducing this interference.

Centralizing Administration: Germany.

Collaborating Administrations: United States of America, France, Dutch East Indies, Italy, and Japan.

QUESTION 11

Study of technical considerations necessary for the establishment of a suitable system of standard frequency transmissions for the checking of wavemeters

Centralizing Administration: Italy.

Collaborating Administrations: Germany, Spain, United States of America, France, Great Britain, Japan, and the Union of Socialist Soviet Republics.

QUESTION 12

Studies relating to the measurement of noises and voice levels

A determination, at the time of the next meeting of the C.C.I.R. of the stage of progress in studies relating to the measurement of noises and voice levels.

Centralizing Administration: France.

Collaborating Administrations: Germany, United States of America, Great Britain, and Japan.

QUESTION 13

Radiotelephony between small vessels and land stations

What are the most suitable means from the point of view of technique and regulations, to insure a satisfactory and economical radiotelephone service connecting small vessels and particularly those which do not fall under the provisions of the Convention for the Safety

of Life at Sea, with coast stations, and if necessary with the public telephone networks?

What method can be followed so that these vessels may, in case of distress, benefit from the telegraph installations on board ships equipped with radio stations in accordance with the above-mentioned Convention?

In cases where frequencies included between 1500 and 2000 kc (200 to 150 m) are used for this service, would it be advisable to provide a general calling wave, for instance, the wave of 1667 kc (180 m)?

Note: It is desirable that these methods be also capable of insuring a radiotelephone service between ships near the coast and the land telephone network.

Centralizing Administration: Germany.

Collaborating Administrations: Belgium, Denmark, Spain, United States of America, France, Great Britain, Dutch East Indies, Japan, Norway, the Netherlands, and Portugal.

QUESTION 14

Telephony with moving trains

The C.C.I.R.,

considering

1. that the radiotelephone system with moving trains produces radio-frequency currents but that the radiation of Hertzian waves is not a factor in the useful transmission, because the distance between the transmitting system and the receiving system is very short;
2. that the technique used is generally similar to radio technique;
3. that the propagation in space of waves transmitted by this system is made only at a relatively short distance in comparison with ranges of radio communications;
4. that experience concerning these communications is still insufficient to permit the expression of a definite opinion,

expresses the opinion

that this question should be studied by the various administrations with a view to its later examination.

Centralizing Administration: Germany.

Collaborating Administrations: United States of America, France, and Italy.

In addition, the German Administration will request the Canadian Administration to be good enough to collaborate in this study.



BOOK REVIEW

High Frequency Alternating Current, by Knox McIlwain and J. G. Brainerd, published by John Wiley & Sons, New York, 510 pages, 226 figures, 11 tables, price \$6.00.

This is a text book of radio principles, designed for senior and first-year graduate students in electrical engineering. It may also be recommended as a reference text for the radio engineer. The student's viewpoint is kept in mind throughout the book and except for prerequisite subjects such as calculus and some familiarity with differential equations and elementary a-c circuit theory, his previous knowledge of the material discussed is not assumed. Where new or difficult mathematical expressions are used or derived the physical significance of each point is carefully explained and interpreted.

The subjects treated include high-frequency a-c circuit theory, thermionic vacuum tubes and their use in amplification modulation, detection and oscillation circuits, electric wave filters, transmission lines, electromagnetic waves, and electromechanical systems. Most branches of radio engineering are considered.

A useful bibliography is given at the end of each chapter. As an aid to the serious minded student in assimilating the text and acquiring facility in using the methods of analysis developed problems are included with the text material throughout the book.

*S. S. KIRBY

* Bureau of Standards, Washington, D. C.



BOOKLETS, CATALOGS, AND PAMPHLETS RECEIVED

Copies of the publications listed on this page may be obtained gratis by addressing a request to the manufacturer or publisher.

Catalog No. 32 of the Sensitive Research Instrument Corporation, 4545 Bronx Blvd., New York City, is a 64-page catalog of laboratory instruments for the measurement of direct and alternating currents and voltages, power, and magnetic flux. In addition to a complete line of portable ammeters, milliammeters, microammeters, voltmeters, millivoltmeters, and galvanometers, the catalog lists laboratory standards, electro-dynamometers, wattmeters, ohmmeters, fluxmeters, thermocouples, and decade resistance boxes. These instruments are available in a large variety of ranges, and the catalog is completely illustrated.

Catalog "B" of Wireless Egert Engineering, Inc., 179 Varick St., New York City, contains illustrated descriptions of several products of interest to the amateur as well as to the engineer. Several high-frequency meters, receivers, and transmitters are listed as well as two-beat frequency audio oscillators, a four-range vacuum tube voltmeter, a temperature control oven for crystal controlled oscillators, a series of audio amplifiers, and several other similar items.

Several types of relays manufactured by the Ward Leonard Electric Company of Mount Vernon, N. Y., are described in a series of recently issued data sheets. A-c operated keying relays for vacuum tube transmitters of one-kilowatt power or less are described in Bulletin 81. These relays operate on 110 volts 60 cycles and may be used for keying speeds up to forty words per minute. Time delay relays designed for use with mercury vapor tubes are listed in Data Sheet 81,007 and are constructed so that the plate voltage cannot be applied until at least fifteen seconds after the filaments have been lit. A line of small rugged relays for operation on either alternating or direct current is described in Data Sheet 81,008 and Bulletin, 81,000 Section 22A1.

Folders have recently been issued by the Weston Electrical Instrument Corp. of Newark, N. J., describing the Weston Photronic cell. This photocell delivers about one microampere per foot-candle of light intensity, requires no batteries for operation, and will operate directly without amplifiers fairly sensitive relays. It has no fatigue, is nonmicrophonic, and, as far as is known, has unlimited life.

A folder describing several resistors, transformers, and small parts for use in the manufacture of radio receivers is available from the Carter Radio Co., of Chicago, Ill.

A number of volume controls for use in sound projection are described in a folder issued by the Central Radio Laboratories, 16 Keefe Ave., Milwaukee, Wisc. Among the items described are "L" and "T" type constant impedance volume controls and a phonograph pick-up fader.



RADIO ABSTRACTS AND REFERENCES

THIS is prepared monthly by the Bureau of Standards,* and is intended to cover the more important papers of interest to the professional radio engineer which have recently appeared in periodicals, books, etc. The number at the left of each reference classifies the reference by subject, in accordance with the "Classification of Radio Subjects: An Extension of the Dewey Decimal System," Bureau of Standards Circular No. 385, which appeared in full on pp. 1433-56 of the August, 1930, issue of the PROCEEDINGS of the Institute of Radio Engineers.

The articles listed are not obtainable from the Government or the Institute of Radio Engineers, except when publications thereof. The various periodicals can be secured from their publishers and can be consulted at large public libraries.

R000. RADIO

- R000 S. C. Hooper. The spokesman for the radio engineer. *PROC. I.R.E.*, 19, 1843-1848; October, 1931.
The need of an official spokesman for the radio engineer is presented.
- R000 O. Böhm and F. Schröter. Die Entwicklung der Kurzwellentechnik. (The development of short-wave technique). *Zeits. für Hochfrequenz.*, 38, 45-52; August, 1931; 97-101; September, 1931.
The rapid development of high-frequency communication is reviewed. Modern apparatus and equipment for radiophone and television is briefly described and problems bearing on the future development in this field are discussed.

R100. RADIO PRINCIPLES

- R111 E. Karplus. Communication with quasi optical waves. *PROC. I.R.E.*, 19, 1715-1730; October, 1931.
×R423.5 A discussion of electromagnetic waves from about 0.001 millimeter to 10 meters is given. Suitable apparatus for generating and receiving such waves is described.
- R113 L. W. Austin. Long-wave radio receiving measurements at the Bureau of Standards in 1930. *PROC. I.R.E.*, 19, 1767-1772; October, 1931.
This report shows tables of the monthly average field intensities of various long-wave stations, and the corresponding atmospheric disturbances measured in Washington in 1930.
- R113 1929-1930 developments in the study of radio wave propagation. *Marconi Review*, No. 31, 1-8; July-August, 1931.
In this article the modern conception of the Heaviside layer, the effect of magnetic storms on wave propagation, the use of ultra-short waves and the question of beam transmission are briefly discussed. The progress made during 1929-1930 and the solution of the problems associated with these questions are given.
- R113.5 H. Plendl. Über den Einfluss der elfjährigen Sonnentätigkeitsperiode auf die Ausbreitung der Wellen in der drahtlosen Telegraphie (The influence of the eleven-year solar period on radio wave transmission). *Zeits. für Hochfrequenz.*, 38, 89-97; September, 1931.
A study of solar effects based on observations made in 1930-1931 yields results which are compared with results of similar observations made in 1927-1928.

* This list compiled by Mr. W. H. Orton and Miss E. M. Zandonini.

- R116
×621.319.2 H. O. Roosenstein. The conduction of high-frequency oscillatory energy. *Proc. I.R.E.*, 19, 1849-1883; October, 1931.
Starting from telegraph equations, the action of high-frequency electric lines is treated theoretically and experimentally. Their efficiency is calculated and the relation to magnitude of the load resistance is determined. The phenomena that occur on lines whose feeding or loading shows dissymmetry with respect to ground, are analyzed and a method is given for removing dissymmetry systematically in practical installations.
- R120 The energy magnification of broadside aerial arrays used for reception. *Marconi Review*, No. 31, 9-14; July-August, 1931.
A mathematical discussion of the power received by a single antenna, a broadside array without reflector, and a broadside array with reflector is given.
- R125 P. S. Carter, C. W. Hansell, and N. E. Lindenblad. Development of directive transmitting antennas by RCA Communications, Inc. *Proc. I.R.E.*, 19, 1773-1842; October, 1931.
The development of short-wave directive antennas for long-distance communications are outlined. Various types of directive antennas are theoretically analyzed and their performances under practical conditions studied. The effects of seasonal variations, heights above the ground and polarization are considered. The radiation properties of simple wires and the radiation patterns of various combinations of wires are described in detail.
- R125.4 The Marconi-Adcock direction finding aerial. *Marconi Review*, No. 31, 21-24; July-August, 1931.
The theoretical principles involved in the design are discussed, and it is shown that the results obtained are in accordance with these principles.
- R130 W. T. Cocking. The mains valve—the advantages of indirect heating. *Wireless World and Radio Review*, 29, 308-310; September 23, 1931.
The indirectly heated vacuum tube has advantages of higher mutual conductance, improved detector efficiency and independent "free" bias.
- R132 J. Kammerloher. Graphische Bestimmung der maximalen Leistungsabgabe von Ein- und Mehrgitterröhren bei gegebener Anodenbatteriespannung und bei voller Aussteuerung der im Negativen liegenden Arbeitskennlinie. (Graphical determination of the maximum power output of single- and multigrid vacuum tubes). *Elek. Nach. Technik*, 8, 371-379; September, 1931.
It is shown that the power delivered by a vacuum tube may be determined graphically from its static characteristic. A similar method of determining amplification and efficiency is described. Experimental verification of these methods is given.
- R133 W. J. Kalinin. Zur Frage der Erzeugung von Elektronenschwingungen nach Barkhausen-Kurz. (The generation of Barkhausen-Kurz, electronic oscillations.) *Ann. der Physik*, 11(1), 113-128; 1931.
The results of a series of comparative experiments with electronic oscillators having different degrees of evacuation are given. Barkhausen's formula for λ is modified to include other observed types of oscillations.
- R165
×534 M. J. O. Strutt. Über die Schallstrahlung einer mit Knotenlinien schwingenden Kreismembran. (On the sound radiation from a vibrating circular diaphragm on which nodal lines exist.) *Ann. der Physik*, 11(1), 129-140; 1931.
Mathematical expressions are derived for determining the sound radiation from a circular vibrating diaphragm on which both circular and radial nodes exist. The diaphragm is assumed to be mounted in a large smooth rigid wall.
- R190 L. B. Hallman. Simplified attenuation network design. *Electronics*, 3, 150; October, 1931.
A method is given which dispenses with the necessity for substituting in formulas and at the same time allows speedy and accurate results.

R200. RADIO MEASUREMENTS AND STANDARDIZATION

- R214 V. E. Heaton and E. G. Lapham. Quartz plate mountings and temperature-control for piezo oscillators. *Bureau of Standards Journal of Research*, 7, 683-690; October, 1931. Research Paper No. 366.

In this paper there are described a number of representative types of mountings for rectangular and circular quartz plates to be used as frequency standard. Some discussion is given the subject of temperature control of the piezo oscillator.

- R220.1 V. V. Sathe and T. S. Rangachari. Measurement of small capacities. *The Wireless Engineer and Experimental Wireless*, 8, 543-547; October, 1931.

A d-c power line operated arrangement working on the principle of substitution for measuring capacities from 0.002 μ f down to minute capacities such as inter-electrode capacities of tubes is described.

- R242 L. Sutherlin. Grid current measurement. *Electronics*, 3, 148; October, 1931.

An indirect and very sensitive method for determining the grid current is schematically outlined.

- R243 K. Schlesinger. A capacitive potential divider for high-frequency measurements. *The Wireless Engineer and Experimental Wireless*, 8, 532-538; October, 1931.

A capacitive potential divider of special construction which gives potential step-down ratios of the order of one million with an error of only one or two percent is described. Its applications to high-frequency measuring technique are also described. The frequency range is from about 10 to 10⁶ kc.

- R270 R. K. Potter. High-frequency atmospheric noise. *PROC. I.R.E.*, October, 1931.

×R114

Measurements of noise over the range from 5 to 20 megacycles made in different parts of the United States and at different times of the year, show a distinct diurnal change in intensity similar to that for long-range high-frequency signal transmission. It is suggested that the intensity of atmospheric noise generated by centers of electrical disturbances is inversely proportional to frequency. Data are included showing the effect of sunrise and sunset, an eclipse of the sun, and disturbances of the earth's magnetic field upon the intensity of high-frequency atmospheric noise.

R300. RADIO APPARATUS AND EQUIPMENT

- R320.8 Principles of radio tower design. *The Post Office Electrical Engineers' Journal*, 24, 231-337; October, 1931.

Consideration of some principles of radio tower design is given.

- R325.31 P. Besson. Procédés de radioalignement. (Progress of radio direction finding.) *O'Onde Electrique*, 10, 369-416; September, 1931; Disc. 417-424; September, 1931.

×R125.31

Principles, methods, and apparatus used in radio direction finding are discussed.

- R329 Half-wave mast antenna. *Radio Craft*, p. 269; November, 1931.

A steel mast mounted on a porcelain base and used for a half-wave antenna is described.

- R333 A. E. Rydberg. WE 212-D as a modulator. *QST*, 15, 25-27; October, 1931.

×R135-

The tube ratings and best working conditions are supplied.

- R335 L. Tulauskas. The problem of pentode output fidelity. *Electronics*, 3, 142-143; October, 1931.

It is the purpose of this article to show that a pentode may be used in the output stage of an amplifier with very gratifying results not only so far as sensitivity and power output are concerned but also from the standpoint of fidelity.

- R339 F. B. Haynes. An electromagnetically controlled three-electrode vacuum tube. *Physics*, 1(3), 192-193; September, 1931.
A three-electrode tube in which the electron current is controlled by means of a magnetic field instead of the customary electrostatic field is described. This is accomplished by means of a special type of grid, the construction of which determines the static characteristic of the tube.
- R355.21 Relay broadcast transmitter—Type BR1a. *Marconi Review*, No. 31, 15-20; July-August, 1931.
An inexpensive low power, broadcast equipment suitable for relaying programs transmitted by wire is described.
- R355.9 E. G. Lapham. An improved audio-frequency generator. *Bureau of Standards Journal of Research*, 7, 691-695; October, 1931. Research Paper 367.
The construction of an audio-frequency generator for use in making radio-frequency measurements is described. The variable audio-frequency output is the beat note between the sources of radio-frequency: the one a piezo oscillator and the other a variable oscillator. The output is continuously variable from 50 to 1500 cycles per second.
- R355.9 W. L. Barrow. Untersuchungen über den Heulsummer. (Research studies of the "howler".) *Ann. der Physik* 11 (2), 147-176; 1931.
A "howler" is understood to be a sound source having practically constant amplitude but periodically changing frequency. An apparatus for producing the "howler" effect is described. An oscillographic wave analysis of the "howler" output is given and the effect of such an emf on a tuned circuit is explained.
- R356.3 D. McDonald. The design of power rectifier circuits. *The Wireless Engineer and Experimental Wireless*, 8, 522-531; October, 1931.
The aim in this investigation is to provide information which will allow power rectifier systems to be designed entirely on paper.
- R365.3 A. Forstmann. Über elektrische Schallplattenaufnahme und wiedergabe (Electrical disk-record recording and reproduction.) *Elek. Zeits.*, 52, 1080-1083; August 20, 1931; 1114-1117; August 27, 1931; 1169-1171; September 10, 1931.
The author gives a mathematical analysis of the phonograph pick-up and recorder for conditions of strict fidelity.
- R366 W. R. G. Baker and J. I. Cornell. DC inverter for radio receivers.
×R357 *Electronics*, 3, 152-154; October, 1931.
An apparatus which employs thyratron tubes to convert direct current into alternating current suitable for radio receivers is discussed. The method of operation of the thyratrons is also given.
- R382 A. L. Sowerby. The modern screened coil. *The Wireless World and Radio Review*, 29, 311-314; September 23, 1931; 397-400; September 30, 1931; 406-409; October 7, 1931.
The influence of screen dimensions on coil inductance, the high-frequency resistance of screened coils, and the designing of coils to suit the screen are discussed. Practical measurements are given which provide the constructor with the necessary data to choose the best size of coil for a given size of screen.
- R500. APPLICATION OF RADIO
- R512.3 New Wireless compass. *The Wireless World and Radio Review*, 29, 410-412; October 7, 1931.
A wireless compass which gives continuous indication of the direction of the transmitting station for as long a period as may be required is described.
- R550 K. Höpfner. Die Leitung im Dienste des Rundfunks. (Cables, in
×621.385.91 their service to broadcast networks). *Elek. Zeits.*, 52, 1061-1064; August 13, 1931; 1087-1090; August 20, 1931.

The particular requirements of wire lines when used for program distribution are studied. Germany's present radio program distributing network is described and compared with similar networks of other countries.

- R583 W. Tanner. Television reception with the superheterodyne. *Radio Engineering*, 11, 23-25; October, 1931.
Engineering details of the design of a superheterodyne receiving set suitable for television is given.
- R583 A. F. Murray. Measurement of fidelity in television systems. *Electronics*, 3, 137-138; October, 1931.
Some charts which were devised in the RCA Victor Research Laboratory as a step toward standardization of the measurement of television fidelity are reproduced.
- R590 H. Olken. Electronic oscillators for industrial process control.
×621.375.1 *Electronics*, 3, 144-145; October, 1931.
Oscillator methods of control permit continuous measurement, and measurement to extremely fine dimensions. The oscillator method makes it possible to measure and control a product without contacting or disturbing that product. Several applications are given.

R700. RADIO MANUFACTURING

- R720 W. Traub and F. Mengler. Eine selbststättige prüf- und Sortiermaschine für Verstärkerröhren (An automatic machine for testing and sorting vacuum tubes). *Elek. Zeits.*, 52, 1277-1278; October 8, 1931.
The construction details of a testing and sorting machine are described. The machine is entirely automatic and has a capacity of 1800 screen-grid tubes per hour.

R800. NONRADIO SUBJECTS

- 531 S. Reisch. Über eine neue elektrische Einrichtung zur Messung kleiner Verschiebungen (A new electrical method for measuring small displacements.) *Zeits. für Hochfrequenz.*, 38, 101-111; September, 1931.
A capacitive displacement micrometer is described. It is especially adapted for measurements in the field of mechanical vibrations.
- 534 H. E. Hallmann and T. Schultes. Ein Brückenarrangement zur Nachhallmessung bei reinen Tönen. (A bridge arrangement for measuring the reverberation of pure tones.) *Elek. Nach. Technik*, 8, 387-392; September, 1931.
A method and apparatus for the exact measurement of the reverberating time of pure tones is described.
- 535.38 The "electric eye" now enters industry. *Electronics*, 3, 132-135; October, 1931.
Many applications of the photo-electric cells to industry are discussed.
- 537.65 R. B. Wright and D. M. Stuart. Some experimental studies of the vibrations of quartz plates. *Bureau of Standards Journal of Research* 7, 519-554; September, 1931. Research Paper 356.
Numerous modes of vibration of 0- and 30-degree cut circular and rectangular crystalline quartz plates are studied experimentally. A number of photographs of patterns produced by vibrating quartz plates are produced and described. Some conclusions are drawn. Equations are derived for the modulus of rigidity and Poisson's ratio for crystalline quartz as functions of orientation, and graphs of these two functions as well as Young's modulus are given.
- 621.325 A cold-cathode 110-volt gaseous illuminant. *Electronics*, 3, 140-141; October, 1931.

A cold-cathode gaseous lamp which combines the advantages of the mercury vapor lamp and the neon tube, and which can be screwed into a 110-volt socket is described.

621.375.1

W. R. King. Electron tubes in industry. *Quarterly Trans. A.I.E.E.* 50, 590-599; June, 1931.

A general discussion of vacuum tubes and their application to industry is given. Special attention is paid to photo-electric and thyatron tubes.

621.385.96

G. Lewin. Studio practice in noiseless recording. *Electronics*, 3, 146; October, 1931.

Special technique of adjusting the spacing of the light valve ribbons to obtain the best over-all results are outlined. A photo-electric cell photometer is used for checking purposes.

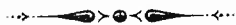

CONTRIBUTORS TO THIS ISSUE

Bailey, Austin: Received A.B. degree, University of Kansas, 1915; Ph.D. degree, Cornell University, 1920; assistant and instructor in physics, Cornell University, 1915-1918; signal corps, U. S. Army, 1918-1919; fellow in physics, Cornell University, 1919-1920; Corning Glass Works, 1920-1921; assistant professor of physics, University of Kansas, 1921-1922; department of development and research, American Telephone and Telegraph Company, 1922 to date. Associate member, Institute of Radio Engineers, 1925; Member, 1925.

Burch, C. R.: Born May 12, 1901. Educated at Oundle and Cambridge. Received B.A. degree, 1922. Physicist, Metropolitan-Vickers Electrical Company, Limited, England, 1923 to date. Nonmember, Institute of Radio Engineers.

Dow, Jennings B.: Born January 2, 1897 at Bowling Green, Ohio. Graduated U. S. Naval Academy, 1919; attended postgraduate school, U. S. Naval Academy, 1924-1925; received M.S. degree in E. E., Harvard University, 1926. Radio amateur, 1908 to date. Various fleet and shore radio assignments, 1919 to date. At present assigned to Radio Division, Bureau of Engineering, Navy Department. Member, Federal Specifications Board; American Standards Association. Member, Institute of Radio Engineers, 1926.

Jen, C. K.: Born Aug. 15, 1906 at Shansi, China. Graduated from Tsing Hua University, Peiping, China, 1926. Received B.S. degree in E.E., Massachusetts Institute of Technology, 1928. Received M.S. degree in E.E., University of Pennsylvania, 1929. Received Ph.D. degree in Physics, Harvard University, 1931. Assistant in Physics in Harvard University, 1930 to date. Research Fellow of the China Foundation for the Promotion of Education and Culture, 1931. Associate member, Institute of Radio Engineers, 1929.

Llewellyn, Frederick Britton: See PROCEEDINGS for March, 1931.

McCann, Thomas A.: Born July 2, 1901 at Dayton, Ohio. Received B.S. degree in E.E., Ohio State University, 1925. Radio operator at sea, Independent Wireless Company, Radio Corporation of America, 1920. Radio Corporation of America, 1920; staff of New Brunswick, New Jersey, radio station, Radio Corporation of America, 1923. Engineering department, Western Union Telegraph Company, summer, 1924; department of development and research, American Telephone and Telegraph Company, 1925 to date. Associate member, Institute of Radio Engineers, 1930.

***Namba, Shogo:** Born July 14, 1904 at Okayama, Japan. Studied electrical engineering, Kyoto Imperial University. Radio engineer, Electrotechnical Laboratory, Ministry of Communications, 1927 to date, at present time, supervisor of Hiraiso Experimental Radio Station. Associate member, Institute of Radio Engineers, 1929.

Roder, Hans: See PROCEEDINGS for August, 1931.



BUILT FOR EQUIPMENT THAT AIMS AT 100% ACCURACY

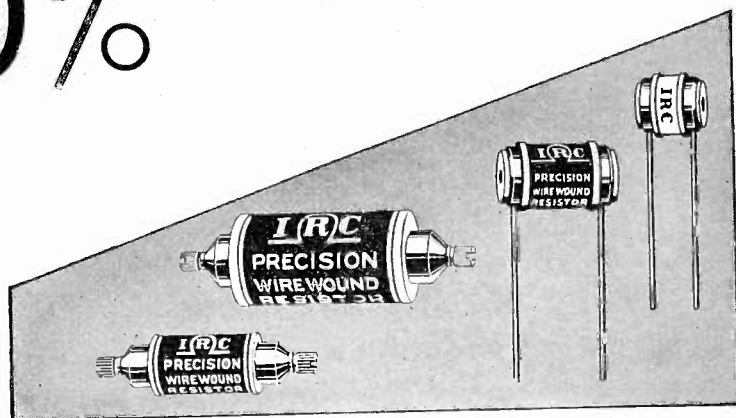

I R C

No matter what electrical apparatus you are concerned with, the cardinal issue is *accuracy*.

Defective resistors cost the electrical industry millions yearly—in faulty contacts, insufficient resistance, breakdowns and shorted turns.

Closer accuracy—this is the distinct achievement of I.R.C. Precision Wire Wound Resistors. Simple in design, rugged in construction, they were evolved only after long study and research—after countless tests under all conditions.

Improved ceramic winding form insures high insulation. Moulded ends eliminate shorted turns. Strictly high-grade wire guarantees low coefficient of resistance. A special impregnating enamel guards against humidity or corrosion. A complete range. Normal tolerances—1 per cent. Also in closer tolerances— $\frac{1}{2}$ or $\frac{1}{4}$ of 1 per cent.

As pioneers in the resistor business we are cooperating with the world's leading engineers. We welcome a discussion of your own problems. Before placing your orders, write for quotations and complete data.

Television
Radio Receivers
Spark Suppression
Amplifiers
Traffic Control
Aviation
X-Ray
Telephone Apparatus
Thermostatic
Control
Electrical Systems
Carrier Systems
And other industrial
uses.

INTERNATIONAL RESISTANCE COMPANY
Philadelphia Toronto

Makers of Type "K" Metallized Resistors and

PRECISION WIRE WOUND RESISTORS

When writing to advertisers mention of the PROCEEDINGS will be mutually helpful.



In the Bradleymeter approximately 50 solid resistance disks are interleaved between metal disks, forming a resistance column that will produce any form of resistance-rotation curve, as shown to the right

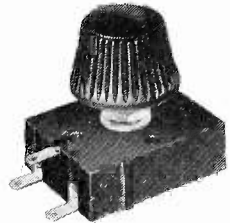
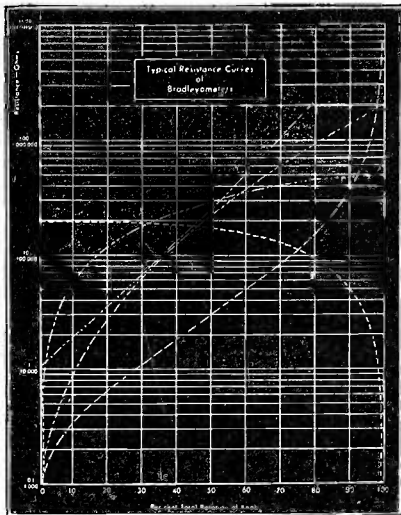

The Bradleymeter is a "stepped" potentiometer for volume level control and tone control. Can be furnished with one to six units operated by one knob. Ideal for sound recording, telephone lines, etc.

Every Radio Engineer should have the latest data on these remarkable resistors

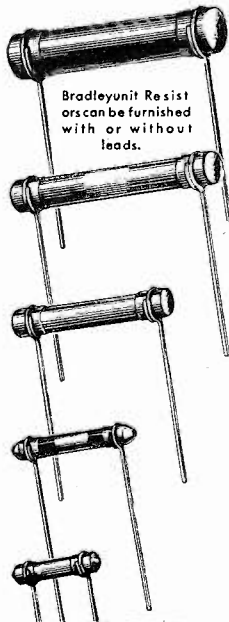

Bradleyunit Resistors can be furnished with or without leads.

Bradleyunit Resistors are made in five sizes, with or without leads. All Bradleyunits are color-coded to meet set manufacturers' specifications. These solid molded resistors are accurately calibrated and have great mechanical strength. They are used by the world's largest radio manufacturers for providing correct C-bias, plate voltage, screen grid voltage, and for use as grid leaks. Get an Allen Bradley quotation on your next order

Bradley Suppressors are special solid molded resistors which minimize the disturbing oscillations in the ignition circuit of cars equipped with radio resistors. They resist the destructive effects of heat, moisture, and age. They are the last word for motor car radio. Send for complete data.

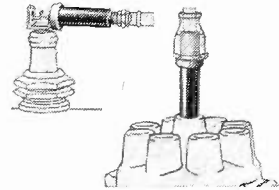

Bradley Suppressors installed on spark plugs and distributor of radio-equipped car.

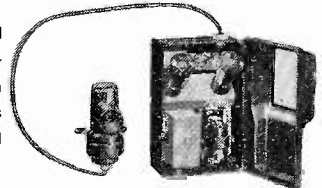

Allen-Bradley Bulletin 880 Photo-electric Relay used with Allen-Bradley Bulletin 875 Light Source. Can be furnished in water-tight enclosures for outdoor service. Send for Bulletins 875 and 880 today

Allen-Bradley Co.

116 W Greenfield Ave



Milwaukee, Wisconsin

ALLEN-BRADLEY RESISTORS

Produced by the makers of Allen-Bradley Control Apparatus

When writing to advertisers mention of the PROCEEDINGS will be mutually helpful.

Continental Resistors

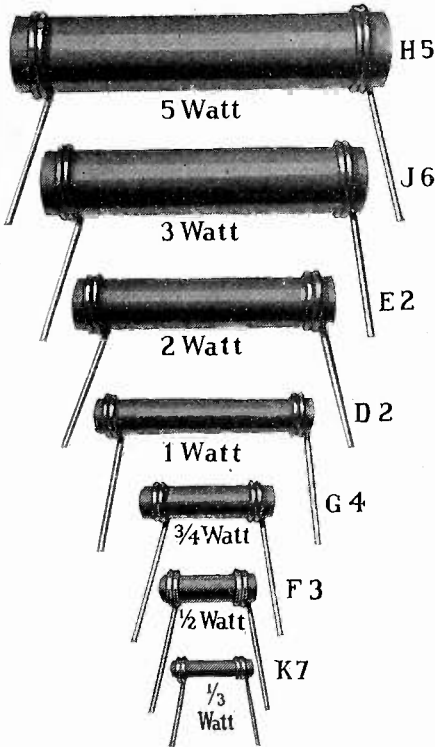

RESISTOR CHARACTERISTICS:

NOISELESS
RESISTANCE CONSTANT
SMALL TEMPERATURE
COEFFICIENT
RUGGED
FIRMLY SOLDERED TERMINALS
DEPENDABLE
COLOR CODED

UNITS SHOWN HALF SIZE

CONTINENTAL SUPPRESSORS

For Radio-Equipped Cars

Stop ignition noise in the automobile radio set when used with suitable by-pass condensers. The distributed capacity is extremely small. The resistors are enclosed in a tough ceramic tube of high crushing and tensile strength, of low coefficient of expansion and of high dielectric strength. They are hermetically sealed in the tube and this renders the suppressors moisture proof.

Suppressors shown full size

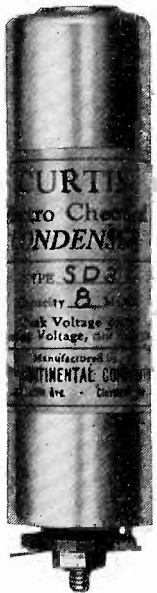
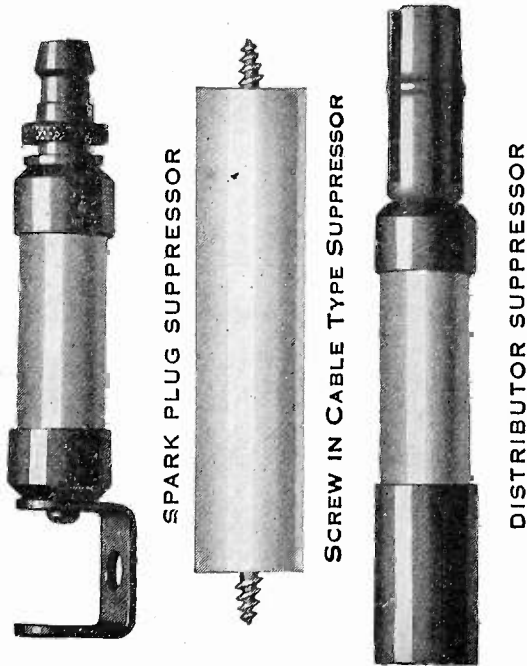

Curtis Electro Chemical Condenser

Essential Characteristics

Full capacity at all voltages

Uniform capacity at all frequencies

Low freezing point

Low internal resistance

Low leakage

Made in shape and size to suit the customer, in round, square or rectangular, metal or cardboard containers. Working voltage from 6 Volts to 450 Volts.

For Further Particulars Write to
Curtis Continental Corp.
13900 Lorain Ave.,
Cleveland, O.

Write for Information and Prices
CONTINENTAL CARBON INC.

13900 Lorain Ave.
WEST PARK, CLEVELAND, O.

When writing to advertisers mention of the PROCEEDINGS will be mutually helpful.

DeJUR-AMSCO

MIDGET CONDENSERS

For Midget T.R.F., Short Wave and Super-Hets

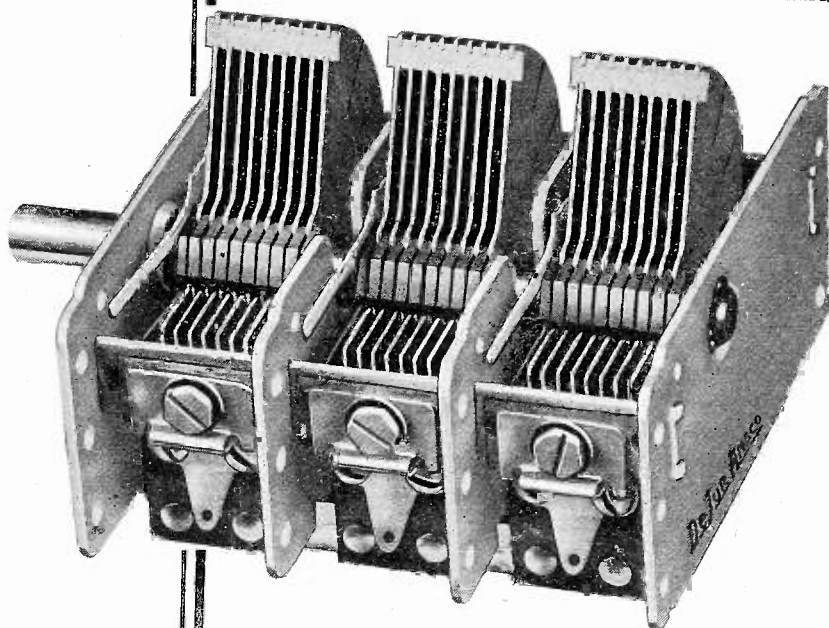

MEET ALL PRESENT DAY
REQUIREMENTS — INCLUDING
LOWER PRICES

Ten years' experience in the designing and manufacturing of variable condensers for the foremost set manufacturers of the world, places us in a pre-eminent position to meet the exacting requirements of the present time. What is your problem? Consultation incurs no obligation.

We invite manufacturers to write for circular giving full particulars and prices.

DeJUR-AMSCO CORPORATION

95 MORTON ST., NEW YORK CITY

When writing to advertisers mention of the PROCEEDINGS will be mutually helpful.

Did you ever
stop to consider
the **EXPERIENCE** behind
the manufacturer of the radio tubes
you buy?

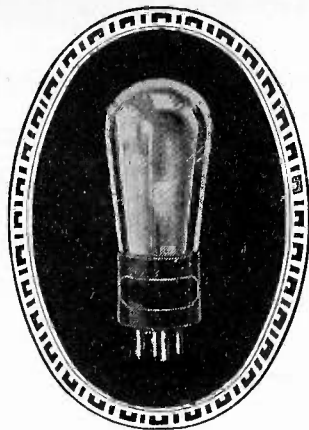

Behind every radio tube made by Hygrade Sylvania Corporation is the experience of 30 years in vacuum tube problems

and the practical knowledge that has come from the steady production of millions of tubes per year, all made to an unvarying standard.

ENGINEERING BACKGROUND. Hygrade Sylvania's experience in manufacture has the background of a large staff of capable radio and lamp engineers.

SOUNDLY FINANCED. Hygrade Sylvania is a soundly financed, profitable concern, operating under the active direction of its principal owners.

Hygrade Sylvania Corporation

HYGRADE LAMP DIVISION

SALEM



MASS.

When writing to advertisers mention of the PROCEEDINGS will be mutually helpful.

BECAUSE OF THIS SPIRIT



THE biggest thing about your telephone is the spirit of the hundreds of thousands of people who make up the Bell System. No matter what their particular jobs may be, they are first of all telephone men and women.

The loyalty of these people to the ideals of their work is reflected in every phase of your telephone service. It shows in the increasing speed with which your local and long distance calls are completed. It shows in the greater accuracy with which they are handled. It shows in the wider and more convenient facilities which are placed at your command—extension telephones, intercommunicating systems for home and office, small and large switchboards, teletypewriters and many others.

Because of this spirit, your needs for fast, complete and inexpensive telephone service are more fully met each year. Men and women of the Bell System are constantly explaining the varied telephone services to more and more users. They prepare the way for the new plant and equipment put at your disposal every year. Through their efforts, you receive better and wider service at a cost made possible only by an organization of this character.

Although it does not appear on the balance sheet, the greatest asset of the Bell System lies in the skill, energy and purpose of the people who carry on its work. Every time you telephone, you get the advantage of this—in better and better service at the lowest possible cost.

★ AMERICAN TELEPHONE AND TELEGRAPH COMPANY ★



When writing to advertisers mention of the PROCEEDINGS will be mutually helpful.

SM

Equipment for Broadcast Stations, Sound-Recording Plants, Sound-Distributing Systems

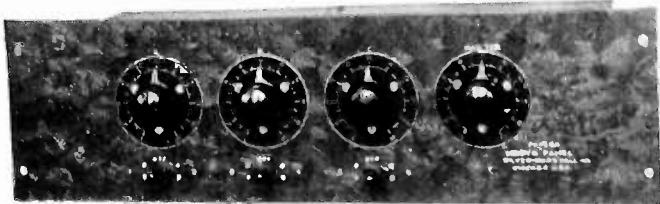

PA54A MIXING PANEL

A three-channel mixing panel with master control.

INPUT—Six 200 ohm circuits, three of which may be used simultaneously. Fully shielded wiring.

IMPEDANCES—Input: 200 ohms each channel.
Output: 500 ohms.

VOLUME CONTROLS—Constant impedance type throughout. No "body-capacity" hum. Special switching arrangement maintains correct impedance relationships when channels are not in use.

SIZE—PA54A 6" by 21" for S-M racks.

PA54AW 5 $\frac{1}{4}$ " by 19" for relay racks.



PA60B VOLUME INDICATOR

A precision power level indicator for quantitative monitoring of audio frequency circuits.

RANGE—Minus 8 to plus 48db

CALIBRATION—Based on zero level of 6 milliwatts in 500 ohms.

BRIDGING IMPEDANCE—5,000 ohms.

METER—Copper-Oxide type.

SIZE—PA60B 4" by 21" for S-M racks.

PA60BW 5 $\frac{1}{4}$ " by 19" for relay racks.

Many other rack and panel units are available

Write to Mr. Gray for lowest prices, and new November Catalogue

SILVER-MARSHALL, Inc.

6401 WEST 65th STREET

CHICAGO, U. S. A.

Export Division: 41 Water Street, New York City, U. S. A.

When writing to advertisers mention of the PROCEEDINGS will be mutually helpful.

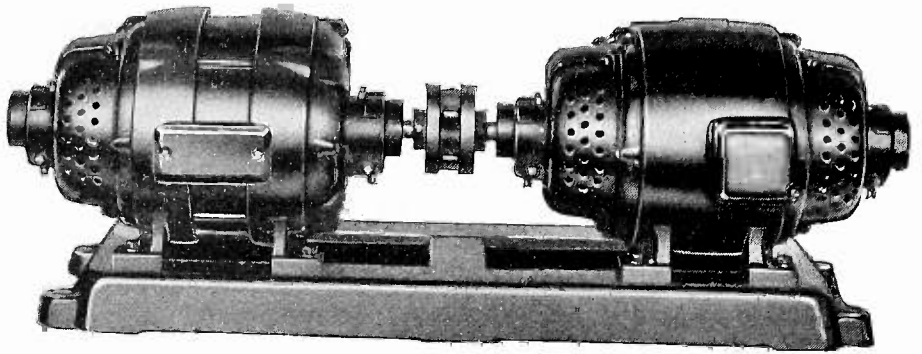

Do You Need Radio Power Supply?

Get in touch with "ESCO." For over twenty years "ESCO" has specialized in Electrical Power Equipment at reasonable cost.

ESCO RADIO PRODUCTS.

MOTOR GENERATORS Motors to fit any kind of power supply. Generators from four to ten thousand volts—double current, high and low voltage. Special units for battery charging, transmitters—plate and filament supply, alternator sets from 25 to 2,000 cycles. Furnished with ball-bearings, wool pack, or wick oil to suit your requirements.

DYNAMOTORS DC to DC for high voltage plate supply, grid bias, or battery charging.

DC to AC for transmitter supply, or for radio receivers.

AIRCRAFT Wind driven generators, double current, high and low voltage. Alternating current up to 1,000 cycles.

Dynamotors, 6 to 12 volts primary, and up to 1,500 volts secondary. Aluminum construction, enclosed.

AUTOMOBILE Efficient, rugged, battery operated dynamotors for receivers—wick oil, or ball bearing.

TELEVISION Synchronous motors, split phase or condenser types. Engineered to fit your individual requirements.

GASOLINE-ELECTRIC Portable and semi-portable power units. Generators for either alternating or direct current, high or low voltage.

ELECTRIC  **SPECIALTY**
COMPANY

300 South St.

Stamford, Conn.

Manufacturers of

Motor Generators—High Voltage for radio transmission, Low Voltage for battery charging. ¶Dynamotors, Rotary Converters for radio receivers and power amplifiers. ¶Airplane generators and dynamotors. ¶Special motors for talkies and television. ¶Portable and semi-portable gasoline electric sets for light and power.

When writing to advertisers mention of the PROCEEDINGS will be mutually helpful.

THE NEW GEN-RAL "MIDGET"

Type R.F.B. No. 105

A complete canned
R.F. coil with high
gain

Midget size only
1 7/8" O.D.
2" high

Supplied in
matched sets of
two or three units



Standard bank
wound-silk "Litz"
construction

Sensitivity curves
sent on request

Priced low for
mass production
receivers

Facsimile Shows Actual Size

GEN-RAL

Super

Hetrodyne

I. F. Trans-
formers

Peaked at
175 K.C.

Shields are re-
movable when
units are mounted
on chassis

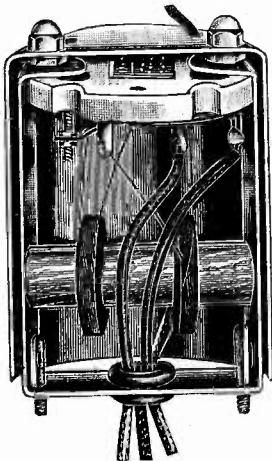

CX100 D.H.M.

A standard I.F. Unit
with ample gain (142)
for most super hetro-
dyne circuits

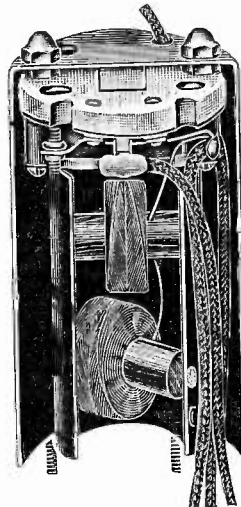

CX200 D.H.M.

A high gain "Litz"
wire I. F. Unit for cir-
cuits requiring very
sensitive I. F. stage

GENERAL MANUFACTURING COMPANY

8067 So. Chicago Ave.

Chicago, Ill.

When writing to advertisers mention of the PROCEEDINGS will be mutually helpful.

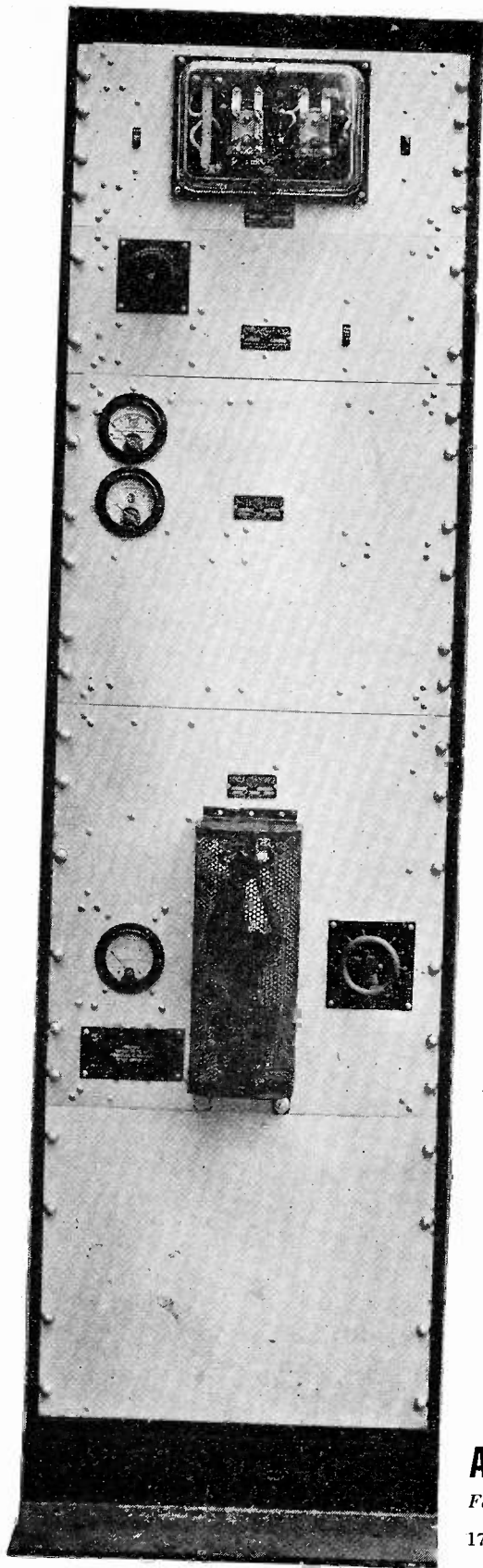

"TIME-TESTED"

the New

AMERTRAN
TRADE MARK REG. U.S. PAT. OFF.

Heavy Duty Filament Supply

After two years of laboratory experimental work and with many units already giving over a year's satisfactory service in actual installations, the American Transformer Company announces the new AmerTran Heavy Duty Filament Supply System.

These systems have been designed to replace batteries in amplifiers (including low level and high gain amplifiers) and other places where pure direct current is required. They are a worthy companion to the AmerTran Type P-77 plate supply announced last fall.

Write for Technical Data Sheet D1 describing in detail AmerTran 10 Ampere "A" Supply System.



A Standard AmerTran 10 Ampere, 12 volt filament supply system (illustrated at left) which includes a power supply, filter system, voltage control and control relay. Similar units are available for D. C. outputs of 3-15-30-60 or 100 amperes at 12 volts or special sizes can be made to your specifications.

American Transformer Company

Factory and
Main Office—
178 EMMET STREET
Newark, N. J.

New York Office
Room 1963
HUDSON TERMINAL
50 Church Street

When writing to advertisers mention of the PROCEEDINGS will be mutually helpful.

Announcing DUBILIER MOULDED TYPE 6 CAPACITOR

Now a highly efficient Dubilier mica capacitor is obtainable in a sturdy 100% insulated housing of low-loss Bakelite. Ideal for transmitter and laboratory uses.

Small mounting area
Low capacity to mounting
High voltage safety factor
High temperature filler
High efficiency

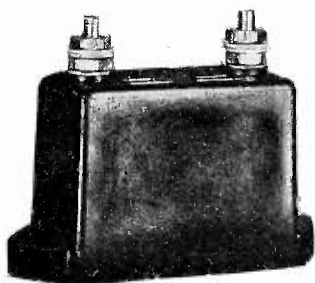

Better appearance
Rigid foot mounting
Substantial terminals
Rating visible from top
Low in cost

Capacity range .000025 to .2 mfd.
Effective Voltage Rating 5000 to 250 volts

DUBILIER TYPE 50 SERIES

Represents the most highly developed type of mica capacitors. The metal end cap terminals allow ease of stacking for large KVA ratings in series parallel combinations to obtain proper voltage and current

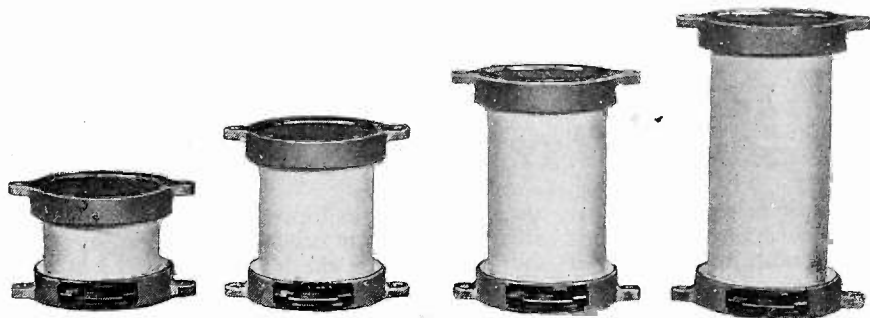

distribution. The proper use of materials and the best design make these units extremely efficient and therefore capable of handling higher KVA per unit. Many sizes are available for all types of transmitters. See catalog for listings.

Dubilier

CONDENSER CORPORATION

4377 Bronx Blvd.
New York, N. Y.

When writing to advertisers mention of the PROCEEDINGS will be mutually helpful.

**ESCAPE
THIS ?
*never!***



EVERY ARCTURUS TUBE
must pass 137 TESTS and CHECKS

Reductions in prices or revisions in methods cannot... will not... interfere with Arcturus' rigid standards of giving each *blue* tube 137 tests and checks before it leaves the factory. The quality of Arcturus *Blue* tubes, recognized by critical engineers of leading set manufacturers, jobbers, dealers, consumers... and even conceded by other tube manufacturers... will not be sacrificed for any reason!

Not an Arcturus Tube escapes these 137 tests and checks. All raw materials, each operation, every part... each tube is interminably "third-degreed."

Each Arcturus Tube must meet

the rigid Arcturus limits, closer than those of any other manufacturer; it must check for the highest degree of vacuum practically obtainable, precise characteristics, humless and undistorted reproduction in actual receivers, gruelling life tests, continuously checked and rechecked.

Then, and only then, is the tube ready.

Certainly a painstaking operation to give you a well-engineered product to complement your well-engineered set. Technical data sheets on Arcturus *Blue* Tubes will be sent to engineers upon request.

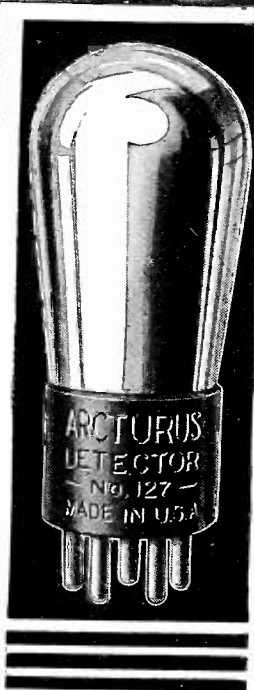

ARCTURUS RADIO
TUBE COMPANY
Newark, New Jersey

ARCTURUS

"The Blue TUBE with the LIFE-LIKE TONE"

When writing to advertisers mention of the PROCEEDINGS will be mutually helpful.

The Institute of Radio Engineers

Incorporated

33 West 39th Street, New York, N. Y.

APPLICATION FOR ASSOCIATE MEMBERSHIP

(Application forms for other grades of membership are obtainable from the Institute)

To the Board of Direction
Gentlemen:

I hereby make application for Associate membership in the Institute.

I certify that the statements made in the record of my training and professional experience are correct, and agree if elected, that I will be governed by the constitution of the Institute as long as I continue a member. I furthermore agree to promote the objects of the Institute so far as shall be in my power, and if my membership shall be discontinued will return my membership badge.

Yours respectfully,

.....
(Sign with pen)

.....
(Address for mail)

.....
(Date)

.....
(City and State)

References:

(Signature of references not required here)

Mr. Mr.

Address Address

Mr. Mr.

Address Address

Mr.

Address

The following extracts from the Constitution govern applications for admission to the Institute in the Associate grade:

ARTICLE II—MEMBERSHIP

- Sec. 1: The membership of the Institute shall consist of: * * * (d) Associates, who shall be entitled to all the rights and privileges of the Institute except the right to hold the office of President, Vice-president and Editor. * * *
- Sec. 5: An Associate shall be not less than twenty-one years of age and shall be: (a) A radio engineer by profession; (b) A teacher of radio subjects; (c) A person who is interested in and connected with the study or application of radio science or the radio arts.

ARTICLE III—ADMISSION

- Sec. 2: * * * Applicants shall give references to members of the Institute as follows: * * * for the grade of Associate, to five Fellows, Members, or Associates; * * * Each application for admission * * * shall embody a concise statement, with dates, of the candidate's training and experience.

The requirements of the foregoing paragraph may be waived in whole or in part where the application is for Associate grade. An applicant who is so situated as not to be personally known to the required number of members may supply the names of non-members who are personally familiar with his radio interest.

Now the Model D

TWO-SPEED (33 1/3 & 78 r.p.m.)

Governor-Controlled

Green Flyer

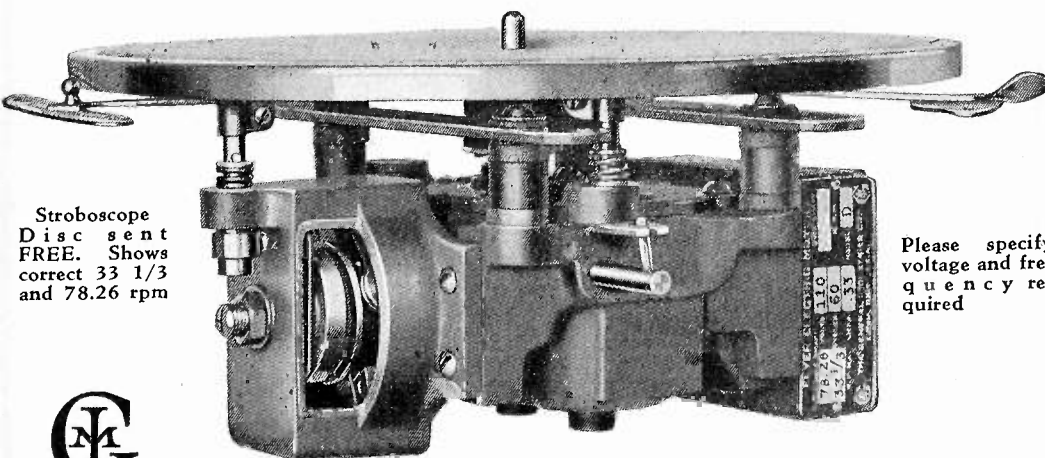

Stroboscope
Disc sent
FREE. Shows
correct 33 1/3
and 78.26 rpm

Please specify
voltage and fre-
quency re-
quired



Induction type. Ample power.

SPECIALLY designed for perfection of dual service, the new Green Flyer Model D Electric Motor with turntable provides for playing the new 33 1/3 r.p.m. records and also those recorded at 78 r.p.m. Shifts from one speed to the other by pushing a convenient lever.

Furnishes positively uniform speed under severe variations of voltage and record drag. Governor control provides a 10% range of speed adjustment as desired.

All gears, completely enclosed and running in oil, are spiral cut and made of laminated Bakelite. No hum. Long oversize self-lubricating bearings. No overheating in closed case or cabinet.

For all voltages and frequencies; also supplied for 110 or 220 volts d.c. Furnished complete with turntable, speed regulator dial and speed change escutcheon. Automatic stop is optional.

The GENERAL INDUSTRIES CO.

3146 Taylor Street, Elyria, Ohio

When writing to advertisers mention of the PROCEEDINGS will be mutually helpful.

IF CONDENSERS

—like men—may be judged by the company they keep, then CARDWELL condensers must indeed possess merit, for they are favored of a particularly distinguished company of users. Any variable condenser may, in a measure and for a time, prove suitable for the job in hand, but since pioneers have blazed a trail for you to follow, why experiment with variable condensers of questionable merit and indifferent performance?



The finish and quality of CARDWELL-built instruments and apparatus have proved a revelation to many people who believed that only by a line of excellent condensers was the world-wide reputation of the name CARDWELL established.

You may be interested to know that a manufacturing plant, with specialists to interpret your requirements, is at your service having every needed facility for producing fine instruments and apparatus exactly according to your specifications or designed by us, if you wish, to suit your needs. We solicit your proposals.

Literature will be sent on request.

CARDWELL CONDENSERS AND MANUFACTURING SERVICE

The Allen D. Cardwell Mfg. Corp'n
93 Prospect Street, Brooklyn, N.Y.

“THE STANDARD OF COMPARISON”

When writing to advertisers mention of the PROCEEDINGS will be mutually helpful.

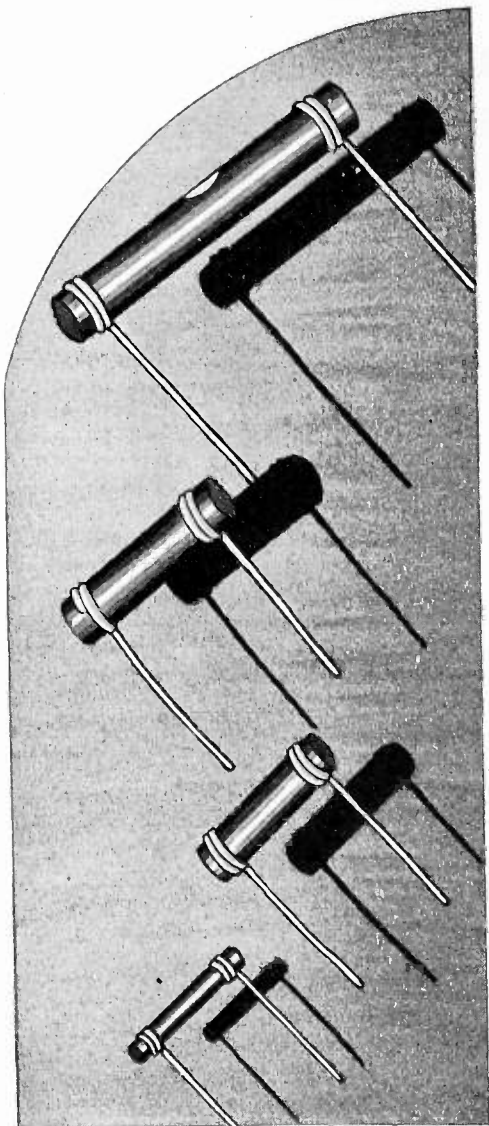

Performance

Leading manufacturers specify ERIE RESISTORS because they know that satisfactory performance under every condition of use is assured. Our experience has proven the need of daily laboratory checks on the different steps in the manufacturing processes to insure resistors of constant quality.

MAY WE SEND YOU SAMPLES AND PRICES?

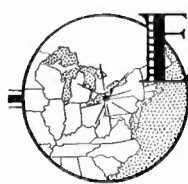

ERIE RESISTORS

Erie Resistor Corporation, Erie, Pa.
In the Center of the Radio Industry

When writing to advertisers mention of the PROCEEDINGS will be mutually helpful.

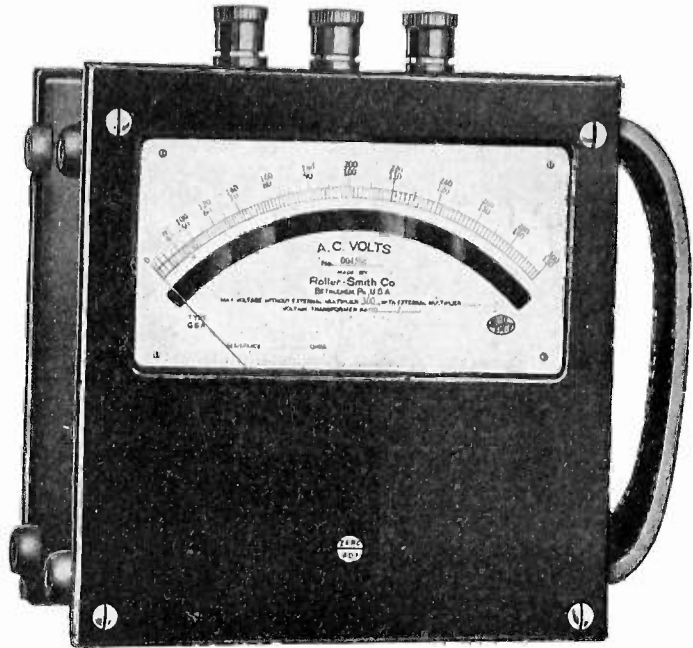

ROLLER-SMITH ANNOUNCES New Bulletin No. K-160

covering a wide variety of
Portable Alternating Current Instruments

Ammeters, Voltmeters, Volt-ammeters, Single and Polyphase Wattmeters, Power Factor Meters and Frequency Meters.

Included in the group are many types of instruments for application in the Radio Industry.

Send for your copy of new Bulletin No. K-160.

"Forty years' experience is back of Roller-Smith"

ROLLER-SMITH COMPANY
Electrical Measuring and Protective Apparatus

MAIN OFFICE:
2134 Woolworth Bldg., New York



WORKS:
Bethlehem, Pennsylvania

Offices in principal cities in U. S. A. and Canada

When writing to advertisers mention of the PROCEEDINGS will be mutually helpful.

SPECIAL ITEMS FOR RADIO MANUFACTURERS

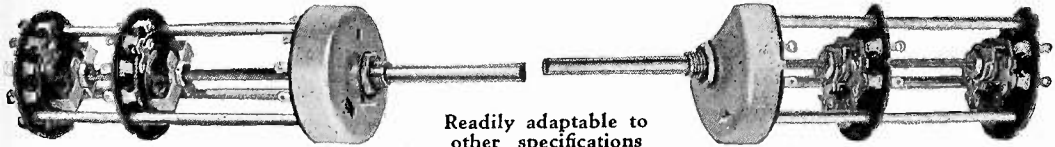

No. 7280A
3 gang, 4 positions
single circuit

Readily adaptable to
other specifications

No. 7260A
3 gang, 2 positions
2 circuits

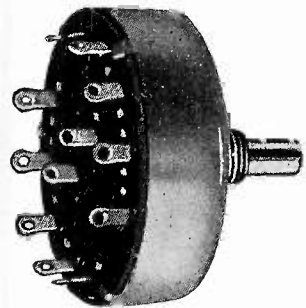

No. 7150A
5 positions, 2 circuits

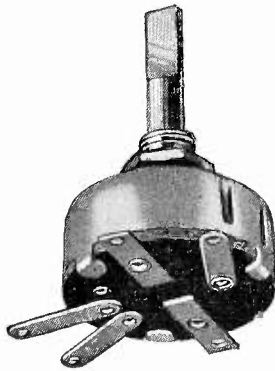

No. 7120A
Combined Acoustic and mut-
ing switch 2 or 3 positions

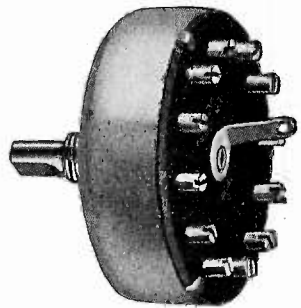

No. 7220A
12 positions, single circuit

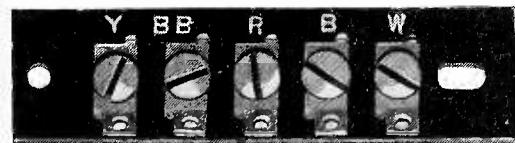

Terminal Strip
5 Lugs No. 6880A, 4 lugs No. 6990A



Terminal Strip
4 Clips, No. 6830A



Terminal Strip
5 Lugs, No. 6950A

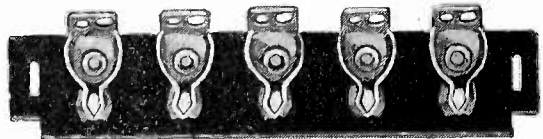

Terminal Strip
5 Clips, No. A6310AA, 4 Clips No. A6320AA

SORENG - MANEGOLD CO.

771 Mather Street, CHICAGO, ILL.

1646 W. Adams St.
Los Angeles, Cal.

701 Stephenson Bldg.
Detroit, Mich.

245-5th Ave.
New York City

When writing to advertisers mention of the PROCEEDINGS will be mutually helpful.

Piezo-Electric Crystals

New Price List Effective Immediately

We are extremely pleased to announce **NEW REDUCED PRICES** for **HIGH GRADE CRYSTALS** for **POWER** use. Due to our **NEW** and **MORE EFFICIENT METHOD** of preparing these crystals, we are allowing you to share in the **LOWER COSTS** of producing these crystals.

We are proud of the confidence our customers have shown toward us, we extend to them our sincere thanks for their patronage thus making this reduction possible.

New prices for grinding **POWER** crystals in the various frequency bands, together with the old prices are as follows:

| FREQUENCY RANGE | NEW LIST |
|-----------------|----------|
| 100 to 1500 Kc | \$40.00 |
| 1501 to 3000 Kc | \$45.00 |
| 3001 to 4000 Kc | \$50.00 |
| 4001 to 6000 Kc | \$60.00 |

The above prices include holder of our Standard design, and the crystals will be ground to within .03% of your specified frequency. If crystal is wanted unmounted deduct \$5.00 from the above prices. Delivery two days after receipt of your order. In ordering please specify type tube, plate voltage and operating temperature.

Special Prices Will Be Quoted in Quantities of Ten or More

POWER CRYSTALS FOR AMATEUR USE

The prices below are for grinding a crystal to a frequency selected by us unmounted, (if wanted mounted in our Standard Holder add \$5.00 to the prices below) said crystal to be ground for **POWER** use and we will state the frequency accurate to better than a tenth of one per-cent. **IMMEDIATE SHIPMENT CAN BE MADE.**

| | |
|---------------------------|--------------|
| 1715 to 2000 Kc band..... | \$12.00 each |
| 3500 to 4000 Kc band..... | \$15.00 each |

LOW FREQUENCY STANDARD CRYSTALS

We have stock available to grind crystals as low as 13 Kilocycles. Prices quoted upon receipt of your specifications.

CONSTANT TEMPERATURE HEATER UNITS

We can supply a high grade heater unit which maintains a constant temperature **BETTER** than a tenth of one degree centigrade. These units have provision for two of our Standard Holders, (one used as a spare) and operate from the 110 V 60 cycle supply mains, entirely automatic and of excellent design. Price and description sent upon request.

PLEASE NOTE NEW ADDRESS

Scientific Radio Service

"THE CRYSTAL SPECIALISTS"

124 Jackson Ave., University Park

Hyattsville, Maryland

When writing to advertisers mention of the PROCEEDINGS will be mutually helpful.

HOW SCOVILL HELPS RADIO MANUFACTURERS

TO **Simplify**

their **Plants**

BECAUSE it is the largest company in the world specializing in the manufacture of small metal parts—where the conditions of precision and quality manufacture, quantity production and practical economy all must be fulfilled—Scovill, since the founding of the radio industry, has been able to serve many radio manufacturers in this unique way. Scovill has been able to translate new inventions and developments into the practical language of production. Then, through its enormous production facilities,

it has been able to combine quantity production with unequaled precision in quality parts. The result of all this is that radio manufacturers, backed by Scovill service, are able to simplify their plants, reduce costs, and to raise the standards of their sets.

It is almost certain that we can help you with your problems. Why not call on us about anything you need, from machine screws to condensers? Write us of any difficult problem, marking your letter for the attention of the General Superintendent.



Scovill

Scovill Manufacturing Company
Waterbury, Connecticut

Boston Providence New York Philadelphia Atlanta
Syracuse Detroit Cleveland Chicago Cincinnati
San Francisco Los Angeles in Europe: The Hague, Holland

When writing to advertisers mention of the PROCEEDINGS will be mutually helpful.

THORDARSON

"PENTRAN"

POWER FOR THE
PENTODE

TO THINK OF TRANSFORMERS IS TO THINK OF THORDARSON

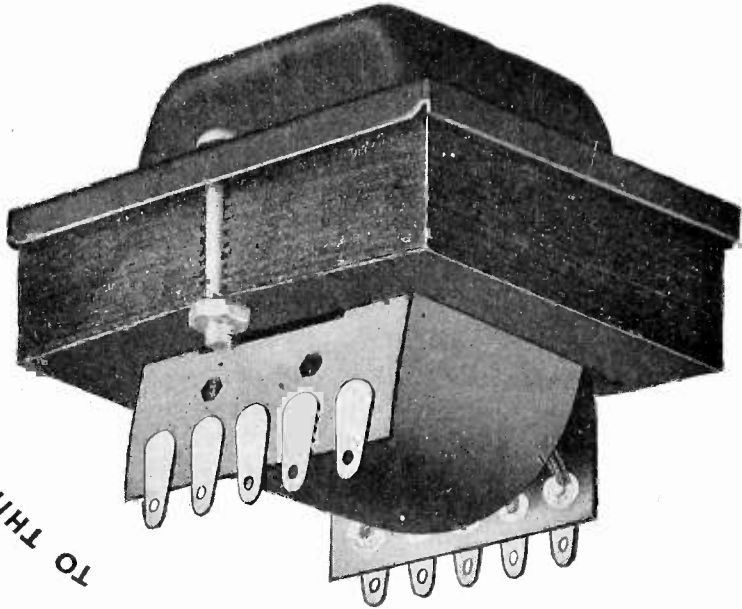

You can adopt the pentode with no transformer worries — and with actual saving in the transformer component, so attractive is the price at which Thordarson offers the new "PENTRAN"—developed and built by Thordarson for Radio Manufacturers whose first consideration is quality in every part, and outstanding performance of the finished product. Thordarson Precision Machines which are marvels of economical manufacturing, and Thordarson straightline assembly, enable set manufacturers to have the "PENTRAN" far below what it would cost them to make their own pentode power transformers.

You are invited to consult Thordarson engineers on the adaptation of this remarkable transformer to your particular requirements.

Thordarson Electric Manufacturing Company
500 West Huron Street, Chicago, Illinois

THORDARSON
Reg. U. S. Pat. Off.

TRANSFORMER
SPECIALISTS
SINCE 1895 . . .

ADAPTABLE—Because skillfully and accurately designed to cover every requirement of the pentode tube—at the same time matching the widest possible range of set characteristics.

DEPENDABLE—Because built with true Thordarson fidelity, from best materials, an extra measure of quality, nothing skimped.

COMPACT—Weighs only 4 pounds 6 ounces. $3\frac{1}{4} \times 4$ inches; total depth $3\frac{3}{4}$ inches; above chassis $2\frac{3}{4}$ inches.

UNIFORM—Because each transformer is rigidly inspected at every step of manufacture and must pass a final, individual test in which all secondary voltages under load are held within plus or minus 5%.

When writing to advertisers mention of the PROCEEDINGS will be mutually helpful.

Simplicity
and Economy
with the new

PHOTRONIC CELL

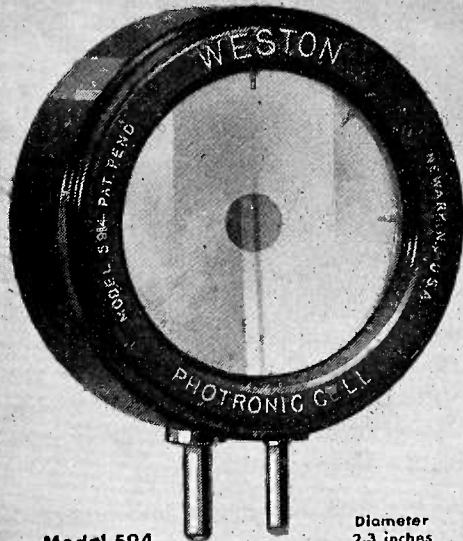

Model 594

Diameter
2.3 inches

• • • • • **NOW**
with the new Weston PHOTRONIC CELL, light sensitive cell applications are reduced to a new simplicity. Reliability increased . . . new fields opened . . . present developments advanced.

In construction and use, the PHOTRONIC CELL is different, utterly simple, low in cost. It operates instruments or relays *directly*. It

uses no batteries, no polarizing or exciting voltages, no amplifiers.

Highly sensitive. Its current output approx. 5 milliamperes in direct sunlight . . . approx. one microampere per foot-candle. No dark current. Response is instantaneous.

Life unlimited—in use or on shelf. No drifting . . . no readjustment of circuit . . . nothing to replace . . . not easily damaged. Constant characteristics.

Amazing in performance, revolutionizing in operation, the new Weston PHOTRONIC CELL advances light sensitive cell applications to a new degree of reliability, simplicity and economy.

Write for Circular YY

WESTON

ELECTRICAL INSTRUMENT CORPORATION

589 FRELINGHUYSEN AVENUE

NEWARK, N. J.

When writing to advertisers mention of the PROCEEDINGS will be mutually helpful.

RADIO NEEDS

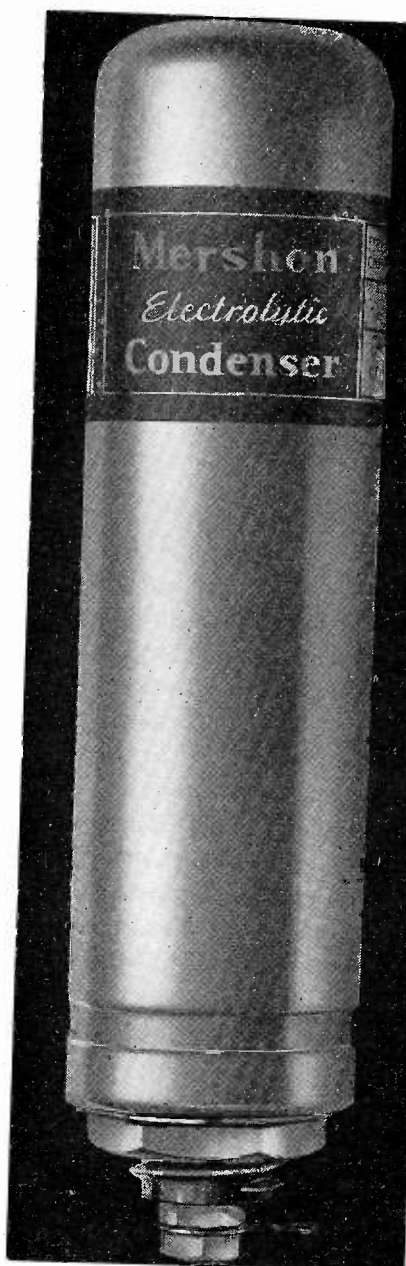

BETTER AUDIO SYSTEMS

Modern radio must deliver *better reception* to match the tremendous improvements in broadcasting, in talent, in programs.

It costs the manufacturer little more to give his sets the superior performance advantage that Mershon Electrolytic Condensers confer—lifetime perfection of noiseless service, never interfering with the listener's enjoyment.

Equip your sets with the original puncture-proof electrolytic condenser—the Mershon—with exclusive quality features that have made this unit the choice of leading engineers for the majority of America's finest radio sets.

Magnavox Company Ltd.

Executive and Sales Offices: 155 East Ohio St.,
Chicago, Ill.

Factories: Fort Wayne, Ind.

SUBSIDIARIES

The Magnavox Company
Electro Formation, Inc.

SUBSIDIARIES

Magnavox (Great Britain)
Ltd.
Magnavox (Australia) Ltd.

MERSHON

ELECTROLYTIC CONDENSERS

AVAILABLE IN A WIDE RANGE OF CAPACITIES TO SATISFY THE REQUIREMENTS OF EVERY MAKE OF RADIO. SEND FOR ENGINEERING DATA

When writing to advertisers mention of the PROCEEDINGS will be mutually helpful.

RCA Victor

Standard Signal Generator

TYPE TMV-18

and

Beat Frequency Oscillator

TYPE TMV-28

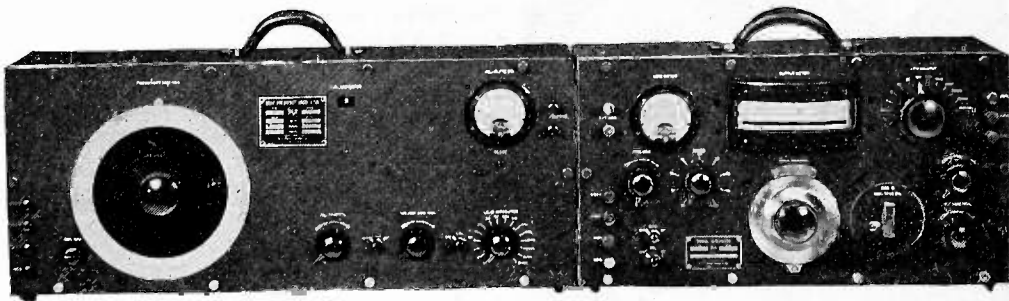

AN IDEAL PAIR

for Receiver Measurements and General Laboratory Calibration Work

MAY BE USED SEPARATELY OR IN COMBINATION

Embodying the Features of

WIDE FREQUENCY RANGE
HIGH PERCENTAGE OF MODULATION

HIGH OUTPUT VOLTAGE
ACCURACY AND CONVENIENCE

Specifications

TMV-18

STANDARD SIGNAL GENERATOR

Output Voltage—0.25 microvolt
to 2 volts
Frequency Range—75 to 10,000 k.c.
Percentage Modulation—0 to 80
Push-Pull Radio Frequency Oscillator
Power Supply—External Batteries

TMV-28

BEAT FREQUENCY OSCILLATOR

Power Output—0.75 watts
Frequency Range—30 to 10,000 cycles
Impedance Range—2 to 24,000 ohms
Reed type Frequency Meter for Adjusting
Calibration
Power Supply—External Batteries

RCA Victor Company, Inc.

INDUSTRIAL PRODUCTS DIVISION

Camden, N. J.

"Radio Headquarters"



When writing to advertisers mention of the PROCEEDINGS will be mutually helpful.

An Audion for Every Need

SINCE 1906, when Lee DeForest gave the world its practical vacuum tube, DeForest engineers have engaged in unrelenting research and development.

A quarter century of pioneering continues. Original work in every phase of tube theory, tube design, tube production and tube application characterizes the products of the DeForest Radio Company.

There is a DeForest Audion of every standard and special type to meet every need. Each Audion is the DeForest version of a given type, incorporating obvious refinements and improvements. In addition, the DeForest engineers work out the most practical applications for their Audions, even to complete DeForest transmitters, amplifiers and allied equipment. Only in this manner can the heritage of true pioneering be justified and maintained.

*After all, there's no substitute for
25 years' experience*

Write for literature descriptive of DeForest receiving and transmitting audions, as well as DeForest transmitting equipment.

De Forest Radio Company
Passaic, New Jersey

Export Department
304 E. 45th Street
NEW YORK

Tideman & Whetter
600 W. Jackson Blvd.
CHICAGO, ILL.



de Forest
(AUDIONS)
**RECEIVING AND
TRANSMITTING TUBES**

When writing to advertisers mention of the PROCEEDINGS will be mutually helpful.

NOT 400 VOLTS —
NOT 450 VOLTS —
BUT 500 VOLTS!

The advanced processes and features in design, combined with the special electrolyte employed in Hi-Farad DRY Electrolytic Condensers make possible a condenser which will continually withstand 500 VOLTS PEAK, a rating considerably higher than other types of electrolytic condensers. A condenser whose characteristics limit it to 400 or 450 volts peak cannot be used at higher voltages because at slightly higher voltages its leakage current becomes excessive.



AEROVOX HI-FARAD DRY ELECTROLYTIC CONDENSER

AN AEROVOX CONDENSER AND RESISTOR FOR EVERY USE

The Aerovox line includes the most complete line of condensers and resistors in the radio and electrical industries. No matter what your requirements are for fixed and tapped condensers or resistors, you are sure to find Aerovox units suited to your needs. In addition, we are equipped to supply special types and sizes of condensers and resistors to meet individual requirements.

Write for our 1931 catalog. Also ask to receive the Aerovox Research Worker, a monthly periodical which will be helpful and interesting to you.

AEROVOX WIRELESS CORP.
70 Washington Street, Brooklyn, N. Y.

When writing to advertisers mention of the PROCEEDINGS will be mutually helpful.

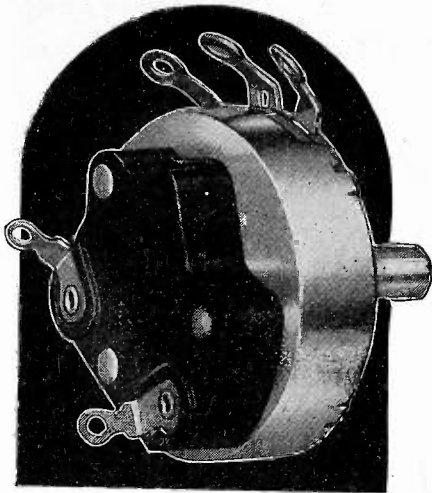

Above: No. 70 Series, with Underwriters' Laboratories Inspected Switch. Rated 1.5 amps., 250 volts; 3 amps., 125 volts. Illustration is actual size.

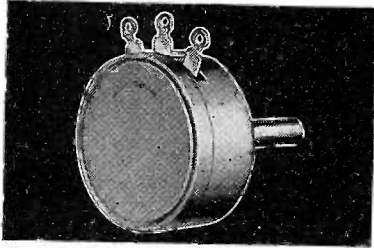

Above: No. 20 Series Single Control, without switch. Below: No. 20 Series Tandem Unit, without switch.

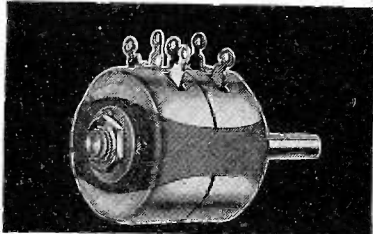

Below: No. 70 Series, without switch. Illustration is actual size. Our complete line includes a number of other types of Volume and Tone Controls.

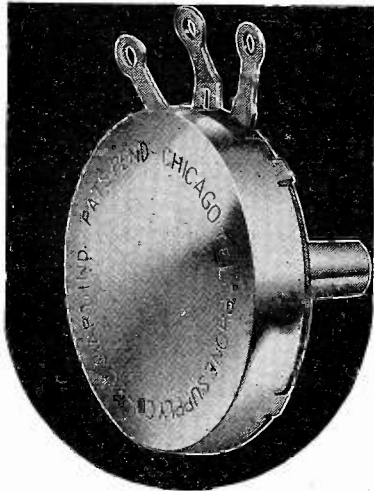

Here are Units that *Serve* and *Save!*

THESE new Volume and Tone Controls recently developed by our engineers are strikingly superior in the quality of the *service* they render, due to the outstanding improvements incorporated in their design. This service is, of course, of vital importance. But these new units do more than serve—they *save*.

How can they serve you—and save for you? By providing you with volume and tone control satisfaction such as you never before experienced, at prices that will amply prove their economy. Whether it be in our practically noiseless No. 20 Series Wire-Wound Controls, with their scientifically designed and thoroughly tested contact member, or in our "70" Series Composition Element Units, you will find in Frost Volume and Tone Controls the one best suited to your needs—"tailored" precisely to fit your receiver requirements. And in addition, you will find that by standardizing on Frost Controls you will make a very worth while saving.

If you will send us your exact specifications, we will, entirely without charge or obligation, submit samples that we believe will fully demonstrate our every claim for these units.

We invite inquiries from interested engineers, and upon request will be glad to send full details of the principles involved in the construction of these controls. Why not write us today?

CHICAGO TELEPHONE SUPPLY CO.

HERBERT H. FROST, Inc., Sales Division

GENERAL OFFICES AND PLANT

ELKHART, INDIANA

When writing to advertisers mention of the PROCEEDINGS will be mutually helpful.

Cornell

TRADE MARK REG.

Specified by the Foremost Radio
Manufacturers of the United States
and Canada

DUAL | "CUB"
CONDENSERS

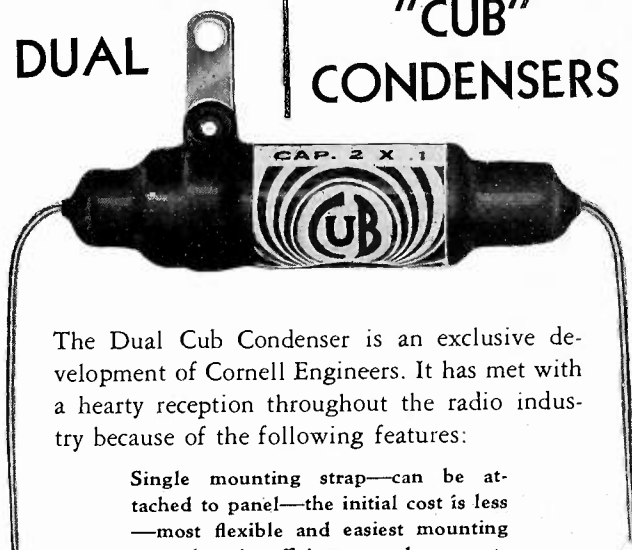

The Dual Cub Condenser is an exclusive development of Cornell Engineers. It has met with a hearty reception throughout the radio industry because of the following features:

Single mounting strap—can be attached to panel—the initial cost is less—most flexible and easiest mounting—no loss in efficiency—reduces costs by cutting assembly operations—high insulation resistance—extraordinary dielectric strength.

The new Dual Cub Condenser is totally enclosed and hermetically sealed against exaggerated temperature and humidity. Light weight and compact. Capacities .00025 to .5 Mfd.

*Write for samples and let us know your requirements.
We shall be glad to send you full particulars.*

CORNELL ELECTRIC MFG. CO., Inc.

Manufacturers of
CORNELL "CUB" CONDENSERS
Filter and By-Pass Condensers, Interference Filters and
All Types of Paper Dielectric Condensers
REDUCES ASSEMBLY OPERATIONS
LONG ISLAND CITY, NEW YORK

When writing to advertisers mention of the PROCEEDINGS will be mutually helpful.

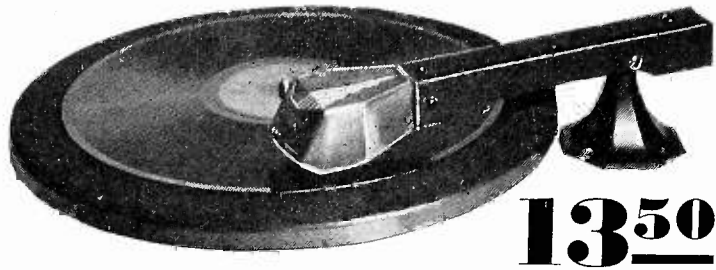

1350

PACENT PHONOVOX

ideal for new long playing records

DUE to its low center of gravity, the PHONOVOX plays the new long playing phonograph records without jumping, although the record grooves are much narrower than ordinary records. All the parts in the PACENT PHONOVOX are adjusted to so accurate a degree of precision that you are insured a constantly correct needle pressure with a minimum wear on the record. You can install a PACENT PHONOVOX on your radio and phonograph in two minutes.

Supplied complete with volume control and 12" or 16" tone arm

Cat. No. 120 Phonovox with 80" tone arm **\$13.50**

Cat. No. 108B Oil Damp Phonovox with 12" tone arm **\$25.00**

Cat. No. 160 Phonovox with 16" tone arm **\$16.00**

Cat. No. 171 Recordovox, combination Phonovox and Home Recorder **\$27.50**

Write to us for full particulars or see and hear the PACENT PHONOVOX at your radio dealer's

Pioneers in Radio and Electric Reproduction for more than 20 years

PACENT ELECTRIC COMPANY INC.
91 SEVENTH AVENUE, NEW YORK N. Y.

PACENT

When writing to advertisers mention of the PROCEEDINGS will be mutually helpful.

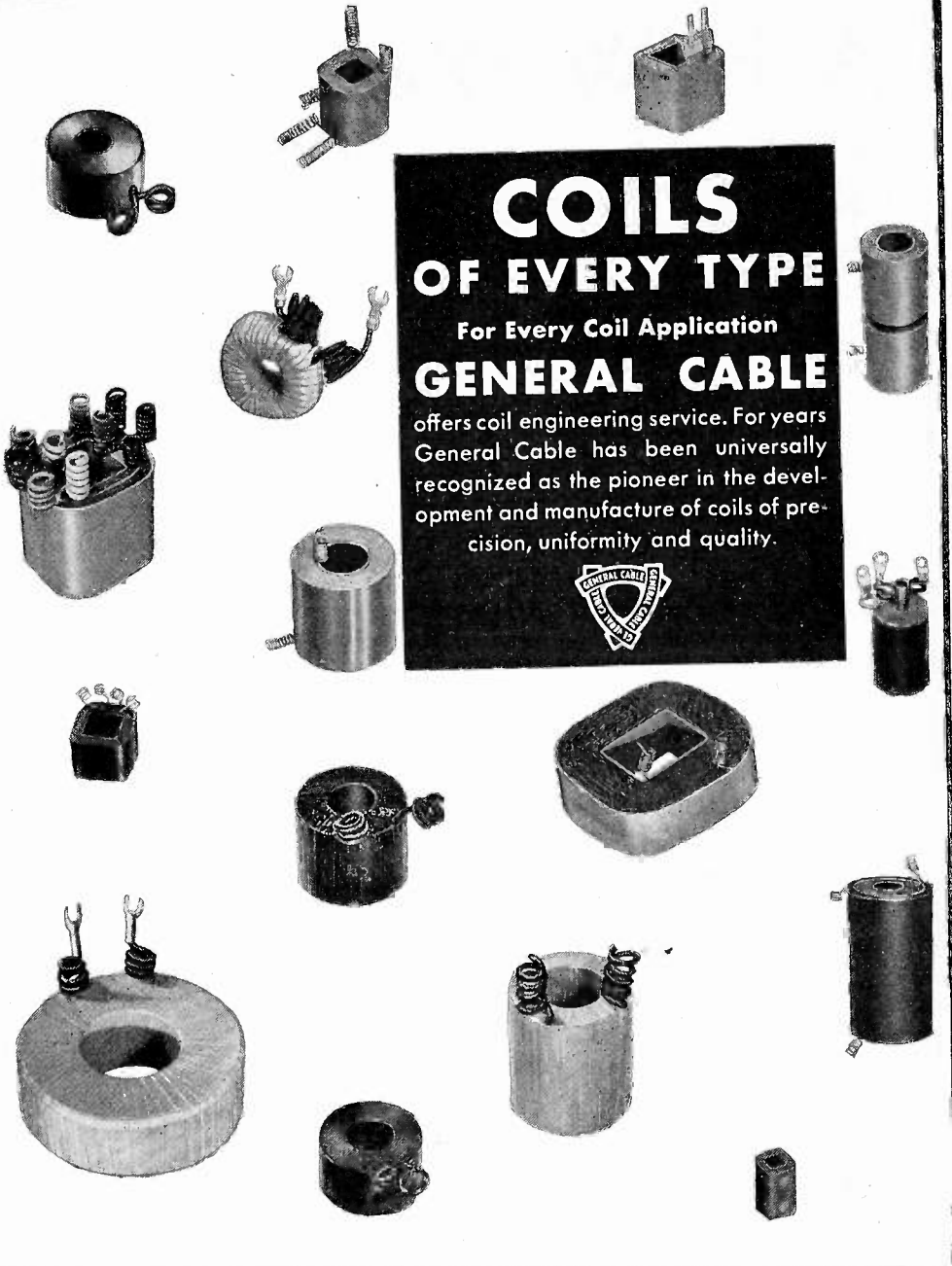

COILS OF EVERY TYPE

For Every Coil Application

GENERAL CABLE

offers coil engineering service. For years General Cable has been universally recognized as the pioneer in the development and manufacture of coils of precision, uniformity and quality.



GENERAL CABLE CORPORATION

420 LEXINGTON AVENUE, NEW YORK • CONSULT OUR NEAREST OFFICE

When writing to advertisers mention of the PROCEEDINGS will be mutually helpful.

A NEW DIAL



INTRODUCES A NEW INNOVATION FOR FRONT PANEL CONTROLLING OF VARIABLE DEVICES. APPLICABLE TO RADIO TRANSMITTERS, LABORATORY EQUIPMENT AND INDUSTRIAL PURPOSES.

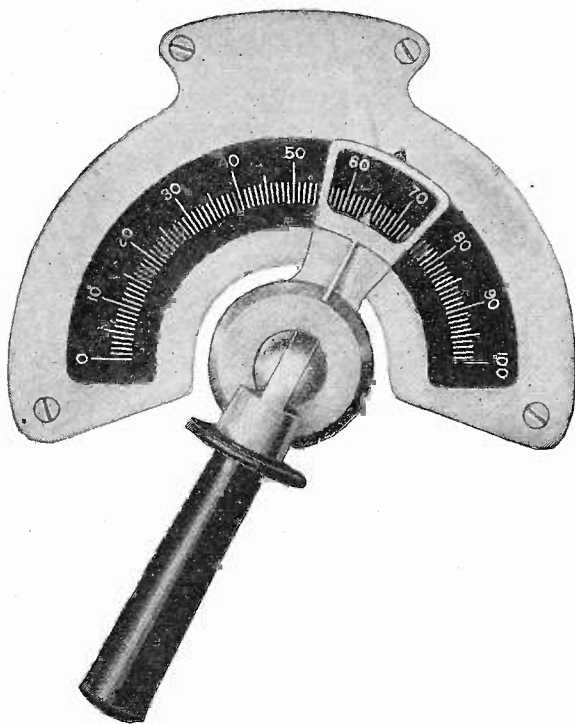

All metal parts specially die cast and finished in cadmium lacquer. Insulated handle and safety washer.

Patented automatic locking device controlled by slight downward movement of the handle.

When handle is in up position away from panel the dial moves freely over the entire scale.

Arbitrary 0-100 division scale.

Second blank scale for individual markings.

Enhance the appearance of any panel.

Ruggedly designed for commercial use.

Can be supplied for $\frac{1}{4}$ " or $\frac{3}{8}$ " shaft mounting.

Manufacturers interested in securing these dials for their products may have special markings or trade marks engraved directly on the upper portion of the scale.

Jobbers, dealers and special set constructors are requested to write for attractive proposition on the new REL Cat. #276 Dial and Scale Arrangement.

MORE NEWS. Literature on the new REL Cat. #278 short wave band spread receiver is ready. A complete short wave receiver with new unique features specially designed for band spreading of particular narrow frequency channels. Ideal for aviation, police, point to point or amateur uses. Employs the latest tubes and circuit arrangements.

RADIO ENGINEERING LABORATORIES, INC.
100 Wilbur Ave. Long Island City, N. Y., U. S. A.

When writing to advertisers mention of the PROCEEDINGS will be mutually helpful.

CHANGE IN MAILING ADDRESS OR BUSINESS TITLE

Members of the Institute are asked to use this form for notifying the Institute office of a change in their mailing address or the listing of their company affiliation or title in the Year Book.

The Secretary,
THE INSTITUTE OF RADIO ENGINEERS,
33 West 39th Street,
New York, N.Y.

Dear Sir:

Effective please note change in my address
(date)
for mail as follows:

FROM

.....
(Name)

.....
(Street Address)

.....
(City and State)

TO NEW ADDRESS

.....
(Street Address)

.....
(City and State)

Please note following change in my Year Book listing.

.....
(Title)

.....
(Company Name)

.....
(Company Address)

Back Numbers of the Proceedings, Indexes, and Year Books Available

MEMBERS of the Institute will find that back issues of the Proceedings are becoming increasingly valuable, and scarce. For the benefit of those desiring to complete their file of back numbers there is printed below a list of all complete volumes (bound and unbound) and miscellaneous copies on hand for sale by the Institute.

The contents of each issue can be found in the 1909-1930 Index and in the 1931 Year Book.

BOUND VOLUMES:

- Vol. 10 (1922), \$8.75 per volume to members
- Vol. 18 (1930), \$9.50 to members

UNBOUND VOLUMES:

- Vols. 5, 6, 8, 9, 10, 11, 12, 13, 14, and 18 (1917-1918-1920-1921-1922-1923-1924-1925-1926-1930), \$6.75 per volume (1917-1926) and \$7.50 per volume (1927-1930) to members

MISCELLANEOUS COPIES:

- Vol. 1 (1913) July and December
- Vol. 2 (1914) June and December
- Vol. 3 (1915) December
- Vol. 4 (1916) June and August
- Vol. 7 (1919) February, April, August, and December
- Vol. 15 (1927) January, April, May, June, July, October, November, and December
- Vol. 16 (1928) February, March, April, May, June, July, August, October, November, December
- Vol. 17 (1929) January, February, March, April, May, June, July, August, September, November, and December.
- Vol. 19 (1931) January, February, March, April, May, June, July, August, September, October, November

These single copies are priced at \$1.13 each to members to the January, 1927, issue. Subsequent to that number the price is \$0.75 each. Prior to January, 1927, the Proceedings was published bimonthly, beginning with the February issue and ending with the December issue. Since January, 1927, it has been published monthly.

MEMBERS will also find that our index and Year Book supplies are becoming limited. The following are now available:

INDEX

The Proceedings Index for the years 1909-1930 inclusive is available to members at \$1.00 per copy. This index is extensively cross indexed.

YEAR BOOK

The 1931 Year Book is available to members at \$1.00 per copy. This Year Book includes the 1931 Report of the Committee on Standardization,—an "up to the minute" report on the most recent standardization information available.

Make remittances payable to the Institute of Radio Engineers and send orders to:

THE INSTITUTE OF RADIO ENGINEERS

33 West 39th Street
NEW YORK CITY, N. Y.

ACRACON

Electrolytic Condensers

**Are Now
Specified By
Over 30
Leading Radio
Manufacturers**

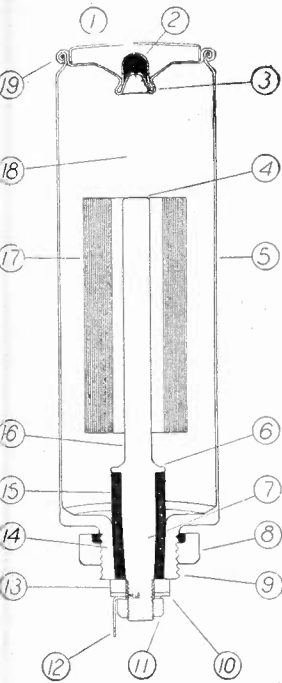

1. Metal cover for protection and appearance.
2. Live, rubber nipple.
3. Nipple spun into aluminum shell. Absolutely leak-proof.
4. Anode spiral cold welded into anode, giving rigid construction.
5. One piece extruded aluminum container.
6. Retaining flange for rubber gasket.
7. Tapered anode stem for snug fit.
8. Large cadmium plated steel mounting nut, concave to insure tight connection.
9. $\frac{3}{4}$ "-16 thread neck for mounting.
10. Metal washer.
11. Anode nut.
12. Anode soldering tab.
13. Large size insulating washer.
14. Tapered hole to take tapered anode.
15. Special live, rubber insulating gasket free from impurities.
16. Heavy, rigid, anode stem of high purity aluminum.
17. High purity anode, spiral, so wound as to eliminate the necessity of insulating liner between anode and container.
18. Special, high, critical voltage electrolyte, well over anode to insure long life.
19. Leak-proof rolled seam as used in canning industry.

Follow the leaders of the industry. Specify Acracon Electrolytic Condensers. Also By-Pass, Wax Impregnated, Oil Impregnated, Power and Transmitting types. Write today, enclosing specifications.

The Acracon unit is now available in capacities up to 16 microfarads at either 440 or 475 volt peak in the single anode type.

Acracon Features are Protected by Patents Pending

Condenser Corporation of America
259 Cornelson Ave., Jersey City, N.J.

Factory Representatives In:

Chicago Cincinnati St. Louis San Francisco Los Angeles Toronto

And Other Principal Cities

When writing to advertisers mention of the PROCEEDINGS will be mutually helpful.



Now in its 3rd
edition

Our Volume Control
Guide should be on
every engineer's desk
and in every service-
man's kit. Priced 25c.

CENTRALAB
VOLUME
CONTROLS

There is a new
and
dramatic
story
to tell

Centralab

Fixed Resistors now take
their place beside Centralab
Volume Controls as stand-
ard equipment in thousands
of radio receivers.

We have just published a
very interesting booklet tell-
ing in detail the unique and
different method of manu-
facturing Centralab Fixed
Resistors. It is yours for the
asking. Why not send for it
today.

Centralab

CENTRAL RADIO LABORATORIES : MILWAUKEE

When writing to advertisers mention of the PROCEEDINGS will be mutually helpful.

INCORRECT ADDRESSES

Listed below are the names of two hundred and seventy-six members of the Institute whose correct addresses are not known. It will be appreciated if anyone having information concerning the present addresses of any of the persons listed will communicate with the Secretary of the Institute.

- | | |
|--------------------------|--|
| Ackerman, F. R. | 119 Columbus Ave., N.W., Canton, Ohio. |
| Adams, Harry | P.O. Box 16, Amperc, N.J. |
| Aikens, Andrew J. | 195 Broadway, Rm. 413, New York City. |
| Alford, Andrew | 708 N. Kenmore Ave., Los Angeles, Calif. |
| Alston, Leroy | Radio Service Co., 7 Main St., Hamilton, Ont., Can. |
| Althoff, Frederick E. | 3415A Hartford Ave., St. Louis, Mo. |
| Anderson, Arthur J. | 52 Mulock St., Toronto, Ont., Can. |
| Andres, Lloyd J. | Carter Sound Equipment Co., Grand Rapids, Mich. |
| Annett, Earl | 3041 Gladstone Ave., Apt. 209, Detroit, Mich. |
| Arnold, Elmer J. | 1031 W. Johnson St., Clinton, Ill. |
| Arnold, Robert W. | 103 West 13th St., Oklahoma City, Okla. |
| Banditson, Harry | Modern Radio & Equipment Co., 191 Franklin St., Buffalo, N.Y. |
| Barker, Howard J. | P.O. Box 742, Atlanta, Ga. |
| Bazley, Paul B. | 278 Orange Ave., Irvington, N.J. |
| Berest, Anton | 52 Lorne St., Dorchester, Mass. |
| Bockhoven, Louis M. | 1341-5th St., Glendale, Calif. |
| Bognar, Charles J. | 1213 South Broadway, Dayton, Ohio. |
| Bonell, Ralph K. | 463 West Street, New York, N.Y. |
| Bov, Raphael F. | 34 Woodlawn Ave., Collingswood, N.J. |
| Bowmaster, J. M. | Sparks Withington Co., Jackson, Mich. |
| Bradford, C. Irving | 15 Hardenbergh St., New Brunswick, N.J. |
| Breeding, Charles S. | 1427 South Chapel Ave., Alhambra, Calif. |
| Brightman, R. B. | U.S. Navy, Eyak, Mile 7, Alaska |
| Brown, Fred H. | 1073-2nd St., Milwaukee, Wis. |
| Brunette, Deo Z. | Radio Corp. of America, Marion, Mass. |
| Bryan, Oscar F. | 1034 East 14th St., Brooklyn, N.Y. |
| Burchard, John C. | Radio Corporation of America, 100 W. Monroe St., Chicago, Ill. |
| Burghard, G. E. | Continental Radio Corp., 160 Varick St., New York City. |
| Butler, Harry F. | 129 Lentz Ave., Lehighton, Pa. |
| Byrd, Harold F. | 1626 Lewis Dr., Lakewood, Ohio. |
| Callahan, Thomas G. | 412 N. Laurel Ave., Apt. 11, Charlotte, N.C. |
| Calvert, James C. | Brookview & Rolling Rd., Springfield, N.J. |
| Campbell, Donald O. | 5347 Paseo, Kansas City, Mo. |
| Carleton, Thomas F. | P.O. Box 1167, Baton Rouge, La. |
| Carr, John | 40 Marsolais Ave., Apt. 3, Outremont, Montreal, Can. |
| Carroll, Franklin M. | 1402 North Alabama St., Indianapolis, Ind. |
| Carroll, Sam C. | 2121 New York Ave., Washington, D.C. |
| Chenik, Aaron | P.O. Box 745, Johannesburg, Transvaal, S.A. |
| Clark, Paul H. | 6171 No. Winchester Ave., Chicago, Ill. |
| Closson, Jr., H. B. | 4034 Shelmire St., Mayfair, Phila., Pa. |
| Clothier, Stewart L. | 11 Cornelia St., New York, N.Y. |
| Collins, Jesse C. | 229 So. Dupree St., New Orleans, La. |
| Comach, Stanley I. | Northern Electric Co., Ltd., 637 Craig St., West, Montreal, Que., Can. |
| Coman, George E. | 41-42nd St., Irvington, N.J. |
| Cone, Weiden W. | 451 Greenwich St., Valparaiso, Ind. |
| Cookson, Walter | Walford Cottage, Paget, Bermuda. |
| Coston, Early G. | 130 E. Hill St., Blackwell, Okla. |
| Cusack, Sidney C. | R.C.F. Ltd., 75 Sherbourne St., Toronto, Ont., Can. |
| Darragh, Willard C. | 107 So. Logan Ave., Apt. 2, Audubon, N.J. |
| Davey, C. V. | 1119 Poinsettia Drive, Hollywood, Calif. |
| Davies, Donald G. | 4314 River Road, N.W., Washington, D.C. |
| Davis, Chester E. | c/o R.C.A. Victor Co., Inc., Camden, N.J. |
| Davis, Dudley J. | 3645 Genesee St., Kansas City, Mo. |
| de Amicis, D. Sicari | 821 Bergen Ave., Jersey City, N.J. |
| Debaun, Lt. G. H. U.S.N. | U.S.S. Saratoga, c/o Postmaster, San Pedro, Calif. |
| Deeley, Paul M. | 5746 Drexel Blvd., Chicago, Ill. |
| Dewey, Fred L. | Mackay Radio & Telegraph Co., 730 So. Spring St., Los Angeles, Calif. |
| Dillard, Gene B. | 1907 Oakdale Ave., Chicago, Ill. |
| Dodds, D. Lowell | 3001-7th St., S.E., Washington, D.C. |
| Donovan, Daniel R. | 543 S. 11th St., Newark, N.J. |
| Doody, William R. | 230 S. Main, Butte, Mont. |
| Drisko, Benjamin B. | c/o Technology Club of N.Y., 22 East 38th St., New York City. |
| Dudley, Jr., Charles B. | 1413 John Street, Baltimore, Md. |
| Du Sair, Paul E. | c/o Lowel Hotel, 68 West 10th St., Eugene, Ore. |
| Edgar, J. Clifton | 1331 East Second St., Long Beach, Calif. |
| Ellis, Thomas H. | Cuyamel Fruit Co., Pier 27, East River, New York, N.Y. |
| Evans, H. Don | 308 Monroe St., Valparaiso, Ind. |
| Evans, W. J. | c/o Southwestern Victor Dist. Co., 2115 Griffin St., Dallas, Texas. |
| Eveleth, Laurence N. | 89 Robinson St., Schenectady, N.Y. |

- Farrow, Jr., F. R.
Faulstich, C. J.
Feld, John
Fiedler, George J.
Fisher-Luttrell, W.
Flomenbaum, Hyman
Fowler, J. Randall
Fox, Charles H.
Fox, John M.
Frassa, Charles F.
Frazier, R. K.
Freyvogel, Eric E.
Frisk, Caleb C.
- R.C.A. Victor Co., Camden, N.J.
c/o R.C.A. Photophone, 51 Terminal Way, Pittsburgh, Pa.
P.O. Box 292, Altoona, Pa.
Walnut Park Plaza Apt., Philadelphia, Pa.
High View, Heath Park Road, Squirrel's Heath, Essex, England.
108 Sutter Ave., Brooklyn, N.Y.
3663 Bainbridge Ave., Cleveland Heights, Ohio.
c/o Electrical Specialties, Ltd., 29 John Street, S., Hamilton, Ont., Can.
Box 173, Walkerville, Ont., Can.
207 West 34th St., Covington, Ky.
R.C.A. Victor Co., Inc., Camden, N.J.
c/o Detroit Radio Products Corp., 1040 West Fort St., Detroit, Mich.
Radio Station WBBM, Atlass Investment Co., Glenview, Ill.
- Gallinger, Lester
Geloso, John
Glassford, J. O.
Glendenning, D. B.
Golding, Robert M.
Goldner, Jack H.
Graham, Maxwell S.
Grahn, Carl E.
Gronoff, Harry
- Dodge's Radio Institute, 405 E. Monroe St., Valparaiso, Ind.
23 Swan Ave., Lawrence, Mass.
804 North County St., Waukegan, Ill.
2302 Salem Ave., Dayton, Ohio.
Electrical Research Products, Inc., 3931 S. Winchester Ave., Chicago, Ill.
34 Hillside Ave., New York, N.Y.
Universal Wireless Comm. Co., Drawer H, Plainfield, Ill.
c/o R.C.A. Victor Co., Inc., Camden, N.J.
2408 Palmgrove Ave., Los Angeles, Calif.
- Haldane-Duncan, B.
Hammer, Robert H.
Hanna, Samuel
Hanson, Harry
Hardison, Arthur A.
Harrison, Harry
Haugh, Arthur T.
Hays, Clarence W.
Heina, William M.
Helgeson, Frank N.
Hendren, Kenneth E.
Herdrich, Harold E.
Herlihy, William J.
Hicks, Kenneth F.
Hinklin, Lewis G.
Hirshman, Cyril L.
Hoover, Jr., Herbert
Horman, Frederick L.
Hudson, Julius
Hull, Ross A.
Humphreys, H. F.
Humphreys, Irl W.
Huntley, Wilfred E.
Hurtwitz, S. B.
- 122 Fifth Ave., Rm. 1009, New York, N.Y.
220 Lincoln Place, Brooklyn, N.Y.
21 Slade Ave., Toronto, Ont., Can.
1172½ No. Hobart Blvd., Hollywood, Calif.
3313½ Bagley Ave., Palms Station, Los Angeles, Calif.
c/o United Radio Engineering Co., 74 Dey St., New York, N.Y.
132 Windemere Road, Rochester, N.Y.
305 Monroe St., Valparaiso, Ind.
Crosley Radio Corp., Cincinnati, Ohio.
c/o R.C.A. Victor Co., Inc., Camden, N.J.
567 Spring St., Aurora, Ill.
4750 Kenmore Ave., Chicago, Ill.
R.C.A. Institutes, Inc., 714 Plaza Building, Pittsburgh, Pa.
c/o Universal Wireless Comm. Co., P.O. Box 266, Milford, Ohio.
643 W. Spring St., Lima, Ohio.
41 Chester St., Coventry, Eng.
Blue Briar Cottage, Asheville, N.C.
c/o R.C.A. Institute, 326 Broadway, New York, N.Y.
Duratron Radio Tube Corp., 409-38th St., Union City, N.J.
1711 Park St., Hartford, Conn.
B.B.C. Station, 417 London Road, West End, Stoke-on-Trent, Eng.
5402 Page Blvd., St. Louis, Mo.
Bremer Tully Mfg. Co., 656 West Washington Blvd., Chicago, Ill.
1268 Stratford Ave., New York, N.Y.
- Jordan, John F.
- Univ. of Cincinnati Dormitory, Cincinnati, Ohio.
- Karcher, Edmund M.
Karick, Bert F.
Klien, Jerry
Knight, Charles
Knowlton, John J.
Krauss, Gustav H.
Kroger, H. S.
Kronenwetter, Harold G.
- c/o R.C.A. Victor Co., Camden, N.J.
Box 72, University of So. Carolina, Columbia, S.C.
411 N. Curson, Hollywood, Calif.
c/o Magnolia Petroleum Co., Beaumont, Texas.
107 Court St., Newark, N.J.
c/o R.C.A. Victor Co., Inc., Camden, N.J.
376 Paulison Ave., Passaic, N.J.
Maud Wuller Apts., Dayton, Ohio.
- Labatt, M. D.
Lang, Connie
Lebedeff, George M.
Lee, Jr., Samuel T.
Levin, Isadore
Lindhurst, Roland W.
Little, Martin B.
Littlepage, Orvole H.
Littman, Leon
Lopes, John
Lutes, Clifford
- 334-6th Ave., Clinton, Iowa.
1801 Alta Vista Drive, Alhambra, Calif.
Dewalt Hotel, 201 Levenworth St., San Francisco, Calif.
943 Emmett St., Schenectady, N.Y.
3462 East 49th St., Cleveland, Ohio.
R.C.A. Victor Co., Inc., Camden, N.J.
c/o R.C.A. Victor Co., Inc., Camden, N.J.
1205 Sherwin Ave., Rm. 903, Chicago, Ill.
760 West End Ave., New York, N.Y.
Ribeiradio, Portugal.
830 Paddington Ave., Flint, Mich.
- Manley, Lee L.
Marshall, Jr., Cloyd
Maylott, Carleton F.
McCash, Perry V.
McClimans, Abner E.
McClintock, Jr., W.S.
McCloskey, J. W.
McCrea, M. Walter
McCreery, M.E.
McDaniels, Donald G.
- R.C.A. Victor Co., Inc., Camden, N.J.
407 East Pico St., Los Angeles, Calif.
55 Lincoln St., Apt. 104, Jersey City, N.J.
3730 Arlington Ave., Los Angeles, Calif.
3839 Yates, Denver, Colo.
EKKO Company, 1865 Daily News Plaza, Chicago, Ill.
14 Conard Ave., Collingswood, N.J.
883 So. 16th St., Newark, N.J.
1104 South Orange Drive, Los Angeles, Calif.
Radio Corporation of Pennsylvania, 331 Fourth Ave., Fitzsimmons Bldg., Pittsburgh, Pa.

- McGonagil, H. A. 3700 Sunset Blvd., Los Angeles, Calif.
 Meyer, R. H. Long's Radio Co., 2812 So. Main St., Los Angeles, Calif.
 Miller, Gerald E. 9303 E. Jefferson Ave., Detroit, Mich.
 Miller, Claude E. 700 South Main St., Tulsa, Okla.
 Miller, Samuel C. 427 West 42nd St., New York, N.Y.
 Morozoff, Harry H. Morozoff Radio Construction Lab., 817 East 175th St., New York, N.Y.
 Morrison, Roy H. 263 Fairmount Ave., Jamestown, N.Y.
 Mountjoy, Garrard 912 W. Michigan Ave., Jackson, Mich.
 Mower, Irving F. 7712 Emerald Ave., Chicago, Ill.
 Mulhollan, Roye Junco Building, Brownsville, Texas.
 Mullett, Chas. B. 265 Hartwell Rd., Buffalo, N.Y.
 Mundie, Evan M. 522 Franklin St., Buffalo, N.Y.
- Nagle, John F. 5553 N. Lawrence St., Philadelphia, Pa.
 Neelands, Frederick J. 5280-45th S.W., Seattle, Wash.
 Nelson, A. L. 414 No. Santa Fe, Pueblo, Colo.
 Newman, William H. 6221 Avalon Blvd., Los Angeles, Calif.
 Nichols, Laurence R. Coyne Electrical School, 801 S. Marshfield Ave., Chicago, Ill.
- O'Connell, Lieut. J. D. Fort Monmouth, Oceanport, N.J.
 O'Connor, James M. 7806 West 65th Place, Argo, Ill.
 O'Connor, John G. P.O. Box 189, Sayville, L.I., N.Y.
 Odenbach, J. F. c/o Robert Scott, Brevent Park, Atlantic Highlands, N.J.
 O'Shea, C. G. Indian Lake, Denville, N.J.
 Owens, Richard M. 7621 Euclid Ave., Cleveland, Ohio.
- Pamphilon, Leon E. R.C.A. Photophone, 438 West 37th St., New York, N.Y.
 Parman, Allen R. 1901½-11th Ave., N., Nashville, Tenn.
 Partch, Paul C. 5419 Buchanan St., Los Angeles, Calif.
 Peters, C. W. 1716 Painter St., New Orleans, La.
 Petrillo, S. E. Radio Engineering Dept., Atwater Kent Co., Philadelphia, Pa.
 Philips, J. Herbert 1023 Chicago Ave., Oak Park Ill.
 Phillips, Virgil G. 405 Monroe St., Valparaiso, Ind.
 Pittman, William A. 29 S.W. 26th St., Oklahoma City, Okla.
 Pitts, A. B. 255 Whitney Ave., New Haven, Conn.
 Procnunier, W. R. 1020 Wellington Ave., Chicago, Ill.
- Ramsey, R. W. Ramsey Radio Service, P.O. Box 139, Chambersburg, Pa.
 Raney, Wilson 276 Hawthorne St., Memphis, Tenn.
 Rankin, Robert C. E. 515 Ermina Ave., Spokane, Wash.
 Reid, Floyd F. Atwater Kent Mfg. Co., Philadelphia, Pa.
 Reifsteck, Carl N. Westinghouse Elec. & Mfg. Co., Radio Eng. Dept., East Pittsburgh, Pa.
 Reihman, Earl F. c/o R.C.A. Victor Co., Camden, N.J.
 Reint'en, Louis W. American Telephone & Tel. Co., 195 Broadway, New York, N.Y.
 Richards, A. R. Michigan State College, P.O. Box 611, East Lansing, Mich.
 Riddle, William E. 9 Stevenson Lane, Saranac Lake, N.Y.
 Robbins, Lynn R. 26 Prentice St., E. Springfield, Mass.
 Roberts, Richard P. 3624 Westfield Ave., Camden, N.J.
 Robinson, King H. 1517 Alamo St., Houston, Texas.
 Rodgers, H. C. 3911 Jefferson St., Houston, Texas.
 Rosenberg, Irving 1075 Home St., Bronx, New York City.
 Rost, William A. 645 N. 39th St., Philadelphia, Pa.
 Rubenstein, Peter 414 S. Wayne St., Angola, Ind.
 Ruelius, Louis F. 210 N. 33rd St., Philadelphia, Pa.
 Russell, Charles P.O. Box 475, Corning, Calif.
 Ryan, Richard 1430 Eddy St., San Francisco, Calif.
- Sachs, Harold S. Envoy Apts., 786 Osage Ave., Portland, Ore.
 Scanlon, Dale L. Federal Bldg., Dallas, Texas.
 Scharf, J. B. 1105 East 63rd St., Chicago, Ill.
 Schick, John R. Kohuku Oahu, Territory of Hawaii.
 Schlichting, Edward N. 3 Harding Ave., Oaklyn, N.J.
 Schofield, William D. 285 Turk St., Apt., 202, San Francisco, Calif.
 Schrader, William A. Armour Institute of Technology, 3305 S. Michigan Ave., Chicago, Ill.
 Schwartz, Nathan 737 Venice Blvd., Los Angeles, Calif.
 Schweizer, Max J. 1031 Dakins St., Chicago, Ill.
 Scozzari, Peter 1630 W. 10th St., Brooklyn, N.Y.
 Seese, William B. Dodges Radio Institute, 405 E. Monroe St., Valparaiso, Ind.
 Shafer, Arthur B. Radio Service Lab., 1221 Jefferson St., Memphis, Tenn.
 Shaffer, Paul E. 4142 N. Mason Ave., Chicago, Ill.
 Sheffield, Charles W. Radio Service, 37 Stanley Road, Bolton, Lancashire, Eng.
 Sherwood, John W. 104 Oswego St., Springfield, Mass.
 Shmied, Ernest A. Radio Experiment Laboratory, 1804 West Congress St., Chicago, Ill.
 Shoup, F. F. 13 Ogden Ave., Collingswood, N.J.
 Siegler, J. 156 Kensington High St., London, W.8, Eng.
 Signer, John J. 1123 Poinsetta Dr., Hollywood, Calif.
 Simpson, Charlotte F. 625 Bush St., San Francisco, Calif.
 Singleton, Harold C. Varney Air Lines, Portland Airport, P.O. Box 3820, Portland, Ore.
 Sleeper, J. Lloyd 1930 S. Primrose, Alhambra, Calif.
 Solis, Jr., Alberto 3108 Montana St., El Paso, Texas.
 Sonberg, Kenneth T. 86 Van Houten St., Paterson, N.J.
 Sorge, Barthold W. 1129 So. Maple, Los Angeles, Calif.
 Sponagle, Charles E. Kolster Radio Corp., 947 Leader Bldg., Cleveland, Ohio.

- Stanford, Kenneth J. c/o Surprenant & Co., 350 Madison Ave., New York, N.Y.
 Stanton, Russell S. 1121 Spruce St., Philadelphia, Pa.
 Sterling, M. F. Alliance Hotel, Alliance, Neb.
 Stewart, Arthur W. 604 Straight St., Cincinnati, Ohio.
 Stewart, H. H. Northern Electric Co., Ltd., 637 Craig St., W., Montreal, Que., Can.
 Strait, Clarence L. Sparks-Withington Co., Jackson, Mich.
 Straughn, James B. 650 Harvard St., N.W., Washington, D.C.
 Summers, R. H. J. National Works High Road, Leyton, London, Eng.
 Sumner, Raymond S. 80 Howe St., New Haven, Conn.
 Sweighert, D. V. Engineering Dept., General Motors Radio Corp., 1420 Wisconsin Blvd.,
 Dayton, Ohio.
 Symes, Wilfrid E. 4345 N. Greenview Ave., Chicago, Ill.
- Taylor, G. W. 521 Crocker National Bank Bldg., 1 Montgomery St., San Francisco, Calif.
 Taylor, Jay L. 8844 Sunset Blvd., c/o Sloan, Hollywood, Calif.
 Templeman, E. J. Interstate Radio Sales & Service, 708 W. Main St., Mandan, N.D.
 Terrill, W. Nessler 5 Emerson Ave., Utica, N.Y.
 Terhune, J. A. U.S. Naval Station, Guam, Mariannas Islands.
 Terry, Clifford B. 27 East 30th St., New York, N.Y.
 Thompson, R. E. 17 Battery Place, New York, N.Y.
 Tighe, John V. 2119 E. 67th St., Chicago, Ill.
 Tomme, M. Brown 729 Asp Ave., Norman, Okla.
 Trumble, L. A. 1044 E. Genesee Ave., Saginaw, Mich.
 Tustin, John L. Tustin Radio & Electric, 428 Sutter St., San Francisco, Calif.
- Valentine, F. C. General Cable Corp., 920 Chamber of Commerce, Cincinnati, Ohio.
 Van Pelt, John c/o Jones, 922 Summit Ave., Bronx, N.Y. C.
 Versfelt, Emery L. 76 Oakwood Ave., Upper Montclair, N.J.
 Victoria, Joseph L. 145 West 4th St., New York, N.Y.
 Volney, S. C. 39 West 51st St., New York, N.Y.
- Walker, M. C. 129 E. Palmer Ave., Collingswood, N.J.
 Ward, Donald G. Engineering Dept., Building 5, R.C.A. Victor Co., Camden, N.J.
 Warren, William 224 Metropolitan Ave., Brooklyn, N.Y.
 Webb, Elmer Bureau of Design & Construction, City of Rochester, 34 Court St., Rm. 224,
 Rochester, N.Y.
- Wettermann, John A. Chapace Realty Corp., 1115 College Ave., New York, N.Y.
 Wetzel, J. A. 343 B. 30th St., San Francisco, Calif.
 Wheeler, George D. 269 East 194th St., Apt. 1A, Bronx, New York City.
 Whitwan, Lloyd F. Federal Telegraph Co., Palo Alto, Calif.
 Wilber, H. E. 607 Santa Fe Bldg., Dallas, Texas.
 Willard, Walter C. Sales Engineer, Mfgs. Agent, 718 Columbia St., Newport, Ky.
 Willet, G. Rush 20 No. Wacker Drive, Chicago, Ill.
 Williamson, C. G. 128 North 4th St., Trenton, Mich.
 Wiskeman, Max 620 Gilman St., Palo Alto, Calif.
 Witt, Harold A. 1352 N. Formosa Ave., Los Angeles, Calif.
 Wolverton, Byron C. Yates Hotel, Syracuse, N.Y.
 Wood, Raymond C. 18 E. 3rd St., New York, N.Y.
 Wood, Stanford J. 4988 Melrose Ave., Hollywood, Calif.
 Woodcock, N. A. 4269 Broadway, New York City.
 Worrall, Edwin J. B. 86 Canning St., Liverpool, Eng.
 Wynne, William A. Hotel Belmont, Cleveland, Ohio.
- Young, Charles J. 1065 Avon Road, Schenectady, N.Y.
- Zaun, Peter E. R.C.A. Institutes, Inc., 75 Varick St., New York, N.Y.
 Zavitz, R. D. 986 Cote des Neiges Road, Montreal, P.Q., Can.
 Zern, Reber T. Trooper, Pa.
 Zinnecker, H. K. Radio-Victor Corp. of America, Camden, N.J.
 Zimmer, Harold F. J. 596-58th St., Oakland, Calif.



PROFESSIONAL ENGINEERING DIRECTORY

For Consultants in Radio and Allied Engineering Fields

Amy, Aceves & King, Inc. *Consulting Engineers*

DESIGN—TEST—DEVELOPMENT

Transmitters, Receivers, Sound Reproducing and Photoelectric Apparatus

Research Laboratories

11 West 42nd Street, New York
Longacre 5-6622

JENKINS & ADAIR, INC. *Engineers*

Designers and manufacturers of apparatus essential to broadcasting, sound recording and sound measurement work.

3333 Belmont Ave., Chicago, U.S.A.
Cable Address: *Jenkadair*
Telephones: Keystone 2130

The J. G. White Engineering Corporation

Engineers—Constructors

*Builders of New York Radio
Central*

43 Exchange Place New York

For EXPORT of Material Manufactured
by:

American Transformer Co.
Allen D. Cardwell Mfg. Co.
Corning Glass Works
Dubilier Condenser Corp.
P. R. Mallory
Radio Engineering Labs.
Universal Microphone Co., Ltd.
Ward Leonard Electric Co.
Weston Elec. Inst. Co.

Apply to

AD. AURIEMA, INCORPORATED
116 Broad St.
New York City, N.Y.

ALLEN B. DU MONT *Consulting Engineer*

Television Transmission and Reception
Vacuum Tube Manufacture, Development
and Application

Phone Office and Laboratory
Montclair 9 Bradford Way
2-2176 Upper Montclair, N.J.

FOR ADVANCED TRAINING

in:

Practical Radio Engineering
Practical Television Engineering

write to

CAPITOL RADIO ENGI-
NEERING INSTITUTE
Riggs Bank Bldg.
Washington, D.C.

ELECTRICAL TESTING LABORATORIES

Tests of Inductances.
Condensers. Transform-
ers etc. Life and charac-
teristics of Radio Tubes

80th. Street and East End Ave.
• • NEW YORK, N.Y. • •

BEN J. CHROMY

Attorney at Law

Patents and Patent Causes

National Press Bldg.

WASHINGTON, D.C.

"Radio Patent Service"

Weekly

When writing to advertisers mention of the PROCEEDINGS will be mutually helpful.

Alphabetical Index to Advertisements

A

Aerovox Wireless Corp.XXXVII
Allen-Bradley Co.XII
American Tel. & Tel. Co.XVI
American Transformer Co.XX
Arcturus Radio Tube Co.XXII

C

Cardwell, Allen D., Mfg. Corp. .XXVI
Central Radio LaboratoriesXLVI
Chicago Telephone Supply Co.
.....XXXVIII
Chicago Transformer Co.
.....Inside Back Cover
Condenser Corp. of AmericaXLV
Continental Carbon Inc.XIII
Cornell Electric Mfg. Co.XXXIX

D

DeForest Radio Co.XXXVI
DeJur-Amsco Corp.XIV
Dubilier Condenser Corp.XXI

E

Electric Specialty Co.XVIII
Employment PageLIII, LIV
Erie Resistor Corp.XXVII

G

General Cable Corp.XLI
General Electric Co.LVI
General Industries Co.XXV
General Mfg. Co.XIX
General Radio Co..Outside Back Cover

H

Hygrade Sylvania Corp.XV

I

Incorrect Addresses
.....XLVII, XLVIII, XLIX, L
International Resistance Co.XI
I.R.E. ...XXIII, XXIV, XLIII, XLIV

M

Magnavox Co., Ltd.XXXIV
Mallory, P. R., & Co., Inc.LV

P

Pacent Electric Co., Inc.XL
Professional Eng. DirectoryLI

R

Radio Engineering Labs.XLII
RCA Victor Co., Inc.XXXV
Roller-Smith Co.XXVIII

S

Scientific Radio ServiceXXX
Scovill Mfg. Co.XXXI
Silver-MarshallXVII
Soreng-Manegold Co.XXIX

T

Thordarson Electric Mfg. Co. .XXXII

W

Weston Elec. Inst. Corp.XXXIII

When writing to advertisers mention of the PROCEEDINGS will be mutually helpful.

EMPLOYMENT PAGE

Advertisements on this page are available to members of the Institute of Radio Engineers and to manufacturing concerns who wish to secure trained men for positions. All material for publication on this page is subject to editing from the Institute office and must be sent in by the 15th of the month previous to the month of publication. (November 15th for December PROCEEDINGS IRE, etc). Employment blanks and rates will be supplied by the Institute office. Address requests for such forms to the Institute of Radio Engineers, 33 West 39th Street, New York City, N.Y.

MANUFACTURERS and others seeking radio engineers are invited to address replies to these advertisements at the Box Number indicated, care the Institute of Radio Engineers. All replies will be forwarded direct to the advertiser.

BROADCAST OPERATOR holding first class commercial operator's license wishes work on the construction and maintenance of radio apparatus. Experience includes two years broadcast operating, one and one half years marine operating, and one half year's work on installation and operation of equipment for radio communications concern. High school graduate. Married. Age, 23. Box 92.

GRADUATE ENGINEER with M.S. in electrical communication engineering desires work in design, construction, installation, engineering, or in radio research preferably on transmitting equipment. Is interested in installation work in foreign country, particularly in South America. One year's experience as engineer in complete charge of erection of point to point and coastal marine radio stations in Honolulu. Slight knowledge Spanish. A.B. 1927. M.S. 1929. Married. Age, 26. Box 93.

COLLEGE GRADUATE with six years experience in research and development work desires new connection in radio field. Interested in college teaching position or in work as sales or technical field representative for New York vicinity. B.S. 1925. Single. Age, 30. Box 94.

STUDENT ENGINEER desires position as instructor, operator, or in aviation or police radio systems. Experience includes two years test and development work on transmitters, transmitting tubes, and facsimile equipment. B.S. in E.E. 1929. Single. Will travel. Age, 23. Box 95.

COLLEGE GRADUATE desires work in radio laboratory or in testing, installation, and operating. Holds commercial operator's license. One year laboratory work on sound amplifiers and phototubes. Two years test work on broadcast and c w telegraph transmitters. B.S. in E.E. 1929. Single. Will travel. Age, 25. Box 96.

When writing to advertisers mention of the PROCEEDINGS will be mutually helpful.

EMPLOYMENT PAGE

BROADCAST OPERATOR with two and one half years college training desires new position. Two and one half years experience in operation and maintenance and three years in charge of broadcast station. Married. Will travel. Age, 26. Box 97.

ASSISTANT CHIEF INSPECTOR with eleven years radio experience in specification of tests and test equipment design desires permanent connection, preferably in laboratory of manufacturer of aircraft radio equipment. Two years installation of manual and automatic telephone equipment. Two and one half years college work. Married. Will travel. Age, 32. Box 98.

ENGINEERS ASSISTANT desires position in radio laboratory. Pratt Institute electrical engineering graduate, 1928. One year laboratory experience in all phases of radio receiver design and development including power supply, hum, audio systems, radio systems and general measurements. Age 25. Single. Box 88.

DESIGNER specializing in development of television transmitting and receiving apparatus, and special tools and equipment for vacuum tube manufacture desires position where past experience can be most advantageously utilized. Experience includes five years work as draftsman, three years in charge of manufacturing equipment and factory planning in tube plant, and two years work on installation of automatic switching devices for telephone exchanges. Married. Will travel. Age 39. Box 99.

WANTED

Assistant to General Sales Manager

A New York City radio and electrical parts manufacturer is looking for a good salesman who understands radio engineering, to assist general sales manager and also handle sales department detail. This is a good position with future in a nationally known organization. State in detail your past experience, education, age and salary desired.

Address C.B.C.

c/o **FRANK KIERNAN & COMPANY**

41 MAIDEN LANE

NEW YORK CITY

When writing to advertisers mention of the PROCEEDINGS will be mutually helpful.

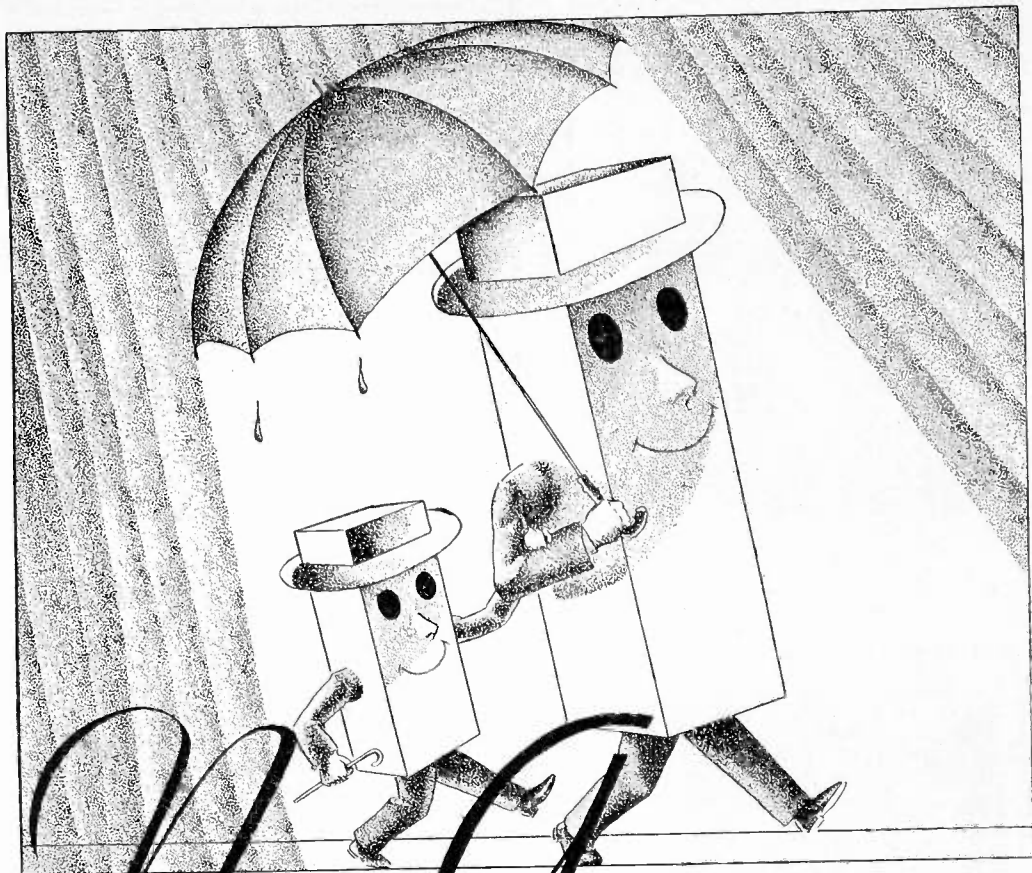

Non-Aqueous

THE Elkon electrolytic condenser is dry—not a drop of free water* in it! Yet it has all the performance characteristics of the best electrolytic condenser—stable—compact—highest filtering efficiency. It costs less than any other good condenser. Furthermore Elkon has practically the same characteristics as paper condensers—but is lower in cost and much less bulky . . . and here's news—all of the above characteristics apply to our new By-pass condensers. 73 leading set manufacturers have standardized on Elkon. A request today will bring you your sample tomorrow. Complete information will be sent to all members of your technical staff. Just send their names.

*water of crystallization, of course—but no free water.

Elkon Division of P. R. MALLORY & CO., Inc., Indianapolis, Ind.

Sales Offices: New York • Cleveland

Detroit • Chicago • Los Angeles

ELKON — E — CONDENSERS

COST LESS TO BUY AND LESS TO INSTALL

When writing to advertisers mention of the PROCEEDINGS will be mutually helpful.

RECTIFIER - TYPE WAVEMETER

1-15 METERS



THE TYPE 419 Rectifier-Type Wavemeter shown above is a tuned-circuit instrument equipped with a vacuum-tube resonance indicator which may be used to give either visual or aural indications. Its guaranteed accuracy of 1% and its compactness and ease of handling make it ideal for experimental work on short-wave circuits.

Write for literature. Price \$100.00

GENERAL RADIO COMPANY

Offices :: Laboratories :: Factory
CAMBRIDGE A, MASSACHUSETTS