

VOLUME 18

MARCH, 1930

NUMBER 3

PROCEEDINGS  
*of*  
The Institute of Radio  
Engineers



Form for Change of Mailing Address or Business Title on Page XLIX

**Fifth Annual  
Convention**

*of the*

**Institute of Radio  
Engineers**



**Toronto, Ontario, Canada**

**August 18-21, 1930**

PROCEEDINGS OF

# The Institute of Radio Engineers

Volume 18

March, 1930

Number 3

Board of Editors, 1930

ALFRED N. GOLDSMITH, <i>Chairman</i>	
STUART BALLANTINE	G. W. PICKARD
RALPH BATCHER	L. E. WHITEMORE
J. W. HORTON	W. WILSON

Contents

Part I

	Page
Frontispiece, Lieut. Col. A. G. Lee.....	364
Institute News and Radio Notes.....	365
Notice to Unpaid Members.....	365
February Meeting of Board of Direction.....	365
Radio Signal Transmissions of Standard Frequency.....	366
Committee Work.....	366
Institute Meetings.....	368

Part II

*Technical Papers*

Standardization in the Radio-Vacuum Field.....	W. C. WHITE	373
Graphs to Prof. Sommerfeld's Attenuation Formula for Radio Waves.....	BRUNO ROLF	391
The Radio Plant of R. C. A. Communications, Inc.....	HARRY E. HALLBORG	403
20-40-Kilowatt High-Frequency Transmitter.....	I. F. BYRNES AND J. B. COLEMAN	422
Power Output Characteristics of the Pentode.....	STUART BALLANTINE AND H. L. COBB	450
Report on Experiments with Electric Waves of about 3 Meters: Their Propagation and Use. ABRAHAM ESAU AND WALTER M. HAHNEMANN		471
Method and Apparatus Used at the Bureau of Standards in Testing Piezo Oscillators for Broadcast Stations.....	E. L. HALL	490
A German Common Frequency Broadcast System.....	F. GERTH	510
On a Double Hump Phenomenon of Current Through a Bridge across Parallel Lines.....	EJIRO TAKAGISHI	513
Weather Forecasting by Signal Radio Intensity: Part I.....	R. C. COLWELL	533
A Method of Measuring the Radio-Frequency Resistance of an Oscillatory Circuit.....	HAJIME IINUMA	537
The Four-Electrode Vacuum Tube as Beat-Frequency Oscillator.....	S. REID WARREN, JR.	544
Booklets, Catalogs, and Pamphlets Received.....		548
Monthly List of References to Current Radio Literature.....		550
Contributors to This Issue.....		556

*Copyright, 1930, by the Institute of Radio Engineers*

1930 Year Book I.R.E., Supplement to This Issue

# The Institute of Radio Engineers

## GENERAL INFORMATION

The PROCEEDINGS of the Institute is published monthly and contains papers and discussions thereon submitted for publication or for presentation before meetings of the Institute or its Sections. Payment of the annual dues by a member entitles him to one copy of each number of the PROCEEDINGS issued during the period of his membership.

Subscription rates to the PROCEEDINGS for the current year are received from non-members at the rate of \$1.00 per copy or \$10.00 per year. To foreign countries the rates are \$1.10 per copy or \$11.00 per year.

Back issues are available in unbound form for the years 1918, 1920, 1921, 1922, and 1926 at \$9.00 per volume (six issues) or \$1.50 per single issue. For the years 1913, 1914, 1915, 1916, 1917, 1918, 1924, and 1925 miscellaneous copies (incomplete unbound volumes) can be purchased for \$1.50 each; for 1927, 1928, and 1929 at \$1.00 each. The Secretary of the Institute should be addressed for a list of these.

Discount of twenty-five per cent on all unbound volumes or copies is allowed to members of the Institute, libraries, booksellers, and subscription agencies.

Bound volumes are available as follows: for the years 1920, 1921, 1922, and 1926 to members of the Institute, libraries, booksellers, and subscription agencies at \$8.75 per volume in blue buckram binding and \$10.25 in morocco leather binding; to all others the prices are \$11.00 and \$12.50, respectively. For the years 1928 and 1929 the bound volume prices are: to members of the Institute, libraries, booksellers, and subscription agencies, \$9.50 in blue buckram binding and \$11.00 in morocco leather binding; to all others, \$12.00 and \$13.50, respectively. Foreign postage on all bound volumes is one dollar, and on single copies is ten cents.

Year Books for 1926, 1927, and 1928, containing general information, the Constitution and By-Laws, catalog of membership, etc., are priced at seventy-five cents per copy per year. The 1929 Year Book is available to members at \$1.00; to non-members, \$1.50.

Contributors to the PROCEEDINGS are referred to the following page for suggestions as to approved methods of preparing manuscripts for publication in the PROCEEDINGS.

Advertising rates for the PROCEEDINGS will be supplied by the Institute's Advertising Department, Room 802, 33 West 39th Street, New York, N. Y.

Changes of address to affect a particular issue must be received at the Institute office not later than the 15th of the month preceding date of issue. That is, a change in mailing address to be effective with the October issue of the PROCEEDINGS must be received by not later than September 15th. Members of the Institute are requested to advise the Secretary of any change in their business connection or title irrespective of change in their mailing address, for the purpose of keeping the Year Book membership catalog up to date.

The right to reprint limited portions or abstracts of the papers, discussions, or editorial notes in the PROCEEDINGS is granted on the express condition that specific reference shall be made to the source of such material. Diagrams and photographs published in the PROCEEDINGS may not be reproduced without making special arrangements with the Institute through the Secretary.

It is understood that the statements and opinions given in the PROCEEDINGS are views of the individual members to whom they are credited, and are not binding on the membership of the Institute as a whole.

All correspondence should be addressed to the Institute of Radio Engineers, 33 West 39th Street, New York, N. Y., U. S. A.

Entered as second class matter at the Post Office at Menasha, Wisconsin.

Acceptance for mailing at special rate of postage provided for in the Act of February 28, 1925, embodied in paragraph 4, Section 412, P. L. and R. Authorized October 26, 1927.

Published monthly by

**THE INSTITUTE OF RADIO ENGINEERS, INC.**

Publication office, 450-454 Ahnaip Street, Menasha, Wis.

BUSINESS, EDITORIAL, AND ADVERTISING OFFICES,

33 West 39th St., New York, N. Y.

## SUGGESTIONS FOR CONTRIBUTORS TO THE PROCEEDINGS

### Preparation of Paper

**Form**—Manuscripts may be submitted by member and non-member contributors from any country. To be acceptable for publication manuscripts should be in English, in final form for publication, and accompanied by a summary of from 100 to 300 words. Papers should be typed double space with consecutive numbering of pages. Footnote references should be consecutively numbered and should appear at the foot of their respective pages. Each reference should contain authors' name, title of article, name of journal, volume, page, month, and year. Generally, the sequence of presentation should be as follows: statement of problem; review of the subject in which the scope, object, and conclusions of previous investigations in the same field are covered; main body describing the apparatus, experiments, theoretical work, and results used in reaching the conclusions and their relation to present theory and practice; bibliography. The above pertains to the usual type of paper. To whatever type a contribution may belong, a close conformity to the spirit of these suggestions is recommended.

**Illustrations**—Use only jet black ink on white paper or tracing cloth. Cross-section paper used for graphs should not have more than four lines per inch. If finer ruled paper is used, the major division lines should be drawn in with black ink, omitting the finer divisions. In the latter case, only blue-lined paper can be accepted. Photographs must be very distinct, and must be printed on glossy white paper. Blueprinted illustrations of any kind cannot be used. All lettering should be  $\frac{3}{16}$  in. high for an 8 x 10 in. figure. Legends for figures should be tabulated on a separate sheet not lettered on the illustrations.

**Mathematics**—Fractions should be indicated by a slanting line. Use standard symbols. Decimals not preceded by whole numbers should be preceded by zero, as 0.016. Equations may be written in ink with subscript numbers, radicals, etc., in the desired proportion.

**Abbreviations**—Write a.c. and d.c., (a.c. and d.c. as adjectives), kc,  $\mu f$ ,  $\mu\mu f$ , e.m.f., mh,  $\mu h$ , henries, abscissas, antennas. Refer to figures as Fig. 1, Figs. 3 and 4, and to equations as (5). Number equations on the right in parentheses.

**Summary**—The summary should contain a statement of major conclusions reached, since summaries in many cases constitute the only source of information used in compiling scientific reference indexes. Abstracts printed in other journals, especially foreign, in most cases consist of summaries from published papers. The summary should explain as adequately as possible the major conclusions to a non-specialist in the subject. The summary should contain from 100 to 300 words, depending on the length of the paper.

### Publication of Paper

**Disposition**—All manuscripts should be addressed to the Institute of Radio Engineers, 33 West 39th Street, New York City. They will be examined by the Committee on Meetings and Papers and by the Editor. Authors are advised as promptly as possible of the action taken, usually within one month.

**Proofs**—Galley proof is sent to the author. Only necessary corrections in typography should be made. *No new material is to be added.* Corrected proofs should be returned *promptly* to the Institute of Radio Engineers, 33 West 39th Street, New York City.

**Reprints**—With the galley proof a reprint order form is sent to the author. Orders for reprints must be forwarded promptly as type is not held after publication.

## INSTITUTE SECTIONS

<i>Chairmen</i>	<i>Secretaries</i>
H. P. Thornton	<b>ATLANTA</b> Philip C. Bangs, 23 Kensington Rd. Avondale Estates, Ga.
George W. Pierce	<b>BOSTON</b> Melville Eastham, 30 State St., Cambridge, Mass.
L. Grant Hector	<b>BUFFALO-NIAGARA</b> E. C. Waud, 235 Huntington Ave., Buffalo, N. Y.
H. E. Kranz	<b>CHICAGO</b> J. H. Miller, Jewell Electrical Inst. Co., 1650 Walnut St., Chicago, Ill.
R. H. Langley	<b>CINCINNATI</b> W. W. Boes, 622 Broadway, Cincinnati, Ohio
D. Schregardus	<b>CLEVELAND</b> C. H. Shipman, 14805 Ardenall Ave., East Cleveland, Ohio
Q. A. Brackett	<b>CONNECTICUT VALLEY</b> F. C. Beekley, 96 S. Main St., W. Hartford, Conn.
A. B. Buchanan	<b>DETROIT</b> W. R. Hoffman, 615 West Lafayette Blvd., Detroit, Mich.
T. C. Bowles	<b>LOS ANGELES</b> Charles S. Breeding, Aero Radio Corp., 5927 Franklin Ave., Hollywood, Calif.
Pendleton E. Lehde	<b>NEW ORLEANS</b> Anton A. Schiele, 1812 Masonic Temple, New Orleans, La.
J. C. Van Horn	<b>PHILADELPHIA</b> <i>Acting Secretary</i> E. T. Darlington, 2848 Idaho Road, Camden, N. J.
L. A. Terven	<b>PITTSBURGH</b> J. G. Allen, Duquesne Light Co., Pittsburgh, Pa.
E. C. Karker	<b>ROCHESTER</b> A. R. Barfield, Valley Appliances, Inc., Rochester, N. Y.
Donald K. Lippincott	<b>SAN FRANCISCO</b> Paul R. Fenner Custom House, San Francisco, Calif.
Austin V. Eastman	<b>SEATTLE</b> Abner R. Willson, 8055—14th Ave., N. E., Seattle, Wash.
V. G. Smith	<b>TORONTO</b> G. E. Pipe, 90 Chestnut St., Toronto, Canada
C. B. Jolliffe	<b>WASHINGTON</b> J. B. Brady, Ouray Bldg., Washington, D. C.

**GEOGRAPHICAL LOCATION OF MEMBERS ELECTED  
 FEBRUARY 6, 1930**

Transferred to the Member grade	
Massachusetts	Springfield, American Bosch Magneto Corp., Radio Lab
New Jersey	New Brunswick, R.C.A. Communications, Inc.
New York	Schenectady, 1454 Glenwood Ave. West Hempstead, L. I., 21 S. Woodfield Rd.
	French, Benedict V. K. Shore, Henry Snyder, Norman Westman, Harold P.
Elected to the Member grade	
Illinois	Chicago, 3333 Belmont Ave.
New York	New York City, 500 Riverside Drive
France	Paris, 26, Rue Desnouettes
	Jenkins, J. Elliott Alker, T. F. Clavier, A. G.
Elected to the Associate grade	
Alabama	Birmingham, Matthews Electric Supply Co.
Arkansas	Hot Springs, 118 Court St.
California	Berkeley, 2319 Oregon St. Beverly Hills, Fox Movietone Studio, Sound Dept. Los Angeles, 214 So. Western Ave. Los Angeles, 1512 West 84th St. Los Angeles, 2711 Alsace Ave. Los Angeles, 2619 Maritau Ave. Los Angeles, 1006 1/2 N. Mariposa St. San Diego, USS <i>Medusa</i> , Box 8. San Pedro, c/o Postmaster, USS <i>California</i> , Radio Dept.
	Wilson, Horace M. Tuggle, Granville D. Reukema, Lester Edwin MacKenzie, Frank B. Anderson, H. Albert Bradley, John C. Ketchum, Robert W. Lee, George Richard Newcomb, Robert Christides, Strafis C.
Colorado	Swink
Dist. of Col.	Takoma Park, 6703 Georgia Ave., N. W. Washington, 3338 O St., N. W., Apt. 11 Washington, 1212—12th St., N. W. Washington, 3001—7th St., S. E. Washington, 1723 Euclid St., N. W. Washington, 1124—12th St. Washington, 631 Princeton Place N. W. Washington, 338 Maryland Ave., N. E. Washington, 3420—16th St., N. W. Washington, 1823 Wyoming Ave., N. W. Washington, 1246 H St., N. E. Washington, 2518—17th St., N. W. Washington, Navy Yard, Y. E. 28 Washington, 3919 First St., S. E. Washington, South Clifton Terrace, Apt. 108
	Coker, Ralph T. Schoch, Robert E. Fox, Corbin C. Bissett, James E. De Rond, Bernard Dodda, D. Lowell Ferguson, Theodore P. French, Richard Dale Friedman, Louis Gnash, Philip Young Hand, James H. Harris, Richard P. Hatter, Angerean A. Mitchell, William Edward Morris, Donald Jay Nair, W. Earl Ness, Delmer N. Herndon, Paul H., Jr. Casciato, Dominick Filmer, Walter L., Jr. Lundeen, Adolph Morris, James E. Ruzkiewicz, Leo Slechta, George W. Symes, W. E. Zylstra, William G. Schellenger, N. C. Herrold, George V. Wang, Y. M. Hieber, Raymond G. Sandretto, P. C. Mollring, Howard S. Mills, Vern D. Webster, Glenn E. Keating, William J. Knight, Charles Partello, M. C. Roberts, James F.
Georgia	Atlanta, Post Office Bldg., Room 528
Illinois	Chicago, 1643 W. 79th St. Chicago, 5811 Maryland Ave. Chicago, 1823 Chase Ave. Chicago, 1645 N. Francisco Ave. Chicago, 4354 Thomas St. Chicago, 7645 Sheridan Road. Chicago, 4345 N. Greenview Ave. Chicago, 718 West 73rd St.
	Ness, Delmer N. Herndon, Paul H., Jr. Casciato, Dominick Filmer, Walter L., Jr. Lundeen, Adolph Morris, James E. Ruzkiewicz, Leo Slechta, George W. Symes, W. E. Zylstra, William G. Schellenger, N. C. Herrold, George V. Wang, Y. M. Hieber, Raymond G. Sandretto, P. C. Mollring, Howard S. Mills, Vern D. Webster, Glenn E. Keating, William J. Knight, Charles Partello, M. C. Roberts, James F.
Indiana	Elkhart, c/o Chicago Tel. Supply Co. Marion, 934 So. Washington St. Marion, Box 75 Terre Haute, Rose Polytechnic Institute West Lafayette, 202 Russell St.
	Schellenger, N. C. Herrold, George V. Wang, Y. M. Hieber, Raymond G. Sandretto, P. C. Mollring, Howard S. Mills, Vern D. Webster, Glenn E. Keating, William J. Knight, Charles Partello, M. C. Roberts, James F.
Iowa	Council Bluffs, 515 N. 6th St.
Kansas	Manhattan, 1509 Humboldt St. Manhattan, Radio Station KSAC
Louisiana	Alexandria, 1147 Barrister St.
Baskin	
Maryland	Annapolis, U. S. Naval Academy Berwyn
Massachusetts	Boston, c/o Wetmore Savage A. E. Co., 588 Commonwealth Ave. Boston, c/o Electrical Research Products, 1327 Statler Bldg. East Pepperell, Groton St. East Springfield, 69 Redlands St. East Springfield, 69 Redlands St. Haverhill, 58 South Elm St. Somerville, 77 Sacramento St. Springfield, 18 Vassar St. Worcester, 55 Providence St.
	Campbell, Donald W. Pfeiff, Frederick J. Frost, Edgar W. Bruce, Birger Bruce, Ragnar Houston, Philip M. Liu, Sui-fan Applegate, Homer E. Joseph, J. Bernard
Michigan	Detroit, c/o Detroit Radio Products Corp., 1040 West Fort St. Port Huron, 2324 Tenth Ave. Republic, P.O. Box 87
	Freyvogel, Eric E. Newland, C. W. Ahlgun, William E.

Geographical Location of Members Elected February 6, 1930

Mississippi	Cleveland, 520 South Court St.	Treft, H. L.
	Greenwood, 400 George St.	Fausett, Floyd
	Meridian, Chief Engineer, WCOC.	Donovan, Jas. R.
Nebraska	Lincoln, 1222 Nelson St.	Kimberly, Herbert B.
	Omaha, Box 440, Y.M.C.A.	Glanton, D. R.
New Jersey	Ampere, Box 39.	Paynter, E. J.
	Ampere, P.O. Box 59.	Porter, J. G.
	Ampere, P.O. Box 3.	Solomon, S.
	Deal, Box 122.	Sowers, Nelson E.
	East Orange, 61 Glenwood Ave.	Price, Harry J.
	Hillside, 1277 Miriam Place.	Holmes, Arnold
	Jersey City, 229 South St.	Scheuerer, John Lehman
	Lawrenceville, Box 132.	Norstrum, B. H.
	Passaic, 22 Broadway.	Freudenthal, Jack
	Paterson, 468 E. 18th St.	Barry, Bert
New Hampshire	Newport, 6 High St.	Walker, Charles M.
New Mexico	Albuquerque, 1005 1/2 East Central Ave.	Holt, S. E.
New York	Brooklyn, 357-9th St.	Bunday, Dale L.
	Brooklyn, 1630 W. 10th St.	Scozzari, Peter
	Ithaca, 201 College Ave.	King, Ronald
	Long Island City, 27-08-39th Ave.	Warren, William
	New York City, 463 West St., Room 375.	Babecock, Stuart M.
	New York City, Bell Tel. Labs., 463 West St., Room K65.	Bain, J. C.
	New York City, Bell Tel. Labs., 463 West St.	Black, Donald M.
	New York City, Bell Tel. Labs., 463 West St.	Kalb, Robert M.
	New York City, SS Maya, c/o United Fruit Co., Pier 16.	King, Walter Milton
	New York City, Bell Tel. Labs., 463 West St., Room 375.	Kircher, Reymond
	New York City, 195 Broadway, Room 1118.	Smith, Delmar E.
	New York City, Bell Tel. Labs., 463 West St.	Vansant, F. T.
	New York, 514 East 138 Street.	Weiler, H.
	Poughkeepsie, 2 Lexington Ave.	Wood, Raymond A.
	Rochester, 17 Upton Pk.	Bond, Roy
	Rocky Point, Radio Central.	MacLean, Kenneth G.
	Savannah.	Ridington, Edmund B.
	Schenectady, 21 No. Ferry St.	Smith, Richard L.
	Scotia, 217 Alexander Ave.	Yerian, Carlos S.
	Watertown, Y.M.C.A.	Hatton, Richard R.
Ohio	Cleveland, 1242 E. 167th St.	Akers, William F.
	Cleveland, National Carbon Co., Inc., P.O. Box 400.	Kellogg, Wm. M.
	Cleveland, 3997 West 226th St., Rocky River P.O.	Zinser, Henry
	Cleveland Heights, 970 Selwyn Road.	Justin, Walter S.
	Columbus, 231 East 16th Ave.	Bell, Richard
	Dayton, 43 W. Norman Ave.	Brump, H. L.
	Dayton, 146 Kirkham St.	Desch, Joseph R.
	Dayton, 12 North Jefferson St.	Snyder, Ellsworth W.
	Dayton, 1540 So. Broadway.	Stanley, Marion W.
	Lakewood, 1626 Lewis Drive.	Byrd, Harold F.
	Portsmouth, P.O. Box 18.	Brake, Basil H.
Oklahoma	Enid, Radio Station KCRC.	Spear, Wade Hampton
	Oklahoma City, 1818 Linden St.	Herrmann, Frank
	Oklahoma City, 2314 So. Oklahoma St.	Nott, Arthur C.
Pennsylvania	Altoona, c/o William F. Gable Co.	Gable, Robert B.
	Brackenridge, 1512 Broadview Blvd.	Porter, Harry F.
	Exeter Boro, 1201 Wyoming Ave.	Ferroni, Joseph A.
	Oil City, Rockmere, Box 435.	Hamilton, George H.
	Philadelphia, 904 W. Rockland St.	Chedaker, Joseph
	Philadelphia, 358 Shedaker St.	Kinnier, Donald
	Pittsburgh, 335 Meyran Ave.	Harmon, Ralph Newton
	Wilkes-Barre, 182 So. Hancock St.	Dziadosz, Frank
Rhode Island	Providence, 296 Veazie St.	Passarelli, Harold C.
Tennessee	Memphis, O. K. Houck Piano Co., 103 S. Main St.	Breedlove, H. B.
Texas	Dallas, 425 1/2 Neches St.	Harrison, L. E.
	El Paso, 3108 Montana St.	Solia, Alberto, Jr.
	Houston, 2120 Blodgett Ave.	Perlitz, W. H.
Virginia	Dumbarton.	Zaun, William J.
Washington	Seattle, 1023 3rd Ave.	Haig, James H.
	Seattle, 2607-2nd Ave.	Merritt, Ronald A.
Wisconsin	Madison, Madison Gas & Electric Co.	Steinike, Edgar Wm.
	Mauwatoosa, 498-4th Ave.	Mattern, Ray P.
Australia	Melbourne, Victoria, Navy Office, St. Kilda Road.	Tours, F. B.
Bermuda	Middletown.	Cadwallader, Carl
Canada	Drummondville, Que. Marconi Station	Smith, Thomas F.
	Toronto, Ont., 121 Clovelly Ave.	Foster, Leonard
	Toronto 12, 82 Hilldale Ave. West.	Fraser, D. M.
	Toronto, 21 Slade Ave.	Hanna, Samuel
	Toronto, 21 Melgund Road.	Maurer, G. P.
	Toronto, 31 Glebe Road, West.	Smith, Clarence M.
England	Derbyshire, Stancliffe Hall, Nr. Matlock	Franklin, T. Bedford
	Teddington, Middlesex, 88 Fairfax Road.	Franklin, R. H.
	Llandudno, North Wales, 23 Dinas Road, North Shore "Norvic"	Hughes, Robert Penry



*Geographical Location of Members Elected February 6, 1930*

England	London W 14, Addison Bridge, 14 Argyll Mansions...	Galloway, C. Hadfield
	Lowestoft, Suffolk, 133 St. Peter's Street...	Rayment, K. G.
France	Paris, International Standard Elec. Corp., 46 Ave. de Breteuil...	Goyder, C. W.
India	Bangalore, Indian Institute of Science, Elec. Dept.	Assthana, Rajendra, Prasada
Japan	Hokkaido, Sapporo City, Teukisappu, Sending Station of JOIK.	Mori, Nobumitsu Sagiyama, E.
Tasmania	Sendai, Teishinkyoku, Komuka. Hobart, University of Tasmania.	Tuck, H. P.

*Elected to the Junior grade*

Alabama	Birmingham, Claridge Manor Apts.	Marshall, Kenneth Glenn Jr.
California	Los Angeles, 332 E. 60th St.	Turner, J. Glen
	Santa Barbara, c o Broadcast Station KDB	Lewis, Evan J.
Dist. of Col.	Washington, 1900 P St. N. W.	Black, Joel Cantrell
	Washington, 4314 River Road, N.W.	Davies, Donald G.
	Washington, 1929 Pa. Ave. N. W.	Eschinger, Earl Edmond
	Washington, 525 Oglethorpe St. N. W.	Hall, Albert Casper
	Washington, 1124—12th St. N. W.	Hedrick, Phil F., Jr.
	Washington, 1430 Belmont St. N. W.	Hollingsworth, Edward
	Washington, 1321 D St. N. E.	Rigney, William M.
	Washington, 1330 L St. N. W.	Sprague, Barbara Russell
Maryland	Berwyn	Parker, Maury McLeod
Massachusetts	Oxford, Main St.	Browning, Elliott Andrew
New Hampshire	Durham, 37 Madbury Road	Evans, Carl B.
New York	Brooklyn, 1569 Ocean Ave.	Haas, Milton J.
	Brooklyn, 2265—85th St.	Mitwol, David
	Corona, L. I., 102-27—47th Ave.	Schubert, Fred
	Utica, 1622 Sunset Ave.	Howlett, Charles, Jr.
North Carolina	Durham, 1506 W. Chapel Hill St.	Underwood, Norman B.
Ohio	Cleveland, 3585 W. 49th St.	Stanik, Joseph M.
Oregon	Portland, 6904 52nd St. S. E.	Harden, Edgar
Texas	Dallas, 4008 Wycliff St.	Schoonmaker, C. Granville
Canada	Toronto, Ont., 57 Hastings Ave.	Butler, Ron



## APPLICATIONS FOR MEMBERSHIP

Applications for transfer or election to the various grades of membership have been received from the persons listed below, and have been approved by the Committee on Admissions. Members objecting to transfer or election of any of these applicants should communicate with the Secretary on or before March 31, 1930. These applicants will be considered by the Board of Direction at its April 2nd meeting.

### For Election to the Fellow grade

England Essex, Weatheroak, Danbury.....Eckersley, T. L.

### For Transfer to the Member grade

California	Los Angeles, 607 N. Mansfield Ave.	Perkins, L. J.
Dist. of Columbia	Washington, Chevy Chase Apts.	Gross, Gerald C.
Massachusetts	Boston, 169 Marlborough St.	Cabot, George E.
New Jersey	East Orange, 216 N. Oraton Parkway	Isler, Samuel
	Neptune, 1115-6th Ave.	Shafer, J. Peter
New York	Newark, 79 Manchester Place	Levine, I. B.
	Buffalo, 52 Locust St.	Brown, Stanley W.
	Buffalo, Buffalo Broadcasting Station	Chamberlain, A. B.
	New York City, Pier 9, North River	Muller, Fred
China	New York City, City College	Taylor, E. Gordon
Japan	Canton, Lingnan University	Knipp, A. R.
	Tokyo, 1278 Omori, Araishiku	So, M.

### For Election to the Associate grade

California	Bolinas, c/o R. C. A. Communications, Inc.	Muller, John H.
California	Burbank, 126 N. Sparks St.	Shaw, Theodore S.
	Los Angeles, 2219 Merton Ave., Eagle Rock	Church, Stanley M.
	Los Angeles, 547 S. Western Ave.	Hassen, Gunnar B.
	North Palo Alto, 501 Laurel Ave.	Byrne, Paul F.
	Oakland, 565 Eldorado Ave.	Wilson, Charles McC.
	Richmond, 700-22nd St.	Trolese, Louis
	San Francisco, 323 Customhouse	Homsy, John H.
	San Francisco, 311 California St.	Kaufman, Jack
	San Francisco, N. B. C., 111 Sutter St.	Kennedy, David W.
	San Francisco, 140 New Montgomery St., Room 1021	MacMahon, A. E.
Connecticut	San Pedro, U. S. S. West Virginia, c/o Postmaster	Anderson, W. A.
	New Haven, 280 Whalley Ave.	Lenzer, Emil
	New Haven, 367 Elm St.	O'Connell, J. D.
	New Haven, 43 Clifford St.	Pierce, E. H.
Dist. of Columbia	New Haven, 367 Elm St.	Willis, J. S.
	Washington, 262-15th St. S. E.	Calvert, F. G.
Delaware	Bethany Beach	Meyers, R. E.
	Chicago, 4440 N. Laporte Ave.	Johnson, E. T.
Illinois	Chicago, 3303 S. Claremont Ave.	Martens, R. L.
	Chicago, 7034 Merrill Ave.	Reed, P. B.
	Chicago, 4236 N. Spaulding Ave.	Ruskin, Henry
	Angola, 512 W. South St.	Ax, Leland S.
Indiana	South Bend, P. O. Box #868	Crockett, David R.
	Davenport, 1525 Grand Ave.	Snyder, Reed E.
Iowa	Hopkinsville, 2121 S. Main St.	Grimwood, F. O.
	Newport, 216 Main Ave. (Clifton)	Richards, A. P.
Kentucky	New Orleans, 201 Magazine St.	Collins, J. C.
	New Orleans, 6014 Catina St.	Havlicek, J. W.
Louisiana	Allston, 80 Brighton Ave.	Becker, C. W.
	Cambridge, 18 Ware St., Harding Apts. (12-A)	Ammon, W. B.
	Chicopee Falls, Westinghouse Elec. and Mfg. Co.	Lee, Donald C.
	Dorchester, 121 Draper St.	Feldman, Sarley M.
	Springfield, Westinghouse Elec. and Mfg. Co., Page Blvd.	Weber, C. A. M.
Massachusetts	Alpena, P. O. Box 178	Wesser, C. H.
	Detroit, 3303 Sturtevant Ave.	Bond, Orville J.
	Detroit, 446 S. Eastlawn	Jackson, C. H.
	Jackson, 226 Orange St.	Schonert, K. E.
Michigan	Rock Port	Wolf, Ray O.
	St. Louis, 720 S. 4th St.	Ferris, Harry J.
Missouri	Audubon, 107 S. Logan Ave., Apt. #2	Darragh, W. C.
	Bound Brook, c/o WJZ	Gullans, John H.
	Camden, 1576 Norris St.	Brail, S. L.
	Guttenberg, 317 24th St.	Framshefer, T. W.
	Jersey City, 61 Gautier Ave.	Nolte, C. L.
New Jersey	Montclair, 114 Midland Ave.	Sandford, R. Y.
	West Orange, 23 Oxford Ter.	Vose, George E.
	Astoria, L. I., 2373-27th St.	Heller, Joe
	Brooklyn, 24 Bay 7 St.	Rice, A. J.
New York	Brooklyn, 1818-61st St.	Tucker, M. H.

## Applications for Membership

New York (cont.)	Brooklyn, 1452-55th St.	Zeiger, Louis B.
	Buffalo, 241 S. Elmwood Ave.	Landis, Oren J.
	Buffalo, 41 N. Putnam St.	Miller, E. C.
	Canandaigua, 66 N. Main St.	Goering, R. A.
	Elmhurst, L. I., 189 Forley St.	Hotchkiss, Earle
	Flushing, L. I., 42-43-147th St.	Davis, Clinton S.
	Hamilton, 67 Main St.	Janes, R. B.
	Jamaica, L. I., 150-05-88th Ave.	Bernhardt, E. E.
	Mount Vernon, 220 Westchester Ave.	Podell, Samuel
	New York City, 147 W. 23rd St.	Ansley, Arthur C.
	New York City, c/o Postmaster, <i>USS Eagle 58</i>	Dodge, F. R.
	New York City, 179 Greenwich St.	Egert, Samuel S.
	New York City, 280 Broadway	Florez, H. A.
	New York City, 233 W. 20th St.	Fung, J. H.
	New York City, 58 E. 93rd St.	Keene, K. W.
	New York City, 77 Irving Pl.	Maddocks, James H.
	New York City, 711 5th Ave., c/o National Broadcasting Co.	Martin, W. G., Jr.
	New York City, 195 Broadway, c/o A. T. and T. Co.	Mattin, W. H.
	New York City, 817 E. 175th St.	Morozoff, Harry
	New York City, 463 West St.	Olander, L. W.
	New York City, 1060 Fox St., Bronx	Samuels, G. J.
	New York City, 601 W. 162nd St.	Schlesinger, B. S.
	New York City, 250 W. 57th St., c/o Electrical Research Products, Inc.	Sterling, M. F.
	New York City, 23 Lexington Ave., George Washington Hotel	Taber, Ira DeWitt
	New York City, c/o Postmaster	Tellman, Herbert A.
	New York City, 326 Broadway, c/o R. C. A.	Williams, H. F.
	New Rochelle, 19 Park View Ave.	Matthews, B. W.
	Richmond Hill, L. I., 108-15-103rd Ave.	Saphir, Frank
	Schenectady, 208 Union St.	Tucker, W. E.
	Scotia, 202 Ballston Ave.	Smith, H. M.
	Bluffton, 155 Thurme St.	Steiner, Harold R.
	Cincinnati, 3452 Colerain Ave.	Best, Paul J.
	Cincinnati, Box #20, Station I	Hoffman, Ralph
Cincinnati, 2415 Auburn Ave.	Tumleson, J. F.	
Cincinnati, 3626 Michigan Ave.	Uchtman, Wm. J.	
Cleveland, 3562 E. 151st St.	Broz, B. G.	
Cleveland, Radio Station WHK, Engineers' National Bank Bldg.	Drysdale, N. M.	
Cleveland, 11126 Glenboro Dr.	Durcanshy, Mike	
Dayton, General Motors Radio Corp., Miami Chapel Rd.	Newill, E. B.	
Lakewood, 2097 Lincoln Ave.	Kope, Carl A.	
Louisville, Box #105	Noreen, Carl O.	
Norman, 729 Asp Ave.	Tomme, M. B.	
Oklahoma City, 3032 North Place	Booth, W. J.	
Oklahoma City, 1623 W. 6th St.	Farris, Glen	
Oklahoma City, 1414 N. Penn.	Mooney, J. B.	
Flemington, Box 194	Kunkle, C. F.	
Harrisburg, 23 S. Front St.	Maurer, E. E.	
Kutztown, 183 Main St.	Sharadin, F. A.	
Lansdowne, 17 N. Lansdowne Ave.	Simons, Russell	
Nanticoke, 44 Coal St.	Hutchko, Francis J.	
Norristown, 624 Chain St.	Davis, G. C.	
Philadelphia, 35 S. 3rd St., c/o R. C. A.	Downey, C. E.	
Philadelphia, 615 E. Woodlawn Ave., Germantown	Hutcheson, C. J., Jr	
Columbia, Box #72, University of South Carolina	Karick, Bert F.	
Nashville, 715 N. 2nd St.	Mason, A. E.	
Abilene, 258 Pine St.	Manciell, M. C.	
Beaumont, c/o Sun Oil Co., Box #790	Bush, C. R.	
Dallas, Baker Studios, Radio Station WFAA	Ellis, W. C.	
Dallas, 2022 Commerce	Parkinson, Lee D.	
Richmond, 4609 Devonshire Rd.	Steele, J. A.	
Pullman, Box #331, College Station	Hatfield, L. N.	
Pullman, 683 College Station	Kuntze, E. L.	
Seattle, Calhoun Hotel	Dailey, A. C.	
Seattle, 6544 Holly Ter.	Foster, C. H.	
Seattle, 1723 Naomi Pl.	Mullaney, H. F.	
Walla Walla, 601 Washington St.	Elam, D. W.	
Middleton	De Soto, C. B.	
Milwaukee, 220 Meinecke Ave.	Kruse, C. C.	
New Glarus, Box #373	Becker, S. J.	
Cheyenne, c/o Boeing Air Transport	Lawrenz, Wm. L.	
Malvern, Victoria, 72 Union St.	Barthold, G. L.	
Sydney, 66 City Rd.	Horton, G. H.	
Adelaide, 33 Hewitt Ave., Rose Park	Adams, C. H.	
Strathalbyn, Dawson St.	Goldfinch, H. R.	
Montreal, Que., 168 Beaconsfield	Barbour, J. H.	
Montreal, Que., 240 Percival Ave.	Carrick, W. E.	
Montreal, Que., P. O. Box #1435	Lord, Wm.	
Montreal, Que., Room 601, Keefer Bldg.	Wallace, O. C. R.	
Sioux Lookout, Ont., Dept. Lands and Forests	Watson, J. E.	
Sudbury, Ont., 98 Cedar St.	Kniffen, L. D.	
Winnipeg, Man., 520 Jubilee Ave.	Ellinthorpe, J. W.	

### *Applications for Membership*

Canada (cont.)	Winnipeg, Man., 128 Lanark St. . . . .	Gillingham, A.
	Winnipeg, Man., 502 Sherburn St. . . . .	Vale, Ronald
	Yamachiche, Que., Canadian Marconi Co. . . . .	Bird, C. H. R.
Colombia	Bogota, c/o Cia. Radio Universal, National City Bank . . . . .	Siemens, R. H.
England	Bedford, Shortstown, 7 Central Ave. . . . .	Disley, Arthur
	Birmingham, 502 Slade Rd., Erdington . . . . .	Finchley, F.
	Bournemouth, The Huon, Branksome Hill Rd. . . . .	Chapman, J. P. J.
	Bradford, Yorkshire, Commercial Bank Bldg. . . . .	Langstaff, H.
	London, W 12, 91 Mellitus St., Shepherds Bush . . . . .	Ogden, S.
	Stoke-on-Trent, 417 London Rd., West End . . . . .	Humphreys, W. F.
Holland	Amsterdam, Tilanusstraat 66 . . . . .	Nouman, H. J. J.
Japan	Shimizu, near Kumamoto City, c/o Shimizuhosozo . . . . .	Tsuji, Uichiro
	Ibarakiken, Hiraiso Musen . . . . .	Iso, E.
	Osaki, near Tokyo, Teishinsho-Denki-Shikenjo . . . . .	Takaya, Michihiro
	Ibarakiken, Isobamamusen . . . . .	Tanimura, I.
	Osakimachi, near Tokyo, Ministry of Communications, Electro-technical Laboratory . . . . .	Jimbo, S.
Philippines	Cebu, Opon . . . . .	Minoza, Maximiano
Sweden	Stockholm, Alsten . . . . .	Rolf, Bruno

#### For Election to the Junior grade

California	Los Angeles, 1042 Stone St. . . . .	Ourieff, Paul
	Whittier, 614 N. Bright . . . . .	Eagle, Roy D.
Massachusetts	Melrose, 28 Rowe St. . . . .	Flanders, W. Hubert, Jr.
New York	New York City, 155 West 82nd St. . . . .	Sandifer, Norwood H.
	New York City, 155 West 82nd St. . . . .	Stauffer, Robert Writner
	Port Jervis, 12 Neversink Ave. . . . .	Rutan, Paul D.
	Rochester, 81 Eiffel Place . . . . .	Norris, Edward
Texas	San Antonio, 402 E. Locust . . . . .	Hyman, Kenneth R.
Hawaii	Honolulu, P. O. Box 2390, c/o J. T. MacIntyre . . . . .	Murai, Fred H.



## OFFICERS AND BOARD OF DIRECTION, 1930

(Terms expire January 1, 1931, except as otherwise noted)

### *President*

LEE DE FOREST

### *Vice-President*

A. G. LEE

### *Treasurer*

MELVILLE EASTHAM

### *Secretary*

HAROLD P. WESTMAN

### *Editor*

ALFRED N. GOLDSMITH

### *Managers*

J. H. DELLINGER

R. A. HEISING

L. M. HULL

R. H. MANSON

A. F. VAN DYCK

ARTHUR BATCHELLER

(Serving until Jan. 1, 1932)

J. V. L. HOGAN

C. M. JANSKY, JR.

(Serving until Jan. 1, 1932)

(Serving until Jan. 1, 1933)

R. H. MARRIOTT

(Serving until Jan. 1, 1933)

---

### *Junior Past Presidents*

ALFRED N. GOLDSMITH

A. HOYT TAYLOR

---

### Board of Editors, 1930

ALFRED N. GOLDSMITH, *Chairman*

STUART BALLANTINE

RALPH BATCHER

J. W. HORTON

G. W. PICKARD

L. E. WHITTEMORE

W. WILSON

---

## COMMITTEES OF THE INSTITUTE OF RADIO ENGINEERS, 1930

### Committee on Meetings and Papers

J. W. HORTON, *Chairman*

Theory, Circuit and General

R. F. FIELD

Generating Apparatus and Theory

L. P. WHEELER

Receiving Apparatus and Theory

H. A. WHEELER

Transmission through Space

G. W. KENRICK

Measurements and Standards

C. B. JOLLIFFE

Vacuum Tubes and Thermionics

W. C. WHITE

Aerials and Aerial Systems

G. C. SOUTHWORTH

Acoustics and Audio Frequencies

IRVING WOLFF

Aircraft Radio

F. M. RYAN

Stations and Operation, Broadcasting

R. M. MORRIS

Television

DELBERT E. REPLOGLE

Picture Transmission

R. H. RANGER

Miscellaneous Communication Sys-

tems, H. A. AFFEL

Miscellaneous Technical Papers

K. S. VAN DYKE

Historical, Book Reviews, Bibliogra-

phies, S. S. KIRBY

Radio Communication Systems

T. A. M. CRAVEN

Radio Manufacturing

G. G. THOMAS

Members at Large

ELLERY W. STONE

HARRY SADENWATER

Committees of the Institute—(Continued)

Committee on Admissions

R. A. HEISING, *Chairman*

C. N. ANDERSON  
ARTHUR BATCHELLER  
C. M. JANSKY, JR.  
A. G. LEE  
GEORGE LEWIS

R. H. MARRIOTT  
E. R. SHUTE  
J. S. SMITH  
A. F. VAN DYCK  
*Chairman of each Section, ex officio*

Committee on Institute Awards

W. G. CADY, *Chairman*

STUART BALLANTINE  
RALPH BOWN

ALFRED N. GOLDSMITH  
A. HOYT TAYLOR

Committee on Bibliography

B. E. SHACKELFORD, *Chairman*

M. C. BATSEL  
W. G. CADY  
J. H. DELLINGER  
MELVILLE EASTHAM  
G. W. GIBBS  
C. B. JOLLIFFE  
F. H. KROGER  
R. H. LANGLEY  
R. H. MANSON  
J. O. MAUBORGNE

DONALD MCNICOL  
G. W. PICKARD  
E. R. SHUTE  
H. M. TURNER  
A. F. VAN DYCK  
H. A. WHEELER  
L. P. WHEELER  
W. C. WHITE  
L. E. WHITTEMORE  
W. WILSON

Committee on Broadcasting

L. M. HULL, *Chairman*

ARTHUR BATCHELLER  
PAUL A. GREENE  
RAYMOND GUY  
J. V. L. HOGAN

C. W. HORN  
R. H. MARRIOTT  
E. L. NELSON

Committee on Constitution and Laws

R. H. MARRIOTT, *Chairman*

ARTHUR BATCHELLER  
MELVILLE EASTHAM  
W. G. H. FINCH  
H. E. HALLBORG

R. A. HEISING  
G. W. PICKARD  
HAROLD A. ZEAMANS

Committee on Membership

I. S. COGGESHALL, *Chairman*

W. H. BELTZ  
F. R. BRICK  
W. W. BROWN  
BEVERLY DUDLEY  
H. C. GAWLER  
F. A. KOLSTER  
S. R. MONTCALM

A. F. MURRAY  
M. E. PACKMAN  
C. R. ROWE  
J. E. SMITH  
JOHN C. STROEBEL, JR.  
A. M. TROGNER  
*Secretary of each Section, ex officio*

Committee on New York Programs

R. H. RANGER, *Chairman*

AUSTIN BAILEY  
H. C. GAWLER

F. M. RYAN  
E. R. SHUTE

*Committees of the Institute — (Continued)*

**Committee on Nominations**

ALFRED N. GOLDSMITH, *Chairman*

ARTHUR BATCHELLER  
W. G. CADY  
MELVILLE EASTHAM

R. H. MANSON  
DONALD McNICOL

**Committee on Publicity**

W. G. H. FINCH, *Chairman*

H. W. BAUKAT  
ZEH BOUCK  
C. E. BUTTERFIELD  
ORRIN E. DUNLAP  
FRED EHLERT  
A. H. HALLORAN  
R. D. HEINL

LLOYD JACQUET  
ARTHUR H. LYNCH  
J. F. J. MAHER  
A. H. MORSE  
U. B. ROSS  
J. G. UZMANN  
WILLIS K. WING

**Committee on Sections**

AUSTIN BAILEY, *Chairman*

L. A. BRIGGS  
D. H. GAGE  
VIRGIL M. GRAHAM  
C. W. HORN  
R. H. LANGLEY

A. F. MURRAY  
A. M. PATIENCE  
B. E. SHACKELFORD  
*Chairman of each Section, ex officio*

**Committee on Standardization**

J. H. DELLINGER, *Chairman*

WILSON AULL  
M. C. BATSEL  
W. R. BLAIR  
E. L. BOWLES  
C. E. BRIGHAM  
E. L. CHAFFEE  
L. M. CLEMENT  
T. A. M. CRAVEN  
T. McL. DAVIS  
E. T. DICKEY  
CARL DREHER  
H. W. DREYER  
ALLEN DU MONT  
C. P. EDWARDS  
S. W. EDWARDS  
P. H. EVANS  
GENERAL FERRIE  
H. A. FREDERICK  
ALFRED N. GOLDSMITH  
W. E. HOLLAND  
C. B. JOLLIFFE  
GEORGE LEWIS

R. H. MANSON  
ALEXANDER MEISSNER  
C. B. MIRICK  
GINO MONTEFINALE  
R. M. MORRIS  
E. L. NELSON  
L. G. PACENT  
HARADEN PRATT  
D. E. REPLOGLE  
J. L. REYNOLDS  
H. B. RICHMOND  
C. E. RICKARD  
A. F. ROSE  
N. H. SLAUGHTER  
H. M. TURNER  
K. B. WARNER  
W. C. WHITE  
DONALD WHITING  
L. E. WHITTEMORE  
C. E. WILLIAMS  
HIDETSUGU YAGI









LIEUT. COL. A. G. LEE  
Vice-President of the Institute, 1930

Lieutenant Colonel A. G. Lee entered the British Post Office Engineering Service in 1903, his first work being in connection with the introduction of Pupin coils into cables. Following this he spent some time on the design and testing of submarine and other cables. Subsequently he spent four years on District telephone and telegraph work, and then returned to the Headquarters in London where he gained further experience in different phases of telephony and telegraphy.

During the World War he volunteered for service, receiving a commission in December, 1914, in the Royal Engineers (Signal Service). During the major portion of the war he was in command of a telegraph construction company and later was Officer-in-Charge, General Headquarters Signal Area, and at the same time second in command of L. Signal Battalion. For his services he received the Military Cross and was mentioned in dispatches. At the conclusion of the war he held the rank of Major. He is now Lieutenant Colonel, Royal Corps of Signals (Supplementary Reserve).

In 1920 Colonel Lee became associated with radio work. He soon became Staff Engineer in charge of the radio section of the British Post Office. He is now Assistant Engineer-in-Chief of the British Post Office. During his period of service in the radio section he has been associated with the development of a coupled circuit arc, the high-power station at Rugby, and the transatlantic telephone and short-wave telephone service.

Colonel Lee is a member of the Institution of Electrical Engineers and served as Chairman of the Wireless Section of that Institution in 1927-1928. He is a member of the Committee on Admissions of the Institute of Radio Engineers, and was elected a Fellow in the Institute in 1929. He is a member of the Radio Research Board and is Chairman of the "Atmospherics" Committee of that Board.

## INSTITUTE NEWS AND RADIO NOTES

### Notice to Unpaid Members

The January, February, and this March issue of the PROCEEDINGS were sent to all members of the Institute whether or not they had paid their 1930 dues.

As ordered by the Board of Direction, the unpaid members will be taken off the PROCEEDINGS mailing list effective with the April issue.

Considerable delay in receiving future issues will be saved members if they will fill in the form attached to the cover of this issue and remit to the Secretary.

### February Meeting of Board of Direction

At the meeting of the Board of Direction of the Institute held in the Institute office at 3 P.M. on February 5, 1930, the following were present: Lee de Forest, president; Melville Eastham, treasurer; Alfred N. Goldsmith, editor; Arthur Batcheller, J. H. Dellinger, R. A. Heising, J. V. L. Hogan, L. M. Hull, C. M. Jansky, Jr., R. H. Manson, R. H. Marriott, Arthur F. Van Dyke, John M. Clayton, secretary; and Harold P. Westman, secretary-elect.

The following were transferred or elected to higher grades of membership in the Institute. Transferred to the Member grade: Norman Snyder, B. V. K. French, Harold P. Westman, and Henry Shore. Elected to the Member grade: Andre G. Clavier, T. F. Alker, and J. E. Jenkins.

One hundred and fifty-three Associate members and twenty-three Junior members were elected.

Harold P. Westman was elected secretary of the Institute to succeed John M. Clayton, resigned.

Mr. Westman has been associated with the Institute for the past nine months as assistant secretary in charge of the Institute's several standardization projects. Prior to this he was technical editor of *QST* of the American Radio Relay League for one and one-half years.

### Associate Application Form

For the benefit of members who desire to have available each month an application form for Associate membership, there is printed

in the PROCEEDINGS a condensed Associate form. In this issue this application will be found on page XXXIII of the advertising section.

Application forms for the Member of Fellow grades may be obtained upon application to the Institute office.

The Committee on Membership asks that members of the Institute bring the aims and activities of the Institute to the attention of desirable and eligible non-members. The condensed form in the advertising section of the PROCEEDINGS each month may be helpful.

### Radio Signal Transmissions of Standard Frequency

MARCH TO JUNE, 1930

The following is a schedule of radio signals of standard frequencies for use by the public in calibrating frequency standards and transmitting and receiving apparatus as transmitted from station WWV of the Bureau of Standards, Washington, D. C.

Further information regarding these schedules and how to utilize the transmissions can be found on pages 10 and 11 of the January, 1930, issue of the PROCEEDINGS and in the Bureau of Standards Letter Circular No. 171 which may be obtained by applying to the Bureau of Standards, Washington, D. C.

Eastern Standard Time	Mar. 20	Apr. 21	May 20	June 20
10:00 P.M.	550	1600	4000	550
10:12	600	1800	4400	600
10:24	700	2000	4800	700
10:36	800	2400	5200	800
10:48	1000	2800	5800	1000
11:00	1200	3200	6400	1200
11:12	1400	3600	7000	1400
11:24	1500	4000	7600	1500

### Committee Work

#### TECHNICAL COMMITTEE ON VACUUM TUBES, A.S.A.

At a meeting of the Technical Committee on Vacuum Tubes of the American Standards Association, held at 2 P.M. on January 16, 1930, in the office of the Institute, the following were present: J. C. Warner, chairman; D. C. Ulrey, C. W. Hansell, F. A. Engle, R. E. A. Putnam, M. J. Kelly, R. M. Wise, A. B. DuMont, P. T. Weeks, Gordon Thompson, and Harold P. Westman, secretary.

#### TECHNICAL COMMITTEE ON RADIO RECEIVERS, A.S.A.

A meeting of the Technical Committee on Receivers of the American Standards Association was held on January 22nd at 10 A.M. in the Institute office, 33 West 39th Street. Those present were E. T.

Dickey, chairman; J. F. Fulmer (representing H. B. Smith), W. A. MacDonald, T. McL. Davis, V. M. Graham, W. W. Grimditch, W. H. Murphy, F. M. Ryan, and Harold P. Westman, secretary.

#### NEW YORK PROGRAM COMMITTEE

The New York Program Committee of the Institute, charged with the responsibility of arranging all of the programs of the New York meetings, met on January 23, 1930, at 9:30 A.M. All of the members of the committee were present: R. H. Ranger, chairman; H. C. Gawler, Austin Bailey, E. R. Shute, and F. M. Ryan. W. E. Holland, director of the engineering division of the Radio Manufacturers' Association, was present as a guest.

Tentative plans for all New York programs through September have been made by the committee.

#### COMMITTEE ON ADMISSIONS

A meeting of the Committee on Admissions was held at 6 P.M. on February 4, 1930, in the Western Universities Club, 11 West 53rd Street, New York City. The following members were present: R. A. Heising, chairman; Arthur Batcheller, C. N. Anderson, C. M. Jansky, Jr., J. S. Smith, A. F. Van Dyck, and R. H. Marriott.

The committee considered twenty-two applications for transfer or election to higher grades of membership in the Institute.

#### TECHNICAL COMMITTEE ON RADIO RECEIVERS, I. R. E. STANDARDIZATION COMMITTEE

A meeting of the Technical Committee on Radio Receivers of the Standardization Committee of the Institute was held on February 6th at 10 A.M. Those present were E. T. Dickey, chairman; Wilson Aull, C. E. Brigham, C. M. Burrill, G. C. Crom, Jr., Harry Diamond, Malcolm Ferris, K. W. Jarvis, W. A. MacDonald, E. J. T. Moore (representing Mr. Graham), and Harold P. Westman, secretary.

#### TECHNICAL COMMITTEE ON RADIO TRANSMITTERS, I. R. E. STANDARDIZATION COMMITTEE

A meeting of the Technical Committee on Radio Transmitters of the Institute's Committee on Standardization was held at 3 P.M., February 6th, in the Institute office. Members present were W. Wilson, acting chairman; P. A. Greene, T. A. M. Craven, R. M. Wilmotte, H. E. Hallborg, J. K. Clapp, Raymond Guy, R. H. Marriott, E. L. Nelson, D. G. Little, A. H. Morse, F. G. Kear, and Harold P. Westman, secretary.

## Institute Meetings

### CINCINNATI SECTION

On January 23, 1930, the Cincinnati Section met in the Chamber of Commerce Building, Cincinnati, Ohio. R. H. Langley, chairman of the section, presided.

Three papers were presented as follows:

"Remote Control of Radio Receivers," by R. H. Langley.

"Notes on the Design of Audio-Frequency Transformers," by R. M. Blair.

"Description of Radio-Frequency Transmission Line for Radio Receiver Testing," by Dorman D. Israel.

These papers were discussed by Messrs. Glover, Kilgour, Austin, Felix, and Langley.

Forty-two members of the section and guests attended the meeting.

### CLEVELAND SECTION

On January 31st the Cleveland Section met in the Case School of Applied Science, Cleveland. D. Schregardus, chairman of the section, presided.

J. A. Victoreen, chief engineer of the Victoreen Radio Company, presented a paper, "Engineering Difficulties of Design and Manufacture of Superheterodynes." The paper included a discussion of the following considerations:

Advantages of superheterodyne receiver over tuned radio frequency, comparison of loop and antenna as input systems, types of coupling for antenna reception, reasons for using one stage of tuned radio-frequency amplification before the first detector, first detector or modulator, advantage of large oscillator component in signal passed through the amplifier condenser construction, use of inductance as part of voltage divider before the two voltage regulator tubes.

Eighty-two members of the section and guests attended this meeting.

### LOS ANGELES SECTION

A meeting of the Los Angeles Section of the Institute was held on January 20, 1930, in the Engineers' Club, 833 S. Spring Street, Los Angeles. Chairman T. C. Bowles presided.

Two papers were presented. The first by T. E. Nikirk, of Western Air Express, Inc., was entitled "Radio Communication as Applied to Aircraft".

The second paper, by T. F. McDonough, was "Ultra Short Waves". Seventy-one members of the section attended this meeting.

## NEW ORLEANS SECTION

A meeting of the New Orleans Section of the Institute was held on January 22, 1930, in the Louisiana Engineering Society, New Orleans. Pendleton E. Lehde, chairman of the section, presided.

W. J. Holey of the Department of Commerce of Detroit, Michigan, presented a paper "Radio Checking Equipment".

Thirty members of the section and guests attended the meeting.

## NEW YORK MEETING

The regular monthly New York meeting of the Institute was held on Wednesday, February 5, 1930, in the Engineering Societies Building, 33 West 39th Street. Lee de Forest, president of the Institute, presided.

Captain S. C. Hooper, U. S. Navy, one of the U. S. delegates to the meeting of the International Technical Consulting Committee at The Hague in 1929, presented a paper, "The Hague Conference." This paper is summarized as follows:

"The Hague Conference having its origin in the International Radiotelegraph Convention, Washington, 1927, this paper quotes extracts from certain articles of the Convention, with its annexed regulations, as a basis for discussion. The initiative taken by the United States Government through the Federal Radio Commission in the matter of radio-frequency channels is briefly mentioned. Then follows the narrative of the work of preparing the United States proposals which were based upon agenda supplied by the Netherlands Government. A list of United States delegates and technical advisers is included, thus completing the ground work preceding the activities at The Hague.

"No time appears to have been lost in effecting a very efficient organization for the first International Technical Consulting Committee on Radio Communications, wherein the delegates and advisers from the numerous nations represented were divided into four main committees. The United States proposals were adopted as a basis for discussions. There follows a summary of the principal agreements adopted at the last plenary session, including standards for measurement, spacing of channels, tolerances, and kindred subjects. Then there follow questions held over for future discussion."

This paper will be published in a forthcoming issue of the PROCEEDINGS.

One hundred and seventy-five members of the Institute attended this meeting.

## PHILADELPHIA SECTION

The Philadelphia Section met on February 5, 1930, in the auditorium of the Franklin Institute, Philadelphia. J. C. Van Horn, chairman of the section, presided.

R. H. Ranger, research engineer of the R. C. A. Communications, Inc., presented a paper, "Recent Developments in Facsimile Transmission."

After outlining briefly the various methods and types of apparatus experimented with, in the earlier stages of its development, Mr. Ranger described in detail the principles of operation of the most recently developed form of R. C. A. facsimile transmitter and receiver. This latest type of machine was on exhibition and was in operation throughout the evening. Many interesting details were made clearer by means of special slides. Of particular interest was the ingenious push-pull modulated oscillator devised for translating the various shades of color, as received by the photo-electric cell, into dots suitable for transmission; the spacing of these "dots" or impulses varying directly with the degree of light or shade under observation at any instant.

The time required for actual transmission was said to vary from fifteen to forty-five minutes. Throughout this period, the picture can be instantly observed while it builds up line by line, so that possible errors may be corrected. Facsimile transmitters are at present in daily operation in London, San Francisco, and New York. It was shown that photographs, as well as drawings and printed matter, may be transmitted by this method.

Seventy members of the section attended this meeting.

#### PITTSBURGH SECTION

A meeting of the Pittsburgh Section was held on January 28th in the physics lecture room of Science Hall, Carnegie Institution of Technology. T. D. Cunningham, acting chairman of the section, presided.

R. C. Hitchcock, of Westinghouse Electric and Manufacturing Co., presented a paper, "Electrical Synthetic Music."

The paper was discussed by Messrs. Nathanson, Jones, Allen, Williamson, Cameron, and others.

One hundred and eighty members of the section and guests attended this meeting.

#### SAN FRANCISCO SECTION

The San Francisco Section held a meeting on January 22, 1930, in the Engineers' Club of San Francisco, 206 Sansome Street. Donald K. Lippincott, chairman of the section, presided.

Frank R. Norton presented a paper, "Engineering Factors in the Design and Operation of Sound Picture Systems". The paper described the technical details of taking and recording sound pictures.



Three methods of recording the sound, the record or disk method, and two forms of film sound tracks were described. The speed control circuit of the drive motor on the projector was illustrated by a lantern slide and described in detail. Other lantern slides were used to illustrate parts of the projectors and amplifiers. Following the presentation of the paper a general discussion took place.

Thirty members of the section were present at the meeting.

#### SEATTLE SECTION

The meeting of the Seattle Section was held on January 29, 1930, in the Telephone Building, Seattle. Austin V. Eastman, chairman of the section, presided.

Engineers of the Pacific Telephone and Telegraph Company were hosts at an open house and inspection tour of the Telephone Building of the Pacific Telephone and Telegraph Company. The inspection trip included eleven features of the telephone plant.

Special emphasis in the inspections was put on the technical features of the control of broadcast programs, dial telephone connections, and toll test rooms.

One hundred and sixty-nine members and friends participated in this interesting meeting.

#### WASHINGTON SECTION

A meeting of the Washington Section was held on January 9th in the Continental Hotel, North Capitol Street, Washington, D. C. Thomas McL. Davis, vice-chairman of the section, presided.

H. J. Walls, airways radio engineer, and Donald T. Stevens, assistant radio engineer of the Bureau of Lighthouses, presented a paper on "The Radio Facilities of the Civil Airways." The paper is summarized as follows:

"The importance of guiding aircraft in fog by means of the radio beacon was discussed. The difficulties of aircraft in locating a landing field in fog were described, and the assistance which the aural method of reception gives to the aircraft pilot was explained with the aid of lantern slides. The several directional transmitters installed along the line of flight across the country and the methods of transmitting energy on signal channels of different frequencies were described. The receiving circuits by which a pilot may distinguish the right or left of the course were described. At intervals along the airways, marker beacons are employed to inform the pilot with respect to his geographical location over different airports.

"The Teletype system of automatically transmitting certain information along the airways and transmitting such information periodically on the navigation channels was explained. The extensive operations now under development by the Airways Division of the Department of Commerce are doing a great deal for the advancement of aviation and are in

creasing the safety of flight. It was pointed out that the success in the Hawaiian flight depended largely upon the radio beacon. It is claimed that many of the recent disasters may have been avoided if planes had been equipped with receivers enabling the pilot to fly a predetermined course on the radio beacon. Every effort is being made to speed up the installation of radio beacons throughout the country for the promotion of aviation."

Fifty-three members of the Washington Section attended this meeting.



PART II  
TECHNICAL PAPERS



## STANDARDIZATION IN THE RADIO VACUUM-TUBE FIELD\*

BY

W. C. WHITE

(Research Laboratory, General Electric Co., Schenectady, N. Y.)

*Summary*—In vacuum-tube engineering the base dimensions, the filament voltage, plate voltage, and grid-bias voltage are the features that require standardization to the greatest degree. The history and present status of standardization of these features are given. Only tube types commonly used for broadcast reception and transmission are included.

A VACUUM tube is a renewable item. Therefore, there are very real reasons, from the viewpoints of both the manufacturer and the user, why the number of types should be kept at a minimum and care taken to see that certain electrical and mechanical features are maintained uniform so as to insure proper interchangeability. These requirements, of course, lead to standardization of certain essential electrical and mechanical features.

As in the case of many other electrical and mechanical devices, the number of applications for vacuum tubes was at first very limited and the ways in which tubes were used not highly specialized nor very complicated. Therefore, only a few types of tubes were needed.

Later, as new requirements and refinements appeared, the number of types of tubes greatly increased.

As in the case of certain other electrical devices, such as lamps and motors, it is very probable that sometime in the future there will be a strong reaction and a return to fewer highly standardized types. However, this desirable state of affairs is only possible after the field of application has been thoroughly explored and the really necessary or competitive receiver and transmitter design features reduced to a minimum.

The history of electrical devices records examples of many schemes that have been tried and either found impracticable or unable to survive for competitive reasons.

In this country vacuum-tube standardization got its real start with the entrance of the United States into the World War. It was obvious then that the quantity requirements for large production, and interchangeability of parts, were factors practically requiring that certain features be standardized.

\* Dewey decimal classification: R330.4. Presented before Eastern Great Lakes District Convention of the Institute at Rochester, N. Y., November 19, 1929.

At the present time there are several agencies for standardization that include vacuum tubes in the scope of their activities. The most important of these are as follows:

**1. International Advisory Committee on Radio Communication of the International Electro-Technical Commission.**

So far the only feature of vacuum tubes that has been standardized by this body is essential base dimensions, and this applies only to the small size tubes commonly employed in radio broadcast receivers.

**2. American Standards Association.**

This is the national standardizing group and was formerly termed the American Engineering Standards Committee. This national body considers for standardization any items that have been standardized by engineering societies and trade or manufacturing associations and that time and usage have shown to be desirable. Its work relative to tubes is carried on through a Sectional Committee on Radio.

**3. Institute of Radio Engineers.**

This is the most active group in initiating tube standards. To date, their field of activity has been along the lines of definitions and methods of testing apparatus together with nomenclature and symbols.

**4. The National Electrical Manufacturers' Association. Radio Manufacturers' Association.**

These groups have also originated standardization work relative to tubes, their field of endeavor being more along empirical lines so that uniform essential dimensions, terms, and marking will be used by the various manufacturers.

**5. United States Government.**

The Bureau of Standards, Bureau of Engineering in the Navy and the Signal Corps of the Army, have established a number of points of standardization largely by means of government specifications for purchase of vacuum tubes.

**6. The Manufacturers of Vacuum Tubes.**

The manufacturing interests associated with the Radio Corporation of America and the American Telephone and Telegraph Company have been important factors in establishing certain characteristics or dimensions that later became standard practice.

The international and national standardizing bodies above mentioned do not, as a general policy, originate standards but consider for adoption only those sponsored by recognized agencies such as the Institute of Radio Engineers, National Electrical Manufacturers' Association, and Radio Manufacturers' Association.

This paper aims only to cover the subject of tube standardization from the viewpoint of general classes of tubes well-known to the great majority of radio engineers. It does not attempt to cover foreign tubes or those not generally available. Electrical characteristics or constants of any particular type of tube, such as mutual conductance and amplification factor, are also not included.

## A. BASES

### Receiving Tubes

Standardization of this item is necessary for satisfactory use. In this country from the very start the idea of a solid base pin and flexible socket contacts was adopted in contrast to the European practice of solid socket contacts and spring pins.

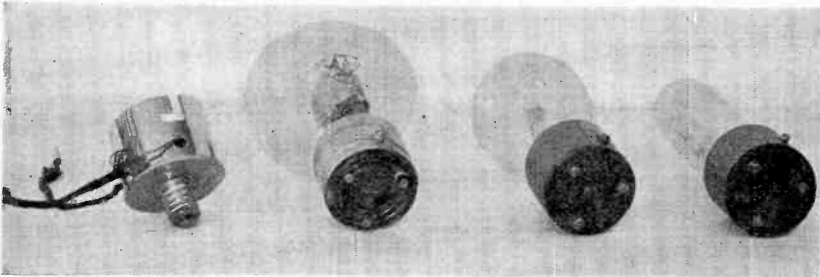
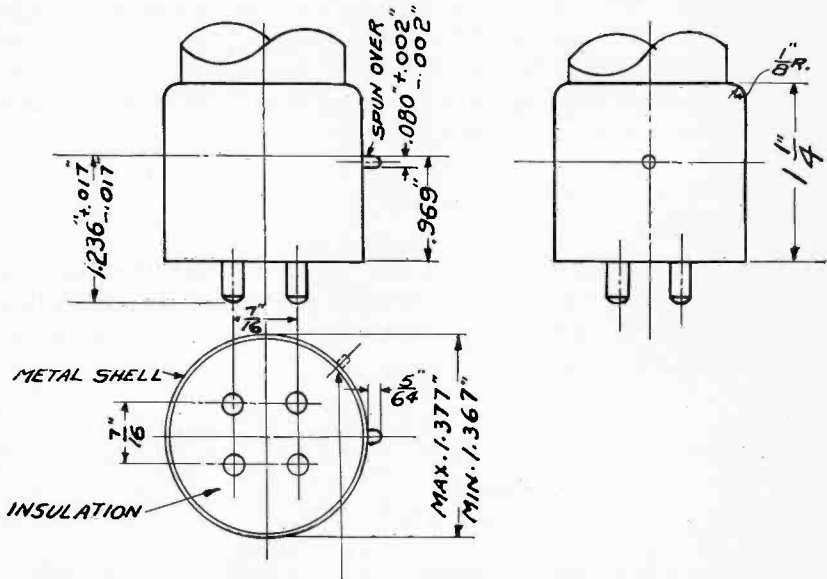

Fig. 1—From left to right: Adaptor, W. E. Co. tube, G. E. Co. tube, and de Forest tube.

The early de Forest audions were the first to utilize a base of any sort, and this base consisted of the so-called "candelabra screw base" as used on lamps. This was, of course, only a two-contact base and was used for the two-filament connections, the plate and grid connections being brought out through two wires at the opposite end of the bulb, sometimes through a protective cap.

About the only other early form of vacuum-tube base that was employed to any extent in this country was a four-contact type used by the United States Navy just before the war period (1916-17). This originated with de Forest audions supplied to the Navy about that date, and a little later was also used in connection with a number of

other tubes made in relatively small quantities for the Navy. This base was made from a black moulded material and was, in a very general way, similar to modern small bases of moulded compound construction. It differed, however, in that only three of the contact pins were on the bottom, a bayonet pin at the side being also used for the fourth contact (one filament connection) in addition to its functioning



**DOTTED PIN IS USED ON TRANSMITTING TUBES. IT IS ROTATED 40° TO THE LEFT OF THE POSITION IN THE RECEIVING TUBE AS SHOWN.**

Fig. 2—Essential dimensions, U. S. Signal Corps tube base of 1918.

as a mechanical holding feature. Three tubes having bases of this type, as made by the Western Electric, General Electric, and de Forest Companies in 1917–18, are shown in Fig. 1. There is also shown an adapter to fit such tubes into an audion socket of the candelabra lamp base type.

The four-pin receiving tube base was originated by the Western Electric Company and adopted by the Signal Corps in 1917 for Army use. An outline drawing of such a base with dimensions copied from a Signal Corps specification of the war period is shown in Fig. 2.

The Signal Corps specifications gave a certain leeway in structural design and as a result the three principal suppliers of vacuum tubes to them at that time utilized slightly different constructional details.



The General Electric Company in its VT-11 tube used a punched brass shell with a porcelain insulating insert holding the four brass pins. The Western Electric Company in its VT-1 Signal Corps tube used a rolled metal shell with a composition insulating insert to support the four contact pins. The deForest Company in its VT-21 utilized a black insulating compound and a metal shell. These three tubes with bases are shown in Fig. 3.

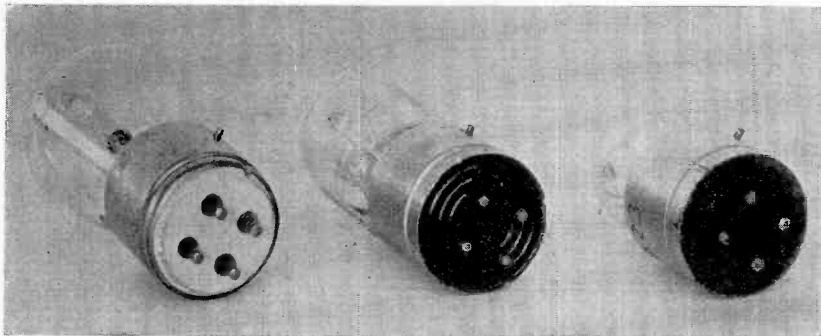

Fig. 3—Signal Corps tubes of war period. From left to right: General Electric, Western Electric, and de Forest.

The Signal Corps also standardized and utilized two variations of this base. For their smallest transmitting tubes during the war period the position of the bayonet pin was changed by rotating it 40 deg. In this way, and by putting in the socket bottom what might be termed a "floor" with four holes in it for the four base pins, they obtained a combination by which receiving tubes and transmitting tubes could only be inserted each in their proper socket. This variation is shown in Fig. 2. Another variation was the elimination of the grid pin for two electrode tubes.

The receiving tube base above described was really the starting point of the present base, as any of the modern tubes using this size of base can be satisfactorily inserted and operated in a socket manufactured in 1917. This is apparent by comparing the dimensions of this early army tube base (Fig. 2) with the essential dimensions of the present standard four-prong base shown in Fig. 4.<sup>1</sup>

Following the formation of the Radio Corporation in 1919, vacuum tubes became available for general use. The early Radiotron tubes were furnished with a base of practically the same design and dimen-

<sup>1</sup> This figure as well as Figs. 5, 7, 8, and 9 are reprinted from the fourth edition of the N. E. M. A. Handbook of Radio Standards.

sions as the Signal Corps type of base with porcelain insert as furnished by General Electric during the war period.

This base was continued in active use by the Radio Corporation until 1924, when it was replaced by one made up of four brass contact pins and a bayonet pin secured into a moulded compound of bakelite composition.

In connection with this original Radio Corporation base, it is rather interesting to note that it is still often referred to as the "old

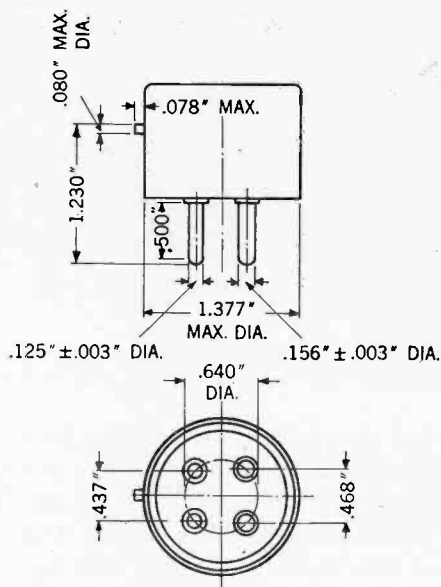

Fig. 4—Essential dimensions, four-pin standard base.

Navy type of base" whereas in reality it was, as has been stated, originated by the Western Electric Company and adopted and actually widely used by the Signal Corps prior to Navy use. Certainly it was used to a far greater extent in the Signal Corps than in the Navy, as the Signal Corps was a much larger consumer of vacuum tubes of the receiving type than the Navy during the war period.

Experience indicated that while a soldered connection at the bottom of the pin was the most satisfactory from the manufacturing viewpoint, such an arrangement from time to time gave difficulty due to the corroding of this solder at the point of contact. This was overcome to some extent by the use of pure tin in place of ordinary soft solder and by a socket design to obtain some sort of a contact on the

side of the brass pin above the solder-covered area. However, these two expedients were not entirely satisfactory. As a result, an analysis of the situation was made by the manufacturing interests associated with the Radio Corporation, and it was very apparent that a side form of contact with long pins, such as used in European practice and on the Westinghouse WD-11 tube, was superior to the bottom contact method with short pins. Also, it was found that approximately 85 per cent of the tubes used at the time the analysis was made (1924) employed this type of base that originated during the war period. From this analysis, there resulted what is known at the present time as the standard four-pin type of receiving tube base. This new design utilized the older type of base as a starting point, the change being to lengthen out the contact pins, to increase the diameter of the two filament pins so as to insure proper insertion into a new form of socket, and to lower the bayonet pin by an amount equivalent to the increase in pin length so that the base could still be used in the old type of socket having bottom contacts and bayonet pin slot.

Tubes with this new type of base were first released for general use in 1925, and surprisingly little complication resulted from this change. At the time this new base was designed, the so-called WD-11 and UV-199 bases were in limited but general use, but the new standardized base removed the need for any use of these other two types of bases on new designs of tubes. Thus the use of the standard arrangement of pins of the new design incorporated in two different sizes of base shell filled quite completely the receiving tube requirements for a number of years.

In view of the subsequent increase in the number of different types of tubes, it is indeed fortunate that this base standardization was effected at such a relatively early date.

A little later, this base was slightly modified by the shortening of the shell which improved the general appearance of the based tube and decreased the amount of moulded material required. However, this change involved no changes in any of the essential dimensions.

The remaining step in this standardization which was originally planned, but has not yet been put into effect, was the elimination of the side bayonet pin when radio equipment requiring it became obsolete.

As has been stated above, the WD-11 and UV-199 types of bases were in limited use on early Radio Corporation tubes and a certain number of tubes utilizing this type of base are still made in relatively small quantities for replacement purposes in existing equipments.

The WD-11 type of base had many of the advantages of the present type, but such a relatively small percentage of tubes using this type of base were in existence at the time the four-pin base was standardized that several new types of tubes would have had to be created in order to take care of the many requirements for the sockets designed for the original Radio Corporation tubes (UV-200 and UV-199 and UV-201).

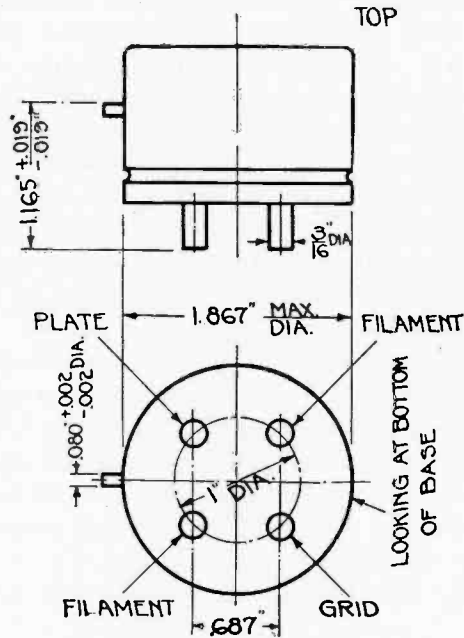

Fig. 5—Essential dimensions, medium-size power tube base.

### Bases for Medium Power Tubes

The Western Electric Company also originated prior to 1918 two larger forms of the bayonet type of base.

The smaller of these was the base used on the so-called fifty-watt type of power tube which, as regards essential dimensions, has been very little changed in either dimensions or general design since its adoption by the Signal Corps and Navy during the war period. The present outline of this base as used on several types of small power tubes is shown in Fig. 5.

In the case of this base, which was quite widely used by both the Signal Corps and Navy well in advance of the formation of the Radio Corporation, its continued general use was the result of standardization by the government departments. A still larger form of this bayonet

type of base is utilized in certain tubes manufactured by the Western Electric Company.

### Bases for Double-Ended Power Tubes

In the development of tubes for greater power outputs, it became necessary to utilize higher plate voltage, and this necessitated the bringing out of the plate lead at the end of the bulb away from the

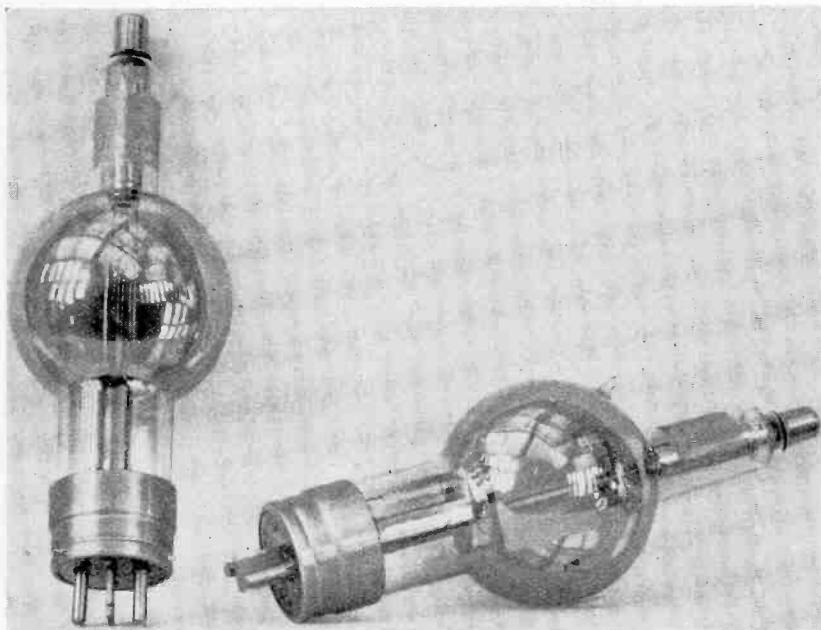

Fig. 6—Double-ended power tube of war period.

grid and filament leads. Also certain types of these tubes used rather heavy filament currents and large glass arm diameters which necessitated a new design of base.

The common form of base for the filament and grid terminals of a double-ended vacuum tube of the war period is shown in Fig. 6. This base was originated by the General Electric Company in 1917, and was adopted in 1918 by the Navy and somewhat later by the Signal Corps. After the formation of the Radio Corporation, it was also adopted for their high power tubes. It is made in three different forms, the pin arrangement being identical in all three forms, but the diameter of the metal shell varying to accommodate different sizes of necks of the glass bulbs.

An outline showing the essential dimensions of the contact portions of these three bases is shown in Fig. 7.

The desire to limit to a minimum the number of different base types has resulted in the use of diameters of glass necks of tube bulbs, for high-power tubes, to fit one of these three standard sizes of bases.

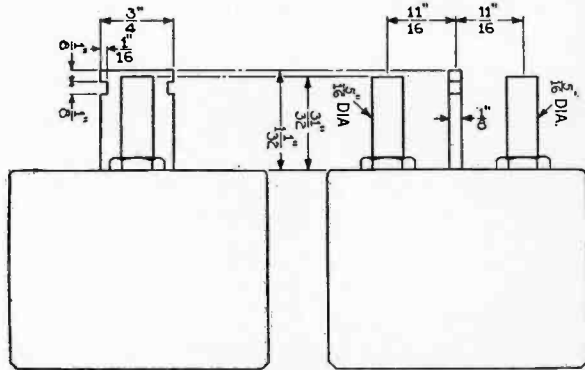

Fig. 7—Essential dimensions, cathode, and base of high-power tube.

In a like manner, the anode terminal has been standardized as shown in Fig. 8, with variations in skirt size so as to accommodate different sizes of glass anode-supporting arms.

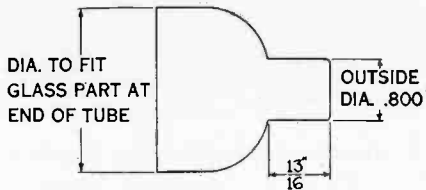

Fig. 8—Essential dimensions, anode cap of high-power glass tube.

### Five-Contact Pin Bases

With the development of the so-called a-c type of tube, it was desirable to provide an additional contact. On some of the early developmental forms of a-c tubes, the two heater terminals were brought out through the upper end of the bulb so that a standard base could be used at the lower end. However, improvements in design and convenience in use resulted finally in the standardization of the five-pin type of base.

In order to introduce as great a standardization as possible, the pins used on this base were all of the same diameter and length as the

small pin of the standard four-pin base, but were spaced so as to allow insertion in the socket in only the correct position. As this base could not be used in any existing sockets, it was not necessary to incorporate a bayonet pin. The standardized essential dimensions for this five-pin base and the connections used on heater-type tubes are shown in Fig. 9.

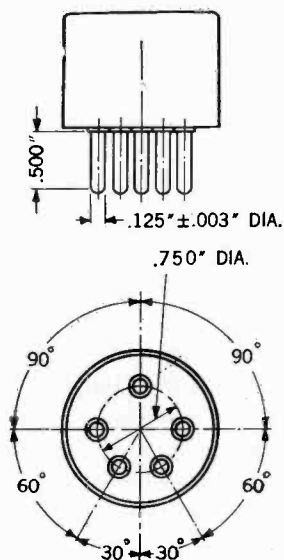

Fig. 9—Essential dimensions of five-pin receiving tube base.

### Miscellaneous

The arrangement of connections between the contacts on the various bases and the tube electrodes is usually established with each type of base. However, the development from time to time of new types of tubes sometimes results in the use of a standard base but with a variation in connections.

Special requirements have necessitated the design and manufacture of certain special tubes, particularly in the point-to-point communications field, and these in turn have led from time to time to the requirement for new bases or terminals. In general, however, insofar as possible the number of socket designs has been kept at a minimum, the same actual terminal dimensions being employed for a number of bases that differ only in the size of the bulb or arm to which they are fitted.

It is not within the scope of this paper to consider special bases that are used only to a very limited extent.

## B. FILAMENT VOLTAGES

In the matter of filament voltages, standardization has not progressed to a point where it has been adopted by national bodies except indirectly. The choice of filament voltage, or heater voltage in the case of a-c tubes, is dependent not only upon the nature of the power supply to be employed, but also upon certain design limitations in the tubes. As will be noted in later paragraphs, circumstance played quite an important part in the selection of filament voltages.

### Receiving Tubes

#### *Storage Battery Supply*

The early de Forest audions, of which there were several varieties, required filament voltages in the range between 4 and 15.<sup>2</sup> A uniform filament voltage was not utilized with these early audions, as filament temperature by means of filament voltage control was utilized to regulate the sensitivity or amplifying property of these tubes. Just prior to the war period, the Navy was using a considerable quantity of 5-cell Edison storage batteries for filament voltage supply. Because of the way in which the tubes were used, as explained above, there was no definite filament voltage rating, but a limit of about 4.5 was utilized.

During the war period, the principal types of receiving tubes used by the Navy together with the filament voltages and currents were as follows:

CG-886	4	volts	0.75	amperes
CW-933	2.4	"	1.1	"
SE-1444	3.65	"	0.65	"
CG-890	3.6	"	1.1	"

Of these tubes probably the CW-933 and SE-1444 were used in the greatest quantities. It will be noted from the above tabulation that there was little filament voltage standardization at that time.

Early in the war period, the U. S. Signal Corps chose for its use a two-cell lead storage battery.

A lead storage cell is generally considered as having a voltage variation between charge and discharge of 2.1 to 1.8. Therefore, for a two-cell battery the variation of voltage may be considered as between 4.2 and 3.6. The Signal Corps assumed a 0.3-volt drop in the leads and terminals which resulted in an available filament voltage of 3.9 to 3.3. This meant an average voltage of 3.6.

Three types of receiving tubes utilized by the Signal Corps during the war period were referred to in earlier paragraphs of this paper.

<sup>2</sup> Lee de Forest, "The Audion-Detector and Amplifier," Proc. I. R. E., 2, 15; No. 1, 1914.



Owing to a peculiar arrangement in the circuit of the receivers utilized at that time by the Signal Corps, tubes having two different filament voltages could be employed. The VT-11 tube utilized the full average battery voltage of 3.6.

The VT-1, however, was designed for an average filament voltage of approximately only 2.4, the remainder of the voltage being absorbed by a series resistance in the filament circuit of the receiver. This use of two tubes of different filament voltage in the same receiver, without the making of any changes in the circuit, was accomplished by connecting the brass shell of the VT-11 base to one filament pin. In the receiver, there was a connection between the shell of the socket and the battery side of the resistance. Thus, when the VT-11 type of tube was inserted in the socket, the series filament resistor was short circuited.

With the formation of the Radio Corporation of America, it became possible to merchandise receiving tubes, and since at that time the most thoroughly satisfactory type of tube utilized a filament rating requiring storage battery operation, this fact was taken into account in determining a filament voltage rating.

The almost universal use of a three-cell six-volt lead storage battery for automobile ignition, lighting, and starting resulted in the choice of this same type of battery for receiving tube filament operation.

On the basis of a minimum voltage of 1.8 a three-cell battery has a minimum voltage of 5.4 and a filament rating of 5 volts was adopted, thus allowing 0.4 volt for unavoidable circuit losses. This figure of 5 volts has been utilized for the great majority of tubes for operation from storage batteries.

### *Dry Battery Supply*

In the use of dry cells for filament supply, a greater voltage variation was encountered between new cells and discharged cells than between the charge and discharge voltage of storage batteries. Therefore, the extent to which a filament could be over-voltaged by improper rheostat setting was an important factor. Also, as a low current was important for satisfactory dry battery life the current values utilized were such as to encourage operation of the filaments in series under certain conditions. Therefore, the filaments of such tubes were sometimes primarily rated by current.

The earliest dry cell tube to come into use to any extent was the "N" tube, designed and manufactured by the Western Electric Company. It was designed for operation through a filament voltage range of 0.85 to 1.1 volts, the recommended current maximum being 1/4 ampere.

With the formation of the Radio Corporation, the WD-11 and next the UV-199 types of tubes became available, the former designed for operation from one dry cell and the latter from three cells in series.

The extended use of the No. 6 type of dry cell for filament supply led to considerable battery development, and it is now common practice to employ a filament voltage rating of the tube of 1.1 for each cell of such battery.

#### *A-C Supply*

As it is impracticable to build or utilize a thoroughly satisfactory receiving tube for operation directly from a 110-volt supply, a transformer is required. Under these conditions, the tube itself is the chief factor in determining filament or heater voltage. The two types of so-called a-c tubes will be considered separately.

#### *Filament Operation Directly from A-C Supply*

In operating the filament of a tube directly from an a-c supply the securing of the lowest hum value is one of the chief essentials, and this is usually obtained by getting a proper ratio between filament current and filament voltage. The hum from the filament due to electrostatic disturbance is opposite in phase from that due to electromagnetic disturbance so that it is possible to get a minimum of hum by a proper ratio of voltage to current.

In general, filament voltages lower than 1.0 are rather impractical from the viewpoint of tube design, and also fractional turns on a transformer are necessary to obtain accurately one volt or lower. In some of the earliest varieties of a-c tubes of this type produced, there was a scattering of voltages employed, but 1.5 volts has now come into general use.

With the present trend in radio receiver and tube design, it would seem unlikely that there will be any great extension of the use of this type of tube.

#### *Heater Type*

In determining a heater voltage for receiving tubes, the effect of this factor on the hum of the tube is not as pronounced as on the filament type. Also, due to certain geometrical relations in the tube itself, 1.5 is too low a voltage and 5 volts a possible but rather high voltage.

As in the case of the filament type of a-c tube, there was a scattering of different voltages at the start, but 2.5 volts has now become general practice. It would appear at the present time as if this figure will be utilized, in general, for the majority of tubes for a-c receivers, at least until some new factor arises that would indicate a very definite advantage favoring a change.

## Power Tubes

### *Small Size*

The use of an 8-volt lead storage battery during the war period determined the filament voltage on the so-called 5-watt type of tube. Two principal types of tubes of this small size were used during the war period.

The first was the U. S. type CW-931 and the equivalent Signal Corps VT-2 manufactured by the Western Electric Company and operated at a filament voltage of 6.5 to 7.0. The other was the Navy CG-1162 corresponding to the Signal Corps VT-14 manufactured by the General Electric Company and operated at a filament voltage of 7.5.

The 7.5-volt figure was perpetuated by the R. C. A. with the introduction of its UV-202 type in 1921, and at intervals a few other tubes having this filament voltage have been added.

### *Intermediate Size*

The filament voltage of the so-called 50-watt type of tube was influenced by the use of a six-cell 12-volt lead storage battery for U. S. Navy aircraft transmitters during the war period. Such a battery when discharged has a voltage of about 10.8, allowing an 0.8-volt loss in wires and terminals. A 10-volt filament rating was adopted. This was incorporated in the CW-1818 manufactured by the Western Electric Company and the CG-1444 manufactured by the General Electric Company. The use of the 10-volt filament for this general size of power tube was continued by the R. C. A. in 1921 with the UV-203 Radiotron. New types of tubes having this same filament voltage have been added from time to time to the R. C. A. Radiotron line.

### *High-Power Transmitting Tubes*

For the purposes of this paper, this classification includes tubes of 250 watts output and above.

During the war period, the U. S. Navy used a CG-916 high-power tube for operation from a 24-volt lead storage battery for aircraft service. However, the nature of this service dictated a very high filament efficiency which resulted in a tube life so short that this type of tube was not utilized later by the R. C. A.

Therefore, when the R. C. A. initiated a line of high-power tubes, the nature of the filament supply was taken into account. This was before the time of broadcast transmission and it was believed that a-c filament operation would probably be utilized for the most part.

Eleven volts at that time (1921) were used to a considerable extent for sign-lighting lamps and, therefore, transformers for obtaining this voltage from standard supply voltages were available, together with certain other items of apparatus. This minor factor determined the choice of 11 volts which, for the most part, has been adhered to. With the development of still higher power tubes, multiples of this voltage (22 and 33) have been utilized.

### C. PLATE VOLTAGES

This paper will consider only plate voltages as used in radio broadcast receivers.

Again, as in the case of filament voltages, there has been no direct formal standardization, but usage has dictated from time to time certain values.

The early deForest audions were quite sensitive in their operation to variations of plate voltage, and most of the apparatus utilizing them was provided with some form of plate voltage adjuster usually a multi-point switch for obtaining the voltage from a varying number of dry cells. In general, voltages in the range between 12 and 30 were employed.

The first general use of a fixed plate voltage was by the Signal Corps during the early part of the war period. This followed the adoption by the Signal Corps of a fifteen-cell block form of "B" battery. A single block was utilized for the most part for detector use and two blocks in series for amplifier use. The general range of voltage for such a block of cells was between 17 and  $22\frac{1}{2}$ , and it became customary to specify a figure of 20 for this voltage as representing an average value with 40 as a value for two blocks in series.

With the coming of radio broadcasting, "B" batteries in blocks came into common use and the fifteen-cell grouping in general continued. A little later, thirty cells also were grouped together in one block.

In 1924, an informal agreement was reached between some of the principal manufacturers of tubes and batteries that plate voltages would be expressed as multiples of  $1\frac{1}{2}$ , thus a fifteen-cell block was rated at  $22\frac{1}{2}$ , a thirty-cell 45, and so on. This custom was later recognized by the National Electrical Manufacturers' Association.

During the evolution of broadcast reception, receiver design dictated higher and higher plate voltages and so there came into use 135  $167\frac{1}{2}$ , and 180.

With the introduction of a-c operated receivers, with a rectifying system for supplying plate voltage, different considerations entered

into the selection of plate voltage values. As in this case no renewable item was involved, standardization was not needed to the same extent as when batteries were utilized. It is probable that condenser ratings will be one of the chief factors in determining plate voltage values in the future.

Another factor in this question is the maximum plate voltage at which tubes can be rated without unduly increasing their cost.

#### D. GRID-BIAS VOLTAGES

As in the case of plate voltage, grid-bias voltage was, during the first few years of radio broadcasting, supplied almost entirely from dry cells. As the voltages used were relatively small compared with plate voltages, tubes were designed so as to utilize values that could be obtained as multiples of  $1\frac{1}{2}$ . Inasmuch as the drain on "C" batteries was exceedingly small, the initial voltage of  $1\frac{1}{2}$  per cell was fairly well maintained through the entire useful life of the battery.

As in the case of plate voltages, with the advent of a-c operated receivers, the necessity for utilizing voltages in multiples of  $1\frac{1}{2}$  no longer exists, and standardization is now not as essential because no renewable items are involved.

#### E. GENERAL

A number of important features of vacuum tubes that involve standardization have been listed. There are certain other items, however, that might be included, but to avoid duplication or repetition it would seem best at the present time merely to name them and list references.

The fourth edition of the N. E. M. A. Handbook of Radio Standards lists on page 65, by means of tabulations, certain features for particular types of tubes. There is a somewhat similar tabulation for rectifier tubes in the same edition (p. 70).

*VACUUM-TUBE NOTATION—LETTER SYMBOLS:* This has been included (p. 51-53) in the Preliminary Draft of Report of the I. R. E. Committee on Standardization dated May 25, 1928.

*DEFINITIONS OF VACUUM-TUBE TERMS AND QUANTITIES:* This is included in the above I. R. E. reference on pages 17-24.

*METHODS OF MEASURING CERTAIN VACUUM-TUBE CHARACTERISTICS:* This is also included in above I. R. E. reference (pages 55-66).

*POWER OUTPUT RATING OF TRANSMITTING AND POWER TUBES:* Definitions to cover operating conditions, particularly as regards distortion, are a necessary first step in the power rating of a tube.

Considerable work has been done on this subject, but only in the case of power tubes for the operation of loud speakers has standardization been approached. This latter point is covered (pages 65-66) in the I. R. E. Standardization Committee Report that has already been referred to.

Further information on this general subject can be found in the following references:

- A. A. Oswald and J. C. Schelleng, "Power Amplifiers in Transatlantic Radio Telephony." *Proc. I. R. E.* 13, 317; June, 1925.
- J. C. Warner and A. V. Loughren, "The Output Characteristics of Amplifier Tubes," *Proc. I. R. E.*, 14, 735; December, 1926.
- H. F. Dart and C. K. Atwater, "Vacuum Tube Amplifier Definitions," *QST*, p. 29, September, 1929.



## GRAPHS TO PROF. SOMMERFELD'S ATTENUATION FORMULA FOR RADIO WAVES\*

By

BRUNO ROLF

(First Meteorologist, Director of the Geophysical Observatory at Abisko, Sweden.)

*Summary*—The importance of close confrontation of Prof. Sommerfeld's attenuation formula with field-strength measurements is stressed. The fallacy of Prof. Zenneck's formula in most practical cases is pointed out, and a short summary given of Prof. Sommerfeld's conclusions, with approximate expressions for the "numerical distance" and the angle determining various shapes of theoretical attenuation curves. At very great distances, the signals over flat ground are shown always to decrease as the inverse square of distance, while at short distances short waves die away approximately as the inverse square root of distance. At intermediate distances, curious phenomena are shown to occur; in some cases, as illustrated by examples, the field vanishes altogether at a finite distance, to reappear farther away. An abac is included and instructions given for its use to obtain the inductivity and conductivity of the ground over which a series of field-strength measurements have been made. Results of such computations in Sweden and England are given. By using a graph reproduced in the paper an easy method of predicting field strengths for all wavelengths over soil, whose electrical constants are known, is devised. A simple semi-empirical formula to account for the curvature of the Earth at moderate distances is presented, and lines for better antenna construction touched upon, minimizing jamming from down-coming rays, and saving power as well.

SOME twenty years have passed since Prof. Sommerfeld published his exhaustive paper<sup>1</sup> on the attenuation of radio waves when spreading out from a vertical dipole placed in the plane interface between two semi-infinite media with very different electric properties. Although the following year he gave a more popular treatment of the subject,<sup>2</sup> accompanied by graphs illustrating some interesting forms of damping curves met with when the conductivity is so low or the frequency or inductivity is so high that the effect of the last factor is not negligible, very little attention has been paid to his formula by radio engineers, when discussing field-strength measurements around a radio station. As far as I am aware, the first attempt to use Prof. Sommerfeld's formula was made by Messrs. Ratcliffe and Barnett not

\* Dewey decimal classification: R113.7. The substance of this paper formed the subject of lectures before the Radiotechnical Society at Stockholm, February 15th, 1928, Stockholm Radioklubb, April 3, 1928, and the Physical Society at Stockholm, November 17th, 1928.

<sup>1</sup> A. Sommerfeld, "Ueber die Ausbreitung der Wellen in der Drahtlosen Telegraphie," *Annalen der Physik* 4, 28, 665; 1909.

<sup>2</sup> A. Sommerfeld, "Ausbreitung der wellen in der drahtlosen Telegraphie. Einfluss der Bodenbeschaffenheit auf gerichtete und ungerichtete Wellenzüge," *Jahrbuch der drahtlosen Telegraphie*, 4, 157; 1911.

earlier than 1925,<sup>3</sup> when confronting their measurements on Daventry (5XX) and London (2LO) with the said formula, neglecting, however, the inductivity of the soil. Mr. Barfield, in 1927<sup>4,5</sup> repeated the process on his extensive measurements around 2LO.

When contemplating the strange patterns often characterizing field-strength contour maps in the U. S. A. and elsewhere, it is obvious that to understand them and to disentangle the various causes influencing their shape, the dissector must have some guide. The propagation of radio waves when sliding along accidented soil of variable composition and with various prominences, natural or man-made, is not so well understood that theory can be altogether dispensed with. Theory must be the guide. That Prof. Sommerfeld's theoretical formula for wave propagation has not been used by radio engineers studying the broadcasting problem cannot be ascribed to doubt or controversy<sup>6</sup> as to its value or validity; the reason is, evidently, that this formula has not been given to the engineer in the form of simple approximate expressions or graphs, or tables. The aim of this paper is to supplement Prof. Sommerfeld's work in this respect.

Zenneck's formula<sup>7</sup> which is not applicable to the practical case of a small radiator, has indeed aroused more interest, obviously because his comprehensive diagrams clearly exhibit its salient features to the practical man. It comprises, just as the familiar Austin formula does, an exponential damping, whose coefficient is easily computed from the electrical data of the soil or water, along which the propagation takes place. Now one unfortunate thing is that the coefficient as computed from Zenneck's theory for propagation over the ocean comes out not 10 per cent of its value in the Austin formula at a wavelength of one kilometer and at distances where the curvature of the Earth plays no very important role. Another remarkable fact is that Austin's formula, well-established in the case of sea-water, requires the damping exponent to be proportional to square-root of frequency, while Zenneck's theory puts square of frequency in the case cited. Sommerfeld's theory supports Zenneck's at nearby distances, but the coefficient

<sup>3</sup> J. A. Ratcliffe and M. A. F. Barnett, "On the attenuation of wireless signals in short distance overland transmission," *Proc. Cambridge Phil. Soc.*, 23, 288; 1926.

<sup>4</sup> R. L. Smith-Rose and R. H. Barfield, "The attenuation of wireless waves due to the resistance of the earth," *Jour. I.E.E.* (London), 64, 766; 1926.

<sup>5</sup> R. H. Barfield, "The attenuation of wireless waves over land," *Jour. I.E.E.*, (London), 66, 204; January, 1928.

<sup>6</sup> H. Weyl, "Ausbreitung Elektromagnetischer Wellen über einem ebenen Leiter," *Annalen der Physik* (4) 60, 481; 1919. A. Sommerfeld, "Ueber die ausbreitung," etc., *Annalen der Physik* (4) 62, 95; 1920, and (4) 81, 1135; 1926.

<sup>7</sup> J. Zenneck, "Ueber die fortpflanzung ebener elektromagnetischer wellen längs einer ebenen Leiterfläche und ihre beziehung zur drahtlosen telegraphie," *Annalen der Physik* (4) 23, 846; 1907.



comes out still less than in the latter. For transmission over land, both theories give too small values for the damping, when using data for inductivity and conductivity as obtained by independent methods in the laboratory or on open flat ground. This discrepancy has, however, been shown to arise from buildings, bushes and trees,<sup>8</sup> which lower the effective conductivity of the soil very considerably. The values of conductivity and inductivity to be used in the study of wave propagation are thus not necessarily those we are acquainted with from the laboratory, but often, as for instance viscosity in meteorology, values *ad hoc* to suit open-air experiments. The main task in the near future is to show by comparison between theory and measurements that these new characteristic constants of the Earth's surface behave as the laboratory ones, i.e., that they are really constants and not dependent on e.g. wavelength. Unfortunately, very few measurements over the same ground on different wavelengths have been published in sufficient detail; those known to the author give no evident reason for further complicating the theory by introducing variable "constants" of the soil. Just because the effective conductivity may be so much lower than formerly anticipated, the results, even at so long wavelengths as the lower edge of the broadcast band, are at times complicated and extremely interesting as they account for various phenomena, whose explanation has hitherto been sought for almost exclusively in the upper air.

Time is ripe for an extensive use of Prof. Sommerfeld's formula when studying various broadcasting schemes and to compare, objectively, the merits and drawbacks inherent in short or long wavelengths when used in this country or that. Only with such background satisfactory agreements will be attainable, when wavelengths are to be distributed between various enterprises, or nations. The world-wide interest in broadcasting, the overwhelming importance of which ought to be patent to all in the near future amply justifies the trouble taken in such investigations.

#### THE THEORY AND SOME CONSEQUENCES

Sommerfeld's formula includes no less than five independent variables, viz., distance from the transmitter  $r$ , wavelength  $\lambda$ , conductivity  $\sigma$ , inductivity  $\epsilon$ , and permittivity  $\mu$  of the soil, which by a judicious combination reduce to two only, when the field at the surface of the soil is considered. These are the modulus and the argument of Sommerfeld's complex symbol  $\alpha^2$ ,<sup>9</sup> the modulus, or *numerical distance* in Sommerfeld's terminology, determines the *scale* of the phenomenon

<sup>8</sup> R. H. Barfield, loc. cit., footnote 5.

<sup>9</sup> See p. 708 in paper cited in footnote 1.

ofattenuation, the argument indicates the *shape* of the attenuation curve. Writing

$$\alpha^2 = \frac{q}{2} e^{ib}, \quad \left( 0 \leq b < \frac{\pi}{2} \right)$$

we have found<sup>10</sup> the following very convenient approximate expressions for  $q$  and  $b$  in terms of  $r$ ,  $\lambda$ ,  $\epsilon$ , and  $\sigma$ , putting  $\mu$  equal to its value *in vacuo* and assuming  $\epsilon$  so great as to permit the dropping of  $1/\epsilon^2$  in comparison with unity:

$$\tan b = (\epsilon + 1) / (6\lambda\sigma 10^{15}) \quad (1)$$

$$q = \frac{2\pi \sin b}{\epsilon + 1} \cdot \frac{r}{\lambda} \quad (2)$$

here  $r$  and  $\lambda$  are measured in kilometers,  $\epsilon$  in electrostatic units, and  $\sigma$  in electromagnetic units.

By *attenuation* we shall understand throughout this paper the quantity by which to multiply  $377hI/(\lambda r)$ , representing the field strength at various distances in empty space, to get the field strength at the surface of the soil, when the distance exceeds some tens of wavelengths. The *attenuation* so defined is  $(u^2 + v^2)^{1/2}$  very nearly, where

$$\left\{ \begin{aligned} u &= 1 - \frac{q}{1} \cos b + \frac{q^2}{1 \cdot 3} \cos 2b - \frac{q^3}{1 \cdot 3 \cdot 5} \cos 3b + \dots \\ &\quad - \sqrt{\frac{\pi q}{2}} e^{-(q/2)(\cos b)} \sin \left[ \frac{q}{2} \sin b - \frac{b}{2} \right] \\ v &= -\frac{q}{1} \sin b + \frac{q^2}{1 \cdot 3} \sin 2b - \frac{q^3}{1 \cdot 3 \cdot 5} \sin 3b + \dots \\ &\quad - \sqrt{\frac{\pi q}{2}} e^{-(q/2)(\cos b)} \cos \left[ \frac{q}{2} \sin b - \frac{b}{2} \right]. \end{aligned} \right. \quad (3)$$

These expressions are not suitable for calculations when  $q$  exceeds, say, 12; in this case there are, however, asymptotic expansions, involving inverse power series and exponential terms, as demonstrated to the author by Dr. Faxén of Upsala.

Fig. 1 shows the *attenuation* as computed from (3) and the corresponding asymptotic series. As abscissas we have taken  $q$ , i.e., Sommerfeld's numerical distance doubled; as ordinates we have chosen the

<sup>10</sup> The mathematics is given fully in a paper by the author to be published shortly in the Memoirs of the Academy of Engineering Sciences (IVA) in Stockholm.

values of  $(u^2+v^2)^{1/2}$  on a logarithmic scale. The numbers inscribed on the various curves are the values of  $b = \arctan [(\epsilon+1)/(6\lambda\sigma 10^{15})]$ . The tangent of  $b$  is thus roughly proportional to inductivity of the soil divided by product of wavelength and conductivity, a fraction which

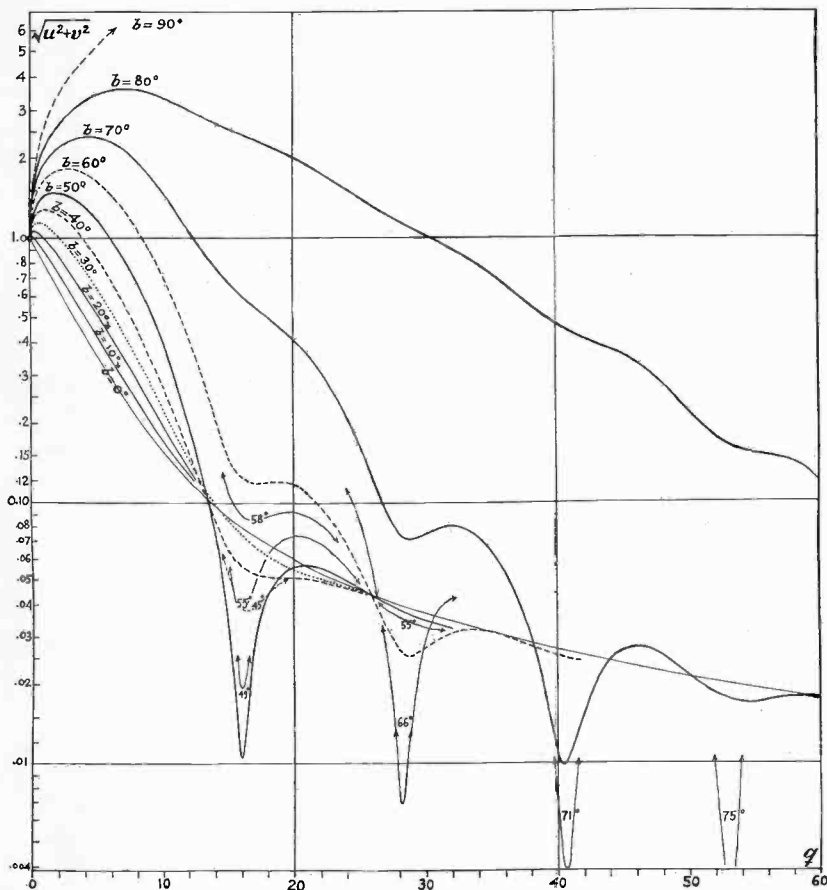

Fig. 1

determines the *shape* of the attenuation curve. When the fraction  $(\epsilon+1)/(6\lambda\sigma 10^{15})$  grows greater than, say, unity, that is when the wavelength is sufficiently short, or the conductivity of the soil sufficiently low, we gather that the attenuation curve shows up more and more curious features.

First, the attenuation near the transmitter becomes *greater* than unity, i.e., the field weakens *less* rapidly than required by the inverse distance law; in fact, for sufficiently great values of  $\tan b$ , i.e., short

1000

- (3) Put sheet of transparent paper so prepared on *abac*, with horizontal line on sheet along horizontal line marked "1.0" on *abac*, and cause vertical line on sheet marked wavelength for  $b=1$  deg. to fit in with vertical line  $100 \lambda$  corresponding to known value of  $\epsilon$  on *abacus*; trace curve  $b=1$  deg.
- (4) Repeat the process, sliding sheet horizontally until vertical line on sheet marked  $b=2$  deg. fits in with vertical line on *abac* mentioned in (3); trace curve  $b=2$  deg.
- (5) Repeat the process for other values of  $b$ .
- (6) If field strengths are wanted instead of the attenuation curves, multiply graphically by  $377 I_h/(\lambda r)$  all the curves just obtained.

The instructions here given are indeed more rapidly put into practice than given verbally.

#### ANOTHER GRAPH

The reverse process last described above, i.e., the prediction of the field-strength changes ensuing upon an arbitrary change of wavelength, when the constants of the ground have been ascertained, is so important that we have further simplified it. This has been done by Fig. 3. Here we again present curves belonging to various values of the angle  $b$ , whose trigonometrical tangent is  $(\epsilon+1)/(6 \lambda \sigma 10^{15})$ . But two changes have been introduced with respect to the earlier ones. First, all the attenuation curves have been divided by the distance; hence, they give *field strength directly* in an arbitrary unit, its value being put equal to e.g. 1000 at unit distance in free space. Secondly, all the  $b$  curves have been drawn to the same absolute scale of lengths, thus enabling the reader to grasp instantly the effect of changing wavelength on whatever kind of ground contemplated, and over the whole gamut of wavelengths.

To perform this *tour de force* he has only:

- (1) To multiply  $(\epsilon+1)/(\sigma \cdot 10^{15})$  by the factors inscribed on each curve, and to substitute the wavelengths thus obtained in meters to the corresponding factors on graph;
- (2) To multiply each of the numbers on scale of lengths at top of graph by  $(\epsilon+1)^2/(\sigma \cdot 10^{15})$ , so as to obtain the adequate distances in kilometers; this multiplication, of course, it is not necessary to perform numerically, as cutting out and pasting a logarithmic scale to graph will do as well. Figs. 4 and 5 give as examples the predicted field strengths, when  $\epsilon=15$ ,  $\sigma=10^{-13}$  (rather open country) and  $\epsilon=15$ ,  $\sigma=7.5 \times 10^{-15}$  (wooded country).

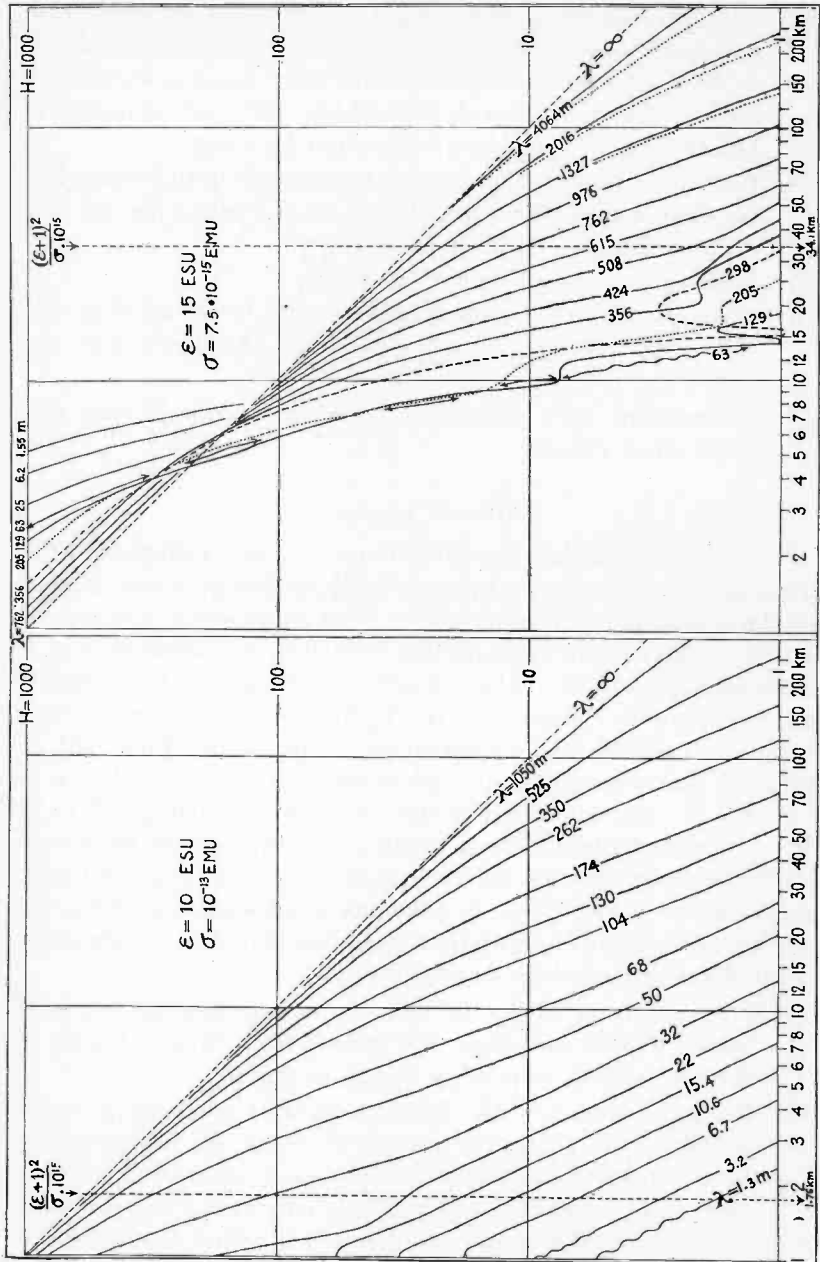

Fig. 5

Fig. 4\*

\* Editor's Note:  $\epsilon = 10 \text{ ESU}$  (above) should read  $\epsilon = 15 \text{ ESU}$ .

The question of the constancy of  $\epsilon$  is here left open; in fact, from the mechanism of the low conductivity caused by woods, as explained by Mr. Barfield,<sup>12</sup> it may be inferred that  $\epsilon$  will increase towards a maximum when the resonant wavelength of the trees is approached from above, and decrease when this wavelength is approached from below. Nothing seems to be known of the magnitude of this effect, to be sought for at about  $\lambda = 80$  meters, but from the high damping of the trees, regarded as antennas, it may be concluded that this effect is not so important as to invalidate the results given above.

### THE CURVATURE OF THE EARTH

Besides the important complications introduced by waves refracted from ionic layers in both daytime and night time which do not enter the scope of this paper, we have to account for the effect of the curvature of the ground. In the absence of a strict formula valid even at moderate distances, we recommend to multiply the field-strength value as calculated above by the following factor:

$$e^{-0.000083\{r^3/\lambda\}^{1/2}}; \quad r \text{ and } \lambda \text{ in km} \quad (4)$$

to obtain a safe upper limit for the weakening of the signals from shielding by the Earth. This method is only empirical, but satisfactorily agrees with the Watson-van der Pol formula<sup>13</sup> at the inner edge of applicability of the latter. Dotted lines in Fig. 5 indicate field strengths thus corrected.

### FURTHER LINES OF ATTACK

As expressly stated, the principal aim of Prof. Sommerfeld's papers is the predicting of fields *at* the soil, though further extensions,<sup>14</sup> of which no account has been taken in this paper, allow the field even higher up to be calculated. The study of these upper-air fields is important as they give rise to the downcoming rays, so detrimental to rational broadcast schemes by jamming, not only other transmissions, but even, at intermediate distances, your own. Certain rather simple arrangements of the transmitting antennas, to be described in another paper, will not only considerably lessen this latter inconvenience, but even secure important economy in power expenditure at equal field strength. The discussion of this problem implies the calculation of the field in all directions from a radiating dipole elevated

<sup>12</sup> R. H. Barfield, loc. cit. Compare also B. Rolf, "Woods and wireless," *Nature*, 121, No. 3049, 539; April 7, 1928, and R. H. Barfield, *Nature*, 121, No. 3058; June 9, 1928.

<sup>13</sup> Balth. van der Pol, "On the propagation of electromagnetic waves round the earth", *Phil. Mag.*, (6), 38, p. 365; London, 1919.

<sup>14</sup> A. Sommerfeld, last reference in footnote 6.

above the ground, and here Prof. Weyl's mode of attacking the problem is preferable.<sup>15</sup> When the radiating part of the antenna is confined e.g. to a height of about one third of a wavelength above the soil, its vertical characteristic becomes in fact so depressed that with equal power the field along zenith distance 45 deg. will be halved, while the field along the soil will be increased by one third, viz., 44 per cent economy of power to attain the same field strength at the soil, and a lessening of the ratio sky ray (ground ray to 3/8 of its ordinary value at distance 200 km).

<sup>15</sup> H. Weyl, first reference in footnote 6.





## THE RADIO PLANT OF R. C. A. COMMUNICATIONS, INC.\*

BY

HENRY E. HALLBORG

(R.C.A. Communications, Inc., New York, N. Y.)

*Summary*—The world-wide short-wave communication system of R. C. A. Communications, Inc., is described, and contrasted with the long-wave system which was the major means of long-distance radio communication six years ago.

The details and effectiveness of the R. C. A. directive antenna systems for transmission and reception, developed for long-distance service, are shown by photographs and characteristic graphs.

A description of the equipment and installations at the transmitting center at Rocky Point, L. I., and the receiving center at Riverhead, L. I., with photographs, is included.

A brief discussion, with typical graphs, of the characteristics of the transmitting medium is presented.

The present status of photo radio and facsimile development with a typical sample is outlined.

The arrangement of central offices controlling the outgoing and incoming signals at distances of 100 miles is described.

### Historical.

THE phenomenal development of radio broadcasting in the last six years is a matter of common knowledge. Equally outstanding, but less widely known, is the remarkable progress made during this period in the field of long-distance radio communication.

As the art of broadcasting has eclipsed in the diversity of its applications the most sanguine hopes of its early proponents, so has the art of short-wave, long-distance communications opened up to the world a network of international and intercontinental radio traffic channels.

It is fitting briefly to pause, and to reflect on the scope of this development, and upon the radio engineers' contribution there to, as exemplified in the existing radio plant of R. C. A. Communications, Inc.

Six years ago, Messrs. E. F. W. Alexanderson, A. E. Reoch, and C. H. Taylor described the expansion of the Transocean Communication System of the Radio Corporation of America to the American Institute of Electrical Engineers in a paper entitled: "The Electrical Plant of Transocean Radio Telegraphy."<sup>1</sup>

The Radio Corporation's Communications System was shown to have progressed from a few isolated stations in 1920 to a unified group of electrical plants in 1923, all controlled from a traffic center in New York City. The receiving facilities were shown to be centralized in

\* Dewey decimal classifications: R610. Presented before Section meetings: Toronto Section, September 16, 1929; Buffalo-Niagara Section, September 17, 1929; Cleveland Section, September 18, 1929; Detroit Section, September 19, 1929; Chicago Section, September 20, 1929.

<sup>1</sup> *Trans. A.I.E.E.*, XLII, 707; 1923.

Riverhead, L. I., and the transmitting facilities in "Radio Central" at Rocky Point, L. I.

The then modern receiving installation at Riverhead, L. I., comprised a single "wave antenna" nine miles long, from which six radio receivers, covering six transatlantic circuits, collected their signals and relayed them to New York.

The then modern transmitting installation at "Radio Central," Rocky Point, L. I., comprised two Alexanderson alternators, energizing two high-power antennas each 7500 feet long, supported by twelve 400-foot steel towers. The wavelengths were of the order of 16,500 meters. It was stated that the site was carefully considered, looking forward to a possible growth of international radio communication which would require as many as twelve such transmitters. Twelve was a figure fixed by land requirements, and by the limited availability of long-wave, high-power channels. Today more than 30 short-wave transmitters operate or are projected for operation from Rocky Point, while the receiving circuits operated through Riverhead are already in excess of 30.

One of the co-authors of the historical paper above mentioned is C. H. Taylor. To his leadership and foresight are largely due the developments which are described in this paper.

The present scope of the world wide communication system, of which R. C. A. Communications, Inc., is an important link, may best be shown by a summary of the countries worked from the Corporation's principal traffic centers, as compared to the 8 or 10 international circuits which comprised the system of six years ago. This summary covers point to point international service only, exclusive of mobile or marine service.

#### World Wide Communication.

The general public is now provided with direct radio service by the system of R. C. A. Communications, Inc., to countries of the world as follows:

To <i>Europe</i> from New York City:	To <i>Latin America</i> from New York City:
Great Britain	Colombia
France	Chile
Germany	Argentina
Holland	Brazil
Italy	Costa Rica
Spain*	Dutch Guiana
Norway	Venezuela
Sweden	Nicaragua*
Poland	Santa Domingo
Portugal	Cuba
	Porto Rico
	Dutch West Indies

\* Soon to be established.

To Canada from New York City to  
Montreal  
and by British Beam connection to  
Australia.

To Asia Minor and Africa from  
New York City:

Syria\*  
Turkey  
Liberia

To the Islands of the Pacific and  
Asia from San Francisco:

Hawaiian Islands  
Fiji Islands  
Philippine Islands  
French Indo China  
China  
Japan  
Java  
Siam

To the Far East and to Europe from  
Manila thus completing a world net-  
work of Radio Communication Service.

\* Soon to be established.

It is not the purpose of this paper, however, to stress the radio service of this particular company, but merely to outline the scope of its service for the purpose of building a background upon which to sketch a general description of the radio plant which makes such a world-wide service possible.

#### Radiation Units.

It was shown in the paper describing the long-wave system of communication that a radiation unit of 50,000-meter amperes was the accepted value for transatlantic service with wavelengths of the order of 16,000 meters. A value of 50,000-meter amperes was obtained in practice by the use of 200-kw alternators of the Alexanderson type, steel towers 400 feet high and antenna structures in some instances more than a mile in length.

Short-wave technique with its higher radiation efficiency has changed the aspect of the meter ampere requirement completely. The short-wave radiation unit, as a result of the inverse relation of radiation resistance and wavelength, is but a small percentage of the well defined long-wave value.

The first result of the low meter ampere requirement of short-wave service has been a corresponding reduction in the size of antenna structures. The second result has been a realization of the removal of previous limitations of the long-wave antenna making feasible great increase of traffic capacity by directive antenna systems. An intensive development of the beam or projector types of antennas has resulted, in all the principal countries of the world.

The traffic speed of a circuit equipped with the broadside projector antennas developed by this company has been found to be proportional to the kilowatts delivered to the antenna multiplied by an antenna proportionality factor. This factor is the figure of merit of the antenna from the viewpoint of traffic capacity. The figure of merit of our broadside projector antenna at a distance of 4000 miles has been determined empirically by the expression:

$$W.P.M. = KW\sqrt{P_e}$$

where  $W.P.M.$  is the number of words transmitted per minute,  $KW$  is the power in kilowatts delivered to the antenna, and the term  $P_e$  is evaluated for different antenna constructions as follows:

Simple Antenna = 1	2 Bay Broadside = 20
1 Bay Broadside = 12	4 Bay Broadside = 30

A graphical representation of the relation between antenna input in kw, signaling speed and number of bays of the broadside projector antenna at a distance of 4000 miles, is shown in Fig. 1.

### The R. C. A. Broadside Projector Antenna.

The typical constructional arrangement of the R. C. A. broadside projector antenna is well illustrated in Fig. 2. This is an end on view of a 33.52 meter, 8950 kc, 2-bay directive antenna installed at Rocky Point, L. I., and directed toward San Francisco. It will be

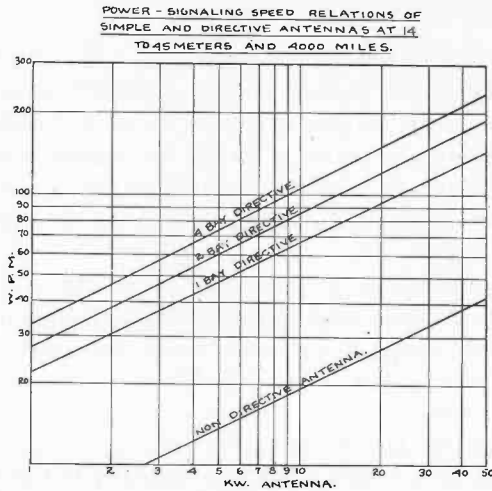

Fig. 1

observed that the radiating elements are arranged in the form of curtains of vertical wires fed in the middle from a common bus which extends the entire broadside length of the antenna system. One row of five composite wood poles supports the antenna, and the second row of five masts the reflector. The reflector is so spaced electrically with regard to the antenna that addition of the wave energy occurs in the direction of the antenna, and cancellation in the opposite direction. This results in a unidirectional concentrated radiation pattern. The antenna and reflector are both directly energized by means of a transmission line.

The electrical broadside width of the 1-bay projector antenna is 3 wavelengths. It contains 24 vertical wires, spaced  $1/8$  wavelength consecutively. A 2-bay antenna is 6 wavelengths wide, and the 4-bay antenna width is 12 wavelengths. The vertical length of the radiating elements is adjusted to drain the feeder bus of energy at such a rate as to prevent standing waves or reflection. The lower ends of the radiators are supported not less than  $1/2$  wavelength above the ground, to reduce earth losses.

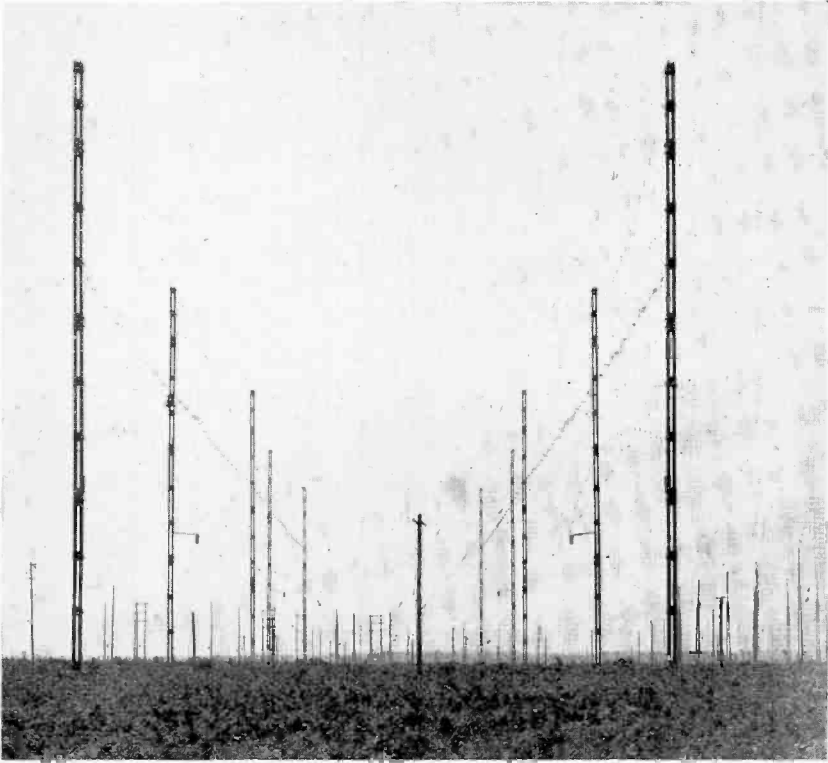

Fig. 2

Typical directivity patterns of the 1-bay, 2-bay and 4-bay broadside projector antennas are shown in Fig. 3. It will be noted that the width of the pattern is reduced from 20 deg. to 6 deg. by increasing the broadside spread of the antenna system from 1-bay to 4-bays, that is, from 3 wavelengths to 12 wavelengths.

The land areas required, and relative costs of directivity, are illustrated by Fig. 4.

Directive antennas are commonly located at distances of 2500 feet, or more, from the transmitter. The antenna energy is supplied by two-wire transmission lines. The load and line impedances are balanced by line terminating equipment to insure that no reflections occur, and that the line shall be non-radiative. A line efficiency of 85 per cent is readily realized. The line impedance is normally adjusted to 600 ohms.

The development of the broadside projector antenna described above is due to Messrs. C. W. Hansell, P. S. Carter, and N. E. Lindenblad.

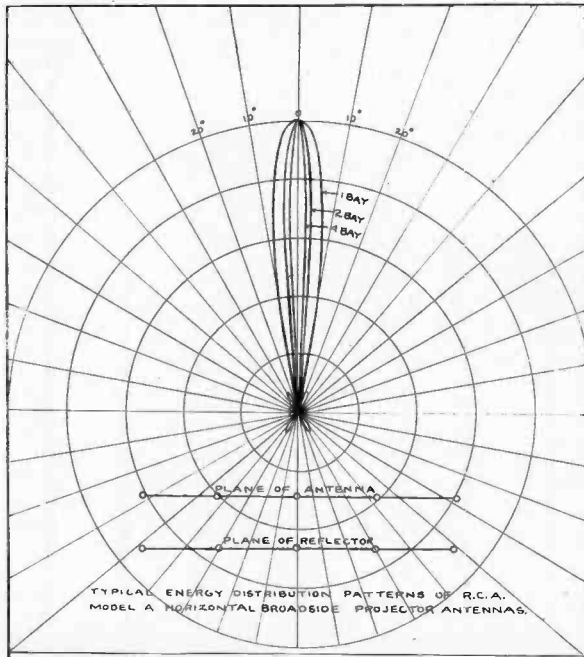

Fig. 3

### 20—40-kw Short-Wave Transmitter.

The development of transmitters for short-wave service has been carried to the point where these units are as stable in operation, constant in frequency, and high in efficiency as were the best transmitters of long-wave practice.

A transmitter nominally rated as a 20—40-kw short-wave transmitter is the standard unit for long-distance communication. It utilizes the principles of crystal-controlled master oscillator, cascade amplification, and frequency multiplication. The transmitter consists of two radio-frequency units, namely, an exciter unit and a power amplifier

unit. The exciter is equipped with air-cooled tubes throughout, and may also be used as a low-power transmitter of 1-kw output. The power amplifier is equipped with water-cooled tubes and delivers to the antenna system an output of 20 to 40 kw, depending upon output frequency.

The frequency range of the transmitter is 6660 to 21,400 kc (14 to 45 meters). Quick switching between two predetermined frequencies for day and night operation over a given circuit is provided from the front of the panel.

The precision frequency control units are provided in duplicate. This provision permits the incoming frequency to be controlled by a quartz crystal already at operating temperature. It also provides a

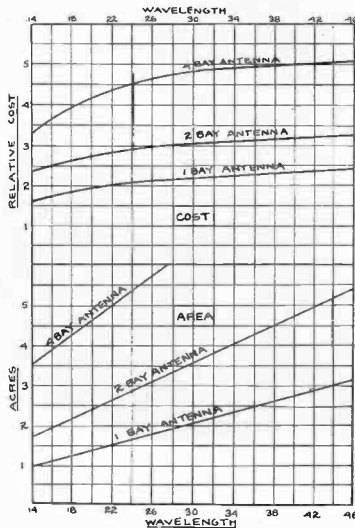

Fig. 4

spare unit which may be utilized for the incorporation of the latest developments in the rapidly advancing art of absolute frequency control. The crystals are operated at a temperature of 45 deg. C in a temperature-controlled chamber. All crystals used in the communication service of this system are carefully checked at the factory, and subsequently rechecked by frequency standards at Riverhead, L. I., before their assignment to circuits on licensed frequencies.

The 20—40-kw short-wave transmitter is adequately protected against overloads and deficiencies in the power supply and water circulating systems. It is completely screened against accidental contact by the operating personnel. The opening of any access door removes all

dangerous voltages. The order of switching is interlocked to prevent damage to the tubes or equipment.

The 20—40-kw transmitter may be operated without rotating equipment of any kind. All plate and bias voltages are supplied from rectifiers equipped with tubes of the mercury-vapor type. Efficiencies better than the best motor-generator units are thus provided in addition to quietness of operation, and excellent voltage regulation.

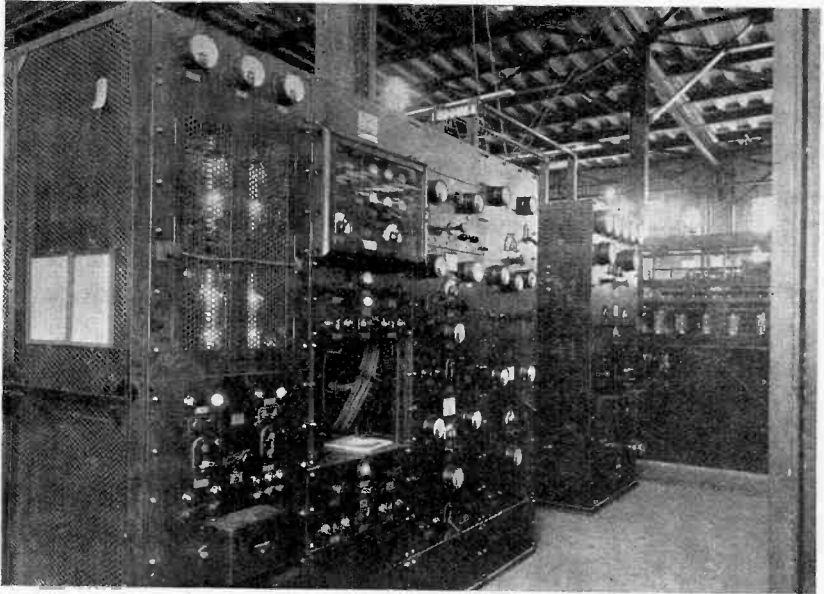

Fig. 5

A typical view of a complete 20—40-kw short-wave transmitter installation at Rocky Point, L. I., is shown in Fig. 5. This transmitter has one of its precision frequency control units removed for standardization purposes. Fig. 6 is a rear view of the 20—40-kw power amplifier unit with protective screening open showing compactness of assembly including the water-cooled tubes.

#### **R. C. A. Short-Wave Receiving System.**

The three major problems encountered in commercial reception on short-wave radio circuits are:

- (1) Stability of frequency.
- (2) Interference—natural or cosmic.
- (3) Signal mutilation by fading.



Frequency stability depends principally upon excellence of transmitter design. The problems of interference and fading are not so readily controlled. The short-wave receiving system used has been developed to minimize the effects of two of the important limitations of the transmitting medium, namely, interference and fading.

Observations have shown that, if a given short-wave signal is received simultaneously at two or more points separated by only a few hundred feet, its fading characteristics are different at each point. If the signal energy is collected simultaneously on two or more spaced

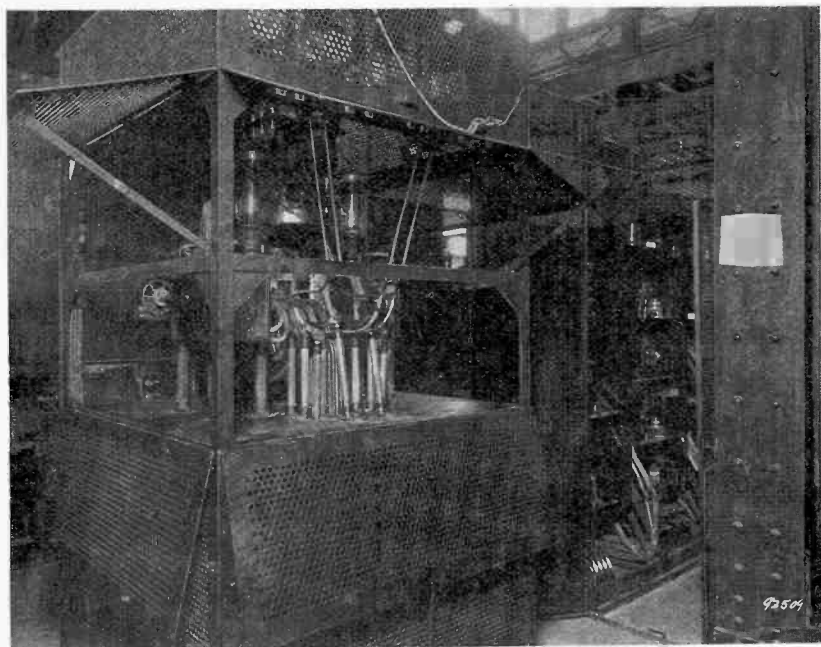

Fig. 6

antennas and then applied in proper phase to energize a common receiver system, fading is reduced as a result of the averaging of the individual fluctuations. Practical advantage of this dissymmetry of fading of short-wave signals has been taken in the development of this short-wave receiving system.

The probability of the signal fading out entirely decreases as the number of spaced antennas is increased. The actual number selected is the usual engineering compromise of theoretical and economic considerations. Three antennas spaced 1000 feet have been adopted as a standard arrangement.

It is of interest to note that the "wave antenna," 9 miles long, of the long-wave receiving system of 6 years ago, previously referred to, is but the prototype of the short-wave "wave antenna" used in the present short-wave receiving system. The short-wave receiving system was developed by H. H. Beverage and H. O. Peterson.

The short-wave "wave antenna" consists of a line of horizontal doublets capacitively coupled to a two-wire transmission line. The

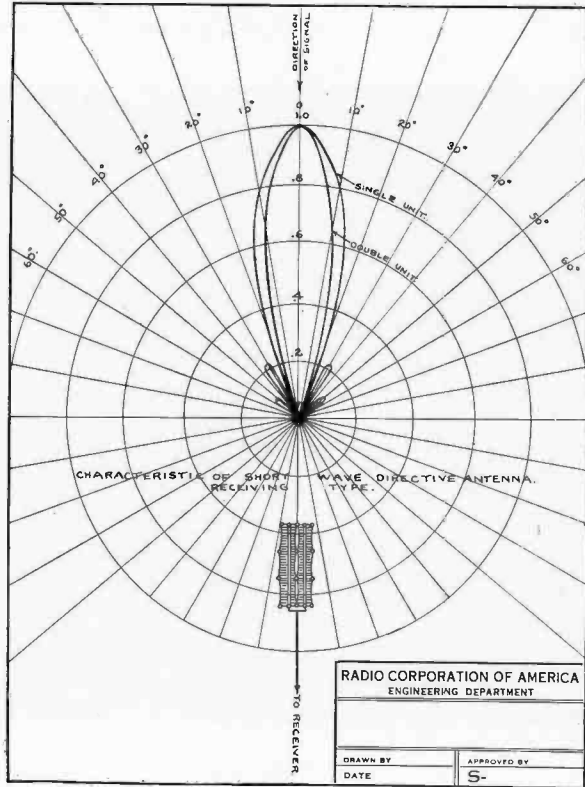

Fig. 7

short-wave antenna array may be vertical or horizontal, but the horizontal array has been found superior because of greater freedom from local disturbances. The principle of its operation is similar to that of the Beverage wave antenna used for long-wave reception. Signals arriving along the desired line of the array build up a voltage as they travel along the line of doublets. The augmented signal voltage is fed to the receiver via the transmission line. Signals from the opposite direction encounter an antenna terminating resistance in which they

are dissipated. Unidirectional and highly selective directional reception is the result as indicated by the typical reception characteristic of Fig. 7.

The directive antenna as normally used is supported 50 feet above the ground by wood poles and steel wire rope triatics broken up at intervals by insulators.

A single unit antenna is  $50 \times 312$  feet. Two units in broadside will produce sharper directivity and greater voltage pickup. The two unit broadside combination requires an area of  $100 \times 312$  feet.

### Multiplex Reception.

The signal voltage delivered to the receiver by the directive antenna is not the result of combination of sharply resonant elements. The

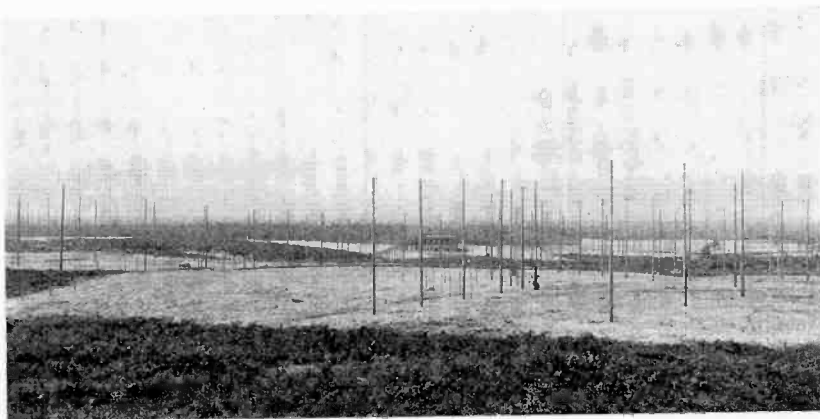

Fig. 8

entire band of frequencies normally used in transoceanic communications, namely, 6660 to 21,400 kc, 14 to 45 meters, may be covered with about equal response by a single antenna array. This fact makes possible the reception of both day and night frequencies on the same antenna. This semi-aperiodic feature also makes possible the reception of a number of different stations simultaneously with a single directive antenna system.

A general view of the area around the receiving center at the Riverhead, L. I., station of R. C. A. Communications, Inc., including a number of directive antenna groups, is shown in Fig. 8. Fig. 9 is a closeup view of the receiving center building. An interior view of the building, showing one of the eleven aisles of short-wave directive receiver racks, each of which contains four complete receivers, is shown in

Fig. 10. A view of the control board for the dispatching of circuits to the central office in New York is shown in Fig. 11.

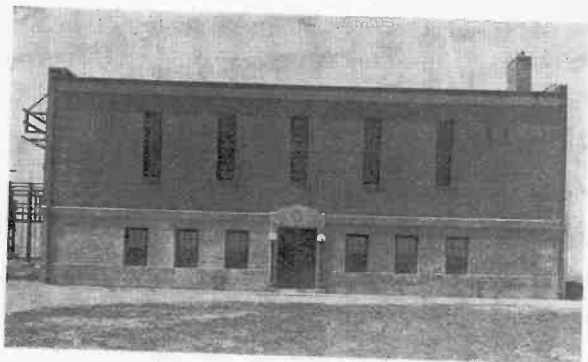

Fig. 9

The design and general arrangement of the receiving center equipment is due to C. M. Griffiths.

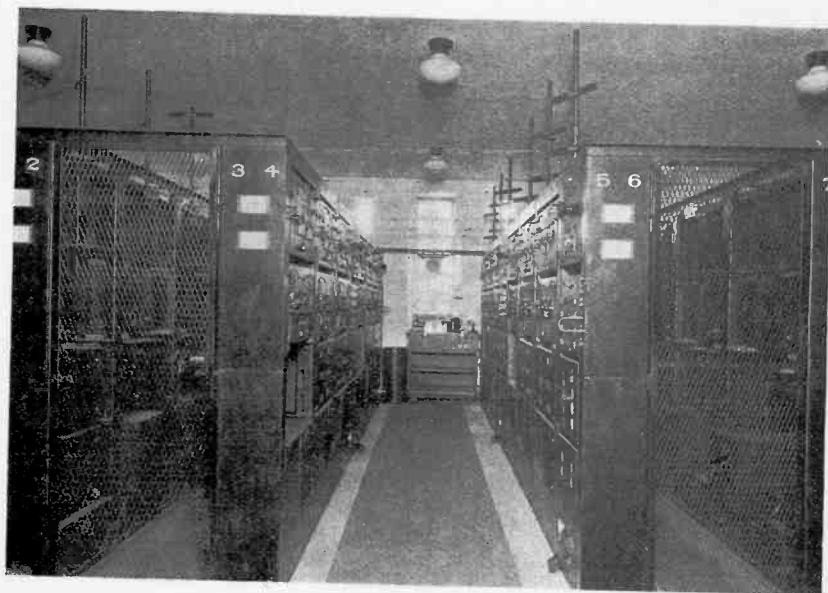

Fig. 10

#### Central Office Installation.

The East and West Coast Transoceanic Terminals and the Hawaii Transpacific Terminals of this system handle their traffic by means

of Central Offices. The actual manipulation of the various international circuits, both transmitting and receiving, is performed in these offices which are located in the hearts of their respective business districts. The transmitting and receiving plants proper, with their widespread and extensive equipments, are consequently merely supplementary to the Central Offices, and are located therefrom at distances varying in different localities from 20 to 100 miles.

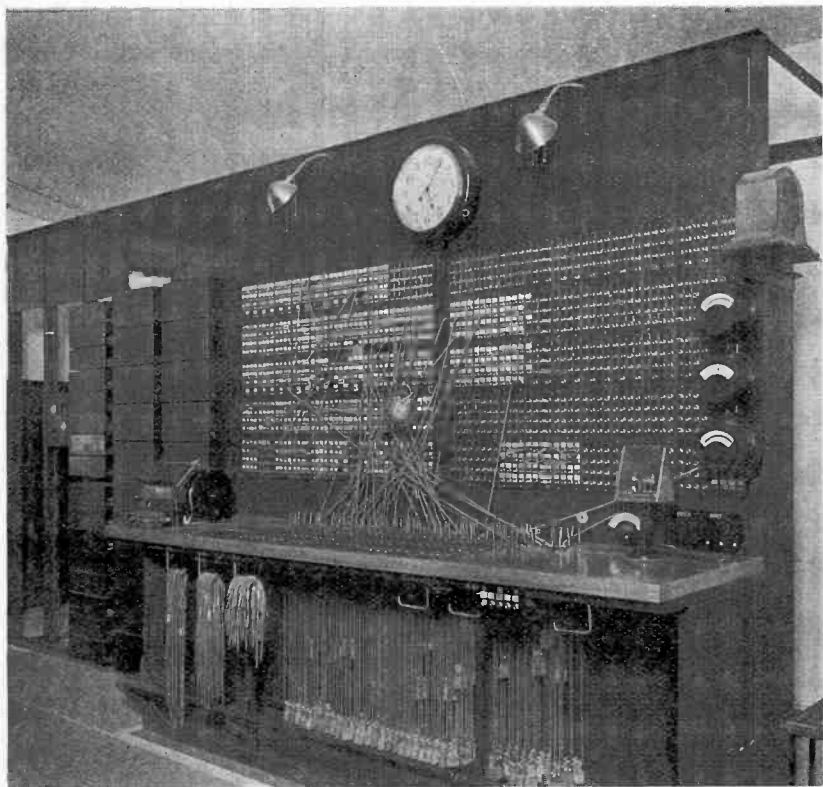

Fig. 11

Two of the major problems in such a distribution of plant are conservation of land lines between the Central Office and its receiving and transmitting stations, and the use of the lines in such manner that the telegraph load will not cause interference to other classes of adjacent wire service. The practical solution of these two problems has been the application to the wire lines of tone signals varying in frequency from 400 to 2000 cycles. Signals of these audio frequencies are readily multiplexed by the well-known use of low- and high-pass filters. It is

possible to put ten audio circuits on a single pair of wires. The maximum speed of each circuit under these conditions is 80 words per minute or the maximum capacity of the two wires becomes 800 words per minute. The use of the tone signal with a balanced network prevents the impression of the steep wave fronts and transients that occur with interrupted direct-current signals and consequently induction is eliminated.

At the Central Office the incoming tone signal from the receiving station passes through its respective filters and into a tone amplifier and volume control device. The output of the tone amplifier energizes simultaneously a high speed tape recorder and the operator's monitor-



Fig. 12

ing head set. The tape passes in view in front of the operator, who can transcribe, on a typewriter, at a maximum speed of 50 words per minute. Signals at the rate of 100 words per minute will consequently require two operators, and higher rates correspondingly. A continuous belt carries the messages to their central collecting and distributing point.

The outgoing Central Office message is punched on tape, fed to an automatic transmitter, which in turn keys a tone generator at the Central Office through a resistance network. The output of the tone generator is passed through its respective filters on to the line. At the distant transmitting station the tone signal is selected by its proper

filter, amplified and applied through a resistance network to the grids of the transmitter keying tubes. These are so arranged that zero tone signal causes the high power tubes to cut off while tone signal results in application of power at the normal transmitter frequency. In this manner a fraction of a watt applied at the Central Office is enabled to control 40 kw of short-wave directed radiation at a distance of 100 miles.

A general view of the Central Office at 66 Broad Street, New York City, is shown in Fig. 12. In Fig. 13 is shown a view of the line amplifier installation in this traffic terminal.

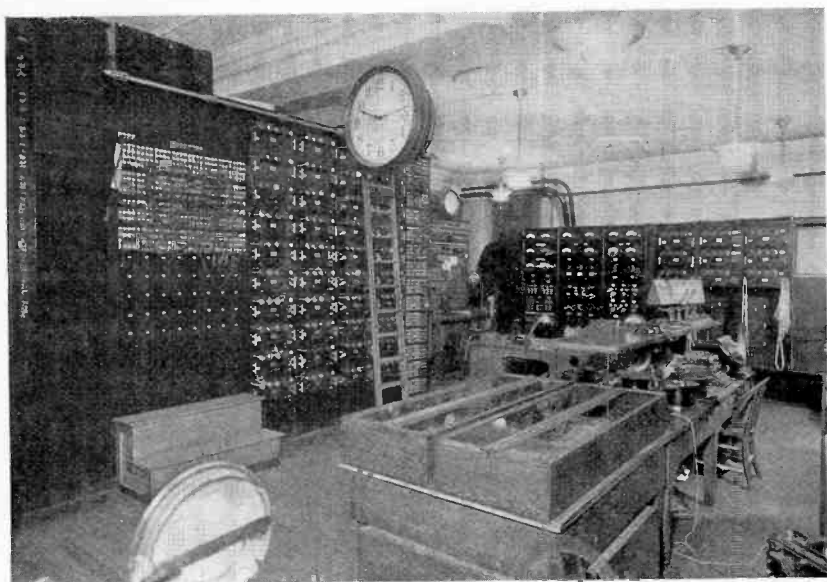

Fig. 13

### Facsimile Transmission.

The development of photo radio and facsimile transmission is being carried on intensively by R. C. A. Communications, Inc., under the direction of R. H. Ranger and his staff. The method of transmission in use has been described by Mr. Ranger in the Institute PROCEEDINGS, and will not be repeated here.

It was stated in the preceding section that there is a speed limitation in the Central Office in the process of transcription from the high speed ink recorder to the typewritten final message. One of the means of obtaining direct copy is by radio reproduction of the original message, or by facsimile transmission, as it is better known.

A high degree of success has been achieved in facsimile transmission on both transoceanic and transcontinental circuits. A commercial facsimile speed of 2 square inches per minute is now realized, corresponding to 24 code words per minute. Constant developments point to continuously higher speeds and more perfect reproduction. While a

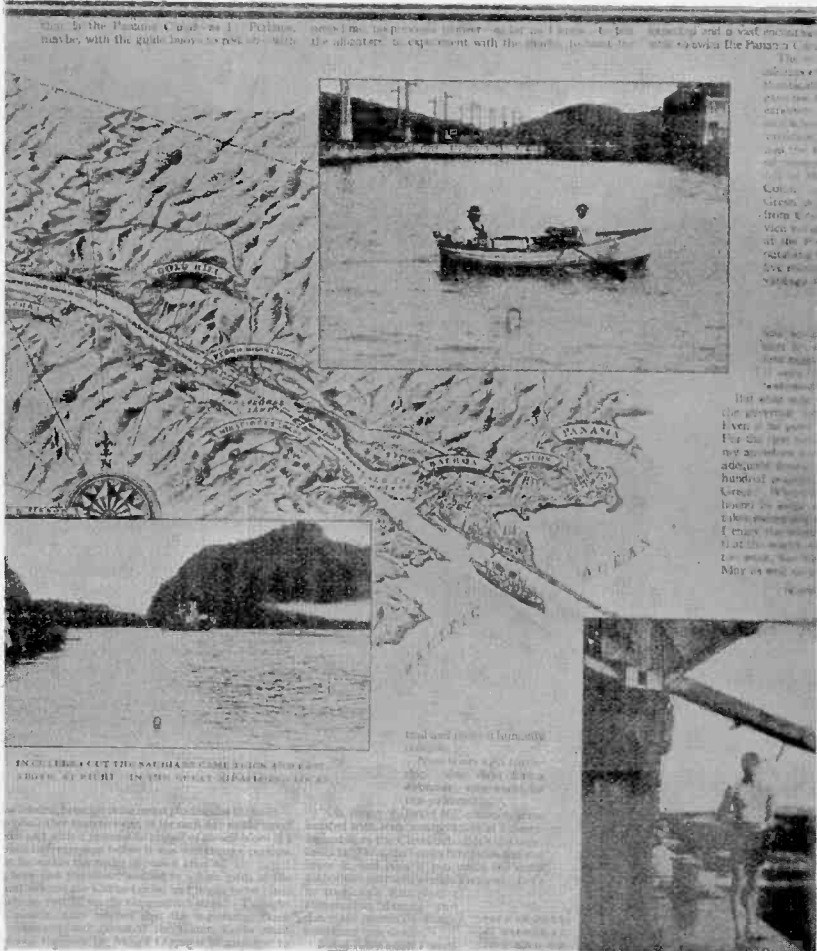

Fig. 14

speed of 24 words per minute is quite nominal in a telegraphic sense, the fact remains that a single operator at the Central Office can handle both the transmission and reception of a facsimile message on a duplex circuit which would necessarily require two operators on a straight telegraph circuit.



**TYPICAL DAILY AND ANNUAL SHORT  
WAVE SIGNAL CHARACTERISTICS  
MANILA - SAN FRANCISCO CIRCUIT  
6750 MILES.**

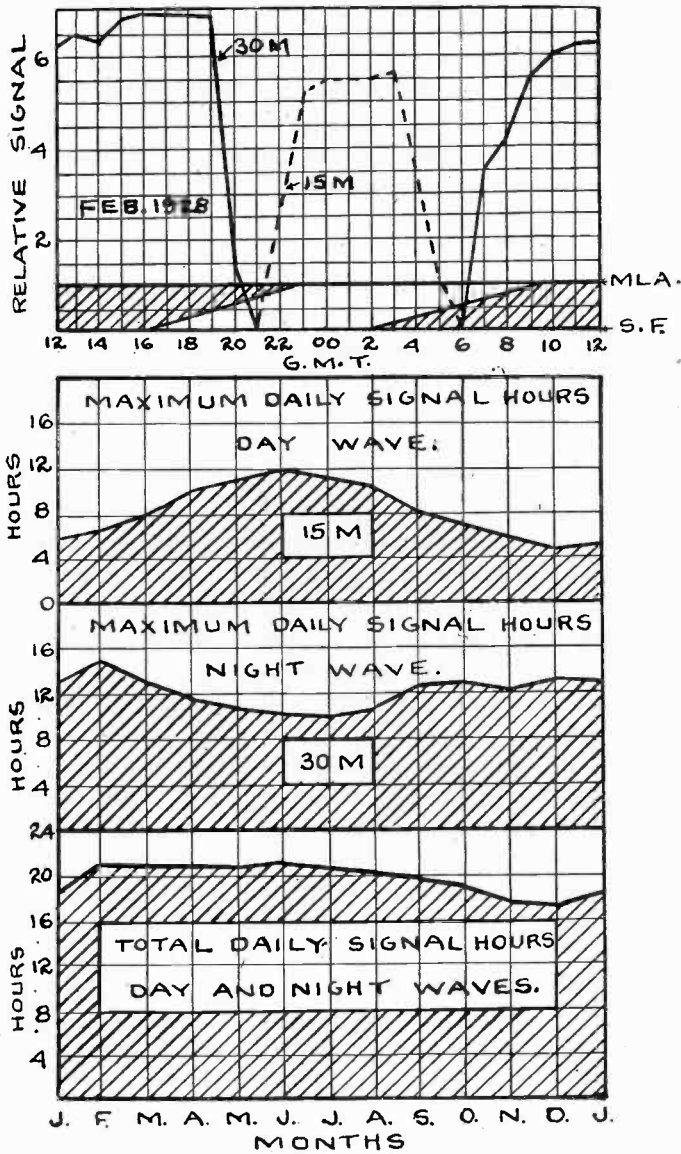

Fig. 15

The normal trend of development in commercial radio traffic is constantly to increase the traffic flow over a given channel. This is necessitated by the definite limitation of available channels, and the steadily increasing traffic volume. A system that permits exact duplication of the original messages, with the attendant reduction in number of handlings, has many commercial and economic factors in its favor. Its development is consequently being steadily pursued.

Fig. 14 shows the results of a radio reproduction of a page of data bearing on the Panama Canal which illustrates the present possibilities of map, type, and picture reproduction.

### **The Transmitting Medium.**

In a paper presented to the Radio Club of America on January 9, 1929, the author discussed the results of observations of the seasonal variations of short-wave transmission on commercial R. C. A. circuits in all parts of the world. These results indicated that there is a difference between North-South and East-West transmission, in addition to the well-known night and day effect. It was also observed that the seasonal characteristic is determined wholly by the relative distribution of light and darkness over the signal path throughout the year, which will obviously vary in different latitudes. The effectiveness of the wave is a function of its frequency and the relative atmospheric ionization which it encounters. The extremely high frequency waves are propagated at high elevations and require a high degree of ionization to bring them down to earth; consequently they are day waves. The lower frequencies are propagated at lower elevation and are consequently effective at night.

The study of signal propagation at short wavelengths is a fascinating one, and has appealed to the imaginations of all workers in this field. There is shown in Fig. 15 a typical transpacific diurnal characteristic at 15 and 30 meters observed between Manila, P. I., and San Francisco. The number of hours that these frequencies were commercially workable each month of the year is also indicated.

### **The World Scope of Modern Radio.**

The importance of short-wave service in modern long-distance communication is graphically illustrated in Fig. 16. This figure shows the relative volume of paid transoceanic traffic via long wave and short wave and their combined total handled by this system for the period 1923 to 1928 inclusive. Of particular interest is the steep rise in short-wave traffic from the year 1927. This rise is the normal result of the steady development of short-wave equipment with continued

## 20—40-KILOWATT HIGH-FREQUENCY TRANSMITTER\*

BY

I. F. BYRNES<sup>1</sup> AND J. B. COLEMAN<sup>2</sup>

(Engineering Department, R.C.A.-Victor Company, Inc., Camden, N. J.)

*Summary*—The rapid growth in the use of high frequencies for long-distance communication has been nothing short of phenomenal. One of the major parts of the high-frequency communication system is the transmitter converting 60-cycle power into a frequency in the order of millions of cycles. Although the first communication work on short waves was accomplished by the radiation of a few watts, reliable and rapid communication requires power of the order of tens of kilowatts. The technique in producing a transmitter of relatively large power to feed an antenna for radiating high frequencies has been found to be quite different from that required for previous design and test of radio transmitters.

This paper presents the results of intensive work of the last two years. It describes some of the interesting problems which have had to be solved. Not least among these problems were the methods of providing a satisfactory artificial load for factory test, the determination of keying characteristics, and the design of the frequency control units.

A NEW design of high-frequency transmitter, with an output rating of 20 to 40 kw, has recently been developed for service in commercial long-distance communication systems. While it is well-known that exceptional distances may be obtained with low power and suitable high frequencies, experience has shown that transmitters with a power output of several kilowatts are necessary for reliable high-speed continuous-wave communication.

Modern high-frequency transmitting stations require equipment that provides rapid change from day to night frequencies, high-speed keying, accurate maintenance of assigned frequencies, and adequate protection to the equipment and the operating personnel. Efficient radio circuits utilizing three- and four-electrode tubes and with a minimum number of adjustments are also primary requirements.

In one design of the 20–40-kw transmitter, plate supply for the tubes is obtained from standard, high-vacuum rectifiers. In another design, hot-cathode mercury-vapor rectifier tubes are used. These mercury-vapor rectifiers operate at high efficiency and have good regulation, the latter characteristic being of special importance in a

\* Dewey decimal classification: R350. Presented before New York meeting of the Institute, November 6, 1929.

<sup>1</sup> Formerly of General Electric Co., Schenectady, N. Y.

<sup>2</sup> Formerly of Westinghouse Electric and Manufacturing Co., Chicopee Falls, Mass.

better understanding and solutions of the engineering problems involved. There can be no doubt that short-wave radio service has become the most important single factor in world-wide radio communication.

No corner of the earth is today too remote for instantaneous contact with its bustling metropolitan centers. No nation need now be

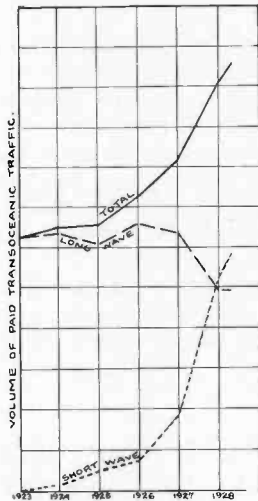

Fig. 16

out of touch with the world's traffic pulse because of its geographic isolation. Great is the contribution which the radio engineer has made to world progress. To have been a factor in such a development, however small, is an inspiration. To be a communications organization rendering service to the far ends of the earth is indeed the achievement of a goal. Such is the position of service held by the plant of R. C. A. Communications, Inc., which has just been described.



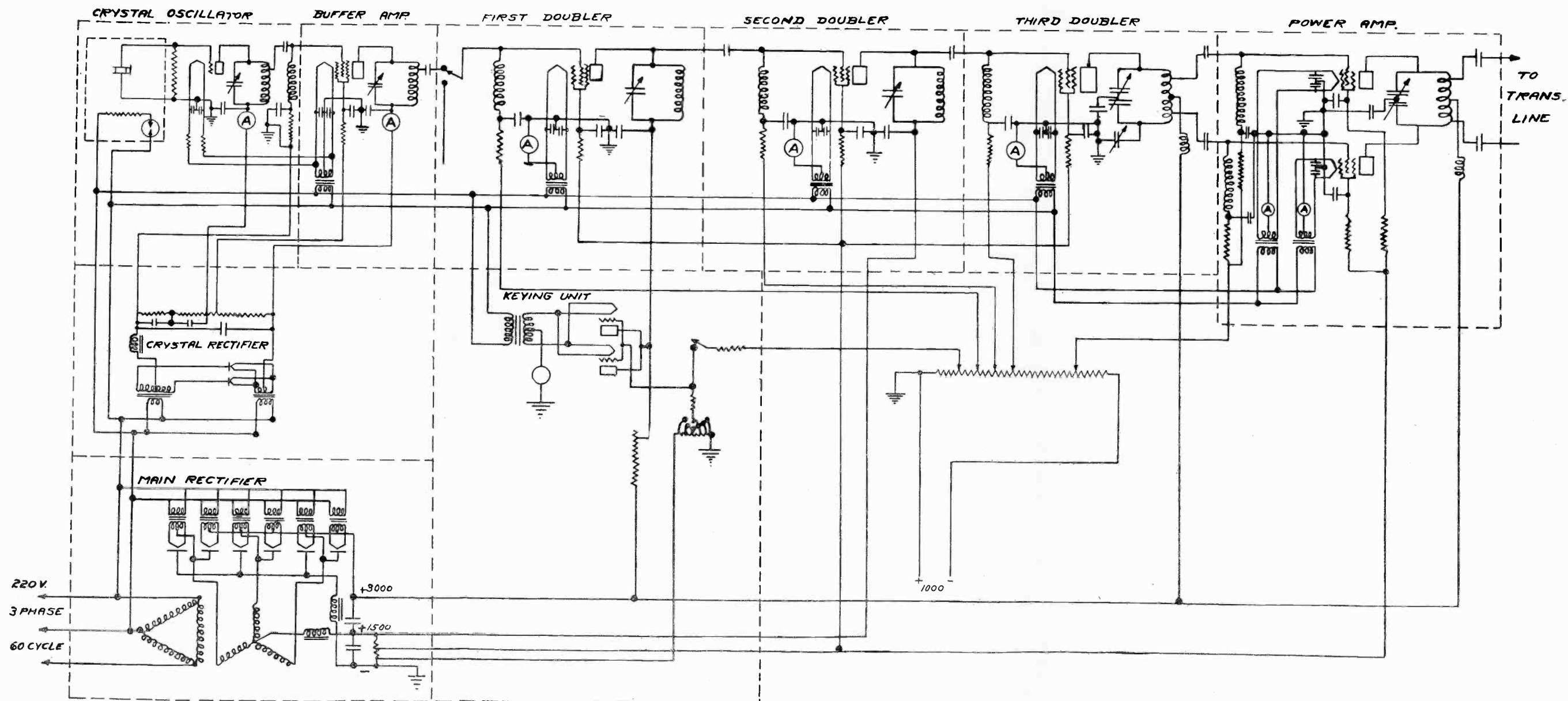

Fig. 1—Exciter unit for 20-40-kilowatt transmitter.

radiotelegraph transmitter where the plate load comes on and off at keying speeds.

The complete equipment is divided into two major sections, a low-power crystal-controlled oscillator-amplifier, terminating with 1-kw output, and a main power amplifier using four water-cooled tubes, delivering 20- to 40-kw output. The low-power and high-power units each have their respective plate-supply rectifiers.

The first part of this paper will describe the crystal oscillator-amplifier unit which is usually known as the "exciter." When used with the main power amplifier, the exciter unit supplies grid excitation to the water-cooled tubes through suitable transmission lines. In other cases, the exciter unit may be employed to supply 1 kw of power to an antenna system, through transmission lines.

A frequency range of 6670 to 21,500 kc (45 to 14 m) is covered by the exciter. Any two predetermined frequencies within this range may be quickly selected from the front of the panel. For daylight transmission, frequencies near the upper limits are usually employed, while the lower frequencies are more suitable for nighttime transmission.

The circuit arrangement employed for the various tubes may be explained with reference to the schematic diagram shown in Fig. 1. Power supply is obtained from a 220-volt, 3-phase, 60-cycle line. The main rectifier plate transformer, in the lower left section of the diagram, has a delta-connected primary and a "Y"-connected secondary, with a mid-tap brought out at the common connection point of the three secondary windings. This mid-tap is for the purpose of supplying a small amount of power at one-half normal output voltage. Six UV-872 hot-cathode mercury-vapor tubes are connected as shown. The UV-872 tube is a new type of rectifier with a peak plate current rating of 2.5 amperes and a peak inverse voltage rating of 5000 volts. The filament, which is a coated type, requires 10 amperes at 5 volts. The voltage-drop through the tubes when carrying rated load is but 15 to 20 volts, with the result that the regulation of the complete rectifier is largely dependent upon the characteristics of the plate transformer and the supply line.

In designing a rectifier using mercury-vapor tubes, it is important to take into account the inverse peak voltage across the tube, which is the voltage present on the negative half cycle when the tube does not pass current. For the UV-872, the inverse voltage should not exceed a value of 5000 volts. In the 3-phase full-wave rectifier circuit shown, the d-c output voltage, when properly filtered, is equal to 2.34 times the r.m.s. voltage across each secondary leg of the transformer. The leg voltage for full output is 1520 corresponding to a voltage across the

load of 3550 volts. Now the peak inverse voltage in the circuit used is equal to 1.045 times the d-c load voltage. This gives a peak inverse voltage of approximately 3700, which is well below the 5000 volt rating of the tube. If the rectifier circuit is traced through, it will be seen that there are always two tubes in series across any two legs of the secondary windings, with the load connected between the two tubes.

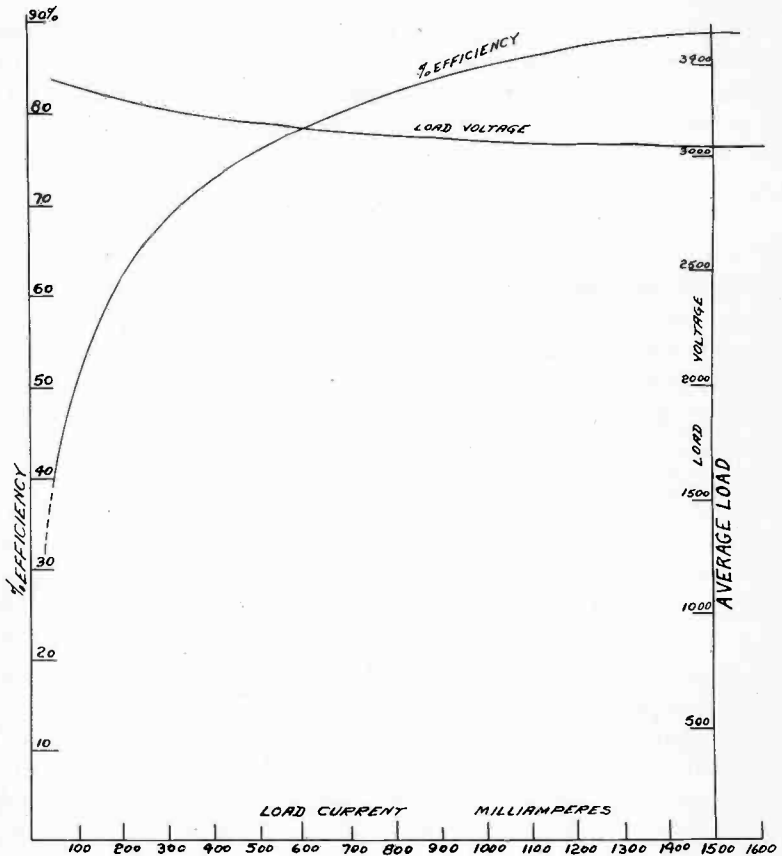

Fig. 2—Main rectifier of exciter unit using six UV-872 rectifier tubes.  
Characteristics for 80 per cent voltage tap.

The ripple frequency is 360 cycles for the full voltage output and 180 cycles at the one-half voltage point. The full load rating of the rectifier is 3500 volts and 1.5 amperes direct current. In order to vary the output voltage of the rectifier conveniently, a primary switch is provided which allows adjustment at approximately 70, 80, 90 and 100 per cent of normal voltage. The reactor, shown connected at the half-

voltage point, is used to provide additional filtering for the 180-cycle ripple. The second reactor, connected in the negative side of the output circuit, prevents high currents from flowing at ripple frequency through the filter capacitors and rectifier tubes, and also functions as a filter.

Certain characteristics of the main rectifier are shown in Fig. 2. With a d-c load of 1.5 amperes at 3000 volts, which is an average operating condition, the efficiency not including the rectifier filament load is approximately 87 per cent. The overall efficiency, taking into account transformer losses, filter losses, and power for filament heating, is approximately 81 per cent. The drop in output voltage from a load of 50 ma (voltmeter load) to full load of 1.5 amperes is but 310 volts, corresponding to a regulation of approximately 10 per cent. Such low regulation is particularly desirable in order to prevent excessive peaks in the keying wave form.

Accuracy and stability of frequency is a paramount requirement in a high-frequency transmitter of this type. Referring again to Fig. 1, a low level piezo-crystal oscillator with a UX-210 tube operating on a

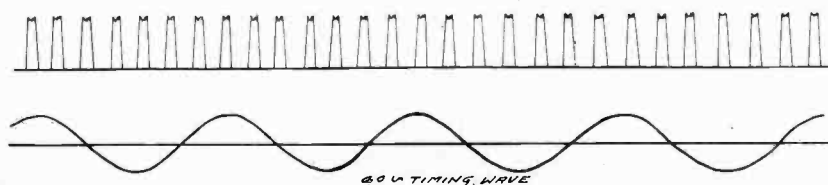

Fig. 3—No. 22 exciter unit 26E. CD-59088. 400-cycle keying 28.8 meters.

plate voltage of approximately 250 volts is used. The crystal is operated at a temperature of 45 deg. C and maintained within 0.25 deg. C of this temperature by means of a thermostat. The crystal plate circuit is tuned by means of a variable capacitor, and is adjusted in the well-known manner to a frequency slightly above that of the crystal in order to present inductive reactance to the plate circuit, an essential condition for good starting characteristics. The crystal stage is followed by a UX-860 four-element tube, which is known as the buffer amplifier and which prevents reaction on the crystal circuit as well as raising the level of the energy from the crystal stage. The crystal oscillator and buffer amplifier receive their plate supply from a separate rectifier consisting of two UX-866 mercury-vapor hot-cathode tubes. The UX-866 is rated 0.6 ampere maximum peak plate current, and the peak inverse plate voltage is 5000. A separate rectifier is used with the crystal oscillator and the buffer amplifier in order to permit these two tubes to operate continuously and not be affected by changes in plate voltage when the remaining tubes are keyed.



A glass cover is provided over the tuning controls and is arranged so that it may be locked, once the correct adjustments have been made in the crystal oscillator and buffer amplifier stages. Frequency measurements made on the exciter unit have shown that it may be calibrated to maintain the output frequency with an accuracy better than 0.025 per cent. Care must be taken to calibrate the crystal in the identical circuit in which it is to be used, or, when this is not practicable, adjustments of temperature, oscillator plate tuning, etc., may be made in the field when setting the frequency to its assigned value. In order to enable future utilization of the maximum number of channels in a frequency band, continuous development is carried on to effect improvement in the crystal-controlled elements of the set.

It will be observed that there are three frequency-multiplying stages, each one operating as a doubler. This enables the crystal

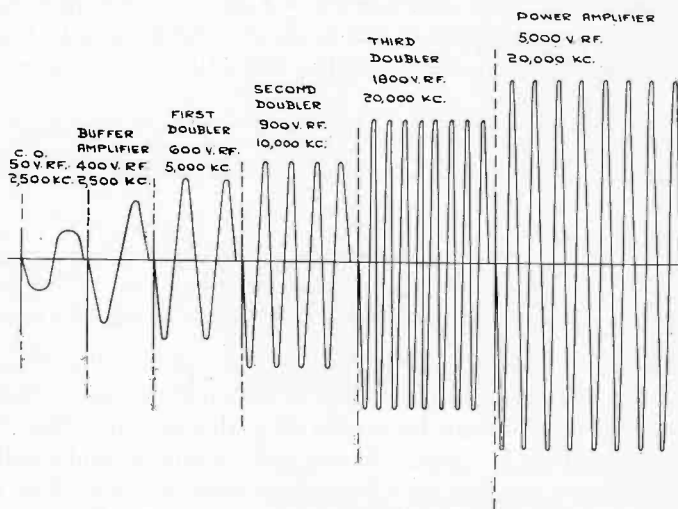

Fig. 4—Frequency multiplication in exciter unit.

to be ground for one-eighth of the output frequency when operating near the upper end of the frequency band. For example, in the band from 12,000 to 21,400 kc, crystals of one-eighth of these frequencies are used. In the band from 6670 to 12,000 kc, the crystal is one-fourth of the output frequency. The crystal-oscillator stage is therefore designed to operate with any crystal in the band from 1500 to 3000 kc. While for some applications, such as military use, portable or aircraft transmitters, it is desirable to use crystals higher than 3,000 kc, this value was set as the upper limit for the exciter unit and three frequency-multiplying stages were used in order to obtain fairly thick and rugged crystals.

The first doubler stage is the one in which keying is introduced by means of a vacuum-tube keying unit. Plate supply for this first doubler is obtained from the 3000-volt source through a suitable series resistor. The keying unit which consists of two UV-211 tubes connected in parallel is so arranged that their plate filament circuit is, in effect, in parallel with the plate circuit of the first doubler. When the transmitting key (or its equivalent, such as a remote keying line)

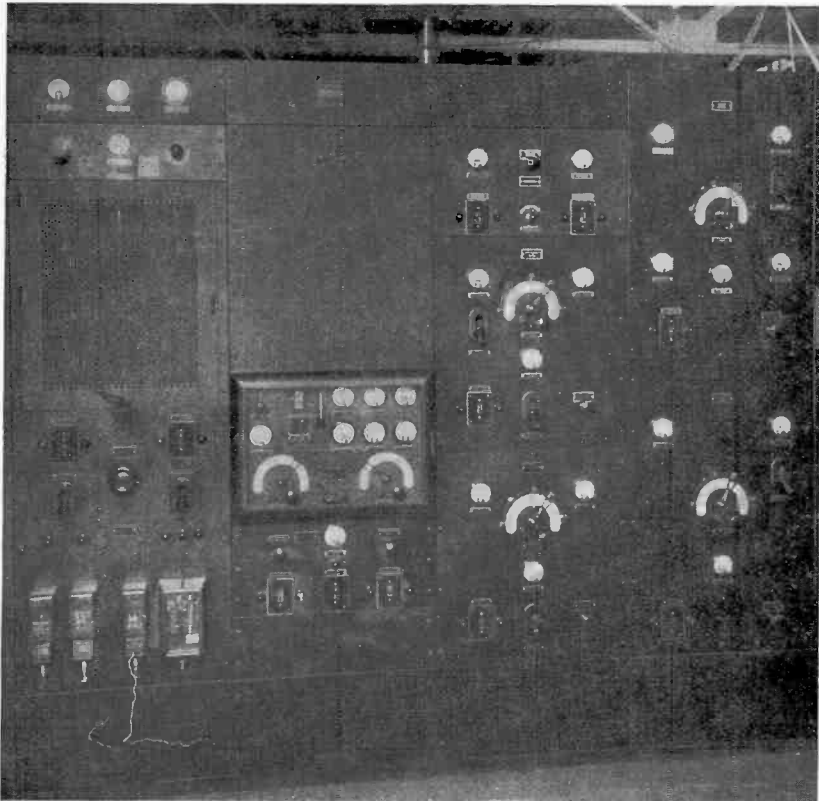

Fig. 5—Exciter with one crystal unit.

is not closed, a small positive potential is maintained on the grids of the UV-211 tubes. Under this condition, the plate current drawn by the keying tubes through the common series resistor causes a sufficient voltage drop to occur which materially lowers the normal plate voltage on the first doubler stage. A negative grid bias maintained on this stage is then sufficient to practically cut off the tube while its plate potential is low. Upon depressing the key, a negative potential is

placed upon the grids of the keying tubes, their impedance is raised, and normal plate voltage appears at the plate of the first doubler. A system of this nature is well adapted to high-speed keying since it is not essential to stop the power completely in the first doubler, as feeble oscillations in its plate circuit are not sufficient to overcome the negative grid bias maintained on the succeeding stages. An oscillogram showing the rectified antenna current for 400-cycle keying and a

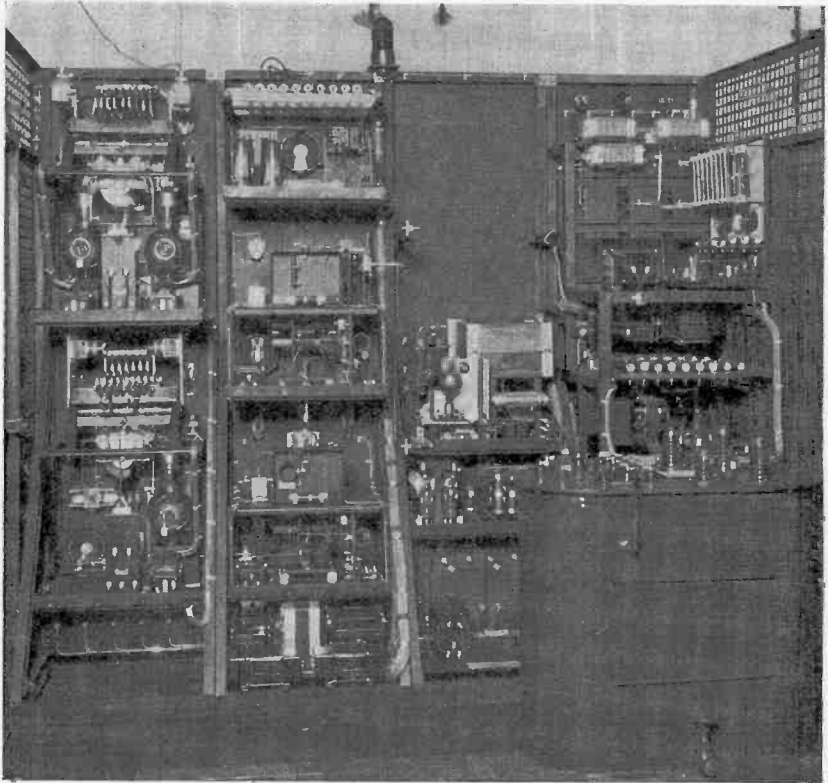

Fig. 6—Exciter unit, rear view. Covers off.

60-cycle timing wave is shown in Fig. 3. This is equivalent to about a rate of 1000 words per minute, assuming an average word requires 24 cycles.

The grid swing on the first doubler, obtained from the plate circuit of the buffer amplifier, is sufficient to overcome a negative bias of approximately 400 volts. The average control-grid current (rectified) is approximately 10 ma. The d-c plate current drawn by the first doubler is approximately 75 ma. A positive screen-grid potential of

325 volts is maintained on this tube. Care must be taken in the construction to provide a low reactance by-pass capacitor near the tube between the screen grid and filament in order to maintain adequate shielding and freedom from regeneration. The plate circuit of the first doubler is designed to cover a frequency range of 3000 to 6000 kc. This range is covered by means of a variable capacitor connected in parallel to the tank inductor and in addition a panel switch is provided which short-circuits a portion of the turns on the tank inductor when operating at the higher frequencies.

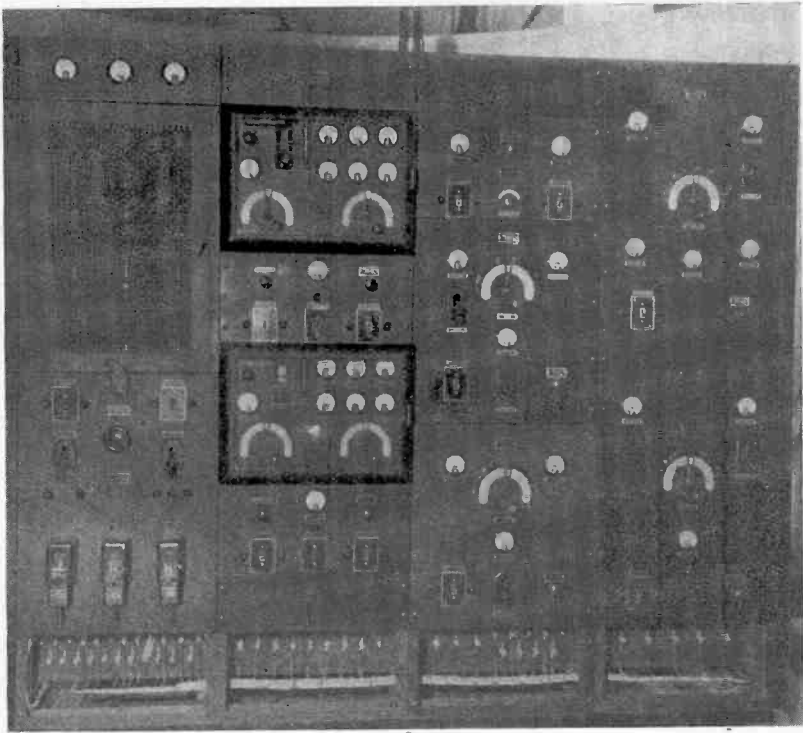

Fig. 7—Exciter unit. Front view.

The plate circuit of each tube that is operated as a doubler in the exciter is tuned, of course, to twice the frequency that is applied to the grid. The efficiency of a tube as a power amplifier under these conditions is not high. A strong fundamental component of plate current flows and as it encounters comparatively low impedance in the plate circuit, it appears as plate loss in the tube. However, since the chief function of the tubes is to multiply frequency, no attempt is made to

operate them at full rated output as would be the case for a fundamental frequency amplifier.

The second frequency doubler utilizes the UX-860 tube and is designed to cover a frequency range of 6000 to 12,000 kc. Tuning of the plate circuit is accomplished in a manner similar to that in the preceding stage, with a variable capacitor, and a switch which includes a suitable number of turns on the tank inductor for the opera-

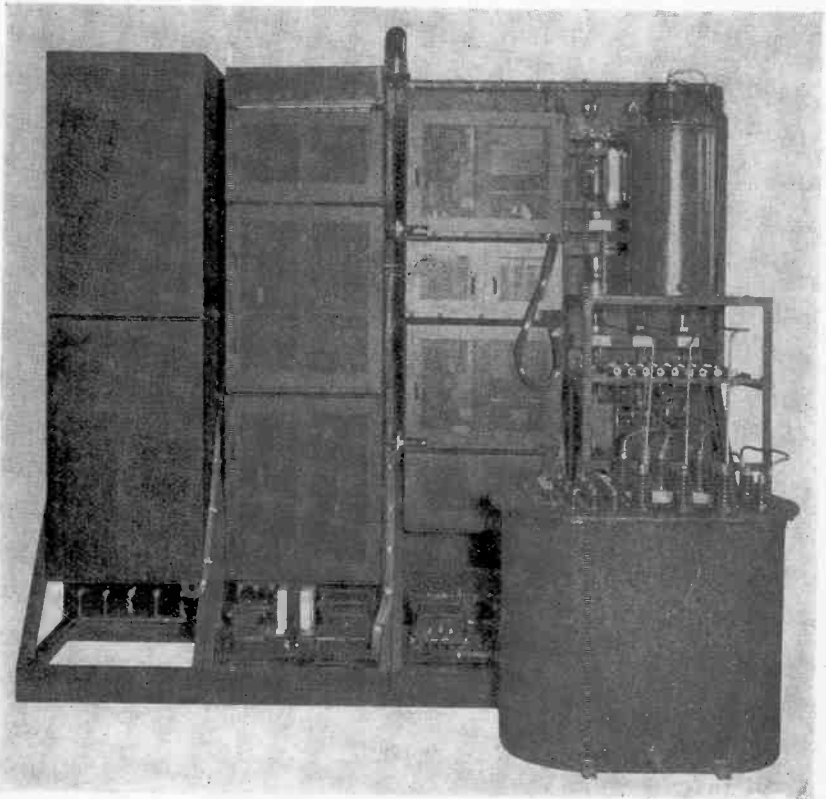

Fig. 8—Exciter unit. Rear view.

ting frequency desired. The d-c grid current in the second doubler is about 12 ma through a negative control-grid bias of 550 volts. The d-c plate current is approximately 100 ma at 1500 volts.

A larger tube is used in the third frequency doubler and consists of a UV-861 four-element tube. This stage operates as a frequency doubler only when output frequencies greater than 12,000 kc are required. Below this value the plate circuit is tuned to the fundamental frequency impressed on the grid. In order to supply grid excitation

to the output or balanced amplifier, it is necessary to arrange the plate circuit of the third doubler so that two output voltages differing in phase by 180 deg. are available. In order to do this, the plate current is fed into the center of the tank inductor and the output for grid excitation is taken from each end of this coil. A small variable capacitor is connected between filaments and the lower side of the tank inductor and, when adjusted to equal the tube capacitance, helps to maintain a balanced output. The d-c grid current on the third doubler is approximately 15 ma through a negative bias of 850 volts. The d-c plate current is approximately 300 ma at 3000 volts.

The power amplifier, frequently known as the balanced amplifier of the exciter unit, utilizes two UV-861 tubes connected as shown in the diagram. Their output circuit is also a balanced tuned tank so arranged that it may feed a transmission line, usually of 600 ohms impedance, which is in turn connected to the succeeding water-cooled power amplifier or to an antenna system. In practice, two transmission



Fig. 9—Quartz crystal cells.

lines are used in the power amplifier for two output frequencies. A normal input to the balanced amplifier is 400 ma at 3000 volts direct current. Under these conditions, the amplifier is not required to deliver a full 1 kw in order to excite the water-cooled tubes. When delivering 1-kw output, the plate input of the balanced amplifier is approximately 450 ma at 3500 volts direct current.

Tuning of the plate circuit in any of the amplifier stages is comparatively simple. The plate circuit is resonated until maximum direct grid current flows in the following stage. This adjustment also corresponds approximately to minimum plate current in the amplifier that is being tuned. It is interesting to note that in a radio-frequency unit of this type, with a multiplicity of tuned circuits, all of the meters required for initial adjustment and routine maintenance are for d-c or a-c operation with but one exception, which is the radio-frequency ammeter in the plate circuit of the crystal oscillator. In other words, with the design once determined, it is not necessary to

provide meters to indicate the radio-frequency tank currents in the various stages.

The sketch shown in Fig. 4 has been prepared to give some idea of the relative change in amplitude and frequency that takes place

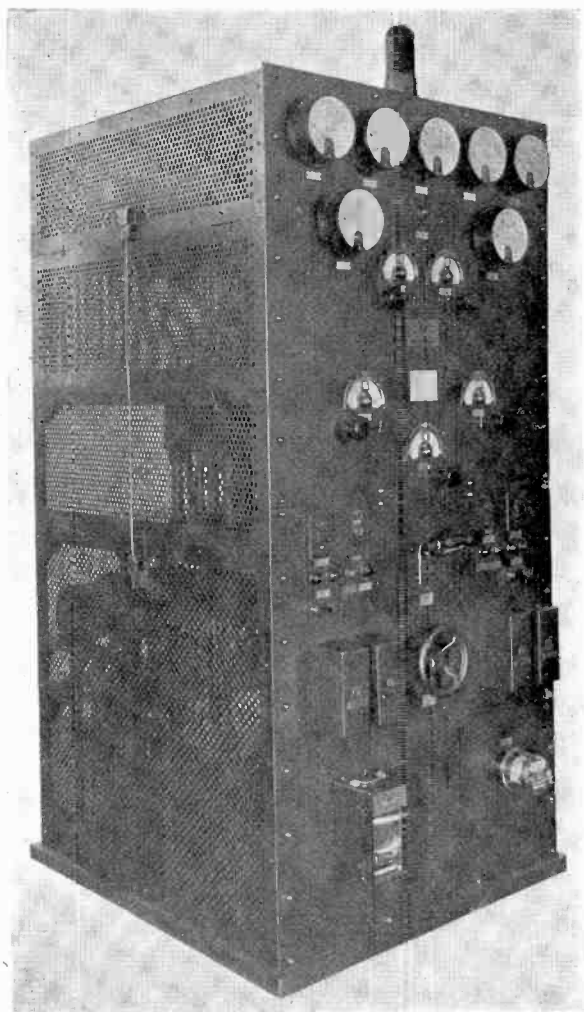

Fig. 10

in the exciter unit from the crystal oscillator through the balanced power amplifier. In this sketch, no attempt has been made to show accurately the relative amplitude of the output voltage in each stage. Under average conditions, the a-c voltage across the tank circuit of

the crystal tube is approximately 50 volts, and that across the power amplifier tank about 5000 volts.

A front view of the exciter unit is shown in Fig. 5. In this view, the blank panel section is that ordinarily occupied by a spare crystal oscillator, buffer amplifier, and plate rectifier. The main rectifier is located in the panel structure to the left with six UV-872 tubes mounted behind a perforated door. All access doors to the equipment are interlocked so that power is removed before any one may be exposed to high-voltage circuits. Overload relays are mounted near the bottom and provide instantaneous overload protection in both d-c and a-c

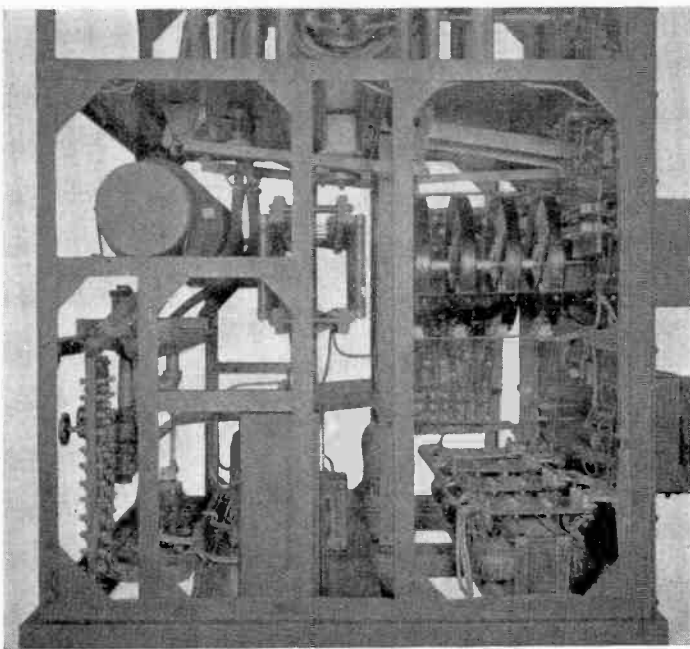

Fig. 11

circuits, and a time delay relay protects from long continued, small overloads. A fourth relay of the undervoltage type shuts down the equipment in case the filament voltage on the tubes falls below a critical value. A small keying panel is mounted above the rectifier tubes to permit quick switching from local to remote keying and to permit a local key relay to be connected in circuit if desired.

A crystal-oscillator buffer-amplifier assembly and plate rectifier is mounted in the panel to the right. Thermometers are provided on the crystal panel to indicate room temperature and oven temperature.



Instruments are provided to read heater current in the oven, plate currents, plate voltages, filament voltages, etc.

The first frequency doubler assembly is located in the third panel to the right and is provided with tuning controls and a selector switch which permits it to be connected to either crystal-oscillator buffer-amplifier unit. The second frequency doubler is mounted directly below the first one, and is in general similar with respect to its controls and meters.

The third doubler assembly, which is mounted in the lower right panel, contains meters to indicate grid current, plate current, and fila-

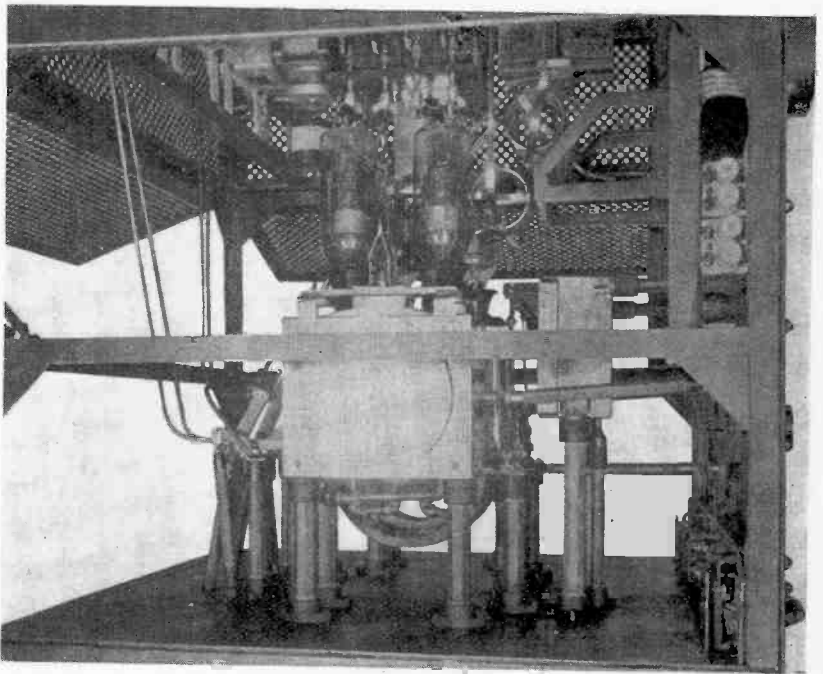

Fig. 12

ment voltage, a frequency selector switch, a variable capacitor for fine tuning, and power indicator lights. The output of this stage is brought up to the control grids of the power amplifier stage which is mounted directly above it.

A rear view of the exciter unit is shown in Fig. 6, with the various shielding compartments removed in order to show the type of construction. Considerable care must be exercised in the design and construction of radio amplifiers operating at frequencies in the neighborhood of 21,000 kc, since the advantages resulting from the

use of shield-grid tubes are restricted if feed back occurs from causes outside the tube. Very short paths are needed for all radio-frequency currents between the various circuits, especially the shield-grid circuits, and common return circuits which carry radio frequency must be avoided. In operating practice, the complete exciter unit is enclosed with a metal grill in addition to the individual shielding compartment for the various stages. A large red indicator light is mounted at the top of the assembly, and is used as an additional safeguard to indicate when power is on the equipment.

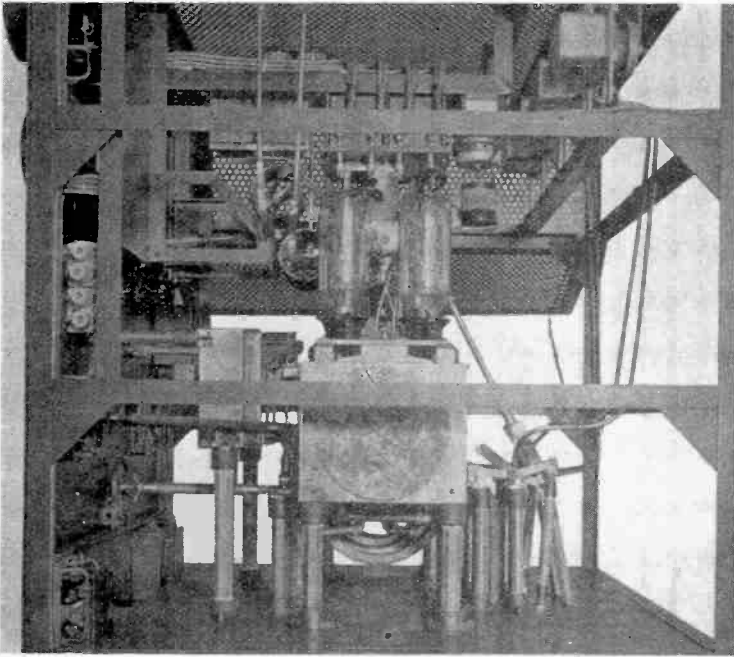

Fig. 13

A view is shown in Fig. 7 with both crystal units mounted in the assembly and with the lower panel strips removed to indicate the terminal boards for the incoming leads. The rear view shown in Fig. 8 is one taken with the various shielding compartments in place and with the main outer protective grill removed. Typical crystal cells which may be used in the exciter are shown in Fig. 9. The cell at the right, which is extensively used, consists of a lower electrode upon which the crystal rests and which is connected to the grid of the crystal-controlled tube. The upper electrode is threaded into a shell and is so arranged that an accurate adjustment of the air gap on the crystal

may be made and then locked. The bakelite cover in the center is used to enclose the assembly. The cell at the left, which is a newer design, is made of monel metal and has the upper electrode properly spaced from the crystal by means of quartz spacers. A considerable

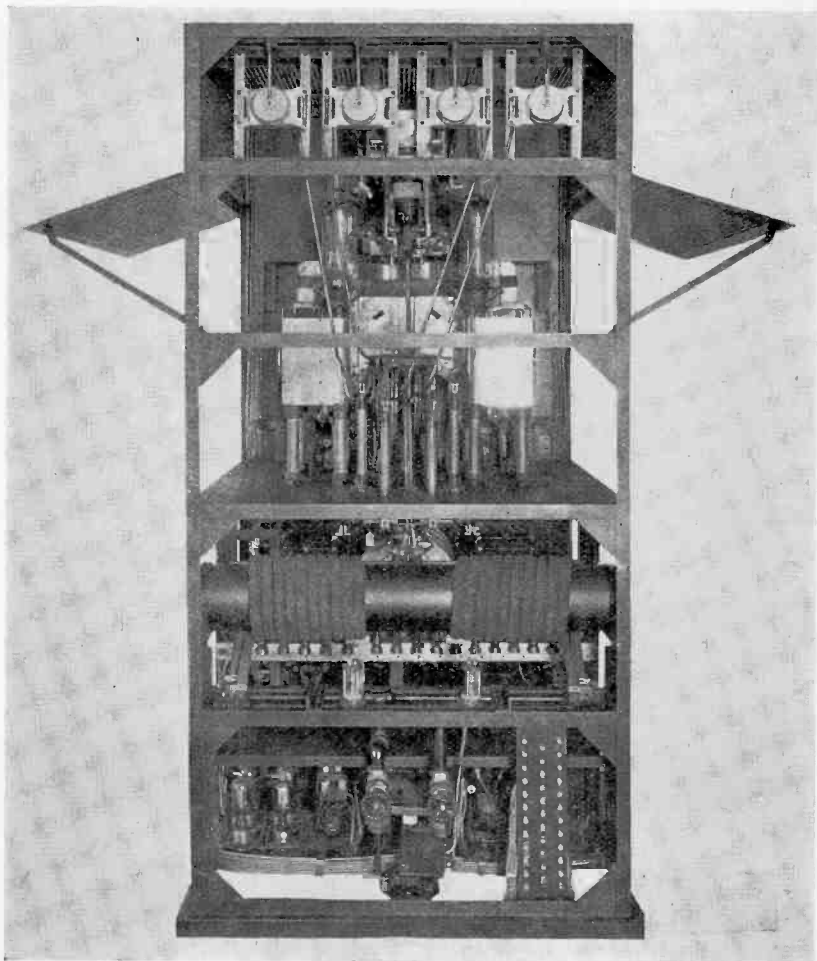

Fig. 14.

mass of metal is used for the lower electrode in order to provide heat storage, and small pins are located on its upper surface to restrict lateral movement of the crystal.

The output power amplifier for the exciter unit just described is similarly designed to operate at any frequency in the band from

6,670 to 21,500 kc. The assembly view of the unit is shown in Fig. 10. The amplifier is arranged to provide quick switching from any frequency in the band 21,500 kc to 10,000 kc for day transmission to any frequency in the band 10,000 kc to 6,670 kc for night transmission by the operation of a single switch and readjustment of the plate-circuit tuning dial. This has been accomplished in a single unit in order to secure a maximum economy in invested cost and space requirements. In the amplifier, four UV-207 water-cooled tubes are employed, operated in a balanced circuit with two tubes on a side. The output of the

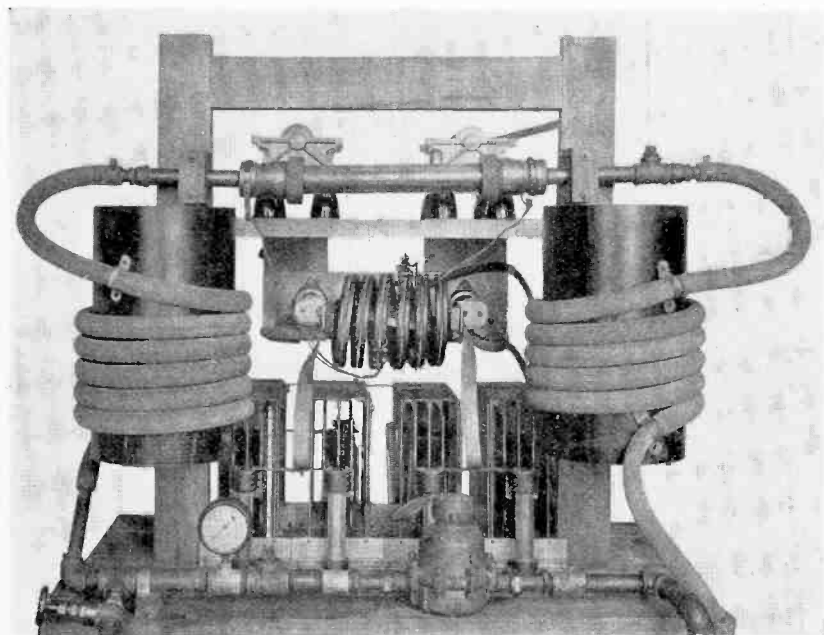

Fig. 15

amplifier is limited by the rating of the tubes which will permit satisfactory life. At 21,500 kc the plate voltage should not exceed 7,500 volts and the plate current 1.3 amperes, and at 6,670 kc, 12,000 volts and 1.7 amperes, respectively. This rating permits outputs in the order of 23 kw at 21,500 kc and 50 kw at 6,670 kc.

For the two operating frequencies, separate input lines are provided from the exciter unit and separate transmission line couplings are provided to feed two antennas. The filaments of each tube are heated from individual transformers and filament voltage is applied in two steps, with a time delay relay providing ten seconds delay be-

tween the first and second steps. This improves tube life by limiting the initial rush of current when voltage is applied to cold tungsten filaments which have a cold resistance of approximately ten per cent of the hot resistance. The separate filament transformers are operated in parallel from a regulated bus. Jacks are provided on the front panel of the unit to permit a precision voltmeter to be connected easily to each tube filament, directly at the filament terminals. This arrangement allows accurate periodic check to be made easily without disturbing the operation of the transmitter. A panel voltmeter is connected

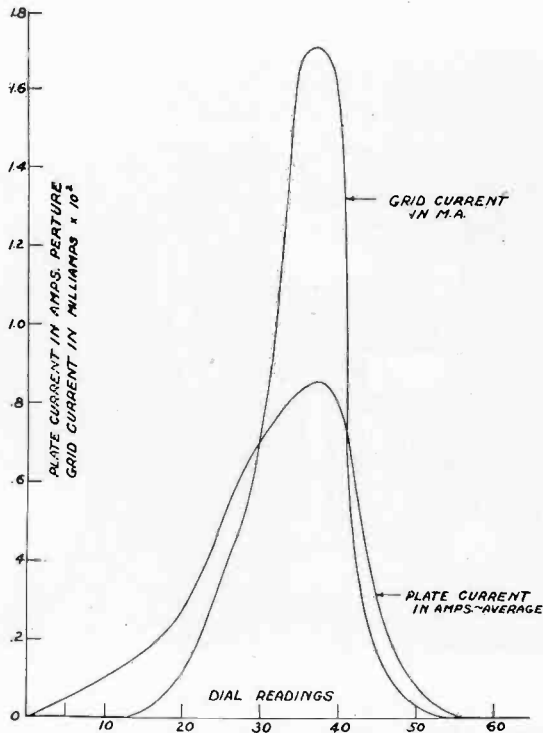

Fig. 16—Plate-grid stability curve. Frequency, 20,225 kc.

to the filament bus to facilitate the adjustment of the bus voltage through the filament rheostat. This voltmeter is calibrated in terms of volts at the tube filaments rather than bus voltage. A meter is provided to totalize the number of hours that the filaments have been lighted, and thus permits an accurate log to be kept of the life of each tube. The use of individual filament transformers permits the placing of an ammeter and overload relay in the ground side of each tube d-c plate return so that the loading condition of each tube is indicated.

The overload relays operate through the rectifier control circuit to remove plate voltage in case of excessive plate current.

The tube grids are biased at a negative potential of approximately 1200 volts. This bias is made adjustable by means of taps on a load potentiometer across the d-c source. An interlock is provided in the potentiometer load circuit to remove plate voltage from the amplifier in case of failure of bias. Fig. 11 shows the details of the lower part of the amplifier where are mounted the filament transformers, water supply hose reel, and control equipment.

The details of the radio-frequency circuit are shown in Figs. 12, 13, and 14. Considering first the grid circuit, the two transmission lines from the exciter unit terminate in separate inductance coils, which provide, when connected to the tubes, separate tuned grid circuits.

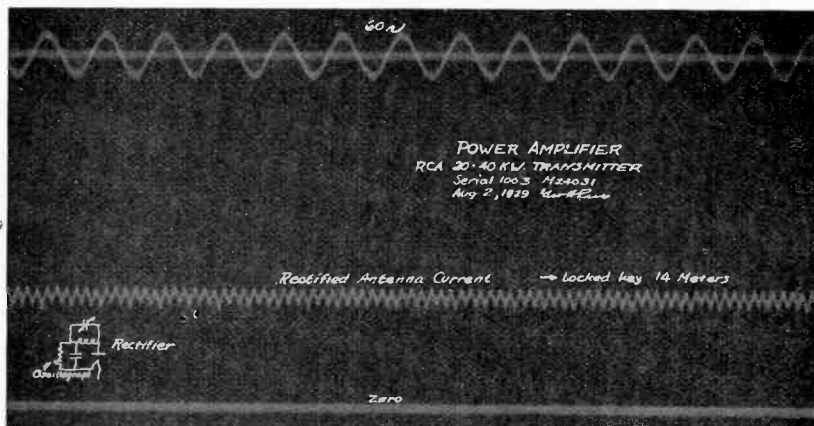

Fig. 17

One circuit is provided for high-frequency operation in the range from 21,500 kc to 10,000 kc, and the other circuit for operation in the range from 10,000 kc to 6,670 kc. The low-frequency coil is shunted by an adjustable air condenser arranged so that the ground capacity is balanced on each side. Frequencies within the ranges given are reached by short-circuiting the necessary number of turns on each end of the coils. Vernier tuning is accomplished by a disk rotating in the center of each coil. The disk provides a limited tuning range, since it acts like a short-circuited turn of variable coupling. Power loss in the disk is negligible since its resistance is low.

The frequency range is covered in the tank circuit by means of a single coil and fixed plate condenser. For frequencies from 21,500 kc to 8,000 kc, tuning is accomplished by short-circuiting turns on each

end of the coil, and for the lower frequencies, from 8,000 kc to 6,670 kc, the fixed condenser is added across the coil. In short-circuiting turns on the ends the straps are arranged so that the coil is at all times electrically balanced to ground. The two transmission lines extending from the tank circuit to the antennas are tapped directly to the tank coil through switches and d-c blocking condensers.

Switching of all circuits to change rapidly from one frequency to another is accomplished by operating one handle from the front panel. This lever operates a series of levers and cams to change the desired connections in the grid circuit, tank circuit, and transmission lines. For example, to change from 21,500 kc to 6,670 kc the position of the grid switch is changed to connect the tube grids from the high-frequency coil to the low-frequency coil. The transmission line switches

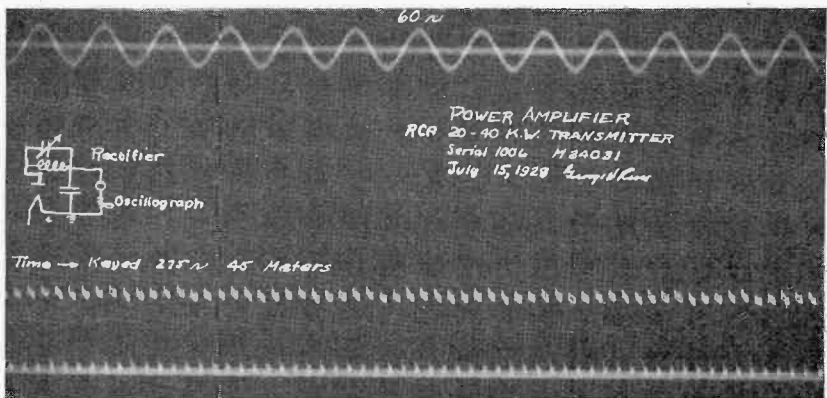

Fig. 18

are operated to connect the line feeding the low-frequency antenna to the proper points on the tank coil to give the desired coupling, and the high-frequency transmission line is disconnected. The tank circuit switch removes the short circuits on either side of the tank inductance coil and connects the condenser across the coil. When the grid switch is thrown for operation on 21,500 kc a short circuit is placed on the low-frequency transmission line from the exciter unit in order to prevent high voltage building up on this line, as a result of harmonics of the natural period of the line at certain frequencies, if open-circuited, being in resonance with the frequency on the other line.

The radio-frequency circuit is arranged so that it is as nearly as possible mechanically and electrically symmetrical about a vertical plane through the center of the unit between the tubes on each side of the circuit. In the design of the radio-frequency circuit every precau-

tion was taken to prevent parasitic oscillation, the inductance of all leads and the capacity of the entire circuit to ground was kept as low as possible. The difficulties of parasitic frequency oscillation are major ones in this type of amplifier operating at high frequencies, where large tube capacities and circuit capacities produce tuned circuits, the natural periods of which are in close proximity to the desired operating frequency. Parasitic oscillation causes unstable operation of the transmitter and may build up to such proportions as to overload the tubes severely. At times there can be considerable radiation from the amplifier at parasitic frequencies while there is still normal output at the desired frequency. This latter type of parasitic oscillation may be the most troublesome in that it causes interference on other frequencies than that assigned to the station.

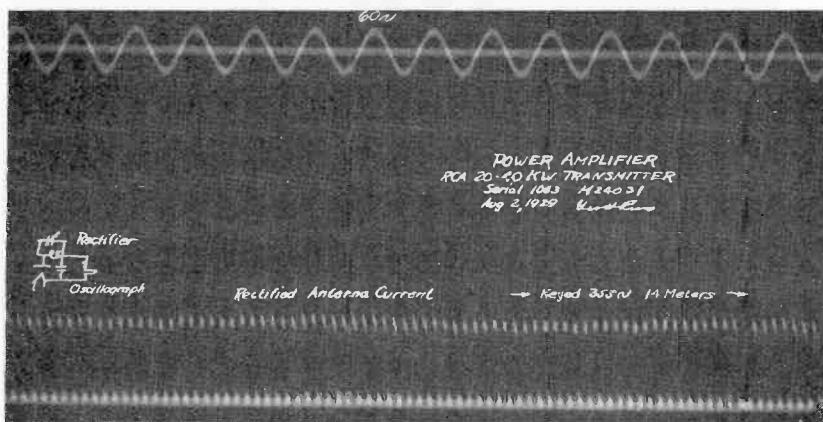

Fig. 19

The high-voltage d-c supply to the anodes of the tubes is connected at the center or ground point of the tank circuit inductance coil. This causes the entire tank circuit to be at a high voltage above ground so that it is necessary to feed the cooling water in and out of the tubes through a 10-ft. length of rubber hose which is sufficient to keep the d-c power loss down to a satisfactory value for water of reasonable purity. In general, the cooling water should have a resistance of not less than 10,000 ohms per cubic centimeter. A water pressure and flow interlock are provided to cut off filament and plate power in case of failure of circulating water.

For the protection of the operating personnel all access doors are provided with cord and plug interlocks, which must be removed before the doors can be opened. The removal of any of the plugs interrupts



the control circuit so that all dangerous voltage is removed from the unit.

In testing these transmitters an effort was made to duplicate actual operating conditions as nearly as possible. To accomplish this with a "dummy" load, a 1000-ft. transmission line was erected |which ter-

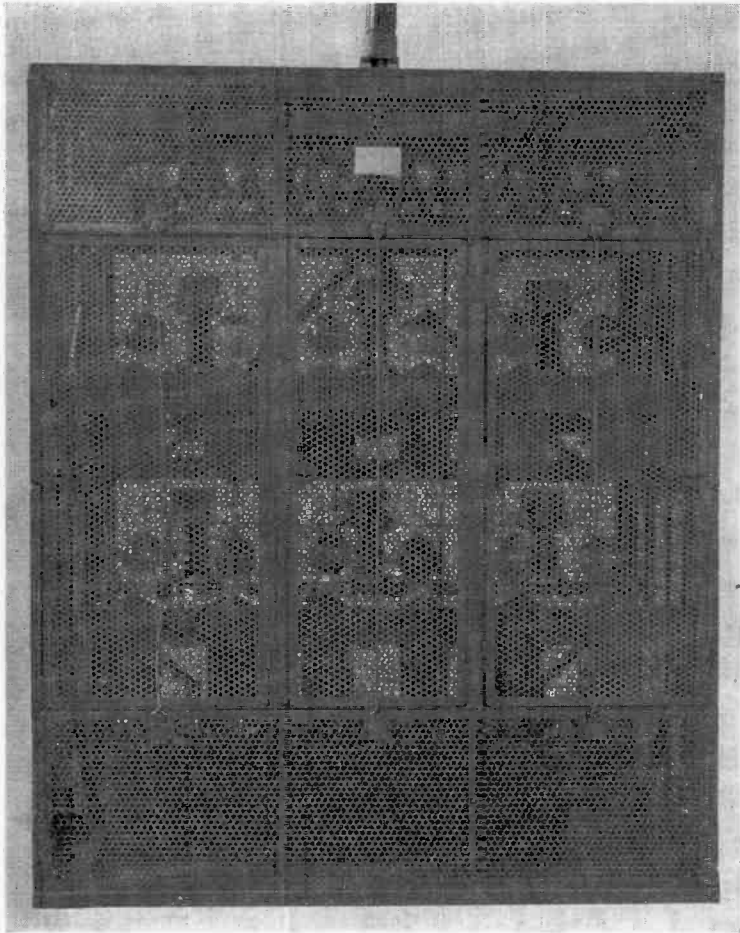

Fig. 20

minated in a tuned load circuit. The loading was provided by a water-cooled resistor connected across the tuned circuit. This resistor was wire wound in such a manner as to keep the inductance at a minimum. The transmission line coupling and the load resistance coupling to the tuned circuit were so adjusted that the line terminating impedance

was equal to the surge impedance of the line. A water flow meter and inlet and outlet water thermometers were provided so that the power dissipated in the load resistor could be calculated by determining the water flow and temperature rise of the cooling water through the

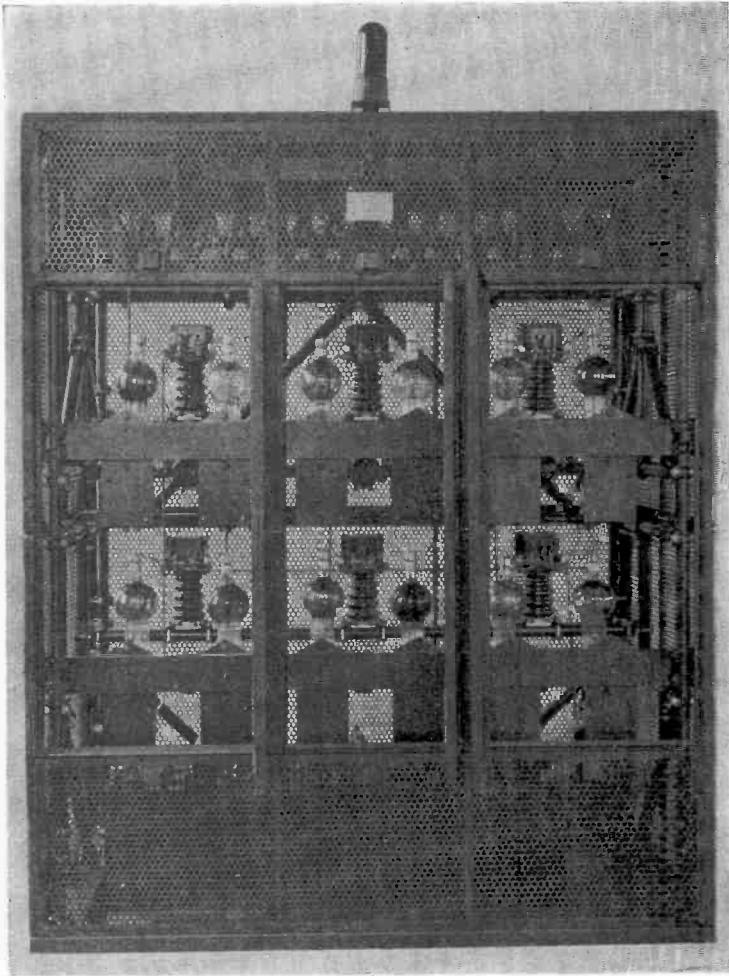

Fig. 21

load resistor. The "dummy" load unit for use from 6670 to 10,000 kc is shown in Fig. 15.

The output of the amplifier was checked by the loss method at the amplifier itself. With the amplifier operating under load the temperature rise and flow of the cooling water was determined, from which

the total power loss in the cooling water was calculated. Plate voltage was then removed from the amplifier, and the power loss in the cooling water due to filament and excitation loss was calculated. The total loss less the filament and excitation loss subtracted from the total d-c plate input gave the amplifier output.

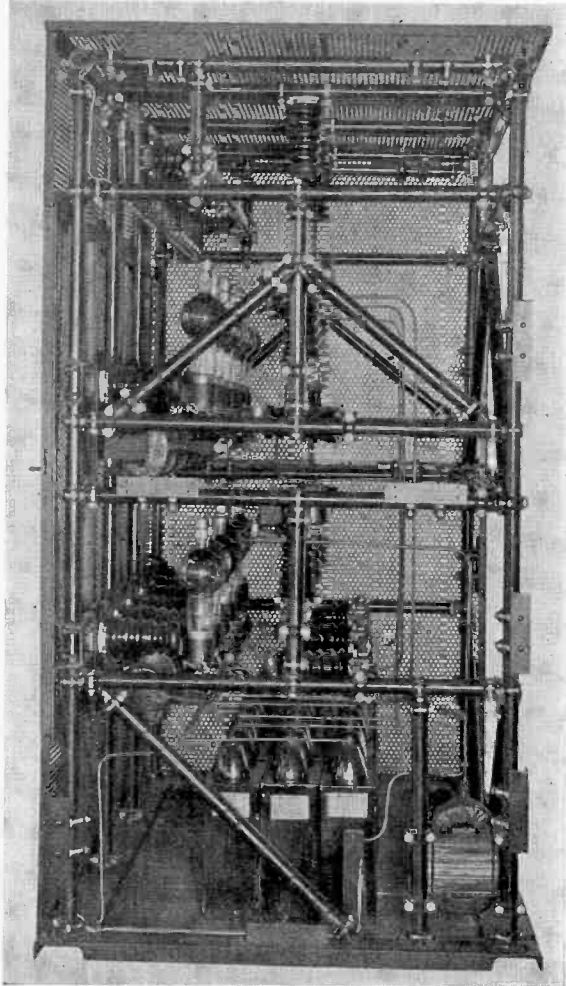

Fig. 22

To check the stability of the amplifier the grid excitation was varied from zero to maximum and back to zero by varying the grid tuning, and Fig. 16 shows the plate current per tube and rectified grid

current plotted against position of the tuning dial. The difference in the shape of the curve above and below the resonant frequency is due to difference in coupling between the rotating disk and coil on either side of the ground point, caused by slight mechanical error in the spacing of the turns. Oscillograms were taken of the rectified r-f output to check the calculated percentage ripple and quality of keying. Fig. 17 shows the rectified r-f output. Fig. 18 shows the r-f output of 45 kw keyed at 275 cycles (690 words per minute) at 6,670 kc. Fig. 19 shows the r-f output of 20.8 kw keyed at 355 cycles (890 words per minute) at 21,500 kc.

The high-voltage d-c plate-supply unit for the power amplifier consists of a 96-kw hot-cathode mercury-vapor rectifier. Twelve UV-869 rectifier tubes are employed in a three-phase full-wave circuit. Tubes

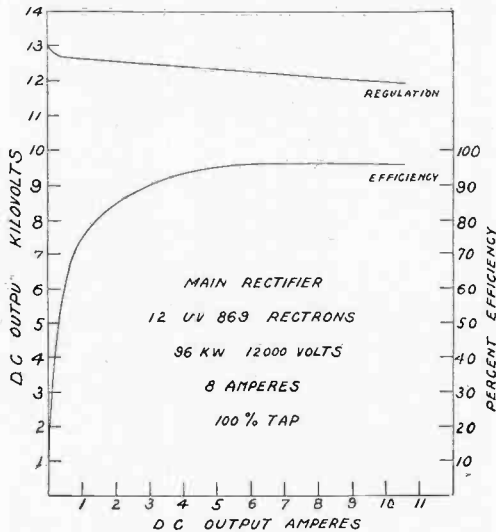

Fig. 23

are operated in parallel to give the desired rating of 8 amperes direct current at 12,000 volts, since the normal peak current rating of the UV-869 tube is 5 amperes. The assembly of the rectifier is shown in Figs. 20, 21, and 22.

In order to parallel the tubes in a satisfactory manner, a balance coil is provided between anodes of tubes in parallel. If the characteristics of the tubes differ slightly the tube tending to take the greater current will increase the voltage, and thus the loading, on the other tube by the auto transformer action of the balance coil until a point of equilibrium is reached. To reduce the ripple in the d-c output a

3- $\mu$ f condenser is provided, and in order to protect the tubes from the instantaneous surge of condenser charging current a 1/2-henry reactor is connected between the rectifier and condenser. Fig. 23 shows the

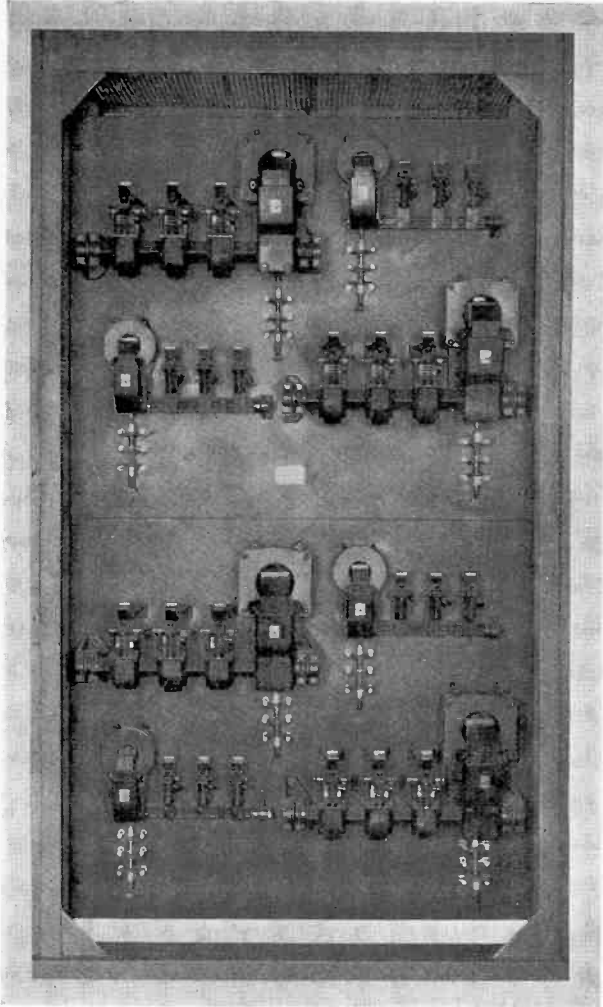

Fig. 24

efficiency and regulation of the rectifier operating on the 100 per cent voltage tap.

Arrangements are made on the rectifier to cut out six of the twelve tubes when reduced load conditions warrant.

The plate-supply transformer is provided with eight primary taps so that the d-c voltage may be regulated from 40 to 105 per cent of 12,000 volts in eight steps. Selection of the proper taps is made through

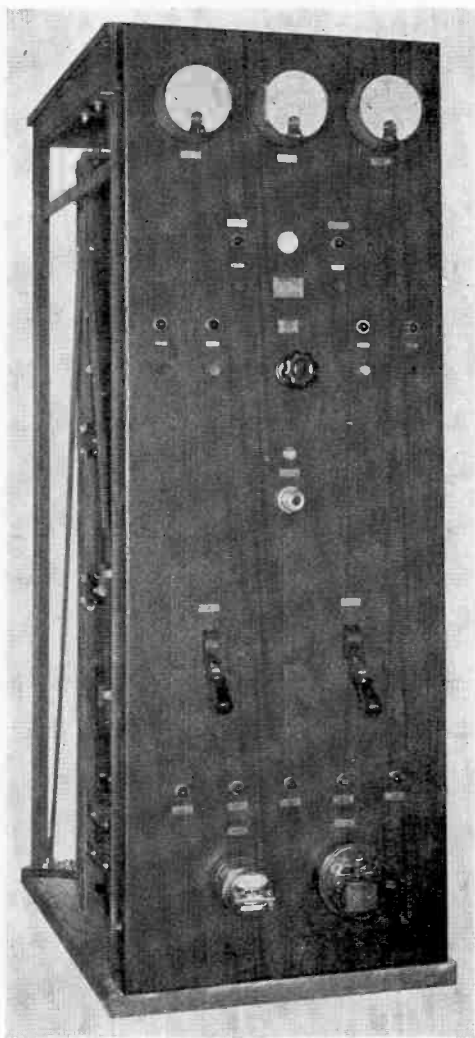

Fig. 25

a series of contactors, which are automatically controlled from a master switch mounted on the power amplifier. Fig. 24 shows the arrangement of the tap changing contactor panel.

The control panel for the rectifier, upon which is mounted all auxiliary equipment, is shown in Figs. 25 and 26. An under-voltage relay serves to remove plate voltage in case the filaments drop more than 5 per cent below the rated value of 5 volts. A 30-sec. time delay

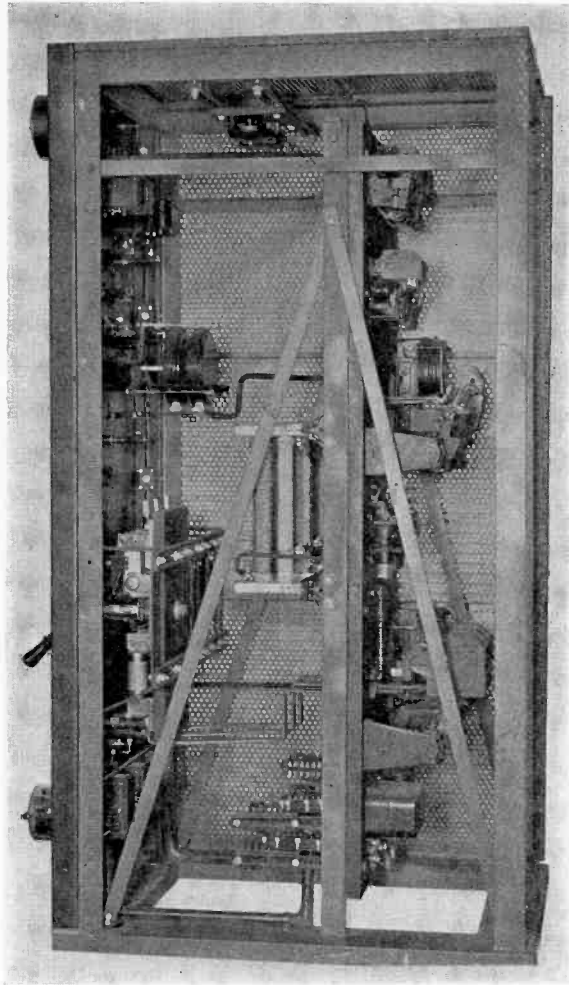

Fig. 26

is also provided to prevent the application of plate voltage before the filaments are evenly heated. In order to permit an accurate log to be kept on tube life a tube-life-hour meter similar to that provided for the tubes on the power amplifier is connected to the filament bus.

An instantaneous overload relay in the d-c output circuit and transformer primary overload relays afford protection to the tubes in case of overload. On this unit are mounted meters for indicating filament voltage, d-c load current, and d-c voltage.

In order to provide safety to the operating personnel all access doors are interlocked so that dangerous voltage is removed when the doors are open.





## POWER OUTPUT CHARACTERISTICS OF THE PENTODE\*

BY

STUART BALLANTINE AND H. L. COBB  
(Boonton Research Corporation, Boonton, New Jersey)

**Summary**—The type of pentode considered in this paper comprises a cathode, a control grid, a screen grid, a grid connected to the cathode to prevent the flow of secondary-electron current from the plate, and a plate.

A quantity called the "power sensitivity" is defined as the square root of the power output divided by the effective value of the applied sinusoidal grid voltage. This quantity permits a direct comparison to be made between two output tubes in terms of an equivalent amplification, or "gain."

The mathematical theory of the Carson first- and second-order effects is developed. The production of harmonics by the second-order effect is calculated and is found to depend upon three non-related parameters representing curvature and fanning of the characteristics. The possibility of mutual cancellation of the terms involving these parameters when the grid bias is more negative than the point of inflection on the  $i_p - e_p$  characteristic is noted. In these circumstances the remaining harmonic distortion is due to higher order terms and is small so that a maximum of undistorted power is obtained. An expression is obtained for the undistorted power as a function of the load resistance.

Three types of power limitation are classified and discussed; (1) distortion due to curvature of the characteristic; (2) distortion due to plate current cut-off; (3) distortion due to the grid potential becoming positive. The circumstances of their occurrence and their effects are examined qualitatively.

Experimental measurements on a specimen low-power pentode are given and an improved and simplified technique is described. For a fixed plate voltage and a variable grid bias the highest undistorted power output was obtained at a value of load resistance equal to about 0.25 of the plate resistance. The optimum undistorted output increases approximately linearly with the plate voltage.

The power sensitivity of the pentode is measured and compared to that of a triode under conditions of equal optimum undistorted output. The pentode was found to be the more sensitive and equivalent to the triode preceded by a stage of amplification giving a gain of 3.3.

### I. INTRODUCTION

THE term pentode has come into use as a logical extension of Professor G. W. O. Howe's Greek prefix nomenclature to designate a five-electrode tube comprising a cathode emitter, a plate and three grids. This device is extensively used abroad as the out put tube in radio broadcast receivers. The possibility of its increasing employment in this country may lend interest and timeliness to a considera-

\* Dewey decimal classification: R139. Excerpt in part from a paper entitled "Recent developments in RFL broadcast receivers," presented by Stuart Ballantine at the meeting of the Philadelphia Section, Institute of Radio Engineers, November 5th, 1929.

tion of its power output characteristics. Our point of view in the following discussion is mainly experimental; but the theoretical expectations are examined to an extent sufficient to keep abreast of, and to explain, the principal experimental facts.

**Structure and Connections of the Pentode.** Several varieties of pentode, differing in the functions and modes of connection of the three grids, are possible and have been described in the literature. One type, which may be termed a *space-charge pentode*, is simply a screen-grid or Schottky tetrode with a Langmuir space-charge grid inserted between the control grid and the cathode for the purpose of increasing the flow of electrons from the cathode. Our present interest, however, is in the type of pentode illustrated schematically in Fig. 1.

If  $G_3$  be omitted the structure and scheme are the same as in the now familiar screen-grid tetrode of Schottky,<sup>1</sup> and this type of pentode can be regarded as a Schottky tube to which an extra grid has been added. The net result of this extra complication appears to be a somewhat lower plate resistance for a given  $G_1$ -plate transconductance\* ("mutual conductance"), and a removal of the fold in the  $i_p = f(e_p, e_0)$  characteristic surface which occurs normally in the Schottky tetrode in a certain range of plate voltages due to the flow of secondary electrons between the plate and screen grid. In this pentode the potential of the third grid is usually at or near that of the cathode so that the secondary electrons from the plate find themselves largely in a retarding field between  $G_3$  and the plate.  $G_2$  is maintained at a positive potential, which is often equal to that of the plate. Under normal conditions the effect of  $G_3$  on the primary electron stream from the cathode is relatively small due to the presence of  $G_2$ . The control grid  $G_1$  is usually negative with respect to the cathode, as in the triode.

The plate circuit is usually the output circuit. The circuits of  $G_2$  and  $G_3$  sometimes contain impedances for special purposes, but are ordinarily by-passed and will be so considered here.

**Distortion. Undistorted Output.** With a sinusoidal impressed grid voltage the amplitude distortion which results from the curvature of the characteristic surface leads to:

- (1) a non-linearity in the relation between the amplitude (maximum value) of the fundamental component of the plate current and the amplitude of the grid voltage, and

<sup>1</sup> W. Schottky, German patent No. 300,617 (1916); *Arch. f. Elec.*, 8, 299; 1919.

Zenneck Rukop, "Lehrbuch der drahtlosen Telegraphie," 5th Ed., p. 561; 1925.

<sup>2</sup> W. Schottky, *previous citation*.

\* See note on nomenclature at the end of this paper.

(2) the appearance of harmonic frequencies in the output.

We have been accustomed<sup>3</sup> to defining the harmonic distortion as the ratio of the r.m.s. value of all the harmonics generated, to the r.m.s. value of the fundamental, or

$$D = \left( \frac{E_2^2 + E_3^2 + \dots + E_k^2}{E_1^2} \right)^{1/2} \quad (1)$$

with a voltage of the type  $\sin \omega t$  applied to the grid. In equation (1)  $E$  represents the amplitude of the  $k$ th harmonic.

Using a sinusoidal applied voltage of this sort, it is conventional<sup>4</sup> to rate the power output capacity of a device of this class as the power delivered to a resistive plate load when the harmonic distortion amounts to 5 per cent. This power is called the "undistorted output," a somewhat deceptive term. This rating is of no absolute significance. The value of 5 per cent is believed to be largely arbitrary and its significance as a limit of recognizable distortion is a debatable and wholly irrelevant question; other small distortion limits would serve equally well. It may be noted that for small values of distortion the undistorted power varies approximately as the square of the  $D$ -limit selected. Thus if a limit of 10 per cent distortion had been agreed upon instead of 5 per cent, the undistorted power would be about 4 times the present ratings.

**Power Sensitivity.** A second factor of fundamental importance in connection with the output tube is the relation between the power output and the a-c grid voltage. This relation may be termed the *power sensitivity*,  $S$ , and defined as the ratio:

$$\text{Power Sensitivity} = S = \sqrt{W/E_{c.c.}}$$

where  $W$  is the power delivered to the load,  $E_{c.c.}$  is the r.m.s. value of the a-c sinusoidal grid voltage.

Hanna, Sutherlin, and Upp<sup>5</sup> have defined the power sensitivity as the ratio  $W/E_c^2$ . We think our factor preferable for the reason that power is really not the thing of primary interest; it is, after all, merely a mathematical quantity which is invariant during certain idealized transformations and whose importance resides almost entirely in the frequent convenience of the principle of conservation of energy. The sound pressure, for example, is proportional to  $\sqrt{W}$ , not to  $W$ . Another

<sup>3</sup> Stuart Ballantine, *Cont. from the Radio Freq. Labs.*, No. 11, p. 1166, Proc. I.R.E., 17, p. 1166, 1929.

<sup>4</sup> E. W. Kellogg, *Jour. A.I.E.E.*, May, 1925; Stuart Ballantine, Report to Daven Radio Corporation, October, 1925; J. C. Warner and A. V. Loughren, Proc. I.R.E., 14, p. 735, 1926; C. R. Hanna, L. Sutherlin, and C. B. Upp, Proc. I.R.E., 16, p. 462, 1928.

<sup>5</sup> Hanna, Sutherlin, and Upp, *previous citation*.

convenience of our definition is that it is applicable as a multiplying factor to a complex system. Consider, for example, a system comprised of the output tube and an amplifier producing a gain of 10. According to the above definition, the overall sensitivity is equal to  $10 S$ ; by the other definition it would equal  $100 S$ . By means of this factor we can compare directly the equivalent gains of two output tubes of equal power capacities. The dimensions of power sensitivity are those of the square root of a reciprocal resistance. The value of sensitivity under conditions of maximum undistorted output will be called the *optimum sensitivity*.

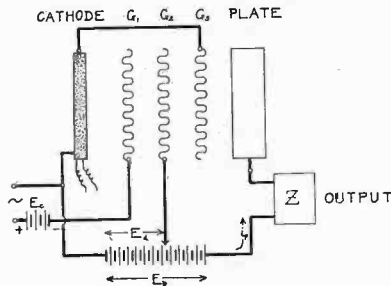

Fig. 1—Relations of electrodes and electrical connections of pentode as used in the output stage.

**Determination of the Undistorted Output.** Three methods of determining the distortion-limited output are available:

- (1) theoretical computation from the curvature of the characteristics. This method is convenient and reliable only in special cases and for low values of the curvature parameters and voltage variations;
- (2) graphical determination from the d-c characteristics;
- (3) direct experimental measurement with the aid of a harmonic analyzer.

It has been our experience that of these three methods the experimental one is the most direct and trustworthy; it has also been found the least laborious, especially in view of several simplifications in technique which we have found possible. Details of the experimental method are given in Section III.

## II. THEORETICAL

When the pentode is connected as shown in Fig. 1 the number of differential parameters  $\partial i_a / \partial e_b$  occurring in the theory of the first-order effect is reduced from the general number,  $(n-1)^2 = 16$  ( $n = \text{no. electrodes}$ ), to 2.

Since the theory is to be used merely as an aid to the interpretation of the experimental results, there is no necessity for its complete and rigorous development. We will therefore consider only the first- and second-order effects. The first-order effect accounts approximately for the fundamental output, and the second-order effect accounts for most of the second-harmonic distortion, and most of the total distortion, for small  $E_c$ . The method of Carson<sup>6</sup> will be followed along lines<sup>7</sup> similar to those of the extended theory of Llewellyn. We have preferred to employ the  $\partial^n i_p / \partial e_c^n$  parameters as fundamental quantities rather than to introduce variable  $\mu$ -factors as Llewellyn did in treating the case of the triode. It may be noted that the present equations are directly applicable to the triode, since the same number of parameters are involved. This application to the triode will be attempted in a separate paper.

Let us suppose that the plate-current function  $i'_p = f(e'_g, e'_p)$  can be developed into a double Taylor's series about the operating points.\*

$$i_p = i_p' - I^{p0} = P_1 e_g + P_2 e_g^2 + \dots R_1 e_p e_g + \dots Q_1 e_p + Q_2 e_p^2 + \dots \quad (2)$$

where  $P_n$ ,  $Q_n$ ,  $R_n$  are differential parameters at the operating point as follows:

$$\begin{aligned} P_1 &= \partial i_p / \partial e_g = s_m; & P_2 &= \frac{1}{2} \partial^2 i_p / \partial e_g^2 = \frac{1}{2} \partial s_m / \partial e_g; \\ Q_1 &= \partial i_p / \partial e_p = s_p = 1/r_p; & Q_2 &= \frac{1}{2} \partial^2 i_p / \partial e_p^2 = \frac{1}{2} \partial s_p / \partial e_p; \\ R_1 &= \partial^2 i_p / \partial e_g \partial e_p = \partial s_m / \partial e_p = \partial s_p / \partial e_g. \end{aligned} \quad (3)$$

Denoting the external resistance in the plate circuit by  $R$ , the alternating part of the plate voltage will be  $e_p = -i_p R$ . The impressed a-c voltage is of the form  $e_c = E_c \sin \omega t$ . Following Carson let:

$$\begin{aligned} i_p &= i_1 + i_2 + i_3 + \dots, \\ e_p &= e_1 + e_2 + e_3 + \dots, \end{aligned} \quad (4)$$

and substitute in (2), in order to express the final result as:

$$\begin{aligned} i_p &= a_1 e_c + a_2 e_c^2 + a_3 e_c^3 + \dots \\ &= i_1 + i_2 + i_3 + \dots \end{aligned} \quad (5)$$

The details of the mathematical work are uninteresting; the results may be simply stated as follows: the currents of the first and second orders,  $i_1$  and  $i_2$ , may be regarded as due to first- and second-order generators acting in a circuit comprising  $r_p$  of the tube and the

<sup>6</sup> J. R. Carson, Proc. I.R.E., 7, p. 187; 1919.

<sup>7</sup> F. B. Llewellyn, Bell Sys. Tech. Jour., 5, 433; 1926.

\* For an explanation of the symbolism employed here see "Note on Nomenclature" at the end of the paper.

load resistance  $R$  in series. The equivalent first- and second-order e.m.f.'s of these hypothetical generators are:

$$\text{equivalent first-order e.m.f.} = P_1 e_o / s_p = s_m r_p e_c; \quad (6)$$

$$\text{equivalent second-order e.m.f.} = r_p (P_2 e_p^2 - R_1 e_g e_1 + Q_2 e_1^2). \quad (7)$$

In equation (7)  $e_1$  represents the voltage developed across  $R$  by the first order current  $i_1$ .

**First-Order Effect. Fundamental Output.** The first-order current is of fundamental frequency and from (5) is simply

$$i_1 = \frac{s_m r_p e_c}{R + r_p} = \frac{s_m r_p}{R + r_p} E_c \sin \omega t. \quad (8)$$

The average power is:

$$W = \frac{1}{2} I_1^2 R = \frac{1}{2} \frac{s_m^2 r_p^2 R E_c^2}{(R + r_p)^2}. \quad (9)$$

In the rigorous theory employing the full power series, terms of fundamental frequency are also contributed by the third-, fifth-, and other odd-order effects.

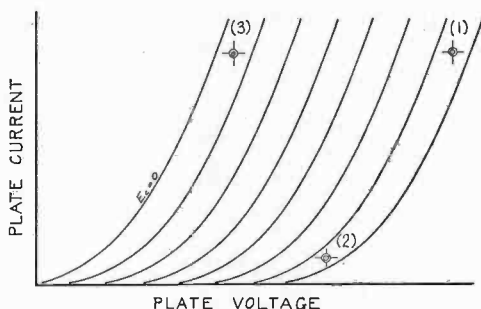

Fig. 2—Illustrating operating points on the  $i_p$ - $e_p$  characteristic favorable to three types of limitations of power output by distortion: (1) limitation by curvature; (2) limitation by plate current cut-off; (3) limitation by positive grid current.

**Second-Order Effect. Second Harmonic Output.** The second-order current comprised a d-c term (zero frequency) and a term of frequency  $2\omega$ . From (8)

$$e_1 = \frac{R r_p}{R + r_p} s_m E_c \sin \omega t = r s_m E_c \sin \omega t, \quad (10)$$

where  $r = R r_p / (R + r_p)$ ; hence from (7) we have for the a-c part of  $i_2$ ,

$$i_2 = \frac{E_c^2}{4} \frac{r_p}{R + r_p} \left( \frac{\partial s_m}{\partial e_g} - 2 r s_m \frac{\partial s_m}{\partial e_p} + r^2 s_m^2 \frac{\partial s_p}{\partial e_p} \right) \cos 2\omega t. \quad (11)$$

Additional terms of frequency  $2\omega$  are contributed by effects of the 4th, 6th, .... orders, which we have neglected.

**Calculation of the Distortion and Undistorted Power Output.** The distortion  $D$  due to the second-order effect only is from (11) and (8),

$$D = \frac{I_2}{I_1} = \frac{E_c}{4s_m} \left( \frac{\partial s_m}{\partial e_g} - 2rs_m \frac{\partial s_m}{\partial e_p} + r^2 s_m^2 \frac{\partial s_p}{\partial e_p} \right) \quad (12)$$

The fundamental power output at a value of  $E_c$  limited by the production of a distortion  $D$  is found by solving (12) for  $E_c$  and substituting in (9) giving, after removing  $r$ :

$$W_c = \frac{8s_m^4 D^2 r_p}{\left( \frac{1+x}{x^{1/2}} \frac{\partial s_m}{\partial e_g} - 2s_m r_p x^{1/2} \frac{\partial s_m}{\partial e_p} + r_p^2 s_m^2 \frac{x^{3/2}}{1+x} \frac{\partial s_p}{\partial e_p} \right)^2} \quad (13)$$

where  $x$  is a convenient dimensionless quantity representing the ratio  $R/r_p$ .

**Special Case; Triode with Constant Mu.** It will be useful to note here, for future reference, the form taken by (13) in the case of a triode satisfying the Langmuir-van der Bijl relation  $\partial e_p / \partial e_g (i_p \text{ const.}) = \mu = \text{constant}$ . There exist in this case special relations between the curvature parameters as follows:

$$\frac{\partial s_m}{\partial e_p} = \frac{1}{\mu} \frac{\partial s_m}{\partial e_g}; \quad \frac{\partial s_p}{\partial e_p} = \frac{1}{\mu^2} \frac{\partial s_m}{\partial e_g}$$

so that (13) simplifies to;

$$W = \frac{8r_p s_m^4 x (1+x)^2}{(\partial s_m / \partial e_g)^2} \quad (14)$$

**Types of Power Limitation Due to Distortion.** The power output may be limited by distortion brought about in three ways:

- (1) by ordinary curvature of the plate-current characteristic surface, or
- (2) by cutting off the plate current during a portion of the cycle, or
- (3) by the grid potential becoming positive when the grid circuit contains external impedance.

These will be referred to as curvature, cut-off, and positive grid limitations, respectively. Operating points at which the various types may be expected to become conspicuous are shown in Fig. 2 for the case of a parabolic characteristic. Limitation by positive grid current

cannot be quantitatively determined in the absence of a specification of the impedances in the external grid circuit, and it is desirable to avoid a separate investigation of this type by imposing the restriction that  $e_g$  shall not be permitted to exceed zero. Limitation by plate cut-off is a property of the plate circuit and is indistinguishable from (1) in the experimental harmonic analysis.

**Power Limited by Curvature Distortion.** The power limitation by distortion due to curvature is expressed approximately by (13). Let us denote by  $W_c$  the power limited in this way. In examining the variations of  $W_c$  it will be convenient to regard the plate voltage,  $E_b$ , as fixed, the grid bias,  $E_{co}$ , as a parameter and the ratio  $x = R/r_p$  as the independent variable.

The functional forms of the various terms (1), (2), and (3) in the denominator of (13) are indicated roughly in Fig. 3.

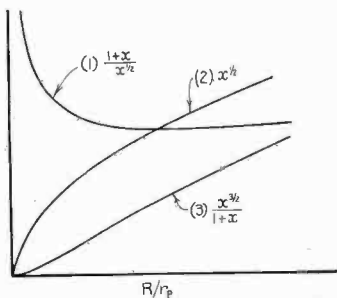

Fig. 3—General form of the functions of  $x = (R/r_p)$  occurring in terms (1), (2), and (3) of equation (13).

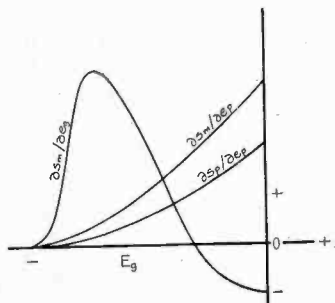

Fig. 4—Suggesting mode of variation with grid bias ( $E_{co}$ ) of the three curvature parameters occurring in equation (13).

The parameter  $\partial s_m/\partial e_g$  represents curvature of the transconductance ( $i_p - e_g$ ) characteristic, and, as will be seen from the specimen d-c curves shown in Fig. 8, is positive for highly negative grid biases, vanishes at the point of inflection, and is negative for  $E_{co}$  near zero;  $\partial s_m/\partial e_p$  represents "fanning," or nonparallelism, of the curves for various  $E_{co}$  in the  $i_p - e_p$  characteristic, or for various  $E_p$  in the  $i_p - e_g$  characteristic, and is positive;  $\partial s_p/\partial e_p$  represents curvature of the  $i_p - e_p$  characteristic and in the pentode is generally negative.

The variations of these parameters in the case of the pentode whose d-c characteristics are shown in Figs. 8 and 9 are shown in Fig. 4. The first thing of interest is the possibility of term (1) becoming positive and balancing out the negative terms (2) and (3). This occurs for  $E_{co}$  below the point of inflection on the  $i_p - e_g$  characteristic. When this occurs, the second harmonic vanishes to the order of approximation we have considered and the distortion is due to harmonics of higher order, which we have neglected in deriving (13).



If  $E_{co}$  is at the point of inflection the undistorted output is limited by terms (2) and (3) representing plate curvature and fanning.  $W_c$  then rises continuously as  $R/r_p$  is decreased, as shown by curve  $E_{co} = -2$  in Fig. 5. As  $E_{co}$  is lowered beyond the inflection point, distortion due to  $i_p - e_g$  curvature (term 1), which decreases with rising  $x$ , and distortion due to terms (2) and (3), which increases with rising  $x$ , may balance at some value of  $x$ , as shown in curve marked  $E_{co} = -3$ . Actually, as we have stated,  $W_c$  does not rise to infinity at this point but is limited by the third- and higher-order harmonics as shown by the dotted lines. For still more negative  $E_{co}$  a curve of the type marked  $E_{co} = -4$  is obtained. The reason for the increase of  $R/r_p$  with more negative  $E_{co}$  may be seen from Figs. 3 and 4; term (1) becomes larger, and more distortion increasing with  $x$  is required to neutralize it. Anticipating the experimental results somewhat, it may be stated

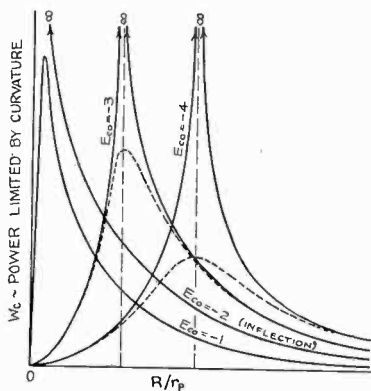

Fig. 5—Theoretical variation of power as limited by curvature distortion (second harmonic) illustrating ( $E_{co} = -3, -4$ ) possibility of curvature balance when  $E_{co}$  is below the point of inflection on the  $i_p - e_g$  curve.

that the maximum value attained by  $W_c$  (probably due to limitation by the third harmonic) decreases with  $E_{co}$ . This appears to be due to the fundamental falling off with  $s_m$ , and the negative contribution to the fundamental by the increasing third-order effect, and to the rise of third harmonic due to the latter effect.

Above the inflection point  $\partial s_m / \partial e_g$  is negative and there is no longer a possibility of a balance between the distortion due to (1) and that due to (2) and (3). Nevertheless the possibility of a maximum of  $W_c$  remains, as can be seen from the forms of terms (1), (2), and (3) in Fig. 3 as a function of  $x$ .  $W_c$  returns to zero with  $x$  regardless of the sign of  $\partial s_m / \partial e_g$  so long as  $\partial s_m / \partial e_g \neq 0$ . This is exhibited by the curve marked  $E_{co} = -1$  in Fig. 5.

As will be seen presently, this rough qualitative description accounts for the principal experimental facts.

**Power Limitation by Plate Cut-Off.** This can be regarded as due to a special curvature in the  $i_p - e_p$  characteristic. In contradistinction to the case of the triode it is but little affected by the value of the load resistance; consequently if we wish to regard it as a definite danger point, as we regard the positive grid, without bothering to investigate the actual effects of exceeding it, the limitation brought about by it is exactly similar to that of the positive grid except that the output ( $W_o$ ) is that due to a fixed grid voltage equal to the difference between the cut-off point and the d-c grid bias. It is, however, decidedly preferable actually to measure the harmonics so produced; theoretical speculations based on an assumed definite cut-off have little value.

**Power Limitation by Positive Grid.** We shall denote by  $W_p$  the power output as limited by the condition that the peaks of the grid voltage shall not exceed zero. This is simply the power output for

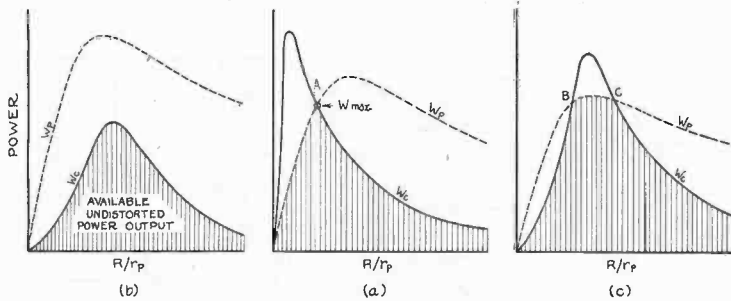

Fig. 6—Illustrating three frequent types of power limitation by distortion; (a) limitation up to A by positive grid, above A by curvature; (b) limitation by curvature; (c) limitation by curvature and by positive grid from B to C.

a fixed applied voltage of maximum value  $E_c$  equal to the bias voltage  $E_{co}$ .

From (14)

$$W_p = \frac{1}{2} I_1^2 R = \frac{1}{2} s_m^2 r_p E_{co}^2 \frac{x}{(1+x)^2}, \quad (15)$$

where  $x$ , as before, denotes  $R/r_p$ . This expression represents the well-known normal power output curve for constant applied grid voltage shown dotted in Fig. 6.

**Total Power Limitation Due to All Causes.** In Fig. 6 are also shown solid curves from Fig. 5 representing  $W_c$ , the power limited by distortion curvature. These diagrams illustrate three possible ways in which the power output may be limited by distortion due to these causes. In Fig. 6a, for  $R/r_p$  up to the point A, the power is

limited by positive grid overload and increases with  $R/r_p$ ; beyond  $A$  it is limited by curvature distortion. The ordinates in the shaded region represent the available undistorted power for various  $R/r_p$ . In Fig. 6b the grid bias is more negative and the power is limited entirely by distortion due to curvature throughout the range of  $R/r_p$  shown. Fig. 6c illustrates another possible situation in which limitation is by curvature from  $O$  to  $B$  and above  $C$ , but through a small range of  $R/r_p$  ( $B$  to  $C$ ) is limited by grid overload. Limitation by plate cut-off is not considered in Fig. 6.

**Calculation of the Sensitivity.** The sensitivity has been defined as the ratio  $S = \sqrt{W}/E_{cc}$ , where  $E_{cc}$  is the r.m.s. value of the sinusoidal

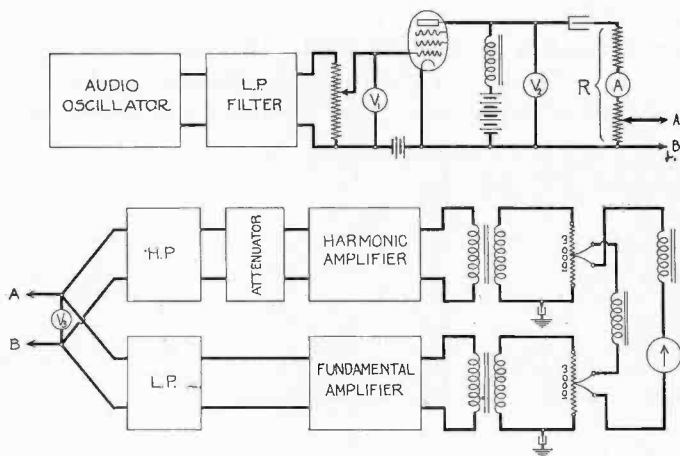

Fig. 7—Electrical connections for experimental measurements of undistorted output, and functional diagram of null method of harmonic analysis.

grid voltage. If we denote by  $A$  the amplification, or ratio of the voltage developed across the load resistance  $R$ , to that impressed on the grid:

$$W = A^2 E_{cc}^2 / R$$

then

$$S = \frac{\sqrt{W}}{E_c} = \frac{A}{\sqrt{R}}$$

If

$$x = R/r_p, A = s_m r_p x / (1+x)$$

and

$$S = \frac{s_m \sqrt{x}}{\sqrt{r_p(1+x)}}$$

The general form of this function will be obvious. In the triode  $s_m r_p = \mu$  so that  $s = \mu/r_p^{1/2} f(x)$  which contains the factor  $\mu/r_p^{1/2}$  which is sometimes taken as the "figure of merit" of a triode as an amplifier.

### III. EXPERIMENTAL TECHNIQUE

The apparatus we have found convenient for experimental measurement of the undistorted power output is shown schematically in Fig. 7.

Of principal interest is the analyzer shown in the lower part of the figure. This was devised in collaboration with K. C. Black of these laboratories, as a rapid null method of indicating the r.m.s. harmonic content. The operation will be obvious from the diagram. The voltage to be analyzed is applied to  $AB$  and is kept within certain limits by means of the voltmeter  $V_3$ . The harmonics and fundamental are separated by suitable low- and high-pass filters and separately amplified. An attenuator is inserted in the harmonic train and is calibrated directly in harmonic percentage. The harmonic and fun-

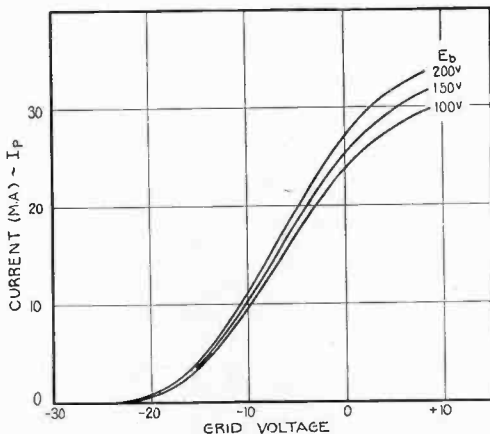

Fig. 8— $i_p - e_g$  characteristic of exp. pentode 1002; screen-grid voltage ( $E_d$ ) = 150 v.

damental trains terminate in thermocouples, the thermojunctions of which are serially connected to a common microammeter in such a way that their e.m.f.'s oppose. With the attenuator set at 100 per cent harmonic content, the transmission through the trains is equal. If now the harmonics total, for example, 5 per cent, the attenuator is adjusted so that the gain in the harmonic train is increased 20-fold, so as to produce no deflection of the microammeter. To make a measurement of r.m.s. harmonic content, the attenuator is adjusted until zero deflection is obtained and the harmonic percentage is read directly from this setting. Arrangements are made to permit frequent and rapid checking of the transmissions to avoid errors due to variations in the amplifiers.

This method is particularly convenient and rapid in measurements of the undistorted output. In this case the attenuator is simply set at the harmonic limit selected, say 5 per cent, and the input voltage to the tube is varied until the microammeter indicates zero. This is repeated for different values of  $R$ . While the variation of the voltage at the analyzer input terminals does not affect the null point, it is advisable to keep it within limits to avoid overloading the system on the one hand, and to keep up the sensitivity of indication on the other. This is obviously not irksome.

The analyzer can be conveniently operated in another way, so that the output microammeter becomes direct reading in percentage of harmonics. In this method the voltage at the input terminals  $A B$  of the analyzer is maintained at a certain constant value and the fundamental train is adjusted so that there is no transmission through

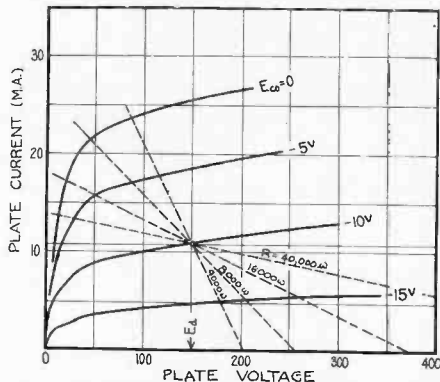

Fig. 9— $i_p - e_p$  characteristic of exp. pentode No. 1002;  $E_d = 150$  v.

it. The output meter then responds only to the harmonic transmission and can be calibrated directly in terms of harmonic percentage. It is important to maintain the transmission through the harmonic train constant, and this can be checked by letting the fundamental go through the harmonic train and adjusting the attenuator in an obvious way.

Since the proportion of harmonics was small (5 per cent) the power was calculated from the current through  $R$  and the value of  $R$ . This power differs from the power of the fundamental component by a negligibly small amount (0.25 per cent).

#### IV. EXPERIMENTAL RESULTS

The experimental picture can best be exhibited by adhering to the data for a typical tube. The following results pertain to a low-power pentode which we have designated as exp. tube No. 1002.

**D-C Characteristics.** The d-c diagrams of interest are those of  $i_p - e_a$  and  $i_p - e_p$ . These are shown in Figs. 8 and 9. The trans-conductance characteristic (Fig. 8) closely resembles that of the triode. The plate characteristic (Fig. 9) shows but a trace of the secondary-electron fold which is such a prominent feature of the Schottky tetrode characteristic. Note that the curvature in Fig. 9 is of opposite sign to that in the triode, and there is besides some fanning of the several curves.

The curves of the currents in the  $G_2$  and  $G_3$  grid circuits are not of direct interest in this discussion.

**Undistorted Output.** The undistorted output is a function of the load resistance  $R$ , the distortion limit  $D$ , and the operating voltages  $E_{bo}$  and  $E_{co}$ . The load resistance will be regarded as the principal independent variable;  $D = 5$  per cent; and  $E_{co}$  and  $E_{bo}$  will be varied in the order given. A series of measurements commence with large  $R$  and continue with decreasing  $R$  until either  $R$  reads zero (Fig. 6b) and the output is limited by curvature distortion over the whole range of  $R$ , or until the peak value of the applied grid voltage  $E_c$  becomes equal to the d-c grid-bias voltage  $E_{co}$  (Fig. 6a). (The curve over which curvature decides the output will be called the  $W_c - R$  curve; that over which the output is limited by positive grid is called the  $W_p - R$  curve.) The grid bias  $E_{co}$  is now changed and the curvature,  $W_c - R$ , curve taken. A family of such curves is shown in Fig. 10 for exp. tube No. 1002,  $E_{ao} = 150$  v,  $E_{bo} = 150$  v.

For  $E_{co}$  below the inflection point ( $-6$  v, approximately)  $W_c$  exhibits the maximum which we have already referred to in Section II as being due to a balancing out of the effects of the  $s_m - e_a$ ,  $s_p - e_p$  curvatures and  $s_m - e_p$  fanning. At this point the second harmonic is zero and the power is limited by residual harmonics, such as the third, fifth, and higher orders. This can readily be detected by ear, listening at the output of the harmonic train of the analyzer, or by means of a Braun-tube oscillograph connected to the output. The main theoretical features of these curves have already been discussed in Section II.

Photographic views of a plaster cast representing the undistorted output as a function of grid bias and load resistance, from the data of Fig. 10, are reproduced in Fig. 10b. The stippled nappe of this surface represents the power limitation due to positive grid current.

The optimum load resistance decreases as the bias becomes more positive and the maximum power steadily increases until the  $W_c$  curve encounters the  $W_p$  curve, which descends to meet the former curve as  $E_{co}$  increases. In Fig. 10 the curves meet at a bias of about  $-9$  volts,

as will be shown presently. As  $E_{co}$  becomes more positive still, the positive grid limitation enters the picture at a certain value of  $R$ . A typical case of this sort is that for  $E_{co} = -7.5$  v. The best power for a given grid bias then lies at the intersection of the  $W_p$  and  $W_c$  curves. This decreases steadily as the grid bias becomes more positive as shown by the curves for  $E_{co} = -5$ ,  $E_{co} = -2.5$  (Fig. 10).

It appears that the highest possible undistorted power output at a given plate voltage and the values of  $R$  and  $E_{co}$  required for getting it may be determined by the intersection of a curve drawn through the maxima of the  $W_c$  curves, and the curve from  $W_p$  which represents the power output for a value of grid peak voltage equal to the d-c bias.

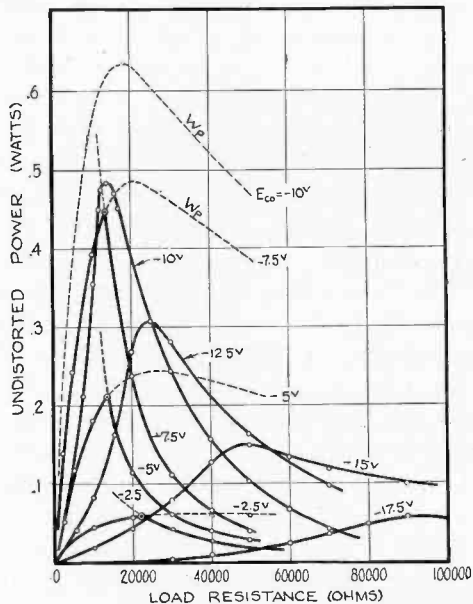

Fig. 10—Undistorted power output versus load resistance; effect of d-c grid bias;  $W_p$  = power limited by  $E_c = E_{co}$ .

The ease with which the  $W_c$  maxima can be located by ear makes it possible to avoid taking separate curves for various  $E_{co}$ , as is done in Fig. 10, and permits a rapid determination of this data. The procedure is as follows: starting with large  $R$ , the grid bias is adjusted for minimum harmonics by ear (or meter), and a measurement of  $W_c$  at this point made as described previously. This is the maximum power and  $R$  for this particular grid bias. This process is repeated with decreasing  $R$  until the peak value of the impressed grid voltage necessary to obtain 5 per cent distortion reaches the value of the d-c bias. This terminal point represents the maximum undistorted power, and load resistance, for  $E_{bo}$  constant,  $E_{co}$  optimum.

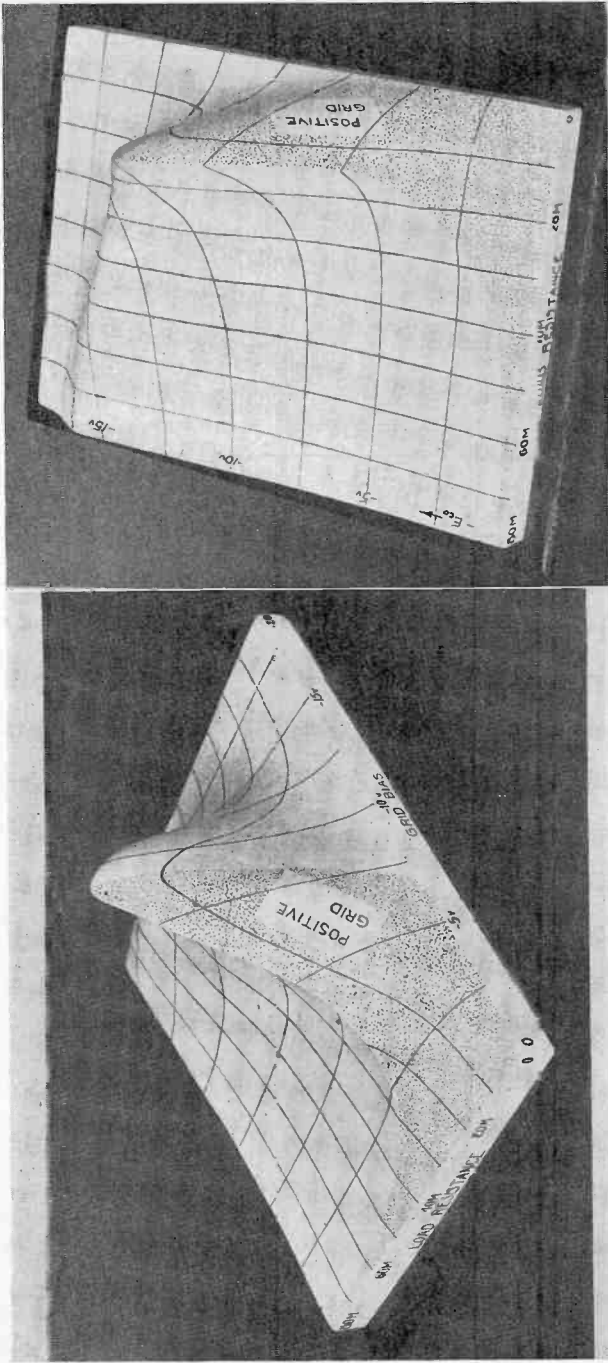

Fig. 10b—Surface representing undistorted power output of pentode as a function of load resistance and grid bias. (Data plotted in Fig. 10.)



The effect of varying the plate voltage may now be readily investigated by repeating this process for different values of  $E_{bo}$ , the screen-grid voltage  $E_{do}$  being maintained constant. A family of such curves for exp. tube No. 1002 is shown in Fig. 11, for plate voltages of 100, 150, and 200 volts ( $E_{do}=150$  v). The dotted line is the locus of the terminal points of best power at a given plate voltage and gives the relation between the required value of  $R$  and  $E_{bo}$ . The optimum values of d-c grid bias are also marked at these terminal points. Curiously enough, the best value of bias changes only from  $-8.8$  to  $-9.2$  volts for a change of plate voltage from 100 to 200 volts. The plate current remains practically constant so that the emissive burden on the filament is constant and the plate dissipation is proportional to  $E_{bo}$ . It is notable that the relation between maximum undistorted power

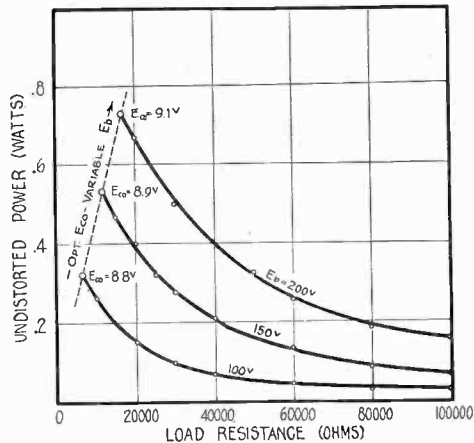

Fig. 11—Effect of plate voltage. Each curve represents maximum undistorted power for various  $R$ ,  $E_{co}$  being adjusted to its best value for each  $R$ . Terminal points represent highest output at the plate voltage marked on the curve.

and plate voltage is almost linear, hence the ratio of the power output to the plate dissipation is approximately constant.

It will be noted that the optimum value of the ratio  $R/r_p$  for this pentode is of the order of 0.25 in contrast with the optimum value in the average triode for the same distortion limit (5 per cent) which is in the neighborhood of 2.

Concerning the shape of the curves of  $W_p$  (positive grid limitation) it is to be noted that from the theory of the first-order effect, the power should be maximum when  $R=r_p$ . The actual maxima in the experimental curves for  $E_{co} = -10, -7.5, -5, -2.5$  shown in Fig. 10, however, do not occur at  $R=r_p$ , but at an  $R$  considerably below this value. ( $r_p=60,000$  ohms at  $E_{co} = -10$  v). As inspection of Fig. 10 shows,

the power at which this maximum occurs is considerably above that for 5 per cent distortion, so that it may be expected that the third- and higher-order effects will decrease the fundamental to such an extent with increasing  $R$  that the maximum will be moved to the left. Another way of expressing this would be to say that the values of  $s_m$  and  $r_p$  for large voltage variations differ from those for small voltage variations.

**Power Sensitivity.** The power sensitivity, as defined in Section II [ $S = \sqrt{W(\text{watts})}/E_{cc}(\text{volts, r.m.s.})$ ], is plotted in Fig. 12. The conditions under which this curve was taken are identical with those for the middle undistorted power curve in Fig. 11;  $E_{d0} = 150$  v,  $E_{b0}$  was held constant at 150 volts, and as  $R$  was varied the grid bias was selected

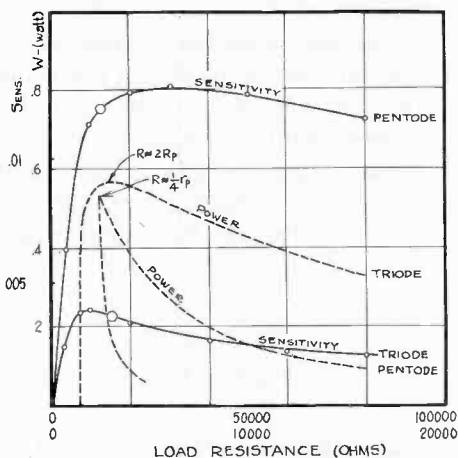

Fig. 12—Comparison of the sensitivities ( $S = \sqrt{W/E_c}$ ) of pentode and a triode (171-A) giving approximately equal maximum undistorted outputs.

to give maximum undistorted power at that value of  $R$ . The curve for maximum undistorted power, reproduced from Fig. 11, is also shown for comparison. The sensitivity at the optimum power point is 0.12.

A summary of the data for undistorted power and sensitivity of the exp. No. 1002 pentode is given in Table I below:

TABLE I

SUMMARY OF DATA FOR EXP. PENTODE No. 1002; OPTIMUM UNDISTORTED POWER FOR 5 PER CENT DISTORTION AND SENSITIVITY FOR VARIOUS PLATE VOLTAGES, AND THE VALUES OF GRID BIAS,  $E_{c0}$ , AND LOAD RESISTANCE  $R$  CORRESPONDING THERETO.

Plate Voltage	Plate Current	Plate Dissipation	Best $E_{c0}$	Best Load $R$	Maximum Undistorted Power	Optimum Sensitivity (watts, volts)
volts	ma	watts	volts	ohms	wat	
100	10	0.100	-8.8	6500	0.320	0.09
150	11	0.166	-8.9	12000	0.535	0.12
200	12	0.240	-9.1	17000	0.730	0.730

**Comparison of Sensitivities of a Pentode and a Triode for the Same Undistorted Output.** The undistorted outputs being equal, and the relative emission burdens and the plate dissipations being left out of account, a pentode of this type is in general more sensitive than the ordinary output triode. In order to form an opinion as to whether or not the extra cost and complication of the pentode is justified by its superior power sensitivity, we have compared the sensitivity of our tube 1002 with that of a triode of the same undistorted power output capacity. The 171-A type triode seemed suitable for this purpose and consulting our experimental data for this tube, we find that with a plate voltage of 150 volts, the maximum undistorted output is approximately equal to that of pentode No. 1002.

The curve of undistorted power output for the 171-A triode at  $E_{bo} = 150$  volts as a function of load resistance ( $E_{co}$  being chosen to give best power output at each  $R$ ) is shown dotted in Fig. 12. The power sensitivity corresponding to this curve is also shown. At the best grid bias ( $-30$  volts) and load resistance (3000 ohms) the power output is .570 w. Interpolating the data on the pentode we find that a slight increase of the plate voltage above 150 volts equalizes the undistorted power output of the two tubes and permits the following quantitative comparison:

	$E_b$	$E_{co}$	Anode diss.	Anode current	$W$	$R/r_p$	Sens.	Ratio Sens.
Pentode exp. No. 1002	167	- 8.9	.225w	15 ma	.57w	0.25	.012	
171-A Triode	150	-30	.315w	21 ma	.57w	1.9	.00365	3.3

The anode dissipation in the case of the pentode represents the total dissipation on the three anodes,  $G_2$ ,  $G_3$ , and plate. This total is about 70 per cent of the plate dissipation of the triode.

We may express the results of this comparison of sensitivity by saying that *the pentode is equivalent to the triode plus a stage of amplification giving a gain of 3.3.*

This statement refers only to these particular tubes and is not intended as a generalization. Virtually the same result has been obtained from a comparison of other pentodes and triodes of somewhat higher power output. The data in a specimen case are:

	$E_{bo}$	$E_{co}$	Anode diss.	Anode current	Power undist.	$R/r_p$	Sens.	Ratio sens.
Pentode 1005	250	-14	8.3 w	33	2.1 w	.14	.148	3.35
245 Triode	260	-44	11.2 w	43 ma	2.1 w	1.8	.044	

The total anode dissipation in this pentode is again about 70 per cent of that of the equivalent triode. In the pentode the dissipation of

power is usually limited, not by the heating of the plate, but by that of the second grid. The dissipation on the second grid in tube No. 1005 for dull red glow is about 1.5 watts.

These data are of significance only for the use of a single output tube. In the push-pull arrangement of two tubes, on account of the nominal removal of even-order harmonics, the picture is quite different. We hope to discuss this in Part II of this paper.

The purpose of this paper is purely scientific, and we have not intended to express any opinion as to the desirability of changing from the present triode output tubes to the pentode. A rational judgment on this question requires the careful consideration of a multitude of factors which are not within the scope of this paper.

It is a pleasure to acknowledge the assistance rendered by K. C. Black in connection with the experimental work. We are also indebted to Radio Frequency Laboratories, Inc., and its manufacturing licensees, in whose behalf this work was originally undertaken, for permission to publish this preliminary report.

#### NOTES ON NOMENCLATURE

The nomenclature employed in this paper follows a generalized system of vacuum-tube nomenclature recently proposed by one of us for consideration by the Standardization Committee (Subcommittee on Vacuum Tubes) of the Institute of Radio Engineers. The symbols and terms which are of interest in reading this paper may be briefly explained as follows:

**Transconductance.** A fundamental quantity in the mathematical theory of a tube of  $n$ -electrodes is the derivative  $\partial i_a^n / \partial e_b^n$ , where  $i_a$  represents the current in the circuit of electrode  $a$ , and  $e_b$  represents the potential of electrode  $b$ , usually with respect to the cathode. For slow variations of  $e$  it is a *variational transfer conductance*,\* (otherwise an admittance). This term can be shortened to *transconductance* without much mnemonic loss. It is denoted by the symbol  $s_{ab} = \partial i_a / \partial e_b$  rather than by the unwieldy  $g$ .

In the triode and in the pentode of the type considered here  $s_m$  denotes the quantity conventionally designated by  $g_m$ , and hitherto referred to improperly as a "mutual conductance." The plate conductance is  $s_p = 1/r_p$ , and so forth. The convenience of  $s_{ab}$  in the case of a tube with a large number of electrodes approximates that of  $e_{ik}$  used in the elasticity theory to denote the components of the strain tensor.

\* The term transfer admittance is conventional in electrical literature; *vide* J. R. Carson; "Electric circuit theory and operational calculus," p. 14; 1926; V. Bush; "Operational circuit analysis," p. 33, 43, 44; 1929. This quantity in the vacuum tube differs from the transfer admittance of a passive electric network in that  $\partial i_a / \partial e_b$  does not in general equal  $\partial i_b / \partial e_a$ .

**Symbols for Currents and Voltage.** The following scheme is employed for electrode currents and voltages, and distinguishes between maximum, effective, average, total values, etc., and also between impressed e.m.f.'s (batteries, etc.) and voltages on the electrodes.

**Currents or Electrode Voltages:**

Total		$e_p, e_g, \dots, i_p, i_g, \dots$
Instantaneous (a-c component)		$e_p, e_g, \dots, i_p, i_g, \dots$
Effective (a-c component)		$E_{pe}, E_{ge}, \dots, I_{pe}, I_{ge}, \dots$
Maximum (a-c component)		$E_p, E_g, \dots, I_p, I_g, \dots$
Average		$\bar{e}_p, \bar{e}_g, \dots, \bar{i}_p, \bar{i}_g, \dots$
D-C Component		$E_{po}, E_{go}, \dots, I_{po}, I_{go}, \dots$

**Impressed e.m.f.'s:**

Total		$e_b, e_c$
Instantaneous (a-c component)		$e_b, e_c$
Effective (a-c component)		$E_{bc}, E_{ce}$
Maximum (a-c component)		$E_b, E_c$
Average		$\bar{e}_b, \bar{e}_c$
D-C component		$E_{bo}, E_{co}$

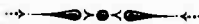

## REPORT ON EXPERIMENTS WITH ELECTRIC WAVES OF ABOUT 3 METERS: THEIR PROPAGATION AND USE\*

By

ABRAHAM ESAU AND WALTER M. HAHNEMANN

(C. Lorenz-Aktiengesellschaft, Berlin-Tempelhof, Germany)

*Summary*—After means became available for generating sufficient power at wavelengths of about 3 meters, and with the development of suitable methods of reception, experiments were carried out with regard to the character of propagation of these waves. Directive devices, in the form of parabolic reflectors, were also used successfully.

Some preliminary experiments upon the maximum range were first made by the Technical-Physical Institute at Jena, and following these, similar experiments were made from Herzogstand jointly by the Institute and the Bavarian Postal authorities. Later more thorough experiments were conducted by the laboratories of the C. Lorenz Aktiengesellschaft, Berlin, in co-operation with the Jena Institute, from airplanes and from the top of the Brocken (1142 meters above sea-level).

These experiments are described and brief explanations are given concerning the apparatus and methods used in each case. The results have clarified the phenomena of propagation of these wavelengths and indicate the possibility of their practical application as a means of signaling over short ranges, and, particularly as a means for transmitting signals in a fog for marine and aerial navigation, and as a possible means for transmission of television in the future.

### I. Experiments on Wave Propagation

ON the basis of the experiments of the Technical Physical Institute in Jena, it had become possible, at the end of 1925, to generate waves with a length of about 3 m, with a capacity of about 100 watts. The next problem taken up was the investigation of the behavior of these waves during their propagation. In the absence of a suitable tube receiver, a simple dipole was first used as a receiver which was tuned to the transmission wave and containing in its center, a normal crystal detector. It was found at once, that as compared with longer waves, only a very few crystal combinations were suitable in this range of extremely short lengths. The most sensitive detector was one consisting of silicon and a metal whisker. This detector arrangement retains its sensitivity even for wavelengths as short as 30 cm, and in all probability, it will still work for considerably shorter wavelengths.

The ranges covered with this device were still very short, however, and could not be increased to any appreciable degree by the application

\* Dewey decimal classification: R113.

of low-frequency amplifiers. Upon increasing the distance from the transmitter, the limit of sensitivity of the detector was very soon reached.

With a view to longer ranges, the problem therefore consisted in greatly increasing the sensitivity of the receiver. This was done by replacing the detector by a tube, as first developed by O. Cords<sup>1</sup> (see Fig. 1), and consisted of a simple wire loop and a rotary condenser for tuning. The return coupling was made by a three-point connection. In addition to this, a three-stage low-frequency amplifier was provided. The receiver worked, it is true, with any kind of receiving tube commonly used, but it appeared that tubes containing some gas produced greater amplification than those with a higher vacuum.

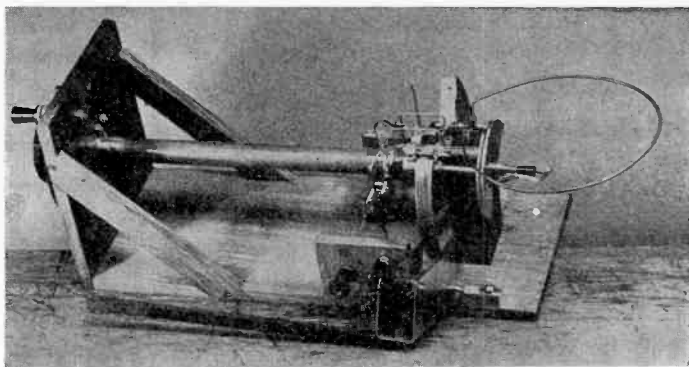

Fig. 1—Tube receiver, wavelength 3 m, first form designed by O. Cords.

With this receiver and a 70-watt transmitter more extensive long-range experiments were carried out during the winter of 1925-1926. Distances from 4 to about 40 km were bridged with success. The latter range was, however, the maximum limit and could be attained only if the capacity of the transmitter was raised to about 200 watts.

These experiments were still very difficult to carry out as the adjustment of the receiver required a good deal of effort due to the difficulty of the sudden starting oscillations, since it was possible only in a few cases to render the receiver really sensitive. It was shown by these experiments that the atmosphere did not influence the propagation of the waves, the intensity of the reception always being the same in all kinds of weather and also during daylight and dark. It was found to be very advantageous to place the transmitter, if possible, in an open, instead of in an enclosed space, in order not to impair its radiation.

<sup>1</sup> O. Cords, "Untersuchungen an einem Empfangsgerät für kurze Wellen," *Zeitschrift für Hochfrequenztechnik*, 1927.

The maximum intensity of reception was attained when an isolated spot, situated at a high level, was selected as the location for the transmitter. Similar results were also obtained when the transmitter was placed at the seacoast, the receiver being located aboard a ship at sea.

After a number of improvements had been made to the above receiver, an effort was then made during the rest of the year 1926 to adapt the transmitter and the receiver for the purpose of telephony. After many receiver design difficulties had been overcome, it became possible to telephone a distance of 20 km. There still occurred, however, much distortion which was not due to the transmitter (as was easily proved), but to the nature of the reception. The basic cause was that (as already mentioned above) the point where oscillations started could not be regulated to a satisfactory degree, so that either a non-distorted, low

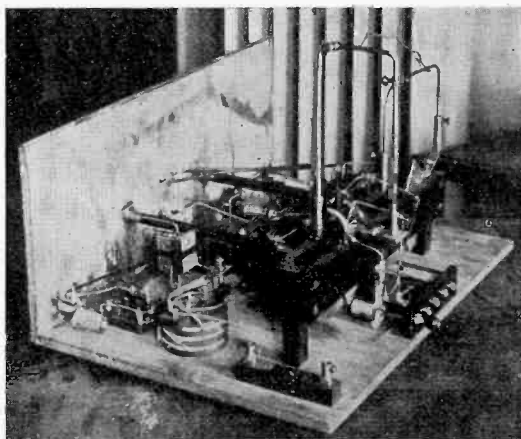

Fig. 2—Improved tube receiver for 3-m wavelength.

volume of tone, or else a much stronger tone more or less distorted was obtained.

During the year 1927, the improvement of the receiving equipment was continued, and after a large number of failures, success was finally reached in getting satisfactory sensitivity and at the same time easy adjustment of the receiver, first, by making the feedback coupling in a different manner (inductive) and secondly, by introducing the principle of super-regeneration (oscillating return coupling). These two factors were responsible for the improvement of the receiver and to them is due the elimination of all the difficulties which had been previously encountered in receiving. (See Fig. 2).

During the second half of 1927, it was easily possible to bridge a distance of 20 km and more by telephone, while the transmitter capac-



ity required (which in the first experiments covering the same range had amounted to more than 100 watts), could be reduced to below 1 watt, without the clarity of reception being impaired in the least.

The experiments on the maximum ranges were then taken up again, and in the beginning of 1928 it was possible to hold a duplex telephone conversation over a distance of 20 km with technical perfection, the sender having a capacity of about 0.5 watt, and the difference in wavelength being only 2 cm (active wave 3 m). Transmitter and receiver were placed close together, in these experiments.

At the end of February, 1928, the same duplex conversation was held over a distance of 85 km. In these experiments, the transmitter

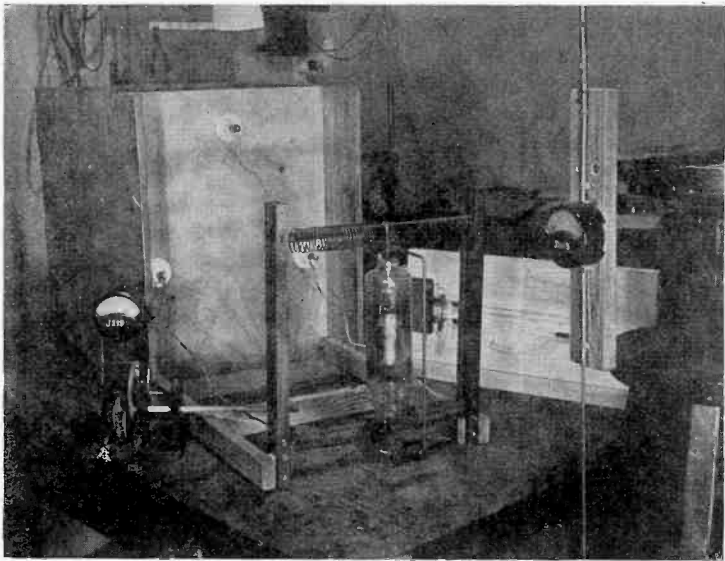

Fig. 3—200-watt transmitter for 3-m wavelength.

was located on the Inselberg (Thuringer Wald, 916 m above sea level), while the receiver was located on the "Fuchsturn" (an isolated mountain in the vicinity of Jena). In this case, also, it was shown that the tone volume at the receiving end was not influenced by the condition of the atmosphere, and moreover, that atmospheric disturbances did not occur, not even—as had already been found during the experiments made in the spring—when lightning struck in the immediate vicinity of the receiving station.

Together with these experiments, another was carried out for the purpose of concentrating the transmitter energy in a single direction by means of reflectors (see Fig. 3). Detailed reports on these experiments

have been made by Gresky.<sup>2</sup> The results of his investigations may be summarized to the effect that by means of a parabolic reflector, consisting of wires and adapted to the wavelength, a concentration of energy of 1 to 12 may be attained. If the dimensions of the reflector are correctly chosen, the radiation characteristic (that is, the sector in which the radiation occurs) becomes very acute, while moreover the back radiation (that is, the amount of energy penetrating backward through the reflector) becomes very small. The opening of the reflector must be made practically about one and a half times the wavelength and it appeared to be essential that the ratio between wavelength and the distance of the sender from the mirror (vertex of the parabola) should not equal 0.25, as was heretofore generally done, but to a somewhat higher value, in the present case 0.28. A further increase in the opening of the reflector c.p. does not result in any appreciable increase in concentration and acuteness of the radiation characteristic. If the parabolic arrangement is replaced by a plane (all reflectors arranged in a straight line), the results obtained are less favorable. The concentration, as well as the directive action and the back radiation, is impaired, the former, for example, being reduced to half its original value.

The question of the transmitting antenna also influences the maximum range. For short ranges, the radiation from the closed oscillation circuit between the anode and the grid is sufficient, and the addition of a dipole coupled to this circuit causes no appreciable increase in volume at the reception end. The influence of this antenna does make itself felt at longer ranges, however, so that in order to cover longer ranges, it is necessary to use dipole antennas, both at the transmitter and the receiver end. It is immaterial in this case, whether the coupling with the generator circuit is inductive or conductive or whether the dipole is horizontal or vertical.

In the above experiments, obstructions between transmitter and receiver that would affect the propagation of the waves had been avoided as much as possible by suitable selection of the locations for transmitter and receiver. There now followed a number of experiments in which the transmitter could freely radiate into space at a high level above the ground, while the receiver was moved around in an automobile in order to determine what influence would be exerted by obstructions such as hills, houses, etc., located between transmitter and receiver. It was found, contrary to expectation, that a screening effect caused by groups of buildings and conductors could not be observed, or only to a very slight degree. During a test ride, made first through the streets of the city of Jena, and then through a valley to a

<sup>2</sup> Gresky, *Zeitschrift für Hochfrequenztechnik*, 1927.

point at a distance of about 20 km, there occurred a considerable decrease in intensity of reception in only two cases, while at all other points the signals were received without difficulty.

In the meantime it had become possible to build transmitters with capacities above 1 kw (see Fig. 4). Experiments were made with these transmitters in July, 1928, in Upper Bavaria. The transmitter was located on the Herzogstand, at a level of about 1700 m (between Kochel and Walchensee), while the receiver could change its location at will. It then appeared, among other things, that in one particular case, signals in the loudspeaker were still extremely strong at a distance

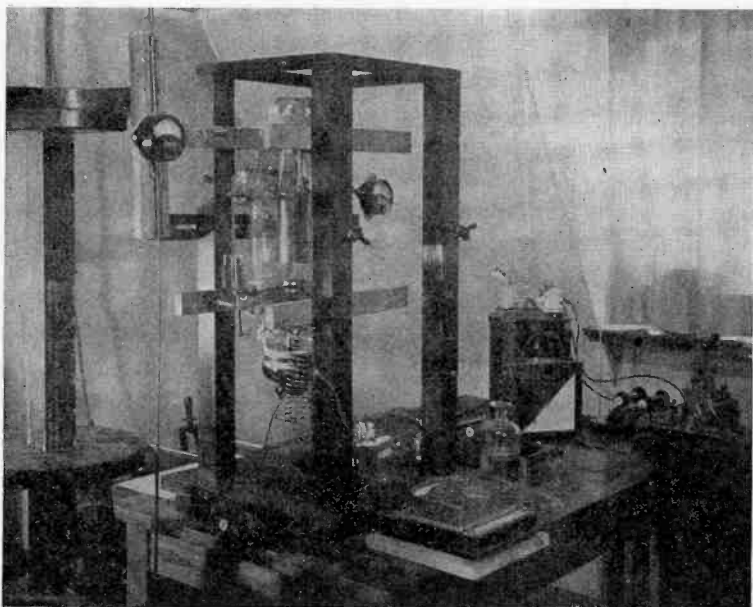

Fig. 4—1.5 kw transmitter for 3-m wavelength.

of 180 km, while nothing could be heard even with considerable amplifications, at a distance of about 50 km. The cause of this sudden drop was assumed to lie in the fact that the optical range has a controlling influence on the reception, as has also been shown by the experiments to be described later on. At one of the nearer reception points, where unexpectedly no reception was possible, it was found that there was a mountain range between transmitter and receiver, which had screened off the waves.

In cases where the receiver was located in one of the valleys adjoining the Herzogstand, reception was obtained, it is true, even when,

strictly speaking, optical sight was not possible between transmitting and reception points, but the signal intensity vanished in those cases where high mountains were located between transmitter and receiver.

## II. Continuation of the Range Experiments by the Firm C. Lorenz

As a continuation of the experiments described above, made by the Jena Institute, the laboratory of the C. Lorenz Aktiengesellschaft, Berlin-Tempelhof, carried out a number of tentative range experiments early in 1928, using small portable apparatus for a wavelength of 3 m, which experiments showed great irregularities in wave propagation. Even for very short ranges of about 1 to 2 km, great differences in tone volume were found, depending on whether the receiver was located close to the ground, or at a certain level above the ground. For example, within an experimental range of 2 km, no reception could be obtained, if transmitter and receiver were both located close to the ground. If the receiver was located, for example, at a height of about 10 to 15 m above the ground, the transmitter could be heard with satisfactory tone volume in every case. In this case also, there was found to be particularly great uniformity in the intensity of reception.

These results also pointed to the fact that a connection between transmitter and receiver is always guaranteed, if direct sight exists between the two. In order to obtain further confirmation of this assumption, the practical importance of which will be emphasized at the end of this paper, the series of experiments described in the following pages were carried out in which the transmitter or receiver, or both, were located in airplanes.

### AIRPLANE EXPERIMENTS

In these experiments apparatus was used whereby the high-frequency parts of sender and receiver were separated from other portions of the apparatus. Both portions were connected with each other by an armored cable.

Fig. 5 shows the experimental transmitter and receiver. The high-frequency parts of each and the connecting cable leading to the rest of the apparatus are distinctly visible. The transmitter (at left) was adapted to telephony and audible telegraphy. The receiver was built on the principle of super-regeneration.

Fig. 6 represents the high-frequency part of the transmitter, the tubes with the oscillation circuit arranged between the anode and the grid, consisting of a small rotary condenser and a self inductance bent into the shape of a *U*. No antenna was used in addition to this small transmitting frame, in these sets. The capacity of the transmitter was about 1 to 2 watts.

The high-frequency part of the receiver is shown by Fig. 7 which also shows the audion tube, the tuning and return coupling condenser, and the self inductance made as a yoke bent into the shape of a U which functioned at the same time as the loop antenna for reception. The super-regeneration tube, and the two tubes of the low-frequency stage, are shown in Fig. 5, in the right half of the picture.

The next series of experiments was carried out during the period from September 3 to 22, 1928, with the assistance of a Junkers cabin airplane, type F13, courteously put at the disposal of the experimenters through the aid of Dr. Herath of the Federal Department of Transportation. The high-frequency part of the transmitter was placed under the cabin outside the plane, by means of a spring suspension. The receiver with its high-frequency part was inside the cabin, this part being located close to a window, by means of a spring connection. In

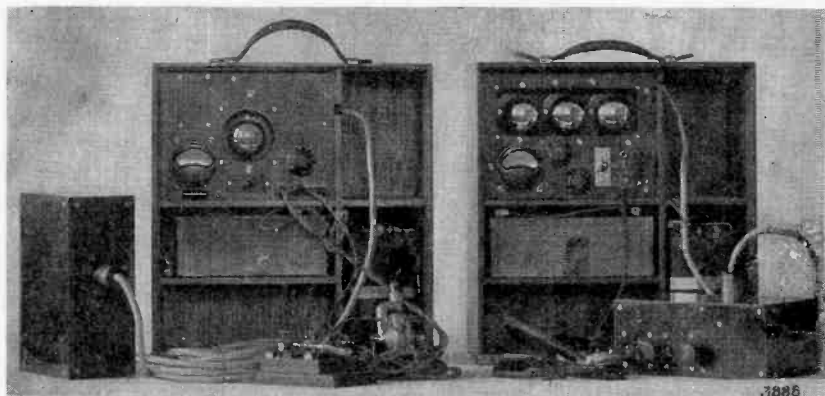

Fig. 5—Transmitter and receiver by C. Lorenz, 3-m wavelength.

these experiments, no antenna was used either for receiving or sending. The first experiment consisted in sending from the airplane and receiving on the ground. First, the maximum range was determined while the airplane was flying at an altitude of 1000 m. The tone volume was R 8 to 9 in this case up to a distance of about 30 km, and then decreased gradually until at a distance of 50 km, reception ceased completely. For distances up to about 10 km, the intensity of the tone received was uniform when the airplane was flying at an altitude of from 100 to 1200 meters, but below an altitude of 100 m the volume decreased, and at an altitude of 30 m reception failed completely at a distance as short as about 5 km.

As a result of the great uniformity of the tone volume in the reception observed for the ultra-short waves within the maximum ranges

so far established as contrasted with the effect of regular short waves the next obvious step was to try out another means of communication; namely, the transmission of pictures by telegraphy. For this purpose a picture transmitting set functioning on the principle of the telautograph was built into the airplane and connected to the 2-watt short-wave transmitter by the grid-control method. The ground station was

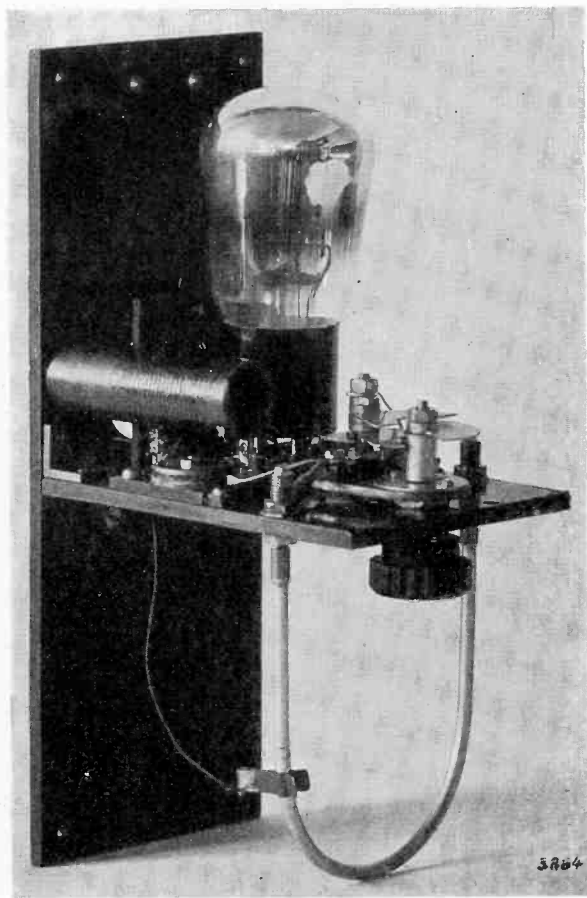

Fig. 6—High-frequency part of transmitter by C. Lorenz, 3 m, 1 to 2 watts.

provided with the receiver used in the experiment described above, the picture receiver being connected through rectifiers and relays. Transmission was carried out at an altitude of about 1000 m, the airplane being a few kilometers from the ground station. The experiment showed that the low transmitter capacities used permit the transmission of pictures from the airplane without any difficulty over the ranges that could be reached.

Fig. 8 shows a picture which was transmitted during these experiments. The only telautographic apparatus available for this experiment was a very primitive one and only very simple pictures could be transmitted.

Subsequent to the transmitting experiments from the airplane to the ground, reception of ground messages in the airplane was carried

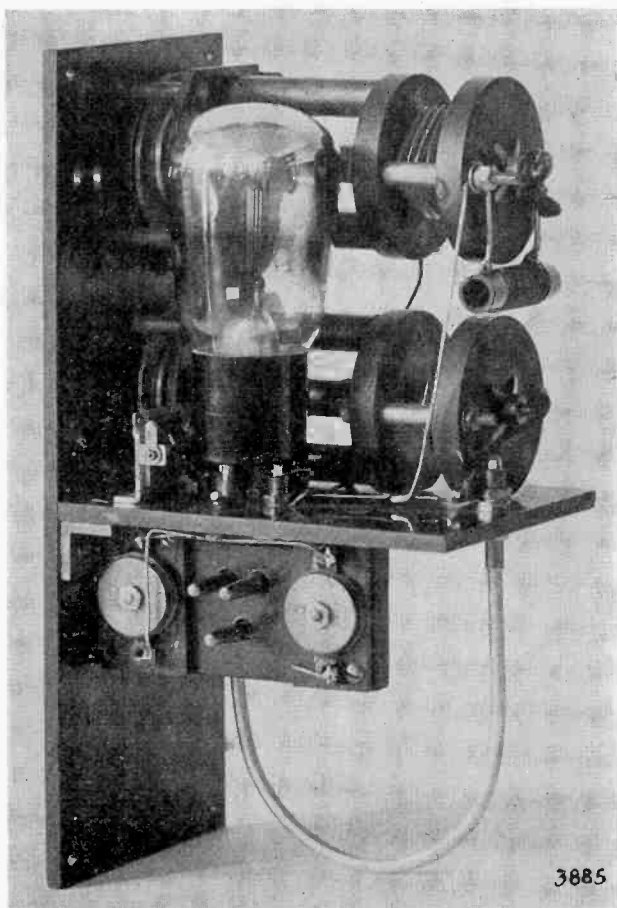

Fig. 7—High-frequency part of receiver by C. Lorenz, 3 m.

out, this being a far more difficult problem since it was not possible to place the receiver outside the airplane, as was done with the transmitter since it was necessary to vary tuning and the return coupling. Moreover, the noise of the motor ignition was disturbing, this noise being a rattling when the motor was getting up to speed, so that reception seemed

to be entirely out of the question. At full speed of the motor, however, there was a very considerable decrease in the disturbance caused by the noise of the ignition, and the latter was no longer of importance. At an altitude of 100 m, the first telegraphic signals were received with a volume of about R 4 to 6. It could be heard up to a distance of about 10 km. This result also checks with the experiments in which the high-frequency part of the transmitter was located inside the cabin. Reception often failed even within the ranges mentioned. Evidently, the airplane in some position then screened the receiver against the sender. When the airplane was landing, the signals could be heard until the altitude was about 30 m, the volume decreasing gradually, beginning at 100 m. In all of the experiments so far described, telegraphy and telephony were received with equally good results within the maximum ranges, the capacity of the sender in all cases being 1 to 2 watts.

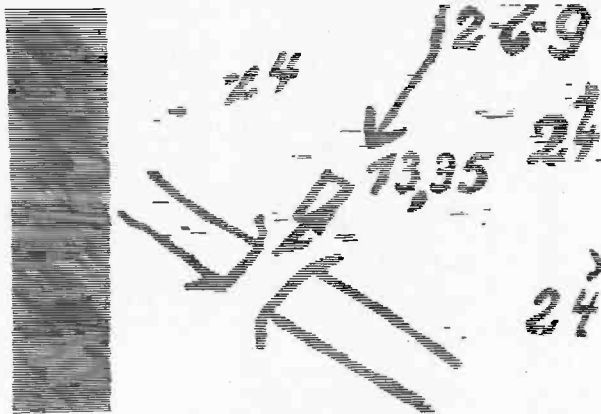

Fig. 8—Picture transmitted from airplane with wavelength of 3 m.

The maximum ranges found in the reception tests with the airplane being relatively short, the transmitting power of the ground transmitter was considerably increased, and the transmitter was arranged as high above the ground as possible. Further test flights were then made during which a 70-watt transmitter acting on a tuned dipole was located at a high point, namely on Fuchsturn near Jena. Reception took place in the airplane during a flight from Berlin to Nurnberg, and in the opposite direction from Nurnberg to Berlin.

Fig. 9 shows all of the essential details of this experimental flight. On the outward flight the sender was heard first at a distance of 44 km, at an altitude of 600 m, with a tone volume of R 4 to 5, which soon increased to R 9 to 10, the airplane rising in the meantime to an altitude of about 1000 m. During the further part of the flight, the signal inten-



sity remained nearly constant for a distance of from 52 to 80 km; and then decreased rapidly, until reception disappeared completely at a distance of about 100 km. During the return flight, the transmitter was heard first at a distance of 38 km, at an altitude of 500 m. In the beginning, the volume increased strongly again, until after continued flight reception became no longer possible at a distance of about 90 km.

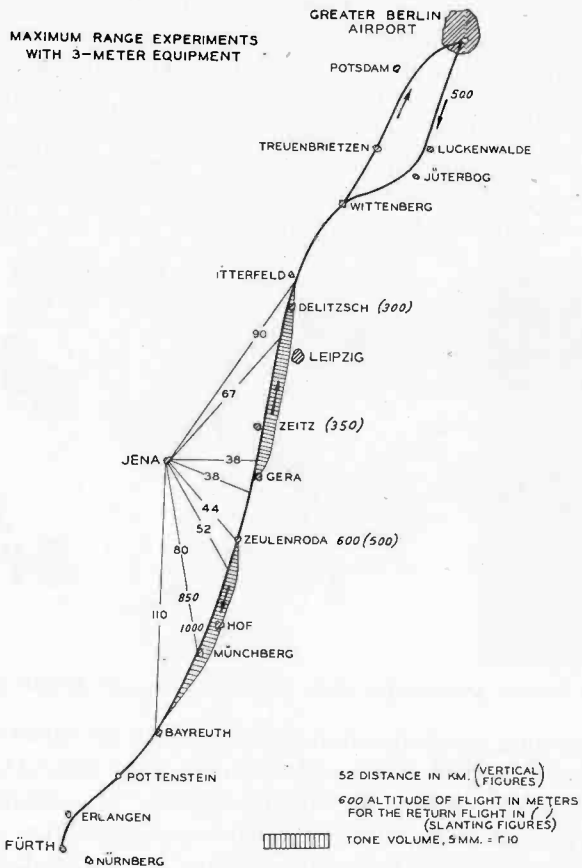

Fig. 9—Experiment with airplane between Berlin and Nurnberg, 3 m.

It is true that the altitude in this case was only 300 to 350 m. This very probably explains the decrease in maximum range during the return flight. It should also be noted that the reception in the airplane never started before the plane had reached a lateral position in relation to the sending station, and became most favorable when the plane was flying away from the latter. Probably this phenomenon is due to a screening action exerted by the wings of the airplane which are located under-

neath and in front of the cabin in which the receiver was placed, so that the wings were located between the transmitting and the receiving stations, when the plane was flying toward the transmitting station.

### III. Theory of the Optical Range

The above experiments confirmed with relative certainty the assumption that the transmission of waves with a length of about 3 m requires direct sight. The experiments also showed that ground-wave extension can hardly play a part here and there is no reflection by layers in the higher portion of the atmosphere, and therefore no fading. We have consequently to deal with a normal optical propagation of the waves.

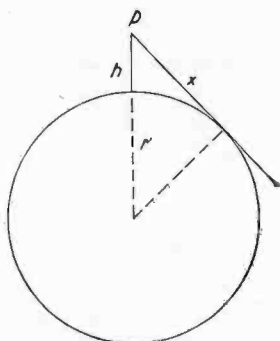

Fig. 10—Theory of maximum optical range.

On the basis of this assumption, which now had become very probable, we find for the maximum range without flexion into the shadow of the earth, the following:

If in Fig. 10, the circle represents the earth, supposed to be a sphere with a radius  $r$ , and  $h$  be the height of the transmitter above the surface of the earth, then the describing lines of the tangential cone of the sphere which has  $P$  for its apex, forms the extreme limit of direct radiation from the point  $P$ . The length of these tangents is  $x = \sqrt{2rh + h^2}$ , or, as  $h^2$  is negligible with regard to  $2rh$ ,  $x = \sqrt{2rh}$ . The maximum range is therefore proportional to the square root of the height, and as  $r \cong 6.4 \times 10^6$  m, we find:  $x = 3550$  m.  $\sqrt{h_m} = 3.55$  km  $x = \sqrt{h_m}$ .

Fig. 11 shows the maximum ranges for direct radiation, as a function of the height of the transmitter above the surface of the earth. If the receiver is also located at a high point (Fig. 12), and if the height of the transmitter above the surface of the earth be  $h_1$  and that of the receiver  $h_2$ , then we find as the longest range attainable with direct radiation:  $x = \sqrt{2rx}$

$$(\sqrt{h_1} \sqrt{h_2}) \text{ or: } (1) x = 3.55 \text{ km } x(\sqrt{h_{1m}} + \sqrt{h_{2m}})$$

The maximum range may therefore be read from Fig. 11, by adding the maximum ranges for the two heights. Placing both the transmitter and the receiver at a certain height above the ground, consequently means a corresponding increase in maximum range. Within the range of direct vision between transmitter and receiver, the radiating energy decreases according to a quadratic law, that is, rather slowly. From the limit of the maximum range attainable for direct sight, the reception tone volume must decrease very rapidly, because there is flexion. Furthermore, it must be assumed that the energy in the shade of an obstruction located between transmitter and receiver, which has a large size in relation to the wavelength, must amount to only a fraction of the energy of the direct radiation, as it can get into this shadow by flexion only.

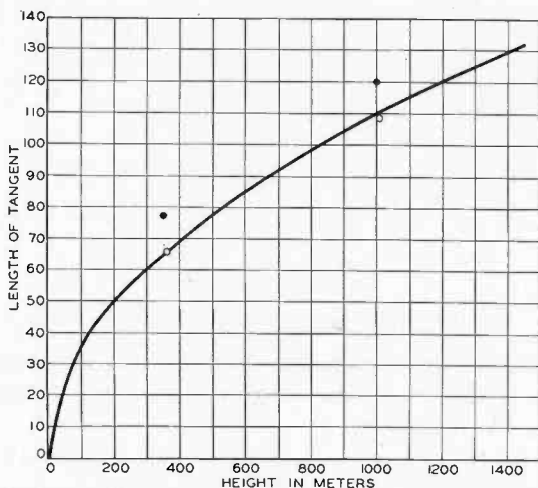

Fig. 11—Curve of maximum optical range.

If the results of the experiments described above, particularly also those of the experiments with the airplane, are compared, it will be found that in general they are in accordance with the theory. Its probability is based especially on the rapid decrease of the tone volume from a minimum altitude of the airplane, toward the earth. However, the variations in screening effect caused by the different positions of the transmitter or the receiver with regard to the airplane, could not be explained in a satisfactory manner by the above theory of the maximum ranges to be expected, so that further experiments had still to be undertaken.

In the meantime, H. Fassbender and G. Kurlbaum<sup>3</sup> published experiments made from an airplane with a wavelength of about 3 m, which also confirm the above theory.

#### IV. The Experiments on the Brocken

In October, 1928, experiments were carried out jointly by the laboratory of the C. Lorenz Aktiengesellschaft, Berlin-Tempelhof, and the Technical Institute, Jena, from the Brocken (highest peak of the Harz mountains, 1142 m above sea level)<sup>4</sup> by means of which the above theory was to be checked; for this purpose, the transmitting equipment was located partly on the top of the Brocken, and partly half way up the mountain. The receiving set was in an automobile, in order to determine easily the maximum range in different directions from the foot of the Brocken. For the reception, the field of the northeast of the Brocken (about 150 m above sea level) was chosen as it is rather flat

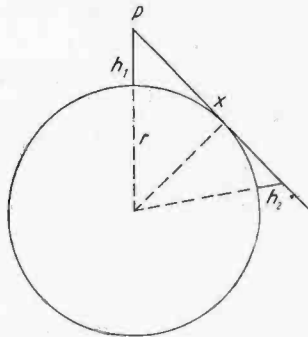

Fig. 12—Theory of maximum optical range.

and permits direct sight to the Brocken. In addition to placing the transmission set at different heights, the energy radiated was also varied in order to find the law of the wave propagation which would predict, for direct optical sight, the independence of the reception from the transmission energy, up to a certain minimum limit.

The transmitter, reproduced in Fig. 13, was provided with a Telefunken tube, type R S 229 g, operated by a 500-cycle anode voltage of about 2000 volts. The capacity of the transmitter was about 200 watts and the wavelength of the transmitter was adjusted to 3.2 m. The transmitter acted through a tuned vertical dipole with a length of 1.6 m. The receiving set was the same as that used in the airplane experiments. See Fig. 5. Reception took place either without an

<sup>3</sup> H. Fassbender and G. Kurlbaum, *Zeitschrift für Hochfrequenztechnik*, 33, 52; 1929.

<sup>4</sup> F. Gerth and W. Scheppmann, *Zeitschrift für Hochfrequenztechnik*, 33, 23; 1929.

antenna, or with horizontal antenna with a length of about 2.5 m, or again with a vertical antenna with a length of about 8 m. The transmitter was first placed on the top of the Brocken, quite close to the ground. It was then found that the maximum range in the different directions varied between 75 and 100 km. In all experiments, the tone volume at the reception end varied but little, up to a certain range, while beyond this range it decreased rapidly to zero. The width of this zone of rapid decrease of the tone volume varied between 5 and 15 km. Within this zone, the effect was therefore due exclusively to the deflected radiation and no longer to the direct radiation. The cause of the variation of the maximum ranges in the different directions may lie in the different elevation of the receiving stations, and in the wavy character of the terrain between transmitter and receiver. In order to make

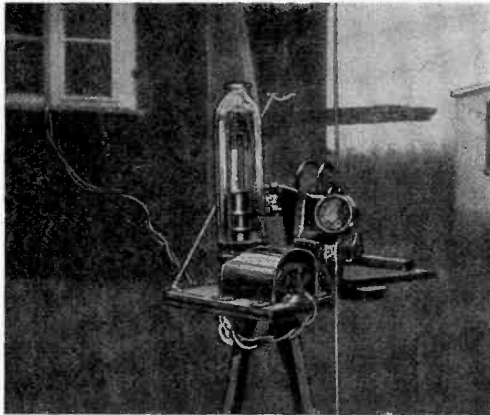

Fig. 13—Transmitter used in Brocken experiments, wavelength 3.2 m, 200 watts.

a further check on the theory, the capacity of the transmitter was varied in steps, in one experiment, in the ratio 80:1. It was found that up to the limit of 80 km, each transmitter power gave successful reception, although with different tone volume. For ranges longer than 80 km, the tone volume decreased rapidly, and at a distance of 85 km reception was possible with full capacity of the transmitter only. This extremely instructive experiment, in which the attainable range of the transmitter varies but very little, in spite of a change in power of 1:80, shows very distinctly that the maximum range is mainly dependent on the range of direct sight, while the differences in attainable ranges caused by variations in transmitter capacity, are simply due to the fact that in the zone of deflected radiation, a lower capacity becomes insufficient, with increasing range, because of the limit of sensitivity of

the receiver, at a somewhat shorter distance than the higher capacity. The next experiments were made by placing the transmitter on the panorama tower with a height of 20 m, on top of the Brocken (consequently about 1160 m above sea level). The maximum range was increased, in a direction where it was 95 km during the previous experiments, by about 20 km, to 115 km: if receiving antennas were used, no difference in tone volume of any importance could be observed, in the zone of direct radiation, as compared with reception without an antenna. In the zone of flexion, however, the maximum range could be increased by a number of kilometers by the use of a receiving antenna; thus, for example, the limit of the direct radiation zone in the experiments mentioned last was about 107 km. The limit of reception was in the zone of the flexion 115 km, without an antenna; and 120 km, with a vertical antenna of 8 m. If the results thus found are compared with the above theory, complete agreement will be found. From Fig. 11 it follows, that for the relative height of the Brocken above the surrounding country of about 1000 m, the limit of the zone of direct radiation is  $x=110$  km. It will therefore be seen that the maximum ranges for direct radiation, found through the experiments mentioned last in which the transmitter is located at a height of several wavelengths above the immediate surroundings, thus evidently radiating freely into space, are in relatively good agreement with the theory. When the transmitter was located close to the ground, the maximum range was shorter than might be expected on the basis of the theory. This difference may perhaps be explained by the assumption that, as a consequence of the large mass of ground in close proximity, an influence is exerted on the radiation which has the same effect as if the radiating point were shifted a certain distance downward.

In order further to check the theory, a second series of experiments were carried out in which the transmitter was placed at about half the height of the Brocken, that is, about 500 m above sea level, and therefore about 350 m above the surroundings. The transmitter was arranged on a tower with a height of 16 m in order to avoid in advance any disturbing influence exerted by the ground. The reception tests were carried out in a direction from the Brocken in which there was direct sight, from the location of the transmitter, for all of the ranges under consideration. Up to the range of 66 km, no essential decrease in tone volume could be observed. From there on, the tone volume dropped off rapidly, until reception ceased entirely at a distance of about 77 km. The reception with and without receiving antenna was practically the same; whereas for a distance as great as 76 km, a tone volume of  $R=1$  could be still heard when the transmitter antenna was

omitted and with reduced capacity; the transmitter could no longer be heard at a distance of 77 km, even when the transmitter antenna was used and with the maximum transmitter capacity. If the maximum range, as found, is compared with maximum range which should result from theory, we find, for an average height of the transmitter 350 m above the experimental grounds, an attainable range of 67 km, read off in Fig. 11. According to the measurements, the zone of direct radiation is 66 km wide, and the zone of deflected radiation 11 km.

The agreement with theory therefore appeared to be very good even for these experiments carried out at half the height of the mountain, and the theory is consequently further confirmed by the latter.

### V. The Possibility of Applying the 3-Meter Waves

In Fig. 11 the values resulting from the experiments on the Brocken have been plotted as small circles and dots; the values of the distances (small circles) for which the reception showed a sudden drop (limit of sight) agree very well with the theoretical curve. The surplus in attainable range above the limit of sight, resulting from flexion, is about the same in both cases (small dots). Therefore experimental data obtained confirm the law established above.

The following characteristics of the maximum ranges for ultra-short waves (3 m) may be considered as having been confirmed by experiment:

The maximum range of these waves depends on the height of the transmitter and the receiver above the surroundings, as expressed by equation (1) established above. The effect of the energy of the transmitter and the sensitivity of the receiver on the maximum range is, above the certain limit, of no importance as compared with the influence of the height of the transmitter and the receiver. The increase in attainable range caused by flexion of the waves over the distance of direct sight as determined by the height referred to above cannot exceed a definite, relatively small amount (5 to 20 km). Inside this maximum range the reception is satisfactory and uniform, without fading or atmospheric disturbances.

As these waves also make it possible to use reflectors of not too large a size which may be mounted rigidly or pivotably, the several points of view relating to the application of these waves are as follows:

The ultra-short waves (3 m) are the most appropriate signaling means for short-distance communication. As far as can be seen at present, they do not have undesirable ranges; within the attainable short ranges, they guarantee good reception, without the possibility of disturbances inherent to the long and short waves used up to now.

Their transmitters and receivers may be provided with reflectors in order to function as directed sets, the dimensions of which are small enough for practical use. Their characteristics therefore indicate at once that it will be useful to add them, as fog signaling installations, to the optical and acoustic signaling means for surface and aerial navigation. In addition to these applications, they may be used advantageously in all cases where electric waves must be transmitted over a definite range or within a definite space, and where it is possible to place transmitter and receiver at the height above the surroundings necessitated by these waves.

As the ultra-short waves may readily be modulated with a very large width of television transmission, they may perhaps some day lead to the practical solution of television transmission.

If it becomes possible to reduce the wavelength somewhat more (down to about 0.5 m), while maintaining as much as possible the transmission energy and the sensitivity of reception obtained for the 3-m wavelength, then still more new applications of the ultra-short waves will become possible by the fact that for these short wavelengths, reflectors may be used whose dimensions are large as compared with the wavelength. In such cases, however, it will be possible to obtain beams of waves with a directive sharpness similar to that of a beam of rays emitted by a searchlight. The consequences of a development of this kind cannot be foreseen at present.

There have also been found possibilities of applying the ultra-short waves other than those concerning the technique of communications, for example, applications for medical purposes. Experiments in this field were started in the beginning of 1927. A separate report will deal with this subject.





## METHOD AND APPARATUS USED AT THE BUREAU OF STANDARDS IN TESTING PIEZO OSCILLATORS FOR BROADCAST STATIONS\*

BY  
E. L. HALL

(Radio Section, Bureau of Standards, Washington, D. C.)

**Summary** — *A piezo oscillator may be used either to check the frequency of the station or to control its frequency. Most of the piezo oscillators tested by the Bureau are for use in checking the frequency of the station. Piezo oscillators are capable of high precision in the measurement of their frequency if a beat note is produced by adjusting another generator to a similar frequency. This principle is employed in the methods and apparatus described in the paper.*

*After preliminary tests to determine the suitability of the quartz plate and its fundamental frequency, the piezo oscillator is kept in a temperature-controlled room for not less than two days, during which frequency measurements are made.*

*The method consists in measuring the frequency of the piezo oscillator under test in terms of a 200-kc temperature-controlled piezo oscillator. This is accomplished by adjusting a radio-frequency generator to the frequency which the piezo oscillator under test should have. This adjustment is made using harmonics from a 10-kc generator which is kept accurately set in terms of the 200-kc standard by observing a special form of beat indicator. The frequency difference between the test piezo oscillator and the generator set in terms of the standard is measured by comparison with an audio-frequency generator. A frequency meter of special design is used to check the frequency difference and determine the sign of the correction to be applied. The method described is also useful in the calibration of frequency meters and the measurement of station frequencies,*

### I. PIEZO OSCILLATORS AS FREQUENCY STANDARDS FOR BROADCAST STATIONS

A BROADCAST station, to maintain its assigned frequency, must be provided with an accurate frequency standard. A piezo oscillator is the most suitable frequency standard thus far devised. It is a generator of radio-frequency current, the frequency of which is determined primarily by the dimensions of the quartz plate used. The Bureau's service to the broadcast stations consists of measuring the frequency of the piezo oscillator, or adjusting the quartz plate so that the piezo oscillator has the frequency to which the station is assigned, and issuing a test certificate. This service is one of the classes of radio tests undertaken by the Bureau.

A piezo oscillator may be used in either of two ways in maintaining a station on its assigned frequency; first, it may be used for checking the frequency of the station; secondly, it may be used to control the

\* Dewey decimal classification: R214. Publication approved by the Director of the Bureau of Standards, of the U. S. Department of Commerce. To be published in a forthcoming issue of the Bureau of Standards Journal of Research.

frequency of the station. Tests at the Bureau are usually limited to piezo oscillators intended for use in the first way mentioned because of the usual practical difficulties in submitting a complete piezo oscillator intended to control the frequency of the station. If the broadcast station uses a piezo oscillator which is maintained at a constant temperature, the complete temperature-control equipment should be submitted with the piezo oscillator so that the test can be conducted at the desired temperature and under the conditions of use.

The Bureau will undertake to adjust a piezo oscillator to the frequency of a station if the frequency as received is not more than 1 per cent below that desired, but will not accept it for adjustment if the frequency is above that desired. Experience in adjusting quartz plates by grinding demonstrates that no guarantee can be made of obtaining satisfactory results. This frequency adjustment is the final step in a series of operations which are required in a technical manufacturing process. Data taken by the Bureau of Standards and other laboratories on the behavior of quartz plates as their dimensions are changed show that there is a small probability of obtaining a suitable frequency standard by submitting a single quartz plate for adjustment, and this type of test is not encouraged. A more satisfactory type of test, both from the standpoint of the Bureau and the station, is to measure the frequency of a piezo oscillator which has been completed and adjusted to frequency by the manufacturer and which operates initially in a satisfactory manner.

## II. TESTING METHOD

While the apparatus and method of use reported herein were developed with the idea of applying them to the testing of piezo oscillators having frequencies within the broadcast band, it was found that the system could be applied with considerable advantage to other tests, such as the measurement of the frequencies of broadcasting stations and the calibration of frequency meters.

A test method and the standards used in calibration work should be capable of a precision at least ten times that of the apparatus to be tested. The precision with which a given adjustment of the apparatus under test can be reproduced should be a guide as to the precision and accuracy of the system to be employed in the test. As the system of measurement to be described is capable of a precision of setting of better than one part in a million, it would be a waste of effort, for example, to use the system to its limit in testing a commercial frequency meter which is only capable of setting to one part in five thousand. Piezo oscillators are capable of high precision of

measurement, but the fact that an extremely precise measurement of the frequency of the piezo oscillator can be made gives no indication whether the device will be a satisfactory frequency standard for a broadcast station. Such precise measurement, however, enables one to determine how much the frequency of the piezo oscillator is changed by varying the conditions of operation, and hence to estimate its ability to maintain its frequency after shipment.

As the high precision possible in measurements of the frequency of piezo oscillators depends upon measurement of frequency differences, a brief discussion of how the frequency differences are produced may assist in a better understanding of the paper by those not familiar with such measurements. In any type of radio-frequency generator the greatest amount of power available is present at the fundamental

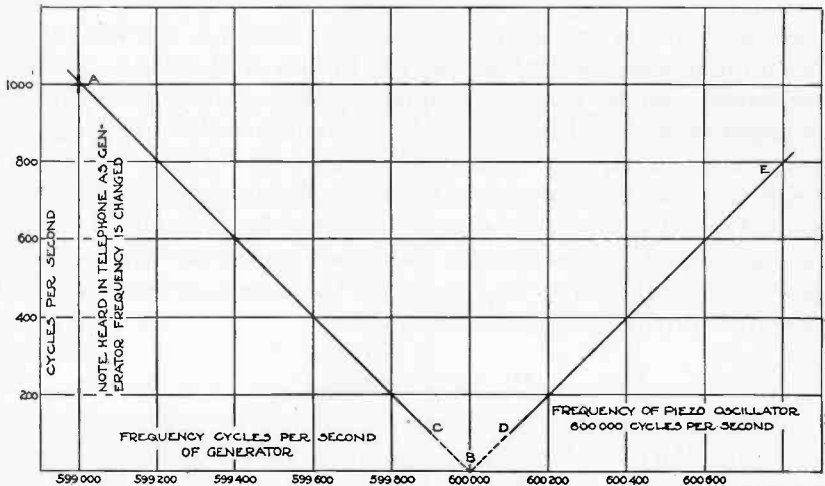

Fig. 1—Diagram illustrating beat note produced between piezo oscillator and a radio-frequency generator whose frequency may be changed.

frequency, which depends upon the value of the inductance and capacity of the resonant circuit. Power is also present at other frequencies which are integral multiples of the fundamental frequency. Although the power available at the harmonic frequencies is very small and decreases as the harmonic number increases, yet it is sufficient to operate a sensitive device such as a telephone receiver. By means of suitable amplification, harmonics as high as the two-hundredth and higher may be employed in measurements.

If a piezo oscillator having a fundamental frequency of 600 kc is assumed to be in operation, loosely coupled to a radio-frequency generator operating at 599 kc, telephone receivers suitably connected to the piezo oscillator or generator will give an audible response or

musical note of 1 kc (1000 cycles), as shown at *A* in Fig. 1. The 1000-cycle note is the difference in frequency between the radio-frequency generator operating at 599,000 cycles per second and the piezo oscillator operating at 600,000 cycles per second. If the frequency of the generator is gradually increased, as represented by line *AB*, Fig. 1, the difference in frequency between it and the piezo oscillator becomes less and, consequently, the audible note heard in the telephone receivers becomes lower. As the frequency of the generator is slowly increased by turning a condenser dial, a setting of the condenser will be reached corresponding to point *C*, Fig. 1, where the telephone receiver is silent, because the frequency is below audibility. If this dial setting is noted and the dial turned slowly in the same direction as before, it may be found that the telephones do not give a response over a certain number of divisions change on the dial until a frequency represented by point *D*, Fig. 1, is reached. This condition of silence in the telephones is often referred to as "zero beat," because the impulses or beats in the telephones can not be heard for they are below audibility. While the lower limit of audibility is usually taken as 16 cycles per second, the average telephone receiver will not respond to so low a frequency. For the purpose of clearness in Fig. 1, and to emphasize the fact that a "zero beat" adjustment is not precise, the lines *AB* and *BE* are shown dotted near their lower ends, indicating no response in the telephones, although the region of zero beat is usually more definite than indicated. A further increase in the frequency of the generator from point *D* towards *E*, Fig. 1, increases the frequency difference or beat frequency between generator and the piezo oscillator. Although frequencies in the neighborhood of the fundamental have been considered, similar results may be obtained using harmonics from either or both sources.

A much more precise adjustment at *B*, Fig. 1, can be obtained using apparatus which will respond to low frequencies. Such apparatus includes oscillographs and beat indicator circuits, which couple to the generator and piezo oscillator and will produce a visual indication of the frequency difference of a small fraction of a cycle per second. The operation of a visual beat indicator as applied to low frequencies is described in a paper by Sylvan Harris.<sup>1</sup> The operation of a visual beat indicator as applied to radio frequencies is similar and is described in a previous paper by the author.<sup>2</sup>

Another manner in which point *B*, Fig. 1, may be used although the generator is not adjusted to that frequency, is to set the generator

<sup>1</sup> Sylvan Harris, "A method of calibrating a low frequency generator with a one-frequency source," *Proc. I. R. E.* 14, 213; April, 1926.

<sup>2</sup> E. L. Hall, "A system for frequency measurements based on a single frequency," 17, 272; February, 1929.

to such a frequency that the frequency difference between it and the piezo oscillator operating at point *B* is equal to the known frequency of a tuning fork. Harmonics of the tuning fork may be used, depending upon the ability of the operator to distinguish differences in the pitch of two notes. An operator having a "musical ear" can readily use this method, although results obtained by an operator not so gifted might be unreliable.

A very precise adjustment of the generator at the frequency corresponding to point *B*, Fig. 1, can also be obtained by employing another radio-frequency generator, which is operated at some frequency having a harmonic within, for example, 500 to 1500 cycles per second of the frequency at *B*. This method has already been described.<sup>3</sup>

The circuits employed in the testing of piezo oscillators make use of the principles outlined in the above paragraphs.

As the piezo oscillators to be tested are capable of precise measurement, it becomes necessary to use a standard for the testing work whose frequency is accurately known and maintained constant. The choice for the standard was a piezo oscillator which operates under constant conditions as to temperature and voltages applied. Its frequency is checked at least once a week by inter-comparison with other temperature-controlled piezo oscillators. The frequencies of all piezo oscillators for broadcast stations are referred to this one standard by means of the apparatus described below.

As the piezo oscillators to be tested for broadcast stations have frequencies which are multiples of ten, beginning at 550 kc and ending with 1500 kc, a system giving frequencies spaced 10 kc apart is convenient for test purposes. A 10-kc generator was accordingly made a part of the apparatus and is precisely adjusted to 10 kc. It is, in fact, manually controlled and slightly readjusted when necessary, rather than automatically held at 10 kc. The reason for this arrangement is that it may be desirable to set the 10-kc generator to some other frequency, such as 15, 25, 50, or 100 kc, when used in other measurement work, in which case the harmonics would be spaced further apart and would be of a lower order and, consequently, stronger. This permits a great extension of the frequency range of the system. The same piezo oscillator can be used and the generator will give harmonics spaced at almost any desired intervals, thus providing a very flexible system.

It should also be pointed out that a piezo oscillator of almost any value can be selected and used as the standard in a manner similar to that here described. The harmonics obtained may not be conven-

<sup>3</sup> J. K. Clapp, "Frequency Standardization," *Journal of the Optical Society of America* and *Review of Scientific Instruments*, 15, 28, 1927.

ient decimal values, but calculations can always be made and the usefulness of any piezo oscillator greatly extended.

The system herein described is best explained by reference to Fig. 2, which shows schematically the apparatus as used. The system includes: a temperature-controlled piezo oscillator *S*, the frequency of which is accurately known, in terms of which the measurements are made; a 10-kc vacuum-tube generator *G*, capable of very precise frequency control, and giving a very constant frequency; a radio-frequency vacuum-tube generator *P*, covering the range of frequencies desired; the piezo oscillator to be calibrated, *PO*; a calibrated frequency meter *FM* for determination of the order of the harmonics of the generator *P* in terms of generator *G*; a calibrated audio-frequency generator *AF*, capable of precise adjustment; a special form of combined beat indicator and generating detector *BI*, by means of

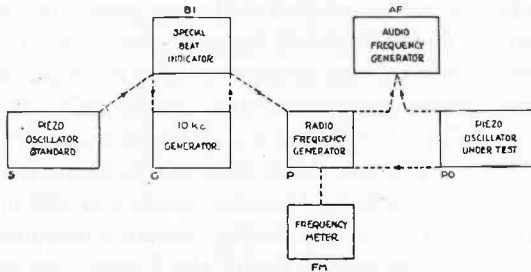

Fig. 2—Diagram of apparatus used in testing piezo oscillators for broadcast stations. The dotted arrows indicate how the various pieces of apparatus work with the remainder of the equipment.

which the operator maintains the various elements of the system in the frequency relationship desired. The method of operating the apparatus is given below.

### III. DESCRIPTION OF APPARATUS

1. *Temperature-controlled room.* Very few of the piezo oscillators submitted for test have been equipped with temperature-control apparatus for maintaining the quartz plate at a constant temperature. Prior to the installation of the temperature-control equipment in the testing laboratory, a variation of 20 deg. C in 24 hours was possible during the winter months and half this variation during the summer months. Considering a mounted quartz plate having a frequency of 1000 kc and a temperature coefficient of the order of 0.003 per cent per degree C, a change in temperature of 10 deg. C would produce a change in frequency of 0.3 kc, which could be indicated on an ordinary frequency meter. The need for a room where the temperature can be maintained constant is evident.

The room available for installation of the temperature-control apparatus was about 21 feet square by 10 1/2 feet high on the main floor of the radio building. The installation of a 2-horsepower cooling system for summer and a 5-kw electric heater for winter, controlled by suitable thermostats, has enabled the room to be maintained at the required temperature.

2. *Frequency standard.* The standard in terms of which the frequencies of piezo oscillators are measured is a 200-kc temperature-controlled piezo oscillator. This type of piezo oscillator has been described by Worrall and Owens.<sup>4</sup> Some changes in the method of operation and use have been made. The piezo oscillator is enclosed in a specially constructed cabinet which is maintained by means of a mercury thermostat at such a temperature as to give a frequency of 200,000 cycles. This cabinet is located in the constant temperature room. Heat is provided by means of electric lamps placed in the outer sides of the box, and the air is circulated by means of a fan. The thermostat is placed in the air stream in a position to give the most sensitive temperature control. Under usual conditions no change in the reading of a thermometer graduated in 0.1 deg. C can be observed.

3. *Generators.* There are three different generators or oscillators required in the testing work: (1) a small generator which may be adjusted to 10 kc; (2) a generator covering the radio frequencies at which tests are to be made, hereafter called the "power generator;" (3) a generator of audio frequencies.

The 10-kc generator employs a 5-watt vacuum tube in a Hartley circuit in which a two-plate variable air condenser permits very minute adjustments in frequency.

The power generator uses the tuned plate circuit and a 250-watt tube with 600 volts on the plate. Slow motion devices on the variable condensers permit the precise adjustment of the generator to the desired frequency. It is equipped with a condenser-switching mechanism which assists in rapidly obtaining "zero beat" with a piezo oscillator. This mechanism changes the frequency from a point above "zero beat" to a point below "zero beat" by operating a switch handle. When the note heard on either side of "zero beat" is the same, the mid-position of the switch gives "zero beat." This is accomplished by changing the variable condenser slightly.

The audio-frequency generator is a commercial product. The low frequencies are produced in a tuned-plate generating circuit using a 5-watt tube, and the output is amplified by another 5-watt

<sup>4</sup> Worrall and Owens, "The Navy's primary frequency standard," *Proc. I. R. E.*, 16, 778; June, 1928.

tube. A filter circuit is provided so that the harmonics above various specified frequencies, as indicated by a switch, are reduced to a minimum.

4. *Special beat indicator.* The special beat indicator circuits used are the result of an attempt to make possible the precise adjustment of the frequency of one circuit to that of another and not have an interaction between them which may change the frequency of the standard. The beat indicator circuits used not only accomplished the desired result, but were found to have other important uses in the measurement system.

Essentially, the beat indicator circuit shown in Fig. 3 is a generating detector circuit. A 1000-turn coil in the grid circuit couples to the 10-kc generator *G* and to the output of the piezo oscillator *S*.

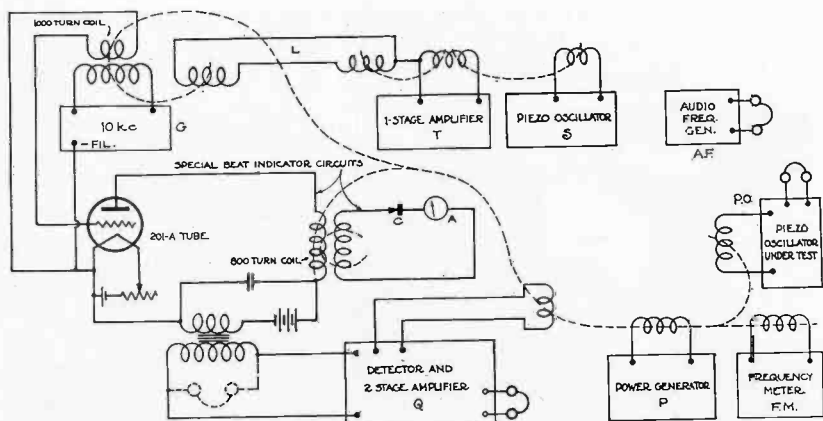

Fig. 3—Schematic diagram of apparatus used in testing piezo oscillators, showing electromagnetic coupling between different units by dotted lines.

A 600-turn coil in the plate circuit couples to a coil of 8 or 10 turns in series with a crystal detector and d-c microammeter *A*, which gives the visible indication. An audio-frequency transformer is connected in the plate circuit as shown, and telephone receivers or a two-stage amplifier may be connected to the secondary winding of the transformer as desired. A detector tube is at times connected in ahead of the two-stage amplifier and serves to increase the sensitivity of the system. A small pickup coil is sometimes connected to the input terminals of the detector tube, and serves to increase the coupling between the power generator and the 10-kc generator.

5. *Frequency meter of high resolving power.* In the course of the development and improvement of frequency standards and apparatus a few years ago, the need was felt for a frequency meter cap-



able of more precise measurement and greater accuracy. About 1925 the frequency meter to be described was constructed, although an improvement in the method of resonance indication has recently been added. The frequency meter as originally constructed was found to be more than capable of the precision expected. It soon was found to be indispensable in frequency measurements made during the adjustment of quartz plates to a desired frequency, as requests for such work began to be received. It is still in use for adjustment work or where small changes in frequency are to be measured.

The frequency meter is shown in Fig. 4, and the series of coils for it is shown in Fig. 5. The condenser is made up of two air condensers, one fixed and the other variable, mounted within the cylindrical shield. The condenser is provided with a special scale and vernier taken

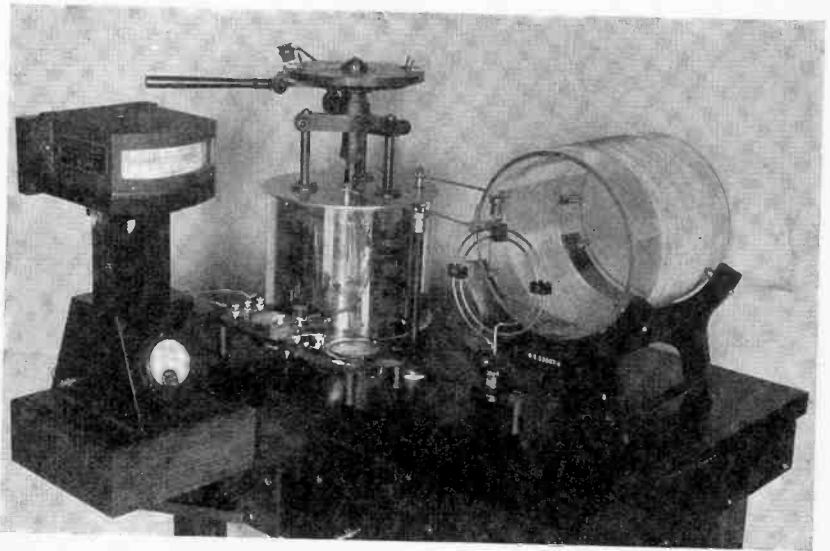

Fig. 4—Special frequency meter used in measuring frequency differences.

from a transit obtained from the U.S. Coast and Geodetic Survey. The scale is graduated throughout the circumference in sixths of degrees. With a vernier of 60 divisions it is possible to read a movement of 10 seconds of arc, or approximately 0.003 degree. This is a fairly high degree of precision in scale reading than is necessary to obtain a high degree of precision in frequency measurement. In practice it is convenient to use but ten main divisions on the vernier, which means reading the condenser scale to approximately 0.016 degree. When such agreement in the condenser reading is obtained, the precision of the frequency measurement is 0.003 per cent.

The maximum capacity of the condenser is approximately 400  $\mu\mu\text{f}$ , half of which is in the fixed portion. This gives a capacity variation of 200  $\mu\mu\text{f}$  and a minimum capacity of 200  $\mu\mu\text{f}$ . The movable plates of the condenser are so shaped as to give practically a straight-line percentage frequency curve and allow the same percentage accuracy of measurement at any part of the scale. Since the ratio of maximum to minimum capacity is about 2 to 1, the frequency ratio for any coil used with the condenser is  $\sqrt{2}$ .

The coils used with this frequency meter are wound on Pyrex glass cylinders. The glass forms were chosen as giving greater constancy and stability than was obtainable with a skeleton-frame inductor. The inductors were wound with different sizes of wire, as selected from the data reported in a previous paper by the author.<sup>5</sup>

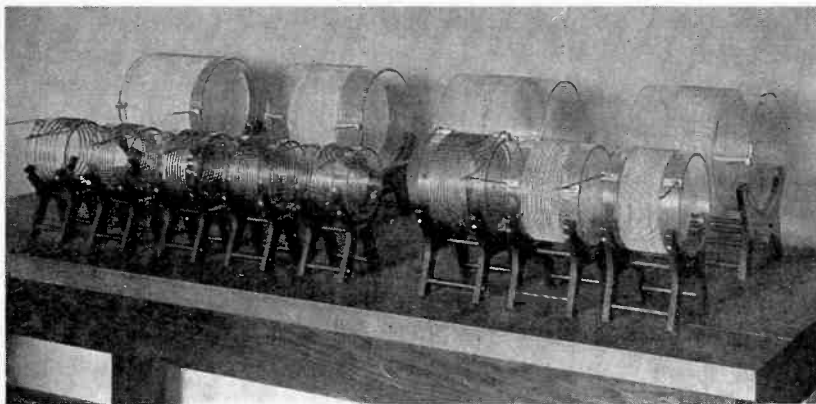

Fig. 5—Series of inductors used on frequency meter shown in Fig. 4.  
Frequency range covered, 170 to 5350 kc.

The frequency meter has been used by adjusting the condenser to resonance, as indicated by the maximum deflection of a d-c microammeter in a separate series circuit containing a crystal rectifier and small coil of two turns coupled to the coil of the frequency meter. Recently an improvement in the precision of setting was obtained by incorporating an arrangement used by a manufacturer of radio apparatus and standards in some special frequency meters. A very small condenser was built into the condenser shield so that the total capacity could be slightly increased by connecting the condenser into the circuit, which is accomplished by means of a spring push button. The main condenser

<sup>5</sup> Bureau of Standards Technologic Paper No. 330, "Resistance of conductors of various types and sizes as windings of single-layer coils at 150 to 6,000 kilocycles." Obtainable from Superintendent of Documents, Government Printing Office, Washington, D. C., for five cents.

is so adjusted that the deflection of the microammeter is the same with or without the small condenser in the circuit. When the frequency meter is correctly adjusted it is not quite in resonance with the generator, but set to a somewhat higher frequency. The calibration is based on this setting.

6. *Auxiliary apparatus.* Among the auxiliary apparatus used in the measurements, the most useful has been a set of tuning forks ranging in frequency from 100 cycles to 2000 cycles. By matching a beat note with the note of a tuning fork, a known frequency difference can be produced, which permits a simple calculation of a frequency which may be inconvenient to set precisely otherwise. Three electrically-driven forks have been available, but the simple type of fork held in the hand and struck with a small mallet has been found more convenient.

A detector and two-stage amplifier has been very useful. A small coil coupled to both the piezo oscillator and the power generator is at times connected to the input of the detector circuit in order to amplify the beat frequency. Other apparatus, such as another radio-frequency generator and a two-string oscillograph, is sometimes useful in making measurements.

#### IV. OPERATION OF APPARATUS

1. *Adjustment of 10-kc generator in terms of piezo oscillator standard by means of special beat indicator.* The approximate setting of the 10-kc generator  $G$  (Fig. 3) is first found by listening in telephones connected in the output of the amplifier  $Q$  which is connected to the special beat indicator. After adjusting the 10-kc generator  $G$  to zero beat, a rather faint high note may be heard, or, if the power generator,  $P$  (Fig.3), is operating near some harmonic of the 10-kc generator, rapid pulsations in the beat note between the two generators may be heard. This renders it much easier to adjust the 10-kc generator correctly. By careful adjustment of the tuning control of the 10-kc generator, this high note will fluctuate in intensity, and when the fluctuation becomes slow enough the pointer of the milliammeter  $A$  will be found to vibrate in step with the fluctuation. By further adjustment of the tuning control of generator  $G$  the pointer can be kept from moving. At this point the 10-kc generator  $G$  can be shifted by further slight adjustment, so that there is either a high-pitched faint note or absolute quiet. The latter condition occurs when the generator is correctly adjusted with respect to the frequency standard used. If the generator gets out of adjustment by as much as one cycle per second in a minute, the operator will detect it by hearing the high-pitched note appear in the telephones. Slight errors in this setting

may not be important unless a high order harmonic is to be used. Errors in adjustment of the order of a few hundredths of a cycle per second are immediately apparent and the 10-kc generator can be readjusted. The milliammeter *A* is used only to indicate the desired adjustment between the frequency standard *S* and generator *G*, and never indicates the adjustment of generator *P*. A second indicator might be used for this purpose, but has not been incorporated thus far because of the added complication of the circuits.

The sensitiveness of the visible beat indicator is shown by the fact that when the coils of an unshielded piezo oscillator and the 10-kc generator were coaxial and from 2 to 3 ft. apart, visible beats of the beat indicator milliammeter *A* (Fig. 3) were readily obtained. Type 201-A tubes were used in both the piezo oscillator and the 10-kc generator. The link circuit *L* and the one-stage amplifier *T* were not used in this case. In other words, the coupling to the piezo oscillator *S* was extremely loose, which meant that there was no danger of the frequency of the piezo oscillator, which was used as the standard, being changed by the other circuits. Thus the beat indicator system could not affect the frequency of the standard.

2. *Adjustment of power generator to desired frequency by means of audible characteristics of beat indicator.* When the 10-kc generator *G* has been adjusted accurately, the next step is to adjust the power generator *P* in Fig. 3 to the desired harmonic of the 10-kc generator. The telephones in the two-stage amplifier *Q* in Fig. 3 also serve to indicate the correct adjustment of the power generator *P*. When working at the higher frequencies in the broadcast band, beat frequencies which otherwise would not be heard are made audible by placing a pickup coil connected in series with the telephone leads in the vicinity of the power generator *P*.

The frequencies of the power generator *P* in which the last digit is zero give a zero beat which cannot be set accurately by aural methods without the use of another generator, because of the uncertainty of the setting for true zero beat. The frequencies ending in  $2\frac{1}{2}$ , 5, and  $7\frac{1}{2}$  can be set accurately by matching beat notes in the telephone receivers, which are beats of beats, as described below.

Fig. 6 illustrates how the various beat notes heard in the telephones can be interpreted, i.e., whether the frequency to which the power generator *P* is set ends in zero or in some other number. The diagonal lines represent the beat notes heard in the telephones, and the breadth of the lines represent their relative strength. Thus it is seen that the beat notes occurring near the frequencies ending in zero are very loud or strong. Zero beat being indefinite, a setting is taken by matching

with the note from a tuning fork, as described above. This method is simpler than providing an extra beat indicator to determine the desired frequency adjustment. When the frequency of the power generator  $P$  is increased from 200 kc, for example, as indicated in Fig. 6, the beat note gradually gets higher and fainter, line  $ab$ , until at a frequency of the order of 204.5 kc the beat note is quite high, but a lower note, line  $cd$ , will also be heard, which becomes lower as the other becomes higher. Soon after the low note has become silent the high note will be heard to pulsate, and, with critical adjustment of the generator  $P$ , beats with another beat note will be heard, which permit a very accurate setting of the generator. This setting gives one of the 5-kc points, and is readily distinguished over a range of several hundred kilocycles by the aural method described. If the frequency

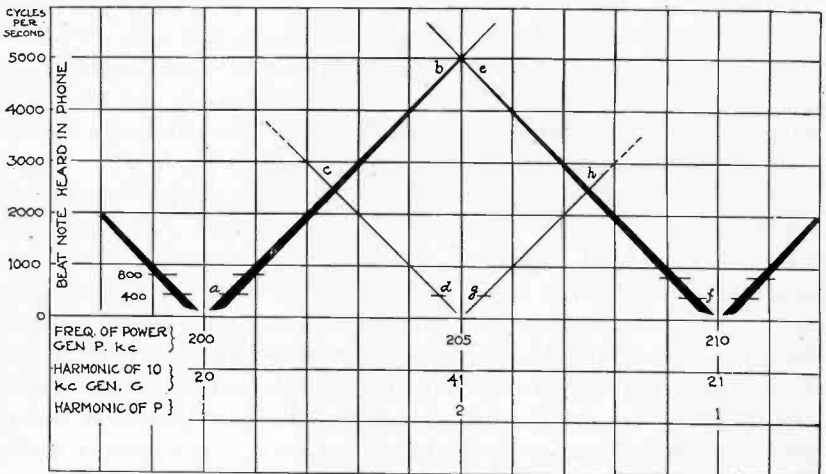

Fig. 6—Chart used in explanation of the beat notes which are heard when working with the system described in the text.

of the power generator is increased further, the other high-frequency beat note, line  $ef$ , becomes lower and stronger, and a weaker beat note, line  $gh$ , becomes higher and fainter. Further change in the power generator brings in a loud beat note and, finally, silence, or zero beat, in the telephones. This is another 10-kc point. The beat note represented at  $b$  is 5000 cycles when a 10-kc fundamental is used. When the frequency of the power generator is being changed from  $a$  to  $b$ , if conditions are right, another beat note may be heard at  $c$  and a precise setting made at this point, which will be midway between the 10-kc point and the 5-kc point. This setting is more difficult to obtain than the 5-kc point because it is indicated by the beats between two 2500-cycle notes of very different intensities. When a piezo oscillator

having a fundamental frequency of 25 kc was used, the 2500-cycle notes were readily distinguishable. Other beat notes may be heard and can be set accurately, but may not be readily usable because of the difficulty in identifying them. Points 5 kc apart are much closer than are usually required.

An explanation of the various beat notes heard in the telephones can be given by further reference to Fig. 6, where harmonic numbers are indicated for the three zero-beat frequencies given. The 200-kc frequency or fundamental of the power generator *P* beats with the 20th harmonic of the 10-kc generator *G*, and the 210-kc fundamental of the power generator *P* beats with the 21st harmonic of the 10-kc generator *G*. When the frequency used is 205 kc, the second harmonic of the power generator, *P*, or 410 kc, beats with the 41st harmonic of the 10 kc generator *G*. As previously explained, the 202.5-kc and 207.5-kc points are obtained by listening to the beats between the beat notes heard in the telephones. Beat notes other than those indicated in Fig. 6 may be heard in the telephones, but those described are usually sufficient for calibration purposes.

Although the 10-kc points cannot be set precisely, they can be accurately determined by matching a beat note in the telephones with a corresponding note from the tuning fork. If the frequency of the fork is known it is only necessary to make the measurement on one side of zero beat.

3. *Measurement of audio-frequency note resulting from difference in frequency between piezo oscillator under test and generator.* The determination of the difference in frequency between the piezo oscillator under test, *PO*, and generator *P*, Fig. 3, is made by matching with a similar note from an audio-frequency generator. While this matching would seem to be an easy matter, sometimes in practice it is found to be very difficult, either because the note is weak or many harmonics are present, or it is modulated with some other frequency such as 60 cycles when the power supply line of this frequency is used to operate the tube of the piezo oscillator, *PO*.

When the two notes are nearly matched, slow beats will be heard when listening in the two telephone receivers which are connected to the piezo oscillator *PO* and the audio-frequency generator *AF*, respectively. Beats may also be heard when there is a small harmonic ratio between the frequencies. While it is convenient to have both notes coming from one head-piece when precise matching is desired, it is essential to be able to listen to each note separately during the process of adjustment, as, otherwise, harmonics are very likely to be obtained.

4. *Measurement of audio frequency with frequency meter.* By means of the frequency meter *FM*, Fig. 3, described in another section, it is possible to check the results obtained with the audio-frequency generator *AF*. The check measurements involve two readings of the frequency meter *FM*, one when the generator *P* is adjusted to zero beat with the piezo oscillator *PO*, and the second when the generator *P* is adjusted in terms of the frequency standard *S*, by means of amplifier *T*, 10-kc generator *G*, and the special beat indicator circuits as described above. The difference in the two readings of the frequency meter *FM* should give a result approximately the same as that obtained with the audio-frequency generator *AF*, and thus serves as a check on those measurements.

## V. TEST PROCEDURE

In starting the test of a piezo oscillator, it is set up on a small portable table, and tried out using the type of tubes and voltages specified. A number of preliminary measurements are made as described below, including test for fundamental frequency, which is only a very approximate measurement, test to determine this frequency value within 1 or 2 kc, and test to discover any undesired frequencies. The apparatus used for these tests consists of the usual type of frequency meter and radio-frequency generator rather than the more complicated equipment described in this paper.

The fundamental frequency of the piezo oscillator is determined approximately by coupling a frequency meter to the oscillator and noting the setting at which the reading of the meter in the plate circuit of the piezo oscillator increases. If the coupling is too close, the piezo oscillator will stop oscillating, in which case the meter in the plate circuit will read the normal plate current of the tube. The coupling can readily be adjusted so that a momentary increase in the reading of the meter may be noted as the frequency meter passes through the fundamental frequency of the piezo oscillator. In general, this coupling is such that no response will be obtained at a harmonic, and therefore the method may be relied upon to give the fundamental frequency within 1 or 2 per cent.

After the fundamental frequency has thus been determined roughly, a more precise determination is made, which may be of the order of 0.2 per cent. This measurement is made by setting a small radio-frequency generator to zero beat with the piezo oscillator and measuring the frequency of the generator with a suitable frequency meter.

It is essential that a quartz plate which is to be used as a frequency standard have but one frequency at which it operates when circuit

constants are not appreciably changed. One of the important tests upon a piezo oscillator, therefore, is that to determine whether the quartz plate may operate at a slightly different frequency than the one desired. Quartz plates are often found to have two or more frequencies separated a few hundred cycles. Such undesired frequencies can often be found by setting a radio-frequency generator so that a certain audio-frequency note is produced in the telephone receivers in the piezo oscillator circuit. Changes are then made in the various adjustments of the piezo oscillator, and the quartz plate is turned from side to side. If the beat note suddenly changes to some other pitch, the quartz plate is operating at a different frequency and will not be satisfactory as a standard. A gradual change in frequency is to be expected if, for example, the condenser setting of the piezo oscillator is varied. If the piezo oscillator appears to operate satisfactorily, it is wheeled into the room where the temperature is maintained constant 24 hours in the day. If the quartz plate requires grinding to bring it to the desired frequency, this work is done before the tests outlined above are made, and then the piezo oscillator is placed in the special room. The above tests complete the preliminary measurements.

The piezo oscillator remains in the constant-temperature room over night, and the first precision measurement of its frequency is made the following day. On the next day the precision measurements are repeated, and if the frequency measured is sufficiently close to the value of the previous day, the piezo oscillator is again tested for two frequencies or other peculiarities in operation, and if found to be satisfactory, is returned to the owner, and a test certificate prepared. However, if the measurements of the second day do not agree with those of the first day, the piezo oscillator is kept over and tried a third time and efforts made to determine the causes of the disagreement in the measurements. Certificates are not issued for quartz plates which operate in an erratic manner.

If the piezo oscillator is to be tested at a given temperature, the temperature-controlled cabinet must be submitted with the piezo oscillator. The complete equipment is set up, and readings of the temperature near the quartz plate are noted at intervals until a constant temperature is obtained or until the limits within which the device operates are found. If the device is satisfactory in operation, the first precision frequency measurement may be made after the piezo oscillator has been at the required temperature at least 24 hours. The remainder of the test is conducted as has previously been described.

Fig. 7 gives a view of the apparatus used in the constant-temperature room.



TABLE I  
MEASUREMENT OF 1370-KC PIEZO OSCILLATOR—VALUES IN KC

Setting of Generator <i>P</i>	Piezo Oscillator under Test	Generator <i>P</i> Fundamental Frequency	Frequency Meter <i>FM</i>	Second Harmonic	Audio Generator <i>AF</i>
Zero beat with piezo oscillator under test	1370±	685±	685.12	1370.24	
Zero beat with standard		685.000	685.00	1370.00	0.193
1370.000 + 0.193 = 1370.193 kc					0.24

Table I shows data taken on a piezo oscillator for 1370 kc. Reading from left to right, zero beat with the piezo oscillator at about 1370 kc is taken by setting the generator *P* to half this frequency, or approximately 685 kc. Reading the frequency of the generator *P* with the

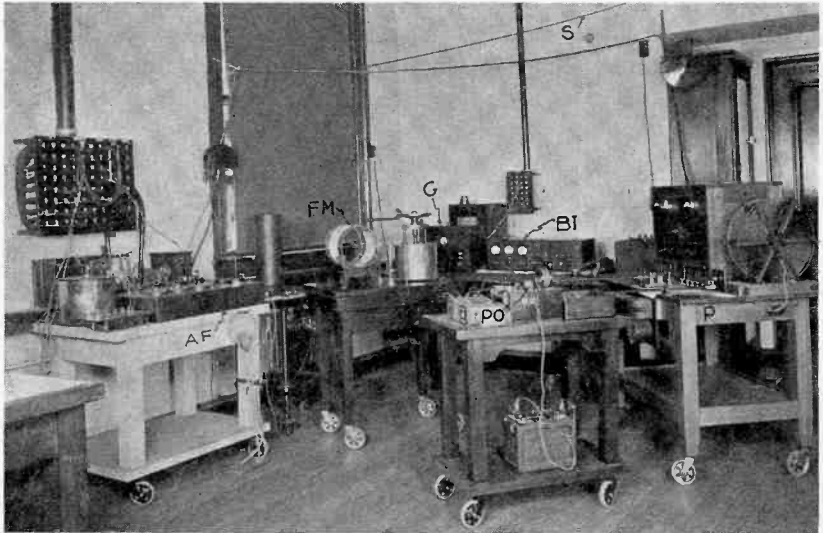

Fig. 7—Photograph of apparatus used in testing piezo oscillators:—  
*S*—wires leading from 200-kc standard  
*G*—10-kc generator  
*BI*—special beat indicator  
*P*—radio-frequency generator  
*PO*—piezo oscillator under test  
*FM*—frequency meter  
*AF*—audio-frequency generator

frequency meter, *FM*, 685.12 kc is obtained, giving 1370.24 kc for the fundamental frequency in terms of the frequency meter. In the second part of the measurement zero beat is obtained with the standard, for which condition the generator *P* is set at 685.000 kc and the frequency meter *FM* indicates 685.00 kc, for which the second harmonic is 1370.00 kc. The beat note between the piezo oscillator under test

and the generator  $P$  is matched by comparison with the audio-frequency generator,  $AF$ , and a value of 0.193 kc obtained. It will be noticed that this value is in fair agreement with the difference obtained from the values in the "second harmonic" column. As the values in the latter column are twice the readings obtained from the frequency meter, the errors in the calibration of the latter are doubled. When this fact is considered, it will be apparent that the frequency meter reading was quite satisfactory. It will be noted that the frequency meter reading for zero beat with the piezo oscillator gave a higher frequency than for zero beat with the standard. The value, 0.193 kc, should therefore be added to 1370.000 kc, giving 1370.193 as the frequency of the piezo oscillator under test. The piezo oscillator probably will not hold its frequency to better than 0.01 per cent so that the value may be reported as 1370.2 kc. The frequency meter readings are used only as a guide or check on the accuracy of the more precise measurements based on beat frequencies.

An interesting point may be noted here. In the above paragraph it is evident that the error in the frequency meter calibration is multiplied or increased when the frequency used in the test is a fractional value of the fundamental of the piezo oscillator. Conversely, the error in the frequency meter calibration is divided or reduced when the frequency used in the test is a harmonic of the fundamental of the piezo oscillator. If an attempt is made to gain this advantage of the reduction in the error of the frequency meter measurement in the case of broadcast frequency testing, other difficulties may more than offset it. It may, however, be applied with considerable success in the measurement of the frequency of quartz plates having a low-frequency fundamental, and the possible error in the frequency meter calibration may be reduced to a small amount.

If the frequency of the piezo oscillator is within 50 or 100 cycles of being correct, it is convenient to change the second step in the measurement so that the generator  $P$  is set off the desired frequency by a known amount, which can be readily accomplished by matching the beat note in the standard circuits with the note from a tuning fork. Table II shows results obtained in such a test.

TABLE II  
MEASUREMENT OF 940-KC PIEZO OSCILLATOR—VALUES IN KC

Setting of Generator $P$	Piezo Oscillator under Test	Generator $P$ Fundamental Frequency	Frequency Meter $FM$	Second Harmonic	Audio Generator $AF$
Zero beat with piezo oscillator under test	940±	470±	469.99	939.98	
Generator $P$ set off from standard using tuning fork		470.000 - 0.400 = 469.600	469.55	939.10	0.833
469.6 × 2 + 0.833 = 940.033 kc				0.88	

The first part of the measurement is made in a similar manner to that given for Table I. In the second part of the measurement if zero beat is obtained with the standard as in Table I, the beat note with the piezo oscillator would be too low to hear. The generator *P* is therefore set off from zero beat by matching the note between the generator *P* and the standard with a 400-cycle tuning fork, which gives 469.600 kc as the generator frequency. According to the frequency meter *FM* it is set at 469.55 kc with a second harmonic of 939.10 kc. The beat note between the generator *P* and the piezo oscillator *PO* is matched with a corresponding note from the audio-frequency generator, which gives a reading of 0.833 kc. It will be noted that the difference in the two frequency meter readings gives 0.88 kc, which indicates that no error from harmonics has been introduced. The frequency of the piezo oscillator *PO* is therefore measured as 940.033 kc, which will be reported as 940.0 kc.

## VI. CONCLUSION

While the method of test described has had reference to the testing of piezo oscillators, the system is likewise applicable to the measurement of the frequency of a transmitting station, or the calibration of a frequency meter. The latter application of the system has been described in the author's previous paper.<sup>2</sup> In the case of the measurement of the frequency of a radio station, the piezo oscillator under test above would be replaced by a radio receiving set tuned to the station whose frequency is to be measured.

The method described is a precise method, and its precision can be increased further by the use of an oscillograph. It is capable of adequate accuracy for any apparatus to be tested.

The system has the following advantages: (1) great accuracy; (2) high precision; (3) use of a given standard over a wide range; (4) large number of calibration points available; (5) flexibility of system; (6) ease of operation.

(1) Great accuracy is possible with the system and method used because all measurements are based upon a temperature controlled piezo oscillator, and the final frequency value is in terms of the standard and an audio-frequency generator which holds its calibration over long periods without appreciable change.

(2) High precision is obtained in the measurements because of the fact that beat notes are used in making the various adjustments.

(3) The usefulness of a given piezo oscillator used as the standard may be greatly extended by reason of the many harmonics which are available from the system as a whole.

(4) The many calibration points available come from the harmonics spaced 5 kc apart and the use of tuning fork notes to displace the setting an accurately known amount.

(5) The method is flexible in that it can be adapted to many kinds of frequency measurements, including those on piezo oscillators, radio stations, and frequency meters.

(6) The system is quite simple to operate when the accuracy and large number of points obtainable are considered.

In conclusion, by means of the method and apparatus described, results of high accuracy are obtained in relatively short time in the testing of piezo oscillators for broadcast stations.



## A GERMAN COMMON FREQUENCY BROADCAST SYSTEM\*

BY  
F. GERTH

(Laboratory of C. Lorenz, Aktiengesellschaft, Berlin, Germany)

*Summary*—The system of equal-wave broadcasting is described, according to which the three first German common frequency transmitters operate. Two cables are necessary between the transmitters, in which the carrier frequency is between 1500 and 2500. Multiplication of frequency is accomplished by static frequency changers in three stages.

**E**VEN in the early days of German broadcasting, engineers thought of doing away with wave congestion, by the use of transmitters operating on perfectly equal waves. Karl Willy Wagner, especially, as president of the Telegraphentechnischen Reichsamts, brought before the radio industry the problem of developing systems for common frequency broadcasting.

After the receiving experiments<sup>1</sup> made by the T. R. A., it was decided to use the system of positive controlled equal-wave transmitters, as these experiments had shown that the width of the disturbed region between two stations amounted to only about 15 percent of the distance between the two. The system constructed in the meantime in the first common frequency sending group Berlin-Stettin-Magdeburg will be described in more detail below.

The problem consisted in the fact that for transmission of the carrier and modulation frequency, no overhead lines but only telephone cable could be used, and consequently, for the modulation frequency, well loaded telephone cable, and for the carrier frequency only normal telephone cable with a limiting frequency of about 2800 cycles, were available. The carrier base frequency therefore was between 1500 and 2500, according to the desired wave in the broadcast band. In order to save lines, the carrier base frequency was transmitted simultaneously on the cable used for communication with the personnel and for operation purposes. The separation of speech and carrier frequency was accomplished by electric filters, the speech being cut off above 1000 cycles and the carrier frequency below 1200 cycles. Although the frequencies above 1000 cycles were lacking, speech was intelligible.

\* Dewey decimal classification: R550.

<sup>1</sup> Eppen, "Ueber Empfangsbeobachtungen bei Gleichwellefunk, *EL Nachr. Technik*, 4, p. 385, 1927.

Thus, only two cables were necessary, the modulation cable, which may be replaced by rebroadcasting, and the operation or carrier frequency cable.

The base frequency is produced by a small, very constant tube generator, and applied above the electric filter of the equal-wave apparatus. As the German broadcast range includes frequencies from 600,000 to 1,500,000 cycles, the applied base frequency must be increased 1000 times. The multiplication is done according to the principle of the alternator transmitter with small static iron frequency changers in three stages. The diagram of the multiplication apparatus is shown in principle in Fig. 1. Fig. 2 shows a photograph of the three

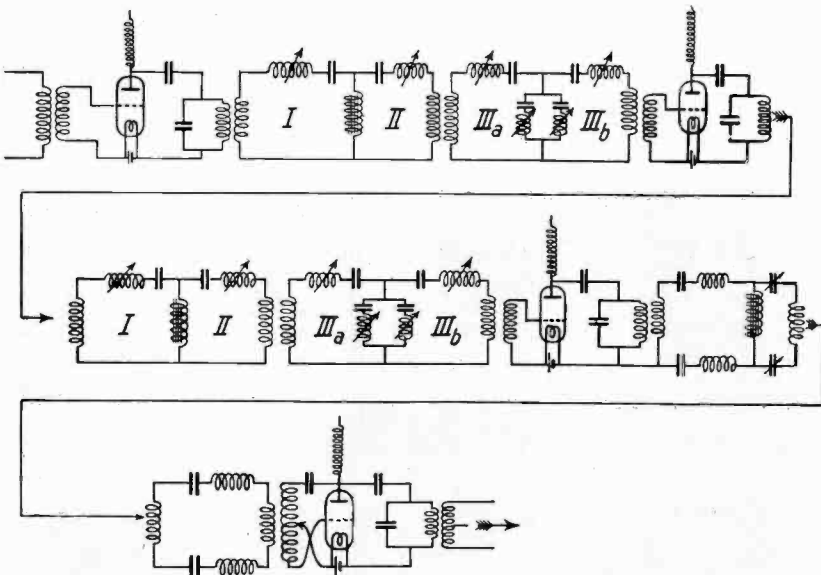

Fig. 1—Diagram showing principles of the amplification equipment.

small changers. According to Fig. 1, the applied base frequency is first amplified several times. To the last amplifier stage there is coupled an oscillation circuit in which is the first frequency changer, at whose terminals there are heavy voltage impulses as a result of the high iron saturation. An oscillation circuit tuned to the ninth harmonic is excited in its natural frequency, so that there is a nine-fold increase in the first stage. In the following tuned circuits any secondary wave residues present are completely removed by hookup arrangements similar to those in the machine broadcast transmitter. Then by intermediate amplifiers, the power which has dropped in the meantime is increased to the original amount. Multiplication by the second frequency changer nine-fold, filtering, amplification, etc., are

utilized, until finally the desired carrier frequency for the broadcast sender is obtained. In the last amplifier, in which modulation also takes place, this is brought to the desired output power. Fig. 3 shows the

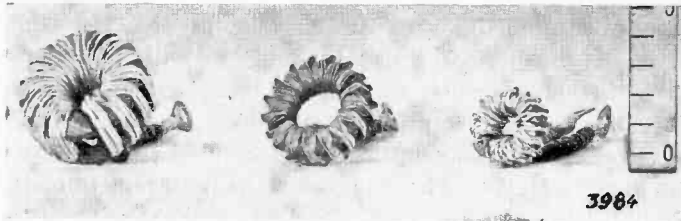

Fig. 2—Frequency transformer of the first, second, and third amplification stage (from left to right).

entire multiplication apparatus, which is placed in one frame, in which those tuning circuits for which a mutual reaction would be harmful are carefully screened from each other.

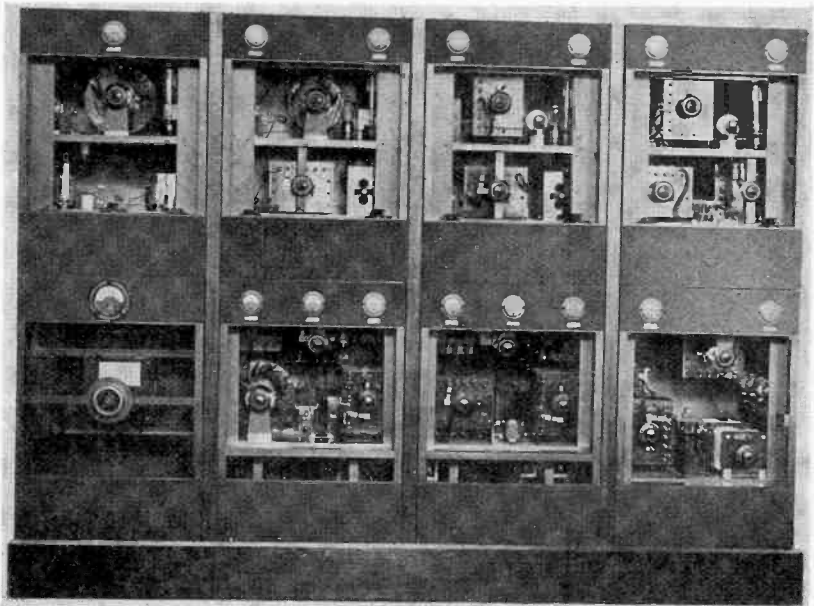

Fig. 3—Amplification equipment, front view. Cover plates removed.

The three first common frequency transmitters, Berlin-Stettin-Magdeburg, built according to this principle, have been in operation since the beginning of January. They are modulated from Berlin and controlled with the base frequency carrier wave. Communications on the operating experiences will follow later.

## ON A DOUBLE HUMP PHENOMENON OF CURRENT THROUGH A BRIDGE ACROSS PARALLEL LINES\*

BY

EIJIRO TAKAGISHI

(The Electrotechnical Laboratory, Ministry of Communications, Tokyo, Japan)

### I. INTRODUCTION

IN wavelength measurement of short electric waves by means of standing waves on a parallel line system, the writer observed that sometimes the current through a bridge circuit did not show a maximum value just at the position of a current loop of the standing waves, but took a minimum between two adjacent maxima, even when the power output of the generating set had been sufficiently large and the coupling between the generator and the parallel line system had been kept very loose. The writer discussed this point briefly in this journal,<sup>1</sup> and F. W. Dunmore and F. H. Engel simply replied that it was doubtless due to the fact that the power output of the generating set was too small, thus requiring too close coupling between it and the parallel line system.

The writer, however, has been convinced, by the results of some more detailed experiments as well as mathematical treatments worked out thereafter, that the phenomenon he had observed was not so simple but much involved.

In the present paper the results of the experimental and theoretical investigations of general characteristics of the bridge current are stated.

It should, however, be borne in mind that though the writer's essential condition of long free ends which are an odd multiple of quarter wavelengths is usually avoided in frequency measurements with parallel line systems because of the fact that the long open ends radiate as an antenna, it has been adopted at will with a view to affording discussion especially on the double hump phenomenon, which may sometimes be a cause of trouble with parallel line systems.

### II. EXPERIMENTAL AND THEORETICAL INVESTIGATIONS OF BRIDGE CURRENT—CASE OF RESISTIVE BRIDGE

The circuit arrangement of the writer's experiment is seen by reference to Fig. 1. The parallel lines are spaced 40 cm apart and the

\* Dewey decimal classification: R116.

<sup>1</sup> Proc. I. R. E., 13, 125; February, 1925.



bridge consists of a hot-wire ammeter  $A_B$ , the terminals of which are connected to the lines through two copper wires each 12 cm long. An ammeter  $A_o$  is inserted in the line to indicate the line current. Throughout the experiments the coupling between the generating set and the parallel line system had been kept so loose that no sensible change in the oscillating condition of the generating set was noticed on sliding the bridge along the lines.

First the bridge being taken off, the system is tuned to the exciting wavelength with the variable condensers  $C_1$  and  $C_2$ , and there are established standing waves. This adjustment is an essential point on which the present phenomenon is based. If the system be far off resonance the phenomenon would not be observable as will be explained later. Along the lines thus adjusted the bridge was slid near a current loop of the standing waves and the readings of ammeters  $A_B$  and  $A_o$  were observed, the results of which are illustrated in Figs. 2 and 3. The latter refers to the case of a larger power supply from the

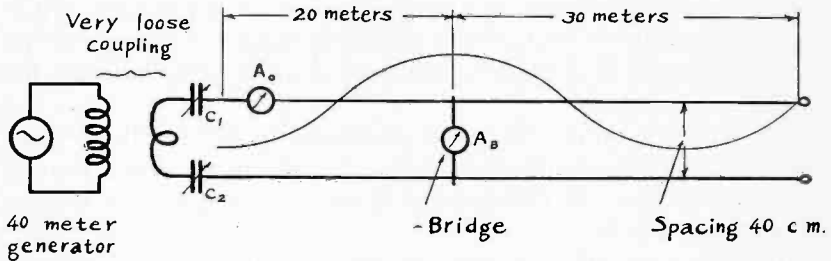

Fig. 1

generator than in the former case. It is interesting to note that there arise two distinct maxima or double hump phenomena in the bridge current in spite of the very loose coupling between the line system and generating set, provided the lines had been initially put to resonance to the exciting wavelength. Thereupon the writer analyzed this fact mathematically and reached the conclusion that the occurrence of the phenomenon is reasonable so long as the resonance conditions above stated have been held.

Referring to Fig. 4, we call the portion of the lines extending from the bridge towards the free ends circuit I, the portion of them between the bridge and the generator circuit II, and bridge itself circuit III; the notation for length, impedance, admittance, propagation constant, etc., of each circuit shall have respectively a corresponding suffix of the same figure as the circuit number.

It may introduce no appreciable errors to assume that the circuit has an inductance and capacity uniformly distributed along whole

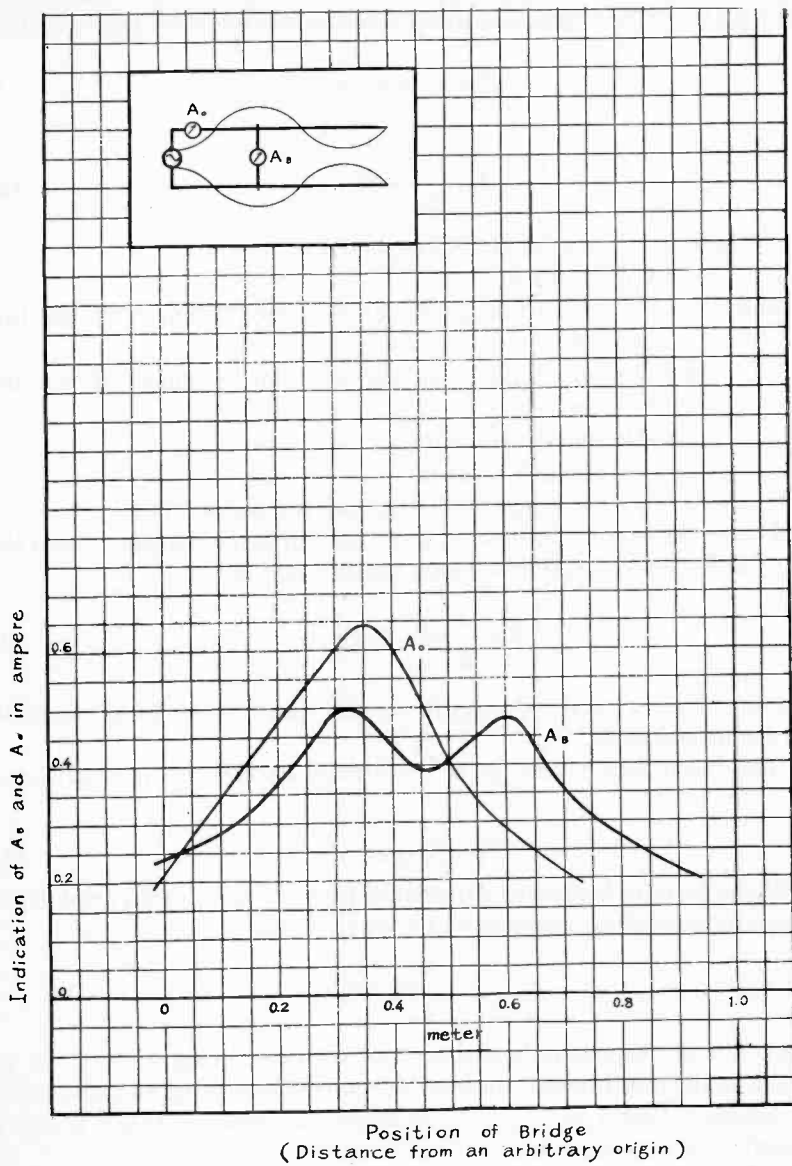

Fig. 2

parallel line system. This being the case it follows that the potential  $E$  and current  $I$  at any point on the line system distant  $x$  from a free end may be represented, as is well known, respectively by the equation:

$$E = E_1' \cosh nx \quad (1)$$

and

$$I = \frac{E_1'}{Z_0} \sinh nx \quad (2)$$

where  $E_1'$  is the potential at the free end, i.e.,  $x=0$

and  $n = \sqrt{YZ} = \alpha + j\beta$ ,

in which  $Y = G + j\omega C$ , admittance per loop cm of length of the line system,

$Z = R + j\omega L$ , impedance per loop cm of length of the line system,

$\alpha =$  attenuation constant,

$\beta =$  wavelength constant,

and  $Z_0 = \sqrt{Z/Y}$ , surge impedance of the line system.

Hence the input admittance  $Y$  of that portion of length  $x$  from the point under consideration towards the free end is

$$Y = \frac{I}{E} = Y_0 \tanh nx, \quad (3)$$

in which  $Y_0$  is a surge admittance of the line system, being equal to the reciprocal of  $Z_0$ .

The input admittance  $Y_1$  of the circuit I at the point of bridging is

$$Y_1 = Y_0 \tanh nl_1. \quad (4)$$

If the point of bridging be displaced by some amount  $\Delta l_1$  away from a current loop of the standing wave, we may put

$$l_1 = \frac{\lambda}{4} m_1 + \Delta l_1$$

where  $\lambda$  is the wavelength of the standing wave, being equal to  $2\pi/\beta$ , and  $m_1$  is the odd integral number of quarter wavelengths included in the length  $l_1$ , say 1, 3, 5, . . . , or so on.  $\Delta l_1$  shall be taken positive towards the generator end.

Substituting this relation into equation (4), we obtain the following expression after a proper approximation,

$$Y_1 = \frac{Y_0}{\alpha l_1 + j\beta \Delta l_1}. \quad (5)$$

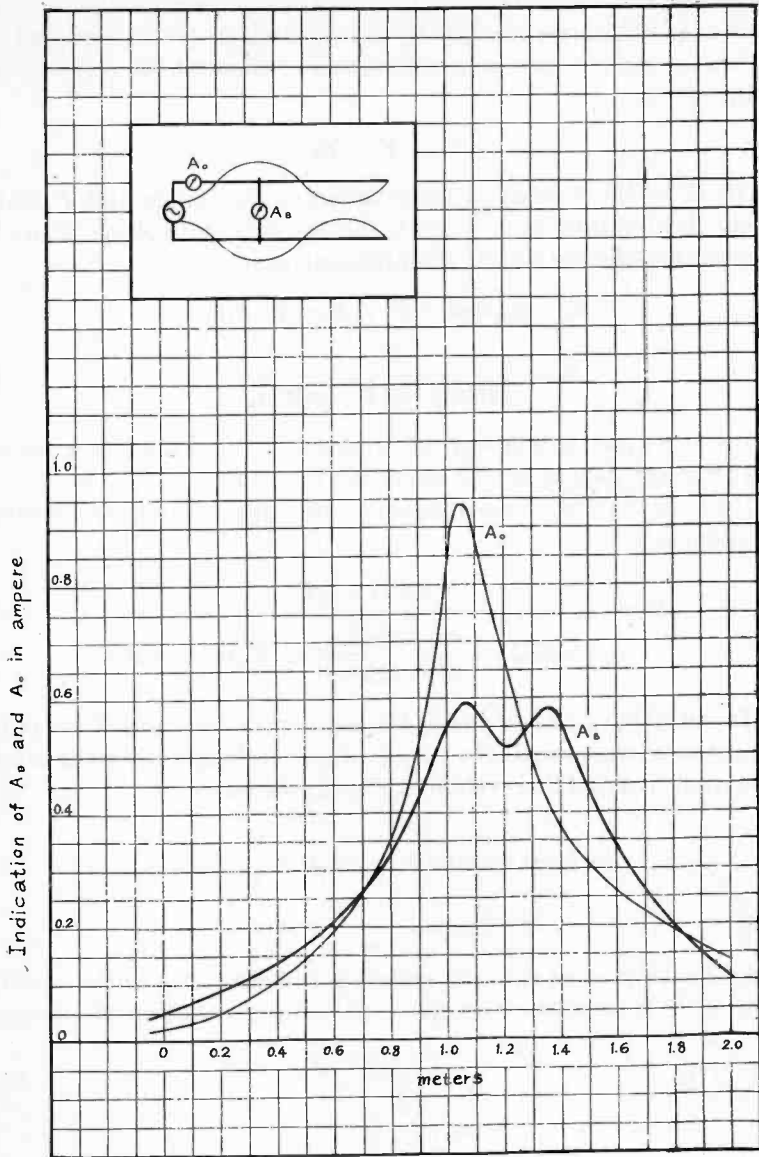

Position of Bridge  
(Distance from an arbitrary origin)

Fig. 3

Next we proceed to consider the voltage at the bridge terminal. In Fig. 5 the right-hand end of the line system associated with a load admittance  $Y_{13}$  corresponding to the position of the bridge and the admittance represents the combined one of those of the circuit I and the bridge, i.e.,

$$Y_{13} = Y_1 + Y_3.$$

Let  $E_3$  be the voltage at the position of the bridge and  $I'$  be the current flowing into  $Y_{13}$ . Then it follows that the voltage  $E_0$  at the generator end distant  $l_2$  from the bridge point is

$$\begin{aligned} E_0 &= E_3 (\cosh nl_2 + Z_0 Y_{13} \sinh nl_2) \\ \text{or} \quad E_3 &= \frac{E_0}{\cosh nl_2 + Z_0 Y_{13} \sinh nl_2} \end{aligned} \quad (6)$$

Now if we put, as before,  $l_2 = \lambda/4(m_2 + \Delta l_2)$ ,  $\Delta l_2$  being taken positive away from the generator end along the line, and  $m_2 = 2, 4, 6, \dots$ , it may be seen that, after rearrangement and approximations, equation (6) becomes

$$E_3 = \frac{(-1)^{m_2/2} \cdot E_0}{1 + j\alpha\beta l_2 \Delta l_2 + \frac{\alpha l_2 + j\beta \Delta l_2}{\alpha l_1 + j\beta \Delta l_1} + Z_0 \cdot Y_3 (\alpha l_2 + j\beta \Delta l_2)} \quad (7)$$

We put  $\Delta l = \Delta l_1 + \Delta l_2$ , which is the measure of detuning of the parallel line system with respect to the exciting wavelength, then the length of the whole parallel line system can be expressed as

$$l = l_1 + l_2 = \frac{\lambda}{4}(m_1 + m_2) + \Delta l \equiv \frac{\lambda}{4}m + \Delta l$$

where

$$m = m_1 + m_2.$$

But in the present case the system is tuned exactly to the exciting wavelength, that is  $\Delta l = 0$ , or  $\Delta l_1 = -\Delta l_2$ , hence equation (7) becomes

$$E_3 = \frac{(-1)^{m_2/2} \cdot E_0}{1 + j\frac{\pi}{2}\delta_2 \alpha l_2 + \frac{\alpha l_2 + j\frac{\pi}{2}\delta_2}{\alpha l_1 - j\frac{\pi}{2}\delta_2} + \left(\alpha l_2 + j\frac{\pi}{2}\delta_2\right) Z_0 Y_3} \quad (8)$$

being assumed  $\beta = 2\pi/\lambda$  and put  $\delta_2 = 4\Delta l_2/\lambda$ .

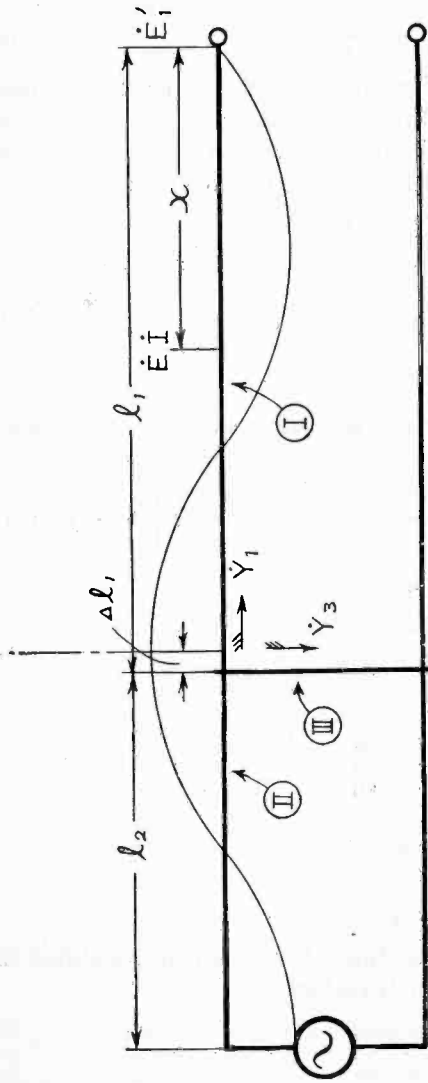

Fig. 4

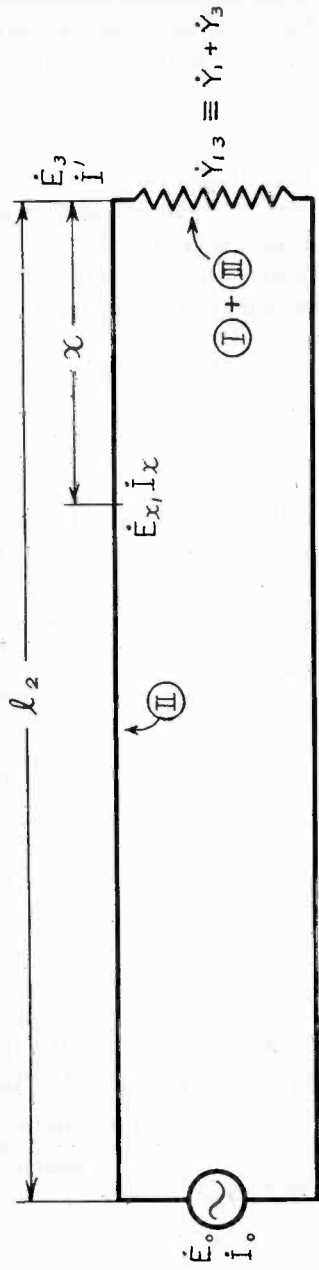

Fig. 5

This is the last expression for the potential difference across the bridge, in which  $m_2$  and  $\delta_2$  are the variables depending upon the bridge position. The potential difference across the bridge being thus determined, the current through it is directly found by the equation

$$I_3 = E_3 \cdot Y_3. \quad (9)$$

Now that a theoretical investigation of the character of the bridge current in a general case of any bridge impedance is much involved, let us first treat a comparatively simple case, where the bridge has pure resistance alone. For the sake of brevity let the denominator of the right-hand term of equation (8) be put  $K$ , namely

$$K \equiv 1 + j \frac{\pi}{2} \delta_2 \alpha l_2 + \frac{\alpha l_2 + j \frac{\pi}{2} \delta_2}{\alpha l_1 - j \frac{\pi}{2} \delta_2} + \left( \alpha l_2 + j \frac{\pi}{2} \delta_2 \right) Z_0 Y_3 = (-1)^{m_2/2} \frac{E_0}{E_3} \quad (10)$$

Let us investigate the character of  $K$  further on. After rearrangement and simplification, the equation (10) becomes

$$K = \left\{ \frac{1}{\mu_1} \cdot \frac{1}{1+x^2} + d_2 \right\} + j \left\{ \frac{1}{\mu_1} \cdot \frac{x}{1+x^2} + d_1 x + (\alpha l)^2 \frac{m_1 m_2}{m^2} x \right\} \equiv a + jb, \quad (11)$$

where

$$d_1 \equiv \frac{l_1 r}{2Z_3}$$

$$d_2 \equiv \frac{l_2 r}{2Z_3}$$

$$\frac{1}{\mu_1} \equiv \frac{l}{l_1} = \frac{m}{m_1}$$

and

$$x = \frac{\frac{\pi}{2} \delta_2}{\alpha l_1}$$

Now as the ratio of the line resistance to the bridge resistance is an important factor in the present investigation, let

$$\nabla \equiv \frac{\text{total resistance of the parallel lines}}{\text{bridge resistance}} = \frac{l r}{Z_3} = \frac{2d_1}{\mu_1}$$

and further let

$$\frac{d_2}{d_1} \equiv 1 + \nu$$

and

$$1 + x^2 = \frac{1}{y}$$

Then designating the magnitude of the vector quantity  $K$  as  $K$ , we have

$$K^2 = \frac{1}{y} \left[ \left\{ \left( \frac{1}{\mu_1} \right)^2 + \nabla \nu \right\} y^2 + \left\{ \nabla + \left( \frac{\nabla}{2} \right)^2 \cdot \mu_1 \nu \right\} y + \left( \frac{\nabla \mu_1}{2} \right)^2 \right] \quad (12)$$

$$\equiv \frac{1}{y} [Ay^2 + By + C]$$

where abbreviations are made as

$$A \equiv \left( \frac{1}{\mu_1} \right)^2 + \nabla \nu$$

$$B \equiv \nabla \left( 1 + \frac{\nabla \nu \mu_1}{4} \right)$$

$$C \equiv \left( \frac{\nabla \mu_1}{2} \right)^2$$

Inspection of (12) would suffice to show that it would take a characteristic as shown by a full-line curve in Fig. 6 against the variable  $y$ ; that is there should give rise a minimum of  $K^2$  or a maximum of the bridge

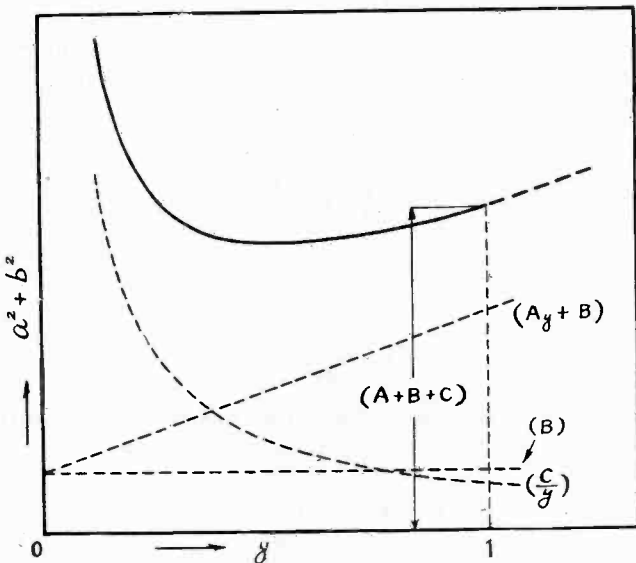

Fig. 6

current for a certain value of  $y$ . Putting some numerical values for geometrical and electrical constants of the line into (12), we obtain a family of curves showing the results of calculation of  $K^2$  against  $\delta_2$ , as shown in Fig. 7. A glance at these curves makes apparent that double hump phenomenon is apt so easily to occur. The condition at which



$K^2$  attains its maximum value will be investigated by differentiation as usual.

$$\frac{d(K^2)}{dy} = 0$$

with the result that

$$y_m = \sqrt{\frac{C}{A}} = \frac{\mu_1 \rightarrow \nabla}{2\sqrt{\nabla\nu + \left(\frac{1}{\mu_1}\right)^2}} \quad (13)$$

where

$$y_m \equiv \frac{1}{1 + x_m^2}$$

$$x_m \equiv \frac{\frac{\pi}{2} \delta_{2m}}{\alpha l_1} = \pi \delta_{2m} \frac{Z_0}{R_1}$$

and

$$\delta_{2m} \equiv \frac{4\Delta l_{2m}}{\lambda}$$

and the suffix  $m$  means the condition of maximum indication of the bridge current. In the equation  $y_m$  should be always positive and less than unity, hence

$$0 < \frac{\mu_1}{2} \cdot \frac{\nabla}{\sqrt{\nabla\nu + \left(\frac{1}{\mu_1}\right)^2}} < 1$$

or

$$0 < \nabla$$

and

$$\nabla^2 < \frac{4\nabla\nu}{\mu_1^2} + \frac{4}{\mu_1^4}$$

The former criterion is too clear to be explained, while the latter is important, which, after rearrangement, becomes:

$$\nabla^2 - \nabla \frac{4\nu}{\mu_1^2} - 4\left(\frac{1}{\mu_1}\right)^4 < 0$$

Solving this quadratic equation with respect to  $\nabla$ , we have

$$\nabla = \frac{2\nu}{\mu_1^2} \pm \left( \frac{2\sqrt{\nu^2 + 1}}{\mu_1^2} - \zeta \right) \quad (14)$$

where  $\zeta$  is a positive arbitrary constant.

Hence we have

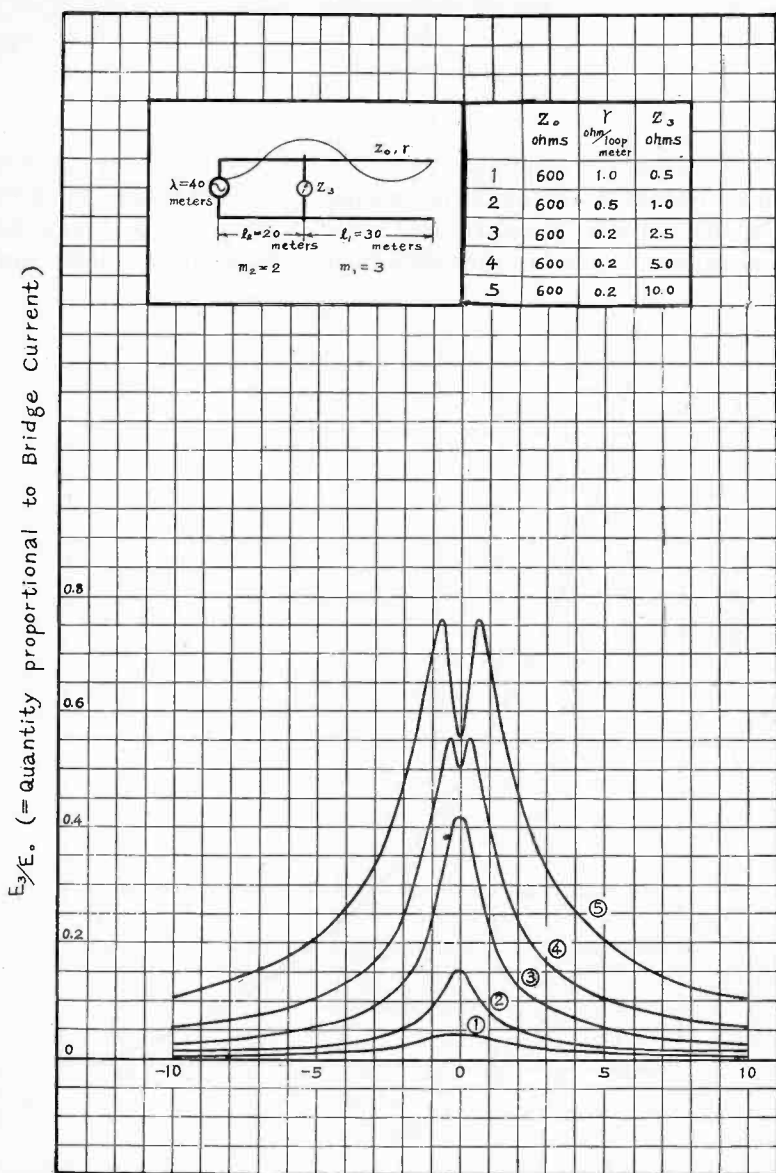

$$\delta_2 \left( \equiv \frac{4\Delta l_2}{\lambda} \right) \text{ in } \%$$

Fig. 7

$$\left. \begin{aligned} \nabla &< \frac{2(\nu + \sqrt{\nu^2 + 1})}{\mu_1^2} \\ \text{and} \quad \nabla &> \frac{2(\nu - \sqrt{\nu^2 + 1})}{\mu_1^2} \end{aligned} \right\} \quad (15)$$

In the upper inequality the right-hand term takes always positive value and hence this criterion is reasonable, while in case of the lower one which is always negative, this criterion need not be taken into consideration. Thus in order that there may occur a double hump

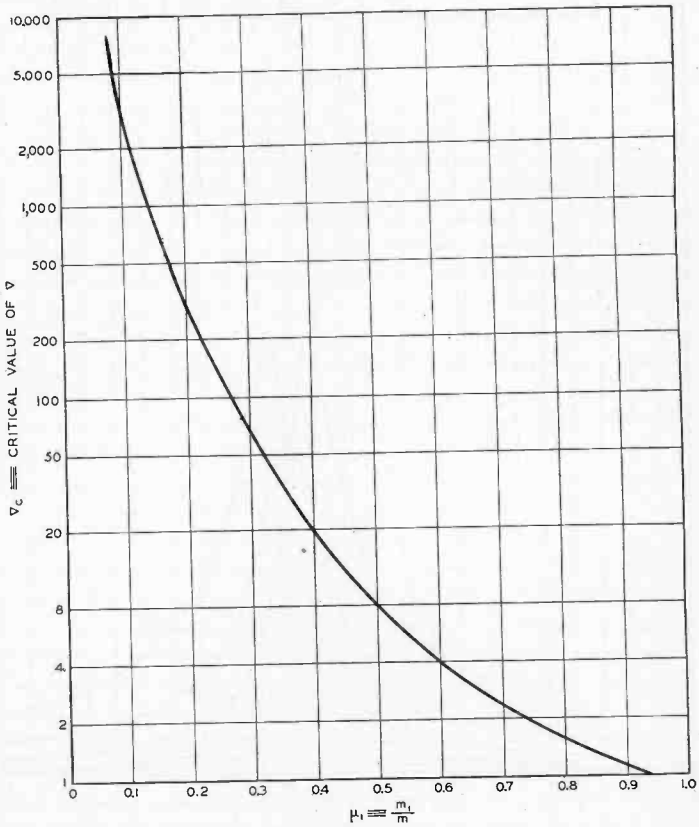

Fig. 8

phenomenon in the bridge current, the ratio of the line resistance to that of the bridge should be smaller than a critical value equal to

$$\nabla_c = \frac{2(\nu + \sqrt{\nu^2 + 1})}{\mu_1^2}$$

$$= \frac{2}{\mu_1^3} \{ (1 - 2\mu_1) + \sqrt{(1 - 2\mu_1)^2 + \mu_1^2} \} \tag{16}$$

which is calculated in the accompanying table.

TABLE I

$\mu_1$	$\nabla_c$
0.0	$\infty$
0.1	3215.0
0.2	308.5
0.3	66.65
0.4	20.20
0.5	8.00
0.6	4.01
0.7	2.375
0.8	1.565
0.9	1.110
1.0	0.528

Fig. 8 is presented to illustrate this quantity against  $\mu_1$ .

With a view to checking this criterion let us consider again some cases already dealt with in Fig. 7. Calculating the values of  $\nabla \equiv rl/Z_3$  for these cases, we obtain the following table. On the other hand, having a given relation  $\mu_1 = 0.6$  for each case, a critical value of  $\nabla$  is determined from Fig. 8, which is shown in the third column of the table. A glance at this table suffices to reveal the correctness of the above criterion.

TABLE II

Curve Number	$\nabla \left( \equiv \frac{lr}{Z_3} \right)$	$\nabla_c$ (from Fig. 8)	Double Hump (in Fig. 7)	Remarks
1	$\left( \frac{50 \times 1.0}{0.5} \right) 100$	4.01 (from $\mu_1 = 0.6$ )	does not occur	$l = 50$ meters
2	$\left( \frac{50 \times 0.5}{1.0} \right) 25$	4.01 (from $\mu_1 = 0.6$ )	does not occur	$m_1 = 3$
3	$\left( \frac{50 \times 0.2}{2.5} \right) 4$	4.01 (from $\mu_1 = 0.6$ )	critical	$m = 5$
4	$\left( \frac{50 \times 0.2}{5.0} \right) 2$	4.01 (from $\mu_1 = 0.6$ )	occurs	
5	$\left( \frac{50 \times 0.2}{10.0} \right) 1$	4.01 (from $\mu_1 = 0.6$ )	occurs	

Next some consideration shall be given to the amount of necessary displacement corresponding to the crest of double hump. From (13) already introduced and its accompanying abbreviations, the following expression for the required displacement degree will be derived:

$$\delta_{2m} = \frac{R}{Z_0} \frac{1}{\pi} \sqrt{\frac{2}{\nabla} \sqrt{\nabla \mu_1^2 + 1} - \mu_1^2} \equiv \frac{R}{Z_0} \xi. \tag{17}$$

Hence we see that the required displacement degree varies in

inverse proportion to the surge impedance of the line system.  $\xi$  in (17) is a function of both  $\nabla$  and  $\mu_1$ , and varies against these variables as shown for example in the following table.

TABLE III  
Values of  $\xi$

$\mu_1 \backslash \nabla$	0	0.5	1.0	2.5	5.0	10.0	25.0	50.0
0.0		0.637	0.451	0.285	0.2015	0.1425	0.0901	0.0637
0.1	$\infty$	0.643	0.458	0.296	0.217	0.1617	0.1142	0.0898
0.2	"	0.644	0.459	0.297	0.210	0.1450	0.1103	0.0817
0.3	"	0.640	0.454	0.289	0.205	0.1046	0.0843	0.040
0.4	"	0.631	0.441	0.270	0.1893			
0.5	"	0.617	0.421	0.236	0.1233			
0.6	"	0.598	0.392	0.177				
0.7	"	0.572	0.350	0.0767				
0.8	"	0.537	0.285					
0.9	"	0.492	0.1586					
1.0	"	0.431						

Moreover from (13) it is easily recognized that the matter should remain unaltered for either positive or negative value of the displacement of the bridge away from the point corresponding to the valley of double hump, which means that the shape of double hump is symmetrical.

Summarizing the investigations described above in the present section, it appears that, provided the bridge has a resistance alone,

1. Whether double hump phenomenon in bridge current may occur or not depends upon the position of the bridge on the parallel lines (which determines the value of  $\mu_1$ ) as well as the ratio of the line resistance to the bridge resistance ( $\nabla$ ) and not on the value of line surge impedance ( $Z_0$ ). (Equation (13))
2. Displacement length ( $\Delta l_{2m}$ ) or displacement degree ( $\delta_{2m}$ ) corresponding to each of the two crests in double hump has a simple relation of inverse proportion to line surge impedance ( $Z_0$ ). (Equation (17))

The above conclusion on the character of double hump phenomenon is seen to hold without much error in a general case for the bridge having combined resistance and reactance, as proved in the subsequent section.

### III. FURTHER EXPERIMENTS AND THEIR THEORETICAL EXPLANATIONS —CASE OF REACTIVE BRIDGE

It was found later that in all of the experiments made in reference to the previous investigations the currents in both of the two lines at its loop point had been not equal and also that the points at which the bridge had been attached to the lines did not lie in a symmetrical position with regard to distribution of standing waves.

It would be easily anticipated that these two undesirable circumstances would result in blurring the characteristics of the double hump phenomenon. Location of the ammeter  $A_0$  in one line together with

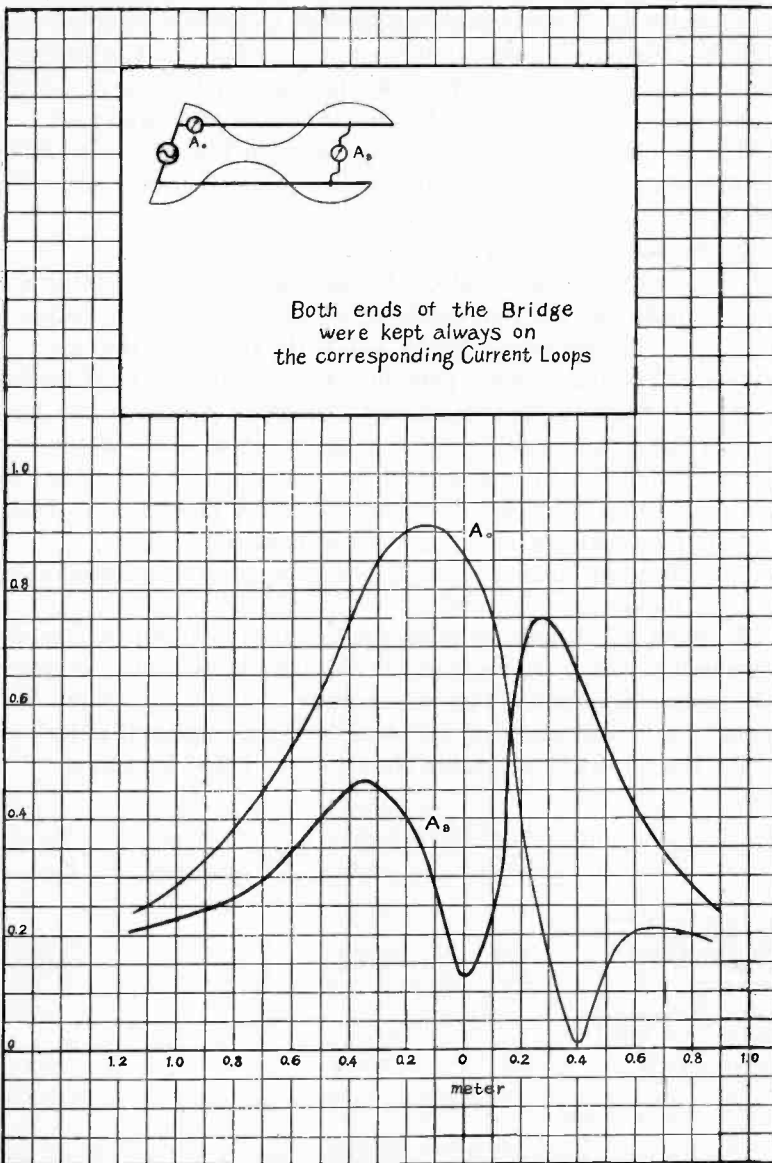

Displacement of Bridge from a Current Loop

Fig. 9

the unequal lengths of the leading wires to the parallel lines from the generating set is probably responsible for such an unsymmetry.

An experiment was made, taking care to obviate as much as possible the undesired circumstances mentioned above. The bridge used in the experiment consisted of two flexible conductors of 0.6 meter length each attached to both terminals of a hot-wire ammeter.

The result of the experiment is plotted in Fig. 9, which shows us the characteristics of the double hump more distinctly than Figs. 2 and 3.

Inspection of these figures reveals the fact that:

1. Two crest values of the bridge current are unequal in amplitude and the one nearer to the generator end is larger than the other, except Fig. 9, where the reverse is the case.
2. The current in the portion of the line running from the bridge toward the generator end (indicated by  $A_0$  in the figures) takes a maximum value at a certain position of the bridge, which is a little displaced from the position where the bridge current takes a minimum value, the direction of this displacement being toward the generator end.
3. The line current sometimes accompanies a minimum near its maximum. See Fig. 9.

In short, all these peculiarities are seen to be due to the existence of an inductance in fair amount in the bridging circuit. In order to substantiate this point, the writer measured and calculated the resistances and reactances of the actual bridges employed in his experiments, the results of which are shown in the following table.

TABLE V

Bridge	Measured at $\lambda = 40$ meters		Calculated from the dimensions	
	Resistance	Reactance	Resistance	Reactance
(A) Ammeter with two wires of length 12 cm each. (Used in reference to Figs. 2 and 3.)	0.5 ohm	16 ohms inductive	0.5 ohm	10.7 ohms inductive
(B) Ammeter with two flexible wires of length 60 cm each. (used in reference to Fig. 9)	0.5 ohm	45 to 75* ohms, inductive	0.5 ohm	77.2 ohms† inductive

\* Varied within these two limits according to whether the flexible wires were stretched or crooked.

† The wires are stretched.

A glance at this table shows that the bridge behaves as an inductance rather than a resistance. For such a case, however, it is hard to discuss rigorously by the similar mathematical process as has been done for the former case of resistance bridge.

The shortest way to make clear the characteristics for the present

case would be to put into the following equations (18) and (19) some appropriate numerics and calculate out the current through the bridge.

The case of a bridging circuit having a pure reactance of magnitude of  $Z_3$  is equivalent to putting  $Y_3 = 1/jZ_3$  into (10), which results in

$$K = \left[ \frac{1}{\mu_1} \frac{1}{1+x^2} + d_1 x \right] + j \left[ \frac{1}{\mu_1} \frac{x}{1+x^2} - d_2 + (\alpha l)^2 \frac{m_1 m_2}{m^2} x \right] \tag{18}$$

$$\equiv a' + j b',$$

where

$$a' \equiv \frac{1}{\mu_1} \frac{1}{1+x^2} + d_1 x$$

$$b' \equiv \frac{1}{\mu_1} \frac{1}{1+x^2} - d_2 + (\alpha l)^2 \frac{m_1 m_2}{m^2} x \tag{19}$$

$$\equiv \frac{1}{\mu_1} \frac{x}{1+x^2} - d_2$$

Dimensions of the parallel lines in actual use are illustrated in Fig. 10 in the light of which calculation of resistance  $R$  was made with the

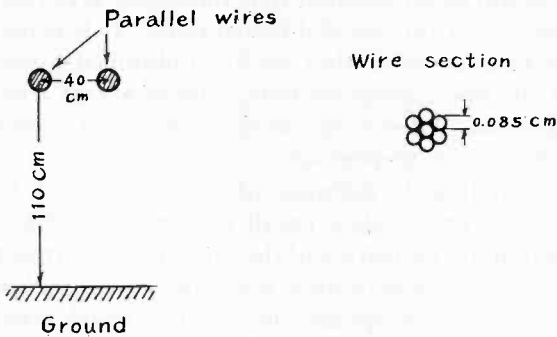

Fig. 10

result that  $R = 0.2$  ohm per loop meter at  $\lambda = 40$  meters. Assumption was made that  $Z_0 = 600$  ohms approximately, and let  $\lambda = 40$  meters,  $l_1 = 30$  meters, or  $m_1 = 3$ ,  $l_2 = 20$  meters, or  $m_2 = 2$ , and  $\mu_1 = 0.6$ .

Putting the above numerics into equations (18) and (19) we have two curves as shown in Fig. 11, in which  $A$  corresponding to the case for the bridge of  $Z_3 = j 15$  ohms and  $B$  for  $Z_3 = j 60$  ohms.

The values of  $\delta_{2m}$  corresponding to the two crests of the bridge current are written in the figure. Comparing these values to those for the case of pure resistance, there exists appreciable difference between the values of both  $\delta_{2m}$ , regardless of whether the bridge circuit is of resistance or reactance. In the figure,  $J$  represents the theoretical value



of the ratio of the minimum of the current through the bridge at the valley to its maximum at the crest.

In the light of the theoretical results shown in Fig. 11, let us proceed to a further discussion on the results of the corresponding experiments actually made with reference to Figs. 2, 3, and 9. Comparing the values of  $\delta_{2m}$  for both the theoretical and actual cases, it is recognized that the values in the latter cases are greater than those in the former.

In the writer's opinion these deviations are probably due to electrical dissymmetry of both lines of the parallel line system, which is an important factor to modify the double humped form of bridge current, and in actual case such dissymmetry was observed with the aid of a neon lamp. The two corresponding current loops on both of the lines were not just face to face but displaced some distance from one another, which amounted sometimes to 0.23 meter. This displacement tends evidently to flatten and widen the form of bridge current.

The matter next to be considered is the effect of bridge reactance on resonance of the parallel line system. As the bridging circuit has some reactance it would be anticipated that there may give rise some effect of it on resonance of the parallel line system. It is considered to be due to the resonance effect that we have obtained a maximum and minimum of the line current on both sides of a true current loop as shown in Fig. 9, attributed in the writer's opinion to a series resonance and parallel resonance, respectively.

When the combined reactance of the bridge and the circuit I becomes infinity, the so-called parallel resonance phenomenon takes place. The minimum indication of the line current corresponds to this condition. In the said condition it is natural to have a heavy current circulating around the bridge and the circuit I, which accounts for the fact that of the two crest points of the bridge current shown in Fig. 9 the one on the side of the parallel resonance point above described shows larger current than the other.

It is to be noted that the reactance component of the circuit I changes its amplitude as well as sign according to the displacement length and direction of the point under consideration away from a current loop. The same is true for circuit II also. Thus it would be easily seen that there may give rise also a series resonance in the system viewed from the generator end. Indeed, referring to Fig. 9, the fact that the line current attains its maximum value at a point a small distance nearer the generator end than a true current loop is due to the series resonance effect.

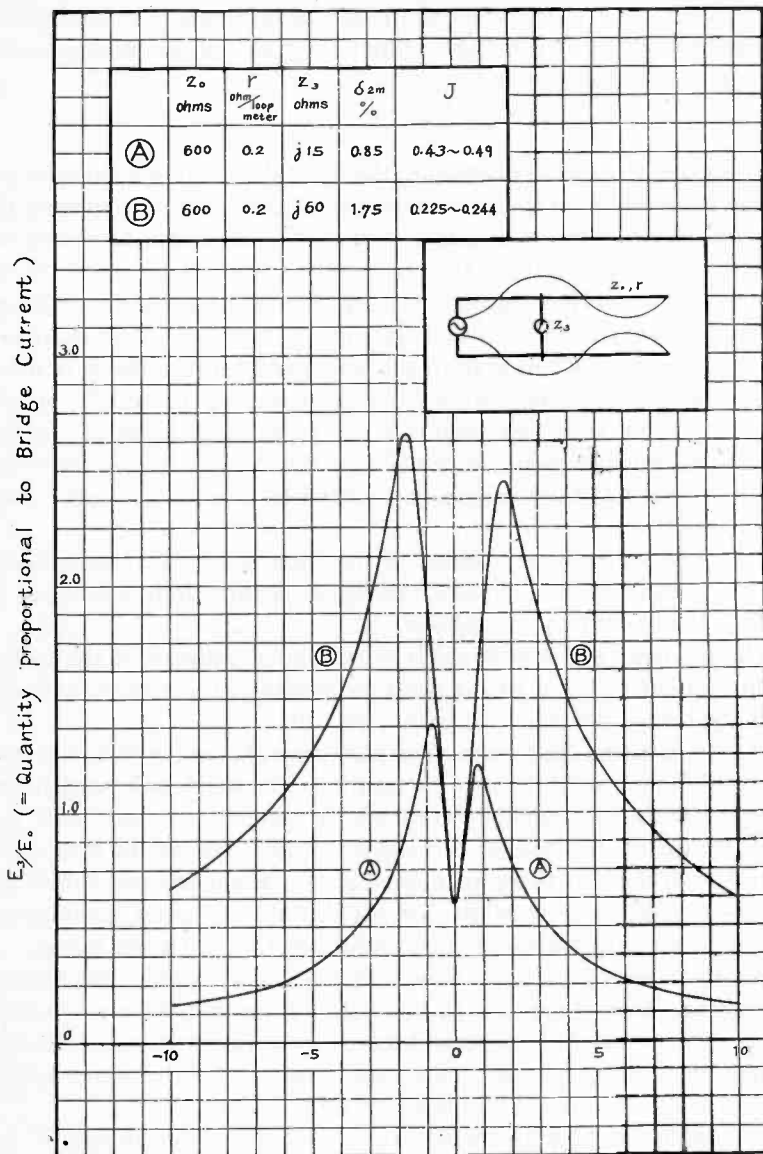

$\delta_2 (\equiv \frac{4\Delta I_1}{I_1})$  in %

Fig. 11

From the viewpoint of coupling of two nearly resonant circuits, it can be considered that the double hump phenomenon is the result of coupling circuit I to circuit II by means of circuit III, though it is ordinarily avoided by making circuit I short so that no mode of oscillation occurs at the free end.

#### IV. CONCLUSION

From the present investigation, theoretical as well as experimental, it is concluded that in the parallel line system for use in frequency determination a double hump phenomenon of bridge current occurs necessarily quite apart from the well-known absorption effect to be encountered when the coupling between generating set and the system is too close, provided the circumstances are sufficient, that is to say,

1. The parallel line system has been put near resonance, in other words standing waves have been set up originally on the system, in which condition the input impedance of the line system between the position of the bridge and its free ends viewed at the bridge point is usually small in the same order as that of the bridge.
2. The ratio of impedance of bridging circuit to the total resistance of the system exceeds a certain limit according to the position of the bridge.

The phenomenon occurs easily when the impedance of the bridge is quite large compared to the total resistance of the system and also when the bridge lies near the generator end.

It is to be noted that when a double hump phenomenon is observed in the bridge current, the true current loop lies at its valley and not at either of two crest points. Doubtless if the line system were put originally far off resonance, the above phenomena would disappear. When the bridge has some reactance other phenomena are sometimes seen in the line current, which are attributable to series resonance as well as parallel resonance of the system together with the bridge.

Briefly, it may be said that the writer has made trouble for himself and then analyzed it, but it may be worth noting that the phenomenon stands on the same theoretical basis as an interesting method of production of three-phase oscillations invented by the same writer, which will be set forth in the near future.

In conclusion the writer wishes to pay the deepest thanks to E. Iso for his valuable assistance throughout the experiments.



## WEATHER FORECASTING BY SIGNAL RADIO INTENSITY: PART 1\*

By  
R. C. COLWELL

(West Virginia University, Morgantown West Virginia)

**Summary**—Along the meridian from Pittsburgh, Pennsylvania, to Morgantown, West Virginia, and at a distance of 60 miles, the night intensity of KDKA sometimes rises above the day signal and sometimes falls below it. Observations during 1927 and 1928 have shown that this phenomenon foreshadows weather conditions from twelve to twenty-four hours ahead. A rising curve after nightfall indicates an approaching storm, while a falling curve is followed by fair weather. Typical curves are shown.

DURING the last three years, many measurements of the signal intensity from KDKA have been taken on a Shaw recorder at Morgantown. These fading curves have certain definite characteristics. During the daylight hours the intensity is fairly steady; as the sun sets there is a twilight fading which gradually turns over into the well-known night signal with its occasional violent fluctuations. Observation has shown that the night signal may on the average be equal to, greater, or less than the day signal. (This statement refers only to the reception of KDKA at Morgantown, which is 60 miles due south of the sending station.) The typical night curves shown in Figs. 1, 2, and 3 were taken during the fall of 1928 and were begun after the twilight fluctuation had disappeared. It will be seen that

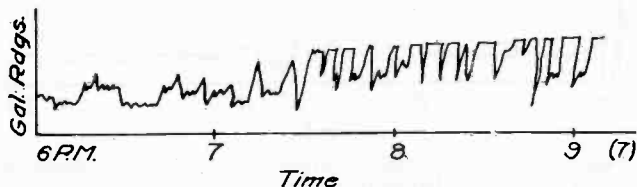

Fig. 1—Tuesday, November 20, 1928. Increasing intensity after nightfall. An indication that November 21 would be stormy.

these curves illustrate the statement regarding the relation between night and day intensity. It was found also that an increasing signal after nightfall indicated a tendency toward rain, while a decreasing signal after nightfall portended clearing weather. If the night signal on any given day neither increased nor decreased, then the weather the following day would be approximately like that of the day on which the curve

\* Dewey decimal classification: R113.5.

was taken. In this way it has been possible to predict weather conditions for one day ahead by radio intensities alone.

The radio intensities referred to are obtained by averaging the signal strength throughout the evening hours. At first a planimeter was used, but it later became possible to estimate the average increase by the eye alone. If the day has been very fine an increase of 75 to 100 per cent in the night signal will almost certainly indicate

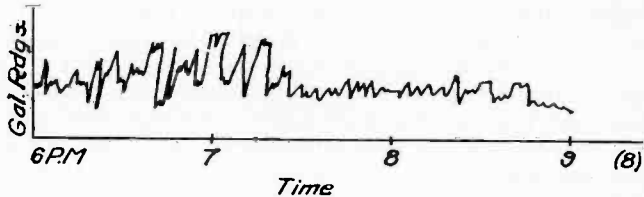

Fig. 2—Sunday, November 18, 1928. Decreasing intensity after nightfall. An indication of clearing weather on the following day.

rain the following day; with a 50 per cent increase, the following day will be cloudy. If the day is cloudy tending toward rain, then a rise of only 50 per cent in the average signal strength of the night curve shows that there will be rain the next day. If the day on which the curve is taken has been very stormy a fall of 50 per cent in the night intensity will indicate clearing weather. These curves seem to hold in both winter and summer, but it is not possible in winter time to foretell whether the storm will be rain or snow. A very large increase of signal

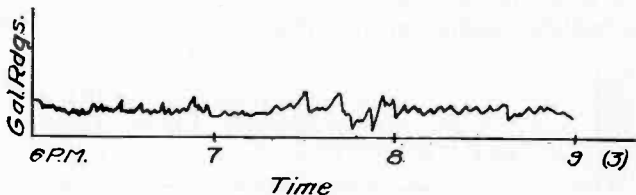

Fig. 3—Tuesday, October 9, 1928. Intensity constant after darkness sets in. No change in weather conditions.

intensity after nightfall is almost invariably a precursor of an approaching storm.

Although these curves have been taken at night, it has often been observed while setting the instrument during the day that a strong day intensity is followed by colder weather from 12 to 24 hours later; while a weak day signal indicates warmer weather.

Several of the curves taken in 1927-1928 are shown and the method of prediction outlined. The curve taken on June 2, 1927 showed that the signal intensity after nightfall remained the same for an hour or so and then tended to decrease. This indicated that the

early part of June 3 would resemble June 2, but there would be some tendency toward clearing weather in the afternoon. June 2 was cloudy with some rain; there was rain in the morning of June 3 with clearing weather in the afternoon. (Fig. 4)

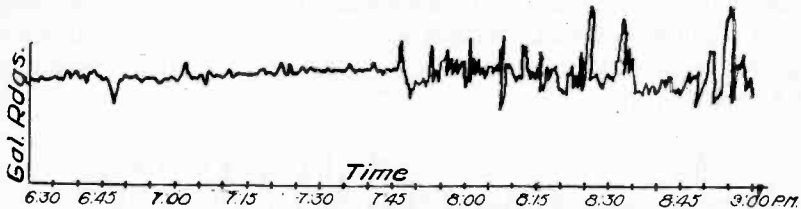

Fig. 4—June 2, 1927.

Fig. 5 shows the curve of July 18. The day was clear and warm, and the curve did not rise very much after nightfall; this indicated a continuation of fine weather on July 19.

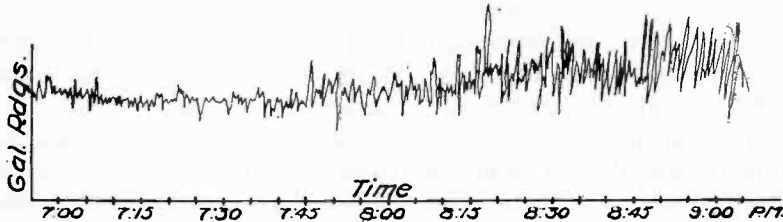

Fig. 5—July 18, 1927.

The curve of August 2 continued to rise after darkness set in (Fig. 6). On August 2 the sky was covered with broken clouds; the high signal intensity by night was indicative of rain. On August 3 it rained most of the day.

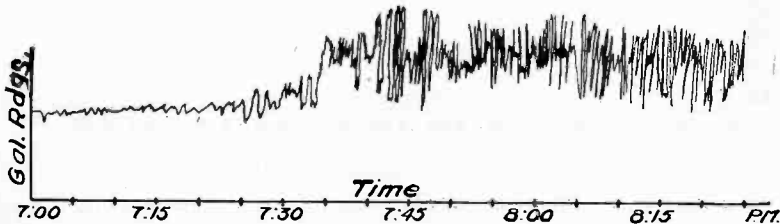

Fig. 6—August 2, 1927.

November 13 was clear and cool without any clouds. The rising curve (Fig. 7) showed a probability of cloudy weather the next day. November 14 was a cloudy day.

On Friday, December 23, 1927, there were broken clouds in the sky with some sunshine. The curve showed that the next day would be much cloudier. (Fig. 8) This turned out to be true.

Although in the curves shown, the prognostications were correct, about 5 per cent of the readings were entirely in error. This error seems to be associated with storms which come directly from the south.

Fifteen curves were taken from June, 1927, to the end of January, 1928, and one only, that of December 26, 1927, was wrong—an average of about 93 per cent. With later readings it was found that such a high degree of accuracy cannot be maintained especially in the months of March and April.

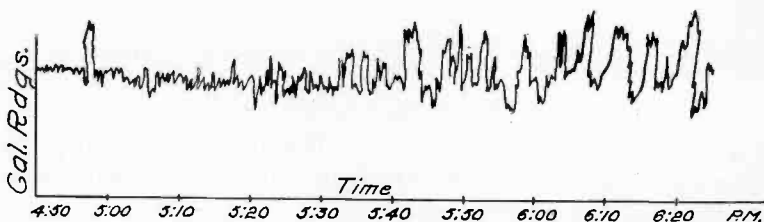

Fig. 7—November 13, 1927.

The curves under discussion in this paper were taken on the following dates: 1927: June 2; July 18, 19, 26, 30; August 3, 13; November 13, 28; December 18, 23, 26. 1928: January 8, 15, 29.

So far this method has only been worked out for the single locality (Morgantown, West Virginia) and the generalization should not be made that other signals in other places will give similar results. Perhaps the most important part of the investigation is the proof that the atmosphere does have a decided effect upon radio signals and that this effect foreshadows weather conditions 24 hours ahead.

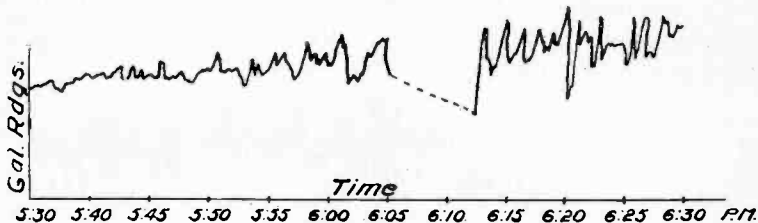

Fig. 8—December 23, 1927.

It seems probable that as the cyclones and anti-cyclones sweep across the continent, the region of low barometric pressure with its ascending columns of air reaches Pittsburgh and Morgantown at the same time provided it comes directly from the west, and similarly for an anticyclone with its descending air column. If this hypothesis is correct, an ascending column of air increases the night signal while a descending column decreases it. If, moreover, the storm approaches from the south, Pittsburgh and Morgantown may have different barometric pressures and then the method fails.

## A METHOD OF MEASURING THE RADIO-FREQUENCY RESISTANCE OF AN OSCILLATORY CIRCUIT\*

BY

HAJIME IINUMA

(Electrotechnical Laboratory, Ministry of Communications, Tokyo, Japan)

*Summary*—A method of measuring the resonant impedance and radio-frequency resistance of an oscillatory circuit, using a screen-grid tube, is described. It is based upon the principle of the dynatron oscillator and it requires neither radio-frequency measuring instruments and standards, nor sources of radio-frequency currents.

The results obtained by this method at frequencies from 600 to 1250 kc per sec. agreed within 2.5 per cent with those obtained by the usual resistance variation method.

### INTRODUCTION

IN designing and operating radio transmitters and receivers, it very often becomes important to know the values of the resonant impedance  $L/Cr$  of a parallel resonance circuit, or the radio-frequency resistance  $r$  of the circuit. In the following pages, the writer presents a simple method of measuring these quantities, using the principle of the dynatron oscillator.

### PRINCIPLE OF THE METHOD

The method is based on the fact that, in an ordinary screen-grid tube, the anode has a negative resistance characteristic at certain operating voltages and the amount of this negative resistance can be varied over a wide range by adjusting the control-grid voltage. If an oscillatory circuit consisting of an inductance and a capacity connected in parallel is inserted in series with the anode circuit of a screen-grid tube and its negative resistance is gradually increased, oscillation will suddenly take place at a moment when it becomes just equal in magnitude to the resonance impedance of the oscillatory circuit. The negative resistance value at which the oscillation starts or stops is obtained from the static characteristics, and the resonance impedance may accordingly be determined.

Let the constants of the oscillatory circuit at high frequencies be  $L$ ,  $C$ , and  $r$ , and let the numerical value of the negative a-c resistance be denoted by  $|R_i|$ . Then by simple calculations it can be easily proved that the critical value of  $|R_i|$  at which the circuit begins to oscillate and the frequency  $f$  of this oscillation will be given by the follow-

\* Dewey decimal classification: R240.



ing equations, provided  $r$  is sufficiently small compared with the reactances of that circuit.

$$|Ri| = \frac{L}{Cr}(1 + \epsilon/4)$$

and

$$f = \frac{1}{2\pi\sqrt{LC}}(1 + \epsilon'/2)$$

where  $\epsilon$  and  $\epsilon'$  are functions of the circuit constants of the resonance circuit

and

$$|0 \leq \epsilon, |\epsilon'| \leq r/(L/Cr)$$

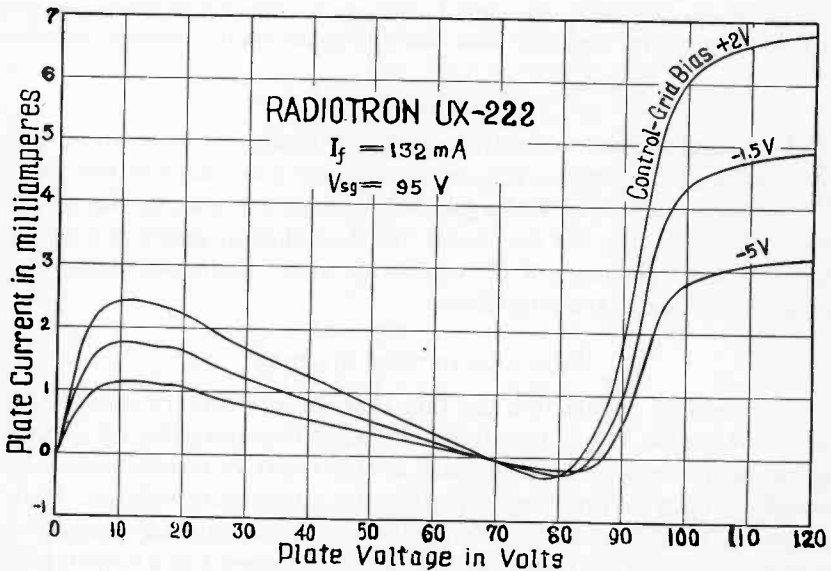

Fig. 1—Static characteristic curves of a Radiotron UX-222 showing falting characteristics.

With usual oscillatory circuits,  $r/(L/Cr)$  will be very small compared with unity. Even at such a very high frequency as 20,000 kc per sec., it will be only a few ten-thousandths and, at lower frequencies, it will rarely exceed a ten-thousandth. With a very close approximation, it can, therefore, be said that the circuit will begin to oscillate with the frequency  $1/2\pi\sqrt{LC}$ , when  $|Ri|$  is lowered just down to the critical value  $L/Cr$ . Therefore, if the frequency  $f$  and the critical value of  $|Ri|$  at which the oscillation begins to take place can be measured, the values of the product  $LC$  and the resonant impedance  $L/Cr$  will be known; hence, if one of the two constants,  $L$  and  $C$ , is known, we can

calculate the resistance  $r$ . The critical condition of the circuit and the frequency  $f$  can be found with sufficient accuracy by using a heterodyne wavemeter, or a heterodyne receiver and an absorption wavemeter. The value of  $|R_i|$  can be measured quite accurately with direct or low-frequency currents, unless  $|R_i|$  is too large and, as the values of  $L$  or  $C$  at high frequencies, those measured at lower frequencies can be used, to the first approximation, because the frequency has a very slight influence on the values of  $L$  and  $C$ .

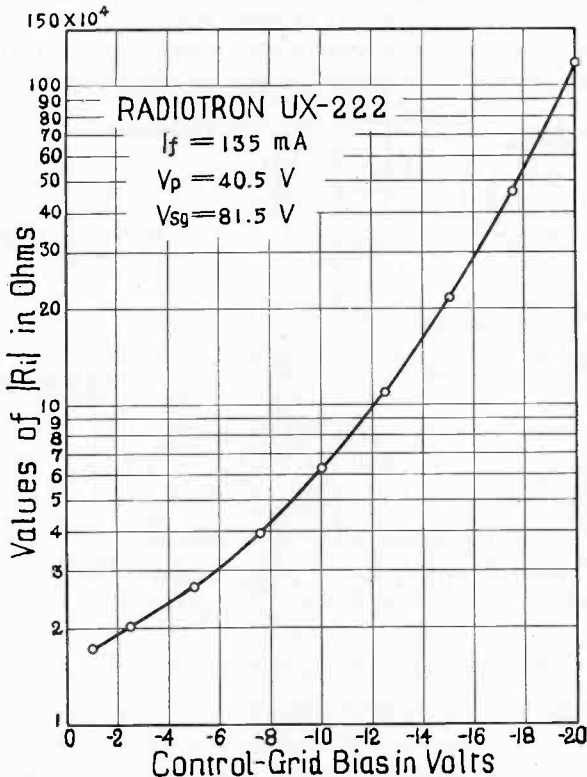

Fig. 2—Curve showing the controllability of  $|R_i|$  by control-grid bias.

#### METHOD OF MEASUREMENT

In the present experiment, a screen-grid tube UX-222 has been used as the negative a-c resistance. This type of tube has, as is well known, a falling current-voltage characteristic, when the plate and screen-grid voltages are properly chosen. (See Fig. 1.) Now if the control-grid bias voltage of this tube is changed, the plate and screen-grid voltages being fixed, the numerical value of the negative internal a-c resistance  $|R_i|$  can be varied over a wide range as shown in Fig. 2. The smaller

values are just applicable to oscillatory circuits for short waves, while the larger values are applicable to those for longer waves of a few hundred kc per sec. The difficulty of measuring  $|R_i|$  will, however, be increased as the value of  $|R_i|$  increases. From this point of view this method may, therefore, be advantageously used for short-wave rather than for long-wave measurement. A preliminary experiment has, however, been made at frequencies from 600 to 1,250 kc per sec., in order that the results obtained by this method may be compared with those obtained by the usual resistance variation method which cannot accurately be carried out at short waves.

The circuit arrangement used in the experiment is shown in Fig. 3. By potentiometer  $R_2$  the grid bias can be adjusted with sufficient

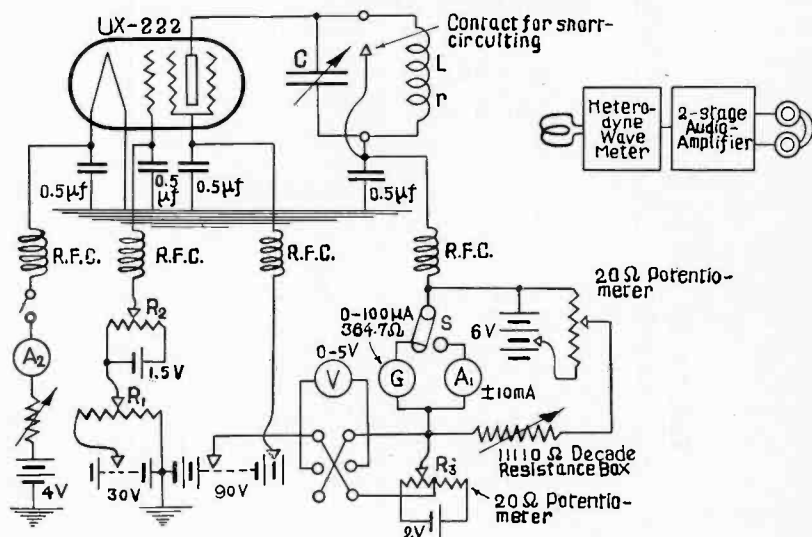

Fig. 3—Circuit arrangement of measurement.

precision to find the exact critical point at which the oscillation starts, while  $R_1$  serves only for its rough adjustment. Low-resistance potentiometer  $R_3$  provides, in measuring  $|R_i|$ , positive and negative voltage increments which voltmeter  $V$  indicates, and galvanometer  $G$  indicates greater portions of the corresponding current increments. To galvanometer  $G$  is supplied a current from the local circuit to compensate a greater part of the main plate current flowing through the galvanometer, so as to keep the pointer nearly at the center of its whole scale when the voltage increment is zero.  $A_1$  is a milliammeter for roughly observing the current balance before throwing off the slider of switch  $S$  to the side of  $G$ . The slider has such a special construction that the main circuit is never cut off in throwing it from one side to another,

in order to avoid any possible change of the internal condition of the tube. The coil in the oscillatory circuit used is a solenoid of 80 turns, 47.5 mm long, wound with d.s.c. B & S No. 24 copper wire on a bakelite former having an external diameter of 73 mm, the inductance of which, measured at the frequency of 1000 cycles, is  $404 \pm 5\mu h$ , while the condenser is of a usual low loss type with semicircular plates, whose maximum capacity is about  $210 \mu\mu f$ .

The procedure of the measurement is as follows. First, keeping the control-grid bias sufficiently high in order to permit the circuit to self-oscillate, a heterodyne wavemeter is adjusted to catch the beat of this oscillation and then the control-grid bias is lowered by means of  $R_1$  until the oscillation stops. In this procedure for roughly finding the critical point, the control of the grid bias affects the frequency so slightly that no further adjustment of the wavemeter is needed. In finding this critical point, one must take the precaution, however, to couple the wavemeter to the oscillatory circuit as loosely as possible, in order to avoid their interaction, as this would considerably affect the position of the critical point if the coupling is close. After finding approximately the critical point, the local circuit is adjusted to make the galvanometer  $G$  ready for the resistance measurement, and then the control-grid bias is again adjusted precisely by means of  $R_2$  to find the exact starting point of oscillation.

In the present experiment, the control-grid bias could be adjusted to this critical value within the error of 0.1 v, which corresponded to the error of about 3 per cent in  $|R_i|$ . Moreover, no appreciable difference could be observed between the values of the control-grid bias at the starting and stopping points of oscillation. After adjusting the grid bias accurately to the critical value, the oscillatory circuit is short-circuited with an auxiliary contact and then the critical value of  $|R_i|$  is measured as described above. It is quite necessary to take as the true critical value the mean of those measured with voltage increments in both positive and negative directions, especially when the voltage increments are large as in the case of measuring large values of  $|R_i|$ ; otherwise an error of 5 per cent may easily be introduced in  $|R_i|$  if the plate and screen-grid voltages are not properly chosen.

In the present experiment, however,  $|R_i|$  has been measured every time after the determination of the critical condition, for fear of involving errors due to possible changes of the tube characteristics. A curve as shown in Fig. 2, which enables one to find the value of  $|R_i|$  by merely measuring the control-grid bias, can also be made use of for its rough measurement. These values of  $|R_i|$  have been measured by the method mentioned above.

## RESULTS OF MEASUREMENT

The values of  $L/Cr$  of the oscillatory circuit measured at various frequencies from 600 to 1,250 kc per sec. are shown in Fig. 4. The capacity of the condenser itself when adjusted to the oscillation frequency of 690 kc per sec. and the total tube capacity measured by the usual substitution method at 1,000 kc per sec. were  $110 \mu\mu f$  and  $18.5 \mu\mu f$ , respectively, while the coil capacity was estimated<sup>1</sup> as  $4.8 \mu\mu f$ . Hence the total effective capacity of the oscillatory circuit is  $133 \mu\mu f$ , from which the inductance for radio frequency is found to be  $400 \mu h$ . The values of the radio-frequency resistance  $r$  calculated from the

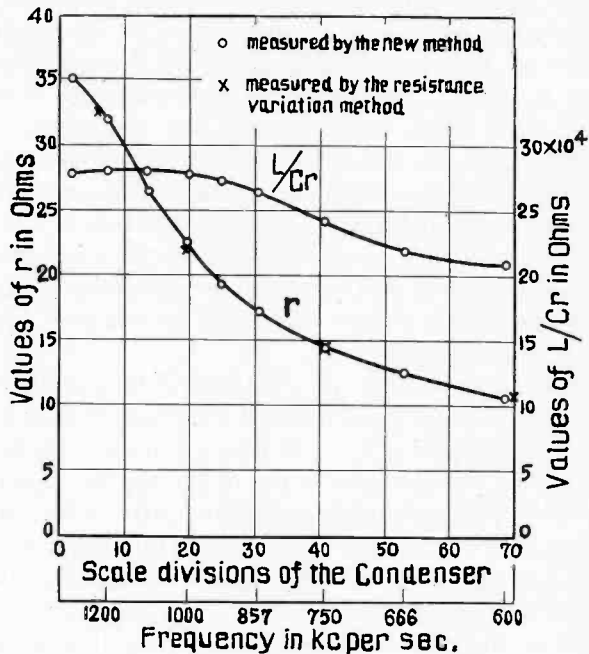

Fig. 4—Values of  $L/Cr$  measured by the new method and those of  $r$  calculated from them, compared with the results obtained by the resistance variation method.

measured values of  $L/Cr$ , assuming that  $L$  keeps a constant value of  $400 \mu h$  within the above frequency range, are also shown in Fig. 4. They agree within 2.5 per cent with the values of  $r$  measured by the usual resistance variation method, as shown in Fig. 4.

## CONCLUSIONS

The method described serves as an accurate method of measuring  $L/Cr$ , as well as  $r$ , of an oscillatory circuit and has many features which

<sup>1</sup> Yamamoto, I., "Self Inductance and Natural Wave Length of Single Layer Coils for Radio Use" *Jour. I. E. E. of Japan*, 43, No. 435, p. 913; Oct, 1924.

cannot be expected in the usual methods of resistance measurement. It requires neither current nor voltage measurement at radio frequencies. The instruments used for such measurements are not only of low accuracy, but also introduce unfavorable effects into the entire measuring circuit, which will make the resistance measurement quite difficult and inaccurate, when the frequency is raised up to the range of short waves. It also requires neither radio-frequency standard resistances which will also cause considerable errors due to the change of their values when the frequency is very high, nor a radio-frequency oscillator which is one of the causes of troubles in ordinary methods. These convenient features of the method enable one to measure  $L/Cr$  and  $r$  of oscillatory circuits quite easily even at very short waves.

The writer desires to acknowledge his indebtedness to Y. Kusunose and S. Kawazoe who often gave him valuable advice.



## THE FOUR-ELECTRODE VACUUM TUBE AS BEAT-FREQUENCY OSCILLATOR\*

BY  
S. REID WARREN, JR.

(Moore School of Electrical Engineering, University of Pennsylvania, Philadelphia, Penna.)

*Summary*—This paper describes briefly the use of one UX-222 four-electrode vacuum tube as a double oscillator and detector. Audio-frequency output is obtained in the beat note between the fundamental of the oscillation due to one grid and the second harmonic of that due to the other, giving a beat-frequency oscillator.

BEAT-FREQUENCY oscillators now available employ a pair of three-electrode vacuum tubes as oscillators. One is adjusted to generate a fixed frequency, while the other is arranged so that the generated frequency may be varied over a band of ten kc above or below the frequency of the fixed oscillator. By coupling to the output of each oscillator, and detecting the combination by means of a third three-electrode tube, there is obtained in the plate circuit of this third tube current of frequency equal to the difference between the frequencies of the two oscillators. By arrangement of the oscillator

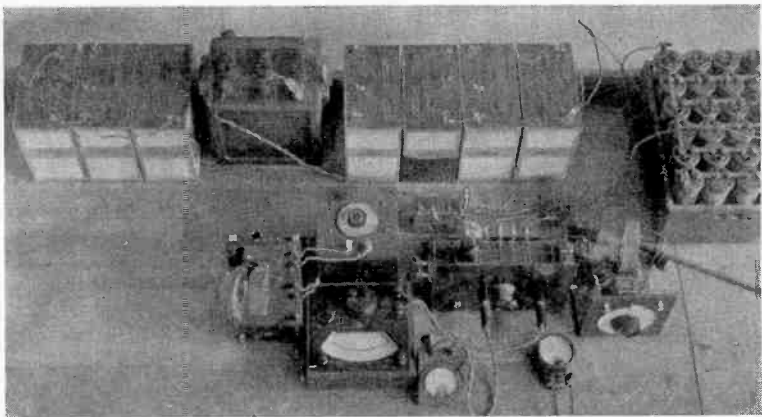

Fig. 1—Laboratory setup of the four-electrode vacuum-tube beat-frequency oscillator.

frequencies as indicated, the beat frequency is in the audio-frequency band and may be amplified for use in conjunction with many important and well-known laboratory tests of audio-frequency apparatus.

\* Dewey decimal classification: R344.

An effort has been made to employ one four-electrode vacuum tube to accomplish three objects: (1) to generate the fixed frequency; (2) to generate the variable frequency; (3) to modulate the two frequencies, making available the resultant beat frequency in the audible range.

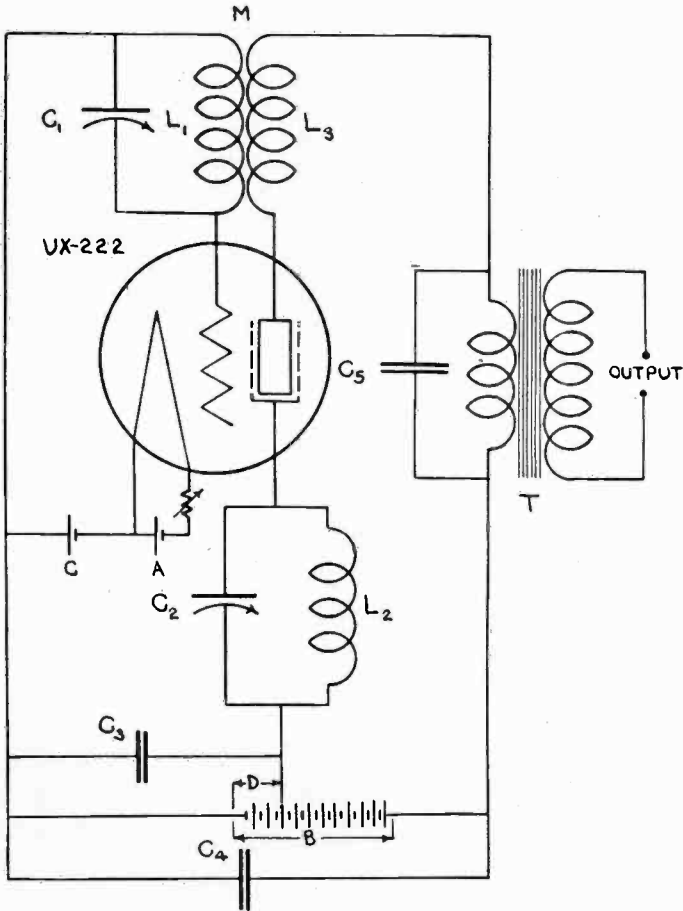

Fig. 2—Four-element vacuum-tube beat-frequency oscillator.

The Radiotron UX-222 four-electrode vacuum was used throughout the experimentation. The audio-frequency output was of correspondingly small amplitude. In order to make oscillographic studies of this output, a straight resistance coupled amplifier, providing uniform gain over the band used, was connected to the oscillator.

In Fig. 1 is shown the beat-frequency oscillator set up in laboratory fashion. Circuit in Fig. 2 shows the details of connection.



It will be noted that the outer grid is coupled to the plate only through the interelectrode capacitance. This was found to provide sufficient reaction to maintain oscillation at a frequency of approximately 32 kc, variable by condenser  $C_2$  to 35 kc. The plate circuit was

Plate voltage 200 v  
Screen-grid voltage 16 v  
Frequency 360 cycles per sec.  
A—12 ma calibrating line  
B—oscillator output  
C—60-cycle timing wave

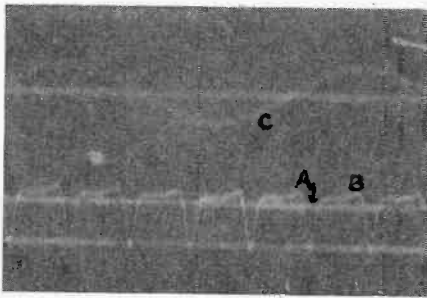
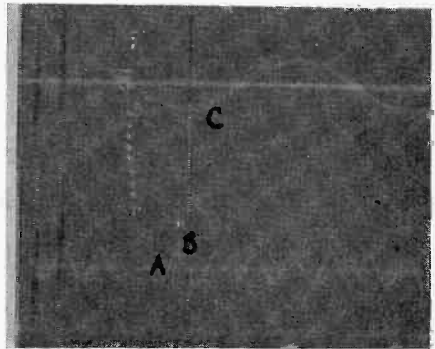

Plate voltage 200 v  
Screen-grid voltage 25 v  
Frequency 286 cycles per sec.  
A—12 ma calibrating line  
B—oscillator output  
C—60-cycle timing wave

Plate voltage 200 v  
Screen-grid voltage 16 v  
Frequency 240 cycles per sec.  
A—12 ma calibrating line  
B—oscillator output  
C—60-cycle timing wave

Coupling of plate to inner grid circuit greater than that used to obtain trace at top of page.

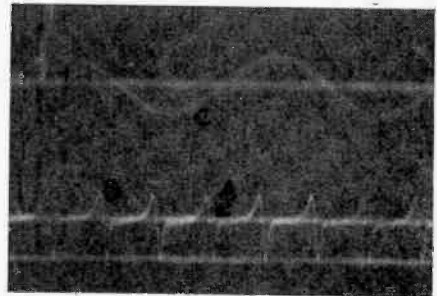

Fig. 3—Wave form of audio-frequency output.

coupled inductively to the inner grid circuit, and the resultant oscillation adjusted to 70 kc.

To obtain audio-frequency output, the difference frequency resulting from the combination of the 70 kc with the second harmonic of

the 32–35 kc variable frequency was filtered and amplified. The second harmonic was used to keep the oscillations from pulling into step for low-frequency outputs.

Several oscillograms, indicating the wave form of the output of the oscillator, are included in Fig. 3, with data affixed.

Of particular interest is the fact that changes in plate voltage have little influence on wave form and amplitude, while changes in screen-

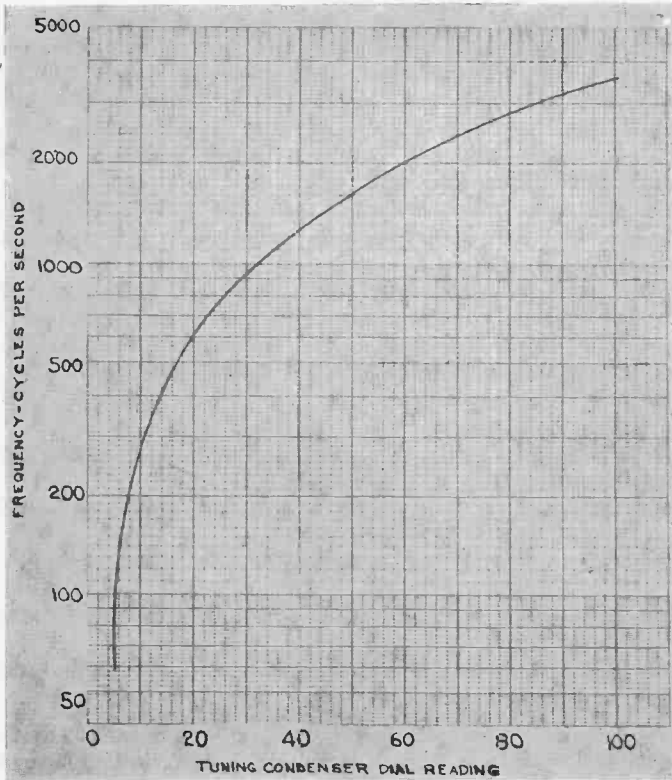

Fig. 4—Calibration curve for beat-frequency oscillator.

grid potential provide great changes in these important characteristics of the output.

Calibration of the oscillator is given in Fig. 4.

This work was undertaken under the direction of Prof. Weyl and Mr. Brainerd of the Moore School faculty. It is described more completely in a master's thesis of that school.

## BOOKLETS, CATALOGS, AND PAMPHLETS RECEIVED

A considerable number of organizations manufacturing broadcast receivers make their service manuals available to others than their authorized distributors and dealers. A list of some of these, together with information as to the particular models covered in the booklets issued, is given below. In some cases, a small charge is made to cover the cost of handling or other expenses met with in the preparation and distribution of the material. Manuals available to authorized distributors and dealers only are not listed.

The A-C Dayton Co. of Dayton, Ohio, has two service manuals available for free distribution to its authorized dealers and distributors, the price to others being fifty cents per copy. The first of these covers models XL-61, AC-63, AC-65, and AC-66 while the second concerns their "Navigator" model.

A manual covering the model 81 receiver of the Amrad Corp. of Medford Hillside, Mass., may be obtained by others than their authorized distributors and dealers at \$1.50 per copy.

Gratis distribution of service data on the model 7330 chassis of the Audiolia Radio Co. is available from that organization, which is located at 430 South Green Street, Chicago, Ill.

The Brunswick-Balke-Collender Co., of Chicago, Ill., has a number of manuals which are supplied to authorized distributors and dealers and may be obtained without charge by other service organizations handling Brunswick apparatus. The numbers assigned to these service bulletins and the models covered by them are as follows:

- No. 63. Radio model 5NO.
- No. 64. Panatropo with Radiola model 3NC8 and radio model 5NC8.
- No. 65. Panatropo with Radiola model 3KR8.
- No. 66. Radio models 5KR, 5KR0, and 5KR6. Panatropo with Radiola models 2KR0, 3KR0, and 3KR6.
- No. 67. Panatropo with Radiola De Luxe model 3NW8.
- No. 68. Radio model R-1.
- No. 69. Radio models 14 and 21. Combination radio and Panatropo model 31.
- No. 70. Radio models S-14, S-21, and combination radio and Panatropo model S-31.

A service manual describing the Screen-Grid 8 Receiver of the Columbia Radio Corp., 711 West Lake Street, Chicago, Ill., is furnished without charge to authorized dealers and distributors, and at \$1.25 per copy to others.

Copies of the service manual issued by Thomas A. Edison, Inc., of Orange, N. J., covering their models R-1, R-2, C-1, and C-2 (chassis "JR," "JC," and "SC") are available to all at \$1.50 each. A manual describing their Light-O-Matic models R-4, R-5, and C-4 is obtainable at no charge.

A service bulletin for the Grebe Super-Synchrophase A-C Screen-Grid Receiver will be supplied upon request to A. H. Grebe and Co., 70-72 Van Wyck Boulevard, Richmond Hill, N. Y.

The Philadelphia Storage Battery Co., of Ontario and C Streets, Philadelphia, Penna., has a number of service manuals for free distribution to service organizations handling large numbers of their receivers. Three manuals on models 86 and 82, 87 and 65, and 95, respectively, as well as a special booklet

entitled "Radio Manual of Useful Information 1928-1929," are available for distribution.

The circuit diagram of the model A.C. 24-25 Pierce Airo receiver may be obtained without charge from Pierce Airo, Inc., 117 Fourth Avenue, New York City, N. Y.

The Stewart-Warner Speedometer Corp., of 1826 Diversey Parkway, Chicago, Ill., has issued two service manuals describing their series 900 and 950 receivers, respectively. They will be sent gratis to service men requesting same.

A parts list and service manual for receivers manufactured by the Emerson Radio and Phonograph Co., 635 Sixth Avenue, New York City, may be had without charge upon request.



## MONTHLY LIST OF REFERENCES TO CURRENT RADIO LITERATURE

THIS is a monthly list of references prepared by the Bureau of Standards and is intended to cover the more important papers of interest to professional radio engineers which have recently appeared in periodicals, books, etc. The number at the left of each reference classifies the reference by subject, in accordance with the scheme presented in "A Decimal Classification of Radio Subjects—An Extension of the Dewey System," Bureau of Standards Circular No. 138, a copy of which may be obtained for 10 cents from the Superintendent of Documents, Government Printing Office, Washington, D. C. The various articles listed below are not obtainable from the Government. The various periodicals can be secured from their publishers and can be consulted at large public libraries.

### R000. RADIO COMMUNICATION

- R009 Reports of Institute of Radio Engineers Committee on Broadcasting. Proc. I. R. E., 18, pp. 15-37; January, 1930.

(Presents subcommittee reports on: (1) requirement of a dummy antenna for use during the warming-up period; (2) location of high-power broadcast stations with respect to populous areas; (3) synchronization—preliminary requirements for the conduct of tests; (4) permissible deviation of carrier frequency from licensed frequency; (5) allowable ratio of day to night power; (6) permissible intensity of harmonics and other spurious radiation; (7) modulation capability; (8) effective methods of power rating and radiation measurement.)

### R100. RADIO PRINCIPLES

- R113 Austin, L. W. Long-wave radio receiving measurements at the Bureau of Standards in 1928. Proc. I. R. E., 18, pp. 101-105; Jan., 1930.

(Monthly averages of daylight signal intensity at Washington for 1928 from a number of European and American low-frequency stations are given. The annual field intensity averages of both European and nearby American stations were found to be slightly lower than those of 1927, while atmospheric disturbances varied little from the earlier year.)

- R113 Heck, L. Experimentelle Untersuchungen an Wasserwellen zwecks Herstellung von Analogien zu elektromagnetischen Strahlungsvorgängen. (Experimental investigation of wave motion in water with the purpose of developing analogies to the propagation of electromagnetic waves.) *Zeitschrift für Hochfrequenztechnik*, 34, pp. 121-131, Oct., 1929.

(A description (well-illustrated) of experiments carried out with water waves and a theoretical discussion of the analogies between water waves and electromagnetic waves.)

- R113.5 Fuchs, J. Die Sende- und Empfangsverhältnisse im Hochgebirge mit besonderer Berücksichtigung der atmosphärischen Störungen. (Transmitting and receiving conditions in high mountains with special reference to atmospheric disturbances.) *Zeits. für Hochfrequenztechnik*, 34, pp. 96-101; Sept., 1929.

(Observations of radio transmission and reception made in August and September, 1928, at the meteorological observatory at Sonnblick, Austria, at an altitude of 3106 meters, gave results similar to those at lower levels, but atmospheric noises such as clicks, grinders, and whistles, which differed qualitatively or quantitatively from the usual diurnal trends appeared related to definite weather conditions in the environment.)

- R113.5 deMontessus de Ballore, R. A propos de la relation entre les orages et les parasites. (Concerning the relation between storms and atmospheric.) *L'Onde Electrique*, 8, pp. 463-64; October, 1929.

(Statistics giving monthly calculated and observed values of the frequency of storms and of temperature (at Paris) are tabulated to aid in the study of the influence of storms on atmospheres.)

- R113.6 Pedersen, P. O. The refractive index of spaces with free electrons.— A mechanical model. *Experimental Wireless & W. Engr.*, 7, pp. 16–21; January, 1930.

(Elementary considerations of an electron in space subject to the electric field of a radio wave show that the dielectric constant of the space may be positive, zero, or negative, and that in consequence, the refractive index may be reduced to values less than one and even to zero. A mechanical model is offered as an illustration of principles involved.)

- R113.6 Eckersley, T. L. Multiple signals in short-wave transmission. *Proc. I. R. E.*, 18, pp. 106–122; Jan., 1930.

(The facsimile records obtained in transmissions between New York and Somerton, England, give measurements of the time intervals between the various signals which produce distortion in the received record. From an analysis of these measurements information is secured (1) as to the angle within which the useful radiation is confined at the transmitter, (2) as to the distortion to be expected on different wavelengths and (3) as to the electron density in the Heaviside layer.)

- R125.6 Gresky, G. Richtcharakteristiken von Antennenkombinationen deren einzelne Elemente in Oberschwingungen erregt werden. (Directional characteristics of antenna combinations in which the individual elements are excited at their harmonics.) *Zeits. für Hochfrequenztechnik*, 34, pp. 132–140, October; pp. 178–82, November, 1929.

(Extending the work of previous investigations which achieved directivity of transmissions in the vertical and horizontal planes separately, the author aims at antenna systems good for directivity in both planes, for reception as well as transmission. Combinations of two antennas excited at the same harmonics are investigated in both series and parallel arrangements. With antenna separation,  $d$ , such that  $d/\lambda = 1/2 \cos B_{\max}$  (where  $B_{\max}$  is the angle made by the antennas with the horizontal plane when maximum radiation is present in the vertical plane), the sharpness of directivity is as great as or greater than with single antenna, and is greater for series than parallel connection. Sharpness in the horizontal plane is considerably greater for the parallel connection.

Part 2.—Combinations of antennas are examined which are excited to oscillation at their higher harmonics, also combinations of two antennas with like or different characteristics in series and parallel connections and combinations of three antennas with like characteristics. For the series arrangement, the characteristic in the vertical plane is somewhat sharper than for the parallel arrangement, while the directional characteristic of the parallel connection in the horizontal plane is considerably greater than that of the series connection.)

- R131 von Ardenne, M. Eine einfache Methode zur Bestimmung der Rohrenkonstanten. (A simple method for determining tube constants.) *Zeits. für Hochfrequenztechnik*, 34, pp. 143–145; Oct., 1929.

(For determination of tube constants the characteristic curve  $i_a = f(e_g)$  with  $R_a$  ohms is drawn and rectilinearly extended to intersect the straight line:  $i_{agr} = E_a/R_a$ . From the coordinates  $a, i_{agr}$  of the point of intersection the tube constants are ascertained by insertion in the characteristic curve equation which is given for direct and indirect heated cathodes.)

- R132 Nelson, J. R. Note on the stability of balanced high-frequency amplifiers. *Proc. I. R. E.*, 18, pp. 88–94; Jan., 1930.

(The question of stability in a balanced or neutralized radio-frequency amplifier is considered for one stage. Experimental and theoretical curves are given for the amplification including regeneration as the plate to control-grid capacity is varied. The results are discussed for  $n$  stages of an impedance-coupled amplifier by using the author's general equation for the limit of stable amplification  $A_s < \sqrt{2g_m/n\omega C_0}$  obtained for one stage. The desirability of using a new tube factor  $\sqrt{g_m/C_0}$  to compare tubes designed for use in high-frequency amplifiers is also discussed.)

- R132.3 von Ardenne, M. Fortschritte beim Bau und bei der Anwendung von Widerstandsverstärkern. (Development in the construction and application of resistance-coupled amplifiers.) *Zeits. für Hochfrequenztechnik*, 34, pp. 161–168; November, 1929.

- (The article discusses recent progress in the field of resistance-coupled amplifiers: (1) Using tubes having extremely high amplification factors in conjunction with high plate resistance, 300 fold amplification is attained with 200 volts on the plate, and 800-900 fold amplification with 1300 volts on the plate. Design of such tubes is discussed. (2) A suitable working out of the voltage transfer between stages is described. (3) New possible applications of the untuned high-frequency amplifier, which depend on its ability to amplify several frequencies at once, are discussed.)
- R133 Hollman, E. Der Elektronenoszillator als negativer Widerstand. (The electron oscillator as a negative resistance.) *Zeits. für Hochfrequenztechnik*, 34, pp. 140-143; Oct., 1929.
- (The writer treats the relation which exists, in the circuit of Barkhausen and Kurz between plate voltage and "negative" plate current. With suitable resonance conditions a negative resistance is found which results in self modulation. The negative resistance is ascribed to secondary electrons regardless of whether the plate potential is positive or negative. A practical application of the self modulation to ultra-short wave reception is suggested.)
- R133 Hollman, E. Das Verhalten des Elektronenoszillators in Magnetfeld. (The behavior of electron oscillators in a magnetic field.) *Elektrische-Nachrichten Technik*, 6, pp. 377-86; Oct., 1929.
- (Discussion of the effect of a homogeneous magnetic field on an electron oscillator, i.e., a three-electrode tube in a Barkhausen and Kurz circuit with regenerative oscillation system. Experiments show that a magnetic field shortens the wavelength of the electron oscillations and can produce a transition from Barkhausen-Kurz to "higher frequency" oscillations. Dependence of oscillation energy upon an external magnetic field permits a simple method of modulation independent of frequency within the range of pure Gill and Morrell oscillations.)
- R133 Martyn, D. F. Frequency variation of valve oscillators. *Experimental Wireless and W. Engr.*, 7, pp. 3-15; Jan., 1930.
- (The several methods by which the frequency of a radio-frequency tube generator is varied from its LC value are described and the theory of the change of frequency is discussed. A generator is described which is immune to these frequency variations to a high degree.)
- R134 Peterson, E. and Llewellyn, F. B. The operation of modulators from a physical viewpoint. *Proc. I. R. E.*, 18, pp. 38-48; Jan., 1930.
- (The mathematical expressions which occur in the treatment of non-linear devices as circuit elements are interpreted in terms of a graphical, physical picture of the processes involved. Application is made to the calculation of the intermediate-frequency output to be expected from a heterodyne detector having an incoming radio signal and a locally generated radio-frequency voltage applied to its grid and a circuit of finite impedance to the intermediate frequency attached to its plate.)
- R190 Terman, F. E. Some possibilities of intelligence transmission when using a limited band of frequencies. *Proc. I. R. E.*, 18, pp. 167-177; Jan., 1930.
- (Possibilities of more efficient employment of the radio frequencies for the transmission of intelligence are reviewed. It is pointed out that technical development awaits economic pressure.)
- R200. RADIO MEASUREMENTS AND STANDARDIZATION
- R201.6 Braden, R. A. and Forbes, H. C. A condenser bridge for factory inspection of variable condensers. *Proc. I. R. E.*, 18, pp. 123-136; January, 1930.
- (A capacity bridge designed for routine factory testing of variable air condensers of the gang type used in modern radio receivers is described. The bridge is balanced by capacity and phase angle adjustments. Its installation and use are described.)
- R210 Jouaust, R. Temps, fréquence, mesure des fréquences. (Time, frequency, standard of frequency.) *L'Onde Electrique*, 8, pp. 421-435; October, 1929.
- (The fundamental identity between the standard of time and the standard of frequency is pointed out. Inherent inaccuracies and irregularities of clocks are reviewed. The tuning fork and the quartz crystal-controlled generator used as secondary standards of frequency are described and factors limiting their accuracy are explained. The

usual method of standardizing the secondary standards of frequency is given. The production of harmonics for the measurement of radio frequencies is explained. A bibliography is included.)

- R210 Lejay, P. La radiotelegraphie et la mesure precise des durees. (Radiotelegraphy and the precise measurement of duration.) *L'Onde Electrique*, 8, pp. 436-448; October, 1929.  
(The precision of present standards of time is discussed. A method of obtaining an electrical impulse from a precision pendulum without a mechanical contact is described. A chronograph permitting a rapid reading of the records to a 10,000th of a second is also described. The use of the instrument for comparing the periods of two pendulums is outlined. Irregularities in the broadcast French time signals are explained.)
- R214 Hall, E. L. Method and apparatus used in testing piezo oscillators for broadcasting stations. *Bureau of Standards Journal of Research*, 4, pp. 115-130; January, 1930. Research Paper No. 135.  
(A method used by the Bureau of Standards for measuring the frequencies of piezo oscillators to be used for checking broadcast station frequencies as well as for calibration of frequency meters and measurement of station frequencies is described. The method combines high accuracy with precision due to employment of visual indication instruments in the zero beat method, and with flexibility due to use of harmonics.)
- R214 Harrison, J. R. Push-pull piezo-electric oscillator circuits. *PROC. I. R. E.*, 18, pp. 95-100; Jan., 1930.  
(The results of comparative tests of five different push-pull piezo-electric generator circuits are stated. The circuits were tested at 90 kc for relative power output and variation of frequency with circuit constants.)
- R220 Kinman, T. H. Measuring the interelectrode capacity of screen-grid valves. *Wireless Wld. and Radio Rev.*, 25, pp. 610-613; Dec. 4, 1929.  
(An adaptation of the substitution method of Hull and Williams is described in which a separate condenser is used to duplicate the shunting effect of plate-screen capacity while measuring the plate-grid capacity. A special standard condenser for matching interelectrode capacities is described and test circuits are given.)
- R261 Suits, C. G. A thermionic voltmeter method for the harmonic analysis of electric waves. *PROC. I. R. E.*, 18, pp. 178-192; January, 1930.  
(A thermionic voltmeter method for the harmonic analysis of complex electrical waves is given. The sensitivity and accuracy of the method are tested by measuring wave forms of known harmonic content. Accuracy greater than 1 per cent referred to the harmonic for a harmonic of 10 per cent of the fundamental and greater than 3 per cent accuracy for a 1 per cent harmonic may be obtained. Examples with oscillograms of various applications of the method are given. Sources of error and limits of sensitivity are discussed.)
- R270 Kiebitz, F. Die Wellenausbreitung des Deutschlandsenders. (Wave propagation of the Deutschland transmitter.) *Zeits. für Hochfrequenztechnik*, 6, pp. 173-175; Nov., 1929.  
(Field intensity measurements made in the autumn of 1928 at approximately 100 points within a radius of 100 km around the Deutschland radio transmitter at Zeesen show the absorption to differ greatly in different directions and to be relatively greater at nearer distances. A map illustrating the effect is given. (More complete article in *Elektrische-Nachrichten Technik*, p. 303, August, 1929.))
- R275 Büge, M. Direkte Messung des Modulationsgrades eines Telephoniesenders. (Direct measurement of the degree of modulation of a radio telephone transmitter.) *Zeits. für Hochfrequenztechnik*, 34, pp. 175-177; November, 1929.  
(For the direct measurement of the degree of modulation of a radiotelephone transmitter two circuit arrangements are given, both of which depend on the fact that the grid of an amplifier tube is influenced by the peak value of the voltage which is induced in a receiving coil by the transmitter to be measured. Whether the average or the instantaneous value of the degree of modulation is measured, is determined by the size of the measuring condenser.)



## R300. RADIO APPARATUS AND EQUIPMENT

- R325.6 Ray, M. American beam stations. *Wireless Wld. and Radio Rev.*, 26, pp. 18-21; Jan. 1, 1930.  
(An account is given of the achievements of the Bell Telephone Laboratories in directed short-wave transmission and reception.)
- R331 Cadwell, H. V. High vacuum. *Radio Engineering*, 10, pp. 38-41; January, 1930.  
(The problems attached to the production and maintenance of high vacuum radio tubes are discussed.)
- R343.7 Miessner, B. F. Hum in all-electric radio receivers. *Proc. I. R. E.*, 18, pp. 137-166; January, 1930.  
(The results are presented of some further work in the field of all-electric receivers directed particularly toward the design of receivers and power supply systems requiring a minimum apparatus and providing a maximum of hum eliminating action. An enumeration of the causes of hum, the analysis and measurement of hum, and methods of its elimination are included.)
- R344 Raguet, E. C. Plate-voltage supply for naval vacuum-tube transmitters. *Proc. I. R. E.*, 18, pp. 49-66; January, 1930.  
(The experience and conclusions of the U. S. Navy with regard to the various types of plate-voltage supply for vacuum-tube transmitters are outlined. The character and control of output, the source of primary power, the reliability and repairs, the ruggedness and efficiency are discussed in some detail for the various types. Data regarding comparative first costs and operating costs are given. The advantages and disadvantages of the motor-generator and the mercury-vapor rectifier tube are tabulated.)
- R360 Wunderlich, N. W. and Dohan, W. R. Sensitivity measurements and performance tests on radio receivers in production. *Radio Engineering*, 10, pp. 31-37; Jan., 1930.  
(A discussion of the test methods used in building the Victor radio sets is given.)
- R385.5 Salinger, H. Beobachtungen am Kohlemikrophon. (Observations on the carbon microphone.) *Elektrische-Nachrichten Technik*, 6, pp. 395-99; October, 1929.  
(Experimental results of a study of the relation between contact pressure and resistance in microphones of the carbon granule type are presented.)

## R500. APPLICATIONS OF RADIO

- R536 Geyger, W. Zusammenfassender Bericht: Die geoelektrischen Untersuchungsmethoden mit Wechselstrom. (Comprehensive report: Methods of geo-electric investigation with alternating currents.) *Zeits. für Hochfrequenztechnik*, 34, pp. 184-190; November, 1929.  
(The theory and application of methods employed in geophysical prospecting, e.g., the potential and the electromagnetic methods, each of which may be employed in various ways.)
- R582 Schröter, F. Abbildung und Verstärkung bei Fernsehern. (Reproduction and amplification in television.) *Elektrische-Nachrichten Technik*, 6, pp. 439-453; November, 1929.  
(Description of apparatus employed and results attained on a new system of television.)
- R582 Mesny, R. La phototelegraphie d'amateur. (Amateur phototelegraphy.) *L'Onde Electrique*, 8, pp. 449-62; October, 1929.  
(The theory of phototelegraphy is simple treated. The principles of apparatus used in transmission and reception are explained. The problem of synchronization is discussed and special apparatus simplifying the problem is described.)

- R592 Shearing, G. and Dorling, J. W. S. Naval wireless telegraph communications. *Experimental Wireless and W. Engr.*, 7, pp. 23-25; January, 1930.  
 (A short account of wireless telegraph apparatus for naval purposes is given. The chief technical features of some of the apparatus used under sea-going conditions are explained. Abstract of paper presented before Institution Electrical Engineers on Dec. 4, 1929.)

## R800. NON-RADIO SUBJECTS

- 534 Janovsky, W. Über die Hörbarkeit von Verzerrungen. (On the audibility of distortion.) *Elektrische-Nachrichten Technik*, 6, pp. 421-430; November, 1929.  
 (An extensive study of the physical and subjective factors determining the detection of various kinds of distortion by the human ear.)
- 534 Sokoloff, S. J. Zur Frage der Fortpflanzung ultra-akustischer Schwingungen in verschiedenen Körpern. (On the question of propagation of ultra-acoustic vibrations in different materials.) *Elektrische-Nachrichten Technik*, 6, pp. 454-61; November, 1929.  
 (A study is made of the propagation of high acoustic frequencies in solid bodies, e.g. in materials of various different shapes, along wires, and in tubes of different materials.)
- 621.313.3 Adams, J. M. Time measuring by commercial alternating current with controlled frequency. *Jour. Optical Soc. of America and Rev. of Scientific Instruments*, 19, pp. 384-86; December, 1929.  
 (Results of experiments on two California power systems show that a synchronous motor driven from a commercial a-c supply with controlled frequency may be depended on for a single measurement of a time interval of the order of one second to one part in about 600.)
- 621.313.73 Steiner, H. C. and Maser, H. T. Hot-cathode mercury-vapor rectifier tubes (with discussion). *Proc. I. R. E.*, 18, pp. 67-87; January, 1930.  
 (A new type of rectifier tube is described which combines the advantages of the high-vacuum tube rectifier with the low and nearly constant arc-drop of the mercury-arc rectifier. Typical tube characteristics and the method of operation are discussed. A method is given for rating rectifier tubes in terms of peak inverse voltage and peak plate current. Single-phase and three-phase circuits are shown for use with the hot-cathode mercury-vapor tube.)
- 621.374.45 Razek, J. and Mulder, P. J. A bridge grid resistor amplifier. *Jour. Optical Soc. of America and Rev. of Scientific Instruments*, 19, pp. 390-403; Dec., 1929.  
 (A vacuum-tube bridge of high sensitivity employing two ordinary commercial tubes and special high grid resistors is described. The circuit may be compensated for small variations in the tube voltages. The method of compensation is explained. An application of the bridge to the measurement of small photoelectric currents is outlined.)



## CONTRIBUTORS TO THIS ISSUE

**Ballantine, Stuart:** Born September 22, 1897, at Germantown, Pa. Operator, Marconi Co., summers 1914–1915; H. K. Mulford Co., bacteriologists, 1916; Bell Telephone Co. of Pa., 1917; expert radio aide, U. S. Navy, in charge of research and development of radio direction-finder apparatus, Philadelphia Navy Yard, 1917–1920; organized Philadelphia Section of the Institute, 1920, and served as chairman until 1926. Studied mathematics at Drexel Institute, 1919, and mathematical physics, graduate school, Harvard University, 1920–1921. With L. M. Hull organized research work at Radio Frequency Laboratories, Boonton, N. J., 1922–1923. John Tyndall Scholar in mathematical physics, Harvard University, 1923–1924. Privately engaged in miscellaneous research work in radio, spectroscopy, astrophysics, propagation of electric waves in the upper atmosphere, at White Haven, Pa., 1924–1927. In charge of Research Division, Radio Frequency Laboratories, 1927 to date. Frequent contributor to the PROCEEDINGS, Associate member, Institute of Radio Engineers, 1916; Fellow, 1928.

**Byrnes, Irving F.:** Born October 15, 1898 at Beacon, N. Y. Entered General Electric Test Department in 1918. Engaged in laboratory work on earlier types of tube transmitters, 1919–1921. Developed duplex radiophone equipment used on *S.S. America* for ship-to-shore tests in 1922. Developed crystal-control equipment now in use at stations WEAf, WGY, KGO and KOA. At present engaged in development work on commercial and military high-frequency transmitters, aircraft radio equipment, crystal control, and train communication apparatus. Associate member of the Institute, 1923.

**Cobb, Howard L.:** Born July 17, 1896, at Salina, Colorado. Radio electrician, radio laboratory, Philadelphia Navy Yard, 1917–1919. Received B. S. degree in electrochemistry, Massachusetts Institute of Technology, 1924; foreman, Zenith Radio Corp., 1924–1925. Superintendent, R. C. A. service station, Chicago, 1925–1926. Radio engineering work, Benjamin Electric Co., Chicago, 1926–1927. Developed electrochemical condenser, Fansteel Products Co., 1927–1929. Developed electrostatic speaker for Potter Mfg. Co., 1929. At present, radio research work, Boonton Research Corporation, Boonton, N. J. Non-member of the Institute.

**Coleman, J. B.:** Born August 29, 1899. Received B. S. degree in E. E., Carnegie Institute of Technology, 1923. Engineer in charge, Radio Station WBZ, Westinghouse Electric and Manufacturing Co., Springfield, Mass., 1923–1925. Radio engineer, Transmitter Design, Westinghouse Electric and Manufacturing Co., East Pittsburgh, Pa., 1925–1927. Section engineer, high power transmitter design, Westinghouse Electric and Manufacturing Co., Chicopee Falls, Mass., 1927–1930. Radio engineer in charge of high power transmitters, R. C. A.-Victor Co., Camden, N. J., 1930. Associate member, Institute of Radio Engineers, 1925; Member, 1929.

**Colwell, Robert C.:** Born October 14, 1884, at Fredericton, N. B., Canada. Received A. B. degree, Harvard University; M. A. degree, University of New Brunswick; Ph. D. degree, Princeton University. Professor of physics, Geneva College, 1913–1923; assistant director of radio laboratory, West Virginia University, 1918–1919; professor of physics, West Virginia University, 1924 to date. Member, American Physical Society, Franklin Institute, American Mathematical

Society. Associate member, Institute of Radio Engineers, 1921; Member, 1929.

**Esau, Abraham:** Born June 7, 1884 at Tiegenhagen, Germany. University of Berlin, 1902-1905. Technische Hochschule, Danzig, 1905-1908. Received Ph. D. degree, University of Berlin, 1908. Assistant under Prof. Max Wein, 1906-1909. Assistant under Prof. Schmidt of Halle, 1910-1912; the Gesellschaft für drahtlose Telegraphie Telefunken, Berlin, 1912-1925. Professor of technical physics and director of the Institute for Technical Physics at Jena University, 1925 to date. Non-member of the Institute.

**Gerth, Felix:** Born 1885 at Nitzschka, Germany. Graduate, college in Altenburg, Germany. Studied mathematics and physical science, Universities at Leipzig, Jena, Munich, and Halle. Received Ph. D. degree, Halle University. Laboratory engineer under Dr. Rein and Professor Pungs, Wireless Telegraph Department, C. Lorenze Aktiengesellschaft, 1911. Manager, transmitter laboratory, same company, 1924 to date. Non-member of the Institute.

**Hahnemann, Walter M.:** Born May 6, 1879, at Annaberg, Saxony. Technische Hochschule, Munich, 1899-1902. Expert and engineer, A. E. G., 1903-1905. Engineer, Telefunken Gesellschaft für drahtlose Telegraphie m. b. H., Berlin, 1905-1906. Chief of wireless telegraphy division, C. Lorenz Aktiengesellschaft, Berlin, 1906-1909. Radiotelegraph engineer, German Navy, 1909-1912. Director, Signal Gesellschaft m. b. H., Kiel, 1912-1925. Director, C. Lorenz Aktiengesellschaft, Berlin-Tempelhof, 1925 to date. Non-member of the Institute.

**Hall, E. L.:** Born April 20, 1893, at Mansfield, Ohio. Received B. S. degree in E. E., Ohio State University, 1918. Radio section, Bureau of Standards, April, 1919, to date. Associate member, Institute of Radio Engineers, 1928.

**Hallborg, Henry E.:** Born April 24, 1884, at Stockholm, Sweden. Received B. Sc. in E. E., Brown University, 1907. Student engineer, Testing Department, General Electric Co., Schenectady, N. Y., 1907-1909. National Electric Signalling Co., Brant Rock, Mass., 1909-1912. Engineering staff, Marconi Wireless Co. of America, 1912. Expert naval radio aide, Norfolk, Va., 1914. General supervision of radio installation and development in the Fifth Naval District during war. After war, high power radio development work, Naval High Power Station, Annapolis, Md. Consulting engineer, C. Brandes, Inc., New York City, 1923. Engineering staff, Radio Corporation of America, 1925. Fellow, Radio Club of America; Fellow, American Institute of Electrical Engineers; Associate member, Institute of Radio Engineers, 1912; Member, 1914; Fellow, 1927.

**Inuma, Hajime:** Born March 3, 1907, at Haranomachi, Fukushima Prefecture, Japan. Graduate Osaka Higher Technical School, 1928. Radio engineer, Electrotechnical Laboratory, Ministry of Communications, Japan, 1928 to date. Associate member, Institute of Radio Engineers, 1928.

**Rolf, Bruno:** Born June 25, 1885, at Stockholm, Sweden. Received Ph. D. degree, University of Upsala, 1918. Director, Geophysical Observatory at Obisko, 1915 to date; superintendent of Radio Station of the Meteorological Bureau, 1920 to date. Non-member of the Institute.

**Warren, S. Reid, Jr.:** Born January 31, 1908, at Philadelphia, Pa. Received B. S. degree in E. E., Moore School of Electrical Engineering, University of Pennsylvania, 1928. Graduate Research Fellow, Moore School, 1928-1929. Received M. S. degree in E. E., Moore School, 1929. Research assistant to

Professor C. N. Weyl, Moore School, 1929 to date. Associate member, Institute Radio Engineers, 1929.

White, W. C.: Born 1890 at Brooklyn, N. Y. Received E. E. degree, Columbia University, 1912. Research laboratory, General Electric Co., Schenectady, N. Y., 1912 to date. Associate member, Institute of Radio Engineers. 1915; Member, 1925.

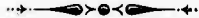

# NO NOTE CAN ESCAPE

## THORDARSON Power Amplification

Realistic reproduction for all occasions . . . and in every circumstance . . . that's what Thordarson's new line of complete Audio Amplifiers means to the listening world. And nothing short of actuality in sound reproduction will be accepted today.

### Thordarson Amplification Equipment Means Consistent Audio Excellence

The engineering laboratories of Thordarson . . . with years of research and experience behind them . . . have succeeded in solving the problems of sound reproduction. And with the utmost in manufacturing facilities, the most exacting specifications are faithfully and efficiently fulfilled.

Why not make use of Thordarson engineering service in your work? We can give you installation suggestions that will make your work easier and more profitable.

# THORDARSON

*Transformer Specialists Since 1895*

**THORDARSON ELECTRIC  
MANUFACTURING COMPANY**

Huron, Kingsbury and Larrabee Streets  
Chicago, Illinois, U. S. A.

*When writing to advertisers mention of the PROCEEDINGS will be mutually helpful.*

# Piezo Electric Crystals and Constant Temperature Equipment

## *Piezo Electric Crystals:*

We are prepared to grind Piezo Electric Crystals for POWER use to your assigned frequency in the 550 to 1500 KC band, *accurate to plus or minus 500 cycles* for \$55.00 fully mounted. Crystals for use in the HIGH FREQUENCY BROADCAST BAND (4000 to 6000 KC) for POWER use, accurate to plus or minus .03% of your assigned frequency, fully mounted, \$85.00. In ordering please specify type of tube used, plate voltage and operating temperature. All crystals guaranteed with respect to output and accuracy of frequency. Deliveries can be made within three days after receipt of order.

## *Constant Temperature Equipment*

In order to maintain the frequency of your crystal controlled transmitter to a high degree of constancy, a high grade temperature control unit is required to keep the temperature of the crystal constant. Our unit is solving the problem of keeping the frequency within the 50 cycle variation limits. Our heater unit maintains the temperature of the crystals constant to **BETTER THAN A TENTH OF ONE DEGREE CENTIGRADE**; is made of the finest materials known for each specific purpose and is absolutely guaranteed. Price \$300.00. Further details sent upon request.

## *Low Frequency Standards:*

We have a limited quantity of material for grinding low frequency standard crystals. We can grind them as low as *15,000 cycles*. These crystals will be ground to your specified frequency accurate to **ONE HUNDREDTH OF ONE PER CENT**. Prices quoted upon receipt of your specifications.

## Scientific Radio Service

*"The crystal specialists"*

P. O. Box 86

Dept. R6

Mount Rainier, Md.

*When writing to advertisers mention of the PROCEEDINGS will be mutually helpful.*



**Donald McNicol, Past President I.R.E., Fellow A.I.E.E., now Editorial Director of Radio Engineering and Projection Engineering.**



**NOTE.** We will be glad to send a sample copy of either publication upon request—

Donald McNicol, Fel. A. I. E. E., Fel. I. R. E., who for some years past has been Advisory Editor of **RADIO ENGINEERING** and **PROJECTION ENGINEERING**, will, in March, 1930, actively take up the work of editing these two technical journals.

Mr. Nicol has been closely identified with radio engineering since the beginning of the science in this country, and is a past president of the Institute of Radio Engineers. He is the author of hundreds of technical papers on radio, including the extensive work: *The Engineering Rise in Radio*, which had a wide reading in all parts of the world.

He was for four years chairman of the Committee on Communication, American Institute of Electrical Engineers, and for eight years a member of the publication committee of that Institute. He is internationally known in radio and communication circles and is the author of four standard textbooks on communication subjects.

**Projection Engineering** is published monthly, and deals with engineering developments of sound and light projection and theatrical engineering. The manufacture, design, installation and operation of home and theatrical motion picture and talking motion picture apparatus is treated exhaustively.

**Radio Engineering** has been published as a monthly journal for ten years. It covers the broad field of radio manufacture, engineering, testing, servicing, etc. It also treats thoroughly of the various industrial applications of radio and electronic circuits—communication, and experimental television, aeronautical and marine communication, public address systems, etc.

*Neither publication is sold on newsstands.*

Bryan Davis Publishing Co., Inc., 52 Vanderbilt Ave., New York City.

Please check your classification.

1. Enclosed find { \$2.00 for 1 yr.  
\$3.00 for 2 yrs. } subscription to { Radio Engineering.  
Projection Engineering.
2. Enclosed find \$3.00 for one year's subscription to both publications.

- Manufacturer Including executives, plant superintendents, foremen, purchasing agents, etc.
- Engineer
- Technician

Name .....  
Address .....  
Town and State .....

PLEASE PRINT YOUR NAME AND ADDRESS

*When writing to advertisers mention of the PROCEEDINGS will be mutually helpful.*



1919  
10 YEARS of RADIO  
MANUFACTURING

*Plus Over 12 Years of Pioneering in  
Electrical Reproduction of Sound*

1930

---

**I**N 1919 when the Pacent Electric Company began to manufacture radio essentials, the industry was truly in its infancy. The years since have seen a steady and healthy growth, until today, the company enjoys the distinction of being one of the oldest and most far-sighted manufacturers.

Today Pacent Electric Company has the largest engineering and research staff in its history. All Pacent devices are examples of modern leadership in engineering and in sound, creative manufacturing.

Pacent Quality and Service are enemies of business depression.

---

**PACENT ELECTRIC CO.**

91 Seventh Avenue, New York

Manufacturing Licensee for Great Britain and Ireland:  
IGRANIC ELECTRIC CO., Ltd., Bedford, England  
Licensee for Canada: White Radio Limited, Hamilton, Ont.

*When writing to advertisers mention of the PROCEEDINGS will be mutually helpful.*

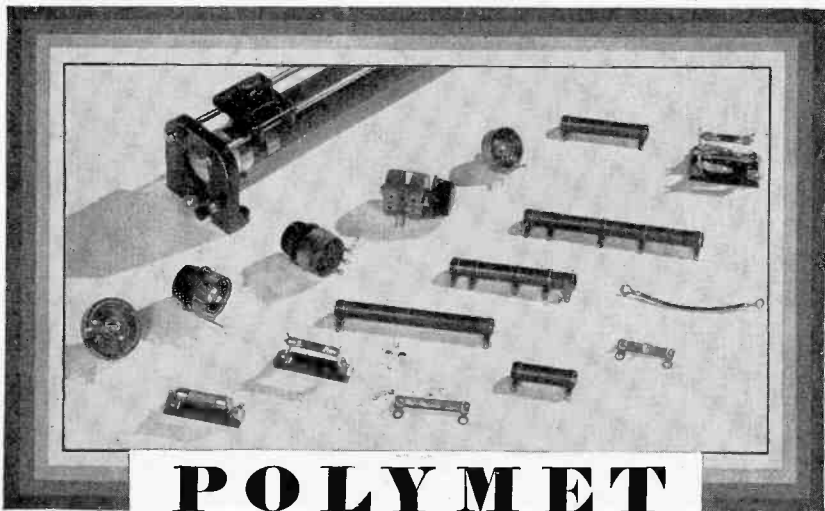

# POLYMET RESISTANCES

Built to those high standards which have led 80%  
of the leading radio set manufacturers to adopt

## POLYMET PRODUCTS

CARBON VOLUME CONTROLS  
 WIRE-WOUND VOLUME CONTROLS  
 DUAL VOLUME CONTROLS  
 SLIDING CONTACT TURE RHEOSTATS  
 TAPPED VOLTAGE DIVIDERS  
 WIRE-WOUND TUBULAR RESISTORS  
 FLEXIBLE RESISTORS — FLAT STRIP RESISTORS  
 GRID LEAKS                      POLYTROLS

*Manufacturers' Resistor Specifications Are Solicited*

### POLYMET MFG. CORP.

Paper and Mica Condensers—Resistors—Electrical Coil Windings—Magnet Wire  
 829 East 134th Street, New York City, N. Y.

*When writing to advertisers mention of the PROCEEDINGS will be mutually helpful.*

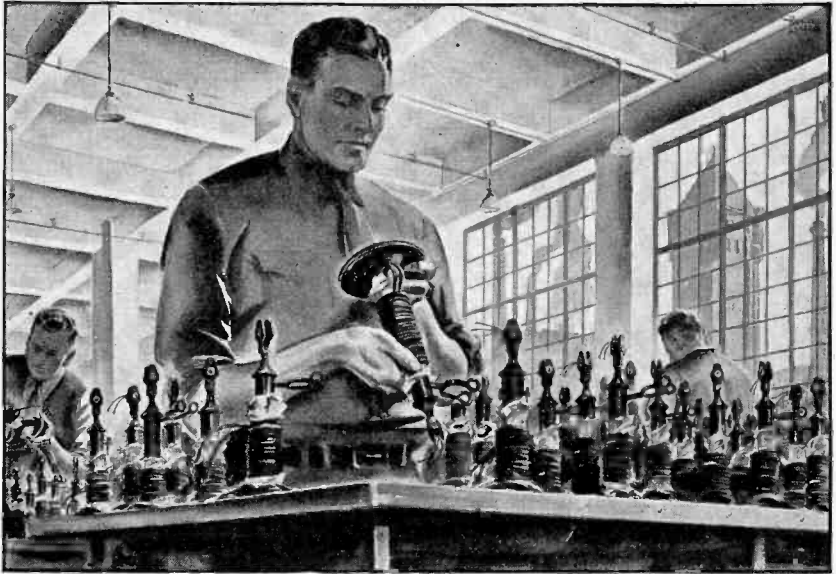

THE WESTERN ELECTRIC COMPANY SEARCHES THE WORLD FOR MATERIALS, AND FASHIONS THEM INTO THE EQUIPMENT OF A NATION-WIDE TELEPHONE SYSTEM

## That time and distance may be subject to your voice

*An Advertisement of the American Telephone and Telegraph Company*

THE Bell Telephone System shapes the stuff of the earth to your communication needs. It delves into the forces and methods that enable you to project your voice where you wish. It searches the world for the materials needed to put its discoveries at your command, and fashions them into the connected parts of a nation-wide system.

It has dotted the nation with exchanges, and joined them and the connecting companies with the wires and cables which enable you to talk with anyone, anywhere.

Each of the 24 operating companies of the Bell System is attuned to the needs of its area. Each is local to the people it serves and backed by national

resources in research, methods and manufacture. Each has the services of the staff of the American Telephone and Telegraph Company, which is continually developing improvements in telephone operation. Each has the advantage of the specialized production of the Western Electric Company. This production embodies the results achieved by the scientific staff of the Bell Telephone Laboratories, one of the great industrial research institutions of the world.

Your telephone company is in a position to offer you the service which you have today because the Bell System is organized to meet your growing communication needs with increasing satisfaction and economy.



*When writing to advertisers mention of the PROCEEDINGS will be mutually helpful.*

# New!

the

## PF 245A

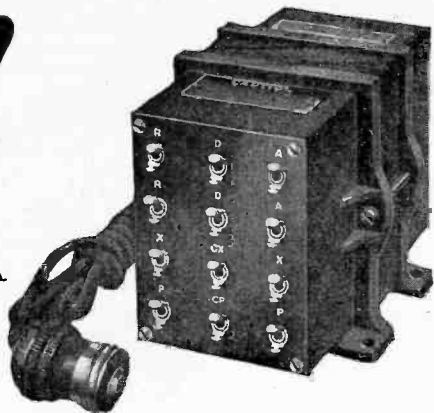

### AmerTran Power Transformer

Continuing its progress in the development of power transformers for all radio receiving sets the American Transformer Company announces the perfection of the new type PF245A. This new power transformer operates a radio receiver equipped with  $2\frac{1}{2}$  volt heater for heater type A.C. tubes and  $2\frac{1}{2}$  volt filament for a power tube (UX245 or CX345) which closely approaches the 210 in undistorted watts output.]

The AmerTran Power Transformer Type PF245A is designed for a 60 cycle 115 volt line source, and has a continuous rating of 100VA. with primary taps for 100—108—115—120 volts. A four point radial switch regulates the operation for different primary voltages. There are five secondary windings. Because of its lower maximum voltages, all secondary connections terminate in solder lugs attached to a bakelite terminal board.

This new, heavy duty power transformer is compact, sturdy, beautifully machined and mounted in cast iron end clamps provided with mounting feet. Like all AmerTran Transformers the PF245A is built to deliver sufficient excess voltage for maximum requirements. Fill out and mail the coupon for AmerTran Bulletin No. 1088 giving complete description of the PF245A Power Transformer.

List Price \$22. East of the Rocky Mountains.

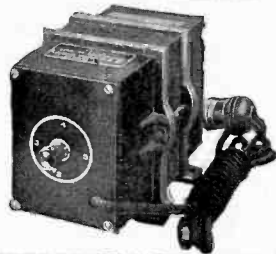

# AMERTRAN

TRADE MARK REG. U.S. PAT. OFF.

AMERICAN TRANSFORMER CO.  
Transformer builders for over 29 years  
178 Emmet Street  
Newark, N. J.

AMERICAN TRANSFORMER CO.,  
178 Emmet St., Newark, N. J.

Please send me complete information on  
the new PF 245A Power Transformer.

Name.....

Address.....

I.R.E. 3-30

When writing to advertisers mention of the PROCEEDINGS will be mutually helpful.

# CARDWELL

---



## ARCHIMEDES AND THE SCREW

**M**ANY centuries ago Archimedes conceived the principle of the screw. Dress up your device as you will, call it what you wish—so long as a simultaneously rotary and progressive motion is employed, Archimedes' screw is the actuating principle. Without it all the intricate accessories you may have added are impotent if the device is to best serve its purpose.

Nearly a decade ago the variable condenser underwent its first revolutionary change—Cardwell introduced the metal end plate—grounded rotor construction with minimum dielectric properly placed. Strip the average "modern" condenser of the superficial accessories added to it to meet certain external conditions and its fundamental and underlying principle is this construction originated by Cardwell, now as then embodied in Cardwell condensers, and still "the Standard of Comparison."

CARDWELL condensers, transmitting and receiving, are used in thousands by the greatest in the radio manufacturing field, a sufficient guarantee that they will serve *your* purpose well.

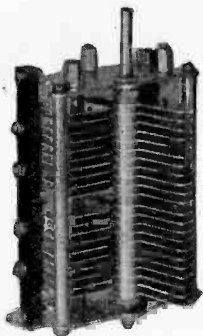

THE ALLEN D. CARDWELL  
MANUFACTURING CORPN.  
81 Prospect St., Brooklyn, N.Y.

CARDWELL  
CONDENSERS

*Since Broadcasting Began*

---

«THE STANDARD OF COMPARISON»

*When writing to advertisers mention of the PROCEEDINGS will be mutually helpful.*

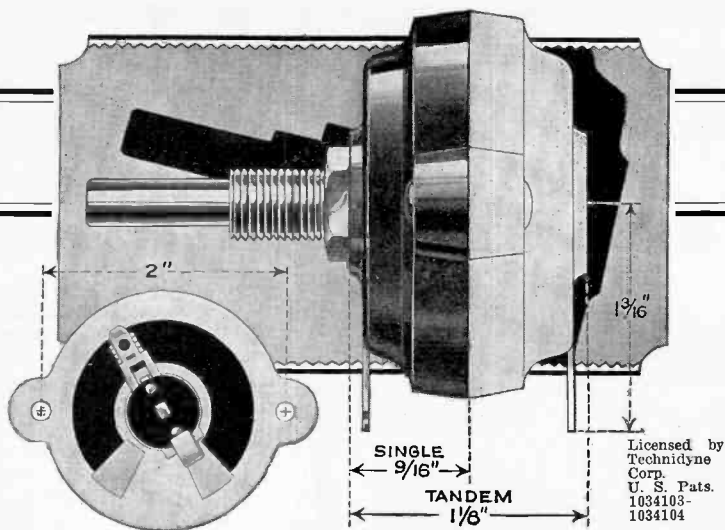

## Make Any Test of ELECTRAD Quality and Satisfy Yourself

**E**LECTRAD Resistances and Voltage Controls sell themselves on their own merit—under any test you may deem conclusive—in your own laboratory.

ELECTRAD hasn't built its reputation for highest quality design and manufacture of radio resistances by hiding its head and crying "beware," at competitors' products—but rather through scientific comparisons with them in all features and refinements.

A sample of any ELECTRAD Product is available to manufacturers or engineers for testing purposes—and if a unit with the characteristics you desire is not stocked, send us your specifications. Our cooperation will be cheerful, prompt and thorough.

### A Covered Resistance that LASTS

Built to run long periods at rated capacity—a generous margin of safety reducing burn-out risks. Heavier-than-usual Nichrome wire—highest grade refractory tube. Insulation baked on at low temperature prevents injured wire and contacts. Can be made in usual resistance values and wattage ratings, tapped as desired. Send for test sample.

### Super TONATROL Model "B" for Manufacturers

The new ELECTRAD Model "B" Super-TONATROL (illustrated above) combines the time-tested operating characteristics of the original Super-TONATROL with the greater compactness necessary in modern receiver design.

Available in single or dual units with insulated shaft. The resistance element in permanently fused to an enameled metal plate, and dissipates a full 3-watts. A pure silver floating contact gives noiseless operation, with stepless variation.

Completely enclosed Bakelite case—practically immune to temperature and humidity changes. Send for test sample.

175 Varick St., New York, N.Y.  
**ELECTRAD**  
 INC.

*Electrad manufactures a complete line of resistances and voltage controls for all radio and power supply needs, including Television.*

ELECTRAD, INC., Dept. PE3, 175 Varick St., New York, N.Y.  
 Please send details and test samples of products checked.  
 Model "B" Super-TONATROL  COVERED RESISTANCE  
 (If samples with special characteristics are desired, attach specifications.)  
 Name.....  
 Address.....

When writing to advertisers mention of the PROCEEDINGS will be mutually helpful.

# JEWELL 199 SET ANALYZER

*A High Grade Instrument  
Backed by a thorough Data Service*

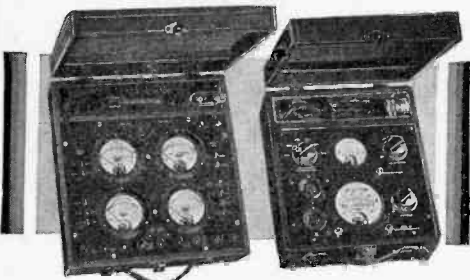
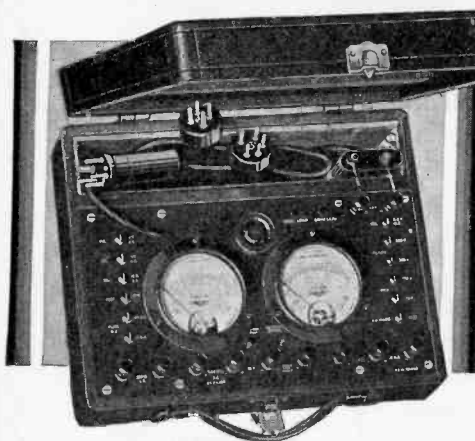

**Pattern 409, 4-Instrument Set Analyzer**, designed especially for expert radio service men, gives plate voltage, plate current, filament, and grid voltages simultaneously. Same high quality throughout as Pattern 199.

List Price, Pattern 409, \$122.50

Dealers' Price \$91.88

**Jewell Pattern 210 Tube Tester** gives direct reading on all tubes from UV199 to UX250, including half and full wave rectifier and screen grid tubes. Every dealer should have this valuable tube tester.

List Price, Pattern 210, \$65.00

Dealers' Price \$48.75

Write for free booklet, "Instructions for Servicing Radio Receivers."

**Jewell Electrical Instrument Co.**

1642-D Walnut St., Chicago, U.S.A.

30 YEARS MAKING GOOD INSTRUMENTS

# JEWELL

THE inherent accuracy and complete reliability of the Pattern 199 have gained for it the confidence of service men from coast to coast.

Nearly thirty years' manufacturing experience, combined with painstaking care in design, has perfected the large  $3\frac{3}{4}$  inch face instruments used in the 199. Thousands of these instruments have been proved in exacting industrial applications.

The Jewell 199 not only makes every worth while radio test, but does it accurately, stands up well in service, and at the same time is the lowest priced, high grade set analyzer on the market today.

In addition to the high quality and low cost of the Jewell Pattern 199, it is backed by the most thorough and complete data service available. Jewell "Instructions for Servicing Radio Receivers," furnished with every Pattern 199 Set Analyzer, contains checking data on sets of leading radio manufacturers.

List Price, Pattern 199 - - \$97.50

Dealers' Price - - \$73.12

Pattern 198, which includes the 199 in a large case with compartments for replacement tubes and tools.

List Price - - - - - \$110.00

Dealers' Price - - - \$82.50



When writing to advertisers mention of the PROCEEDINGS will be mutually helpful.



# United Scientific type S. G. SHIELDED CONDENSER

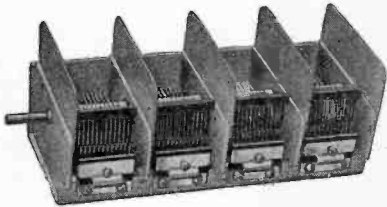

*Solves  
Your  
Tuning  
Problem*

*Improves  
Mechanical  
Appearance  
of Receiver*

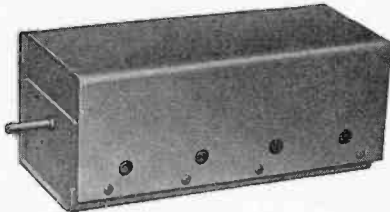

Completely shielded stators; individually grounded contacts; extra heavy steel frame; minimum compensators of novel construction; smooth rotor action; bosses arranged for either bottom or side mounting; heavily cadmium plated metal parts; dust proof cover enclosing entire unit; uniform precision spacing of rotors and stators. These are a few of the many features of our new type S.G. Shielded Condenser.

*Complete Specifications, Full Information, Sample and Prices Sent on Request.*

**UNITED SCIENTIFIC LABORATORIES, Inc.**  
115-C Fourth Avenue, New York City

*Branch Offices for Your Convenience in*

St. Louis  
Chicago  
Boston  
Minneapolis  
Cincinnati

Los Angeles  
Philadelphia  
San Francisco  
London, Ontario



*When writing to advertisers mention of the PROCEEDINGS will be mutually helpful.*



# Range **FULL-TONED** and rich

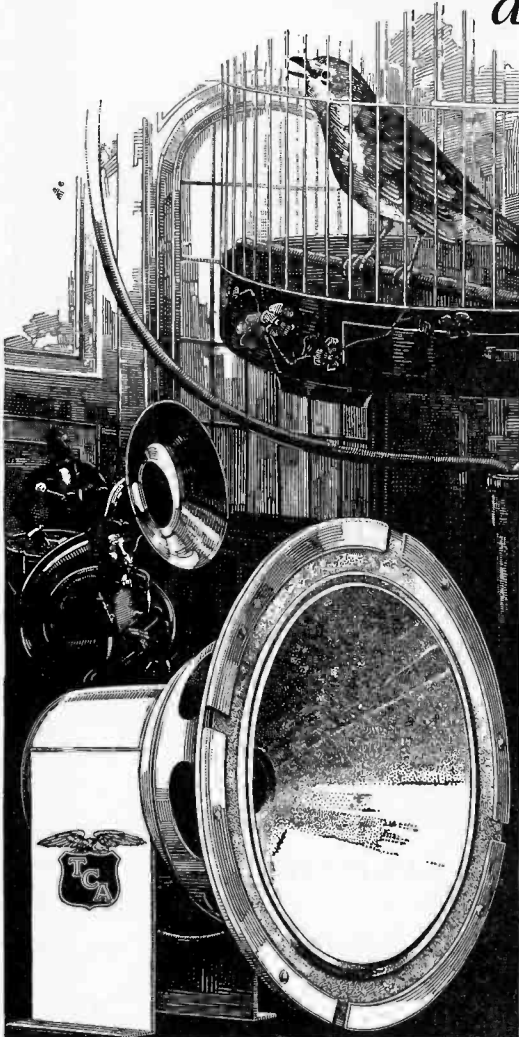

**I**F studio programs were planned to fit the limitations of the average loud speaker, the problem of full range tone reproduction would be simplified.

But with a listening public eager for variety . . . with pipe organs, symphony, orchestras, and lyric sopranos, all crowding around the microphone, the reproducer has, indeed, an almost impossible job.

The new T.C.A. Dynamics show astonishing fidelity on both high and low extremes of studio broadcasting, together with the same extraordinary freedom from noise and hum that made the 1929 model so outstanding. Comparative tests have been unanimous in their unqualified endorsement.

No receiving set can have an output which is more full-toned and rich than the sets equipped with these new T.C.A. Dynamics.

*Write or wire for information on these new T.C.A. products*

**TRANSFORMER  
CORPORATION  
OF AMERICA**

2301-2319 S. Keeler Ave.  
CHICAGO, ILL.



*When writing to advertisers mention of the PROCEEDINGS will be mutually helpful.*

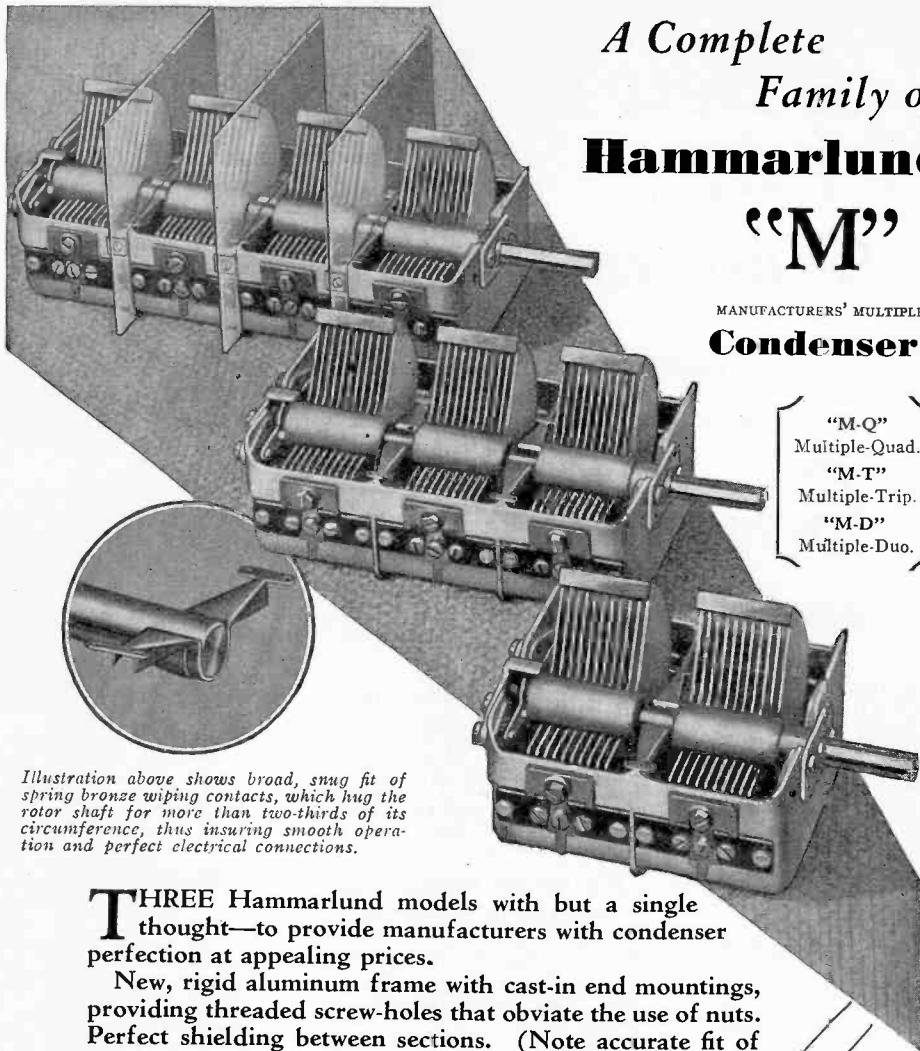

# A Complete Family of Hammarlund "M"

MANUFACTURERS' MULTIPLE  
**Condensers**

- "M-Q" Multiple-Quad.
- "M-T" Multiple-Trip.
- "M-D" Multiple-Duo.

*Illustration above shows broad, snug fit of spring bronze wiping contacts, which hug the rotor shaft for more than two-thirds of its circumference, thus insuring smooth operation and perfect electrical connections.*

**T**HREE Hammarlund models with but a single thought—to provide manufacturers with condenser perfection at appealing prices.

New, rigid aluminum frame with cast-in end mountings, providing threaded screw-holes that obviate the use of nuts. Perfect shielding between sections. (Note accurate fit of demountable upper shields, shown in phantom on quad-ruple model.) Steel shaft working in long, hand-reamed bearings. Anchored, non-microphonic, aluminum plates. Separate stator insulating strips. Large area trimmer condensers.

You couldn't ask more of any condensers than these new Hammarlunds offer.

*Write us your needs. Use coupon.*

**HAMMARLUND MFG. CO.**  
424-438 W. 33rd St., New York

**Hammarlund**  
PRECISION  
**PRODUCTS**

For Better Radio

MAIL COUPON FOR FULL PARTICULARS

HAMMARLUND MFG. CO., Dept. PE3  
424-438 W. 33rd St., New York

Please send information on "M" Condensers.

Name .....

Address .....

*When writing to advertisers mention of the PROCEEDINGS will be mutually helpful.*

# A New **EBY** Idea in Plugs and Receptacles

For speaker field and voice coil connections

*Two contacts short when plug is withdrawn*



Base held in top of plug by small ring. Solder cable leads to lugs at top of prongs. Avoid expensive wire-stripping and soldering operation required when leads are threaded into prongs.

A brand new idea to protect filter condensers and resistors when speaker field and voice coil connections are broken.

In sets where the field coil of the speaker is part of the filter circuit, the voltage surge, when the speaker is disconnected and this much of the load is removed, may damage the condensers. In "bleeder" circuits, it may also damage resistors. By using the two contacts which short when the plug is removed for field connections, the chances of damage are minimized.



Base held in top of plug by small ring. Solder cable leads to lugs at top of prongs. Avoid expensive wire-stripping and soldering operation required when leads are threaded into prongs.

## Approved by Underwriters

The EBY method of shorting two of the contacts when the plug is removed makes the prongs of the plug inaccessible while they are making contact. This feature and the excellent insulation of the plug have induced the Underwriters' Laboratories to approve this device.

## For Use with Pentode Tube

Looking into the future a little, the EBY Model 2080 Plug and Receptacle has still another important application. It is ideal for speaker connections in sets using the Pentode tube. When this tube is used, field connections, when they are broken, MUST be shorted to prevent damage to the tube. All the more reason for adopting this unit as standard now!



Two of the contacts in this receptacle short when the plug is removed. Prongs of plug are, therefore, inaccessible even when receptacle is mounted flush on panel. No recessing necessary.



Two of the contacts in this receptacle short when the plug is removed. Prongs of plug are, therefore, inaccessible even when receptacle is mounted flush on panel. No recessing necessary.

## SEPARATE PLUGS

Here's a plug similar in construction to the Model 2080 Plug, illustrated and described above, with the base arranged to fit into standard UX and UY sockets. When standard UX and UY sockets are used as receptacles, the contacts do not short when the plug is removed, but this plug provides a safe, economical way to make speaker field and voice coil connections. The plug is available with either four or five prongs.



Four prong plug arranged for use with standard UX sockets. Base held in top of plug by small ring. Solder cable leads directly to lugs at top of prongs. No threading leads.



Five prong plug arranged for use with standard UY sockets. Base held in top of plug by small ring. Solder cable leads directly to lugs at top of prongs. No threading leads.

**THE H. H. EBY MFG. CO., Inc.**

22nd Street and Lehigh Avenue  
Philadelphia, Pa.

*When writing to advertisers mention of the PROCEEDINGS will be mutually helpful.*

# New!

# EBY PARTS

## *in Laminated Bakelite*

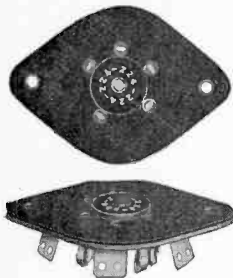

**MODEL 5-27 UX**

Available in any marking desired.

3500 Volts lowest breakdown point under normal conditions; 3100 volts after exposure to 90% humidity for forty-eight hours.

Mounting holes on 1-27/32" centers.

Also available in UX type.

### SOCKETS

Assembled with *two* bakelite punchings. The top plate, in addition to completely insulating the contact eyelets in accordance with approved Underwriters' Standards, also acts as a bakelite barrier between the contacts, and minimizes the chances of breakdown. Built-in guide for tube prongs. Each socket marked with number of tube to be inserted. Two eyelet assembly.



*Close-up view of EBY contact plug.*

*Punched from highest grade .012" phosphor bronze tinned in sheets. Delivers positive wiping contact at top and bottom of both sides of tube prongs. Two holes in soldering lug.*

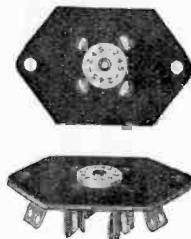

**MODEL 5-9 UX**

Available in any marking desired.

3100 Volts lowest breakdown point under normal conditions; 2700 volts after exposure to 90% humidity for forty-eight hours.

Mounting holes on 1-9/16" centers.

Not available in UX type.

### BINDING POST STRIPS

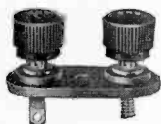

**No. 2710**

Assembled with posts marked ANT and GND. Ground post automatically grounded to panel and antenna post insulated. Two posts with engraved non-removable tops completely assembled and insulated with one eyelet, one nut and one soldered connection.

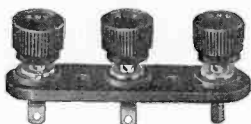

**No. 2700**

Assembled with posts marked LONG ANT, SHORT ANT and GND. Ground post automatically grounded to panel and both antenna posts insulated. Quick, easy and economical way to assemble and insulate three posts with engraved non-removable tops.



**No. 2720**

Assembled with two posts with non-removable tops engraved ANT and GND arranged so that both posts are insulated when unit is mounted on panel with one eyelet. Also available assembled with posts marked as desired.

### TIP JACK STRIPS



**TWIN JACKS**

Two eyelets and two soldered connections completely assemble, insulate and mark these two jacks. Available marked PHONO, SPEAKER and FIELD. Mount sub-panel.

EBY Laminated Bakelite Tip Jack Strips are assembled with new contact prongs which deliver a positive wiping contact at the top and bottom of both sides of standard phone tips. Tips can't wobble when inserted.

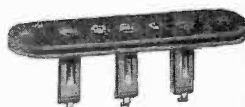

**TRIPLE JACKS**

Two eyelets and three soldered connections completely assemble, insulate and mark these three jacks. Available marked per specifications. Mount sub-panel.

**THE H. H. EBY MFG. CO., Inc.**

22nd Street and Lehigh Avenue

Philadelphia, Pa.

*When writing to advertisers mention of the PROCEEDINGS will be mutually helpful.*

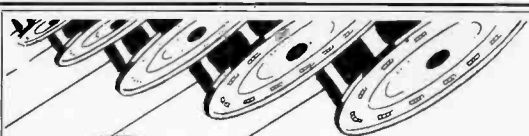

## GILBY FILAMENT WIRE AND SELVAGE MESH *for BETTER TUBES!*

**SELVAGE MESH** a comparatively late development has taken the field by storm. The solid even edges simplify welding and this screen material in which the mesh is interlocked is rigid and rugged beyond belief. It may be supplied accurately within

.005 plus or minus as specified. Its use will cut production shrinkage and lend a more finished appearance to your product. This Selvage Mesh has proven itself so valuable that it is being widely imitated. In fairness to all concerned we give notice that our rights will be vigorously defended. Patent applications fully cover both the material itself and the tube of which it is a part.

**FILAMENT WIRE**—A tube is no better than its filament. There is no filament better than Gilby. Gilby Filament Wire has long been recognized as the Superior Product. Its uniformity, accuracy and long life is readily testified to by tube manufacturers.

*We would appreciate inquiries and an opportunity to co-operate with your staff. Samples of Filament Wire and Selvage Mesh on request. Resistance and Ballast Wires too!*

**GILBY WIRE COMPANY**  
*Wilbur B. Driver, President*  
**NEWARK, NEW JERSEY**



*When writing to advertisers mention of the PROCEEDINGS will be mutually helpful.*

An illustration of a radio shop. In the foreground, a man in a dark suit and tie is shown in profile, facing right, as if in conversation. In the background, another man wearing a light-colored suit and a fedora hat is seen from the back, looking towards the first man. The shop is filled with various pieces of radio equipment, including cabinets and dials. The scene is framed by a large, stylized red lightning bolt graphic on the right side.

What does *your* set say  
to  
"the man who knows"?

*"Who really buys your set?"*

*"What points actually sell it?"*

**T**HE success of today's manufacturer and builder depends upon how well he knows the answers to these two questions.

The man who knows enough about radio to understand causes as well as results is becoming an increasingly important sales factor in the receiver market. Those who are not radio-wise hesitate to purchase sets without relying upon the advice of an acquaintance who has some knowledge of radio. To this man, Sangamo Transformers stamp your set as O.K. Sangamo in

the "audio end" means true TONE!

TONE QUALITY is the magic key that finally opens the purse and closes the sale.

Transformer building is a science in itself—best left to an organization like Sangamo, whose research, experience and precision manufacturing facilities guarantee results. Sangamo "A" Line Transformers are built for the custom set maker or manufacturer who wants a "tone" advantage over competition. They cost a little more, but the set is easier to sell.

SANGAMO ELECTRIC CO.

SPRINGFIELD, ILLINOIS, U. S. A.

*Manufacturers of Precision Electrical Apparatus for 30 years*



See Reverse  
Side

# "A" Line Transformers

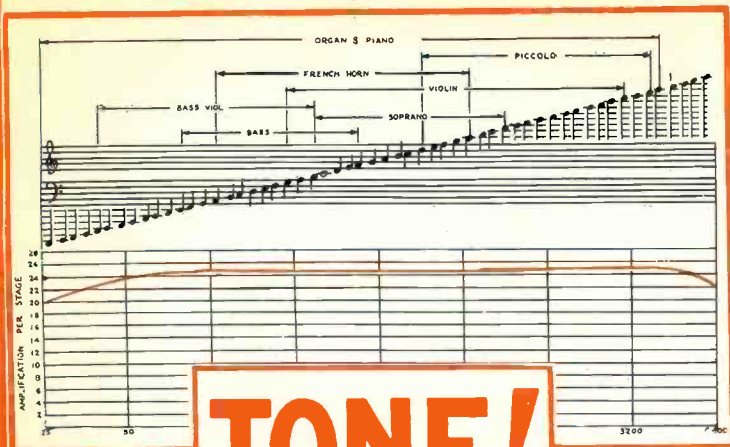

Curve of Type "A" Sangamo Straight Audio Transformer showing uniformity of amplification at all audible frequencies.

## TONE!

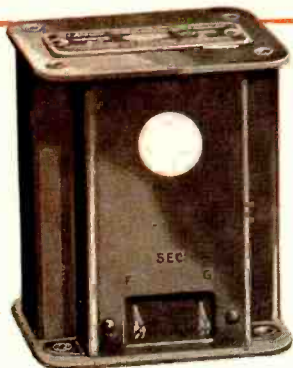

Type "A" straight audio amplification. List price..... \$10

Type "B" Push-pull Input Transformer for all tubes. List price..... \$12

Type C-171 Push-pull Output, for 171 or 250 type power tubes with cone speaker. List price..... \$12

Type D-210, same as C, except for 210 and 112 power tubes. List price..... \$12

Type H-171, Push-pull Output for 171 or 250 power tubes for Dynamic Speaker. List price..... \$12

Type G-210, same as type H, except for 210 and 112 power tubes. List price..... \$12

Type F Plate Impedance for use as a choke to prevent oscillation and for impedance coupled amplifiers. List price.... \$5

*Unusual facilities for furnishing transformers with or without cases ready for mounting and quick assembly with the receiver. Prices on application.*

## SANGAMO Type "A" Condensers



No item can cost so little and cause so much trouble in a receiver as a fixed condenser. This fact is especially appreciated by the manufacturer with an eye to the service problem. Likewise, experience has shown that a fixed condenser is not necessarily a good condenser just because it is molded in Bakelite.

The immunity to thermal changes and to mechanical damage rendered by the Bakelite enclosure is supplemented in Sangamo Condensers by accurate rating and sound construction of the mica condenser within the Bakelite casting.

The standard line of Sangamo Fixed Condensers leaves the factory tested to maximum variation of 10%. Also furnished with closer ratings and in high voltage types.

## SANGAMO "Illini" Condensers



"Illini" Condensers are standard with those manufacturers who insist on ratings being actually what the specifications call for. Manufactured by exclusively designed equipment, held to the tolerances your engineering department demands, Sangamo Condensers will reduce to a negligible quantity inspection department rejects and "re-assembly" losses in profit.

Prices on request

PIN THIS TO YOUR LETTERHEAD AND MAIL

SANGAMO ELECTRIC CO.  
Springfield, Illinois, U. S. A., Dept. S-9

- (For manufacturers) I am interested in engineering data regarding your transformers and condensers.
- (For set builders) Please send circulars describing your apparatus and latest audio hook-ups. I enclose 10c to cover cost of mailing.

Name \_\_\_\_\_

Address \_\_\_\_\_

# The Institute of Radio Engineers

Incorporated

33 West 39th Street, New York, N. Y.

## APPLICATION FOR ASSOCIATE MEMBERSHIP

(Application forms for other grades of membership are obtainable from the Institute)

To the Board of Direction  
Gentlemen:

I hereby make application for Associate membership in the Institute.

I certify that the statements made in the record of my training and professional experience are correct, and agree if elected, that I will be governed by the constitution of the Institute as long as I continue a member. I furthermore agree to promote the objects of the Institute so far as shall be in my power, and if my membership shall be discontinued will return my membership badge.

Yours respectfully,

.....  
(Sign with pen)

.....  
(Address for mail)

.....  
(Date)

.....  
(City and State)

### References:

(Signature of references not required here)

Mr. .... Mr. ....

Address ..... Address .....

Mr. .... Mr. ....

Address ..... Address .....

Mr. ....

Address .....

The following extracts from the Constitution govern applications for admission to the Institute in the Associate grade:

### ARTICLE II—MEMBERSHIP

Sec. 1: The membership of the Institute shall consist of: \* \* \* (d) Associates, who shall be entitled to all the rights and privileges of the Institute except the right to hold the office of President, Vice-president and Editor. \* \* \*

Sec. 5: An Associate shall be not less than twenty-one years of age and shall be: (a) A radio engineer by profession; (b) A teacher of radio subjects; (c) A person who is interested in and connected with the study or application of radio science or the radio arts.

### ARTICLE III—ADMISSION

Sec. 2: \* \* \* Applicants shall give references to members of the Institute as follows: \* \* \* for the grade of Associate, to five Fellows, Members, or Associates; \* \* \* Each application for admission \* \* \* shall embody a concise statement, with dates, of the candidate's training and experience.

The requirements of the foregoing paragraph may be waived in whole or in part where the application is for Associate grade. An applicant who is so situated as not to be personally known to the required number of members may supply the names of non-members who are personally familiar with his radio interest.



**RECORD OF TRAINING AND PROFESSIONAL EXPERIENCE**

1 Name .....  
(Give full name, last name first)

2 Present Occupation .....  
(Title and name of concern)

3 Permanent Home Address .....

4 Business Address .....

5 Place of Birth..... Date of Birth..... Age.....

6 Education .....

7 Degree .....  
(college) (date received)

8 Training and Professional experience to date.....

NOTE: 1. Give location and dates. 2. In applying for admission to the grade of Associate, give briefly record of radio experience and present employment.

DATES HERE

9 Specialty, if any.....

Receipt Acknowledged..... Elected..... Deferred.....  
Grade..... Advised of Election..... This Record Filed.....

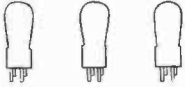

**Leading  
Radio Tube  
Manufacturers  
Will Tell You ..**

*... that they have  
found*

**PRECISION FILAMENT**  
(uncoated)

**FOR VACUUM TUBES**  
*thoroughly dependable—  
surviving every  
test of wear*



*A Product of*  
**SIGMUND COHN**  
44 Gold Street  
New York

*When writing to advertisers mention of the PROCEEDINGS will be mutually helpful.*

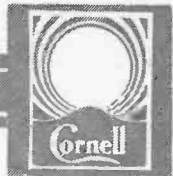

## RADIO FREQUENCY Multiple By-Pass Assembly

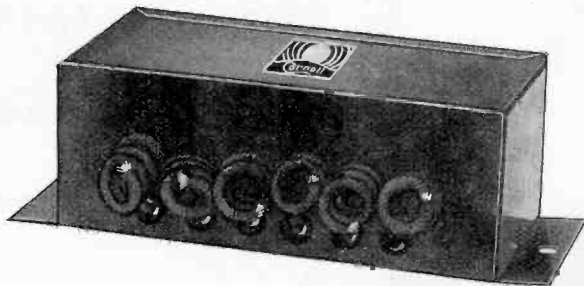

We show here a Cornell Assembly that has been designed particularly for radio frequency circuits where each stage of radio frequency is to be independently isolated. It has been designed with the idea of economy, using one housing for the entire block of by-pass condensers, and also so that the larger and more economical condenser can be used.

*Send us your specifications or blueprints. We shall be glad to quote on any size can or by-pass combination you desire.*

# Cornell

UNIFORMLY HIGH INSULATION RESISTANCE  
PAPER DIELECTRIC CONDENSERS  
(ALL TYPES)

Cornell is equipped to give you what you want when you want it at prices within the range of commercial set manufacturing. Cornell quality and service will meet your most exacting requirements.

*Write for a Sample "Cub" Condenser and Catalog of Complete Line of Cornell Products.*

**Cornell Electric Mfg. Co., Inc.**  
LONG ISLAND CITY, NEW YORK

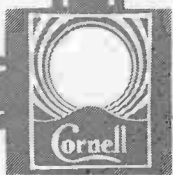

*When writing to advertisers mention of the PROCEEDINGS will be mutually helpful.*

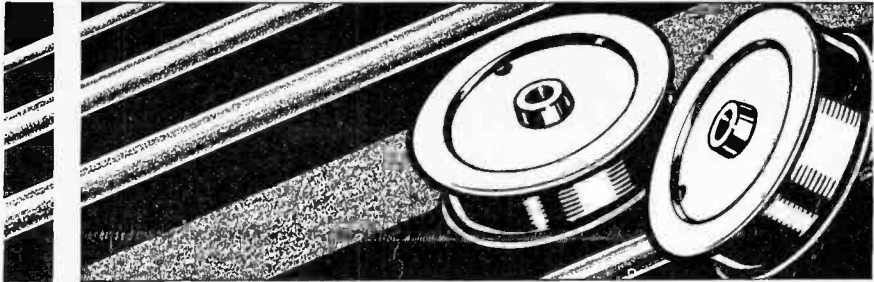

**Tube Makers**  
*. . . who guard their*  
**REPUTATIONS**  
*use Fansteel Metals . .*

**M**ANY of the performance troubles which crop out in vacuum tubes can be traced to the metals from which the tubes are made. And many manufacturers who have changed to Fansteel Tantalum, Molybdenum and Alloys have minimized rejections, and have made definite improvements in tube performance.

Fansteel metals are refined to a high state of purity especially for use in tubes. These metals are tested daily under actual operating conditions in tubes made in the Fansteel laboratory, which also conducts intensive research in tube design.

Tube manufacturers have in Fansteel a dependable source of supply for metals, and a source of information and cooperation on tube problems. And the manufacturers who use this source are making dependable tubes.

Ask your tube maker if he uses Fansteel metals.

**FANSTEEL PRODUCTS  
COMPANY, INC.  
North Chicago, Illinois**

---

---

# Volume Controls

**T**O vary the intensity of the faithful reproduction built into radio receivers without introducing noise or distortion, can only be accomplished by a careful and complete consideration of both mechanical and electrical features of the volume control.

Mechanically—The Centralab exclusive and patented rocking disc contact precludes any possibility of wear on the resistance material. This feature adds to the smoothness of operation since the contact shoe rides only on the disc. The shaft and bushing are completely insulated from the current carrying parts—eliminating any hand capacity when volume control is placed in a critical circuit.

Electrically — Centralab engineers have evolved tapers of resistance that produce a smooth and gradual variation of volume. These tapers have been thoroughly tried and tested for each specific application for current carrying capacity and power dissipation.

Centralab volume controls have been specified by leading manufacturers because of their quality and ability to perform a specific duty—Vary the intensity of faithful reproduction—faithfully.

*Manufactured in three sizes*

*Standard*

*Junior*

*Midget*

*Also Double Standard  
and Double Junior*

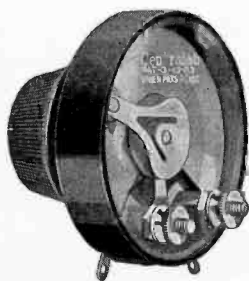

*Write for full particulars of  
specific application.*

## Centralab

CENTRAL RADIO LABORATORIES

36 Keefe Ave.

Milwaukee, Wis.

**A CENTRALAB VOLUME CONTROL IMPROVES THE RADIO SET**

---

---

*When writing to advertisers mention of the PROCEEDINGS will be mutually helpful.*

# Each Test Assures Quality and Uniformity of Products



**REPEATED** *checking and testing against a standard!* That's the rule from the time the raw materials come into our factory until the finished product is shipped out. Tests are made, not of one unit out of a "run," but of *each and every individual unit we produce.*

Everything humanly and physically possible is done to assure you that only the best will come out of our factory.

**OPERADIO MFG. CO.**  
*St. Charles, Ill.*

# OPERADIO

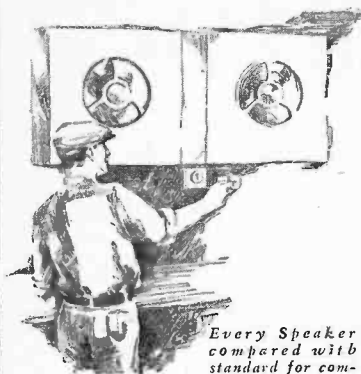

*Every Speaker compared with standard for complete frequency range.*

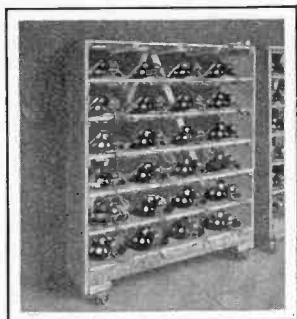

*A real shake-down! Every Speaker given 15 minute test under 50% over-load.*

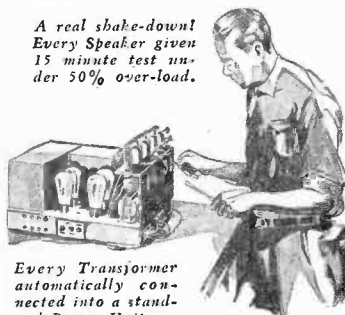

*Every Transformer automatically connected into a standard Power Unit.*

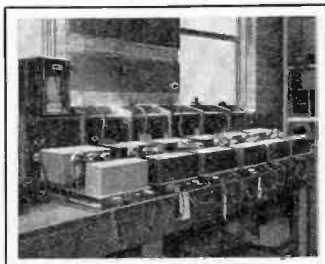

*The break-down test. The Operadio Power Units illustrated ran under full load July 28, 1928 to July 28, 1929.*

*When writing to advertisers mention of the PROCEEDINGS will be mutually helpful.*

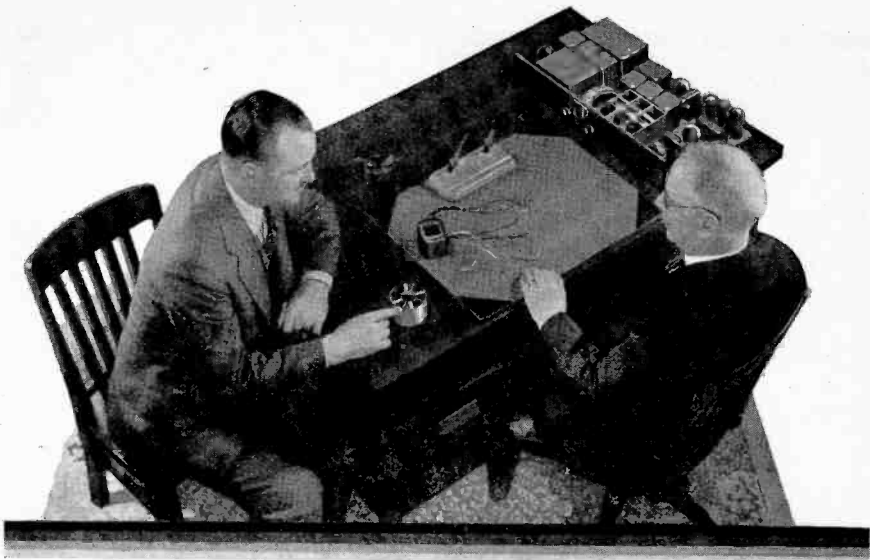

## The Dudlo COIL ENGINEER is called in

"I'm not objecting to your coil prices, understand," said the set manufacturer, leaning back reflectively. "But the cost of this new set is running into too much money considering present retail price levels. We must cut costs but we can't cut quality."

"That's what we engineers are for," the Dudlo man replied. "We have often suggested modifications in coil design which have effected great savings for set manufacturers."

*Such engineering assistance is a regular feature of Dudlo service. You are invited to take advantage of it.*

# DUDLO

DUDLO MANUFACTURING COMPANY, FORT WAYNE INDIANA  
Division of General Cable Corporation

*When writing to advertisers mention of the PROCEEDINGS will be mutually helpful.*

# NEW TESTING EQUIPMENT

*For complete Receiver Service Work and  
in the Laboratory*

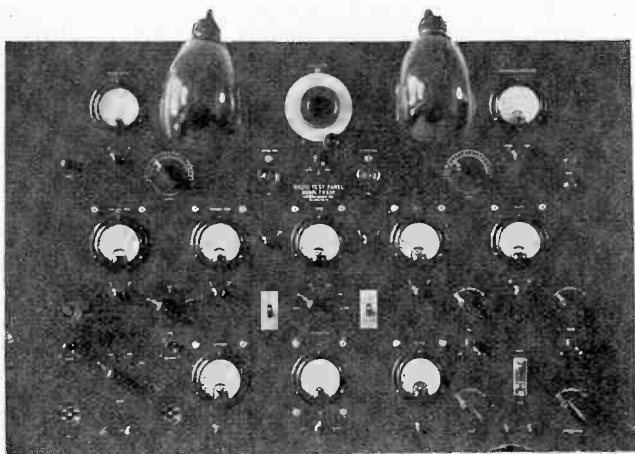

Size 24" x 38" x 1/4" — Weston Equipped

## PANEL TX-600

Every possible Receiver and Tube test\* is made instantly on this new Tester with direct readings.

The time loss and bother in assembly of meters and various parts for different operations, as with small portable equipment, is all eliminated by TX-600 Panel.

It is the fastest complete Tester made, and in fact the only instrument of its kind on the market.

No progressive Service Organization can really afford to be without this up-to-date equipment and its big time-saving factor.

\* Including Pentodes.

**QUICK - ACCURATE - DIRECT READING  
COMPLETE - ALL ELECTRIC**

*Descriptive Literature on request*

**NORDEN-HAUCK, Inc., Engineers**  
Delaware Avenue & South Street  
PHILADELPHIA, PA., U.S.A.

*When writing to advertisers mention of the PROCEEDINGS will be mutually helpful.*





# *Faradon*

**ELECTROSTATIC  
CONDENSERS**

*for All Purposes*



*The Accepted Standard  
for Exacting Service as well as  
General Application on  
Land and Sea and  
in the Air*

**WIRELESS SPECIALTY  
APPARATUS COMPANY**

*Est. 1907*

**Jamaica Plain**

**Boston**

*When writing to advertisers mention of the PROCEEDINGS will be mutually helpful.*

Fused Pure Silica  
**Vitreosil**

## THE IDEAL INSULATION

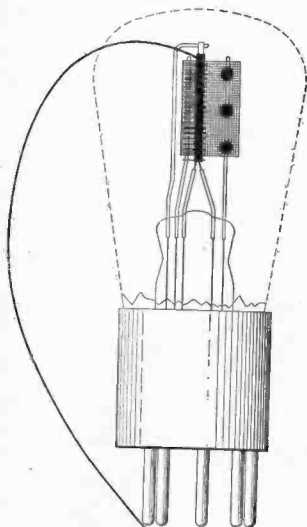

**P**ROGRESSIVE manufacturers, making the better kind of AC heater-type radio tubes use Vitreosil insulation for its freedom from gas and uniform wall which produces even heat distribution. It easily meets the thermal conditions of sudden heating and cooling, is mechanically strong, and available at low cost in single or multibore styles, and twin bore in either oval or circular cross section.

*You can identify this Vitreosil product, illustrated herewith, by its smooth satin finish.*

*Let us send samples and quote on your requirements.*

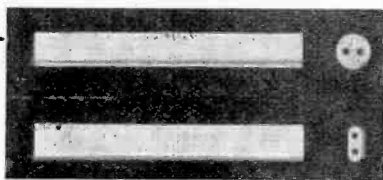

**THE THERMAL SYNDICATE, Ltd.**

1716 Atlantic Avenue

Brooklyn, New York

# Put Yourself in the Pilot's Seat

On a plane, particularly a mail plane like this one, your first impression is a condition of extreme vibration . . . You are next impressed with the fact that a plane, more than many other machines, is subject to extremes of heat and cold . . . Then, should you be "instrument minded," you will wonder how supposedly delicate instruments, subject to such extremes, can provide absolute dependability . . . The only answer is **THEY MUST . . .** We are speaking especially of the two Roller-Smith instruments on the left panel . . . They meet in the highest degree the above **ESSENTIALS** on planes carrying more than half the nation's air mail.

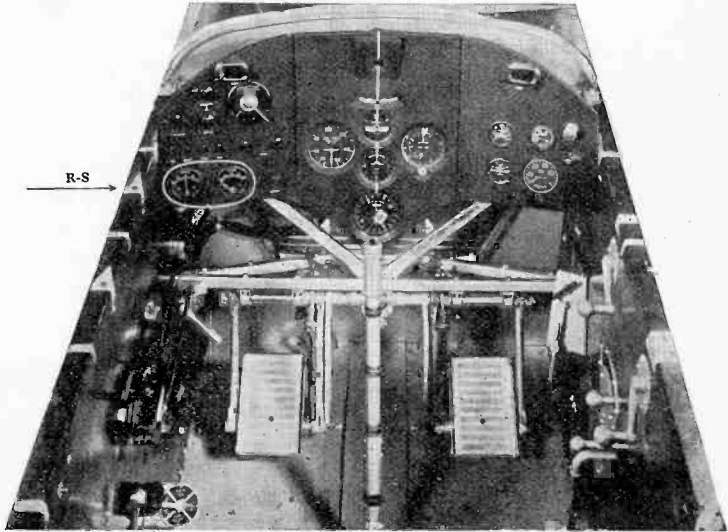

You can get similar service from all instruments made by

## ROLLER-SMITH COMPANY

Electrical Measuring and Protective Apparatus

Main Office:  
2134 Woolworth Bldg.  
NEW YORK



Works:  
Bethlehem  
Pennsylvania

Offices in principal cities of U. S. A. and Canada.  
Representatives in Australia, Cuba, Japan and Philippine Islands.

*When writing to advertisers mention of the PROCEEDINGS will be mutually helpful.*

# Continental Resistors

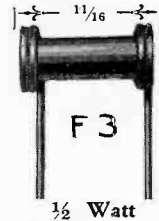
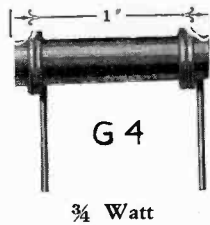
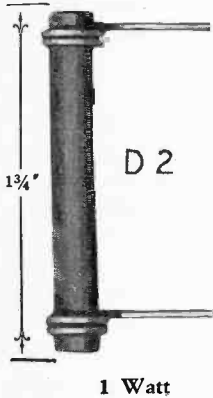
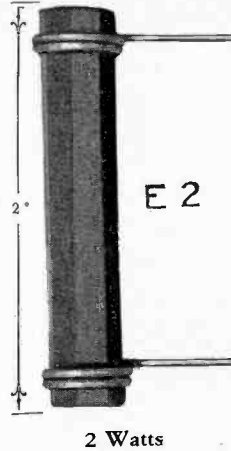
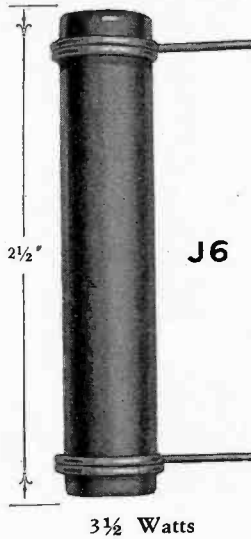
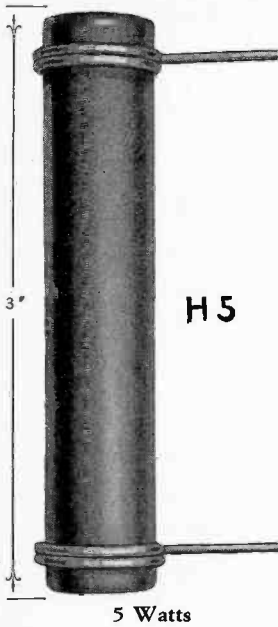

## CHARACTERISTICS:

NOISELESS  
RESISTANCE CONSTANT  
SMALL TEMPERATURE COEFFICIENT  
RUGGED  
FIRMLY SOLDERED TERMINALS  
DEPENDABLE  
COLOR CODED

*Write for Information and Prices*

**CONTINENTAL CARBON INC.**  
**WEST PARK, CLEVELAND, OHIO**

*When writing to advertisers mention of the PROCEEDINGS will be mutually helpful.*

millions  
of  
lock  
washers

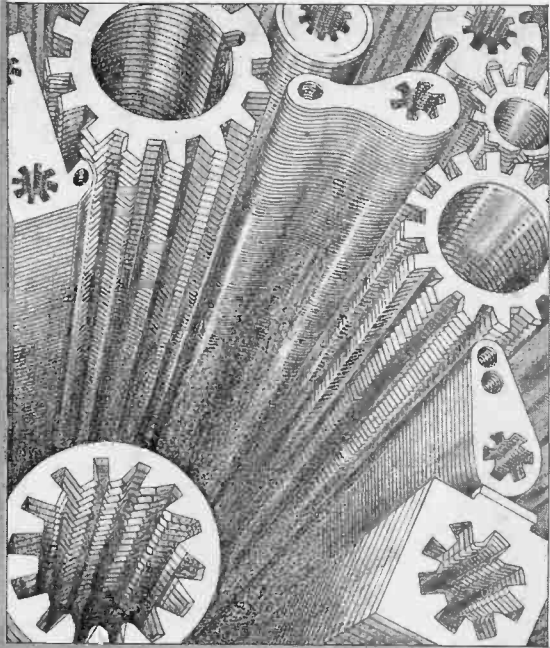

FOR EVERY PURPOSE



Type 20  
Lug Terminal



Type 15  
Countersunk



Type 12  
Internal Teeth



Type 11  
External Teeth

WRITE  
FOR SAMPLES

L

OOK AT Lock Washers from any standpoint — they must lock nuts and bolts permanently — they must be easily applied — they must not tangle. Only one Lock Washer meets your demands — SHAKEPROOF. Today on practically every type of mechanical device you will find SHAKEPROOF Lock Washers. The SHAKEPROOF principle has been adapted to many special locking problems and is saving manufacturers thousands of dollars on their production. SHAKEPROOF has a place on your product — we will gladly mail you samples of SHAKEPROOF Washers for you to test in your own shop — or our Engineering Department will work with you on adapting SHAKEPROOF for your use. Write for samples today!

**SHAKEPROOF**  
*Lock Washer Company*

[ Division of Illinois Tool Works ]

2501 North Keeler Avenue

Chicago, Illinois

*When writing to advertisers mention of the PROCEEDINGS will be mutually helpful.*

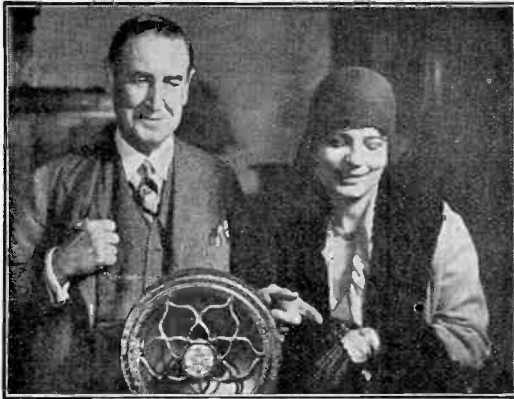

*7 seconds by the  
customer's watch!  
That's how quick  
your sets will act  
when Arcturus  
Tubes are used.*

# HOW TUBE PERFORMANCE HELPS SELL YOUR SETS

by GEORGE LEWIS

*Vice-President, Arcturus Radio Tube Company*

Right now, in many cities, dealers are demonstrating your sets to prospective customers. Naturally, you want to be sure of the best possible performance—for buyers are critical these days.

You want your set to start quickly, without an embarrassing 30 to 60 second wait . . .

You want the reproduction to be clear and true, free from hum or other outside noises . . .

You want to be sure that your set will operate dependably, without requiring frequent service calls.

There is one sure way to give your set *all* these advantages. Use *Arcturus Blue Tubes* for standard equipment. Critical engineers know that Arcturus' 7-second action, clear reproduction, and long life make any set perform at its best.

Familiarize yourself with Arcturus Tubes. Know what modern tube performance means in present day merchandising of receivers.

ARCTURUS RADIO TUBE COMPANY, NEWARK, N. J.

# ARCTURUS

QUICK ACTING

# RADIO TUBES

*When writing to advertisers mention of the PROCEEDINGS will be mutually helpful.*

# E Exploring

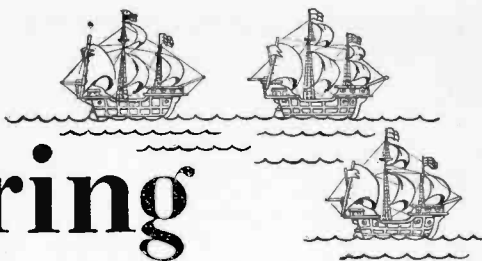

## New Realms of Radio Efficiency

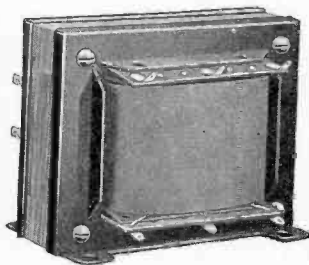

**Transformers and Chokes, cheaper than you can make them in your own Factory**

As specialists, Jefferson can supply any type transformer or choke at interesting prices. By buying these units from Jefferson you are assured quality, precision and prompt deliveries. You need buy only what you actually use—thus eliminating the possibility of overstocking raw materials or completed units which may become obsolete overnight due to the constantly changing conditions in the radio field.

Receiving set manufacturers, no matter how small, need not do without Jefferson quality. Through standardization, Jefferson can give all set builders the same high quality equipment which heretofore was restricted to large manufacturers.

**S**INCE the first tinkering of the amateur set builder, Jefferson has been interested in radio transformers, because transformer designing and building is our business.

Almost any amateur builder remembers the first Jefferson Audio Transformer. They were crude affairs compared to present day audios but they were the fruit of our best efforts and the result of our experience.

From that day to this, our engineering specialists have watched every development—every new tube—every new circuit.

From that day to this, Jefferson has given its best engineering thought to developing better and more efficient transformers.

As each new tube—amplifier or power—was announced, Jefferson developed a transformer that would function in connection with it to give the set manufacturer the quality he desired, at a fair price.

Jefferson engineers are still busy exploring the new realms of radio efficiency. Our experience has multiplied a hundred fold. We have solved many receiver problems. We have helped many a set manufacturer to achieve the best solution of his audio and power problems.

Whether you are a large manufacturer who desires the best transformer for your set, or a smaller manufacturer who would like the benefit of our experience, just drop us a line. We have a proposition which is sure to interest you.

Jefferson Electric Company  
1591 S. Laflin St., Chicago, Ill.

# JEFFERSON

**AUDIO and POWER TRANSFORMERS and CHOKES**

*When writing to advertisers mention of the PROCEEDINGS will be mutually helpful.*

# CHANGE IN MAILING ADDRESS OR BUSINESS TITLE

Members of the Institute are asked to use this form for notifying the Institute office of a change in their mailing address or any change in the listing of their company affiliation or title for the Year Book membership list.

The Secretary,  
THE INSTITUTE OF RADIO ENGINEERS,  
33 West 39th Street,  
New York, N.Y.

Dear Sir:

Effective ..... please note change in my address  
(date)  
for mail as follows:

FROM

.....  
(Name)

.....  
(Street Address)

.....  
(City and State)

TO NEW ADDRESS

.....  
(Street Address)

.....  
(City and State)

Also for the membership list for next year's Year Book note change in my business address (or title) as follows, this <sup>is</sup> <sub>is not</sub> my mailing address:

.....  
(Title)

.....  
(Company Name)

.....  
(Address: Street, City and State)

PLEASE FILL IN, DETACH, AND POST TO THE  
INSTITUTE PROMPTLY



## Back Numbers of the Proceedings Available

**M**EMBERS of the Institute will find that back issues of the Proceedings are becoming increasingly valuable, and scarce. For the benefit of those desiring to complete their file of back numbers there is printed below a list of all complete volumes (bound and unbound) and miscellaneous copies on hand for sale by the Institute.

The contents of each issue can be found in the 1914-1926 Index and in the 1929 Year Book (for the years 1927-28).

### BOUND VOLUMES:

Vols. 8, 9, 10 and 14 (1920-1921-1922-1926), \$8.75 per volume to members

Vol. 16 (1928), \$9.50 to members.

### UNBOUND VOLUMES:

Vols. 6, 8, 9, 10, 11 and 14 (1918-1920-1921-1922-1923-1926), \$6.75 per volume (year) to members

### MISCELLANEOUS COPIES:

Vol. 1 (1913) July and December

Vol. 2 (1914) June

Vol. 3 (1915) December

Vol. 4 (1916) June and August

Vol. 5 (1917) April, June, August, October and December.

Vol. 7 (1919) February, April and December

Vol. 12 (1924) August, October and December

Vol. 13 (1925) April, June, August, October and December

Vol. 15 (1927) April, May, June, July, October, November and December

Vol. 17 (1929) April, May, June, July, August, September, November and December

These single copies are priced at \$1.13 each to members to the January 1927 issue. Subsequent to that number the price is \$0.75 each. Prior to January 1927 the Proceedings was published bi-monthly, beginning with the February issue and ending with December. Since January 1927 it has been published monthly.

Make remittances payable to the Institute of Radio Engineers and send orders to:

**THE INSTITUTE OF RADIO ENGINEERS**

*33 West 39th Street*  
NEW YORK, N. Y.

YOU CAN **HEAR** THE DIFFERENCE  
 AND **SEE** THE REASON  
 IN EVEREADY RAYTHEON  
 4-PILLAR TUBES « «

**H**ERE is an entirely new type of tube . . . Eveready Raytheon! It combines the highest degree of sensitivity with lasting, rugged strength. The patented Eveready Raytheon 4-Pillar construction—a revolutionary improvement—safeguards fragile elements against the dangers of shipment and handling. Eveready Raytheon elements are assembled on jigs, to put them in most sensitive relation to each other. The 4-Pillar construction anchors these elements where they belong—assuring you of a new standard of reception.

You can see this exclusive construction inside an Eveready Raytheon. Look at the diagram on this page. See the solid, four-cornered glass stem. Notice, imbedded in it, the four sturdy pillars supporting the elements. That shows why Eveready Raytheons are stronger than ordinary tubes—and why they give you the best reception you can possibly get from your present receiver. No other tube can be made like this, because the 4-Pillar construction is patented.

Eveready Raytheons come in all types. They fit the sockets in every standard A. C. and battery-operated receiver in use today. They are built by the makers of the famous Eveready Layerbilt "B" Batteries—another radical improvement in radio. Get a set of new Eveready Raytheons from your dealer, and enjoy their reception today.

NATIONAL CARBON CO., Inc.

General Offices: New York, N. Y.

Branches: Chicago, Kansas City, New York,  
 San Francisco



Unit of Union Carbide  
 and Carbon Corporation



4-PILLAR TUBES

Showing the exclusive, patented EVEREADY RAYTHEON 4-Pillar construction with its solid, four-cornered glass stem, its four rigid pillars, and anchorage to a stiff mica plate at the top.



Trade-marks

When writing to advertisers mention of the PROCEEDINGS will be mutually helpful.

# Solid Molded



**Bradleyunit  
Fixed  
Resistors**

## *Rugged-Accurate-Permanent*

### *Compare These Oscillograms*

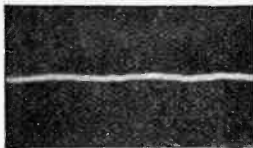

*Oscillogram showing noiseless performance of Bradleyunit Resistors.*

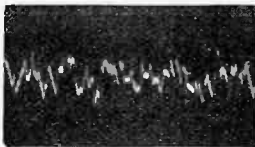

*Oscillogram showing noisy performance of other types of resistors.*

SOLID MOLDED—that is the secret of the superior performance of the Bradleyunit. Made in ratings from 500 ohms to 10 megohms, these accurate, noiseless fixed resistors are the choice of the leading set manufacturers for grid leaks and plate coupling resistors.

All Bradleyunits are color-coded for quick and easy identification. They are not fragile. There are no production losses due to breakage. Temperature, moisture, and age do not affect Bradleyunit accuracy.

Follow the example of leading radio manufacturers, and standardize on the Bradleyunit. Write for further information and prices.

ALLEN-BRADLEY CO., 282 Greenfield Ave., Milwaukee, Wis.

# Allen-Bradley

**PERFECT RADIO RESISTORS.**



*When writing to advertisers mention of the PROCEEDINGS will be mutually helpful.*

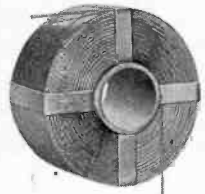

To the Manufacturer

Who Winds His Own Coils —

When the development of an improved winding process sets new and higher coil standards, it is worth while for you to investigate; to find out how you can profit by the purchase of coils made by that process.

The Rome Coil Department is prepared to supply a wide variety of coils for any purpose.

Particularly, the new method by which Rome Precision Heavy Wire Coils are wound not only improves the coils themselves, but also bears on component parts of the device to

take the coils. It effects CUMULATIVE economies. Such economies are IMPORTANT.

Rome Coil Engineers are eager to demonstrate, by means of sample coils, the extent to which you can profit by the new principles involved in making Rome Precision Coils.

A demonstration of that sort will prove interesting. Write for it.

ROME WIRE COMPANY  
Division of General Cable Corp.  
ROME, NEW YORK

ROME PRECISION COILS

*When writing to advertisers mention of the PROCEEDINGS will be mutually helpful.*

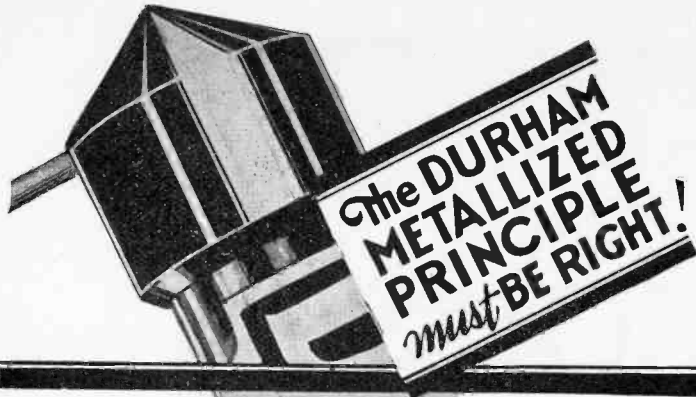

A Million and a half used Monthly during 1929  
in American Radio

To keep pace with 1930 receiver developments, Durham Metallized resistors and powerohms are now more accurate, have a greater power safety factor and can be obtained in even greater variety.

The advantages of the Durham Metallized principle have been proven by the millions of Durham resistors and powerohms now used by America's foremost manufacturers of radio receivers and allied products.

These units are now in standard production in all ratings, all types of tips for radio work.

*Engineering data and samples for testing sent upon request. Please state ratings required.*

**International Resistance Company**

2006 Chestnut Street, Philadelphia, Pa.

**DURHAM**  
METALLIZED  
**RESISTORS &  
POWEROHMS**

*When writing to advertisers mention of the PROCEEDINGS will be mutually helpful.*

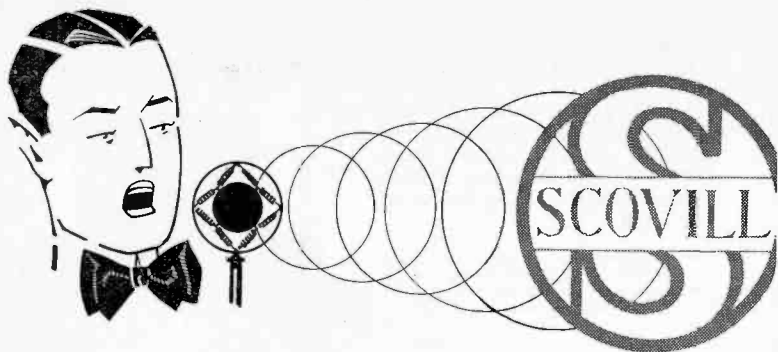

# Talking and *SPEAKING!*

**T**O a radio listener a condenser means nothing. But when you have given years to its development it is an important article. Frankly, we admit that the condenser is only a "part" in the "set." But without it you could hear nothing. The "speaker" couldn't talk.

It's important, then, to have a quality condenser, accurate to the full extent of engineering knowledge, adequate for every job it is called upon to do.

SCOVILL has been making such condensers since radio was in its infancy. Today SCOVILL radio condensers are known to engineers and manufacturers as the finest products of their kind. SCOVILL service and SCOVILL condensers have kept abreast—even perhaps a little ahead—of progress. And you may rest assured that this SCOVILL reputation will be maintained for the benefit of those leading manufacturers who insist on using SCOVILL condensers in the radio sets they build.

# SCOVILL

Established 1802

MANUFACTURING COMPANY

· WATERBURY · CONNECTICUT ·

BOSTON  
ATLANTA  
CHICAGO  
PROVIDENCE

CLEVELAND  
LOS ANGELES  
NEW YORK

DETROIT  
SAN FRANCISCO  
PHILADELPHIA  
CINCINNATI

*In Europe—THE HAGUE, HOLLAND*

*When writing to advertisers mention of the PROCEEDINGS will be mutually helpful.*

## «ESCO» Power Supply for Radio Equipment

Machines for operating 60-cycle A. C. Radio Receivers, Loud Speakers and Phonographs from Direct Current Lighting Sockets Without Objectionable Noises of any Kind.

The dynamotors and motor generators are suitable for radio receivers and for combination instruments containing phonographs and receivers. Filters are usually required. The dynamotors and motor generators with filters give as good or better results than are obtained from ordinary 60-cycle lighting sockets. They are furnished completely assembled and connected and are very easily installed.

These machines are furnished with wool-packed bearings which require very little attention, and are very quiet running.

Write for Bulletin No. 243-D

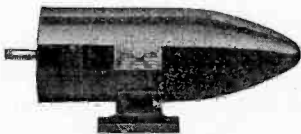

Type NA Aircraft Generator

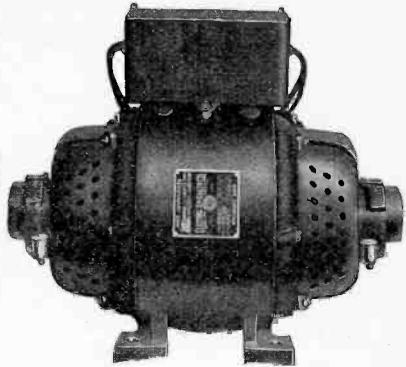

Dynamotor with Filter for Radio Receivers

Low wind resistance, light weight, non-corroding parts, ball bearings, tool steel shafts, steel shells, cast steel pole pieces, weather proof construction, many sizes to choose from, high voltage and low voltage windings to suit individual requirements, are a few of the many reasons for «ESCO» generators or dynamotors being the first choice.

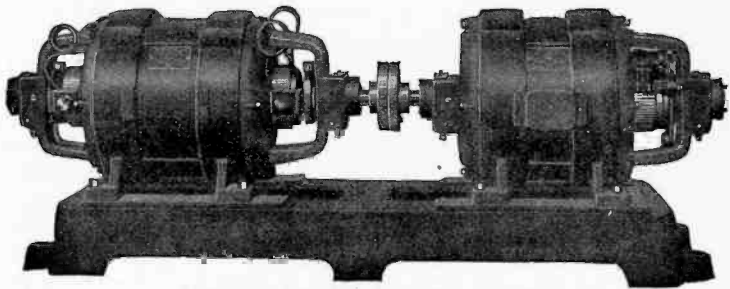

Type BFR, Two Unit Motor Generator Set

«ESCO» two and three unit sets have become the accepted standards for transmission. The «ESCO» line consists of over 300 combinations. These are covered by Bulletin 237G.

«ESCO» also manufactures synchronous motors for television and «talkie» projectors. Motor generators and dynamotors for power amplifiers and public address systems.

**ELECTRIC**  **SPECIALTY**  
**COMPANY**

300 SOUTH ST., STAMFORD, CONN.

Manufacturers of motors, generators, dynamotors and rotary converters.

When writing to advertisers mention of the PROCEEDINGS will be mutually helpful.

# What are your exact requirements?

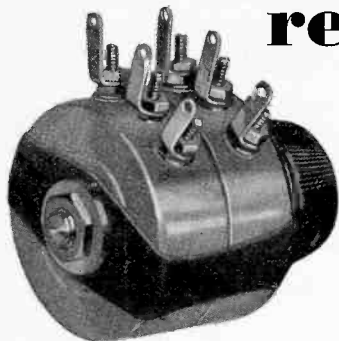

No. 280-280. Combination metal shell wire wound and composition elements. Wire wound up to 15,000 ohms. Composition, 5,000 1 megohm. Rheostat or potentiometer type in either unit. Units insulated from each other. Diameter, 1 11-16 in. Depth of shell, 1 3-8 in.

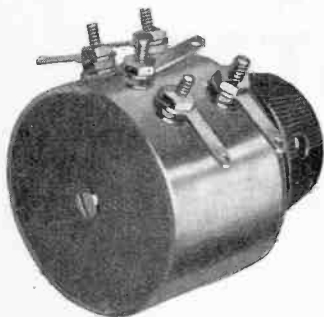

No. 890. Double depth metal shell unit in rheostat or potentiometer type. Rotors in same electrical connection. Composition elements, 5,000 ohms to 1 megohm in each unit. Diameter, 1 7-8 in. Depth of shell, 1 3-16 in.

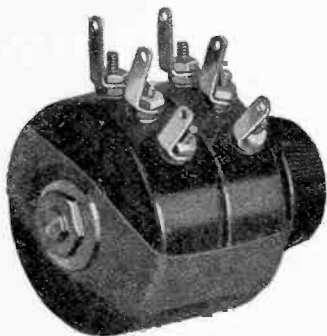

No. 1880-1880. Same as 280-280 except all bakelite.

Your volume control requirements—*what are they?*

We know, if you are at all like most manufacturers, that your requirements as to volume controls are exceedingly precise. That is why we ask you: What are your *exact* requirements?

Not knowing how we can best serve you, we invite you to tell us. We ask you to use our very considerable facilities to help you secure precisely the volume controls that you require. We maintain a large research department whose sole function is to cooperate with manufacturers who seek perfection in fixed and variable high resistors—and who have not yet found what they want.

Won't you do this? To start on a solution of your volume control problem, we suggest you mail the coupon below for fuller, more complete information about the unique service this company offers. Do this today.

## HERBERT H. FROST, INC.

*Largest manufacturers in the world of high grade variable resistors*

**Main Offices and Factory  
ELKHART, IND.**

**160 North La Salle Street, Chicago**

**Herbert H. Frost, Inc.  
Elkhart, Ind.**

IRE 3-30

We are interested in securing further facts about your ability to supply us with suitable variable resistors for our .....

Name .....

Address .....

City ..... State .....

*When writing to advertisers mention of the PROCEEDINGS will be mutually helpful.*



# INSURE!

## For Satisfactory Performance!

Can you afford to assume the risk of having your sets perform poorly in many territories, due to line voltage, and thereby lose many sales as well as jobbers and dealers?

Can you afford to have your sets burn out tubes in quick order, with your dealers called upon to make good on tube replacements, and the tube manufacturers, in self-defense, branding your sets as defective?

Can you afford to have the power packs of your sets break down in service, with the dealer and jobber compelled to handle the servicing and replacement, while you must supply fresh power packs in return for the broken-down units?

Can you afford to jeopardize dealer and jobber, as well as public, good will?

In a word—can you afford to gamble with questionable line voltage?

The greatest insurance policy today for the radio set manufacturer is the

## LINE BALLAST CLAROSTAT

The LINE BALLAST CLAROSTAT is an automatic regulator of the input voltage to any radio set for which it is specifically designed. Although line voltage may vary as much as 30 per cent, it maintains the input voltage within 5 per cent plus or minus of the rated voltage specified by tube manufacturers.

Don't confuse the LINE BALLAST CLAROSTAT with other so-called ballasts. It is free from delicate glass bulbs. It contains no chemicals, gases, liquids or delicate filaments. Nothing to burn out. Cannot short-circuit. Nothing to oxidize or change resistance value. Sturdy—with perforated metal case. Responds immediately to any voltage fluctuation. May be designed for any power transformer, for the desired regulation, either as a built-in or as an accessory feature. Positively fool-proof.

*Write for engineering and merchandising data regarding this SATISFACTORY performance insurance. Better still, send a sample power transformer, together with data regarding the number and types of tubes employed and we shall gladly make up sample ballasts for your tests.*

**Clarostat Manufacturing Company**



*Specialists in Variable, Fixed and Automatic Resistors*

289 North Sixth Street, Brooklyn, N.Y.

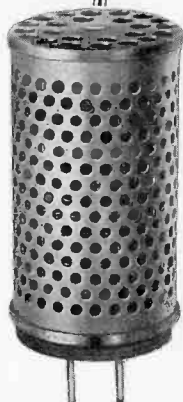

1/2 Actual Size

*Remember—there's a* **CLAROSTAT** *for Every Purpose*

*When writing to advertisers mention of the PROCEEDINGS will be mutually helpful.*

# A SAFE GUIDE

in the selection of insulation for Radio Transmitting and Receiving Sets

OVER 300 broadcasting stations, leading radio telegraph systems, the United States Army, Navy, Air Mail, Coast Guard and Ice Patrol Services, explorers like Commander Byrd, and exacting amateurs everywhere have utilized PYREX Insulators in many spectacular achievements.

Regardless of whether you are sending or receiving—on land, sea or airplane—you should be thoroughly familiar with the PYREX Antenna, Strain, Entering, Stand-off and Bus-bar Insulators that are helping these leaders to make radio history.

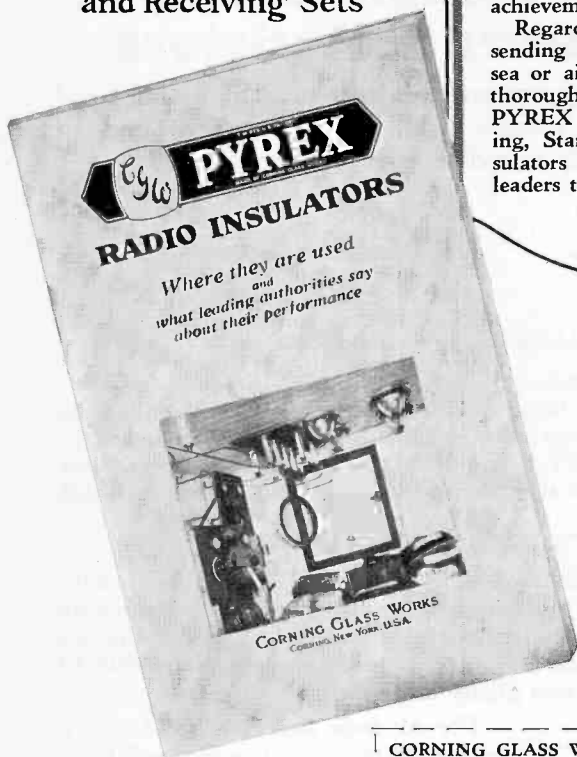

The new PYREX Radio Insulator booklet lists all types and sizes with data that you will want for ready reference.

Return the coupon for your copy, and if you want further advice on any insulation problem, our Technical Staff will answer your questions promptly.

CORNING GLASS WORKS, Corning, N. Y.  
Send copy of your new bulletin on Radio Insulators

Name .....

Address .....

I. R. E.-2-30

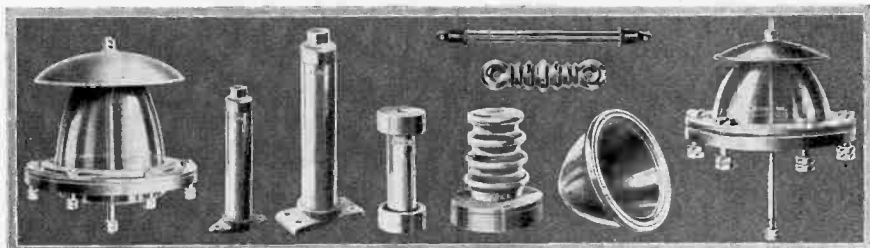

When writing to advertisers mention of the PROCEEDINGS will be mutually helpful.



## Without A Doubt The Most Complete Line of Condensers & Resistors

**N**O matter what your requirements may be in the fixed condenser or resistor field, you are sure to find an Aerovox unit exactly suited to your needs.

Filter Blocks  
Buffer Blocks  
Socket Power  
High Voltage  
Transmitting  
Bypass  
"A" Power  
Bakelite Moulded Mica  
Condenser  
Interference Filters

Pyrohm Heavy Duty  
Edison Base Pyrohms  
Tapped Pyrohms  
Wire Wound Units  
Grid Suppressors  
Center-Tapped Units  
Non-Inductive Lavite  
Grid Leaks  
Resistofomer Kits  
Resistor Mountings

In addition to the large number of stock sizes of condensers and resistors, the Aerovox Wireless Corporation is equipped to supply to manufacturers special types and sizes of condensers, filter blocks and resistors in all fixed and tapped combinations on short notice.

### SEND FOR COMPLETE CATALOG

Complete specifications of all Aerovox units, including insulation specifications of condensers, carrying capacities of resistors and all physical dimensions, electrical characteristics and list prices of condensers and resistors are contained in a complete 1929-30 catalog which will be sent gladly on request.



The Aerovox Research Worker is a free monthly publication that will keep you abreast of the latest developments in radio. Your name will be put on the mailing list free of charge on request.



*When writing to advertisers mention of the PROCEEDINGS will be mutually helpful.*

# ENGINEERS AVAILABLE

Advertisements on this page are available only to members of the Institute of Radio Engineers. For rates and further information address the Secretary, The Institute of Radio Engineers, 33 West 39th Street, New York, N.Y.

MANUFACTURERS and others seeking radio engineers are invited to address replies to these advertisements at the Box number indicated, care the Institute of Radio Engineers. All replies will be forwarded direct to the advertiser.

---

**ENGINEERING EXECUTIVE** of thirteen years' experience desires suitable connection. From 1917 to 1922 in U. S. Navy Department on research and development, testing of radio-compass equipment and high and low-power transmitters. In charge of radio laboratory in Philadelphia for three of these years. 1922 to 1925, chief radio engineer for large manufacturer of broadcast receiving sets handling research, design, supervision of manufacture, training of personnel, and responsible for design of all apparatus sold during that period. 1925 to 1927 spent as consulting engineer. 1927 to 1929, chief engineer for an organization manufacturing parts and theatre amplifying equipment. Four months of 1929 on receiver design. 35 years of age. Box 8.

---

**RADIO ENGINEER**, college graduate with more than twelve years' exclusive experience in radio, having a thorough knowledge of the art and requirements of the receiver industry, and for the past three years chief engineer for a national manufacturer is desirous of making new connection in responsible capacity. Box 9.

---

**GRADUATE** of industrial electrical engineering course at Pratt Institute, also radio course at same school, is interested in experimental or test work on receivers or tubes. Experienced in factory testing and trouble shooting. Age 23. Box 10.

---

**COLLEGE GRADUATE**, 27 years of age, three years' research in Dutch tube laboratory, two years with large U.S. set manufacturer on inspection and maintenance work, one year with talking moving picture firm as service engineer, desires position with receiver or tube manufacturing organization. Address Box 1.

---

**GRADUATE** of National Radio Institute with five years' experience in inspection and test work, also development of test equipment, desires connection with broadcast station, preferably in northeastern states, as radio operator. Has amateur experience over period of several years. Age 24. Box 11.

---

**FORMER STUDENT** of Bradley Polytechnic Institute with six years' experience as service manager for distributor of broadcast receivers desires similar position with manufacturer or well-established distributor. Age 28. Box 12.

---

**GRADUATE** of University of Kiev (U.S.S.R.), B.A., '13, has built, repaired, and serviced receivers and power-supply units and has considerable experience in audio amplifiers having frequency-response characteristics better than those available in manufactured units. Is interested in work concerning the building, control, installation, and servicing of sound-amplifier systems. Age 38. Box 13.

---

**COLLEGE GRADUATE**: B.S., in E.E., 1925. 26 years of age. Has two years' experience in transmitter and receiver development and measurement work; three years of acoustical development and design of sound recording, reproducing, and measuring systems with large electrical manufacturing company. Desires position with engineering laboratory or manufacturer. Box 14.

*When writing to advertisers mention of the PROCEEDINGS will be mutually helpful.*

# QUALITY

AFTER ALL QUALITY IS THE THING  
THAT COUNTS IN A FILTER  
CONDENSER

WHEN IT CAN BE OBTAINED AT SUCH  
REASONABLE PRICES IT IS COSTLY TO  
OVERLOOK THE OPPORTUNITY.

SEND YOUR SPECIFICATIONS NOW.



---

**CONDENSER CORPORATION OF AMERICA**  
259-271 CORNELISON AVE.                      JERSEY CITY, N. J.

**The Ekko Co.**  
Daily News Bldg.  
Chicago, Ill.

**W. C. Laing**  
Building Industries, Inc.  
Cincinnati, Ohio

*When writing to advertisers mention of the PROCEEDINGS will be mutually helpful.*

# One Industry Gathers Stimulating Facts from Hundreds of Others

---

Offers them free to men in thousands of Other Industries—to  
Workers in all ranks, and to Executives—First step  
in the “Democratizing” of Knowledge  
hitherto restricted to a Few

---

## FACT-SHEETS OF INDUSTRY NO. 1

will be mailed to ANY Worker or Executive. No charge or obligation. Just state work you do; company's name and products; and whether request is for self. Address: Librarian; (X-3); Fact-Sheets of Industry; National Vulcanized Fibre Company, Wilmington, Del. (Card will do).

## Send for This

**T**HE kind of facts that spur thought. The kind of thought that results in those small and large savings and advantages originated by workers and executives; which, in the total, have already done so much for the advancement and prosperity of each industry.

And that can be still more help-

ful to the prosperity of each industry, right NOW.

(Because, right now, if you realize what is going on, industry's thinking is getting ready for a new turning point, a new prosperity, a new and greater advancement than ever before.)

Write for these Fact-Sheets today.

---

The publication of this, the first of the Fact-Sheets of Industry, is the start of a plan which, when at its full growth, will supply freely to thinking workers in ALL levels of industry, practical knowledge which hitherto has not been readily accessible; facts from many other industries which may stimulate their own productive thinking; and which (though they affect practically every business, every department and every worker), are usually known only in part and only by a limited group of specialists in each industry. . . .

As a movement in line with national measures for further improvement of business conditions and of the circuit of producing, earning, consuming, equipping, etc.—and as the initial step in this democratizing of inter-industry knowledge, (which, under present conditions, is more needed by thinking workers, and can yield more important results than ever before)—all expenses of issuing the first of the Fact-Sheets of industry are being borne by The National Vulcanized Fibre Company and its various divisions and associated industries.

## NATIONAL VULCANIZED FIBRE COMPANY

*When writing to advertisers mention of the PROCEEDINGS will be mutually helpful.*

# VARIABLE CONDENSERS for TRANSMISSION

CAT. No. 149

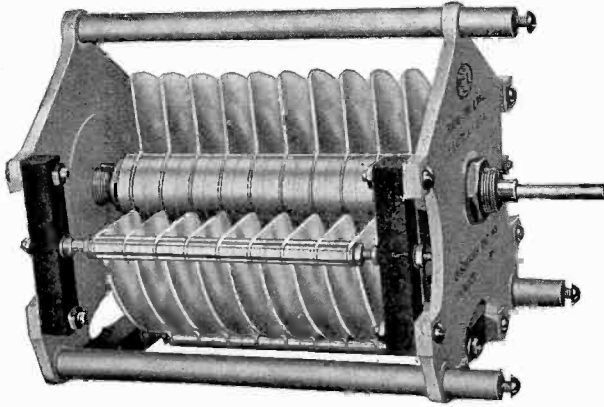

## Super-Construction

Heavy Brass Plates . . . Substantial Cast Aluminum End Plates . . . Steel Shaft Projecting Through Both Ends . . . Cone Bearings with Locking Device . . . Heavy Isolantite Insulating Blocks.

The following table gives data on stock condensers:

Type No.	Breakdown Voltage	Number of Plates	Max. Cap. Mmfd.	Plate Spacing Inches	Overall Depth Inches	Wt. Lbs.	Price
K	3,000	19	200	.250	6.750	4.0	\$17.50
L	3,000	33	350	.250	9.100	8.0	21.00
M	3,000	59	650	.250	13.620	12.5	29.00
N	5,000	11	60	.500	6.750	3.5	17.25
O	5,000	19	100	.500	9.100	7.0	20.00
P	5,000	33	180	.500	13.620	10.5	28.00
R	10,000	7	25	1.000	6.750	3.0	17.00
S	10,000	11	45	1.000	9.100	6.0	19.00
T	10,000	19	80	1.000	13.620	9.5	27.00

Write for Bulletin 39



MANUFACTURES A COMPLETE LINE OF  
APPARATUS FOR SHORT WAVE TRANS-  
MISSION AND RECEPTION

## Radio Engineering Laboratories, Inc.

100 Wilbur Ave.

Long Island City, N.Y., U.S.A.

When writing to advertisers mention of the PROCEEDINGS will be mutually helpful.

## PROFESSIONAL ENGINEERING DIRECTORY

For Consultants in Radio and Allied Engineering Fields

### THE MAGNAVOX COMPANY

Oakland, Calif. & Chicago, Ill.

*PIONEERS AND SPECIALISTS  
IN THE ART OF  
SOUND PRODUCTION.*

*DYNAMIC SPEAKERS SINCE  
1911.*

### P A T E N T S WM. G. H. FINCH

Patent Attorney  
(Registered U. S. & Canada)

Mem. I. R. E. Mem. A. I. E. E.

303 Fifth Ave. New York  
Caledonia 5331

### RADIO ENGINEERS

Ten dollars will introduce you directly to over 7,000 technical men, executives, and others with important radio interests. For details write to

Advertising Dept., I.R.E.

### The J. G. White Engineering Corporation

Engineers—Constructors

*Builders of New York Radio  
Central*

43 Exchange Place New York

# Radio



# Engineers

Your card on this professional card page will give you a direct introduction to over 7,000 technical men, executives, and others with important radio interests.



*Per Issue—\$10.00*

*When writing to advertisers mention of the PROCEEDINGS will be mutually helpful.*



## *Alphabetical Index to Advertisements*

<b>A</b>	Aerovox Wireless Corp. .... LX Allen-Bradley Co. .... LII American Tel. & Tel. Co. .... XX American Transformer Co. .... XXI Arcturus Radio Tube Co. .... XLVII	I.R.E. .... . . . XXXIII, XXXIV, XLIX, L, LXI
<b>C</b>	Cardwell, Allen D., Mfg. Corp. . . . XXII Central Radio Laboratories. . . . XXXVIII Clarostat Mfg. Co., Inc. . . . . LVIII Cohn, Sigmund . . . . . XXXV Condenser Corp. of America. . . . LXII Continental Carbon Inc. . . . . XLV Cornell Electric Co. . . . . XXXVI Corning Glass Works . . . . . LIX Cornish Wire Co. . . . . LXVIII	<b>J</b>
<b>D</b>	De Forest Radio Co. . . . . LXIX Dudlo Manufacturing Co. . . . . XL	Jefferson Electric Co. . . . . XLVIII Jewell Electrical Instrument Co., XXIV
<b>E</b>	Eby, H. H., Mfg. Co., Inc. . . . . . . . . . XXVIII, XXIX Electrad, Inc. . . . . XXIII Electric Specialty Co. . . . . LVI	<b>N</b>
<b>F</b>	Fansteel Products Co., Inc. . . . XXXVII Formica Insulation Co. . . . . LXX Frost, H. H. . . . . LVII	National Carbon Co. . . . . LI National Vulcanized Fibre Co. . . . LXIII Norden-Hauck, Inc. . . . . XLI
<b>G</b>	General Radio Co., Outside Back Cover Gilby Wire Co. . . . . XXX Grebe, A. H., and Co., Inc. . . . . . . . . . Inside Back Cover	<b>O</b>
<b>H</b>	Hammarlund Mfg. Co. . . . . XXVII	Operadio Mfg. Co. . . . . XXXIX
<b>I</b>	International Resistance Co. . . . . LIV I.R.E. Publications . . . . . XVII	<b>P</b>
		Pacent Electric Co., Inc. . . . . XVIII Polymet Manufacturing Corp. . . . . XIX Professional Engineering Directory . . . . . LXV
		<b>R</b>
		Radio Engineering Laboratories, LXIV Roller-Smith Co. . . . . XLIV Rome Wire Co. . . . . LIII
		<b>S</b>
		Sangamo Elec. Co. . . . . XXXI, XXXII Scientific Radio Service . . . . . XVI Scovill Manufacturing Co. . . . . LV Shakeproof Lock Washer Co. . . . . XLVI Sprague Specialties Co. . . . . LXVII
		<b>T</b>
		Thermal Syndicate, Ltd. . . . . XLIII Thordarson Electric Co. . . . . XV Transformer Corp. of America XXVI
		<b>U</b>
		United Scientific Labs. . . . . XXV
		<b>W</b>
		Wireless Specialty Apparatus Co. . . . . . . . . . XLII

*When writing to advertisers mention of the PROCEEDINGS will be mutually helpful.*

## Fool Proof Condenser Performance

Compare the new Sprague Electrolytic with any other condenser. Use it—test it—and judge for yourself its amazing performance. And here are just a few of the reasons why Sprague Electrolytic Condensers can give you better service.

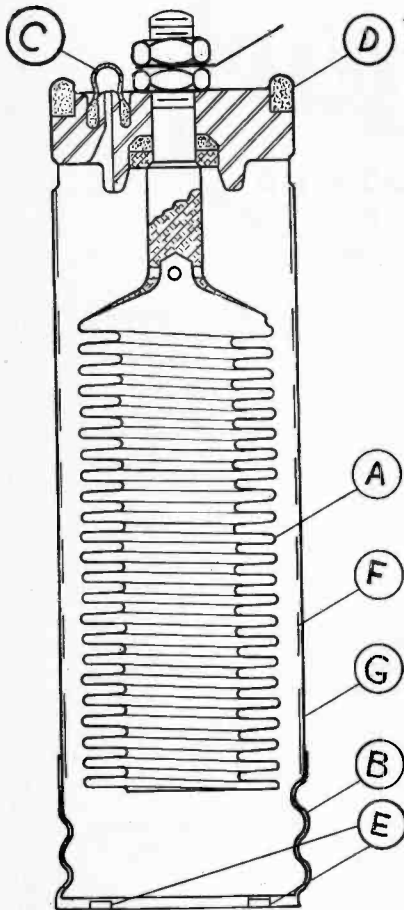

- A One piece anode made entirely of pure aluminum; no welded or riveted joints either above or below the electrolyte.
- B Screw type socket mounting making for maximum flexibility in receiver design.
- C Protected vent eliminating the possibility of damaging the nipple.
- D Pressure seal, with no possibility of cutting gasket.
- E Locking lugs in socket to prevent condenser shaking loose during shipment.
- F Shield, precluding possibility of internal short circuit.
- G Individual container allowing space to be utilized with maximum flexibility.

Individual cathodes eliminate all leakage between anodes and allow maximum flexibility in circuit design. Increased life, less leakage and much better shelf characteristics due to anode with edge effect of less than 10% of spiral type. Leakage current guaranteed not to exceed .2 milliamperes per MFD at 400 volts after 5 minutes or .065 milliamperes per MFD at 350 volts after 5 minutes.

*And there are the well known paper condensers made by Sprague—made with the same precise skill as the Sprague electrolytic. Types and sizes to fit your every condenser need.*

**SPRAGUE SPECIALTIES COMPANY**  
QUINCY, MASSACHUSETTS

SPRAGUE ELECTROLYTIC AND PAPER CONDENSERS  
WILL SOLVE YOUR CONDENSER PROBLEMS



*When writing to advertisers mention of the PROCEEDINGS will be mutually helpful.*



**Breakdown Voltage Tests**  
*Prove the Superiority of*



To prove the superiority of Corwico Super Braidite Hook-up Wire, we had samples tested by the Electrical Testing Laboratories. The results are as follows. They speak for themselves.

Test No.	Corwico "Super Braidite"	Ordinary Hook-up Wire
1	1300 volts	1100 volts
2	1370 volts	970 volts
3	1350 volts	950 volts
4	1100 volts	950 volts
5	1400 volts	1020 volts
6	1500 volts	....
Average	1340 volts	1000 volts

The samples were tested in a mercury bath with about 3" of the sample in the mercury for each puncture. Voltage was applied at a low value between the mercury and the conductor, and raised to puncture at the rate of 100 to 200 volts per second.

Because of its increased voltage breakdown, its ease in handling, neat appearing, glossy, flame-proof insulation, and moderate cost, Corwico Super Braidite Hook-up Wire is the choice of many of radio's leading engineers.

With Corwico Super-Braidite we furnish our Model "A" Stripping Machines for use in your plant. Write for a sample of Super-Braidite and full particulars.

*More Than a Wire—A Hook-Up Service.*

**CORNISH WIRE COMPANY Inc.**  
 30 CHURCH ST., NEW YORK CITY

*When writing to advertisers mention of the PROCEEDINGS will be mutually helpful.*

# de Forest

## AMATEURS, EXPERIMENTERS, SPECIALTY DESIGNERS

Don't overlook the possibilities in the new De Forest Audions 422 and 422A. The high mutual conductance and low plate resistance to these Audions make them far superior to the ordinary type—22 tubes. An extremely high gain is obtained both at broadcast and high frequencies when used as Radio Frequency Amplifiers. That these Audions give outstanding performance is evident from the manner they have been accepted and speci-

fied by many experimental laboratories and amateurs in the short period they have been offered to the public. Two additional advantages to be gained by use of the Audion 422 or 422A are—long, satisfactory life, and absence of microphonic disturbances so common with ordinary—22 type tubes. These features are the result of tireless efforts of De Forest Engineers, whose aim is to give to radio as fine a product as is possible to produce.



### Characteristics of Audion 422

Filament Voltage 3.3 volts  
 Filament Current .132 amps  
 Plate Voltage 135 volts  
 Screen Grid Voltage 45 volts  
 Control Grid Voltage 1.5 volts  
 Plate Resistance 250,000 ohms  
 Amplification Factor 150  
 Mutual Conductance 600

### Characteristics of Audion 422A

Filament Voltage 3.3 volts  
 Filament Current .06 amps  
 Plate Voltage 135 volts  
 Screen Grid Voltage 45 volts  
 Control Grid Voltage 1.5 volts  
 Plate Resistance 250,000 ohms  
 Amplification Factor 150  
 Mutual Conductance 600



### Audion 503A

Filament Voltage 10.0 volts  
 Filament Current 3.25 amps  
 Max. Plate Voltage 1000 volts  
 Max. Plate Current .175 amps

The "fifty-watter," is back again to stay! The new Audion 503A is just the tube for the 2500 K. C. phone, or any moderate power intermediate frequency work. Audion 503A is a very sturdy oscillator or radio frequency power amplifier. Interchangeable with UV-203A.

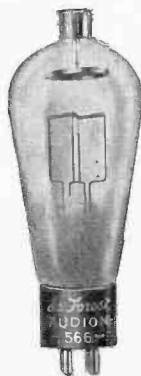

### Characteristics of Audion 566

Filament Voltage 2.5 volts  
 Filament Current 5.0 amps  
 Max. Inverse Peak Volt. 7500 volts  
 Max. Peak Current .6 amps

New Audion 566 is especially designed to withstand high voltage surges without breakdown, and is rated 7500 inverse peak volts at peak current load of .6 Ampere. Audion 566 is interchangeable with UX-866.

For further information consult your local dealer or address

**DE FOREST RADIO CO.**  
**PASSAIC, NEW JERSEY**

When writing to advertisers mention of the PROCEEDINGS will be mutually helpful.

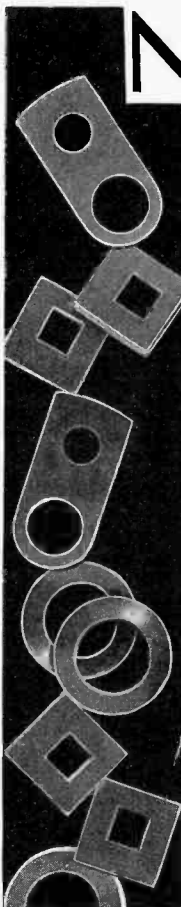

# NEW *Equipment and Resources* »» *for* **BETTER SERVICE** •

**F**ORMICA is constantly adding more buildings and more machinery to the equipment it has available for service to the electrical and radio industries.

An addition to the plant of 50,000 square feet of floor space has just been occupied. New and bigger presses have been installed for making larger sheets—and new equipment for fabricating is also ready.

**THE FORMICA INSULATION  
COMPANY**

4618 Spring Grove Avenue  
CINCINNATI, OHIO



---

• **FORMICA** •

---

*When writing to advertisers mention of the PROCEEDINGS will be mutually helpful.*



**A.H.GREBE & CO., Inc.**

RICHMOND HILL, NEW YORK

**Grebe  
radio**

SUPER-SYNCHROPHASE 

WESTERN BRANCH

443 South San Pedro Street  
Los Angeles, California

MAKERS OF QUALITY RADIO SINCE 1909

# Temperature-Control Boxes

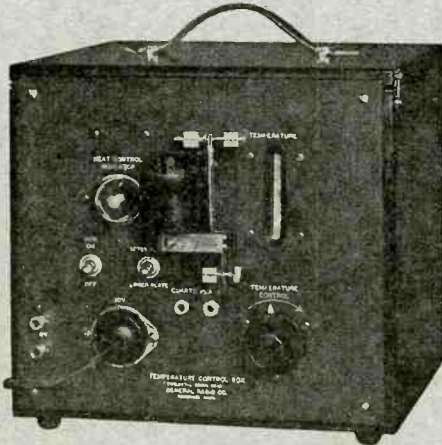

Type 547-A Temperature-Control Box

**A** TEMPERATURE-CONTROL box worthy of the name must maintain its temperature within specified limits over a wide variation in the temperature of the room in which it operates. General Radio temperature-control devices will remain within their specified limits for room temperature variations of  $\pm 20$  degrees F., a range of 40 degrees. They are practically independent of the weather and the janitor's ability to keep constant the temperature of the operating room.

The Type 547 Temperature-Control Boxes are made in the two types listed above but the second one is

recommended only for use where it is necessary to adjust the operating temperature while the unit is in operation.

Both are encased in walnut cabinets within which are arranged (in order) a balsa-wood insulating layer, the heaters (on all six faces), an aluminum distributing layer, an asbestos pressboard attenuation layer, and a second casing of aluminum which forms the temperature-controlled chamber.

**GENERAL RADIO COMPANY**  
CAMBRIDGE A, MASSACHUSETTS  
British Branch: 76 Old Hall Street, Liverpool

## TYPE 547-A

Controls to 0.1 degree C.

Mercury-type thermo-regulator, adjustable for any operating temperature between 40 degrees and 60 degrees C.

Price \$150.00.

## TYPE 547-B

Controls to 1.0 degree C.

Bimetallic-type thermo-regulator, adjustable while operating for any temperature between 40 degrees and 60 degrees C.

Price \$140.00.

GENERAL RADIO INSTRUMENTS

FOR MEASURING ELECTRICAL QUANTITIES AT ALL FREQUENCIES



STANDARD AND SPECIAL ITEMS FOR LABORATORY AND INDUSTRIAL USE