

VOLUME 15

APRIL, 1927

NUMBER 4

PROCEEDINGS
of
**The Institute of Radio
Engineers**



PUBLISHED MONTHLY BY
THE INSTITUTE OF RADIO ENGINEERS
Publication Office 21 Center St., Middletown, N. Y.
Editorial and Advertising Departments
37 West 39th Street, New York, N. Y.

Subscription \$10.00 per Annum in the United States
\$11.00 In all other Countries

General Information and Subscription Rates on Page 267

Entered as second-class matter, at the Post-Office, at Middletown, N. Y.,
under the Act of March 3, 1879.

Acceptance for mailing at special rate of postage provided for in Section 1103,
Act of October 3, 1917, authorized October 7, 1918.

Cunningham

RADIO TUBES

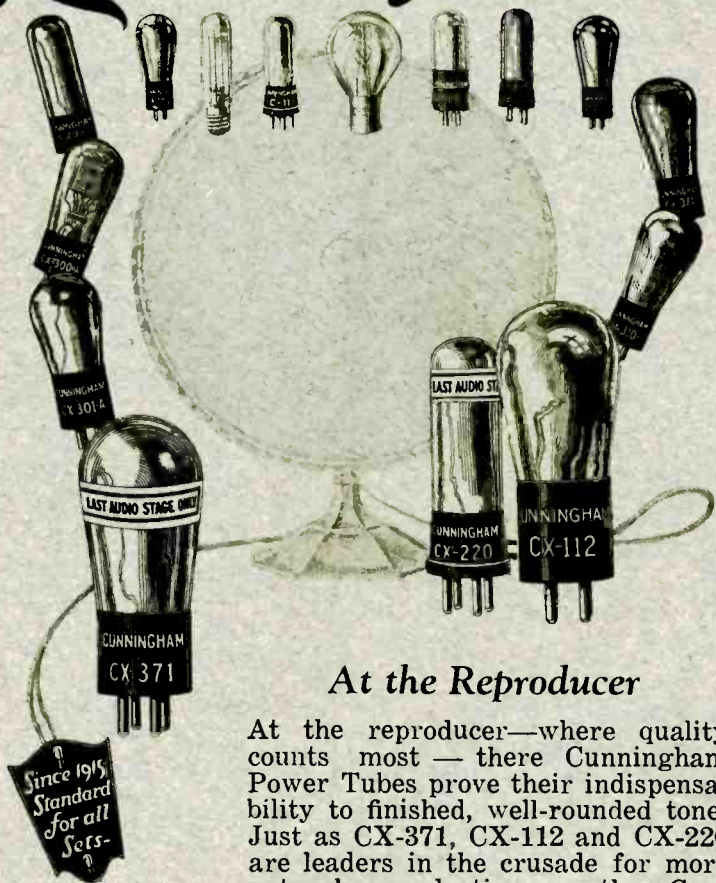

At the Reproducer

At the reproducer—where quality counts most — there Cunningham Power Tubes prove their indispensability to finished, well-rounded tone. Just as CX-371, CX-112 and CX-220 are leaders in the crusade for more natural reproduction, so other Cunningham types are leaders in their various fields.

Fifteen Types all in the Orange and Blue Carton

E. T. CUNNINGHAM, Inc.

NEW YORK

CHICAGO

SAN FRANCISCO

Manufactured and sold under rights, patents and inventions owned and/or controlled by Radio Corporation of America.

“We’re equipping with
Faradon again this year”---

New specifications, new equipment and new policies are now under discussion. But, for the manufacturer who recognizes the value of capacitor durability, there is one certain answer to his condenser problems—Faradon.

Recognized generally as standard quality equipment by radio manufacturers, Faradon Capacitors have also been specified for other exacting work—Automatic Train Control Systems and Marine Direction Finders.

Manufacturers are urged to avail themselves of the Faradon engineering co-operation covering all types of fixed electrostatic condenser equipment.



WIRELESS
SPECIALTY
APPARATUS
COMPANY

Jamaica Plain,
Boston, Mass.,
U. S. A.

Established 1907

Faradon

782

ELECTROSTATIC CONDENSERS
FOR ALL PURPOSES

It will be of mutual benefit to mention Proceedings in writing to advertisers

A Much Needed Instrument
ROLLER - SMITH
 Type GSA
 A. C. Portable Volt-Ammeter

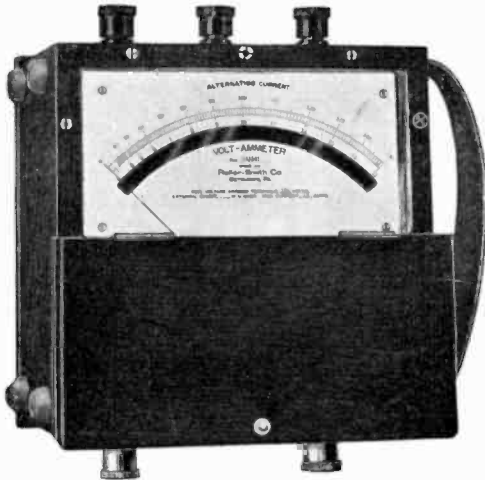

Bulletin No. K-160 describes the new ROLLER-SMITH Type GSA Volt-Ammeters and also Type GSA Ammeters, Voltmeters, Single and Polyphase Wattmeters, Frequency Meters, Power Factor Meters, Transformers, Resistors and "Y" Boxes, which represent a complete testing outfit for any shop or station.

Send for a copy of Bulletin K-160.

"Over thirty years experience is back of Roller-Smith"

ROLLER-SMITH COMPANY
 Electrical Measuring and Protective Apparatus



MAIN OFFICE
 2134 Woolworth Bldg.
 NEW YORK

WORKS
 Bethlehem, Penna.

Bethlehem
 Buffalo
 Boston
 Chicago
 Cleveland
 Dallas

Detroit
 Los Angeles
 Montreal
 New Haven
 New Orleans

New York
 Pittsburgh
 Philadelphia
 Portland, Ore.
 San Francisco

Seattle
 St. Louis
 St. Paul
 Toronto
 Washington

It will be of mutual benefit to mention Proceedings in writing to advertisers

Amplifier Test Set



The Type 355 amplifier test set embodies in a single instrument the necessary set-up for taking characteristic curves on all types of coupling units.

Its use embraces the taking of characteristic curves on transformer, impedance, and resistance coupled amplifiers for the audio frequencies, intermediate frequency transformers, and filters for audio and carrier frequencies.

Price \$180.00

Described in Bulletin 7211

GENERAL RADIO COMPANY
30 STATE STREET
CAMBRIDGE, MASSACHUSETTS

Bass Note Energy



The AmerTran DeLuxe
Made in 2 Types
for 1st and 2nd Stages
\$10.00 Each

The production of deep bass notes at the source requires the expenditure of energy beyond that of sounds with higher tones and frequencies.

This greater energy is radiated by the best broadcast stations. When received and amplified uniformly by high grade transformers such as the AmerTran DeLuxe, it has a tendency to overload the last tube. The reason is not the volume of sound, but the relative increase in energy required to produce the sound naturally.

Prevention of overloading in the last stage lies in the choice of a tube which will permit the use of a high plate voltage and current. There are power tubes now on the market that will utilize these higher voltages. In obtaining these voltages economically, the ordinary 110 volt alternating house current can be stepped up and rectified with the proper apparatus and delivered to this tube.

Observing this principle you will obtain finer and more real reception through the use of AmerTran DeLuxes in your circuit.

Literature will be sent gladly on request describing the use of AmerTran Radio Products in the best of high voltage plate supplies.

The American Transformer Co.

178 EMMET STREET

NEWARK, N. J.

"Transformer Builders for over 26 Years"

OTHER AMERTRAN PRODUCTS

AmerTran Power Transformer
Type PF 52—\$18.00 Each

AmerTran Audio Transformer
Type AF6 and AF7—\$5.00 Each

AmerChoke Type 854—\$6.00 Each

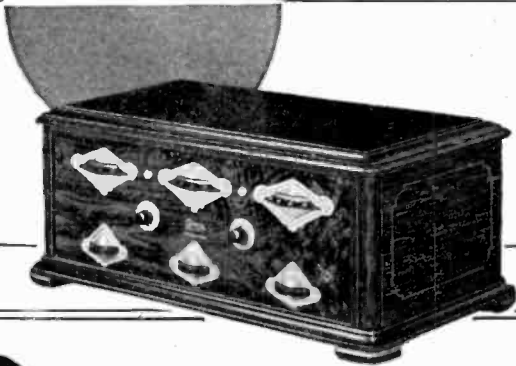

Tone Quality

so tangible, so difficult to describe,
is the very foundation stone of radio
enjoyment.

There are very definite and tangible
reasons why the tone of the Grebe
Synchrophase is so superior.

*Booklet I explains them.
Send for it.*

A. H. Grebe & Company, Incorporated,
109 West 57th Street New York City

Western Branch:
443 South San Pedro St., Los Angeles, Calif.

Factory: Richmond Hill, New York

The oldest exclusive radio manufacturer



The **GREBE** Synchrophase **RADIO**



The Synchrophase
is also supplied in
five console models.

It will be of mutual benefit to mention Proceedings in writing to advertisers



A
Quality
Instrument

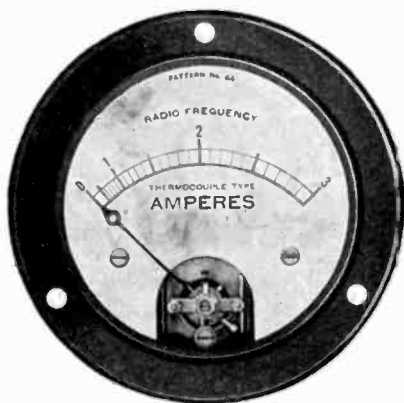

Pattern
No. 64
Radio Frequency
Ammeter

Reliable Instruments

Jewell radio instruments have been serving Amateurs and radio engineers satisfactorily for several years.

For uniformity in appearance, our panel mounting instruments, alternating, direct or radio frequency currents, are available in a uniform size miniature case.

Many styles of small portables are available for special test purposes.

Write for our special radio catalog No. 15-C which gives complete information on all Jewell radio instruments.

JEWELL ELECTRICAL INSTRUMENT CO.

1650 Walnut St., Chicago

"27 Years Making Good Instruments"

It will be of mutual benefit to mention Proceedings in writing to advertisers



The "Mountie" isn't lonely any more

WHEN the supply ship steams south from the last outpost of northern civilization in September, not to return until the following July, loneliness will never again beset the lives of the Royal Canadian Mounted Police who patrol that vast, wild area.

Radio is now brightening the long winter nights with music, special programs, messages and greetings from their "home folks." And in the receiving sets of the "Mounties" is the best equipment obtainable. The batteries they use *must* be dependable. They *must* serve until the supply ship drops anchor in the harbor a year later.

Ask Any Radio Engineer

BURGESS BATTERY COMPANY
GENERAL SALES OFFICE: CHICAGO

Canadian Factories and Offices:
Niagara Falls and Winnipeg



BURGESS RADIO BATTERIES

It will be of mutual benefit to mention Proceedings in writing to advertisers.



The stations are there get them !

You're not getting the most out of that storage battery set of yours. The *set* has a bigger distance reach . . . all it needs is a different tube in the detector socket. Put in the RCA super-detector—Radiotron UX-200-A. You'll get more stations—get the far-away ones more regularly and more easily! It's a small change, but it brings big results.

.



Bring your storage battery set up-to-date with a power RADIOTRON UX-171 or UX-112, a detector RADIOTRON UX-200-A and RADIOTRONS UX-201-A for all-round quality.

Bring your dry battery set up-to-date with a power RADIOTRON UX-120 and RADIOTRONS UX-199 for all-round quality.

RADIO
CORPORATION
OF AMERICA
New York
Chicago
San Francisco

RCA Radiotron

MADE BY THE MAKERS OF THE RADIOLA

It will be of mutual benefit to mention Proceedings in writing to advertisers

PROCEEDINGS OF
The Institute of Radio Engineers

Volume 16

APRIL, 1927

Number 4

CONTENTS

	Page
Officers and Board of Direction	268
Institute Sections	269
Committees 1927	270
Institute Activities	273
News of the Sections	275
Committee Work	277
A. Meissner, "Piezo-Electric Crystals at Radio Frequencies"	281
G. Anders, "Quantitative Measurements on Reception in Radio"	297
G. T. Royden, "The Frequency Checking Station at Mare Island"	313
Discussion on Warner and Loughren Paper	319
Discussion on O. C. Roos Paper	319
Discussion on G. W. Pickard Paper	326
Discussion on W. A. MacDonald Paper	329
Review of Current Literature by Stuart Ballantine—	
"Propagation of Short Waves Around the Earth"—E. Quack	341
Geographical Location of Members Elected March 2, 1927	347

GENERAL INFORMATION

The Proceedings of the Institute are published monthly and contain the papers and the discussions thereon as presented at meetings.

Payment of the annual dues by a member entitles him to one copy of each number of the Proceedings issued during the period of his membership.

Subscriptions to the Proceedings are received from non-members at the rate of \$1.00 per copy or \$10.00 per year. To foreign countries the rates are \$1.60 per copy or \$11.00 per year. A discount of 25 per cent is allowed to libraries and booksellers.

The right to reprint limited portions or abstracts of the articles, discussions, or editorial notes in the Proceedings is granted on the express conditions that specific reference shall be made to the source of such material. Diagrams and photographs in the Proceedings may not be reproduced without securing permission to do so from the Institute through the Secretary.

It is understood that the statements and opinions given in the Proceedings are the views of the individual members to whom they are credited, and are not binding on the membership of the Institute as a whole.

Copyright, 1927, by
THE INSTITUTE OF RADIO ENGINEERS, Inc.
Publication Office 21 Center Street, Middletown, N. Y.
Editorial and Advertising Departments, 37 West 39th St., New York, N. Y.

OFFICERS AND BOARD OF DIRECTION, 1927

(Terms expire January 1, 1928, except as otherwise noted)

PRESIDENT

RALPH BOWN

VICE-PRESIDENT

FRANK CONRAD

TREASURER

WARREN F. HUBLEY

SECRETARY AND EDITOR

ALFRED N. GOLDSMITH

MANAGERS

MELVILLE EASTHAM	R. H. MANSON	L. E. WHITTEMORE (Serving until Jan. 1, 1929)
L. A. HAZELTINE	A. E. REOCH	J. F. DILLON (Serving until Jan. 1, 1930)
J. V. L. HOGAN	R. H. MARRIOTT (Serving until Jan. 1, 1929)	R. A. HEISING (Serving until Jan. 1, 1930)

JUNIOR PAST PRESIDENTS

J. H. DELLINGER

DONALD MCNICOL

ASSISTANT SECRETARY

JOHN M. CLAYTON

ASSOCIATE EDITOR

GEORGE R. METCALFE

INSTITUTE SECTIONS

BOSTON SECTION

CHAIRMAN
George W. Pierce

SECRETARY-TREASURER
Melville Eastham, 11 Windsor St.,
Cambridge, Mass.

CANADIAN SECTION

CHAIRMAN
D. Hepburn

SECRETARY
C. C. Meredith, 110 Church St., Toronto, Ontario

CHICAGO SECTION

CHAIRMAN
G. M. Wilcox

SECRETARY
H. E. Kranz, 4540 Armitage Ave., Chicago, Ill.

CONNECTICUT VALLEY SECTION

CHAIRMAN
W. G. Cady

SECRETARY-TREASURER
K. S. Van Dyke, Scott Laboratory,
Middletown, Conn.

DETROIT SECTION

CHAIRMAN
Thomas E. Clark

SECRETARY-TREASURER
W. R. Hoffman, 615 West Lafayette Blvd.,
Detroit, Mich.

LOS ANGELES SECTION

CHAIRMAN
L. Taufenbach

SECRETARY
L. Elden Smith, 340 N. Painter Ave.,
Whittier, Cal.

PHILADELPHIA SECTION

CHAIRMAN
J. C. Van Horn

SECRETARY
David P. Gullette, 1533 Pine Street,
Philadelphia, Pa.

ROCHESTER, N. Y. SECTION

CHAIRMAN
V. M. Graham

SECRETARY
Harvey Klumb, 34 Clinton Ave.,
Rochester, N. Y.

SAN FRANCISCO SECTION

CHAIRMAN
J. F. Dillon

SECRETARY-TREASURER
D. B. McGowan, Custom House,
San Francisco, Cal.

SEATTLE SECTION

CHAIRMAN
John Greig

SECRETARY-TREASURER
R. B. Wilson, 1132 Highland Ave.,
Bremerton, Washington

WASHINGTON SECTION

CHAIRMAN
A. Hoyt Taylor

SECRETARY-TREASURER
F. P. Guthrie, 122 Conn. Ave., Washington, D. C.

COMMITTEES OF THE INSTITUTE OF RADIO
ENGINEERS, 1927

*Committee on Meetings and
Papers*

R. H. MARRIOTT, Chairman
STUART BALLATINE
R. R. BATCHER
CARL DREHER
W. G. H. FINCH
ERICH HAUSMANN
S. S. KIRBY
G. W. PICKARD
PAUL WEEKS
W. WILSON

Committee on Admissions

F. CONRAD, Chairman
ARTHUR BATCHELER
HARRY F. DART
C. P. EDWARDS
A. H. GREBE
L. A. HAZELTINE
R. A. HEISING
L. M. HULL
F. H. KROGER
A. G. LEE
F. K. VREELAND

*Committee on Revision of the
Constitution*

J. H. DELLINGER, Chairman
J. V. L. HOGAN
DONALD MCNICOL

Committee on Publicity

W. G. H. FINCH, Chairman
DAVID CASEM
ORRIN E. DUNLAP

F. EHRET
E. H. HANSEN
LLOYD JACQUET
J. F. J. MAHER
J. G. UZMANN
WILLIS K. WING
R. F. YATES

Committee on Membership

HARRY F. DART, Chairman
M. C. BATSEL
M. BERGER
GEORGE BURGHARD
E. M. DELORAINE
COL. J. F. DILLON
DR. L. J. DUNN
C. P. EDWARDS
W. G. H. FINCH
C. M. JANSKY, JR.
ROBERT S. KRUSE
WILLIAM J. LEE
PENDLETON E. LEHDE
C. L. RICHARDSON
F. H. SCHNELL
E. R. SHUTE
G. S. TURNER
E. H. ULRICH

*All Section Secretaries,
ex-officio*

*Committee on Institute
Sections*

DAVID H. GAGE, Chairman
M. BERGER
L. F. FULLER
D. HEPBURN

COMMITTEES OF THE INSTITUTE—(Continued)

L. G. PACENT
M. C. RYPINSKI
E. R. SHUTE

*Committee on
Standardization*

L. E. WHITTEMORE, CHAIR-
man.
M. C. BATSEL
EDWARD BENNETT
A. J. CARTER
E. L. CHAFFEE
J. H. DELLINGER
MELVILLE EASTHAM
C. P. EDWARDS

GENERAL FERRIE
A. N. GOLDSMITH
L. A. HAZELTINE
J. V. L. HOGAN
L. M. HULL
F. A. KOLSTER
MAJOR J. O. MAUBORGNE
R. H. MANSON
DONALD MCNICOL
E. L. NELSON
H. S. OSBORNE
LT. COMDR. W. J. RUBLE
E. H. SHAUGHNESSY
H. M. TURNER
C. A. WRIGHT
HIDETSUGU YAGI
J. ZENNECK

INSTITUTE ACTIVITIES

MARCH MEETING OF BOARD OF DIRECTION

At the meeting of the Board of Direction, held at Institute Headquarters on March 2, 1927, the following were present: Dr. Ralph Bown, President; Frank Conrad, Vice-President; Dr. A. N. Goldsmith, Secretary; W. F. Hubley, Treasurer; Dr. J. H. Dellinger, Junior Past President; Donald McNicol, Junior Past President; Melville Eastham, L. A. Hazeltine, J. V. L. Hogan, R. A. Heising, R. H. Manson, R. H. Marriott and J. M. Clayton, Assistant Secretary.

The following were transferred to the grade of Member: Walter Van Nostrand, Jr., Ralph M. Heintz, Charles R. Rowe, Earl S. Fletcher and Charles H. Stewart.

The Board approved the election of the following to the Member grade: Charles C. Shumard, F. L. Pendergrass, W. R. McCanne, I. G. Maloff, E. S. Rogers, Dr. G. Leithauser, L. E. B. Everett and Albert Hall.

Eighty-five Associate and nineteen Junior members were elected.

A petition, from Institute members residing in Detroit, for the formation of a Detroit Section of the Institute was presented and the formation of the Detroit Section was approved.

NEW YORK MEETING OF THE INSTITUTE

The meeting of the Institute was held on March 2, 1927 in the Engineering Societies Building, 33 West 39th street. A paper by Dr. A. Meissner on, "Piezo-Electric Crystals at Radio Frequencies" was read by Dr. K. S. Van Dyke of Wesleyan University.

The paper was discussed by Dr. J. H. Dellinger, Dr. K. S. Van Dyke and others. The attendance at this meeting was over two hundred.

MEETING OF COMMITTEE ON ADMISSIONS

At the meeting of the Committee on Admissions held in the offices of the Institute on March 2nd, the following were present: Frank Conrad, Chairman; Messers. Hazeltine, Heising, Hull and Kroger. The Committee approved

nine applications for election to the grade of Member and four applications for transfer to this grade. The Committee failed to approve the applications of two Associates for transfer to Member grade, and two non-members for direct election to this grade of membership.

1927 YEAR BOOK

The 1927 Year Book probably will be mailed to the entire membership within the next month. This Year Book will contain the names and addresses of the members of the Institute together with much information of value to the members.

The list of membership will appear in geographical as well as alphabetical order.

Each member is requested to advise the office of the Institute of any incorrect listing of names or addresses.

MORRIS LIEBMANN MEMORIAL PRIZE

For a number of years the donor of the fund from which the annual award of the Morris Liebmann Memorial Prize has been made possible has requested that his name be withheld.

At the Banquet of the Convention it was announced that the donor was Emil J. Simon, a Fellow of the Institute and a well-known radio engineer.

APPLICATION FOR MEMBER AND FELLOW GRADE

The work of passing upon applications for admission or transfer to the grade of Member or Fellow will be aided materially if the applicant, at the time of filing his application for admission or transfer, will write to his references giving them a copy of his training and experience record as it appears upon his application form.

In many cases the persons to whom the applicant refers are acquainted with the applicant but do not recall the details of his past training and experience and are therefore unable to give information of value to the Admissions Committee.

In general, applications for the grade of Junior or Associate can be accompanied with references from non-members of the Institute, when the applicant is not acquainted

with five Associates, Members or Fellows of the Institute, if the names of five of the applicant's business associates or friends are given. These should be men engaged in engineering or scientific work, if possible.

News of the Sections

ROCHESTER SECTION

The Rochester Section held a meeting on the roof of the Sangamo Hotel, Rochester, N. Y., on February 11, 1927. The meeting was addressed by George C. Furness who described in detail the work required in preparing and presenting the "Eveready Hour".

Through the courtesy of station WHEC, the program was broadcast.

The attendance at this meeting was two hundred.

BOSTON SECTION

A meeting of the Boston Section was held on February 25th in Cruft Laboratory, Harvard University. Glenn Browning presented a paper on "Inter-Stage Tuned Radio Frequency Transformers". In the discussion which followed, the following participated: Professor Pierce, Professor Field, Messrs. Murray, Lamson, Brown and others.

The attendance was seventy.

PHILADELPHIA SECTION

On February 25, 1927, the Philadelphia Section held a meeting in the Bartol Laboratories, 131 N. 19th street, Philadelphia. Paul E. Ritter delivered a paper on, "A Talk on Telephotography". A general discussion followed.

At this meeting there were thirty-five members present.

The next meeting of the Philadelphia Section will be held on March 25, 1927 in the Bartol Laboratories.

LOS ANGELES SECTION

A meeting of the Los Angeles Section was held on February 21, 1927 in the Los Angeles Commercial Club. Talks were given by Messrs. Wallace and Heller on, "Short Wave

Experimental Work" and, "Master Oscillators in Broadcast Transmission". The talks were discussed by Messrs. Heller, Nikirk, Leighton, Wallace and Waters.

The attendance was thirty-five.

CHICAGO SECTION

The Chicago Section held a meeting on February 25, 1927 at which Professor G. M. Wilcox presided. The meeting was held in the auditorium of the Western Society of Engineers. Two papers were presented, one by Professor E. M. Terry on, "Factors Affecting the Constancy of Quartz Piezo-Electric Oscillators", and the second by E. S. Andrews on "Electrolytic Condensers for "A" Current Filters".

The papers were discussed by Messrs. Arnold, Marco, Adair, Miller, Terry, Brack and others.

The next meeting of the Chicago Section will be held in Fullerton Hall, Art Institute, Chicago on March 18th. A. A. Oswald of the Bell Telephone Laboratories will deliver a paper on, "Trans-Oceanic Telephone Transmission".

WASHINGTON SECTION

A meeting of the Washington Section was held in Harvey's Restaurant, 11th and Pennsylvania Avenue, Washington, on March 9th. C. Francis Jenkins read a paper on, "Visual Radio". The presiding officer at this meeting was Captain Guy Hill.

Thirty-five members attended the meeting.

The next meeting of the Washington Section will be held on April 13th at which time Dr. L. P. Wheeler of the U. S. Naval Research Laboratory will deliver a paper on, "Establishment of Standard Radio Frequencies".

DETROIT SECTION

A meeting of Institute Members residing in Detroit was held on February 18, 1927. This is the third of the preliminary organization meetings looking to the formation of the Detroit Section.

Thomas R. Clark presided and a talk was given by

Earle D. Glatzel on, "Development of Power Line Carrier Systems". The attendance was thirty-five.

Since this meeting was held the Board of Direction has approved the petition submitted by the Detroit members, and the Detroit Section has been formed.

The next meeting will be held on March 18, 1927.

PROPOSED SECTION AT CLEVELAND

For some time correspondence has been carried on between Institute Headquarters and members residing in and around Cleveland, Ohio, for the purpose of establishing a Cleveland Section of the Institute.

On February 25, 1927, an organization meeting was held in the Lecture Room of the Physics Building of the Case School of Applied Science in Cleveland. The meeting was called to order by B. W. David. Colonel L. R. Krumm, acting as the Institute's representative, delivered a talk on the Institute, Sections and benefits to be derived from Sections.

Officers of the temporary organization were then elected as follows: John R. Martin, Chairman; R. E. Farnham, Vice-Chairman; L. L. Dodds, Secretary-Treasurer. The following temporary Committee Chairmen were appointed: Committee on Meetings and Papers, D. Schregardas and Publicity Committee, B. W. David.

Following the business part of the meeting, D. E. Replegle of the Raytheon Manufacturing Company delivered a paper on, " 'B' Power Supply Devices".

A petition requesting recognition of the proposed Cleveland Section has been forwarded to Institute Headquarters.

Committee Work

SECTIONAL COMMITTEE ON RADIO, A. E. S. C.

The following is a report of the activities of the Technical Committees of the Sectional Committee on Radio, A. E. S. C., for January 1927:

Committee on Transmitting and Receiving Sets and Installations

A number of changes in the personnel of this Committee have been made during the month. The membership of

the Committee with their respective affiliations is as follows:

National Electric Manufacturers Association

C. J. Young (General Electric Company)
J. D. R. Freed (Freed-Eisemann Corporation)
W. H. Leathers (Graybar Electric Company)
G. Lewis (Ken-rad Corporation)

Pacific Radio Trades Association

E. M. Sargeant

Association of Electragists

A. L. Abbott

Bureau of Standards

J. H. Dellinger

Inter-Department Radio Advisory Committee

J. H. Dellinger

Institute of Radio Engineers

M. Eastham (General Radio Company)

American Institute of Electrical Engineers

W. R. G. Baker (General Electric Company)

National Fire Protection Association

H. B. Smith (Underwriters Laboratories)

Committee on Component Parts and Wiring

A meeting of this Committee was held at the American Electrical Railways Association Board Room on February 2nd, 1927. A Subcommittee was appointed to investigate variable condenser standardization. No standardization material was adopted for recommendation to the Sectional Committee, the Committee awaiting reports from the various Subcommittees which have been investigating various subjects for standardization. The next meeting of the Committee will be on March 2nd, 1927.

Committee on Vacuum Tubes

The Chairman of this Committee has been active this month in an attempt to secure exact dimensional data on bases of vacuum tubes for possible standardization.

Committee on Electro-Acoustic Devices

Some material for consideration by the members of the Committee has been received from Dr. Hund of the Bureau of Standards. No meeting of the Committee was held during January.

Committee on Power Supply and Outside Plant

No action has been taken by this Committee during January, 1927.

MEETING OF SUBCOMMITTEE ON RECEIVING SETS

A meeting of the Subcommittee on Receiving Sets, of the Standardization Committee of the Institute, was held in the Institute offices on March 3rd. Those present were J. H. Dellinger (Chairman), A. F. Van Dyck, T. A. Smith, V. M. Graham, E. Austin, L. A. Hazeltine, E. E. Hiler, G. C. Crom, J. V. L. Hogan and L. C. F. Horle.

The meeting was largely devoted to the perfecting of the descriptions of basic methods of testing three overall characteristics of receiving sets, for which a preliminary draft had been prepared at a previous meeting. These three overall characteristics are sensitivity, selectivity, and fidelity. The Subcommittee prepared definitions of these terms and outlined testing methods and standard ways of expressing the results. The apparatus required for the measurements is a source of radio-frequency voltage, of adjustable frequency, intensity, and modulation percentage, a standard artificial antenna (if the receiving set does not have a self-contained antenna), and instruments to measure audio-frequency power output. The results of the measurements are expressed in graphs.

The Subcommittee has not completed this work. Some of the features of the tests remain to be specified by further work of the Subcommittee.

PIEZO-ELECTRIC CRYSTALS AT RADIO FREQUENCIES *

By

A. MEISSNER

(Telefunken Company, Berlin, Germany)

Piezo-electric crystals were first introduced into practice by Cady¹ for the control of high-frequency oscillations and for the production of oscillations used in transmitter control. In general, quartz plate elements, cut parallel to the optical axes and perpendicular to one of the electrical axes, are employed in practice as piezo-electric bodies. The plate element (Fig. 1) has three natural periods of mechanical vibration to correspond to its three dimensions. If the

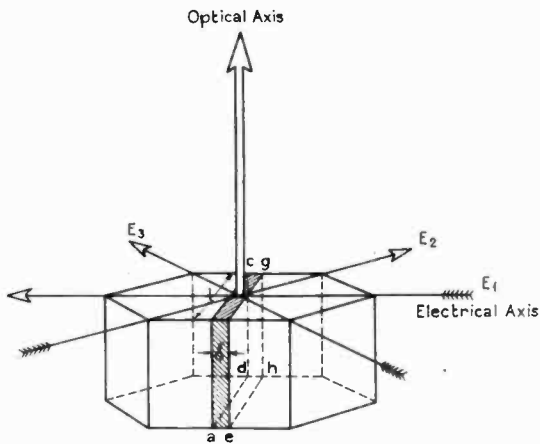

Figure 1—Orientation of Quartz Plate

plate element be excited by radio frequency (electrodes on faces *abcd* and *efgh*), two of the natural periods of mechanical vibration—to wit, the transverse, corresponding to the thickness δ , and the longitudinal, corresponding to the length l —will appear as natural electric oscillations².

*Translated from manuscript received October 11, 1926. Presented at the Institute of Radio Engineers Meeting, New York, N. Y., March 2, 1927.
¹U. S. A. Patent No. 1,450,246 (Wave Control) and No. 172,583 (Generation of Oscillations).

²Literature: See Scheibe's Summary, Jahrbuch, Bd. 28, Page 15.

Quartz crystals were first applied to wave control. A large number of circuits were devised for this purpose. A very interesting application is that of Mr. Giebe; namely, the utilization of the glow, such as the glow effect in a vacuum, arising from a high-frequency excited crystal.

In order to make the adjustment to any desired wave as simple as possible and the luminous effect at crystal resonance as sensitive as possible, a wave control was tried such as is shown in Fig. 2. *A* is a circuit excited at the controlled frequency.

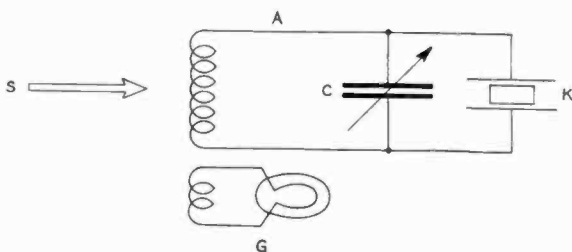

Figure 2—Wave Control by Means of an Incandescent Lamp.

The crystal lies parallel to the tuning condenser *C*. A small incandescent lamp *G* is coupled to this circuit. The lamp lights when the circuit *A* is roughly tuned to the transmitter frequency by the variable condenser *C*. If the wave of the transmitter to be controlled is exactly tuned to crystal resonance, the crystal draws so much energy from the tuned circuit that the lamp dims. The incandescent lamp is a much more positive light indicator for this purpose than the self-luminous crystal (in a vacuum). Besides, the adjustment to crystal resonance by means of the dimming of an incandescent lamp as an indicator is much sharper than by the method of adjusting to highest luminosity. The adjustment from darkness to luminosity is to a certain extent a method of minima. Quite astounding figures of precision of adjustment—within one part in 100,000 or more—are attainable with this method.¹ Such sharpness of tuning is not of paramount importance. It may be only a hindrance. For the furtherance of crystal technique, it was first necessary to establish a method for the study of crystals, an arrangement for positive indications of resonance maxima, a method which would enable us to reproduce the

¹Literature: See Scheibe, "Jahrbuch," Bd. 28, beginning p. 21.

resonance curve of the crystal. Fig. 3 shows a circuit of Dr. Heegner's for this purpose. An amplifier tube is used. The transmitter acts only by induction. If the crystal K is excited to resonance, an indication is obtained on the instrument J in the plate circuit. We get the resonance curve by varying the frequency of the transmitter and reading the current indications of J .

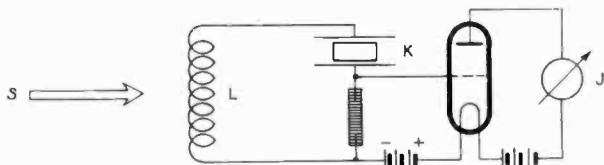

Figure 3—Wave Control by Means of a Vacuum Tube.

A still simpler arrangement resulted through the combination of a crystal with a detector; e.g., as in Fig. 4. The crystal transfers part of its oscillation energy to the detec-



Figure 4—Wave Control by Means of a Detector.

tor. The transmitter S acts upon the coil L . If the frequency of S is varied J will indicate the current values of the resonance curve. At resonance the crystal transfers maximum energy to the detector.¹ This manner of reproducing the resonance curve offers us a method, free from objection, for obtaining the values of the damping of the crystal bodies, as well as a way for studying all mechanical and electrical effects on crystal oscillation. Curve 1 (Fig. 5) gives the resonance curve of the transverse oscillation; curve 2, of the longitudinal oscillation. The damping of the crystal for transverse vibration is $d=0.000\ 04$ ($\lambda=500\ m.$); the damping for longitudinal oscillations, $d=0.00012$.

¹The somewhat small and disturbing steady deflection of the detector at wave lengths under 500 meters can be minimized in a simple way.

Indeed, we have been able to find means to modify the resonance curves of crystals.

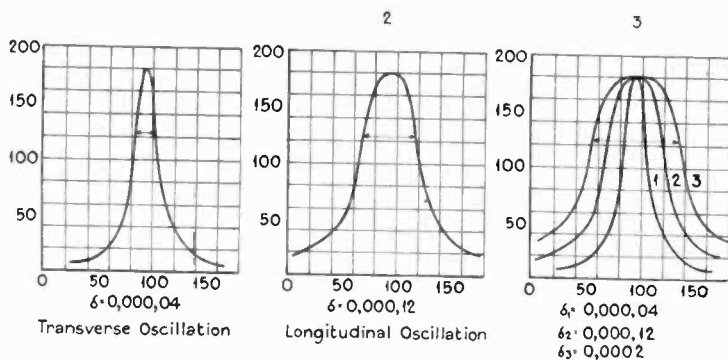

Figure 5—Damping of Crystals.

The damping can be changed either electrically or mechanically. Curve 3 (Fig. 5) shows the crystal of curve 1 damped by mechanical means. Curve 2 shows the same crystal damped electrically. The damping can be increased tenfold or twentyfold.

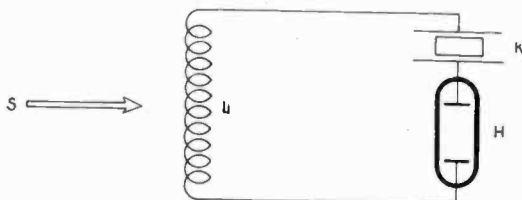

Figure 6—Wave Control by Means of a Glow Tube.

Other methods were found for proving and demonstrating crystal resonance. Fig. 6 shows one such method. In this method, a glow tube is in series with the crystal which consists of a single quartz plate element between two electrodes in an air medium.* The glow tube is separate from the crystal. In the figure, it is in series with the crystal. If the crystal is excited, its energy will be imparted to the glow tube. The glow tube brightens at the maximum of resonance.†

Following are the advantages of a wave control system of this kind:

* (Translator's Note: "in an air medium", as distinguished from some other medium, such as oil.)

† One must see that the capacity of the crystal mounting is not too great.

1. As the crystal is a self-contained unit, it can be made for any, and every wave length.
2. The crystal can be damped to avoid excessive sharpness of resonance.
3. The crystal operates at its optimum excitation and its best utilization factor.
4. The resonance indication is given by large glow tubes with greater light emission.

Thus, the question of wave control seems to be satisfactorily solved technically. However, we must now ask whether, on the whole, the control of the transmitter in this way, by means of a wave standard, is a practical solution. All these methods of control are very complicated. First, one must juggle to and fro with the transmitter, until one finally hits on the usually excessively sharp resonance point of the crystal. Such a method is generally too difficult for the type of personnel that we must count on in engineering. The most convenient and logical solution is the following: To fix the frequency of the oscillator from the very beginning by means of a crystal, using the crystal as a control and as a calibration source for the transmitter, so that it will be impossible for the transmitter to oscillate at a frequency other than the normal crystal frequency. The crystal

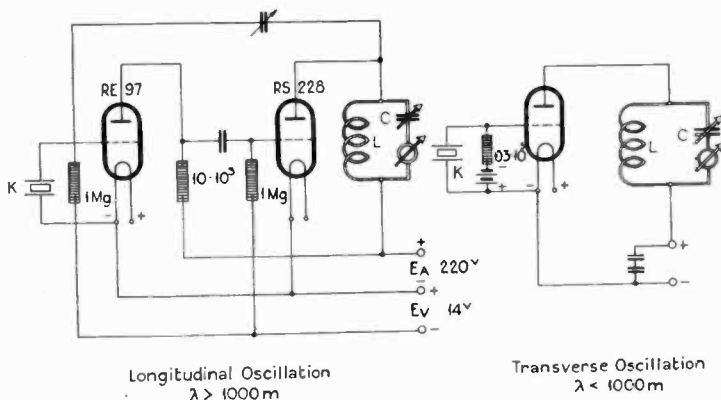

Figure 7—Crystal Oscillator.

must be used as an oscillator only. The crystal is placed together with a resistance and a choke in the grid circuit of an amplifier tube; the plate circuit is tuned. This circuit is only to be used for the transverse oscillation of the crystal. For this purpose, the limit of thickness of crystal for

the shorter waves ($\lambda=100$ m.) is about 1 mm; and, for practical reasons, not over 1 cm. for the longer wave lengths ($\lambda=1,000$ m.).

A harmonic of the 1 mm. crystal is used for shorter wave lengths; while the longitudinal oscillations of the crystal are of importance for wave lengths over 1000 m. The circuit for such oscillations is the two-tube outfit of Dr. Heegner (Fig. 7, left). The crystal is in the circuit of the first tube, the tuned circuit in the circuit of the second tube.

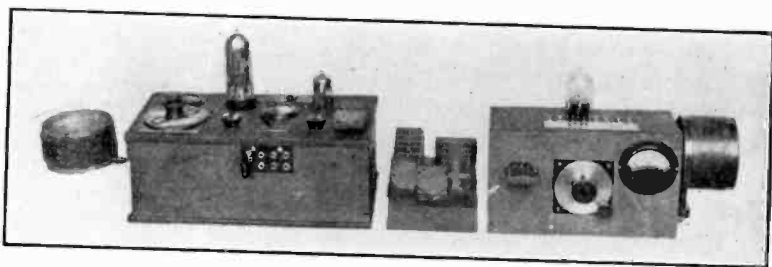

Figure 8—Small Test and Measuring Crystal Transmitters with Wave Range from 100 to 8000 Meters.

There is regenerative capacitive coupling between the tuned circuit and the crystal. The photographs (Fig. 8) show two small test and measurement transmitters of 1 to 3 ohms connected to 220 to 440 V.), with a wave range from 100 to over 8,000 m. In the future, there will certainly be no lack of these small transmitters as wave length standards for all testing purposes. The first unit has one tube designed for

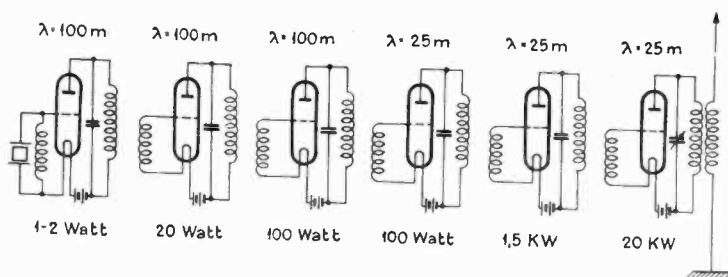

Figure 9—Crystal Excitation for a 25-Meter Transmitter.

100 to 1,000 m. The second unit has two tubes and is designed for wave lengths over 1,000 m. The crystal lies between two metal surfaces which are held in position by a hard rubber mounting. The crystal for the desired wave

length is inserted in each of the two units at the left and right, respectively, of the containing box. The condenser is set to the calibrated value; the deflection of the ammeter in the tuned plate circuit serves as an indication that oscillations have set in. Crystal excitation is now the universal solution for purposes for which a very exact maintenance of transmitter frequency is required. This solution is, therefore, especially important for short wave lengths. Fig. 9 shows the arrangement for the two short wave transmitters at Nauen, for wave lengths from 25 to 40 m. 100 meters is the wave length of the crystal oscillation. The energy output is stepped up to 100 watts by two tubes, then quadrupled and passed through three more amplifiers. The final energy in the antenna is 10 kw. Crystal excitation is also of importance for broadcast transmitters.

A whole series of broadcast stations in America operate with crystals. Our setups for this purpose are identical with those shown in Fig. 9. The stages of amplification back of the crystal tube are 5 w., then 75 w., 500 w., and 3 kw. in the antenna.

An attempt was made to solve the present-day problem in present broadcasting of single-wave broadcasting by several stations utilizing crystal transmitters. The solution therefore consists in giving two separate transmitters controlling crystals ground to the same wave length; i.e., to exactly the same thickness. The studies made showed that a disproportionately high accuracy in the wave equality is necessary. The two transmitters must not vary from one another by more than 5-10 cycles; i.e., their frequency must be exact within 10^{-3} to 10^{-4} per cent.* Naturally, such accuracy of agreement can not be attained by grinding. The problem was solved electrically. The coupling between the crystal and the tuned circuit behind the transmitter tube was made variable. The crystal shown in the circuit of Fig. 10 is electrically nothing but a tuned circuit, and this crystal circuit is coupled electrically to the circuit of the tube assembly *LC* by means of a tube. The self-excited natural oscillation may be changed to a small extent by varying the coupling between the crystal and the tuned circuit in such a system. This variation in coupling is here brought about by means of a small variable condenser C_1 in the circuit element *AB*. The wave length ($\lambda=500$ m.) is

*Translator's note: From within 1 part in 100,000 to 1 part in 1,000,000.

changed by 30 cycles by varying C_1 from 4 cm. to 40 cm. in capacity. The variable capacity can be replaced by the capa-

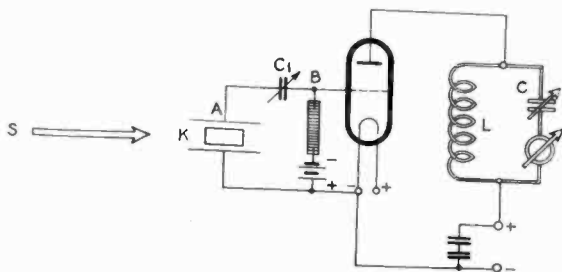

Figure 10—Variation of Wave Length by Means of C_1 .

city of the electrodes; i.e., by varying the capacity of the electrodes by change of electrode separation, due to lifting one of the crystal electrodes, the frequency changes through 150 cycles.

Increase of the crystal temperature offers a further possibility for changing the crystal frequency. If the crystal temperature is raised 10° by heating, in a hot box, the frequency of 600,000 cycles decreases by 60 cycles. The variation is approximately as follows:

T=20 to 30° —	60 cycles
50 to 60° —	90 cycles
70 to 80° —	200 cycles
90 to 100° —	50 cycles

Experience must show us whether such crystal-controlled equal-wave broadcasting can be attained such that both transmitters will maintain equality of wave length over an extended period of time without extremely careful supervision.

A peculiar phenomenon was encountered in the study of radio-frequency excited quartz crystals. If we bring a crystal, which is longer in the direction of the optical axis than is usually necessary for the production of oscillations—e.g., a crystal of the dimensions 5 mm. (along its optical axis), 1.5 mm. (along its electrical axis), 3 mm. (at right angles to the optical and electrical axes)—, to its sharpest resonance by means of radio-frequency excitation, we usually do not perceive any movement. If we move the crystal somewhat, it begins to rotate and it continues to rotate with accelerating rapidity. The experiment usually ends with the

crystal being catapulted out from its two electrodes to distances as much as $\frac{1}{2}$ meter. The crystal rotation is based on two new phenomena; namely, a purely acoustic effect and a crystalline deviation (or anomaly) in the direction of the optical axis.

The acoustic phenomena are very obvious on a longitudinal-vibrating crystal of the dimensions $28 \times 13 \times 5$ mm. It is excited at its most intense natural wave length ($\lambda = 3,080$ m.). Very intense air fluctuations appear at both surfaces (Fig. 11) at the moment of inception of oscillations, (and they continue as long as the oscillations are

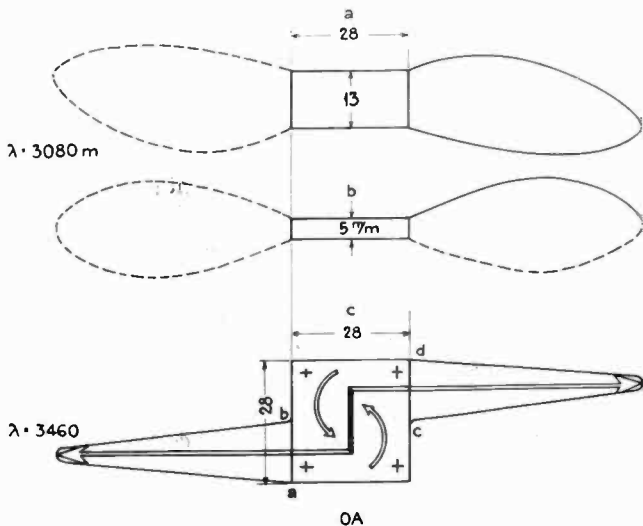

Figure 11—Air Fluctuation Near the Crystal.

sustained). If we drop lycopodium powder in the vicinity of the surfaces it is immediately blown away. A candle flame is extinguished; a wind-actuated pinwheel, brought within the field of the air current, rotates. If we move the pinwheel towards the center of the air current, its rotation stops; moving the pinwheel in the other direction of the air current, makes it rotate in the opposite direction. Fig. 11a shows the distribution of these very intense air currents around the crystal in the horizontal direction, and Fig. 11b in the vertical direction. The limit of flow at the sides is quite definite.

We must delve into the reaction on the air of the high-

frequency acoustic effects of the crystal for an explanation of these air currents. For these acoustic effects, the crystal oscillates as a longitudinal rod; i. e., the sound waves originate from its end surfaces. No air currents are produced by the sound waves alone, even for high frequencies, in the vicinity of the vibrating body. The sound waves merely produce equal condensations and rarefactions. The production of air currents must be explained by some anomalous relations. The very intense sounds set up, entirely disproportionate to the dimensions of the crystal, are anomalous. The crystal surfaces have the dimensions 13×5 mm. During condensation, the air particles are repelled either normal to, or at an angle to, the small surfaces. During rarefaction, the same air particles should move in the opposite direction towards the receding surfaces. Nevertheless, since the surfaces are small, and their perimeters relatively large, air particles can stream in from all sides during rarefaction. At the next outward impulse, there are, therefore, in addition to the former particles, all the particles which were added during rarefaction. The condensation and the rarefaction are no longer equally intense. The condensation overweighs the rarefaction. One experiences the sensation of a continuous current of air on account of the rapid succession of condensations.¹

Of course, the crystal can not be set in rotation by these air currents and the forces of reaction accompanying them. The forces set up by the air currents vanish as far as their action on the crystal is concerned. A moment of rotation is needed to produce rotation. This we obtain through a crystalline anomaly in the direction of the optical axis. If we lengthen the crystal in the direction of the optical axis (Fig. 11c)—i. e., if it is 28 mm. instead of 13 mm. in the direction of the optical axis—we find, on the one hand, that the air currents are no longer distributed over the whole of the side surfaces, but rather over half the surfaces; and, on the other hand, these air current surface areas are no longer symmetrical. The air current on the right side is towards the upper right of the side surface, that on the left side towards the lower left of that surface. No matter where the air currents are located, the sound produced is always the same for the same crystal.

Concerning ponderomotive effects of sound waves see Neesen, *Annalen*, 1887, p. 441; Davis, *Sill. Journ.* 1902, p. 129.

A turning moment is exerted on the whole crystal by such dissymmetry of air flow.

The direction of rotation is the same as that of a Seegner waterwheel. If we reverse the crystal plate element, it rotates in the reverse direction because the air currents are attached to the surfaces *ab* and *cd*.

The rotation of the crystal can be used to form a small crystal motor. Fig. 12 shows an example. The crystal ($10 \times 10 \times 1.5$) is kept within bounds by a small spindle

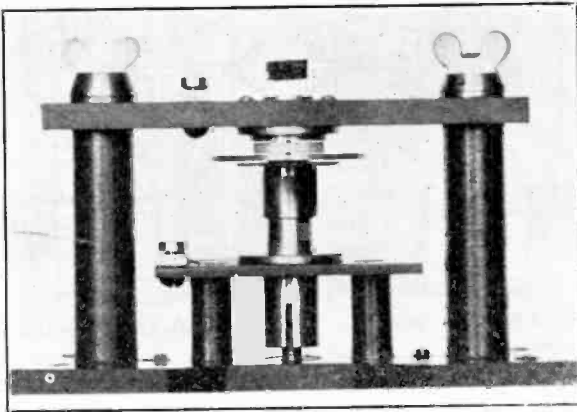

Figure 12—A Crystal Motor.

through its center. This spindle or shaft extends outwards and carries a small disk for ease in observing the rotation. As soon as the high-frequency source is connected, the crystal element begins to rotate; and stops when the source is disconnected.

A study was now made to see whether the electric-acoustic anomalies in the direction of the optical axis stood in any definite relation to the optical properties of the quartz. First, two similar elements of right and left optical-rotative quartz ($28 \times 28 \times 5$ mm.—Fig. 13b and Fig. 13d) were investigated. The electrical polarity of these elements, their electrical axes, were determined by first heating the elements to about 80° and dusting with red lead and sulphur powder during the process of cooling.* When the elements, placed between two electrodes with their negative sides uppermost, were excited at their most intense longitudinal os-

*The mixture should be shaken through muslin, when, by friction, the sulphur becomes negatively electrified and adheres to one side of the crystal, and the red lead, which is positively electrified, adheres to the other side.

cillation, $\lambda=3430$ m., air currents arose, corresponding to those of Fig. 13b and Fig. 13d. Indeed, viewed in the direction of the electrical axis on the positive surface, the mo-

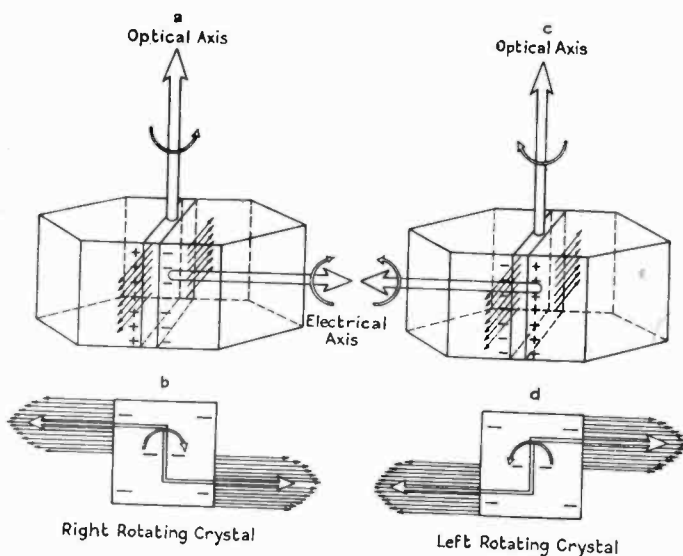

Figure 13—Right and Left Rotating Crystals.

ments of rotation of the air currents for the crystal rotating optically to the right are seen in the sense of a spatial rotation to the right; and in the sense of a spatial rotation to the left for the crystal rotating optically to the left. The optically to-the-right-rotative crystal rotates mechanically about the electrical axis to the right, while the optically left-rotative crystal rotates mechanically about the electrical axis to the left.

The direction in which the optical rotation of a quartz crystal takes place can, therefore, be determined from purely electrical and acoustical data without any optical study. A plate element parallel to the optical axis is cut from the crystal, the electrical polarity is determined by dusting the side with powder during cooling, and the element is excited at its longest and most intense natural wave length. If the air currents thereby produced are in the direction of a right turn about the electrical axis, the crystal rotates optically to the right. If the air currents of the crystal make a left turn about the electrical axis, the crystal rotates optically to the left. Fig. 14 shows figures of flow for the quartz plates of various widths, in the direction of the optical axis for

quartz rotating to the right, and to the left, and for the fundamental and two harmonics.' Below, to the right, are given the diagrams of flow for a pair of crystals of the dimensions $5\text{ mm.} \times 7\text{ mm.} \times \delta=4\text{ mm.}$ That side which is negative in cooling was uppermost for all the crystals. We see in all the figures that the crystals which turn to the right optically also rotate to the right when excited in their fundamental frequency, and vice versa. For the appreciably weaker harmonics of the crystal, the rotation is in the reverse direction to that of the fundamental, being again of

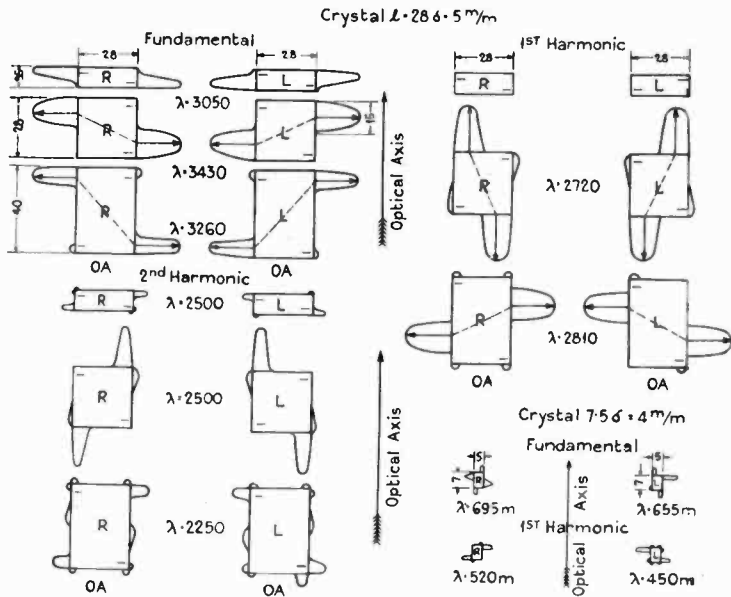

Figure 14—Right and Left Rotating Crystals.

opposite sign for crystals turning optically to the left and right. The line connecting the points of inception of the air currents at the crystal, "the angle of inclination," makes an angle of 40 deg. with, and to the left of, the optical axis for the main wave length of the right-rotative crystal. The "angle of inclination" of the first harmonic*, on the contrary slopes to the right, forming an angle of approximately 60 deg.—70 deg.

The lines, connecting the points of most intense sound production on both sides of the crystal for the fundamental

*The measurements were carried out by Dr. F. Michelson and P. Hagen.

*Translator's note. "Nearby vibration frequency" is a more correct interpretation of the German "Nebenwelle" than the term "harmonic".

and for the first harmonic, point to the fact that there are surfaces across the crystal forming angles of 40° and 60° to the optical axis, such that the conditions for the propagation of sounds are especially favorable. If we assume as most probable that the surfaces of the crystal most favorable for the propagation of sounds are at the same time the surfaces of greatest molecular density in the crystal structure, these surfaces are indications of the manner in which the individual horizontal planes of the crystal structure are oriented. We thus have a new point of view for a conception of the crystal structure. The molecular density must be a maximum for those series of planes, the slopes for which we determined above. A structural model of the quartz element, which is based on these requirements, would have the following appearance. The structure-element consists of 3 horizontal planes. The planes are approximately equally spaced. In the planes are grid-molecule structures

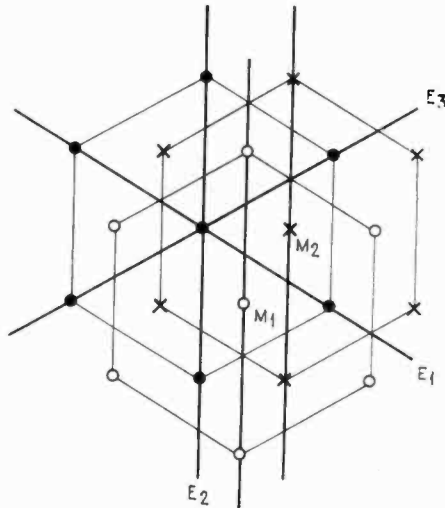

Figure 15—Displacement of the Crystal Planes.

consisting of equilateral triangles and hexagons, respectively. The dots in Fig. 15 correspond to Si-atoms of greatest atomic weight. The height (c) of the lattice structure is approximately equal to the length of a side of the triangle ($a=4.89 \text{ \AA}$; $c=5.375 \text{ \AA}$).^{*} The 2nd and 3rd planes are displaced from the first plane, and this displacement is such that points M_1 and M_2 are displaced in the direction of the

^{*}(Translator's Note: a equals 4.89 angstroms is evidently the length of a side of the equilateral triangle; while c equals 5.375 angstroms is the height of the lattice structure.)

bisector of the angle between the electric axes E_1 and E_2 , and E_1 and E_3 , respectively, above the centers of gravity of the triangles that lie under them. The 4th plane is displaced with respect to the first plane by the length of a side of the triangle in the direction of one of the electrical axes.

It is thereby identical with the first plane. The left-rotative crystal is evolved from the right rotative one by exchanging the two planes 2 and 3. It is assumed in the model with respect to each Si-atom that there is an O-atom present above and below the Si-plane for each Si-atom. These atoms are intended merely to signify the direction of optical rotation of the crystal. The projection of the connecting line O-Si-O forms an angle of 120 deg. A rotation of 120 deg. is assumed from one plane to the neighboring plane—to the right for the right-rotating crystal; to the left for the left-rotating. This model corresponds to the following requirements:

Complete symmetry to all three electrical axes is maintained both for the right and for the left-rotating crystal.

There are planes of greatest molecular concentration. The angle of these surfaces to the optical axis is the same as was obtained from electric-acoustic observations—approximately 40 deg. These surfaces slope the same angle to the right away from the optical axis for the left-rotating crystal; and to the left for the right-rotating crystal.

There is another set of planes of largest molecular concentration (of the second order). The ratio of the molecular concentration of these planes to those of the first order are as 1:1.4. The surfaces are at a greater angle to the optical axis (60 deg.), and slope towards the other side of the optical axis from that to which the fundamental slopes. These surfaces correspond to the angle of inclination of the sound propagation for the first harmonic ($\lambda=2,810$ m.). The slopes of the planes, etc., of the left-rotating crystals are the reverse, as the corresponding sound diagrams require.

The translation of the mechanically right-rotating into the mechanically left-rotating system simultaneously changes the optically right-rotating crystal into an optically left-rotating crystal. Of itself, the optically right and left rotation of the polarization plane in the crystal has nothing to do with the mechanical rotation and the position of the surfaces of greatest molecular thickness. The optical rotation has to do with the atoms, the mechanical rotation with

the structure of the space lattice of molecules. However, these quite independent phenomena are here rigidly associated. One rotation does not take place without the other.

If we cut a plate element out of the model, normal to one of the electrical axes, the element, in accordance with former conclusions, viewed in the direction of the electrical axis with negative plate uppermost, will be subjected to a moment of rotation to the right for the case of an optically right-rotating crystal with high-frequency excitation. We do not know the polarity of the plate; we know only the direction of surfaces of greatest molecular thickness, and know only that the corresponding crystal is, e.g., capable of rotation to the right. However, these two things suffice to define the polarity of the plate. For the slope of the surfaces of greatest molecular concentration to the optical axis is defined by these two items. The "angle of inclination" is translated into the optical axis by a rotation from the left to the right of a crystal rotating optically to the right. The negative face of the crystal ought to lie towards the spectator, according to previous statements with regard to simultaneously optical and mechanical right-rotating crystals.

The charges that go with the polarized condition of the faces are, therefore, fixed by the polarization rotation. One should progress from the position of the atom in one plane to the next in the structure element, for an elementary explanation of the appearance of the charge and its sign for quartz elements cut out at various angles. A point of reference is obtained from the atom positions along the axes of the structure element. By drawing the atoms of the three structural planes around one of the axes we get for each of the planes cut by the axis polarities differing from 30° to 30° on turning the plane.

In the construction of the above structural model the main stress was laid on the absence of contradictions to the results of electric-acoustic experiments. The model does not take into account the modern Roentgen-ray investigations. This method serves merely as a conclusion and may be regarded as a possibly useful aid to the understanding of the more specialized Roentgen-ray method.

The electric-acoustic excitation method may be applied even to non-piezo-electric crystals without much difficulty. Perhaps we may succeed in discovering some entirely new methods of gaining a conception of crystal structure.

QUANTITATIVE MEASUREMENTS ON RECEPTION IN RADIO TELEGRAPHY¹

BY
G. ANDERS

(Abstract From Original Article Appearing in *Elektrischen Nachrichtentechnik*, Vol. 12, No. 2, 1925.)

In a recent Institute publication*, M. Baumler showed the results of a comprehensive series of measurements of American long wave stations, made by the National Telegraphic Engineering Bureau of Germany (Telegraphentechnische Reichsamt). Reference was made to the work of G. Anders who was responsible for the development of the system of measurement employed in obtaining these results. A complete description of this apparatus has been published in *E. N. T.*** , and the material is given here in somewhat abbreviated form.

Starting with a description of the simplest system of measurement in which the current in a loop is measured directly, the author gives a discussion of previous systems for the measurement of field intensities, their limitations and sources of error. Particular reference is made to the work of Hollingworth, Vallauri, Guierre, and Round in Europe, and of Pickard, Austin, Englund and Friis in this country.

The author has perfected a method of field intensity measurement in the German Bureau of Telegraphic Engineering. By this method a series of monthly measurements of several days' duration have been made of the field intensities at Berlin and Strelitz-Alt (Mecklenburg), and of the American Stations Marion and Rocky Point I and II†. This work started in February 1923, and was carried out with the cooperation of the Radio Corporation of America. The scheme employs the usual elements in signal strength mea-

¹Received by the Editor, February 9, 1927. Presented before the Institute of Radio Engineers, New York, N. Y., March 6, 1927.

*M. Baumler "New Investigation Concerning the Propagation of Electromagnetic Waves." *E. N. T.* Vol. 1, Part 2, p. 50, 1924.

**Vol. 2, No. 12, P. 401, 1925.

†*Proc. I. R. E.* Vol. 13, No. 1, 1925 "Recent Investigations on the Propagation of Electromagnetic Waves" by M. Baumler.

suring work, viz. wave collector, receiving set with indicator and calibrating apparatus. The basic arrangement is shown in Figure 6.

The calibrating method is essentially a current-measuring device. Referring to Fig. 6, the secondary receiving circuit is coupled through the mutual inductance M_1 to a small

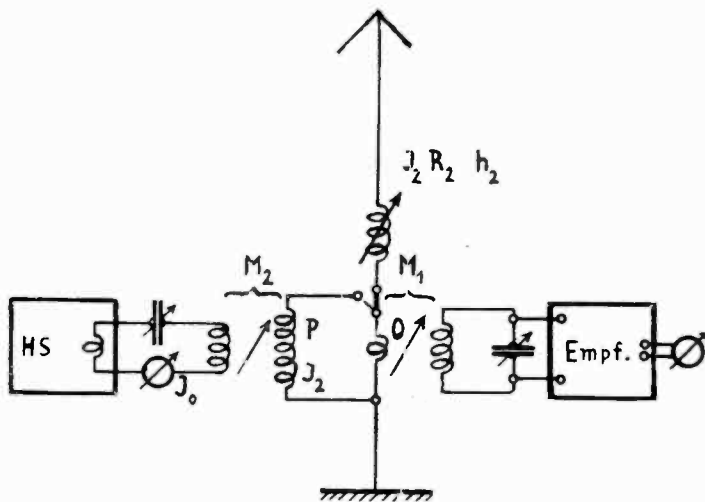

Figure 6

coil Q , which is alternately switched to the ground lead of the antenna circuit, and to the ends of a coil P of a relatively large number of turns, and of small effective resistance. This latter circuit is in turn coupled with the calibrating oscillator HS by means of the mutual inductance M_2 . These two coils may be considered as a current transformer. The primary current, I_0 is measured by means of a vacuum barretter, (hot-wire resistance), and the secondary current, I_2 , is made equal to the current produced by the receiving signal, as indicated by the meter in the output of the receiver. Then knowing the ratio of transformation of the current transformer it is possible to determine antenna currents which do not allow of direct measurement.

The use of a loop instead of the vertical antenna shown is equally permissible with this method, and it has been found possible to measure field intensities as low as 10 microvolts per meter at a wave length of 10 km. (30 kc.), using a 30-turn loop 3 meters square having an effective resistance of 10 ohms.

The receiving set proper consists of a two-stage radio frequency amplifier, heterodyne oscillator, detector, and an audio amplifier. A Wulf thread electrometer* with a transformer is connected in series with the telephone receivers to indicate the output. The thread of the electrometer is protected by the secondary winding of the transformer, because the short-circuit current of the transformer is too small to burn out the thread if it touches the electrode edges.

Fig. 7 shows the external appearance of a portable measuring set built in the workshops of the Telegraph Engineering Bureau, and capable of covering the range of 200-25,000 meters by means of interchangeable coils. Figure 8 and 9 give the scheme of connections with overhead and loop antenna, respectively.

*The single-thread electrometer produced by the Gunther and Tegetmeyer Company of Brunswick and herein illustrated has two sharp-edged electrodes *a* and *b* each 69 millimeters (0.236 inch) long between which is placed a platinum wire *c* 0.002 millimeter (0.00008 inch) thick. The edges are parallel and 12 millimeters (0.47 inch) apart. The platinum wire is stretched taut by a thin bowed quartz fiber *d* placed below the edges and parallel to the line joining them.

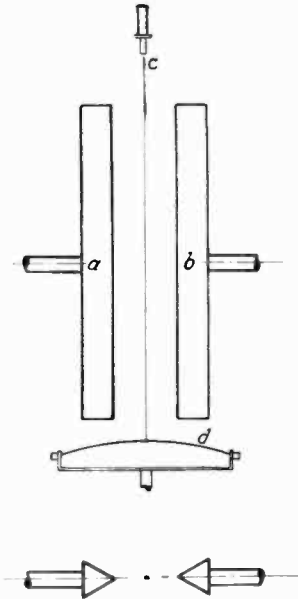

When the electrometer is used as an audio frequency indicator for receiver measurements, the circuit used is such that one edge is connected to the wire and the other to the case of the instrument. As a direct or alternating potential is applied to the thread (wire), it is attracted to one edge and repelled from the other. The deflection is observed with a microscope and measured by means of a micrometer eyepiece. The range of potentials covered by the electrometer with a normal tension on the thread is from 25 to 100 volts.

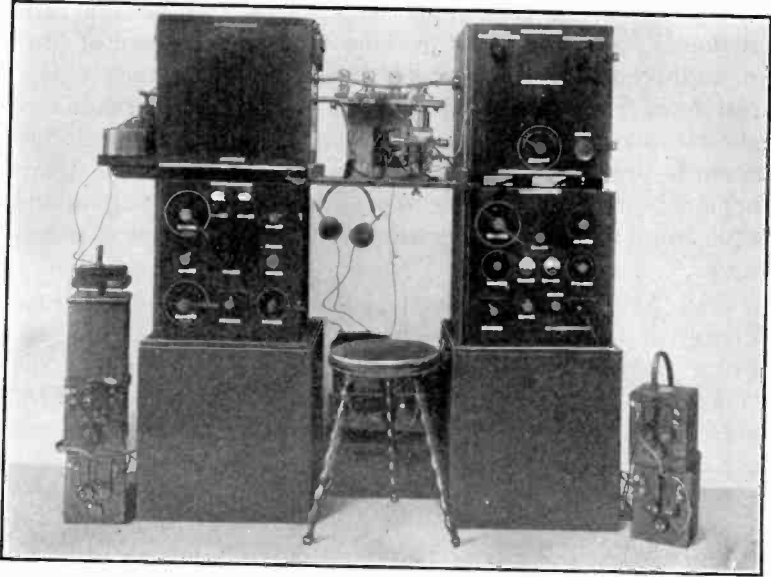

Figure 7—Portable Measuring Set

The apparatus consists of four square boxes, each 50 cm. on a side. The lower left box is No. 1 (see Figures 7 to 9). Box No. 2 is immediately above. The upper right box is No. 3. The lower right box is No. 4.

Toward the back of a shelf connecting the compartments

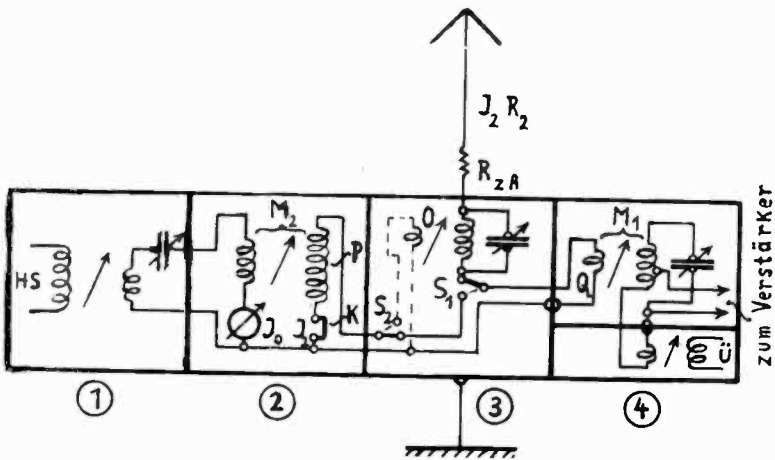

Figure 8

is located a two to four-tube audio amplifier with a resonant circuit below it, and an electrometer to the right.

It was found necessary to protect the receiving circuit from the influence of interfering radio frequency fields. On the other hand, the difficulty of preventing reaction between oscillator and loop, especially at short waves, does not influence this method, since the aerial and oscillator act alternately on the winding Q of the receiver.

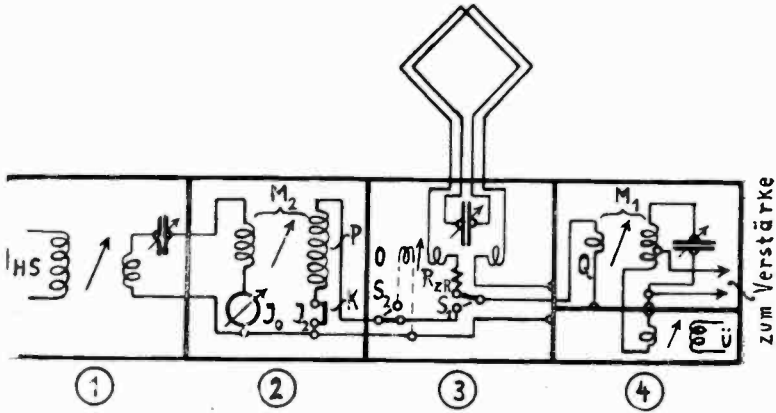

Figure 9

Stray coupling is prevented by the use of differential coils, and by enclosing each compartment in 0.3 mm (0.012) sheet copper, with appropriate interconnection of the circuit with this copper casing to minimize electro static disturbances. Interfering capacitive coupling within the compartments themselves is diminished by the use of symmetrical circuit connections.

The construction of the differential coils can be seen in Fig. 10. Each pair of coils consists of two pancake coils lying in the same plane and wound in the same sense, the current flowing in opposite directions. Differential variometers are used in the following parts of the apparatus :

1. The oscillator-measuring circuit coupling,
2. The current transformer,
3. Antenna loading coil and excitation winding (coil O), and
4. Coupling between coil Q and receiver coil.

The coupling between the oscillator and the measuring circuit is always made as close as possible, and the current in the measuring circuit is regulated by varying the oscilla-

tor plate potential by means of a rotating contact form of potentiometer consisting of 25 steps of 400 ohms each. This keeps the oscillator power at a minimum and avoids excessive stray fields.

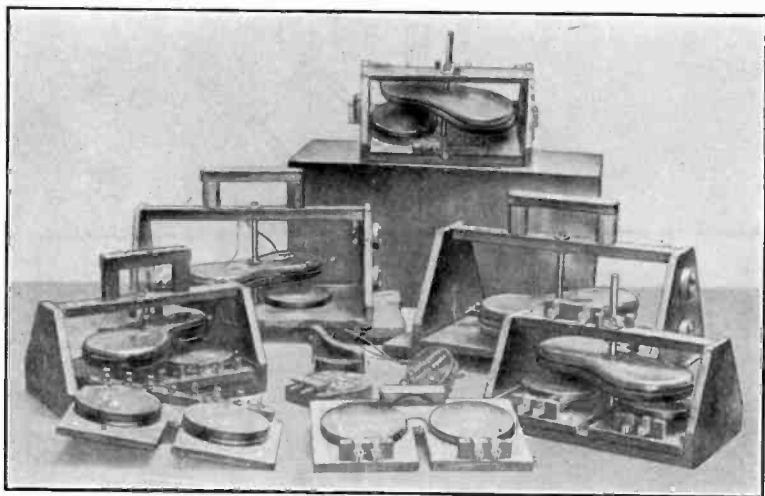

Figure 10—Construction of Differential Coils

In order to increase the sharpness of tuning of the receiver a low frequency anti-resonant circuit is connected in parallel with the primary of the transformer which couples the first and second stages of the audio-frequency amplifier. This tuned circuit consists of a 0.2-henry coil and a 0.1-microfarad condenser, and resonates at $\omega=7,500$, which corresponds to the main resonant frequency of the telephone receiver used. The effective resistance of the tuned circuit was found by experiment to be 32 ohms, and the anti-resonant impedance 71,500 ohms. The sharpness of this circuit is often found to be too great when receiving short waves from stations with insufficient constancy of frequency, so that a step-by-step resistance is provided for adjusting the damping of this tuned circuit. In order to keep the impedance of this shunt constant, and so to keep the amplification the same, an appropriate value of resistance is inserted in series with the tuned circuit.

An important element in the calibrating apparatus is the current transformer. The theory of the current transformer is simple, being merely that of a transformer with-

out an iron core. The current transformation ratio is given by the expression

$$\mu = \frac{\sqrt{R^2 + (\omega L)^2}}{\omega M} = \frac{I_0}{I_2}$$

where R and L are the secondary constants, M the mutual inductance, and I_0 and I_2 the primary and secondary currents, respectively.

For a low-loss secondary coil R^2 is negligible as compared with $(\omega L)^2$, so that

$$\mu = \frac{L}{M}$$

It will be noted that this expression is independent of frequency. However, at the higher frequencies a dependance of μ upon frequency may arise as the result of capacity coupling between the coils, and the distributed capacity of the coils and leads. These effects may produce a decrease in μ . The relation is given by the expression*

$$\mu_1 = \frac{\mu}{1 + \omega^2 K}$$

where μ_1 is the apparent ratio of transformation for a frequency factor ω , μ the ratio without capacity effects, and K a constant depending upon the magnitude of the capacity effect. K can be determined experimentally from two apparent ratios of transformation μ_1 and μ_2 at the two frequency factors ω_1 and ω_2 ,

$$K = \frac{\mu_1 - \mu_2}{\mu_2 \omega_2^2 - \mu_1 \omega_1^2}$$

(For a transformer in which $L = 192 \times 10^{-4}$ henry, $K = 1.76 \times 10^{-12}$ for $\mu = 32.5$, and $K = 2.73 \times 10^{-7}$ for $\mu = 2.03$. The useful range of this transformer was from $\lambda = 6,000$ m (down.)

The tuned receiver circuit is coupled with the secondary circuit of the current transformer through the mutual inductance M_1 (Fig. 6). The receiver circuit induces into this circuit a resistance:

$$R_k = \frac{M_1^2 \omega^2}{R_3}$$

in which R_3 is the receiver circuit resistance. But as long as $(R + R_k) \ll \omega^2 L^2$, R_k does not affect μ and consequently the calibration.

*Moller and Schrader: "Concerning the Production of Small Alternating Currents of Known Amplitude", *Jahrb. der drahtl. Telegr.*, 22, p. 64, 1923.

A calibrated current meter is connected (in place of the short circuiting link, K , Figs. 8 and 9) in the secondary circuit for calibrating the current transformer. A sensitive thermocouple is used for the secondary and a less sensitive thermocouple or hot-wire meter for the primary according to the ratio of transformation to be determined. The current used will, of course, have to be larger than that used during measurements, so that larger tubes are employed. The ratio of transformation μ is independent of the current used because the transformer does not contain any resistance which is dependent on the current magnitude. The calibration may therefore be carried out at any arbitrary current values; in every case $\mu = I_0 \div I_2$, where I_0 and I_2 are the measured primary currents and secondary currents, respectively.

Ammeters which cannot be calibrated by connecting them in series with a d-c-calibrated radio frequency instrument can be calibrated very easily at radio frequencies by means of a calibrated transformer. The vacuum-barretter, the range of measurement of which -5×10^{-3} to 5×10^{-1} amperes—coincide with the range of sensitive vacuum-thermocouples only for its highest values, belongs to this class of current meters. The barretter resistance, which is highly variable with change in current (the resistance changes from 330 to 420 ohms as the current is changed from 0 to 0.4 milliampers), need not be considered in calibration so long as $\omega^2 L^2 \gg R^2$. ωL must be at least 5000 ohms if R^2 is to be 1% of $\omega^2 L^2$, the barretter resistance 450 ohms, and the effective coil circuit resistance 50 ohms. (For $\lambda = 3,020$ meters, L must be at least 80×10^{-4} henrys).

Antenna calibration is required. It is necessary to determine the resistance of the overhead or loop antenna, in order to be able to ascertain the emf. induced by the received signal. This is accomplished by the substitution method with the adjustable resistances R_{za} and R_{zr} and the exciting coil O (see Figs. 8 and 9), using the measuring set as an indicator.

The disadvantage of the overhead antenna in measurement work is the necessity for determining its effective height. The effective height is dependent upon the wave length in question. It is constant only for wave lengths which are a multiple of the natural period of the antenna. The effective height may be determined:

- (a) By means of a sending station of known effective height h_1 , and removed from the point of measurement by a distance of several wave lengths.
- (b) With a loop set up at the same point as the overhead receiving antenna, or
- (c) By the triangulation method of Pession.*

A discussion of these methods and the necessary formulas are given.

During the reception of signals, resistance is introduced into the aerial circuit as a result of its coupling with the tuned received circuit. The current flowing under the influence of an incoming wave is thus dependent upon the resistance introduced as well as upon the resistance of the aerial alone. Since in the calibration method a measured current is passed through coil Q , the introduced resistance must be known, or made negligible. It is satisfactory to make $M_1=1/10$ of the maximum value of M_1 . There is then the advantage that it is unnecessary to take into consideration the induced resistance R_n , since it amounts to only one per cent. of R_2 for this case, while the emf. in the receiver circuit is decreased to but $1/5$ of the value obtained by using the maximum value of M_1 .

The limits of the allowable values of M_1 are determined in practice by investigating the dependence of the electrometer readings on the angular position of the aerial-receiver coupling variometer, first with the aerial connection, and then with the oscillator connection. Before this is done the deflection produced by the oscillator with loose coupling is made equal to the deflection produced by a distant transmitter.

Receiver Requirements. Not every receiver is suited for this particular purpose. A receiver may be employed if it satisfies the following conditions:

1. The amplification must be sufficient and adjustable.
2. The deflection of the output-indicating device should be linearly related to the received signal intensity for any value of amplification.
3. The amplification factor should remain constant over long periods of time.
4. The selectivity should be as great as the constancy of frequency of the sending station permits.

*Radio Review, Vol. 2, p. 228, 1921.

5. The apparatus should be as simple and as easy to inspect as possible, and as easily installed and tuned as practicable.

The receiving apparatus used consists of a two-stage radio frequency amplifier without regeneration, a heterodyne oscillator, an audio frequency amplifier with selective circuit, a thread electrometer, and a telephone receiver, all connected with a receiver circuit.

Three adjustments are necessary to tune the set-up to a given station:

1. The tuning of the antenna circuit,
2. The tuning of the receiver circuit, and
3. The tuning of the heterodyne oscillator, after first adjusting the antenna coupling to a suitable value.

All three tuning adjustments are effected by obtaining maximum electrometer deflection, and therefore can be more quickly and exactly carried out than adjustment for

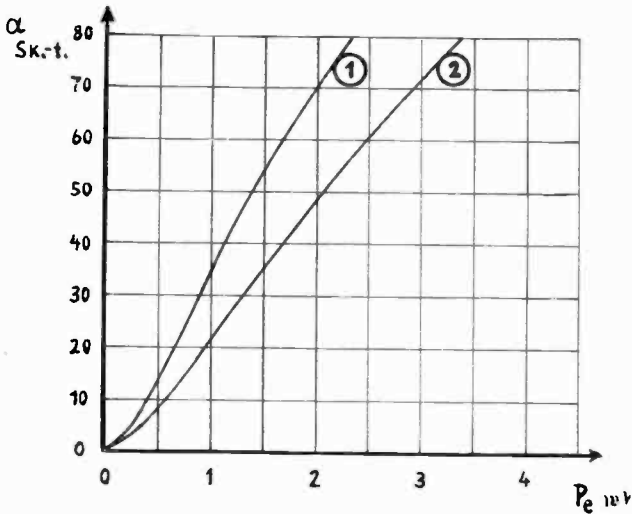

Figure 12—Electrometer deflection in scale divisions as a function of audio input voltage. (1) without resonant circuit, (2) with resonant circuit.

maximum sound intensity in the telephone receiver. The mutual independence of the three settings is of great importance in securing ease and rapidity of tuning. The aerial and receiver tuning adjustments are independent of one another because the coupling between the circuits is very loose. The heterodyne oscillator setting is not influenced

by these adjustments because the position of the low frequency resonant circuit makes it independent of the input voltage of the audio amplifier. Without this tuned circuit this independence is absent because resonance effects, dependent upon the current through the audio transformers, influence the maximum electrometer deflections.

The proportionality of received emf. and electrometer deflection is of importance in the accuracy of measurement. The relation between electrometer deflection α and effective a. c. voltage P across the electrometer terminals, is almost exactly a parabola, and can be represented very closely, for normal electrometer thread tensions, by the equation:

$$\alpha = 5.9 \times 10^{-3} P^2$$

The relation between the current in the primary of the electrometer transformer and its secondary terminal voltage is approximately linear up to the greatest current values em-

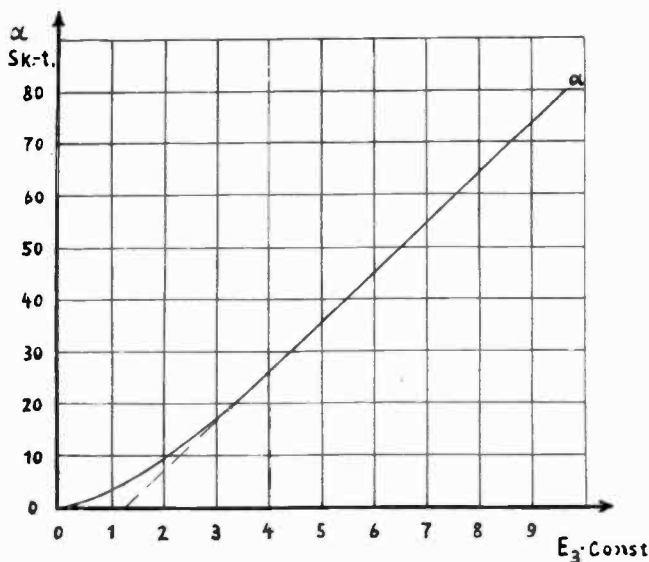

Figure 13—Electrometer response as a function of emf. across receiving circuit secondary.

ployed. The relation between electrometer deflection and voltage P_0 applied at the input transformer of the three stage audio amplifier was arrived at experimentally: (1) without the resonant circuit, and (2) with the resonant circuit back of the first stage. Fig. 12 shows the two curves.

The voltage amplification of the audio amplifier (ratio of electrometer voltage to the input voltage on the amplifier) is 77,500 without the resonant circuit, for $a=30$ scale divisions.

Fig. 13 shows the electrometer deflection a as a function of the secondary receiving circuit emf. E_s , for a wave length of 16,500 meters and for average set sensitivity. The curve is linear from 20 to 80 scale divisions. The relatively small initial sensitivity is unimportant since the deflection can always be brought up to at least 40 divisions by changing the combined amplification factor.

Tests of the Overall Accuracy of the Measuring Apparatus. The following tests were made to ascertain the accuracy of the results obtained with this apparatus. The transmitting current of one of the Königswusterhausen transmitters operating at a wave length of 7,200 meters, was varied from 4 to 29 amperes at intervals, and without the knowledge of the observer. Direct proportionality of measured signal strength to transmitting antenna current was observed.

A further proof was undertaken in June, 1923 in cooperation with the Nauen station using a 13,000 meter wave length. Since Nauen transmitted its normal power, sufficient signal intensity was received at Berlin to permit direct measurement with a simple collector and current measuring device. After making these observations the transmitter current was then reduced by a factor of 130, using a 10-watt oscillator to excite the aerial, and a measurement made with the present measuring equipment.

The per cent. deviation from the ratio of transmitting currents was + 4.29 % in the first case, and + 4.76 % in the second. These errors represent the combined inaccuracies of all measuring devices at both transmitter and receiver, for the large and small intensities. This investigation served to show that the values of field intensity produced by American stations could be measured with this apparatus with an accuracy of at least ten per cent. Investigation has indicated that the average ratios of the received field strength and the product of ammeter indication by effective height of the Nauen station, as measured in the United States independently by Austin, Pickard, and Englund, were three to five times smaller than the corresponding ratios for the Marion and the Rocky Point I and II sta-

tions, as measured in Germany, using the ammeter readings and the effective heights furnished by the Radio Corporation of America.

COMPARISON WITH PREVIOUS METHODS

The use of a local calibrating oscillator is common to all methods for measuring weak fields. With methods in which comparison between the received signal intensity and the strength of the local oscillator is made by sound comparison with the telephone receiver, the optimum attainable accuracy is of the order of 10 % if the pitch and quality of audio notes remain the same. The accuracy drops markedly if the tone used as a basis of comparison is modified by non-uniform interfering sounds, especially if the signal is broken up by the rhythm of the Morse code, while the oscillator gives a uniform tone free from interference. This is the case for the methods employed by Round and by Austin. Ordinarily, the comparison oscillator intensity is set too low (up to 70 % error), as investigations of the author with the cooperation of non-partisan persons showed. The methods of Vallauri, Pickard, and Englund which employ a loop antenna also use a certain amount of interfering sound with the comparison oscillator, but it is possible that on account of the directional properties of the loop the interference emf. component perpendicular to the direction of reception does not affect reception.

Still more unsuitable is the "parallel resistance" method of comparison by means of a sound minimum, though this method is still used frequently for determining relative sound intensities with a telephone receiver. The highest attainable accuracy for complete absence of interference is $\pm 25\%$. The errors which occur in practice are discussed by Dr. Baumler in the paper already referred to.

The thread electrometer used in this method as an indicator is so greatly superior to the telephone receiver that one might assume that it was unknown outside of Germany, or at least that it had not been employed as yet for the above purpose. On account of the small mass and the high natural period of the moving thread (wire), it is possible to tune all circuits quickly and exactly and to equalize accurately and reliably the energy of the oscillator without tiring the observer. The absence of interference in the calibrating

source, a condition which leads to errors of measurement if the telephone receiver is used, actually allows of greater precision of adjustment when the thread electrometer is used. Moreover, outside interference is not marked by an increase in deflection, the suspension vibrating non-uniformly about the deflection which would be produced if interference were absent, so that one can distinguish between deflections caused by reception and by interference. The one disadvantage of the thread electrometer as compared with telephone receiver is the necessity for higher audio amplification, two more stages being required.

An added advantage of the Telegraph Engineering Bureau method is the possibility of making measurements with an overhead antenna without the use of an artificial antenna, the inexact determination of the constants of which might cause errors, and without the complications involved in Austin's method.

In the methods of Guierre, Vallauri, Pickard, and Englund (Friis) there occur difficulties in eliminating undesirable coupling of the oscillator and measuring circuits with the aerial or loop, especially with short waves. This defect is not present in the methods of the Telegraph Engineering Bureau and of Round, because the aerial or loop is disconnected when the oscillator is in the circuit.

Examined critically, it appears that errors may easily arise from failure to take into account capacitative coupling and the shunting effect of distributed capacity, if the mutual inductance of the aerial to measuring circuit is determined from the dimensions of the arrangement, as is done in the methods of Vallauri, Guierre, and Round. Still larger errors may arise from the use of resistance coupling between measurement circuit and loop.* (Methods of Pickard, Englund, and Austin.)

The current transformer principle used by the Telegraph Engineering Bureau is satisfactory, simple, and avoids the above mentioned disadvantages. Care must be exercised to see that the mutual inductance between the ground coil Q and the receiver circuit does not exceed the allowable values. Still, this need be set but once.

The difficulties encountered in the development of apparatus for measuring weak fields, particularly for short

*See the paper of Moller and Schrader previously mentioned.

waves, are only partly evident from the above discussion, and only one who has carried out extensive researches in this field learns to know them all. The receiver part of the apparatus must satisfy much more rigid requirements than the ordinary receiver. The testing of a receiving set for suitability of result yielded cannot be carried out too carefully.

THE FREQUENCY CHECKING STATION AT MARE ISLAND

BY

GEORGE T. ROYDEN*

Interference has always been one of the problems of radio communication, and it has become a serious problem, with the large number of high power radio stations now operating, to keep them from interfering with one another. To avoid congestion, a carefully planned allocation of frequencies to the several stations is made and measures taken to maintain the assigned frequency at each station. This paper describes the frequency checking established at Mare Island Navy Yard for the purpose of measuring the transmitted frequencies of naval radio stations extending from St. Paul, Alaska, to San Diego, California, as far west as Cavite, Philippine Islands, and as far south as Tutuila, Samoa. The frequencies transmitted during special test periods were measured at the Mare Island Radio Laboratory and the Officer-in-Charge of the transmitting station informed so that he might re-tune his transmitter in case of an error exceeding one half of one per cent.

The available methods may be divided into two general classes: individual control at the station, and supervisory control at a centrally located point in a limited region. The frequency meters at each radio station were not entirely satisfactory and subject to too great an inaccuracy to be suitable for the purpose of maintaining the frequency constant within the desired limits. Because of the limitations of equipment and difficulties of adequate coordination, the former method was considered less desirable than the supervisory control. The radio laboratory at Mare Island Navy Yard was designated to undertake this work in the Pacific Area. After considerable experimental work a method was devised which was sufficiently accurate, reliable, and sensitive enough to measure the frequency of the more important stations.

*Formerly Associate Radio Engineer, Mare Island, Navy Yard; Radio Engineer, Federal Telegraph Company.
Received by the Editor February 4, 1927.

A primary standard frequency meter of special design was constructed and apparatus purchased for calibrating it. This frequency meter consisted of two variable air condensers and a set of ten inductance coils. The condensers have rigid brass plates widely spaced and mounted within a metal case. The fixed plates are supported by three quartz pillar insulators. A vernier scale enables the scale to be accurately read to 1 part in 1800. The coils are wound with finely divided and insulated radio frequency cable on bakelite tubes 5 inches long and 5 inches in diameter. The table shows the number of turns and other pertinent data concerning these coils.

The calibration of the standard frequency meter depends primarily on the accuracy of a steel tuning fork, which had been carefully adjusted to 1000 cycles in com-

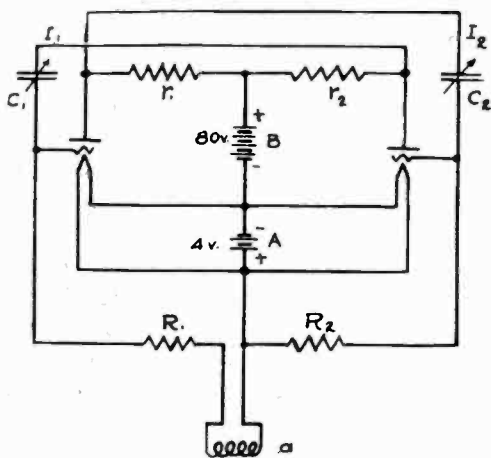

Figure 1—Multi-vibrator Circuit

parison with the standard clock at Paris. To avoid error due to a change in its frequency with temperature, this tuning fork was kept and used in a room, the temperature of which was the same as that when the fork was adjusted.

The comparison between the tuning fork and the frequency meter is made in a screened room by means of a multivibrator together with an amplifier and a heterodyne oscillator. The multivibrator consists of two vacuum tubes so connected, Figure 1, that a distorted alternating current is produced, illustrated in Figure 2. With such a peaked wave form, current will be sustained in a coupled circuit

which is resonant to one of the harmonics. The set-up is made as indicated in Figure 3. After the apparatus has been operating long enough to maintain steady conditions, the multivibrator is set to 1,000 cycles, so that no beats

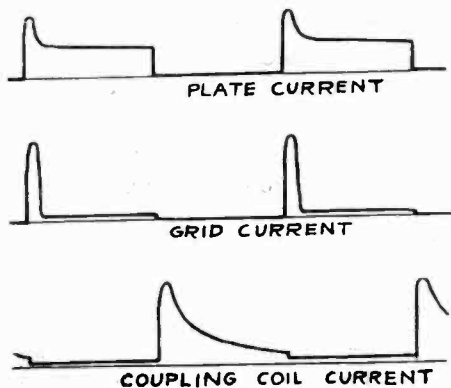

Figure 2—Multi-vibrator Wave Form

occur between it and the standard 1,000 cycle tuning fork. The frequency meter, which had been approximately calibrated in comparison with a separate standard, is set to the lowest harmonic within the range of the meter and the heterodyne oscillator adjusted, with close coupling, for a convenient beat note. The coupling is then reduced and the

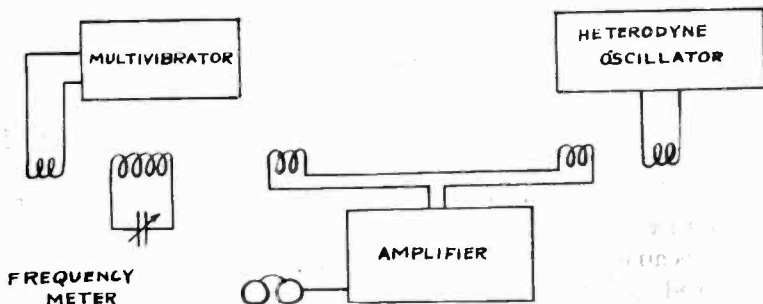

Figure 3

condenser varied for maximum response. This is repeated for the other harmonics, as many as 150 having been utilized without changing the fundamental frequency of the multivibrator.

This method gives a calibration point for each 1000 cycles, but with slight modifications, it is possible to obtain

intermediate points. With close coupling between the heterodyne and multivibrator coils, the heterodyne is set at a frequency approximately midway between two harmonics, say the 14th and 15th. If set to 14,510 cycles there will result two audible beat frequencies, 510 and 490 cycles, which beat with each other. When adjusted so that this double beating does not occur, the heterodyne oscillator frequency is exactly 14,500 cycles. This can be transferred to the frequency meter by the grid reaction method or by noting the disturbance in the telephones when the frequency meter reaches resonance with the oscillator.

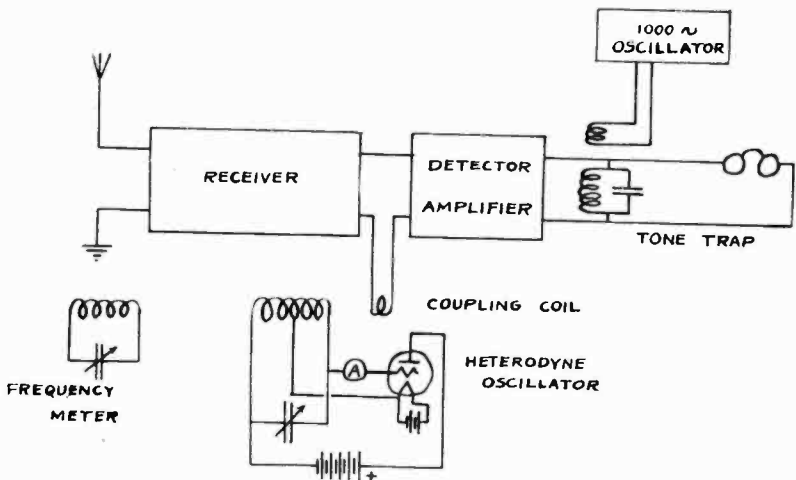

Figure 4

When this work was first undertaken, the frequency of a distant transmitter was measured by adjusting the heterodyne oscillator to zero beat note and then obtaining its frequency by the grid reaction method. This was not satisfactory because the silent period was fairly broad and easily obscured by interference, especially with weak signals. Another method used the sharply tuned standard frequency meter to increase the coupling between the primary and secondary circuits of the receiver. This was better but was abandoned in favor of a still more satisfactory method, in which the oscillator is adjusted to give a beat frequency of approximately 1,000 cycles which in turn beats against a 1,000 cycle tuning fork oscillator. The tone trap, comprising an inductance coil and condenser in parallel with the

telephone receivers, serves as a means for adding the 1,000-cycle current from the tuning fork oscillator, increases the selectivity, reduces interference and facilitates adjusting the beat frequency to 1,000 cycles. Figure 4 illustrates the set-up. A very important advantage of this method is the check afforded by two independent observations, made with beat frequencies 1,000 cycles above and below the incoming frequency, which should be 2,000 cycles apart.

Another method is mentioned, originating in Europe and used at the Riverhead receiving station of the Radio Cor-

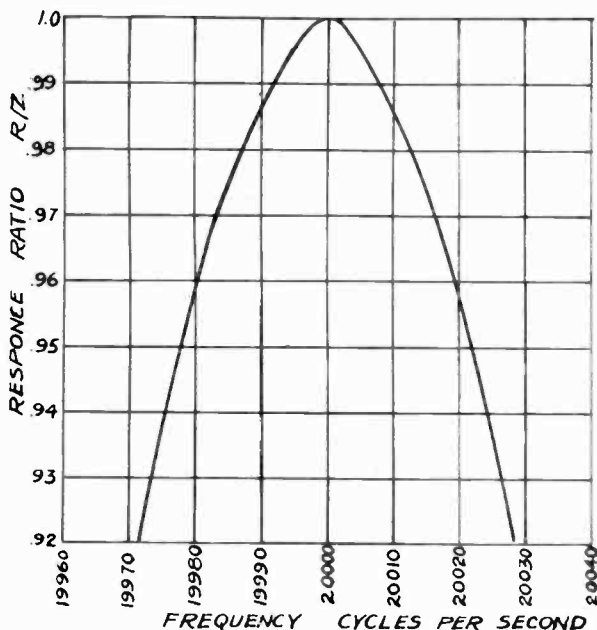

Figure 5—Frequency Meter Resonance Curve

poration of America, in which the frequency meter is connected with the coil and condenser in series as one arm of a bridge network, the other bridge arms being resistances. The signal is conducted to opposite terminals and the receiver connected to the other two. After tuning in the station the frequency meter is varied for minimum signal and the bridge arms further adjusted for a null point. A readjustment of the frequency meter balances the bridge network and indicates the desired frequency. Being a direct method, this permits great accuracy, but weak signals may be obscured by interference.

The accuracy is dependent on the sharpness of resonance of the frequency meter and to some extent on maintaining the accuracy of the standard tuning fork. The resonance curve, Figure 5, with the coil for the 20-kilocycle range indicates that the band over which the frequency meter may be varied for a 1 % change is approximately 20 cycles. This should make it possible to determine the frequency within say 10 cycles for a single determination and say 8 cycles when several observations are averaged. Counting the calibration error it is not likely that the average of two observations will be in error greater than 15 cycles or better than 0.1 %. Repeated observations have demonstrated that such an accuracy with this method is easily obtained.

When measuring the frequency of a spark transmitter or a vacuum tube set with alternating current plate supply the 1,000-cycle oscillator is not used and the heterodyne beat note adjusted first to zero and then to beat with the modulation frequency, adjusting the oscillator frequency both above and below the incoming frequency, giving three observations, which are averaged.

This system has been in use for about five years, regular tests being held each month, and has been of material assistance in mitigating the interference problem in the Pacific region.

COIL DATA

PRIMARY STANDARD FREQUENCY METER

Coil	Wire Size No. B. & S.	Turns	Inductance Hy.	Resistance D. C.	R. F.* Ohms
A	3x11x10 30	7	0.0000063	0.012	...
B	" " "	11	0.000018	0.020	...
C	" " "	23	0.000057	0.041	...
D	3x 3x16 38	39	0.00016	0.28	0.81
E	3x 3x16 38	65	0.00050	0.45	1.06
F	" " "	110	0.0015	0.83	1.7
G	2x 3x16 "	198	0.0045	3.0	4.4
H	" 3x16 "	339	0.013	6.8	9.0
I	" " "	559	0.041	12.6	15.5
J	" " "	973	0.111	25.2	48.5

*Determined with a tuning capacity of 0.002 mfd.

DISCUSSION ON THE OUTPUT CHARACTERISTICS OF AMPLIFIER TUBES (WARNER AND LOUGHREN)

E. Green: I have read with great interest the above paper in the Proceedings of the Institute of Radio Engineers for November 1926, as I have myself written an article on somewhat similar lines entitled "The Use of Plate Voltage Plate Current Characteristics in Studying the Action of Valves", which was published in "Experimental Wireless" for July and August 1926.

My object in writing to you is to point out that Captain H. J. Round has recognized the value of such characteristics for combining the characteristics of the valve and that of the output circuit to determine the behaviour of the combination. In the *Journal* of the Institution of Electrical Engineers for March, 1920, there is a paper by Captain H. J. Round on "Direction and Position Finding", and as Appendix 2 of this paper he dealt with the case of a simple resistance amplifier by means of plate current plate voltage characteristics. As far as I know this is the first published description of such use. In 1923 he explained the method to me, and realizing that it might be of value to others I set myself to write out, and to some extent apply, his method to various cases. The resulting article was accepted by the Editor of E. W. and W. E. in November 1924, but was not published until July and August, 1926. I am forwarding copies of this for reference.

DISCUSSION ON SIMPLIFIED S-L-F AND S-L-W DESIGN (O. C. Roos)

R. R. Batcher:* It seems strange that an article containing this excellent analysis of S-L-F condenser design methods should contain such a statement as the following, "The S-L-F plate has its lower frequencies crowded together on the initial dial divisions." This statement is at variance with the very definition of an S-L-F condenser, the basic idea upon which this type of plate was initially advanced. This

*A. P. Grebe & Co. Inc.

statement, however, is not new; it has been advanced for over a year as a sort of alibi by several manufacturers who have found that a true S-L-F condenser requires plates with a large swing so that it is difficult to manufacture accurately due to the large relative bulk for a given capacity. Before the advent of S-L-F condensers upon receivers, three years ago, the public had been used to having long wave stations separated at least five degrees for each myriacycle. After S-L-F condensers, all stations are separated equally, if true S-L-F operation is obtained. If this separation is sufficient for accurate manipulation of the dials on high frequency stations, it will always be enough on the low frequency stations.

It must be remembered that there is only a definite amount of dial space available. Assuming 100 dial divisions and 100 stations spaced equidistant on the frequency scale, there will be one station per degree. It is easy to set a dial manually to an accuracy of $\frac{1}{4}$ degree on any part of the dial.

Now assume that the hybrid condition of condenser plate as outlined (in Fig. 6 loc. cit.) has the same total area. Using the values set forth at the bottom of page 777 it is seen that we have crowded 80 stations in the S-L-F portion of the dial, i. e.—in approximately 42 dial divisions, or about one station every $\frac{1}{2}$ division. We have actually thus crowded about 75 per cent. of the total number of the wave bands into half of the normal space. On the other hand we have allotted 105° to 28 wave bands or 28 stations to 58 dial divisions, or approximately one station to two divisions.

It can be stated that S-L-F design for condensers over the whole range is the only true and scientific method as long as stations are maintained in the present bands.

I devised a universal formula a number of years ago that will permit S-L-F operation over all or over any portion of the dial. It is necessary to know the same quantities outlined in the above article: the wavelength range desired (X) and the minimum capacity of the circuit (including that anticipated due to the condenser itself), also the maximum desired radius of the plates (ρ_m).

This formula is:—

$$\rho = \sqrt{\frac{K}{\left[1 - \frac{\theta}{100} \left(1 - \frac{1}{X}\right)\right]^2} + \rho_0^2}$$

The formula for factor K has been worked out but in general it is found by substituting for ρ the maximum radius desired and $\theta=100$ (note θ bears values from 0 to 100 corresponding to dial divisions) and solving for K .

Should occasion arise where S-L-F operation be desired over any portion of the dial it is only necessary to use the actual wavelength range for that portion in determining X and to assume θ refers to this dial section only.

It should be noted that it is to the designer's advantage to accurately determine the minimum capacity C_0 before starting, since a much greater plate area for a given rotor radius is obtained when C_0 is considered. Apparently a number of so-called S-L-F condensers were designed with this factor neglected, judging from the resulting plate shapes obtained.

O. C. Roos: Mr. Batcher deserves my thanks for "lighting" on the apparent slip—"The S. L. F. plate has its lower frequencies crowded together in the initial dial divisions". Of course this statement was meant for the generally manufactured "parts" condenser used by both radio telegraph workers and B. C. L. I meant to specify that when used at waves longer than 547 meters there would be crowding at "lower (than broadcast) frequencies etc". The intent is rather obvious in view of my analysis of S.L.W. design.

Regarding Fig. 6 of my paper this was in no wise intended for a practical case but simply as an illustration of the mechanism of designing procedure. Manufacturers and engineers nowadays often illustrate dimensions of their "machinery" without giving literal transfers of the constants used. The method is the thing and longer than broadcast waves were purposely included in Fig 6 to include "parts" condensers, which cover a wide range of use.

Mr. Batcher's formula resembles that of H. C. Forbes and like it fails to indicate the bearing of the physical factors by simple inspection. The ability to do this is the chief advantage aside from the saving of time inherent in my procedure and formulas.

Manufacturers who use gang condensers with uni-control must not use auxiliary condensers to correct coil errors and consequent failure to start off with all frequencies synchronized. The only possible remedies are either accurate duplication of inductances in all respects or else a reduction

of range by turning the defective-stage condenser to a new starting point, thus reducing the range on the other stages. The auxiliary capacitances must not be touched however; since so-called "trimming" condensers, as such, are taboo. They "trim" the public—that's all.

As I am showing in other papers, digging into this subject, we must reduce the "separation" problem between stations to one of the relation between the dial detuning interval—D.D.I.—which reduces our resonance current by a given fraction—say 90 per cent., and the "dial spreading"—D.S.—which I define as the dial movement between stations divided by their frequency-change or practically the first derivative of dial movement in terms of frequency.

I have derived some interesting laws covering the four classes of commercial plates now used, S.L.F., E.L.W. (Exponential line wavelength, as in the Kolster Decremeter); S.L.W. and S.L.C.

Thus both the D.D.I and the D.S. vary as follows:

The D.D.I. and D.S. in S.L.F. are constant

The D.D.I. and D.S. in E.L.W. $\propto \lambda$

The D.D.I. and D.S. in S.L.W. $\propto \lambda^2$

The D.D.I. and D.S. in S.L.C. $\propto \lambda^3$

Here it is easily seen that the S.L.F. shape for broadcast frequencies which are equally spaced, is better than the famous E.L.W. or erroneously so-called Duddell "logarithmic" plate. Not only is the D.D.I constant all over the S.L.F. scale,—if the resistance is assumed by balancing of condenser and coil effects to be constant—but even if it varies as the frequency—as Bur. of Standards Bulletins indicate for some single larger coils,—the D.D.I. tends to a constant *percentage* of the scale reading throughout the scale and give what the E.L.W. could not give except by simultaneous coil and condenser variation!

Even if we could arrange our broadcast stations so that the next higher station frequencies were say, 102 per cent. of the last, we could not, employing a E.L.W. condenser and variable L, equal the performance of the S.L.F. plate with its practically fixed L. and fixed D.D.I. Many have dreamt about such a change but it has no practical foundation.

Note that all four types of condensers have with "flat" resistance characteristics, the same relative immunity from interference between stations. As the "Dial Spreading"

varies so does the "Dial Detuning Interval" for all. Where they differ is in their power of spreading the stations themselves, so the manufacturer who wants to cover both the longer wavelengths and the broadcast band, must not only shift his coils, he must change his calibration. He will of course narrow his range and have only say 218 to 526 meters or even less.

It is easy to design an E.L.W. plate from a series of small S.L.F. or S.L.W. segments which step-by-step change their constants as we proceed from those covering the broadcast band to the longer waves. I have a paper on this subject which will shortly appear, but we "must break eggs to have an omelette" and our range must suffer as we "spread" stations. There seems no way out of it.

In conclusion, I believe Mr. Batcher's final paragraph is too meticulous. It should be precised as a well known first consideration among designers. He says "it is to the designer's advantage to accurately determine the minimum capacitance C_0 before starting; since a much greater plate area for a given rotor radius is obtained—" This may with justice imply that the number of active dielectric "spaces" between rotor and stator should not be too great. We might leave too narrow a margin of constancy in C_0 for the adjustable auxiliary calibration condenser (A.A.C.C.) to automatically compensate by its tested adjustment, the stray capacitances which may vary, through tube changes. Small plates tend in addition to a less constant value of stray flux with rotor movement than do large plates, but we have nevertheless assumed a constant stray flux, in all design methods.

In implying large plates he is adumbrating a critical condition of design when they become small; since for a given value of C_0 and of calibration range, his number of dielectric spaces or double the number of rotor plates varies inversely as the square of his maximum radius i.e. reducing this from say 2.5 inches to 2.00 inches would increase the number of his rotor plates about 50 per cent. Machine shop studies have shown the best compromise between these factors, with results that dictate the proper range of values for C_0 .

However, I may have misunderstood the more direct import of Mr. Batcher's last paragraph, which may mean that the "shape" of the S.L.F. or S.L.W. plate is dependent on

something except the total turning angle (assumed 180 degrees or constant) and the range.

Assuming his "given rotor radius" to equal either the maximum or minimum radius permissible, his statement "that the designer should accurately determine the minimum capacitance C_0 before starting; since a much greater plate area for a given rotor radius is obtained when C_0 is considered.....a number of so-called S.L.F. condensers were designed with this factor neglected, judging from the resulting plate shapes obtained", is not a final criterion of design; since to assume a maximum rotor radius is the only safe procedure and will give a perfectly definite minimum or "zero" radius. If this radius is too small we must increase our maximum by redesigning. There's no other way out; as my range equations clearly show.

On the other hand if we follow Mr. Batcher's advice and start with the minimum or "zero" plate radius, in most cases we have too great a maximum radius and must redesign or use less than 180 degrees in our plate. The only difference lies in the fact that in the latter case we have fewer large plates and in the former more small plates, though the number of plates will not generally differ by more than 10 per cent. The question of the constancy of C_0 during the rotor movement determines the choice.

The latter part of his statement about the shape of the plates is erroneous if it implies that all actual S.L.F. segments for a given range are not "similar" geometrically, no matter what the value of C_0 . Probably he referred to designs which showed no knowledge whatever of the effect of C_0 in the design, in which case I quite agree with him.

Paul M. Mueller: I have read Mr. Roos' paper on condenser designs appearing in the December issue and hasten to congratulate him on a very able presentation.

To augment his treatment of this problem I should like to call attention to some work on this same subject which I did about two years ago and which I published under the title "Tuning Tricks" in the August, 1926 edition of Q. S. T.

In this article, which was written primarily to show a method of properly balancing gaged multistage condensers, I brought out the fact that the polar area, approaching the origin and below zero of the dial must either be represented by stray capacitances in the circuit or by a small adjusta-

ble auxiliary condenser. I then developed a design in which this neglected polar area was purposely made greater than the strays encountered in the usual circuit and outlined a graphical method for determining the proper adjustment of the auxiliary condenser to bring the total capacitance of the circuit up to the design value. Following this argument I was able to construct single control sets which functioned remarkably well throughout the entire change.

In this same article I indicated a method which is generally applicable for the design of condensers and which has some marked advantages, since determination of the plate generators follows mathematically when the five major considerations have been decided.

When one has decided upon

1. Minimum wavelength
2. Maximum wavelength
3. Type of tuning
4. Maximum stray capacity per stage
5. Thickness and type of dielectric

all of which are independent and empirical the following equations are applicable and lead to a concise result without recourse to "rule of thumb" methods.

Assume that the calibration must satisfy the condition that the rate of change of wavelength is proportional to the wavelength. (This calibration is intermediate between S.L.F. and S.L.W. and gives a more desirable station distribution than either of the more common methods.)

$$\gamma = \gamma_0 a^{\theta} \text{ satisfies the condition} \dots\dots\dots (1)$$

Substituting and rewriting the terms of capacity

$$C = C_0 a^{2\theta} \dots\dots\dots (2)$$

The total circuit capacity C is made up of the geometrical capacity C_G plus the phantoms or strays and may be expressed thus:

$$C = C_G + C_0 \dots\dots\dots (3)$$

subst. in equation 2

$$C_G = C_0 a^{2\theta} - C_0 \dots\dots\dots (4)$$

Now the geometric capacity is a function of the engaged area A of one plate

$$\text{thus } f(A) = C_G \dots\dots\dots (5)$$

$$\left(\text{When } f = \frac{.2248 (N-1)}{t} \right)$$

Subst. (5) in (4)

$$A = \frac{C_o}{f} a^{2\theta} - \frac{C_o}{f} \dots \dots \dots (6)$$

$$\text{But } A = \frac{1}{z} \int_0^{\theta} (\rho^2 - r^2) d\theta \dots \dots \dots (7)$$

which is the general eq. for area in polar coordinates differentiating in terms of θ and combining

$$\frac{dA}{d\theta} = 2 \frac{C_o}{f} x^{2\theta} \log_E a = \frac{1}{z} (\rho^2 - r^2)$$

or

$$\left(\frac{4C_o}{f}\right) a^{2\theta} \log_E a = (\rho^2 - r^2)$$

or

$$\rho = \sqrt{\left(\frac{4C_o}{f}\right) a^{2\theta} \log_E a + r^2} \dots \dots \dots (8)$$

If r or the inner radius of the rotor is constant as is usual we now have the outer generatrix in terms of the dial setting θ modified by the design constants phantom capacity C_o , dielectric f , and calibration a .

The shape of the condenser plate is now completely determined and we need only to design the inductance from the formula $\lambda_o = f' \sqrt{LC_o}$ to fulfill the five major conditions and complete the problem.

It will be noted, since we have already considered the strays, that the numerical value of L is the pure or theoretical quantity which can be nicely established by mechanical measurement.

DISCUSSION ON THE CORRELATION OF RADIO RECEPTION WITH SOLAR ACTIVITY AND TERRESTRIAL MAGNETISM (G. W. PICKARD)

J. H. Dellinger: Mr. Pickard's paper marks a definite step in advance in our knowledge of the mechanism of radio transmission. It is not generally appreciated to what an extent this question of radio wave vagaries is the outstanding problem of radio engineering at the present time. It is not too much to say that this subject is the major and typical subject of the present era of radio development.

Last week Dr. Pupin gave an address, as Retiring President of the American Institute for the Advancement of Science, on the subject of "Fifty Years' Progress in Electrical Communication." It is well for us to stop and realize that radio has been with us thirty of those fifty years. It was indeed just thirty years ago that the pioneer experiments of Marconi gave radio to the world. Broadly speaking, the radio era can be said to have had its beginnings at the commencement of this century, and the first three decades of the century are marked by distinct stages in its progress. The first decade (1900 to 1910) was the period of conquest of distance. Starting with a few miles and with the crude spark gaps and coherers of those days, the few pioneer radio engineers struck out in every direction for improvements, and by one ingenious means after another succeeded in steadily increasing the distance of communication. By the end of the decade radio had reached its goal of communicating to any desired distance on the earth's surface. There was a beginning of radio telephony but it was of a crude sort, and the real achievement of the decade was the establishing of radio telegraphy as a successful service.

The second decade was the period of development of the electron tube. Beginning with it as a low-power and imperfect device, it was steadily improved and made to handle higher and higher power. Its possibilities for the realization of radio telephony were steadily developed with the result that at the end of the decade everything was in readiness for broadcasting to make its appearance. This made radio an everyday necessity to a large fraction of the world's population.

Did it remain for the third decade of the century, the one in which we now are, merely to go on with minor improvements and refinements? Not at all. In spite of the perfection of transmitting and receiving apparatus, radio engineers and the public have been surprised to find that radio reception is far from perfect. We have no cure for fading, atmospheric disturbances, wave direction shifts, and other forms of interference and disturbances of reception. At the beginning of the decade we did not even know what caused them. There was very little information as to the laws of their behavior, much less of the laws of their production. For those scientists and engineers who are con-

cerned with fundamental progress, this subject of wave vagaries was clearly a problem which had to be met and so it has remained.

Gratifying progress has been made and it may even be hoped that this decade may close with some generalization or climax of achievement in this field which will elevate radio to a new plane of service comparable with the arrival of broadcasting at the end of the last decade. The outlines of the mechanism of radio wave vagaries are now being discerned. It is still too early to give a positive explanation of the causes and characteristics of such things as fading and atmospheric disturbances, but there are a number of elements in the solution which are now well established. Numerous investigators have been doing pioneer work and assembling much valuable data giving the characteristics of fading, wave intensities, atmospheric disturbances, wave polarization, etc., as a function of various conditions such as time of day and year, frequency, weather, distance, topography, terrestrial magnetism, etc. Among the numerous things that stand out as a result of this work, one conclusion of interest, is that there is no important correlation between radio conditions and weather. Among the principal elements of the new knowledge are the role of the ionized upper portions of the atmosphere and the phenomena of very high frequencies. At the beginning of the decade the high-frequency phenomena were non-existent either in the activities or the thoughts of radio engineers. The theories of wave behavior were fairly simple and consistent for frequencies from the lowest to the highest then used. The work done during the past few years at frequencies from 2000 to 20,000 kilocycles has revealed a new world of wave behavior not fitting in with previous knowledge or theories at all. While introducing complications and inconsistencies with wave actions at other frequencies, the high frequencies have nevertheless introduced a vast amount of new information.

It is not my purpose in a discussion of this paper to give a summary of the knowledge of radio wave phenomena as it stands today. I would like to point out, however, that the correlation which Mr. Pickard has established is a major contribution to this picture of the radio wave mechanism which is now being assembled. How fruitful it will be to have this demonstration that the variations of electrical

condition on the sun give rise to some of the characteristic radio wave variations, only time can tell. It can certainly be concluded that it will give a new impetus to further studies and analysis not only of radio wave phenomena but also the phenomenon of related sciences such as terrestrial magnetism and astrophysics.

DISCUSSION ON IMPORTANCE OF LABORATORY MEASUREMENTS IN THE DESIGN OF RADIO RECEIVERS

(W. A. MACDONALD)

H. D. Oakley and Norman Snyder:* Mr. MacDonald says, "It is obvious that an exact knowledge of the individual and over-all characteristics of a radio receiver should be accurately known, yet experience shows that many manufacturers, including some of the largest, are practically unaware of the exact performance of the apparatus they produce".

We are ignorant of the facts upon which the second part of this statement is based, but agree, heartily, with the first part. Now inasmuch as Mr. MacDonald has put on record an accusation against many manufacturers of radio receivers and in his paper has dealt with the measurement of characteristics of individual units of a receiver, and not at all with the measurements of over-all characteristics of receivers, the manufacturers should be permitted, and should consider it their duty, to make a proper reply.

We should like to describe briefly the apparatus used by the General Electric Company for making tests on radio receivers, the quantities measured, and the method of test.

The testing equipment consists of two shielded rooms, a signal generator, voltage attenuating device, and an output voltmeter. In one of the rooms are the signal generator and input controls of the attenuator. In the other room are the attenuator, dummy antenna, (not used in the case of loop sets) receiver to be tested, and output voltmeter. These rooms shield both the testing equipment and the receiver from external disturbances and also prevent the signal generator from affecting the receiver except through the attenuator. The signal generator is a miniature broadcast transmitter employing the Heising system of modulation,

*Of the General Engineering Laboratory of the General Electric Company.

and consists essentially of an audio frequency oscillator with a range of from 20 to 10,000 cycles, a radio frequency oscillator with a range of from 550 to 1500 k. c., a modulator, a radio frequency power amplifier, and a device for measuring the degree of modulation. The attenuator consists of a special form of inductor, the current through which can be adjusted to produce in the output of the inductor a known value of voltage. The output voltmeter is a device for measuring the effective value of audio frequency voltage existing across the output of the receiver.

Mr. MacDonald has described various tests made on individual parts of receivers, and since during the development of receiving apparatus this company makes similar tests, the tests described here will be those dealing with over-all characteristics, alone.

The tests and results to be described do not necessarily conform to our latest practice in investigating over-all

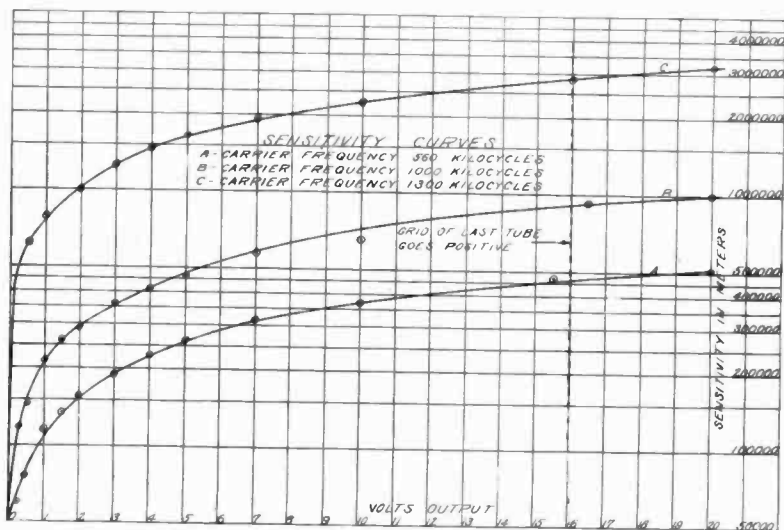

Figure 1

characteristics, but are representative of what has been and is being done in this class of measurements.

The quantities measured are sensitivity, selectivity, radiation, and quality. Figures 1, 2, 3 and 4 show the results obtained from tests made on a well known make of broadcast receiver. The circuit of this receiver consists of a

two stage tuned radio frequency selector amplifier, detector, and two stages of transformer coupled audio frequency amplification.

If the receiver is designed to operate with an antenna, it is connected to a dummy having characteristics similar to those of an average broadcast receiver antenna, and in the ground side is inserted the output of the attenuator. If tests are to be made on a loop type receiver, the dummy, of course, is not used, but the low side of the loop is opened and the output of the attenuator inserted. The output of the receiver is connected to an RCA model 100 loudspeaker across which is the output voltmeter.

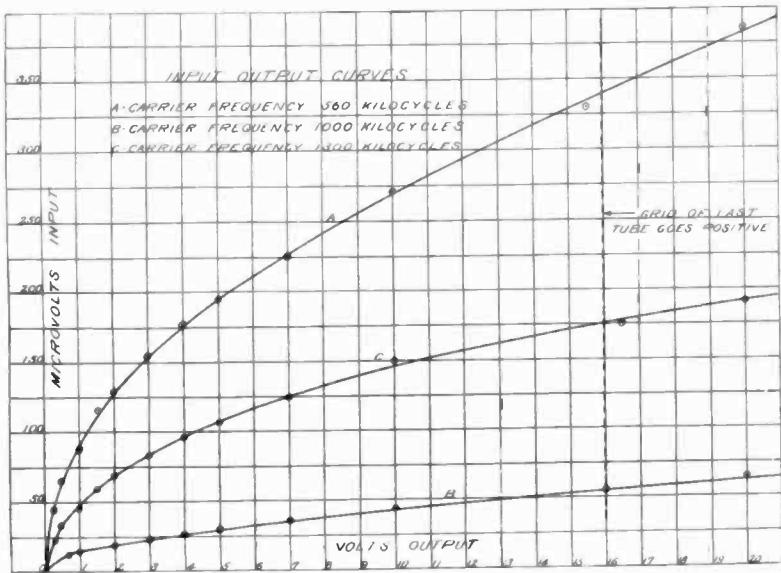

Figure 2

Sensitivity measurements are made in this way. The receiver is tuned to some frequency within the broadcast band, and the signal generator is adjusted to give an output modulated 50% with a modulation frequency of 1000 cycles. The voltage induced in the input of the receiver (antenna or loop circuit) is increased in steps and at each step the corresponding output voltage is recorded. The test is continued until a point is reached where the grid of one of the receiver tubes (usually the second audio) starts to pass current. This is considered the operating limit of

the set, since beyond this point distortion occurs. Dividing the voltage induced in the input by the effective height of the dummy antenna, or of the loop, the field strength is obtained. A plot of field strength against corresponding output voltage is one form of sensitivity curve. Another is sometimes preferred. This is a plot of sensitivity in meters against output voltage. The unit of sensitivity is called the meter and is defined as one volt output per one volt per meter input. Figures 1 and 2 illustrate sensitivity curves.

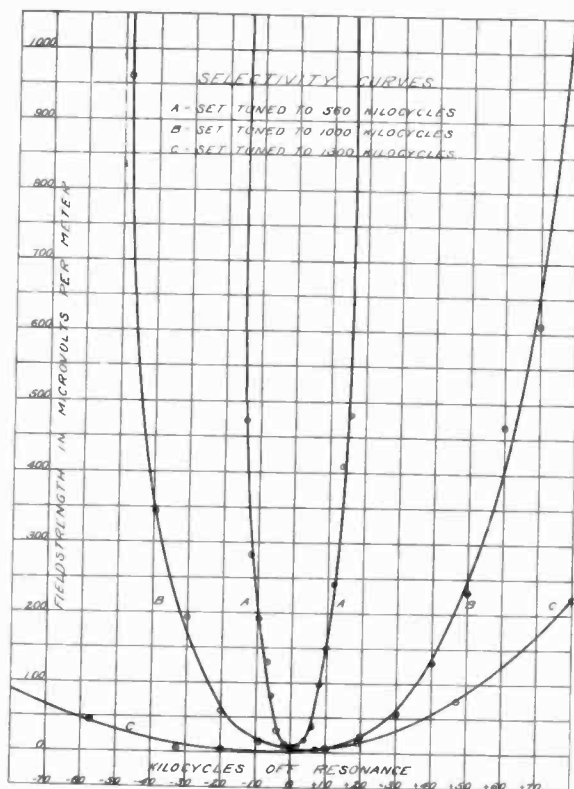

Figure 3

For selectivity measurements, the frequency of the signal generator is changed in small steps (maintaining the modulation frequency and degree constant) and at each step the frequency and also the input voltage, to receiver, required to maintain constant some value of output voltage are recorded. A plot of field strength against frequency is the selectivity curve. From it may be obtained directly the

field strength an interfering station must have to produce a signal equal to the desired one. Knowing the response law of the receiver and the field strength of an interfering station, the signal strength may be indirectly determined. Figure 3 shows the selectivity curves.

The method of making radiation measurements is merely indicated here because a description of it would be rather long. The receiver produces an effect upon an indicator. The source of radiation is then replaced by a device having known characteristics, and a current flowing

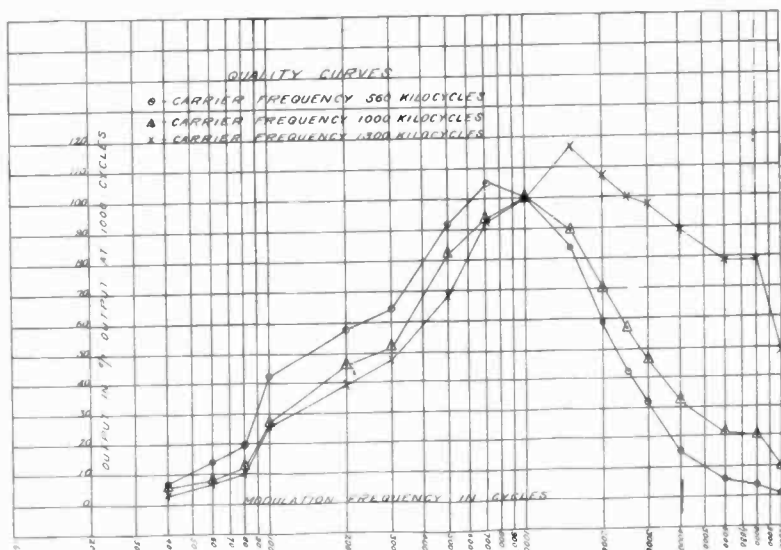

Figure 4

through it is adjusted so that the effect produced upon the indicator is the same as before. The radiation as determined from these tests is expressed in meter amperes. The particular receiver, whose characteristic curves are shown here, had no oscillator, nor could any of its circuits be made to oscillate, so of course no radiation could be measured.

The test for quality shows the discrimination of the receiver as a whole among the frequencies within the audible range, and does not show the presence of distortion due to the introduction of harmonics by the receiver itself. The test consists of maintaining a constant input to the receiver, at a constant carrier frequency and constant degree of

modulation, but the modulation frequency is varied from 40 to 10,000 cycles and the output voltages at the different frequencies are recorded. The results are plotted as output voltage in per cent. of output voltage, at some one frequency, against frequency. The drooping of the low frequency part of the curve is practically all due to the audio transformer and loudspeaker characteristics. The drooping of the high frequency end is due partly to the detector circuit, partly to the radio frequency circuits tuning too sharply, and partly to some effect in the audio frequency amplifier. Figure 4 is an example of over-all quality characteristics.

J. H. Dellinger: The discussion of this paper at the Convention indicated some difference of opinion as to the relative desirability of overall measurements vs. measurements of components of the receiving set. Mr. MacDonald's paper omits overall measurements entirely and in justification of his position I wish to point out that his subject has to do with measurements for design purposes. There are at least three different purposes for receiving set tests, and it is altogether likely that the appropriate tests should be different depending upon which purpose is in view. These three different types of receiving set measurements would be those for—(a) the design of sets; (b) factory inspection tests of output; (c) tests suitable for the comparison of one receiving set with another. I assume that every receiving set manufacturer has an engineer whose duty it is to consider receiving sets from the last point of view. From the standpoint of the set user this is the most important type of receiving set test.

This subject is under consideration at the present time by the Receiving Sets Subcommittee of the Standardization Committee. This subcommittee has taken as its task of first importance the laying down of overall test methods, on the idea that methods which permit discrimination between the sets on the basis of final performance are most easily subject to standardization. While recognizing fully the difficulties of overall tests and the necessity of extremely careful specification of the conditions of operation of a set during such tests, it was nevertheless thought possible to render a useful service in standardizing testing methods by which one set could be compared with another. It seems

much less likely that design tests or factory inspection tests could be standardized to advantage, since the designing engineer or production manager of any given manufacturer might be hampered rather than hindered by the endeavor to follow a standardized type of test. I wish to mention here the present ideas of the receiving set subcommittee in order to place the matter before the Institute for discussion and to gain for the subcommittee the advantage of criticism which any member may care to offer. I would be very glad to receive criticisms or suggestions from any Institute member or reader of the Proceedings.

The subcommittee has adopted tentative definitions of three overall characteristics, namely, sensitivity, selectivity, and fidelity. These are measured by the aid of a generator producing radio-frequency voltage of controllable modulation together with a means of measuring audio-frequency voltage across the output terminals of the set. In the following tentative definitions numerical values are to be inserted later for the quantities indicated by the letters s , t , u , v , w , x , y , and z .

Sensitivity.—Sensitivity is quantitatively defined as the ratio of the power output to the radio field intensity input measured as follows: Radio-frequency voltage, modulated $s\%$ at t cycles, is induced in the antenna if the receiving set includes one, otherwise in an artificial antenna consisting of a series arrangement of a capacity of u micromicrofarads, an inductance of v microhenries, and a resistance of w ohms. A curve is plotted of which the abscissas are the carrier frequency from 550 to 1500 kilocycles, and the ordinates are the radio field intensity in millivolts per meter required to produce x watts in a noninductive resistor connected across the receiving set output terminals (usually the loudspeaker terminals), the resistance of the resistor having been adjusted to give maximum output power. When the artificial antenna is used, radio field intensity is calculated from an assumed antenna height of y meters. The value of sensitivity for any one frequency is x divided by the ordinate of the curve for that frequency. The complete expression of sensitivity is the entire curve.

Selectivity.—Selectivity is expressed in terms of the frequency separation and the ratio of voltages produced across the output terminals, at and off resonance. It is not expressible by a single numerical value but requires one

or more curves for its expression. It is measured by the same apparatus used for the sensitivity test. With the apparatus adjusted for the same input voltage, modulation frequency and percentage, and output resistance, as in the sensitivity test, the frequency of the source of voltage is varied without changing the receiving set tuning. The difference of frequency from resonance and the corresponding output voltage are observed. Pairs of curves are plotted, one of each pair for above resonance and the other for below resonance. Selectivity can be considered as expressed by any of three sets of curves, as follows:

1. Pairs of curves, taken at 550 and 1500 kilocycles and at any frequency between these two at which the selectivity is greater or less than at either extreme frequency, the curves having as abscissas the frequency separation from resonance in kilocycles, and as ordinates the ratio of output voltage across the output terminals at each frequency separation from resonance to the output voltage at resonance.

2. A pair of curves, one for above and one for below resonance, having as abscissas the carrier frequency from 550 to 1500 kilocycles, and as ordinates the frequency separation from resonance at which $1/z$ of the output voltage at resonance is produced by the same input voltage as produces x watt output at resonance.

3. That one of the two curves of paragraph 2 which shows the poorer selectivity.

Fidelity.—Fidelity is defined as the accuracy of reproduction at the receiving set output terminals of the modulation of the received wave. It is expressed by two or more curves, having as abscissas the modulation frequency from 30 to 10,000 cycles, and as ordinates the ratio of volts output at the modulation frequency of t cycles to output voltage at the modulation frequency of measurement, both at $s\%$ modulation.

Harold A. Wheeler: Several of the points mentioned in the above paper, or in the discussion which followed its presentation, seem sufficiently interesting to warrant further discussion.

Reduction of Sidebands in a Radio Frequency Amplifier. In a tuned radio frequency amplifier, the selectivity is sometimes so great that there is a reduction in the amplitude of the outer sidebands carrying the modulation at the higher

audio frequencies. This effect is proportional to the ratio A_s/A_c of the voltage amplification of the sidebands to that of the carrier, and is equivalent to only a reduction in the degree of modulation at the audio frequency in question.

Take the modulated wave of voltage e in the antennas of the transmitting and receiving stations,

$$\begin{aligned} e &= e_o(1 + m \cos \omega_m t) \cos \omega_c t \\ &= e_o(\cos \omega_c t + \frac{m}{2} \cos \omega_s' t) + \frac{m}{2} \cos \omega_s'' t), \end{aligned}$$

in which $\omega_s' = \omega_c - \omega_m$ and $\omega_s'' = \omega_c + \omega_m$

ω_m = angular frequency of modulation, and

ω_c = angular frequency of carrier.

In general, when the amplifier is tuned to give maximum response at the carrier frequency, the ratio A_s/A_c is less than unity, and there is a "symmetrical" phase displacement of the sidebands. That is, the two sidebands have equal but opposite phase displacements $\theta, -\theta$. Then the wave form delivered from the amplifier is

$$\begin{aligned} e' &= e_o[A_c \cos \omega_c t + A_s \cdot \frac{m}{2} \cos(\omega_s' t + \theta) + A_s \cdot \frac{m}{2} \cos(\omega_s'' t - \theta)] \\ &= A_c e_o[1 + m' \cos(\omega_m t - \theta)] \cos \omega_c t \end{aligned}$$

where $m' = m \cdot A_s/A_c$.

Therefore the principal effect is a reduction of the degree of modulation.

This is not accentuated in a detector whose response is proportional to the square of the applied voltage, since the modulated response is then proportional to the product of the carrier and sideband amplitudes, not to the square of the sideband amplitudes.

The phase displacement of the modulation is not detected by the ear, but is interesting in that it is the result of the "inertia" of an oscillating circuit. That is, there is an opposing reaction to any change in the amplitude of oscillation. For example, the time constant of equilibrium for oscillations in a simple series circuit (L, C, R) is $2L/R$. This corresponds to the time constant L/R for direct current in the simple inductive circuit L, R .

Reduction of High Audio Frequencies in a Detector. In the detector of Fig. 1, the grid condenser (C) requires some time to charge or discharge, which causes a discrimination against the higher audio frequencies of modulation. This effect can be reduced to a minimum by making C as small as possible without materially reducing the radio frequency

voltage on the grid. Reducing the resistance ($1/g$) of the grid leak has a similar advantage, but results in a material decrease in sensitivity to weak signals, accompanied by a material reduction of selectivity in the case of a tuned grid circuit.

It is generally immaterial whether the grid leak is connected to the positive filament terminal directly or through the coil, since any radio frequency current in the

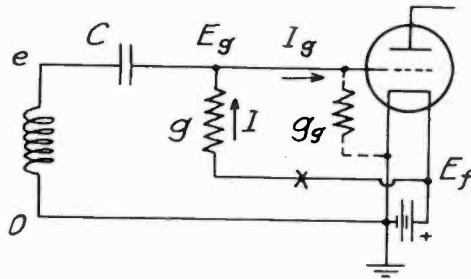

Figure 1

grid leak is ordinarily very small as compared with that in the tube grid conductance (g_g). There is no definite ratio between g_g and g , but one increases at about the same rate as the other.

The response of the detector to an unmodulated carrier can be explained by Fig. 2. In the absence of any signal, the

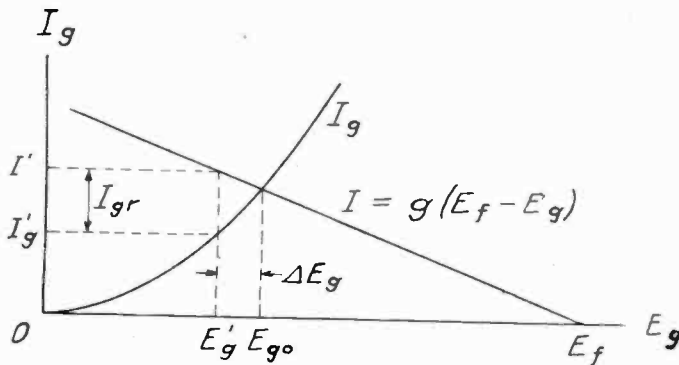

Figure 2

initial grid voltage (E_{g0}) is determined by the intersection of the two curves, making $I_0 = I_{g0}$. When the signal is applied, the rectified component of the grid current (I_{gr}) requires that the grid voltage shift to E_g , such that

or the equivalent $\Delta I = \Delta I_g + I_{gr}$.

$$I' = I'_g + I_{gr},$$

$$I_{gr} = \Delta I - \Delta I_g = -\Delta E_g (g_g + g).$$

Therefore
$$\Delta E_g = \frac{-I_{gr}}{g_g + g}.$$

If e_g is the applied radio frequency voltage on the grid, then to a first approximation

$$I_{gr} = \frac{e_g^2}{2} \cdot \frac{d^2 I_g}{dE_g^2} = \frac{e_g^2}{2} \cdot \frac{dg_g}{dE_g}, \quad \Delta e_g = -\frac{e_g^2}{2} \cdot \frac{dg_g}{g + g_g}.$$

This solution fails for a strong carrier, since g_g is defined only for small grid voltages. The behavior with a strong carrier is essentially the same, however. The conclusion is that for great sensitivity, $(g_g + g)$ must be made small, which is secured by increasing the resistance of the grid leak.

When the carrier is modulated, the variations in the rectified grid voltage (ΔE_g) are accompanied by currents in C , as well as in g_g and g . The total grid admittance,

$$\left| g_g + g + j\omega_m C \right| = (g_g + g) \sqrt{1 + \left(\frac{\omega_m C}{g_g + g} \right)^2},$$

takes the place of $(g_g + g)$ in the denominator. The response to different audio frequencies of modulation is then proportional to

$$\frac{1}{\sqrt{1 + \left(\frac{\omega_m C}{g_g + g} \right)^2}},$$

so that the discrimination against the higher frequencies is small if $\omega_m C < g_g + g$.

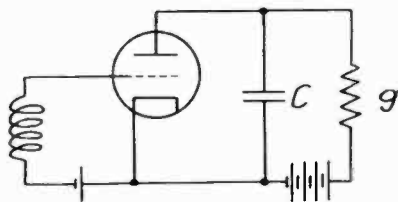

Figure 3

The magnitude of this effect is not easy to predict, because g_g is subject to so many conditions. Measurements of the relative response over the audio frequency range

have been made, as mentioned in the paper, by introducing an audio frequency voltage at "X" in series with the grid leak. The resulting grid voltage then varies with the frequency in the same manner as it would with the frequency of modulation of a received signal.

The same effect is observed in the "plate detection" circuit of Fig. 3, with g_p taking the part of g_k in parallel with C . No general statements can be made as to the relative merits of the two detector circuits. The latter circuit is generally less sensitive, but the grid conductance is not present across a tuned grid circuit. In this case, $g_p + g$ must be made small to secure great sensitivity.

Review of Current Literature

Prepared by
STUART BALLANTINE

White Haven - - - - - Pennsylvania

PROPAGATION OF SHORT WAVES AROUND THE EARTH

BY
E. QUACK

(Zeitschrift fuer Hochfrequenztechnik, 28, 177, 1926)

Some very interesting results have recently been obtained from observations of the commercial operation of short-wave transmitting stations, which furnish an important key to the propagation of radio waves of short-wavelength around the earth. In the month of October (1926) the Radio Corporation of America placed in operation the short-wave transmitting station 2XSA (now 2XT) with a wavelengths of 16.175 m. (18,550 kc), establishing communication with the German station Transradio A. G. für draht. Übersee-Verkehr (German Transatlantic Communication Co.). During the hours of communication the intervening space is in full daylight. It has been possible to employ signaling speeds up to and exceeding 80 words per minute. This communication, and also that previously established with Buenos Aires by means of the transmitter AGA (15 meters wavelength or approximately 20,000 kilocycles) at Nauen, has demonstrated the practical feasibility of daylight transatlantic communication with short waves. The American transmitter 2XT operates with about 12 kw. in the antenna.

In examining the autographic records of the signals received at Transradio Central, disturbing signals have often been discovered in spaces which one would normally expect to be blank. These may be interpreted as waves which have taken the other path around the earth. The signals of the American station have been photographed at the Transradio receiving station at Geltow by means of a Siemens oscillograph, and the records (see Fig. 1) clearly indicate the occurrence of a doubled-signal ("doppelzeichen") a short time later than the principal signal.

These doubled-signals from 2XT are occasionally so strong as to interfere effectively with the operating records. Evidence of this is to be found in Fig. 2 which is a reproduction of a section of the recorder tape. During this test the American station transmitted the test letters *a, b, c*, and in the upper part of the record it will be observed that an extra dot appears to be added to the *b* (— . . .) thus converting it into a *6* (— . . .); the lower record contains a distortion of the letter *c*. It is evident that we must shield our receivers from the subsidiary wave which encircles the earth in the other direction.

In order to make a more careful determination of the time which elapses between the incidence of the two signals, the American station was requested to transmit a special signal consisting of short dots at the rate of 5 per second. These signals were picked up by two short-wave receivers located at Geltow and each of the receivers was connected to a vibrator of the oscillograph. The first receiver was connected to a linear sloping antenna 20 m (65 ft) long and 15 m (49 ft.) high at one end; the second receiver was connected to a dipol (Hertz) antenna making an angle of 40° with the vertical and supported by a mast about 10 m. (32 ft.) high.

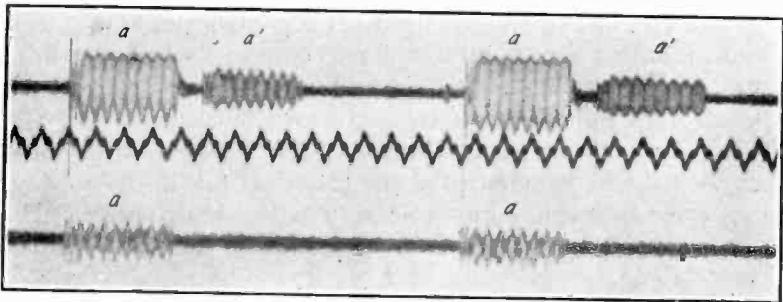

Figure 1—Doubled signals from the American short-wave station 2XT, $\lambda = 16.175\text{m}$. Photographed at Geltow, Oct. 11, 1926. 15³⁰ h. (Timing wave 50 pps). *a* = principal signal; *a'* = subsidiary signal.

The upper oscillographic trace in Fig. 1 shows the signal received by the first receiver, the lower trace that of the second; a 50-cycle timing wave appears in the middle. Unfortunately this timing current was not sufficiently constant. In more accurate measurements it will be necessary to use a steadier timing current of higher frequency in

order to determine more precisely the small time-interval involved. Measurements of the upper curve show that the subsidiary signal lags behind the principal signal by about 0.096 second, hence it appears to traverse a path about 28,382 km. (17,600 miles) longer than that followed by the principal signal.

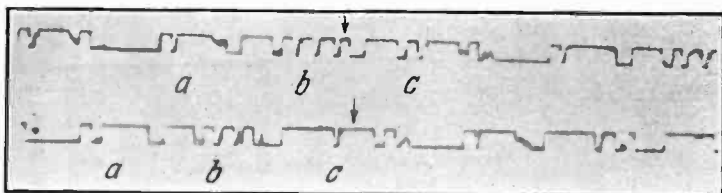

Figure 2—Automatically recorded signals distorted by doubling.

The oscillographic record of the second signal is also of interest in that it shows no trace of a subsidiary signal. This is probably because at the particular time of the photograph the dipole had an unfavorable position with respect to the polarization plane of the wave. It is likewise probable that the subsidiary wave had experienced fading; in earlier comparative observations of the kind, with less fading, no difference between the two antennas could be noticed.

A more accurate measurement with a steady timing wave of 1800 cycles was subsequently made (Fig. 3) which

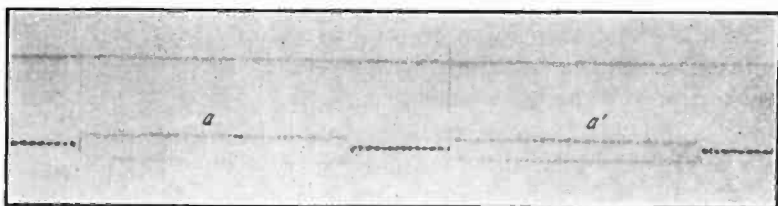

Figure 3—Doubled signals from 2XT. photographed at Geltow. Timing wave 1800 pps.

yielded 0.0857 sec. for the time interval, corresponding to a path difference of 28,705 km. (17,830 miles).

The foregoing results suggested a measurement of the signals originating at the station AGA (15 meters, 8 kw.) at Nauen. This investigation was equally successful. In Fig. 4 there is reproduced a section of the oscillograph record, in which will be noticed the incidence of the subsidiary

signal after a time lag of 0.135 sec. Assuming a wave-velocity of 299,800 km./sec. the corresponding path-length turns out to be 41,499 km. (25,750 miles), which of course exceeds the circumference of the earth. (A still more accurate determination gave the result 41,200 km.). If it be assumed that this path corresponds to the circumference of a circle parallel to the great circle of the earth it appears from computation that the short wave has been propagated

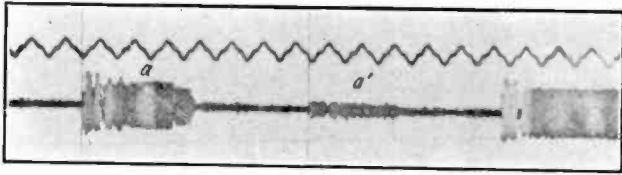

Figure 4—Photograph of subsidiary signal *a'* which had encircled the earth. Transmitter AGA (Nauen). $\lambda=15$ m., Oct. 20, 1926, 12⁰⁰ h.

along a super-atmospheric stratum 182 km. (113 miles) above the surface of the earth. No proof that the wave actually takes this path is submitted, nor an explanation of how many such circular paths are utilized by the wave in returning to the receiver.

It may be remarked that these doubled-signals have been observed only in the case of very short wavelengths, 15—22 m. At longer wavelengths they are not registered, probably because their amplitudes have fallen too low. By suitable increase of the receiver sensitivity it should again be possible to detect a doubling on longer wavelengths. The method applied here should prove of service in further investigations of the processes of wave-transmission. It would be of particular interest to investigate the influence of the time of day and year upon the subsidiary wave. The preceding account is merely of operating experience and makes no pretense of exact measurement. It has at least unearthed the problem and shall leave its further investigation and explanations to more scientific methods.

SUMMARY

The autographic records of the signals received from the American short-wave station 2XT, $\lambda=16.175$ m., often contain disturbing signals the time lag of which behind the principal signal is such that they appear to be due to waves

which have encircled the earth in the other direction. Such doubled-signals were oscillographically recorded and measured.

The signals from the station AGA (15 meters) at Nauen were also studied and a subsidiary wave which had traveled completely around the earth was likewise registered by the oscillograph. In this case the time interval was 0.138 sec., which with normal light-velocity gives a path of 41,200 km. This corresponds to a great circle girdling the earth at a height of 182 km.

GEOGRAPHICAL LOCATION OF MEMBERS

ELECTED MARCH 2, 1927

Transferred to Member Grade

California	San Francisco, 219 Natoma St.	Heintz, R. M.
Georgia	Atlanta, 524 Post Office Building	Van Nostrand, W. Jr.
New Jersey	Irrington, 219 Part Place	Rowe, C. M.
New York	New York, U. S. Coast Guard Barge Office	Fletcher, E. S.
Pennsylvania	St. David's	Stewart, Chas. H.

Elected to Member Grade

Georgia	Atlanta, Ga. School of Tech.	Shumard, Chas. C.
Louisiana	New Orleans, 109 Tchoupitoulas St.	Pendergrass, F. L.
New York	Rochester, 1060 University Ave.	McCanne, W. R.
	White Plains, 8 Church St.	Maloff, I. G.
Canada	Toronto, 90 Chestnut St.	Rogers, E. S.
Germany	Berlin-Sudende	Leithausen, G.
England	Bournemouth, Chintford	Everett, L. E. B.
	Stockport, Heaton Chapel	Hall, Albert.

Elected to Associate Grade

Arizona	Douglas, P. O. Box 1134	Schwamm, L. E.
Louisiana	Los Angeles, 3091 Pico St.	Burnell, J. H.
New York	Mountain View, State Highway	Winnegar, W. A.
	Pasadena, 53 N. Meredith St.	Nikirk, T. E.
	San Jose, P. O. Box 529	Cozens, B.
Colorado	Pueblo, 1418 Bragdon St.	Ewen, C. L.
Connecticut	New Haven, 66 Norton St.	Conrad, V. A.
	New Haven, 66 Norton St.	Cordeman, W. P.
	New Haven, 66 Norton St.	Fatten, S. F.
	West Hartford, 31 N. Main St.	Gade, W. H.
Florida	Key West, P. O. Box 201	Fernandez, M.
	Orlando, Western Union Teleg. Co.	Clark, M. D.
	St. Petersburg, P. O. Box 23	Rosseter, E. A.
	Winter Park, Box 344	Gree, C. M. Jr.
Illinois	Champaign	Hall, I.
	Chicago, 630 Roscoe St.	Adams, R. G.
	Chicago, 200 East Ontario St.	Brittin, F. L.
	Chicago, 3243 Congress St.	Callahan, J. J.
	Chicago, 4620 N. Leamington Ave.	Kahlitz, A. P.
	Chicago, 1677 Milwaukee Ave.	Michael, C.
	Chicago, 851 Addison St.	O'Brien, W. J.
	Tuscola	Moulden, R. B.
	Urbana, 606 W. Elm St.	Morris, L. P.
Iowa	Dubuque, 1696 West 3rd St.	Short, D. W.
	Shenandoah, 205 W. Lowell Ave.	Rydberg, A. E.
	Villisca, Box 381	Harris, M. C.
Kentucky	Hopkinsville, Station WFIW	Harness, S. A.
Louisiana	New Orleans, 2222 Lapeyrouse St.	Galle, L. J.
	New Orleans, 4918 Saratoga St.	Gardberg, J.
	New Orleans, 1800 Broadway	Maier, O. J.
	New Orleans, 620 Fern St.	Moore, F. C.
	New Orleans, 511 E. Alexander St.	O'Neil, M. B.
	New Orleans, 1017 Peniston St.	Stevens, W. J.
	New Orleans, 5665 Rosemary	Zimelman, F. A.
Maryland	Baltimore, 11 S. Gay St.	Ashbaugh, E. C.
Massachusetts	Boston, 186 Commonwealth Ave.	Cummings, L. G.
	Cambridge, 139 Mass. Ave.	Himoe, C. E.
	Newton Center, 25 Bothfeld Road	Miller, W. T.
	East Springfield, 20 Durgea St.	Hutcheson, J. A.
	Springfield c/o Westinghouse	Smith, H. Jr.
	Springfield, 20 Monrovia St.	Wells, D. W.
	Wollaston, 115 Clay St.	McGrath, J. L.
Michigan	Detroit, 2035 Calvert Ave.	McWood, W. L.
	Detroit, 1425 Park Place	Trowbridge, O. H.
Missouri	Kansas City, 4555 Main St.	Cook, Ellis C.
New Jersey	Atlantic City, 2707 Pacific Ave.	Flett, W. J.
	Bound Brook	Marks, D. R.
	Jersey City, 210 Jackson Ave.	Bremer, F. V.
	New Milford, Box 211	De Lime, T. L. Jr.
	Rutherford, 6 East Newell Ave.	Sargeant, C. E.
New York	Brooklyn, 214-6th Ave.	Gerel, A.

Geographical Location of Members Elected January 5, 1927

	Brooklyn, 144A McDougal	Gibbons, J. J.
	Brooklyn, 132 Willoughby Ave.	Moxon, A. W.
	Hurley, Ulster County	Warren, W. A.
	Jamaica, 150-26 116th Ave.	Schwartz, N.
	New York, 233 Broadway	Bonett, D. J.
	New York, 233 Broadway	Cohen, C. M.
	New York, 227 East 239th St.	Howell, C. A.
	New York, 61 Cortlandt St.	Kendall, J. A.
	New York, 372 West 29th St.	Longboat, H. M.
	New York, 233 Broadway	Morehouse, T. B.
	New York, 233 Broadway	Smith, S. B.
	New York, 233 Broadway	Tunick, H.
	Rochester, c-o Stromberg-Carlson Mfg. Co.	
	Woodside, 43-18 58th St.	Seoville, G. A.
Ohio	Bryan, 428 No. Cherry St.	Corcoran, L. F.
Oregon	Eugene, 1306 E. 18th St.	McEvoy, P. T.
Pennsylvania	Bellevue, 25 S. Sprague Ave.	Gardner, L. E.
	East Plymouth, 45 West First St.	Todd, W.
	Philadelphia, c-o Leeds & Northrup Co.	Budenkaye, A. C.
	Stonehurst, 7251 Guilford Road	Doyle, E. D.
Texas	Wilkinsburg, 269 Halsey Ave.	Borkow, A. L. Jr.
Washington	Houston, 1625 Oxford St.	Bock, A. P.
	Seattle, U. S. S. Seattle, c/o Postmaster	Knittle, M. B.
Canada	Ontario, Hespler	Mackay, W. S.
	Ontario, Toronto, Canadian Westinghouse	Weaver, W. E.
	Ontario, Toronto, 75 Fulton Ave.	Leslie, J. M.
	Ontario, Toronto, 5 Triller Ave.	Smith, V. G.
	Ontario, Windsor, 22 Pierre Ave.	Wilkinson, A. E.
England	British Columbia, Vancouver	Olding, N. R.
	Birmingham, 32 Dudley Park Road	Bartholomew, J.
	London, N22, 198 Boundary Road	Griffiths, H. V.
	Stockton-on-Tees, 81 Londonderry Rd.	Baekr, G. E.
India	Ballard Estate, Marconi Shahibag House	Wooler, R. G.
Straits Settlements	Singapore, College Quay	Reidy, M.
		McLennan J.

Elected to Junior Grade

California	Stanford University, Box 1408	Miles, K.
Connecticut	Hartford, 1711 Park St.	Jones, L. A.
Illinois	Chicago, 3050 East 80th St.	Jackowski, I. F.
	Chicago, 3117 West 42nd St.	Ostrowski, W. Jr.
Indiana	River Forest, 66 Franklin Ave.	Edwards, G. W.
	Crown Point, 702 Grant Ave.	Hall, F. F.
	Valparaiso, 601 East Jefferson St.	Gray, C. R.
	Valparaiso, 40 Calumet Ave.	Shoen, D. A.
Kentucky	Louisville, 1336 Castlewood Ave.	Du Rand, E. Jr.
Nebraska	Omaha, 3415 Lafayette Ave.	Fetterman, D. M.
New Jersey	Newark, 238 Bigelow St.	Collins, J.
	Nutley, 11 High St.	Hebert, A. A. Jr.
New York	New York, 520 West 124th St.	Aston, G. H.
	New York, 932 East 173rd St.	Held, S.
Pennsylvania	Norristown, 500 Buttonwood St.	Hausmann, E. O.
Washington	Centralia, 169 E. Street	Begg, E. S.
	Centralia, 704 West Cherry St.	Jenkins, L. A.
Canada	Montreal, 138 Selby St.	Moore, W. H.
	Toronto, 642 Spadina Ave.	Hill, J. H.

At Your Service!

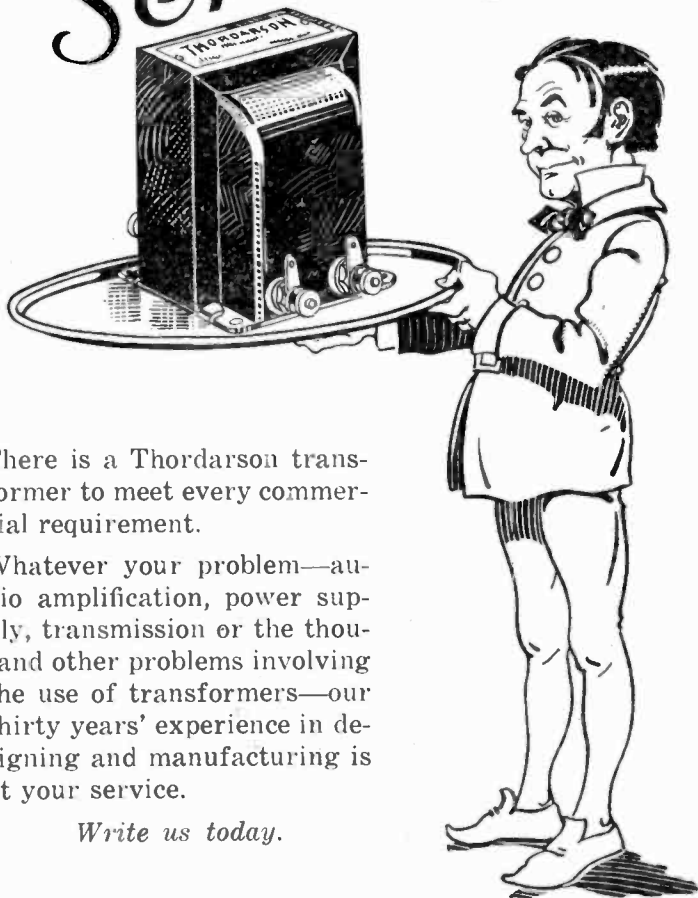

There is a Thordarson transformer to meet every commercial requirement.

Whatever your problem—audio amplification, power supply, transmission or the thousand other problems involving the use of transformers—our thirty years' experience in designing and manufacturing is at your service.

Write us today.

THORDARSON

RADIO TRANSFORMERS

Supreme in Musical Performance!

FOR EVERY PURPOSE

THORDARSON ELECTRIC MANUFACTURING CO.

Transformer specialists since 1895

WORLD'S OLDEST AND LARGEST EXCLUSIVE TRANSFORMER MAKERS

Chicago, U.S.A.

It will be of mutual benefit to mention Proceedings in writing to advertisers



Announcement

THE ENGINEERS of the Central Radio Laboratories have developed a new rheostat to withstand the heavy service of socket power "A" or "B" substitutes.

The new Centralab Power Rheostat is so constructed that the space occupied in assembly is no greater than the ordinary rheostat. Single hole mounting. Resistances up to 400 ohms to dissipate 50 watts. Extreme temperature will not effect efficiency.

[*Write for detailed information to
fit your particular need.*]

Central Radio Laboratories

16 KEEFE AVENUE

MILWAUKEE, WISCONSIN.



◆ AIDING INDUSTRY ◆

SCOVILL is the name of a broad service to industry. It places acres of factories, forests of machinery, hosts of skilled workmen, metallurgists, modern laboratories and trained representatives at the disposal of those who require parts or finished products of metal. To make possible quick consultation of your important problems, Scovill maintains trained service organizations at strategic points from coast to coast. Warehouses with stocks for immediate shipment are placed at important distribution centers. To get full details on how Scovill can serve you, call the nearest Scovill office.

A SCOVILL SERVICE

THESE ARE SCOVILL PRODUCTS

Made to Order: Condensers—Variable and Vernier and parts for same. Metal Stampings, Screw Machine Products, Switches, Decorated Metal Radio Panels, Parts from Brass, Steel and Aluminum.
Carried in Stock: Butts and Hinges, Continuous Hinges, Machine Screws. *Brass Mill Products:* Sheet, rod, wire, tubing.

SCOVILL MANUFACTURING COMPANY Waterbury Connecticut

New York, Boston, Chicago, Providence, Philadelphia, Cleveland,
San Francisco, Los Angeles, Atlanta, Cincinnati

Stocks of Brass Mill Products at Waterbury, Providence, Chicago,
San Francisco, and Los Angeles.

Stocks of Cap Screws, Buttons and Fasteners at Waterbury and
Chicago.

Member, Copper and Brass Research Association



It will be of mutual benefit to mention Proceedings in writing to advertisers



TRADE MARK REG'D U. S. PAT. OFFICE

Tobe High Voltage Power Pack Type Condenser

This is a high-voltage condenser for use with the 216-B Rectifying Tube, supplying 400 to 500 volts for the plate of the UX-210 power tube. Designed primarily for use with the Amertran Power Pack, it is equally applicable to all similar B-current supplies and power amplifiers.

Now made also in a block containing condensers with taps 2-4.4 Mfd. Price of this B-BLOCK Type 766—\$12.00.



CONDENSERS

—are made just as well as it is possible to make them. They are made and sold to stand up in service and do the work for which they are intended. Their ratings are conservative:—for instance, the new TINYTOBE Condenser in capacities of from .00007 to .02 will stand 1500 volts A. C. continuously, and will stand 2200 volts A. C. for one minute. Yet has been rated at only 500 volts D. C. operating voltage.

Write for Price List 0-3

Tobe Deutschmann Co.

*Engineers and Manufacturers of
Technical Apparatus*

CAMBRIDGE,

MASSACHUSETTS.

It will be of mutual benefit to mention Proceedings in writing to advertisers

PROFESSIONAL ENGINEERING DIRECTORY

For Consultants in Radio and Allied Engineering Fields

The J. G. White Engineering Corporation

Engineers—Constructors
Builders of New York Radio Central
Industrial, Steam Power and
Gas Plants, Steam and Elec-
tric Railroads, Transmission
Systems.

43 Exchange Place New York

Electrical Testing Laboratories

Electrical, Photometrical,
Chemical and Mechanical
Laboratories

RADIO DEPARTMENT
80th St., and East End Ave.,
New York, N. Y.

John Minton I. G. Maloff
JOHN MINTON, Ph. D.
CONSULTING ENGINEER
for
Developing — Designing —
Manufacturing
of

Radio Receivers, Amplifiers,
Transformers, Rectifiers, Sound
Recording and Reproducing ap-
paratus.

Radio and Electro-Acoustical
Laboratory

8 CHURCH ST. WHITE PLAINS, N. Y.

WILLIAM W. HARPER
Consulting Engineer
CHICAGO

Research and design problems
relative to improvements and
cost reductions — production
testing systems — develop-
ment special research equip-
ment — radio engineering
service

161 EAST ERIE STREET
Telephone Superior 7614

Radio Engineer

desires connection. Twelve years
commercial radio experience.
Specialized in Vacuum Tube De-
sign and Manufacture. Thorough
knowledge of Vacuum Tube En-
gineering and Production Prob-
lems.

Address Box 42
Institute of Radio Engineers.

Engineers

Your card on this page will
be seen by nearly 5000 read-
ers — technical men, execu-
tives and others with im-
portant radio interests. Rate:
Per year (12 issues) \$90.00.

Q R V RADIO SERVICE, Inc.

JOHN S. DUNHAM
J. F. B. MEACHAM

**DEVOTED TO SERVICING
BROADCAST RECEIVERS
EXCLUSIVELY**

1400 BROADWAY, NEW YORK
WISCONSIN 9780

J. E. JENKINS & S. E. ADAIR ENGINEERS

Broadcasting Equipment
General Radio Telephone
Engineering

1500 N. DEARBORN PARKWAY
CHICAGO, ILLINOIS

It will be of mutual benefit to mention Proceedings in writing to advertisers

Farrand

B

ELIMINATOR

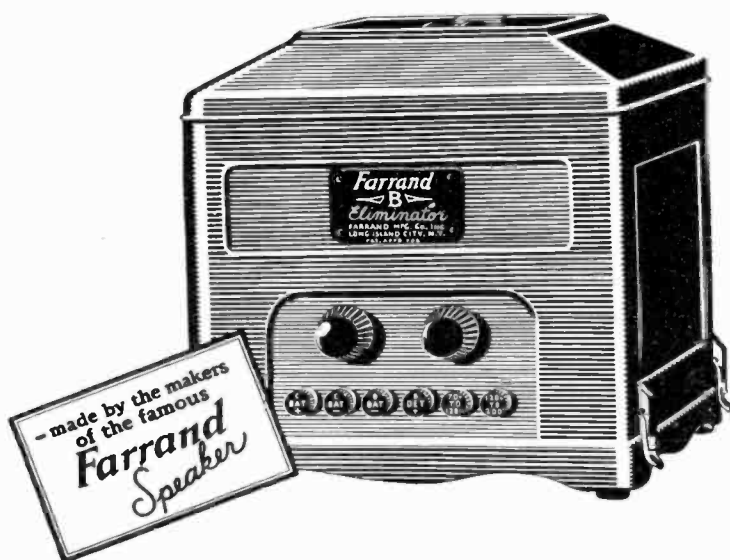

KNOWN QUALITY

It will be of mutual benefit to mention Proceedings In writing to advertisers

Always specify—
"ESCO" Maximum miles per watt
Power supplies for transmission.

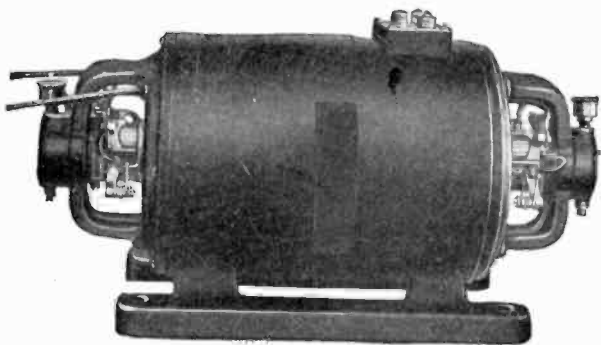

"ESCO" has developed a line of over 100 standard 2-bearing Motor-generators for plate or filament. These include D.C., A.C., single phase and polyphase motors.

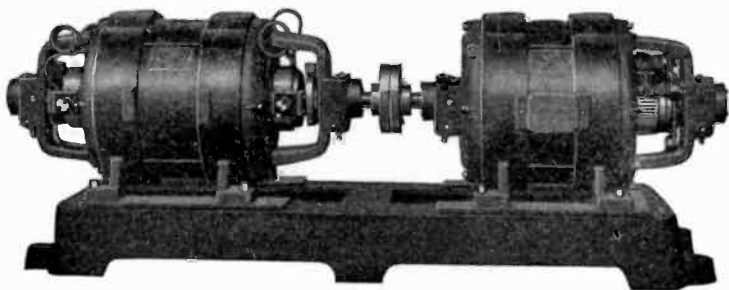

"ESCO" two and three unit sets have become the accepted standards for transmission. The "ESCO" line consists of over 200 combinations. These are covered by Bulletin 237C.

Our engineers are always willing to cooperate in the development of special sets.

"ESCO" is the pioneer in designing, developing and producing Generators, Motor-Generators, Dynamotors and Rotary Converters for all Radio purposes.



HOW CAN "ESCO" SERVE YOU?
ELECTRIC SPECIALTY COMPANY

TRADE "ESCO" MARK



300 South Street

Stamford, Conn.

It will be of mutual benefit to mention Proceedings in writing to advertisers

DUDLO

MAGNET WIRE AND WINDINGS

The Coil's the Thing That Makes Radio

Radio manufacturers using DUDLO Coils for Transformers, Chokes, Reactances and Impedances are obtaining an efficiency reflected in increasing sales and satisfaction.

Like the hairspring of a watch, these delicate coils control the power which does the work. They make or break a radio unit or receiving set. Let them be the best the world affords.

In the winding of Tuning Coils, successful radio manufacturers are using DUDLO silk covered or cotton covered and enameled magnet wire DUDLO Litzendraht wire and other small flexible cables are made to specifications.

The engineering and experimental departments are at your service without obligation. You are invited to send your specifications for samples and estimates.

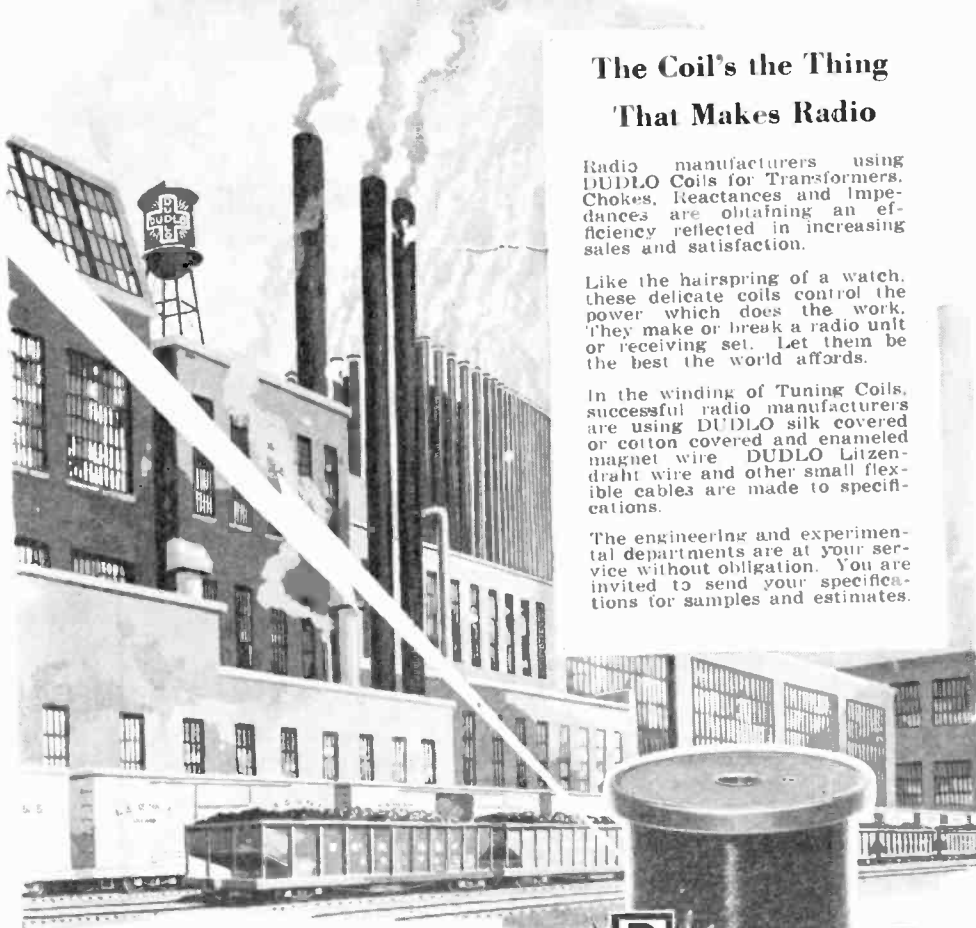

DUDLO MANUFACTURING CORPORATION

56 Earl street, Newark, N. J.
274 Brannan St., San Francisco, Calif.

FORT WAYNE, IND.

160 North La Salle St., Chicago, Ill.
4153 Bingham Ave., St. Louis, Mo.

It will be of mutual benefit to mention Proceedings in writing to advertisers

PIEZO ELECTRIC QUARTZ CRYSTALS

We are at your service to grind for you quartz crystals, ground to a guaranteed accuracy of BETTER than a tenth of one per cent of your specified frequency.

Crystals are so ground to produce their maximum vibrations, thereby making them suitable for use in power circuits, besides excellent for frequency standards.

Crystals ground to any frequency between 40 and 10,000 Kilo-cycles. We will be pleased to quote prices on your requirements.

*Attention! Owners of
Broadcasting Stations*

We will grind for you a crystal, ground accurate to BETTER than a tenth of one per cent of your assigned frequency for \$50.00. Why not have the most up-to-date means of keeping your station on its assigned frequency? Prompt deliveries.

Scientific Radio Service

BOX 86, DEPT. R.

MOUNT RAINIER, MARYLAND

FERRANTI



*These characteristics of Ferranti Audio
Frequency Transformers warrant
your serious attention*

High amplification ratio with flat curve.

High primary inductance maintained under normal operating conditions.

Low leakage reactance resulting in uniform amplification at high frequencies.

Primary winding of ample cross section to withstand continuously, plate currents resulting from all usual operating conditions.

No compound or fibrous material used in construction, therefore low self and mutual capacity with durability and long life.

For the best results use two Ferranti audio frequency transformers, type AF-3, ratio 3.5/1.

Core of specially tested material, of ample cross section. Laminations thoroughly insulated and assembled to produce an efficient magnetic circuit.

Primary shunted with built in condenser of correct capacity.

Every transformer subjected to ten tests to insure uniformity of product.

Tested to one thousand volts between primary and secondary, and between primary and secondary and ground; therefore specially suited for use with power tubes requiring high plate voltages.

Ferranti, Inc.

130 West 42nd Street, New York City

Ferranti, Ltd.
Hollinwood,
England

Ferranti Electric, Ltd.
26 Noble St., Toronto,
Canada



Designed and Built
by Engineers---not
Experimenters

MODERN

Transformers and "B" Eliminators

Set manufacturers who decide on the use of MODERN Audio Transformers and "B" Eliminators will enjoy the satisfaction of knowing that those units going out under their endorsement are the product of skilled engineers.

The fact that both MODERN designing and production are in the hands of engineers who are the principals of the company guarantees an unusual degree of uniformity and dependability.

MODERN Transformers are available in a variety of types that provide a wide price range, and characteristics suitable for the requirements of any set manufacturer. Each type offers the utmost in performance consistent with its price.

MODERN "B" Eliminators for set manufacturers are built to the same standards that gave MODERN "B" Compacts so enviable a reputation last season—with practically no returns or complaints.

Modern
Electric
Mfg. Co.

Toledo, Ohio



It will be of mutual benefit to mention Proceedings in writing to advertisers

XX

RADIO SUPREMACY

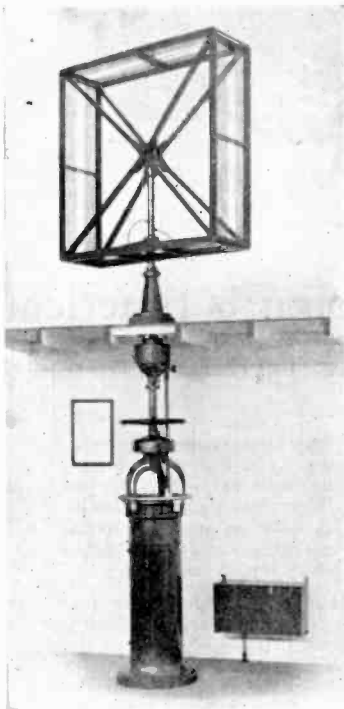

This Kolster Radio Compass is an investment in safety of life and property at sea.

16 Years
of remarkable
radio
developments
Responsible
for

—the development of the *continuous wave* arc converter for use on shipboard—

—the first successful commercial point - to - point radio telegraph system in the world—

—the Kolster Radio Compass, the use of which permits the *safe* navigation of vessels during foggy or thick weather.

And most recently---

KOLSTER RADIO for the Home

Engineers will be interested in the complete bulletins that are available upon request

FEDERAL TELEGRAPH COMPANY

SAN FRANCISCO

25 BEAVER STREET, NEW YORK CITY

Japan-China Representatives:

Sperry Gyroscope Co., Mitsui Building, Tokio

It will be of mutual benefit to mention Proceedings in writing to advertisers

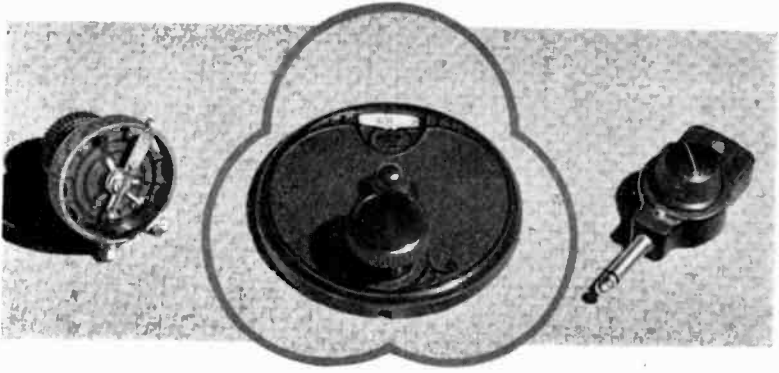

Marco rheostat, Centralab modu-plug, Eby dial, all of Bakelite Molded and made by the Martin-Copeland Co., Providence, R. I.

Refinement of design is practical with Bakelite Molded

THERE is a very definite trend toward refinement in design and beauty of finish in the making of radio parts. The fact that Bakelite Molded lends itself to the accurate reproduction of every kind of intricate design accounts, in part, for its wide use by the radio industry.

The parts pictured above are excellent examples of the possibilities of Bakelite Molded. The Bakelite insulation piece of the Marco air-cooled rheostat is molded with a "linen-finish" for the flat surface and

a high lustre on the raised surfaces. The Centralab Modu-Plug has a uniformly lustrous surface throughout. The Eby dial, with its attractive ornamentation, is molded of Bakelite in a single operation.

Radio engineers and manufacturers will find that Bakelite molded is well suited to the making of parts that require the utmost refinement of detail. In carrying out their ideas, they may also find the cooperation of Bakelite engineers and research laboratories of value.

Write for Booklet 33

BAKELITE CORPORATION

217 Park Ave., New York, N. Y.
BAKELITE CORP. OF CANADA, LTD.

Chicago Office: 636 W. 22nd St.
163 Dufferin St., Toronto, Ont.

BAKELITE

REGISTERED U. S. PAT. OFF.



THE MATERIAL OF A THOUSAND USES

The registered Trade Mark and Symbol shown above may be used only on products made from material manufactured by Bakelite Corporation. Under the capital "B" in the symbol sign, the industry, or subsidiary company. It conveys the definite number of patents and trade uses of Bakelite Corporation's product.

It will be of mutual benefit to mention Proceedings in writing to advertisers

XXII

CARTER PRODUCTS

*Favorably Known and Sold
Everywhere*

**Specified in the
popular circuits**

Complete line of:—

JACKS

RECEPTICAL OUTLETS

PLUGS

RESISTORS

POTENTIOMETERS

ADAPTERS

JACK SWITCHES

SWITCHES

DIAL LIGHTS

PELOB LIGHTS

**Rheostats plain or combined with
Filament Switch**

**Volume Controls plain or combined
with Filament Switch**

To experimenters and engineers Carter products have an unusual appeal. Each part is developed from original research, it is original in design, new in conception and built to meet a specific requirement.

In Canada: Carter Radio Co., Limited, Toronto

CARTER RADIO CO.

Chicago, Ill.

Offices in principal cities of the world.

MEMBER
RMA

It will be of mutual benefit to mention Proceedings in writing to advertisers

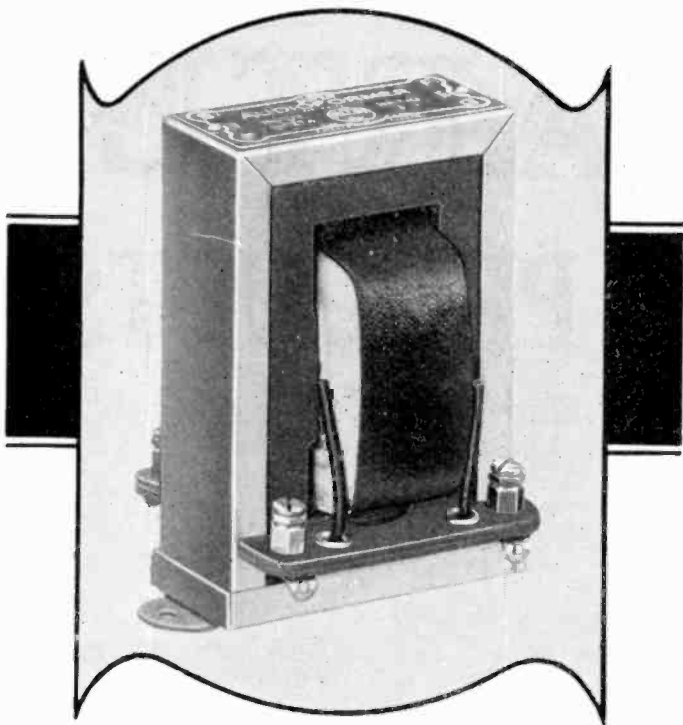

*Built for present day
amplifying requirements*



A trade mark symbol
of quality.

THE PACENT Superaudioformer has been designed by transformer engineers who have specialized in audio frequency amplification.

It has been designed and built for present-day audio amplifying requirements—a high uniform energy amplification covering the entire musical range without distortion and especially adapted for use in modern power amplifying circuits where high plate potentials are necessary.

Put your audio amplification problems up to our engineering staff—there is no obligation involved.

PACENT ELECTRIC CO., Inc.

91 Seventh Ave.

NEW YORK CITY

Pacent

**AUDIO
TRANSFORMERS**

It will be of mutual benefit to mention Proceedings in writing to advertisers

XXIV

Alphabetical Index to Advertisements

A	
American Transformer Company	IV
B	
Bakelite Corporation	XXII
Burgess Battery Company	VII
C	
Carter Radio	XXIII
Central Radio Laboratories	XI
Cresradio Corp.	XXVI
Cunningham, E. T., Inc.	Inside Front Cover
D	
Deutschmann Co. Tobe	XIII
Dubilier Condenser and Radio Corp.	Back Cover
Dudlo Manufacturing Corporation	XVII
E	
Electric Specialty Company	XVI
Electrical Testing Laboratories	XIV
F	
Farrand Manufacturing Company	XV
Ferranti	XIX
Federal Telegraph Company	XXI
Formica	X
G	
General Radio Company	III
Grebe, A. H. & Company	V
H	
Harper, W. W.	XIV
J	
Jewell Electrical	VI
J. E. Jenkins & S. E. Adair, Engineers	XIV
M	
Minton, John	XIV
Modern Electric	XX
N	
National Carbon Co.	Inside Back Cover
P	
Pacent Electric Company	XXIV
Q	
Q. R. V. Radio Service	XIV
R	
Radio Corporation of America	VIII
Roller-Smith Company	II
S	
Scientific Radio Service	XVIII
Scovill Manufacturing Company	XII
T	
Thordarson	IX
W	
Wireless Specialty Apparatus Company	I
White, J. G., Engineering Corporation	XIV

When writing the advertisers please mention The Proceedings of The Institute of Radio Engineers.

It will be of mutual benefit to mention Proceedings in writing to advertisers



Your
**Condenser
Problems**

DUBILIER condensers are used in practically every radio installation of the United States Army and Navy. They are the condensers that have been tried by time and found thoroughly dependable.

Dubilier manufactures every type of condenser from the largest used in superpower transmitting stations to the smallest used in portable receiving sets.

As new condenser problems arise, the Dubilier research laboratories will find new and efficient ways to meet them.

Dubilier
CONDENSER AND RADIO CORPORATION

