

VOLUME 2

MARCH, 1914

NUMBER 1

PROCEEDINGS  
*of*  
THE INSTITUTE OF RADIO  
ENGINEERS

(INCORPORATED)

OFFICERS, COMMITTEES AND SUPPLEMENTARY  
LISTS OF MEMBERS AND ASSOCIATES  
OF THE INSTITUTE

THE AUDION—DETECTOR AND AMPLIFIER

DR. LEE DE FOREST

RADIO RANGE VARIATION

ROBERT H. MARRIOTT

THE INFLUENCE OF ALTERNATING CURRENTS ON  
CERTAIN MELTED METALLIC SALTS

C. TISSOT

THE GOLDSCHMIDT SYSTEM OF  
RADIO TELEGRAPHY

EMIL E. MAYER



EDITED BY

ALFRED N. GOLDSMITH, Ph.D.

PUBLISHED QUARTERLY BY  
THE INSTITUTE OF RADIO ENGINEERS  
SEVENTY-ONE BROADWAY  
NEW YORK



## GENERAL INFORMATION

---

The right to reprint limited portions or abstracts of the articles, discussions, or editorial notes in the Proceedings is granted on the express condition that specific reference shall be made to the source of such material. Diagrams and photographs in the Proceedings may not be reproduced without securing permission to do so from the Institute thru the Editor.

Manuscripts and letters bearing on the Proceedings should be sent to Alfred N. Goldsmith, Editor of Publications, The College of the City of New York, New York.

Requests for additional copies of the Proceedings and communications dealing with Institute matters in general should be addressed to the Secretary, Emil J. Simon, 71 Broadway, New York City.

The Proceedings of the Institute are published quarterly and contain the papers and the discussions thereon as presented at the meetings in New York and other cities.

Payment of the annual dues by a member entitles him to one copy of each number of the Proceedings issued during the period of his membership. Members may purchase, when available, copies of the Proceedings issued prior to their election at 75 cents each.

Subscriptions to the Proceedings are received from non-members at the rate of \$1.00 per copy or \$4.00 per year. To foreign countries the rates are \$1.25 per copy or \$5.00 per year, 25 per cent discount being allowed to libraries and booksellers.

Members presenting papers before the Institute are entitled to ten copies of the paper and of the discussion.

It is understood that the statements and opinions given in the Proceedings are the views of the individual members to whom they are credited, and are not binding on the membership of the Institute as a whole.

---

COPYRIGHT, 1914, BY  
THE INSTITUTE OF RADIO ENGINEERS, INC.  
SEVENTY-ONE BROADWAY  
NEW YORK, N. Y.

---

Beginning with the next issue of the Proceedings, a list of "positions available and positions wanted" will be published, without the names of the applicants or companies appearing, unless requested. Radio companies and individuals interested may gratuitously avail themselves of this service by communicating with the Secretary. All such communications will be considered strictly confidential.

---

## CONTENTS

	PAGE
OFFICERS, BOARD OF DIRECTION AND PAST PRESIDENTS . . . . .	5
STANDING AND SPECIAL COMMITTEES . . . . .	6
SUPPLEMENTARY LIST OF MEMBERS . . . . .	8
SUPPLEMENTARY LIST OF ASSOCIATES . . . . .	9
SUMMARY OF MEMBERSHIP . . . . .	14
DR. LEE DE FOREST, "THE AUDION—DETECTOR AND AMPLIFIER" . . . . .	15
Discussion on the above paper . . . . .	30
ROBERT H. MARRIOTT, "RADIO RANGE VARIATION" . . . . .	37
Discussion on the above paper . . . . .	53
C. TISSOT, "THE INFLUENCE OF ALTERNATING CURRENTS ON CERTAIN MELTED METALLIC SALTS" . . . . .	59
Discussion on the above paper . . . . .	63
REFERENCE TO A FURTHER DISCUSSION BY LOUIS COHEN ON FREDERICK A. KOLSTER'S PAPER, "THE EFFECTS OF DISTRIBUTED CAPACITY OF COILS USED IN RADIO TELEGRAPHIC CIRCUITS" . . . . .	68
EMIL E. MAYER, "THE GOLDSCHMIDT SYSTEM OF RADIO TELEGRAPHY" . . . . .	69
Discussion on the above paper . . . . .	93

**OFFICERS AND BOARD OF DIRECTION, 1914**

(Term expires January 8, 1915)

---

**PRESIDENT**

LOUIS W. AUSTIN

**VICE-PRESIDENT**

JOHN STONE STONE

**TREASURER**

JOHN HAYS HAMMOND, JR.

**SECRETARY**

EMIL J. SIMON

**MANAGERS**

JOHN L. HOGAN, JR.  
GUY HILL

ROBERT H. MARRIOTT  
ROY A. WEAGANT

**EDITOR OF PUBLICATIONS**

ALFRED N. GOLDSMITH

---

**ASSOCIATE EDITORS**

JOHN STONE STONE

GEORGE H. CLARK

**ADVERTISING MANAGER**

ARTHUR A. HEBERT

**ASSISTANT TREASURER**

THOS. T. TRAPNELL

**ASSISTANT SECRETARY**

RALPH H. LANGLEY

**SECRETARY-TREASURER,  
WASHINGTON SECTION**

CHARLES J. PANNILL

**GENERAL COUNSEL**

HAROLD R. ZEAMANS

---

**PAST-PRESIDENTS**

**SOCIETY OF WIRELESS TELEGRAPH ENGINEERS**

JOHN STONE STONE, 1907-8

LEE DE FOREST, 1909-10

FRITZ LOWENSTEIN, 1911-12

**THE WIRELESS INSTITUTE**

ROBERT H. MARRIOTT, 1909-10-11-12

**INSTITUTE OF RADIO ENGINEERS**

ROBERT H. MARRIOTT, 1912

GREENLEAF W. PICKARD, 1913

## STANDING COMMITTEES

1914

---

### COMMITTEE ON PAPERS

ALFRED N. GOLDSMITH, <i>Chairman</i>	College of the City of New York, New York
ARTHUR E. KENNELLY	Cambridge, Mass.
JOHN STONE STONE	New York
LOUIS W. AUSTIN, <i>Ex-officio</i>	Washington, D. C.

### COMMITTEE ON STANDARDIZATION

JOHN STONE STONE, <i>Chairman</i>	National Arts Club	New York
GUY HILL, <i>Secretary</i>	Navy Yard	New York
ARTHUR E. KENNELLY		Cambridge, Mass.
ERNEST R. CRAM		Washington, D. C.
GREENLEAF W. PICKARD		Boston, Mass.
FREDERICK A. KOLSTER		Washington, D. C.
GEORGE W. PIERCE		Cambridge, Mass.
EMIL E. MAYER		Tuckerton, N. J.
LOUIS W. AUSTIN, <i>Ex-officio</i>		Washington, D. C.

### COMMITTEE ON PUBLICITY

ROBERT H. MARRIOTT, <i>Chairman</i>	Custom House	New York
JOHN L. HOGAN, JR.		New York
ROY A. WEAGANT		New York
V. FORD GREAVES		Washington, D. C.
LOUIS W. AUSTIN, <i>Ex-officio</i>		Washington, D. C.

---

## SPECIAL COMMITTEES

### COMMITTEE ON INCREASE OF MEMBERSHIP

JOHN HAYS HAMMOND, JR., <i>Chairman</i>	Gloucester, Mass.
THOMAS E. CLARK	Detroit, Mich.
GEORGE S. DAVIS	New Orleans, La.
CHARLES P. EDWARDS	Ottawa, Canada
CYRIL F. ELWELL	London, England
V. FORD GREAVES	Washington, D. C.
OSCAR C. ROOS	Manila, P. I.
ROY E. THOMPSON	Seattle, Wash.
FRANCIS J. BEHR, Capt. U. S. A.	Gloucester, Mass.
STANFORD C. HOOPER, LIEUT. U. S. N.	Flagship "Wyoming"
LOUIS W. AUSTIN, <i>Ex-officio</i>	Washington, D. C.

#### COMMITTEE ON FINANCE

JOHN HAYS HAMMOND, JR., <i>Chairman</i>	Gloucester, Mass.
JOHN STONE STONE	New York
ROBERT H. MARRIOTT	New York
ALFRED N. GOLDSMITH	New York
HAROLD R. ZEAMANS	New York

#### COMMITTEE ON SPECIFICATIONS FOR STEAMSHIP RADIO EQUIPMENT

ROBERT H. MARRIOTT, <i>Chairman</i> , Custom House	New York
GEORGE S. DAVIS	New Orleans, La.
LEE DE FOREST	New York
LEONARD F. FULLER	San Francisco, Cal.
GUY HILL	New York
JOHN L. HOGAN, JR.	New York
FRITZ LOWENSTEIN	New York
EMIL E. MAYER	Tuckerton, N. J.
RICHARD PFUND	New York
GREENLEAF W. PICKARD	Boston, Mass.
EMIL J. SIMON	New York
FRED. G. SIMPSON	Seattle, Wash.
ROY A. WEAGANT	New York
LOUIS W. AUSTIN, <i>Ex-officio</i>	Washington, D. C.

#### COMMITTEE FOR ORGANIZATION OF BOSTON SECTION

ARTHUR E. KENNELLY, <i>Chairman</i>	Cambridge, Mass.
MELVILLE EASTHAM, <i>Secretary</i>	Cambridge, Mass.
SEWELL CABOT	Brookline, Mass.
GREENLEAF W. PICKARD	Boston, Mass.
GEORGE W. PIERCE	Cambridge, Mass.
LOUIS W. AUSTIN, <i>Ex-officio</i>	Washington, D. C.

#### EDITING COMMITTEE

(To act during any absence of the Editor)

JOHN L. HOGAN, JR., <i>Chairman</i>	New York
LLOYD ESPENSCHIED	New York
ARTHUR A. HEBERT	New York
LOUIS W. AUSTIN, <i>Ex-officio</i>	Washington, D. C.

## SUPPLEMENTARY LIST OF MEMBERS

ARRANGED ALPHABETICALLY.

*(Transferred from Associate grade of membership since March 1st, and not appearing in the Year Book.)*

ANDREWS, EDMUND R., Lieut., U.S.A., 17th U. S. Infantry, Eagle Pass, Tex.	A	Apr. 8, 1914
	M	May 22, 1914
BRADFIELD, WILLIAM W., Manager, Marconi's Wireless Telegraph Co., London, Eng.; res., 40 Albert Hall Mansion, Kensington, London, Eng.	A	May 6, 1914
	M	May 22, 1914
CABOT, SEWELL, Electrical Engineer, Electric Conversion Co.; res., 232 High St., Brookline, Mass.	A	Charter Member, S.W.T.E.
	M	May 22, 1914
CULVER, CLARENCE C., 1st Lieut., U. S. A., 3rd Cavalry, War Department, Washington, D. C.	A	Apr. 8, 1914
	M	Apr. 8, 1914
DAY, MAXWELL W., Engineer, Marine Dept., General Electric Co., Schenectady, N. Y.; res., 26 Rugby Road, Schenectady, N. Y.	A	May 6, 1914
	M	May 22, 1914
EDWARDS, JOHN RICHARD, Rear-Admiral, U.S.N., Navy Department, Washington, D. C.	A	Apr. 1, 1914
	M	Apr. 1, 1914
EWEN, HARRY A., Engineer (Chief of Design Dept.), Marconi's Wireless Telegraph Co., "Braemar," Shenfield, Essex, Eng.	A	May 22, 1914
	M	May 22, 1914
FULLER, LEONARD FRANKLIN, Chief Electrical Engineer, Federal Telegraph Co., San Francisco, Cal.; res., 411 Kipling St., Palo Alto, Cal.	A	May 6, 1914
	M	May 22, 1914
HALLBORG, HENRY E., Engineer in Charge, Marconi Trans-Atlantic Stations, New Brunswick and Belmar, N. J.; res., 220 Lincoln Ave., New Brunswick, N. J.	A	June 3, 1912
	M	May 22, 1914
HAMMOND, JOHN HAYS, JR., [Treasurer], Investigator, Hammond Radio Research Laboratory, Gloucester, Mass.	A	June 3, 1912
	M	Mar. 24, 1914
JANKE, ALFRED H., Technical Associate, Knight Bros., New York; res., 203 W. 9th St., Plainfield, N. J.	A	Apr. 1, 1914
	M	May 22, 1914
McNICOL, DONALD, Assistant Electrical Engineer, Postal Telegraph Co., New York; res., 53 Vermilyea Ave., New York.	A	Apr. 1, 1914
	M	May 22, 1914
STEPHENSON, LEONARD W., Engineer, Radio Service, Dominion Government, Victoria, B. C.	A	Apr. 8, 1914
	M	Apr. 8, 1914
WEBSTER, ARTHUR GORDON, Professor of Physics, Clark University, Worcester, Mass.	A	May 22, 1914
	M	May 22, 1914
WILDMAN, LEONARD D., Major, Signal Corps, U.S.A., Director, Army Signal School, Fort Leavenworth, Kan.	A	Apr. 8, 1914
	M	May 22, 1914

### OMITTED FROM YEAR BOOK.

TAYLOR, CHARLES HENRY, Assistant Chief Engineer, Marconi's Wireless Telegraph Co., 233 Broadway, New York.	A	Nov. 5, 1913
	M	Nov. 5, 1913

## SUPPLEMENTARY LIST OF ASSOCIATES

ARRANGED ALPHABETICALLY.

*(Elected since March 1st, and not appearing in the Year Book.)*

BARRETT, HOWARD A., Instructor, Barrett's School of Telegraphy; res., 343 East 152nd St., New York.	Apr. 15, 1914
BEAKES, WILLIAM E., Chief Engineer, Tropical Radio Telegraph Co., 321 St. Charles St., New Orleans, La.	May 6, 1914
BICAK, EDWARD THOMAS, Radio Telegrapher, Marconi Wireless Telegraph Co., New York; res., 357 E. 72nd St., New York.	Apr. 22, 1914
BROWN, EDWARD H., Student, Shaw High School; res., 2208 Harcourt Drive, Ambler Heights, Cleveland, Ohio.	Apr. 22, 1914
BROWN, ROLLA, Clerk, Dept. Carriers' Accounts, U. S. Interstate Commerce Commission, Washington, D. C.; res., 509 Rhode Island Ave., N.E., Washington, D. C.	Apr. 1, 1914
CARR, STEPHEN C., Student, College City of New York, New York; res., 18 West 96th St., New York.	Apr. 22, 1914
CAROLIN, ROBERT, Electrical Assistant, U. S. Signal Corps, New York; res., 100 East 34th St., New York.	Apr. 1, 1914
CHAMBERLAIN, E. T., Commissioner of Navigation, Department of Commerce, Washington, D. C.	Apr. 15, 1914
CLAYTON, ROYAL S., Radio Operator, National Electric Signaling Co., New York.	Apr. 8, 1914
COCKADAY, Lawrence M., General Secretary, Cathedral Choir School; res., 227 Audubon Ave., New York.	Apr. 15, 1914
COHEN, WALTER A., Draughtsman, Keller Mechanical Engineering Co., New York; res., 2071 Fifth Ave., New York.	Apr. 22, 1914
CONLEY, CHARLES B., Telephone Operator, Pennsylvania R. R.; res., 709 N. 39th St., Philadelphia, Pa.	Apr. 15, 1914
CONNER, GEORGE W., Engineer, 18 Sheldon St., Roslindale, Mass.	Apr. 22, 1914
COOPER, CHARLES B., Chief Operator, Northern Division, Marconi Wireless Telegraph Co., Seattle, Wash.; res., 738 19th Ave., N. Seattle, Wash.	May 22, 1914
COWPER, NORMAN CLAIR, Electrician, Lynbrook, L. I., N. Y.	May 22, 1914
CREASER, ISAAH, Electrician, Narragansett Electric Light Co., Providence, R. I.; res., 8 Alfred St., Providence, R. I.	May 6, 1914
CRESSY, LOUIS A., Electrician, 104 Huntington St., Hartford, Conn.	May 22, 1914
DALY, THOMAS J. M., Gulf Compress Company, Memphis, Tenn.	May 6, 1914
DANE, FRANCIS W., Radio Operator, Tropical Radio Telegraph Co.; res., Main St., Hamilton, Mass.	Apr. 15, 1914
DROSTE, GEORGE I., Draughtsman, Thompson-Starrett Co.; res., 1309 Pugsley Ave., Bronx, New York.	Apr. 22, 1914
DUDLEY, DEWITT CLINTON, Constructing Engineer, Radio Apparatus Co., Philadelphia, Pa.; res., 3916 Market St., Philadelphia, Pa.	Apr. 15, 1914



DUVALL, EDWARD B., Radio Experimenter, 809 Park Ave., Baltimore, Md.	Apr. 1, 1914
EAVES, AUGUSTUS J., Telegraph Engineer, Postal Telegraph Cable Co.; res., 506 W. 113th St., New York.	Apr. 1, 1914
EMMERSON, FRANK, Student, Portsmouth High School; res., 419 High St., Portsmouth, Va.	May 22, 1914
ESTEY, F. CLIFFORD, Electrician, National Calfskin Co.; res., 22 Oakland St., Salem, Mass.	Apr. 15, 1914
EVANS, LOUIS M., Electrical Engineer, Signal Corps, U.S.A., Washington, D. C.; res., 408 N. Alfred St., Alexandria, Va.	Apr. 1, 1914
FERRIS, MALCOLM, Student, Electrical Engineering, Haverford College; res., 3409 Baring St., Philadelphia, Pa.	May 22, 1914
FISCHER, GEORGE H., JR., Radio Operator, Marconi Wireless Telegraph Co.; res., 5423 Baltimore Ave., Philadelphia, Pa.	Apr. 15, 1914
FITE, THOMAS A., Manager, Berkeley Radio Laboratories, Berkeley, Cal.	Apr. 22, 1914
FITLER, EUGENE B., JR., Clerk, Electrical Products Co.; res., 40 West 129th St., New York.	May 22, 1914
FLEISS, ROBERT ANTON, Master Signal Electrician, Company A, 1st Aero Squadron; res., 99 Claremont Ave., New York.	Apr. 1, 1914
FOLEY, LEWIS B., Superintendent, Telegraph, Telephone & Wireless Department, D. L. & W. R. R. Co., New York; res., Denville, N. J.	Apr. 1, 1914
FOWLER, HARRY A., Editor, 17, Board of Trade, Kansas City, Mo.	Apr. 22, 1914
FREEMAN, WALTER CLARKSON, Engineer, Stromberg Carlson Telephone Mfg. Co.; res., 49 Darwin St., Rochester, N. Y.	Apr. 1, 1914
GEARE, GEORGE A., Mechanic, General Electric Co.; res., 23½ Cottage St., Jersey City, N. J.	Apr. 1, 1914
GIFFIN, SIDNEY H., Student, Baltimore Polytechnic Institute; res., 2614 North Calvert St., Baltimore, Md.	Apr. 15, 1914
GODLEY, PAUL F., Radio Inspector, Brazilian Government, res., Leonia, N. J.	May 6, 1914
GOGEL, ADELBERT J., Designer, Gogel Manufacturing Co.; res., 628 S. Erie St., Toledo, Ohio.	May 22, 1914
HALL, THOMAS C., Engineer, Pacific Wireless Equipment Co.; res., 1278 Market St., San Francisco, Cal.	Apr. 22, 1914
HALLER, GEORGE F., Vice-President, Haller-Cunningham Electric Co., San Francisco, Cal.; res., San Mateo, Cal.	Apr. 22, 1914
HANCE, SPENCER W., Superintendent, Radio Service, Vaccaro Bros. & Co., New Orleans, La.	Apr. 1, 1914
HART, M. EMANUEL, General Manager, Gulf Radio Co., 407-21 Baronne St., New Orleans, La.	May 6, 1914
HENDERSON, JOHN C., Operator of Wireless Telegraphy Station, Shortridge High School, Indianapolis, Ind.; res., 1659 Central Ave., Indianapolis, Ind.	May 6, 1914
HITT, PARKER, Capt., Signal Corps, U.S.A., Instructor, Army Signal School, Fort Leavenworth, Kansas; care Chief Signal Officer, Washington, D. C.	Apr. 8, 1914

HOGGER, CHARLES, Inspector, Russian-American Line, res., 471 41st St., Brooklyn, N. Y.	Apr. 1, 1914
HOPPOCK, ALLEN H., Student, New York University; res., 215 Clark St., Westfield, N. J.	Apr. 22, 1914
INWRIGHT, JOHN A., Student, New York University; res., 400 H. Fairmount Ave., Jersey City, N. J.	Apr. 15, 1914
JOHNSON, THEOPHILUS, JR., Draftsman, City of New York; res., 17 Third St., Woodside, L. I., N. Y.	May 6, 1914
KELLEY, GEORGE W., JR., Operator, Marconi Wireless Telegraph Co.; res., 1738 N. 16th St., Philadelphia, Pa.	Apr. 15, 1914
KELLEY, WILLARD S., Master Signal Electrician, Signal Corps, U.S.A., Washington, D. C.	Apr. 8, 1914
KINGSBURY, KENNETH, 24 Chestnut St., Binghamton, N. Y.	Apr. 15, 1914
KNOTTS, HARRY J., Experimenter, and Publisher of "The State Center-Record," Illiopolis, Ill.	May 6, 1914
LACHAPELLE, JACQUES DE, Student, The College of the City of New York; res., Highwood, N. J.	Apr. 15, 1914
LAMB, EDWIN S., Instructor, Kenosha Wireless School; res., 119 Milwaukee Ave., Kenosha, Wis.	Apr. 22, 1914
LANE, DAVID M., Electrical Engineering Student, Cooper Union; res., 343 Ninth St., Jersey City, N. J.	May 6, 1914
LEISTER, FAYETTE, Student, Drexel University, West Philadelphia, Pa.; res., 68th and Jefferson Sts., West Philadelphia, Pa.	Apr. 15, 1914
LITTLEFIELD, CHAS. I., 2662 East 24th St., Sheepshead Bay, N. Y.	Apr. 15, 1914
MACLELLAN, LESLIE W., Radio Operator, National Electric Signaling Co., Brooklyn, N. Y.; res., 11 Myron Ave., New Haven, Conn.	May 6, 1914
MANUEL, FLOYD, Post Office Clerk, U. S. Post Office Dept.; res., 106 Second St., Newport, R. I.	Apr. 22, 1914
MARTIN, DeLoss K., Student, Polytechnic College; res., 1459 Harrison St., Oakland, Cal.	May 22, 1914
McKNIGHT, W. ROSS, Advertising Man, International Correspondence School; res., 243 Jefferson Ave., Scranton, Pa.	May 6, 1914
NENNSBERG, ALEXIS A., Chief of the Radio Station, "Kerbinskaja," Russian Government; res., Kerby, Nikolajevsk Primorsky, Russia.	Apr. 1, 1914
OGG, GLEN ROY, Chief Radio Electrician, U.S.S. "Nebraska"; care Postmaster, New York.	May 22, 1914
OXNER, EDWIN K., Radio Operator, Marconi Company, Boston, Mass.; res., 5 Oakman St., Dorchester, Mass.	Apr. 8, 1914
PARKER, JAMES F., Cable Clerk, New York Railways Co.; res., 113 East 75th St., New York.	Apr. 1, 1914
PELHAM, FRED B., Motion Picture Operator, Hiawatha Theatre, Washington, D. C.; res., 603 Howard Place, N.W., Washington, D. C.	Apr. 22, 1914
PICKERILL, ELMO NEALE, Instructor, Marconi Wireless Telegraph Co. of America, New York; res., 248 West 46th St., New York.	Apr. 1, 1914

POWELL, EDWIN L., Topographic Draftsman, U. S. Geological Survey, Washington, D. C.; res., 1206 E. Capitol St., Washington, D. C.	Apr. 22, 1914
PRASTKA, ANTHONY, Gunner (Radio Duty), U.S.N., U.S.S. "New York"; care Postmaster, New York.	Apr. 1, 1914
PRATT, HARADEN, Student, University of California; res., 1510 Lombard St., San Francisco, Cal.	Apr. 1, 1914
REDE, G. ROSS, Radio Experimenter, 210 W. Madison St., Baltimore, Md.	Apr. 22, 1914
REINHARD, CYRIL DEWITTE, in Charge of United Fruit Co.'s Radio Station, Santa Marta, Republic de Colombia, South America.	May 22, 1914
RICE, REGINALD K., Construction Engineer, Marconi's Wireless Telegraph Co., Ltd., Strand, London, W.C., England; res., The Nutshell, Cheam Road, Sutton Surrey, England.	May 22, 1914
RINGGOLD, PAUL C., Stenographer, Marconi Wireless Telegraph Co.; res., 606 St. Ann Ave., Baltimore, Md.	Apr. 1, 1914
SADENWATER, HARRY, Instructor, East Side Y. M. C. A., New York; res., 740 Herman Place, New York.	Apr. 15, 1914
ST. JAMES, ROBERT T., Electrician, Mahaiwe Theatre, Great Barrington, Mass.; res., Great Barrington, Mass.	May 22, 1914
SANTOS, ANTHONY SILVA, Clapp-Eastham Co., Cambridge, Mass.	Apr. 1, 1914
SEIBERT, LAWRENCE W., Electrical Assistant, U. S. Signal Service, New York; res., 34 Benton St., Trenton, N. J.	Apr. 15, 1914
SMITH, MALCOLM H., Student, Lowell Textile School; res., 115 Prospect St., Gloucester, Mass.	May 6, 1914
SNYDER, NORMAN G., President, Ithaca Communication Club; res., 214 University Ave., Ithaca, N. Y.	Apr. 15, 1914
SPRADO, HUGH RALPH, Radio Engineer, Federal Telegraph Co.; res., 911 Grand St., Alameda, Cal.	May 22, 1914
STANLEY, LYMAN ROBERTS, Treasurer, The Stanley Co.; res., 52 Burrill St., Swampscott, Mass.	May 22, 1914
STEINER, CHARLES I., Student of Engineering, Columbia University, New York; res., 596 Jackson Ave., Long Island City, N. Y.	May 6, 1914
STEVENS, THOMAS M., Superintendent, Eastern Division, Marconi Wireless Telegraph Co., Boston, Mass.; res., Watertown, Mass.	Apr. 1, 1914
STONE, ELLERY W., Student, University of California; res., 317 Lee St., Oakland, Cal.	Apr. 22, 1914
TAYLOR, JAMES B., Capt., Coast Artillery Corps, U.S.A., Director, Coast Artillery School, Fort Monroe, Va.	Apr. 8, 1914
THOMPSON, VANCE, Student, Memphis University School; res., 267 Pasadena Place, Memphis, Tenn.	Apr. 22, 1914
TRENOR, ALBERT D., Assistant Engineer, John Hays Hammond, Jr., Gloucester, Mass.; res., 142 East 62nd St., New York.	Apr. 1, 1914
TROGNER, ARTHUR M., Radio Draftsman and Tester, Machinery Division, Philadelphia Navy Yard; res., 1211 Locust St., Philadelphia, Pa.	Apr. 1, 1914
TURNER, HUBERT M., Instructor, Electrical Engineering, University of Minnesota; res., 719 Erie St., S.E., Minneapolis, Minn.	May 6, 1914

<b>UNDERHILL, CHARLES R.</b> , Chief Electrical Engineer, Acme Wire Co., New Haven, Conn.; res., 84 Stanley St., New Haven, Conn.	Apr. 8, 1914
<b>VANSIZE, WILLIAM BALDWIN</b> , Patent Expert, Marconi Wireless Telegraph Co., New York; res., 181 Woodruff Ave., Brooklyn, N. Y.	Apr. 22, 1914
<b>WAGGONER, CHAUNCEY W.</b> , Professor of Physics, West Virginia University, Morgantown, W. Va.; res., 727 N. Front St., Morgantown, W. Va.	May 22, 1914
<b>WATTS, FELIX J.</b> , Radio Engineer, University of Michigan, Ann Arbor, Mich.; res., 318 N. Ingalls St., Ann Arbor, Mich.	May 6, 1914
<b>WASHINGTON, BOWDEN</b> , Tester, Clapp-Eastham Co.; res., The Ludlow, Trinity Place, Boston, Mass.	Apr. 1, 1914
<b>WERTHER, ARTHUR G.</b> , Wireless Apparatus Manufacturer; res., 1514 76th St., Bath Beach, Brooklyn, N. Y.	Apr. 1, 1914
<b>WILDE, PHILLIPS B.</b> , Assistant Engineer, U. S. Light House Service, Dept. of Commerce; res., Woods Hole, Mass.	Apr. 15, 1914
<b>WOODWARD, RAYMOND W.</b> , Student, Trinity College, Hartford, Conn.; res., 14 Tremont St., Hartford, Conn.	May 22, 1914
<b>WORRALL, JOSEPH ALLEN</b> , Radio Operator, Marconi Wireless Telegraph Co.; res., 163 Logan St., Brooklyn, N. Y.	Apr. 1, 1914
<b>WYBLE, JAMES F.</b> , Construction Engineer, Marconi Wireless Telegraph Co., Baltimore, Md.; res., 2743 Harlem Ave., Baltimore, Md.	May 22, 1914
<b>ZINSZER, HARVEY A.</b> , Inspector, Consolidated Telephone Co.; res., 920 South 6th St., Allentown, Pa.	Apr. 22, 1914

---

OMITTED FROM YEAR BOOK.

<b>KNOLL, LLOYD M.</b> , Instructor in Physics, Central High School; res., 3260 Chestnut St., Philadelphia, Pa.	Oct. 15, 1913
<b>WRIGHT, GEORGE B.</b> , Lieut., U.S.N., Assistant Radio Officer, Bureau of Steam Engineering, Navy Department, Washington, D. C.	Mar. 12, 1913

## SUMMARY OF MEMBERSHIP

June 1, 1914.

MEMBERS.....	79
ASSOCIATES.....	<u>311</u>
Total.....	390

---

It is requested that *changes of address* be forwarded promptly to:

THE SECRETARY, INSTITUTE OF RADIO ENGINEERS,  
71 Broadway, New York.

## THE AUDION—DETECTOR AND AMPLIFIER \*

BY DR. LEE DE FOREST

*Past-President, Society of Wireless Telegraph Engineers*

Notwithstanding the now wide-spread use of the Audion as a detector in radio telegraph and telephone service few accounts of independent research into the nature of this instrument, or even cursory descriptions of its operation, seem to have been recorded, since the original paper presented before the American Institute of Electrical Engineers in 1906.

At that time, pending patent applications prevented the presentation of a detailed description of certain forms and improvements which are to-day common knowledge among radio engineers. It is my purpose herein to outline briefly the subsequent development of the Audion, both as a radio detector and as an amplifier of minute electric impulses.

For the benefit of those not familiar with radio detectors a brief description of the Audion follows:

A small incandescent lamp bulb is provided with a tantalum filament F (Figure 1), operated at from 4 to 15 volts. There is mounted close to one side of this filament, and parallel to its plane, a small plate of nickel, W. This plate is connected thru a telephone receiver, or other indicating device, R, with the positive terminal of a number of dry cells, B, arranged to give from 15 to 40 volts by the use of a multi-point switch. The negative terminal of this battery is connected to one side or terminal of the filament, which latter is lighted from a suitable storage battery, A.

Between the filament and the plate is mounted a third electrode, G, usually in the form of a grid-shaped wire, or a perforated plate. Approximately 1/16th of an inch (1.5 mm.) separates the grid from the plate on one side, and from the filament on the other.

In Figure 4, a regular commercial Audion receiver set, with its bulbs and adjusting switches, is shown. The two bulbs are mounted in an inverted position in order that the heated filaments do not sag into contact with the grid and their supporting wires after prolonged use. The plates of these bulbs are clearly visible.

---

\* Delivered before The Institute of Radio Engineers, December 3, 1913.

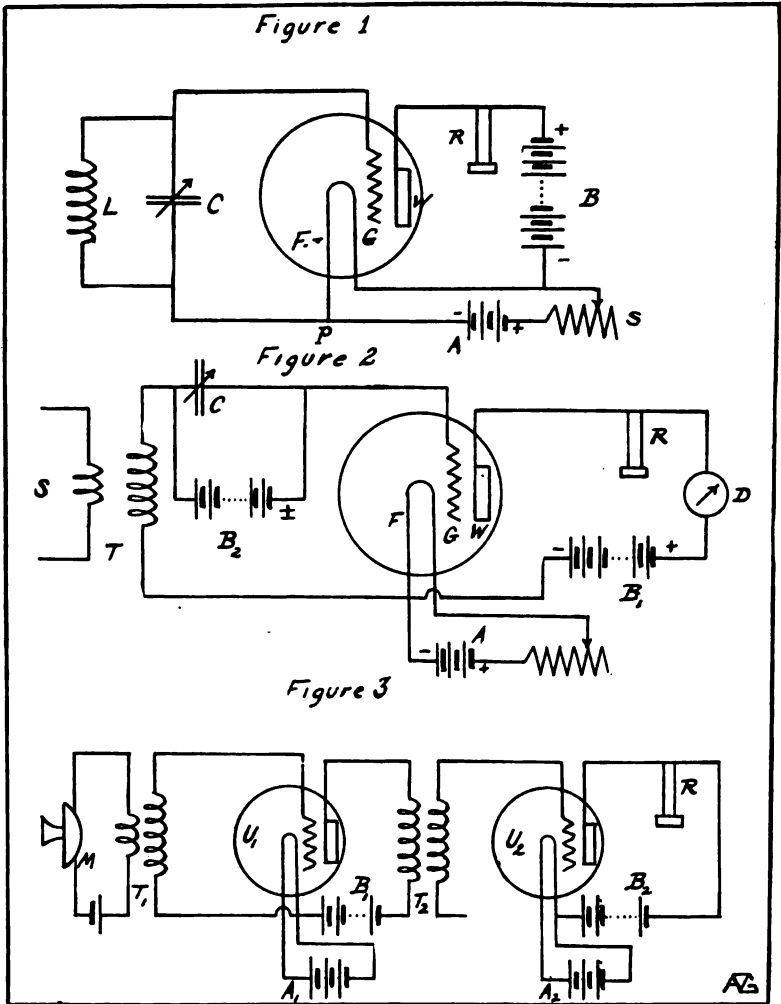

From the protected lower ends of these bulbs the terminal wires of the grid and plate pass out. The top three-point switch places either of the Audions in circuit. The center rotary switch inserts more or less resistance in the "A" battery circuit. The lower nine-point switch enables the insertion of extra batteries in the "B" battery circuit; these batteries being inserted in sets of three at a time.

When used as a detector, this grid electrode is connected to one terminal of the source of received radio frequency oscillations, the other terminal being connected to the Audion filament at P.

In the unlighted bulb, the resistance between the electrodes is practically infinite. When the filament is at white heat, a resistance of from 10,000 to 30,000 ohms is found between it and the cold anode. The value of this resistance depends upon a variety of conditions; such as filament temperature; size, shape, condition and location of the two outside electrodes; amount of electromotive force impressed on the gas; degree of vacuum; nature and degree of purity of the gas; magnetic forces to which the ions are subjected; *and the instantaneous value and sign of the electric potential impressed, or residing, on the intermediate, or grid, electrode.*

The introduction within the exhausted bulb of this third electrode (preferably, but not necessarily, located between the filament and the anode plate) at once placed the Audion in a distinct class, both as to sensitiveness when used as a responsive radio detector, and also as to its mode of operation. No longer, by any form of argument, could the grid Audion be classed as a rectifier, or "vacuum valve." Attempts to confuse it with the so-called Fleming "valve tube" have, I believe, failed to convince any one who has actually compared these two detectors, when each is properly constructed and connected. The difference observed in their operation is more than merely one of degree.

The vacuum valve, as first discovered by Edison, and carefully studied by Elster and Geitel\*, has most marked rectifying properties, excelling in efficiency any electrolytic or crystal rectifier.

In this original device the cold electrode (or electrodes), was connected to the positive terminal of the filament. It was itself subjected to what may be, under favorable conditions, a very energetic bombardment of negatively charged corpuscles from the negative portions of the filament, while itself giving off prac-

---

\* Wiedemann's Annalen, XVI, 1882.





FIGURE 4—Audion Receiver.

tically no negative carriers. This valve rectifies small currents of any frequency, and can therefore be used in connection with a continuous current galvanometer to detect and measure the half-oscillations impressed on a tuned radio frequency transformer, the secondary terminals of which are connected to the anode plate and to one end of the filament respectively.

Starting from my experiments with the rectifying qualities of a gas flame (where the sources of heat energy and of the impressed e. m. f. across the electrodes were distinct and separate), the writer early found that if this incandescent-filament vacuum-rectifier were provided with a second battery, of proper voltage, independent of the lighting source and connected between one leg of the filament and the plate, (which plate must *always* be made the anode); then the device became more than a simple rectifier.

It took on the nature of a true detector, a "wave-responsive" device. In other words, it became to a degree a "trigger" tube, a genuine *relay*, giving responses in the indicating instrument (which was now preferably the telephone receiver) of considerably greater intensity than could be had from the received currents simply rectified. The regular and steady departure of negative ions, or carriers, from the cathode under stress of the "B" battery was found subject to sudden and great variations, following the variations of the applied radio-frequency e. m. f.; the degree of sensitiveness depending, for any given bulb, upon the heat of the filament and the amount of this applied "B" battery voltage.

At once the old vacuum valve took rank in sensitiveness with the electrolytic detector, until that time the most sensitive known.

The next step in advance was, as above stated, the introduction of the electrical impulses into the gaseous medium by means of a third and independent electrode.

This grid and filament, connected across the condenser of a receiving circuit, adds a slight capacity and a very high resistance shunt to that condenser. The additional damping thus introduced in the oscillating circuit is excessively small, its resonant qualities are unimpaired. The Audion thus lends itself, far more than any other form of energy-transforming detector, to sharp tuning. I have found properly designed receiving circuits equally sharply tuned, whether the Audion or the make-and-break contact detector (Poulsen tikker) be used therewith.

There appears to be no lower limit of sensitiveness to the Audion, no minimum of suddenly applied e. m. f., below which

the received impulses fail to produce any response. The exciting impulse, it is true, may be too minute to cause a directly discernible effect in the "B" circuit, but if this effect be amplified through one or more steps, as will be hereafter described, the effect of the original excitation is found to exist.

Even in this day of universally accepted long-distance "wireless records," it is difficult for those who have not actually used the Audion detector to believe some of the receiving feats which are scored to its credit.

The Audion has the further advantage of entire absence of adjustment in the receiver itself. If the two battery potentials are once properly adjusted it requires no further attention. There is no fatigue under any conditions of use. A powerful spark discharge in close proximity may cause the "blue arc," or visible cathode discharge, to pass, but after a second or two this "paralysis" will automatically disappear, while a high resistance path (of the order of several megohms) between plate and grid will generally prevent this blue arcing.

This is therefore a suitable detector to use with a telegrapher's "breaking key." If a key-actuated relay be arranged to open the filament circuit with each depression of the Morse key, the Audion is always ready to catch the distant operator's call, or attempt to "break" in the midst of a message. On the other hand, the sensitiveness of the electrolytic and that of the best of the crystal detectors is frequently destroyed by one violent impulse, unless protected by shunting and disconnecting switches.

If there is any justification in the attempt to classify radio detectors as "current-operated" or "potential-operated" devices, there can be not the slightest hesitancy in classing the Audion as a potential-operated detector. Obviously it is in no sense a contact device, perfect or imperfect. Its response is strictly quantitative, up to the critical point of the voltage-response curve where "saturation" of ions or gas carriers begins. Up to that critical point the change in current passing from plate to filament is essentially proportional to the voltage applied to the grid electrode.

This voltage may be merely that of the hand discharging into the grid. When the lead to this grid is suddenly grasped, a click may be heard in the telephone receiver in the "B" circuit. If the charge thus impressed upon the grid be negative a repulsion or scattering of the negatively charged carriers emanating from the filament occurs. If the impressed charge be positive, then

these carriers may be attracted to the grid and discharged there, or delayed in the neighborhood. In either case, therefore, a diminution in the number of ions reaching the plate results, and we observe a diminution in the deflection of a sensitive milliammeter or galvanometer in the "B" circuit when a prolonged series of impulses is delivered to the grid. The normal current is usually of the order of a milliamperere, and its response diminution may vary from an undiscernible amount to 50 or even 90 per cent. of its full value.

An insight into what forces are at work in the Audion is afforded by experiments with a special circuit, such as that shown in Figure 2. When a negative charge is applied to the grid a click is heard in the telephones. When a positive charge is applied, almost no sound is heard. If G is negatively charged to 20 volts, while a sound from telephonic currents from source S is being received, the sensitiveness of the Audion is practically annulled. When G is positively charged the sound is greatly reduced, but not to the foregoing extent. This experiment seems to show that in the normal operation of the Audion the imposition of a charge, negative or positive, upon the grid acts either to repel from its neighborhood the ionic carriers or to hold them idle there, thus in either case increasing the effective resistance in the filament-to-plate path.

The first establishment of the ionic circuit of an Audion when the filament is suddenly lighted is perfectly silent—no sound is heard in the telephone, altho a galvanometer in series shows that the "make" is practically instantaneous. The establishment of the gaseous conductivity is sufficiently gradual, however, to make no sound. I do not know of any similar rapid circuit-closing device which is thus silent. While this "B" current assumes nearly its maximum amplitude practically instantly, its full value may not be reached for several seconds. A slow and irregular creeping of the milliammeter needle reveals how gradually the ions adjust themselves to a completely stable condition. Upon the rupture of the filament circuit, however, the "B" circuit opens practically instantly, invariably accompanied by a click in the receiver telephone.

Referring again to the arrangement in Figure 2: when the grid is positively charged, the voltage of  $B_2$  made nearly equal to that of  $B_1$ , and the heating current carefully adjusted, a very intense whistling note may be obtained in the telephone receiver, loud enough to be heard a meter from the instrument.

The pitch of this note slowly rises to a maximum, at which it remains for some time. A higher voltage at  $B_2$  (18 volts) gives a higher initial pitch, which also increases to a maximum. The tone produced is a very pure sound. This note will sometimes increase from a very low to an extremely shrill pitch, then drop again down the scale, and suddenly cease.

Such siren effects with this circuit are always transient and critical, and are usually obtained only when the blue glow is visible to the eye. The effect is not dependent on the presence of the condenser  $C$ , but a high impedance on the  $B_1$  circuit is essential. An impedance in the  $B_2$  circuit aids the phenomenon. When the grid is negatively charged the Audion cannot be made to whistle. Its sensitiveness is nil, and if this  $B_2$  voltage is made large enough the current thru the  $B_1$  circuit is completely cut off.

These siren phenomena are probably due to the alternate effect of the suddenly altering positive charge of the grid on the positive charge of the plate, and vice versa; i. e., to the reaction of the two circuits upon each other thru the coupling medium: the gas path in the bulb. The gradual increase of pitch observed may be due to the gradual increase in the intensity of the cathode discharge, which increase would take place, without the presence of the positive charge on the grid, very suddenly, but is now greatly retarded by the disturbing reciprocal action of the two charging circuits. When a stable state, or pitch, is reached, the ensuing decrease of pitch may be due to the rapid running down in voltage of the small dry cells used, until the voltage across the gas is again reduced below the critical "blue arc" stage, whereupon the phenomenon ceases. These siren effects are not found with every bulb.

Even when the grid is uncharged an Audion can be made to give out a loud piercing whistle if a magnet be held in the proper position nearby. The pitch of this note may now be found to decrease as the "B" voltage is raised. Considerable impedance, but no condenser, is necessary to obtain these effects, showing that we are not dealing here with ordinary oscillating-circuit phenomena, where the frequency is proportional to the square root of the product of inductance and capacity.

My experiments with tungsten and other filaments, and with platinum filaments coated with alkali metals or salts, and with various gases or vapors in the bulb, have not shown any method of increasing the sensitiveness obtained with tantalum as a filament and with atmospheric air exhausted to the most effective pres-



FIGURE 5—Audion Three-Step Amplifier, digitized by Google

sure. The best value of "B" potential required to produce maximum sensitiveness depends on the degree of vacuum, being roughly proportional to the degree of exhaustion.

An interesting phenomenon is observed in certain bulbs where the "B" voltage is adjusted until a sheaf of visible blue cathode rays spreads out, fan-like, from around the edge of the plate. Then, when powerful impulses are received on the grid a momentary flaring out of this blue aura can be observed with each signal, so that it is possible to read the telegraph signals directly by sight. This effect has been observed at radio receiving stations separated many miles from the transmitter.

For radio telephony, whether in true radio service, or in the so-called "wired wireless," the Audion is practically the only suitable receiver. Its extraordinary sensitiveness, its reliability, and perfectly *quantitative* response have earned for it a general recognition, abroad as well as here. The range of communication is easily increased by 50 to 100 per cent over that possible with the crystal or electrolytic detectors.

### THE AUDION AS AMPLIFIER.

In a patent issued to the author in 1907 is described an arrangement whereby a grid Audion can be so connected that it acts as a relay and also amplifies minute pulsating electric impulses. Of late this amplifier has been much studied and is now being applied to a variety of purposes.

Figure 3 shows the simplest arrangement using two amplifiers "in cascade." The source of energy to be amplified may be an Audion used as a radio-detector, a microphone, a magneto telephone receiver over a long distance line, a cable transmitter, or the like.  $T_1$  represents a step-up transformer, which is essential if the impulses from S be of low voltage.

For a single amplifier,  $T_2$  will represent the indicating instrument. For a two-step amplification,  $T_2$  is a one-to-one transformer. Where the two amplifiers are supplied from separate lighting batteries  $T_2$  may consist of one coil only. Similarly amplifier Number 2 may actuate a third, and so on; the successive steps requiring, as a rule, larger bulbs, with larger heating areas and larger cold electrode surfaces.

The assembled three-step amplifier is shown in Figure 5. The switches for adjusting "B" battery voltage and "A" battery circuit resistance, and for throwing the bulbs on or off are clearly

visible. It will be seen that the apparatus has been arranged so that a single bulb can be used, or a two or three-step amplification as may be desired.

By measurements made with the shunted-telephone-receiver method, a good Audion amplifier shows an amplification of 500 per cent. This general ratio holds also for the second and third steps, so that with three Audion amplifiers in cascade I have obtained an energy amplification of one hundred and twenty times, and this including losses from the three transformers in circuit.

The strictly quantitative action above described holds for the hundred-fold, three-step amplifications as well; so that the ear at least, detects no distortion in this process. This holds unless the third amplifier is over-excited, so that the "blue arc" passes. This latter effect can always be prevented, as above explained, even while relatively large current variations are registered. To what limits of amplification this Audion principle can be carried has not yet been determined.

The principle involved differs so radically from that of any form of telephone, microphone, or mechanical amplifying device that the Audion opens up entirely new possibilities in all lines of micro-electrics. First of all, its extraordinary sensitiveness is attended with no delicate adjustments and is absolutely non-microphonic. No amount of jarring or mechanical vibration disturbs its complete reliability. The ticking of a watch placed upon an ordinary microphone connected with one dry cell in a primary current can be amplified and heard thru a telephone when a coupling of less than five per cent unites the microphone circuit with the amplifier-telephone circuit; whereas from the most sensitive telephone receiver connected directly in this secondary circuit not a trace of a sound can be heard. Thus any microphone, or *even an ordinary magneto receiver*, with a two- or three-fold amplifier becomes a "Dictograph"—but with a delightful clearness of articulation.

If, in the radio telephone receiver, we add one or two amplifiers to the usual Audion detector, it is possible to bring up, clear and loud, articulation which, with this detector and telephone receiver alone, is too faint to understand. Similarly with the radio telegraph. The amplifier when used to relay the signals received on the Poulsen tikker at San Francisco has postponed by two hours the time of "daylight fading" from Honolulu.

The current changes in the circuits of the second or third amplifier are sufficient to operate reliably a moderately sensitive contact relay; so that it is now possible to operate any desired



form of calling device, or remote control apparatus, by any radio signals which are clearly audible, as well as to read easily signals which are quite inaudible with the ordinary detectors.

Inasmuch as a theoretically perfect single rectifier can have an efficiency of only 50 per cent., the fact that the Audion, amplifying alternating currents of practically any frequency, shows an efficiency of from 100 to 500 per cent., should most effectively silence the old and recurrent contention that this detector is merely a sensitive and efficient rectifier, or "vacuum valve."

In the long-distance telephone field lies the most obvious and useful application of this amplifier. The Audion used as a two-way amplifier at the middle of a metallic circuit requires, it is true, some type of the usual balanced circuits, with precautions to prevent "singing"; but the difficulties here afforded are less serious than with the microphone-telephone repeater. The relative constancy of adjustment, and especially the freedom from microphonic troubles and distortion, simplify the problem. It is the writer's hope that more detailed information of exceedingly interesting work which is being done in this direction by telephone engineers may shortly be presented.

Aside from long distance work, other applications of this telephone relay, of more radical and far-reaching significance, may be produced in the future. For example, it has been suggested that a magneto telephone receiver be used in place of the microphone at each subscriber's station, allowing once more that original clearness and fidelity of voice which was sacrificed when the microphone was made a part of every telephone equipment. No central battery energy need be supplied to the subscriber, except for calling purposes. His voice supplies the energy for driving this magneto dynamo. The minute, but correct, currents thus generated might be carried to central station over a pair of wires of such size that twice the present number of conductors could be inclosed in the standard sized cables. With these minute currents, troubles from cross-talk would be minimized, while high resistance or microphone contacts in the lines would cease to be the serious matters they are at present. The Audion, being an extremely high-resistance device, requires for a transformer a high-resistance primary, with a secondary adapted to standard telephone receivers.

At the central stations, then, we would have banks of Audion amplifiers fed from the common storage battery. In-coming and out-going calls would operate signal devices with this central battery energy as at present, but when the talking circuit was

made, the subscriber's magneto transmitter would be connected, thru an induction coil, to the grid of an idle Audion, amplified, sent out over a trunk line, re-amplified, if necessary, at the other exchange, transformed, and sent out to the receiver's station.

## THE AUDION AMPLIFIER IN CONNECTION WITH THE TELEGRAPHONE.

The ease with which voice records are made on the fine steel wire of a Telegraphone, the fidelity of these records (when not intense enough magnetically to saturate the wire), and the practically unlimited length of a record (30 minutes or more), once appeared to give to this wonderful device possibilities which were quite beyond any to be hoped for from the cylinder or disk phonograph. However, the faintness of the reproduction has limited the commercial application of the Telegraphone to an office dictating and telephone-recording machine. All attempts reliably to amplify Telegraphone records so as to throw the sound out into a room, by the use of microphone relays, have failed. The adjustments are too delicate and transient, and the distortion excessive.

With a three-step Audion amplifier I am able to supply a number of "loud-speaking" telephone receivers, and to distribute music, or voice records, over a small hall in sufficient volume. From four such loud-speaking receivers nested together, a violin record on the Telegraphone has been heard at a distance of 250 feet in quiet open air. By the use of larger bulbs for the third amplification, and with two or more of these in parallel, each supplying six or more loud-speakers, any enclosed space of reasonable size can be filled.

This amplification of Telegraphone records has revealed a number of interesting peculiarities of that instrument hitherto unrealized. Notably it has shown how imperfect and unreliable a device is the carbon microphone, voice actuated. The haphazard action of packing, friction, and the effect of the natural vibration periods of the diafram, are exasperatingly demonstrated. I am at work on these problems at the present time, investigating the best methods for recording various types of music, voice, etc., and using for this purpose both the microphone and special forms of magneto transmitters. I believe the application of the Telegraphone to the music-reproduction field now awaits a perfection of proper methods of recording.

The problem of recording high speed radio telegraph signals has been repeatedly attacked, using photographic tape records with the Einthoven string galvanometer and crystal rectifier detector. The multiplicity of delicate adjustments, and the obliterations which even moderate atmospheric disturbances cause in the records, convince, in time, the most optimistic investigators in this field of the basic fallacy of this method.

Attempts have been made to record radio signals by means of the Telegraphone, but the fact that excessively loud signals (such as can be heard three feet from the telephone receiver) are needed to make satisfactory Telegraphone records, has kept this method inapplicable.

Now, however, with the three-step Audion amplifier relaying the detector signals, the Telegraphone becomes a simple and surprisingly reliable rapid recorder. A tape-actuated Wheatstone transmitter, controlling by two successive relays the wave length of a 12 K. W. Poulsen arc transmitter, sends Morse signals at the rate of sixty words per minute. The received Tikker signals are amplified and recorded on a Telegraphone wire running at a rate of about eight hundred feet per minute. In reproducing the record this wire speed is reduced to approximately one-third. The pitch of the tikker signals as thus reproduced is of course very low; but with the above speed-reduction ratio these signals, even without re-amplification, are still sufficiently loud to permit the use of a typewriter by the transcribing operator.

For speeds higher than sixty words per minute it is necessary to obtain the incoming signal in the form of a high-pitched note, which, upon reduction for transcribing at 25 words per minute, has still a pitch of some 150 cycles per second. Methods for accomplishing this latter have been recently worked out by the writer.

The Telegraphone rapid receiver has been in daily commercial use for several months at the arc stations of the Federal Telegraph Company, between San Francisco and Los Angeles. The method is not limited to arc transmitters. In fact, the musical spark stations offer certain advantages for this method of high speed recording. It is necessary only that the received signals should be 50 to 100 times "audibility" before amplification.\*

While it is yet too early to speak authoritatively on the subject there appears no reason why the Audion amplifier should not also be applied with excellent advantage to submarine cable recording and relaying.

---

\* Loud enough to be taken down by the operator, using the typewriter.

**SYNOPSIS.** *The improved Audion, containing one hot and two independent cold electrodes, is described, and its action as a sensitive detector in radio telegraph and telephone work outlined. Its action is shown to be not that of a simple rectifier or valve, but that of a true relay device. The secondary circuit of a radio receiving transformer is connected in shunt between the "grid" electrode and the filament. The telephone receiver and dry battery are connected between the plate electrode and filament.*

*There appears to be no known limit of sensitiveness below which the effect of minute received energy fails to be registered.*

*The device is constant and reliable, requiring only initial adjustments of battery voltages. The Audion is incontestably a "potential operated" device.*

*The normal current across the gas is of the order of a milliampere. Positive or negative charges impressed upon the grid causes a diminution in this current. Some unique unstable conditions, e. g. whistling are described.*

*The Audion is especially well adapted as a radio telephone receiver, and with or without the addition of the amplifier greatly increases the range of such communication.*

*The Audion as an amplifier of minute telephonic and other currents is described, together with circuits which permit successive amplifications, up to 120 times the initial energy.*

*This new amplifier, or relay, while exceedingly sensitive is not microphonic, nor delicate, but reliable and free from distortion. It promises a solution to the long-sought telephone-relay problem, and opens up new possibilities in micro-electrics. A sensitive and reliable calling device for radio purposes is readily attained.*

*The general use of magnetic telephone transmitters in place of microphones, together with smaller telephone cables, is suggested as a possible future development in telephoning.*

*In connection with the Telegraphone the new amplifier permits voice and music records, of practically any length, to be heard thruout large-sized rooms. Recording of rapid radio signals by means of the Telegraphone is now feasible.*

*The Audion amplifier may be applied equally well to problems of cable receiving and relaying.*

## DISCUSSION.

A partial reprint of Dr. de Forest's paper on "The Audion—Detector and Amplifier" appeared in "The Electrician" of November 21, 1913, page 285.

Professor J. A. Fleming objected strongly to Dr. de Forest's claims of priority in the discovery of ionised gas detectors of the Audion type, and embodied his objections in a letter addressed to the Secretary of The Institute of Radio Engineers. This letter was also printed in full in "The Electrician" of December 5, 1913, page 377.

Dr. de Forest, in an answering letter, upheld his original contentions, maintaining that there was an essential difference between the Audion and those forms of gas detector with which Professor Fleming had been engaged. Dr. de Forest's letter appeared in "The Electrician" for January 23, 1914, page 659.

In further support of his original contentions, Professor Fleming addressed a letter to "The Electrician," holding that his priority of invention in the ionised gas detector was established. This letter appeared on January 23, 1914, page 660.

In the "Elektrotechnische Zeitschrift" for November 27, 1913, page 1359, Eugen Reisz described a form of gas valve detector, and amplifier, in an article entitled "Verstärkung Elektrische Ströme, usw." The detector described therein is the gas valve which is claimed for Messrs. R. von Lieben and Reisz. The English description of the same device appears in "The Electrician" for February 6, 1914, page 726, et seq. In answer to the contentions of the authors of the above article, Dr. de Forest in an open letter in "The Electrician" for March 13, 1914, page 956, denies that their device is anything more than the Audion as discovered and worked out by him.

The above correspondence, being lengthy, is not here reprinted; and the reader is referred to "The Electrician" and the other periodicals mentioned for further details thereof.—EDITOR'S NOTE.

**John Stone Stone:** The problem of the telephone amplifier is one of great difficulty. I became interested in it in 1892, and soon found that the question of amplifying without producing distortion was prominent. The amplifying relays which were furnished were all mechanical instruments; their parts had inertia—and consequently distortion was always produced. We never had

the instrument of our ambitions which, being without inertia, would amplify correctly even the weakest impulses without distortion. It is therefore with earnest scientific pleasure that I recognise that we have at last an instrument which uses the cathode stream to produce amplification, and which will therefore amplify even the weakest currents.

There is an application of this amplifier which is of great interest to me, namely to the field of "wired wireless." By this method of transmission it is possible to send simultaneously over the same line a great number of conversations, each being carried by its own extremely rapidly alternating current. The receiving station can be appropriately tuned to any of the frequencies used. This is an older art than radio telegraphy. Up to the present it has not materialized because the energy of the currents thus transmitted was too small to enable competition with ordinary telephony. This new amplifier promises to bring the "wired wireless" telephone to a par with the usual wired telephone. There is then a prospect of a satisfactory solution of the problem of multiple telephony. As many as twenty messages might be transmitted simultaneously over the same line.

If any of the usual detectors in radio communication, e.g. the crystal rectifier, be overloaded, it is difficult to restore it to an adjustment for sensitiveness. Tinkering is required. Not so with the Audion. With excessive strength of signals, we get the blue arc in the bulb. It is merely necessary to open the battery circuit for an instant, to restore the Audion to full sensitiveness. There is no need to hunt for a sensitive point on a crystal. And the Audion is unique among detectors in that it is an amplifier as well.

**An Auditor:** Does the blue coating which forms on the plate render the Audion less efficient?

**Dr. de Forest:** If the bulb were run long enough this effect might lower the sensitiveness. However, the life of the bulb is three or four hundred hours, and in that time no lowering of the sensitiveness for this reason can be noticed.

**C. H. Sphar:** Is the "singing" of the Audion, when on critical adjustment, accounted for in the same way as the whistling on a telephone line when the receiver is held to the transmitter?

**Dr. de Forest:** Yes; it is due to an electromagnetic reaction in the Audion. A similar effect is produced in the telephone repeater. Probably in the case of the Audion it is due to an interaction of the charges on the grid and the wing.

**Chas. A. Le Quesne, Jr.:** I have noticed a ringing sound when the Audion is mechanically disturbed, for example, by jarring the table. What is the cause of this?

**Dr. de Forest:** It is due to the swinging or vibration of the grid. It is purely mechanical, and has never troubled us in our work.

**An Auditor:** Why does the filament lean toward the grid when it has been in use for some time?

**Dr. de Forest:** If the Audion is properly suspended, in an inverted position, this does not happen. There might be a slight electric attraction between the filament and the plate, but I do not think its effect would be easily observable.

**Roy W. Weagant:** Is there any multiplication of the frequency of audible sounds by the Audion, as in an unpolarised telephone receiver?

**Dr. de Forest:** No such effect is found.

**Alfred N. Goldsmith:** In a recent modification of the Audion, due to Majorana, the plate and filament are connected as usual.

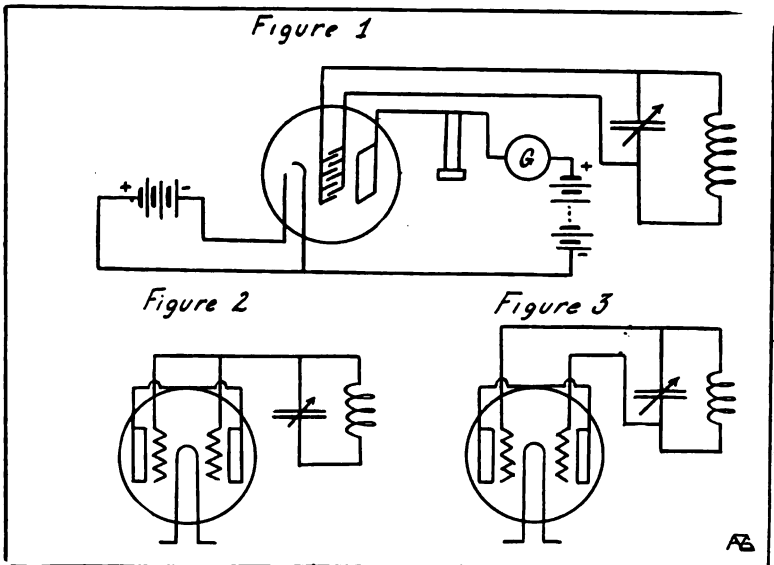

The grid, however, is double, consisting of two sets of interleaved but mutually insulated wires. Each of these sets of wires is connected to one side of the condenser in the radio receiving circuit. Majorana calls this grid an "electron deflector" or "deviator," and bases the action of this type of Audion on the deflection of the cath-

ode stream which occurs as the wire systems of the deflector are successively oppositely charged. The sensitiveness of this arrangement is given as superior to that of the usual Audion. May I ask if any experimental work has been done by Dr. de Forest with this arrangement? It is shown in Figure 1.

**Dr. de Forest:** I had previously tried the arrangement advocated by Majorana. Sometimes the sensitiveness is thereby increased, but with other bulbs it may be diminished. For example, using the latest type of Audion, with two plates and two grids, I have used the connections shown in Figures 2 and 3. The sensitiveness of the arrangement of Figure 2, which is high, is usually equal or superior to that shown in the Majorana arrangement.

**C. H. Sphar:** I have noticed an illustration showing the use of the Fleming valve in the secondary circuit of a step-up transformer, e. g. a ten inch coil. What is the purpose of that connection?

**Dr. de Forest:** I have never tried this. However, one can always wind the telephone receivers and the other portions of the radio receiving set to the suitable inductance and resistance so as to permit the proper functioning of the Audion without using such an arrangement.

**Charles A. Le Quesne, Jr.:** When one side of the receiving condenser is connected to the grid, and the other terminal of the condenser to one side of the filament, changing the latter connection to the other side of the filament alters the strength of the signals. Why?

**Dr. de Forest:** The antenna side of the receiving condenser should always go to the grid, and the earth side of the condenser to the filament of the Audion; so that the highest potentials possible are impressed on the grid.

**Lester Israel:** Dr. de Forest has mentioned the fact that, altho no sound is heard in the telephone when an Audion bulb is lighted, a distinct click occurs when it is extinguished. A very plausible explanation of this phenomenon occurs to me.

It is a well known fact that the emission of ions from a hot electrode practically begins at a red heat, and increases almost linearly with the temperature as a white heat is approached. From this fact it follows at once that current changes in the telephone circuit occur only when the temperature of the tantalum



filament is varying between red and white heats, and further that the current is very nearly directly proportional to the temperature above the red heat.

Now consider the manner in which the temperature of the filament changes between the above limits. When the lamp is lighted, the temperature increases very rapidly at first to above the red heat, and then more and more slowly, as the rate at which heat is dissipated approaches the rate at which heat is supplied. In consequence, the telephone current increases to its full value during a comparatively long period of time, probably between a tenth and fiftieth of a second.

When the lamp is extinguished, however, the temperature drop from white to red heat, and consequent current drop from maximum to a practical zero, occur very rapidly—probably in one one-hundredth to one five-hundredth of a second. This difference in the rate change of telephone current probably accounts for the phenomena mentioned by Dr. de Forest.

**Dr. de Forest:** This is probably the correct explanation.

**Charles A. Le Quesne, Jr.:** It has been mentioned that to avoid the blue arc on powerful signals a shunt resistance may be placed across the Audion. Must this shunt resistance have a high value?

**Dr. de Forest:** Of the order of magnitude of several megohms otherwise the sensitiveness of the Audion is diminished.

**G. H. Clark:** All other telephone amplifiers are of the carbon microphone type. Very slight mechanical disturbances interfere markedly with their action, and, tho I have investigated carbon amplifones, I have not found them to be successful, at least for weak signals. I have recently seen a carbon amplifier which does not "whisper," but it does not amplify sufficiently either.

In working with the Audion amplifier, I have found that the amplifications at the three steps (including all losses) were approximately 8, 64, and 200 times. I may also state that in working between Honolulu and Arlington, even when the signals were totally inaudible without the Audion amplifier, with it they could be heard very well.

**John L. Hogan, Jr.:** I wish to congratulate Dr. de Forest on this solution of the amplifier problem. In the 1906 paper, an arrangement was shown wherein a telephone in series with a galvanometer constituted the indicator. May I ask whether you have

determined why, altho changes in the intensity of the telephone signals sometimes occurred, the galvanometer deflections remained unchanged? It is my recollection that in 1906 you stated this was not understood.

**Dr. de Forest:** This may have been because the telephone was so much more sensitive than the galvanometer used. Since that time I have employed only the grid and wing type of Audion, but I have not investigated the matter further.

**John L. Hogan, Jr.:** From your experiments with the Audion, can you say that the modification in battery "B" current, due to impulses from incoming wave groups, is always in the nature of a pulsating reduction in amperage, a single pulse reduction being produced by each wave group? That is, does the "B" current value always have forced upon it a reduction corresponding (as plotted against time) to the boundary curve or "envelope" of each wave group? If this has not been proven, it seems possible that the peculiarly loud response of the telephones to impulses which would not deflect your galvanometer (as described in your 1906 paper) might be analogous to the action in tikker circuits. Where the rapid vibrating contact is used to discharge a resonating circuit condenser thru a telephone, the impulses applied to the latter are irregular in amplitude and polarity. The sum of all these discharges thru a definite time which is long compared to the time of discharge is nearly zero, hence a slow period instrument, such as a galvanometer, will show no deflection altho a telephone may be responding loudly to the individual discharge impulses. I have encountered similar effects when solid rectifiers were used, and so am suggesting the possibility of a like action in the case of the Audion.

**Dr. de Forest:** My understanding is that the Audion acts as you have first described, and therefore that the tikker is not analogous.

**John L. Hogan, Jr.:** When the Audion is operating as a detector, it is, then, a non-polarized device? That is, an incoming impulse will, regardless of its polarity, produce a proportional diminution in the battery "B" current?

**Dr. de Forest:** Yes. The reduction is produced sensibly without regard to the polarity of excitation.

**John L. Hogan, Jr.:** Is this effect or characteristic in any way altered when the Audion is operated as an amplifier?

**Dr. de Forest:** No, I believe not. I have found no reason to believe that change of excitation frequency produces any change in the method of operation.

**George H. Clark:** What relation is found between the sensitiveness of the Audion bulbs as detectors and their value for amplifier use?

**Dr. de Forest:** Good detectors are sometimes poor amplifiers, but the opposite relation is not found.

## RADIO RANGE VARIATION\*

BY ROBERT H. MARRIOTT

*Past-President of the Institute*

Thruout this paper, whenever radio range variation is mentioned I shall refer to a variation in the distance over which messages could be transmitted and read on reception. This is a subject to which I have given considerable attention, having taken observations on it and on the strength of atmospheric disturbances intermittently over a period of about fourteen years. In the following paper I shall attempt to present a record of the most interesting and useful of these observations.

The first records which we shall consider were made at the Manhattan Beach station of the United Wireless Telegraph Company. This station was located at Coney Island in New York City, and its call letter was "DF" (American Morse code).

At the Manhattan Beach station care was taken to cut down all losses in transmission and reception. Air insulation was used wherever possible in the transmitting circuit, and wherever solid insulators were employed they were made as long and narrow as practicable. A United Wireless "Steamship Type" transmitter using about 2 kilowatts was installed in this station. The spark gap itself was not enclosed. For reception, inductively coupled tuners, equipped with Perikon detectors, were usually in use. The receiving apparatus was changed occasionally, but apparently the receivers used were so nearly equal in efficiency that no material change in the range of reception was thus produced.

The vessels worked with were mainly equipped with what were known at that time as the United Wireless 1 kilowatt sets. The evolution of this type of apparatus may be of interest. It was first known as American De Forest Wireless Telegraph Company equipment; later, with a few changes introduced, as United Wireless Telegraph Company equipment; and at present these sets, used at a looser coupling and frequently including non-synchronous rotary gaps, are known as American Marconi equipments. A

---

\* Delivered before The Institute of Radio Engineers, January 7, 1914.

test on 28 of these sets showed transformer inputs between 350 and 1,850 watts, the average transformer input being about 1.1 kilowatts. The average antenna current on the ships at the time the tests shown on Chart 3 were made, was probably about 5 amperes. Characteristic wave lengths and couplings employed are indicated on Chart 4. The tuners used on board ship were equipped with carborundum detectors. They were, as a rule, inductively coupled.

Referring to Chart 3, Figure 1, there is shown the maximum daily range between 5 P.M. and 1 A.M. for the period between October 12, 1908, and October 15, 1909. The ranges, indicated by dots and connected by lines, refer to the *longest distances* over which messages were sent and received on the respective days. The distances were checked by reference to the message records kept on board the ship. Practically no records of distance, were made except where the distance in question was actually attained in handling *business* either sent or received, and *acknowledged*. Messages handled during this time included approximately 115,600 words, of which about 82,800 were received and about 32,800 were transmitted, not counting checks, repetition, acknowledgements or conversation. The operators who made these records were selected for their reliability and were given a *bonus*, the amount of which depended on the *number* of words handled and the *distance*; that is, ten words sent or received over a distance of 1,000 miles paid a considerably higher bonus than ten words sent or received over a distance of 100 miles. Attention is called to the fact that these ranges represent the *maximum* distance attained on their respective dates.

In Figure 2 of the same chart, a rough estimate of the relative strength of the "atmospherics" for the same dates and times of day as those represented by the readings of Figure 1 is presented. The dots were placed in accordance with the report of the operator, who noted the strength of the atmospherics as heavy, medium or light, or else in similar terms. With the exception of short periods, two operators made these records, as is indicated in Figures 1 and 2. These operators did not express themselves in quite the same way in classifying atmospheric disturbances as to strength and quality.

A number of figures which follow are provided for purposes of comparison. Thus, Figure 3 shows the daily minimum, mean, and maximum Fahrenheit temperature, as reported by the Weather Bureau from New York City.

In Figure 4 are given the weekly averages of the daily maximum

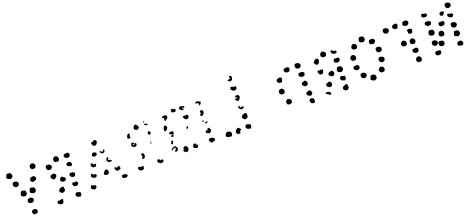
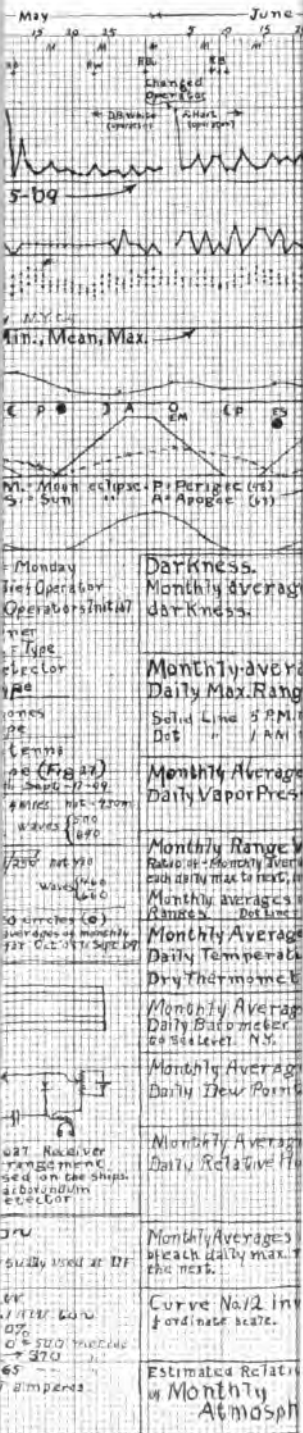



ranges. These were obtained by taking the weekly averages of the ranges shown in Figure 1.

Figure 5 shows in the heavy solid line the number of hours of moonlight between 5 P.M. and 1 A.M. for the period of time covered by Figure 1; and the dotted line shows approximately the area of the moon exposed multiplied by the inverse square of the distance of the moon from the earth.

In Figure 6 is given a curve which represents the total moonlight between 5 P.M. and 1 A.M. It is based on the number of hours of moonlight during that time multiplied by the exposed area of the moon and by the inverse square of the distance of the moon from the earth. On comparing Figure 6 with Figure 4, it will be found that in some cases the curve of Figure 4 is low where the curve of Figure 6 is high, and conversely. That is, the range was greater when there was minimum moonlight and less when there was maximum moonlight. However, this might have been due to other things than the effect of the moonlight. For example, between September 21 and October 5, 1909, there is a decided dip in the weekly range curve corresponding to the peak in the total moonlight curve, but this dip in the weekly range curve was probably principally due to interference from the fleet of the United States navy, which was in the vicinity at that time.

Figure 7 is a continuation of Figure 1 for 1909 and 1910, and was obtained in the same way as Figure 1.

Figure 9 was obtained in the same way as Figure 1, except that it applies to the hours between 1 A.M. and 9 A.M. During this part of the day there were probably less interference and better atmospheric conditions, but there were not so many ships with which to work, because many of the operators were asleep during these hours. Vessels, as a rule, carried only one operator.

In Figure 10, the solid line shown is a continuation of the weekly average curve in Figure 4. The dotted line is a similar average curve for the hours between 1 A.M. and 9 A.M.

In figures 1 to 10, all dates mentioned refer to those given at the top of the Chart. The dates given for operation between 5 P.M. and 1 A.M. are always for the day preceding dates referring to operation between 1 A.M. and 9 A.M.

Figure 11 represents the hours of darkness by monthly averages from October 15, 1908, to March 15, 1910.

Figure 12 shows the range variation by monthly averages from October 15, 1908, to March 15, 1910. These quantities are the monthly averages of the daily ranges given in Figure 1. On comparing Figure 12 with Figure 11, it will be seen that the in-



crease in range is not as rapid as the increase in number of hours of darkness, and that the decrease in range is not as rapid as the decrease in hours of darkness. That is, the range curve may be said to lag behind the darkness curve, which probably would not have been the case if the ionization and consequent conductivity produced by sunlight were the only factors which determined the radio range.

In Figure 13 are shown the monthly averages of the daily vapor pressure at New York. It will be seen that this figure is something like an inverted range curve. There is a somewhat similar type of lag between the vapor pressure curve and the hours of darkness curve as mentioned in the preceding paragraph.

In Figure 14, the monthly range variation in per cent. is shown; that is, the ratio of the monthly average of the variation (of each daily maximum to the next daily maximum) to monthly averages of daily maximum ranges. This curve indicates that there really were more *so-called "freaks"* in the month of August than in the winter months; that is, the ranges showed a greater percentage variation in the summer than in the winter, altho the winter is usually spoken of as the period of "freak" work. Probably none of the variations mentioned should be called "freaks," since approximately similar variations occur on the average from year to year at the same season. They are simply the more pronounced examples of radio range variation.

Figure 15 shows the monthly averages of the mean daily temperatures in New York. It will be seen that this curve is also somewhat similar to an inverted range curve.

The monthly averages of daily dew point for New York are given in Figure 17. These also somewhat resemble an inverted range curve.

In Figure 18, the monthly averages of daily relative humidity are shown. As will be seen, the relative humidity during January, 1909, was high while the temperature was low. This may have something to do with the dip or minimum in the range curve for January, 1909. Moisture may have been deposited on the insulators to a sufficient extent to cause serious losses at both the transmitting and receiving stations.

Figure 19 gives the monthly average of variation in miles between each daily maximum range and the next daily maximum range. This variation is greater, so far as number of miles is concerned, in the winter time than in the summer time, altho it is smaller in percentage, as will be seen from Figure 14.

In Figure 20, an inverted range curve, with halved ordinates, is given for comparison with the other curves.

Figure 21 shows roughly the estimated relative strengths of atmospherics by monthly averages.

In Figure 22, the dotted line shows approximately the area in which the vessels working with Manhattan Beach were located, these being the ones with which the range records were made. Nearly all of the records were made from distances reached with ships. During the winter months, messages were exchanged with Chicago and vessels on the Great Lakes. On one occasion, Chicago was unable to hear a message sent from a vessel on the Great Lakes, but this message was copied at Manhattan Beach and re-transmitted by radio direct to Chicago.

In Figure 23, the curve ordinates are proportional to the number of vessels within one day's sail of New York, between 5 P.M. and 1 A.M., for each day of the week. It will be seen that the greatest number of vessels were within one day of New York on Saturday, and that those vessels apparently caused sufficient interference to reduce the working range on Saturday during the winter months. This is evident by comparison with Figures 1, 7 and 9, wherein the "M" indicates each Monday of the week in these figures.

The intensity of the signals from Manhattan Beach received at Amesbury, Massachusetts, which is about 200 miles from Manhattan Beach (300 kilometers), is given in Figure 24. The intensity of these signals is expressed in number of times audibility, as measured by Mr. G. W. Pickard, using the shunted telephone method. At the same time, I measured the strength of the Manhattan Beach signals, using a small antenna at my residence about two miles distant from the station. There I found the signals to be about 30 times audibility, using the same method, and I found practically no variation in the strength of these signals. The same applies to Figure 25.

Figure 26 shows the comparative areas over which communication could be maintained at different times of the year, and is based on the monthly averages given in Figure 12, used as radii.

A diagrammatic sketch of the arrangement at the Manhattan Beach station, and the methods used for coupling the open and closed circuits at this station and on the ship stations are given in Figure 27.

We pass to Chart 1. In the upper part, A, of this chart, there is shown, in solid lines, the vapor pressure at 6 P.M. at Denver, Colorado, for 1906, the vapor pressure at 6 A.M. being shown in

Chart #1

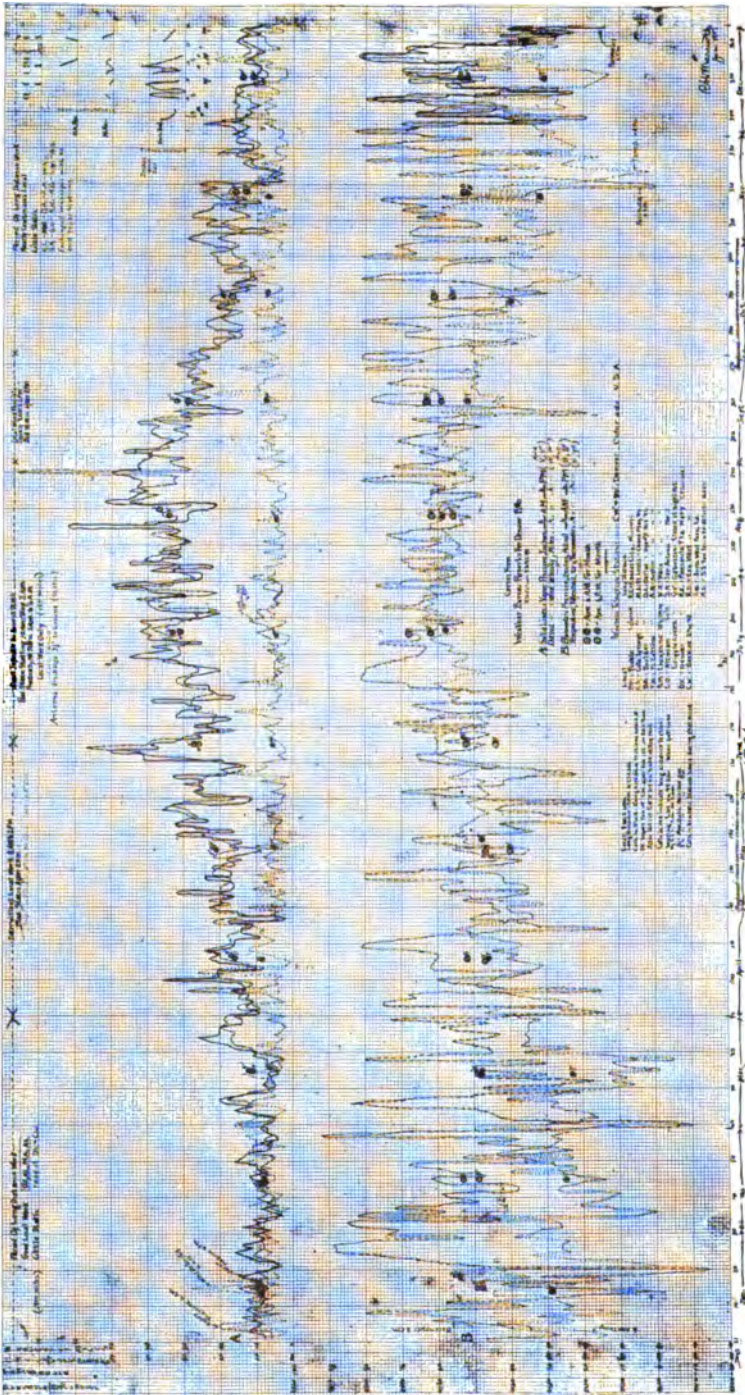

CHART 1.

light lines with superimposed dashes. The wind velocity is shown by the dotted line. The lower part of the chart, B, shows barometric pressure and temperature. In Colorado, the period between about October 1st and April 1st was the period of minimum atmospheric, of excellent local communication, and of frequent long-distance work. January was probably the best month for long distance ranges. Between about April 1st and June 15th local work with Cheyenne (Wyoming), Fort Collins, Boulder, Colorado Springs, and Pueblo (Colorado) was intermittent in character. Atmospheric usually became stronger at about 2 P.M. During the month of September some similar effects were observed. From about the middle of June to the 1st of September it was frequently almost impossible to carry on even local work because of the heavy atmospheric. During this period these disturbances began about 10 A.M. and lasted until about 2 A.M. Between 2 A.M. and 10 A.M. there was frequently only comparatively slight disturbance from atmospheric. During this period of the day time, for example when there was a storm near Pike's Peak, long spark discharges could be obtained between the antenna and ground. From an antenna 200 feet (60 meters) high at Pueblo, on one occasion I obtained an intermittent discharge about 3.5 inches (9 cm.) long. The frequency of this discharge increased as the spark gap shortened, until finally a short hissing spark was obtained.

Figure 35 of Chart 2 is intended to point out the periods of good and poor reception at Denver. The Denver antenna was similar to that at Manhattan Beach, but the ground was very dry. The receivers were like those used for ship work. On the dates for which no records are shown on Figure 35, no receiving was done at the Denver station. During this time Kansas City sent nightly in order that we might be able to carry on these tests. The records from other stations were naturally based on business handled by these stations under ordinary conditions, and I do not know whether they were operating every night during the time I was receiving at Denver.

In Figure 36 are given the strength of the signals received at Denver in number of times audibility. The signals from Kansas City were measured by the distance the telephone could be held from the ear and the signals still read; and this method was later compared with the shunted telephone method and is here indicated in times audibility by the shunt method. Kansas City did no transmitting after about January 15, 1907.

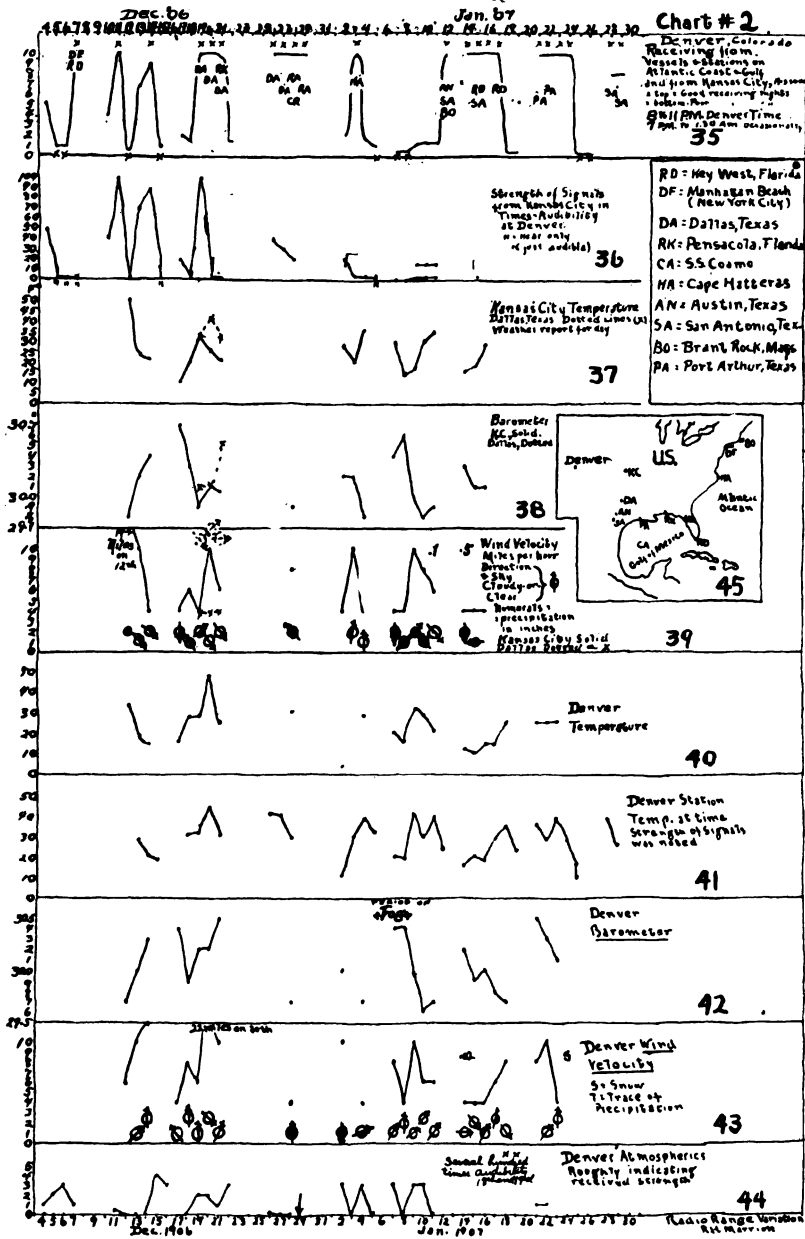

CHART 2.

The strength of atmospheric disturbances during the time of the measurements is roughly illustrated in Figure 44.

Figure 45 shows the relative positions and distances of the stations heard at Denver during December and January, 1906 and 1907.

The remaining figures on Chart 2 indicate the weather conditions at Kansas City and Denver during this period, as reported by the Weather Bureau.

Returning to the work of Manhattan Beach, Chart 4 shows a fairly characteristic list of the wave lengths and other data for the vessels which did the work given in Figure 1 of Chart 3. Data on some vessels with which Manhattan Beach did not work at that time, is recorded on Chart 4, and, on the other hand, some vessels with which Manhattan Beach did work during that period are not shown on Chart 4.

It is of considerable interest to note that out of twelve cases in which vessels worked over 1,000 miles with Manhattan Beach, it was found that in 10 cases the free end of the antenna was pointing toward Manhattan Beach and in 2 cases the free end was pointing away from it.

The effect of outside noises on the range of reception was shown quite markedly by the following. When measuring the strength of incoming signals by the shunt method, signals which were 20 times audibility at quiet moments, were reduced to 7 times audibility when a train passed the receiving station.

The Manhattan Beach station was so located that the tide rose and fell directly under the station and this alteration in the ground conditions may have somewhat affected the range.

Variations of range from minute to minute are sometimes caused by heating of the spark gap, and very marked variations in antenna current have been observed when quenching gaps were used without a fan or blower to carry away the heat produced. A somewhat similar variation was sometimes noticed using the plain United Wireless gaps on the ship stations.

The greatest number of long distance records made by a ship between October, 1908, and October, 1909, were achieved by an operator on a very small vessel, ship Number 53, shown on Chart 4. This vessel was only about 300 feet (90 meters) long, and was of about 1,900 net tons displacement. The long ranges achieved were apparently very largely due to the excellence of the operator in matters of skill, judgment, and perseverance.

Before I started the operating scheme with bonus for these

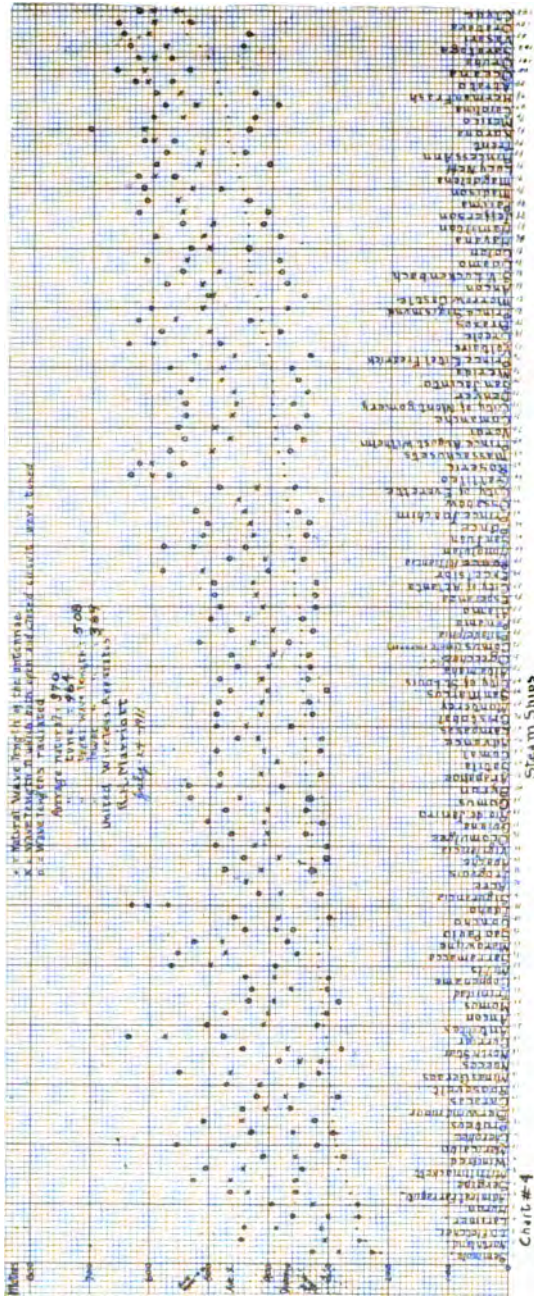

CHART 4.

tests at Manhattan Beach, the operators for that station were not particularly carefully chosen, and they were given no particular incentive to handle considerable amounts of business, except that they were reprimanded from time to time if they did not carry on sufficient work. As a matter of fact, they handled very little business. When selected operators were in charge and were paid a bonus depending on the amount of business handled and the distance over which this business was handled, the range was materially increased and the business handled was multiplied many times. In one instance the increase over a corresponding time was found to be 2,700 per cent.

Apparently, in the winter time, the operator expects to receive long distance messages, and he therefore makes a greater effort to carry on such work, but during the time of summer atmospheric disturbances he is discouraged by the difficulty of communicating over long distances and therefore he does not even attempt long distance work. There are apparently considerable individual differences in the ability of persons to receive signals, and the acuteness of the individual in receiving signals also varies from time to time and from place to place. For example, among other peculiarities, it was noted that weaker signals could be received in a room which was noticeably cold than when the room was quite warm. It was also noted that if barely audible signals were received, placing a cigar in the mouth rendered the signals inaudible. It is quite clear that a great amount of the variation in the strength of received signals which has been ascribed to ionization and consequent conductivity of the atmosphere is due to some other factors.

Some interesting matters are illustrated in Figures 12 and 15 of Chart 3. Considering monthly averages, and in some cases daily and hourly values of the strength of received signals, it was found that the range increased as the temperature decreased, even under unfavorable seasonal conditions. Perhaps sufficiently careful measurements of temperature of several points between the stations under consideration would show temperature changes corresponding to the minute to minute radio range changes.

While the daily local temperature may not be an accurate indication of the average temperature over the entire range of communication, the monthly average local temperature is probably proportional to the monthly average temperature over the range between stations. Figures 1 and 3 of Chart 3 show that the local daily temperature is not closely related to the daily range variation. It was also found that cloudy conditions in the



neighborhood of Kansas City frequently resulted in weaker signals as received in Denver. Referring to Figures 35 and 36 of Chart 2, it will be seen that Manhattan Beach, New York, and Key West, Florida, were heard at times in Denver, altho the signals from Kansas City were weak. According to the weather maps for that date, cloudless weather was practically universal for the section of the United States east of Denver, but a rapid change of temperature was occurring in the vicinity of Kansas City. On December 19th, signals from Dallas, Texas, and Kansas City were strong while other stations were not heard at all. From the weather maps for that date, it was seen that there was a cloudless area from Denver to Kansas City and Dallas, with a cloudy and rainy area east of Kansas City and Dallas. On December 21, 1906, Pensacola, Florida, and Dallas were heard loudly at Denver, while Kansas City was weak. At this time there was a cloudless space which included Denver, Dallas, and Pensacola, and there was a large equal pressure area surrounding Denver. On January 3, 1907, Cape Hatteras and Kansas City were loudly received at Denver, altho it was cloudy with precipitation over the greater portion of the area between Kansas City and Cape Hatteras. From December 7th to January 3rd there was a high pressure area in Colorado, southwest of Denver. On January 12, 1907, Austin, Texas, San Antonio, Texas, and Brant Rock, Massachusetts, gave signals which were strong in Denver, and yet the Kansas City signals were weak. At that time Austin, San Antonio, and Denver were in a cloudless area, while it was cloudy near Kansas City and somewhat cloudy with precipitation between Denver and Brant Rock, Massachusetts.

It is a question for careful consideration whether the strength of received signals may be influenced more by the refracting, reflecting or absorbing powers of the atmosphere at or near the receiving station than by the same atmospheric conditions at or near the transmitting station. It may be reasonable to expect that the former is the case.

High relative humidity, or rising temperature with less relative humidity on cloudy days, have repeatedly been found to produce very marked leakage of transmitter current by decreasing insulation. Extreme cases of this effect have been observed during January and frequently in the summer months. Damp spark mufflers caused considerable leakage losses in the United Wireless ship transmitters. In general, it appears that water in the air seems to be markedly associated with range variation. Such moisture directly decreases the range when it condenses on the surfaces

of the transmitter and receiver insulators. In cases where the transmitter spark gap is placed directly in the antenna circuit, moisture frequently causes the radiation to drop to zero. When coupled circuits are employed, moisture frequently lowers the current in both the open and closed circuits, the diminution of current in the open circuit being sometimes as much as 25 per cent. Marked losses at the receiving station have also been noted. In some cases, these were apparently due to moisture on crystal detectors, and the operation of such detectors was improved when the temperature was raised above that of the surrounding air.

Water vapor in the air seems to be intimately connected with atmospheric disturbances, both when these are produced by direct contact of the antenna with charged particles and also when the disturbances are produced by distant electrical discharges. Water vapor in the air possibly has a greater reflecting, refracting, and absorbing effect in transmission than is commonly attributed to it. Particularly is this the case if the density of the vapor is markedly non-uniform. If water is condensed on the surface of intervening vertical obstacles of large dimensions, it may also cause a material loss of energy from the wave.

Atmospheric disturbances in general may be said to cause more serious and erratic changes in the range of transmission than is commonly believed. Measured in arbitrary units, the atmospherics in Colorado, (expressed in terms of "times audibility") were roughly proportional to the fifth power of the vapor pressure, provided the vapor pressure were replaced by ten times its actual value; that is, the fifth power of ten times the vapor pressure approximately equaled the sound produced by atmospherics expressed in "times audibility." - For example, from section A of Chart 1, the average 6 P.M. August vapor pressure approximately equalled 0.37 inches, (0.94 cm.). If ten times 0.37, or 3.7, be raised to the fifth power, the result is 663. That is to say, atmospheric disturbances approximate 663 times audibility in August. In January and February, they averaged between one and two times audibility.

As will be noted in Figure 44 of Chart 2, they were very strong on January 18th and 19th. On December 29, 1906, the atmospheric disturbances were possibly fifty times audibility at 8 P.M. and decreased very rapidly in strength as the evening advanced. This decrease with increasing darkness was characteristic for that season but was particularly marked on the date mentioned.

Possibly a greater decrease in range is sometimes caused by

atmospherics than can be accounted for by the strength of the sound due to them in the telephone receivers. Such atmospheric disturbances may markedly decrease the sensitiveness of the detector. Furthermore, closing a spark gap in the antenna circuit has been found to increase materially the spark frequency during times of heavy static. The sounds produced when receiver circuits are rapidly opened and closed during periods of practically inaudible atmospherics, as well as other observations, lead me to believe that under some conditions there may be atmospheric discharges which follow each other at a rate above audibility, and that these, altho they are not heard, decrease the sensitiveness of the detector for signals.

As a plausible explanation of some of these effects, we may consider that during times of high vapor pressure there are more particles of water carrying electric charges present in the air; and these may be discharged by contact with the antenna. Then again, they may combine to form larger aggregates of water which discharge to other conducting bodies, such as other bodies of water or the earth. There are thus produced electromagnetic waves, which are picked up by the receiving antenna.

If we assume that the air contains one charged particle per cubic foot, such charged particle being just capable of producing an audible disturbance, and that the antenna presents a contact area of about 20 sq. feet to the air, then if the air be moving against this surface at the rate of 1.5 feet per second, or about 1 mile per hour, there will be about 30 discharges to the antenna per second. If this air have a velocity of ten miles per hour, there would be produced 300 discharges in the antenna per second; and so on. If, however, there are a thousand charged particles per cubic foot of air instead of only one, then an air velocity of one mile per hour would correspond to a discharge rate of 30,000 per second, which is practically an inaudible frequency. Even tho the particles in question are not uniformly distributed, provided the discharge rate is very high, the detector might be rendered in effect insensitive to incoming signals, altho the sound due to atmospherics might be weak, especially if there were no very marked grouping of the charges. An effect of this type has seemed to occur on a number of occasions, particularly during dust storms in Colorado. Also, I have been lead to believe that this occurs at times of a redistribution of charged moisture near the antenna.

It has been reported that atmospheric disturbances nearly always follow a sudden change of wind on the north Atlantic coast, and that this is particularly the case when the wind changes from

south to north. It is further stated that atmospherics always accompany a rise of temperature in this region, and that they decrease when the temperature falls.

Perhaps it may be said that some of the requisites for great ranges are maximum darkness with continued, stable, uniform, and cloudless atmosphere at low temperatures and low vapor pressures between the transmitting and receiving stations, and that these conditions should obtain for considerable areas surrounding the stations and particularly near the receiving station. Conditions which approach the opposite to those mentioned will permit only very short ranges; and such conditions are maximum amount of daylight, unstable, stratified, clouded atmosphere at maximum temperature and vapor pressure between the stations and in the neighborhood of the stations, particularly in the neighborhood of the receiving stations.

A portion of the radio range variation may be due to ionization produced by the light from the sun. However, the heat which is received from the sun directly and stored by the earth may vaporize water and thus produce a portion of the radio range variation. Furthermore, the suspended water vapor may be the vehicle for the electric charges which so markedly affect radio service ranges.

It will be seen that since the heat absorption by the earth and the vaporization of the water lag somewhat behind the corresponding rising and setting of the sun, the range curve will naturally lag behind the darkness curve; and that the ionization produced by sunlight may cause the range curve to be sharper than the temperature curves. These points are well indicated in Figures 11, 12, 15 and 20 of Chart 3.

As shown by Curve 1 of Chart 3, the *best* night ranges obtainable were quite small, and occasionally fell to 100 miles (160 km.) and less during the summer months. The ordinary induction coil apparatus now supplied for final recourse in case of distress apparently has a very much shorter range. It gives only about one-third of the antenna current produced by the ship sets we have been considering, and the sound which it produces is harder to read thru atmospherics.

From reports which have been received, the service range from steamship radio equipments now in use, and similar to the United Wireless one-kilowatt transmitter, may be even less than at the time these Manhattan Beach tests were made. The reason for this is the greater interference which has resulted from placing practically all equipments on a wave length of 600 meters, whereas formerly the wave lengths of 105 vessels, as shown in

Chart 4, were between 230 meters and 700 meters, each vessel radiating two waves. Greater service ranges and more efficient service would probably be obtained if the vessels had had loosely coupled inductive sets, so that they would have radiated practically only a single wave at the wave length to which both the open and closed circuits were adjusted. In the case of these 105 vessels, the wave lengths would have been between 300 and 600 meters.

Commercial business and distress communication could probably be kept above a fairly satisfactory minimum of range and efficiency by using more modern and proven apparatus than is in use at present. For example, efficient quenched spark apparatus furnishing notes of an audio or sound frequency of from 800 to 1,200 cycles per second with an easily variable output of from 500 to 1,200 watts in the antenna would be far more satisfactory. The antenna output could be varied in accordance with the requirements imposed by atmospheric conditions. The highly sensitive crystal and gaseous detectors, supplied with ample spare parts, should be provided. However, a spark frequency which enables reading thru atmospherics should also be used. In addition, an emergency storage battery of sufficient capacity to supply full power to the transmitter for message service during six hours would be of great advantage. And further, the salaries paid to operators should be in keeping with their responsibility and should be made sufficiently high to raise radio operating to a profession worthy of consideration by experts. Such modern apparatus and better paid operators have been tried, and are in use on one line of steamships, and the results have been markedly successful. It seems that commercial radio practice is altogether too far behind the radio scientists and engineers. A greater amount of effort should be applied toward bringing into use highly efficient, powerful, and reliable apparatus, in the hands of properly paid expert operators.

It is quite clear that in order to study radio range variation and atmospherics, as thoro a record as possible of weather conditions around and between the stations should be obtained. The amateur is probably a particularly appropriate individual for the study of ranges and atmospherics, because his financial situation is not dependent upon the nature of his reports. It may well be that the studying of radio ranges and atmospherics will be of considerable use to weather bureaus. Possibly we shall obtain considerable information regarding the upper atmosphere thru such study, and this, too, of a nature which cannot be ob-

tained by present methods. In addition, such study may get us much data concerning the lower atmosphere, and thus assist and supplement our present methods. For the purposes of such measurement, the time signals which are sent out by such stations as Arlington may be received in various parts of the country and be carefully measured for intensity.

---

## DISCUSSION.

**Vice-President John Stone Stone:** To The Institute of Radio Engineers I wish to state that I am honored by my election to the vice-presidency of that body.

Mr. Marriott's paper is rarely encyclopedic. Even the human element in its effects upon radio range variation has been considered. I think Mr. Marriott may have underestimated the influence on range variation of the diurnal variation; that is, the effect due to the sun's rays on the upper layers of the atmosphere. It may not seem to be very important, and yet it may prove the key to many of the effects observed. The losses which the sun's rays indirectly effect are due to currents which are conductively produced in the upper air layers by the traveling electric waves after the sun's rays have imparted conductivity to this portion of the atmosphere thru ionization. The currents thus produced vary directly as the conductivity, and they also vary directly as the potential gradient on the wave front. It may be that continuous waves are more effective because, for the same R. M. S. energy value, their wave front potential gradient is less than for strongly damped waves.

Recently some long-distance tests have been made, covering several thousand miles, and during these tests, the continuous and the damped waves were compared as to the absorption they experienced. The continuous waves proved to be much less affected by sunshine on the upper atmosphere. This immediately suggests how sunlight absorption can be successfully cut down.

**John L. Hogan, Jr.:** It has been suggested that atmosphericics at a frequency above audibility may exist. In this connection the following observations are of interest. A continual succession of sparks may sometimes be drawn across a  $\frac{1}{8}$ -inch (3 mm.) gap from an open antenna. This is usually explained as due to a succession of charged dust or water particles coming into contact with the antenna. It is, in fact, sometimes possible to get 2- or

3-inch (5 to 8 cm.) sparks in this way. And yet, when the antenna is grounded thru an ordinary receiving set, no sound is heard in the telephones. This may be because there is a succession of small but very frequent charges passing down the antenna, or else that the individual charges passing down the antenna are too small to produce an audible effect. When the heterodyne receiver is used with an antenna under these conditions, sometimes a steady hiss is heard in the receivers, altho no sound could be heard with the usual receiving set with crystal detector. In this case the heterodyne oscillator is tuned to nearly the wave length of the antenna.

In connection with Dr. Austin's long distance tests comparing the arc and spark transmitters, and Mr. Stone's comment on them, it seems that the simple potential gradient explanation of absorption is new. We must, however, be careful not to confuse energy and power. The gradient may be much less on the front of the continuous wave, but the total time during which the absorption is taking place may be much greater.

**John Stone Stone:** In answer to Mr. Hogan's last remark, the volt-ampere curve for currents in ionized gases at low pressures indicates that absorption may be more marked in proportion at high potential gradients than at low, so that the effect of the greater time of absorption for continuous waves may be more than offset by the relatively great absorptive power of the gas at higher potential gradients.

The absorption due to conducting obstacles in the path of the waves will in general be small, unless resonance phenomena occur therein. But tho such resonant absorption will be greater for continuous waves than for damped waves, it will be of rare occurrence, while with damped waves, and particularly with highly damped waves, all conducting obstacles will respond to and absorb the energy of the waves.

**Dr. de Forest:** Remarkable distances are sometimes covered in the daytime using continuous waves. Thus, 12 kilowatts has been used for transmission over 1,000 miles (1600 km.) by daylight. Probably reflection in the upper layers of the atmosphere and diminished ground absorption account for this unusual range.

The superiority of the arc transmission over the spark transmission gave rise to a lively discussion in "The London Electrician." The foreign authorities hesitated to accept Dr. Austin's conclusions at first. Yet there was every reason to expect his results.

Tyndall showed the reflection of sound waves by rising or

vertical air sheets or strata of heated air, and the phenomenon has been reproduced in the laboratory. Similar reflecting layers exist for electromagnetic waves. Hence we obtain a less absorption by night than by day.

That these reflection effects are often extremely prominent is shown by the short wave to long wave reversal effect (PROCEEDINGS INSTITUTE RADIO ENGINEERS, Vol. I, Number 1, page 42). Using two waves of slightly different length, signals by one will rapidly become very loud and those by the other disappear (working with arc sets, of course). In fact, two stations near San Francisco, and six miles (10 km.) apart, showed the following peculiarity at times. One received the best on longer waves, and the other on the shorter waves; the common distant station sending continuous waves. This effect has never been observed from spark transmitters except possibly from the best quenched spark sets.

**John Stone Stone:** Has the tikker ever shown a continuous radio frequency static, and an inaudible static such as described by Mr. Hogan?

**Dr. de Forest:** Yes, signals just like those from the arc are thus received. This is caused either by continuous wave static or by a *very* rapid succession of damped wave trains. The tikker would hardly enable us to differentiate between the two cases. In this test, the tikker was inductively coupled to the antenna circuit.

**Austin Curtis:** On a ship's antenna, just before a thunder or snow storm, there can be produced a rapid succession of discharges. These are sometimes loud, and sometimes nearly inaudible. The effect is quite easily produced, even wind carrying moisture giving a swish as it blows across the antenna. If the ship rolls to windward, the strength of the discharge increases and its group frequency increases, and when the ship rolls to leeward, the strength of the discharge diminishes and the group frequency is lowered. This shows that particular sort of discharge here considered is caused by charged particles of air or water being driven against the antenna by the wind, the group frequency and also the intensity depending on the number of charged particles striking the antenna per second. The detector was inductively coupled thru-out.

**Austin Curtis (by letter):** So far as the variation of range with temperature is concerned, I may say that in the tropics the changes caused by temperature alone are small. To begin with, there is



a rainy and a dry season, rather than a cold and a hot season. Best reception is accomplished in the dry hot season, which is when the sun and the equatorial rain belt are distant from the station, the sun is not directly overhead, and the static is not bad. As the sun gets nearer the station, it brings the rainy season with it, and the static becomes very bad, a continuous roar at night of about 500 times audibility being the rule. But signals are also much weaker in the morning, when there is little static, than in the dry season.

The variation in range between December and June is much less in the South Atlantic than here (at least, as far south as Buenos Ayres), but we find there irregular short freak periods, of two weeks or so at a stretch. The continuous roar of static which commences with sunset in the summer in the North Atlantic, and is very weak or absent in the winter, may be explained by the moving of the "equatorial calm belt," with its thousands of lightning storms, north and south with the sun. It is several hundred miles south of the equator in our midwinter, and several hundred miles north in our midsummer. The static coming from this source may be sharply separated from that caused by local thunder storms; the one being a dull, continuous roar, and coming only at night, the other a succession of sharp, distant discharges.

Static discharges in the tropics may thus be divided into distant and local static. The long distance static increases as the rain belt approaches the receiving station. (See also PROCEEDINGS OF INSTITUTE OF RADIO ENGINEERS, Vol. I, Number 3, pages 70 and 72.)

**Julius Weinberger:** F. Kiebitz in a recent article in the "Jahrbuch," \* gives the results of calculations of the refractive index for electromagnetic waves of air containing various amounts of water vapor. The effect of the varying refractive index of the air at different heights is to cause the electric waves to be bent toward the earth (or rather the effect is to tend to make them follow the curvature of the earth) to a considerable extent. He also shows that, while this varying index of refraction will not entirely account for long distance transmission, it still has a decided influence. He further assigns to the presence of more water vapor over the ocean a portion of the well-known superiority of over-water transmission.

**Mr. A. E. Kennelly** (communicated): Mr. Marriott's paper is of great interest from many standpoints, but particularly on

\* Jahrbuch der Drahtlosen Telegraphie, Vol. 7, page 154.

account of its wealth of statistical material. The relation between season of the year and the average range of signaling from "DF" is very marked, being apparently four times greater in midwinter than in midsummer, corresponding to a relative ocean-area range of sixteen to one under those conditions. The paper throws much light upon the climatic and atmospheric conditions attending this remarkable annual cycle of range variation.

Comparing Figures 11 and 12 on Chart 3, it might be supposed, at first glance, that from their close resemblance the range depended directly upon the daily darkness, as well as on the length of night time in the twenty-four hours. The daily range curve seems to lag about a month behind the daily darkness curve. This resembles the annual mean-temperature curve, which is shown in Figure 15 to lag behind the solar cycle by about the same amount. The question presents itself as to how far the seasonal variation in range is due to solar radiation acting directly on the atmosphere by ionization, and how far to secondary effects of that radiation, such as on water vapor in the air.

A satisfactory solution of this problem may take a long time to attain. It is possible that both direct and indirect actions of insulation are involved. That is, part of the diminution in summer range may be due to a more powerful ionization of the air during summer daylight hours, and part to the effects of more water vapor in the air during summer. It is to collections of observations such as are given in this paper that we must look for aid in arriving at a judgment.

The effect of aqueous vapor might manifest itself either at the sending and receiving aeriols or in the atmosphere between them. Mr. Marriott points out that electrified water droplets, impinging on the receiving aerial, could account for at least a part of the disturbances. On the other hand, such observations as are indicated in Figures 24 and 25 of Chart 3, where rapid fluctuations appeared in received signals at 200 miles range, whereas no such fluctuations were found at 2 miles range, suggests that the disturbing influence was in the intervening 200 miles of air. One might suppose that intervening cloud-like masses of water vapor, undergoing change of state, such as evaporation or condensation, could account for the erratic changes shown.

Co-ordinated records on the part of amateur radio telegraph operators, at many different points of the country and at various hours of the day, employing an approved technique, might be able to throw much light on this mysterious and fascinating sub-

ject. It is to be hoped that the Institute of Radio Engineers will appoint an active committee for promulgating such activities.

**George H. Clark:** A very striking illustration of the effect of atmospheric conditions on radio ranges was observed several years ago during a long distance test between a high-power shore station and a ship. The curve of received signals was quite regular, until one afternoon when the distance between the stations was about 1,000 miles. The weather was very sultry and the humidity excessive at the time, and the signals measured only one-fourth the value that was to be expected from the extrapolated curve. After a time a lightning storm was seen approaching from the direction of the sending station, passed over the receiving station, and receded in the opposite direction. The air became cool and refreshing and the humidity decreased. The received signals showed a remarkable increase, the measured value being several times greater than would be expected from the curve. Both tests were made in daylight, and were about three hours apart. On the next day, when the weather conditions were "average," the signals fell to the value indicated by the curve.

**John L. Hogan, Jr. (by letter):** Referring again to the much discussed differences between arc and spark transmission absorption, I would say that while the suggestion that a reduced absorption might be due simply to a change in potential gradient seemed new and possibly not valid, the conception involving the resistance-current function of gases is entirely familiar. It has been clear for some time that if in transmission any dissipation is produced at a rate higher than the square of the current or voltage, for a given power, continuous waves with their small amplitudes will be likely to have an advantage over damped waves. The existence of a type of energy loss such as this would be seems entirely speculative as yet, however.

## THE INFLUENCE OF ALTERNATING CURRENTS ON CERTAIN MELTED METALLIC SALTS \*

BY C. TISSOT

My attention has been directed to certain novel points in connection with the conductivity of several melted metallic salts and to the variation in conductivity caused by alternating currents ("electric oscillations").

The observations were made on the following salts: Chlorid of lead, chlorid of thallium, bromid of cadmium, chlorid of silver, bromid of silver, iodid of silver, acetate of silver. All the observations were made on salts which were in the solid state; that is, salts which were first melted and then cooled nearly to solidification.

To perform the experiments, there are placed parallel to each other in a porcelain dish, and at a separation of about 1 mm., two sheets of platinum about 4 or 5 mm. long and bent at right angles. A refractory material is piled up around these sheets in such a way that only the space between the sheets is left open in the dish. This space is then filled with the salt which is to be studied, and the dish is then heated over a good Bunsen burner so as to melt the salt. After the fusion and re-solidification of the salt, a lozenge of the salt will be found to adhere closely to the electrodes. An alternative, and nearly as satisfactory method, is to place a large drop of the melted salt on one of the sheets. This drop will spread if the sheet is heated, and the other sheet can be conveniently stuck to the same drop, if the second sheet is also properly heated.

These two methods of operation yield resulting sheets of salt which differ only in thickness. They behave similarly when current is applied.

After the salt has solidified, the sheets of metal are inserted as electrodes in a circuit composed of several storage battery cells, a device for reducing the electromotive force, and a galvanometer furnished with appropriate shunts. For all the salts mentioned above the general appearance of the phenomena is the same.

Under the conditions mentioned, and at ordinary temperatures,

---

\* Delivered before The Institute of Radio Engineers, February 4, 1913.

these different salts have a resistance of the order of magnitude of a megohm. This resistance does not change so long as the applied potential difference does not exceed a certain value (of the order of about a volt). But if this potential difference is increased slightly above the critical value, the resistance of the salt diminishes somewhat, at first slowly, and then more and more rapidly. The increase in conductivity proceeds more quickly in proportion as the applied voltage is higher.

In cases where the thickness of the layer of salt is about 1 or 2 mm., the true conductivity is established only after several minutes. (For example, in the case of chlorid of lead under an applied voltage of 10, after 15 or 20 minutes.) In those cases where the layers of salt are considerably thinner, the true conductivity appears much sooner under an applied voltage of 1 or 2; e.g., after about 2 minutes. The resistance of the salt passes then from a value near a megohm to a value of several thousand ohms.

Instead of applying a constant difference of potential to the melted salt and waiting till the true conductivity appears, which, as has been seen, takes a certain time, one may hasten the final condition by applying a gradually increasing difference of potential. A value is thus very quickly reached for which the conductivity appears to be established rapidly.

In one way or the other, once conductivity is established by the application of the difference of potential, this difference of potential may be considerably reduced (without completely removing it), and yet the values of the galvanometer deflections will be simply reduced in the same ratio as the voltage is diminished.

It sometimes happens that in passing from a considerable difference of potential to a much lower value, that the acquired conductivity disappears. But this does not occur if one takes the precaution of reducing the applied voltage gradually. The applied difference of potential may thus be reduced to a fraction of its original value, say to several tenths of a volt, and still the layer of salt will remain conducting.

In all cases, no matter what be the value of the difference of potential applied to the salt layer, *once the conductivity is established, it may be made to disappear immediately by applying to the salt "electric oscillations" (alternating currents) of sufficient intensity.*

In order to permit these free alternating currents to act on the system, it may be excited by a distant spark from an induction coil or simply by the "break" spark of a buzzer. The salt layer

may also be inserted in place of the detector in a radio receiving circuit. A "decohering" of the system will be produced at the passage of each train of waves. The expression "decohering" which I have here employed is not intended to indicate the nature or mechanism of the effect produced. I simply intend to state that the system, when acted on by free alternating currents of radio frequency, behaves in the opposite way to a coherer; that is, there is an *increase* of resistance.

After the decohering has been produced by the alternating current, a steadily applied potential will cause the system to become conducting again. The growth of conductivity occurs gradually in general, as has been described above, but much more rapidly than previously. And, as before, the higher the applied potential difference, the shorter the time for the conductivity to be produced. Furthermore, the lower the value of the steady electromotive force applied to the system at the instant that the alternating E. M. F. is applied, the lower the value of the alternating E. M. F. required to produce the decohering.

By regulating properly the value of the applied potential difference (taking account of the intensity of the alternating current received), it is possible to cause the decohering which occurs when the oscillations cease to be practically instantaneous, that is, sufficiently rapid to permit registering signals. The arrangement given is therefore a new type of detector. I hasten to add, however, that there is no danger of the replacement by it of the excellent types of detectors now known, because of its smaller sensitiveness—at least there is no danger of the replacement of the excellent types of detectors now known by it, because of its smaller sensitiveness—at least in the present crude form. Be that as it may, and leaving aside all question of a practical application, the phenomenon, because of its general character, merits attention.

I shall therefore present some details as to the manner in which the separate salts which I have examined behave. The haloid salts of silver deserve mention because they are very satisfactory experimentally, being easy to obtain in a pure state and readily melted in air without decomposition. They have the further advantage of adhering well, after fusion, to the platinum electrodes. However, it was not with the silver salts that the phenomenon in question was first observed, but with chlorid of lead. After having proven the increase of conductivity of chlorid of lead under the action of a gradually increasing voltage, the haloid salts of silver, and particularly the chlorid, were investigated in the hope of avoiding the possible effects of polarization. We were aware of the work

of F. Le Blanc and Kerschbaum\* who made some observations on chloride of silver which were quite similar to our own (neglecting the subsidiary question of the effects of electric oscillations).

We substituted for the platinum electrodes sheets of silver, and to our great surprise, failed utterly to obtain the results desired. The system made up of chlorid of silver which had been melted and connected between sheets of silver behaves entirely like a metallic conductor.

If a section of the salt between the electrodes is made, it is found that it is made up of thin bright sheets of metallic silver buried in an excess of the melted chlorid. This effect is not produced unless the chlorid is in contact with the metallic electrodes (of silver) for some time while it is melted. It is as if the chlorid when melted was *reduced* by the electrodes of silver. Gladstone and Tribe have observed and described this phenomenon. But it is probable that this is not a case of reduction of the silver salt but rather of a solution of the silver in the melted salt. On solidification, the silver crystallizes out of the salt forming links of a conducting chain thruout the mass. To avoid this objectionable effect, it is only necessary to work sufficiently rapidly so that the melted salt is not in contact with the silver electrodes for any length of time. If this is done, we obtain a system which behaves exactly as in the case of the platinum electrodes, thus showing that the phenomenon in question is not due to polarization.

On the other hand, with certain salts where a strong polarization is produced, the diminution of resistance due to the passage of a direct current is not produced. Such is the case with iodid of mercury. This salt melts without decomposition but with partial volatilisation. It has a yellow color when hot, which changes to red on solidification. It is thus easy enough to obtain a lozenge of this salt between the platinum sheets. But the conductivity of the salt, which is relatively large even at ordinary temperatures, diminishes continually under the action of an applied difference of potential. In no case have we been able to produce with mercuric iodid the phenomenon of "cohering" under the action of a direct voltage or of "decohering" by means of oscillations.

In the present state of our knowledge, any attempts at an explanation seem premature. It will be seen that the salts investigated fall in widely different classes. The effect is certainly not peculiar to chlorid of silver (or the haloid salts of silver) as F. Le Blanc seemed to think. For it can be equally well produced with a

---

\* F. Le Blanc and Kerschbaum, "Zeitschr. für Elektrochemie", 1910, pages 242 and 680.

number of salts of other metals. I should like to mention with particular stress bromid of cadmium, which gives exceedingly regular results. As I used bromids and chlorids at first, I thought that these elements of the halogen group might play an essential part. This opinion was not well founded, however, for I have apparently been able to produce the same effects with silver nitrate, the acid radical of which contains only nitrogen and oxygen.

It may be that we have something analogous to the variations of conductivity of certain solid salts which Baedeker\* has mentioned. It is known, particularly, that iodid of copper, which is ordinarily a poor conductor, becomes a good conductor when it is placed in an atmosphere of iodine vapor. Another experiment may be suggested; namely to observe the behaviour, when slowly heated, of the various salts which have been experimented with, a continuous current at the same time passing thru them.

Even a slight heating has at first the effect of making them better conductors. In general, the effect is temporary, and disappears on cooling. But if one heats them sufficiently, the conductivity obtained persists after cooling; heating has accelerated "cohering."

Even tho these experiments have treated only in an indirect way the matter of the detection of electric oscillations, I have made them public in the hope that they will suggest to the physicists who are working in the field of radio communication some interpretation applicable to other detectors.

(Translated from the French by the Editor.)

PARIS, October 28, 1913.

---

## DISCUSSION.

**John Stone Stone:** This paper naturally suggests the "anti-coherers" of the earlier days of radio communication. For example, S. G. Brown's detector, consisting of a lead point resting lightly on a lead surface which had been peroxidized, behaved similarly. Later he employed an "electrolytic" type, consisting of a lump of lead peroxid between a sheet of lead and a platinum point. The forms of detector described are also somewhat like the de Forest "Goo" detector, which consisted of a tube containing a fine metallic powder in glycerin. Before the International Electrical Congress at St. Louis, Dr. de Forest stated in

---

\* Baedeker: "Die elektrischen Erscheinungen in metallischen Leitern," 1911, page 23.



his 1904 paper that metallic chains were formed by a small direct current passed thru such a tube, and that these chains were broken up by the radio frequency currents, thereby causing a marked increase in resistance. The chains were rebuilt by the direct current shortly afterward. The effects produced are similar to those described by Tissot, but there is a question as to the resemblance in the ultimate mechanism in the two cases.

**Robert H. Marriott:** This paper indicates one interesting possibility. If it can be shown that the indication produced depends (with detectors of the type described by Tissot) on the thickness of the salt layer and the applied electromotive force and the received energy, and on nothing else, then it might be possible to use the device for measuring received energy accurately. In connection with the recording of the strength of "atmospherics," this would be quite useful, for it gives rise to the possibility of recording the strength of such disturbances on a chronograph sheet.

It might be possible, using a small quantity of the salt, to increase the sensitiveness of this device markedly, and make it more valuable commercially as well.

It is extremely gratifying that the Institute should receive papers from such eminent investigators as M. Tissot, in view of the increasingly international character of the Institute.

**John Stone Stone:** Mr. Marriott has called attention to an important point. A sufficiently thin film of the salt would probably permit of a marked reduction in the minimum radio frequency electromotive force producing indications, and would give high sensitiveness. A practical difficulty appears, however. After raising the direct electromotive force and current, it must again be reduced to a very small value for sensitiveness. Therefore the radio frequency electromotive force may have to be actually large enough to bring the resultant current back to zero, thereby allowing the cell to "snap back" to its high sensitiveness.

**Julius Weinberger:** There seems to be a certain relation between this device and the crystal rectifier.

I suggest that, in cooling the salts and electrodes, cool them at different rates, so as to produce interstices between the electrodes and resulting imperfect contact. This will probably increase the sensitiveness and make the response quantitative as well.

**John Stone Stone:** The cell might be made between plates in such a way that in cooling, only the contact surface of the fused salt was strained.

The paper indicates that some salts are unreliable in their action and others are noted as reliable. I have worked with selenium cells, and in their earlier forms some were extremely unreliable, but such cells have since been made very reliable. It may prove possible to do the same in this case.

**Julius Weinberger:** If we take the expression of Dr. Tissot, "cooled nearly to solidification," to mean that the salt is still in a semi-liquid, viscous state, with no evidences of crystallization present, another explanation for the action of the cell could be conceived.

In such a viscous state electrolytic conduction of direct current would be quite possible; however, ionic action must necessarily be slow; that is, attended with considerable inertia. The fact that electrolytic conduction exists is borne out by Dr. Tissot's observation that the resistance of the cell is lowered as the applied D. C. potential is increased, until a constant resistance is reached; and this is a characteristic of electrolytes. Now, as the radio frequency oscillations are applied they travel mainly over the surface of the viscous mass of salt, and since the conductance of the cell is electrolytic in nature, and since ionic action is already inseparable from some inertia, the ions of the salt will remain practically at a standstill when subjected to the rapid reversals of the radio frequency current.

Thus, the surface of the salt, at least, will, to all intents, become an insulator while the oscillations are passing. An insulating film is therefore thrust between the two electrodes and the direct current ceases to pass. As the oscillations are stopped, however, ionic conduction of the direct current again slowly starts, and the salt assumes its lower resistance.

**John Stone Stone:** I think that polarization of the cell is still a possibility.

**Julius Weinberger:** Pierce has shown that, under many conditions, there is no polarization with crystal rectifiers.

**John Stone Stone:** But such cells as those considered are made up of amorphous material.

**Julius Weinberger:** Not necessarily; crystals may be formed in cooling.

**John Stone Stone:** Such crystals as are formed in this cell are not dehydrated, thereby still permitting polarization of the usual sort.

**Emil J. Simon:** Does the conductivity of such cells fail to follow Ohm's law?

**John Stone Stone:** Not at all.

**Emil J. Simon:** This effect is analogous, possibly, to the ionized gas effects. We can also get a large change in resistance accompanying a small change of electromotive force in that case.

**John Stone Stone:** More data is required to enable us to judge whether the resistance of the cells is sufficiently critical to furnish an "unstable" condition. If such instability were sufficiently marked, and the inertia of the cell were low, we could get the "singing arc" effects.

**Emil J. Simon:** The trigger action of such cells might be of value.

**John Stone Stone:** Yes, provided that the response was reasonably quantitative.

**Robert H. Marriott:** Carborundum shows the same decrease of resistance on high electromotive force, but its resistance does not remain low when the electromotive force is reduced.

**John Stone Stone:** That is true, and ionized gases show the same effect. The rate of such changes may be very high in gases, thereby providing the necessary conditions of instability and for sustained oscillations, under suitable circumstances.

---

Mr. Stone then described briefly the nature of the apparatus which was used in the Paris-Arlington transmission in connection with the time-difference tests. Professor Abraham, of Paris, had given him the details of the photographic receiver. In this photographic recorder, the moving or driven element was the film and a tuning fork of known pitch recorded the time on the film. A special galvanometer was used to receive the Paris signals, a narrow beam of light reflected from the galvanometer mirror, and passing thru a suitable lens giving a sharp moving image. The distance from mirror to film was large, considerable amplification being secured. The average signals received extended just above the zero line, but sometimes the deflection of the galvanometer was so great that the signals ran completely off the tape. The spark frequency at Paris was 60 to the second, and a separate image was produced on the tape for each one. The tuning fork in question was free, not being driven electrically, and thus highly accurate timing was secured. The procedure was as follows: At a given

time Paris began transmitting. The signals were received slightly later. A specified time after the receipt of the signal Washington began sending the return signals. This operation was repeated many times and the average difference between the *total time* and the *time interval* between transmission and reception at Washington gave the time required for the transmission itself. A large number of observations were made to reduce the probable error. So far no difference was found between the results of rough computations of the velocity of transmission and the known velocity of light.

---

**Lester L. Israel:** Conceiving the fused salt to be either a solid solution of some of the metal in the salt, or to have some of the properties of an electrolyte, it follows that during passage of direct current, metal would be deposited at points of heterogeneity (also probably at points of high resistance), thereby lowering the resistance. Since the deposited metal particles are minute, they would redissolve (or recombine chemically) comparatively rapidly. Thus, while the current is below a critical value, the metal deposited would be rich and the resistance high. Above this critical value of current, the rate of deposition exceeds the rate of solution and the deposited metal lowers the resistance. Bringing the E. M. F. back to that which established the original critical current does not reduce the current to the critical value so that the resistance remains low. The radio frequency wave opposing the direct current brings the current below the critical value, solution exceeds deposition, and the original high resistance becomes established. Or it may be that the deposited metal is a "saturated solute," and is suddenly redissolved on the application of radio frequency energy somewhat as mechanical vibration will cause a supersaturated solution to crystallize.

**EFFECT OF A SHORT-CIRCUITED SECONDARY ON  
AN OSCILLATING CIRCUIT.**

**BY LOUIS COHEN.**

(Reference to a further discussion on Frederick A. Kolster's paper,  
"The Effects of Distributed Capacity of Coils Used  
in Radio Telegraphic Circuits.")

It will be noted that on pages 32 and 33, of Volume I, Part 2, of the PROCEEDINGS OF THE INSTITUTE OF RADIO ENGINEERS, the effect of short-circuiting a number of turns of the secondary of an inductive or direct coupler was discussed. In an article printed in "The Electrical World" for November 1, 1913, page 899, Mr. Louis Cohen discusses this question mathematically and reaches conclusions of interest to the readers of the above paper. A reprint of the same article by Mr. Cohen appears in "The Electrician" for January 23, 1914, page 652.—(EDITOR'S NOTE.)

# THE GOLDSCHMIDT SYSTEM OF RADIO TELEGRAPHY\*

By EMIL E. MAYER

The problem of producing very high frequency energy by electrical machinery has aroused great interest ever since the beginning of the development of radio telegraphy. To its solution have been contributed much inventive thought and engineering skill. I need only recall to you the names of Nikola Tesla, Reginald Fessenden, and E. F. W. Alexanderson.

So far as obtaining large amounts of energy is concerned, the first to arrive at a practical solution of the difficulties was Professor Rudolph Goldschmidt, former Chief Electrician of the English Westinghouse Company, and Professor of Electrical Engineering at the Technical College of Darmstadt. Some of his large generators, which furnish an antenna output of 150 kilowatts, have now been in operation for almost a year, and the results obtained are quite unusual.

## PRINCIPLES OF THE GOLDSCHMIDT ALTERNATOR.

The principles used by Goldschmidt are as ingenious as they are simple.

1. The non-rotating part of an alternator may be excited by an alternating current. Since the time of Ferrari, it is well known that the magnetic field produced by an alternating current may be resolved or split into two separate fields, each of half the amplitude. These component fields are to be regarded as rotating in opposite directions with the same frequency as that of the exciting current. To understand this, we need merely consider that every north pole changes into a south pole (with a sinusoidal variation); and that at the middle of this variation the magnetic field is equal to zero.

2. If a rotor revolves in the field of the exciting alternating current, two electromotive forces are produced in its windings. Calling the initial frequency  $n$ , and the frequency of the rotor  $n_1$ , it is obvious that the frequencies of the electromotive forces produced in the rotor are  $(n+n_1)$  and  $(n-n_1)$ . If the revolving parts rotate synchronously, that is, if  $(n-n_1) = 0$ , the frequencies produced are  $2n$  and  $0$ . We can thus explain the well known fact that by

---

\* Delivered before a joint meeting of The American Institute of Electrical Engineers and The Institute of Radio Engineers, March 13, 1913.

simply adding a number of such machines on the same shaft, the field of each being excited by the current produced by the preceding one, the frequencies of the currents produced will increase in arithmetical progression.

3. The ingenious process of producing this continuous increase of frequency in *one* machine was the invention of Goldschmidt. If a current of frequency  $n$  is permitted to flow in the rotor, it will produce a magnetic field of the same frequency. If the stator is appropriately wound, there will be produced in it, in turn, the frequencies  $(2n+n)$  and  $(2n-n)$  that is  $3n$  and  $n$ . Obviously, so far as the mutual induction between them is concerned, it makes no difference which of the parts is the exciter, or which the rotating portion. The current of frequency  $3n$  in the stator, will produce a magnetic field, which will excite electromotive forces of frequencies  $4n$  and  $2n$  in the rotor windings. If the process is continued for five frequency transformations, or "reflections," electromotive forces of the following frequencies will be produced:

<i>Stator</i>	<i>Rotor</i>
$n$	$2n$ and $0$
$3n$ and $n$	$4n$ and $2n$
$5n$ and $3n$	$6n$ and $4n$

4. It is not necessary to provide separate windings for the currents of different frequencies, for they will all flow in the same stator or rotor windings provided they find an appropriate closed circuit.

As an example of this effect, the well-known fact may be cited that in the direct current exciter circuit of an ordinary single phase alternator there is an alternating current of double the fundamental frequency superposed on the direct current. This double frequency current has been produced in the way described, and had found its way over the commutator of the direct current exciter.

5. In dealing with the frequencies used in radio telegraphy, a simple short circuit is not the circuit of least impedance, for even a small piece of cable has considerable inductance and a very small capacity, which, when added to the inductance of the winding itself will make the reactance of the circuit

$$\left(2\pi nL - \frac{1}{2\pi nC}\right)$$

high even if the ohmic resistance is neglected. To have minimum impedance, particularly at such very high frequencies, the cir-

circuits must be so tuned that the effects of inductance and capacity balance each other, that is,

$$2\pi nL = \frac{1}{2\pi nC}$$

In this case, only the ohmic resistance, which is naturally made as small as possible, remains.

By properly tuning the circuits containing the inductance of the armature, currents lagging behind e. m. f. are avoided; and the only limits to the growth of current are the ohmic resistance of the circuit and the losses due to hysteresis and eddy current as well as losses in the insulating material. These latter losses may be summed up in a single resistance factor, properly calculated.

If in all the circuits electromotive force and current are in phase, the frequencies of the *same* magnitude produced by rotation in two *different* magnetic fields must be in *opposite* phase, and therefore cancel each other to a certain extent. They may be simply considered as action and reaction. For example, there is obtained by rotation in the field of the rotor current of frequency  $2n$  another current of frequency  $n$ ; that is, of the same frequency as the fundamental current. But the frequency  $2n$  has been produced by rotation in the field of the original current of frequency  $2n$ . So that the current of frequency  $n$  produced by rotation in the field of frequency  $2n$  will be in exactly opposite phase to the original current of frequency  $n$ , and will therefore reduce its magnitude. Experiments shows that if all the circuits are properly tuned and connected, only a very small margin of the intermediate frequencies will remain. The intermediate frequencies will exist in only sufficient amount to cover the losses in the tuning circuits and that portion of the loss in the machine which is necessarily due to the definite frequency considered.

The process of increasing the frequency can be stopped at any point merely by not adding any further tuned circuits to those already present, for no currents of the higher frequencies will flow without tuning.

As regards the magnetic fields, a similar phenomenon occurs. Only the magnetic field of the highest frequency will exist in its full intensity, for all the intermediate frequency fields will be partially neutralized. Therefore only the last field will add noticeably to the hysteresis and eddy current losses.

The Goldschmidt alternator, built as described, is a combined generator and frequency transformer. It is remarkable that theoretically the process of energy transformation to the higher



frequencies takes place in such a way that all of the generated energy is transformed. The limit of the "reflection" is determined solely by the copper losses, and the losses in the iron and insulation of the machine; if we consider efficiency only. If actual output for a given amount of exciting energy is considered, the limit is reached when the magnetic leakage between the rotor and stator becomes excessive. Since the influence of the leakage will be to decrease the output per unit of exciting current at each reflection, it is of the highest importance to keep it small.

The diagram of connections (Figure 1) shows a Goldschmidt alternator with four frequency-transforming circuits. For each

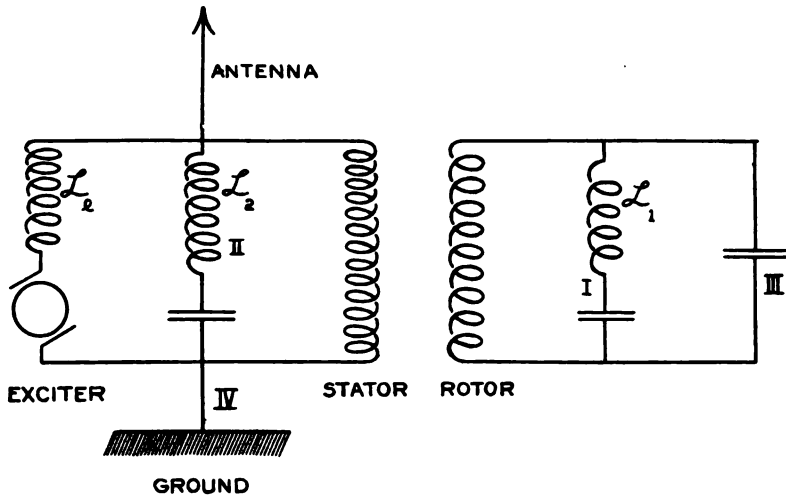

FIGURE 1—Connections of Goldschmidt Alternator.

frequency there is a tuned circuit. The exciter circuit, and also the circuit of the lowest frequency are protected against the higher frequency currents by additional inductances, or choke coils. As can be readily seen, this measure is necessary to render tuning feasible.

It is necessary that there shall be a certain relation between the inductances in the tuning circuits for, say, the third and fifth frequency currents produced in the stator. If this relation is not obtained the addition of a further circuit in the tuning process would detune the other circuits so considerably that it would be exceedingly difficult to tune again. It is clear that, however, we adjust the tuning circuits, a certain detuning will occur under the conditions. But if the inductances are properly chosen, this detuning can be easily calculated and allowed for.

## GENERAL NOTES ON THE DESIGN.

It has already been stated that every process of reflection involves certain losses which are due to losses in the tuning circuits and also in the machine itself; and further, that the obtainable energy becomes less at each process of reflection because of magnetic leakage between the circuits. This fact makes it desirable to reach the highest frequency (which is to be used for radio telegraphy) without having more than, say four or five reflections in the machine. Consequently the designer is forced to use an unusually high fundamental frequency. For example, the wave length of 6,000 meters, which is frequently used for trans-Atlantic work, corresponds to a frequency of 50,000 cycles per second. (These quantities are connected by the equation  $\lambda = v/n$  where  $\lambda$  is the wave length,  $v$  the velocity of light, and  $n$  the frequency.) If not more than five reflections are to be permitted, the initial frequency must be 10,000 cycles. Consequently a high speed and a large number of poles are necessary. Let us assume a maximum speed of rotation of 3,000 revolutions per minute. Then, as the following equations show, we must have 400 poles.

$$\frac{P U}{120} = n$$

where  $P$  is the number of poles,  $U$  the revolutions per minute, and  $n$  the frequency.

Using the best materials and the highest engineering skill, the maximum speed which can be safely maintained is 200 meters per second at the periphery. This is already rather unusual, but, as experience shows, it is permissible, if proper precautions are taken. We find therefore, that for 3,000 revolutions per minute, the greatest diameter of the rotating portion of the machine must not exceed 1.25 meters (4 feet 1 inch). This gives a circumference of 400 centimeters (12 feet 10 inches). Consequently, the width of each pole is 1 centimeter (0.4 inch). If account is taken of the necessary iron and insulation, it will be seen that we are limited as to the current which can be carried by the conductor in each slot.

To save room and to avoid capacity and inductance between parts of the winding, the safest and most economical method is to place only one conductor in each slot; that is, one winding per pole. To make it possible to adapt the voltage produced to the

resistance of the antenna which is employed, the winding is arranged so that it can be divided into groups which can be arranged in series or parallel. The wire itself must be stranded, and the strands must be the finest the manufacturers will consent to use. For example, a number of Number 40 B. & S. gauge wires, each separately insulated and properly stranded, will prevent undue losses due to the skin effect. In addition, the outside insulation of this wire must be very reliable. In Figure 2 is shown a simple diagram of the winding of the rotor and stator.

Iron which is in a magnetic field of frequency of 30,000 or 40,000 cycles must be of the best quality and very well laminated. In addition to high mechanical strength it must have a large

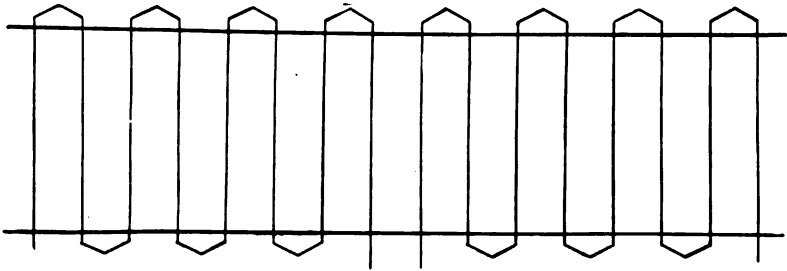

FIGURE 2—Winding Diagram of Rotor and Stator.

ohmic resistance to keep the eddy currents small. Eddy currents not only produce heat losses, but also weaken the magnetic fields by the reaction of their own fields. They will, therefore, decrease the output of the machine. In our machines we use steel of a thickness of 0.05 millimeters (or 2 mils = 0.002 inch) insulated by paper about 0.03 millimeter thick (1.2 mils). It will be seen that the body of the rotor and of the stator are more than one-third made up of paper, and the combination is a rare one to be used as a construction material of high quality. It is needless to say that an enormous amount of detail work and experimenting were necessary before it became possible to subject a rotor made of such materials to the strains arising at a speed of 200 meters per second. Great credit must be given the manufacturers, Messrs. Bergmann, of Berlin, for the ingenious manner in which they worked out every detail of this machine.

I feel that I am not speaking too strongly if I state that I believe that we shall consider the construction of these very high frequency machines as marking the beginning of a new era in engineering exactitude. For we have here an extremely large and heavy machine, which must be built with the precision of a

watch. Consider, for instance, the air gap. We have seen the great importance of a low stray factor. This stray factor will depend almost entirely on the size of the air gap, for this is practically the only region of any marked reluctance to the magnetic flux. Therefore this air gap is made 0.8 millimeter wide; that is, a trifle more than 1-32 of an inch. This clearance, in combination with a peripheral speed of 200 meters per second for a rotor weighing about five tons, forces the manufacturer to adopt absolutely new engineering methods.

Another example of the unusual precision required is the following. In any electrical machine the slots must be approximately parallel, but in this particular case a divergence from parallelism of 1 millimeter in 1 meter's length causes 20 per cent. of the total output to disappear.

All of these effects could be foreseen, and were guarded against. We shall consider an unforeseen special difficulty which arises when handling such a large current at very high frequencies in a machine. This trouble arose at the slip rings. It is necessary to connect the ends of the rotor windings to slip rings in order to make it possible to attach the tuning circuits. In order to avoid having an excessively high voltage in the rotor, Goldschmidt placed a number of the rotor windings in parallel. Consequently the current flowing in the rotor was very high. A large number of brushes were put on to handle this current, but the current would not distribute itself equally between the various brushes. As soon as full load was put on, some of the brushes would heat and spark, while others would not. We soon found that because of the additional resistance of the particular circuit in which it was placed the impedance of that path would be considerably increased, and the brush in question would not take its share of the total current. Furthermore, if because of some unavoidable unevenness in the surface of the slip ring, one of the brushes was raised slightly, the current flow would not be interrupted, because the inductance of the circuit prevented a sudden change of current, the time constant,  $L/R$ , being large. As a result of this effect the slip ring would be burnt. A long time was required to find the necessary materials and design whereby these disadvantages were eliminated.

In addition, it was rather difficult to handle the currents outside of the machine. In usual power engineering the capacity of the windings of the machine to ground is of importance only in connection with certain transient phenomena such as occur when closing circuits or at a short circuit. This capacity plays

a very important part in high frequency machines. A portion of the current which has been produced will escape to the ground thru this capacity without being usefully employed in producing the higher frequencies or being sent into the antenna. Under the worst conditions, the capacity to ground of the windings and the inductance of the iron paths from winding to winding or from windings to ground will combine to produce a resonant effect for currents of some one of the frequencies produced, with the result that the current itself will pass partly through the iron of the machine. In such a case it would be impossible to get the expected output even if the excitation be abnormally increased.

#### EXCITATION OF THE ALTERNATOR.

Because of the ease of handling it, direct current proved most suitable for use in excitation.

In radio telegraphy, it is necessary to vary the energy sent into the antenna rapidly in accordance with the signals (dots and

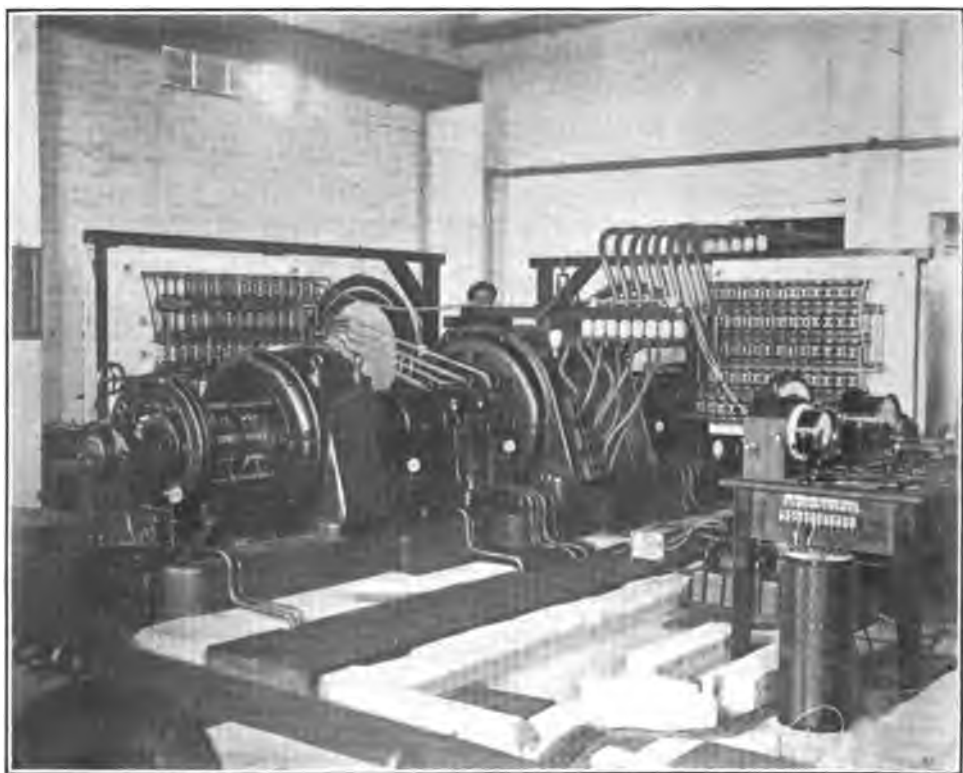

FIGURE 3—Goldschmidt 100 K. W. Radio Frequency Alternator.

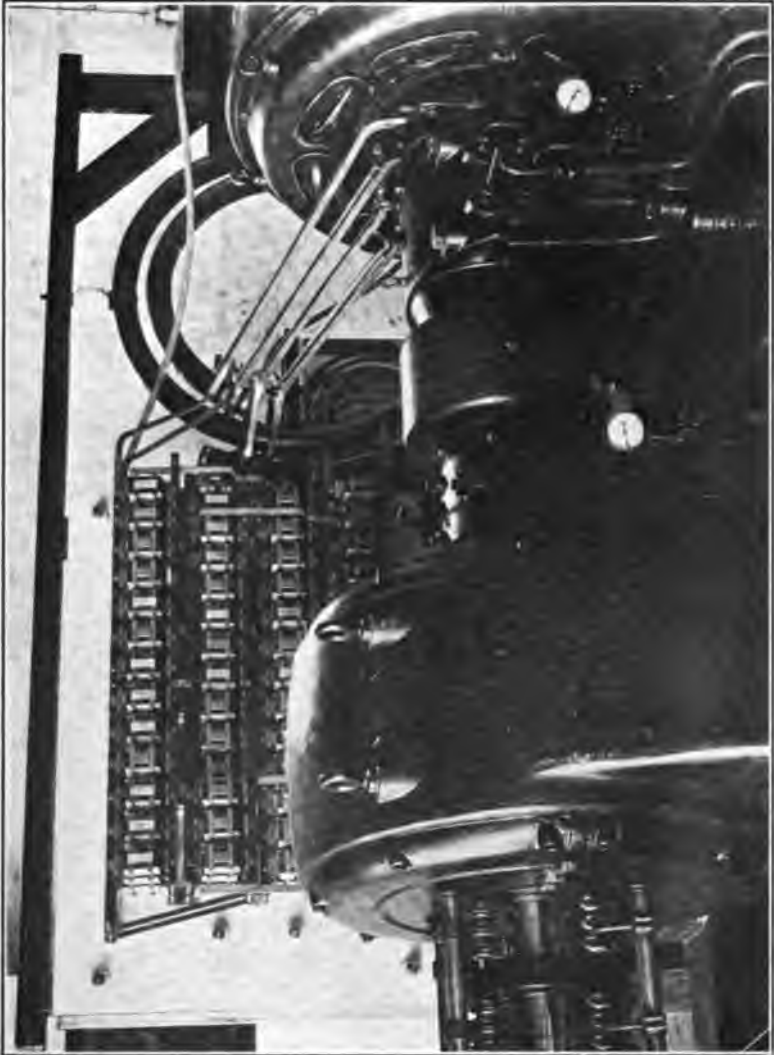
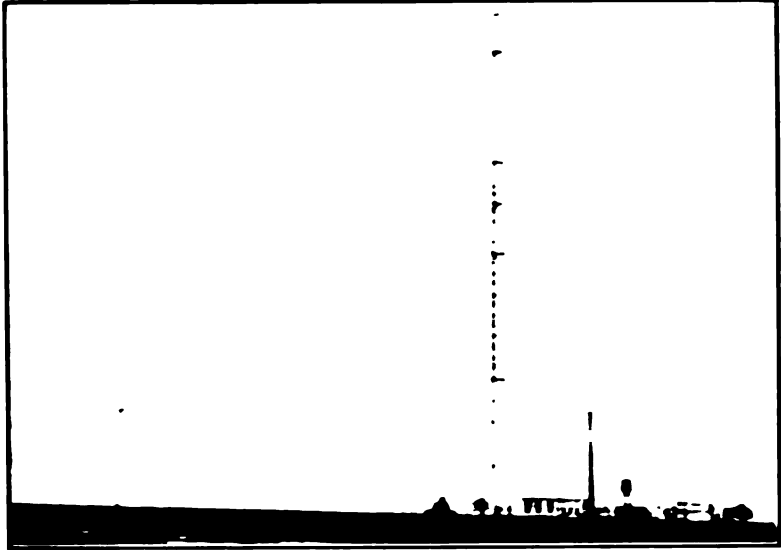

FIGURE 4—Driving Motor and Condenser Boards.



**FIGURE 5—Tuckerton Radio Station. Showing 225 foot Steel Tower.**



**FIGURE 6—Tuckerton Radio Station Power House.**

dashes) which are being sent. Assume, for example, an average speed of transmission of 30 words per minute, each word consisting of five letters of two signals each. We have, then, 300 signals, or 300 makes and breaks per minute. It is therefore vastly preferable to govern this energy flow in the exciter circuit, where the amount of energy to be controlled is so much smaller. The exciting energy is between 5 and 10 kilowatts for an output of from 100 to 200 kilowatts from the machine.

The phenomena which occur when the exciter circuit is closed are of interest. It is obvious that before reaching the final state, there will be damped oscillations having a time constant  $L/R$ .



FIGURE 7—Eilvese Radio Station Power House.

These free alternating currents are represented by an equation of the following kind:

$$i = I_m \left( 1 - e^{-\frac{R}{L}t} \right)$$

We see that it is desirable to choose large capacities and small inductances for the tuning circuits, and that it might be advisable to insert additional resistance in the exciting circuit, or perhaps even in some of the other circuits to make the signals very distinct.

This might be the case for automatic transmission and automatic reception at high speed. With automatic transmission and



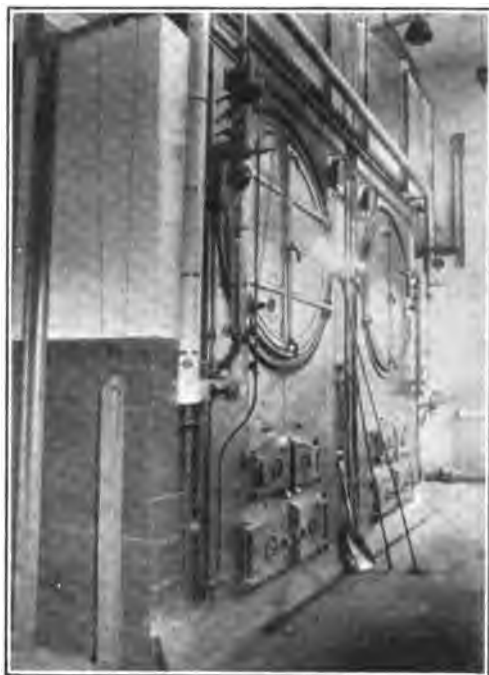

**FIGURE 8—Tuckerton Radio Station Boiler Room.**



**FIGURE 9—Tuckerton Radio Station Dynamo Room.**

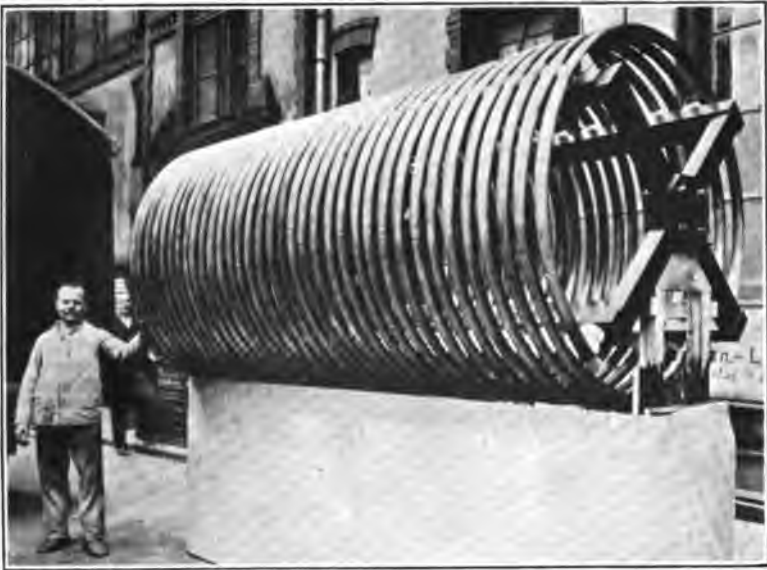

FIGURE 10—Antenna Loading Coil.



FIGURE 11—Base of Steel Tower Supported on Columns of Glass Insulators.



FIGURE 12—View Looking Up Steel Tower.

reception the number of makes and breaks per minute may be three times as great as in the case just described, and if the final state is not rapidly attained, the signals would not be distinct.

### TRANS-ATLANTIC RADIO COMMUNICATION.

Since April of last year, a Goldschmidt machine of maximum output of 200 kilowatts (normal output 100 kilowatts) has been in use at the German radio station at Neustadt-am-Ruebenbergen near Hanover, Germany. A point of interest in connection with this station, and also the nearly completed station at Tuckerton, New Jersey, is that they resemble a medium size power plant of the usual kind more than a typical station for radio telegraphy. The following illustrations of the machine and of the power house show this. (Figures 3 thru 9).

The antenna, with a loading coil of large dimensions, (Figure 10) is connected to the last tuned circuit of the alternator. The antenna output can therefore be readily measured by simply connecting a volt-meter across the antenna and ground, and placing an ammeter in the antenna. As an antenna, (Figures 5, 11, 12) we use a double cone wire system, consisting of thirty-six wires attached to the top of a steel tower 825 feet (250 meters) high. The outer ends of these wires are fastened to poles 40 feet (12 meters) high, which poles are placed in a circle around the tower, the radius of the circle being 1,500 feet (450 meters). The antenna itself is only about one-third of the length from the top of the tower to the surrounding circle of poles, and is supported by a chain of heavy saddle insulators. The tower is insulated from the ground, (Figure 11) and there is also an insulating joint in its middle. These separating insulators consist of a number of columns of glass insulators. Glass is used as an insulating material because it is satisfactory when used, as here, only under compression. The ends of the guy ropes which support the tower are fastened to reinforced steel beams which are sunk in heavy concrete foundations. They are shown in Figure 5.

It is unnecessary to describe the prime mover in detail. It may be of some interest to know that in Germany we use a 400 horse power "Wolf" engine which contains boiler and engine together. This engine meets the requirements of economical operation, small space required, and reliability of operation very satisfactorily.

The radio frequency machine is connected by means of a flexible coupling to a direct current motor, which draws its energy from two direct current generators in Ward-Leonard connection. By



**FIGURE 13—Photographic Printer for High Speed Reception.**

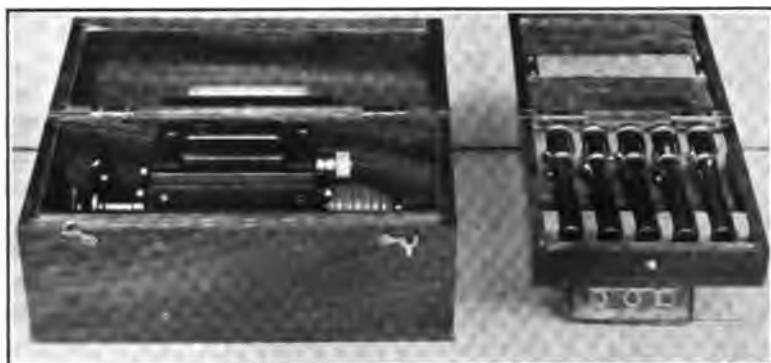

**FIGURE 14—Vibrating Thread Cases and Holders for Photographic Printer.**



FIGURE 15—Twenty-five Microhenry Inductance Coil Unit, 200 Amperes.

regulating the voltage of the two Ward-Leonard dynamos, ease in starting and convenience in speed regulation are obtained.

The motor, which was built by Messrs. Bergmann of Berlin, is somewhat out of the ordinary. It is a 4,000 revolutions per minute, 250 horse power, 220 volt direct current motor.

The inductances of the tuning circuits, which must carry currents of about 200 amperes, are made of tubing, and are partly of the cylindrical and partly of the spiral pan cake type. Experiment and theory agree, however in pointing to properly made cylindrical coils are preferable.

Quite a discussion has arisen concerning the possibility of satisfactory speed regulation for such machines employed for radio

telegraphy under conditions of continuous and rapid variation from no load to full load. Certain individuals have feared that the inconstancy of speed might prove a serious drawback to the use of

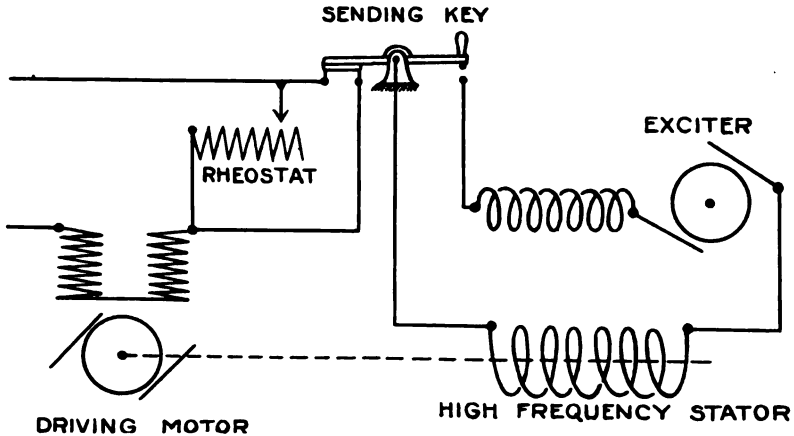

FIGURE 16—Speed Regulation Device for Driving Motor.

such alternators. Practice, however, has shown that speed regulation is really a very simple matter because of the influence of the enormous rotating masses which, thru their inertia, oppose any changes in speed. As an additional method of obtaining speed constancy, Professor Goldschmidt originated the design shown in Figure 16. While the sending key is open, a part of the field resistance of the driving motor is short circuited. This short circuit is broken when the key is pressed.

Theory shows that a slight variation in speed would, so far as transmission is concerned, have the effect of making the sustained waves equivalent to slightly damped waves. That is, the sharpness of tuning would be slightly impaired. However, we were unable to find any such effect in our tests.

#### RECEIVING APPARATUS.

An important portion of the Goldschmidt system of radio telegraphy is the receiving apparatus, of which the most novel and important portion is the tone wheel. This is the simplest form of frequency transformer that can be imagined, and yet has an exceedingly high efficiency. For normal telephone reception, the problem is the following. The incoming waves, of a frequency of about 50,000 cycles, are to have their energy so transformed as to give rise to alternating currents of audible frequencies, say between 250 and 3,000 cycles per second.



FIGURE 17—Sending Key.

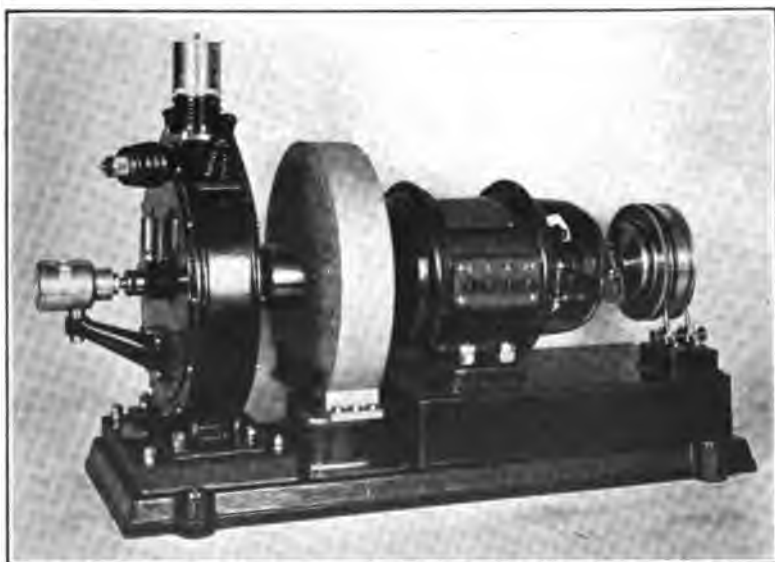

FIGURE 18—Tone Wheel, Showing Centrifugal Speed Control, Eddy Current Brake Disc, and Special Motor for 4,000 R. P. M.

The usual crystal, electrolytic, and magnetic detectors are capable of making only damped wave trains audible. For sustained waves, they react by giving a sort of click in the telephone receivers at the beginning and end of each incoming signal. The so-called "Tikker" of Waldemar Poulsen, a very sensitive detector for sustained waves, does not give a musical note in the receivers but only a sort of buzzing noise. Furthermore, it uses only a fraction of the incoming energy. The buzz produced is very similar to the sounds produced by atmospheric disturbances, (static) and make it very difficult to receive with the tikker if atmospheric conditions are unfavorable. The Goldschmidt frequency transformer transforms the incoming frequencies to a note of well defined frequency, and therefore gives a pure and musical tone. The principle of its operation is the following. A simple toothed wheel, acting as a make-and-break commutator, has such a number of teeth or poles that, at a reasonable speed its interruptions are synchronous with the incoming frequency. For example, 800 teeth on the wheel, and a speed of 3,750 revolutions per minute, would produce a frequency of interruption of 50,000 cycles per second.

The width of the teeth may be made equal to the width of the spaces between them. For the sake of simplicity in explanation, let us assume that the contact which slides on these teeth is merely a point (or line). If this device, running synchronously, is connected in any way to the receiving antenna, it will produce a pulsating direct current, for it will always make contact for just the length of a positive or negative half-period. The telephone diaphragm will not be displaced under the influence of this rapid succession of uni-directional impulses because of its mechanical inertia. Conse-

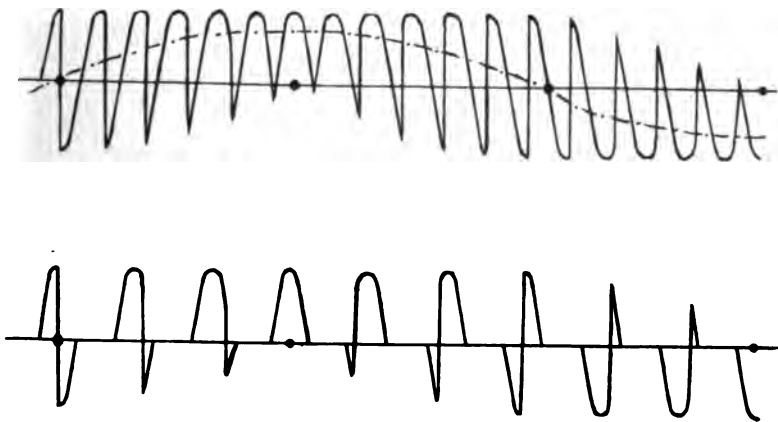
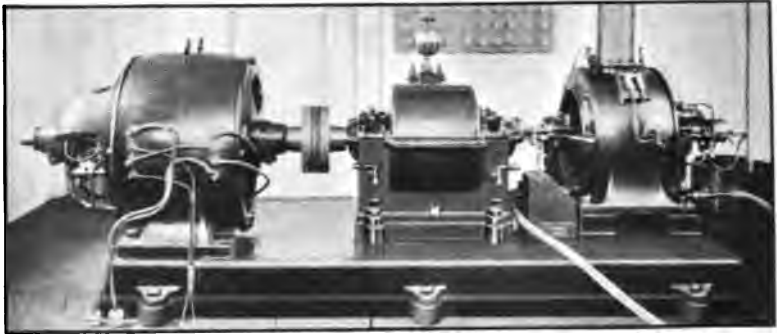
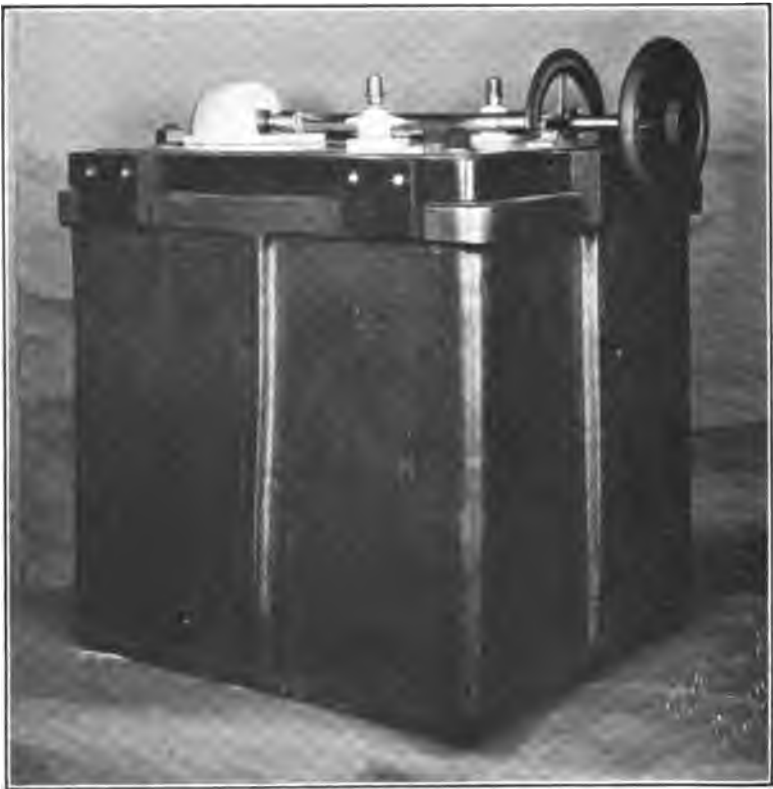

FIGURE 19—Current in Tone Wheel.





**FIGURE 20—Ten K. W. Goldschmidt Alternator.**



**FIGURE 21—Antenna Variometer.**

quently no sound will be heard. If now the speed be altered, so that the wheel runs slightly above or below synchronism, the full amount of energy of the positive half-period will be admitted to the receiver for only *one half period*, while for the next half period a smaller portion of the energy of the positive half period will be admitted. For each successive half period a smaller amount of the positive energy and a larger amount of the negative energy will be admitted, until, when the amounts of positive and negative energy admitted are equal, the telephone diaphragm will receive no net impulse at all. The amount of negative energy admitted will gradually increase from this time on, until finally all the energy of the negative half periods will be admitted to the telephone circuit. In other words, the telephone diaphragm is subjected to recurrent forces of the beat frequency, which latter may be easily adjusted to the sound of maximum audibility by altering the speed of the tone wheel. The current in the tone wheel circuit is shown in Figure 19. Higher harmonics, which will be superposed on the fundamental frequency, will be of small amplitude because of the large inductance in circuit, and will not affect the clearness of the note in any way.

It is not necessary to run the tone wheel at approximately its synchronous speed. The same effects will be produced if we run it at near one-half, one-third, etc., of its synchronous speed, with the only difference that a smaller portion of the incoming energy is transformed. The apparatus is very compact and convenient when used as a wave meter, for when synchronism is attained all sound disappears, and the wave length can be readily calculated from the number of teeth in the wheel and the speed of rotation.

Since this apparatus does not add to the losses of the telephone circuit, its energy efficiency is high and it permits very sharp tuning. It may be coupled electrically, inductively or capacitively to either the primary or secondary of the receiver, the choice being determined by the amount of interference to be avoided.

This type of receiving apparatus makes it possible to use a musical note which can be read through static, and also frees us from interference to a very large extent. A very slight difference in the wave length sent from an interfering station will be sufficient to produce an entirely differently pitched sound in the telephones when the tone wheel is used. Thus the interfering station can be readily distinguished from the desired one. An alternative method of procedure in avoiding interference is to alter the speed of the tone wheel to a point at which it is in syn-

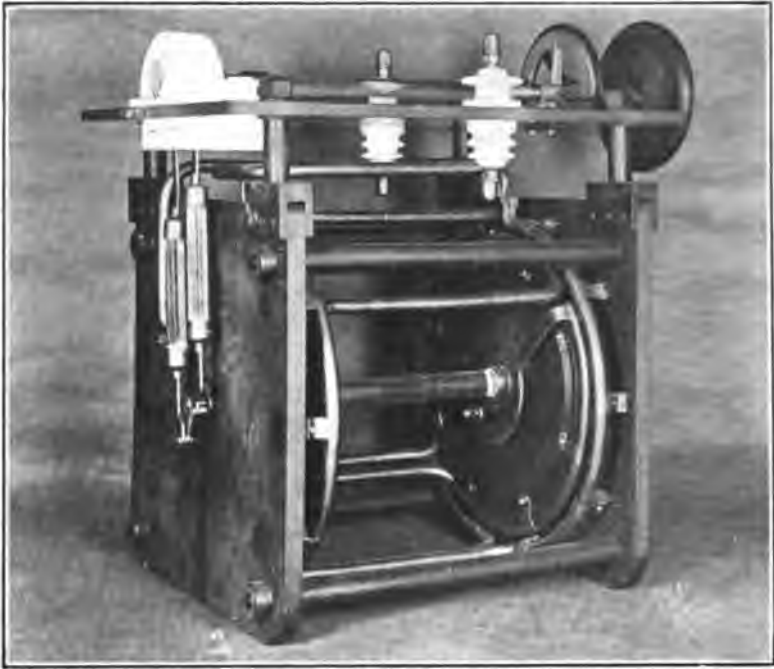

FIGURE 22—Antenna Variometer.



FIGURE 23—Receiving Room.

chronism with the undesired signals, which latter, as explained above, will then not be heard. The desired signals will however remain audible.

As an example of the application of this latter method, suppose we are receiving a wave length of 6,000 meters (corresponding to a frequency of 50,000 cycles). The tone wheel having 800 teeth will be at synchronous speed at 3,750 revolutions per minute. In order to get a high note in the telephones, we employ a slip of 1.5 per cent. thus running the wheel at 3,694 revo-

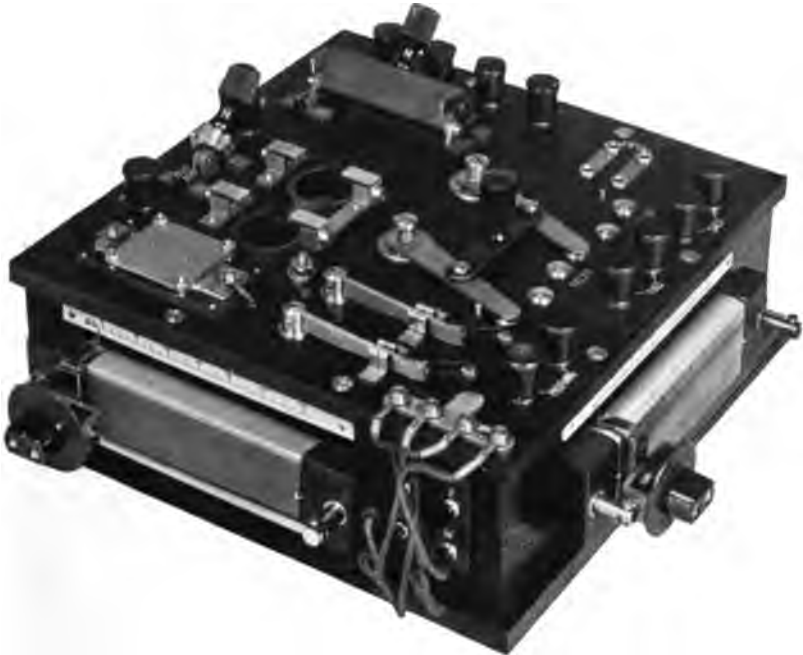

FIGURE 24—Receiving Set.

lutions. The note will therefore have a frequency of 750 cycles. Suppose that another radio station, working at a wave length of 6,100 meters should interfere. If the strength of the incoming signals in both cases is the same, it would be extremely difficult for operators using ordinary receiving sets to avoid this interference. They would be forced to use a very loose coupling, with the accompanying faint and doubtful signals. But with the tone wheel, there is no possibility of any interference at all. For the wave length of 6,100 meters, which corresponds to a frequency of 49,200, the synchronous speed of the tone wheel is 3,690. So

that the tone wheel, which is running at 3,694, is just slightly above synchronism for the incoming interfering signals, and will therefore produce a current in the telephones of frequency of 50 cycles (0.1 per cent slip). This latter tone is below the limit of audibility.

Using the devices described above, we have been able to telegraph from Eilvese to Tuckerton, a distance of nearly 4,000 miles (6,500 km.) beginning in July of last year. Since that time we have been in communication, and have transmitted messages at different times of day and night, except for a few weeks, when, because of a break down in the antenna, we were not able to transmit. We found the same difference between day and night transmission which has already been remarked by others.

While it is not so large with the long waves as with short waves, the difference is still considerable. There is also a large difference in the strength of the signals received on different days, which leads naturally to the idea that there are reflection and refraction effects which sometimes aid and sometimes hinder communication.

But it may be confidently said that, whatever the conditions, the problem of reliable commercial communication between our stations is practically solved.

#### THE POSSIBILITY OF RADIO TELEPHONY.

In radio telephony, we find an interesting possibility of future development of the Goldschmidt system. Without discussing the question of the commercial value of radio telephony over long distances, I may say that we feel sure that the problem will meet an early solution. It is possible now to produce sufficient energy in an appropriate form. It is possible to control it, and it is very easy to receive it. A machine invented by Professor Goldschmidt, which, with very slight excitation, gives an extremely large output and so may be considered an amplifying or "trigger-control" generator, will certainly help to solve the problem. Its theory, together with some data obtained in tests, may be given in a future paper.

Tuckerton, New Jersey,  
January 14, 1914.

## DISCUSSION.

**Robert H. Marriott:** Transoceanic means of communication in addition to the cables are certainly desirable, and the radio station described evidently was designed with a view to approaching as nearly as possible to cable utility. I presume duplication of parts is contemplated to insure continuous service.

The development of high power generators for radio frequency, equal amplitude alternating current has been spoken of for some time as the solution of the problem of long distance radio communication and this paper describes stations which are believed to be beyond anything which has been done in this line.

The radiation of high power in the form of equal amplitude waves, as is accomplished by this machine, may take the place of the ordinary method of sending groups of waves of decreasing amplitude, because the ordinary method insuring high powers where the station is located near the track of vessels may interfere with communication with ships. And ship communication is not to be interfered with because it is relied upon for the saving of life.

The tone wheel is an unexpected instrument in that it apparently provides an efficient detector and an interference preventer in one.

I believe you will all admit that these stations are an engineering proposition. What would have been said twenty years ago if a man had stated he could connect one end of a conductor to earth, hold the insulated end 800 feet in the air, put 100 K. W. in that conductor, and use that arrangement for telegraphing 4,000 miles? I have prepared a chart which, I believe, will illustrate that these stations are in a way very large things. As you will note from Figure 1, there is considerable land as well as water between Tuckerton, New Jersey, and Hanover, Germany. If we assume that Tuckerton sends equally well in all directions, its messages must travel over an area which includes, as seen by the large circle 2, Hanover (Germany), Spain, Peru, Nome (Alaska), and the North Pole. Furthermore, it is well known that the range of a radio station varies. In order that this station may compete with the cable its minimum range must not fall below 4,000 miles for any very great part of the time; which means it must reach much further under the best conditions. I have found by some hundreds of tests that shorter waves of rapidly decreasing amplitude, such as were used by vessels, give rise to a range variation somewhat as shown in the smaller circles in Figure 2. That is, the range of these small stations is about ten times as great at

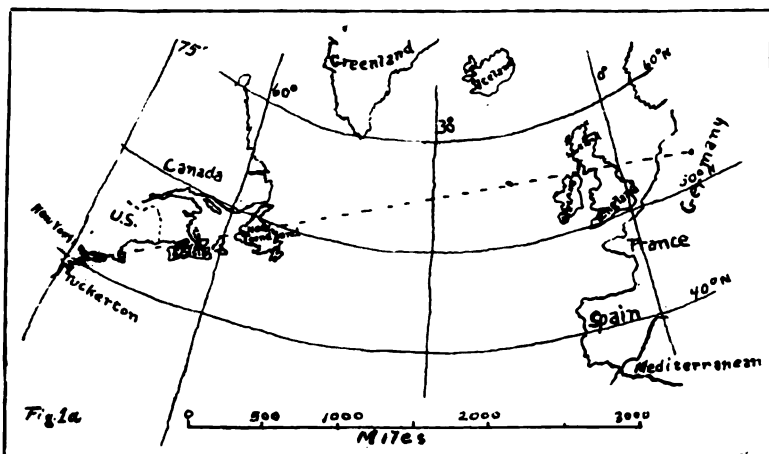

FIGURE 1.

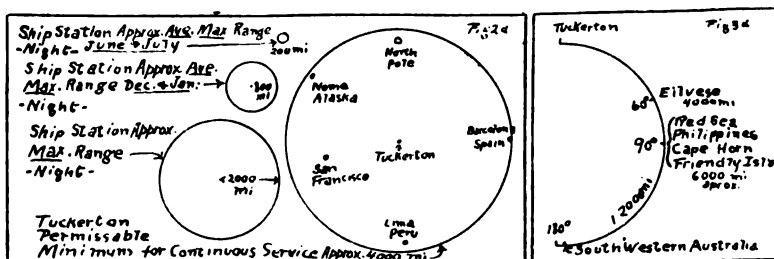

FIGURE 2.

FIGURE 3.

night under the best winter conditions as it is under the average July day conditions. Ten times the normal Tuckerton range is 40,000 miles. If, on the basis of diminished variation with long equal amplitude waves and less total atmospheric variation over very long ranges, we discount this 40,000 mile range seventy per cent., we still have a possible range of 12,000 miles, which is half way around the earth. That is, Tuckerton under favorable conditions may be capable of transmitting as far as any station will transmit, so long as transmission is confined to this earth. South-western Australia is nearly opposite Tuckerton, and there are radio stations in that locality which possibly could be used with kites for such an experiment.

Time and news are now sent to many receiving stations in areas two thousand miles or more in diameter, and some of these receiving stations have cost but a few dollars. We may be very

near to a time when news will be sent from one or two stations to a great many inexpensive receiving stations scattered all over the world.

**E. F. W. Alexanderson:** The development of the Goldschmidt alternator represents a masterful application of the principles of alternating current design. The difficulties that must have been encountered can best be appreciated by those who have done work along similar lines. When, on the instigation of Prof. Fessenden I took up the development of a 100,000 cycle alternator on behalf of the company with which I am connected, the difficulties encountered seemed to be almost insuperable, and a number of models had to be discarded before a practical machine was produced. The Goldschmidt alternator works on an entirely different principle. It might be said that the Goldschmidt alternator is equivalent to such dynamo machines as the induction motor, where the active field is produced by the armature reaction of the winding itself; while the 100,000 cycle alternator, to which I referred, is equivalent to the salient pole alternator, the field being produced by the shape of the pole pieces and the armature reaction being incidental. In the 100,000 cycle alternator the winding pitch is only 1-16 of an inch (1.5 mm.), and it is, therefore, evident, that the armature reaction can play no considerable part in creating the active field. In the Goldschmidt machine, on the other hand, the winding pitch is 1 centimeter, as we have been told.

It is difficult to come to an understanding of the two working principles without comparing them on the basis of the same frequency. When a machine is designed for 50,000 cycles, the problem is in many ways easier. For instance, a 200,000 cycle alternator, which has been built, has so small a pole pitch that a special winding had to be devised with less than one slot per pole. If the same principle is applied to a 50,000 cycle machine we get a winding pitch of one-half centimeter, which is not so far from the dimensions of the Goldschmidt machine, and the same principle of reducing the number of slots can be carried still further. Thus we will deal with structures of substantially the same dimensions.

The difference is in the method by which the pulsation in the magnetic field is produced. One machine has a rotor made as a solid disk, designed for high speed, while the other must be operated at a lower speed because the rotor supports laminations and windings.

For those who are familiar with the parallel operation of ordinary alternators, it may be of interest to know that the machine



with which I am familiar can be synchronized, and operated in multiple, and it is worth noting that the constants which apply for parallel operation for ordinary machines apply to the same degree to a 100,000 cycle machine; in other words, the relation between reactance and resistance must be within certain limits, in order to insure stable operation. In connection with this subject I would ask whether it is possible to operate the Goldschmidt alternators in multiple. On general principles, it ought to be possible with any alternator, but with the rigid requirements of tuning in order to multiply the frequency, it is conceivable that these limitations would be outside the limitations of multiple operation.

I can confirm the statement in the paper that it is perfectly feasible to regulate the speed with sufficient accuracy for radio communication. In tests made with a receiver working on the Fessenden Heterodyne principle, by creating beats between two frequencies, it has been ascertained that the frequency can be kept so constant that no appreciable fluctuations are heard in the tone produced by the difference between the two frequencies.

I am much interested in what was said in the paper about the alternator for radio telephony. I demonstrated a number of years ago a trigger alternator for that purpose. It was built for 15,000 cycles and excited by telephone currents. In order to produce the necessary excitation, with as small an amount of energy as possible, a winding was used in which the same conductors served as a magnetizing winding and as an armature winding for the generated current. The results produced by this trigger alternator were very satisfactory. We obtained good articulation and large amplification, but another device was then developed which was more promising for this particular purpose. The object of this latter is to control the output of the radio frequency alternator in the same way as it might be controlled by regulation of the field strength. The controlling device is built like a transformer, with two magnetic circuits and two electrical circuits interlinked in such a way that there is no mutual induction between the two windings, but the exciting circuit controls the inductance of the radio frequency circuit by varying the iron core saturation. The current which can pass through the radio frequency coil is proportional to the exciting current. This device thus makes it possible to use an alternator with a solid field, and to get the same results as if it had a laminated field and were controlled by regulation of the field strength.

While it has proven possible to build radio frequency alternators of considerably higher frequency than the one described, and while

there is every reason to think that other machines can be built in equally large units, the accomplished fact that an alternator as large as the one described has been successfully completed has given an impetus to radio communication by the continuous wave system. For this, we must congratulate the inventor, for this invention will undoubtedly prove of benefit to all those who are working along similar lines.

**Lee de Forest:** The paper is particularly interesting to me, because for two years I was associated with the development of another method of producing continuous oscillations: the development of the Poulsen arc for radio frequencies; and I should like briefly to sum up what occurred to me as the points of distinction between the two methods and the parallel advantages and disadvantages.

In the Goldschmidt machine the disadvantages are high cost and the necessity for absolute constancy of speed (tho the latter problem has now been sufficiently solved), complication of circuits and the constructions involved by them, and especially the lack of flexibility for changes of wave length. You will realize that in long distance radio telegraphy it is very important, at times, to be able to change the wave length very suddenly, because of the "selective absorption" by reflection from the outer atmosphere. In California we found, using certain wave lengths, that the intensity of signals changed from, say, 40 times audibility to 2 or 3 times audibility, and this effect appeared sometimes within a period of four or five minutes, generally near twilight. At the same time the "compensation wave," the wave length of which varied from that of the first by not more than 5 per cent., did not decrease to any such extent. Sometimes it was found to be increased in intensity. At such times, therefore, it is important to change the wave frequency very quickly. Such a change in frequency with the Goldschmidt system of circuits can not be made very readily, I believe.

Naturally, an apparatus as beautifully built and as costly as this would require higher salaried operators than the much simpler arc apparatus. Then again, the key control is limited to one wave length. I mean that one cannot change the wave length with the key as is done with the Poulsen system, but that signaling is done by controlling either the output direct, or the field excitation (and simultaneously the excitation of the motor, so that there will be no change of speed).

With the Poulsen arc, the disadvantages are the necessity for

occasional changes of the carbon electrode, the attention which that requires on the part of the operator (who need be by no means exceptionally skillful), and the gas and water cooling supply. This latter, of course, is not a particular complication. The arc has probably a lower efficiency than the Goldschmidt alternator, altho in connection with that I will say that the efficiency of the large Poulsen generators has been increased from 20 per cent. to 60 per cent. during the last three years. This valuable work has been done entirely by American engineers.

Among the advantages of the Goldschmidt alternator are particularly the constancy of operation, for there should be no change whatever in the wave length or power output due to speed variation. This criticism, however, does not now apply to the larger Poulsen arcs, because the accidental changes in wave lengths are usually small and insufficient to interfere with the energy of the radiation. The larger power of the Goldschmidt alternator (at present 150 kilowatts in the antenna) has not yet been equalled at any Poulsen station. Sixty kilowatts in the antenna has been attained in the South San Francisco station. But one principal advantage of the Poulsen system is the utmost simplicity of the oscillating circuit, and that no condenser except that comprised by the antenna and earth is required. It is perfectly easy to change the wave length within reasonable limits instantly by simply throwing a switch. Ease of key control in the Poulsen system is a favorable factor. The key controls and short circuits a certain amount of inductance in the transmission antenna, and this permits both a sending wave and a "compensation wave," so that it is perfectly simple to transmit on either one at will merely by throwing a switch at the key itself. This double wave also adds to the secrecy of transmission. Amateurs, who are not equipped with refined apparatus for cutting out interference and tuning properly, especially on the long wave lengths, are generally baffled. This element of secrecy does not, of course, apply to stations equipped for reading either the Goldschmidt or the Federal stations. Both the Goldschmidt and Federal companies' systems represent great strides beyond all methods of transmission by sparks with slowly damped wave trains. But I do not think either of these systems is the last word in radio transmission. Apropos of the amounts of energy radiated, I would say that in Washington and in New York messages are now being received daily both from Hanover and from South San Francisco. The power at Hanover is 150 kilowatts in the antenna and at South San Francisco about 60 kilo-

watts, and I am credibly informed that the signals from South San Francisco are considerably stronger than those from Hanover. At night we get signals from an arc station at Honolulu using 25 kilowatts and practically 6,000 miles away (or a quarter of the earth's circumference) with surprising loudness.

**John Stone Stone:** Besides the very unusual and interesting dynamo described in this paper, the paper has considerable interest, as showing the extent of the very rapid evolution of the art of radio-telegraphy in two particulars:

- 1st. The increase in wave lengths used, and
- 2d. The gradual but rapid departure from the highly damped wave trains of the early open spark systems, first to the more persistent wave trains of the quenched spark system and finally to continuous or undamped wave trains.

I notice that the author regards both of these features as advantageous, but I am inclined to believe that so far as the enormous increase in wave length described in this paper is concerned, he is making a virtue of necessity, since the difficulty of constructing a dynamo to produce directly currents of more than 50,000 cycles at a capacity of 100 K. W. or more is at present evidently well-nigh insurmountable.

If the wave length used at the station described, with its gigantic antenna, had been that corresponding to the fundamental of the antenna, or approximately 1,500 meters, instead of 6,000 meters, the radiating capacity of the antenna for given antenna current would have been 16 times greater, and what is perhaps more important, the receiving or absorptive power of the antenna of distant receiving station would also have been increased 16 fold. Furthermore, this is but one of the numerous advantages that would follow from a decrease of the wave length. But to obtain a wave length of 1,500 meters would require a current having a frequency of 200,000 cycles.

On the other hand, there is no question of the great advantages which result in the use of continuous or undamped wave trains. There is not sufficient time now to enumerate these. I feel that the continuous wave train has come to stay, while I believe that the wave lengths developed at high power, long range stations must eventually be reduced to as near the fundamental or natural wave length of the antenna at such stations as is practicable.

If the continuous or undamped wave train is destined to completely supersede the damp wave trains, as I believe it is, this

does not mean that high frequency dynamos will necessarily be used to supply the electrical energy at the frequency radiated. I say this for the reason that the antenna of the average radio station is incapable of radiating or absorbing any practically effective amount of energy per second at wave lengths of three thousand meters or more, while this is the shortest wave length that a dynamo of more than a small fraction of a K. W. capacity has been able to generate. Moreover, when we consider the enormous gyroscopic force of the rotor in either the Goldschmidt or the Alexanderson dynamo, we see that the use of such high frequency dynamos on board ship is out of the question, as either of these machines would tear itself to pieces, if operated at full speed on anything but a practically immovable foundation. In this connection it is to be remembered that a majority of the radio stations is to be found on board ships. Further, in this connection, ships' antenna systems are necessarily entirely too small to radiate or receive energy effectively at a frequency of the order developed by high frequency dynamos.

It seems as if in spite of the great skill and originality displayed by Goldschmidt, Alexanderson and others in designing high-frequency dynamos, we should, nevertheless, ultimately be forced to use the undamped oscillator of the general type first suggested by Elihu Thompson in 1892, or thereabouts. I understand that a modified form of such an oscillator with a capacity of 100 K. W. has been used with some success recently by the Federal Telegraph Company on the Pacific Coast in telegraphing from San Francisco to Honolulu and to ships on the Pacific Ocean. This oscillator is practically unlimited as to the frequency of the current it can generate.

**John Stone Stone** (by letter): The high frequency dynamo of this paper resembles a dynamo I designed some fourteen years ago, and differs from it chiefly in that my dynamo had no winding on the rotor. In fact my dynamo had but one winding, which served both as field and armature winding.

In its simplest form, illustrated in Figure 4, the machine develops, on open circuit, an e.m.f. comprising a fundamental *and all the odd* harmonics, but the instant you begin to draw a current corresponding to one of these *odd* harmonics, say of the frequency  $n$ , there immediately springs into existence in the e.m.f. of the machine, *all the even* harmonics of the fundamental, but chiefly, the even harmonics of the frequencies  $n-1$  and  $n+1$ .

The elementary theory of this early machine of mine is very

simple, and because there is no winding on the rotor, there is a minimum of magnetic drag or transverse field, so that the elementary theory gives a much closer approximation to the actual behavior of the machine than could be expected of an elementary theory of the Goldschmidt dynamo. Nevertheless this elementary theory of my simpler machine does not differ materially from that of the Goldschmidt dynamo described by Mr. Mayer and sheds considerable light on the behavior of the Goldschmidt dynamo. For that reason I venture to touch upon it here.

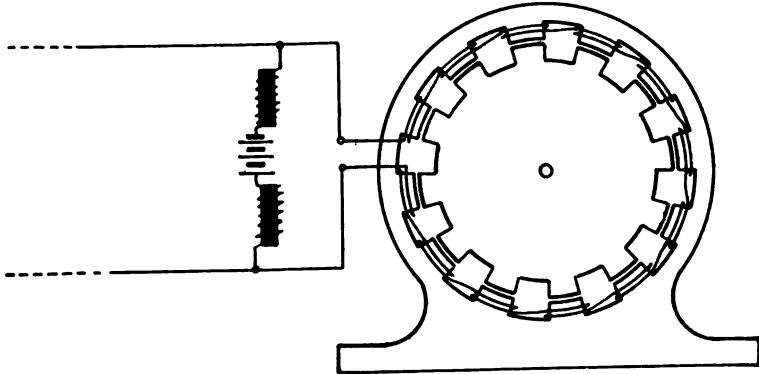

FIGURE 4.

The approximate value of the permeance per pole of the machine, as it varies with time, is given graphically by the zig-zag full line (1) of Figure 5, and analytically by the cosine series.

$$P = P_0 - P_1 \left( \cos \omega t + \frac{1}{3^2} \cos 3 \omega t + \frac{1}{5^2} \cos 5 \omega t \dots \dots \right)$$

in which  $\frac{P_0}{P_1}$  is but slightly greater than unity.

If  $I_0$  (full line 3 of Figure 5) be the constant unidirectional exciting current, the total excitation flux per pole will be .

$$\phi_0 = \Phi_0 - \Phi_1 \left( \cos \omega t + \frac{1}{3^2} \cos 3 \omega t + \frac{1}{5^2} \cos 5 \omega t \dots \dots \right)$$

where  $\Phi_0 = 4\pi N I_0 P_0$   
and  $\Phi_1 = 4\pi N I_0 P_1$

$N$  being the number of turns of the winding per pole.

This flux  $\phi_0$  may be represented graphically by the same zig-zag line (1) of Figure 5, if, as in the case of the particular

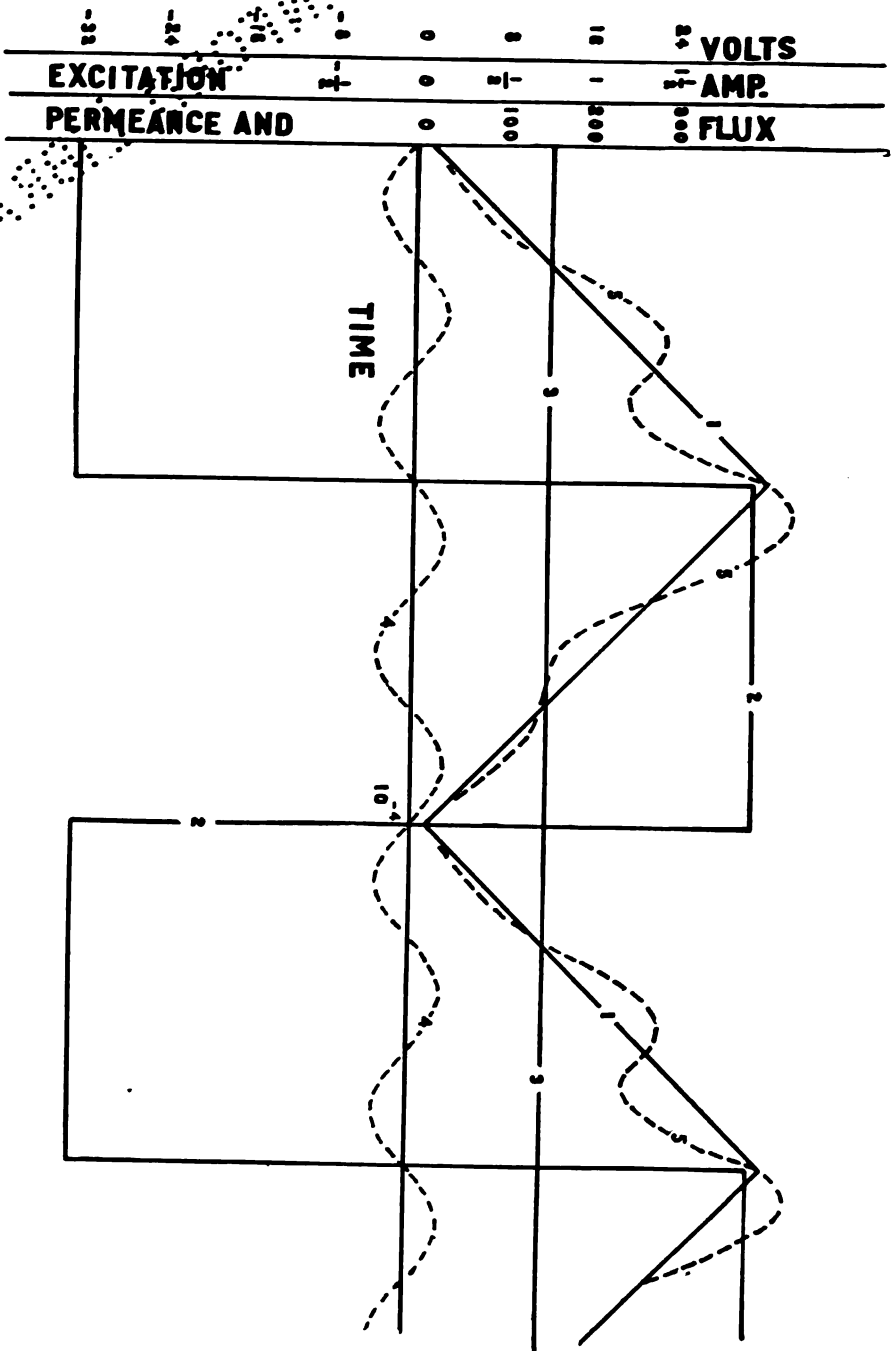

FIGURE 5.

machine therein illustrated, the magnetomotive force of excitation per pole is unity.

The induced e.m.f. of the machine on open circuit will be represented by the succession of rectangles of the full line (2) Figure 5, and analytically by the expression

$$e_0 = -E_0 \left( \sin \omega t + \frac{1}{3} \sin 3 \omega t + \frac{1}{5} \sin 5 \omega t \dots \dots \right)$$

But let us now see what happens when we draw off a current from this machine. Suppose we draw off a current of periodicity  $5\omega$  and of that periodicity only. Further, for the sake of simplicity, suppose we so adjust matters that the current is in phase with the e.m.f. engendering it. Let us call this current— $I_5 \sin 5 \omega t$ , then the magnetomotive force per pole due to it will be— $F_5 \sin 5\omega t$  where  $F_5 = 4\pi N I_5$ . The flux per pole due to this current will be

$$\phi_5 = -F_5 P_0 \sin 5 \omega t + \frac{1}{2} F_5 P_1 (0.04070 \sin 2 \omega t + 0.9877 \sin 4 \omega t + 0.9918 \sin 6 \omega t + 0.1052 \sin 8 \omega t + 0.0356 \sin 10 \omega t \dots \dots)$$

This shows the importance of the *even* harmonics introduced by permitting a current to be developed of a frequency of one of the *odd* harmonics of the fundamental. We see that of the even harmonics only the components of periodicity  $4\omega$  and  $6\omega$  are of much importance. These even harmonics will give rise to voltages in the windings of the machine and the question immediately suggests itself, what will result from permitting a current to flow which has the frequency of one of these even harmonics? What will its effect be on the e.m.f. of periodicity  $5\omega$ ? Will it help or will it hinder the machine in developing a current of periodicity  $5\omega$ ? Let us draw a current— $I_4 \sin 4 \omega t$ . Then the flux per pole due to it will be

$$\phi_4 = -F_4 P_0 \sin 4 \omega t + \frac{1}{2} F_4 P_1 (0.07111 \sin \omega t + 0.9796 \sin 3 \omega t + 0.9876 \sin 5 \omega t + 0.1028 \sin 7 \omega t \dots \dots)$$

From this expression we see that, other things being equal, drawing off a current of periodicity  $4\omega$  increases the e.m.f. of the machine at periodicity  $5\omega$  and that in order to increase the output at periodicity  $5\omega$  it is desirable to draw off a current at both periodicities  $4\omega$  and  $6\omega$ .

Further consideration of the subject along the same lines shows that drawing off currents of frequency corresponding to the fundamental and to each of the harmonics, assists in the development of the e.m.f. of any one of the other harmonics.



A good deal that is of interest, in a quantitative way, can be dug out of such an elementary theory of these machines.

Of course on open circuit, even my machine shows slight even as well as pronounced odd harmonics in its E.M.F. These even harmonics are due to hysteresis and to eddy currents. Since each of those phenomena produces a lag in the change of flux of the rotor, they make the machine act exactly as if there were a winding on the rotor and small currents were being drawn from this second winding, one corresponding to each of the odd harmonics.

The resonant circuits used to draw off the component currents in the case of such machines should each have sufficient selectivity

$\sqrt{\frac{L_n}{C_n R_n^2}}$  to prevent the passage through it of any appreciable

amount of current of a frequency different from  $n$ , namely that which the circuit in question is designed to draw from the machine, but it should not *per se* be resonant to the frequency  $n$ , of the current it is designed to pass. It should have, for such a current, a negative reactance equal to the positive reactance of the winding of the machine for that frequency.

The values of the auxiliary inductances of these branch circuits do not affect the various components of the voltage of the machine in the same way as does the inductance due to the leakage flux of the machine and we may therefore safely conclude that they do not act as a simple loose coupling between the two circuits of the Goldschmidt dynamo to reduce the number and magnitude of the harmonics developed, as has been suggested by Professor Pupin. They exert no harmful effect. In this connection it is to be noted that there is a separate inductance coil and condenser in each tuned branch circuit.

In Figure 5, the dotted line 4 illustrates a current of periodicity  $3\omega$  drawn from the machine, and the dotted line 5 illustrates the resulting modification of the flux when the amplitude of the current corresponding to the third harmonic is one-fourth the value of the excitation current (3) of Figure 5.

On the occasion of the presentation of Mr. Mayer's paper before the American Institute of Electrical Engineers and the Institute of Radio Engineers, Professor M. I. Pupin discussed the Goldschmidt alternator critically. He drew certain conclusions as to the maximum efficiency of such machines as limited by magnetic leakage between rotor and stator and the effective resistance of the machine. He further claimed priority in the

development of the theory of such machines. According to Professor Pupin, the tone wheel was analogous to the "heterodyne" receiver, being based on the beat principle, whereby thru the interaction of tones of inaudible frequencies a note of audible frequency is produced.

Because the stress of other duties prevented him from giving the necessary time to the revision of his discussion, Professor Pupin requested the Editor to withdraw it from publication. This has accordingly been done.

A portion of the answers by Professor Goldschmidt and Mr. Mayer are however published, for the technical information of the readers of the PROCEEDINGS.—(EDITOR'S NOTE.)

**Dr. Rudolph Goldschmidt** (by letter to Mr. Mayer): . . . I was very pleased to hear that so prominent a man as Professor Pupin has become interested in my invention, especially as he himself has studied the problem of the production of very high frequency energy by the reflection principle. Since he has stated that a great variety of higher harmonics are obtained in the circuits, I believe he has not applied the actual principle of my invention, which involves, as you know, the building up of the highest frequency energy by providing paths of minimum impedance for all the lower frequencies. This latter method is the only one which makes these machines practicable. I think you would do well to invite Professor Pupin to see the machine working at Tuckerton. I have no doubt that he will be convinced that not only is the principle correct but also that the machine works perfectly as a whole. It will further be evident to him that any amount of power can be obtained by simply increasing the dimensions, as with any ordinary dynamo.

At the same time Professor Pupin may satisfy himself that the method of reception of signals by means of the tone wheel is not at all related to the method of reception involving beats and tone production in the telephone receiver used in conjunction with a crystal rectifier. The tone wheel is an actual frequency transformer, which directly changes the radio frequency energy into audio frequency energy.

(Mr. Mayer has informed the Editor that an invitation to visit the Tuckerton station was sent Professor Pupin on May 27, 1914.)

**Mr. Emil Mayer** (by letter): I wish to express my regret that, because of the late hour at which the original discussion on

my paper terminated, it was not possible for me to answer the speakers on that occasion.

. . . It has been stated by Professor Pupin in connection with his claims to priority that higher harmonics are produced in a simple closed circuit rotating in a magnetic field. These harmonics are undoubtedly present, but this is far from being the principle of the Goldschmidt alternator. No doubt there are higher harmonics of all values produced when the field is not sinusoidal but of such space or time distribution that, when analyzed, these upper frequency components of the field would be discovered. But of all these frequencies, the Goldschmidt alternator uses *only the fundamental*. And if it were possible to produce by direct current excitation a field such that only this pure fundamental frequency were present in the first circuit, a Goldschmidt alternator of maximum efficiency would be obtained. The machine conceived by Professor Pupin must therefore be entirely different in nature from the Goldschmidt alternator.

As has already been pointed out in this paper, magnetic leakage is a serious factor in limiting the output of all radio frequency alternators. But it is in just this respect that we find one of the advantages of the Goldschmidt principle, for Goldschmidt is able to design his alternator for a much lower frequency than the one which is radiated. A smaller number of poles is therefore required, and accordingly a very much lower magnetic leakage is secured. As a matter of fact, the experimentally determined ratio of exciting direct current to final antenna current after a fourfold frequency transformation is one to one if the antenna resistance is not higher than 6 ohms. This shows that the magnetic leakage cannot be excessively large.

. . . It has been claimed by Professor Pupin that an exact theory shows that all the lower frequencies exist in their full strength. . . . This is not the case. On the contrary, the exact mathematical theory enables us to calculate in advance what must be the constants of the different circuits (inductance, resistance, and capacity), in order that the lower frequencies shall cancel absolutely. The very simplest experimenting with such alternators as these shows that the addition of any one of the higher frequency circuits markedly reduces the lower frequency currents, provided that correct tuning methods are employed. This same reduction applies, naturally, to the corresponding lower frequency magnetic fields, and consequently to their respective hysteresis and eddy current losses. . . . The extent to which these losses are reduced is perhaps best shown by the fact

that with 150 kilowatts input for the driving motor, an antenna current of 150 amperes is obtained while a rapid succession of dots and dashes were sent.

That the tone wheel depends on the beat principle may be positively denied. Beats are produced if two frequencies of nearly the same value are combined. In the case of the tone wheel, there is energy of only *one* frequency present, and this energy, by purely mechanical means, is changed into an audible form. There are no beats produced. . . .

In answer to Mr. Alexanderson's question as to the feasibility of running Goldschmidt alternators in parallel, it is possible to respond affirmatively. So long as the driving power is reasonably constant this can be done. In an alternator of this kind, the "synchronising force," that is, the available energy which corrects discrepancies from the "in phase" position of the moving parts of the machines when the driving power of one of the machines changes slightly, is comparatively low. The reason for this is that the rotating masses are very large in proportion to the output per pole.

I agree heartily with Mr. Alexanderson's statement that it is not difficult to keep the speed of these machines constant. The trigger control devices which Mr. Alexanderson described seem to me very ingenious, and I should be interested to learn more of them.

A few remarks may be added to Dr. de Forest's summary of the relative advantages and disadvantages of the Goldschmidt and Poulsen systems. He has overestimated the trouble required to keep the alternator speed constant and the amount of skill required on the part of the operator. All the operator has to do is press a key and watch the ammeter. These duties are no more difficult than removing arc electrodes, etc. Dr. de Forest has also overestimated the difficulty of changing wave lengths quickly. Using the Goldschmidt alternator, it is very easy to arrange matters so that such changes of wave length can be secured by merely throwing over a few switches and increasing or decreasing the speed of the machine. Naturally the adjustments must be properly made in advance, and not more than two or three given wave lengths will, in general, be available.

So far as over-all efficiency in operation is concerned, a great advantage of the Goldschmidt system is that in the interval between signals the full energy is not radiated unnecessarily. Control of the radiated energy is by means of the exciting current, which is made and broken, so that between signals the machine

is running at approximately no load. As to the comparative loudness of the signals received from San Francisco and from Hanover in Washington and New York, there may be some special reason for this effect applicable to these latter stations only. At Tuckerton, however, the signals from Hanover are very much louder than those from San Francisco.

As Mr. Stone has said regarding the best wave length for long-distance service, there is no doubt that for trans-Atlantic work there is a minimum absorption and a maximum efficiency of transmission at a wave length which is considerably higher than that naturally radiated by our antenna. Whether or not this most desirable wave length is above or below the one we are now using remains to be determined. Which ever, however, it will be readily possible by certain mechanical devices to work at the desired frequency with, perhaps, a slight diminution of over-all efficiency.

Since the date of the opening of the Tuckerton station, it has been successfully received at Eilvese with sufficient strength to permit the use of a photographic recorder (Einthoven thread galvanometer), according to information received by the Editor.—  
(EDITOR'S NOTE.)