

# IEEE spectrum

## features

- + 39 Spectral lines: A plea for plurals**  
*In the 18th century, to no less an authority than Dr. Johnson, of dictionary fame, the plural of phenomenon was phenomenons, and Fowler, almost 50 years ago, in his "Modern English Usage" wrote of the tendency to abandon Latin plurals*
- + 40 Haraden Pratt—in memoriam**
- + 41 Sixty years of wireless and radio**  
**Autobiographical reminiscence by Haraden Pratt**  
*The recent death of Haraden Pratt brought to a close a career of more than 40 years of service to the IRE and IEEE. Some of his own reminiscences provide a fascinating and highly personal look at the early days of telegraphy*
- + 48 Ultrasonics in medicine**  
 Nilo Lindgren  
*First used for the nondestructive testing of materials, the ultrasonic transducer has now found its way into medicine where it serves as a kind of X-less X ray*
- + 58 Fluidics—a new control tool**  
 Rolf E. Wagner  
*Although fluidic logic components have the major disadvantages of relatively slow response time and comparatively large size, they are virtually insensitive to high temperatures, nuclear radiation, and explosion-hazardous areas*
- + 69 Logarithmic converters**  
 Robert C. Dobkin  
*Conveniently, the bipolar transistor operates in a precisely logarithmic fashion over a range of several decades. In multiples of two, these transistors therefore can make valuable computational circuits*
- + 77 The future of cable TV**  
 Archer S. Taylor  
*Some controversy exists among analysts about the speed with which cable TV will grow once restraints are lifted. However, growth is inevitable and necessary*
- + 82 Applications of Walsh functions in communications**  
 Henning F. Harmuth  
*KRC networks are obviated with IC's and the designer must resort to alternate filters. It remains expedient, however, to work with electrical functions that are mathematically complete—a situation solved by Walsh functions*



THE INSTITUTE OF ELECTRICAL AND ELECTRONICS ENGINEERS, INC.

# Computer-Controllable!

## AUTOMATED SWEEP-RECEIVERS for S-T-R-E-T-C-H-I-N-G MANPOWER

- SURVEILLANCE
- COMMUNICATIONS
- RFI/EMC TESTS
- FIELD STRENGTH TESTS
- SPECTRUM ANALYSIS

### SOLID STATE EMC-25 FUNCTIONS FROM COMPUTER PROGRAMS.

Whether used alone or with one of its specially-designed peripheral instruments, Interference Analyzer Model EMC-25† is the most advanced receiver system currently available. Hundreds of these varactor-swept instruments are already in field and laboratory use, speeding up tests and monitoring, and relieving manpower shortages. It has outstanding sensitivity and two bandwidths throughout the full range. Fully remotely controllable...digitally over telephone lines if required or from a computer!

With its accessory programmer, the full range of 14 kHz to 1000 MHz can be plotted on a single sheet of pre-calibrated paper in minutes.

When used with the accessory Display Module, a full octave band dispersion can be shown on the CRT at one



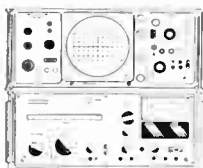
14 kHz to 1000 MHz IN SINGLE COMPACT PACKAGE—BATTERY POWERED—IDEAL FOR MIL-STD-461/462.

†Military Nomenclature AN/URM-178; FSN 2Z6625-115-2775, Category A approved.

time...or any selected portion...in linear or log!

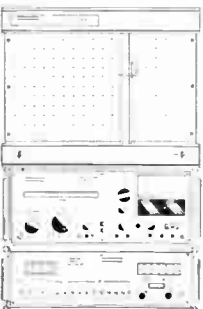
When combined into the fully automated Spectrum Surveillance System, all these functions are performed, plus many more, and computer control can be added later.

Hundreds of EMC-25's, with and without peripheral equipment, are being used all over the world. Contact your Fairchild/Electro-Metrics representative for your catalog, to see how you too can s-t-r-e-t-c-h your valuable manpower.



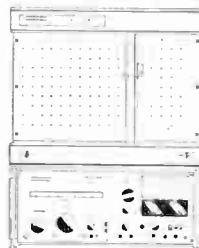
### BAND-BY-BAND SPECTRUM DISPERSION

By displaying the EMC-25's 15 octave bands, one at a time, on the CRT of Display Module SPD-125, the full range of 14 kHz to 1 GHz is visually displayed in the Calibrated Spectrum Analyzing Receiver CSR-200.



### FULL FREQUENCY RANGE AUTOMATIC PLOTTING

The ESC-125A Programmer adds the capability of plotting the EMC-25's 14 kHz to 1 GHz range on a single sheet of pre-calibrated graph paper, and with automatic antenna selection.



### BAND-BY-BAND SPECTRUM PLOTTING

Built-in electronic sweep in EMC-25 provides push-button control of octave-band plots on the EXY-125A X-Y Plotter. Add the Digital Interface Unit Model DIU-125 and you are Computer-Controllable.



### DUAL-SYSTEM FSS-250

For full 20 Hz to 1 GHz range:

Here is a system with both visual CRT octave dispersion and automated X-Y plotting...plus built-in calibrator control, amplifier and speaker, and many optional operator controls. And computer control can be added at any time.



### EMC-10 for VLF

Interference Analyzer EMC-10 covers the frequency range from 20 Hz to 50 kHz. It also is solid-state, battery operated and electronically scannable. Category A approved; FSN 6625-911-0840 and (for "E" model) 6625-937-6523.

Use for Mil-Std-461/462.

## FAIRCHILD

## ELECTRO-METRICS CORPORATION

A SUBSIDIARY OF FAIRCHILD CAMERA AND INSTRUMENT CORPORATION

100 CHURCH STREET, AMSTERDAM, N.Y. 12010

Channelized systems may overload if too many signals occupy one channel. Ed Buyer of AIL's Advanced Engineering Department describes a technique to compute occupancy statistics.

# Maximum Channel Occupancy

The problem of the amount of traffic which can be expected in the most populated channel of a system is of interest to the designer, who must equip the channels to handle the workload. An example of the type of system under discussion is an anti-aircraft defense consisting of three guns in each of the four quadrants, each gun capable of covering only one quadrant. Obviously, an attack by four aircraft in any one quadrant could overload the system.

This problem differs from the computation of the probabilities of given traffic densities in specific channels which are normally solved by binomial or Poisson techniques. Of the several methods which have been explored to compute maximum occupancy statistics, the following has been found the most efficient:

1. Form all possible combinations of the given number of signals in the given number of channels.
2. Compute the probability of each combination. Each signal is assumed to have the same probability of occupying any channel.
3. Sum the probabilities of all combinations which have N, and no more than N, signals in one or more channels for all values of N from 1 to the total number of signals.

Let us examine the case of five signals in six channels. All the possible combinations are shown in Table I.

TABLE I

Combination Number	0	0	0	0	0	0
1	5	0	0	0	0	0
2	4	1	0	0	0	0
3	3	2	0	0	0	0
4	3	1	1	0	0	0
5	2	2	1	0	0	0
6	2	1	1	1	0	0
7	1	1	1	1	1	0

The above table is constructed as follows:

1. For the first combination, let the first element be the totality of signals, and the remaining elements be zero.
2. Scanning from right to left, reduce the first multiple occupancy by 1.
3. Moving to the right, maximize each element until all the signals are accommodated. No element is permitted to be higher than the preceding element. The next combination is now formed.
4. Return to step 2 and repeat until no further allowable combinations can be formed.

The probability of each combination will now be computed. The probability that the first A out of E signals go into the first H channels and that the remainder go into the other H - 1 channels is:

$$\binom{1}{H}^A \binom{H-1}{H}^{E-A} \quad (1)$$

Thus the probability that the first channel receives exactly A signals (for A > 0) is

$$\binom{1}{H}^A \binom{H-1}{H}^{E-A} \times \frac{E(E-1)\dots(E-A+1)}{A!} \quad (2)$$

If we populate the channels in order, the probability of a specific level of occupancy in each successive channel can be computed on the basis of the numbers of signals and channels remaining.

Let:

- S = total number of signals
- J = channel number
- A<sub>J</sub> = number of signals in channel J
- H<sub>J</sub> = number of channels remaining (including channel J)
- E<sub>J</sub> = number of signals remaining (including A<sub>J</sub>)
- K = number of populated channels

Thus the probability of the permutation A<sub>1</sub>, A<sub>2</sub>, ... A<sub>K</sub> is:

$$\frac{K}{\pi} \prod_{J=1}^K \frac{(H_J - 1)^{E_J - A_J}}{H_J^{E_J} A_J!} \times \frac{E_J(E_J - 1)\dots(E_J - A_J + 1)}{A_J!} \quad (3)$$

or

$$S! \frac{K}{\pi} \prod_{J=1}^K \frac{(H_J - 1)^{E_J - A_J}}{H_J^{E_J} A_J!} \quad (4)$$

The probability of the combination A<sub>1</sub>, A<sub>2</sub>, ... A<sub>K</sub> is:

$$S! \frac{K}{\pi} \prod_{J=1}^K \frac{(H_J - 1)^{E_J - A_J}}{H_J^{E_J - 1} A_J! M_J} \quad (5)$$

where

M<sub>J</sub> = order of appearance of population level A<sub>J</sub>. For example, when level 7 occurs for the third time, M<sub>J</sub> = 3.

Expression (5) is now evaluated to obtain the probability of each of the seven combinations of Table I. Since the value of the first element is the maximum channel occupancy, the probability of a given level of maximum occupancy is determined by summing the probabilities of all combinations that have a common value for the first element. Table II gives the maximum occupancy, the combination numbers (see Table I) which have the specified maximum occupancy, and the computed sums of the probabilities of these combinations.

TABLE II

Maximum	Combination Numbers	Probability
1	7	0.0926
2	5, 6	0.6314
3	4, 3	0.1929
4	2	0.0193
5	1	0.0008
		1.0000

Table II shows, for the case under study, that the most probable level of maximum occupancy (the mode) is 2. We ran the occupancy statistics for a considerable range of channels and signals and developed the contour plot of the mode seen in Figure 1.

As an example of the application of Figure 1, the most probable maximum traffic level in a system with 20 signals and 25 channels is three. A first cut at the design for this case, therefore, is to install sufficient processing capacity in each channel to handle three signals simultaneously or to provide one processor per channel and allow sufficient time to sequentially process three signals.

## Acknowledgment

The friendly interest and advice of Mr. Matthew Dwork and Mr. Harold Levenstein of AIL are gratefully acknowledged.

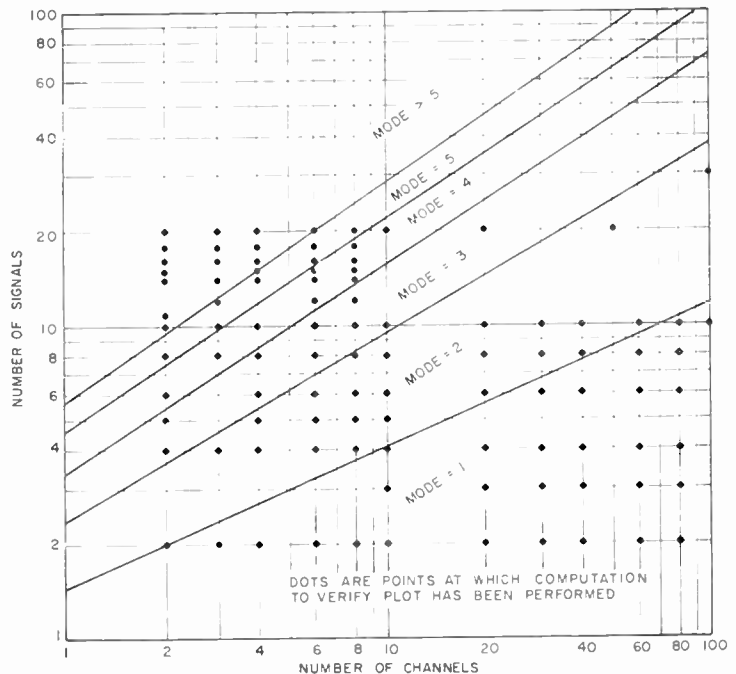


FIGURE 1. PROBABLE MAXIMUM OCCUPANCY

A complete bound set of our thirteenth series of articles is available on request. Write to Harold Hechtman at AIL for your set.

**AIL** a division of **CUTLER-HAMMER** CONTROL

DEER PARK, LONG ISLAND, NEW YORK 11729

**the**  
**GIANT**<sup>TM</sup>  
GENERAL INSTRUMENT ADVANCED NITRIDE TECHNOLOGY  
**MUX**

# Forum

Readers are invited to comment in this department on material previously published in IEEE SPECTRUM; on the policies and operations of the IEEE; and on technical, economic, or social matters of interest to the electrical and electronics engineering profession.

## Views on controversial articles

Thank you for publishing Professor Wald's "A Generation in Search of a Future" (June 1969) and the most illuminating articles on the ABM decision by Tilson, Rathjens, and Brennan (August 1969).

More attention needs to be focused on the paragraph headed "Human implications of the Safeguard system," page 31 in the article by Tilson, dealing with strontium 90 and the research published by Dr. Ernest J. Sternglass, professor of radiation physics, University of Pittsburgh School of Medicine. Dr. Sternglass published a four-page article in the September issue of *Esquire* magazine, "The Death of All Children," which the editors appropriately stamped *Urgent* in bold letters.

After carefully reading that thoroughly analytical treatment and re-reading the brief paragraph by Tilson, I was struck by the feeling that most of the congressional and public debate has overlooked the central issue, namely: What is the point of trying to survive a nuclear attack if we are to be the last generation of mankind on this planet?

Suppose, as an electronics engineer, that I were to work on the ABM system, and suffer, and survive, an ICBM attack. How could I live with myself or my family with the knowledge that the odds would then be overwhelming that neither my children nor any other prospective parents remaining alive on the entire earth could ever again raise children?

Don't we owe ourselves and mankind something more than that we will survive? "... Give me liberty or give me death." Yes! But *my* death. Not the death of all future generations.

Charles R. Hogge, Jr.  
Raleigh, N.C.

The Sternglass findings are also discussed by him and by F. J. Dyson in *Bulletin of the Atomic Scientists*, pp.

26-27, June 1969. They are called into question in *Science*, vol. 166, pp. 195-200, 10 Oct. 1969.

Editor

This is in response to the request for comments on controversial articles, such as that by Professor Wald in the April issue of IEEE SPECTRUM.

I do not understand how a person as obviously intelligent as Professor Wald can manage to be so ill-informed on the Vietnam issue. It must have taken a deliberate effort on his part to acquire that much misinformation. Nevertheless, he is not alone in his views. He is an unusually articulate spokesman for a rather widespread point of view. I believe it is important to the membership of IEEE to be informed of such widespread opinions, even if, in the views of some of us, the opinions are ill-founded. The existence of those opinions is a fact, a fact with which we must all contend. Those of us in the defense business, for instance, have to contend with the very real fact of Professor Wald's views, which are shared by a number of members of the U.S. Congress. There are views on other controversial subjects that are equally important to the engineering profession, whether or not we all agree with the views. The existence of the views is a fact we must become informed about.

My only reservation about the publication of controversial views in SPECTRUM is that an effort must be made to present responsible views from both sides. This was done admirably in the set of articles on the ABM. This series set a high standard that the editors of the SPECTRUM should make every effort to equal in the future.

Joseph P. Martino  
Major, U.S. Air Force  
Holloman AFB, N.Mex.

I am amused and bemused by the pompous puritanical attitudes of some

IEEE members who are apparently appalled by the thought of editorially discussing political realities in an engineering journal such as IEEE SPECTRUM.

Do these people really believe that, because we are engineers, we must abdicate our rights and duties as citizens? Are engineers truly a breed unto themselves in an ivory tower of splendid isolation?

This stuffy faction had better catch up with the times and realize that the socioeconomic, political, scientific, and technical aspects of our culture are inextricably interlocked into the same fabric, and that each one is dependent upon all of the others.

Gordon D. Friedlander  
Burndy Library  
Norwalk, Conn.

The time has arrived. The IEEE must encourage debate by concerned scientists and promote a technology that responds to the needs of our society. It is time for the design of automobiles, appliances, color television sets, bridges, gas pipelines, and our defense system to be based on independent tests and judgments and not dictated by profiteers and their advertising agencies.

It is time the technical societies speak responsibly in the U.S. Congress and in the lobby. Our members represent a top echelon of society, and we must be aware of social needs, which we must debate honestly, scientifically, and with compassion for humanity.

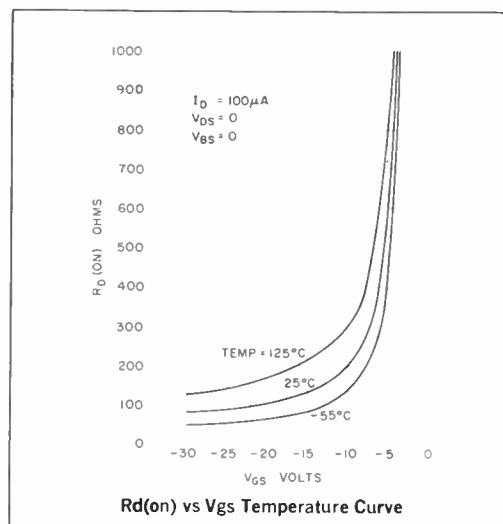
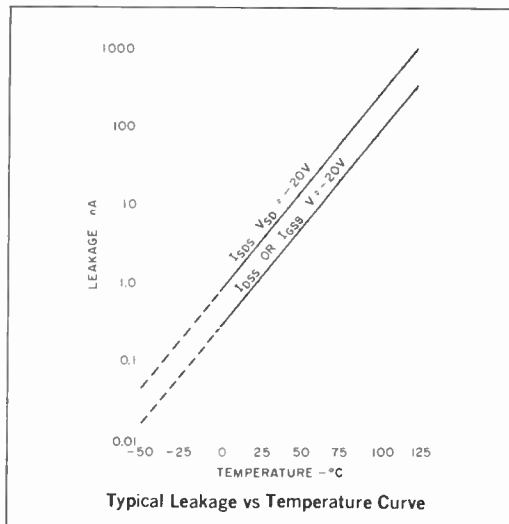
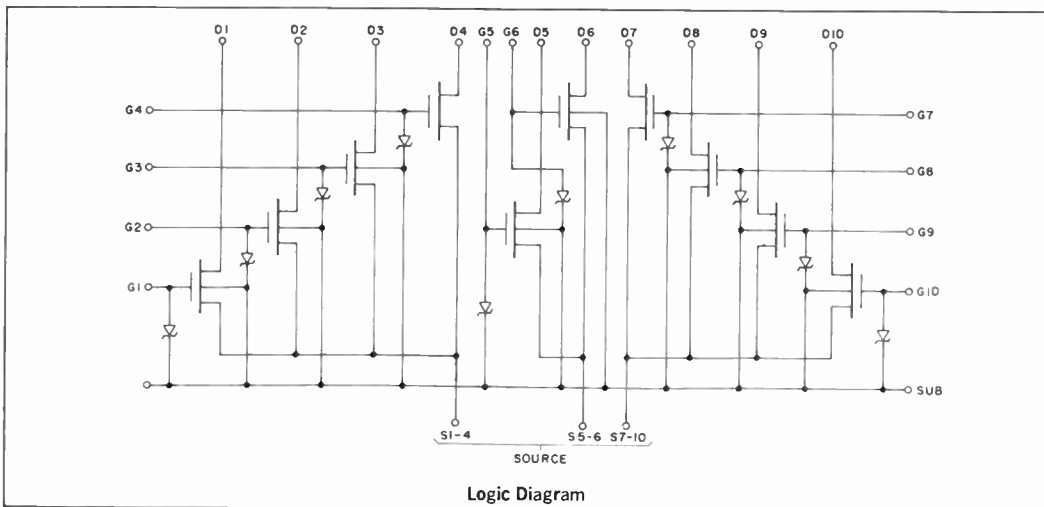
Those who cry "subversion and Communist-inspired" do so mainly because they are unwilling to face the demands for a more meaningful and better social order. The problems *are* here; there *are* better solutions, and a healthy society will grant a fair profit.

The alternative is to continue a technology that poisons the environment, depletes the land, and breeds an anarchy that cannot be controlled by even the most oppressive law and order.

Yes, engineers must listen, debate, and earn the respect of those who demand a better life. There simply is no other way.

Laurence G. Cowles  
Bellaire, Tex.

# the first and only nitride passivated 10 channel multiplexer is also the lowest priced per channel (\$2.12)\*



The newest GIANT is General Instrument's 10 channel multiplexer containing 10 P-channel nitride passivated insulated gate field effect transistors. It is the first MUX to use General Instrument's exclusive MTNS (Metal-Thick Oxide-Nitride-Silicon) process with its well-known performance and reliability advantages.

Significant parameters of the GIANT MUX are: low threshold capability, low "ON" resistance (150  $\Omega$  max), and wide operating temperature range (-65° to +125° C).

The high dielectric resulting from the use of silicon nitride in the gate structure is the feature which makes possible the low threshold voltage capability and the lower "ON" resistance. And it is silicon nitride's virtual imperviousness to contaminants which assures the reliable -125° C operation.

With the unique arrangement of its source connections, the

\*\$21.20 per 10 channel GIANT MUX in quantities of 100 pcs.

MUX gives the user maximum flexibility for switching applications. And, by proper biasing, it can be employed as a multiple switch, rotary switch, "AND" gate or "NOR" gate.

The design flexibility of the MUX, along with the benefits inherently derived from its MTNS construction, combine to make it the giant in its field.

The 10 channel GIANT MUX (part #MU-6-2281) is available now from your authorized General Instrument Distributor.

For full information write, General Instrument Corporation, Dept. M, 600 West John Street, Hicksville, L.I., N.Y. 11802. (In Europe, write to General Instrument Europe S.P.A., Piazza Amendola 9, 20149 Milano, Italy; in the U.K., to General Instrument U.K., Ltd., Stonefield Way, Victoria Road, South Ruislip, Middlesex, England.)



GENERAL INSTRUMENT CORPORATION • 600 WEST JOHN STREET, HICKSVILLE, L. I., NEW YORK

Circle No. 6 on Reader Service Card.

## Engineers and public policy

The article of Alger and Holt in the August issue of IEEE SPECTRUM correctly makes the point that engineers and scientists must begin to take part in deciding public policy. However, in addition to pursuing these goals through the engineering societies, I believe we should emphasize the more direct and immediate approach of individual participation by engineers in civic affairs at the local level.

Every citizen is served (or confronted) by a large array of local agencies: elementary, high school, and college boards; city council, planning commission, finance, personnel, and park/recreation committees; fire commission, water board, etc. Policy-making positions in these agencies are filled by appointment or election. It is unusual to find, in such agencies, even one official who has an engineering background. As a result, such agencies are very reluctant to consider technical innovations.

Technical capability now in hand could revolutionize our society. However, numerous technically based companies have discovered, to their great economic sorrow, that local governmental agencies refuse to accept and use this capability. Housing costs could be halved by use of new materials and fabrication techniques, but archaic codes block progress. Instantaneous relay and computer analysis of data can make traffic control and law enforcement much more efficient. We already know how to dispose of waste in ways that are better and cheaper than dumping it into someone else's drinking water. The list is long. The blockage is poor communication across the interface between the engineering and local-government communities. The fastest and most productive way to solve this problem is for engineers to work directly in local government.

*Jeff Montgomery  
Belmont, Calif.*

## Engineers as professionals

I am a fourth-generation engineer.

Last week I was privileged to sweat through the eight-hour California Professional Electrical Engineer examination after completion of a six-year internship. Before that I served an eight-year apprenticeship in our trade, passed the engineering fundamentals exam, and acquired six years of college.

I have twice, formally and publicly,

affirmed the Engineer's Creed and Canons of Ethics.

My great-grandfather, my grandfather, my father, and I are now shamed by "Spectral Lines" in August's IEEE SPECTRUM.

Such a blurb shows a crass ignorance of democratic process, existing tests of competence, supply and demand, problems of branch registration, the powerful position of a citizen, journeyman engineer compared with a client-pleasing independent, and the work of NSPE, ECPD, Maslow, Hertzburg, Drucker, and our labor unions.

I am disgusted that our journal would print even an unqualified opinion so poorly researched.

Service to God and man and promotion of the public welfare is the very essence of the hundreds of hours of unpaid volunteer work by our Society members. Incidental experience and growth achieve status and reward for the individual.

Integrity is our watchword as engineers.

I suggest that J. J. G. McCue stick to his mudpuddling until he can write P.E. after his name.

*William G. Naef  
Engineer in Training  
San Francisco, Calif.*

To my inquiry as to how much Mr. Naef had researched the situation in states other than California, and whether he was willing for his letter to be published, I added a note calling his attention to the letters on this topic in the October issue, by colleagues who differed with him. His reply follows.

*Editor*

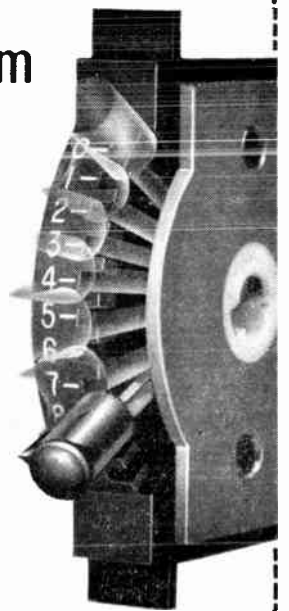
When my well-qualified technical organization blunders into the field of employee relations, I require that it be real and earnest. This affects my paycheck and my supper! Your editorial caused me considerable gut-level "emotional involvement." Anyone who would do the disservice to his fellows of comparing them to mudpuddlers, should be chased up a butt-rotted, shell-barked, 13.8-kV pole in a sleetstorm on Christmas Eve to cut in transformers with mutilated rubber gloves and a tripple-gaffed scare strap!

And to send me an old maidish "sorry that you found the editorial distasteful." Man, now I could work you over with wood hooks and skinning knife, and sing three stanzas of "Scotland the Brave" while chop chop chopping!

I will be proud to have you publish

Go from  
**HERE**

to  
**HERE**



without contacting  
intermediate  
positions

*and 10 times as fast  
as thumbwheel switches*

**NEW SEALECTRO  
SLIDE 'N SWITCH**  
Pat. Pend.

- Random access operation.
- Modular, expandable construction ■ 11 position, single pole per unit. ■ Guaranteed for 250,000 operations.

The new Sealectro Slide 'n Switch is a unique random access switching device for the programming of all types of automated equipment. Built-in "skip" function permits you to switch from position "1" to position "11" without contacting any intermediate switch point and simultaneously provides electrical readout indicating "open" position.

Units can be stacked side-by-side to provide any number of decade switches desired. Interested? Write for complete details.



PROGRAMMING DEVICES DIVISION

**SEALECTRO  
CORPORATION**  
MAMARONECK, N. Y. 10543

PHONE 914 698-5600 TWX 710-566-1110  
Sealectro Ltd. Portsmouth Hants. England  
Sealectro S.A. Villiers-le Bel Paris, France

Circle No. 7 on Reader Service Card.

both my letters. I try to think before I write, and then stand behind what I've said. Having been proved wrong, I will be glad to acknowledge the fact. But to cry "I'm sorry." My Gawd!

I have observed that all organizations have a certain number of weak sisters who are carried along out of charity. The problem is that these cry the loudest when pinched, and the whole group is judged. Incidentally, these engineers cause the most laughs among entrepreneur-minded managers. The letters you sent me are typical.

One wants a labor union to do his financial planning for his old age plus the security of staying with one organization while retaining the privileges of leaving upon a whim. Where is the old spirit of "Have slide rule, will travel?"

Another complains of being forced to go to graduate school evenings and the time it takes. This is a rare privilege. The fact of having the mind stretched, exercised, and challenged is ample reward for the effort. Again, we have a national pension plan now, called Social Security. What is his objection to it?

Another nit-picks the Canons of Ethics because he wants to buy a car wash and doesn't want to work a few extra hours at his job when he is needed. If he wants money and is lacking in talent, let him grow some gonads, and go do dangerous work, or unpleasant traveling work that pays better.

It is interesting that none of these men identify themselves as P.E.'s. Then they are not colleagues of mine.

The people of our blessed, free democracy, in their wisdom, have delegated the power to certify who is a Professional Engineer to their state boards. (In recognition of the realities of the economy, not all states can hold to the same standards.) The power is then properly shared. Schoolteachers can testify that a man has studied in engineering school and give him a certificate called a degree and cause a certain self-image. A few schools still grant an "Engineer" degree for two years of graduate work and a thesis to the Ph.D. candidates who can't cut it. But all are careful never to proclaim "This man is an Engineer." The ECPD accredits the schools. The balance of power is completed when Professional Engineers who know him, serve as references and vouch for his internship, capabilities, and experience.

In my experience, engineers fall into five groups. The first-rater quietly gets his license and doesn't say much about it. The second-rater does nothing be-

cause it takes voluntary effort. The third-rater ignores the fact in hope it will go away. The fourth-rater lives in fear of the self-discipline needed to take a 16-hour test and belittles it. The fifth-rater screams and whines and defies "the establishment to make him get one."

With a few glowing exceptions, industrial management insists on authoritarianism, does little to encourage professional registration or recruit professionals, and is content with second- and third-rate engineers.

There was a time when engineers chewed tobacco, carried a bottle, and mopped their face with a red handkerchief. If they didn't like their job they hauled on down the road to another one. They are the men who built this country. I'm afraid in our strife for status we have lost something.

*William G. Naef  
E.I.T.*

A very important problem facing the engineer today is the conspicuous lack of recognition afforded engineers by the public in general and industrial management in particular. Most engineers are resentful of this fact and feel that they should be treated as members of a profession; more important, that they should be able to reap those benefits normally connected with professional status such as economic security and welfare, and professional recognition to the same extent as, for instance, doctors and lawyers do. The status of these professionals is not so much due to their individual efforts as to the fact that they are backed up by strong professional societies—the AMA and the Bar Association. These societies are not at all restricting their efforts to the dissemination of information but direct a great deal of their time and resources toward representing the interests of their members.

Contrary to the policies of these organizations, the engineering societies in the past have behaved in an ostrich-like fashion; they either did not wish to recognize the existence of the problematical status of the engineer, or, if there was any recognition, they apparently hoped that complete silence would make the problem go away. For this reason, attempts of unionization of engineers or creation of quasi-union representative bodies are gaining in frequency and success. This fact should be sufficient warning to the societies, as it clearly indicates that, in increasing numbers, engineers are very much dissatisfied

with the policies of their respective societies.

Unionization, I feel, is not the answer, however. The preferable alternative is a change in the makeup of the engineering societies. They should be reorganized into bodies that, in addition to their present activities, implement policies to represent the economic interest of the membership in a professional rather than union-like manner.

Some of the societies are in the process of formulating such plans of action. One, in particular, is going further—the American Society of Civil Engineers (ASCE).

I am enclosing a reprint of an article published recently in *Civil Engineering* entitled "ASCE Responsibility for the Welfare of Its Members," indicative of a trend that should be adopted more widely, and the sooner, the better.

*H. B. Waterman  
TRW Inc.  
Redondo Beach, Calif.*

The article, too long to reprint here, states that the ASCE does not intend to let its exemption from Federal income taxes "hinder the fulfillment of its responsibilities to the public and to its members as a professional society. Should the acceptance of these responsibilities even be held to exceed the limitations of Section 501(c) (3) of the Internal Revenue Code, it is expected that the Board of Directors will decide whether to curtail programs or to accept exemption as a non-profit 'business league' under the more liberal provisions of Section 501(c) (6) of the Code."

It goes on to say: "Sound standards [for economic advancement and professional development] should be established after careful analysis and evaluation of existing practices in context with other professions and occupations requiring trained and skilled personnel. Then every professional engineering society should press aggressively for universal compliance with these standards, in industry, in government, and in private practice."

The full text appears on page 35 of *Civil Engineering* for April 1969.

*Editor*

## **Ethics**

The August issue of IEEE SPECTRUM carried an article on "The New Responsibility of the Engineer."

The field of ethics is not one to be considered lightly. The material presented is based on the author's premise



that "the ethical basis for this proposal is that the engineer is obligated to serve society."

Back to the drawing board!

Such an ethical consideration is characteristic of a slave or collectivist society—not a free one.

The fact that an engineer serves his own self-interest does not imply that he does it at the expense of others. Creativity and productivity must not be confused with theft.

*Herbert Heller  
Pittsburgh, Pa.*

## Trade secrets

I wish to submit the following comments on the article, "Trade Secrets and the Technical Man," by Charles M. Carter in the February issue of IEEE SPECTRUM (pp. 51-55).

A company or organization has a legitimate right to maintain secrecy on the following matters:

1. Research for the purpose of obtaining practical or theoretical knowledge.
2. Development of new products and strategies for marketing them.
3. Technical, artistic, or stylistic designs.
4. Industrial, commercial, or financial plans of expansion.
5. Work in connection with national security.
6. Internal information that can be used in labor or commercial negotiations.

These should be called confidential information to remain undisclosed until the knowledge has been applied to the solution of a problem, or a patent, a copyright, or a trademark has been filed, or a product marketed, or an expansion carried into reality. The matters mentioned in points 5 and 6 should remain undisclosed longer than the others, although not forever.

The bribing or hiring of insiders by outsiders to obtain legitimate confidential information, or the putting on sale of that information by insiders, must be considered industrial espionage and be subject to penalties in accordance with the law.

The methods, practices, procedures, skills, and general knowledge of the company, as well as the research results that are purposely not patented but are utilized, can be termed "trade secrets" when the company wants to keep them in secrecy. It is the attempt to treat them the same as legitimate confidential in-

formation is treated that is the source of my disagreement with Mr. Carter's article.

The majority of organizations require engineer and scientist employees to sign promises not to divulge information that go far beyond the protection of legitimate confidential information and cover virtually every aspect of their lives, seriously impairing their rights as citizens.

The fact that a company entering into a new business needs people skilled in that field cannot be disputed. To seek an injunction to prevent a man who holds trade secrets from joining a competitor has serious implications. First, the company holding the trade secret is limiting that man's right to work because his special knowledge is his most important asset, and if he cannot work in the field where he can profit most he is condemned for the rest of his life to be his company's property or to use his talent in what is not the best manner for him or society. Second, the company becomes the absolute judge of a privilege granted to it by nobody but itself. Third, a monopolistic practice is exerted in the brainpower market, which becomes depressed. Fourth, to avoid injunctions the companies can establish so-called "gentlemen's agreements" not to hire employees of competitors, agreements that in many parts of the world bring as a consequence very low salaries for engineers, forcing them to emigrate (this being one of the causes of the "brain drain") or to open a grocery store.

To award damages, profits, or royalties for the breach of trade secrets is to grant an economic reward not granted by the Patent Office, not taking into account that the value of those secrets could be disputed by the latter. A company could then legally dominate a market for more time than that allowed by the law to a patentee, exerting on it a monopolistic pressure, just by keeping a secret. Furthermore, a trade-secret law would be wholly ineffective against a man who can use his skills in a foreign country.

Trade secrets are reactionary; they bring mankind back into the practices of the medieval guilds. They are immoral because nobody is an unrestricted owner of knowledge, but an heir who has the duty to bequeath his inherited knowledge to others. Such secrets are anti-economic and constitute obstacles to progress because the interchange of practices and skills is the key to betterment and improvement.

What would have become of all of us, even of the companies holding trade secrets, if Faraday, Maxwell, and Einstein had not freely published their theories or Edison patented his inventions?

Trade secrets do not insure, in themselves, a company's success. The case of The Coca-Cola Company is an excellent example. Its ultrasecret formula is only a publicity device, because the beverage's flavor has been duplicated thousands of times. The public is attracted by secret ingredients, be they in beverages, toothpaste, or gasoline, although all of them are totally valueless or nonexistent. And so trivial and easily capable of being duplicated is the majority of trade secrets. The success of Coca-Cola, as well as of its archrival Pepsi-Cola—which does not advertise secret ingredients—can only be attributed to good management and excellent advertising.

Laws against industrial espionage should be welcome. Trade secrets, as well as privileges not granted by patents, copyrights, or trademarks, and the monopolistic practices that go with them, should be outlawed. No man should be deprived of his right to work or compelled to sign an agreement of secrecy that goes far beyond the needs of an organization. And everybody can be sure that the results will be mutually satisfactory for all the parties involved, and for society.

*A. H. R. Klimann  
Buenos Aires, Argentina*

As is pointed out in the opening paragraph of my article, the purpose thereof is to provide people in the scientific and technical community some insight into the laws in the U.S. as applied to trade secrets. Mr. Klimann has taken issue with my paper on the basis that *he personally* feels that trade secrets should not be treated as legitimate confidential information. In my article, I did not express personal views or definition of what I felt the law should be, but rather pointed out the rights, obligations, and liabilities that exist today under the laws in the U.S. as applied to trade secrets by the courts. Mr. Klimann is obviously entitled to his own opinions as to whether or not the laws in this area are appropriate. However, I feel that certain statements made by Mr. Klimann require my comment.

First, Mr. Klimann in setting forth those items that he feels should be called confidential information asserts that such information should remain con-

# The second revolution in computer time sharing continues.

## And we're winning it.

■ **The AL/COM interactive time sharing network will electrify every sophisticated computer user in the United States.**

AL/COM now gives you more interactive computing power with faster response time, than any other time-sharing system . . . 32,000 36-bit words per user. Cycle time one microsecond. Your access to this increased computer power is instantaneous and direct. Through your telephone. Privately. It's a "tough-job" system and it has the best price/performance ratio there is.

■ **AL/COM has a policy about insoluble time sharing problems. We solve them.**

We're after the tough jobs, the big ones. We're talking about price/performance . . . good response time . . . and freedoms that time-sharing hasn't granted you before. Things like:

**Core Capacity** — AL/COM gives you 160,000 characters (32,000 words) in active core per user.

**On-Line Storage** — AL/COM has a billion characters of disc storage.

**Large Files** — AL/COM gives you 1,250,000 characters per file.

**Fast Access** — AL/COM can search a 2.5 million character bank in seconds.

■ **The things you can do with AL/COM time sharing are limited only by your imagination.**

AL/COM has the bugs worked out. We've been up for 3 years. We can connect you with teletypes, line printers, CRT's and multiplexers. We speak eight languages . . . BASIC, FORTRAN IV, COBOL, etc. We're adding others. AL/COM solves problems in science, engi-

neering, and banking. It's for operations research, marketing and statistical analysis, and bridge building . . . for management information, investments, and manufacturing. We even do little problems well.

■ **When comparing time sharing services, you can't include AL/COM with the others.**

AL/COM service stands out because we've interlaced a string of multi-processing AL-10 systems, with one computer backing up another in each system, and a second dual system backing up the first . . . and we'll soon have ten. They're all side by side, but as close as your local phone. Think about that . . . central files . . . back-up . . . speed . . . reliability . . . distributed nationwide by the AL/COM Time-Sharing Network.

■ **When you select AL/COM you get a nationwide network of computer software professionals.**

We bring AL/COM to you through a nationwide network of professional software organizations. We're more than reps, dealers or branch offices. We're AL/COM Associates; local, independent firms, among the best in the industry. Systems and applications expertise is an integral part of the AL/COM network. This means you have the largest group of independent computer software experts to help you solve problems more efficiently, right at your elbow . . . through AL/COM. Two new "Associates" are selecting AL/COM each month. Why don't you?

■ **In just 30 seconds, you can arrange for a demonstration of the world's best price/performance computer time sharing service.**

Experiencing AL/COM is believing. We'll benchmark AL/COM against your present system. Compare the response, the speed, the cost. Do you have a problem you can't solve on your present system? Try us. We're after the tough ones.

■ **It takes guts to start a revolution.**

Revolutions are started by people dissatisfied with the way things are. Success depends on a change for the better. That's what AL/COM is all about . . . and it's revolutionary.

Contact us for information or demonstration

**AL/COM** 

The Revolutionary Time-Sharing Network

AL/COM is a service of  
**APPLIED LOGIC CORPORATION**

One Palmer Square  
Princeton, New Jersey 08540  
(609) 924-7800

Call me  Send data

Name  Title

Company

Address

City  State

Zip  Tel.

Boston (617) 523-3636 — Buffalo, Rochester, Toronto Area (716) 634-9090 — Philadelphia Area (609) 665-6088 — Hartford (203) 522-0665 — New York Metropolitan Area (201) 678-6300, (212) 349-1531, (212) 486-1670 — Ohio Area (513) 771-0362 (Cincinnati), (513) 276-5215 (Dayton), (216) 292-2661 (Cleveland), (412) 462-7515 (Large, Pennsylvania) — Pittsburgh (412) 372-6226 — Princeton (609) 924-7800 — San Jose (408) 292-9857 — Washington, D.C. (202) 638-5575 — Chicago (312) 641-1856

See us at **FJCC, Booths 5007-5008 at the main Convention Center.**

Circle No. 8 on Reader Service Card.

confidential and undisclosed until "a patent, a copyright, or a trademark has been filed." Upon issuance of a patent, a copyright, or a trademark, the information contained therein becomes public information. However, the act of filing a U.S. patent application, for example, does not render the information contained therein material within the public domain. Under 35 U.S.C. 122, it is made clear that patent applications are maintained in confidence unless (1) disclosure is authorized by the applicant or owner, (2) disclosure is necessary to carry out the provisions of an Act of Congress, or (3) the Commissioner of Patents has determined that special circumstances necessitate disclosure.

Mr. Klimann has indicated that in his opinion certain information may be designated as trade secret when it is not legitimate confidential information. It is not the right of a corporation in the U.S. to determine arbitrarily what is legitimate confidential information. Rather, it is determined by the law and its application by the courts. The courts provide the safeguard against corporations overextending their rights in this area.

Mr. Klimann has implied that, in my article, I have taken the position that trade secrets by themselves can insure a company's success. Obviously, this is not true. However, a trade secret can prove to be a major asset in this regard as shown by the Coca-Cola case. Granted, Coca-Cola's success can be attributed to good management and excellent advertising, but it is well known that their secret formula likewise contributed to their success. Although many have tried to duplicate the flavor of Coca-Cola, I am sure that a large segment of society will dispute Mr. Klimann's contention that the flavor has in fact been duplicated.

With regard to the granting of injunctions, this only occurs on rare occasions under exceptional circumstances. There is a balancing (of the scales of justice) between the right of an employer and the right of an individual in our system, which favors free competition.

In conclusion, Mr. Klimann is entitled to his opinion of what the law should be as summarized in his last paragraph. My article set forth the U.S. law as it is. It is quite apparent that our system has not depressed our brain-power market or forced engineers to emigrate or change professions.

*Charles M. Carter  
Warwick Electronics Inc.  
Chicago, Ill.*

## New electronic services

"Electronically Expanding the Citizen's World" in the July SPECTRUM was both interesting and a needed viewpoint considering that much of the electronics industry follows the simpler short-term goals of designing for government-defense needs, or building ever-more-sophisticated instruments for use within the industry itself.

I was particularly awakened by Dr. James Hillier's statement that the major means of introducing new black boxes into the home "is by the introduction of a new *service*" (italics mine). If mass production with its low costs is the foundation of the United States' industrial power, then the millions of electronic boxes for the consumer must be at least a major contributor to our industry.

With this generalized and simplified bit of background, let me suggest a service or two that may have been overlooked. Consider that:

1. The public has been paying \$50, or even hundreds of dollars, for really accurate watches.

2. The Swiss and others have been spending hundreds of thousands trying for even better watches—almost portable quartz-oscillator standards.

Then why not an electric watch, coupled with an integrated circuit or two, that would perform as a radio-synchronized watch? One countrywide frequency would be all that was needed, and at that it could be exceedingly narrow band.

Let's follow this trend of thought involving information that John Q. Public might like to have, which can be provided practically through integrated circuit technology, and uses an absolute minimum of valuable spectrum space. Think about:

1. Another "watchlike device" with several small dials or other indicators providing recent weather forecasts, temperature-humidity index, and present weather conditions (a must for people working in windowless buildings).

2. An attachment to a standard television set using an LSI memory to receive and store information, perhaps using slow-scan techniques and a sub-carrier channel. By pushing one of several buttons the owner could then get displayed on his screen such items as

- (a). The television schedule for the next two hours.
- (b). Latest headlines.
- (c). Local school and activities information.

(d). Emergency information (storms, etc.).

(e). Stock market reports.

(f). Traffic reports.

(g). Sports scores.

I would almost bet that these services could be provided without any major reallocation of spectrum space since an "up-to-date" every half hour would require an extremely low bit rate and hence bandwidth. An industry that could figure out how to cram the extra color information into a standard television channel can surely find a few dozen extra hertz for these further services.

The "information broadcasting" channels, although low cost due to narrow bandwidth, low power, and essentially complete automation of transmission, would, however, need a source of revenue. Perhaps this could be in the form of royalties from the receiver manufacturers. Item 2 (the television receiver attachment) could, if nothing else worked out, add a line of advertising to the bottom of each information display. Further revenue could be obtained by having one of the information displays contain the day's "specials" at the local supermarkets. Housewives would push this button even though they knew full well that it was only advertising! Job opportunities might be another self-supporting "instant information display."

The possibilities for instant information without a computer tie-in or even any major new utility are very broad and thus contain the possibilities of high sales without high capital investment—inviting further investigation.

*Peter Lefferts*

*Electro Audio Research Laboratories  
Hopewell, N.J.*

## Reviewer and author disagree

As a reviewer, I have read Archer Taylor's article with interest (see pages 77-81 of this issue), but feel that some comments are due regarding the expected growth of cable television as represented in the graph showing low, medium, and high growth projections.

The "high" growth curve appears to be unduly pessimistic for a new and aggressive industry that may be about to shuck the shackles of a highly restrictive regulatory climate. Mr. Taylor's "high" growth curve represents an average growth rate of 14.2 percent for an industry that has been experiencing growth at rates of 25-40 percent (25 percent for the year ending January 1, 1969). A "medium" curve projecting growth at

*Coming for tomorrow's cities: more efficient people-movers. Snow-free moving sidewalks. "Personalized capsule" systems that traverse building fronts. Elevated automated traffic "guide-ways" with propel-on and eject-off ramps. IR can help make the scene.*



## Electrifying change coming. We'll control the power.

We're talking with people who are making it their business to get things moving. Because our business is keeping things moving with precisely controlled power. Air, surface, rail and undersea craft. Earthmovers. Ore carriers. Motorized production and material-handling equipment. So if you're involved today in closing the loop on tomorrow, get IR wired in. Early. We've got a controlling interest in electrifying change.

- Silicon Controlled Rectifiers
- Power Logic Triacs
- Silicon Power Rectifiers
- Selenium Rectifiers
- Zener Diodes
- Custom -engineered Sub-assemblies and Systems
- Light Sensitive Devices

**INTERNATIONAL RECTIFIER** 

Semiconductor Division, 233 Kansas Street, El Segundo, California 90245, Phone (213) 678-6281  
MANUFACTURING FACILITIES UNITED STATES, CANADA, GREAT BRITAIN, INDIA, ITALY, JAPAN, WITH SALES OFFICES AND DISTRIBUTION IN MAJOR CITIES THROUGHOUT THE WORLD  
**Circle No. 9 on Reader Service Card.**

a rate of 25 percent for 1969, declining slowly to 15 percent by 1980, is a more likely projection. This would result in 27 million subscribers by 1980 (nearly twice Mr. Taylor's estimate). The "high" curve estimate should show even greater potential by 10 million or so (by 1980) based upon the likelihood of some favorable changes in FCC regulation or congressional legislation.

Based upon Bureau of Census projections and location data, there will be 50 million households within 32 km of U.S. television cities by 1980. A 60 percent penetration of this potential seems entirely possible within the next ten years if one or more of the following were to happen:

1. If the FCC were to relieve its interdiction on the carriage of distant signals into major markets. (This is a distinct possibility in view of the changing constituency of the Commission; two of the seven FCC Commissioners are being replaced in 1969 and one is likely to be replaced in 1970.)

2. If cable television (CATV) were to be included in the omnibus copyright bill about to be reported by Sen. McClellan, Chairman of the Subcommittee on Patents, Trademarks, and Copyright (Committee on the Judiciary). It is believed that the copyright bill will call for *compulsory* licensing of cable television systems, thus removing the basis for the interdiction imposed on systems by the FCC.

3. If new low-cost programming sources were to be made available to the industry, thus allowing a cable television system to become viable in major markets on the basis of local signals plus several channels of origination. (The CBS and 3-M developments of electron-beam recording on film offer hope here.)

4. If cable television participation in the domestic satellite program is allowed such that we could have direct-to-CATV headend interconnect service.

The point may be raised that cable television expansion into 25-35 million homes in ten years places some strain on the production facilities of the manufacturers as well as on the financial and technical capability of the companies installing the systems but the ingenuity of the U.S. business entrepreneur, in this respect, has never failed in the past.

One interesting yardstick is the fact that the Colorado Springs underground system was built in front of some 30 000 homes (650 km of plant) in less than one year. The system owners reported 11 000 orders for service prior to the system turn on—and the owners are predicting a

60 percent saturation of this market in two years.

*G. Norman Penwell  
Director of Engineering  
National Cable Television  
Association, Inc.  
Washington, D.C.*

Projecting the growth of the cable television industry is necessarily a matter of judgment. I sincerely hope Mr. Penwell's optimistic judgment proves to be more nearly correct than my own.

My view of the future differs primarily with respect to the imminence of major developments that would either remove the regulatory and legal inhibitions or by-pass them with new program services. I am completely confident that the use of cable for multiple-address distribution of visual communications into homes must inevitably continue to expand, although at a gradual and perhaps erratic pace determined by the inertia of the status quo as well as by the operational lag in developing new program sources.

Careful analysis of the mechanism of subscriber growth indicates the extrapolation of trends in the annual rate of growth is not a reliable method of projection. It does appear to be reasonable to project the cumulative total number of homes available to, or "in front of," completed cable plant at a more or less constant growth rate, analogous to the growth of a principal sum at compound interest. If new cable plant could be constructed so that the number of homes available would increase by 23 percent each year, cable service would be available to all of the 56 million urban homes projected by 1980. This is not impossible or entirely unrealistic. However, even at this rate, cable would be available to only 35 percent of the 56 million homes by 1975; and only 80 percent by 1979.

On the other hand, it is obvious that no subscribers can be added until the cable becomes available to them. The rate at which subscribers connect after the cable is available tends to be exponentially asymptotic to some saturation level, such as 50 percent or 60 percent of the number of available homes, in a manner analogous to the charging of a capacitor. The "time constant" for subscriber growth is a function of a number of management factors, such as promotional effort, sales efficiency, economic conditions, and the price and desirability of the service. Although there are some examples of growth to 50 percent or more in two years, they are exceptional. Five years or more to saturation is the

more typical experience, with some "disasters" failing to reach more than 25 percent after ten years or more.

Considering these factors, only the 35 percent that become available by 1975 could be expected to reach sales saturation by 1980. At least 20 percent would not even become available for sales efforts until the tenth year of the decade.

An optimistic projection of 34 million or so subscribers by 1980, therefore, would presume that:

1. By 1971, either the regulatory climate or availability of alternate programming will be such as to clearly establish the viability of cable television in any urban community.

2. Promotional and managerial methods will be so improved by 1975 as to assure 60 percent saturation in two years.

3. The total number of homes available to completed cable plant increases by 35 percent (compounded) each year.

I simply cannot accept such premises as a reasonable basis even for the most optimistic projections. Under the best circumstances that could reasonably be anticipated in the real world, there could be as many as 17 million subscribers by 1980, with sufficient momentum established to support continued rapid growth.

So, notwithstanding some difference in degree, Mr. Penwell and I obviously share an expectation that cable television will become an increasingly significant aspect of home communications in the next decade.

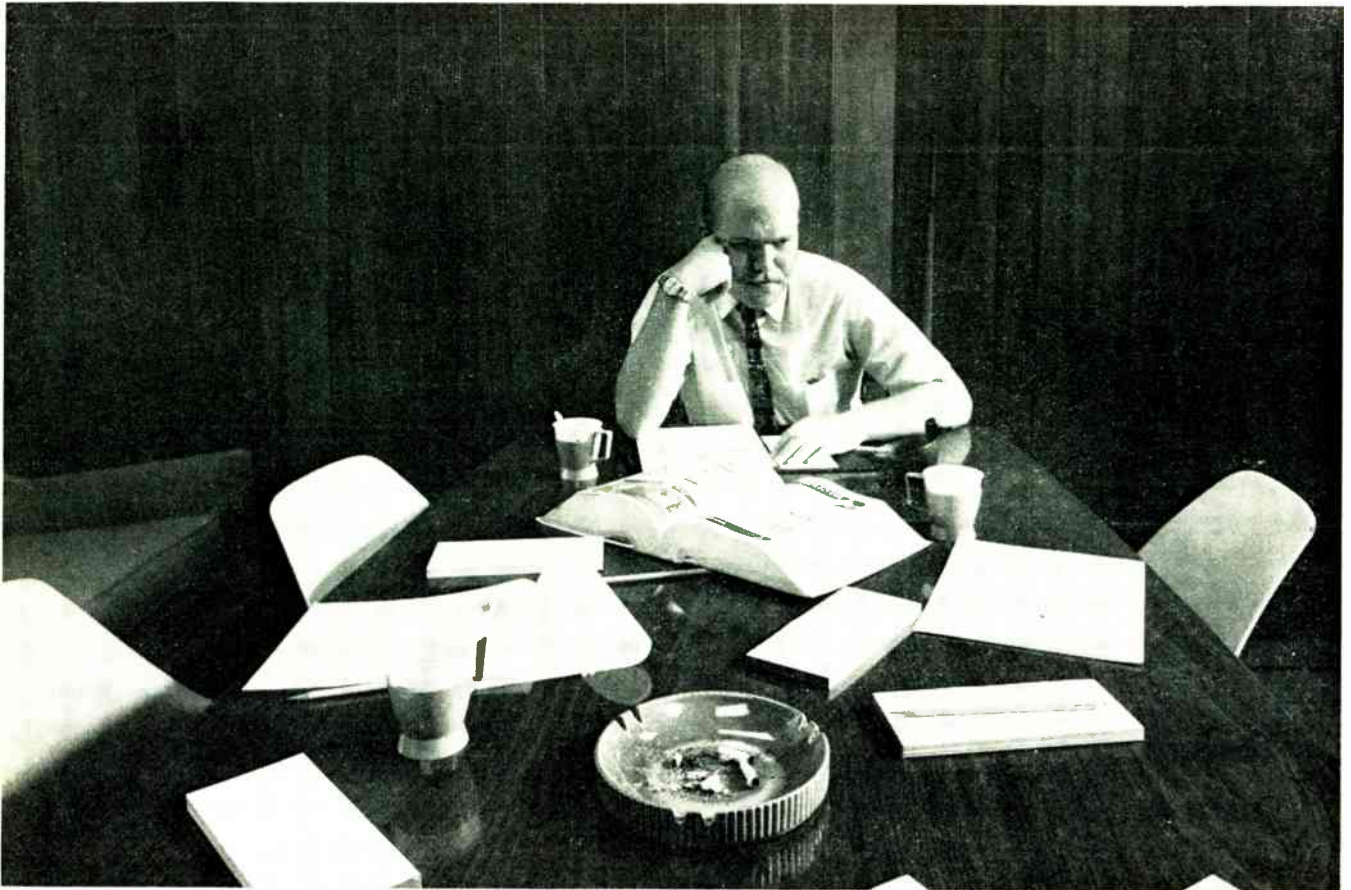
*Archer S. Taylor  
Malarkey, Taylor & Associates Inc.  
Washington, D.C.*

## Greek and Latin plurals

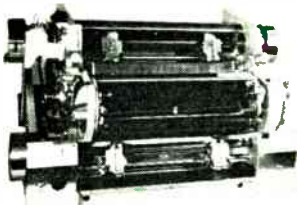
Correct formation of the classical plurals ("Spectral lines," this issue) is a complicated business. Here are some examples.

Singular	Plural
<i>gnomon</i>	<i>gnomai</i>
<i>dogma</i>	<i>dogmata</i>
<i>charism</i>	<i>charismata</i>
<i>hysteresis</i>	<i>hystereses</i>
<i>ephemeris</i>	<i>ephemerides</i>
<i>metropolis</i>	<i>metropoleis</i>
<i>pharynx</i>	<i>pharynges</i>
<i>forceps</i>	<i>forcipes</i>
<i>status</i>	<i>status</i>
<i>opus</i>	<i>opera</i>
<i>octopus</i>	<i>octopodes</i>

It is doubtful to me that even if we could keep them, we would get any



**So . . . they left it up to you to decide on High-Speed Line Printers.  
Make it painless . . . call MDS!**



MDS SERIES 5013 HIGH-SPEED  
LINE PRINTER MECHANISM



MDS SERIES 5320 HIGH-SPEED  
LINE PRINTER (CONSOLE)

After all the talking is done, someone has to do the work. If you're the one who has to come up with recommendations for high-speed line printers, do what others in similar situations have done for years . . . call MDS.

MDS Line Printers are called the "work-horses of the industry". This reputation for reliable, long-term performance has contributed significantly to the MDS position as a leading independent source for line printers. This "work-horse" reputation works equally well for you.

MDS High-Speed Line Printers (1000-1250 lpm) offer you three choices: *The 5013 Printer Mechanism only, for integration with your own equipment; the 5320 Buffered Line Printer (Console); the 5300 Line Printer (Console, unbuffered).* Console models are complete with MDS electronics and DC power supplies.

MDS 5013, the high-speed rotating drum, on-the-fly printer mechanism, is the indispensable, vital center of every MDS High-Speed Printer. It contains the critical precision-built components that assure top performance.

**OTHER IMPORTANT FEATURES:** Dual Tractor Paper Feed; improved Clutch/Brake mechanism with vacuum cleanout system; Tape Control Vertical Format with standard 8 channels (12 channels optional); Improved Ribbon Tracking Mechanism; New Fibre Optics System with only 3 light sources . . . plus others.

Phone or write for literature. Your Man from MDS will gladly help you make your decision.

**HELP FOR OEM  
DECISION-MAKERS**

**MOHAWK** **MS**  
DATA SCIENCES CORPORATION  
**OEM MARKETING**

Palisade Street, Herkimer, N.Y. 13350  
Phone 315/866-6040

**REGIONAL MANAGER OFFICES:**

Orlando, Fla., Phone 305/841-3091 • Waltham, Mass., Phone 617/891-5870 • Des Plaines, Ill., Phone 312/298-4141 • Los Angeles, Calif., Phone 213/685-5165  
BUFFERED TAPE UNITS • DIGITAL STRIP PRINTERS • LINE PRINTERS • CARD PUNCHES AND READERS • PAPER TAPE PUNCHES AND READERS

**Circle No. 10 on Reader Service Card.**

benefit from these holdovers from the genteel culture.

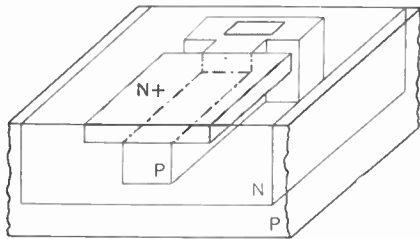
*The Editor*

### Corrections

The article by Herschel T. Hochman, "The Art of Building LSIs," which appears on pages 29-36 of the September issue, contains two errors.

On page 31, Fig. 3 (B) should appear as shown in the line drawing below.

The first sentence of the second full

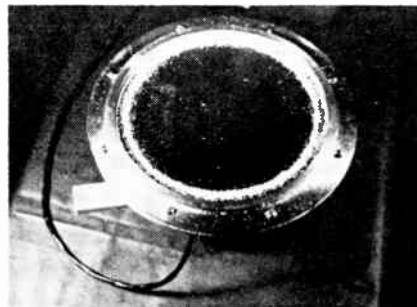


paragraph in column 2 of page 30 should read, "The choice of which sheet resistivity is to be used depends, to a degree, upon the tolerance that must be maintained over the wafer."

In regard to the article by Eric G. Rawson, "Vibrating Varifocal Mirrors for 3-D Imaging," which appears on pages 37-43 of the September issue, one error and one omission should be brought to the attention of our readers:

1. The "A" and "B" portions of Fig. 8 were reproduced in the wrong order; they should be interchanged. The caption is correct as it stands.

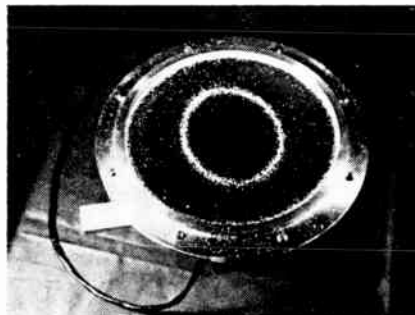
2. Figure 10 originally consisted of six parts, with oscillation modes shown at frequencies ranging from 60 to 2325 Hz. Since five of these parts were deleted prior to final publication, full understanding of the text discussion was sacrificed. We are therefore reproducing the entire series of six photographs below.



60 Hz



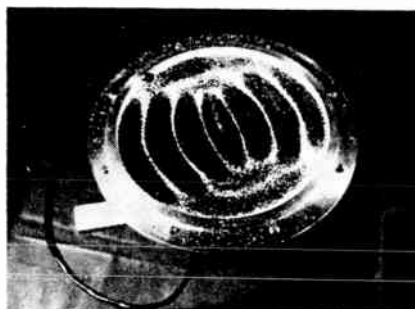
370 Hz



450 Hz



880 Hz



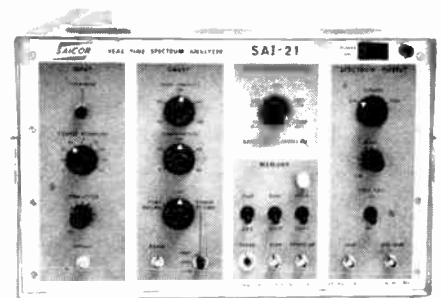
1300 Hz



2325 Hz

# HELL TO HEAVEN & between SAICOR REAL TIME SPECTRUM ANALYZERS MAKE SENSE!

Devour and analyze data fast — subsurface or space; natural or man-made; esoteric or explosive — with no sacrifice of resolution. Engineered for instant action, simple operation, continuous and transient analysis in real time with almost any output format—digital or analog. Solid-state, MOS FET shift register memory for non-spurious data. Options to fit any application: 1/3 octave, frequency tracking, translator, etc.



**Don't buy more resolution than you can use.**

5 standard models, each designed for the resolution required. SAI-21 (above) was developed for applications requiring 200 point resolution. Only SAICOR makes such a unit; priced at the lowest cost anywhere for the finest real time spectrum analyzer. Lighter weight, smaller size, portability, make it ideal for field and laboratory.

Just developed! A brand new scientific instrument —  
**SAICOR DIGITAL CORRELATION AND PROBABILITY ANALYZER**  
Contact us for full details

For literature, write or call Dept. J,  
Signal Analysis Industries Corp.  
595 Old Willlets Path, Hauppauge, N. Y. 11787  
Phone 516/234-5700

# SAICOR

Circle No. 11 on Reader Service Card.

*Designed for*



*Application*



90662-A

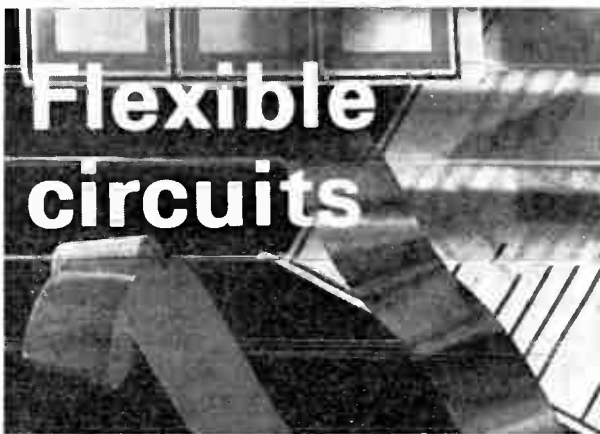
**NO. 90662-A INDUSTRIAL  
GRID DIP METER**

225 kc. to 300 mc. Hand calibrated  $\pm 0.5\%$ . Rugged 1-milliamper meter with transistor d. c. amplifier for maximum sensitivity. Transistor modulator. Silicon rectifiers. Convenient single-unit one-hand operation. Eleven individual coils with form-fitting molded covers. Complete in carrying case.

**JAMES MILLEN MFG. CO., INC.**

**MALDEN  
MASSACHUSETTS**

Circle No. 12 on Reader Service Card.



**Flexible  
circuits**

Kapton\* or Mylar\* flexible printed circuits are a specialty at Buckbee-Mears. We make them to standards of precision unsurpassed in the industry. We produce small wires to two mil apart on four mil centers, sizes up to five feet square. Tolerances held to  $\pm .0002$  inches on wires and space, shrinkage control guaranteed.

May we tell you more? See your Buckbee-Mears technical representative, or call or write Bill Amundson, industrial sales manager.

\*DuPont trademarks



**BUCKBEE - MEARS  
COMPANY**

245 E. 6th St., St. Paul, Minn. 55101 / (612) 227-6371

Circle No. 13 on Reader Service Card.



What you  
should know  
about

**Magnetic  
laboratory  
equipment**

Write for it! All in a useful 16 page catalog of precision quality instruments - Hysteresisgraphs, Fluxmeters, Gaussmeters, Laboratory Electromagnets, Superconductor magnets, Power Supplies, Coils and Special Magnetic Systems -

**O. S. WALKER COMPANY, INC.**  
ROCKDALE STREET, WORCESTER, MASS 01606  
TELEPHONE 617-853-3232 TWX 710-340-7629



**MAGNETIC SYSTEMS  
& INSTRUMENTS DIVISION**  
(MIL Division)

Circle No. 14 on Reader Service Card.



# Spectral lines

A plea for plurals. The indispensable characteristic of good engineering writing is freedom from ambiguity. But more and more frequently, we run into a sentence such as "This phenomena was first noticed in 1943." Anybody sensitive to English syntax will wince. He knows that "phenomena" means "more than one phenomenon," so that "this phenomena" is garbage. Those who pride themselves on being too manly to care about syntax will not notice anything wrong; if anybody tells them that they are overlooking a violation of the rules, they may counter with "Does it matter?"

Yes, it does matter. In the next paragraph, one reads "The criteria for making this choice will be apparent." If we could trust the writer to be using good syntax, we would know that he has in mind more than one criterion. From the previous paragraph, however, we know that he is not to be trusted. But whether there is one criterion or three criteria really does matter to us as engineers.

Greek words like *criterion* and *phenomenon* were adopted into the English language in the 17th century, when modern science was young and still mindful of its Greek ancestry. When they were transliterated into our alphabet, such terms were often treated as English words, their plural versions being formed by adding *-s*. In the 18th century, to no less an authority than Dr. Johnson, of dictionary fame, the plural of *phenomenon* was *phenomenons*. In the 19th century, nearly every boy in England who was likely to write for the press was taught Latin and Greek in childhood. To him, the Latin and Greek plurals came naturally, and he used them throughout life when he wrote English, confident that his readers had had a similar classical education.

We have come a long way since then. There are now too many more important things to learn. It is fully time to abandon the tradition that certain words have plural forms dictated by ancient declensions, and to revert to the sensible custom of forming a plural by adding *-s*. We shall then have *curriculum*s, *spectrum*s, *phenomenon*s, *criterion*s.

All these forms—with the exception of *curriculum*s, which nevertheless has been in regular use in its own publications by the National Council of Teachers of English for at least the past 40 years—have long been recognized in dictionaries of English, British as well as American. Engineers are notoriously impatient with

nuances of language that look like snobbery; why they should have ignored this legitimate simplification is a mystery. While they could still handle the complex rules for forming plurals in the ancient style, no harm was done by adhering to the quaint old endings. For the past five years or so, however, the younger writers have hardly even been aware that the special rules exist, and they have been using the plural endings whether they intend a plural or not. The result has been a breakdown of meaning.

We cannot keep the old forms, based on the Greek and Latin declensions, because students no longer learn them. The choice is whether we will have singulars that form plurals in the regular way, or whether, through ignorance, the old plural forms will become singular, and there will be no plurals. To help prevent the loss of clarity that the lack of plurals would entail, the Publications Board of the IEEE now recommends that the plurals of English words derived from Greek and Latin be formed by adding *-s* (or, sometimes, *-es*) to the singular forms. We have no trouble saying *electrons* and *photons* and *fulcrums* and *antennas*; *criteria*s and *spectrum*s are just as easy and have been part of the language for much longer.

Details of implementing the policy will be worked out pragmatically. A word list for guidance will appear in the next issue of IEEE SPECTRUM. A few irregular plurals, such as *axes*, will no doubt be retained so long as most authors use them correctly.

There are always a few people who like complication for its own sake. Before they object to the new policy, they should see whether they really do understand the formation of Latin and Greek plurals, by writing down the classical plurals of the following words: *gnomon*, *dogma*, *charism*, *hysteresis*, *ephemeris*, *metropolis*, *pharynx*, *forceps*, *status*, *opus*, *octopus*. The classical plurals are given at the end of this month's Forum (p. 16).

Nearly 50 years ago H. W. Fowler (who was himself an accomplished Latinist) wrote in his *Modern English Usage*: "All that can safely be said is that there is a tendency to abandon the Latin plurals, and that when one is really in doubt which to use, the English form should be given the preference." In adopting this advice, the Publications Board has taken a useful step toward improving the clarity of engineering writing and speech.

J. J. G. McCue



**HARADEN PRATT JULY 18, 1891–AUGUST 18, 1969**

**Resolution adopted unanimously by the Board of Directors of the Institute of Electrical and Electronics Engineers, Inc., at Ottawa, August 27, 1969:**

**RESOLVED:**

That this Board of Directors, saddened by the death of Haraden Pratt, Director Emeritus, hereby expresses its profound admiration, respect and appreciation for the more than forty years of devoted service as an Officer and Director he has rendered to the Institute of Radio Engineers and to IEEE.

Few men had such a long and commendable record of participation in the affairs of our Institute. He joined the IRE in 1914, two years after its founding. His active service began in 1928 when, upon moving to New York, he was persuaded to join the IRE Standardization Committee. The following year he was elected to the Fellow grade. He served as IRE President in 1938, thereafter served a term as Treasurer, and in 1943 was appointed Secretary of the Institute. He held this office without interruption until 1965, after which he became Director Emeritus. He shared with Director Emeritus Alfred N. Goldsmith a record of long and distinguished service equalled by no other among the past and present Officers of the Institute.

In addition to his service as Officer and Director, Haraden Pratt served on 25 Committees of the Institute, and as Chairman of 11 of these. The Institute granted him in 1944 its highest award, the Medal of Honor, and another major honor, The Founders Award, was bestowed on him in 1960. Beyond the Institute, he was Chairman of the Radio Technical Planning Board, which undertook a comprehensive and constructive review of radio services in the United States after World War II. In 1951–1953 he served as Communications Adviser to Presidents Truman and Eisenhower. In industry, he was an early pioneer and an important leader in the planning, implementation and administration of international telecommunications.

This Board is particularly grateful for Director Pratt's personal contribution to the principles of government on which IEEE is based. More than any other, he was responsible for the present structure of the Institute's Bylaws and he completed within recent months a thorough and detailed review on which important revisions, aimed at further strengthening of the Institute operations, will be based. All of his fellow members of the Board recall with respect and pride the many occasions on which he briefly but cogently summarized discussions, with a clarity that led to confident action by the Board as a whole.

The Members of the Board hereby convey their gratitude for his many contributions to IEEE.

*F. Karl Willenbrock  
President*

# Sixty years of wireless and radio

Autobiographical reminiscence by Haraden Pratt

*These notes on his career have been drawn from a much larger body of autobiographical material written by Mr. Pratt near the end of his life and placed on deposit with the History Committee of the IEEE. The memoirs were written for his friends rather than for publication; the extracts presented here are printed essentially as written, without alteration of style, in order to preserve their informal spirit. There has been no attempt to remove any inaccuracies that may have crept into the manuscripts, which were doubtless composed from unaided memory.*

*The Editor*

My birth took place on July 18, 1891, in a cottage on a wooded lot at Jones and Lombard Streets in San Francisco. Father and Mother were both telegraph operators, and I learned Morse code at an early age.

It was in 1905 that I read in the Sunday newspaper that Major Squier of the Army was experimenting with wireless telegraphy between Fort Mason and Fort Alcatraz, using trees instead of wires for antennas. The Signal Corps had established a wireless system there in 1900. Since I lived close to Fort Mason, I wanted to hear these signals and built crude receiving apparatus and an antenna using discarded wire the telephone linemen were throwing in vacant lots (they were replacing galvanized iron wire with copper). My cash outlay was less than one dollar for a telephone receiver from a New York mail-order house. I failed to hear any signals. The earthquake and fire terminated these experiments but when President Theodore Roosevelt sent The Great White Fleet around the world in 1908 I tried it again. It was a school holiday and we went to the Presidio to see the fleet enter the Bay. During lunch an idea came to me. I rushed to the basement and dusted off the cobwebs; sure enough, here were the signals, loud and clear. I did not know the International Morse code they were using but I did have a copy of it. Many of the characters were the same as American Morse, but some were not. Mother wrote down the characters while I translated them. The messages had to do with greetings, invitations to officers for parties ashore, and acceptances. They were handled through two shore stations of the Navy, one at Mare Island and the other at Yerba Buena Island.

This experience started me again in wireless. A neighbor of my uncle in St. Helena, who had at one time been a telegraph operator, purchased equipment and established a wireless station. Needing someone to communicate with, he offered me a 20 dollar gold piece if I would equip myself with a transmitter. With this I was able, in 1909, to have quite a powerful station. It was necessary to wire the house for electric lights and get the power connected. A friend who was secretary of a lumber company donated timbers with which I erected a 110-foot-high guyed mast in the back lot. Every morning at seven for years, before starting for school, I held schedules with other amateurs spread from Los Angeles to Seattle and with ships out as far as 1600 miles. Sometimes I would pick up the new station at Kahuku in the Hawaiian Islands built by Arthur Isbell in 1908, the Navy Station at Key West, and ships of the United Fruit Company in the Gulf of Mexico. I was able to improve my apparatus from profits earned on the sale of equipment—mostly transformers—that I manufactured for other amateurs. One day a stray horse kicked out one of my wooden mast anchors and wrecked the structure. Another benefactor in the person of a wealthy cousin donated new materials and the mast was rebuilt in 1911—this time with strong iron anchors. Incidents in my wireless education included the burning out of 14 light fixtures in a nearby apartment house, the damaging of a special power transformer serving my home so my operations would not blink the lights in other homes, and the burning down of a 13 000-volt power line feeding the city's trolley car system when some of my antenna wires fell across it during a storm at night. Luckily, I was not even interviewed about this last casualty.

Early wireless amateurs had many interesting experiences. When I needed electric power, for which our house was not supplied, a friend, secretary of the Pacific Gas and Electric Company, took me to see the proper official, who told me I could not have power because they had so much trouble with wireless amateurs. He cited the case of my friend Bill Larzelere on Haight Street. In those days of combination gas and electric light fixtures an insulated joint was put in the gas pipeline supplying a house. This made the gas pipe system of the house into an excellent antenna. One day, when Bill was transmitting, a spark jumped across the insulating joint in the house next door and an explosion blew out the front wall. It seems there



**HARADEN PRATT** in his wireless operator's uniform, August 1912.

had been a slow gas leak in the basement room, where the gas meter was. A few days later I got power installed by applying at the window where people came to get service.

Graduating from high school in December 1909, I found that nothing was to be gained by entering college before the usual opening in September 1910, so I got a job as a wireless operator on ships. The first trip was to Seattle, Tacoma, and Olympia on the *S.S. Riverside*, a lumber carrier. As a pay cargo she carried black powder to an explosive factory near Olympia, but I did not know this until the cargo was being discharged.

In September 1910, I entered the University of California at Berkeley. Each summer, and during Christmas vacations, I would work on ships or at the San Francisco shore station. Altogether I was on nine vessels, most of which became wrecks. The *Falcon* was run onto Blunt's reef on a clear moonlight morning, despite the presence of the Lightship. The *Pectan* was run aground on San Miguel Island. I was on the passenger ship *Santa Rosa* in May and June of 1911, making a round trip each week between San Francisco and San Diego. To attend surveying school, I left the ship at the same time that Captain Alexander took his annual vacation. This man personally set the new course after passing Point Arguello going south about 3 A.M. every Friday, because if it was not done correctly, the ship might run ashore on the Point or on San Miguel Island. On the next voyage, the substitute captain gave the chore to the deck officer on duty and turned in for the night. This officer changed course, not when passing the Point Arguello lighthouse light, but on the headlight of a railroad locomotive that was going up the coast. The ship ran on a sandbar and broke in half when the tide went out.

In 1912, Congress passed the Act requiring the licensing of wireless sets, ships, and operators. It contained other

provisions that made the operating of amateur stations uninteresting. I used mine no longer, but maintained it because my father liked to listen in. Congress passed a Ship Act, which took effect in 1911, that required wireless operators to be licensed. I called on Radio Inspector Cadmus in San Francisco, who gave me a perfunctory examination and issued the license; he issued me the first one, serial number 1201.

Having an idea that I might want to become an astronomer, I took that subject in addition to engineering at the university, but after two years realized that I was not a genius and would only be able to earn a bare living at astronomy, so I dropped it. In 1912 I undertook to set up a laboratory concerned with radio communication at the university, being assisted by other interested students, principally Lewis M. Clement, S. D. Browning, and H. H. Buttner. To have a good antenna, we surreptitiously stretched a wire from the top of the new Campanile, then under construction, since the authorities had refused our application on the grounds that it would disfigure the campus. Up to the time I left Berkeley nobody seemed to have seen it, because the wire was so small and high. We accomplished some fantastic receiving, getting the German stations on Nauru and Yap islands, some 5000 and 6000 miles away. The astronomy department asked me if I could receive signals from the station at Arlington, Va., that were being transmitted on a program with French astronomers for the purpose of correcting the difference of longitude between Washington and Paris. This we did, and the astronomers finally achieved a substantial correction between Berkeley and Washington.

Graduating in May 1914 with the B.S. degree, I accepted a position as assistant engineer of construction of a gigantic 300-kW radio station in California intended for transpacific working, the transmitting station being at Bolinas and the receiving station on Tomales Bay near Marshall. These plants cost almost \$800 000. The companion plants in the Hawaiian islands obtained the services of my amateur and college friend, Lewis M. Clement. Clement had a fairly knowledgeable boss whereas mine was completely out of his element. He took a honeymoon vacation right at the time of the toughest part of the job, when we were installing equipment and machinery. Blueprints were missing, some were in error, and my only technical assistant electrocuted himself, but when the boss returned, I was testing with Honolulu. Telegraph service with the islands was opened in September 1914. I resigned in February, by which time operations had settled into a routine. Besides, the management of the American Marconi Company had become rocky, their technique had already become obsolete, and greener fields beckoned. Clement also resigned and took a position with the laboratories of the Western Electric Company, later the Bell Telephone Laboratories. I took a job as a machinist at the Mare Island Navy Yard after spending two weeks seeing the Panama Pacific Exposition.

This machinist job was a dodge to get me on the payroll. It paid \$4.32 a working day but I had to work awhile in the machine shop on ships' engines. Soon a special Civil Service examination was opened up and I became a minor official, with the title "Expert Radio Aide," which I held until 1920. Meanwhile, I also qualified as an engineer-at-large and was offered a post with the Reclamation Service in Denver at \$100 a month salary, but declined this as the Navy job was much more in my line and paid

considerably more. The engineer-at-large rating qualified me to take the week-long examination for second lieutenant in the Army Engineers Corps. They made this examination so tough that it was said nobody ever passed it, thus the Corps could pick persons who suited them. After the war started the Corps wrote me several times, waiving one requirement after another, and finally offering me a much higher rank if I could get past the medical exam. I declined.

The Navy work had both advantages and disadvantages. The latter included the opportunity of loafing extensively. The future seemed cloudy. A current saying was that "Above the entrance to the Civil Service was a sign 'All those who enter here give up hope forever.'" The advantages included no interference, because nobody around the place knew anything about radio communication. Soon naval officers came beating at my door and I took on other responsibilities. I acquired a small staff, operated a laboratory, designed equipment that was built in the local yard shops, acted as inspector for items purchased from contractors, installed apparatus on naval vessels, and maintained shore stations from Mexico through Alaska. In 1916 came the construction of a 200-kW plant near San Diego and I became involved in some of that. With the coming of the war in 1917 the Navy took over all commercial radio communication properties and it was my lot to deal with this, keep them in running order, effect modernizations, and move some of them to war uses elsewhere.

Some time after the war started I was making an installation for Commander Dodd, Pacific Coast Communication Superintendent on Goat Island. The Commander asked me if I were still using my wireless station in San Francisco because if not he would like to stop the flow of letters from self-appointed patriots who were reporting my station as one perhaps communicating with the enemy. Since it was only used by my father for listening in, I dismantled the outside antenna and installed one in the attic under the roof.

Near my 27th birthday, in July 1918, I was transferred to Washington, D.C., and had charge of the construction and maintenance of all the Navy's high-powered radio stations. These were San Diego, Pearl Harbor, Cavite in the Philippines, and Tuckerton, N.J., with new ones going up at Sayville, N.Y., Annapolis, Md., El Cayey, Puerto Rico, and Guam, as well as the massive 1000-kW station at Croix d'Hins near Bordeaux, France, and a number of smaller ones, including Vladivostok and Murmansk in Russia and Siberia.

Resigning from the Navy Department, I became an engineer for the Federal Telegraph Company of San Francisco at its factory in Palo Alto, starting in January 1920. Soon thereafter the chief engineer, Mr. Beal, left for France to supervise the tests of the 1000-kW plant near Bordeaux and I was put in charge. The company at that time was operating a public telegraph system along the Pacific Coast, which started with wireless stations established in 1910 and 1911, but as the Navy took these over in 1917, the company leased circuits from the telephone company to continue the service. They had no intention of returning to the use of radio transmission but were forced into it when, about March 1920, the telephone company canceled the leases. The reason given for this was need of the wires to meet demands for telephone use, but the real reason was a complaint from the Western Union Tele-

graph Company in New York because of the competition created, and the telephone company officials responded helpfully. Later they came to us and offered new leases but it was too late. We had obtained injunctions from the Federal Courts in California and Oregon and had already commenced construction. I designed and built a system that provided three circuits between Portland and San Francisco with three more between San Francisco and Los Angeles. It cost about \$635 000; the northern portion opened in 1921 and the southern in 1922. In a few years this system moved more than half of the telegraph business between the Pacific Coast cities. We also established a comprehensive service with ships at sea.

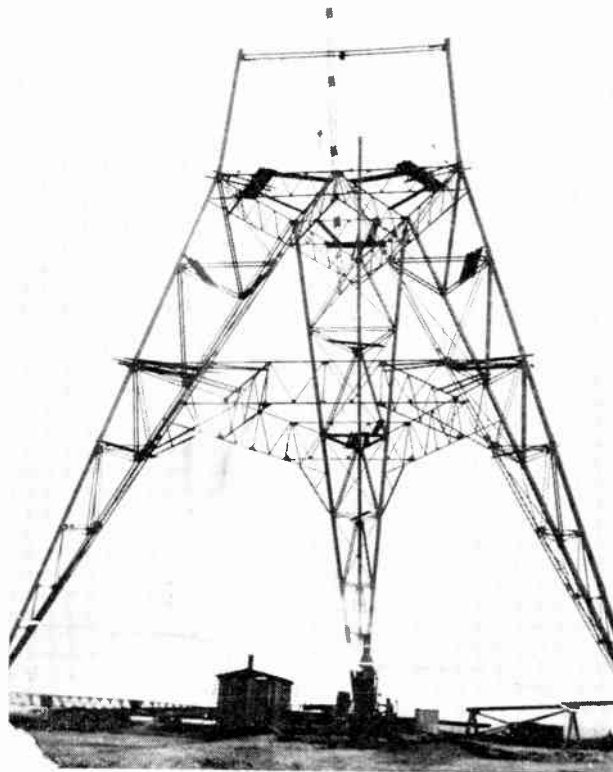
Resigning upon the completion of this project, I went to Mexico, hoping to secure some business, as the long period of revolution had left the country with a great lack of communication facilities. My group negotiated a number of contracts with the Obregon government, but before the financing was completed, Senor de la Huerta, the then Secretary of the Treasury, organized a revolution and we received a telegram canceling everything, as Mexico was forced to use all its slender funds to purchase munitions. Senor de la Huerta was finally forced to flee to France. I moved to Los Angeles and purchased a small orange by-products business.

On October 31, 1924, I married Florence Irene Bacon in Riverside, Calif. In 1925 I chanced to meet on the street an old friend named Robert A. Morton, a lawyer who had been assigned to my staff during the war. He told me he was the secretary of a company just organized that was called Western Air Express. Its purpose was to bid for the airmail route between Salt Lake City and Los Angeles. Henry Ford had purchased the Stout Airplane Company in Michigan that was to make metal airplanes. Ford wanted customers for this factory and had asked his Pacific Coast representative, Byron L. Graves, to organize a local company to bid for this contract. Soon they secured the bid and Morton asked me to build a radio communication system for it. The chief pilot, C. C. Moseley, did not want the Ford planes as they had not yet become stable enough for safe flying, and he was looking for a way out of the obligation to Ford. It came

**VIEW OF Marconi station no. 4, taken on February 5, 1914.**



while Western Air's officers were on their way to Michigan; before the train got to Chicago a fire at the Ford hangar destroyed the model planes, so the party delightedly took the first train home and ordered planes from Donald Douglas. Douglas was a small operator but had achieved a reputation for the planes he built for the successful flights the army made around the world. The craft he made for Western Air Express (now called Western Airlines) were so good that the Post Office Department ordered 50 of them for the main transcontinental line.



**EAST TOWER of the 200-kW plant near San Diego, February 20, 1916.**

**PRATT in 1922, at Big Bear Lake, near Los Angeles.**



In later years the Post Office contracted out the entire route and that was the beginning of United Air Lines.

Building this system was a challenge. The new short-wave method for radio was just coming into being but little was known about the correct wavelengths to use for particular circumstances. I made a survey. With a base station in Mr. Graves' garage in Los Angeles sending signals, I toured the California, Nevada, and Utah deserts with my wife in our Studebaker, which was equipped with a small radio receiver and later with a transmitter taking power from the car battery. Wavelengths were selected and stations built at Los Angeles, Las Vegas, and Salt Lake City. Signals between Las Vegas and Salt Lake City were not always reliable so a station at Milford, Utah, was added. I made another survey, discovering that the mountain where the Bingham copper mine was located created a shadow on the Salt Lake City airport. Renting a vacant lot behind the State Capitol and moving the radio shack there cured the trouble, and one day we flew into Milford and dismantled the installation. Due to the patent situation we could not get any transmitting vacuum tubes in the United States and manufacturers abroad could not sell to us due to their agreements with the American monopoly. Luckily, I found an advertisement of a manufacturer of X-ray tubes in Germany, who made good tubes for us. We purchased a stock sufficient to last several years. To avoid patent suit troubles we created a Nevada corporation named Airways Radio Service, Inc. We were not worried too much because the patent-owning company had been given an opportunity to provide the equipment—but they refused to quote, stating that they did not have apparatus suitable for the purpose. There being no stockholders' liability in Nevada, we established our company to remove further incentive for patent infringement suits.

Western Air Express opened service on April 17, 1926. The pilots were all aces from the war. Pilot Maury Graham left Los Angeles with the mail that morning. The weather was not good. Pilot Jimmy James left Salt Lake City about the same time. After refueling at Las Vegas, Graham found the mountains to the northeast covered with clouds. But the mail had to get through, so he followed the tracks of the Union Pacific Railroad through a winding canyon, keeping the rails in view by looking back over his shoulder. Suddenly he saw a plane pass him below going the other way! James was navigating by the same method. James later became president of the company. Graham, after racking up awards for flying the most miles without an accident, ran out of fuel one winter day in a snowstorm just west of Zion National Park. Many weeks later the plane was found intact with mail bags aboard; about five miles away Graham had prepared and consumed a meal and had fallen asleep in the snow, never to awake.

In 1926 Congress passed the Air Commerce Act creating an Assistant Secretary for Aviation in the Department of Commerce and providing funds for a radio-aid development program. Harris Hanshue, Western Air's president, told me about this at lunch in Salt Lake City and thought I should apply for the job of running the development program. Since my orange by-products business was being whittled away by the big operators, I took the suggestion seriously and wrote Dr. J. H. Dellingner at the Bureau of Standards, who had charge of the program. He enthusiastically offered the position at an

attractive salary. Leaving my wife to sell my company, I moved to Washington and immersed myself in an exceedingly interesting program. I had a biplane, a pilot, and a mechanic at the old College Park Field where the army had done its first flying years before. We established another center at Bellefonte, Pa., a fueling stop for the air-mail route. I approached the Ford Motor Company for aid and they provided a trimotor plane with their test pilot Harry Brooks and a mechanic. Other firms helped to develop apparatus and services. Our first objective was the radio range. This navigation method was useless at night because of what was called the "night effect," which caused a bending of the courses. We conquered this defect. I hired a college professor named Harry Diamond, who did pioneering work and started the Instrument Landing System project. Diamond achieved fame as a developer of many things, particularly the proximity fuze, used so effectively in World War II. It was during this period that Admiral Byrd organized his first expedition to the Antarctic and South Pole. One day a young man who was to go with the expedition was sent to me at College Park to get acquainted with our program. He was the late Lloyd Berkner, who became famous as a leader in geophysics, atomic energy, and other fields.

During early 1928 I received three offers. One was from Stanley Dollar who wanted to create a transpacific radio communication system to serve the Dollar Steamship Company and its ships, another was from the Bell Telephone Laboratories to head a new Aviation Department, and the third was from the Mackay Companies, successors to the radiotelegraph properties of the Federal Telegraph Company. I refused the Dollar proposal after becoming disenchanted with their patent position. The Bell System offer was not appealing because I did not want to get swallowed up in a large cumbersome organization. I became chief engineer of the newly organized Mackay Radio and Telegraph Company. This grew out of the Postal Telegraph Company. Hardly had I taken the position when the Mackay interests were purchased by the International Telephone and Telegraph Corporation, then just rearing its head as a great telecommunication empire. Its redoubtable organizer, Col. Sosthenes Behn, a one-time banker in Puerto Rico, acquired the San Juan telephone system in payment of a bad debt, became interested in communications, built an island-wide telephone plant, and then secured a concession in Cuba where a modern telephone system was created throughout the island, connected with the United States by submarine cables between Havana and Key West. He then went to Spain where the Cuban performance was repeated. In 1928 he acquired the \$31 million manufacturing business the Bell System had abroad and purchased the All American Cable Company that served North, Central, and South America. That year he acquired the telephone system in Buenos Aires and other properties in the Americas. Soon the Spanish performance was repeated in Romania.

Our objective was to build and expand communication properties where we could, but the going was slow. Hard days came with the financial crash of 1929 and Behn had to shrink his programs but the brakes did not seem to be applied to the group I was with, which at the time was expanding across the oceans to Asia, Europe, and South America, and to ships. Even when very hard put for funds, the Colonel would always conjure up money for a

project if convinced it was worthwhile. Of course, we always had to battle the long-established wire and cable services with which we were in competition, but we knew this was inevitable and prepared for it.

Immediately following World War I, a patent monopoly in the field of radio communications was organized in the formation of the Radio Corporation of America. Rights held by the General Electric Company, the Marconi Company of America, the Westinghouse Company, the Electric Specialty Company, and the American Telephone and Telegraph Company were consolidated. Anyone who attempted to operate systems or manufacture equipment was sued or was threatened with suit for patent infringement. Then this monopoly extended its scope by making cross-licensing agreements with firms in foreign countries. They made radio communication traffic agreements with foreign operating agencies, making them exclusive where they could, with cross-traffic agreements between themselves. As an example, they partitioned South America up and handed the pieces out to themselves. In a few years suit was brought by our Department of Justice and the patent monopoly was partially corrected, but from a practical point of view this did not help much. My company was the only one with a good asset, which consisted of a shop right to a basic vacuum-tube device that had been

**ON BOARD the U.S.S. Panamint to witness the atom bomb tests at Bikini, 1946. Haraden Pratt is second from right. At left are Past IRE President Arthur Van Dyck and IEEE General Manager Don Fink, then editor of "Electronics." At the far right is Sidney Kirkpatrick, then editor of "Chemical and Metallurgical Engineering."**



invented and developed in the laboratories of the Federal Company in 1911 and 1912. That gave us an entering wedge. For the first few years we spent large sums devising ways to avoid patented methods. Once we were sued but, after some six years, were completely vindicated by the United States Supreme Court. Obtaining communications circuits with foreign countries went very slowly and with great difficulty. Our first one was with Austria, then Hungary, and soon after that with Denmark. In the Pacific we fought the monopoly first in the Philippines, then in China, and lastly in Japan. In all three we secured concessions but it took six years to accomplish this. Eventually our system covered the major part of the civilized globe.

Part of my earlier activities concerned technical supervision over some of the developments going forward in South America. Starting in 1928, the parent company planned radiotelephone connections between the United States, Argentina, Brazil, Chile, Peru, and Colombia. Another program was for radiotelephone connections between Argentina and the European countries of England, France, Germany, and Spain. Another was an internal system within Brazil. Eventually all these were accomplished. I recall that shortly after the New York-Buenos Aires connection was opened to public service, Colonel Behn had for a luncheon guest a prominent man from Spain. This visitor happened to mention that his brother was then in Santiago, Chile. The Colonel had a telephone brought to the table, entered a call for the man, and after a few moments was informed he was out on a golf course and that a messenger had been sent for him. The surprise when the visitor heard his brother's voice was a thing to see. He did not have the faintest idea that it was possible to talk with another continent so far away.

Very soon after joining the Mackay Company I was appointed a vice president. In 1931 we purchased the Federal Telegraph Company, which—after selling its Pacific Coast telegraph system—continued its manufacturing business. The factory was moved from California to Newark, N.J., and its scope of activities became enlarged. One of these was the supplying of large vacuum tubes for the broadcasting industry, catering to the needs of those stations and networks competitive with the National Broadcasting Company. I became a vice president of it and later general manager. Another development company was established to make and market selenium rectifiers. For a time I was in charge of that.

A while after the war started in Europe in 1939, it became obvious that the United States would become involved. To prepare for this effort, the National Defense Research Committee was created by the government. It became a part of the Office of Scientific Research and Development. Dr. C. B. Jolliffe of the Radio Corporation of America was given the post of Chief of its Division 13, on Communications. He asked me to become a member of it. When he resigned in 1943, I became Chief. This organization was established to promote technical developments for military purposes, and the top people in the science and engineering fraternities of the country became its administrators. It had its own appropriations for conducting developmental work. Even if the military officials were not in favor of a project—and there were numerous cases of that—we could proceed independently if that was our decision. It was mostly in the beginning that the military roadblocks were encountered; e.g., for

radar development. Not that they did not want to develop radar, but they did not want any outsiders dabbling in their operations. But we progressed nevertheless—following the example of Great Britain, where the best talents in the United Kingdom were mobilized in order to save the country. The National Defense Research Committee oversaw many successful projects, including the development of microwave radar and parts of the development of the atomic bombs. After the committee was disbanded in 1946 the Research and Development Board of the Department of Defense was created, and I became chairman of its Communication Panel.

About 1943 an industry set of committees was established at a suggestion from the government, to plan for postwar conditions. It was called The Radio Technical Planning Board. I became chairman of its Panel on Communications. Later I became chairman of the Board. The patterns for postwar developments in broadcasting, television, and all other fields comprising the radio industry were set by this Board and received the blessings of the government insofar as governmental regulation was involved. After the conclusion of its work the Institute of Radio Engineers and the Radio Manufacturers' Association created an independent group called the Joint Technical Advisory Committee to advise government departments should assistance be requested, and I became one of its eight members. An early accomplishment was the organization of suitable standards for color television. This committee continues to be active. In 1952 it produced a valuable book entitled *Radio Spectrum Conservation*; there was a new and revised edition in 1966.

In 1946 I was given the opportunity of attending the atom bomb tests made at the island of Bikini in the Marshall Island group, called "Operation Crossroads."

**AS IRE PRESIDENT, Haraden Pratt delivers a paper, "The Problems of the Radio Engineer," at the World Radio Convention in Sydney, Australia, April 1938.**





My title was: Official U.S. Government Technical Observer. Comfortably quartered on the command ship *Panamint* of the Navy along with numerous other technical people, including two from the Soviet Union, I witnessed the first test, visiting the target ships before and after. We were parked 20 miles away to see the explosion.

In 1950, President Truman established a "President's Communication Policy Board" consisting of Lee A. DuBridge, William L. Everitt, James R. Killian, Jr., David H. O'Brien, and Irvin Stewart as chairman. Telecommunications in the Federal Government was uncoordinated and this Board was asked to submit recommendations for policies seeking to improve administrative procedures, the relationship of government communications to nongovernment communications, and policies with respect to international radio and wire communications. The Board produced a report entitled "Telecommunications—A Report for Progress." It recommended a permanent three-man Advisory Board to advise the President. But President Truman said that there were too many Boards, and so one person was appointed. In June, while in Spain, I was asked whether I would accept such an appointment. I flew to Washington to discuss it. The outcome was that I accepted after President Truman told me that I was the only person acceptable to all of the government departments involved. Upon concluding my European trip, I was sworn in during October 1951 with the title: Telecommunications Advisor to the President. I had previously arranged a premature retirement from the American Cable and Radio Company.

I had a permanent staff of five persons. The activity was a sort of experiment since it was impractical to accomplish its objective by law. While I had a very interesting, if not frustrating, time, I early realized that we would not make much progress without legislation, but I could not find any Senator who was interested. To enact legislation in Congress it is usually necessary to find an enthusiastic, devoted sponsor. Since the death of Senator Wallace White of Maine, who had sponsored telecommunication legislation for many years, no successor to him had appeared. The office I held was discontinued by President Eisenhower in 1953 on the recommendation of a Board headed by Nelson Rockefeller, on the ground that too many individuals were reporting to the President.

As a person, President Truman was human, sociable, and loyal to his people; in fact, he often backed some when he knew they were wrong. I avoided seeking his aid as much as possible as he was in the habit of picking up the telephone and talking to anyone he thought would assist. Such telephone calls always stirred up officialdom and for days thereafter one would get calls asking what it was all about. He was a hard worker and on Monday mornings his desk usually was piled high with papers that he called his weekend homework.

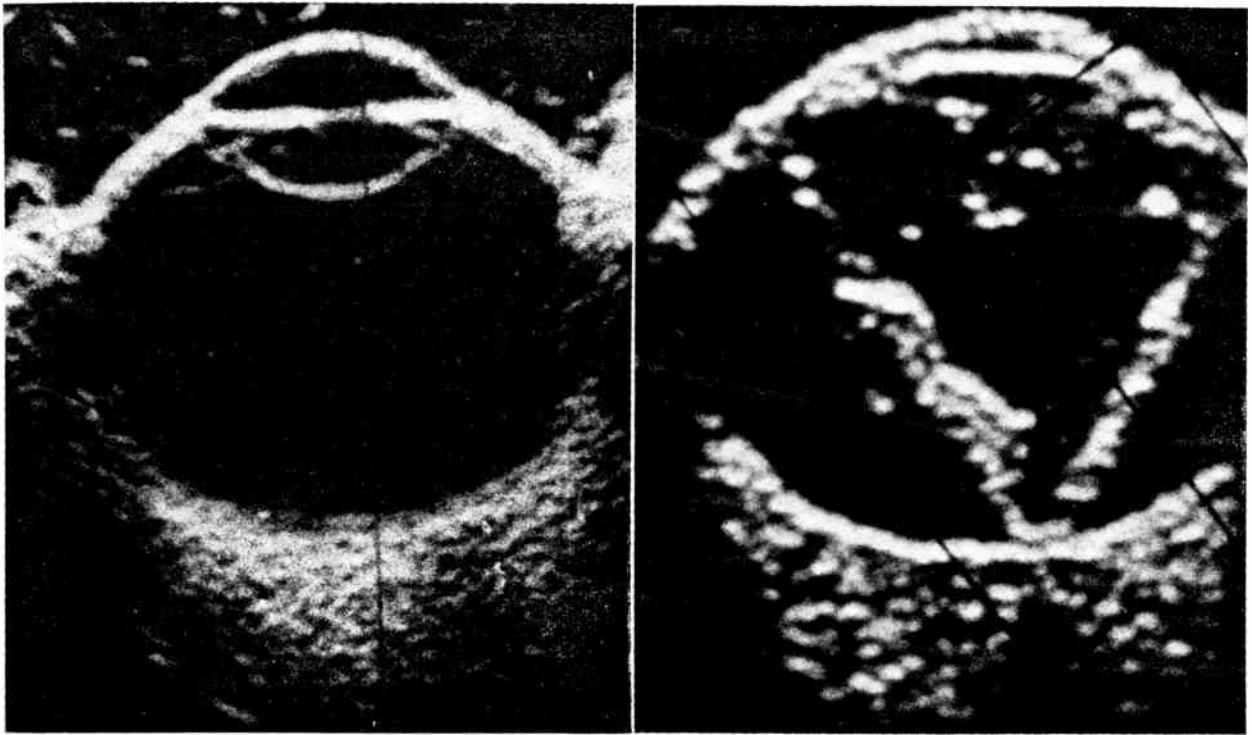
Soon after leaving this White House job I became associated with a developmental enterprise operating under the name of Dualex Corporation. James Durkee—who once worked for me at the Mare Island Navy Yard when he was a chief electrician in the Navy—had an inventive mind and had created an improved method for printing radiotelegraph systems, particularly adapted for use in aviation. This company was established to exploit his inventions. The firm of Bell and Gossett in Illinois was given a license for the United States and Canada and carried on development and manufacturing activities. This

firm, which made pumps and heating apparatus on a large scale, was very forward-looking but did not understand the way electronic development had to be carried out so the program lagged through lack of foresight. We finally decided to sell out to them and I retired from business life late in 1958.

In 1914 I became a member of the American Institute of Electrical Engineers, organized in 1884. The same year I joined the Institute of Radio Engineers, organized in 1912, and actually a reorganization of the Wireless Institute and the Society of Wireless Telegraph Engineers, both of which started in 1908. In 1935 I became a Director of the Institute of Radio Engineers and in 1938 its President. At that time it had about 5500 members. By 1962 it had 100,000, a measure of the growth of the industry. In 1963 the two societies were merged into the IEEE and today we have 160,000 members. Over a period of 13 years, I was involved in standardization activities and was, during 1939–1942, a Director of the American Standards Association, Secretary of the Institute from 1942 to 1965. I have been a Director continuously since 1935 and now am Director Emeritus. In the American Institute of Electrical Engineers I also helped with standards work and at one time was chairman of its Communication Committee. The Institute of Radio Engineers awarded me its Medal of Honor in 1944 and its Founders Award in 1960.

I have belonged to a pioneer group called the Radio Club of America, which started about 1909, and am a Life Member of the Veteran Wireless Operators Association, which awarded me their Marconi Medal of Achievement in 1951. At the time of graduation from college in 1914 I was made a member of the scientific honor society Sigma Xi. Over the years I have held licenses to practice professional engineering in the States of New York, California, Oregon, and Washington.

There is not much left of the wireless and radio communications of the kind that developed during the major part of my career. Long-distance communications, first by what we called long waves (now called very low frequencies) and later by what we first called short waves (now called medium high frequencies), have largely been replaced by other methods, except for special purposes. These two methods, which filled a worldwide void in communications and provided inexpensive communications to sparsely settled countries, were subject to the vagaries of nature caused by interferences from lightning discharges and disturbances in the ionosphere caused by solar events and the 11-year solar cycle. As the demands for greater reliability and accuracy and the need for larger volumes of traffic arose, newer methods were gradually developed. Now, only the ship–shore services continue very much the same as they have in the past. Individual message service by telegraph, which, a few years ago, constituted practically all telegraph traffic, now takes second place to leased circuits and automatic printer connections established by dialing as is done with telephones. Data processing and the connection of computers on networks such as are used by the airline reservation services are demanding more and more communication facilities of high quality. Astonishing performances have been attained in outer space communications for the control of vehicles and the transmission back from them of information such as pictures, over many millions of miles. Most of these present-day accomplishments were not even dreams not so long ago.



A COMPOUNO-SCAN ultrasonogram of a normal human eye taken at 15 MHz is shown at left; at right is an ultrasonogram of an eye containing a complete retinal detachment.

# Ultrasonics in medicine

*Ultrasonics — a kind of X-less X ray — has found applications in many diagnostic, therapeutic, and surgical situations. Highlighted here are some of the unique things ultrasonics can do in medicine*

**Nilo Lindgren** Technology Communication, Inc.

*This article describes how a device developed by engineers for engineering applications — the ultrasonic transducer — was slowly converted to medical research and application. Like the X ray, ultrasonics can penetrate the living body, and can be used for studying inner structures, with the advantage that it avoids the hazards of X radiation. The development of appropriate ultrasonic systems, many of whose problems parallel those encountered in early radiology, has brought ultrasonics to the point where it can be used almost routinely in the study of conditions in the eye, brain, heart, and abdomen.*

Back in 1944, one of the first things that happened to the visitor to the laboratory of Dr. F. A. Firestone at the University of Michigan was to be invited to stick his foot into a bucket of water. "I will show you the bones."<sup>1</sup> said the inventor of a device that was then used to detect flaws

in metals by the reflections of high-frequency sound waves.<sup>2</sup> Figure 1 shows how Firestone described the principle of his "supersonic reflectoscope."<sup>3</sup>

Although Firestone's device was not immediately used in medical applications, and although details on the "supersonic reflectoscope" were restricted from publication during the war, its capabilities for penetrating the human body, and returning echoes from various tissue structures, without the accompanying hazards of X radiation, soon attracted medical researchers.

In 1942, the same year that Firestone invented his flaw detector, the first explorations of low-energy ultrasound as a diagnostic tool were being carried out by K. T. Dussik.<sup>4</sup> However, Dussik used the new tool like an X ray, passing sound *through* the patient to get a kind of shadow picture on film. Moreover, he worked on the head, so the high absorption of the skull virtually defeated the transmission technique. It was the echo-loc-

tion technique of Firestone that has gained widespread use in medicine.

By about 1950 efforts at using the tool of “ultrasonics” to detect tumors in the brain had led to the demonstration that it is possible to get relatively strong echoes from certain structures about the midline of the brain<sup>5</sup>—structures that might shift through the pressure of a tumor growing in either hemisphere.<sup>6</sup> Although the diagnostic possibilities raised by this research were especially attractive to clinicians, in view of the inaccessibility of the brain to ordinary X rays, there were discouragements too. For instance, a commission of scientists concluded in 1955 that there was no possibility of adapting ultrasonics “to detecting intracranial lesions, for,” as the commission wrote, “even if the skull did not have high absorption properties of its own, the distance involved would make the application foolish.”<sup>7</sup> Subsequent progress in such applications, however, although it has not yet produced a wholly reliable technique, has at least been dramatic enough to put one in mind of another commission of technical experts, which once decided that Edison’s idea of putting a wire and a telephone into nearly every home was idiotic.

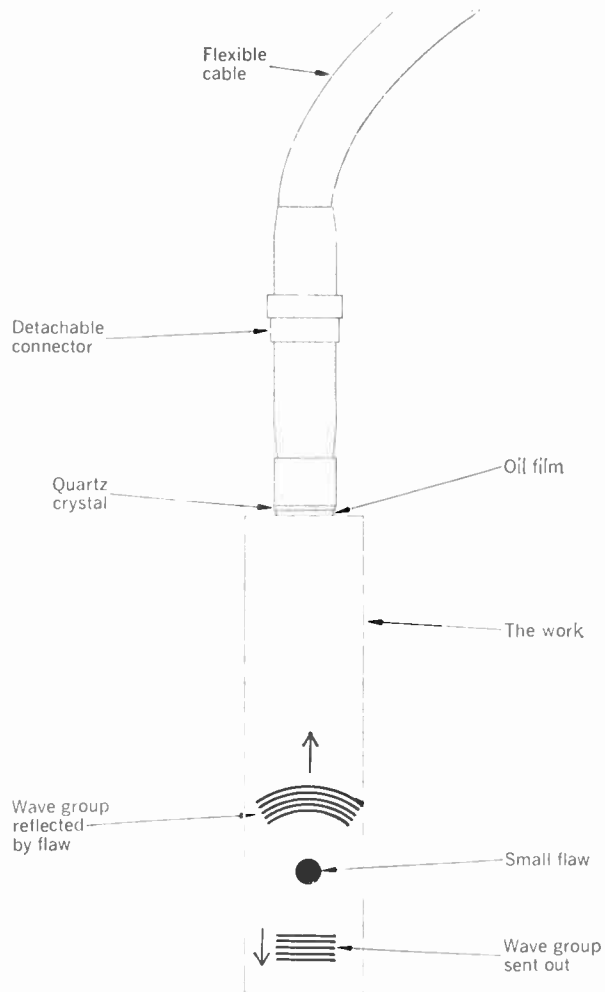
Today, the application of ultrasonic radiation for the visualization of body internal structures is already an important adjunct of the clinician’s armamentarium of diagnostic aids. In general, diagnosis relies on the use of relatively weak, relatively unfocused, ultrasonic energy. High-energy, lower-frequency ultrasonic radiation was converted into a dentist’s tool in 1952.<sup>8</sup> Recently, carefully focused ultrasonic radiation has been applied surgically to the brain, in the treatment of Parkinsonian tremors and for the relief of Ménière’s disease.

In short, ultrasonics has found significant applications in diagnostic, therapeutic, and surgical situations. Many of the same kinds of problems now being worked on in ultrasound were encountered in early radiology.<sup>9</sup> However, a significant difference between the two is that radiology, which was largely pushed forward by the medical profession, found little direct application in engineering fields, whereas ultrasonics has enjoyed an intensive development and application in engineering, notably in materials testing.<sup>9</sup>

### The ultrasonic spectrum

To envision the potential medical role of this tool, it is necessary to understand the character of ultrasonic vibrations. In contradistinction to electromagnetic waves, mechanical vibrations require a physical medium to support the wave propagation. In other respects, these two kinds of waves have much in common: they can be reflected and refracted at interfaces between different substances, they can be focused, they can be made to cast shadows, their energies are attenuated by the substances through which they travel, and so on.

It is useful to consider the spectrum of mechanical vibration. Figure 2 shows the ultrasound region that has proved useful in medical diagnosis, a range running roughly between 1 and 10 MHz, and a range of applications requiring small amounts of power of the order of milliwatts. Further down the spectrum is the region of power applications, a region roughly between 16 kHz and 40 kHz. Around 25 kHz, one finds the ultrasonic tools used in dentistry. In this region, one has the advantages of using high power while keeping internal stresses in the vibrating transducers within the material capabilities, and



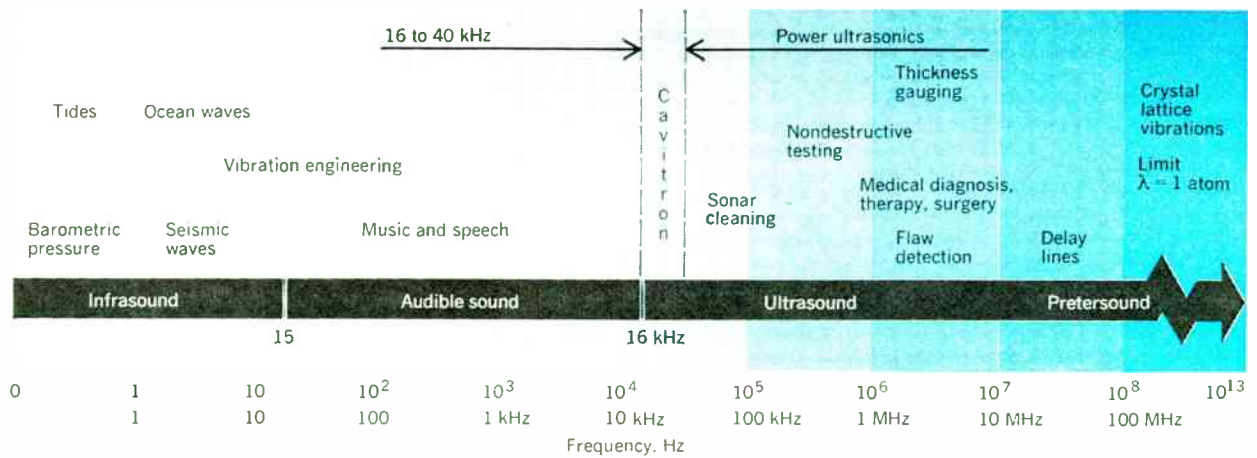
**FIGURE 1.** Firestone’s “supersonic” reflectoscope, patented in 1942, and devised for detecting flaws nondestructively in the interior of solid materials, used ultrasonic waves radiated by quartz crystal. A short burst of high-frequency sound was sent into the solid part through a thin oil-film contact. If a flaw were present in the part, the group of waves reflected from the flaw arrived back at the crystal transducer before the reflection from the distant side. The returning waves generated a voltage in the crystal that could be observed on a cathode-ray oscilloscope. The arrival times of the reflections thus served to locate the positions of flaws. Not many years later, medical researchers began to realize that the principle might be applied to a new kind of X-less X ray for studying the interior of the human body.

of working above the audio range that would be painful for the tool operators.<sup>10</sup>

### Basic transducer action

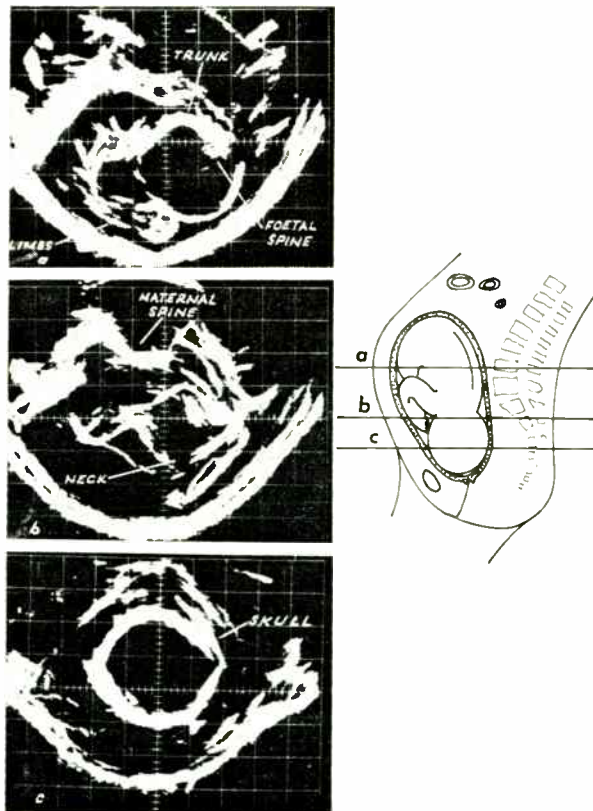
In an ultrasonic system, there must be a means for producing, receiving, and displaying ultrasonic signals. Two general types of transducers for interconversion of electric and mechanical energy are widely used—the magnetostrictive and the piezoelectric.

Magnetostrictive transducers (typically made of nickel and nickel alloys) are rugged and capable of handling high power. Piezoelectric transducers (e.g., quartz) are small and more efficient. The application of a magnetic or electric field causes the transducer to vibrate at a frequency corresponding to the exciting frequency. When this trans-



**FIGURE 2.** Chart of the entire spectrum of mechanical vibrations and types of applications developed.

**FIGURE 3.** Typical ultrasonic two-dimensional visualizations or echograms taken in normal late pregnancy. The three cross sections display different features.



ducer is matched properly to a mounting connecting it with the signal source, and is linked by a suitable transmission medium to the subject (work part, person, etc.), it can both send out and receive ultrasonic energy. Through the display and study of the modifications that such energy undergoes as it is transmitted, refracted, or reflected, say, by different bodily tissues, it is possible to make some interpretations about the size, location, and character of interior structures. In this act of interpretation begins the art of ultrasonic diagnosis.

One of the main problems is that various types of im-

aging devices have had to be developed. However, the imaging systems that have been invented thus far are unsatisfactory for many reasons, and the "reading" of them is still a matter of interpretive skill.<sup>11</sup>

There are 20 or more ultrasonic imaging detection systems, which can be gathered roughly into four categories: (1) photographic and chemical methods; (2) thermal effects; (3) optical and mechanical techniques; and (4) electronic methods. Of these methods, one especially should be noted. This is the one first described by the Russian, Sokoloff, in 1937—the ultrasonic image converter—which has been extensively investigated for years.

An excellent account of ultrasonic imaging appears in a recent review<sup>12</sup> by Dr. John E. Jacobs, director of the Biomedical Engineering Department at Northwestern University; it contains a bibliography encompassing nearly everything that could be found up to the mid-60s.

### The opacity of the art of opacity

A review of the recent literature on ultrasonic diagnosis reveals, on the one hand, impressive gains in clinical situations, and on the other hand, just how much of an art it still is. Although for some forms of diagnosis, practitioners can claim correctness in as many as 95 percent of the cases examined, the technique remains at the mercy of subjective factors—that is, if the operator of the ultrasonic equipment knows what evidence he is supposed to be looking for, he may often be able to find it in the ambiguous displays he must necessarily rely upon. It takes an experienced physician to interpret correctly the anatomical features called out in the two-dimensional ultrasonic visualization shown in Fig. 3. Such "obviously recognizable echograms," writes Dr. George Kossoff of the Commonwealth Acoustic Laboratory in Sydney, Australia, "are useful for interpretive experience. For instance," he goes on, "until clear spine echoes were obtained, it was difficult to distinguish a fetal trunk from a fetal head, both of which gave a circular cross section. Once the spine echoes had been identified, the trunk and head could be recognized in less clear echograms. Similarly, various other structures such as the placenta, the fetal heart, and fetal kidneys have now been recognized."<sup>13</sup>

Various kinds of displays of sonic echo information continue to be under development, but as yet none is wholly satisfactory. Nor are there consistent standards for

the kinds of equipment and measurements now being made. For instance, physicians do not know exactly how much energy is being coupled into body tissue; there is no clear way of checking the performance of any one transducer against others; definition of the ability to separate closely spaced structures is still rather vague<sup>14</sup>; the manner of applying the transducer to the patient apparently varies from one situation to another.

Nor, it is said, are there firm standards of safety in the use of ultrasonic energy. Although most investigators have assumed that the low power levels being used in diagnostics were well below levels dangerous to tissues, it is not yet known what the threshold is for damage to such tissue. One veteran physician reports, for instance, putting his hands in front of the ultrasonic equipment every day for 17 years without, as he puts it, losing his "fingernails as the early radiologists did."<sup>15</sup> But, as he implies, it is a pretty good test only for demonstrating obvious destructive damage. Definition of the threshold of damage thus awaits not only a scientific answer but a legal answer as well.<sup>14</sup> The question becomes more pressing among investigators who are starting to work with so-called B-scan techniques because, to get better ultrasonic pictures, there is a trend toward using focused transducers. In the focus of such transducers, says Dr. D. M. Makow of the National Research Council in Canada, "the power density is much higher than in the unfocused transducer at the same distance."<sup>16</sup> Makow then asks for the details of accumulated experience as to safe peak pulse power (especially as it applies to brain work), for the effect of heating at high average powers, and whether or not there are permanent changes in cells or in body molecules at excessive pulse peak powers.<sup>16</sup>

Dr. Ian Donald of the University of Glasgow puts the ultrasonic safety problem even more dramatically, recalling that it took the developers of the X-ray techniques 40 years to discover the harmful results of ionizing radiations. Now, he warns, ultrasonic investigators in medicine face a real condemnation by history if the safety question is not settled as quickly as possible.

In any case, in the young art of ultrasonic diagnosis, there are problems in two directions. In one direction, not enough is known about the interaction of ultrasonic energy and body tissues.<sup>17</sup> Such information is needed not only to resolve the question of hazards, but also to assist in the correct interpretation of echograms. In the other direction, there must be further refinements in equipment. On top of technical problems, there are the inevitable language barriers between the manufacturers of ultrasonic diagnostic equipment and the physicians who must use them.<sup>14</sup>

### Scanning methods

As one authority puts it, "the properties of tissues and the physics of sound waves conspire to limit the resolution and sensitivity capabilities of the basic ultrasonic echo-ranging system."<sup>18</sup> Thus, although one wishes to use equipment with the greatest sensitivity and high resolution, compromises must be made. For different ranges, or depths of penetration of ultrasonic energy, one must select a frequency in accord with the absorption and velocity characteristics of the tissues (e.g., liquid-filled cavities have high transmission; bones have high absorption), and the frequency chosen sets a limit on the resolution.

To minimize the effect of such limitations, various

methods of scanning have been developed. Historically, all the methods employed in ultrasonic diagnostic work go back to the radar cathode-ray-oscilloscope displays that were developed during World War II<sup>19</sup>; and the methods of data presentation are defined according to the engineering classic *Principles of Radar* by the M.I.T. Radar School Staff (edited by Reintjes). According to Dr. D. H. Howry (who developed the "compound scanning" method for improving echo-ranging systems<sup>19</sup>), of the 15 different methods of CRT data presentation listed in the M.I.T. radar work, the two most commonly used now in medical work are the A-scan and B-scan.<sup>15</sup>

A-scan, the simplest type, plots intensity as ordinate and time (corresponding to range, which is distance) as abscissa. The intensity is not modulated.

B-scan plots time (range, distance) as ordinate and azimuth as abscissa; the brightness of display indicates the intensity of echo.

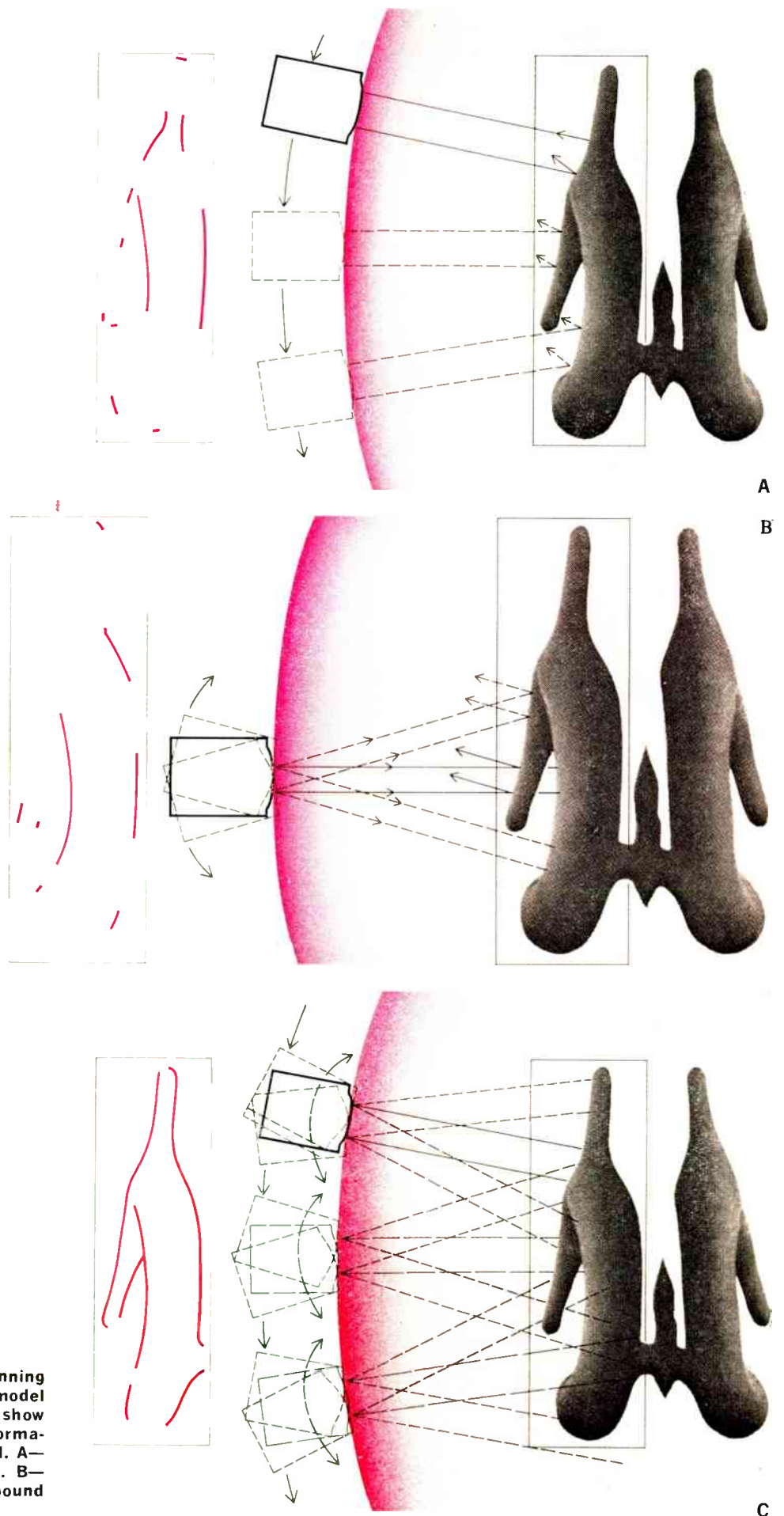
In medical applications, A-scan is used for work like encephalography, but because it presents only time amplitude information along the axis of a single beam, and since this information varies with the viewing angle and position of the transducer, the information, in most cases, is meaningful only to the operator of the equipment. Nevertheless, because A-scan equipment is simple, relatively cheap, and portable, it is used almost routinely in many situations. In Japan, for instance, ambulances carry A-scan equipment so that rapid assessments can be made on internal head injuries and possible subdural hemorrhage suffered by accident victims.<sup>20</sup> B-scanning, which provides cross-sectional pictures (sometimes called tomograms), requires more complex and more expensive equipment; but it provides wider and more easily interpretable views of whole internal structures.

Actually, there is quite a confusion of terminology in ultrasonic scanning, although there has been some effort to adopt standards.<sup>21</sup> Therefore, it will undoubtedly be useful for the reader to see a simplified visualization of some of these methods of scanning. Figure 4, which is drawn after the work of J. J. Denier van der Gon and his colleagues at the Department for Medical Physics, Municipal Hospital "Dijkzigt," Rotterdam, provides a straightforward contrast.<sup>22</sup> It shows several scanning techniques applied to the visualization of the ventricular system (in this case a model) in the brain.

In Fig. 4(A), linear contact scanning, one sees that the crystal transducer is pressed flat against the head. When the transducer is held in one position, an ultrasonic pulse is sent into the head, and the detected echo is displayed on the vertical scale of the CRT according to its amplitude and its distance (based on transmission time). Only those echoes that come back in the direction of the receiver will be detected. Thus, the search with this method usually consists in moving the transducer around the head in order to find identifiable echoes. The box to the left in Fig. 4(A) shows how relatively little information can be picked up.

Figure 4(B) shows sector scanning, in which the transducer is rocked back and forth in the plane in which a cross section of the head is to be viewed.

A third method, called compound scan, combines the scanning movements of Figs. 4(A) and 4(B) to produce the result shown in Fig. 4(C). For different parts of the body, medical investigators have worked out many sophisticated variations on these basic techniques. The compound scanning method is obviously the preferable one,



**FIGURE 4.** Several scanning techniques applied to a model of the ventricular system show the kind of reflected information that can be obtained. A—Linear contact scanning. B—Sector scanning. C—Compound scanning.

but it still presents many technical difficulties.<sup>15</sup>

Doppler equipment is also available for medical applications in the study of interior motions as, for instance, in the measurement of blood flow.<sup>23,24</sup>

### Ultrasonic image converters

Of the many different methods that have been devised for visualizing ultrasonic energy, the most sensitive thus far for detecting the variations of ultrasound energy over an extended area is the electronically scanned ultrasound image converter or ultrasonic camera.<sup>25</sup> All such systems, so far as is known, are versions of the method first proposed by S. Sokoloff in 1937.

The methods of composing ultrasonic images with the single-transducer scanning methods discussed in the foregoing have the disadvantage that the transducers must be moved about as described and then have their motions correlated with the reflected signals the transducers pick up in the subject under examination. The image converter, however, detects the reflected ultrasonic signals on an array of transducers or on a planar piezoelectric transducer, which is then scanned with an electron beam. Figure 5 shows the principle of the image converter.<sup>25-28</sup>

One problem with these image converter or ultrasonic camera systems, however, and the reason they have not been used more widely, is that they have been limited in their detail-resolving power. Inasmuch as they display images in varying shades of gray, of which the eye recognizes at most nine or ten, the actual commercially available systems usually show images in only about five distinct shades. But now a remarkable jump in the sensitivity, performance, and applicability of the ultrasonic camera has been achieved by Dr. J. E. Jacobs and his colleagues at the Biomedical Engineering Center, Northwestern University, by the adaptation of the NTSC color-processing system to the display of the images produced by the ultrasonic camera.<sup>25</sup> Dr. Jacobs writes that the resultant display is sensitive not only to the magnitude, but also to the phase of the received ultrasonic signal. The

improvement in sensitivity to acoustic impedance changes, through the use of commercially available television equipment, is of the order of 20 to 40 times that obtainable with the older gray-tone displays.

Figure 6 shows schematically the arrangement of the ultrasonic imaging system that uses the color processing display. Technical details of the system are available in the Jacobs papers.<sup>25,28</sup>

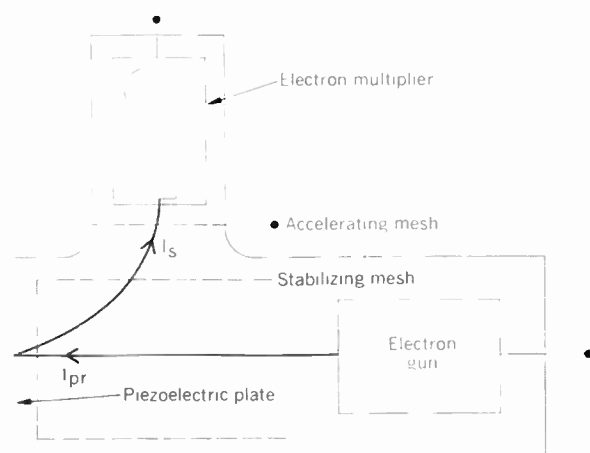
It only needs to be added here that the color display techniques, of which one example is shown on this month's cover (image from soft-tissue tumor in the forearm), endow the ultrasonic camera with an important new potential not only in many biological applications—particularly in pathological work—but also in industrial nondestructive testing. The full impact of this advance is perhaps yet to register on the scientific, technical, and medical communities to whom it should be most useful.

### Ultrasonics in medical diagnostics

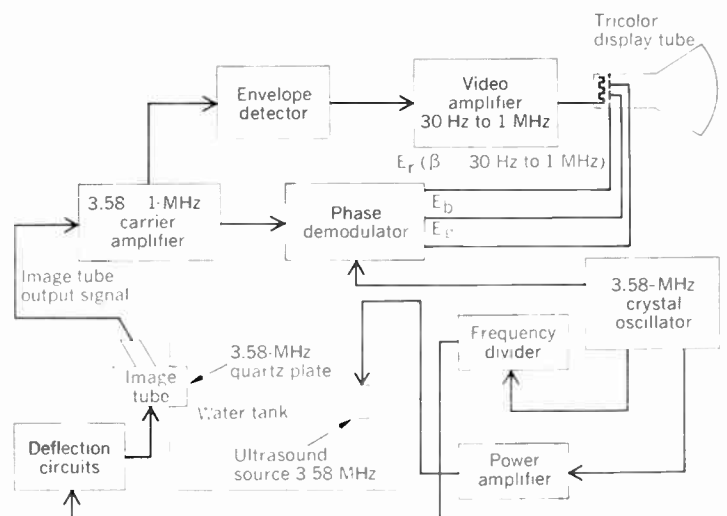
It was pointed out in previous paragraphs that ultrasonics is now used in the study of conditions in the eye, brain, heart, and abdomen, and in the fields of obstetrics and gynecology. A review of some of the recent literature in these specialties presents something of a mixed picture. Although the general domain of diagnostics seem to have been roughly mapped out, the hard work now seems to be concentrated on the improving of equipments and techniques, with some sense of the diminishing returns procurable through refinements of a maturing art. No one doubts, however, that in diagnostics, ultrasonics can do things no other tools can do. Following are a few highlights of such applications.

**Eye research.** The use of ultrasonics in ocular research is relatively recent.<sup>29</sup> However, the eye is regarded as an ideal subject for study because its transmission qualities allow good, clean ultrasonograms that can be compared directly with the visible appearance of the eye. The introductory illustrations show, for instance, two specimens of clinical ophthalmic ultrasonograms prepared by Dr.

**FIGURE 5.** Principle of ultrasonic image converter or camera. In this tube, an electron beam scans the quartz piezoelectric faceplate on which the ultrasonic field reflected from the subject under study impinges, thus modulating the secondary-emission electrons produced by the scanning beam. The electron multiplier eliminates stray signal inputs.



**FIGURE 6.** Ultrasound image system using the conventional NTSC color system, which is the standard for color television broadcasting in the U.S., produces ultrasonic images that are far superior to those produced by the traditional monochrome systems.



Gilbert Baum at Albert Einstein College of Medicine, Yeshiva University, New York. At the left is a compound-scan ultrasonogram of a human eye. An ultrasonogram of an eye containing a complete retinal detachment is shown at right.

In view of the ultrasonic studies of the anatomical structure and physiological behavior of the eye, Dr. Adnan Sokollu of the Western Reserve University School of Medicine summarizes the applications.<sup>30</sup> These include studies of the eye length and its changes, studies of the thickness of the cornea and sclera and their changes under different influences, studies of the accommodation and thickness of the lens, and length and thickness measurements versus intraocular pressure. Sokollu points out that although in eye research thus far the pulse-echo technique has been used almost exclusively, other interactions of sound with tissue could lead to useful information.

One of the particularly dramatic uses of ultrasonics is in the location and removal of foreign bodies in the eye. The first report of the location of an intraocular foreign body dates from 1957; it is the work of two Finnish investigators, Dr. Arvo Oksala and A. Lehtinen of the Ophthalmic Department of the Turku University Hospital.<sup>31</sup> Oksala reports that although the application of ultrasonics for locating and measuring foreign bodies in the eyes is still rare, he feels that it could become at least as important as X-ray examination, and in the proper hands might even replace the X ray.<sup>32</sup>

**Ultrasonics in brain examinations.** A much more active field than ophthalmology is the use of ultrasound in brain diagnoses—echoencephalography. Interest is strong because, as was pointed out earlier, the brain is inaccessible to the usual visual, palpatory, or auscultatory methods of clinical practice.<sup>33</sup>

But workers in this field seem sharply split on the question of the efficacy of present ultrasonic techniques. On the one hand, it is claimed that echoencephalography is now a standard technique for neurologic examination,

and that it can indicate the positions of a number of dividing planes in the brain.<sup>22</sup> And on the other hand, it is stated emphatically that since Prof. Lars Leksell of the University of Lund, Sweden, originally described the measurement of the displacement of midline intracranial structures in 1955, echoencephalography has *not* established itself as a tool for neurological investigation.<sup>33</sup> Moreover, although there appears to be widespread agreement (with exceptions, of course) that certain midbrain structures giving rise to the so-called midline or M-echo get shifted in cases of unilateral cerebral disease, there is no agreement as to what structures produce the M-line.

Among the rich diversity of echoes that it is possible to receive from the brain, the midline echo has the most distinctive signature—it has a double peak from which it gets its name of M-line, it pulsates synchronously with the heart beat, and it usually has the highest amplitude deriving from the bitemporal region of the brain.<sup>34</sup>

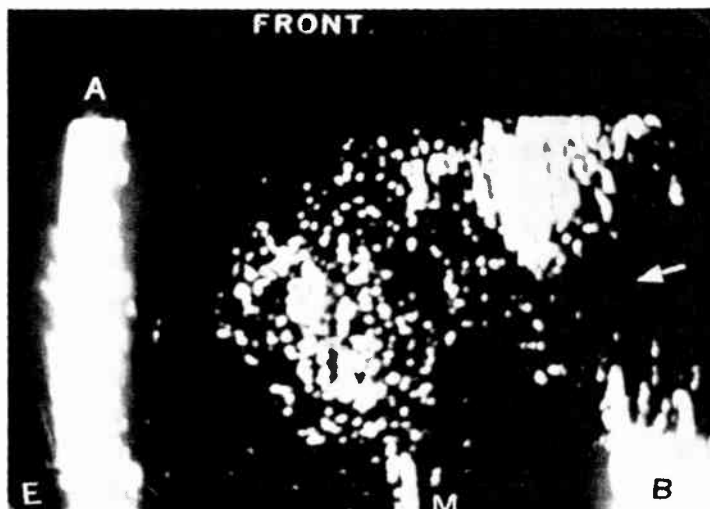
No such triad of features exists for other echoes detected from brain structures. Dr. C. C. Grossman points out that in the frontal section of the brain, which is unyielding to X-ray techniques, ultrasonic pulses produce such a richness of echoes from the reflecting surfaces of white and gray matter and spinal fluid that there is a problem of how to identify them intelligently.<sup>35</sup> His comparison of the usefulness of ultrasound in brain diagnosis with other available methods is noteworthy for its conclusion. He states that in clinical brain work, the point is being reached where too many rather than too few diagnostic procedures are available. These include such methods as plain skull X rays, pneumoencephalograms, angiography (in which a radio-opaque substance is injected in the bloodstream<sup>36</sup>), examination of spinal fluid, electroencephalography, radioisotope scanning, and, in certain cases, exploratory surgery and autopsy. All but a few of these methods are relatively new, however, and some are not simple or considered entirely safe. Considering this battery of possible procedures, he nonetheless affirms that ultrasonics has brought about a new diagnostic dimension in neurology.<sup>35</sup> Figure 7 shows how a brain section looks on an ultrasonic visualization.

A possibility beginning to receive more attention among ultrasonic medical investigators is the observation of dynamic rather than static qualities of the brain.<sup>37</sup>

One of the basic limitations of ultrasonic visualization is its dependence upon differences in acoustic impedance of adjoining tissues. Only from such interfaces is it normally possible to get reflections of acoustic energy. The problem is that there are tissues whose acoustic impedances differ hardly at all, as in the case with the gray and white matter of the brain, so that the interfaces are virtually invisible to ultrasonic radiation.

An ingenious method that gets around this problem, developed by the Frys and their associates at the University of Illinois, relies on the fact that the acoustic absorption coefficients of different tissues differ more sharply than their acoustic impedances. The acoustic absorption of gray and white matter, for instance, differs by a factor of two. Thus, the Fry method is to alter the propagation characteristics of such brain regions by irradiating them with one relatively long pulsed beam of ultrasonic energy so as to cause transient temperature changes, and then with a second beam of shorter pulses to detect by normal reflection techniques the structural interfaces that emerge owing to the temperature differences (and thus impedance

**FIGURE 7. Ultrasonic cross section of the head showing tumor mass (glioblastoma multiforme). Arrow at right points to acoustic shadow opposite the tumor, M is the midline of the brain displaced by the tumor, A is the cranial wall under the transducer, and B is the back wall. This picture was prepared under the direction of Dr. C. C. Grossman, University of Pittsburgh School of Medicine.**





differences) between tissues of differing absorptions.<sup>17</sup> By restricting such temperature changes to a few degrees (which is sufficient to cause a detectable amount of energy reflection between certain tissues), these investigators assert that no tissue damage will result. With this kind of "artificial" method, then, which can be selectively applied to chosen regions, there is the potential of considerably enhancing the usefulness of ultrasonic visualization of soft tissues. In fact, variations on such techniques are being pursued.<sup>38</sup>

Most recently, Fry demonstrated the great power of ultrasonic visualization of intracranial structures using a combination of the most advanced methods of scanning, echo data composition, and echogram presentation.<sup>39</sup> Recently developed instrumentation at the Interscience Research Institute incorporates omnidirectional scanning, relief presentation, and computer control of transducer positioning, data handling, and display parameters.

F. J. Fry, president of Interscience Research Institute, writes of the use of ultrasound: "As an investigative tool in both brain modification and visualization, there is no comparable method. We now have supportive evidence to show that ultrasonic lesions produced in brain can be directly viewed ultrasonically as they are produced."<sup>40</sup> Inasmuch as the exact mechanism by which ultrasound destroys tissue is not yet completely understood,<sup>12</sup> these sophisticated methods hold considerable promise for research.

**Ultrasound in cardiology.** The use of ultrasound in studies of heart functioning, first investigated by Keidel<sup>12</sup> in 1950, in recent years has come increasingly into clinical use. Ultrasound cardiography has been used to detect pericardial effusions, tumors, or thrombosis in the left atrium, and, particularly, in determining the amount of hardening (stenosis) in mitral valve disease.<sup>41</sup>

Except for Keidel's work, which attempted to transmit continuous ultrasound through the chest in the manner of X rays, most ultrasound cardiographic studies have relied on reflection techniques,<sup>12</sup> with recordings being made of the Doppler frequency shifts that result from the moving cardiac structures. A general diagnostic procedure that has evolved (pioneered by I. Edler and C. H. Hertz in 1954<sup>42</sup>) is to correlate ultrasound cardiographic recordings (UCG) with normal electrocardiographic recordings (ECG) and other information, in order to understand the causes of deviations in various forms of heart disease.<sup>12</sup>

**Abdominal diagnostics.** Ultrasonics has already had considerable clinical use for the visualization and diagnosis of conditions in various organs and soft tissues of the abdomen. In fact, in the early work of Dr. J. D. Holmes, Dr. D. H. Howry, and others of the pioneering group at the University of Colorado Medical School, Denver, the liver served as an anatomical standard, because its homogeneous character allows it to transmit sound well.<sup>43</sup> The presence of sound-reflecting tissue almost always indicates a pathological condition. Kidneys have been studied for the presence of stones, and explorations of the spleen have been attempted.<sup>44</sup>

**Obstetrics and gynecology.** In this area, ultrasound is finding nearly unlimited applications.<sup>45</sup> Among other things, it has been used to diagnose early pregnancy, multiple pregnancy, and tumors; also, it has served as a unique tool for the measurement of the biparietal diameter of the fetal head.<sup>46</sup> Extensive work in this field has been done, for instance, by Dr. G. Kossoff and his col-

leagues,<sup>13, 17, 18</sup> and by Dr. Ian Donald and his colleagues at the University of Glasgow.<sup>49</sup>

### Therapeutic uses of ultrasonics

In contrast to diagnosis, which uses low-energy ultrasound, and in which great care is taken not to expose the patient to high dosages, there are various therapeutic situations in which ultrasound is used precisely for its controlled destructive effects. The two best-known applications of this technique appear in the treatment of Ménière's disease and Parkinsonian tremor.

Ménière's disease, which affects the inner ear and results in severe vertigo attacks, has been treated by irradiation of the lateral semicircular canal ever since Krejci first reported success of the method in 1952. Another early investigator of ultrasonics in this application was M. Arslan.<sup>20</sup> However, in the earlier treatments, patients have suffered the risk of hearing loss and facial paralysis. A new approach that avoids these dangers through the application of ultrasonic energy directly to the inner ear through the round window has been developed by Dr. G. Kossoff and his colleagues.<sup>50</sup>

Among the other types of applications of intense ultrasound is the modification and destruction of soft-tissue malignant tumors.<sup>12</sup>

Ultrasonics is also used, and in fact is well established, for therapeutic heating within the human body, as in the treatment of rheumatic and arthritic conditions, in the softening of hard tissues, and so on. In such applications, it is regarded as being superior to ultrashort-wave and microwave therapy.<sup>12</sup>

### Ultrasonics and dentistry

Probably the most direct transformation of ultrasonics as an industrial tool to a medical application was that which occurred in dentistry. It all began officially, it is recorded, in November 1952 when an ultrasonic impact grinder was tried out experimentally—and cautiously—to drill a tooth that had already been extracted.<sup>51</sup> (Actually, the Cavitron Equipment Corporation, which pioneered the technique, was conscious of the dental application possibilities as early as 1947, but the application of ultrasonics to industrial needs at that time still was at the foreground of the company's attention.<sup>52</sup>) Working down in the range just above the frequencies of audible sound, the technique combines the vibrating tool with a fluid slurry that actually does the cutting of the tooth. In contrast to the other forms of ultrasonics applications, dental work can claim use most routinely.

### The future of medical ultrasonics

What then is the likely future of this versatile tool? In some respects, the art is being pushed hard against the basic limitations of this form of radiation,<sup>53</sup> and much work being done must be considered to be refinement of existing technique.

The elucidation of tissue reactions with ultrasonic radiation promises new knowledge: on the positive side, the clarification and quantification of such interactions should prove fruitful in strengthening and expanding existing techniques; on the negative side, here may be a definite need to restrict the present rather unlicensed use of ultrasound in medicine, as was made evident at U.S. Senate Hearings in May of 1968 on the question of the possible hazards of such nonionizing radiations as micro-

waves, ultrasonic waves, and lasers. As Prof. Herman Schwan of the University of Pennsylvania testified at these Hearings: "It has been indicated in the very few studies published so far that sound levels of a few watts/cm<sup>2</sup> can cause cavitation in tissue and do harm. Of particular concern may be ultrasonic visualization techniques in gynecology since nothing is known about the sensitivity of embryos to ultrasonic energy."<sup>54</sup>

Aside from these aspects, however, the place where ultrasonic applications might break out into new important territory is in ultrasonic holography—that is, in the production of three-dimensional pictures of interior biological structures. The engineering development that brought life to this possibility was the laser with its coherent light.

In ultrasonic holography, three separate remarkable engineering achievements—the laser of 1960 (Theodore Maiman), the holography of 1948 (Dennis Gabor), and the ultrasonics of 1942 (F. A. Firestone)—come together to offer medicine the possibility of a new spectacular.

### Acoustical holography

With the holographic technique proposed by Dennis Gabor, and with the coherent light of a laser, it is possible to make a true three-dimensional photograph. Everyone, by this time, has seen examples of such photographs.

In holography, an object to be photographed is illuminated with a laser beam, and a reference beam from the same laser is set up so as to interfere with the reflection of the illuminating beam; the resulting interference pattern (the interferogram) is recorded in the emulsion of the photographic plate.<sup>55</sup> The interference pattern contains both amplitude and phase information so that when the plate is illuminated from the back with a laser beam, the original image will be reconstructed. Looking through the plate, the viewer sees (if he is not astigmatic like James Thurber in that famous story of the microscope) the original three-dimensional object. Fine! Moreover, if the

viewer shifts his angle, he sees parts that were hidden, just as in the real world.

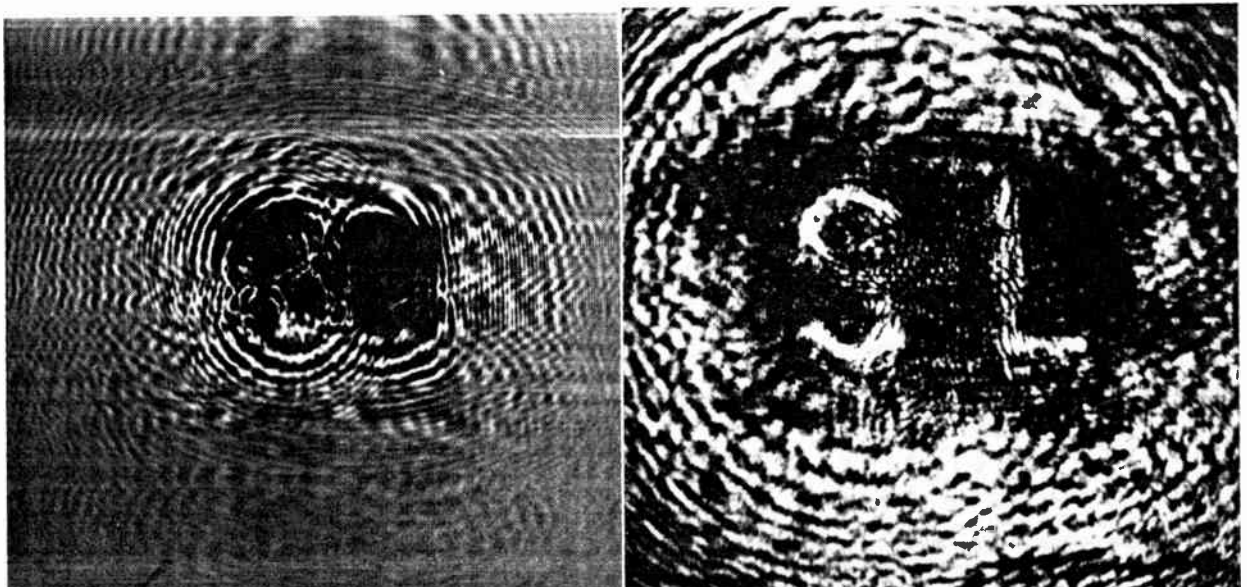
Recently, there has been interest in trying to pull off an analogous trick with ultrasound vibrations. By adding an acoustic reference beam to the sound field, and then using an acoustic image converter, a fringe pattern containing amplitude and phase information is obtained on the image-conversion device. This pattern is then photographed and the photograph is illuminated with a laser beam. If the image is scaled down and viewed with a microscope, a three-dimensional image of the original acoustically detected structure is obtained.<sup>56</sup>

Although this technique is in a developmental stage, and although there are some investigators who are pessimistic about its being successful,\* it may become valuable in medical diagnosis and in such things as material testing. With the technique, internal structures in the living body might be displayed visually in three dimensions. One of the prominent investigators in this new art, F. L. Thurstone of the Biochemical and Electrical Engineering Department at Duke University, says that primarily the technique offers the possibility of recording and using more of the information in the coherent sound field than do conventional acoustical imaging systems.<sup>57-59</sup> Figure 8 shows the hologram of a sonic transparency and the reconstructed real image that Thurstone obtained with his scanning system.

This kind of research, which brings together principles and technologies from many fields (ultrasonics, lasers, photography, medicine, and electronics engineering), is intriguing. One of these days, a new Firestone may be greeting his guests thusly: "Here, step into this tank of water up to your neck. I'll show you a three-dimensional, real-time movie of your heart beating and your guts run-

\* Because acoustic holograms are recorded at sound wavelengths and reconstructed at light wavelengths, exact 3-D is not possible.<sup>56</sup>

**FIGURE 8.** Hologram of a sonic transparency and the real image reconstructed on a system being developed by Dr. F. L. Thurstone, Duke University.



bling!" The technology for such movies is already being developed in a number of laboratories.

The writer owes thanks for their kind assistance to all of these people: Peter Edmonds, Prof. Samuel Fine, David Geselowitz, H. Philip Hovnanian, Dr. John E. Jacobs, Dr. George Kossoff, Dr. Charles D. Ray, Dr. C. G. Riggle, Dr. R. J. Rockwell, Jr., Prof. Otto Schmitt, Dr. F. L. Thurstone.

#### REFERENCES

1. Remarks by Carlin in *Diagnostic Ultrasound*, Proc. First Internat'l. Conf., Univ. of Pittsburgh, 1965, ed. by C. C. Grossman et al. New York: Plenum Press, 1966, p. 518.
2. Firestone, F. A., U.S. Patent 2 280 226, granted April 1, 1942.
3. Firestone, F. A., "The superonic reflectoscope, an instrument for inspecting the interior of solid parts by means of sound waves," *J. Acous. Soc. Am.*, vol. 17, pp. 287-299, Jan. 1946.
4. Dussik, K. T., "Possibility of using mechanical high frequency vibrations as a diagnostic aid," *Z. Neurol. Psychiat.*, vol. 174, pp. 153-168, 1942.
5. French, L. A., et al., "Detection of cerebral tumors by ultrasonic pulses: pilot studies on post-mortem material," *Cancer*, vol. 3, pp. 705-807, 1950.
6. White, D. N., "Accuracy of a scan determination of mid-line echo," in *Diagnostic Ultrasound*. New York: Plenum Press, 1966, pp. 142-147.
7. Grossman, C. C., "A and B scan sonoencephalography (SEG)—A new dimension in neurology," in *Diagnostic Ultrasound. Ibid.*, pp. 130-141.
8. Oman, C., and Applebaum, E., "Ultrasonic cavity preparation: preliminary report," *N.Y. State Dental J.*, vol. 20, no. 6, pp. 256-260, 1954.
9. Holmes, J. H., "The present status of ultrasonic diagnostic techniques in internal medicine," *Ultrasonics*, pp. 60-66, April 1967.
10. "What is ultrasonics?" Cavitron Corp. report, 1968.
11. Turner, W. R., "Ultrasonic imaging," *Ultrasonics*, pp. 182-187, Oct.-Dec. 1965.
12. Jacobs, J. E., "Ultrasonics in biology," in *Advances in Bio-engineering and Instrumentation*, Fred Alt, ed. New York: Plenum Press, 1966, pp. 185-288.
13. Kossoff, G., et al., "Ultrasonic two-dimensional visualization for medical diagnosis," *J. Acous. Soc. Am.*, vol. 44, no. 5, pp. 1310, 1318, 1968.
14. Remarks by A. Sokollu, in *Diagnostic Ultrasound, op. cit.*, p. 486.
15. Remarks by D. H. Howry, in *Diagnostic Ultrasound, op. cit.*, p. 489.
16. Remarks of D. M. Makow, in *Diagnostic Ultrasound, op. cit.*, p. 487.
17. Fry, W. J., et al., "Ultrasound transmission in tissue visualization," in *Diagnostic Ultrasound, op. cit.*, pp. 13-26.
18. Ried, J., "A review of some basic limitations in ultrasonic diagnosis," in *Diagnostic Ultrasound, op. cit.*, pp. 1-12.
19. Howry, D. H., "Techniques used in ultrasonic visualization of soft tissue structure of the body," *IRE Con. Rec.*, pt. 9, pp. 75-88, 1955.
20. Smyth, C. N., "Ultrasonics in clinical practice," *Ultrasonics*, p. 59, Apr. 1967.
21. Grossman, C. C., remarks in *Diagnostic Ultrasound, op. cit.*, p. 496.
22. Denier van der Gon, J. J., "Comparison of scan techniques in two-dimensional echo-encephalography," in *Diagnostic Ultrasound, op. cit.*, pp. 155-165.
23. Salomon, H., and Snyder, P., "Indirect blood pressure by ultrasonic detection of arterial wall motion," *Proc. 21st ACEMB*, Houston, Tex., Nov. 1968.
24. Mount, B., et al., "Signal analysis and processing," *Proc. 21 ACEMB*, Houston, Tex., Nov. 1968.
25. Jacobs, J. E., "Ultrasonic image converter systems utilizing electron-scanning techniques," *IEEE Trans. Sonics and Ultrasonics*, vol. SU-15, pp. 146-152, July 1968.
26. Jacobs, J. E., "Present status of ultrasound image converter systems," *Trans. N.Y. Acad. Sci.*, ser. II, vol. 30, pp. 444-456, Jan. 1968.
27. Jacobs, J. E., "Performance of the ultrasound microscope," *Materials Evaluation*, pp. 41-45, Mar. 1967.
28. Jacobs, J. E., et al., "Use of color display techniques to enhance sensitivity of the ultrasound camera," *Materials Evaluation*, pp. 155-158, Aug. 1968.
29. Purnell, E. W., "Ultrasound in ophthalmological diagnosis," in *Diagnostic Ultrasound, op. cit.*, pp. 95-110.
30. Sokollu, A., "The use of diagnostic ultrasound in eye research," in *Diagnostic Ultrasound, op. cit.*, pp. 46-58.
31. Oksala, A., and Salminen, L., "Some aspects dealing with the ultrasound diagnosis of intraocular foreign bodies," in *Diagnostic Ultrasound, op. cit.*, pp. 79-94.
32. Bronson, N. R., II, "Localization and extraction of foreign bodies by ultrasound," in *Diagnostic Ultrasound, op. cit.*, pp. 72-78.
33. White, D. N., "The limitations of echo-encephalography," *Ultrasonics*, pp. 88-90, Apr. 1967.
34. White, D. N., "Accuracy of a scan determination of midline echo," in *Diagnostic Ultrasound, op. cit.*, pp. 142-147.
35. Grossman, C. C., "A and B scan sonoencephalography (SEG)—a new dimension in neurology," in *Diagnostic Ultrasound, op. cit.*, pp. 130-141.
36. Makow, D. M., and Real, R. R., "Development of a 360° compound immersion head scanner," in *Diagnostic Ultrasound, op. cit.*, pp. 166-185.
37. McKinney, W. M., et al., "The significance of intracranial echo pulsations," in *Diagnostic Ultrasound, op. cit.*, pp. 114-116.
38. Fry, W. J., "Electrical stimulation of brain localized without probes—theoretical analysis of a proposed method," *J. Acous. Soc. Am.*, vol. 44, pp. 919-931, Oct. 1968.
39. Fry, W. J., "Intracranial anatomy visualized in vivo by ultrasound," *Investigative Radiology*, vol. 3, pp. 243-266, Jul.-Aug. 1968.
40. Fry, F. J., Private communication, Feb. 26, 1969.
41. Edler, I., "Mitral valve function studied by the ultrasound echo method," in *Diagnostic Ultrasound, op. cit.*, pp. 198-228.
42. Edler, I., and Hertz, C. H., "The use of ultrasonic reflectoscope for the continuous recording of movements of heart walls," *Kungl. Fysiogr. Sallsk. i Lund Forhandl.*, vol. 24, no. 5, 1954.
43. Holmes, J. H., "Ultrasonic diagnosis of liver disease," in *Diagnostic Ultrasound, op. cit.*, pp. 249-263.
44. Lehman, J. S., et al., "Ultrasound exploration of the spleen," in *Diagnostic Ultrasound, op. cit.*, pp. 264-295.
45. Gottesfeld, K. R., "The practical applications of ultrasound in obstetrics and gynecology," in *Diagnostic Ultrasound, op. cit.*, pp. 428-451.
46. Von Miesky, L. I., "Ultrasound tomography in obstetrics and gynecology," in *Diagnostic Ultrasound, op. cit.*, pp. 348-368.
47. Kossoff, G., et al., "Two dimensional ultrasonography in obstetrics," in *Diagnostic Ultrasound, op. cit.*, pp. 333-347.
48. Robinson, D. E., et al., "Ultrasonic echoscopy in clinical obstetrics and gynaecology," Report No. 40, Commonwealth Acoustic Labs., June 1967.
49. Donald, I., "The interpretation of abdominal ultrasonograms," in *Diagnostic Ultrasound, op. cit.*, pp. 316-332.
50. Kossoff, G., et al., "The round window ultrasonic technique for treatment of Ménière's disease," *Arch. Otolaryng.*, vol. 86, pp. 83-90, Nov. 1967.
51. Balamuth, L., "Ultrasonics and dentistry," *Sound*, vol. 2, pp. 15-19, Mar.-Apr. 1963.
52. Balamuth, L., "Technical aspects of the Cavitron ultrasonic process in dentistry," *IRE Con. Rec.*, pt. 9, pp. 89-97, 1955.
53. Kelman, C. D., "Phaco-emulsification and aspiration—preliminary report on a new technique of cataract removal," *Am. J. Ophthalmology*, vol. 64, pp. 23-35, July 1967.
54. Radiation Control for Health and Safety Act of 1967, Hearings before the Committee on Commerce, U.S. Senate, 90th Congress, Second Session on S.2067, S.3211, and H.R. 10790, ser. No. 90-49, pt. 2, p. 709, May 6-15, 1968.
55. Stroke, G. W., "Holography," from science seminars at Conv. of National Science Teachers Assoc., Detroit, Mich., Mar. 1967.
56. Korpel, A., "Acoustic imaging and holography," *IEEE Spectrum*, vol. 5, pp. 45-52, Oct. 1968.
57. Thurstone, F. L., "Holographic imaging with ultrasound," *J. Acous. Soc. Am.*, Apr. 1969.
58. Thurstone, F. L., "Ultrasound holography and visual reconstruction," Bowman Gray School of Medicine, Wake Forest Univ., 1969.
59. Thurstone, F. L., and Tyrer, H. W., "Acoustic energy detection for holographic imaging," *Proc. 21st ACEMB*, Houston, Tex., Nov. 1968.

**Nilo Lindgren**, formerly a staff writer on *IEEE Spectrum*, is now a senior editor of a new magazine, *Innovation*, aimed at people concerned with the management of technological change. A full biography of Mr. Lindgren appears in the September 1968 issue of *Spectrum*, page 38.

# Fluidics—a new control tool

***The advantages of fluidic logic consist of more than just an operational substitute for electronic systems under extreme environmental conditions. In addition to their high reliability, these devices can be applied using existing design techniques***

**Rolf E. Wagner**    *Mechanical Technology Inc.*

*Ten years have passed since a team of engineers at Harry Diamond Laboratories had the idea of using fluid-flow phenomena for control applications, starting a boom in fluidic technology. By creating the fluid amplifier, which amplifies an air signal rather than an electric signal but with otherwise similar characteristics, they started an industry that today has a market volume of several million dollars and is still on the rise. The purpose of this article is to describe the present state of the art and future prospects for fluidics. Without pretending to be complete, an understanding is given of where fluidic elements are used, what their advantages and disadvantages are, and the requirements for building fluidic control systems. Fluid phenomena that represent the basis for fluid amplifier operation are briefly described, and the characteristics of fluid amplifiers are discussed. Although fluid amplifiers are used for both analog and digital applications, this article will be limited to digital systems, concluding with some general remarks that apply to both.*

The basis for logical and sequential systems is the so-called switching theory that was first introduced by Boole<sup>1</sup> and further developed by Caldwell,<sup>2</sup> McCluskey,<sup>3</sup> Maley,<sup>4</sup> and others. Systems that are based on this theory operate in an identical manner, whether they depend upon a fluidic circuit, a hydraulic circuit, or an electrical circuit.

Why is it necessary to develop circuitry using compressed air when a wide range of electric and electronic control systems is already available? The answer, in short, is that fluid elements can operate reliably in environments where electronic circuits are prohibited (high nuclear radiation, extreme temperatures, etc.), and that, in certain fields, fluid logic circuits can perform control functions similar to electronic circuits, with a saving in cost and an increase in reliability.

Fluid logic circuits are, in general, not intended to perform extremely complicated computations. Since many

plant processes and automatic machines require only simple logic systems to control them, fluid logic can be used to advantage. Devices with no moving parts are virtually indestructible. Many moving-part elements, operating as they do at extremely low stress levels, have been found to have similar reliability. Switching lives of over 10<sup>8</sup> operations are usual. In addition, the cost of generating input signals for the control system is often considerably reduced, and amplifier valves, which drive devices controlling usable energy levels with the outputs of control systems, are again less expensive and more reliable than the conventional electric solenoid-operated valves.

Because compressed air is used as the control medium, fluid logic circuits are inherently slower than electrical systems. It might be thought on first examining this problem that the relationship would be the ratio of the speed of light to the speed of sound, but in actual fact most compressed-air circuits perform at speeds much slower than the speed of sound as the pressure variations in the circuit are considerably higher than the pressure variations involved in the transmission of sound through the atmosphere.

When considering a possible application for a fluid logic circuit, it should be remembered that distance increases delay, as does logic circuit complexity. Individual logic devices are capable of switching in less than one millisecond, but delays associated with complete circuitry are more often in the range of 10 to 100 milliseconds. Bearing these facts in mind, fluid logic can be considered for applications falling into the following broad categories:

1. Control systems employing simple logic with moderate speed requirements.
2. Complex logic circuits with low speed requirements.

In addition to these categories, there are others where fluidic circuits present advantages due to their adaptability and inherent environmental tolerance. Such

- applications are typified by:
- Control systems where information is supplied in the form of punched tape or cards.
  - Control systems for hazardous environments, where flame-proofing is required or where there is a high level of nuclear radiation.

Owing to the functional similarity among logic elements of all media, the logic theory that has been extensively developed by electronic engineers is directly applicable to fluidic logic circuits. This is more true for digital elements than it is for analog elements, where linear range and types of existing nonlinearities, such as backlash, hysteresis, etc., play an important role.

The design of a fluidic logic system follows steps similar

to the design of an electronic logic system. The convention for logic level "0" and "1" has to be defined, and "fanout" (output impedance) and "fan-in" (input impedance) have to be studied for all types of elements that will be used. One must also pay attention to the compatibility of elements with each other, a condition that represents an actual problem, as will be seen.

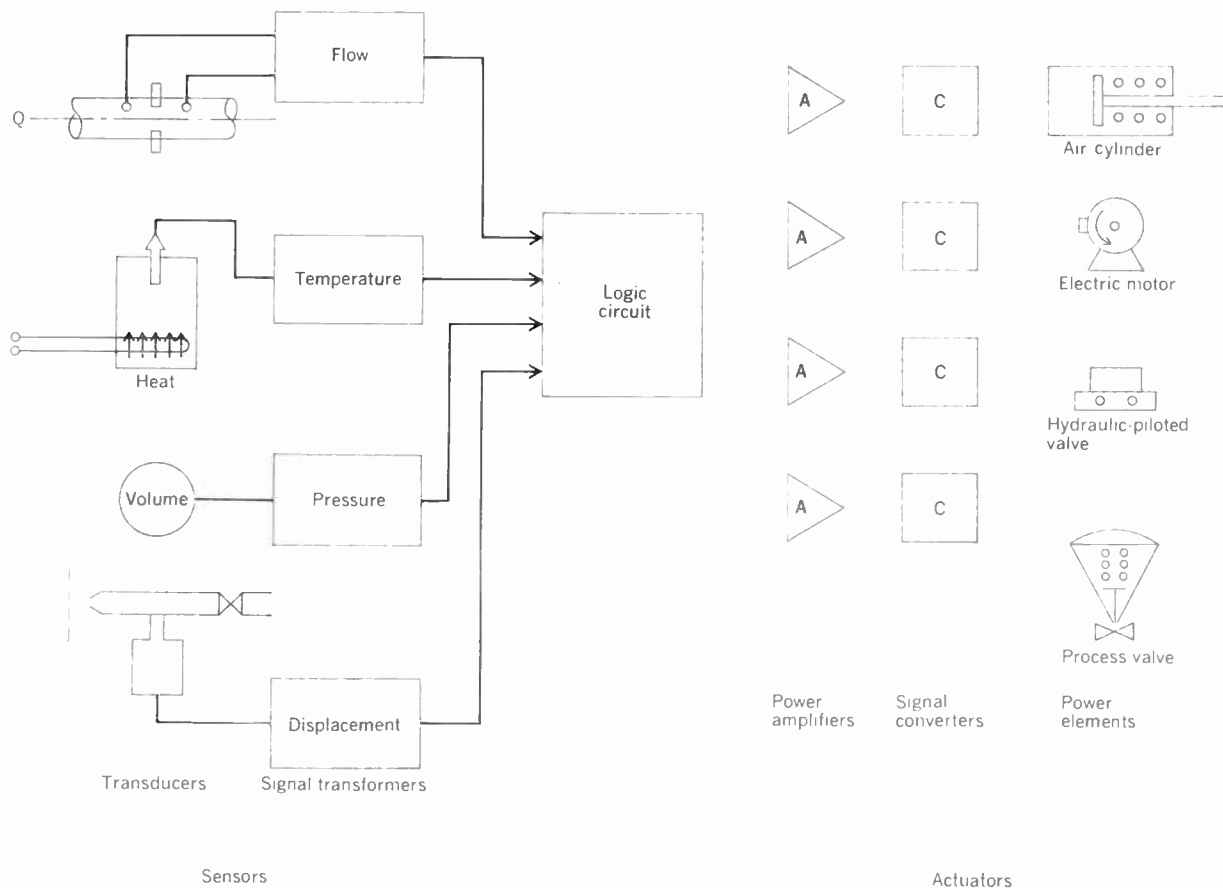
### Composition of a fluidic logic system

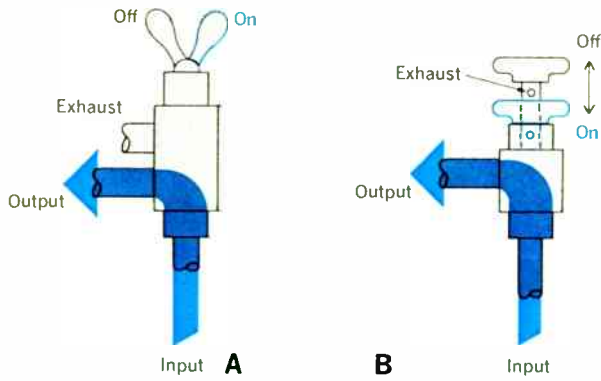
A logic or sequential system consists of three basic parts:

- The input sensors delivering signals that are either ON or OFF (manually operated switches for human operator interfaces also fall into this category).

**FIGURE 1. Complete logic control circuit. Transducers to sense flow, temperature, pressure, and displacement are shown at the left. Each transducer is connected to a signal transformer that either adapts the signal to the correct level or converts it from an electric into a pneumatic**

**signal. Signal converters are also shown on the right, supplied by output amplifiers; they are not required if the signal is already in proper form. For example, a pneumatic amplifier issuing 35 N/cm<sup>2</sup> of pressure can drive an air cylinder without passing through the signal converter.**





**FIGURE 2. Pneumatic toggle switch (A) and push button (B).** Basically, these are lever-operated “two-way” or “three-way” valves. The three-way valve provides a connection between the output and atmosphere through the exhaust port when the valve is in the OFF position. With the push button, the exhaust port is located in the stem of the moving port. Three-way valves must be used if the downstream element is dead-ended (pneumatic diaphragm devices). Fluidic elements do not require the exhaust; hence, two-way valves can be used.

2. The logic or sequential circuit, which realizes the desired interrelations and is composed of logic devices.

3. The output elements that perform the functions as required, including amplifiers.

Figure 1 shows the layout of a typical system. Various input devices are connected to the logic block through transformers that transform the signal into the required medium used in the logic block. The outputs of the logic block pass through amplifiers and converters that enable transformation from the control-unit medium into the medium used in the various actuating elements.

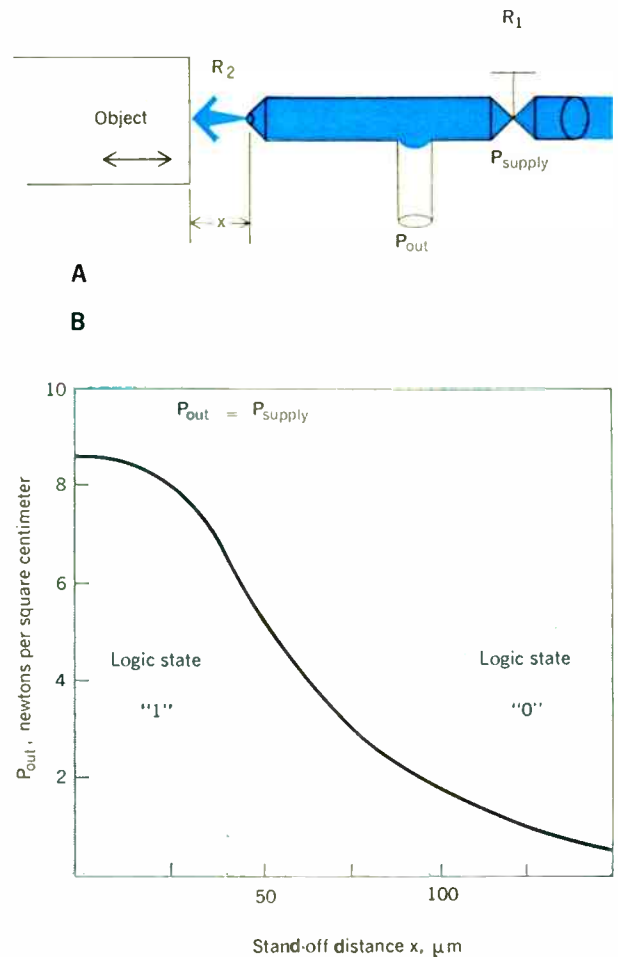
It seems appropriate at this time to make the general statement that the overall reliability of a system will depend strongly on the number of interfaces required to change from one medium into another. Particularly crucial are the electric-pneumatic or electric-hydraulic interfaces. The smaller the number of such interfaces, the higher the reliability of the system will be.

Interfaces can be avoided by adapting the logic block to the controlled medium. In general, if the actuating elements are electric motors or typical electric actuators, an electronic logic circuitry should be used; if they are air cylinders or hydraulically operated devices, a fluidic, pneumatic, or hydraulic logic circuitry should be used. The conversion from an air signal to a hydraulic signal is achieved through a piloted valve, which is a very reliable device.

In the logic block, we distinguish between two basic elements, the “path” element—typified by the electromagnetic relay—and “level” elements such as AND and OR—which realize more complex functions than “path” elements. In a circuit built with “path” elements, we analyze the signal flow, whereas in a “level” system the levels of inputs and outputs of the various elements are analyzed.

#### Manual switches and input sensors

The input variables of a logic circuit are generated by either manual switches or by sensors. We can distinguish



**FIGURE 3. Back-pressure sensor (A) and its characteristic (B).** Used in most conventional pneumatic controllers, this sensor is used here as an amplifier around which the various correcting networks are built. Operating range is generally between 25 and 75  $\mu\text{m}$ .

between two types of manual switches, the toggle switch and the push button. A typical pneumatic toggle switch and push button are shown in Fig. 2.

A sensor is used when the state of a process variable is used to initiate certain operations of the control process. Some of the sensors are very similar to manual switches. If the sensed action is a motion, the push-button switch could be used without any modification.

In many cases, it is desirable to sense a position without exercising any significant force on the approaching object. The sensor used in such a case is the flapper-nozzle arrangement, the principle of which is shown in Fig. 3(A). A supply pressure signal passes through a first resistor to create a certain pressure drop. A second resistor is provided by the combination of the nozzle and the approaching object. If the object gets very close to the nozzle, the pressure between the two resistors starts to build up and finally reaches the value of the supply pressure when the nozzle is completely blocked. The condition for this statement is that the sensing output is dead-ended and does not require any flow.

Figure 3(B) plots the characteristic of this “back-pressure” sensor, which can be used as an analog sensing

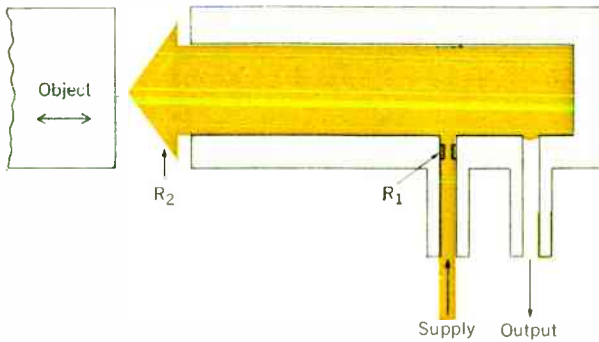


FIGURE 4. Industrial version of back-pressure sensor.

FIGURE 5. A diverging-cone sensor.

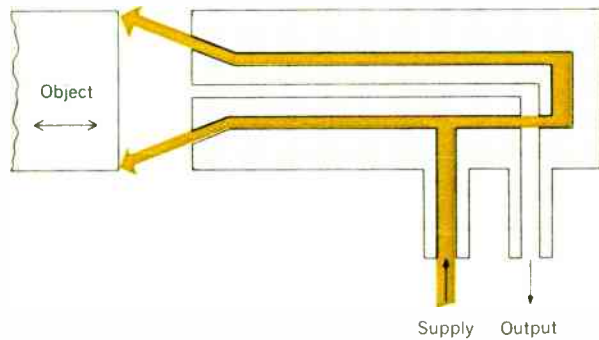
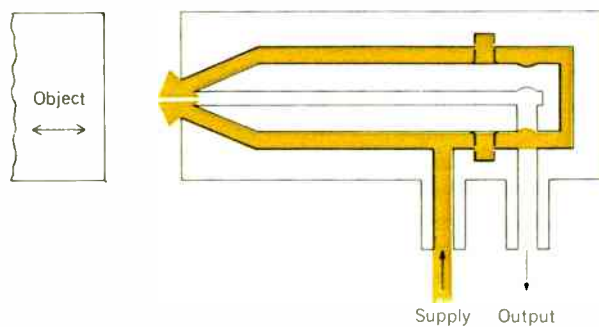


FIGURE 6. A converging-cone sensor.



device as well as an ON-OFF device. The ranges chosen for ON-OFF operation are shown on the characteristic by the tinted regions.

The inconvenience of the back-pressure sensor is that a variation in the pressure  $P_{out}$  can only be noticed if the object is very close to the nozzle. The distance between sensor nozzle and object is called "standoff" distance. For any considerable standoff distance ( $> 0.5$  mm), the logic state will always be "0." An industrial version of a back-pressure sensor is shown in Fig. 4.

Figure 5 shows a sensor that has been developed by Raymond Auger. This sensor operates on less than 2 newtons per square centimeter (3 lbf/in<sup>2</sup>) and produces an output of more than 0.07 N/cm<sup>2</sup> (0.1 lbf/in<sup>2</sup>). Objects up to 3.3 cm away can be sensed with this sensor coupled to standard logic elements, and it is envisioned that it

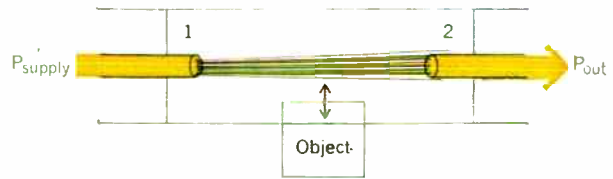
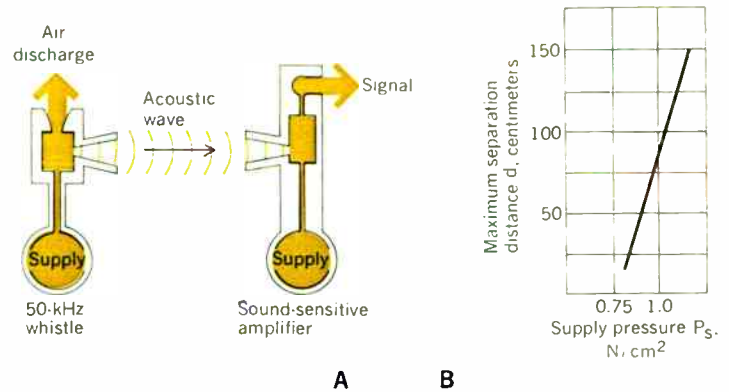


FIGURE 7. The interruptible-jet sensor.

FIGURE 8. Fluidic sound sensor (A) and characteristic (B).



could operate up to distances of 25 cm. The principle of this "diverging-cone" sensor is that when no object is in front of the sensor, the air, after diverting over a certain distance, forms a cone with converging walls. The pressure inside this cone is very low because of the entrainment of air. As soon as an object passes in front of the sensor, the cone is destroyed and a pressure zone builds up in the central tube.

Another sensor was developed by the Fluidonic Division of Imperial Eastman Corporation. Displayed in Fig. 6, it was specifically designed to detect the passage or proximity of plastic porous foam. The sensor has a detectable standoff distance of approximately 7 mm. It consists of four jets of air, which are focused into a cone whose apex is a little more than 7 mm from the nozzle exit plane. If the cone is undisturbed, the pressure inside the cone remains atmospheric. As soon as any object moves into the sensing range, the apex is compressed, and a pressure buildup occurs inside the cone.

To overcome the problem of proximity sensors with large standoff distances, the so-called interruptible-jet sensor (schematically shown in Fig. 7) was developed several years ago. The sensor consists of a laminar jet leaving the supply tube at point 1 and entering the output tube at point 2. The output pressure is only slightly smaller than the inlet pressure. With nothing between the tubes, a free jet travels from left to right and  $P_{out}$  consists of the dynamic head of this jet. If an object is passed in between the two tubes, the output pressure ( $P_{out}$ ) becomes equal to atmospheric pressure. The disadvantage of this sensor is that it can easily entrain dust particles into the receiver tube and contaminate the fluidic devices connected to the sensor. A modification of such a device includes an adapter consisting of a chamber that is connected to the output of the interruptible-jet sensor. One wall of this chamber is a flexible membrane. The displacement of the membrane is sensed with a flapper-nozzle

lected by the output tube. Now, if an input pressure signal is applied perpendicular to the jet in the area where the jet has left the supply tube, the jet will be disrupted and become turbulent [Fig. 12(B)]. The amount of flow collected by the output now becomes very small. Removal of the input signal will reestablish the laminar jet, and cause an increase of the pressure in the output port.

The input-output characteristic of the turbulence amplifier is plotted in Fig. 12(C). Several variations of the turbulence amplifier do exist. Some are a combination of turbulence-amplifier and jet-deflection devices. The principle of operation is more or less the same.

**The impact modulator.** The principle of the impact modulator is depicted in Fig. 13. Very often the impact modulator is used for analog applications, but digital applications are possible as well. The device uses two axially opposed power jets  $S_1$  and  $S_2$  to provide a planar "impact region." The input signal is applied at port C, and the amplifier output is at port O. When an input signal is applied, the impact region moves from the left to the right. This results in increased flow in output port O. Removal of the input signal will move the impact region back to the left. The impact modulator can be used as a monostable device or as an analog device. Its outstanding feature is high gain, which can be as large as 200.

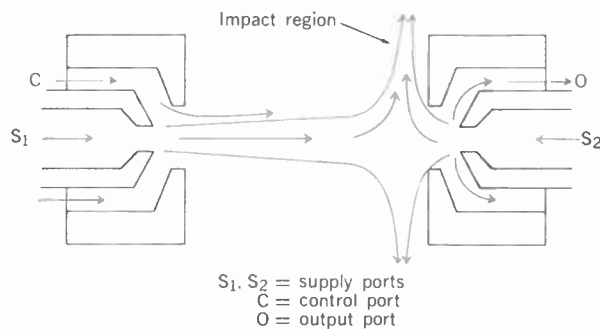
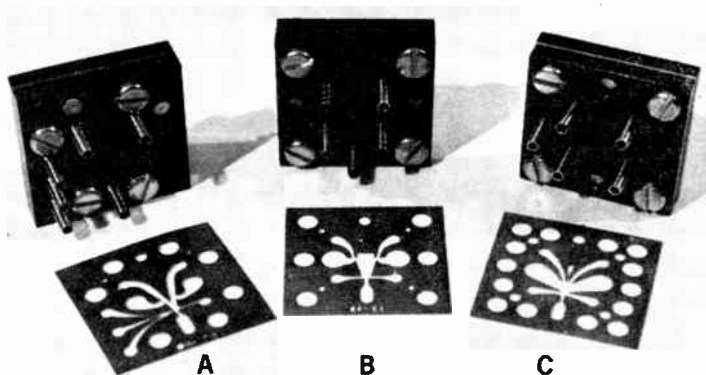


FIGURE 13. The impact modulator.

FIGURE 14. Fluidic logic components. A—Fluidic OR-NOR element with three inputs. B—Fluidic flip-flop element. C—Fluidic digital amplifier. (Courtesy of General Electric Company)



## Realization of logic functions with fluidic devices

The three basic logic demands that must be realized are the AND, OR, and complementation functions. Whereas the complementation function can have only one input, the AND and the OR function must have two or more inputs. The AND element provides an output only if all the inputs are equal to one or, in terms of a fluidic device, if all the inputs are pressurized. If one or more inputs are at zero pressure level, the output is zero. The OR element requires only one of the inputs to be pressurized in order to generate a pressure signal at the output; only if all inputs are at zero will the output be zero. The complementation element complements the input. If the input is equal to one or pressurized, the output is zero, and vice versa.

Although the complementation element is always an active element with an internal power supply, the AND and OR element can be built as either active or passive elements. Passive elements are fabricated from diodes or resistors, their disadvantage being that they degenerate the signal and malfunctions can occur if too many passive elements are connected in series. In most fluidic systems, only active elements are used. The discussion will, therefore, be limited to active fluidic elements. However, it must be clearly pointed out that fluidic diodes, resistors, and integrated passive fluidic AND and OR elements also exist.

By combining the OR function and the complementation function, the so-called "NOR function" is created and, by combining the AND function and the complementation function, we obtain the "NAND function." The NOR and NAND functions are, for most logic designs, even more important than the basic functions OR, AND, and "complement." They can be realized electronically and fluidically by one single element.

In fluidics, only the NOR function is used because the convention for logic levels "0" and "1" is in general

- 0 → no pressure
- 1 → presence of a pressure signal

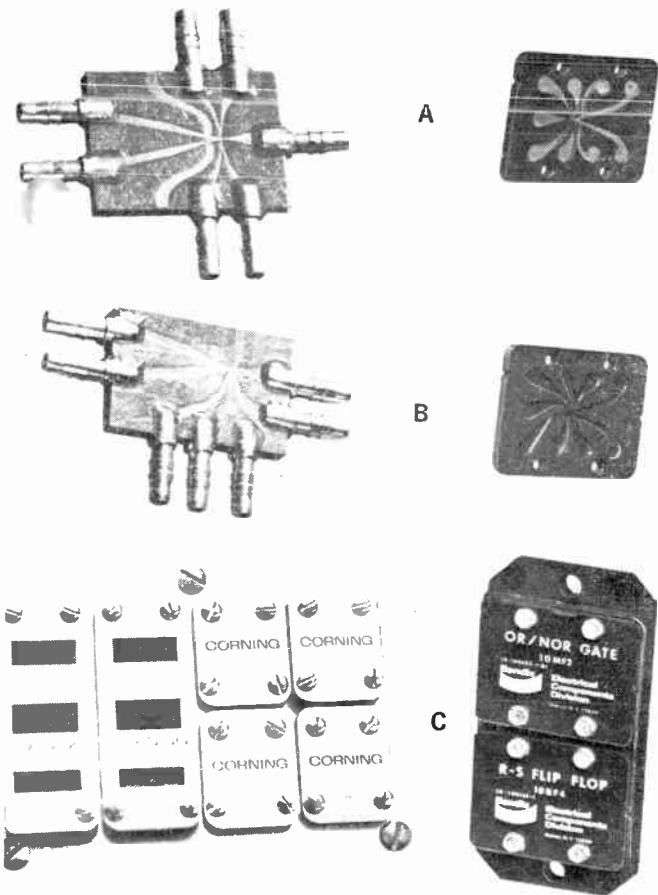
The definition of the NAND element is that all inputs have to be "1" in order to obtain a "0" output. The fluidic realization of such an element would require the presence of a pressure signal on all unused inputs, which is uneconomical. The NOR function issues a "1" output if and only if all inputs are equal to "0." Using the NOR element, all possible logic combinations can be realized. The analysis of a circuit using only NOR elements is relatively simple compared to the analysis of a circuit using different functions such as AND and OR.

Fluidic AND, OR, "complement," and NOR elements are built by a variety of companies using the different physical phenomena described in the previous section.

Figure 14 shows three fluidic logic components that were developed by the General Electric Company. Both the OR/NOR and the flip-flop element are wall-attachment elements, and the digital amplifier is a typical jet-deflection device. The OR/NOR element is slightly asymmetric, which will cause the jet to return from the right output leg to the left output leg if all input signals are removed. The left output leg, therefore, achieves a realization of the NOR function and the right output leg realizes the OR function.

Fluidic logic components manufactured by Bendix Corporation and Corning Glass Works are shown in



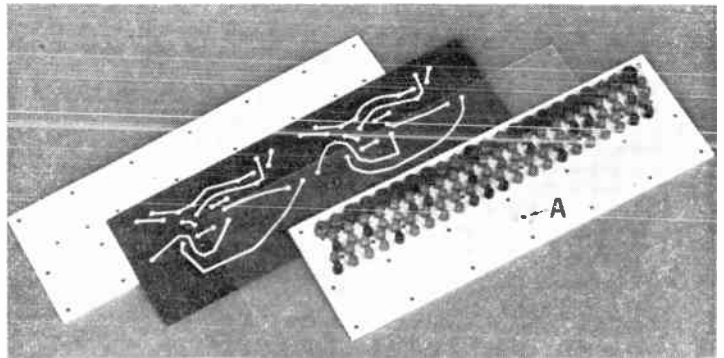


**FIGURE 15. Fluidic elements and their assembly technique. A—Basic flip-flop layout. B—Basic OR-NOR layout. C—Combination of elements into an integrated system. [Courtesy of Bendix Corporation (right-side elements) and Corning Glass Works (left-side elements)]**

Fig. 15. Both the flip-flop elements and the OR/NOR elements are wall-attachment-type devices.

Digital elements that are based on a change-of-flow regime (e.g., turbulence amplifiers) and the impact modulator in general only realize the NOR function. This seems obvious if we recall the principles of both elements as discussed earlier. Each element only has one type of output. The number of inputs is in general limited only by the available space; elements with up to eight inputs do exist. Elements that operate on a principle very similar to that of the turbulence amplifier are displayed in Fig. 16. The NOR elements have four inputs and a fanout capability of four, which means that the inputs of four NOR elements can be controlled in parallel by the output of one NOR element.

The components manufactured by Pitney-Bowes, Inc., also demonstrate the tendency toward integration of fluidic components that is found among many manufacturers today. The supply to all eight NOR elements is common (A). The interconnections can be made externally by plastic tubing. By inserting a molded or engraved rubber gasket between the two outer layers of Fig. 16, internal interconnections are realized. This principle of interconnections corresponds almost exactly to the printed-circuit technique in electronics.



**FIGURE 16. Fluidic NOR elements with four inputs and a common supply A. (Courtesy of Pitney-Bowes, Inc.)**

**FIGURE 17. A plug-in fluidic NOR logic element based on the impact modulator principle (A) and an example of its assembly technique (B). (Courtesy of Johnson Service Company)**



The industrial version of the impact modulator manufactured by The Johnson Service Company is shown in Fig. 17. The NOR element (A) has all of its connections on the top. The four white tubes coming out of the top of the element are the four inputs. The other six tubes are parallel outputs. The supply connections are made by simply inserting the element in the manifold. The impact modulator has a relatively fast response time (less than 1 ms) and a large fanout capability. Up to 11 inputs can be connected in parallel to one output.

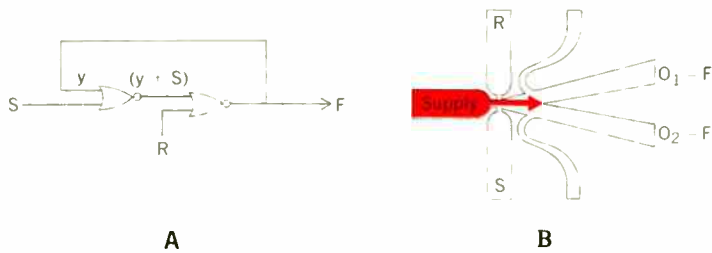


FIGURE 18. Memory function circuit and bistable amplifier.

FIGURE 19. Circuit diagram for binary counter stage.

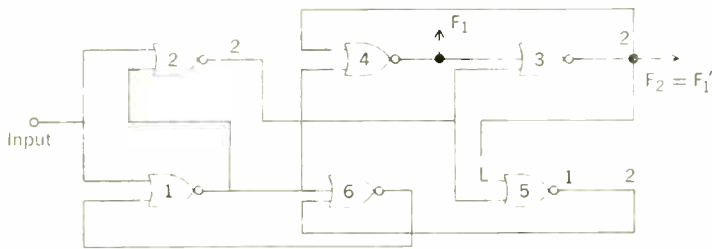


FIGURE 20. The Warren binary counter and principle of operation. The outputs of the device are  $P_1$  and  $P_2$ , where  $P_2$  is the complement of  $P_1$ ;  $C_1$  and  $C_2$  are the set and reset signals. The supply flow to the element is provided through  $P_c$ . The basic amplifier is a bistable wall-attachment type that can be controlled by signals  $C_1$  and  $C_2$ . The jet is stable when leaving through output leg  $P_1$  or output leg  $P_2$ . If  $P_2$  is the output leg (B), a counterclockwise air circulation is created in the loop A-B, due to the pressure gradient established in the power jet. By applying a pulsed pressure signal at  $P_c$  (C), the signal in the circulation loop A-B will be amplified, thus destroying the pressure gradient and causing the jet issued by  $P_c$  to switch to  $P_1$ , adhering to the upper wall. After the control signal  $P_c$  has been removed, the pressure gradient in the power jet will cause a clockwise air circulation (D) in the loop A-B that, when amplified by a further signal from  $P_c$ , cause another switching of the output jet.

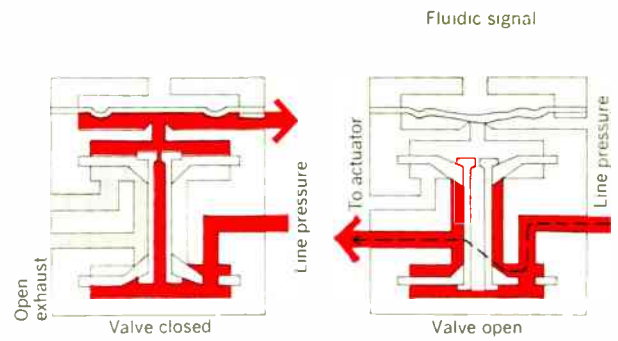
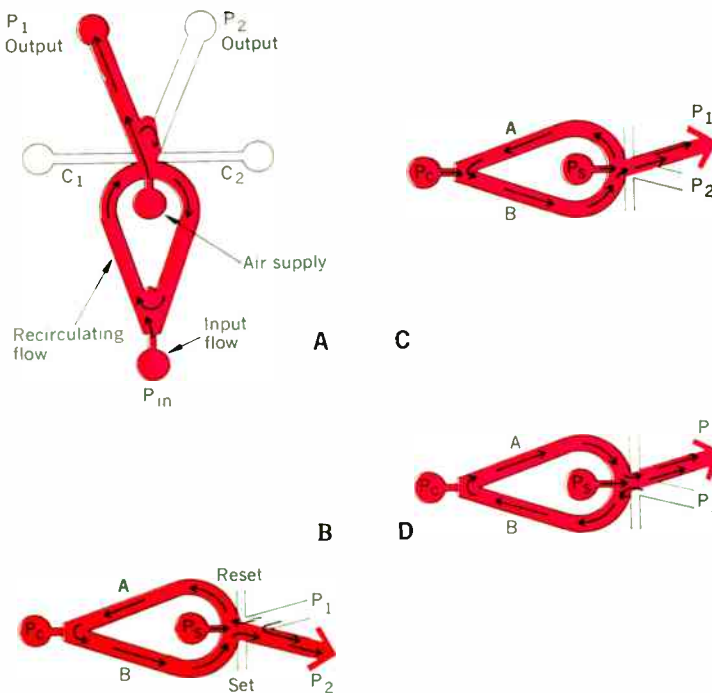
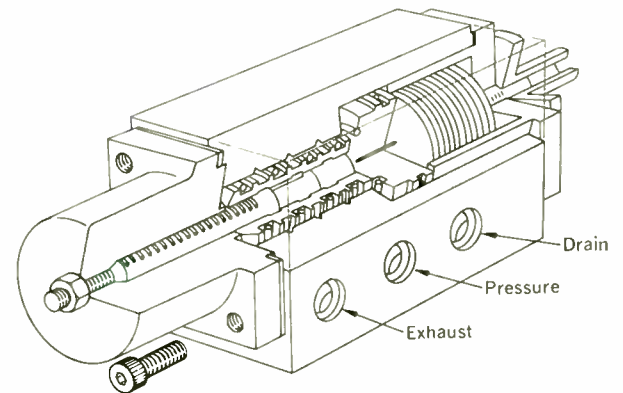


FIGURE 21. A pneumatic amplifier.

FIGURE 22. Fluidic-hydraulic interface valve. Developed by Norris Brothers, England, this moving device can be considered an ideal interface for hydraulic actuators. Of extremely high gain, it is possible to obtain an output as high as  $1400 \text{ N/cm}^2$  with a  $0.35 \text{ N/cm}^2$  input signal. Through a mechanical linkage, the displacement of the bellows caused by the input pressure is transmitted to a spool valve that has very low friction between the spool and the cylindrical wall. The displacement of the spool, in turn, changes the output from a zero-pressure level to the high-pressure level. After removal of the input signal, the spool returns to its initial position and the output signal returns to zero.

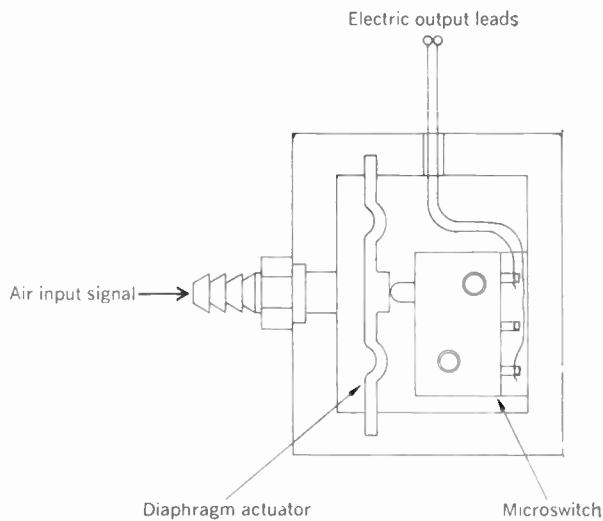


### Various elaborate and common logic functions

As an example of how to develop a logic function, we will use some common circuits, such as flip-flops, counters, etc. The interesting part about these circuits is that they can be designed logically, but they can also be built as an integrated unit where the same function is obtained by an entirely different concept. Both concepts will be shown and discussed for different circuits.

**The memory element (flip-flop).** The memory element or flip-flop serves a very important function in sequential circuits because of its ability to memorize previous sequences. The set-reset type of flip-flop can be realized with NOR elements as given in Fig. 18(A). The same outcome can be achieved with one single element, as demonstrated in Fig. 18(B).

The jet delivery by the supply in Fig. 18(B) will be in a stable condition if it leaves through  $O_1$  or  $O_2$  even if all input signals are deleted. The input signals are again  $R$  and  $S$  as in Fig. 18(A). The single element is not developed on the basis of logic, but it performs the same func-



**FIGURE 23. Fluidic-to-electric interface.**

tion. Its principle of operation is based on the previously discussed Coanda or wall-attachment effect. The jet is stable when attached to either wall, even after the inputs *R* or *S* are removed.

**Fluid binary counter.** Another very common logic circuit is the binary counter stage or divider-by-two. Such a divider-by-two can be designed logically and implemented by using fluidic NOR elements as their symbols indicate in Fig. 19. The circuit is taken from Maley and Earle.<sup>4</sup>

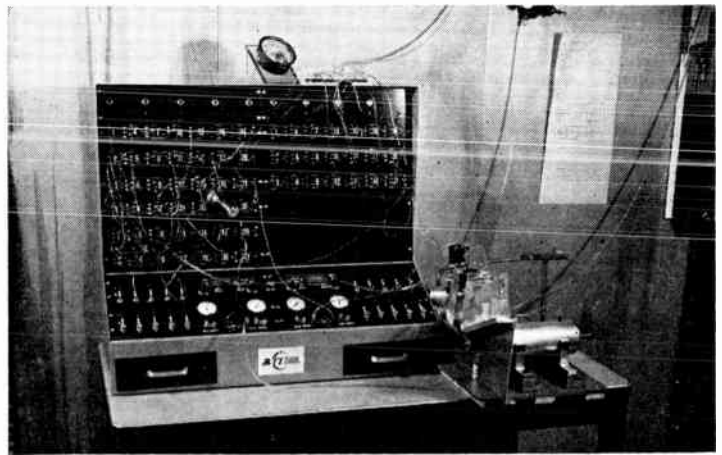
The counter stage uses six NOR elements that are connected by combining different terms. The circuit is based on logic equations. As with the example of the fluidic flip-flop circuit, it is also possible to realize a fluidic counter circuit that is not based on a logic development. The concept of a counter based on aerodynamic properties has been developed by Raymond E. Warren of Harry Diamond Laboratories, and is shown in Fig. 20.

Other examples could be given for shift registers, Schmidt triggers, and other circuits but, because their principles are well known and the basic concepts have already been given, these circuits will not be demonstrated.

### Output devices and actuators for logic circuits

The only elements that have not yet been discussed are the output and output-interface devices. Most of the output devices can be considered to be amplifiers with large gains. The comments made previously about amplifiers are, therefore, entirely valid here; however, some additional remarks concerning output devices are appropriate. A high-gain logic amplifier, which requires an input signal of the order of 10–15 cm of water and which has a response time of approximately 10 ms, is given in Fig. 21.

It is important that such an amplifier have a very-high input impedance and a low output impedance. The loading line of the output amplifier must be checked against the output impedance of the upstream logic element to assure reliable operation. A low output impedance of the amplifier is desirable in order to decrease the response time of the actuators (air cylinders, air motors, etc.).



**FIGURE 24. Fluidic control of a ball counting and packaging system. (Courtesy of Mechanical Technology, Inc.)**

This response is determined to a certain extent by the flow resistance of the output amplifier and the volume between amplifier and actuator.

The output amplifier in Fig. 21 is not a pure fluidic device in the sense that its operation is purely determined by fluid-flow phenomena since it contains a moving part. Output or power amplifiers based on the wall-attachment or jet-deflection principle also have been developed by various companies. However, for most industrial applications, their power consumption is prohibitive. All pure fluidic devices are flow-operated devices, a change from the ON state to the OFF state, therefore, does not change considerably the consumption of the device. An output amplifier with moving parts is a pressure-operated device. If the element is in the OFF state, the orifice is closed and the air consumption is practically zero. If many power or output amplifiers are used in a system, the air consumption can become an important factor. A well-designed moving-part output device is, therefore, a decided advantage.

An output-interface device that establishes the interface between a low-pressure fluidic signal issued by a fluidic device and a high-pressure hydraulic signal is illustrated in Fig. 22. Fluidic-to-electric interfaces also exist in some variety. Most of these devices have a mechanical interface; the fluidic signal is transferred into a mechanical movement that in turn operates an electric microswitch. The mechanical displacement is obtained through a diaphragm arrangement, shown schematically in Fig. 23.

### Applications of fluidic logic devices

In the past, many fluidic logic systems have been built without any thorough knowledge of the theory of switching circuits. The more complex the circuit becomes, the more a basic knowledge of logical design is required. As is true in much electronic logic design, more and more fluidic systems are being built using only one component—the NOR element.

Because the function that is realized with the fluidic element is identical to the function realized with the electronic element, the logical design of a fluidic circuit can

be done by any applications engineer who is familiar with switching theory, whether he has a mechanical or an electrical background. Fluidic logic components, compared with electronic components, have one major disadvantage—their relatively slow response time. Also, compared with microelectronics, the size of fluidic components is relatively large. The advantages of fluidic components over their electronic counterparts include a large insensitivity to environmental conditions such as high temperatures and high nuclear radiation, and a large safety factor in explosion-hazardous areas. The cost of fluidic components is decreasing with an increasing volume of components and, in areas where electronic components have to be enclosed because of a danger of explosion, the cost of a fluidic system can well be less than that of an electronic system.

In other applications where expensive explosion-proof equipment is not required, the choice between a fluidic or an electronic logic system should be determined by the number of interfaces that have to be incorporated. If, for example, sensors are used in the system that deliver a pneumatic output signal rather than an electric one and if the output devices are pneumatically operated cylinders or valves, a fluidic logic system is appropriate. On the other hand, if electric sensors are used and electric motors are the main output devices, it is preferable to use an electric or electronic logic system.

A breadboard model of a system where the fluidic systems approach was of advantage is displayed in Fig. 24. The requirement was to load boxes that were carried by a pneumatically driven conveyor system with a certain number of balls delivered through a feeding mechanism. The number of balls to be loaded was programmed on a card fastened to the box. The programming was done by cutting out certain parts at the top of the card. A pneumatic card reader discerned the information corresponding to the number of balls to be loaded and stopped the conveyor system. The card reader consisted of a number of sensors that operated similar to the sensor shown in Fig. 7. The jet was interrupted by the card itself. At the stop of the conveyor system, a pneumatic cylinder that closed the feeding system was retracted and the balls were fed into the box. A flapper-nozzle sensor (described in Fig. 3) sensed the passage of the balls and fed the information into a fluidic counter. When the number of the counted balls and the number that was programmed in through the card reader coincided, the feeding mechanism was stopped and the conveyor system started until the next box was in position. To breadboard the system, a fluidic logic simulator built by Mechanical Technology Inc. was used; the entire logic circuit was built with NOR elements.

Because the input and output elements were pneumatic devices, the use of a fluidic logic system to achieve the desired operation was of advantage. Of course, the speed required of the system was not in excess of what a fluidic system is capable of achieving. After the breadboarding stage, the logic system was integrated into a small package with only a few tubing interconnections.

### Conclusion

It is hoped that this article will generate a more realistic picture among electrical engineers of the potential of fluidic systems. It is also intended to create a larger interest in fluidics among these engineers. Many of the

terms and representations used here are very familiar to electronics engineers but are far from being generally accepted in the fluidic field.

The present introduction was limited to fluidic logic devices. There is an even greater number of fluidic analog components available. Within the last two years, fluidic operational amplifiers have been developed that give excellent performances compared with standard pneumatic devices, with gains of the order of 2000. Other available components consist of such devices as oscillators, frequency-to-analog converters, rectifiers, phase discriminators, etc. It goes without saying that discussion of these devices would provide enough material for a separate article.

There is a crying need for standardization of such parameters as operating pressures, representation of impedances, etc., and it is the author's belief that only with the active participation of electrical and electronics engineers can this problem be solved and fluidic technology be made an integral part of an industry-wide accepted control technology.

### REFERENCES

1. Boole, G., *The Mathematical Analysis of Logic*. Cambridge, England: Cambridge, 1847; reprinted by Basil Blackwell & Mott, Ltd., Oxford, England, 1948.
2. Caldwell, S. H., *Switching Circuits and Logical Design*. New York: Wiley, 1958.
3. McCluskey, E. J., *Introduction to the Theory of Switching Circuits*. New York: McGraw-Hill, 1965.
4. Maley, G. A., and Earle, J., *The Logic Design of Transistor Digital Computers*. Englewood Cliffs, N.J.: Prentice-Hall, 1963.
5. Coanda, H., "Procédé et dispositif pour faire dévier une veine fluide pénétrant autre fluides," French patent no. 788,140, 1934.

### BIBLIOGRAPHY

- Auger, R. N., in *Advances in Fluidics*, F. T. Brown, ed. ASME publication, 1967. Auger, R. N., "How to use turbulence amplifiers for control logic," *Control Eng.*, June 1964.
- Auger, R. N., in *Applying Fluidics to Control Systems*. Course manual on fluidics, sponsored by Union College and Mechanical Technology Inc., 1968 and 1969.
- "Fluidics: the PB flowboard," Instruction Manual, Pitney-Bowes, Inc., 1967.
- Kompass, E. J., "The state of the art in fluid amplifiers," *Control Eng.*, Jan. 1963.
- Wagner, R. E., and Meyer, E. L., "A fluidic element test device and logic simulator," Tech. Rept. WVT-747, Watervliet Arsenal, U. S. Army.

**Rolf E. Wagner**, a native of Germany, received the Dipl. Ing. degree from the University of Darmstadt, after which he attended the University of Grenoble in France under a fellowship, receiving the doctor of engineering degree from the Laboratory of Automatic Control in 1965. Upon invitation by the U.S. Government, he came to the United States to join the research laboratory of the U.S. Army Watervliet Arsenal, where he participated in, among other projects, a program of fluidic control of weapons. After heading the automatic control group at the Arsenal for two years, he became a senior control systems engineer for Mechanical Technology Inc., responsible for control systems and hardware development, including pneumatic, hydraulic, and fluidic components. Dr. Wagner has authored innumerable technical papers and presented many lectures on pneumatic and fluidic control. In 1968 and 1969, he organized a course on fluidic control, sponsored by Union College and MT Inc.



Wagner—Fluidics: a new control tool

# Logarithmic converters

*In many areas of signal processing, it very often is expedient to generate nonlinear functions. Bipolar-transistor networks can provide the key*

**Robert C. Dobkin** National Semiconductor Corporation

*Logarithmic converters have an important place in signal processing and the bipolar transistor can be an invaluable element for generating such functions. As with most any design, there are tradeoffs. With logarithmic converters composed of bipolar transistors, response time must be weighted against dynamic range. Several basic circuits for log and antilog generators, with differently weighted operating characteristics, are analyzed and applications are described.*

Log generators are useful in many areas of signal processing. For example, the dynamic range of most telemetry systems can be increased by compressing the input data with a log generator and expanding the output signal with an antilog generator. Then, too, the compressive action of a log converter allows signals with a 100-dB dynamic range to be displayed on a simple meter. Finally, log generators are conceptually versatile. They are shown as inverters in this article, but with minimal changes, can be converted to a noninverting mode.

One of the most suitable nonlinear elements commonly available for logarithmic generation is the bipolar transistor. The relationship between collector current and emitter-base voltage is precisely logarithmic from currents below one picoampere up to currents of the order of one milliamper. Using a matched pair of transistors plus integrated-circuit operational amplifiers, it is relatively easy to construct a linear-to-logarithmic converter with a dynamic range in excess of five decades.

The circuit in Fig. 1 generates a logarithmic output voltage for a linear-input current. Transistor  $Q_1$  is used as the nonlinear-feedback element around an LM108 operational amplifier. Negative feedback is applied to the emitter of  $Q_1$  through divider  $R_1$ - $R_2$  and the emitter-base junction of  $Q_2$ . This forces the collector current of  $Q_1$  to equal the current through the input resistor. Transistor  $Q_2$  is used as the feedback element of an LM101A operational amplifier. Negative feedback forces the collector current of  $Q_2$  to equal the current through  $R_3$ . For the values shown, this current is 10  $\mu$ A.

Since the collector current of  $Q_2$  remains constant, the emitter-base voltage also remains constant. Therefore, only  $V_{BE}$  of  $Q_1$  varies with a change of input current. However, the output voltage is a function of the difference in emitter-base voltages of  $Q_1$  and  $Q_2$ :

$$V_{out} = \frac{R_1 + R_2}{R_2} (V_{BE2} - V_{BE1}) \quad (1)$$

For matched transistors operating at different collector currents  $I_c$ , the emitter-base differential is

$$\Delta V_{BE} = \frac{kT}{q} \log_e \left[ \frac{I_{c1}}{I_{c2}} \right] \quad (2)$$

where  $k$  is Boltzmann's constant,  $T$  is temperature in degrees Kelvin, and  $q$  is the charge of an electron. Combining equations (1) and (2) and substituting equivalent expressions for the collector currents give

$$V_{out} = \frac{-kT}{q} \left[ \frac{R_1 + R_2}{R_2} \right] \left[ \log_e \frac{V_{in} R_3}{V_{ref} R_{in}} \right] \quad (3)$$

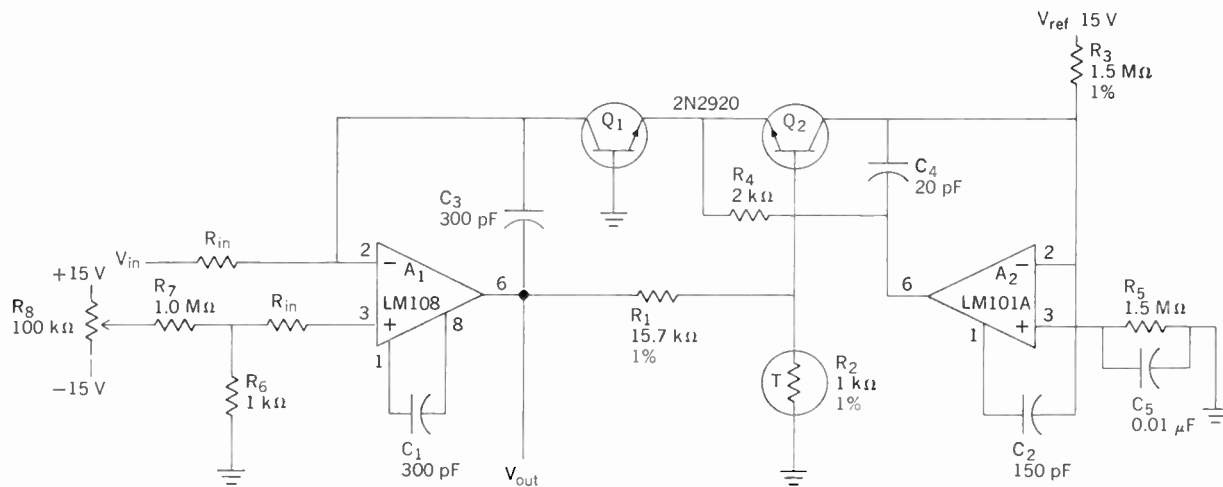
for  $V_{in} \geq 0$ . This expression shows that the output is proportional to the logarithm of the input voltage.

The coefficient of the log term in Eq. (3) is directly proportional to absolute temperature. Without compensation, the scale factor will also vary directly with temperature. However, by making  $R_3$  directly proportional to temperature, constant gain is obtained. The temperature compensation is typically one percent over a temperature range of  $-25^\circ\text{C}$  to  $100^\circ\text{C}$  for the resistor specified. For limited temperature-range applications, such as  $0^\circ\text{C}$  to  $50^\circ\text{C}$ , a 430-ohm sensistor in series with a 570-ohm resistor may be substituted for the 1-k $\Omega$  resistor, also with one percent accuracy. The divider  $R_2$ - $R_1$  sets the gain while the current through  $R_3$  sets the zero. With the values given, the scale factor is one volt per decade, and

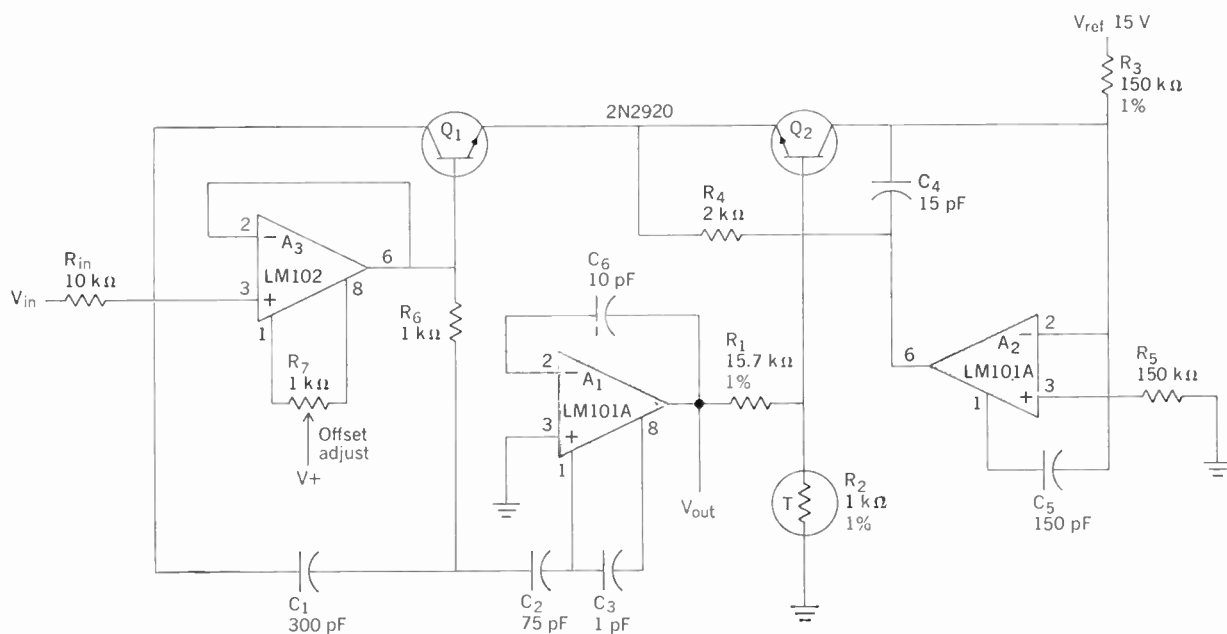
$$V_{out} = - \left[ \log_{10} \left| \frac{V_{in}}{R_{in}} \right| + 5 \right] \quad (4)$$

where the absolute-value sign indicates that the dimensions of the quantity inside are to be ignored.

For any current between 10 nA and 1 mA, the log output is accurate to one percent—about 3 percent referred to the input. At currents over 500  $\mu$ A, the transistors used deviate from log characteristics due to resistance in the emitter, whereas at low currents the offset current of the LM108 is the major source of error. These errors occur at the ends of the dynamic range and, from 40 nA to 400  $\mu$ A, the log converter is one percent accurate referred to the input.

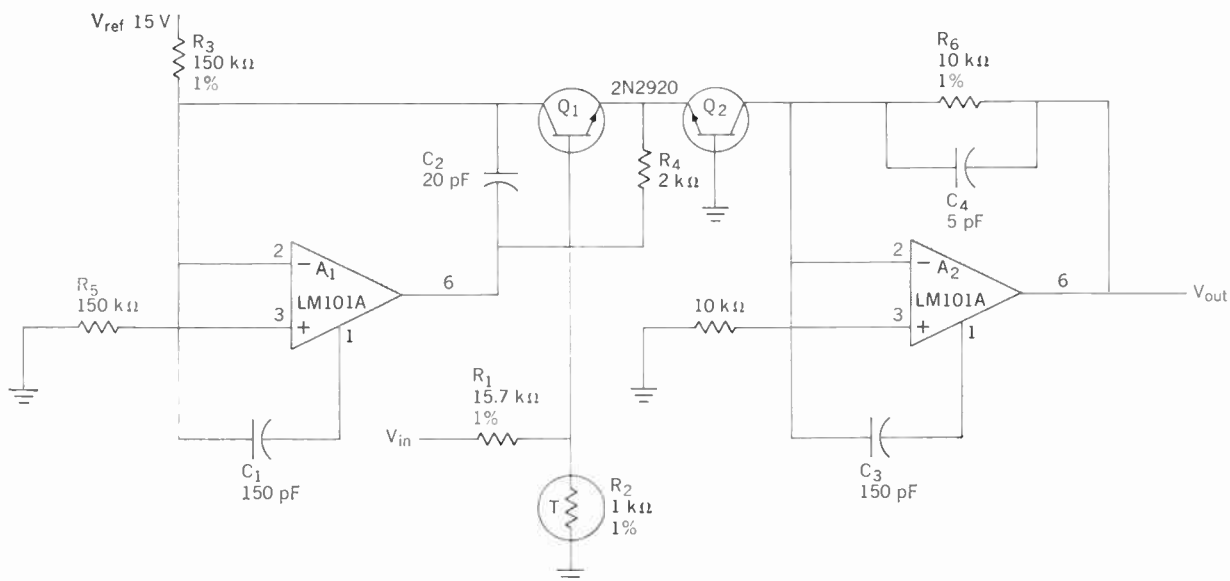


**FIGURE 1. Log generator with a 100-dB dynamic range. Device T, shown here and in Figs. 2 and 3, is a Tel Labs type 981 compensator.  $R_6$  is an offset-voltage-adjust resistor.**



**FIGURE 2. Fast log generator.**

**FIGURE 3. Antilog generator.**



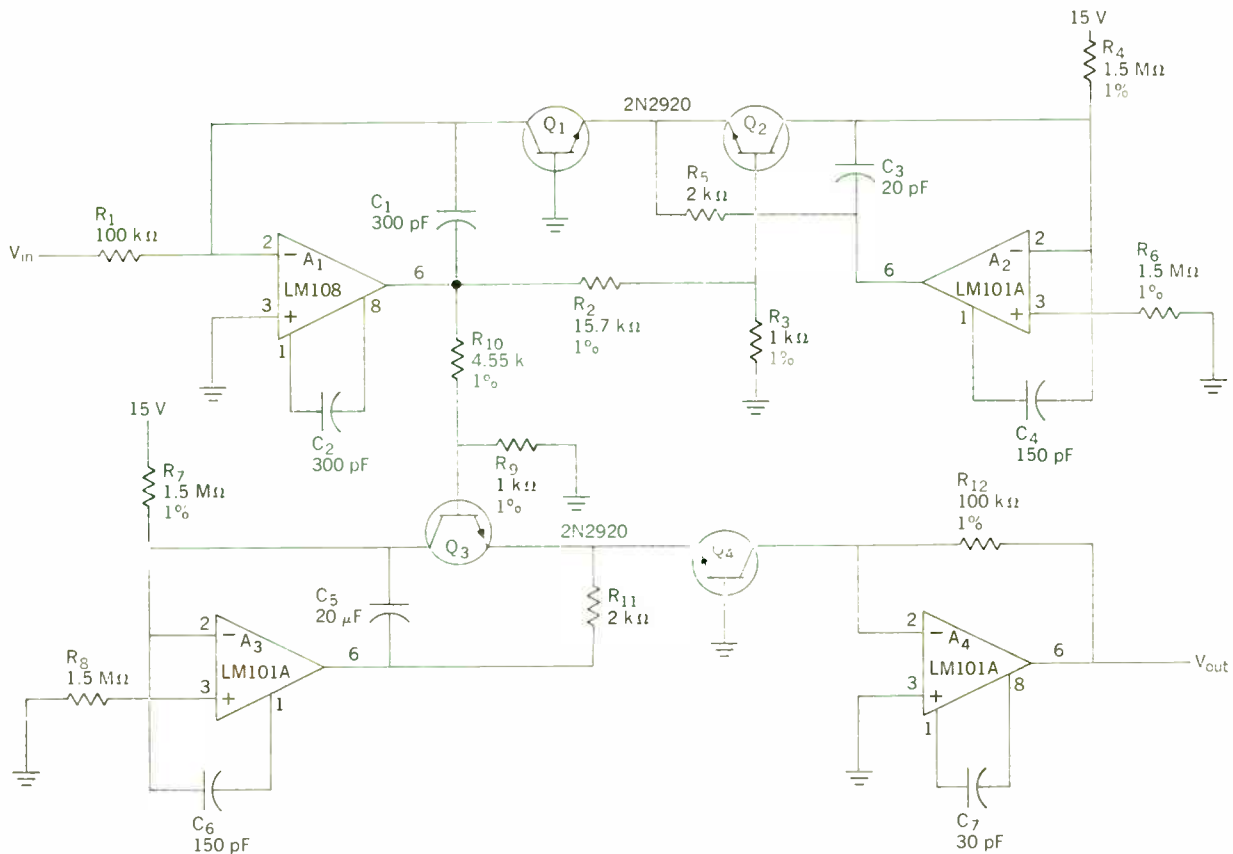


FIGURE 4. Cubic-function generator.

Both of the transistors in Fig. 1 are used with a grounded base connection, rather than a diode connection, to eliminate errors due to base current. Unfortunately, the grounded base connection increases the loop gain. More frequency compensation is necessary to prevent oscillation, and the log converter is, necessarily, slow. It may take 1 to 5 ms for the output to settle to one percent of its final value. This condition is especially true for low currents.

Insuring frequency stability of log generators is most easily done experimentally. Analysis is difficult because the loop gain, impedance levels, and bandwidth change with input level. One technique that encourages stability is to compensate the amplifiers for unity gain and provide a high-frequency feedback path through a lead capacitor from the output to the input. Also, an emitter degeneration resistor,  $R_1$ , is included to limit the loop gain at high input levels. The stability may be checked by observing the pulse response for overshoot and ringing at high and low levels.

#### Range down, rate up

The circuit shown in Fig. 2 is two orders of magnitude faster than the previous circuit and has a dynamic range of 80 dB. Operation is the same as the circuit in Fig. 1; however, the configuration optimizes speed rather than dynamic range. Transistor  $Q_1$  is diode-connected to allow the use of feed-forward (i.e., phase) compensation<sup>1</sup> on an LM101A operational amplifier. This compensation extends the bandwidth beyond 3.5 MHz and increases the output-voltage-response rate. To prevent

errors due to the finite dc gain of  $Q_1$  and the bias current of the LM101A, an LM102 voltage follower buffers the base current and input current. Although the log circuit will operate without the LM102, accuracy degrades at low input currents. Amplifier  $A_2$  is also compensated for maximum bandwidth. As with the previous log converter,  $R_1$  and  $R_2$  control the sensitivity, and  $R_3$  controls the zero crossing of the transfer function. With the values shown, the scale factor is one volt per decade and

$$V_{out} = - \left[ \log_{10} \left[ \frac{V_{in}}{R_{in}} + 4 \right] \right] \quad (5)$$

from less than 100 nA to 1 mA.

Antilog or exponential generation is simply a matter of rearranging circuitry. Figure 3 shows the circuitry of a log converter for generating an exponential output from a linear input. Amplifier  $A_1$ , in conjunction with transistor  $Q_1$ , drives the emitter of  $Q_2$  in proportion to the input voltage. The collector current of  $Q_2$  varies exponentially with the emitter-base voltage. This current is converted to a voltage by amplifier  $A_2$ . With the values given,

$$V_{out} = 10^{-V_{in}} \quad (6)$$

#### Logging functions

Many nonlinear functions such as  $X^{1/2}$ ,  $X^2$ ,  $X^3$ ,  $1/X$ ,  $XY$ , and  $X/Y$  are easily generated with the use of logs. Multiplication becomes addition, division becomes subtraction, and powers become gain coefficients of log terms.

Figure 4 shows a circuit whose output is the cube of

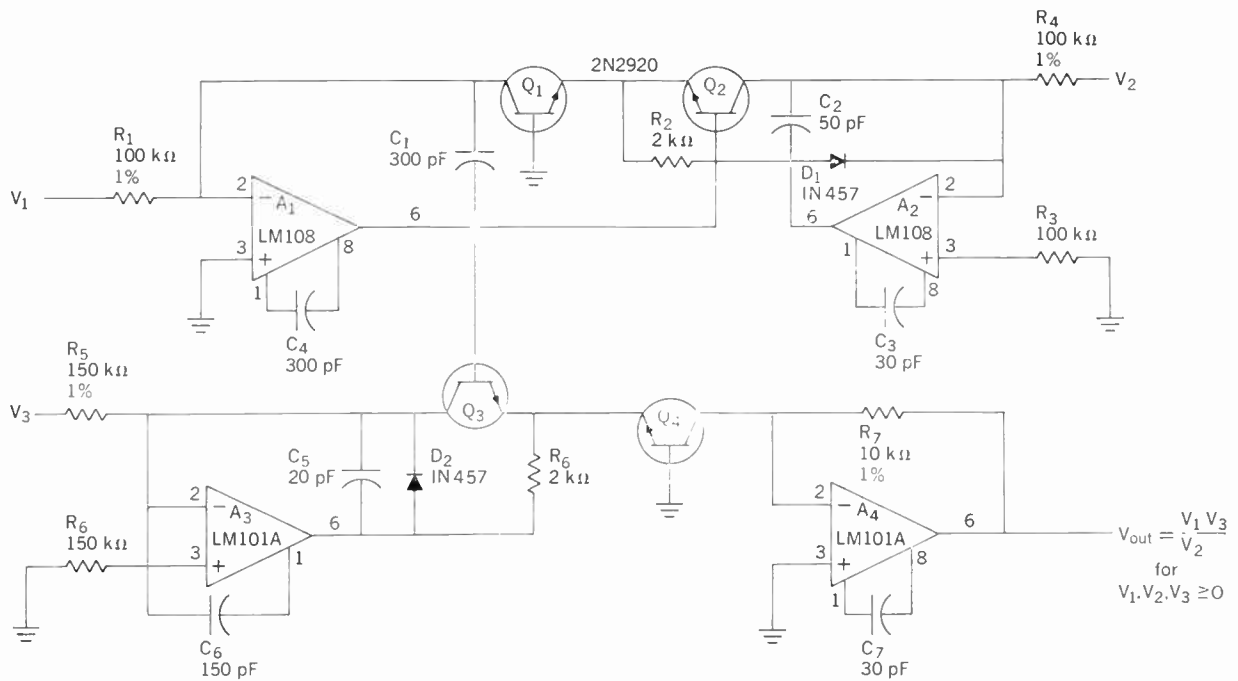


FIGURE 5. Divider-multiplier network can be used as a reciprocal-function generator.

the input. Actually, any power function is available from this circuit, by changing the values of  $R_9$  and  $R_{10}$ , in accordance with the expression:

$$V_{out} = V_{in}^{16.7R_9/(R_9 + R_{10})} \quad (7)$$

Note that when log and antilog circuits are used to perform an operation with a linear output, no temperature-compensating resistors are needed. If the log and antilog transistors are at the same temperature, changes in gain with temperature cancel. It is a good idea to use a heat sink that couples the two transistors to minimize thermal gradients. A 1°C temperature difference between the log and antilog transistors results in a 0.3 percent error. Also, in the log converters, a 1°C difference between the log transistors and the compensating resistor results in a 0.3 percent error.

Either of the circuits in Figs. 1 or 2 may be used as dividers or reciprocal generators. Equation (3) shows that the outputs of the log generators are the ratio of two currents: the input current and the current through  $R_3$ . Used as a log generator, the current through  $R_3$  was held constant by connecting  $R_3$  to a fixed voltage, making the output the log of the input. If  $R_3$  is driven by an input voltage, rather than a 15-volt reference, the output of the log generator is the log ratio of the input current to the current through  $R_3$ . The antilog of this output voltage is the quotient of the currents through  $R_3$  and  $R_{in}$ . Of course, if the numerator is held constant, the output is the reciprocal of the input voltage.

The complete one-quadrant multiplier/divider shown in Fig. 5 is basically a log generator (Fig. 1) driving an antilog generator (Fig. 3). The log generator output from  $A_1$  drives the base of  $Q_2$  with a voltage proportional to the log of  $V_1/V_2$ . Transistor  $Q_2$  adds a voltage proportional to log  $V_3$ , and drives the antilog transistor  $Q_4$ . The collector current of  $Q_4$  is converted to an output voltage by  $A_4$  and

$R_7$ —the scale factor being set by  $R_7$  at  $V_1V_3/10V_2$ . One application of this circuit is measurement of transistor dc current gain.

To achieve a wide dynamic range with high accuracy, the input operational amplifier necessarily must have low offset voltage, bias current, and offset current. The LM108 has a maximum bias current of 3 nA and offset current of 400 pA over a -55°C to 125°C temperature range. By using equal source resistors, only the offset current of the LM108 causes an error. The offset current of the LM108 is as low as in many FET amplifiers. Further, it has a low, constant temperature coefficient that does not double every 10°C as in FET amplifiers. This results in a greater accuracy over a broad temperature range than is achievable with FET amplifiers. The offset voltage may be zeroed, if necessary, to improve accuracy with low input voltages.

#### REFERENCE

1. Dobkin, R. C., "Feedforward compensation speeds op amp," Linear Brief 2, Semiconductor Corp., Apr. 1969.

**Robert C. Dobkin**, for the past year, has worked on the development of linear integrated circuits in the advanced circuit development section of National Semiconductor Corp., Santa Clara, Calif. Previously he had worked for the Re-Entry Systems Department of the General Electric Co., Philadelphia, designing instrumentation and automatic and semiautomatic equipment. Leaving GE in 1968, he joined Philbrick/Nexus Research, and developed operational amplifiers and nonlinear function modules. Mr. Dobkin attended the Massachusetts Institute of Technology.





# The future of cable TV

*Some 20 years ago, several innovative and enterprising men “wired up” some small towns — remote from VHF signals — for direct-line television reception. Cable TV has since flourished, but its potential hardly has been tapped*

**Archer S. Taylor** *Malarkey, Taylor and Associates*

*The problem of polluting our skies extends beyond man's senses; our ether is becoming ensnared with electromagnetic emanations. The situation has become critical and, if our technology is not to mire in a morass of radio signals, something will have to be done to quiet the confusion. Some systems by nature of their operation must pick their inputs from the airwaves. But there are a host of others that can do just as well — if not better — linked directly to a transmitter. Thus, many receivers now operating, and envisaged for future operation, will be phased to cable operation.*

In 1947, there were only seventeen television stations in the United States including the six that were in operation at the end of World War II, as shown in Fig. 1. In 1948, with fewer than 50 stations, imaginative experimenters in central Pennsylvania and northwestern Oregon, simultaneously and independently, sought to overcome the obstacles of terrain and distance that blocked reception of TV signals from Philadelphia and Seattle. They were able to extract a few microvolts of television carrier, using a variety of antenna structures: from stacked arrays of 32 Yagis to multiple arrays of corner reflectors; from massive, 600-centimeter waveguide horns to 75-meter parabolics and 10-lambda rhombics. The receiving sites were strategically located, either on a mountaintop or in a “hot spot” caused by complex diffraction patterns developed over rough terrain. These isolated receiving antennas were connected to homes in blacked-out valleys with many miles of transmission lines and frequent repeater amplifiers.

The systems worked! Appliance dealers sold TV sets. Power companies relished the increased electrical consumption. The public was excited by a new technology that could transmit pictures into their living rooms.

Thus was born the cable television industry. It quickly became apparent that many would pay a reasonable monthly fee for a television receiving service not otherwise

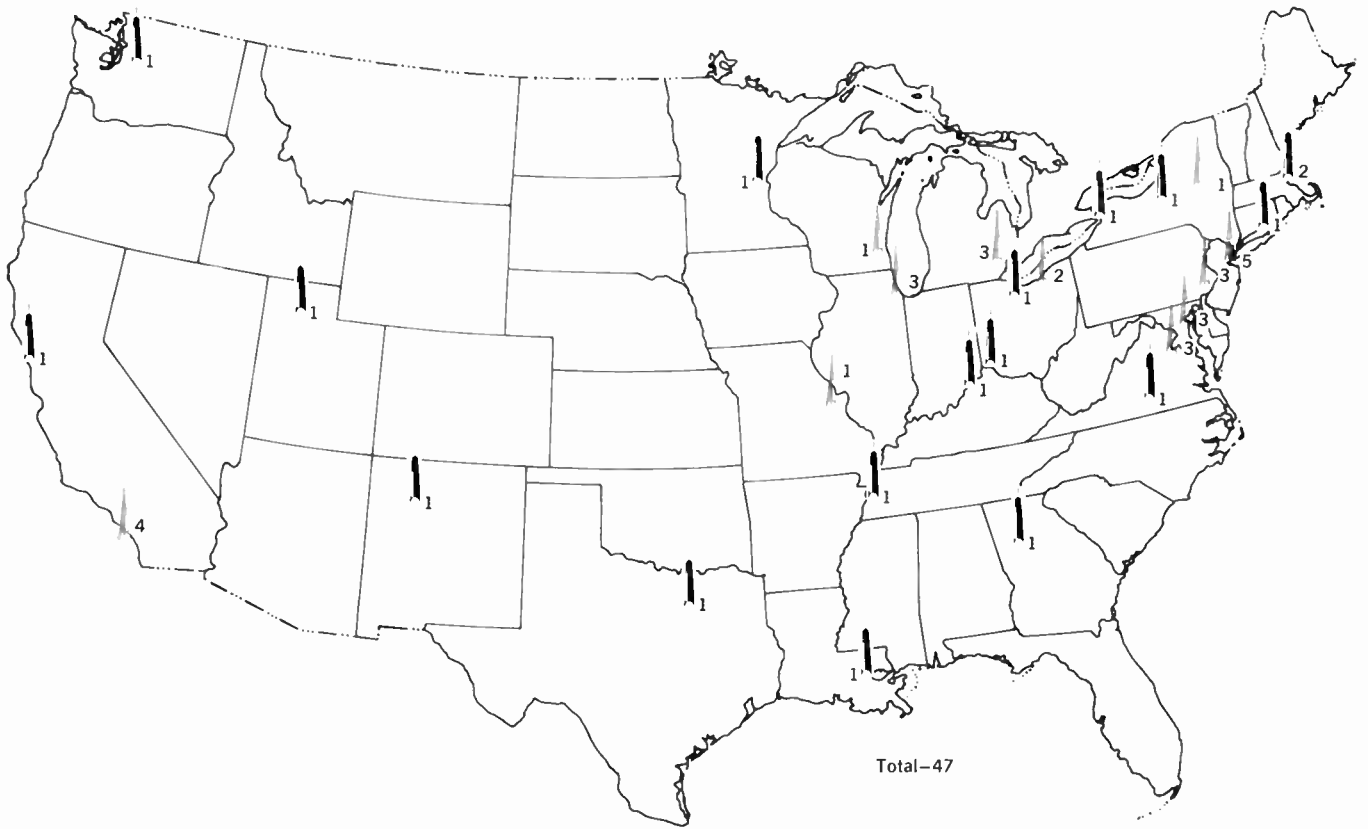
available: In 1950 there were only five known cable TV systems (Fig. 2); by 1953, there were almost 300—concentrated in the Appalachian Mountains and the Pacific Northwest. Virtually all of these systems were located in areas otherwise devoid of TV reception—a situation that was soon to change.

By 1958, there were more than 700 cable TV systems—still concentrated in mountain country, but now also extending into the wide, sparsely settled plains areas of Texas. And at that time, a few cable systems had commenced operations—if somewhat timorously—in towns where a single TV station already existed. Perhaps not surprisingly, most of the people in these latter communities were willing to pay a fee for receiving a service that added program diversity.

By 1963, there were well over 1000 cable TV systems encompassing most of the one-station, and quite a few two-station, markets. By 1968, the count exceeded 2000 and included virtually all towns and cities served by less than three full-time network affiliates.<sup>1-3</sup>

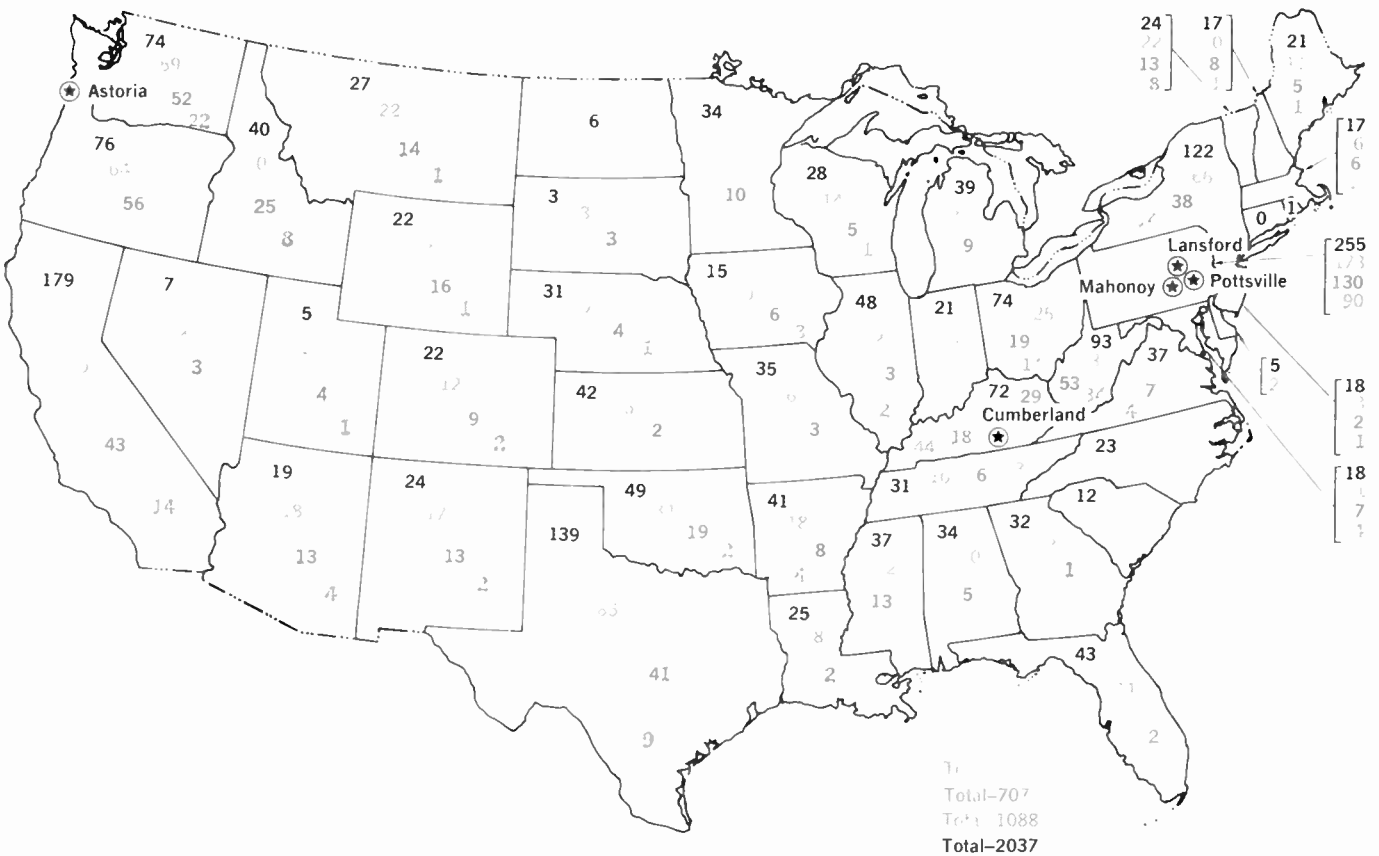
Cable TV is now developing in major markets not ordinarily considered to be in the underserved category. However in such places as Manhattan (New York), Los Angeles, Seattle, and San Francisco—wherever there are reception problems from terrain or man-made obstructions—cable TV reception is also proving to be economically viable.

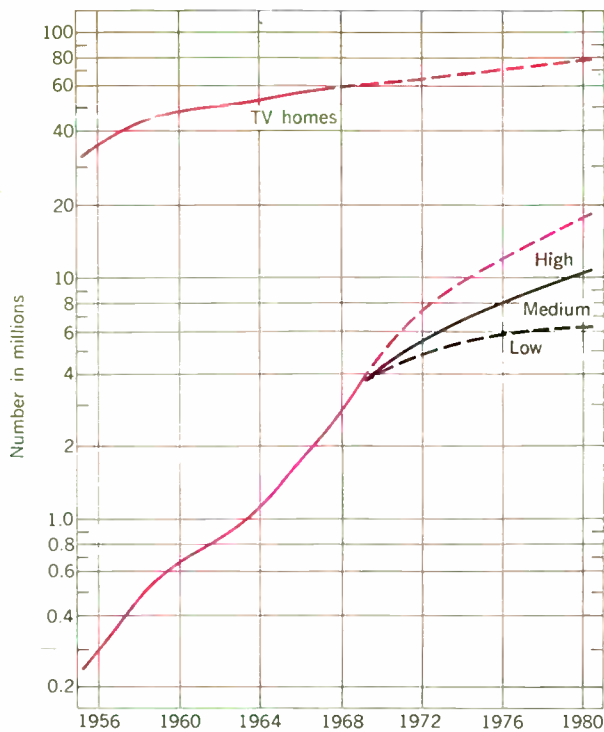
Some communities, particularly in the mountainous West, were so far from television stations that microwave relays were required. Sometime about 1956, Mountain States Telephone and Telegraph Company—in a bellwether case—was authorized by the FCC to relay TV signals from a customer's receiving antenna outside Denver to a cable system in Casper, Wyo. Because the MST&T tariff appeared prohibitive to most other cable TV operators, a number of more or less independent common carriers were formed to provide a low-cost microwave relay service for cable TV. The FCC also



**FIGURE 1.** The greater part of the United States was devoid of TV in 1947 (color only). Conditions were not too different one year later (total effect) when cable TV began.

**FIGURE 2.** A new breed of television sprouted in 1948 and by 1950 five cable systems (starred) were operational. These multiplied as indicated. (Light color signifies 1953, dark color represents 1958, grey stands for 1963, and the black numbers show the number of cable TV stations in 1968.)





**FIGURE 3. Riding high.** The list of cable subscribers has been and will continue to grow at a high rate. The number of TV homes will keep pace with population explosion.

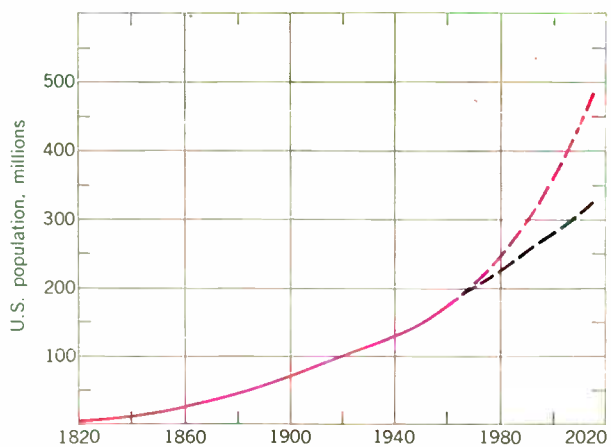
authorized microwave facilities in the Business Service and later established the non-Common Carrier Community Antenna Relay Service known as CARS.

Approximately 6 percent of all TV homes are now connected to a cable system. A substantial number of the nonconnected homes are in the major television markets. However, development of cable distribution facilities in most of these major markets has been severely restrained while the FCC, the U.S. Congress, and the courts seek to develop a public policy regarding the future of cable TV.

In spite of this *de facto* freeze,<sup>4</sup> it seems likely that there will be at least 6 million cable subscribers within the next decade. If action in Congress or the courts or the FCC in the next year or so permits resumption of construction in or near major cities, it seems probable that, in ten years, there could be 17 million or more subscribers (Fig. 3). Twenty-two percent of all TV homes would be connected to cable, generating a billion-dollar annual revenue. Many consider this estimate too conservative.\* However, in view of the delays and interruptions already evident and the need for significant new developments in technology, it is doubtful that cable could realistically be expected to expand any faster.

Except for a few controversial situations, most authorities agree that, up to the present, the net impact of cable TV on broadcasting has, in general, been to provide a somewhat enhanced coverage area. Vigorous controversy rages, however, over potential impact—not simply on broadcasting, but on all aspects of communications.

\* A discussion of this point appears in "Forum" in this issue beginning on page 14.



**FIGURE 4. The future U.S. population will lie somewhere between the two projected lines.** Simply supplying the necessary new radio and TV facilities for this growth will tax spectrum capacity. New technologies can be expected to overburden available spectrum. (Source: Census Bureau)

### Aid to spectrum management

Population growth is an important and inexorable circumstance in the development of public policy. Despite "the pill," demographic experts predict a population of 250–285 million in 20 years and 310–430 million in 40 years (see Fig. 4).<sup>5, 6</sup>

As of June 30, 1968, the FCC had authorized more than 1¼ million radio stations—only 7784 of which are broadcasting stations.<sup>7</sup> The great majority operate below 1 GHz. More than a million stations are in the Citizen's Band and amateur radio services, suggesting the tremendous public interest in greater access to the electromagnetic spectrum (Table I).

Population growth, no doubt, would tend to provide the economic support now lacking for some new TV stations. It also cannot help but escalate the demand for greatly expanded access to the radio spectrum for a variety of new and larger mobile communication facilities.

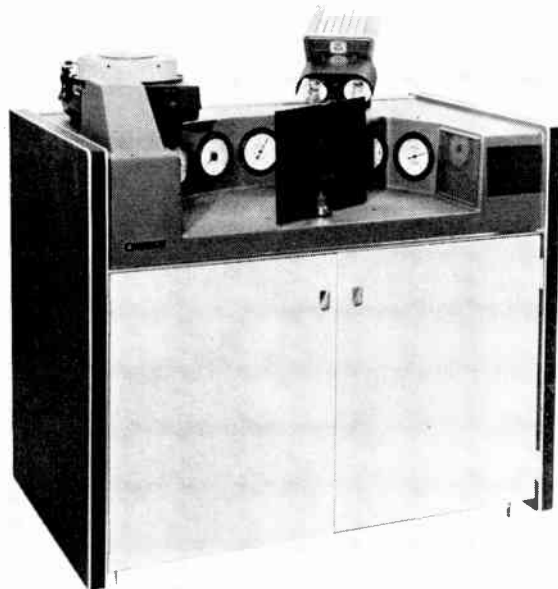
Aeronautical-safety improvements will create a spiraling demand for spectrum. Law enforcement and crime detection can be expected to create an explosive demand for radio facilities, a demand far exceeding population growth. Use of private automobiles cannot continue to expand more rapidly than population without new radio facilities for traffic control, emergency repair, and ambulance service. Mobile-telephone services on air-

#### I. Authorized station count as of June 30, 1968<sup>7</sup>

Aviation	140 799
Marine	164 000
Public safety	63 160
Industrial	185 046
Land transportation	20 016
Common carrier	13 124
Cable TV relay (CARS)	60
Citizen's Band	867 552
Amateur and disaster	282 525
Television and broadcasting	1 023
Radio (AM and FM)	6 761
Broadcast related	15 341
Research and development	966
<b>Total stations authorized</b>	<b>1 760 373</b>

planes, trains, busses, and automobiles should become universally available, requiring a very large spectrum—perhaps in conjunction with synchronous satellites.

Increased efficiency of spectrum utilization and expanded use of the electromagnetic spectrum above 1 GHz are two obvious ways to try to meet the demand. In recent years, equipment designers have split mobile channels repeatedly. They have devised ingenious channel-sharing and time-sharing schemes. They have also developed new equipment for shorter wavelengths



**FIGURE 5.** Equipment like this provides continuous programming of public service information (such as time, weather, and special news items).

**FIGURE 6.** A typical service of cable TV picks up information directly from teletypewriter or stock market quotation service.



to accommodate new services. But demands on the spectrum below 1 GHz continue to grow faster than utilization can be made more efficient.

Roughly half of the spectrum below 1 GHz is reserved exclusively for broadcasting. There have been only a few significant advances in efficient use of this spectrum. The ingenious NTSC color TV system, introduced in 1950, added a substantial dimension of information without increased bandwidth; SCA and stereo information were added to FM radio without increased spectrum demand.

Utilization of the AM-radio band has increased almost to the point of self-destruction. The All-Channel TV Receiver Law has added the prospect of increased TV assignments in the allocated UHF band, although assignments thus far have been scattered and unproved financially. Indeed, efficiency-of-use improvements within the large slice of spectrum allocated to broadcasting have been insignificant in comparison with the need.

It is, therefore, becoming increasingly clear to many students of spectrum management that nonradiating coaxial cable could be used to a substantial degree for distributing aural and visual information, education, and entertainment to the public. It would appear almost axiomatic that mobile services must use radiated-signal carriers, and that fixed services should, therefore, use nonradiating wires, cable, or guides, wherever possible, but especially where closed-circuit capability has been shown to be technologically and economically feasible.

### Wired city

One concept of the future has been labeled the "wired city."<sup>8</sup> Advertising-supported programs would be produced by national networks and regional studios just as now, except that coaxial cable would replace electromagnetic radiation for distribution to home receivers. In addition, a wide variety of less-popular programming

### II. Present uses for multiple-address coaxial cable

- Community antenna television
- Continuous, automated time and weather
- Continuous, automated news and market quotations
- Public service events—live or tape
- Local film origination
- FM radio and tape-recorded music
- TV programming schedules
- Emergency alert
- Security- and fire-sensing alarms
- Classroom instructions
- Interschool exchange
- In-class teacher training
- Educational and instructional networks

### III. Future uses for multiple-address coaxial cable in next five to ten years

- Facsimile newspaper and shopper information
- Merchandise display for telephone shopping
- Library-information retrieval
- Opinion surveys
- ESSA satellite weather pictures
- Distribution of TV relayed by satellite
- Utility-meter reading
- Wholesale merchandise display to merchants
- Slow-scan video
- Centralized bookkeeping
- On-line computer network
- Commercial data-storage and retrieval network
- Instruction and training for professionals

might be distributed over cables by common carriers. The wired-city TV proposal is predicated on the availability of at least 20 standard TV channels into all but the most isolated rural homes. Satellites could be utilized for interconnection of program centers for national or regional networks.

In addition to releasing electromagnetic spectrum for essential mobile-communications services, the use of wire has certain technical advantages. The availability of abundant cable spectrum could permit higher technical quality at lower cost: (1) Wide dynamic-range AGC would not be necessary. (2) The complete lower sideband could be retained to avoid quadrature distortion and other vestigial sideband problems. (3) The aural sub-carrier could be respaced to permit slow roll-off for improved phase reproduction. There could even be high-fidelity channels with 5- to 8-MHz resolution. Forms of modulation other than AM might be desirable.

Cable television systems are uniquely able to provide a compatible transition from present TV standards to something better. Both the standard and the improved signals could be carried on the cable—simultaneously. The viewer would make the decision about when or whether to replace his standard receiver with a new model adapted to the special high-quality cable signals.

Programming formats would almost certainly change as a result of an abundance of interference-free spectrum. Time would become less critical. Program repetition might be feasible.

Cable TV operators have demonstrated the public interest in automated programming (Table II). Many systems carry signals from a simple, industrial vidicon camera constantly scanning, in sequence, a clock, barometer, thermometer, wind velocity and direction gauges, rainfall, humidity, and even a blank panel suitable for weather forecasts, community announcements, or advertisement (Fig. 5). The blank panel is sometimes replaced with a rear-projection screen for automated showing of slides or movies.

A growing number of systems use a video character generator connected to the teletypewriter newswire, or the New York Stock Exchange quotation wire (Fig. 6).

It would not be difficult to adapt a weather radar plan-position indicator for continuous and automatic video presentation. With a little effort, the ESSA satellite weather photos could be continuously displayed.

Automated crawls, or card drums, or flip charts could be used to display community bulletin board notices, TV program guides, and the like.

### Looking ahead

The opportunities for visual programming opened by the availability of time and spectrum are great. But even greater is the potential of a wide-band, nonradiating cable for other communications services between a central office and multiple addresses (Table III).

Switching facilities such as the elaborate matrices required for telephone services are not needed for cable TV. For this reason, cable TV is an entirely different kind of operation, well adapted to any communication service, one-way or two-way, not requiring switching.

A very large number of voice-frequency circuits could be provided in the coaxial-cable spectrum in addition to the video circuits. Tone coding, commonly used to provide limited privacy for multiple uses of various mobile radio

services, could be adapted to cable channels for voice and slow-scan video for a simplified data retrieval service. For example, a subscriber might order the microfilm version of a particular book from the library. The librarian would put the film on an automated reader digitized to a voice channel, and send the tone code that opens the receiver at the particular subscriber's home.

Private services, however, such as computerized banking, credit inquiries, and electronic-mail delivery, may be too sensitive for exposure to "party-line" communications, unless adequately secure coding can be designed.

The inescapable conclusion is that coaxial cable is a better medium than electromagnetic radiation for delivering aural and visual information to private homes. It is capable of technically better performance because it is not necessarily forced into a limited bandwidth. It is capable of greater reliability because of its freedom from the vagaries of propagation. Because the entire spectrum on cable is available, new dimensions for programming beyond the mass audience are made feasible. Repetitive and automated programs become possible when time and spectrum are no longer scarce commodities. The development of widespread multiple-address, nonswitched wide-band communications to private homes will also make possible many new services only dreamed of today.

### REFERENCES

1. *Television Digest*, vol. 9, no. 17, pp. 1-2, Apr. 28, 1969.
2. "An industry report on community antenna television (CATV)," Drexel Harriman Ripley, Inc., New York, N.Y., Oct. 15, 1968.
3. "President's Task Force on Communications Policy, final report," U.S. Government Printing Office, Washington, D.C., Dec. 7, 1968.
4. "Notice of proposed rule making and notice of inquiry," Federal Communications Commission Docket No. 18397, Washington, D.C., Dec. 13, 1968.
5. "Revised projections of the population of states, 1970 to 1985," U.S. Department of Commerce, Bureau of the Census, Washington, D.C., series P-25, no. 375, Oct. 3, 1967.
6. "Projections of the population of the U.S. by age, sex and color to 1990, with extensions of populations by age and sex to 2015," U.S. Department of Commerce, Bureau of the Census, Washington, D.C., series P-25, no. 381, Dec. 18, 1967.
7. "The FCC in fiscal 1968 (summary of the annual report of the FCC)," Federal Communications Commission, Washington, D.C.
8. Barnett, H. J., and Greenburg, E., "A proposal for wired city television," *Washington Univ. Law Quart.*, vol. 1968, p. 1ff, Winter 1968.

**Archer S. Taylor (SM)** has been a professional consulting engineer for the broadcast and cable TV industries for more than 25 years and is currently vice president of engineering for Malarkey, Taylor and Associates, Inc., Washington, D.C. He was a partner in the first cable TV system in Montana, which, in 1953, was one of the earliest in the West. A director of the National Cable Television Association from 1961 to 1967, he was national vice chairman in 1964 and served as chairman of the Educational and TV Policy Committee and of the Committee on Technical Standards; he is now chairman of the Engineering Subcommittee of the Standards Committee. Mr. Taylor also serves the IEEE Task Force Committee on Cable TV, and Ad Com of the Broadcasting Group. Previously, during a five-year association with the National Bureau of Standards, he was a participant in a 1941 Arctic expedition researching ionospheric radio propagation. Mr. Taylor's B.S. degree in physics is from Antioch College.



# Applications of Walsh functions in communications

*It is—with our advanced technology—no longer necessary to design communications equipment around a concept of trigonometric-based functions. A possible sophistication now is neatly netted with Walsh functions*

Henning F. Harmuth University of Maryland

Communication theory was founded on the system of sine-cosine functions. A more general theory has become known more recently; it replaces the sine-cosine functions by other systems of orthogonal functions, and the concept of frequency by that of sequency. Of these systems, the Walsh functions are of great practical interest since they lead to equipment that is easily implemented by semiconductor technology. Filters, multiplexing equipment, and a voice analyzer/synthesizer have been built successfully for Walsh functions. Some interesting applications of electromagnetic Walsh waves have been found theoretically.

Traditionally, the theory of communication has been based on the complete, orthogonal\* system of sine and cosine functions. The concept of frequency is a consequence of these functions, since frequency is defined as the parameter  $f$  in  $\sin 2\pi ft$  and  $\cos 2\pi ft$ . The question arises whether there are other systems of functions on which theories of similar scope can be based, and that lead to equipment of practical interest. Since sine and cosine form a system of orthogonal functions, it is reasonable to investigate other systems of orthogonal functions.

Figure 1 shows three orthogonal systems: sine-cosine functions, Walsh functions, and block pulses, for which the normalized time  $\theta = t/T$  is the variable. The block pulses are representative of several pulse shapes used for time multiplexing. The notations  $\text{sal}(i, \theta)$  and  $\text{cal}(i, \theta)$  are used here for the Walsh functions. (The letters  $s$  and  $c$  allude to the sine and cosine functions which are closely related to Walsh functions; the letters  $al$  are derived from the name Walsh.)<sup>1-5</sup>

Block pulses form an incomplete system; sine-cosine and Walsh functions form a complete system. Explicitly, the difference is that additional sine-cosine or Walsh

\* The two functions  $f(j, x)$  and  $f(k, x)$  in Fig. 1 are orthogonal in the interval  $-\frac{1}{2} \leq x \leq \frac{1}{2}$  if the integral

$$\int_{-1/2}^{1/2} f(j, x) f(k, x) dx$$

is zero for  $j \neq k$ . They are orthogonal and normal or orthonormal if the integral equals 1 for  $j = k$ . A system of functions  $\{f(j, x)\}$ , orthogonal in a certain interval, is called complete if any function  $F(x)$  quadratically integrable in that interval can be represented by a superposition of the functions  $f(j, x)$  with a vanishing mean-square error.

functions may be drawn in Fig. 1 for  $i = 5, 6, \dots$  in the interval  $-\frac{1}{2} \leq \theta < \frac{1}{2}$ , but no other block pulses are orthogonal to the eight shown. Practically, the difference between complete and incomplete systems of functions is shown by the existence of elaborate theories based on sine-cosine functions for antennas, waveguides, and filters; no such theories exist for block pulses although used in communications much longer.

The Walsh functions in Fig. 1 assume the values  $+1$  and  $-1$  only—a useful feature if circuits are to be constructed with binary digital components. The functions  $\text{cal}(i, \theta)$  and  $\sqrt{2} \cos 2i\pi\theta$  are symmetric (even). The functions  $\text{sal}(i, \theta)$  and  $\sqrt{2} \sin 2i\pi\theta$  are asymmetric.

In Fig. 1, the parameter  $i$  in  $\sqrt{2} \sin 2i\pi\theta$  and  $\sqrt{2} \cos 2i\pi\theta$  gives the number of oscillations in the interval  $-\frac{1}{2} \leq \theta < \frac{1}{2}$  (that is, the normalized frequency  $i = fT$ ). One may interpret  $i$  as "one half the number of zero crossings per unit time" rather than as "oscillations per unit time." (The zero crossing at the left side,  $\theta = -\frac{1}{2}$ , but not the one at the right side,  $\theta = +\frac{1}{2}$ , of the time interval is counted for sine functions.)

The parameter  $i$  also equals one half the number of zero crossings in the interval  $-\frac{1}{2} \leq \theta < \frac{1}{2}$  for Walsh functions. In contrast to sine-cosine functions the sign changes are not equidistant.† If, unlike Fig. 1,  $i$  is not an integer, then it equals "one half the average number of zero crossings per unit time." The term "normalized sequency" has been introduced for  $i$ , and  $\varphi = i/T$  is called the nonnormalized sequency:

Sequency in zps =  $\frac{1}{2}$  (average number of zero crossings per second)

The general form of a sine function  $V \sin(2\pi ft + \alpha)$  contains the parameters amplitude  $V$ , frequency  $f$ , and phase angle  $\alpha$ . The general form of a Walsh function  $V \text{sal}(\varphi T, t/T + t_0/T)$  contains the parameters amplitude  $V$ , sequency  $\varphi$ , the delay  $t_0$ , and time base  $T$ . The normalized delay,  $t_0/T$ , corresponds to the phase angle. The time base  $T$  is an additional parameter and it causes a major part of the differences in the applications of sine-cosine and Walsh functions.

† The first five Walsh functions look like heavily amplitude-clipped sine or cosine functions and have equidistant sign changes. This does not in general hold for functions with  $i$  larger than 2.

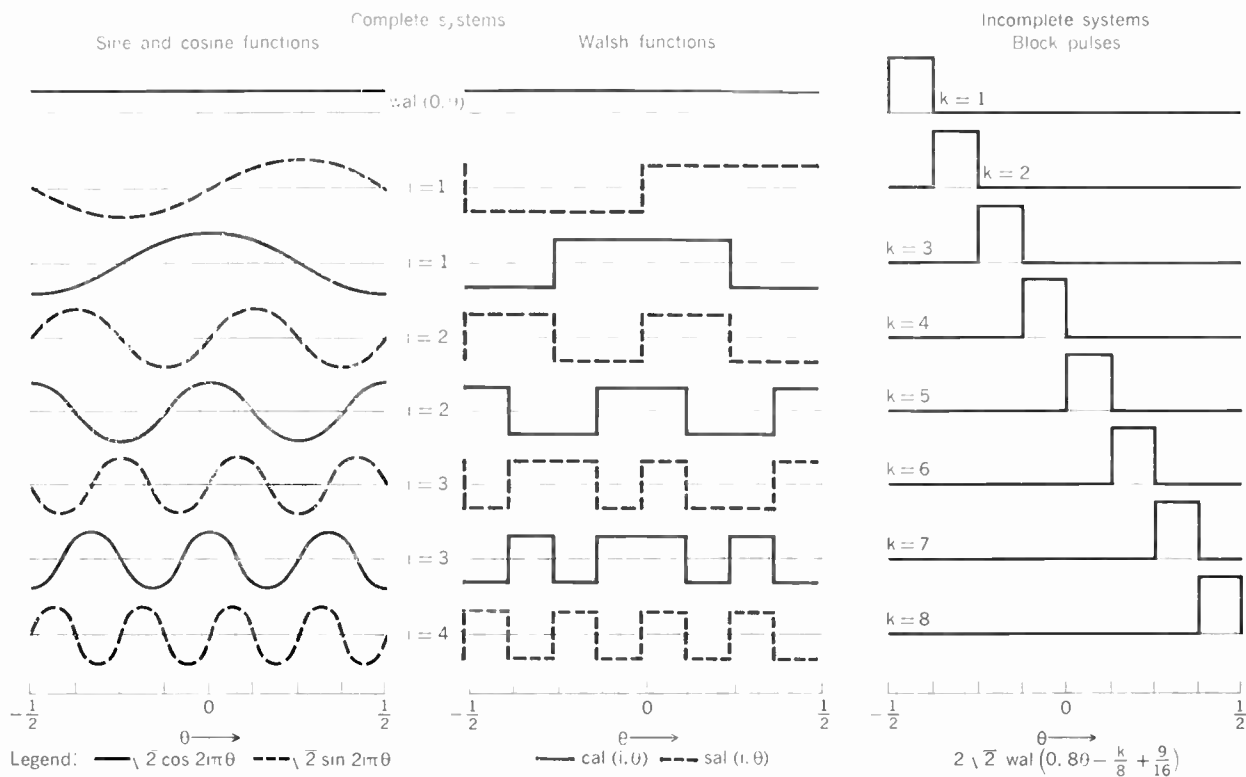


FIGURE 1. Orthonormal systems of functions.

### Another alternative

So far, Walsh functions are the only known functions with desirable features comparable to sine-cosine functions for use in communications.\* Development of semiconductor technology has imparted practical interest in them at this time. As an example of how this development has changed the approach to filter synthesis, consider the role of the capacitor and coil, which until recently were the most desirable components of filters. Such frequency-selective filters are linear, time-invariant, and thus a theory based on sine-cosine functions has indisputable advantages. But filters based on Walsh functions are linear and periodic time-variable. Generally speaking, the transition from sine-cosine functions to other complete systems of orthogonal functions means a transition from linear, time-invariant components and equipment to linear, time-variable components and equipment, which, of course, constitute a much larger class.

Figure 2 lists features of sine-cosine functions, Walsh functions, and block pulses. The mathematical theory of Walsh-Fourier analysis corresponds to the Fourier analysis used for sine-cosine functions. There is no theory of similar scope for block pulses, because they are incomplete.

\* Walsh functions are closely related to Hadamard matrices. These matrices are orthogonal, consisting of square arrays of plus and minus ones, and are of the order  $2^n$ . Other complete systems can be derived from Hadamard matrices of different rank.

Sine and cosine transforms of a function  $F(\theta)$  are†

$$a_s'(\mu) = \int_{-\infty}^{\infty} F(\theta) \sqrt{2} \sin 2\pi\mu\theta \, d\theta \quad (1)$$

$$a_c'(\mu) = \int_{-\infty}^{\infty} F(\theta) \sqrt{2} \cos 2\pi\mu\theta \, d\theta$$

The corresponding sal and cal transforms of Walsh-Fourier analysis are defined by

$$a_s(\mu) = \int_{-\infty}^{\infty} F(\theta) \text{sal}(\mu, \theta) \, d\theta \quad (2)$$

$$a_c(\mu) = \int_{-\infty}^{\infty} F(\theta) \text{cal}(\mu, \theta) \, d\theta$$

$$F(\theta) = \int_{-\infty}^{\infty} [a_s(\mu) \text{sal}(\mu, \theta) + a_c(\mu) \text{cal}(\mu, \theta)] \, d\mu \quad (3)$$

where  $\mu = \nu T$  and  $\theta = t/T$ .

### Walsh-function filters

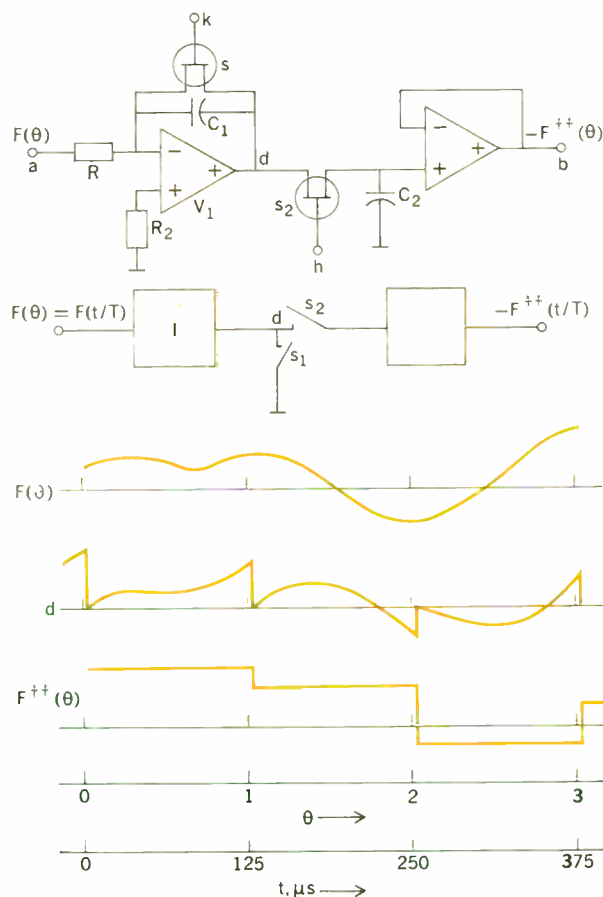
Figure 3 shows the block diagram, the time diagram, and a practical circuit of a frequency low-pass filter based

† The functions of Fig. 1 are defined in a finite interval but may be continued periodically to infinity. The parameter  $i$  is an integer and assumes denumerably many values. These functions are used for Fourier and Walsh-Fourier series expansions. The functions used for the Fourier and Walsh-Fourier transforms in Eqs. (1) and (2) are defined in the infinite interval. The parameter  $\mu$  may be any real number and assumes nondenumerably many values.

	Sine Functions	Walsh Functions	Block Pulses
Parameters	Amplitude Frequency Phase angle ...	Amplitude Sequency Delay Time base	Amplitude ... Pulse position Pulse width
Mathematical theory	Fourier analysis	Walsh-Fourier analysis	...
Power spectrum	Frequency spectrum	Sequency spectrum	...
Filters	Time-invariable, linear	Periodically time variable, linear	Time variable, linear
Characterization	Frequency response of attenuation and phase shift	Sequency response of attenuation and delay	Attenuation as function of time
Multiplex	Frequency division	Sequency division	Time division
Modulation	Amplitude, phase, frequency modulation	Amplitude, time position, time base, code modulation	Amplitude, pulse position, pulse width modulation
Radiable	$\sin 2\pi ft, \cos 2\pi ft$	$\text{sal}\left(i, \frac{t}{T}\right), \text{cal}\left(i, \frac{t}{T}\right)$	...

**FIGURE 2.** List of features and applications of sine-cosine functions, Walsh functions, and block pulses.

**FIGURE 3.** Sequency low-pass filter. Top to bottom: practical circuit, block circuit, time diagrams.



on Walsh functions. The input signal,  $F(\theta)$ , is transformed into a step function,  $F^{++}(\theta)$ , with steps of a certain width, by integrating  $F(\theta)$  during an interval equal to the step width (see line  $d$ ). The amplitudes of the steps are chosen so that  $F^{++}(\theta)$  yields a least-mean-square approximation of  $F(\theta)$ . In addition,  $F^{++}(\theta)$  is delayed with respect to  $F(\theta)$  by one step width. The voltage obtained at the end of the interval is sampled by the switch  $s_2$  and stored in the holding circuit  $SP$ . Immediately after sampling, the integrator is reset by  $s_1$ . If the width of the steps is  $125 \mu\text{s}$ ,  $F^{++}(\theta)$  will have 8000 independent amplitudes per second.  $F^{++}(\theta)$  may be considered to consist of a superposition of Walsh functions having 0 to 8000 zero crossings per second or a sequency between 0 and 4 kcps. The output signal of a frequency low-pass filter with 4-kHz cutoff frequency also has 8000 independent amplitudes per second. Hence, the sampling theorems of Fourier and Walsh-Fourier analysis permit the comparison of frequency and sequency filters.

Consider the multiplication theorems of sine and cosine shown in Fig. 4. The product of these two functions always yields a sum of two functions with argument  $(k - i)\theta$  and  $(k + i)\theta$ . Let  $\cos i\theta$  and  $\sin i\theta$  represent carriers and let  $\cos k\theta$  and  $\sin k\theta$  represent Fourier components of a signal. The terms on the right sides of the multiplication theorems of Fig. 4 represent "lower" and "upper components" produced by amplitude modulation. Lower and upper sidebands are obtained if a carrier is amplitude-modulated by many rather than by one Fourier component. Hence, double-sideband modulation is a result of the multiplication theorems of sine-cosine functions.

Figure 4 also shows multiplication theorems for Walsh functions. The symbol  $\oplus$  indicates an addition modulo 2: The numbers are written in binary form and added



$$\begin{aligned}
 2 \cos k\theta \cos i\theta &= \cos(k-i)\theta + \cos(k+i)\theta \\
 2 \sin k\theta \cos i\theta &= \sin(k-i)\theta + \sin(k+i)\theta \\
 2 \cos k\theta \sin i\theta &= \sin(k-i)\theta - \sin(k+i)\theta \\
 2 \sin k\theta \sin i\theta &= \cos(k-i)\theta - \cos(k+i)\theta
 \end{aligned}$$

$$\begin{aligned}
 \text{cal}(k, \theta) \text{cal}(i, \theta) &= \text{cal}\{k \oplus i, \theta\} \\
 \text{sal}(k, \theta) \text{cal}(i, \theta) &= \text{sal}\{[i \oplus (k-1)] + 1, \theta\} \\
 \text{cal}(k, \theta) \text{sal}(i, \theta) &= \text{sal}\{[k \oplus (i-1)] + 1, \theta\} \\
 \text{sal}(k, \theta) \text{sal}(i, \theta) &= \text{cal}\{(k-1) \oplus (i-1), \theta\} \\
 \text{cal}(0, \theta) &= \text{wal}(0, \theta)
 \end{aligned}$$

FIGURE 4. Multiplication theorems of sine-cosine and Walsh functions.

FIGURE 5. Sequency bandpass filter (A) and multiplier for Walsh functions (B).

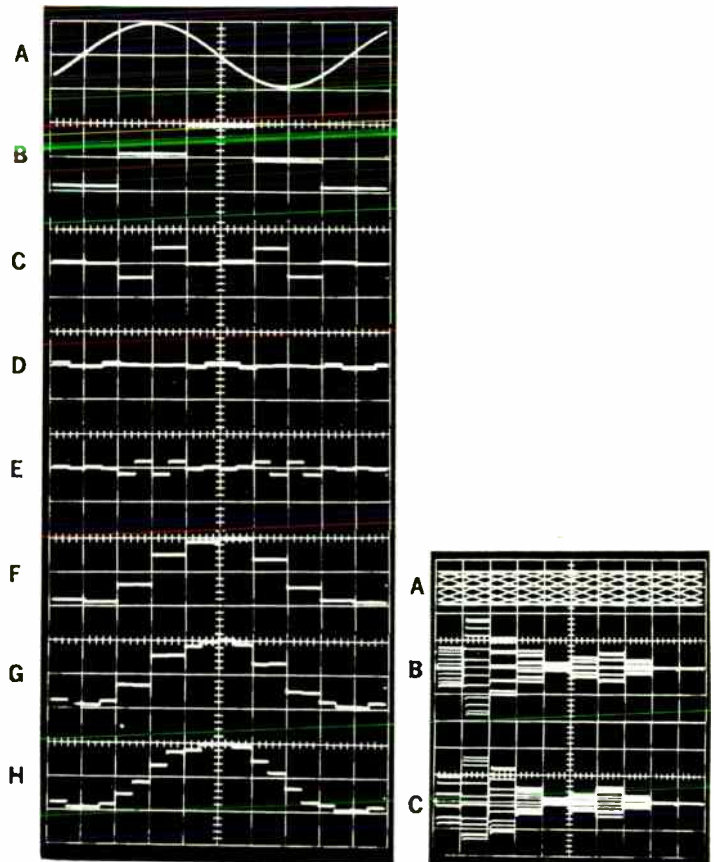
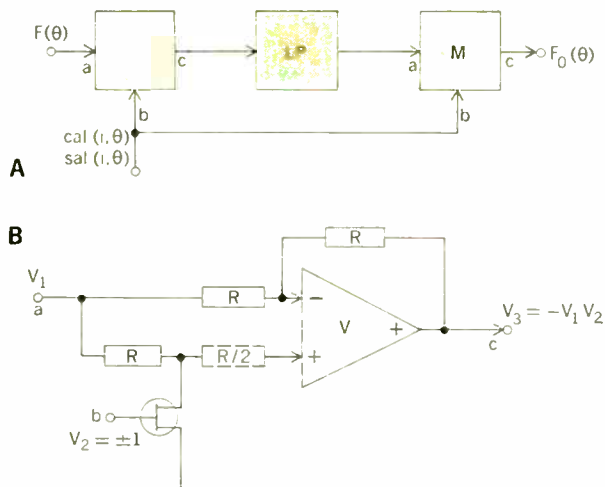


FIGURE 6 (left). Filtering of a sinusoidal voltage by various sequency filters; (A) is a sinusoidal function, frequency 250 Hz. Time base  $T = 1$  ms; horizontal scale 0.5 ms/div. The following functions pass through the filters: (B)  $\text{cal}(\varphi T, t/T)$ ,  $0 \leq \varphi < 1$  kzps; (C)  $\text{sal}(\varphi T, t/T)$ ,  $0 < \varphi \leq 1$  kzps; (D)  $\text{cal}(\varphi T, t/T)$ ,  $1$  kzps  $\leq \varphi < 2$  kzps; (E)  $\text{sal}(\varphi T, t/T)$ ,  $1$  kzps  $< \varphi \leq 2$  kzps; (F) sum of B and C; (G) sum of B, C, and D; (H) sum of B, C, D, and F. (Courtesy Boeswetter and Klein)

FIGURE 7 (right). Amplitude spectra of sinusoidal voltages. Line (A) represents sinusoidal voltages, frequency 1 kHz, various phases; horizontal scale 0.1 ms/div. Lines (B) and (C) are amplitude spectra  $a_s(\varphi T)$  and  $a_c(\varphi T)$ ; time base  $T = 1.6$  ms; horizontal scale 625 zps/div. (Courtesy Boeswetter and Klein)

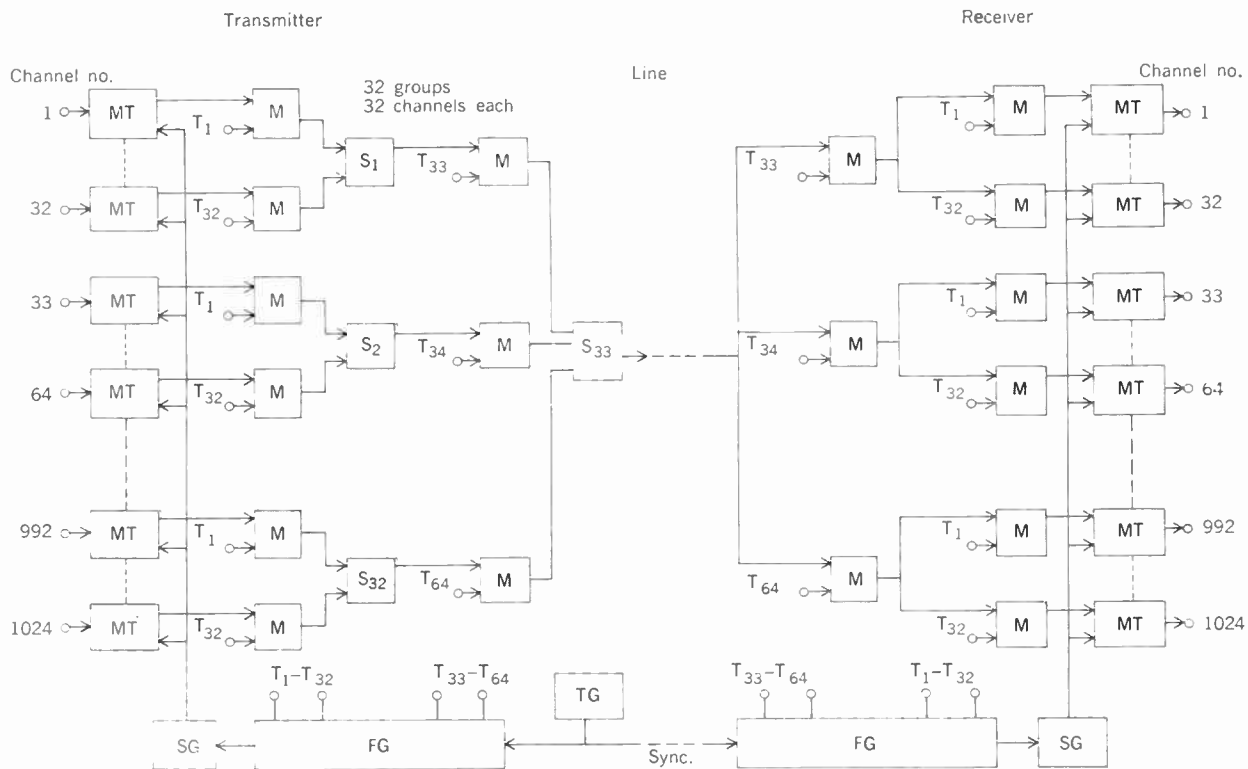
according to the rules  $1 \oplus 0 = 0 \oplus 1 = 1$ ,  $0 \oplus 0 = 1 \oplus 1 = 0$  (no carry). The point is, the product of two Walsh functions yields only one Walsh function and not two. Let  $\text{cal}(i, \theta)$  and  $\text{sal}(i, \theta)$  represent carriers and let  $\text{cal}(k, \theta)$  and  $\text{sal}(k, \theta)$  represent Walsh-Fourier components of a signal. The amplitude modulation of a Walsh carrier yields only one component or only one (sequency) sideband.

A typical application of the multiplication theorems of Walsh functions is in the design of sequency-bandpass filters. Figure 5 shows the operating principle of such a bandpass. The input signal  $F(\theta)$  is shifted in sequency by multiplication with a Walsh carrier,  $\text{cal}(i, \theta)$  or  $\text{sal}(i, \theta)$ , and then passed through a sequency low-pass filter  $LP$  shown in Fig. 3. The filtered signal is subsequently shifted to its original position in the sequency domain by multiplication with the same Walsh carrier used to shift the input signal. Figure 5 also shows a typical multiplier for Walsh functions. Note that a signal

$F(\theta)$  is multiplied by only  $+1$  or  $-1$ . Multiplication by  $+1$  leaves the signal unchanged;  $-1$  reverses amplitude.

Sequency filters based on Walsh functions have been built by Boeswetter (Technische Hochschule, Darmstadt, W. Germany) for a voice analyzer and synthesizer, and also by Lueke and Maile (AEG-Telefunken, Research Department, Ulm, W. Germany) for a telephony multiplex system. In the latter application, a minimum crosstalk attenuation of about  $-60$  dB was achieved in the stop bands. Such high-quality filters differ, of course, from the circuits shown in Figs. 3 and 5. Vandivere (Telcom Inc., McLean, Va.) has developed sequency filters for a signal analyzer.

Decomposition of voice signals by Walsh functions first seems to have been investigated theoretically by Sandy<sup>9</sup> in 1962. Another early investigator of sequency power spectra was Ohnsorg (Honeywell Inc., St. Paul, Minn.) whose work has not yet been published. Klein (Technische Hochschule, Darmstadt, W. Germany) has



**FIGURE 8. Block diagram of a sequency-multiplex system for 1024 telephony channels. Designations are: MT, sequency low-pass filter; M, multipliers; S, adder; FG, function generator; TG, clock pulse generator; SG, timing generator for the filter.**

shown experimentally for some simple cases that voice signals have sequency formants just as they have frequency formants. Work on voice signals was also recently started by Elsner (Technische Hochschule, Braunschweig, W. Germany) and Strum (Mitre Corp., McLean, Va.). C. Brown (Systems Research Labs., Dayton, Ohio) is investigating signal processing techniques using sequency spectra for the purpose of detection and recognition of signals in noise, signal sorting, and signal parameter identification.

Figure 6 shows oscillograms of a sinusoidal voltage (A) and the voltages it produces at the output of various sequency low-pass filters (B, F, G, H) and sequency bandpass filters (C, D, E). Figure 7 shows sinusoidal voltages of fixed frequency and their sequency amplitude spectra  $a_c(\mu) = a_c(\varphi T)$  and  $a_s(\mu) = a_s(\varphi T)$ .

### Signal multiplexing

The multiplication theorems of the Walsh functions make signal multiplexing an attractive application. Figure 8 shows the principle of a sequency-multiplex system for 1024 telephony channels. Analog or digital signals are fed through sequency low-pass filters *MT* to multipliers *M*. For voice signals the bandwidth of these low-pass filters is  $\Delta\varphi = 4$  kzps. Thirty-two carriers,  $T_1$  to  $T_{32}$ , consisting of Walsh functions  $\text{cal}(i, \theta)$  and  $\text{sals}(i, \theta)$  are fed to the multipliers.\* The time base of these functions equals  $\Delta\varphi/2 = 125 \mu\text{s}$ . Each of the output voltages of the 32 multipliers is summed by the adders  $S_1$  to  $S_{32}$ .

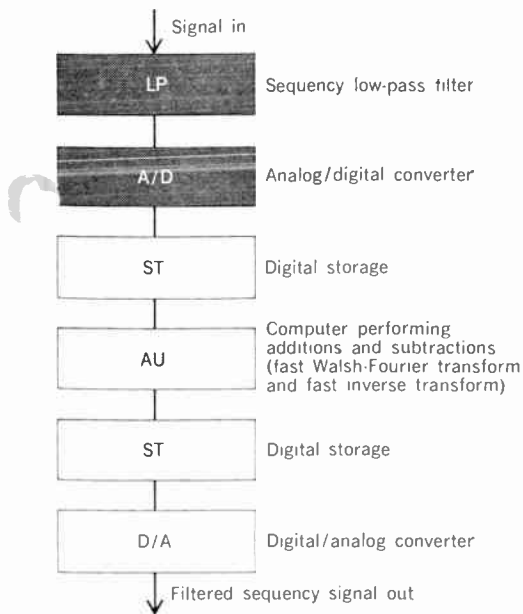
\* Rules for the selection of carriers that avoid crosstalk and waste of sequency bandwidth can be derived from the multiplication theorems of the Walsh functions.<sup>10</sup>

These summed voltages may further be multiplied by another set of multipliers with other Walsh carriers, denoted  $T_{33}$  to  $T_{64}$  in Fig. 8. A sequency-multiplex system permits repeated sequency shifting just as a frequency multiplex system permits repeated frequency shifting.

The signals are separated at the receiver by multiplication with the same synchronized Walsh carriers used in the transmitter. The block diagram of Fig. 8 differs from that of a frequency-multiplex system only by the missing single-sideband filters. The circuitry inside the blocks is, of course, very different.

A sequency-multiplex system according to Fig. 8 has been developed by Lueke and Maile. The system is designed for 256 voice channels, of which three are fully completed.† More channels are presently being added by Huebner<sup>12</sup> of the West German Post Office Department in preparation for tests on post office lines. One of the tests will be the transmission of PCM voice signals via a scatter link, since, compared with time-division PCM, a gain of some 3 dB is predicted for this application. A Walsh-function tracking filter is used in the equipment of Lueke and Maile to establish synchronization between transmitter and receiver. The synchronization is good enough to yield a crosstalk attenuation of  $-57$  dB, or better, in back-to-back operation. Crosstalk due to all

† Development of sequency-multiplex equipment was also started at ETH Zurich (Swiss Federal Institute of Technology, Institute for Advanced Electrical Engineering) and at the Research Institute of the West German Post Office Department in Darmstadt. Considerable theoretical work on PCM transmission by Walsh functions was done by Taki and Hatori<sup>11</sup> of Tokyo University, Japan. Experimental work has also been reported by Cox of the M.I.T. Instrument Laboratory, Cambridge, Mass.



**FIGURE 9. Digital sequency filter.**

causes is  $-53$  dB or better in back-to-back operation. Using a compandor (compressor plus expander), the apparent crosstalk attenuation could be made some  $-75$  dB. These figures are, of course, in excess of that required for good PCM transmission.

Sequency-multiplex systems do not need single-sideband filters. The low-pass and bandpass filters required do not cause attenuation or delay distortions. These features are highly important for data transmission. All filters can be implemented by integrated circuit techniques. No individual tuning of the filters is required. The bandwidth of the filters is determined by the timing of the pulses that drive the switches  $s_1$  and  $s_2$  in Fig. 3; correct timing of the pulses replaces the tuning of filters; no temperature compensation is needed. The Walsh carriers can be produced by means of binary counters and gates. The only part in a sequency-multiplex system that requires tuning and temperature compensation is the clock pulse-generator.

Time-multiplex systems do not need single-sideband filters either, and they are also well suited for implementation by semiconductor technology. The advantage of a sequency-multiplex system here rests with reduced sensitivity to disturbances—brought about by two causes:

1. Only a fraction of all channels is active in a multiplex system at any one time. For instance, the activity factor of a telephone system does not exceed one quarter even during peak traffic.\* Hence, the power amplifiers are not used three quarters of the time and the average useful signal power is reduced correspondingly in a time-multiplex system. Sequency-multiplex systems yield a higher average signal power for equal peak power. Particularly advantageous is that the average power can be maintained approximately constant by means of automatic gain-con-

\* The activity factor gives the number of channels actually carrying signals. It is smaller than one during peak traffic because one party must listen while the other one talks, because there are idle periods in conversations, because a channel becoming available is not immediately used, etc.

trol amplifiers when the activity factor drops during low-traffic hours. It is also noteworthy that the sequency bandwidth of a sequency-multiplex signal is not changed by a nonlinear compressor or expander characteristic; hence, sequency-multiplex signals can readily be passed through instantaneous compandors.

2. Digital signal errors during transmission through telephone lines are mainly caused by pulse-type disturbances. Time division is more susceptible to these disturbances than frequency or sequency division since a particular block pulse may be changed appreciably by a disturbing pulse, although the preceding and the following pulses are not changed at all. In the case of frequency or sequency multiplexing, many sine-cosine or Walsh pulses are transmitted simultaneously. The energy of a disturbing pulse is thus spread over many signal pulses. Only considerable energy can disturb signal pulses that are quantized. Measurements with binary sine-cosine pulses have yielded—and theoretically Walsh pulses should yield—error rates 100 times smaller than for block pulses having the same average power.

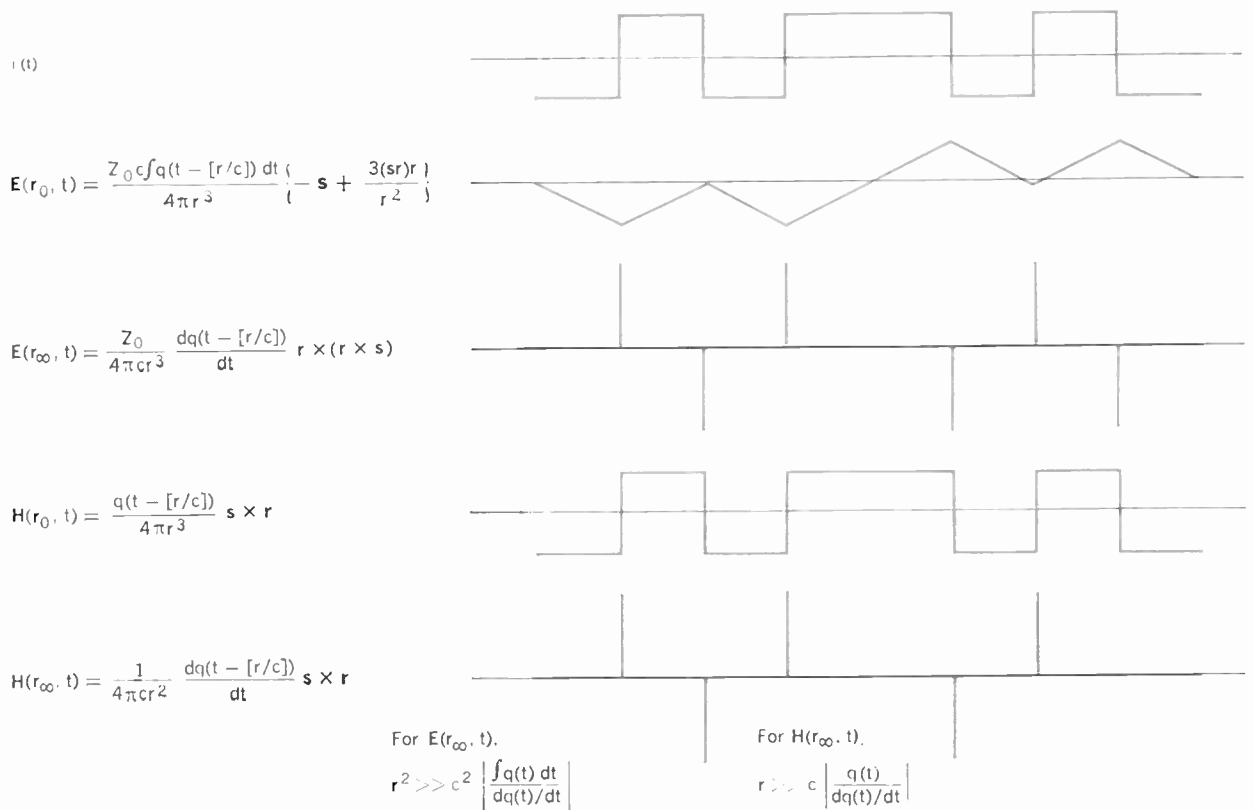
There are several additional—although not so important—differences between time- and sequency-multiplex systems. For example, equipment for time division is often less expensive; sequency multiplexing is more adaptable to the problems of communication networks and makes it easier to mix voice and data signals with different average power.

### Digital filtering and multiplexing

One of the most promising aspects of Walsh functions is the ease with which filters and multiplex equipment can be implemented as digital circuits. The reason is that numerical Walsh-Fourier transformation and numerical sequency shifting of signals require summations and subtractions only. In the case of sine-cosine functions, the corresponding operations require multiplications with irrational numbers. The simplification of numerical computations by the use of Walsh functions has been recognized by many scientists.<sup>12-17</sup>

Figure 9 shows the block diagram of a digital filter based on Walsh functions. The input signal passes first through a sequency low-pass filter  $LP$  that transforms it into a step function. This step function is sampled and the samples are transformed into numbers by an analog/digital converter. A series of these numbers is stored in a digital storage  $ST$ . A Walsh-Fourier transform of this series is obtained by performing certain additions and subtractions in the arithmetic unit  $AU$ . Some or all of the obtained coefficients, that represent sequency components, may be suppressed or altered—in effect, a filtering process. An inverse Walsh-Fourier transform yields the filtered signal as a series of numbers. These numbers are stored in a second digital storage  $ST$  and transformed into an analog signal by digital/analog converter  $DA$ . Since there is a fast Walsh-Fourier transform just as there is a fast Fourier transform, the arithmetic operations in a digital sequency filter are not only simpler than in a digital frequency filter but can be performed faster.<sup>16, 18, 21</sup>

Voice signals are functions of the one variable, time. A black-and-white photograph is a function of two space variables, and a black-and-white television picture is a function of two space variables and time. Digital filters may be applied to signals that are functions of two or three variables by using a two- or three-dimensional



**FIGURE 10. Electric and magnetic field strengths in the near and wave zones due to a current  $q(t)$  fed into a Hertzian dipole. The functions on the right show the time variations caused by a Walsh-shaped current  $q(t)$ .**

Walsh Fourier transform.\* This has been done by Pratt, Kane, and Andrews<sup>18</sup> for functions of two variables. Roth and Lueg (Technische Hochschule, Aachen, W. Germany) as well as Held (Technische Hochschule, Darmstadt, W. Germany) and Klein have also recently started to develop digital sequency filters. A very general method for digital signal filtering—not restricted to Walsh functions—was devised by Andrews<sup>22</sup> and Caspari (International Telephone and Telegraph Corporation, Electro-Physics Laboratories, Hyattsville, Md.).

Digital multiplexing is a straightforward extension of digital filtering. Rather than multiplying signals and Walsh carriers represented by voltages, one multiplies signals and Walsh carriers represented by series of numbers. Multiplexed signals are again represented by a series of numbers that may be transmitted by any digital communication equipment. The promising feature of such a digital-sequency-multiplex system is that it has essentially the same immunity to disturbances as the previously discussed analog-sequency-multiplex equipment, but is compatible with existing transmission equipment.

### Electromagnetic Walsh waves

At the present time, sinusoidal electromagnetic waves exclusively are used for radio communication. Such

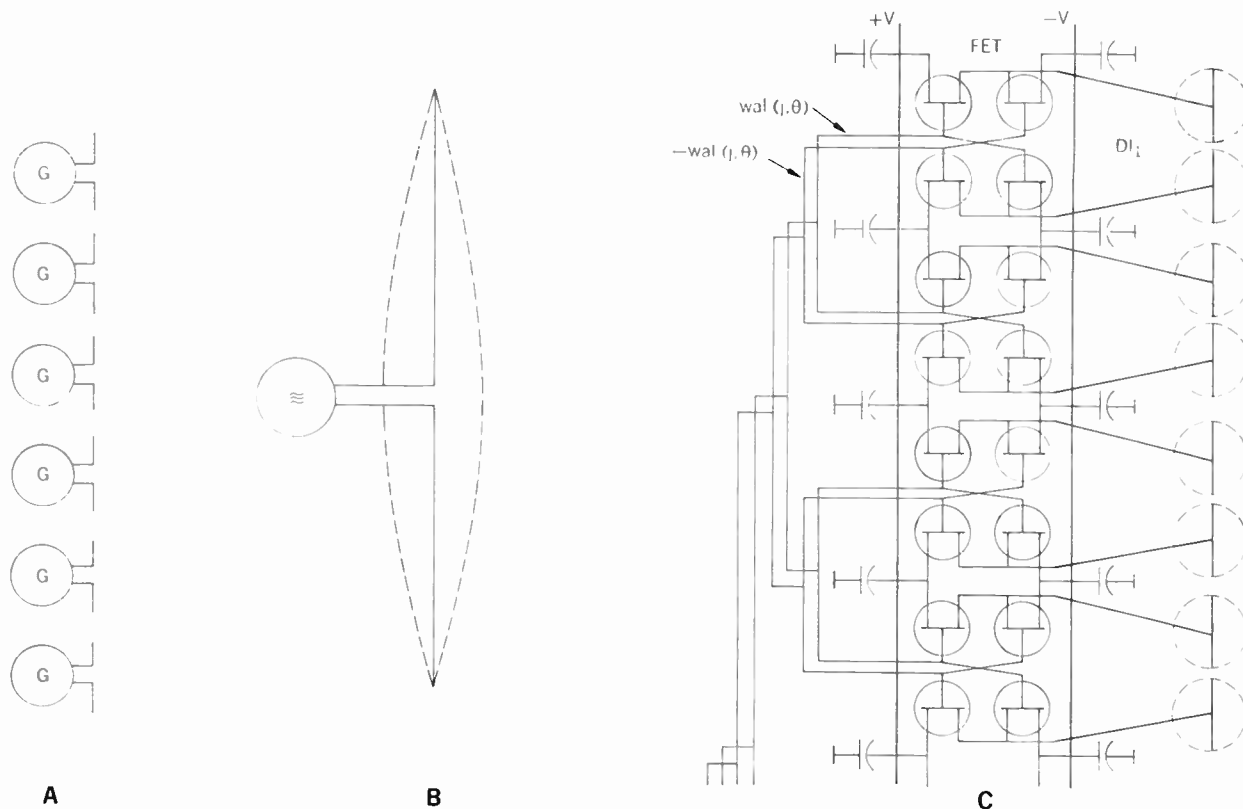
\* Analog filters based on sine cosine functions can be implemented for functions of two space variables by optical means. Analog filters based on Walsh functions can be implemented with relative ease for functions of two space variables by resistors and operational amplifiers; their implementation for functions of two space variables and time, or three space variables with and without the time variable, is possible but expensive.

waves are characterized by a sinusoidal variation with time of the electric and magnetic field strengths  $\mathbf{E}(\mathbf{r}, t)$  and  $\mathbf{H}(\mathbf{r}, t)$ . These field strengths are produced by feeding a sinusoidal current into the antenna.

Figure 10 shows the time variation of electric and magnetic field strengths for a Walsh-shaped current  $q(t)$  fed into a Hertzian dipole. A typical current is shown in the first line.  $\mathbf{E}(\mathbf{r}_0, t)$  and  $\mathbf{H}(\mathbf{r}_0, t)$  are the field strengths in the near zone,  $\mathbf{E}(\mathbf{r}, t)$  and  $\mathbf{H}(\mathbf{r}, t)$  the field strengths in the wave zone.  $Z_0$  (377 ohms) is the wave impedance of free space,  $c$  the velocity of light,  $r$  the distance between dipole and observation point,  $\mathbf{r}$  the vector from dipole to the observation point, and  $\mathbf{s}$  the dipole vector. The spatial variation of  $\mathbf{E}$  and  $\mathbf{H}$  depends on the vectors  $\mathbf{s}$  and  $\mathbf{r}$ ; it is the same for sine, Walsh, and other waves. The time variation depends solely on the current  $q(t)$  fed into the Hertzian dipole. This time variation is plotted in Fig. 10 on the left for the near zone and the wave zone of  $\mathbf{E}$  and  $\mathbf{H}$ . In the wave zone, one obtains Dirac delta functions for  $\mathbf{E}$  and  $\mathbf{H}$  that are located at the jumps of  $q(t - r/c)$ . The time variation of  $\mathbf{H}$  in the near zone equals  $q(t - r/c)$ ; the time variation of  $\mathbf{E}$  equals  $\int q(t - r/c) dt$ .

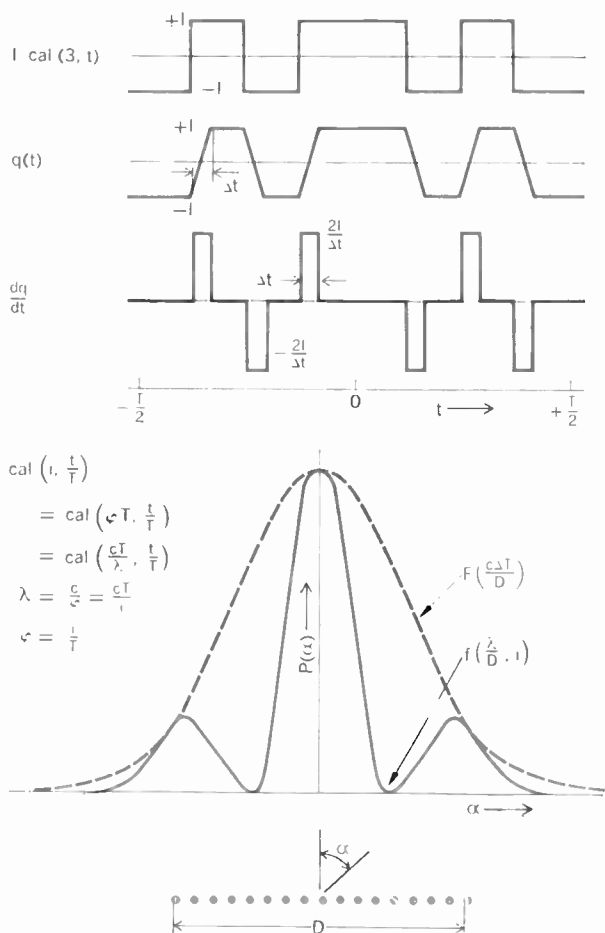
The wave zone of  $\mathbf{E}$  and  $\mathbf{H}$  is the region in which the distance  $r$  between dipole and observation point satisfies the conditions shown in the bottom line of Fig. 10. In the near zone, the "much larger" signs in the inequalities are replaced by "much smaller" signs. These conditions have the more familiar form  $r \gg \lambda$  or  $r \ll \lambda$  for sinusoidal currents  $q(t) = I \sin 2\pi ft = I \sin (2\pi ct/\lambda)$ .

A receiver always receives the sum of the field strengths



**FIGURE 11. A—General array of Hertzian dipoles. B— $\lambda/4$  dipole for sine waves. C—Array of Hertzian dipoles and power amplifiers for Walsh waves [wal ( $2j, \theta$ ) = cal ( $j, \theta$ )].**

**FIGURE 12. Beam width of an antenna for Walsh waves.**

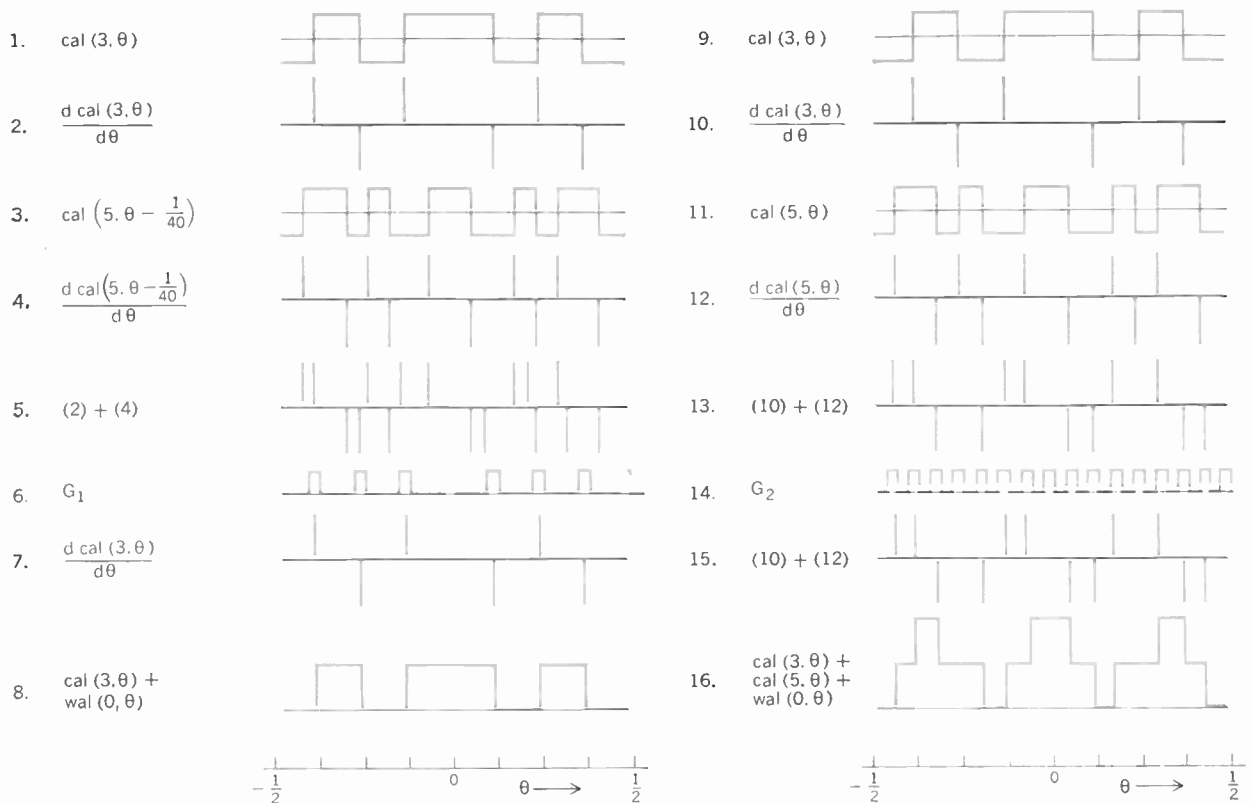


from the near and wave zones.  $E(\mathbf{r}, t)$  and  $H(\mathbf{r}, t)$  decrease proportionally with  $1/r$ , whereas  $E(\mathbf{r}_0, t)$  and  $H(\mathbf{r}_0, t)$  decrease proportionally with  $1/r^3$  and  $1/r^2$ . Hence, a comparison of the field strengths of the near and the wave zones allows the distance of the transmitter to be determined. This determination of course, requires the time variation of the near- and the wave-zone components to be different in order to distinguish between them. A sinusoidal current  $q(t)$  produces sinusoidal near-zone and wave-zone components since the differential as well as the integral of a sine function is simply a time-shifted sine function.

A Hertzian dipole radiates vanishingly little power. Many such dipoles may be used simultaneously to radiate more power. Figure 11(A) shows several Hertzian dipoles, each fed by one generator. In the case of sinusoidal waves, one may feed many Hertzian dipoles by a single high-power generator using standing waves in a half-wave or similar dipole [Fig. 11(B)]. This is also possible but not economical for Walsh waves. Since a generator for Walsh-shaped currents consists of switches that feed positive or negative currents into the dipole, it is better to feed many Hertzian dipoles through many switches as shown in Fig. 11(C). These switches must feed constant currents and not constant voltages to the dipoles. Current feed is automatic if the switches are semiconductors.

The Hertzian dipoles  $DI$  in Fig. 11(C) are circular areas of conducting material. They do not have to be arranged along a line as in Fig. 11(C), but may be arranged in two dimensions. Such a two-dimensional arrangement, however, cannot be used for antennas that use the standing-wave principle such as the one in Fig. 11(B).

The deviations of the antenna current  $q(t)$  from the ideal shape shown in Fig. 10 must be taken into account



**FIGURE 13. Principle of the separation of two Walsh waves in mobile radio communication.**

if the directional characteristic of an antenna, consisting of many Hertzian dipoles, is to be determined. For example the idealized current,  $I \text{ cal}(3, t)$  shown on the first line of Fig. 12 is not achievable since it is not possible to switch back and forth between  $+I$  and  $-I$  in zero time. The current  $q(t)$  with finite switching times  $\Delta t$  is more realistic. The time differential  $dq/dt$  of the current  $q(t)$  is shown in the third line. Narrow, rectangular pulses with finite amplitude—not delta pulses—result.

A row of Hertzian dipoles is shown at the bottom of Fig. 12. The length of this row is  $D$ ; each dipole is short compared to  $c\Delta t$ . Let a current  $q(t)$ , as shown in the second line of Fig. 12, be fed into each dipole. A radiation diagram  $P(\alpha)$  gives the average radiated power in the wave zone as function of the angle  $\alpha$ . A typical radiation diagram is shown in Fig. 12 by the solid line above the row of dipoles. The dashed line is the envelope of the main lobe and the sidelobes. This dashed line is a function of  $c\Delta t/D$ , where  $c$  denotes the velocity of light and  $\Delta t$  the switching time of the current  $q(t)$ . A reduction of  $\Delta t$  makes the dashed line approach zero for angles  $\alpha \neq 0$ , and the antenna radiates into a very narrow angle for small  $\Delta t$ .

The location of the zeros of the solid curve in Fig. 12 depends on the ratio  $\lambda/D$  and the normalized frequency  $i$  of the Walsh waves. ( $\lambda$  is the average wavelength.)

The following definitions apply to  $\text{cal}(i, t/T)$ :

$$\text{cal}(i, t/T) = \text{cal}(\varphi T, t/T) = \text{cal}(cT^2/\lambda, t/T)$$

where  $\lambda = c/\varphi = cT/i =$  average wavelength,  $\varphi = i/T =$  frequency, and  $i = 1, 2, \dots =$  normalized frequency.

The directivity of an antenna is determined by the ratio  $\lambda/D$  for sine waves. In the case of Walsh waves it is

determined by the ratios  $\lambda/D$  and  $c\Delta t/D$ , and by the normalized frequency  $i$ . The important point is that a reduction of  $\Delta t$  yields a significantly better directivity without a need to decrease  $\lambda$  or increase  $D$ . These results not only hold true for a row of dipoles in Fig. 12, but also for other antenna shapes, particularly parabolic reflectors. ( $D$  represents the reflector diameter.)

#### Maintaining orthogonality after time shifting

It is known that orthogonal functions—for example, voltages or field strengths varying with time—can be separated. It is not necessary that this separation be by frequency or time division; the more general orthogonal division is sufficient.<sup>10</sup> Hence, a point-to-point transmission is perfectly possible with Walsh waves. Mobile communication is more difficult, since waves radiated from various transmitters show various time shifts at the receiver due to the propagation times of the waves. These unknown time shifts generally destroy the orthogonality of the received functions. Up to now, the only known exception has been sine waves. A time shift destroys only the orthogonality between sine and cosine functions of the same—not different frequency.\*

Walsh waves in the wave zone are a second exception† and may also be separated regardless of any time shift.

\* The relation  $\sin(\omega t + \gamma) = \sin \gamma \cos \omega t + \cos \gamma \sin \omega t$  shows that a time-shifted sine function consists of not-shifted sine and cosine functions with the same frequency. Any function orthogonal to  $\sin \omega t$  and  $\cos \omega t$  is thus orthogonal to  $\sin(\omega t + \gamma)$ .

† These waves have the shape of differentiated Walsh functions according to Fig. 10 rather than the shape of the Walsh functions.

Figure 13, line one, shows the function  $\text{cal}(3, \theta) = \text{cal}(3, t/T)$ ; line two shows its differential, which represents the time variation of the electric and magnetic field strength in the wave zone—Dirac pulses at the jumps of  $\text{cal}(3, \theta)$ . (The deviation from this theoretical shape is neglected here, just as it is usual to neglect other than idealized, infinitely long sine functions.)

Line three shows another Walsh function,  $\text{cal}(5, \theta - 1/40)$ , time-shifted relative to  $\text{cal}(3, \theta)$ ; line four shows its differential; line five shows the sum of lines two and four. This sum is received if one transmitter radiates the wave  $\text{cal}(3, \theta)$  and another the wave  $\text{cal}(5, \theta)$ . The voltage produced in the receiving antenna also varies with time according to line five. As shown by line six, a gate permits those pulses to pass that arrive at the proper time; the pulses of line seven are thus derived from those of line five. These are the same pulses as those of line two. Hence, the desired signal is separated from the non-desired one.\* Integration of the pulses of line seven yields the function  $\text{cal}(3, \theta)$  and a superimposed dc component in line eight. The dc component is of no consequence.

Lines nine to 16 in Fig. 13 show what happens if  $\text{cal}(3, \theta)$  and  $\text{cal}(5, \theta)$  are not time-shifted relative to each other. This case cannot occur if the Dirac pulses in lines two and four as well as the gating intervals in line six are infinitely short, but it is important for the practical pulses of finite duration. (More precisely, the probability of this case to occur is zero.) Lines nine to 13 correspond to one to five except for the time shift. The gate, however, opens 16 times according to line 14. Integration of the pulses passed (line 15) yields the sum,  $\text{cal}(3, \theta) + \text{cal}(5, \theta) + \text{dc component wal}(0, \theta)$  [equals  $\text{cal}(0, \theta)$ ] in line 16. Correlation of this sum with a sample function  $\text{cal}(3, \theta)$  suppresses the components  $\text{cal}(5, \theta)$  and  $\text{wal}(0, \theta)$ . The general rule for the opening times of the gate is as follows:

Let an arbitrary number of transmitters radiate Walsh waves  $\text{cal}(i_1, t/T)$ ,  $\text{cal}(i_2, t/T)$ ,  $\dots$ , and let the normalized sequences  $i_1, i_2, \dots$  assume values from 1 to  $2^k$  only ( $k = \text{integer}$ ). The gate must open periodically  $2 \times 2^k$  times during the time  $T$  and allow pulses to pass. Example:  $i_1$  equals 3 and  $i_2$  equals 5 in Fig. 13, line nine. These numbers are between 1 and  $8 = 2^3 = 2^k$ . Hence, the gate of line 14 must open periodically  $2 \times 8 = 16$  times during the time  $T$  (the interval  $-T/2 \leq t < +T/2$  corresponds to the interval  $-1/2 \leq \theta < +1/2$ ). The time interval during which the gate stays open should be about as wide as the received pulses.

\* The problem of separation is essentially the same as for synchronous reception of sinusoidal waves. Walsh waves of different frequency can be distinguished and thus separated like sine waves of different frequency. On the other hand, two waves caused by antenna currents  $I \text{sal}(i, \theta)$  and  $I \text{cal}(i, \theta)$  cannot be distinguished without a synchronization signal just as two waves caused by antenna currents  $I \sin \omega t$  and  $I \cos \omega t$  cannot be distinguished without a synchronization signal.

#### REFERENCES

- Walsh, J. L., "A closed set of orthogonal functions," *Am. J. Math.*, vol. 55, pp. 5-24, 1923.
- Fine, N. J., "The generalized Walsh functions," *Trans. Am. Math. Soc.*, vol. 69, pp. 66-77, 1950.
- Selfridge, R. G., "Generalized Walsh transform," *Pacific J. Math.*, vol. 5, pp. 451-480, 1955.
- Watari, C., "Mean convergence of Walsh-Fourier series," *Tôhoku Math. J.*, vol. 16(2), pp. 183-188, 1964.
- Yano, S., "On Walsh-Fourier series," *Tôhoku Math. J.*, vol. 3(2), pp. 223-242, 1951.

- Price, J. J., "A density theorem for Walsh functions," *Proc. Am. Math. Soc.*, vol. 18, pp. 209-211, 1967.
- Harrington, W. J., and Cell, J. W., "A set of square wave functions orthogonal and complete in  $L_2(0, 2)$ ," *Duke Math. J.*, pp. 393-407, 1961.
- Pichler, F., "Das System der  $\text{sal}$  und  $\text{cal}$ -Funktionen als Erweiterung des Systems der Walsh-Funktionen und die Theorie der  $\text{sal}$ - und  $\text{cal}$ -Fourier Transformation," Ph.D. thesis, Innsbruck University, Austria, 1967.
- Sandy, G. F., "Square wave (Rademacher-Walsh functions) analysis," Mitre report WP-1585, Oct. 1968.
- Harmuth, H. F., *Transmission of Information by Orthogonal Functions*. New York/Berlin 1969; Springer-Verlag. (This book contains an extensive list of references on Walsh functions.)
- Taki, Y., and Hatori, M., "PCM communication system using Hadamard transformation," *Electron. Commun. Japan*, vol. 49, no. 11, pp. 247-267, 1966.
- Polyak, B. T., and Shreider, Yu. A., "The application of Walsh functions in approximate calculations," *Voprosy Teorii Matematicheskix Mashin*, vol. 2, Yu. Ya. Bazilevskii, ed. Moscow: Fizmatgiz, 1962 (in Russian).
- Howe, P. W., "The use of Laguerre and Walsh functions in materials problems of variable loading at high temperature," rept. AD-434122, 1964.
- Corrington, M. S., "Advanced analytical and signal processing techniques," rept. AD-277942, Apr. 1962.
- Ito, T., "A way of approximating functions by computer - an application of the Walsh functions," IEEE Computer Group, paper depository R-69-49.
- Gibbs, J. E., "Walsh spectrometry, a form of spectral analysis well suited to binary digital computation," (to be published).
- Meltzer, B., Searle, N. H., and Brown, R., "Numerical specification of biological form," *Nature*, vol. 216, pp. 32-36, Oct. 1967.
- Pratt, W. K., Kane, J., and Andrews, H. C., "Hadamard transform image coding," *Proc. IEEE*, vol. 57, pp. 58-67, Jan. 1969.
- Shanks, J. L., "Computation of the fast Walsh-Fourier transform," *IEEE Trans. Computers*, vol. C-18, pp. 457-459, May 1969.
- Whelchel, J. E., and Guinn, D. F., "The fast Fourier-Hadamard transform and its use in signal representation and classification," 1968 *EASCON Record*, pp. 561-571.
- Green, R. R., "A serial orthogonal decoder," Space Programs Summary, Jet Propulsion Laboratory, Pasadena, Calif., No. 37-39, vol. IV, pp. 247-251, 1966.
- Andrews, H. C., and Caspari, K. L., "A generalized spectrum analyzer," *IEEE Trans. Computers*, vol. C-18, in print.

#### BIBLIOGRAPHY

- Crowther, W. R., and Rader, C. M., "Efficient coding of Vocoder channel signals using linear transformation," *Proc. IEEE*, vol. 54, pp. 1594-1595, Nov. 1966.
- Huebner, H., "Walsh-Funktionen und ihre Anwendung," *Gesellschaft No Fuer Ortung und Navigation*. Dusseldorf: Amwehrhahn 94, W. Germany, 1969.
- Nambiar, K. K., "A note on the Walsh functions," *IEEE Trans. Electronic Computers*, vol. EC-13, pp. 631-632, Oct. 1964.
- Swick, D. A., "Walsh function generation," *IEEE Trans. Information Theory*, vol. IT-15, p. 167, Jan. 1969.
- Szok, W. G., "Waveform characterization in terms of Walsh functions," master's thesis, Syracuse University, June 1968.
- Weiser, F. E., "Walsh function analysis of instantaneous non-linear stochastic problems," Ph.D. thesis, Polytechnic Institute of Brooklyn, June 1964.

**Henning F. Harmuth (M)** left West Germany—where he was a consulting engineer—a year ago to assume a staff position with the Electrical Engineering Department, University of Maryland, College Park, Md., as visiting associate professor. A native of Austria, he earned the degree of Diplom-Ingenieur in 1951 and the doctor's degree of technical science in 1953 from the Technische Hochschule in Vienna. An active author, Dr. Harmuth has written some 40 papers and one book, "Transmission of Information by Orthogonal Functions."



# New product applications

## Digital instrument displays in real time cross-correlation and autocorrelation functions

The new Model 3721A Correlator is an all-digital, dc-to-250-kHz signal analyzer that computes and displays in real time the correlation between two input signals—or between one input signal and itself—as a function of the time delay between the signals. The display is a series of 100 simultaneous dots on a built-in cathode-ray tube with each dot representing the value of the correlation function (vertical axis) for a particular value of the delay parameter (horizontal axis).

In addition to computing correlation functions, the instrument can also recover repetitive signals buried in noise using the technique of signal averaging, or display probability distributions (histograms). Recovered signals and probability are displayed on the cathode-ray tube as 100-point functions of time, amplitude, or time interval.

A specific application example of correlation is for system identification. Given a system, network, or other device that produces an output in response to an input, how can you predict its response to any input? For systems operating linearly, the output can be predicted if either the transfer function or the impulse response of the system is known.

Identification of complex systems tends to be difficult because the results of the analysis are often obscured by background noise unless a large-amplitude test signal is used. But such a large signal might have a disturbing effect on normal functioning of the system. If a low-level test signal is used, however, an approximation to the impulse response of a linear system can be obtained by cross-correlating the noise signal with the system output signal.

Correlation can isolate sources of noise in structures such as buildings and automobiles. When the objectionable noise is cross-correlated with the sounds or vibrations coming from various sources, the peaks in the resulting cross-correlation functions show how much each source is con-

tributing to the total noise, how many transmission paths there are, and how long each path is.

Contactless measurement of speed is another possible application. It is particularly applicable to the speed control of a hot rolling mill for steel strip or sheet as shown in Fig. 1. With suitable transducers, correlation can be employed to measure flow in almost any application.

Correlation techniques are applicable in many diverse fields—measuring torsion in power transmission shafts; investigating the acoustic properties of broadcasting studios, concert halls, etc.; speech research; checking acoustic properties of unfinished structures; measuring acoustic absorption coefficients; underground and underwater direction finding; pipeline leak detection; brain surgery; analysis of electromyographs;

and radio astronomy.

Signal recovery, or signal averaging, is a method of extracting repetitive signals from noise. It is used for such applications as study of nervous disease, high-resolution spectroscopy, recovering brain waves, and vibration analysis.

The probability density function is a statistic of a signal that gives wave-shape information and is independent of the spectrum. It tells what proportion of time, on the average, is spent by the signal at various amplitudes. Probably the most familiar probability density function is the bell-shaped Gaussian curve that is characteristic of many naturally occurring random disturbances. Probability density functions are used for theoretical studies and systems design and for detecting distortion.

More information is available from Hewlett-Packard, 1501 Page Mill Road, Palo Alto, Calif. 94304.

Circle No. 85 on Reader Service Card

**FIGURE 1.** Surface irregularities in strip or sheet steel will provide signals to two photocells with time delay determined by velocity of emergent metal. This delay,  $T_d$ , is displayed directly on the instrument by cross-correlation.

