

Elementary
Electronics

elementary Electronics

JANUARY-FEBRUARY 1979

\$1.25
IN CANADA
\$1.50

**SIMPLY
BASIC**

Make your own odds
with our
sports program

MICROCOMPUTER PROJECTS

Make computer music, page 29

Match wits with a
microprocessor, page 53

Count like a computer, page 61

SPOTS

Super DX

Radio Happiness

cks out...

50 programmable

tor auto

tachometer

Information

Unlimited

Mutt Minder

Four new

hot CBs



Hoof your way through
computer logic with
Rhythm & Blues Box

A DAVIS PUBLICATION

12 68 9095 BLA-17K16-D DEC79
G BLANDINO
17 KATHERYN DR
HIPPIANY NJ 07981



FOR THOSE OF YOU WHO ARE HAVING SECOND THOUGHTS ABOUT YOUR FIRST CB.

Move up to the all-new Cobra 29GTL. It's the third generation of the trucker-proven Cobra 29. And like the 29 and the 29XLR before it, it advances the state of the art.

Transmitter circuitry has been refined and updated to improve performance.

Receiver circuits have been redesigned to include dual FET mixers, a monolithic crystal filter and a ceramic filter to reduce interference and improve reception.

By improving the transmitter circuitry the 29GTL keeps you punching through loud and clear. By incorporating new features for better reception everything you copy comes back loud and clear.

So if you're having second thoughts about your first CB, make your next CB the Cobra 29GTL.

We back it with a guaranteed warranty and a nationwide network of Authorized Service Centers where factory-trained technicians are available to help you with installation, service and advice.

But more important than that, we sell it at a price you won't have second thoughts about.



Punches through loud and clear.

Cobra Communications Products
DYNASCAN CORPORATION
6460 W. Cortland St., Chicago, Illinois 60635

Write for color brochure
EXPORTERS: Empire • Plainview, N.Y. • CANADA: Atlas Electronics • Ontario



CIRCLE 8 ON READER SERVICE COUPON

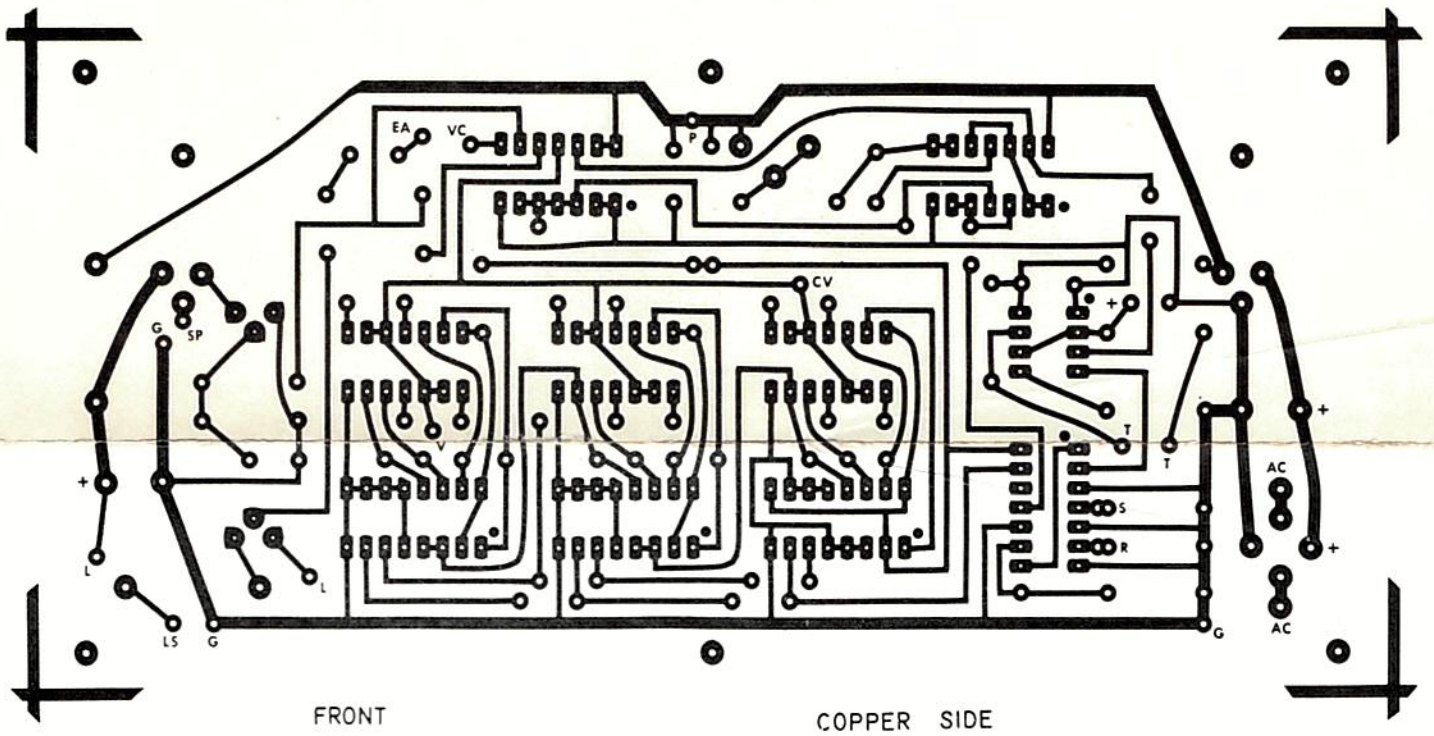

FRONT

COPPER SIDE

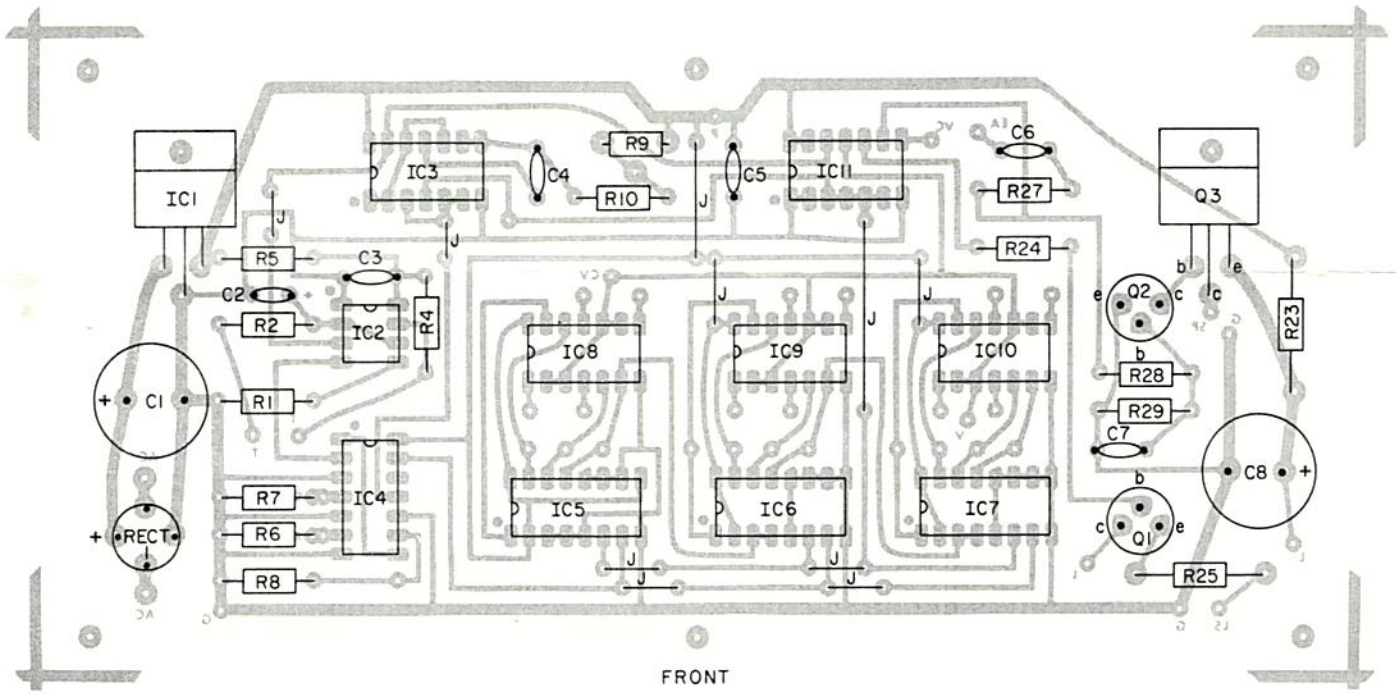

FRONT

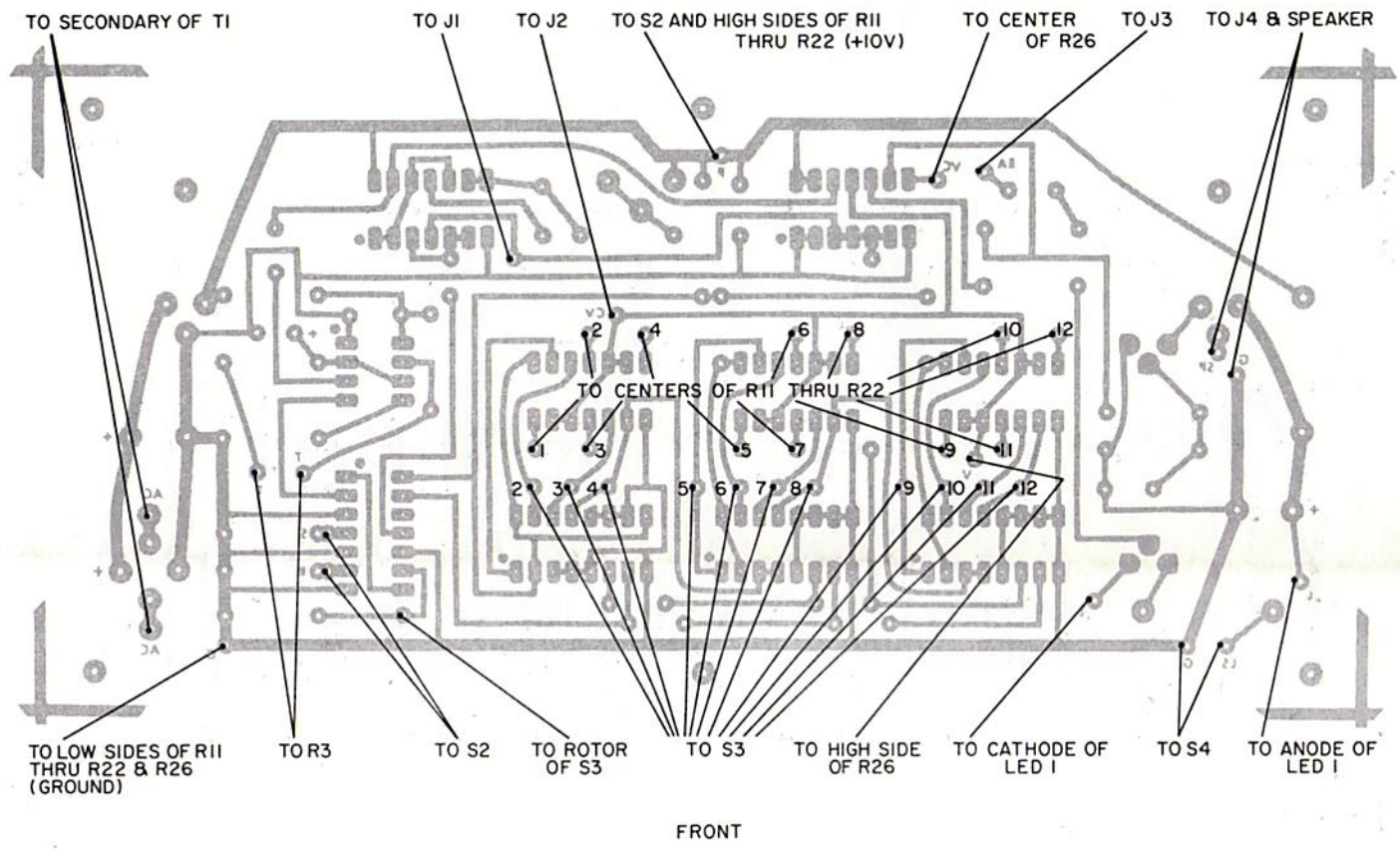

TO SECONDARY OF T1

TO J1

TO J2

TO S2 AND HIGH SIDES OF R11 THRU R22 (+10V)

TO CENTER OF R26

TO J3

TO J4 & SPEAKER

TO CENTERS OF R11 THRU R22

TO LOW SIDES OF R11 THRU R22 & R26 (GROUND)

TO R3

TO S2

TO ROTOR OF S3

TO S3

TO HIGH SIDE OF R26

TO CATHODE OF LED 1

TO S4

TO ANODE OF LED 1

FRONT

elementary Electronics

A DAVIS PUBLICATION

380 LEXINGTON AVENUE • NEW YORK, N.Y. 10017 • 212-557-9100

RHYTHM AND BLUES BOX

Here is your free printed circuit board template, parts location diagram and PC board wiring guide. This will enable you to build the PC board for the "Rhythm and Blues Box" project that appeared in the January/February 1979 issue of ELEMENTARY ELECTRONICS. We hope you enjoy building this terrific little music maker.

New Avanti Astro-Fantom™ the perfect CB antenna for...

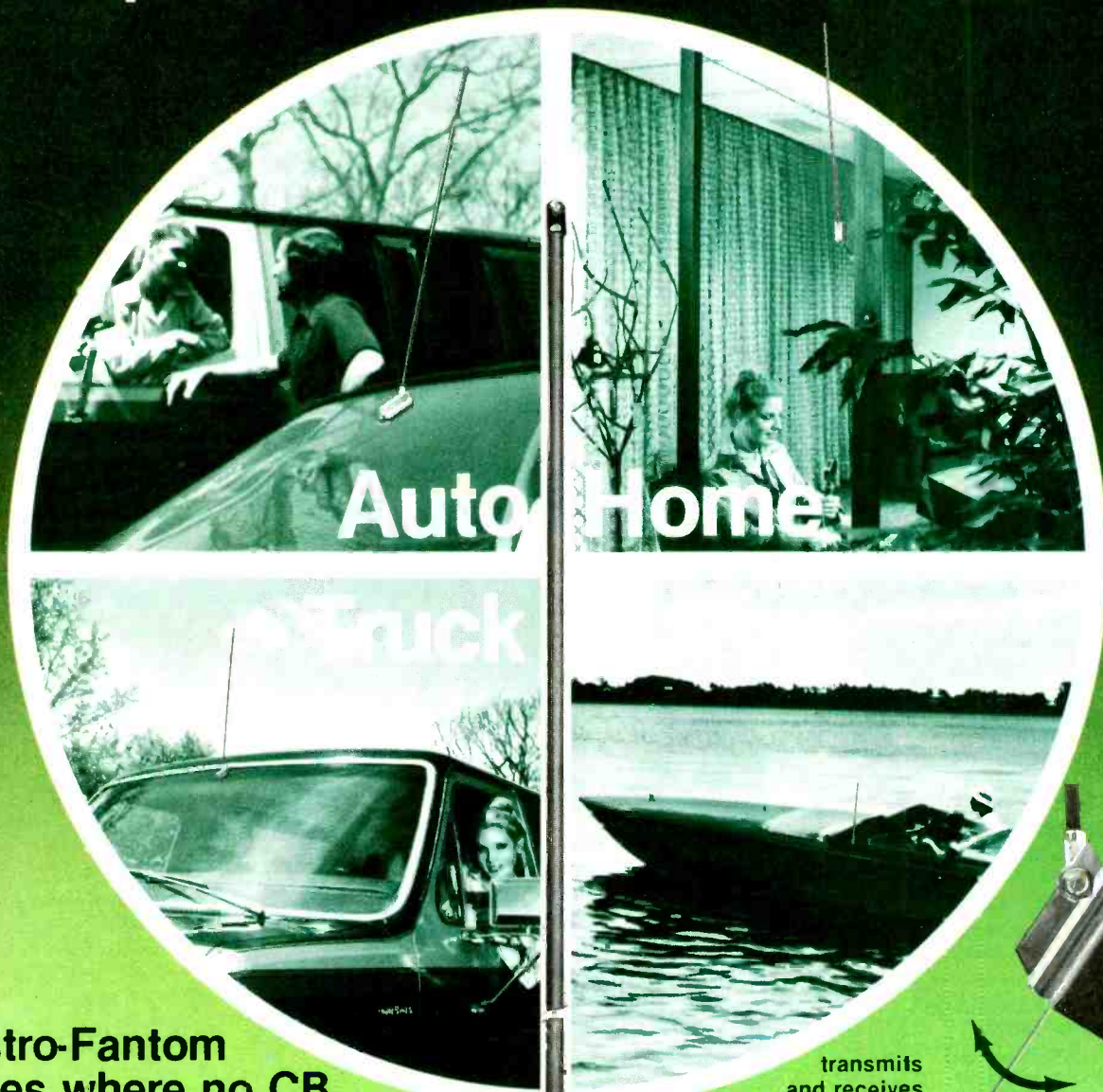

Astro-Fantom goes where no CB antennas has gone before

Now from the AVANTI Research Laboratories comes a sleek, 22" full 1/2 wave antenna, so unique that it mounts on glass with a special adhesive, transmits through glass and receives through glass...yet requires no grounding to metal as do conventional 1/4 wave antennas. No holes to drill... no clamps, clips or magnets to ever mar or scratch your car's finish! No more leaks or pinched cables to run in through doors, windows or trunk. The Astro-Fantom is a handsome, low profile antenna that provides the ultimate in convenience!



Patents Pending

Mounts on glass...

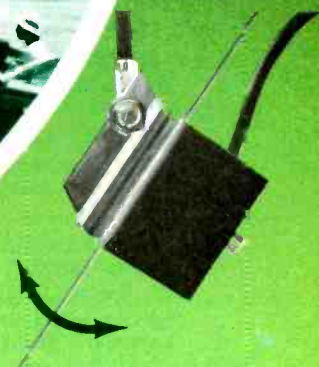

transmits and receives thru glass!

- Easy Installation.** Takes only 5 minutes
- One Mount Satisfies Every Need.** Vehicles (including fiberglass bodies), boats, motorcycles, and homes.
- Clearest Communications.** Co-inductive coupling box rejects static and interference.
- 360° Signal.** Full 1/2 wave design.

It really works!
Go to your Avanti dealer for your personal demonstration



340 Stewart Avenue, Addison, IL 60101 • (312) 628-9350
IN CANADA: Lenbrook Industries, 1145 Bellamy, Scarborough, Ontario M1H 1H5

CIRCLE 28 ON READER SERVICE COUPON

©1978 all rights reserved

THE STAFF

Editor-in-Chief
Julian S. Martin

Managing Editor
Alan H. Rose, K2RHK

Technical Editor
Gordon Sell, KBDA1464

Associate Editor
Lee Lensky, KAJR2410

Citizens Band Editor
Kathi Martin, KGK3916

Editorial Assistant
Cynthia McClean

Workbench Editor
Hank Scott

Art Director
Ralph Rubino

Assistant Art Director
David Pindar

Cover Art Director
Irving Bernstein

Art Editor
Joe Groom

Art Assistants
Celeste Barbera
Michael Vessio
Leslie Wallant

Advertising Manager
Ralph Vega

Advertising/Research Associate
Jyll Holzman, KAKZ1490

Production Director
Carl Barte

Production Manager
Carole Dixon

Production Assistant
Annette Simon

Newsstand Circulation Director
Don Gabree

Subscription Circulation Director
Robert V. Enlow

Subscription Circulation Manager
Eugene S. Slawson

Marketing Director
James C. Weakley

President and Publisher
Joel Davis

Vice President and
General Manager
Leonard F. Pinto

Vice President and Treasurer
Victor C. Stable, KBP0681

ISSN: 0013-595X

ELEMENTARY ELECTRONICS is published bi-monthly by Davis Publications, Inc. Editorial and Executive offices: 380 Lexington Ave., New York, NY 10017; all subscription orders and mail regarding subscriptions should be sent to P.O. Box 2630, Greenwich, CT 06835. In U.S.A. and possessions, one-year subscription (six issues) \$6.95; two-year subscription (12 issues) \$12.95; three-years (18 issues) \$18.95; and four years \$23.95. Elsewhere, add \$1.00 postage for each year. For change of address, please advise 6 to 8 weeks before moving. Send us your current mailing label with new address. Advertising offices: New York, 380 Lexington Ave., New York, N.Y. 10017, 212-557-9100; Chicago, 520 N. Michigan Ave., 312-527-0330; Los Angeles; J. E. Publishers' Rep. Co. 8732 Sunset Blvd. 213-659-3810. Second-class postage paid at New York, NY and at additional mailing office. Copyright 1978 by Davis Publications Inc.

elementary electronics

January/February 1979
Volume 19, No. 1

CONSTRUCTION PROJECTS FOR HOME AND WORKBENCH

- ☆ 29 Rhythm & Blues Box—*be your own computer music-maker*
- 40 Hi-Amp Meters—*heavy currents are a snap with these shunting techniques*
- 43 Mini-Reg—*now your power supply worries are over for good*

COMPUTER CAPERS

- 51 Computer Readout—*watch computers gossip with each other*
- ☆ 53 Basically Fun—*how to match wits with a microprocessor*
- 56 Computer New Products—*some of the newest in computer equipment and accessories*
- ☆ 70 Simply Basic—*this BASIC program lets you make odds on your favorite sports team*

THEORY FOR TODAY'S HOBBYIST

- ☆ 61 Digital Counting—*you can learn to count like a computer*
- 67 Stop Static—*build the cleanest circuits on the block*
- ☆ 79 Basic Course—*bone up on all the transformer theory you've forgotten*

SHORTWAVE SUBJECTS

- 22 DX Central—*Don Jensen guides you around Columbian shortwave broadcasting*
- ☆ 34 Here Come The Sunspots—*you won't recognize shortwave for the next few years, and e/e tells why*

CB SPECIFICS

- 71 Kathi's CB Carousel—*Kathi looks at some interesting new circuitry from Lafayette*
- ☆ 77 CB Transceiver Checkout—*four of the hottest new sets get the going-over*

e/e CHECKS OUT...

- ☆ 50 Indy/Cator Auto Tach—*find out how fast your engine's racing*
- ☆ 60 Information Unlimited Mutt Minder—*their bark isn't always worse than their bite*
- ☆ 75 Bearcat 250 Programmable Scanner—*what more can technology do?*
- ☆ 78 Emergency Multicore Solder—*throw away that extension cord*

ANTIQUÉ RADIO REVISITED

- 41 Antique Restoration—*fix up those old receivers and pack away your troubles*
- 73 Antique Radio Corner—*antique radio museums and other miscellany*

OUR REGULAR DEPARTMENTS

- 4 Hey, Look Me Over
- 14 Bookmark—*by Bookworm*
- 16 Hi-Fi Reports
- 24 Newscan
- 26 Ask Hank, He Knows
- 59 Test Bench New Products
- 65 Getting Your BNEE, Third Semester
- 95 Literature Library

☆ Cover Stories



AUTHORS IN THIS ISSUE

James A. Fred, Larry Friedman, Harry L. Helms, Jr., Don Jensen, Jeff Jonas, Randall Kirschman, Adolph A. Mangieri, Kathi Martin, Hank Scott, Gordon Sell, Neil Shapiro, Walter Sikonowiz, Tom Sundstrom, Tom Williams, and the ELEMENTARY ELECTRONICS Staff.





Your taste is showing.

Whatever you buy, it has to be the best.

When you buy a CB radio, it has to be a President. Because anything less is not quite up to snuff.

The Thomas J. for example. It's our finest 40-channel AM mobile unit. The *crème de la crème*.

It has unsurpassed receiver selectivity *and* sensitivity. And talkpower that's becoming a highway legend.

Thirteen knobs and switches put you in total command of this impressive performer. They include mike gain as well as RF gain, delta tune, noise blanker/ANL switch, even a panel light dimmer switch for easy reading, day or night.

Turn the meter mode selector and read signal strength received, relative RF power output, modulation or standing wave ratio, all from the same, big, precision meter.

In addition to the digital channel display, there's an LED to tell you when you're switched to Channel 9. Another LED tells whether you're receiving or transmitting. Still another lights up if you have an antenna problem.

Inside the Thomas J. looms President's advanced electronic circuitry that puts it right at the top of anybody's list for performance and dependability.



If you think just any CB is better than none at all, buy the cheapest.

If it must be the very best or none at all, buy the President.

PRESIDENT

Engineered to be the very best.

16691 Hale Avenue · Irvine, CA 92714 · (714) 556-7355
In Canada: Lectron Radio Sales Ltd., Ontario

CIRCLE 17 ON READER SERVICE COUPON

Hey, look me over

Showcase of New Products

Musicians Only

Organtua, an innovative extension of combo organ technology designed by Craig Anderton, is now available from PAIA Electronics. Unlike the "thin" sound of single voice combo organs, Organtua has three individual ranks, each with a five-position octave switch, for a thick, textured sound. The multi-voice feature allows ranks to be detuned slightly for flanging or chorusing effects, or ranks can be tuned to wider intervals



CIRCLE 69 ON READER SERVICE COUPON

such as the 4th or 5th to simulate drawbar organ or multi-oscillator synthesizer effects. The master rank utilizes a voltage controlled clock to allow pitch bending, vibrato (two waveforms), and percussion effects. The two slave ranks can each be synchronized to either the master clock or an alternate tunable clock. The output amplifier allows variable attack time and overdrive control. Available footpedals and footswitches allow the musician to bend pitch up or down, introduce vibrato or trilling, and switch the slave ranks in and out. Organtua also features a unique "octave jump" footswitch capability, which raises all ranks one octave. Organtua is available in kit form or custom assembled by PAIA. Kit price, including PAIA's usual fully-illustrated step-by-step assembly instructions and operating manual, is \$279.95 shipped freight collect. For more info, contact PAIA Electronics, Inc., 1020 W. Wilshire Blvd., Oklahoma City, OK 73116.

Incohol Aldicator

From Palmetto International comes the Breth-Alyzer, the latest thing in personal electronics for the person who has—or wants—everything. A pocket sized intoxicimeter, the Breath-Alyzer will tell you objectively if you or a friend are in a safe



CIRCLE 47 ON READER SERVICE COUPON

condition to drive after drinking alcohol. Scale shows intoxication degree from 0.1 mg/liter or less (slightly drunk) to .25 mg/liter (smashed). Selling for \$44.95, the Breath-Alyzer comes with test vial of alcohol and attractive carrying case. Palmetto International Corp., P.O. Drawer 1306, Lake City, SC 29560.

Mirror Image Speakers

A new bookshelf-size loudspeaker system, the Koss CM/530, has been computer-assisted in its design in order to achieve maximum musical performance. It comes in mirror-imaged pairs to assure identical musical reproduction from the right and left speakers, providing listeners with a very natural, life-like sound. The system has flat frequency response range and deep bass. The three-position treble control switch permits the listener to alter the high frequency response to suit room characteristics, source material and personal taste. The Koss CM/530 cabinet is finished in select pecan wood veneer with a removable chocolate brown fabric grille cover. Weighing 35 lbs. and measuring 24-in. by 13¼-in. by 11¼-in. each, the



CIRCLE 60 ON READER SERVICE COUPON

speaker system has a suggested retail price of \$175.00. For details on the CM/530 and other Koss products, write to Koss Corporation, 4129 N. Port Washington Ave., Milwaukee, WI 53212.

Four-Band Portable Scanner

A new scanning monitor receiver, the Bearcat "Four-Six" by Electra, combines reception of VHF and UHF bands in one portable unit. The "Four-Six" scanner (named for its four-band, six-channel capability) measures just 3-in. by 7-in. by 2-in. and weighs only 12 ounces. Each of the six channels has a bright red LED indicator light and individual lock-out switches for by-passing channels when desired. The Bearcat Four-Six is designed for user convenience with the

"Rubber Ducky" antenna and a belt clip as standard features. Sensitivity is rated 1 microvolt or less on VHF, 1.5 microvolt on UHF and the radio's audio power is a full 300 milliwatts. A wire antenna is included for difficult reception conditions. The external antenna jack can also be used for plugging in mobile or base antennas for extended range reception. A slide-away compartment is provided



CIRCLE 79 ON READER SERVICE COUPON

for easy access and crystals can be plugged-in in any sequence of frequency or band. The suggested retail price of the new Bearcat Four-Six is \$169.95. Complete details on this new Bearcat Four-Six hand-held scanner are available from Bearcat scanner dealers or by writing to Electra Company, P.O. Box 29243, Cumberland, IN 46229.

Mini-Solderless Breadboard

Smallest addition to the Continental Specialties Corporation Experimentor series of solderless breadboard sockets is their new Model EXP-325, a "quarter-length" model featuring DIP-standard 0.3-in. center channel spacing. The "quarter-length" reference is made by comparison with the original, roughly dollar-bill size EXP-300. The new EXP-325, 1.86-in. long by 2.1-in. wide by ¾-in. thick, is about the size of a small cookie, yet it affords two rows of 11 five-point terminals each, plus two ten-point bus strips. The EXP-325 has CSC's tongue-and-groove edge

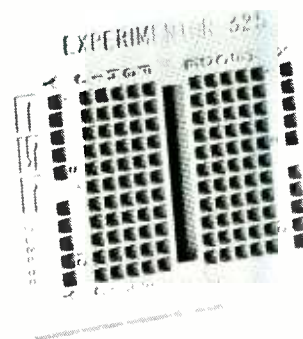

CIRCLE 62 ON READER SERVICE COUPON

construction, which also permits the attachment of a small "front panel" plastic or metal sheet to hold controls, indicators or other oversize components. The suggested resale price for the EXP-325 is \$2.75. For additional information, con-

(Continued on page 12)

step up to antenna specialists quality...



® "Stripes of Quality"

25th anniversary

our Silver Sale! makes it easy!



New "customized" look!
Model M-500 sidebody mount,
top loaded fiber glass whip
with super performance.

For over a quarter century, buying the very best CB antenna has meant buying Antenna Specialists. From superior materials, like resilient 17-7 PH stainless steel whips – to superior engineering, like the cool running coil in the famous "Big Momma" – these are the finest antennas money can buy. Only now you can buy them for less! Because your Antenna Specialists dealer is offering big 25th Anniversary savings on over a dozen of our newest and most popular models. It's a silver opportunity to move up to the stripes of quality... so see your dealer today!



® "Stripes of Quality"

the antenna specialists co.

a member of The Allen Group Inc.
12435 Euclid Ave. Cleveland, Ohio 44106
Export: 220C Shames Drive, Westbury, L.I., New York 11590
Canada: A. C. Simmonds & Sons, Ltd.

CIRCLE 34 ON READER SERVICE COUPON

SHAKESPEARE HAS

At a loss for words?

Big Stick™ Antenna gets out when the skip gets thick. With its unique design, this antenna delivers the longest possible range, the strongest signal capture area, and the lowest radiation angle of any omni-directional antenna in its class.

Only two pieces make one Big Stick

You can count on Big Stick's engineering for performance that'll keep you talking. It's the one and only two piece antenna that's a cinch to install **and** trouble-free.

U.S. Patent #4,097,870

- ① Big Stick has a band spread tuned circuit that yields a low SWR across all 40 channels. (See SWR chart)
- ② Its DC ground provision lowers static noise and reduces lightning hazard.
- ③ Signal loss is prevented by its innovative polystyrene air cell dielectric structure.
- ④ The silver plated copper braid in the decoupling sleeve lowers resistance and increases efficiency.
- ⑤ The metal radiator is completely protected by a sheath of high grade fiberglass.
- ⑥ Its aluminum mounting sleeve includes U-bolts for easy installation.
- ⑦ Factory designed crimping permanently locks the SO 239 connector in position.
- ⑧ And the connector is sealed and protected from the elements.

SWR CHART/Big Stick #176

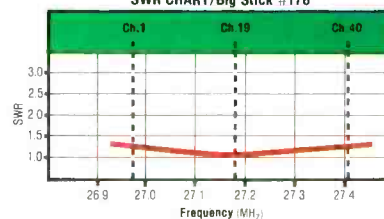

Style No. 176 Big Stick™ CB base antenna

- 300 watts power rating / DC ground
- 125 MPH wind rating
- 12 times more capture area at 60' height
- conductor sealed in fiberglass
- 18' height, includes U-bolts for mounting to 1¼" and 1½" pipe
- accepts standard PL259 connector and 50 ohm cable

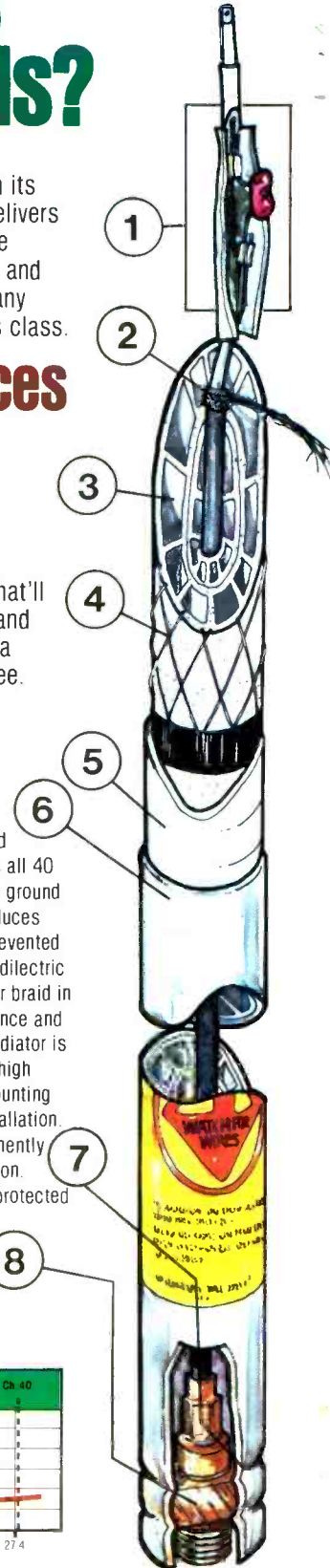

EVERYONE TALKING!

DETERIORATION, SEVERE ENVIRONMENT

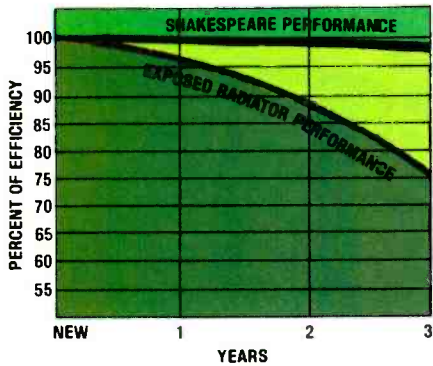

The principal of "skin effect." A transmitted signal, in the form of energy, travels on the surface of the metal radiator of an antenna. This occurs regardless of the length, density, or thickness of the metal radiator. Picture an antenna surface after it has been bombarded by millions of tiny particles day after day. Dust, dirt, pollutants, salt, chemicals...all of them impinging on the surface to create obstacles that offer resistance to your transmitted signal. Within six months exposure, surface resistance on an exposed radiator can rob you of up to 20% of your power.

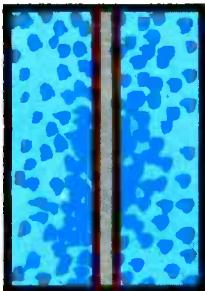

METAL ANTENNA (TYPICAL)

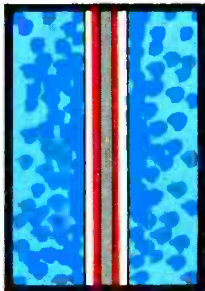

SHAKESPEARE FIBERGLASS ANTENNA

**A speck of dust?
It's hell in your eye...
even worse on your
antenna!**

When it's the surface of an antenna that's designed to radiate the signal, you're in for problems...

Metal corrodes...fiberglass does not. And the fiberglass surface of the Big Stick is far less susceptible to pollution and contaminants in the environment.

With a Shakespeare fiberglass antenna, surface contamination and crud does not mar performance because the surface is not the radiator. Instead, the radiator is sealed inside the fiberglass sheath, which is transparent to radio frequencies and lets the signal through without interference or distortion.



Tried and True!

Built in the factory so you don't have to rebuild it on your roof. Big Stick comes in two pieces. Not like the multi-pieced antenna puzzle you helped your neighbor put up last summer. You know...the one with all those radials and that huge bag of bolts. The same one that came crashing down during the windstorm.

The Big Stick is super engineered. Quick, easy installation allows you more time to modulate. High winds or solid ice...it's built to keep you talking whatever the weather.

RELAX...the world's largest Fiberglass antenna plant just made your next antenna.



200,000 square feet devoted entirely to communications antennas and related fiberglass products, complete with advanced testing facilities and laboratories for research and development.



ELECTRONICS AND FIBERGLASS DIVISION
Antenna Group/P.O. Box 246, Columbia, S.C. 29202

The Shakespeare Company / Manufacturers of Communication Equipment, Fishing Tackle, Industrial Fiberglass, Wonderthread and Specialized Monofilaments, Golf Equipment, Automotive Products, Saddlery and Equestrian Accessories, and Marine Taxidermy.

CIRCLE 25 ON READER SERVICE COUPON

At CIE, you get electronics career training from specialists.

If you're interested in learning how to fix air conditioners, service cars or install heating systems – talk to some other school. But if you're serious about electronics, come to CIE – The Electronics Specialists.

John E. Cunningham

**Special Projects Director
Cleveland Institute of Electronics**



My father always told me that there were certain advantages to putting all your eggs in one basket. "John," he said, "learn to do one important thing better than anyone else, and you'll always be in demand."

I believe he was right. Today is the age of specialization. And I think that's a very good thing.

Consider doctors. You wouldn't expect your family doctor to perform open heart surgery or your dentist to set a broken bone, either. Would you?

For these things, you'd want a specialist. And you'd trust him. Because you'd know if he weren't any good, he'd be out of business.

Why trust your education and career future to anything less than a specialist?

You shouldn't. And you certainly don't have to.

FACT: CIE is the largest independent home study school in the world that specializes exclusively in electronics.

We have to be good at it because we put all our eggs in one basket: electronics. If we hadn't done a good job, we'd have closed our doors long ago.

Specialists aren't for everyone.

I'll tell it to you straight. If you think electronics would make a nice hobby, check with other schools.

But if you think you have the cool—and want the training it takes—to make sure that a sound blackout during a prime time TV show will be corrected in seconds—then answer this ad. You'll probably find CIE has a course that's just right for you!

At CIE, we combine theory and practice. You learn the best of both.

Learning electronics is a lot more than memorizing a laundry list of facts about circuits and transistors. Electronics is interesting because it's based on some fairly recent scientific discoveries. It's built on ideas. So, look for a program that starts with ideas—and builds on them.

That's what happens with CIE's Auto-Programmed® Lessons. Each lesson uses world-famous "programmed learning" methods to teach you important principles. You explore them, master them completely... before you start to apply them!

But beyond theory, some of our courses come fully equipped with the electronics gear to actually let you perform hundreds of checking, testing and analyzing projects.

In fact, depending on the course you take, you'll do most of the basic things professionals do every day—things like servicing a beauty of a Zenith color TV set... or studying a variety of screen display patterns with the help of a color bar generator.

Plus there's a professional quality oscilloscope you build and use to "see" and "read" the characteristic waveform patterns of electronic equipment.

You work with experienced specialists.

When you send us a completed lesson, you can be sure it will be reviewed and graded by a trained electronics instructor, backed by a team of technical specialists. If you need specialized help, you get it fast... in writing from the faculty specialists best qualified to handle your question.

People who have known us a long time, think of us as the "FCC License School."

We don't mind. We have a fine record of preparing people to take... and pass... the government-administered FCC License exams. In fact, in continuing surveys nearly 4 out of 5 of our graduates who take

the exams get their Licenses. You may already know that an FCC License is needed for some careers in electronics—and it can be a valuable credential anytime.

Find out more! Mail this card for your FREE CATALOG today!

If the card is gone, cut out and mail the coupon.

I'll send you a copy of CIE's FREE school catalog, along with a complete package of independent home study information.

For your convenience, I'll try to arrange for a CIE representative to contact you to answer any questions you may have.

Remember, if you are serious about learning electronics... or building upon your present skills, your best bet is to go with the electronics specialists—CIE. Mail the card or coupon today or write CIE (and mention the name and date of this magazine), 1776 East 17th Street, Cleveland, Ohio 44114.



Patterns shown on TV and oscilloscope screens are simulated.

CIE Cleveland Institute of Electronics, Inc.

1776 East 17th Street, Cleveland, Ohio 44114

Accredited Member National Home Study Council

YES... John, I want to learn from the specialists in electronics—CIE. Send me my FREE CIE school catalog—including details about troubleshooting courses—plus my FREE package of home study information.

EL-06

Print Name _____

Address _____ Apt. _____

City _____

State _____ Zip _____

Age _____ Phone (area code) _____

Check box for G.I. Bill information: Veteran Active Duty

Mail today!



HOBBY WORLD CATALOGUE

The new Hobby World Catalogue. 20 pages of factory prime, professional quality equipment (no surplus). Computers, add-on boards, prototype boards, IC's, sockets, resistors, supplies, tools, test equipment, books, and more. Shop your buy list. You'll find what you want in Hobby World, and at a solid savings.

SPECIAL
16K MEMORY ADD-ON FOR
APPLE OR TRS 80.
ONLY \$98.00
TERRIFIC PRICE!
(Specify when ordering)

To order or request free Catalogue
write Hobby World
19355 Business Center Drive #6
Northridge, California 91324
TELEPHONE ORDERS
Inside Calif. 213-886-9200
Outside Calif. 800-423-5387

CIRCLE 35 ON READER SERVICE COUPON

BY POPULAR DEMAND!

MS-215 Dual Trace Miniscope



With Rechargeable
Batteries & Charger Unit. **\$435**

- 15-megahertz bandwidth.
- External & internal trigger.
- Auto or line sync modes.
- Power usage — < 15 W.
- Battery or line operation.
- 2.9" H x 6.4" W x 8.0" D.



Non-Linear Systems, Inc.

Originator of the digital voltmeter.

Box N, Del Mar, California 92014

Telephone (714) 755-1134 TWX 910-322-1132

CIRCLE 38 ON READER SERVICE COUPON

HEY, LOOK ME OVER

(Continued from page 4)

tact Continental Specialties Corporation, 70 Fulton Terrace, New Haven, CT 06509.

Checkbook Calculator

The all new National Semiconductor Data Checker, a new thinline "checkbook" calculator with three continuous memories, allows a user to maintain and update both checkbook balance and balances for any two selected charge accounts. The three memories are simple to use, and do not interfere with usage of the calculator. The Data Checker, designated NS 103, was engineered for consumer ease of use. Balances are maintained even when the unit's power is off, and automatically updated as each new transaction is made. Balance figures, as well as calculator read-outs, are dis-



CIRCLE 44 ON READER SERVICE COUPON

played on large Liquid Crystal Display (LCD), with 6mm digits. The Data Checker is also a full-function calculator, including a "live" percent key with automatic add-on, discount, and net. Suggested retail price for the Data Checker is \$39.95, with checkbook case and pen included. The unit is now available from National Semiconductor's Consumer Products Division, 1120 Kifer Road, Sunnyvale, CA 94086.

Blood Pressure Unit

Edmund Scientific is offering an electronic blood pressure gauge ideal for home use. The gauge gives a reading by sight and sound and is a simple one-handed operation. Equipped with a Vello cuff, it is easy to use, will hold firmly for accurate readings and does not require a stethoscope. It is equipped with a flashing light and audible beep for systolic and diastolic readings. Complete unit includes blood pressure record charts, gauge unit, 9-volt battery, instruction booklet and a vinyl carrying case. No prior knowledge or experience is necessary. Praised by physicians and bio-medical engineers, it completely automates the taking of blood pressure. Its easy-to-read scale is graduated from 0 to 300 millimeters of mercury. The



CIRCLE 56 ON READER SERVICE COUPON

Electronic Blood Pressure Gauge (stock no. 61,188) is priced at \$79.95 post-paid. Your electronic blood pressure gauge can be ordered by mail from Edmund Scientific Co., 7782 Edscorp Bldg., Barrington, NJ 08007.

Hog the Channel

Valor Enterprises' Road Hog antennas have been completely redesigned to deliver the power and performance that big rig truckers demand, like top loading, a 3/8 wave and 1000 watt rating. Super strong construction is built into every Road Hog by using a 3/8-in. fiberglass rod which is permanently bonded inside a longer, chrome plated ferrule by a special adhesion process. Precision wound, 16 gauge, insulated copper wire is terminated and soldered inside for positive electrical contact, reducing the potential of wire breakage. SWR is checked after initial construction and checked again after a super strong, black, heavy duty polyolefin dielectric shielding is applied to assure a consistently low SWR (under 1.5:1 over 40 channels and more). Road Hog Antennas come in three sizes: Model 335 is 48-in. \$16.95, Model 336 is 60-in. \$17.95 and Model 337 is 69-in. \$18.95. All three are available separately or in a variety of single



CIRCLE 75 ON READER
SERVICE COUPON

and double kits. The single kits are pre-wired with Valor's exclusive in-line mini-connector system. Hog Antennas are now available in three colors: red, black and white. For more information on the Road Hog or any Valor Communication product, write to Valor Enterprises, Inc., 185 West Hamilton Street, West Milton, OH 45383.

Preassembled Beam CB Antenna

Channel Master has just introduced a CB beam antenna called Signal Tracker. The new beam antenna can be completely assembled and ready for mount-

ing in less than 10 minutes. Its elements snap into place like those elements found on preassembled TV antennas. Takes less time to assemble, and requires very few pieces of hardware. Signal Tracker is a high-efficiency CB beam antenna made of heavy-strength drawn aluminum tubing. Its boom length is only 12.9 ft. Signal Tracker features a 13.5 dB gain over an isotropic source and front-to-back and side separation of

CIRCLE 66 ON READER SERVICE COUPON

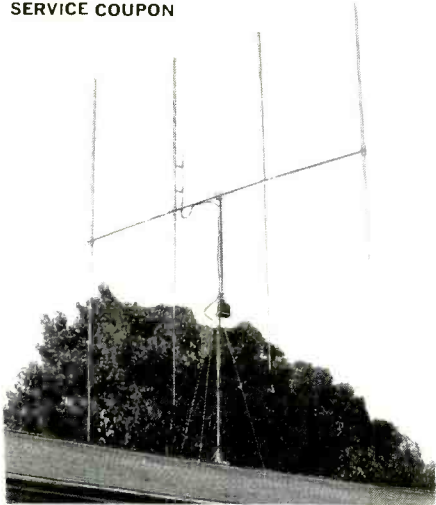

30 dB. SWR at resonance is 1.1:1. Impedance match is 50 ohms. Signal Tracker is gold EPC coated for maximum weather protection. VSWR can be adjusted to obtain optimum performance

on a desired channel. The antenna works with 23 and 40 channel transceivers, both AM and SSB. Model 5059—price \$79.95. For more information, write to Channel Master, Ellenville, NY 12428.

Calculator Size Counter

CSC has introduced their new Mini-Max Counter, a small, inexpensive counter with 50 MHz performance. The Mini-Max features a six-digit magnified LED display with 100 Hz resolution. Decimal points after the second and fifth digits act as pilot lights and indicate MHz and KHz points on the display. The counter



CIRCLE 62 ON READER SERVICE COUPON

display updates ten times per second, permitting easy "speed-read" mode frequency tuning without the usual one second delay between counter readings.

A UHF FET preamplifier provides weak-signal performance, permitting the Mini-Max to be driven directly from an optional accessory whip antenna. Using a standard TV color burst crystal for its timebase, the Mini-Max achieves ± 3 ppm timebase accuracy, user trimmable. Suggested resale price for CSC's Mini-Max is \$89.95. A number of optional accessories are also being made available, including an antenna, input cables, a carrying case, AC and automotive battery eliminators. For additional information, contact Continental Specialties Corp., 70 Fulton Terrace, New Haven, CT 06509.

Mobile Speaker

Acoustic Fiber Sound has a new 8-inch round Model 2831 extended range dual cone speaker that is designed for use

CIRCLE 58 ON READER SERVICE COUPON



in motor homes and other recreational vehicles, cars, trucks and for commercial *(Continued on page 94)*

ok® wire wrapping center ok®



WIRE WRAPPING KIT WK-5

CONTAINS:

- Battery Tool BW-630
- Hobby Wrap Tool WSU-30 M
- PC Edge Connector CON-1
- DIP IC Extractor Tool EX-1
- DIP IC Insertion Tool INS-1416
- PC Card Guides & Brackets TRS-2
- Mini-Shear with Safety Clip SP-152
- 14, 16, 24 and 40 DIP Sockets
- Terminals WWT-1
- Tri-Color Wire Dispenser WD-30-TRI
- Hobby Board H-PCB-1

\$74.95

ADD \$2.00 FOR SHIPPING
(N. Y. CITY AND STATE RESIDENTS ADD TAX)

OK MACHINE & TOOL CORPORATION

3455 Conner St., Bronx, N.Y. 10475 (212) 994-6600 / Telex 125091

CIRCLE 5 ON READER SERVICE COUPON



BOOKMARK BY BOOKWORM

Keeping Cool. It is amazing how an electromechanical-fluid system can seem so complex to us. So much so, that we cannot analyze what is wrong with it when it fails. *You and Your Air Conditioner* by Louis J. Mangro, Jr., is a practical guide to air conditioning repair. The layman will find easy-to-follow, step-by-step explanations of what must be done and how to do it. This service manual is for the use of the average air conditioner owner who would like to save money by avoiding expensive service calls. The author tells the reader how to troubleshoot and then shows how to replace defective parts and perform other maintenance on both central and window-



Repairing your air conditioner the easy way.

Soft cover
54 pages
\$5.00

unit air conditioners. Photographs and schematic drawings make it possible for the less experienced do-it-yourselfers to work safely and confidently from the directions in this manual. Published by Dorrance & Company, 35 Cricket Terrace, Ardmore, PA 19003.

Build a TV Projection System. Edmund Scientific is offering a new booklet: *How to Design Your Own TV Projection System*. Written by Al Nagler, an optical designer, it explains how a do-it-yourselfer, using Edmund's Super TV Projection Lens, can have big screen television with his own home table-top system for as little as \$390. Edmund estimates that a contemporary cabinet system can be constructed for about \$458.00—a tremendous savings when compared with complete systems



Big screen TV for a little price.

Soft cover
14 pages
\$1.95

selling today for \$1500 to \$4000. Contents of this simplified booklet include: Building a Projection TV System, Cabinet Construction Ideas, Setting Up the System, Specifications and Cost Estimates. Nagler points out that maximum bright-

ness, contrast and sharpness should be achievable at the highest brightness control setting, and that regardless of the TV used, one should have excellent reception to fully enjoy the giant picture. Prices approximated above include all the materials, but not the price of the TV set. The simplified booklet which has been designed to save money and to give the family an interesting weekend project can be obtained by mail (Stock No. 9565) by writing to Edmund Scientific Co., The Edscorp Bldg., Barrington, NJ 08007. An Edmund catalog, cover-priced at \$1.00, can be obtained free, by writing to the above address.

Get Started. Now you can study basic electronic principles at home and use what you learn in simple experiments. *NCR Basic Electronics Course with Experiments*, offered by E&L Instruments, teaches basic electronic circuit principles in a home study text written for technicians and hobbyists. Prepared by the technical education department of the National Cash

Your introduction to electronic experimentation

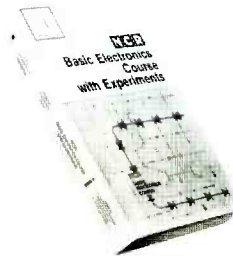

Soft cover
440 pages
\$9.50

(Continued on page 93)

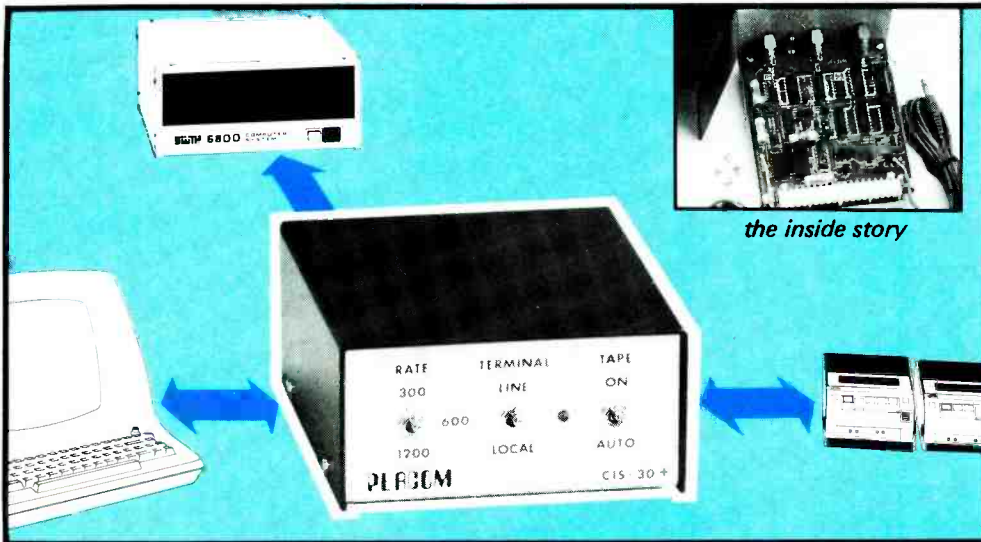

the inside story

- Record and playback at 120, 60 or 30 self-clocking bytes per second (extended Kansas City Standard)
- 1200, 600 or 300 baud data terminal interface
- Dual cassette operation
- Compatible with SWTPC cassette software
- Optional kit permits program control of cassettes
- Optional adaptor permits interfacing with any computer

Upgrade your SWTPC 6800 system to 1200 baud with PerCom's CIS-30+ dual-cassette/terminal interface

The CIS-30+ . . . four times as fast as SWTPC's AC-30 with the same dual-cassette capability . . . plus a 1200-baud data terminal interface . . . in a SWTPC color-compatible package that's only 1/10 the size of the AC-30.

Dependable? The simplicity of Harold Mauch PerCom Data designs says more than any well-chosen words. Simply put, for only \$79.95* you get the fastest, most dependable dual function interface you can buy for your SWTPC 6800.

See your nearest dealer or order direct from PerCom.

PerCom 'peripherals for personal computing'



PERCOM DATA COMPANY, INC.
DEPT. E • 318 BARNES • GARLAND, TX 75042
(214) 272-3421

*Kit price. Assembled and tested: \$99.95 + shipping. Tex. res. add 5% tax. BAC & MC available.

CIRCLE 16 ON READER SERVICE COUPON

The New Realistic[®] High-Power, 3-Way Speaker for Sensational Autosound

6x9" Woofer! 2-3/4" Midrange! Solid-State Tweeter!

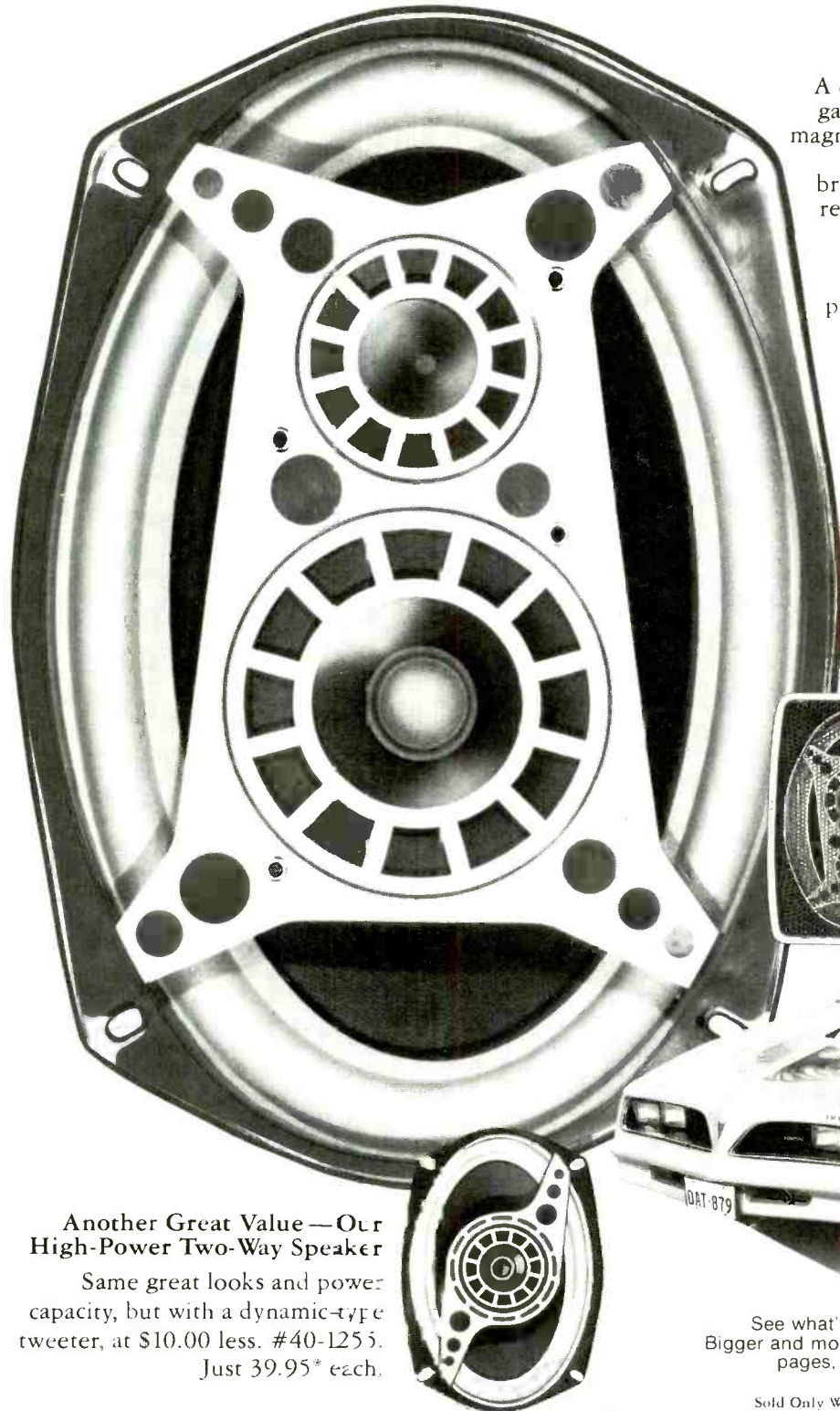

A car speaker like no other. Why? We gave it a big woofer with a 1 1/4-pound magnet and a 4-layer voice coil for deep and powerful bass — without cone breakup and distortion. For midrange realism, we built-in a separate coaxial cone with its own magnet and 4-layer voice coil. And for brilliant high frequencies, we added a piezoelectric tweeter with solid-state reliability, simplicity and freedom from distortion. The result? True hi-fi quality in a system handling up to 60 watts RMS, yet efficient enough for moderate power amplifiers. Manufactured by Radio Shack in *our own* Fort Worth factory. Ask for #40-1256 and drive a thunderous bargain at 49.95* each.

*Retail prices may vary at individual stores and dealers

Heavy-duty acoustically transparent grill included!

"Installing my Realistic speakers was easy — all mounting hardware and instructions were included."



Another Great Value — Our High-Power Two-Way Speaker

Same great looks and power capacity, but with a dynamic-type tweeter, at \$10.00 less. #40-1255. Just 39.95* each.

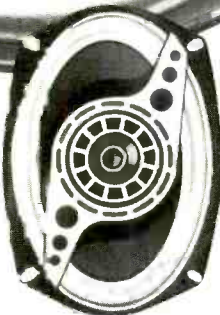

FREE '79 Catalog!

See what's really new in electronics. Bigger and more colorful than ever — 176 pages, over 2000 exclusive items!



Sold Only Where You See This Sign:

Radio Shack[®]

A Division of Tandy Corporation, Fort Worth, Texas 76102



STEREO ONE

Auto FM Signal Booster

to eliminate signal fading

Compliments Any Dash Board.



List Price \$24.95

Write for catalog #20-803/Dept. 46

THE FINNEY COMPANY
34 West Interstate Street, Bedford, Ohio 44146

CIRCLE 12 ON READER SERVICE COUPON

ADVANCED Electronic Music

Products....effects devices to computer controlled modular synthesizers. Select from experimenter's kits, step-by-step product kits or fully assembled professional equipment.



FREE color catalog

RAIA ELECTRONICS, INC.
1020 W. Wilshire Blvd., Oklahoma City, OK 73116

SEND FREE CATALOG TO:

name _____

address _____

city _____ state _____ zip _____

RAIA ELECTRONICS, DEPT. EE

1020 W. WILSHIRE BLVD., OKLAHOMA CITY, OK 73116

CIRCLE 15 ON READER SERVICE COUPON

HI-FI REPORTS

Give your system the cassette advantage with Sanyo's budget priced RD-5350 or Pioneer's microprocessor controlled CT-F-900. By Gordon Sell

CASSETTE TAPE DECKS have come a long way towards meeting the needs of the audiophile in the past few years. Considering that the cassette tape format was originally designed for use in car units and portables, it is amazing how fast it has been adapted to high-fidelity recording. While few tape units can match the dynamic range and frequency response of a good turntable and cartridge combination, their ability to record material live, off-the-air, or to copy other tapes and records makes them invaluable to the hi-fi enthusiast. The boom in car stereo systems has also given the home cassette deck a boost in popularity, since you can play your favorite cuts both at home and away from home. If you are reading this magazine your interest in electronics obviously includes more than just hi-fi; you can use a cassette for recording shortwave catches, hard-to-copy code or perhaps even wire it up to your computer.

If you want this kind of versatility in your home you might find these two new cassette decks of interest.

Pioneer CT-F-900 Cassette Deck. Featuring microprocessor control and outstanding performance this set is a great buy at \$475. It not only works impressively but it looks clean and businesslike with lots of switches, knobs, push buttons and flashing LEDs. It features adjustable bias that allows you to fine-tune the deck to the characteristics of the type of tape you use, plus a manual switch for standard or chrome tapes and an automatic chrome detector for tapes equipped with a so-called "chrome detection hole." I'll just mention that this set has a Dolby noise suppression circuit, but I haven't seen a Dolby-less cassette deck for three years.

The engineering on the CT-F-900 is impressive. There are two motors with dual capstan drive and all the tape drive controls are servo-operated so

that you are free of the usual records' clicks and clanks. There are separate record, playback and erase/bias heads and the performance on our test bench really reflects the effort that was put into this set.

With Dolby on and using Maxwell UD/XL Type II (chrome) tape the record/play frequency response measures +0/-3 dB from 40 to 13,500 Hz. Distortion at the meter-indicated zero-dB level is 1.1 percent THD with 7 dB headroom to 3 percent THD. The signal to noise ratio is 48 dB wideband and 63 dB narrowband. Wow and flutter is granite steady at 0.08 percent and the output level corresponding to a zero-dB recording level is 700 millivolts.

The best thing about the Pioneer



CIRCLE 54

Pioneer CT-F-900 Cassette Deck

CT-F-900, however, is the microprocessor control. This provides memory rewind, time controlled record or play preset, partial play, and repeat, all monitored via a bright clear LED numeric display. Instead of your standard VU meter this deck has a bar-graph type fluorescent display that not only gives average recording level but can be programmed to read peak recording level or hold on the highest peak in a section of music. For more information about the Pioneer CT-F-900, circle number 54 on the reader service coupon.

Sanyo RD-5350 Dolby Cassette Deck. The RD-5350 is an excellent low to medium priced (\$219.95) cassette deck that performs very well with budget priced tapes. It features a bias/equalization switch with positions for normal, ferrichrome and chrome tapes; two well-calibrated VU meters; three peak recording level indicators calibrated at 0 dB, +3 dB, and +6 dB; and, of course, Dolby.

CIRCLE 68

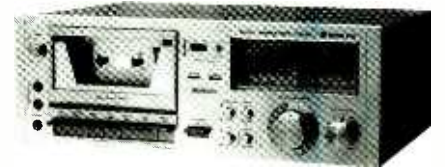

Sanyo RD-5350 Cassette Deck

It has smooth functioning piano key type tape controls; switches for power, Dolby, input selection, bias and equalization, and controls for left and right input levels, and ganged output.

Using TDK-SD tape but without Dolby the record/play frequency response measures +0.6/-1.8 from 40 to 14,000 Hz—down 2.5 dB at 35 and 15,000 Hz. THD is 1.1 percent with 5 dB headroom to 3 percent THD. The signal to noise ratio is 49.5 dB. With Dolby, however, the signal to noise ratio is up to an impressive 55 dB wideband and 59.5 dB narrow band with some loss in frequency response.

The maximum output level corresponding to a zero VU average recording level is 620 millivolts. The peak level indicator calibrations are right on the mark at 0.0 dB, +3 dB and +6 dB. The wow and flutter measures in at 0.09 percent with peaks to 0.15 percent.

Overall this is a very good set for the money. The tape handling mechanism is one of the best ever to pass through our laboratory. It's easy to load and unload, and a snap to keep clean. If you want more information about the Sanyo RD-5350, circle number 68 on the reader service coupon.

What's New? Here are a few little jems that you might like to add to your systems. Just circle the appropriate number on the readers service coupon elsewhere in this issue and a brochure will be sent to you.

Radio Shack has a new Realistic integrated amplifier called the SA-2001 that puts out 60 watts RMS of very clean music power for \$279.95 with a wood cabinet. Circle number 32.

Hitachi has a new microprocessor controlled cassette deck in the works that automatically tests a tape and adjusts the bias in a whirl of flashing LEDs. On the market in January for about \$1,000. Circle number 46.

Audio Technica has a super new phono cartridge, the AT20SS, with a beryllium cantilever stylus arm and Shibata tip. List price \$195. Circle No. 65.

Nakamichi has introduced an Audio Analyzer that will measure power, wow and flutter, speed, drift, total harmonic distortion and more. Retail for \$800. Circle No. 73.

TDK has a cure for magnetized cassette heads, the HD-01 head demagnetizer. It is shaped like a cassette for easy use. Suggested price: \$21.99. Circle No. 70.

Technics is temporarily winning the "Watt War" with a wild 330-watt RMS per channel into 8 ohms receiver called the SA-1000. Retail for \$1500. Circle No. 81.

Empire Scientific seems to have the answer to gritty grooves, a record cleaning liquid that dries and peels off taking dirt with it. Retail for \$29.95. Circle No. 78.



CREATE!

You don't waste a second on "mechanics" with A P All-Circuit Evaluators.

You figure out the circuit you want, then plug it in for testing. You decide to improve your layout, and you make your moves as quickly as you think them up. There's just no faster or easier way to build and test circuits and circuit ideas.

But just because breadboarding is now such a cinch, don't get the idea that you don't have electronic integrity. Our solderless plug-in tie

points are made of a special non-corroding alloy. Use them as often as you like.

How many tie points do you need? Our smallest ACE has 728, our largest has 3,648. And all of them accept all DIP sizes.

Everything is quality all the way. You can even see the difference in our harder, shinier plastic matrix.

See for yourself. Phone (toll-free) 800-321-9668 for the address of your nearby A P Products dealer. And ask for our complete A P catalog, *The Faster and Easier Book*.



A P PRODUCTS INCORPORATED

Box 110C • 72 Corwin Drive
Painesville, Ohio 44077
Tel. 216/354-2101
TWX: 810-425-2250

Faster and Easier is what we're all about.

Now NRI makes it TV/Audio home

**Side-by-side
equipment comparison
of NRI and two
other leading schools
shows that you get
for what you pay.**

**When you have to pay
as much as \$985 more
for another school's course,
you should carefully
consider your tuition
investment.**

When you sit down and try to pick out the school that's best for you, it gets

to be a problem. Catalogs are radically different and some are not too clear as to what you actually get for your money. So NRI has done a lot of the work for you. And put the prices right up front so you can make your own judgment.

Of course, we can't compare everything. Lesson clarity and content vary. What one covers here, another covers there... or not at all. The material one school breaks down into eight lessons may be four at another. And the qualifications and abilities of instructors are another question.

One Million Students, Over 60 Years' Experience

So we can only tell you what NRI has to offer. We've been in education since 1914, starting as a radio school six years before commercial broadcasting was even on the scene. Since then, we've kept right up with the times, improving techniques, adding material, creating new courses to help people improve their skills and income.

Early on, we learned to keep our lessons compact...thoroughly covering a subject, but not so much that students would be overwhelmed. We call them "bite-size" lessons because they're easy to digest.

Learn by Doing with "Hands-on" Training

And, we pioneered the concept of "hands-on" training. NRI goes far beyond theory and textbooks to give our students actual bench experience and prepare them for the realities of electronic servicing. Every piece of equipment in our Master Course in TV and Audio Servicing is designed for learning. As you assemble the kits we supply, you build a highest-quality, up-to-date 25" (diagonal) color TV, a 4-channel amplifier and tuner with speakers, your own oscilloscope,

	NRI	SCHOOL A	SCHOOL B
COURSE TITLE	Master Course in TV, Audio, and Video System Servicing	Master Course in Color TV Servicing	Electronics Technology and Advanced Troubleshooting I & II
CASH PRICE (terms available)	\$1295	\$1539	\$2280
TV SET	NRI designed-for-learning kit. Dual speaker 25" (diagonal) color TV with cabinet	Heathkit GR-2001 25" (diagonal) color TV (cabinet extra)	Zenith model G4020W 19" (diagonal) color TV (fully assembled)
OSCILLOSCOPE	NRI designed-for-learning kit. 5" (8 x 10 cm) triggered sweep	Heathkit IO-4541 5" (8 x 10 cm) triggered sweep (not given until after graduation)	Heathkit IO-4541 5" (8 x 10 cm) triggered sweep
COLOR BAR GENERATOR	NRI designed-for-learning kit. 10 patterns	Elenco SG-200 (kit) 10 patterns	Elenco SG-200 (fully assembled) 10 patterns
FREQUENCY COUNTER	NRI designed-for-learning kit. Complimentary metal oxide semiconductor digital type		
METER	NRI designed-for-learning kit. Transistorized AC/DC volt-ohm meter	Heathkit (part of TV kit) DC only; 1K Ohm/volt	Private label multimeter
AUDIO	NRI designed-for-learning kit. Four-channel high-fidelity AM/FM tuner with speakers	Private label pocket transistor AM radio kit and AM-FM-SW solid-state portable radio kit	
TRAINER	NRI Discovery Lab	Breadboard	Experimental Electronics Lab
MISCELLANEOUS EQUIPMENT		EICO Digital Logic Probe	

All data as shown in each school's catalog as of September 1, 1978.



Learn as you build with "hands-on" training.

easy to compare study courses.

digital frequency counter, and other instruments you'll use in your course, use later to earn good money as a TV/Audio technician.

The point is, none of this equipment is hobby-kit or commercial assembly line units with lessons "retro-fitted" to what was at hand. NRI has designed each so you get invaluable training and experience you just can't get any other way. As you build, you study operation of circuitry, see how sections interact, perform "power-on" experiments only possible with NRI. This total training is exclusive with NRI...no other school, home study or resident, offers it.

Instructors Who Know Their Business

NRI instructors are thoroughly qualified, with both technical and educational experience. Most of them helped develop NRI courses, lessons, and equipment, so they really know what they're talking about. They're interested in their students, always ready to help with a question, a problem...give good advice to help you reach your goals.

It's instructors and training like this that have made NRI the choice of professional TV servicemen who have taken home study courses. As a national survey shows (summary on request), they recommend NRI by a majority of three to one over any other school.

So how does NRI give you all this and still cost so little? We keep costs down by designing our own training kits, eliminating the middleman's profit on hobby kits or commercial units. And by offering our training by mail only. We have no sales force, no commissions to pay. You make up your mind in your own time, without pressure, let the facts speak for themselves. We pass these savings on to you in the form of lower tuitions, more equipment, carefully designed courses and effective lessons.

Send for Free Catalog, No Salesman Will Call

Send for our free catalog today and get all the details. See every piece of equipment and kit you get...a complete listing of fully described lessons...explanations of each and every experiment you perform. Read about NRI's background and qualifications...career opportunities...what NRI graduates say about their training...costs and monthly payment plans for the courses that interest you. Then compare NRI value and results and make your decision. Like the million that have gone before you, we think you'll choose NRI. Send the card today.



Build and keep 2-meter transceiver, test equipment for a communications career.

Or check out NRI value-training in Computer or Communications/CB Equipment Servicing.

If you're interested in learning how to service and maintain digital computers, check out our NRI course. You learn at home, in your spare time, and actually

build a programmable, integrated circuit, digital computer with expanded memory.

Or maybe your interest is CB or the expanding world of communications...mobile radio, microwave,

TV broadcasting, and much more. NRI can help you there, too, as you build and experiment with your own digitally synthesized 2-meter transceiver. For these and other NRI home study courses, just check the postage-paid card and mail today. If card is missing, write to:



NRI Schools
McGraw-Hill Continuing
Education Center
3939 Wisconsin Avenue
Washington, D.C. 20016

FREE SWL
CATALOG
Audio—Computers
Instruments
Kits & Assembled



Southwest Technical Products Corporation
219 W. RHAPSODY
SAN ANTONIO, TEXAS 78216

CIRCLE 26 ON READER SERVICE COUPON

**The world of
electronics
gee-wizardry**



-YOURS FREE.

32-pages of test instruments — from the latest digital multimeters to the famous EICO scopes. Security systems. Automotive and hobbyist products. Kits and assembled. EICO quality. EICO value. For FREE catalog, check reader service card or send 75¢ for first class mail.

EICO® 108 New South Road
Hicksville, N.Y. 11801

CIRCLE 2 ON READER SERVICE COUPON

**DX central
reporting**

A world of SWL info!

BY DON JENSEN

□ "Columbia, the Gem of the Ocean!" So goes the patriotic verse. But for shortwave listeners, it's Colombia—with an "o," not a "u" in the middle—that's a gem when it comes to DXing.

Colombia is the linchpin of South America that ties the southern continent to Central America, a major Latin nation washed by both the Atlantic and the Pacific. It is a land of contrasts; humid jungles, sunbaked plains, lofty Andean mountains, sunny, sandy beaches, major cities and tiny villages.

That contrasting nature of Colombia holds true when it comes to shortwave broadcasters. There are the pop and Latin sounds of the big city stations, and the uplifting programs and classical music of the national government's shortwave voice. On Colombia's great plain, where beef is king, you'll hear numerous "ranchera" selections, music more Mexican than one would expect.

Programming from the many Colombian shortwave stations is almost exclusively in the Spanish language. I think almost any SWL who is willing to put forth the effort can in time manage to pick out the identification announcements even in Spanish. Here are a few of the Colombian shortwave outlets you may hear.

Radio Nacional—This is the shortwave outlet of the national government and broadcasts from Bogota, capital of Colombia. This has been widely heard on 15,335 kHz, approximately, with programs that tend to be a bit more on the highbrow level than the typical Latin American station. Don't be surprised to hear classical selections from this station. One of the rare opportunities to hear English on a Colombian station is the English-Spanish lesson at 1045 GMT.

Radio Sutatenza—This shortwave station may be the beginner's best bet for logging a Colombian SW'er. Radio Sutatenza, in Bogota, is owned and operated by a Roman Catholic organization dedicated not only to religious goals but also to social and educational improvement. At 50 kilowatts of power, it is one of the stronger stations in South America. Perhaps of equal importance is the fact that Radio Sutatenza operates on a somewhat isolated

frequency, 5,095 kHz, where most SWLs, even with relatively inexpensive receivers with only average frequency readout abilities, can find it.

From this point on, most of the Colombian stations are commercial operations heavy on the Latin sound when it comes to music. There are a couple of dozen stations that can be tuned without great difficulty. These are some of those which have been putting out decent signals in recent months. Most of them can be heard during the evening hours.

Emisora Nuevo Mundo, HJEU, Bogota, 4,755 kHz, operates 24 hours a day.

Radio Guatapuri, HJVG, Valledupur, 4,815 kHz.

Radio Bucaramanga, HJGF, Bucaramanga, signs off at 0400 GMT, 4,845 kHz.

Ondas del Meta, HJIG, Villavicencio, 4,885 kHz.

Emisora Meridiano 70, HJJU, Arauca, 4,925 kHz.

Radio Colosal, HJHD, Neiva, 4,945 kHz, 24 hours a day, a good bet for all. For those not familiar with Spanish pronunciation, it is "ko-lo-SAHL."

Radio Santa Fe, HJAE, Bogota, 4,966 kHz, another easily heard 24-hour-per-day station.

Radio Surcolombiana, HJOX, Neiva, 5,010 kHz.

Radio Cinco, HJOW, Villavicencio, 5,040 kHz., beware, several Latin stations use this frequency.

LA Voz del Llano, HJIA, Villavicencio, 6,115 kHz, the name means Voice of the Plain, and especially the early morning programming is directed to Colombia's cattlemen and cowboys.

La Voz del Huila, HJFR, Neiva, 6,150 kHz, another non-stop station.

La Voz de la Selva, HJKF, Florencia, 6,170 kHz, the name stems from another of Colombia's climatic contrasts; the Voice of the Jungle.

There you have 14 shortwave outlets that you can hear, but only part of the Colombian listening targets for DX'ers.

ANARC 1978. The Association of North America Radio Clubs, (ANARC) is the umbrella organization linking the various major radio listening hobby clubs in the U.S. and Canada. Each year, ANARC holds a convention in the summer in some major city in the United States or Canada where listening hobbyists can get together.

ANARC '78, hosted by Radio Canada International for four days last July, was the most successful such gathering in the 14 year history of the association. Hobby listeners came to Montreal from across the continent, from California to New Brunswick

and from as far south as Trinidad! In addition the world of broadcasting was represented by Arne Skoog of Radio Sweden, Ambrosio Wong An-Po of Radio TV Espana in Madrid, and Paul Modic of the Voice of America, plus RCI's host, Ian McFarland.

The convention program included tours of the RCI facilities and live demonstrations of the Canadian experimental HERMES satellite-to-home TV broadcasting. There were DX'ing workshops conducted by a variety of experts in various broadcasting and listening areas. Dr. David Meisel spoke on future sunspot activity which will affect radio propagation. Denis Casey, supervisor of the Canadian Broadcasting Corp. monitoring station, discussed his division's activities. A busload of convention goers who stayed for the fourth day of the ANARC convention, traveled from Montreal to Ottawa to view the monitoring station's activities firsthand.

For more information about the Association of North American Radio Clubs, and its numerous affiliated clubs, and data on what these clubs offer to SWLs and listening fans, simply drop a line to Dave Brown, Executive Secretary of ANARC, 557 Madison Avenue, Pasadena, CA 91101. Since ANARC is a non-profit organization, please include a self-addressed envelope (business size) with 15¢ postage affixed.

What's New. As many listeners know, it is possible to hear some of your favorite programs of various shortwave stations without even listening to shortwave. Yes, particularly the PBS stations in the United States air off-the-air relays of such programs as the British Broadcasting Corporation's Radio Newsreel and various program transcriptions from stations such as Radio Nederland.

Many readers are using the Yaesu FRG-7 receiver, or, the same radio with its own house brand name, the Sears shortwave receiver.

Now the Japanese manufacturer has come out with a big brother to the popular FRG-7 (which SWLs have dubbed the "Frog-Seven"). The new receiver is the Yaesu FRG-7000, and costs something over twice as much as the baby brother—that is, between \$500 and \$600.

The big improvement in the 7000 model is the addition of electronic digital frequency readout to an accuracy of one kilohertz. Also the receiver has an LED (light-emitting-diode) digital clock which can be switch-selected.

Down The Dial. (Times in GMT, frequencies in kilohertz)—3,985—If this month's lead article on Colombian stations has whetted your interest, why not try for this station in neighboring Ecuador. The station, an educational

voice, is Radiofonica Poulares in Riobamba. Try around 1030 GMT. . . . 4,803—There is another Ecuadorian station with a similar sounding name, Radio Popular de Cuenca on this frequency, though it may vary a few kHz up or down. During the evening hours, say around 0500 to 0530 GMT or so, you can often hear this station with the distinctive and plaintive music of the Andes. If you're familiar with Simon and Garfunkel's "El Condor Pasa," you'll know what I mean. . . . 6,135—Radio Tahiti is always a fun catch, especially when the station gets going with its pulse-pounding island

rhythms. Look for it around 0430 to 0530 or so. . . . 9,435—Israel's IBA should be an easy catch for even the most inexperienced SWL. Between 2230 and 2300 look for the news in English, editorials and the Israel Hit Parade. . . .—11,678 Here's a station that a lot of listeners are looking for, Radio Pakistan. Music typical of the subcontinent of Asia should be the tip off around 2145.

(Credits: Claud J. Ethen, OR; Josephine Bryan, CA; Robert Foxworth, NY; Aaron Hywarren, Manitoba, Canada; North American SW Association, P.O. Box 13, Liberty, IN 47353). ■

Build the REAL THING-Yourself!

Whether your thing is nautical, a Pow'r Pup or a suburban tractor, the CRAFT PRINT DO-IT-YOURSELF Division of Davis Publications has it for you. Order your new catalog today and go a-crafting!

3 AMAZING OFFERS

- All Craft Prints are unconditionally guaranteed; if you are not completely satisfied, return them and your money will be promptly refunded.
 - Catalog price (\$1.00) completely refunded with first order.
 - You can deduct 10% from total price if 2 or more sets of plans are ordered.
- If you can't afford it—make it yourself.

MAIL TODAY

BOAT BUILDER, Craft Print Division
Davis Publications, Inc., Dept. EE J/F-79
229 Park Avenue S., New York, N.Y. 10003

Please send me _____ copy(ies) of the
Craft Print Catalog for only \$1.00 each... COM-
PLETELY REFUNDED WITH FIRST ORDER.

NAME _____

ADDRESS _____

CITY _____ STATE _____ ZIP _____

Get Top Mileage
from your own
craft skills.

GREAT
EASY-TO-BUILD
PLANS

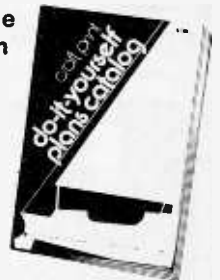

ONLY \$1.00

Compare our job placement record with any school's. Any.

Probably there's nothing more convincing to be said concerning the quality of our electronics education programs beyond the simple statement of our placement record.

In 1977, more than 92% of the graduates seeking our assistance were placed in jobs related to their training within sixty days after graduation.

Although we can't guarantee jobs, we know of no school in our field that exceeds this record of success. We invite you to compare. Then if you'd like to know more about how easy it may be for you to acquire an electronics education, call us or return the coupon below.

BELL & HOWELL EDUCATION GROUP, INC.

DeVry Institutes of Technology;
Atlanta, Georgia; Chicago,
Illinois; Dallas, Texas; Phoenix,
Arizona; Toronto, Ontario,
Canada

Ohio Institute of Technology;
Columbus, Ohio

Missouri Institute of Technology;
Kansas City, Missouri

DeVry Technical Institute;
Woodbridge, New Jersey

Equal opportunity in placement,
housing and admissions.

Return coupon
Today!

BELL & HOWELL EDUCATION GROUP, INC.
2201 W. Howard, Evanston, IL 60602

NAME _____ AGE _____

ADDRESS _____

CITY _____ STATE _____

ZIP _____ PHONE _____

8x4152

CIRCLE 41 ON READER SERVICE COUPON

Jim DeNinno wants your name for his mailing list and is offering Three Super Specials to Get It

3.95 BUYS ALL OF THIS Old & Rare Coins

- 1 - Old Indian Head Cent
- 1 - V Liberty Nickel
- 1 - Buffalo Nickel
- 1 - Large Cent eng
- 1 - 1943 WWII Cent
- 1 Cent 1920 or Older
- 1 Wooden Nickel
- 1 D Mint Cent - 25 years
- 1 - S Cent - 25 years
- 1 - 1968 - S Penny (unc.)
- 1 - 1960 - D Small Date



OR 3.95 BUYS THESE TWO RARE UNCIRCULATED COINS

The mint made a mistake but we didn't. Now is your chance to take advantage of their mistake.

55

1955/5 Cents
'Poorman's Double Die'



• PLUS •
1 - 1960 D
Small Date



OR 6.95 BUYS EVERYTHING IN BOTH OF THE ABOVE SPECIALS

With Every Offer you Receive

PLUS

- More Free Coins
- Or Free Brochures

Add \$.25
for
Postage

JIM De NINNO & CO.

Suite 5 - Pike Bldg., Viewmont Village
Scranton, Pa. 18508
(717) 961-0203

CIRCLE 36 ON READER SERVICE COUPON

FREE SHORTWAVE CATALOG



- NEWEST EDITION-ONE-STOP SHOPPING FOR SWLS
- RECEIVERS special DX mods
 - ANTENNAS
 - PRESELECTORS
 - TUNERS
 - CALIBRATORS
 - CLOCKS
 - HEADPHONES
 - BOOKS
 - LOGS

GILFER SHORTWAVE

Dept. EE-1, Box 239, Park Ridge NJ 07656

BE A LOCKSMITH



"Was never so enthused and delighted with lessons in my entire life. I grossed over \$3,000 in one year just working weekends."
Rocky Orsi
Azusa, California

You'll enjoy your work as a Locksmith because it is more fascinating than a hobby—and highly paid besides! You'll go on enjoying the fascinating work, year after year, in good times or bad because you'll be the man in demand in an evergrowing field offering big pay jobs, big profits as your own boss. Train at Home—Earn Extra \$\$\$\$ Right Away! Send for FREE booklet today!

LOCKSMITHING INSTITUTE
Div. Technical Home Study Schools
Dept 1472-019 Little Falls, N.J. 07424

Name _____ (Please Print)

Address _____

City/State/Zip _____

Check here if Eligible for Veteran Training

newscan

Electronics in the News!

Telephone Laser Line

Vista-Florida Telephone System, serving Walt Disney World's 10,000 phones, has scored a first by installing a laser transmission system. Already possessing the first all-electronic phone system, the company now has the nation's first commercial installation of fiber-optic phone cable—a five mile transmission line—using laser beams to send more than 3,300 calls simultaneously over a thumb-size cable. Digital light impulses carry 672 calls at one time over each pair of glass "wires" the size of sewing thread. The new line running from Vista-Florida headquarters at Lake Buena Vista to a switching center near the Magic Kingdom, will increase capacity and improve the quality of sound and service on the phone lines which serve hotel guests and company offices.



The fiber-optic line on the left—one inch in diameter—equals the capacity of the ten-inch copper cable on the right of the photo.

re-transmission. It is so small that technicians use microscopes and miniature electric arc welding unit to splice the tiny fibers.

How far away is laser-cable transmission from your home? It may be within 10 years in big cities where copper mining in the city streets may become big business!

Checking on Electrical Noise

A specially shielded and sealed microwave anechoic chamber at General Motors Engineering Staff is a test cell for developing future automotive electronic systems which perform safely, reliably and compatibly with electromagnetic fields in the surrounding atmosphere. Real world conditions are simulated with test cars run on a dynamometer while subjected to electromagnetic fields.

Constructed with welded steel walls, ceiling and floor, the GM facility was designed to protect against outside electromagnetic interference. It also prevents the same type of energy from getting to the outside atmosphere during test.



A GM technician is shown focusing a remotely controlled TV camera on a test car's instrument panel and controls. Energy absorbing spikes on walls and ceiling reduce interior surface's overall reflectivity.

According to GM engineers, importance of electromagnetic compatibility testing will increase as "electronic content" of products increases. Electromagnetic energy from AM and FM radio transmitters, radar, mobile radios, medical apparatus and other sources can upset electronic controls.



Splicers work on the first commercial installation of fiber-optic phone cable at Walt Disney World. The five mile transmission line uses laser beams to send more than 3,300 calls simultaneously over the cable.

Fiber-optic cable is particularly important in an area with a high incidence of electrical storms since it is entirely non-metallic and does not attract lightning. This also eliminates annoying "crackling" sounds on phone lines during thunderstorms. And because it is free of metal even a leaky cable does not short out.

The fiber-optic line itself looks like a monofilament fishing line but carries light impulses from laser diodes around corners and over several miles without

BUILD 20 RADIO and Electronics Circuits

Reg. U. S.
Pat. Off.



Training Electronics Technicians Since 1946

PROGRESSIVE HOME RADIO-T.V. COURSE

Now Includes

- ★ 12 RECEIVERS
- ★ 3 TRANSMITTERS
- ★ SQ. WAVE GENERATOR
- ★ SIGNAL TRACER
- ★ AMPLIFIER
- ★ SIGNAL INJECTOR
- ★ CODE OSCILLATOR
- ★ No Knowledge of Radio Necessary
- ★ No Additional Parts or Tools Needed
- ★ Solid State Circuits
- ★ Vacuum Tube Circuits

YOU DON'T HAVE TO SPEND HUNDREDS OF DOLLARS FOR A RADIO COURSE

The "Edu-Kit" offers you an outstanding PRACTICAL HOME RADIO COURSE at a rock-bottom price. Our Kit is designed to train Radio & Electronics Technicians, making use of the most modern methods of home training. You will learn radio theory, construction practice and servicing. THIS IS A COMPLETE RADIO COURSE IN EVERY DETAIL.

You will learn how to build radios, using regular schematics; how to wire and solder in a professional manner; how to service radios. You will work with the standard type of Punched metal chassis as well as the latest development of Printed Circuit chassis.

You will learn the basic principles of radio. You will construct, study and work with RF and AF amplifiers and oscillators, detectors, rectifiers, test equipment. You will learn and practice code, using the Progressive Code Oscillator. You will learn and practice trouble-shooting, using the Progressive Signal Tracer, Progressive Signal Injector, Progressive Dynamic Radio & Electronics Tester, Square Wave Generator and the accompanying instructional material.

You will receive training for the Novice, Technician and General Classes of F.C.C. Radio Amateur Licenses. You will build Receiver, Transmitter, Square Wave Generator, Code Oscillator, Signal Tracer and Signal Injector circuits, and learn how to operate them. You will receive an excellent background for television, Hi-Fi and Electronics.

Absolutely no previous knowledge of radio or science is required. The "Edu-Kit" is the product of many years of teaching and engineering experience. The "Edu-Kit" will provide you with a basic education in Electronics and Radio, worth many times the low price you pay. The Signal Tracer alone is worth more than the price of the kit.

THE KIT FOR EVERYONE

You do not need the slightest background in radio or science. Whether you are interested in Radio & Electronics because you want an interesting hobby, a well paying business or a job with a future, you will find the "Edu-Kit" a worth-while investment. Many thousands of individuals of all

ages and backgrounds have successfully used the "Edu-Kit" in more than 79 countries of the world. The "Edu-Kit" has been carefully designed, step by step, so that you cannot make a mistake. The "Edu-Kit" allows you to teach yourself at your own rate. No instructor is necessary.

PROGRESSIVE TEACHING METHOD

The Progressive Radio "Edu-Kit" is the foremost educational radio kit in the world, and is universally accepted as the standard in the field of electronics training. The "Edu-Kit" uses the modern educational principle of "Learn by Doing." Therefore you construct, learn schematics, study theory, practice trouble shooting—all in a closely integrated program designed to provide an easily-learned, thorough and interesting background in radio.

You begin by examining the various radio parts of the "Edu-Kit." You then learn the function, theory and wiring of these parts. Then you build a simple radio. With this first set you will enjoy listening to regular broadcast stations, learn theory, practice testing and trouble-shooting. Then you build a more advanced radio, learn more advanced theory and techniques. Gradually, in a progressive manner, and at your own rate, you will find yourself constructing more advanced multi-tube radio circuits, and doing work like a Professional Radio Technician.

Included in the "Edu-Kit" course are Receiver, Transmitter, Code Oscillator, Signal Tracer, Square Wave Generator and Signal Injector Circuits. These are not unprofessional "breadboard" experiments, but genuine radio circuits, constructed by means of professional wiring and soldering on metal chassis, plus the new method of radio construction known as "Printed Circuitry." These circuits operate on your regular AC or DC house current.

THE "EDU-KIT" IS COMPLETE

You will receive all parts and instructions necessary to build twenty different radio and electronics circuits, each guaranteed to operate. Our Kits contain tubes, tube sockets, variable, electrolytic, mica, ceramic and paper dielectric condensers, resistors, tie strips, hardware, tubing, punched metal chassis, Instruction Manuals, hook-up wire, solder, selenium rectifiers, coils, volume controls, switches, solid state devices, etc.

In addition, you receive Printed Circuit materials, including Printed Circuit chassis, special tube sockets, hardware and instructions. You also receive a useful set of tools, a professional electric soldering iron, and a self-powered Dynamic Radio and Electronics Tester. The "Edu-Kit" also includes Code Instructions and the Progressive Code Oscillator, in addition to F.C.C. Radio Amateur License training. You will also receive lessons for servicing with the Progressive Signal Tracer and the Progressive Signal Injector, a High Fidelity Guide and a Quiz Book. You receive Membership in Radio-TV Club, Free Consultation Service, Certificate of Merit and Discount Privileges. You receive all parts, tools, instructions, etc. Everything is yours to keep.

PRINTED CIRCUITRY

At no increase in price, the "Edu-Kit" now includes Printed Circuitry. You build a Printed Circuit Signal Injector, a unique servicing instrument that can detect many Radio and TV troubles. This revolutionary new technique of radio construction is now becoming popular in commercial radio and TV sets.

A Printed Circuit is a special insulated chassis on which has been deposited a conducting material which takes the place of wiring. The various parts are merely plugged in and soldered to terminals.

Printed Circuitry is the basis of modern Automation Electronics. A knowledge of this subject is a necessity today for anyone interested in Electronics.

FREE EXTRAS

• SET OF TOOLS

- SOLDERING IRON
- ELECTRONICS TESTER
- PLIERS-CUTTERS
- VALUABLE DISCOUNT CARD
- CERTIFICATE OF MERIT
- TESTER INSTRUCTION MANUAL
- HIGH FIDELITY GUIDE • QUIZZES
- TELEVISION BOOK • RADIO TROUBLE-SHOOTING BOOK
- MEMBERSHIP IN RADIO-TV CLUB: CONSULTATION SERVICE • FCC AMATEUR LICENSE TRAINING
- PRINTED CIRCUITRY

SERVICING LESSONS

You will learn trouble-shooting and servicing in a progressive manner. You will practice repairs on the sets that you construct. You will learn symptoms and causes of trouble in home, portable and car radios. You will learn how to use the professional Signal Tracer, the unique Signal Injector and the dynamic Radio & Electronics Tester. While you are learning in this practical way, you will be able to do many a repair job for your friends and neighbors, and charge fees which will far exceed the price of the "Edu-Kit." Our Consultation Service will help you with any technical problems you may have.

FROM OUR MAIL BAG

Ben Valerio, P. O. Box 21, Magna, Utah: "The Edu-Kits are wonderful. Here I am sending you the questions and also the answers for them. I have been in Radio for the last seven years, but like to work with Radio Kits, and like to build Radio Testing Equipment. I enjoyed every minute I worked with the different kits; the Signal Tracer works fine. Also like to let you know that I feel proud of becoming a member of your Radio-TV Club."

Robert L. Shuff, 1534 Monroe Ave., Huntington, W. Va.: "I thought I would drop you a few lines to say that I received my Edu-Kit, and was really amazed that such a bargain can be had at such a low price. I have already started repairing radios and phonographs. My friends were really surprised to see me get into the swing of it so quickly. The Trouble-shooting Tester that comes with the Kit is really swell, and finds the trouble, if there is any to be found."

SOLID STATE

Today an electronics technician or hobbyist requires a knowledge of solid state, as well as vacuum tube circuitry. The "Edu-Kit" course teaches both. You will build vacuum tube, 100% solid state and combination ("hybrid") circuits.

Progressive "Edu-Kits" Inc., 1189 Broadway, Dept 594-DJ Hewlett, N.Y. 11557

Please rush me free literature describing the Progressive Radio-TV Course with Edu-Kits. No Salesman will call.

NAME

ADDRESS

CITY & STATE ZIP

PROGRESSIVE "EDU-KITS" INC.

1189 Broadway, Dept. 594-DJ

Hewlett, N.Y. 11557

CIRCLE 18 ON READER SERVICE COUPON

HIGHLY PROFITABLE **ONE-MAN ELECTRONIC FACTORY**

Investment unnecessary, knowledge not required, sales handled by professionals. Postcard brings facts about this unusual opportunity. Write today! Barta-EN, Box 248, Walnut Creek, CA 94597.

WRITE NOW FOR **McGEE'S BIG SPEAKER CATALOG**

1001 BARGAINS IN
SPEAKERS—PARTS—TUBES—HIGH FIDELITY COMPONENTS—RECORD CHANGERS
Tape Recorders—Kits—Everything in Electronics
1901 McGee Street, Kansas City, Missouri 64108

AUDIO & ANALOG EXPERIMENTERS

- music synthesis stuff • ideas
 - quality parts
 - circuit theory
 - plans
 - electronic equipment
- send 25¢ or stamp for OUR LATEST FREE CATALOG/FLYER
- CFR ASSOCIATES, INC.**
NEWTON, MA 02459



THIS SPACE CONTRIBUTED BY THE PUBLISHER



Ask Hank, He Knows!

Got a question or a problem with a project—ask Hank! Please remember that Hank's column is limited to answering specific electronic project questions that you send to him. Personal replies cannot be made. Sorry, he isn't offering a circuit design service. Write to:

Hank Scott, Workshop Editor
ELEMENTARY ELECTRONICS
380 Lexington Avenue
New York, NY 10017

Project Boards

I was wondering where I could get the printed circuit boards that are used in ELEMENTARY ELECTRONICS construction projects? Also is there any place near or in Dayton, Ohio that makes P.C. boards from designs on paper?

—J. B., Dayton, OH

On a few projects, printed circuit boards are available and so indicated in the parts list. In others, we offer the printed circuit board template free of charge, if you send us a stamped, self-addressed envelope as mentioned in the article. The remainder have the board templates printed in the issue. Another option is to use the solderless boards. They are easy to use and can be used over and over.

Wheel of Fortune

I built that roulette wheel in the September/October 1977 issue of ELEMENTARY ELECTRONICS and it works great. While I was building it, I found that if you add an 8-ohm speaker between ground and the junction of R19, R20, and b2 of Q13, you get a clicking sound that is in sync with the LED's. It is kind of neat to "hear" the blinks! I just thought you would like to know what I discovered.

—S. H., Colorado Heights, MN

The LED roulette wheel was a real hot project. Glad that you and many others

enjoyed it!

Couple of Clubs

Please tell me the address of any American radio club that specializes in the reception of AM broadcast stations. Thanks.

—E H., Delray Beach, FL

National Radio Club, Membership Center, P.O. Box 118, Poquonock, CT 06064 and International Radio Club of America, (IRCA), P.O. Box 26254, San Francisco, CA 94126, both specialize in medium wave AM broadcast DX exclusively.

How Old is 20?

What's all this baloney about CB being born 20 years ago. Why, I was operating legally on CB in 1954. How old is CB?

—D. Q., Chicago, IL

CB as we know it, on 27 MHz, was initiated in fall of 1958. It was Class D CB. There were three other classes, of which one was for RC. So, happy 20th Anniversary of Class D CB—which is the mobile radio service we know so well.

Lend a Hand, Boys!

△ Here we go doing the sort of thing we do best—helping others. Pitch in and lend a hand whenever and wherever you can.
△ Approved Electronic Instrument Corp. Model A-100 RF signal generator; needs owner's manual; David Wozniak, 14908 Richfield, Livonia, MI 48154.

△ RCA Model 8K (530 kHz-22.3 MHz) receiver; needs power transformer; Rick Birtchet, 8605 Meadow Brook Lane, Norfolk, VA 23503.

△ Grundig-Majestic Musical Instrument Model 8080 radio; need schematic diagram and volume control; Stephen D. Stoltfus, R.D. #2, Limestone Rd., Parkersburg, PA 19365.

△ EMC Model 208 tube checker; needs operator's manual; Bruce C. Pierce, Jr., Star Route, Ginger Bread House, Richlandtown, PA 18955.

△ RF Communications Assoc., Inc., Remote Control Transceiver, Model SB-6MR; need schematic diagram and operating manual; Bob Ruppe, 4176 Pomeroy Ave., Drayton Plains, MI 48020.

△ Radio Shack Micronta 3-way CB Tester Meter; urgently needs schematic diagram; Adam Kaletski, 59 Lorelei Rd., West Orange, NJ 07052.

△ Zenith Model 6GO38R Transoceanic table radio needs battery pack Z-884; want plans for substitute or replacement; H. D. Scoregal, P.O. Box 705, Douglas, AK 99824

△ U.S. Army frequency deviation meter test unit 1-86-A manufactured by G.E.; needs any and all information; Greg Ames, 3017 Glenwood Pk., Erie, PA 16508. ■

for the Experimenter!

INTERNATIONAL CRYSTALS and KITS



OF-1 OSCILLATOR

\$4.25 ea.

The OF-1 oscillator is a resistor/capacitor circuit providing oscillation over a range of frequencies by inserting the desired crystal. 2 to 22 MHz, OF-1 LO, Cat. No. 035108. 18 to 60 MHz, OF-1 HI, Cat. No. 035109. Specify when ordering.

.02% Calibration Tolerance

EXPERIMENTER CRYSTALS

(HC 6/U Holder)

\$4.75 ea.

Cat. No.

031300

031310

Specifications

3 to 20 MHz — For use in OF-1L OSC

Specify when ordering.

20 to 60 MHz — For use in OF-1H OSC

Specify when ordering.



- MX-1 Transistor RF Mixer**
3 to 20 MHz Cat. No. 035105 \$5.50 ea.
20 to 170 MHz, Cat. No. 035106
- SAX-1 Transistor RF Amp**
3 to 20 MHz Cat. No. 035102 \$5.50 ea.
20 to 170 MHz Cat. No. 035103
- BAX-1 Broadband Amp**
20 Hz to 150 MHz Cat. No. 035107 \$5.75 ea.

Enclose payment with order inc. C.O.D. Shipping and postage (inside U.S., Canada and Mexico only) will be prepaid by International. Prices quoted for U.S., Canada and Mexico orders only. Orders for shipment to other countries will be quoted on request. Price subject to change. Address orders to:

M/S Dept., PO Box 32497
Oklahoma City, Oklahoma 73132

WRITE FOR BROCHURE



International Crystal Mfg. Co., Inc.
10 North Lee Oklahoma City, Oklahoma 73102

CIRCLE 24 ON READER SERVICE COUPON

ANIXTER-MARK

heliwhip[™]

Broad Stick[™]

The standard of excellence in CB Antennas!

THE BROAD STICK is the first *totally new concept* in top loaded CB antenna design. In 1957 Anixter-Mark originated the industry standard — the Heliwhip[™]. Now, a new industry standard — THE BROAD STICK. Designed for *maximum power* output and input, THE BROAD STICK has been tested up to 700 watts and provides constant VSWR across 40 channels... high operating efficiency because it's wound with 32' (7/8 wave-length) of heavy gauge wire... separate loading and matching coils and much, much more! THE BROAD STICK. It's all new from ANIXTER-MARK and it's a beauty!

It's Rugged! It's Broad! It's the Superstar Antenna

Because it's tested up to 700 Watts

Constant VSWR Across 40 Channels

And no matter what your communication needs... there's an ANIXTER-MARK antenna or accessory engineered for you! Here are just a few examples:

THE *little devil*[™]

CB Antenna Adaptor

Used for upgrading to a higher performance antenna. fits any 3/8"-24 antenna including the "Heliwhip". No new mount or cable is needed with this adaptor. Model HWA-1.



Heavy Duty Truck Mirror Mount

Heavy duty aluminum mount with gripping teeth in both pieces, bites through paint for good ground connection. Chrome plated ferrule with 3/8"-24 thread. Clamps to 1 3/8" pipe. Model HWM-12.



Quick-On Connect

Chrome plated connector for rapid removal of "Heliwhip". Simply twist for removal. Fits all antennas and mounts with 3/8"-24 thread, including the "Heliwhip". Model QOC.



Top loaded CB antenna with CLASS!

Anixter-Mark's new standard of excellence. Combines sturdy heliwhip fiberglass construction with a heavy brass chrome plated mast. Height 54" Tuning Range 26.9-27.5 MHz. Model AAC-11-4.



"THE GREAT GRIPPER" gives you a totally designed package including:

- ★ Super powerful ceramic magnets
 - ★ New antenna design to complement the mount
 - ★ A full 18 feet of cable
- Fiberglass and top loaded. THE GREAT GRIPPER antenna looks sleek and slim in black and chrome. And it's a 40 channel antenna—with an average VSWR of 1.4:1 over all 40 channels. Model MAR-11-S3.



Mark V Base Station Antenna

The Mark V is a full 20 ft. tall. It is extremely sturdy and designed for heavy-duty commercial use. Lowest VSWR over the greatest bandwidth. Supplied with universal mast mounting kit—mounts on any pipe with O.D. from 1" to 1 3/4". Model MK-V.

ANIXTER-MARK

Manufacturers of a Full Line of Point-To-Point Antennas
Microwave • Two-Way • Amateur • CB

5439 W Fargo, Skokie, IL 60076 (312) 675-1500
Made in U.S.A.

ANIXTER-MARK

5439 W. Fargo
Skokie, IL 60076
(312) 675-1500

Mail this coupon for additional information on the BROAD STICK and the other fine Anixter-Mark products.

NAME _____ PHONE _____
COMPANY _____
ADDRESS _____
CITY _____ STATE _____ ZIP _____

For cost effective capacitance measurement



One C-meter stands out of the darkness— the \$130 B&K-PRECISION 820

For about one-third the cost of the most popular digital capacitance meter, you can own five times more measurement capability. The new B&K-PRECISION 820 reads from 0.1pF all the way to 1 Farad, in ten ranges. With 0.5% accuracy, the 820 resolves to 0.1pF for a maximum count of 9999.

The 820 retains its high accuracy in freezing cold to blistering 100 degree heat, making it ideal for field use. The bright LED display is easily readable under all lighting conditions. It has the versatility needed for any application and the durability to stay on the job. The 820 can be powered by disposable batteries or optional rechargeable batteries.

Unlike many specialized instruments, the 820 has almost unlimited applications in engineering, production line work, QC, education and field service. First time users are quickly discovering that the number of time-saving applications exceed their original expectations. For example, you can measure unmarked capacitors... Verify capacitor tolerance... Measure cable capacitance... Select and match capacitors for critical circuit applications... Sample production components for quality assurance... Measure capacitance of complex series-parallel capacitor networks... Set trimmer capacitors to specific amounts of capacity... Check capacitance in switches and other components.

*You can start discovering
your own applications today by seeing
your local distributor for immediate delivery.*

B&K PRECISION DYNASCAN
CORPORATION

6460 W. Cortland Street • Chicago, IL 60635 • 312/889-9087

In Canada: Atlas Electronics Ontario
International Sales: Empire Exporters, Inc. 270 Newtown Road, Plainview, L.I., N.Y. 11803

CIRCLE 23 ON READER SERVICE COUPON



Rhythm & Blues Box

Boogie to the sound of this electronic drummer

by Randall Kirschman

RHYTHM IS THE TIME-PATTERN of sounds that enables us to distinguish a march from a mazurka, and it is one of music's basic ingredients. It could also earn a stack of votes from both beginner and veteran musician alike as one of the most troublesome. But help can be close at hand if you build the rhythm synthesizer described here.

Use our Rhythm and Blues Box while practicing on an instrument, to analyze or demonstrate rhythms, even for learning dances. It can also be connected to a percussion generator to provide simple accompaniments, or can serve as a programmable controller for music synthesizers. Whatever your particular involvement with rhythm, you will find the R&B Box a valuable companion.

A metronome is the traditional aid for timing in music, but it falls short in the rhythm department because the clicks it produces are all identical. In music, rhythm comes about when each beat does *not* receive identical emphasis. With the R&B Box you can overcome metronomic monotony by giving each click in a sequence a different emphasis to produce musical rhythms.

A notable feature of this rhythm synthesizer is that it is not limited to standard or preset rhythms, but can be set up to generate thousands of rhythms of all kinds. Furthermore, each rhythm is precise to the micro-second.

Let's find out how the Rhythm and Blues Box accomplishes its feat by taking a tour of the circuit. Even at second glance the circuit may seem formidable, but it can be understood by tackling it a section at a time. Each

section is a basic building block which you may meet in other circuits also—the multivibrator, shift register, flip-flop, latch, analog switch, and multiplexer.

Good Vibes! We'll begin our tour with IC2, a 555 timer, and its associated components. These form an astable (free-running) multivibrator that generates a continuous train of pulses

flip-flops in the synthesizer. They occur at the same rate as the tempo pulses from IC2, but are narrower.

Shift Into High. The next section on our itinerary is a *shift register*. Basically, a shift register is a string of flip-flops connected in cascade. The output of each flip-flop is connected to the input of the next and all are clocked by the same clock pulse. Thus, at each

Just by properly setting the controls, you can program our Rhythm and Blues box for any kind of beat you might want to tap your toes to. Any sequence of one to twelve beats, with any of the individual beats accented, is readily set.



to drive the rest of the circuitry. The pulse rate, which sets the tempo of the rhythm, is controlled by *Tempo* pot R3. The pulses from IC2 (pin 3) go to IC3A. IC3A and IC3B, both NOR gates, are connected as a monostable (one-shot) multivibrator, which puts out a pulse each time it is triggered by a pulse from IC2. This pulse is then fed to NOR gates IC3C and IC3D to improve its shape and to generate both an inverted (negative-going) pulse (from pin 3 of IC3C) and a positive-going pulse (from pin 4 of IC3D). As we'll see, these pulses serve as *clocking* (or simply *clock*) pulses for the

clock pulse, the *high* or *low* bit held in each flip-flop is shifted to the next flip-flop (except at the ends). This mode of operation of the shift register, where the bits play follow-the-leader, is called the *serial* mode. Some shift registers, like the one in the Rhythm Synthesizer, can also operate in the *parallel* mode. In this mode the inputs of the flip-flops are disconnected from the outputs so that all the flip-flops can be *loaded* simultaneously from outside during a single clock pulse.

In the R&B Box, IC's 5, 6, and 7, each a four-bit shift register, are cascaded to form a 12-bit shift register.

As described later, to start a rhythmic pattern the shift register is loaded in the parallel mode with a *high* in stage 1 and *lows* in the remaining 11 stages. The shift register is then put into the serial mode and clocked by the positive clock pulses from pin 4 of IC3D, which shift the single *high* from stage to stage (left-to-right in the circuit diagram). Thus the output of each stage goes *high* in sequence. This continues until the *high* reaches the stage selected by the *Sequence Length* switch, S3. S3 then feeds the *high* to the input of a *D*-type flip-flop (pin 9 of IC4).

A *D*-type flip-flop has the characteristic that the logic level (*high* or *low*) present at its input before it is clocked will be assumed by its output after it is clocked. However, note that the clock input (pin 11 of IC4) of the *D* flip-flop is fed the inverted clock pulse from pin 3 of IC3C. So when the shift register is being clocked by the rising edge of the positive clock pulse, and the *high* is fed to the *D* flip-flop input, the *D* flip-flop sees the falling edge of the inverted clock pulse and just sits there with its output still *low*. A few milliseconds later, at the end of the clock pulse, the *D* flip-flop is clocked and then the *high* is transferred to its output (pin 13 of IC4), which connects to the load enable input of the shift register (pin 7 of IC5, 6, and 7). This puts the shift register into the parallel mode. Nothing happens until the next clock pulse, at the beginning of which the shift register is loaded with a *high* in stage 1 and *lows* in the other stages, and at the end of which the output of the *D* flip-flop goes *low*, putting the shift register back into the serial mode. The situation is now the same as it was when we began our analysis, and the whole sequence repeats.

Here we have been assuming that S3 is set to a number (2-12), causing the shift register to keep reloading automatically as described, so that the sequence repeats indefinitely. However, if *Sequence Length* is set to *off*, the *high* in the shift register is shifted through all 12 stages and out the end without being fed to the *D* flip-flop, so the shift register is not automatically re-loaded. Thus the sequence only occurs once, after which the R&B Box quiets down. To start the action again, it must be loaded manually.

The shift register is loaded manually by means of the *Reset/Start* pushbut-

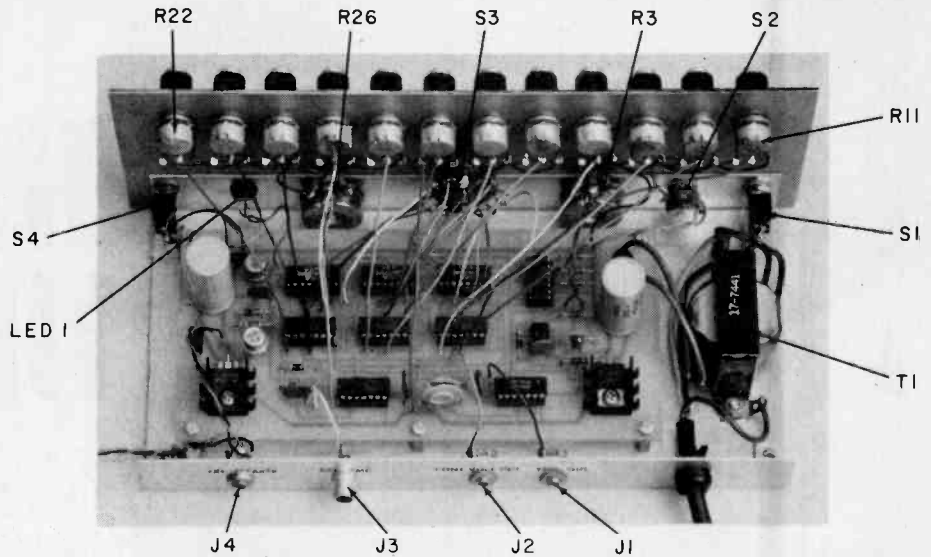

With the cover removed, the placement of all components can be observed. When wiring the front panel pots, it's a good idea to tag the wires from the PC board for identification. For more work room, install only every other pot at first, wire, then install the rest.

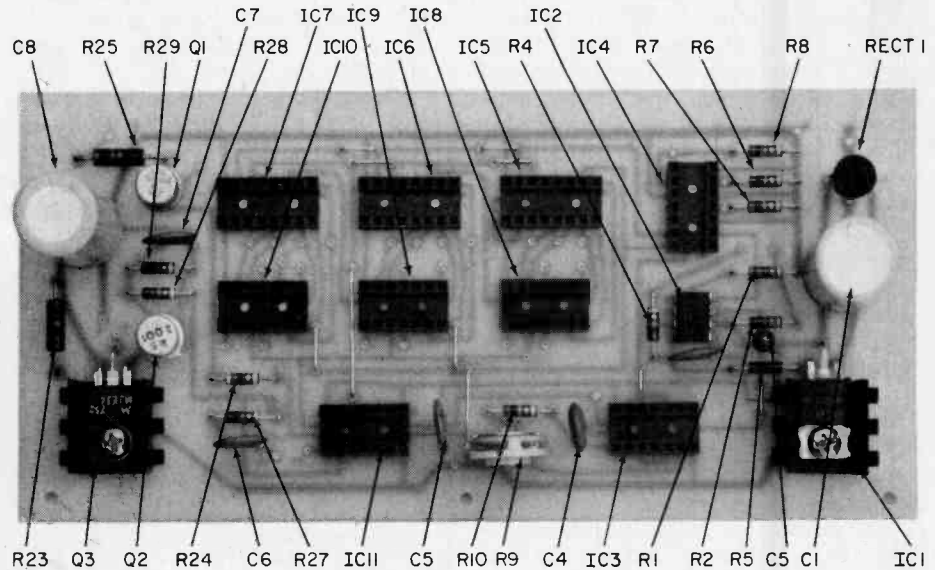

A neat, clean, professional printed circuit board can be made using the free template available from e/e. To obtain one, send a stamped, self-addressed envelope to: Rhythm & Blues Box, ELEMENTARY ELECTRONICS, 380 Lexington Ave., N.Y., NY 10017.

ton, switch S2, and the other half of IC4. This half of IC4 is also a *D*-type flip-flop but is used here as a *set-reset* flip-flop or *bistable latch* to eliminate the effects of switch bounce from S2. Pushing S2 makes pin 6 of IC4 *high*, setting the latch. This in turn sets the other flip-flop (via pin 1 to pin 8) in IC4, which puts a *high* on the load enable input of the shift register (pin 7 of IC5, 6, and 7), putting it into the parallel mode. At the same time, the latch makes pin 4 of IC2 *low*, stopping the tempo pulse to keep the synthesizer silent.

Releasing S2 makes pin 4 of IC4

high, which resets the latch, and IC2 and IC3 start producing pulses. The initial pulse first clocks the shift register, loading it, and then clocks the *D* flip-flop so its output goes *low*, putting the shift register into the serial mode. After that the *high* in the shift register is clocked from stage to stage as described previously.

Move To Multiplexing. Let's move on to the next section of the circuit to see why the *high* is being shifted around. The output of each stage of the shift register is fed to the control input of an *analog switch* (in IC8, 9, and 10). An analog switch is a solid state ver-

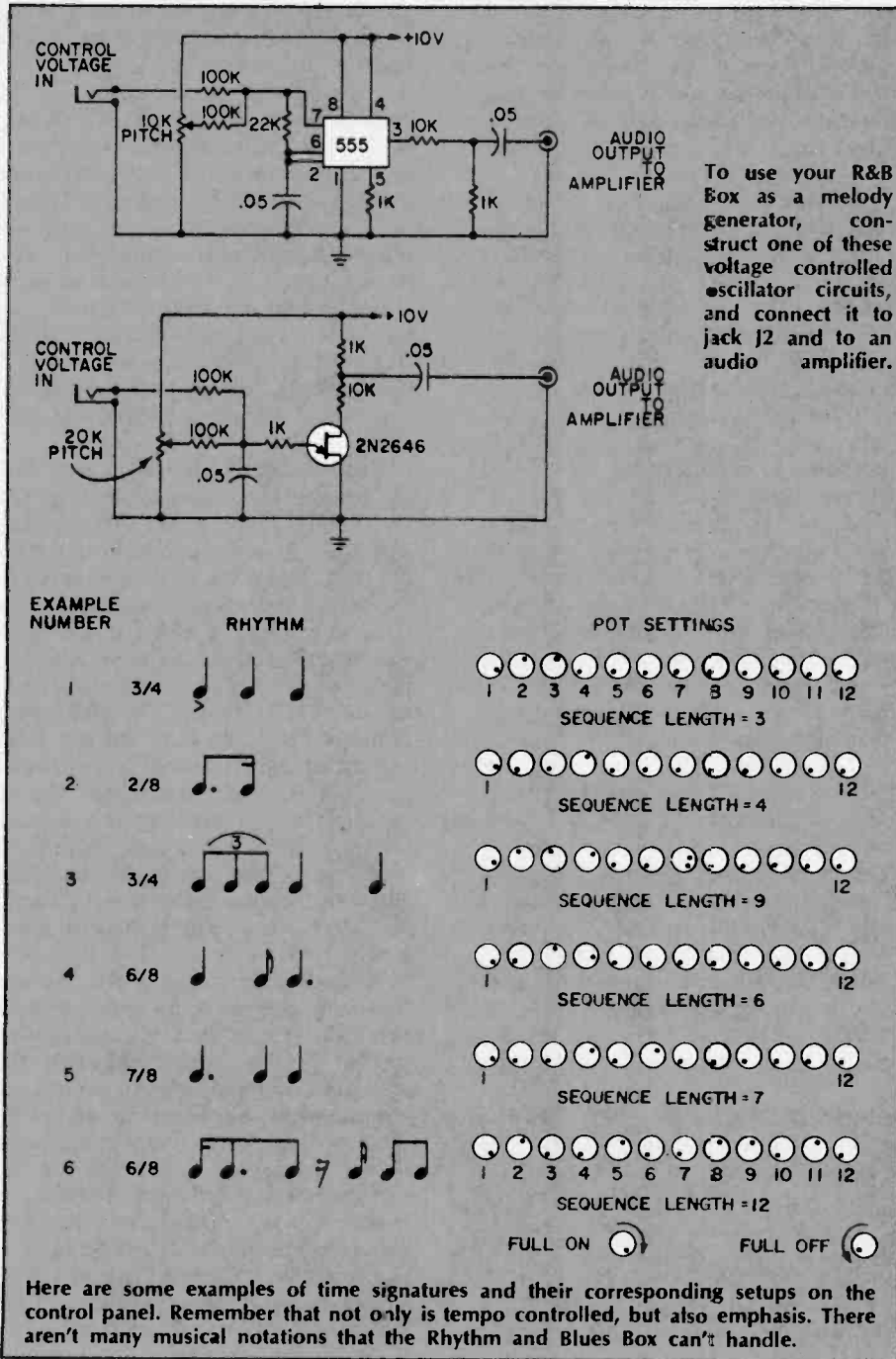

To use your R&B Box as a melody generator, construct one of these voltage controlled oscillator circuits, and connect it to jack J2 and to an audio amplifier.

This type of circuit, where a common line is connected to a series of inputs (or outputs) one at a time in sequence is called a *multiplexer*.

On To The Output. The last stop on our tour is the output section, where the voltage levels from the multiplexer are converted into loudness levels of audible clicks and into brightness levels of LED flashes. The voltage levels are gated through two more analog switches (in IC11), one for the clicks, one for the flashes. We'll see how the clicks are produced first.

The sequence of voltage levels is fed into a signal input of one of the switches (pin 8 of IC11). This switch is turned on briefly during each voltage level by the clock pulses from pin 4 of IC3D. Coming out of the switch (pin 9 of IC11) is a sequence of short pulses whose amplitudes are the same as the voltage levels from the multiplexer, which in turn correspond to the settings of the numbered pots. An amplifier consisting of Q2, Q3, and associated components gives the pulses sufficient current to drive the speaker, producing a sequence of clicks. The loudness of each click in the sequence corresponds to its pot setting.

A similar arrangement is used to drive the LED, with another analog switch (pins 10, 11, and 12 of IC11) and Q1. In this case the analog switch is turned on by pulses directly from IC2 (pin 3), which are longer than the clock pulses from IC3. If the shorter clock pulses were used, the LED flashes would be too brief and dim.

Pins from the two unused switches in IC11 (pins 1 to 5 and 13) are tied (as indicated in the schematic) to convenient points to keep them from picking up stray signals.

Power for all the above is provided by a regulated power supply of conventional design, consisting of T1, RECT1, C1, and IC1. R5-C3, C5, and R23-C8 isolate the power lines to IC2 and to the output section from the rest of the circuit to prevent undesirable interactions.

Getting It Together. Although it involves a fair amount of wiring, there is nothing particularly difficult about assembling the Rhythm & Blues Box. Follow the directions given here and the diagrams and photos and you shouldn't have any trouble. If this is one of your first projects, enlist the help of someone experienced in electronic construction.

When assembling the rhythm synthesizer, keep in mind that CMOS IC's (IC3 through IC11) can be damaged by static electricity or other excessive voltages, so handle them appropriately.

sion of a relay; when the control input is *high* the two signal lines are connected together with a low resistance; when it is *low* they are disconnected. An analog switch differs from a logic gate in that a logic gate deals only in *highs* and *lows*, whereas an analog switch passes any voltage level (within limits), and passes it in either direction.

At the beginning of a rhythmic sequence, the *high* in stage 1 of the shift register turns on the first analog switch (pins 1 and 2 of IC8 are connected), while the remaining switches are off. At this time the common output line of

the analog switches (pins 2, 10, 3, and 9 of each of the chips IC8, 9, and 10) is connected only to the wiper of pot #1 (R11) and assumes the voltage level set by that pot. At the next clock pulse the *high* shifts to stage 2 of the shift register, which turns on the second analog switch, while all others are off. The output line is now connected to the wiper of pot #2 (R12), and so on down the line. As the shift register goes through its sequence, a sequence of voltage levels that correspond to the settings of the numbered pots appears on the common line.

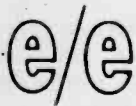

RHYTHM & BLUES

Leave them in their packages until the final steps of construction, as described later.

Although the R&B Box could be hand wired, a printed circuit (PC) board will make the job easier and the finished product neater. An actual-size PC etching guide is provided. Most of the components of the synthesizer mount on the PC board, as shown in the parts placement diagram. Note that ten jumper wires are required (identified by J). These are all inserted from the component side of the board and may be bare wire. Use sockets for the nine CMOS IC's; using a socket for IC2 is optional. Heat sinks are recommended for IC1 and Q3, either commercial or homemade from a scrap of metal.

The optimum value for R28 depends on the particular transistors used for Q2 and Q3 and on the speaker. You will want to determine its optimum value as described later, so, do not install R28 at this time; in its place temporarily wire a 100 K pot in series with a 10 K fixed resistor. Set the pot approximately at midrange.

After assembling the PC board, check carefully for solder bridges, bad connections, etc. The PC board may be mounted to the chassis or cabinet by means of six sets of screws and spacers at the location indicated near its edges.

Arrangement of the components off

the PC board is not critical. The author's arrangement is shown in the photos. Some of the connections from the PC board to these components are indicated by circles on the schematic diagram. Letters within these circles also appear on the etching guide.

If you use the switch specified in the parts list for S3, you will need to make a simple modification to it. The specified switch has a rotation stop which allows only eleven positions to be indexed. Bend the stop out of the way to allow all twelve positions to be indexed. Note that in the newly-created position the switch rotor does not contact any of the stationary terminals; this position is used as the *off* position. When wiring switch S3 and pots R11 through R22, take care to connect the wires in the correct order. Note that S3 is wired only to stages 2 through 12 of the shift register. The chassis, panel, and cabinet were custom made for the author's unit, but standard commercial items could be used. The author's cabinet measures 4-in. high by 10½-in. wide by 5-in. deep.

Tuning Up. After you have completed the wiring and assembly, but *before* you insert the CMOS IC's, check out the power supply. Plug the unit in, switch it on, and measure the voltage between the point labeled P and either one of the points labeled G on the PC board. It should be 10 volts (plus or minus 0.1 volt) with P positive. If not, check the power supply (S1, T1, RECT1, C1, IC1) for wiring errors or faulty parts. When the power supply

checks out, unplug the R&B Box and insert the IC's, observing their orientations.

To continue the checkout, set the controls as follows: pots #1 through #12 fully clockwise; *Tempo* about ¾ of the way clockwise; *Sequence Length* to 12; *Volume* fully clockwise; *Light* to *on*. Turn the power on and push and release *Reset/Start*. Immediately after it is released, a continuous series of clicks should be heard (actually the synthesizer may start without pushing *Reset/Start*). The clicks should all be equally loud, at evenly-spaced intervals, and the LED should flash for each click.

Sour Notes? If your R&B Box doesn't behave as it should, first recheck the PC board and all wiring. Make sure the IC's are properly installed and oriented. Next, try to determine which indicates that the clock (IC2 and IC3) is working. Check for a series of 10-volt pulses at the *External Amplifier* jack, which indicates that the shift register (IC5, 6, and 7) and analog switches (IC8, 9, and 10) are working. If either the sound or light operates, but not the other, check the appropriate output circuitry. If one of the clicks is weak or absent, look for a problem in the corresponding stage. The troublesome stage can be identified by varying each numbered pot in turn.

Assuming everything is OK, the next step is to determine the optimum value for R28. Verify that all controls are set as specified earlier; be sure that *Volume* is at maximum. If you can get an oscilloscope, connect it across the speaker terminals to observe the pulses; if not, make the adjustment by ear. First set the 100 K pot (which you temporarily wired in place of R28) for maximum resistance. Turn the synthesizer on and start it pulsing. Now, slowly decrease the resistance of the pot, which should cause the amplitude of the pulses to increase up to point of saturation—in other words, a point where the amplitude of the pulses no longer increases with a further decrease of the pot's resistance. Back the pot off slightly from this point and, without disturbing its setting, unplug the synthesizer and remove IC11. Measure the combined resistance of the pot and 10 K resistor, and install in their place a fixed resistor of the same value (or the nearest standard value).

Reinsert IC11, start the R&B Box again and continue the checkout by turning all the numbered pots except #1 down to about ¾. This should result in one loud click (corresponding to pot

(Continued on page 88)

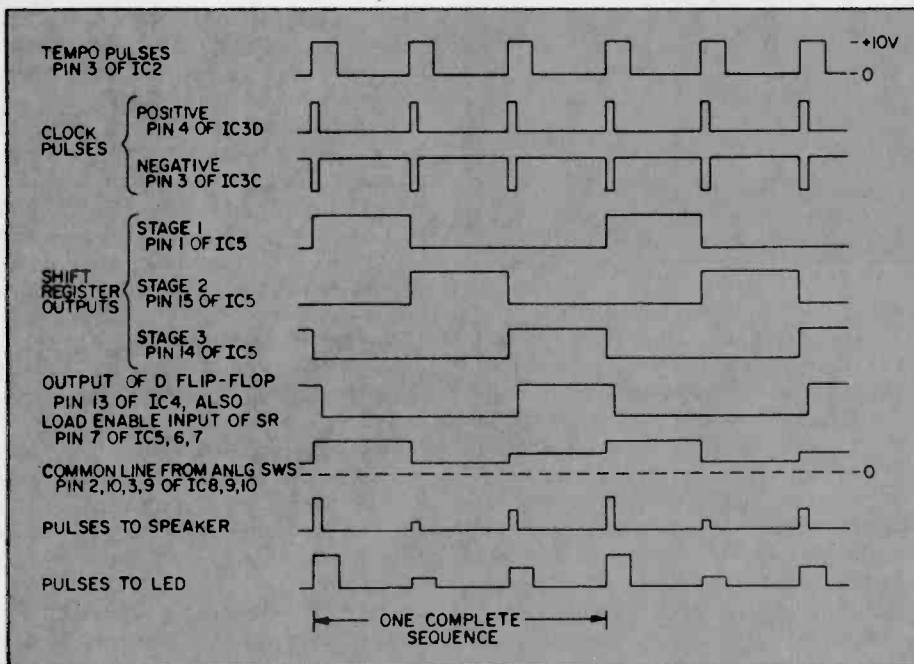

Need an adjustable waveform generator? The Rhythm and Blues Box can handle that too. Simply tap in at the appropriate point, hook up your scope, and you're ready to go.

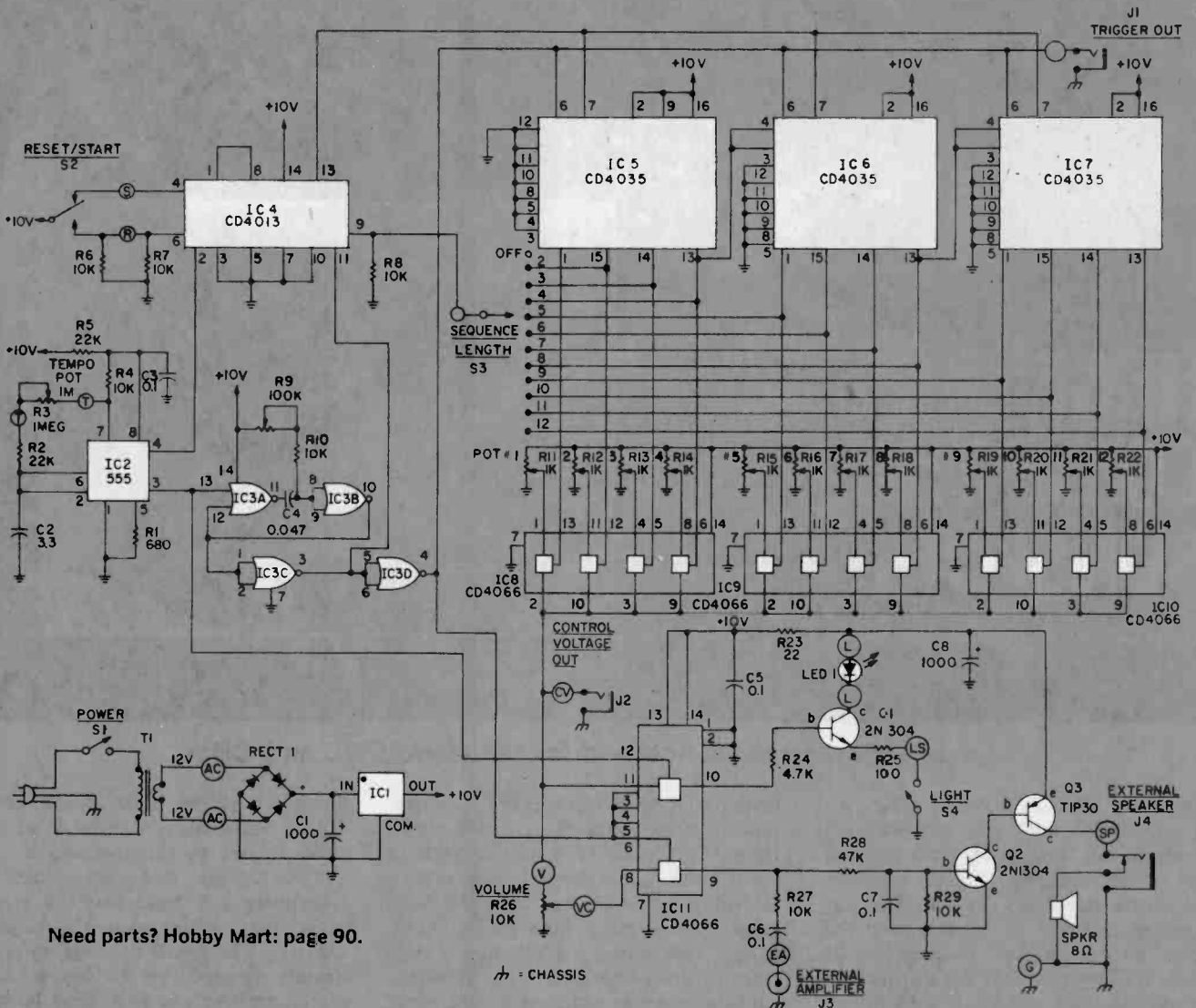

Need parts? Hobby Mart: page 90.

♣ = CHASSIS

PARTS LIST FOR RHYTHM AND BLUES BOX

- C1, C8—1000- μ F, 25-VDC electrolytic capacitor with radial leads (Sprague QV1-185, or equiv.)
- C2—3.3- μ F, 16-VDC tantalum capacitor
- C3, C5, C6, C7—0.1- μ F, 16-VDC disc ceramic capacitor
- C4—0.47- μ F, 16-VDC disc ceramic capacitor
- IC1—Positive 10-volt regulator in TO-220 package (National LM340T-10, UA7810 or equiv. See note.)
- IC2—555 timer
- IC3—CD4001 CMOS quad NOR gate
- IC4—CD4013 dual D-type flip flop
- IC5, IC6, IC7—CD4035 CMOS 4-stage shift register
- IC8, IC9, IC10, IC11—CD4066 (preferred) or CD4016 CMOS quad bilateral switch
- J1, J2—miniature phone jack, or to suit
- J3—phono jack
- J4—miniature phone jack with NC switch (Switchcraft 42AP2 or equiv.)
- LED1—Jumbo red LED, 70-mA (Radio Shack

- 276-041 or equiv.)
- Q1, Q2—General-purpose NPN germanium transistor (2N1304 or equiv.)
- Q3—PNP silicon power transistor in TO-220 package (TIP30 or equiv.)
- RECT 1—Full-wave bridge rectifier, 50-PIV, 200-mA or greater (Radio Shack 276-1151 or equiv.)
- R1—680-ohm, 1/4-watt resistor
- R2—22,000-ohm, 1/4-watt resistor
- R3—1-megohm, linear-taper potentiometer
- R4, R6, R7, R8, R10, R27, R29—10,000-ohm, 1/4-watt resistor
- R5—22-ohm, 1/4-watt resistor
- R9—100,000-ohm PC-mount trimpot
- R11-R22—1,000-ohm miniature linear-taper potentiometer (Mallory MLC13L or equiv.)
- R23—22-ohm, 1/2-watt resistor
- R24—4,700-ohm, 1/4-watt resistor
- R25—100-ohm, 1/2-watt resistor
- R26—10,000-ohm, linear-taper potentiometer
- R28—47,000-ohm, 1/4-watt resistor (see text)

- S1, S4—SPST miniature toggle switch
- S2—SPDT, break before make, miniature push-button switch (Switchcraft 953 or 963 or equiv.) or two NO SPST pushbutton switches
- S3—single pole, 12-position, non-shorting rotary switch (Calectro E2-161, modified as explained in text, or equiv.)
- SPKR—8-ohm speaker, size to suit (author used 4-in. diam.)
- T1—12-VAC, 150-mA or greater power transformer (Triad F-113X or equiv.)
- Mics.—Cabinet, knobs, line cord, IC sockets (3 16-pin, 6 14-pin), heat sinks, PC board, solder, wire, hardware, etc.
- Note—IC1, TH7 LM340T-10 IS AVAILABLE FOR \$1.25 FROM DIGI-KEY, P.O. BOX 677, THIEF RIVER FALLS, MN 56801.
- Free Template—Get a Free printed-circuit board template and parts location guide by sending a stamped, self-addressed business envelope to: Rhythm & Blues Box, ELEMENTARY ELECTRONICS, 380 Lexington Avenue, New York, NY 10017.

HERE COME THE SUNSPOTS...

by Harry L. Helms Jr. WA4EOX

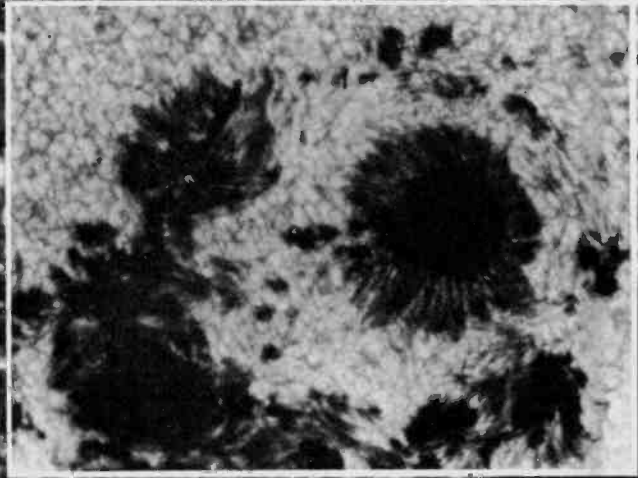

...bearing good news and bad for the Ham, SWL and CBer

OLD SOL FINALLY AWOKED from its long quiet spell and sunspots are appearing all across the face of the sun! If you're a SWL or ham operator this means happiness, as rare DX signals begin to roll in from around the globe on the higher frequencies. If you're a CBer, you face the prospect of around the clock skip conditions which, at times, may make the CB band almost useless. The intense level of solar activity may also cause brief radio blackouts in which all shortwave frequencies will be rendered useless for communication, and spectacular auroral displays in both the northern and southern hemispheres. And the clue that tells scientists how to predict these events are the rapidly increasing number of sunspots.

Sun and Radio. Although the sun is over 93,000,000 miles from earth, it is the controlling factor in all long-distance communication at shortwave frequencies. Shortwave radio can cover long distances because the radio waves are bent back to earth in the *ionosphere*. The ionosphere is the region between 60 and 200 miles in altitude that contains many free electrons and ions. Under the influence of ultraviolet light and charged particles from the sun, the free electrons and ions in the ionosphere combine to form various

layers of high ionization. If the ionization is dense enough, a radio signal from the ground is deflected back to earth by the ionosphere. If the level of ionization is not high enough, the radio signal passes clear through the ionosphere into outer space. Many CBers refer to this phenomenon as "skip" because of the way radio waves "skip off" the ionosphere. Whatever it is called,

the effect is the same. Radio signals can be heard many thousands of miles away thanks to the ionosphere.

The highest frequency which the ionosphere can bend back to earth is called the *maximum usable frequency* (MUF). The MUF depends upon how densely ionized the various layers of the ionosphere are. Ionization increases when the sun is active, pumping out

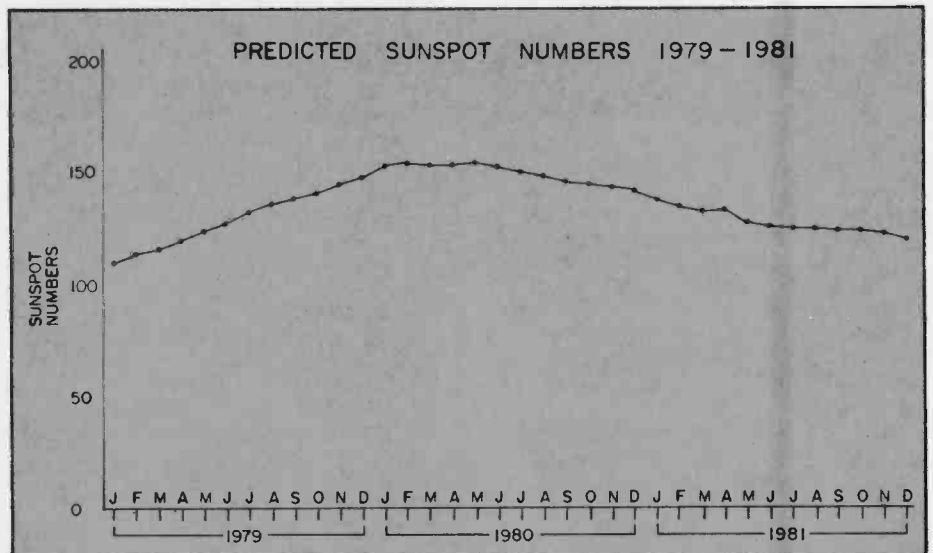

Sunspot numbers are expected to peak-out in first half of 1980, when the number should exceed 150 for the third time since 1947. Already the numbers well above normal rates.

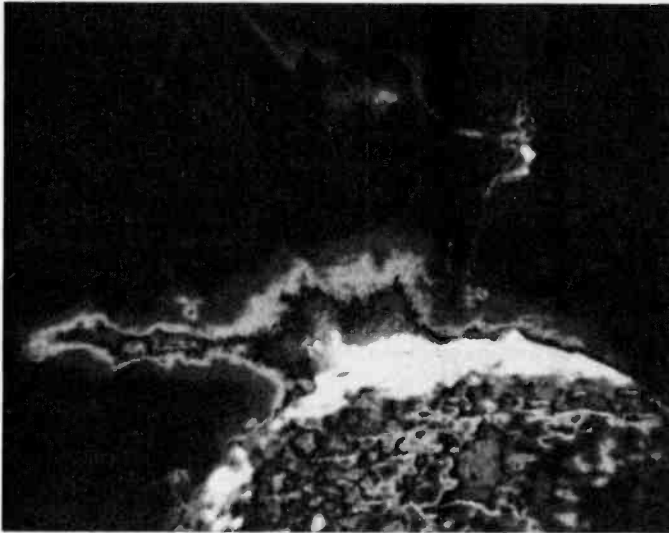

Skylab astronauts took this photo of a solar flare using an (EUV) extreme ultraviolet spectroheliograph to measure the intensity.

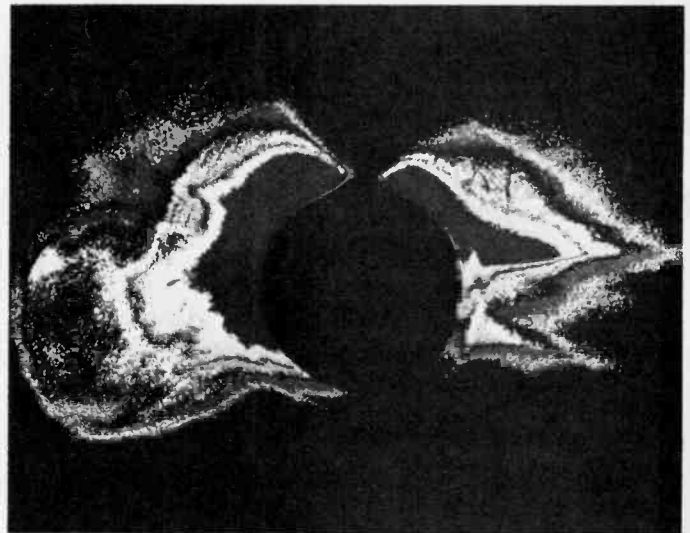

The Sun's energetic atmosphere reaches far beyond the area of its visible disc as this Skylab coronagraph graphically demonstrates.

more ultraviolet radiation and charged particles. Sunspots are an excellent barometer of solar activity. When the sunspot number climbs, so does the MUF.

Sunspot numbers go through cycles which average approximately eleven years in length. When sunspot numbers are low, the higher shortwave frequencies (above 14 MHz) are generally only useful in daytime. There are often many days when such higher frequencies are completely "dead" for long distance communication even in daytime. But during periods of high solar activity frequencies up to 30 MHz may be useful for long distance communication day and night, and even low powered stations can find themselves able to communicate all over the world. Moreover, during periods near the peak of a sunspot cycle, frequencies not normally bent by the ionosphere may open up for long distance work. For example, during a sunspot cycle peak in the late 1950's TV DXers in New York were able to bag TV signals from a Hawaiian TV station operating on channel 2 (55.25/59.75 MHz)!

Solar Weather. Sunspots were one of the first things noted by Galileo when he began surveying the heavens with his telescope. His first recorded observation of sunspots happened in August, 1610 and the puzzled Galileo speculated that the spots were the result of spent fuel ejected from the sun. Today we know that sunspots represent intense disturbances deep within the sun. They can be thought of as "thunderstorms" on the sun. While sunspots appear as dark areas upon the solar disc, they are actually over 100 times brighter than our moon. It is

only by comparison with the brighter solar surface that they seem to be dark.

Sunspots have a dark nucleus called the *umbra* and a lighter surrounding area called the *penumbra*. These areas are less bright than the rest of the sun because they are approximately 1500°F cooler than the usual temperature of the solar surface. While sunspots seem to be small compared to the sun, some may measure over 30,000 miles in width, many times the diameter of the earth. Sunspots are also the centers of

powerful magnetic fields, although the process which causes these is not yet fully understood.

Astronomers have long noted the tendency for sunspots to join together into groups. In 1849 the Swiss astronomer Wolf developed the concept of the "relative sunspot number" to keep track of solar activity. The method took into account both the number of individual sunspots and the number of sunspot groups. Wolf's method, with a few minor revisions, is still used today.

(Continued on page 87)

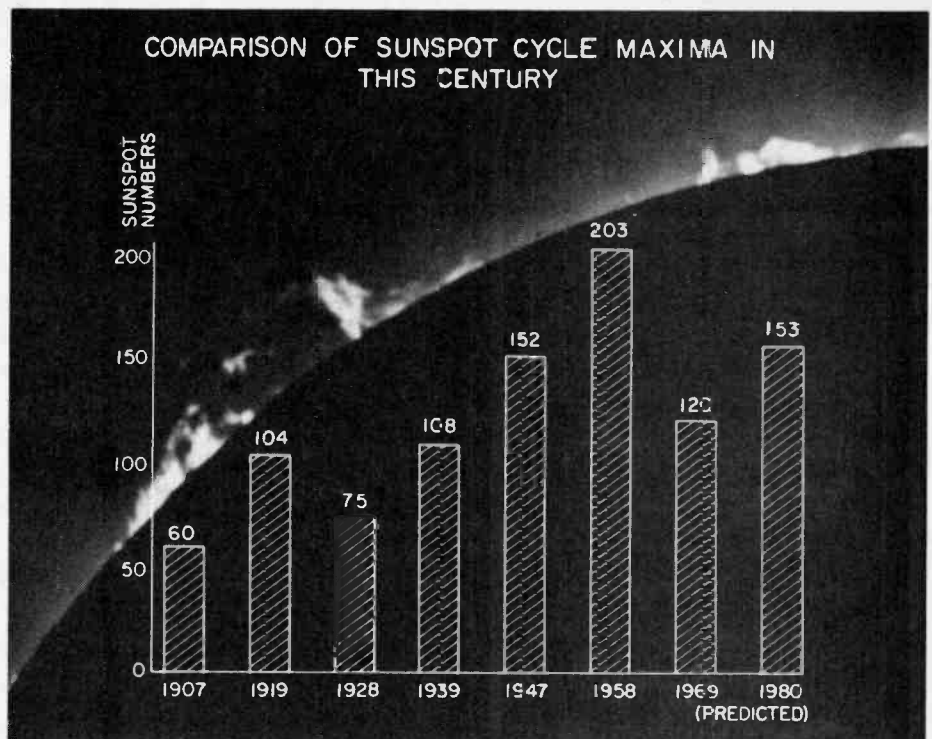

The amount of sunspot activity appears to be increasing according to this chart. The peaks occur at about 11-year intervals but this varies enough to be statistically significant.

Train with NTS for the MicroComputers, digital the first name



MicroComputers

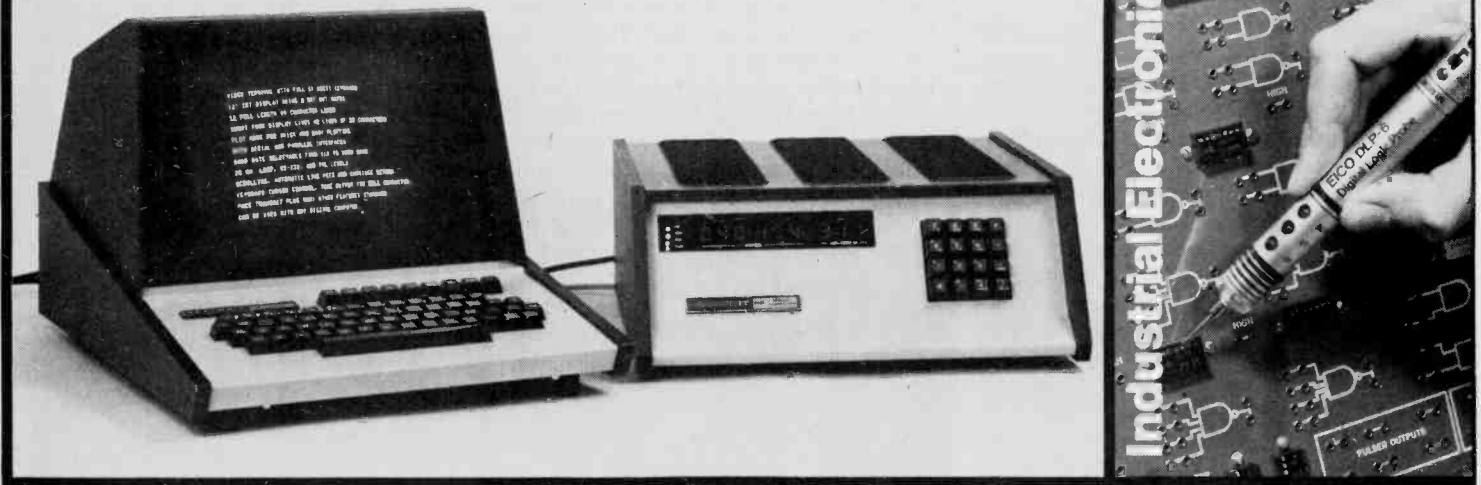

The world of electronics is daily becoming more challenging. Technology is growing more specialized, and the importance of digital systems increases every day. Test instruments, home entertainment units and industrial control systems are all going digital. And now, NTS training programs include a wider choice of solid-state and digital equipment than ever before offered in any home study course:

Advanced NTS/Heath digital color TV (25" diagonal with optional programming capability), NTS/Heath microcomputer, digital test equipment, digital stereo receiver (70 watts per channel), NTS compu-trainer, plus much more state-of-the-art equipment to make your training exciting and relevant.

The equipment you receive with NTS training programs is selected to provide you with a solid

background in electronic systems. Kits and lessons are designed to work together to demonstrate electronic principles and applications. The kit-building not only shows you how electronic hardware functions, but how various circuit designs accomplish different purposes. Your lessons guide you through any number of experiments associated with many projects. This is the Project-Method, and it works. Step-by-step, you learn how and why digital electronics has become a part of our world, and the even bigger role it is sure to play in the future.

Whether you are looking for training in Consumer, Commercial, or Industrial electronics, NTS offers fourteen courses, some basic, many advanced, in several areas of electronics. An all-new full-color NTS catalog shows you what each course covers,

electronics of the future.

systems and more...from
in home study.

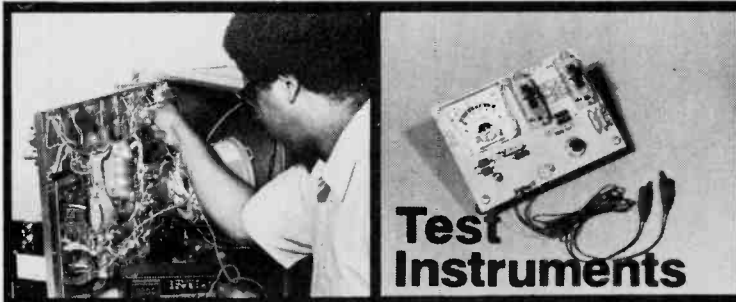

Test Instruments



Simulated TV Reception

**Digital
Color TV**



**Basic
Electronics**

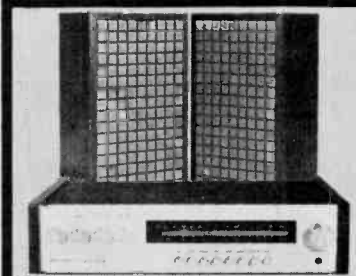

and every piece of equipment included.
Send for it today, and see for yourself what's really happening in electronics training technology at NTS. Find out how much has changed, and what new directions the field is taking. You'll probably want to be a part of it.
It's free. Just mail the card or coupon. Today.

**NO OBLIGATION. NO SALESMAN WILL CALL.
APPROVED FOR VETERAN TRAINING.**

NATIONAL TECHNICAL SCHOOLS

TECHNICAL-TRADE TRAINING SINCE 1905
Resident and Home-Study Schools
4000 South Figueroa St., Los Angeles, Calif. 90037

NATIONAL TECHNICAL SCHOOLS Dept. 222-019
4000 South Figueroa Street, Los Angeles, California 90037

Please send FREE Color Catalog and Sample Lesson.

- Color TV Servicing
- B & W TV and Radio Servicing
- FCC License Course
- Electronic Communications
- Electronics Technology
- Audio Electronics Servicing
- Digital Electronics
- MicroComputers/MicroProcessors

Name _____

Address _____

Apartment Number _____ Age _____

City _____

State _____ Zip _____

- Check if interested in G.I. Bill information.
- Check if interested ONLY in classroom training in Los Angeles.

Keep up with current events by expanding your meter's amp-ability

HIGH-AMP METERS

by Jeff Jones

WITH THE RISING COST of test equipment it is advantageous to be able to perform several operations with one meter. For instance a DC milliammeter can be converted to read higher values of current by adding a shunt to bypass the bulk of the current around the delicate meter. By following a few simple steps a milliammeter can be converted to read 10 to 20 amps or more. The first step is to determine the internal resistance of the meter. From this you can calculate the shunt resistance needed and the type of material to be used.

To find the internal resistance of the meter, construct the test circuit illustrated here. The 4700 ohm resistor is used to limit current and serves no other purpose. Start with the power supply set to zero volts, leaving S2 open and S1 closed. Slowly increase the current flow by varying R3 until the meter needle moves to full-scale deflection. Without touching the setting of R3, close S2 and adjust R2 until the meter reads half of full scale. According to Ohm's Law the resistance of the meter and of R2 are now equal. Open switch S2 and measure the resistance across R2. This value will be equal to the internal resistance of the meter.

Shunt. Precise shunt resistance is important for accurate current readings and must be chosen carefully. With the shunt connected across the meter, most of the current is diverted past the meter. This is the theory behind a small meter being able to read high currents. The shunt can be a wire, steel or copper bar, or almost any material that will offer the proper resistance. To determine the needed shunt resistance we will consider an example. If we want a 0 to 10 milliammeter to be able to read full-scale for a current of 10 amps. Therefore 10 mA will flow through the meter when 9.990 Amps are diverted through the shunt. If the meter resistance was 100 ohms, using Ohm's Law the voltage across this parallel circuit is found by using the following equation:

$$E = (\text{Current}) (\text{Resistance}) \\ = (10^{-3}) (100 \text{ ohms}) \\ = 1 \text{ Volt}$$

Using the calculated voltage and

$$\text{Resistance} = \frac{\text{Voltage}}{\text{Current}} \\ = \frac{1 \text{ Volt}}{9.990 \text{ Amps}} \\ = .1001 \text{ Ohms}$$

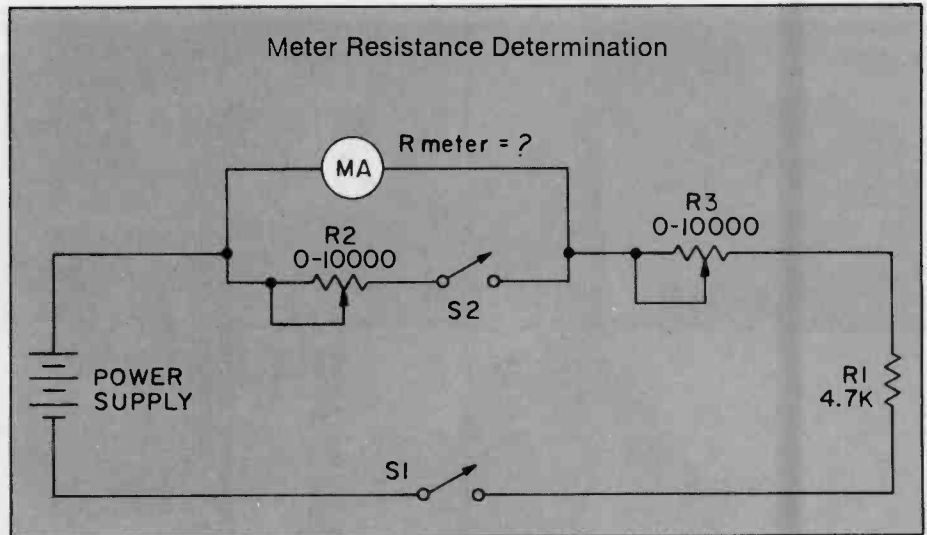

To determine the internal resistance of a meter construct a circuit like the one illustrated above. If you don't have the parts in your junk box then check an electronics surplus outlet.

A shunt resistor bypasses the bulk of the current around the meter while allowing a regulated amount to pass through the meter's coil and give an accurate reading. A shunt can be a resistor or a measured length of wire. Make sure it will handle the current.

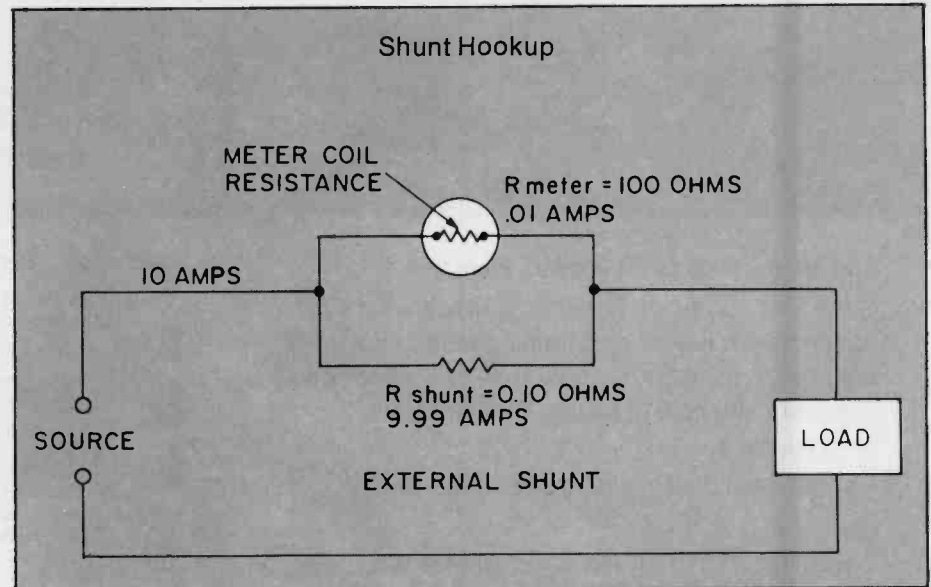

solving Ohm's Law for resistance the proper shunt can be found. This derivation is shown below:

In this case the milliammeter would be capable of giving a readout directly in amperes.

By following these few simple steps you will greatly expand the versatility of your test equipment. It will increase your ability to handle a greater variety of test and trouble shooting situations. ■



RESTORING

ANTIQUE RADIOS

by James A. Fred

Put that flea-market eyesore back in showroom shape

SOME TIME AGO I wrote a story for BUDGET ELECTRONICS telling where to find, how to buy, and how to sell old radios. Since then many readers have written to me asking just exactly how to go about restoring an old radio. There are several levels of restoration, and while one collector will be happy just to have his radio play many others want the set to look and play like it did the day it was shipped from the factory. In this story I will tell you how to refinish the cabinet and restore the radio to playing condition. If you want to stop at any point along the way that is your privilege.

Break It Down. First you must find a radio. The one I show you in this story is a five-tube Airline, (Montgomery Ward) wooden cabinet, table model, made around 1935. It cost \$1.50 at a farm auction. It did not play, but for this price I didn't expect it too.

The first thing to do is to remove the knobs, dial escutcheon, the back if it has one, and remove the chassis from the cabinet. The speaker may be fastened to the front panel or it may be chassis mounted. Remove the chassis, speaker, and any other item that may be attached to the cabinet. In-

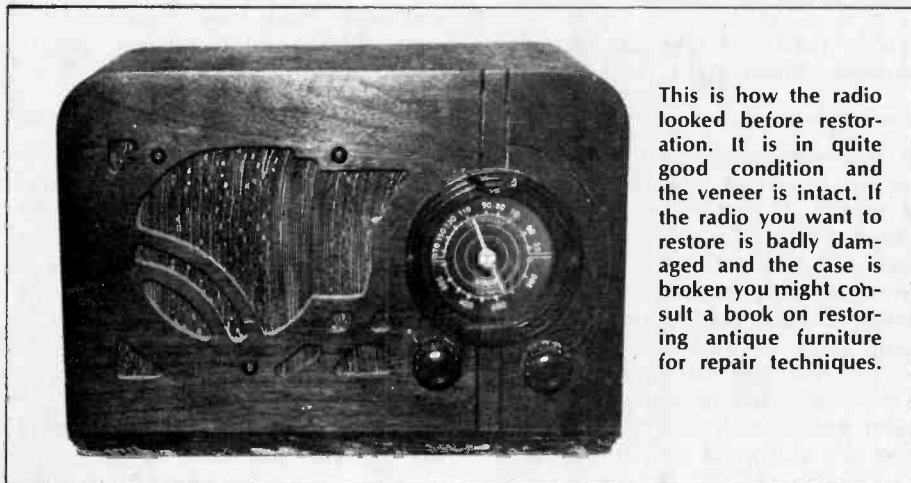

This is how the radio looked before restoration. It is in quite good condition and the veneer is intact. If the radio you want to restore is badly damaged and the case is broken you might consult a book on restoring antique furniture for repair techniques.

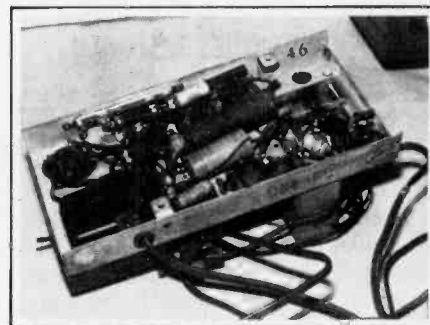

The chassis was in surprisingly good shape and all I had to do was replace the cracked line cord, a filter capacitor and all of the tubular capacitors (see text for details).

spect the speaker grill cloth and if it is so badly damaged that it will spoil the appearance of the restored radio throw it away. Set the chassis aside and restore the cabinet first.

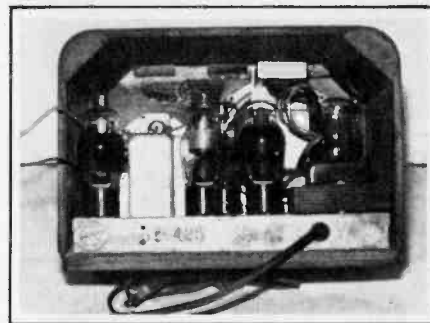

This is how the chassis looks now that the repairs and replacements have been made. Get out all the old spiderwebs and dust. Give the tubes a good wash, make sure they are dry before you fire up the old rig.

Scrub It Down. The cabinet should first be washed with a damp cloth and a mild detergent. Do not soak the cabinet, just scrub it, and rinse it. You will be surprised at the improvement

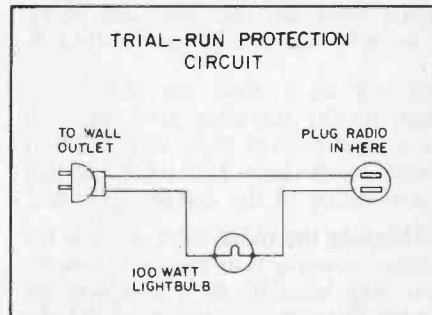

This circuit can keep your first trial-run from being a disaster, by protecting the radio from faulty transformer or capacitor.

this will make. If there are grooves cut through the veneer for decoration clean them with an old tooth brush. After the cabinet is clean look for scratches, cigarette burns, white rings left by wet glasses or other defects in the finish. If there are only a few scratches these can be touched up with stain, and a

e/e ANTIQUES RESTORED

small brush, even iodine will cover scratches in some wood. You can also find color sticks in lumber yards to match the cabinet color. If you have a can of brown paste shoe polish you can touch up the cabinet and give it a wax job all at the same time. If you have never tried shoe polish, don't knock it. You can also buy colored Simoniz wax or perhaps you know of other products



There are lots of old plastic radios available at junk shops and flea markets throughout country. This was bought for \$1.50.

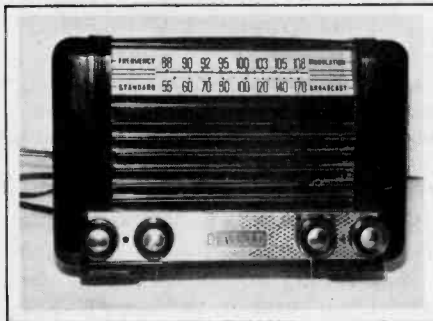

After washing cleaning and polishing the cabinet looks just like new, and it will fit in with the rest of your collection.

that will do a good job. After you touch up the scratches give the cabinet a good coat of paste wax and buff it with a soft cloth. This treatment will restore many of the cabinets you find.

Stripping the Wood. Now suppose the damage is worse than you first thought. You may want to do a complete refinishing job. The original finish usually consisted of a coat of shading stain and one or two coats of clear lacquer. If you want the natural color of the wood to come through you must remove the finish down to the bare wood. Always follow the directions on the can of paint stripper you are using. To remove the finish on our cabinet we used Treadway's Paint and Varnish Remover. You can purchase a complete Treadway's refinishing kit for \$9.95. It

includes remover, Tung oil finish, steel wool, brass brush, and instructions for use. Pour some of the remover into a bowl and dip the steel wool supplied into the remover. Now rub with the steel wool and the finish will begin to come off the cabinet. After the cabinet is stripped and washed clean sand it lightly with No. 220 Garnet paper or extra fine sandpaper. Wipe the cabinet with a tack rag to remove all traces of dust.

Now you are ready to put a new finish on the cabinet. You can use the Tung oil that comes with the Treadway

ventilated.

If the speaker grill cloth was ruined shop the fabric stores and Hi-Fi shops for a suitable replacement. Install the cloth in the cabinet, replace the speaker, and put back the escutcheon. Now you are ready to restore the radio electrically.

Getting It Working. About the first thing to do is to remove the tubes and clean out all the dust, dirt, and mice corrosion. A small air compressor is handy to blow out dust and dirt. If there is rust or corrosion on the chassis or other metal parts a small brass or

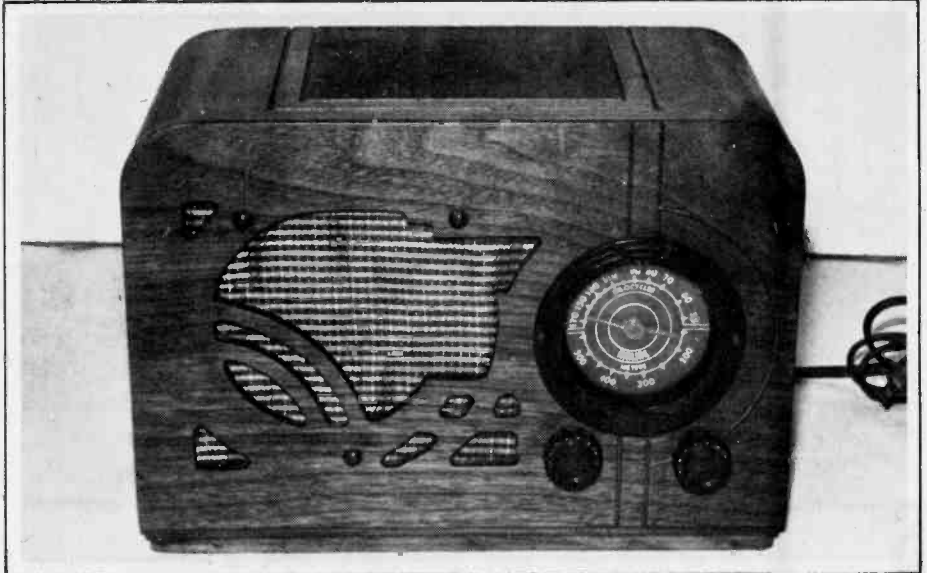

The finished product will be the pride of your showcase. With a like-new finish on the wood, a new speaker grill and a cleaned-up dial face its value is greatly increased.

APPENDIX

Plastic cleaner and polish, small wire brushes, glass cutter and tools; Brookstone, 127 Vose Farm Road, Peterborough, NH, 03458.

Small brushes and tools; Consumers Bargain Corp., 109 Wheeler Ave., Pleasantville, NY 10570.

Tubes, parts and schematic drawings; Antique Radio Parts, P.O. Box 42,

Rossville, IN 46920. Also Puett Electronics, P.O. Box 28572, Dallas, TX 75228.

Power Supplies for old battery radios; G. B. Schneider, 6848 Commonwealth Blvd., Parma Heights, OH 44130.

Treadway's Paint and Varnish Remover; Treadway's Refinishing Products, P.O. Box 1, Lima, OH 45802.

kit or if you prefer a varnish finish you can put on several coats of your favorite varnish. If you are a highly-skilled refinisher you may spray on several coats of lacquer. If you want the cabinet to be a different color than the bare wood you must first stain it. There are many kinds of stain available, but I prefer a non-grain raising stain because it minimizes sanding. If the weather is warm work outside in a spot sheltered from the wind and sun. If you must work inside be sure the area is well

stainless steel wire brush is useful in removing it. A hand held motor tool with a round wire brush will also do a good job. You may want to paint the metal parts with chrome or aluminum paint to hide the damage. After the chassis is clean pay special attention to the line cord. If it has hardened, broken, frayed, or in any way is unsafe replace it. If the set is very old, i.e., made before 1930, it probably had a silk covered line cord. Most electric

(Continued on page 86)

MINI-REG

the regulated IC Power Supply

by Adolph A. Mangieri

Keep your projects cool, calm and under control with this peppy power supply



HERE'S A LOW-COST precision regulated DC power supply which is sure to be a welcome addition to any workbench—provided some family member doesn't appropriate the power supply for use as a universal AC adaptor! Compactly assembled in an eye-catching low profile, the Mini-Reg is continuously adjustable from 3.4 volts to 15 volts DC and delivers up to 500 milliamperes, enough for just about any job. Using the HEP C6049R precision monolithic IC regulator, the Mini-Reg effects 0.01% regulation with line voltage variations, 0.05% regulation for load variations, and its output impedance is a mere 35 milliohms. Short-circuit proofed, the Mini-Reg also features adjustable current limiting which greatly reduces the chances of damaging valuable components in the circuits you are working on. You can also use the Mini-Reg as a constant-current source and recharge nicad batteries.

Circuit Operation. The HEP C6049R is actually a DC regulator within a regulator which accounts for its high performance. As shown in the block diagram, a very stable reference voltage (V_r) is applied to the non-inverting or voltage follower input of an op-amp which serves as the first regulator and DC level shift amplifier. The output voltage of this stage can be varied from

3.4 volts to 15 volts by varying pot R11. This voltage is applied to the non-inverting input of the second op-amp which is capable of supplying up to 5000 milliamperes current to the load. This stage has unity voltage gain wherein V_{out} follows the input voltage to this stage. This double regulator arrangement fully isolates the DC level shift amplifier and results in very close regulation. Capacitor C4 provides frequency compensation and precludes possible circuit oscillation.

External components consisting of transistor Q1 and selectable resistor Rsc provide constant-current limiting should the supply be short-circuited. When the load current passing through Rsc becomes sufficiently high, the base of Q1 becomes forward biased causing Q1 to conduct. When Q1 conducts, the voltage regulator delivers an essentially constant current to the load at a level depending on the value of Rsc. In the schematic diagram, resistor R3 places a minimum load on the regulator. Switch S3 selects the desired current limit. Jacks J1 and J2 permit insertion of a milliammeter to read load current but without impairing regulation. Diode D2 provides meter protection and diode D1 provides reverse voltage protection.

Construction. Assemble the Mini-Reg in an aluminum case or in a plastic case with aluminum cover plate. Select a case which will accommodate the particular meter and transformer you plan to use. Plan the layout allowing room for the PC board assembly when the cover plate is secured.

Begin by laying out and drilling mounting holes for IC1 in the heatsink. Drill a 7/16 inch diameter hole in the heatsink to pass the lead wires of IC1. File off drill burrs and ridges so that IC1 mates perfectly on the heatsink. Drill matching holes in the cover plate. For ventilation, drill a number of holes in the cover plate and on the bottom of the case.

Make the PC board using the circuit pattern shown, taking care to locate

pads for IC1 just right. Push IC1 into the drilled board and mark and drill the mounting holes. For easier mating, countersink the lead holes for IC1 on the insulation side of the board by twirling a small drill bit.

Install and solder the jumper on the insulation side of the board and install and solder T42-1 micro-clips (Vector) on the copper side at all resistor and board take-off terminals. Clip a small heatsink (Radio Shack 276-001) on the leads of Q1 when soldering. Install remaining circuit board components excepting trim resistor R5. Using 6-32 machine screws, bolt IC1 and the heatsink to the cover plate. Place a lock washer and two 6-32 nuts on each mounting bolt. *Omit the mica washer between IC1 and the heatsink* and apply a bit of silicone heatsink grease be-

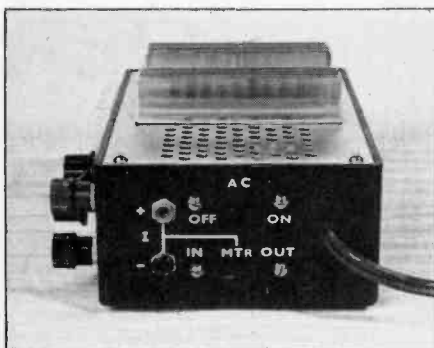

The AC line switch, current jacks and current meter switch are on the end of the case.

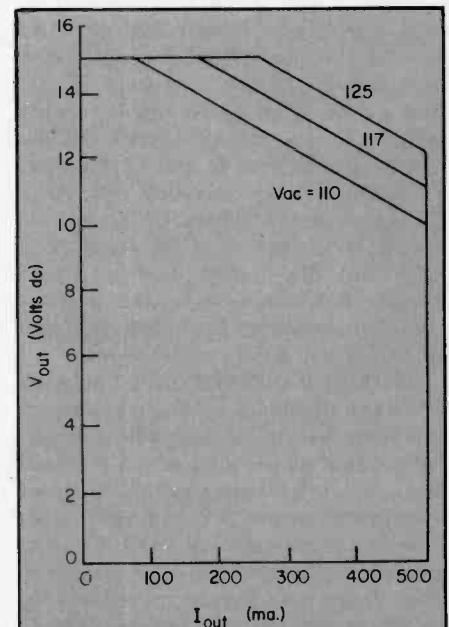

This chart shows the operating range of the Mini-Reg at various line voltages. The full 15 VDC is only available at lower currents, but few IC projects ever require that much voltage or current supply.

tween IC1 and the heatsink. Coil a ¼-by 1½-inch strip of fishpaper insulation and slip it down into the hole in the cover plate around the IC lead wires. Push the PC board assembly down on the mounting screws and mate with the protruding IC leads and secure. If you can't install the assembly, look for bent pins or reversed installation of IC1.

Install switches S1 and S2 along with jacks J1 and J2 on the left side of the case. Install diode D2 and capacitor C7 on switches S2. Secure two solder lugs on each binding post and install diode D1 and capacitor C6 on the binding posts. Pass the AC line cord through the left side of the case and knot the cord for strain relief. Install resistors R6 thru R10 on switch S1. Depending on the base-emitter characteristics of Q1, the specified values of current limit resistors R6 through R10 may differ somewhat in your power supply. This is why trim resistor R5 was included to properly trim the 500 mA current limit. For this reason, you may defer installation of R6 thru R9 but *do* install R10.

Place RECT-1, R1, C5, and C8 on a small piece of perfboard and situate this sub-assembly behind the meter. Connect meter M1 directly to binding posts BP1 and BP2. Use #20 stranded wire for connections to the PC board. Connect a wire from board pin G to BP2. Run a wire from board pin E to the rotor lug of S3. Connect a wire from board pin D to resistors on S3. Run a wire from board pin F directly to BP1. Run a pair of wires from pot R11 to board pins B and C. Connect a wire from *V-in minus* directly to BP2. Do not make the connection from *V-in plus* to board pin A at this time. You may omit the double-fused plug and provide but one fuse in the primary side of transformer T1. Carefully check all wiring and solder connections.

Checking It Out. We intentionally deferred installation of several components and some wiring, so that you can perform a few simple tests which preclude damage to circuit components. Connect a voltmeter across R1 and verify that *V-in plus* is nineteen volts DC. Connect a milliammeter and 100-ohm resistor in series from *V-in plus* to board pin A. Set S3 to pick up R10 and set R11 to minimum resistance. Turn S1 on and observe about five milliamperes current on the milliammeter and 3.4 volts on meter M1. Advance R11 and observe a voltage increase up to fifteen volts

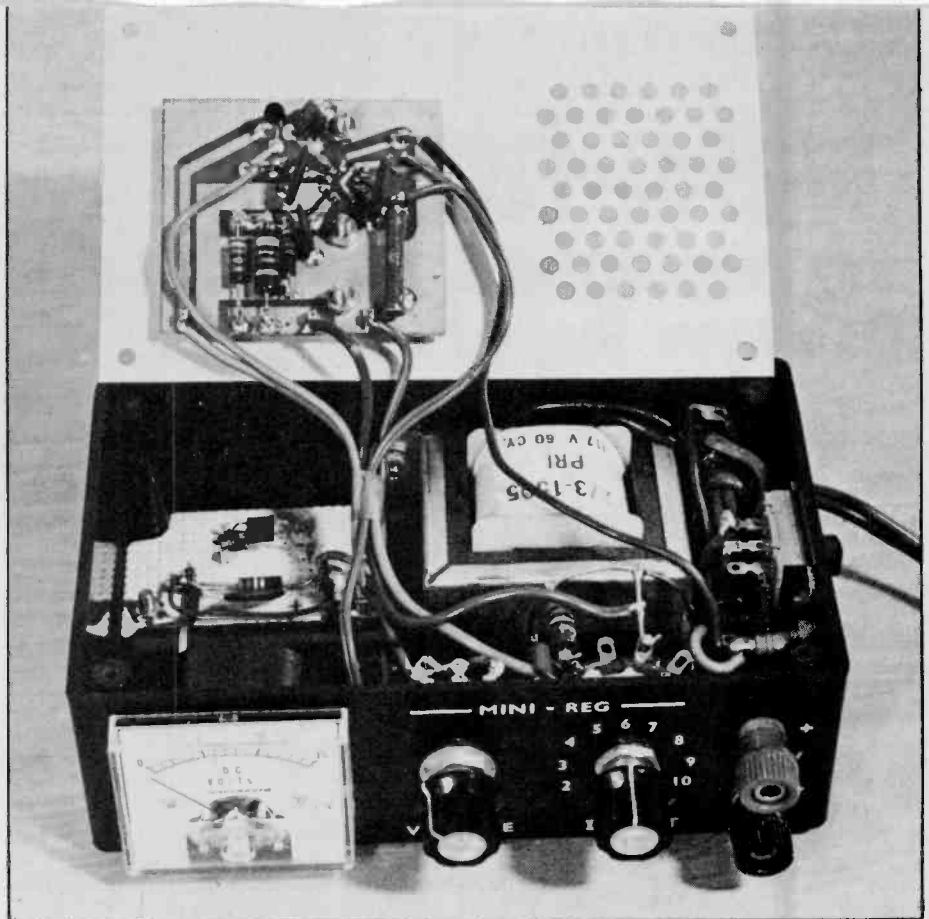

Internal view of the Mini-Reg. The circuit board is positioned so that it doesn't come in contact with the meter and transformer. The case is perforated for ventilation. You can see the tiny, square HEP 176 rectifier on the small circuit board in the bottom of the case. In front of it is R1, C5 and the 2500uF capacitor C8.

DC. If the output voltage is less than fifteen volts, the value of R11 may be too small or R2 may be too large. Having verified the above, you may now install the wire from *V-in plus* to PC board pin A.

Plug the milliammeter into jacks J1 and J2 and open S2 (Meter In). Adjust R11 for ten volts output and set S3 to ten milliamperes current limit. Then, connect a 500-ohm ½-watt resistor across the output terminals. If current limiting action is taking place, the milliammeter should indicate roughly ten milliamperes and the output voltage should drop to about five volts. If much higher values are observed, current limiting is not taking place. Look for a

defective or improperly installed Q1. If your current limit is, say, seven milliamperes, you can bring it up to ten by using a smaller value for R10 or by connecting a suitably larger value resistor across R10.

Only after you have verified current limiting action at low current, set S3 to pick up R4 (500 ma setting) and set the VOM accordingly. You will need either a 50-ohm 10-watt rheostat or adjustable power resistor to gradually load the supply. Or, you can use a number of small-valued power resistors. Set the rheostat to maximum resistance and connect it across the output terminals. Gradually reduce load resistance while observing output voltage and cur-

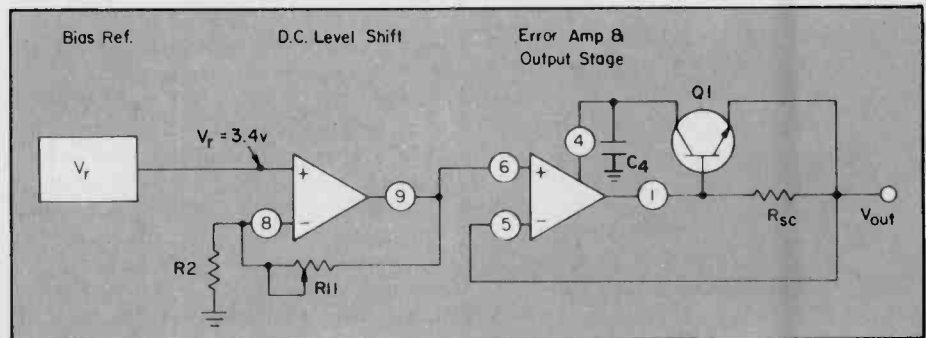

This is a simplified block diagram of the C6049R regulator chip—the heart of the Mini-Reg power supply. Thanks to such ICs construction projects are easy to build.

rent. Current limiting should occur at below 500 ma. To increase the limit to 500 milliamperes, select and install a suitable resistor for R5. Proceed similarly to size or trim resistors R6 thru R10. You can easily include other current limits in the spare positions on S3 to match the charging currents of your nicad batteries. Do not exceed 500 milliamperes or else IC1 will be damaged.

Application. The operating range of the Mini-Reg for several line voltages is shown. The supply "drop-out" shown in the upper right hand corner of this chart is due to an insufficient difference between V-in plus and V-out which in turn depends on transformer T1 voltage. When you are not using a meter at jacks J1 and J2, close S2.

The adjustable current limiting feature of the Mini-Reg greatly reduces the chances of damaging circuit components of the circuit powered by the supply. Suppose you are experimenting with a transistorized circuit drawing five milliamperes at five volts. You would then set S2 to ten milliamperes. At these settings, the maximum power the supply can deliver is but a mere fifty milliwatts.

If you plug a transistor in backwards, the most it can draw is fifty milliwatts,

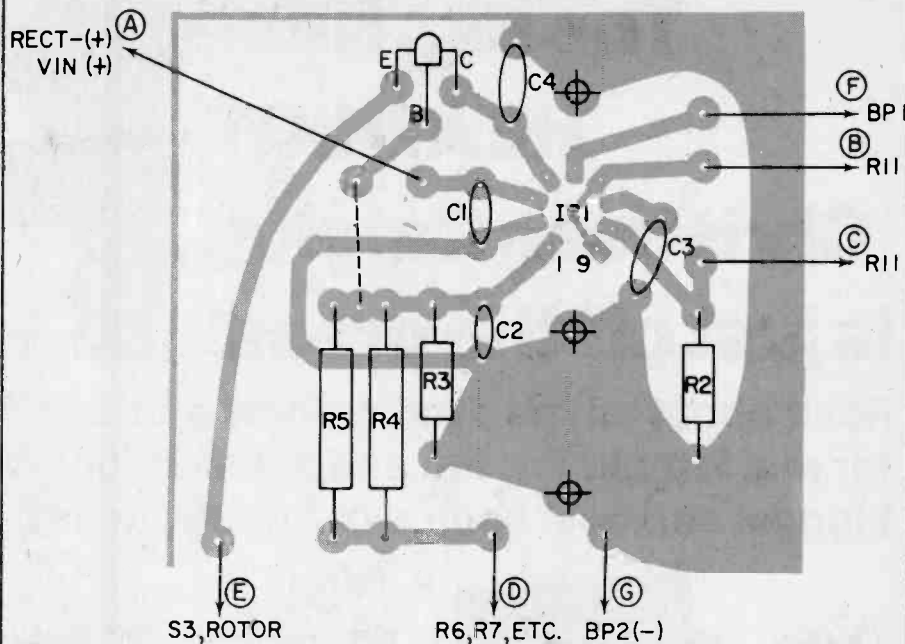

The parts should be placed according to this diagram. Note the location of the three drill holes for securing the IC and the board to the chassis. Locate the IC mounting holes very carefully so that everything mates snugly. This will help keep the chip cool.

probably much less; hence, the device will survive the error. However, certain semiconductors can be damaged with but microwatts of power. Nevertheless, you are far better off using current limiting supplies. If your experimental

circuit draws 400 milliamperes at five volts, set S3 to 500 milliamperes limiting the power to 2.5 watts. This power level is more than enough to zap many devices if you make an error. If you have
(Continued on page 85)

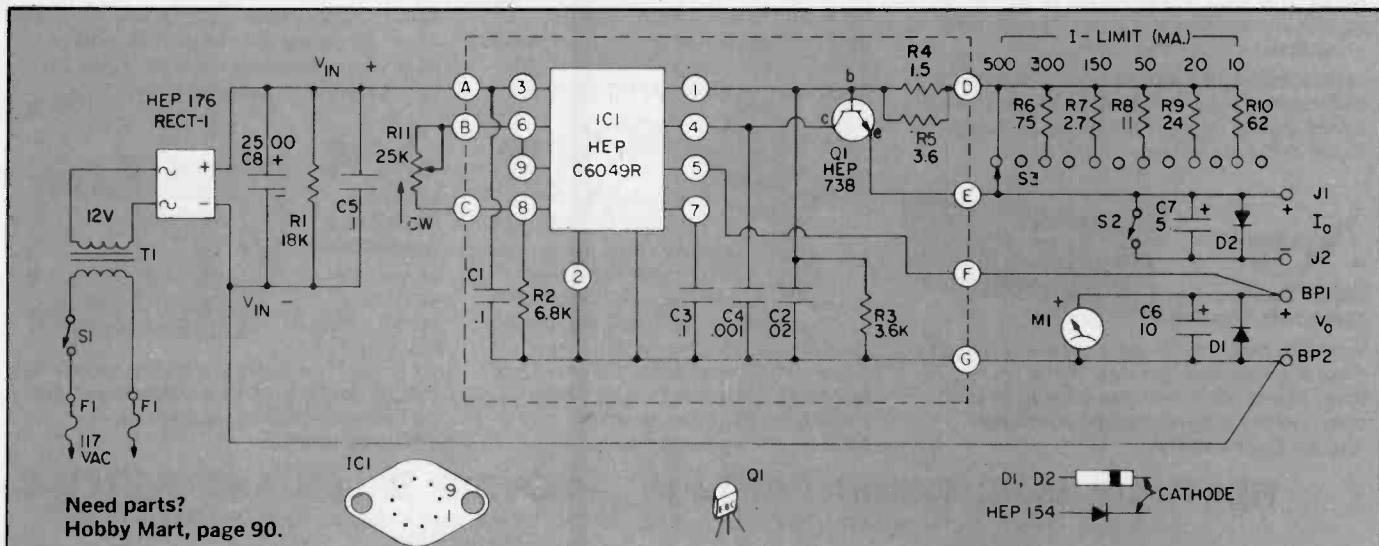

Need parts?
Hobby Mart, page 90.

PARTS LIST FOR MINI-REG

- BP1, BP2—binding posts, red, black
- C1, C3, C5—0.1- μ F 25-VDC capacitor, ceramic
- C2—0.02- μ F 25-VDC capacitor, ceramic
- C4—0.001- μ F 25-VDC capacitor, ceramic
- C6—10- μ F 25-VDC electrolytic capacitor
- C7—5- μ F 25-VDC electrolytic capacitor
- C8—2500- μ F 25-VDC electrolytic capacitor
- D1, D2—1-Amp 50 PIV silicon rectifier diode, HEP 154
- F1— $\frac{1}{2}$ -Amp fuse
- IC1—HEP C6049R voltage regulator
- J1, J2—insulated phone tip jacks, red, black
- M1—0-15 VDC miniature DC voltmeter
- Q1—HEP 738 transistor

- R1—18,000-ohm, $\frac{1}{2}$ -watt resistor
- R2—6800-ohm, $\frac{1}{2}$ -watt resistor
- R3—3600-ohm, $\frac{1}{2}$ -watt resistor
- R4—1.5-ohm, 2-watt wire-wound resistor, IRC type BWH
- R5—3.6-ohm, $\frac{1}{2}$ -watt resistor
- R6—0.75-ohm, 2-watt wire-wound resistor, IRC type BWH
- R7—2.7-ohm, 2-watt wire-wound resistor, IRC type BWH
- R8—11-ohm, 1-watt resistor
- R9—24-ohm, 1-watt resistor
- R10—62-ohm, 1-watt resistor
- R11—25,000-ohm linear taper potentiometer

- RECT-1—HEP 176 1-amp, 200-PIV bridge rectifier.
- S1, S2—SPST slide switch
- S3—1-pole, 12-position switch, non-shorting (Mallory 32112) or equiv.)
- T1—12-volt, 1.2-ampere filament transformer

Misc.—Plastic case with aluminum top, 6 $\frac{1}{4}$ x 3 $\frac{1}{4}$ x 2 inches; heat sink, 3 x 3 $\frac{1}{2}$ inches, (Allied Electronics 957-2840 or equiv.); T42-1 micro-clips (Vector); AC line cord; fused cord plug or fuseholder; perforated board; copper clad board; rubber feet (4); hardware, etc.

The Big, NEW HEATHKIT[®] Christmas Catalog is just off the press!

FR

Read about all the exciting new products you can give, or get, for real kitbuilding fun and satisfaction! We're the world's biggest and best source of quality money-saving electronic kits.

New

Computerized Weather Monitor



If you need weather information for ANY purpose, the ID-4001 is the way to get it! This microcomputer-based weather instrument digitally displays—time of day in 12 or 24-hour format; wind direction and magnitude; indoor and outdoor temperature; barometric pressure; even wind chill factor! What's more, the computer's memory stores the highest and lowest data for each function so you can recall it for easy and accurate record keeping. Chart recorder and computer outputs provide even more versatility!

Includes remote transmitter with windcups and weathervane that have been wind-tunnel tested and an outdoor temperature sensor using the latest infra-red technology.

New

Hand-Held 2-Meter Transceiver

Superb features, specifications and a great low price make the VF-2031 a terrific buy in a hand-held two-meter transceiver. Features 8-channel simplex with ± 600 kHz offset using one crystal per channel, minimum 2 watts out, and $0.5 \mu V$ sensitivity for 20 dB quieting. Includes built-in antenna, nickel-cadmium batteries and battery charger. An optional tone encoder and other accessories are also available. Units will be available in January, subject to FCC approval.



New

WH14 Line Printer for "Hard Copy" Computer Readout

Low-cost microprocessor-controlled line printer is designed to give you a convenient "hard copy" printout of your computer programming. It eliminates losing and recalling program lines after they have scrolled off a CRT, it also provides handy printed lists of address lines, lists or other program data for easy editing and manipulation. Prints the standard 96-character ASCII set (upper AND lower case) on a 5x7 dot matrix print head. Designed for use with Heathkit computers and others as well. Available fully assembled and tested only.

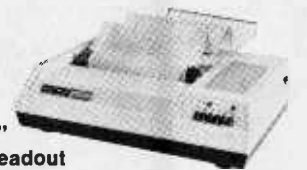

New

Digital Readout Car Clock with Trip Timer

Versatile clock/timer for any vehicle shows time in hours and minutes, has 24-hour timer that reads to nearest second. Bright, easy-to-read display, low-power circuit doesn't drain battery.



New

Battery-Operated Portable Timing Light

Operates on its own rechargeable batteries for safety, convenience and complete portability. Ideal for use on boats or other vehicles where battery may be inaccessible. Also features dual-range tachometer, rugged pistol grip, extra-bright xenon tube for easy-to-see timing flashes.



New

Low-Cost Dual-Trace Oscilloscope

Low-priced dual-trace scope ideal for audio and TV servicing. Features outstanding sensitivity, extra-bright traces, selectable triggering, 7-position variable time base, DC to 5 MHz bandwidth.

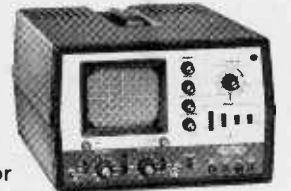

HEATHKIT ELECTRONIC CENTERS* PROVIDE SALES AND SERVICE

ARIZONA — Phoenix, 85017, 2727 W. Indian School Rd. 602-279-6247.

CALIFORNIA — Anaheim, 92805, 330 E. Ball Rd. 714-776-9420; El Cerrito, 94530, 6000 Potrero Ave. 415-236-8870; Los Angeles, 90007, 2309 S. Flower St. 213-749-0261; Pomona, 91767, 1555 N. Orange Grove Ave. 714-623-3543; Redwood City, 94063, 2001 Middlefield Rd. 415-365-8155; Sacramento, 95825, 1860 Fulton Ave. 916-486-1575; San Diego, (La Mesa, 92041), 6363 Center Dr. 714-461-0110; San Jose (Campbell, 95008), 2350 S. Bascom Ave. 408-377-8920; Woodland Hills, 91364, 22504 Ventura Blvd. 213-883-0531.

COLORADO — Denver, 80212, 5940 W. 38th Ave. 303-422-3408.

CONNECTICUT — Hartford (Avon, 06001), 395 W. Main St. (Rte. 44) 203-678-0323.

FLORIDA — Miami (Hialeah, 33012), 4705 W. 16th Ave. 305-823-2280; Tampa, 33614, 4019 West Hillsborough Ave. 813-886-2541.

GEORGIA — Atlanta, 30342, 5285 Roswell Rd. 404-252-4341.

ILLINOIS — Chicago, 60645, 3462-66 W. Devon Ave. 312-583-3920; Chicago (Downers Grove, 60515), 224 Ogden Ave. 312-852-1304.

INDIANA — Indianapolis, 46220, 2112 E. 62nd St. 317-257-4321.

KANSAS — Kansas City (Mission, 66202), 5960 Lamar Ave. 913-362-4486.

KENTUCKY — Louisville, 40243, 12401 Shelbyville Rd. 502-245-7811.

LOUISIANA — New Orleans (Kenner, 70062), 1900 Veterans Memorial Hwy. 504-722-6321.

MARYLAND — Baltimore, 21234, 13, E. Joppa Rd. 301-661-4446; Rockville, 20852, 5542 Nicholson Lane. 301-881-5420.

MASSACHUSETTS — Boston (Peabody, 01960), 242 Andover St. 617-531-9330; Boston (Wellesley, 02181), 165 Worcester Ave. (Rt. 9 just west of Rt. 128) 617-237-1510.

MICHIGAN — Detroit, 48219, 18645 W. Eight Mile Rd. 313-535-6480; E. Detroit, 48021, 18149 E. Eight Mile Rd. 313-772-0416.

MINNESOTA — Minneapolis (Hopkins, 55343), 101 Shady Oak Rd. 612-938-6371; St. Paul, 55106, 1645 White Bear Ave. 612-778-1211.

MISSOURI — St. Louis (Bridgeton) 63044, 3794 McKelvey Rd. 314-291-1850.

NEBRASKA — Omaha, 68134, 9207 Maple St. 402-391-2071.

NEW JERSEY — Fair Lawn, 07410, 35-07 Broadway (Rte. 4) 201-791-6935; Ocean, 07712, 1013 State Hwy. 35. 201-775-1231.

NEW YORK — Buffalo (Amherst, 14226), 3476 Sheridan Dr. 716-835-3090; Jericho, Long Island, 11753, 15 Jericho Turnpike. 516-334-8181; Rochester, 14623, 937 Jefferson



*Units of Schlumberger Products Corporation.

Retail prices may be slightly higher.

Heath Company, Dept. 139-490
Benton Harbor, Michigan 49022

EE

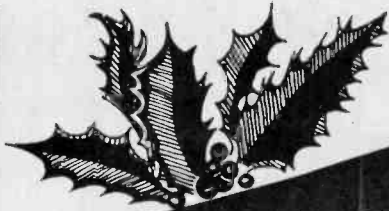

Heathkit®

41 New Products for Christmas Giftgiving-1978

NO EXPERIENCE NECESSARY
 Thousands of people with no electronics experience whatsoever — people who have never handled a soldering iron before — have proved that you can build any Heathkit product you want — and enjoy every moment of it! Simple step-by-step manuals make it easy as 1-2-3.



New
Portable Room-Size Electronic Air Cleaner

An important addition to any household — it removes dust,

dirt and pollutants from any room in your house while cleaning and refreshing the air — and all for just pennies a day. It's especially important for insulated and tightly sealed houses where air can get "stale" after parties, smoking, etc. Features 3-way cleaning operation to remove both large and small particles and household odors. Variable speed control that lets you "quick-clean" a room, then lower the speed to maintain a fresh air level. Handsome Southern-Pecan vinyl finish cabinet blends nicely with any decor. Easy NO SOLDER kit assembly too.

Read about these and nearly 400 other fascinating and practical electronic kits you can build yourself for fun, for satisfaction and for savings. Mail coupon for your catalog today!

A Heathkit gift is a truly satisfying way to celebrate the holiday season. In addition to giving a fine piece of electronic equipment that will perform beautifully for years to come, you also give the pride, satisfaction and sense of accomplishment that come with building it yourself.



HEATHKIT MAIL ORDER CATALOG 842
1978 Heath Company

SUPER HOLIDAY SPECIAL!
 FREE Remote Control worth \$89.95 with purchase of any 25" or 21" Heathkit Color TV! See pages 90-94.

See handy index on back cover.

COAST-TO-COAST

- Rd. 716-244-5470; White Plains (North White Plains, 10603), 7 Reservoir Rd. 914-761-7690.
- OHIO — Cincinnati (Woodlawn, 45215), 10133 Springfield Pike. 513-771-8850; Cleveland, 44129, 5444 Pearl Rd. 216-292-7553; Columbus, 43229, 2500 Morse Rd. 614-475-7200; Toledo, 43615, 48 S. Byrne Rd. 419-537-1887.
- OKLAHOMA — Oklahoma City, 73112, 2727 Northwest Expressway. 405-848-7593.
- PENNSYLVANIA — Philadelphia, 19149, 6318 Roosevelt Blvd. 215-288-0180; Frazer (Chester Co.) 19355, 630 Lancaster Pike (Rt. 30) 215-647-5555; Pittsburgh, 15235, 3482 Wm. Penn Hwy. 412-824-3564.
- RHODE ISLAND — Providence (Warwick, 02886), 558 Greenwich Ave. 401-738-5150.
- TEXAS — Dallas, 75201, 2715 Ross Ave. 214-826-4053; Houston, 77027, 3705 Westheimer. 713-623-2090; San Antonio, 78216, 7111 Blanco Road. 512-341-8876.
- UTAH — Salt Lake City (Midvale, 84047), 58 East 7200 South. Opening Mid-November.
- VIRGINIA — Alexandria, 22303, 6201 Richmond Hwy. 703-765-5515; Norfolk (Virginia Beach, 23455), 1055 Independence Blvd. 804-460-0997.
- WASHINGTON — Seattle, 98109, 505 8th Ave., N. 206-682-2172.
- WISCONSIN — Milwaukee, 53216, 5215 W. Fond du Lac. 414-873-8250.

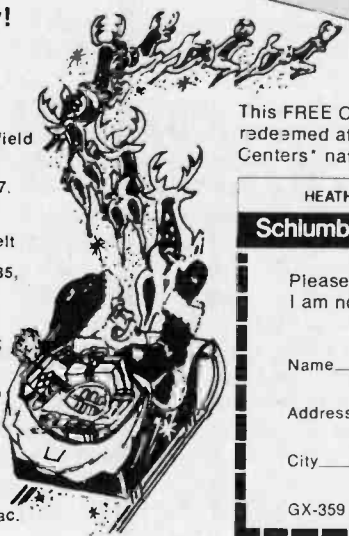

This FREE Catalog coupon can also be redeemed at any of the Heathkit Electronic Centers* nationwide. (See list at left.)

HEATH	Schlumberger	Heath Company, Dept. 139-490 Benton Harbor, Michigan 49022
Please send me my FREE Heathkit Catalog. I am not on your mailing list.		
Name _____		
Address _____		
City _____		State _____
GX-359		Zip _____

CIRCLE 1 ON READER SERVICE COUPON

e/e installs the...



CIRCLE 53 ON
READER SERVICE
COUPON

INDY/CATOR Dual-function Digital Tachometer

This super RPMs counter is a digital winner on any car

□ Accelerating out of Turn 4 at the Indy 500, a championship race car driver like Mario Andretti or Janet Guthrie will be passing through 200 mph; a situation demanding 100% concentration on track and competitors. To see how fast they are driving they might take a passing glance at their tachometer, an instrument that measures engine speed in revolutions-per-minute (rpms). If the tach reads 7800 rpms at a place where it used to read 7700 they know they have picked up a few fractions of a second on their lap time. Even if you are not a racer you can take advantage of a tach, it will help you pick a fuel-efficient cruising speed, tell you when to change gear or make your back-yard tune-ups a snap.

One of the neatest tachs we've seen lately is this Indy/Cator, Dual-function Digital Tachometer (Model 17306). It will measure engine speed, in revolutions-per-minute, on any four-cycle engine with spark plug ignition. The tachometer will read engine speeds of up to 9,900 rpms with an accuracy of plus or minus 100 rpms. It operates by detecting ignition pulses on one of the spark plug cables. The digital readout is updated every 1.2 seconds.

In addition to reading instantaneous rpm the unit is capable of storing a preset "Red Line" speed. When the

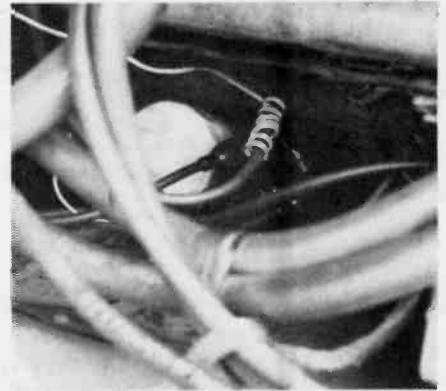
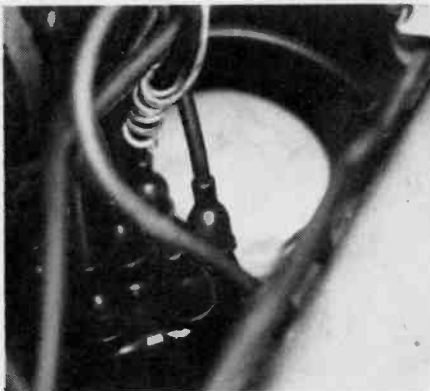

There's no hard wire connection to your car's ignition system with this tachometer. All you need do is wrap the sensor wire around any of the spark plug wires at any point.

engine reaches this speed a warning light will tell the driver to let up on the gas pedal. The unit comes with all the wiring and mounting hardware—it can be glued or screw mounted to the top of the dashboard of most American and foreign cars.

Installation is easy thanks to the clear concise directions. The tach is connected to the car's battery (negative ground only) and the sensor wire passes through the firewall to the engine. If there is no appropriate hole in the firewall one will have to be drilled. The sensor wire is wrapped counter-clockwise around one of the spark plug

cables. If the readout is shakey or it tends to switch into the red line setting mode, it helps to increase the number of sensor turns around the spark plug cable. The entire installation should take about two hours. Read the directions ahead of time so that you will know what tools are needed.

The Indy/Cator Dual-function Digital Tachometer retails for \$59.95. If you would like more information about this interesting and useful product circle number 53 on the readers service coupon, or write to the manufacturer: Digital Concepts, 249 Route 46, Saddle Brook, NJ 07662. ■

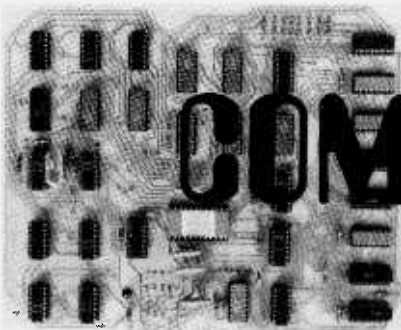

COMPUTER READOUT

by Tom Williams

Regular Computers Editor Norm Meyers is on temporary foreign assignment. For this issue, we asked computer authority Tom Williams to fill in.

Networks—the next step for home computers

□ WHEN ALL THE CHOICES of hardware and software have been made by the home user, and the checkbooks have been balanced, and air conditioners and lights put on a 24 hour schedule, there is another new avenue open for exploration with the microcomputer, and that is network link-up. With access to the readout of the computers of large corporations, credit balances could be instantly displayed, shopping might be done from the comfort of the living room, and even your choice of television program may be ordered direct from the network, or local cable TV company. How about all of those infuriating computer letters demanding payment on bills that you've paid 5 months ago? Haven't you at least once said, "I'd like to tell that computer a thing or two?" If you had direct access from your own terminal, then you could, and get an answer back in seconds.

The ability to do all of these things stems from the ability of the computer and micro-computer to process the text of a statement in what are called "strings". Strings are simply groups of alphanumeric characters which are represented in the computer as binary numbers. Any written text can therefore be represented within the computer as binary numbers which can be processed at fantastic speed. The most extensive use of this capability presently, is in the generation of those familiar advertising form letters in which your name is repeatedly inserted within the text, even though you know that thousands of people are receiving the same letter.

Computer Networks. The string handling capabilities become even more significant when individual computers are tied into very large banks of data called data bases. It is in this application that one is dealing primarily with text material. Personal computers can now be linked together via telephone lines to communicate with other computers, computer-based bulletin boards and larger community data-base com-

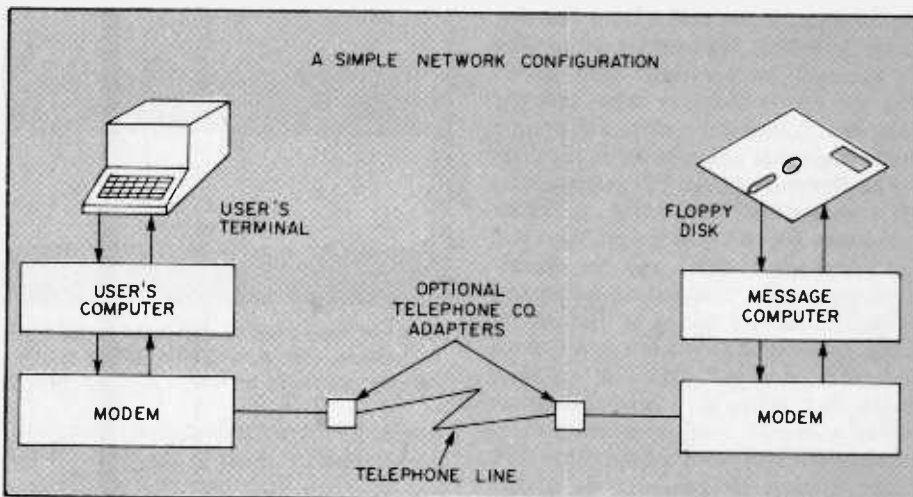

Here is a simplified, two-station network set-up. While the phone company adapters are optional equipment from some phone companies, others insist that they be used to insure proper input matching. They also serve to inform the phone company that your line to the central switcher must be of uniform data transmission quality. Some phone lines aren't.

puters. A few of these Personal Computer NETWORKS (PCNETs) are already in operation and we will discuss them shortly.

Basically, what the personal computer needs in order to link up with a network is an interface to the telephone system known as a modem (modulator/demodulator). There are already two such products available on the market, one from D. C. Hayes Associates (P.O. Box 9884, Atlanta, GA 30319), and another from International Data Systems (400 North Washington Street, Suite 200, Falls Church, VA 22046). Both these devices have the capability of dialing and answering the telephone automatically under software control, an important consideration for using the computer with a network.

Most telephone company tariffs require that there be an adaptor on the phone line. This can, of course, be rented from the telephone company. The adaptor may or may not be useful electronically, but it does insure that the user is treated as a data customer by the telephone company. This means that the loop between your house and the central office must conform to the spe-

cifications for data transmission, and there is less likelihood of losing data due to poor communications lines.

Computers operating on the same network must all use an agreed upon *protocol*, or format, for their data. That is, it must be transmitted at a standard baud rate and in a configuration with such things as headers, data blocks, and checksums as a standard. These formats should also be compatible with or translatable to the formats used by mass storage devices such as floppy disks.

One common form of protocol is to transmit data in *packets*, which consist of a header telling various things about the data such as its type, source, destination, length, etc., and then a block containing the actual data followed by a checksum to test the validity of the transmission. The destination computer would receive the packet, perform a checksum, and if the data was received intact, copy the packet into its memory. During this time the source computer would wait to receive acknowledgement from the destination computer that the packet had been received and was not lost or garbled. After receiving acknowledgement, the source

e/e COMPUTER READOUT

computer would send the next packet.

If receipt of a packet is not acknowledged in a specified amount of time, the packet is re-transmitted until the acknowledgement is received. Packets are placed into an area of memory in the destination computer known as a buffer. When this buffer is filled or when the complete message has been received, the destination computer creates a file on the disk and outputs the contents of the buffer onto the disk under a unique file name that can then be accessed by someone who knows that the file is there or who asks the computer to look for a certain file name in the hope that one will be on the disk.

The Network. Given the prerequisites of a means of connection to other computers (in this case via modems and the telephone system) and an agreed-upon protocol, a personal computer network can be set up in a number of ways. One possibility is to use a control computer equipped with one or more floppy disk drives as a central message center. It would accept incoming communications and store them on the disk under a name or special code of the intended recipient. At some later time, a person using the network could dial the central computer to see if any messages were stored under his name or code. For additional privacy, messages could be encoded by the sender's computer before being sent and could then only be decoded by the intended receiver who would run them through a decoding program after requesting them from the central disk storage.

Data transfer rates on personal computer networks are currently 110 or 300 baud, but baud rates of 1200 are feasible. The message can therefore be written, checked, and edited on the sender's home computer terminal while the computer is off-line. When the message is ready, the sender simply goes to his transmit program, enters the telephone number and file name and the computer will automatically dial up the central system and, when it is acknowledged, transmit the message at a rate faster than any human could type. The savings on telephone bills should be substantial.

Neither rain nor Snow. The use of a central system as an electronic "post office" does not preclude direct access between individual personal computers. Exchanges of software and personal communications would make possible fast distribution of newly written programs and participation by many peo-

ple in ongoing conferences, games, simulations, and educational programs. The use of a larger, central computer as a mostly "read only" device would make possible the creation of a large public data base, or community computerized library.

Projects to realize many of these ideas already exist. In the San Francisco Bay area, a PCNET has been operating for more than a year. In the Chicago area, a computerized bulletin board has been established and is now doing a poll to see if people around the country are able to log onto the system and

which enable them to read protected messages. You can even "whisper" to someone clear across the table. Perhaps it's better to call it electronic note-passing.

Digital Broadcasting. If it is possible to digitally encode an audio cassette tape, the most popular mass storage medium for home computers, then it can be no major problem to encode an FM radio carrier with the same information. This is precisely what is being done on the San Francisco Peninsula by the Digi-cast™ Project. The hardware investment will be relatively simple; the soft-

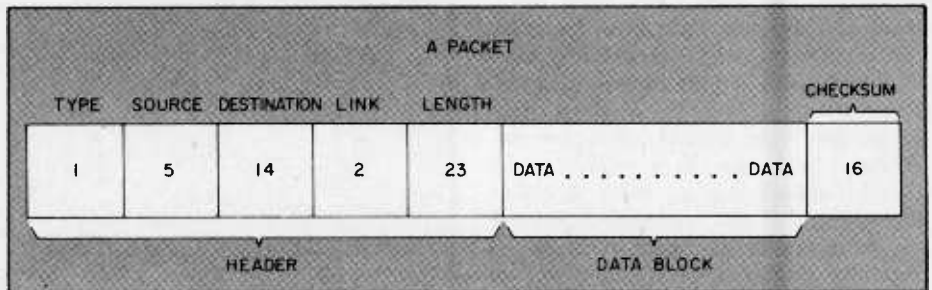

One common form of data transmission protocol which enables computers to understand each other is the packet. The header contains the transmission coding necessary for the receiving computer to accept the incoming data. The checksum verifies correct reception.

use it. Readers owning computers with modems might wish to try (312) 528-7141. When you hear the dial tone, connect the modem (this system does not depend on auto-dial). Then press "RETURN" several times until the system responds. The system will prompt you from then on. Any ASCII terminal, 110 or 300 baud should work.

The existence of personal computer networks will make possible for smaller businesses and individuals what larger businesses, scientific institutions and the military have been doing for some time - computer conferencing. Computer conferencing is not really so different from a conference telephone call except that everyone does not have to be present at the same time. A participant can log on to the system, follow the discussion through the messages that have been left by the other participants since he last logged on, add his own comments, and still maintain a busy schedule.

A computer conference of this nature gives the participants a different perspective on the proceedings. For one thing, it does not take place in real time so there is time for everyone to review what has been said and to consider his response. It is a "cool" medium without face-to-face contact and it has been noticed that participants have a greater tendency to stick to the topic. That does not mean that there can be no "whispering" with one's neighbor. Individuals can work out private keywords

ware can be quite simple and still be useful, or it can be as complex as one desires.

"Digicasting," as it is called, works from the fact that every FM broadcast station generates subcarriers that can also be used for broadcasting. Generally, they are used to broadcast background music for dentist's offices, supermarkets and the like. The idea is to use one such subcarrier to broadcast digital information which can then be received, demodulated and fed into the computer. The receiver, it is estimated, can be marketed for between fifty and one hundred dollars. This does not include the cost of the computer or the software. The receiver is, in effect, an input device attached to one port of the computer. The real sophistication will come in the material people choose to send and receive and most importantly in the software they write to receive, manipulate, scan, catalogue, search, and record the information presented.

In digital broadcasting, it is once again the string handling capability of the computer that is decisive. The basic function of the system will be for the user to enter a list of keywords (strings) into the computer corresponding to subjects he would like information about: The computer inputs the broadcast information into an input buffer and compares it with the keyword list. If the text contains one of the keywords anywhere in it, it is transferred to an output

(Continued on page 94)



BASICALLY FUN!

Learn to speak to your computer while having the time of your life!

By Neil Shapiro WB2KQI

WITH A SIGH BORN of both triumph and relief, you turn away from the control board of the *USS Enterprise*, and order the crew to stand down from Red Alert. On the view-screen, the Klingon starship that once swooped down on you like a technological bird of prey is now only a destroyed cloud of expanding gas, a wispy nebula against the starry sky.

Having defeated the might of the Klingon Empire, you now turn to your next adventurous assignment. Perhaps it will be governing the ancient land of Sumeria, filling in for old Hammurabi. Being a benevolent despot can be fun—but there are dangers attached. If you estimate your crop yield too low, do not allow for population expansion, sell off too much farmland, then you're bound to starve a good percentage of your countrymen whose outraged, surviving relatives might just assassinate you.

Maybe you'll go to the horse races, play a quick game of craps for a thousand dollars a throw, sit at an exclusive Blackjack table with a wise-cracking dealer, or indulge in any of hundreds of games of skill and chance.

If you own a personal computer, you already know that gaming is one of the most popular uses for the hobbyist's machine. Of course there are other, more useful applications. But, when it comes to simple enjoyment, thousands of hobbyists turn to games.

You don't have a personal computer? The thought of programming, even in a high-level language like Basic, is just a bit on the scary side? Perhaps you have even read a textbook or two on Basic, but have been lost in a maze of example programs for mortgage amortization, depreciation, plotting of functions, and so on. It can be hard enough to learn a new language without further confusing the issue. Just imagine if you had to learn French by studying treatises from the Sorbonne College of Higher Mathematics!

There's an easier way to learn Basic. A fun way.

First, sit yourself down with a good introduction to the Basic language such as the book *Basic* (by Albrecht, Finkel and Brown, published by John Wiley and Sons, Inc., 605 Third Ave., New York, N.Y. 10016); the first few chapters of which were serialized in our November 1977 through March 1978 issues of *ELEMENTARY ELECTRONICS*. Now, to gain a deeper understanding of how to apply your knowledge of Basic to programming, sit down with a few game programs. Try to play *both* sides of the game—the human's *and* the computer's.

Flowcharting Fun. At first, stick to some of the less complex game programs. If you can get a program which includes a flowchart, so much the better. A flowchart may look complicated but it simplifies understanding.

Start out by using flowcharts. When you begin to design your own programs such familiarity will pay off. Take a look at the flowchart and program which accompany this article.

Get ready—you're about to pretend you're a computer. This may seem a strange thing to do, but you'll find it's really quite logical.

Look at lines 100 through 200 of the program. Note that all four begin with REM. As a computer, you know this means *Remark* and that you're not supposed to pay any attention to these lines. They are there simply for the benefit of any human readers.

Move along to lines 210 through 240. These are PRINT statements and you know this means to print them out onto your teletype or CRT screen. These lines let you tell your human friend the rules of the game.

While your human pal is plodding his way slowly through the rules, as a computer you are using your time wisely. You've ignored the REM at line 300 and gone on directly to line 310. Here, at line 310, you do your first real bit of computerized thinking.

You pick a number, call it X, the value of it being $\text{INT}(100 * \text{RND}(0)) + 1$. The RND tells you to generate a random number, the parenthesized zero tells you the random number should be between zero and 1. The INT is an *Integer* command which tells you to simply chop off any numbers to the

e/e BASICALLY FUN

right of the decimal point. In other words: You will let X be the integral value of a random number between 0 and 1 multiplied by 100 and with 1 added to it.

Why? Well, it had to be an INT command because in line 210 you told your human you would pick a whole number and computers never cheat (programmers sometimes do but never computers). The 1 was added so that the

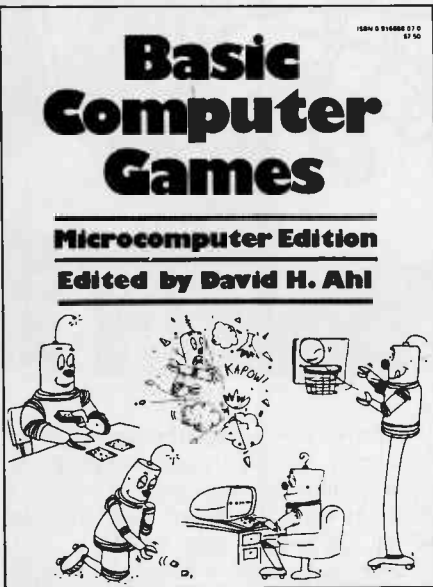

From Creative Computing Publishers, this book features clear typography and complete sample runs. Circle no. 93 for info.

secret number will never be a zero.

OK, compute. . . . Let's see now, RND (0), well, this time around let's pick .33456709 at random. Multiplying that by 100, we get 33.456709. Chopping off to the right of the decimal point leaves 33, and adding one makes 34. Ah Ha! Our secret number, X, is equal to 34!

At line 330 you leer computerishly and tell your human partner that you now have a number for him to guess. You ignore REM line 400, PRINT a line-space as per line 410, then go onto line 420 which tells you to PRINT out a question to your human. You do so, then see the line ends in a semicolon. The semicolon tells you to put whatever comes next on the same line. Next is line 430, an INPUT statement. Whatever number the human types here will become variable G. The INPUT statement causes you to output a prompting question mark, and the question mark is placed on the same line as the PRINTed question.

Fast as you could reasonably expect



People's Computer Company is dedicated to making computers fun—and this book is somewhat a classic. Circle number 84.

of a hunk of animated protoplasm, your homo sapient inputs his first guess, 50. Therefore, the variable G now equals 50. In line 440 you compare G with X. If they were equal you would jump to line 510. 50 obviously does not equal 34 so you just go straight on to line 450. Line 450 asks if the G variable (the human's guess) is larger than the X variable (your secret number). Sure enough, 50 is larger than 34, so you jump to line 480 just as programmed.

Line 480 causes you to PRINT that your human guessed too big and should try a smaller number. Line 490 sends



This book will help explain the programming concepts behind computer gaming with game examples. Circle no. 98 for info.

you scuttling back to line 410—and you get your human's second guess.

This time through the loop, your human buddy picks 28. Now, 28 is smaller than 34 so you ignore line 450, and fall through to line 460. You nudge the user with the info that now he's chosen too small a number. Again, through the loop and back to line 410 for what is now the third guess. Through luck, blind chance or divine intervention, the human now guesses 34. At line 440 you see that if $G=X$ you go to line 510. You print out a congratulatory message (after all, the



Join in an amazing underground adventure then use the flowcharts to help you modify the plot. Circle number 94 for info.

human does keep you supplied with voltage) and—as computers are real sports—you offer him another game and leap on back to line 310 to pick another secret number.

You see, you don't necessarily need a computer if you get together with a friend and one of you takes the computer's part. Not only will it be fun, but both of you will learn Basic. Of course, if you have a computer you have much greater access to experimentation by changing lines to achieve varying goals. Flowcharting will make such experiments much easier. One suggestion: Try to have the computer limit the number of guesses given to the human.

Games, Games, Games! You'd like to investigate game playing via computers more fully, so where do you turn? Right now, there are a number of fine books containing programs (in Basic) for games of varying complexity. Some of the books contain flowcharts, program runs and/or modification sug-

(Continued on page 84)

Start here

HOW DOES IT WORK? FOLLOW THE



```
100 REM *** NUMBER *** A NUMBER GUESSING GAME ***
110 REM *** COPYRIGHT PEOPLE'S COMPUTER COMPANY
120 REM *** P.O. BOX 310, MENLO PARK CA 94025
```

```
200 REM *** PRINT INSTRUCTIONS ON HOW TO PLAY
210 PRINT "I WILL THINK OF A WHOLE NUMBER FROM 1 TO 100."
220 PRINT "TRY TO GUESS MY NUMBER. AFTER EACH GUESS, I WILL"
230 PRINT "TELL YOU IF YOU HAVE GUESSED MY NUMBER OR IF YOUR"
240 PRINT "GUESS IS TOO SMALL OR TOO BIG."
```

```
300 REM *** COMPUTER 'THINKS' OF A NUMBER - CALL IT X
310 LET X=INT(100*RND(0))+1
320 PRINT
330 PRINT "OK, I HAVE A NUMBER. START GUESSING."
```

```
400 REM *** HUMAN STARTS GUESSING
410 PRINT
420 PRINT "WHAT IS YOUR GUESS?";
430 INPUT G
```

computer checks guess (G)
against its number (X)

```
440 IF G=X THEN 510
```

follow me if guess is correct

follow me if guess
is *not* correct

```
450 IF G>X THEN 480
```

follow me if guess is too big

if guess was
- not right on
- not too big

```
460 PRINT "TOO SMALL. TRY A LARGER NUMBER."
470 GO TO 410
```

```
480 PRINT "TOO BIG. TRY A SMALLER NUMBER."
490 GO TO 410
```

```
500 REM *** HUMAN HAS GUESSED THE COMPUTER'S NUMBER
510 PRINT
520 PRINT "YOU GUESSED IT!!! LET'S PLAY AGAIN."
530 PRINT
540 GO TO 310
```

999 END

go back for a new game

go back for new guess

correct

guess is too big

This flowchart and game program is reprinted with permission from People's Computer Company's book "What To Do After You Hit Return, or PCC's First Book of Computer Games" (Menlo Park, CA: PCC, 1977). See the text for details on how use such aids.

COMPUTER NEW PRODUCTS

Here in one place each issue of e/e you will find product information on the newest hobby computers and accessories.

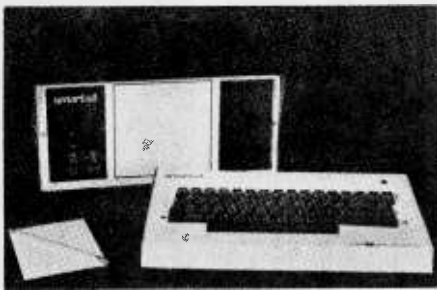

Smarts for Home Use—Smarts II is now made available "to the man on the street" by Firebird Sales Company. The microcomputer is claimed to be a powerful business data processing system and the "most advanced" personal computer. There's nothing else to buy to use it, but add-ons are easy to make. The 32K of RAM can be expanded to a maximum of 630K RAM. The mini floppy disk drive can be increased to three drives or replaced with two standard size floppy disk drives. Up to four more can be added to the one RS 232 interface port. Other possible peripherals include a CRT terminal and printer. Smarts II offers a full 16 lines of 64 characters per line on a standard ASCII keyboard. Color displays (7 by 9 characters) can be created on a color TV screen, along with action sounds. The Smarts II system includes games, income tax, bookkeeping, inventory and educational programs. Smarts II "Fundamentals" is said to provide "the natural first interface between man and machine for both business, personal use" because it provides all that is needed to reach the first level of comprehension. Price: \$1,595 as shown. Circle 45 on Reader Service Coupon.

Floppy Disk Kit—Heath now offers a new H8 Floppy Disk System in kit form that is identical in features and specifications to the assembled and tested WH17 floppy disk made available earlier by the company. The unit includes 102K Bytes of available storage area per disk, a fully-assembled Wangco Model 82 disk drive (expandable to dual disk), the interface/disk controlled circuit board kit which plugs directly into the H8 mainframe, and a self-contained power supply. The storage media is the expanded 40-track seek time and a typical random sector access time is less than 250 milliseconds for the new unit. The operating system software for the H8/H17 Floppy Disk System is available and designated H8-17. This software includes the Heath Disk Operating System (HDOS) with diagnostic for unit evaluation and optimization; the BUG-8 console debugger; TED-8 text editor; HASL-8 assembly language and extended Benton Harbor Basic. An extra diskette is also included. Prices: H17 Floppy Kit, \$530; H17-1 optional second drive, \$295; H8-17 operating system software, \$100. Circle number 1 on Reader Service Coupon.



Dual-Floppy, Z-80 Based Microcomputer—Vector Graphic's "Vector MZ" is a general purpose byte oriented digital computer based on the Z-80 microprocessor and industry standard S-100 bus. This new high-performance "low cost" (\$3750) unit also features two Micropolis Quad-density floppy disks which makes it suitable for hobby and

small business markets, according to the company. Notable features include the Z-80 CPU with 158 basic machine language instructions and a minimum instruction cycle of two microseconds. An 18-slot motherboard provides flexibility and expansion capabilities for up to 64K of directly accessible memory using a parallel 8-bit-word/16-bit address. Up to 256 separate input and output devices can be addressed. Two disk drives are mounted directly to the front panel to provide instant access and ease of operation. These advanced 5¼-inch floppy disk drives offer the much larger capacity and greater reliability previously available only in 8-inch disk drives. Storage capacity of each drive is 315K bytes, formatted. Also includes: 32K of static RAM; 12K 2708 PROM/RAM board with extended monitor and Vector's powerful Basic. Comes assembled and tested, ready for connection to an intelligent terminal and printer. A single disk version is available for under \$3,000. Circle number 71 on Reader Service Coupon.

Apple 2 Serial I/O Board—Electronic Systems offers a serial I/O board for the Apple 2 computer. Software includes input and output of basic programs and monitor to a teletype or other serial device, and a program for using the Apple 2 for a video terminal. Input and output are RS-232. The board has switch selectable parity, number of stop bits, and jumper selectable address. Data rate to 30,000 baud. Full documentation included. The

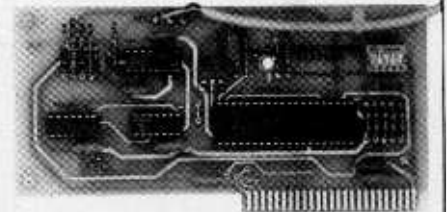

serial I/O is available as an assembled and tested unit for \$62, as a kit with parts for \$42, or as a circuit board only for \$15. Circle 72 on Reader Service Coupon.

Calculator Programming Aids—Specialized computer programming aids offered by Texas Instruments are designed for use with the company's TI Programmable 59 handheld calculator. The programs provide easier conversion of ASCII and EBCDIC codes, routines for debugging and analyzing TMS 9900 and Intel 8080 microprocessor programs and a number of general programmer aids covering base conversions and logical arithmetic operations. The Programmer's Aid Pakette is a 64-page booklet providing documentation for six full-length programs: EBCDIC Code Converter, ASCII Code Converter, ASCII and ABCDIC Encoder, TMS 9900 Disassembler, Intel 8080 Disassembler and TI Programmer Simulator. All require a TI 59 with attached PC-100A thermal printer, plus blank TI 59 magnetic program cards. Pakettes are



also available on securities, statistical testing, civil engineering, electronic engineering, blackbody radiation, oil/gas/energy, astrology, and TI59/PC-100A printer utilities. All Pakettes have a suggested retail price of \$10, plus \$1.50 handling charge, plus your state, local taxes if ordering directly from TI. Circle number 74 on Reader Service Coupon.

TEST BENCH NEW PRODUCTS

e/e looks at the latest in fast-moving test equipment field

For Fast Count

Telco Products Corporation announces its new 7 digit LED Digital Frequency Counter, the Count 500, which features large bright easy-to-read half-inch high LED displays with polarizing lens. Easily read under all lighting conditions. Highly sensitive input accounts for its capability to pick up and display low power

CIRCLE 76 ON READER SERVICE COUPON

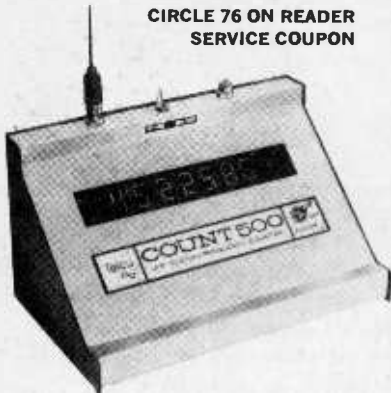

transmissions without the need of direct hookup. Frequency measurements are accomplished by means of its pickup antenna. The Count 500 is crystal controlled offering high accuracy over its entire operating frequency range. Displays frequencies from 3 to 500 MHz without the need of any expensive add-on devices. Designed for portable use; may be used for either base use with AC power pack supplied with the Count 500, or as a mobile unit with the Telco optional DC cable with auto lighter plug connector. Suggested retail price is \$184.00. For additional information, write to Telco Products Corporation, 44 Sea Cliff Avenue, Glen Cove, NY 11542.

Bi-Directional Wattmeter

The new wide-band Bi-Directional Wattmeter, the IM-4190 (SM-4190 assembled version), is a self-contained unit that

CIRCLE 1 ON READER SERVICE COUPON



measures transmitted radio power up to 300 watts and reflected power up to 30 watts. Covering the 100 MHz to 1 GHz spectrum, the IM-4190, according to Heath, is an ideal tool for two-way radio

service and repair or for the amateur radio enthusiast. The IM-4190 is capable of withstanding full power overloads on its lower scales without damage to the meter movement. A single 9-volt battery powers the IM-4190 so it may be used portably. N-type coax connectors are utilized for minimal high-frequency insertion loss. Adaptors for use with RF-type connectors are included. The IM-4190 kit retails for \$114.95 and the SM-4190 assembled version \$195.95 (mail order Benton Harbor). For more information on the IM/SM-4190, write Heath Company, Dept. 350-630, Benton Harbor, MI 49022.

Lab Power Supply

Intended for engineers and discriminating hobbyists who design and test breadboards and prototypes, a new low-cost, dual-output bench power supply from Hewlett-Packard offers two independently adjustable and isolated power sources in one compact unit. Both of the DC power sources are of the constant voltage/current limit type with each output voltage being adjustable continuously over a 0 to 25V range. The maximum current available per output is 0.2A and

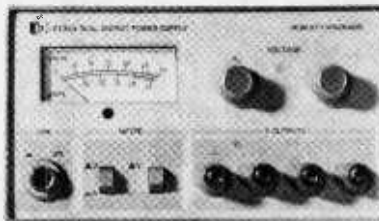

CIRCLE 55 ON READER SERVICE COUPON

is limited automatically to prevent overloading. The outputs can also be connected in series to provide up to 50V at 0.2A. Both sources are full isolated to permit either of the output terminals to be grounded. With pushbutton switches users can select either voltage or current for each output to be monitored on the unit's meter. Other features include two multiple-turn controls for precise voltage setting, regulation to 0.01% and ripple and noise of less than 200 microvolts rms. The Hewlett-Packard Model 6234A dual-output power supply is priced at \$175.00 (U.S. price only). For more information, write to Inquiries Manager, Hewlett-Packard, 1501 Page Mill Rd., Palo Alto, CA 94304.

Today's Breadboard

The CSC Model DM-1 Design Mate provides the three elements most basic to electronic circuit investigations—a power supply, breadboarding area and meter—in one convenient package for only \$69.95. The meter measures 0 to 15 VDC (5% accuracy) and is independent of

the power supply, with leads brought out to a pair of five-way binding posts. Thus the meter can be used to set the adjustable power supply's voltage, then to monitor circuit action. The built-in power supply is adjustable from 5 to 15 VDC output at up to 600 milliamps, with better than 1% load and line regulation and less than 20 mV ripple and



CIRCLE 62 ON READER SERVICE COUPON

noise at full load. The solderless breadboarding area is configured from CSC QT-series ("Quick Test") socket and bus strip elements. It provides enough area to comfortably breadboard a circuit with 6 DIP ICs, plus associated components. The DM-1 requires only 12 watts or less at 117 VAC 60 Hz. For additional information, contact Continental Specialties Corp., 70 Fulton Terrace, New Haven, CT 06509.

VOM Workhorse

A new battery-operated VOM from Leader reads as low as 0.25 Volt and 50 micro-Amps, full scale. The Model LT-70B, Volt/Ohm Meter is protected against overload and polarity reversal. Voltage ranges are from 0.25 V, ten steps DC, to 1,000 and 2.5 V to 250 VAC, in three steps. There are four current ranges: 0.50 microAmps to 50 milliAmps, DC and 0 to 2.5 Amps, AC. Diodes testing is from 0-75 microAmps to 750 milliAmps and 0.75 milliAmps to 75 milliAmps. The LT-70B sells for \$42.95 and is complete



CIRCLE 61 ON READER SERVICE COUPON

with one set of heavy duty test leads and one set of alligator clip adapters. For further details contact: Leader Instruments Corp., 151 Dupont St., Plainview, NY 11803.

e/e assembles the...

MUTT MINDER

Ultrasonic canine cop keeps Fido off your case

□ MAN'S "BEST FRIEND" isn't always as friendly and loving as we would like him to be. Ol' Fido can sometimes develop nasty nipping habits, and if you deliver mail or newspapers, sell door-to-door, jog or ride a bicycle through a dog infested neighborhood, then Mutt Minder might be for you.

Mutt Minder is not a toy and it should be used with care. It works by giving the attacking dog a loud blast of ultrasonic sound. Most humans can't hear it although, according to the manufacturer, it can be irritating to some children and young women, whose ears are most sensitive to high frequencies. Above all, keep it away from eyes and ears and do not let children play with it. The manufacturer's instruction sheet says, "Use common sense as the device could be classified as an infernal machine requiring special license to possess and use it in your state."

To use the Mutt Minder you just press the button on top of the unit while waving it in the dog's face. The dog will associate the harshly unpleasant noise with you and Mutt Minder, and retreat. Remember that discretion is the better part of valor—do not test

CIRCLE 50 ON
READER SERVICE COUPON

this on attack dogs or extremely menacing dogs. They may instinctively attack rather than retreat.

How It Works. The heart of the circuit is an ultrasonic transducer which will oscillate at around 20,000 Hz when driven by an oscillator based on a 555 timer chip. The transducer takes a lot of power. Two 15-volt batteries in series put a 30-volt potential across



The finished product is no larger than a pack of cigarettes and is easily carried.

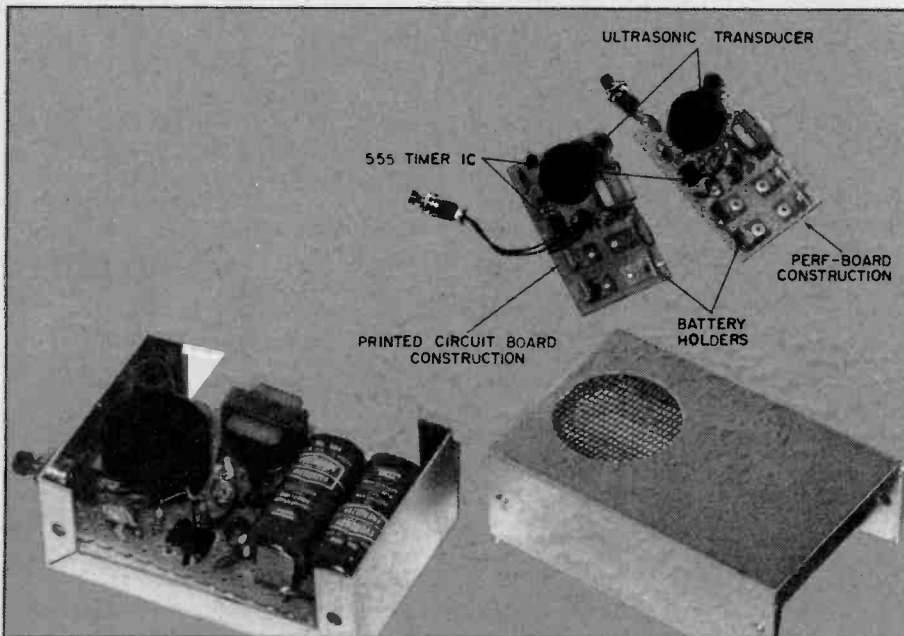

Shown above are the optional printed circuit board (\$4.50) and perf-board methods of construction. Note how we attached the battery holders with pop rivets on the perf-board. The ultrasonic transducer is the heart of the circuit, emitting a 20+ kHz tone.

the power transistor and the transducer. Don't overuse it—the batteries do not last very long.

If you have had any electronic assembly experience whatsoever, then putting Mutt Minder together will be easy. If not, then go slowly. The instructions are abbreviated but adequate, and with a little patience you should have an operable 'hound hounder' in a few hours. The only annoyance is with the battery holder assembly. The kit didn't include any kind of fastener to attach the four L-shaped clips that make up the holder. Pop rivets were the easiest solution, but it did mean an extra trip to the hardware store.

All the parts fit on the perforated board as is indicated in the instructions but you should follow the recommendations to be careful with the spacing. There isn't a whole lot of extra room on the board. If you have trouble with perf board construction then you might consider ordering the optional printed circuit board.

For more information about Mutt Minder, circle number 50 on the readers service coupon. It is available from Information Unlimited, Amherst Professional Building Box 716, Amherst, NH 03031 for \$29.50 in kit form and \$44.50 fully assembled. The printed circuit is available for \$4.50 and batteries can be ordered for \$3.00. Remember Mutt Minder is not a toy but a device that will repel hostile dogs. It is not to be abused. ■

by Gordon Sell



DIGITAL NUMBERING FOR THE HOBBYIST

Teach your projects to talk back digitally.

DIGITAL NUMBERS — they are everywhere! The entire electronics world has been caught up in the digital revolution — watches, radios, TVs, VOMs, frequency counters — the list is almost endless. But, have your construction projects been a part of the revolution or are you still back in the hobbyist stone age of meters and light bulbs? Do your projects look like 20th Century state-of-the-art or do they look more like a turn-of-the-century patent application?

If you think it is time to go digital but feel that the technology is beyond your grasp you are not alone. There is a mumbo jumbo that has grown up around digital electronics that makes people think they have to learn all about computers before they can do any kind of digital project. If you have ever made the mistake of asking a "computer know-it-all" how digital number displays work, you are sure to have received a two-hour lecture on binary numbers, Boolean algebra and assorted flip flops, and come away knowing less than when you started.

Learn Backwards. All this hassle is unnecessary, however, if you learn digital electronics *backwards!!* Start with the familiar end result, a decimal number display, and work backwards into

the circuitry that makes it possible.

Digital displays come in a number of different forms but all the circuits discussed here will use a common cathode, seven-segment LED (Light Emitting Diode) numeric display. These are cheap, easily obtainable and the circuitry can be adapted to other types—especially the liquid crystal type displays. The best way to learn about numeric displays is to put one together so you can physically see how it works and how the various components interact.

To simplify construction of the demonstration circuit accompanying this article a Continental Specialties Corporation PB-203 solderless breadboard was used. It allowed almost infinite experimentation with various circuit arrangements — experimentation that would have otherwise consumed a prohibitive amount of time. All parts mentioned in the parts list and article are easily obtainable through mail-order houses (see the HOBBY MART in the back of this issue) or from most electronics parts distributors. The parts in the article are referred to by their common name since many parts with different numbers can perform the same tasks. The parts used in the demonstration circuit are identified by their generic

part number—most parts distributors will have a cross-reference from this number to the manufacturer's part number.

Translating. As you can see in the diagram of the seven-segment display, any digit from zero to nine can be represented by a certain combination of lit LED segments. Each of these segments is an individual LED with its cathode tied to a common ground; hence the name common cathode (some have common anodes). Each segment can now be activated by a switch between the anode and a power source. Switching on segments a, c, d, f and g, for example will cause the digit five to be lit. (As a practical consideration be sure to use a current limiting resistor—110 ohms in the circuit shown.)

We can now represent any digit by various combinations of "on" or "off" of the seven switches. There is a potential for 49 different character displays with this set-up—well beyond the needs of a numeric display.

So, by using a common integrated circuit chip we can reduce the number of switches to four. The internal circuitry of the BCD to seven-segment decoder (the name will make more sense later), as the chip is called, takes the

e/e DIGITAL COUNTING

combinations of the four "ons" and "offs" and applies power to the appropriate LED segments. This representation of a digit by four combinations of "on" and "off" is called Binary Coded Decimal or BCD for short. A binary number uses only zero and one rather than zero through nine. The one can be represented electronically by a high level voltage and the zero by a low level voltage. The following chart shows decimal numbers, their BCD equivalent and the segments that are lit on a numeric display:

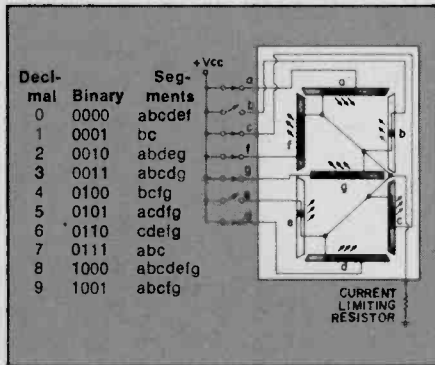

We now have a circuit that can translate "computerese" BCD numbering into the decimal numbers we have used all our lives.

Learning to Count. Now we need to teach our circuit to count from zero to nine. We can do this by adding an integrated circuit chip called a decade counter. This integrated circuit has one input line and four outputs. The outputs, as you have probably guessed, are connected to the four input lines of the BCD to seven-segment decoder. The outputs are all at zero until a single pulse appears on the input line. Then one of the outputs changes to a "one" so that the BCD to Seven-Segment decoder receives the number 0001 and lights segments b and c. On the second pulse the decade counter sends out the number 0010 and a 2 lights up on the display. This continues until the decade counter gets to nine; it then recycles to zero.

You should congratulate yourself—you now have a practical event counter that will total (up to nine) the number of pulses generated by the occurrence of some event. A switch on a refrigerator door that will turn on once each time the door is opened might allow you to record how many times it has been opened. Unfortunately there is a phenomenon of mechanical switches called contact bounce, where one switch-closing can trigger 3 or 4 pulses.

This can be eliminated by adding a one-shot multivibrator, or similar circuit, to clean up the unwanted pulses. For the demonstration circuit the event pulses were obtained from a free-running multivibrator signal generator for simplicity and freedom from unwanted pulses.

Extra Digits. Now it is time to add a few more digits. After all, how many useful things can be measured by a single digit. To do this we must add a second set of the three components already mentioned: a numeric display, a BCD to Seven-Segment Decoder and a Decade Counter. Everything is wired the same way except that the input for the second decade counter is attached to the "carry out" pin of the first counter. This pin gives off an output pulse each time the counter resets from nine to zero. So, after the first display gets to nine and then resets the second display counts one so that the display reads ten. When the decade counter resets a second time the display clicks to 20. An almost infinite number of digits could be added that would count once each time the preceding stage resets to zero.

A counter such as this could be used for any sort of tallying operation where you have to keep a record of how many events have taken place. Most digital applications, however, involve rate operations — cycles-per-second, miles-per-hour, gallons-per-day or even dollars-per-week.

Rate Measurements. For the above counter to be converted to measure the number of events per unit of time a few additions have to be made. The first of these is called a clock. A clock

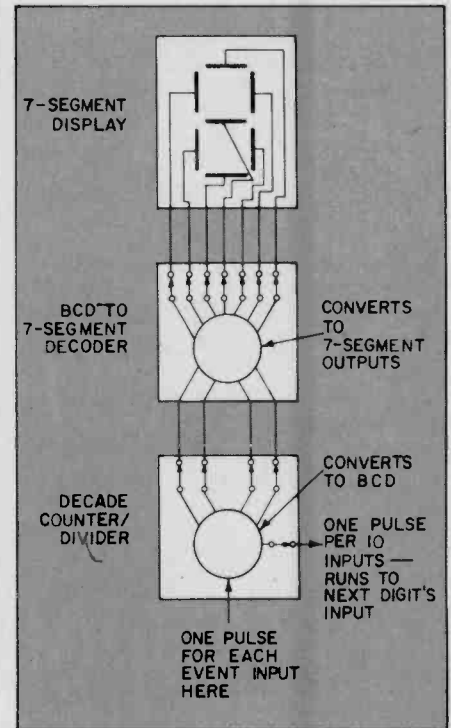

This block diagram shows how the sequence of pulses at the input are first translated to BCD and then to seven-segment coding.

gives you the seconds of miles-per-second or the hour of inches-per-hour. It sets the interval over which the number of events is counted. This is achieved by adding a simple freerunning multivibrator. In the case of the circuit shown it puts out five volts with momentary negative going pulses at regular intervals. Once calibrated to the proper rate this multivibrator remains at a constant frequency.

The clock has two main jobs: It must

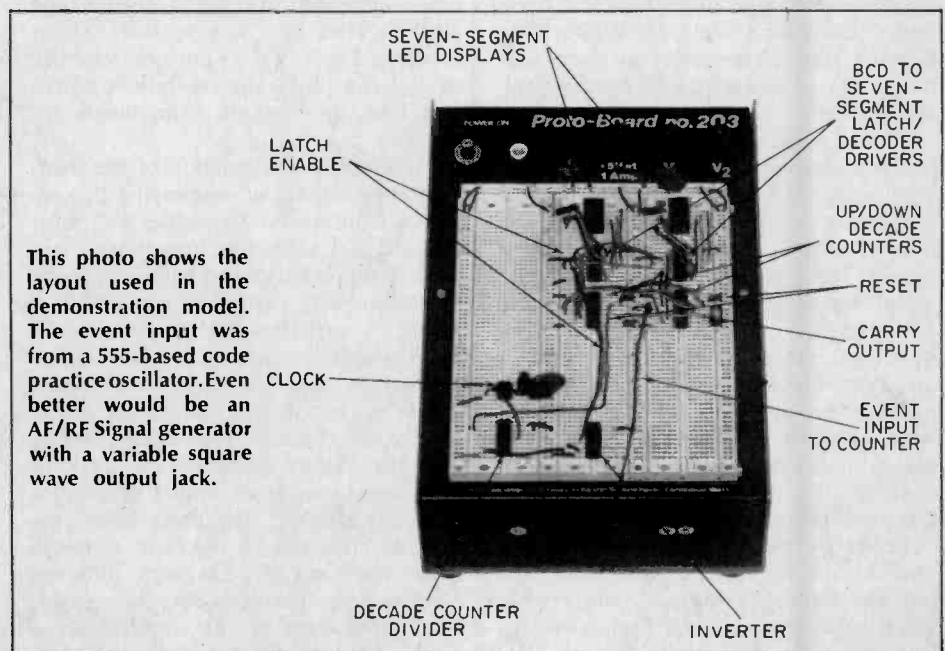

This photo shows the layout used in the demonstration model. The event input was from a 555-based code practice oscillator. Even better would be an AF/RF Signal generator with a variable square wave output jack.

reset the entire counter circuit to zero at the appropriate time and it must freeze the display at the appropriate part of the counting cycle so that it is a readable and meaningful number rather than a blur of speeding digits.

This last task requires a device known as a latch. A latch is a circuit that freezes on whatever BCD number is in its register when a high voltage is applied to the "latch enable" pin. If your circuit is counting from zero to 1000 every 10 seconds and you put a high voltage on the "latch enable" pin at 6 seconds the display will hold at 600. If it is grounded at seven seconds the display will resume the count at 700. So the count doesn't stop—it is only the display that freezes. In the circuit shown on these pages the latch is incorporated in the BCD to Seven-segment decoder IC chip.

By carefully coordinating the counter "reset-to-zero" pulse and the latch pulse so that the latch freezes the count display a moment before the CIRCLE 62 ON READER SERVICE COUPON

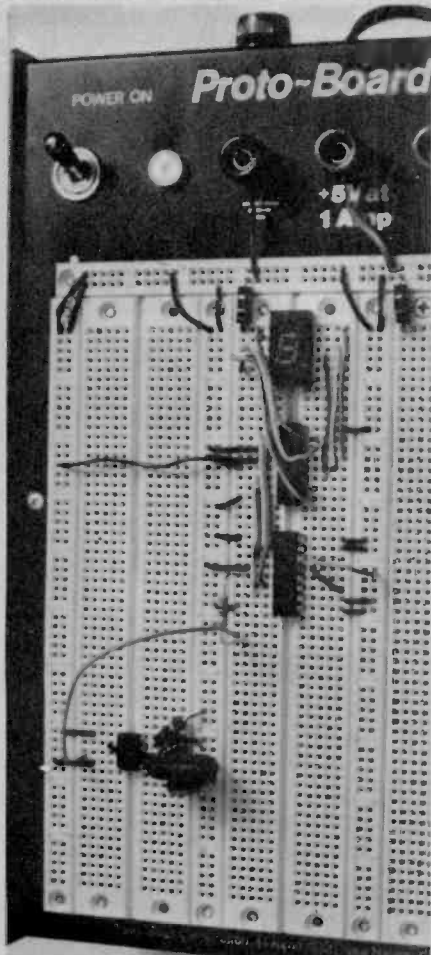

This is a simple one digit event counter. It will count from zero to nine, recycle to zero and start the count again. The resistor added between the clock on the lower left and the decade counter is to lower the level of the input voltage peaks. 220 ohms is fine.

counter resets, we have a event per unit time display.

Synchronizing. To get this proper synchronization of clock, latch and reset, a Johnson counter or decade counter/divider is used. In this chip there are 10 output pins that go high (puts out a 5-volt pulse) in a repeating sequence. So for every 10 input pulses each pin goes high once, one after the other. If we control the latch with the pin that goes high on the first input pulse to the counter and then reset with the pin that goes high on the third input pulse we can control the display so that it will latch and reset at the proper time. The pin that goes high on the second pulse isn't used because of pulse overlapping.

One slight problem with the output to the latch is that it needs to be in-

verted. This is accomplished by sending the pulse by way of an inverter. You can use a common inverter. An inverter is a device that produces a high output with a low input and a low output from a high input.

Putting It All to Work. You have now finished your basic rate measuring device. Now it's up to you to incorporate all of this into your pet project. All you have to do is convert your project's output into series' of pulses of high and low voltage—high being about five volts and low about zero volts. A high-frequency of pulses will give a high numeric readout and a low frequency of pulses a low readout.

If your project gives a variable voltage readout you can buy a chip called an analog to digital converter—this puts out a higher frequency of pulses in

The clock sets the timing of the latch and reset. In this circuit the latch holds the count eight clock pulses after the clock has reset so that the number on the display is only proportional to the number of events per cycle rather than a total of the events.

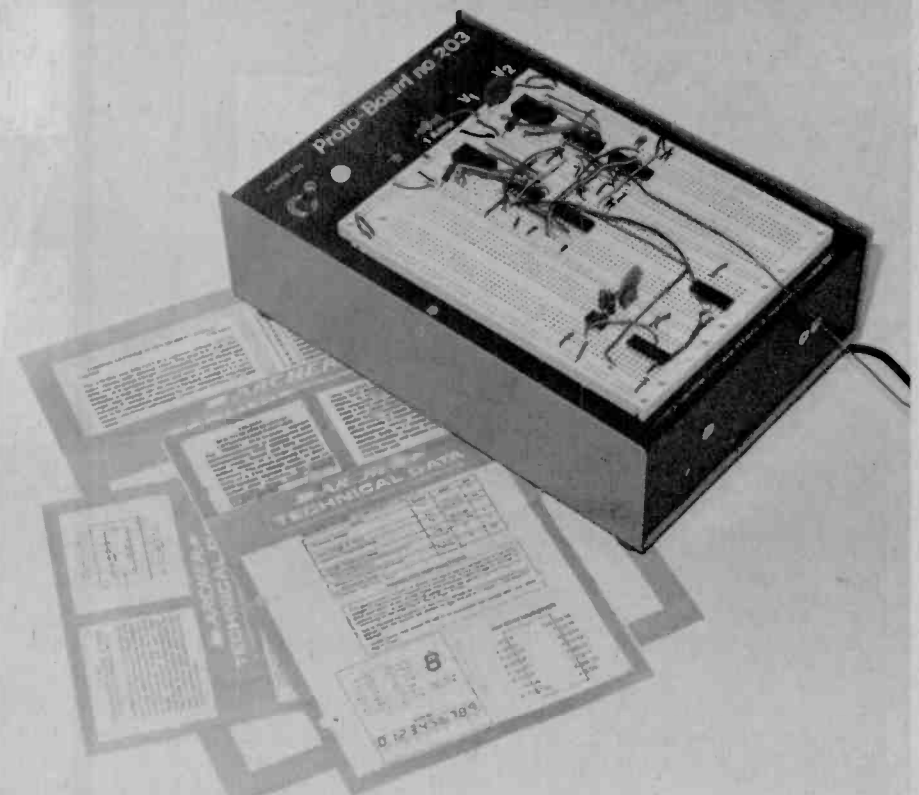
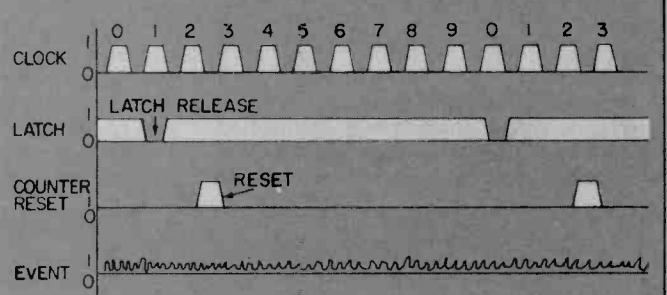

The CSC Proto-Board made experimentation a snap. Connections could be swapped around without muss or fuss. Hang on to the data sheets that come with IC chips, they are an invaluable reference source. Some, like the Radio Shack/Archer ones shown here, have lots of ideas for future experimentation and circuit design modifications.

e/e DIGITAL COUNTING

proportion to an increase in voltage.

The chips used in this article were referred to by their general name rather than number since the attached schematic is only an example of a typical digital numbering circuit. There are hundreds of other combinations of

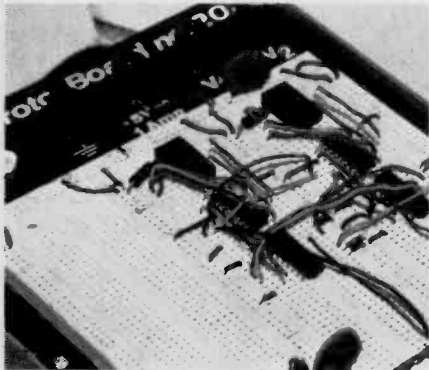

The connections appear complicated but once you understand the principles involved they all will make sense. Note the despiking capacitor added to stabilize the circuit.

similar integrated circuit chips. After you have worked with these circuits for a while you will begin to understand the system better and will find yourself designing more and more complex circuits.

If you want to extend the number of digits much beyond two or three this technique starts to get very expensive and you should consider mul-

tiplexing the circuitry, but that is another article altogether. To describe it as simply as possible, multiplexing is the running of many displays off a single BCD to seven-segment decoder. Power goes to the display digit only when that digit is being decoded. Multiple digits are decoded in sequence so rapidly that they appear to be all lit at once.

More Help. Two books which were extremely helpful in putting this circuit together are: *CMOS Databook* by Bill Hunter and published by TAB Books/No. 984, \$6.95; and *Radio Shack's Archer Semiconductor Reference Handbook* (276-4002) \$1.95.

You can learn a lot from these and other books, but nothing takes the place of actually putting one of these circuits together. It is only by trial and error that you learn how to use these basic digital building blocks—learn how to get all the parts ticking over in the proper sequence and humming along to the beat of the clock, the way a good orchestra plays to the rhythm of the conductors baton.

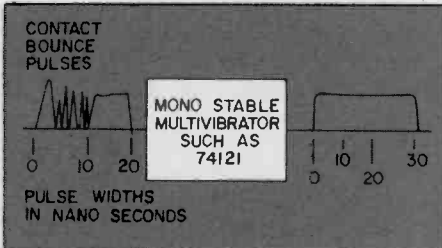

If the output of a mechanical switch were put straight into a counter, each one of the contact-bounce pulses would trigger a cycle of the counter. The monostable multivibrator triggers as the pulse first goes high. The output remains high for a time longer than any continuation of bounce pulses so the unit only counts once. The pulse widths are typically measured in nanoseconds.

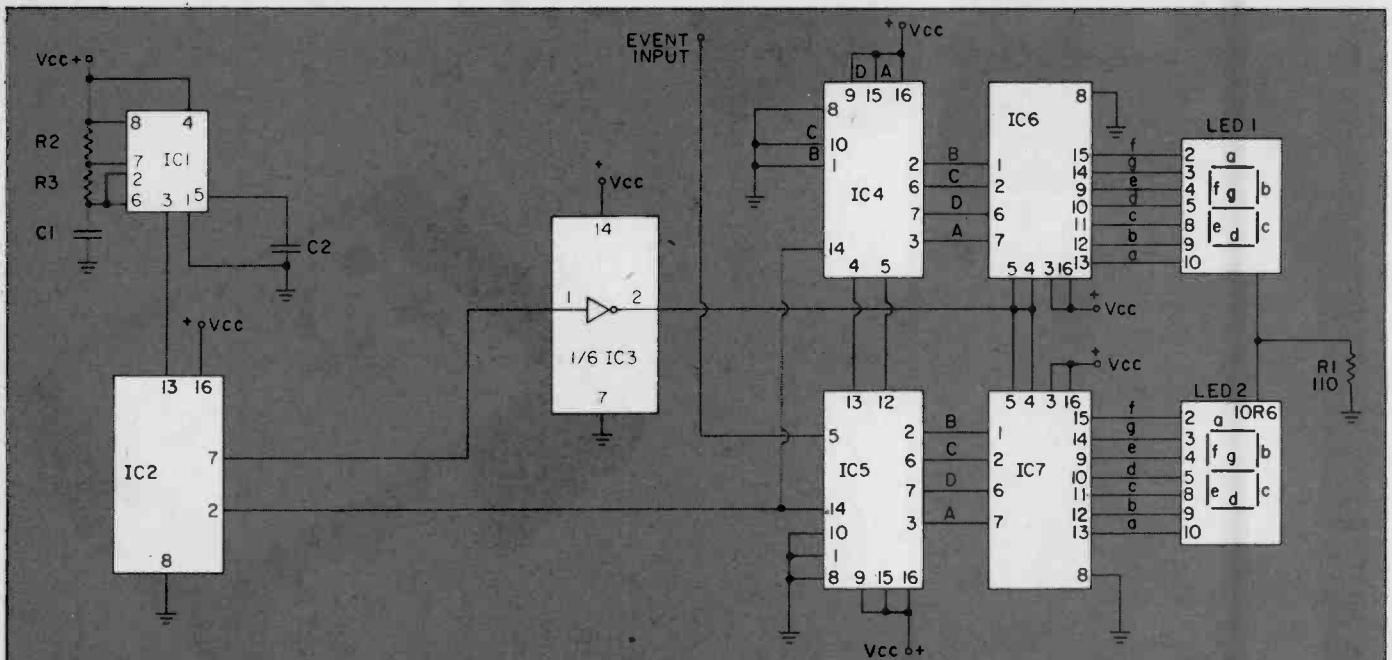

Got parts problems? Solve 'em with Hobby Mart, page 90.



PARTS IN DIGITAL DEMONSTRATION CIRCUIT

- C1—0.1- μ F capacitor
- C2—0.1- μ F capacitor
- IC1—555 timer
- IC2—4017 Decade Counter/Divider
- IC3—7404 Hex Inverter
- IC4, IC5—74192 Up/Down Decade Counter

- IC6, IC7—4511 BCD to Seven-Segment Latch/Decoder/Driver
- LED1, LED2—Common Cathode Seven-Segment LED display
- R1—110-ohm, 1/2-watt resistor
- R2—1-megohm, 1/4-watt resistor

- R3—500,000-ohm, 1/4-watt resistor
- Misc.—CSC PB-203 Solderless Breadboard, jumper wires, and a variable frequency, 5-volt peak-to-peak, square wave signal generator or equivalent free running multivibrator.

GETTING YOUR BNEE THIRD SEMESTER

IN THE FIRST TWO PARTS of this series, we've talked about selecting either a transceiver or separate receiver and transmitter, and then about installing an antenna. Now, let's complete the installation by matching the transmitter to the antenna. It's not just as simple as plugging things in. The transmitter, transmission line, and antenna all have to be tuned to each other's electrical characteristics. This operation requires the optimization of what is known as the SWR, short for Standing Wave Ratio.

The Perfect Match. The SWR is a measure of how much of the power that is poured into the transmission line and antenna by the transmitter is wasted, or reflected back towards the transmitter, and never gets into the ether (or the other guy's headphones). Almost all of today's commercially designed ham equipment is meant to work into a 50- to 75-ohm load. That means that the transmission line and antenna should be designed and adjusted so that they will present a 50- to 75-ohm impedance across the output terminals of the transmitter, in the same way that most audio amplifiers specify an 8-ohm load in terms of speaker resistance (impedance).

Basically, an SWR of 1:1 indicates to you that close to 100% of the output power of the transmitter is flowing out of the antenna, while one of 3:1 indicates that only about 33% of the transmitter's power is actually getting out onto the air. Wattage doesn't come cheaply, so be sure to make the most of what your transmitter has to offer.

While we don't advocate the purchase of a lot of extraneous equipment, especially for the novice, there are certain pieces of equipment that no ham shack should be without.

SWR Meters. SWR meters do not have to be expensive. Some of the smaller SWR meters marketed for CB will cover 3 to 30 MHz, and they will do just fine (check the power handling capability).

SWR readings are relative. All that you have to remember is that you want maximum forward and minimum re-



Putting your station on the air

Thomas Sundstrom, W2XQ

The Heathkit HD-1410 is one of the most popular electronic keyers in use today. With proper technique, there is little fatigue even in extended QSOs. Price: \$49.95

flected power. On a meter the ideal reading is 1:1 (read "one to one"). Most transmitters will accept up to a 3:1 SWR before showing signs of having difficulty loading into an antenna; certainly anything less than a 2:1 should be of no concern to your running the maximum input power of 250 watts.

Antenna Tuners. If you elected to install an end-fed long wire (as described in the second part of this series), you will need an antenna tuner to "fool" the transmitter into "seeing" a perfect antenna connected to it.

A long wire, depending upon its length and the operating frequency, or a trapped vertical not resonant on the frequency being used, may exhibit loads which vary greatly above and below the optimum 50- to 75-ohm load for the transmitter.

A basic antenna tuner has two varia-

ble capacitors and an inductor. Using low power and keeping the transmitter in resonance, the two capacitors are adjusted to minimize SWR. I should caution you to carefully read the operating manual of the transmitter and the antenna tuner before attempting to load the transmitter into the antenna. You can damage expensive output tubes if you keep the transmitter in the tune mode for too long a period of time, fail to keep the transmitter in resonance, or have too high an SWR.

You can build an antenna tuner (one is described on pages 98 and 99 of *Simple Low Cost Wire Antennas* by Orr and Cowan and published by Radio Publications, Inc. Box 149, Wilton, CT 06897) for relatively little money but, if you elect to buy a commercial unit, shop carefully because features vary.

Some of the low-cost units tune only

CIRCLE 82 ON READER SERVICE COUPON



MFJ Enterprises offers a variety of antenna tuners starting around \$40.00 for a simple end-fed long wire tuner. Pictured here is one that will handle all types of feedlines from 10 to 160 meters. Some models are offered with and without built in SWR meters. The MFJ-941 is priced at \$70.00 and will handle 200 watts input power.

an end-fed long wire, yet one of the most expensive units tunes only coaxial cable.

There are a number of multi-purpose tuners in the \$80 to \$130 range. These will handle a long wire, coaxial cable, and open wire feedline. The price of the units varies in proportion to the power handling capability of the tuner. You may wish to buy an antenna tuner that will handle 1 or 2 kilowatts if you intend to purchase a linear amplifier once you upgrade your ticket.

By the way, don't be fooled by the various commercial names being used; a matchbox or a transmatch are other terms used in the literature, but they refer to the same type of product we're discussing.

Do you absolutely need an antenna tuner? No! If your antenna is resonant and the transmitter loads properly, an antenna tuner is not necessary. However, some amateurs use tuners regardless of whether or not their antenna systems are tuned properly; tuners can help reduce harmonics and other spurious signals that may be radiated from a multi-band antenna.

TV Interference. Television interference (TVI) is a touchy subject these days. Diplomacy is a key word if you get complaints from neighbors. The local FCC office has a brochure to help you explain "Why TVI?"

The best defense is a good offense. If your own televisions are free from interference, that is a powerful argument to show that your equipment is not at fault.

On the frequencies below 30 MHz, probably the most damaging TVI is caused by harmonics, multiples of the fundamental frequency. Most Novices seem to have the worst problem with the third harmonic of 21 MHz (15 meters) tearing up channel 13 (60-66 MHz).

Filters may help here. R. L. Drake Company and Barker & Williamson are the two largest manufacturers of both low-pass and high-pass filters.

A low-pass filter will pass frequencies lower than a cut-off frequency of 30 or 40 MHz. The low-pass filter is mounted at the rear of the transmitter in the antenna line.

The high-pass filter will pass frequencies higher than 54 MHz (the lower edge of channel 2). The high-pass filter is mounted in the TV set as close to the VHF tuner antenna input as possible.

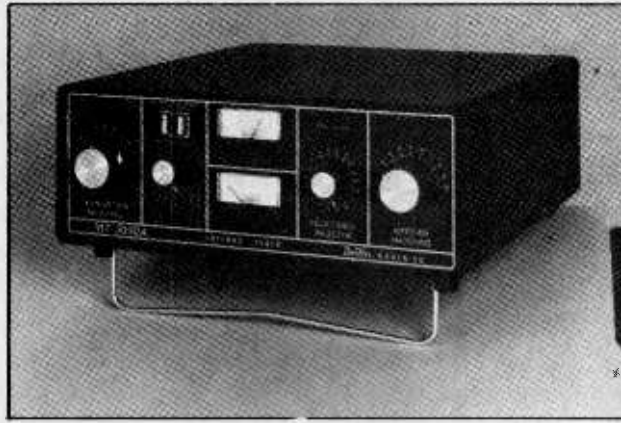

CIRCLE 27 ON READER SERVICE COUPON



The DenTron Super Tuner tunes every type of antenna between 10 and 160 meters. The 1 kw version goes for \$130.00, and the 3 kw version for \$230.00. Other DenTron tuners have built-in wattmeters and SWR meters, along with antenna switchers, helpful features if space in your shack is at a premium. The top-of-the-line model MT-3000A includes a built in dummy load for off-the-air transmitter tuning, and it retails for \$350.00

A word of advice is in order. Don't offer to acquire or install high-pass filters on your neighbor's TV sets. Invariably you will be accused of causing the set's breakdown whenever it fails in the next six or twelve months.

Television manufacturers will usually supply high-pass filters free of charge to those customers requesting them. Have your neighbor write to the manufacturer's corporate headquarters (see the instruction manual) and include the information off the service data label affixed somewhere in or on the rear of the set. Include a statement of the problem.

Connecting the Equipment. In order and as necessary, the items connected to the back of the transmitter should be: (1) the low-pass TVI filter; (2) the SWR meter; (3) the antenna tuner; and (4) the antenna. If you use more than one antenna, an antenna switch can be installed before or after the antenna tuner depending upon how many antennas require the use of the

tuner.

The transceiver (or the separate receiver and transmitter), the TVI filter, and the antenna tuner should all be grounded to an eight-foot long ground rod outside. Use #8 or #10 solid, insulated wire. An alternative ground, but usually less effective, is the cold water pipe system of the house.

If you are using a vertical antenna with above-ground radials, attach a wire from the radials to the antenna tuner's ground post. Leave the ground wire attached (a total of two wires).

Morse Code. The only item now needed to complete your station is a device to send the code. You practiced on a straight key to learn to send the code as a part of the Novice license examination. As the code tests for the higher-grade licenses are receiving only, you don't have to stay on a straight key any longer.

The choice of a straight key, an electronic keyer (either self-contained

(Continued on page 88)

The Heathkit HM-102 Wattmeter/SWR meter is an easy-to-build kit that separates the meter and the sensing unit; the meter can be placed anywhere up to six feet from the back of the transmitter. \$37.95

CIRCLE 1 ON READER SERVICE COUPON

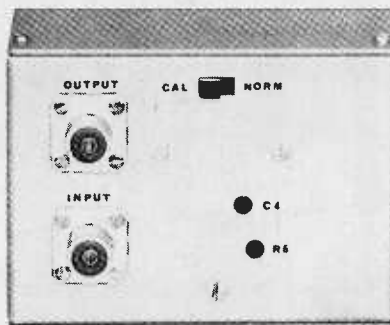

STOP STATIC

e/e's electronics hit-man tells how to bump-off annoying circuit gremlins
by Walter Sikonowicz

PROJECT-BUILDING is supposed to be, and generally is, a challenging and entertaining adventure. Yet, there are times when it can turn out to be a miserable disappointment, all because of a pesky little gremlin known as electronic noise. To the electronic engineer, noise is a catch-all term that refers to any signal appearing someplace where it does not belong. Even if you have constructed just a few projects, chances are that you have been introduced to noise, whether you realized it or not. While noise cannot be eradicated completely, it can be effectively minimized once you understand its origins. In most instances, the key to a noise-free project lies in good construction practice, so let's examine some of the techniques used by skilled project builders.

When dealing with electrical interference, it is helpful to define two classes of devices: noise sources and noise receivers. Noise originates at some source and appears in another electronic circuit, the receiver. Almost anything can be a noise source. Some of the more common ones are automobile alternators, arcing motors, the ever-present 60-Hz power line, high-voltage or high-current electronic circuits, and digital logic. Similarly, almost any electronic circuit can be a receiver, although high-gain, low-level, high-impedance stages are often the most susceptible. While the source and receiver may belong to two different pieces of equipment, they may just as well be different stages of a single piece of equipment.

Coupling. In order to transfer energy from the source to the receiver, some form of coupling must exist. The two important modes of coupling consist of an electromagnetic field or a common ground impedance between the two circuits in question. Consideration of an electromagnetic field is usually broken down into two subcases:

electric-field coupling and magnetic-field coupling. A high-voltage, low-current circuit radiates energy chiefly through an electric field, whereas high-current, low-voltage circuitry radiates predominantly through a magnetic field. Most noise sources radiate through both fields, but it is easier to deal with one field at a time.

Let's begin with electric-field coupling, also known as capacitive coupling. In Figure 1 we have voltage source V_1 , with internal impedance R_{G1} , driving a load, R_L . This voltage generator might be anything—a transistor, op-amp, logic gate, or even an alternator; the exact nature of the source is unimportant. Nearby, we have a second voltage generator, V_2 , with an internal impedance of R_{G2} . An amplifier, with input impedance equal to R_{IN} , is supposed to amplify V_2 . However, electric-field coupling between the two circuits exists through stray capacitance C . Now, C 's capacitance will be very small. As an example, consider that the capacitance between two closely spaced

#22 wires amounts to less than 40-pF per foot of wire. Despite the small magnitude of capacitance C , however, it can result in the appearance of a noise voltage, V_N , across the amp's input impedance. We are in trouble if V_N is a significant fraction of V_2 's magnitude, and the situation is hopeless if V_N equals or exceeds V_2 .

To see what determines the size of noise voltage V_N , note that current from generator V_1 can flow in a complete loop: first through R_{G1} , then through C , and finally through R_{G2} and R_{IN} back to source V_1 . Since R_{G2} is effectively in parallel with R_{IN} , and since V_N is developed across this parallel resistance combination, we are interested in the equivalent parallel resistance, which we abbreviate as R_{G2}/R_{IN} . Basically, what we have here is a voltage divider— R_{G1} , C , and R_{G2}/R_{IN} —across V_1 . The noise voltage caused by V_1 will be increased by the following factors: 1) an increase in the magnitude of V_1 ; 2) an increase in the frequency of V_1 , since C 's impedance

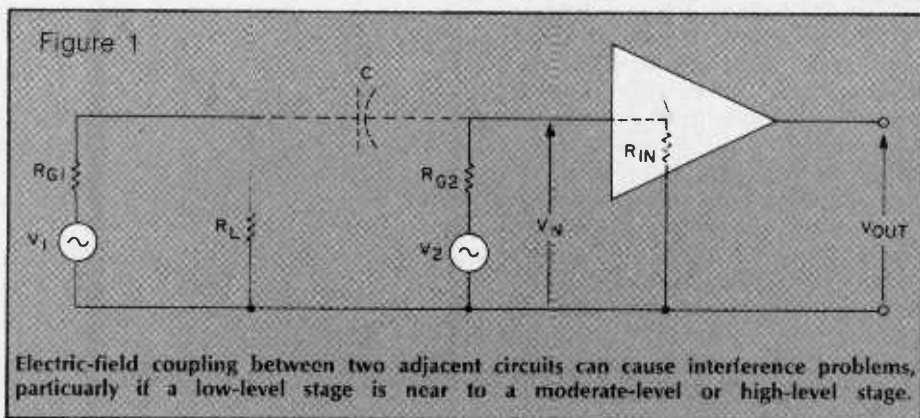

e/e STOP STATIC

drops at higher frequencies; 3) a decrease in source-to-receiver distance, because this increases C ; and 4) an increase in the equivalent parallel resistance, R_{G2}/R_{IN} .

Voltage and Frequency. It is apparent that high-voltage, high-frequency circuits are the most troublesome noise sources, as far as the electric field is concerned. Digital logic is one of the most common examples of this type of circuitry. Signal swings are large—between five and fifteen volts usually. Furthermore, even though the repetition rate of the pulses or square waves involved may be low, these signals still have a high harmonic content. For example, pulses with a 5-nano-second rise-time have significant harmonic energy right up to 30 MHz., even if the repetition rate is much less than that.

At the receiving end, the most noise-susceptible circuits will have high impedances and operate at low levels (that is, with small V_2). This latter factor, low levels, is very often accompanied by high gain. Common examples of such noise-sensitive circuits are: high-gain FET preamps, low-level analog comparators, and op-amps with large feedback resistors.

Assuming that you cannot change the design of the source and receiver circuits, the only practical method of reducing noise from an electric field is to minimize the coupling capacitance. Separation of the two stages helps; at least an inch or two should intervene between the circuits. Separation beyond this distance will reduce pickup still more, but the noise level does not drop as quickly as it does over the first inch or so.

Shielding. More effective than separation is the use of metallic shield when pickup is severe. In Figure 2, the two possible methods for shielding are diagrammed. Figure 2A shows a conductive metal shield, grounded to source common, that completely encloses source V_1 . Electric-field coupling between source V_1 and the shield is symbolized by capacitor C_1 . Outside the shield, another stray capacitance, C_2 , exists between the shield and the equivalent parallel resistance, R_{G2}/R_{IN} . (The rest of the amplifier has been deleted because, so far as we are concerned here, its only important characteristic is R_{IN} .) An electric field exists within the shielded enclosure; however, the field outside the shield is zero every-

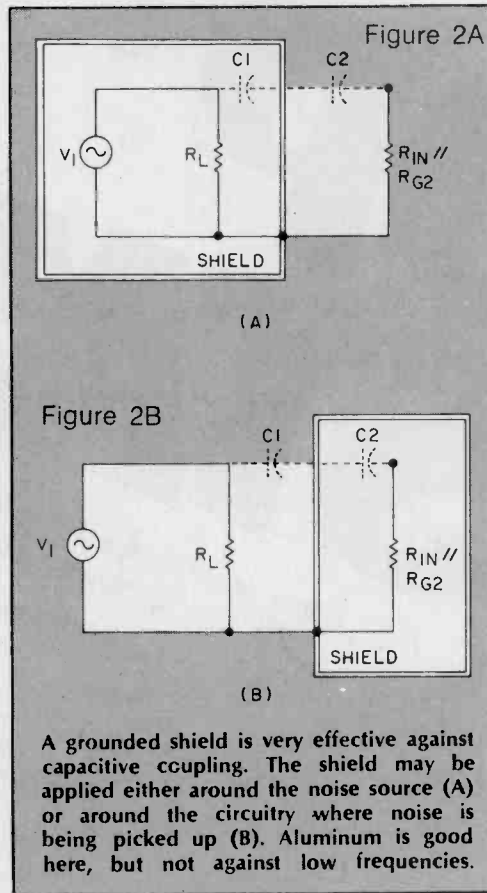

where. This comes about because, at least ideally, the entire surface of the shield remains at ground potential. Since the external field is zero, no energy is transferred across stray capacitance C_2 .

In part B of Figure 2, the grounded metallic shield envelops the receiver. Energy transfer occurs between source V_1 and the grounded shield via C_1 . The field within the shield is zero since the shield is at ground potential. As a result, no noise is picked up by the receiver.

Any metallic sheet makes a good electric shield. Aluminum, a common cabinet material, is excellent at all frequencies. A shield may be placed

between two stages of a single piece of equipment. On the other hand, a grounded metallic cabinet constitutes a shield between a particular piece of equipment and all noise sources in the outside world. The only precaution necessary when shielding is that the shield must be in electrical contact with the circuit's ground. Note that this does not necessarily mean an earth ground, such as a pipe in the soil. Connection to circuit common is all that is ever required.

At this point, you are probably wondering what happens if the source and receiver circuits do not share a common ground connection. We can treat this coupling by means of two stray capacitances, as shown in Figure 3. You should be able to see for yourself that the previously discussed shielding methods still apply. A shield around either circuit, connected to that circuit's ground potential, is all that is required.

Before leaving the electric-field case, let's note that wires may also need shielding if they connect to possible receivers or sources. When wires exit a particular piece of equipment, they may be protected by shielded cable. Likewise, shielded cable may be used within a single piece of equipment when interstage noise coupling is a problem. Often, however, you can obtain the benefits of a partial shield by simply routing wires close to the grounded chassis. The electric field near the chassis/shield is minimal, so any pickup by wires is likely to be small. As a final precaution, keep wiring to low-level circuitry separated from high-level wiring.

Inductance. Now, let's turn to the magnetic field and Figure 4. The most important aspect of this is that there are two current loops, a source loop and a receiver loop. In the source loop, generator V_1 drives a current I_1 through load R_L . The current flow is, in turn, responsible for a magnetic field that exists in the vicinity of the source

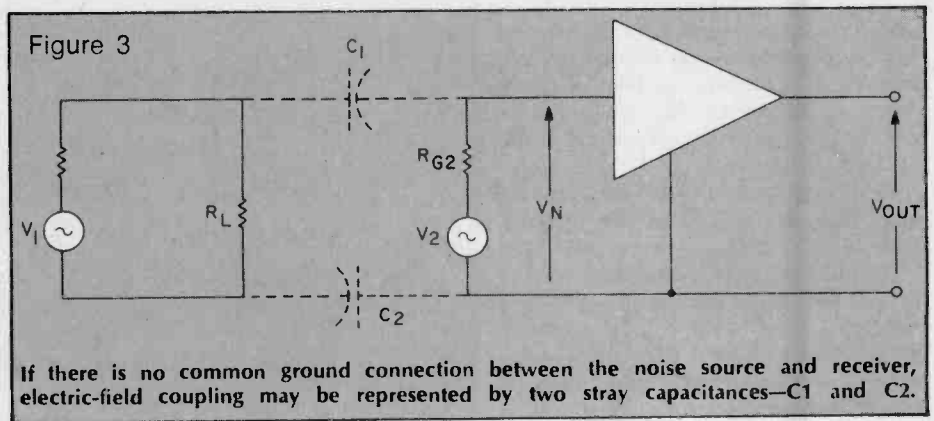

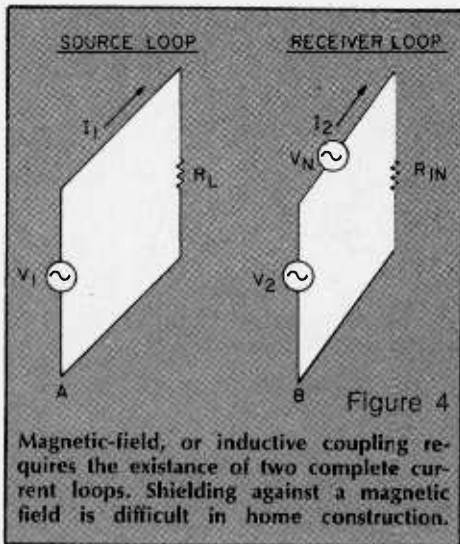

loop.

The receiver loop consists of generator V_2 driving a stage with input impedance R_{IN} . (Note that no internal resistances are indicated for the voltage generators since such impedances have a negligible effect here.) In addition, a noise voltage, V_N , which is due to source V_1 , appears in series with V_2 . If V_N is not negligible compared with V_2 , then we must find ways of minimizing the noise pickup.

What we have in Figure 4 is a simple transformer, which suggests why magnetic coupling is also known as inductive coupling. Alternating current I_1 generates a changing magnetic field that induces a voltage in any loop it intersects. As Figure 4 shows, the two current loops may be completely isolated. However, points A and B could be connected with no change in the induced noise voltage. Therefore, as was the case with the electric field, we must consider coupling between stages of the same device, or between stages of two separate devices.

Let's examine the factors that cause increased noise coupling: 1) an increase in the magnitude of I_1 ; 2) a decrease in the separation of the two loops; 3) an increase in the frequency of I_1 ; 4) orienting the loops so that their planes are parallel; and 5) an increase in the area of the receiver loop. From the above, several methods of noise reduction are suggested. First, separate the two loops; in particular, keep high-current stages away from low-level stages. Second, minimize receiver loop area. This applies especially to the wiring associated with a receiver stage. All wires to a jack, a switch, or a potentiometer should be twisted together, thus minimizing pickup loop area. Third, try to minimize the source loop's magnetic field. This is

most conveniently done by using twisted wired again. To see why this is effective, imagine taking the source loop, stretching it, then twisting the wires together. The currents in the twisted pair flow in opposite directions, and because twisting keeps the two wires in close proximity, the magnetic field of one wire cancels that of the other. Even better than twisted pair, especially at high frequencies, is coaxial cable; for most hobbyist requirements, however, a twisted pair is sufficient to reduce magnetic radiation. Finally, changing the orientation of the source with respect to the receiver often helps. Consider, for example, the magnetic radiation from a power transformer. You may carefully twist the leads, but you cannot do anything about the magnetic flux from the transformer coils. Usually, however, some mounting orientation of the transformer will result in minimized pickup in your noise-sensitive stage.

Comparing magnetic coupling with electric coupling, one thing you may have noticed is that the impedance of the receiver has no effect on its susceptibility to inductive coupling. Also, you may have wondered whether a shield would be as effective against a magnetic field as it is against an electric field. The answer is no. Aluminum, which is so effective as an electric shield, begins to be effective against magnetic fields only at higher frequencies (above 100 kHz). At the important frequency of 60 Hz, aluminum is use-

shielding.

Wiring Problems. So far we've dealt with stray pickup from a more or less familiar viewpoint—familiar at least in the sense that whenever noise problems occur, the first thing to be blamed is some mysterious, invisible field. Very often, however, the trouble is the handiwork of a more mundane villain: your circuit's electrical wiring.

Figure 5 shows a serial power distribution system, the most common way of delivering power to the various stages of a piece of equipment. Two power leads run from the supply to one stage, and then from there to the next stage, and so on. Such a scheme is simple and generally practical, except when you have the situation shown in Figure 5. Here we have a low-level source, V_s , driving a high-gain amp stage, with resistor R and inductor L representing the resistance and inductance of the interconnecting ground lead. Current I_1 from the high-current stage and current I_2 from the switching stage both flow through the power bus—in particular, through R and L . Since the amp responds to the potential difference between its input and ground leads, any voltage developed across R and L due to I_1 and I_2 appears in series with V_s , and this noise voltage V_N gets amplified right along with V_s .

Now, let's suppose R and L represent a piece of #22 wire. One foot of #22 has a resistance of 16.14 milliohms, and if I_1 is a direct current of about 61 milliamps, then V_N equals

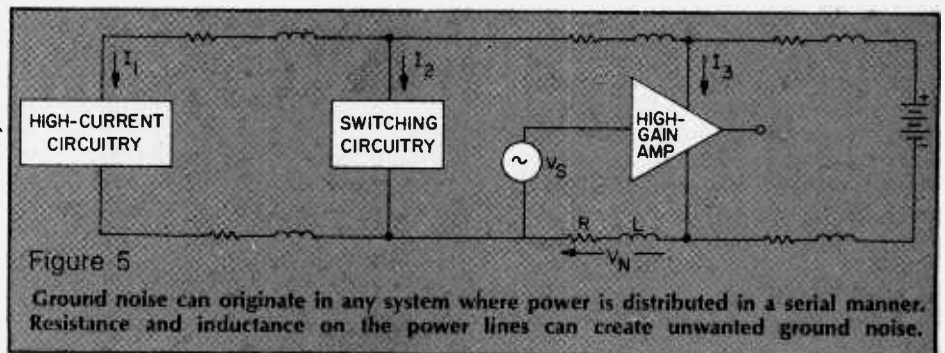

less. In order to obtain better magnetic shielding, your shield must be a ferromagnetic substance, such as steel. Because it is harder to machine than aluminum, steel is rarely used by hobbyists, even though its magnetic-shielding properties are superior to those of aluminum. At 60 Hz, however, even steel is only partially effective (shielding effectiveness increases with frequency). Special magnetic alloys, such as mu-metal, are necessary at low frequencies. All things considered, magnetic shielding is more difficult than electric

1 millivolt. This is small, but certainly significant if V_s is also on the order of millivolts. At high frequencies, the impedance of inductance L increases to become the dominant factor, and this gives us even more trouble. For example, a foot of #22 wire has a 4-ohm impedance at 1 MHz, and a whopping 40 ohms at 10 MHz. Needless to say, high-current and high-frequency stages (and this includes our old friend, digital logic) can wreak havoc on low-level circuits.

(Continued on page 86)

It's Simply BASIC

by Larry Friedman

The odds are 2 to 1 that you'll want to try your luck with Gamble—this issue's BASIC program

□ Two COMMON SUBJECTS many of you write about are the reproductions of the listing directly from my teleprinter, and various ways the programs can be shortened and/or improved. Actually, there are good reasons for the way programs are handled in ELEMENTARY ELECTRONICS. We photocopy the teleprint of the listings to avoid typographical errors, because one single typo is all it takes to crash a program. Imagine if a typesetter substituted a semi-colon for a colon in a multiple statement line: it would be a wipe-out. If you read the other hobby computer publications you'll note they are also switching entirely to direct copy of the programmer's listing.

Versatility. As for the way programs are written; the programs are meant to be used on as many computers as possible using as many versions of BASIC as is possible, though we must eliminate the integer BASICS because they are too restrictive for electronic hobbyist use. This means we cannot use functions, features, or "cute tricks" common to one particular version of BASIC. The only exception made is for Heathkit Extended BASIC because programs using some of its special functions are very easily modified for other BASICS, such as we did with the LINE INPUT statement in an earlier program.

The SWTP Co version 2.0 BASIC which is generally used for our programs is perhaps the best hobbyist BASIC in terms of easy adaptation, or direct use, with computers having other versions of BASIC. We have found that, as a general rule, if the program works with a simple construction in SWTP Co BASIC, it will work in any floating point BASIC.

This month's program, Gamble, is a straight fun program that will help you determine the odds on a particular game or event. It won't make you another Nick The Greek, nor should you mortgage the old homestead hoping you'll find the pot of gold at the end of the rainbow, but it will allow you to challenge the "officially approved"

(Continued on page 98)

GAMBLE

```
0100 REM "GAMBLE" BY LARRY FRIEDMAN
0101 REM IF YOU DESIRE A PRINTED SET OF INSTRUCTIONS FOR THIS
0102 REM PROGRAM, CHANGE THE 'REM' STATEMENTS (LINES 105-165)
0103 REM TO 'PRINT' STATEMENTS.
0104 REM -----
0105 REM THIS PROGRAM CALCULATES THE POTENTIAL RELATIVE
0110 REM PERFORMANCE OF TEAMS IN A GAME OR EVENT IN ORDER TO
0115 REM DETERMINE APPROXIMATE ODDS. FIRST, EACH GENERAL AREA OF
0120 REM COMPETANCE IS RATED BY YOU ON A SCALE
0125 REM OF 1-5 (5 IS THE HIGHEST RATING).
0130 REM YOU MAY SELECT AS MANY AREAS OF
0135 REM COMPETANCE AS YOU FEEL IS REQUIRED TO
0140 REM DETERMINE THE ODDS. THEN YOU RATE EACH INDIVIDUAL
0145 REM TEAM ON A SCALE OF 1-5 FOR EACH SELECTED AREA OF
0150 REM COMPETENCE.
0155 REM THE COMPUTER WILL PRODUCE A RELATIVE PERFORMANCE VALUE
0160 REM FOR EACH TEAM IN THE EVENT.
0165 REM
0170 PRINT "HOW MANY FACTORS IN RATING PERFORMANCE?";
0180 INPUT F
0190 FOR I=1 TO F
0200 PRINT "# ";I;
0210 INPUT FS(I)
0220 NEXT I
0230 PRINT
0240 PRINT "RATE EACH FACTOR ON A SCALE OF 1-5 (5 IS BEST)"
0250 FOR I=1 TO F
0260 PRINT FS(I);" ";
0270 INPUT F(I)
0280 NEXT I
0290 PRINT
0300 PRINT "HOW MANY TEAMS ARE BEING RATED?";
0310 INPUT T
0320 FOR I=1 TO T
0330 PRINT "TEAM # ";I;
0340 INPUT TS(I)
0350 NEXT I
0360 PRINT
0370 PRINT "RATE EACH TEAM FOR EACH FACTOR ON A SCALE OF 1-5"
0380 FOR I=1 TO T
0390 PRINT TS(I)
0400 FOR U=1 TO LEN(TS(I))
0410 PRINT "-";
0420 NEXT U
0430 PRINT
0440 Y=0
0450 FOR X=1 TO F
0460 PRINT FS(X);
0470 INPUT S(X)
0480 NEXT X
0490 PRINT
0500 PRINT TAB(15);"RELATIVE PERFORMANCE FACTORS"
0510 FOR X=1 TO F
0520 PRINT FS(X);TAB(24);"POINTS = ";S(X)*F(X)
0530 Y=Y+(S(X)*F(X))
0540 NEXT X
0550 PRINT
0560 PRINT "TOTAL RELATIVE PERFORMANCE FACTOR = ";Y
0570 PRINT
0580 PRINT
0590 NEXT I
0999 END
```

READY

#

SAMPLE RUN SHOWING BASEBALL TEAM COMPARISONS

READY

#RUN

HOW MANY FACTORS IN RATING PERFORMANCE? 5

1 ? PITCHING

2 ? HITTING

3 ? FIELDING

4 ? BASERUNNING

5 ? BUNTING

RATE EACH FACTOR ON A SCALE OF 1-5 (5 IS BEST)

PITCHING ? 5

HITTING ? 5

FIELDING ? 4

BASERUNNING ? 3

BUNTING ? 1

Programs are written in SWTP type 2.0 8K basic, and might require some modification for use with other BASIC interpreters. Programs for this column are checked and debugged using a SWTP 6800 computer with 12K memory, a Micro-Term ACT-1 CRT terminal, an ASR 33 TTY, and a National Multiplex CC8 recorder. Printout will fit single line TTY or two lines on most CRT terminals.



Kathi's CB Carousel

by Kathi Martin, KGK 3916

Lafayette launches a new CB classic

□ FOR MORE YEARS than I care to remember, the "Lafayette" marque on a CB transceiver meant the highest level of performance and the very latest in operating features. Some models, such as the 500, 525, 625, and Dyna-com 23, were legends in their own time.

As with almost everything else, however, others caught up, often surpassing Lafayette transceivers in both performance and features, and the Lafayette brand became just another line of CB transceivers ranging from adequate to good.

Now Lafayette has come back with a roar, and their model LM-300 40-channel AM rig leads the way with one of the best features I've used in many a year—a secondary channel selector.

One of the problems I have out here in the east is the use of two different highway channels on roads that intersect and intertwine. In my case, it's channels 13 and 19. Often, I'm continuously exchanging between the super-slabs and it's a first rate pain in the arm to keep flipping back and forth between channels 13 and 19.

With my new Lafayette LM-300 and its secondary channel selector, the problem no longer exists because the rig keeps track of both channels, and will lock the transmitter to the monitored channel, unlike some scanning rigs that lock the transmitter to a main channel while scanning two channels. If one channel comes alive with a traffic re-

port, the LM-300 locks onto the channel and I can immediately transmit to get the complete story.

Before I get too far ahead of myself, let's take a break, and take a look at the LM-300 as it comes out of the box.



The rear apron is "standard," with an antenna connector, jacks for P.A. and external (remote) speakers, and a power receptacle.

The LM-300 is a 40-channel mobile rig measuring 2-3/16-in. high by 8 3/8-in. wide by 9 7/8-in. deep. The power requirement is 13.8 VDC with positive or negative ground, and power is applied through a polarized plug and receptacle. Standard features include jacks for P.A. and remote speaker, L.E.D. digital channel indicator, both a noise blanker and noise limiter, an audio tone control (hi-cut switch), a continuously variable channel indicator dimmer, and a plug-in microphone. Extra features are a built-in SWR indicator (one meter serves for S/RF-output/SWR) the secondary channel selector, and a tone alert for the secondary channel selector.

Okay, no more suspense. I'll tell you about the secondary channel and its associated scanner and tone alert.

The LM-300 has two independent VCOs (voltage controlled oscillators) phase locked to a quartz oscillator. Each VCO has its own digital channel selector and its own digital channel indicator, the primary channel indicator being red, the secondary being green. Understand that the remainder is a single, double-conversion receiver. What this means is that there are two oscillators which can be used to control the same receiver section. The Lafayette engineers have cleverly eliminated the need for separate receiver sections and additional, unnecessary circuitry, with an ingenious front panel switching system.

Two switches determine the action of the VCOs. One switch is labeled "M/SC/S"; meaning main, scan, secondary. The other switch is labeled "PRI" and "IND", PRI meaning the unit automatically switches to the channel containing a signal and IND, meaning an audible tone alert when a signal is present on the secondary channel with the rig remaining tuned to the main channel.

If the switch is set to Main, the rig is tuned to the main channel. If the switch is set to S, the rig is tuned to the secondary channel. In the SC (Scan) position, the rig is tuned to the main channel, and the secondary channel is sampled (scanned) approximately once each second. The rig will lock to the first channel on which a signal appears, and will resume scanning when the sig-

Lafayette's LM-300 Dual receiver CB set is a great unit to use on the road. It lets the user monitor two channels at once. Dual LED readouts tell you what channels are on primary and secondary circuits. For more information on the LM-300, circle number 40 on the reader service coupon.



CIRCLE 40 ON READER SERVICE COUPON

e/e KATHI'S CAROUSEL

nal goes off, if the second switch is set to PRI. If the second switch is set to IND, the rig will remain tuned to the main channel and an alerting tone will sound about once every second if a signal appears on the secondary channel.

As soon as I hear a signal that I want to work, I flip the M/SC/S switch to lock the rig to the main or secondary channel. The operating technique comes naturally after an hour or so of use, and I assure you, it's nowhere near as difficult as I may have made it sound. In point of fact, the unit works beautifully, and I really miss it when I go back to one of my single channel rigs.

As for performance, it's first class all the way. The receiver checked out with a 0.4 μ V sensitivity for 10 dB S+N/N (signal plus noise to noise); selectivity (adjacent channel rejection) was 63 dB, and the AGC action was an outstanding 2 dB for a 100 dB variation in input signal level. In plain terms, it means that if you have the volume cranked wide open to hear a weak signal almost buried in the background noise level, a powerful signal coming on the channel will sound just a little stronger. It won't blast you out of your seat!

The transmitter delivered 3.5 watts RF output to a 50-ohm load. Modulation was limited to 100% and the sensi-

Switch the transceiver on and flip a switch marked M/SC/S to M (for main), and the main channel indicator turns on to indicate the main, or normal, channel. Flip switch to S (for secondary) and the secondary channel indicator turns on. If the switch is set to SC (Scan), the transceiver will work on the main channel and sample the secondary channel approximately every second. If a signal comes on the secondary channel its presence will be announced by a beeping alert tone, or the transceiver will lock to the secondary channel, as determined by the Alert selector switch.

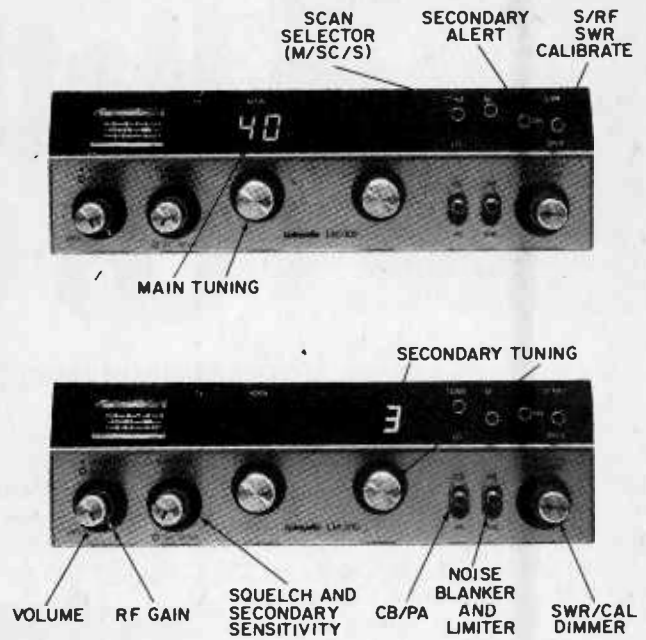

tivity for 85% modulation was -32 dB, which was a pleasure to use in this age of super microphone sensitivity that picks up a pin dropping five blocks away. The LM-300 has just enough mike gain to produce maximum talk power with a low voice level, but not enough sensitivity so that every sound and creak from a car fifty feet down the road gets transmitted along with your

modulation.

As you can tell, I'm really impressed by the Lafayette LM-300. It's well thought out, and priced right at \$169.99, which includes the mike, power cable, and mobile mounting bracket.

For additional information on the LM-300, circle No. 40 on the readers' service coupon. ■



□ ANY DRIVER WHO has ever come upon a cyclist, who's bicycle has poor lights, at night knows how really hard they are to see. What seems bright and easy-to-notice to a bike rider is almost invisible at 100 feet. In fact, in a high per-

centage of accidents, where a bicycle is hit by a car at night, the driver often says that they never even saw the cyclist or saw them only when it was too late.

A Boulder, Colorado firm has come up with a device that they hope will re-

duce the hazards of nighttime cycling by making the bicycle highly visible from all directions. The "Laser Lite" as it is called (it has nothing to do with lasers), is a fluorescent tube powered by a small, wheel-mounted generator. The unit emits a bright green light that is easily visible for more than a quarter-mile and can usually be seen more than a half-mile away.

Green Lantern. The light begins to glow at 2½ mph and, because of its construction, it remains uniformly bright over the total speed range. This color of green was selected because it has been shown that it is the most visible color in the spectrum. The unit is reported to be durable, weather resistant and to last for about 3,000 hours of use. The entire system weighs only 19 ounces.

The "Laser Lite" retails for \$14 and is manufactured by Life-Lite Safety Products, Inc., 1140 Pearl Street, Boulder, CO 80302. Although it is recommended that the "Laser Lite" be used in conjunction with ordinary bicycle lights, it is not strictly necessary, says the manufacturer. ■

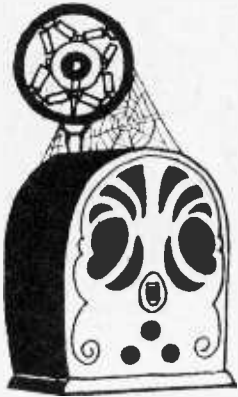

ANTIQUE RADIO CORNER

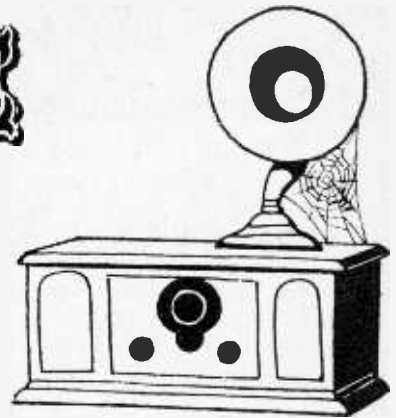

by James A. Fred

Some short insights into the world of antique radio

□ HELLO OUT THERE IN RADIOLAND! I often read the "Books for sale" columns in the antique collector's newspapers I subscribe to. Recently I found a book about the life of a rather unique character from the early days of radio: Norman Baker. If your memory is good you may remember that Norman Baker manufactured the Tangley Air Calliope which was also called the Calliophone. It was a musical instrument operated by compressed air rather than steam which made it much safer for the operators of the calliope. Baker was also the founder of radio station KTNT in Muscatine, IA. Because of his claims of curing many victims of cancer he became involved in disputes with the AMA and, later with the FCC, which led to the loss of his station license in Iowa.

He then went to Mexico and established radio station XENT. This station was one of the most popular and powerful in North America. The book makes fascinating reading for the radio collector who is interested in the history of the 1930's.

Phonograph Museum. I attended an IHRS meeting held at the Midwest Phonograph Museum located on Indiana 252 just off Indiana 37, near Martinsville, IN. The museum was founded by a retired doctor E. T. Drake and his wife. The museum contains over 300 phonographs on display with about 300 more in storage. Those in storage are either used for parts or are rotated periodically with those on display to make a repeat visit worthwhile. The museum contains a complete display of the phonograph from its start to about 1930. Also on display are some late 1930's radio-phono combinations and six Jukeboxes. The owners conduct guided tours and the commentary is outstanding in its completeness. The museum is open to the public on Saturday, Sunday and Holidays from May 1 to November 1. Hours are



This view from inside the Midwest Phonograph Museum shows a forerunner of the jukebox on the near right. At the far left is a Wurlitzer jukebox with a Bando just above.

from 2:00 PM until 6:00 PM and an admission is charged.

During the tour of the museum you will learn about Thomas Edison, Emile Berliner, and Eldridge Johnson, all early pioneers of the phonograph industry. There is a large painting of the dog Nipper listening for "His Masters Voice." If you are in central Indiana while on vacation or business I would recommend that you take time to visit the museum. Visitors are encouraged to bring cameras and take as many photographs as they like.

Meters. We will continue our discussion on voltmeters in this column. In one of the photos you will see a wooden cigar box that is a six-inch cube and inside is an old Jewell multi-range voltmeter. If I might digress a moment I would like to mention that cedar cigar boxes were once the favorite enclosure for many kinds of homemade radio gadgets. I have found nice

crystal radio receivers built into cigar boxes. I have seen radios built on cigar box chassis. Cigar boxes used to come in many sizes and shapes. If you enjoy going to flea markets and antique shows cedar cigar boxes are often for sale, but prices are going out of sight. You will also find vendors with thousands of cigar box labels. You can make your own replica cigar boxes and glue the available label on if you can't find the real old ones. Shun the modern cigar boxes however because they are solid cardboard covered with paper.

You will usually find DC voltmeters made in two basic types. You will find voltmeters made in D'Arsonval (moving coil) and iron vane movements. Most of the inexpensive nickel plated or watch case meters had iron vane movements. Iron vane meters need an appreciable amount of current to move the pointer from zero to full scale reading. This was OK when radio men

e/e ANTIQUE RADIO CORNER

were measuring battery voltages and wanted a moderate load on the battery, but later when it became necessary to measure plate voltages in resistance coupled amplifiers the iron vane meter was worthless. You may wonder why this is true. Many iron vane meters had a resistance of 100 ohms per volt or less. This means that a 0 to 100 volt DC meter might have a total of 10,000 ohms resistance. This means that it would take 10 milliamps of current to move the pointer to full scale. Now let's look at the circuit of the resistance coupled amplifier. Suppose the voltage at the plate of the tube is normally 65 volts. This means there is a drop of 35 volts in the 100,000 ohm plate load resistor. If you want to measure this voltage with your iron vane voltmeter you will be placing 10,000 ohms in parallel with the 100,000 ohm resistor. By ohms law for parallel resistors our resistance is less than 10,000 ohms. The plate voltage is no longer 65 volts, but will measure near zero. To get a nearly correct plate voltage reading you must have a voltmeter whose internal resistance is much greater than the 100,000-ohm plate load resistor. The ideal meter for this is a Vacuum Tube Voltmeter (VTVM) or at least a meter that has a resistance of 20,000 ohms per volt. We will discuss the VTVM in a future column. The conclusion to this example is that an iron vane voltmeter is OK for repairing battery radios made up to 1927, since resistance coupled amplifiers didn't become popular until 1929 or 1930.

D'Arsonval. The preferred type for radio work is the D'Arsonval or moving coil type meter. The working parts of this meter are shown in one of the illustrations. If a current carrying coil is mounted on pivots and placed between poles of a strong permanent magnet, the current flowing through

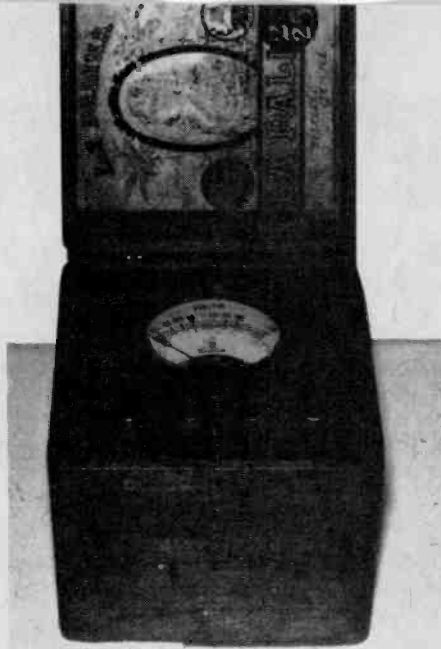

This Jewel voltmeter is mounted in an old cigar box. These boxes can sometimes be found at flea markets but they are rare.

the coil will cause it to rotate. A pointer mounted on the moving coil will then move across a calibrated dial scale and indicate the amount of current flowing in the coil. As mentioned previously resistors placed in series with a milliammeter will make it a voltmeter. The meter shown in the cigar box had a dial scale calibrated to read 10 and 250 volts full scale. Since the meter re-

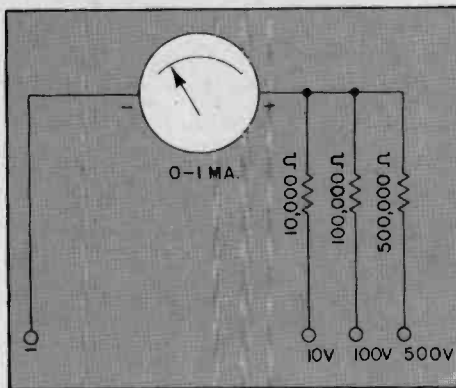

A simple three-range voltmeter can be made by constructing the above circuit from parts in your antique junk box.

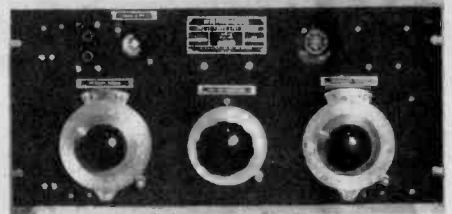
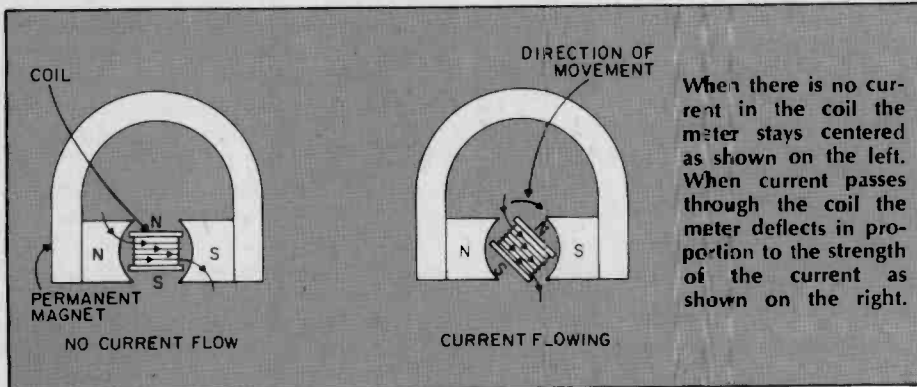

The front panel of the Carrier Current Receiver looks almost like an old time amateur radio transmitter. Really a classic!

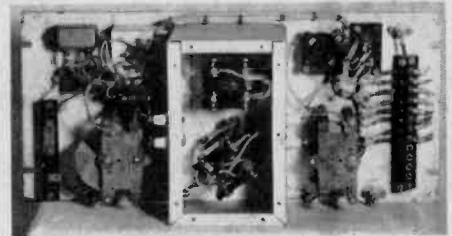

Inside the Carrier Current receiver there aren't many parts to cause trouble. Maintaining this set would have been simple.

quired one milliamp (.001 ampere) to deflect full scale, one resistor should be 10,000 ohms and the other 25,000 ohms (by ohms law we learned that volts divided by amperes equals ohms, is $10 \div \text{by } .001 = 10,000$ for one resistor and $250 \div \text{by } .001 = 25,000$ ohms for the other resistor). In the circuit shown separate binding posts are used for each range. If you want to build an old type voltmeter you will find old meter movements at almost every Amateur Radio "Hamfest" flea market. I've found several and the price is usually right. You can purchase nice old meters for prices ranging from 50 cents to \$5.00.

Carrier Current Radio. I recently received a letter from George Hausske of Wheaton, Illinois that included a story about "Carrier Current Radio." Carrier Current Radio while unfamiliar to many, has been in commercial use since 1928. The equipment is very simple, a modulated oscillator on a frequency of 70kHz is sufficient for transmitting while a power detector is often adequate for voice signals and telemetering.

"Public Utilities and electric generating systems are now the largest users of this equipment. Their transmission lines lend themselves to use as one conductor of the signal with ground used as the return conductor. The transmitter power is coupled through capacitors to isolate the transmitter from the high voltage on the power lines. Low frequencies such as 70 kHz tend to follow the wires and are not radiated into space as are the higher frequencies. Large wave traps

(Continued on page 93)

e/e checks out the...

CIRCLE 79 ON READER SERVICE COUPON



five-band scanner **BEARCAT** **250**

This computerized scanner keeps track of radio traffic without jamming your brains circuits

□ A SCANNER THAT THINKS FOR ITSELF is about the best way to describe the Bearcat 250 Five Band Scanning Receiver. No longer need the user know the precise frequency of a station or service: the Bearcat will discover the station's frequency. No longer need you wonder which is the most "popular" police, fire or public service frequency: the Bearcat will keep a running total of transmissions on each channel. And if all this isn't enough, the Bearcat can also scan a range of frequencies and electronically log each frequency used without stopping for the transmissions, individually program a delay or lockout for any channel, and even program automatic recorder control for specific channels. For example, if you are interested in recording only the activity on say, channel 14, you can program the receiver so a recorder starts only when a channel 14 signal is received, no other frequencies will be recorded. If you are interested in recording what's happening on multiple channels, say Nos. 1, 3, 5, 18, and 22, you can likewise program the recorder to start only when signals are received on any of these.

How is all this "magic" accomplished? Through use of an on-board microprocessor (microcomputer) that provides even more heretofore unimagined performance. But before we get too far ahead of ourselves, let's go back to the beginning and take a look at the big picture.

The Bearcat 250 is housed in a cabinet measuring 10¾-in. wide by 3½-in. high by 8-in. deep. It will operate off 120 VAC or 13.8 VDC. Though it covers five bands—32-50 MHz, 146-148 MHz, 148-174 MHz, 420-470 MHz, and 470.0125-512.0125 MHz, the tuner sections are so arranged that a single antenna input can be used. Provision is made for an external an-

tenna through a "Motorola" jack, or a supplied telescopic whip that protrudes through the top of the cabinet. The whip can be unscrewed when not needed. As with the antenna jack, the whip antenna serves for reception on all bands.

All functions and frequencies are entered through a keyboard having thirty pushbuttons. An eleven character L.E.D. display indicates frequency, time, and all programmed functions.

Heading the list of functions is a

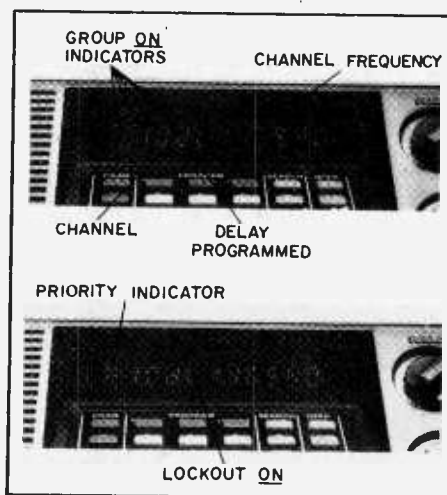

A typical display. Numerals 10 indicate channel 10 is being monitored. "D" indicates the 2-second delay has been programmed for the channel, meaning the scan will hold for at least 2 seconds after the station goes off before scanning is resumed. "L" means the channel has been temporarily locked out of the scanning: it can be selected manually, but not by scanning. Finally, the frequency readout is 146.450 MHz. The five dots at the upper left, directly over and to the right of the "10" indicate all five channel groups are switched on. A "P" showing before the "10" would indicate the priority has been switched on. During scan channel 1 will be scanned every 2 seconds.

digital time clock indicating hours, minutes, and seconds that is always on even with the receiver turned off, or if the display is used to indicate frequency. Under any operating condition, the time is displayed when the time pushbutton is depressed. Pressing the button a second time turns off the time display and restores whatever was indicated prior to the clock display being turned on.

50 Channels. Next, is a 50 channel memory arranged in five switch selected groups of 10 channels each. Any group or combination of groups can be selected for scanning. The selected groups are indicated by small "dots" at the top left of the L.E.D. display. Even with the power switch off the on-board computer remembers the last group selection, and will resume scanning the selected groups as soon as power is turned on. The programming is such that you cannot turn off all groups. Attempting to place all groups on standby automatically activates the channel 1 through 10 group. The 1-10 group can only be turned off (placed on standby) if another group(s) is selected.

In addition to the 50 scan channels, the Bearcat 250 has a separate memory for 64 frequencies. These 64 frequencies are stored independent of the 50 channel programming. If desired, any of the 64 frequencies can be entered as channel programming.

To "discover" unknown services or frequencies the receiver can be programmed to search any frequency range within a single band. The search can be programmed to stop each time a station is detected so the user can listen to the signal to see if it's a worthwhile service to store in a main channel memory. Or, the scan can be used just to locate frequencies; instead of stopping on the station until the transmis-

e/e BEARCAT 250

sion is over, the search stores the "working" frequency in the 64 channel memory. The user can then step through the memory one frequency at a time to determine which frequencies were active, or can step and hold in order to monitor the signal. Again, any desired stored frequency can be entered into one of the 50 scan channels.

At the touch of a button marked *priority*, channel 1 can be programmed as a priority channel so that regardless of the channel groups programmed for scanning, the receiver will scan channel 1 for activity every two seconds. Any frequency within the five bands can be programmed into channel 1. With the *priority* switch off, channel 1 functions as any other channel.

If you're not certain which frequencies are the "hot" ones in your area, you can get a count on the number of transmissions by simply pressing a button marked *count*. The indicated frequency on the display turns off and the number of transmissions on that particular channel is indicated. Each channel's counter can be individually erased so it starts from zero whenever desired. Other channel counters are not affected by a counter erase. Pressing *count* a second time restores the frequency indication and the counter works "unseen."

The signal on any channel can be used to control an associated recorder (or other device) through the *aux* function. Pressing the *aux* and E (for *enter*) buttons programs any channel for remote control through a closed circuit providing up to 500 mA. As soon as a signal breaks the squelch the *aux* control circuit is closed. It is normally capable of handling the remote start circuit of a portable cassette recorder. For a higher power control device, an intermediate relay or transistor switch must be used. The *aux* function is indicated by a small dot in the lower right of the L.E.D. display.

Goodby Birdies. One of the problems with some digitally synthesized scanners in the past has been "birdies", unwanted signals generated by the scanner's internal oscillators. The *search* mode often picked up some of these unwanted signals and locked the scanning onto the birdie, because as far as the receiver is concerned the birdie is a legitimate unmodulated carrier. In the Bearcat 250, however, the user programs the birdies out first by disconnecting the antenna and making one search pass, storing the birdie fre-

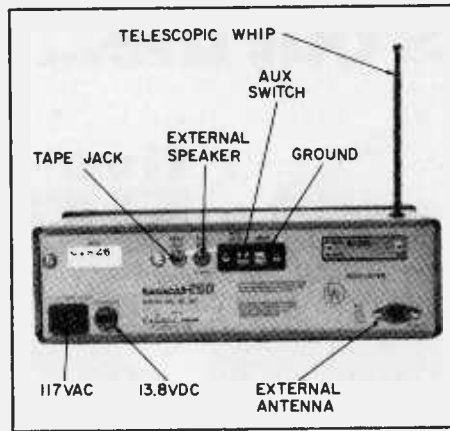

All connections are through rear apron connectors. The power source is automatic: simply plug in the AC or DC power cord. The aux switch terminals can be used to start a recorder and are specifically programmed for one or more channels as required by the user.

quencies in the store memory. Then the antenna is connected and the search resumed. Now the search literally skips over the birdie frequencies and the only signals that will be "locked up" during the search will be legitimate signals. Of course, the birdie frequencies are entered in the 64 channel store memory, and by stepping through the memory the user can get a "listing" of both the birdie and signal frequencies.

You get the listing by pressing a *recall* button; each press steps the tuning and display to the next frequency in store memory. To let you know you have run through all the frequencies discovered through the last search run, the display will blank after the last searched frequency, and then repeat ("playback") from the lowest frequency.

The Hardware. The front panel has only two controls: one for volume/power switch; the other for squelch. Somewhat unusual, the squelch control has a detented, switch position at full CCW labeled *auto*, meaning automatic squelch. It's a factory set squelch level that appears to be "just about right."

The rear apron has sockets for the AC linecord, a DC power cord, the antenna jack, a remote speaker, and a line level output for a recorder. Screw type binding terminals are used for the *aux* control.

A gimbal bracket such as supplied with mobile CB transceivers is provided for mounting the Bearcat 250 in a vehicle. Plugs in the side of the cabinet normally conceal the threaded eyelets for the mobile bracket's screws.

Summing Up. The Bearcat 250, priced at \$399.95 complete with AC and DC power cords, mobile bracket, and telescopic antenna is one heck of a scanner. Overall performance is just about typical for high performance scanners such as previous Bearcats. The thing that makes the 250 stand head and shoulders above other scanners is the on-board computer. Fact is, it does so much that it takes a thorough read-thru of the manual before you can even start to get maximum utilization of the special computer features. Best bet is to stop into a local Bearcat dealer and get a hands-on demonstration. (Make certain you get a salesperson who really knows the 250 inside and out or you're likely to miss one or more of the outstanding features in a store demo.)

For more information on the Bearcat 250, circle No. 79 on the reader's service coupon.

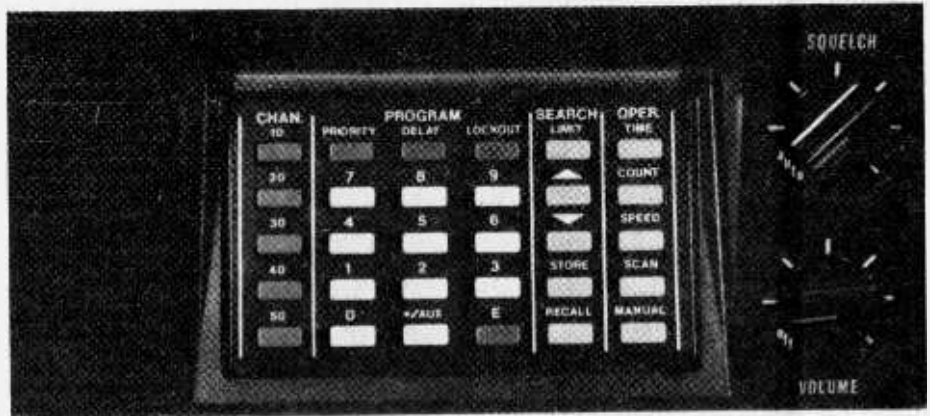

Thirty pushbutton keys control all functions and the frequency selection. The five keys in the left vertical row select channels in groups of 10: 1-10, 11-20, 21-30, etc. The receiver scans only the groups "punched up." Individual channels in each group can be "locked out" by pressing the lockout key. The group scanning can be in any order: for example, if the 10 and 40 keys are depressed the receiver will scan channels 1 through 10 and 31 through 40. An individual channel is manually selected by simply pressing the key corresponding to the channel number and then the manual key. Direct selection of channel 15 would be selected by pressing keys: 1, 5, and manual.

CB XCVR CHECKOUT

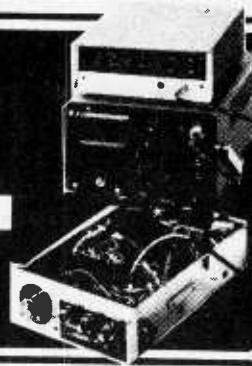

- COBRA 142 GTL
- MOTOROLA ELECTROSCAN CR-520
- PRESIDENT VEEP
- REALISTIC TRC-470

ELEMENTARY ELECTRONICS has been able to obtain some of the latest 40-channel CB transceivers for review, and presents the test reports here. These units are not prototypes, but are "stock standard," the same as the transceivers that you can buy over the counter. If you don't find the particular unit you are interested in reported on here, check for the 1979 edition of CB YEARBOOK, soon to be on the newsstands.

• COBRA 142 GTL

\$379.95 (Dynascan Corp.)

General Description: A 40-channel AM/SSB transceiver for mobile, P.A., base operation. Fine tuning ± 1 kHz is provided. Power supply is 12 to 13.8 VDC with negative or positive ground and 120 VAC. Overall dimensions are 5-in. H x 13½-in. W x 13-in. D. There are front panel controls for: channel selection, volume, squelch, Dynamike, RF gain, SWR CAL, and Voice Lock (fine tune). Switches for: CB/PA, noise blanker/ANL, and Modulation/SWR meter mode. Standard accessories include a microphone, DC power cable, A.C. power cord.

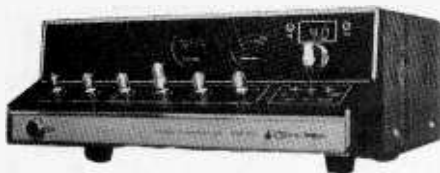

CIRCLE 85 ON READER SERVICE COUPON

Receiver Section Test:

Input sensitivity 0.5 μ V
 Adjacent channel rejection 69 dB
 AGC action 16 dB
 SSB opposite sideband rejection 40+ dB
 Input level for S9 meter indication 15 μ V

Transmitter Section Test:

AM RF output 3.8 watts
 SSB RF output 12 watts P.E.P.

Modulation to 85% yes
 Relative sensitivity for 85% mod. off to -45 dB
 Modulation limited to 100% yes

Editorial Remarks: The 142 GTL has a relative reading S-meter, jacks for P.A. and remote speakers, L.E.D. digital channel indicator, S/RF-output meter, and Modulation/SWR meter. ■

• MOTOROLA ELECTROSCAN CR-520

\$159.95 (Motorola Inc.)

General Description: A 40-channel AM remote transceiver for mobile, operation. Power supply is 12 to 13.8



CIRCLE 97 ON READER SERVICE COUPON

VDC with negative ground. Main transceiver package mounts behind dash, under seat, or in trunk. All controls on microphone. There are microphone controls and switches for: channel selection, volume, squelch, local/distance sensitivity, and power on/instant channel 9 selection. Standard accessories include a microphone, DC power cable, installation kit. No internal speaker. Requires optional external speaker.

Receiver Section Test:

Input sensitivity 0.4 μ V
 Adjacent channel rejection 50 dB
 AGC action 4 dB

Transmitter Section Test:

AM RF output 3.2 watts
 Modulation to 85% yes

Relative sensitivity for 85% mod. -29 dB
 Modulation limited to 100% yes

Editorial Remarks: The CR-520 has double conversion, jack for remote speaker, L.E.D. digital channel display on microphone, and "memory," which remembers the channel last used or tunes channel 9 when the transceiver is turned on. ■

• PRESIDENT VEEP

\$99.95 (President Electronics Inc.)

General Description: A 40-channel AM transceiver for mobile and P.A. operation. Power supply is 12 to 13.8 VDC with negative or positive ground. Overall dimensions are 1-9/16-in. H x 5-7/16-in. W x 7-15/16-in. D. There are front panel controls for: channel selection, volume, squelch. Switches for: PA on-off, ANL. Standard accessories include a microphone, mobile mount, DC power cable.

Receiver Section Test:

Input sensitivity 0.4 μ V
 Adjacent channel rejection 69 dB
 AGC action 13 dB
 Input level for S9 meter indication 150 μ V

CIRCLE 104 ON READER SERVICE COUPON



Transmitter Section Test:

AM RF output 4.0 watts
 Modulation to 85% yes
 Relative sensitivity for 85% mod. -21 dB
 Modulation limited to 100% no

Editorial Remarks: The Veep has a relative reading S-meter, double conversion, jacks for P.A. and remote

e/e CB XCVR CHECKOUT

speakers, L.E.D. diigital channel indicator, S/RF-output meter.

- **REALISTIC TRC-470**
\$229.95 (Radio Shack)

General Description: An in dash 40-channel AM/FM stereo radio and 40-channel AM, transceiver for mobile operation. Power supply is 12 to 13.8 VDC with negative ground. There are front panel controls for: channel selection, volume, squelch, balance, tone, and AM/FM tuning. Switches for: AM/FM/CB, mono FM, noise blanker/ANL, and CB Monitor (while listening to radio). Standard accessories include a microphone, DC power cable, stereo speaker cables and universal mounting kit.



CIRCLE 32 ON READER SERVICE COUPON

Receiver Section Test:

Input sensitivity 0.5 μ V
Adjacent channel rejection 70 dB
AGC action 10 dB

Transmitter Section Test:

AM RF output 3.6 watts
Modulation to 85% yes
Relative sensitivity for 85% mod. -28 dB
Modulation limited to 100% yes

Editorial Remarks: The TRC-470 has plug in speaker/power wires and CB monitoring while listening to AM/FM, and an L.E.D. digital channel indicator.

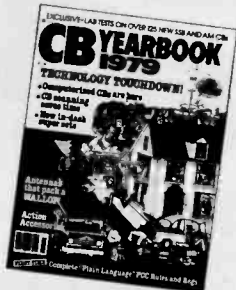

• CB INFORMATION CENTER

CB YEARBOOK 1979 is jam packed with CB transceiver test reports and just about anything else a CBer could want to know. Pick one up at your local newsstand.

e/e checks out...



CIRCLE 86 ON READER SERVICE COUPON

EMERGENCY MULTICORE SOLDER



Make quick clean solder joints with a flick of your BIC

HOW MANY TIMES have you made an electrical repair with twisted wire connections and tape when you knew, deep down in your heart, that you should have used solder. Sure, you know the correct way to fix things—first clean off the parts, tin the parts and apply heat and solder. That's not so hard. What is hard is going down to the basement when you're making one lousy repair in the attic, or connecting a mile after mile of extension cord so you can climb on the roof to solder an antenna wire, or an important wire on your car lets go when you're in the middle of nowhere—that is what's hard about soldering.

When you were young and didn't know better you probably tried the old "match and solder trick" and learned all the fine points of why it didn't work. So like the rest of us you make a lot of twisted wire and tape repairs and justify your actions by calling it "field expediency."

Fire Up. Now, thanks to Multicore Solder, a British Industries Company (B.I.C.), there is a new type of solder that will make the old "match and solder trick" work like a charm. Emergency Multicore Solder is designed to do everything normal solder does but with only the heat of a match, candle or a lighter needed to melt it. Emergency Multicore Solder comes in tape form. You wrap a short length around the splice and heat it with a match—until it melts and solders the joint. One match is usually all you need.

Another nice thing about being in tape form is that you can keep a foot or two of it folded up in a credit card

slot in your wallet. Great for those unexpected emergencies.

Don't worry about bad joints, the stuff works great. In some situations it is a real temptation to use this even when the regular solder is easily available, and there is absolutely no reason why you shouldn't. One of the ELEMENTARY ELECTRONICS editors used it to repair a long heavy dipole ham radio antenna—he says the antenna works better than ever.

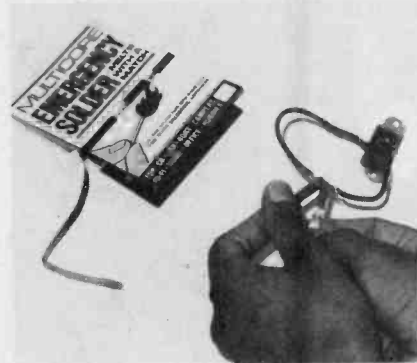

To use Emergency Multicore Solder just strip and clean the wires and then twist the wires together for a good physical connection. Next wrap a short length of the solder around the joint about two or three times. Heat the connection with a match or, better yet, a butane gas lighter.

Emergency Multicore Solder comes in packets with 36 inches of solder for 89 cents. Your best bet is to pick up a packet now before you regret not having bought it. For more information circle number 86 on the reader service coupon.

E/E BASIC COURSE IN ELECTRICITY & ELECTRONICS



E/E takes a look at one of the simplest and yet most useful electronic devices in the hobbyist's inventory—the transformer. In these days of hyper-fast electronic evolution the transformer has remained basically unchanged for the past fifty years and we will probably be still using them fifty years from now. Understanding how they work is easy if you just read through this Basic Course.

This series is based on material appearing in Vol. 2 of the 5-volume set, BASIC ELECTRICITY/ELECTRONICS published by Howard W. Sams & Co., Inc. @ \$25.50. For information on the complete set, write the publisher at 4300 West 62nd St., Indianapolis, Ind. 36268.

UNDERSTANDING TRANSFORMERS

What You Will Learn. To understand how two common electrical devices work. You will learn how a transformer transfers power from one winding to another. You will learn how to calculate the change in voltage, current, and impedance produced by a transformer with a known turns ratio, and how to select the proper turns ratio to produce a particular change. You will also learn how a magnetic amplifier controls a large AC current with a smaller DC current.

WHAT IS A TRANSFORMER?

A **transformer** is a device for changing the voltage of AC electricity. Transformers work on the principle of induction. Basically, a transformer has two windings—a primary and a secondary—wound on the same core. This core can be laminated iron, ferrite, or air.

Through the principle of **induction**, the alternating current flowing through the primary winding sets up an alternating magnetic field in the core. This magnetic field, in turn, **induces** an alternating voltage in the secondary winding (or windings). In this way, **energy is transferred** from the primary to the secondary.

A transformer that reduces the voltage in a circuit is called a **step-down** transformer. This is true, for example, of a radio-receiver filament transformer, which steps the 117-volt main supply down to 6.3 volts.

A transformer that is used to increase the voltage in the circuit is known as a **step-up** transformer. An example is the high-voltage transformer which produces the several thousand volts needed to operate a television picture tube.

The basic transformer has two windings—primary and secondary—wound on a laminated-iron core. The two windings are insulated from each other and from the core.

The primary winding is connected to the energy source, and the secondary winding is connected to the load. As alternating current flows through the primary, a pulsating magnetic field is set up in the core. As the constantly changing magnetic field cuts the turns of the secondary, a voltage is induced in the secondary winding.

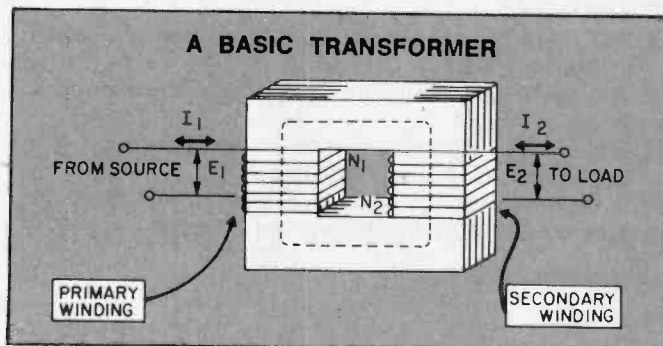

The amount of voltage induced in the secondary winding depends on how many turns of wire the secondary contains compared to the number of turns of wire in the primary winding. So, if the secondary has only half as many turns as the primary winding, the voltage will be stepped down to half its original value. If the secondary has twice as many turns as the primary, the voltage will be stepped up to twice its original value.

The difference in the number of turns is known as the **turns ratio** of the transformer. If the primary winding has N_1 turns and its voltage is E_1 , the secondary winding with N_2 turns produces voltage E_2 .

$$\frac{E_1}{E_2} = \frac{N_1}{N_2}$$

The power consumed in the secondary circuit of a transformer must be supplied by the primary. Since the voltages are constant in each circuit, the current in the primary circuit must vary to supply the amount of power demanded by the secondary. Current in the primary depends on the current drawn in the secondary circuit.

A TRANSFORMER WITH NO LOAD ACTS LIKE AN INDUCTOR





QUESTIONS

1. If a transformer primary has 1,000 turns and the secondary has 6,500 turns, what is the turns ratio?
2. If 85 volts is applied to the primary winding of the transformer in Question 1, what is the voltage at the secondary?
3. What would happen if the leads were reversed and 85 volts was applied to the 6,500-turn coil?
4. What happens if 130 volts is fed into the 6,500-turn winding of the transformer?
5. Can a transformer be used with DC? Why?
6. What will be the phase relationship between the voltage across the primary of a transformer and the voltage across the secondary, assuming the coils are wound in the same direction?
7. If there is no load between the terminals of the secondary of a transformer, will current flow in the secondary?
8. Will there be a magnetic field produced by current in the secondary?
9. Will there be a magnetic field produced by current in the primary?
10. What effect will this magnetic field have on the impedance of the primary circuit?
11. If the magnetic field were weaker, would more or less current flow in the primary circuit?

ANSWERS

1.

$$\frac{N_1}{N_2} = \frac{1,000}{6,500} = 1 \text{ to } 6.5$$

2.

$$\frac{E_1}{E_2} = \frac{1}{6.5}$$

$$E_2 = E_1 \times 6.5 = 85 \times 6.5 = 552.5 \text{ volts}$$

3. If you reverse the leads, the turns ratio is:

$$\frac{N_1}{N_2} = \frac{6,500}{1,000} = \frac{E_2}{E_1}$$

The output would be:

$$E_2 = \frac{1,000 \times 85}{6,500} = 85 \times 0.153$$

= 13 volts (approx.)

4. The voltage appearing at the 1,000-turn winding will be

$$\frac{1,000}{6,500} \times 130 = 20 \text{ volts.}$$

5. A transformer cannot be used with direct current. A direct current in the primary does not produce a pulsating magnetic field.

6. The voltage across the secondary will be 180° out of phase with the voltage across the primary.

7. No current will flow.

8. If no current flows, no magnetic field will be produced by the secondary.

9. Yes.

10. The stronger the magnetic field, the greater will be

the impedance of the primary circuit.

11. More current would flow in the primary.

TRANSFORMER POWER

If the transformer was 100% efficient, all the power from the primary winding would be transferred to the secondary and delivered to the load.

Suppose a transformer has 1,000 turns in the primary and 6,500 turns in the secondary. If 100 volts is applied to the primary, 650 volts will appear at the secondary. Now suppose the load connected to the secondary is a 65-ohm resistor. It will draw a current of $\frac{650}{65}$

10 amperes, and the power consumed will be 650×10 , or 6,500 watts. This power must be supplied by the primary winding. Assuming no loss in the transformer, the primary winding must supply 6,500 watts. The primary current, therefore, will be $\frac{6,500 \text{ watts}}{100} = 65$ amperes.

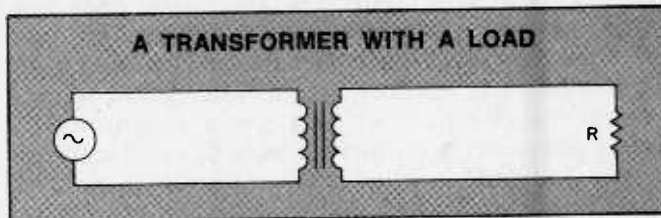

In the example above, the current was stepped down in exactly the same proportion as the voltage was stepped up. The power transferred from the primary to the secondary does not change, however, regardless of the turns ratio. This is true providing the rating of the transformer has not been exceeded and assuming 100% efficiency.

QUESTIONS

12. What happens to current in the secondary of a transformer when a load is connected across its terminals?
13. Will a magnetic field be produced by the current in the secondary?
14. Will the magnetic field add to or oppose the magnetic field produced by the primary? (Remember the coils are wound in the same direction but the currents are in opposite directions.)
15. How will the magnetic field produced by current flow in the secondary affect the current drawn by the primary?
16. What will happen if the load resistance in the circuit above is increased to 6,500 ohms?

ANSWERS

12. There will be a current in the secondary when a load is connected across its terminals.

13. A magnetic field will be produced by a current in the secondary.

14. The secondary magnetic field will oppose that of the primary.

15. The secondary magnetic field will decrease the total magnetic field acting on the primary and, therefore will decrease the impedance of the primary circuit. The primary will draw more current.

16. Current in the secondary will be

$$\frac{650 \text{ volts}}{6,500 \text{ ohms}} = 0.1 \text{ ampere.}$$

Power dissipated in the secondary will be $0.1 \text{ ampere} \times 650 \text{ volts} = 65 \text{ watts}$. Therefore, power drawn in the primary must be 65 watts. The current in the primary will then be

$$\frac{65 \text{ watts}}{100 \text{ volts}} = 0.65 \text{ ampere.}$$

TRANSFORMER EFFICIENCY

So far we have assumed that no power is lost in the transfer from the primary winding to the secondary winding. However, no transformer has absolutely 100% efficiency. Some power is lost in heating the core, and some is lost in the resistance of the windings. But, transformers are very efficient; their efficiency often reaches very nearly 100%. Therefore, for rough calculations, it is permissible to assume 100% efficiency.

As with any other device, the efficiency of a transformer is equal to:

$$\frac{\text{output power}}{\text{input power}}$$

Most transformers have an efficiency in the range of 97 to 99%. So, even if you neglect the losses, your calculations using 100% as the transformer efficiency will still be accurate within 1 to 3%.

TRANSFORMER LOSSES

The power loss in transformers is due to three factors. The first is simply **resistance** in the windings; no winding is a perfect conductor.

The second factor that causes power loss in transformers is **eddy currents**. The iron in the core of a transformer is a conductor. When the changing magnetic field produced by the primary coil cuts through the iron of the core, small currents are generated in the core material. These currents dissipate power as they pass through the resistance of the iron. These currents are called **eddy currents**. This type of loss is held to a minimum by using thin sheets of iron, called **laminations**, in the core. These thin sheets are insulated from each other (often by oxidizing the surface of the sheets) and thus shorten the conducting path for the eddy currents.

The third factor that causes power loss in transformers is **hysteresis**. It takes a certain small amount of power to magnetize a piece of iron. This power must be expended again when the magnetic field is reversed. Since the magnetic field in a transformer is reversed many times each second, these tiny expenditures of power add up to a noticeable loss. Hysteresis loss can be reduced by constructing the core with a type of iron that is very easily magnetized and demagnetized.

QUESTIONS

17. If a transformer supplies 1.9 amperes at 100 volts to a resistive load in the secondary circuit, and if it dissipates 200 watts of power in the primary circuit, what is the efficiency of the transformer?
18. This transformer has a relatively (high, low) efficiency.

ciency.

19. If the secondary of a transformer supplies 0.99 watt at 1,000 volts and the transformer has an efficiency of 99%, what power will the primary draw at 120 volts?
20. How could you find the amount of power lost due to resistance in a transformer?
21. Does an air-core transformer have hysteresis or eddy currents?

ANSWERS

17. The power dissipated in the secondary will be $1.9 \times 100 = 190 \text{ watts}$. The efficiency of the transformer will be $190/200 = 95\%$.
18. It has a relatively **low** efficiency. (An efficiency below approximately 97% is considered to be low)
- A19. The voltages have no effect on the problem. The efficiency of the transformer is equal to output power divided by input power.

$$\frac{0.99}{?} = 99\%$$

The input power must be **1 watt**.

20. You would have to **measure the resistance** of both windings and then calculate the **power dissipated** due to the current in the windings.
21. An air-core transformer has neither **eddy-current** nor **hysteresis losses**.

TYPES OF TRANSFORMERS

There are many varieties of transformers, ranging from huge power-station units to tiny subminiature radio-frequency types.

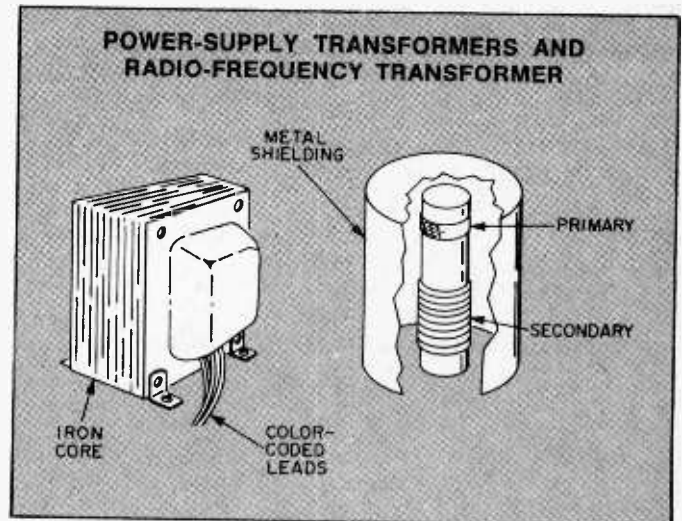

Most transformers are designed to transfer power. Others, however, are built to transfer only signal voltages.

Power distribution transformers are rated in KVA (kilovolt-amperes) rather than in kilowatts or other power units. The KVA rating refers to the apparent power carried by the transformer—the real power is smaller by the load power factor.

Special transformers, wound to precision specifications, are used in metering applications to measure the current and voltage passing through large power-trans-



mission lines.

A step-up transformer increases voltage (which increases impedance) and decreases current (resulting from an increased impedance) at the same time. A step-down transformer decreases voltage (which decreases impedance) and increases current (which results from a decreased impedance) at the same time. Therefore, a transformer changes impedance, but the impedance change is more pronounced than the voltage change. In fact, a transformer changes impedance by the square of the turns ratio:

$$\frac{Z_1}{Z_2} = \frac{N_1^2}{N_2^2}$$

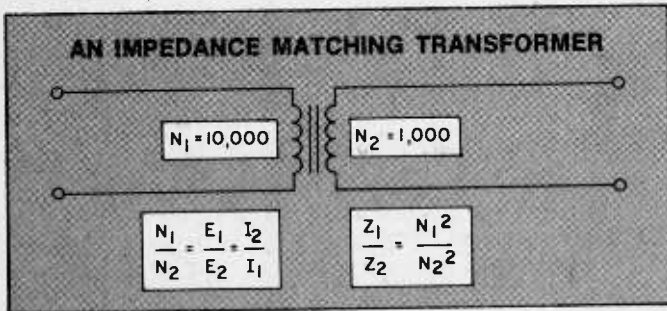

QUESTIONS

- 22. If the primary of a transformer has 10,000 turns and the secondary has 1,000 turns, what is the turns ratio?
- 23. If 100 volts is applied to the primary, what voltage will appear at the secondary?
- 24. If the load impedance of the secondary circuit is 1 ohm, how much current will flow in the primary?
- 25. What is the impedance of the primary?

ANSWERS

22.

$$\frac{10,000}{1,000} = 10 \text{ to } 1 \text{ turns ratio}$$

23.

$$\frac{N_1}{N_2} = \frac{10}{1} = \frac{100}{E_2}; E_2 = 10 \text{ volts}$$

24. Current in the secondary is $\frac{100}{1} = 10$ amperes.

$$\frac{10}{1}$$

$$\frac{N_1}{N_2} = \frac{I_2}{I_1}; \frac{10}{1} = \frac{10}{I_1}$$

$I_1 = 1$ ampere

25. The impedance of the primary circuit is:

$$\frac{E_1}{I_1} = \frac{100}{1} = 100 \text{ ohms}$$

MAGNETIC AMPLIFIERS

Magnetic amplifiers are special transformer-like devices that use a small amount of power to control larger amounts of power, thus acting as amplifiers. They are simple, rugged, and efficient as compared to

other forms of amplification.

Magnetic amplifiers take advantage of a special property of iron or steel in a strong magnetic field. To explain how a simple magnetic amplifier works, let's first review the basic principles of a coil.

When a current flows in a coil, a magnetic field (flux) is set up inside and around the coil. If the current is AC, the field also alternates. But, in any case, the strength of the magnetic field (the number of lines of flux produced) depends on the material inside the coil as well as how much current is flowing through the coil.

A very simple type of magnetic amplifier is based on the fact that an iron core normally allows greater changes in the magnetic field and, therefore, increases the inductive reactance of a coil at a given frequency.

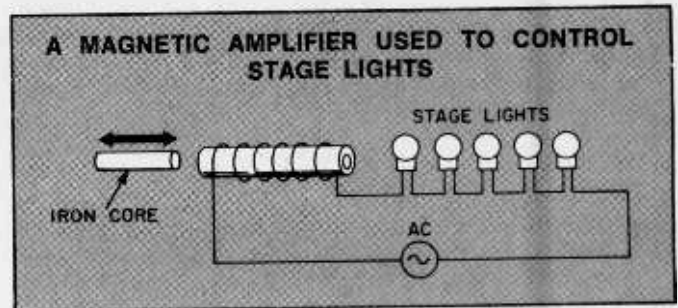

QUESTIONS

- 26. A coil with an air core has a (greater, smaller) inductance than a similar coil with an iron core.
- 27. Inductive reactance is the result of a (constant, changing) magnetic field.
- 28. How would you increase the inductive reactance of the device illustrated on the opposite page.
- 29. What effect would increasing XL have on the brightness of the lights?
- 30. How should the core be set to obtain maximum brightness of the lights?
- 31. Would this device work with a DC power supply?

ANSWERS

- 26. A coil with an air core has a smaller inductance than an iron-core coil.
- 27. Inductive reactance is the result of a changing magnetic field.
- 28. Push the iron core into the coil.
- 29. Increasing XL would dim the lights.
- 30. The iron core should be totally removed.
- 31. The device would not work with DC.

WHAT YOU HAVE LEARNED

- 1. The changing magnetic field produced by the primary winding in a transformer induces a changing voltage in the secondary winding.
- 2. The ratio of the primary voltage to the secondary voltage is the same as the ratio of the number of turns in the primary winding to the number of turns in the secondary winding.
- 3. If a transformer steps up voltage, it steps down current, and vice versa. The power drawn by the primary winding is equal to the power dissipated in the

(Continued on page 85)

An Extraordinary Offer to introduce you to the benefits of Membership in

ELECTRONICS BOOK CLUB

take any **4** of these 22 unique electronics books (values to \$65⁸⁰) for only **49¢** each

with a Trial Membership in the Book Club that guarantees to save you 25% to 75% on a wide selection of electronics books



May we send you your choice of 4 of these practical time-and-money-saving books as part of an unusual offer of a Trial Membership in Electronics Book Club?

Here are quality hardbound volumes, each especially designed to help you increase your know-how, earning power, and enjoyment of electronics. Whatever your interest in electronics, you'll find Electronics Book Club offers practical, quality books that you can put to immediate use and benefit.

This extraordinary offer is intended to prove to you through your own experience, that these very real advantages can be yours...that it is possible to keep up with the literature published in your areas of interest, and to save substantially while so doing. As part of your Trial Membership, you need purchase as few as four books during the coming 12 months. You would probably buy at least this many anyway, without the substantial savings offered through Club Membership.

To start your Membership on these attractive terms, simply fill out and mail the coupon today. You will receive the 4 books of your choice for 10-day inspection. **YOU NEED SEND NO MONEY.** If you're not delighted, return the books within 10 days and your Trial Membership will be cancelled without cost or obligation.

ELECTRONICS BOOK CLUB, Blue Ridge Summit, Pa. 17214

Facts About Club Membership

- The 4 introductory books of your choice carry publisher's retail prices of up to \$65.80. They are yours for only 49¢ each (plus postage/handling) with your Trial Membership.
- You will receive the Club News, describing the current Selection, Alternates, and other books, every 4 weeks (13x a year).
- If you want the Selection, do nothing; it will be sent to you automatically. If you do not wish to receive the Selection, or if you want to order one of the many Alternates offered, you simply give instructions on the reply form (and in the envelope) provided, and return it in us by the date specified. This date allows you at least 10 days in which to return the form. If, because of late mail delivery, you do not have 10 days to make a decision and so receive an unwanted Selection, you may return it at Club expense.
- To complete your Trial Membership, you need buy only four additional monthly Selections or Alternates during the next 12 months. You may cancel your Membership anytime after you purchase these four books.
- All books—including the Introductory Offer—are fully returnable after 10 days if you're not completely satisfied.
- All books are offered at low Member prices, plus a small postage and handling charge.
- **Continuing Bonus:** If you continue after this Trial Membership, you will earn a Dividend Certificate for every book you purchase. Three Certificates plus payment of the nominal sum of \$1.99 will entitle you to a valuable Book Dividend of your choice which you may choose from a list provided Members.

ELECTRONICS BOOK CLUB

Blue Ridge Summit, Pa. 17214

Please open my Trial Membership in **ELECTRONICS BOOK CLUB** and send me the 4 books circled below. I understand the cost of the books I have selected is only 49¢ each, plus a small shipping charge. If not delighted, I may return the books within 10 days and owe nothing, and have my Trial Membership cancelled. I agree to purchase at least four additional books during the next 12 months, after which I may cancel my membership at any time.

101 300 578 800 811 841 856 874
919 929 966 1011 1015 1019 1023
1028 1054 1055 1060 1064 1070 1088

Name _____ Phone _____

Address _____

City _____

State _____ Zip _____

(Valid for new Members only. Foreign and Canada add 10%) EE-19

CIRCLE 30 ON READER SERVICE COUPON

NEW FROM ASIMOV 2ND ISSUE



Large size—
8½" x 10½"



If you missed our sold-out first issue, we're real sorry!

Here now is the Spring '79 issue—112 pages with lots of illustrations, full of SF excitement, adventure and fun—

The cover pic is reproduced in a full-color 10" x 16" poster. It comes with every copy.

Chock-full of stories, this issue brings you, for example, "Starschool," the first collaboration by the noted SF writers and brothers, Joe and Jack Haldeman. And "Keeper-Smith," a novelette by Randall Garrett and Vicki Ann Heydron. And a short story by Isaac Asimov himself, "How It Happened"!

**ASIMOV'S SF
ADVENTURE MAGAZINE
380 Lexington Avenue
New York, NY 10017**

Enclosed is \$1.75 plus 25¢ handling/shipping (total of \$2.00) for the Spring 1979, issue #2, of ASIMOV'S SF ADVENTURE MAGAZINE.

EEJ/F-79

Name _____
(please print)
Address _____
City _____
State _____ Zip _____

Basically Fun

(Continued from page 55)

gestions while others contain just listings.

What To Do After You Hit Return published by People's Computer Company, P.O. Box E Menlo Park, California 94025, is the book we drew our sample program and flowchart from. It's a large, oversize volume which retails for \$8.00 and contains the listings for forty-eight games along with sample runs and hints as to playing strategies. About twenty-five or more of the games will run in a system with 4K free RAM.

What To Do's table of contents divides the game programs into ten different categories—everything from number guessing games to truly sophisticated science-fiction programs requiring more than 20K of memory.

This is a book which has become a classic in a new field, and most computer stores stock it. When it was originally published, a great many hobbyists were time-share users. If you own a microcomputer, you may have to change things around to fit your Basic and some of the programs will likely be too lengthy to load without cutting modifications.

Creative Computing Magazine has just released *Basic Computer Games—Microcomputer Edition* by David H. Ahl (Creative Computing Press, P.O. Box 789-M, Morristown, N.J. 07960, \$8.50). The book enjoyed a previous incarnation under the title *101 Basic Computer Games*. Originally, the programs were written in different dialects of Basic and the print quality of the listings was—to put it very mildly—rough on the eyeballs.

The games (102 this time!) are almost all capable of being run in 4K if you don't mind cutting off the instructions and REMs. This is a veritable potpourri of computer programs. Each game is listed and a sample run given.

PUBLISHER'S ADDRESSES

John Wiley and Sons, Inc., 605 Third Ave., New York, N.Y. 10016

People's Computer Company, P.O. Box E, Menlo Park, Calif. 94025

Creative Computing Press, P.O. Box 789-M, Morristown, N.J. 07960

Engel Enterprises, Box 16612-I, Tampa, Florida 33687

Hayden Book Company, 50 Essex St., Rochelle Park, N.J. 07662

This new edition is truly an improved model. The games have all been debugged and—most importantly—rewritten all in the same language, the Altair version of 8K Basic from MITS. This is a Basic which calls for very little, if any, conversion to run on almost every personal computer. Even better, the listings are now ultra-clear and easy to read.

Take heart, there are a new series of publications just arrived, authored by Dr. C. William Engel, which can be run in 4K with a Tiny Basic such as Radio Shack's Level One. While the volumes are thin, they are among the best in the field as far as quality of the games.

Stimulating Simulations from Engel Enterprises, Box 16612-I, Tampa, Florida 33687 is little short of invaluable to the computer gamer. Though it contains but ten programs for \$5.00, this little book is full of exciting extras. For one thing, every program is completely flowcharted. If you are learning Basic and just getting into programming, the education you can get from these programs is worth the price. Further, each program has a list of suggested modifications and hints on how to achieve them. The games are lively, unique, and can be played over and over again without being boring.

The Devil's Dungeon, also from Engel Enterprises retails for \$3.50. It contains a very exciting program which is a switch on the usual computer-labyrinth style of "cave" game. You are placed in a many-tiered underground cavern. There are levels and levels of caves below you and each level is different and more challenging than the last. There may be gold and treasure in a room—along with evil creatures, demons and poison gas. How well you do is based on your strategy, your experience, your strength and other variables. It's an adventure that can easily consume an afternoon.

A good overview of this field is offered in the book *Game Playing With Basic* by Donald Spencer (Hayden Book Company, 50 Essex St., Rochelle Park, N.J. 07662, \$6.95). This book delves into the nuts and bolts of programming using games as teaching devices.

There is extensive treatment of flowcharting, as well as general hints and maxims concerning programming. There are many game programs scattered in the pages, but this book is less concerned with presenting programs than teaching programming.

The last chapter of the book is entitled "Games For Reader Solution." The rules for twenty-six games of skill and chance are explained, and then it is up to the reader to sit down, use what he or she has learned, and actu-

ally program the game(s) for the computer. Some are fairly easy to do, but many of them are dyed in the wool

stinkers! There are no solutions given, so it's like a final exam in computer gaming.

Why not get in on all the excitement? Learn to speak Basic, it's the language of fun all over the world! ■

Basic Course

(Continued from page 82)

- secondary circuit of an ideal transformer.
- Most transformers have an efficiency of nearly 100%, so very little power is lost in them.
 - Transformers alter the impedance of a load. The

change in impedance depends on the square of the turns ratio.

- Magnetic amplifiers control the inductive reactance of a coil by altering the magnetic property of its core.
- A very simple magnetic amplifier is basically a coil with a removable iron core. When the core is inserted, XL increases, and the power supplied to the load decreases. ■

Mini Reg

(Continued from page 45)

another five volt supply, split the circuit supply lines and protect those devices you cannot spare with the Mini-Reg.

Almost any circuit operating off three volts can safely operate at 3.4 volts. The output voltage can be further reduced by connecting a low-voltage zener diode in series with the plus lead to the load and monitoring the load voltage with a voltmeter. In this case, load voltage regulation now depends on zener diode characteristics.

When recharging batteries with the Mini-Reg, connect a silicon rectifier diode in series with the plus lead going to the battery. This eliminates "back-leak" when the supply is turned off with battery yet connected. Observe battery polarity when making connections. Circuits using op-amps usually require a dual or split supply. To provide a dual six-volt supply, set the output voltage to fifteen volts, set S3 to 100 milliamperes, and connect two six-volt zener diodes in series across the output terminals. Then, connect a 100 uF 25V electrolytic capacitor across each zener diode.

The Mini-Reg handily checks and sorts zener diodes of fifteen volts or less. Set R11 for fifteen volts output and set S3 to ten milliamperes. Connect the diode across the output terminals with plus lead wire to BP1. Observe zener diode voltage on M1. Advance S3 to high currents but do not exceed rated current of the diode. The better the quality of the diode, the less increase in voltage observed on M1.

When you operate radio or audio equipment from the Mini-Reg, set S3 to a current level which supplies peak currents on audio peaks. Otherwise, you will notice audio distortion on audio peaks. With some radio and audio equipment, operations off an AC adaptor or the Mini-Reg may introduce an AC hum. Reversing the AC plug usually remedies the problem. If not, connect a ground wire to either the plus or minus terminal of the Mini-Reg,

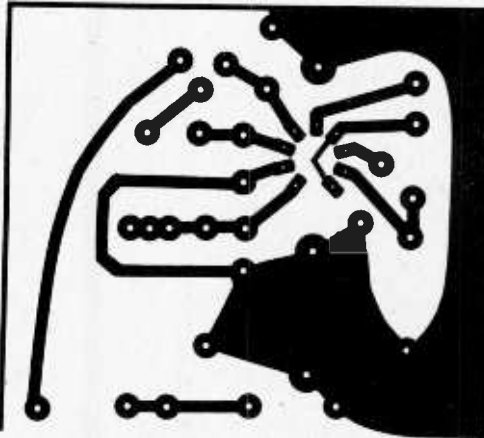

This is an exact-scale printed circuit board pattern showing the foil side of the board. This side contrary to normal, is, where the components are to be mounted. Only the jumper and the IC chip are mounted on the other side. Be careful to keep the foil-side component bodies off the metal surface to avoid shorts. Be especially careful with resistors R4 and R5 and capacitor C3.

whichever proves most effective. In addition to its use as a universal AC adaptor; the Mini-Reg serves as an excellent power supply when servicing

battery operated transistorized equipment. You'll wonder how you ever solved your power supply problems before you discovered Mini-Reg! ■

Have you outgrown your music system too?

A lot's happened in high fidelity since you bought your first music system. So if you're thinking of replacing or upgrading your golden oldie with a new music system, let the Institute of High Fidelity help you.

We've completely revised, updated and expanded our popular "Official Guide to High Fidelity." This abundantly illustrated 207-page guide gives you a step-by-step approach to help you select the latest and best hi-fi component system for your home. Use the coupon and send \$5.50* per copy to cover cost, postage and handling.



INSTITUTE OF HIGH FIDELITY, INC.

489 Fifth Ave., New York, N.Y. 10017

Please send _____ copies of the new "Official Guide to High Fidelity." Enclosed is \$5.50* per copy, postage paid.

Name _____

Address _____

City/State _____ Zip _____

*N.Y. state residents add appropriate tax.

Stop Static

(Continued from page 69)

What can be done? First, current spikes from digital logic may be reduced by bypassing ICs with .1-mfd. ceramic capacitors. These capacitors are applied as closely as possible to the power pins of the various IC packages. Another scheme that is successful at frequencies below 1 MHz is the use of a parallel power distribution system, as shown in Figure 6. Since I_1 and I_2 cannot flow in R or L, they produce no troublesome noise. In order for this system to work well, however, the power supply must have a low impedance and be connected to points A and B via very short wires.

Now, in most instances, you don't need to worry about how to distribute power in a project; all the interconnections are established on the author's PC board, and you just copy that layout. This eliminates a lot of trial and error, and makes your life that much simpler in the process. Using a PC board, and following the construction practices that we've discussed here, you should be able to turn out a perfect project every time. ■

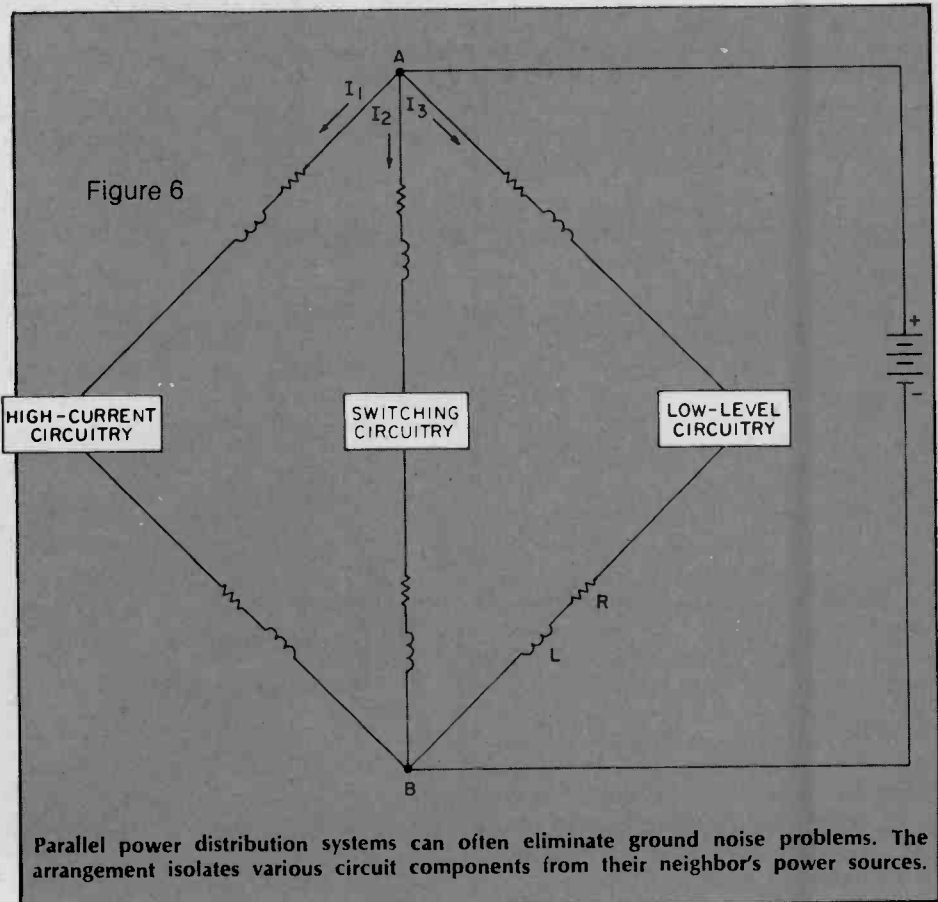

Antiques Restored

(Continued from page 42)

shops in larger cities carry this wire in stock for use in rewiring antique table or floor lamps, otherwise use a brown plastic linecord unless the radio cabinet is white in which case a white line cord looks best.

Next check all the tubes if you have access to a tube checker; otherwise check the filaments with an ohmmeter. Wash them carefully and put them back into the proper sockets. Connect a 100-watt lamp in series with the radio and wall outlet, (see circuit) and plug in the radio. Why do I recommend this step? Simply because the set may have a short in it, if so the lamp will burn brightly and you will not burn up a power transformer or other part. If the light bulb does burn brightly pull the rectifier tube, if the set has a power transformer, and if the lamp doesn't dim the transformer is probably shorted or a filter capacitor is shorted. If the light bulb burns dimly then you can plug the radio line cord directly into the wall outlet.

Filter Caps. Listen for hum in the speaker, a barely audible hum is good, a loud hum like a buzz saw is bad, if you have a loud hum, replace the filter capacitors. They will either be in a round aluminum or cardboard tube about 1 inch in diameter and 3 inches

long with a red, blue, and black wire coming out the end, mounted under the chassis; or an aluminum or copper can about 1¼ inches in diameter and 4 inches long, mounted on top of the chassis with three or more wires or 1 threaded stud on the bottom. If the radio is from the 1930's you had better replace the filter capacitors as a form of insurance against early failure. Other small capacitors should be replaced since most cardboard tube capacitors have leakage resistance and will cause the radio to play poorly or not at all. While you are under the chassis look for burned resistors, wire with hardened or broken insulation etc. Use capacitors with the same capacity and with the same or higher working voltage.

Now when you plug in the radio you should hear a faint hum in the speaker. When you rotate the volume control you should not hear a loud click, static, etc., but only a rushing noise as you turn the control clockwise. If you do get a loud static noise the volume control is noisy or worn out. The only permanent repair is to replace the control. If you want to try cleaning it, buy a can of contact cleaner at a radio parts store and follow their directions. If your radio has no built in loop antenna you will need about 50 feet of wire connected to the antenna lead to pick up stations. The ideal solution is to put up an outdoor antenna. A shorter piece of wire may

bring in local stations.

Speaker Repair. One more problem may be the speaker. Look for holes and loose seams in the cone, especially in the center around the voice coil or around the edge where the cone is cemented to the metal basket. Recement the cone or small holes in the cone, larger holes or tears can be repaired with speaker cement and strips torn from a paper towel. Speaker cement can be purchased at Radio Shack stores. If the sound is distorted or raspy you may have dirt or iron filings in the space between the voice coil and pole piece. This is difficult to repair and you may have to buy a new speaker.

By now your radio should be working quite nicely unless you have a rare fault in some component. If it is you can put it back into its cabinet. If you have replaced the grill cloth, put the speaker back, and mounted the dial escutcheon, you can put the chassis back in place. Install the knobs, after polishing them, and replace the back if there is one. Now turn the radio on, sit back and enjoy the real old fashioned tone of a tube type radio. Now really! doesn't it sound much better than your transistor radio with its 2 inch loudspeaker?

Antique Plastic. What? you say you have looked all over and cannot find a wooden cabinet radio to restore. All you could find were sets with plastic

cabinets covered with dirt, paint spots, grease, and scratches all over the cabinet, well I'll tell you what to do. Buy the oldest plastic cabinet radio you can find and practice on it and one of these days you will find a wooden cabinet radio. First remove the knobs, back, radio chassis and speaker. Carefully wash the cabinet and dial glass. Use warm water and a dish washing detergent, then rinse and wipe dry. Washing should remove dirt, grease, etc. but will leave paint spots. Your fingernail or alcohol will usually remove the paint. After washing the cabinet will probably still be dull and dingy looking so a plastic cleaner and polish should be used to restore the original luster. The best polish and cleaner I've found is Meguiar's Mirror Glaze, Plastic Cleaner and Plastic Polish. They are sold by Mirror Bright Polish Co., Inc., Irvine, CA 92664. A catalog source is listed in the appendix.

Once again an old tooth brush will be handy to clean the grooves in the knobs and cabinet. Follow the directions carefully when you are cleaning and polishing your cabinet and it will look as good or better than when it came from the factory.

The appendix lists sources to whom you can write for tubes, schematics, and other parts for set restoration. You will also find a listing for hard to find tools, brushes, etc. The source of the Paint and Varnish Remover is also listed.

We have tried to give you the overall picture of what is involved in restoring a small table model radio so you will have a set you will be proud to show to your friends and neighbors. A lot of these small wooden radios are still available so look around. ■

Sunspots

(Continued from page 35)

Using old observatory records, astronomers have been able to compute a sunspot number for each year since 1749.

If sunspots can be thought of as solar thunderstorms, *solar flares* are the sun's "lightning." Solar flares usually occur near sunspots and are more common during periods of high sunspot activity. Like lightning, flares are very short-lived events. Sunspots may last for several weeks while flares usually last less than an hour. Flares resemble a tongue of flame leaping up from the sun's surface from a sunspot or from one sunspot to another.

A solar flare can severely disrupt radio communications by causing a *sudden ionospheric disturbance* (SID). When a SID occurs, all shortwave frequencies between 3 and 30 MHz may

become completely useless for long distance communication for periods of up to an hour. During a SID, it's not unusual for electronics technicians to be swamped with calls from hams, SWLs, and commercial users of the shortwave bands who all complain that their equipment is not working! Solar flares cause SIDs because they release enormous quantities of X-rays. When these X-rays reach the lower regions of the ionosphere (around 60-80 miles) they cause ionization much like ultraviolet light does. Yet X-rays cause ionization much heavier than does ultraviolet light. In fact, the ionization is so dense that the ionosphere begins to *absorb* all shortwave signals instead of bending them back to earth! Fortunately, this effect is usually of short duration.

A solar flare also releases many highly charged particles which travel away from the sun at speeds of 250 to 1000 miles per second. At this rate, the particles may take anywhere from one to four days to reach the earth. The charged particles are attracted by the earth's magnetic field and enter the ionosphere at the polar regions. The most spectacular effect of these charged particles is a display of the northern lights (*aurora borealis*). Users of the shortwave bands notice the ionosphere absorbing signals instead of bending them. However, the effects are not as severe as a SID. Generally only paths running along east-west lines in the higher latitudes are affected, with north-south paths not disturbed. Such conditions are known as *ionospheric storms*. During an ionospheric storm, listeners in eastern North America may be unable to hear signals from Europe while stations in Latin America are heard without difficulty. Ionospheric storms generally last for only a few days.

The Future. The sunspot number at the peak of a sunspot cycle has ranged in this century, from a low of 60 in 1907 to well over 200 in 1958. While the peak of the coming cycle won't be as high as the 1958 maximum, it could well be the second highest peak in recorded history!

Only three times since 1749 has the sunspot number exceeded 150, in 1780, 1947, and 1958. The latest sunspot cycle peak, in 1969, peaked at only 120. The Space Environment Services Center in Boulder, Colorado predicts that we are headed for a peak sunspot number of approximately 153 during the first six months of 1980. Yet currently the sunspot number is running *ahead* of the Center's prediction. For example, the predicted sunspot number for February, 1978 was 64; the actual sunspot number for that month was already one of the highest in history, 90. Thus the predicted peak of 153,

may actually be on the low side!

What kind of radio conditions will we experience during this cycle peak? Hams and SWLs will delight in the improved conditions on the higher shortwave frequencies. Many bands above 14 MHz will be useful for world wide communication around the clock, and not much power will be required to span the globe. Hams who like to chase DX on the six meter (50-54 MHz) band will likely find this band useful near the cycle peak for world-wide communications, as was the case back in 1956-59 when distances of up to 12,000 miles were covered. TV DXers will also experience chances for reception of TV stations from Europe. Shortwave listeners will find less crowding on the shortwave broadcasting frequencies as more stations move up to higher frequencies.

Not all users of the radio spectrum will benefit, however. The "skip" conditions which have, on occasion, made a hash out of the CB channels during the past few years may well become a twenty-four-hour fact of life on the band; rendering it useless for anything but close range communications. Mobiles trying to talk each other five miles away in New York will find themselves getting squashed by base stations in California on a regular basis. Likewise, public service stations operating in the 30 to 50 MHz range will find their communications disrupted. The sunspot cycle peak will find police cars in Oregon answering calls from a dispatcher in Arkansas and home scanners in Florida intercepting police calls from Iowa.

Hams and SWLs will not find the outlook for them entirely rosey, though. The increasing solar activity will lead to numerous solar flares, causing more sudden ionospheric disturbances and radio blackouts. Further, there will be more periods of unsettled conditions due to ionospheric storms caused by charged particles emitted during solar flares.

Even non-users of the radio spectrum will feel the effects of the sunspot cycle peak. Displays of the northern lights will become more frequent and will be observed further south than normal. Astronauts in space will have to beware of the X-rays unleashed by solar flares. The possibility exists for damage to some satellites if the X-rays unleashed by flares become intense.

No matter whether the current cycle has good news or bad in store for you, it won't be a permanent situation. By August of 1980 the sunspot cycle will be headed back down, eventually reaching a minimum sometime in the middle to late 1980's. So enjoy—or endure—the conditions of this sunspot peak while you can! ■

BNEE

(Continued from page 66)

or a set of paddles—one for dits and one for dahs—with separate electronics), or a “bug” is pretty much up to you and what you feel most comfortable in using.

If you elect to go with an electronic keyer, make sure the output of the keyer is compatible with the keying circuit of the transmitter. Read the manuals carefully! An improper connection or too much voltage on the switching transistor in the keyer's electronics will lead to an early repair job, and some warranties don't cover owner abuse.

What do I use? A straight key . . . but one of these days I'll get around to working with an electronic keyer.

In Closing. Next time we'll talk about sending and receiving code, and review some basic operating practices. In advance of this discussion, you may wish to order some supplemental material.

The American Radio Relay League, 225 Main St., Newington, CT 06111, will supply the following operating aids free of charge: (1) CD 5/9 W1AW Schedule; (2) CD-139 Current On-the-Air Code Practice Stations; (3) CD-220 The R-S-T System/Time Conversion; and (4) CD-218 Amateur Message Form. Also ask for an order blank for the ARRL Logbook.

Although the Operating Aids are not required for an understanding of our upcoming discussion, each aid has some useful information that will probably be of interest to you. ■

Rhythm & Blues

(Continued from page 33)

#1) followed by eleven softer ones (corresponding to pots #2 through #12). The brightness of the LED flashes should follow the same pattern. Holding the *Reset/Start* button in should stop the clicks. Releasing it should immediately start the sequence of clicks again, beginning with #1, the loudest. Now set *Sequence Length* to 11; a repeating sequence of one loud click followed by ten softer ones should be heard. Similarly check *Sequence Length* settings of 10, 9, 8, etc. When changing the *Sequence Length* setting the pulse may be “lost” from the shift register with the result that the clicks are no longer produced. This is normal, and if it happens, simply push and release *Reset/Start* to restore operation. With *Sequence Length* at off, a sequence of twelve clicks should be produced (the first one should be loudest)

each time *Reset/Start* is pushed and released.

Check that the loudness of each of the twelve clicks in the sequence can be varied from zero to maximum by adjusting the corresponding pot. The brightness of the LED flashes should also correspond approximately to the pot settings. Finally, adjust trimpot R9 to give the desired sound quality to the clicks.

Performance. After going through the circuit description and checkout you should have a general idea of what the synthesizer does. To use it, decide how many beats or pots you need for your rhythm: this will be the *Sequence Length* setting. Then turn the appropriate numbered pot up to emphasize a beat, down to de-emphasize it, or off to delete it.

As you have seen, the R&B Box can operate in two modes, either *single-shot* or *continuous*.

For the *single-shot* mode set *Sequence Length* to off. In this mode a sequence of all twelve clicks is produced each time *Reset/Start* is pushed and released. The sequence always begins from the left with pot #1. If fewer than 12 pots are needed in this mode, turn the unused pots (on the right) completely off to prevent unwanted clicks following the end of the rhythmic pattern.

For the *continuous* mode set *Sequence Length* to one of the numbers (2 through 12) as required for your particular rhythm. The pot with that number will be the last one in the sequence. The sequence will repeat indefinitely once it is started by pushing and releasing *Reset/Start*. In this mode the settings of the unused pots on the right do not matter; otherwise, operation is the same as in the *single-shot* mode.

The fastest way to become familiar with the Rhythm & Blues Box is to experiment with all the controls. There is no way you can damage it by experimenting, so don't be timid.

Examples of how to set up various rhythms are shown in the pictorial. For these examples, the initial beat, or downbeat, is louder than the others to identify the beginning of the rhythmic pattern, but this is not mandatory. In fact, none of the pots needs to be set exactly as shown, so feel free to do your own thing.

Example #1 is a simple “waltz” rhythm with three beats: LOUD-soft-soft. Set SEQUENCE LENGTH to 3, pot #1 fully on (clockwise), pots #2 and #3 about halfway up as shown. *Tempo*, *Volume* and *Light* may be set as desired. In a similar way you can set up rhythms of 2, 4, 5, 6, etc. beats with the first beat emphasized.

Example #2, a “dotted” rhythm, has

two notes of unequal duration; the first (dotted eighth) is three times as long as the second (sixteenth). The shortest time unit in the pattern is a sixteenth and the total length of the pattern is four times this (2/8 or 4/16). Consequently, *Sequence Length* should be set to 4. Pot #1 should be fully on, pot #4 about halfway, pots #2 and #3 fully off. For this rhythm, clicks #2 and #3 are deleted. As illustrated by this example, a rule of thumb is that the *Sequence Length* setting should equal the total length of the pattern divided by the shortest time unit.

Example #3 begins with a “triplet”, whose note each have a time value of 1/12; the total pattern has a time value 3/4 or 9/12. Thus a *Sequence Length* of 9 is used.

Example #4 is a common rhythm and is a straightforward set up on the Synthesizer.

Example #5 is an uneven rhythm typical of Eastern music. Such rhythms are frequently troublesome, but are easily handled with our rhythm synthesizer. If you need to analyze such rhythms it may be helpful to turn on the “silent” beats slightly; in this example #2, 3, 5, and 7.

The final example, #6, illustrates how the synthesizer can accommodate fairly complex rhythms. All twelve pots are needed since the smallest time unit is a 1/16 note and the total pattern duration is 6/8 or 12/16.

Off-Beat Uses. As mentioned at the beginning, the rhythm synthesizer is also useful as a programmable controller for electronic music synthesizers and other equipment. The *Control Voltage Out* jack (J2) puts out a sequence of voltage levels corresponding to the settings of the numbered pots.

For example, the sequence of voltage levels can be fed to a VCO (voltage controlled oscillator) to generate programmed melodies of up to twelve notes. If you want to try this, two simple VCO circuits which can be controlled in this way by the rhythm synthesizer are given in the figure.

You can also use the R&B Box as a waveform generator for square, pulse, staircase, and other waveforms, again by using the signal from the *Control Voltage Out* jack. To get an idea of the possibilities, connect an oscilloscope set at a slow sweep rate to J2, turn *Tempo* all the way up, set *Sequence Length* to 12, and vary the numbered pots.

In case you want to run your rhythms through another amplifier or speaker, an *External Amplifier* jack (J3) and *External Speaker* jack (J4) are provided.

Get into the swing of things with our Rhythm and Blues Box and be the most percussive constructionist who ever drummed up a storm! ■

How to subscribe to America's most down-to-earth magazine for the electronics and radio hobbyist!

Each issue brings you--

- *fascinating electronic devices to build*
- *Instructive articles on CB, electronics, shortwave, and lively columns*
- *a Basic Course in electronics theory*
- *a great Q & A column to help with your projects or anything electrical*

**ELEMENTARY ELECTRONICS, Box 2630
Greenwich CT 06830**

Bill me \$3.98 for ONE YEAR (6 issues).

Enclosed is \$3.98.

(Canada, all other countries \$5.69)

Name (please print) _____

Address _____

City _____ State _____ Zip _____

Allow 6 to 8 weeks for delivery of your first copy.

H8L017



WHAT'S THE NEWEST AND FRESHEST ... MOST HELPFUL ... MOST INFORMATIVE ... LIVELIEST MAGAZINE FOR BACKPACKERS AND HIKERS?

Backpacking Journal

BACKPACKING JOURNAL is popular because it is the one magazine with something for everybody-- for the beginner, intermediate and expert alike. It doesn't assume everyone has done the Appalachian Trail end to end or conquered Mt. Everest. But, if Everest or something slightly less challenging is your cup of tea, you'll be at home with BACKPACKING JOURNAL.

You'll enjoy the trail a lot more if you're reading BACKPACKING JOURNAL, the newest outdoor publication by the publishers of CAMPING JOURNAL. Order your subscription today.



BACKPACKING JOURNAL, Box 1855, GPO, New York, NY 10001

Enclosed is \$3.97 (includes shipping and postage) for 5 quarterly issues of BACKPACKING JOURNAL. All other countries add \$4.82.

Name _____

Address _____

City _____ State _____ Zip _____

H8L009

ELEMENTARY ELECTRONICS HOBBY MART

FREE THE GREAT ELECTRONIC THINGS & SURPLUS CATALOG!

Many Unusual Items & Specials not found in stores or catalogs anywhere!
Circle Reader Service Coupon or write today for exciting Free Catalog!



99.9

MAGIC SOUND SWITCH!!
SURPLUS BARGAIN!
Sensitive crystal mike picks up sound which is amplified to trigger an SCR switch. Operates on 3-6 VDC. With schematic. (2 oz.) 024SU210.
10/\$8.95
100/\$79.95

12 VOLT 2 AMP POWER SUPPLY!
10/\$89.95

9.95

Sensational purchase of European Inventory! 3-4 amp surge. Excellent for CB, car stereo and general hobby and school shop applications. Excellent battery charger. Excellent dealer item. 024HP233. (2 lb.)

BUILD A PARABOLIC MICROPHONE!

Giant 22" diameter plastic parabolic sound reflector. For construction of long distance mikes and sound projectors. Construction ideas included. (5 lb.) 024MP233.

19.95

Rush your order with full remittance please. Visa & MasterCard OK. Allow 15% for UPS & handling. (N.Y. state residents add 7% tax). 24 hour, 7 day telephone order desk. Call when rates are low!

ETCO ELECTRONICS, Dept. 024
NORTH COUNTRY SHOPPING CENTER, PLATTSBURGH, N.Y. 12901
518-561-8700.
CIRCLE 11 ON READER SERVICE COUPON

DIGI-KEY CORPORATION

Quality Electronic Components

TOLL FREE 1-800-346-5144
MN., AK., HI. RESIDENTS 218-681-6674

IC'S • RESISTORS • TRANSISTORS • CAPACITORS • DIODES • I.C. SOCKETS & PINS • SWITCHES
CLOCK MODULES • OPTOELECTRONICS • BREADBOARD & TESTING DEVICES • DRAFTING SUPPLIES
DATA BOOKS • HEAT SINKS • WIRE • TOOLS... AND MORE... WRITE FOR FREE CATALOG

DON'T FORGET OUR DISCOUNTS WHEN COMPARING PRICES

NEW! DIGI-CLOCK KIT ONLY \$21.90

Part No. 5001K

- Trouble-free Module
- 270° Swivel Mount
- Inlaid Walnut Chrome Trim Bezel
- Ideal for Car, Van or Boat
- 3-5/8" x 2-3/16" Tall x 2-1/8" Deep
- Quick and Easy to Install!



MA1003 CLOCK MODULE BY NATIONAL SEMICONDUCTOR...
ATTRACTIVE INLAID WALNUT & CHROME TRIM BEZEL...
3 PUSH BUTTON SWITCHES...
MA1003 Clock Module and Switches only... 15.95
401 Bezel and Enclosure only... 5.95
5001K Digi-Clock Kit (Includes MA1003 and 401) 21.90

ELECTROLYTIC CAPACITORS

Part No.	Value	Price
1000	1000µF	1.25
2200	2200µF	1.50
4700	4700µF	1.75
10000	10000µF	2.00
22000	22000µF	2.25
47000	47000µF	2.50
100000	100000µF	2.75
220000	220000µF	3.00
470000	470000µF	3.25
1000000	1000000µF	3.50

CLOCK MODULE SALE OF SALES

MA1010 10 digit high display

JMU DIGITAL DISPLAY

FOR MA1003 AND MA1010 CLOCK MODULES

\$4.95

SILICON TRANSISTORS

Part No.	Value	Price
2N2222	2N2222	1.25
2N2907	2N2907	1.25
2N3055	2N3055	1.25
2N4351	2N4351	1.25
2N4352	2N4352	1.25
2N4353	2N4353	1.25
2N4354	2N4354	1.25
2N4355	2N4355	1.25
2N4356	2N4356	1.25
2N4357	2N4357	1.25

MOLEX I.C. SOCKET PINS

Part No.	Value	Price
100	100	1.25
200	200	1.50
300	300	1.75
400	400	2.00
500	500	2.25
600	600	2.50
700	700	2.75
800	800	3.00
900	900	3.25
1000	1000	3.50

NEW! THE "NIBBLER" A MICRO-COMPUTER

FEATURES:

- Assembled and Tested in House
- Standard 8080, 8K RAM, 256K ROM
- 40K Baud Rate for easy maintenance
- Memory expansion to 128K
- 1150VAC Power Supply
- 1150VAC Power Supply and 256K RAM
- Expandable to 128K RAM or 256K RAM
- Expandable to 128K RAM or 256K RAM

HALOGEN BULBS

Part No.	Value	Price
100	100	1.25
200	200	1.50
300	300	1.75
400	400	2.00
500	500	2.25
600	600	2.50
700	700	2.75
800	800	3.00
900	900	3.25
1000	1000	3.50

MICROPROCESSORS

Part No.	Value	Price
8080	8080	1.25
8085	8085	1.25
8088	8088	1.25
8080A	8080A	1.25
8085A	8085A	1.25
8088A	8088A	1.25
8080B	8080B	1.25
8085B	8085B	1.25
8088B	8088B	1.25
8080C	8080C	1.25

DOUBLE DIGIT DISCOUNTS SAVE YOU EVEN MORE!

VOLUME DISCOUNT

Quantity	Discount
1-99	0.00%
100-499	5.00%
500-999	10.00%
1000-4999	15.00%
5000-9999	20.00%
10000-49999	25.00%
50000-99999	30.00%
100000-499999	35.00%
500000-999999	40.00%
1000000-4999999	45.00%
5000000-9999999	50.00%
10000000-49999999	55.00%
50000000-99999999	60.00%
100000000-499999999	65.00%
500000000-999999999	70.00%
1000000000-4999999999	75.00%
5000000000-9999999999	80.00%
10000000000-49999999999	85.00%
50000000000-99999999999	90.00%
100000000000-499999999999	95.00%
500000000000-999999999999	100.00%

BISHOP COOLGLO Light Table

30 VOLT DISCS

Part No.	Value	Price
100	100	1.25
200	200	1.50
300	300	1.75
400	400	2.00
500	500	2.25
600	600	2.50
700	700	2.75
800	800	3.00
900	900	3.25
1000	1000	3.50

DIGI-KEY CORPORATION
Quality Electronic Components
P.O. Box 637
11815 Highway 109, Millerville, ME 04261 (218) 681-6674

AMAZING DEVICES

(((PHASERS)))

PPF-1 PHASER PAIN FIELD — This device recently developed and patented in our labs is being evaluated by law enforcement agencies for riot and crowd control. It is now available but soon will come under the jurisdiction of weapons and internal machine control making it unavailable to the public. The device is hand-held and looks like a BUCK ROGERS ray gun. It is hazardous if not used with discretion.

PPF-1 PLANS \$10.00
IPG-1 INVISIBLE PAIN FIELD GENERATOR — This amazing, simple hand-held device is about the size of a pack of cigarettes and generates a directional field of moderate to intensive pain in the lower part of the head up to a range of 50'. Device is simple and economical to make.
IPG-1 PLANS \$6.00 **IPG-1K ALL PARTS \$39.50**
IPG-10 ASSEMBLED & TESTED FOR ANIMAL CONTROL \$44.50

LASERS

HIGH POWERED CARBON DIOXIDE BURNING AND CUTTING
Complete plans and all parts sources **\$10.00**

SOLID STATE IR 12 WATTS with built in power supply plans **\$6.00** Complete kit with collimator **\$44.50**

POCKET LASER pulsed, visible red plans **\$6.00**
Complete kit **\$39.50** Also complete plans and parts sources for RUBY, YAG, NEDDYNIUM, HeNe ARGON, DYE, NITROGEN and many more lasers

SECURITY

SNP-2 SNOOPER PHONE — Connects to telephone in seconds — enables you to check home or office while on vacation. User simply dials his number from anywhere activating highly sensitive mike and amp combination capable of detecting normal sound levels throughout area without phone ringing. Anyone with this capability would breathe a sign of relief, while away hearing the familiar sounds of appliances and other systems properly operating.

SNP2 PLANS \$7.00
SNP2K ALL PARTS FOR ABOVE \$49.50
SNP20 ASSEMBLED & TESTED \$79.50

LONG RANGE XMTR PLANS \$6.00
SEE-IN-THE-DARK PLANS \$5.00
DIRECTIONAL SHOTGUN MIKE PLANS \$6.00
SUPER SENSITIVE PARABOLIC MIKE PLANS \$6.00
SOUND & TELEPHONE OPERATED TAPE RECORDER \$5.00
CATALOG ON PLANS, KITS & FINISHED UNITS \$1.00

Send check or money order to
SCIENTIFIC SYSTEMS, Dept. A10, Box 716
AMHERST, N.H. 03031

CIRCLE 14 ON READER SERVICE COUPON

POLY PAKS®

INFLATION REVOLT

WE'RE FIGHTING BACK INFLATION WITH THIS EXCLUSIVE 1¢ SALE
BUY 1 AT SALE PRICE, GET 2ND FOR 1¢ MORE!!!

ORDERING INSTRUCTIONS:
When ordering, always use catalog number, pgs no., the ordering form, the magazine you are ordering from and the month



LED WATCH GUTS

\$1.95 2 for **\$1.96**

Factory "lay-arounds"... Do they work? Who knows! A micro digital technician's bonanza. The complete guts are there, with black plastic case and leatherette band. 6 functions: HOURS, MINUTES, SECONDS, MONTH, and DATE. Sorry, no specs. Wt. 2 oz. Cat. No. 5267



SALE

7-SEGMENT READOUTS

3 1/2 DIGIT LCD WRISTWATCH DISPLAY (3960).....	3 for \$1.19
SPERRY FLAT MIXIES, orange, 3" dual digit (5014).....	3 for 1.19
SPERRY FLAT MIXIES, orange, 3", 1 1/2" dig (5015).....	3 for 1.19
MAX-3 BUBBLE READOUT, 19" red, com, cath. (3338).....	6 for 1.00
MAX-4 READOUTS, bubble, red, com, cath. 19" (1503).....	2 for 1.19
FND-10 BLOCK READOUT, 122" com cathode (2042).....	2 for 1.19
8-DIGIT READOUT, led, com cathode, red (5180).....	1 for 1.95
FND-503, 3" red, com cathode, 7-seg. (2948).....	1.50
FND-500, 5" red, com anode, 7-seg. (3058).....	1.50
FND-800, 8" red, common anode, (3030).....	1.50
FND-803, 8" red, common cathode, (3327).....	3.95

ONE CENT SALE

6 for \$1.20	4.96
8 for 1.20	1.50
6 for 1.20	1.01
12 for 1.01	1.01
4 for 1.01	1.20
4 for 1.20	1.96
2 for 1.96	1.51
2 for 1.51	1.51
2 for 1.51	3.96
2 for 3.96	

AMPLIFIERS!

9 WATTS ON A CHIP, Toshiba TA7205 (5057).....	Each 2 for 4.95
3 WATTS ON A CHIP, C.E. PA 263 (1522).....	1.50 1.51
1 - 10 WATT STEREO AMPLIFIER, PA, hi-fi, mobile, 12V (8324).....	2 for 8.99

IC SOCKETS!

8-PIN MINI-DIP (2123).....	4 for \$1.19	8 for \$1.20
14-PIN DIP (1308).....	3 for 1.19	6 for 1.20
16-PIN DIP (1309).....	3 for 1.19	6 for 1.20
18-PIN DIP (3378).....	4 for 1.19	12 for 1.20
24-PIN MS/DIP (3886).....	2 for 1.19	1.20
28-PIN MS/DIP (3887).....	2 for 1.19	4 for 1.20

DIP SWITCHES!

2 SWITCHES ON A DIP (3649).....	Each 2 for \$7.75 5.78
3 SWITCHES ON A DIP (3649).....	88 .88
6 SWITCHES ON A DIP (3671).....	1.29 3.00
8 SWITCHES ON A DIP (5160).....	2.60 2.61

"TIE-PIN" TYPE CONDENSER MIKE
4.95 2 for **\$4.96**

It's a little giant in sound quality. Metal encased, built in P.T. circuitry, omnidirectional, frequency response 20-20,000 Hz. Less tie pin or lapel clip. 600 ohm impedance. 1.5 VDC. Cat. No. 3178 7/16" long

TTL'S AT "CENT-CIBLE" PRICES

Order By Cat. No. 1981	Type No.	Each	2 For	Type No.	Each	2 for	Type No.	Each	2 for		
□	SN7400	\$ 19	\$ 20	□	SN7471	.18	.36	□	SN74184	1.78	1.78
□	SN7401	.19	.20	□	SN7472	.18	.20	□	SN74185	.79	.80
□	SN7403	.28	.28	□	SN7474	.99	.80	□	SN74186	.39	.40
□	SN7404	.18	.20	□	SN7478	.68	.70	□	SN74187	.99	1.00
□	SN7405	.19	.20	□	SN7480	.78	.80	□	SN74188	.99	1.00
□	SN7406	.18	.20	□	SN7482	.28	.30	□	SN74189	1.25	1.28
□	SN7410	.28	.28	□	SN7483	.99	1.00	□	SN74193	1.39	1.40
□	SN7418	.35	.36	□	SN7486	.48	.50	□	SN74194	.78	.80
□	SN7420	.32	.33	□	SN7488	.80	.80	□	SN74195	.99	1.00
□	SN7421	.48	.50	□	SN7489	3.45	3.50	□	SN74196	1.99	2.00
□	SN7422	.29	.30	□	SN7490	.99	1.00	□	SN74197	1.99	2.00
□	SN7423	.29	.30	□	SN7491	1.28	1.30	□	SN74198	1.99	2.00
□	SN7424	.29	.30	□	SN7492	.28	.30	□	SN74199	1.99	2.00
□	SN7426	.29	.30	□	SN7493	.68	.70	□	SN74200	1.99	2.00
□	SN7428	.25	.26	□	SN7494	.78	.80	□	SN74201	.49	.50
□	SN7440	.19	.20	□	SN7495	.80	.80	□	SN74202	1.78	1.80
□	SN7443	.59	.60	□	SN7496	.28	.30	□	SN74203	1.78	1.80
□	SN7444	.19	.20	□	SN7498	.78	.80	□	SN74204	1.25	1.26
□	SN7446	1.25	1.26	□	SN74107	.99	.30	□	SN74205	1.50	1.51
□	SN7451	.19	.20	□	SN74113	.38	.40	□	SN74206	1.78	1.80
□	SN7453	.19	.20	□	SN74121	.59	.60	□	SN74207	1.78	1.80
□	SN7454	.29	.30	□	SN74123	.88	.70	□	SN74208	1.50	1.51
□	SN7455	.19	.20	□	SN74128	.99	1.00	□	SN74209	3.50	3.51
□	SN7456	.35	.36	□	SN74129	.48	.50	□	SN74210	5.99	6.00
□	SN7458	.19	.20	□	SN74140	.48	.50	□	SN74284	5.99	6.00
□	SN7459	.19	.20	□	SN74145	.68	.70	□	SN74288	3.75	3.78
□	SN7470	.19	.20	□	SN74153	1.29	1.30				

POP-AMPS AT "CENT-CIBLE" PRICES

Type No.	Each	2 for	Type No.	Each	2 for	Type No.	Each	2 for
LM300H	.59	.70	LM340T-18	1.49	1.50	LM709H	.19	.20
LM300N	.49	.50	LM340T-24	1.49	1.50	LM709N	.49	.50
LM301A	.45	.46	LM376V	.29	.30	LM729H	.49	.50
LM308H	.29	.30	LM377M	2.25	2.26	LM733H	.79	.80
LM308N	.69	.70	LM380N	1.39	1.40	LM747H	.59	.60
LM309K	.49	.50	LM386M	1.49	1.50	LM1304	1.49	1.50
LM311V	.29	.30	LM387M	1.49	1.50	LM1310	1.79	1.80
LM320T-6	1.49	1.50	LM332N	.25	.26	LM1312	2.49	2.50
LM322N	1.19	1.20	LM332M	.25	.26	LM1414V	.19	.20
LM339H	1.79	1.80	ME540M	5.95	5.96	LM1458V	.39	.40
LM340K-5	1.49	1.50	LM555V	.75	.76	LM1800M	.79	.80
LM340K-6	1.49	1.50	LM556M	1.79	1.80	LM3028H	.65	.66
LM340K-8	1.49	1.50	LM558V	.39	.40	LM3900N	.49	.50
LM340K-12	1.49	1.50	LM558M	.39	.40	LM3909V	1.25	1.26
LM340K-15	1.49	1.50	LM561M	1.00	1.01	LM75451	.69	.70
LM340K-18	1.49	1.50	LM565N	1.00	1.01	LM75453	.69	.70
LM340K-24	1.49	1.50	LM565H	1.00	1.01	LM75491	.80	.81
LM340T-5	1.49	1.50	LM567M	2.49	2.50	LM75492	.80	.81
LM340T-7	1.49	1.50	LM567H	2.39	2.40	LM75494	.60	.61
LM340T-12	1.49	1.50	LM703M	.59	.60	PA263	1.50	1.51
LM340T-15	1.49	1.50	LM704H	.19	.20	DM8864N	1.29	1.30

PENNIES FOR YOUR MEMORIES

Type	Description	Sale	1¢ Sale!	Order by Cat. No.	
□	1K103	1K Dynamic RAM	1.29	1.30	3459 A
□	5282	2K x 1 Dynamic RAM	.99	1.00	
□	1702A	256 x 8 EPROM	4.95	4.96	
□	MM5280A	4K x 1 Dynamic RAM	3.95	3.96	

1 AMP SCR'S

Order by Cat. No.	5 Watts	Sale	1¢ SALE
□	6.2V	5 for \$1.10	10 for \$1.01
□	8.2V	5 for 1.10	10 for 1.01
□	9.1V	5 for 1.10	10 for 1.01
□	10.0V	5 for 1.10	10 for 1.01
□	11.0V	5 for 1.10	10 for 1.01
□	12.0V	5 for 1.10	10 for 1.01
□	15.0V	5 for 1.10	10 for 1.01

RIBBON CABLE

Cond.	Sale	1¢ Sale
□	26	4-ft. 1.98 8-ft. 1.99
□	34	4-ft. 1.98 8-ft. 1.99
□	40	3-ft. 1.98 6-ft. 1.99

ZENERS! Order by Cat. No. 5210A & voltage & wattage

1 Watt	Sale	1¢ SALE
□	7.5V	5 for \$1.10 10 for \$1.01
□	8.2V	5 for 1.10 10 for 1.01
□	9.1V	5 for 1.10 10 for 1.01
□	10.0V	5 for 1.10 10 for 1.01
□	11.0V	5 for 1.10 10 for 1.01
□	12.0V	5 for 1.10 10 for 1.01
□	15.0V	5 for 1.10 10 for 1.01

5 WATTS Sale 1¢ SALE

Order by Cat. No.	5 Watts	Sale	1¢ SALE
□	6.2V	3 for 1.6 for 1.01	
□	8.2V	3 for 1.6 for 1.01	
□	9.1V	3 for 1.6 for 1.01	
□	10.0V	3 for 1.6 for 1.01	
□	11.0V	3 for 1.6 for 1.01	
□	12.0V	3 for 1.6 for 1.01	
□	15.0V	3 for 1.6 for 1.01	

PARTS & SEMI "ONE-CENTERS"

100 CAPACITOR SPECIAL, disc, mylar, more (2738).....	2.00	200 for 2.01
10-VOLTAGE REGULATORS, hobby, LM320, 340, TO-3 (3330).....	2.00	20 for 2.01
30-PANEL SWITCHES, slides, rotaries, mod, etc (3268).....	2.00	60 for 2.01
200-RESISTOR SPECIAL, 1/4 to 1W, carbon, metal (3054).....	2.00	400 for 2.01
200-HALF WATERS, resistors, metal film, marked (3413).....	2.00	400 for 2.01
100-NATIONAL IC BONANZA, linears, 7400s ROMS (2860).....	2.00	200 for 2.01
15-15M340T VOLTAGE REGULATORS, 5 to 24V, TO-220 (2635).....	2.00	30 for 2.01
100-POLYSTYRENE CAPS, ass't'd values, voltage, hi-0 (2720).....	2.00	200 for 2.01
50-THERMISTORS, resistors that change with temp (4089).....	2.00	100 for 2.01
20-BRIDGES, untested, 2, 4, 6, amp, full wave (4022).....	2.00	40 for 2.01
25-LAMP-N SOCKET SETS, micro, 1.5V, T2 (3957).....	2.00	50 for 2.01
15-MIXED READOUTS, hobby, untested, 127, 3, 5, etc. (3619).....	2.00	30 for 2.01
150-GLASS ZENERS, 400 mw, untested, better 50K yield (3413).....	2.00	300 for 2.01
100-PLASTIC TRANSISTORS, untested, TO-18 (2604).....	2.00	200 for 2.01
200-PRE-FORMED RESISTORS, 1/4, 1/2, 1W, marked, ass't'd (2608).....	2.00	400 for 2.01
200-PRECISION RESISTORS, 1/4, 1/2, 1W, 1%, 2% marked (2428).....	2.00	400 for 2.01
60-DIPPED WTLARS, shiny finish, ass't'd values (2587).....	2.00	120 for 2.01
30-VOLUME CONTROLS, audio, linear, ass't'd values (2421).....	2.00	60 for 2.01
30-CLOCK CHIPS, NATIONAL, hobby & untested, alarm (5088).....	2.00	60 for 2.01
30 MM5262 2K RAMS, hobby, untested (3940).....	2.00	60 for 2.01
40-500 OHM RESISTORS, 1/4W, untested, better 50K yield (5288).....	2.00	500 for 2.01
25-CD-COMM 2K SERIES CMOS, untested, 50% usable yield (5284).....	2.00	50 for 2.01
1-CHARACTER GENERATOR, 5 x 7 Mostek MK 2002P (3898).....	4.95	2 for 4.96
1-CONDENSER MIKES, sensitive, 500 ohms 1.5 Volts (3178).....	4.95	2 for 4.96
75-40-CHARACTER GENERATOR, 5 x 7 Mostek MK 2002P (3898).....	4.95	2 for 4.96
75-CARBON FILM RESISTORS, 1/4, 1/2 watt, 5, 10%, marked, ass't'd (3534).....	2.00	150 for 2.01
250-UNMARKED CAPACITORS, polystyrene, molded, pop values (3805).....	2.00	500 for 2.01
300-SILICON SIGNAL DIODES, micro, glass, geners total 50% yield (2628).....	2.00	600 for 2.01
40-500 OHM RESISTORS, 1/4W, untested, better 50K yield (5288).....	2.00	500 for 2.01
100-1N4148/914 SWITCHING DIODES, 50%+ yield, untested (2418).....	2.00	200 for 2.01
30-PC TRIM POTENTIOMETERS, thumbwheel, screwdriver ass't. (3345).....	2.00	60 for 2.01
15-SLIDE VOLUME CONTROL, ass't'd values, duals, singles (3057).....	2.00	30 for 2.01
10-40-CHARACTER GENERATOR, 5 x 7 Mostek MK 2002P (3898).....	4.95	2 for 4.96
10-CRYSTALS, may include CB, Ham & more (3250).....	2.00	20 for 2.01
100-TERMINAL STRIPS, from 2 lugs up to (3138).....	2.00	200 for 2.01
30-NE-TRIM LAMPS, all 100% good (2613).....	2.00	60 for 2.01
40-500 OHM RESISTORS, 1/4W, untested, better 50K yield (5288).....	2.00	500 for 2.01
3-SOUND TRIGGERS, sound triggers scr/w/amp (3625).....	2.00	6 for 2.01
10-CB CRYSTALS, for phase lock loop, HAM, MC/10 (5050).....	2.00	20 for 2.01

IMAGINE GETTING A CALCULATOR REJECT FOR ONLY A PENNY!!!!

Your Choice **\$5.95** 2 for **\$5.96**

LED RED CALCULATOR GAMBLE!

PARTS ALONE ARE WORTH MORE THAN PRICE!

The gamble of a lifetime. YOU CAN'T LOSE! Factory dumps his production-line rejects and customer returns. Why are these rejects? Mostly keyboard problems, we are told. But at these prices, who cares! Most pocket size, only 3 1/2 x 6 1/2" deep.

RED all-LED 125' digits. Both styles feature 8 digits, 22 keys, 4 arithmetic functions, 4 memory functions, percent, equals, clear. All units complete. Vestigial operation manual. (Batteries not included). Wt. 6 ozs.

□ 5291 1 E.D.

1-VEEDED ROY COUNTER, 000-999, reassemblable, panel mt. (5081).....	1.49	2 for 1.50
2-DUAL GATE MOSFET, sim. to 3N200, 3N187, for RF & mixer (5101).....	1.00	4 for 1.01
2-LCD THERMAL INDICATORS, 88-108°F, 7x1", flexible (5195).....	1.00	4 for 1.01
1-10Y-5CT, four 400K pots, with knob (3808A).....	4.95	2 for 4.96
1-ELECT THUMBWHEEL SWITCH, BCD, 0-7 (2870A).....	1.95	2 for 1.96
1-PLESSEY TV SIDEBAND FILTER, for chas, 3 or 4 (3978).....	1.95	2 for 1.96
2.9V NI-CAD CHARGER PAK, plug-in, 125ma, 125 VAC pri (4098).....	1.49	2 for 1.50
1-10Y-5CT, four 400K pots, with knob (3808A).....		

Active Electronic Sales Corp.

LINEAR I.C.'S

LM324N	.49	Quad Op Amp
LM339N	.49	Quad Comparator
LM555N-8	.29	Timer
LM556N-14	.59	Dual Timer
LM723CN	.34	Voltage Regulator
LM723CH	.39	Voltage Regulator
LM741CH	.37	Op Amp
LM741CN-8	.24	Op Amp
LM1458N-8	.39	Dual Op Amp

TTL LOW POWER SCHOTTKY PLASTIC DUAL-IN-LINE I.C.

Part No.	Price	Part No.	Price	Part No.	Price	Part No.	Price	Part No.	Price	Part No.	Price
74LS00	.15	74LS47	.89	74LS123	.79	74LS170	1.25	74LS258	.75	74LS368	.55
74LS01	.15	74LS48	.89	74LS124	.99	74LS173	.95	74LS259	1.45	74LS373	1.75
74LS02	.15	74LS49	.89	74LS125	.59	74LS174	.69	74LS260	.29	74LS374	1.75
74LS03	.15	74LS51	.19	74LS126	.59	74LS175	.69	74LS261	1.85	74LS375	.65
74LS04	.19	74LS54	.19	74LS132	.79	74LS181	2.50	74LS266	.39	74LS377	1.50
74LS05	.19	74LS55	.19	74LS133	.29	74LS183	3.50	74LS273	1.65	74LS378	1.25
74LS08	.19	74LS56	1.50	74LS136	.39	74LS190	.89	74LS275	4.50	74LS379	1.35
74LS09	.19	74LS73	.29	74LS138	.64	74LS191	.89	74LS279	.59	74LS386	.49
74LS10	.15	74LS74	.35	74LS139	.64	74LS192	.95	74LS280	1.75	74LS390	1.50
74LS11	.19	74LS75	.49	74LS145	.99	74LS193	.95	74LS283	.85	74LS393	1.25
74LS12	.19	74LS76	.39	74LS147	1.95	74LS194	.75	74LS290	.85	74LS395	1.50
74LS13	.35	74LS78	.39	74LS148	.99	74LS195	.66	74LS293	1.10	74LS396	1.70
74LS14	.59	74LS83	.79	74LS151	.59	74LS196	1.09	74LS295	1.25	74LS398	2.65
74LS15	.19	74LS85	.99	74LS153	.59	74LS197	1.09	74LS298	1.25	74LS399	1.50
74LS20	.15	74LS86	.35	74LS155	.99	74LS221	1.25	74LS299	2.95	74LS424	4.50
74LS21	.19	74LS90	.59	74LS156	.80	74LS240	1.95	74LS324	1.25	74LS445	1.25
74LS22	.19	74LS91	.99	74LS157	.59	74LS241	1.95	74LS326	2.55	74LS447	1.25
74LS26	.25	74LS92	.59	74LS158	.69	74LS242	1.95	74LS327	2.55	74LS490	1.95
74LS27	.21	74LS93	.49	74LS160	.84	74LS243	1.95	74LS328	2.55	74LS668	.90
74LS28	.21	74LS95	.70	74LS161	.84	74LS244	1.95	74LS347	1.25	74LS669	.90
74LS30	.15	74LS96	.99	74LS162	.84	74LS245	1.95	74LS348	1.75	74LS670	2.00
74LS32	.25	74LS107	.39	74LS163	.84	74LS247	1.25	74LS352	1.35		
74LS33	.27	74LS109	.32	74LS164	.89	74LS248	1.25	74LS353	1.35		
74LS37	.23	74LS112	.32	74LS165	1.25	74LS249	1.25	74LS362	7.00		
74LS38	.23	74LS113	.39	74LS166	1.45	74LS251	.85	74LS365	.55		
74LS40	.19	74LS114	.39	74LS168	1.50	74LS253	.85	74LS366	.55		
74LS42	.54	74LS122	.50	74LS169	1.50	74LS257	.60	74LS367	.55		

Dual In-line Sockets

Finest Quality Sockets Available Anywhere

- PLUGGABLE SOCKET FOR IC PACKAGES WITH LEADS
- HIGH RELIABILITY GAS-TIGHT JOINT FULLY QUALIFIED TO MIL-8374
- COMPACT LOW PROFILE DESIGN
- NO WICKING WHEN SOLDERED TO PC BOARD
- FLAMMABILITY RATING-UL-940V-0

Stock level	Contacts	Price
14000	8 PIN	.11
345000	14 PIN	.13
156000	16 PIN	.15
33000	18 PIN	.19
18000	22 PIN	.27
84000	24 PIN	.28
25000	28 PIN	.36
46000	40 PIN	.48

All new major manufacturer production material offered. Largest variety of device types available anywhere.

UV EPROM

Stock level	Part No.	Price
7300	2708	7.99
6800	TMS 2716	24.95

3 power supply version, 16K pin for pin plug in replacement for 2708.

MOS Static RAM'S

Stock level	Part No.	Price
41400	2114 4K (1K x 4) 450NS	7.50
59500	2102LFPC 1K 350NS (Low Power)	1.19

MICROPROCESSOR CHIPS

CPU's

Stock level	Part No.	Price
21600	8080A	3.95 5.50
2700	6800	8.95 7.95

GENERAL INSTRUMENT 1 Amp Rectifiers (Epoxy)

Stock level	Part No.	Price	Stock level	Part No.	Price
1.7 Million	1N4001	.50V .029	29000	W02M	200V .28
9 Million	1N4002	100V .039	57000	W04M	400V .32
5 Million	1N4003	200V .045	390000	W06M	600V .34
5.7 Million	1N4004	400V .049	80000	W08M	800V .39
1.6 Million	1N4005	600V .055	7000	W10M	1000V .60
8 Million	1N4006	800V .065			
1.8 Million	1N4007	1000V .07			

MOS Dynamic RAM'S

Stock level	Part No.	Price
21110	4K 4060 300NS	3.95
27550	16K 416-3 200NS	11.95
18650	16K 416-5 300NS	8.95

INTERFACE SUPPORT CIRCUITS

Stock level	Part No.	Price
1250	8212	1.98
1800	8214	4.95 3.95
11200	8216	1.98
1700	8224	2.75
2800	8226	1.98
1500	8228	4.75
1000	8238	4.75
4900	8251	5.95 4.95
500	8253	14.95
5200	8255	5.95
1100	8257	9.95
300	8259	14.95

SWITCHING DIODES

Part No.	Price
1N914 (100V 4NS)	.027
1N4148 (100V 4NS)	.027

UART'S

Stock level	Part No.	Price
29000	AY5-1013A	4.95
9200	AY3-1015	5.95

1K CMOS RAM

Stock level	Part No.	Price
4400	5101 450NS (Low Power)	4.95

Zilog

Z80-CPU	14.95	Z80-S10/0	59.00
Z80A-CPU	24.95	Z80A-S10/0	68.00
Z80-PIO	7.95	(common TX & RX clocks with DTRB)	
Z80A-PIO	11.95		
Z80-CTC	7.95	Z80-S10/1	59.00
Z80A-CTC	11.95	Z80A-S10/1	68.00
Z80-DMA	46.00	(separate TX & RX clocks without DTRB)	

P.O. BOX 1035 FRAMINGHAM, MASSACHUSETTS 01701

Over-the-counter sales, 12 Mercer Rd., Natick, Mass. 01760 Behind Zayres on Rte. 9 Telephone Orders & Enquires (617) 879-0077

IN CANADA 3 LOCATIONS

5651 FERRIER ST. MONTREAL, QUEBEC H4P 2K5 Tel: (514) 735-6425

4800 DUFFERIN ST. DOWNSVIEW, ONTARIO M3H 5S9 Tel: (416) 661-1115

BAXTER CENTRE 1050 BAXTER ROAD OTTAWA, ONTARIO K2C 3P2 Tel: (613) 820-9471

MINIMUM ORDER \$10.00 • ADD \$2.00 TO COVER POSTAGE & HANDLING • Canadian customers add 30% for exchange and handling. All federal and provincial taxes extra. Foreign customers please remit payment on an international bank draft or international postal money order in American dollars.

master charge VISA

Bookmark

(Continued from page 14)

Register Co., Inc., this textbook combines explanations, experiments, and self-assessment tests. Assuming no previous experience, the text begins with a discussion of how electrons flow in conductors, and shows the novice how to read schematic diagrams and component identification codes. Three chapters containing numerous experiments investigate Ohm's Law and DC circuit analysis. Proceeding to capacitors and RC time constants, the book discusses differentiator and integrator waveforms, filters, and RC coupling. The text explains transformers and inductive coupling, and concludes with chapters on diodes and transistors that include clamp and logic circuits, zener regulators, rectifiers, and transistor amplifiers. Published by E&L Instruments, Inc., 61 First Ave., Derby, CT 06418. ■

Antique Radio Corner

(Continued from page 74)

are used to keep the signals confined to the transmission lines between power stations so that the signals are not lost in the various transformers and oil circuit breakers in the transmission lines.

"Telemetry signals as well as voice transmissions are possible between power stations. This has been a convenient way for utilities to coordinate load requirements among stations in a system.

"During WWII amateur radio operators were encouraged to try carrier current systems when they were not allowed to transmit over the airways. In fact some amateur radio handbooks carried circuit diagrams and suggestions for its use. Many old 175 kHz IF transformer coils were modified to provide low frequency coils for receivers. I tried this with a friend, but Chicago distribution lines were not direct routes so we only had very short range communication.

"The photographs are those of a 1950 carrier current receiver built by Westinghouse. National dials labeled "Primary" and "Second" tuning and coupling help create the feeling that you are looking at old home made amateur radio equipment. The empty tube socket on the upper right of the panel is for a 6L6 detector tube. This detector could operate telemetry devices directly or operate headphones without further amplification. The other empty socket is for a neon lamp across incoming signal lines to prevent overloading the receiver.

"The rear view shows the nice Card-

well tuning condensers plus the rotating tuning coil on the variable coupling control. Another form of C C radio is the wireless intercoms advertised in most radio catalogs. This device consists of an oscillator modulated by a voice frequency. The house wiring carries the signal.

At a recent IHRS auction sale a CC transmitter and receiver sold for a very low price considering all the nice parts and tubes that were in it. I guess I must have been asleep when it was sold.

Crystal Receivers. There is another new book out about crystal radio receivers. The book is titled, "The Cat's Whisker" by Jonathan Hill. The book is very nicely done and was written and published in Great Britain. The book has 96 pages and is in a large format with large type and many pictures, all of sets made in Great Britain before 1946. There are 50 pages showing crystal radios while the balance of the book covers AC operated radios. Even though it was printed in England and shows English radios I believe that there is enough information in it to give American collectors their moneys worth. You may secure a copy by sending a check or money order for \$9.95 for the book plus 50 cents for shipping to Antique Radio Press, P.O. Box 42, Rossville, IN 46920. ■

PROTECT YOUR VALUABLES

TOUCH SWITCH ALARM SYSTEM

NEW packaged system. A super close out item. Protects your valuables; gun's, CB's, stereo equipment, test equipment, etc. . . . List Price \$22.88
Sh. Wt 1 Lb. . . . 8M10474 . . . \$7.88
3 for \$22.88. . . . 8M10474 . . . \$22.88/3

REMOTE CONTROL SYSTEM

Ultrasonic

This handy control was part of an Admiral remote control package for color TV. The original functions were On-Off, volume, VHF-UHF, and channel select. Receiver contains 3-relays and one four position stepping relay. Also includes a complete data pkg. Control section operates on 115 VAC. Good for toys, garage door openers, TV, stereo systems or any of those STAR TREK innovations you would like to make on your own. (Energize or de-energize your alarm system remotely. Range 30' Transmitter requires AA cell (not included). Qty Ltd.
Sh. Wt 1 Lb. . . . 8C30372 \$25.00/Set
3 for \$69.88 . . . 8C30372 . . . \$69.88/3

SPEAKER ENCLOSURES

Mfg. Close-out FAMOUS NAME MFG. had model change & close-out of production run. They might have slight blemishes, or 2nds. on the finish - Only we saved big for you. (Sample picture shown) - most are ducked port 3 & 4 way with pop off grills & tweeters mid-range controls on front.

8" - 35wt - 3 way - DP - L.P. \$198.00	Cost \$118.88
10" - 50wt - 3 way - DP - L.P. \$279.50	Cost \$179.88
12" - 70wt - 3 way - DP - L.P. \$349.50	Cost \$199.88
12" - 90wt - 4 way - 12" P.R. - \$399.50	Cost \$248.88

ULTRASONIC MOTION DETECTOR

This alarm sensor has up to 50' range and fills the protected area with an energy screen that cannot be seen, felt or heard. Triggers your alarm whenever burglar moves through detector field. Mounts on ceiling, wall desk, shelf etc. Optional delay mode, auto-reset. Operates on 12.5 VDC. A close-out that originally sold for \$179.00 3 Lbs. Qty Ltd.
8D30336 . . . \$49.88

ALSO AVAILABLE:

- Power Supply Kit . . . 8D0472 . . . \$3.88
- Connector Kit . . . 8D0504 . . . \$1.50

AM-FM MULTIPLEX RECEIVER CHASSIS

Intended for use in a console by "Big Name" Mfg. AM, FM, FM multiplex, plus phono & a x inputs. Great for building-in. Just add case & speakers. 115 VAC. All solid-state. Qty Ltd.
Wiring instructions included
Sh. Wt 3 Lbs. . . . 8S20307 . . . \$24.88 ea or \$68.88/3

SPECIAL!

"AA" NICAD 8 PACK

NEW! 8 "AA" cells in handy package, gives 10V Split into single cells for 1.25V ea.
8 oz/pack. . . . 8V20305 . . . \$8.00/pack

RECHARGEABLE 1.25V

1.25V per cell. Used, good condition Sizes are AA-oversize; & sub-C (check dimensions).
Size (in.) Amp. Hr. Sh. Wt. Order No.
365X1.91 .60 4 oz. 7V70468
865X1.63 1.20 5 oz. 7V70470

MOTOROLA®

PIEZO-ELECTRIC TWEETERS

SALE

Hot . . . Super-Horns & Direct Radiators. No crossovers required/High Impedance/High Output/ Excellent Transient Response/ Low Harmonic Distortion. Tomorrow's tweeters today from B&F.

3 1/2" SUPER HORN.
Sh.Wt. 2 Lbs. . . . 8E30248 . . . \$14.88/Pr.
† 2 x 5" Piezoelectric Horn Tweeter.
Sh.Wt. 3 Lbs. . . . 8H30332 . . . \$17.88/Pr.
† 2 X 6" Piezoelectric Horn Tweeter.
Sh.Wt. 4 Lbs. . . . 8H30331 . . . \$23.98/Pr.

RACK CABINET EQUIPTO

Size: 24"x 68" with rails on front & back for mounting equipment on 19" centers. No doors or sides - List Price \$185.00 - NEW SURPLUS! Your cost only \$50 each. Qty Ltd. Frt Collect
80B2049 \$50.00

GAME BOARD TV TENNIS

NEW game board, just off production run. These boards contain a 5V, 1A power supply (less xformer); a "TV-computer interface" (modulator), plus 16 or 20 "74L series IC's & a handful of other components. Complete with schematic for a TV Tennis/Handball game, etc. Instructions are included for using the 5V 1A power supply.
Sh. Wt 8 oz. 8T30322 . . . \$6.88
3 for \$17.88. . . . 8T30322 . . . \$17.88/3
† TRANSFORMER for power supply above.
Sh. Wt 1 Lb. . . . 8T30339 . . . \$1.00

Visit our Retail Stores 119 Foster St., Peabody, Mass. 01960 or our NEWEST store THE TOWN OF DUMPE, INC., next to BOOLCO, 777 Willow St., Manchester, New Hampshire.

SPECIAL OFFER - MENTION THIS AND TAKE 10% OFF ANY ORDER OVER \$10.00

POSTAGE: Please add postage, All material is F.O.B. Peabody, Ma. No C.O.D.'s please. Massachusetts Residents add 5% sales tax.

PHONE ORDERS WELCOME!

Use your Bank Americard, Master Charge or American Express Credit Card!
\$10.00 min. on all charge orders.

B&F ENTERPRISES
DEPT. E-121
119 Foster Street
Peabody, MA. 01960
(617) 531-5774

SAVE WITH SURPLUS **B&F**

Computer Readout

(Continued from page 52)

buffer and then either to a printer or a mass storage device. The user can then retrieve at his convenience the information which has been saved.

Digicasting will provide an inexpensive means of linking a home computer into a large, continuously updated data base. Until now, the largest data bases open to the public have been newspapers and television. These required a person to sit and search the media himself for the items of interest. With Digi-

casting, you can "let your digits do the searching" and seek out a new item, want ad or service, or a collection of items having some subject in common which is of interest to you and which you can define yourself.

One example might be to tell the computer to save all news items containing the words Brazil and coffee. This one would have a file of the political and other events taking place in Brazil as well as a report on the coffee market and prices. Similar applications come to mind with real estate listings. Specify the size and price of the house you are looking for as well as the area. There will not even be any need to

classify ads prior to broadcasting. Each individual's computer will take care of that. Even magazine subscriptions could be sold this way by simply giving subscribers the monthly code/keyword. It is estimated that no more subscriptions would be lost by having keywords passed around than are now lost by people passing around actual copies of magazines.

Let me point out that two years ago, the topics in this article would have been classified as "blue-skying" or "realizeable fantasy." Today they exist. Several Personal Computer Networks are operating and more are getting started. The Digicast™ Project hopes to have at least one broadcast facility in operation by early 1979. Information about Digicasting and the Digicast Project can be found in the *Intellegent Machine Journal* (\$18/year, 345 Swett Road, Woodside, CA 94062).

Another similar data base breakthrough is the agreement between Apple Computer and Dow-Jones to allow owners of Apple II computers to subscribe to Dow-Jones. The computer is linked to the service via a modem and a portfolio of stocks is programmed into the machine. The computer then monitors the daily stock prices and keeps track of the whole portfolio. There is then additional software in the computer to analyze the portfolio and figure profit and other things.

The example of Apple brings home a further point. Once information, especially carefully selected information, has been obtained from a data base, we can read it and make our own decisions about it or we can subject it to further analysis on the individual computer. The forms this will take in the future will be as varied as peoples' needs and interests. But with the ability to access large bodies of information, the personal computer will change from what was mostly an educational and fascinating toy into a truly useful home appliance. It is, however, a kind of appliance nobody really expected it to be when it was first introduced. One is reminded of the eighteenth century scientist who was asked of his recent discovery, "Of what use is it?" His reply was, "Of what use is a child?"

Hey, Look Me Over

(Continued from page 13)

sound applications where exceptionally good music response is required. The Model 2831 is designed to reproduce a broad frequency response spectrum, 50 Hz-15,000 Hz, and will accept 30 watts RMS of continuous power. Suggested retail price is \$19.40. For further information, contact: Acoustic Fiber Sound Systems, Inc., P.O. Box 50829, Indianapolis, IN 46250.



W-H-O-O-P!!
W-H-O-O-P!!

\$24.50

ONLY AT DELTA

Burglar ALARM

MOTION DETECTOR

When there is a new development in electronics, it takes some time before that development is available to hobbyists and experimenters, especially at surplus prices. This time we have reversed the trend, and announce a DELTA EXCLUSIVE, the DELTA MOTION DETECTOR. This device detects any motion or movement for a minimum distance of 8-ft. The secret is in the ultra-complex custom ILSI chip, which combines the latest in linear & digital circuitry. The device is completely self-contained in a case 6 x 3 1/2" and operates from four "AA" NiCad batteries. Nothing else is needed, for the device to perform its basic function, motion detection. When motion or movement is detected a "whoop" alarm is sounded. The MOTION DETECTOR is designed to provide either an audible or silent alarm. The silent alarm is controlled by a timer, which delays the alarm up to 30 seconds. The silent alarm activates a relay, whose contacts are brought out to plug, and will activate ANY device, such as siren, horn, tape record, telephone dialer, etc.

AMPEX TAPE We have acquired an inventory of AMPEX 1.0 mil recording tape. These tapes have been used one time by government weather stations, and then weket them. On standard 7" AMPEX reel. 55885 **\$1.75 (4 for \$6)**

The Motion Detector works on a CHANGE OF LIGHT. Any change of +5% or more, triggers the detector. Works within a range of 0.1 candlepower (almost dark), to 100 candlepower, (quite bright), a range of 1000 to 1: NO external light source is needed.

When left in a darkened or semi-darkened room, the Motion Detector acts as a fantastic FIRE ALARM. The light from a single match, anywhere in the room, triggers the alarm, so that the device becomes an intrusion alarm and fire alarm, all in one.

Delta No.	Description	Sale
□ 56115	Complete motion detector kit (less batteries)	\$24.50
□ 10725	Motion Detector Chip only, with data	8.95
□ 56115	P.C. boards, set of 2	6.50
□ 52885	"AA" NiCad Batteries, set of 4	4.50
□ 56365	Battery charger for above	5.95
□ 56355	Completely assembled kit, w/batteries & charger	69.50

H. H. SCOTT POWER TRANSFORMERS!

4.95

AS LOW AS

DELTA has the entire surplus inventory of H.H. SCOTT transformers that were used in their various amplifiers & receivers. H.H. SCOTT was famous for the quality of their equipment and now here it is better shown than in these transformers. Almost all have a copper magnetic shield for hum reduction. Ratings given below are conservative.

Delta	Second. 1	Second. 2	Size	Lbs.	Each	2 for
9318S	26V @ 1A	6.3V @ .5A	2 x 2 1/2 x 2 1/2"	4	\$4.95	\$9.00
9888S	34V @ .5A	6.0V @ .2A	3 x 3 1/2 x 4 1/2"	9	11.95	22.00
9315S	36V @ 1A	6.3V @ .2A	3 x 2 1/2 x 2 1/2"	4	4.95	9.00
9319S	38V @ 1.5A	6.0V @ .5A	4 x 3 1/2 x 3 1/2"	6	6.95	12.00
6757S	48V @ 2A	6.0V @ .5A	4 1/2 x 4 1/2 x 3 1/2"	7	8.95	16.00
6768S	48V @ 6.5A	5.4V @ .6A	4 1/2 x 4 x 3 1/2"	9	10.95	20.00

50-0-50 MICRO AMP DC CENTER READING METER

Has 12V 4 amp winding & 26V CT @ 15A. For building computers, lab power supplies, battery chargers. Brand new, designed for computer buffer. Complete with 6 mfd capacitor. Wt. 25 lbs. 68355 **\$24.95**

50 MICRO AMP DC DUAL SCALE

Legend: Intermodulation or Input Volts R.M.S. Scales: into 1 10 or 0 to 1. Meter has a true hand & is enclosed in a plastic case with a removable scale. Size: 4 1/2" x 5 1/2" x 2 1/2". #54225 **\$12.95 Each**

Legend: Intermodulation or Input Volts R.M.S. Scales: into 1 10 or 0 to 1. Meter has a true hand & is enclosed in a plastic case with a removable scale. Overall: 4 1/2" x 4 1/2" x 2 1/2". #55025 **\$8.95 Each**

G-E HORIZON LINE TAUT BAND METER

GF Model 251 - 50 microamp movement. 2 Scales: 20 - 0 - 100 and 0 - 3.2" mtg. hole. Shielded movement. Distributor's price \$3.80; our spectacular price less than 25%. Delta No. 56435 **\$7.95**

SMALL GENERAL PURPOSE

325

each 2 for \$6.

6 or 12V 1.25A

This small xfmr meets a multitude of requirements. Either 6 or 12V @ 1.25 A, depending on how the dual primary is wired. If used with 12V, one of the primaries may be used as an isolation winding. Mounts either vertically or horizontally. Size: 2 1/2 x 2 1/2 x 1 1/2" Wt. 1 lb. No. 66235

SERIES SN74XX BENT PIN SPECIAL

Delta has a lot of SERIES SN74XX ICs, plus a few linears, which were removed from wire wrap boards. Included are just about every SN74XX in the book, plus op amps, phase locked loops, etc., and others found in a sophisticated computer system. Only defect is pins bent when removed from board. We are selling these in lots of 125 which will include a good cross-section of the mixture. Money back guarantee if not 100% satisfied. No choice at this price, but you will get a good working supply of these useful devices. 45915 **125-pc. set, SN74XX & linears** (3 for \$25) **\$10**

Free CATALOG

DELTA

ELECTRONICS

P.O. BOX 2, DEPT. 15
7 OAKLAND ST.,
AMESBURY, MASS.
01913

TELEPHONE
AREA 388-4705
617

Send for new catalog 19 - 120 pages of computer & electronic bargains... the best in the world!

Enclose sufficient postage. Excess refunded.

ATLANTA, GEORGIA
DELTA ELECTRONIC HOBBIES
5151 BUFORD HWY, DORAVILLE, ATLANTA, GA.

When in our area, North-eastern Massachusetts or Southern New Hampshire, visit our new show room, loaded with many desirable items that never get in the catalog or ads, due to a limited quantity.

LITERATURE LIBRARY

301. Get into the swing of microcomputer and microprocessor technology with *CREI's* new Program 680. New 56 page catalog describes all programs of electronics advancement.
302. Big catalogs are coming back. *Burstein-Applebee* will send you theirs. It's a parts bonanza every experimenter would want to see. Latest catalog is over 200 pages.
303. *Graymark's* catalog reveals a host of products and kits every experimenter would like to have. Unusual binary clock is a winner. A *must* catalog for the beginner.
304. *Dynascan's* new *B & K* catalog features test equipment for industrial labs, schools, and TV servicing.
305. A new 4-page directional beam CB antenna brochure is available from *Shakespeare*. Gives complete specs and polarization radiation patterns for their new fiberglass directional antennas.
306. *Antenna Specialists* has a new 32-page CB and monitor antenna catalog, a new amateur antenna catalog, and a complete accessory catalog.
307. *Atlas* calls their 210X and 215X the perfect amateur mobile rigs. Their 6-page, full-color detailed spec sheet tells all. Yours for the asking.
308. Your guide to equipment for radio communication is an informative product booklet offered by *R. L. Drake Co.* Hams and SWLers alike should scan this 20-page shopper's guide.
310. New and used personal computer machines, and peripherals you never dreamed existed, or were available are in the *Newman Computer Exchange* catalog. Get yours today.
311. *Midland Communications'* line of base, mobile and hand-held CB equipment, marine transceivers, scanning monitors, plus a sampling of accessories are covered in a colorful 18-page brochure.
312. *E.D.I. (Electronic Distributors, Inc.)* carries everything from semi-conductors to transformer/relays to video cameras. In prices ranging from 19¢ to \$500, products appear from over 125 electronic parts manufacturers. The catalog is updated 3 times a year.
313. Get all the facts on *Progressive Edu-Kits* Home Radio Course. Build 20 radios and electronic circuits; parts, tools, and instructions included.
314. Cover the Ham bands from 80 to 10-meters with one classy rig—*Swan Electronics'* 100-W 100 MX mobile transceiver. Get the details direct from *Swan*.
316. Get the *Hustler* brochure illustrating their complete line of CB and monitor radio antennas.
318. *GC Electronics* offers an "Electronic Chemical Handbook" for engineers and technicians. It is a "problem solver" with detailed descriptions, uses and applications of 160 chemicals compiled for electronic production and packaging. They are used for all types of electronic equipment.
320. *Edmund Scientific's* new catalog contains over 4500 products that embrace many sciences and fields.
321. *Cornell Electronics'* "Imperial Thrift Tag Sale" Catalog features TV and radio tubes. You can also find almost anything in electronics.
322. *Radio Shack's* 1979 catalog colorfully illustrates their complete range of kit and wired products for electronics enthusiasts—CB, ham, SWL, hi-fi experimenter kits, batteries, tools, tubes, wire.
330. There are nearly 400 electronics kits in *Heath's* new catalog. Virtually every do-it-yourself interest is included—TV, radios, stereo and 4-channel, hi-fi, hobby computers, etc.
331. *E. F. Johnson* has a CB 2-way radio catalog to help you select equipment for your vacation, business travel, or normal day-to-day "bucking the mob."
332. If you want courses in assembling your own TV kits, *National Schools* has 10 from which to choose. There is a plan for GIs.
333. Get the new free catalog from *Howard W. Sams*. It describes 100's of books for hobbyists and technicians—books on projects, basic electronics and related subjects.
335. The latest edition of the *TAB BOOKS* catalog describes over 450 books on CB, electronics, broadcasting, do-it-yourself, hobby, radio, TV, hi-fi, and CB and TV servicing.
338. "Break Break," a booklet which came into existence at the request of hundreds of CBers, contains real life stories of incidents taking place on America's highways and byways. Compiled by the *Shakespeare Company*, it is available on a first come, first serve basis.
342. *Royce Electronics* has a new 1979 full line product catalog. The 40-page, full-color catalog contains their entire new line of 40-channel AM and SSB CB transceivers, hand-helds, marine communications equipment, and antennas and accessories.
345. For CBers from *Hy-Gain Electronics Corp.* there is a 50-page, 4-color catalog (base, mobile and marine transceivers, antennas, and accessories). Colorful literature illustrating two models of monitor-scanners is also available.
354. A government FCC License can help you qualify for a career in electronics. Send for Information from *Cleveland Institute of Electronics*.
355. New for CBers from *Anixter-Mark* is a colorful 4-page brochure detailing their line of base station and mobile antennas, including 6 models of the famous Mark Heliwhip.
356. *Continental Specialties* has a new catalog featuring breadboard and test equipment for the professional and hobbyist. Descriptions, pictures and specifications aid your making a choice.
359. *Electronics Book Club* has literature on how to get up to 3 electronics books (retailing at \$58.70) for only 99 cents each . . . plus a sample Club News package.
361. "Solving CB Noise Problems" is published by *Gold Line* and tells you how to reduce the noise and get a clearer signal. In discussion and diagram you can find out about the kinds of noise, their sources, and the remedies.
362. *B&F Enterprises'* Truckload Sale catalog offers 10% off all merchandise: (military or industrial surplus) speaker kits, TV games, computer terminals, tools, TV components, lenses, and more.
364. If you're a component buyer or specifier, you'll want this catalog of surplus bargains: industrial, military, and commercial electronic parts, all from *Allied Action*.
365. *Electronic Supermarket* has a new catalog of almost everything in the field—transformers, semi-conductors, tv parts, stereos, speakers, P.C. boards, phones, wire and cable, tools, motors.
366. How about a hybrid 13-watt audio module for \$8.88? Or ultrasonic transducer for \$1.49? You find these and other exotic parts and products aplenty in *Poly Paks* flyer. Get your copy now!
367. *Optoelectronics'* new catalog features their new Frequency Counter, a 6-digit clock/calendar kit, mobile LED clock, biorhythm clock, digit conversion kit, and many others.
371. Your computer system needn't cost a fortune. *Southwest Technical Products* offers their 6800 computer complete at \$395 with features that cost you extra with many other systems. Peripheral bargains are included here.
372. See how you can save with *Olson's "Erector Kit" Computer System*; also their factory wired version which includes a 2-volume Bell & Howell instruction course. Send for information.
373. *ETCO* has a Grand Opening Catalog which anyone in the electronics field shouldn't miss. Full of all kinds of products from surplus and warehouse sales, they claim everyone is a bargain.
374. *Radatron's* Catalog 1006 lists many projects from a self-contained portable lab station for an electricity-electronics course to many texts, lab manuals, and applied activities.
375. *CompuColor Corp.* has a personal computer system with an 8-color integral display, a typewriter-like keyboard, and a mass storage device. Programs are ideal for checkbook and income tax figuring.
376. *Sparkomatic* offers all the car sounds for the "travelin' man"—speakers, amplification systems, radios, speaker accessories along with CB antennas, all presented in 4-color pics with descriptions.
377. We can't enumerate all the products in *John Meshna, Jr.'s* catalog of surplus electronic parts: power supplies; computer keyboards; kits for alarms, clocks, speakers; and more.
378. *Delta Electronics* is a complete parts source for electronics experimenters. Discrete parts, modules, boards, subassemblies and complete gadgets. Get *Delta's* 120-page catalog today.
379. There's everything in the area of musical synthesizers for drums, strings, other instruments and full orchestras, as well as audio gear, video display modules, and a computer in *PAIA Electronics'* catalog.
380. If your projects call for transistors and FETS, linear and digital ICs, or special solid-state parts, then look into *Adva Electronics'* mini-catalog for rock bottom prices.

Classified

MARKET

ELEMENTARY ELECTRONICS—is published Bi-monthly. The rate per word for CLASSIFIED ADVERTISEMENTS is \$1.30 payable in advance—minimum ad \$15.00. Capitalized words 40¢ per word additional.

ADDITIONAL INCOME

MECHANICALLY INCLINED INDIVIDUALS WANTED—ASSEMBLE ELECTRONIC DEVICES IN YOUR HOME. Get started in spare time. Experience, Knowledge or Investment Not Necessary. Expect big profits: \$300-\$600/Wk. Possible. Write for free literature telling how. Electronic Development Lab, Box 1355E, Pinellas Park, FL 33565.

NO experience—earn \$53/per day at home, guaranteed. Newsletter \$1.00. Spirit Delight, 97-23 100 Street, Dept. 4, Queens, NY 11416.

\$200 WEEKLY: BECOME COMMISSION MATTER. FREE REPORT. GRAHAM'S, DPBX 99371, TACOMA, WA 98499.

ACCOUNTING & TAX SERVICE

CUT YOUR INCOME TAX! Amazing report reveals 20 money saving secrets. \$1.00 refundable! John Malson, 256 EE(1) South Robertson, Beverly Hills, California 90211.

AUTHOR'S SERVICE

PUBLISH YOUR BOOK! Join our successful authors. Publicity, advertising, beautiful books. All subjects invited. Send for fact-filled booklet and free manuscript report. Carlton Press, Dept. SMM, 84 Fifth Avenue, New York 10011.

BIG MAIL

RECEIVE MONEYMAKING OPPORTUNITIES. Your name placed with 2,000+ Importers, wholesalers, manufacturers, etc. Year listing—\$1.00 (SAVE \$160.00 Postage!) Advertising Agency, Box 123-YNA, Wenhonah, NJ 08090.

BLUEPRINTS, PATTERNS & PLANS

NEW CRAFT-PRINT CATALOG—Choose from over 100 great easy-to-build plans. Send \$1.25 (completely refunded with your first order). BOAT BUILDER, (CP Div.)—380 Lexington Ave., New York, NY 10017.

WHAT'S going on in housing? Get advice on how to economize in modernizing or improving or adding space from idea to completion. Working blueprints available. Send \$1.50 (includes postage) for 110 Better Building Ideas to: Davis Publications, Inc., 380 Lexington Ave., New York, NY 10017.

BOOKS & PERIODICALS

FREE! CATALOG, SELF IMPROVEMENT BOOKS. The Mail Sack, Dept. C1179, 600 Welch Blvd., Flint, Michigan 48503.

CBer's! Personalized CB decal with a 1-year subscription to Elementary Electronics only \$3.97. E/E the magazine that covers CB and all areas of radio communication. Send check: Elementary Electronics, Decal Dept., 380 Lexington Ave., New York, NY 10017.

BUSINESS OPPORTUNITIES

BECOME our Mail Order Distributor with \$150 investment. Free brochure. Audit Controls, Box D-35, Emerson, NJ 07630.

BORROW ANY AMOUNT. Enjoy A-1 credit. Keep money in bank—get 80% more. Send Stamp. Various

BUSINESS OPPORTUNITIES—Cont'd

MANUFACTURING Business paying High Weekly Profits. Begin home, spare/full time. Many opportunities presently available Without investment. Businesses, 92-D Brighton 11th, Brooklyn, NY 11235.

OVER \$16.50 an hour. Spare time at home! Rubber Stamp industry needs small manufacturers. We furnish all equipment and know-how! Particulars free! Write: Roberts, Room RC-107-1A, 1512 Jarvis, Chicago, IL 60626.

\$500 Monthly Clipping Newspaper Items. Experience unnecessary. Free Details. American 1108 Colonial, Inkster, MI 48141.

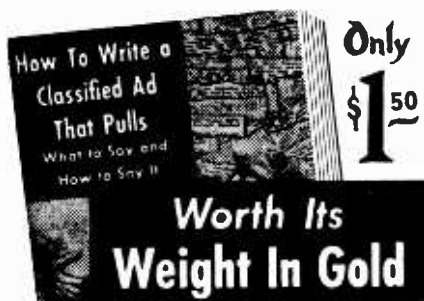

MAKE YOUR CLASSIFIED AD PAY. Get "How to Write A Classified Ad That Pulls." Includes Certificate worth \$2.00 towards a classified ad in this publication. Send \$1.50 (plus 25¢ for postage) to R. S. Wayner, Davis Publications, Inc., Dept. CL 380 Lexington Avenue, New York, NY 10017.

PLEASE Be sure to include your zip code when ordering merchandise from classified advertisements. You'll receive faster delivery.

ULTIMATE Security System for homes, businesses, property. Not an alarm, not a gimmick. A remarkably innovative product with 17 issued patents. Nothing else like it. Reliable, effective, inexpensive. Send \$1.00 for complete information. Security Control Research, 932 West First, Birdsboro, PA 19508 Dealerships available.

DIRECT TO FARM SALES. New Patented Product! \$100/Day. Free Details! Conservtek P.O. Box 35305, Edina, MN 55435.

BORROW \$25,000 interest free! indefinitely! Anyone! Free report: "Executive IO11, Box 368, Buford, GA 30618.

GUARANTEED WEEKLY Income of \$178.00 (\$35.60 daily working one hour at home). Earnings guaranteed. FAS, Box 13703, San Antonio, Texas 78213.

BUSINESS OPPORTUNITIES—Cont'd

BUY WHOLESALE! Over 1001 gifts and specialty items, details free! McCord's Distributors, 2932 Caswell Dr., Anderson, IN 46012.

FREE Details: \$100.00 Day Possible Buying Scrap Gold!!! Meredith, Box 11216VE, Reno, Nevada 89510.

COMPLETE Color Picture Tube rebuilding equipment with four place oven. Top condition. Contact Mr. Scholz, Box 271, Christina Lake, B.C., Canada V0H 1E0.

\$400 WEEKLY!! Home mailers needed. Send now for FREE details. Wilson, Combo-1, 5211 Fredericksburg #128, San Antonio, TX 78229.

BUY IT WHOLESALE

QUALITY COSTUME JEWELRY BELOW WHOLESALE! Excellent Selection. Manufacturer Direct. IMC, Box 336-EE, Sylvania, Ohio 43560.

400,000 BARGAINS Below Wholesale! Many Free! Liquidations . . . Closeouts . . . Job Lots . . . Single Samples. Free Details Worldwide Bargain-hunters, Box 730-IO, Holland, MI 49423.

SAVE MONEY! Buy low cost items. 5 catalogs \$4.00 World Directory \$3.00. International Directory \$3. 1001 Things Free \$2.00. All (8) \$10.00. Winchester Enterprises, Inc., 2807BC Hargrave Street, Phila., PA 19136.

CB RADIO

GET a CB Installer's Kit Free! You're just 10 days away from making \$12 to \$25 an hour in your spare time. Our self-study CB radio repair course can prepare you for a career in electronics. For more information call toll free 1-800-654-6785 or write CB Radio Repair Course, Inc., Dept. EE-108, 531 N. Ann Arbor, O klahoma City, OK 73127.

DO IT YOURSELF

REPAIR TV'S, ANYONE CAN. Easy. Guaranteed. Free Details. Publication, Box 517Y, Brea, CA 92621.

FREE Encyclopedia Winemaking, Beer-making Supplies, Equipment, Ingredients. Vynox Industries, Box E/E-7498, Rochester, NY 14615.

BUILD YOUR OWN BUGGING DEVICE. Quite small, transmission to any FM radio. Plans and parts list \$2.00, or complete kit for beginners \$16.95. Send to: JRC Electronics Corp., Box 711-C, Glen Ellyn, IL 60137.

SPEAKER REPAIR—Complete How-to. 24 Illustrations. \$2: Repair, 2860 Park St., Honolulu, HI 96817.

FOR anyone who wants the satisfaction and economy of repairing, furnishing and maintaining the furniture in his home. Send \$1.50 to FURNITURE, 380 Lexington Ave., New York, NY 10017.

EDUCATION & INSTRUCTION

USED Courses! Books! Lists 25¢ SMITH'S, 124 Marlborough, Salem, MA 01970.

GET INTO BROADCASTING: Become DJ engineer. Start your own station, get free equipment, records. Free details. "Broadcasting," Box 130-GIE, Paradise, CA 95969.

COLLEGE degree by mail, via resume. Education. 256D South Robertson, Beverly Hills, CA 90211.

LEARN Computer Programming (BASIC or FORTRAN), Electronics, FCC License, Mathematics, through correspondence study. Free information: Intermountain Technical Institute, (Room 13), Box 258, Jerome, ID 83338.

sp.
781

ito
Cit

in-
E.,

PLACE

Classified

To be included in the next issue, please send order and remittance to R. S. Wayner, ELEMENTARY ELECTRONICS, 380 Lexington Ave., New York, N.Y. 10017

ELECTRICAL EQUIPMENT & SUPPLIES—Cont'd

LIGHT Triggered IC Relay Driver. 6 VDC Adjustable. Threshold. All Assembled only \$3.00 #302AT. Sonic Switch turns on Lamps, Motors, etc. Completely Assembled Solid State Super Buy only \$3.00 #210AT. 3 Transistor Audio Preamp for Mike, Phono, Tape, etc. HI-Q-input, 8-45 Ohm output. 3 VDC Completely Assembled. Only \$4.00 #AT032 ABT Systems, POB 173, Schererville, IN 46375.

TRS-80 SOFTWARE Level I BASIC 4K-ROM. Free brochure. FH Curley Services, PO Box 156, Rochester, MN 55901.

EMPLOYMENT INFORMATION

AUSTRALIA-New Zealand want you!! Big pay. All occupations. Reports \$2.00. AUSTCO, Box 8489-EE, Long Beach, CA 90808.

FOR THE HOME

PRACTICAL tips for home, garden and workshop can be found in "1001 How-To Ideas." Send \$1.50 for your copy (includes postage) to 1001 How-To Ideas, 380 Lexington Ave., New York, NY 10017.

BUDGET Recipes. SASE \$1.00. Churchco Distributors, 625 St. Clair St., Box 5, Chatham, Ontario, Canada N7L 3L3.

FRANCHISE OPPORTUNITIES

2000% profit selling information by mail, free details. International, 1 Tay, Dartmouth, N.S. B2X 1K5.

GOVERNMENT SURPLUS

JEEPS—\$59.30—CARS—\$33.50! 200,000 ITEMS—GOVERNMENT SURPLUS—MOST COMPREHENSIVE DIRECTORY AVAILABLE tells how, where to buy—YOUR AREA—\$2.00—MONEYBACK GUARANTEE. Government Information Services, Department E11, Box 99249, San Francisco, CA 94109 (433 California).

HOBBIES & COLLECTIONS

"NEW" Electronics Kits for the Hobbyist. \$1.00 for Catalog and monthly Kit News. Hobbi Shack, P.O. Box 235, Jersey City, New Jersey 07303.

HYPNOTISM

FREE Fascinating Hypnosis Information! Startling! DLMH, Box 447, Anaheim, California 92805.

INVENTIONS WANTED

IDEAS, inventions, new products needed by innovative manufacturers. Marketing assistance available to individuals, linkers, universities, companies with feasible concepts. Write for Kit-EE, IMI, 701 Smithfield, Pittsburgh, PA 15222.

JEWELRY

FREE! 48 page color jewelry catalog. Russo, Box 1106-D, Wayne, NJ 07470.

LOANS

BORROW \$25,000 "overnight." Any purpose. Keep indefinitely! Write: Success Research, Box 29293-SM, Indianapolis, IN 46229.

MAGNETS

MAGNETS. All types. Specials—20 disc, or 10 bar, or 2 stick, or 3 assorted magnets, \$1.00. Magnets, Box 192-E, Randallstown, MD 21133.

MISCELLANEOUS

NEW occult products including King Tut jewelry! Free Catalog! World, 7247-1 Eccles, Dallas, TX 75227.

MISCELLANEOUS—Cont'd

DOUBLE DUTY ALERT. Unique electronic alarm protects against vandals, fire. Portable or permanent installation. Ideal for mobile homes. Guaranteed. \$12.95. Danshee Enterprises, 73A Oak St., Closter, NJ 07624.

P.C. BOARDS, your artwork. No setup charge. \$.45/sq in. single sided, \$.60/sq in. double sided. Ohio residents add 4.5% sales tax. Digitronics, P.O. Box 2494, Toledo, Ohio 43606.

GREETING Cards—Custom made for any occasion. Paul Reich Productions, Box 384, Peconic, NY 11958.

AWARD Medals, enameled pins. Made from your design. Very inexpensive when ordered by the hundred. Trinity Enameled Pins, P.O. Box 322, La Mesa, CA 92041.

PRINTED Circuit Boards From Sketch or Artwork. Free Details. DANOCINTHS, Box 261, Westland, MI 48185.

MONEYMAKING OPPORTUNITIES

\$250.00 profit/thousand possible—stuffing—mailing envelopes. Offer: Rush stamped addressed envelope: Universal-ADVS X16180 Fort Lauderdale, FL 33318.

FANTASTIC Profits: Mailing Circulars Free Samples. Grahamco. DPBX 99371, Tacoma, WA 98499.

\$180.00 WEEKLY Mailing Circulars. Start immediately. Everready, 422A Clermont Ave., Brooklyn, NY 11238.

MAKE YOUR CLASSIFIED AD PAY. Get "How to Write A Classified Ad That Pulls." Includes certificate worth \$2.00 towards a classified ad in this publication. Send \$1.50 (plus 25¢ for postage) to R. S. Wayner, Davis Publications, Inc., Dept. CL, 380 Lexington Ave., New York, NY 10017.

"WIN thousands! Thoroughbred, Harness, Dog! Guaranteed. Free report. Finish-A, Box 6226, Toledo, OH 43614."

\$83,501.00 FREEBIES WAITING! GOVERNMENT DIRECTORY \$3.00. PALMER, B1244DG, Phenix City, AL 36967.

\$300.00 WEEKLY Mailing Circulars. Write: McGuire, Box 91054, Tacoma, WA 98491.

HOW To Make Money Writing Short Paragraphs. Information free. Barrett, Dept. C21Y, 8 South Michigan, Chicago 60603.

AMAZING NEW PROGRAM for making money. Details—\$1.00. Der, Box 53, Station Cotdes Neige, Montreal, Canada H3S 2S4.

\$200 WEEKLY stuffing envelopes spare time possible. Details, stamped, self-addressed envelope, Mail Sales-I, 8023 Leavenworth Rd., Kansas City, KS 66109.

NEWEST INCOME OPPORTUNITIES. \$100's-\$1,000's easily! FREEBIES/exciting details FREE! Ben Gee's-1; 288 N. Livingston, Livingston, NJ 07039.

GUARANTEED big money making program. Abraxas Ent., P.O. Box 6072, Evansville, IN 47712.

\$45,000 in Three Weeks—Guaranteed. \$1 for Info & Handling. John Davidson, 5483 Holly Ridge, Camarillo, CA 93010.

\$300 WEEKLY! Home Mailing Program. Details: Thomas, Dept-D1, Box 11773, Charlotte, NC 28220.

\$2000.00 MONTHLY Possible Stuffing Envelopes! Send Stamped-Self-Addressed Envelope. Continental, Box 3419D, Mission Viejo, CA 92675.

EARN \$100 Week at home. Details 25¢, stamped addressed envelope. D. Annas, Grandview Street, Granite Falls, NC 28630.

MONEYMAKING OPPORTUNITIES—Cont'd

STUFF Envelopes, \$500/Thousand. Free Details. Cew Company, 533 Wooster Road, Mt. Vernon, Ohio 43050.

EXCELLENT Second Income Without Leaving Your Home. Send self-addressed stamped envelope to Ben E. Johnson, 9152 S. Carpenter St., Chicago, Illinois 60620.

FREE details, \$9 profits on \$10 orders. International, 1 Tay, Dartmouth, N.S. B2X, 1K5.

MOTION PICTURE PROJECTORS, FILMS, SLIDES & SUPPLIES

FREE discount catalog. Super 8, 16mm movies, supplies. Coastal, 1428R San Marco, Jacksonville, FL 32207.

OF INTEREST TO ALL

ASTONISH your friends with magic. ESP. card tricks You can do. Details: Langen, Box 191-DA, Downsview, Ontario M3M 3A3.

TRS-80 MICRO COMPUTER by mail at 15% discount off list price. All other RADIO SHACK equipment at 10% off. Offered by MICRO MANAGEMENT SYSTEMS, an authorized RADIO SHACK DEALER. Downtown Shopping Center, Cairo, GA 31728. 912-377-7120.

PEN PALS

JOIN North America's leading penpal club. Details from Friends Worldwide CP-95/F Anjou, Montreal, H1K 4G5.

PERSONAL

NEW Luxury Car Without Cost! Free Details. Codex-CC, Box 6073, Toledo, OH 43614.

DATES GALORE! Meet singles-anywhere. Call DATELINE, toll-free (800) 451-3245.

RECORD Telephone conversations privately—automatically. Leave recorder Unattended. Robert's, 2618 Elmwood Blvd., Wausau, WI 54401.

BEAUTIFUL GIRLS from all continents want correspondence, friendship, marriage. Sample photos free. Hermes-Verlag, Box 110660/D, 1000 Berlin 11, Germany.

SINGLE? Widowed? Divorced? Nationwide introductions! Identity, Box 315-DC, Royal Oak, MI 48068.

CONFIDENTIAL REPORT. Electronic Surveillance Devices. Send \$10.00—CPS, Attn. Leroy K. Thompson, 5420 N. College Avenue, Indianapolis, Indiana 46220.

JAPANESE Girls Make Wonderful Wives. We have large number of listings. Many interested in marriage. Only \$1.00 brings application, photos, names, descriptions, questionnaire, Etc. Japan International, Box 156 AA, Carnelian Bay, CA 95711.

SURPRISE—send 25¢ to: Langen, Box 191-DC, Downsview, Ontario M3M 3A3.

A Card Players Dream. 25¢ to: Langen, Box 191-DB, Downsview, Ontario M3M 3A3.

BEAUTIFUL Mexican-Oriental girls Needing American Boy-Friends. Free Details "actual" photos. World, Box 3876-DC, San Diego, CA 92103.

"DATE WITH DIGNITY" Professional Matching. Drawer 8765, Fort Worth, 76115 (817) 921-0281.

MEET SEXY SWINGERS Nationwide. FREE Details. (State Age). Gateway, Box 338-DC, Lafayette, CO 80026.

FREE: 1,000 LADIES PHOTOS. World's largest Matrimonial Catalog. Postage/Handling \$1.00. Inter-contact, Box 12, Toronto, Canada M4A 2M8.

MORE

For Greater Advertising Savings... Results... and Profits...

Place your ad in one of our SPECIAL COMBINATIONS: Combo #1, Combo #2, or Combo #3. Each combination is designed to give your ad the largest audience available. For further information write to R. S. Wayner, Classified Ad Manager, Davis Publications, Inc., 380 Lexington Ave., N.Y., N.Y. 10017.

Classified Continued

PERSONAL—Cont'd

BECOME ORDAINED MINISTER legally. Credentials free. Use title "Reverend." Write: Church of the God Within. Box 01-5313, Miami, Florida 33101.

BEAUTIFUL MEXICAN GIRLS! Friendship, marriage! Photos, information free. "Latinas," Box 1716-E, Chula Vista, CA 92012.

PERSONALIZED BIORHYTHMS—Three month printout only \$1.00. Send birthdate. Brian Peterson, Box 231-E, Northfield, Minnesota 55057.

JAPANESE Introductory! Girls' photographs, descriptions, brochure, details, \$1.00 INTER-PACIFIC. Box 304-SC, Birmingham, MI 48012.

DO YOU KNOW "How to Write a Classified Ad That Pulls" includes a certificate worth \$2.00 toward a classified ad in any of our publications? For your copy send \$1.50 (plus 25¢ for postage) to R. S. Wayner, Davis Publications, Inc., Dept. CL, 380 Lexington Ave., New York, NY 10017.

LOVELY? LOVELY LADIES? 200 names, photos, addresses, descriptions, 16 page illustrated magazine, only \$3. Hurry! Write: Meitt, Box 74758-C, Los Angeles, California 90004.

RADIO & TELEVISION

TV TUBES 36¢ each. Send for Free 48 page color catalog. Cornell, 4217-W University, San Diego, California 92105.

LINEAR AMPLIFIERS, 25-100 watt solid state. OMNIPOLARIZED BASE ANTENNAS. Portable/mobile/memory/00 MHZ FREQUENCY COUNTER. Construction plans: \$3.00 each, 3/\$7.50. Specify frequency band! Kits available. Free catalog! PANAXIS, Box 130-GIE, Paradise, CA 95969.

TUBES Oldies, latest. Supplies, components, schematics. Catalog free. (Stamp appreciated). Steinmetz, 7519-EE Maplewood, Hammond, IN 46324.

BUILD Distance Crystal Sets. 10 plans—25¢; Hand-book "18 Different"—50¢; "20 Different"—50¢. Catalog 50¢. Laboratories, 1477-G, Garden Grove, CA 92642.

SAVE 50% build your own speaker system. Write McGee Radio Electronics, 1901 McGee Street, Kansas City, MO 64108.

CONSUMER TV REPAIR PROTECTION GUIDE. 35 fact-filled chapters. Non-technical language. Save service calls. Reduce anxiety about radiation, burning sets, lightning damage, picture tube failure. New protection for lightning. When to repair or buy. Detailed, illustrated major & minor repair symptoms and defects. Installing antennas illustrated. Who to call—TV man or antenna man? Consumer questions and answers. 33 years experience. Copyrights. Complete Guide \$6.95 Postpaid. Send check or Money Order (No COD). GENE'S COLOR TV, 79 West St., Lunenburg, MA 01462.

VERY Interesting! Next 5 issues \$2. Electronics Trader, Folly Beach, SC 29439.

LINEAR Amplifiers 3.5-30 MHZ. Schematics, Detailed Instructions For Base BL-200, Mobile BL-100 and BL-200. All, \$6.00. Bomar's, Box 541, Pendleton, SC 29670.

RUBBER STAMPS

RUBBER stamps made. Three lines \$3.75. Rubber Stamps, B1337-E9, Waldo, AR 71770.

SCIENCE & CHEMISTRY

FIREWORKS! Spectacular novelties. Simplified manufacturers textbook. \$5.00. Tropic, Box 95M, Palm Bay, FL 32905.

SONGWRITERS

SONGWRITERS: Exciting offer—poems, songs needed—Free evaluation—Creative Music Productions, Box 1943-A11, Houston, TX 77001.

START YOUR OWN BUSINESS

GET World's Biggest Wholesale Import Merchandise Catalog. Details Free. Worldround-P, Medina, WA 98039.

TURN SCRAP WOOD into bowls, lamps etc. Complete directions—jig plans \$3. Halcraft, Box 13422, Gainesville, FL 32604.

EVERYONE a prospective customer. Show our line of belt buckles, badges and accessories to truckers, police, firemen, postal carriers, taxi and bus drivers and others. Personalizations available. Over 8000 emblems available. Hook-Fast, Box 1088-IN, Providence, RI 02901.

WATCHES, WATCHMAKING & REPAIRING

WATCH and clock repairing books, tools, materials. Free Catalog. North American, Box 77, EE47, Fox River Grove, IL 60021.

Simply BASIC

(Continued from page 70)

odds-makers whose prognostications appear in your local newspapers.

Gamble allows you to plug in as many performance factors as you need in order to estimate the relative performance between contenders in a sporting event. You assign a relative value to each performance factor. Then you rate each team, player, or even horse, for its individual performance for each performance factor. (Note: Some BASICS cannot handle more than 10 entries for one subscribed variable, hence, you will be limited to 10 teams and factors unless you modify the program by adding a DIMENSION statement. For example, to enter up to 50 teams or factors add the following line: 168 DIM F\$(50),T\$(50),S(50). Your only limitation on entries is the amount of RAM available in your computer.)

Our sample run is for a baseball game. And while we know the old adage that "On any given day any baseball team can beat any other team," it does serve for a good example. (That's why you shouldn't bet on a baseball game.) We show five factors for two teams though if we were handicapping a horse race we could show, perhaps, six factors for seven horses.

Okay, now run all of this weekend's sporting events through your computer and see how your handicapping stacks up against the actual outcome of the games and races.

HOW MANY TEAMS ARE BEING RATED? 2

TEAM # 1 ? BUFFALO BEARS

TEAM # 2 ? GREENPORT GIANTS

RATE EACH TEAM FOR EACH FACTOR ON A SCALE OF 1-5

BUFFALO BEARS

PITCHING ? 4
HITTING ? 5
FIELDING ? 4
BASERUNNING ? 3
BUNTING ? 4

RELATIVE PERFORMANCE FACTORS

PITCHING POINTS = 20
HITTING POINTS = 25
FIELDING POINTS = 16
BASERUNNING POINTS = 9
BUNTING POINTS = 4

TOTAL RELATIVE PERFORMANCE FACTOR = 74

GREENPORT GIANTS

PITCHING ? 2
HITTING ? 4
FIELDING ? 3
BASERUNNING ? 3
BUNTING ? 5

RELATIVE PERFORMANCE FACTORS

PITCHING POINTS = 10
HITTING POINTS = 20
FIELDING POINTS = 12
BASERUNNING POINTS = 9
BUNTING POINTS = 5

TOTAL RELATIVE PERFORMANCE FACTOR = 56
READY

STATEMENT OF OWNERSHIP

Statement of ownership, management and circulation (Act of August 12, 1970: Section 3685, Title 39, United States Code) of Elementary Electronics published bi-monthly at 380 Lexington Ave., New York, NY 10017 for October 1, 1978. Annual subscription price: \$6.95. Publication No. 172540.

General business offices of the publisher are located at 380 Lexington Ave., New York, NY 10017. Names and addresses of publisher, editor, and managing editor: Publisher, Joel Davis, 380 Lexington Ave., New York, NY 10017; Editor, Julian S. Martin, 380 Lexington Ave., New York, NY 10017; Managing Editor, Alan H. Rose, 380 Lexington Ave., New York, NY 10017.

Owner is: Davis Publications, Inc., 380 Lexington Ave., New York, NY 10017; the names and addresses of stockholders owning or holding 1 per cent or more of total amount of stock are: Davis Publications, Inc., 380 Lexington Ave., New York, NY 10017; Joel Davis, 380 Lexington Ave., New York, NY 10017; B. G. Davis Trust, 380 Lexington Ave., New York, NY 10017; Carol Davis Teten, 380 Lexington Ave., New York, NY 10017. Known bondholders, mortgagees, and other security holders owning or holding 1 per cent or more of total amount of bonds, mortgages, or other securities: None.

The average number of copies of each issue during the preceding 12 months are: (A) Total number of copies printed: 280,254; (B) Paid circulation: (1) Sales through dealers and carriers, street vendors and counter sales: 39,938; (2) Mail subscriptions: 171,051; (C) Total paid circulation: 210,989; (D) Free distribution by mail, carrier or other means—samples, complimentary, and other free copies: 863; (E) Total distribution (sum of C and D): 211,852; (F) Copies not distributed: (1) Office use, left-over, unaccounted, spoiled after printing: 807; (2) Returns from news agents: 67,595; (G) Total: 280,254.

The actual number of copies of single issue published nearest to filing date are: (A) Total number of copies printed, 288,645; (B) Paid Circulation: (1) Sales through dealers and carriers, street vendors and counter sales: 39,000; (2) Mail subscriptions: 190,182; (C) Total paid circulation: 229,182; (D) Free distribution by mail, carrier or other means—samples, complimentary, and other free copies: 1,200; (E) Total distribution: 230,382; (F) Copies not distributed (1) Office use, left-over, unaccounted, spoiled after printing: 825; (2) Returns from news agents: 57,438; (G) Total: 288,645.

I certify that the statements made by me above are correct and complete.

(signed) V. C. Stabile
Vice President and Treasurer

For completion by publishers mailing at the regular rates (Section 132.121, Postal Service Manual). 39 U.S.C. 3626 provides in pertinent part: "No person who would have been entitled to mail matter under former section 4359 of this title shall mail such matter at the rates provided under this subsection unless he files annually with the Postal Service a written request for permission to mail matter at such rates." In accordance with the provisions of this statute, I hereby request permission to mail the publication named in item 1 at the reduced postage rates presently authorized by 39 U.S.C. 3626.

(signed) V. C. Stabile
Vice President and Treasurer

INDEX TO ADVERTISERS

RS.#	ADVERTISER	PAGE
39	Active Electronics	92
21	Anixter Mark	27
34	Antenna Specialties	5
29	A.P. Products	17
28	Avanti	1
	Barta	26
41	Bell & Howell	23
6	B & F Enterprises	93
23	B & K Precision	28
	— CFR Associates	26
	— C.I.E.	8-11
8	Cobra	CV2
9	Continental Specialties	CV3
13	Delta Electronics	94
36	Dennio Jim & Co.	90
22	Digi Key	24
2	Eico	22
30	Electronics Book Club	83
11	ETCO	90
12	Finney	16
	— Gilfer	24
1	Heath Co.	46-49
35	Hobby World	12
24	International Crystal	26
	— Locksmithing Institute	24
	— McGee	26
38	Non Linear	12
	— N.R.I.	18-21
	— N.T.S.	36-39
5	OK Machine & Tool	13
15	PAIA	16
16	Percom Data	91
20	Poly Paks	14
17	President	3
18	Progressive Edu-kit	25
	— Radio Shack	CV4
	— Radio Shack	15
14	Scientific Systems	90
25	Shakespeare	6, 7
26	Southwest Technical	22

Spend less. Test more.

Faster, easier and more economical digital testing. That's what CSC's Logic Probes are all about. And that's what engineers, technicians and hobbyists need, to deal with the increased use and complexity of digital circuits.

Unlike oscilloscopes, meters and other conventional test equipment, CSC probes are *logic-state oriented*: Just touch the probe to a circuit node and *instantly* read logic state, detect level transitions, check duty cycles. And store high-speed, low-rep-rate events that even fast scopes miss.

By accurately detecting the state of individual logic elements without removing ICs or cutting copper paths, CSC's circuit-powered,

without pulse memory capability. Handling a minimum pulse width of 300 nanoseconds, this 300 K ohm probe is the economical way to test



circuits up to 1.5 MHz. It detects pulse trains or single-shot events in TTL, DTL, HTL and CMOS circuits, replacing separate pulse detectors, pulse stretchers and node state analyzers.

LP-3 LOGIC PROBE. \$69.95*

Our LP-3 has all the features of the LP-1 plus extra high speed. It captures pulses as narrow as 10 nanoseconds, and monitors pulse trains to over 50 MHz. Giving you the essential capabilities of a high-quality memory scope at *about 1/100th the cost*. LP-3 captures one-shot or low-rep-rate-events all-but-impossible to detect any other way. All without the weight, bulk, inconvenience and power consumption of conventional methods.



multi-family Logic Probes locate over 95% of circuit problems in minutes instead of hours. And they're easy to use. Simply connect two clip leads across the power supply, touch the probe tip to a node and watch the LEDs.

LP-1 LOGIC PROBE. \$44.95*

LP-1 has a minimum detectable pulse width of 50 nanoseconds and maximum input frequency of 10 MHz. This 100 K ohm probe is an inexpensive workhorse for any shop, lab or field service tool kit. It detects high-speed pulse trains or one-shot events and stores pulse or level transitions, replacing separate level detectors, pulse detectors, pulse stretchers and pulse memory devices. All, for less than the price of a DVM.

LP-2 LOGIC PROBE. \$24.95*

LP-2 performs the same basic functions as the LP-1, but for slower-speed circuits and



Use CSC's highly versatile logic probes for testing, debugging or servicing any type of digital circuit. They give you a lot of information about IC circuit conditions... and help you do more in less time. For less money.

NEED MORE INFORMATION? CALL 203-624-3103 to order, or for the name of your local distributor. Prices slightly higher outside U.S.A.

© 1978, Continental Specialties Corporation. Prices, specifications, subject to change without notice.

* Manufacturer's suggested retail.

Corporate Headquarters:
Continental Specialties Corporation
70 Fulton Terr., Box 1942, New Haven, CT 06509
351 California St., San Francisco, CA 94104
(415) 421-8872, TWX 910-372-7992

CONTINENTAL SPECIALTIES CORPORATION



CIRCLE 9 ON READER SERVICE COUPON

Europe, Africa, Mid-East: CSC UK LTD.
Shire Hill Industrial Estate, Units 1 and 2
Saffron Walden, Essex CB 11 3AQ
Telephone Number: SAFFRON WALDEN 21682
TLX 817477

The Realistic SCT-30 tells it like it is:

Why 3 heads are better than 2. Why 2 capstans are better than 1. Why double Dolby* is better than single.

3 Heads.

Two independent record and play heads eliminate the compromises of one combined r/p head, and the head assembly is integrated to eliminate azimuth error. The result: cleaner sound. The third head lets you monitor



your recording an instant after it's made, without interrupting the program. SCT-30 has 3 heads!



2 Capstans.

Dual capstans (instead of the usual 1) reduce wow and flutter to an inaudible 0.06% WRMS or less, and extend the audio frequency response. SCT-30 has dual capstans!

Double Dolby.

You know the single Dolby system cuts noise and adds dynamic range. But let's examine double Dolby. You get Dolby on both record and monitor so you know exactly what your tape will sound like.

You get a decoder for recording superb Dolby FM stereo. And you get simultaneous listening enjoyment of the decoded broadcast on receivers with tape monitoring. The Realistic SCT-30 has double Dolby! About \$380.



P.S. - Supertape® Gold.

To go with 3 heads, 2 capstans and double Dolby, you need a cassette tape that will enhance — not degrade — performance. That's why we design and manufac-

ture Supertape Gold in our own Fort Worth factory. Like SCT-30, it's a playmate you can believe in at a price you can afford.

Why Realistic®?

Because Radio Shack has delivered quality audio at sensible prices since 1921, its Realistic tape and recorder line can point to over 5,000,000 customers as living proof of these claims. Add after-sale service that isn't lip service. Add in-house engineering and manufacturing of much of the Realistic line. And add the convenience of neighborhood shopping where you get "sound talk" from a specialist. That's Realistic!

*TM Dolby Laboratories, Inc.



Radio Shack®
The nationwide supermarket of sound T.M.