

MULTIMETERS—understanding test instrument fundamentals

Lightbulb
Electronics

CC

02342

SEPTEMBER-
OCTOBER
1978
\$1.25

elementary Electronics

**SIMPLY
BASIC**
Set up and use
your own mailing list
with this unique
program in BASIC

COMPUTER CONFRONTATION

CompuChess, Chess Challenger
and Boris fight it out
to the finish (Page 50)

10 CAR RADIO REPAIR TIPS

EASE INTO HAM RADIO

Lesson One
for the
N

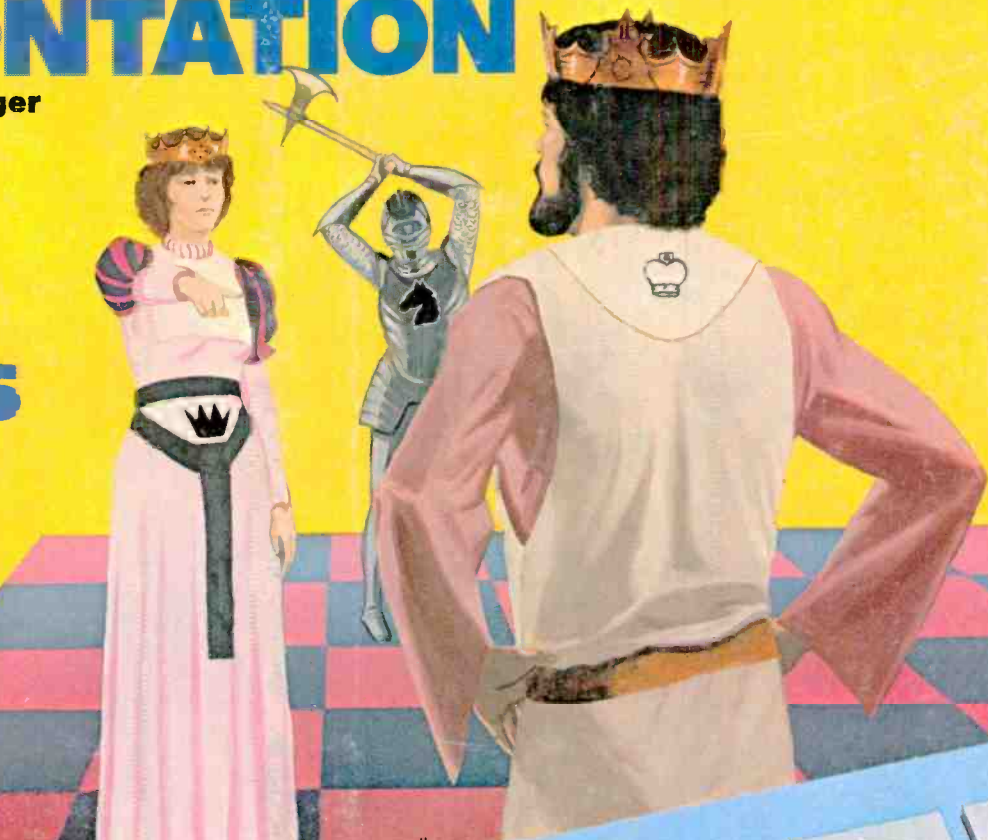

PROJECTS— THEN AND NOW

- ✓ Shortwave Supercharger
- ✓ Grandpa's Whisker Radio
- ✓ Hi-Fi Mini-Mixer
- ✓ Antique Ohmmeter

12 69 6608 DEAR5KRR-1 AUG79 P
KEN DEARS
845 KERRY HILL DR
PITTSBURGH PA 15210



A DAVIS PUBLICATION

www.americanradiohistory.com



Introducing President's newest and lowest priced CB. Veep.

Now you can get the full power and prestige of a President in a very economical package. The new, low-priced Veep.

All the sophisticated circuitry is there... low pass filter, audio compressor, PLL synthesizer. The big, bright LED indicators are there. The every-unit-tested quality is there.

But the price is a lot lower than any past President.

So the Veep makes a perfect second CB—for your second car, your boat, your snowmobile, even

your motorcycle.

It also makes a great first CB—because it gives you real CB quality without costing an arm and a leg.

Veep from President.

Now you don't have to settle for second class in your second CB.

Or your first.



PRESIDENT

Engineered to be the very best.

President Electronics, Inc. 16691 Hale Avenue · Irvine, CA 92714 · (714) 556-7355
In Canada: Lectron Radio Sales Ltd., Ontario

CIRCLE 35 ON READER SERVICE COUPON

www.americanradiohistory.com

A fantastic base antenna encounter.

Superb CB performance plus great FM reception. Unreal!

STARDUSTER II outperforms any 5/8 wave omni-directional CB antenna at horizon gain ever designed — but that's only half the story. **We also designed it to work simultaneously on 88-108 MHz FM.** It receives FM broadcasts right alongside your CB rig so you get superb double duty from one great antenna.

FM reception is vertically polarized for a perfect omni pattern. Tuned traps and prasing coil provide excellent performance across the entire band. And you still get the STARDUSTER'S fantastic CB performance — **tremendous 5dB gain*** with our original full aperture design that punches your signal farther out on the horizon.

Installation? STARDUSTER II's super lightweight and compact — weighs just 5 1/4 pounds. STARDUSTER II. You've reached the outer limit in base antenna performance.

*FM = FM STEREO GAIN S ONLY

Starduster II
Model M-300



© "Stripes of Quality"

**the antenna
specialists co.**

a member of The Allar Group Inc.
12435 Euclyd Avenue Cleveland, Ohio 44106
Export: 2200 Strames Drive Westbury, L.I. New York 11590
Canada: A.C. Simmonds & Sons, Ltd.



IN 25 YEARS... WE'VE NEVER BEEN OUTDISTANCED.

CIRCLE 20 ON READER SERVICE COUPON

THE STAFF

Editor-in-Chief
Julian S. Martin

Managing Editor
Alan H. Rose, K2RHK

Technical Editor
Neil Shapiro, WB2KQI, KAFA7222

Associate Editor
Gordon Sell, KBDA1464

Citizens Band Editor
Kathi Martin, KGK3916

Workbench Editor
Hank Scott

Art Director
Ralph Rubino

Assistant Art Director
David Pindar

Cover Art Director
Irving Bernstein

Art Assistants
Joe Groom
Celeste Barbera
Michael Vessio
Leslie Wallant

Advertising Manager
Ralph Vega

Advertising/Research Associate
Jyll Holzman, KAKZ1490

Production Director
Carl Barte

Production Manager
Carole Dixon

Assistant Production Manager
Mary Carfagno

Newsstand Circulation
Director
Don Gabree

Subscription Circulation Director
Robert V. Enlow

Subscription Circulation Manager
Eugene S. Slawson

Marketing Director
James C. Weakley

President and Publisher
Joel Davis

Vice President and
General Manager
Leonard F. Pinto

Vice President and Treasurer
Victor C. Stabile, KBP0681

ELEMENTARY ELECTRONICS is published bi-monthly by Davis Publications, Inc. Editorial and Executive offices: 380 Lexington Ave., New York, NY 10017; all subscription orders and mail regarding subscriptions should be sent to P.O. Box 2630, Greenwich, CT 06835. In U.S.A. and possessions, one-year subscription (six issues) \$6.95; two-year subscription (12 issues) \$12.95; three-years (18 issues) \$18.95; and four years \$23.95. Elsewhere, add \$1.00 postage for each year. For change of address, please advise 6 to 8 weeks before moving. Send us your current mailing label with new address. Advertising offices: New York, 380 Lexington Ave., New York, N.Y. 10017, 212-949-9190; Chicago, 520 N. Michigan Ave., 312-527-0330; Los Angeles; J. E. Publishers' Rep. Co. 8732 Sunset Blvd. 213-659-3810. Second-class postage paid at New York, NY and at additional mailing office. Copyright 1978 by Davis Publications Inc.

elementary electronics

September/October 1978
Volume 18, No. 5

LATEST THEORY FOR THE THINKING MAN

- 37 Getting Out—spring your signal with these radiating tips
- 41 Bio Logic—tells you why you can still give your computer a run for its money
- ☆ 50 Chess Board Rumble—computers meet head on and show what they're made of
- ☆ 77 Basic Course—freshen up on the fundamentals of multimeter operation

CONSTRUCTION PROJECTS THAT'LL SNAP UP YOUR EVENINGS

- ☆ 44 Shortwave Supercharger—put this up front and watch your receiver beat the field
- ☆ 59 Grandpa's Whisker—there's life in the carborundum detector yet
- ☆ 63 Passive Mixer—build this miniature control center for your audio needs
- ☆ 67 Construction Quickies—seven simple circuits save time and cash
- 75 Antique Radio Corner—antique ohmmeter measures antique ohms

ELECTRONICS FOR YOUR AUTO

- ☆ 54 Ten Tips for Car Radio Repairs—even the best models need a little care
- 64 Quadricycle Cutie—this little runabout may be in your future
- 65 e/e installs the . . . Optoelectronics ALR-1 auto burglar alarm

PUT A HAM IN YOUR HOME

- 70 e/e assembles the . . . Atronic digital code reader
- ☆ 71 Learn to be a Novice—lesson one

CB—TWENTY YEARS AND STILL TRUCKIN'

- 49 CB New Products—e/e looks at the latest and the best
- 58 Kathi's CB Carousel—give yourself the best ears on the band

KEEP UP WITH YOUR COMPUTER

- ☆ 52 Simply Basic—lets you set up your own mailing list program
- 62 e/e checks out the . . . AVDEX Typits
- 73 Computer Readout—microprocessors in CB communications

OUR REGULAR DEPARTMENTS

- 10 Hey, Look Me Over—see more about the newest products
 - 16 Bookmark—by Bookworm
 - 22 DX Central—Don Jensen tracks some SW pirates
 - 26 Ask Hank, He Knows—everything
 - 32 Hi Fi Reports—quality isn't everything, but it sure helps
 - 34 Bit Bucket—our newest check on the latest in computers and accessories
 - 88 Literature Library
- ☆ Cover Stories

AUTHORS IN THIS ISSUE

Homer Davidson, James Fred, Larry Friedman, Tom Galway, Charles Green, Don Jensen, Cass Lewart, Kathi Martin, Norm Meyers, Hank Scott, Sheila Schwindler, Gordon Sell, Neil Shapiro, Walter Sikonowiz, Thomas Sundstrom, James Toth, and the ELEMENTARY ELECTRONICS Editorial Staff.

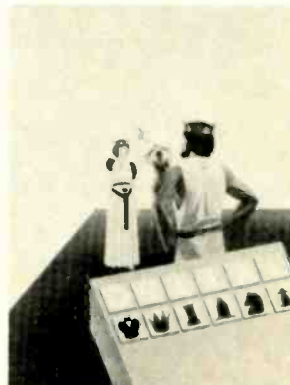

FOR THOSE OF YOU WHO ARE HAVING SECOND THOUGHTS ABOUT YOUR FIRST CB.

Move up to the all-new Cobra 29GTL. It's the third generation of the trucker-proven Cobra 29. And like the 29 and the 29XLR before it, it advances the state of the art.

Transmitter circuitry has been refined and updated to improve performance.

Receiver circuits have been redesigned to include dual FET mixers, a monolithic crystal filter and a ceramic filter to reduce interference and improve reception.

By improving the transmitter circuitry the 29GTL keeps you punching through loud and clear. By incorporating new features for better reception everything you copy comes back loud and clear.

So if you're having second thoughts about your first CB, make your next CB the Cobra 29GTL.

We back it with a guaranteed warranty and a nationwide network of Authorized Service Centers where factory-trained technicians are available to help you with installation, service and advice.

But more important than that, we sell it at a price you won't have second thoughts about.



Punches through loud and clear.

Cobra Communications Products
DYNASCAN CORPORATION
6460 W. Cortland St., Chicago, Illinois 60635

Write for color brochure
EXPORTERS: Empire • Plainview, N.Y. • CANADA Atlas Electronics • Ontario



CIRCLE 8 ON READER SERVICE COUPON

You gotta shop around.

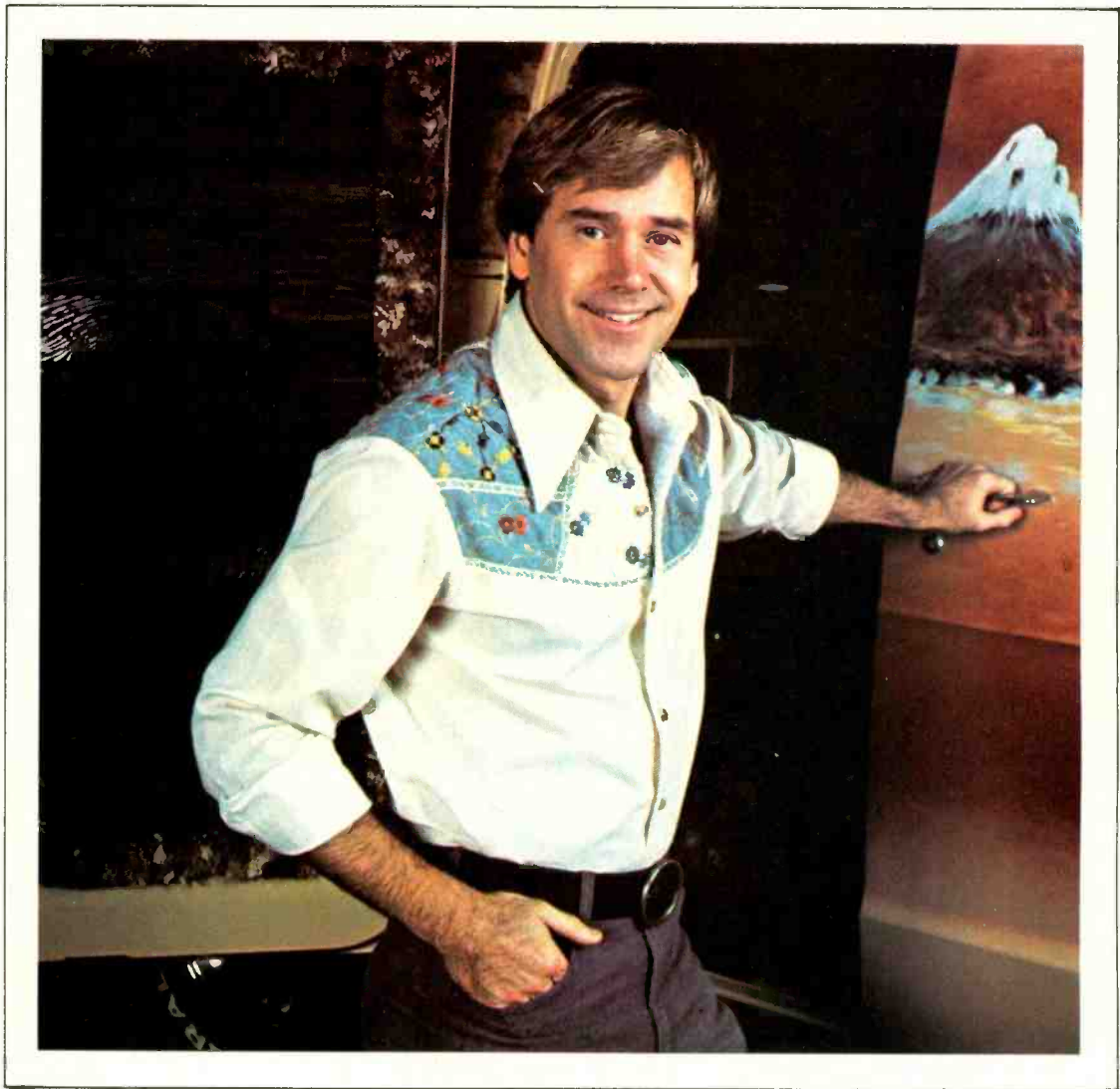

**When you do, you'll probably pick CIE.
You can't afford to settle for
less when it comes to something like
electronics training that could
affect your whole life.**

When you shop around for tires, you look for a bargain. After all, if it's the same brand, better price — why not save money?

Education's different. There's no such thing as "same brand." No two schools are alike. And, once you've made your choice, the training you get stays with you for the rest of your life.

So, shop around for your training. Not for the bargain. For the best. Thorough, professional training to help give you pride and confidence.

* * *

If you talked to some of our graduates, chances are you'd find a lot of them shopped around for their training. They pretty much knew what was available. And they picked CIE as number one.

Why you should shop around yourself.

We hope you'll shop around. Because, frankly, CIE isn't for everyone.

There are other options for the hobbyist. If you're the ambitious type — with serious career goals in electronics — take a close look at what we've planned for you at CIE.

What you should look for first.

Part of what makes electronics so interesting is it's based on scientific discoveries — on ideas! So the first thing to look for is a program that starts with ideas and builds on them!

That's what happens with CIE's Auto-Programmed® Lessons. Each lesson takes one or two principles and helps you master them — before you start using them!

How practical is the training?

This is the next big important question. After all, your career will be built on what you can do — and on how well you do it.

Here are ways some of CIE's troubleshooting programs help you get your "hands-on" training...

With CIE's Experimental Electronics Laboratory...



you learn and review the basics — perform dozens of experiments. Plus, you use a 3-in-1 precision Multimeter to learn testing, checking, analyzing!



When you build your own 5 MHz Triggered-Sweep, Solid-State Oscilloscope you take your first real professional step. You use it as a doctor uses an X-ray machine — to "read" waveform patterns... lock them in... study, understand and interpret them!

When you get your Zenith 19-inch Diagonal Solid-State Color TV you



Pattern simulated.

apply your new skills to some real on-the-job-type troubleshooting! You learn to trace signal flow... locate malfunctions... restore perfect operating standards — just as with any sophisticated electronics equipment!



When you work with a completely Solid-State Color Bar Generator —

actually a TV signal transmitter — you study up to ten different patterns on your TV screen... explore digital logic circuits... observe the action of a crystal-controlled oscillator!

Of course, CIE offers a more advanced training program, too. But the main point is

simply this:

All this training takes effort. But you'll enjoy it. And it's a real plus for a troubleshooting career!

Do you prepare for your FCC License?

Avoid regrets later. Check this out before you enroll in any program.

For some troubleshooting jobs, you must have your FCC License. For others, employers often consider it a mark in your favor. Either way, it's government-certified proof of specific knowledge and skills!

More than half of CIE's courses prepare you for the government-administered FCC License exam. In continuing surveys, nearly 4 out of 5 CIE graduates who take the exam get their Licenses!

Shop around... but send for CIE's free school catalog first!

Mail the card. If it's gone, cut out and mail the coupon. If you prefer to write, mention the name and date of this magazine. We'll send you a copy of CIE's FREE school catalog — plus a complete package of independent home study information! For your convenience, we'll try to have a representative contact you to answer your questions. Mail the card or coupon — or write: CIE, 1776 East 17th St., Cleveland, OH 44114.

CIE Cleveland Institute of Electronics, Inc.

1776 East 17th Street, Cleveland, Ohio 44114
Accredited Member National Home Study Council

YES... I'm shopping around for the **right** kind of career training in electronics troubleshooting — and CIE sounds well worth looking into. Please send me my FREE CIE school catalog — including details about troubleshooting courses — plus my FREE package of home study information! EL-98

Print Name _____

Address _____ Apt. _____

City _____

State _____ Zip _____

Age _____ Phone _____

(area code)

Check box for G. I. Bill information:

Veteran Active Duty

Mail today!

SHAKESPEARE HAS



Black Knight™
Antenna Style
#4156-1
Base loaded
with graphite tip.
Trunk mounted.

White Knight™
Antenna Style
#4125-1
Base loaded
with fiberglass tip.
Trunk mounted.

Silver Knight™
Antenna Style
#4156-1S
Base loaded
with steel tip.
Trunk mounted.

Talk power. Some CBers have it. Some don't.

If you don't have talk power, the odds are twenty to one the fault's in the antenna. You're not getting out. You're not coming through.

'Tis far better to transmit than to receive

Frankly, you can receive a signal with almost any antenna. A wire coat hanger might do.



But the name of the game in CB antennas is transmission (unless you like talking to yourself).

Talk power is what separates the men from the boys, the Knights of the Road from the weaklings. Your nearby Shakespeare antenna dealer will show you how *Shakespeare has everyone talking...loud and clear!*

Now you're talking!

- ① A protective sheath of high grade resin fiberglass totally encompassing the metal radiator.
- ② Silver plated copper radiator lowers resistance and increases efficiency.
- ③ Solid brass insert, hand soldered at the coil termination (not just crimped) to permanently seal out moisture.
- ④ Strength and elegance in this polycarbonate housing offer immediate protection and years of aesthetic beauty.
- ⑤ Helical wound tin plated copper coil on a tapered low-loss polycarbonate dielectric core
- ⑥ Molten dipped silver mica matching capacitor (not the typical varnished pasteboard).
- ⑦ Solid brass threaded fitting for positive coupling to antenna mount.

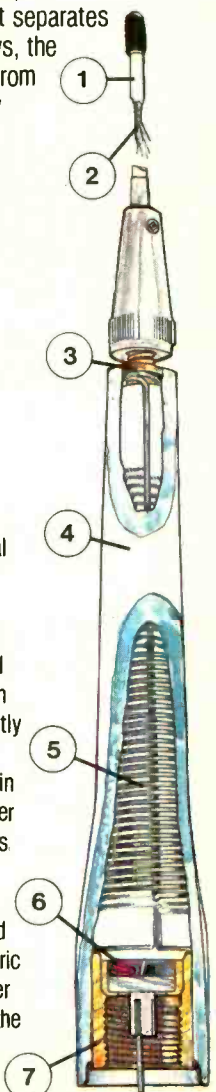

EVERYONE TALKING!

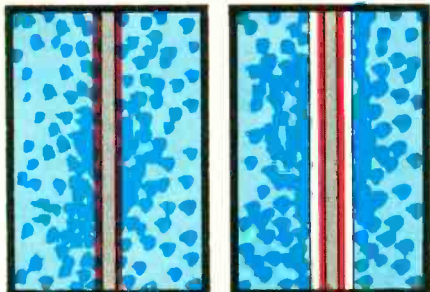

METAL ANTENNA
(TYPICAL)

SHAKESPEARE
FIBERGLASS ANTENNA

The principle of "skin effect": A transmitted signal, in the form of energy, travels on the surface of the metal radiator of an antenna. This occurs regardless of the length, density, or thickness of the metal radiator. Picture an antenna surface after it has been bombarded by millions of tiny particles as it travels through our air day after day. Dust, dirt, pollutants, salt, chemicals...all of them impinging on the surface to create obstacles that offer resistance to your transmitted signal.

The principle of "skin effect". Within six months exposure, surface resistance on an exposed antenna can rob you of up to 20% of your power.

DETERIORATION, SEVERE ENVIRONMENT

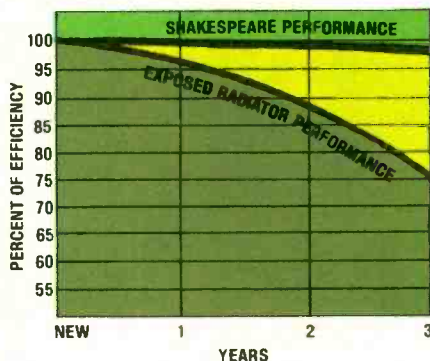

A speck of dust? It's hell in your eye... even worse on your antenna!

Like we said, it's the surface of a metal antenna that radiates the signal. Or is meant to.

Metal corrodes. Fiberglass does not corrode. And the fiberglass surface is far less susceptible to pollution and contaminants in the environment.

With a Shakespeare fiberglass antenna, surface deterioration does not mar performance because *the surface is not the radiator*. Instead, the radiator is sealed inside the fiberglass sheath, which is transparent to electronic radiation and lets the signal through without interference or distortion.

Thousands of glass filaments, running parallel the entire length of the antenna, are molded and cured under extreme heat and pressure to provide a structure amazingly strong, durable, and corrosion resistant.



Fiberglass... the way we do it.

Shakespeare has created "The Big Three" in antenna design: The Black Knight. The White Knight. The Silver

Knight. Each of these great base loaded antennas is engineered to be *the best of its kind*. Each is pre-tuned at the factory.

The Black Knight™ antenna is Shakespeare's triumph in a new space age material, graphite. Providing unheard of strength and rigidity to keep your Black Knight antenna erect at highway speeds.

The White Knight™ antenna is Shakespeare's fiberglass beauty. The metal radiator that transmits the signal is sheathed in enduring fiberglass; safeguarded for life against moisture, salt, dirt, dust, pollution, and corrosion.

The Silver Knight™ antenna is Shakespeare's metal antenna, just to prove we're able to take on our competition at its own game. If it's a metal antenna you want, we've got the best metal antenna you can buy.

RELAX...the world's largest Fiberglass antenna plant just made your next antenna.



200,000 square feet devoted entirely to CB and marine antennas and related fiberglass products, complete with advanced testing facilities and laboratories for research and development.

Shakespeare®

ELECTRONICS AND FIBERGLASS DIVISION
Antenna Group/P.O. Box 246, Columbia, S.C. 29202

The Shakespeare Company/Manufacturers of Fishing Tackle, Communication Equipment, Industrial Fiberglass, Wonderthread and Specialized Monofilaments, Golf Equipment, Automotive Products, Saddlery and Equestrian Accessories, and Marine Taxidermy.

CIRCLE 17 ON READER SERVICE COUPON

ELEMENTARY ELECTRONICS/September-October 1978

www.americanradiohistory.com

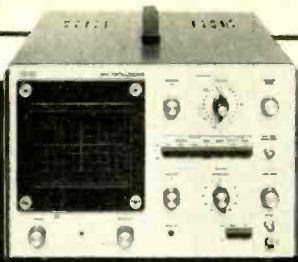

NEW EICO 480 TRIGGERED SWEEP 10 MHz SCOPE

100% Solid State • Includes 10:1 Probe

More Professional scope performance for your money! DC to 10 MHz bandwidth, AC and DC coupling, 11 position calibrated attenuator, 10 mV/cm sensitivity, push-button operation. Outstanding features: Built-in TV Sync Separator; Digitally controlled trigger circuits; reference baseline display; calibrated 21 step sweep speed; Fully regulated power supply; Custom Bezel for standard camera mounting. **Assembled \$425.00**

FREE '78 EICO CATALOG

Check reader service card or send 50c for first class mail. See your local EICO Dealer or call (516) 681-9300, 9:00 a.m.-5:00 p.m. EST. Major credit cards accepted.

EICO—108 New South Rd.
Hicksville, N.Y. 11801



CIRCLE 2 ON READER SERVICE COUPON

WIRE CIRCUITS FASTER WITH SOLDER-THRU PENCIL WIRING VECTOR P178-1

\$7.95
NET

NEW IMPROVED TOOL

- Makes solder wrapped connections 3 times faster than usual way.
- Quick-melt insulation for clean, fast solder joints with 250°F. iron.
- Fast snap-in spools.
- Easy threading & finger controlled tension & advance.
- Slim, light, comfortable tip angle.

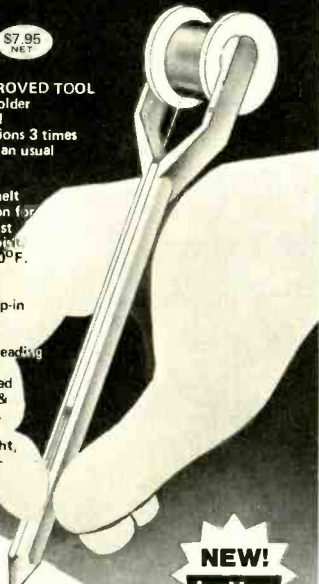

NEW!
better

EVERYONE
NEEDS ONE!

If unavailable locally, factory order. Add \$2.00 shipping and handling charge. California residents add 6% sales tax.

VECTOR ELECTRONIC COMPANY, Inc.
12460 Gladstone Av., Sylmar, CA 91342
phone (213) 365-9661
twx 910-496-1539

CIRCLE 23 ON READER SERVICE COUPON

Hey, look me over

Showcase of New Products

Super Car Radio

Just hitting the retail shelves is Midland's Model 67-440 AM/FM/MPX Digital tuning radio with automatic reverse cassette and quartz clock function. A digi-tuner programmed electronic scanner electronically seeks a station, holds it for 5 seconds, seeks the next station, holds again and continues until a "hold" button is touched, stopping the scanning action and locking onto the station. Any station can be programmed into the radio's electronic memory, which can store as many as 5 AM and 5 FM stations. An LED digital clock of quartz crys-



CIRCLE 82 ON READER
SERVICE COUPON

tal design displays the time in hours and minutes when the radio is off or when manually selected to replace the station frequency readout while the radio is in use. The radio's amplifier is rated at 15 watts RMS per channel at 1% THD, and frequency response from 70-20,000 Hz. The tape cassette player section of the "440" offers a frequency response of 30-15,000 Hz, crosstalk of 46 dB, S/N ratio of 48 dB, and wow and flutter (JIS weighted) of only 0.2%. Sells for \$399.95. For further information, contact Midland International Corporation, P.L. Box 1903, Kansas City, MO 64141.

New Fit for Smaller Cars

Detroit has squeezed the rear deck in their new, smaller car models, so AFS has developed dual cone (Model 2031) and coaxial (Model 2032) 4-in. x 10-in.

CIRCLE 81 ON READER SERVICE COUPON

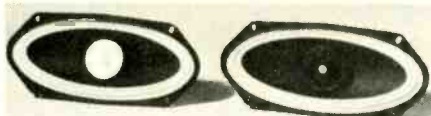

KLASSIC bulk pack speakers to fit where 6-in. x 9-in. speakers used to go. The new speaker size also fits nicely into the rear posts in most models of station wagons, under the dashboard up front in many cars, trucks and recreational vehicles, or anywhere in a boat or airplane. The specs for the Model 2032 are: 4-in. x 10-in. coaxial design, 10 oz. ceramic magnet, 1-in. voice coil, 25 watts

RMS, 55 Hz to 18,000 Hz, 8 ohms; and sells for \$24.60. The specs for the Model 2031 are: 4-in. x 10-in. dual cone design, 10 oz. ceramic magnet, 1-in. voice coil, 25 watts RMS, 55 Hz to 16,000 Hz, 8 ohms; and sells for \$17.50. For further information on the 2032 and 2031, write Acoustic Fiber Sound Systems, Inc., P.O. Box 50829, Indianapolis, In 46250 or call (317) 842-0620.

Ultrasonic Cleaning

Cleaning electronic components and other small parts is easy and economical with the new Branson B-3 ultrasonic cleaner from Branson Cleaning Equip-



CIRCLE 85 ON READER
SERVICE COUPON

ment Company. A self-contained unit with a one pint capacity, the Branson B-3 is said to remove dirt, tarnish, oils, wax and other residue from small sub-assemblies in seconds. This tabletop unit plugs into any 115 volt outlet, comes with a stainless steel tank and a shock flame resistant housing. Common water base cleaning solutions, also available from Branson, are suitable for use in the B-3. The Branson B-3 ultrasonic cleaner is priced at \$69.95. Further information may be obtained from Branson Cleaning Equipment Company, Parrott Drive, Shelton, CT 06484 or phone (203) 929-5841.

New Slinky Dipole

The Slinky Dipole model SWL-1 is a new ultra-broadband adjustable length short wave antenna that may be used in either the tuned or un-tuned mode. In many cases, even the untuned mode is reported to give excellent perform-

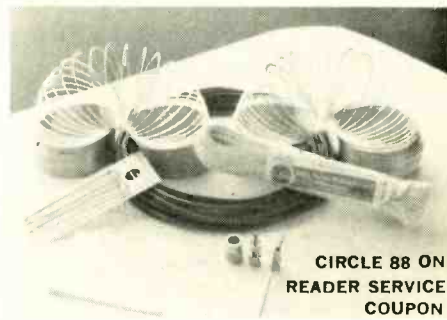

CIRCLE 88 ON
READER SERVICE
COUPON

ance, and the tuned mode will further peak the antenna efficiency right at your desired band. The special Slinky coils, which form the heart of the antenna, are used as the arms of the dipole. These giant coils look like the toy coils, but are five times the size and contain 335 feet of conductor. When in use, the spiral arms of the dipole provide the special distributed helical load-

ing. This acts like distributed inductance, enabling the electrical length to be as much as five times the physical length. Complete Slinky Dipole Kit, Model SWL-1, mail-order priced at \$39.95 postpaid. The Slinky may also be used for transmitting on the ham bands. Order from Teletron Corp., Suite 602, Box 84, Kings Park, NY 11754.

Attache PA

The Sound Attaché P.A. from Perma Power Electronics is a complete public address system in an attaché case—designed for demonstrations, seminars, club meetings or sales meetings. It has the power to cover a large audience, but weighs only 22 pounds with batteries. Identified as Perma Power Model S-210A, it includes a 35 watt amplifier, a cardioid microphone, and a full-fidelity



CIRCLE 74 ON READER SERVICE COUPON

speaker built right into the case, with 40-feet of cable supplied for free movement while you speak. The Sound Attaché is battery powered and will operate up to 200 hours on one set of alkaline flashlight batteries. Sells for \$215.50. Literature is available upon request from Perma Power Electronics, Inc., 5615 W. Howard Avenue, Chicago, IL 60648 or telephone (312) 647-9414.

New Dip Plugs and Covers

For the hobbyist or prototype-concerned engineer who needs to make his own interconnect assemblies, OK Machine and Tool Corporation now offers 14 and 16 pin plugs that fit into standard DIP sockets. Plugs feature U.L. recognized glass filled

CIRCLE 84 ON READER SERVICE COUPON

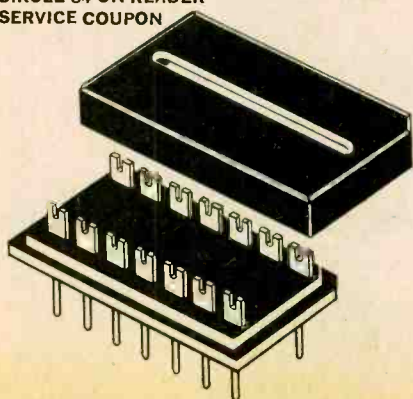

thermoplastic bodies and solder lugs on the top side are slotted for each attachment of cable leads. Rectangular legs assure dependable insertion into DIP socket. Leg/solder lug is one-piece gold plated phosphor bronze. Packed 2 to a package, complete with slotted top-entry covers, the plugs are \$1.45 for 2 14-pin units and \$1.59 for the 16-pin version. Available from your local electronics distributor or OK Machine and Tool Corporation, 3455 Conner Street, Bronx, NY 10475 at (212) 994-6600.

Biorhythm Cycles

Starting from birth humans have built-in biological "clocks" that vary their physi-

CIRCLE 79 ON READER SERVICE COUPON



cal, emotional and intellectual capacities during regularly repeated cycles. By simply looking at this unique clock each day, these cycles are shown in digital form exactly where they are in relationship to the individual for which the unit has been set. This way, you can actually predict your good and bad days well in advance. It lets you put off important decision during "off" days or to make important decisions on "high" days. The Personal Biorhythm Digital Clock is available factory wired for only \$64.95 each (plus \$2.00 for postage and handling per order). It is fully guaranteed and available from Optoelectronics, Inc., P.O. Box 219, Hollywood, FL 33022, or phone (305) 921-2056.

Emergency Solder

Multicore Solders new, handy tape-like, solder strip may be used for quick on-the-spot soldering repairs. Called Emergency Solder, it can be easily carried in

CIRCLE 86 ON READER SERVICE COUPON



a shirt pocket or stored flat and requires only an ordinary match or candle flame

NEW FROM ASIMOV!



Large Size
8½" x 10½"

—on newsstands nationally, but you can be sure to have this first/collector's issue by ordering now!

Brand new! Exciting! 112 pages, generously illustrated. Chock-full of SF fun and adventure!

☆☆☆

EXTRA! You'll also get with this issue a full-color 11" x 17" color poster (the cover picture, especially commissioned).

☆☆☆

Amongst a lot of other exciting stories, you'll enjoy a novelette by Poul Anderson ("Capture of the Centaurianess")... a short novel by Harry Harrison ("The Stainless Steel Rat Wants You")... and a short story by Dr. Asimov himself!

**ASIMOV'S
SF ADVENTURE MAGAZINE
380 LEXINGTON AVENUE
NEW YORK, NY 10017**

Enclosed is \$1.75 plus 25¢ handling/shipping (total of \$2.00), for the first/collector's issue of ASIMOV'S SF ADVENTURE MAGAZINE.

Name _____ (please print)

Address _____

City _____

State _____ Zip _____

H8H065

HEY, LOOK ME OVER

(Continued from page 11)

to melt the solder. Multiple cores of rosin flux are incorporated into the flat strips during the manufacturing process eliminating any requirement for a separate fluxing application. The flux is non-corrosive and non-conductive, and need not be removed after soldering. To solder two wires, simply twist the wires together, wrap the solder strip lightly around them and apply the flame from a match. Move the flame slowly back and forth until the solder flows into the splice. Packaged with 36 inches of the solder strip with complete illustrated directions for use in package. Sells for 89¢. Available at electronic parts outlets nationwide. For more info, write to Multicore Solders, Westbury, NY 11590.

Self-Powered Logic Monitor

The new Continental Specialties' LM-2 advanced Logic Monitor lets you clip onto an IC and then a series of 16 LEDs arranged at the top of the clip in the IC pin-pattern light on and off to follow the logic levels of the circuit you're testing. A rotary switch selects the proper threshold for monitoring logic levels in RTL/DTL, TTL/HTL and CMOS circuits. A separate cable for CMOS circuits picks up the voltage of the circuit under test to determine the logic threshold level. It operates up to a maximum useful input



**CIRCLE 76 ON
READER SERVICE COUPON**

frequency of 30 kHz (at 50% of duty cycle). The LM-2, complete with built-in 117 VAC, 50/60 Hz power supply, is priced at \$129.95. For additional information, write Continental Specialties Corporation, 70 Fulton Terrace, New Haven, CT 06509 or telephone (203) 624-3103.

Removes Pins from Nylon Connectors

"Deluxe" and "Econo" extractor tools for quickly removing male or female pin terminals from Molex nylon connector housings have just been introduced by

Waldom Electronics. The Model HT-2285 extractor tool is designed for .062-in. pins and the Model HT-2038 accommodates .093-in. pin removal. Both of these models, priced at \$6.70 each, feature anodized aluminum handles and spring loading. Sure-grip replacement extractor tips are also available. The "Econo" Model HT-2023 and HT-2054 are designed for .062-in. and .093-in. pin removal, respectively. These low cost tools (only \$2.95 each) offer economical, fast pin removal. See these handy pin extractors at your local Waldom Electronic Distributor, or write: Waldom Electronics, Inc., 4301 W. 69th Street, Chi-



**CIRCLE 83
ON READER
SERVICE
COUPON**

ok® wire wrapping center ok®

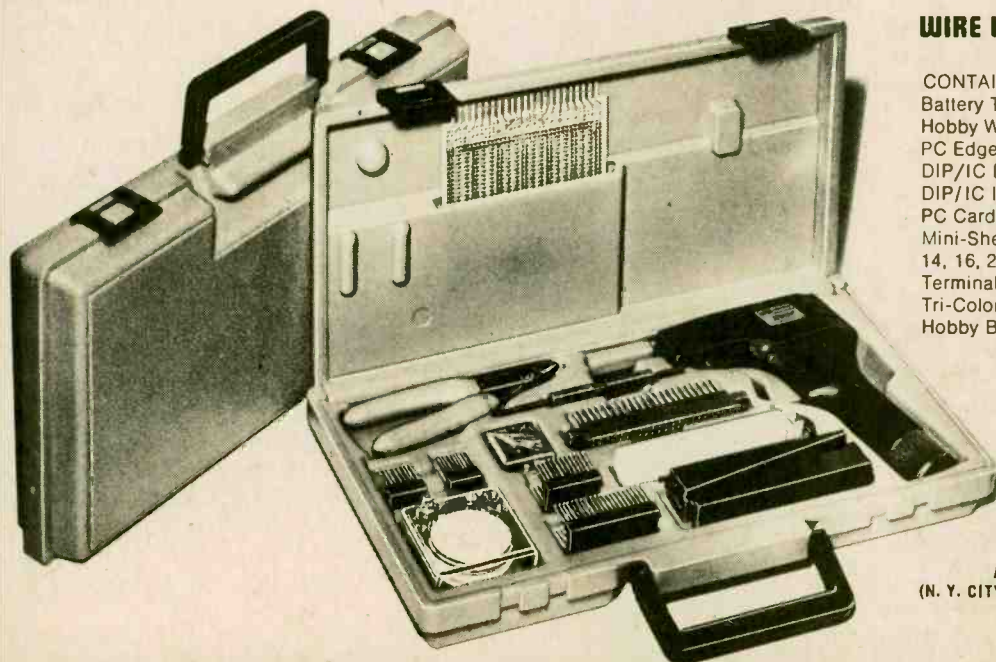

WIRE WRAPPING KIT WK-5

CONTAINS:
 Battery Tool BW-630
 Hobby Wrap Tool WSU-30 M
 PC Edge Connector CON-1
 DIP/IC Extractor Tool EX-1
 DIP/IC Insertion Tool INS-1416
 PC Card Guides & Brackets TRS-2
 Mini-Shear with Safety Clip SP-152
 14, 16, 24 and 40 DIP Sockets
 Terminals WWT-1
 Tri-Color Wire Dispenser WD-30-TRI
 Hobby Board H-PCB-1

\$74.95

ADD \$1.00 FOR SHIPPING
(N. Y. CITY AND STATE RESIDENTS ADD TAX)

OK MACHINE & TOOL CORPORATION

3455 Conner St., Bronx, N.Y. 10475 (212) 994-6600 / Telex 125091

CIRCLE 43 ON READER SERVICE COUPON

www.americanradiohistory.com

ELEMENTARY ELECTRONICS/September-October 1978

NEW ASTRO-FANTOM™



CB ANTENNA

**GOES WHERE
NO CB
ANTENNA
HAS GONE
BEFORE!**

**SUPERIOR
PERFORMANCE FOR
AUTO, TRUCK, MARINE,
RV, MOTORCYCLES AND
HOME USE**



avanti antennas

AVANTI RESEARCH AND DEVELOPMENT, INC.
34C Stewart Avenue, Addison, IL 60101
IN CANADA: Lenbrook Industries,
1145 Bellamy, Scarborough, Ontario M1H 1H5

It Mounts On Glass Transmits and Receives THRU Glass

Now from the AVANTI Research Laboratories comes a sleek, 22" full 1/2 wave antenna, so unique that it mounts on glass, transmits through glass and receives through glass...yet requires no grounding to metal as do conventional 1/4 wave antennas. No holes to drill...no clamps, clips or magnets to ever mar or scratch your car's finish! No pinched cables to run in through doors, windows or trunk. The Astro-Fantom is a handsome, low profile antenna that provides the ultimate in convenience!

EASY INSTALLATION. The Astro-Fantom is so uncomplicated that installation takes only five minutes and requires no tools. It bonds securely to the glass with an all weather tested 3M press-on adhesive, yet can be quickly transferred when desired. The fiberglass whip removes instantly for storage, car wash or theft protection.

ONE MOUNT SATISFIES EVERY NEED. Astro-Fantom's unique mount attaches anywhere there's a metal framed window. Front, side, or rear of vehicle, boat and motorcycle windshields, even home installation.

CLEAREST COMMUNICATIONS. Avanti's exclusive space age co-inductive™ coupling box actually rejects static and interference as it establishes a highly tuned circuit to transmit and receive radio signals through the glass.

FULL 360° SIGNAL. Astro-Fantom's full 1/2 wave design eliminates dead spots and directional problems found in conventional CB antennas.



PATENT PENDING **Model AV-200**
Length 22"



© 1978, all rights reserved

CIRCLE 47 ON READER SERVICE COUPON

HEY, LOOK ME OVER

(Continued from page 13)

cago, IL 60629. Their phone is (312) 585-1212.

Portable TV Sound

Now you can listen to your favorite TV news and sports broadcasts, soap operas, talk shows and other programs wherever you go, indoors or out. The Realistic PortaVision portable radio from Radio Shack lets you hear your favorite VHF (channels 2-13) television programs as well as regular FM and AM radio broadcasts. May also be used as a remote speaker for the hard-of-hearing, or with an earphone for TV viewing without disturbing others. Features include a four-band selector for FM, AM, TV chan-

CIRCLE 32 ON READER SERVICE COUPON



nels 2-6 (54-88 MHz) and TV channels 7-13 (174-216 MHz) with a "Day-Glo" pointer to indicate which channel you are listening to, speaker jack, earphone and AC cord. Uses 4 "C" cells for portable operation. The Realistic PortaVision AM/FM/VHF-TV portable radio is priced at \$39.95. Available from Radio Shack.

Superphone

The new Superphone is a remarkable new pushbutton phone. With Superphone you never pick up the receiver until the party is on the line. The Superphone will



CIRCLE 87 ON READER SERVICE COUPON

operate on rotary dial lines as well as touch-tone lines. If you make a call and get a busy signal, the Superphone will hang up and call again up to eighteen times and when call goes through, you will hear the phone ring and the party you called, answering! You then pick up the receiver. The Superphone also provides an easily programmed electronic memory for ten most often used numbers. Superphone has met all F.C.C.

requirements for legal connection to the telephone line without couplers and with no monthly charge from your telephone company. The complete price of Superphone is only \$199.95 each and is available from Phone Control Systems, 92 Marcus Avenue, New Hyde Park, New York 11040.

AC/TVI Line Filter

Designed to overcome the problem of annoying television interference caused by transmission of the CB radio signal through AC power lines, the Avanti AV-820 AC line filter, installed at the CB transmitter or at the TV set, prevents the signal from entering the TV through the AC line. The unit plugs into a wall receptacle and has a receptacle for the TV or CB plug-in. Sells for \$19.95. Avanti Research & Development, Inc., 340 Stewart Ave., Addison, IL 60101. ■

CIRCLE 78 ON READER SERVICE COUPON

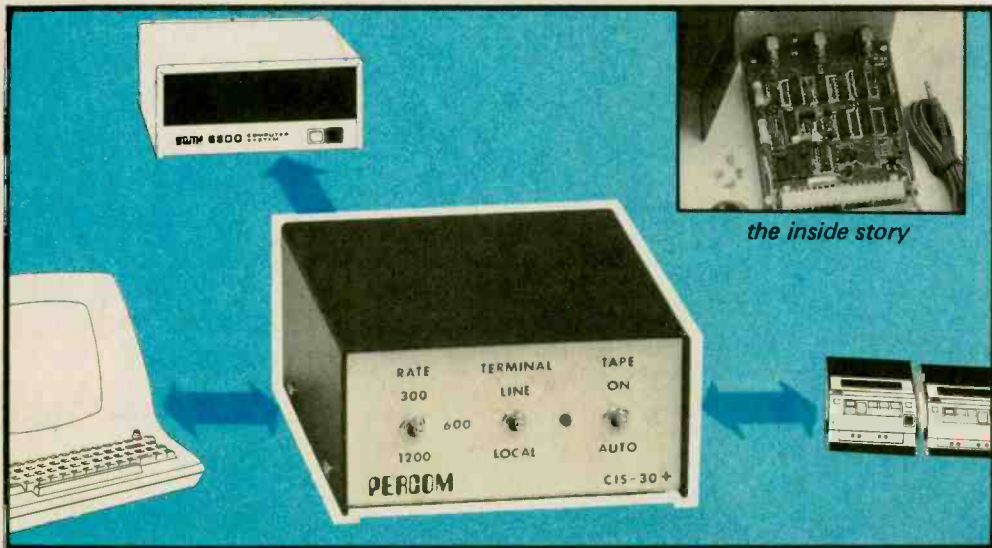

the inside story

- Record and playback at 120, 60 or 30 self-clocking bytes per second (extended Kansas City Standard)
- 1200, 600 or 300 baud data terminal interface
- Dual cassette operation
- Compatible with SWTPC cassette software
- Optional kit permits program control of cassettes
- Optional adaptor permits interfacing with any computer

Upgrade your SWTPC 6800 system to 1200 baud with PerCom's CIS-30+ dual-cassette/terminal interface

The CIS-30+ . . . four times as fast as SWTPC's AC-30 with the same dual-cassette capability . . . **plus** a 1200-baud data terminal interface . . . in a SWTPC color-compatible package that's only **1/10** the size of the AC-30.

Dependable? The simplicity of Harold Mauch PerCom Data designs says more than any well-chosen words. Simply put, for only **\$79.95*** you get the fastest, most dependable dual function interface you can buy for your SWTPC 6800.

See your nearest dealer or order direct from PerCom.

PerCom *'peripherals for personal computing'*

PERCOM

PERCOM DATA COMPANY, INC.
DEPT. E • 318 BARNES • GARLAND, TX 75042

(214) 272-3421

*Kit price. Assembled and tested: \$99.95 + shipping. Tex. res. add 5% tax. BAC & MC available.

CIRCLE 15 ON READER SERVICE COUPON

BUILD 20 RADIO

and Electronics Circuits

PROGRESSIVE HOME RADIO-T.V. COURSE

Now Includes

- ★ 12 RECEIVERS
- ★ 3 TRANSMITTERS
- ★ SQ. WAVE GENERATOR
- ★ SIGNAL TRACER
- ★ AMPLIFIER
- ★ SIGNAL INJECTOR
- ★ CODE OSCILLATOR

- ★ No Knowledge of Radio Necessary
- ★ No Additional Parts or Tools Needed
- ★ Solid State Circuits
- ★ Vacuum Tube Circuits

YOU DON'T HAVE TO SPEND HUNDREDS OF DOLLARS FOR A RADIO COURSE

The "Edu-Kit" offers you an outstanding PRACTICAL HOME RADIO COURSE at a rock-bottom price. Our Kit is designed to train Radio & Electronics Technicians, making use of the most modern methods of home training. You will learn radio theory, construction practice and servicing. THIS IS A COMPLETE RADIO COURSE IN EVERY DETAIL. You will learn how to build radios, using regular schematics; how to wire and solder in a professional manner; how to service radios. You will work with the standard type of punched metal chassis as well as the latest development of Printed Circuit chassis.

You will learn the basic principles of radio. You will construct, study and work with RF and AF amplifiers and oscillators, detectors, rectifiers, test equipment. You will learn and practice code, using the Progressive Code Oscillator. You will learn and practice trouble-shooting, using the Progressive Signal Tracer, Progressive Signal Injector, Progressive Dynamic Radio & Electronics Tester, Square Wave Generator and the accompanying instructional material.

You will receive training for the Novice, Technician and General Classes of F.C.C. Radio Amateur Licenses. You will build Receiver, Transmitter, Square Wave Generator, Code Oscillator, Signal Tracer and Signal Injector circuits, and learn how to operate them. You will receive an excellent background for television, Hi-Fi and Electronics.

Absolutely no previous knowledge of radio or science is required. The "Edu-Kit" is the product of many years of teaching and engineering experience. The "Edu-Kit" will provide you with a basic education in Electronics and Radio, worth many times the low price you pay. The Signal Tracer alone is worth more than the price of the kit.

THE KIT FOR EVERYONE

You do not need the slightest background in radio or science. Whether you are interested in Radio & Electronics because you want an interesting hobby, a well paying business or a job with a future, you will find the "Edu-Kit" a worth-while investment. Many thousands of individuals of all

ages and backgrounds have successfully used the "Edu-Kit" in more than 79 countries of the world. The "Edu-Kit" has been carefully designed, step by step, so that you cannot make a mistake. The "Edu-Kit" allows you to teach yourself at your own rate. No instructor is necessary.

PROGRESSIVE TEACHING METHOD

The Progressive Radio "Edu-Kit" is the foremost educational radio kit in the world, and is universally accepted as the standard in the field of electronics training. The "Edu-Kit" uses the modern educational principle of "Learn by Doing." Therefore you construct, learn schematics, study theory, practice trouble shooting—all in a closely integrated program designed to provide an easily-learned, thorough and interesting background in radio.

You begin by examining the various radio parts of the "Edu-Kit." You then learn the function, theory and wiring of these parts. Then you build a simple radio. With this first set you will enjoy listening to regular broadcast stations, learn theory, practice testing and trouble-shooting. Then you build a more advanced radio, learn more advanced theory and techniques. Gradually, in a progressive manner, and at your own rate, you will find yourself constructing more advanced multi-tube radio circuits, and doing work like a Professional Radio Technician.

Included in the "Edu-Kit" course are Receiver, Transmitter, Code Oscillator, Signal Tracer, Square Wave Generator and Signal Injector Circuits. These are not unprofessional "breadboard" experiments, but genuine radio circuits, constructed by means of professional wiring and soldering on metal chassis, plus the new method of radio construction known as "Printed Circuitry." These circuits operate on your regular AC or DC house current.

THE "EDU-KIT" IS COMPLETE

You will receive all parts and instructions necessary to build twenty different radio and electronics circuits, each guaranteed to operate. Our Kits contain tubes, tube sockets, variable electrolytic, mica, ceramic and paper dielectric condensers, resistors, tie strips, hardware, tubing, punched metal chassis, Instruction Manuals, hook-up wire, solder, selenium rectifiers, coils, volume controls, switches, solid state devices, etc.

In addition, you receive Printed Circuit materials, including Printed Circuit chassis, special tube sockets, hardware and instructions. You also receive a useful set of tools, a professional electric soldering iron, and a self-powered Dynamic Radio and Electronics Tester. The "Edu-Kit" also includes Code Instructions and the Progressive Code Oscillator, in addition to F.C.C. Radio Amateur License training. You will also receive lessons for servicing with the Progressive Signal Tracer and the Progressive Signal Injector, a High Fidelity Guide and a Quiz Book. You receive Membership in Radio-TV Club, Free Consultation Service, Certificate of Merit and Discount Privileges. You receive all parts, tools, instructions, etc. Everything is yours to keep.

PRINTED CIRCUITRY

At no increase in price, the "Edu-Kit" now includes Printed Circuitry. You build a Printed Circuit Signal Injector, a unique servicing instrument that can detect many Radio and TV troubles. This revolutionary new technique of radio construction is now becoming popular in commercial radio and TV sets.

A Printed Circuit is a special insulated chassis on which has been deposited a conducting material which takes the place of wiring. The various parts are merely plugged in and soldered to terminals.

Printed Circuitry is the basis of modern Automation Electronics. A knowledge of this subject is a necessity today for anyone interested in Electronics.



Reg. U. S. Pat. Off.

Training Electronics Technicians Since 1946

FREE EXTRAS

• SET OF TOOLS

- SOLDERING IRON
- ELECTRONICS TESTER
- PLIERS-CUTTERS
- VALUABLE DISCOUNT CARD
- CERTIFICATE OF MERIT
- TESTER INSTRUCTION MANUAL
- HIGH FIDELITY GUIDE • QUIZZES
- TELEVISION BOOK • RADIO TROUBLE-SHOOTING BOOK
- MEMBERSHIP IN RADIO-TV CLUB: CONSULTATION SERVICE • FCC AMATEUR LICENSE TRAINING
- PRINTED CIRCUITRY

SERVICING LESSONS

You will learn trouble-shooting and servicing in a progressive manner. You will practice repairs on the sets that you construct. You will learn symptoms and causes of trouble in home, portable and car radios. You will learn how to use the professional Signal Tracer, the unique Signal Injector and the dynamic Radio & Electronics Tester. While you are learning in this practical way, you will be able to do many a repair job for your friends and neighbors—and charge fees which will far exceed the price of the "Edu-Kit." Our Consultation Service will help you with any technical problems you may have.

FROM OUR MAIL BAG

Ben Valerio, P. O. Box 21, Magna, Utah: "The Edu-Kits are wonderful. Here I am sending you the questions and also the answers for them. I have been in Radio for the last seven years, but like to work with Radio Kits, and like to build Radio Testin' Equipment. I enjoyed every minute I worked with the different kits; the Signal Tracer works fine. Also like to let you know that I feel proud of becoming a member of your Radio-TV Club."

Robert L. Shuff, 1534 Monroe Ave., Huntington, W. Va.: "Thought I would drop you a few lines to say that I received my Edu-Kit, and was really amazed that such a bargain can be had at such a low price. I have already started repairing radios and phonographs. My friends were really surprised to see me get into the swing of it so quickly. The Trouble-shooting Tester that comes with the Kit is really swell, and finds the trouble, if there is any to be found."

SOLID STATE

Today an electronics technician or hobbyist requires a knowledge of solid state, as well as vacuum tube circuitry. The "Edu-Kit" course teaches both. You will build vacuum tube, 100% solid state and combination ("hybrid") circuits.

Progressive "Edu-Kits" Inc., 1189 Broadway, Dept. 592-DJ Hewlett, N.Y. 11557

Please rush me free literature describing the Progressive Radio-TV Course with Edu-Kits. No Salesman will call.

NAME

ADDRESS

CITY & STATE ZIP

PROGRESSIVE "EDU-KITS" INC.

1189 Broadway, Dept. 592-DJ Hewlett, N.Y. 11557

CIRCLE 16 ON READER SERVICE COUPON

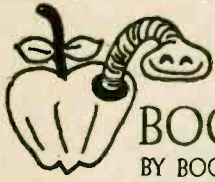

BOOKMARK BY BOOKWORM

Buried Gold! Enjoy looking for treasure. It'll keep you out in the sun looking for coins, relics, even buried gold treasure, and there is more than luck involved according to George Sullivan, author of *The Modern Treasure Finder's Manual*. True,

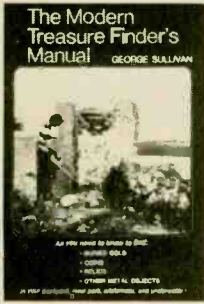

Become a treasure detector.

Soft Cover
187 pages
\$6.95

it's not an electronic theory text, but it contains the practical facts for getting started in the search for treasure in your backyard, local park, wilderness and underwater. Published by Chilton Book Company, Radnor, PA 19089.

Saving the Phone Toll. How to Buy, Install, and Maintain Your Own Telephone

Equipment is the title of a new booklet designed to help consumers cut the costs of telephone and related telephone equipment. This savings is possible because of recent rulings which allow users to replace specific items of telephone equipment with privately purchased equipment. In a compact paperback, two independent telephone installation engineers, Joseph La

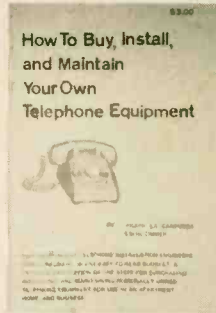

A guide to telephone systems.

Soft Cover
52 pages
\$3.00

Carrubba and Louis Zimmer give a detailed easy-to-follow description of the steps for purchasing, installing, and maintaining privately owned telephone equipment. Easy-to-read diagrams and illustrations of basic telephone parts show where existing equipment can be replaced and new equipment installed as remodeling and new construction are completed. The authors estimate that the average user could save as much as 40 percent on equipment and installation charges by following their directions, depending on local telephone company tariffs. Available from Almar Press, 4105 Marietta Drive, Binghamton,

NY 13903.

Guide for DXers. Better Shortwave Reception. The new fourth edition of this long-time favorite is packed with important information for the shortwave listener and radio amateur. The book is a joint effort by William I. Orr and Stuart D. Cowan who have been involved with amateur and professional radio engineering since the early 1930s. There are extensive discussions of the theory of radio wave propagation, including some fascinating sections on how propagation is effected by sun-



All the hows, whys and wherefores of SWling.

Soft Cover
160 pages
\$4.95

spots, meteor showers, auroral and equatorial zones, and by atmospheric layers. It is available from leading dealers and bookstores for \$4.95 (\$5.95 in Canada), or from the publisher; send check or money order to: Radio Publications, Inc., Box 149, Wilton, CT 06897 (add 35¢ for postage and handling—Connecticut residents should add sales tax).

Performance you can count on. A professional 3 1/2 digit DMM kit, incredibly priced under \$70.

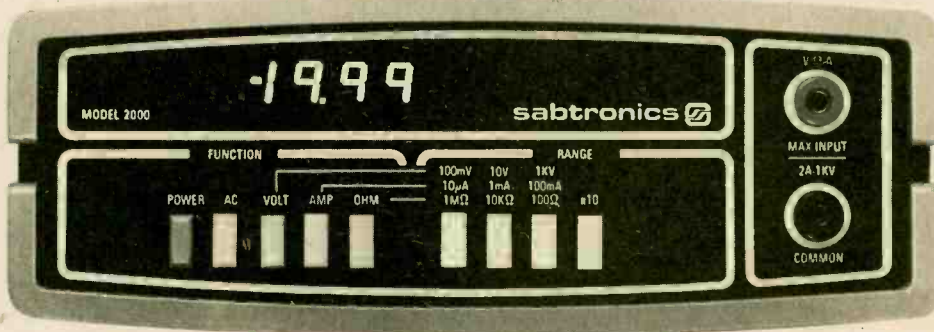

The amazing Sabtronics 2000 is the choice of both professionals and hobbyists. It's the only portable/bench DMM that offers so much performance for the astonishingly low price of \$69.95.

You get basic DVC accuracy of 0.1% ± 1 digit; 5 functions giving 28 ranges; readings to ± 1999 with 100% overrange; overrange indication; input overload protection; automatic polarity; and automatic zeroing.

The all-solid-state Model 2000 incorporates a single LSI circuit and high-quality components. Our clear, step-by-step manual simplifies assembly. Complete kit includes a high-impact case.

Guarantee: Examine the 2000 DMM kit for 10 days. If not completely satisfied, return unassembled for full refund of purchase price (less shipping and handling).

BRIEF SPECIFICATIONS

DC volts in 5 ranges: 100 μ V to 1kV • AC volts in 5 ranges: 100 μ V to 1 kV • DC current in 6 ranges: 100 nA to 2 A • AC current in 6 ranges: 100 nA to 2 A • Resistance: 0.1 Ω to 20 M Ω in 6 ranges • AC frequency response: 40 Hz to 50 kHz • Display: 0.36" (9.1 mm) 7-segment LED • Input impedance: 10 M Ω • Size: 8" W x 6.5" D x 3" H (203 x 165 x 76 mm) • Power requirement: 4 "C" cells (not included).

Order Your Model 2000 Kit Now. Use your Master Charge or Visa or send \$69.95 plus \$5.00* per unit shipping and handling. Texas residents add sales tax. * (U.S.A. only. Canada, \$6.50; all other countries, \$19.00. Airmail.)

sabtronics

INTERNATIONAL INC.

13426 FLOYD CIRCLE, # E • DALLAS, TEXAS 75243 USA • 214/783-0994

CIRCLE 26 ON READER SERVICE COUPON

"I'm very impressed with the way Radio Shack has translated latest technology into good looks and precision record playing in the 400."

Peter Nero
Composer/
Pianist

Peter Nero

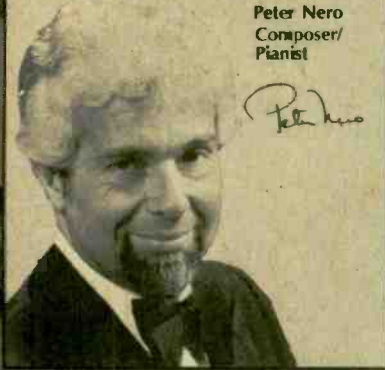

"Direct" to you from Radio Shack



Realistic® Direct-Drive Automatic . . . Finest Turntable We've Ever Offered

Two motors, damped cue/pause, S-shape tonearm, speed controls, \$39.95-value Realistic/Shure cartridge

The LAB-400 makes studio performance both affordable and convenient. Its massive die-cast platter rests directly atop a 16-pole brushless DC servomotor. The platter and motor rotate at the same speed, either 33 $\frac{1}{3}$ or 45 RPM — no idler wheels, reduction gears or belts to alter the music that's stored in your record's grooves. The result: wow and flutter is less than 0.03% WRMS and rumble is better than -63 dB (DIN B). The fully automatic tonearm has an effective length of 8 $\frac{1}{16}$ ", for flawless tracking down to $\frac{1}{2}$ gram. Handsome walnut vinyl veneer base with ultra-modern, slim design. Elliptical-stylus magnetic cartridge and detachable hinged dust cover — significant "extras" that aren't extra. All for \$199.95.*

Fully Automatic Tonearm Operation

You need never touch the tonearm — just select record size and push start switch. An independent motor does the rest, cueing the arm, gently lowering it onto the record, and removing it at disc's end. With repeat mode, cue/pause, anti-skate and tracking force controls.



Two speeds with controls for $\pm 4\%$ pitch adjustment.



Neon light with strobe disc for checking speed.



Low-profile styling with precision shock-mounts to stop acoustic feedback.



Available
Sept. 5th

FREE! New '79 Catalog

Come in for your copy and see what's really new in electronics. Bigger than ever! 176 pages, over 100 in full color. 2000 exclusive items.

* Price may vary at individual stores and dealers.

Radio Shack®

A DIVISION OF TANDY CORPORATION • FORT WORTH, TEXAS 76102
OVER 7000 LOCATIONS IN NINE COUNTRIES

**NRI training in TV
and Audio Servicing
keeps up with the
state of the art.
Now you can learn to
service video cassette
and disc systems.**





You build color TV, hi-fi, professional instruments.

Now, in addition to learning color TV and audio systems servicing, you get state-of-the-art lessons in maintaining and repairing video cassette recorders, playbacks and the amazing new video disc players, both mechanical and laser-beam types.

Learn at Home in Your Spare Time

And you learn right at home, at your own convenience, without quitting your job or going to night school. NRI "bite-size" lessons make learning easier... NRI "hands-on" training gives you practical bench experience as you progress. You not only get theory, you actually build and test electronic circuits, a complete audio system, even a color TV.

Build Color TV, 4-Channel Audio

As part of your training in NRI's Master Course in TV and Audio Servicing, you actually assemble and keep NRI's exclusive,

designed-for-learning 25" diagonal color TV. As you build it, you introduce and correct electronic faults, study circuits to gain a better understanding of what they're for and how they interface with others.

Likewise, as part of your audio training, you construct a 4-channel stereo amplifier and tuner, complete with cabinet and speakers. You even assemble professional-grade test instruments, so you know what makes them tick, too. Then you use them in your course, keep them for actual TV and audio servicing work.

NRI Includes the Instruments You Need

You start by building a transistorized volt-ohm meter which you use for basic training in electronic theory. Then you assemble a digital CMOS frequency counter for use with lessons in analog and digital circuitry, FM principles. You also get an integrated circuit TV pattern generator, and an advanced design solid-state 5" triggered-sweep oscilloscope. Use them for learning, then use them for earning.

NRI Training Works... Choice of the Pros

More than 60 years and a million students later, NRI is still first choice in home study schools. A national survey of successful TV repairmen shows that more than half have had home study training, and among them, it's NRI 3 to 1 over any other school. (Summary of survey on request.)

That's because you can't beat the training and you can't beat the value! For hundreds of dollars less than competing schools, NRI gives you both color TV and audio... and now includes training in video cassette and disc systems. Send for our free catalog and see for yourself why NRI works for you.



Other NRI training includes Computer Technology, Complete Communications Electronics.

Free Catalog... No Salesman Will Call

Our free 100-page catalog completely describes all the equipment and every lesson. You can choose from five different TV and audio courses. Or explore the opportunities in other NRI home study courses like Computer Technology, CB and Mobile Radio, Aircraft and Marine Radio, or Complete Communications. Send the postage-paid card today and get a head start on the state of the art.

If card has been removed, write to:



NRI-Schools
McGraw Hill Continuing
Education Center
3939 Wisconsin Ave.
Washington, D.C. 20016



Learn at home at your convenience.

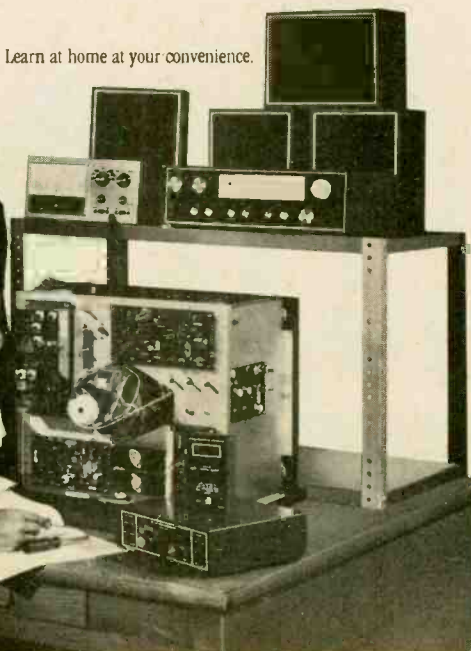

This is easy- anyone can solder- WITH KESTER SOLDER

**KESTER
SOLDER**



Handymen! Hobbyists! DO-IT-YOURSELFERS!

Let Kester Solder aid you in your home repairs or hobbies. For that household item that needs repairing — a radio, TV, model train, jewelry, appliances, minor electrical repairs, plumbing, etc. — Save money — repair it yourself. Soldering with Kester is a simple, inexpensive way to permanently join two metals.

When you Solder go "First Class" — use Kester Solder.

For valuable soldering information send self-addressed stamped envelope to Kester for a FREE Copy of "Soldering Simplified".



KESTER SOLDER

Litton 4201 WRIGHTWOOD AVENUE/CHICAGO, ILLINOIS 60639

CIRCLE 71 ON READER SERVICE COUPON

BUILD YOUR OWN BIG SCREEN COLOR TV!

Convert any portable color TV! TV not included.
Can be built in a few spare hours.
No special tools or electronic skills required.
SAVE \$15 ON ALL PACKAGE ORDERS!

NEW!
TRON-EX F/1.9 LENS
featured in November
Popular Science.

LIFESCREEN III
The LIFESCREEN III projection system gives you all the enjoyment and excitement of the \$4000 systems. Our new injection molded Tron-Ex lens (F/1.9) produces an amazing image that is over 3 times brighter than most nationally marketed big-screen TVs—including Sony. And the Tron-Ex delivers sharper focus to the screen edge for better overall clarity. Our light-enhancing Extron LS-50 screen is 6 times brighter than most movie screens, because the molded parabolic contour rejects extraneous light, concentrating a directionally selective TV image for clear, colorful viewing. The LIFESCREEN III plans provide exact dimensions to fit the 13" Toshiba (model C389), but they can be modified to fit most 12" to 19" portables. Pre-constructed LIFESCREEN III lens housings available for most TVs. Order the components catalog below.



COMPLETE PACKAGE \$319

LIFESCREEN II

The self-contained projection system that uses any transistor portable TV (12" to 19") requires only 2 x 4 feet of floor space. It fits neatly against any wall and lends its beauty to the decor of any room. Includes Tron-Ex F/1.9 lens, Extron LS-50 screen, two front surface mirrors, and building plans for the cabinet.

COMPLETE PACKAGE \$369

LIFESCREEN I

The original independent projection system from Extron. Works with the Sharp 13" model 13A29 color TV or Sony 15" model KV1541R color TV. Can be used with any size screen. The LIFESCREEN I includes our new Tron-Ex F/1.9 lens, one front surface mirror, building plans for cabinet, and the LS-50 screen, 32" x 40" / 50" diagonal.

COMPLETE PACKAGE \$339

EXTRON GUARANTEES EVERYTHING: the professional quality, accuracy of description and availability of components described in this ad. After building your LIFESCREEN PROJECTION SYSTEM, if you are not satisfied for any reason, return all components to EXTRON for instant refund.

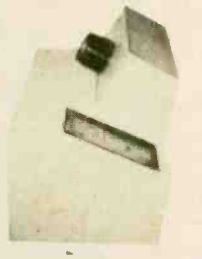

LARGER SCREENS FOR THE LIFESCREEN I AND LIFESCREEN III SYSTEMS CAN BE ORDERED FROM OUR CATALOG.

Please send me the items checked below:

- ONE COMPLETE SET OF LIFESCREEN I PLANS \$9.00
- ONE COMPLETE SET OF LIFESCREEN II PLANS \$9.00
- ONE COMPLETE SET OF LIFESCREEN III PLANS \$9.00
- COMPLETE LIFESCREEN I PACKAGE \$339.00
- COMPLETE LIFESCREEN II PACKAGE \$369.00
- COMPLETE LIFESCREEN III PACKAGE \$319.00
- EXTRON COMPONENTS CATALOG (Applicable toward any purchase) \$1.00

All prices F. D. B. factory—Cal. residents add 6% sales tax

TOTAL \$



EXTRON LIFESCREEN PROJECTION SYSTEMS
8833 Sunset Boulevard Suite 202
West Hollywood, CA 90069

Name _____
Address _____
City _____ State _____ Zip _____
CARD NAME _____
CARD NUMBER _____ EXP. DATE _____
SIGNATURE _____

CIRCLE 11 ON READER SERVICE COUPON

DX central reporting

A world of SWL info!

BY DON JENSEN

□ Don't look now but the pirates have landed on our shores! The kind of pirates I am talking about are short-wave pirates, unlicensed and—let's face it—illegal broadcasters.

These types of stations have flourished for a number of years in Europe. Recently, however, a few of them have turned up, operating on shortwave, in the U.S.

Pirates. First of all, don't mistake these so-called hobby pirates with the propaganda-oriented clandestine broadcasters of the world. The clandestines—and the Voice of the Malayan Revolution is typical of the breed—have an ideological message of one sort or another, often presented under false colors. The Voice of the Malayan Revolution, critical of the Malaysian government and pro-communist, operates under the guise of being operated by and for Malaysians. In fact it is just another of Peking's propaganda voices.

Secondly, don't mistake the hobby pirates with the handful of commercially run pirate broadcasters. A few of these still operate, mostly off the coast of Europe, from radio ships, beaming pop music and commercials to Continental audiences. Taking advantage of the safety of offshore, international waters, these commercial pirates trade on the desire by many European young people to hear American-type pop radio programming they can't hear on many of the government-run domestic networks.

The type of pirate station I'm talking about, the hobby pirate, is mostly operated just for the fun of it by non-professional (often quite young) radio hobbyists.

In Europe there are exceptions. Some of these second-level pirate stations seem to be very well equipped technically. Some, it is true, have rather professional sounding programming and good quality sound. But most are amateurish, to some degree, in sound and programming; the efforts of non-pros playing at radio broadcasting.

Although station names frequently change on the European pirate scene, the overall situation has existed so long—and in its way, successfully—that certain traditions have been established.

(Continued on page 24)

The Sinclair PDM35.

A personal digital multimeter for only \$49.⁹⁵

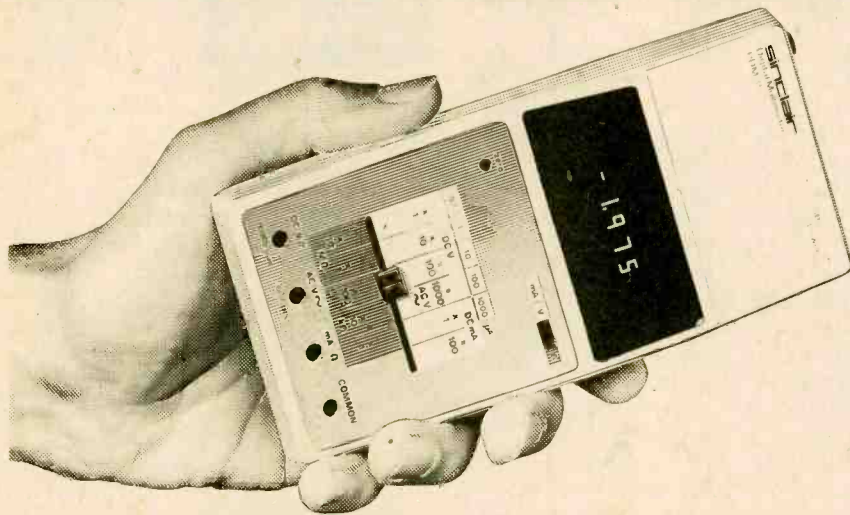

Now everyone can afford to own a digital multimeter

A digital multimeter used to mean an expensive, bulky piece of equipment.

The Sinclair PDM35 changes that. It's got all the functions and features you want in a digital multimeter, yet they're neatly packaged in a rugged but light pocket-size case, ready to go anywhere.

The Sinclair PDM35 gives you all the benefits of an ordinary digital multimeter — quick clear readings, high accuracy and resolution, high input impedance. Yet at \$49.95 it costs less than you'd expect to pay for an analog meter!

The Sinclair PDM35 is tailor-made for anyone who needs to make rapid measurements. Development engineers, field service engineers, lab technicians, computer specialists, radio and electronic hobbyists will find it ideal.

With its rugged construction and battery operation, the PDM35 is perfectly suited for hand work in the field, while its angled display and optional AC power facility make it just as useful on the bench.

What you get with a PDM35

- 3½ digit resolution.
- Sharp, bright, easily read LED display, reading to ±1.999.
- Automatic polarity selection.
- Resolution of 1 mV and 0.1 nA (0.0001 μA).
- Direct reading of semiconductor forward voltages at 5 different currents.
- Resistance measured up to 20 MΩ.
- 1% of reading accuracy.

Operation from replaceable battery or AC adapter.
Industry standard 10 MΩ input impedance.

Compare it with an analog meter!

The PDM35's 1% of reading compares with 3% of full scale for a comparable analog meter. That makes it around 5 times more accurate on average.

The PDM35 will resolve 1 mV against around 10 mV for a comparable analog meter — and resolution on current is over 1000 times greater.

The PDM35's DC input impedance of 10 MΩ is 50 times higher than a 20 kΩ/volt analog meter on the 10 V range.

The PDM35 gives precise digital readings. So there's no need to interpret ambiguous scales, no parallax errors. There's no need to reverse leads for negative readings. There's no delicate meter movement to damage. And you can resolve current as low as 0.1 nA and measure transistor and diode junctions over 5 decades of current.

Technical specifications

DC Volts (4 ranges)

Range: 1 mV to 1000 V.
Accuracy of reading 1.0% ± 1 count.
Note: 10 MΩ input impedance.

AC Volts (40 Hz-5 kHz)

Range: 1 V to 500 V.
Accuracy of reading: 1.0% ± 2 counts.

DC Current (6 ranges)

Range: 1 nA to 200 mA.
Accuracy of reading: 1.0% ± 1 count.
Note: Max. resolution 0.1 nA.

Resistance (5 ranges)

Range: 1 Ω to 20 MΩ.
Accuracy of reading: 1.5% ± 1 count.
Also provides 5 junction-test ranges.

Dimensions: 6 in. x 3 in. x 1½ in.

Weight: 6½ oz.

Power supply: 9 V battery or Sinclair AC adapter.

Sockets: Standard 4 mm for resilient plugs.

Options: AC adapter for 117 V 60 Hz power. De-luxe padded carrying wallet. 30 kV probe.

The Sinclair credentials

Sinclair have pioneered a whole range of electronic world-firsts — from programmable pocket calculators to miniature TVs. The PDM35 embodies six years' experience in digital multimeter design, in which time Sinclair have become one of the world's largest producers.

Tried, tested ready to go!

The Sinclair PDM35 comes to you fully built, tested calibrated and guaranteed. It comes complete with leads and test prods, operating instructions and a carrying wallet. And getting one couldn't be easier. Just fill in the coupon, enclose a cheque/MO for the correct amount (usual 10-day money-back undertaking, of course), and send it to us.

We'll mail your PDM35 by return!

For Instant Service, CALL TOLL FREE: 1-800-528-6050, EXT. 1052.
Ariz. Res. Call Collect 602-955-9710 or send coupon:

Starshine Group.

Dept. 357, 924 Anacapa Street, Santa Barbara, Calif. 93101
Please promptly send _____ Sinclair PDM35 Digital Multimeter(s) @ \$49.95 (plus 53 shipping and insurance) each. I have the option of returning it within 1 week of receipt for an immediate refund.

- Also Send AC Adaptor(s) @ \$4.95 ea.
 - Also Send Deluxe Padded Carrying Case @ \$4.95 ea.
 - Also send 30 kV probe @ \$29.95
 - Check or Money order Encl. (Calif. Res. add 6% Sales Tax)
 - Charge to The Credit Card Checked Below:
 - BankAmericard/Visa MasterCard (Interbank # _____)
 - American Express Carte Blanche Diners Club
- Credit Card # _____ Exp. Date _____
Name _____
Address _____
City State Zip _____
Signature _____

CIRCLE 18 ON READER SERVICE COUPON

DX CENTRAL

(Continued from page 22)

For one thing, almost all the overseas pirate stations operate in one self-defined "band" between 6,200 and 6,300 kHz. Clearly, since they all are illegal, no authority assigned them this band; that's just where they all hang out.

Also, being hobby pirates, these tend to be weekend operations and almost all of these shortwave stations operate Sunday mornings and early afternoons, from about 0900 or 1000 to perhaps 1300 to 1500 GMT. The typical station might be on the air for an hour or two during this time slot.

Not Always on Sunday. But not all the European hobby pirates broadcast every Sunday. Some only make it on the air once or twice a month. In fact, there seem to be some informal tacit agreements among stations that amount to "you use the frequency this Sunday and we'll use it next weekend."

Don't the authorities vigorously crack down on the illegal hobby pirates? Official enforcement activity seems to vary from fairly vigorous to ho-hum, depending on the country. There seem to be hobby pirates operating from Great Britain, Ireland, Italy, West Germany, Holland and the Scandinavian countries. The efforts in some

of the Continental countries seem to get "serious" only when the hobby pirates get too ambitious, fire up too potent a transmitter and are too widely heard.

But most of the pirates take no chances, though they do seek listener feedback. There are a handful of postal "drops," usually box numbers to which listeners may mail their reports for forwarding by some "free radio" (as the pirates like to style themselves) advocate who is not personally involved in the broadcasting efforts.

From time to time in the past there have been hobby type pirate shortwavers on this side of the Atlantic, but they have been far fewer in number than the illegal medium wave AM bootleggers who seem to crop-up regularly in our major cities. This is probably because SW is much less a pop medium than regular AM radio in the U.S. and Canada.

Home Brewed. There have been a few notable SW pirates in the U.S. in the past decade, though most were very short lived. There was the Voice of the Purple Pumpkin and Wild Turkey Radio, to name but two of the more colorfully named operations.

A few years ago I was able to track down one pirate which called itself WRVU, Radio Voice of the Underground, which operated in the heart of

the 40 meter ham band, presumably with an amateur radio type transmitter. By the time I managed to locate the 17-year-old operators of the station, they had already been visited by the FCC. They had been thoroughly scared by the warning they received and had no intention of returning to the air.

WRVU's downfall was, at least in part, the almost overpowering desire to hear from listeners, to know that the illegal signal is getting out—and how far? The station gave a mailing address that could be, and was, traced. The FCC, it seems, is more intent on actively policing the shortwave frequencies than are some of its European counterparts. Still, there have been a number of SW hobby pirates that have become active in the last few months.

Several of these stations, or perhaps it is the same station with varying identities, seem to operate from the greater New York City area. These stations use call letters such as WFSR, WFCC, WGOR and operate between about 1610 and 1630 kHz, the range just above the standard AM medium wave band that most listeners consider SW.

Not long ago, another shortwave pirate calling itself Jolly Roger Radio popped up on shortwave (though it is said that in an earlier "life" JRR oper-

(Continued on page 87)

Save even more when you build your own ACE.

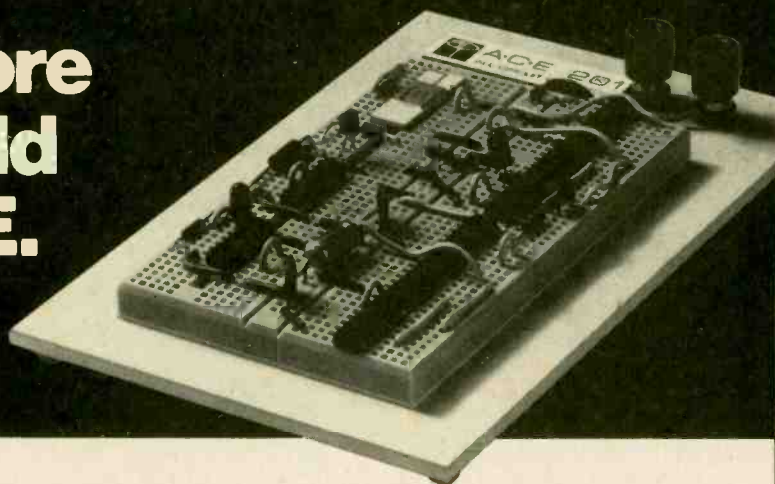

Yes, now you can save even more when you build an ACE from one of our two ACE Models kits. ACE is the better solderless breadboard from A P Products. There's just no faster or easier way of building and testing circuits and circuit ideas.

Part No.	ACE Model No.	Tie Points	DIP Capacity	No. Buses	No. Posts	Board Size (inches)	Price Each
923333	200-K (kit)	728	8 (16s)	2	2	4 $\frac{1}{6}$ x 5 $\frac{5}{6}$	\$18.95
923334	201-K (kit)	1032	12 (14s)	2	2	4 $\frac{1}{6}$ x 7	\$24.95

Order from your A P distributor today. Our distributor list is growing daily. For the name of the distributor nearest you call Toll-Free 800-321-9668.



Send for our complete A P catalog, the **Faster and Easier Book**.

A P PRODUCTS INCORPORATED

Box 110 • 72 Corwin Dr., Painesville, OH 44077 • (216) 354-2101 TWX: 810-425-2250

CIRCLE 65 ON READER SERVICE COUPON

NTS trains you on tomorrow's equipment. Today.

Microcomputers, digital systems and more...
from the first name in home study.



Now NTS training programs include an even wider choice of solid-state digital equipment than ever before offered in any electronic home study course. Advanced NTS/Heath digital color TV (25" diagonal with optional programming capability), NTS/Heath digital computer, digital test equipment, digital stereo receiver (70 watts per channel) plus much more state-of-the-art equipment to make your training exciting and relevant. Learn servicing and maintenance easily with step-by-step Project Method lessons and kits.

An all-new full color catalog shows you exactly what each of the fourteen courses cover, and every piece of equipment you receive.

Send for it today and see for yourself what's really happening in electronics training technology at NTS. It's free. Just send the coupon.

**NO OBLIGATION. NO SALESMAN WILL CALL.
APPROVED FOR VETERAN TRAINING.**

NATIONAL TECHNICAL SCHOOLS

TECHNICAL-TRADE TRAINING SINCE 1905
Resident and Home-Study Schools
4000 South Figueroa St., Los Angeles, Calif. 90037

NATIONAL TECHNICAL SCHOOLS Dept. 222-098
4000 South Figueroa Street, Los Angeles, California 90037

Please send FREE Color Catalog and Sample Lesson.

- | | |
|---|---|
| <input type="checkbox"/> Color TV Servicing | <input type="checkbox"/> Electronics Technology |
| <input type="checkbox"/> B & W TV and Radio Servicing | <input type="checkbox"/> Audio Electronics Servicing |
| <input type="checkbox"/> FCC License Course | <input type="checkbox"/> Digital Electronics |
| <input type="checkbox"/> Electronic Communications | <input type="checkbox"/> MicroComputers/MicroProcessors |

Name _____

Address _____

Apartment Number _____ Age _____

City _____

State _____ Zip _____

- Check if interested in G.I. Bill information.
 Check if interested ONLY in classroom training in Los Angeles.

74LS22N, NSN69, LD130, 8095

IT'S YOUR MOVE!



It's no game! When you need ICs for your project, move at once to Hobby Mart, the hobbyist's special advertising section in the back of **ELEMENTARY ELECTRONICS**. Prices are right, selection is large, and you're only a postage stamp away from your fully-stocked supplier.

Need parts? Find them in **HOBBY MART**—page 82.

CATCH-A-PULSE II LOGIC PROBE

**10 Nsec SPEED AT
3.5 to 15V LEVELS**

Compatible with RTL, DTL, TTL, CMOS, MOS, and Microprocessors using a 3.5 to 15V power supply. Thresholds automatically programmed. Automatic resetting memory. No adjustment required. Visual indication of logic levels, using LEDs to show high, low, bad level or open circuit logic and pulses. Highly sophisticated, shirt-pocket portable (protective tip cap and removable coil cord). Eliminates need for heavy test equipment. A definite savings in time and money for engineer and technician.

- 10 Nsec pulse response
- Open circuit detection
- Replaceable tip & cord
- High input impedance
- Pulse stretching
- Multi-family

ONLY \$39.95

SPECIAL PAK-II \$45.95

Includes a standard coiled cord, coiled cord with micro hooks, adapter for using CATCH-A-PULSE on logic families whose power supply is 15V to 25V. Shipping add \$2.00 per probe.

AV ELECTRONICS
Box 19299, San Diego CA 92119
(714) 447-1770

CIRCLE 41 ON READER SERVICE COUPON

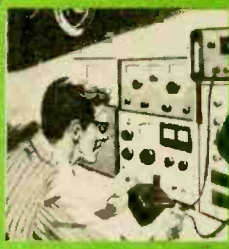

Ask Hank He Knows!

Got a question or a problem with a project—ask Hank! Please remember that Hank's column is limited to answering specific electronic project questions that you send to him. Personal replies cannot be made. Sorry, he isn't offering a circuit design service. Write to:

**Hank Scott, Workshop Editor
ELEMENTARY ELECTRONICS
380 Lexington Avenue
New York, NY 10017**

Wayne Whines Again

My Goodness, what was Wayne Green so upset over in his latest editorial in 73 Magazine? He accused Elementary Electronics of being in cahoots with the American Radio Relay League—some sort of international sixth column! All this time I thought you fellows were just trying to help us all get our Novice ham radio licenses. I know that article on the Morse Code convinced me to get going on my own "ticket." I've already ordered the Heathkit course that was mentioned. How could 73 have said the article was a "sales pitch for the ARRL" and a shameful thing? You mentioned many other manufacturers, at least a half-dozen—and even 73 Magazine once. What gives, Hank?

—A.R., Lodi, NJ

I can't tell you for sure. I was just as shocked as you must have been. Perhaps old Wayne is taking some speed reading course or another. You know the kind, where you read by paragraphs instead of lines. That's the only way I can think that he would have failed to spot all those manufacturers besides the ARRL. Come on, Wayne—fess up! You just got up on the wrong side of the bed that morning!

Wants More Info!

What are the advantages and disadvantages of a solid-state (semiconductor) diode over a vacuum tube diode? Please don't tell me about wasted filament power—I know about that!

—A. K., St. Louis, MO

For all practical purposes, the vacuum tube diode has no reverse current and the solid-state has. However, we are talking about reverse currents of one-thousandth or less, so that for all practical circuits you may build, there is no measurable effect. The solid-state diode cannot stand very high reverse voltages. Power supply solid-state diodes can be obtained with reverse-voltage or peak-reverse voltage (PRV) ratings up to several hundred volts, but in vacuum-tube type diodes, these ratings may be in the thousands of volts. Also, the solid-state diode cannot stand any over-voltage. It will usually break down and ruin itself, if the reverse voltage is just over the rating. The solid-state diode's advantages are its small size and its ability to conduct large current with low voltage drops. The low voltage internal drop results in very little power loss in the rectifier.

A Cuban Mystery?

I heard Radio Huayacocotla on 2400 kHz but not enough to place it in a coun-

try. Sounded like a Cuban to me. Hank, can you help?

—S. T., Tulsa, OK

It seems that everyone who hears a low-in-the-noise station speaking Spanish has hit on some exotic Cuban station. Sorry. R. Huayacocotla is Mexican. It's a good catch, anyway!

PM is to Station

What is phase modulation? I know about AM and FM modulation.

—E. W., Erie, PA

Think of phase modulation (PM) as a stuttering continuous wave (CW) signal. The CW signal proceeds until at a point in time there is a brief delay or advance of the next string of cycles. Actually, this a form of FM (frequency modulation) where the frequency change affects only one cycle of the signal. However, there is a definite phase, or time change relationship between the CW signal before and after this frequency "stutter." A sensitive receiver detects this phase change and produces a useable output.

Cops Get Religion

I have a problem with an amplifier and an electronic organ installed in our church. When a police car passes in front while transmitting, its signal overrides whatever program is on, whether it is a speech on the amplifier or music from the organ. Can you help?

—H. J., Val St-Michel, Quebec

The long leads on the PA system, are acting as antennas, and somewhere in the circuit a dielectric effect is taking place, causing rectification. Not good for the PA output. So, take some action by shielding all speaker leads and double shielding audio input leads. Ground the entire system to one common ground point. Place a small capacitor across the speaker leads at the amplifier terminals. Keep reducing the value until the capacitor does not affect sound performance. Also, talk to the cops about their chatting habits.

Solder Saver

Mr. Robert Smith has suggested this modification to our popular "Friendly Flasher" project, which ought to save builders about forty solder connections and twenty resistors! If 7448 ICs are substituted for 7447s no resistors are needed for the LEDs. However, the 7448 is a common cathode driver, so you must feed the anodes of the LEDs and connect their cathodes to ground. Our thanks to Mr. Smith.

101-416p.—Electronic Circuit Design Handbook—4th Edition (\$17.95) (8½" x 11")

An Extraordinary Offer to introduce you to the benefits of Membership in

ELECTRONICS BOOK CLUB

take any **4** of these unique electronics books (values to \$65⁸⁰) for only **99¢** each

with a Trial Membership in the Book Club that guarantees to save you 25% to 75% on a wide selection of electronics books

841-236p.—Build Your Own Working Robot (\$8.95)

752-518p.—Computer Programming Handbook (\$12.95)

984-280 p.—CMOS Databook (\$9.95)

Modern Communications Switching Systems

Master Handbook of 1001 Practical Electronic Circuits
800-602p.—Master Handbook of 1001 Practical Electronic Circuits (\$12.95)

COMPUTER PROGRAMMING HANDBOOK

The Illustrated Dictionary of Broadcast-CATV-Telecommunications

950-420 p.—Illustrated Dictionary of Broadcast/CATV/Telecommunications (\$14.95)

CMOS DATABOOK

856-476p.—Master OP-AMP Applications Handbook (\$14.95)

MASTER OP-AMP APPLICATIONS HANDBOOK

678-276p.—Modern Communications Switching Systems (\$17.95)

913-476p.—The Complete Handbook of Electrical & House Wiring (\$10.95)

INTERNATIONAL TRANSISTOR SELECTOR

1010-200p.—Tower's International Transistor Selector—2nd Edition (\$9.95)

BEGINNER'S GUIDE TO MICROPROCESSORS

995-182p.—Beginner's Guide to Microprocessors (\$8.95)

3RD CLASS FCC LICENSE STUDY GUIDE

893-322p.—Third Class FCC License Study Guide (\$9.95)

The Complete Handbook of Electrical & House Wiring

811-280p.—The Complete Handbook of Videocassette Recorders (\$9.95)

57 PRACTICAL PROGRAMS & GAMES IN BASIC

1000-210p.—57 Practical Programs & Games in BASIC (\$10.95)

132-168p.—How to Test Almost Everything Electronic (\$6.95)

DIGITAL LOGIC: Processors, Memories & Interfaces

709-294p.—Modern Guide to Digital Logic: Processors, Memories & Interfaces (\$9.95)

Programming Microprocessors

985-280p.—Programming Microprocessors (\$9.95)

AIR CONDITIONERS

520-208p.—How to Repair Home & Auto Air Conditioners (\$8.95)

THE COMPLETE HANDBOOK OF VIDEOCASSETTE RECORDERS

876-352p.—Color TV Case Histories Illustrated: Photo Guide to Troubles/Cures—Vol. 2 (\$10.95)

OSCILLOSCOPE

472-96p.—Working With the Oscilloscope (\$8.95)

May we send you your choice of 4 of these practical time-and-money-saving books as part of an unusual offer of a Trial Membership in Electronics Book Club?

Here are quality hardbound volumes, each especially designed to help you increase your know-how, earning power, and enjoyment of electronics. Whatever your interest in electronics, you'll find Electronics Book Club offers practical, quality books that you can put to immediate use and benefit.

This extraordinary offer is intended to prove to you through your own experience, that these very real advantages can be yours...that it is possible to keep up with the literature published in your areas of interest, and to save substantially while so doing. As part of your Trial Membership, you need purchase as few as four books during the coming 12 months. You would probably buy at least this many anyway, without the substantial savings offered through Club Membership.

To start your Membership on these attractive terms, simply fill out and mail the coupon today. You will receive the 4 books of your choice for 10-day inspection. YOU NEED SEND NO MONEY. If you're not delighted, return the books within 10 days and your Trial Membership will be cancelled without cost or obligation. ELECTRONICS BOOK CLUB, Blue Ridge Summit, Pa. 17214

Facts About Club Membership

- The 4 introductory books of your choice carry publishers retail prices of up to \$65.80. They are yours for only 99¢ each (plus postage/handling) with your Trial Membership.
- You will receive the Club News, describing the current Selection Alternates and other books, every 4 weeks (13x times a year).
- If you want the Selection, do nothing, it will be sent to you automatically. If you do not wish to receive the Selection, or if you want to order one of the many Alternates offered, you simply give instructions on the reply form (and in the envelope) provided, and return it to us by the date specified. This date allows you at least 10 days in which to return the form. If, because of late mail delivery, you do not have 10 days to make a decision and so receive an unwanted Selection, you may return it at Club expense.
- To complete your Trial Membership, you need buy only four additional monthly selections or alternates during the next 12 months. You may cancel your Membership any time after you purchase these four books.
- All books—including the introductory Offer—are fully returnable after 10 days if you're not completely satisfied.
- All books are offered at low Member prices, plus a small postage and handling charge.
- Continuing Bonus If you continue after this Trial Membership, you will earn a Dividend Certificate for every book you purchase. Three Certificates plus payment of the nominal sum of \$1.99 will entitle you to a valuable Book Dividend of your choice which you may choose from a list provided Members.

ELECTRONICS BOOK CLUB

Blue Ridge Summit, Pa. 17214

Please open my Trial Membership in ELECTRONICS BOOK CLUB and send me the 4 books circled below. I understand the cost of the books I have selected is only 99¢ each, plus a small shipping charge. If not delighted, I may return the books within 10 days and owe nothing, and have my Trial Membership cancelled. I agree to purchase at least four additional books during the next 12 months, after which I may cancel my membership at any time.

101 132 472 520 678 709 752
800 811 841 856 876 893
913 950 984 985 995 1000 1010

Name _____ Phone _____

Address _____

City _____

State _____ Zip _____

(Valid for new Members only. Foreign and Canada add 10%) EE-98

CIRCLE 28 ON READER SERVICE COUPON

FREE

World's biggest and best source of top-quality electronic kits!
Look at what's new in our new just-off-the-press catalog!



NEW
ASX-1383
High-Fidelity
Speaker System

Easily one of the finest speaker systems in its price range! Linear Phase design uses stepped speaker components and a 1st order crossover so all frequencies reach your ears at the same time; for a hi-fi improvement you can really HEAR. A special edge-free cabinet and acoustically "invisible" grill cloth provide outstanding dispersion and accurate stereo imaging. Great looks too. Brazilian Rosewood cabinetry adds a look of elegance to any decor.



NEW
CS-2048
Automatic
Cruise Control

Set your desired cruise speed, press the button and that's it — the CS-2048 maintains your car's speed on level roads, up and down hills, around curves, anywhere, automatically. Perfect for long-distance driving. A touch of the brake pedal returns the car to pedal control instantly — an important safety feature. Fits most domestic cars, vans and trucks with open driveshafts.



NEW
GD-1114
FM Wireless
Intercom

Simply plug into AC outlets and use for reliable two-way communications between units on the same AC power line. Has phase-locked loop solid-state circuitry for clean, clear transmission and reception; automatic squelch for quiet operation.



NEW
IT-7410
Logic Probe

Provides performance levels equal to units costing much more. Shows TRUE logic levels at high frequencies, has TWO indicator lights for unambiguous readings. Ideal for quick testing of any TTL or CMOS digital circuits.



NEW
OC-1401
Aircraft
Navigation
Computer

The world's FIRST hand-held navigation computer with true, on-board computer power — provides complete airport-to-airport flight management for up to 9 flight legs. Computes magnetic heading, true air speed, ground speed, true course, ETA to checkpoint, ETA to destination, clock time to check point and destination. A built-in clock/timer and three on-board microprocessors allow real time display which counts down to check point or destination. There's even a fuel warning indicator. It's the only navigation computer with complete pre-flight, in-flight and navigation functions. Another Heath EXCLUSIVE!

NO PREVIOUS EXPERIENCE NECESSARY

Thousands of people with no electronics experience whatsoever — people who have never handled a soldering iron before — have proved that you can build any Heathkit product you want to — and enjoy every moment of it! Simple step-by-step manuals make it easy as 1-2-3, and every Heathkit product you build will be a source of pride and satisfaction for years to come as you say "I built it myself!"

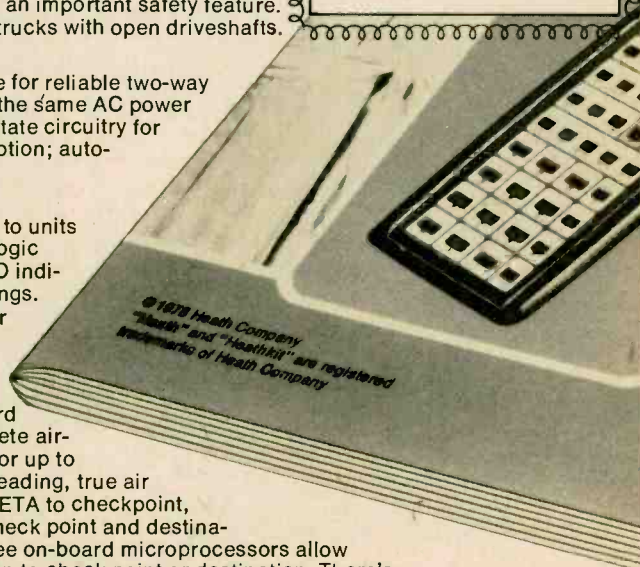

HEATHKIT ELECTRONIC CENTERS* PROVIDE SALES AND SERVICE



*Units of Schlumberger Products Corporation.

ARIZONA — Phoenix, 2727 W. Indian School Rd. (602) 279-6247.

CALIFORNIA — Anaheim, 330 E. Ball Rd. (714) 776-9420; El Cerrito, 6000 Potrero Ave. (415) 236-8670; Los Angeles, 2309 S. Flower St. (213) 749-0261; Pomona, 1555 Orange Grove Ave. N. (714) 623-3543; Redwood City, 2001 Middlefield Rd. (415) 365-8155; Sacramento, 1860 Fulton Ave. (916) 486-1575; San Diego (La Mesa), 8363 Center Dr. (714) 461-0110; San Jose (Campbell), 2350 S. Bascom Ave. (408) 377-8920; Woodland Hills, 22504 Ventura Blvd. (213) 882-0531.

COLORADO — Denver, 5940 W. 38th Ave. (303) 422-3408.

CONNECTICUT — Hartford (Avon), 395 W. Main St. (Rte. 44) (203) 678-0323.

FLORIDA — Miami (Hialeah), 4705 W. 16th Ave. (305) 823-2280; Tampa, 4019 West Hillsborough Ave. (813) 886-2541.

GEORGIA — Atlanta, 5285 Roswell Rd. (404) 252-4341.

ILLINOIS — Chicago, 3462-66 W. Devon Ave. (312) 583-3920; Chicago (Downers Grove), 224 Ogden Ave. (312) 852-1304.

INDIANA — Indianapolis, 2112 E. 62nd St. (317) 257-4321.

KANSAS — Kansas City (Mission), 5960 Lamar Ave. (913) 362-4486.

KENTUCKY — Louisville, 12401 Shelbyville Rd. (502) 245-7811.

LOUISIANA — New Orleans (Kenner), 1900 Veterans Memorial Hwy. (504) 722-6321.

MARYLAND — Baltimore, 1713 E. Joppa Rd. (301) 661-4446; Rockville, 5542 Nicholson Lane (301) 881-5420.

MASSACHUSETTS — Boston (Peabody), 242 Andover St. (617) 531-9330; Boston (Wellesley), 165 Worcester Ave. (Rte. 9 just west of Rt. 128) (617) 237-1510.

MICHIGAN — Detroit, 18645 W. Eight Mile Rd. (313) 535-6480; E. Detroit, 18149 E. Eight Mile Rd. (313) 772-0416.

MINNESOTA — Minneapolis (Hopkins), 101 Shady Oak Rd. (612) 938-6371.

MISSOURI — St. Louis (Bridgeton), 3794 McKelvey Rd. (314) 291-1850.

NEBRASKA — Omaha, 9207 Maple St. (402) 391-2071.

NEW JERSEY — Fair Lawn, 35-07 Broadway (Rte. 4) (201) 791-6935; Ocean, 1013 State Hwy. 35 (201) 775-1231.

NEW YORK — Buffalo (Amherst), 3476 Sheridan Dr. (716) 835-3090; Jericho, Long Island, 15 Jericho Turnpike (516) 334-8181; Rochester, 937 Jefferson Rd. (716) 244-5470; White Plains (North White Plains), 7 Reservoir Rd. (914) 761-7690.

If quality...value...and the pride of craftsmanship
turn you on, get your **NEW HEATHKIT®**

CATALOG!



COAST-TO-COAST

OHIO — Cincinnati (Woodlawn), 10133 Springfield Pike (513) 771-8850; Cleveland, 5444 Pearl Rd. (216) 886-2590; Columbus, 2500 Morse Rd. (614) 475-7200; Toledo, 48 S. Byrne Rd. (419) 537-1887.
PENNSYLVANIA — Philadelphia, 6318 Roosevelt Blvd. (215) 288-0180; Frazer (Chester Co.), 630 Lancaster Pike (Rt. 30) (215) 547-5555; Pittsburgh, 3482 Wm. Penn Hwy. (412) 824-3564.
RHODE ISLAND — Providence (Warwick), 558 Greenwich Ave. (401) 738-5150.
TEXAS — Dallas, 2715 Ross Ave. (214) 826-4053; Houston, 3705 Westheimer (713) 623-2090; San Antonio, 7111 Blanco Rd. (512) 341-8876.
VIRGINIA — Alexandria, 6201 Richmond Hwy. (703) 765-5515; Norfolk (Virginia Beach), 1055 Independence Blvd. (804) 480-0997.
WASHINGTON — Seattle, 505 8th Ave. North (206) 582-2172.
WISCONSIN — Milwaukee, 5215 W. Fond du Lac (414) 973-8250.

HEATH Schlumberger	Heath Company, Dept. 139-450 Benton Harbor, Michigan 49022
Please send me my FREE Heathkit Catalog. I am not on your mailing list.	
Name _____	
Address _____	
City _____ State _____	
GX-352 _____ Zip _____	
NOTE: This FREE Catalog Coupon can also be redeemed at any of the Heathkit Electronic Centers* nationwide. (See list at left)	

CIRCLE 1 ON READER SERVICE COUPON

Measure resistance to .01Ω...



at a price that has
no resistance at all.

- 3½ digit bright LED display
- 100μ V, .01Ω resolution
- 0.5% accuracy typical
- Autozeroing
- Completely overload protected on all 29 ranges
- RFI shielded for use in RF fields
- 100% overrange reading
- Selectable high-/low-power ohms
- Full range of optional accessories available

At \$119.95, the 2810 is a "best buy" among DMM's currently available. Its 10 ohms range allows you to check the low contact resistance of switches, relays, breaker points or connectors. Poor solder connections can also be spotted. Place your order now... contact your local distributor for immediate delivery.

BK PRECISION
DYNASCAN
CORPORATION

6460 West Cortland Avenue
Chicago, Illinois 60635 • 312/889-9087

In Canada: Atlas Electronics, Ontario
Intl. Sis: Empire Exp., 270 Newtown Rd.
Plainville, LI, NY 11803

CIRCLE 46 ON READER SERVICE COUPON

HI-FI REPORTS
HI-FI REPORTS HI-FI
REPORTS HI-FI REPORTS HI-FI
REPORTS HI-FI REPORTS HI-FI REPO
I REPORTS HI-FI REPORTS HI-FI REPC
I REPORTS HI-FI REPORTS HI-FI REPORT
FI REPORTS HI-FI REPORTS HI-FI REPORT
REPORTS HI-FI REPORTS HI-FI REPC
REPORTS HI-FI REPORTS HI-FI REPC
REPORTS HI-FI REPORTS HI-FI
REPORTS HI-FI REPORTS H
HI-FI REPORTS

Gordon Sell tunes in a finely-crafted Kenwood receiver and a Heathkit build-it-yourself AM/FM digital read-out tuner

□ ONE OF THE BEST and, at the same time, worst things about listening to good hi-fi equipment is that it improves your hearing ability. No you won't be able to hear a pin drop at 100 yards with 10 hours a week of training, but you will learn to tell good audio reproduction from bad. And you will learn to distinguish quality audio from quantity audio. You will also find that your ears are telling you to become a bigger spender than you would like.

Quality sound is not loud sound nor is it high-bass, low-treble sound. Audio salesman are the worst offenders on this point. Go into the average audio showroom and check out base and treble knobs. You'll find on the lower priced and usually lower quality equipment (this is a very broad generalization, price is not always proportional to quality), that the base knobs are cranked over almost all the way to the right and the treble cranked about half-left. When listening to a receiver keep those two knobs (and a midrange knob if the set has one) centered so you can compare one unit to another. These controls are intended to fine-tune the levels of high and low frequency, not to make gross adjustments in a futile attempt to make up for a deficient amp or speaker.

Getting Value for Your \$. Contrary to what many advertisements would have you believe, you've got to pay the price for quality. The trick is to keep what you pay to a minimum compared to what you get. In this column I'm going to look at two units that I believe make a good compromise between quality, quantity and cost, although in both cases the latter figure has suffered a bit to keep the first two well above average. One is a factory-built 80-watt receiver from Kenwood and the other a build-it-yourself FM/AM tuner from Heath.

Kenwood KR-6030 AM/FM Stereo Receiver. At first glance, the KR-6030 doesn't seem like anything spectacular

—just a good traditional receiver. But then, after a closer look, there seems to be something more there—a certain look of quality that's hard to pin down. Perhaps it is that the KR-6030 has the look and feel of a finely tooled piece of machinery. The click detent knobs have a delicate but positive action, the flywheel tuning knob is smooth but not phony and the aircraft-style toggle switches are light and crisp.

However, it's only after you turn it



Kenwood KR-6030 AM/FM Receiver

CIRCLE 56 ON
READER SERVICE COUPON

on that you notice what a really fine machine you have on your hands. When that first blast of sound hits the speaker grill you are enveloped in a wave of deep, rich sound. The kind that makes your ribs shake when the volume is turned all the way up. In the opinion of our listening panel the deep bass is among the very best we've ever heard. It makes a large speaker with a healthy woofer sound rich and natural. That's the sound that people who turn the bass up and the treble down are after without knowing how to get it.

If I had believed what Kenwood said on their spec sheets I would have thought that the KR-6030 was only an 80-watt RMS set with less than 0.1% Total Harmonic Distortion (THD) into 8 ohms from 20 to 20,000 Hz. When we hooked the set-up to our test bench we recorded a whopping 88 watts RMS with less than 0.04% THD from 20 to 20,000 Hz. The rest of the specs on the KR-6030 were just as impressive.

The signal-to-noise ratio for the FM tuner was 73 dB; at standard test level the stereo frequency response measured +0.2/-1.0 dB from 20 to 15,000 with 75 μSec de-emphasis—with 25 μSec de-emphasis the frequency response was +0/-1.8 dB; stereo separation was 40+ dB and selectivity was very good.

At \$500 this is not a budget stereo but quality doesn't come cheap; in the long run it usually pays to buy the best. The Kenwood KR-6030 has all the power you'll ever need—power that can be distributed to different speaker systems all over your house, or concentrated in one room. And quality that you will appreciate more and more as your ability to hear quality stereo gets better and better.

If you want more information about this product, circle No. 56 on the readers service card and we'll have a packet of information sent along to you.

Heathkit AJ-1515 AM/FM Digital Tuner. Here is an item that's tailor-made, or should I say tailor unmade, for the electronics hobbyist who has a hankering to get into hi-fi. As 99.99% of you have already guessed, since this is a Heathkit product, it is a kit. And a very comprehensive kit at that.

If you have never put a kit of this size, or any kit for that matter, together before this might be a good time to start. There is no better way to learn how a tuner operates than to assemble one yourself. This is not a project for someone who doesn't know the difference between a resistor and a transistor but, at the same time, the instruction manual is so complete and comprehensive that almost anyone who step-by-stepped it would have a functioning unit in about a week of evenings. A more-experienced builder could finish the project quicker. If you are unsure of yourself it might be a good idea to try building one of Heath's less complex projects as a training exercise. If you've got a couple of ELEMENTARY ELECTRONICS construction projects under your belt you don't have a thing to worry about. If you really get into trouble Heath has technicians standing by who will answer any questions.

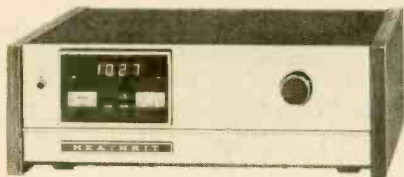

Heathkit AJ-1515 AM/FM Tuner

CIRCLE 31 ON
READER SERVICE COUPON

The Heathkit AJ-1515 is a good-looking, solid set with a nifty large-digit digital readout. The only visible controls are power on/off and the tuning control. All the rest are behind a fold-down front panel and on the rear of the set. In addition to the digital readout there is a center-channel tuning meter, a signal strength meter and indicator lights for various functions.

The AJ-1515 really shines after it's all put together and aligned (it comes with built-in alignment circuitry so you don't have to buy a bunch of expensive signal generators to get everything in tune). It is a good idea to get the optional Dolby FM module (AD-1504—retail price \$39.95). Our lab men claim that it's one of the best they have ever used.

The FM tuner performs very well. Full limiting was attained with 3.8 μ V; the mono sensitivity (60 dB quieting) measured 6 μ V and the stereo sensitivity (55 dB quieting) was 48 μ V; mono distortion measured 0.19% THD

and stereo distortion was 0.6% THD. The signal-to-noise ratio measured 72 dB and the stereo separation was 40+ dB. The maximum output level of the tuner, corresponding to 100% modulation of the transmitter, measured 700 mV.

Heath has a sister 70-watt, 0.08% THD amplifier of matching style that sells for \$299.95 and is called the AA-1515. Whether you buy the AJ-1515 alone or both units, you are going to have an educational and enjoyable, building and listening experience. If you would like to know more about the AJ1515 and the AA-1515 please circle number 31 on the reader service coupon. Retail price of the AJ-1515: is \$379.95.

Just Out. Every week the audio industry introduces dozens of new and interesting products for the hi-fi consumer. I thought I would mention a few that had caught my eye. If you want more information about any of them, circle the appropriate number on one of the free Readers Service Cards that are inserted in this magazine.

Technics has just introduced a handsome pair of direct-drive turntables. The SL-1301, retail price \$299.95, and SL-1401, retail price \$279.95, have outstanding performance specifications. Circle No. 68.

Audiovox has a super item for the car stereo buff. An AM/FM cassette stereo with a neat, digital read-out tuner, clock, calendar and an elapsed time indicator. The In-Dasher DGC-10, as it is called, carries a suggested retail price of \$299.95. Circle No. 59.

Pioneer is marketing a hi-fi quality TV audio receiver, the TVX-9500, for audio buffs who cringe at the low quality sound from their high priced TVs. Retail for \$250. Circle No. 72.

Marantz has presented three nice-looking front-loader cassette decks; the 5010B for \$269.95, the 5025B for \$309.95 and the 5030B for \$419.95. All feature a Dolby noise reduction system. Circle No. 55.

Acoustic Research's new AR-18 bookshelf speaker "... puts out exceptional sound. Close your eyes and you won't believe it all comes from such a little box," say Hans Fantel and Chris Greenleaf of *Hi-Fi/Stereo Buyers' Guide*. \$65 each. Circle No. 70.

Sony has introduced a new direct drive turntable, the PS-1. Its wow and flutter is a mere 0.045% the rumble is -68 dB. Retail for \$130. Circle No. 50.

Nikko is now offering four low to mid priced receivers with good performance. The NR-315 for \$175 puts out 10 watts RMS, the NR-515 has 15 watts for \$220, the 28-watt NR-615 sells for \$270 and the NR-715 with 38 watts sells for \$310. Circle No. 63. ■

GOING DIGITAL ? — GO ALL THE WAY! KEYBOARD & ENCODER

Assembled & Tested
Hookup instructions



Only
23.98
Complete

- TTL Compatible
- Temporary or Permanent Installation
- Edgeboard for Hookup Convenience
- Compact 3/8 x 3 1/8 x 5 1/8
- Mounting Brackets 1/8 Holes
- Black Keyboard — White Keys/Black Numerals

TRINETIC ENTERPRISES
P. O. BOX 424, TWO RIVERS, WI. 54241
Please rush! Enclosed is my check () or M.O. (). No C.O.D. please.

Name _____
Street _____
City/State/Zip _____

CIRCLE 30 ON READER SERVICE COUPON

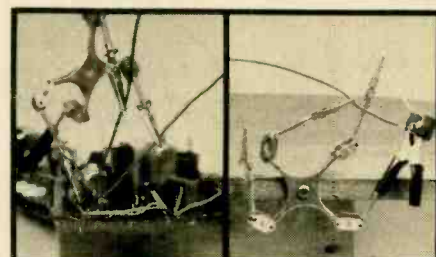

THE PORTABLE HAND

A holding device usable almost anywhere. All angle ball and joint connections. Steel construction. Replaceable clips — Glueing, Soldering, Jewelry & Modelmaking.

Join clips together for grasping heavy objects.

clips or hooks to any edge

12 inches overall

rust resistant

Patented
Made in U.S.A.

Spyderco

\$9.95

Add 75¢ shipping
Cost. Tax. Add 6%

P.O. Box 3517 E

Redding, CA 96001

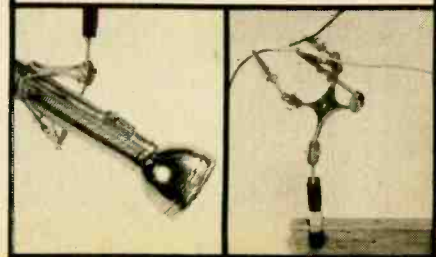

CIRCLE 36 ON READER SERVICE COUPON

SCANNER OWNERS REJOICE!

Finally, there's an exclusive club for scanner owners in North America... a united voice dedicated to the advancement of scanning... with dozens of special membership benefits!

- Feature packed quarterly newsletter with news, tech tips, great feature stories and more!
- Exciting contests with super prizes!
- Membership in the SCAN Buyer's Co-op... group buying power on items of special interest!
- Award program for public safety officials you nominate!
- FCC frequency assignment chart!
- Handsome Official Membership Certificate, I.D. card, and vehicle decal!

Plus much, much more!
All for only \$5.00 annual dues.

ACT NOW WHILE WE'RE ACCEPTING CHARTER MEMBERSHIPS AT A SPECIAL \$4.00 ANNUAL RATE!

SEND CHECK OR MONEY ORDER TODAY... OR WRITE FOR FREE DETAILS.

SCANNER ASSOCIATION OF NORTH AMERICA



Dept. A, 111 East Wacker Drive, Chicago, IL 60601

CIRCLE 25 ON READER SERVICE COUPON

ADVANCING the state of the art



in automatic percussion units... the **PROGRAMMABLE DRUM SET** features: score editing, bridges, intros, external sync. to sequencers foot controls, memory save switch & much more.

Enter scores in seconds - **NO PROGRAMMING KNOWLEDGE IS REQUIRED!**

High Fidelity describes the 3750 as "an easy project... fun to do and yields delightful results... an excellent educational tool and versatile aid to the musician who can't afford a live rhythm section."

#3750 \$84.95... (+\$3 shipping)

Another Great Kit from: **FAA**

888 1020 WEST WILSHIRE BLVD. OKLAHOMA CITY, OK 73116

- Send Programmable Drum Set Kit (\$84.95+ shipping enclosed)
- TELL ME MORE... Send the instruction manual first (\$2.00 refundable upon kit purchase)

name: _____

address: _____

City: _____ State: _____ Zip: _____

SEND FREE CATALOG

CIRCLE 13 ON READER SERVICE COUPON

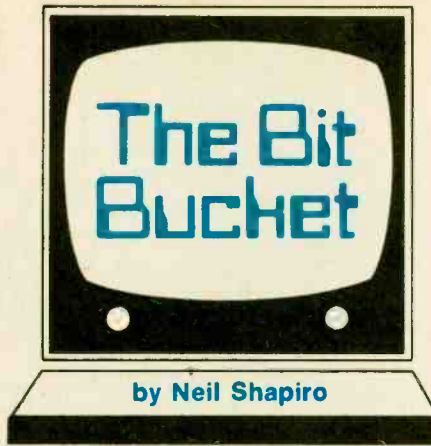

by Neil Shapiro

Take the confusion out of Personal Computing. We show you that its bark is worse than its bite!

If you're not yet into Personal Computing—the odds are you soon will be! It may seem a sweeping statement, but we're willing to bet that if you're a steady reader of this magazine, then sooner or later, you won't be able to stop yourself from joining in on all the fun and excitement of this captivating, new hobby.

Remember that thrill of accomplishment when you built one of our construction projects, plugged it in and watched it run? You can have that feeling all over again when you build your own computer—a sophisticated machine with more power than ITT could have latched onto just a few short years ago. If you're a solderer, you'll be finding all sorts of reasons for entering this hobby.

Check the September-October 1977 issue of *ELEMENTARY ELECTRONICS* for a review of the SWTP 6800 computer—a machine representative of some of the best computer kits. Wiring it will call for a certain amount of patience, demand a true dexterity with the soldering iron, and will provide just the sort of challenge you love to meet. Perhaps, instead, you'll build one of the many other top-flight computer kits such as the ones from Heathkit, one of the Altairs, or the Sol-20. Then, there are the peripherals. From memory boards to graphics, you'll find plenty to occupy your building hours.

Maybe you're an "armchair" hobbyist. The thing you enjoy most about electronics is "mentally" tinkering. If so, you'll find Personal Computing to be a dream come true. You can change around the entire concept of your system, without touching a tool.

Once you get the hang of programming—and it's fairly simple using an English-based language such as BASIC—you can no sooner think of a change than implement it. The only limit this hobby will impose on you is your own ingenuity.

Some of the best computers around for the home computerist are the ones

you can buy fully wired and assembled—such as the Apple II (reviewed in our last issue) or the Radio Shack TRS-80 (reviewed in the March-April issue). We'll be reviewing and contrasting these and many other hobby computers in future columns to help you decide how best to get in on the fun.

Maybe you're the utilitarian amongst us. Your darkroom work is electronically timed; your alarm clock long ago sprouted LED digits; your favorite symphony is a few, warbling notes on a home-brew synthesizer. Get ready, Personal Computing is entering your life.

Many hobby computers are equipped with ports, input/outputs that allow you to hook the computer directly to your own environment, not to control your life but to enrich it. We will be showing you how to use a personal computer to do everything from keeping your bar recipes on file to updating your shortwave logbooks daily; you'll even be able to manage your finances with almost no hassle once you set your computer to watch over the bank's.

Into electronics just for fun? You can have more fun with a personal computer than is easily described. Imagine yourself fighting the evil Klingons, or elected governor of a country, as an intrepid explorer in endless caverns, all this adventure and more is yours through computer gaming. The gaming field is attracting the interests of more and more hobbyists and we'll be telling you how to modify existing programs, design your own, and where you can find new ones. Though IBM might be loath to admit it, computers really are the most amusing of mankind's technological devices.

Input/Output. No matter what your main interest, this will be your column, dedicated to helping you find your own niche in Hobby Computing.

Coming up will be looks at color graphics; computers with the built-in talent to converse in BASIC; computers that can be programmed to talk; computers that will listen; and computers that play jive music. We'll help you choose your system, or decide on which peripheral you really need. We'll be pointing out the best of the new published literature, and we'll be answering your questions.

Send any questions you have about Personal Computing to this column, Neil Shapiro, *Elementary Electronics*, 380 Lexington Ave., New York, N.Y. 10017. Also send me your suggestions as to what you'd like to see covered here or, if you're a manufacturer, let me in on your newest items.

Microprocessor Theory. The right place to start Personal Computing is to begin with a good book on the subject. There is a new volume from Sybex publishers entitled *Microprocessors*,

written by Rodnay Zaks, which is one of the best introductory texts to the hardware end of things.

The strength of this well planned and executed text lies in the way the first few chapters are handled. Far too often, a coursebook such as this will begin in a "chatty" tone but quickly digress into computerese gibberish and jargon—leaving the reader confused and even annoyed. *Microprocessors* begins, continues, and ends all on the same, even and well-balanced keel.



rodnay zaks

microprocessors

WORLDWIDE
microprocessors
WORLDWIDE
microprocessors
WORLDWIDE
microprocessors

from chips to systems

The book is subtitled "From Chips To Systems" and that's exactly the journey it takes the reader on. Chapter by chapter, author Zaks guides the non-engineer from Fundamental Concepts, through Systems Components and Interfacing, all the way to Systems Development, with a short excursion into the Future. It is a complete treatment but, even more importantly, it is a self-contained and self-defined one. No term is used without having been first explained. No knowledge is assumed on the part of the reader—unless such knowledge has been previously put forth. This may be no more than the basics of good teaching, but such a teaching philosophy is rare in computer books.

According to Sybex, Dr. Zaks has "published over thirty books and research papers on microprocessors" and "has presented courses and seminars to more than two thousand participants worldwide, ranging from the introductory level to bit-slice design. The book is directly based on his teaching experience.

We were impressed with the chapter "Internal Operation of a Microprocessor" which is the best explanation we have thus far seen in print. There is a lucid breakdown of the exact sequence involved when a microprocessor *fetches* and *executes* an instruction; there is a

(Continued on page 90)

for the Experimenter!

INTERNATIONAL CRYSTALS and KITS

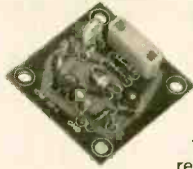

OF-1 OSCILLATOR

\$4.25
ea.

The OF-1 oscillator is a resistor/capacitor circuit providing oscillation over a range of frequencies by inserting the desired crystal. 2 to 22 MHz, OF-1 LO, Cat. No. 035108. 18 to 60 MHz, OF-1 HI, Cat. No. 035109. Specify when ordering.

.02% Calibration Tolerance

EXPERIMENTER CRYSTALS

(HC 6/U Holder)

\$4.75
ea.

Cat. No.	Specifications
031300	3 to 20 MHz — For use in OF-1L OSC Specify when ordering.
031310	20 to 60 MHz — For use in OF-1H OSC Specify when ordering.



MXX-1 Transistor RF Mixer

3 to 20 MHz, Cat. No. 035105
20 to 170 MHz, Cat. No. 035106

\$5.50 ea.

SAX-1 Transistor RF Amp

3 to 20 MHz, Cat. No. 035102
20 to 170 MHz Cat. No. 035103

\$5.50 ea.

BAX-1 Broadband Amp

20 Hz to 150 MHz Cat. No. 035107

\$5.75 ea.

Enclose payment with order (no C.O.D.) Shipping and postage (inside U.S., Canada and Mexico only) will be prepaid by International. Prices quoted for U.S., Canada and Mexico orders only. Orders for shipment to other countries will be quoted on request. Price subject to change. Address orders to:

M/S Dept. PO Box 32497
Oklahoma City, Oklahoma 73132

WRITE FOR BROCHURE

International Crystal Mfg. Co., Inc.
10 North Lee Oklahoma City, Oklahoma 73102



CIRCLE 12 ON READER SERVICE COUPON

Take stock in America.
Buy U.S. Savings Bonds.

FREE KIT MANUALS

- 40-Watt x 2 complete stereo amp kit with latest BI-FET IC
 - LEACH 100-Watt x 2 Low TIM power amp kit
 - LEACH Wide Bandwidth Preamp kit
 - 30-Watt Class A power amp kit
- All complete with cabinets
Moonlighter Electronics, 117 Inverness
San Francisco, CA 94132

BRAND NEW 1978 EDMUND SCIENTIFIC CATALOG

PACKED WITH
SCIENCE
BARGAINS



Thousands of Items . . .
Telescopes, Binoculars, Weather Instruments, Biofeedback, Magnets, Optics, Surplus Bargains, and Much More.

GET
YOUR
COPY
FREE!

We'll send your Free personal copy of the brand new 172-page Edmund Scientific Catalog just as soon as we receive your name and address. You'll find over 4,000 amazing and unique products available from no other single source. It's our biggest and best catalog in our 36-year history.

SEND COUPON
TODAY
FOR YOUR
VALUE-PACKED
COPY.

EDMUND SCIENTIFIC COMPANY

Dept. EK18, Edscorp Building, Barrington, N.J. 08007

Name _____
Address _____
City _____ State _____ Zip _____

A \$\$ COMPETITIVE SYSTEM

YOU CAN OWN A VERSATILE
6800 COMPUTER SYSTEM
FOR AS LITTLE AS \$799.50!



MP-68/1 Computer Kit	\$395.00
CT-64 Terminal Kit (less monitor)	\$325.00
AC-30 Cassette Interface Kit	\$ 79.50



You can add a 40-column printer and a professional quality data terminal monitor for only \$460.00

PR-40 Printer Kit	\$250.00
MP-L Interface Kit	\$ 35.00
CT-VM Data Terminal Monitor	\$175.00



You can expand to a full-scale personal computer system with dual disk drives for only \$1,445.00

MF-68 Dual Disk System Kit	\$995.00
MP-16 16K Memory (assembled)	\$450.00

...OR buy the complete system at our special low price of \$2,595.00

- YOU GET:
- ▶ A 20K byte computer
 - ▶ A true "stand alone" data terminal and monitor
 - ▶ A 40-column dot matrix printer
 - ▶ A dual drive 200K byte disk system
 - ▶ Disk BASIC with file handling

These are the same proven, reliable components used in our industrial and business systems. Why settle for the limitations of a so-called "personal computer" or hobby system?

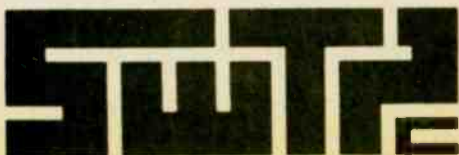

SOUTHWEST TECHNICAL PRODUCTS CORPORATION
219 W. RHAPSODY
SAN ANTONIO, TEXAS 78216
CIRCLE 22 ON READER SERVICE COUPON

GETTING OUT

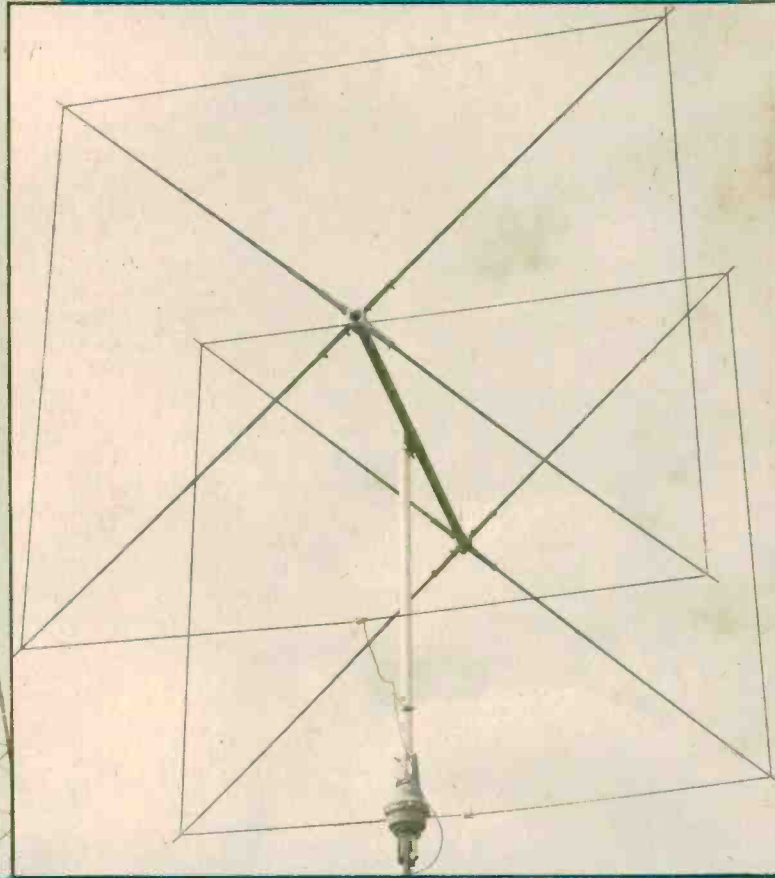

Whip your signal into shape with these antenna tuning tips by James Toth

IF YOU HAPPEN TO BE in jail and have just eagerly flipped this magazine open to this article, then sorry, but it won't help you in spite of the title. But if you happen to be a CB radio enthusiast and are interested in "getting out" in the CB slang sense of the phrase, then you have come to the right place, for here you will find everything you need to know in order to squeeze every last inch of range out of your CB setup.

Here are six things to think about while trying to boost your CB's range.

Antenna Height. First, for maximum range your antenna should be as high as legally possible. It is said that you can talk about one-third farther than the line-of-sight distance between the tip of your antenna and the tip of the other fellow's antenna, and the higher the antennas, the greater the line-of-sight

distance. This effect comes from the fact that although light travels in a straight path, radio waves tend to follow the shape of the earth's surface somewhat. Therefore, although someone's antenna may be below the horizon so you can't see it, your radio signals may still reach him if he isn't too far below.

The question, then, is what is the legal maximum height? For omnidirectional antennas (those which radiate equally in all horizontal directions), the height limit for the tip is 60 feet. The limit for directional antennas is 20 feet.

But it is possible to do a lot within these limits if you want to increase your range badly enough. For example, put your antenna on top of a nearby hill instead of right next to your house. But of course, you will need a lot of line for this trick.

Another thing you can do is put your antenna on top of a tall building. If the building is more than 30 feet high, you are allowed 20 feet above the top of it. Obviously, mounting your antenna on top of a good-sized building can put it well above what a neighbor could achieve working from the ground up.

Standing Wave Ratio. Second, there is the matter of SWR or standing wave ratio. A good way to visualize this is through a physical analogy. Imagine a ball bearing rolling along. Since it is moving, it possesses some energy of motion (kinetic energy). Suppose this ball bearing were to collide with another ball bearing which had equal mass and was stationary. Upon collision, the rolling bearing's kinetic energy will be totally transferred to the formerly stationary bearing. The transfer of kinetic energy will be 100 percent, but only

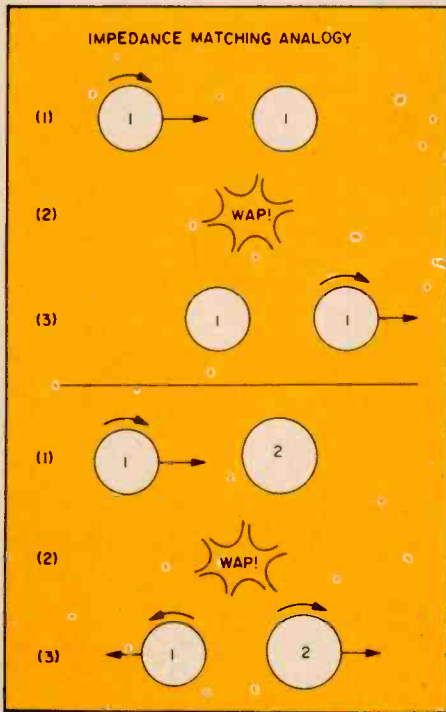

Impedance matching can be represented by the transmission of energy from one rolling ball to another stationary one. If both have equal mass the first will stop and the second take off at equal speed (in a frictionless system). If the second ball is more massive, as illustrated in the three bottom drawings, the first ball will bounce back just as RF will bounce back if an antenna is improperly matched to the transmitter and line.

because the bearings are of the same mass. It reminds one of head-on collisions between billiard balls.

In electronics, impedance (like resistance) plays the role that mass played in the ball bearing analogy. Ideally you want 100 percent energy transfer from the transmitter to the antenna, but this can happen only if the impedance of the transmitter and that of the antenna match. Otherwise, some of the energy is reflected back from the antenna to the transmitter.

What you have then is waves traveling from your transmitter to your antenna and from your antenna to your transmitter, both at the same time. The two sets of waves interact to form standing waves, which decrease the efficiency from maximum and could damage your radio to boot.

The presence of such waves can be detected by an instrument which measures standing wave ratio. This quantity is a number which you want to be as low as possible.

Here are some sample SWR readings together with what they will do to your

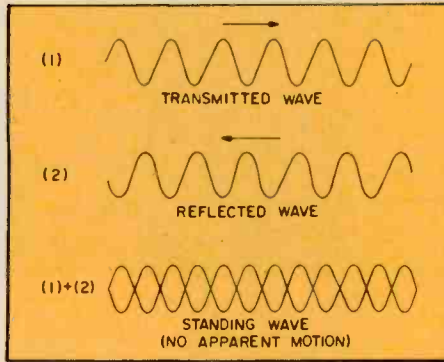

These diagrams show how the transmitted wave and the reflected wave interact to form a standing wave that decreases the efficiency of your transmission.

3:1 generally is considered to be the highest SWR a CB radio can live with. And really, that is too high, too. 1.5:1 or less is more like it.

So buy yourself an SWR meter (they're inexpensive) and check your radio from time to time. If the SWR is too high, getting it down to size usually is just a matter of changing the length of the antenna, provided it is not a fiberglass one.

The procedure for checking a mobile antenna's SWR goes like this: Check the SWR on the highest channel, and then check it on the lowest channel.

SWR	Percent Reflected Power	Radiated Power
1:1	0%	4.00 watts
1.5:1	4%	3.84 watts
2:1	11%	3.56 watts
2.5:1	18%	3.28 watts
3:1	25%	3.00 watts
∞:1	100%	0.00 watts

Ideally, these two numbers will be the same and as low as possible. If the SWR on the highest channel is higher, this indicates the antenna is a bit too long and must be shortened. If the SWR on the lowest channel is higher, then the antenna is too short and must be extended a little. When the two SWR's are identical, then the SWR on the middle channel should be as low as it is going to get, hopefully near 1:1.

Changing the SWR of a base antenna is another story. There is no convenient little screw to allow you to manipulate the length. If a base antenna's SWR is too high, there is probably something wrong with it or the line leading to it, like bad or wet connections or broken wires. Use your own ingenuity to figure out just what is messed up.

Antenna Gain. Third, there is the fact that all antennas are not created equal. There are those which radiate the legal 4 watts and that's it, and there are those

which radiate 4 watts but seem as though they have more effective radiated power (ERP). By mathematically relating the real power output with the ERP we can derive the antenna gain which is normally measured in dBs or decibels.

An easy way to visualize this is to try the following simple experiment: Look at a low-power electric lightbulb, say 10 watts. Your eyes are perceiving 10 watts of light power. Now, hold up a mirror next to the bulb so that you now see two bulbs side by side. Your eyes perceive 20 watts of light power. If you put up a second mirror to see three images you will see 30 watts even though the bulb is still only putting out 10 watts. The ratio of ERP to power is three to one and the ERP multiplication factor is three.

All antenna gain measurements work in much the same way but instead of a 10-watt bulb we use a "standard dipole" antenna. The power received from a test antenna is compared to the power received from the "standard dipole" and the ERP multiplication factor and gain is determined by applying the mathematical equation that is explained elsewhere in this article.

This equation, if reduced to a more

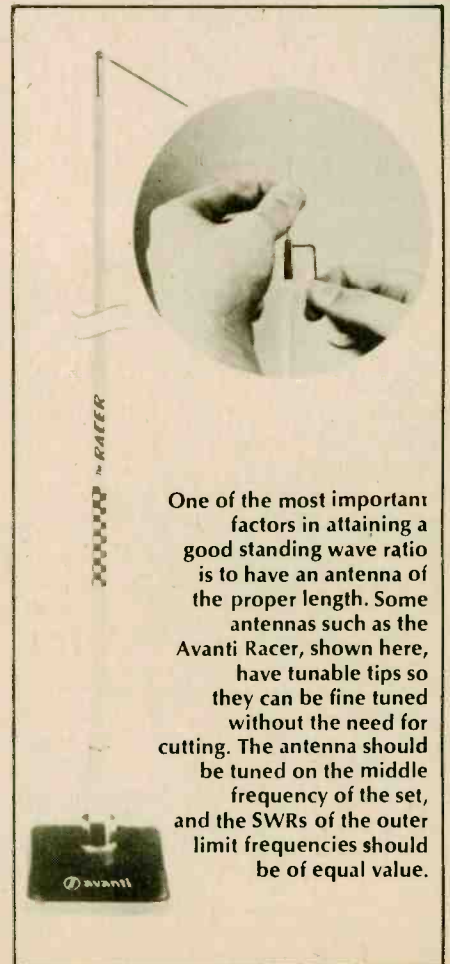

One of the most important factors in attaining a good standing wave ratio is to have an antenna of the proper length. Some antennas such as the Avanti Racer, shown here, have tunable tips so they can be fine tuned without the need for cutting. The antenna should be tuned on the middle frequency of the set, and the SWRs of the outer limit frequencies should be of equal value.

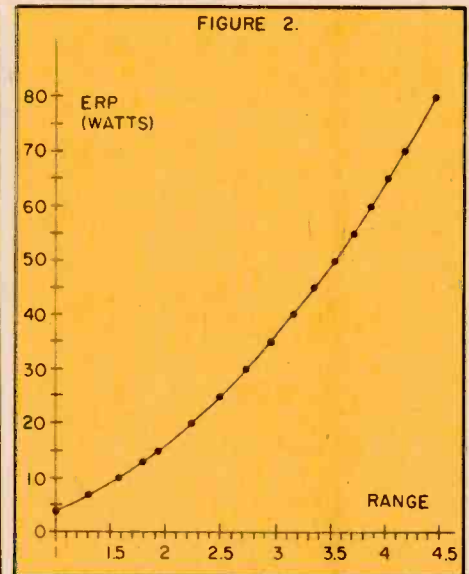
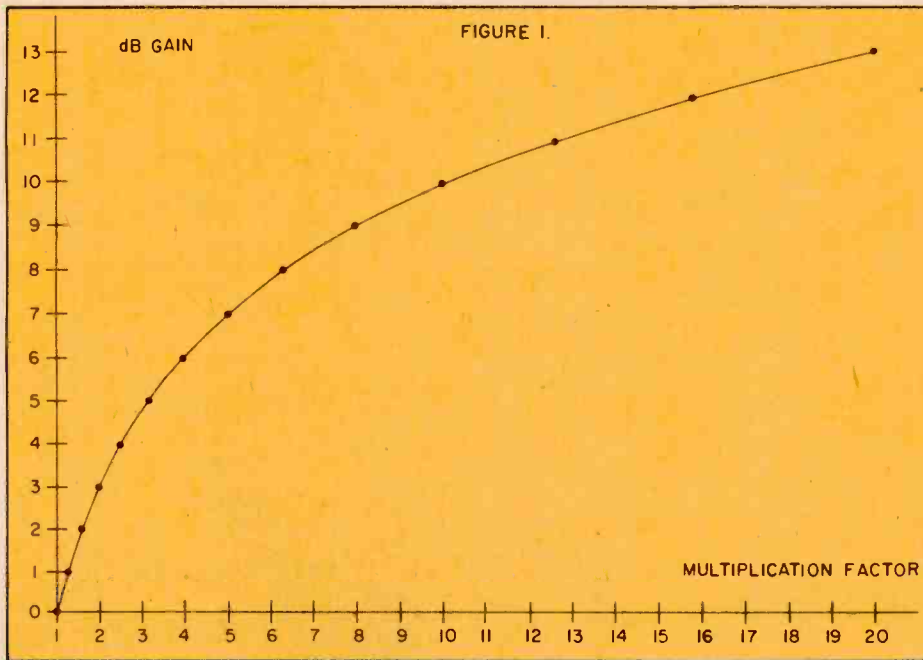

By using this graph your probable range can be determined if you know your effective radiated power (ERP). For example: If your set has a range of 5 miles with no gain (ERP 4 watts for CB), increasing the ERP to 35 watts will up your range to 15 miles (Range factor of 3, times 5 miles).

This graph can be used to determine the dB gain if you know the multiplication factor or the multiplication factor if you know the gain. For example; a 12 dB gain will equal a multiplication factor of 15.5. This is much more convenient than the formula.

readily useable graph form, looks like figure 1. The graph can be used to find an antenna's multiplication factor (and hence ERP) whenever its dB gain is known. If you know the dB gain, just go up to that number on the dB gain axis, then go straight across until you hit the curve, and then drop down to the multiplication factor axis and read off the antenna's multiplication factor. That number times 4 will get ERP.

ERP and Range. So now you know just what your ERP is. What does this mean in a practical sense? If your ERP is, say, three times the basic 4 watts, does this mean you can talk three times as far?

No, it doesn't. You will be able to talk farther, but not three times as far. To find out exactly how much farther, consider the following:

Suppose that at some distance R some radio signal comes in just as strong as some other radio signal at some other distance r . For the two signals to come in at the same strength, their intensities (power per unit area) must be the same, but the ERP must be greater for the signal to travel distance R . By turning this all around mathematically it is possible to discover how much farther a signal will reach (in terms of r) if you know the ERP. Again the mathematics are shown elsewhere in this article and can be reduced to the graph form as shown in Figure 2.

On the graph, the range of an antenna whose ERP is only 4 watts is taken as 1. The range of other antennas will then be so many times this distance.

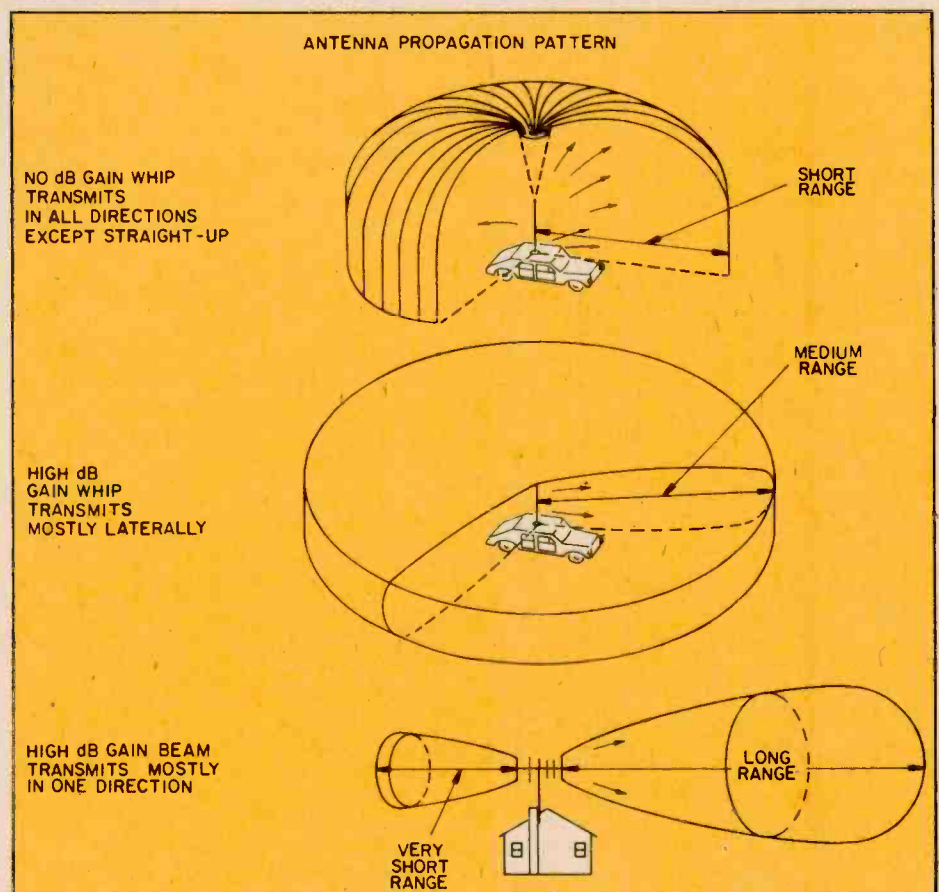

These three drawings are simplified illustrations of antenna propagation patterns. The top diagram is of a unity gain whip antenna—RF propagates equally in almost every direction. The middle antenna is a whip with some gain such as a $5/8$ wave VHF antenna or an antenna with an effective ground plane. It will transmit more of its radiation horizontally rather than waste it trying to reach birds. There are thousands of different types of beam antennas but they all try to achieve the results shown in the third drawing—to put the RF out in one direction with as little wasted energy as possible. These antennas also receive directionally. At short ranges they transmit and receive in all directions.

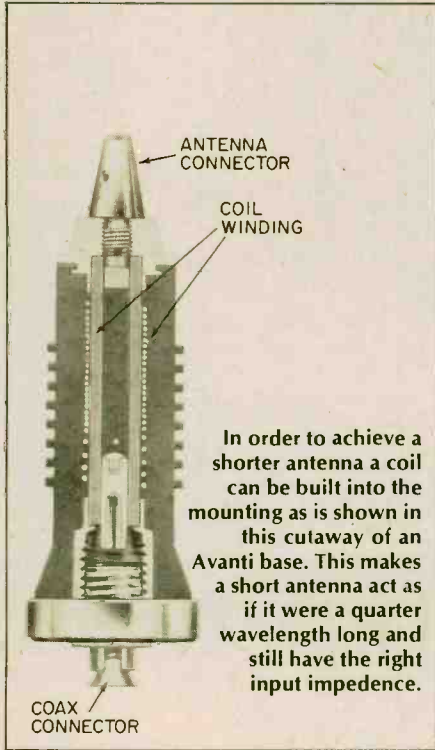

In order to achieve a shorter antenna a coil can be built into the mounting as is shown in this cutaway of an Avanti base. This makes a short antenna act as if it were a quarter wavelength long and still have the right input impedance.

For example, the original question was, if an antenna's ERP is 12 watts, how much farther should you be able to talk than with just the basic 4 watts? The answer is readily attained using the graph. Go up the ERP axis until you find 12, then go straight to the right until you hit the curve, and then drop down to the range axis and read off the relative range. In the case of 12 watts you get 1.73, which means you can talk 1.73 times as far as with an antenna with no dB gain.

Beams. But there is just so much dB gain which can be built into an omnidirectional antenna, no matter how clever the designer is. If you want more than five or so dB gain, then you have to move on to a directional antenna, a beam.

A beam gets its super dB gain from taking the idea behind omnidirectional antennas with gain and taking it one step further. An omnidirectional antenna with no gain takes your 4 watts and sprays it all over the place, a lot of it skyward. The skyward part is of no use to anyone, so if it could be eliminated, there would be more to spray out parallel to the ground where it is needed—there would be a gain in useful power, a dB gain.

But even if all your power were sprayed out parallel to the ground, a lot of it still would be wasted. Since gen-

(Continued on page 91)

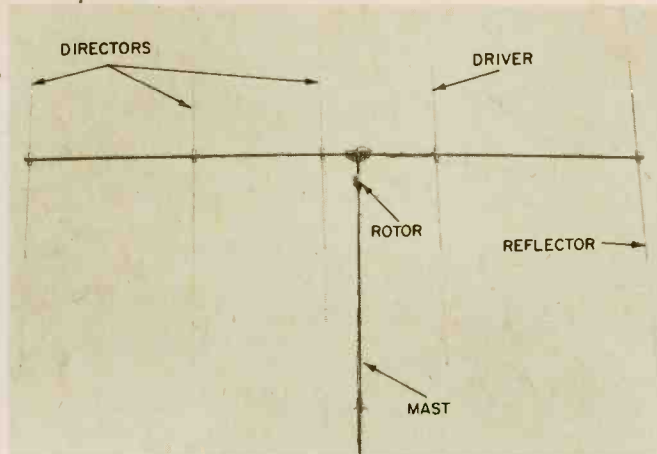

This beam antenna is more commonly called a five element yagi. It has one driven element, one reflector and three drivers. With a yagi the ratio of the interelement spacing to the wavelength is vital to the efficiency of the unit. An electric rotor is needed to aim the unit in the desired direction.

CIRCLE 32 ON READER SERVICE COUPON

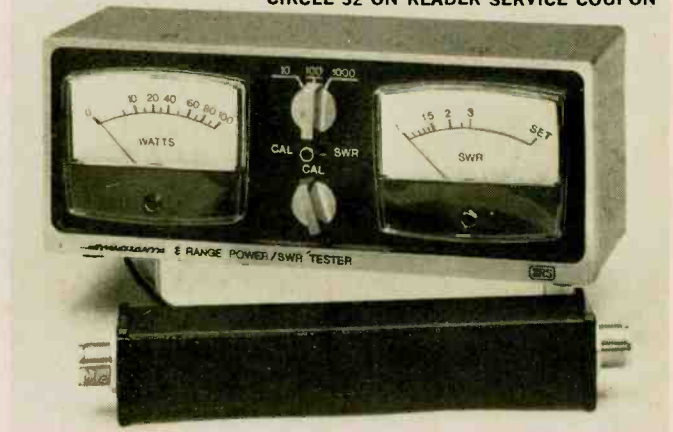

One of the most important gadgets for anyone serious about getting out, is a standing wave meter such as this Micronta unit by Radio Shack. By comparing the transmitted and reflected power the standing wave ratio can be determined, and you can see how efficient your antenna is at getting out!!

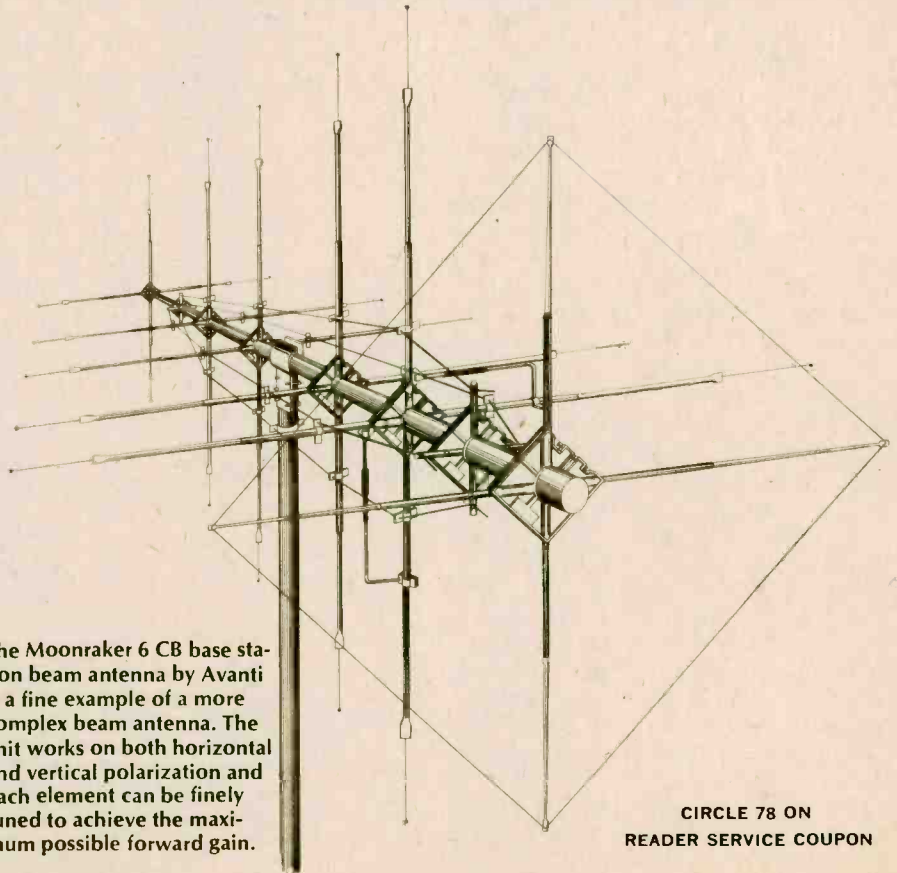

The Moonraker 6 CB base station beam antenna by Avanti is a fine example of a more complex beam antenna. The unit works on both horizontal and vertical polarization and each element can be finely tuned to achieve the maximum possible forward gain.

CIRCLE 78 ON READER SERVICE COUPON

BIO LOGIC

The ultimate personal computer is inside your head.

by Walter Sikonowiz

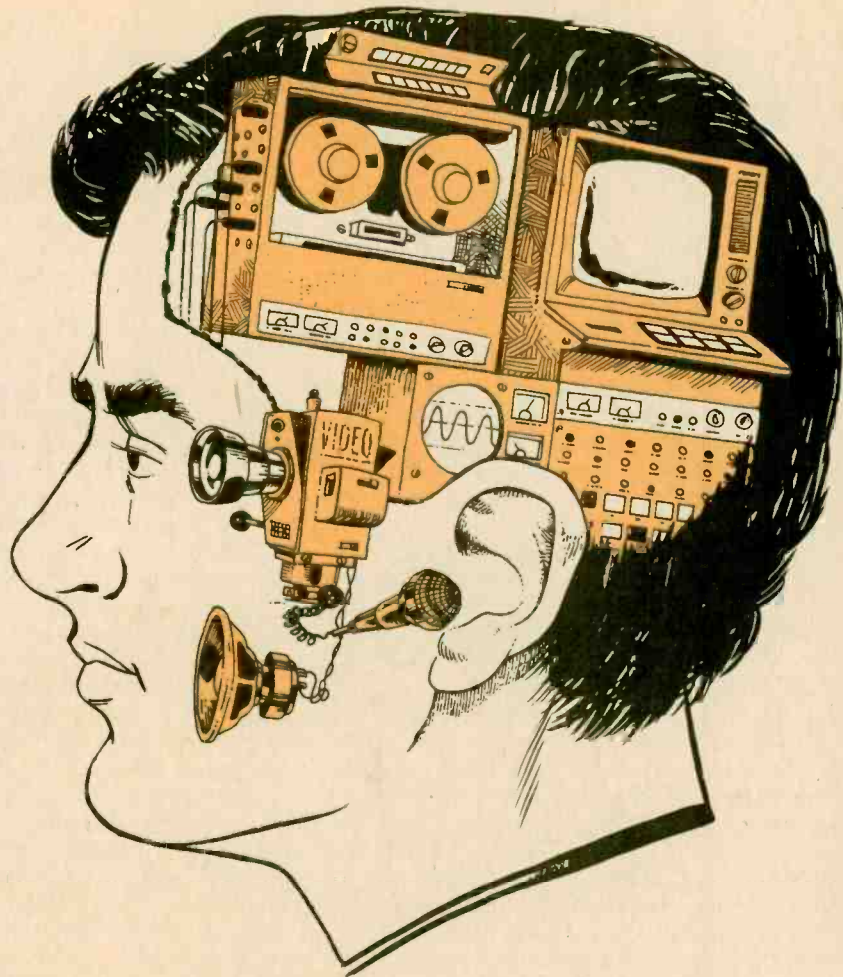

It seems that the day of the home computer has at last arrived. Everywhere, we read about these new machines that are changing our lives, running things better than we ever could ourselves. Everybody tells us that the solid state computer is the newest and most radically advanced thing to come along since the sun. But, you know, in spite of all these claims, the personal computer is not all that new. In fact, you've been using one all your life; it's called a brain.

Many people, electronics hobbyists in particular, have long suspected some fundamental similarities between brains and electronic computers. In this article we're going to compare these two types of information-processing systems.

Let's begin on familiar ground. In Figure 1 we have the various logic gates; the important building blocks of any electronic computer, big or small. The NAND gate's output state is a function of its two inputs, and it remains at a logical 1 so long as the input state is not 11. An input of 11 sends the output to a logical 0. On the other hand, the NOR gate's output is usually a logical 0 except when the input is 00, in which case the output assumes a logical 1 value. Using combi-

nations of just these two gates we can synthesize any desired logic function, no matter how complex.

As you know, the 0 and 1 symbols can denote voltages, with 1 usually representing a high voltage and 0 a low voltage. The ones and zeros may also be interpreted in a philosophical sense as True and False, respectively. Why

should we use numbers to represent qualities such as truth and falsity? It's mainly a convenience which allows logic to be expressed in mathematical form. If logic can be handled algebraically, then solution of logical problems becomes routine, and can be handled by machines—computers.

But a computer needs more than

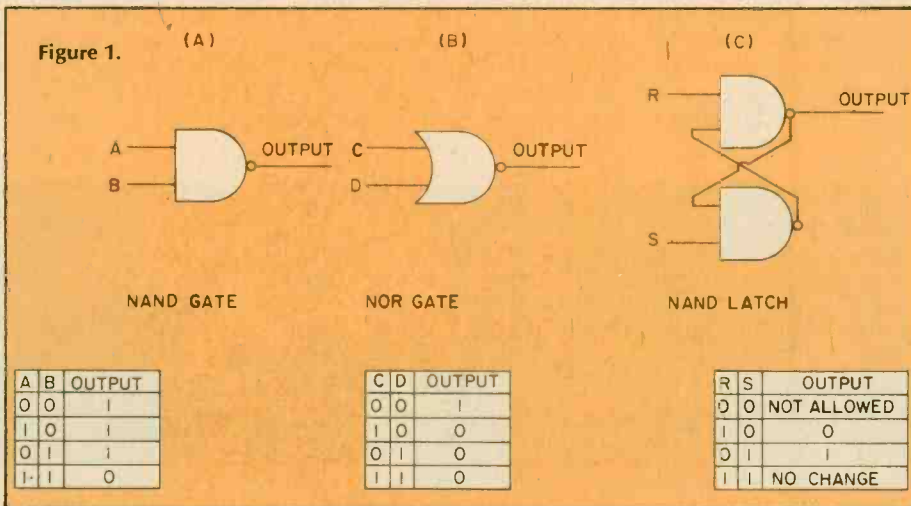

Some Basic logic circuits: a) A NAND gate gives a 1 output for any input except 11. b) the NOR gate only gives a 1 output when both inputs are 0. The NAND latch (c) is a memory device which is the basis of the common flip-flop circuit.

decision-making apparatus (NAND and NOR gates); it needs memory. We store the computer's instructions (program) in memory, and also use memory to retain the solutions generated by the computing process. One basic form of memory is the NAND latch (Figure 1c). When a little control gating is added to this basic circuit, we can get various flip-flops, which are probably the most familiar storage elements. Other forms of storage include magnetic cores, magnetic tape, paper tape, and the exotic magnetic bubble devices. Regardless of the storage form, however, memory simply holds data until it's called up for processing or readout.

Neurons. Contrast the human information-processing system to the electronic computer. Like a computer, the human brain is a complex entity built up from enormous numbers of simpler fundamental units. These basic units are called nerve cells or neurons. Several classes of neurons exist; nevertheless, all share the same generic traits. Figure 2 shows one typical neuron. The tentacle-like elements are called dendrites, and they function as the input leads to the cell. The single long filament leaving the cell is an axon, which is the cell's output. Nerve signals travel along the thin membrane that encloses the cell's protoplasm. Adjacent cells communicate with one another across synapses—gaps between axons and dendrites of different cells.

Logically the neuron is more complex than a NAND or NOR gate. It functions as a majority gate, which may be described as follows: Suppose, for example, that we construct a gate with five inputs and one output, and that the output will be a logical 1 whenever a majority (3, 4, or 5) of the inputs is in the 1 state. If there are less than a

majority (0, 1, or 2 that is) of logical 1 inputs, the output is a logical 0. Such majority gates are not encountered too frequently in electronics, one notable exception, however, being Motorola's CMOS MC14530 dual 5-input majority gate. As a rule a neuron has more than five inputs—typically, up into the hundreds. Regardless of its complexity, however, a majority gate can be expressed in equivalent form as a combination of NAND and NOR gates.

From the foregoing you can see that computers can be logically equated to neuron networks; nevertheless, certain physical differences exist between biological and electronic systems. To begin with, electronic signals are viewed as differences in potential, which govern the flow of free electrons. Signals in nerve nets, however, consist of waves of polarity reversal on the surface of polarized neuronal membranes. In Figure 3 you can see that a nerve's membrane normally possesses excess positive charge on its outer surface, and excess negative charge on the inner surface. Excitation of the nerve brings about a polarity reversal at some point on the membrane, which then induces polarity reversal at adjacent points on the membrane, and the signal spreads. The reversed-polarity condition at any given point reverts to normal after several milliseconds, while the wave of polarity reversal propagates to new points on the membrane. Charge distribution on the membrane's surface is controlled by movements of sodium and potassium ions, and the rate of ion flow through the membrane limits the speed at which nerve signals travel to about 100 meters/second. Contrast this with the speed of an electronic signal traveling down a transmission line with a polyethylene dielectric: about 2×10^8 meters/second. Biological systems are thus inherently slower than electronic ones.

Memory. Two physical characteristics distinguish the human nervous

system from the electronic computer. Communication between the functional units in a computer is established by connecting wires. Interneural communication involves diffusion of certain chemicals across synapses. Memory is likewise a chemical phenomenon, involving chemical changes in nerve cells and associated structures. Regardless of these physical differences, however, the two systems possess a fundamental logical similarity, as we've seen. Is it now possible to map the information flow in the human system in the same way that we are accustomed to in electronics?

Yes, to a certain extent. First of all, no one alive and in good health would consent to have men in white lab coats probing about inside his or her head. So direct information about the living, functioning nervous system is hard to come by. But a lot of data can be obtained concerning brain structure in an indirect way, and this is the domain of cognitive psychology. Research along these lines can be frustrating; it's very much like trying to figure out what's inside a computer by seeing how the machine responds to different sequences of input signals. Nevertheless, psychological data, together with whatever biologists can provide, has allowed many deductions about the brain's organizations.

Let's look at Figure 4, which is a simplified human cognitive map. Memory elements are represented by squares, while circles stand for control processes. This is an arbitrary distinction because both functions, memory and control, are apparently performed by cells. Keeping that fact in mind, let's analyze the major features of Figure 4, saving the details for later. First, visual and auditory information from the outside world are converted by the eyes and ears respectively into nervous impulses. These signals are routed to buffer memories, the sensory registers, which act to preserve fleeting data long enough for the rest of the system to process it. By convention the visual and auditory sensory registers are called, respectively, the "icon" and the "echo."

The block labelled LTM is long-term memory, a presumably permanent storehouse filled with all the important facts accumulated during a lifetime. For example, LTM contains enormous quantities of information such as $1+1=2$, $V=IR$, the rules of English grammar, telephone numbers, and so on. In contrast, STM or short-term memory has a very limited capacity. Furthermore, information fades away or gets dislodged very easily from STM. It is possible to consciously retain STM information, however, by the process of

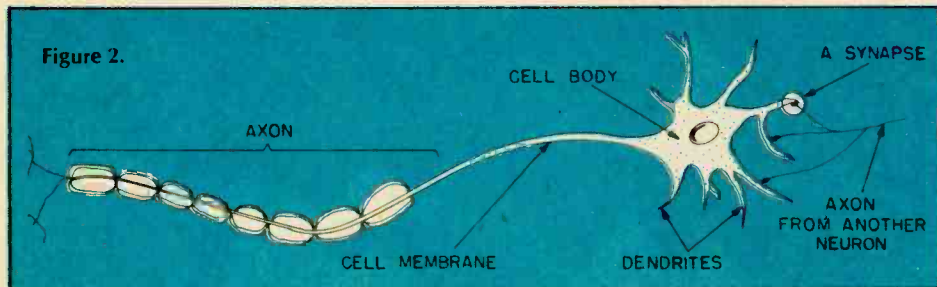

A motor neuron, one of the basic building blocks of the biological information processing system, is a single cell and functions as a multi-input majority gate. The inputs to the dendrites and the cell body come from other neurons. These inputs, often numbering in the hundreds, are averaged and the majority input determines the output along the axon—sort of biological democracy. The axon then leads to another neuron.

rehearsal, repeating things mentally to one's self. As the arrows of Figure 4 indicate, rehearsal takes information out of STM and then re-enters it. At the same time, rehearsal can facilitate entry of information into LTM, as we'll see later.

Recognition. The final circle represents two independent processes, chunking and pattern recognition. Because these processes seem to have the same inputs and output, they coincide on the map. Chunking is an organizational process whereby sensory register information gets grouped by means of LTM rules before entering STM. This chunking does two important things: 1) it allows more information to be crammed into STM, and 2) it makes the information easier for LTM to assimilate. Note that information cannot enter LTM directly; instead, it must be worked on in STM first. For this reason, STM is commonly called working memory by psychologists. Apparently, STM is the site of what we experience as consciousness. The last process, pattern recognition, is the identification of visual or auditory inputs, and is a very important part of conscious experience.

As we stated earlier, the map in Figure 4 is far from complete. Missing entirely are the autonomic processes, such as breathing, which the brain controls. Gone too are the outputs which, for example, would control muscular action. It would also appear from Figure 4 that all inputs are processed equally, yet we know this is not true. As you read these lines countless sounds, sights, and pressure sensations are available to your senses, yet your attention is fixed on the letters that you scan. This phenomenon of selective attention is extremely important, but a little too complex to cover here.

Keeping in mind the fact that our cognitive map is greatly simplified, let's consider its features in more detail, starting with the sensory registers. Experiments with the icon have revealed that visual information is stored for less than a second before fading. Moreover, new visual stimuli erase the old iconic information. If this did not happen, our apprehension of an image would lag about a second behind its appearance. By contrast, echoic storage lasts longer than that of the icon (the exact duration is subject to dispute, however), and erasure per se doesn't seem to occur. The necessity of echoic storage is readily seen when you consider that language is a serial phenomenon, made up of sounds which follow each other in time. To make sense out of language, what is and what was must both be available. For example, a sin-

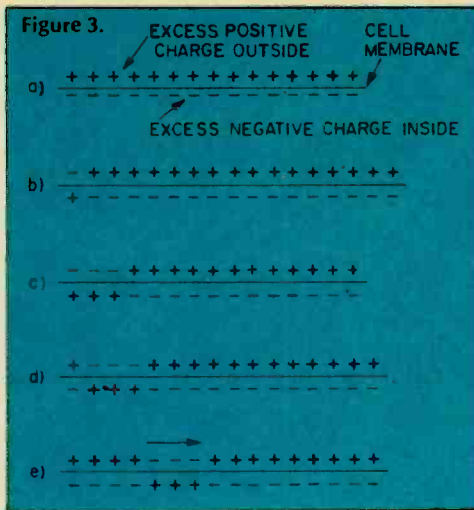

Nerve signals are waves of temporary polarity reversal along the cell membrane. In the first drawing above (a) the nerve membrane is in a quiescent state, in (b) the polarity reversal begins and progresses along the membrane (c & d). The polarity returns to normal (e) and this return travels behind the reversal at an equal speed (about 100 mps).

gle word like *computer* is made up of many basic sounds called phonemes. All must be available in order for the pattern recognition process to identify the word.

STM. Let's consider STM. One piece of evidence suggesting an STM that is distinct from LTM is Milner's Syndrome, a mental impairment caused by damage to the hippocampal area of the brain. Victims of this syndrome are quite normal in most respects, but are unable to permanently memorize new information. For example, given a list of words, they can retain the list in

memory for any desired length of time by continually rehearsing. When instructed to stop rehearsing, they lose the list in a matter of a minute or so. One patient was able to read the same magazine again and again without getting bored. The patient's doctor had to introduce himself daily, even though he had been treating the man for years. Yet, the patient could recall the events in his life before the accident. According to our cognitive map, we can theorize that the damage broke the link between LTM and STM. The victim could use STM and recall old items from LTM, but he was unable to put new information into long-term storage.

Not only is STM storage temporary but it also possesses only limited capacity—typically five to nine items. This figure varies according to the nature of the items being memorized, but the average person's short-term capacity is about seven letters, numbers, or words. This seven-item limit is commonly referred to as the memory span. Let's clarify the memory span concept now. If a list of items is presented one at a time to a subject, that person can recall the list in perfect order, after seeing the items just once, if the list length is less than or equal to about seven items. Mistakes will appear with longer lists. Of course, we can memorize more than seven items, but to do so will require several presentations of the list plus some rehearsing. Since rehearsal both refreshes STM and transfers information to LTM, learning of lists longer than the memory span evidently requires storage space in LTM.

Suppose that the following list of
(Continued on page 90)

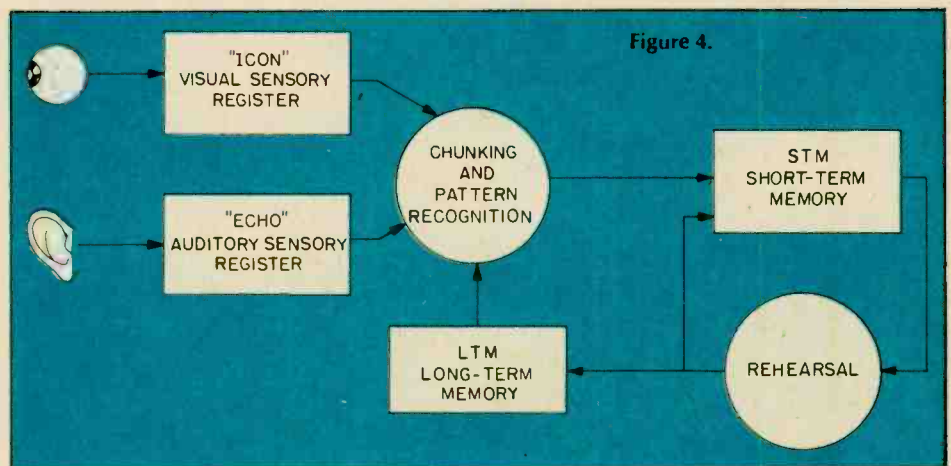

A simplified model of the information processing system of humans and higher animals. In addition to the "ECHO" and "ICON" sensory registers there are others for taste, smell and touch. In the lower box, the LTM, is stored everything you know except for the most recent inputs which are being processed as you read this page. These immediate inputs are going into the short term memory and rehearsal loop; some of what you have read will be recorded in the LTM—there is, however, no guarantee your brain will be able to recall it. Something may be in memory but the brain can't always find it.

SOME BIG CHANGES are on the way for the SWL, especially in the upper shortwave bands from the 25-meter band on up to 30 MHz and beyond. The Sun is now entering one of its periods of increased sunspot activity after a 20-year period of relative calm. This will make short range communications unreliable and long range DX an everyday affair. Signals from stations just down the road will be, literally, lost in outer space, and wishy washy signals from outer nowhere will come booming



SHORTWAVE SUPERCHARGER

Turn your old SW clunker into a high-band hot-rod.

by Cass Lewart

into your listening post like they were right next door.

Under these conditions many old and some not-so-old shortwave receivers will need a bit of help when they try to work the high bands. Their circuits tend to get a little frazzled. As a matter of fact, almost any SWL would appreciate a bit of a signal boost now and then. It might just

make the difference between a very good DX catch and a record breaking DX discovery.

If you decide you want a DX boost or you need to increase the versatility of your old set then you should build this Shortwave Supercharger.

This unit will boost selectively the RF signal by 20-30 dB and it will compensate for many deficiencies of your set.

It will not only improve the gain of the shortwave receiver but will also improve its selectivity and the image frequency rejection. Simple, single conversion superhet SW sets have the annoying tendency of receiving spurious signals separated by twice the IF frequency from the desired signal. For example if you tune to 20 MHz you may also receive $20 + (2 \times 0.455) = 20.910$ MHz (image frequency) signal which will interfere with the 20 MHz signal. In addition you will be able to pull in many SW stations you didn't even know existed. With 10- to 15-foot of wire behind your sofa as an antenna you may receive stations as distant as Australia or mainland China.

How does it work. The circuit is based on an inexpensive Integrated circuit manufactured by Motorola and its HEP subsidiary. Its innards consist of three transistors, a diode and four resistors which together form an excellent automatic gain controlled (AGC) radio frequency amplifier. To build the circuit with separate discrete components would cost a bundle and the result would not be as good. The incoming RF signal is coupled with a few turns of wire to the coil L1. The tuned parallel-resonant circuit consisting of L1 and C1 selects the wanted signal by rejecting adjacent frequencies and feeds the sig-

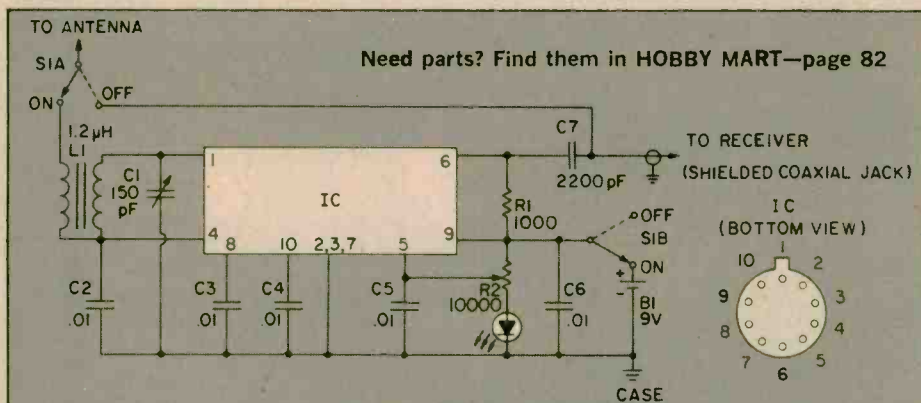

PARTS LIST FOR SHORTWAVE SUPERCHARGER

- B1—9V transistor radio battery
- C1—150-pF variable capacitor
- C2, C3, C4, C5, C6—0.01 uF capacitor
- C7—2200-pF capacitor
- R1—1000-ohm ¼-watt resistor
- R2—10,000-ohm variable resistor
- IC—Motorola MC1550, HEP 590 or HEP C6091

- LED—Red LED indicator
- L1—Miller 4502, 1.1-1.5-microhenry coil (for winding your own, see text), for antenna connection use 3 turns of wire wound tightly around the coil.
- S1—DPDT switch
- Misc.—case, knobs, jacks for shielded cable

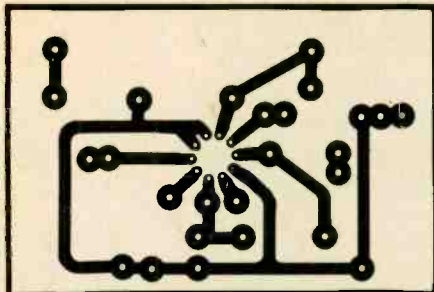

Use this full-size circuit-board template to build your Shortwave Supercharger. You can find etching materials at a radio shop.

nal to pin 1 of the integrated circuit. The amplified signal leaves the IC on pin 6. The AGC input on pin 5 is used to control the gain of the amplifier when you turn potentiometer R2. The light emitting diode indicates that the circuit is on and that the battery is still alive. The DPDT switch S1 selects between straight-through connection, booster off and booster on.

Construction. This is a radio frequency project which requires a neat soldering job and short connections. However, if you do a half-decent job the supercharger should fulfill your expectations. The author used point-to-point wiring on a perf board. If you have some experience with PC boards you might use the layout shown here. The Supercharger with the indicated component values will cover approximately 10-30 MHz. Using different values for L1 or C1 will change this range, though the ratio of minimum to maximum frequency will remain 1:3. Doubling the capacitor or inductance value lowers the frequency by 1.41 and lowering either value increases the frequency by the same factor. If you want to substitute some parts, or wind your own coil or use a different capacitor, the circuit is quite flexible in this respect. For example you may want to replace the 150 pF capacitor C1 used by the author since this is often difficult to find. Use instead the oscillator half of the stand-

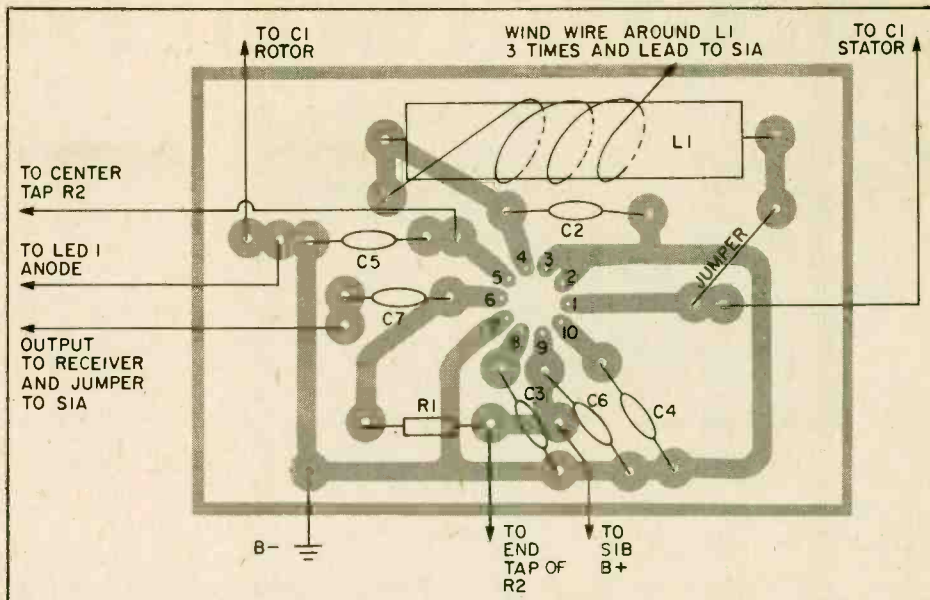

This part's location overlay is twice the actual size in order to make the positioning clearer. If you use a loop different than specified in the parts list you may want to modify the appropriate spacing on the printed circuit board. Don't forget to wrap the L1-to-antenna wire around the loop stick three times. You might install an integrated circuit socket on the printed circuit board to simplify installation and repair.

ard AM tuning capacitor from any pocket transistor radio. Instead of the coil mentioned in the parts list you might try to wind 15-20 turns of insulated copper wire on a pencil.

Mount the Shortwave Supercharger inside a metal case which you can find in most electronic supply stores. Use shielded cable between the supercharger and your receiver otherwise the connecting wire will behave like an antenna and some of the features of your supercharger will be lost. The final job is to make a dial. You can calibrate it with your shortwave receiver by tuning C1 to optimum reception.

If you find that the circuit "whistles" at certain frequencies (this may easily happen if you do not use a PC board or your connections are too long), the simplest cure is to thread a few small ferrite cores through pins 1 and 4 of the

IC. Such cores can be purchased from many electronic surplus dealers.

Operation. Tune your receiver to the desired frequency and then tune C1 till you can hear maximum signal or noise, if no station is present. Returning your receiver with the fine tuning knob should require no readjustment of the supercharger. You can use R2 as your volume control or leave it in some intermediate position and use the volume control of the receiver. For strong signals you may want to turn R2 back to prevent overloading the receiver with the corresponding increase in the background noise.

Once you get it working, start digging deeper into the higher shortwave frequencies. There is a lot going on out there and with the increased sunspot activity and a Shortwave Supercharger you can't go wrong.

The author's prototype, shown here, used perf-board and point-to-point construction. You may build your Shortwave Supercharger using this technique or by making a printed circuit board and soldering on all the parts. The author added a small LED power indicator to prevent dead batteries if left on.

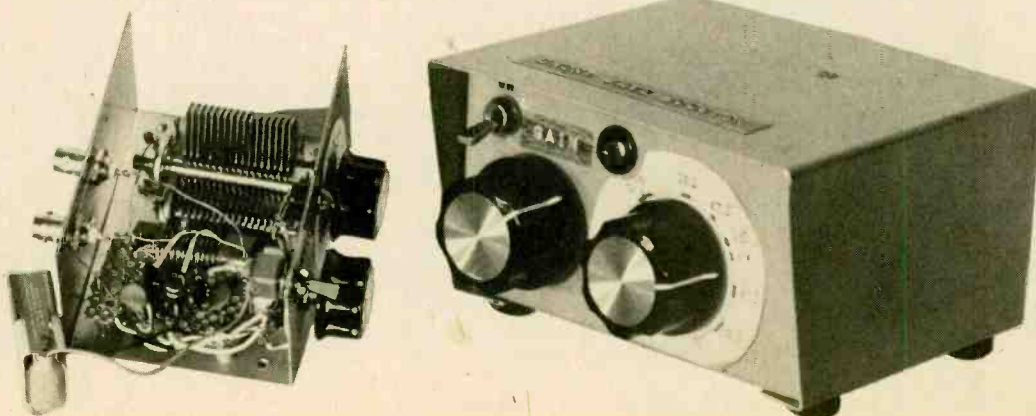

COMPUTER NEW PRODUCTS

Here in one place each issue of e/e you will find product information on the newest hobby computers and accessories.

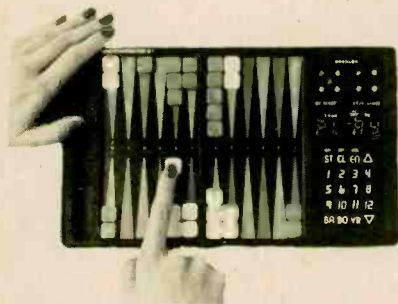

Computerized Backgammon—If you are into backgammon as well as computers, Gammonmaster II by Tryom Inc. could be intriguing. The \$199.50 game utilizes microprocessor technology but does away with any need to set up a TV monitor. Gammonmaster II adheres to the rules of classical backgammon, and is programmed to recognize and defend itself against all strategies of the game including; running, blocking, blot hitting contest, back and semi-back games, bearing off strategies and combinations

of these basic techniques. An electronic rolling of the die ensures randomness of play, uniqueness of games. There's an optional "Doubling Cube" device that adds excitement to the game through the use of betting, controlled by tournament play regulations. Other features include: new keyboard with sound; dice simulation with sound; highest roll of dice goes first; position verification; score keeping. Comes in a sturdy carrying case. Circle number 48 on Reader Service Card.

Full ASCII Keyboard—A new Model 756 full ASCII Keyboard has been designed by George Risk Industries especially for personal, industrial and business micro-computer users. The keyboard provides encoding for all 128 ASCII characters and control functions, imposing no limitations on software design or hardware capability, according to the company. Reliable KBM Series keyswitches and low-power MOS encoder circuitry help bridge the gap between basic keyboards and expensive custom O.E.M. models. Assembly and mounting are simplified through use of O.E.M. industrial grade components and a rugged MIL-grade printed circuit board. Other features include custom molded keytops and a line of heavy-gauge steel enclosures for desktop use. Accessories include: numeric pad, custom cables and connectors. The versatile interface permits user selection of parity, positive or negative logic data and strobe outputs, alpha lock operation and both DC level and pulse strobe signals. A latching shift lock key is included, and all outputs are TTL-DTL-MOS compatible. Prices: kit, \$64.95; assembled and tested, \$75.95; matching enclosure, Model 702, \$29.95. Circle number 66.



Shielded Motherboard—This shielded motherboard by Artec Electronics is claimed to eliminate all noise and ringing in buses. It's compatible with S-100 computer systems, and is made of heavy-duty FR4 glass-epoxy board. Most of the bus noise in S-100 computer systems is said to be caused by unwanted coupling between adjacent lines on the motherboard. By placing substantial ground traces between adjacent bus

lines, Artec has eliminated line-to-line coupling. A new termination technique also eliminates the ringing commonly found on a bus. The fast rise time signals on a microcomputer bus can cause ringing if the bus is not properly terminated, and this ringing can, in turn, cause data errors. In the Artec motherboard each bus line is terminated in an optimum impedance without increasing the zero state leading of the bus drivers. This PRC terminator uses a complex impedance which has no DC current associated with it. Hence the critical zero state voltage of the bus drivers is not affected. The motherboard fits any standard chassis, and is easy to install without soldering. Prices: kit sells for \$150; assembled and tested it's \$190. Circle number 60 on Readers Service Card for more information.



Teaching Microcomputer—This KX-33B Microcomputer was designed by Energy Electronic Products Corp. to serve as a teaching aid toward better understanding of the basic concepts of computer technology, including the execution of functions by combining your instructions with input signals. The KX-33B, basically a controller, is built around a Panasonic 4-bit MN1400 microprocessor. In addition



to the arithmetic/logic unit, the chip includes 1024 words by 8 bits of read-only memory for the system program and 64 words by 4 bits of random-access memory which stores keyboard data. Other features: two static RAM chips with 256 words of 4 bits each; 8-bit latch; audio amplifier and multivibrator ICs, and a speaker. The unit can store any song that does not exceed a three octave range, and can perform control tasks over a 24-hour period. You can even play a number of games, making various simulated sounds such as door bell, siren, Morse codes. A built-in external speaker jack is for listening to or recording programmed music. Price, assembled and with instruction manual: \$229. Circle number 53 for information.

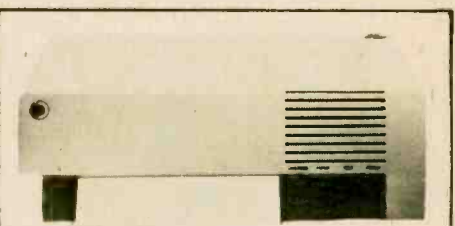

Impact Printer—This Integral IP-125 Impact Printer is offered by Integral Data Systems for \$799. The printer utilizes 8½" plain paper and features an RS232C serial interface, parallel TTL level interface and full upper and lower case ASCII

(Continued on page 96)



CB NEW PRODUCTS



e/e puts together in one neat package some of the newest CB rigs, antennas and accessories for you to use in CB contacts this year!

Mod Buster

The speech compressor built into the GC Electronics Range Booster III increases total average modulation (output) by reducing instantaneous peak voice sounds and eliminating possible overload distortion in the transmitter. The result is better overall transmission power and clarity. This feature is very useful where several operators use the



CIRCLE 57 ON READER SERVICE COUPON

rig. Amount of compression is fully variable with a control in the mike. Maximum gain of 56 dB available. Unit incorporates dynamic microphone element with response of the mike shaped to the speech range for maximum clarity and elimination of unwanted noise in transmission. Range Booster III features volume control, separate push-to-talk and lock-to-talk levers for a "hands free" operation. Standard 9-volt battery (not supplied) will provide approximately 200 transmit hours. Range Booster sells for \$63.72. Get all the info direct from GC Electronics, 400 South Wyman, Rockford, IL 61101.

CB Matchbox

Get the best possible performance from your CB rig-antenna combo with Avanti's Match Box, Model AV-500. Corrects impedance mismatch as high as 5:1 SWR down to 1.1:1 delivering almost all the power to the antenna.



CIRCLE 78 ON READER SERVICE COUPON

Uses pi networks for easy tuning, dependability and power handling. Simple installation into existing antenna cables. The AV-

500 sells for \$24.95. Get the info on all Avanti CB accessories by writing to Avanti Research and Development, Inc., 340 Stewart Avenue, Addison, IL 60101.

Low Silhouette Antennas

Two low-silhouette CB antennas featuring hand-wound, hand-tuned loading coils in the counting cup eliminates the need for a vertical loading coil and shock spring while providing performance equal to traditional base loaded antennas. Antenna Incorporated's coil-in-cup antennas feature a unique hand-wound loading coil, offering the CB user a low silhouette design. The two new completely pre-assembled antennas are the Firelock, Model 13503, and the Snub Nose, Model 17603, which sell for \$20.00 and \$16.76, respectively. The Firelock is a mobile base loaded magnet mount antenna which holds at speeds up to 100 mph on metal roofs and up to 70 mph on vinyl

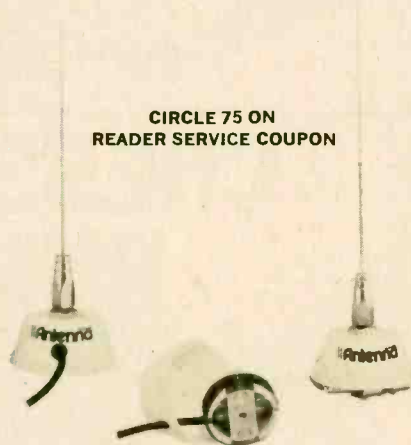

CIRCLE 75 ON READER SERVICE COUPON

roofs. The Snub Nose is a trunk lip mount designed for quick and easy installation on the auto's rear deck lip or on the front hood of rear-engine vehicles. For further information on the new coil-in-cup antennas, contact Antenna Incorporated, 26301 Richmond Road, Cleveland, OH 44146.

CB with Dual Channel Monitor

The new Viking 270 by Johnson with a dual channel monitoring feature is making its debut on dealer shelves. Made by E. F. Johnson, the Viking 270 unit has, in addition to the dual channel monitoring feature, an automatic channel display, brightness control, and several advances in performance technology. A twin, ceramic selectivity filter is said to offer superior rejection of adjacent channel interference. Johnson's newly developed NoiseGate noise blanker works in combination with an automatic noise limited to sharply reduce electrical and impulse-type noise. The Viking 270 sells for \$239.95. The



CIRCLE 80 ON READER SERVICE COUPON

Viking 270 is U.S. manufactured and covered by the Johnson one-year parts and labor warranty which is honored by the nationwide network of over 1,000 authorized Johnson CB Service Centers. Get all the facts direct by writing to E. F. Johnson Co., 299 10th Avenue, S.W., Waseca, MN 56093.

All New Antenna Line

Antenna Specialists has just released its Scorpion line—a whole new breed of CB antennas combining bold, contemporary styling with the latest in antenna technology. A new solid-state circuit replacing the loading coil delivers consistent performance over all 40 CB channels. The new Scorpion line is built for durability, and has a unique level-action quick release system for protection from vandalism or car washes. The Scorpion antenna line now includes the four most popular mounts; roof mount, trunk lid mount, hatchback mount and magnetic mount. All four units come with 17 feet (24 feet on magnetic mount) of type 58/U coaxial cable with a permanently attached PL-259 type connector. They are priced at

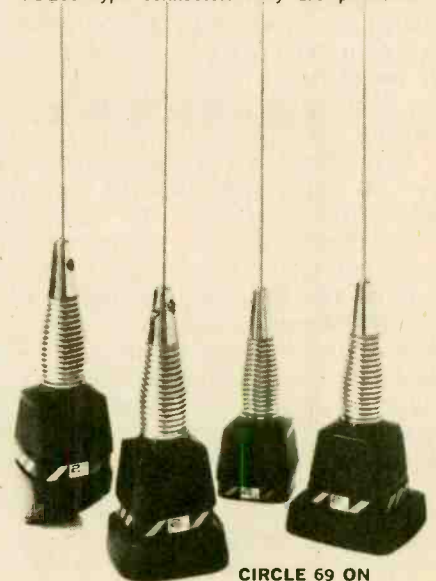

CIRCLE 69 ON READER SERVICE COUPON

\$29.50 to \$34.50. For further information, contact The Antenna Specialists Co., 12435 Euclid Avenue, Cleveland, OH 44106.

FEW DEVELOPMENTS HAVE struck the imagination of hobbyists and engineers like microprocessors—and few applications have dazzled hobbyists, engineers, and the public in general more than the new microcomputer chess games. These units actually play chess and help teach you to play the game. The Computer Readout column in the last issue of *ELEMENTARY ELECTRONICS* talked about the history and current activity with chess games on large computers. We showed how a small, computerized chess game was impossible only a few years ago, the basics of how these present-day micro chess masters think, and the integrated circuits inside one specific unit, the “Chess Challenger” by Fidelity.

Now we will do something never done before—as far as we know. We have located and tried three different computer chess games. In this brief space we will discuss the basics of each and then—hold your seat—we will play two of those computers against each other.

Let's Meet the Players. All three units are becoming available in department stores; their prices are shown herein along with the manufacturers' addresses.

First there is our old friend the *Chess Challenger* with the four character LED display, three levels of play (although it is available as a basic model with one level), and a response time ranging from a few seconds to about one minute. It will play either black or white, as you wish. If you want to set up pieces on the board in a particular way so as to try the computer against, for example, the Sunday *New York Times* chess problem, you can do it. You can verify the location of pieces on the board by pressing a key that causes a read-out for each square.

Then there is *CompuChess* which also has a four character LED display, but it has six levels of play with the first four requiring from a few seconds to 15 minutes for average players, and the next two levels requiring up to 18 and 48 hours, respectively, for super players and problem crunching. The level can be changed at any time during the game so you can start with low levels, then move up in level as the pieces thin out so its response time is not quite so long. *CompuChess* will play either black or white pieces and will let you set up the pieces on the board in any way you wish in case you want to try a specific situation.

Finally, there is *Boris*. This Russian-named unit is a bit different from the other two. Besides playing either black



CHESSBOARD RUMBLE

e/e squares off three chess-playing computer combatants!

by Norm Myers

or white, it will play against itself at any point during a game. So if it is your move, and you want to see what Boris would recommend, just let it make the move for you. The display is also different. Instead of a four character LED display where each character can only be made from the form of a block figure eight, there are eight characters and each can display a whole range of strange looking symbols and characters. The result is that Boris, when asked, will show a four row across the board with the King's knight on one square, the queen on some other, etc. A knight actually looks like a stick horse on this display, and a queen looks like a Miss America crown. It's easy to correct a dumb move you just made, or to set up the

pieces in a certain way on the board. Simply call up row One, put pieces where you want them and go on to row Two, etc. This can be done anytime during a game. Boris is a *kibitzer*, he *loves* to comment on your moves. He may spell out “I expected that” along the display or “Are you ranked?” or some other friendly remark.

Boris also has a different approach to level of play. Instead of selecting one of the several levels at the beginning of the game, you select the amount of time you will allow Boris to think. This can be any duration from a few seconds to 100 hours. The duration can be changed at any time during the game. The designers claim that at 100 hours for each move Boris will give a chess master a challenging game, but I

have found it to be quite challenging at ten seconds. As with the other computer units, Boris looks ahead a few moves; the point of the time is to let it look ahead as far as it can in the time allotted.

One interesting pitfall is that computer units do not want to let go if the software algorithms indicate that there is an advantage to a certain move or set of moves. This causes trouble when, for example, a piece of yours is locked into a corner and you can only move it back and forth in this endless cycle with no way to break it. The cycles can be complicated, with many moves, or just simple ones. In a person-to-person chess game, someone has to give or a stalemate is declared. We have found that of the pitfalls listed above, our Boris unit appeared to be programmed to avoid the obvious mistakes, but actually all three units provide a very challenging chess game.

Playing one computer chess unit against the other turned out to be very interesting because each unit planned ahead a couple of moves so we could see each computer setting traps for the other.

Onward, To the Battlefield! We pitted Boris against Chess Challenger for three games and CompuChess against Chess Challenger for three games. The

first game of each three-game set was at the lowest level on each unit with one playing white (starting the game), the second game with the other playing white, and the third on level 2 (around 10-15 seconds per move). The result was a lot of intriguing chess—all tied up like a novel with lots of little side plots, pitfalls, defenses, and threats.

The computers do, however, appear to behave differently. Boris will shoot one of its phrases across the screen that adds humor to the game; he also appears very willing to exchange queens rather than running away if they are attacking each other. This strategy simplifies the board a lot and probably gives Boris an edge over having to compute moves with the queens because it can make more trial moves in its microprocessor before time is up. So Boris comes on as somewhat aggressive, and it is designed to have different opening moves to add variety to the games.

CompuChess also has variety in its moves, not only at the beginning but throughout the game. If two moves are of nearly equal value, it will choose one and during another game it may choose the other. It appears to think carefully through every possibility before making a move, which gives it a defensive posture during a game but

A COMPUTER REYKJAVIK

As for the games, sometimes one computer would really whip its challenging computer one game, only to be defeated on the next game. The games were not duplicates of each other. One small difference in a move would turn a whole game around. Let's look at the beginning of a Boris (white) versus Chess Challenger (black) game. (E2E3 means move the piece at E2 to E3).

White	Black	
E2E3	D7D5	Advanced openings being used by both units.
F1D3	G8F6	
B1C3	C8G4	Challenger attacks queen. "Very interesting," says Boris.
F2F3	G4G7	Challenger retreats from its attack. Boris opens side to breathe a little.
B2B4	E7E4	
A1B1	B8C6	Challenger attacking white pawn.
C1A3	F8E7	Boris protects that pawn with bishop.

You can see the intrigue—attack, retreat, try again somewhere else, etc. This particular game lasted about two hours and required over one hundred moves by each computer. In the end Boris won, but it was a close game with only five white pieces and four black pieces left.

when an opportunity arises to gain an opponent's piece it will set up its moves to do just that. On level one it makes every possible move in its memory and looks at the opponent's possible responses before selecting the best move. On level two it will look at its possible responses to the opponent's response—and so on for the other levels. Boris and Chess Challenger are programmed in a similar manner because it is impossible to build a full array of pattern recognition solutions (Ah! This is pattern R, so I'll set up my Sicilian defense!) in a microcomputer. The only way is to have the computer try to move every piece and then to evaluate what will happen.

Chess Challenger appears to have a little less variety in its play than the CompuChess unit and that may be because it rarely ends up evaluating two situations as equal and therefore almost never "flips a coin" to decide which move to make. It uses a full 16 bit register to score evaluations, giving it a resolution of one part in 216 (64,000), so it rarely calls moves equal in value. From an opponent's viewpoint this means the Chess Challenger will not give you the slightest break—it always does its level best.

Chess on a microcomputer? It's here now, all three of these units giving a
(Continued on page 87)

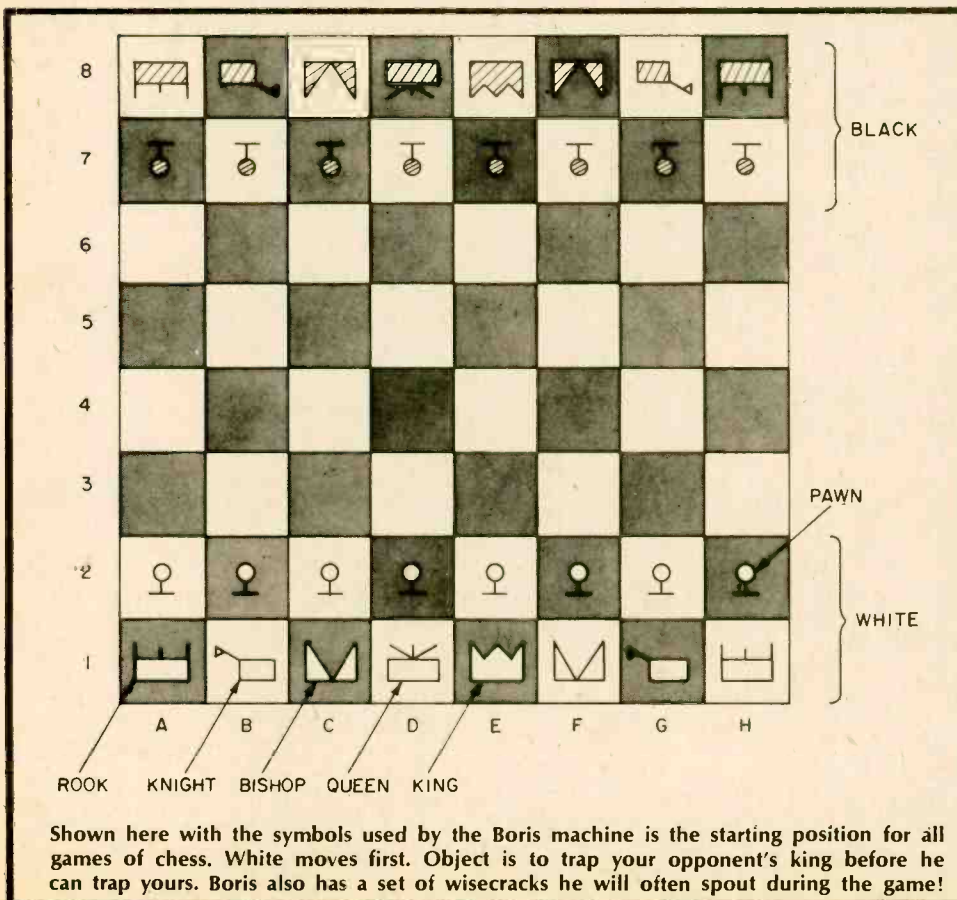

Shown here with the symbols used by the Boris machine is the starting position for all games of chess. White moves first. Object is to trap your opponent's king before he can trap yours. Boris also has a set of wisecracks he will often spout during the game!

IT'S SIMPLY BASIC

Keep Your Mailing List Up To Date and Sort It Any Way You Wish With This Amazing Program!

by Larry Friedman, WB2AHN

□ In previous columns we showed the computer being used to process electronic formulas and how to do simple data handling. But as BASIC languages for personal computers become more advanced, home computer hobbyists are able to perform sophisticated data processing routines that were impossible just a few short months ago. This month's program, "LIST", is written in Heathkit's *Extended Benton Harbor BASIC Version 10.02*, a BASIC so advanced it offers almost the power of a disc system when using an inexpensive cassette recorder(s) for data storage and retrieval.

LIST is essentially a mailing list file system for small clubs, organizations, etc., which allows up to four lines of information per person. Generally, the name goes on the first line, the address on the second, the city, state and ZIP on the third, and the fourth line can be blank or contain a code word or words, such as "Amateur", or "Short Wave Listener", etc.

By use of the appropriate command you can get a printout of the entire list, the information on just one name, all the persons in a given city (CITY SEARCH), all the persons with the same fourth line coding (OPTION SEARCH), the persons in the same city with the same option (C/O

SEARCH). If you want to print mailing labels the program is already designed to space for 1-inch TTY labels. If you use a tractor-feed TTY—other than a model 33—you might have to change the size of the mailing labels, so the printing doesn't miss the label after twenty-five or so have been printed. (Three PRINT statements one after the other control the TTY feed; lines 2100, 2101, 2101.)

Type START to enter names when creating a list. Each time the computer is ready for a name (four lines of information, use a carriage return if you have no information for a line) it will print the entry number, such as #1, #2, etc. To leave the START mode after making the last entry type a double asterisk (**).

Warning: Never type START unless you are actually starting a new list or want to delete an entire list of names. If you accidentally type START, immediately type JUMP to get out of the START mode.

To add names to a list use the command UPDATE. To change information on a name type EDIT; the computer will respond with NAME. Type in the name of the person whose information is to be changed and then make the changes. NAME SEARCH will list the address for a given name.

The command DELETE removes all information on a given name. The other commands are self-explanatory.

The overhead for this program is about 6K, which must be added to the overhead required by your particular BASIC. 20K of memory in a Heathkit H8 computer will handle about 50 names per file. Each name entry (all four lines) takes an average of 80 bytes. Therefore, each additional 8K of memory will add about 100 names per file. To handle more names than allowed by your computer's memory simply batch load them in groups of, say, 50, on cassette tape, assigning a List Name or header to each file, such as "DATA 1", "DATA 2", etc. The data is stored and retrieved through the PUT and GET computer commands, or whatever your version of BASIC uses for the PUT and GET functions. (Note: Extended Benton Harbor BASIC Version 10.02 records and retrieves only the data through PUT and GET. It does not also record the program. To record both program and data use FDUMP—though FDUMP slows down the data processing. For other computers check the "Bowling" program in our May/June column. If you have a system such as the SWTP 6800 use the port numbers as explained. If your computer does

not have an option to dump just variables or variables/program you might try going to machine language to dump the entire core.)

This program has too many features to describe in one article. We suggest you load the program, make at least two recordings (one for safety), and then experiment with the various features. You will find there are changes required to make it more closely meet your personal needs. To make editing of the program as easy as possible, it is broken down into sections numbered in units of 1000. Just make certain to change lines 260, 270 and 340 if you add or subtract command sections.

One final note. Some BASICs, no matter how large—8K, 10K, 12K, 14K—might require extensive modifications of this program to make it bug-free. This is because the size of a BASIC does not necessarily indicate its sophistication in terms of up-to-date programming techniques. While we have kept "LIST" as simple as possible to allow conversion to other BASICs, the truth of the matter is that *Extended Benton Harbor Basic Version 10.02 and 10.02.01* is more sophisticated than many other forms of BASIC and it might take considerable effort to get this program to run in a different BASIC.



Just fourteen years old, Larry Friedman, who set up this program, is an old hand with computers. He has built his own computer system using an SWTP 6800 as the base. The computer gets such diverse uses as processing complex electronic equipment test reports and keeping the statistics for Larry's baseball and bowling teams. Larry is also a consultant on programs for electronics experimenters, and a real whiz as an amateur radio operator and as a beginning pilot.

MAILING LIST PROGRAM

LISTING OF "LIST" BY LARRY FRIEDMAN
BENTON HARBOR BASIC, VERSION 10-02-80

```

105 DIM N$(101),A$(101),C$(101),O$(101)
110 LINE INPUT "DO YOU WANT A LIST OF COMMANDS (Y/N)";A$
120 IF A$="N" THEN 250
130 PRINT
140 PRINT "INSTRUCTION SET FOR THIS PROGRAM"
150 PRINT "DELETE FOR TAKING NAMES OUT OF LIST"
160 PRINT "LIST FOR LISTING ENTIRE LIST OF NAMES"
170 PRINT "START TO ENTER NAMES INTO LIST"
180 PRINT "UPDATE TO FIND QUANTITY OF NAMES IN LIST"
190 PRINT "TOTAL TO LOCATE ONE NAME WITH ADDRESS"
200 PRINT "NAME SEARCH TO LOCATE ALL NAMES IN ONE CITY"
210 PRINT "CITY SEARCH TO LOCATE NAMES WITH IDENTICAL 4TH LINE"
220 PRINT "OPTION SEARCH TO LOCATE BY CITY AND 4TH LINE OPTION"
230 PRINT "C/O SEARCH TO LEAVE PROGRAM"
232 PRINT "LEAVE"
235 PRINT "EDIT"
237 PRINT
239 PRINT "NOTE: IF START COMMAND IS ENTERED BY MISTAKE,"
240 PRINT "TYPE 'JUMP' TO EXIT START MODE."
241 IF A$<"LEAVE" THEN 250
242 A$=""
243 STOP
250 LINE INPUT "COMMAND >";A$
252 IF A$="LEAVE" THEN 242
255 RESTORE
260 DATA "DELETE","LIST","START","UPDATE","TOTAL","NAME SEARCH"
270 DATA "CITY SEARCH","OPTION SEARCH","C/O SEARCH","EDIT"
280 FOR R=1 TO 10
290 READ B$
300 IF A$=B$ THEN 340
310 NEXT R
320 PRINT "SORRY, THAT COMMAND DOES NOT EXIST"
330 GOTO 250
340 ON R GOTO 1000,2000,3000,4000,5000,6000,7000,8000,9000,10000
1000 PRINT "HOW MANY NAMES TO DELETE?"
1001 INPUT A
1010 PRINT
1020 FOR R=1 TO A
1030 LINE INPUT "NAME >";N$
1040 FOR X=1 TO 100
1050 IF N$=N$(X) THEN 1100
1060 NEXT X
1070 PRINT "SORRY, NAME NOT FOUND IN LIST."
1080 PRINT
1090 GOTO 1120
1100 PRINT "DELETED."
1105 N$(X)="JUMP"
1110 PRINT
1120 IF N$(X)="*" THEN 250
1122 NEXT R
1130 GOTO 250
2000 LINE INPUT "WANT LIST WITH 4TH LINE OPTION? (Y/N) >";Y$
2010 FOR R=1 TO 5
2020 PRINT
2030 NEXT R
2040 FOR R=1 TO 100
2050 IF N$(R)="*" THEN 2200
2055 IF N$(R)="JUMP" THEN 2110
2060 PRINT N$(R)
2070 PRINT A$(R)
2080 PRINT C$(R)
2090 PRINT O$(R)
2100 PRINT
2110 NEXT R
2120 PRINT
2130 NEXT R
2140 PRINT
2150 NEXT R
2160 PRINT
2170 NEXT R
2180 PRINT
2190 NEXT R
2200 FOR R=1 TO 5
2210 PRINT
2220 NEXT R
2230 GOTO 250
3000 PRINT "TYPE ** (TWO ASTERISKS) AFTER LAST DATA ENTRY"
3020 PRINT
3030 FOR R=1 TO 100
3040 PRINT "#";R
3050 LINE INPUT ">";N$
3051 IF N$="JUMP" THEN 250
3052 N$(R)=N$
3055 IF N$(R)="*" THEN 250
3060 LINE INPUT ">";A$(R)
3070 LINE INPUT ">";C$(R)
3080 LINE INPUT ">";O$(R)
3090 NEXT R
3100 GOTO 250
4000 INPUT "HOW MANY NAMES ARE CURRENTLY IN LIST >";JA
4010 PRINT "TYPE ** (TWO ASTERISKS) AFTER LAST DATA ENTRY"
4020 PRINT
4030 FOR R=(A+1) TO 100
4040 PRINT "#";R
4050 LINE INPUT ">";N$(R)
4060 IF N$(R)="*" THEN 250
4070 LINE INPUT ">";A$(R)
4080 LINE INPUT ">";C$(R)
4090 LINE INPUT ">";O$(R)
4100 NEXT R
4110 GOTO 250
5000 PRINT
5005 R=0
5010 FOR E=1 TO 100
5015 IF N$(E)="JUMP" THEN 5030
5020 IF N$(E)="*" THEN 5050
5025 R=R+1
5030 NEXT E
5050 PRINT "THERE ARE ";R;" NAMES IN THE LIST."
5060 GOTO 250
6000 LINE INPUT "NAME >";N$
6010 PRINT
6020 FOR R=1 TO 100
6030 IF N$=N$(R) THEN 6100
6040 NEXT R
6050 PRINT "NAME NOT FOUND IN LIST"
6055 PRINT
6060 GOTO 250
6100 PRINT N$(R)
6110 PRINT A$(R)
6120 PRINT C$(R)
6130 PRINT
6140 GOTO 250
7000 LINE INPUT "WANT LIST WITH 4TH LINE OPTION? (Y/N) ";Y$
7005 LINE INPUT "WHAT IS CITY NAME >";C$
7010 PRINT
7020 FOR R=1 TO 100
7030 IF C$=C$(R) THEN 7100
7050 IF N$(R)="*" THEN 7180
7060 GOTO 7180

```

(Continued on page 90)

TEN

Ninety percent of auto radio repair problems don't require a trained technician with thousands of dollars worth of test equipment. Many car radio problems concern mechanical connections—a broken wire, loose capacitor or a broken dial cord—others are caused by defective power supplies or overheating parts. What ever the problem it can almost always be fixed without taking it into a shop and running up a big bill—just learn these tricks-of-the-trade and get down to business.

An auto radio, however, can be very tricky to work on. Sometimes it includes FM as well as the standard AM, not to mention FM multiplex, 8-track, cassette and even CB. When all of this is jammed into a seven-inch wide package it can be pretty confusing to figure out what is what, so you don't want to make things harder than they need be.

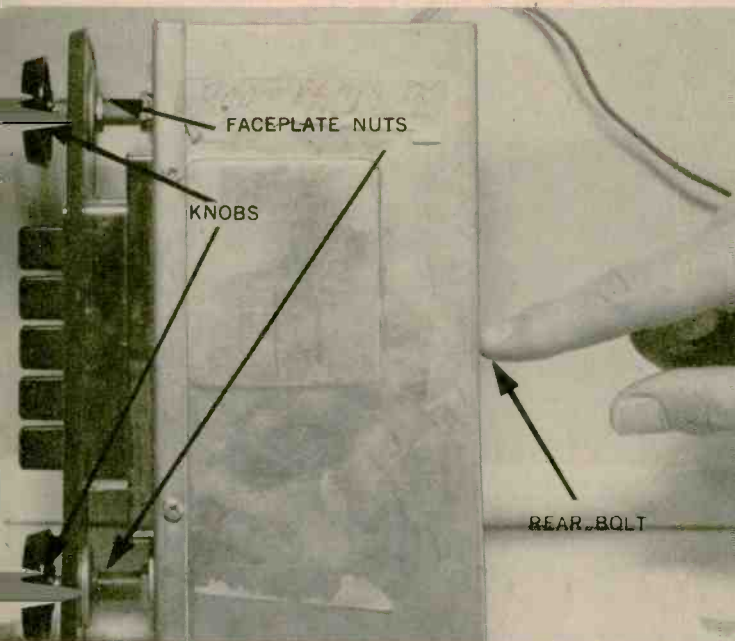
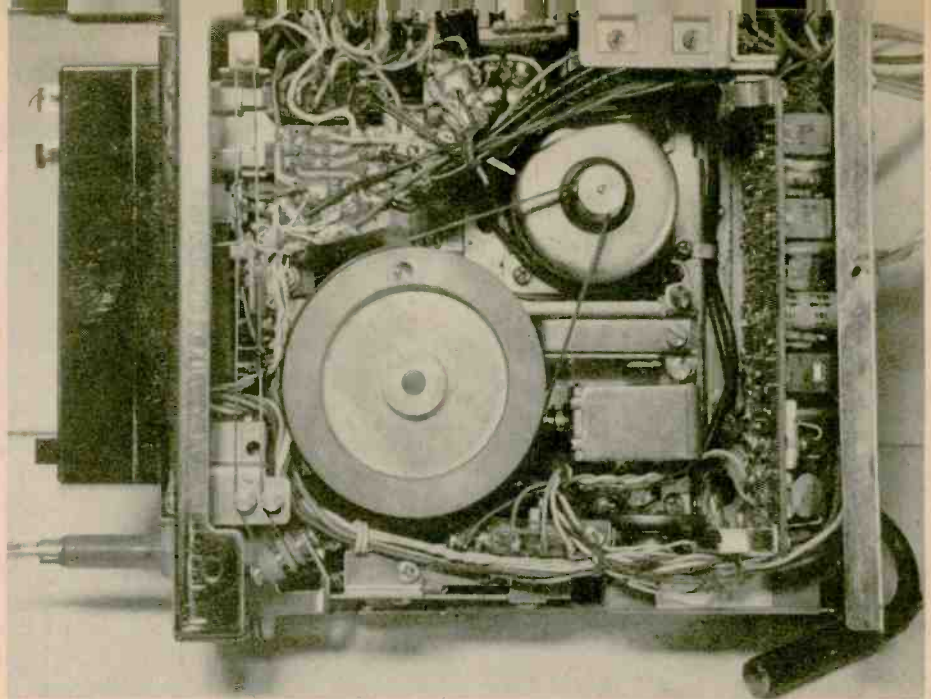

2. Doing without a dial light on a car radio is like fixing a flat tire with a dead flashlight after Friday night's football game. Most car radios must be pulled out to replace the dial light. Before removing the radio check to see if the pilot light may be wired to the dash light control switch. Trace two (black) wires leading to the fuse block or auto wiring harness. A defective plug or poor wiring connection may be the trouble.

After removing the radio, inspect the front dial assembly to locate the defective dial light. On some radios you unclip the dial light assembly from the radio chassis. Other models mount the dial light close to the bottom of the dial assembly. You may have to remove the whole front dial assembly to get at the dial light mounted behind a white plastic cover. Within some Japanese models, you may find a dial light with long wire leads.

Most American-made radios use a 12-volt bayonet dial light such as an 1891, 1892, 57 or 47. Foreign radios may have screw type bulbs which are sometimes difficult to obtain. They can be replaced with a bayonet type or one with leads. Since all dial lights are 12-volt types you can solder a bayonet bulb in place of a screw type. If not, replace it with one having a 12-volt flexible lead (like those found in tape players) and cement it in position with black silicone cement.

1. Before removing the radio make sure the troubles are definitely in the unit itself. You may have a blown fuse, defective speaker, antenna or bad wiring connections. First thing: locate and check the fuse. The fusebox is normally under the dash and to the left of the steering wheel. When a tape player is included in the radio you will find it in the plug or harness. If you can't find it trace the largest wire out of the radio and see where it goes. The color of the "A" lead wire may be black, red or blue.

A defective speaker may be causing the problem and the type of sound is a clue to the cause. If the music is intermittent then the speaker voice coil wires may be partially broken into. A dropped speaker cone will produce a tinny and mushy sound. Typically on loud volume certain vibrations may be caused by a torn or loose speaker cone. Excessive blattling music may result from a loose voice coil support. You should check the speaker for continuity with ohmmeter or a flash-light battery. When using a small battery just temporarily touch the speaker leads and listen for a clicking noise. If you don't get a new speaker.

Check the radio wiring for possible loose or broken connections. If the radio is a universal type, mounted under the dashboard, it's likely that the speaker and "A" lead connections are just twisted together. Remove the tape and solder all connections then retape with plastic tape. In case of stereo speakers, with one side intermittent or dead, inspect the speaker wiring to see if it is frayed.

An open or poor antenna connection may cause weak or noisy reception. If radio reception is very noisy, check the bond between antenna base and metal car body. Another source of car noise may be a broken shielded cable where the male plug enters the radio. With antennas molded into the front windshield check for a broken connection at the bottom of the windshield. Be real careful and don't pull on the antenna connection or you may end up replacing the whole windshield. If another auto antenna is handy simply plug it in and hold the base outside the car window. You would be surprised how many antenna problems are identified by this test.

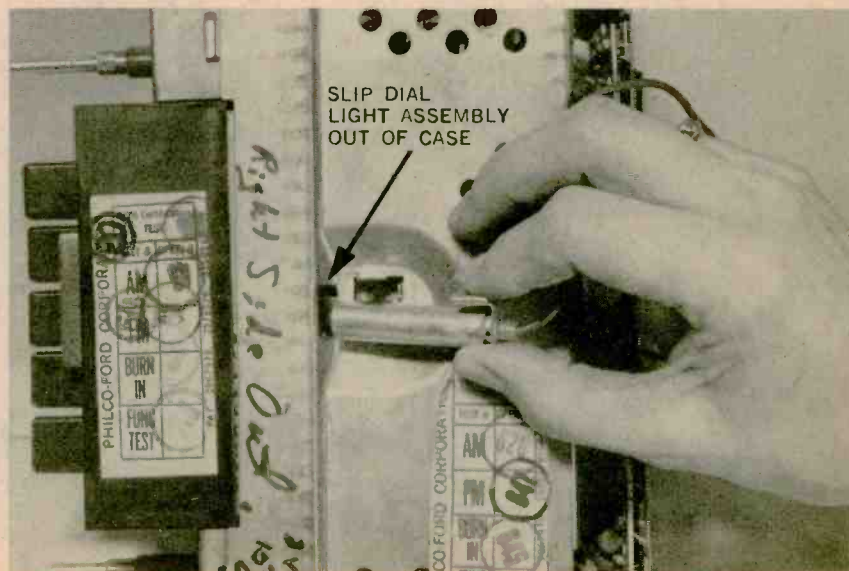

CAR RADIO REPAIR TIPS

by Homer L. Davidson

3. There are two different types of dial mechanisms found in an auto radio—mechanical and dial cord operations. The mechanical system employs a couple of worm and gear assemblies. The most common problem with mechanical tuning is slippage between the clutch and tuning coil assembly. Clutch tension may be adjusted with a set screw, or liquid rosin and phono-grip may be applied to prevent the clutch from slipping.

You should suspect a broken dial cord if the radio will tune in stations, but the dial pointer doesn't move. You will find two basic dial cord arrangements; a simple one with tuning shaft, two small pulleys and dial pointer; the other with additional small pulleys and dial cord spring. When a spring is not used to take-up the slack, most of the dial cord is wound around the tuning shaft. The small spring keeps the dial string taut around larger pulleys.

Do not attempt to tie a knot in the broken dial cord and make it do. Select a cord of medium or fine dial cord (found in most radio and TV supply houses). If a dial stringing schematic is not handy, draw a diagram the way you found the broken dial wound. Nine times out of ten you have come up with the right method. Remember, when the tuning coil cores are all the way into the coils, your dial pointer should rest at the low end of the dial. Another helpful method is to tie the end of the dial cord to the tuning drum and leave the dial spring to attach at the end of the line.

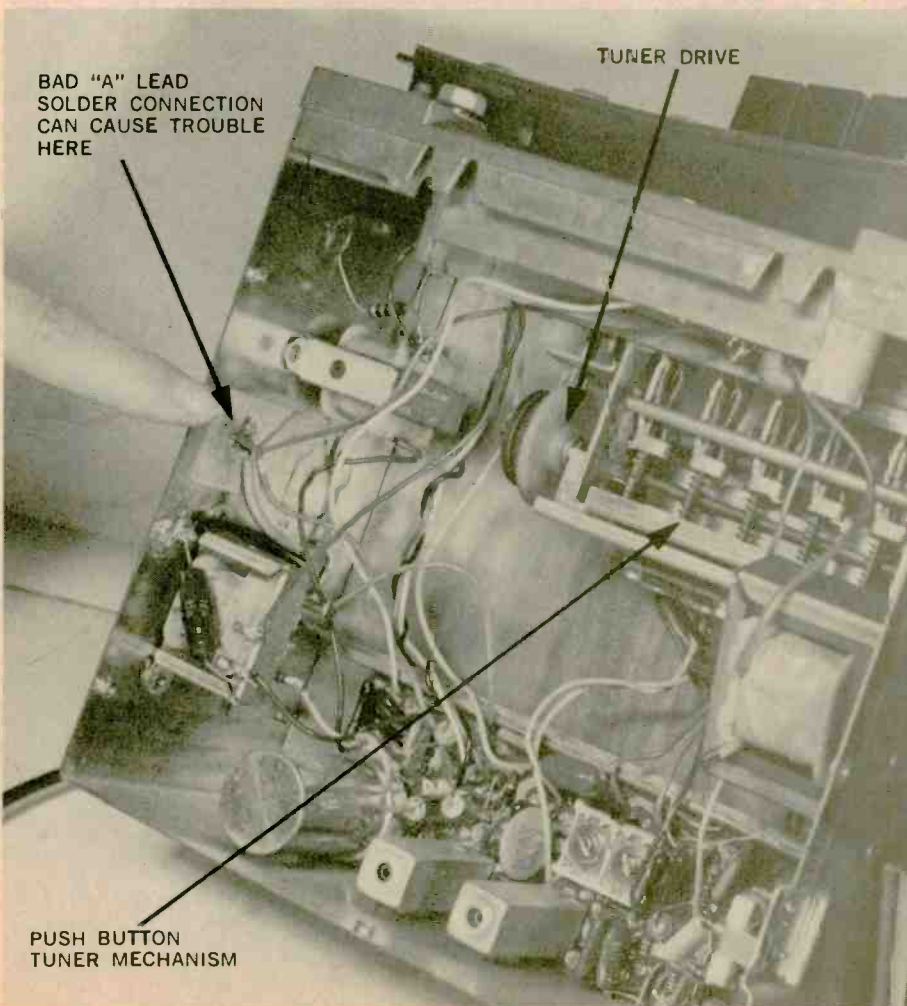
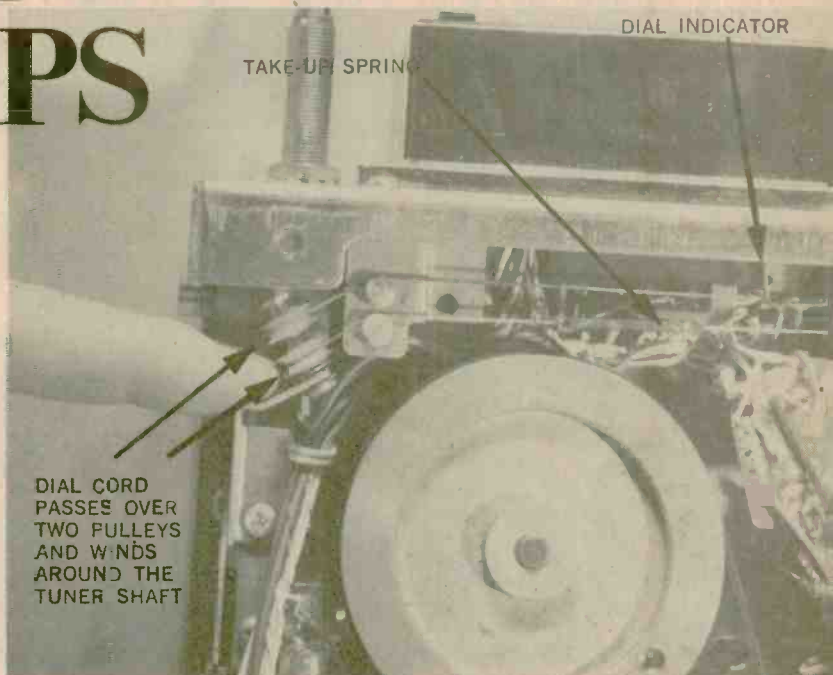

4. If your car radio won't produce a sound, look at the small fuse. Visually inspect the fuse holder and "A" lead. Most solid-state radios may pull from 1 to 5 amps.

Always replace the defective fuse with one of the same value. You will find this stamped in the metal edge of the fuse. If in doubt, check the correct radio fuse listed in your car manual. Most Japanese car radios will have a 1- or 2-amp fuse for protection. American manufactured auto radios are protected with a 3- or 5-amp fuse. Very large Japanese radios with tape players may be protected with a 3- or 5-amp fuse, while American made radios with tape players may be fused with a 10- or 20-amp fuse.

Trace the hot lead inside the radio to the spark plate and on-off switch. A poor or broken switch connection can put a radio completely out of action. If the dial light is on you know the switch is good. If not, clip a jumper around the switch connection and check for a 12-volt source at this point.

Substitute a new PM speaker. An open voice coil or poor speaker lead may cause problems. If the sound returns after speaker substitution you may want to check out the defective speaker. With the speaker still connected, push down on the cone of the speaker and see if the sound cuts in and out. A poor or broken voice coil lead may cause intermittent sound conditions. Disconnect the leads and check for continuity across the voice coil leads with the ohmmeter. If the PM speaker is defective, replace it with one of the same voice-coil impedance. You may encounter a 3, 2, 4, 8, 10 or 20-ohm speaker on a car radio. Replace a Japanese radio's speaker with an 8-ohm speaker.

When you turn on the radio switch and a click is heard on the speaker, you may assume that the power output transistor and power voltage are normal. An open or shorted power output transistor may not produce any sound on the speaker. If the output transistor becomes leaky you should at least hear hum or distortion on the speaker.



5. Does your auto radio start to play only after it's been turned on for twenty minutes or so? Perhaps, it's real weak in volume and then comes on with a bang! These symptoms are caused by intermittent transistors. Since transistors are solid-state devices, cold or heat may make them become open or leaky. Sometimes after applying heat or cold spray the defective transistor will return to normal operation.

Problems caused by heat and cold usually occur in the RF oscillator and IF transistors. If the radio is cold and does not come on instantly, apply heat to the body of each transistor. Start at the RF transistor and apply heat for no more than a second or two. If left on too long you may damage the transistor. Then move on to the oscillator and IF transistors. Sometimes just moving the suspected transistor may cause it to "pop" on. Apply heat when the radio will not come on and coolant if the unit cuts out or becomes weak after it warms up.

Weak conditions may be caused by transistors, the antenna or bad capacitors. When you can hear every station on the dial but weakly, suspect a defective antenna system or RF transistor.

You have eliminated the antenna system as a possible problem if the same weak condition exists on the workbench. Go to the RF transistor and take voltage measurements. A very high collector and very low, or no, base voltage indicates the transistor is open. You may have the same condition if the emitter bias resistor opens up. Check for broken wires or replace it.

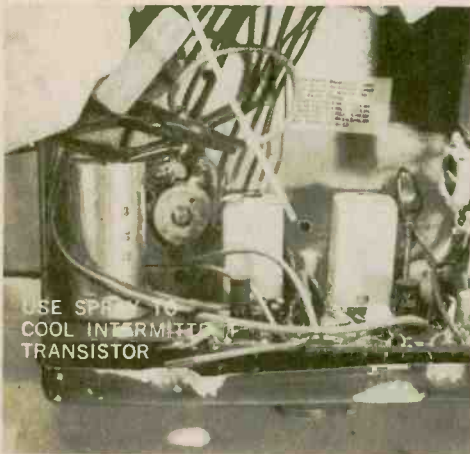
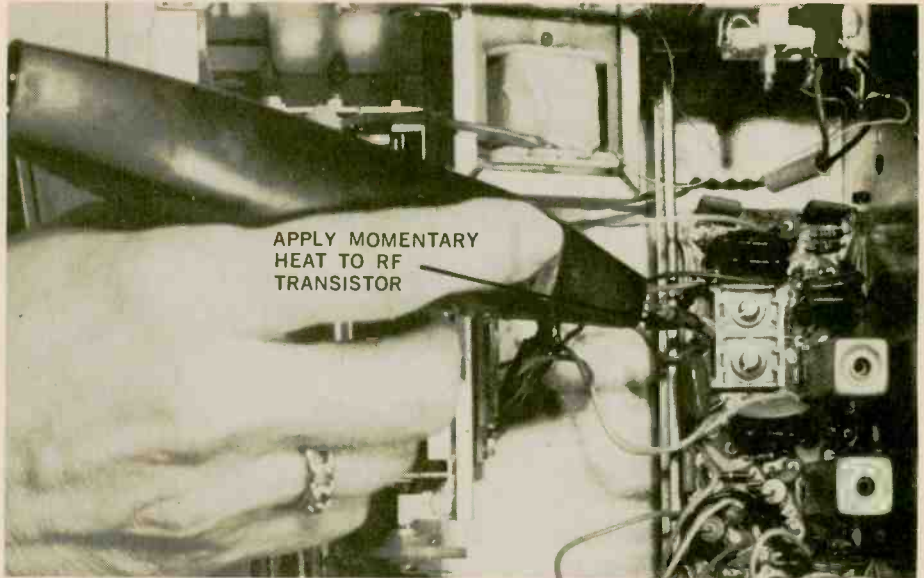

6. A coolant or cold spray is essential for locating intermittent transistors. Your radio may play for several hours before cutting down in volume or maybe it will only do it once a week. But, it always acts up while listening to your favorite song or football game.

You may waste hours and even weeks trying to locate an intermittent transistor if it only happens once a week or twice a day. Play it until it begins to really act up—like every hour or two. Then carefully remove it from the auto and connect it to the workbench. Of course, you must have a 12-volt DC source to operate the auto radio, or you may be able to extend the power leads from the auto to the radio and check it out on the front seat. Always, observe and connect each wire to its hookup.

Try to isolate the intermittent problem. Start at the volume control when the radio is in the intermittent state and notice if the audio section is functioning. Simply hold a screw-driver blade on the center tap of the volume control and you should hear a loud hum. If not, the audio section is intermittent. Then start at the driver transistor and work towards the front of the receiver. Spray each transistor at least three or four times. If the music begins to play you have located the defective transistor. Don't remove that transistor just yet. Let the radio go into the intermittent condition and spray it once more—to make sure the transistor is intermittent. You may also find coolant sprayed upon certain areas of the PC board will bring out those poor, soldered connections.

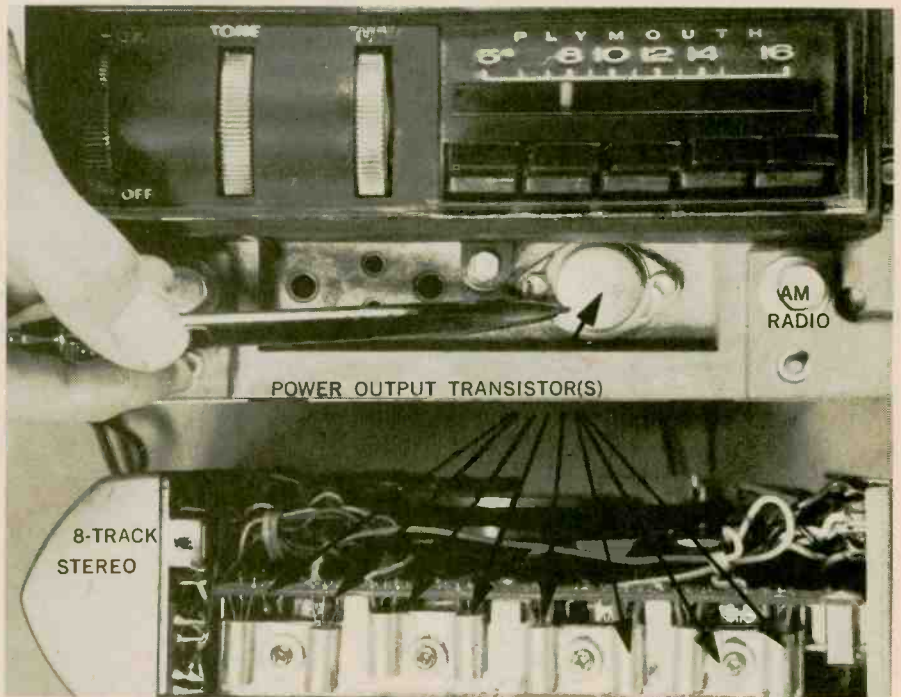

7. You may find one, two or possibly four power output transistors in your receiver. Within the AM radio you may locate one single or two push-pull power output transistors. Generally, four power output transistors are found in the AM-FM-MPX and tape player receivers. If your radio incorporates an eight-track tape player there are eight power output transistors. Just go slow and easy when replacing the defective output transistors.

After locating the defective output transistor check to see if the transistor and mounting screws are insulated from the heat sink with a piece of mica or plastic material. In a push-pull output circuit you may find one transistor insulated from the heat sink and the other mounted directly upon it. Sometimes a single output transistor may be mounted upon the heat sink and the heat sink is insulated away from the radio chassis. Remove only one transistor at a time if both output transistors are being replaced.

Replace the power output transistor with an identical unit. If a piece of mica insulation is found between the transistor and heat sink apply silicone grease to both sides of the insulation. You will find most output transistor replacements enclose an insulator in each package. Remove the old grease and dirt with alcohol and a cloth. Now firmly tighten down both mounting screws. Be careful, too much pressure may bite through the insulation and short out the transistor.

When mounting output transistors with only one mounting screw be sure the three terminals of the transistor go through the correct holes of the insulator. The terminals are then bent at a right angle and fitted into the transistor socket. Make sure the terminals are clear through the socket piece to make a good contact. In many cases these flat type transistors are soldered directly to the audio PC board. You may find this single-hole mounted transistor at the rear heat sink, on the chassis near the volume control or just inside of the front tuning panel.

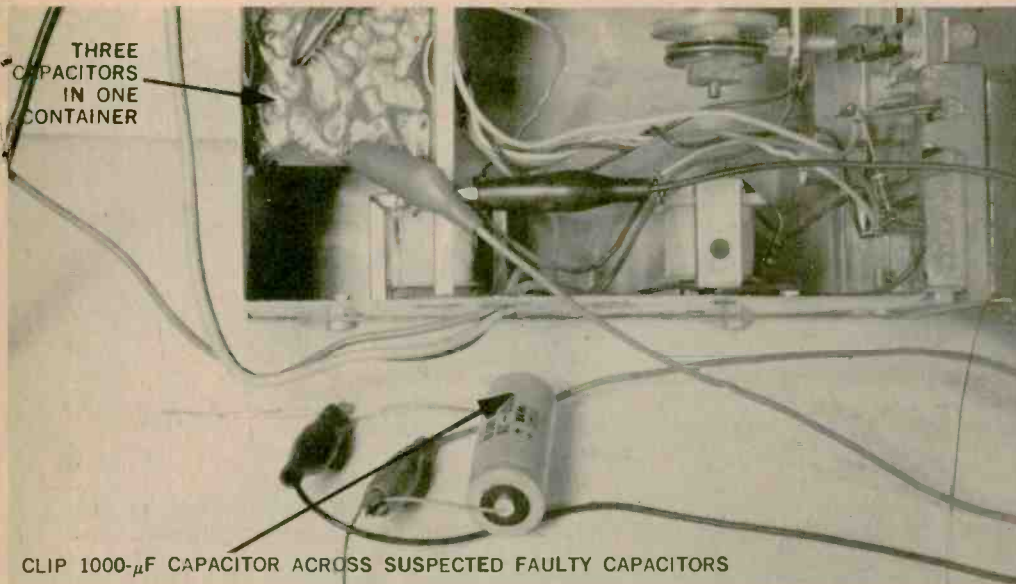

8. With all those odd noises coming out of the speaker you may think a swarm of bees or mice are trapped inside the radio. Actually, all of these noises can be caused by an open filter capacitor in the power supply. Locate either a filter pack or a single filtering capacitor upon the radio chassis. To find out which one is defective, turn off the power and clip a new capacitor (1000 mfd) across the suspected one. This test will uncover an open capacitor.

When more than one filter capacitor is located in one container, shunt the clips to the tie point (+) and chassis ground. To test a single filtering capacitor, clip the new capacitor across those found upon the PC board. You may find two or three single filter capacitors on the board. Observe correct polarity (+) in testing and replacement. The negative terminal (outside metal case) connects to chassis ground. Clip the new capacitor across each suspected one until the noise stops being very bothersome.

If you locate a defective capacitor in a container with several other capacitors, replace the entire filter network. Replace the defective capacitor with one of the same capacitance and voltage value. If you cannot locate one of the same value, use one with a little higher capacitance and operating voltage.

CLIP 1000- μ F CAPACITOR ACROSS SUSPECTED FAULTY CAPACITORS

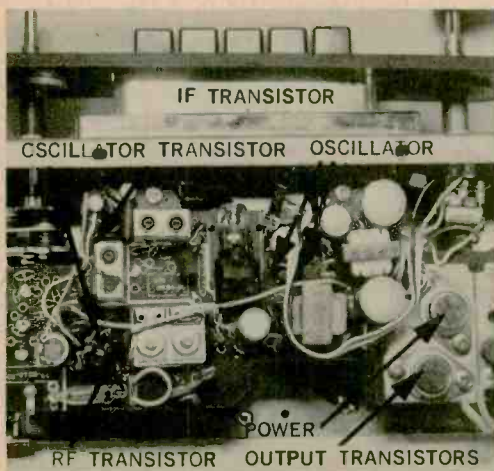

10. Suspect a defective oscillator transistor when one half of the tuning dial is alive. Usually the high end of the dial is dead but it may be either end. The oscillator transistor is located close to the tuning mechanism oscillator coil and padder capacitors. In some auto receivers it may be marked on the PC board. A transistor test may show that the transistor is good but will not oscillate across the whole broadcast band. Simply remove the transistor and install a new one.

One important thing to remember is to avoid the temptation to put a small screwdriver into the tuning coils and capacitors. It is improbable that you will be able to improve the radio's performance this way. You should never adjust these unless you have the proper test equipment and have been trained in its use. More radios go to the junk pile thanks to well-meaning coil and capacitor adjusters. Most of the time these adjustments are made at the factory and then sealed with wax so they can't vibrate out of tune.

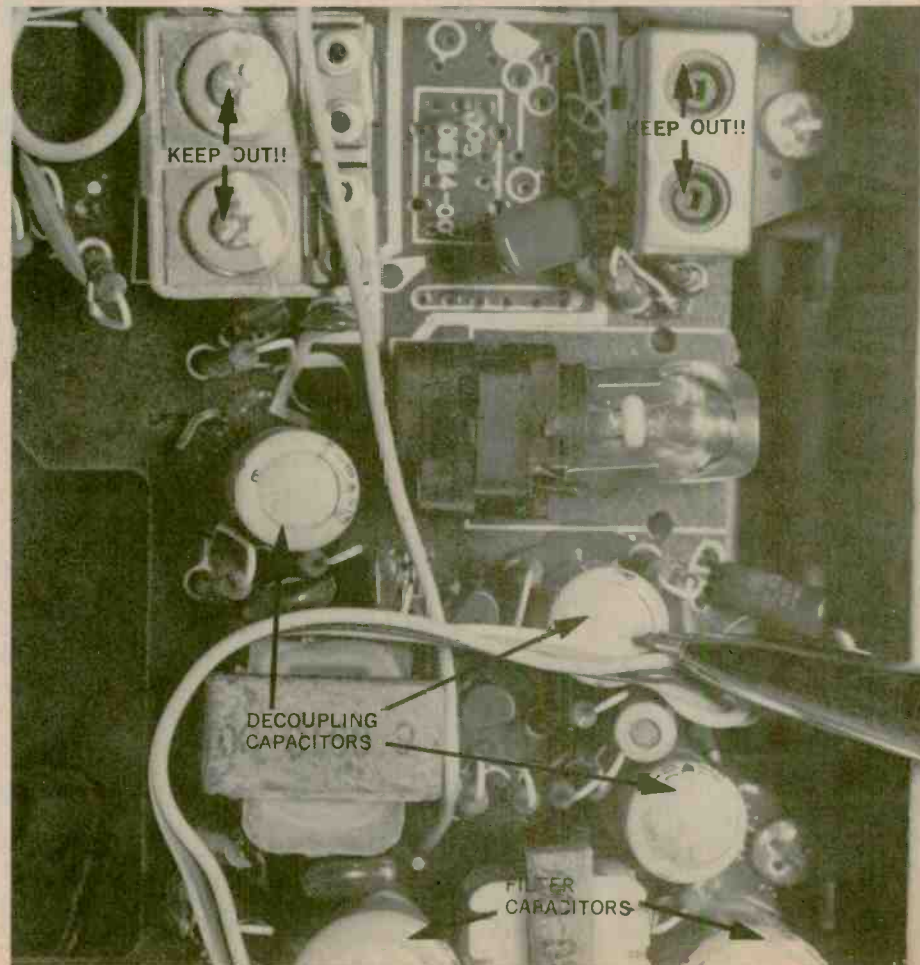

9. Don't be too surprised if your car radio begins to sound like a small gasoline engine. The put-put noise you may hear in the speaker may be a sign that excessive motorboating is occurring in the RF, AF and power supply circuits. Go directly to the filter circuits of the power supply and shunt a large (1000 mfd) electrolytic capacitor across each one. Always, remember to turn off the receiver and clip the capacitor in place to prevent damage to other transistors. Also, observe correct capacity polarity. When the motorboating noise quits, you have located the defective filter capacitor.

If the filter capacitors in the power supply are not causing the motorboating action, shunt smaller electrolytic capacitors in the B+ and decoupling circuits. These (100- to 250- μ F) capacitors may be found anywhere in the PC board. Also, check for defective bypass capacitors in the emitter circuits of RF and AF circuits for motorboating problems. Simply shunt a new one of the same value across the suspected capacitor.

Excessive motorboating may be caused by an audio output or AF transistor. Try to isolate the AF or driver transistor by shorting the base and emitter terminals together. Be careful to make sure you are on the right terminals. If motorboating ceases either the transistor is defective or the fault is in the preceding stage. Replace the audio output transistor if suspected of motorboating. Most of these audio output transistors are easily replaced since they are mounted to the heat-sink with a couple of screws.



by Kathi Martin, KGK 3916

Kathi's CB Carousel

Put your CB in four-wheel drive with this super preamp.

□ THERE IS AN OLD ADAGE in communications that says: "You can't work 'em if you can't hear 'em." Fortunately, CB transceivers—as a general rule—have greater sensitivity than their counterparts in other radio services.

But there are times when the *signal sniffer* needs just a little extra sensitivity to pull a signal out of the background; when we need just a bit more gain to get 100% copy on the received signal.

The only way to get that extra gain without changing to a more expensive antenna system or redesigning the receiver is to connect a 27-MHz broadband preamplifier between the antenna and the transceiver. The only problem with this idea is that the same circuit is used for transmitting, and a receive-only preamp would prevent RF from getting from the transmitter to the antenna. In short, the preamp gets in its own way.

One way to enjoy the benefit of extra sensitivity without interfering with the transmitter is to use a specially designed CB preamplifier such as the Communications Power "Range Plus," which automatically takes itself out of the circuit when the transmitter is keyed.

The *Range Plus* consists of a receiver-preamplifier providing up to 13 dB gain (a little more than two S-units) combined with an RF-sensitive relay

circuit. The device can be powered by the 120 VAC powerline, or 13.8 VDC from an auto battery. Normally connected between the transmission line and the transceiver, the Range Plus is completely bypassed when its power switch is off. When the power switch is turned on a "bypass relay" is activated, switching the preamplifier into the transmission line. When the transmitter is keyed an RF detector instantly

that plagued many other earlier preamplifiers with automatic RF-controlled bypass.

The Range Plus is housed in a very attractive cabinet 4 $\frac{3}{8}$ -in. wide by 2 $\frac{3}{8}$ -in. high by 4-in. deep. It has an internal AC line power supply and terminals for 13.8 VDC. The rear apron has standard coaxial connectors for the antenna and transceiver connections, a terminal strip for a 13.8 VDC power



causes the bypass relay to drop out, restoring the direct transmission line-to-transmitter (transceiver) connection.

When the bypass relay is caused to drop out by RF flowing from the transmitter a small lamp inside the cabinet is turned on, which illuminates a red front panel "ON THE AIR" sign, showing the user the control circuit is working.

At this point you are probably asking: "Hey Kathi! How does the RF bypass work on an SSB rig since there's no carrier to trigger the relay?"

Here's how the Range Plus handles SSB. An SSB/AM selector switch provides for an SSB hold on the bypass circuit. Normally, for AM the relay connects the preamplifier the instant it senses carrier loss. But for SSB, the first RF burst triggers the relay and a delayed release keeps the bypass closed long enough to fill the gap between normal speech syllables. In this way the relay doesn't continuously cut in and out at the syllabic rate—a problem

source, and the AM/SSB selector switch.

The front panel has the power switch, *(Continued on page 91)*

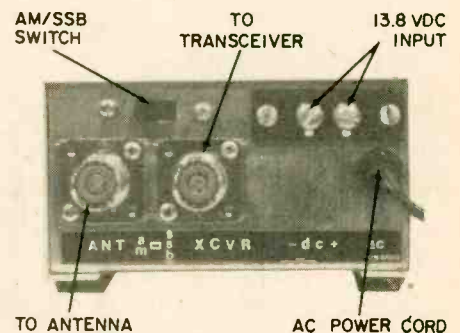

The rear apron is self-explanatory. The AM/SSB switch provides a time delay to prevent drop out of the bypass relay at the syllabic rate during an SSB transmission. For mobile operation the 13.8 volt power connects to the terminals at the right rear. For base use you use the linecord. No rewiring or jumper(s) is required to change from 120 VAC to 13.8 VDC operation on the Range Plus.

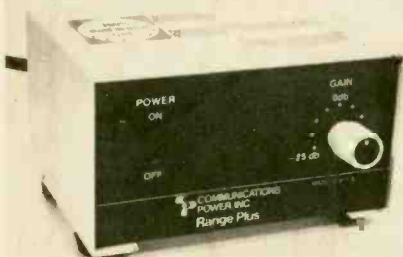

CIRCLE 52 ON READER SERVICE COUPON
The Communications Power "Range Plus" not only looks snazzy, it puts real pizzazz into receiving with 13 dB extra sensitivity.

GRANDPA'S WHISKER

Build a carborundum detector from the days of the not-so-ancient mariners

by Charles Green

IN THE BEGINNING OF this century, when radio was still called "wireless," the crystal set was used by most of the early radio pioneers. The simple "catwhisker" touching a piece of galena or silicon crystal, and a coil wound on an oatmeal box, formed a primitive yet effective radio receiver that stayed popular for many years. Even the later development of the vacuum tube could not entirely bury the crystal set; it still remained popular as a first set for many radio experimenters who later went on to more complicated electronic developments. Even today, the simple crystal set is still being built using modern germanium or silicon diodes in place of the moveable catwhisker and crystal.

Back in the old days, the popular galena and silicon crystals had a rival for the more specialized ship-to-shore communication work. It was the carborundum crystal detector. The carborundum

crystal detector did not require a light touch with the catwhisker, but instead required a heavy contact pressure. This heavy catwhisker pressure was more suitable for the early radio stations on ships. The lesser sensitivity of the carborundum detector was compensated by the crystal's ability to take stronger radio signal energy (such as leakage from nearby spark transmitters) without burning out, then the galena and silicon crystals could. What is really different about the carborundum detector, is the requirement for a bias battery. This bias battery is normally not used with galena and silicon crystals.

You can experiment with the carborundum detector by building our *Grandpa's Whisker*, which is patterned after the early crystal sets. The receiver is in a series tuned circuit with L1, and serves to tune the antenna for maximum RF current flow. The resultant tuned signals are detected by D1 and the audio is fed through the R1 bypass C3 to J5-J6 and external headphones. R1 adjusts the D1 bias voltage from B1 and C4 is the RF bypass for the headphones.

broadcast band and for maximum signal coupling to the detector. A separate assembly is provided for the carborundum detector and a control is mounted for convenient adjustment of bias battery voltage for maximum detector sensitivity. The receiver is built "breadboard style" on a 8½-inch by 7¼-inch by ¾-inch wood base which is similar to the style of construction used by early radio experimenters.

The Receiver Circuit. Signals from the antenna are fed through J1 and coupled through C1A-C1B to the parallel tuned circuit of L1-C2. C1A-C1B is in a series tuned circuit with L1, and serves to tune the antenna for maximum RF current flow. The resultant tuned signals are detected by D1 and the audio is fed through the R1 bypass C3 to J5-J6 and external headphones. R1 adjusts the D1 bias voltage from B1 and C4 is the RF bypass for the headphones.

Carborundum. Not a natural mineral like galena or silicon, carborundum is the name given to a compound of silicon carbide by its American inventor Edward Goodrich Acheson (a former assistant of Thomas Edison), Acheson was experimenting with a primitive electric furnace in 1891, when he fused a mixture of clay and powdered carbon. He found that the resultant crystals would cut glass similarly to a diamond (silicon carbide is next to a diamond in hardness), and he called his discovery Carborundum; thinking it was a substance composed of carbon and corundum (a crystallized form of alumina). Scientific analysis later showed it to be silicon carbide, but the designation Carborundum was kept as a trade name. Industrial usage of carborundum is primarily grinding compounds and grinding wheels.

Its use as a detector was discovered by experimenters around the beginning

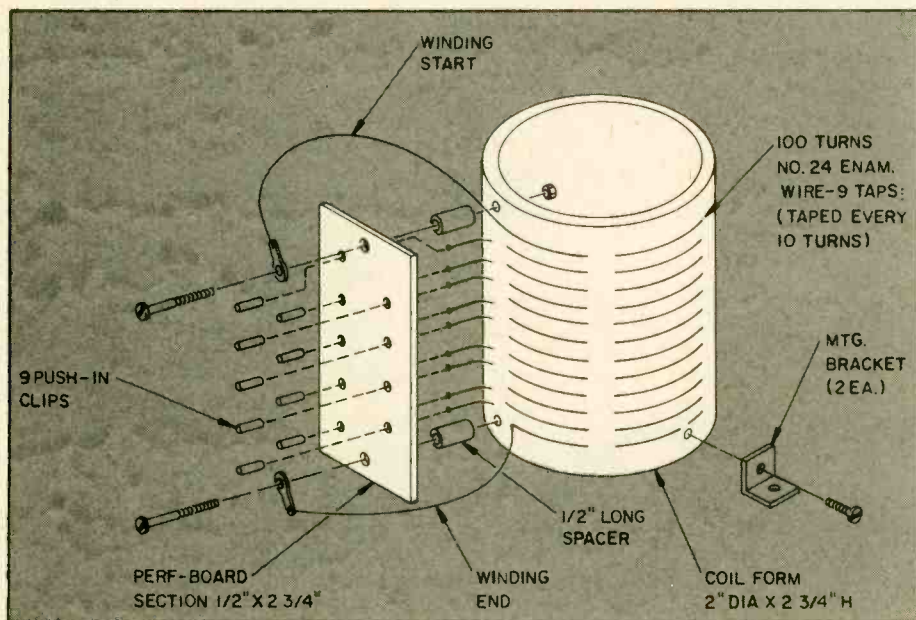
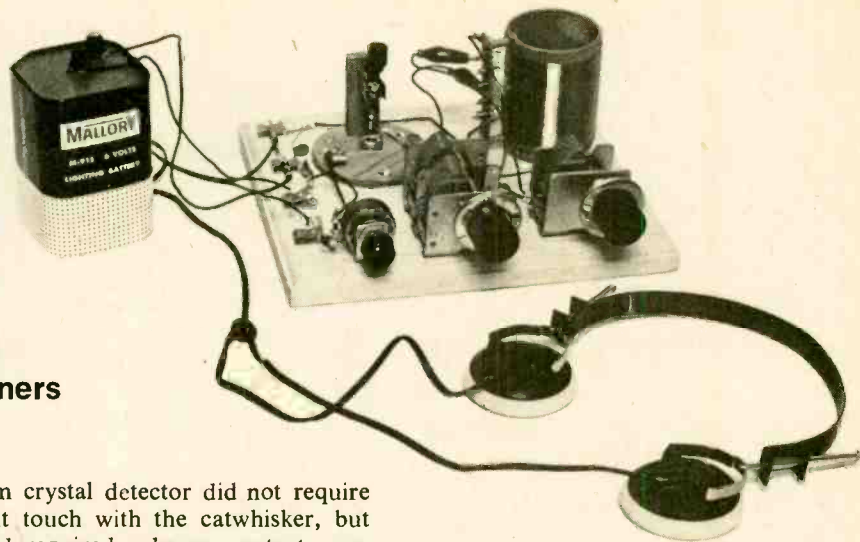

The tuning coil is wound on a cardboard mailing tube section for 100 turns of #24 enameled wire, tapped every ten turns. The taps should be stripped bare with sandpaper before soldering to the clips which are mounted on a section of perfboard. See the text.

e/e GRANDPA'S WHISKERS

of this century who tried various minerals and substances in their search for better types of radio wave detectors; much as Edison tested many materials in his search for the proper material for his incandescent lamp filament.

A crystal diode has a high current flow with voltage applied so that it conducts in the forward direction (cat-whisker to crystal), and a very low current flow in the reverse direction. The amount of current flow in the forward direction depends upon the characteristics of the crystal material and the applied forward voltage. As shown in the Crystal Forward Conduction Curves graph, Germanium minimum voltage is approximately 0.3 V, Silicon is 0.6 V, and Carborundum is 3 V. (The high Carborundum voltage is the reason why a bias battery is necessary to move the threshold down so that the weak RF signal voltages can be detected.)

Tuning Coil (L1) Construction. Look at the drawing of the L1 construction details. The tuning coil is wound on a cardboard mailing tube section 2-inches in diameter and 2¾-inches long. Start winding approximately ¼-inch from the form edge with #24 enameled copper wire. Punch a small hole to feed the wire into the cardboard before you start winding, then wrap the wire around the edge of the form to hold it in place while winding; or, a section of plastic tape can be used to keep the wire from moving.

As shown in the drawing, the tuning

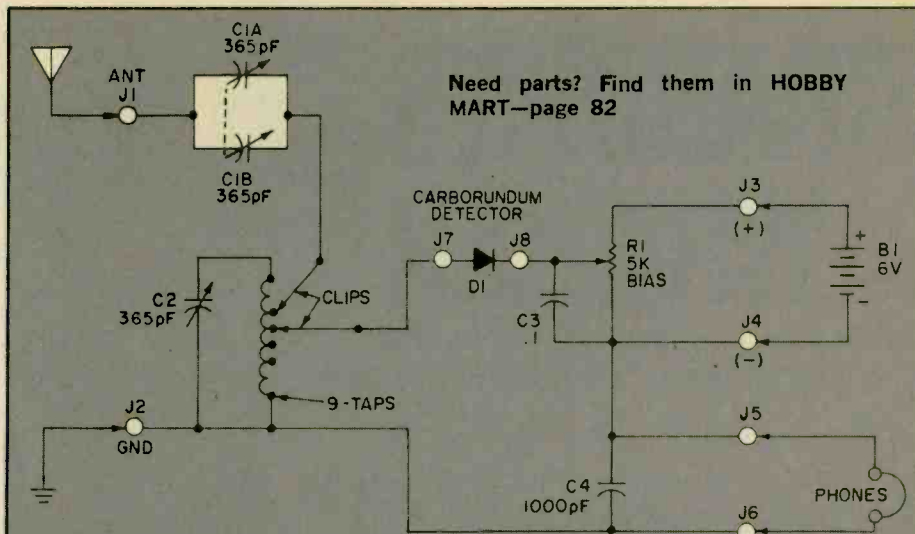

Need parts? Find them in HOBBY MART—page 82

PARTS LIST FOR GRANDPA'S WHISKER

- B1—6 V battery
- C1A-C1B—Dual 365-pF tuning capacitor (dual gang)
- C2—365-pF tuning capacitor (single gang)
- C3—0.1-uF capacitor
- C4—1000-pF capacitor
- D1—Carborundum Crystal (Modern Radio Labs, P.O. Box 1477, Garden Grove, CA 92642), and Crystal Detector Assembly (Philmore #7003 open type detector, or equiv.)
- J1-J8—Fahnestock Clips

- L1—See drawing and text
- R1—5,000-ohm potentiometer. (linear taper)
- MISC: 2000-ohm earphones, 2¾-in. x 2-in. dia. coil form, clips, #24 enam. wire, ½-in. long spacers, perfboard strip, push-in clips, solder lugs, mtg. brackets, wood sections for detector assembly, knobs, 8½-in. x 7¼-in. x ¾-in. wood base, hook-up wire, wood screws, headphones (2000-ohms), and a 1N34A germanium diode (or equiv.) for initial adjustment of the receiver.

coil is wound with 100 turns and is tapped every 10 turns. An easy way to make the taps is to twist the wire together for a half-inch and position the free end out. Then, when all of the taps have been made, used sandpaper to take the enamel off the tap-wire ends. At the end of the winding, punch another hole in the coil form and after cutting a three inch lead, thread the free end of the coil wire through the

hole and wrap it one turn around the coil form edge (or tape it in place).

Mount 9 push-in clips in a ½-inch by 2¼-inch perf board section and mount it on the coil form with machine screws and nuts and two ½-inch long spacers (as shown in the drawing). Then solder the coil taps to the push-in clubs. Connect the coil start and end wire leads to solder lugs mounted on the perf-board screws. Punch two holes



Most of the crystal detector assemblies you can turn up will be of the horizontal type. You will need a heavier pressure for the carborundum crystal, so convert the assemblage to a vertical format. None of the dimensions shown are all that critical.

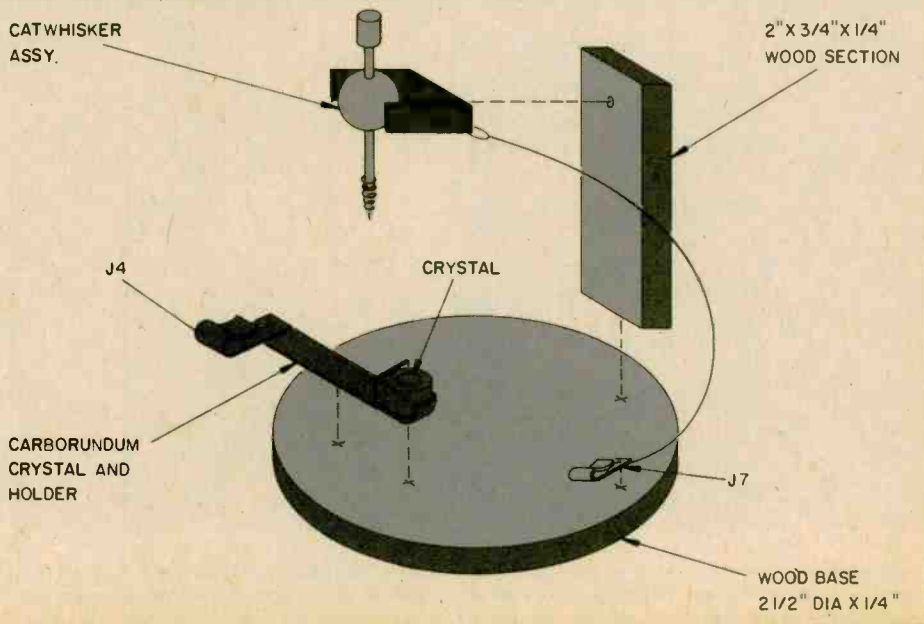

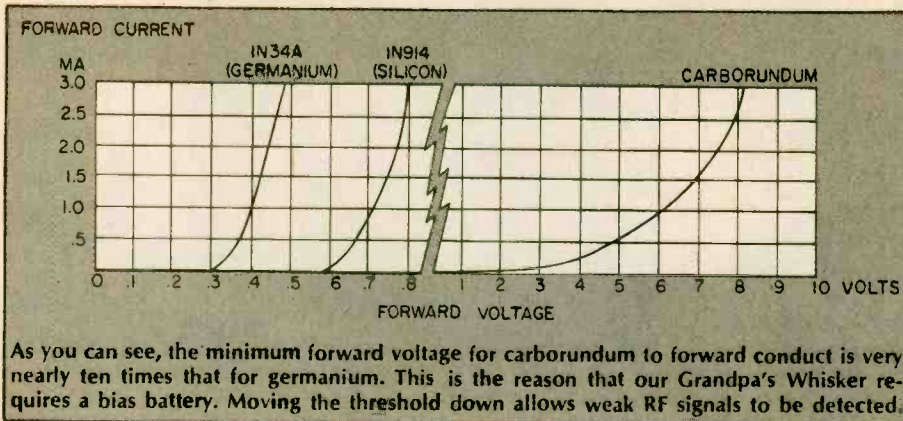

on opposite sides of the base of the coil form, mount two brackets, and the tuning coil is completed.

Detector Assembly Construction. Most of the crystal detector assemblies available nowadays are of a horizontal type; designed for fine adjustment of a galena crystal. The carborundum crystal requires a heavier catwhisker pressure than the galena crystal, so the detector assembly (as shown in the drawing) is constructed in a vertical configuration.

Begin construction by cutting a 2-inch x 3/4-inch x 1/4-inch wood section, and then gluing or using wood screws to fasten it to a 2 1/2-inch diameter x 1/4-inch high wood base. This wood base is readily available from art, or hobby, supply stores that stock wood plaques. Or, a suitable base can be cut out of a section of plywood. The dimensions of the detector assembly are not critical and should be modified as necessary to fit your particular crystal mount and catwhisker configuration. If necessary, the rivets holding the catwhisker mount to a metal strip can be

drilled or ground out, and then reassembled with a solder lug as shown in the drawing.

Mount the crystal holder on the base of the detector as shown in the drawing and photos, and then mount the catwhisker assembly on the vertical section with small wood screws, or machine screws and nuts. Make sure that the crystal holder screws do not protrude below the base bottom. Connect a lead between a solder lug on the catwhisker assembly and a terminal clip mounted on the base. If the crystal cup does not have an attached metal strip and terminal clip as in our model, it will be necessary to mount a solder lug with the cup and connect a lead to a terminal clip mounted on the base.

Receiver Construction. Most of the receiver components are mounted on a 8 1/2-in. x 7 1/4-in. x 3/4-in. wood base. The base dimensions are not critical and any size wood base can be used that will be large enough to mount the components as shown in the photos. The model wood base shown was obtained from an art supply store and was



Grandpa's Whisker is a nostalgic look back at the days when a ship's radio lifeline to shore was dependent on no more than a coil, a battery, a catwhisker, and carborundum.

originally intended for use as a wood plaque. Small wood screws were used to hold most of the components on the base, except the variable capacitors C1A-C1B and C2 are mounted with machine screws in countersunk holes drilled through the base bottom. If the particular capacitors in your model do not have tapped bottom holes, metal brackets must be fabricated to fit either front or back capacitor mounting holes. The Bias Adjustment Control R1 is also mounted on the wood base with a metal bracket.

Begin construction by locating the component mounting holes on the wood base, and then mounting the parts as shown in the photos. Install solder lugs on all of the terminals J1 to J6 and also on the metal frames (rotors) of the variable capacitors C1A-C1B and C2. Install the detector assembly with three wood screws to the wood base and then install L1 positioned as shown in the photos (with the taps facing the detector assembly).

Wire the components as shown in the schematic diagram and position the wiring for short, direct connections. Install a clip on the lead to C1A-C1B and also on a lead to J7 of the Detector Assembly (the connection to the catwhisker). These clips will be connected to the coil taps during operation of the receiver. Install knobs on the variable capacitors and also on the Bias Adjustment Control, then mark the terminals with rub-on lettering or with small slips of typed, paper designations cemented on to the board.

Operation. All types of crystal set receivers require a good, outside antenna and a good ground for best results. If you are located near a high-power radio station, an inside antenna and a waterpipe ground will probably work. For distant stations, an outside antenna, 50 to 100 feet long will be necessary. Check the mail order houses for supplies and antenna kits.

The taps on L1 are provided to compensate for antenna loading as well as for the loading effect of the carborundum detector. The position of the clip leads on the coil taps must be determined by experiment as they will vary according to the length (loading) of your antenna and the frequency of the radio station being received. Inasmuch as the carborundum detector also requires adjustment (both in determining a sensitive crystal point and in the proper bias voltage adjustment), a saving in initial L1 tap set-up time can be achieved with the use of a fixed crystal diode (1N34A, or equivalent germanium type).

(Continued on page 96)

e/e checks out ...

AVDEX Typits

Make computer symbols appear like magic on your old typewriter



CIRCLE 73 ON READER SERVICE COUPON

□ SO YOU HAVE WORKED out a program on your personal, home computer that you'd like to have printed in your computer club's newspaper but some standard programming symbols such as the *up-arrow* aren't to be found on your typewriter keyboard. Or perhaps you'd like to swap programs with a programming pen-pal but your penciled-in symbols, like the *reverse slash*, really do look as bad as you think they are. What to do?

You do what the pros do. You use *typits*—plug-in letters made to work with any typewriter that can be equipped with an adaptor to hold the typit. Let's look at the *up-arrow* (teletype shift-N), the almost standard symbol for exponentiation. On CRT terminals the *up-arrow* is an upside-down V, so we can use either an *up-arrow* or inverted V. Once the typewriter is equipped with the appropriate type guide you simply type until you get to the needed symbol, stop, reach into your type box, select a typit, insert the typit in the typewriter guide and strike any letter: you'll get a \uparrow or a \wedge depending on which typit symbol you prefer to use.

Typits are available in a vast assortment of Greek letters, math and science symbols, subscripts, etc. As shown in the illustration, at least nine standard programming symbols are available. Note the superior appearance of a program typed with typits compared to the one where the symbols are inked in with a pen.

Each typit costs \$5 for standard typewriters, \$2.50 for the IBM Selectric. The guides range in price from \$5 (for the Selectric) to \$25, the exact cost depends on your particular typewriter. With rare exception the guides are easily installed.

Unpack the guide and read the mounting instructions enough times so you have no questions concerning installation. Don't try to install the guide as you read; make certain you understand every step—there aren't that many
(Continued on page 96)



The Typit guide assemblies come with illustrated installation instructions and a hex adjusting wrench. All that's usually needed for installation is a screwdriver.



Make certain you are familiar with the installation procedure then begin by removing the ribbon and the typing element. The correcting ribbon can remain attached.

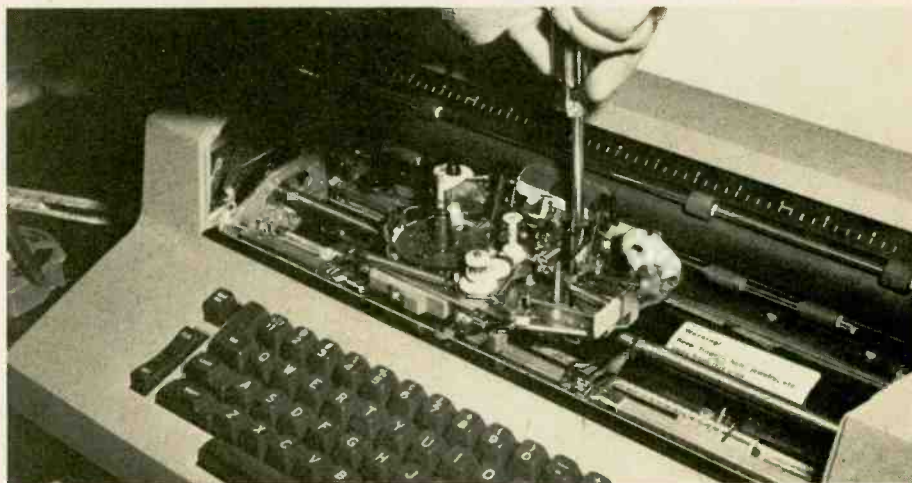

Install the guide with a screwdriver. The supplied self-threading screw fits a pre-drilled hole on an IBM Selectric. Typit guide assemblies are available for most typewriters.



Reinstall the element and the ribbon. Make certain the element just clears the guide. If the element rubs against the guide you haven't centered the guide (made it parallel to the element assembly).

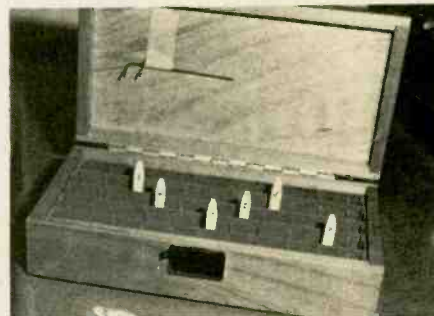

Typits are best stored in a special case or holder, which varies in size from 10 to 50 compartments (the 50 typit case is shown). Note the hex adjusting tool has been taped to the cabinet in case they are needed in the future. (Hex tools tend to disappear when not taped to something.)

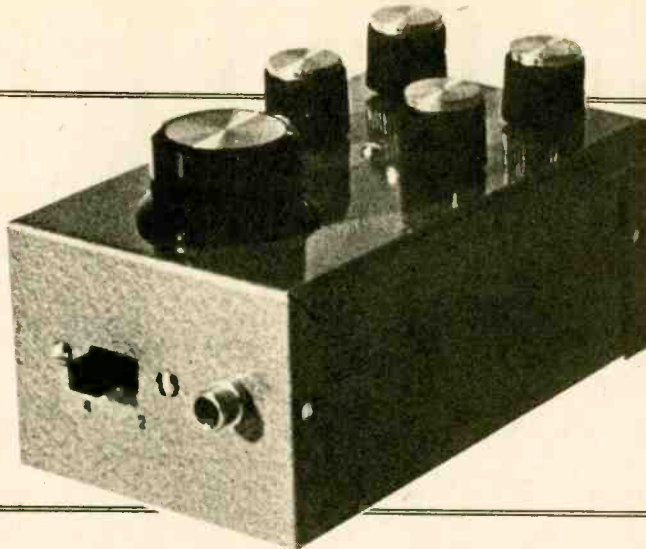

PASSIVE MIXER

Mix music like a pro with this low-cost passive mixer.

by Walter Sikonowiz

□ One of the handiest accessories that an audio enthusiast can own is a mixer, a device to combine several channels of sound into one. Mixers are especially useful to the tape recordist, who mixes sounds from several sources so that they occupy a single track of his recording tape. For P.A. applications as well, a mixer is indispensable. Perhaps you too have wanted to try your hand at the creative effects possible with a mixer, but have been turned off by the high prices asked for these devices. Generally, commercial mixers provide other functions besides mixing (i.e., amplification, impedance-matching, filtering, sometimes reverberation, etc.), and it is the presence of these extra functions that causes the price to soar.

A bare mixer is an amazingly simple device that requires only passive components such as resistors and capacitors. Such a passive mixer is not only simple and cheap, but it is also free from the gremlins that haunt you whenever active elements are put into a device: distortion, hum and noise. If you can spare a few hours of your time plus less than ten dollars, you can easily duplicate the passive mixer presented here. In fact, if you shop wisely, you should spend considerably less than ten dollars.

From the schematic you can see that this is a four-channel mixer. Potentiometers R1, R2, R3 and R4 control the relative levels of the four channels, and potentiometer R9 acts as a master gain control. Resistors R5, R6, R7 and R8 tie the four input channels to the single output. The input impedance of each channel is 10,000 ohms, while the output impedance ranges as high as 40,000 ohms.

When switch S1 is closed you have full four-channel mixing capability. Should you need to mix only two channels, open S1. This will give you about

70 percent more output voltage, and this may come in handy when your inputs are low-level. Remember, a 70 percent increase in the input voltage to an amplifier approximately triples the power delivered by the amp to its load.

Construction of the mixer is non-critical, but a metal (aluminum) cabinet is recommended for shielding purposes. Such a shield will prevent the high resistances in the circuit from intercepting any unwanted electrical interference. The shield is denoted in the schematic by a dotted line that connects to system ground. Apart from providing a shield, you have a free hand in the mixer's construction.

One nice thing about a passive mixer is that you don't have to provide power,

so you can build it into another piece of equipment, such as an amplifier, without much fuss. On the other hand, because the device is passive, its gain must be less than or equal to one. We can illustrate that fact like this. If your input consists of four sources having 10-volt peak-to-peak amplitudes, the largest possible composite output signal will be less than 10 volts peak-to-peak.

Use of the mixer is fairly obvious; just hook it up and experiment. However, you should keep an eye on impedances. The impedance of any source should be less than 10,000 ohms in order to avoid loading by the mixer. At the opposite end, the mixer should drive a load whose impedance is greater than 100,000 ohms. Both of these rules may

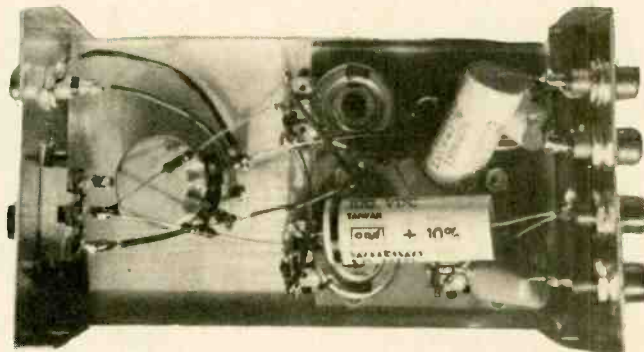

The passive mixer is a very simple device and it requires no complex or expensive parts. The unit pictured here is very obviously a junk box special. Note the two slightly different RCA jacks and the variety of capacitors used.

The concept of the mixer is simplicity in itself—the four inputs are individually controlled by the four variable resistors labeled 1 through 4 and the overall output is governed by the large variable resistor.

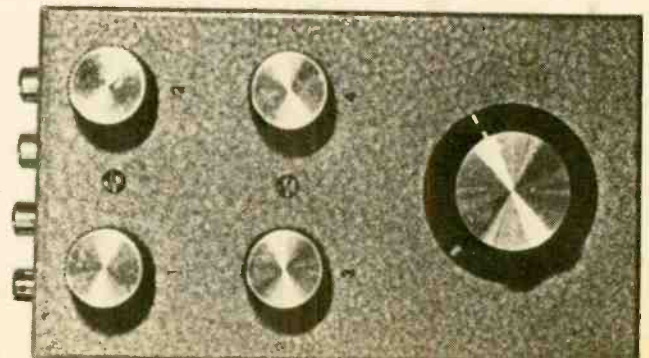

e/e PASSIVE MIXER

be violated, but at the expense of decreased output. However, you will find that neither of these rules is very restrictive. Low-impedance microphones, tuners, most preamplifiers and power amplifiers can all drive the mixer with ease. And so far as the load is concerned, most amplifiers and tape decks have high-impedance inputs that can be easily driven by the mixer. Note that since the mixer's output impedance is fairly high, it is wise to use a shielded coaxial output cable as well as shielded input cables. When building this project you might try putting all the inputs and outputs on the rear of the box and all the potentiometers and switches (you might like to add a switch to each input) on a nice looking front panel.

This wraps up the discussion on the mixer; the rest is up to you. After you've used this handy mixer for a while, you'll probably agree that the little money spent on this project was money well spent. ■

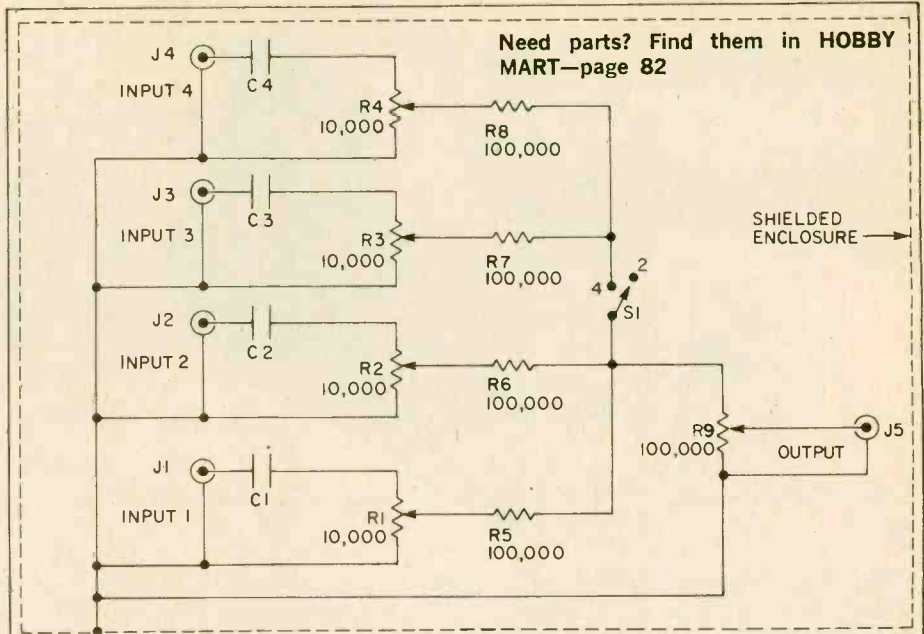

Need parts? Find them in HOBBY MART—page 82

PARTS LIST FOR PASSIVE MIXER

C1, C2, C3, C4—1 uF., 250-Volt mylar capacitors	potentiometers
J1, J2, J3, J4, J5—Phono jacks	R5, R6, R7, R8—100,000-ohm, ½-watt, 10%
R1, R2, R3, R4—10,000-ohm audio-taper	R9—100,000 audio-taper potentiometer
	S1—SPST slide switch

Quadricycle Cutie

Charge up and shock the town with this little electric four-wheeler.

by Sheila Schwindler

□ The under \$2,000 car is not quite a thing of the past thanks to the Lyman Electric Company, but their "car" is not your typical Detroit (or for that matter Tokyo) offering. This electric bicycle, or quadricycle to be exact, it can reach a speed of 15 mph and cruises at eight to 10 mph with a range of up to 30 miles. It can be recharged overnight and can travel the public highways when licensed as a motorcycle (better check your local laws before ordering one). To meet road-safety requirements the car is fitted with all the necessary running lights, has front and rear brakes mud guards and hefty 24-in. bicycle wheels.

If your battery is dead, dying or you need an extra boost the Lyman Electric Quad, as the vehicle is called, has two sets of bicycle pedals fitted. Great if you need a bit of exercise.

The unit features an adjustable bench seat for two that can be adjusted by two large handles on each side of car. These handles double as passenger restraints. ■

Cynthia Siegel of Long Island City, NY wanted a new bicycle, preferably electric, so she ended up with a new Lyman Quadricycle. By plugging the built in battery charger Cynthia can recharge anywhere.

When the batteries are low, or when she needs some extra power the driver or a lucky friend can pedal the car just like a bicycle. This can be great exercise even for someone in as good a shape as Cynthia.

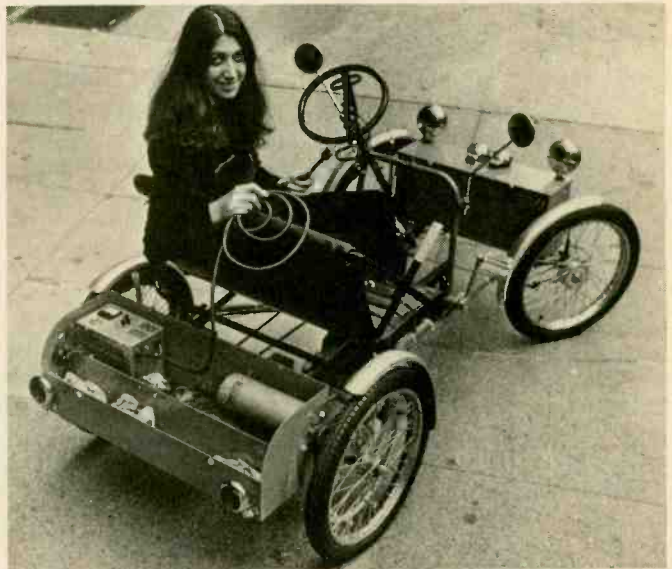

e/e installs the...

Optoelectronics ALR-1 Car Burglar Alarm

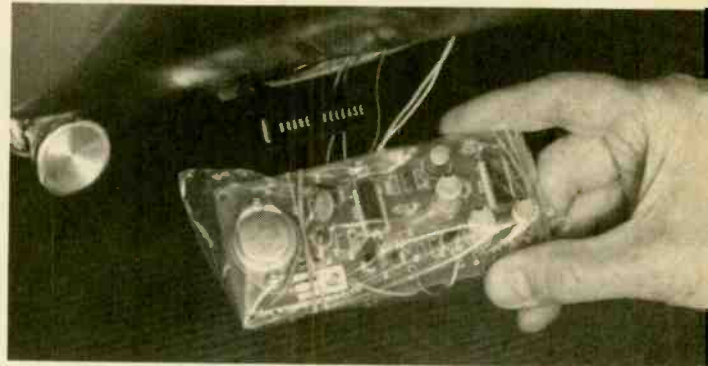

CIRCLE 51 ON READER SERVICE COUPON

Keep your car safe and sound by installing your own alarm system

□ Don't be too surprised if one fine day Big Brother mandates that all new cars must be delivered with factory-installed intruder alarm systems as a curb on the escalating automotive rip-off problem. That inflationary trend, which would probably add another couple of hundred dollars to the cost of a new car, can be postponed if enough car owners install their own alarm systems at relatively low costs.

There are many good alarm systems on the market, so shop around. This article reveals what would be involved in the installation of one type—specifically the ALR-1 Vehicle Intrusion Alarm, sold by Optoelectronics, Inc. It is a flexible unit utilizing CMOS integrated circuits for “ultra-reliable” 12-volt operation. The device features three different time delays; it can be made to

sound a car horn or a separate siren; and it can even be adapted to convert an existing car alarm system into a keyless system.

Using the information provided in this article, you can inspect your car wiring to determine how much work would be involved to install the ALR-1. Any additional information you would need comes with the unit.

The ALR-1, in kit form, is priced at \$9.95. You will have to buy a small amount of hookup wire locally, and perhaps a few pin switches for the rear doors of your car (if they are not already present to operate the dome light) and for the trunk lid and hood if you want complete protection. In the unlikely event that you run into difficulties with your self-assembled kit, return it to the company with an addi-

tional payment of \$7.50 to receive a functional and fully tested replacement. If assembling PC board circuits is not your bag, buy a pre-wired and tested unit (Model ALR 1WT) for \$19.95.

How It Works. On leaving your car, you flick a hidden switch which activates the unit. A time delay gives you about a half-minute to close the car door. When you again open the car door, you have about five seconds to flick the hidden switch. A burglar could not find the switch in that time even if he suspected its presence, and the alarm would sound. If the system is wired to the car horn, there will be loud honks at one minute intervals for about three minutes, or until you turn off the unit with the hidden switch. The third time delay sets the alarm cycle to about three minutes after which the system resets itself for detecting further intrusion. Thus even if a burglar is scared off, after a vain attempt to silence the alarm by closing the car door, the unit will automatically go into another watch cycle and responds if anyone attempts to enter through the now unlocked door. You can easily change any of these time delay intervals by changing the values of key resistors in the alarm circuit.

Trigger Switches. Your car has one or more door pin switches that operate the dome light, and these can be used to also trigger the alarm. However, the exact manner of attaching the alarm circuitry depends on whether your dome light has a “hot” or “grounded” circuit.

You can make a simple test lamp that will help check out the car wiring in minutes. Just solder lengths of electrical wire (unzipped lamp cord is fine) to the two base terminals of a spare 12-volt tail light bulb. Add an alligator clip to the other end of each lead. Clip the two alligator clips to the dome light terminals after removal of the cover glass and open a car door to see if your

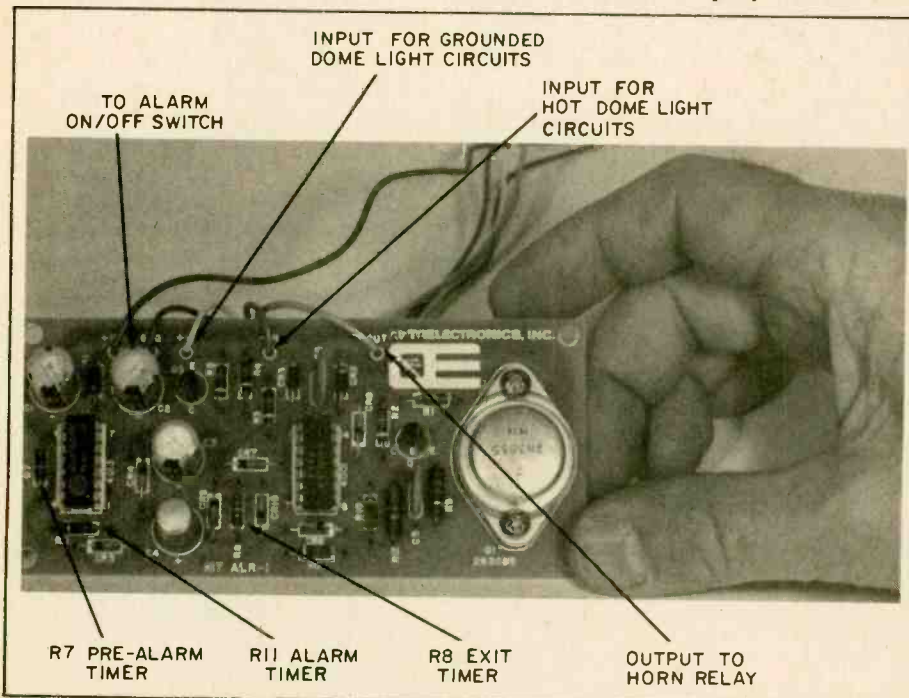

The completed alarm circuit ready for installation on a car. Note that both the +IN and -IN are wired when the unit comes from the factory. You will have to determine which connection is appropriate for your car. R7, R8 and R11 control the timing.

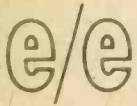

AUTO ALARM

test lamp lights. This is just to make certain that you are using a good bulb, not one that is burned out.

Now move one alligator clip to any good metallic ground on the car body (just clip to a convenient place on the car dash). Close all car doors so that all dome light switches are open. If the test lamp lights, you have a "hot" dome light. Move the alligator clip to the other dome light terminal to double-check your observation. If the test lamp does not light, you have a "grounded" type dome light.

If you study the circuit diagrams, you'll see that a hot dome light requires the alarm circuit input to be connected from the hot side of the dome light circuit to the negative input on the PC board. On the other hand, a grounded dome light requires this connection to be made from the grounded side of the door switch to the positive input on the PC board.

Chances are that it will be far more convenient to tap the existing car wiring at or near one of the door switches rather than at the dome light. The only problem is knowing which of two leads coming from the switch is hot, which is grounded. Use your test light to answer the question. Just clip one alligator clip to a good ground and attach the other clip to the blade of a sharp knife. Carefully nick the insulation on each switch wire with the knife to make electrical contact with the conductors. Make the test with all car doors closed so that the switches are all open. Only the hot wire will cause the test lamp to light.

On/Off Switch Wiring. The hidden switch, which is pre-attached to the PC board, must also be connected to ground and to a +12V power supply.

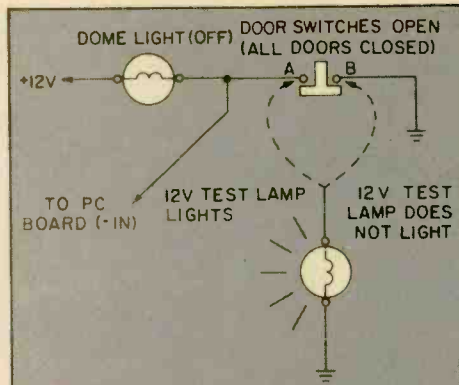

A grounded dome light requires connection of the alarm circuit board wire to the grounded side of a door switch. Test lamp indicates which lead is grounded. Note that wire goes to the positive input on the alarm circuit board.

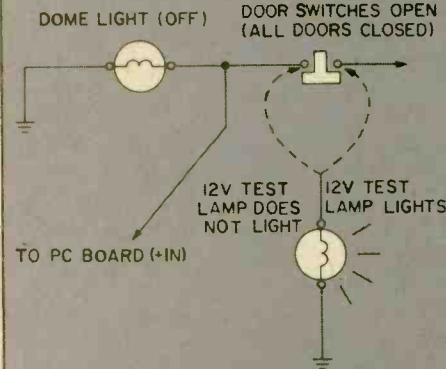

A hot dome light requires connection of the alarm circuit board wire between the dome light and the hot side of any door switch. Test lamp indicates which switch lead is hot. Note that wire goes to the negative input on the alarm circuit board.

Finding a ground is no problem, and you can use the test light to determine a convenient source of 12 volts on your fuse board just by clipping one lead to ground and exploring fuse connections for a terminal that is always hot—even when the car ignition system is not turned on.

Horn Connection. Your biggest problem may be to find the car horn relay if you opt to use the car horn as the sounding device. If you can reach the horn, unplug the connecting wires, then push the horn button while listening for the "click" of the horn relay. That way you should be able to locate it quickly. If you can't find the relay, check with your local car repairman. It's possible that your car does not use a relay, in which case a relay will have to be added.

The alarm output is a negative going 1 Hz pulse designed to drive the vehicle's horn relay by grounding. If the horn relay is energized by grounding (perhaps through the horn mounting bracket) just connect a wire from the PC board to the same place where the horn button wire is attached. Use heavy gauge (#18) wire for this alarm output as well as for the circuit board ground. Incidentally, don't forget to reconnect the horn wires after testing to find the relay.

Any one of the following conditions indicates that you will have to add a horn relay obtainable at low cost from any automotive supply shop: (1) horn only works when key is on; (2) horn relay cannot be found; (3) horn and relay wiring is not like that shown in the diagram; (4) wires to an existing horn relay are not readily accessible.

Siren Option. If you prefer to use a separate siren instead of the car horn, you can obtain a non-pulsed output from the alarm circuit by leaving CR6, R6, R12, R10 and C5 off the circuit board and by connecting pins 8 and 9 of IC2 socket with a solder bridge. This modification makes the alarm output go low for the duration of the alarm period.

Extra Switches. For complete protection, you may have to add pin switches to the rear doors of the car, (Continued on page 92)

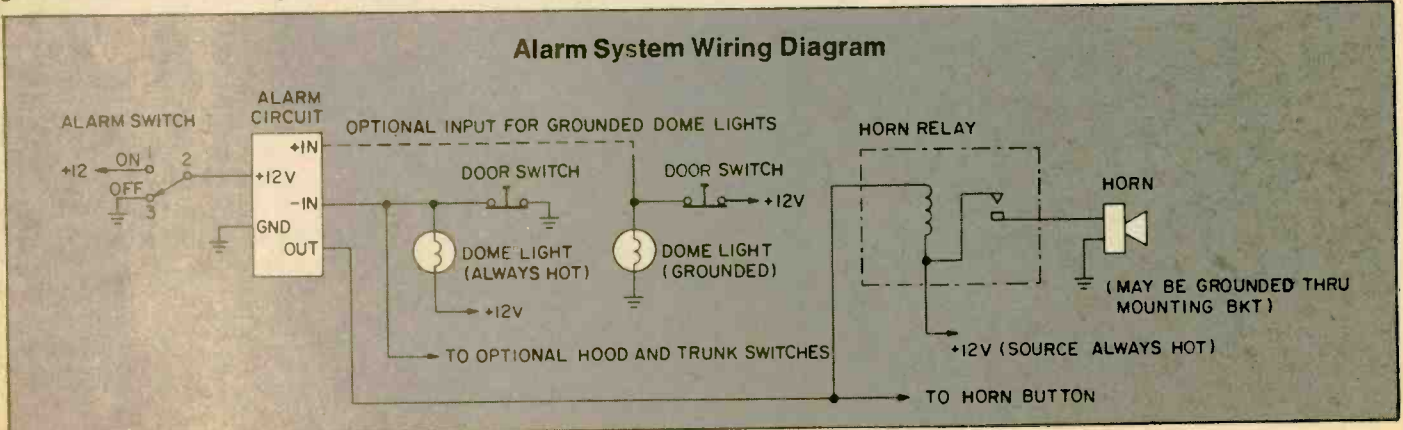

This schematic shows how all the parts are wired-up in a typical automobile installation. Try to install all the wiring in well-concealed locations and use strong, weather-proof wire, especially for wires that go to the trunk or to the engine compartment.

Construction Quickies

Build 'em in less time than it takes to bake a cake

by Tom Galway

Logic Probe

While not as sophisticated as some of the very sensitive and much more expensive professional logic probes, you'll be able to see the 1's and 0's in your logic circuits as you probe. The probe tip is connected to the base of Q1 through resistor R3. When the probe tip is reading a high, or "1" signal, the transistor will conduct, turning on LED1. It will also conduct the current from R2 through D1 and Q1, effectively shorting out LED2.

If the probe tip is connected to ground (a logical low or "0"), transistor Q1 will not conduct, so LED1 will not light. The R2 current will then be "steered" into LED2 instead of D1 and Q1, lighting LED2. Some logic families switch states in circuits

with "1" and "0" levels very close together, near a value of half the supply voltage; this probe may not work with those families. For TTL and most CMOS circuits, you should get good results. The probe is powered by the circuit under test.

One more caution: if you find this probe loading the lines in a CMOS or other low-power logic circuit, try either increasing the value of R3, or adding an additional logic buffer between the probe and the circuit you wish to monitor.

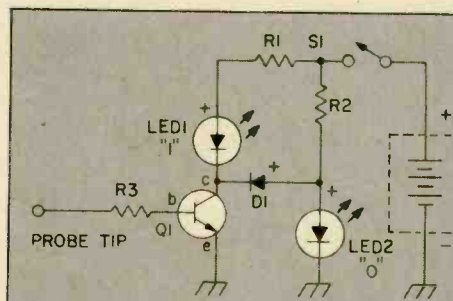

Need parts? Find them in HOBBY MART—page 82

PARTS LIST FOR LOGIC PROBE

- D1—Silicon signal or switching diode (1N914 or equiv.)
- LED 1, LED 2— Light emitting diodes
- Q1—General purpose NPN transistor (2N2222, 2N3904 or equiv.)
- R1—100-180-ohm resistor, 1/2-watt
- R2—150-330-ohm resistor, 1/2-watt
- R3—1000-3300-ohm resistor, 1/2-watt
- S1—SPST (may not be needed)

The Light Touch

Here's an intriguing substitute for that light you're always flicking on for just a second, then right off again. This touch-actuated switch stays on only for as long as you need it, just as long as you keep your finger on the touch plate.

R1 sets the input impedance of the very sensitive JFET Q1 to a very

high 10 Megohms. Q1 picks up stray signals coupled through your body to the touch plate and amplifies to turn on Q2, which turns on lamp driver Q3. Lamp I1 is any small 12 Volt lamp, such as are found in auto dashboards.

R4 and C1 add a small amount of hysteresis (delay) to keep the light

from constantly flickering. If a light isn't what you need to switch this way, try substituting a relay for I1. You may want to raise B1 to 12 or 15 Volts.

PARTS LIST FOR THE LIGHT TOUCH

- B1—9VDC battery
- C1—15-uF capacitor
- I1—Any 12 volt lamp
- Q1—FET (Field Effect Transistor), 2N5458 or equiv.
- Q2—NPN transistor, 2N2222, 2N3904 or equiv.
- Q3—PNP transistor, 2N3906 or equiv.
- R1—10-Megohm resistor, 1/2-watt
- R2—47,000-ohm resistor, 1/2-watt
- R3—120,000-ohm resistor, 1/2-watt
- R4—470-ohm resistor, 1/2-watt
- I—SPST switch

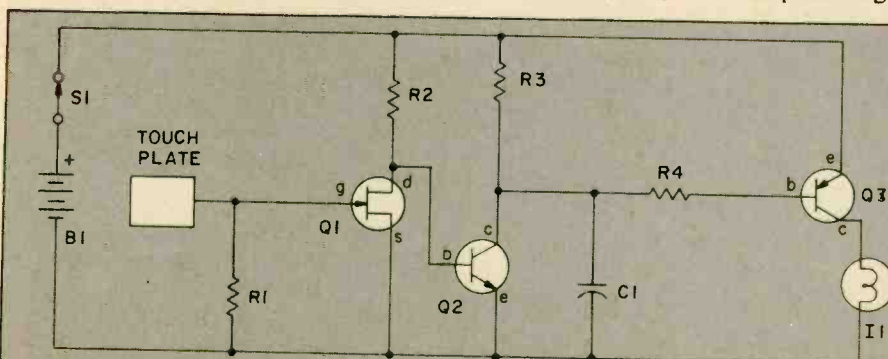

Need parts? Find them in HOBBY MART—page 82

Metal Detector

□ This not only demonstrates how metal detectors work, it actually will detect metal—with the help of a transistor radio.

The search coil, C1 and C2 form a tuned circuit for oscillator Q1, which can be tuned to operate near the center of the broadcast band. Tune your portable radio to a sta-

tion near the middle of the band, then turn on the metal detector and tune C2 until you hear a squeal as the two signals mix to produce a beat (heterodyne) note.

Metal near the search coil will detune the circuit slightly, changing the pitch of the squeal. The spot that exhibits the biggest change is where

you dig for your treasure. The search coil is 20 turns of number 30 enameled wire, wound on a 6"x8" wood or plastic form. It is affixed at the end of a 30" to 40" wooden pole, and connected to the remainder of the metal detector circuit through a coaxial cable.

PARTS LIST FOR METAL DETECTOR

- B1—9VDC battery
- C1—500-pf capacitor
- C2—365-pf variable capacitor
- C3—47-pf capacitor
- C4—120-pf capacitor
- J1—SO239 jack
- PL1—PL239 plug
- Q1—FET (Field Effect Transistor), 2N5458 or equiv.
- R1—5600-ohm resistor, ½-watt
- S1—SPST switch
- MISC—#30 enameled wire, 6" x 8" wood or plastic form, 30" to 40" wooden pole, coaxial cable

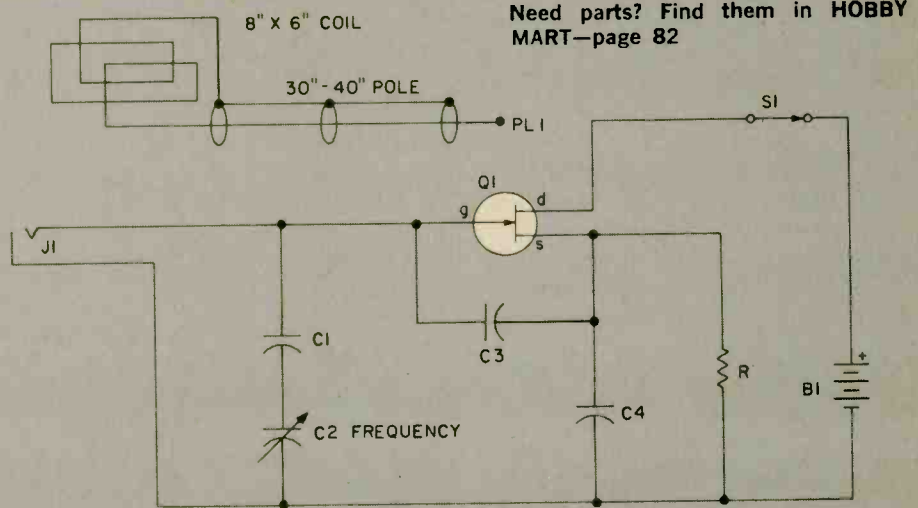

Need parts? Find them in HOBBY MART—page 82

Conference Mike Mixer

□ After trying for several years, I finally came to the conclusion that there's no way to tape record a conference or roundtable discussion with one mike. This scheme allows four, and can be expanded.

JFET transistor Q1 is used as a

high-to-low impedance converter. The input of the amplifier-impedance converter is between about ½ and 1 Megohm as shown, but can be increased by increasing R5-8 to 10 Megohms if necessary. The output is about 1000 ohms impedance, but can

be increased or decreased by changing the value of R9. Use 560, 620 or 680 Ohms, for example, to feed a 600 Ohm input; use 100K-1 Meg for a high impedance input. You will want to use shielded cable on all input and output leads, of course.

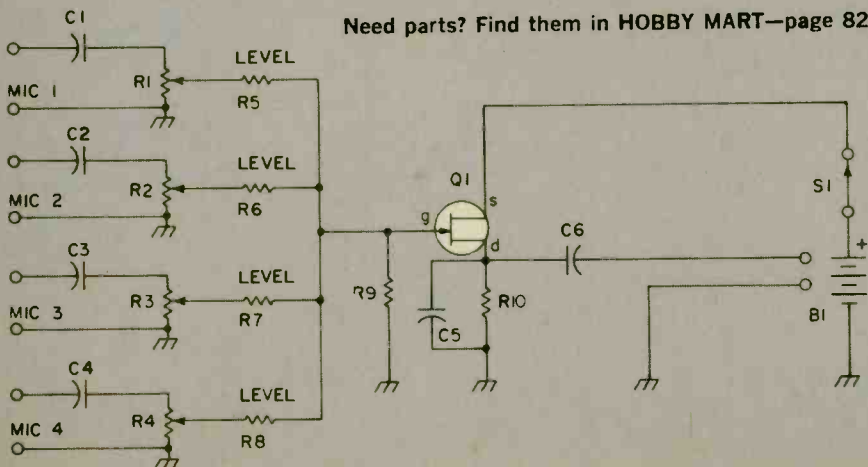

Need parts? Find them in HOBBY MART—page 82

PARTS LIST FOR CONFERENCE MIKE MIXER

- B1—9 VDC battery
- C1, C2, C3, C4—.1-uF capacitor
- C5, C6—10-uF capacitor
- R1, R2, R3, R4—1-Megohm potentiometer, audio taper
- R5, R6, R7, R8—2.7-Megohm resistor
- R9—10-Megohm resistor
- R10—1000-ohm resistor
- Q1—FET (Field Effect Transistor), 2N5458 or equiv.
- S1—SPST switch

Pierce Crystal Oscillator

□ This JFET Pierce oscillator is very stable, very simple, and can prove very useful. With a suitable crystal, this oscillator can be the clock of a microprocessor, a digital timepiece or a calculator. With a probe attached at the output, it can be used as a precise injection oscillator for troubleshooting. You can attach a small length of wire at the output to act as an antenna and use this circuit as a micropower transmitter. With suitable crystals it can then provide reference marker frequencies for short wave listening, receiver tuneup, tv repairs and more. Transistor Q1 can be a Siliconix 2N5458, a Motorola MPF102 or similar.

**PARTS LIST FOR
PIERCE CRYSTAL OSCILLATOR**

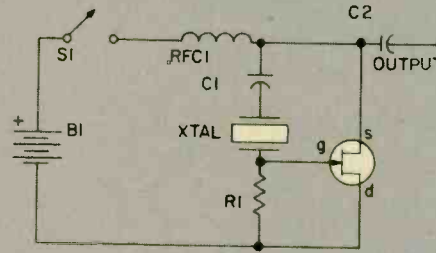

**Need parts? Find them in
HOBBY MART—page 82**

B1—6-15 VDC battery
C1—.001-.01- μ F capacitor
C2—100-pF-.001- μ F capacitor
Q1—N-channel JFET (Junction Field Effect Transistor) (2N5458 or equiv.)
R1—1-2.2 Megohm resistor, 1/2-watt
RFC1—Radio frequency choke, 2.5-mH
S1—SPST switch
XTAL—Crystal

Weirdly Wailing Oscillator

□ Once you hear the nifty sound effect this tiny circuit puts out, you'll be dreaming up places to use it. The combination of C1 and C2 causes this oscillator to work at two widely separated frequencies at once. One, determined mostly by C2, determines the basic tone the oscillator will produce. The other, determined mostly by C1, governs the number of times per second the basic tone will be interrupted.

The output sounds very much like a pumping whistle—it's a sound effect associated with toy ray guns, tv and

**PARTS LIST FOR
WEIRDLY WAILING OSCILLATOR**

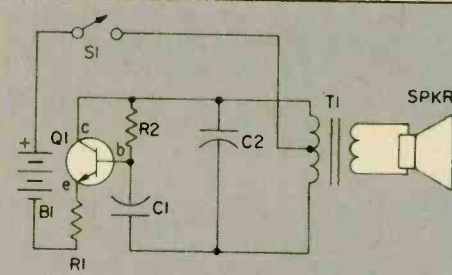

**Need parts? Find them in
HOBBY MART—page 82**

B1—6-15 VDC
C1—100-500- μ F capacitor
C2—.1-5- μ F capacitor
Q1—NPN transistor (2N2222, 2N3904 or equiv.)
R1—15-27-ohm resistor, 1/2-watt
R2—8200-15,000-ohm resistor, 1/2-watt
S1—SPST switch (see text)
T1—250-1000-ohm primary, center tapped; 4-16-ohm secondary

the movies. If you wish to build this as a toy, try using a momentary switch or microswitch for S1.

Attache Alarm

□ Who knows what evils lurk, ready to pilfer the Twinkies out of your attache case when you're not looking? This squealer does. Because when you arm the alarm by turning on S1,

the lightest touch will set it off. More accurately, the touch of light. Light striking Q1 turns on transistor switch Q2, which energizes oscillator Q3-Q4. And that blows the whistle.

PARTS LIST FOR ATTACHE ALARM

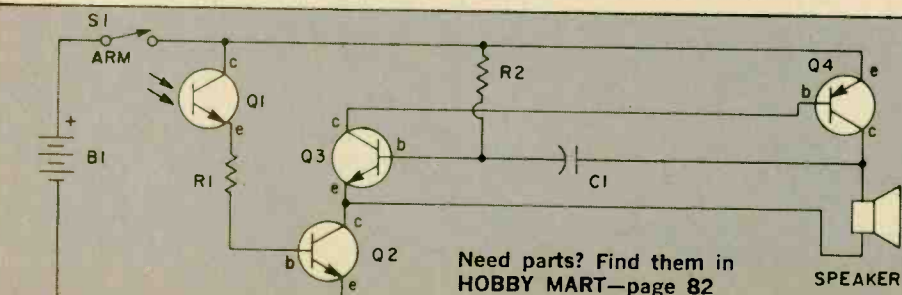

**Need parts? Find them in
HOBBY MART—page 82**

B1—9 VDC battery
C1—.01- μ F capacitor
Q1—Photoelectric transistor, FPT 100 or equiv.
Q2—NPN transistor, 2N2222 or equiv.
Q3—NPN transistor, 2N3904 or equiv.
Q4—PNP transistor, 2N3906 or equiv.
R1—2200-ohm resistor, 1/2-watt
R2—100,00-ohm resistor, 1/2-watt
S1—SPST switch
SPKR—8-ohm speaker



e/e assembles the... ATRONICS CODE READER

Copy those dots and dashes in the blink of an eye!

CIRCLE 119 ON READER SERVICE COUPON

□ If the sound of *dahdidahdit-dahdah-didah* is more Greek than music to your ears—if you'd have a better chance understanding an outraged Patagonian peasant than the Morse Code—well, you could be missing out on a lot of fun. Some of the best DX around is yours for the tuning, if you can copy the dots and dashes of Mr. Morse.

Maybe you've tried to learn the code and—for one reason or another—haven't been successful. Or perhaps you do know the code at five or even ten words per minute but you still wish you could listen in on the stations that send at fifteen or even fifty words per minute.

The Atronics Code Reader has come to the rescue. One simple connection to your shack's receiver and you'll be able to *watch* as the Morse Code is visually decoded right before your eyes.

Alphanumeric. Each character of the Code, as received, is displayed on the code reader's 16-segment LED. The code reader can visually display letters of the alphabet just as clearly and precisely as you're used to seeing numbers displayed on a calculator.

At this point, you may be thinking that you've seen "letters" on a calculator and weren't all that impressed. Maybe a friend once told you to put 07734 on a calculator display and then

turn the calculator upside down. Sure enough, it looked a little bit like the word "HELLO." But, when it comes to displaying letters like W or Q even the trickiest calculator nut has to be left scratching his head.

The code reader uses an LED which has been especially engineered for displaying English letters A-Z as well as the numbers 1-10. The LED is a 16-segment device which uses the same philosophy as a calculator's 7-segment LED. Individual segments are lit up and the eye sees the finished result. On a 7-segment LED, the number 1 is made up of two lit-up segments, one above the other on the right-hand edge of the LED. Similarly, the number 8 is formed when all seven segments are lit. As you can see, if you play around with this idea, there's just not enough segments for many of our letters.

The alphabet is easily accomplished with *sixteen* segments. Examine how the letter W is formed by this type of LED. The sides of the W are each formed by two segments above each other, but the interior rise is formed by two segments that originate at opposite corners of the LED at 45-degree angles to meet at a point. Other letters, such as B, D, X, etc., can be formed in just such a fashion.



The front panel controls are adjusted by means of LEDs above them. Practice will enable you to quickly change the station.

Also, there is absolutely no doubt if you are seeing a letter or a number. Many 7-segment "alphabets" make the lower case "b" do double duty as a "6." Unfortunately, this can result in some confusion as to which is being displayed. The 16-segment LED is able to display a capital letter "B" besides the normal configuration of a "6."

Copying the Code. The Code Reader is certainly one of the easiest accessories to hook into a station's receiver. All that is required is to connect the reader in parallel with your receiver's speaker terminals. Many receivers even have a SPKR OUT jack where this connection is already made. Once hooked up, operation is simple enough, but requires some practice before you can get the controls quickly adjusted when you change stations.

There are two controls on the front panel, *level* and *speed*. Each of the controls—one on either side of the 16-segment LED—has a small LED above it. The LED above the *speed* control indicates the anticipated length of a received Morse Code dot. The LED which is above the *level* control indicates "Mark" (ON) and "Space" (OFF) conditions.

Tune across the band until you are receiving a good, clear signal. Adjust the *speed* control (which is calibrated in words per minute) until the LED

(Continued on page 91)

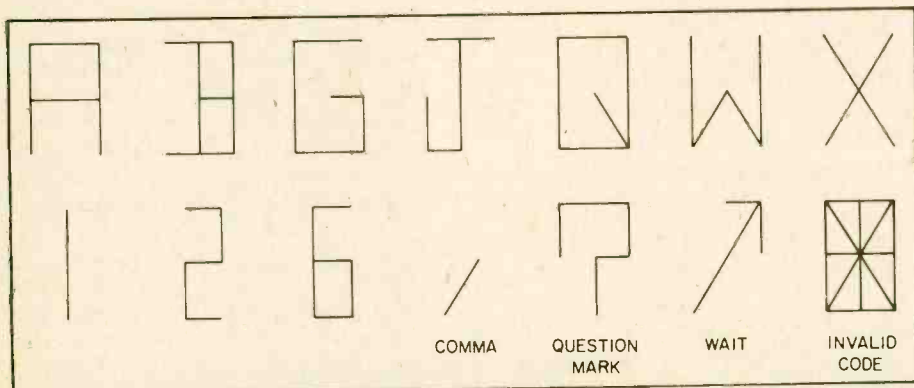

The Atronics Code Reader is able to display not only the numbers 1-10, but the letters from A-Z in a clear, concise style. It makes copying the morse code possible for those with little experience, and enjoyable even for the pro. Circle number 119 for more info.

GETTING YOUR BNEE* DEGREE

*Bachelor of Novicetry from
Elementary Electronics in ham radio

Thomas Sundstrom, W2XQ

TOO OFTEN a newly-licensed Novice is left to his or her own devices following the conclusion of a course taught by an amateur radio club. Some of the writings in the amateur radio field are just plain scary for the neophyte who has mustered the courage to get that first ticket.

"Where do I go from here? What do I do now? How can I get on the air? Where can I get help?" The purpose of this article (the start of a mini-series) is to help the Novice, faced with these problems. This material should also be of value to the Technician class licensee just venturing onto the HF (high frequency: 10-80 meters) bands for the first time.

Let's Get On the Air. The first order of business is to get on the air. To do that, you need a receiver, a transmitter, a code key, and antenna. Assuming you have to buy your own equipment, what do you choose?

I cannot recommend specific brands of equipment. Choosing one unit over

another must be left to you. But, I can talk about some factors to consider in the selection process.

Transceiver or Separates? Most of the rigs sold nowadays are transceivers. A transceiver combines the receiver, the transmitter, and sometimes the power supply into one neat package, quite attractive to the space-conscious Novice attempting to build a station into a corner of the kitchen or den. Most (but not all) transceivers are all solid-state (transistors and integrated circuits) except for the driver and final amplifier tubes.

The main disadvantage of a transceiver is that, unless the unit has RIT (receiver incremental tuning) or the capability to add an external VFO (variable frequency oscillator) at extra expense, you are limited to receiving and transmitting on exactly the same frequency shown on the tuning dial. Not all transceivers have RIT or an external VFO jack.

A separate receiver and transmitter

are usually preferred by the DX hunter chasing rare or distant stations ("DX" in ham lingo). Whereas a RIT control will only allow a transceiver a ± 3 kHz deviation from the transmitting frequency, separate components allow the use of any two frequencies within the range of the equipment.

Separates, or a transceiver with an external VFO, were an absolute must to work the FP expedition on Clipper-ton Island in March 1978. The operators spread their receiving frequencies anywhere from 15 to 60 kHz above the transmitting frequency so they could pick out individual stations from the thousands of hams calling from all over the world.

Receiver specifications. In a QSO (contact) on 40 meters the other day, a Novice asked me, "How much power are you running? I have 200 watts!" That fellow had missed the boat. By increasing power output from 10 to 100 watts, you will only increase a signal 10 dB. That's less than 2 s-units on most receivers without considering antenna and transmission path losses.

Receiving is the name of the game. Lots of hams run QRP (low power) and a few of them have worked over 100 countries with less than 5 watts input power! You gott'a hear 'em before you can work 'em; factors to consider are sensitivity, selectivity and stability.

Receiver sensitivity and stability are areas that have been pretty well solved by manufacturers today. Sensitivity (measured in microvolts) is often 1 μ V or less. Solid state receivers, VFOs, and regulated power supplies have licked the thermal drift problems encountered in some older tube-type equipment.

Selectivity is probably the most important criteria in evaluating a receiver; look for two sets of bandwidth specifications or something called a "shape factor." Typically, you should find a 400 or 500 Hz bandwidth for CW, and a 2.1 or a 2.4 kHz bandwidth for SSB, selectable from the front panel.

Each bandwidth will be expressed in terms of dB and kHz. Normally, bandwidth is measured at 6 kHz (± 3 kHz) and 60 kHz (± 30 kHz). The shape factor is usually defined as the ratio of the bandwidth at 60 dB to the bandwidth at 6 dB.

For example, a general coverage receiver here in my station has a CW bandwidth of .4 kHz at 6 dB, 2.7 kHz at 60 dB, with a shape factor of 6.75. The transceiver (same manufacturer) on CW has a bandwidth of .5 kHz at 6 dB, 2.0 kHz at 60 dB, with a shape factor of 4. Even though the receiver is slightly more selective at the 6 dB

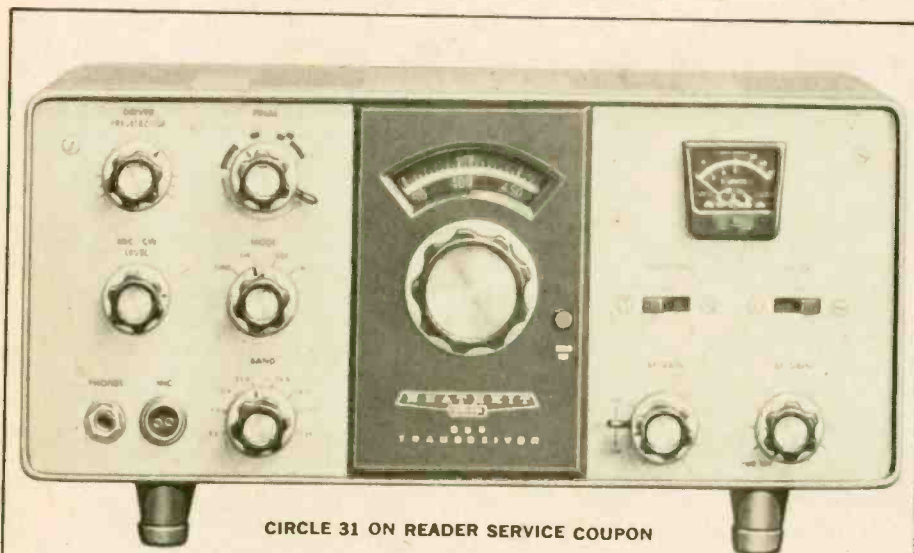

CIRCLE 31 ON READER SERVICE COUPON

The-Heathkit HW-101 is a kit, covering 80-10 meters both in the CW and SSB modes, using tubes. Thousands of HW-101's are in use on the HF bands; built with care, there should be no problems. This is probably the least expensive way of acquiring both modes; cost, including the optional CW filter and the external power supply, is about \$430 FOB Benton Harbor. You can check their catalog for other ham radio kits.

e/e GETTING YOUR BNEE

points, the transceiver is probably a bit more immune to splatter from nearby stations.

Other specifications should also be considered. Image rejection is expressed in dB, the higher the number the better. The dynamic range of the receiver (its ability to handle strong

signals before overloading) is also measured in dB and the larger the number, the better.

For a thorough discussion of what makes a receiver work, written in an easy-to-understand style, I highly recommend reading chapters 3-5 in *Better Shortwave Reception* by William I. Orr (W6SAI) and Stuart D. Cowan (W2LX). This *Radio Publication, Inc.*, paperback is available directly from the publisher at P.O. Box 149, Wilton, CT 06897, for \$4.95 (\$5.95 in Canada) plus .35 postage.

New or Used? This is not an easy question to answer. What's the age and condition of the piece? Are service manuals available? Is the company still in business so you can get parts? Do you know the previous owner, and how does he treat his other gear? If a store is selling it, what kind of guarantee is there?

If you are not yet knowledgeable about electronics, or if you do not have a friend who can help in the selection of used equipment, be careful in your choice. Check it out *before* you buy.

Sources of used equipment? Look in the classified ads of the larger newspapers, or talk to members of the local MHz repeaters.

Comparison shop when buying gear. If you know what features and prices are available on new equipment, you won't get stuck with a "bargain" at a hamfest.

If I had the Money . . . I would buy a new piece of equipment. There is nothing more frustrating to a new Novice than getting on the air and having the rig break down. There are a number of new transceivers that can be had for \$700 to \$800, with lasting features, to take you all the way up to the top ticket, the Amateur Extra Class.

Much more than that—in dollars and in frustration—can be spent in fixing up and trading up. I know some hams will disagree with me and accuse me of fostering "appliance operators," but I recall my early days of continuous transmitter failures as worn components burned out and power transformers melted.

Later on, once you've upgraded and gotten your feet on the ground, you can get into purchasing used equipment with some knowledge and experience under your belt.

In Closing. One last point should be made. Don't start off in the Novice bands with a QRP rig. Low power just does not work very well in the clutter, unless your hours of operating are limited to the very early morning hours before sunrise.

Next time, we'll conclude the equipment discussion by talking about some useful accessories and antennas.



CIRCLE 89 ON READER SERVICE COUPON

Yaesu's FT-101E covers the ham bands from 160-10 meters. This solid-state transceiver offers features such as switchable selectivity, RF attenuation, and a form of RIT. Calibration is done by receiving WWV signals. The self-contained rig retails for about \$799.



CIRCLE 92 ON READER SERVICE COUPON

The Drake TR-4Cw transceiver is a tube-type 80-through-10 CW-SSB-AM piece that requires an external power supply and speaker. It is just been discontinued in favor of a new solid-state transceiver, but new units may still be available from some dealers. The design is time-proven; various models are in use around the world. Of the transceivers pictured in this article, the TR-4Cw is the only one capable of running the Novice maximum input power of 250 watts. Price with power supply and speaker, about \$870.

Manufacturers' Addresses

R. L. Drake Company
540 Richard St.
Miamisburg, OH 45342

Heath Company
Benton Harbor, MI 49022

Yaesu Electronic Corporation
P.O. Box 498
Paramount, CA 90723



COMPUTER READOUT

by Norman Myers, Computers Editor

Microcomputers are causing a revolution in radio

□ THERE IS PROBABLY NOT a single electronic device that cannot benefit from the addition of a microcomputer. Radio systems of all types are an example. Within the last two years microcomputers have been wed to ham radio, navigation devices, car radios, and more. It is a brand new and changing area. The next two or three years will show not only a whole host of new radio/microcomputer marriages, but also an awareness among the general public that this is just the beginning. In this issue we will explore some of the radio applications of microcomputers and we will look a bit into the future.

Transmission of Radio/TV. Microprocessors have been successfully used to aid in the transmission of radio and television signals. One example is a system developed for the Air Force which uses microcomputers to compress a television signal sent from a camera on a flying missile. The objective is twofold; one, to send a signal which requires less band width than an ordinary TV signal of 4 or 5 megahertz; and second, to make the signal jam-proof. Until microcomputers came along, the amount of hardware that had to be mounted on board the missile was a bit impractical to handle. Analog systems were unstable and the digital mini computers really too big for the job besides using a lot of power. Microcomputers available right now offer the needed speed of moving information around, the low power requirements, and the small size.

Here is how the microcomputer compression system works. A TV camera on the missile is to send pictures to a base station where a navigator can steer the missile according to the picture on the base station screen. The TV signal is digitized—that is, sampled at a fixed rate and broken up into voltage amplitude levels that are digitally encoded—by an analog-to-digital converter on board the missile. That signal is then in a form the microcomputer can use because it is really just a stream of 1s and 0s. The computer is programmed to compress that data stream,

which basically means it must throw away as much as 80 percent of the data without causing the TV picture at the base station to be severely distorted. The trick is to know which data to discard and which to keep. This is what the microcomputer can do. The key is that the computer stores essentially a whole frame of a picture in its memory, where a frame is made up of 256 lines of 256 picture elements, or data. Then the computer looks for repetition, or nearly equal signals, between lines and between picture frames. If a new signal is just like the old, there is no need to send it. By eliminating repetitious signals, the computer compresses the data and less bandwidth is needed to send it. At the receiving end, a similar microcomputer is used to expand the signal so as to restore the TV picture to a virtually normal appearance. This is done by building the repetition back-in according to information sent by the on-board computer. Jam-proofing, or protecting the transmittal signal from being jammed, can be achieved with this compression approach both in the way the

computer can specially encode the new signal before it is transmitted, and in the way the new signal takes up less radio spectrum.

Ham Radio. The first microcomputer controlled ham radio should soon be off the drawing boards at Palomar Electronics (665 Opper Street, P.O. Box 2403, Escondido, Cal. 92025). The predecessor to this unit is the PTR-130K Programmable Transceiver also made by Palomar and selling for around \$695. That version uses a calculator chip rather than a microprocessor chip, and achieves such features as frequency control and storage of specified frequencies to facilitate automatic frequency selection by the press of a single keyboard button. The new unit, for which I could not get the name or price, will not be available for quite a while, will have a host of convenient features, including a digital LED display, that will someday be the standard fare for almost every ham operator. These features are too useful to imagine that a ham would pass them up.

First, the built-in microprocessor controls the frequency you select to

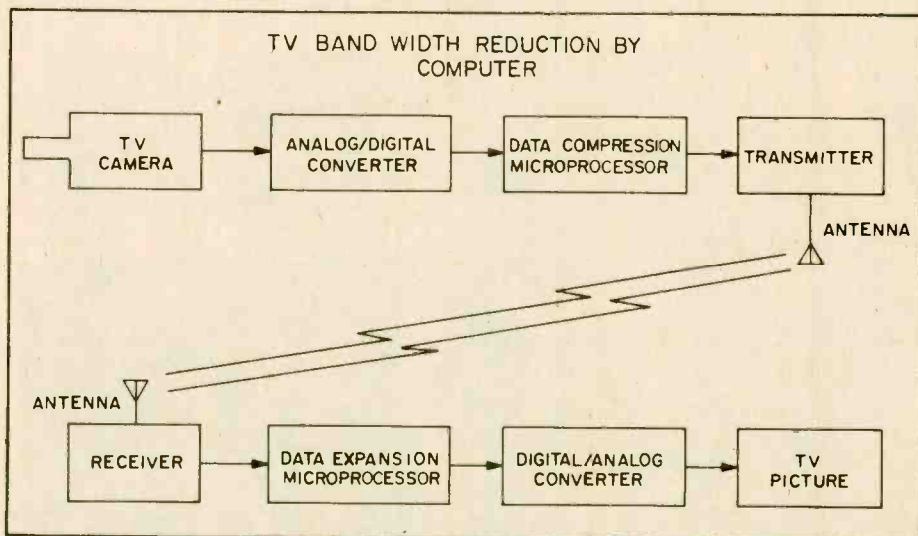

Microprocessors have been used to modify radio and TV signals to reduce their bandwidths and to reduce the effects of interference. Here a microprocessor compresses a signal from a TV camera by rejecting redundant parts of the picture. At the receiver end the reverse procedure occurs under microprocessor control. This sort of system is used in TV guided missiles to reduce bulk and to protect against the jamming of the signal.

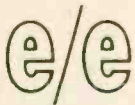

COMPUTER READOUT

Hz steps, or 1000 Hz, etc., and you also specify the starting frequency. The computer will then cause the transceiver to scan up or down from your starting point with the step sizes you specify. If an active frequency is found, it will either pause or camp on that frequency as you wish. The memory unit allows the user to easily recall any frequency at the push of a button and, of course, the transceiver is immediately tuned to that frequency.

Morse Coder. Speaking of ham radios and equipment, several clever hobbyists have, independently, written programs for their microcomputers which automatically translate Morse Code and print the English words on a typewriter. A ham radio converts the carrier frequency to audible dots and dashes that are then sampled by some electronic gates that, in turn, are controlled by the microcomputer. The sampled signals are converted to a digital stream that is then sent to the computer for translation into English. The computer program looks for a relatively long space—which it assumes is a space between words—then goes to its memory to find a match between the sequence of digitized dots and dashes it has received and English letters.

Car Radios. Some 1978 cars, such as Cadillacs, certain Buick models, and

Cordobas, have electronic tuning and conveniences, and more cars will have such features in 1979. Chrysler, in particular, uses a microprocessor chip and a keyboard to give the driver a host of conveniences and improvements over mechanically tuned radios. The unit allows you to enter the frequency of any AM or FM station via a keypad. Only FCC authorized frequencies are recognized by the processor chip—so on the AM band, 540KHz, 550 KHz, etc., are allowed, while on the FM, 88.1 MHz, 88.3 MHz, etc., are permitted. The tuner can be instructed to scan up or down the AM or FM bands until a station is found. It will either pause on a station or clamp on it, as you wish. The microprocessor—especially developed for this use—includes a read-only memory (ROM) directly on the chip. That ROM contains the allowable frequencies and the program instructions for scanning up or down.

Navigational Radio. Navigation always requires a computer, whether it is the primitive sextant Columbus used, or just a pencil, ruler and map, or a minicomputer, or a microcomputer. The object in navigation is to find out where you are (at sea, in the air, etc.), what direction you are going, and how long it will take you to reach some point. These calculations require some form of computer. One interesting NASA-sponsored development involved the use of a microcomputer for navigation based on a rather unheard-of

radio system called Omega. The Omega system uses very low frequencies (VLF) around 10KHz from eight transmitters around the world. Each transmitter has a specifically assigned set of three frequencies and emits a burst of energy on one frequency at a specified time within a worldwide 10-second cycle before going on to the energy burst at another frequency. Timing accuracy among stations is achieved via atomic clocks. Now suppose you are somewhere on this earth but you have no idea where—however, you happen to have an Omega receiver. It turns out that by receiving signals from any two Omega transmitters and noting the time difference between signals at different frequencies, one can determine that he is on a certain imaginary line, or path, drawn on the surface of the earth. By receiving one more transmitter's signal you can establish another line and where the two intersect is where you are sitting on the globe. As you might guess, this cannot be done unless you have the maps and tables supplied by the U.S. Coast Guard, and the need for storage and translation of such information is where the microcomputer comes in.

By feeding the computer digital samples of the Omega radio signals, it can accurately measure time differences between energy bursts, accurately determine what frequency was transmitted, accurately identify each station being received, make corrections for timing differences caused by humidity and temperature, and—finally—specify where the receiver is located on the globe.

Marine Radio. The Key/Com Fifty Five made by SBE (220 Airport Boulevard, Watsonville, Calif. 95076) was the first microprocessor controlled, keyboard-entry marine radio available, says Gordon West of SBE. Unlike CB, marine radio uses 78 channels in the VHF (156 to 162 MHz) range and only uses FM, whereas CB uses AM and single-side-band (SSB). The Key/Com Fifty Five uses a special microprocessor chip called the Nitron developed for SBE by McDonald-Douglas Corporation. Built into the chip is a list giving the weather channel, and, in addition to the 78 marine channels, 30 police and fire channels. The microprocessor lets the user access these 30 public safety channels for receive only. Further, the Nitron processor unplugs easily, so if the International Telecommunications Union changes the number of channels, or introduces another channel for emergency broadcasts—or anything else—that processor can be

(Continued on page 92)

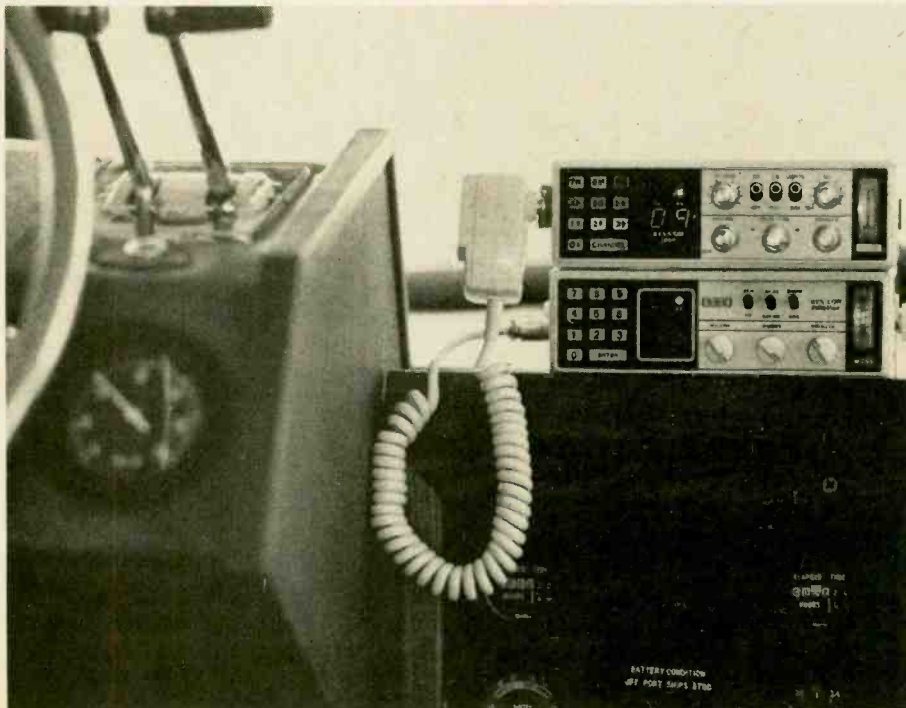

Many a ship has foundered or gone aground while her skipper was twiddling the radio dials. These microprocessor controlled marine radios are designed for easy operation. The top radio is a SBE Key/Com Marine CB and the other a SBE Key/Com Marine VHF.

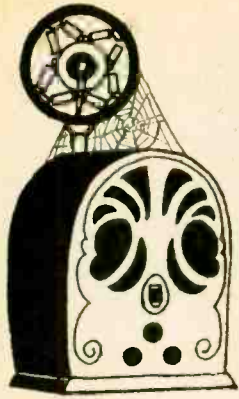

ANTIQUE RADIO CORNER

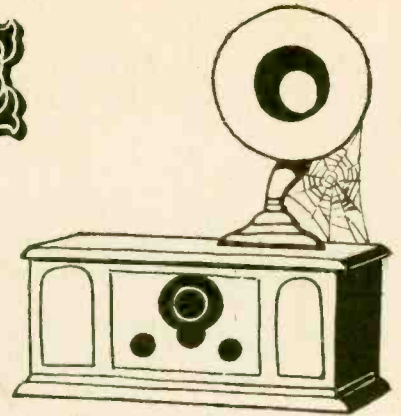

Measure antique ohms with an antique ohmmeter

by James A. Fred

□ HELLO! OUT THERE IN RADIOLAND. I've just traded for a book titled *Radio for the Amateur*, written by A. H. Packer and R. R. Haugh, which was published in 1922. As I read and looked at the illustrations I began to gain a new respect for the radio experimenter of that period. I am almost surprised that the radio industry grew to its greatness of today when I read some of the explanations of radio theory and the operation of radio receivers. I don't know how many of my readers are interested in building a loose coupler or making a radio from the instructions in this book, but if I get enough requests I will adapt the directions in the book to

asks him where he found the radio. He replies that it was in the attic. She then wants to know what program he is listening to. In the last panel he replies that it is dance music from Frank Daley's Meadowbrook ballroom.

the average house. Now that we have tape and cassette players it is more convenient to use them with a wireless broadcaster. The FCC regulations permit the use of these wireless devices if the radiated output is low enough to qualify under their rules for a non-licensed station. Wireless broadcasters used to be found in all the radio catalogs, but I just made a quick survey and found that they are getting scarce.

I can't possibly list all the sources of old program material, but a couple I can recommend are: Radio Yesteryear, Box C, Sandy Hook, CT 06482 and The Radiola Company, at the same address. Program material from Radio

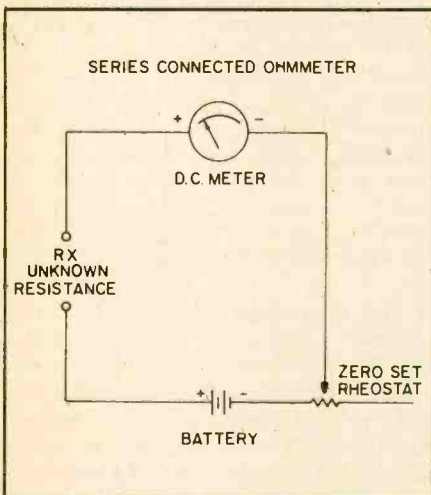

The series type ohmmeter reads from zero to infinity on one scale. Great for continuity checks but terrible for accuracy.

present-day materials and show how to build a replica of an old radio.

Antique Programs. After you have restored a radio it is fun to hear it play, especially if you can pick up some old time radio programs on it. I remember seeing a cartoon strip in our newspaper several years ago that I really enjoyed. In the first panel there was a man sitting in his chair listening to a program from a cathedral radio. In the second panel his wife appears and

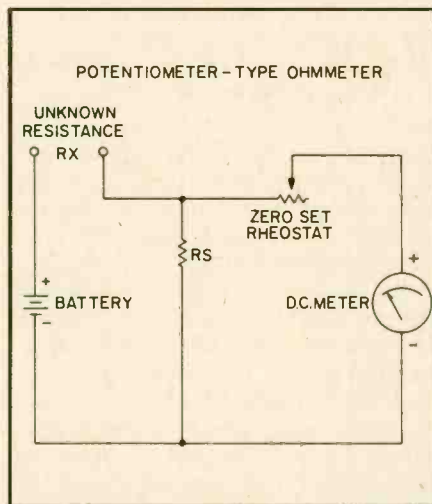

The potentiometer type (used in your hobbyist VOMs) is useful for determining accurate measurements over a wide range.

We can't expect to pick 1929 radio programs off the air with a 1929 radio, but we can do just as well by playing old time radio programs through our antique radios. You may not be aware that several companies are selling recorded radio programs from the past. The programs are available on tapes, cassettes and LP records. You may choose music, drama, mystery, suspense, adventure, or comedy programs. To broadcast the program material you can use what we used to call a wireless record player.

A wireless record player was a 78-RPM turntable and crystal pickup with an RF oscillator whose frequency could be adjusted to give you a radio signal at some point on your radio dial where there was no station coming in. The signal could be picked up on any radio tuned to that frequency anywhere in

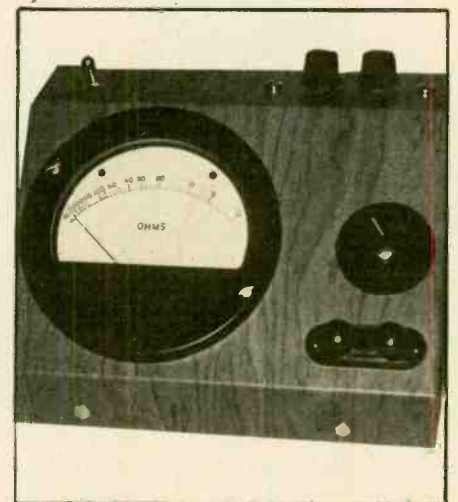

The ohmmeter has a clean uncluttered look. This model has a potentiometer with a built-in push button zero-set switch.

Yesteryear is available only on tape, i.e. cassettes, 8-track cartridges, and reel-to-reel. LP phonograph records are available only from The Radiola Company. The prices are competitive with the other companies offering old recorded radio programs. They have an excellent assortment of material available. Why don't you send for their catalogs today? My personal favorites were the "Big Bands" of the 1930's. Our income was so low that us kids

e/e ANTIQUE RADIO CORNER

couldn't afford to attend live theater performances, but with a radio the music came in free.

Antique Test Gear. Some of the collectors I visit do all their own radio repair and restoration. Many collectors have a desire to repair the old radios with old test equipment built at the same time their radios were. They have either bought old test benches or created their own with old factory made equipment or have made replicas of the old test instruments. Several companies used to supply complete test benches and test equipment. Two companies come to mind: United Motors Service, with an auto-radio test-bench, and the Sylvania Tube Company. There are still a few of these old test benches available around the United States, but I am afraid most collectors will have to settle for replicas or buy modern test equipment.

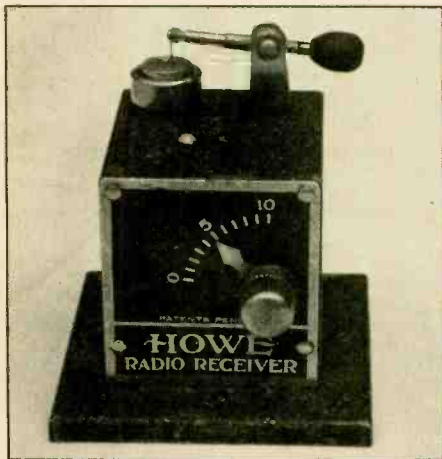

This Howe crystal radio receiver is from the collection of George Hausske. It is a rare example of an early crystal set.

It makes a lot of sense to repair your old radios with test equipment of the same period. When I started repairing radios in the early 1930's the multi-meter and VTVM were laboratory instruments. The radio repairman had separate meters to measure AC and DC volts, current, resistance, and usually had a tube tester and a signal generator. This is all the competent radio-man needed until about 1942. If he repaired auto radios he would need a 6-volt storage battery and charger or an "A" battery eliminator. Vibrator testers were also available if needed.

Since some of our readers have little or no background in radio-electronics I think it would be wise to start at the beginning and review the subject of meters, and then move into ohmmeters,

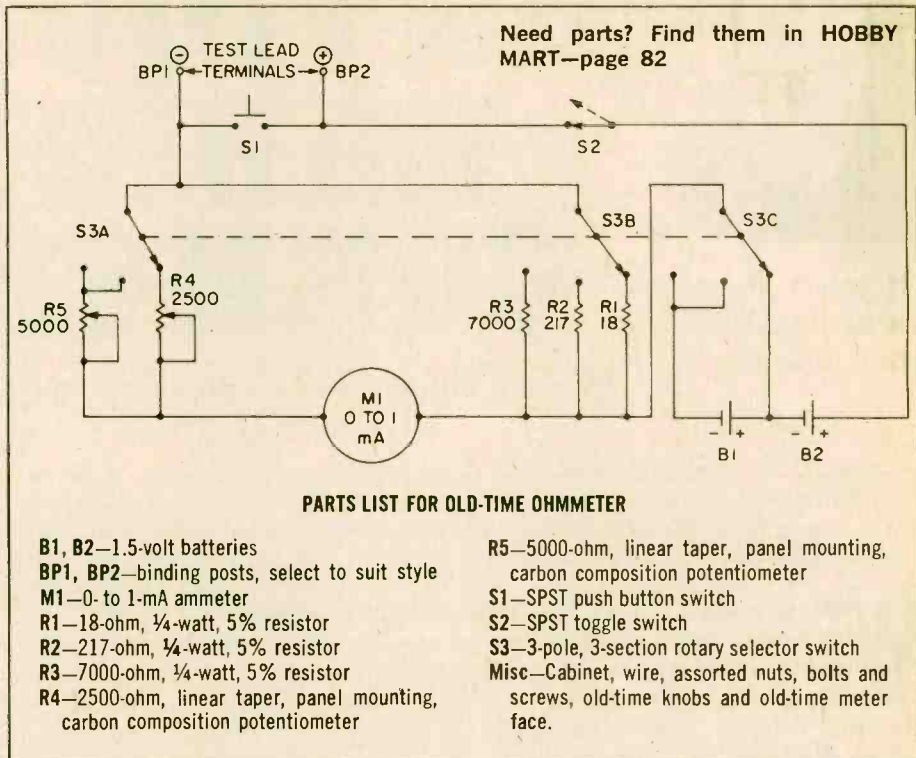

voltmeters, milliammeters and combination Volt-Ohm-Milliameters, commonly called a VOM. Basically we are interested in two types of meters: the first is the d'Arsonval, after Jacques Arsene d'Arsonval a French physicist who made, in 1882, the first reflecting galvanometer containing a moving coil, and the second the iron vane type. There were many other kinds of meters for specific uses such as the Hot Wire Ammeter, the Solenoid movement, Dynamometer, Thermocouple etc. If

Ohmmeter. We shall leave the voltmeter and ammeter for future columns and consider the ohmmeter at this time. Resistance is measured in ohms, after Georg Simon Ohm, a German physicist, who developed Ohms Law. By using a voltmeter, an ammeter, and a voltage source we can determine the value of resistors by measuring the voltage drop across the resistor, and the current flow through the resistor. Resistance (R) is equal to voltage (E) divided by current (I), thus:

$$R = \frac{E}{I} \quad I = \frac{E}{R}$$

$$E = I \times R$$

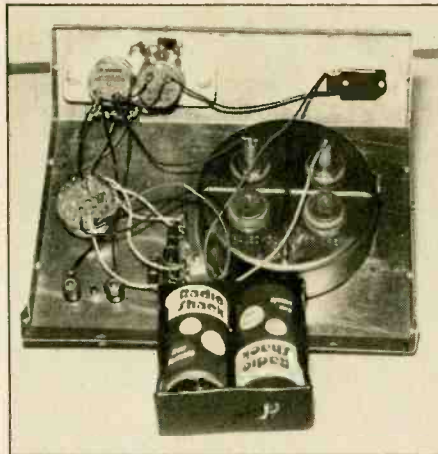

The wiring on the inside of the antique ohmmeter is point-to-point. On the end of the battery holder you can see how the third wire is connected between the batteries.

you want to learn more about meters after you read this article you can find textbooks that will explain all the various types of meters.

This method is slow and cumbersome so we use an ohmmeter instead. There are three basic types of ohmmeters: a series, a shunt connected, and a potentiometer type. Since the shunt connected type is only useful in measuring resistances under 500 ohms we will not discuss it here. The basic circuits of the other two types are shown. The series type ohmmeter is characterized by its resistance scale reading from right (zero) to left (infinite). The worst feature of the series ohmmeter is the overall crowding of its scale. The condition is much improved by the potentiometer type ohmmeter circuit as shown. In this circuit the unknown resistor (connected to terminals RX) is in series with a standard resistance Rs.

(Continued on page 89)

E/E

BASIC COURSE IN ELECTRICITY & ELECTRONICS

RECOMMENDED THEORY FOR ALL CB OPERATORS



If you're interested in Electronics, it won't take you long to find out that a VOM can be a technician's best friend. Knowing how to use a multimeter is an absolute must. Follow this lesson carefully and you will agree that learning how to use a test meter is easy and fun—done the **ELEMENTARY ELECTRONICS** way!

This series is based on material appearing in Vol. 1 of the 5-volume set, **BASIC ELECTRICITY/ELECTRONICS** published by Howard W. Sams & Co., Inc. @ \$25.50. For information on the complete set, write the publisher at 4300 West 62nd St., Indianapolis, Ind. 36268.

HOW YOU MEASURE ELECTRICITY

What you will learn. Just about every electronic technician, experimenter or hobbyist would agree that a VOM (Volt-Ohm-Milliammeter) is a crucial device to understand how to operate. If you work with volts and amperes, which are units of measurement, you must have a device with which to measure them—these devices are called meters. Meters, if used properly are invaluable. Herein we will show you exactly how to operate the most popular sort of meter, how to understand the readings, and the pitfalls to watch out for when you use such an instrument.

HOW DO METERS WORK?

Meters, like motors, convert electrical power into mechanical motion. In a motor, current-generated magnetic fields cause the armature to rotate. In most meters, similar magnetic fields cause a pointer to move across a scale. The position of the pointer (sometimes called a needle or indicator), when it comes to rest on the scale, indicates the amount of current flowing through the meter.

Most homes, or cars without "idiot" lights, have meters similar in principle to those that will be discussed. An electrical meter measures consumption of house current. The gasoline, temperature, amp, and other automobile gauges are all basically meters which measure current flow. Quantities being measured are converted to equivalent values of current.

Measuring Current Drawn By A Lamp

QUESTIONS

1. Voltage and current are measured by
2. The reading of a meter is taken where a pointer comes to rest on a
3. Pointer movement is caused by

ANSWERS

1. Voltage and current are measured by **meters**.
2. The reading of a meter is taken where a pointer comes to rest on a **scale**.
3. Pointer movement is caused by **magnetic fields**,

READING METERS

The illustration shows how a meter is connected to a circuit to measure the amount of current flowing.

Meters are read by noting to which number (or division "mark" between numbers) the needle is pointing.

If the needle points to a division mark between two numbers, the value of the division is added to the lower number.

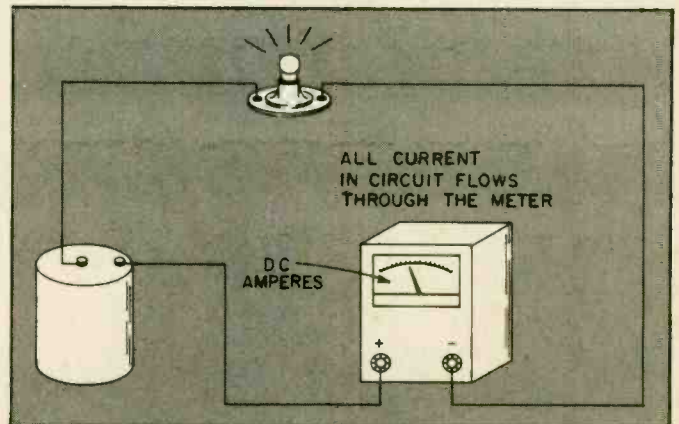

Of course, some of today's more sophisticated meters offer digital readout, where LED numbers actually tell you, without interpretation, what the measurement is. Right now, even the least expensive reliable digital meter goes for around \$70.00 in kit form. It's a good buy if your application demands quick and super accurate readings. However, most beginning hobbyists would likely be just as satisfied with the type of scale-and-pointer meters discussed here.

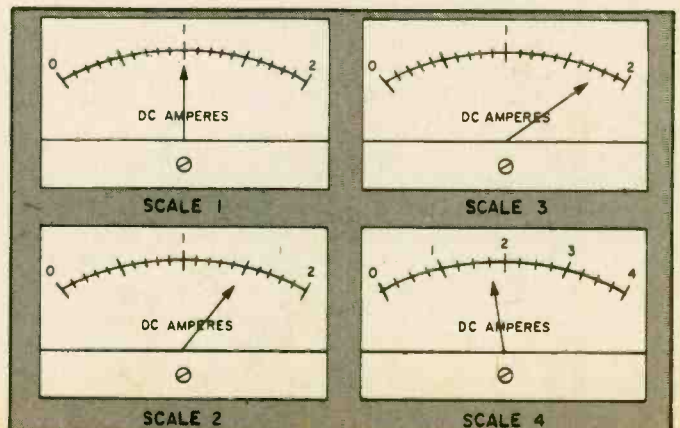



QUESTIONS

4. What is the reading for scale 1?
5. What is the value read on scale 2?
6. How many amps according to scale 3?
7. What does scale 4 read?

ANSWERS

4. The reading for scale 1 is **1 amp**.
5. The value read on scale 2 is **1.5 amps**. (Note the pointer is halfway between 1 and 2 on the scale.)
6. There are **1.8 amps** registered on scale 3. (There are ten equal division marks between numbers 1 and 2. The pointer rests on the eighth division, indicating a current of 1.8 amperes. Counting of the divisions is shown in the illustration below.)

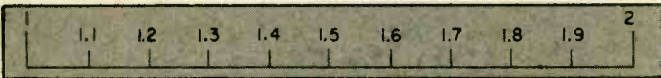

7. Scale 4 reads **1.75 amps**. (This scale has four divisions between the numbers. Thus, each division has a value of $\frac{1}{4}$ or 0.25 amp as shown in the following illustration. Since the pointer is on the third division between 1 and 2, its reading is, 1.75 amps.)



VOLTMETERS

Voltmeters are used to measure voltage. When the voltmeter is connected across the terminals of a voltage source, a current proportional to the source voltage flows through the meter mechanism. The meter scale is graduated in (marked to indicate the value of) volts. The procedure for reading a voltmeter scale is similar to that of the current scale you have just done.

PRECAUTIONS

There are two basic types of voltmeters—one for measuring DC voltage and the other for AC voltage. Be sure to use the correct one for the type of voltage to be measured. When an AC voltmeter is applied to a DC source, an incorrect measurement will occur. But when a DC meter is used to measure AC voltage, the meter may be damaged.

READING A VOLTMETER

A voltmeter scale is similar to a current-measuring scale. Values between numbers are read in the same manner as a current-reading scale.

VOLTAGE RANGES

Voltmeters are designed to read to certain maximum values. From zero to a maximum voltage is called the range of a voltmeter. Some commonly used ranges are 0 to 1.2 volts, 0 to 10 volts, 0 to 50 volts, 0 to 250 volts, or 0 to 1,000 volts.

Always be sure that any voltage to be measured is within the range of the voltmeter you are using. A meter may be damaged if used to measure a voltage greater than the maximum value for which it is designed. Excess voltage will cause excess current to flow. As a result, the pointer may be bent in trying to move beyond the end of the scale, or meter circuits may overheat and damage delicate parts.

QUESTIONS

8. What type of meter is used to measure DC voltage?

9. What may happen if a voltmeter is used to measure voltages beyond its range?

ANSWERS

8. A **DC voltmeter** is used to measure DC voltage.
9. A **meter may be damaged** if used to measure voltages beyond its range. Either the pointer will be bent and/or delicate parts within the meter will be ruined.

AMMETERS

A meter which reads current is called an ammeter. It can only be used to measure amperes.

CURRENT RANGES

Commonly used current ranges for work on electrical appliances are 0 to 10 amps and 0 to 30 amps. When working with electronic devices, ranges such as 0 to 500 microamps, 0 to 10 milliamps, and 0 to 250 milliamps may be required.

PRECAUTIONS

Ammeter precautions are the same as for voltmeters. Never use DC meters for AC, or AC meters for DC. Do not measure a current value that is beyond the range of the meter.

The first rule can be observed if you know the type of voltage source supplying the current. For example, you know that batteries supply DC and most wall outlets supply AC.

The second rule can be followed as you gain experience. If your meter has a selection of ranges, always use the highest range first. Then switch to the appropriate range to obtain the most accurate reading. Quickly remove the meter leads if the pointer swings beyond the limits of the scale.

A third rule must be added to the above. Never use an ammeter to measure voltage nor a voltmeter to measure current. Each meter is designed to measure only certain electrical values. If either type of meter is used for measuring other values, it may be damaged.

MULTIMETERS

A multimeter is a combination voltmeter and ammeter. It can be used to measure either AC or DC voltages and currents. A multimeter is also called a volt-ohm-milliammeter (VOM) or a circuit analyzer.

READING MULTIMETERS

A multimeter face has a combination of scales that may include several ranges of voltage and current readings. A typical multimeter scale having three ranges is shown.

A Typical Mutimeter Face

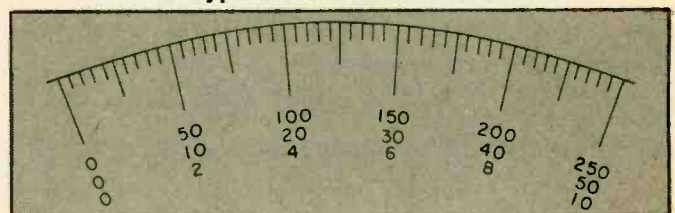

By proper front-panel settings, a multimeter can be used to measure AC and DC current and voltage.

QUESTIONS

10. To measure current, use a(an)

11. State three precautions that must be observed when using ammeters or voltmeters.

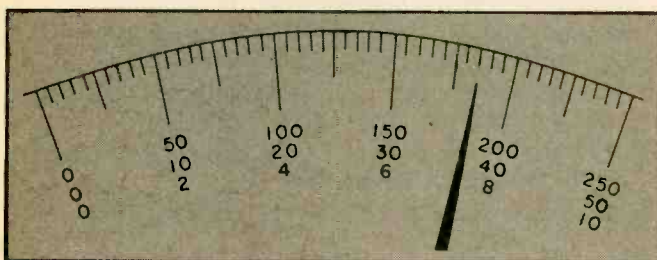

12. Shown here is a portion of the scale illustrated above. What is the reading on the 0 to 10 range?

13. What is the reading on the 0 to 250 range?

ANSWERS

10. To measure current, use an ammeter.

11. Brief statements of the three meter precautions are:

1. Never use DC meters for AC, or AC meters for DC.
2. Do not measure a value beyond the range of the meter.
3. Do not use a voltmeter to measure current or an ammeter to measure voltage.

12. The reading is 7.4 on the 0 to 10 range.

13. The reading is 185 on the 0 to 250 range.

MULTIMETER CHARACTERISTICS

We hope that studying this course will familiarize you with the theory of using a multimeter—but you should be aware that there is just no substitute for good old, hands-on experience. If you try out some of the techniques shown, as you are reading about them, you'll find such experience invaluable. This will be true throughout everything in electronics—if you can actually use the meter, the tool, whatever you are studying, you will learn it better.

A Typical Mutimeter

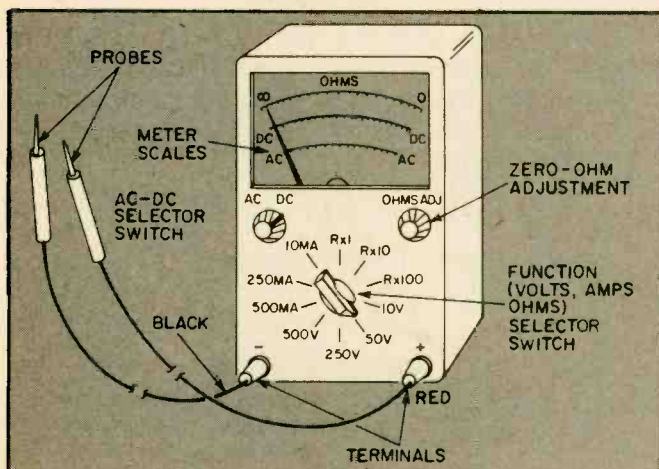

Although you may not desire to purchase a multimeter until a later date, you should have some knowledge of what to look for. A good multimeter can be purchased in most electronic parts stores for around

\$30.00. Or it can be ordered from one of the catalogs of the many mail order companies.

A multimeter from which you can obtain suitable accuracy and which has useful ranges should have the following characteristics. **Sensitivity:** 5,000 to 10,000 ohms/volt on AC and 20,000 ohms/volt on DC. **Voltage Ranges:** 0 to 10, 0 to 50, 0 to 250, and 0 to 500. **Current Ranges:** 0 to 500 microamps, 0 to 10 milliamps, and 0 to 250 milliamps. **Current and Voltage:** Both AC and DC. **Resistance Ranges:** 0 to 10K, 0 to 100K, and 0 to 1 Meg.

A typical multimeter is shown. Study it to become familiar with the location and names of the various parts, controls, and scales. Next, we describe each in detail.

Of course, not all multimeters look like this one. Each, however, is used similarly to accomplish the same measuring tasks.

QUESTIONS

14. A good multimeter can generally be purchased for less than00.

15. A multimeter having an AC sensitivity of 10,000 ohms/volt will have (suitable, unsuitable) accuracy for most purposes.

16. If the AC-DC Selector Switch in the illustration were set on DC, you would read the position of the pointer on the (top, middle, bottom) scale.

17. What is the meaning of the "10V" marking on the Function Selector Switch?

18. What are the tip ends of the two test leads connected to the meter called?

ANSWERS

14. A good multimeter can be purchased for less than \$30.00.

15. A multimeter having an AC sensitivity of 10,000 ohms/volt will have suitable accuracy for most purposes.

16. You would read the position of the pointer on the middle scale.

17. It indicates a setting at which a voltage between 0 and 10 volts may be read.

18. The tip ends of the leads are called the probes.

VOLTAGE MEASUREMENTS

The term multimeter means literally many meters. It is, in fact, a single instrument performing many measuring functions. The multimeter shown measures AC volts, AC amps, DC volts, DC amps, and ohms (to be discussed shortly).

Learning to use a multimeter properly requires you to think only of the particular function for which you are using the instrument. If you are measuring DC voltage, think DC voltmeter. If the next measurement is AC amperes, change your thinking to an AC ammeter. By concentrating in this manner, you are more certain to make the proper settings and observe the appropriate measuring precautions. For this reason, the multimeter will be discussed in terms of its separate measuring functions.

VOLTMETER CONNECTIONS

The voltmeter, like other electrical devices, has two terminals. Both terminals are connected into a circuit



when using the instrument. The terminals are sometimes colored red (+) and black (-).

Voltmeter With Test Leads

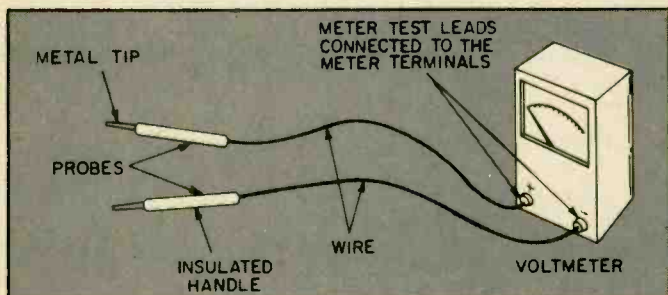

A voltmeter requires a pair of test leads to connect the meter to the circuit being tested. Test leads are lengths of flexible insulated wire. One end has a means of joining the lead to the voltmeter terminal. The other end has a metal probe encased in an insulated handle.

When measuring voltage, the metal tips of the probes are touched to the terminals of the voltage source or device. A voltage measurement is always taken across the terminals, and is never made between a terminal and an open wire.

QUESTIONS

19. List the five electrical quantities that a typical multimeter will measure.
20. How are AC and DC different?
21. When measuring battery voltage, how should you think of a multimeter?
22. How are the positive and negative terminals of some voltmeters identified?
23. What part of a test lead is placed in contact with the circuit being tested?
24. A voltage is always measured the terminals of a source or a device.

Measuring DC Voltage

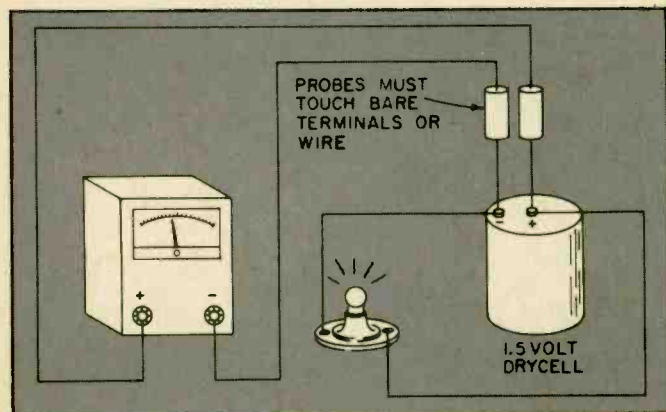

ANSWERS

19. AC volts, AC amps, DC volts, DC amps, ohms.
20. AC changes its direction of flow periodically; direct

current (DC) flows in only one direction.

21. When measuring battery voltage, think of the multimeter as a **DC voltmeter**. (You will be more certain to safely make the correct measurement.)
22. The positive and negative terminals of some voltmeters are colored **red** and **black** to indicate **positive (+)** and **negative (-)** connections.
23. The **probe end** of a test lead is placed in contact with the circuit being tested.
24. A voltage is always measured **across** the terminals of a source or a device.

Connection To A Voltmeter

You should know that a DC voltage source has both a negative and a positive terminal. The distinction between negative and positive voltage is identified by the term polarity. The polarity of a DC voltage source (a battery, for example) is usually indicated in some way at its terminals; one is negative and the other positive. In a DC circuit, the terminal polarity of an operating device is the same as the supply source.

The terminals of a DC voltmeter are either colored or marked to indicate the polarity. A red color or a plus (+) mark identifies a positive terminal. Black or minus (-) indicates a negative terminal. The negative terminal of a DC voltmeter is connected through a test lead to the negative terminal (source or device) of the circuit. The other test lead is connected to the corresponding positive terminal of the meter and of the circuit.

Always observe this rule: The polarity marking of the DC voltmeter terminal must be the same as the polarity of the voltage being measured.

If you disobey the rule, the scale pointer will move opposite to its normal direction and may be damaged. The rule does not apply when measuring AC voltage.

The illustration shows the proper connections to be made when measuring DC voltage.

DC VOLTMETER CONNECTIONS

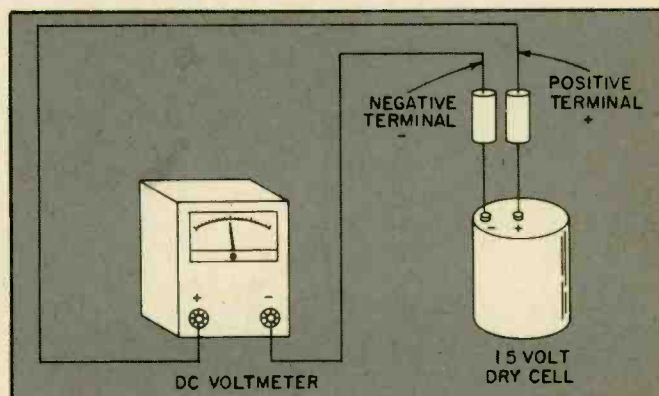

Various multimeters use different ways of adjusting to measure either AC or DC voltage. Most commonly, there will be a selector switch which the user simply sets for the measurement desired. Other multimeters will use multiple jacks on the front of the meter. Selec-

tion of the meter's function depends on what jack the test leads have been plugged into.

CURRENT MEASUREMENTS

Methods used to measure current with an ammeter or multimeter are different from those used to measure voltage.

An ammeter, like a voltmeter, has two terminals. Both terminals must be connected into the circuit when using the meter.

To measure current, the ammeter must be connected in series with the circuit (in such a way as to allow the current being measured to flow through the meter).

Multimeter connections for measuring current are made as if the instrument were an ammeter. The circuit must be opened (usually at a terminal) and the probes inserted, one on either side of the break.

When measuring DC current, a polarity rule must be observed: DC current should enter the negative terminal of a DC ammeter and leave by its positive terminal. Since you know that DC current flows through a circuit from the negative to the positive terminals of a power source, current direction can easily be determined.

If you plan to do many experiments that require measuring currents, the board shown should be worth constructing. The ammeter probes are inserted into the Fahnestock clips.

When a multimeter is used as an ammeter, the function switch is set to the appropriate range. In addition, the AC-DC switch is set for the kind of current (AC or DC) to be measured.

QUESTIONS

25. What is the difference between connecting a voltmeter and an ammeter into a circuit?
26. DC current should enter the terminal of a DC ammeter.

ANSWERS

25. Voltmeter measurements are made across the terminals of a device or source. Ammeters are inserted into a circuit so that the circuit current flows

Experimenter Board For Current Measurement

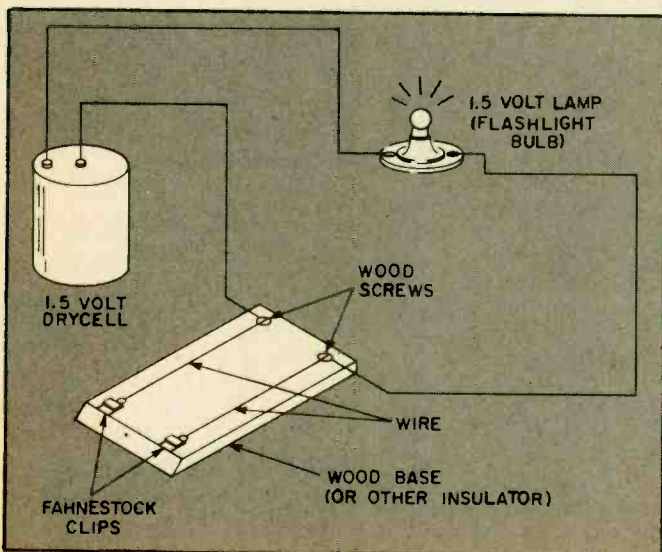

through the meter.

26. DC current should enter the **negative** terminal of a DC ammeter.

MULTIMETER SAFETY RULES AND PRECAUTIONS

Rule 1: *When not in use, always set the selector switches to the highest AC voltage position.*

There are two reasons for this rule. First, a multimeter contains batteries; at the voltage position the batteries are disconnected from the internal circuits and will not be supplying current. Second, this position of the selector switch provides the best protection for the delicate meter movement in the event the probes should accidentally come in contact with an energized circuit.

Rule 2: *When the meter is in use, forget that it is a multipurpose instrument and think of it only in terms of the function for which you are using it.*

A multimeter with its many switch positions and multiple scales can be confusing and can lead even the best technician into making unnecessary errors. Regard the instrument each time as a particular single-purpose meter.

Rule 3: *When measuring any voltage or current always use the highest range available first.*

This advice not only provides the best protection to the meter, but it also quickly identifies the best range scale you should use. If the quantity being measured on this or any range causes the needle to move past the end of the scale, immediately remove the probe from the circuit.

QUESTIONS

27. A multimeter should be stored with the switches in what position?
28. Make all measurements first at the setting.

ANSWERS

27. Before storing a multimeter, set the AC-DC switch to AC and the function selector switch to the highest voltage range.
28. Make all measurements first at the **highest** range setting.

WHAT YOU HAVE LEARNED

1. Meters are used to indicate the quantity of value of voltages and currents.
2. Meters are read by noting the position of a pointer on a marked scale.
3. The range of a meter is indicated by the highest marking on the scale. The range is read as zero-to-some number. For example, 0 to 150 volts.
4. Never connect a meter to measure a quantity known to be above the meter range. Meter damage may result. You should have some idea of the maximum value of the quantity before making the measurement.
5. A multimeter is a multipurpose meter. A typical instrument will measure AC volts, AC amps, DC volts, DC amps, and ohms, it will measure each of these functions in several ranges. ■

ELEMENTARY ELECTRONICS HOBBY MART

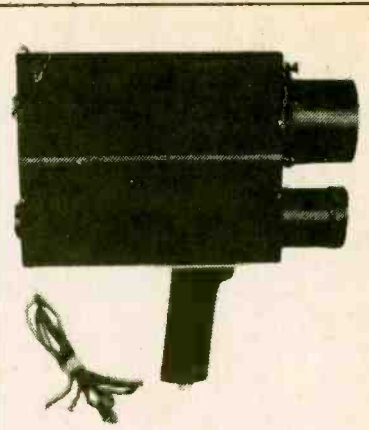

SEE IN THE DARK

IR viewer complete ready to operate. Guaranteed by the manufacturer. Portable, runs on lantern battery. New, see in total darkness. No shipments to Calif. Comes complete with built in IR source and adjustable focus lens. SPL-21 \$199.00

CHARACTER GENERATOR CHIP
Memory is 512X5 produces 84 five by seven ASCH characters. New by National, w/specs \$8.00

TOUCHTONE ENCODER CHIP
Compatible w/Bell system. Ideal for repeater work. W/specs \$8.00

HAWKEYE RADAR SPEED TRAP alarm.
Runs from cigar lighter outlet. New \$30

12 VOLT DC POWER SUPPLY 2 1/4 amps.
Run CB's, tape decks in house. New in metal cabinet. \$14

customer pays all postage
MESHNA, PO BOX 62, E. Lynn Ma 01904

CIRCLE 38 ON READER SERVICE COUPON

ALDELCO ELECTRONICS COMPANY

NEW IMPROVED DIGITAL ALARM CLOCK KIT
0.5 LED Display 12 hour format
Snooze Feature
Elapsed Timer
Simulated Wood Grain or Black Leather Cabinet \$24.95
12 or 24 Hour Clock Kit. Similar to Above but without Alarm or Timer features. Only \$23.95
Crystal Time Base Kit for 12 Volt DC use 4.95

DIGITAL MULTIMETER • THERMOMETER KIT
3 1/2 Digit - 5 Ranges on Each
Functions: AC/DC, 2 to 2000 Volts,
2 Microamps to 2 Amps, 2000 Ohms to 2 Meg Ohms

VOLTAGE REGULATORS
TO220 Package
Positive Negative
\$1.00 \$1.25
7805 7905
7806 7906
7808 7912
7812 7918
7815 7918
LM309H \$1.10
LM309K 1.10
LM723 .55

INCLUDES:
PC Board ICL7107
Chip and All Parts
ONLY \$49.95
Cabinet for Above \$8.95
LOGIC PROBE KIT
DIGIPEAK-A \$9.95
Kit of parts for power supply
Includes schematic
5 Volt, 6 Amp \$17.95
+15 and -15 2 Amp \$16.95

FETS 40673 1.55 We have transistors.
MPF102 .55 Send stamp for catalog.

MA 1003 National Car Clock Module \$19.95 **MC1458P**
With 3 push button switches and filter \$19.95 **SPECIAL**
New aluminum cabinet for MA 1003 6.95 **Only 49c**

JUMBO RED LEDS 10 for \$1.00
Monsanto MV5053 Jumbo Red
LED and holder 25c each

Green, Yellow or Orange LEODS
5 for \$1.00

FND 70 CC 0.3 Display LED .49
FND 500 CC 0.5 Display LED .89

CLOCK FILTERS 2 1/2 x 5 1/2"
Red, Blue, Green or Amber 60 ea.

BLINKY-FLASHER-TIMER KIT
Includes 555, PC Board
Parts & Instructions \$2.50

BRIDGE RECTIFIERS
25 Amp 200 Volt \$2.50
25 Amp 600 Volt \$5.50
25 Amp 1000 Volt \$9.95

SPEAKERS 8 OHM
2 1/2" \$ 75 2 1/2" 100 Ohm
2 1/2" 1.25 \$1.50
2 1/2"x5" 3.00

VARIABLE POWER SUPPLY KITS 5 Amps 5-15 Volt DC \$6.95
add \$1.00 per kit shipping 5 Amps 21-28 Volt DC 6.95

Visit Our Store. Hours 9:00 AM to 6:00 PM Mon. to Fri. Sat 9:00 AM to 2:00 PM. Phone Orders accepted. Visa & Master Charge. ADD 5% FOR SHIPPING ORDERS UNDER \$10.00 add \$1.00. Foreign Orders add 15% shipping (except Canada & Mexico). Send Certified Check or Money Order in USA funds.

ALDELCO
228 E BABYLON TURNPIKE, MERRICK, N.Y. 11566
(516) 378-4555

DIGI-KEY CORPORATION
TOLL FREE **1-800-346-5144**
MINNESOTA RESIDENTS 218-681-6674

Quality Electronic Components

DON'T FORGET OUR DISCOUNTS WHEN COMPARING PRICES

IC'S • RESISTORS • TRANSISTORS • CAPACITORS • DIODES • I.C. SOCKETS & PINS • SWITCHES
CLOCK MODULES • OPTOELECTRONICS • BREADBOARDING & TESTING DEVICES • DRAFTING SUPPLIES
DATA BOOKS • MEAT SINKS • WIRE • TOOLS... AND MORE... WRITE FOR FREE CATALOG...

INTEGRATED CIRCUITS

NEW! The "NIBBLER"
A MICROCOMPUTER AT A MICROPRICE!
FEATURES:
• Assembled and Tested, yet only \$149.95
• Standard 4.5" by 6.5" card with 72 pin edge connector pattern
• All IC's are socketed for easy maintenance
• Memory expandable to 28K
• 110 Baud Serial I/O
• It Speaks Basic Beautifully
• 4K NIBL Basic in ROM and 2K of RAM
• Easily Interfaced with CRT or Teletype
CATALOG NUMBER NIBLND \$149.95
SOFTWARE/HARDWARE MANUAL MANI-ND \$5.00

MA1002 e.s. High Digits
MA1010 e.s. High Digits

POWERACE SOLDERLESS BREAK-BOARDING WITH POWER FROM AP
POWERACE 103 \$124.95 POWERACE 101 \$231.01 POWERACE 102 \$484.95 \$231.02 \$114.95

3% CARBON FILM RESISTORS

LED DIGITS AND LAMPS

CLOCK MODULES
Prices Slashed
Beyond All Recognition

JMJ DIGITAL DISPLAY
NEW \$4.95

DOUBLE DIGIT DISCOUNTS SAVE YOU EVEN MORE!

HANDLING CHARGES
\$ 6.95 \$ 4.99... Add \$3.00
\$ 1,000-\$5,000... Add \$6.75
\$ 5,000-\$10,000... Add \$8.50
\$ 10,000-\$50,000... Add \$12.25
\$ 50,000-\$100,000... Add \$16.25
\$100,000 & Up... No Charge

VOLUME DISCOUNT
\$ 600-\$1,999... 10%
\$ 2,000-\$4,999... 15%
\$ 5,000-\$9,999... 20%
\$ 10,000-\$24,999... 25%
\$ 25,000-\$49,999... 30%
\$ 50,000-\$99,999... 35%
\$ 100,000 & Up... 40%

DIGI-KEY CORPORATION
Quality Electronic Components
P.O. Box 877, Dept. 877, Minneapolis, MN 55401 (312) 681-6674

CIRCLE 67 ON READER SERVICE COUPON

CIRCLE 5 ON READER SERVICE COUPON
ELEMENTARY ELECTRONICS/September-October 1978



POLY PAKS' 1C REBELLION

WE'RE FIGHTING BACK INFLATION WITH THIS EXCLUSIVE 1C SALE

RIBBON CABLE:
Order by Cat. #N3939
and Conductors

Cond.	26	4-ft.	1.98	1c Sale
	34	3-ft.	1.98	8-ft. 1.99
	40	3-ft.	1.98	6-ft. 1.99
				8-ft. 1.99

PENNIES FOR YOUR MEMORIES!

Type	Description	1c Sale!	Order by Cat. No.
1103	1K Dynamic RAM	1.29	1.30
5202	2K Prom	2.95	2.96
5262	2K x 1 Dynamic RAM	.99	1.00
1702A	256 x 8 EPROM	4.95	4.96

TTL'S AT "CENT-CIBLE" PRICES

Order by Cat. No. #N1981	Type No.	Each	2 For	Type No.	Each	2 For	Type No.	Each	2 For
87400	\$1.19	\$2.00	87462	.35	.36	874140	.49	.50	
87401	.19	.20	87464	.19	.20	874141	1.79	1.80	
87403	.25	.26	87485	.19	.20	874145	.69	.70	
87404	.19	.20	87486	.19	.20	874151	1.29	1.30	
87405	.19	.20	87471	.35	.36	874153	1.29	1.30	
87406	.19	.20	87472	.19	.20	874154	1.75	1.76	
87407	.39	.40	87473	.59	.60	874155	.79	.80	
87409	.39	.40	87474	.69	.70	874156	.39	.40	
87410	.25	.26	87475	.69	.70	874157	.99	1.00	
87411	.79	.80	87476	.79	.80	874158	.99	1.00	
87412	1.19	1.20	87477	.19	.20	874161	1.25	1.26	
87413	.35	.36	87478	.29	.30	874163	1.39	1.40	
87414	.35	.36	87479	.19	.20	874164	.79	.80	
87415	.29	.30	87480	.19	.20	874165	.99	1.00	
87416	.35	.36	87481	.29	.30	874166	1.99	2.00	
87417	.35	.36	87482	.99	1.00	874173	.99	1.00	
87418	.32	.33	87483	.99	1.00	874174	1.79	1.80	
87419	.49	.50	87484	.49	.50	874175	.99	1.00	
87420	.19	.20	87485	.79	.80	874177	.79	.80	
87421	.39	.40	87486	.79	.80	874178	1.99	2.00	
87422	.19	.20	87487	.39	.40	874179	.99	1.00	
87423	.19	.20	87488	.79	.80	874180	.49	.50	
87424	.19	.20	87489	.99	1.00	874182	.49	.50	
87425	.19	.20	87490	.99	1.00	874183	.99	1.00	
87426	.19	.20	87491	1.29	1.30	874184	1.25	1.26	
87427	.45	.46	87492	.79	.80	874185	1.25	1.26	
87428	.19	.20	87493	.79	.80	874186	1.25	1.26	
87429	.19	.20	87494	.79	.80	874187	1.25	1.26	
87430	.19	.20	87495	.59	.60	874188	.49	.50	
87431	.19	.20	87496	.79	.80	874189	.99	1.00	
87432	.19	.20	87497	.79	.80	874190	1.75	1.76	
87433	.19	.20	87498	.79	.80	874191	.99	1.00	
87434	.19	.20	87499	.79	.80	874192	.85	.86	
87435	1.25	1.26	87500	1.99	2.00	874193	.85	.86	
87436	1.25	1.26	87501	.29	.30	874194	1.25	1.26	
87437	1.35	1.36	87502	.39	.40	874195	1.25	1.26	
87438	.19	.20	87503	.25	.26	874196	.75	.76	
87439	.19	.20	87504	.59	.60	874197	.75	.76	
87440	.19	.20	87505	.59	.60	874198	1.50	1.51	
87441	.19	.20	87506	.69	.70	874199	3.50	3.51	
87442	.19	.20	87507	.69	.70	874200	3.50	3.51	
87443	.19	.20	87508	1.35	1.36	874201	3.50	3.51	
87444	.19	.20	87509	1.35	1.36	874202	3.50	3.51	
87445	.35	.36	87510	.49	.50	874203	3.50	3.51	
87446	.35	.36	87511	.49	.50	874204	3.50	3.51	

Parts & Semi One Centers

Qty.	Description (Order by Cat. No. in parenthesis)	Sale	1c Sale
1-40	CHANNEL CB SELECTOR, w/knob, for PLL circuits (#N5045)	1.00	2 for 1.01
1-23	CHANNEL CB SELECTOR, w/knob, for PLL & stat. (#N5044)	1.00	2 for 1.01
10-10	"DICE", microscopic circuits, teaches theory (#N5055)	1.19	20 for 1.20
1-4"	HIF OPTICAL CONDENSER, full size, for color home TV (#N5264)	4.95	2 for 4.96
1-LED	WAVE GUTS, men's good? We don't know (#N5267)	1.95	2 for 1.96
1-UHF	TUNER, solid state, standard type (#N2927)	1.00	2 for 1.01
10-SLIDE	SWITCHES, ass't pop styles (#N9C1495)	1.00	20 for 1.01
7-TANTALUM	CAPACITORS, 6.8 uF 35V, dip, ant. (#N5281)	1.00	8 for 1.01
5-PANCAKE	PHOTOCELLS, 600 to 15K ohms (#N2939)	1.00	10 for 1.01
1-100KHZ	MARKER CRYSTALS, approx for marker gen. (#N3896)	1.95	2 for 1.96
1-MOTHERBOARD	EDGE CONNECTOR, 106 pins, 1.25" (#N3987)	3.50	2 for 3.51
1-48-PIN	HIF OPTICAL CONDENSER, 1.55" spacing (#N5264)	1.95	2 for 1.96
1-METER,	50uA, 1 1/4" square, 0-200uA (#N3705)	1.19	2 for 1.20
1-SPST	RELAY, norm. open 12-24 VDC, 1250 ohms, dip style (#N5175)	1.00	2 for 1.01
1-VEEDER	ROOT COUNTER, 000-999, resettable, panel mt. (#N5081)	1.49	2 for 1.50
2-DUAL	GATE MOSFET, sim. to 3N200, 3N187, for RF & Mixer (#N5101)	1.00	4 for 1.01
2-LCD	THERMAL INDICATORS, 88-108°F, 7.1", Resilia (#N5195)	1.00	2 for 1.01
1-JOYSTICK,	four 100K pots, with knob (#N3808A)	4.95	2 for 4.96
1-ECCO	THUMBWHEEL SWITCH, BCD, 0-7 (#N2870A)	1.49	2 for 1.50
15-"POP"	OPTICAL LENSES, plano-convex, 1" dia, plastic (1" 75043)	1.19	30 for 9.96
1-PLESSEY	ON SIDEBAND FILTER, for TV (#N3975)	1.95	2 for 1.96
30-FL	WIRE WRAP WIRE, 30 gage, for ICA, terminals (#N3803)	1.00	60-ft for 1.01
2.9V	MC-CAD CHARGER PAK, plug-in, 125mA, 125 VAC pr. (#N4098)	1.49	2 for 1.50
20-DATA	ENTERY PUSH-SWITCHES, ass't, norm. open, for keyboards (#N5279)	2.00	40 for 2.01
7-TANTALUM	CAPACITORS, 100uf 50V, 50uf 50V, 20uf 50V (#N2415)	1.00	8 for 1.01
100-MINI	DIP ICA, inners, untested 50%+ yield, pop types (#N3245)	2.00	200 for 2.01
75-LINEARS,	OP AMPS, untested 50%+ yield, amps-dips-mini-dips (#N2416)	2.00	150 for 2.01
100-TTL &	LINEAR MIXED, with 7400s, 50%+ yield (#N2431)	2.00	200 for 2.01
100-JOYSTICK	ON SIDEBAND FILTER, for TV (#N3975)	1.95	2 for 1.96
1-B-TAPE	TAPE HEAD, with plug'n cord (#N3448)	2.50	2 for 2.51
150-PREFORMED	DISC CAPACITORS, marked values, ass't (#N2605)	2.00	300 for 2.01
150-TRIMMER	CAPACITORS, mica compression, marked, ass't (#N3714)	2.00	120 for 2.01
150-YELLOW	MARKET MYLAR CAPACITORS, marked, pop values (#N3476)	2.00	150 for 2.01
150-CLASS	ZENERS, 400 MW, untested, bet. 50% yield (#N2740)	2.00	300 for 2.01
75-CARBONFIL	RESISTORS, 1/4" watt, 5 & 10%, marked, ass'ts (#N3534)	2.00	150 for 2.01
250-UNMARKED	CAPACITORS, polystyrene, molded, pop values (#N3805)	2.00	500 for 2.01
100-SILICON	DIODES, 1N4148, 1N4149, 1N4150, 1N4151, 1N4152, 1N4153, 1N4154, 1N4155, 1N4156, 1N4157, 1N4158, 1N4159, 1N4160, 1N4161, 1N4162, 1N4163, 1N4164, 1N4165, 1N4166, 1N4167, 1N4168, 1N4169, 1N4170, 1N4171, 1N4172, 1N4173, 1N4174, 1N4175, 1N4176, 1N4177, 1N4178, 1N4179, 1N4180, 1N4181, 1N4182, 1N4183, 1N4184, 1N4185, 1N4186, 1N4187, 1N4188, 1N4189, 1N4190, 1N4191, 1N4192, 1N4193, 1N4194, 1N4195, 1N4196, 1N4197, 1N4198, 1N4199, 1N4200, 1N4201, 1N4202, 1N4203, 1N4204, 1N4205, 1N4206, 1N4207, 1N4208, 1N4209, 1N4210, 1N4211, 1N4212, 1N4213, 1N4214, 1N4215, 1N4216, 1N4217, 1N4218, 1N4219, 1N4220, 1N4221, 1N4222, 1N4223, 1N4224, 1N4225, 1N4226, 1N4227, 1N4228, 1N4229, 1N4230, 1N4231, 1N4232, 1N4233, 1N4234, 1N4235, 1N4236, 1N4237, 1N4238, 1N4239, 1N4240, 1N4241, 1N4242, 1N4243, 1N4244, 1N4245, 1N4246, 1N4247, 1N4248, 1N4249, 1N4250, 1N4251, 1N4252, 1N4253, 1N4254, 1N4255, 1N4256, 1N4257, 1N4258, 1N4259, 1N4260, 1N4261, 1N4262, 1N4263, 1N4264, 1N4265, 1N4266, 1N4267, 1N4268, 1N4269, 1N4270, 1N4271, 1N4272, 1N4273, 1N4274, 1N4275, 1N4276, 1N4277, 1N4278, 1N4279, 1N4280, 1N4281, 1N4282, 1N4283, 1N4284, 1N4285, 1N4286, 1N4287, 1N4288, 1N4289, 1N4290, 1N4291, 1N4292, 1N4293, 1N4294, 1N4295, 1N4296, 1N4297, 1N4298, 1N4299, 1N4300, 1N4301, 1N4302, 1N4303, 1N4304, 1N4305, 1N4306, 1N4307, 1N4308, 1N4309, 1N4310, 1N4311, 1N4312, 1N4313, 1N4314, 1N4315, 1N4316, 1N4317, 1N4318, 1N4319, 1N4320, 1N4321, 1N4322, 1N4323, 1N4324, 1N4325, 1N4326, 1N4327, 1N4328, 1N4329, 1N4330, 1N4331, 1N4332, 1N4333, 1N4334, 1N4335, 1N4336, 1N4337, 1N4338, 1N4339, 1N4340, 1N4341, 1N4342, 1N4343, 1N4344, 1N4345, 1N4346, 1N4347, 1N4348, 1N4349, 1N4350, 1N4351, 1N4352, 1N4353, 1N4354, 1N4355, 1N4356, 1N4357, 1N4358, 1N4359, 1N4360, 1N4361, 1N4362, 1N4363, 1N4364, 1N4365, 1N4366, 1N4367, 1N4368, 1N4369, 1N4370, 1N4371, 1N4372, 1N4373, 1N4374, 1N4375, 1N4376, 1N4377, 1N4378, 1N4379, 1N4380, 1N4381, 1N4382, 1N4383, 1N4384, 1N4385, 1N4386, 1N4387, 1N4388, 1N4389, 1N4390, 1N4391, 1N4392, 1N4393, 1N4394, 1N4395, 1N4396, 1N4397, 1N4398, 1N4399, 1N4400, 1N4401, 1N4402, 1N4403, 1N4404, 1N4405, 1N4406, 1N4407, 1N4408, 1N4409, 1N4410, 1N4411, 1N4412, 1N4413, 1N4414, 1N4415, 1N4416, 1N4417, 1N4418, 1N4419, 1N4420, 1N4421, 1N4422, 1N4423, 1N4424, 1N4425, 1N4426, 1N4427, 1N4428, 1N4429, 1N4430, 1N4431, 1N4432, 1N4433, 1N4434, 1N4435, 1N4436, 1N4437, 1N4438, 1N4439, 1N4440, 1N4441, 1N4442, 1N4443, 1N4444, 1N4445, 1N4446, 1N4447, 1N4448, 1N4449, 1N4450, 1N4451, 1N4452, 1N4453, 1N4454, 1N4455, 1N4456, 1N4457, 1N4458, 1N4459, 1N4460, 1N4461, 1N4462, 1N4463, 1N4464, 1N4465, 1N4466, 1N4467, 1N4468, 1N4469, 1N4470, 1N4471, 1N4472, 1N4473, 1N4474, 1N4475, 1N4476, 1N4477, 1N4478, 1N4479, 1N4480, 1N4481, 1N4482, 1N4483, 1N4484, 1N4485, 1N4486, 1N4487, 1N4488, 1N4489, 1N4490, 1N4491, 1N4492, 1N4493, 1N4494, 1N4495, 1N4496, 1N4497, 1N4498, 1N4499, 1N4500, 1N4501, 1N4502, 1N4503, 1N4504, 1N4505, 1N4506, 1N4507, 1N4508, 1N4509, 1N4510, 1N4511, 1N4512, 1N4513, 1N4514, 1N4515, 1N4516, 1N4517, 1N4518, 1N4519, 1N4520, 1N4521, 1N4522, 1N4523, 1N4524, 1N4525, 1N4526, 1N4527, 1N4528, 1N4529, 1N4530, 1N4531, 1N4532, 1N4533, 1N4534, 1N4535, 1N4536, 1N4537, 1N4538, 1N4539, 1N4540, 1N4541, 1N4542, 1N4543, 1N4544, 1N4545, 1N4546, 1N4547, 1N4548, 1N4549, 1N4550, 1N4551, 1N4552, 1N4553, 1N4554, 1N4555, 1N4556, 1N4557, 1N4558, 1N4559, 1N4560, 1N4561, 1N4562, 1N4563, 1N4564, 1N4565, 1N4566, 1N4567, 1N4568, 1N4569, 1N4570, 1N4571, 1N4572, 1N4573, 1N4574, 1N4575, 1N4576, 1N4577, 1N4578, 1N4579, 1N4580, 1N4581, 1N4582, 1N4583, 1N4584, 1N4585, 1N4586, 1N4587, 1N4588, 1N4589, 1N4590, 1N4591, 1N4592, 1N4593, 1N4594, 1N4595, 1N4596, 1N4597, 1N4598, 1N4599, 1N4600, 1N4601, 1N4602, 1N4603, 1N4604, 1N4605, 1N4606, 1N4607, 1N4608, 1N4609, 1N4610, 1N4611, 1N4612, 1N4613, 1N4614, 1N4615, 1N4616, 1N4617, 1N4618, 1N4619, 1N4620, 1N4621, 1N4622, 1N4623, 1N4624, 1N4625, 1N4626, 1N4627, 1N4628, 1N4629, 1N4630, 1N4631, 1N4632, 1N4633, 1N4634, 1N4635, 1N4636, 1N4637, 1N4638, 1N4639, 1N4640, 1N4641, 1N4642, 1N4643, 1N4644, 1N4645, 1N4646, 1N4647, 1N4648, 1N4649, 1N4650, 1N4651, 1N4652, 1N4653, 1N4654, 1N4655, 1N4656, 1N4657, 1N4658, 1N4659, 1N4660, 1N4661, 1N4662, 1N4663, 1N4664, 1N4665, 1N4666, 1N4667, 1N4668, 1N4669, 1N4670, 1N4671, 1N4672, 1N4673, 1N4674, 1N4675, 1N4676, 1N4677, 1N4678, 1N4679, 1N4680, 1N4681, 1N4682, 1N4683, 1N4684, 1N4685, 1N4686, 1N4687, 1N4688, 1N4689, 1N4690, 1N4691, 1N4692, 1N4693, 1N4694, 1N4695, 1N4696, 1N4697, 1N4698, 1N4699, 1N4700, 1N4701, 1N4702, 1N4703, 1N4704, 1N4705, 1N4706, 1N4707, 1N4708, 1N4709, 1N4710, 1N4711, 1N4712, 1N4713, 1N4714, 1N4715, 1N4716, 1N4717, 1N4718, 1N4719, 1N4720, 1N4721, 1N4722, 1N4723, 1N4724, 1N4725, 1N4726, 1N4727, 1N4728, 1N4729, 1N4730, 1N4731, 1N4732, 1N4733, 1N4734, 1N4735, 1N4736, 1N4737, 1N4738, 1N4739, 1N4740, 1N4741, 1N4742, 1N4743, 1N4744, 1N4745, 1N4746, 1N4747, 1N4748, 1N4749, 1N4750, 1N4751, 1N4752, 1N4753, 1N4754, 1N4755, 1N4756, 1N4757, 1N4758, 1N4759, 1N4760, 1N4761, 1N4762, 1N4763, 1N4764, 1N4765, 1N4766, 1N4767, 1N4768, 1N4769, 1N4770, 1N4771, 1N4772, 1N4773, 1N4774, 1N4775, 1N4776, 1N4777, 1N4778, 1N4779, 1N4780, 1N4781, 1N4782, 1N4783, 1N4784, 1N4785, 1N4786, 1N4787, 1N4788, 1N4789, 1N4790, 1N4791, 1N4792, 1N4793, 1N4794, 1N4795, 1N4796, 1N4797, 1N4798, 1N4799, 1N4800, 1N4801, 1N4802, 1N4803, 1N4804, 1N4805, 1N4806, 1N4807, 1N4808, 1N4809, 1N4810, 1N4811, 1N4812, 1N4813, 1N4814, 1N4815, 1N4816, 1N4817, 1N4818, 1N4819, 1N4820, 1N4821, 1N4822, 1N4823, 1N4824, 1N4825, 1N4826, 1N		

WIREWAP

PRECUT WIRE

Why buy wire on rolls?

PRECUT & STRIPPED WIRE IS:

- Fast - No more cutting & stripping by hand
- Reliable - Good, clean, uniform strip
- Economical - Cheaper than using bulk wire

Precut Wire

100 pcs of 3' at \$2 = 34¢/ft. 50 ft. roll at \$1.99 = 4¢/ft.
100 pcs of 6' at 1.06 = 2¢/ft. 100 ft. roll at 2.95 = 3¢/ft.
Wire Kit 1 at \$6.95 = 2 1/3¢/ft.

30 Kynar # Stripped 1" on each end. Lengths are overall.
Colors: Red, Blue, Green, Yellow, Black, Orange, White.
Wire packaged in plastic bags. Add 25¢/length for tubes.

	100	500	1000	5000
2 1/2 in.	78	240	430/K	3.89/K
3 in.	82	260	471/K	4.22/K
3 1/2 in.	86	280	512/K	4.55/K
4 in.	90	300	552/K	4.88/K
4 1/2 in.	94	321	593/K	5.21/K
5 in.	98	342	634/K	5.52/K
5 1/2 in.	102	363	675/K	5.86/K
6 in.	106	385	716/K	6.19/K
6 1/2 in.	110	405	757/K	6.52/K
7 in.	114	426	798/K	6.85/K
7 1/2 in.	118	445	839/K	7.18/K
8 in.	122	465	880/K	7.53/K
8 1/2 in.	126	485	921/K	7.84/K
9 in.	130	505	962/K	8.17/K
9 1/2 in.	134	525	1003/K	8.50/K
10 in.	138	545	1044/K	8.83/K
Advt. In.	10	41	82/K	86/K

WIRE KITS

# 1	\$6.95	# 2	\$19.95
250 3' 100 4 1/2"	250 2 1/2"	250 4 1/2"	250 6'
250 3 1/2" 100 5"	500 3"	250 5"	100 6 1/2"
100 4" 100 6"	500 3 1/2"	100 5 1/2"	100 7"
	500 4"	1,250 ft. Roll Bulk	

Choose One Color or Assortment

WIREWAP SOCKETS

	1-9	10-24	25-99	100-249	250-999	1K-5K
8 pin	.41	.38	.35	.31	.29	.27
14 pin	.42	.39	.36	.32	.29	.27
18 pin	.46	.43	.39	.35	.32	.30
18 pin	.63	.58	.54	.47	.44	.41
20 pin	.84	.78	.71	.63	.59	.54
22 pin	1.30	1.20	1.10	.95	.90	.84
24 pin	.91	.84	.78	.68	.64	.59
28 pin	1.25	1.15	1.08	.95	.89	.82
40 pin	1.65	1.55	1.42	1.25	1.15	1.09

Gold 3-level Closed Entry Sockets
End & Side Stackable
Tin sockets and 2-level sockets available

WIREWAP TOOLS



\$34.95
HOBBY WRAP
Model BW 630
With Free Wire Kit 1
(\$6.95 Value)
Batteries & Charger \$11.00
WSU 30 Hand Wrap-Unwrap Strip Tool 5.95
WSU 30M for Modified Wrap 6.95
BT 30 Extra Bit 2.95

INTERCONNECT CABLES

Ribbon cable connectors for connecting boards to front panels, or board to board.

	SINGLE ENDED			DOUBLE ENDED		
	14 pin	16 pin	24 pin	14 pin	16 pin	24 pin
6"	1.24	1.34	2.05	2.24	2.45	3.37
12"	1.33	1.44	2.24	2.30	2.55	3.92
24"	1.52	1.65	2.53	2.52	2.76	4.31
48"	1.91	2.06	3.40	2.91	3.17	5.08

Ordering Information:

- Orders under \$25 and COD's, add \$2
 - All others, shipped Ppd in U.S. via UPS
 - For Blue Label (Air) or 1st Class, add \$1
 - We accept Visa & MasterCard
 - Most orders shipped same day
- Dealer Inquiries Invited

PAGE DIGITAL ELECTRONICS

135 E. Chestnut Street 4A
Monrovia, California 91016
Phone (213) 357-5005

CIRCLE 14 ON READER SERVICE COUPON

MAKE YOUR OWN AUTOMATIC STROBE KIT

We have all the parts to custom design your own automatic photo graphic strobe.

These individual modules may be put together in several different ways, depending on how powerfull, or whether you want automatic shut off. We have a DC to DC power supply, that raises the output of 4 NICADs from 4.8 volts, to 320 volts. We have the trigger coil, to fire the flash tube. We have 2 flash tubes, a straight tube 2" long, and a horse-shoe tube 1 1/2" long.

a small, high voltage, high capacity capacitor, rated at 360 V, 600 mfd. 38 watt seconds., an electronic cut off device that shuts off the flash tube when the exposure is correct. You may make up your own kit by choosing the parts you wish. We list the price of each part, but when 3 or more parts are chosen, you may deduct 10% from the total. We suggest that only one capacitor be used if the the straight flash tube is used. With the horseshoe tube, 2 capacitors may be used for greater output. Use of the cut off module is optional. We provide circuitry for the entire system.

STOCK NO.

DC to DC power Supply	5528E	\$4.95
Trigger Coil	5565E	\$1.50
Capacitor	2675E	\$2.00
Horseshoe Flash Tube	9941R	\$3.00
Straight Flash Tube	9244E	\$2.50
Cut-off module	6423E	\$2.50

VIDEOCUBE-COMPUTER/TV INTERFACE

VIDEOCUBE is a self contained oscillator-modulator, allowing easy interface with any video output device to a standard TV set. We provide reprint from RADIO-ELECTRONICS. Approved by FCC.

STOCK NO.5500E, Complete kit of parts. \$13.95 2/26.00
STOCK NO.5500PE Partial kit(All special parts) \$9.95 2/18.00

Enclose Sufficient postage. Excess will be refunded. Send for new 112 page catalog. Minimum order \$5.00

DELTA ELECTRONICS

P.O. Box 2, 7 Oakland St.
Amesbury, Ma. 01913
617-388-4705

ATLANTA, GA.

DELTA ELECTRONIC HOBBIES
5151 Buford Hwy.
Doraville, Atlanta, Ga.

CIRCLE 39 ON READER SERVICE COUPON

Video Monitor

Great for CCTV or Micro-Computer

Reconditioned
With New CRT!

12" Diagonal
These reconditioned solid state monitors have a new CRT installed & are checked out. They can display up to 80 characters X 16 lines, accepting std. comp. video signal, 75 ohm input via SO-239 connector, 115VAC. 12 page manual incl. (may require front bezel)
40 Lbs. #8A30240. . . . \$98.88 each

VIDEO GAME PARTS!

Unused electronic TV games that are missing the TV interface section. Has some 30 IC's, including 2-555 timers and lots of CMOS stuff. Also has two 7-segment .5" LED displays . . . all on 2 PC boards. Also: 2 joystick controls (each with 2-10K pots); 2" 8 ohm speaker; large sloping-top case & more & more!
Sh. Wt. 5 Lbs. . . . 8GE0028 . . . \$7.88

4-Way COMPONENTS SPECIAL

A SUPERB ENSEMBLE including: Flaredome 3" tweeter; two (2) 5" Middlers; heavy-duty 12" Woofer; & an L-C-R crossover with two controls. For optimum performance, this system should be mounted in an air tight enclosure of at least 2 cubic feet in volume (available separately, send for catalog). Alnico V type magnets, 5-70 Watts, 25 to 20,000 Hz., 6-8 ohms. Simply GREAT!
30 Lbs. . . . 8EU80063 . . . \$119.50/pair (pair=8 speakers, for two 4-way systems)

NEW! Radar Detector



HAWKEYE RADAR DETECTOR
This all-new radar detector gives you a very early audio/visual warning . . . as much as 3 miles from the radar source. Detects all X-band radar, around corners, over hills, etc. Smartly styled unit mounts atop dashboard in a special quick-release bracket, so that it may be removed while auto is left unattended. 12VDC operation, comes complete with cigarette lighter adapter; just plug it in and you're ready to go! Original price for this detector was \$79.95 . . . now priced at a super-low B&F price of only \$28.88!
Sh. Wt. 3 Lb. . . . #8K30262 . . . \$28.88

NiCad's

RECHARGEABLE, 1.25V per cell. Used, good cond. Sizes are: AA-over-size; & sub-C. (Check dimensions)
Size (in.) Amp. Hr. Sh. Wt. Order No.
.550x1.90 . . . 0.45 . . . 3 oz . . . 7V70469
.865x1.63 . . . 1.20 . . . 5 oz . . . 7V70470
. 88¢ each or \$8.00/10
"AA" NI-CAD 8-PACK!
10V @ 500ma!
NEW: 8 "AA" cells in handy package, gives 10V (mfr. says 9.6V) @ 500ma. Split into single cells for 1.25V ea.
8 oz./pack . . . #8V20305 . . . \$8.00/pack

Enclosures

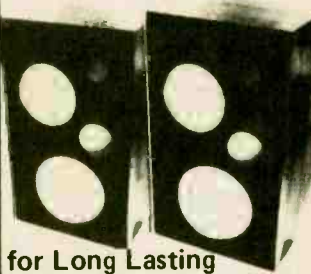

for Long Lasting Performance & Beauty
A real premium enclosure constructed of real wood veneer over tough particle board for long lasting performance and good looks. You can build a system that is equal to . . . or better than . . . a \$250-each (\$500/pair) system for less than half of that! These handsome units have pre-cut holes for: 10" woofer; 8" passive radiator; 5" mid-dler; and 3 1/2" tweeter. There is a 2 1/2 x 6 1/2" rectangular hole in the rear panel for your brilliance controls, crossovers, etc. Overall size: 11 1/2" x 15" x 26". Qty. Ltd. A real premium enclosure, ready for the components of your choice. Qty. Ltd. Wt. 35 Lbs. ea. #8A40313 . . . \$40.00 ea. -or- \$68.88 pair

AM-FM MULTIPLEX RECEIVER CHASSIS

Intended for use in a console by "big name" mfr. AM, FM, FM multiplex, plus phono & aux inputs. Great for building-in. Just add case & speakers. 115VAC. All solid-state. Qty. Ltd. Wiring instructions incl. Sh. Wt. 3 Lbs. #8S20307 . . . \$24.88 ea -or- \$68.88/3

Speaker Kits

SPEAKER SYSTEMS KIT No. 1
Super cabinets, size is 21x12x8". Includes 8" woofers w/whizzers; 4" dome tweeters; cross-overs; damping; hardware and instructions. System sells for \$198 if bought ready - to - go. B&F kit price only \$69.95/pair! 45 Lbs.
Order No. 7ZU70283 \$69.95/pair

SPEAKER SYSTEMS KIT No. 2

Fantastic cabinets designed for direct dispersion of high freq. and wide dispersion of low freq. Size: 17x10 1/2x9 1/2" Sold with 8" woofers, 4" dome tweeters, cross-overs and instructions. 35 Lbs.
Order No. 7ZU70242 \$49.50/pair

POSTAGE: Please add postage. All material is U.S. Peabody, Ma. No C.O.D.'s please. Massachusetts Residents add 5% sales tax.
PHONE ORDERS WELCOME!
Use your Bank Americard, Master Charge or American Express Credit Card!
\$10.00 min. on all charge orders!

B&F ENTERPRISES
Dept. E-910
119 Foster Street
Peabody, MA. 01960
(617) 531-5774

SAVE WITH SURPLUS! **B&F**

For free catalog including parts lists and schematics, send a self-addressed stamped envelope.

APPLE II SERIAL I/O INTERFACE *

Part no. 2
Baud rate is continuously adjustable from 0 to 30,000 • Plugs into any peripheral connector • Low current drain. RS-232 input and output • On board switch selectable 5 to 8 data bits, 1 or 2 stop bits, and parity or no parity either odd or even • Jumper selectable address • SOFTWARE • Input and Output routine from monitor or BASIC to teletype or other serial printer. • Program for using an Apple II for a video or an intelligent terminal. Also can output in correspondence code to interface with some selectrics. Board only — \$15.00; with parts — \$42.00; assembled and tested — \$62.00.



T.V. TYPEWRITER

Part no. 106
• Stand alone TVT
• 32 char/line, 16 lines, modifications for 64 char/line included • Parallel ASCII (TTL) input • Video output • 1K on board memory • Output for computer controlled cursor • Auto scroll • Non-destructive cursor • Cursor inputs: up, down, left, right, home, EOL, EOS • Scroll up, down • Requires +5 volts at 1.5 amps, and -12 volts at 30 mA • All 7400, TTL chips • Char. gen. 2513 • Upper case only • Board only \$39.00; with parts \$145.00

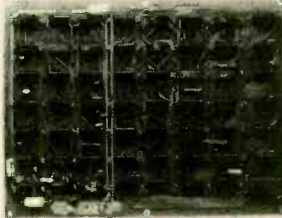

8K STATIC RAM

Part no. 300
• 8K Altair bus memory • Uses 2102 Static memory chips • Memory protect • Gold contacts • Wait states • On board regulator • S-100 bus compatible • Vector input option • TRI state buffered • Board only \$22.50; with parts \$160.00

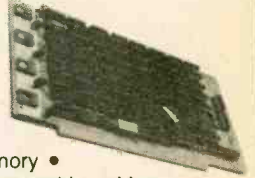

MODEM *

Part no. 109
• Type 103 • Full or half duplex • Works up to 300 baud • Originate or Answer • No coils, only low cost components • TTL input and output-serial • Connect 8 ohm speaker and crystal mic. directly to board • Uses XR FSK demodulator • Requires +5 volts • Board \$7.60; with parts \$27.50

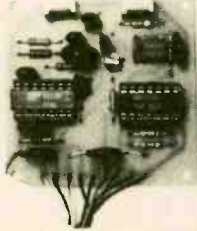

TIDMA *

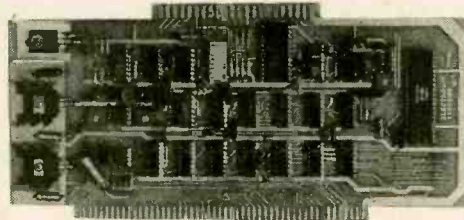

Part no. 112
• Tape Interface Direct Memory Access • Record and play programs without bootstrap loader (no prom) has FSK encoder/decoder for direct connections to low cost recorder at 1200 baud rate, and direct connections for inputs and outputs to a digital recorder at any baud rate. • S-100 bus compatible • Board only \$35.00; with parts \$110.00

Part no. 107
• Converts video to AM modulated RF, Channels 2 or 3. So powerful almost no tuning is required. On board regulated power supply makes this extremely stable. Rated very highly in Doctor Dobbs' Journal. Recommended by Apple. • Power required is 12 volts AC C.T., or +5 volts DC • Board \$7.60; with parts \$13.50



DC POWER SUPPLY *

Part no. 6085
• Board supplies a regulated +5 volts at 3 amps., +12, -12, and -5 volts at 1 amp. • Power required is 8 volts AC at 3 amps., and 24 volts AC C.T. at 1.5 amps. • Board only \$12.50; with parts excluding transformers \$42.50



RS 232/TTY *

Part no. 600
• Converts RS-232 to 20mA current loop, and 20mA current loop to RS-232 • Two separate circuits • Requires +12 and -12 volts • Board only \$4.50, with parts \$7.00

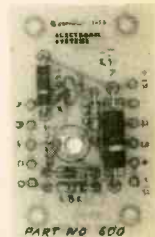

TAPE INTERFACE *

Part no. 111
• Play and record Kansas City Standard tapes • Converts a low cost tape recorder to a digital recorder • Works up to 1200 baud • Digital in and out are TTL-serial • Output of board connects to mic. in of recorder • Earphone of recorder connects to input on board • No coils • Requires +5 volts, low power drain • Board \$7.60; with parts \$27.50



UART & BAUD RATE GENERATOR *

Part no. 101
• Converts serial to parallel and parallel to serial • Low cost on board baud rate generator • Baud rates: 110, 150, 300, 600, 1200, and 2400 • Low power drain +5 volts and -12 volts required • TTL compatible • All characters contain a start bit, 5 to 8 data bits, 1 or 2 stop bits, and either odd or even parity. • All connections go to a 44 pin gold plated edge connector • Board only \$12.00; with parts \$35.00 with connector add \$3.00

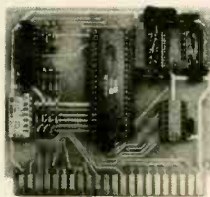

RS 232/TTL *

Part no. 232
• Converts TTL to RS-232, and converts RS-232 to TTL • Two separate circuits • Requires -12 and +12 volts • All connections go to a 10 pin gold plated edge connector • Board only \$4.50; with parts \$7.00 with connector add \$2.00

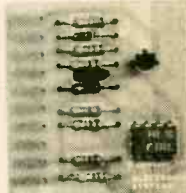

ELECTRONIC SYSTEMS

Dept. EE,

P.O. Box 21638, San Jose, CA. USA 95157

To Order:

Mention part number and description. For parts kits add "A" to part number. In USA, shipping paid for orders accompanied by check, money order, or Master Charge, BankAmericard, or VISA number, expiration date and signature. Shipping charges added to C.O.D. orders. California residents add 6.5% for tax. Outside USA add 10% for air mail postage, no C.O.D.'s. Checks and money orders must be payable in US dollars. Parts kits include sockets for all ICs, components, and circuit board. Documentation is included with all products. All items are in stock, and will be shipped the day order is received via first class mail. Prices are in US dollars. No open accounts. To eliminate tariff in Canada boxes are marked "Computer Parts." Dealer inquiries invited. 24 Hour Order Line: (408) 226-4064



* Circuits designed by John Bell

YES!! A CLOCK THAT'S EASY TO BUILD, INEXPENSIVE, BEAUTIFUL... AND ONLY \$16.50!

The MA1003 is a complete unit: add only time setting switches and case. A natural for no-hassle car clock installations: runs from 12 VDC and includes crystal timebase. Fluorescent readouts (not LEDs) give good looks and high visibility.

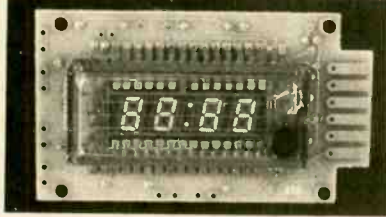

ELECTRIC MOTOR SPECIAL

These are the type found in games, electric toothbrushes, motorized plastic models, window displays, and the like. Run on 1 to 5 V DC. On special at 10/\$2.95.

HOW TO MAKE LIFE EASIER:

With AP test clips for 14 and 16 pin ICs, of course. Removes ICs from sockets without damage as well as furnishing sturdy pins for probe points and alligator clips. Gold-plated wiping action.

Model TC-14
(14 pins):
\$4.50



Model TC-16
(16 pins):
\$4.75

IT'S HERE AND YOU NEED IT.

Our flyer, that is... we've got a lot of neat stuff, and our flyer tells you all about it. Send name and address, we'll do all the rest.

GODBOUT
BILL GODBOUT ELECTRONICS
BOX 2355, OAKLAND AIRPORT, CA 94614

TERMS: Please allow up to 5% for shipping; excess refunded. Add \$1 handling for orders under \$10. Cal res add tax. COD OK with street address for UPS. For VISA®/Mastercharge® orders call our order desk (24 hrs) at (415) 562-0636. Prices good through cover month of magazine.

CIRCLE 21 ON READER SERVICE COUPON



This year, discover America for yourself.

FREE THE GREAT ELECTRONIC THINGS & SURPLUS CATALOG!

Many Unusual Items & Specials not found in stores or catalogs anywhere!
Circle Reader Service Coupon or write today for exciting Free Catalog!

MAGIC SOUND SWITCH!!
SURPLUS BARGAIN!
Sensitive crystal mike picks up sound which is amplified to trigger an SCR switch. Operates on 3-6 VDC. With schematic. (2 oz.)
024SU210.
10/\$8.95
100/\$79.95

12 VOLT 2 AMP POWER SUPPLY!
10/\$89.95

995 Sensational purchase of European inventory! 3-4 amp surge. Excellent for CB, car stereo and general hobby and school shop applications. Excellent battery charger. Excellent dealer item.
024HP233. (2 lb.)

BUILD A PARABOLIC MICROPHONE!
Giant 22" diameter plastic parabolic sound reflector. For construction of long distance mikes and sound projectors. Construction ideas included. (5 lb.)
024MP233. **19.95** VISIT OUR STORE!

Rush your order with full remittance please. Visa & Mastercharge OK. Allow 15% for UPS & handling. (N.Y. state residents add 7% tax). 24 hour - 7 day telephone order desk. Call when rates are low!

ETCO ELECTRONICS,
Dept. 024
NORTH COUNTRY SHOPPING CENTER,
PLATTSBURGH, N.Y. 12901
518-561-8700.

CIRCLE 42 ON READER SERVICE COUPON

AMAZING DEVICES

(((PHASERS)))

PPF-1 PHASER PAIN FIELD — This device recently developed and patented in our labs is being evaluated by law enforcement agencies for riot and crowd control. It is now available but soon will come under the jurisdiction of weapons and infernal machine control making it unavailable to the public. The device is hand-held and looks like a BUCK ROGERS ray gun. It is hazardous if not used with discretion.

PPF-1 PLANS \$10.00

IPG-1 INVISIBLE PAIN FIELD GENERATOR — This amazing, simple hand-held device is about the size of a pack of cigarettes and generates a directional field of moderate to intensive pain in the lower part of the head up to a range of 50'. Device is simple and economical to make.

IPG-1 PLANS \$6.00 IPG-1K ALL PARTS \$39.50
IPG-10 ASSEMBLED & TESTED FOR ANIMAL CONTROLS \$44.50

LASERS

HIGH POWERED CARBON DIOXIDE BURNING AND CUTTING. Complete plans and all parts sources \$10.00

SOLID STATE IR 12 WATTS with built in power supply plans \$6.00 Complete kit with collimator \$44.50

POCKET LASER pulsed, visible red. plans \$6.00 Complete kit \$39.50 Also complete plans and parts sources for RUBY, YAG, NEDYNIUM, HeNe ARGON, DYE, NITROGEN and many more lasers.

SECURITY

SNP-2 SNOOPER PHONE — Connects to telephone in seconds — enables you to check home or office while on vacation. User simply dials his number from anywhere activating highly sensitive mike and amp combination capable of detecting normal sound levels throughout area without phone ringing. Anyone with this capability would breathe a sign of relief, while away hearing the familiar sounds of appliances and other systems properly operating.

SNP2 PLANS \$7.00
SNP2K ALL PARTS FOR ABOVE \$49.50
SNP20 ASSEMBLED & TESTED \$79.50

LONG RANGE XMTR PLANS \$6.00

SEE-IN-THE-DARK PLANS \$6.00

DIRECTIONAL SHOTGUN MIKE PLANS \$6.00

SUPER SENSITIVE PARABOLIC MIKE PLANS \$6.00

SOUND & TELEPHONE OPERATED TAPE RECORDER \$5.00

CATALOG ON PLANS, KITS & FINISHED UNITS \$1.00

Send check or money order to:
SCIENTIFIC SYSTEMS, Dept. A10, Box 716
AMHERST, N.H. 03031

CIRCLE 34 ON READER SERVICE COUPON

Chess Rumble

(Continued from page 51)

CHESS CHAMPIONS AT A GLANCE

	Manufacturer	List Price
BORIS	APPLIED CONCEPTS BOX 2582 GARLAND, TEXAS 75041	299.95
CHESS CHALLENGER	FIDELITY ELECTRONICS 5245 W. DIVERSEY CHICAGO, ILL. 60639	195.95
COMPU CHESS	STAID, INC. BOX 65 LARGO, FL. 33540	169.95

challenging game to the weekend player. As for the future—who knows? Perhaps even Bobby Fisher may someday hear a computer generated call of "checkmate!"

DX Central

(Continued from page 24)

ated in the FM band, equally illegally, of course). Jolly Roger was heard throughout much of the midwest on 6,210 kHz, supposedly running about 30 to 40 watts of power. Unlike the New York operations JRR's programming a lot of pop music and chatter. Jolly Roger apparently had wide ranging musical tastes, from contemporary to classical, from easy listening to ethnic selections.

Feedback. Not having third party "mail drops" for listeners' letters, as do most European pirates, the U.S. versions have devised other ways of getting listener feed back.

Some of the pirate operators, it seems, belong to several of the hobby SWL and DX listening clubs in North America. On the air, these announcers tell listeners to report their reception to the clubs. Those loggings eventually are published in the club bulletins where they are seen by the station operators who, so they say, will then send QSLs to the reporters.

Still, despite these precautions, it seems that if a pirate broadcaster operates too regularly, or on frequencies such as the ham bands where he makes a real nuisance of himself, the feds will track him down and put him off the air.

I don't condone illegal broadcasting any more than I condone the many thousands of unlicensed CB operators across the nation. But like the no-license citizen banders, the hobby pirate broadcasters are a very real fact of life and can't be ignored.

LITERATURE LIBRARY

301. Get the '78 Elco Catalog and see their do-it-yourself kits and factory assembled electronic equipment. Specialties are test equipment, burglar/fire alarms, hobbyist and auto electronics.
302. *International crystal* has illustrated folders containing product information on radio communications kits for experimenters (PC boards; crystals; transistor RF mixers & amplifiers; etc.).
303. *Regency* has a new low cost/high performance UHF/FM repeater. Also in the low price is their 10-channel monitorradio scanner that offers 5-band performance.
304. *Dynascan's* new *B & K* catalog features test equipment for industrial labs, schools, and TV servicing.
306. Get *Antenna Specialists'* catalog of latest mobile antennas, test equipment, wattmeters, accessories.
308. Compact is the word for *Xcelite's* 9 different sets of midget screwdrivers and nutdrivers with "piggyback" handle to increase length and torque. A handy show case serves as a bench stand also.
310. *Turner* has two catalogs on their CB microphones and antennas. They give individual specifications on both lines. Construction details help in your choice.
311. *Midland Communications'* line of base, mobile and hand-held CB equipment, marine transceivers, scanning monitors, plus a sampling of accessories are covered in a colorful 18-page brochure.
312. *The EDI (Electronic Distributors, Inc.)* catalog is updated 5 times a year. It has an index of manufacturers literally from A to X (ADC to Xcelite). Whether you want to spend 29 cents for a pilot-light socket or \$699.95 for a stereo AM/FM receiver, you'll find it here.
313. Get all the facts on *Progressive Edu-Kits* Home Radio Course. Build 20 radios and electronic circuits; parts, tools, and instructions included.
316. Get the *Hustler* brochure illustrating their complete line of CB and monitor radio antennas.
318. *GC Electronics* offers an "Electronic Chemical Handbook" for engineers and technicians. It is a "problem solver" with detailed descriptions, uses and applications of 160 chemicals compiled for electronic production and packaging. They are used for all types of electronic equipment.
320. *Edmund Scientific's* new catalog contains over 4500 products that embrace many sciences and fields.
321. *Cornell Electronics'* "Imperial Thrift Tag Sale" Catalog features TV and radio tubes. You can also find almost anything in electronics.
322. *Radio Shack's 1978* catalog colorfully illustrates their complete range of kit and wired products for electronics enthusiasts—CB, ham, SWL, hi-fi, experimenter kits, batteries, tools, tubes, wire, cable, etc.
323. Get *Lafayette Radio's* "new look" 1978 catalog with 260 pages of complete electronics equipment. It has larger pictures and easy-to-read type. Over 18,000 items cover hi-fi, CB, ham rigs, accessories, test equipment and tools.
327. *Avanti's* new brochure compares the quality difference between an Avanti Racer 27 base loaded mobile antenna and a typical imported base loaded antenna.
328. A new free catalog is available from *McGee Radio*. It contains electronic product bargains.
329. Semiconductor Supermart is a new 1978 catalog listing project builders' parts, popular CB gear, and test equipment. It features semiconductors—all from *Circuit Specialists*.
330. There are nearly 400 electronics kits in *Heath's* new catalog. Virtually every do-it-yourself interest is included—TV, radios, stereo and 4-channel, hi-fi, hobby computers, etc.
331. *E. F. Johnson* offers their CB 2-way radio catalog to help you when you make the American vacation scene. A selection guide to the features of the various messenger models will aid you as you go through the book.
332. If you want courses in assembling your own

TV kits, *National Schools* has 10 from which to choose. There is a plan for GIs.

333. Get the new free catalog from *Howard W. Sams*. It describes 100's of books for hobbyists and technicians—books on projects, basic electronics and related subjects.

334. *Sprague Products* has L.E.D. readouts for those who want to build electronic clocks, calculators, etc. Parts lists and helpful schematics are included.

335. The latest edition of the *TAB BOOKS* catalog describes over 450 books on CB, electronics, broadcasting, do-it-yourself, hobby, radio, TV, hi-fi, and CB and TV servicing.

338. "Break Break," a booklet which came into existence at the request of hundreds of CBers, contains real life stories of incidents taking place on America's highways and byways. Compiled by the *Shakespeare Company*, it is available on a first come, first serve basis.

342. *Royce Electronics* has a new 1978 full line product catalog. The 40-page, full-color catalog contains their entire new line of 40-channel AM and SSB CB transceivers, hand-helds, marine communications equipment, and antennas and accessories.

345. For CBers from *Hy-Gain Electronics Corp.* there is a 50-page, 4-color catalog (base, mobile and marine transceivers, antennas, and accessories). Colorful literature illustrating two models of monitor-scanners is also available.

353. *MFJ* offers a free catalog of amateur radio equipment—CW and SSB audio filters, electronic components, etc. Other lit. is free.

354. A government FCC License can help you qualify for a career in electronics. Send for information from *Cleveland Institute of Electronics*.

355. New for CBers from *Anixter-Mark* is a colorful 4-page brochure detailing their line of base station and mobile antennas, including 6 models of the famous Mark Heliwhip.

356. *Continental Specialties* has a new catalog featuring breadboard and test equipment for the professional and hobbyist. Descriptions, pictures and specifications aid your making a choice.

359. *Electronics Book Club* has literature on how to get up to 3 electronics books (retailing at \$58.70) for only 99 cents each... plus a sample Club News package.

361. "Solving CB Noise Problems" is published by *Gold Line* and tells you how to reduce the noise and get a clearer signal. In discussion and diagram you can find out about the kinds of noise, their sources, and the remedies.

362. *B&F Enterprises'* Truckload Sale catalog offers 10% off all merchandise: (military or industrial surplus) speaker kits, TV games, computer terminals, tools, TV components, lenses, and more.

363. Send for *computer enterprises'* catalog of microcomputer systems for personal, business, educational and industrial users. They claim the greatest bargains in microcomputer equipment, systems, parts and supplies.

364. If you're a component buyer or specifier, you'll want this catalog of surplus bargains: industrial, military, and commercial electronic parts, all from *Allied Action*.

365. *Electronic Supermarket* has a new catalog of almost everything in the field—transformers, semi-conductors, tv parts, stereos, speakers, P.C. boards, phones, wire and cable, tools, motors.

366. Send for *Poly-Packs'* new catalog featuring hundreds of bargains: new Barrel Pack kits, hobby computer peripheral parts, fiber optics, solar energy chips, digital clocks, and more.

367. *Optoelectronics'* new catalog features their new Frequency Counter, a 6-digit clock calendar kit, mobile LED clock, biorhythm clock, digit conversion kit, and many others.

368. *Cherry Electrical Products* has a handbook describing their new "PRO" keyboard for personal computer, hobbyist and OEM users. Included are instructions on how to customize it on-the-spot, schematics, charts, and diagrams.

369. *Motorola Training Institute* offers a brochure on two new home-study courses: Four lessons cover semiconductors, designed for all technicians servicing electronic equipment; the 34-lesson professional FM two-way radio course is for those planning to service land-mobile equipment.

370. The 1978 catalog from *Computer Warehouse* has data on 10 different microcomputers, with used peripherals, and available for immediate delivery. Over 1,500 products are covered, new and used, from over 170 different vendors.

371. Your computer system needn't cost a fortune. *Southwest Technical Products* offers their 6800 computer complete at \$395 with features that cost you extra with many other systems. Peripheral bargains are included here.

372. See how you can save with *Olson's* "Erector Kit" Computer System; also their factory wired version which includes a 2-volume Bell & Howell instruction course. Send for information.

373. *ETCO* has a Grand Opening Catalog which anyone in the electronics field shouldn't miss. Full of all kinds of products from surplus and warehouse sales, they claim everyone is a bargain.

ELEMENTARY ELECTRONICS Box 1849, G.P.O. New York, NY 10001

SEPTEMBER/OCTOBER 1978
Void After February 17, 1979

Please arrange to have the literature whose numbers I have circled below sent to me as soon as possible. I am enclosing 50¢ for each group of 10 to cover handling. (No stamps, please.) Allow 4-6 weeks for delivery.

- | | | | | | | | | | | | |
|-----|-----|-----|-----|-----|-----|-----|-----|-----|-----|-----|-----|
| 301 | 302 | 303 | 304 | 306 | 308 | 310 | 311 | 312 | 313 | 316 | 318 |
| 320 | 321 | 322 | 323 | 327 | 328 | 329 | 330 | 331 | 332 | 333 | 334 |
| 335 | 338 | 342 | 345 | 353 | 354 | 355 | 356 | 359 | 361 | 362 | 363 |
| 364 | 365 | 366 | 367 | 368 | 369 | 370 | 371 | 372 | 373 | | |

300 Enter my subscription to Elementary Electronics for 9 issues at \$5.97.
Check enclosed. Add \$1.00 for Canada and all other countries. **H81014**

NAME (print clearly) _____

ADDRESS _____

CITY _____

STATE _____

ZIP _____

Antique Radio Corner

(Continued from page 76)

Current from the battery flows through these two resistances, setting up a voltage drop across each one. A high-resistance meter is deflected by the voltage drop across the standard resistor. The meter is set initially to full scale by the Zero Set rheostat with terminals RX temporarily shorted. When a resistor is connected to the RX terminals, the deflection of the meter will be some value less than full scale, and will be proportional to the unknown resistance. The meter scale therefore may be calibrated directly in ohms.

In order to have a versatile ohmmeter with more than one resistance range, the battery voltage, standard resistor, and meter voltage multiplier can be switched simultaneously. The same Zero Set rheostat can be used on all ranges.

Each scale of the potentiometer type ohmmeter is wide spaced in its low resistance section, i.e., clockwise end of the meter scale, and more crowded at the high resistance end. Resistance

values may be read more accurately by selecting the resistance range where the reading falls near the center of the meter scale.

Since many of our readers are interested in building their own testing equipment, which is really the ideal way to learn, I designed an ohmmeter in the 1932 tradition. It uses an easily obtained 0-1 mA ammeter with a couple of refinements which make it much easier to use. My meter shown in the photo isn't completely finished as to the housing, but electrically it is complete. I used a 4½-inch diameter meter just because I happened to have one. The larger the meter face the easier the meter is to read. You can use any diameter meter as long as the full scale deflection is 1 milliamp. The rest of the parts are easily obtained. In order to check continuity of tube filaments it is necessary to keep the current flowing through the test leads as low as possible. Another unusual feature is two zero-set rheostats. Since there are two battery voltages, two zero-set rheostats keeps you from having to reset the zero every time you switch ranges. Normally you short the test leads together when you zero-set an ohmmeter, but I

have incorporated momentary push switches into the zero-set rheostats. With this arrangement you merely push down the knob to short the inputs together. If you cannot find potentiometers with a momentary push switch attached you can use a push button switch or merely short the test leads together. Both zero adjust controls can be 5000 ohms, but since the battery voltage is halved, I halved the resistance of the low range zero set by putting a 5000-ohm resistor in parallel with it. This effectively makes it into a 2500-ohm control.

The meter scale was custom drawn to match this circuit. If you want to duplicate this ohmmeter a brochure listing the parts needed and how to buy a meter scale is available from Meters Unlimited, R1, Box 41, Cutler, IN 46920. There is no charge for this information, but you must send a long, stamped, self addressed envelope.

The ohmmeter case wasn't completely finished when the photos were made, but it was finished electrically and proved to be quite accurate and very useful in my radio repair shop.

So long for now. Next time we will discuss voltmeters and ammeters. ■

Bio-Logic

(Continued from page 43)

letters is presented to you. Could you memorize it at one pass?

VTVMSCRFETUJT

You could if you treated the items like this:

VTVM SCR FET UJT

This type of organization is called chunking, which means ordering the list into meaningful groups. Since meanings are governed by the pattern of storage in LTM, previously acquired LTM information is being used here to facilitate STM storage. The chunked list has four items, well within the memory span, and can be quickly memorized by anyone familiar with electronics. But to an uninitiated person the list contains thirteen items; a few rehearsals would be necessary to enable perfect recall.

Let's try another experiment. Can you memorize the following list quickly and without a lot of rehearsing?

110001100101000011

If you can count in binary, it's a cinch. Look at the list in this way:

110 001 100 101 000 011

6 1 4 5 0 3

Below each triplet is its decimal equivalent. If you can mentally do such a conversion, you're left with only six decimal digits to memorize. When the time comes for recall, simply change the decimal numbers you've memorized

back to binary. With some practice, you should be able to handle lists of about twenty-one ones and zeros, much to the amazement of your friends. Note that you're using old LTM information—the rules of binary-to-decimal and decimal-to-binary conversion—to assist in memorizing new material.

RAM. Leave STM now and consider long-term storage. First of all, think of all the different kinds of information contained in LTM. Sights, sounds, tastes, smells, and words are all stored in some codified form. The information can be reached quickly without first searching through a lot of extraneous material. In electronics we call such a memory structure random-access. This random-access characteristic is one of LTM's most important features, and current theories hold that a close relationship exists between the structure of LTM and the grammar of language.

Certainly one of the most important characteristics of LTM is its relative permanence of storage. However, we all know that recall is often marred by forgetting. Is this a memory failure? It might be, but some say no. Consider the experiences of the neurosurgeon Wilder Penfield. While performing surgery he electrically stimulated areas of patients' brains. Since the patients were conscious during brain surgery (there are no pain receptors in the brain), they were able to report their sensations. Many reported long-since forgotten, seemingly trivial incidents from the past. These sensations were vivid, filled

with minute visual and auditory details. In fact, they were often described as being like movies. This type of evidence is frequently cited in support of the notion that everything stored remains stored, and that forgetting is the inability to find stored information.

There is no question, however, about the role of the chunking process in LTM. Chunking is the most effective method of guaranteeing long-term storage. Tests on mnemonists, people with exceptional powers of memory, show conclusively that structuring information in some imaginative way is the key to successful memorization. For instance, given a list of words to memorize, the mnemonist might weave them together into a fanciful story. Even if the process sounds silly, it works remarkably well.

So far we've only scratched the surface of the topic of human information-processing, and in an article of this size we can't do much more than that. Many questions remain unresolved. For instance, are STM and LTM two physically separate blocks of memory in the brain, as they would be in a calculator or computer? Probably not. For more fascinating unanswered questions try *Human Memory* by Roberta Klatzky (\$6.95, W. H. Freeman and Co., 660 Market St., San Francisco, Calif., 94104). Much work remains to be done in this field, and if you like computers, you may just become hooked on cognitive psychology—the psychology of comprehension. ■

Bit Bucket

(Continued from page 35)

chart giving the activity during each clock cycle and machine state.

The text is well illustrated with clear and precise diagrams. These diagrams and charts are referred to when they appear, and referenced back to later in the text—so even the most complicated concepts are clarified by the artwork.

Reading this will not make you into a computer engineer. But, it will give you a good understanding of just what is going on inside your computer's microprocessor.

Microprocessors, by Rodney Zaks, is available for \$9.95 direct from Sybex Incorporated, 2161 Shattuck Avenue,

Berkeley, California 94704.

Product News. If you're an Apple II owner, you'll be pleased to note that Apple Computer has just released the very first of their "intelligent" peripherals. All are designed to plug directly into the eight I/O (Input/Output) slots in an Apple. Available from stock are the Parallel Interface (\$180.00) and the Communications Interface (\$180.00).

We had the opportunity to view the parallel interface hooked up to one of the popular 40-column, matrix printers that now sell to hobbyists for \$400 to \$700. With the interface plugged in, the Apple computer was able to output to the printer almost as quickly as if it were a CRT. The printer we saw used the aluminized, silvery paper many

hobbyists are familiar with. Though the paper is a bit hard on the eyes a hint (courtesy of Apple) is to photocopy it. We tried that and, sure enough, the silver background copied blank-white. Maximum speed of the interface is said to be 3700 lines/minute at 80 characters/line.

We hope to see the Communications Interface in action soon, but we can tell you it is designed to turn an Apple II into an intelligent on-line terminal to communicate via modem with time-sharing systems and other similarly equipped Apples. This seems good news for those amongst us eagerly looking forward to vast, national networks of home computer users.

Remember—send in your questions for our Input/Output section. ■

Simply BASIC

(Continued from page 53)

```
7100 IF N$(R)="JUMP" THEN 7180
7101 PRINT
7110 PRINT N$(R)
7120 PRINT A$(R)
7125 PRINT C$(R)
7130 IF Y$="Y" THEN PRINT O$(R)
7150 PRINT
7160 PRINT
7180 NEXT R
7185 PRINT
7190 GOTO 250
8000 LINE INPUT "WHAT IS THE KEYWORD(S) >";K$
8010 FOR R=1 TO 100
8020 IF O$(R)=K$ THEN 8080
8025 IF N$(R)="***" THEN 250
8030 GOTO 8140
8080 IF N$(R)="JUMP" THEN 8140
8081 PRINT
8090 PRINT N$(R)
8100 PRINT A$(R)
8110 PRINT C$(R)
8120 PRINT
8130 PRINT
8140 NEXT R
8150 PRINT
8160 GOTO 250
9000 LINE INPUT "ENTER CITY NAME >";C$
9010 LINE INPUT "ENTER KEYWORD(S) >";K$
```

```
9020 PRINT
9030 FOR R=1 TO 100
9035 IF N$(R)="***" THEN 9210
9040 IF K$=O$(R) THEN 9100
9050 GOTO 9200
9100 IF C$<>C$(R) THEN 9200
9105 IF N$(1)="JUMP" THEN 9200
9110 PRINT
9120 PRINT N$(R)
9130 PRINT A$(R)
9140 PRINT C$(R)
9200 NEXT R
9210 PRINT
9212 PRINT
9220 GOTO 250
10000 LINE INPUT "NAME >";N$
10010 FOR R=1 TO 100
10015 IF N$(R)="***" THEN 10140
10020 IF N$=N$(R) THEN 10070
10030 NEXT R
10040 PRINT "SORRY, NAME NOT FOUND."
10050 PRINT
10060 GOTO 250
10070 LINE INPUT "NEW NAME >";N$(R)
10080 LINE INPUT "ADDRESS >";A$
10090 A$(R)=A$
10100 LINE INPUT "CITY >";C$
10105 C$(R)=C$
10110 LINE INPUT "OPTIONAL LINE >";O$
10120 O$(R)=O$
10130 PRINT "O.K."
10140 PRINT
10150 GOTO 250
32000 END
```

Adapting To Other Computers

□ This month's program is written in Extended Benton Harbor BASIC, Version 10.02.01. It was structured for, and checked, on a Heathkit H8 computer with 20K of memory, using a model 33 TTY for the terminal.

To make it as easy as possible to adapt the program to other forms of BASIC the program does not use multiple statement lines. If your BASIC has the multiple statement feature a more compact program using less overhead (RAM) will be attained through the use of multiple statement: For example, lines 2100, 2101 and 2102 can be compacted to: 2100 PRINT: PRINT: PRINT. You can carry compaction up to the limit allowed by your computer's particular BASIC.

LINE INPUT is Heathkit's way of avoiding the quotation mark (" ") delimiters to input string variables. It also eliminates the question mark (?) prompt. While an INPUT statement would normally call for something like "LIST NAMES," the LINE INPUT statement allows the simplified entry LIST NAMES, eliminating the delimiters. Simply adapt the command to whatever you need if not using Extended Benton Harbor Basic.

Data is stored on cassette tape using the PUT and GET statements which are available only on BASIC version 10.02 and higher. The data can be stored in batches by using a "header" such as "NAMES 1," "NAMES 2," etc. The data is batch retrieved by calling for GET

"NAMES 1," GET "NAMES 2," etc. Adapt these commands to your own particular BASIC if you're not using EBHB version 10.02 and higher. Some BASICs do not permit recording and retrieval from batch-loaded tapes.

Take special notice that in order to run the program after loading data from the cassette you must use the CONTINUE command. If you attempt to run the program with a RUN command all the data is erased from the computer memory (the tape is not affected). This instruction was completely missing from the documentation supplied with our version of EBHB. Heathkit might have rewritten the documentation for EBHB Version 10.02 by the time you read this. ■

Getting Out

(Continued from page 40)

erally you are interested in being heard in only one horizontal direction at a time, why waste a lot of power in all the other horizontal, non-skyward directions, too? Why, indeed. So a beam more or less eliminates all wasted energy and radiates in one and only one direction at a time.

The only problem is that if someone is trying to talk to you from a direction other than the one in which your beam is pointed, you may never even notice him. Therefore, a beam is seldom used all by itself. An omnidirectional antenna is usually used with the beam as a stand-by antenna. You listen for callers on the stand-by antenna and then point the beam at them to talk.

Power Mikes. And finally, there are power mikes. When a microphone is

keyed, a carrier wave is sent out. It is a steady kind of radio wave, having the same amplitude always. (On a wave diagram, the amplitude is represented by the height of the wave.)

There are various ways to increase your modulation. You can hold the microphone very close to your lips and talk loudly into it, and this will give good modulation. Or you can buy a power mike and then not worry about where the mike is or how loudly you speak—the power mike will take care of it.

If you do want to buy a power mike, there are some things to remember. First, not all power mikes fit all radios. Second, it takes some skill to install a power mike. And third, if your radio has a mike gain knob on it, you already have a power mike.

Now, I don't want to offend you or make you feel unwelcome, but why don't you take your radio and get out?!

Atronic CW Readout

(Continued from page 70)

above it seems to be flashing off and on at about the same rate as the *dots* in the received morse code. Then, adjust the *level* control until the LED above that control blinks on and off in time with the received signal—*on* whenever a dot or dash is sent, and *off* when the station is between letters.

You should be seeing letters and/or numbers blinking on the 16-segment LED. At this point, it may be necessary to readjust the controls to decode as best as conditions allow. A good signal, with no interference, and sent properly, can be decoded 100%.

QRN (which is shortwave slang for static interference) and *QRM* (meaning man-made interference from another station) will both hurt operation of the code reader to some extent. If the *QRN* level is too high, bringing the background noise up to or even peaking beyond the signal strength of the station to be decoded, it will be difficult to get an accurate level. What can really mess things is two or more stations both within the passband of your receiver. Simply put, the poor code reader doesn't know who to listen to first.

Even with the high *QRN/QRM* levels found on the ham radio bands, our test facilities were able to utilize the code reader in more than seventy percent of received signals that were copyable by ear. Even a very weak (S-4) station in Norway on 15 Meters was able to be copied via the reader.

A very nice feature is that there is a *speed* margin of 70% to 140%. This means, if you are copying one side of

a two-way code contact which is being sent at 20 wpm, you do *not* have to readjust the settings—if the other fellow is sending from 14 to 28 wpm.

There are also special characters used mainly in ham radio transmissions, though some utilities also make use of them. These are AS (meaning *wait* and displayed as an arrow); BT (which stands for *break between thoughts* displayed as a dash); and AR (which means *end of transmission* and is displayed as a square).

Roll Your Own? The Atronics Code Reader is available as a kit for \$149.00 or fully assembled as \$225.00. The kit version went together quite nicely.

If you have a few Heathkits under your belt, and if you've done any integrated circuit PC board wiring, you should be able to put the code reader together in an evening. However, this is a kit which requires much attention to detail. Every single step is *not* spelled out for you and/or illustrated. You receive two PC boards (the main board and the readout board), all parts, a schematic diagram, a component side diagram, and five pages of instructions.

Other options are available as accessories from Atronics. An electronic keyer module (that includes a speaker) will turn the code reader into a code sender as well (for \$29.00). If you'd like hard copy of your listening activity then Atronics offers a Teletype Interface Module, for \$85.00, which will turn your teletype into a decoding demon.

For more information on the Atronics Code Reader, write direct to the company at Bldg. E, Suite 1103, Canada Business Center, 22600 Lambert St., El Toro, California 92630—or circle number 119 on the Reader Service Card.

Kathi's Carousel

(Continued from page 58)

an LED power indicator lamp, a normally blacked-out ON THE AIR sign, and a gain control calibrated at 0 dB (no gain or loss), +13 dB, and -25 dB.

The gain control is connected between the antenna input and the preamplifier and actually serves as a level control for the preamplifier's input signal. In this manner overload from strong local signals is avoided—you just turn down the gain until the overload disappears. It even prevents the overload which can take place normally in certain model transceivers if the received signal is too powerful.

Summing Up. The Communications Power Range Plus delivers everything that's claimed for it, which is a lot more than I can say for many of the "CB accessories" presently cluttering the marketplace. If you need a receive preamplifier you probably can't do better than the Range Plus, particularly if you need one that can work, without modification, for both base and mobile CB radio operation.

The Range Plus is priced at \$59.95. For additional information circle No. 52 on the reader's service coupon.

NEW & DAZZLING!!!

MS-15 Miniscope



With Rechargeable Batteries & Charger Unit

\$318

- 15-megahertz bandwidth.
- External & internal trigger.
- Auto or line sync modes.
- Power usage — < 15 W.
- Battery or line operation.
- 2.9" H x 6.4" W x 8.0" D.



Non-Linear Systems, Inc.

Originator of the digital voltmeter.

Box N, Del Mar, California 92014

Telephone (714) 755-1134 TWX 910-322-1132

CIRCLE 29 ON READER SERVICE COUPON

DEFEND YOURSELF

Precision made
7 shot
.22 Cal.
Tear Gas
Non-Lethal
Automatic —
No Federal
Firearms License Required.

Send **\$24.99** ADD \$5.00 FOR 25 ROUNDS & PREPAID INSURED DELIVERY NO COD'S PLEASE

DEFENDER
DEPT A-2340 NEW CASTLE, DEL. 19720



WRITE NOW FOR **McGEE'S**
BIG SPEAKER CATALOG

1001 BARGAINS IN

SPEAKERS — PARTS — TUBES — HIGH FIDELITY COMPONENTS — RECORD CHANGERS
Tape Recorders — Kits — Everything in Electronics

1901 McGee Street, Kansas City, Missouri 64108

HIGHLY PROFITABLE **ONE-MAN ELECTRONIC FACTORY**

Investment unnecessary, knowledge not required, sales handled by professionals. Postcard brings facts about this unusual opportunity. Write today!
Barta - E.J. Box 248, Walnut Creek, CA 94597.

LEARN MICROCOMPUTER PROGRAMMING

Send for **FREE Brochure.**
Logical Services Incorporated
1080 H East Duane Avenue
Sunnyvale, CA (408) 245-8855

Be a LOCKSMITH!

EARN WHILE YOU LEARN

Send for **FREE BOOK**



Big opportunities. Big profits. Earn quickly. Full or part time. Learn at home, it's easy. Do real jobs: All Tools — Materials Supplied. Accredited member NHSC. Lic. State of NJ — Appd. for Vet. Send name and address for **FREE book.**

Locksmithing Institute, Dept. 1472-098 Little Falls, N. J. 07424
Div. Technical Home Study Schools,

PARTS! CORNELL TUBES!

FREE Send For FREE CORNELL'S New Color Catalog 48 Pgs. New Items

33¢ per tube

IN LOTS OF 100

36¢ per tube

ORDER FREE IF NOT SHIPPED IN 24 HOURS!

4219 E UNIVERSITY AVE. SAN DIEGO, CALIF. 92105

NEW! 1978 **MICROCOMPUTER CATALOG**

Giant, information-packed catalog lists 1,000's of mini/micro computer products, plus books & peripherals for professionals & beginners alike.

NCE/Compumart
Dept EYH Box 8610 Ann Arbor, MI 48107

FREE
Norm.
\$1.00

**Take stock in America.
Buy U.S. Savings Bonds.**

Computer Readout

(Continued from page 74)

unplugged and updated with another one from SBE. The Nitron has other instructions built into its memory such as automatically handling channels for ship-to-ship and ship-to-shore communications, and a memory for a channel you may want to save for later use. Accurate frequency control is another advantage of such a radio. The radio cost about \$650. A new unit to be available very soon is called the Sea Command. In addition to the features of the Key/Com Fity Five, this new marine radio will automatically scan through the 78 channels

CB Radio. As with marine radios, a processor chip makes the job of selecting channels, finding a conversation, quickly targeting on emergencies, and locking onto frequencies with great accuracy. The Key/Com 1000 is a mobile AM unit and was the first CB rig with a microprocessor and a keyboard. Giving the units commands to scan up or down, fast or slow, is like using a pocket calculator—you just have to know what key to press. The front shows a big, bright, LED display for showing all channels, power output, et cetera. There are two very nice ideas programmed into the Key/Com microprocessor. First, you can put up to ten of your favorite channels into a special memory, then hit a "go" button. The CB rig will scan those channels repeatedly until a conversation is found,

Auto Alarm

(Continued from page 66)

and to the trunk lid, station wagon tailgate and the hood. You can buy such switches at an automotive supply store and wire them in as shown for the more common type dome light circuit (see diagram). Similar additions can be made to a grounded type dome light system.

Programming the Delays. After installation of the alarm system, make some tests to determine whether you are satisfied with the three time delays. If so, just wrap the PC board in a heavy plastic bag and hang in any convenient, out-of-sight place under the car dash by means of a tie cord. You don't need a fancy casing.

You can alter any of the time delays by simply changing the values of appropriate resistors: R7 for the pre-alarm timer; R8 for the exit timer; R11 for the alarm timer. Increase the value of a resistor to lengthen the time delay, reduce the value to decrease the time

at which point it stops. The processor is programmed to sit on each channel for one half second, then proceed to the next. Second, one channel can be placed in a special register and treated as a high priority channel. The processor will sample that channel every three seconds for activity and if incoming conversation is found it will automatically switch the radio from the channel you are listening to, onto the high priority channel. A noise blanker, power output meter and signal strength meter are all part of the Key/Com 1000, which sells for about \$295. Scheduled for entry on the market very soon is the Console VI by SBE which is a base station with all the processor controls the 1000 has but with SSB in addition to AM.

What Next? By now you may be convinced that microcomputers are an aid to the world of radio communications, and once you try some of the above units you will probably be hooked. But the future holds more. What can you dream up? Send me a note; I would like to hear your ideas. As for myself, I am waiting to hear (this is my blue sky idea) that some company has built a microprocessor into the control panel of a radio controlled airplane. Left banks, spins, sudden dives, and figure eights could all be precisely timed by the processor. In fact, two planes could be controlled at one time by the single processor so as to make near misses and elaborate Thunderbird-like patterns. How about you—any ideas? I'll take the five best and mention them in a future column.

delay.

You can figure the approximate resistor value (or calculate the time provided by any resistor/capacitor combination) by using a simple $T = RC$ equation in which $T =$ seconds, $R =$ ohms and $C =$ farads. Capacitor values are given in microfarads, so you must divide by one million to obtain the equivalent value in farads.

Example: Calculate the time delay for the pre-alarm timer in which $R = 100K$ and $C = 47 \mu F$:

$$T = 100,000 \text{ ohms} \times \frac{47 \text{ farads}}{1,000,000}$$

$$T = 4.7 \text{ seconds}$$

Order your ALR-1 kit (\$9.95) or pre-wired ALR-1WT (\$19.95) from Optoelectronics, Inc., Box 219, Hollywood, Fla. 33022. For orders in USA and Canada add 5% for shipping, handling & insurance. All others add 10%. There's an additional \$1.00 charge for orders under \$15.00, and another \$1.00 for COD shipment. Florida residents add 4% tax. For additional information circle No. 51 on the reader service coupon.

**Lab Test
Elementary
Electronics
For
Yourself**

**Get switched-on with - the
magazine for electronics
fans and hobbyists**

it gives you the complete, ground-floor lowdown on a variety of important electronics subjects. For example— Understanding Transistors . . . How Radio Receivers Pull in Signals . . . Cathode Ray Tubes Explained . . . How Capacitors Work . . . Using Magnetism in Electronics. And more!

In case you're not all that familiar with us, were *not* a publication for electrical engineers and other wizards. *No way.* ELEMENTARY ELECTRONICS is expressly for people who like to build their own projects and gadgets—and maybe get a little knee-deep in tape, solder and wire clippings in the process.

In fact, we have a sneaking suspicion that our readers like us because they think we're just as bug-eyed and down-right crazy over great new project ideas as they are. And I guess they're right!

E/E thinks of you who dig electronics as the last of a special breed. It's more than just the "do-it-yourself" angle—it's also the spirit of *adventure*. In this pre-packaged, deodorized world, building your own stereo system, shortwave receiver, darkroom timer or CB outfit is like constructing a fine-tuned little universe all your own. And when it all works perfectly—it really takes you to another world.

ELEMENTARY ELECTRONICS knows the kinds of projects you like—and we bring 'em to you by the truckload!

Ever hanker to build a sharp-looking digital clock radio? Or to hook up an electronic game to your TV? Or an easy-to-build photometer that makes perfect picture enlargements? Or a space-age Lite-Com so you and the family can talk to each other on a light beam? We've got it all to get you started.

WHEN IT COMES TO REPAIRS E/E can save you time, trouble and a pile of money!

Has your sound system gone blooey just when the party's going great? Do you shudder when your friendly neighborhood electrician hands you the bill? E/E can help.

Of course, we can't make you a master electrician overnight. But we can show you the fundamentals of repair plus maintenance tips.

IF YOU'RE NEW TO ELECTRONICS YOU GET A "BASIC COURSE"!

That's right! It's a regular feature. And

- ENJOY GREAT ARTICLES LIKE THESE**
- How to Build Your Own Transformer
 - How to Select the Right Shortwave Receiver
 - The Burgeoning World of Microcomputers
 - Quickdraw Rickshaw—The Electric Car that Really Gets Around
 - What's Really Wrong with FM Radio?
 - How to Power-Up Your Antique Radio
 - The Vanishing Vacuum Tube
 - How to Customize Your CB Antenna
 - Those Incredible TV Sets of the Future
 - Listening in on the Forgotten Continent
 - DXing Endangered Species
 - Sandbagging—CB Fun Without a License
 - The World's Worst Hi-Fi Components

TRY A FEW ISSUES AND EVALUATE OUR . . .

► **GREAT PROJECT IDEAS.** Simulate space flight with our computer analog project. Build your own audio/visual darkroom timer. Restore your old car radio. Construct a see-through crystal radio.

► **HOW-TO-DO-IT HELP.** Tips and pointers that add up to money saved. For example—tuning up your tape player . . . all about radios . . . whys and hows of turntables . . . care and feeding of speakers.

► **NO-NONSENSE TESTS.** The scoop on Pioneer's TP-900 FM stereo car radio . . . How well does GE's NiCad charger pep up your pooped batteries? . . . What's your best bet in video games? Plus help in making buying decisions.



► **EXCITING DISCOVERIES.** Whatever your particular interest in electronics, you'll be entering a world of discovery in the pages of ELEMENTARY ELECTRONICS.

ELEMENTARY ELECTRONICS is regularly \$6.95 for 6 issues (one year).

But with this special introductory offer you can enjoy a full year for only \$3.98.

ORDER TODAY

"PLUG IN" to the excitement and satisfaction of
ELEMENTARY ELECTRONICS
 P.O. Box 2630, Greenwich, CT 06835 H8C399

Yes. Enter my subscription—6 issues for ONLY \$3.98.
 Payment enclosed. Bill me.
 (Outside U.S.A. and possessions \$5.00)

Name _____ Address _____
 City _____ State _____ Zip _____

Please allow 6 to 8 weeks for delivery of your first copy.

H8H081

ELEMENTARY ELECTRONICS—is published Bi-monthly. The rate per word for **CLASSIFIED ADVERTISEMENTS** is **\$1.30** payable in advance—minimum ad **\$15.00**. Capitalized words **40¢** per word additional.

ADDITIONAL INCOME

\$1 Investment pays \$50 (\$50 pays \$2500). Detailed instructions \$1.00. Cew Company, 533 Wooster Rd., Mt. Vernon, Ohio 43050.

AUTHOR'S SERVICE

PUBLISH YOUR BOOK! Join our successful authors. Publicity, advertising, beautiful books. All subjects invited. Send for fact-filled booklet and free manuscript report. Carlton Press, Dept. SMI, 84 Fifth Avenue, New York 10011.

BIG MAIL

RECEIVE MONEYMAKING OPPORTUNITIES. Your name placed with 2,000+ Importers, Wholesalers, manufacturers, etc. Year listing—\$1.00 (SAVE \$160.00 Postage!) Advertising Agency, Box 123-YNA, Wenonah, NJ 08090.

BLUEPRINTS, PATTERNS & PLANS

NEW CRAFT-PRINT CATALOG—Choose from over 100 great easy-to-build plans. Send \$1.25 (completely refunded with your first order). **BOAT BUILDER**, (CP Div.)—380 Lexington Ave., New York, NY 10017.

WHAT'S going on in housing? Get advice on how to economize in modernizing or improving or adding space from idea to completion. Working blueprints available. Send \$1.50 (includes postage) for 110 Better Building Ideas to: Davis Publications, Inc., 380 Lexington Ave., New York, NY 10017.

BOOKS & PERIODICALS

FREE subscriptions to 101 idea magazines. Yours for the asking. Confidential list tells how. Guaranteed. \$3 to WRA-11, Box 538, Belmont, CA 94002.

CBer's! Personalized CB decal with a 1-year subscription to Elementary Electronics only \$3.97. E/E, the magazine that covers CB and all areas of radio communication. Send check: Elementary Electronics, Decal Dept., 380 Lexington Ave., New York, NY 10017.

FREE Catalogs—Discount Paperbacks—Gambling Systems. Destiny, Box 366-R, Roundlake, IL 60073.

BUSINESS OPPORTUNITIES

BECOME our Mail Order Distributor with \$150 investment. Free brochure. Audit Controls, Box D-35, Emerson, NJ 07630.

BORROW ANY AMOUNT Enjoy A-1 credit. Keep money in bank. Get 80% more. Send Stamp. Vernon, Box 75010-HH, Oklahoma City 73107.

OWN Your Own Business! Correspondence Club Magazine. Information. Details 25¢. Destiny, Box 5637-BC, Reno, Nevada 89503.

MAILORDERS \$2,000+ Monthly selling information by mail. Free proof! Associates, Box 123-L, Wenonah, NJ 08090.

MILLIONS in Mail! Free Secrets. Transworld-3, Box 6226, Toledo, OH 43614.

NEW Luxury Car Without Cost! Free details. CODEX-A, Box 6073, Toledo, OH 43614.

HOW TO RECRUIT COMMISSION SALES-PEOPLE! Free Details! Success Publications, P.O. Box 35305, Edina, MN 55435.

\$300.00 MONTHLY. Start immediately. Stuff envelopes at home. Information, send self-addressed stamped envelope. Village, Box 2285-DFI, Irwindale, CA 91706.

OPPORTUNITY! Earn at home! Good business. Free booklet! Fay's 484E N. Main, Kalispell, MT 59901.

100% PROFIT Bronzing Baby Shoes. Free Literature. NBC Box 1904-DG, Sebring, FL 33870.

STAY HOME! EARN BIG MONEY addressing envelopes. Genuine offer 10¢. Lindco, 3636-DA, Peterston, Chicago 60659.

PHOTO mus-photo button machines. Brochure. Sample button \$1.00. Write Coffman, 3973M, Glenhaven, Abilene, TX 79603.

MAIL-ORDER BOOK DEALERS WANTED! Free Details! Books, P.O. Box 395 B, Excelsior, Minnesota 55331.

BUSINESS OPPORTUNITIES—Cont'd

SAVE \$25.00 Or More On Postage. Eliminate Unnecessary Time Spent Mailing and Addressing! \$2.00 Forwards Your Name and Address to **BUSINESS OPPORTUNITIES, ADDITIONAL INCOME, MONEY-MAKING OPPORTUNITIES, Advertisements**, this Issue. G & G MAILING SERVICE, INC., P.O. Box 4676, MANCHESTER, NH 03105.

\$3000.00 MONTHLY. Start immediately. Stuff envelopes at home. Information, send self-addressed stamped envelope Village, Box 2285-DFG, Irwindale, CA 91793.

\$30.00 HUNDRED stuffing our circulars into stamped addressed envelopes. No limit. Beginners Kit \$2.00 (Refundable). Colosso!—Box 333-DC, Brooklynn, NY 11219.

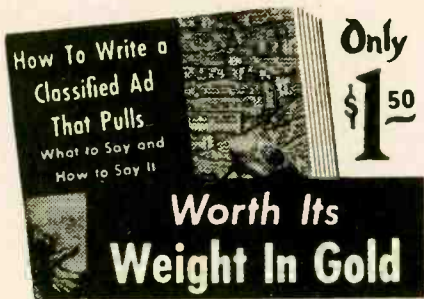

MAKE YOUR CLASSIFIED AD PAY. Get "How to Write A Classified Ad That Pulls." Includes Certificate worth \$2.00 towards a classified ad in this publication. Send \$1.50 (includes postage) to R. S. Wayner, Davis Publications, Inc., Dept. CL, 380 Lexington Ave., New York, NY 10017.

PLEASE Be sure to include your zip code when ordering merchandise from classified advertisements. You'll receive faster delivery.

EASY-to-start rubber stamp business at home in spare time. Make up to \$16.50 an hour without experience. Facts free! Write to: Roberts, Room RC-107-HJ, 1512 Jarvis, Chicago, IL 60626.

HOMEWORKERS—\$1000 Weekly mailing circulars! Stamped envelope: KV Advertising, Box 13283, Ft. Carson, CO 80913.

\$500 Monthly Clipping Newspaper items. Experience unnecessary. Free Details. American 1108 Colonial, Inokster, MI 48141.

\$60 hundred addressing envelopes. Guaranteed earnings. Rasmussen, DP98, 1747 N. 450 I, Ogden, UT 74404.

EXTRA Money Selling Information By Mail. Jones, D98, 145 14 Avenue, Vancouver, B.C., Canada V5Y 1W8.

DIRECT TO FARM SALES. New Patented Product! \$100/Day. Free Details! Conservtek P.O. Box 35305, Edina, MN 55435.

\$250 Weekly Possible. Unique Circular Plan: Kings Way Enterprises, Box 16184C, Portland, OR 97216.

FREE! NEW report: MAIL ORDER MADNESS! Amazing "Insiders" SECRETS EXPOSED! Winter, Box 442-NOP, Brooklynn, NY 11230.

117 Services Anyone can sell by mail. 12 page report tells how. Free details. EmJay Sales, Box 27611-C, Escondido, CA 92027.

4,000 Monthly Possible Stuffing and Mailing Envelopes. Free Details. Martin and Associates, P.O. Box 24266, Columbus, Ohio 43224.

EARN BIG PROFITS in Wholesale! We will show you how. Write: The Walton Co., 3765 Eudora St., Denver, CO 80207.

\$480 WEEKLY. Home mailing program. Free Details. Glad, Box 5368-JIC, Lighthouse Point, FL 33064.

BUSINESS OPPORTUNITIES—(Cont'd)

NEW 5 "proven" wholesaling opportunities. Make \$100.00 daily! "Capital/experience unnecessary." Free brochure! Allrightco, Box 91309-Z, Cleveland, OH 44101.

BUY IT WHOLESALE

400,000 BARGAINS Below Wholesale! Many Free! Liquidations, Closeouts, Job Lots, Single Samples. Free Details. Worldwide Bargain-hunters, Box 730-IO, Holland, MI 49423.

YOU save money on CB-record-tape accessories. Send self addressed stamped envelope. TapeC, Box 19, Santa Maria, CA 93456.

DETECTIVES

INVESTIGATORS' MANUALS: Electronic surveillance, lock picking, etc. Write: Mentor, Dept. 5, 135-53 No. Blvd., Flushing, NY 11354.

DO IT YOURSELF

15W-60Wx2 Amplifier Modules under \$82.00. Free Catalog. Audiovision Service, Box 955, Stn. B, Willowdale, Ont., Canada M2K 2T6.

FREE encyclopedia winemaking, beermaking supplies, equipment, ingredients. Vynox Industries, Box IC 7498, Rochester, NY 14615.

FOR anyone who wants the satisfaction and economy of repairing, furnishing and maintaining the furniture in his home. Send \$1.50 to FURNITURE, 380 Lexington Ave., New York, NY 10017.

EDUCATION & INSTRUCTION

USED Courses! Books! Lists 25¢ SMITH'S, 124 Marlborough, Salem, MA 01970.

GET INTO BROADCASTING: Become DJ engineer. Start your own station, get free equipment, records. Free details. "Broadcasting," Box 5516-G9E, Walnut Creek, CA 94596.

COLLEGE degree by mail, via resume. Education, 256D South Robertson, Beverly Hills, CA 90211.

TAX BENEFITS! Information \$1.00 donation. SASE. UDM, Box 100, Wolf Point, Montana 59201.

ELECTRICAL EQUIPMENT & SUPPLIES

FREE CATALOG: Electronic supplies—kits for the hobbyist. Low prices. Anklam Electronics, 4709 nth. 6th St., Wausau, WI 54401.

BUILD YOUR OWN TV CAMERA. Great for home and business. Free illustrated catalog. Phone or write: 402-987-3771. ATV Research, 13 E. Broadway Dakota City, NB 68731.

B&K test equipment. Free catalog. Free shipping. Dinosaur discounts. Spacatron-FJ, 948 Prospect, Elmhurst, IL 60126.

WALKIE TALKIE CRYSTALS—We made a great buy and we want to share it with you! Special! While they last. All 40 channels available—in stock—transmit and receive—fits all walkie talkies \$2.95 each. Certified check or money order. C.O.D. ok plus postage and charges—ROLIN DISTRIBUTORS P.O. Box 436, Dunellen, NJ 08812. 201-469-1219.

FOR THE HOME

PRACTICAL tips for home, garden and workshop can be found in "1001 How-To Ideas." Send \$1.50 for your copy (includes postage) to 1001 How-To Ideas, 380 Lexington Ave., New York, NY 10017.

GOVERNMENT SURPLUS

JEEPS—\$50.30 — **CARS**—\$33.50! **200,000 ITEMS**—**GOVERNMENT SURPLUS**—**MOST COMPREHENSIVE DIRECTORY** AVAILABLE tells how, where to buy—**YOUR AREA** — \$2.00 — **MONEYBACK GUARANTEE.** Government Information Services, Department E9, Box 99249, San Francisco, CA 94109 (433 California).

JEEPS \$60.00, typewriter \$4.00. "HOW TO MAKE MONEY ON GOVERNMENT SURPLUS" tells how and where to buy in your area for your own use or for resale. Send \$2.40. The Mail Sac, Dept. C1978, 600 Welch Blvd., Flint, MI 48503.

HYPNOTISM

FREE Fascinating Hypnosis Information! Startling! DLMH, Box 487, Anaheim, California 92805.

UNIQUE 8 lesson hypnosis course. Details: Jefco, Rt. 12 Box 330G6, Indianapolis, Indiana 46236.

THERE IS NO CHARGE FOR THE ZIP CODE—PLEASE USE IT IN YOUR CLASSIFIED AD

PLACE

To be included in the next issue, please send order and remittance to R. S. Wayner, ELEMENTARY ELECTRONICS, 380 Lexington Ave., New York, N.Y. 10017

INVENTIONS WANTED

INVENTIONS, ideas, new products needed for production, licensing or marketing. Contact Pixonix Corporation, 22 Walter Street, Pearl River, NY 10965. Request Kit DP.

JEWELRY

SILVER and ABOLONE JEWELRY WHOLESALERS! DETAILS \$1.00 REFUNDABLE. Buddy, 3641 Capitol Heights, Baton Rouge, LA 70806.

MAGNETS

MAGNETS. All types. Specials-20 disc, or 10 bar, or 2 stick, or 8 assorted magnets, \$1.00. Magnets, Box 192-E, Randallstown, MD 21133.

MAIL-ORDER OPPORTUNITIES

GET 300% interest on your savings account. Rush \$1 to G. Thistle, 6452 1/2 Lanershim Blvd., North Hollywood, CA 91606.

MISCELLANEOUS

PRINTED Circuit Boards from Sketch or Artwork. Free Details DANOCINTHS, Box 261 Westland, MI 48185.

NEW Invention guarantees substantial mileage increase or refund. Dealership information: \$2.00. Anderson Engineering, Epsom, New Hampshire 03234.

MONEYMAKING OPPORTUNITIES

\$250.00 profit/thousand possible-stuffing-mailing envelopes. Offer: Rush stamped addressed envelope: Universal-ADVS X16180 Fort Lauderdale, FL 33318.

\$500 thousand stuffing envelopes. Free details. Rush self stamped envelope. R. Mognet Co., Box 449D, Warren, OH 44482.

FANTASTIC Profits: Mailing Circulars Free Samples. Grahamco, DPBX 99371, Tacoma, WA 98499.

WIN \$5000.00 in monthly free contest. \$5 enrollment enters you full year! Contests, 2830DI-Gaffey, San Pedro, CA 90731.

\$180.00 WEEKLY Mailing Circulars. Start immediately. Eveready, 422A Clermont Ave., Brooklyn, NY 11238.

MAKE YOUR CLASSIFIED AD PAY. Get "How to Write A Classified Ad That Pays" includes certificate worth \$2.00 towards a classified ad in this publication. Send \$1.50 (includes postage) to R. S. Wayner, Davis Publications, Inc., Dept. CL, 380 Lexington Ave., New York, NY 10017.

\$2,000 monthly possible stuffing envelopes! Send stamped self-addressed envelope! Craft, Box 2230 D, Oceanside CA 92054.

"WIN thousands! Thoroughbred, Harness, Dog! Guaranteed. Free report. Finish-A, Box 6226, Toledo, OH 43614."

WATCH IT! Get literature first! Mailorder seminar \$2. Details free. Maelbux, 18028BC, East Hartford CT 06118.

\$400 Weekly extra income possible. Proven program. Guaranteed. Free details. Write: Goodson, P.O. Box 91110, Cleveland, OH 44101.

STUFFING ENVELOPES \$800/\$1000 IMMEDIATELY. SEND SELF-ADDRESSED STAMPED ENVELOPE to R. Murray Enterprise, 6775E, 6750S, Box 88, Jensen, Utah 84035.

PROFITABLE Mailorder plans. \$1.00 and stamped envelope. N. Daugherty, 255-D Bluegrass Drive, Hendersonville, TN 37075.

\$100 weekly/kitchen table! American, Box 438-ZI, Pomona, Kansas 60676.

\$45,000-Three weeks-Guaranteed! Send self-addressed stamped envelope. Bob Burt, Rt. 6 Box 460, Fort Payne, AL 35967.

MAKE lots of money selling new magnetic padlock. Send for details. Suburban, 36 Concord Rd., Westford, MA 01886.

\$83,501.00 FREEBIES WAITING! GOVERNMENT DIRECTORY \$3.00. PALMER, B1244DG, Phenix City, AL 36867.

STUFF ENVELOPES \$250 per thousand. Free supplies. Rush stamped addressed envelope. L/L Enterprises, Box 226-D, Danville, AL 35619.

MONEYMAKING OPPORTUNITIES-Cont'd

UNIQUE! money making opportunity from your home! Rush stamped addressed envelope. Ronald Gress, 7214 Lowell Drive, Overland Park, Kansas 66204-Dept. 12.

\$300.00 WEEKLY, Mailing Circulars. Write: McGuire, Box 91054, Tacoma, WA 98491.

\$3,000 MONTHLY stuffing envelopes. Details free. Northeast Enterprises, P.O. Box 537, Dept. IN, Laurel Springs, NJ 08021.

GUARANTEED \$240 WEEKLY! Sparetime-mailing circulars. Write: YJCO, 3469 Pondview, Erie, PA 16506.

\$500 CASH ADVANCE mailing circulars. Information-SASE and \$1. Freedom 2122, Box 20451, Columbus, OH 43220.

WIN cash prizes entering famous national million dollar sweepstakes! Free details! Contests, Box 7469-DV, Philadelphia, PA 19101.

FAST Money-makers. Any age. 1mm \$2.00, 2mm \$3.00, both \$4.00. Frescas, Box 480, Waimanalo, Hawaii 96795.

\$480 WEEKLY mailing circulars! NEW, easy program. FREE details! SAWYER'S, 3411 Wellington, Wichita, Kansas 67204.

OF INTEREST TO WOMEN

FREE pair sterling silver earwires and money-making ideas. Wind River Lapidary, 3039 Pheasant Drive, DPJ-3, Decatur, Georgia 30034.

OLD GOLD WANTED

BUYING GOLD, silver, platinum, any form! Jewelry, sterling, coin, industrial. Prompt appraisal and payment. Your approval guaranteed. American Metallurgy Company, P.O. Box 33009, Charleston, SC 29407.

PEN PALS

JOIN North America's leading penpal club. Details from Friends Worldwide CP-95/F Anjou, Montreal, HIK 4G5.

PERSONAL

NEW Luxury Car Without Cost! Free Details. Codex-CC, Box 6073, Toledo, OH 43614.

DATES GALORE! Meet singles-anywhere. Call DATELINE, toll-free (800) 451-3245.

PINSTRIPES your way to riches! You can teach yourself and make \$1000 or more each week. Send \$6 for additional information Sundance Enterprises, Box 57945, Webster, TX 77598.

ADULT pleasure products-over 600 items! Giant catalog \$1.00. Clifton's, D-1068, Saugus, CA 91351.

DO YOU KNOW "How to Write a Classified Ad That Pays" includes a certificate worth \$2.00 toward a classified ad in any of our publications? For your copy send \$1.50 (includes postage) to R. S. Wayner, Davis Publications, Inc., Dept. CL, 380 Lexington Ave., New York, NY 10017.

BEAUTIFUL GIRLS from all continents want correspondence, friendship, marriage. Sample photos free. Herms-Verlag, Box 110660/D, 1000 Berlin 11, Germany.

SINGLE? Widowed? Divorced? Nationwide introductions! Identity, Box 315-DC, Royal Oak, MI 48068.

JAPANESE Girls Make Wonderful Wives. We have large number of listings. Many interested in marriage. Only \$1.00 brings application, photos, names, descriptions, questionnaire, Etc. Japan International, Box 156 AA, Carnelian Bay, CA 95711.

BEAUTIFUL Mexican-Oriental girls Needing American Boy-Friends. Free Details "actual" photos. World, Box 3876-DC, San Diego, CA 92103.

"DATE WITH DIGNITY" Professional Matching. Drawer 6765, Fort Worth, 76115 (817) 921-0281.

RECORD telephone conversations privately-automatically. Leave recorder unattended. Robert's, Box 495M, Parkridge, IL 60068.

FREE: 1,000 LADIES PHOTOS. World's largest Matrimonial Catalog. Postage/Handling \$1.00. Inter-act, Box 12, Toronto, Canada M4A 2M8.

BEAUTIFUL MEXICAN GIRLS! Friendship, marriage! Photos, information free. "Latinas," Box 1718-E, Chula Vista, CA 92012.

PERSONAL-Cont'd

"MIRACLE ACNE CURE" by Swedish doctors! Free details: LABORATORIES, 2830-EE Gaffey, San Pedro, CA 90731.

JAPANESE Introductions! Girls' photographs, descriptions, brochure, details, \$1.00 INTER-PACIFIC, Box 304-SC, Birmingham, MI 48012.

SWEDISH women travelling country! All cities, towns. Details, photos \$1.00. Ingrid, 2520 N. Lincoln, Suite 255-A, Chicago 60614.

LOVELY? Write Johnson's dating service, 228 Banner St., Danville, VA 24541.

FOREMOST MATRIMONIAL CATALOG with Your Type Girls and Combined Action. Extra Large Photos, Details, 45 pages, Mailed for \$2, by OIB, Box 893, Sta. A, Montreal, Canada H3C 2V8.

RADIO & TELEVISION

TV TUBES 36¢ each. Send for Free 48 page color catalog. Cornell, 4217-W University, San Diego, California 92105.

BROADCAST STATION: Operate from home, school, church. Receive free tapes, records. Learn details! Broadcasting, Box 5516-G9E, Walnut Creek, CA 94596.

SHORTWAVE DXers! Reception report sheets and postcards now available 4x6 inches. Large space for program details and all information needed for QSL. Pad of 30-1.00. Postcards-10 each. Minimum order: \$2.00. RAB, Box 386, North Myrtle Beach, South Carolina 29582.

LINEAR AMPLIFIERS, 25-100 watt solid state. OMNIPOLARIZED BASE ANTENNAS. Portable/mobile/memory/300 MHZ FREQUENCY COUNTER. Construction plans: \$3.00 each, \$37.50. Specify frequency band! Kits available. Free catalog! PANAXIS, Box 5516-G9E, Walnut Creek, CA 94596.

TUBES Oldies, latest. Supplies, components, schematics. Catalog free. (Stamp appreciated). Steinmetz, 7519-EE Maplewood, Hammond, IN 46324.

DISTANCE crystal set construction handbook-50¢. Coil winding-50¢. Catalog 50¢. Laboratories, 1477-G, Garden Grove, CA 92642.

DIAGRAM manuals, television-radio, fourteen volumes, regular price \$50.75, only \$19.85. Supreme Publications, Box 46, Highland Park, IL 60035.

SCANNER crystal certificates, \$2.50 each. CB and scanner catalog \$1.00 refundable with order of \$5.00 or more. We accept visa and master charge. Randall Communications, P.O. Box 23174, Milwaukee, WI 53223.

RECORDERS, SOUND EQUIPMENT

"CASSETTE recorder tune-up tips." Do-it-yourself! Save! Illustrated booklet \$2.00 postpaid. Cassetteco, 2060 Sunderland, Maitland, Florida 32751.

RUBBER STAMPS

RUBBER stamps made. Three lines \$3.75. Rubber Stamps, B1337-E9, Waldo, AR 71770.

SCIENCE & CHEMISTRY

FIREWORKS. Spectacular novelties, simplified manufacturers textbook, \$5.00. Guaranteed. Tropic, Box 95M4, Palm Bay, FL 32905.

SONGWRITERS

SONGWRITERS: Exciting offer-poems, songs needed-Free evaluation-Creative Music Productions, Box 1943-A9, Houston, TX 77001.

SPECIAL SERVICES

PCB DESIGN AND DRAFTING SERVICE, FAST SERVICE, LOWEST RATES. ENERTEC, POB 2436, SAN JOSE, CA 95109.

SPORTING GOODS, FISHING TACKLE, ARCHERY, ETC.

DALLAS COWBOY CHEERLEADERS Posters, Calendars, T-Shirts. For information, write: COWBOYS, P.O. Box 1412, San Angelo, Texas 76902.

START YOUR OWN BUSINESS

GET World's Biggest Wholesale Import Merchandise Catalog. Details Free. Worldround-P, Medina, WA 98039.

WATCHES, WATCHMAKING & REPAIRING

WATCH and clock repairing books, tools, materials. Free catalog. North American, Box 77, EE45, Fox River Grove, IL 60021.

THERE IS NO CHARGE FOR THE ZIP CODE-PLEASE USE IT IN YOUR CLASSIFIED AD

Grandpa's Whiskers

(Continued from page 61)

CAUTION. Make sure that the battery is disconnected for this initial adjustment.

Connect an antenna to J1, a ground to J2, and a pair of high-impedance headphones to J5 and J6. A pair of 2000-ohm phones was used with our model; do not use low impedance headphones (8, or 16 ohm stereo types). Do not connect the 6-volt battery at this time.

Make sure that the catwhisker is not touching the crystal or the crystal cup (open circuit to the carborundum crystal), and then connect the crystal diode across J7 and J8 (the polarity is not important; it will work either way). Connect both of the clip leads (lead to J8 and lead to C1A-C1B) to L1 coil taps; any of the mid-coil taps will do for an initial start. Set C1A-C1B to mid-capacity range and then tune C2 until you hear a radio station in the headphones. Readjust the setting of C1A-C1B for best headphone volume. Then readjust each one of the clip leads for best headphone volume of the received radio station. All of the adjustments and coil tap settings will interact,

and will require careful retuning of both C1A-C1B and C2 for best results.

When a radio station is tuned in for best headphone volume, carefully disconnect the germanium crystal diode from J7 and J8 without disturbing the tuning capacitor settings or the positions of the L1 tap connections. Then place a carborundum crystal in the detector assembly and connect the 6-volt battery to J4 (negative lead) and J3 (positive lead). Adjust the catwhisker until it touches the carborundum surface and then set the bias control R1 to mid-range.

Carefully adjust the catwhisker for a sensitive spot on the crystal surface at the same time adjusting R1 for best volume of received signal. If this seems like a lot of trouble to hear a radio station, remember the radio pioneers around the turn of the century would spend considerable time with equipment even cruder than Grandpa's Whisker in order to capture the elusive wireless signals. After a station is found with the carborundum detector, it may be possible to achieve a bit more received volume by readjusting the coil taps and tuning capacitors.

You can experiment with different types of silicon and germanium crystals as well as other materials with this circuit; but remember, do not use the battery unless it is with a carborundum crystal. The battery will burn out the more conventional germanium and silicon crystals. You can also try chips of carborundum broken off of sharpening stones, etc. and held with melted solder or lead. Or you can also try packing the crystals with sections of crumpled aluminum or lead foil in place of the melted lead bodies. The received crystal set volume will vary according to the type of crystal used; generally germanium will be loudest, and silicon a bit less, and the carborundum crystal will usually be lower in volume. ■

ELEMENTARY ELECTRONICS INDEX TO ADVERTISERS

RS#	ADVERTISER	PAGE
65	AP Products	24
41	AVR	26
5	Aldelco	82
20	Antenna Specialists	1
47	Avanti	13
6	B & F Enterprises	84
46	B & K Precision	32
—	Barta	92
—	C.I.E.	4-7
8	Cobra	3
9	Continental Specialties	CV3
—	Cornell	92
—	Defender	92
39	Delta	84
67	Digi-Key	82
—	Edmund Scientific	35
2	Eico	10
25	The Electra Co.	34
28	Electronics Book Club	27
—	Electronics Systems	86
11	Extron Life Screen	22
21	Godbout	84
1	Heath Co.	28-31
34	Information Unltd.	87
12	Int'l Crystal	35
45	Jameco	85
71	Kester	22
—	Locksmithing	92
—	Logical Services	92
—	McGee	92
38	Meshna	82
—	Moonlighter	35
—	NRI	18-21
—	Newman Computer	92
29	Non Linear	91
43	OK Machine	12
14	Page	84
13	PAIA	34
15	Percom Data	14
19	Polypaks	83
35	President	CV2
16	Progressive Edu-Kit	15
—	Radio Shack	17
—	Radio Shack	CV4
26	Sabtronics	16
17	Shakespeare	8, 9
22	Southwest Tech. Supply	36
36	Spyderco	33
18	Starshine	23
30	Trionette	33
23	Vector	10

Computer New Products

(Continued from page 46)

character set (96 characters) as standard equipment. It can print on roll, fanfold or sheet paper. A 256 character multi-line buffer is used to achieve an instantaneous print rate up to 100 characters per second with a sustained throughput of 50 cps at 80 columns per line. There are few moving parts and the ribbon is re-inking. Line length is 80 columns at 10 characters per inch (7x7 dot matrix format), with line lengths to 132 columns, print rates to 165 cps, print densities of 8.3, 10, 12 and 16.5 characters per inch and a full CRT screen size multi-line buffer of 2048 characters as optional equipment. Serial baud rates of 110 to 1200 are switch selectable. Circle number 64 on the Reader Service Card.

AVDEX Typits

(Continued from page 62)

Typewritten Program With Handmade Characters

```
10 PRINT "ENTER 3 NUMBERS"
20 INPUT A,B,C
30 IF A>B THEN 90
40 IF A<C THEN 90
50 X=A/B↑C
60 PRINT
70 GOTO 100
90 X=C/A↑B
100 LET P=(A/X) * (B/C) * A↑3 / C
110 PRINT P
120 END
```

Same Program Using Typits

```
10 PRINT "ENTER 3 NUMBERS"
20 INPUT A,B,C
30 IF A>B THEN 90
40 IF A<B THEN 90
50 X=A/B↑C
60 PRINT
70 GOTO 100
90 X=C/A↑B
100 LET P=(A/X) * (B/C) * A↑3 / C
110 PRINT P
120 END
```

Some Common Program Characters (symbols) available as Typits

[,], ↑, <, >, ^, \, +, *

As you can see in the above sample the Typits characters are clear and sharp—they look just like they came from the typing element. To get an impression just put the typit in place and type any letter.

to begin with. The photographs show how easy it is to install the guide assembly on a Selectric. Other typewriters might be easier or slightly more difficult.

Remove the typing element and ribbon, secure the guide assembly with the single supplied screw, and then replace the ribbon and element. Insert a typit into the guide and strike a letter (preferably the letter Z on a Selectric as the element doesn't rotate for a Z). If the typit symbol doesn't print exactly centered (vertical or horizontal) the position can be corrected by adjusting two small screws with the supplied Allen (hex) wrenches. The guides for other typewriters have similar adjustments. Once initially adjusted for centering (and it's never that far off to begin with) the symbol centering is more or less permanent. If the centering does drift off it can be corrected in seconds.

A catalog illustrating the typewriter guides and computer symbols (as well as Greek letters and scientific symbols, etc.) is available from AVDEX Corp., Box 146, Baldwin, N.Y. 11510 (Yes, the same outfit that manufactures low-cost personal computer data cassettes.) For more information circle No. 73 on the readers' service card. ■

FREQ OUT. FOR LESS.



100 Hz to 50 MHz.
\$89.95*

Introducing CSC's new Mini-Max. It brings down the cost of counting up the frequency for CB-ers, hams, computer enthusiasts, audiophiles... just about any engineer, technician or hobbyist will find it indispensable.

It's "mini"-sized, too — a pocketable 3 x 6 x 1½ inches.

But when it comes to performance, Mini-Max means maximum value. Measuring signals as low as 30 mV from 100 Hz to a *guaranteed* 50 MHz, with ± 3 ppm timebase accuracy and better than 0.2 ppm/°C stability from 0 to 50°C. *Completely automatically.* Advanced LSI circuitry with a crystal controlled timebase provides precise frequency readings on a bright, six-digit LED display, with automatic KHz/MHz indications. Mini-Max is versatile, too. You can connect it directly to the circuit under

test, or use its matching mini antenna for easy RF checking. Either way, the input is protected against overload to 50V (100V below 1 KHz).

Mini-Max is as inexpensive to use as it is to own. An ordinary 9 volt alkaline battery gives up to 8 hours of intermittent operation, and you have the flexibility of a battery eliminator for AC operation. For increased versatility, there's a complete line of accessories, including standard clip-lead cable and mini antenna — eliminator and carrying case are optional.

CSC's new, all-American made Mini-Max is everything you need for highly-accurate checking of frequencies up to 50 MHz. At a price that will Freq you out. *Order today.* Call 203-624-3103, 9 a.m. — 5 p.m. Eastern Standard Time. Major credit cards accepted. Or see your CSC dealer. Prices slightly higher outside U.S.A.

CONTINENTAL SPECIALTIES CORPORATION



*Manufacturer's suggested retail price.
© 1978 Continental Specialties Corporation

70 Fulton Terrace, Box 1942, New Haven, CT. 06509, 203-624-3103 TWX 710-465-1227
WEST COAST: 351 California St., San Francisco, CA 94104, 415-421-8872 TWX 910-372-7992
GREAT BRITAIN: CSC UK LTD., Spur Road, North Feltham Trading Estate, Feltham, Middlesex, England, 01-890-8782 Int'l Telex. 851-881-3669
CANADA: Len Finkler Ltd., Ontario

CIRCLE 9 ON READER SERVICE COUPON

Scanners will never be the same

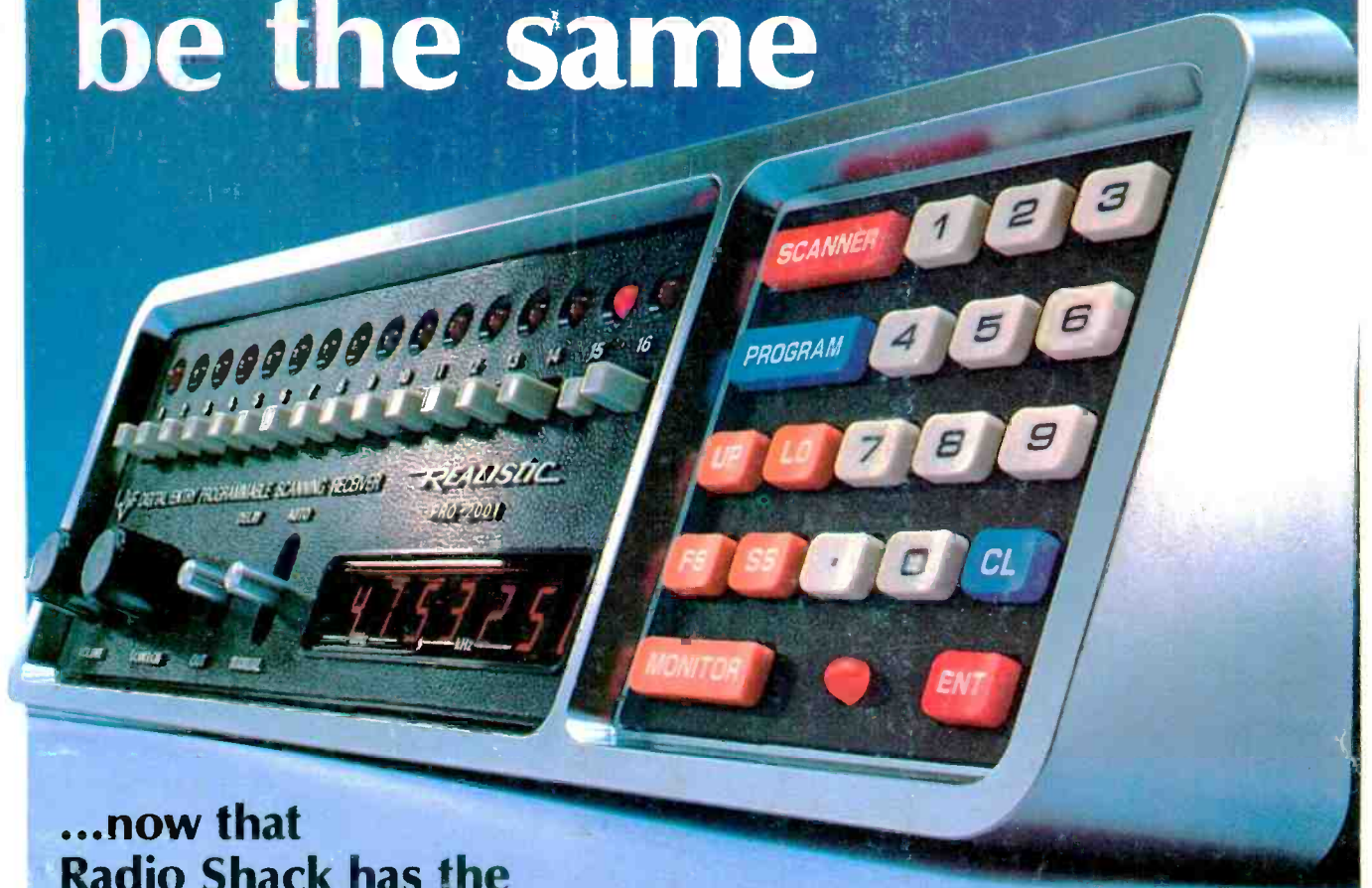

...now that Radio Shack has the amazing new Realistic 2001 with built-in microprocessor!

The PRO-2001 makes possible continuous, automatic reception of six UHF and VHF bands for all kinds of action — police, fire, Ham, weather, mobile telephone, railroad communications and more. And with its microprocessor you can program it for any 16 of 16,650 frequencies, without buying crystals!

Enter familiar area frequencies. Use the digital keyboard to punch-in actual frequencies for monitoring, storing or exploring — no codes or switches to slow you down. A special ENTER button reduces accidental entries. Digital readout shows which frequencies are being scanned, monitored or programmed into the memory. And you can monitor any frequency without entering it into the

scanner — it's like having a seventeenth channel for even greater versatility!

Search for "unknown" frequencies. The 2001's powerful search capability lets you find new, often unpublicized channels. Just enter lower and upper limits (they can even be in different bands) and select the search speed. The rest is automatic!

"Traditional" deluxe scanner features. LED channel indicators and individual lockout buttons. Automatic or manual scan. Switchable scan delay. High-speed skipper circuit. Built-in speaker, jacks for recorder, headphone, external speaker. With power cables for home or mobile use. The Realistic® 2001 — a revolution in action radio. About \$400.*



Mobile use in some states and localities may be unlawful or require a permit — check with local authorities.



FREE! New '79 Catalog

Come in for your copy and see what's *really* new in electronics. Bigger than ever! 176 pages, over 100 in full color. 2000 exclusive items.

*Price may vary at individual stores and dealers.

SOLD ONLY WHERE YOU SEE THIS SIGN:

Radio Shack®

A DIVISION OF TANDY CORPORATION • FORT WORTH, TEXAS 76102
OVER 7000 LOCATIONS IN NINE COUNTRIES