

elementary JANUARY-FEBRUARY 75¢
Electronics

All the facts!
**HAM RADIO'S
INCENTIVE
LICENSING
NEW 2-YEAR
NOVICE TICKET**

**FREE
PRINTED CIRCUIT
BOARD**

**BUILD THIS TONE SYNTHESIZER!
HEAR THE WEIRDEST
SOUND AROUND!**



**BONUS
PROJECT**
beginner's
1-tube
SW receiver

**STUDY
SESSION**
the transistor
that makes
like a tube

**TV
SPECIAL**
what to do
when the
color's gone

EICO Makes It Possible

Uncompromising engineering—for value does it!
You save up to 50% with Eico Kits and Wired Equipment.



Cortina Stereo

Engineering excellence, 100% capability, striking esthetics, the industry's only **TOTAL PERFORMANCE STEREO** at lowest cost.

A Silicon Solid-State 70 Watt Stereo Amplifier for \$89.95 kit, \$129.95 wired, including cabinet. Cortina 3070.

A Solid-State FM Stereo Tuner for \$89.95 kit, \$129.95 wired, including cabinet. Cortina 3200.

A 70-Watt Solid-State FM Stereo Receiver for \$159.95 kit, \$239.95 wired, including cabinet. Cortina 3570.



Eicocraft

The newest excitement in kits. 100% solid-state and professional.

Fun to build and use. Expandable, interconnectable. Great as "jiffy" projects and as introductions to electronics. No technical experience needed. Finest parts, pre-drilled etched printed circuit boards, step-by-step instructions.



EICOCRAFT Electronic Siren \$4.95, Burglar Alarm \$6.95, Fire Alarm \$6.95, Intercom \$3.95, Audio Power Amplifier \$4.95, Metronome \$3.95, Tremolo \$8.95, Light Flasher \$3.95, Electronic "Mystifier" \$4.95, Photo Cell Nite Lite \$4.95, Power Supply \$7.95, Code Oscillator \$2.50, FM Wireless Mike \$9.95, AM Wireless Mike \$9.95, Electronic VOX \$7.95, FM Radio \$9.95, AM Radio \$7.95, Electronic Bongos \$7.95.

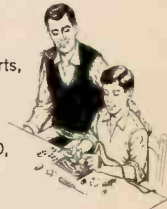

Citizen's Band

Two years ahead! Model 7923 All Solid-State 23-Channel 5W Transceiver. 4 exclusives: dual-crystal lattice filter for razor-sharp selectivity; efficient up-converter frequency synthesizer for advanced stability; precision series-mode fundamental crystals; Small: only 3"H, 8"W, 8 1/4"D. \$189.95 wired only.

The best buy in tube-type CB—"Sentinel-Pro" 23-channel dual conversion 5W Transceiver \$169.95 wired only.



EICO Trans/Match (Model 715) is a professional test set designed for complete checking of ham and CB equipment. Kit \$34.95; Wired \$49.95.



Truvohm

Professional Portable Multimeters by EICO. The industry's greatest V-O-M values. Designed, made to Eico's high standards of professionalism. Each complete with batteries & test leads. Backed 100% by famous EICO warranty.

- Model 100A4, 100,000Ω/V, \$34.95.
- Model 30A4, 30,000Ω/V, \$19.95.
- Model 30A3, 30,000Ω/V, \$15.95.
- Model 20A3, 20,000Ω/V, \$12.95.
- Model 4A3, 4000Ω/V, \$8.95.
- Model 1A1, 1000Ω/V, \$5.95.

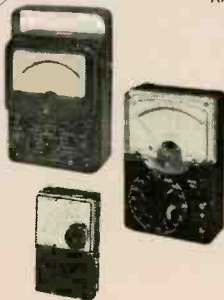

Automotive

EICO 888—Car/Boat Engine Analyzer.

For all 6V/12V systems; 4, 6, 8-cyl. engines.

Now you can keep your car or boat engine in tip-top shape with this solid-state, portable, self-powered universal engine analyzer. Completely tests your total ignition/electrical system.

Complete with a Tune-up & Trouble-shooting Manual. Model 888; \$44.95 kit, \$69.95 wired.



Model 232 Peak-to-Peak VTVM. A must for color or B&W TV and industrial use. 7 non-skip ranges on all 4 functions. With exclusive Uni-Probe.® \$29.95 kit, \$49.95 wired.

Test Equipment

100 best buys to choose from.

"The Professionals"
—laboratory precision at lowest cost.

Model 460 Wideband Direct-Coupled 5" Oscilloscope. DC-4.5mc for color and B&W TV service and lab use. Push-pull DC vertical amp., bal. or unbal. input. Automatic sync limiter and amp. \$109.95 kit, \$149.95 wired.

FREE 1968 CATALOG

EE-1

EICO Electronic Instrument Co., Inc.
131-01 39th Ave., Flushing, N.Y. 11352

Send me FREE catalog describing the full EICO line of 200 best buys, and name of nearest dealer.

Name _____
Address _____
City _____
State _____ Zip _____

10 Reasons why RCA Home Training is your best investment for a rewarding career in electronics!

1 LEADER IN ELECTRONICS TRAINING

RCA stands for dependability, integrity and pioneering scientific advances. For over a half century, RCA Institutes, Inc., has been a leader in technical training.

2 RCA AUTOTEXT TEACHES ELECTRONICS FASTER, EASIER

Beginner or refresher - AUTOTEXT, RCA Institutes' own method of Home Training will help you learn electronics faster, easier, almost automatically.

3 THOUSANDS OF WELL PAID JOBS ARE OPEN NOW

RCA Institutes can help you qualify for a rewarding career if you have an interest in electronics. Every year, thousands of well paid electronics jobs go unfilled just because not enough men take the opportunity to train themselves for these openings.

4 WIDE CHOICE OF CAREER PROGRAMS

Start today on the electronics career of your choice. On the attached card is a list of "Career Programs", each of which starts with the amazing AUTOTEXT method. Look the list over, pick

the one best for you and check it off on the card.

5 SPECIALIZED ADVANCED TRAINING

For those working in electronics or with previous training, RCA Institutes offers advanced courses. Start on a higher level. No wasted time on material you already know.

6 PERSONAL SUPERVISION THROUGHOUT

All during your program of home study, your training is supervised by RCA Institutes experts who become personally involved in your efforts and help you over any "rough spots" that may develop.

7 VARIETY OF KITS, YOURS TO KEEP

At no extra cost, a variety of valuable specially engineered kits come with your program—yours to keep and use on the job.

8 FROM RCA INSTITUTES, INC. TRANSISTORIZED TV KIT AND VALUABLE OSCILLOSCOPE

All students receive a valuable oscilloscope. Those enrolled in the TV program or courses receive the all-new Transistorized TV Receiver—both at no extra cost and only from RCA.

9 UNIQUE TUITION PLAN

You progress at your own pace. You only pay for lessons as you order them. There's no long-term contract or large down-payment to lose. Even if you decide to interrupt your training, you don't lose a single cent.

10 RCA GRADUATES GET TOP RECOGNITION

Thousands of graduates of RCA Institutes are now working for leaders in the electronics field; many others have their own profitable businesses... proof of the high quality of RCA Institutes training.

SEND ATTACHED CARD TODAY FOR FREE DESCRIPTIVE BOOK

All courses and programs approved for veterans under new G.I. Bill.

CLASSROOM TRAINING ALSO AVAILABLE. FREE CATALOG ON REQUEST. NO SALESMAN WILL CALL.

RCA INSTITUTES, INC. Dept. EA-18

320 West 31st Street
New York, N.Y. 10001

ACCREDITED MEMBER NATIONAL HOME STUDY COUNCIL



The Most Trusted Name In Electronics

Transistor experiments on programmed breadboard—using oscilloscope.



Construction of Oscilloscope.



Construction of Multimeter.



ELEMENTARY ELECTRONICS is published bimonthly at \$4.00 per year, by Science & Mechanics Publishing Co., 505 Park Avenue, New York, N.Y. 10022. Second class postage paid at New York, N.Y. and at additional mailing office. Copyright 1967 by Science and Mechanics Publishing Co.



elementary Electronics

Dedicated to America's Electronics Experimenters

SPECIAL CONSTRUCTION FEATURE

- ☆ 41 Fuzz-A-Tort—Hot number for way-out sounds

INSIDE ELECTRONICS

- ☆ 53 It Looks Like A Transistor—Meet the FET
- ☆ 81 What To Do When Color's Gone
- 91 Transducers—Man's electronic sixth sense
- 111 Operation Fixit—For troubled transistors

CONSTRUCTION PROJECTS

- 51 1-FET BCber—The receiver with a difference
- ☆ 57 Neophyte 1—1-tube shortwave Hertz grabber
- 87 Travelin' Happening—Guitar pickers, you can take it with you
- 122 Anti-Q Receiver—Days of yore revisited

ELECTRONICS FEATURES

- 40 Hamming It Up—Cartoon page
- 45 Today the Moon, Tomorrow . . .
- 60 Tracking the Atom's Tiniest Particles
- 66 Tiny-Talkie for Waterlogged Airmen
- 67 Low Down Measurements Way Up
- 73 Ham Radio's Dilemma—Solved at last?
- 86 Ten Tiny Megahertz
- 90 Oh, to DX Vegas
- 110 Airplanes, Alight!
- 118 How Good Are Stylus Pressure Gauges?
- 125 At Home With Electronics—Cartoon page

PRODUCT TESTS

- 65 Triplett Model 600 Transistorized Volt-Ohm-Milliammeter
- 71 Hickok Model 860 Combination Injector-Tracer and Power Supply
- 79 Globe-Union Instant Power Emergency Battery

DEPARTMENTS

- 21 Positive Feedback—Editorial chit-chat
- 26 NewScan—Electronics in the news
- 28 Hey Look Me Over—New products showcase
- 30 En Passant—Chess column
- 32 e/e Etymology
- 33 DX Central Reporting—SWL news
- 106 FCC Q & A
- 109 Home Study Bluebook
- 126 Literature Library

☆ Cover Highlights

AUTHORS IN THIS ISSUE:

Bill Britton, Robert M. Brown—K2ZSQ, Len Buckwalter—K10DH, John W. Collins, Homer L. Davidson, Herb Friedman—K2ZLF, Webb Garrison, David Jay Green—W6FFK, Carl L. Henry, Robert E. Kelland, K. C. Kirkbride, John D. Lenk, Ray McGlew, C. N. G. Matthews, O. K. Ryan, Jack Schmidt, C. M. Stanbury II, Marvin Townsend, Art Trauffer.

JULIAN M. SIENKIEWICZ WA2CQL/KMD4313	<i>Editor</i>
RICHARD A. FLANAGAN	<i>Managing Editor</i>
W. KRAG BROTTY	<i>Technical Editor</i>
JIM MEDLER	<i>Art Editor</i>
HELEN PARKER	<i>Editorial Assistant</i>
ANTHONY MACCARRONE	<i>Art Director</i>
EUGENE F. LANDINO III	<i>Associate Art Director</i>
IRVING BERNSTEIN	<i>Cover Art Director</i>
BARBARA GABRIEL	<i>Art Associate</i>
JIM CAPPELLO	<i>Advertising Manager</i>
LEONARD F. PINTO	<i>Production Director</i>
CARL BARTEE	<i>Production Manager</i>
MICHELLE WOLFFS	<i>Assistant Production Manager</i>
WILFRED M. BROWN	<i>Kit Division Manager</i>

President and Publisher

B. G. DAVIS

Executive Vice President and Assistant Publisher

JOEL DAVIS

Vice President and Editorial Director

HERB LEAVY, KMD4529



ELEMENTARY ELECTRONICS, Vol. 5, No. 3 is published bi-monthly by SCIENCE & MECHANICS PUBLISHING CO., a subsidiary of Davis Publications, Inc. Editorial, business and subscription offices: 505 Park Ave., New York, N. Y. 10022. One-year subscription (six issues)—\$4.00; two-year subscription (12 issues)—\$7.00; and three-year subscription (18 issues)—\$10.00. Add 75c per year for postage outside the U.S.A. and Canada. Advertising offices: New York, 505 Park Ave., 212-PL-2-6200; Chicago: 520 N. Michigan Ave., 312-527-0330; Los Angeles: 1709 W. 8th St., 213-483-3582; Atlanta: Pirnie & Brown, 3108 Piedmont Rd. N.E., 404-233-6729; Long Island: Len Osten, 9 Garden St., Great Neck, N. Y., 516-487-3305; Southwestern advertising representative, Jim Wright, 4 N. Eighth St., St. Louis, 314-241-1965.

SPECIAL 16-PAGE SECTION

RADIO SHACK®

America's Gift Headquarters

THE ULTIMATE IN Christmas MUSIC



The Unique Sound
of a Music Box
in Stereo!

197

Make this a musical Christmas with Audio Fidelity's Yuletide stereo classic. All your favorite carols beautifully played on a charming Old World Music Box! 50-5982

LOUDSPEAKER FIRE HELMET

Special Purchase



3⁹⁸

- Transistorized Ampl
- Real Microphone!
- Built-in Speaker!

An action toy for every active boy this Christmas! Rugged plastic fire chief's helmet features a built-in loudspeaker that really works! Adjusts to all sizes. 60-3078

Science Fair 50-in-1 ELECTRONIC PROJECT KIT



- No Soldering Required!
- 62 Page Manual Included!

17⁹⁵

Give your budding engineer hours of pleasure and education building these 50 projects: radios, amps, and others! 28-201

REALISTIC-323 2-SPEED CAPSTAN DRIVE PORTABLE



29⁹⁵

All solid state!
All pushbutton controls!
Records at 3¾ & 1½ IPS; 3¾" reels hold
600' of tape! 14-785

Get Radio Shack's Holiday Special!

FREE!

with any mail or store order for any item in this special 16-page section

4X FRESNEL

Unbreakable! Flexible! 1/32" Thick!

MAGNIFIER!

Amazing new optical miracle with genuine fresnel lens! This wafer-thin magnifier measures just 3 7/8" x 1 1/4" x 1/32" thick and slips easily into any pocket or wallet. Though the lens itself is no thicker than a credit card, its Fresnel-principle engraved surface actually enlarges 4 times with good linearity. Get yours FREE today with any mail order or store purchase of any item in this ad! Offer limited to supply available, so act promptly to avoid disappointment. Limit: one free per customer.



EXTRA 4X FRESNEL MAGNIFIERS (Cat. No. 64-444)

50¢ EA.

Store Addresses, Order Form, See Page 20

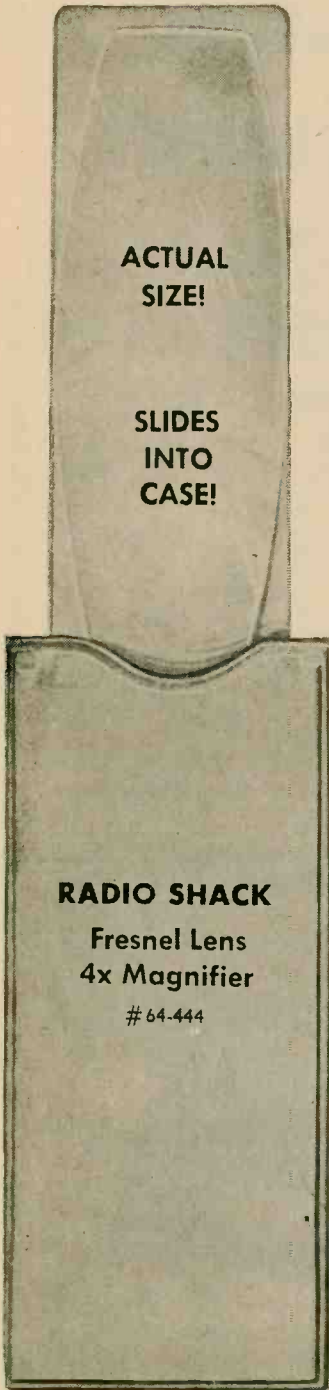

ACTUAL
SIZE!

SLIDES
INTO
CASE!

RADIO SHACK

Fresnel Lens
4x Magnifier

64-444



BRILLIANT NEW KIT LINE!

Science Fair™

Perf-board electronic projects make soldering optional, let builder re-use parts or change circuit!

At last! — electronic kits that let you work the same way engineers do — by "bread-boarding". Designed by Radio Shack's engineers and produced by its new Science Fair Electronics division, the kit line features step-numbered construction data, pictorial, schematic and add-on instructions.

**AC/DC
POWER
SUPPLY KIT**

6⁹⁵ NO. 28-104

Converts 117 VAC (house current) to either 6 or 9 volts DC. Play battery operated equipment on house line! Also ideal for use with Science Fair™ kits & other projects.

**"OTL" AUDIO
AMPLIFIER
KIT**

4⁹⁵ NO. 28-106

Ideal for use with tuners, mikes, phonograph systems. OTL output. Frequency response up to 15,000 cycles. Rated up to 2 watts peak.

For Store Addresses, Order Form, See Page 20

**TRANSISTOR
RADIO KIT**

3⁹⁵ No. 28-102

Tunes the standard AM broadcast band; can also be used as a tuner. Battery-operated. Comes complete with earphone. Perf-board construction.

**TRANSISTOR
ORGAN KIT**

5⁹⁵ NO. 28-101

Each note on the seven-note scale is separately tone variable. Unit is battery-operated and features perf-board construction. Fun to build & operate!

**WIRELESS AM
MIKE KIT**

3⁹⁵ NO. 28-103

Transmit through any radio up to 20 feet away! Battery-operated microphone is a real broadcaster! Constructed of sturdy perf-board.

**1-TUBE DC
RADIO KIT**

3⁹⁵ NO. 28-100

Battery-operated! Learn tube theory and build a real working radio. Equipped with sturdy perf-board construction. Kit comes complete with earphone.

RADIO SHACK SPECIAL PURCHASE!

4 AND 8-TRACK AUTO STEREO TAPE CARTRIDGES

FOR AUTO AND HOME PLAYERS / \$2 TO \$4 BELOW MARKET!

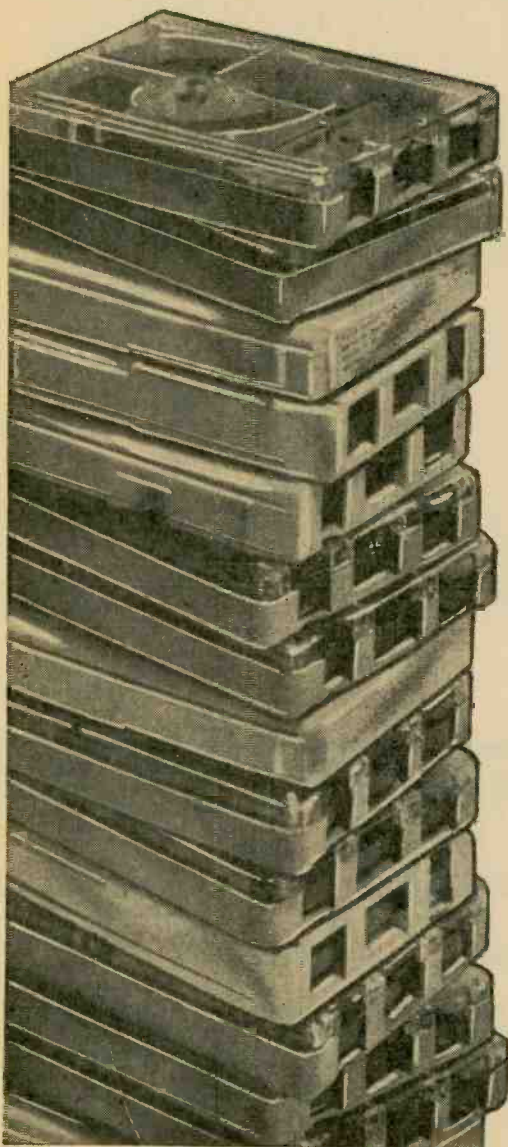

**HUGE ASSORTMENT!
PRERECORDED**

ATTENTION MAIL BUYERS: Space prohibits listing separate titles. Please specify quantity—we will send an assortment of all different titles.

2⁹⁵
EACH
4-TRACK
51-1059

3⁹⁵ EACH
8-TRACK
51-1058

**DEDUCT
10% IN
LOTS OF
5 OR OVER**

Now you can buy full length 4-track and 8-track auto stereo tape cartridges for \$2 to \$3 less per reel than ever before! Radio Shack cleaned out a famous U.S. tape cartridge manufacturer of thousands of popular auto stereo cartridges, and we're passing the savings to you! A vast assortment of over 50 titles: shows, jazz, country, folk, pop, western, classical. Buy now while our supply lasts! (NOTE: See recent Radio Shack catalogues for 4 and 8-track tape players at our low, low prices!)

Store Addresses, Order Form, See Page 18

ELEMENTARY ELECTRONICS

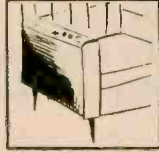
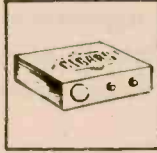
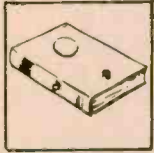
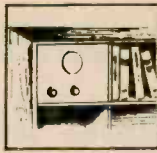
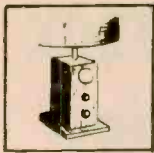

RADIO SHACK
44TH
BIRTHDAY
SPECIAL

What's your project for our "Build In" radio?

Here's a wired transistor radio in 3 pieces. Dextrous do-it-yourselfers should have a field-day with this one.

You carpenters, metal-workers and gift designers will really appreciate Radio Shack's novel "Build In" — a 6-transistor superhet that's really *a kit that isn't a kit*. Confused? Part *one* is the radio, 100% wired, installed in a crystalline 2¼ x 1 x 3½" case with the tuning knob sticking out of one end, and 8 wires out of the other. Part *two* is a separate volume control with built-in switch, knob, and soldered leads. Part *three* is a 2¼" PM speaker installed in a plastic case, with soldered leads.

The three parts (plus a flat 9V battery, not included) can be installed in, on, or under anything, in just about any desired angle or position. And you don't have to be an engineer — Radio Shack's geniuses have provided a simple, idiot-proof lashup pictorial. Now all you need is the price (*just \$6.98, Cat No. 12-1150*) and some Yankee ingenuity! Whether you hide "Build In" in a jug of corn likker, junior's wagon or Tillie's sewing box, the result is sure to please.

The basic radio itself looks like a little jewel, a real work of art — our photo doesn't do it justice. And the "kit that isn't a kit" is another of Radio Shack's exciting exclusive products that can't be bought elsewhere. Get a "Build In" at your nearest Radio Shack store . . . and start your Christmas *project* early!

For Store Addresses, Order Form, See Page 20

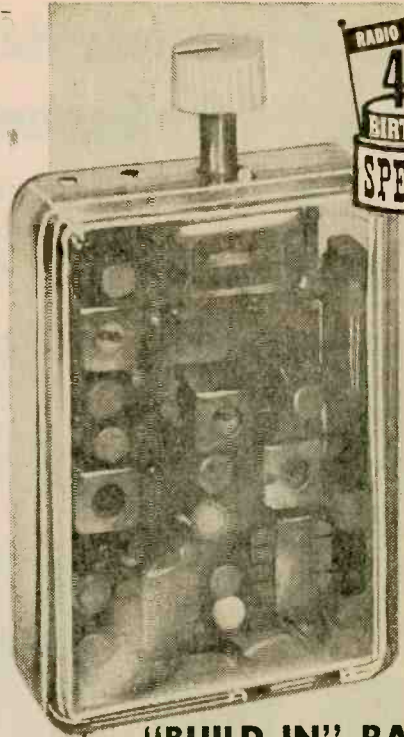

"BUILD-IN" RADIO



VOLUME CONTROL AND SWITCH

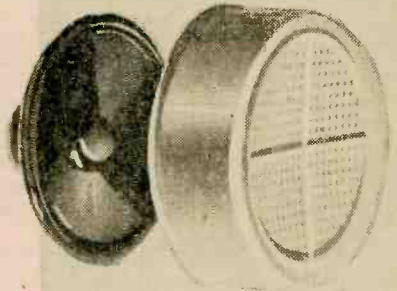

PM SPEAKER IN CASE

RADIO SHACK PROJECT BOOKS (4¢ A PROJECT)



"50 EASY TO BUILD SOLID STATE PROJECTS"

Build your own transistor radios, electronic organs, amplifiers, code oscillators, megaphones, generators, etc. Ideal for hobbyists.

62-1050 Net 2.00

"A MODERN TRANSISTOR WORKBOOK"

Build your own wireless microphone, AM broadcast tuner, audio pre-amp, PA system, experimenter's power supply, etc. 50 schematics.

62-2025 Net 2.00

EACH BOOK \$2



Ingenious New Radio Shack PERFBOX™ "Professionalizes" Project Building!

The bloody-knuckle brigade will appreciate
Radio Shack's effort to eliminate chassis
cutting and drilling, and make things prettier!

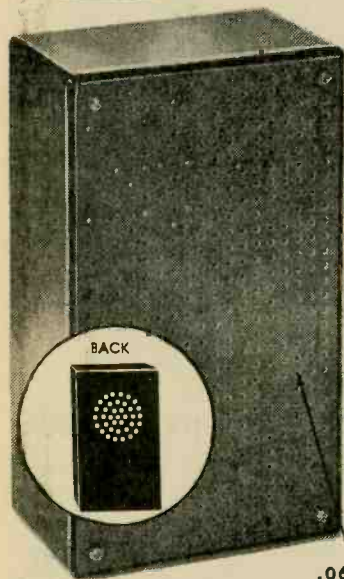

.062" HOLES

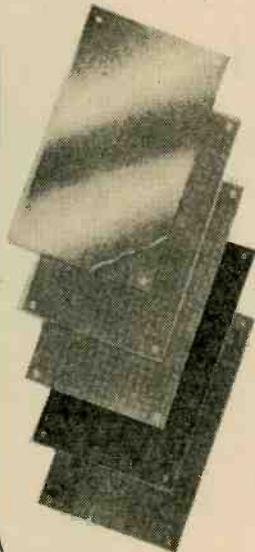

Somebody at "The Shack"—thank heaven! —must hate metal chassis and the generally sloppy look of breadboard projects. Now they've come up with a bakelite chassis box into which they've installed (4 screws) a 3½" x 6" perfboard top. But that's not all—the back of the box is pre-drilled for a 2¼" or other PM speaker, and there's a pre-drilled ¼" outlet hole on one side! This much-needed item is called the Radio Shack Experimenter's PERFBOX™. (Cat. No. 270-097, price \$1.69) and should sell like film at Expo 67. As an added fillip, there's a companion deal they call Radio Shack Experimenter's 5-Piece Panel Set, consisting of 3 perfboards and 1 aluminum and 1 bakelite panel board, all 3¼" x 6" predrilled to fit the PERFBOX™. The latter two boards are un-perfed (to coin a word), and the 5-piece set (Cat. No. 270-100, price \$1.69) should answer just about any need for extending the usefulness of the PERFBOX short of filling it with champagne!

RECOMMENDED PARTS FOR USE IN PERFBOX PROJECTS

DESIGN, CONSTRUCT YOUR OWN CIRCUITS . . . using these time-saving phenolic boards, breadboard or permanent type. 3/32" holes punched on 0.265" centers. Can be sawed. Shipping weight 1 lb.

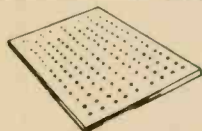

Punched

UNCLAD PERF-BOARD

- Accepts Miniature Components!
- Easy-In, Easy-Out Mounting!
- Ideal for Modular Construction!

276-1582, 3.65x6.87x1/16" Net .59
276-1583, 6.87x9.8x1/16" Net 1.15

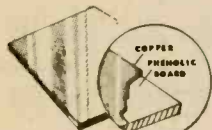

(Unpunched)

COPPER-CLAD SOLID BOARD

- Make Your Own Printed Circuits!
- Quality-Manufactured Board
- Bonded with Copper!

276-1586, 3.65 x 6.87 x 1/16" Net .79
276-1587, 6.87 x 9.8 x 1/16" Net 1.50

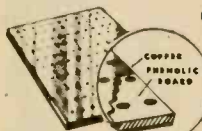

(Punched)

COPPER-CLAD PERF-BOARD

- For Printed Circuit Design and Circuit Checkout!
- Easily Etched and Worked!

276-1584, 3.65x6.87x1/16" Net .89
276-1585, 6.87x9.8x1/16" Net 1.75

PUSH-IN TERMINAL KIT



149
Kit of
100

Use with prepunched perf boards. .062 diameter holes (1/16"). Serated slots. Easy multiple connections.
270-1394, ¼ lb. Net 1.49



SPRING BANANA PLUGS

99c
Set of 10

Ideal for 3/32" hole perforated boards. Overall length 1".
270-1543, 2 oz. Net 99¢



SOLDERLESS TERMINALS

99c
Set of 15

Use with .093 diameter holes. Takes up to 7 leads without soldering. USA made. Spring action.
270-1395, 4 oz. Net 99¢



ALLIGATOR CLIP SET

99c

10 brass plated 1 3/8" long with insulated phenolic barrels. Strong spring. 5 red, 5 black.
270-1540, 2 oz. Net 99¢

For Store Addresses, Order Form, See Page 20

**No One Beats Radio Shack
on Reconditioned Phones!**

Colored Desk Phones



• Complete with Plug • Ready to Use

Just the ticket for private phone and intercom systems . . . and priced so low that everyone can own one . . . or two . . . or more! They're real time and step-savers you can install in any room, and so attractive they'll complement every interior decor. Complete with chrome dial, bell, induction coil and cable. Specify your second choice of color when ordering. Factory reconditioned, guaranteed.

279-375, Beige, Sh. wt. 10 lbs. Net 12.95
279-376, White, Sh. wt. 10 lbs. Net 12.95
279-377, Green, Sh. wt. 10 lbs. Net 12.95

12⁹⁵

★ **Beige!**
★ **White!**
★ **Green!**

30 Ft. Telephone Extension Cord



Move your phone from room to room! Highest-quality 4-conductor flexible cord plus standard telephone jack and plug. Ideal for intercom. Use 2 or more for extra length.

279-1261, Sh. wt. 1 1/4 lbs. Net 2.98

Telephone Plugs & Jacks



Ideal for making extensions, these plugs and jacks each weigh approximately 1/4 pound.

279-366, plug Net 1.25
279-367, jack Net 1.40

Coiled Phone Cords



Stretches up to six feet. 3-conductor. Shipping weight: 1/4 pound.

278-361 Net 1.19

Four conductor extends up to fifteen feet. Shipping weight: 1/2 pound.

278-1389 Net 5.95

Shoulder Rest



Frees both hands! Spring mechanism enables arm to be folded out of sight when not in use. Easy to attach to any phone. Long lasting metal construction. Manufactured in the United States. Weight: 1 pound.

279-606 Net 1.49

Telephone Wall Jack



For 2, 3, 4-wire systems. Fits standard wall conduit boxes. 1 lb.

279-1507 Net 1.99

Carbon Type Handset For Mobile and Replacement Use!



Great for use with mobiles & intercoms, or as outdoor mike for camps and construction sites. Withstands extreme temperatures. High output mike can be used with low gain circuits. Adapt to your CB transceiver or radio. Includes earpiece and 3-conductor cord.

279-1351, Sh. wt. 1 lb. Net 2.99

Sound-Powered Elements



Kit of two! Talk without electricity — your voice powers these devices. Hook them up and talk up to 300 feet. Shipping weight: 1/2 pound.

279-1353 Net .99

100 Ft. 3-Conductor Telephone Wire



Multi-use 100' 3-conductor wire for telephone work. Ideal for linking temporary phones for field uses.

278-370, Sh. wt. 2 lbs. Net 3.49

Handset Hanger



Hang up your phone without cutting off party on other end. Ideal for wall telephones. Anodized black aluminum.

279-1528, Sh. wt. 1/4 lb. Net 1.25

Telephone Dials

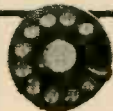

Standard Western Electric unit. Can be used with automatic control circuits, & electronic combination lock circuits.

279-359, Sh. wt. 1 1/4 lbs. Net 2.99

RADIO SHACK

44th
BIRTHDAY
SPECIAL

MICRANTA TEST EQUIPMENT AVAILABLE ONLY AT RADIO SHACK



1000 OHMS/VOLT POCKET AC/DC VOM

5⁹⁵

- Ultra Compact Size; Only 3 1/2" x 2 1/8" x 1"
- Convenient Thumb-Set Zero Adjustment

Pin jacks for 5 ranges. 2-color 1 3/4" meter scale. Reads AC or DC volts in 3 ranges: 0-5, 150, 1000V. DC Current: 0-150ma. Resistance: 0-100K ohms. Accuracy ±3% DC, ±4% AC. Bakelite case with test leads, instructions, batteries.

22-4027, Sh. wt. 1 lb. Net 5.95

HOME/AUTO TESTER



11⁹⁵

 Factory Wired

- Checks Electrical Circuits in the Home or Garage!

Volt, ohm, ammeter, wattage and leakage checker; checks 6-12V batteries. 0-7.5/15/150/300V, 15 amps. Resistance 0-1000Ω. With leads, power cord. 6 1/4" x 3 3/4" x 2 1/8".

22-011, Wt. 3 lbs. 11.95

DYNAMIC TRANSISTOR CHECKER

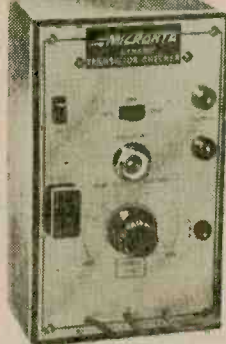

9⁹⁵

- Test Transistors "In" or "Out" of Circuit. Tests Low, Medium, High Power

Visual indication of electrode open & short circuits, current gain, GO/NO-GO test 5ma-50ma, clip leads for in circuit tests. 6 1/4" x 3 3/4" x 2 1/2".

22-024, Wt. 2 lbs. 9.95

TRANSISTORIZED REGULATED VARIABLE DC POWER SUPPLY



16⁹⁵

- 25% Ripple, 0-20 Volts, Current 0-200 ma

Continuously variable output of 0-20 VDC. 2 operating ranges deliver 0-20ma to 0-200ma. Meter reads output voltage and milliamps. 115 VAC @ 50/60 cy. Test leads. 4 7/8" x 2 7/8" x 2 3/4". 22-023, Sh. Wt. 4 lbs. Net 16.95

For Store Addresses, Order Form, See Page 20

EDGEWISE PANEL METERS



1⁹⁹ up

- Moving Coil Type! 2% Accuracy!
- Compact! Easy-To-Read Scales!

Moving coil of 1 MA with zero adjust set screw. 2% accuracy, soldier lug terminals. 1 7/8" mounting hole centers. Size: 2 1/8" W x 1-7/16" D x 7/8" H.

22-004, Signal Strength Net 1.99
22-006, VU, -20 to +3 (0-100%) Net 2.50
22-003, Balance & Tuning Meter Net 2.50



SAVE BIG! ELECTRONIC PARTS NOW WAY OFF REGULAR PRICES

RUNNING TIME METER



Reg. ~~\$6.95~~ Sale Price **5.44**

- Records 0 to 9999.99 Hours!

Measures elapsed operating time of electronic equipment, transmitters, receivers, industrial machines, etc. Records running time in hours, tenths and hundredths. Operates either from 40 or 110/125 VAC, 60 cy., with external resistor (supplied). Synchronous motor drive. Size: $2\frac{1}{4} \times 2\frac{1}{4} \times 3\frac{1}{8}$ ".
273-1628, Sh. wt. 3 lbs. Net 5.44

500' OF HOOK-UP WIRE



Solid & Stranded **2.98**

Five 100-ft. coils, sizes #18 through #22. Cotton, vinyl insulation; different colors.
278-1484, Wt. 2 lbs. Net 2.98

75' MINI-SPEAKER WIRE



1.19

Place speaker away from amplifier. 2-conductor #24 wire. Plastic insulation.

278-1509, Sh. wt. $\frac{1}{4}$ lbs. Net 1.19

6-FOOT LINE CORDS



39c

Feature #18 wire complete with molded plug. Ideal for home or shop!
278-1255, Sh. wt. $\frac{1}{4}$ lb. Net .39

NUMERAL LAMPS



Orig. ~~1.44~~ **1.19**

Bayonet type socket with 11 interchangeable lenses. For $\frac{3}{4}$ " hole.
272-343, Sh. wt. 4 oz. Net 1.44

5-LB. ELECTRONIC MYSTERY BOX



1.98 Worth at Least \$25!

Hobbyist's delight! Assorted switches, resistors, capacitors, transformers.
270-496, Sh. wt. $\frac{5}{2}$ lbs. Net 1.98

DPDT SWITCH Neutral Center



99c Pak of 2

Kit of two DPDT toggle switches with long bar handles. Heavy duty excellent for power circuits, PA systems, etc. Rated at 10 amps, 125 VAC. With on/off plate, screw terminals, and mounting nut.

275-1533, Sh. wt. $\frac{1}{4}$ lb. Net .99

6-PDT PUSH BUTTON SWITCH



49c

Replacement switches for most walkie talkies. May also be used in circuits where momentary action is required. Size: $1 \times 1\frac{1}{2} \times \frac{7}{16}$ ". Shaft length, with knob: $\frac{3}{4}$ ".

275-051, Sh. wt. $\frac{1}{4}$ lb. Net .49

COAX CABLE CONNECTORS



278-200, PL-259 Net .59
278-201, SO-239 Net .50
278-1370, UG175/U, Adapter for RG58/U cable Net .16

FUSE HOLDERS



99c Kit of 6

Chassis mounting fuse holders for popular $1\frac{1}{4} \times \frac{1}{4}$ " fuses. 3 holders accept 2 fuses, and 3 take single fuse. Each equipped with snap-on dust cover.

270-337, Sh. wt. $\frac{1}{4}$ lb. Net .99

COMPOSITION RESISTORS



1.99 Pak of 100

$\frac{1}{10}$, $\frac{1}{2}$, 1, 2 watts. Many 5% and "Magnetic Film" types. Comes complete with free Color Code Chart.

271-810, 2 lbs. Kit of 100 Net 1.99

6.3 VOLT FILAMENT TRANSFORMER



1.19

Hundreds of applications! Input: 117 volts at 60 cy. Output: 6.3 volts at 1.2 amps. Tinned color-coded leads. Size: $1-15 \times 16 \times 1\frac{1}{4} \times 9 \times 16$ ".

273-050, Sh. wt. 1 lb. Net 1.19

ARCHER

TWILIGHTER

- Automatically Turns Light On at Dusk, Off at Dawn!
- Silent Guardian of Your Home or Office!

Reg. ~~\$5.95~~ Sale **4.44**



An electronic "eye" that automatically controls selected lights, turning them on at sunset, off at dawn, daily — without resetting. Ideal for controlling driveway lights, interior lights, displays. Size: $3\frac{7}{8} \times 1\frac{3}{8} \times 2\frac{3}{8}$ ".
275-1399, Sh. wt. 1 lb. Net 4.44

Store Addresses, Order Form, See Page 20

24 VOLT POWER TRANSFORMER



1.98

Use for transistor, semi-conductor circuitry conversions, etc. Operates from primary 117V 60 cy. Secondary: 24 VAC 1.2 amps. Open frame. Size: $2 \times 1-15 \times 16 \times 3-3 \times 16$ ".

273-1480, Sh. wt. 2 lbs. Net 1.98

THESE ELECTRONIC PROJECTS HAVE EARNED CASH AWARDS FOR RADIO SHACK CUSTOMERS

Build Yourself — or Win Cash by Sending Us Your Own Ideas!

G.M.

La Habra,
California

HIGH POWERED FLASHER

A Flashing Light that Can Be Used as a Warning Light, Clearance Lamp or Signaling Device. Great for Protection When Your Auto Breaks Down on the Turnpike!

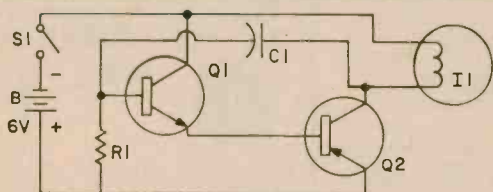

PROJECT PARTS LIST

Stock No.	Item	Net Each
23-541	Six Volt Lantern Battery (B1)	2.55
272-955	50mf @ 15 Volts (C1)31
276-409	2N170 NPN Transistor (Q1)	1.15
276-406	2N155 PNP Transistor (Q2)	1.19
70-0195	47K 1/2W Resistor (R1)12
275-602	SPST Toggle Switch (S1)30
272-344	6V Bulbs (Kit of 4)99

This circuit is a real powerhouse — a relaxation oscillator capable of flashing a clearance lamp to full brilliance. The current drain is low since most of the current is drawn at the time of flash. Project takes no longer than one hour to wire.

R.V.

Oklahoma City
Oklahoma

LIGHT OPERATED BUZZER

Excellent Burglar Alarm or Warning Buzzer! For an Interesting Experiment, Use Power Flasher Above to Work Buzzer.

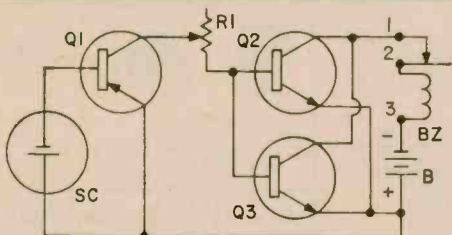

PROJECT PARTS LIST

Stock No.	Item	Net Each
27-1701	PNP Transistor (Q1)49
27-1703	NPN Transistor (Q2, Q3)	1.17
27-1716	50k Potentiometer (R1)59
276-1710	Solar Cell (SC)	1.79
20-1086	Buzzer (BZ)79
23-466	Batteries (2 D Cells) (B)16
270-1439	Battery Holder35

Here's an "electric eye" circuit that really works! By focusing a beam of light (flashlight or lens/bulb system) on the solar cell enough voltage is amplified to operate the buzzer. Adjust both the buzzer contacts and the sensitivity control (R1) for best sound.

\$\$ FOR YOUR ELECTRONIC IDEAS!

Turn Ingenuity and Hobby into Spare-Time Profits!

We are looking for experiments built around Radio Shack or other electronic parts. These will be published regularly in our catalogs. If published by us WE WILL PAY YOU AN AUTHOR'S FEE and reimburse you for parts bought from us — maximum \$50 cost. By submitting it, you state it's original with you. If we accept it, it is understood we can publish it for use by our catalog, flyer, book and magazine readers. Submissions cannot be returned. Send description, parts list, stock numbers, and schematic. DO NOT SEND ACTUAL SAMPLE as we will build it here to see if and how it works. Write today!

SEND TO: Radio Shack, Attn: Lewis Kornfeld, Vice-President
730 Commonwealth Avenue, Boston, Mass. 02215





MIKES, SPEAKERS, HEADSETS, TOOLS FOR THE ELECTRONICS EXPERIMENTER

BUILD "EI'S" MIGHTY SUB-MINI SPEAKER

4" Acoustic Suspension
FE-103 Speaker System!

The fabulous Realistic FE-103, complete with cabinet construction details as published in Electronics Illustrated! 30-17,000 cps; 15 watts; 8 Ω.

7⁹⁵

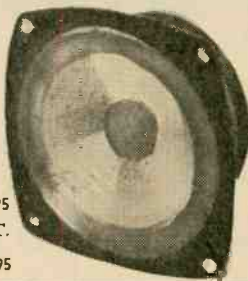

40-1197, FE-103, Wt. 5 lbs. Net 7.95
CONTOUR NETWORK KIT. With instructions.
40-808, coil, capacitor, etc., Net 3.95

MINIATURE PM SPEAKERS FOR TRANSISTOR PROJECTS, RADIOS

8 Ohm Impedance

Small in size but big in sound! Three sizes to choose from: 2 1/2", 2 3/4", or 2". All for the same bargain price!



40-247, 2 1/2" Net .98
40-246, 2 3/4" Net .98
40-245, 2" Net .98

ONLY 98¢ EACH!

MIDGET EARPHONES

For Transistor Radios



98¢

Resp. 50-9000 cps. With replaceable earplug, cord. 10 ohms.
33-175, Wt. 2 oz. Net .98
33-174, w/3/32" plug, Net .98

STEREO HEADSET

Separate Transducers!



2⁷⁹

Perfect for use with receivers, tuners, amplifiers, kits and recorders! 8 ohms.
33-1008, Net 2.79

FABULOUS THERMO-ELECTRIC GLUE GUN REALLY WORKS!

60-Second Bonding Plus Instant-set Caulking!
No Clamping! No Cleaning!



Makes all other kinds of gluing obsolete! Uses unique hot-melt glue sticks: melted glue bonds permanently in 60 seconds, providing a flexible bond that's perfect for furniture, pottery, metal, leather, plastic or fabric. Use with white sealer sticks for water proof caulking. Glue and caulking included.
64-2860, Gun, 2 lbs. Net 5.99
64-2861, 7 Glue sticks, 1 lb. Net .49
64-2862, 7 Sealer Sticks, 1 lb. Net .49

5⁹⁹

for make-or-mend jobs

CRYSTAL LAPEL MIKE

• For Recorders, PA, Paging!



1⁸⁹

Sensitive! Concealable! Response: 200-300 cps.
73-100, Wt. .8 oz. Net 1.89

CRYSTAL MIKE CARTRIDGE



89¢

Precision made crystals! Response up to 7000 cy.
270-095, 8 oz. Net .89

POWERFUL CERAMIC MAGNETS

1,000's of Home, Office, Auto Uses!

64-1885



64-1875

10¢ **15¢** **25¢**
Each Each Per Pair
For Singly
10

10 FOR 1⁰⁰

6⁹⁵ LAVALIER DYNAMIC MIKE

Neck/Hand/Desk Use!



Pencil-slim hi-Z for use at home, studio, or in PA and guitar systems! With cord, stand. 50K.
33-928, Ship. wt. 2 lbs. Net 6.95

LOW COST 25-W. SOLDERING IRON

1⁸⁹



Precision designed! Comes complete with UL Cord and Plug. Uses 117V AC/DC.
64-2182, 1 lb. Net 1.89
64-2178, Extra copper Tip .. Net .25

OUR OWN 60/40 SOLDER

69¢ Each
12 & UP
59¢ Each



U.S. made with superactive rosin core. Fits fed. specs. QQ-S-571d
64-0002 Net .69

STEEL CATCH-ALL STORAGE BOX

6" H x 8 1/4" D x 5 3/4" W



1⁹⁵

4 draws with adjustable compartments.
64-2050, 3 lbs. Net 1.95

ASSORTED ELECTRIC HARDWARE

6" H x 8 1/4" D x 5 3/4" W



99¢

Over 600 pieces! Something here for everyone! All brand new — no sweepings! One full pound. Comparable value: \$4.50!
64-2890, Wt. 1 lb. Net .99

For Store Addresses, Order Form, See Page 20

ANY
ARCHER-PAK
ON
THIS
PAGE

\$1
PER
PAK

Celebrating Our 44TH Anniversary



20 Power Resistors



Package consists of high-quality vitreous, cand-ohm and wire-wound types. Includes 5 to 25-watt power resistors; individual catalog net — \$10!
271-1202, 2 lbs. Net 1.00

35 Precision 1% Resistors



Large assortment of popular 1/2, 1 and 2-watt values; includes wire-wound types; includes encapsulated, bobbin, carbon film, etc. Made by Aerovox, Shellcross, IRC, and other famous names.
271-1196, 1 lb. Net 1.00

50 Tubular Capacitors



An assortment of quality tubular capacitors, 100 mmf to .1 mf to 600 WVDC. Includes molded, paper and porcelain types. \$10 if purchased individually from catalog!
272-1568, 1 lb. Net 1.00

4 Subminiature 455KC IF Transformers



Slug tuned, made for printed circuitry mfg., shielded. Size: 3/8 x 3/8 x 1/2".
273-515, 1/4 lb. Net 1.00

8 Sets - RCA Plugs & Jacks



Quality items, ideal for use in phono amplifiers, tuners, recorders, etc. Take advantage of this Radio Shack Special low price!
274-1575, 1/2 lb. Net 1.00

35 Miniature Resistors



World's smallest 1/4-watt carbon type resistors! All have axial leads; built for transistor and subminiature circuitry. Assorted values, with resistor color code chart.
271-1566, 1/2 lb. Net 1.00

40 Coils and Chokes



Shop assortment consisting of RF, OSC, IF, parasitic, peaking and many more types. Individually purchased, this would cost you \$15!
273-1569, 1 lb. Net 1.00

45 Mica Capacitors



Famous name micas — Aerovox, Sangamo, C.D., etc. This assortment includes popular values 100 mmf to .01 mf, as well as silver type condensers. A \$10 catalog net value!
272-1573, 1 lb. Net 1.00

8 Volume Controls



Most Popular Values
Contains 8 assorted values including long and short shaft types. A tremendous bargain for servicemen!
271-127, 1 lb. Net 1.00

Special! 50 Capacitors



Assortment of many types including disc, ceramic, mylar, temperature coefficient, molded, paper, oil, Vit-Q. You save \$9 over industrial net catalog prices!
272-1199, 1 lb. Net 1.00

60 Half-Watt Resistors



Made by Allen Bradley and IRC. Many 5% and 10% tolerance. Color chart. All most popular values. An absolute "must" for hobbyists and kit-builders.
271-1612, 1 lb. Net 1.00

50 Ceramic Capacitors



Wide variety of popular values by Centralab and other famous-name makers. 10 mmf to .04 mf to KV. Assortment includes tubulars, discs, NPO's, temp. coefficient, etc.
272-1566, 1 lb. Net 1.00

48 Terminal Strips



You get a wide variety of screw and solder lug type terminal strips with 1 to 6 lugs. Outstanding value at this low price! 101 uses for the builder and experimenter.
274-1555, 1 lb. Net 1.00

35 Disc Type Capacitors



A varied assortment of types, including NPO's, Hi-Q, N-750's, mylar and ceramic. 10 mmf to .01 mf to 6 KV. A \$10 catalog net value!
272-1567, 1/4 lb. Net 1.00

150' of Hook-Up Wire



Assortment consists of 6 V rolls of 25' each — solid and stranded wire, #18 through #22. Necessary for multitude of jobs and always useful!
278-025, 1/2 lb. Net 1.00

40 One-Watt Resistors



Here are resistors for hundreds of uses! Assortment has Allen Bradley and IRC carbons, with 5% values included. This pack is a regular \$8.00 catalog net!
271-1576, 1 lb. Net 1.00

4 Transistor Transformers



Made by UTC and Remington Rand. Famous miniatures. Includes sub-ouncer, mike, input types. Color coded leads.
273-1581, 1 lb. Net 1.00

50 Plugs and Sockets



Ideal bench assortment for servicemen, hams, etc. Subminiature and printed circuit types included! This assortment saves you \$10 over individual catalog prices!
274-1562, 1 lb. Net 1.00

30 2-Watt Resistors



These quality 2-watt resistors are non-inductive, magnetic film, carbon types. Many with 5% values. Made by famous-name manufacturers.
271-1211, 1/2 lb. Net 1.00

\$25 SURPRISE PACKAGE!

Loaded with \$

1
Parts!

The biggest surprise package yet! Enough electronics components to make your eyes pop! Resistors, capacitors, condensers, diodes, your guess is as good as ours. The famous-make parts are worth at least \$25.00!
270-1251, 1 lb., Net 1.00

For Store Addresses, Order Form, See Page 20



Celebrating Our 44TH Anniversary

ANY
ARCHER-PAK
ON
THIS
PAGE



4 Type 2N107 PNP Transistors

One of the most widely used transistors today for general audio use. Complete with base wiring diagram.

276-501, 1/2 lb. Net 1.00



6 Zener Rectifiers

Includes zener references! Ratings from 250MW-10 Watt. Stud, axial lead, upright types, assorted voltages; 1N429, 1N821, etc.

276-538, 1/2 lb. Net 1.00



10 MAT High Frequency Transistors

Similar to 2N501 type PNP Freq. 30-180 MCS. Used in RF and switching circuits. Ideal for CB, Hams, and experimenters.

276-522, 1/2 lb. ... Net 1.00



4 100 Mc. NPN Planar Transistors

Similar to 2N1613, 2N-1893 and 2N2049: Made by Fairchild and Rheem. Rated at 700 MW. Vce 75; Hfe 40-120; 150 Ma; TO-18, TO-46 cases.

276-536, 1/2 lb. Net 1.00



8 Pre-Etched Boards

Assorted types of pre-punched boards ideal for transistor experiments, hobby work. Any path may be used.

276-1572 Net 1.00



5-10W PNP Power Transistor Pak

Ideal for the experimenter wanting higher wattage rating transistors. Types similar to 2N155.

276-527, 1 lb. Net 1.00



2 Silicon NPN 400 Mc. Planar Transistors

Excellent for VHF, switching and oscillator applications. Made by Sylvania. Similar to 2N-707-8, 360 MW; Vcb 15; Hfe 12-75; 10 Ma.

276-541, 1/2 lb. Net 1.00



5-6 Volt Zener Diodes

Rated at 1 watt. Gold plated. Long axial leads. Ideal for voltage regulated power supplies, transistor bias, etc.

276-518, 1/2 lb. ... Net 1.00



3 Coax Silicon Transistors

Similar to Hughes 2N1241-2N1243 type PNP. Used in audio and switching circuits Vcb 35 Hfe 30 Ic 10. Rated 1 watt.

276-550, 1/2 lb. ... Net 1.00



Pak of 8 PNP Switching Transistors

PNP includes TO-5, TO-22, cases. Similar to 2N1305, 2N394, 2N404. Frequency: 4 MC, 150MV, Vcb 10; Hfe 70, 10 Ma.

276-539, Sh. Wt. 1/2 lb. Net 1.00



25-Pc. Surprise Pak

Includes both PNP and NPN's Silicon and Germanium types. Assorted cases TO-5, TO-18, and TO-46. Ideal assortment for the experimenter.

276-524, 1 lb. Net 1.00



3 Silicon 100MC 2W Transistors

PNP type TO-5 case. Similar to 2N1132, 2N2104 and 2N2303 types. Ideal for high frequency work. Vcb 60 Hfe 40-120.

276-523, 1/2 lb. ... Net 1.00



Pak of 8 NPN Switching Transistors

NPN Type: Similar to 2N333, 2N336-337, Specifications as above. With diagram.

276-540, Ship. Wt. 1/2 lb. Net 1.00



25 Germanium Diode Surprise Pak

Used in computer switching and general experimental use. Long axial leads. Ideal for experimenter and builder.

276-519, 1/4 lb. Net 1.00



3 RF Silicon Transistors

NPN type — similar to 2N790-2N792, 2N1150 and 2N170 types. Rated at 150 MW. Freq. 13 MC. Vcb 45. MA 22; TO-22 case.

276-528, 1/2 lb. ... Net 1.00



10 Popular PNP and NPN Transistors

Includes most popular types: CK-722, 2N35, 2N107, 2N440, and 2N335. Invaluable to experimenters and hobbyists.

276-510, 1/2 lb. Net 1.00



20 Top Hat Rectifier Pak

Some up to 1 AMP. Flangeless types too! Assorted voltages and current. Long leads. Each Pak a real surprise!

276-520, 1 lb. Net 1.00



3 PNP High Power Transistors

Rating: 10-40 W. Similar to 2N155, 255, 2N1320, 2N1504. Top quality manufacturer. Includes cases TO-3, TO-10, TO-13.

276-529, 1/2 lb. ... Net 1.00



New! 6 NPN and PNP Micro-Transistors

Both silicon and planars with T and T-46 cases. Similar to T-706, 2N995, 2N834, 2N2357. Frequency: to 200 MC. Wiring diagram.

276-542, 1/2 lb. Net 1.00



25 250MW Silicon Zener Diodes

Glass miniature diodes in assorted voltages. Long axial leads. Excellent for transistor power supply regulation.

276-521, 1/2 lb. ... Net 1.00



New! 4-Micro Silicon Epoxy Rectifier

Rated at 1 amp a 400 PIV. Mfg. by GE. Long axial leads. Ideal for micro miniature circuitry where space is a factor.

276-549, 1/2 lb. ... Net 1.00

For Store Addresses, Order Form, See Page 20



SEMI CONDUCTORS FOR THE HOBBYIST



Replacement Transistors

PNP TYPES

For high frequency, RF-IF, and converter circuits. Replaces: 2N247, 2N248, 2N267, 2N274, 2N309, 2N310. 276-412, Wt. 3 oz. 1.29

For mixer/oscillator converter circuits. Replaces: 2N113, 2N114, 2N136, 2N137, 2N175, etc. 276-401, Wt. 3 oz. .99

For universal IF circuits. Replaces: 2N111, 2N112, 2N139, 2N218, 2N219, 2N315, 2N366, 2N406, etc. 276-402, Wt. 3 oz. .99

For 6 volt audio circuits. Replaces: 2N77, 2N104, 2N105, 2N107, 2N109, 2N130, 2N131. 276-403, Wt. 3 oz. .99

For 12 volt audio circuits. Replaces: 2N36, 2N37, 2N38, 2N41, 2N43, 2N44, 2N45, 2N46, etc. 276-404, Wt. 3 oz. .99

For 9 volt audio circuits. Replaces: 2N188, 2N189, 2N190, 2N191, 2N192, 2N195, 2N196, 2N197, etc. 276-405, Wt. 3 oz. .99

For auto radio AF amplifier circuits. Replaces: 2N176, 2N178, 2N179, 2N234, 2N235, 2N35B, 2N236, 2N242, etc. 276-406, Wt. 3 oz. 1.19

For high power AF circuits in auto radios. Replaces: 2N173, 2N174, 2N277, 2N278, 2N441, 2N442, 2N443, 2N1515, etc. 276-407, Wt. 3 oz. 2.29

NPN TYPES

For mixer/oscillator converter circuits. Replaces: 2N193, 2N194/A, 2N211, 2N212, 2N233, 2N234, 2N358, etc. 276-408, Wt. 3 oz. 1.09

For universal IF amplifier circuits. Replaces: 2N98, 2N99, 2N100, 2N145, 2N146, 2N147, 2N148, 2N149, etc. 276-409, Wt. 3 oz. 1.15

For 9 volt AF amplifier circuits. Replaces: 2N35, 2N169A, 2N213, 2N214, 2N228, 2N306, 2N312, 2N313, etc. 276-410, Wt. 3 oz. .99

For 12 Volt AF amplifier circuits. Replaces: 2N306A, 2N445A, 2N446A, 2N447A, 2N556, 2N557, 2N587, 2N649, etc. 276-411, Wt. 3 oz. .99

Twin PAK "POP" SERIES

Popular PNP Types

- 5-2N107 Types
- 5-CK722 Types

Radio Shack Exclusive! Great for experimenters, hams, hobbyists... all audio applications. Complete with transistor base diagrams. 276-031, Wt. 3 oz. 1.98

Popular NPN Types

- 5-2N35 Types
- 5-2N170 Types

Big savings on NPN type transistors! Especially suited for audio applications. Great for hams, hobbyists! Includes transistor base diagram. 276-032, Wt. 3 oz. 1.98

ARCHER Twin-Pak Transistor Kit

198 Kit of 25 • 10 NPN • 15 PNP

BIGGEST BUY yet for the hobbyist or experimenter. Brand new with full length leads. Ideal for RF applications, switching and general purpose audio types. Replace many popular numbers without circuit change. 276-1516, Ship. wt. 2 lbs. Net 1.98

3 Amp Silicon-Controlled Rectifiers

195

TO-66 Case! 200V

Designed to deliver loads up to 3 amps. Ideal for use in speed control operation, power converters, 276-1065 Net 1.95 276-1066, TO-66 mtg. hdwr. .30

10 GERMANIUM DIODES

Similar to 1N34, 1N34A, 1N60

99c

Equivalent in use to silicon diodes with lower forward voltage drop. 276-821, Ship. wt. 1/4 lb. Net .99

Silicon Field-Effect Transistors

198

- High Impedance Input!
- Low Noise! High Gain!
- Characteristics Similar to Pentode Vacuum Tube!

1000's of applications where pentode tubes are used in low level circuits: field strength meters, "gate dippers," receivers, flea power transmitters, etc. TO-5 case. Includes specifications. 276-664, Sh. wt. 2 oz. Net 1.98

IBM Component Boards

29c

SAVE!

4 for 1.00

All quality American made parts; ideal for builder and hobbyist alike. Each board contains at least two transistors, plus loads of other components: resistors, capacitors, coils, diodes, modules, chokes, and heat sinks. Size: 2 3/8 x 3 3/8". 276-616, Sh. wt. 1/4 lb. Net 29

Photo-Multiplier Power Transistor

198

Photo-sensitive cell, power transistor amplifier, electronic relay. Includes specs. and diagrams. 276-847, Wt. 1/4 lb. Net 1.98

750 MA Top Hat Rectifiers

25c PAK of 2

From 50-1000 PIV

276-1107	50 PIV	Pak of 2	.25
276-1108	100 PIV	Pak of 2	.39
276-1109	200 PIV	Pak of 2	.59
276-1110	400 PIV	Pak of 2	.89
276-1111	600 PIV	Pak of 2	1.39
276-1112	800 PIV	Pak of 2	1.79
276-1113	1000 PIV	Pak of 2	1.98

Transistor Sockets

99c Kit of 10

Takes PNP or NPN transistors with 3 contacts in line or triangle; complete with mounting plates. For every experimenter! 274-1510, Wt. 2 oz. Net .99

RADIO SHACK EXCLUSIVE! ADD A SLAVE "WALKIE" TO YOUR BASE, MOBILE, OR WALKIE TALKIES!

Actual
Size!

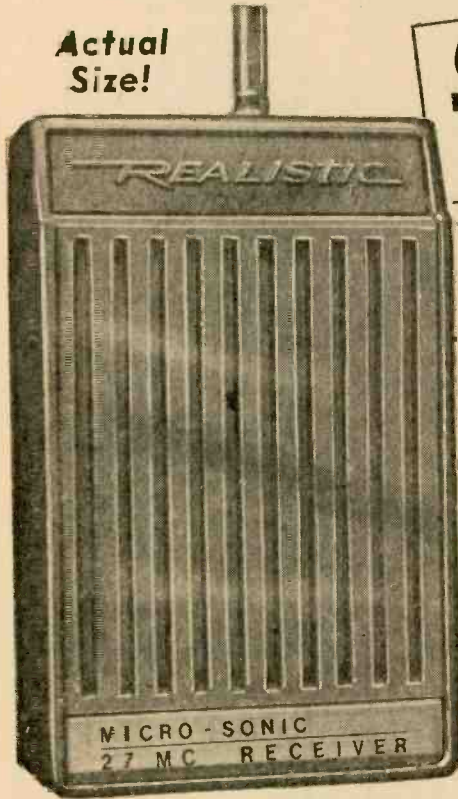

ONLY
7⁹⁵

Crystal-controlled superhet receiver ONLY! Add as many ears to your network as you want. Fits in a shirt pocket — an excellent paging or guided tour device!

This unusual Radio Shack product, called the Realistic Microsonic 27MC Receiver, comes complete with a Ch. 11 CB crystal — and because it's a plug-in, it can be changed to any of the 23 channels. It's a teeny $3\frac{1}{2} \times 2\frac{1}{2} \times 1\frac{3}{8}$ ". It includes an earphone with clip, and the phone's lead acts as the antenna. So if you want to hide it away as a pager, there's nothing showing. For DX we've included a 16" telescopic whip to be used only if necessary. Let your imagination run wild with this novel device!

21-109 Microsonic 27MC Receiver Only 7.95

NEW IDEA #2 — as a companion to the above, or a wireless CB microphone (!), there's also the Realistic Microsonic CB transmitter. Same size, color, everything. But transmit only, 100mw of course, with plug-in crystal for Ch. 11. Uses? For example: one of these plus x-number of receivers and you have a guided tour technique that'll never quit!

21-110 Microsonic CB Transmitter Only 7.95

FREE ACCESSORIES:

- Receiver — earphone and whip antenna
- Transmitter — 35" telescopic antenna

Note: both units include crystals but require a 9V transistor battery to operate. 23-464, 29¢ each.

RADIO SHACK'S FABULOUS SPACE PATROL® TWOSOME

STANDARD
FULL SIZE

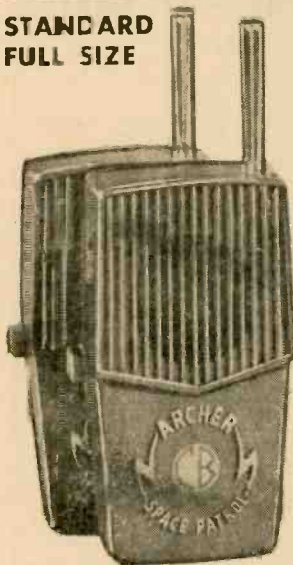

→ ARCHER →
**SPACE
PATROL®**

Talk up to $\frac{1}{4}$ mile with our perennial favorite in the 100MW no-license class. Over 100,000 of these transceivers now in use! "Lock-on" talk switch for continuous transmission when needed. Extra-long 43" telescopic antenna! Channel 14 crystal & battery included.

11⁹⁵
PER PAIR

→ ARCHER → **MICRO
SPACE PATROL®**



Double transformer talk-power in the world's smallest ($3\text{-}5/16 \times 2\text{-}7/16 \times 1\text{-}1/4$ ") case. Fits easily in your shirt pocket (and your budget). Handsomely styled hi-impact, custom-chromed case. Easy to operate with a hideaway "push-to-talk" button. 9-section telescoping antenna. With channel 14 crystal and battery.

14⁹⁵
PER PAIR

ORDER BY MAIL FROM YOUR NEAREST RADIO SHACK STORE

ARIZONA
Phoenix: 3905 East Thomas Rd.

ARKANSAS
Little Rock: University Plaza

CALIFORNIA
Anaheim: 507 East Katella Ave.
Bakersfield: Valley Square Shop. Ctr.
Covina: 1065 West Badillo
Downey: Stonewood Shopping Center
Garden Grove: 9836 Garden Grove Blvd.
Glendale: Broadway & Chevy Chase Dr.
Inglewood: 4736 West Century Blvd.
La Habra: 1511 West Whittier Blvd.
Long Beach: 4684 Long Beach Blvd.
Los Angeles:

830 W. Olympic Blvd.
Ladera Shop. Ctr., 5305 Centinela Ave.
Mission Hills, 10919 Sepulveda Blvd.
Reseda, 19389 Victory at Tampa
West L.A., 10650 W. Pico Blvd. at Overland
Mountain View: San Antonio Shop. Ctr.
No. Hollywood: Laurel Plaza Shop. Ctr.
Oakland (San Leandro): Bay Fair Shop. Ctr.
Pasadena: 1715 East Colorado Blvd.
Pomona: 1335 Holt Ave.
Sacramento: 600 Fulton Ave.
San Bruno: 481 El Camino Real
San Diego: Grammont Shopping Center
305 Mission Valley Ctr., W. San Diego
College Grove Shop. Ctr.
San Francisco: 36 Geary Street

Santa Ana:
Bristol Plaza Shop. Ctr.
2713 South Main St.
Santa Monica: 732 Santa Monica Blvd.
Torrance: 22519 Hawthorne Blvd.
West Covina: 2516 East Workman Ave.

COLORADO
Denver:
798 South Santa Fe Dr.
Westland Shopping Center
2180 So. Colorado Blvd.
North Valley Shop. Ctr.

CONNECTICUT
Bridgeport: Lafayette Plaza
Hamden: Hamden Mart Shopping Center
Manchester: Manchester Shopping Parkade
New Britain: Newwrite Plaza
New Haven: 230 Crown St.
New London: New London Shop. Ctr.
Orange: Whiteacre Shop. Ctr.
Stamford: 29 High Ridge Rd.
Torrington: Torrington Parkade
West Hartford: 39 So. Main St.

FLORIDA
Jacksonville: Regency Square Shop. Ctr.
Orlando: Winter Park Mall, Winter Park
W. Palm Beach: 1801 Palm Beach Lake Blvd.

GEORGIA
Atlanta:
917 Peachtree St.
Greenbriar Shopping Center
No. DeKalb Shop. Ctr., Decatur

ILLINOIS
Belleville: Bellevue Plaza Shop. Ctr.
Chicago: Evergreen Plaza at 95th St.
Harvey: Dixie Square Shop. Ctr.
Waukegan: Belvidere Mall

INDIANA
Richmond: 753 Richmond Sq. Shop. Ctr.

KANSAS
Kansas City: Ranch Mart So. (Leawood)
Wichita: Parklane Shop. Ctr.

KENTUCKY
Bowling Green: Bowling Green Mall
Newport: Newport Plaza, 70 Carothers Rd.

LOUISIANA
Gretna: Oakwood Shop. Ctr.
New Orleans: 3112 Paris Ave.

MAINE
Portland: Pine Tree Shop. Ctr.

MARYLAND
Baltimore: Perring Pkwy. Shop. Ctr.
Langley Park: Hampshire-Langley Shop. Ctr.
Rockville: 1600 Rockville Pike

MASSACHUSETTS
Boston:
167 Washington St.
594 Washington St.
Bayside Mall
Braintree: South Shore Plaza
Brookline: Westgate Mall
Brookline: 730 Commonwealth Ave.
Cambridge: Fresh Pond Shopping Center
Dedham: Dedham Mall, 300 VFW Pkwy.
Framingham: Shoppers' World
Leominster: Whiteacre Shop. Ctr.
Lowell: Central Shop. Plaza
Medford: 3505 Mystic Valley Pkwy. (Durrell Div.)
Natick: 136 Worcester Rd. (Durrell Div.)
Quincy: 221 Quincy Ave. (Durrell Div.)
Saugus:
N. E. Shop. Ctr.
704 Broadway (Durrell Div.)
Springfield: Springfield Plaza
Waltham: 922 Main St. (Durrell Div.)
West Springfield: Century Shop. Ctr.
Worcester: Lincoln Plaza

MICHIGAN
Detroit:
Macomb Mall (Roseville)
Lincoln Ctr. (Oak Park)
Lincoln Park: 18 Sears Lincoln Pk. Shop. Ctr.

MINNESOTA
Duluth: 29-31 East Superior St.
Minneapolis:
1121 Nicollet Ave.
140 Apache Plaza
Hub Shopping Ctr.
St. Paul: 471 No. Snelling Ave.

MISSOURI
Kansas City:
1234 Grand Ave.
Antioch Shop. Ctr.
St. Joseph: East Hills Shop. Ctr.
St. Louis:
1125 Pine St. (Walter Ashe Div.)
South County Shopping Center
Northland Shopping Center
10483 St. Charles Rock Rd., St. Ann

NEBRASKA
Omaha: 3002 Dodge St.

NEW HAMPSHIRE
Manchester: 1247 Elm St.

NEW JERSEY
Pennsauken: Rt. 130 and Browning Rd.

NEW MEXICO
Albuquerque:
6315 Lomas Blvd., N.E.
4th and Copper N.W.

NEW YORK
Albany: Colonie Shop. Ctr., Colonie
Binghamton: Vestal Shopping Plaza
Buffalo:
725 Main Street
Transitown Ctr. (Williamsville)
New York: 1128 Ave. of the Americas
Schenectady: Shoporama Ctr., Rotterdam
Syracuse:
3057 Erie Blvd. East
Fairmount Fair Ctr., 3675 W. Genesee St.

NORTH CAROLINA
Charlotte: 1010 Central Ave.

OHIO
Cincinnati: 740 Swiftan Ctr.
Cleveland:
725 Village Ctr. (Maple Hts.) Village Shops
Richmond Mall (Richmond Hts.)
Lima: Lima Mall
Willowick: Shoregate Shop. Ctr.

OKLAHOMA
Oklahoma City:
Mayfair Shop. Ctr.
Hillcrest Shop. Ctr.
Tulsa: 2730 South Harvard

OREGON
Portland: 1928 N.E. 42nd St.

PENNSYLVANIA
Greensburg: Greengate Mall
Philadelphia:
2327G Cottman Ave., Roosevelt Mall
1128 Walnut St.
Pittsburgh:
309 So. Hills Village Ctr.
East Hills Shop. Ctr.
Plymouth Meeting: Plymouth Meeting Mall

RHODE ISLAND
Providence: 355 Reservoir Ave.
East Providence: Shoppers' Town
TENNESSEE

Memphis:
1208 Southland Mall, Whitehaven
96 North Avalon
Eastgate Shopping Ctr.
Frayser Plaza Shop. Ctr.
1825 South 3rd St.
Nashville: 100 Oaks Shop. Ctr.

TEXAS
Arlington: Collins at Park Row
Austin: Hancock Shopping Center
Brownsville: 847 S.E. Elizabeth St.
Corpus Christi: 520 Everhart Rd.
Dallas:

Medallion Center
125 Wynnewood Village
Plymouth Park Shop. Ctr.
138 Marsh Lane Plaza
156 Inwood Village
307 Casa Linda Plaza
1424 South Buckner Blvd.
El Paso: 85 Bassett Center
Forth Worth:
3324 Denton Highway
2615 West 7th St.
6303 Camp Bowe Blvd.
138 Seminary South

Houston:
7949 Katy Freeway
8485 Gulf Freeway
322 Northline Mall
Bellaire, 4759 Bissonnet
9417 Jensen Rd.
1407 Spencer Hwy. (So. Houston)
Lubbock: B-10 Caprock Shop. Ctr.
Midland: South "9" Meta Drive
San Antonio:
150 Wonderland Shop. Ctr.
684 S.W. Military Drive
71071/2 San Pedro Highway 75 North
Sherman: 1620 Highway 75 North
Waco: K-Mart Shop. Ctr.

UTAH
Salt Lake City: Cottonwood Mall
VIRGINIA
Arlington: Parkington Shop. Ctr.
Hampton: Mercury Plaza
Norfolk: 4016 Granby St.
Portsmouth: 3109 South St.
Virginia Beach: Pembroke Mall Shop. Ctr.

WASHINGTON
Seattle:
2028 Third Ave.
837 N. E. 110th St.
116 SW 148th St.

RADIO SHACK® A DIVISION OF Dept. TANDY CORPORATION WH

For CATALOG ONLY — mail to Radio Shack, 2727 W. 7th St., Ft. Worth, Texas 76107
For ORDER plus CATALOG — mail to store nearest you.

CAT. NO.	QTY.	DESCRIPTION	PRICE EACH
NEW 1968 CATALOG			FREE
Min. order: \$2.50. Orders up to \$5.00: add 50¢; over \$5.00: add 75¢ to cover cost of handling and postage in U.S.			
Add STATE TAX where Applicable:			
<input type="checkbox"/> Add to My Acc't.			TOTAL
<input type="checkbox"/> Check Enclosed. <input type="checkbox"/> Free Catalog			
NAME _____			
STREET _____			
CITY _____ STATE _____ ZIP _____			

ELEMENTARY ELECTRONICS



POSITIVE FEEDBACK

JULIAN M. SIENKIEWICZ, EDITOR

The fantastic changes that electronics will create in home life in the next decades were outlined to this editor by the vice president of Philco-Ford's Consumer Products Group. Carl E. Lantz, speaking to a group of New York area editors, said that the products that will evolve in the future will resemble those of today in function only.

"The housewife," Mr. Lantz said, "will become mistress of a computer-directed household system that will help her greatly improve the health, education and safety of her family. And the electronic features of the home such as shopping by videophone and automatic meal preparation will enable her to preserve her energies so that she can devote more time to creative, family-centered activities and to her own self-improvement.

(Continued on page 22)



In the computer-controlled "House of Tomorrow," as envisioned by Philco-Ford Corporation, the housewife will have a computer control console in the kitchen area. Above, she looks at a blouse on a large video screen used for shopping. The video shopper scans shelves through a camera in the store and she selects what she wants by pushbutton. Above the shopping screen are a household monitor (left) and a video phone.



**NEW
HOLLOW
SHAFT**

nutdriver set

with Locknut/Screw adjusting feature

Speeds, simplifies setting of combination lock-nut/slotted screw adjustments on rheostats and similar controls used in a wide variety of electrical and electronic equipment.

Handle is drilled so you can run an 8" screwdriver blade right through its center and down through the hollow nutdriver shaft.

Ideal for all-round production, maintenance, and service work, this new HSC-1 Set contains eight interchangeable hollow nutdriver shafts in the most popular hex opening sizes from $\frac{3}{16}$ " thru $\frac{1}{8}$ "



Really compact! Set is small enough, light enough to carry in your hip pocket. Sturdy, see-thru, plastic carrying case doubles as a bench stand.

XCELITE

XCELITE, INC. • 80 BANK ST., ORCHARD PARK, N. Y. 14127

Send Bulletin N867 with information on HSC-1 Hollow Shaft Nutdriver Sets.

name _____

address _____

city _____

state & zone _____

Olson



* **FREE**

Fill in coupon for a **FREE One Year Subscription to OLSON ELECTRONICS' Fantastic Value Packed Catalog—Unheard of LOW, LOW PRICES on Brand Name Speakers, Changers, Tubes, Tools, Stereo Amps, Tuners, CB, and other Values. Credit plan available.**

NAME _____
ADDRESS _____
CITY _____ STATE _____
GIVE ZIP CODE _____

If you have a friend interested in electronics send his name and address for a **FREE** subscription also.

OLSON ELECTRONICS
INCORPORATED

783 S. Forge Street Akron, Ohio 44308

FIRST WITH

- ★ Digital Integrated Circuits
- ★ 4 Crystal-Controlled Oscillators
- ★ Battery & AC Operation Standard



The New Pace-Setting **CONAR Model 680**

COLOR GENERATOR
KIT \$83.50 WIRED \$114.50

Until now, no commercially available color generator has offered so many quality features in a single instrument at such a low price. Only the **CONAR SIGNAL GENERATOR** has all these features at any price: exclusive digital integrated circuits; exclusive 4 crystal-controlled oscillators; exclusive AC or battery operation standard; completely solid state; color amplitude control; color phase adjustment; regulated power supply; stability control; TV station sync and blanking pulses; nine patterns; red, blue and green gun killers; compact; lightweight; portable.

For details write Dept. AV8C

CONAR instruments

DIVISION OF NATIONAL RADIO INSTITUTE
3939 Wisconsin Ave., Washington, D.C. 20016

WRITE FOR FREE CONAR CATALOG

POSITIVE FEEDBACK

The electronic technology that will make all this possible will serve as a bond to family unity because the home will become a much more self-contained center for education, work and recreation. The technology for the house of tomorrow, as we see it, exists today. However, the elements of the system require refinement and cost reduction before they can become part of the American home."

The heart of the home of the future, as conceived by Philco-Ford engineers and scientists, will be a computer. Through an environmental control system, the computer will analyze the air for impurities, odor, temperature and moisture content. The air will be filtered, warmed or cooled, moisture added or removed and a pleasant odor injected—all directed by the computer.

The computer will keep health records of all family members and prescribe the type and amount of exercise needed. Each morning, a "medicouch" will record blood pressure, pulse rate, temperature and weight and take an electrocardiogram. This information will be fed into the computer. Based on each person's nutritional needs, the computer will suggest daily menus and keep an inventory of foodstuffs. The housewife will program the computer from her kitchen console to select meals to be served at a time of her choosing.

The kitchen will contain a food processor that is both a freezer and microwave oven. The various portions will be fed automatically from the freezer into the oven for a few seconds of thawing or warming. A dishwasher that uses powdered plastic will produce disposable dishware quickly and cheaply, eliminating dishwashing and dish storage.

The housewife will use electronics for shopping, too. Her console will be equipped with a video screen that will put her in finger-tip contact via microwave transmission with the store of her choice. As the video shopper scans shelves and counters, she will order by pushbutton.

The education room will contain a variety of devices designed to satisfy the learning needs of all members of her family. The audio center will provide tape instruction in foreign languages, mathematics, space navigation, or whatever you wish. Another area, called the library terminal, will specialize in computer-assisted instruction. Equipment will be programmed with courses ranging from the most elementary reading instructions to the most complicated science course.

The library terminal will tap the home computer for answers that might be found in the encyclopedia. It also may draw from a community library computer that will store more exhaustive information on all disciplines.

Students will be supplied daily with a reel of tape instead of books. The tape will provide all video and audio material for home study and

Now...18 different professional-quality amplifiers, tuners & preamps

- completely assembled...
- solid state, printed circuits...
- priced lower than kits.

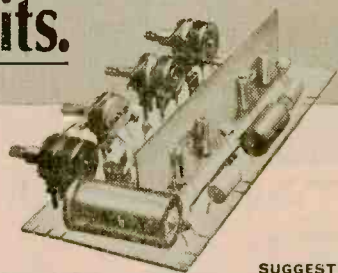

There are so many ways you will use these easy-to-install, printed-circuit assemblies; in hi-fi equipment, ham gear, P.A. and intercom systems, or as guitar and organ amplifiers. Employing the most advanced Complementary-Symmetry transistorized designs, these assemblies provide the ultimate in economical circuitry for reliable audio applications from one watt to twenty. They have already become the design standard for a large group of audio equipment manufacturers, as well as a basic teaching tool in many educational institutions.

TYPE	DESCRIPTION	SUGGESTED LIST PRICE
PCA-1-9	1W, 9V D.C. 4 Transistor Amplifier	\$7.20
PCA-1-14	2W, 14V D.C. 4 Transistor Amplifier	7.00
PCA-2-9	3/4W, 9V D.C. 3 Transistor Amplifier	5.90
PCA-2-14	1W, 14V D.C. 3 Transistor Amplifier	5.90
PCA-3B-18-1	4W/Channel Stereo Amplifier with Bass, Treble, Volume and Balance Controls	19.20
PCA-4-9	1W, 9V D.C. High Gain, 4 Transistor Amplifier for Radio, Ceramic or Crystal Phono Cartridge, etc.	8.30
PCA-4-9A	Same as PCA-4-9 with Tone Control Circuit	9.20
PCA-4-14	2W, 14V D.C. High Gain 4 Transistor Amplifier for Radio, Ceramic or Crystal Phono Cartridge, etc.	8.30
PCA-4-14A	Same as PCA-4-14 with Tone Control Circuit	9.20
PCA-4-18A	3W, High Sensitivity, 4 Transistor Amplifier with Volume and Tone Controls for use as Guitar, Radio or Phono Amplifier	9.52
PCA-5A-14	2W/Channel 14V D.C. Stereo Amplifier with Balance, Tone and Volume Controls	15.80
PCA-6A-25	8-10W/Channel Stereo Amplifier with Preamp for Ceramic Phono Cartridge and Bass, Treble, Balance, and Volume Controls	30.10
PCA-6A-25SCS	Same as PCA-6A-25 with Separate Control Assembly	31.80
PCA-7B-18	Tape Cartridge Stereo Preamp with Level Set Controls	12.00
PCA-7C-18	Same as PCA-7B-18 without Level Sets; 4 Transistor	9.50
PCA-8-36	20W Mono Basic Amplifier	18.85
PCA-9-18	3W/Channel, 10 Transistor Stereo Tape Playback Amplifier with Volume, Tone and Balance Controls	25.30
PCR-1-9	9V 2 Transistor AM Tuner	11.30

For brochure containing complete technical data on all 18 assemblies and for name of distributor nearest you, write: Amperex Electronic Corporation, Distributor Sales Dept., Hicksville, New York 11802.

Amperex®

TOMORROW'S THINKING IN TODAY'S PRODUCTS

SHOPPING MART

Selection of products available by mail. Money-back guarantee. Order by Stock No. Send check or M.O.

"FISH" WITH A MAGNET



Stock #70,571EK \$12.50 Ppd.

Go treasure hunting on the bottom! Fascinating fun & sometimes profitable! Tie a line to our 5-lb. Magnet—drop it overboard in bay, river, lake or ocean. Troll it along bottom—your "treasure" haul can be outboard motors, anchors, other metal valuables. 5-lb. Magnet is war surplus—Alnico V Type—Gov't. cost \$50. Lifts over 150 lbs. on land—much greater weights under water.

WORKING MODEL DIGITAL COMPUTER



Stock #70,683EK \$5.98 Ppd.

Solve problems, teach logic, play games with miniature version of giant electronic brains! Adds, subtracts, multiplies, shifts, complements, carries, memorizes. Colored plastic parts easily assembled. 12" x 3 1/2" x 4 3/4". Incid. step-by-step assembly diagrams, 32-p. instruction book covering operation, computer language (binary system) programming, problems & 15 experiments.

IT'S HERE—BIG, NEW DIGICOMP II!



Stock No. 70,946EK—(Intro. price) \$16.00 Ppd.

Master the terrific challenge of DIGICOMP II! Loads of fun! Terrific challenge! Actually works like electronic digital computer but needs no power. Adds, subtracts, multiplies, divides, memorizes. 1st mech. computer w/auto. switch action. 1st model designed for programming. Speed reduced by factor of million to 1—See what's happening! Demonstrates new math. computer techniques.

NICKEL-CADMIUM BATTERY BARGAINS

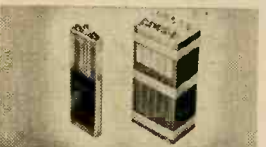

Stock No. 70,942EK—(Battery) \$15.00 Ppd.

Stock No. 40,798EK—(1.2 V. Cell) \$ 3.95 Ppd.

Stock No. 70,807EK—(Charger Kit) \$ 8.00 Ppd.

Terrific value—used government surplus. Quick-charge, lightweight 6-volt nickel-cadmium battery. 4-amp. hour capacity. Almost unlimited life. Charges in 1 hr. w/ Edmund Charger Kit. Hundreds of uses. Few drops of water yearly for full maintenance. Minimum of electrolyte—sealed to prevent loss. Delivers nearly 100% output at below freezing. Five vented 1.2 volt cells. 3 1/2" x 2" x 6".

SAVE 50% ON PHOTOCONDUCTOR CELLS



Stock No. P-41,110EK \$5.00 Ppd.

Terrific bargain! Package of 10 surplus minimum sulfide cells for only \$5. Perfect to open-close doors, operate burglar alarms, stop-start conveyors, bin-level indicators, etc., and as accurate light-metering device. Sensitive to all light but most responsive to light in green-yellow spectrum—resistance varies with changes in light intensity. Maximum power 0.3 watts. Hermetically sealed. Full instructions.

FLY 9-FT. HOT AIR BALLOON



Stock No. 60,691EK \$2.00 Ppd.

9 Ft. tall. Rises to amazing heights on just hot air. Supplied with tether attached, so can be used over and over. Easy to make, launch, fly. Loads of fun. Great for celebrations, science fairs, plain fun. Will lift model gliders, parachutes, instruments, etc. anything up to 1/2 lb. Approx. 5 ft. diam. when fully inflated. Kit contains 10 pre-cut red & white gores (No. 1 model paper), 6 ft.

MAIL COUPON FOR FREE CATALOG

SEND FOR FREE CATALOG "EK"
Completely new 1968 edition. New items, categories, illustrations. 148 easy-to-read pages packed with nearly 400 unusual items. Dozens of electrical and electromagnetic parts, accessories. Enormous selection of Astronomical Telescopes.

NAME
ADDRESS
CITY STATE ZIP

ORDER BY STOCK NUMBER • SEND CHECK OR MONEY ORDER • MONEY-BACK GUARANTEE
EDMUND SCIENTIFIC CO. 300 EDCDRP BUILDING
BARRINGTON, NEW JERSEY 08007

POSITIVE FEEDBACK

will reproduce enlarged copies of maps and pictures from the home computer and central library facility.

Another area will be for educational TV, which is expected to be used as much in the house of tomorrow as in the future classroom. In fact, television and a huge TV screen will be the dominant feature of living rooms. The TV screen will be *holographic*, or three-dimensional, enabling you to see around corners just as if you were in the scene being projected. A living room console will control all entertainment functions in the home. It also will control light intensity and color to match the entertainment mood of the moment.

Yep, the Philco-Ford people have some big and grand ideas about your future. I guess now is the time for this editor to trade in his "old faithful" 1964 Rambler.

Get with MATV. With increasing popularity of low-priced television sets, small-size "personal" black-and-white sets, and FM and high fidelity equipment, many homes today need the ability to distribute TV signals to two, three or four (and sometimes even more) receivers. Although homes in many areas as yet receive only VHF and FM, the increasing number of UHF stations now makes it advisable to install amplifiers, coaxial cable and outlets capable of receiving and distributing signals on all channels from 2 to 83, including FM. Thus, planning ahead for the whole spectrum of signals will eliminate the possibility of prematurely obsoleting home MATV equipment (that's *Master Antenna Television System*).

Proper installation and wiring of a small home distribution system now is as simple as that for a doorbell, intercom or telephone. It's best done at the time the home is being built. Then the outlet boxes and coaxial cables can be led most easily through wall cavities, just like electric wires and plumbing pipes. Thus, builders and electrical contractors are natural installers. But, it is by no means impractical for existing homes. Anyone who can wire a lamp can install his own MATV.

A few years ago, TV dealers and installers hesitated on installing relatively complicated small master antenna television systems in homes. But today with greatly simplified equipment, such systems can be installed easily and profitably by common-sense technicians, and you, the reader of ELEMENTARY ELECTRONICS.

Mail-order catalogs and radio parts dealers will sell the coax cable and parts to anyone who has the scratch to cover the bill and the guts to climb his roof and break through walls. Don't let your home be blind to UHF-TV. Install MATV today! Then, the next time you see snow it'll be on your driveway. ■

NEW!
MASTER COURSE
IN COLOR TV...

WITH NTS COLOR KITS

Big 25" Color TV kits included in new Master Color TV Home Study program. Learn Color TV; keep the new 25" color TV receiver you build with exciting kits we send you. 10 million homes in this country will have color TV by the end of 1967. This industry needs technicians as never before, and NTS-trained men can move quickly into the big money.

COLOR TV SERVICING BRINGS HIGH PROFITS

New color sets need careful installation, precision tuning and skilled servicing. NTS home training can put you in this profit picture—prepare you for big pay, security, or start a business of your own.

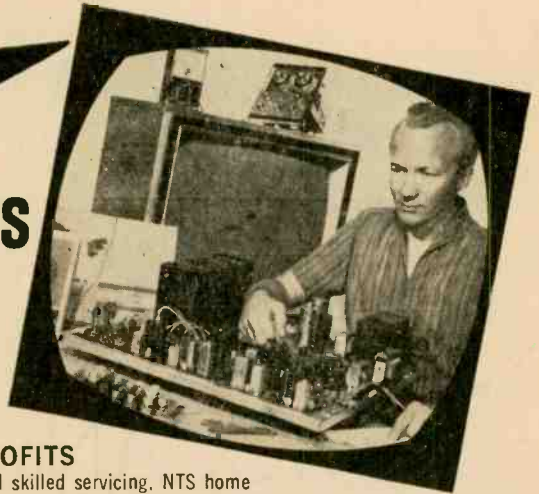

LIFT OFF... TO
A "SPACE AGE"
CAREER IN
ELECTRONICS

This is the "space age". It offers new opportunities in communications, industrial electronics, computer technology, and many others. Automation has increased the need for skilled electronics technicians in thousands of manufacturing plants. Only the well trained man makes it big. Industry wants and demands this kind of man... the NTS man. Pick your field. Let an NTS Project Method Program help you toward a well-paid career in Electronics wherever you travel.



NEW CAREER KIT... FAST, EASY START TO NTS HOME TRAINING

The exclusive Project Method Career Kit helps you move quickly into your training program. Earn while you learn as you progress with your shop-tested Project Method lessons and kits.

Send for the New illustrated NTS Color Catalog. It shows the equipment and kits you work with and keep. Describes in detail the advantages of NTS Project Method Home Training. Tells you everything you need to know about starting your career in electronics.



HIGH SCHOOL AT HOME

National offers accredited high school programs. Take only subjects you need. Study at your own pace. Everything included at one low tuition. Check special High School box in coupon for full information & FREE catalog.

CLASSROOM TRAINING AT LOS ANGELES

You can take Classroom Training at Los Angeles in Sunny Southern California. NTS occupies a city block with over a million dollars in facilities devoted exclusively to technical training.

MAIL REPLY CARD OR COUPON FOR NEW, FREE COLOR CATALOG AND SAMPLE LESSON.



NATIONAL TECHNICAL SCHOOLS

World Wide Training Since 1905
 4000 S. Figueroa St., Los Angeles, Calif. 90037
 You enroll by mail

We have no salesmen: This means lower tuition for you. Accredited Member National Home Study Council. Accredited Member: National Association of Trade & Technical Schools

NATIONAL TECHNICAL SCHOOLS

4000 S. Figueroa St., Los Angeles, California 90037

APPROVED FOR VETERANS

Please rush Free Color Catalog and Sample Lesson, plus detailed information on field checked below. No obligation.

- MASTER COURSE IN COLOR TV SERVICING
- COLOR TV SERVICING
- MASTER COURSE IN TV & RADIO SERVICING
- PRACTICAL TV & RADIO SERVICING
- MASTER COURSE IN ELECTRONIC COMMUNICATIONS
- FCC LICENSE COURSE
- INDUSTRIAL & COMPUTER ELECTRONICS
- STEREO, HI FI & SOUND SYSTEMS
- BASIC ELECTRONICS
- HIGH SCHOOL AT HOME

Dept. 222-18

Name _____ Age _____

Address _____

City _____ State _____ Zip _____

- Check if interested in Veteran Training under new G.I. Bill.
- Check if interested ONLY in Classroom Training at Los Angeles.





NEWSCAN

Listen to This

Troubleshooting transformers and circuit breakers with an ultrasonic detection instrument is a new practice at substations of the Pacific Power & Light Company. The result is a considerable reduction in the time necessary to isolate faulty hardware. In one instance at an outlying substation, a defective insulator on a 69-kilovolt bus was located instantaneously. There had been no outward symptoms of

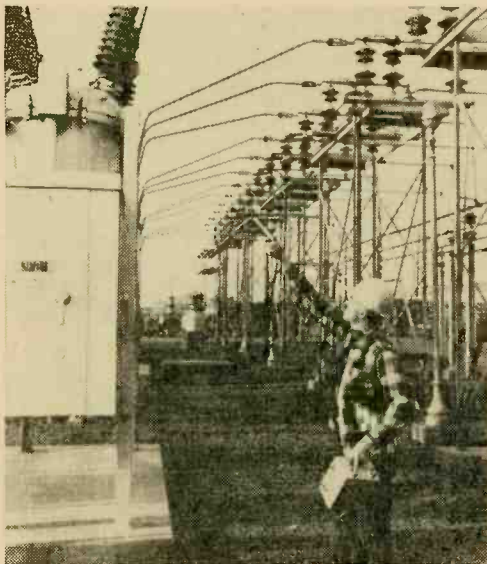

Pacific Power & Light Company technician Phil Young surveys 115-kv circuit breaker bushings. Probe connected to ultrasonic test unit zeroes in on ultrasonic energy from the source of corona or arcing to isolate the defective component.

trouble, yet the ultrasonic energy was so pronounced it sent the needle on the ultrasonic unit's dB meter zooming toward its upper limit. The insulator was replaced. Careful examination on the ground indicated the unit would have failed in a matter of hours.

The ultrasonic test unit consists of a hand-held probe/microphone responsive to acoustic energy in the 36 to 44 kHz range and a battery-powered, nine-pound instrument with solid-state electronics which translates high frequency sonics to the audible range and reproduces the sounds through its speaker or headset.

The characteristics associated with a phenomenon are preserved through translation, that is, it reduces high frequency energy to audio levels very much like a superhet radio. When 40-kHz energy is released by corona or arcing, its high frequency sound energy is translated, and is instantly recognizable to anyone familiar with high voltage as the familiar "frying" sound. Similarly, air pressure leaks emit hissing sounds at 40 kHz; and faulty bearings render recognizable squeaks or clicks. Therefore, the ultrasonic test unit can detect troubles in many different types of electrical and mechanical machinery long before they break down. (Editor: *I've got to install one in my car.*)

Easy on the Salt

An electrostatic salter, a new concept in automatic electrostatic salting machines for processors of foods, especially snack items, is being marketed by Morton Salt Company. Electrostatic salting uses the high-voltage acceleration of negative electrons. In the salter a negative charge is given to salt as it passes over a variable-speed roller. The salt then passes a controllable, positively charged rod which attracts the negatively charged salt, dispersing it. This creates the desired salting pattern as the salt free-falls to the product passing below. The product, having a different charge, attracts the salt and forms a static bond with it. This causes the salt to cling firmly to the product.

This unique bond makes it possible to effectively salt even cold products and to achieve a high uniformity of product never before possible. How important is this electrostatic development? Figure it out for yourself. Imagine how long it would take to salt by hand all the potato chips made each year in the United States.

Chow Call

An inventive Indianapolis restaurateur has come up with an idea which Alexander Graham Bell might well applaud. An old-fashioned "Jot-Em Down Store" telephone which is actually a tape recorder has been installed by Lloyd W. Laughner in one location of his cafeteria chain. Via table cards customers are invited to ring a side bell and make comments on the cafeteria's food and service. Alerted by the bell, the man-



Here's one call that doesn't cost a cent. Restaurant patron sounds off on quality of food and service into a tape recorder. From the smile on her face the chef's job is secure.

ager can listen in, or he can play the tape later. Between luncheon and dinner periods when the cafeteria is closed for cleaning, the tape is played over the PA system for the whole staff to hear. According to Laughner, "Comment cards are common in restaurants, but it takes so much time to read them that they stack up. With this recorder we'll be able to hear what our customers want and take care of it immediately."

Like Back to Mama, Baby!

A space "MOOSE" may prove a friend in need for astronauts who must abandon ship. MOOSE (Manned Orbital Operations Safety Equipment) was developed by the General Electric Company. The astronaut slips into a six-foot plastic bag, then fills the bag with polyurethane foam from two pressurized containers. A foldable shield, bonded to the bag, protects the astronaut from the searing heat as he enters the atmosphere. The MOOSE "life beat" is also equipped with a radio beacon, dye markers and a built-in parachute. You can almost predict that the poor astronaut will assume a fetal position. ■

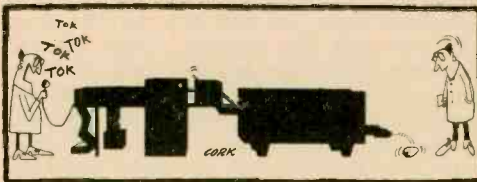

People who built their own Schober Organs wrote this ad

Here's what they say about the pleasure of assembling the Schober Electronic Organ from kits . . . and enjoying the magnificent sound of an instrument they've created in their spare time.



The NEW Schober THEATRE ORGAN one of four models available

Building was fun
"Building it was at least as much fun as playing it!"
Mr. Lester F. Schwartz,
Somerset, N. J.

So proud I could pop
"I've done over 90 per cent of the work on this organ myself—and I'm so proud I could about pop!"
Mrs. V. P. Allbert,
Topeka, Kansas

Nothing as fine under \$4,000
". . . I could not find any organ that sounded as fine as the Schober under \$5,000."

Mr. Jerome J. Fraenkel,
Franklin Square, N. Y.

Proud to own

"I am proud to own such a valuable instrument."

Mr. Jean J. Juteau, Montreal, Canada

Most cherished possession

"My spinet has become the most cherished possession in our home—fabulous, indeed."

Mr. Frank J. Marion, North Bergen, N. J.

Tremendous sound

"The sound is conservatively, tremendous."

Mr. Paul DeForest Wren, Westbrook, Conn.

Unbelievably easy to build

"When we ran out of instruction, the organ was finished . . . To me it was unbelievable!"

Mr. Ted Sowinski, Chicago, Illinois

Thousands of music lovers in every walk of life—from teen-agers to grandmothers, from people who are "all thumbs" to electronic engineers—have enjoyed the pleasure of assembling, playing and hearing the magnificent sound of the Schober organ. Whether you favor Bach or Bop, there is a Schober organ that gives you full range of expressional and tonal quality—so like a fine pipe organ that many listeners can't tell the difference. You can build a Schober organ for as little as \$645. And—even if you've never played a note before—Schober's enjoyable self-teaching courses give you immediate musical results.

Over 50% of Schober Organ owners never handled an electronic job before and didn't play a note, yet assembled some of the best organs ever designed and get a daily thrill from making their own music. Isn't it time for you to take this cost-saving road to greater musical pleasure—and enjoy the satisfaction of doing it yourself?

Free Information and Demonstration Recording

Send today for your free copy of Schober's 16-page, full color booklet, plus 7" free recording.

The Schober Organ Corp., Dept. EE-2
43 West 61st Street, New York, N. Y. 10023

- Please send me Schober Organ Catalog and free 7-inch "sample" record.
 Enclosed please find \$1.00 for 12-inch L.P. record of Schober Organ music.

NAME _____
ADDRESS _____
CITY _____ STATE _____ ZIP _____



☆☆☆

Noise Killing Bubbles

Introduction of an entirely new line of noise suppression accessories in attractive bubble packs is announced by Estes Engineering Co. The new Electro-Shield line includes kits for Ignition Suppression, Alternator Filtering w/ Shielding, DC Power Line Filters w/Cable and Universal Suppression packages. These units will permanently reduce engine noise, thereby providing improved long-range communications and increased reliability. Dealers in the mobile 2-way communications field will be interested in the new eye-catching merchandising board, holding up to 24 assorted bubble packs, plus literature



Man, here's one product display from Estes Engineering that caught the Editor's eye.

racks illustrating the entire Electro-Shield line of products. The immediate benefits of Electro-Shield products makes them highly recommended for Police and Fire vehicles, Ham operators, CB operators, truck fleets and other users of 2-way radio communications. For further information and prices, write Estes Engineering Co., 543 W. 184th St., Gardena, Calif. 90247.

Table-Top Music System

Concord's new model F-200 is an unique high-fidelity system for AM/FM listening and off-the-air recording on the built-in cassette recorder. Designed as a table-top music source, the F-200



Concord's Compact F-200 Table Hi-Fi

contains the Concord F-100 Sound Camera. The F-100 is detachable and may be removed easily for portable tape recording or dictation elsewhere. Up to two hours of musical favorites can be recorded on a single cassette. Commercials can be eliminated by a remote control switch. A single control starts, stops and rewinds the tape. The F-200 Radiocorder is all solid-state and includes a superhet AM/FM receiver with mode switch for AM, FM, FM-AFC, and tape play; precision capstan-drive tape-transport mechanism for constant 1 7/8-ips recording and playback; Concord's flux-field recording heads and professional remote control dynamic mike. Priced at under \$150. Write Concord Electronics Corp., 1935 Armacost Ave., Los Angeles, Calif. 90025 for additional information.

Hot Hertz Grabbers

Jerrold has come out with two recently developed lines of 300-ohm outdoor antennas. The 82-channel VUfinder and the VHF-TV/FM ColorPeak series are high-gain periodic types with unusually flat response across the full frequency range. They provide strong, clear signals even in difficult reception areas. The five Jerrold VUfinder models, for local to deep fringe applications, can be converted for coaxial lead-in by using an 82-channel matching transformer

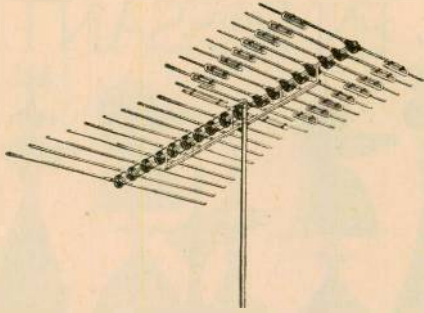

Jerrold's 82-channel ColorPeak TV Antenna

model MUV-374. VUfinders are shipped with Jerrold model FS-1314 frequency separators to split VHF from UHF for separate inputs into TV sets. VUfinder prices range from \$17.95 to \$79.95. The seven ColorPeak models, for local to deepest fringe use, can also be converted for coaxial-lead-in through use of a VHF matching transformer, model TO-374A. List prices range from \$15.95 to \$79.95. Both highly efficient types have excellent front-to-back ratios. They are finished with Jerrold's corrosion-resistant Golden Armor Coating. "Cyclac" insulators provide superior strength at assembly points. Further information about VUfinder and ColorPeak antennas can be obtained from Jerrold Electronics Corp., 401 Walnut St., Philadelphia, Pa. 19105.

Have A Hear

Unimetrics has introduced a new VHF/FM dual-conversion monitor receiver. The HA-153/155 may be operated on up to 6 crystal controlled channels in the 153-155 MHz land mobile and marine band. Its sensitivity is 0.7 μ V for 20 db quieting. Selectivity is 60 db down at ± 30 kHz. Image rejection is 60 db and audio output is 3 watts. The six crystal-controlled channels permit monitoring of fire, police, special emergency, Civil Defense, industrial and business FM communications as well as radio paging and alerting stations and the VHF marine band channels. It's a professional receiver for professional users and employs advanced electronic circuitry. Silicon mesa transistors are used in the RF, IF and oscillator circuits. It is designed for trouble-free, rugged heavy duty use in trucks, cars, homes, boats, and offices, as well as a base station satellite or standby receiver. It is feather-light and miniaturized, smaller than a cigarbox, 6 x 8 x 2 in. It comes complete with all mounting hardware and operates from an external 12-volt battery, drawing less than 0.7 ampere, or with optional 117 VAC power supply (Model HB 502) from house current. The price is only \$99.95. Tone decoders are available which are compatible with Channel Guard, Private Line and all CCTS systems. For details write to Unimetrics, Inc., 1037 Providence Rd., Charlotte, N. C. 28207.

EARN A KING-SIZE PAY CHECK AS A COLOR TV SERVICE SPECIALIST!

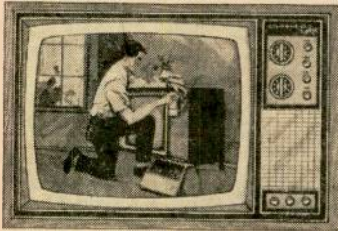

BUILD AND KEEP THIS BIG SCREEN COLOR TV RECEIVER!

Money, skill and experience come fast with CTI training. You learn by doing! CTI provides you with more than just lessons. As part of your training you build an ultra-modern Big Screen Color TV Receiver (as illustrated above)—and you keep it! Plus parts, kits, tools—everything you need to become a highly paid color TV technician. Get the facts that can put more money in your pockets—fast! Use the coupon to send for the free CTI book—TODAY!

New Color TV Training Program Puts You in The BIG MONEY LEAGUE!

8,000,000 color sets in use in 1967. About 70-million regular black and white TV sets. That's a conservative estimate by the television industry. It should give you an idea of the urgent demand for trained TV technicians. Now is the time to get in on the ground floor and reap the rewards—higher pay, wider range of top-money job opportunities and greater job security.

APPROVED FOR GI TRAINING If you served since January 31, 1955 or are in service, check GI line in coupon

COMMERCIAL TRADES INSTITUTE—Dept. EE-268
1400 Greenleaf, Chicago, Illinois 60626

Please send me all the facts on **COLOR TV Servicing.**

Name _____ Age _____
Address _____ Phone _____
City _____ County _____
State _____ Zip Code _____

Check for facts on GI Bill

CTI specializes in training men in 4 other high-paying fields. Check one for free information.

- Automation Electronics
- Air Conditioning, Refrigeration & Heating
- Modern Auto Mechanics
- Building Construction

FREE! 5-WAY INSTRUMENT & DRAFTING APTITUDE TEST
 lets you see for yourself if you are suited for a high pay **CAREER IN DRAFTING**

YOUR FUTURE IN DRAFTING
 APTITUDE TEST
 SAMPLE LESSON

TAKE YOUR PICK OF THOUSANDS BIG SALARY JOBS OPEN TO DRAFTSMEN (see "help wanted" sections of metropolitan newspapers). Huge nationwide demand... U.S. Dept. of Labor reports "42% more draftsmen needed in next 10 years—not enough applicants to fill drafting jobs available now!" Our easy "Quick-Learn" home-study method has helped hundreds of beginners toward good income, security and prestige as Draftsmen. Many have succeeded with only grade school training. Others report good earnings drafting part time while still learning! Why not you?

WE FURNISH EVERYTHING
YOU GET 3 BIG KITS WHEN YOU ENROLL!

Rush Coupon for FREE KIT!
 Mail coupon today for FREE "DRAFTING CAREER KIT," Sample Lesson, Drafting Aptitude Test, intriguing new 5-Way Drafting Instrument & 20-page Book, "Your Future in Drafting"—packed with revealing facts on your opportunities to win top pay and security in Drafting. No salesman will call. Everything sent FREE and POSTPAID. Write today!

ALL 4 FREE RUSH Coupon

NORTH AMERICAN SCHOOL OF DRAFTING, Dept. 1351
 4500 Campus Dr., University Plaza, Newport, Calif. 92660
 Rush "DRAFTING CAREER KIT," including Book, Sample Lesson, Aptitude Test & Drafting Instrument—ALL FREE! No salesman will call.

Name _____ AGE _____
 ADDRESS _____
 CITY _____ STATE _____ ZIP _____

When answering advertisements say you saw it in ELEMENTARY ELECTRONICS

World Famed BREVETTATA TEAR GAS PISTOL

Appearance of this fine tear gas weapon is similar to real gun. It is ideal for people who work in lonely, dark locations and require protection. Men give this gun to wives and daughters for night security. Many industrial applications. Shooting of gun stuns aggressor without permanently injuring him. Neither permit nor license is needed, but it is not sold to minors. It fires six cartridges without reloading. Each gun comes with six tear gas shells and six blanks for practice and is shipped prepaid. Gun unit prices include, 12 shells and all shipping costs.

<input type="checkbox"/>	1 Gun-unit at	\$13.07
<input type="checkbox"/>	2 Gun-units at \$22.86	(\$11.43 ea.)
<input type="checkbox"/>	3 Gun-units at \$29.94	(\$ 9.98 ea.)
<input type="checkbox"/>	4 Gun-units at \$35.16	(\$ 8.79 ea.)

Extra boxes of ten tear gas shells at \$1.50 per box (prepaid with gun orders). Extra boxes of blanks at \$1.25 per box.

UNITED SAFETY SUPPLY CO.
 310 West 9th Street
 Kansas City 11EE, Missouri 64105



EN PASSANT

BY JOHN W. COLLINS

↑ "A combination is a forced variation with sacrifice," wrote former World Champion M. M. Botwinnik. While technically precise, this is a rather bloodless, undramatic definition of one of the most glamorous and stirring happenings in a chess game. Richard Reti, author of "Masters of the Chessboard," expressed it better with: "Now we see wherein lies the pleasure to be derived from a chess combination. It lies in the feeling that a human mind lies behind the game, dominating the inanimate pieces with which the game is carried on, and giving them the breath of life." This feeling and breath are embodied in the following famous combinations.

Paul Morphy joins together mating threats on the last rank with an attack on an unprotected Bishop.

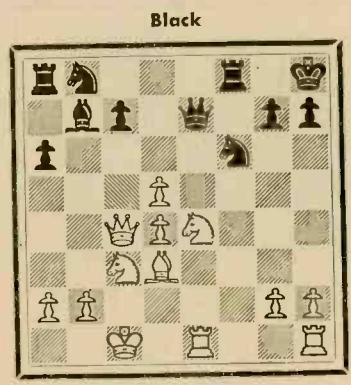

White

Morphy-Mongredien Paris, 1859

1 NxN	QxN	3 RxR#	QxR
2 KR-B1	Q-Q1	4 Q-N4!	...

A "deflecting" sacrifice which threatens the Bishop.

4 . . . Q-B1

If 4... QxQ 5 R-K8# Q-B1 6 RxQ mate.

5 QxB Resigns

After this second deflecting sacrifice, Black can only give up, for if 5... N-Q2 he remains a piece behind and if 5... QxQ 6 R-K8 mate.

Jose R. Capablanca exploits an "overloaded" Queen.

Black

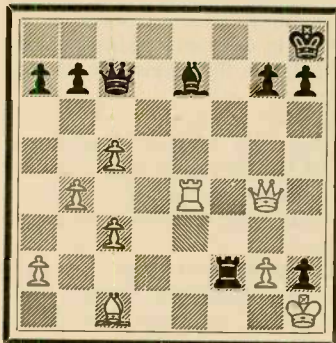

White

Capablanca-Spielmann
San Sebastian, 1911

1 B-B4 Q-Q1

Now the Black Queen is overloaded because it must guard both the last rank and the Bishop.

2 RxB1 Q-KB1

If 2... QxR 3 Q-B8# Q-B1 4 QxQ mate.

3 QxP#! QxQ 5 B-K5# R-B3
4 R-K8# Q-N1 6 BxR mate

Incredibly, Alexander Alekhine played this in one of twenty-six simultaneous blindfold games!

Black

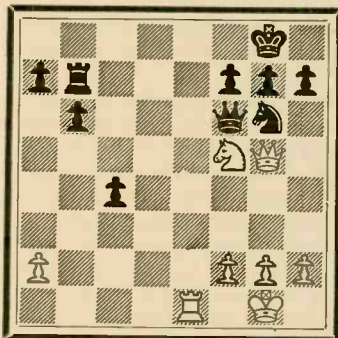

White

Alekhine-Freeman
New York, 1924

(Continued on page 129)

NAVY MARINE BAND WALKIE-TALKIE

TRANS. & RECEIVER—Crystal controlled, can be operated on any one channel in freq. range 2.3 to 4.5 MC. Voice (A3) communication only; output of Trans. is 0.2 watts & satisfactory communication between units over average terrain should be maintained approx. up to one (1) mile. With Tubes: 1/1K5, 1/1B5, 2/1T4, 3/3B4. Voltages required: 67.5 VDC 3 MA; 135 VDC 4 MA; 1.5 VDC 225 MA f/Receiver, 67.5 VDC 1.5 MA; 135 VDC 10 MA; 1.5 VDC 225 MA & -6 VDC 30 MA f/Trans. In a waterproof plastic case w/space for batt. or power supply. Telescoping antenna 8 ft. Has specc. loading coil. Complete w/tubes, antenna, 2 crystals FT-243 (no choice of freq.) headphones, carbon microphone, canvas cover, & manual. Sizes 8x8x 2 1/2". Wt.: 8 lbs. \$9.95



"DAV" MODEL—Same as above, but with direction finding loop and lip mic., plywood case w/straps. Size: 14x10x3" \$12.95

VIBRATOR Power Supply f/MAB & DAV. Operates from 6 VDC 4 A N-T-6 Batt. or other power source. 6 1/2x3 3/4x1 3/4". 2 lbs. New. \$6.95

Dry Charge Battery N-T-6 f/above power supply. 6 VDC 4 A... \$3.95

Prices F.O.B. Lima, O.—25% Deposit on COD's—Address Dept. M

BIG FREE CATALOG—Write for your FREE copy now!

FAIR RADIO SALES

1016 E. EUREKA • Box 1105 • LIMA, OHIO • 45802

WRITE NOW FOR MCGEE'S 1968 CATALOG

1001 BARGAINS IN

SPEAKERS—PARTS—TUBES—HIGH FIDELITY

COMPONENTS—RECORD CHANGERS—

Tape Recorders—Kits—Everything in Electronics

1901 McGee Street, Kansas City, Missouri 64108

How to Write a Classified Ad That Pulls

Deluxe 48 page booklet—only \$1 per copy. And, with the booklet, you get a \$2 credit towards your payment of your classified ad in ELEMENTARY ELECTRONICS. Send \$1 now to ELEMENTARY ELECTRONICS, 505 Park Avenue, New York, New York 10022.

TAKE A BREAK...AND PICK UP THE 1968 CB YEARBOOK NOW!

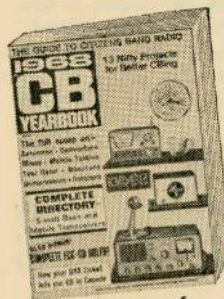

Just \$1 at your local newsstand or ask us to send you a copy!

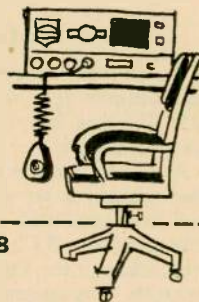

136 pages of great CB chit-chat

CB YEARBOOK EE-168

505 Park Avenue
New York, N. Y. 10022

Yeah! Send me a copy of the 1968 CB Yearbook and make it snappy. Enclosed find \$1.25 to keep the mail-room boy in fish-n-chips.

Name.....

Address.....

City..... State..... Zip.....



ELEMENTARY ELECTRONICS ETYMOLOGY

By Webb Garrison

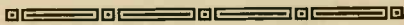

Rheostat

▲ Many pioneers in the study of electricity were classical scholars. Hence it was natural for them to turn to Greek for words with which to name the phenomena and devices they observed.

A form of the Greek noun for "stream of water" was adopted as a prefix to indicate a flow of electrical current. Coined in this fashion, *rheo-* entered a great variety of combinations.

Rheocord was used to name the wire employed in measuring the resisting strength of an electrical current. *Rheophore* (coined by Andre Ampere himself) indicated the connecting wire of a voltaic cell. *Rheotrope* designated an instrument for reversing a flow of current, and so on.

Many of these names have vanished. But one of the earliest is still hale and hearty. In the 1843 volume of *Philosophical Transactions* of England, Wheatstone described a gadget designed to "adjust or regulate the circuit so that any constant degree of force may be obtained."

From Greek for "to stand" plus *rheo-*, the resistor that "made the stream of electricity stand still at any desired level" was called the *rheostat*.

Mercury

▲ A common metal that melts at ordinary temperatures (but doesn't boil until it reaches 675° F.) has been an item of commerce for many centuries.

A recent archaeological dig in the Middle East yielded a jar partly filled with the queer stuff and produced shortly before or after the 15th century, B.C. Phoenicians were doing a brisk trade in the liquid metal by 700 B.C., and Aristotle was acquainted with it twenty-three centuries ago.

In spite of the fact that it found many uses and was regarded as holding the key to many of nature's secrets, there was no spectacular demand for it until recent years. It now has many important applications in specialized controls,

switches, and other electronic gear. As a result, its price has jumped 800 percent since 1950—when it sold for about a dollar a pound.

Globules of the heavy, brilliant white metal change position at the slightest touch. Hence for centuries it has been popularly called *quicksilver*.

The scientific name for the element that is No. 80 in the periodic table is *hydrargyrum*—often abbreviated to Hg. Adapted from Greek terms meaning something like "silver water," this name is seldom used in commerce. Most persons prefer a different title that grew out of medieval experiments.

Alchemists (who generally spoke and wrote Latin in preference to Greek) conferred the names of all the known planets upon various metals. It seemed appropriate that the metal which refuses to stand still should bear the name of Mercurie.

The planet of the same name was christened in honor of the fleet-footed Roman god who played the role of messenger—and hence was perpetually on the move. These complex links were forged because early astronomers knew that Mercurius (sometimes called "the wandering one") moves in an elliptical rather than a circular orbit.

Alchemists long used a single sign (☿) for both the wandering planet and the restless metal that bore its name. In common use, it came to be abbreviated to *mercury*.

Chaucer mentioned mercury in the 14th century, and within 300 years it was a generally-known scientific marvel. Not anticipating its crucial role in the electronic era, however, 17th-century investigator W. Barclay observed that its most marvelous trait is the fact that "There is no vegetall in the world, hath such affinitye with any minerall, as hath Tabacco with Mercurie."

To Jam

▲ Late in the 17th or early in the 18th century, Englishmen invented a new word. It quickly became popular. Anything squeezed or pressed so that it was wedged immovably came to be described as "jammed."

Some scholars think the word emerged in imitation of the sound made when two objects are suddenly forced together. If so, it is kin to *champ* (in such uses as "champing at the bit").

But speech analysts of 250 years ago had a more picturesque explanation. Housewives had already learned to preserve fruit by bruising or "jamming" pieces, then boiling them with sugar. Writing in 1730, one analyst ventured to guess that jam of cherries, raspberries, etc., was named from French *jaime* ("I love!").

One of the first appearances of the term in lasting literature was in Daniel DeFoe's *Robin-*

(Continued on page 131)

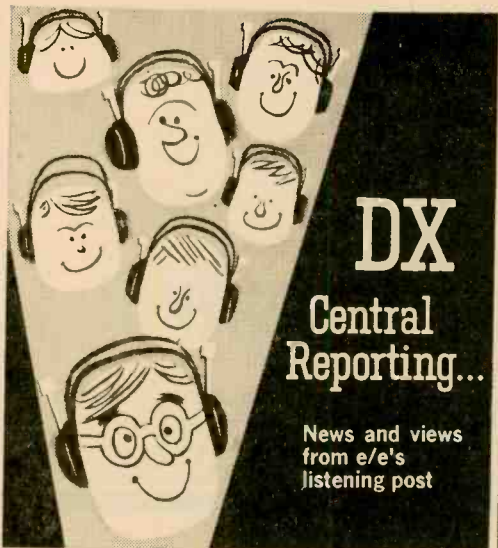

DX Central Reporting...

News and views
from e/e's
listening post

Station WNYW, R. New York Worldwide, has come up with what looks like a major breakthrough in commercial shortwave broadcasting. For the first time in history, a program aimed strictly at DXers will be regularly sponsored by a large corporation. The program is called "DXing Worldwide" and the sponsor is R. L. Drake Co., a leading manufacturer of communications, amateur, and shortwave gear.

Drake is probably best-known for its SW-4 receiver, which many SWBC listeners swear by —though a few have been known to swear at it, too. Who can account for taste!

It's not really surprising that WNYW scored with this one. "DXing Worldwide," though not necessarily the best source of SW news, is by far the liveliest and most topical of all DX programs currently aired on the SWBC bands. It covers everything from new product developments and technical tips to DX loggings. (And, then, too, there may be something in the fact that the guys over at WNYW helped design Drake's SW-4.)

"DXing Worldwide" is aired every Saturday at 1235 EST, then repeated Sundays at 1435 EST. Best frequency in North America should be 15440 kHz. In the New York City area, listeners can also hear this program on FM station WRFM, 105.1 MHz.

Aeronautical Weather Broadcasts. Now let's switch from one kind of special-interest program to another. As most shortwave listeners are aware, a few aeradios scattered across the globe have regularly scheduled weather broadcasts. Technically, a broadcast is any transmission intended for reception by an unspecified number of listeners. During the past couple of years, several new weather broadcasts have been added to the list, some of which constitute pretty fair DX.

For example, Asuncion Aeradio (Paraguay)
(Continued on page 38)

FREE!



1968
ALLIED
CATALOG

SAVE ON:

- Famous Knight-Kits®
- Stereo Hi-Fi
- Tape Recorders, Tape
- CB 2-Way Radios
- Walkie-Talkies
- FM-AM & AM Radios
- Shortwave Receivers
- Portable TV
- Phonographs
- Amateur Gear
- Intercoms & PA
- Automotive Electronics
- Test Instruments
- TV Antennas & Tubes
- Power Tools, Hardware
- Tubes, Transistors
- Parts, Batteries, Books

518
PAGES

Shop by mail and save at Allied, world's largest electronics headquarters. Hundreds of money-saving values. **NO MONEY DOWN.** Up to 2 years to pay!

MAIL COUPON BELOW

.....
 • **ALLIED RADIO, Dept. 51-A,**
 • **P.O. Box 4398, Chicago, Ill. 60680**

 NAME (Please Print) _____
 ADDRESS _____
 CITY _____
 STATE _____ ZIP _____



Hours of "How-To" Fun
For Pro & Novice

NEW 1968 ELECTRONICS HOBBYIST ANNUAL

at your newsstand January 11th

Now you can reserve the newest, most exciting magazine for those whose interest in electronics is on the hobby level. The **ELECTRONICS HOBBYIST** contains easy to build, tested and proven construction projects of every description.

FOOLPROOF DESIGN! EASY CONSTRUCTION!

Each construction project has been carefully researched and tested by experts. Each article is complete with theory, construction tips, parts lists, diagrams and photos.

RESERVE YOUR COPY NOW!

THE ELECTRONICS HOBBYIST
505 Park Avenue / New York, N.Y. 10022 EE-168

Please reserve my copy of the 1968 Electronics Hobbyist Annual. Enclosed is \$1.25 which includes postage and handling.

Name _____
 Address _____
 City _____ State _____ Zip _____

Discover the ease
and excitement of NRI's

3 DIMENSIONAL METHOD

of ELECTRONICS TV-RADIO TRAINING

12 HOME-STUDY PLANS TO CHOOSE FROM

Ask men whose judgment you respect about NRI's three dimensional method of home-study training. Ask about the new, remarkable NRI Achievement Kit. Ask about NRI custom-designed training equipment, programmed for the training of your choice to make Electronics come alive in an exciting, absorbing, practical way. Ask about NRI "bite-size" texts, as direct and easy to read as 50 years of teaching experience can make them. Achievement Kit . . . training equipment . . . bite-size texts . . . the three dimensions of home-study training; the essentials you must have to make

learning easier, more interesting, more meaningful. You get them all from NRI.

Whatever your interest . . . whatever your need . . . whatever your education . . . pick the field of your choice from NRI's 12 instruction plans and mail the postage free card today for your free NRI catalog. Discover just how easy and exciting the NRI 3-DIMENSIONAL METHOD of training at home can be. Do it today. NATIONAL RADIO INSTITUTE, Electronics Division, Washington, D.C. 20016.

**BEGIN NOW AN ABSORBING
ADVENTURE—LEARN ELECTRONICS
THE EASY NRI WAY—MAIL CARD TODAY**

OVER 50 YEARS OF LEADERSHIP

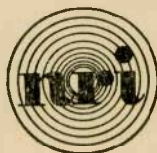

IN ELECTRONICS TRAINING

1 Start Fast with NRI's New Remarkable Achievement Kit

The day you enroll with NRI this new starter kit is on its way to you. Everything you need to make a significant start in the Electronics field of your choice is delivered to your door. It's an outstanding way of introducing you to NRI training methods . . . an unparalleled "first dimension" that opens the way to new discoveries, new knowledge, new opportunity. The Achievement Kit is worth many times the small payment required to start your training. No other school has anything like it. Find out more about the NRI Achievement Kit. Mail the postage-free card today.



2 NRI "Bite-Size" Lesson Texts Program Your Training

Certainly, lesson texts are a necessary part of any training program . . . but only a part. NRI's "bite-size" texts are simple, direct, well illustrated, and carefully programmed to relate things you read about to training equipment you build. Here is the "second dimension" in NRI's training method. Here are the fundamental laws of electronics, the theory, the training of your choice, presented in a manner you'll appreciate. And in addition to lesson texts, NRI courses include valuable Reference Texts related to the subjects you study, the field of most interest to you.



3 Custom-Designed Training Kits Make Learning Come Alive

Electronics becomes a clear and understandable force under *your* control as you build, experiment, explore, discover. Here is the "third dimension" . . . the practical demonstration of things you read about in NRI texts. NRI pioneered and perfected the use of training kits to aid in learning at home. NRI invites comparison with equipment offered by any other school, at any price. Prove to yourself what 750,000 NRI students could tell you . . . that you get more for your money from NRI than from any other home-study Radio-TV, Electronics school. Mail postage free card for your NRI catalog. (No salesman will call.)

AVAILABLE UNDER NEW GI BILL — If you served since January 31, 1955, or are in service, check GI line in postage-free card.

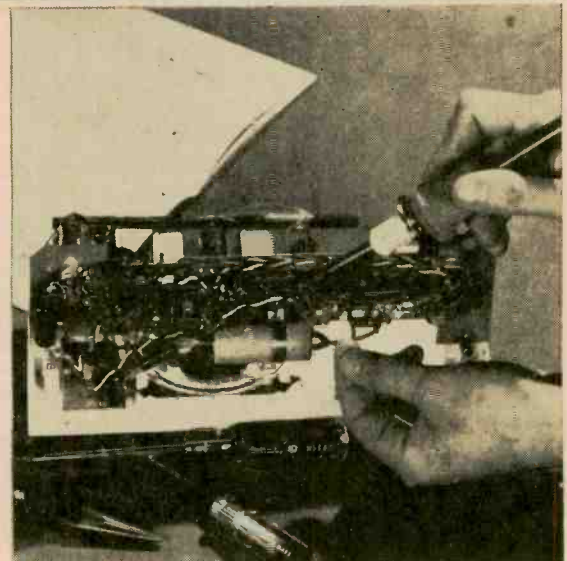

EIP!



**BRAND NEW
FALL AND WINTER
RADIO-TV
ELECTRONICS
CATALOG**



**YOUR BUYING GUIDE
FOR:**

- Stereo & Hi-Fi Systems & Components
- Tape Recorders • Electronic Parts, Tubes, Tools
- Phonos & Records
- Ham Gear • Test Instruments & Kits • Cameras & Film • PA • Citizens Band • Radio & TV Sets • Musical Instruments

MAIL TODAY TO:

BURSTEIN-APPLEBEE

Dept. EEM 1012 McGee, Kansas City, Mo. 64106

Name _____
 Address _____
 City _____
 State _____ Zip Code _____

ZAP! YOU'RE DEAD!

Read all about the newest of the top-secret weapons; an infra sound death ray, capable of annihilating entire cities, of wiping out armies to the last man. Also, a special new series ("SEX FACTS FOR TEENAGERS") and many more exciting features.

Don't Miss the January issue of S&M, on your newsstand now!

SCIENCE & MECHANICS EE-168
 505 Park Ave., N. Y., N. Y. 10022

12 issues \$4; 24 issues \$8; 36 issues \$12. (Foreign: Add \$1 a year.)

Please enter my _____ year(s) subscription.

I enclose \$ _____ Bill me.

Name _____ (Please Print)
 Address _____
 City _____ State & Zip _____

DX CENTRAL REPORTING

Continued from page 33

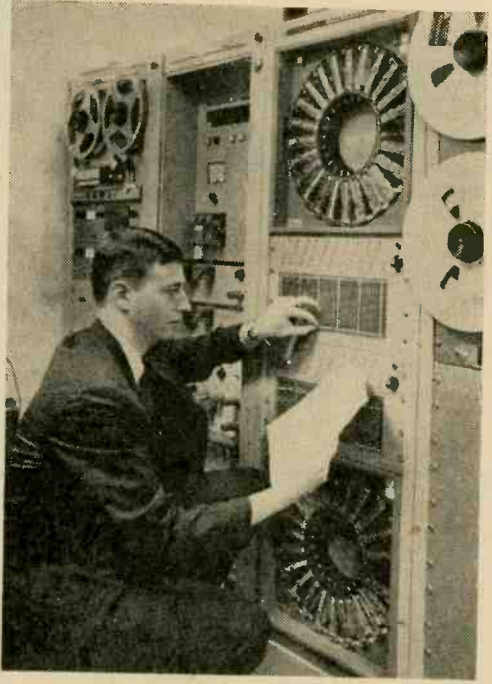

FM station WRFM repeats WNYW's "DXing Worldwide" program for local listeners.

is a newcomer that has a broadcast at 5 minutes past each hour on 8905 kHz. While broadcasts from Oakland, Calif. on the same frequency will cause some headaches, Paraguay is one of the more difficult countries to hear on regular short-wave broadcast so this weather-cast is one way you might snag this country.

Another interesting target is Karachi Aeradio (Pakistan), which has a weather transmission at 15 and 45 minutes past each hour on 10048, 6529½, and 2924 kHz. That first frequency is often the clearest of any transmission from Pakistan—especially if you try after midnight. Also using 10048 kHz on the hour and half-hour is Calcutta Aeradio (India). At 10 and 40 minutes it's Bangkok, Thailand, while at 20 and 50 minutes past the hour Singapore Aeradio comes on.

Lowest SW Frequency of All. Technically speaking, shortwave frequencies run between 3000 and 30,000 kHz (3 and 30 MHz). Below that is medium wave and above is VHF. The lowest regular SWBC band is 90 meters (3200 to 3400 kHz), used as a regular BCB in the tropics only. Below 90 is Aeronautical territory.

And it is Aeronautical weather broadcasters who can boast of using the lowest SW frequency of all—3001 kHz. Three of these share the channel on a non-interference basis. Each air two transmissions an hour. EIP, Shannon Aeradio (Eire), appears on the hour and half-hour. WSY,

New York Aeradio, broadcasts at 15 minutes before and after the hour, while VFG, Gander (Newfoundland, Canada), has its turn at 20 and 50 minutes past the hour. Eire has no regular SWBC stations at all, so EIP is an especially good catch. All these transmitters identify by location only and call letters are never actually used on the air.

DX on 3001 kHz will take place exclusively at night. As you read this, static will have reached its winter low, while conditions for upper latitude stations will be comparatively good but with considerable variation from night to night. If Gander is strong, you should be able at least to hear Shannon faintly.

Nasser's Entry. Shannon, Gander, and New York Aeradio also air their broadcasts on 5559 and 8828½ kHz, where, except for EIP, Shannon, they are not really considered DX. But on this trio's frequency is a fourth station—SUO, Cairo Aeradio (U.A.R.), with two 10-minute sessions at 20 and 50 minutes past the hour. To bag SUO you will have to buck QRM from Gander, a rough assignment (though possible on 8828½, it's virtually impossible on 3001).

Since the Israeli-Arab war, SWBC R. Cairo has been extremely anti-American and the flow of QSLs our way is likely to be very slow for a long time to come. It might be interesting to test SUO's verification policies.

To send a report to any of the Aeradios listed, just address it to: Officer in Charge, Aeradio, Airport, at the appropriate city and country. As these Aeronautical transmissions are broadcasts, no one will object if you quote items heard over the air to prove reception. (This practice is illegal when reporting other Utility transmissions—i.e., emissions intended only for reception by certain specific persons, which is quite the opposite of "broadcasting.")

A self-prepared card which the operator merely has to sign and mail back to you might help if your first report goes unanswered. But do allow two or three months for the station to reply. ■

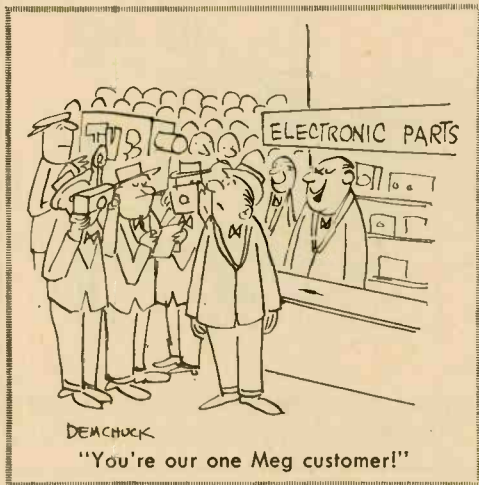

Can't find the key to electronics?

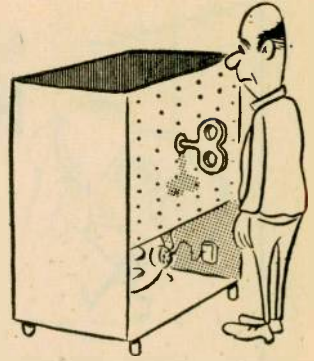

— then get your electronics cool with this introductory offer to the 2 leading electronics magazines! Use coupon:

DAVIS PUBLICATIONS, INC. EE-168
505 Park Avenue/New York, N.Y. 10022

Yes! I want to find the key to electronics.

Begin my subscription to both **RADIO-TV EXPERIMENTER** and **ELEMENTARY ELECTRONICS** at your special low-subscription rate of **\$7.00**

Bill me later. Check enclosed.

Name

Address

City State Zip
(Outside U.S.A. & Canada add \$1.50 pstge. & hndlg.)

— Now, both of these fine magazines will be delivered to you at the special subscription rate of just **\$7.00** . . . save \$2 from newsstand price.



ELEMENTARY ELECTRONICS

The magazine that serves up electronics theory in pleasant spoonfuls and reinforces the knowledge you gain with exciting and useful projects.

RADIO-TV EXPERIMENTER

The magazine dedicated to the hobbyist—the man who wants to obtain a fuller and broader knowledge of electronics through the applications of his hobby.



By Marvin Townsend

HAMMING IT UP!

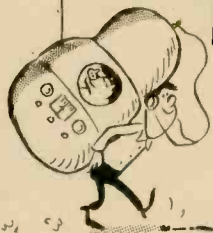

"This is merely a preliminary step toward my ultimate goal of becoming a nuclear instrumentation engineer."



"Sorry, ol' man, you don't stand a chance with WB2YYL!"



"It worked! I've got Paris!"

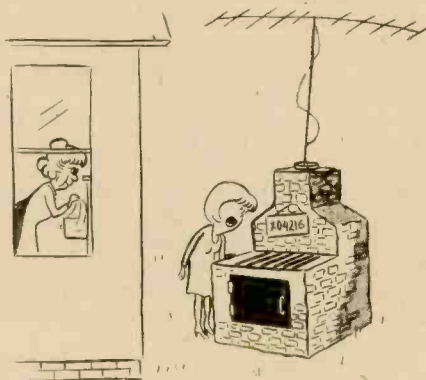

"Stop grumbling! Mother will only be here two weeks."

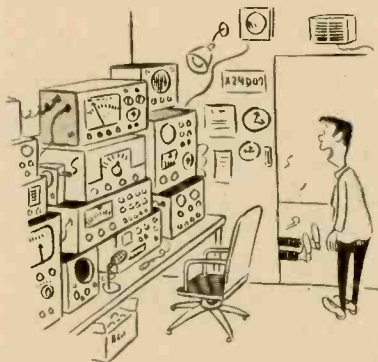

"I was only kidding, Dad, when I said I had lost all interest in electronics!"

By O. K. Ryan

FUZZ-A-TORT

If you're trying to duplicate the latest rock sounds, stop looking at your guitar amplifier's effects controls. You probably won't find the answer. For unless you have one of the very latest guitar amps, you'll need our add-on Fuzz-A-Tort to obtain that deep, throaty saxophone sound.

The Fuzz-A-Tort is a specially designed transistor amplifier—connected between the guitar and the amplifier—that deliberately distorts the guitar's normal sound over a wide, user-selected range. In essence, the Fuzz-A-Tort is a fuzz box with two big advantages. For one thing, it costs considerably less than a standard fuzz

box. Secondly, and more important, unlike the cacophonous, ear-shattering distortion generated by the typical fuzzbox, the Fuzz-A-Tort adds a controlled and real fuzz effect to the basic guitar sound.

As a result, the listener actually hears the basic tone, plus the Fuzz-A-Tort's fuzz effect. What's more, the fuzz effect can easily be adjusted from just a light *(Continued overleaf)*



Photo by Moto

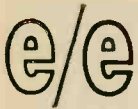

FUZZ-A-TORT

fuzzing of the basic guitar sound to the deep, throaty sound of a saxophone.

Our great goody provides for user adjustment of the degree of fuzz and output level, allowing the fuzzbox sound level to be balanced with the normal guitar sound output level. An oversize rocker switch allows the fuzz effect to be keyed in-and-out with the foot while playing.

The power switch is combined with the rocker fuzz selector switch, automatically turning the power on when the fuzz effect is desired. The *Fuzz-A-Tort's* response to the power application is instantaneous—there is no delay before the fuzz effect is cut-in.

Options. You can build the *Fuzz-A-Tort* in any of three different ways. The hard way is to build it following the schematic, using your own parts layout. The easy way is to send for the *free* printed circuit board—just fill out the coupon at the end of this article. There is no hidden charge (like postage); all it takes is the coupon. Or, if

desired, you can purchase a complete set of components, including a pre-punched, anodized cabinet and a pre-drilled circuit board, from the source listed in the Parts List.

How It Works. Transistor Q1, an emitter follower of normally relatively high impedance, in combination with R1, presents a high impedance input at J1. Transistor Q2 functions as a variable-gain amplifier. Since Q2's base bias is obtained through R4 and R5 from the collector of Q2, the setting of R5 determines the effective gain that is realized by this stage.

Transistor Q3 functions as a "class C" amplifier. The normal leakage in Q3 (a germanium type) allows very low signal input levels to be amplified with little distortion. As the signal input level to Q3 is increased via R5, the signal level becomes greater than the leakage bias current and the signal is distorted; the greater the signal input level, the greater the degree of distortion or fuzz effect.

Construction. The model shown is built on the free printed circuit board. While we show the cabinet supplied in the parts kit, you can substitute any aluminum cabinet measuring approximately 6 x 3½ x 1¾ in.

PARTS LIST FOR FUZZ-A-TORT

B1—1.5-V type AA battery
C1, C4—.001- μ F capacitor
C2, C3—5- μ F, 6-VDC electrolytic capacitor
J1, J2—Phone jack
Q1, Q2, Q3—2N2613 transistor
R1, R4—100,000-ohm, ½-watt resistor
R2—1,000,000-ohm, ½-watt resistor
R3, R7, R10—10,000-ohm, ½-watt resistor
R5—1,000,000-ohm linear-taper potentiometer
R6—18,000-ohm, ½-watt resistor

R8—22,000-ohm, ½-watt resistor
R9—50,000-ohm audio-taper potentiometer
S1—D.p.d.t. switch (see text)
Misc.—Battery clamp, cabinet, knobs, wire, solder, etc.

(A complete kit of parts, including the PC board and cabinet, is available for \$12.50, postpaid, from Sentry Mfg. Co., Box 12322, Oklahoma City, Okla. 73112. See coupon on page 44.)

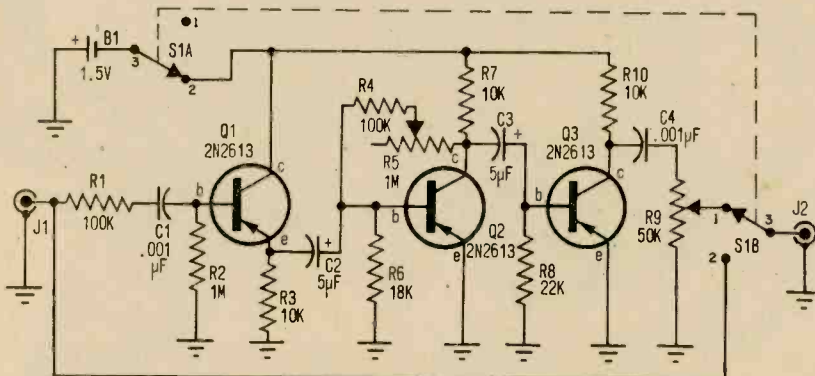

Schematic of Fuzz-A-Tort is primarily for reference since wiring is already done on free PC board, though die-hards can build hand-wired version.

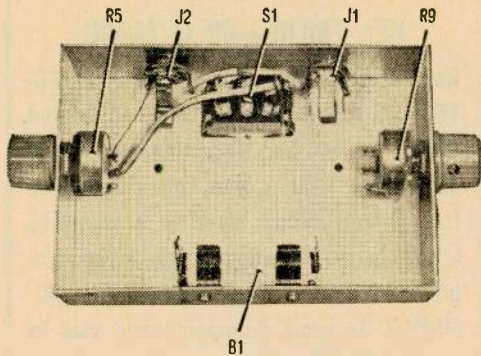

First step is to mount hardware and controls on chassis. This is the one supplied with the complete kit but any chassis of about same size can be used.

Start construction by mounting the cabinet components. Switch S1 is mounted on the cabinet's centerline as close as possible to one edge of the cabinet. While any d.p.d.t. switch can be used, one with an oversize rocker-type actuating lever will allow the *Fuzz-A-Tort* to be keyed with the foot while playing.

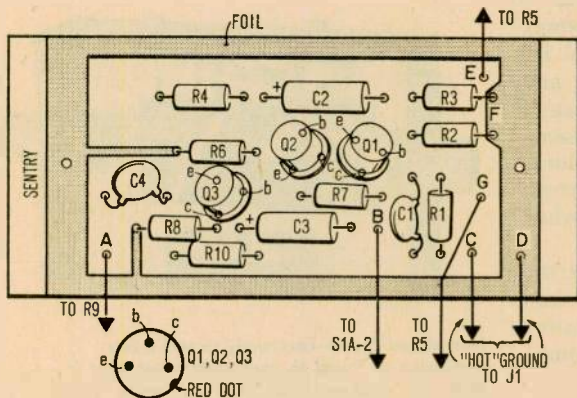

Bottom view of the Sentry PC board is shown here for ease of assembly. Take care not to damage components when soldering and use a heat sink on the transistors.

Input and output jacks J1 and J2 are mounted on the front panel, near the sides of S1. The fuzz and volume controls (R5 and R9) are mounted on the sides of the cabinet approximately centered in such a manner that their terminals are roughly $\frac{1}{2}$ in. from the bottom of the cabinet.

The battery clamp, a standard AA battery holder, is positioned on the bottom cabinet edge.

Pre-wire as much of the cabinet components as is possible, using insulation to prevent the wires from shorting to the switch contacts. Connect one wire from volume control R9 to J2's ground lug. Connect R9's wiper contact to S1b terminal #1. Connect S1b terminal #2 to J1's "hot" lug. Connect S1b terminal #3 to J2's "hot" lug. Now set the cabinet aside and assemble the printed circuit board.

PC Connections. The illustration shows how the components are mounted on the PC board. Insert the components from the back of the board so the leads come through the board to the wiring side (facing you). Install the resistors first, then the capacitors, finally the transistors (indicated by the three circles). Note that the transistor leads are installed in their normal e-b-c triangle—no lead "crossover."

Complete the PC board by in-

FREE PRINTED CIRCUIT BOARD OFFER

As a special service to readers, the Editors of *ELEMENTARY ELECTRONICS* have arranged for you to receive a Free Fuzz-A-Tort Printed Circuit Board from Sentry Manufacturing Company. Just fill out and mail the coupon on the next page so it's postmarked on or before March 1, 1968. Should you desire to purchase the complete parts-package, place an X in the appropriate box and include a check or money order for \$12.50 (price includes postage). Make checks payable to Sentry Mfg. Co. This free offer is invalid unless accompanied by the coupon on the following page.

The Editors
ELEMENTARY ELECTRONICS

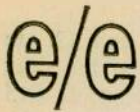

FUZZ-A-TORT

stalling 2-in. lengths of bare, solid #20 or #22 wire at points A, B, C, D, E, and G. These will be connected to the cabinet-mounted components. If you've followed the layout shown, or used the kit cabinet, the bare wire leads will be adjacent to their matching cabinet components.

Final Assembly. Install the PC board in the bottom of the cabinet positioned directly under the switch as shown. To avoid shorting the printed wiring to the cabinet, place a spacer or stack of washers between the board and the cabinet at each mounting screw. Use only enough spacer to lift the PC wiring off the cabinet.

Connect the bare wire PC board leads to the appropriate cabinet components. Install the battery, taking care the polarity is correct (positive terminal to ground), and the *Fuzz-A-Tort* is ready for use.

Using Fuzz-A-Tort. Connect the guitar to J1 and the amplifier to J2. Set S1 to power on (fuzz effect in). Set volume control R9 to the desired sound level as you play, and then adjust fuzz control R5 for the desired fuzz effect. Note that there might be some interaction between the fuzz and volume control as far as sound level is concerned. However, this will be noticeable only when the fuzz is varied over a broad range.

One fuzz control technique is to set the guitar's volume control "wide open," then set the fuzz control to the maximum desired fuzz effect. Reducing the guitar's volume control setting will then reduce the fuzz.

HEY, FRIEND—DO IT AGAIN!

Reserve your copy of **ELEMENTARY ELECTRONICS** now for the full scoop on Printed Circuit Project No. 3! Coming next issue: easy-to-follow plans, plus your choice of a free printed circuit board or a complete kit of parts (including a pre-drilled, tin-plated PC board) for building the SYNC/CAL MARK I. To avoid disappointment, mail in your subscription or see your local news-dealer now!

Further experience in using *Fuzz-A-Tort* will soon make you a pro at determining the variety of effects to be had. And, whether a rank beginner or old-timer at guitar picking, the *Fuzz-A-Tort* will give you the "mostest" in way-out weird sounds for just about the "leastest" in time and bucks. ■

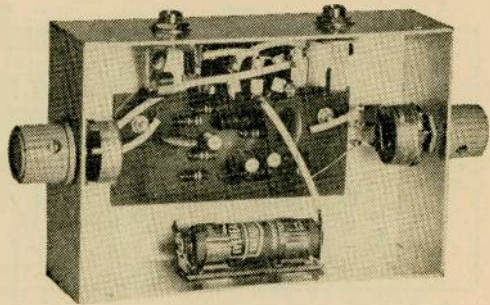

Completed *Fuzz-A-Tort* ready to add a new dimension of sound to your guitar: just plug in guitar and amp and hear the wildest sound around.

• CUT HERE

FREE PRINTED CIRCUIT BOARD: FUZZ-A-TORT PROJECT

Sentry Manufacturing Co.
Box 12322, Oklahoma City, Okla. 73112

- Please send the Free Printed Circuit Board for the Fuzz-A-Tort as described in the January/February 1968 issue of **ELEMENTARY ELECTRONICS**.
- Please send the Sentry parts package and the Free Printed Circuit Board for the Fuzz-A-Tort. I am enclosing a check or money order for the sum of exactly \$12.50, payable to Sentry Mfg. Co.

THIS FREE OFFER IS NOT VALID UNLESS ACCOMPANIED BY THIS COUPON

Name _____
Address _____
City _____ State _____ Zip _____

Sorry, Free Offer expires March 1, 1968

Today the Moon. Tomorrow...

NASA's amazing plans for our future in space

By K. C. Kirkbride

■ In the late spring of 1964, President Johnson called on NASA to submit comprehensive Post-Apollo programs within three months. And what's Post-Apollo? Quite simple. By 1969-70, we will have a man on the moon they say. During the 70s we will commute to the moon and, in time, set up a colony there. But as R. P. Ragan of Douglas Aircraft put it, landing a man on the moon will be but a beginning, a first kindergarten step, in man's long exploration of space. What should follow that first step is known, appropriate y enough, as Post-Apollo.

Thing is, Congress and Senators aren't that convinced. "First step" had already cost the nation \$40 billion dollars and ten years of technological effort. Imagine the tab for further exploration. And why should we (Continued on next page)

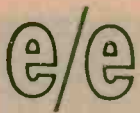

TODAY THE MOON

spend such vast amounts on a program promising to yield little practical value? Already the nation's space budget averages five billion a year; manned exploration could run it to seven. In time the whole program might total 100 billion dollars annually.

One Senator called space investigations "nothing more than intellectual curiosity;" another moaned he was cooling on the whole space program. Then in February of 1967, the President's Science Advisory Committee came up with a 1000-page answer.

Pro Explo. Exploration of space beyond the moon was warranted if only to keep abreast of Soviet achievements. More importantly, it was necessary because man's number-one quest since the beginning of time had been to comprehend his role in the universe, his own origin, the origin of the universe, the evolution of the system he lives in, and its ultimate destiny. If possible, being a nosy creature, he would even find out if there were any more "out there" like him.

Employment too was also part of the picture. For to limit Post-Apollo would mean shutting down a vital American industry, one now employing 400,000 people. And it

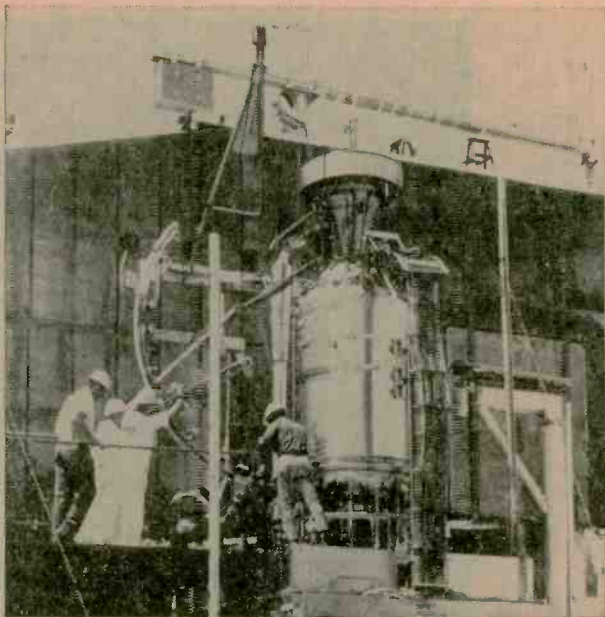

Technicians at Jackass Flats, Nev. prepare for test firing of NERVA—Nuclear Engine for Rocket Vehicle Application. This long-sought-after atomic rocket engine shown above will be used to provide power for long-haul deep space travel. Thrust is produced by liquid hydrogen coming in contact with the extremely hot reactor core, resulting in spectacular blast shown on preceding page. Due to radioactive contamination danger, NERVA will only be fired in outer space. The complex test bed for NERVA is shown below.

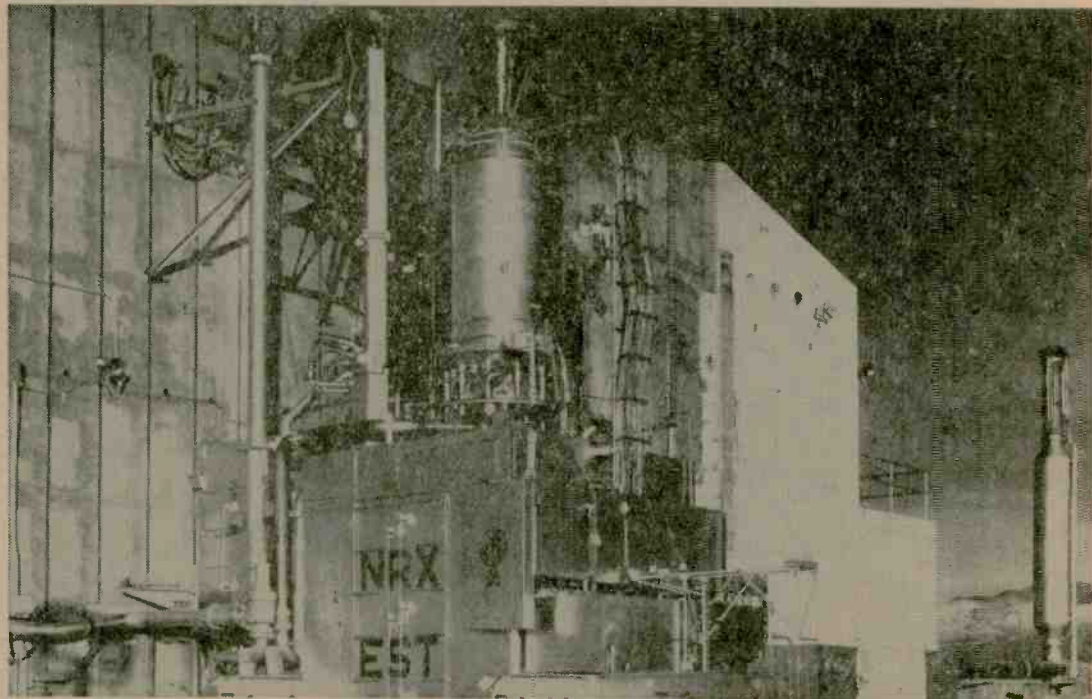

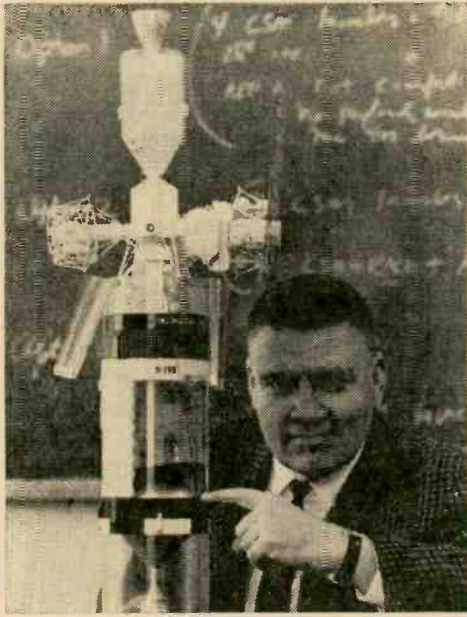

Deputy Director John H. Disher of NASA's Saturn Applications Office points to a model of the proposed orbiting laboratory. The space station, which will be hoisted aloft by four uprated Saturn I rockets, consists of (below) the command and service module (CSM), docking adapter to connect the four sections, a large telescope (M&SS), solar cell and power distribution assembly (square panel), and a space-built workshop and lab in the fuel tanks of a spent Saturn second stage (S-IVB).

would do so in a day when a nation's economy is based on its technological industries. The effect would be as drastic as if Senators ordered us to stop making automobiles and go back to the horse and buggy!

A better answer, said the panel, would be an orderly, economical sequence of "space journeys", journeys that would ultimately land man on distant planets. Significantly, such journeys would prove the most exciting, the most adventurous man has ever known. So while Congress battled budgets, space scientists planned man's greatest venture.

In the late months of 1968 the first of four uprated Saturn Is will swing into 300-mile circular orbit about the earth. Carrying a multiple docker, it will form man's first station in space. Four or five days later, a sister Saturn will soar up to meet it to add a spent fuel tank built by Douglas Aircraft—one where astronauts will live and work for periods of 26 to 52 days to one year. Checking out their chances of surviving long periods of flight, the future astronauts will learn to live in space environment, build their own sleeping quarters, recreational rooms, workshops, and laboratory, moving from one "craft" to the other through McDonnell-built airlock.

Given three to six months' experience in space, this crew will return to earth. Next,

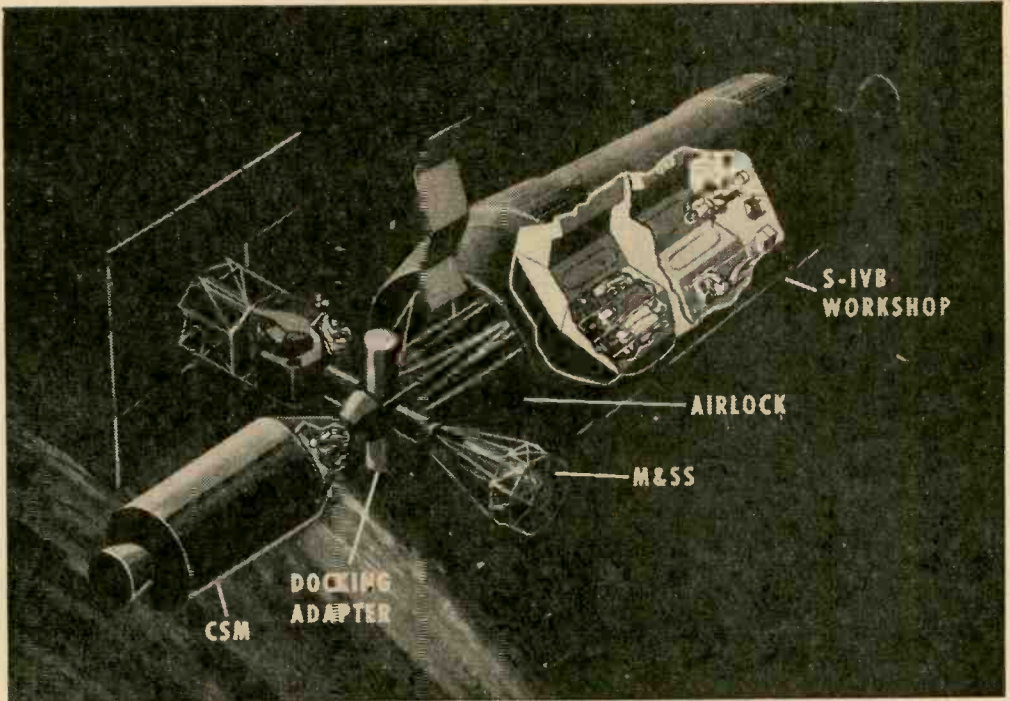

e/e TODAY THE MOON

a third Saturn will loft a second crew of scientist-astronauts, bringing fresh supplies and a 25,000-lb. Apollo telescope to dock with the craft. Then, with man's first fully-assembled station in space, the new crew will study the stars as well as the sun, gas, and dust in space from wavelengths man cannot perceive from earth. They will picture their findings on television monitoring screens, and radio their new-found information to earth.

Hot Stars. What they will see are busy little "hot stars," the eager-beavers literally burning themselves out so they live only short lives in space time—in the ultraviolet. They will "see" the activity and atmosphere of the new "a-borning" stars in the infra-red. And then, believing planets were once formed of space gas and dust, they will point their electronically-guided telescope at clouds of gases.

They will also see the dust and the gases explode, while they speculate on how the universe was born. For scientists suspect from recent studies that space may prove quite different from what we believe we have "discovered" or theorized from earth-bound research. But with the aid of spectroscopic studies, observations in newly-probed wave-

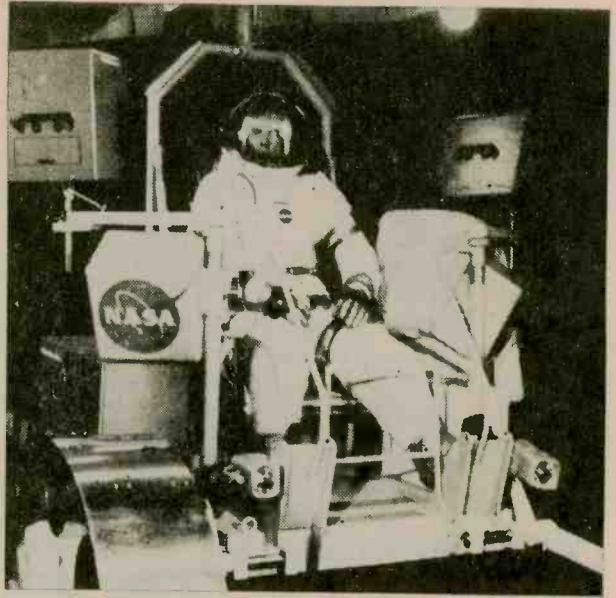

New problems find new solutions. This is the chassis and control station for the lunar mobile laboratory. It will carry living quarters and equipment for a two-week lunar surface exploration jaunt. With soft spring steel tires, independent torsion bar suspension on all wheels, and four wheel drive through a DC motor in each wheel hub, the vehicle should be able to traverse the lunar surface without difficulty. Steel tires are employed because rubber won't withstand the extreme temperatures the explorers will encounter (see photo below).



lengths of ultra-violet, infra-red, X-rays and gammas, they hope to find new clues to the universe. Is it truly expanding? Or exploding within its expansions?

Sun Flares. One "practical" pattern they feel pretty certain they'll find. For with the aid of electronic flare detectors, they'll map the behavior of the sun's flares. In time, they should be able to predict the Sun's behavior when future astronauts set out for Mars.

Next question on the "intellectual curiosity" list will be, is there truly life in space? Most scientists believe there must be many planets entertaining life. Even recent "radio" emissions hint at civilizations far in space. But as intelligent life is considered an "accident" of evolutionary fate in the billions of years of a planet's existence, finding it will take a long search.

Mariner 1971 might give us a first hint. Far more sophisticated than Mariner IV

(which photographed at a distance of almost 7000 miles from the red planet), Mariner '71 will aim its television cameras from within 2000 miles of Mars. What's more, it will multiply its playback data rate 32 times as it radios back to earth.

Carrying a computer and memory system, it will take close-ups at a range where the whole planet can be "seen." An infrared radiometer will map temperatures of areas scanned by TV cameras, while both ultra-violet and infrared spectrometers will search for chemical elements man believes vital to the formation of life.

What Mariner '71 doesn't find, its successor Voyager should—if the Surveyor-type lander can survive Congressional axes. For Voyager will drop an acorn-shaped reporter to the Mars surface. Directed by its own computer, this instrument will open up an eight-foot VHF self-levelling antenna, sending its information back to its orbiting mother craft as well as directly to its boss-men on earth. It will television-scan the Mars surface, its automated laboratory picking up information from gas chromatographs, ultra-violet and infrared spectrometers, and radiation detectors. It will then transmit the information to the orbiter at a rate of 50,000 to 200,000 bits per second, and to earth at a rate of 600 bits per second.

When American astronauts first set foot on the moon, they'll come with a variety of equipment for testing and measuring the lunar environment with precision. This equipment will be set up and left behind when the ship blasts off for home and will transmit back to earth a stream of continuous information about the moon, primarily in the areas of geology, geophysics, geochemistry, particle impact, and lunar magnetic and gravitational field variations. Here, the telemetry antenna is being assembled.



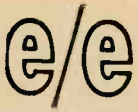

But Voyager, the first Mars probe planned to ride into space on a mighty Saturn V, has its troubles. Not only do Congressional cutbacks threaten its future, but international agreements spell problems of another kind. Calling for sterilization of crafts that will touch planet surfaces, such treaties specify baking the lander 53 hours at temperatures high enough to kill all the electronic "organisms" on the craft.

Blue Plants. Even if Voyager is hardy enough to survive its woes, it should at least tell us a few things about Mars—whether its plants are blue, its clouds are yellow or brown, and whether there are any little Mars men around.

Cloud-covered Venus has many times seemed too hot to sustain life, but a Mariner flyby in 1972 may check for sure. Picking up atmospheric news from the planet by ultraviolet and microwave spectrometer, it will send topographical "news" by radar and television camera. Later, in '73, Mariner is to fly by both Mercury and Venus for a first good look at the hottest planet.

Until recently scientists believed only Mars, Venus, and earth in this solar system could possibly sustain life. Mercury they believe, is too hot; other planets too cold—especially that great gas giant, Jupiter, a wallflower too chilly for folksy life.

Then suddenly, scientists buzzed with news of a new glamor planet in space—Jupiter. It was April 9, 1967; two NASA scientists were reading a paper before a Florida meeting of the American Chemical Society. Drs. Cyril Ponnampertuma and Fritz Woeller of Ames Research Center, Moffett Field, Calif., had proved by experiment that there could be life on Jupiter!

Soup Sense. First, they had built a "model" of Jupiter's atmosphere drawn from studies of Jupiter's enormous gravity, the behavior of its moons, and spectroscopic analyses of sunlight as reflected from the giant planet. Their model consisted of a layer of frozen ammonia crystals, a cloud layer of ammonia droplets, a clear layer of ammonia vapor, a layer of ice crystals, a layer of water droplets, a layer of waste vapor, and a flat area representing the surface of the planet. All layers contained methane, hydrogen, helium, ammonia, and neon; Jupiter's

surface itself, interestingly enough was not considered critical since it is believed to consist mostly of compressed hydrogen.

Reasoning that methane, ammonia, and water existed in earth's primordial "soup" before ultraviolet radiations from the sun and lightning charges brought chemical changes that evolutionized into life, the experimenters fired electric arcs to simulate lightning into the pressure chamber holding the "atmosphere."

Lightning Everywhere. Explaining their use of the arcs, scientists said lightning is common to all planets. But Jupiter is believed to be especially electrical in nature, a mighty dynamo with a powerful magnetic field. As a result, its ten-hour day-and-night changes—from warm to cold—cause continuous atmospheric turbulence and electric charges.

Simulating the layers of the planet's 2500-mile-deep atmosphere, they charged the first layer of ammonia and methane with their man-made "lightning." They thus produced quantities of hydrogen cyanide, the source of a wide range of chemicals needed to form living systems. Meanwhile, a weaker arc delivered more hydrogen cyanide, plus amino nitriles, the forerunners of many organic chemicals, which, with water, immediately produce amino acids—the building blocks of protein!

Electric charges with ammonia and methane, plus water, in the second layer, some 1800 miles below the visible top layer, produced even more complex organic molecules. These same molecules are believed to have existed on primitive earth.

Centaur Calling. Overnight the giant gas planet, 84,000 miles in diameter, with a mass 318 times that of the earth and spinning some 500 million miles from the sun, was the talk of "life" scientists. Now NASA engineers plan a probe that may one day send a craft aboard a three-stage Atlas-Centaur on a 600-day mission. Carrying a high-gain parabolic antenna powered by radioisotope thermoelectric power, the probe will find out if Dr. Ponnampertuma is right.

But no scientist really believes we will get the full answers until we send the real explorer—man himself—to the planets. To send him, we'll need far more sophisticated rocketry: a Saturn to lift the heavy payload into earth orbit with a nuclear NERVA third stage to thrust into the far distances of space. For NERVA (Nuclear Engine for Rocket

(Continued on page 130)

1-FET BCBer

Built around one of those new-fangled FETs, this broadcast set is modern as the day is long

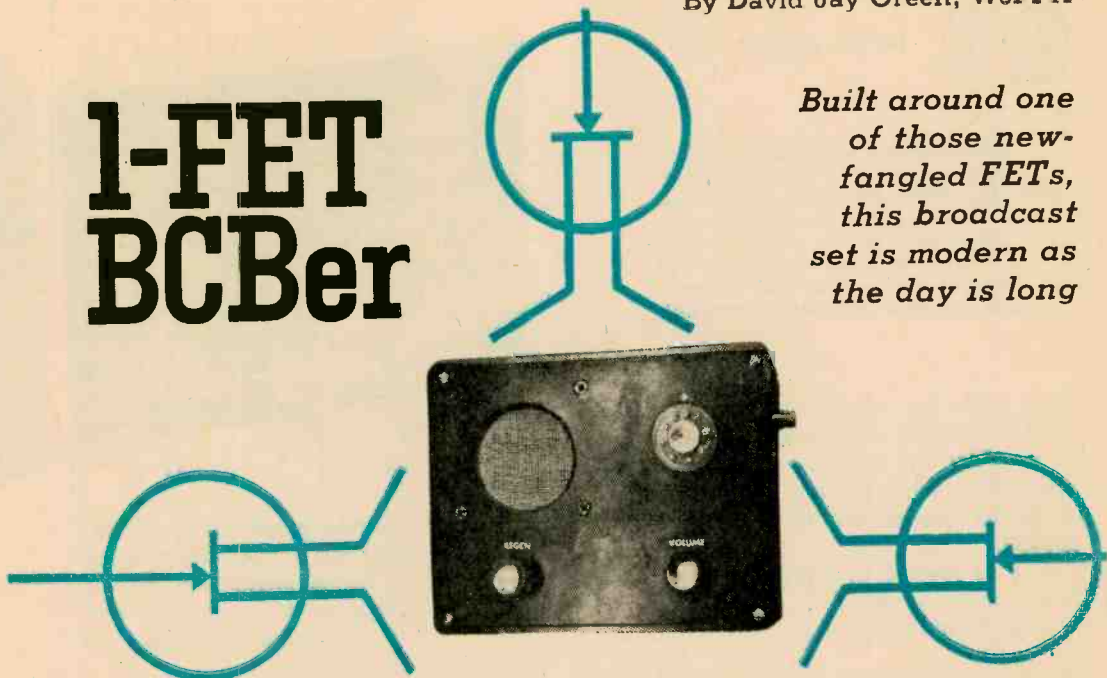

One of the most important developments in electronics has been the transistor, and one of the newest wrinkles in solid-state devices is the Field Effect Transistor. The FET has operating characteristics very similar to that of a vacuum tube. It is controlled by voltage, as opposed to a transistor that is controlled by current. Because of this, the FET does not load tuned circuits and can give better performance in simple receivers than a transistor.

You can gain practical experience in FET circuit operation by building our 1-FET broadcast band receiver. And for the complete scoop on the why's and how's of the FET, check out "It Looks Like a Transistor," appearing on page 53 in this issue.

How It Works. The signal from the antenna is tuned in the L1A-C1 tank circuit, and fed through the *gate* leak (R1-C2) to the gate of Q1. The signals are detected between the source and gate (the PN junction acts like a diode) and a portion of the amplified signal is fed back to the gate through the coil L1B, for regeneration which is controlled by R2. T1 is used to couple the detector to the amplifier.

The amplifier is a ready-made job available from Radio Shack. Because of its low cost and to ease assembly, this amp was chosen, though any comparable unit could be used.

Construction. Care must be taken in

construction as the bakelite panel and case are rather brittle and liable to crack under pressure. Follow the layout shown in the photos for approximate hole location. Placement of the front panel controls can be rearranged to suit if desired.

The battery holder is made from an aluminum strap mounted on the volume control (R6). The coil (L1A) is mounted on a small aluminum bracket which also mounts on the volume control (R6) as shown. This bracket should be grounded with a connection to a large solder lug on the coil to reduce the effect of hand capacitance. Serrated washers should be placed under the pots and the tuning capacitor, next to the panel, to prevent them from turning.

Speaker Mount. The speaker is mounted under solder lugs on four mounting screws attached to the front panel. Place a small piece of grille cloth in front of the speaker to protect the cone. The amplifier board is mounted, using solder lugs for brackets, on two mounting screws. It should be mounted so that the component side is away from the speaker and the connection to the battery lead is on top. This will enable ground connections to be made to the mounting screws. A 1½ x 2½-in. perforated board is also mounted on solder lugs. This board will be used to mount the detector components.

The green wire of the amplifier is connected to the wiper arm of volume control

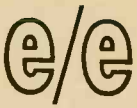

1-FET BCber

Follow layout of parts as shown in photo approximately for quick and easy assembly of this little BCber. The AMP is a ready made unit that can be had at nominal cost from Radio Shack and the only wiring is the detector and interconnection. The FET detector circuit is constructed on a perf-board mounted on the bakelite front-panel.

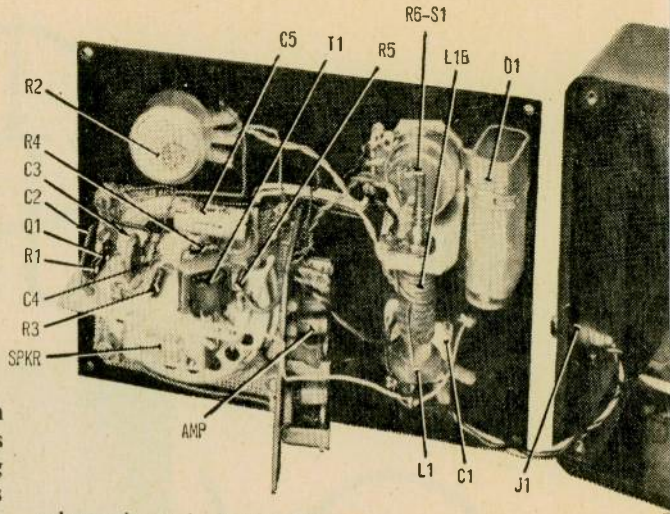

(R6) while the red wires lead to the switch (S1). The black lead on the same side goes to a solder lug on the nearest mounting screw to provide a ground. The output leads go to the speaker with the black lead as a ground.

L1B is formed by wrapping 8 turns of hookup wire around L1A.

The detector circuit is wired from the

schematic and should present no problem. Keep RF-carrying wires away from other wires to prevent signal attenuation. When everything is wired, check for mistakes and

(Continued on page 129)

PARTS LIST FOR THE 1-FET BCber

- AMP—4-transistor, 100-milliwatt, audio amplifier (Radio Shack 27-1240 or equiv.)
- B1—9-volt battery (Radio Shack 23-464 or equiv.)
- C1—10-365 pF miniature variable capacitor (Lafayette 99C6217 or equiv.)
- C2—100-pF ceramic disc capacitor
- C3—47-pF ceramic disc capacitor
- C4—470-pF ceramic disc capacitor
- C5—100-μF, 15 volt, electrolytic capacitor
- J1—Phono jack (Radio Shack 274—346 or equiv.)
- L1A—Antenna-stage broadcast band coil (J. W. Miller A-5495-A or equiv.)
- L1B—8 turns of #22 hookup wire (see text)
- Q1—N-channel field effect transistor (Motorola MPF103 or equiv.)

- R1—3,300,000-ohm, 1/2-watt resistor
- R2—2500-ohm linear taper potentiometer
- R3—330-ohm, 1/2-watt resistor
- R4—1800-ohm, 1/2-watt resistor
- R5—1000-ohm, 1/2-watt resistor
- R6—5000-ohm audio taper potentiometer
- S1—S.p.s.t. switch on R6
- T1—Input transformer—20,000-ohm primary, 1000-ohm secondary (Midland 25-618, Argonne AR-104, or equiv.)
- 1—6 3/4 x 5 1/4 x 2 1/4-in. bakelite case and panel (case, Lafayette 19C2002; panel 19C3702 or equiv.)
- SPKR—8-ohm, 2 1/2-in. dia. speaker.
- Misc.—2 1/2 x 1 1/2-in. perforated board, aluminum bracket and clamp, solder lugs, push-in terminals, mounting screws, wire, solder, etc.

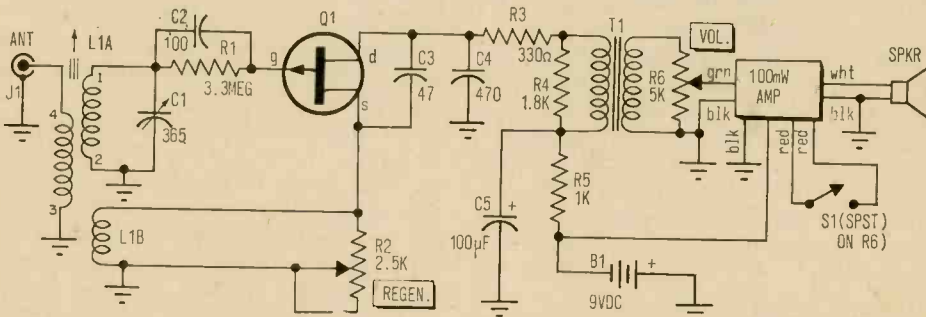

Wire the BCber using the schem. 's above. Coil L1B is the regeneration winding; if it is connected backwards the receiver will not oscillate. If this happens, just reverse the leads.

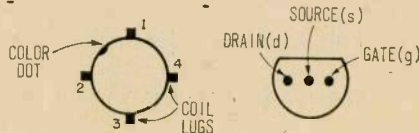

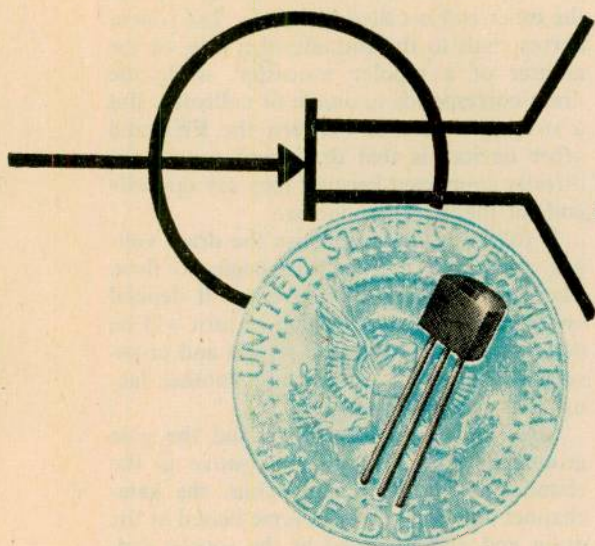

it looks like a Transistor

But looks aren't everything and the FET is more like a solid-state pentode

Field effect transistors have been described as devices which look like transistors and work like pentodes. Though this is an oversimplification, there is a certain amount of truth in it. Unlike a conventional or bipolar transistor, the FET (Field Effect Transistor) is operated by voltage rather than by current. Thus, it draws no input current and throws no load on the signal source which drives it. And under normal working conditions, its output resistance is so high that supply voltage has virtually no effect on device current. In these two respects at least, the FET resembles a pentode. But like a transistor, it is small in size, physically rugged and requires no heater supply.

In spite of similarities to both pentode tube and transistor, the FET is in a class by itself. Its basic operation is completely different from that of either of the other two devices and trying to make close comparisons can lead only to confusion. Our best approach is to forget about both tubes and transistors, and start by reminding ourselves of what goes on in a reverse-biased *pn* junction.

Fig. 1 shows carrier (electrons or holes) distribution in a junction diode when the *n*-type material is made positive relative to the *p*-type. Since the electrons—carriers in *n*-type material—are negative charges, they are attracted away from the junction by the positive battery terminal. In *p*-type material, the current carriers are holes, which are positive charges. So these are attracted away

from the junction by the negative battery terminal.

The result is that nearly all the current carriers in the diode are concentrated at the ends away from the junction and no current will flow because the device can conduct only when current carriers combine at the junction.

Minority Carriers. There will, however, be a small leakage current due to the presence of *minority* carriers—holes in *n*-type

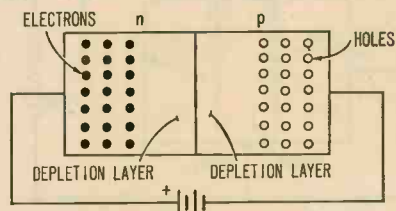

Fig. 1. Reverse biased *pn* junction area has shortage of current carriers (depletion layers).

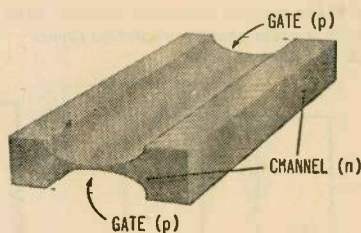

Fig. 2. In this FET, depletion layers control current flow in the *n*-type channel.

e/e LOOKS LIKE A TRANSISTOR

material and electrons in *p*-type. These "see" the reverse bias applied to the junction as a forward bias. Consequently, a current flows. The magnitude of this reverse or leakage current will depend upon the number of minority carriers in the material. Since under the same ambient conditions, silicon has far fewer minority carriers than germanium, a silicon junction will have a much lower leakage current.

At present, what concerns us most is that the current carriers in a reverse biased junction are drawn away from the junction, thus creating *depletion layers* (areas containing no current carriers) on either side of it. The greater the reverse bias, the further out from the junction the depletion layers extend.

Fig. 2 is a simplified sectional diagram of a junction field effect transistor. It consists of a thin *channel* of *n*-type material with sections of *p*-type material on either side of it. These outer sections are called the *gate*. Usually they are connected within the package of the device. So we have the channel virtually surrounded by a *pn* junction.

Grounded Gate. Now suppose we connect the gate to one end of the channel, ground this point and make the other end

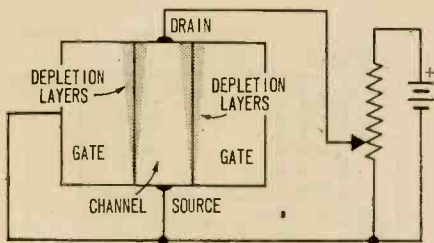
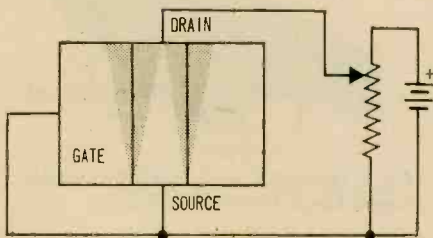

Fig. 3. Depletion layers width are controlled by gate to drain voltage difference.

Fig. 4. When voltage difference between gate and drain is great enough, depletion layers "pinch off" current flow.



positive as shown in Fig. 3. The grounded end of the channel is called the *source* and the other end is called the *drain*. The source corresponds to the cathode of a tube or the emitter of a bipolar transistor, while the drain corresponds to anode or collector. But a striking difference between the FET and other devices is that drain and source are directly connected because they are opposite ends of the same conductor.

It follows that as we raise the drain voltage a channel current will begin to flow. The magnitude of this current will depend on channel resistance, which in turn will be determined by its physical length and cross-section area. But we must take another factor into consideration.

Since the drain is positive and the gate grounded, the gate will be *negative* to the channel at the drain end. Thus, the gate-channel junction will be reverse biased at the drain end and unbiased at the source end. From drain to source, the reverse bias will fall off with the potential gradient along the channel.

Silicon FETs. All FETs are made from silicon or one of the newer metal oxide semiconductor materials, so we can safely assume that the leakage current across the reverse-biased junction will be negligible. Thus, the reverse bias will produce no appreciable effect in the gate-source circuit. It will however cause depletion layers (areas of no current carriers) to spread into both channel and gate.

Since the gate is not conducting, it will not be influenced by its own depletion layer. But we must remember that the gate-channel junction almost completely surrounds the channel, so that the depletion layer will spread into the *n*-type material from all sides. Now a depletion layer in a semiconductor is a region which has no current carriers, so the result of the depletion layer spreading into the channel is to reduce its *conducting* cross-section area, thus increasing its effective resistance.

Reverse Bias. At low drain voltages, the reverse bias is low. Therefore the depletion layer does not extend very far into the channel and has little influence on its resistance. Thus, the initial rise in current as we increase the drain voltage from zero, is determined mainly by the channel resistance, typically from about 100 to 1000 ohms according to FET type. So the drain current will increase with drain voltage as it would in a normal resistor.

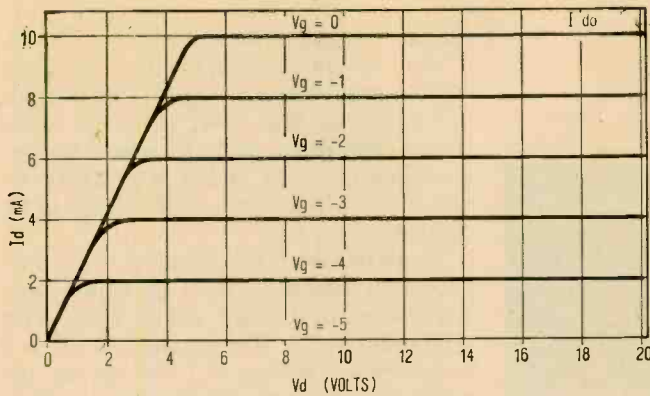

Fig. 5. Biasing the gate (V_g) in relation to the source from 0 to -5 volts results in the drain current (I_d) and voltage (V_d) curves at left.

But as we continue to increase the drain voltage, the potential difference between drain and gate becomes progressively greater. The reverse bias increases and the depletion layer spreads further into the channel. Eventually we arrive at the situation shown in Fig. 4. The depletion layer has extended almost completely across the channel, producing a very large increase in effective resistance. Any further increase in drain voltage will increase the resistance so much that there will be virtually no rise in current. In FET language we say that a device under these conditions is pinched off.

Pinched FET. In a typical FET, pinch-off occurs when the gate is 5 volts negative to the channel. When the gate is connected to source, pinch-off current is determined by resistance of the channel. According to the FET type, current magnitude may be anything from less than 0.5 mA to more than 50 mA. At pinch-off, a typical change in drain current produced by a change of 1 volt on the drain is one ten billionth of an ampere (.000000001 A), corresponding to a resistance of ten billion ohms (10,000,000,000 ohms).

So far, we have been considering what happens when gate and source are at the same voltage. But suppose we bias the gate 1 volt negative. If pinch-off occurs when the gate is 5 volts negative to the drain, we can now only make the drain 4 volts positive before reaching pinch-off. So the pinch-off current, which is determined by drain voltage and resistance of the channel, must be lower.

If we make the gate 2 volts negative, pinch-off current will be lower still and so on until we arrive at a gate bias of -5 volts. The gate is now 5 volts negative to the channel before we apply any voltage to the drain, so the FET is permanently pinched off and no drain current at all flows.

Fig. 6. Basic FET amplifier is very similar to vacuum tube circuit even to the values of components. FET characteristics make it interchangeable in many other standard tube circuits as well.

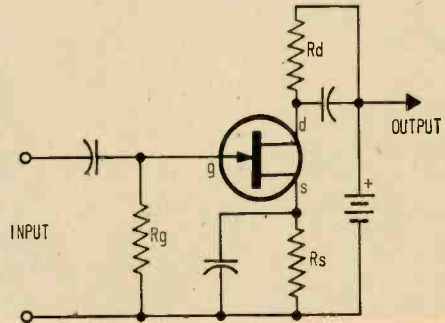

Gate Voltage Curves. We can illustrate the effect of gate voltage by drawing a family of curves as shown in Fig. 5. Here the top curve is marked $V_g = 0$, signifying that gate and source are connected. The drain current rises steeply until the drain is 5 volts positive to the gate. Then the graph turns over into a straight horizontal line, indicating that a further increase in drain voltage brings no corresponding increase in current. Electrically, the line slopes upwards, but the full 15 volts shown might increase the drain current by only .0000000015 A. To scale on the graph, this would be less than the thickness of the line. The maximum drain current which can be reached is marked I_{do} on the curves. For this particular FET it is 10 mA.

In the next curve down, the gate has been biased 1 volt negative. The current rises as before, but now the drain is only 4 volts positive when pinch-off is reached. Since the potential difference across the channel is now lower at pinch-off, the pinch-off current must also be lower. Here it is 8 mA. Similarly, with a gate bias of -2 volts, pinch-off current is 6 mA and so on till the gate is 5 volts negative. At this bias, the drain current never starts.

Breakdown Limits. A limiting factor that we must take into consideration is the

e/e LOOKS LIKE A TRANSISTOR

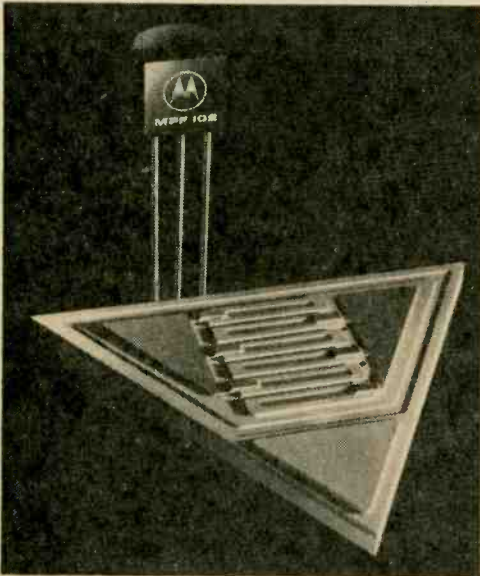

One of the new low-cost plastic encapsulated FETs now available from Motorola. Triangle is model of FETs internal structure.

breakdown voltage of the gate-channel junction, normally in the region of 50 volts. If the voltage between channel and gate exceeds 50, the junction will break down. The FET will not be harmed provided there is enough series resistance in the circuit to keep the current down to a safe limit, but a current will flow in the gate circuit. This is something we normally wish to avoid.

The important fact shown by Fig. 5 is that provided the drain voltage is high enough to produce pinch-off, a change of 1 volt on the gate of this particular FET will change the drain current by 2 mA. So gate voltage has a very effective control over drain current.

To express the mathematical relationship between gate voltage and drain current, we use an old tube term—transconductance—which of course is measured in micromhos. If a change of 1 volt on the gate changes the drain current by 2 mA, the transconductance is given by

$$gm = \frac{\Delta I}{\Delta V} = \frac{2 \times 10^{-3}}{1} \times 10^6 \mu\text{mho} = 2000 \mu\text{mho}$$

FETs are now readily available to give a choice of gm ranging from below 100 to 30,-

000 micromhos or even more in special cases.

Now we can consider the basic FET amplifier circuit shown in Fig. 6. This diagram introduces the field effect transistor circuit symbol with drain, gate and source labeled. Fundamentally, the circuit is precisely the same as that of a tube amplifier, even to the "grid leak."

Transistor G_m ? In a circuit of this nature, the gain is determined basically by the transconductance of the FET and the value of the load resistor, R_d . For instance, if gm is 2 micromhos, a change of 1 volt on the gate will change the drain current by 2 mA. If we make R_d say, 5000 ohms, this will change the drain voltage by

$$2 \times 10^{-3} \times 5000 = 10 \text{ volts,}$$

giving a gain of 10.

R_s , the resistor in series with the source, sets the bias of the FET by making source positive to gate. Just as with a tube, we calculate its value by applying Ohm's Law. But in deciding upon bias, we have to remember that like all semiconductor devices, the FET

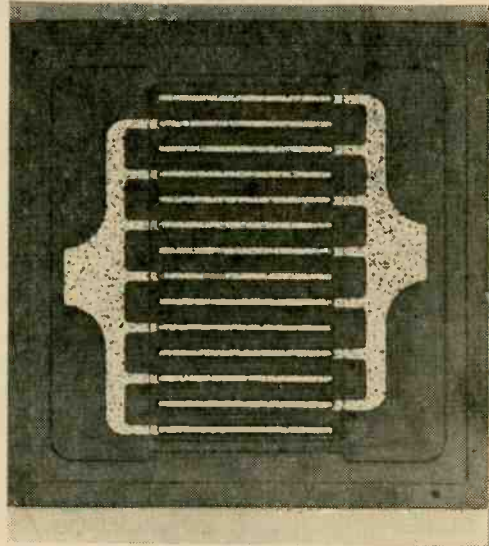

Symmetrical internal construction of this FET allows source and drain connections to be interchanged without affecting performance.

is affected by variations in temperature.

Fortunately, temperature effects occur in two opposite directions at once, so we can make them cancel out. As the channel temperature increases, its resistance increases, cutting down the current by about 0.7% per 1°C . At the same time, extra current carriers gener-

(Continued on page 134)

NEOPHYTE 1

Many newcomers to experimental electronics never get off the ground because of one or both of these reasons: their first project is too involved and difficult to adjust for proper operation; or the project is extremely simple and the results not rewarding enough to sustain sufficient interest to pursue other projects.

With these facts in mind, we present Neophyte 1 which will work for any beginner who can read schematic diagrams and follow simple instructions. No involved adjustment or alignment is required to hear shortwave stations from all over the world on this one-tube radio.

What's With It. Neophyte 1 may be broken down into two stages—a regenera-

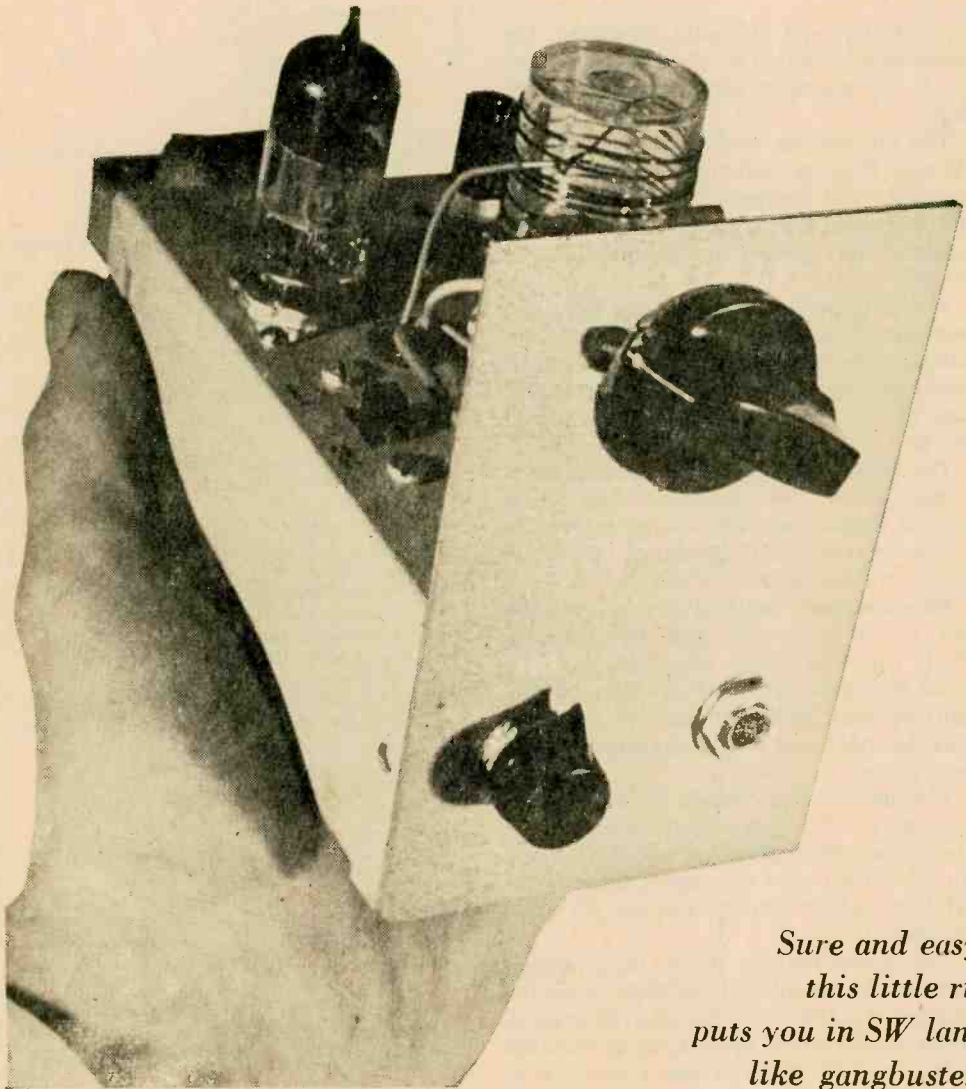

*Sure and easy,
this little rig
puts you in SW land
like gangbusters*

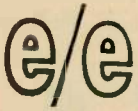

NEOPHYTE 1

Schematic of Neophyte 1 shows conventional regenerative detector circuit followed by a stage of audio. Note how band is changed simply by switching capacitor C2 in and out of tuning circuit.

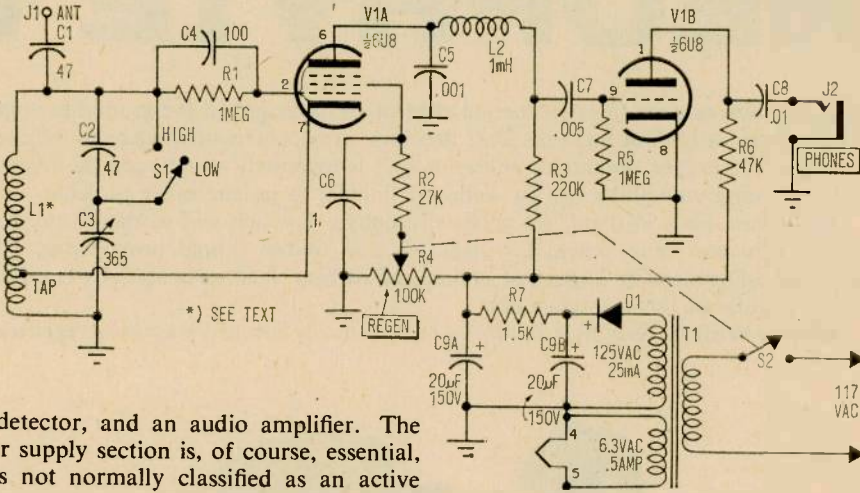

tive detector, and an audio amplifier. The power supply section is, of course, essential, but is not normally classified as an active stage.

The circuits are traditional. A regenerative-type detector, although no longer in use in commercial equipment, still finds plenty of applications where budget-minded experimenters and space requirements are involved.

The detector, besides extracting the audio from the carrier signal, also provides a considerable amount of audio amplification. It would certainly take more than half of one tube to do this using other conventional circuits.

The amplified signal from the detector is coupled to the audio amplifier stage where its level is increased still further to operate a pair of standard high-impedance headphones with adequate volume.

Wherewithal. Starting at the antenna jack in the schematic, you will notice a 47-pF capacitor (C1) connected between it and the tuned circuit. This capacitor prevents antenna loading effects and results in smoother operation of the regenerative feedback circuit.

The tuned circuit consists of coil L1, tuning capacitor C3 and a fixed capacitor, C2. The single-pole-single-throw switch S1 shorts out C2 when closed and places C2 in series with the variable tuning capacitor C3 when it's open.

The closed position places more capacitance in the circuit and therefore tunes the receiver to a low frequency shortwave band. When the switch is open, total capacitance is less than 47 pF maximum (the value of

PARTS LIST

- C1, C2—47-pF disc ceramic capacitor
- C3—10 to 365- or 10 to 410-pF variable capacitor
- C4—100-pF disc ceramic capacitor
- C5—.001-uF disc ceramic capacitor
- C6—0.1-uF capacitor
- C7—.005-uF disc ceramic capacitor
- C8—.01-uF disc ceramic capacitor
- C9A, C9B—20-20-uF 150-VDC dual section electrolytic capacitor (Radio Shack 272-105 or equiv.)
- D1—400-piv., 200-ma or better silicon rectifier diode (Radio Shack 276-1126 or equiv.)
- J1—Insulated binding post (Radio Shack 274-736 or equiv.)
- J2—Headphone jack (Radio Shack 274-293 or equiv.)
- L1—Wound from #22 AWG enamel covered copper wire (see text)
- L2—1-mH radio frequency choke
- R1, R5—1,000,000-ohm, 1/2-watt resistor
- R2—27,000-ohm, 1/2-watt resistor
- R3—220,000-ohm, 1/2-watt resistor
- R4—100,000-ohm linear taper potentiometer with s.p.s.t. switch S2
- R6—47,000-ohm, 1/2-watt resistor
- R7—1500-ohm, 1-watt resistor
- S1—S.p.s.t. slide switch
- S2—Mounted on R4
- T1—Power transformer: 117-VAC pri., 125-VAC, 25-mA; 6.3-VAC, 0.3-A sec.
- V1A, V1B—6U8A vacuum tube
- 1—5 1/4 x 3 x 2 1/8-in. aluminum minibox (Radio Shack 77-0683 or equiv.)
- 1—High impedance (2000-ohm or more) headphones
- Misc.—9-pin tube socket, scrap aluminum for front panel, knobs, grommets, line cord and plug, terminal strips, screws and nuts, etc.

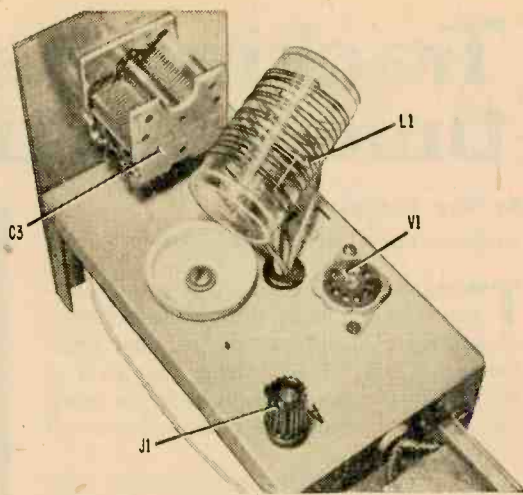
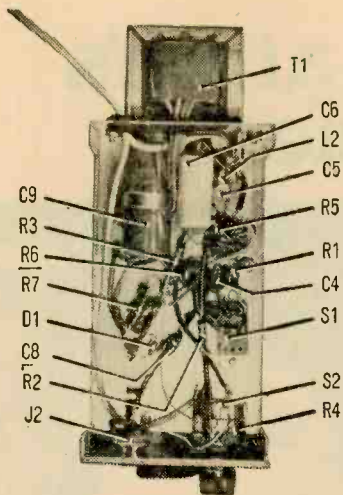

At left, parts arrangement in Neophyte is compact but uncluttered. Coil at right is wound on plastic pill bottle as shown.

C2) and this provides a second, higher frequency shortwave band. Using the specifications given for the coil and the capacitor values, Neophyte 1 covers from about 3 to 7 MHz on the low band, and from about 9 to 12 MHz on the high band. Other frequencies, higher or lower, may be covered by changing the value of C2 and the number of turns in L1. If you use variations, experimentation with the "tap" may be necessary.

Audio Extraction. As mentioned before, the first, or pentode section, of the dual section tube extracts the audio from the received signal and passes it to the triode audio amplifier stage. However, plenty of unwanted radio frequency signals also appear

at the plate of the pentode section and they must be dispensed with for proper operation. The radio frequency choke L2 and bypass capacitor C5 are placed in the circuit for this purpose. The choke blocks or "chokes" higher frequencies, but allows lower audio frequencies to pass; conversely, the bypass capacitor blocks low frequencies and bypasses unwanted RF to ground. The result is a relatively clean audio signal appearing between the grid and cathode of the audio section for additional amplification.

Regeneration. The current in the detector stage must flow through the lower portion of coil L1 and up to the cathode where it divides between the plate and the screen grid. The screen grid is connected to the positive (B+) supply through a limiting resistor and potentiometer R4. By changing the resistance of the pot, the screen voltage is varied and the tube current changes. The pot thereby varies the current through the tapped portion of the coil. The degree of current flow determines the amount of signal that is coupled to the upper portion of the coil which, in turn, determines the amount of feedback. The potentiometer is called a regeneration control, and it, as its name implies, controls the regeneration or feedback of the signal voltage.

Building Neophyte I. All parts mount on or in a 5¼ x 3 x 2½-in. aluminum mini-box. A small piece of scrap aluminum measuring 3 x 4½-in. is used for the front panel. Follow the photos to locate mounting positions. (Continued on page 134)

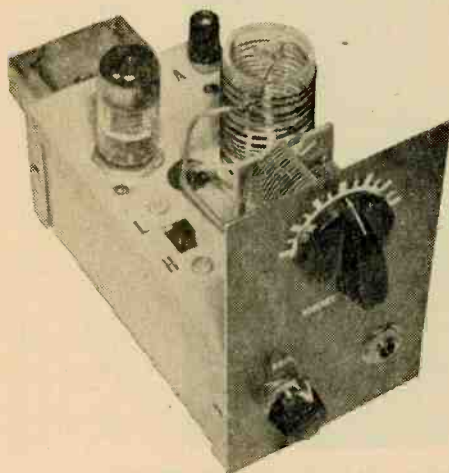

Neophyte 1 will provide many hours of entertainment receiving the most active shortwave bands.

Tracking the atom's tiniest particles

By Ray McGlew

Associate Editor, DuPont Magazine

Taking an alarm clock apart with a hammer is undoubtedly the quickest method of gaining a visual concept of what made the clock tick. Reassembling the parts in working order, though, is probably the surest way to acquire any real comprehension of the mechanism.

A comparison between tinkering with timepieces and current nuclear research would certainly be deemed "way out" by men of science. Nonetheless, the example proves rather handy to physicists here at Brookhaven National Laboratory when they attempt to explain their seemingly anachronistic preoccupation with the secrets of the atom.

Illusions Anyone? To anyone laboring under the illusion that all the atom's secrets were revealed when the first atomic bomb was exploded at Alamogordo 22 years ago, however, even a mere listing of the components of the "modern" atom may come as a shock. The science-fiction flavor of many recent accounts has enabled laymen to remain *au courant* with the wily neutrinos and the suspect antinucleons as well as the electrons, positrons, neutrons, photons, and protons. But consider some of the atomic particles now acknowledged in up-to-date physics textbooks: the mu, pi, eta and K mesons; the lambda, sigma, xi and omega hyperons.

Recognize them? The mesons, according

A 50 million electron volt beam from linear accelerator enters synchrotron's field where it is accelerated to more than 30 billion electron volts.

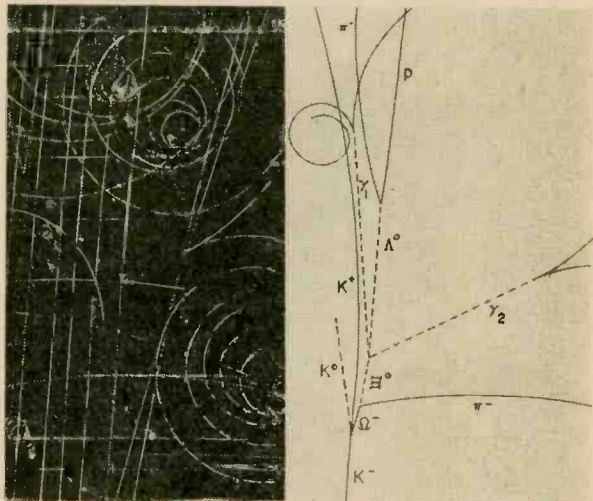
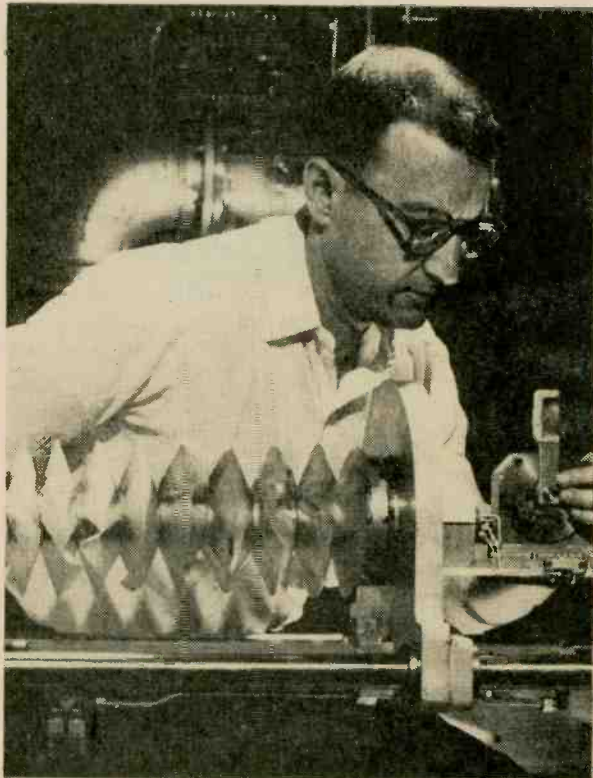
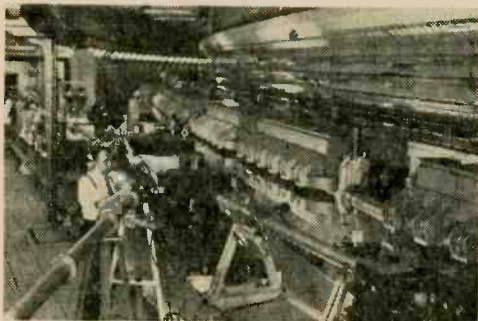

Photographs like this are major products of Brookhaven's research effort. These patterns are the result of high-energy particle collision in bubble chamber.

Here, chemist is placing a copper target in the synchrotron for proton bombardment to study reaction between high-energy nuclear particles and complex nuclei.

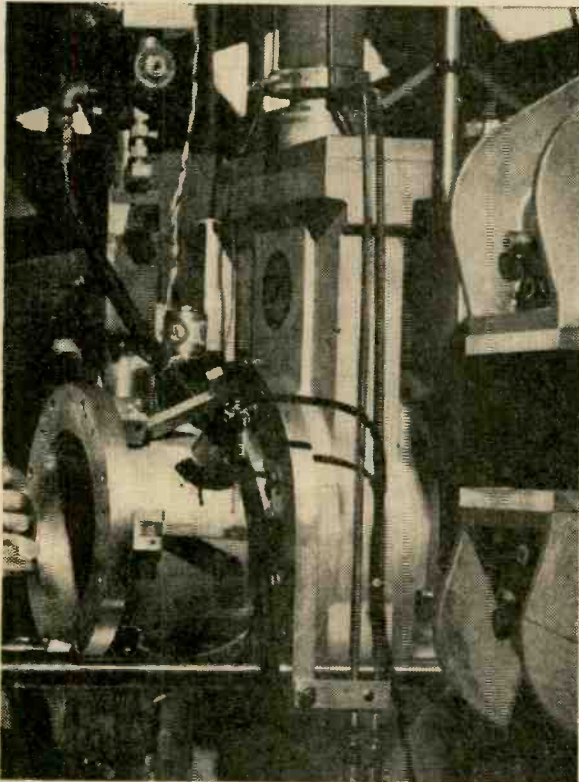

to Dr. Robert Louttit, a Brookhaven staff researcher, are particles with a mass greater than that of an electron and less than that of a nucleon. Hyperons are any of a class of short-lived particles with masses greater than that of the neutron.

"Mesons and hyperons are particles that are sometimes formed when atoms or parts of atoms collide," explains Louttit. "Meson exchange may represent the forces that are exerted along with magnetic and electrical forces to bind an atom's constituents together. We've identified perhaps a hundred particles and resonances of particles so far, but there could be a lot more."

Long Range Goals. Describing all of the atom's particles in mathematical equations and formulating laws to explain their properties are immediate goals of high-energy physicists like Louttit and his associates. The long-range goal: "Well, if you know why protons stick to neutrons, the reasons for the existence of all particles and resonances, and can predict their behavior," he offers, "then you can predict the behavior of atoms, molecules, and groups of any other particles. In principle, you can understand in a very fundamental way the behavior of microscopic matter."

Researchers at this installation, operated by Associated Universities, Inc. for the Atomic Energy Commission, shy away from "Buck Rogerish" interpretations. But the possibilities are clear. The work here could someday lead to man's complete control of his environment. *(Continued overleaf)*

Site of Brookhaven National Laboratories. Alternating gradient synchrotron is underground in the 900-yard perimeter of cup-shaped depression.



Photos courtesy of Brookhaven National Laboratories

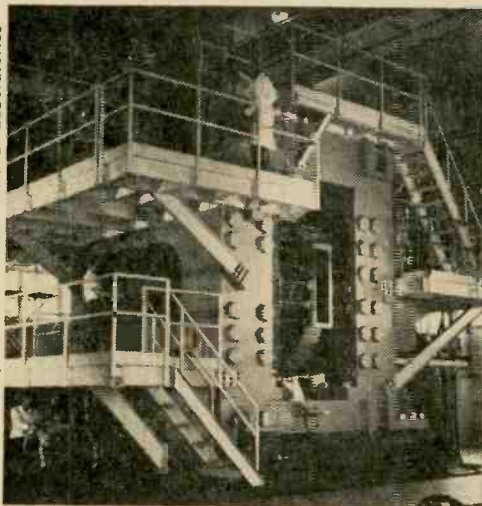

The 80-in. bubble-chamber assembly provides visual indication of particle collision. Curvature of resulting tracks indicate particle mass, velocity, charge, and other properties.

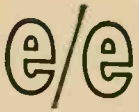

ATOM'S TINIEST PARTICLE

Can't See Where You're Going? It is a fantastic assignment. Even more so when you consider that, even with the most powerful electron microscope, no one has ever seen an atom, much less one of its subparticles. Then how do you deal with particles whose size is measured in fractions of a light wavelength (4×10^{-5} or four 100,000ths of a centimeter) and whose life expectancy can be as short as one ten billionth (1×10^{-10}) of a second?

"We photograph them," says Louttit. "Or, at least, we photograph their tracks."

It is a technique that predates the modern planetary view of an atom as a nucleus surrounded by orbiting electrons. In 1896, when the atom was still thought of as a pudding-shaped mass in which raisin-like electrical charges were embedded, Henri Becquerel observed a radioactive "fog" on a photographic plate accidentally exposed to uranium. Subsequent identification of this fogging (by Lord Rutherford in 1911) as the tracks or imprint of an atom-in-motion gave impetus to nuclear research.

Giga-Poop. As practiced here at Brookhaven, the technique is considerably more sophisticated than it was in Becquerel's time. Positioning the particles requires the world's most powerful accelerator, a 30-billion-electron-volt, alternating gradient synchrotron. The focal point of the resulting phenomena is the world's largest operational "bubble chamber," an 80-in. stainless steel vat filled with 240 gallons of (-418°F) liquid hydrogen.

Even the photographic film on which more than a million "events" a year are recorded is specially designed. The photographic medium: DuPont's "Cronar" bubble chamber film, a 70-millimeter film that offers unusual light sensitivity, high contrast, and dimensional stability for accurate calibration and archival permanence.

Say Cheese, Please. Posing an atomic particle for the most basic of portraits begins with the electronic bombardment of hydrogen atoms in a linear accelerator to produce high-speed protons. Injected into the circular synchrotron, which is 840 feet in diameter, the protons are whirled through an oscillating electromagnetic field that pushes them to a speed near that of light.

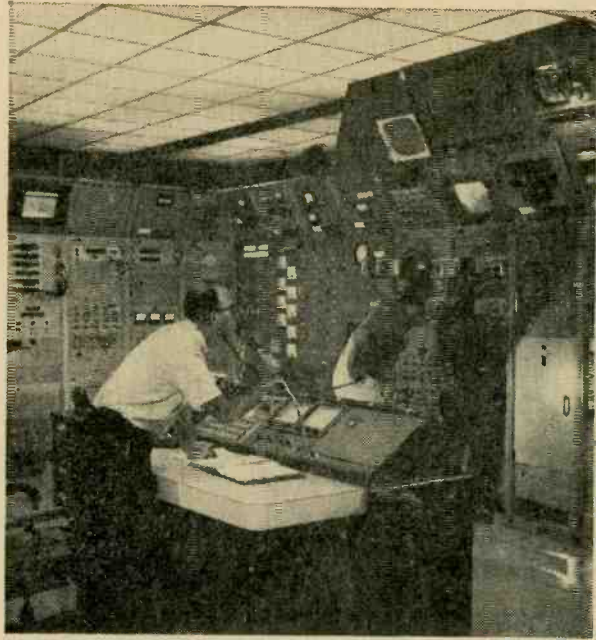

Control room of the 80-in. liquid-hydrogen bubble chamber. Photo shows some of the many controls and instruments needed to monitor and regulate operation of the chamber.



This is the linear accelerator used to accelerate protons to 50 million electron volts prior to injection into synchrotron for final boost to more than 30 billion electron volts.



Fantastic complexity of overall system is evidenced by this view of synchrotron's main control room. All functions of synchrotron operation and monitoring take place here.

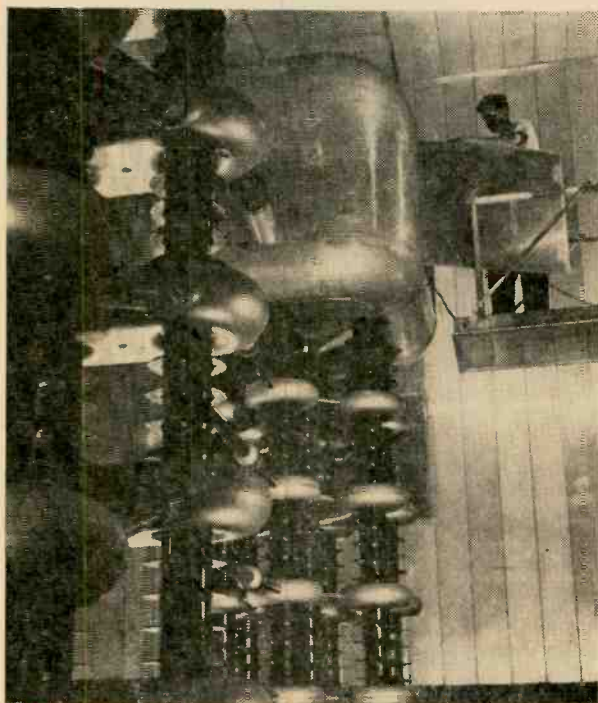

The Cockcroft-Walton generator above provides initial proton acceleration to a level of 750 thousand electron volts. Protons then go to linear accelerator and on to the synchrotron.

Focusing and deflecting magnets, that can discriminate between particles by virtue of their charge or mass, then aim a beam of less than 20 particles into the bubble chamber.

"To understand what takes place in the chamber," advises Louttit, "you might look closely at what happens when a bottle of champagne is uncorked or when any container filled with liquid under pressure is opened. The bubbles that rush to the top are not formed willy-nilly. They take shape at the sides or bottom of the bottle where the sudden release of pressure has caused a change in temperature and provided heat spikes around which vapor can form."

A similar reaction, the physicist explains, occurs inside the bubble chamber when a piston is raised slightly to decrease chamber pressure, thus superheating the hydrogen. The protons entering the chamber during this brief period (5/1000ths of a second) produce ionization heat spikes. The liquid begins to boil first at these points, leaving trails of bubbles slightly curved by the presence of the magnetic field that guides them through the center of the liquid. A flash of light at this point automatically exposes the view to film in three stereoscopic cameras trained on the beam path through a glass port.

Collisions Wanted. Should the beam particles somehow avoid a collision with any of the myriad hydrogen protons adrift in the chamber, the photographs would reveal only 18 or 19 almost horizontal lines of bubbles. However, every hydrogen atom is made up of one electron and one proton, and chances of one or more proton-to-proton collision are high. And when protons do collide, the pattern of bubbles captured on a strip of "Cronar" bubble-chamber film can resemble the burst of a skyrocket.

"What you would then view," Louttit points out, "is something similar to the tire tracks left at the scene of an accident. A curved bubble track stops abruptly at the point where the collision took place. The secondary tracks curving away from it are those of the fragments or particles produced by the impact. And since each constituent of the collision event is characterized by its trajectory through the liquid, we simply measure its direction, curvature, and frequently the density of the bubbles along the track to ascertain mass, velocity, and momentum. Thus, we often can identify the particle itself."

No Brownie This. Measurements ac-

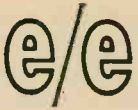

ATOM'S TINIEST PARTICLE

curate to a few thousandths of an inch can be obtained when the six-inch frames—2500 to each reel of "Cronar" film—are enlarged on scanning screens. Such blowups also allow trained observers to search for the unusual. When they find it, they trace the pattern on the screen with measuring optics or light pencils that feed the data into a computer.

"This is where 'Cronar' bubble chamber film makes its special contribution," reports John Garfield, manager of the photography and graphic arts division at Brookhaven. "If

swell, curl, or become brittle with temperature or humidity changes.

This dimensional stability of "Cronar" polyester photographic film base is also an asset in photographing the events. Timed to occur in series 1.8 seconds apart—exposing more than 30 frames in each of the three cameras every minute—the experiments leave only brief intervals for film advance. In that split second, film must move smoothly forward the required six inches and adjust snugly to the camera platen. Any ripple or rise could cause optical distortion that would render the photo and experiment valueless.

Still another advantage: Four-and-one-half-mil "Cronar" offers 25% more photographic coverage in 1250-ft. reels that take

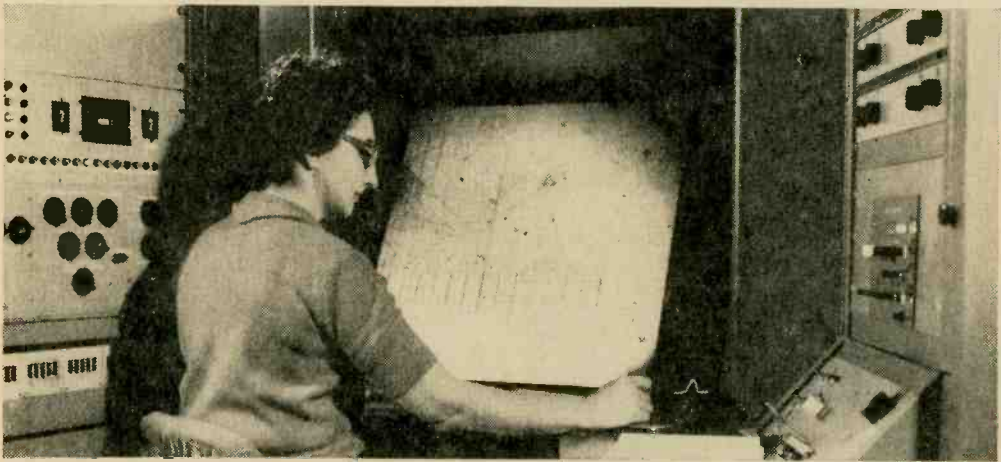

Tracks produced in bubble chamber are fed into computer for analysis and categorization.

you've ever tried to snap a photo of a child blowing soap bubbles, you know how frustrating it can be to attain the right proportions of background and reflective light. The film's high-contrast imagery makes each bubble stand out, lessening the possibility of unobserved phenomena."

By The Twos. Read-out binary code data, photographed simultaneously with each event, also project sharply and clearly, according to Garfield, as a result of the high contrasts attained. These digital reference or file marks can be especially important should a recorded phenomenon defy immediate inclusion in physics law or theory.

When a photographic record of a particular event is re-scrutinized four or five years from now, measurements will be just as valid as those taken immediately after the experiment. The photos will not shrink,

up no more space than the conventional 1000-ft. acetate film reels the cameras were designed to hold. And Brookhaven takes a lot of pictures.

Just Make Pictures. "You might say that our principal output is photos," agrees Garfield. "Three pictures of every event, and it takes us approximately 100,000 events to come up with something really new and unusual."

Oddly, though, Brookhaven's most spectacular success to date was achieved in considerably less than the average number of events. Somewhat less than 50,000 "triads" (three exposures per event) were made to discover the long-sought-after omega-minus particle. Predicted in 1959 but never "seen," the hyperon was the "missing link" in a theory advanced to correlate certain "strong"

(Continued on page 128)

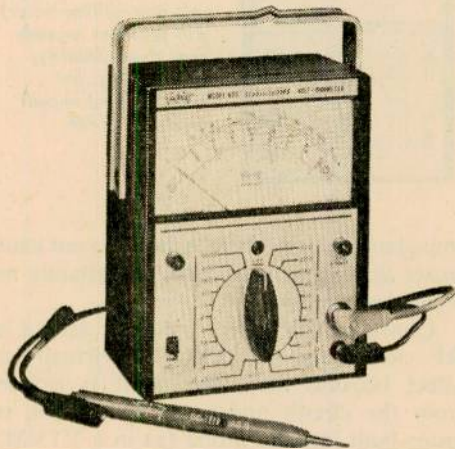

TRIPLETT Model 600
Transistorized
Volt-Ohm-Milliammeter

■ For many years, the *Triplet 630* series VOMs have been the work horses of the service bench. Extremely rugged, accurate under even brutal handling, and among the most convenient meters to use because all the functions and ranges were determined by a single selector switch, the 630 series meter commanded considerable respect. It was only natural then that *Triplet*, in its new 600 series transistor-amplified VOM, retained the styling, convenience and ruggedness of its predecessors.

The new *Triplet 600 TVO* (transistorized volt-ohmmeter) looks just like a modern styled 630, and retains all the former front panel conveniences. A single selector switch selects any of the DC, AC or ohms ranges—there is no AC/DC selector switch. But unlike earlier 630s, the new 600 has a DC polarity reversing switch that provides for negative voltage measurement without the need to reverse the test probes.

Another new convenience is half-scale ranges, whereby the center of the next highest range is one-half the lower range. For

example, the lowest DC range is 0.4V. The next higher range is 0.8V, thereby placing the top of the 0.4V range midscale of the higher range. The half-scale system is used for both the DC ranges (which go from 0.4V to 1600V), and the AC ranges (ranging from 4V to 800V). In effect, the user nearly always can take readings at the high end of the scale, the most accurate part.

Six ohms ranges are provided, allowing measurement from 0 to 100 megohms. The center of the lowest (Rx1) scale is 10 ohms, about the most convenient to use ohms scale.

A convenience more common to a VTVM, but provided here, is a zero-center scale—useful for FM discriminator alignment.

The voltage scales, unlike most VOMs, are linear from one end to the other, and one set of scales is used for both AC and DC measurements. There are only four scales total (including zero-center), resulting in a very high degree of scale legibility.

The final convenience is the range selector *off* position which not only disables the battery power supply but damps the meter for transit. The damping is so effective it is almost impossible to budge the pointer no matter how hard the meter is joggled.

Testing. The meter movement itself proved extremely rugged; we accidentally dropped the meter twice—three feet to a

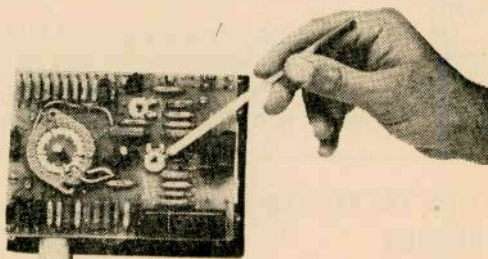

Pencil points to one of 600's two calibration pots. Instruction manual outlines simple calibration procedure.

concrete floor—and the pointer still stayed on the "0" mark. (Few meters can take this type of treatment *once*.)

Like any good service or lab grade meter, the accuracy was well within the manufacturer's specification of 3 percent AC and DC. The ohms range was as accurate as

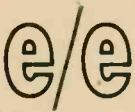

TRIPLETT 600 TVO

we have found on any other standard VOM.

The big plus with the 600 TVO is the zero set stability. Once the meter is zeroed, it stays on zero regardless of the voltage range selected, either AC or DC. The shift off zero when the meter polarity is switched from + to - is negligible, less than 1/4-scale division. Unfortunately, the zero set does not hold for the ohms range, and as with a VTVM, the ohms and zero adjust must be set for each ohms range.

When You Need The 600 TVO. A logical question would be: "Why pay extra for a transistorized VOM when its functions are essentially those of a high grade VOM?". The answer lies in the input impedance. The average VOM has a terminal impedance of

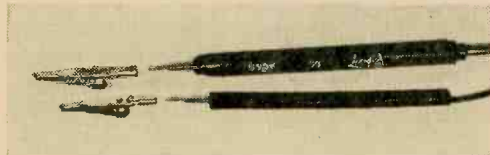

Triplett 600 comes complete with slip-on alligator clips for both hot and ground probes. Hot probe features built-in AC/ohms-DC switch as well as an isolation resistor.

20,000-ohms-per-volt for each volt of range. For example, set to the 100V range a VOM would represent an impedance of 20,000 x 100, or 2 megohms; set to a 1V range the VOM would represent 20,000 x 1, or 20,000 ohms.

On the other hand, the transistorized 600 TVO represents 11 megohms on all DC ranges except 0.8V where it is 5.5 megohms, and 0.4V where it is 2.75 megohms. This

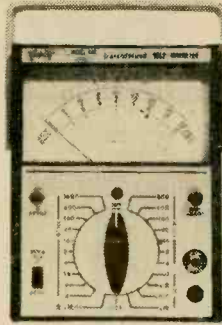

Looking much like its famed predecessors, Triplett's new Model 600 TVO (transistorized volt-ohm-milliammeter) still provides ruggedness, dependability, and stability, but with the input impedance of a VTVM.

impedance range is high enough to not cause meter loading of most circuits, certainly not transistor circuits.

Unlike a VOM, which would detune an RF circuit, the 600 TVO has virtually no effect because the meter itself is isolated from the circuit under test by a 680k resistor built into the probe (as in a VTVM).

It must be kept in mind that the Triplett 600 TVO is not a replacement for the service grade VTVM because it does not indicate peak-to-peak voltages. Rather, the 600 TVO functions as a high-impedance VOM, insuring minimum loading of the circuit under test. Also, the very low 0.4V and 0.8V ranges allow high scale readings on low-voltage transistor circuits.

Summing Up. As you can see, we were impressed by both the quality and performance of the Triplett 600 TVO. We feel, that just as its predecessors, the 630 series VOMs, the 600 TVO will become the workhorse of the modern service shop.

Priced at \$78.00 the 600 TVO is supplied with a complete set of batteries, probes, and two alligator clips for the probes. A leather carrying case is optional. For additional info., write to Triplett Electrical Instrument Co., Dept. KB, Bluffton, Ohio 45817 ■

TINY TALKIE FOR WATERLOGGED AIRMEN

Not much larger than a pack of seven-minute smokes, this two-way radio is the latest wrinkle in rescuing downed Navy airmen. Designated the AN/PRC-63, the little rig packs quite a wallop and provides communications over a better than fifty-mile range. The solid-state micro-circuitry unit features a homing beacon that is automatically activated by the opening of the airman's parachute, and a voice transmitter-receiver to chat with rescuers. The transmitter-receiver is produced by Sylvania Electric. ■



This story is based on material contained in an article appearing in ESSO Air World.

Low Down

Measurements Way Up

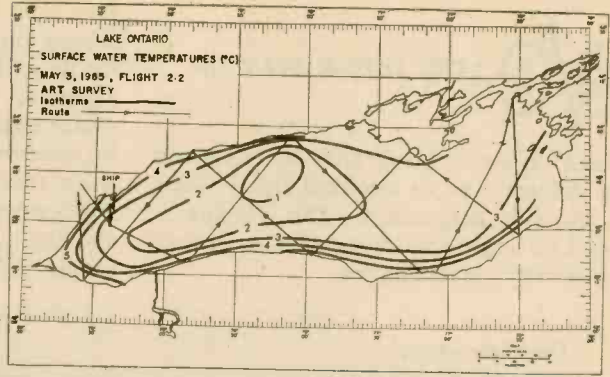

The temperature of oceans and large lakes is usually taken by immersing a thermometer "in a bucket"; the Climatology Division of The Canadian Department of Transport's Meteorology Branch however is now taking water temperature from heights of 500 feet or more in the air. Since the beginning of 1965, flights have been made over the Great Lakes testing an infrared airborne radiation thermometer as an airborne indicator of surface water temperature.

Lloyd Richards, who, as head of the Lakes Investigation unit, is in charge of the project, explains that some means of taking temperatures over an extensive area in a short space of time would be extremely useful in forecasting meteorological conditions

over large lakes and their adjacent land areas.

It could also help very much in assessing water losses through evaporation and in studying the formation and dissipation of ice. You can fully appreciate this research the next time a goofed weather forecast snags you in miles from home.

The radiation thermometer seemed worth investigating and the area of experimentation chosen was the Great Lakes, where there is a continuing need for observations of surface temperatures.

Radiation's The Thing. The thermometer works by sensing the radiant energy from the surface at which it is directed. It compares this reading with an accurately cali-



Researcher sits at controls of thermometer that takes water temperatures from high in the sky.



Thermometer here is taking temperature of Lake Ontario though it's a full mile away.

e/e LOW DOWN WAY UP

brated reference black body and converts the difference to an electrical signal which varies with temperature. This reading is shown on a meter and transcribed to a traveling chart by a recording pen.

One of the research aircraft used in the airborne survey of surface water temperatures of the Great Lakes. Arrow points to the streamlined cover of the temperature sensor.

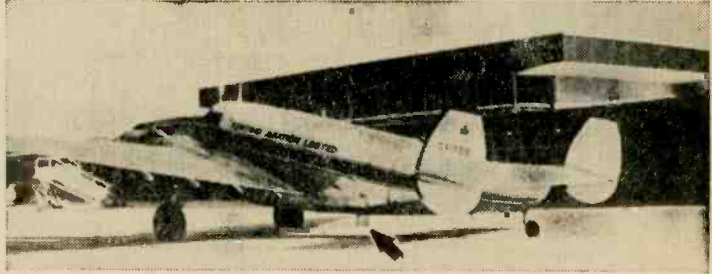

Don Massey, a research assistant, made his first flights in conjunction with the meteorological branch's regular ice survey of the Great Lakes, pointing the sensor through a camera-bay in the bottom of a twin-engine Lockheed 14. The first readings fluctuated wildly, mainly because of the bay's currents of cold air flowing around the sensor. It didn't take much thinking to decide what was needed to avoid this problem.

The result was a baffle, like a streamlined stovepipe, which protrudes from the bottom of the aircraft and induces a gentle outflow of air from the cabin. Fluctuation was further cut down by raising the sensor higher above the floor in a shock-resistant bracket. Experiments were also made with a polyethylene film placed over the sensor head. This cut down fluctuation, but made the reading two or three degrees high.

How Accurate? Next phase of the pro-

gram was to evaluate the instrument's usefulness for making lake-wide surveys and for detecting small-scale water temperature variations. It was also necessary to study the causes and extent of errors. This was where the department-operated C.C.G.S. Port Dauphine research vessel came in. Numerous flights were made over the research vessel at altitudes ranging from a few hundred to a couple of thousand feet as technicians on the

ship measured water temperatures and the meteorological conditions in the air between the aircraft and the water. In all these tests, the new instrument did well and the technique is now considered reliable to within about one-degree Celsius.

In The Final Analysis. "We feel that we have already developed a valuable and practical research tool," says Lloyd Richards, "but there are numerous implications of a highly scientific nature that call for more sophisticated research. The higher the aircraft flies, the more distortion exists in the readings, depending on moisture content and temperatures of intervening air."

Basic temperature measurement experiments have been completed and operational flights have been taking place. Besides this specific application, the project has made a considerable contribution to general scientific knowledge. ■

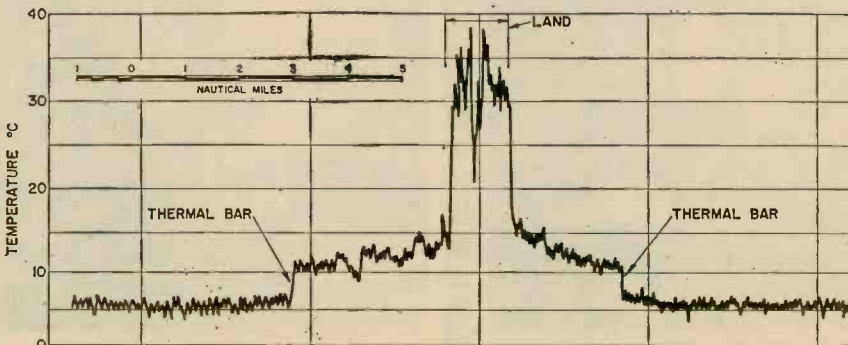

Typical graph of airborne temperature readings taken near shore at height of 500 ft.

Mail This Card Today →

FREE LAFAYETTE 1968 CATALOG



Over
500
Pages

Featuring Everything in Electronics for
• HOME • INDUSTRY • LABORATORY
from the "World's Hi-Fi & Electronics Center"

Use LAFAYETTE'S Easy-Pay
Budget Plan **NO MONEY DOWN . . .**
Up to 24 Months to Pay

Satisfaction guaranteed
or Money Refunded

Mail This Card Today for Your Friend →

STORE LOCATIONS

NEW YORK	NEW JERSEY	MASSACHUSETTS
Bronx	Manhattan	Newark
Brooklyn	Scarsdale	Paramus
Jamaica	Syosset	Plainfield
PENNSYLVANIA	CONNECTICUT	WASHINGTON, D.C. Area
King of Prussia	Hamden	Falls Church, Va.
Philadelphia	W. Hartford	Mt. Rainier, Md.
Pittsburg		

Mail the Coupon Today for Your
FREE 1968 Lafayette Catalog 680

LAFAYETTE Radio ELECTRONICS
Dept. DA-8 P.O. Box 10
Syosset, L.I., N.Y. 11791

Send me the Free 1968 Lafayette Catalog 680

Name

Address

City State Zip

(Please Give Your Zip Code No.)

Mail This
Card Today
For Your

FREE!

1968 Lafayette Catalog 680

Dept. DA-8

Name

Address

City

State

Zip

(Please Give Your Zip Code No.)

PLACE
STAMP
HERE

LAFAYETTE RADIO ELECTRONICS

P.O. BOX 10
SYOSSET, L.I., N.Y. 11791

Mail This Card Today For Your

FREE!

1968 Lafayette
Catalog 680



Over
500
Pages



Shop At the "World's Hi-Fi
& Electronics Center"
For Widest Selection, Low Prices

Stereo Hi-Fi • Citizens Band • Ham Gear • Tape
Recorders • Test Equipment • TV and Radio
• Phonographs, Accessories • Intercoms and PA
• Closed Circuit TV • Tubes and Parts • Cameras
• Auto Accessories • Musical Instruments • Tools
• Books

Featuring Everything in Electronics for
• HOME • INDUSTRY • LABORATORY
from the "World's Hi-Fi & Electronics Center"

NOW - REVOLUTIONARY NEW



Electronic Miracle
of the Space Age



New! Solid State "IC"
Stereo Receivers



New! Revolutionary "IC"
2-Way Radios
"IC" (Integrated Circuit)



New!
Dyna Com
Series
Super
Walkie-Talkies



New! Musical
Instruments and
Accessories

Do A Friend A Favor . . .

Have a friend interested in hi-fi or electronics? Send us his name and address and we will send him his own personal copy of the 1968 Lafayette Catalog 680.

FREE!

 MAIL THE CARD TODAY!

LAFAYETTE

RADIO ELECTRONICS

P.O. BOX 10
SYOSSET, L.I., N.Y. 11791

PLACE
STAMP
HERE

Dept. DA-8

Name _____

Address _____

City _____

State _____

Zip _____

(Please Give Your Zip Code No.)

FREE!

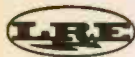

Mail The Card Today for Your

FREE!

LAFAYETTE 1968 Catalog 680



HICKOK Model 860
Combination Injector-Tracer
and Variable Power Supply

■ There are two ways to easily service transistor radio receivers and amplifiers. One method is to use a tunable signal tracer, a device which can trace a signal all the way back from the antenna, through the RF and IF amplifiers, to the audio output. The second easy way is to inject a signal at the audio output, then at the IF, RF, and work back to the antenna. In both instances the service technician would look for a stage that cannot pass a signal.

For years, there has been a mild debate over which is the better way: to inject the signal or to trace. Hickok has solved all problems and settled all questions for all time by providing an instrument that can do both—either inject or trace.

To start off, the Hickok *Injecto-Tracer* 860 is specifically designed for transistorized equipment (though it most certainly can be used with tube gear). A built-in variable voltage power supply provides up to 15 volts DC at up to 100 mA for battery substitution. Both voltage and current are fully metered: the voltage in two ranges of 5 or 15

volts and the current in two ranges of 10 or 100 mA.

More Than One. For injection tracing, several generators are provided. First there is a 1000 Hz oscillator used for audio signal injection or as a modulator for the RF generators. Secondly, there is an IF and RF tunable oscillator. When the instrument is set to *IF*, the instrument will deliver an output signal either modulated or unmodulated from 240 to 690 kHz—the IF band.

When the instrument is set to *RF*, the output is either modulated or unmodulated RF in the range of 600 to 1750 kHz. In both instances the output frequency is determined by a calibrated dial.

The third injection function is FM modulated or unmodulated 10.7 MHz output for servicing FM receivers.

Signal Tracing. Except for the 10.7 MHz oscillator circuits, everything else dou-

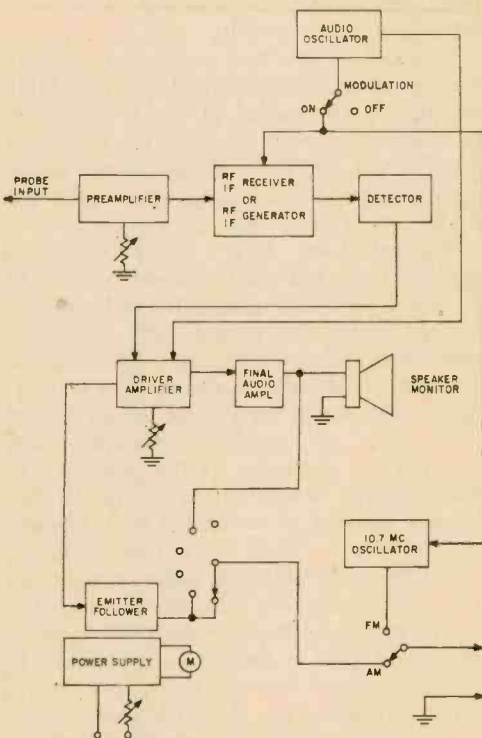

Block diagram of Hickok 860. IF/RF receiver section (used for signal tracing) doubles as IF/RF generator. Audio oscillator modulates IF/RF generator and 10.7-MHz oscillator, also delivers separate AF test signal.

e/e HICKOK 860

bles as a signal tracer. Flip a switch and the *Injecto-Tracer* becomes a tunable signal tracer with a range of 240-690 kHz. Move the switch another notch and you have a signal tracer tunable in the range of 600-1750 kHz. Move the selector switch again and you have an audio signal tracer.

Though the generator has many functions, there are only two test leads. One is the signal tracer probe which has a two stage Darlington amplifier built-in. The Darlington emitter-follower amplifier—which has a relatively high input impedance—in combination with a series-connected 1-megohm resistor results in an input impedance at the tip of the probe of greater than 1 megohm: high enough to prevent capacity loading of critical tuned circuits. The probe can be connected directly to the base, emitter or collector of an IF or RF amplifier without a serious loading effect.

The probe's Darlington amplifier is wide-band, functioning for both the AF and IF-RF signal tracer circuits.

The second test lead is the output cable for the IF-RF oscillator and the 10.7 MHz oscillator. The output of the IF-RF oscillator is continuously variable, the FM oscillator is not. If the FM test signal is too strong, the technician simply moves the end of the cable away from the circuitry.

Typical Uses. Here's a typical way a transistorized AM receiver could be checked by the injection method. With the output set for *audio*, the output cable would be connected across the speaker. Sound in the speaker would indicate the speaker is okay. Still using audio, the output would be fed into each AF amplifier working back towards the antenna. At the detector, the unit's output would be set to the IF frequency and the probe moved back towards the convertor. Then the output would be set to the same RF as the radio receiver and the signal would be injected into the convertor input and back towards the antenna, finally injected at the antenna. Failure to push the signal through any circuit would point directly at the defective stage.

For signal tracing you would follow the opposite procedure, working from the antenna to the audio output. First you'd tune the Hickok 860 to the same frequency as

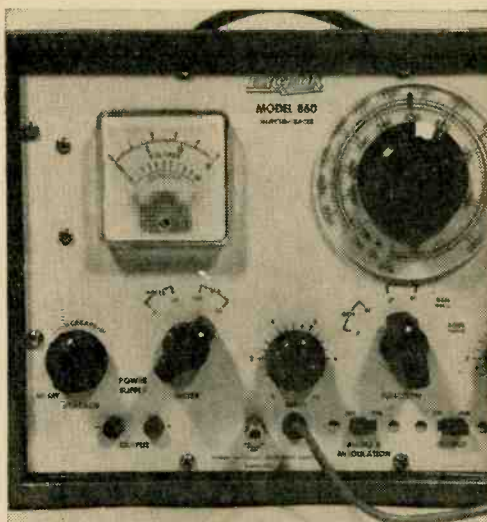

Meter at left of 860's front panel measures output of power supply, knob at right controls tracer tuning.

the radio and trace up to the convertor. Then you'd set the 860 to the IF signal and trace to the detector. Finally, you switch to audio tracing and trace from the detector output to the radio's AF output. Again, the defective circuit is any stage that failed to pass the received signal.

How It Performed. After a few minutes orientation we found the Hickok 860 easy to use. The controls are plainly marked and self explanatory—there is no need for constant referral to the instruction manual. The tracer circuits have extremely high gain—probably more than any other signal tracer we've so far used. In actual injection and tracer checks on defective pocket radios, the 860 was able to localize the defective circuits in a matter of minutes.

Our only complaint lies with the *Injecto-Tracer's* audio output (for the tracer function). While it is relatively undistorted at low output levels, the distortion rises rapidly if you try to get a moderately loud signal tracer volume.

But, aside from its distortion at the high audio levels, the Hickok is a great, new instrument, and we would recommend it for any radio service shop.

The *Injecto-Tracer's* power supply is AC only. The probe and output leads are permanently attached, the only accessory equipment being the power supply output leads.

The *HICKOK Injecto-Tracer Model 860* is priced at \$149.50. For additional information write to Hickok Electrical Instrument Co., Dept. RE, 10514 Dupont Ave., Cleveland, O. 44108. ■

HAM RADIO'S DILEMMA

SOLVED AT LAST?

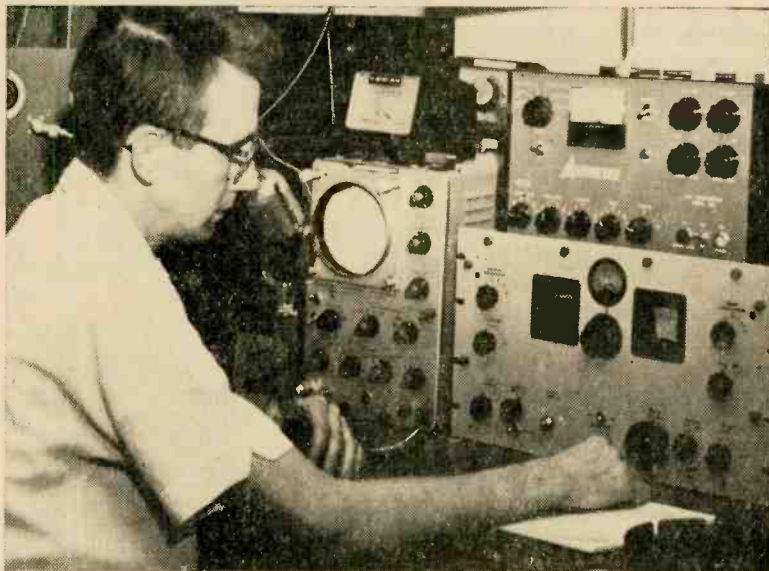

Ending a war which has been raging furiously on the ham scene now for nearly five years, the FCC has formally adopted its version of the controversial "incentive licensing" program—a plan whereby amateurs would be rewarded for their technical and operational competence through "exclusive frequencies" and other special privileges. Originally sparked by a 1963 remark in hamdom's *QST* magazine (which suggested that perhaps the amateurs would be better off if they had to demonstrate their abilities in order to obtain prime operating rights), the concept has been responsible for more internal friction than has ever before befallen the normally-docile world of amateur radio.

Shortly after the ARRL (*QST* is the official organ of the American Radio Relay League) "teaser," the association followed through with a formal petition to the FCC recommending how such an incentive program could best be implemented. And it is at this point that the war got going, with hams separating into well-armed camps: those who were in favor of the plan, and those unalterably opposed for one reason or another. Shaking the hobby at its very foundations, thousands upon thousands of members resigned from the group, renounced their subscriptions to *QST*, and fled in search of greener pastures. But we're getting away from our story.

When? Effective November 22 of '67, the first phase of the slightly-watered-down incentive licensing program took hold of the hobby—like it or not. In what would seem to be an attempt to make the whole business a bit more palatable, the Commission elected to enact the program on the installment plan, saving the worst for last. What's happened so far?

e/e HAM DILEMMA

Well, for one, the long-unused Amateur Advanced Class license has been resurrected and seems to be the crux of the entire U. S. amateur revamping scheme. A license which approximately 40,000 old timers still hold (but one which hasn't been issued in over 15 years), the new Advanced Class ticket will become available immediately to any ham who now holds a General or Conditional license.

Although ARRL originally called for a 16 word-per-minute code exam, the FCC has decided that 13 wpm will be fine for the new class of licensee. However, the theory examination will be tougher—somewhere between the present General written test and the difficult Extra Class exams which have been offered all along. Should a General ticket-holder present himself at an FCC examination point to take the Advanced, he'll get credit for the code part and can proceed directly into the multiple-choice computer-graded theory test.

So why all the fuss? Simply that if you don't go for the Advanced, you're going to be losing out on all sorts of choice operating privileges very soon, to say nothing of your deflated ego when the boys at the club find out you're still a lowly General.

It'll Be Tougher. Of course nothing comes easy these days, so if you're figuring on dashing right down to take the test, bear in mind that you'll be expected to prove that

Ham Bands As Of November 22, 1968

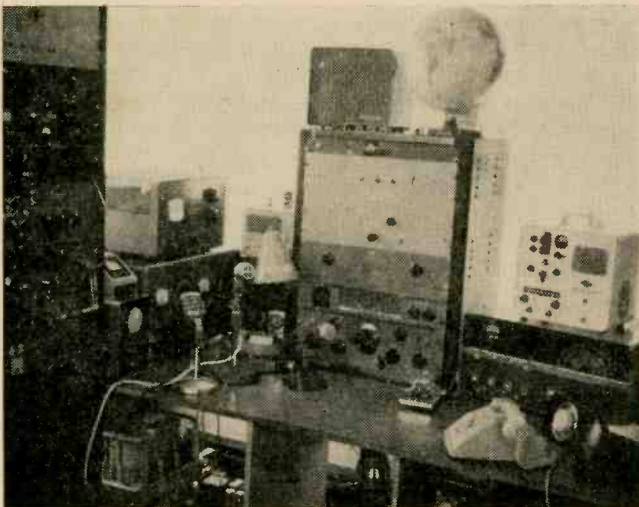
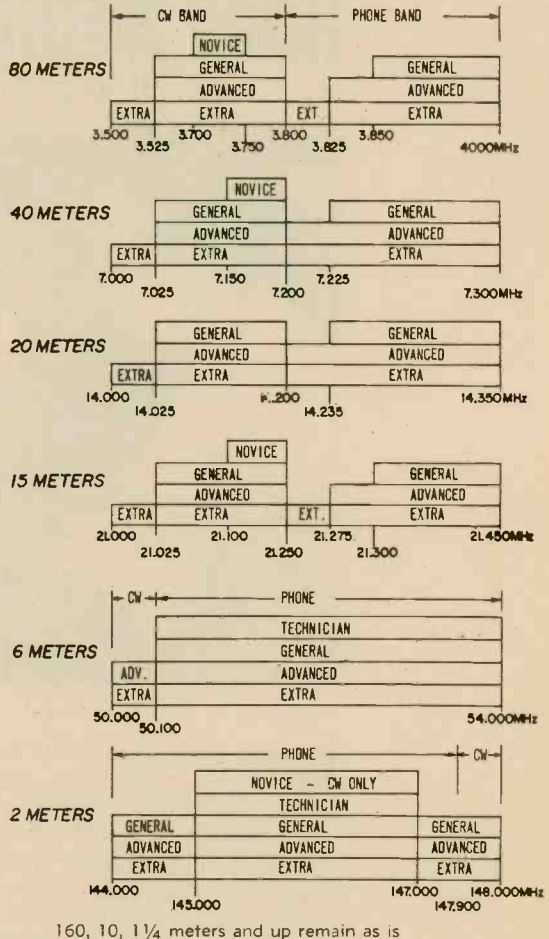

Frank Charlie Charlie's new rules and regs are going to put a crimp in the style of many General Class ticket holders unless they upgrade themselves to Advanced or Extra class. Full utilization of equipment, such as that in the complex operating station of K9EID, should spur considerable interest in obtaining the higher classes of licenses.

Ham Bands As Of November 22, 1969

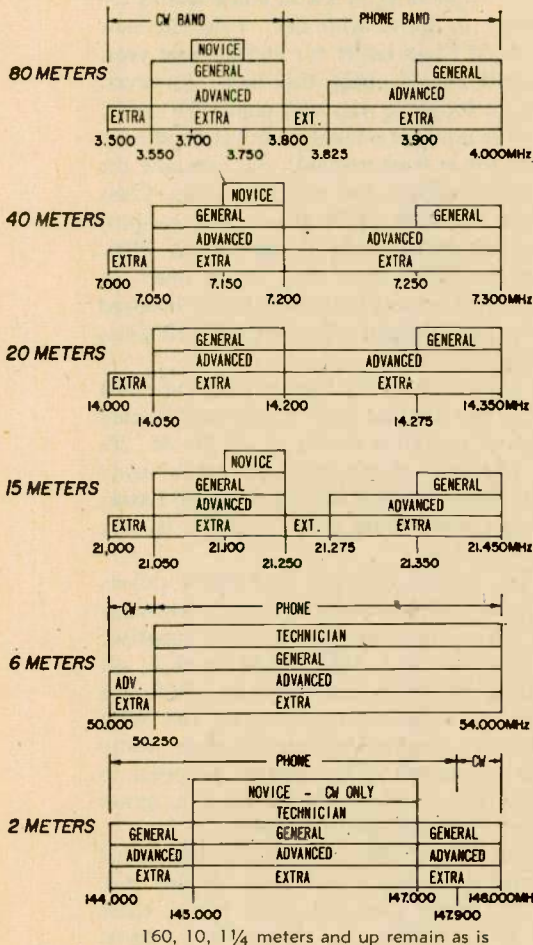

you've been a Conditional or General for at least 365 days prior—which is going to make it darned near impossible to jump from Novice to Advanced!

Speaking of Novices (ham radio's beginner group), some good news in the wind: Effective November 22, 1967 this mail-order class will be permitted two years of on-the-air operation before the time comes to separate the men from the boys. (Unlike the other ham licenses, this one can never be renewed.)

Although a significant part of the ballyhoo over incentive licensing pertained to a suggested "distinctive callsign" clause, the Commission has apparently dropped the whole idea like a hot potato and commented in their conveniently Federal manner, that "means of identification now in use are sat-

isfactory." This ought to gladden the hearts of many worried hams, since the proposal originally called for WIAAA-type calls for Generals, WCIAAA calls for Conditionals, WTIAAA calls for Technicians, etc. One can imagine the confusion of a European DXer tuning across 20 meter phone!

Of course, there will be some distinctive calls for those Extra Class'ers who for so long have been crying for a reward that would separate them from the masses of hams: All they have to do is have been a ham for over 25 years, throw the Commission a crisp \$20 bill, and they'll get a brand-new two-letter (W2AA-type) call. Unfortunately, however, they'll have to give up their present callsign altogether; worse yet, they get no choice of new call letters!

Other Happenings. Another November '67 happening of note was the much-debated grandfather clause, which took effect simultaneously with all we've covered so far. For those 40,000-odd Advanced Class oldsters who just wouldn't seem to fit into the scheme of things under incentive licensing, the FCC is offering instant equal status with the new Advanced hams. This means no new exams, no changing of callsigns.

Originally, the FCC had proposed in Docket #15928 to down-grade these fellows to the class of General, but such an uproar followed the announcement that a counter-proposal calling for modification of this section was enacted in the new regs.

Novices Lose 2-Meter Phone. Beginning on November 22, 1968, an important spectrum change takes place, shifting the emphasis from examinations and upgrading to actual on-the-air frequency crimping. On that date, all Novice Class licensees will either have to get off the 2-meter phone band once and for all, or face Federal penalties for violation of FCC regulations.

So that the equipment won't be a total loss, the Commission will still allow Novice code transmission in the 145-147 MHz band section, but phone will be out altogether. Of course, the Novice not entirely hung up on CW will still be eligible for the Technician Class license, but should he elect to go this route he'll be on the VHF's for the term of his license.

Elaborating a mite on this point, the FCC stated this last August that one of the "prime purposes" of the Novice license "is to prepare for the higher classes of licenses which require increased code proficiency." Putting it bluntly, "too many Novice Class licensees

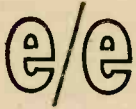

HAM DILEMMA

operate telephony equipment to the neglect of improvement of their telegraphy speed." So apparently, that's that.

Of particular interest, however, is what happens to Extra Class licensees next year. Seemingly the only ham group that stands to lose nothing under incentive licensing, this extremely rare block may increase in numbers with the inception (or reinstatement) of the somewhere-in-between Advanced Class'ers who will certainly wish to further advance themselves. Why? Simply because the Commission is opening a 25 kHz CW section at the low end of 80, 40, 20, and 15 meters exclusively for Extra's.

Further, this section stands to be expanded in 1969 for an even wider expressly-Extra Class code band. But, perhaps the most significant of all, come Nov. 22, 1968, is that a permanently-restricted Extra Class phone section will become available for the first time ever on the lower edges of the 75 meter and 15 meter phone bands, ending (at least temporarily) the congestion and chaos now running rampant on these popular bands.

TIME TABLE FOR HAM RADIO LICENSING

Nov. 22, 1967

- All new novices get 2-year term ticket. Retain 2-meter phone until next year.
- Advanced Class exams become available with 13 WPM code test or general code test endorsement. Requires 1-year status as General or Conditional.
- Extra Class license tests conducted only for present holders of Advanced tickets or those who first pass new Advanced license written exam.
- Present Advanced ticket holders awarded identical status with new advanced licensees.
- Two-letter calls available upon application (with \$20) for persons with Extra Class tickets and at least 25 years' Amateur standing. No choice of 2-letter call.
- Callbook will begin to identify class of license in future listings.

Nov. 22, 1968

- All novices lose 2-meter phone, but retain CW privileges.
- Extra exams now opened for advanced licensees who have held ticket for at least one year.
- First phase of incentive frequencies in full swing. See '68 Chart.

Nov. 22, 1969

- Final phase of incentive frequencies now in full implementation. See '69 Chart.

More Difficult Extra. Also at this time, the FCC will implement new rules restricting the availability of Extra Class exams exclusively to those who have held the new Advanced Class ticket for at least one year. If you'd like to beat this now, however, there's a loophole you can capitalize upon: If you've now got a General ticket (and have held it for at least a year), you can take the Advanced theory test and the Extra Class written and code exam at one sitting—provided you do it before November 22, 1968. After this date, there may be as much as four years standing between a newly-licensed Novice and his goal of attaining Extra Class status!

A glance at the first accompanying chart reveals that another new "happening" occurs in '68: a pretty big chunk of the 80, 40, 20, and 15-meter phone bands is taken away from Generals and offered only to Extras and Advanced Class men. And this is only the beginning.

VHF addicts holding Technician tickets and who pride themselves in their low-edge CW DX contacts are also in for a surprise: the 50.0 to 50.1 MHz code band is off limits to all Techs and Generals. With the exception of the loss of phone on 144 MHz to Novices, however, 2 meters remains pretty much untouched. The original proposal to include this band in the incentive program has been mysteriously scrapped.

Interestingly, the Commission has failed to implement any restrictions on the 160, 10, 1¼ meter and 220 MHz bands; these will be available as they always have. Some observers feel that the underlying reason behind this "as is" business is the fact that in many areas, these are the least-used ham frequencies, and the first up for grabs at the next Geneva Conference. Rather than risk loss of these ham bands, the Commission may have simply elected to leave them alone.

Tougher Tests Too. Incidentally, there may be at least one change in the wind for Novices as a result of this up-grading procedure just adopted. Under the incentive program it will be harder than ever before for an aspiring ham to become anything meaningful, since the theory tests he'll be expected to pass for even moderate phone privileges will be more difficult than before.

And under current regulations, if he has "at any time prior, held any class of Commercial or Amateur license," he's ineligible for Novice and must face the at-least 13-

Experimental VHF installations, such as this Technician-operated complex antenna array, will not be affected by the new regulations. The FCC has decided that experimental radio work above 144 MHz should not be restricted to special grades of license holders.

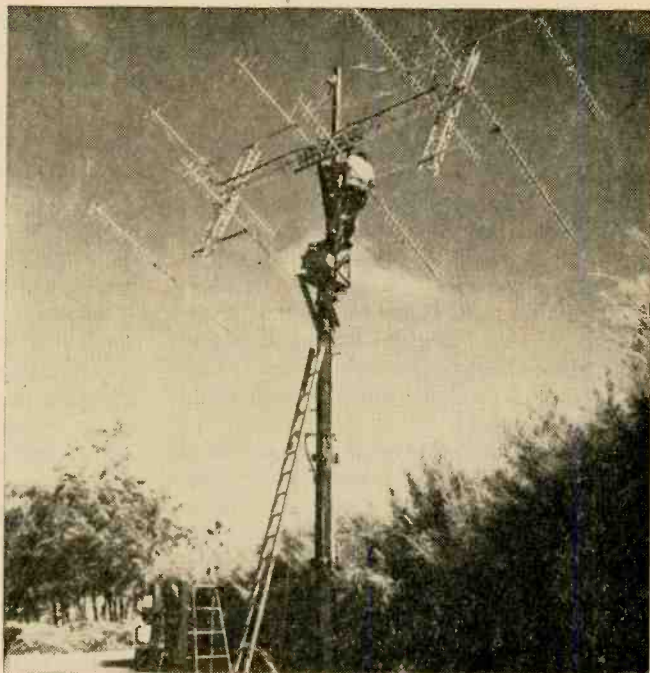

wpm code test immediately for low-band on-the-air rights. Obviously, what everyone's campaigning for is to have this restriction lifted—and it may well be before the end of 1968.

The people really hurt under the present regulations are those who are today retired and looking to return to ham radio as an interesting pastime, but face the fact that they're "convicts" in the eyes of Washington, having held ham tickets for a short while when they were teenagers.

In just two short years from now, November 22, 1969, ham radio will undergo the final full-swing implementation of the recently enacted incentive licensing program. In one fell swoop, Generals will be relegated to one-half (and less, in some cases) of their pre-incentive low-band phone bands. Simultaneously, Advanced and Extra Class licensees will enjoy a doubling of their shared exclusive bands, which will first come into being in '68. Those expressly-Extra 75- and 15-meter phone bands remain off limits to all comers.

Additionally, the low-edge Extra-only CW bands will double in size, moving both the Advanced and Generals closer to the phone band. As is evident on the second chart, Technician Class license holders will be permanently relegated to operation above 50.25 MHz, a very real blow to those

who follow the MUF (maximum usable frequency) up the spectrum during ionization periods when Sporadic-E and F2 skip normally provide exciting long-haul DX contacts to alert low-edge hangers-on equipped with good antennas and VFOs.

The Advantages. For all the internal strife and controversy, there is much to say for the incentive licensing program as finally enacted into law. For one, it puts the U. S. ham structure at last on a par with those in the vast majority of foreign countries, many of whom have their eyes trained on American low-frequency bands. Since the last Geneva Conference, many new countries—particularly on the African continent—have emerged and are currently clamoring for usable spectrum space. Some couldn't care less about ham radio; their first requirements are for governmental and military frequencies. And, it's been known for some time that the U. S. lagged far behind foreign powers in maximum utilization of available ham radio operators and ham bands.

Another plus for the program comes in what it promises to offer the nation as a whole. Ham radio has lost prestige in recent years, partly due to advances made in the solid-state microelectronics areas (computers, IC's, FET's, etc.) and partly due to the wide general acceptance of CB communications.

(Turn page)

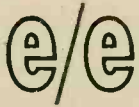

HAM DILEMMA

Whereas in the past, radio amateurs were largely responsible for new developments in electronics, today these seem to come from R&D labs, from college campuses, and from laboratories working under Federal contracts and subsidies. With very few exceptions, hams have come to be known as a group of "nuts," bent on talking incessantly into store-bought rigs, messing up TV reception, and generally doing everyone more harm than good.

Where in the past, hams were constantly in the news, for heroic deeds in emergencies such as flood disasters, today the CBers—who outnumber hams 5 to 1—capture most of the publicity. So bad has this problem become, that the ARRL has hired a Public Relations firm headquartered on Madison Avenue to do something about ham radio's failing image.

Public Image. It is felt by many that the incentive program will do a lot to uplift the radio amateur in the eyes of the public, to say nothing of his value to the mushrooming electronics industry.

Thirdly, the program will probably tend to alleviate the almost insurmountable congestion (or QRM) presently plaguing the HF ham bands, resulting in much more pleasurable on-the-air operation for those amateurs who advance themselves accordingly. For the first time in recent memory, it may be possible to easily QSO Asia any time on 20 meters, without chaotic pileups on the DX station's frequency.

Lastly, incentive licensing may do a lot more than most people realize in spreading good relations abroad. "The ugly American" has been a cold fact in ham radio ever since the post-war amateur boom in the early 1950's. The sad truth is that U. S. hams have all but dominated the usable amateur spectrum with high-powered transmitters (which exceed the power limitations afforded most overseas hams), obnoxious operating techniques, and sheer numbers—due in part to our affluent society. The incentive-regulation crimping should actively attack this problem head-on on all fronts, leaving the Burmese operator, for example, with a much more pleasant outlook, at least as far as ham radio is concerned.

The Disadvantages. While the main portions of the original proposal which tended to alienate many amateurs from the ARRL have been deleted from the final FCC rule-adoption, there still remains a significant number of people who will stake their lives on the "fact" that ham radio is truly doomed. And many of these arguments appear to have merit.

As any honest observer will admit, ham radio has suffered in many ways ever since the 27 MHz CB band was opened in the late fifties. Not only has prestige gone
(Continued on page 133)

Youngsters, like these two sub-teen Alaskan Novices, are going to lose all phone privileges, though their license term has been extended to two years. However, to reach Extra class may take as much as four years, raising the question whether the average Novice will wait that long for full operating privileges.





■ When the big power blackout hit the Northeast not too long ago, an almost instantaneous black market in candles developed. The reason was not that people didn't have emergency flashlights (they did); trouble was, the batteries had long since expired on the shelf.

Now, Globe-Union Inc. offers almost absolute protection against battery failure in the home, office, shop, or in your car on a dark night. Their answer is an *Instant Power* battery, a battery with no "life" until it's activated. In a sense, an *Instant Power* battery is similar to a dry charge auto battery—the battery is "dead" until activated by pouring in an electrolyte.

Unlike an auto battery, however—which uses an acid electrolyte—an *Instant Power*

Below, any liquid containing water can be used to activate the Instant Battery—in this case it's root beer. Output from Instant Power (right) is slightly less than from fresh lantern battery but is more than adequate.

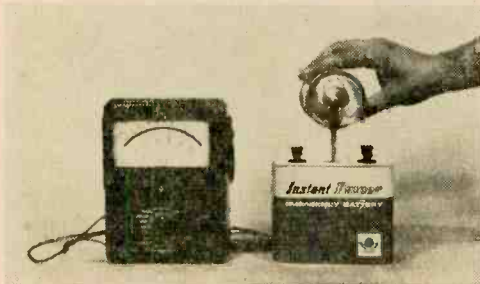

GLOBE UNION INSTANT POWER

Liquid Activated Emergency Battery

battery uses any *water based* liquid for electrolyte; as examples, soda, orange juice, tea, coffee, etc. At least that's the claim of the manufacturer in his advertisements.

Since the *Instant Power* battery appears to be the answer to two important battery uses—the "car flashlight" and the home's emergency light—we decided to see if the *Instant Power* battery lived up to its claims.

One Available. As it turned out, there is presently only one *Instant Power* battery: the model IP-3, a standard lantern size battery; available individually for \$5.59 or in a \$10.95 kit that includes a two-way lantern with a red flasher, a standard lantern battery, and an *Instant Power* battery.

Since the battery is intended for emergency use, we ran our three batteries through simulated emergency conditions. The first battery was filled with an 8 ounce can of cold soda. Almost as soon as we started to pour the soda through the access hole in the top of the battery, a voltmeter connected



e/e INSTANT POWER

across the terminals indicated the battery had sprung to life.

The second battery was activated with muddy water scooped from a puddle in the road. Again the battery instantly sprang to life.

Finally, we ran the acid test. Assuming the user's car was stuck on a deserted road, he had no soda or juice in the car, there were no dirty pools of water, and there was not enough moonlight to drain some water from the radiator, we used the only water-based product available—what is medically termed a "specimen." Again, the battery instantly came to life.

Power Output. Measurements indicated that the *Instant Power* battery produces nominally 5 volts under no load, the voltage under lantern-light load ranging from 4 to 4.5 volts. Measurements with a light meter at the center of the attached lantern indicated that the light output with the *Instant Power* battery was approximately 2 stops less than that of a fresh 6-volt lantern battery. But after about an hour's use, both batteries provided roughly the same amount of power output due to the lantern battery's sharp discharge curve.

The battery is rated by the manufacturer for a shelf life (unactivated) of up to five years. After activation, the battery will produce 2 hours of usable light output during a 72-hour total life period. (This assumes a lantern bulb drain of 500 mA.) The battery

CUTAWAY VIEW

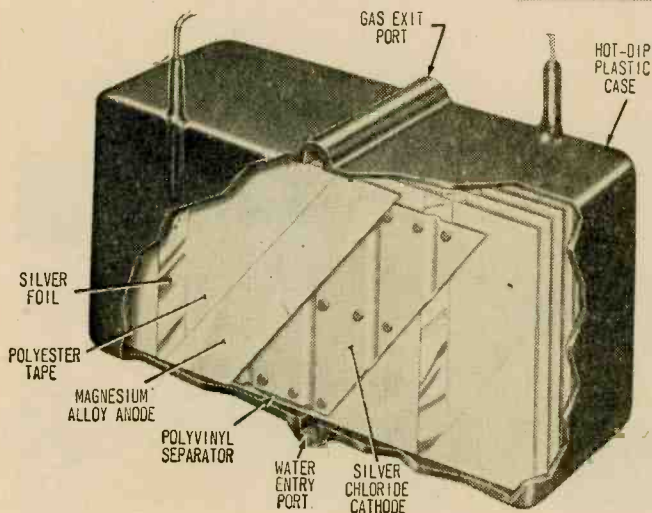

has a total capacity of 1 amp/hour. If you draw less current than a standard lantern bulb, the life will be essentially proportionately longer.

It is important to remember that the total usable time is 72 hours. The available capacity can be used in any manner as long as it is within 72 hours. If the total capacity isn't used during this period, it is gone for good and ever.

The battery has a relatively flat discharge curve, producing its nominal voltage under load almost until the cell is exhausted, at which time the terminal voltage falls rapidly.

Summing Up. Until shown otherwise, we unhesitatingly recommend the *Instant Power* battery for all emergency kits, whether it be for the average driver and homeowner, police, volunteer rescue, or Citizen Band REACT team.

The *Instant Power* battery or the full kit is available only from the manufacturer, the Globe Battery Div., Globe-Union Inc., P.O. Box 591, Milwaukee, Wis. 53201. Prices given earlier in this article include all postage and handling charges. ■



Complete *Instant Power* Light Pack (above) contains a standard lantern battery, 2-way lantern with red blinker, and an *Instant Power* battery for emergencies. Construction of *Instant Power* battery is shown at left.

The troubles that plague a color TV could fill a volume of "Who's Hue." There's *runny* color, where tints sprint across the screen. There's *wrong* color that makes a bowl of tomato soup resemble crankcase sludge. But one of the most outstanding symptoms is *no* color. And it's about as exciting to look at as our peacock without a tail.

Missing color first seems like total disaster. Could the costly picture tube (about \$100-plus) have expired? Fortunately, whenever color *only*—not the black-and-white image—disappears, it probably means an inexpensive repair. Total color loss can be traced to a few stages in the receiver.

Pre-operative Procedure. Before taking off the back of the set, carefully check symptoms. In the case of the missing color, it's assumed the set is receiving normal black-and-white pictures (even on color programs as in Fig. 1). This proves that a vast section of the receiver, including the precious picture tube, is above suspicion. First, be certain the set is tuned to a station known to be transmitting color. Since the color signal tends to pop in at a narrow setting of the fine tuning control, run the knob over its complete range. No hue? Check if the chroma or color control on the front panel is turned up. Jiggle the knob a few times just in case a control is intermittent. If proper color flashes on the screen, you've located the trouble. If not, here's how to check further.

Up Tight Color Killer. There's a good chance the color killer is set too "tight." This adjustment, found on the rear chassis apron or behind a front panel knob, disables color circuits during black-and-white programs (Fig. 2). Though correctly set at one time, the passage of time might shift circuit components enough so the killer is squelching color, too. Turn the control full range to see if you can restore color. Then try it on an unused channel. At some point in the color killer adjustment, snow on the screen should turn to colored confetti. (The proper setting of this control is usually at the point where color in the snow just disappears.)

If you're convinced that loss of color is not due to any of these superficial reasons, consider the antenna system. Although it's not common for an antenna to kill color completely, you might be victim of the ex-

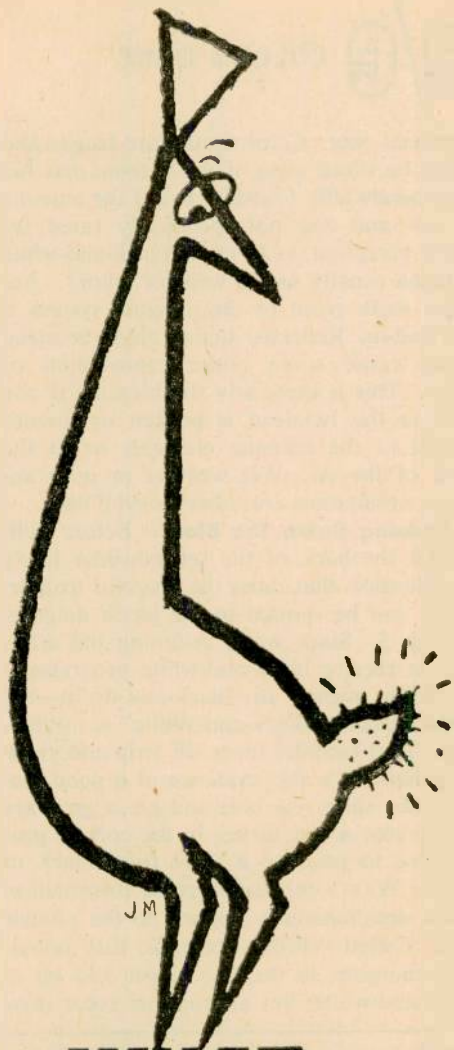

WHAT TO DO WHEN COLOR'S GONE

BY
LEN BUCKWALTER, K10DH

e/e COLOR'S GONE

ceptional case. Color signals are fragile and could be sliced away if the antenna has too little bandwidth. Consider this if the antenna is new and one not specifically rated for color reception. (A good black-and-white antenna usually works well for color). Another weak point in the antenna system is the lead-in. Reflected signals along twinlead could cause some phase cancellation of color. This is especially troublesome if one wire in the twinlead is broken or disconnected at the antenna elements or at the back of the set. Wet weather or poor antenna orientation are other possibilities.

Running Down The Block. Before pulling off the back of the set, consider likely trouble spots that cause the no-color trouble. These can be spotted in the block diagram of Fig. 3. Since we're assuming the set is able to receive black-and-white programs—or color shows in black-and-white—the block marked "Black-and-White" is trouble-free. That includes tuner, IF strip and video amplifiers. It's also evidence of a good picture tube since red, blue and green guns are firing color at the screen in the correct proportions to produce a scale from black to white. What's missing is color information that's simultaneously applied to the picture tube. Called "chroma" signals, they unbalance the guns so they no longer add up to black-and-white, but appropriate color mix-

tures. Consider the other blocks in Fig. 3:

Color Amplifier. This is the first point where the incoming color signal is split from black-and-white. Thus it comes under suspicion in the no-color symptom. A dead tube here, for example, prevents the complete color signal from penetrating further into the chroma circuitry of the receiver. It may easily explain why you can receive perfect black-and-white and absolutely no color.

You're apt to encounter different designations for stages in this region of the receiver. We've shown it as Color Amplifier, but some call it Chroma IF or Chroma Bandpass. You'll note in Fig. 3 there is another block marked "Bandpass Amp." Whatever the name, the purpose of this stage (which may occupy two tubes) is to separate color from the black-and-white signal. It does it by suitable coils and capacitors which tune only a portion of the incoming frequencies. The black-and-white signal at this time is ranging from about 0 to 3 MHz. (Large details of the BW picture occupy the low frequency section; small details occur at the higher frequencies.) The color signal is borne in the vicinity of 3.58 MHz. So the Color or Bandpass Amplifier is designed to be selective in the color-signal region and thus prevent black-and-white from disturbing the following chroma stages.

Demodulators. The demodulator section of the block diagram in Fig. 3 appears in a dotted line because only in rare instances does it remove all color from the picture. But it's included since it's helpful

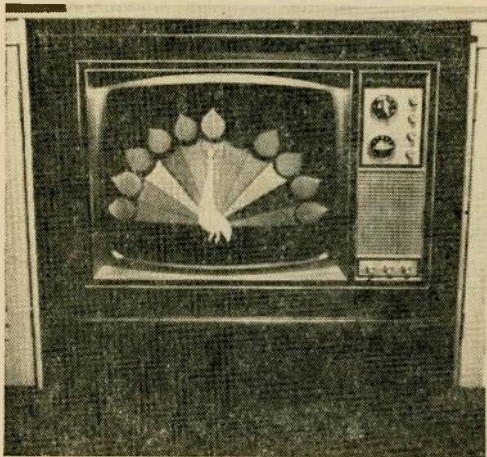

Fig. 1. TV showing perfect black-and-white picture during color program provides important clue to nature of problem and shows that majority of set's circuits are functioning correctly.



Fig. 2. Lack of color can be caused by incorrect setting of color killer control. On set above, this control is accessible after removing color knob though most sets have control on rear apron.

to know its function as a guide to other important stages that do affect overall color reception.

The demodulators take raw color signals transmitted in the 3.58 MHz region and convert them to a form which is usable by the picture tube. And since demodulators consist of several stages working with more than one color, any trouble in this section rarely leads to total color loss on the screen. A defect here generally knocks out just one hue. So the demodulator circuits are probably the last points to check.

It would be a remarkable coincidence if all circuitry failed at once. (One exception, though, is a defect in the power supply leg which powers the demodulators and the red, blue and green amplifiers which they operate.)

3.58 MHz Oscillator. The 3.58 MHz crystal-controlled oscillator aids the demodulator in converting transmitted color to the form required by the picture tube. Complete failure of this stage to oscillate can disable the demodulators and thus cause the no-color condition. In some sets, the picture goes completely green when this stage is inoperative, so watch for this useful clue.

The 3.58 MHz oscillator must generate a carrier which is exactly in step with the carrier at the transmitter. To lock receiver and transmitter in perfect synchronization, the TV station broadcasts a string of short 3.58 MHz bursts. (The burst system conserves spectrum space, and keeps the color signal narrow.)

In most cases, failure of the burst amplifier causes loss of color sync on the screen; colors are incorrect or they ripple across the screen. But it may also cause complete absence of color.

Color Killer. This stage, as mentioned earlier, prevents color from intruding into a BW program. Since it controls the band-pass amplifier(s), a defect in the killer might block the total color signal as well. The color killer is turned on and off at appropriate times by the burst amplifier.

Thus, the block diagram reveals that missing color can spring from a number of stages in the "chroma" section of the receiver. Certain circuits, like color or bandpass amplifiers, are prime suspects since they stand directly in the path of the total color signal. In remaining circuits—burst, killer, demodulator—there might be color loss, but often there will be a lack of color sync, too.

Troublesome Bottles. Tubes are usually the major cause of trouble so check them first. Since the no-color problem is almost always in receiver circuitry that handles only color, you won't have to look very far. It is common practice for the manufacturer to localize all chroma stages in one area. In many cases it is a separate printed circuit board, as in Fig. 4. And usually the function of one or more chroma stages is contained within a multi-purpose tube. There might be eight or nine separate stages in the schematic of the chroma section, but often they add up to approximately five tubes. Some typical combinations in a single tube

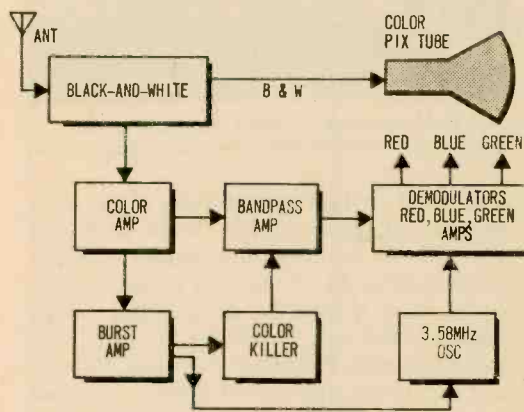

Fig. 3. When color's gone, these are the circuits to check first. Since defective tubes cause the majority of TV troubles, checking the tubes in these stages will often solve the problem.

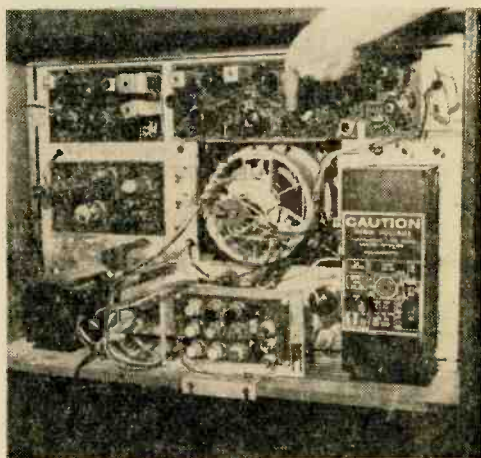

Fig. 4. Most color circuits are located on the "chroma" board. In typical set above, finger points to chroma board that occupies most of top half of chassis.

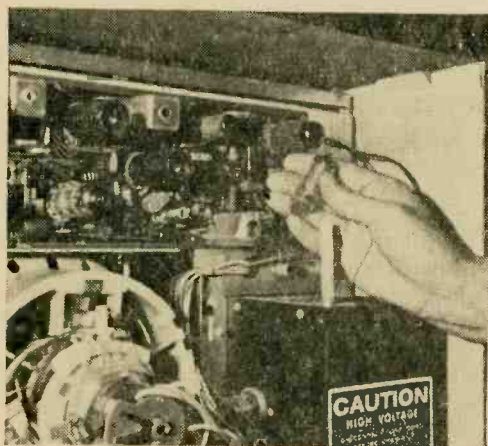

Fig. 5. The best way to check for defective tubes on chroma board is to substitute with new ones.

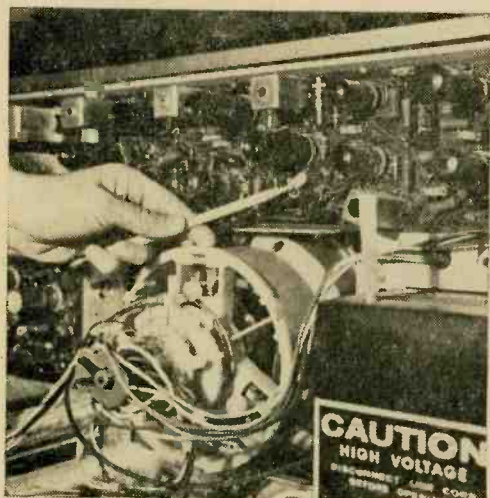

Fig. 6. If tubes don't seem to be causing the problem, try checking the 3.58 MHz crystal.

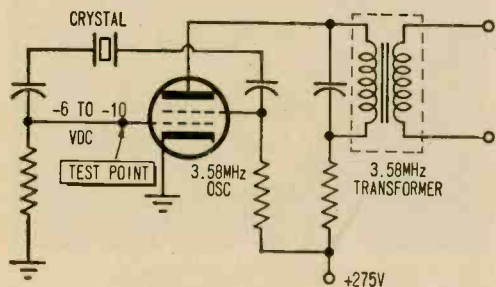

Fig. 7. Circuit of typical 3.58 MHz oscillator. A voltage check with a VTVM will determine if it's OK.

envelope: bandpass amplifier and color killer; 3.58 MHz oscillator and its reactance control; phase detector and color demodulator.

The recommended system for tube checking is substitution (Fig. 5). Plug a known good tube into the socket of a suspicious stage. It's a good idea to try only one new tube at a time and note if color returns. Substituting all new tubes in the chroma section simultaneously is wasteful since you won't isolate a bad one.

Crystal Oscillator. If tubes don't restore color, you'll need a VTVM to do some further checking. And a good place to start is at the 3.58 MHz oscillator (Fig. 6). Set makers often provide a test point for measuring grid voltage developed by the oscillator during normal operation. Voltage in a typical oscillator (see Fig. 7) is about -6 to -10 VDC.

If a check at this point produces no reading in this range, the oscillator transformer

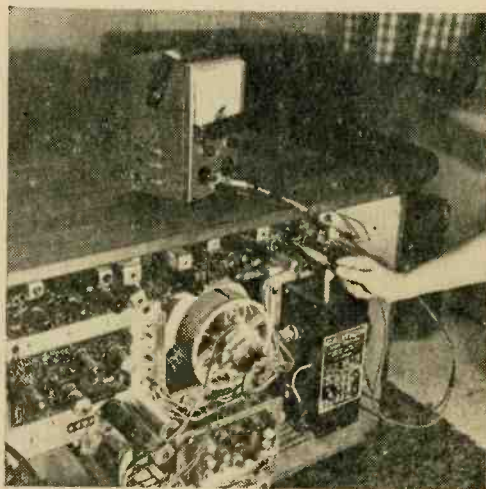

Fig. 8. Manufacturer's service literature is very helpful when locating test points for voltage checks.

may need to be adjusted with a tool that matches its alignment slug. While observing the VTVM, try to obtain highest negative reading (Fig. 8). Failure to obtain a peak could mean a defective crystal. But before replacing the unit, be certain no other part associated with that stage is at fault. Voltage and resistance tests should agree with those supplied by the service literature for your particular set.

Bandpass Amplifier. This stage is another major cause of missing color. As you can see in Fig. 9, it is little more than an

e/e COLOR'S GONE

which injects standard color signals into the circuit. If a stage is functioning properly, the signals emerge with correct shape and level. Viewing the signals is done on an oscilloscope rated at a bandwidth of MHz. The probe used with the scope must be a low-capacity type to prevent any warping of the color signal as it passes through the chassis.

Service literature prepared for your specific model is a virtual necessity in signal tracing. And most manufacturers go to great lengths to provide guideposts you'll need in troubleshooting. A good example is in Fig. 11 which shows the various signals in the chroma circuits of a Heath chassis. Here are some details on using such information.

Scope Points. The shaded arrows on the schematic (see Fig. 11) refer to points where the oscilloscope is connected. If we locate the one near the bottom right, we see it's at the plate of the 6EW6 burst amp. Then, if we study the two waveforms below, it's seen the scope should display 15750 cps at 180 volts peak-to-peak when the stage is functioning normally.

Literature To Service By. Service literature also provides other important information you'll need. On many Philco chassis, for example, the manufacturer states that to observe these waveforms, the generator is applied to the antenna terminals and adjustments made to the set's controls until .5 volt appears at a given point.

TEN TINY MEGAHERTZ

Putting a complete crystal oscillator in a transistor can isn't hard considering the state of integrated circuits. But getting a trimmer capacitor with which to fine-tune the oscillator into the can is pretty tricky since even small trimmers are bigger than the TO-5 cans. General Electric engineers solved the problem. Using a thick-film hybrid process, the oscillator is constructed so that its frequency is a little higher than required. The finished unit is then tuned to the desired frequency by vacuum depositing silver onto the crystal's electrodes, thereby lowering the resonant point. The gentleman at right which holds the complete oscillator (right hand) contain all the discrete components on the perf-board he's also holding.

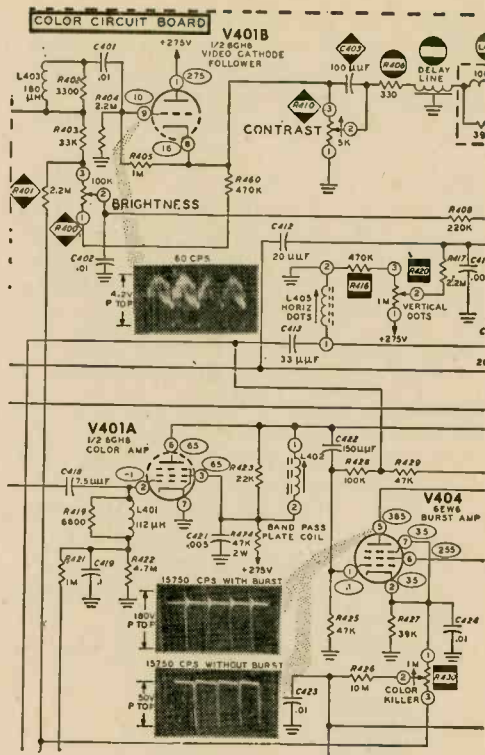

Fig. 11. Tough-dog problems can be tracked down using service literature, VTVM, and scope.

This establishes the same standards used by the manufacturer in obtaining normal waveforms. Once you learn how to handle this kind of information—and gain a bit of experience with a set in good operating condition—much of color's complexity fades out, and hue fades in.



TRAVELIN' HAPPENING

By Herb Friedman, W2ZLF



American Airlines

In-case add-on amp lets you and your guitar swing in on the action most any old time and place

Hey man, next time the gang has a blast at the beach or a picnic at the wood-side, there's no need to let the folk singers and their hollow boxes steal the limelight just because your guitar needs an amplifier and there's no power plug out in the boonies.

For just a few bucks and an evening's work you can build a battery powered amplifier right into your guitar's case. It takes up next to no room, doesn't interfere with proper seating of the guitar in the case, and doesn't take up any of the compartmented storage space.

As shown in the photographs, the whole installation can be tucked up in the corner of the case—a generally unused part. Of course, you must have a square case; a form fitted case can accommodate just a few picks and a sandwich, certainly not an amplifier.

Megawatt It's Not. Our Travelin' Happening is not going to crush anyone's ears under a wall of sound. Fact is, it's just about as loud as a good portable phonograph, and any more power would require a battery too heavy to be really portable.

Installation in your guitar's case is a snap because only four components are used, not including the battery. There's a speaker assembly, input jack, volume control, and a completely assembled transistorized amplifier rated at 3 watts. Add the battery and your electric guitar can be used anyplace, anytime.

The complete wiring is shown in the schematic. Resistor R1 is optional, though its use is recommended. Some guitar pickups require a 22,000-ohm termination for proper sound quality. However, if you find the amplifier appears to lack gain, R1 can be reduced to 10,000 ohms.

Low Power Pickup. Some low-output guitar pickups may require the total elimination of R1 for maximum power output. We suggest you first assemble the amplifier with R1; then make modifications if required.

The speaker cannot be a cheap replacement type. Music reproduction requires a speaker capable of handling peak power cleanly. Therefore, if possible, use a so-

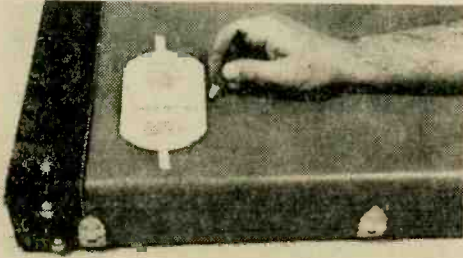

1 Taping the speaker grille template to the outside of guitar case is the first step. Then draw outline on case with grease pencil or china marker.

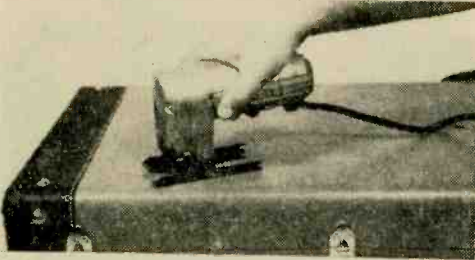

2 Drill a starting hole in case inside outline. Using a saber saw, or a keyhole saw, cut out the speaker hole and sand off any ragged edges.

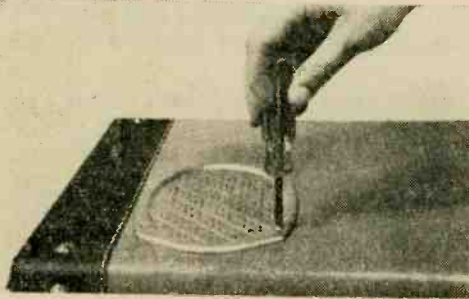

3 Using the speaker grille as a template, drill the speaker mounting holes. Now mount the speaker and grille with the supplied screws and nuts.

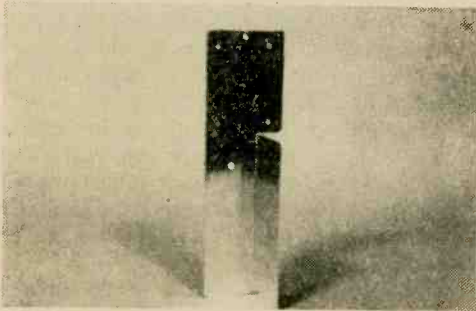

4 Make a mounting plate as shown from scrap aluminum. The bent piece is used to hold the battery against the case as shown in photo nine.

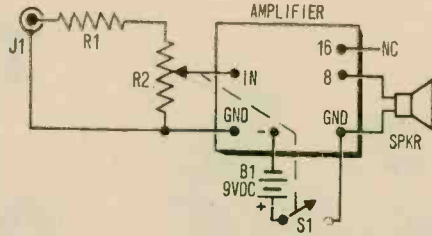

Wiring up Travelin' Happening is a snap. Be sure to hook up the two ground connections as shown; tying them together will cause oscillation.

PARTS LIST

Amp.—3-watt audio amplifier module (Lafayette 99H9132 or equiv.)
 B1—9-volt battery (Burgess C6X or equiv.)
 R1—22,000-ohm, 1/2-watt resistor (see text)
 R2—10,000-ohm audio-taper potentiometer with switch
 S1—S.p.s.t. switch, (part of R2)
 SPKR—8-16-ohm 6x9 in. oval transistor auto speaker (Lafayette 32H2204 or equiv.)
 Grille—See text
 Misc.—Wire, solder, screws, etc.

called music speaker; the music rating will generally insure higher efficiency and lower distortion than a "standard" speaker of equivalent size.

If you're pressed for space, the 6 x 9-in. universal transistor replacement speaker specified in the parts list will prove adequate.

The amplifier output impedances are 8 and 16 ohms; don't use a 3.2- or 4-ohm speaker. The transistor replacement type shown in the photographs provides—through two 20-ohm voice coil windings—impedances of 10, 20 or 40 ohms. Use the 10-ohm connections as shown in the accompanying speaker instructions and connect the unit to the amp's 8-ohm terminals.

Doin' It. The speaker grille is the type used for automobile rear-speakers. They are available in chrome or Hammertone Grey; use whichever style complements the guitar case's color. The speaker cutout template is part of the grille's plastic bag. Cut along the outline with scissors, tape the outline to the outside of the guitar case, and then trace the outline with a grease pencil or China Marker. You might mark the speaker-grille mounting holes at the same time.

Drill a 1/2-in. hole inside the outline and then use a saber or keyhole saw to cut out the speaker opening. Install the grille and speaker before proceeding with the instal-

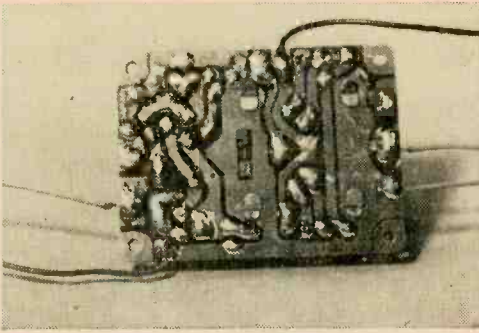

5 The amplifier is a ready made unit and just has to be wired to the battery, volume control and input jack as shown in the schematic.

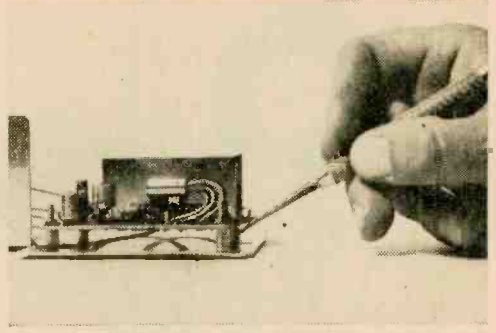

6 The amplifier circuit board is mounted on the aluminum plate with stand-offs as shown to keep the printed wiring from shorting out.

lation. Since space is at a premium, you'll need the speaker in position in order to position the amplifier and associated components. Take care you don't puncture the speaker when installing the amplifier.

Amp Mount. The amplifier is mounted on a formed aluminum plate (from scrap aluminum or a chassis bottom plate) along with the input jack J1, and volume control R2. While each guitar case will probably require a customized installation, the photographs show the general idea.

Cut the aluminum plate so that a portion the exact length and height of the battery can be bent at right angles to the plate. When the plate is mounted, the upright plate section will press the battery against the side of the case as shown. When the case's cover is closed, the battery will be sandwiched between the case and the plate, assuring a rigid battery mounting.

The amplifier must be mounted to the aluminum plate on stand offs to avoid shorting the printed circuit terminals to the grounded plate. Because the amplifier connections are made directly to the printed wiring on the bottom of the board, the connecting leads must be soldered-in before the amplifier is mounted to the plate.

Ground Where Shown. The input ground lead must be soldered to the PC board exactly where shown in the supplied amplifier instructions. The positive battery connection—through power switch S1—should be soldered to the same point as the ground (common) speaker lead. Under no circumstances should the positive battery lead be soldered to the same point as the input ground lead.

J1 and R2 are mounted on the aluminum plate in any convenient location, though they
(Continued on page 128)

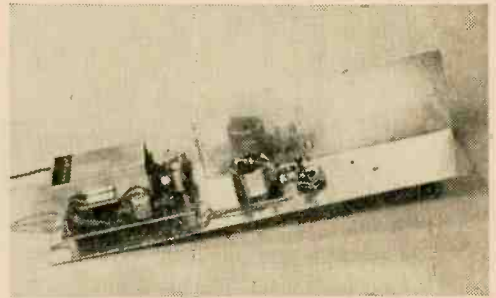

7 The volume control and input jack are now installed on the mounting plate as shown and are then wired to the amplifier (see text).

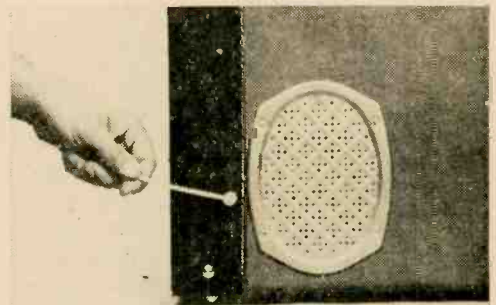

8 Two half-inch holes must be layed-out and drilled in the guitar case to allow access to the input jack and the volume control.



9 Finish up by securely mounting the amplifier assembly in the guitar case and install the battery. Now you're ready to sound off any time, any place.

Oh, to DX Vegas



By C. M. Stanbury II

■ At 6:00 p.m. EST. November 30, 1967, I was all set. It was a cold clear night with no static and in an hour WWV would move its transmission site from Colorado to downtown Las Vegas. This would be a momentous event in DX history, complete with special QSL card, and I wasn't going to miss it. Even had a scratch pad right next to my WR-600 so I could scribble down that all-important first announcement.

Lou Ann checked her makeup in the mirror of her compact. "How long did you say we were going to wait *around* here?" She toyed with a shiny black pendant which dangled around her neck.

"We can leave about 7:15. You see 7:00 p.m. EST is midnight GMT, that's when the changeover happens." I located WWV at 2500 kHz. which is actually medium-wave territory and, therefore, the best catch of any of its six frequencies.

"I'm *thrilled!*" She went over and sat

down on a couch across the room. WWV announced the time, then began a period of 600 Hz tone. "Are we going to listen to *that* for the next hour?"

I considered it. "We could put my receiver on standby and get some music on your transistor."

"We better or I'm *going* home!" She opened her purse and brought forth the transistor. "*Well?*"

I checked my WR-600 one more time then threw the standby switch. Lou Ann fished around on her dial until she found a folk-rock record by the Lovin' Spoonfuls, moved her head in time with the beat, her lovely brunette hair swaying back and forth, keeping cadence.

When the record was over, "6:15 on your clock, 1590 on your dial, WWVZ Center-ville."

When I switched on WWV again, it was

(Continued on page 132)

transducers

By John D. Lenk

our electronic sixth sense

A transducer is any device that changes one form of energy into another. In electronics, the most common use for a transducer is to change some physical quantity into an electrical current, or vice versa.

You are probably already familiar with a number of transducers. The microphone, loudspeaker, and phonograph pickup are all transducers of sorts. The microphone changes sound waves into an electrical current.

The loudspeaker does the opposite, since it converts electrical current into sound waves. The phonograph pickup converts mechanical movement of the stylus over the grooves on a record into electrical current. You could even consider a light bulb as a form of transducer since it converts electrical energy into visible lightwaves.

These same basic principles are used in many phases of electronics to measure or detect pressure, temperature, liquid level, motion, vibration, acceleration, impact, radiation, mechanical position, gas density, flow, altitude, strain, and frequency, to name a few.

Remote Measurement. Transducers are often used in conjunction with telemetry systems. We are all familiar with the moon probes and other outer space explorations where telemetry systems are used to measure radiation, temperature, pressure, etc., and then send this information back to earth. Although the telemetry systems are fairly complicated, their basic operating principles are simple. The purpose of this article is to show you how the transducer makes measurements, and then converts the measurement into an electrical signal that can be transmitted to a remote location.

(Continued overleaf)

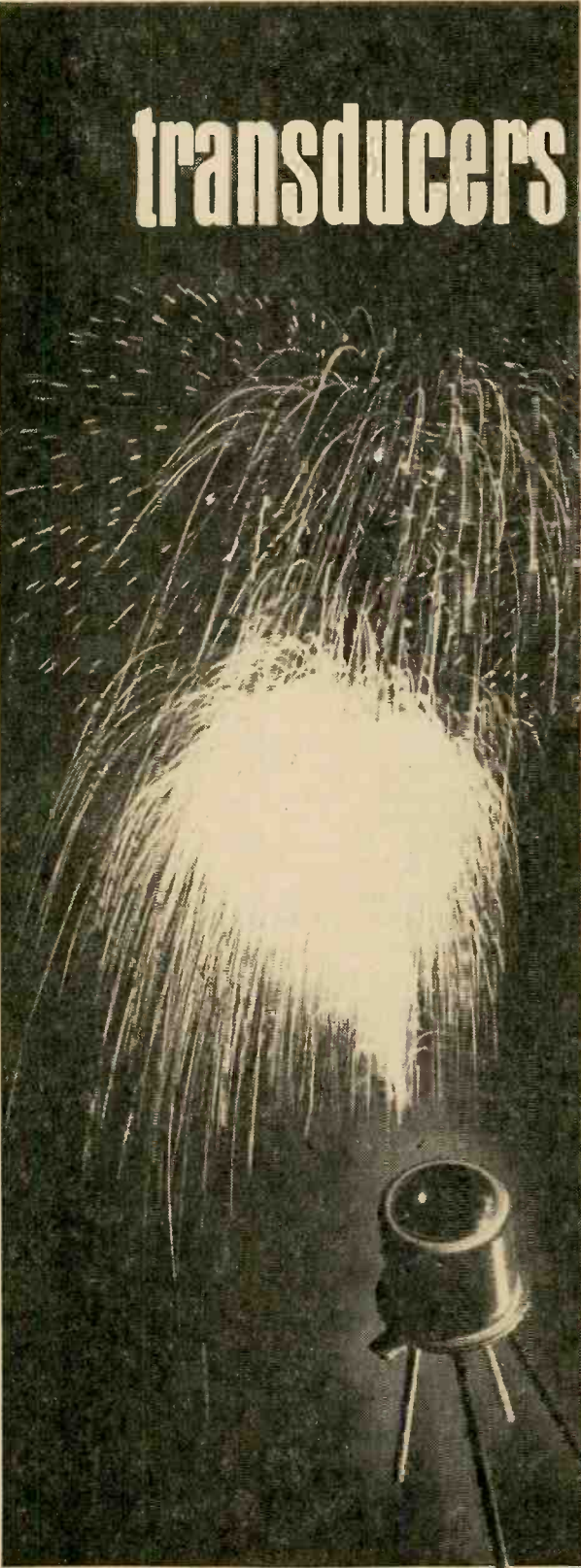

e/e TRANSDUCERS

We will not be too concerned with how the information is transmitted in telemetry systems, since that is the subject of another article. Instead, we'll concentrate on how the transducers do their job.

Although there are many transducer types, they can be divided into three broad classes: resistance-changing, self-generating, and inductance or capacitance changing. Let's start with the resistance changing types since they are the most common transducers in use today.

Resistance Changing Transducers. Resistance-changing transducers operate on the voltage-divider or bridge principles. A typical transducer using the voltage-divider principle is shown in Fig. 1. Here, a full 5 volts

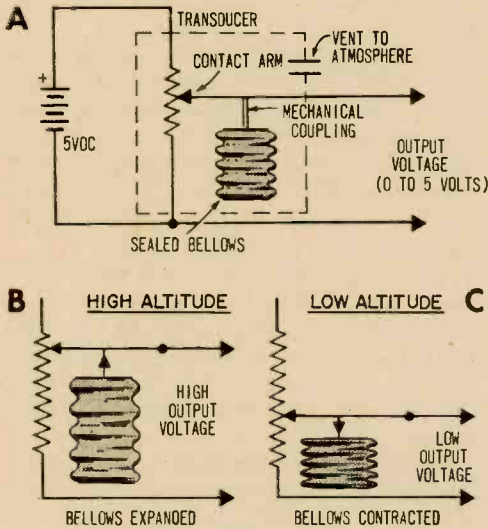

Fig. 1. Sealed bellows attached to wiper arm of variable resistor in circuit A produces output proportional to atmospheric pressure. Air pressure changes cause bellows to contract or expand in B and C.

is placed across the resistance element. (Five volts is chosen since it is common practice in aerospace telemetry to standardize transducers of all types so they will operate in a range from 0 to 5 volts.)

The contact arm (or wiper) of the resistance element is moved by mechanical force. In this case, the force is produced by a bellows which has been sealed at a given air pressure. If the air pressure around the bellows is changed, the bellows will expand or contract, and move the contact arm across

the resistor changing the output voltage.

Altimeter. Such an arrangement could be used to measure (and transmit) the altitude of a missile or aircraft. Let's see how this is done. We know that air pressure changes with altitude; the higher the altitude, the lower the pressure. Since we have sealed the transducer bellows and the internal air pressure will remain steady, the bellows must expand when altitude is increased (outside air pressure decreases). Likewise, when the altitude decreases, the outside air pressure increases, causing the bellows to contract.

If we arrange the bellows and contact arm as shown in Fig. 1, the output voltage will increase when the bellows expand (altitude increases) and will decrease when the bellows contract (altitude decreases). Therefore, the voltage output will follow the altitude change.

Now assume that the system is to measure from sea level to 50,000 feet. We must then arrange the bellows and resistance element so that the contact will be at the full voltage position (5 volts output) when the bellows is expanded by the air pressure at 50,000 feet. The contact must also be at the zero voltage position when the bellows has been contracted to a given position by the air pressure at sea level.

Scale Factor. With this arrangement, a change of 10,000 feet in altitude changes the air pressure so that the bellows moves the contact arm to vary the output by one volt. The ratio of voltage output to altitude is known as *scale factor*. Many different scale factors are used in transducers. However, they are usually in terms of volts (or amps or ohms) per physical quantity, such as 25 millivolts per ounce of pressure, 25 ohms per degree of temperature, etc.

Electric Thermometer. Now let's see how the resistance-changing transducer can be used in a bridge circuit such as shown in Fig. 2. Here, a thermistor is used as one

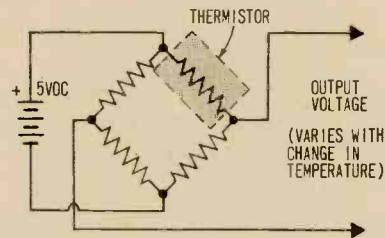

Fig. 2. Negative temperature coefficient thermistor in bridge circuit gives output voltage changes directly proportional to temperature changes.

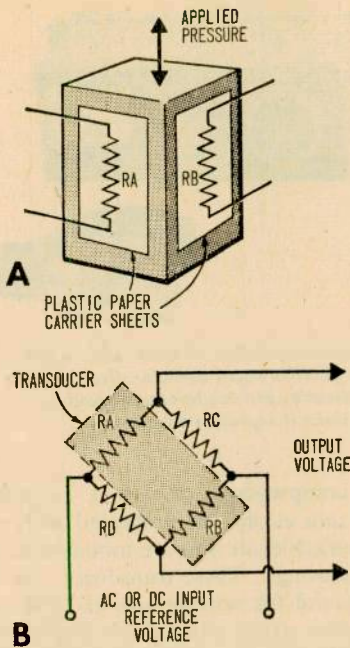

Fig. 3. Film resistors deposited on plastic carrier sheets change resistance when stretched or compressed. Pressure on block in A changes value of RA and RB, unbalancing bridge in B and causing output voltage to change.

arm of a bridge. A thermistor is a resistor that has *negative temperature* characteristics. This means that the resistance of the thermistor drops when temperature goes up, and vice versa.

The values of the remaining resistors are chosen so that the bridge will be balanced, and there will be no output voltage when the thermistor is at a given resistance. Any change in temperature will change the resistance, unbalance the bridge, and produce an output. The voltage will be proportional to the value of the thermistor resistance change. This, in turn, is proportional to the temperature change around the thermistor. So again we have a system where the output voltage will vary with a physical quantity (temperature change, in this case).

When the output voltage of a transducer varies in the same proportion to the physical change throughout the complete range, the output is said to be linear. Linearity is highly desirable in most (but not all) transducers. That is, if a transducer is supposed to produce a one volt change for a one degree change in temperature, this should be true over the entire range of the transducer (a 5 degree temperature change should produce a 5 volt change; a 7 degree change a 7 volt change, etc.).

Volts Per Strain. The strain gauge is a classic example of the resistance-changing transducer. A strain gauge is based on the elementary principle of electronics involving resistance of conductors. The amount of resistance within a conductor or resistor depends upon its cross section and length (as well as temperature and the composition of the materials making up the resistor).

If a section of thin resistance wire is stretched, the decrease in its diameter and increase in its length will change its resistance. The strain gauge uses this principle to measure force, weight, or (simply) strain.

One type of strain gauge is shown in Fig. 3. Here, the resistance wire is cemented to a plastic coated paper carrier sheet, and this is bonded directly to the material which is to be checked for pressure, strain, or the stress resulting when force is applied. Such a strain gauge is known as a bonded type since it is fastened directly to the device under pressure.

The actual resistance change for any applied pressure is very slight. That is why strain gauges are usually used with bridge circuits. The output voltage can be amplified if needed. When force is applied to the

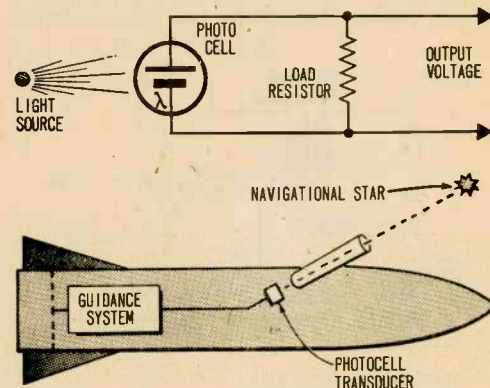

Fig. 4. Output voltage of circuit depends on amount of light hitting photocell. Used to keep missile on course, guidance system senses change in voltage if photocell isn't lined up with star.

top and bottom of the material which is being tested, the pressure created changes the resistance of the RA and RB resistor strips. Since these are part of the bridge circuit, the bridge becomes unbalanced with a change in the resistance values of RA and RB, and an output is produced.

Light Measure. The light-dependent resistor is another form of resistance-changing transducer. The light-dependent resistor uses a photocell as the basic element. Photocells

e/e TRANSDUCERS

are essentially resistors that change in value with changes in light. (These are not to be confused with solar cells, which actually produce a voltage of their own when exposed to light; we'll talk about them later).

As shown in Fig. 4, a constant voltage is applied to the photocell and a fixed resistor which acts as a load resistance. The voltage across the load resistance will remain constant unless the resistance of the photocell changes. Any changes in the intensity of light falling on the photocell will change the photocell's resistance. This, in turn, will change the current through (and the voltage across) the output resistance. Therefore, the output voltage varies with changes in light.

One practical use for such a transducer is in the guidance system of certain missiles. The transducer is placed on the missile so that the light from a particular star will fall upon the photocell. If the missile changes its direction to go off course, the light will be blocked off. This will change the resistance of the photocell, and the transducer output

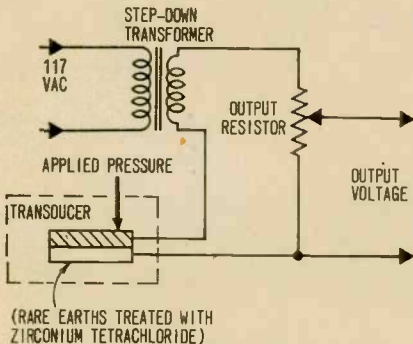
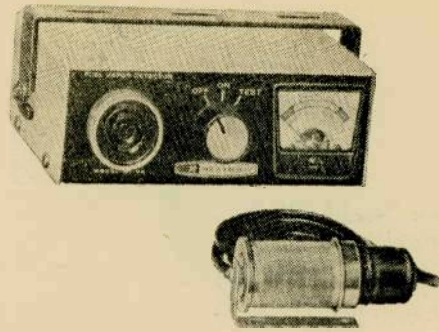

Fig. 5. Solid state strain or pressure transducer is highly sensitive and reacts by changing resistance in direct proportion to amount of pressure. Operating voltage can be either AC or DC.

will vary. This variation in transducer output voltage is applied to the missile's guidance system which returns the missile to the correct heading.

Pressure Measure. In recent times, a number of solid-state pressure transducers have been developed that operate on the resistance-changing principle. One type is manufactured from rare earths which, when processed, undergoes a change in resistance



Commercial application of solar cell is in this Heathkit gasoline vapor detector. Unit provides visual indication of fume level and sounds audible alarm if explosion danger exists.

when compression or strain is applied.

The rare earths are processed with zirconium tetrachloride and are mounted in small metal housings. These transducers are especially useful for sensing any variable physical tension, strain, vibration or displacement.

A typical input system using a solid-state pressure transducer is shown in Fig. 5. Here, 117 VAC is stepped down to the voltage required for the particular pressure transducer. The pressure cell resistance will remain unchanged when no pressure is applied. Current flow through the output resistor is limited by the value of this resistor, as well as the resistance of the pressure transducer and the transformer secondary.

When pressure is applied to the cell, its resistance decreases and more current flows through the output resistor. The increased current through the output resistor will raise the voltage drop across this resistor. Consequently, the output voltage will increase for an increase in pressure on the cell.

Self-Generating Transducers. Self-gen-

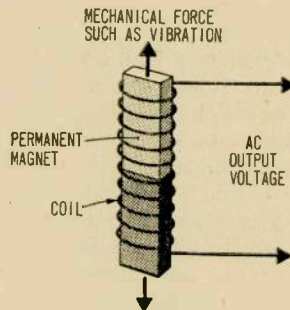

Fig. 6. Vibration or other motion moves magnet in coil. Magnetic lines of force passing through coil winding produce AC output voltage representative of motion amplitude and frequency.

erating transducers do not require a reference voltage as do resistance changing units. Instead, the self-generating transducers create their own output signal which is in proportion to the physical quantity being measured.

Magnetic induction transducers are particularly effective as self-generating devices. Their basic operating principle is the same as that of sound-powered telephones. Magnetic induction transducers consist essentially of a permanent magnet within a coil as shown in Fig. 6. An electrical current will be developed whenever a conductor is moved through a magnetic field, or when the magnetic field is moved across the conductor. In our case, the magnetic field is moving past the coil.

Skin Check. Assume that the magnet is suspended within the coil, and that the magnet is joined directly to a surface subject to vibration such as the outer skin of a missile. As the magnet is vibrated it moves back and forth within the coil.

The magnetic lines of force also move back and forth across the coil. Each time they move in one direction, the coil develops an output current in one direction. When the magnetic lines change direction, the current also changes direction. Therefore, vibration of the magnetic field pro-

duces an alternating current. The amplitude or strength of this current is proportional to the amplitude of vibration. Stronger vibrations would produce a larger voltage. Since the unit for measuring vibration is G (gravitational force), the scale factor would probably be volts-per-G in this case.

The same transducer could also be used to measure the frequency of vibration, if a frequency counter were connected to the output. For example, if the magnet is vibrated at a frequency of 300 Hz, the cur-

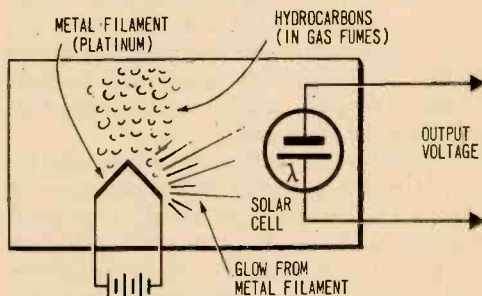

Fig. 8. Hot platinum filament glows brighter in presence of hydrocarbons. Increased light output causes solar cell output voltage to increase setting of alarm or showing up on meter.

rent will alternate at this same frequency. Therefore, the frequency of the output voltage is directly proportional to the frequency of vibration.

Thermocouple. The thermocouple is another example of a self-generating transducer. The thermocouple, shown in Fig. 7, is based on the fact that a voltage will be produced when two dissimilar metals are joined, and heat is applied to the junction. Chromel and alumel are often used for the dissimilar metals.

One of the drawbacks to a thermocouple transducer is that the voltage output is very low. This is usually resolved by adding a DC amplifier between the thermocouple and the system to which the heat information is being fed.

Thermocouple transducers can be used simply to produce a voltage output in the presence of heat, or to measure the actual temperature. On the temperature measuring systems, the thermocouple is connected to a voltmeter (usually a millivolt-meter). The thermocouple junction is subjected to a wide range of temperatures, and the voltage is noted for such temperature. Then a chart or table is made up to show the actual temperature for any given voltage indication.

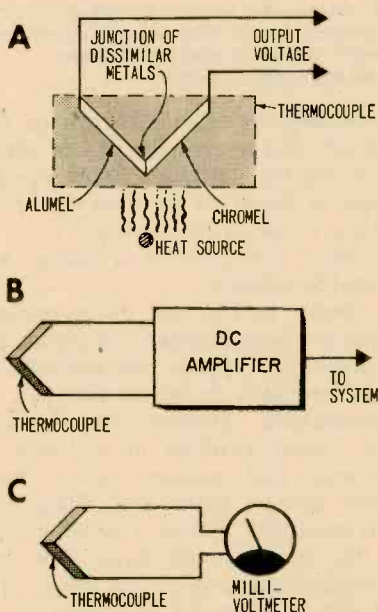

Fig. 7. Voltage is produced when dissimilar-metal junction is heated in A. In B, small voltage generated by thermocouple junction can be amplified or (C) used to give temperature reading on meter.

e/e TRANSDUCERS

Solar Cells. Solar-cell transducers are often used in telemetry systems and in industrial control circuits to detect the presence of gas or, in some cases, the presence of radiation. In either case, the solar cell produces a voltage output proportional to the amount of light applied to the cell surface.

In the case of a gas detector, a metal filament is placed near the solar cell, and a current is passed through the filament as shown in Fig. 8. This current causes the filament to heat and glow, producing a voltage output from the solar cell.

A metal which will glow with greater intensity in the presence of various gases is chosen for the filament metal. One good example of this is platinum, which will glow brighter in the presence of hydrocarbons such as those of gasoline fumes. Such gas-detectors are used in industrial plants and on ships.

In use, the transducer is placed in an area where gasoline fumes are likely to concentrate (such as in the bilge of a power boat). The voltage output of the solar cell is adjusted so that it is just below the point where it triggers an alarm, when there are no fumes, or the fumes are not at a dangerous level. If the fumes become concentrated to a point where they are dangerous, the hydrocarbon count will go up, the metal filament will glow brighter, and the solar cell output voltage will go up to the point where the alarm is triggered.

Radiation. In the case of a radiation detector, the solar cell is placed in a sealed chamber with a chemical or mineral that will

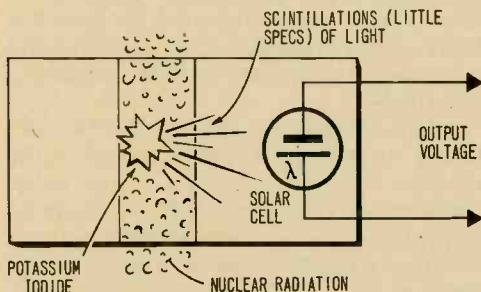

Fig. 9. Scintillation counter uses potassium iodide to produce light from nuclear radiation. Solar cell generates an output voltage in proportion to total light produced, indicating radiation amount.

emit light in the presence of nuclear radiation (Fig. 9). Usually, the chemical is a crystal of some phosphor such as potassium iodide which emits scintillations (little specs) of light when struck by alpha, beta or gamma rays. (Such transducers or detectors are known as *scintillation counters*, when the solar cell output is applied to a counter.)

In use, the transducer is placed in an area where radiation is anticipated, or carried to such an area as is the case when missiles or satellites are used to measure radiation in outer space. If there is enough radiation to produce a measurable amount of light from the chemical, the light causes the solar cell to produce an output voltage. Since the amplitude of the output voltage is proportional to the amount of light, it is possible to both detect and measure the amount of radiation.

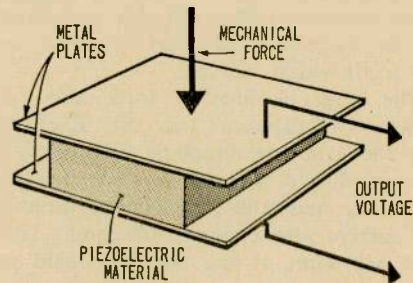

Fig. 10. Piezoelectric material (quartz and Rochelle salts) generate current when subjected to pressure or vibration and can be used as transducer for strain and pressure gauges.

Piezoelectrics. Piezoelectric type transducers are also in common use as self-generating sensing devices. Their operating principle is based on the fact that certain materials (such as quartz crystal and Rochelle salts) will produce a voltage when subjected to pressure.

As shown in Fig. 10, the piezoelectric material is placed between two plates. Each time pressure is applied, the piezoelectric material produces an output voltage.

Flowmeters. Turbine type flowmeters are a typical example of self-generating transducers that measure some physical property such as liquid flow. Their operation is similar to that of a tachometer, except that they measure liquid flow rather than mechanical rotation. As shown in Fig. 11, a simple flowmeter transducer is made up of a turbine placed in the flow path, a magnet in one of the turbine blades, and a pickup coil placed near the turbine blade

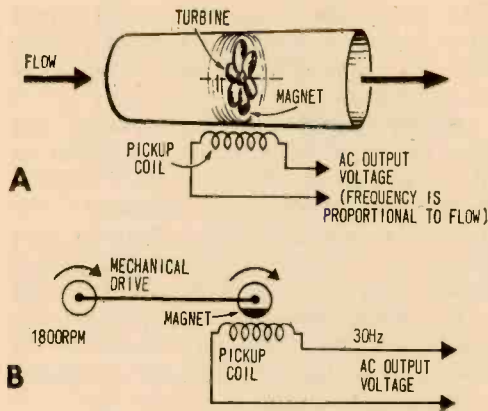
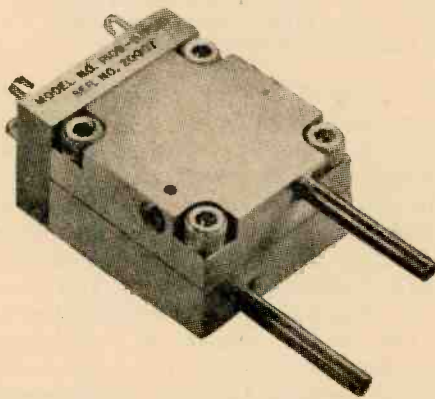

Fig. 11. Rotary speed of turbine in A is function of flow velocity. Magnet in blade will induce an AC voltage in coil (B) whose frequency is proportional to turbine RPM and therefore to flow rate.

tips. As the turbine turns in the flow path, the pickup coil produces an alternating current or signal.

The frequency of this signal is proportional to the flow rate (an increase in flow speeds up the turbine, increasing the alternating current frequency).

Tachometer type transducers operate the same way except that their function is to measure actual frequency rather than to produce an output where the frequency is proportional to some other value. Usually, tachometer type transducers are used to measure mechanical rotation as are conventional tachometers. These transducers also consist of a pickup coil and magnet arrangement. The magnet is driven past the coil by mechanical rotation and produces an alternating current, usually at the rate of one cycle per rotation.



Transducer used to measure difference in pressure between two gases or liquids. Gas or liquid is fed into tubes and internal diaphragm attached to variable resistor measures pressure difference.

Inductance And Capacitance Changing Transducers. Inductance and capacitance changing transducers are usually used with a bridge circuit operating on alternating current.

The linear, or control, transformer is a good example of an inductance changing transducer used to measure mechanical position. As shown in Fig. 12, the transducer is essentially a transformer with a secondary winding that can be rotated in relation to the primary winding.

A reference voltage is applied to the primary and a mechanical driving force is applied to rotate the secondary winding. This driving force could be any one of the guidance controls in a missile or aircraft such as rudder or ailerons.

For example, assume that the rotating secondary winding were connected to the ailerons of a guided aircraft. As the secondary is rotated toward the parallel

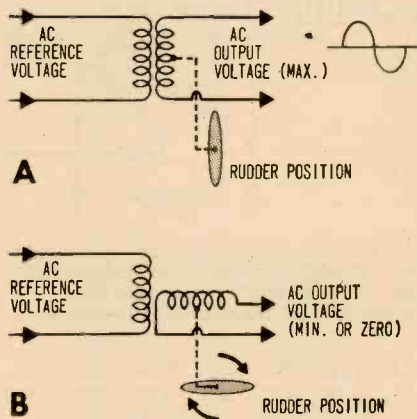

Fig. 12. Linear, or control, transformer couples percentage of input signal to secondary winding depending on angle between the two. Here, output voltage is in relation to rudder position.

position (Fig. 12A), the output voltage increases. Conversely, the output will decrease when the secondary winding is moved toward the right angle position (Fig. 12B). Therefore, the output of the transducer is proportional to the mechanical position of the aircraft aileron.

Liquid Level Capacitance. The liquid-level-measuring transducer is an example of a capacitance-changing transducer. With such a transducer, the liquid itself forms one plate of essentially a variable capacitor as shown in Fig. 13.

Since the capacitance value of any capacitor is determined both by plate size and

e/e TRANSDUCERS

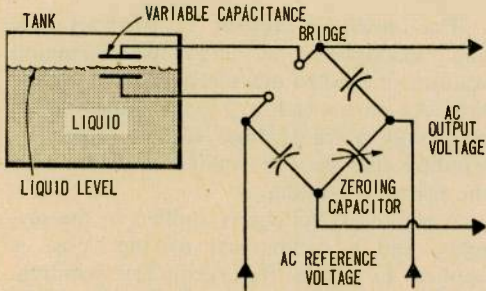

Fig. 13. Conductive liquid acts as one plate of variable capacitor. As liquid level changes, spacing between capacitor surfaces also change, unbalancing capacitive bridge and varying output voltage.

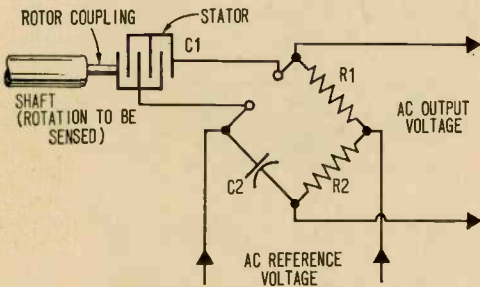

Fig. 14. Rotating capacitor goes from minimum to maximum capacitance value during each rotation. Capacity variation of C1 in relation to C2 causes change in AC output voltage amplitude.

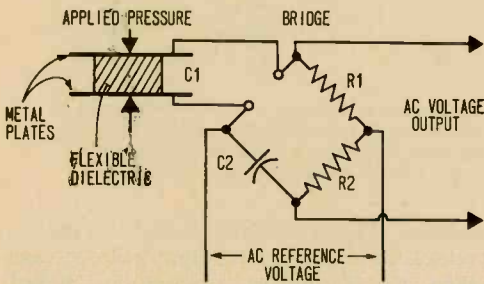

Fig. 15. Using flexible dielectric between capacitor plates allows applied pressure to vary capacitance value of C1. Result is that varying output voltage amplitude varies in proportion to force of pressure.

spacing, any variation in liquid level will cause a corresponding variation in capacitance.

The capacitor formed by the liquid and the transducer plate is usually connected to a bridge circuit. The matching leg of the bridge is formed by a variable capacitor.

This permits the bridge circuit to be zeroed at minimum or maximum capacity. Either way, the output of the bridge is proportional to liquid level.

Rotary Capacitor. Shaft rotation can also be sensed by a variable capacitor as shown in Fig. 14. Here, the shaft which is to be tested for rotation is connected to the rotor of a variable capacitor which can turn completely without stop. The output is then applied to a capacitive bridge and when the shaft rotates from its normal position, the degree and rate of rotation is sensed by the amount of bridge unbalance and is reflected in the output voltage.

The capacitance-changing transducer principle can also be used to sense pressure changes as shown in Fig. 15. Here, two metal plates are separated by a flexible dielectric material as shown. With no pressure applied, the transducer capacitor C1 has the same value as capacitor C2 in the bridge circuit. When pressure is applied, it compresses the dielectric material and brings the plates of the capacitor closer together. The result is an increase in capacity and an

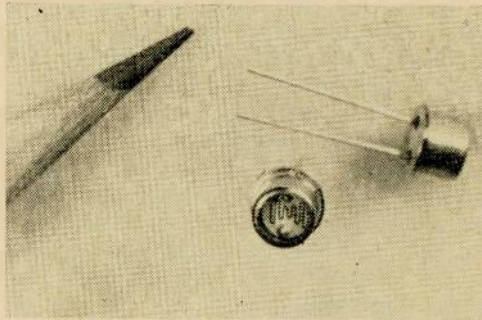

Photoelectric cells of the resistive type in TO-5 transistor cans. Light dependent resistive element is wavy line on top of can. This type of transducer finds application in a variety of fields.

unbalancing of the bridge. The output voltage produced when the bridge is unbalanced will be in proportion to the physical pressure applied to capacitor C1.

As you can see, transducers come in all sizes and shapes and have the capabilities to translate any motion into an analogous electrical current and vice versa. This is one of the things that make electronics the versatile and capable "servant" of man's enterprises that it is. And now that you have the essential basics of electronic measurements under your belt, the rapid advance of technology won't catch you with your understanding down. ■

What In The World's Going On? Find Out With A Heathkit® SWL Radio

NEW! Professional 10-Band Shortwave Receiver... Slices Stations Down To The Last kHz

Covers 6 shortwave bands (49, 31, 25, 19 & 16 meters) . . . 80, 40 and 20 meter ham bands . . . 11 meter CB. Includes 5 kHz crystal filter for AM, SSB and CW listening. 11-tube circuit. 1 kHz dial calibrations — 100 kHz per dial revolution . . . no more guessing station frequencies. Crystal-controlled front-end for same rate tuning on all bands. Prebuilt & aligned Linear Master Oscillator. Tuning dial to knob ratio 4 to 1. Calibrated "S" meter. Automatic noise limiter. Separate RF and AF gain controls. Headphone jack. Non-backlash vernier tuning dial. "Sub-pack" packaging for easy 20-hour kit assembly. Modern "low-boy" cabinet styling, plus many more "pro" SWL features. Optional crystal filters for optimum CW & SSB available.

Kit SB-310, 20 lbs. . . . no money dn., \$23 mo. **\$249.00**



Kit SB-310
\$249⁰⁰
\$23 mo.

(SB-600 8 ohm, 6" x 9" speaker \$18.95)

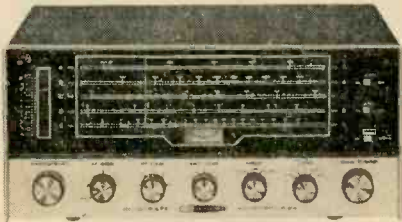

Kit GR-54
\$87⁹⁵
\$9 mo.

For The Seasoned SWL . . . Deluxe 5-Band Shortwave Receiver

Features 5 bands . . . 3 shortwave bands cover 2 MHz to 30 MHz, plus AM broadcast and 180 kHz to 420 kHz aeronautical & radio navigation bands. Tuned RF stage. Crystal filter for sharp selectivity. Separate product detector for SSB & CW. 6 diode, 6 tube superhet circuit. 4" x 6" speaker. Built-in code practice monitor. Switchable BFO, metal cabinet and more. Includes FREE SWL antenna.

Kit GR-54, 25 lbs. . . . no money dn., \$9 mo. **\$87.95**



Kit GR-64
\$39⁹⁵
\$5 mo.

Low-Cost 4-Band AM/Shortwave Receiver

Hear "live" broadcasts from around the globe, ham operators, Voice of America, ship-to-shore, CW, plus local AM on this single receiver. 4 bands . . . 3 shortwave bands cover 1 MHz to 30 MHz, plus AM broadcast. 5" speaker for crisp, bold-sound. 7" slide-rule dial with logging scale. Lighted bandspread tuning dial. Relative signal strength indicator. BFO control. Headphone jack. Metal cabinet and more.

Kit GR-64, 15 lbs. . . . no money dn., \$5 mo. **\$39.95**



Kit GR-43
\$139⁹⁵
\$13 mo.

Deluxe 10-Band AM/FM/Shortwave Transistor Portable

10 bands tune Longwave, AM, FM and 2 MHz to 22.5 MHz shortwave. Separate AM & FM tuners and IF strips. 16 transistors, 6 diodes and 44 factory assembled and pretuned circuits. 4" x 6" speaker. Earphone, time zone map, listener's guide. Build in about 10 hours. Optional converter/charger for AC operation \$6.95.

Kit GR-43, 19 lbs. . . . no money dn., \$13 mo. **\$139.95**



Kit GC-1A
\$89⁵⁰
\$9 mo.

Last Call For The "Mohican" Portable 5-Band Shortwave Receiver

Tunes 550 kHz to 32 MHz in 5 bands. Fixed-aligned IF ceramic "transmitters" for best selectivity. Self-contained for portability, yet can run on 117 v. AC with optional power supply @ \$9.95. 10 transistor, 6 diode circuit. Slide-rule dial, "S" meter, BFO control, electrical bandspread, 4" x 6" speaker, headphone jack, metal cabinet and more.

Kit GC-1A, 18 lbs. . . . no money dn., \$9 mo. **\$89.50**

Turn Page For More Heathkit Values!

Instant Gift-Solving Guide From Heath...

Now There Are 3 Heathkit Color TV's To Choose From

Introducing The NEW Deluxe Heathkit "227" Color TV

Exclusive Heathkit Self-Servicing Features. Like the famous Heathkit "295" and "180" color TV's, the new Heathkit "227" features a built-in dot generator plus full color photos and simple instructions so you can set-up, converge and maintain the best color pictures at all times. Add to this the detailed trouble-shooting charts in the manual, and you put an end to costly TV service calls for periodic picture convergence and minor repairs. No other brand of color TV has this money-saving self-servicing feature.

Advanced Performance Features. Boasts new RCA Perma-Chrome picture tube with 227 sq. in. rectangular viewing area for 40% brighter pictures... 24,000 v. regulated picture power and improved "rare earth" phosphors for more brilliant, livelier colors... new improved low voltage power supply with boosted B+ for best operation... automatic degaussing combined with exclusive Heath Magna-Shield that "cleans" the picture every-time you turn the set on from a "cold" start, and keeps colors pure and clean regardless of set movement or placement... automatic color control and gated automatic gain control to reduce color fade and insure steady, flutter-free pictures even under adverse conditions... preassembled & aligned 3-stage IF... preassembled & aligned 2-speed transistor UHF tuner and deluxe VHF turret tuner with "memory" fine tuning... 300 & 75 ohm VHF antenna inputs... two hi-fi sound outputs... 4" x 6" 8 ohm speaker... one-piece mask & control panel for simple installation in a wall, your custom cabinet or either optional Heath factory-assembled cabinets. Build in 25 hours.

Kit GR-227, (everything except cabinet)
...\$42 dn., as low as \$25 mo. \$419.95

GRA-227-1, Walnut cabinet... no money dn., \$6 mo. \$59.95

GRA-227-2, Mediterranean Oak cabinet (shown above),
...no money dn., \$10 mo. \$94.50



Kit GR-227
\$419.95
(less cabinet)
\$25 mo.

Kit GRA-27
\$19.95

New Remote Control For Heathkit Color TV

Now change channels and turn your Heathkit color TV off and on from the comfort of your armchair with this new remote control kit. Use with Heathkit GR-227, GR-295 and GR-180 color TV's. Includes 20' cable.

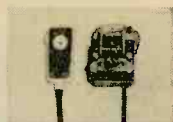

Kit GR-295
\$479.95
(less cabinet)
\$42 mo.

Deluxe Heathkit "295" Color TV

Has same high performance features and built-in servicing facilities as new GR-227, except for 295 sq. in. viewing area (industry's largest picture)... 25,000 volt picture power... universal main control panel for versatile in-wall installation... and 6" x 9" speaker.

Kit GR-295, (everything except cabinet), 131 lbs.
\$48 dn., \$42 mo. **\$479.95**

GRA-295-1, Walnut cabinet (shown above), 35 lbs.
no money dn., \$7 mo. **\$62.95**

Other cabinets from \$94.50



Kit GR-180
\$349.95
(less cabinet & cart)
\$30 mo.

Deluxe Heathkit "180" Color TV

Same high performance features and exclusive self-servicing facilities as new GR-227 (above) except for 180 sq. in. viewing area.

Kit GR-180, (everything except cabinet), 102 lbs.
\$35 dn., \$30 mo. **\$349.95**

GRA-180-5, table model cabinet & mobile cart
(shown above), 57 lbs. no money dn., \$5 mo. **\$39.95**

Other cabinets from \$24.95

Deluxe 12" Transistor Portable B&W TV - First Kit With Integrated Circuit

Unusually sensitive performance. Plays anywhere... runs on household 117 v. AC, any 12 v. battery, or optional rechargeable battery pack (\$39.95); receives all channels; new integrated sound circuit replaces 39 components; preassembled, prealigned tuners; high gain IF strip; Gated AGC for steady, jitter-free pictures; front-panel mounted speaker; assembles in only 10 hours. Rugged high impact plastic cabinet measures a compact 1 1/2" H x 15 3/4" W x 9 3/4" D. 27 lbs.

Kit GR-104
\$119.95
\$11 mo.



Kit GR-104, 27 lbs. no money dn.,
\$11 mo. **\$119.95**

No Money Down On \$25 to \$300 Orders — Write For Credit Form

Turn Page For 11 More Solutions

Enjoy The Sounds Of Christmas With A Heathkit® Stereo System



Kit AR-17
\$72⁹⁵
 (less cabinet)
 \$8 mo.

NEW! Lowest Cost Solid-State Stereo Receiver

Features wide 18-60,000 Hz response $\omega_{\pm 1}$ db at full 5 watts RMS power per channel ... 14 watts music power ... inputs for phono and auxiliary ... automatic stereo indicator ... outputs for 4 thru 16 ohm speakers ... adjustable phase for best stereo ... flywheel tuning ... and compact 9 7/8" D. x 2 7/8" H. x 11 1/4" W. size. 12 lbs. Optional factory assembled cabinets (walnut \$7.95, beige metal \$3.50).

Kit AR-17, (less cab.) 12 lbs. ... no money dn., \$8 mo. **\$72.95**



Kit AR-27
\$49⁹⁵
 (less cabinet)
 \$5 mo.

NEW! Low Cost Solid-State FM Mono Receiver

Features cool, solid-state circuit ... 7 watts music, 5 watts RMS power ... 18 to 60,000 Hz response $\omega_{\pm 1}$ db ... inputs for phono and auxiliary ... outputs for 4 thru 16 ohm speakers ... flywheel tuning ... front panel controls ... preassembled & aligned FM front-end ... and 9 7/8" D. x 2 7/8" H. x 11 1/4" W. bookshelf size. 9 lbs. Optional Heath factory assembled cabinets (walnut veneer \$7.95, beige metal \$3.50).

Kit AR-27, (less cab.) 9 lbs. ... no money dn., \$5 mo. ... **\$49.95**



Kit AR-15
\$329⁹⁵
 (less cabinet)
 \$28 mo.
 Assembled ARW-15
\$499⁵⁰
 (less cabinet)
 \$43 mo.

World's Most Advanced Stereo Receiver ... Choose Kit Or Factory Assembled

Acclaimed by owners & audio experts for its advanced features like integrated circuits and crystal filters in the IF amplifier section; ultra-sensitive FET FM tuner; 150 watts dynamic music power; complete AM, FM and FM stereo listening; positive circuit protection; all-silicon transistors; "black magic" panel lighting; stereo only switch; adjustable phase control for best stereo and many more. 34 lbs. Optional wrap-around walnut cabinet \$19.95.

Kit AR-15 (less cab.), 34 lbs. ... \$33 dn., \$28 mo. ... **\$329.95**

Assembled ARW-15, (less cab.), 34 lbs. ... \$50 dn., \$43 mo. ... **\$499.50**

NEW! Heathkit Stereo Headphone Control Box



Kit AC-17
\$7⁹⁵

Now enjoy the convenience of switching from speaker to private headphone listening without leaving the comfort of your favorite chair. Connects to any headphone regardless of power, and has standard jacks to accommodate two sets of any impedance. 3 or 4 connector, stereo or mono headset. Tandem volume and balance controls. About the size of a pack of cigarettes. Includes 20' cable.

Kit AC-17, 3 lbs. ... **\$7.95**

NEW! Exclusive Heath Hi-Fi Furniture ... Fully Assembled And Finished

Contemporary Walnut Stereo/Hi-Fi Cabinet Ensemble Complements Modern Furnishings

Masterfully crafted of fine veneers and solids with walnut finish. Statuary Bronze handles. Equipment cabinet features adjustable shelves to accommodate all makes of hi-fi components, record storage or tape recorder compartment, turntable compartment. Speaker cabinet features special Tubular-Duct Reflex design for matching 8" or 12" speakers, plus slot for a horn tweeter.

Model AE-37, equipment cabinet ...

no money dn., \$12 mo. ... **\$125.00**

Model AEA-37-1, speaker cabinet ...

no money dn., \$6 mo. ... each **\$59.50**

Early American Stereo/Hi-Fi Cabinet Ensemble

Early American richness with modern component layout. Constructed of specially-selected solids and veneers finished in popular Salem-Maple. Statuary Bronze handles. Equipment cabinet has adjustable shelves to accommodate any make hi-fi component, record storage or tape recorder compartment, turntable compartment. Speaker cabinet can be matched to any 8" or 12" speaker ... has slot for horn tweeter.

Model AE-47, equipment cabinet ...

no money dn., \$13 mo. ... **\$135.00**

Model AEA-47-1, speaker cabinet ...

no money dn., \$7 mo. ... each **\$64.50**

Mediterranean Pecan Stereo/Hi-Fi Cabinet Ensemble

Beautifully constructed of fine furniture solids and veneers with Pecan finish. Statuary Bronze handles. Equipment cabinet has adjustable shelves to house any make hi-fi component, record storage or tape recorder compartment, turntable compartment. Speaker cabinet can be matched to any 8" or 12" speaker ... has slot for horn tweeter.

Model AE-57, equipment cabinet ...

no money dn., \$14 mo. ... **\$150.00**

Model AEA-57-1, speaker cabinet ...

no money dn., \$8 mo. ... each **\$74.50**

Complete Ensemble
\$244⁰⁰



Complete Ensemble
\$264⁰⁰

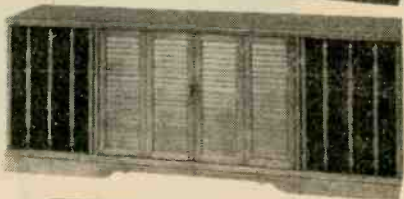

Complete Ensemble
\$299⁰⁰



Enjoy Widest Kit Selection, Easy Credit,

"Starmaker" Dual-Channel Solid-State Guitar Amplifier



Features 25 watts EIA, 60 watts peak power; two channels, each with two inputs; handles lead guitar, singer's mike; tremolo & reverb; two 12" speakers; line bypass reversing switch for hum reduction; foot switches; black vinyl-covered wood cabinet with aluminum front panel & chrome knobs. 52 lbs.

Kit TA-16 **\$134⁹⁵**
\$13 mo.

Assembled TAW-16 **\$199⁹⁵**
\$19 mo.

NEW! Single-Channel Solid-State Guitar Amplifier



Compare To Amps Costing \$175 & More! Boasts 20 watts EIA, 40 watts peak power; tremolo & reverb; two inputs for lead guitars, singer's mike; 12" speaker; line bypass reversing switch to reduce hum; foot switches; transformer power supply; black vinyl-covered wood cabinet with aluminum front panel & chrome knobs. 35 lbs.

Kit TA-27 **\$89⁹⁵**
\$9 mo.

Assembled TAW-27 **\$134⁹⁵**
\$13 mo.

NEW! Deluxe Solid-State Combo Amplifier & Speaker System... Choose Kit Or Factory Assembled

Kit TA-17 Amplifier
\$175⁰⁰

\$17 mo.
(Wired TAW-17, \$275)

Kit TA-17-1 Speaker System
\$120⁰⁰

\$11 mo.
(Wired TAW-17-1, \$150)

Kit TAS-17-2 Special Combination Offer! 2 Speaker Systems & Amplifier
Save \$20

\$395⁰⁰

\$40 dn.
\$34 mo.
(Wired TAW-17-2, \$545)

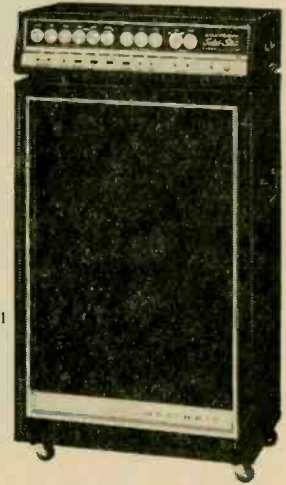

All the "big sound" features every combo wants... tremolo, built-in "fuzz", brightness, reverb, separate bass and treble boost and more. Delivers a shattering 120 watts EIA music power (240 watts peak power) through two TA-17-1 speakers... or 90 watts through one TA-17-1 speaker. Features 3 independent input channels, each with two inputs. Handles lead or bass guitars, combo organ, accordion, singer's mike, or even a record changer. All front panel controls keep you in full command of all the action.

Speaker system features two 12" woofers, special horn driver and matching black vinyl-covered wood cabinet with casters & handles for easy mobility.

Save Up To \$500 On This Heathkit®/Thomas "Paramount" Transistor Theatre Organ



Kit TO-67
\$995⁰⁰

(including bench)

Write for credit details

All Genuine Thomas Factory-Fabricated Parts. Features 15 manual, 4 pedal voices; instant-play Color-Glo; all solid-state circuit; 200 watts peak power; two separate speaker systems... 2-speed rotating Leslie plus main system with two 12" speakers; two 44-note keyboards; professional horseshoe console with stop tablets; 28 notes of chimes; 13-note bass pedals; selective repeat & attack percussion; reverb; stereo headset outlet; assembled walnut finish hardwood cabinet and bench; and more. 265 lbs. 7", 33-1/3 rpm demonstration record 50c.

America's Lowest Cost Solid-State Organ

Save Up to \$205! Features instant-play Color-Glo; 10 organ voices; 13-note bass pedals; repeat percussion; two 37-note keyboards; 75 watt peak power; vibrato; matching preassembled walnut cabinet & bench; 5-year warranty on plug-in tone generators. 172 lbs. 7", 33-1/3 rpm demonstration record 50c.

Kit GD-325B
\$394⁹⁰

\$40 dn., \$34 mo.



NEW! Heathkit®/Thomas Organ Accessories

Exclusive Band Box Percussion

Automatically or manually adds 10 percussion voices to any Heathkit/Thomas organ. Build & install in 12 hours.

Kit TOA-67-1, no money dn., \$145.00
\$14 mo.

Exclusive Playmate Rhythm Maker

Adds 15 fascinating rhythms to any Heathkit/Thomas Organ. Requires Band Box percussion (above) for operation.

Kit TOA-67-5, no money dn., \$189.90
\$18 mo.

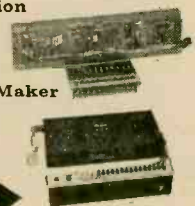

Order Now! Use The Handy Coupon Opposite Page

Direct-To-You Delivery From Heath



Kit TO-68
\$349⁹⁵

NEW! VOX "Jaguar" Transistor Combo Organ By Heathkit

Save Up To \$150 on the world's most popular combo organ with this new Heathkit version. Features the most distinctive sound of any combo organ. Has a special bass output that gives a brilliant stereo bass effect when played through a separate or multi-channel amplifier, 4 complete octaves, vibrato, percussive effects and reversible bass keys. Includes hand crafted orange and black cabinet, fully plated heavy-duty stand, expression pedal and waterproof carrying cover and case for stand. Requires a bass or combo amplifier like Heathkit TA-17 (opposite page).

Kit TO-68, 80 lbs... \$35 dn., \$30 mo. \$349.95

NEW! Amateur Novice CW Transceiver



Kit HW-16
\$99⁵⁰
\$10 mo.

Novices! New Hams! Get on-the-air at lowest cost. Provides CW operation on the first 250 kHz of the 80, 40 & 15 meter bands. 75 watt CW input, up to 90 watts for general class operation. True "break-in" CW operation. Crystal control transmit with VFO receiver tuning. Built-in sidetone. Grid-block keying. Metal cabinet and simple assembly. 25 lbs.

Kit HW-16, 25 lbs... no money dn., \$10 mo. \$99.50

NEW! Heathkit Jr.® Solid-State Portable Phonograph

Kit JK-17
\$19⁹⁵



Perfect for the youngster in your family. Plays all 4 speeds, all record sizes. Crystal cartridge with sapphire stylus for all types of records; 4" speaker; built-in 45 rpm adaptor; preassembled turntable and hardboard cabinet. Build in 1 to 2 hours. 117 VAC, 60 Hz operation. 11 lbs.

Heathkit Jr.® Electronic Workshop "19"

Kit JK-27
\$13⁹⁵

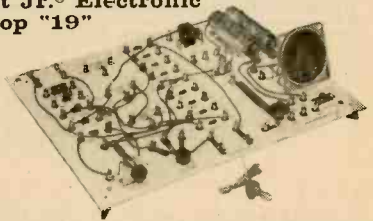

Ideal gift for any youngster who wants to learn electronics. Contains principles of operation & instructions for building 19 electronic projects... PA system, transistor radio, burglar alarm, etc. Spring-type connectors. Safe, flashlight battery operation. 4 lbs.

NEW! Heathkit Jr.® Guitar Amplifier

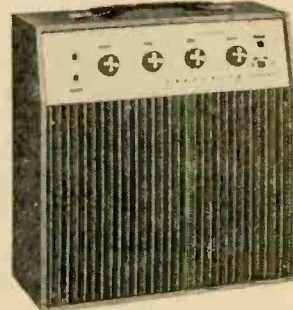

Kit JK-37
\$29⁹⁵
\$5 mo.

Ideal For Youngsters! Build in an evening. All solid-state. 9 watts music power. 8" speaker. Single channel, two inputs. Variable tremolo. Volume & tone controls. Red vinyl-covered wood cabinet with striped grille cloth and carrying handle. 12 lbs.



NEW
FREE 1968
CATALOG!

Now with more kits, more color. Fully describes these along with over 300 kits for stereo/hi-fi, color TV, electronic organs, electric guitar & amplifier, amateur radio, marine, educational, CB, home & hobby. Mail coupon or write Heath Company, Benton Harbor, Michigan 49022.

HEATH COMPANY, Dept. 139-1
Benton Harbor, Michigan 49022
In Canada, Daystrom Ltd.

Enclosed is \$ _____, including shipping.

Please send model (s) _____

Please send FREE Heathkit Catalog.

Please send Credit Application.

Name _____

Address _____

City _____

State _____

Zip _____

Prices & specifications subject to change without notice.

CL-308

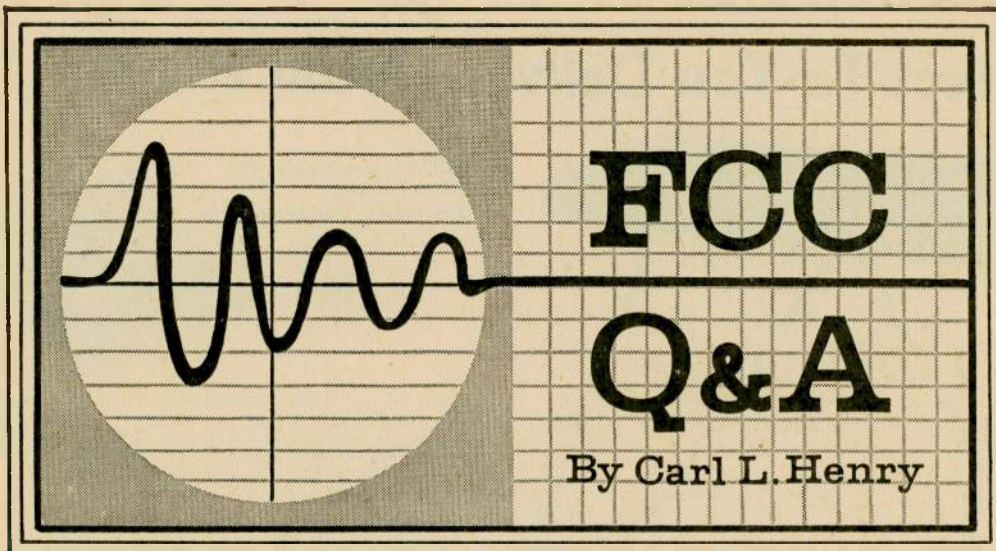

The ability to accurately measure everything the electron does in a circuit is the basis of modern electronics technology.

In electronics, we deal with something that cannot be seen, felt, or heard. So we deal with this intangible stuff as best we can; and the best we can is pretty good today. Voltmeters, frequency meters, oscilloscopes, and sophisticated devices like ten-channel differential discriminators are available that can tell us exactly what is going on in the electronics circuit provided we know how to use this equipment. That's a big "if" too because without knowledge of proper usage, measurements can be a mile off. We cannot use our common-sense to judge the results of a test; we must be sure on the basis of experience and training. Knowing this fact, part of the FCC license examinations test your knowledge of measurement technique with questions similar to these.

Q. *What is the full scale accuracy required in the ammeters and voltmeters associated with the final radio stage of a broadcast transmitter?*

A. The accuracy of D'Arsonval type instruments is always specified as full-scale accuracy, not as accuracy at any point on the scale. This means that a 10-volt meter, accurate to 5%, can vary by as much as 0.5 volt at any point on the scale. You can see why it is best to make all readings where possible from the upper third of the meter scale. The higher on

the scale the reading is made, the greater the relative accuracy. In measuring final input power in a transmitter, bear in mind the FCC power tolerance of plus 5% and minus 10%. We could expect the required accuracy of the current and voltage indication to be such that the power tolerance is maintained even with maximum error on the meters. The required accuracy of the ammeter and voltmeter should be 2% as this will give a 4% power error at the maximum tolerance point of both meters. This keeps the power reading error to within the power tolerance requirement of 5%.

Q. *What portion of the scale of an antenna ammeter having a "square" (or, logarithmic) low scale is considered as having acceptable accuracy for use at a broadcast station?*

A. From the FCC "Standard of Good Engineering Practice," indicating instruments having a "square" low or logarithmic scale must conform to the following specifications. First of all, an indicating instrument of this type does not have a linear scale. The S.G.E.P. takes this into consideration as follows: no scale division above one-third full scale reading (in amperes) shall be greater than one-thirtieth of the full scale reading. In

other words, an ammeter having a full scale reading of 6 amperes is acceptable for reading currents from 2 to 6 amperes provided no scale division between 2 and 6 amps is greater than 1/30 of 6, or greater than 0.2 ampere. The answer to the question then is that the top two-thirds of the scale may be considered as having acceptable accuracy, as long as the scale divisions are at least 1/30 of the full scale indication.

Q. *When may a remote reading antenna ammeter be employed to check antenna current?*

A. A remote reading ammeter may be used if it conforms to the specifications listed in the previous question, as long as the calibration of the ammeter is checked against the regular ammeter at least once a week.

Q. *What indicating instruments may be considered satisfactory for determining the power output of an FM transmitter by the indirect method?*

A. The indirect method of calculating final plate power is determined by $E_p \times I_p \times F$, where F is an efficiency factor given by the manufacturer for his equipment. Examples of the factor:

(1) transmitter with plate modulation in last stage, $F = 0.70$ to 0.80

(2) transmitter with low level modulation, $F = 0.35$ to 0.65

(3) transmitter with grid modulation in last stage, $F = 0.25$ to 0.35 .

To figure power by the indirect method, you must therefore know the final amplifier plate voltage (E_p) and cathode current (I_p). The specifications for indicating instruments apply to meters used to measure these values. Instruments to measure plate voltage and plate current shall be linear scale instruments. The length of the scale on the instrument shall be not less than 2.3 inches. Accuracy shall be at least 2% of full-scale reading. The scale shall have at least 40 divisions. And the full scale reading shall not be greater than 5 times the minimum normal indication.

Q. *Describe the technique used in frequency measurements employing a 100 kilohertz oscillator, a 10 kilohertz multivibrator, a heterodyne frequency meter of known*

accuracy, a suitable receiver, and a standard frequency transmission.

A. Frequency measurements are of vital concern to anyone operating a transmitter. Tolerance is specified for the assigned frequency, and not only is improper frequency transmission illegal, but "netting" with other units on the channel becomes difficult, giving inefficiency in the operation of the system. The normal method of using the equipment described above would be as follows: first, the receiver would be tuned to the unknown frequency. The heterodyne frequency meter is adjusted to the same frequency, achieving a zero beat condition with the unknown signal. The exact frequency is noted from the frequency meter dial. Now the frequency meter is adjusted to a lower frequency where the next zero beat is obtained. Designating the first frequency F_1 and the second F_2 , the harmonic of the unknown signal being tested is determined by:

$$H = \frac{F_2}{F_1 - F_2}$$

Knowing the harmonic, the fundamental can be determined by $F = H \times F_1$. Knowing the frequency approximately prepares us to measure it exactly. The 100 KHz oscillator is now adjusted against the standard frequency transmission, using the receiver, until it is exactly correct. The 10 kHz multivibrator is coupled to the 100 kHz oscillator, which gives us a harmonic every 10 kHz. The unknown frequency will fall between two of these harmonics. The heterodyne frequency meter can be used to accurately interpolate the position of the unknown in respect to the 10 kHz harmonic signals, and so determine the exact frequency. The limits of accuracy are the stability of the 100 kHz oscillator after adjustment to the standard transmission, and the accuracy with which the interpolation is done. Ordinary measurements to one Hertz are possible with this method using good quality commercial equipment.

Q. *A milliammeter with a full-scale deflection of 1 milliampere and having a resistance of 25 ohms was used to measure an unknown current by shunting the*

meter with a 4-ohm resistor. The meter then read 0.4 milliamperes. What was the unknown current value?

A. The unknown current value was 2.9 milliamperes. A basic formula can be developed for a problem such as this from Ohm's Law. Since we are concerned with a parallel circuit, the voltage across both branches is equal. We can then say $I_m R_m = I_s R_s$. Thus $1.0 \text{ mA} \times 25 \text{ ohms} = I_s \times 4 \text{ ohms}$. This formula can be used on any meter shunt problem, given the original full-scale current of the meter and its internal resistance, and the proposed shunt resistance.

Q. Describe the construction and characteristics of (1) a thermocouple type of meter; (2) a wattmeter.

A. (1) A thermocouple type meter is composed of three parts. The first is a heater strip, a thermocouple adjacent to the heater wire, and a microampere or milliammeter. The thermocouple consists of a junction of two wires, usually constantan and platinum, welded together on the heater strip. This formed junction, due to the metals used, will produce an electrical current when subjected to heat. In fact, junctions of this type are used to measure temperatures in furnaces and other high temperature applications. The current we wish to measure is connected to the heater strip, and heats the junction. The junction then develops a DC current that is proportional to the square of the heater strip current. This DC current is measured by the microammeter or milliammeter connected to the wires from the junction. It matters very little whether the applied current is AC, DC, or RF. What's measured is the heating effect of the current, and the indication is proportional to the square of the effective value of the measured current. Since the heater strip can be made small, such meters can measure currents to 100 MHz accurately. Above this frequency, the heater strip has too much inductance and capacitance to maintain its accuracy. Since they are not frequency sensitive below their frequency limit, thermo-

couple type meters can be used for very accurate comparisons between DC and RF currents. They are available commercially from 200 microamperes to 1000 amperes. (2) A wattmeter is basically a voltmeter and ammeter connected so that power factor is automatically compensated for in the indicated reading. Usually, the wattmeter consists physically of a few turns of wire made into a stationary coil, developing a torque value proportional to the current of the circuit, and connected in series with the load. A movable coil is provided inside the stationary coil, developing a torque proportional to the voltage applied to it and connected in parallel with the load through a suitable dropping resistor. The torque that deflects the indicating needle is proportional to the instantaneous voltage and current product, or the instantaneous power. The moving element is generally damped sufficiently so that the indication is not instantaneous but average power. Wattmeters of this type are available for either AC or DC, some being usable on either.

Q. Describe the construction and characteristics of a D'Arsonval type of meter.

A. A D'Arsonval meter is not some new Japanese import, but the common old meter you use for just about every measurement. It consists of a horseshoe type permanent magnet between whose poles is a coil. This coil is pivoted at its centers on jeweled bearings, so that it is free to move. Small spiral springs are attached to the coil, top and bottom, so that there is a slight linear force to resist any random movement of the coil. The indicating needle is also attached to the coil. The basis of all measurements utilizing this system is the basic electrical law that tells us a wire in a magnetic field, carrying a current, tends to move. And this is exactly what happens. The coil moves an amount determined by the strength of the current, and the needle attached to the coil indicates this amount on a scale. Sensitive meters must have high flux permanent magnets and large coils (and therefore high internal resistance); high current meters can use weak magnets and small coils. However, with mass production it is easier to build standard meters and shunt them to

(Continued on page 131)

HOME STUDY BLUEBOOK

e/e's Guide to selected
Home-Study Courses
now being offered by
Electronics Schools



☞ Home study is considered today one of the most effective approaches to education. More than two million enroll in home-study courses each year. This means that more people are investing in their future via the mail box than in all the colleges and universities combined. And this is easily understood when the exclusive advantages of home study are brought to mind. Some advantages are: you study at your convenience, you study at your own pace, you

develop self-starting qualities, your instruction is effective and you pay less for more training.

☞ Listed below are a few courses from several home study schools. For more information, circle those course numbers that interest you on the coupon below, and fill out both sides of the coupon. **ELEMENTARY ELECTRONICS** will forward your request to the schools and ask that additional data be sent to you directly. All courses listed are GI Bill approved.

20. 2-Way Radio. *National Radio Institute's* Complete Communications Course gets you to pass the FCC First Class Radiotelephone license exam or returns your money. This "beginner-oriented" course covers mobile, marine, aircraft, and railroad communications, plus radio-TV transmission, microwave relay, and teletype. Course contains 70 lessons with texts, 13 reference texts, 7 training kits.

21. TV Servicing. *RCA Institutes'* Television Servicing Career Program 200 is for the beginner and completely prepares you for a career as a television serviceman. There are 110 pay-as-you-order lessons, starting with basic electricity and electronics, going into black-and-white television and completing training with a thorough study of color television. The total number of kits is 24, and the program breaks down into Study Groups 1-15; 16-29. There are two optional kits which are the picture tube and a cabinet.

22. Technology for the Technician. *CREI* (Capitol Radio Engineering Institute) offers Program 200—Electronic Engineering Technology, a broad education in theory and application of advanced electronics. From Program 200 you can go to a *major elective*, such as Communications Engineering, Servomechanisms and Computer Engineering, Aerospace Systems, Space Data Systems, or Communications Theory. Program 200 was created for technicians with at least two years' experience. For those with less there is Optional Program 100—Introduction to Electronic Engineering Technology.

23. Sound Info on Sound. *International Correspondence Schools* have a course called "Hi-Fi/Stereo and Sound Systems Servicing" which, they say, the average student completes in about 295 hours, at which time you'll be qualified as a mono/stereo sound technician. If you're a hobbyist you'll be able to troubleshoot your own equipment. There are 27 instruction units, each with its own text; i.e., "Mono and Stereo High Fidelity Systems" by Edward M. Noll.

CUT HERE

ELEMENTARY ELECTRONICS, Dept. HS-5
505 Park Avenue, New York, N. Y. 10022

☞ Yes! I would like to know more about the electronics home study courses described above. I am interested in only the course numbers circled below.

20 21 22 23

Name _____ Age _____

Address _____

City _____ State _____ Zip _____

(Fill in facts on reverse side)

Airplanes, Alight!

DRIPPING a multi-ton jetliner thousands and thousands of feet to a safe touch-down may *seem* like cat's play, but many's the crew whose experience has been otherwise. Especially challenging are those all-instrument landings when ceilings are of the sort everyone must duck under and visibility of the kind one might be tempted to carve with a knife.

To be sure, instruments brought the plane in on a near-perfect approach, but there still remained that biggest thorn among thorns: touchdown. Reason is that while instruments safely guided the plane to within yards of the runway, in most instances it was still up to the crew to once again assume control of the craft at the crucial moment and actually set the plane down.

Latest—and perhaps simplest—device in the move toward all-instrument landings is a distinctive V-ring antenna array, looking for all the world like a cross between a UHF skyhook and a one-way traffic sign. Produced by the Avionics Division of IIT Federal Laboratories for the Federal Aviation Agency, the new V-ring antennas promise to make the crew's task roughly half as difficult as it has been.

Plans call for the new antennas to provide navigation assistance to aircraft approaching and landing under instrument flight rules at airports in 29 U.S. cities. Basically, the antennas are localizer arrays that radiate a directional localizer pattern to provide lateral guidance to approaching aircraft. Operating



Destined for installation at end of airport runways in some 29 cities across the country, IIT Federal's V-ring antenna array will simplify instrument landings.

in the frequency range of 108 to 112 MHz, the antennas will be installed at ports as far distant as New York (La Guardia) and San Francisco, Duluth and Houston.

In some cases, the antennas, with their 15-arrow-like V-ring structures, will replace existing 8-loop arrays to meet the FAA's "Category II" ceiling and runway visual range requirements of 100 and 1200 feet, respectively. Since Category II landing operation minimums are approximately half the Category I requirements which previous antenna installations met, airports equipped with the newly developed V-ring antenna arrays will be able to bring in planes with something approaching half the ceiling and runway visual range they once could handle. ■

HOME STUDY BLUEBOOK COUPON

(See previous page)

Age _____ Are you a Veteran? _____ Employed in Electronics? _____

Occupation _____ Male _____ Female _____ Single _____ Married _____

Are you a student? Full-time _____ Part-time _____ Home Study _____

Check the last school you attended: Circle schools you graduated:

Grade School _____ High School _____ College _____ Graduate School _____

Have you ever taken a Home-Study course? _____ Completed? _____

What school(s)? _____

What is your yearly income to the nearest thousand? \$ _____

(If your income is \$6745, write in \$7000)

OPERATION FIXIT

For Transistors on the Fritz

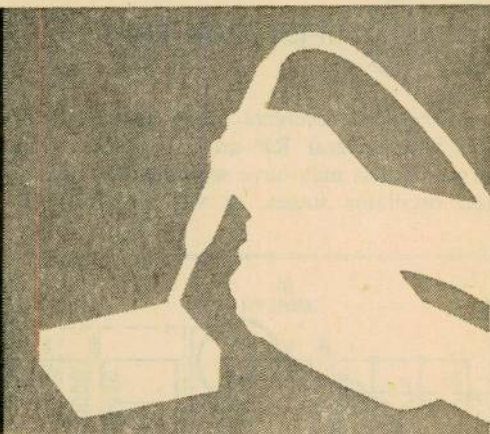

Going to a baseball game or to that favorite fishing spot for a little bait soaking? Better take along the portable radio for the latest news, sports, and weather. Of course, if the big multi-band solid-state job is on the fritz, and Suzy dropped her little purse radio, the next best thing is to take a few minutes and repair at least one of them. Anyone can do it if they pay heed to our words of transistor wisdom.

The Little Ones. Solid-state portable radios come in all sizes and shapes. Some are so tiny they will fit in the vest pocket or a lady's handbag. Others are mounted in table lamps, bean bags, desk sets, fur hats, etc. Speaker size on these jobs ranges from one to four inches in diameter.

The earlier low-cost models had a reflex circuit with three or four transistors. Today, most transistor radios use a superhet circuit and several stages of audio. Even the miniature solid-state jobs employ push-pull audio output stages, and most have provisions for adding an earphone.

Let's take a squint at the schematic diagram of a typical small transistor superhet radio. Fig. 1 shows a basic block diagram. The ferrite antenna coil picks up the station signal, which is inductively coupled to the base of the convertor stage. (The little receivers seldom have separate RF stages.)

The local oscillator signal is coupled to the base of Q1 (see Fig. 2). The IF signal is snatched out of the combined local oscillator and station frequency by T1 and fed to IF amplifier Q2.

IF Amplifiers. Seldom do we see more than two intermediate frequency (IF) stages in these receivers. The cascade IF stages have emitter-type bias using emitter resistors. The IF frequency is usually 455 kHz. From the secondary of the second IF stage we find a diode detector. At this point, the IF frequency is rectified to audio.

The audio signal level is controlled with volume control R10. As shown in Fig. 3, C16 couples the controlled audio signal to the base of the first driver stage. The last two audio transistors are used in a push-pull circuit for power output.

Some of the earlier low-cost models had only a single-ended audio output stage, as shown in Fig. 4. At present, many of the little jobs employ a transformerless audio output stage, like the one in Fig. 5.

Multi-Band Receivers. Transistor multi-band receivers are produced with two and three separate frequency bands covering AM, FM and/or shortwave. A multi-band receiver may have up to nine separate bands for listening to the entire world of shortwave.

(Continued overleaf)

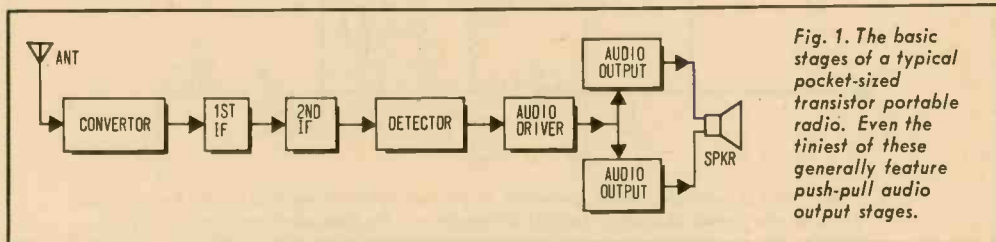

Fig. 1. The basic stages of a typical pocket-sized transistor portable radio. Even the tiniest of these generally feature push-pull audio output stages.

e/e OPERATION FIXIT

Multi-band receivers use a superhet circuit with several RF and IF stages. The larger models may have separate RF, mixer, and oscillator stages, as well as three IF

stages and push-pull audio output. AM and shortwave bands use the same front-end transistors simply by switching in or out the various coils as required for the frequency being tuned.

In the FM band, separate RF, convertor, IF, and discriminator stages may be added to the existing AM transistor stages. The frequency range of a 3-band receiver is

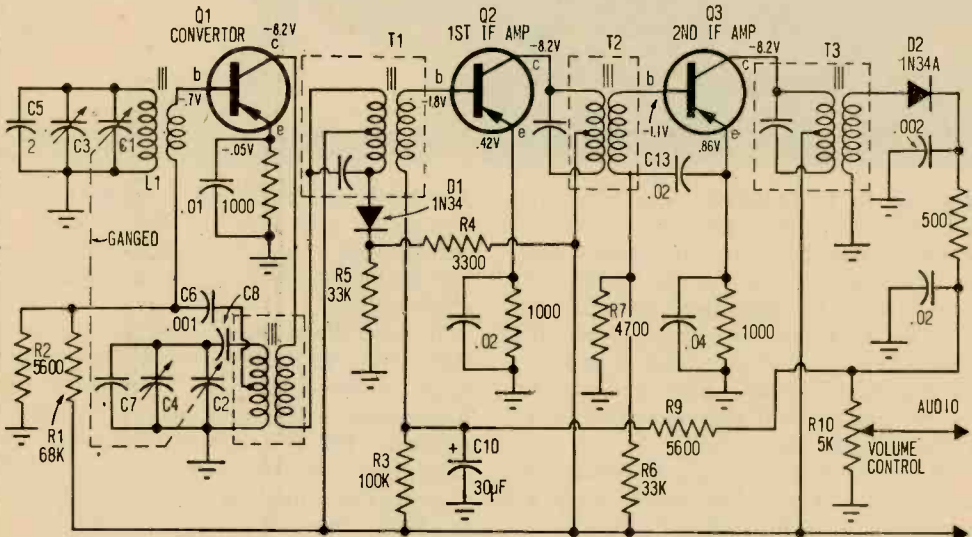

Fig. 2. Precise data on component values and circuit voltages requires schematic of radio. Still, typical circuit of transistor front-end above can be used as guide for do-it-yourself troubleshooters.

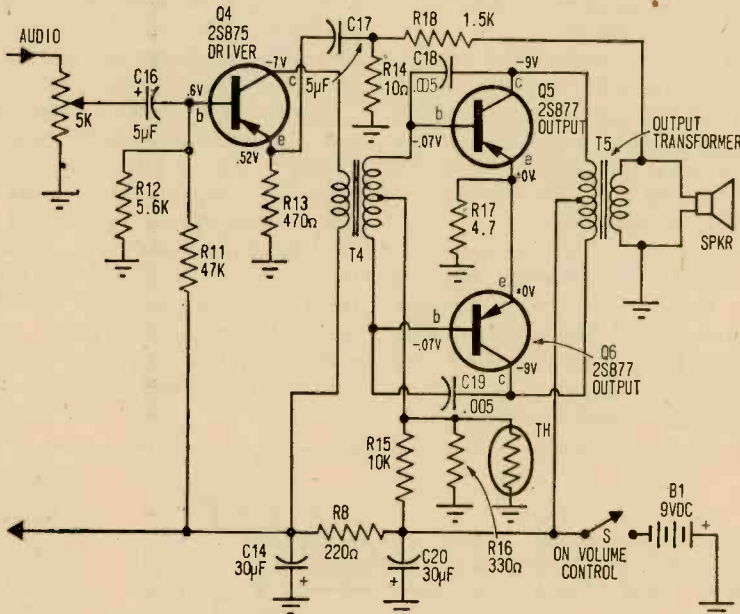

Fig. 3. Older types of transistor radios generally employ an audio driver and output transformer (such as that shown above) to provide adequate volume from relatively simple circuit.

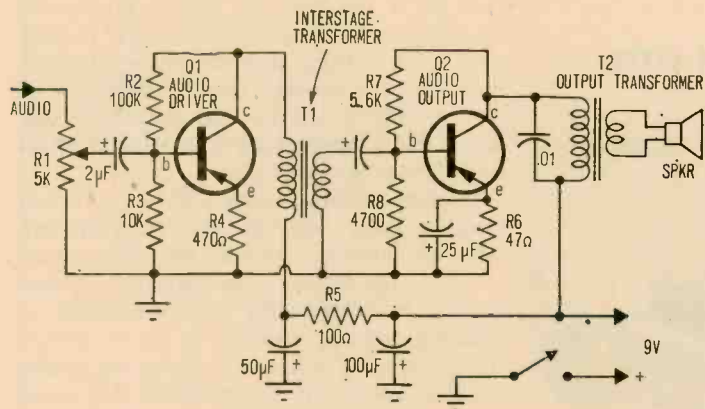

Fig. 4. The first of the small portable transistor radios had a single-ended audio output to conserve space and reduce cost, since transistors were expensive in those days.

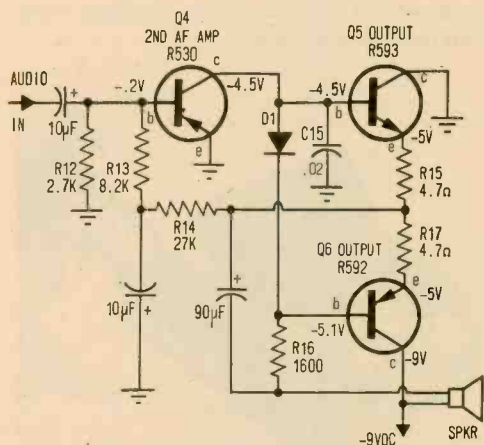

Fig. 5. With transistors costing next to nothing now, modern portables save weight, space, and cost by using transformerless audio output circuit.

to the variable tuning capacitor lugs. If all the stages are performing, loud clicking sounds should occur. Next, touch the screwdriver blade to the antenna terminals; sometimes a local station can now be tuned in, indicating a broken antenna wire (Fig. 7).

Another simple test is to hold the radio close to a neon or fluorescent lamp. You should hear a loud static noise. This noise test will prove that the audio and IF stages are functioning and the trouble possibly lies in the oscillator or antenna circuit. When only one or two local stations can be tuned in, the trouble probably lies in the antenna coil circuit. If the signal is not tunable and only one station can be heard, check the oscillator and RF circuit.

(Continued overleaf)

usually from 540 kHz to 18 MHz. See Fig. 6 for a typical multi-band unit.

Quick Checkout. There are a few practical tests you can make without using any test equipment. First, turn the unit on and listen for a plop or snap in the speaker. This indicates the battery and speaker are performing.

Of course, this does not say they are flawless, but it is a good indication they are working normally. As a further check, rotating the volume control up and down should cause a swishing noise, indicating the audio section is functioning. If these tests don't work out, insert the earphone and try once again. A rushing noise in the phone would suggest a defective speaker.

Now take the blade of a small screwdriver and go to the volume-control terminals. Place the screwdriver tip on the center lug of the volume control, and you should hear a 60 Hz hum.

Now carefully touch the screwdriver blade



Fig. 6. Advanced technology has made low-cost multi-band transistor sets available. Though more complicated, they basically work the same as the little ones.

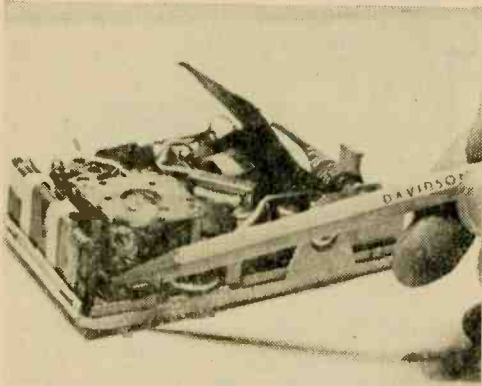
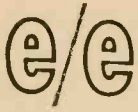

Fig. 7. Pencil points to fragile loopstick antenna wires that can easily be broken if radio is dropped or subjected to abuse. Weak local-station-only or no pickup can be caused by this defect.

Earphone For Noise. Under noisy conditions, it is best to insert and use the earphone for signal indication, instead of the speaker. Do not at any time attempt to adjust the IF or RF slugs or screws. These adjustments will be given in detail, later, for correct receiver alignment.

In case you have another portable or table radio handy, place it next to the defective radio and turn it on. Twirl the tuning capacitor through the entire broadcast band. If the local oscillator in the defective radio is performing, you should hear a whistle when you pass through the same band of frequencies.

No rushing or snapping noise in the speaker? Now check and replace those batteries. Still no sound? Check the battery terminals for excessive corrosion. The old batteries may have been left in too long and leaked out over the battery terminals. Dress down the terminals with a pocket knife and fine sandpaper.

Be sure to check battery polarity, since it's easy to get them in backwards. If your radio has one wire-coiled spring battery terminal, place the negative end of the battery against it (see Fig. 8). Check for tell-tale battery terminal marks on the battery case, or on the back cover of the radio. Usually, battery polarity marks are found next to the battery terminals.

Now take a visual check of the earphone jack. A dead radio can be caused by a defective earphone contact. Try the earphone

and see if you hear any music. In case the earphone is working and the speaker is dead, check the shorting contacts on the earphone jack and the speaker itself. Conversely, if the speaker is OK but the earphone dead, check for a broken cord at the plug or where it enters the earphone piece.

Current Check. Using a VOM on the low voltage scale, check the quality of the battery or batteries. Be sure the radio switch is on so the battery is in operation. Always have a load across the battery terminals in making voltage checks. A good battery tester (Fig. 9) is handy to check the quality of any battery. Try a new battery if in doubt or if a VOM isn't available—remember that 85 percent of portable radio problems stem from defective batteries.

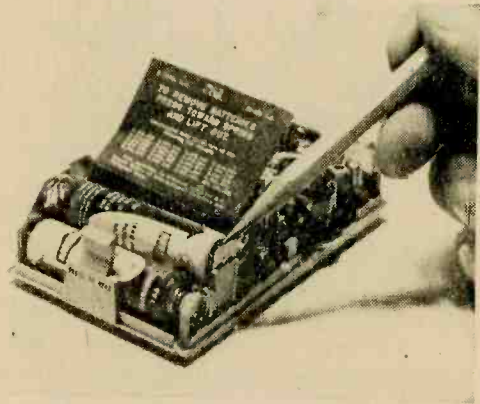

Fig. 8. Defective or corroded battery terminals are often the cause of transistor radio troubles—pencil points to a typical battery holder used in portables. When replacing batteries, be sure to check polarity.



Fig. 9. Weak or corroded batteries are transistor radio's number-one enemy and account for majority of problems. Checking batteries with a good battery checker that tests output voltage under load will locate defective unit.

Now the new batteries are installed and still the little radio remains silent. Let's take a quick current check. This may tell us if the defective radio is pulling too much current or not enough. Leaky transistors and capacitors can produce excessive current drain in the solid-state receiver. Most portable solid-state radios will pull from 5 to 16 mA—the large multi-band receivers up to 30 mA. A very low current reading or no reading at all indicates an open on/off switch, bad battery connection, bad battery cable, or open earphone shorting contacts. Excessive current readings will indicate a short or heavy leakage of one or more components in the receiver.

Too Much. Say, for example, the current meter shows a high reading somewhere between 50 and 100 mA. We definitely know that some component is leaky and drawing heavy current. A dead battery or several batteries used within a short time will bear this out. Don't overlook a possibility that the on/off switch never turns the receiver off.

If the switch seems OK, unplug the battery from the circuit and take an ohmmeter check across the large filter capacitor. A defective filter should be suspected if the reading is under 1000 ohms. Sometimes it is best to unsolder the filter capacitor from the circuit to make a proper check.

If things still look A-Okay, proceed to the audio output transistors. Since these transistors pull the most current, they are the most likely cause of excessive current drain. Most transistors must be unsoldered from the PC board (be sure to heat-sink the leads and use a small iron). Check them on a transistor tester for leakage and quality.

Voltage and Resistance Checks. A voltage check on the circuit can indicate the area at fault. Suppose we suspect a driver

TRANSISTOR RADIO DIAGNOSIS CHART

Symptom	Check
Weak Receiver	<ol style="list-style-type: none"> 1. Audio coupling capacitor 2. Transistors 3. Antenna connections 4. Weak batteries 5. Bad board connections
Dead Receiver	<ol style="list-style-type: none"> 1. Batteries 2. Audio output transistor 3. Earphone jack terminals 4. Transistors 5. Capacitors 6. Bad switch or battery terminals
Intermittent Receiver	<ol style="list-style-type: none"> 1. Transistors 2. Coupling capacitors 3. Intermittent IF transformer 4. Broken board 5. Bad battery connections
Noisy Reception	<ol style="list-style-type: none"> 1. Check audio transistors and replace 2. Isolate stage from audio or rf section
Distortion	<ol style="list-style-type: none"> 1. Audio output transformer 2. Burned bias resistors 3. Defective speaker 4. Leaky coupling capacitors

transistor of being defective. Measuring the collector voltage to ground potential will determine what's wrong. If the collector voltage is quite low compared to that shown on the schematic, suspect a shorted or leaky transistor. But if the collector voltage is the same as the supply voltage, the transistor is probably open.

When checking the low voltages on the emitter terminals of the RF, convertor, and IF stages, use the lowest possible voltage range on the VOM. These voltages on solid-state radios will vary from -0.1 to -1.5 volt. No voltage at all will indicate an open transistor or a defective emitter resistor.

The base voltage will be somewhat close to the emitter voltage with emitter resistor bias. This also holds true in the first audio and driver stages. The same amount of voltage on collector and base will indicate a shorted transistor.

Resistance measurements are not as effective as voltage readings, though emitter bias resistors and transformer windings are easily checked with an ohmmeter. But since resistors in solid-state circuits often are of very low value and internal transistor resistances are low as well, incorrect resistance readings frequently are obtained due to parallel current paths. (Continued overleaf)

TRANSISTOR REPLACEMENT CHART

Transistor	RCA	GE
RF	SK3007	GE-1
	SK3005	
Convertor	SK3006	GE-1
FM RF	SK3006	GE-11 npn
FM Oscillator	SK3006	GE-11 npn
1st IF and 2nd IF	SK3005	
	SK3002	GE-1
1st Audio or Driver	SK3004	GE-2
	SK3003	
Output	SK3004	GE-2
Power Output	SK3009	GE-3

Fig. 10. Transistors commonly used in portable radios.

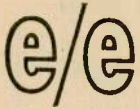

OPERATION FIXIT

Transistor Troubles. The transistor can go open, become weak, or leaky. With signal-tracing methods and voltage checks, a defective transistor can readily be located. Remove the transistor from the circuit if voltage checks indicate a defective unit.

You should use a transistor tester to check the suspected transistor. Some transistor testers are small and low in cost, while in-circuit transistor checkers are quite expensive. Any low-cost transistor tester will show up a weak, open, or leaky transistor.

The in-circuit transistor tester will quickly indicate an intermittent transistor. With the transistor hooked to the tester, tap the top of the transistor and wiggle its leads (a broken connection inside the transistor can cause an intermittent condition). Another method is spraying "coolant" or "freeze" liquid on the suspected transistor. If intermittent, the transistor will give an erratic meter reading.

No Oscillator Poop. Weak transistors show up first in the oscillator and audio stages. When the radio will only receive stations on part of the broadcast band, the oscillator transistor is probably at fault. A defective output transistor, in contrast, causes weak reception on the entire band.

Noisy transistors can show up in any stage of the receiver. First check the driver and audio output transistors to see if the noise is generated in the audio or RF end of the radio. If the noise is still present with vol-

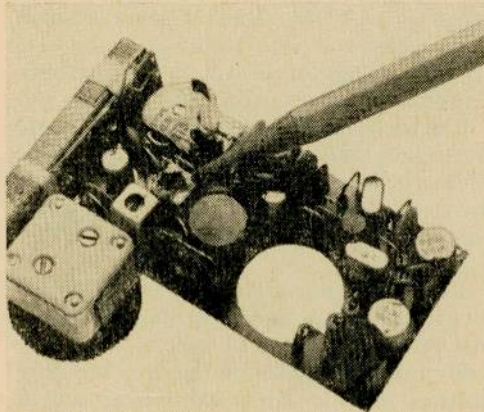

Fig. 11. Pencil tip points to one of the IF transformers on a typical transistor radio circuit board. A defect here can cause intermittent operation.

ume control turned all the way down, the trouble lies in the RF section.

Distortion in transistor receivers is usually caused by a defect in the audio stages. A leaky transistor is probably at fault, so start by taking voltage measurements. While the transistor is out of the circuit, check the emitter and collector resistors for quality.

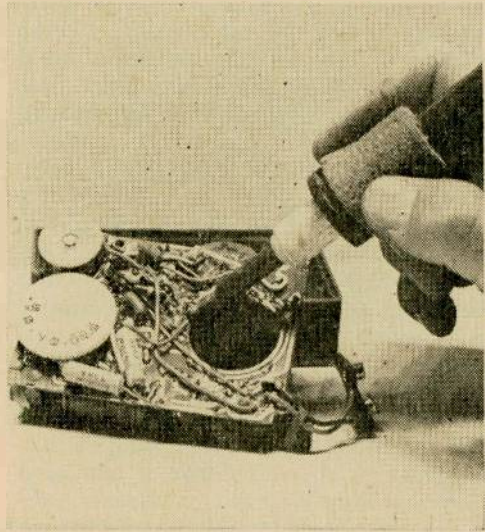

Fig. 12. Dropping the little radios can cause a cracked PC board or broken solder connections. Resoldering all suspicious-looking connections may remedy this.

Incorrect bias and supply voltage also produce distortion.

Microphonic transistors are most troublesome in the first audio-driver and oscillator stages. Of course, you may find them in other stages but these are the ones most likely to bring headaches. Tapping a microphonic transistor with a pencil will result in oscillation or ringing; the remedy is to replace the defective unit with a new one. See Fig. 10 for a list of equivalent transistors.

Component Failures. In case of intermittent reception, suspect a defective IF transformer, coupling capacitor, poor battery connections, or a broken PC board. If adjusting an IF slug doesn't seem to make any difference during alignment, the transformer is probably defective (Fig. 11).

When a portable radio is dropped, nine times out of ten the PC board will be cracked or broken (see Fig 12). Look closely around the heavy objects mounted on the PC board, such as tuning capacitor, output transformer, and volume control. Twist the board while the radio is on and see if reception becomes intermittent. If so, repair the



Fig. 13. Careful inspection of the radio can often uncover the problem. When soldering these jobs, use a small low-power iron to avoid damage from excess heat.

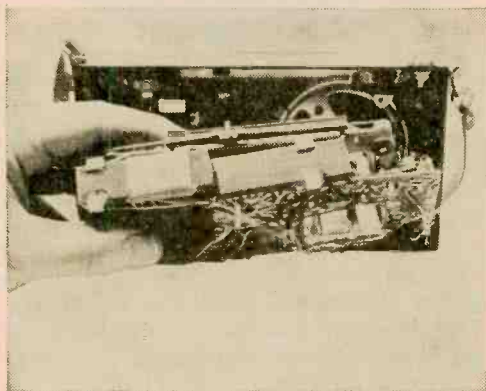

Fig. 14. Visual inspection of this one quickly determined why reception was weak—the loopstick antenna was broken. The cure is to replace the antenna with a new one.

PC board by placing bare hook-up wire across the broken joint.

Check for broken wire joints from the windings of the interstage or output transformer to the PC board. Use a magnifying glass to see if any small resistors are broken or cracked. Generally, a close view of the PC board will point out many trouble spots (see Figs. 13 and 14).

A worn volume control will cause intermittent or noisy reception. When the volume control is rotated, listen for a grating sound. To quiet the control squirt tuner lube between the cover and connecting terminals.

If this doesn't do the job, replace the control.

Check the speaker for a rattling or torn cone. Also, turn the volume down low and check for mushy sound due to the cone rubbing on the center pole piece. A rattling or loose cone can generally be repaired with speaker cement; a rubbing cone ordinarily indicates need for a new speaker.

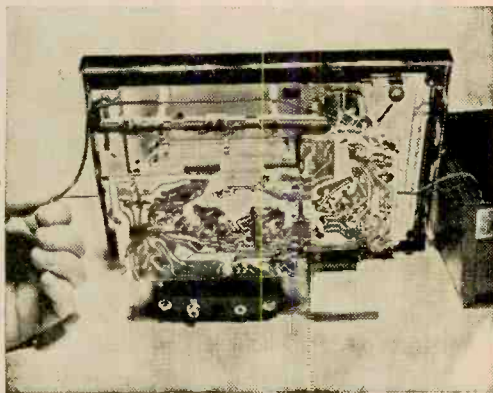

Fig. 15. Alignment of a portable transistor radio is fairly simple (see text). Here, the signal generator is coupled to the radio with a wire loop next to the antenna.

A defective filter capacitor can become leaky or go open. In the output stage, a putt-putt noise can stem from the electrolytic capacitor between speaker and output circuit. In the case of constant squealing, suspect a defective filter capacitor.

Receiver Alignment. To align the IF, RF, and oscillator stages, take several turns of hook-up wire and form a loop, placing it near the ferrite antenna, as shown in Fig. 15. Hook the output meter to the speaker leads. Set the generator for modulated signal, and turn the receiver's volume control to maximum. Set the signal generator frequency to 455 kHz and set the receiver to 1600 kHz. Now, adjust the IF transformer slugs for maximum indication, using an IF alignment tool. Go back and peak the IF adjustments again.

Now set the signal generator to 550 kHz (tuning capacitor plates fully closed), and adjust the slug in the oscillator coil for maximum strength on the output meter. After the adjustment, rotate the tuning capacitor fully open, and set the signal generator to 1630 kHz. Adjust the oscillator trimmer on the variable tuning capacitor for maximum meter reading. Set the tuning capacitor to 1400 kHz and rock the tuning capacitor while tuning RF and oscillator adjustments for maximum meter reading. ■

HOW GOOD ARE STYLUS PRESSURE GAUGES?



By Bill Britton

As most hi-fi buffs are well aware, the most important and critical part of any record-reproduction system is the microscopic area at the tip of the stylus. All things being of high quality, the fit between the tip of the stylus and the record groove is going to determine whether your neighbors are envious, the record "wears out" after a few playings, or nerve-jangling distortion rears its head.

Since the pickup manufacturer (supposedly) optimizes the point of the stylus—and there is as yet no do-it-yourself stylus-regrinding kit—it's only necessary for the

user to set stylus pressure to the correct value for optimum reproduction.

But what is optimum stylus pressure? Based on the questionable thesis that the-lighter-the-pressure-the-better-the-pickup, a manufacturer may recommend a pressure so light that the slightest error on the light side results in the stylus rattling in the groove. The inevitable consequence, of course, is accelerated record wear and a substantial increase in distortion.

On the other hand, you yourself might prefer to use the recommended stylus pressure specified in test reports. But either way,

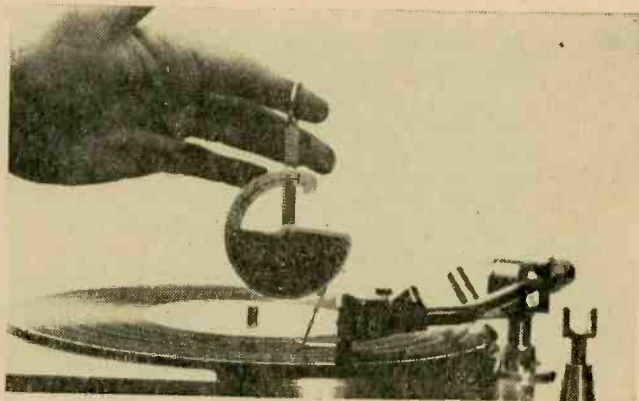
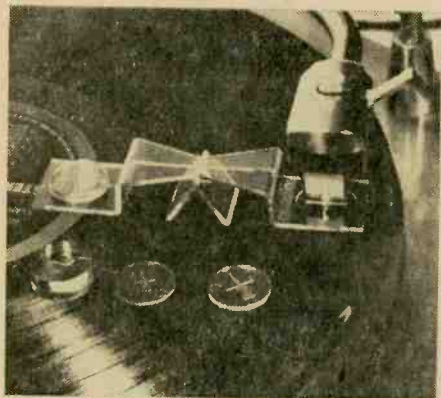

57
you must depend on a *stylus pressure gauge*—a device that measures the pressure exerted by the stylus on the record groove—to establish the desired pressure.

You And Your Gauge. Thing is, can you depend on your stylus-pressure gauge? In fact, is *any* gauge presently on the market accurate enough to measure the flea-weight pressures required by the most modern of stereo cartridges—such as $\frac{3}{4}$ gram? And, if judged to be accurate, is such gauge accurate over the entire measurement range?

Ten years ago, stylus-gauge accuracy was no problem. If a cartridge was to be set for 6 grams pressure and the gauge was off by $\frac{1}{2}$ gram there wasn't much to-do about it; $\frac{1}{2}$ gram out of 6 was too small an error to be important. But when a modern cartridge requires, say, $\frac{3}{4}$ -gram pressure, a $\frac{1}{2}$ -gram error becomes serious, if not devastating. (There are few cartridges that won't chew a groove wall to pieces at $\frac{1}{4}$ gram total pressure—not to mention delivering some rather third-rate sound.)

By now you have the idea; we tested all popular stylus-pressure gauges. And we found that some are almost error-free while others are worthless for the serious audiophile. As is frequently the case, price is absolutely no indication of accuracy.

What We Looked For. Since $\frac{1}{2}$ gram or so error is essentially of no importance at higher stylus pressures (3 grams and up), we concentrated solely on accuracy below 2 grams—the stylus pressure range of most high-quality pickups. For standards we employed a set of accurate weights of the type used by chemists for quantum analysis. With these weights, the arm on a popular quality turntable/arm combination was set to $\frac{1}{2}$, 1, $1\frac{1}{2}$, and 2 grams pressure. This provided our standard of reference, which we then

used to check each pressure gauge in turn for accuracy, repeatability of measurement, and convenience of operation.

Basically, there are two types of pressure gauges: the spring and the balance types. In the spring gauges, stylus pressure is determined either by the force necessary to move a spring-loaded pointer a specific distance, or by the spring force needed to overcome the force of the cartridge and arm.

Balance-type gauges, in contrast, are all of the beam-balance type, somewhat on the order of a child's seesaw. Pressure is indicated by the amount of weight required on one end to balance the force of the stylus on the other end.

On some balance-type gauges the weight is fixed and the position of the pickup arm needed to balance the weight determines the stylus pressure. On other balance types the position of the phono arm is fixed and the weight is changed until balance is obtained. On still others, the weight is positioned along the arm until balanced, with the weight position indicating the stylus pressure.

Two of each model of pressure gauge were tested. And since the results with one exception were always identical, we assume that the models we tested were typical of the standard production run. The prices we show, incidentally, are what we paid a consumer electronics parts distributor—not the manufacturer's list.

• **AR (Acoustic Research) Stylus Pressure Gauge (89¢, \$1.00).** The AR gauge is an inexpensive beam-balance type. On one side the plastic is grooved to accept the $\frac{1}{4}$ -, $\frac{1}{2}$ -, 1- and 2-gram weights supplied. On the other side there is a dimple which the stylus is lowered into. As shown in our photo, the gauge is placed on a record at right angles to the arm; the stylus pressure

Far left: AR gauge is simple plastic device supplied with set of plastic weights. Operating on fulcrum principle, gauge responds to 50-milligram pressure.

Left: Calrad gauge is supposed to indicate correct stylus pressure when gauge is carefully lifted until stylus just clears record surface. Gauge is calibrated 0 to 30 grams.

Right: Clarkstan gauge requires that stylus be placed in one of two small cups; associated spring leaf indicates pressure in grams or ounces directly on calibrated scale.

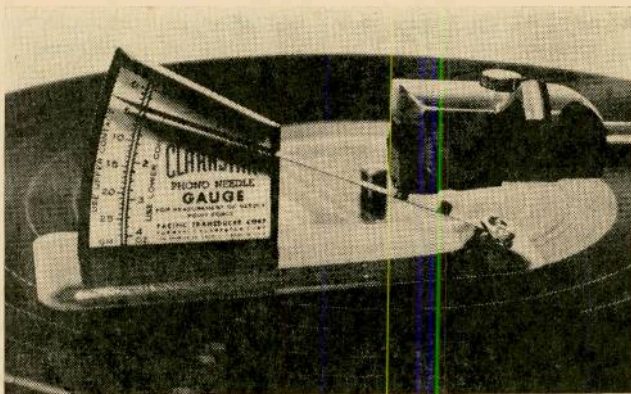

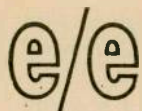

PRESSURE GAUGES

is the amount of weight required to balance the beam. To set the pressure to a predetermined force the appropriate weights are placed on the beam, then the arm's counter-balance or spring-load is adjusted until the beam is optimally balanced.

The AR weights, though plastic, proved extremely accurate at all test pressures. And while the beam was a shade off-balance at 1 and 2 grams, it must be kept in mind that only 50 milligrams (0.05 gram) is sufficient to completely unbalance the AR gauge to the point where the beam rests on the record. Obviously, the AR's accuracy is essentially 100 percent. Repeatability of measurement was also 100 percent; the gauge indicated

At the low-force test points, the Calrad calibration left quite a bit to be desired. With a test force of $\frac{1}{2}$ gram, the Calrad indicated 1 gram; at 1 gram test, the gauge indicated $1\frac{1}{2}$ grams; at $1\frac{1}{2}$ grams test, 2 grams; at 2 grams test, $2\frac{3}{4}$ grams. Worse yet, repeatability of measurement ranged from $\frac{1}{2}$ to 1 gram error, depending on how the gauge was handled. Further, care must be exercised to prevent the arm slipping off the pad.

• **Clarkstan Phono Needle Gauge (\$1.76)**. As shown in our photos, the Clarkstan indicates in ounces or grams the force needed to move a spring. Two needle "cups" are provided on the spring, one for measurement in grams and one for ounces. The gauge is calibrated for 0-28 grams. The calibration marks represent 1 gram, and are extremely close together. This, combined with relatively large parallax error between

Garrard gauge is unique in that it can be user-calibrated.

Unit is supplied with 5-gram calibrating weight (shown held in tweezers), which is placed on stylus cup. Screw in center of setting knob is then adjusted until scale indicates reading of precisely 5 grams.

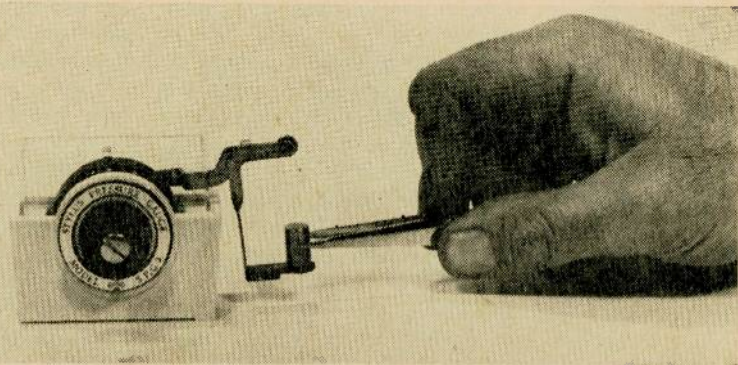

the same pressure every time it was tested.

• **Calrad PG-22 (\$1.00)**. The Calrad PG-22 appears identical to the Lafayette Radio 99 C 1011 (which was not available for test). It is similar to a lightweight postage-stamp scale in that the pressure applied to a felt-padded "foot" pulls the scale down, and the pressure (weight) is indicated by a pointer. To use the scale, the user places the foot under the stylus and then raises the scale until the arm just lifts clear of the turntable. As the arm is lifted the scale rotates, until the force required to lift the arm appears under the pointer.

The Calrad is calibrated from 0 to 30 grams, with 0-5 grams in 1-gram units. However, the closest "between calibration" force that can be estimated between 0-5 grams is $\frac{1}{2}$ gram. Further, the space between calibration marks gets progressively smaller as the pressure increases.

the spring and scale, plus the fact that the spring tends to vibrate, means that *any* reading in between the calibration marks can only be estimated as being something on the order of $\frac{1}{2}$ gram.

The position of the stylus in the cup affected the readings each time we took a measurement, which means that repeatability was poor. The readings below tell the story:

$\frac{1}{2}$ gram test, $\frac{1}{2}$ to $1\frac{1}{2}$ gram indicated

1 gram test, $\frac{1}{2}$ to 2 grams indicated

$1\frac{1}{2}$ grams test, $\frac{1}{2}$ to 2 grams indicated

2 grams test, 1 to $2\frac{1}{2}$ grams indicated.

Too, handling ease is poor. For while we show the gauge on top of a record for clarity, the manufacturer recommends the gauge be propped on the motorboard or cabinet so that the cup is exactly at the record height. On some modern compact turntables this is an almost impossible feat.

• **Garrard SPG3 (\$2.95)**. A spring-

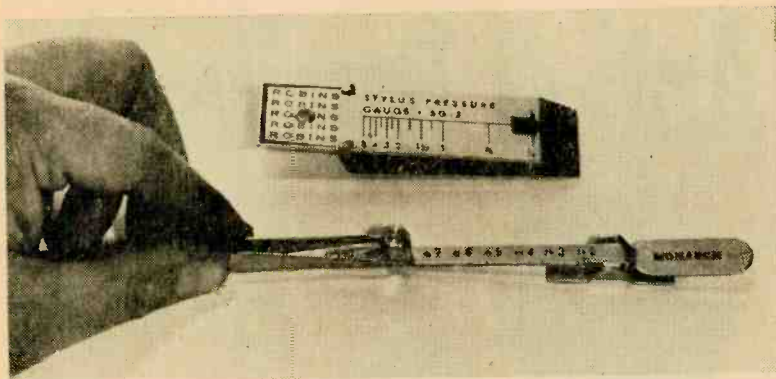

Robins gauge (top) has fixed counterweight. To balance beam, cartridge is moved along right side; stylus pressure is then read off scale directly under stylus. Monarch gauge (bottom) is equipped to measure "full-gram" pressures only, does not indicate fractions.

loaded gauge, the SPG3 is a beautiful piece of machinery which indicates stylus pressure as the amount of spring force needed to counterbalance the force of the cartridge. The gauge is calibrated from 0 to 12 grams with ½-gram divisions. The space between the ½-gram marks is sufficient for accurate estimate of ¼-gram increments.

To use the scale, the stylus is placed on a plastic scale pan, thereby pulling the balance arm and the attached pointer down. When the setting knob is rotated the spring pressure against the arm is increased, causing the pointer to rise. When the pointer is opposite a setting line, the stylus pressure is read off the scale attached to the setting knob.

The SPG3 is supplied with a 5-gram calibrating weight, which stores inside the scale. Unfortunately, while the calibrating weight ensures that the scale is calibrated for 5 grams, it doesn't ensure accuracy below 2 grams.

Repeatability of measurement is essentially 100 percent. Handling ease is very good, and the position of the gauge in relationship to the arm isn't critical.

• **Lafayette Radio 99-1035 (25¢).** This beam-balance consists of a plain piece of metal approximately 5/8 x 2¼ in. with two dimples pressed-in to form a pivot point. It has calibration marks for 2, 3, 4, 5, 7, and 10 grams. Each calibration mark is a groove into which the stylus is placed. For example, if an arm with 2 grams pressure has its stylus placed in the 2-gram groove, the beam rises to balance. Amazingly, the 2-gram mark was within 50 milligrams accurate. Still, it is impossible to measure or estimate pressures of less than 2 grams.

Repeatability of measurement is of course 100 percent. The handling is poor, since the grooves are very shallow and it is difficult to

locate the stylus in the grooves.

• **Robins PEG2 (59¢).** The Robins is a beam-balance with a fixed counterweight. The position of the torque arm on the beam necessary to balance the gauge determines the stylus pressure. The scale is calibrated from ½ to 8 grams, with ½ to 2 grams utilizing most of the scale; calibration marks between ½ and 2 grams is at ¼ gram. The test results:

*½ gram test, 7/8 gram indicated (sometimes)
1 gram test, 1½ grams indicated (sometimes)
1½ gram test, 2¼ grams indicated (sometimes)*

2 gram test, 3 grams indicated (sometimes)

Repeatability of measurement was very poor (the results shown above are the majority of ten test runs). Handling ease was also very poor.

• **Monarch SPG-2VP (79¢) and Walco W-10PG (\$1.00).** With a very minor difference—the shape of the stylus groove—these two gauges appear to be identical. Both are the beam-balance type where the stylus is placed in a calibrating groove and a weight is moved down the other end of the beam until the scale balances. Actually, the weight fits into a hole on gram marks between 2 and 10 grams.

Fractional readings, such as 3½, are indicated when the weight is in the 3-gram hole and the stylus side of the beam is just about pushed all the way down. The 2-gram mark proved to be ¼ gram on the high side, and it was impossible to indicate less than 2 grams with any degree of acceptable accuracy.

Repeatability of measurement at 2 grams was, of course, good. Handling ease was very poor: the stylus groove is extremely shallow and extreme care must be taken to ensure that the stylus is in the groove. ■

Anti-Q Receiver



By Art Trauffer

Technology has progressed so far that many of us forget where it all began. And the days of filament rheostats, black bakelite panels, fluted knobs and 0 to 100 tuning dials are now gone forever. Yet this era, with its paraphernalia and mechanical approach to little-understood electronics, has its own inimitable romance.

These were days when the tinkerer was king and factory-made equipment looked homebrew. It was a time of interstage transformers, two or three stages of separately tuned RF, regen detectors and variometers, long wire antennas and good cold-water grounds. Many will remember those good old days from first-hand experience, but for

some it is an era depicted only on the pages of electronics history books.

Yesteryear Today. Our Anti-Q receiver will revive fond memories and recreate those happy days of broadcast listening in the early twenties. The finished unit makes a neat addition to any home and works far better than the original model it's based on ever did.

A Radio Shack "Build In" Radio is the "works," and consists of the radio, a volume control with switch, and a 2¼ in. speaker, as shown.

The photo shows the front view of the completed Anti-Q. An old-fashioned 3-in. dial is used for tuning. (If you can't locate one, you can make it as described later.) A

fluted knob with pointer is used on the volume control and it looks like the filament rheostat knobs of the old days.

Seven Peep Holes. The group of seven small holes are like the "tube peep holes" on the early radios, but here they serve as a grille for the speaker. The circuit-closing jack lets you plug in a pair of low-impedance earphones, or an outboard speaker. The wood cabinet is of walnut, or other hardwood, and is styled like the battery-radio cabinets of the early days.

If you cannot locate any 1/8-in. black bakelite or hard rubber for the front panel, composition board can be covered with black "Contact" material as the writer did.

The photo below shows how the parts are mounted on the back of the front panel. The radio comes with two holes in the front of the plastic case for panel mounting, but it's best to drill another hole on the other side of the shaft—for this, use a #34 (0.111) drill. The radio is then mounted on the

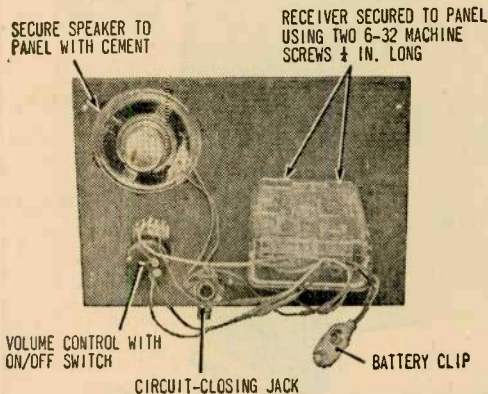

All internal parts for Anti-Q come with the Built-In radio kit, except for the circuit-closing jack. Parts are mounted on front-panel approximately as shown.

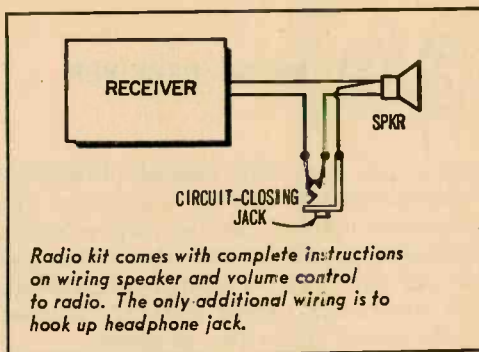

Radio kit comes with complete instructions on wiring speaker and volume control to radio. The only additional wiring is to hook up headphone jack.

panel using two 6-32 machine screws 1/4-in. long. The speaker is mounted over the group of seven holes using cement around the edge of the speaker rim.

The radio, volume control and speaker are wired up as per directions on the box of the "Build-In" radio. All wire leads are color-coded for ease of wiring. The circuit-closing jack is wired as shown in the schematic.

Dial To Tune By. Old-fashioned 3-in. diameter tuning dials, with a set screw for 1/4-in. shaft, are still available from junked radios, antique shops, or antique radio collectors, but if you have trouble finding one, you can make your own as shown in the drawing and photo.

To make the 3/8-in. bevel on the tuning dial, simply fasten the compo-board disc on a 1/4-in. bolt, using washers and nuts on either side of the disc, and then chuck the bolt in a drill press. File away the bevel using hard-grit sandpaper on a wood block as the drill press rotates the disc. Finish the disc with fine-grit sandpaper and give it a coat or two of black enamel.

White On Black. Calibration lines are drawn on the dial edge using a draftsman's

BILL OF MATERIALS FOR THE ANTI-Q RECEIVER

1—"Build In" Radio (includes radio, volume control with switch, and speaker) (Radio Shack 12-1150 or equiv.)

1—3-in. dia. tuning dial for 1/4-in. shaft (see text)

1—Fluted knob with set-screw for volume control (Allied Radio 47B4117)

1—Circuit-closing phone jack

1—Black non-metallic panel, 5x7x1/8-in. (see text)

1—9-volt transistor battery

Wood for Cabinet:

2—8 1/2 x 4 1/2 x 1/2-in. hardwood for top and bottom

2—5x4 1/4 x 1/2-in. hardwood for sides

1—5x7x1/2-in. hardwood for back

2—5x1/2 x 1/2-in. hardwood (holds panel)

2—Cabinet hinges with screws (about 1x1 1/2-in.)

For Home-made Tuning Dial:

1—3-in. dia. disc of 1/4-in. composition board or hardwood

1—Fluted knob (Allied Radio 47B4117, remove pointer from knob)

Misc.—Finishing nails 1-in. long, 4 small rubber tack bumpers for bottom of cabinet, aluminum eyelets for front panel, glue, 4 round-head wood screws 1/2-in. long for front panel.

e/e ANTI-Q RECEIVER

ruling pen and white enamel. Frequency numerals are lettered with white enamel. The frequency numerals can be used as shown instead of the old-fashioned 0 to 100 to give the old dial a modern touch. Using cement, the fluted knob (Allied 47B4117) is glued to the center of the disc, as shown.

For the cabinet, the writer used 1/2-in. walnut put together with short finishing nails and glue. The drawing gives all constructional details. The wood is finished off with fine-grit sandpaper, brushed with walnut stain, given several coats of good wax and then hand-rubbed with facial tissues. This

results in a beautifully finished surface.

Anti-Q's tone is considerably better than a conventional transistor radio because the speaker is in a large wooden cabinet. For the perfectionist who wants even better sound from the little radio, it's possible to install a larger speaker on the front panel. If this modification is desired, more holes should be made for the grill, or the seven holes specified should be made larger to get the full benefit of a bigger speaker.

Operation. Operation of the Anti-Q is simple, just like your pocket transistor radio. No antenna is needed and the unit provides plenty of volume.

Anti-Q makes quite a conversation piece and combined with the fact that it's also a practical radio, it's a great project for those long winter evenings. ■

CABINET ASSEMBLY

Taking care in constructing Anti-Q cabinet will pay off in neat-looking finished unit. Cabinet can be built as shown by any amateur craftsman using only hand tools, or it can be modified to suit individual tastes and requirements.

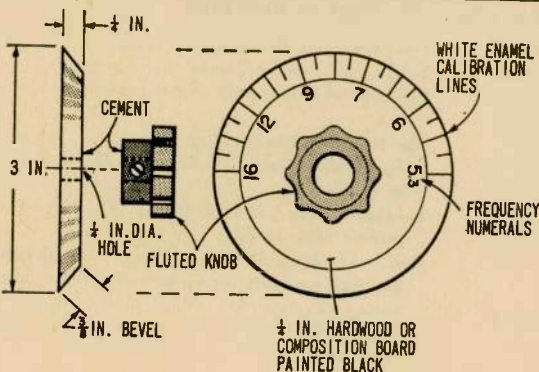
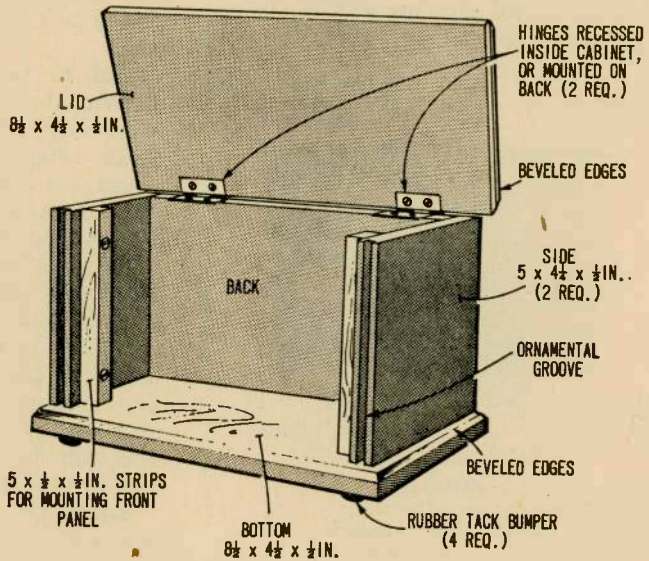

DIAL DETAILS

Failing to locate an old-time tuning dial, one can be made from a composition board or wooden disc. Markings showing either frequency or 0 to 100 in numerals can be used. Be sure to center fluted knob on disc when gluing it on.

At Home with Electronics

By Jack Schmidt



"Must be a bum tube in the garage door opener."



"Wha'da you mean, you hate to tackle it without a schematic?"



"His wife says he was trying to mash potatoes with a laser."

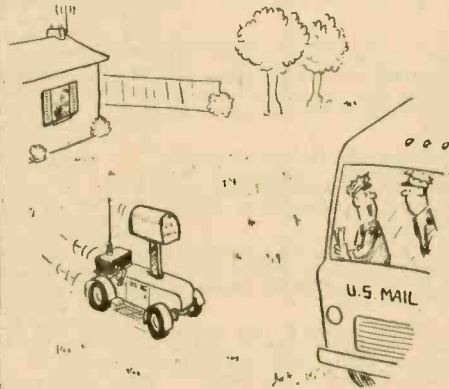

"This is the laziest guy on the route."



"No, it's not a secret experiment— I blew a fuse!"

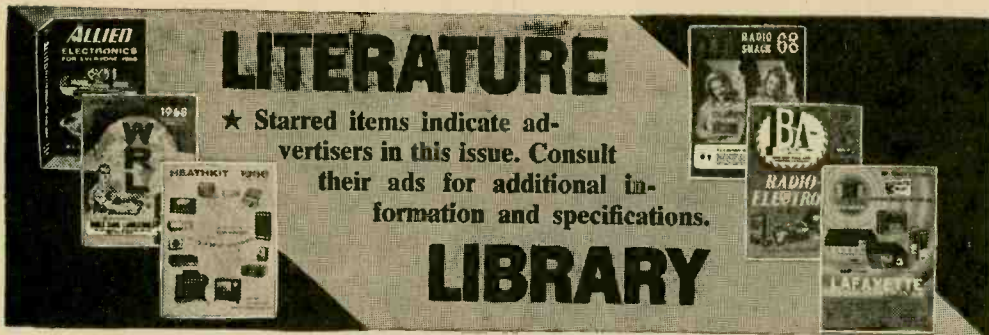

LITERATURE

★ Starred items indicate advertisers in this issue. Consult their ads for additional information and specifications.

LIBRARY

CB—AMATEUR RADIO— SHORTWAVE RADIO

★129. Boy, oh boy—if you want to read about a flock of CB winners, get your hands on *Lafayette's* new 1968 catalog. *Lafayette* has CB sets for all pocketbooks.

122. Discover the most inexpensive CB mobile, Citi-Fone II by *Multi-Elmac Company*. Get the facts plus other CB product data before you buy.

50. Get your copy of *Amphenol's* "User's Guide to CB Radio"—18 pages packed with CB know-how and chit-chat. Also, *Amphenol* will let you know what's new on their product line.

121. Going CB? Then go *CB Center of America*. Get their catalog and discover the big bonus offered with each major product—serves all 50 states.

107. Want a deluxe CB base station? Then get the specs on *Tran's* all new Titan II—it's the SSB/AM rig you've been waiting for!

116. Pep-up your CB rig's performance with *Turner's* M+2 mobile microphone. Get complete spec sheets and data on other *Turner* mikes.

48. *Hy-Gain's* new CB antenna catalog is packed full of useful information and product data that every CBER should know. Get a copy.

111. Get the scoop on *Versa-Tronics* Versa-Tenna with instant magnetic mounting. Antenna models available for CBERs, hams and mobile units from 27 MHz to 1000 MHz.

45. Hams, CBERs, experimenters! *World Radio Labs* 1968 catalog is a bargain hunter's delight. Get your copy—it's free.

115. Get the full story on *Polytronics Laboratories'* latest CB entry—Carry-Comm. Full 5-watts, great for mobile, base or portable use. Works on 12 VDC or 117 VAC.

100. You can get increased CB range and clarity using the "Cobra" transceiver with speech compressor—receiver sensitivity is excellent. Catalog sheet will be mailed by *B&K Division of Dynascan Corporation*.

54. A catalog for CBERs, hams and experimenters, with outstanding values. Terrific buys on *Grove Electronics'* antennas, mikes and accessories.

★93. *Heath Co.* has a new 23-channel, all-transistor, 5-watt CB rig at the lowest cost on the market, plus a full line of CB gear. See their new 10-band AM/FM/Shortwave portable and line of shortwave radios.

101. If it's a CB product, chances are *International Crystal* has it listed in their colorful catalog. Whether kit or wired, accessory or test gear, this CB-oriented company can be relied on to fill the bill.

96. If a rugged low-cost business/industrial two-way radio is what you've been looking for, be sure to send for the brochure on *E. F. Johnson Co.'s* brand new Messenger "202."

103. *Squires-Sanders* would like you to know about their CB transceivers, the "23'er" and the new "S5S." Also, CB accessories that add versatility to their 5-watters.

46. A long-time builder of ham equipment, *Hallcrafters* will send you lots of info on ham, CB and commercial radio equipment.

ELECTRONIC PRODUCTS

★128. If you can hammer a nail and miss your thumb, you can assemble a *Schober* organ. To prove the point, *Schober* will send you their catalog and a 7-in. disc recording.

126. *Delta Products* new capacitive discharge ignition system in kit form will pep up your car. Designed to cut gas costs and reduce point and plug wear. Get *Delta's* details in full-color literature.

★42. Here's a colorful 108-page catalog containing a wide assortment of electronic kits. You'll find something for any interest, any budget. And *Heath Co.* will happily send you a copy.

★44. Get your copy of *EICO's* colorful 36-page catalog on 200 "best buys" products. Ham radio, CB, hi-fi, test gear, both wired and kit, are illustrated.

★125. Need TV camera kit, touch control lamp, hi-fi component, test unit or shop gear? Then you need *Conar's* latest catalog. Born from *NRI*, *Conar* has become a major supplier of electronics hobbyist parts.

66. Try instant lettering to mark control panels and component parts. *Datak's* booklets and sample show this easy dry transfer method.

109. *Seco* offers a line of specialized and standard test equipment that's ideal for the home experimenter and pro. Get specs and prices today.

ELECTRONIC PARTS

★1. *Allied's* catalog is so widely used as a reference book, that it's regarded as a standard by people in the electronics industry. Don't you have the 1968 *Allied Radio* catalog? The surprising thing is that it's free!

★2. The new 1968 Edition of *Lafayette's* catalog features sections on stereo hi-fi, CB, ham gear, test equipment, cameras, optics, tools and much more. Get your copy today.

102. Before you buy your next xtal, get ahold of *Sentry's* 1968 catalog. *Sentry* lists the best in precision quartz crystals and communications goodies.

8. Get it now! *John Meshna, Jr.'s* new 46-page catalog is jam packed with surplus buys—surplus radios, new parts, computer parts, etc.

★23. No electronics bargain hunter should be caught without the 1968 copy of *Radio Shack's* catalog. Some equipment and kit offers are so low, they look like misprints. Buying is believing.

★5. *Edmund Scientific's* new catalog contains over 4000 products that embrace many interests and fields. It's a 148-page buyers' guide for Science Fair fans.

106. With 70 million TV and 240 million radios somebody somewhere will need a vacuum tube replacement at the rate of one a second! Get *Universal Tube Co.'s* Troubleshooting Chart and facts on their \$1 flat rate per tube.

★4. *Olson's* catalog is a multi-colored newspaper that's packed with more bargains than a phone book has names. Don't believe us? Get a copy.

★7. Before you build from scratch check the *Fair Radio Sales* latest catalog for electronic gear that can be modified to your needs. *Fair* way to save cash.

6. Bargains galore, that's what's in store! *Poly-Paks Co.* will send you their latest eight-page flyer listing the latest in available merchandise, including a giant \$1 special sale.

★10. *Burstein-Applebee* offers a new giant catalog containing 100s of big pages crammed with savings including hundreds of bargains on hi-fi kits, power tools, tubes, and parts.

11. Now available from *EDI (Electronic Distributors, Inc.)*: a catalog containing hundreds of electronic items. *EDI* will be happy to place you on their mailing list.

120. *Tab's* new electronics parts catalog is now off the press and you're welcome to have a copy. Some of *Tab's* bargains and odd-ball items are unbelievable offers.

117. Harried by the high cost of parts for projects? Examine *Bigelow's* 13th Anniversary catalog packed with "Lucky 13" specials.

SCHOOLS AND EDUCATIONAL

61. *ICS (International Correspondence Schools)* wants to send you a 64-page booklet on the most often asked questions on preparing for an electronics career. You also get "How to Succeed" and a sample *ICS* lesson.

★74. Want to whiz through circuit problems in seconds without pencil and paper? Then get the facts on an amazing electronics slide rule and course from *Cleveland Institute of Electronics*.

114. Prepare for tomorrow by studying at home with *Technical Training International*. Get the facts today on how you can step up in your present job.

59. For a complete rundown on curriculum, lesson outlines, and full details from a leading electronic school, ask for this brochure from the *Indiana Home Study Institute*.

105. Get the low-down on the latest in educational electronic kits from *Trans-Tek*. Build light dimmers, amplifiers, metronomes, and many more. *Trans-Tek* helps you to learn while building.

★3. Get all the facts on Progressive Edu-Kits Home Radio Course. Build 20 radios and electronic circuits; parts, tools and instructions come with course.

HI-FI/AUDIO

124. Now, *Sonotone* offers you young ideas in microphone use in their new catalog. Mikes for talk sessions, swinging combos, home recording, PA systems and many more uses.

26. Always a leader, *H. H. Scott* introduces a new concept in stereo console catalogs. The information-packed 1968 Stereo Guide and catalog are required reading for audio fans.

85. Write the specs for an ideal preamp and amp, and you've spelled out *Dynaco's* stereo 120 amp and PAS-3X preamp. So why not get all the facts from *Dynaco*!

119. *Kenwood* puts it right on the line. The all-new *Kenwood* stereo-FM receivers are described in a colorful 16-page booklet complete with easy-to-read-and-compare spec data. Get your copy today!

15. *Acoustic Research* would like to send you literature on their speaker systems and turntable. It's "must have" literature before you buy.

16. *Garrard's* Comparator Guide clues you in on the new Synchro-Lab turntable/changer series: Discover how *Garrard* locks on to the correct disc speed.

17. Mikes, speakers, amps, receivers—you name it, *Electro-Voice* makes it and makes it good. Get the straight poop from *E-V* today.

19. *Empire* has made exceptional advances in speaker cabinet design you should read about. Also, *Empire's* successes in the turntable and cartridge fields are worth discovering.

27. 12 pages of *Sherwood* receivers, tuners, amplifiers, speaker systems, and cabinetry make up a colorful booklet every hi-fi bug should see.

95. Confused about stereo? Want to beat the high cost of hi-fi without compromising on the results? Then you need the new 24-page catalog by *Jensen Manufacturing*.

99. Get the inside info on why *Acoustech's* solid-state amplifiers are the rage of the experts. Colorful brochure answers all your questions.

TAPE RECORDERS AND TAPE

123. Yours for the asking—*Elpa's* new "The Tape Recording Omnibook." 16 jam-packed pages on facts and tips you should know about before you buy a tape recorder.

31. All the facts about *Concord Electronics Corp.* tape recorders are yours for the asking in a free booklet. Portable, battery operated to four-track, fully transistorized stereos cover every recording need.

32. "Everybody's Tape Recording Handbook" is the title of a booklet that *Sarkes-Tarzian* will send you. It's 24-pages jam-packed with info for the home recording enthusiast. Includes a valuable table of recording times for various tapes.

33. Become the first to learn about *Norelco's* complete Carry-Corder 150 portable tape recorder outfit. Four-color booklet describes this new cartridge-tape unit.

34. "All the Best from Sony" is an 8-page booklet describing *Sony-Superscope* products—tape recorders, microphones, tape and accessories. Get a copy before you buy!

35. If you are a serious tape audiophile, you will be interested in the all new *Viking/Telex* line of quality tape recorders.

HI-FI ACCESSORIES

112. *Telex* would like you to know about their improved *Serenata* Headset—and their entire line of quality stereo headsets.

98. Swinging to hi-fi stereo headsets? Then get your copy of *Superelectronics' 16-page* catalog featuring a large selection of quality headsets.

104. You can't hear FM stereo unless your FM antenna can pull 'em in. Learn more and discover what's available from *Fincos' 6-page* "Third Dimensional Sound."

TOOLS

★78. Need pliers to hold, bend or cut fine wires? Check *Xcelite's* new line of miniatures shown in Catalog 166 along with a complete selection of regular pliers and snips.

118. Secure coax cables, speaker wires, phone wires, etc., with *Arrow* staple gun tackers. 3 models for wires and cables from 3/16" to 1/2" dia. Get fact-ful. *Arrow* literature.

TELEVISION

★70. Need a new TV set? Then assemble a *Heath* TV kit. *Heath* has all sizes, B&W and color, portable and fixed. Why not build the next TV you watch?

★127. *National Schools* will help you learn all about color TV as you assemble their 25-in. color TV kit. Just one of *National's* many exciting and rewarding courses.

97. Interesting, helpful brochures describing the TV antenna discovery of the decade—the log periodic antenna for VHF and UHF-TV, and FM-stereo. Get it from *JFD Electronics Corporation*.

ELEMENTARY ELECTRONICS

Dept. 168

505 Park Avenue

New York, N. Y. 10022

Please arrange to have the literature whose numbers I have circled sent to me as soon as possible. I am enclosing 25¢ for 1 to 10 items; 50¢ for 11 to 20 items to cover handling. No stamps, please.

11-20 items

1-10 items



CHECK ONE

maximum number of items = 20

Indicate total number of booklets requested

1	2	3	4	5	6	7	8	10	11
15	16	17	19	23	26	27	31	32	33
34	35	42	44	45	46	48	50	54	59
61	66	70	74	78	85	93	95	96	97
98	99	100	101	102	103	104	105	106	107
109	111	112	114	115	116	117	118	119	120
121	122	123	124	125	126	127	128	129	

NAME (Print clearly) _____

ADDRESS _____

CITY _____

STATE _____ ZIP _____

En Passant

Continued from page 31

- 1 R-K8# N-B1
 2 N-R6# !! QxN
 3 RxN# KxR
 4 Q-Q8 mate.

Mrs. Gisela Kahn Gresser of New York won the United States Women's Championship last May. She won seven games, drew two, and lost one. This was the eighth time she has captured the title and it demonstrated again that her play is sharper, steadier, and more methodical than that of the other women. In our "Game of the Month" she obtains the better opening, maneuvers for a king-side foray, and concludes with a mating attack against Mrs. Lena Grumette of Los Angeles.

- | | | | |
|----------|-------|-----------|---------|
| 1 P-K4 | P-QB4 | 19 PxP | N-Q4 |
| 2 N-KB3 | P-Q3 | 20 Q-N4 | KR-Q1 |
| 3 P-Q4 | PxP | 21 N-R5 | P-N3 |
| 4 NxP | N-KB3 | 22 P-B3 | Q-B4? |
| 5 N-QB3 | P-QR3 | 23 R-B3 | B-K1 |
| 6 B-QB4 | P-K3 | 24 B-R6 | Q-N3 |
| 7 O-O | B-K2 | 25 QR-KB1 | R-Q2 |
| 8 B-N3 | O-O | 26 NxP! | N-K6 |
| 9 P-B4 | Q-B2 | 27 BxN | QxN |
| 10 B-K3 | N-B3 | 28 QxQ | PxQ |
| 11 Q-B3 | B-Q2 | 29 B-R6 | B-B2 |
| 12 QR-K1 | P-QN4 | 30 RxB | PxN |
| 13 QN-K2 | N-QR4 | 31 P-KN3 | QR-Q1 |
| 14 N-N3 | N-B5 | 32 R-N7# | K-R1 |
| 15 BxN | PxB | 33 R/1-B7 | R-Q8# |
| 16 K-R1 | QR-B1 | 34 K-N2 | B-B1 |
| 17 B-B1 | Q-R4 | 35 RxP# | K-N1 |
| 18 P-K5 | PxP? | 36 BxB | Resigns |

Position after 36 BxB

Black

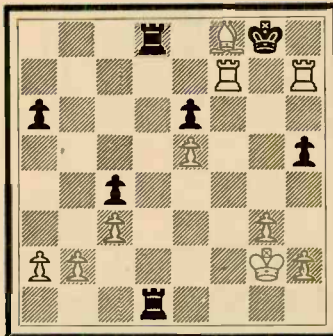

White

Why did Black resign? Because she is a piece behind and will soon be mated. Here is the analysis—

- A. If 36 RxB 37 R(B7)-N7 mate.
 B. If 36 R/1-Q7# 37 K-P3, R-KR8
 38 K-R4, R/8xP# 39 K-N5, R(Q7)-N7 40 R

(R7)-N7# K-R1 41 K-R6, RxKNP (otherwise White plays 42 R-R7#, K-N1 43 R(B7)-N7# KxB 44 R-R8 mate) 42 RxR, any 43 R-R7 mate.

C. If Black just marks time then White mates with 37 B-R6, 38 R(B7)-N7# and 39 R-R8 mate.

Solution to Problem 9: 1 N-B4.

Note: The unmoved king should be White, not Black, in problem 9. Sorry 'bout that!

Problem 10

By Prof. J. Berger, Germany

Black

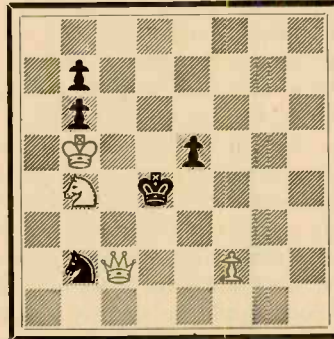

White

White to move and mate in two.
 Solution in next issue.

1-FET BCBer

Continued from page 52

then insert the battery for a test run. Switch the receiver on and check operation by turning the regeneration control clockwise; the unit should break into oscillation. The most sensitive and selective operation will be obtained with the regen control set just below the point of oscillation.

Operation. For local stations use 25 feet of hook-up wire for an antenna. To improve the reception of weaker stations, use an outside antenna and a ground.

Tune C1 for signals while adjusting R2. If there is too much regeneration, the circuit will oscillate and stations will come in as whistles. If whistles occur, turn R2 back below the point of oscillation. C2 may then have to be readjusted.

Overall operation of the receiver is quite good and it has enough power to give room-level reception on local stations. The high input resistance of the FET doesn't load down the tuned circuit and therefore both sensitivity and selectivity are adequate.

Today The Moon

Continued from page 50

Vehicle Applications) produces twice the thrust of a chemical rocket, using only half the fuel.

Three feet in diameter, and some four feet high, the NERVA engine produces thrust of 130,000 lbs., using the lightest fuel known—hydrogen. The fuel passes through the reactor's core heated by capsules of U-235 through a turbo-pump, regenerative cooling tubes and out through the nozzle, achieving its amazing thrust and impulse.

General Electric engineers believe we could achieve a 15-month go-to-Mars mission with four Saturns and NERVA in the late 1980s. Once in orbit, the station would assemble in space and soar on to Mars on its nuclear thrust. One command module could carry a two-story "house." Its lower floor would boast a neat layout of stores, galley, and work areas for a six-man crew; its upper floor would be smartly decorated for recreational areas and sleeping quarters. AEC men, too, think we could send six to eight men to Mars on a 450-day-round trip in the 1980s.

Dr. Wernher von Braun is even more optimistic. He thinks we could very well put an 8-man crew on Mars to stay some twenty days by 1982, making a return trip within 465 days after earth departure. Later, we could establish some sort of semi-permanent foothold on the planet. He suggests sending a first expedition to Mars without complete return capability. His wish: give this crew all the weight they would otherwise need for return flight to use for their extended survival on the planet, and tell them, Congress willing, that we will hope to raise enough money the following year to pick them up.

Mars Colony. This way we could leave the group of eight to twelve men on Mars for 1½ years, with life-support equipment, ground transportation, and just about anything a man could want. All would weigh no more than their return-trip weight. They could carry with them six Mars excursion modules (MEMs), including four cargo landers holding water, oxygen, food, transportation, and scientific equipment.

Such a mission, von Braun says, could go to Mars in '84. And we could go back, picking them up in 1986. By that time we would

find a fine little Mars village, the MEMs acting as "homes," a reactor supplying heat and power, other MEMs outfitted as laboratories. Four of the MEMs could be used to fly back into orbit to meet the pickup mission and return to earth.

All this von Braun envisions within our present financial framework, or, for what people are now "used to paying for space." For we would have plenty of sophisticated hardware to work with by that time. And as for Congress asking who could be practical about such a mission, von Braun answers he hasn't heard yet of any other workable solution to the population explosion.

And while he says he is an optimist, not a pessimist, he admits the pessimists may be right. If science *has* brought man to the brinkmanship stage of blowing himself off this planet, von Braun suggests, "We should hurry, so we can establish a foothold on a new planet as long as we still have one left to take off from."

Dr. Ponnampereuma sees our Post-Apollo needs another way. He says he is among the scientists who believe, "we are involved in an existence, and evolution that inspires deep reverence. While we are seeking knowledge of man and his universe, we are continually awed by the mysteries we cannot fathom. Such seeking, in fact, carries out the very essence of the human spirit." ■

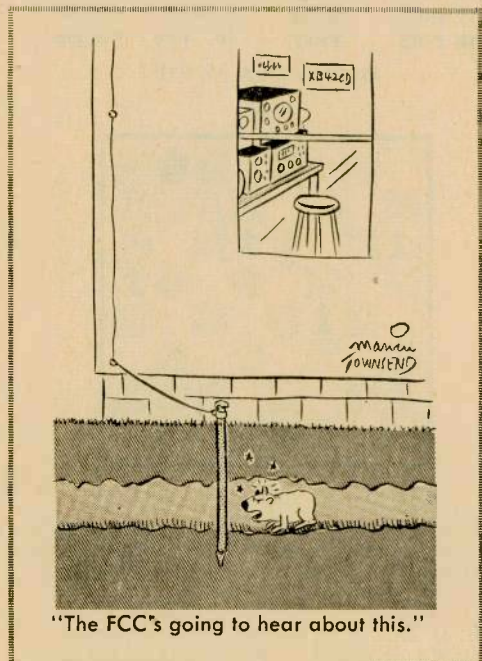

FCC Q & A

Continued from page 108

read higher current values. Microammeters cost more, since they must have a lower friction mechanical system, stronger magnets and more precisely wound coils. All voltmeters are, of course, simply microammeters or milliammeters with an appropriate series resistance added.

Q. Describe the construction and characteristics of a repulsion-type ammeter.

A. The repulsion-type ammeter is considerably different in construction from the D'Arsonval type meter. The D'Arsonval meter is basically insensitive to AC, due to the method of construction. The repulsion-type meter is equally sensitive to AC or DC. It consists of a stationary coil, a stationary iron vane within the coil, and a movable iron vane with needle, concentric with the stationary iron vane. The current to be measured is applied to the coil. The field developed magnetizes both iron vanes so that they tend to oppose each other. Since one is movable, it moves an amount related to the magnetizing effect of the measured current. The needle attached to it indicates this current on a scale. The deflection of the iron vane is proportional to the square of the current, and a voltmeter using this type of meter is a square-law voltmeter. Since on AC, the changes of the magnetic field still tend to cause opposition of the iron vanes, the meter will measure low frequency AC as well as DC. RF currents cannot be measured, due to the inductance of the internal coil, and the uncertainty of the distributed capacitance.

Q. Why are copper-oxide rectifiers not suitable for RF measurements?

A. Copper-oxide rectifiers are generally used to allow a D'Arsonval type meter to measure AC voltages. Most VOMs use this type of rectifier in their AC circuits. Any voltage or current measurement, to be accurate, must be made with known resistances involved in the meter circuit. Since the distributed capacitance and inductance of a copper-oxide rectifier is not an accurate or reliable value, their

use in RF circuits should be avoided. Although they may indicate accurately up to 20 kHz or so, their error increases rapidly with frequencies above this point.

Q. Does an AC ammeter indicate average, effective, or peak values?

A. All meters are calibrated to read effective, or rms value of a pure sine wave. This does not mean they necessarily respond to the rms value of the current. A D'Arsonval meter with series rectifier will respond to peak value. An iron-vane meter will respond to the square of the average value. And a Thermocouple meter will respond to the square of the effective value. They are all calibrated in effective value, and will all read the same on a pure sine wave. On a signal with high harmonic content, each will read different, but each will still be correct, since it is measuring exactly what it was designed to measure.

Q. Describe the construction and characteristics of a dynamometer type indicating instrument.

A. A dynamometer consists of two basic parts: (1) two stationary coils connected to be series aiding, and (2) a movable coil to which a needle is attached. All the coils are connected in series. Here we use the stationary coils as the permanent magnet is used in the D'Arsonval type meter. The coils generate a magnetic field that the movable coil tends to oppose. The amount of movement of the coil is proportional to the square of the current. ■

Etymology

Continued from page 32

son Crusoe, where he described his hero's doomed ship as "stuck fast, jammed between two Rocks."

Applied to crowds of persons and carriages, to ice packs and logs piled up in rivers, the term proved remarkably versatile. Hence experimenters turned to it when they discovered a new radio technique. Though no physical squeezing or wedging is involved, one who nullifies a radio broadcast by creating an interference signal on or near the same frequency is said to jam the air waves. ■

To DX Vegas

Continued from page 90

just beginning the computerized portion of its transmission (that rasping sound they give out with every five minutes) which made WWVZ's time a whole three minutes fast. What was worse, during the time I had my receiver on standby, somebody had camped right on WWV's frequency, creating a heterodyne so strong you could hardly make out WWV. Man, talk about a cat on a hot tin roof!

Lou Ann waved a delicately formed hand at me. "Turn it off. I can't hear."

I flipped the standby switch and hoped the next time I checked the QRM would be gone. With that kind of QRM on 2500 kHz, WWV would never make those 1000 miles on medium wave all the way from Vegas land.

A gong from WWVZ. "Remember now! At 7:00 we bring you a whole half hour of Super Bum."

Fiddled with my scratch pad. "I guess that's one program you won't mind missing."

She gave me an indignant look. "Are you kidding? Super Bum's the wildest thing on the air."

WWVZ's DJ went on with his spiel. "Tonight, Super Bum, after disposing of Thatman and Bobin in a pit of quicklime, jams a spoke in the wheel of time and makes the whole universe stand still."

Lou Ann got up, transistor in hand, crossed the room and showed me that pendant of hers which turned out to be this same Super Bum, complete with black hood. "Groovy, huh?"

Another gong from her transistor. "You'll hear all the action on 1590." This was followed by the Monkees, beating out "Words."

It hit me then. I switched back on my WR-600 and that interference was twice as strong. "Turn off your radio for a minute."

"What for?"

"Just for a second. Please."

She pouted, but did it. The QRM completely disappeared. It was the transistor's local oscillator which operates 910 kHz above whatever frequency the thing is tuned to. On came "Words" again. "That was a whole 5 seconds," she snapped and went back to the couch. "Now turn yours off."

I hit that standby switch and considered the situation. WWVZ announced the time

again. They were still three minutes fast, which meant that Super Bum would actually begin three minutes before 7:00 and run right through WWV's changeover. I decided to try diplomacy. "What's so special about Super Bum?"

"Where else on the radio can you hear all the squares get theirs?" She fiddled with her nifty super-mod hairdo. "Last week Super Bum locked up every cop in North America. And abolished the whole government. Man, he's psychedelic!"

It sounded downright subversive. "Couldn't you just miss the first five minutes?" I sat down on the couch beside her. "For me?"

Lou Ann seemed to soften a little. "I might miss the best part."

I looked across at my waiting WR-600. "Won't ever get another chance for DX like this." I tried to imagine what WWV's special first day Vegas QSL would look like. "Then after I log it, we can do anything you want the rest of the evening."

She rested her head on my shoulder. "Just the first five minutes?"

"That's right." A peck on the cheek clinched it.

WWVZ broke in again, after a soft drink ad followed by another spot, for a deodorant. "And remember, swingers, on tonight's Super Bum program the great man himself will tell you how you can join the Super Bum Society. Right during the first few minutes of the show, SB will take time out from demolishing the space-continuum to give you the scoop."

Lou Ann pulled away. "That settles it. I'm not missing a minute of Super Bum." She stood up so I could fully appreciate her 36-24-34 ship-shape. "And if you don't like it, I'll take my transistor and go home."

Which means I have to choose. Thanks to WWVZ's Super Bum I'm going to lose either WWV's first-day Vegas QSL or Lou Ann. And I've only got 20 minutes to make up my mind. ■

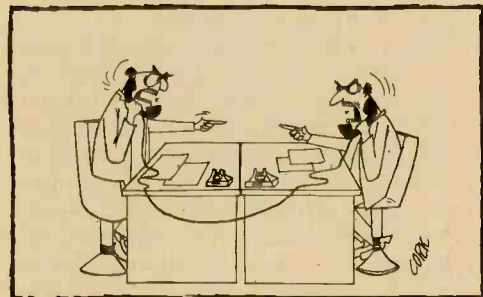

Ham Dilemma

Continued from page 78

down the drain, but the amateurs in sheer numbers have leveled off at approximately 200,000 people out of a country of nearly 200 million. New ham applications dropped drastically as people discovered that they could communicate easily, instantly, and completely without examination by simply applying for a Class D CB ticket and tossing \$8.00 in the Gettysburg till. Attempts by ARRL and others to bring new people—especially youngsters—“into the fold” have failed dramatically. Holding that any group succeeds primarily by its numbers and consequent growth and influence (labor unions are a good example of this), it can only be said that ham radio will indeed suffer under the new FCC regulations.

With the complete abolishment of the 2-meter phone band next year, the hobby may lose the one attraction it had to the aspiring radio communicator: the ability to talk virtually without restrictions to anyone on the band, to “taste” the attraction of professional ham radio inexpensively, and the ability to accomplish all this with only the requirement of passing a simple 20-question multiple-choice mailed exam and 5-wpm code test under the supervision of a licensed friend.

Unless the chap in question is extraordinarily well-versed in electronic communications, it'll be virtually impossible to get on the air with a microphone via ham radio. He'll either have to be made “to see the light” through a miraculous scheme no one has yet made public (or through sheer ignorance or supervised isolation), or he'll quite naturally be moved to plunk down \$8.00 for a CB license when he turns 18.

No New Hams. Where will the new hams come from? This remains to be seen. If the concept is to up the age of the average amateur, clearly this will be rapidly accomplished. Surely, the youngster casually interested in electronics will not endure the 2-year hardship of CW-only communications when the temptation of CB is constantly in front of him. If professionalism and engineer-like qualities are the underlying cause for the incentive licensing rule-adoption, then this will gradually come about, though the numbers be small.

Many opponents also feel that a good

number of presently-licensed Technicians and General/Conditional ticket-holders will evaporate into thin air when faced with the operational restrictions aimed at up-grading them ultimately to Extra Class status. The Extra exam will be no easier than before, and certain camps feel the Advanced exam will be the stumbling block responsible for the almost-predestined disappearance of ham radio in this country.

Further, certain groups question the validity of the ARRL's initial efforts toward adopting these rules. What were their real motives? These hams contend that from the outset, the vast majority of amateurs have opposed the proceeding, while the League answered these charges thusly: “It is well known that those opposed to a proposal are normally much more vocal than those in favor,” a remark made in a *QST* editorial in mid-1965. Since then, the ARRL and the FCC have insisted that anywhere from $\frac{2}{3}$ to $\frac{3}{4}$ of the written comments on incentive licensing have been in favor. Opposing camps claim collusion.

But, the biggest argument is this: What will happen when the numbers of ham radio operators in the most powerful country in the world begin to dwindle into oblivion? The contention here is simply that if the bands are not used, they'll be lost forever to other nations. And with less hams to fill the bands, this seems to be a certainty to a significant block of U. S. amateur enthusiasts. In short, they ask, “Are we being sold down the river?”

What Lies Ahead For Ham Radio? Unless a rapid turnaround is realized in one of the two major ham camps fast, this question will remain unanswered for some time. Without internal support, newcomers will not be drawn into the hobby. On the other hand, unless hams as a whole go for the idea of an incentive program, the goals of up-grading technical and operational competence will go the way of the horse-and-buggy, leaving the hobby worse off than when it began.

One thing is certain: The new rules are here and are here to stay. The shoe is now on the other foot; it's up to the amateurs to decide right now what their future will be.

Will amateur radio slowly drift off into another “Lost Horizon”? Or will it successfully reclaim its proper place as an exciting and personally-rewarding hobby while at the same time, making significant technical contributions to our society?

Only time will tell. ■

Neophyte I

Continued from page 59

Start by cutting the large holes first, and finish up with all the small holes using the parts themselves for templates. The panel is secured to the box by the phone jack and regeneration control mounting hardware.

The power transformer T1 is mounted on the rear of the minibox. Two holes are made to pass the transformer leads inside the box for wiring. Make sure that all holes and mounting plans are such that the other half of the chassis box will fit in place without obstruction.

Cool Coil. A 1 x 2-in. long plastic pill vial is put to use as a coil form. The plastic cap of the vial serves as the coil form "socket" and is mounted on the chassis with a nut and bolt.

The coil consists of 17 turns of #22 AWG enamel-covered copper magnet wire. A tap is made 4 turns from the bottom or ground end of the coil.

The turns of the coil are spaced to cover approximately 1¼ inches. The #22 wire is stiff enough to be self-holding and cement is not needed. Minor frequency adjustments may be made later by adjusting the spacing between the turns.

Hookup wire brought through a grommet-protected hole in the minibox connects the coil to the proper circuit points. The band switch S1 is mounted on the top of the minibox, but a layout variation on the front panel will allow enough mounting space there.

When all components are wired in the circuit, make a careful check to insure that no short circuits exist and that there is proper clearance for the bottom of the chassis box.

Fire It Up. Turn Neophyte 1 on and check that the tube lights. Then make sure nothing is smoking or overheating. Connect an antenna to the jack and advance the regeneration control to a point just before the set breaks into oscillation. Turn the band switch to the high band and tune for a station. Readjust the regeneration control for best reception. Receiving conditions will be best after dark so don't be discouraged if you turn the little Hertz-grabber on during daylight hours and don't find much action. Try various inside antenna lengths and use the best one. A high outside antenna will be best for long-distance reception. ■

It Looks Like A Transistor

Continued from page 56

ated by heat reduces the width of the depletion layer, thus allowing the current to increase by causing the effective gate-channel voltage to change at the rate of about 2.2 mV per 1°C. If we arrange the bias so that I_d/g_m is about 0.3, the two effects will tend to cancel out and we have a reasonably stable amplifier.

What Else. Of course, this is only part of the FET story. We have been talking only about devices in which the channel is of *n*-type material, but naturally there are *p*-channel FETs, too. And though it is possible to make up rule-of-thumb FET amplifiers which will work by selecting a suitable value for the drain load and choosing the bias for stability, for the best results we have to be as meticulous over design details as with transistors or tubes.

On the whole though, FET amplifiers are a little easier to design than their transistor equivalents. And though the FET has its limitations, its high input resistance enables us to avoid many of the circuit complications that have to be introduced when we wish to couple a transistor amplifier to a high impedance signal source. Against this, we have not yet developed FETs with the high voltage capability of a tube or the high power range of a transistor. And the frequency range of a normal FET is limited because it has a fairly high input capacitance.

Next. At the present state of the art then, the FET is most widely used to couple signals at not too high a level and at a reasonable frequency from some high impedance source to a conventional transistor amplifier which does the real donkey work. A simple example is in the first stage of a preamplifier following a capacitor microphone. For this kind of purpose, it offers a simple solution to a very tricky problem.

Other current applications for the FET are in transistorized VTVMs (high input resistance) and receiver front-ends (rapidly replacing the nuvistor).

To get better acquainted with the practical side of the FET and how it works, have a look at the article on page 51 in this issue on building an FET radio.

Meanwhile, though the FET has power and frequency limitations, it seems highly probable that this new little polly seed may soon into a great sunflower grow. ■

CLASSIFIED Market Place

FOR BIGGER PROFITS! NEW CAREER OPPORTUNITIES!
READ AND REPLY TO THESE CLASSIFIED ADS

Classified Ads 65¢ per word, each insertion, minimum 10 words, payable in advance. To be included in the next available issue of ELEMENTARY ELECTRONICS, copy must be in our New York Office by Jan. 10th. Address orders to C. D. Wilson, Manager, Classified Advertising, ELEMENTARY ELECTRONICS, 505 Park Ave., New York, N. Y. 10022.

ADDITIONAL INCOME

COLLECT Coins! Profitable! How, where to start, sell. Valuable coins listed. Detailed report \$1.00. Martin's, 503 E. Houk St., Ironwood, Mich. 49938.

AUTHOR'S SERVICE

PUBLISH your book! Join our successful authors publicity advertising promotion, beautiful books. All subjects invited. Send for free manuscript report and detailed booklet. Carlton Press, Dept. SMH, 84 Fifth Avenue, New York 10011.

BUSINESS OPPORTUNITIES

I MADE \$40,000.00 a year by Mailorder! Helped others make money! Start with \$10.00—Free Proof! Torrey, Box 318-T, Ypsilanti, Michigan 48197.

FREE BOOK "990 Successful Little-Known Businesses." Fascinating! Work home! Plymouth 111-P, Brooklyn, N. Y. 11218.

EARTHWORMS

BIG Money Raising Fishworms and Crickets. Free Literature. Carter Farm-O, Plains, Georgia 31780.

EDUCATION & INSTRUCTION

TOP Paying Jobs—Guidance Manual \$1.00. Canadian Institute of Science & Technology, 263J Adelaide St. W., Toronto.

FCC License and Associate Degree correspondence/residence courses. School bulletin free. Grantham Institute of Electronics, 1505 N. Western Ave., Hollywood, California 90027.

TELEPHONE Engineering: Complete Correspondence Course \$39.50. Instruments to DDD including Tariffs. Super Hobby Catalog 25¢. Don Britton Enterprises, 7906 Santa Monica Blvd., Hollywood, California 90046.

EARN Your Degree In Electronics Engineering. Highly Effective Home Study Courses In Electronics Engineering Technology And Electronics Engineering Mathematics. Free Literature. Cook's Institute Of Electronics Engineering, P. O. Box 36185, Houston, Texas 77036. (Established 1945.)

ELECTRONIC COMPONENTS

MOS ICs, JFETs, MOSFETS-MOS NAND, NOR gates \$1.00, P MOSFET 75¢, N JFET 75¢, P JFET 50¢. Minimum Order \$3.50. PET E6, Box 593, Cupertino, Calif. 95014.

FOR SALE—MISCELLANEOUS

MAGNETS. All types. Specials—20 disc magnets, or 2 stick magnets, or 8 assorted magnets, or 10 small bar magnets, \$1.00. Maryland Magnet Company, 5412-R Gist, Baltimore, Md. 21215.

FOR THE HOME

PRACTICAL tips for home, garden and workshop are in "1001 How-To Ideas." Send \$1.00 for your copy includes Postage, to 1001 How-To Ideas, 505 Park Ave., New York, N. Y. 10022.

FORMULAS & TRADE SECRETS

ANYTHING Analyzed — Professional Chemist. Johnson Laboratory, Delaware Turnpike, Delmar, New York 12054.

HYPNOTISM

SELF-Hypnosis for self-improvement. New concept. Free literature. Smith-McKinley, Box 3038, San Bernardino, California 92404.

INVENTIONS WANTED

WE either sell your invention or pay cash bonus. Write for details. Universal Inventions, 298-3, Marion, Ohio 43302.

MACHINERY, TOOLS & SUPPLIES

SAW Sharpening Machines: Simplified one-hand filing method. Zapart One-hand Filer, 586 Manhattan Ave., Brooklyn, New York 11222.

PERSONAL

BILL Problems? Poor credit no trouble. Not a loan company. Send for free application. Automatic Acceptance, 318DC Broadway Blvd., Reno, Nev. 89502 or 307DC Pocasset Ave., Providence, R. I. 02909.

FOR the best in Mystery Reading—Subscribe to Ellery Queen's Mystery Magazine, 505 Park Ave., New York, N. Y. 10022. Send \$2.49 for 10 issues.

RADIO & TELEVISION

McGEE Radio Company. Big 1966-1967 Catalog Sent Free. America's Best Values. Hi-Fi, Amplifiers, Speakers, Electronic Parts. Send Name, Address and Zip Code Number to McGee Radio Company, 1901 McGee Street, Dept. RTV, Kansas City, Missouri 64106.

MODEL Car Fans—Rolls Royce Radio—Exact Scale. 6-TR, Battery, Earphone, Only \$19.95. C E Sales, P.O. Box 5, Bronx, New York 10473.

CANADIANS—Giant Electronic Catalogs. Hi-Fi, Shortwave, Ham, CB. Rush \$1.00. ETCO, Dept. EX, Box 741, Montreal, Canada.

MINI CirKits, Amplifier Oscillator \$2.95, others, Lectronix, Box 42, Madison Heights, Michigan 48071.

"DISTANCE Crystal Set Construction" Handbook—50¢. Catalog. Laboratories, 12041-G Sheridan, Garden Grove, Calif. 92640.

SALESMEN—DISTRIBUTORS

EARN \$400.00 Weekly on only Two Enrollments! Homestudy Courses. 50% Commissions! Part-time, Full-time. International Institute, City National Building-SM, Miami 33130.

SONGWRITERS

POEMS Wanted for musical setting and recording. Send poems. Free examination. Crown Music, 49-SC, West 32, New York 10001.

STAMP COLLECTING

FREE Literature! Samples! Stamps. Amazing Booklet. Views 30¢. Large Stamp Assortment \$1.00. Persil, 436 New York Ave., Brooklyn, N. Y. 11225.

START YOUR OWN BUSINESS

UP to 90¢ Profit On Each \$1.00 Sale. Details 25¢. Carpenter, 2907-C West 39th Place, Chicago, Ill. 60632.

MAKE Mail Order pay. Get "How To Write a Classified Ad That Pulls." Includes certificate worth \$2.00 toward classified ad in S & M. Send \$1.00 to C. D. Wilson, Science & Mechanics, 505 Park Ave., New York, N. Y. 10022.

For Greater Classified Profits

WHY NOT TRY THIS NEW

combined classified ad medium

Your classified ad will appear in SCIENCE & MECHANICS MAGAZINE as well as in a minimum of four other SCIENCE & MECHANICS PUBLICATIONS. Write now for information to C. D. Wilson, Manager, Classified Advertising, SCIENCE & MECHANICS, 505 Park Ave., New York, N. Y. 10022.

You can earn more money if you get an FCC License

...and here's our famous CIE warranty that you will get your license if you study with us at home

NOT SATISFIED with your present income? The most practical thing you can do about it is "bone up" on your electronics, pass the FCC exam, and get your Government license.

The demand for licensed men is enormous. Ten years ago there were about 100,000 licensed communications stations, including those for police and fire departments, airlines, the merchant marine, pipelines, telephone companies, taxicabs, railroads, trucking firms, delivery services, and so on.

Today there are over a million such stations on the air, and the number is growing constantly. And according to Federal law, no one is permitted to operate or service such equipment without a Commercial FCC License or without being under the direct supervision of a licensed operator.

This has resulted in a gold mine of new business for licensed service technicians. A typical mobile radio service contract pays an average of about \$100 a month. It's possible for one trained technician to maintain eight to ten such mobile systems. Some men cover as many as fifteen systems, each with perhaps a dozen units.

Coming Impact of UHF

This demand for licensed operators and service technicians will be boosted again in the next 5 years by the mushrooming of UHF television. To the 500 or so VHF television stations now in operation, several times that many UHF stations may be added by the licensing of UHF channels and the sale of 10 million all-channel sets per year.

Opportunities in Plants

And there are other exciting opportunities in aerospace industries, electronics manufacturers, telephone companies, and plants operated by electronic automation. Inside industrial plants like these, it's the licensed technician who is always considered first for promotion and in-plant training programs. The reason is simple. Passing the Federal government's FCC exam and get-

ting your license is widely accepted proof that you know the fundamentals of electronics.

So why doesn't everybody who "tinkers" with electronic components get an FCC License and start cleaning up?

The answer: it's not that simple. The government's licensing exam is tough. In fact, an average of two out of every three men who take the FCC exam fail.

There is one way, however, of being pretty certain that you will pass the FCC exam. And that is to take one of the FCC home study courses offered by the Cleveland Institute of Electronics.

CIE courses are so effective that better than 9 out of every 10 CIE-trained men who take the exam pass it... on their very first try! That's why we can afford to back our courses with the iron-clad Warranty shown on the facing page: you get your FCC License or your money back.

There's a reason for this remarkable record. From the beginning, CIE has specialized in electronics courses designed for home study. We have developed techniques that make learning at home easy, even if you've had trouble studying before.

In a Class by Yourself

Your CIE instructor gives his undivided personal attention to the lessons and questions you send in. It's like being the only student in his "class." He not only grades your work, he analyzes it. And he mails back his corrections and comments the same day he receives your assignment, so you can read his notations while everything is still fresh in your mind.

Mail Card for Two Free Books

Want to know more? The postpaid reply card bound-in here will bring you free copies of our school catalog describing opportunities in electronics, our teaching methods, and our courses, together with our special booklet, "How to Get a Commercial FCC License." If card has been removed, just send your name and address to us.

Matt Stuczynski,
Senior Transmitter
Operator, Radio
Station WBOE



"I give Cleveland Institute credit for my First Class Commercial FCC License. Even though I had only six weeks of high school algebra, CIE's AUTO-PROGRAMMED™ lessons make electronics theory and fundamentals easy. I now have a good job in studio operation, transmitting, proof of performance, equipment servicing. Believe me, CIE lives up to its promises."



Chuck Hawkins,
Chief Radio
Technician, Division
12, Ohio Dept.
of Highways

"My CIE Course enabled me to pass both the 2nd and 1st Class License Exams on my first attempt...I had no prior electronics training either. I'm now in charge of Division Communications. We service 119 mobile units and six base stations. It's an interesting, challenging and rewarding job. And incidentally, I got it through CIE's Job Placement Service."

Glenn Horning,
Local Equipment
Supervisor, Western
Reserve Telephone
Company



"There's no doubt about it. I owe my 2nd Class FCC License to Cleveland Institute. Their FCC License Course really teaches you theory and fundamentals and is particularly strong on transistors, mobile radio, troubleshooting and math. Do I use this knowledge? You bet. We're installing more sophisticated electronic gear all the time and what I learned from CIE sure helps."

ENROLL UNDER G.I. BILL

All CIE courses are available under the new G.I. Bill. If you served on active duty since January 31, 1955, or are in service now, check box on reply card for G.I. Bill information.

CIE Cleveland Institute of Electronics
1776 E. 17th St., Dept. EL-6, Cleveland, Ohio 44114

Accredited by the Accrediting Commission of the National Home Study Council, and the only home study school to provide complete coverage of electronics fundamentals plus such up-to-date applications as: Microminiaturization • Laser Theory and Application • Suppressed Carrier Modulation • Single Sideband Techniques • Logical Troubleshooting • Boolean Algebra • Pulse Theory • Timebase Generators...and many more.



Better than
9 out of 10
CIE men win
their "ticket"
the very first
time they try
**(NATIONAL AVERAGE
IS ONLY 1 OUT OF 3)**

Cleveland Institute of Electronics

WARRANTY

of success in obtaining a
Government FCC License

The Cleveland Institute of Electronics hereby warrants that upon completion of the Electronics Technology, Broadcast Engineering, or First-Class FCC License course, you will be able to pass the FCC examination for a First Class Commercial Radio Telephone License (with Radar Endorsement);

OR upon completion of the Electronic Communications course you will be able to pass the FCC examination for a Second Class Commercial Radio Telephone License;

AND in the event that you are unable to pass the FCC test for the course you select, on the very first try, you will receive a FULL REFUND of all tuition payments.

This warranty is valid for the entire period of the completion time allowed for the course selected.

G. O. Allen

G. O. Allen
President

BUILD YOUR OWN RADIO

CIRCUITS AT HOME
with the New Improved
PROGRESSIVE RADIO "EDU-KIT"®

only
\$26.95



Reg. U. S.
Pat. Off.

A Practical Home Radio Course

Now Includes

- ★ 12 RECEIVERS
- ★ 3 TRANSMITTERS
- ★ SQ. WAVE GENERATOR
- ★ SIGNAL TRACER
- ★ AMPLIFIER
- ★ SIGNAL INJECTOR
- ★ CODE OSCILLATOR

EXPANDED "EDU-KIT" NOW INCLUDES

- ★ TRANSISTOR (Solid State) CIRCUITS
- ★ VACUUM TUBE CIRCUITS
- ★ PRINTED CIRCUITS
- ★ HAND WIRED CIRCUITS

YOU DON'T HAVE TO SPEND HUNDREDS OF DOLLARS FOR A RADIO COURSE

The "Edu-Kit" offers you an outstanding PRACTICAL HOME RADIO COURSE at a rock-bottom price. Our Kit is designed to train Radio & Electronics Technicians, making it one of the most modern methods of home training. You will learn radio theory, construction practice and servicing. This is a COMPLETE RADIO COURSE IN EVERY DETAIL. You will learn how to build radios, using regular schematics; how to wire and solder punched metal chassis as well as the latest development of Printed Circuit chassis. In a professional manner; how to service radios. You will work with the standard type of RF and AF amplifiers and oscillators, detectors, rectifiers, test equipment. You will learn trouble-shooting, using the Progressive Signal Tracer, Progressive Signal Injector, Progressive Dynamic Radio & Electronics Tester, Square Wave Generator and the accompanying instructional material.

You will receive training for the Novice, Technician and General Classes of F.C.C. Radio Amateur Licenses. You will build Receiver, Transmitter, Square Wave Generator, Code Oscillator, Signal Tracer and Signal Injector circuits, and learn how to operate them. You will receive an excellent background for television, Hi-Fi and Electronics. You will gain absolutely no previous knowledge of radio or science is required. The "Edu-Kit" is the product of many years of teaching and engineering experience. The "Edu-Kit" will provide you with an excellent background for the future. The "Edu-Kit" will allow you to teach yourself at your own rate. No instructor is necessary.

THE KIT FOR EVERYONE

You do not need the slightest background in radio or science. Whether you are interested in Radio & Electronics because you want an interesting hobby, a well paying business or a job with a future, you will find the "Edu-Kit" a worth-while investment. Many thousands of individuals of all

ages and backgrounds have successfully used the "Edu-Kit" in more than 79 countries. The "Edu-Kit" has been carefully designed, step by step, so that you cannot make a mistake. The "Edu-Kit" rate. No instructor is necessary.

PROGRESSIVE TEACHING METHOD

The Progressive Radio "Edu-Kit" is the foremost educational radio kit in the world, and is universally accepted as the standard in the field of electronics training. The "Edu-Kit" uses the modern educational principle of "Learn by Doing." Therefore you construct, learn schematics, study theory, practice trouble shooting, and receive progressive program designed to provide an easily-learned, thorough and interesting background in radio. You begin by examining the various radio parts of the "Edu-Kit." You then learn the function, theory and wiring of these parts. Then you build a simple radio. With this first set you will enjoy listening to regular broadcast stations, learn theory, practice testing and trouble-shooting. Then you build a more advanced radio, learn more advanced theory and techniques. Gradually, in a progressive manner, and at your own rate, you will find yourself constructing more advanced multi-tube radio circuits, and doing work like a professional Radio Technician.

Included in the "Edu-Kit" course are Receiver, Transmitter, Code Oscillator, Signal Tracer, Square Wave Generator and Signal Injector Circuits. These are not unprofessional "breadboard" experiments, but genuine radio circuits, constructed by means of professional wiring and soldering on metal chassis, plus the new method of radio construction known as "Printed Circuitry." These circuits operate on your regular AC or DC house current.

THE "EDU-KIT" IS COMPLETE

You will receive all parts and instructions necessary to build twenty different radio and electronics circuits, each guaranteed to operate. Our Kits contain tubes, tube sockets, variable, electrolytic, mica, ceramic and paper dielectric condensers, resistors, tie strips, hardware, tubing, punched metal chassis, Instruction Manuals, hook-up wire, solder, selenium rectifiers, coils, volume controls and switches, etc.

In addition, you receive Printed Circuit materials, including Printed Circuit chassis, special tube sockets, hardware and instructions. You also receive a useful set of tools, a professional electric soldering iron, and a self-powered Dynamic Radio and Electronics Tester. The "Edu-Kit" also includes Code Instructions and the Progressive Code Oscillator, servicing with the Progressive Signal Tracer and the Progressive Signal Injector, a High Fidelity Guide and a Quiz Book. You receive Membership in Radio-TV Club, Free Consultation Service, Certificate of Merit and Discount Privileges. You receive all parts, tools, instructions, etc. Everything is yours to keep.

Progressive "Edu-Kits" Inc., 1186 Broadway, Dept. 522DJ, Hewlett, N. Y. 11557

Training Electronics Technicians Since 1946

FREE EXTRAS

• SET OF TOOLS

- SOLDERING IRON
- ELECTRONICS TESTER
- PLIERS-CUTTERS
- VALUABLE DISCOUNT CARD
- CERTIFICATE OF MERIT
- TESTER INSTRUCTION MANUAL
- HIGH FIDELITY GUIDE & QUIZZES
- TELEVISION BOOK & RADIO TROUBLE-SHOOTING BOOK
- MEMBERSHIP IN RADIO-TV CLUB
- CONSULTATION SERVICE & FCC AMATEUR LICENSE TRAINING
- PRINTED CIRCUITRY

SERVICING LESSONS

You will learn trouble-shooting and servicing in a progressive manner. You will practice repairs on the sets that you construct. You will learn symptoms and causes of trouble in home, portable and car radios. You will learn how to use the professional Signal Tracer, the unique signal injector and the dynamic Radio & Electronics Tester. While you are learning in this practical way, you will be able to do many a repair job for your friends and neighbors, and charge fees which will far exceed the price of the "Edu-Kit." Our Consultation Service will help you with any technical problems you may have.

FROM OUR MAIL BAG

J. Statalls, of 25 Poplar Pl., Waterbury, Conn., writes: "I have repaired several sets for my neighbors, and made money. The 'Edu-Kit' paid for itself. I was ready to spend \$240 for a course, but I found your ad and sent for your kit."

Ben Valerio, P. O. Box 21, Magna, Utah: "The Edu-Kits are wonderful. Here I am sending you the questions and also the answers for them. I have been in Radio for the last seven years, but like to work with Radio Kits, and like to build Radio Testers. Equipment. I enjoyed every minute I worked with the different kits; the Signal Tracer works fine. Also like to let you know that I feel proud of becoming a member of your Radio-TV Club."

Robert L. Shuff, 1534 Monroe Ave., Huntington, W. Va.: "Thought I would drop you a few lines to say that I received my Edu-Kit, and was really amazed that such a bargain can be had at such a low price. I have already started repairing radios and phonographs. My friends were really surprised to see me get into the service. This revolutionary trouble-shooting Tester that comes with the Kit is really swell, and finds the trouble, if there is any to be found."

— UNCONDITIONAL MONEY-BACK GUARANTEE —

Please rush my Progressive Radio "Edu-Kit" to me, as indicated below:

- Check one box to indicate choice of model
- Regular model \$26.95.
 - Deluxe model \$31.95 (same as regular model, except with superior parts and tools)
 - Expanded model \$36.95 (same as Deluxe model, except with 5 additional solid state circuits plus valuable Radio & TV Tube Checker).
- Check one box to indicate manner of payment
- I enclose full payment. Ship "Edu-Kit" post paid.
 - Ship "Edu-Kit" C.O.D. I will pay postage.
 - Send me FREE additional information describing "Edu-Kit."

Name _____
Address _____

PROGRESSIVE "EDU-KITS" INC.

1186 Broadway, Dept. 522DJ, Hewlett, N. Y. 11557

PRINTED CIRCUITRY

At no increase in price, the "Edu-Kit" now includes Printed Circuitry. You build a Printed Circuit Signal Injector, a unique servicing instrument that can detect many Radio and TV troubles. This revolutionary new technique of radio construction is now becoming popular in commercial radio and TV sets.

A Printed Circuit is a special insulated chassis on which has been deposited a conducting material which takes the place of wiring. The various parts are merely plugged in and soldered to terminals. The revolutionary Printed Circuitry is the basis of modern Automation Electronics. A knowledge of this subject is a necessity today for anyone interested in Electronics.