

THE SECRET TIMETABLE FOR KILLING CB

# elementary Electronics

JULY-AUGUST 75¢

an e/e exclusive

## FLAME SPEAKER

YOU BUILD IT, FIRE IT UP,  
AND HEAR IT IN ONE OF THE  
GREAT EXPERIMENTS

OF ALL TIME!

FREE PRINTED CIRCUIT

VHF Police Converter for

9310137 14 710006 1169  
E NICOLA I  
1860 12TH ST SE  
SEALED FOR YOUR PROTECTION

# CUT ANY MATERIAL with Naval Super-HACK Blades

As low as \$1.60 ea.



Naval Carbide Drill Bits for glass, steel, etc. in diam. 1/16" and 1/8" for \$9 and 1/4" \$16 ppd.

Rip thru hardest metal (a file) in less than 2 minutes. Cut even curves or notches in materials formerly considered unworkable like glass, glazed tile, bricks, roof steel, drapery, Very little effort. This famous cousin of the diamond, forage-jump tungsten carbide, now joins the real saw blade. Fits any hacksaw. Only \$2.75 for one blade, 3 for \$8.20, 6 at \$2 each (total \$12.50, 24 at \$1.60 each (total \$38.40). All postpaid.

**MEREDITH,** Dept. EE-7, 310 West 9th St., KANSAS CITY, MO. 64105

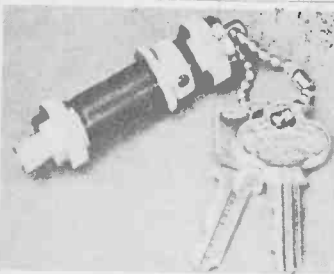

## Secret Tear Gas Ornament

looks like a tiny key chain ornament, made for British Secret Service, blasts a wide spread 38 cal. charge of the new Mc Namara Choice Tear Gas (CS

stun gas)—a real professional, safe, completely secret device that stops an aggressor in his tracks, renders him utterly helpless instantly but is harmless (he recovers in an hour). Precision machined from steel and brass, will not fire accidentally, requires no license or permit. Complete with 2 38-cal. shells, one talcum powder practice shell. We pay all shipping costs anywhere in USA. \$16.50 —3 for \$32 ea.

**MEREDITH,** Dept. EE-7, 310 West 9th St., KANSAS CITY, MO. 64105



## INCREASE Your Seeing Power

Franklin-style half-frame glasses with precision-ground lenses. For sharp magnification, just right for most people. Frame-top eliminated for unimpeded distant viewing. Black frame is metal-cored, metal hinged, a great value at \$4.95 ppd. 3 for \$4 each, 6 for \$3 each. Please state age with order.

**MEREDITH,** Dept. EE-7, 310 West 9th St., KANSAS CITY, MO. 64105



## LIQUID PLASTIC

Polyurethane that applies like paint forms a skin so tough it won't crack, chip or peel. Cuts painting costs... covers and protects like a shield of unbreakable glass.

# \$50 REWARD



for Any Spider, Bug, Insect that Bugmaster Electric Units fail to kill. Here is your automatic, odorless electrical way to rid apartment, home, office or plant of disease carrying bugs, roaches, fleas, bedbugs, ants, moths, silverfish.

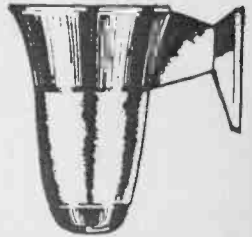

## KILL BUGS INDOORS

### THE INSTITUTIONAL WAY

- Model H—\$9.95 plus 75¢ p&h
- Xtra Crystals for H—75¢ per box
- Model G—\$15.95 plus \$1 p&h
- Xtra Crystals for G—\$1.50 per box

Model H— 6,000 cubic feet  
Model G—12,000 cubic feet

- Pkg. Chrysothyll Odor Kill Crystals 75¢

When Ordering refill crystals only please add 40¢ p&h. & bulg.

**MEREDITH,** Dept. EE-7, 310 West 9th St., KANSAS CITY, MO. 64105

## \$70 AIR-GUN only \$29.95

Complete with chisel this 3 lb. Air-Gun rips into metal, chips concrete, drives pins, etc. Delivers 5500 2" strokes a minute. Operates on a 3 to 5 hp compressor. Made especially for govt. and manufacturer made too many. At only \$29.95 ppd. while they last, a \$70 value. Three extra attachments for exhaust pipe cutting and other uses. \$1 ppd.



**MEREDITH,** Dept. EE-7, 310 West 9th St., KANSAS CITY, MO. 64105

## WATCH RUST DISAPPEAR NAVAL JELLY

is an extremely active new cleaner that removes rust by chemical combination... sticks to verticals and overheads. Brush it on, hose it off.

Use on pipes, fences, tools, tanks, all machinery. Eliminates sandblasting, scraping, etc. Easy and quick.

- 40# @ .65/lb. \$26
- 10# @ 1.50/lb. \$15
- 4# @ 2.00/lb. \$8.00
- #4 ppd.—other units FOB KC

**MEREDITH,** Dept. EE-7, 310 West 9th St., KANSAS CITY, MO. 64105

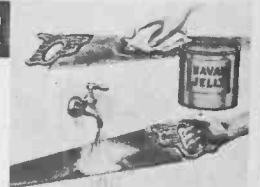

## WATERPROOF in 30 MINUTES

Adheres to practically anything, stops leaks. Ideal for concrete, aluminum, wood, masonry, canvas, any metal. Clear—any major color. Just specify. \$5.95 per qt., \$18.50 per gal. We pay all shipping costs. Order NAVAL 5.

**MEREDITH SEPARATOR CO.,** Dept. EE-7, 310 West 9th St., Kansas City, Mo. 64105

- Ship as follows: Satisfaction Guaranteed:
- Super-Hack  1  3  6  24
  - Carbide Drills (specify diameter)
  - Bugmasters as checked above
  - Naval Jelly as checked above
  - Air Guns
  - Tear Gas Ornaments  1  3  6
  - Naval  Qt.  Gal.
  - Stending Glasses (Franklin style)  1  3  6
- (State age with order.)

Name..... Address.....

City..... State..... Zip.....

# Let I.C.S. equip you for success in radio-TV-electronics— with professional equipment!



Brand-new "Electronic Laboratory," now being offered for the first time, can help you land in this big money-making field—FAST!

Here's an opportunity for you to turn spare time into cold cash, or begin a whole new career—in a field where the rewards have never been greater. And you *don't* need previous experience to do it!

International Correspondence Schools has just developed a new I.C.S. Electronic Laboratory you can construct in your own home. Includes series of training kits, plus the new I.C.S. VTVM—the professional quality vacuum tube voltmeter shown here. With it comes complete course instruction combining all the fundamentals with practical knowledge you can apply at once. And best of all, you build your own professional test instrument!

**I.C.S. instruction gets you going with equipment you can really use!**

A famous manufacturer of nationally known electronic testing equipment worked closely with I.C.S. to develop the Electronic Laboratory and the VTVM itself. Everything you get is geared to increase your skill and knowledge step by step. Until finally, you've completed a precision testing

unit you can use for practically any kind of experimentation, design or servicing work.

Here's how I.C.S. instruction works. You begin with basic study lessons. Texts are clearly worded and easy to follow. At the same time, you "act out" what you learn with simple experiments. Then, in 3 easy stages, you assemble your own precision testing unit. Throughout, your instructor gives you expert, professional help. You learn at home, in spare time, as fast as ability permits.

**Coupon brings full details on your future in this fast-growing field!**

Make up your mind right now to find out how I.C.S. training in Radio-TV-Electronics can pay off for *you*. See how it can help you cash in on the tremendous demand for men skilled in installation, maintenance and servicing of radios, TV sets, hi-fis, computers, automation systems and a host of other space-age devices. Clip and mail the coupon below. You'll receive 3 valuable *free* booklets—including sample lesson. They'll show how you can land in this big-money field *fast!*

**Coupon brings 3 valuable FREE booklets. MAIL IT TODAY!**

## INTERNATIONAL CORRESPONDENCE SCHOOLS I C S

Dept. K9334E, Scranton, Penna. 18515

(In Hawaii: P.O. Box 418, Honolulu. In Canada: I.C.S. Canadian, Ltd. In other countries: I.C.S. World, Ltd.)

Please rush me your new 64-page booklet "ElectronICS" which answers the most often-asked questions about preparing for an electronics career. Also send me "How to Succeed," and a sample I.C.S. lesson. I have indicated my field of interest below.

- |  |   |   |   |   |
|--|---|---|---|---|
| <input type="checkbox"/> Electronic Fundamentals | <input type="checkbox"/> Hi-Fi/Stereo & Sound Systems | <input type="checkbox"/> Electronic Principles for Automation | <input type="checkbox"/> Industrial Electronics Engineering | <input type="checkbox"/> Industrial Electronics Telephony |
| <input type="checkbox"/> Computer Fundamentals   | <input type="checkbox"/> General Electronics          | <input type="checkbox"/> Semiconductor-Transistor Circuits    | <input type="checkbox"/> FCC Radiotelephone Licenses        | <input type="checkbox"/> Other (please specify) _____     |
| <input type="checkbox"/> Radio-TV Servicing      | <input type="checkbox"/> Electronics Technician       |   |   |   |

Name \_\_\_\_\_ Age \_\_\_\_\_

Address \_\_\_\_\_

City \_\_\_\_\_ State \_\_\_\_\_ Zip Code \_\_\_\_\_

Occupation \_\_\_\_\_ Employed by \_\_\_\_\_

Working Hours \_\_\_\_\_ A.M. to \_\_\_\_\_ P.M. Convenient payment plan \_\_\_\_\_ Training Programs for Industry \_\_\_\_\_

I am a member of U.S. Armed Forces. Send me facts about special low rates.



# elementary Electronics

Dedicated to America's Electronics Hobbyists

**HOTTEST CONSTRUCTION PROJECT EVER!**

- ☆ 55 Flame Speaker—*everything you need to know for building the most revolutionary loudspeaker to sound off in 40 years!*

**SHOCKING IN-DEPTH EXPOSE**

- ☆ 41 The Secret Timetable For Killing CB—*so there's a method to the FCC's madness after all!*  
*PLUS*
- 44 CBers Lose 39 Channels—*with 16 in the hole, this must be the beginning of the end!*

**CALLING ALL SWLS**

- 36 DX Central Reporting
- 63 The ABCs of QSLs—*how to snag the lion's share of those long-distance calling cards*

**QUICKEE CONSTRUCTION PROJECTS**

- ☆ 67 HiBander—a *VHF police converter for your car*
- 73 RMS Rfer—*low-cost accessory does its own math*
- 87 Dial-A-Light Telephone—*for what you might call a no-party line*

**THEORY-ETICALLY SPEAKING**

- 49 Tuning Diodes Snatch Signals The Easy Way
- 81 Putting The Ionosphere To Work
- 93 A Basic Course in Electricity and Electronics Part III—*Understanding Capacitors*

**HAPPENINGS FAR & NEAR**

- 46 Sachem High School—*On The Air*
- 66 Supermarket Super Sell
- 80 Skip Signals—*cartoon page*
- 86 Bus 57, Where Are You?
- 90 World's Tiniest Radar—*next to a bat's, that is*

**AS OUR LAB SEES IT**

- 60 Scott 388B Stereo Receiver
- 91 Heathkit IM-17 Solid-State Voltmeter

**THE REGULARS**

- 21 Random Noise—*editorial chit-chat*
- 23 En Passant—*chess column*
- 24 Literature Library—*info you can use*
- 30 e/e Etymology
- 31 Hey Look Me Over—*new products showcase*
- 38 Newscan—*electronics in the news*

**JULIAN M. SIENKIEWICZ** *Editor*  
WA2CQL/KMD4313

**RICHARD A. FLANAGAN** *Managing Editor*  
KQD2566

**CLIFFORD L. FORBES** *Technical Editor*

**HELEN PARKER** *News Editor*  
KQD7967

**JIM MEDLER** *Art Editor*

**ANTHONY MACCARRONE** *Art Director*

**JOHN YUSKO** *Associate Art Director*

**IRVING BERNSTEIN** *Cover Art Director*

**JACK GOLDEN** *Art Associate*

**JIM CAPPELLO** *Advertising Manager*

**CARL BARTEE** *Production Manager*

**STEVE LEVINSON** *Assistant Production Manager*

**PAULA S. HELFANT** *Production Assistant*

**WILFRED M. BROWN** *Kit Division Manager*

*President and Publisher*  
**B. G. DAVIS**

*Executive Vice-President and Assistant Publisher*  
**JOEL DAVIS**

*Vice-President and Editorial Director*  
**HERB LEAVY, KMD4529**

*Vice-President and Production Director*  
**LEONARD F. PINTO**

*Vice-President and Treasurer*  
**VICTOR C. STABLE**



Cover Photo by Leonard Heicklen

☆ Cover Highlights

**AUTHORS IN THIS ISSUE:**

Bill Britton, Len Buckwalter—K1ODH, John W. Collins, Webb Garrison, Jorma Hyypia, Paul T. Judkins, Robert Levine, Jack Schmidt, Vernon Simms, Art Trauffer, and the ELEMENTARY ELECTRONICS' Editorial Staff.

ELEMENTARY ELECTRONICS (Vol. 6, No. 3) is published bi-monthly by SCIENCE & MECHANICS PUBLISHING CO., a subsidiary of Davis Publications, Inc. Editorial, business and subscription offices: 505 Park Ave., New York, N. Y. 10022. One-year subscription (six issues)—\$4.00; two-year subscription (12 issues)—\$7.00; and three-year subscription (18 issues)—\$10.00. Add 75c per year for postage outside the U.S.A. and Canada. Advertising offices: New York, 505 Park Ave., 212-752-6200; Chicago, 520 N. Michigan Ave., 312-527-0330; Los Angeles, 1709 W. 8th St., 213-483-3582; Atlanta: Pirnie & Brown, 3108 Piedmont Rd. N.E., 404-233-6729; Long Island: Len Osten, 9 Garden St., Great Neck, N. Y., 516-487-3305; Southwestern advertising representative, Jim Wright, 4 N. 8th St., St. Louis, 314-241-1965.



SPECIAL 16-PAGE SECTION 

# RADIO SHACK 200<sup>th</sup> STORE CELEBRATION!

**FREE**  
with any order:  
**50¢ COMPUTER!**

Buy anything (in person or by mail) from the following Radio Shack pages using the order blank on page 20 and we'll automatically include one of our handy "MATH-MILE" COMPUTERS. It's 7½" long and made of tough stock to give years of use. It multiplies and divides as fast as you can twirl the dial. It computes interest, figures percentages, does all kinds of auto computations. For example: you used 12 gallons of gas to drive 180 miles. How many miles did you get per gallon? Set the inner circle 12 against the outer circle 18.0 and read the answer at the black 10. It is 15 — as shown in the illustration. Complete detailed instruction for all computer functions are clearly printed on the back.

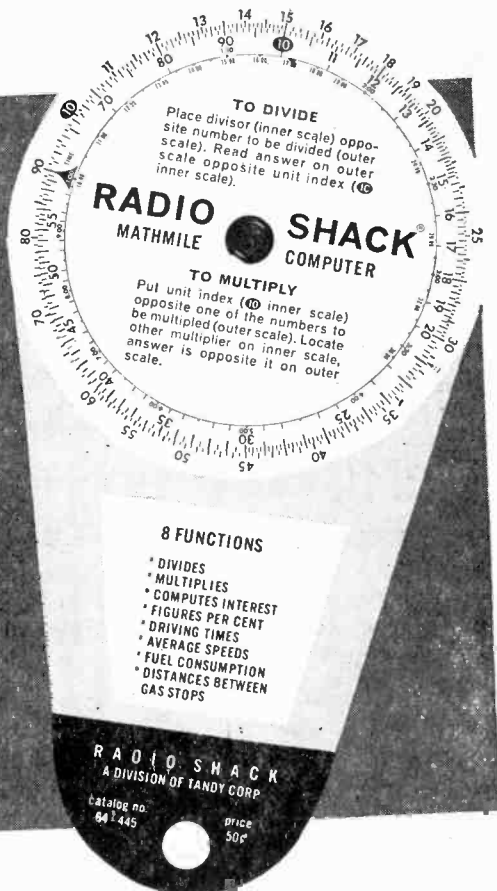

Store Addresses, Order Form, See Page 20

# GIANT VALUES FOR "SOUND" HOBBYISTS

## 8-WATT STEREO AMPLIFIER SEMI-KIT

• *Designed and Made in U.S.A.!*

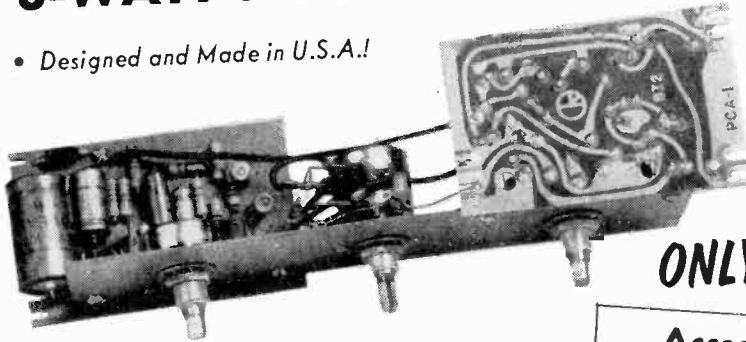

• *A Cinch to Assemble — Just Add Leads!*

**ONLY 9<sup>95</sup>**

Your chance to scoop up a pre-wired solid state stereo amplifier for only \$9.95! Devise your own custom-installation! No engineering skills are required! Just add the leads. 2 volume controls, one for each channel, plus a wide-range tone control. Input impedance is 600K $\Omega$  with frequency response from 50-20,000 cps. Operating either on AC or battery, the amplifier accepts 8-16 $\Omega$  speakers; crystal or ceramic cartridge of AM/FM stereo tuner. Transformerless output circuit. You needn't shop around for other parts. Purchase the accessory kit especially designed for the amplifier (see right). #30-1969

### Accessory Kit for 8W Amplifier

**ONLY 3<sup>95</sup>**

- Knobs
  - Transformer
  - Line Cord
  - Switch
  - Diode
  - Battery and Clips
  - Cables
- 30-1968, Ship. wt. 1 lb. Net 3.95

### THE COMPLETE STEREO SEMI-KIT PACKAGE!

**24<sup>95</sup>**

Hook Up, Install Anywhere!



- 8-Watt Stereo Amplifier Semi-Kit Complete with Accessory Kit!
- Turntable, Tone Arm and Stereo Cartridge!
- Two 8-Inch Round Speakers! • No Extras to Buy!

30-1933, Package, Wt. 11 lbs. Net 24.95

### PHONOGRAPH MOTOR/TURNTABLE

**4<sup>95</sup>**

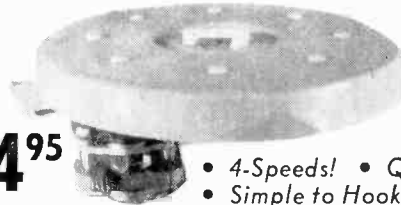

- 4-Speeds!
- Quiet!
- Simple to Hook Up!

Use with stereo amplifiers! Vibration-free AC operation assured by rubber shock-mounted friction drive motor. Speed changes controlled by idler driving the 8" metal turntable. 4 1/2" x 3 3/8" mounting centers; 2 1/8" below base plate. #42-129; #278-1255, AC Line Cord, .39 net.

### Special Manufacturer's Closeout! Purchase!

### 8" ROUND SPEAKER

- The Perfect Low-Cost Extension or Replacement Speaker!
- 2 449 for 4**

Use with semi-kit shown above! Our huge 190-store buying power brings you this quality speaker at sensational savings! Buy several — bring stereo to every room in your home! U.S.-made. Magnet weight: 1.47 oz. 8 ohms. #40-1271.



### STEREO ARM/CARTRIDGE

- Simple to Mount!
- Straight Line Design!

**2<sup>99</sup>**



Modernistic 8" tone arm has off-set head, and high output stereo crystal cartridge (2 1/2V) with dual synthetic sapphire styli. Stylus pressure is adjustable by variable spring tension. Comes with finger lift. #42-128

Store Addresses, Order Form, See Page 20

# GREAT SAVINGS ON *REALISTIC* RECORDS, PRERECORDED TAPES!



## 3-HOUR LONG PLAY PRE-RECORDED STEREO TAPES

- 4-Track, Reel-to-Reel
- Same as Getting 6 Stereo Tapes!
- Top Artists Perform Top Arrangements!
- 7" Reel! • 3 3/4 IPS!

**4<sup>95</sup>** Each  
In Sets of 3

SEPARATELY: \$5.95 EACH

**QUIET JAZZ:** Pool some of America's top jazz musicians, mix in top-notch musical repertoires, and the result: a really great 47-hit tape! Pete Jolly and Bob Freeman are just two of the artists. A "must" for every jazz lover! #51-3001

**EVENINGS AT THE SYMPHONY:** These 8 complete classical masterpieces give you an outstanding concert. Selections by Respighi, Khachaturian, Debussy, Mozart, Tchaikovsky and Strauss, all performed by famous conductors and orchestras. #51-3002

**CURTAIN UP!:** 62 all-time hit show tunes are combined to bring you the musical magic of Broadway theater! Selections from My Fair Lady, West Side Story, Gigi, Bells are Ringing, Oklahoma, many more favorites! #51-3003



## TRIPLE PLAY 8 TRACK STEREO TAPE CARTRIDGES

Available Only  
at Radio Shack

- 3 Complete Stereo Albums — IN ONE CARTRIDGE!
- 30 Full-Length Tunes!

**4<sup>95</sup>** EA.

**THE HERITAGE OF BROADWAY:** A variety of artists "belting-out" 30 show-tune greats of our time! A family favorite. #51-3004

**THE MELODIES OF LOVE:** Carol Lawrence, Lena Horne and more stars give you hours of soothing music. #51-3005

**SOUNDS SMOOTH:** "I'm in the Mood for Love," "Shine on Harvest Moon" — and other popular instrumentals. #51-3006

**SAY IT WITH STRINGS:** Marcel Lenoir conducts — 30 greats including "Tenderly," and "How Deep is the Ocean." #51-3007

**FOREVER FAVORITES:** Features a variety of songs by the Hi-Lo's, Ink Spots, Pied Pipers, Fred Astaire, etc. #51-3008

**AND THEN THEY WROTE:** Hits of Porter, Gershwin, Lerner and Loewe, etc., played by the Kingsbridge Strings. #51-3009

## 3-Disk Audio Fidelity Stereo LP Sets!



### ORGAN IN STEREO

3 Record  
Stereo Set

**4<sup>95</sup>**

- Studio Quality!
- 20-20,000 CPS!

An Audiophile Series standout! 36 selections engineered to bring out the best in any stereo system. Leon Berry at the giant Wurlitzer organ; Al Melgard at the Chicago Stadium organ, and Eddie Osborn at the Baldwin and bongos. 2 hours of entertainment! #50-2000



### ARMED FORCES SOUND EFFECTS

3 Record  
Stereo Set

**4<sup>95</sup>**

- Studio Quality!
- 20-20,000 CPS!

The drama of actual combat; the sound of airpower; a nuclear explosion and the fast-paced action of the world's greatest aircraft carrier. Listen to ceremonial military drills and marches. 3 records at what you'd expect to pay for one! #50-2001

For Store Addresses, Order Form, See Page 20

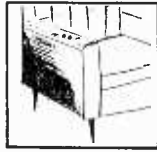
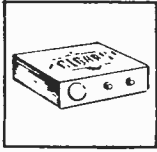
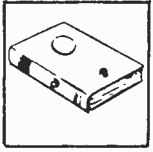
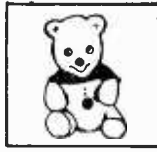
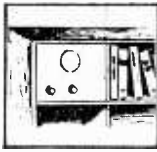

# RADIO SHACK 200<sup>th</sup> STORE CELEBRATION!

## What's your project for our "Build In" radio?

*Here's a wired transistor radio in 3 pieces. Dextrous do-it-yourselfers should have a field-day with this one.*

You carpenters, metal-workers and gift designers will really appreciate Radio Shack's novel "Build In" — a 6-transistor superhet that's really *a kit that isn't a kit*. Confused? Part *one* is the radio, 100% wired, installed in a crystalline 2¼ x 1 x 3⅛" case with the tuning knob sticking out of one end, and 8 wires out of the other. Part *two* is a separate volume control with built-in switch, knob, and soldered leads. Part *three* is a 2¼" PM speaker installed in a plastic case, with soldered leads.

The three parts (plus a flat 9V battery, not included) can be installed in, on, or under anything, in just about any desired angle or position. And you don't have to be an engineer — Radio Shack's geniuses have provided a simple, idiot-proof lashup pictorial. Now all you need is the price (*just* \$6.98, *Cat No. 12-1150*) and some Yankee ingenuity! Whether you hide "Build In" in a jug of corn likker, junior's wagon or Tillie's sewing box, the result is sure to please.

The basic radio itself looks like a little jewel, a real work of art — our photo doesn't do it justice. And the "kit that isn't a kit" is another of Radio Shack's exciting exclusive products that can't be bought elsewhere. Get a "Build In" at your nearest Radio Shack store.

For Store Addresses, Order Form, See Page 20

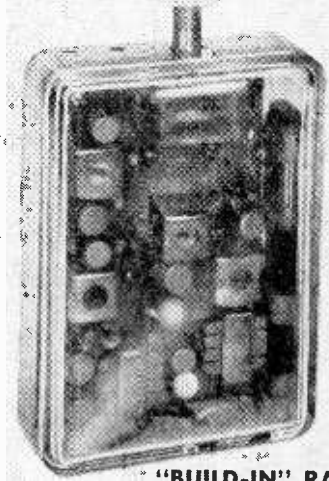

"BUILD-IN" RADIO



VOLUME CONTROL AND SWITCH

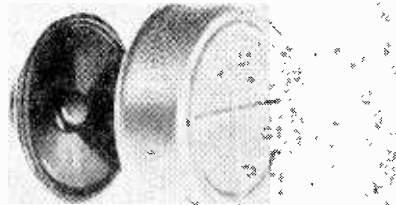

PM SPEAKER IN CASE

## RADIO SHACK PROJECT BOOKS (4¢ A PROJECT)



### "50 EASY TO BUILD SOLID STATE PROJECTS"

Build your own transistor radios, electronic organs, amplifiers, code oscillators, megaphones, generators, etc. Ideal for hobbyists.

62-1050 ..... Net 2.00

### "A MODERN TRANSISTOR WORKBOOK"

Build your own wireless microphone, AM broadcast tuner, audio pre-amp, PA system, experimenter's power supply, etc. 50 schematics.

62-2025 ..... Net 2.00

EACH  
BOOK

\$2



# SPEAKERS, MIKES, TOOLS FOR THE EXPERIMENTER

## BUILD "EI'S" MIGHTY SUB-MINI SPEAKER

4" Acoustic Suspension  
FE-103 Speaker System!

The fabulous Realistic FE-103, complete with cabinet construction details as published in Electronics Illustrated! 30-17,000 cps; 15 watts; 8 Ω.

**7<sup>95</sup>**

40-1197, FE-103, Wt. 5 lbs. Net 7.95  
CONTOUR NETWORK KIT.  
With instructions.  
40-808, coil, capacitor, etc., Net 3.95

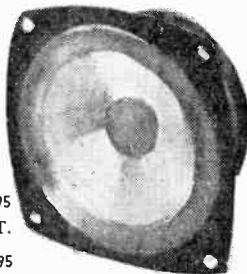

# RADIO SHACK 200<sup>th</sup> STORE CELEBRATION!

## MINIATURE PM SPEAKERS FOR TRANSISTOR PROJECTS, RADIOS

8 Ohm Impedance

Small in size but big in sound! Three sizes to choose from: 2 1/2", 2 3/4", or 2". All for the same bargain price!

40-247, 2 1/2", ..... Net .98  
40-248, 2 3/4", ..... Net .98  
40-245, 2", ..... Net .98

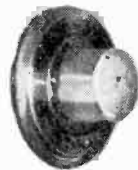

**ONLY 98¢ EACH!**

## MIDGET EARPHONES

For Transistor Radios



**98¢**

Resp. 50-9000 cps. With replaceable earplug, cord, 10 ohms.

33-175, Wt. 2 oz. .... Net .98  
33-174, w/3/32" plug, Net .98

## DUOFONE™ HEADPHONES

• Switchable Mono/Stereo!



**6<sup>95</sup>**

Wide-range dynamic phones for mono or stereo! 8Ω, matching 4-16Ω.  
33-196, 1/2 lb. .... 6.95

## FABULOUS THERMO-ELECTRIC GLUE GUN REALLY WORKS!

60-Second Bonding Plus Instant-set Caulking!  
No Clamping! No Cleaning!



Makes all other kinds of gluing obsolete! Uses unique hot-melt glue sticks: melted glue bonds permanently in 60 seconds, providing a flexible bond that's perfect for furniture, pottery, metal, leather, plastic or fabric. Use with white sealer sticks for water proof caulking. Glue and caulking included.  
64-2860, Gun, 2 lbs., Net 5.99  
64-2861, 7 Glue sticks, 1 lb. Net .49  
64-2862, 7 Sealer Sticks, 1 lb. Net .49

**5<sup>99</sup>**

for make-or-mend jobs

## CRYSTAL LAPEL MIKE

• For Recorders,  
PA, Paging!



**1<sup>89</sup>**

Sensitive! Concealable! Response: 200-300 cps.  
73-100, Wt. .8 oz. .... Net 1.89

## CRYSTAL MIKE CARTRIDGE



**89¢**

Precision made crystals! Response up to 7000 cy.  
270-095, 8 oz. .... Net .89

## 6<sup>95</sup> LAVALIER DYNAMIC MIKE Neck/Hand/Desk Use!



Pencil-slim hi-Z for use at home, studio, or in PA and guitar systems! With cord, stand. 50K.  
33-928, Ship. wt. 2 lbs. .... Net 6.95

## POWERFUL CERAMIC MAGNETS

1,000's of Home,  
Office, Auto Uses!

64-1885

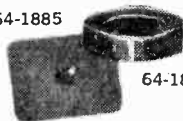

64-1875

**10¢**   **15¢**   **25¢**  
Each   Each   Per Pair  
For   For   For  
10   10   10

**10 FOR 1<sup>00</sup>**

## LOW COST 25-W. SOLDERING IRON



**1<sup>89</sup>**

Precision designed! Comes complete with UL Cord and Plug. Uses 117V AC/DC.  
64-2182,  
1 lb. .... Net 1.89  
64-2178, Extra copper Tip ... Net .25

## OUR OWN 60/40 SOLDER



**69¢** Each  
**12 & UP**  
**59¢** Each

U.S. made with superactive rosin core. Fits fed. specs. QQ-5-571d  
64-0002 ..... Net .69

For Store Addresses, Order Form, See Page 20

## STEEL CATCH-ALL STORAGE BOX

6"H x 8 1/4"D x  
5 3/4"W



**1<sup>95</sup>**

4 draws with adjustable compartments.  
64-2050, 3 lbs. .... Net 1.95

## ASSORTED ELECTRIC HARDWARE



6"H x 8 1/4"D x  
5 3/4"W

**99¢**

Over 600 pieces! Something here for everyone! All brand new — no sweepings! One full pound. Comparable value: \$4.50!  
64-2890, Wt. 1 lb. .... Net .99

# NEW Science Fair™ ELECTRONIC KITS

**Recommended by Reviewers, Educators!**

Created by Radio Shack Engineers to give youngsters and adults alike a ground floor introduction to the theory and practice of modern electronics. You build the way the "pros" do — by breadboarding — so soldering is easy. You can move or interchange parts, even create additional experiments. Detailed pictorials and schematic diagrams, add-on ideas, and all necessary parts are included in each fascinating project. An excellent classroom tool!



**NEW! EXCITING! EASY TO BUILD!**

## Science Fair™ SIREN KIT

- Ear-Splitting Volume!
- A Great Burglar Alarm!
- Loud Automatic "Rise-Fall" Sound!
- Adaptable for Bikes!

**5<sup>95</sup>**

Construct a powerful "rise-fall" oscillator that doubles as a siren or burglar alarm! A wailing sound very similar to a police siren can be produced with ear splitting volume loud enough to be heard on a crowded street. The alarm circuit is completely automatic; no button has to be pushed to control the oscillator's "wailing" rate. Use as a burglar alarm to protect your home while you're away. When activated, a simple micro-switch strategically located in a doorway, window or vehicle, turns the oscillator on at full blast to deter any intruder.

23-468, AA Battery, 4 Req. (Portable use) Ea. .10  
 270-383, Battery Clip for above ..... Net .45  
 28-107, Siren Kit, Wt. 1 lb. .... Net 5.95  
 23-006, 6V Lantern Batt. (Normal) ..... Net 1.19  
 23-541, 6V Lantern Batt. (Heavy duty) ..... Net 2.59

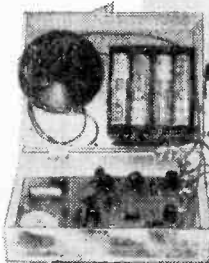

**EACH KIT IS COMPLETE — NO EXTRAS TO BUY! EACH INCLUDES A STEP-BY-STEP INSTRUCTIONAL MANUAL PLUS ADDITIONAL IDEAS FOR SCHOOL AND HOME USE!**

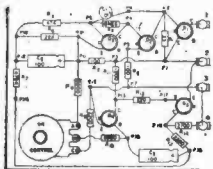

Detailed Pictorials



All Necessary Parts



Perf-Board Construction

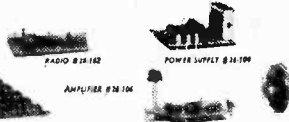

Add-On Ideas

### 11 KITS TO CHOOSE FROM:

28-102, 2-Transistor Radio Kit .....	3.95	28-106, "OTL" Audio Amplifier Kit ...	4.95
28-100, 1-Tube DC Radio Kit .....	3.95	28-112, Bell/Buzzer/Code Key .....	1.49
28-101, Transistor Organ Kit .....	5.95	28-113, Stereo Amplifier Kit .....	8.95
28-103, Wireless AM Mike Kit .....	3.95	28-109, FM Wireless Microphone Kit ..	6.95
28-104, AC/DC Power Supply Kit ...	6.95	28-110, 3-Transistor Shortwave Radio Kit	7.95
28-105, 3-Way Code Oscillator Kit ...	3.95		

In Stock at Any One of the  
200 Radio Shack Stores Coast to Coast

NEW from RADIO SHACK

# Science Fair™

## BATTERY KIT

Make 2 "D" Batteries



ONLY  
**1.25**

Learn the Basics of Electrochemistry

- All Parts and Accessories for Making 2 Working "D" Cells
- 8-Page Instruction Manual

The ideal project kit—developed and endorsed by educators—for youngsters from 7 to 16! Contains all material needed for making 2 Radio Shack 50% Longer-Life "D" Batteries, plus step-by-step instruction manual, theory of operation, and suggested practical experiments. Completed batteries are top-quality and usable wherever needed!

28-125, Ship. wt. 2 lbs. ..... Net 1.25



## Science Fair™ 50-IN-1 ELECTRONIC PROJECT KIT

**17.95**

- Makes 50 Different Projects
- Safe—No Soldering—No AC
- All Solid State Circuitry
- 15 Solar Energy Projects
- 62-Page Illustrated Manual!

Imagine! Now you can get one of the biggest bargains in electronic kits ever offered—and enjoy the "fun" way to learn the theory of electronics! Build 50 different projects as you learn. Packed (in hardwood case) with everything you need. Read some of the things you can build: home broadcasting station, electronic "organ," germanium radio, one- and 2-transistor radios, morse code key, telephone, radio telegraph, transistor amplifier, wireless phonograph amplifier, oscillator tester, signal tracer, field transistor testers, continuity tester, sensitive galvanometer, Wheatstone bridge, A.C. bridge, solar telemeter, sound level meter, photometer, water purity indicator, light-powered oscillator, electronic metronome, telephone amplifier. And these are only SOME of the things you can build from this king-sized 50-in-1 kit!

28-201, Ship. wt. 5 lbs. .... Net 17.95



For Store Addresses, Order Form, See Page 20

# CB'ers MOBILE *REALISTIC* TRANSCEIVERS!

## *REALISTIC* 12-CHANNEL SOLID STATE CB TRANSCEIVER

**FREE  
CRYSTAL BONUS!**

With Purchase of TRC-15

**4 SETS  
OF CRYSTALS**

Channel 11 Installed in Set;  
YOUR CHOICE OF 3 ADDI-  
TIONAL CHANNELS — FREE!

A Regular \$19.92 Value When  
Crystals Purchased Separately

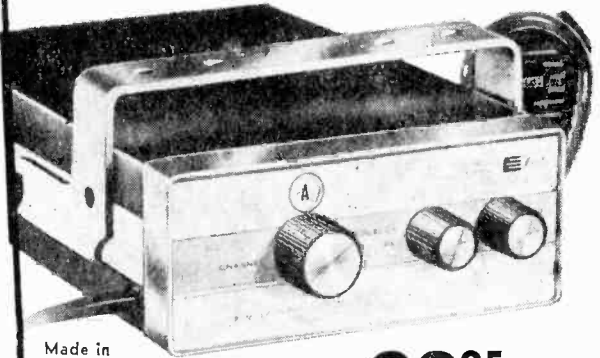

Made in  
U.S.A.

Model TRC-15 **89<sup>95</sup>** NO MONEY DOWN

The \$100-quality 2-way radio for any 12V (neg. ground) car, truck or boat! 5 full watts of input power; 1  $\mu$ v sensitivity; solid 100% modulation! Includes built-in ANL; provision for connecting PA speaker. Complete with set of Ch. 11 crystals, push-to-talk mike with coiled cable, adjustable mounting bracket, DC cable, instructions.  
21-033, Sh. wt. 5 lbs.; 8 $\frac{1}{4}$ x5 $\frac{1}{8}$ x2 $\frac{3}{8}$ " Net 89.95

★ 13 Silicon Transistors; 4 Diodes! ★ 12 Crystal-Controlled Channels! ★ Illuminated Channel Selector! ★ Adjustable Squelch! ★ Electronic Antenna Switching! ★ No Warm-Up Delay! ★ Die-Cast Panel; Extruded Trim! ★ Provision for PA!

## *REALISTIC* 12 CHANNEL CB TRANSCEIVER

Single Crystal Operation for Receive and Transmit



**99<sup>95</sup>**

- Solid State Circuitry!
- Dual Conversion 6.2 MHz and 455 KHZ for Greater Sensitivity & Selectivity!
- Mechanical 455 KHZ Filter!
- Push-to-talk Dynamic Mike!

A truly versatile communications package. Incorporates advanced frequency synthesis technique used on higher priced models, the TRC-18 transmits and receives with only one crystal per channel. Up to 3-watts output with a full 5 watts of RF input. Low battery drain in any 12 VDC neg. ground

vehicle. Adjustable squelch control; automatic noise limiter; illuminated channel selector and meter. Sensitivity: 0.5  $\mu$ v for 10 db S+S/N. With cords, brackets, crystal for channel 11. 7 $\frac{1}{2}$ " x 6 $\frac{3}{8}$ " x 2 $\frac{3}{8}$ ".  
21-120, Ship. Wt. 8 lbs. Net 99.95

## TRC-24 23-CHANNEL CRYSTAL-CONTROLLED TRANSCEIVER

- 18 Transistors, 4 Diodes!
- Low Battery Drain!
- Antenna Changeover Relay!
- Synthesizer Circuitry!
- Illuminated S Meter and Channel Selector!
- Chrome and Wood Grain Front Panel!

**139<sup>95</sup>**

No Money Down

Obsoletes all 23-channel crystal-controlled CB transceivers! 0.25  $\mu$ v sensitivity at 10db S/N! Includes adjustable squelch, automatic series gate noise limiter . . . all wanted features! 12 VDC neg. ground. Plug-in ceramic mike, fusable DC cable, bracket, instructions.  
21-124, Sh. wt. 6 lbs. Net 139.95

ALL CRYSTALS  
SUPPLIED!

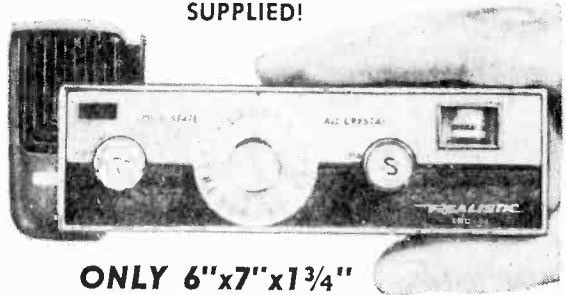

**ONLY 6"x7"x1 $\frac{3}{4}$ "**

# CB WALKIE TALKIE VALUES!



## TRC-1B 7-Transistor Superhet

**13<sup>95</sup>**  
Each

- Low in Cost — High in Quality!
- Compact and Lightweight!
- With Push-Pull Audio Output!
- 100MW — No License Needed!
- Rugged Die-Cast Front Panel!

More RF output power, more audio and greater sensitivity than most others in its price class! Push-pull audio output modulator, 1 diode, on/off volume control switch, and 45" 10-section telescopic antenna. Includes set of crystals for Channel 11, battery, and carry strap. 6 x 2½ x 1½".  
21-102, Ship. wt. 2 lbs. ..... Net 13.95

**NOW — SAVE UP TO 15% OFF  
OUR ALREADY LOW, LOW PRICES!**

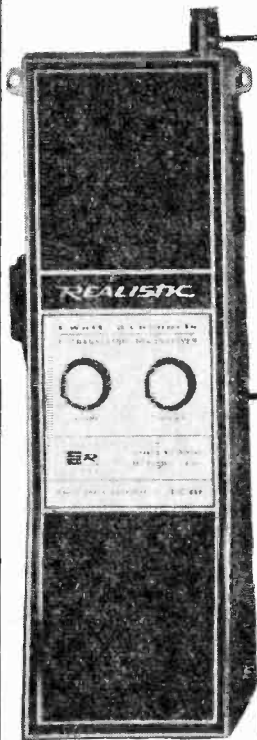

### 1-WATT 3-CHANNEL TRC-44B

- Adjustable Squelch!
- Automatic Noise Limiter!
- Push-Pull Audio Output!

SAVE \$5.00  
REG. \$44<sup>50</sup>      **SALE 39<sup>50</sup>** Each

Plenty of sock! Exclusive "lock-switch" for continuous transmit; Beep Signal feature; separate microphone and speaker! Has 12 transistors, 3 diodes and a thermistor. With set of Ch. 11 crystals, batteries, telescopic antenna, carry strap. 9x2¾x2" Sale 39.50  
21-106, Sh. wt. 5 lbs. ....

### 1½-WATT 2-CHANNEL TRC-66

- Center-Loaded Telescopic Antenna Increases Effective Radiated Power!
- Battery Meter Indicator!
- Beep Signal!

SAVE \$10  
REG. \$59<sup>95</sup>      **SALE 49<sup>95</sup>** Each

15 times the power of 100 MW units! This husky feature-packed unit has 14 transistors, 4 diodes and 1 thermistor, plus ANL and "DX-boost" for better modulation. With crystals, batteries, earphone.  
21-105, Sh. wt. 5 lbs. .... Sale 49.95





# EASY-TO-USE *MICRANTA* TEST EQUIPMENT!

## 1,000 OHMS/VOLT MULTITESTER

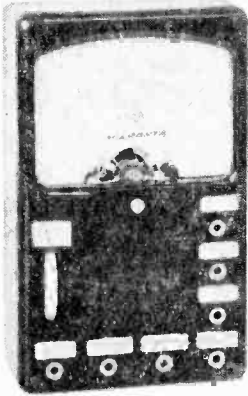

**SPECIAL!**

**3<sup>95</sup>**  
Factory  
Wired

Our Regular \$5.95

- Convenient Thumb-Set Zero Adjustment!
- Reads AC/DC Volts in 3 Ranges: 0-5, 150, 1000!

Only 3 1/2 x 2 1/8 x 1"!

Great for home or workshop! Pin jacks for all 5 ranges; 2-color 1 3/4" meter scale. DC Current 0-150 ma. Resistance: 0-100,000 ohms. Accuracy is  $\pm 3\%$  of full scale value on DC ranges,  $\pm 4\%$  of full scale on AC ranges. A rugged black bakelite case. Comes with pair of color-coded test leads, instructions, battery.

22-4027, Ship. Wt. 1 lb. Net 3.95

## 30,000 $\Omega$ /V 26-RANGE MULTITESTER

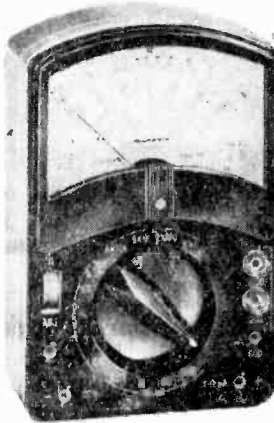

**16<sup>95</sup>**  
Factory  
Wired

- 30,000 Ohms/VDC!
- 15,000 Ohms/VAC!
- Single Knob Selector!
- Easy-to-Read Meter!

Makes easy work of the big jobs with precision 1% resistors and recessed zero ohm adjustment! DC volts: 0-0.6/3/15/60/300/600/1200/3000; AC volts: 0-6/30/120/600/1200. Resistance: R x 1/100/1000/10,000. Current (ma): 0-0.03/6/60/600. -2 to +63db in 5 ranges. With leads, instructions, battery.

22-049, Wt. 2 lbs. Net 16.95

## 50,000 OHMS/VOLT MULTITESTER *MICRANTA* 6 1/2" VTVM METER



**27<sup>95</sup>**  
Factory  
Wired

- 4" Full View Meter with Mirrored Scale!
- Meter Protection Circuit!
- 1% Precision Resistors!
- 26-Ranges!

Only 7 x 5 1/2 x 5 5/8"!

Great for technicians, mechanics and hobbyists. Specs: DC volts: 0-0.5-2.5-10-50-250-500-1000V @ 50,000  $\Omega$ /volts. AC volts: 0-2.5-10-50-250-1000V @ 12,500  $\Omega$ /volts. DC current: 0-25ma-2.5ma-250ma-1 amp-10 amps. DC Resistance: 0-10,000/100,000/1 meg./10 meg-ohms. Center scale: 90/900/9000/900,000 ohms. Decibels: -20 to +62 (5 Ranges).

22-150, Ship. Wt. 5/2 lbs. Net 27.95

For Store Addresses, Order Form, See Page 20.

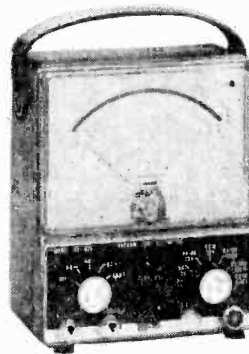

**39<sup>95</sup>**  
Factory  
Wired

- Precision Resistors!
- Measures Peak-to-Peak and RMS (7 Ranges on Each Function)!
- Frequency Response: 30 cps to 10 mc!
- Easy-to-Read 2-Color Full View Mirrored Scale!

Features a zero-center scale for alignment of FM-TV detector circuits. Specs: AC volts: RMS 0.1 to 1500 V. (7 ranges); DC volts: 0.1 to 1500 V. (7 ranges). Peak-to-peak 4-4000 V. (7 ranges). Output -20 db to +65 db (7 ranges). Resistance: 0.2 $\Omega$  to 1000 meg-ohms (7 ranges). Tubes: 12AU7, 6AC5 and SR1A. Power: 117 VAC, 50/60 cycles.

22-025, Ship. Wt. 7 lbs. Net 39.95

# SEMI-CONDUCTORS FOR THE HOBBYIST



## Replacement Transistors

### PNP TYPES

For high frequency, RF-IF, and converter circuits. Replaces: 2N247, 2N248, 2N252, 2N267, 2N274, 2N308, 2N309, 2N310, 276-412, Wt. 3 oz. .... 1.29

For mixer/oscillator converter circuits. Replaces: 2N112, 2N113, 2N114, 2N135, 2N136, 2N137, 2N140, 2N175, etc. 276-401, Wt. 3 oz. .... .99

For universal IF circuits. Replaces: 2N111, 2N112, 2N139, 2N218, 2N219, 2N315, 2N366, 2N406, etc. 276-402, Wt. 3 oz. .... .99

For 6 volt audio circuits. Replaces: 2N77, 2N104, 2N105, 2N107, 2N109, 2N130, 2N131. 276-403, Wt. 3 oz. .... .99

For 12 volt audio circuits. Replaces: 2N36, 2N37, 2N38, 2N41, 2N43, 2N44, 2N45, 2N46, etc. 276-404, Wt. 3 oz. .... .99

For 9 volt audio circuits. Replaces: 2N188, 2N189, 2N190, 2N191, 2N192, 2N195, 2N196, 2N197, etc. 276-405, Wt. 3 oz. .... .99

For auto radio AF amplifier circuits. Replaces: 2N176, 2N178, 2N179, 2N234, 2N235, 2N35B, 2N236, 2N242, etc. 276-406, Wt. 3 oz. .... 1.19

For high power AF circuits in auto radios. Replaces: 2N173, 2N174, 2N277, 2N278, 2N441, 2N442, 2N443, 2N1515, etc. 276-407, Wt. 3 oz. .... 2.29

Silicon Epoxy high gain. Replaces: 2N940-2N946, 2N2333-2N2337, 2N3548-2N3550. 276-420, Wt. 3 oz. .... Net 1.09

Silicon Epoxy medium gain. Replaces: 2N1132, 2N923-2N928, 2N2372, 2N859, 2N865. 276-421, Wt. 3 oz. .... Net .99

### NPN TYPES

For mixer/oscillator converter circuits. Replaces: 2N193, 2N194/A, 2N211, 2N2-12, 2N233, 2N234, 2N357, 2N358. 276-408, Wt. 3 oz. .... 1.09

For universal IF amplifier circuits. Replaces: 2N98, 2N99, 2N100, 2N145, 2N146, 2N147, 2N148, 2N149, etc. 276-409, Wt. 3 oz. .... 1.15

For 9 volt AF amplifier circuits. Replaces: 2N35, 2N169A, 2N213, 2N214, 2N228, 2N306, 2N312, 2N313, etc. 276-410, Wt. 3 oz. .... .99

For 12 volt AF amplifier circuits. Replaces: 2N306A, 2N445A, 2N446A, 2N447A, 2N556, 2N557, 2N587, 2N649, etc. 276-411, Wt. 3 oz. .... .99

Silicon Epoxy high gain. Replaces: 2N3704-2N3709, 2N3415-2N3417, 2N3877. 276-422, Wt. 3 oz. .... Net 1.09

Silicon Epoxy Medium gain. Replaces: 2N3663, 2N3843A, 2N3900, 2N3901, etc. 276-423, Wt. 3 oz. .... Net .99

## Silicon Field-Effect Transistors



198

- High Impedance Input!
- Low Noise! High Gain!
- Characteristics Similar to Pentode Vacuum Tube!

1000's of applications where pentode tubes are used in low level circuits; field strength meters, gate dippers, receivers, flea power transmitters, etc. TO-5 case. Includes specifications. 276-664, Sh. wt. 2 oz. .... Net 1.98

## Hard-to-Find IBM Component Boards



8 For 100

All quality American made parts. Each board contains at least two transistors, plus loads of other components: resistors, capacitors, coils, diodes, modules, chokes, and heat sinks. Size: 2 3/8" x 3 3/8". 276-617 ..... 8 for 1.00

## NEW! Twin-Pak Transistor Kit

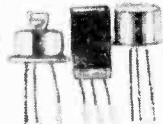

198 Pak of 50

- 25 NPN • 25 PNP
- Silicon & Planars Included

A sensational value! Full-length leads; ideal for RF applications, switching and general-purpose audio use. Silicon and planar types included to provide replacements for many popular numbers without circuit change. Think of it — less than 4¢ per transistor! 276-1516, Wt. 2 lbs. .... Net 1.98

## 100-Pc. Jumbo Pak Assorted Transistors

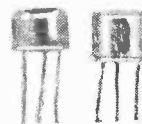

398

Includes Germanium & Silicon

PNP and NPN's in assorted cases. TO-18, TO-5, TO-3, TO-22, etc. Ideal for RF, IF, OSC., audio and power. 276-544, Sh. wt. 1 lb. .... Net 3.98

## Integrated Circuit Specials!

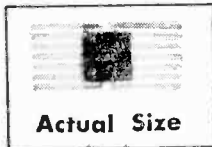

Actual Size

198 • Ideal for the Hobbyist, Builder, Experimenter!  
Up • Fantastic Savings!

New from Radio Shack! Resistor-Transistor Logic type ICs are ideal for builders, hobbyists, labs, industry etc. Guaranteed to be 100% perfect electronically and mechanically. Each comes complete with diagram and lead locations. Power requirements: 3 volts. Flat Pak type. Size 3/8" x 5/16" x 1/16".

DUAL 3 INPUT GATE. Can be used as a 6 input microphone mixer. Contains up to 6 transistors & 8 resistors in pak. Elements can be used parallel to increase current capabilities. 276-430, Wt. 3 oz. .... Net 1.98

DUAL JK FLIP-FLOP. Construct your own binary computers, digital adding machines, etc. Contains up to 25 transistors and 32 resistors per pak. 276-431, Wt. 3 oz. .... Net 2.49

For Store Addresses, Order Form, See Page 20

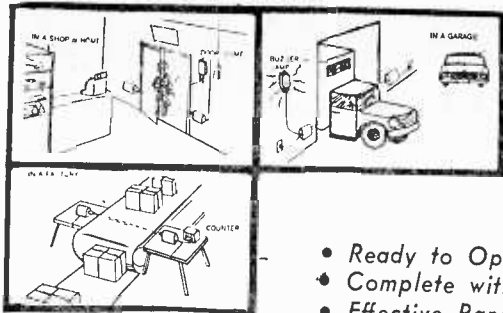

# ARCHER PHOTO-ELECTRIC RELAY SYSTEM

- Ready to Operate — Not a Kit!
- Complete with Exciter Lamp and Photo-Cell Receiver!
- Effective Range: up to 50 Feet!
- Each Unit Is Separately Powered!

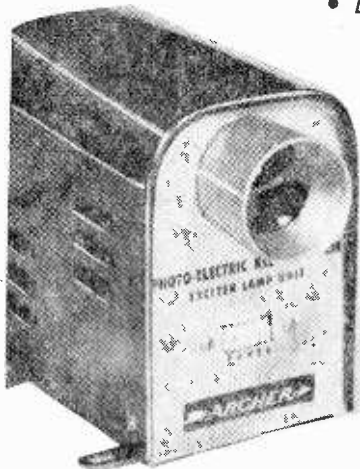

ONLY 19<sup>95</sup>

The ideal multi-purpose photo-relay for business, retail store, home or warehouse use! System consists of an exciter lamp and photo-cell receiver, each housed in a rugged metal case. Both plug into standard 117 VAC house current. The system can be used (with bell or buzzer) to signal when someone enters a room and "breaks" the beam; to count people or objects; or to trigger an alarm to deter intruders. A variable sensitivity control adjusts for ambient light level, or can be used to inactivate the system temporarily. Each unit 5½x4x2½". 275-489, Sh. wt. 6 lbs. .... Net 19.95



## RADIO SHACK "EXTRA-LIFE" BATTERIES

- 50% Longer Life!
- Higher Lumen Output!
- Higher MNO Content!
- Steel Encased with Anti-Corrosive Caps!

Radio Shack's new 50% Extra Life cells yield fresher, longer life without sacrificing "shelf life" or adding weight. Ideal for radios, recorders, flashlights, etc. Designed to exceed U.S. Government standards! Buy 'em by the box — save more!

Fig.	Cat. No.	RADIO SHACK	Interchangeable with			Pack	Per Box
			Eve-ready	Burgess	RCA		
A	23-1538	1.5V "D" Cell	950	2	VS036	4/.98	24/5.59
B	23-478	1.5V "AA" Cell	915	Z	VS034A	4/.69	72/9.95
C	23-153	1.5V "C" Cell	935	1	VS035A	4/.88	24/4.49
D	23-152	9V Rect.	216	2U6	VS323	2/.98	50/19.95

## AMAZING HOME BATTERY CHARGER

Don't Discard Your "Dead" Batteries!

Accepts All These Types:

- 1½V "AA" Cells
- "D" and "C" Cells
- 9V Transistor Radio Batteries

Count the number of batteries you use around the house right now — then count how much you'd save by recharging them over and over again. End replacement costs! Get the handy battery charger that plugs into any 117 VAC house outlet and recharges batteries overnight! Accepts up to 4 batteries at a time. Cannot overcharge or burn out. Start saving money today!

270-1526, Sh. wt. 1½ lbs. .... Net 4.95

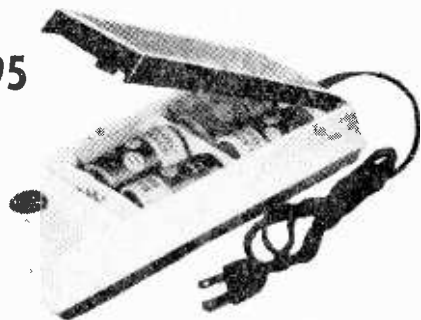

**ANY ARCHER-PAK ON THIS PAGE**

**\$1 PER PAK**

# RADIO SHACK 200<sup>th</sup> STORE CELEBRATION!

## 20 Power Resistors



Package consists of high-quality vitreous, cand-ohm and wire-wound types. Includes 5 to 25-watt power resistors; individual catalog net — \$10! 271-1202, 2 lbs. .... Net 1.00

## 35 Precision 1% Resistors



Large assortment of popular 1/2, 1 and 2-watt values; includes encapsulated, bobbin, carbon film, etc. Made by Aerovox, Shellcross, IRC, and other famous names. 271-1196, 1 lb. .... Net 1.00

## 50 Tubular Capacitors



An assortment of quality tubular capacitors, 100 mmf to .1 mf to 600 WVDC. Includes molded, paper and porcelain types, \$10 if purchased individually from catalog! 272-1568, 1 lb. .... Net 1.00

## 4 Subminiature 455KC IF Transformers



Slug tuned, made for printed circuitry mtg., shielded. Size: 3/8 x 3/8 x 1/2". 273-515, 1/4 lb. .... Net 1.00

## 8 Sets - RCA Plugs & Jacks



Quality items, ideal for use in phono amplifiers, tuners, recorders, etc. Take advantage of this Radio Shack Special low price! 274-1575, 1/2 lb. .... Net 1.00

## 40 Micro Resistors



World's smallest 1/4-watt carbon type resistors! All have axial leads; built for transistor and subminiature circuitry! Assorted values, with resistor color code chart. 271-1566, 1/2 lb. .... Net 1.00

## 40 Coils and Chokes



Shop assortment consisting of RF, OSC, IF, parasitic, peaking and many more types. Individually purchased, this would cost you \$15! 273-1569, 1 lb. .... Net 1.00

## 55 Mica Capacitors



Famous name micas — Aerovox, Sangamo, C.D., etc. This assortment includes popular values 100 mmf to .01 mf, as well as silver type condensers. A \$10 catalog net value! 272-1573, 1 lb. .... Net 1.00

## 8 Volume Controls



**Most Popular Values**  
Contains 8 assorted values including long and short shaft types. A tremendous bargain for servicemen! 271-127, 1 lb. .... Net 1.00

## Special! 50 Capacitors



Assortment of many types including disc, ceramic, mylar, temperature coefficient, molded, paper, oil, Vit-Q. You save \$9 over industrial net catalog prices! 272-1199, 1 lb. .... Net 1.00

## 60 Half-Watt Resistors



Made by Allen Bradley and IRC. Many 5% and 10% tolerance. Color chart. All most popular values. An absolute "must" for hobbyists and kit-builders. 271-1612, 1 lb. .... Net 1.00

## 50 Ceramic Capacitors



Wide variety of popular values by Centralab and other famous-name makers. 10 mmf to .04 mf to KV. Assortment includes tubulars, discs, NPO's, temp. coefficient, etc. 272-1566, 1 lb. .... Net 1.00

## 48 Terminal Strips



You get a wide variety of screw and solder lug type terminal strips with 1 to 6 lugs. Outstanding value at this low price! 101 uses for the builder and experimenter. 274-1555, 1 lb. .... Net 1.00

## 40 Disc Type Capacitors



A varied assortment of types, including NPO's, Hi-Q, N-750's, mylar and ceramic. 10 mmf to .01 mf to 6 KV. A \$10 catalog net value! 272-1567, 1/4 lb. .... Net 1.00

## 150' of Hook-Up Wire



Assortment consists of 6 V rolls of 25' each — solid and stranded wire. #18 through #22. Necessary for multitude of jobs and always useful! 278-025, 1/2 lb. .... Net 1.00

## 40 One-Watt Resistors



Here are resistors for hundreds of uses! Assortment has Allen Bradley and IRC carbons, with 5% values included. This pack is a regular \$8.00 catalog net! 271-1576, 1 lb. .... Net 1.00

## 4 Transistor Transformers



Made by UTC and Remington Rand. Famous miniatures. Includes sub-ouncer, mike, input types. Color coded leads. 273-1581, 1 lb. .... Net 1.00

## 50 Plugs and Sockets



Ideal bench assortment for servicemen, hams, etc. Subminiature and printed circuit types included! This assortment saves you \$10 over individual catalog prices! 274-1562, 1 lb. .... Net 1.00

## 30 2-Watt Resistors



These quality 2-watt resistors are non-inductive, magnetic film, carbon types. Many with 5% values. Made by famous-name manufacturers. 271-1211, 1/2 lb. .... Net 1.00

**\$25 SURPRISE PACKAGE!**

Loaded with \$ **1** Parts!

The biggest surprise package yet! Enough electronics components to make your eyes pop! Resistors, capacitors, condensers, diodes, . . . your guess is as good as ours. The famous-make parts are worth at least \$25.00! 270-1251, 1 lb., Net 1.00

# RADIO SHACK EXCLUSIVE! ADD A SLAVE "WALKIE" TO YOUR BASE, MOBILE, OR WALKIE TALKIES!

Actual Size!

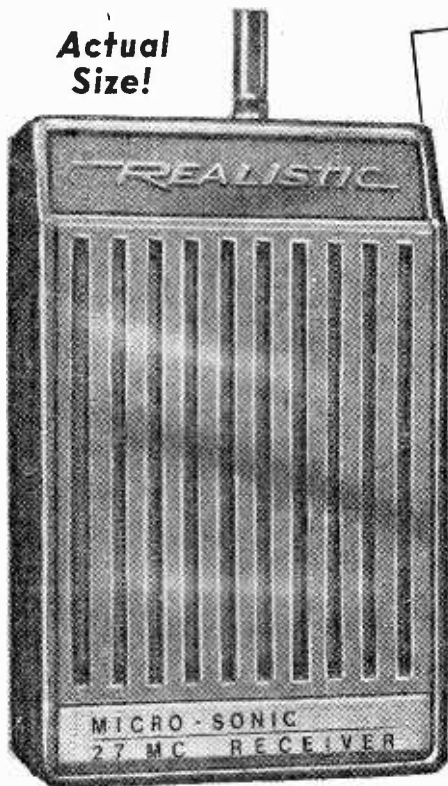

**ONLY 795**

*Crystal-controlled superhet receiver ONLY! Add as many ears to your network as you want. Fits in a shirt pocket — an excellent paging or guided tour device!*

This unusual Radio Shack product, called the Realistic Microsonic 27MC Receiver, comes complete with a Ch. 11 CB crystal — and because it's a plug-in, it can be changed to any of the 23 channels. It's a teeny  $3\frac{1}{2} \times 2\frac{1}{2} \times 1\frac{3}{8}$ ". It includes an earphone with clip, and the phone's lead acts as the antenna. So if you want to hide it away as a pager, there's nothing showing. For DX we've included a 16" telescopic whip to be used only if necessary. Let your imagination run wild with this novel device!

21-109 Microsonic 27MC Receiver ..... Only 7.95

**NEW IDEA #2** — as a companion to the above, or a wireless CB microphone (!), there's also the Realistic Microsonic CB transmitter. Same size, color, everything. But transmit only, 100mw of course, with plug-in crystal for Ch. 11. Uses? For example: one of these plus x-number of receivers and you have a guided tour technique that'll never quit!

21-110 Microsonic CB Transmitter ..... Only 7.95

### FREE ACCESSORIES:

- Receiver — earphone and whip antenna
  - Transmitter — 35" telescopic antenna
- Note: both units include crystals but require a 9V transistor battery to operate. 23-464, 29¢ each.



## 100 MW TRANSMITTER AND REMOTE CONTROL

**3.99** *Perfect as a CW Transmitter or Wireless Mike!*

Loads into almost any antenna; 100 milliwatt output; plays into any CB set. Use as low-power CB transmitter, band marker, or signal generator.

Range to  $\frac{1}{4}$  mile, uses plug-in crystal (not supplied). Get yours now at Radio Shack's low price! 21-1166, Sh. wt.  $\frac{1}{2}$  lb. .... Net 3.99

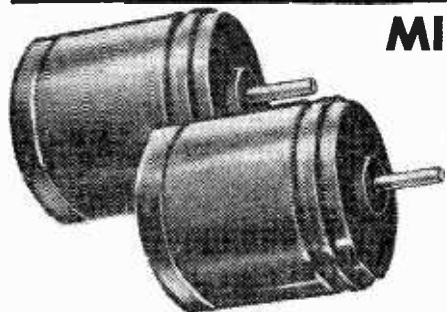

## MINIATURE 6V SYNCHROS

For All Remote Control Applications

Ideal for:

- Amateur & CB Beam Antennas
- Weathervanes and Other Indicating Uses

**4.44** Pair

Used originally in aircraft equipment. Compact, ruggedly built. Operate on 26 VAC @ 400 cycles. Guaranteed to operate efficiently at 6 VAC @ 60 cycles. With wiring diagram. Size  $1\frac{3}{8} \times 1\frac{1}{4}$ "; shaft  $\frac{1}{8} \times \frac{1}{2}$ ".  
273-2006, Ship. wt. 1 lb. .... Pair 4.44  
273-050, 6.3 VAC Transformers ..... Net 1.19



**Now Everyone Can Own  
a Second Telephone!**

# Standard Desk Telephone

Ready to Install **8<sup>95</sup>**

Enjoy the extra convenience of an extra phone! Our most popular style; it's modern, low-cost, and easy to install. Each phone is factory reconditioned to give trouble-free service. Bakelite body and handset; metal base. Dial, bell and coil included. (Note: use of telephone equipment not installed by a telephone company may be subject to local tariff.)  
279-371, Sh. wt. 10 lbs. .... Net 8.95



**For Private Phone  
and Intercom Systems.**

- **Save Time!**
- **Save Steps!**
- **Save Money!**

## 30 Ft. Telephone Extension Cord

Move your phone from room to room! Highest-quality 4-conductor flexible cord plus standard telephone jack and plug. Ideal for intercom. Use 2 or more for extra length.  
279-1261, Sh. wt. 1 1/4 lbs. .... Net 2.98

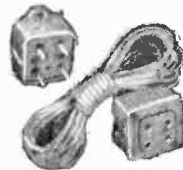

## Telephone Plugs & Jacks

Ideal for making extensions, these plugs and jacks each weigh approximately 1/4 pound.  
279-366, plug ..... Net 1.25  
279-367, jack ..... Net 1.40

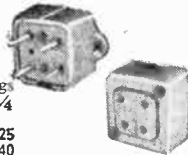

## Coiled Phone Cords

Stretches up to six feet. 3-conductor. Shipping weight: 1/4 pound.  
278-361 ..... Net 1.19  
Four conductor extends up to fifteen feet. Shipping weight: 1/2 pound.  
278-1389 ..... Net 5.95



## Shoulder Rest

Frees both hands! Spring mechanism enables arm to be folded out of sight when not in use. Easy to attach to any phone. Long lasting metal construction. Manufactured in the United States. Weight: 1 pound.  
279-606 ..... Net 1.49

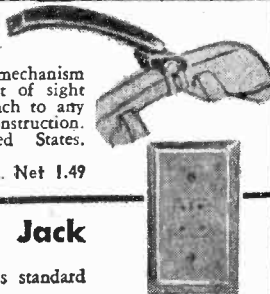

## Telephone Wall Jack

For 2, 3, 4-wire systems. Fits standard wall conduit boxes. 1 lb.  
279-1507 ..... Net 1.99

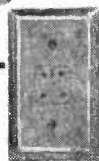

## Carbon Type Handset For Mobile and Replacement Use!

Great for use with mobiles & intercoms, or as outdoor mike for camps and construction sites. Withstands extreme temperatures. High output mike can be used with low gain circuits. Adapt to your CB transceiver or radio. Includes earpiece and 3-conductor cord.  
279-1351, Sh. wt. 1 lb. .... Net 2.99



## Sound-Powered Elements

Kit of two! Talk without electricity—your voice powers these devices. Hook them up and talk up to 300 feet. Shipping weight: 1/2 pound.  
279-1353 ..... Net .99



## 100 Ft. 3-Conductor Telephone Wire

Multi-use 100' 3-conductor wire for telephone work. Ideal for linking temporary phones for field uses.  
278-370, Sh. wt. 2 lbs. .... Net 3.49



## Handset Hanger

Hang up your phone without cutting off party on other end. Ideal for wall telephones. Anodized black aluminum.  
279-1528, Sh. wt. 1/4 lb. .... Net 1.25



## Telephone Dials

Standard Western Electric unit. Can be used with automatic control circuits, & electronic combination lock circuits.  
279-359, Sh. wt. 1 1/4 lbs. .... Net 2.99



Store Addresses, Order Form, See Page 20



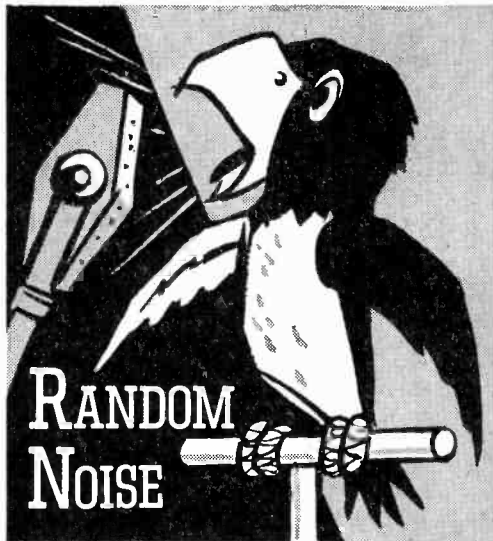

By JULIAN M. SIENKIEWICZ, Editor

**Who Would Have Expected It?** Recently I was working on a VHF receiver that was quite insensitive. Even after tearing it apart I still couldn't locate the trouble. I had determined that the cause was due to spurious RF radiations from somewhere in the receiver. After checking out every stage except the power supply, I decided to pump in the required plate voltage from an external power supply, and—*Zonk!* In came downtown Burbank police calls for Rowan and Martin.

Armed with a trusty .01- $\mu$ F, 600-volt capacitor I began probing circuit elements in the receiver's power supply. Lo and behold, the cause of the RF radiation was the power diodes in the bridge rectifier circuit. After connecting capacitors across the four diodes the noise was

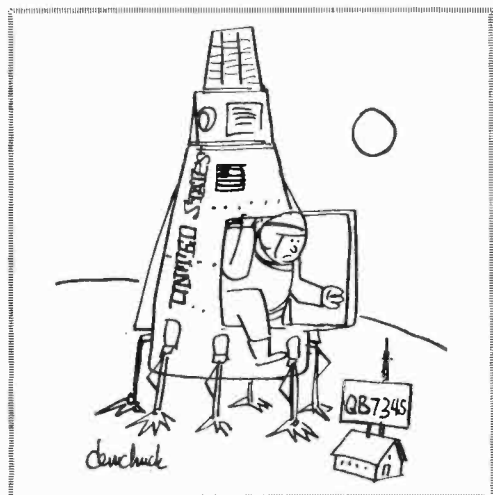

how often could  
you have used...

**a Seizer?**

two-position snap-lock

**Nandy as an extra hand or helper. Clamps lightly or tightly... for moments or minutes.**

A remarkably versatile tool with unusual holding qualities. Clamps tightly. Holds wires for soldering, acts as a heat sink, retrieves small parts from hard-to-reach places. Two-position snap-lock. Box joint construction. Precision machined from perfectly tempered stainless steel.

**4 MODELS: 6" (serrated jaws) Nos. 42H straight and 43H curved nose; 5" Jr. (smooth, slim jaws) Nos. 32H straight and 33H curved nose.**

**XCELITE**

XCELITE, INC., 80 Bank St., Orchard Park, N. Y. 14127  
Send Bulletin N564 on Seizers®.

name \_\_\_\_\_  
address \_\_\_\_\_  
city \_\_\_\_\_ state & zip \_\_\_\_\_

In Canada contact Charles W. Poynton, Ltd.

## RANDOM NOISE

gone, and the receiver functioned normally.

Let this be a lesson to you. When building home-brew receivers and tuners always physically isolate the power supply and keep it away from the first stage and antenna connections. If possible, include a sheet-metal shield or totally box the power supply, heat permitting.

**Everyone needs** a sounding board. And, (as if you hadn't guessed) Random Noise is where this Editor sounds off. For this column belongs to the Editor. He can use it to make a lot of noise whenever he wants to take on a crusade. Or he can just ramble whenever issues are small. Every so often, however, a letter crosses my desk that is worthy of bringing to my readers' eyes; the letter you're about to read is one of them. Disregard its so-so style and just read it.

*Dear Mr. Sienkiewicz:*

*I want to write a few lines to let you know what I think about amateur radio. I am not a radio amateur operator, because I never could get any help from them characters. Yet hams are supposed to offer their services of amateur radio in the public interest.*

*That is why the Citizens Band is such a mess, because that is where a lot of illegal communications goes on. There are a few good Citizens Banders that use the band for what is intended for.*

*From now on you will see less newcomers (hams) on the amateur radio bands because the incentive license goes in effect November 1968. You can thank the ARRL for that.*

—N.R., Green Bay, Wis.

Granted, this letter is no great literary effort. But it does hit at least one nail, maybe two, on the head as regards some of the major problems in CB and ham radio. In the first paragraph the writer points out the lack of interest hams have in increasing their numbers. Maybe this explains why CB social clubs spring up and grow, while the ranks of major amateur radio clubs and leagues diminish, shrink, and wrinkle.

CB clubs can appoint a membership chairman who gathers up friends, neighbors, fellow employees, and even whole family groups, enrolls them, and sends off applications to the FCC for their *talkathon* tickets. Hams have it a bit more difficult.

Hams must be missionaries. Everyone at one time or another is bitten with the ham radio bug. In essence, it's making like Dick Tracy. But from dream to fulfillment the path is lined with all the stumbles and brambles that theory and code can provide. Sure, schools and home-study institutions do a lot of good work in the making of hams; good, too, are the efforts of editors and

authors who fill shelves with magazines and books.

But what have hams done to increase their ranks?

We know from our reader that Green Bay, save for the Packers, is a vast wasteland. And this is true throughout the country (with a few notable exceptions, who, I am sure, will be writing to me).

Can anyone point to the program hams have established to swing a flood of new members to their ranks? As our reader's last paragraph points out, incentive licensing, sponsored by that great ham fraternity, will greatly *reduce* newcomers to the ham ranks. It's only human that as hams advance to super-superior advanced classes they'll communicate less and less with the lower classes, especially the Novice ticket holder—their future elite. What better way can be found to prevent the knowledge of super-hams from passing down to Novices than a license caste system—shades of India!

But here I go after the good hams again when I should be poking CBers in the ribs, too. In swelling their ranks with owners of eight bucks and citizenship, CBers have gone light on quality, heavy on quantity. The channels bear testimony any evening to even an occasional listener—let alone some poor soul who would care to use them. Also, the CBers should be engaged in some missionary work, too. How about making Part 95 known to and practiced by all CBers in the land?

One possible solution could be the addition of a few new channels just above Channel 23 for the exclusive use of Class E Citizens Radio Service licensees who have proven their proficiency in both rules and theory and who have not been cited by the FCC within the last five years. That's a big sentence and it requires an equally big amount of thought.

What say, fellows (fellows in this case referring to CBers and hams alike)? Jot down your comments and get those letters in. The idea is certainly worth tossing around.

But before you write those letters, take a gander at the lead story on page 41 of this issue. Our original thoughts for the "Secret Timetable for Killing CB" was for a big spoof. But, the deeper we got into it, the higher our eyebrows were raised. Now what we'd like to know is, does the FCC really have a timetable?

**CB Jamboree.** The Citizens Band Club Inc. of Pensacola and The Blue Angels Radio Assistance Club of Pensacola will hold a National CB Jamboree at Pensacola (where else?) on August 10 and 11, 1968. Both clubs are working together to raise funds for the Northwest Florida Zoological Society to further develop the Northwest Florida Zoo. So, if you are foot-loose and free, why not drop in on the National CB Jamboree in Pensacola? For more details write to Pat Beisden, Secretary, P. O. Box 374, Pensacola, Fla. ■

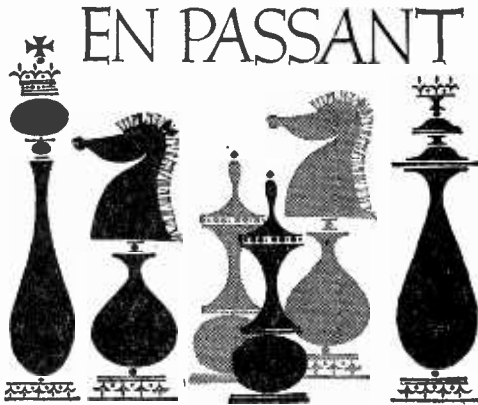

BY JOHN W. COLLINS

♠ In my previous column I presented examples of "Overworked Piece" and "Breaking Communication"—two tactical motifs from the middle-game. Here are four more: Removing the Guard, Skewer, Queening Combinations, and Surprise Move.

**Removing the Guard.** Here the idea is to capture or drive away the guard or support of a piece.

Black

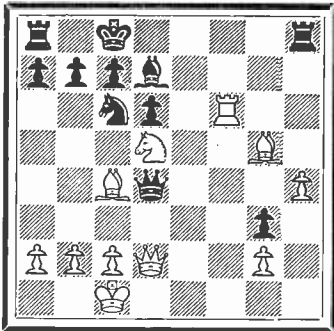

White

Black's Queen is defended only by the Knight. Logically, therefore, the Knight is removed with 1 N-K7# K-N1 (if 1 . . . NxN 2 QxQ wins) 2 NxN# BxN 3 QxQ and White wins.

**Skewer.** The Skewer is an attack which pierces one piece in order to transfix another one behind it, on the rank, file, or diagonal. A follow-through attack.

Diagram for Skewer top of page 26

After 1 RxB#! KxR, White has an easy, clear skewer in 2 B-B2#—winning the Rook behind the King.

**Queening Combinations.** Mason said: "Every  
(Continued on page 26)

Live Better Electronically With

# LAFAYETTE RADIO ELECTRONICS

1968 Catalog 680 **FREE!**



Now OFF PRESS  
BETTER THAN EVER  
Over 500 Pages

Stereo Hi-Fi • Citizens  
Band • Ham Gear • Tape  
Recorders • Test Equip-  
ment • TV and Radio Tubes  
and Parts • Cameras •  
Auto Accessories • Musical  
Instruments • Tools • Books

Featuring Everything in Electronics for  
• HOME • INDUSTRY • LABORATORY  
from the "World's Hi-Fi & Electronics Center"

LAFAYETTE Radio ELECTRONICS  
Dept. DG-8, P.O. Box 10  
Syosset, L.I., N.Y. 11791

Send me the FREE 1968 LAFAYETTE Catalog 680 DG-8

Name

Address

City  State

Zip

(Please Give Your Zip Code No.)

## POWERFUL WIRELESS TRANSMITTER

... the size of  
a package of  
cigarettes

ONLY \$12.95

Completely Assembled  
Incl. 2 Microphones  
& Battery

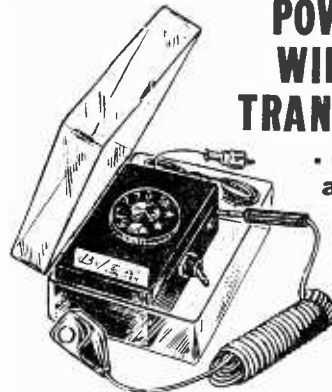

Here's a compact marvel of transistorized electronics that does just about everything . . . yet is tiny enough to fit in a pack of cigarettes. Called the WIRELESS BROADCASTER, this battery operated transmitter picks up sound through its sensitive microphone and transmits (without wires) thru any nearby AM radio. Unlimited applications:

- Broadcasting
- Remote Recording
- Guitar amplification
- Sickroom Signal
- Baby minding
- Auto to Home

This Really Modern Wonder Package comes completely assembled, and includes two microphones (1 Xial for broadcasting, 1 contact type for musical instrument amplifying) plus a 9-volt battery. Fully guaranteed.

Send Cash, Check or Money Order to: (\$12.95)

**IMPERIAL ELECTRONICS** Dept. EE-2  
114 East 32nd St., Rm. 1602, New York, N.Y. 10016



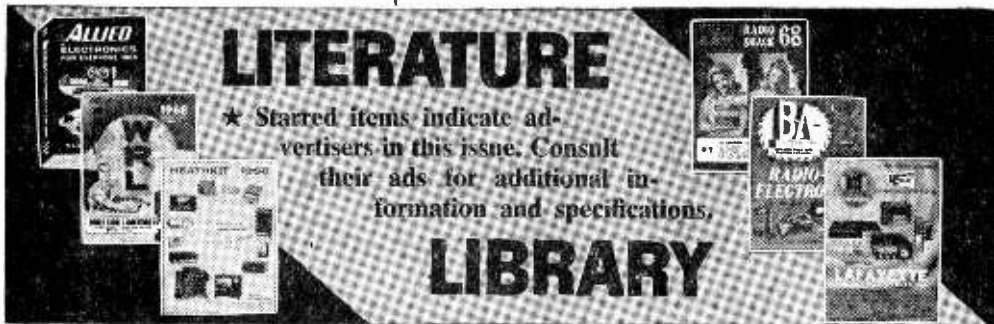

# LITERATURE

★ Starred items indicate advertisers in this issue. Consult their ads for additional information and specifications.

# LIBRARY

## CB—AMATEUR RADIO— SHORTWAVE RADIO

**102.** No never mind what brand your CB set is, *Sentry* has the crystal you need. Same goes for ham rigs. Seeing is believing, so get *Sentry's* catalog today. Circle 102.

**130.** Bone up on the CB with the latest *Sams* books. Titles range from "ABC's of CB Radio" to "99 Ways to Improve your CB Radio." So Circle 130 and get the facts from *Sams*.

**107.** Want a deluxe CB base station? Then get the specs on *Tram's* all new Titan II—it's the SSB/AM rig you've been waiting for!

**101.** If it's a CB product, chances are *International Crystal* has it listed in their colorful catalog. Whether kit or wired, accessory or test gear, this CB-oriented company can be relied on to fill the bill.

**96.** If a rugged low-cost business/Industrial two-way radio is what you've been looking for, be sure to send for the brochure on *E. F. Johnson Co.'s* brand new Messenger "202."

**103.** *Squires-Sanders* would like you to know about their CB transceivers, the "23'er" and the new "55S." Also, CB accessories that add versatility to their 5-watters.

**46.** A long-time builder of ham equipment, *Hallierasters* will send you lots of info on ham, CB and commercial radio equipment.

★**129.** Boy, oh boy—if you want to read about a flock of CB winners, get your hands on *Lafayette's* new 1968 catalog. *Lafayette* has CB sets for all pocketbooks.

**122.** Discover the most inexpensive CB mobile, Citi-Fone II by *Multi-Elmac Company*. Get the facts plus other CB product data before you buy.

**50.** Get your copy of *Amphenol's* "User's Guide to CB Radio"—18 pages packed with CB know-how and chit-chat. Also, *Amphenol* will let you know what's new on their product line.

**116.** Pep-up your CB rig's performance with *Turner's* M+2 mobile microphone. Get complete spec sheets and data on other *Turner* mikes.

**48.** *Hy-Gain's* new CB antenna catalog is packed full of useful information and product data that every CBER should know. Get a copy.

**111.** Get the scoop on *Versa-Tronics' Versa-Tenna* with instant magnetic mounting. Antenna models available for CBERs, hams and mobile units from 27 MHz to 1000 MHz.

**45.** Hams, CBERs, experimenters! *World Radio Labs* 1968 catalog is a bargain hunter's delight. Get your copy—it's free.

**115.** Get the full story on *Polytronics Laboratories' latest CB entry—Carry-Comm*. Full 5-watts, great for mobile, base or portable use. Works on 12 VDC or 117 VAC.

**100.** You can get increased CB range and clarity using the "Cobra" transceiver with speech compressor—receiver sensitivity is excellent. Catalog sheet will be mailed by *B&K Division of Dynascan Corporation*.

**54.** A catalog for CBERs, hams and experimenters, with outstanding values. Terrific buys on *Grove Electronics' antennas, mikes and accessories*.

## ELECTRONIC PARTS

★**135.** Get with ICs! *RCA's* new integrated Circuit Experimenter's Kit KD2112 is the first of its kind and should be a part of your next project. Get all the facts direct from *RCA*. Circle 135.

**132.** Discover 18 new and different professional-quality amplifiers, tuners, and preamps completely assembled on PC-boards now offered by *Amperex*. Prices will amaze you!

**1.** *Allied's* catalog is so widely used as a reference book, that it's regarded as a standard by people in the electronics industry. Don't you have the 1968 *Allied Radio* catalog? The surprising thing is that it's free!

★**2.** The new 1968 Edition of *Lafayette's* catalog features sections on stereo hi-fi, CB, ham gear, test equipment, cameras, optics, tools and much more. Get your copy today.

**8.** Get it now! *John Meshna, Jr.'s* new 46-page catalog is jam packed with surplus buys—surplus radios, new parts, computer parts, etc.

★**23.** No electronics bargain hunter should be caught without the 1968 copy of *Radio Shack's* catalog. Some equipment and kit offers are so low, they look like misprints. Buying is believing.

★**5.** *Edmund Scientific's* new catalog contains over 4000 products that embrace many interests and fields. It's a 148-page buyers' guide for *Science Fair* fans.

**106.** With 70 million TV and 240 million radios somebody somewhere will need a vacuum tube replacement at the rate of one a second! Get *Universal Tube Co.'s* Troubleshooting Chart and facts on their \$1 flat rate per tube.

★**4.** *Olson's* catalog is a multi-colored newspaper that's packed with more bargains than a phone book has names. Don't believe us? Get a copy.

**7.** Before you build from scratch check the *Fair Radio Sales* latest cat-

alog for electronic gear that can be modified to your needs. *Fair way* to save cash.

**6.** Bargains galore, that's what's in store! *Poly-Paks Co.* will send you their latest eight-page flyer listing the latest in available merchandise, including a giant \$1 special sale.

**10.** *Burstein-Applebee* offers a new giant catalog containing 100s of big pages crammed with savings including hundreds of bargains on hi-fi kits, power tools, tubes, and parts.

**11.** Now available from *EDI (Electronic Distributors, Inc.)*: a catalog containing hundreds of electronic items. *EDI* will be happy to place you on their mailing list.

**120.** *Tab's* new electronics parts catalog is now off the press and you're welcome to have a copy. Some of *Tab's* bargains and odd-ball items are unbelievable offers.

**117.** Harried by the high cost of parts for projects? Examine *Bigelow's* 13th Anniversary catalog packed with "Lucky 13" specials.

## ELECTRONIC PRODUCTS

★**42.** Here's a colorful 108-page catalog containing a wide assortment of electronic kits. You'll find something for any interest, any budget. And *Heath Co.* will happily send you a copy.

**44.** Kit Builder? Like wired products? *EICO's* 1968 catalog takes care of both breeds of buyers. 32 pages full of hi-fi, test, CB, ham, SWL, automotive and hobby kits and products—do you have a copy?

★**128.** If you can hammer a nail and miss your thumb, you can assemble a *Schober* organ. To prove the point, *Schober* will send you their catalog and a 7-in. disc recording.

**126.** *Delta Products* new capacitive discharge ignition system in kit form will pep up your car. Designed to cut gas costs and reduce point and plug wear. Get *Delta's* details in full-color literature.

**66.** Try instant lettering to mark control panels and component parts. *Data's* booklets and sample show this easy dry transfer method.

**109.** *Seco* offers a line of specialized and standard test equipment that's ideal for the home experimenter and pro. Get specs and prices today.

## TOOLS

★**78.** You can drive nuts and screws, ream, scribe, pierce holes with *Xcelite Series 99* handles and economical, interchangeable blades. Many kits available. Get your copy of *Catalog 166* today.

118. Secure coax cables, speaker wires, phone wires, etc., with *Arrow* staple gun tackers. 3 models for wires and cables from 3/16" to 1/2" dia. Get fact-full *Arrow* literature.

**SCHOOLS AND EDUCATIONAL**

★74. A 40-page illustrated book on "How to Succeed in Electronics" and a 24-page book on "How to Get a Commercial FCC License" are yours for the asking from *Cleveland Institute of Electronics*.

★136. *ICS (International Correspondence Schools)* wants to send you a 64-page booklet on the most often asked questions on preparing for an electronics career. You also get "How to Succeed" and a sample *ICS* lesson.

114. Prepare for tomorrow by studying at home with *Technical Training International*. Get the facts today on how you can step up in your present job.

137. For success in communications, broadcasting and electronics get your First Class FCC license and *Gratham School of Electronics* will show you how. Interesting booklets are yours for the asking.

138. For a complete rundown on curriculum, lesson outlines, and full details from a leading electronic school, ask for this brochure from the *Indiana Home Study Institute*.

105. Get the low-down on the latest in educational electronic kits from *Trans-Tek*. Build light dimmers, amplifiers, metronomes, and many more. *Trans-Tek* helps you to learn while building.

★3. Get all the facts on *Progressive Edu-Kits Home Radio Course*. Build 20 radios and electronic circuits; parts, tools and instructions come with course.

**HI-FI/AUDIO**

134. Discover *PlayTape*—America's newest tape cartridge and tape players. Units priced at under \$17 with cartridges at 45-disc prices. *PlayTape* has one of America's largest recording libraries.

19. *Empire's* new 16-page, full-color catalog features speaker systems in odd shapes for beautiful room decor. Also, rediscover *Empire's* quality turntable line and cartridges.

124. Now, *Sonolone* offers you young ideas in microphone use in their new catalog. Mikes for talk sessions, swinging combos, home recording, PA systems and many more uses.

26. Always a leader, *H. H. Scott* introduces a new concept in stereo console catalogs. The information-packed 1968 Stereo Guide and catalog are required reading for audio fans.

85. Write the specs for an ideal preamp and amp, and you've spelled out *Dynaco's* stereo 120 amp and PAS-3X preamp. So why not get all the facts from *Dynaco!*

119. *Kenwood* puts it right on the line. The all-new *Kenwood* stereo-FM receivers are described in a colorful 16-page booklet complete with easy-to-read-and-compare spec data. Get your copy today!

131. Let *Elpa* send you "The Record Omnibook." It's a great buy and *Elpa* wants you to have it free. Your records will thank you when the mail-man delivers it.

17. Mikes, speakers, amps, receivers—you name it, *Electro-Voice* makes it and makes it good. Get the straight poop from *E-V* today.

27. 12 pages of *Sherwood* receivers, tuners, amplifiers, speaker systems, and cabinetry make up a colorful booklet every hi-fi bud should see.

95. Confused about stereo? Want to beat the high cost of hi-fi without compromising on the results? Then you need the new 24-page catalog by *Jensen Manufacturing*.

99. Get the inside info on why *Telex/Acoustech's* solid-state amplifiers are the rage of the experts. Colorful brochure answers all your questions.

**TAPE RECORDERS AND TAPE**

123. Yours for the asking—*Elpa's* new "The Tape Recording Omnibook." 16 jam-packed pages on facts and tips you should know about before you buy a tape recorder.

31. All the facts about *Concord Electronics Corp.* tape recorders are yours for the asking in a free booklet. Portable, battery operated to four-track, fully transistorized stereos cover every recording need.

32. "Everybody's Tape Recording Handbook" is the title of a booklet that *Sarkes-Tarzian* will send you. It's 24-pages jam-packed with info for the home recording enthusiast. Includes a valuable table of recording times for various tapes.

34. "All the Best from Sony" is an 8-page booklet describing *Sony-Super-scope* products—tape recorders, microphones, tape and accessories. Get a copy before you buy!

35. If you are a serious tape audiophile, you will be interested in the all new *Viking/Telex* line of quality tape recorders.

**HI-FI ACCESSORIES**

112. *Telex* would like you to know about their improved *Serenata Headset*—and their entire line of quality stereo headsets.

104. You can't hear FM stereo unless your FM antenna can pull 'em in. Learn more and discover what's available from *Finco's* 6-page "Third Dimensional Sound."

**TELEVISION**

★70. Need a new TV set? Then assemble a *Heath* TV kit. *Heath* has all sizes, B&W and color, portable and fixed. Why not build the next TV you watch?

127. *National Schools* will help you learn all about color TV as you assemble their 25-in. color TV kit. Just one of *National's* many exciting and rewarding courses.

97. Interesting, helpful brochures describing the TV antenna discovery of the decade—the log periodic antenna for VHF and UHF-TV, and FM-stereo. Get it from *JFD Electronics Corporation*.

**ELEMENTARY ELECTRONICS**

Dept. 768  
505 Park Avenue  
New York, N. Y. 10022

Please arrange to have the literature whose numbers I have circled sent to me as soon as possible. I am enclosing 25¢ for 1 to 10 items; 50¢ for 11 to 20 items to cover handling. No stamps, please.

1-10 items



11-20 items

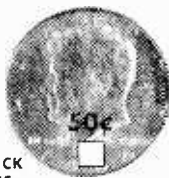

CHECK ONE

maximum number of items = 20

Indicate total number of booklets requested

1	2	3	4	5	6	7	8	10	11
17	19	23	26	27	31	32	34	35	42
44	45	46	48	50	54	66	70	74	78
85	95	96	97	99	100	101	102	103	104
105	106	107	109	111	112	114	115	116	117
118	119	120	122	123	124	126	127	128	129
130	131	132	134	135	136	137	138		

NAME \_\_\_\_\_

ADDRESS \_\_\_\_\_

CITY \_\_\_\_\_

STATE \_\_\_\_\_ ZIP \_\_\_\_\_

# Olson



**\* FREE**

Fill in coupon for a FREE One Year Subscription to OLSON ELECTRONICS' Fantastic Value Packed Catalog—Unheard of LOW, LOW PRICES on Brand Name Speakers, Changers, Tubes, Tools, Stereo Amps, Tuners, CB, and other Values. Credit plan available.

NAME \_\_\_\_\_  
 ADDRESS \_\_\_\_\_  
 CITY \_\_\_\_\_ STATE \_\_\_\_\_  
 GIVE ZIP CODE \_\_\_\_\_

If you have a friend interested in electronics send his name and address for a FREE subscription also.

**OLSON ELECTRONICS**  
 INCORPORATED

901 S. Forge Street Akron, Ohio 44308

## DOES CB CONFUSE YOU? LET CB BUYERS' GUIDE'S Experts Help You—

- Pick a rig, upgrade your station, with authoritative, exclusive reports on 64 CB TRANSCEIVERS LAB-CHECKED & TESTED!
- Choose a mobile rig
- Set up a base station,
- Get on the air
- Select antennas, mikes, whatnots
- Get the hang of walkie-talkies
- PLUS our Who's Who of CB, Manufacturers, Accessories, Gadgets and Goodies.

The 1968 Edition of CB BUYERS' GUIDE will be on sale July 2nd. Reserve your copy NOW!



CB BUYERS' GUIDE CBBG-68  
 505 Park Avenue, New York, N. Y. 10022

Enclosed is \$1.25 which includes postage & handling. Send me the 1968 Edition of 'CB BUYERS' GUIDE.

Name \_\_\_\_\_  
 Address \_\_\_\_\_  
 City \_\_\_\_\_ State \_\_\_\_\_ Zip \_\_\_\_\_

## EN PASSANT

Diagram for Skewer From page 23

Black

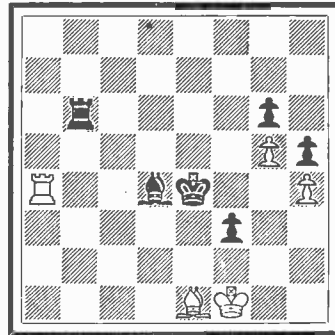

White

Pawn is a potential Queen." But before it can promote all obstacles must be removed from its path.

Black

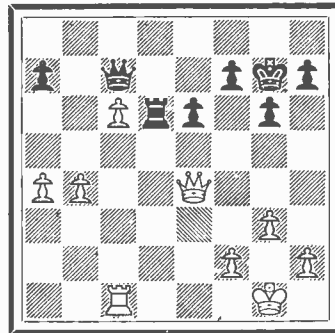

White

The blockading Black Queen is drawn off with 1 Q-K5# K-N1 2 QxR1 QxQ. And now 3 P-B7 followed by 4 P-B8=Q(♯) wins or 3 P-B7, Q-Q2 4 P-B8=Q♯ QxQ 5 RxQ♯ wins.

**Surprise Move.** As the Proverb says, "A man surprised is half-beaten." Black is all-beaten by the surprising Rook sacrifice in the position below.

Diagram for Surprise Move top of page 107

1 R-Q5!!—the Rook is offered in four ways!  
 If 1 . . . QxR 2 Q=B6 mate. If 1 . . . RxR 2 Q-B8 mate. If 1 . . . PxR 2 QxR mate. Yet the Rook must be captured, as 2 QxR mate and 2 RxQ are menaced.

**Game of the Issue.** The game between Paul Morphy of New Orleans, World Champion, and the Duke of Braunschweig and Count Isouard, played at the Paris Opera House in 1858, dur-

(Continued on page 107)

# SOMEONE SHOULD DEVELOP AN EASY WAY TO LEARN ELECTRONICS AT HOME

## RCA INSTITUTES DID!

RCA introduces new **CAREER PROGRAMS**—beginning with the student-proved "AUTOTEXT" Programmed Instruction Method—the faster, easier way to learn. You start to learn the field of your choice immediately. No previous training or experience needed.

Pick the career of your choice—and RCA Institutes will do the rest! RCA's new, revolutionary "Career Programs" help you go directly to the career you want! You waste no time learning things you'll never use on your job! Each Career Program is designed to get you into the kind of job you want in the fastest, easiest possible way!

### SEPARATE COURSES

In addition, in order to meet specific needs, RCA Institutes offers a wide variety of separate courses which may be taken independently of the above Career Programs, on all subjects from Electronics Fundamentals to Computer Programming. Complete information about these courses will be sent with your other materials.

**CHOOSE A CAREER PROGRAM NOW** your first step to the job of your choice!

- Television Servicing
- Telecommunications
- FCC License Preparation
- Automation Electronics
- Automatic Controls
- Digital Techniques
- Industrial Electronics
- Nuclear Instrumentation
- Solid State Electronics
- Electronics Drafting

### RCA INSTITUTES BONUS EXTRAS

Only RCA Institutes offers you a **Liberal Tuition Plan**, one of the most economical ways to learn. Plus, you get top quality equipment in all kits furnished to you with your courses—yours to keep and use on the job. And now, RCA's **NEW PROGRAMMED ELECTRONIC BREADBOARD GIVES YOU LIMITLESS EXPERIMENTATION**—scientific laboratory procedures

right in your own home! You build a working signal generator, AM Receiver, Multimeter, Oscilloscope, and other valuable equipment—**ALL AS A PART OF YOUR COURSE!** Get the facts today!

**Classroom Training Also Available.** Day and Evening Classes are available to you in New York City at RCA Institutes Resident School. You may be admitted without any previous technical training; prep courses are available if you haven't completed high school. Coeducational classes start four times a year.

### SEND ATTACHED CARD TODAY FOR FREE DESCRIPTIVE BOOK

All courses and programs approved for veterans under new G.I. Bill. **Canadians:** These same RCA courses are available to you in Canada. No postage. No customs. No delay. Your inquiry will be referred to our school in Canada.

RCA INSTITUTES, INC. Dep't. EA-78  
320 West 31 Street,  
New York, N.Y. 10001

Accredited Member National Home Study Council

# RCA



# ELEMENTARY ELECTRONICS ETYMOLOGY

By Webb Garrison



## Graphite

▲ No one knows when man discovered that a special form of carbon is a good writing material. It had been used for centuries before Werner, about 1789, proposed calling it *graphite* from a Greek term for "to write."

Earlier known to the English chiefly as black lead or plumbago, graphite was now recognized to be kin to diamonds—but quite different from them. A diamond may be transparent and colorless; it is the hardest natural substance known. Graphite is opaque, black, and very soft. Diamonds are poor conductors of electricity; graphite is an excellent conductor.

Once this trait was discovered, the substance so long regarded as merely a writing material became a constituent of batteries, electrolytic cells, electrodes, electrical contacts, carbon brushes, and other devices.

Then it leaped into world prominence as a slowing material or moderator in nuclear chain reactions. Without the aid of graphite's special properties, Enrico Fermi and his colleagues would have had to take a quite different route to achieve the first controlled nuclear reaction on December 2, 1942.

Regardless of its immense importance in electronics and in atomic reactions, the crystalline allotropic carbon "writing substance" is still widely used for making pencils—plus shoe polish and stove polish! ■

## Fuse

▲ Derived from *fusus*, past participle of the Latin verb *fundere* ("to pour or melt"), the term *fuse* was long more prominent in medicine than any other discipline.

Its first appearance in print was in 1704, when Francis Fuller issued his *Medicina Gymnastica*—a handbook on the beneficial effects of exercise. In it Fuller described various substances including common purgatives, designed to "fuse and

divide [the blood] and break its globules."

Once fixed in speech, the name labelling a substance considered to facilitate the flow of blood, was adopted by artisans. Applied to a variety of materials and devices with low melting point, it was a natural term for use in the developing field of electricity. Here the original fuse was a length of special wire designed to melt when current through it exceeded rated value of the circuit.

Dozens of kinds of fuses have been developed since. Strictly speaking, the name should be reserved for those which employ an element that melts readily. But in practice, plug-type and cartridge-type fuses are rapidly giving way to circuit-breakers. Force of custom is so great that in common speech many persons now employ "fuse" to name any device that cuts off current—even though nothing melts when it kicks open. ■

## Cobalt

▲ Since antiquity, craftsmen have used certain ores to obtain distinctive shades of blue. Chinese of the Ming dynasty employed them in making their exquisite blue porcelains.

But the ores that some persons prized as sources of color were regarded with annoyance by many miners. Abundant supplies in the Harz mountains of central Germany were repeatedly tested by workmen. Roasted in hope of extracting their supposed copper content, these compounds not only yielded no red metal; they emitted dangerous fumes.

Long a stronghold of paganism, the Harz region was a source of many legends. In this context it was easy for miners to conclude that the queer, stubborn ore was inhabited by a demon. So they gave it their name for a goblin or evil spirit, *kobalt*. From their speech it spread into most European languages.

About 1742, G. Grandt found the blue color yielded by many kobalt ores to stem from presence of a previously unidentified metal. Greyish tinged with red, the brittle stuff has weak magnetic characteristics. For years the metal with "demonic traits" was regarded as having no practical use outside the glass and pottery industries.

After World War I, unusual properties of *cobalt* were found ideal for manufacture of magnets, high temperature alloys, and tool steel. But the real break-through came with the dawn of the atomic age.

Exposed to radiation from an atomic pile,  $\text{Co}^{60}$  is transformed into radioactive  $\text{Co}^{60}$ . Since it has a half-life of 5.3 years, this isotope has found many uses in medicine, science, and industry.

Reflecting on the fact that radioactive cobalt is a product of bombardment by neutrons, editors of the staid *Encyclopedia Britannica* concluded that the "mischievous spirit" origin of its name can properly be termed "prophetic." ■





### Protect Your Wheels!

To ward off car vandals and thieves, install the Police Auto Alarm (under the bumper, under the dash, on the floorboard) and switch it ON when you lock your car. Any disturbances thereafter to the doors, windows, antenna, trunk, wheels or hood transfers a vibration to the alarm which sets off piercing blasts from your horn for about 15 seconds. When tampering stops, Police Alarm stops. If tampering is resumed, horn blast-off starts again. It's 6-in. long, weighs less than 2 lb., costs \$9.95, and there's a 10 year manufacturer's guarantee. No batteries—just horizontal and vertical vibrators which react to any type pressure. Write to J. Ross, 80-34 Kent St., Jamaica, N.Y. 11432.



Ross Police Auto Alarm

### 1, 2, 3 Go! for the Science Fair!

For all you budding engineers (recommended for 10 year-olds up), here's Radio Shack's 50 in 1 Electronics Project Kit. One kit contains ma-

Now...  
the most enjoyable,  
most rewarding  
electronic kit project  
of your life



### a Schober Electronic Organ!

HAD YOUR FILL of amplifier kits, receiver kits, meter kits, all the conventional kits? Then go to work on the biggest, most fascinating kit of them all—and end up with a finer musical instrument than you could buy for twice the price. The Schober Theatre Organ at left, for example, plus Schober's self-teaching music courses, lets you *participate* in music, not just listen to it. This is one electronic project the wife and kids will encourage—because it's for them, too! It contains the best components available—thousands of them—plus the kind of unmistakable, step-by-step instructions you've dreamed of and Schober is famous for.

The Theatre Organ (above) costs just \$1550 if you use your own amplifier and speaker system, and you can pay as you build to spread out the cost. There are three other Schober Organ models, too, starting at \$643. Each one includes every bit and piece you need, including a magnificent walnut console—unless you want to build your own woodwork and save even more. And each model has the kind of pipelike tonal variety you don't often find in electronic organs. The free Schober color catalog has lots of pictures and data; and for 25¢ we'll send you 72 pages of schematics and tech specs so you can see just what you're buying.

FREE INFORMATION AND DEMONSTRATION RECORDING  
Send today for your free copy of Schober's 16-page, full color booklet, plus 7" free recording.

The Schober Organ Corp., Dept. EE-3  
43 West 61st Street, New York, N. Y. 10023

- Please send me Schober Organ Catalog and free 7-inch "sample" record.
- Enclosed please find \$1.00 for 12-inch L.P. record of Schober Organ music.
- Enclosed is 25¢ for schematics and tech specs.

NAME .....

ADDRESS .....

CITY..... STATE..... ZIP NO.....

## HEY, LOOK ME OVER . . .

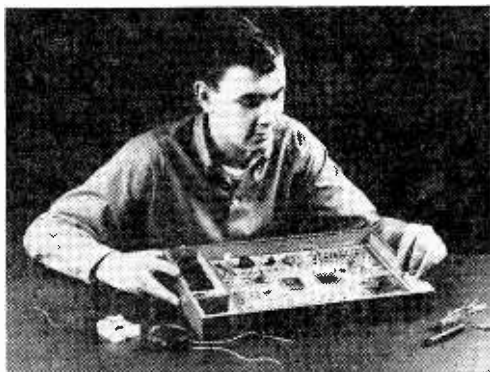

Radio Shack 50 in 1 Electronics Projects Kit

materials for making 50 different electronic projects, including a germanium radio, one-transistor radio, two-transistor radio, Morse code key, light-operated Morse Code key, home broadcasting station, 15 solar energy projects, etc. Parts can be moved or interchanged to make additional experiments. No soldering necessary, and the 62-page instruction manual gives step-by-step directions. This is a bona-fide fundamental do-it-yourself workshop for only \$17.95, plus postage (shipping weight 5 lb.). Available at Radio Shack stores or write to Radio Shack Science Fair Dept., 2727 W. 7th, Fort Worth, Texas 76101.

### Be a Sound Engineer at Home!

Here's a new compressor-preamp, the model ACP-1, from Caringella. It can be used with any tape recorder for automatic control of recording level, and with any PA system for maintaining constant output level and eliminating feedback. The unit is also a valuable accessory for amateur radio and CB transmitters for providing added modulation punch and protection against overmodulation. The ACP-1 uses a low-noise high-impedance FET input stage in its 5-transistor 1-diode circuit. Compression range is 30 dB. Frequency response extends from 20 to



Caringella Model ACP-1 Compressor-Preamp

20,000 Hz; input and output signal levels are completely adjustable. It will install in the microphone line of any tape recorder, PA system, amateur radio or CB transmitter. The metal cabinet measures 2½ x 3 x 4¼-in. and the power comes from a built-in 9-volt battery. In kit form the price is \$18.50; wired and tested it's \$26.50. For more specs write directly to Caringella Electronics, Inc., Box 327, Upland, Calif. 91786.

### Convertible TV Antenna

A new series of 300-ohm rooftop television antennas, called *Paralog 300 Plus*, can be converted to use with 75-ohm Coloraxial downleads by means of a new snap-on transformer (STO-83), available separately. The new VHF-FM antennas are upgraded from the Paralog Plus series, and feature higher front-to-back ratios and sharper directivity to suppress ghosts and produce clearer pictures. Flat response of  $\pm 1$

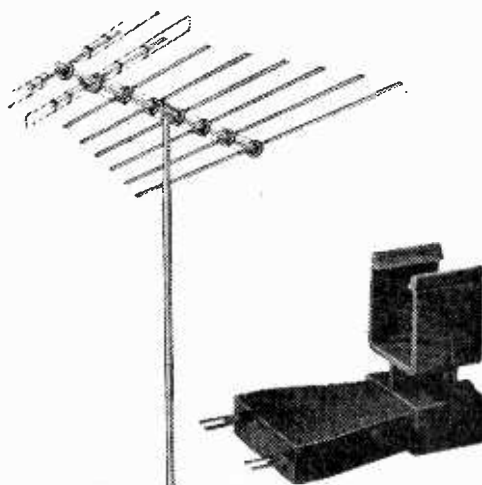

Jerrold Paralog 300 Plus TV Antenna and Impedance Matching Transformer

dB per channel results in good color fidelity, and a bi-modal director system produces extra gain. Mechanical features include a twist-resistant square boom, high-strength insulators, vibration-proof point-to-point element locks, and Golden Armor coating for resistance to corrosion. The impedance-matching transformer (STO-83, \$2.39) can be snapped over the boom of the antenna where it can be pushed into contact with two 300-ohm terminals. No special connector is needed for coaxial cable. The Paralog 300 Plus antenna series comes in seven models (VIP-301 through 304), for metropolitan to deep fringe areas, with list prices ranging from \$15.95 to \$79.95. More information can be obtained from the Distributor Sales Div., Jerrold Electronics Corp., Box A, Philadelphia, Pa. 19105. (Continued on page 108)

# Now There Are 3 Heathkit® Color TV's

## The NEW Deluxe

### Heathkit "227" Color TV

Exclusive Heathkit Self-Servicing Features. Like the famous Heathkit "295" and "180" color TV's, the new Heathkit "227" features a built-in dot generator plus full color photos and simple instructions so you can set-up, converge and maintain the best color pictures at all times. Add to this the detailed trouble-shooting charts in the manual, and you put an end to costly TV service calls for periodic picture convergence and minor repairs. No other brand of color TV has this money-saving self-servicing feature.

Advanced Features. Top quality American brand color tube . . . 227 sq. in. rectangular viewing area . . . 24,000 v. regulated picture power . . . improved phosphors for brilliant, livelier colors . . . new improved low voltage power supply with boosted B+ for best operation . . . automatic degaussing . . . exclusive Heath Magna-Shield to protect against stray magnetic fields and maintain color purity . . . ACC and AGC to reduce color fade and insure steady, flutter-free pictures under all conditions . . . preassembled & aligned IF with 3 stages instead of the usual 2 . . . preassembled & aligned 2-speed transistor UHF tuner . . . deluxe VHF turret tuner with "memory" fine tuning . . . 300 & 75 ohm VHF antenna inputs . . . two hi-fi sound outputs . . . 4" x 6" 8 ohm speaker . . . choice of installation — wall, custom or optional Heath factory assembled cabinets. Build in 25 hours.

**Kit GR-227**, (everything except cabinet) . . . \$42 dn., as low as \$25 mo. . . . . **\$419.95**  
**GRA-227-1**, Walnut cabinet. . . no money dn., \$6 mo. . . . . **\$59.95**  
**GRA-227-2**, Mediterranean Oak cabinet (shown above), . . . no money dn., \$10 mo. . . . . **\$94.50**



Kit GR-227  
**\$419.95**

(less cabinet)  
 \$25 mo.

Kit GRA-27  
**\$19.95**

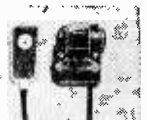

### New Remote Control For Heathkit Color TV

Now change channels and turn your Heathkit color TV off and on from the comfort of your armchair with this new remote control kit. Use with Heathkit GR-227, GR-295 and GR-180 color TV's. Includes 20' cable.

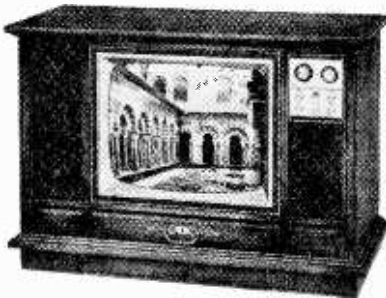

Kit GR-295  
**\$479.95**  
 (less cabinet)  
 \$42 mo.

### Deluxe Heathkit "295" Color TV

Has same high performance features and built-in servicing facilities as new GR-227, except for 295 sq. in. viewing area (industry's largest picture) . . . 24,000 volt picture power . . . universal main control panel for versatile in-wall installation . . . and 6" x 9" speaker.

**Kit GR-295**, (everything except cabinet), 131 lbs. . . . \$48 dn., \$42 mo. . . . . **\$479.95**  
**GRA-295-4**, Mediterranean cabinet (shown above), 90 lbs. . . . no money dn., \$11 mo. . . . . **\$112.50**  
 Other cabinets from \$62.95.



Kit GR-180  
**\$349.95**  
 (less cabinet & cart)  
 \$30 mo.

### Deluxe Heathkit "180" Color TV

Same high performance features and exclusive self-servicing facilities as new GR-227 (above) except for 180 sq. in. viewing area.

**Kit GR-180**, (everything except cabinet), 102 lbs. . . . \$35 dn., \$30 mo. . . . . **\$349.95**  
**GRA-180-5**, table model cabinet & mobile cart (shown above), 57 lbs. . . . no money dn., \$5 mo. . . . . **\$39.95**  
 Other cabinets from \$24.95

## Deluxe 12" Transistor Portable B&W TV - First Kit With Integrated Circuit

Unusually sensitive performance. Plays anywhere . . . runs on household 117 v. AC, any 12 v. battery, or optional rechargeable battery pack (\$39.95); receives all channels; new integrated sound circuit replaces 39 components; preassembled, prealigned tuners; high gain IF strip; Gated AGC for steady, jitter-free pictures; front-panel mounted speaker; assembles in only 10 hours. Rugged high impact plastic cabinet measures a compact 1 1/2" H x 15 3/4" W x 9 3/4" D. 27 lbs.

Kit GR-104  
**\$119.95**  
 \$11 mo.

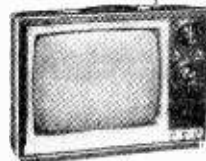

**Kit GR-104**, 27 lbs. . . . no money dn., \$11 mo. . . . . **\$119.95**

**No Money Down On \$25 to \$300 Orders — Write For Credit Form**

# 11 New Kits From Heath...

## New! Heathkit Wireless Home Protection System for Your Family's Safety



GD-97  
Utility Transmitter  
for Universal Protection



GD-77 Wireless Receiver/Alarm  
fail-safe, always alert



GD-87  
Wireless Smoke/Heat  
Detector-Transmitter

Applications Unlimited . . . Customize Your Own System. Here's reliable, low cost, 24-hour protection for your family and property. System warns of smoke, fire, intruders, freezing, thawing, cooling, rising or receding water, pressures . . . any change you want to be warned about. Uses unique new signaling method developed by Berkeley Scientific Labs.; exclusively licensed to Heath. Your house is already wired for this system, just plug the units into any AC outlet. "Load transmission" design (not a carrier type as in wireless intercoms) generates unusual signal that is practically unduplicable in other devices or random noise sources. Solid-state circuitry has built-in fail-safe capability to sound alarm if power fails, if power supply components in any unit fail, or if 50,000 hour bulb in smoke detector fails. Receiver/Alarm has 2800 Hz transistor alarm and receptacle for extra 117 VAC bell or buzzer to extend range, plus rechargeable battery (always kept charged) to sound alarm if power fails. Smoke-Heat Detector-Transmitter capability may be extended to other areas by adding extra heat sensors to its built-in sensor. Utility Transmitter accepts any type of switch or sensor for any purpose; examples: magnetic reed switches for doors and windows to warn of entry; step-on switches for door or driveway; micro switches with trip wire around yard; heat sensors; water pressure switches warn of pump failure; thermal switches warn of freezing in gardens, or thawing in freezers; two wires act as switch to warn of changing water levels in sump-pump wells, pools, etc. Units are small and unobtrusive in beige and brown non-reflecting velvet finish. Any number of units may be used in the system. All units feature circuit board construction; each unit takes only 3 hours to build. Operating cost similar to electric clocks. Invest in safety for your family now with this unique Heath system.

- Kit GD-77, receiver/alarm, 4 lbs. . . . . \$39.95  
 Kit GD-87, smoke/heat det.-trans., 5 lbs. . . . . \$49.95  
 Kit GD-97, Utility trans., 4 lbs. . . . . \$34.95  
 (numerous accessory switches available from Heath)

## New! Heathkit/Kraft 5-Channel Digital Proportional System with Variable Capacitor Servos

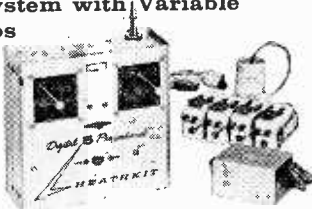

System Kit GD-47  
**\$219.95**  
 \$21 mo.

This Heathkit version of the internationally famous Kraft system saves you over \$200. The system includes solid-state transmitter with built-in charger and rechargeable battery, solid-state receiver, receiver rechargeable battery, four variable capacitor servos, and all cables. Servos feature sealed variable capacitor feedback to eliminate failure due to dirty contacts, vibration, etc.; three outputs: two linear shafts travel 1/2" in simultaneous opposite directions plus rotary wheel. Specify freq.: 26.995, 27.045, 27.145, 27.195 MHz.

- System Kit GD-47, all of above, 5 lbs. . . . . \$219.95  
 Kit GDA-47-1, transmitter, battery, cable, 3 lbs. . . . . \$86.50  
 Kit GDA-47-2, receiver, 3 lbs. . . . . \$49.95  
 GDA-47-3, receiver rechargeable battery, 1 lb. . . . . \$9.95  
 Kit GDA-47-4, one servo only, 1 lb. . . . . \$21.50

## New! Heathkit 2-Channel, 200 Watt SSB Transceivers for CAP, MARS & 160 Meters



Assembled  
HWW-18-1  
CAP model  
with crystals  
**\$179.95**

Kit HW-18-1  
CAP model  
with crystals  
**\$119.95**

Kit HW-18-2  
MARS model  
less crystals  
**\$109.95**

Kit HW-18-3  
160 Meter model  
less crystals  
**\$109.95**

Good News For CAP, MARS And 160 Meter Ops. This unique series of Heathkit SSB Transceivers was designed with your needs in mind. No more adaptations, no more conversions, no more make-shift rigs. These new transceivers are tailored for your needs with the sensitivity, selectivity, power output and operating convenience that make for effective communications at a fraction of previous costs.

Compare. 200 watts PEP SSB input, 25 watts input with carrier for compatibility with AM stations. Crystal filter sideband generation, 2 channels, switch-selected, crystal controlled. Fixed tuned for easy PTT operation. Transmit and receive freqs. locked together for true transceive operation. Clarifier control adjusts transceiver frequency  $\pm 250$  Hz. Relayless transmit-receive switching. Local-Distance switch prevents receiver overload from strong local stations. Built-in speaker, PTT mic. & mobilemount included. Carrier & sideband suppression 45 dB. Sensitivity 1  $\mu$ V. Selectivity 2.7 kHz. 50 ohm coax output. Accessory power supplies (Kit HP-13, mobile, \$64.95; Kit HP-23, fixed station, \$49.95).

## New! Solid-State Portable

So Handy, So Low Cost we call it "every man's" meter. Just right for homeowners, hobbyists, boatowners, CBer's, hams . . . it's even sophisticated enough for radio & TV servicing! Features 12 ranges . . . 4 AC & 4 DC volt ranges, 4 ohm ranges; 11 megohm input on DC, 1/2 megohm input on AC; 4 1/2" 200 uA meter; battery power; rugged polypropylene case and more. Easy 3 or 4 hour kit assembly. 4 lbs.

## Volt-Ohm-Meter



Kit IM-17  
**\$19.95**

## New! Heathkit Solid-State Utility Monophonic Amplifier

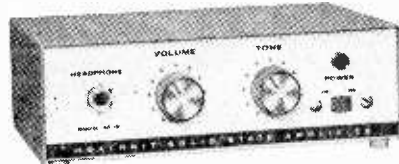

Kit  
AA-18  
**\$19.95**

This amazing little amplifier accepts ceramic phono cartridges, AM tuners, FM tuners, tape recorders, etc., and delivers a solid 4 watts of music power from 20 Hz to over 100 kHz at a low 1.5% THD. Drives high efficiency speakers of 4 to 16 ohms. Ideal for small music system or testing amp. for service shops. Circuit board construction is easiest; just 5 short hookup wires and 6" cable. Single knob tone control. Headphone jack. Pilot lamp. Transformer operated, 120/240 VAC, 50-60 Hz,

# See 300 More in FREE Catalog

What would you expect to pay  
for a Vox "Jaguar" Combo organ  
with a 180-watt 3-channel amp?  
\$1000? \$1250? \$1500? More?

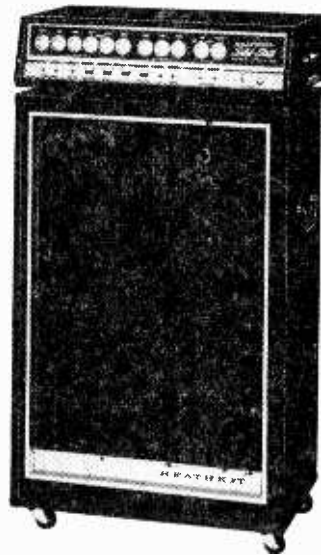

You can get both for only \$598  
during this Special Heathkit Offer!

Now you can get this famous professional combo organ with a versatile high-power piggy-back amp. and matching speaker system for just a little more than you'd expect to pay for the "Jaguar" alone! The Heathkit/Vox "Jaguar" is solid-state; two outputs for mixed or separated bass and treble; reversible bass keys for full 49 key range or separate bass notes; bass volume control; vibrato tab; bass chord tab; four voice tabs (flute, bright, brass, mellow); keyboard range C<sub>2</sub> to C<sub>6</sub> in four octaves; factory assembled keyboard, organ case with cover, and stand with case. Also available separately; you'll still save \$150 (order Kit TO-68, \$349.95).

The Heathkit TA-17 Deluxe Super-Power Amplifier & Speaker has 180 watts peak power into one speaker (240 watts peak into a pair); 3-channel

with 2 inputs each; "fuzz", brightness switch; bass boost; tremolo, reverb; complete controls for each channel; foot switch; 2 heavy duty 12" speakers plus horn driver. Also available separately kit or factory assembled (Kit Amplifier TA-17, \$175; Assembled \$275; Kit Speaker TA-17-1 \$120; Assembled \$150; Kit TAS-17-2, amp. & two speakers \$395; Assembled TAW-17-2, amp. & two speakers \$545).

Kit TOS-1  
Organ, Amplifier  
& Speaker Kits (240 lbs.)  
**\$598.00**

Kit TOS-2  
Organ Kit, Assembled  
Amplifier & Speaker (240 lbs.)  
**\$698.00**

## New! Heathkit Solid-State "Fuzz Booster" For Guitar Amplifiers

Kit TA-28  
**\$17.95**



"Fuzz" is what it's called, harmonic distortion is what it is, and you can add it to your guitar amp with this kit. Transistor circuit is contained in die cast footswitch housing and powered by internal battery (not supplied). Two controls adjust tone and intensity of "fuzz". Build it in one evening. 4 lbs.

## New! Heathkit Guitar Headphone Amplifier

Kit TA-58  
**\$9.95**



Now you can play and practice your electronic guitar in private! Just plug this miniature amplifier into the jack of your guitar and use a pair of headphones. Solid-state circuit has tailored response; automatic off-on switching; self-contained battery (not supplied); and capability of operating one or two pairs of mono or stereo headphones of 4 to 2 megohms. Ideal for practice or instruction. Easy to build.

Kit TA-58, 2 lbs. .... **\$9.95**



## NEW FREE 1968 CATALOG!

Now with more kits, more color. Fully describes these along with over 300 kits for stereo/hi-fi, color TV, electronic organs, electric guitar & amplifier, amateur radio, marine, educational, CB, home & hobby. Mail coupon or write Heath Company, Benton Harbor, Michigan 49022.

HEATH COMPANY, Dept. 139-7  
Benton Harbor, Michigan 49022  
In Canada, Daystrom Ltd.

Enclosed is \$ \_\_\_\_\_, including shipping.

Please send model (s) \_\_\_\_\_

Please send FREE Heathkit Catalog.

Please send Credit Application.

Name \_\_\_\_\_

Address \_\_\_\_\_

City \_\_\_\_\_ State \_\_\_\_\_ Zip \_\_\_\_\_

Prices & specifications subject to change without notice.

CL-325

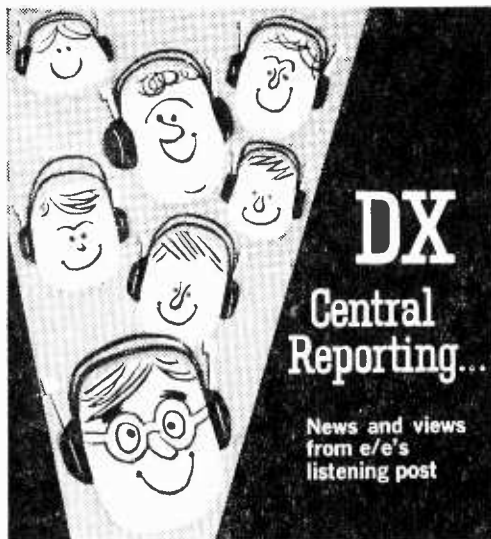

**Everything changes**—even shortwave. Sometimes a station that was once a real power in SWBC will become, 10 or 20 years later, just an also-ran. Such a station is R.Denmark. In the early 1950s its 50-kW transmitter was one of the most popular overseas voices with U. S. listeners (admittedly, there were considerably fewer American SWLs in those days than in 1968). Today, 50 kW makes for only a whisper on the crowded international bands.

A couple years ago this QRM problem became so severe that R.Denmark gave up on broadcasts to the Middle East entirely. All R.Denmark transmissions are designed to promote tourism and good will for Danish products generally, a format that proved non-too-successful in stirring up burning interest among listeners in Egypt, Jordan, and Israel. However, R.Denmark still struggles to be heard in the Far East, the Pacific, North and South America.

On the plus side, R.Denmark's efforts aimed at North America do provide SWLs using simple receivers an excellent opportunity to test their DX skills (the station is just "hard enough"). English to NA is scheduled at 0515 EST on 15160 kHz and at 2100 on 9520 kHz. On Sundays a program of DX tips is included in the proceedings. It is entitled DX Window and produced by the Danish Short Wave Club International.

**Remember OTC?** Another fallen giant is the Belgian government's former International Goodwill Station which operated under the call OTC at Leopoldville (now Kinshasa) in the Congo. This first went on the air during World War II for the best of purposes—to broadcast anti-Nazi programs on behalf of the Belgian government (then in exile). Like R.Denmark, its power was 50 kW.

By the 1950s it turned to promoting international tourism and peace, a move which was

just a trifle ironic. The reasons: Belgium's Congo seemed least prepared of any African colony for independence, and the result of Belgium's neglect was anything but peace. Absurd as it may seem, however, OTC in its day was, even more popular with American SWLs than R.Denmark. It was so popular, in fact, that it became the first SWBC station in a position to sponsor its own SWL organization—the OTC Club (annual dues, \$1.00).

Today, this 50-kWer is used by the Congolaise government for more serious business—providing a primary broadcast service to the outlying areas of this still primitive land. However, when QRM permits, it can still be heard on our side of the Atlantic with programs in French and various African languages. Current frequency is 15245 kHz, where you should watch for it during daylight hours and again at 2300 EST S/On.

**Mini Clubs?** It has only been during the past five years that SWLing has really become hip. Stations like OTC and R.Denmark have been pushed from the center of the scene by such operations as R.Americas, R.Libertad, BBC Botswana, and the projected R.Free America. This new look, however, is strictly a grass-roots happening.

There are roughly one million Americans with some form of shortwave interest, but less than

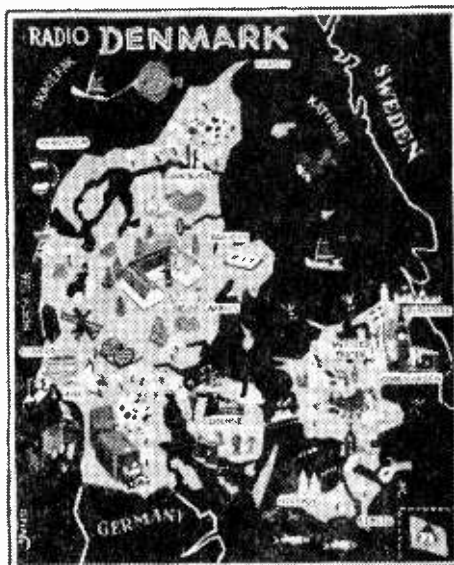

Copenhagen, 9/14/1962

DEAR LISTENER

Your report of 8/20/62 concerning our broadcast on 15160 kHz, 50 kw, call letters OTC, is hereby verified.

Sincerely yours,

SHORTWAVE DEPT.

Here's Radio Denmark's QSL card. You'd have to see it in full color to realize the great catch it is.



five percent belong to organized radio clubs. There are two major reasons for this. First, aside from the purely DX aspects of it, SWLing is primarily a lone-wolf thing; the true shortwave listener wants to hear and think for himself (otherwise he would stick with his local AM, FM, and TV stations). Secondly, many SWL clubs are 10 or maybe even 20 years behind the times.

For example, the African interests of some clubs stop with that ancient struggle to revive OTC (a battle long since lost). They are terrified if any current controversy should find its way into the pages of their monthly bulletins. As a case in point, a well known SWL (with deliberate malice of forethought) recently lit the fuse to a long smoldering club feud by telling the organization's chief executive, "I will continue to suggest that Washington has kept its part in this Botswana/anti-Rhodesian operation secret for fear of offending S.Africa" (which may or may not be true; only Washington knows for certain). Whereupon said chief executive completely blew his cool and removed our malicious friend as an officer of the club.

A situation like this is set up by the very mechanics of operating a club. There is so much work involved, even with a membership of only a hundred, that the organization usually falls into the hands of individuals who are all work and no imagination (would you believe gutless androids?). And this, of course, is very unfortunate because the exchange of info that flows through a club (last-minute frequency and schedule changes, special programs arranged on short notice, etc.) can be helpful to the SWL.

One possible answer to the problem would be a myriad of very small clubs devoted to special projects (like the Botswana mystery). These would each be limited to a dozen very active members with a bulletin easily produced on high-quality carbon paper.

Of course, our proposed Botswana Listeners Association will soon be just as out of date as the OTC Club, because BBC Botswana is about to be written off as an expensive fiasco. Some of its transmissions will be taken over by BBC Ascension and the rest will be just dropped. ■

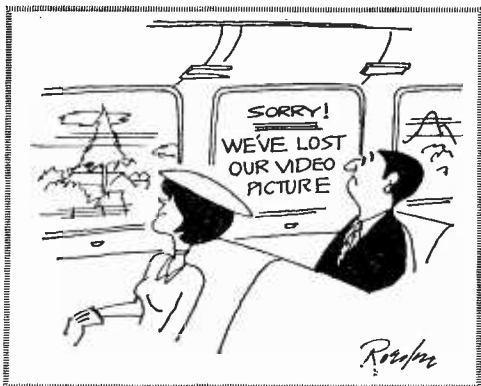

# THE SUPERSENSITIVE DARKROOM METER

## S & M MODEL A-3

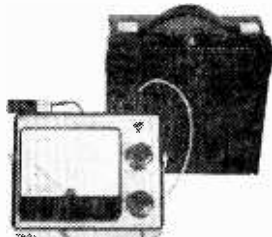

**\$44.50**  
in kit form\*

**\$49.50**  
fully  
assembled\*

\*Carrying Case  
Included

Here is a precision instrument that meets the highest standards of any meter available today. The S & M A-3 uses the newest cadmium sulfide light cell to measure light levels from twilight to bright sunlight at ASA speeds of 3 to 25,000. This supersensitive darkroom meter is successfully used with movie or still cameras, microscopes, telescopes and it can also be set up for use as a densitometer.

The computer gives F stops from .7 to 90 and lists exposure time from 1/15,000 sec. to 8 hours; 4 range selection; EV-EVS-LV settings. The unit is also equipped with a large (4½") illuminated meter, paper speed control knob and a new battery test switch.

The S & M A-3 darkroom meter is ideal for darkroom and studio applications where accuracy is a necessity. It's available fully-assembled from the factory, or in easy to assemble kit form.

SCIENCE & MECHANICS — Kit Division  
505 Park Ave./New York, New York 10022

EE-768

Please send the A-3 Supersensitive Darkroom Meter as checked below. I understand that if I am not satisfied, I may return the meter within 10 days for a complete refund.

Add 10% for Canadian and foreign orders  
N.Y.C. residents add 5% for sales tax

- |   |   |
|---|---|
| <input type="checkbox"/> \$44.50 — in kit form                          | <input type="checkbox"/> \$49.50 — fully assembled  |
| <input type="checkbox"/> Check or money order enclosed, ship post paid. | <input type="checkbox"/> Enclosed \$3.00 deposit, ship balance COD, plus postage and COD charges. |
| <input type="checkbox"/> A-3 Extra Carrying Case — \$4.95               |   |

NAME \_\_\_\_\_ (Please print)

ADDRESS \_\_\_\_\_

CITY \_\_\_\_\_ STATE \_\_\_\_\_ ZIP CODE \_\_\_\_\_

# Can't find the key to electronics?

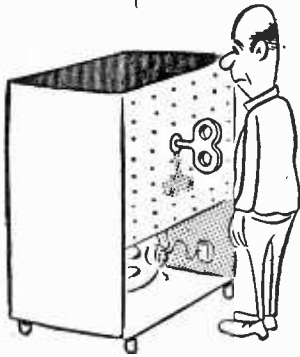

—then get your electronics cool with this introductory offer to the two leading electronics magazines! Use coupon:

DAVIS PUBLICATIONS, INC. EE-768  
505 Park Avenue/New York, N.Y. 10022

Yes! I want to find the key to electronics.

■ Begin my subscription to both **RADIO-TV EXPERIMENTER** and **ELEMENTARY ELECTRONICS** at your special low-subscription rate of **\$7.00**

Bill me later.       Check enclosed.

Name .....

Address .....

City ..... State ..... Zip .....

(Outside U.S.A. & Canada add \$1.50 pstge. & hndlg.)

—Now, both of these fine magazines will be delivered to you at the special subscription rate of just \$7.00 . . . save \$2 from newsstand price.

## ELEMENTARY ELECTRONICS

The magazine that serves up electronics theory in pleasant spoonfuls and reinforces the knowledge you gain with exciting and useful projects.

## RADIO-TV EXPERIMENTER

The magazine dedicated to the hobbyist—the man who wants to obtain a fuller and broader knowledge of electronics through the applications of his hobby.



# NEWSCAN

## Pop-Up Hertz Grabber

A "pop-up" antenna which retracts when not in use minimizes exposure of combat radio operators to enemy fire but still assures maximum efficiency and range of packset communications. The 3-foot antenna would be extended only when the radio is transmitting. The operator would raise and lower the antenna by pressing a button on his microphone.

Covering the 30-MHz to 76-MHz range, the antenna is made of a 2-inch wide length of pre-



Stainless steel tape which spirals into a 3-ft. self-supporting tube has been proposed for combat pack radio antennas by an engineer at Avco Electronics Division, Cincinnati. The "pop-up" antenna would be extended only during radio transmission and retracted on a spool when not in use. Betsy Kipp, Avco secretary, shows how the thin tape unwinds from the antenna tube. Thanks, Betsy.

formed stainless steel tape 0.002 to 0.004 inches thick. Stored on a spool when retracted the tape would form a self-supporting, helically overlapping tapered tube when extended. It would be stored in a fiberglass housing outside the radio case.

Full extension of the antenna is accomplished without power in one second and retracted in two to three seconds by a small motor turning the storage spool.

To avoid the tell-tale presence of a whip antenna in combat, radio operators often bend the flexible whips 90 or 180 degrees from vertical, causing a reduction in efficiency and range.

Also, the typical three-foot packet whip antenna radiation for VHF is inefficient at frequencies below 50 MHz because of high antenna reactance and low radiation resistance at the lower frequencies and substantial ground losses seen by the antenna. These losses are due to the lack of a good counterpoise for the whip and also the large coupling of antenna to the operator's body.

The bent whip also results in a degradation of pattern and polarization. The upright whip gives a reasonably omnidirectional pattern, modified somewhat by coupling to the operator who can act as a director or reflector at frequencies above or below about 60 MHz. The bent-over packet antenna will have a pattern with a wide variations in the horizontal plane and will not radiate the desired vertical polarization.

Since the proposed "pop-up" antenna will permit the radio operator to transmit as well as receive, it can offer as great a range as present three-foot whip antennas.

When the "pop-up" whip is retracted, a ferrite rod loop antenna at the rear of the packet is used for reception. This loop is housed in its own fiberglass cover on the side of the radio and spaced far enough from metal of the radio housing to maintain a good Q. The loop will become part of a parallel-tuned input circuit to the receiver and a relay can be provided to disconnect the loop whenever the whip is extended.

Use of the ferrite loop antenna for reception somewhat reduces the system sensitivity and range over a typical packet antenna, but the radio still retains the capability of maximum sensitivity and range while using the extendible antenna.

## Nellie Has a Pink Belly

A new dimension in equestrian performance has been furnished to the Westernaires, one of the West's leading youth groups of precision riders, by Panelescent Tape-Lite and fluorescent black light lamps.

"Each light source complements the other," said Mr. E. E. Wyland, who with his wife founded the Westernaires as a non-profit group in 1949. "The Tape-Lite gives form to both rider and horse," he said. "The black light provides



*Most of the 51 different costumes worn by the Westernaires, a well-known precision horse riding group, were designed specifically for use with Panelescent Tape-Lite and fluorescent black light produced by Sylvania Electric Products, Inc.*

vivid color. Both sources give eye appeal and glamour to the Westernaires."

The Westernaires was organized at the request of a local youth council to provide an outlet for young people who wished to learn about horses and to ride in the tradition of the West. It now consists of over 800 young riders, who receive weekly training at the Ft. Westernaire Museum and Training Grounds near Denver.

Recent attendees at the 62nd Annual National Western Stock Show and Rodeo, in Denver, saw horsemanship and precision riding performances of the Westernaires and its top riding group called "The Big Red." Its 22 girls and six boys were billed as the "dashing, colorful Westernaires" and thrilled audiences with original and traditional formations and riding feats.

Sylvania's Panelescent Tape-Lite, a flexible form of an electroluminescent lamp, is wrapped around each rider. It is sewn into top hats and range hats worn by each rider. It is also attached to the animal trappings. Each rider wears a small battery pack around the waist to power the Tape-Lite. Four standard AA size batteries are used in the power pack to produce the 108-volt, 400 Hz current needed to energize the Tape-Lite. The low energy light source consumes only  $\frac{1}{3}$  watt at 60 Hz and only about one watt at 400 Hz. Because of the low power requirements, Tape-Lite is ideally suited to battery operation using a simple DC/AC converter and transformer.

The Sylvania Tape-Lite is an ideal decorative lighting device for the spectaculars. Various riding teams go through a hard, fast riding act prior to the 'lighted symphony of motion' finale. A conventional incandescent light source would be apt to fail under such abuse. The beauty and drama

## NEWSCAN

of The Big Red team ends with a patriotic finale during which the 'Torch of Liberty' is lit and raised, the house lights go out, and the riders switch on their Tape-Lites. At the same time Sylvania black lights are turned on over the riders to fluoresce their costumes.

The veteran Westernaires have appeared in motion pictures and recently completed a film for the State Historical Society of Colorado dealing with the early Indians and the Conquistadores.

### Programmed Punishment

After a 6324-hour "torture test" simulating and often exceeding actual environment levels encountered in jet flight operations, the first

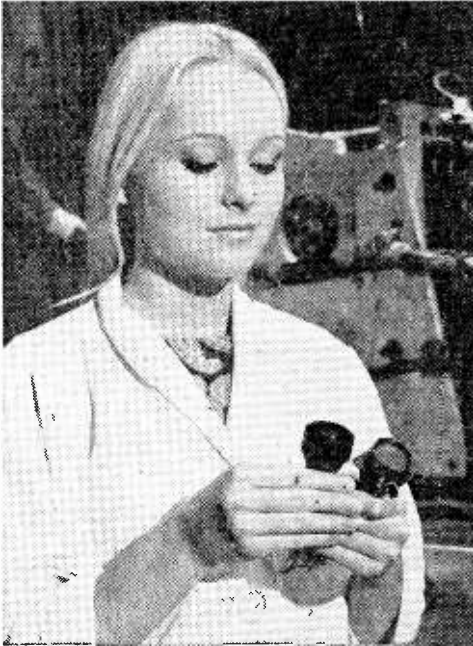

*Gwen Richards, reliability test technician at Amphenol's Connector Division, holds the mating halves of the first electrical connector to be placed in the company's new \$300,000 "torture test" aerospace flight simulator.*

electrical connector ever to be subjected to such gruelling punishment has emerged with flying colors. The test was conducted in a revolutionary new reliability test center recently completed by Amphenol Connector Division of Amphenol Corporation, in Broadview, Ill.

The miniature (55 contacts, size 22 shell) cylindrical connector, developed for military aerospace applications as well as for Boeing's 700 Series jets has in fact far exceeded expectations by remaining in service during the entire

test period without a single failure. The connector withstood a total of 1054 separate six-hour test cycles in the new simulator.

The complex testing chamber (in itself a worldwide "first") takes Amphenol's connectors through every conceivable environment that such a device could encounter in real aircraft operation, regardless of mechanical problems or weather changes.

The cycle itself begins after the connector is placed in the chamber and hooked to a circuit with current flowing through it. First, severe vibration similar to that caused by "revving" a jet's engines during take-off is created. Next, temperature dives from 44 C to a sub-freezing -55 C as "altitude" soars to 110,000 ft. At this point, the connector just sits there, freezing.

Halfway through the cycle, the chamber temperature rises to 0 C and altitude returns to "ground zero." Almost instantaneously, however, temperature soars to 200 C and atmospheric pressure again reaches 110,000 ft. Electrical characteristics are monitored during this process.

For 90 minutes the connector "cooks" at this temperature, only to later return to zero altitude and 44 C temperature for another take-off and recycling. On a weekly basis, certain preselected connectors undergoing these tests are coupled and uncoupled and contacts are cycled in and out to simulate field maintenance experience.

This type of reliability life testing, in addition to aiding engineers in developing new designs, may ultimately save millions of dollars by ensuring correct application, installation and servicing of connectors.

Until the new \$300,000 installation was completed, no such testing chamber existed anywhere in the world. Although the industry has given lip service to reliability, this facility is the first really responsible, concrete effort in that direction. ■





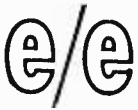

gawky and gangling 10-year-old who frequently displays a child's typical ingratitude and rebelliousness. Back in 1959, when Class D (27 MHz) stations first began taking to the airwaves, things were different.

The FCC had prepared a neat and tidy set of rules and regulations to govern this new service, which, hopefully, would realize the Flash Gordon-esque dream of every citizen having his own personal 2-way radio in car, home, store, office, boat, and doghouse.

Charlie Jones could call Mrs. Jones to tell her that he was stuck in traffic and would be late for dinner. Bill Brown could locate his store's delivery truck in a hurry. Mr. and Mrs. Smith could radio from their car for roadside dinner reservations while traveling. So neat was the idea that the FCC presented its new baby as the answer to "short distance personal and business communications."

In the FCC's Utopian zeal to get the service going, they made a terrible error. They didn't think of all the possibilities of 200 million Americans running loose with a mike button in one hand and a QSL card in the other. Yes, it was an American dream alright, but more in the nightmare category. For while "short distance . . . etc." was the dream of the FCC, the people who were getting licensed in this new service had a few dreams of their own.

Mainly, it seems, they were dreaming about finally being able to get a "sort of" ham radio license. They could do so without going through the bothersome formality of learning how to send and receive code, or studying about the technical end of radio in order to pass a silly exam. As soon as the first sprinkling of CB licensees hit the airwaves back in 1959 it was apparent that the FCC had, unwittingly, created a fabulous new type of license-free ham service.

Yes, those gabby Americans—well trained after years of sneaking bits of news off the local telephone party line—could now press a microphone button and join the big party line in the sky. Due to ionospheric conditions affecting radio frequencies used by the CB service, CBers quickly found that they could easily chat with others of their ilk from coast to coast—and this despite the fact that maximum power input was limited to a mere 5 watts.

As word spread through the masses, the rush to CB-dom became awesome. The license, after all, was both free and could be acquired simply by filling out a short questionnaire and mailing it to the FCC.

The FCC's reaction was, as expected, stark horror. "What have we created?" they muttered, as they set out to clarify their position to the misguided licensees who had apparently not realized that the FCC's plan was that CBers would be talking mostly to stations within their own little network—the store, the wife, and so on.

A few conservatively worded bulletins were issued by the FCC. The licensees were reminded of the rules and told that it wasn't really cricket for them to call unknown stations just for the sake of yacking away with someone else, that it wasn't sporting of them to "work skip" (stations hundred or thousands of miles away) in this "short distance" radio service.

So busy were CBers having a ball, however, that they didn't get the message.

It was then that the FCC decided to pull their big gun, their final solution to the CB problem. In March of 1960, scarcely a year after the service was opened, they modified the CB rules and regulations to make them more specific about shall-nots for operators. Now there would be no more misunderstandings, now CBers would straighten up and talk right!

Right there in the new rules it said that you couldn't work skip, call CQ and engage other ham-type nonsense, that all CB messages must be "substantive." The FCC, with a sly but firm smile, then sat back to survey the fruits of their efforts.

*Ecccch!* CBers seemed totally unaware of the rule changes. Worse yet, more and more people were filing for licenses. Each new station was a jab in the FCC's ribs. Within a short time the FCC had its monitoring division spending a great deal of its time eavesdropping on CBers and sending out violation notices for illegal operation. Still the rule-breaking continued.

It wasn't that CBers didn't know the rules: *they just didn't care!* The attitude was one of, "Let them change the rules to suit our needs." The FCC's feelings, however, went basically along the lines that CBers were breaking rules simply because they didn't comprehend what the rules said. (The FCC still feels this way.)

By 1964 the crush of stations wanting to participate in the unlicensed ham service was



## TIMETABLE FOR THE DEATH OF CITIZENS BAND RADIO

- Sept. 11, 1958** First stations take to the air.
- Sept. 12, 1958** FCC realizes CBers are using stations contrary to the manner the FCC visualized (and did not announce).
- Jan. 10, 1960** FCC begins campaign to educate CBers on proper use of band.
- Mar. 4, 1960** FCC uses "big gun" against CBers and clarifies its CB rules and regulations to eliminate working skip, calling CQ, and sending non-substantive messages.
- Mar. 5, 1960** FCC tunes in on CB to hear results; finds CBers sticking to their rights and the channels in shambles.
- July 8, 1960** FCC steps up monitoring of CB channels, starts concentrated campaign of violation notices and license revocations.
- Mar. 15, 1964** FCC begins charging \$8 for each CB license.
- Apr. 25, 1965** FCC drags out their really biggest gun; clarifies CB rules again to the point of giving specific examples of what cannot be said over the air. Chit-chat channels cut to seven.
- Apr. 26, 1965** FCC learns that CBers still stick to unrestricted use of all 23 CB channels.
- Feb. 3, 1967** FCC announces plan to force manufacturers of CB equipment to have their gear "accepted" by FCC before it may be marketed.
- Mar. 14, 1967** FCC Chairman Rosel Hyde hints of written exams for CBers, mentions possibility of putting a freeze on new CB licenses.
- Apr. 13, 1967** FCC announces plan to remove unlicensed 100-milliwatt walkie talkies from CB frequencies.
- July 20, 1969** FCC adopts type acceptance proposal; many manufacturers forced to go out of business because their products cannot comply.
- Oct. 30, 1970** FCC institutes written exams for CBers; license fee increased to \$30.
- July 6, 1971** Channels cut down from 23 to two.
- Nov. 4, 1972** CB useless in all populated areas because of severe congestion of both channels; license fee increased to \$160. Fines imposed on CBers run into millions of dollars daily.
- Jan. 26, 1978** Only CBER to transmit a message so that it could be received more than 1700 ft. distant is said to live in Death Valley Estates, Calif. (pop. 2).
- Jan. 8, 1979** FCC announces that soon no more CB licenses will be issued.
- July 5, 1979** Last CB license is issued; it is given to an astronaut who just returned from 5 years on the moon and doesn't know what's going on.
- July 4, 1984** Last CB license issued finally expires; Big Brother decides to give frequencies to Singapore Networks as part of his program to keep a toe-hold in S.E. Asia.

beginning to overwhelm the FCC. And a new wrinkle was added. CBers had found that with very little trouble they could buy something called a linear amplifier, which, when attached to a CB rig, would run their

power output up to several hundred watts. This gave them undisturbed command of any of the 23 channels they chose to occupy.

The FCC then dragged out their super H-Bomb, yet another rule change which

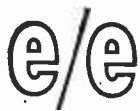

could only be termed as truly ultimate in its corrective powers. The year was 1965. Hundreds of thousands of stations were then active on CB and would be affected. The new rules spelled out in no uncertain terms *exactly* what the FCC had in mind when the service was created.

They gave actual examples of the things which could not be said over a CB station (lest there be any doubts). They spelled out in exacting detail the power requirements for CB transmitters. They cut down the number of channels which could be used for communications between different licensees from 23 to 7.

You guessed, didn't you? Yup, same pandemonium on the band. Only difference now was that since there were more rules to follow, more rules were being broken. And despite the facts that the FCC vigorously patrolled the channels with their monitoring squad, doled out copious fines, even revoked licenses, the channels became still more crowded with each passing month.

Licensees swelled to a grand total of roughly one million, CB transceivers in operation exceeded an estimated 3 million. Even when the FCC decided to charge \$8 for a CB license, the tide was not stemmed.

**There are a few** more cards up the FCC's sleeve. FCC's Chairman Rosel Hyde

has hinted at CBers being forced to take a written exam and has even mentioned the possibility of suspending issuance of new CB licenses. The FCC's proposed Type Acceptance plan would, if passed, force all manufacturers to submit their gear to the FCC for the green light before it could be marketed; it would also make use of unauthorized gear a serious violation of the rules for the user.

Further, the FCC is planning to remove all of the little unlicensed walkie-talkies from CB channels and exile them to an exclusive band of their own.

The Federal Trade Commission has even been called in to lend a hand. A few years ago they told CB manufacturers that their advertising must contain a certain long and involved paragraph alerting prospective CBers to FCC regulations. Some manufacturers inserted a modified form of the paragraph in their ads; others ignored the whole scheme.

Meanwhile, the FCC continues to tighten its hammerlock on the CB service, convinced that 1) CBers violate the rules because they don't understand them, and 2) what the FCC puts on paper can somehow alter the nature of the beast. Thing is, the rules are so cockeyed now that it's actually difficult to transmit any message at all and not squash at least a few FCC statutes.

In other aspects of the situation, the American Radio Relay League, an organization which claims to represent the interests of ham radio operators, has been giving the

## — CBERS LOSE 39 CHANNELS —

WASHINGTON, D. C.—The FCC has abolished Class B CB and taken away 39 CB channels. How the FCC took away 39 channels when there were only 23 in the first place may confuse some hobbyists until they recall that there were always more than 23. In fact, there were 72 CB voice communications channels—23 in the infamous 11-meter Citizens Band, and 49 in that almost unknown "other" Citizens Band within the 450- to 470-MHz allocation.

Before 1958, CBers had radio spectrum space for 400

FM, 1000 AM, or 2000 SSB channels. The entire 10-MHz wide (10 million Hertz) 460-470 MHz band was available to the Citizens Radio Service. No channels were allocated. You could operate on any frequency in the band under a Class A license, and on 465 MHz under a Class B license.

CBers once had 10,000 kHz of band space; now they have only 630. Of that total, 230 lie in the 11-meter band, 400 in the 460-MHz band.

In 1958, the FCC cut the 10 MHz of UHF band space down to 2.4 MHz for Class A

stations, 4.95 MHz for Class B Stations. The band was divided into 48 Class A channels and one Class B channel. But, a Class B station using type-accepted equipment could operate on any or all of the Class A channels as well as on 465 MHz, the Class B channel.

CBers lost 9370 kHz of band space because very few of them used or even were aware of the UHF Citizens Band. Equipment for that band has been available for some 15 years, but it has been expensive—\$500 and

## PROS AND CONS FOR SAVING THE CITIZENS RADIO SERVICE

### PROS—

- ✓ Offers economical and easy-to-use communications for the masses.
- ✓ Easier to get than a ham or business radio license.
- ✓ Equipment is inexpensive and simple to install, operate, maintain, repair.
- ✓ Good for emergency use on local and national basis.
- ✓ Offers citizens right to use their fair share of the public airwaves.
- ✓ Saves money for business; gives convenience to personal users.

### CONS—

- ✗ Creates much work for FCC.
- ✗ Licensees are unwilling to pay attention to FCC rules.
- ✗ Has cut into growth of ham radio.
- ✗ Service is growing too fast for number of channels available.
- ✗ Conditions for communicating are almost impossible in many areas.
- ✗ By its very nature, the service is self-defeating.

hairy eyeball to CBers, claiming that it is their presence on the communications scene which has cut deeply into the progress of ham radio (the *real* ham radio service, that is, not the CB service).

Rather than looking into the mirror to find the real culprit responsible for the decline (and perhaps the ultimate demise) of ham radio, the ARRL has picked CB as a scapegoat. Because of the ARRL's size, financial backing, and known abilities to exert pressure on the FCC, one can only imagine how the interesting relationship between the ARRL and FCC will eventually affect the future of the CB service.

**Going still further** into the situation we have the simple fact that CB band itself has only *so much* space and can hold only *so many* stations. Unless new channels are added (and that doesn't seem particularly likely, since the current trend is to whittle away rather than add), the service is sure to reach a saturation point when there are just too many stations jammed onto the existing

channels (this point is already close at hand in several metropolitan areas).

While the FCC polices the channels to try to bring some minute degree of order, one wonders why they are strangely lax when it comes to specific complaints received from CBers regarding areas of the nation which are useless for CBing because of deliberate jamming.

One case in point is in Illinois/Indiana, where a "hell's angels" group of bootleg CBers has been disrupting communications for months, has continuously operated several unlicensed broadcast band stations, and has even physically attacked CBers. Despite repeated pleas for urgently needed help from local CB operators, the FCC seems quite willing and content to stay clear of the situation, save for a few token warnings.

**Could it be** it's all part of a big and juicy plan to slowly tighten the noose with regulations while the victim (the CB service) rapidly fattens itself up with new stations?

*(Continued on page 105)*

up for a mobile unit. But lower cost UHF CB equipment is being made ready for the market by at least two companies.

If CBers don't want to lose the remaining 16 UHF CB channels, they had better start using them—now! On the UHF band there's almost no noise, there's no skip interference, and there's no channel congestion—at least not yet.

Furthermore, there are no 5-minute time limits and 5-minute silent periods. And you can use AM or FM trans-

mitters rated at up to 60 watts input or 44 watts mean power output. Using an antenna with 10-dB gain, effective radiated output up to 440 watts can be attained.

To use the UHF Citizens Band, you need a Class A CB license, which costs \$10. To apply, get a copy of FCC Form 400 from the Federal Communications Commission, Washington, D. C. 20554. From our table, pick a channel and note it on the application form. You're entitled to two frequencies—one for your base station as well as

one for your mobile units.

Besides a license, you'll need equipment. You can get reconditioned mobile units for around \$100 from surplus dealers. New equipment (which runs considerably more) can be obtained directly from RCA or Motorola or from dealers handling Kaar, COMCO, DuMont, GE, Johnson, Storno, or Pye equipment. You can also get UHF hand-held portables made by Micro, Motorola, Pye, and Storno.

The cost of the parts for a  
*(Continued on page 105)*



*Susan Foley, station manager of WSHR-FM, checks as technician Bob Klein prepares a tape recorder for the next program. Students handle equipment with loving care.*

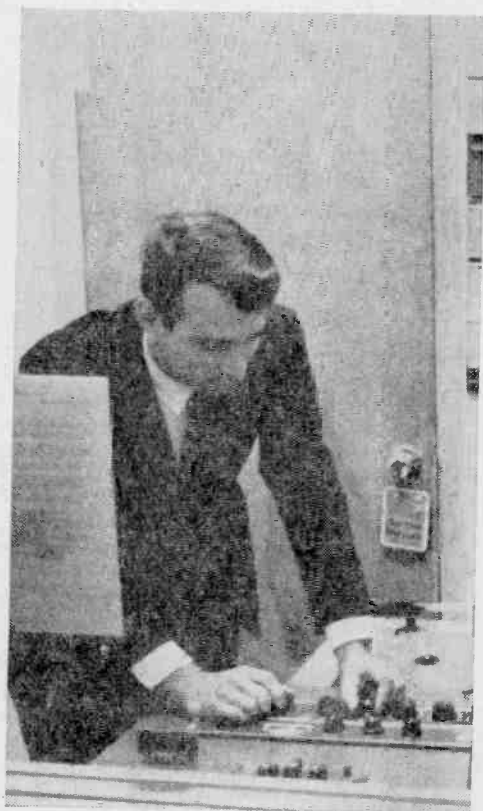

*Above, a staff announcer and technician gets ready to audition a tape which has been pre-recorded for use on a coming broadcast. At right, faculty adviser Richard Fearn supervises personnel as they broadcast weather. At controls is Randy Padgett; John Francavillo and Bill McNamara are in booth.*

# Sachem High School ...on the air

**L**ake Ronkonkoma, N. Y. is on the eastern end of Long Island, a mere 50 miles from New York City. There, the audience at Lake Ronkonkoma's Sachem High is just wild about the crew at WSHR-FM—35 fellow students who belt out the teen scene from 8:40 to 10:30 a.m. every weekday.

Run for both students and the community, the station transmitter covers a



*Above, Richard Fearn demonstrates turntable controls to student announcers and engineers. Below, a student interviews an art teacher during an actual class session.*

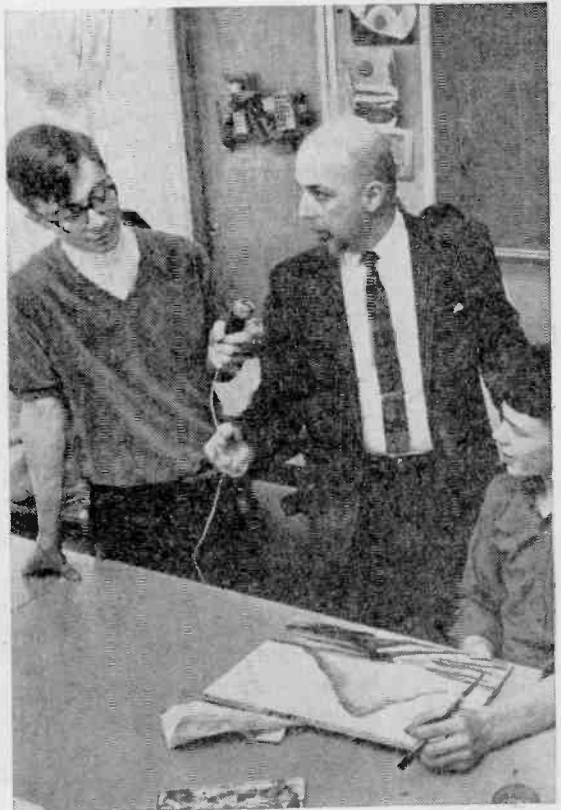



*A Sachem High band rehearsal directed by Dr. Thomas Ramsey is recorded on the scene by WSHR-FM.*

15-mile broadcasting radius and is licensed by the FCC. Richard E. Fearn is faculty adviser to the station. A wise man, he leaves the whole operation to the students—except for the transmitting equipment.

WSHR-FM offers music, news, weather reports, book reviews and discussions, as well as opening exercises for the high school, homeroom announcements, and ed-

ucational programs. The station now operates only when school is in session, but plans are in the works to expand its schedule.

Licensed as an educational station, there is no advertising. So it's easy to understand why bewildered parents and teachers enjoy listening to—and learning about—Sachem's Swinging Generation. ■

*A discussion program on world affairs goes over the wire. At right, students check out local reception.*





# tuning diodes snatch signals...



Bye-bye, tuning capacitor; hello, pot! Varactor diodes with voltage control are finally here —along with remote controls, and a smaller tuning unit.

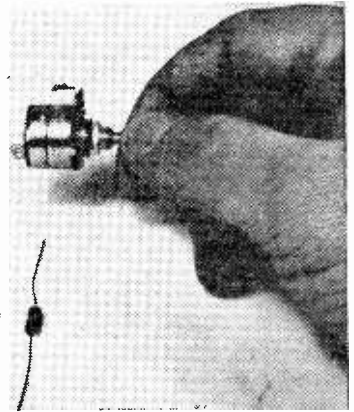

By  
Len Buckwalter  
K1ODH

## ...THE EASY WAY

One of the nation's big semiconductor manufacturers recently took a full-page ad in an electronics newspaper. It read like an obituary. "At long last," said Motorola, "it's possible to say goodbye to the old mechanical monster."

The monster turns out to be one of radio's most venerable components—the variable capacitor. Like the relay, rheostat, and other devices that mix the electronic and mechanical, the variable capacitor may soon mesh its plates for the last time and quietly expire. The variable capacitor is about to go completely solid-state.

And it isn't more space-age hornblowing, either. There's growing evidence that the old-time variable will end up dead as a dodo. A new FM radio recently introduced by the Fisher Company proves the point. It has something called "Tune-O-Matic." It lets you punch up stations with pushbuttons (like a car radio), but doesn't contain the usual Tinker Toy assembly of gears and levers. And in Germany, another manufacturer is producing TV sets that tune channels in a brand new way. In one experimental transistor AM portable, the plastic container that houses the tuning capacitor is curiously missing. In all these cases the reason is solid-state tuning—another example of semiconductors topping the status quo.

**Naming the Baby.** Solid-state tuning isn't exactly new. If your FM radio boasts automatic frequency control (AFC), chances

are it's done with a special semiconductor that grabs a station and prevents it from drifting off frequency. It's an electronic hand on the tuning knob that knowingly retunes the receiver. The heart of the system is a semiconductor that goes under a bewildering variety of names. It's a *Varicap*, *Semicap*, or *Epicap*, depending on the manufacturer. Others call it a "variable capacitance diode," while some are partial to VVC, for "voltage variable capacitor."

To keep the record straight, we'll call it a *varactor*, a generic term obtained by fracturing the phrase *variable reactance*. Whatever the name, it adds up to this: a tiny diode, usually smaller than a half-watt resistor, that changes capacity when a DC voltage is applied to its terminals.

**Newer, Wider Range.** Varactors have plodded along for years taking over for an occasional tuning capacitor in some circuit or another. These spotty victories, though, were hardly a threat to conventional tuning circuits. The varactor could automatically make up for small drift in an FM receiver. There it operated over a narrow range to retune the oscillator. But it's always been a dud over a wide frequency swing—for the complete AM broadcast band, say. If you count the moving plates in the tuning capacitor of a regular radio, you'll find about a dozen. The varactor was hard-pressed to equal half those plates.

That's all changed. Within the past year,

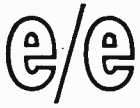

## TUNING DIODES

a new generation of varactors has made the scene. Specs are nothing less than dramatic, thanks to sophisticated technology. Old varactors could hardly stretch over a tuning ratio of about 3-to-1. New ones swing over a huge capacity range of 10-to-1. And that's only part of the story. Late models also have high Q—roughly a measure of the selectivity of the tuning circuit. The Q is now good enough so a circuit won't lose its sharpness at catching signals. Tally up these developments and you have a semiconductor spelling doom for the regular variable capacitor.

**Vive La Différence.** The impressive benefits offered by the varactor, as we'll see in a moment, stem from its operation. Shown in Fig. 1 is the standard variable capacitor vs. the varactor. The variable obtains its capacity by two sets of metal plates separated by air. By turning the dial, you change the capacity in mechanical fashion as the movable plates cover more or less

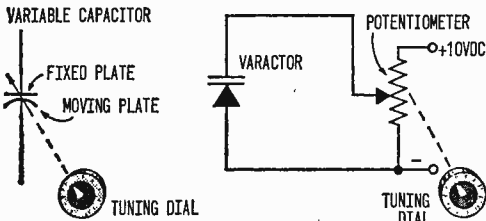

Fig. 1. Mechanical operation of variable capacitor contrasts with a voltage-controlled varactor that requires only a single pot to control DC voltage source.

fixed-plate area. The usual capacity change is from a few pF (picofarads) to a few hundred pF.

Let's check the varactor in Fig. 1 for comparison. (That symbol is not yet standard, but it usually resembles a regular diode plus a capacitor.) Something new has been added: a source of voltage (10 VDC) and a potentiometer for controlling voltage to the varactor. It is the DC voltage—not moving metal plates—that varies the capacity. Thus the potentiometer serves as the tuning knob.

How can DC voltage change capacity? Let's take a look at the guts of the varactor shown in Fig. 2. The semiconductor material (usually silicon) is divided into two blocks, roughly equivalent to metal plates of a regular capacitor. Each block has been doped

with impurities to enrich the substance with opposite electrical charges. The N block is treated so it contains a surplus of electrons and thus becomes negative. It's butted against the P block, a region doped for a surplus of positive charges. (They're also termed "holes" since impurity atoms snap up electrons, thereby leaving behind areas of positive charge.)

Both the N and P materials behave like metal plates of a regular capacitor, which similarly become charged in operation. The separation between plates—air in the variable capacitor—becomes the dividing junction in the varactor. Anything looking into the varactor will see a "capacitor" in its maximum-capacity condition.

Next, to apply battery voltage to the varactor to change its capacity. Note that the battery's positive terminal attracts negative electrons in the N block. Similarly, the negative battery terminal attracts the positive charges or holes. As these charges move away from the varactor's junction, there remains a gaping region termed the Depletion Layer. Now, an external circuit looking into the varactor sees very low capacity—equivalent to unmeshing plates of a variable capacitor. It's possible to swing the varactor over a range of capacity by simply changing the DC voltage source.

**The Practical Pot.** The potent reasons for, today's excitement about the varactor emerge when you examine a basic tuning

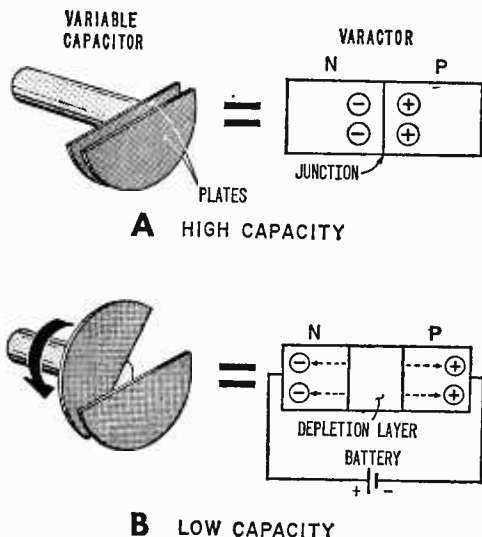

Fig. 2. Operation of variable's metal plates has its analogy in change of varactor's depletion layer. The larger the control voltage, the larger the layer.

circuit. In Fig. 3 is a conventional tuning circuit—coil and variable capacitor—typically found in a radio receiver for tuning an antenna circuit. The variable capacitor is manually operated by a dial on the front panel. In the varactor-tuned circuit, the identical electronic action occurs, but now tuning is accomplished by varying the potentiometer.

But look again. There's much more than meets the eye. The pot can be located many feet, even miles, from the tuning circuit. All the pot controls is DC voltage through a pair of wires. There's no radio-frequency energy present in the long connections to the tuned circuit (the RF signal returns to ground through the small DC blocking capacitor just below the varactor). And this supplies the engineer with the huge design advantage of extremely simple remote tuning.

It just isn't practical to take a regular variable capacitor and locate it away from its tuning coil. Radio frequencies are easily lost, not to mention the destructive effect of stray capacity through long circuit leads. So most remote-control tuning is done by a com-

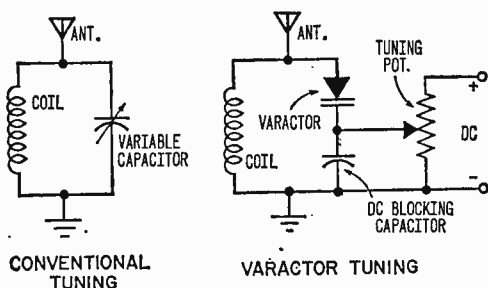

Fig. 3. An antenna circuit incorporating a varactor can be remotely tuned. The distance between pot and tuner has no effect on selectivity of unit.

plicated mechanical system that drives the tuning circuit at a distance. Motors, relays, solenoids, and other devices have been used to drive tuning assemblies. Now it can be done with the simplicity of a potentiometer.

Consider the pushbutton tuning shown in Fig. 4. Instead of a pot there's a string of resistors controlling DC voltage to the varactor. As pushbuttons are depressed, varying amounts of resistance are inserted into the circuit, each producing the correct capacity for tuning a station. This is a far cry from the pushbutton assembly you have in your car radio with its collection of rods, springs, and clutches. (For a detailed, practical pushbutton circuit, see box on "Fisher Tune-O-Matic" on next page).

One semiconductor maker, ITT, sees a coming invasion of varactors in TV sets. Three or four tuning diodes, as ITT calls varactors, might replace dozens of regular tuned circuits in a TV tuner. Instead of fancy mechanical switching or a rotating drum assembly, a few varactors and a tuning potentiometer would turn the trick.

**Shrinking Front End.** Stylists should have a field day when the varactor is operational across the board. Transistors triggered the low-profile craze in cabinets, and integrated circuits (ICs) are shrinking equipment like a one-dollar shirt in a laundromat. The varactor will speed the elimination of the variable capacitor, one of miniaturization's last big hold-outs. The diode-and-pot combination is hundreds of times smaller, as our photos show. And a dime-size pot could be tucked almost anywhere on a front panel. Servicemen should delight in the fact that dial cords (a nightmare to re-string) will virtually disappear.

Some observers see other electronic possibilities arising from the remote-tuning feature. A remote-controlled TV tuner is one example. This would remove the tuner completely from the set and mount it outdoors on the mast below the antenna. It would eliminate any antenna preamp or booster to overcome signal losses in the line. Better still, the amplifier of the tuner wouldn't have to be broadly tuned over a vast spectrum of TV channel frequencies, as is now done in electronic boosters. With varactor tuning, however, merely changing a DC voltage through the antenna line will sharply resonate each channel. As a result, the selectivity and sensitivity of the system greatly improves.

**Ganging Up.** An intriguing benefit of the varactor is that it allows many tuned circuits to be shifted by a single potentiometer. This is equivalent to a ganged capacitor in a radio receiver. Most table radios have a

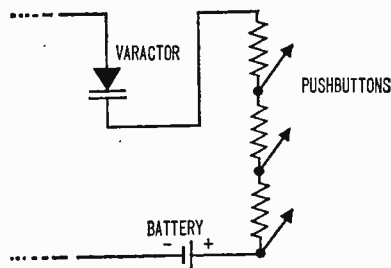

Fig. 4. Automatic control is achieved by combining fixed resistors and pushbuttons so it becomes possible to pre-select changes in varactor capacitance.



## TUNING DIODES

two-section variable; one set of plates tunes the antenna circuit, while the other tunes the local oscillator.

In more expensive receivers, there's a three-gang variable to handle the addition of an RF amplifier stage. Even more complexity occurs in the AM/FM receiver where a variable might have six sets of plates rotating on a single shaft. In varactor tuning, however, almost any number of tuning diodes can be controlled by one DC source.

A prototype AM receiver that's been built by one company illustrates how it's done. In Fig. 5(A) we've shown the front end of a typical AM radio receiver tuned by conventional capacitors, and, in Fig. 5(B), by varactors. In the conventional circuit there's a two-gang variable which tunes the antenna loopstick to select stations in the broadcast band. The signal is passed to the transistor for amplification.

Since this is a superheterodyne circuit, there is also a local oscillator signal (generated by the same transistor). The oscillator circuit is tuned by the lower gang of the tuning capacitor. As incoming and oscillator signals mix in the transistor, there is an intermediate-frequency output on 455 kHz. The critical feature of the circuit is that antenna and oscillator circuits must track together and produce the correct IF, or difference frequency.

How the same process is accomplished in a receiver using varactors appears in Fig. 5(B). The new circuit has barely changed except for varactors and a tuning potentiometer. But note how the pot simultaneously controls the two varactors from a single voltage source. There is no mixing of radio signals

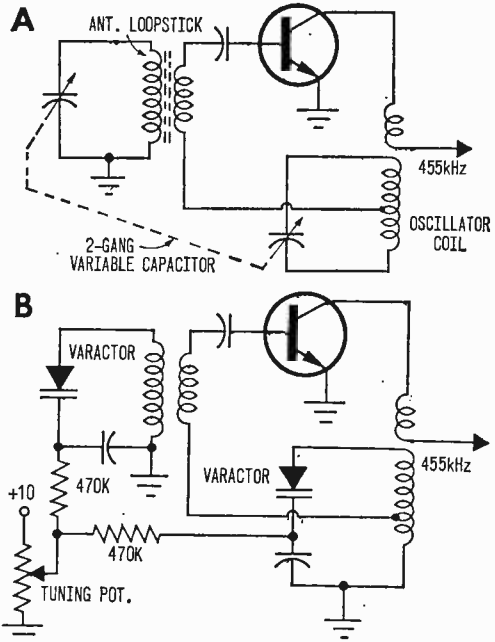
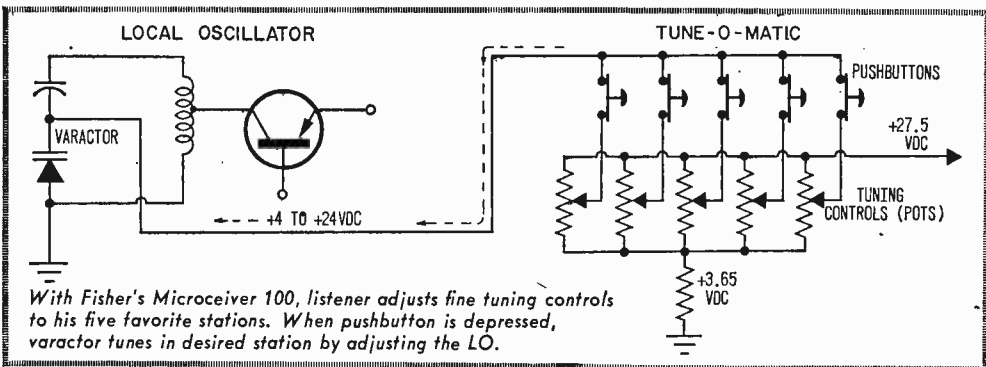

Fig. 5. Conventional tuning of AM front end, as compared with the same circuit using varactors. A single voltage source for control of many semiconductors has great advantages over the bulky ganged plates of a large variable capacitor, that must tune two (and sometimes more) stages.

since the two 470k resistors isolate antenna and oscillator circuits. The DC control voltage, however, can get through to each varactor and exercise tuning control. If this circuit is expanded to include an RF amplifier stage, a third varactor could similarly tie across the tuning potentiometer.

The DC voltage source is hardly strained by additional varactors. These devices operate on negligible power. Voltage is used mainly to operate the diode in a reverse-bias condition, rather than control large amounts of power as in the case of a diode rectifier in a power supply.



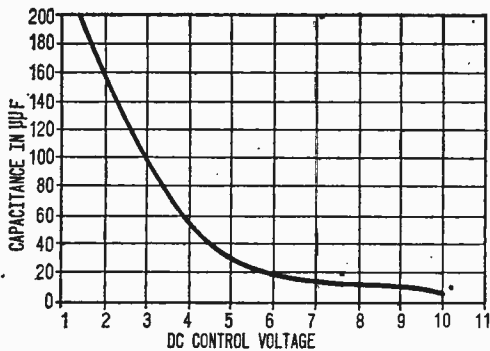

Fig. 6. Response curve indicates how varactor capacitance is a function of the control voltage. With little DC applied, depletion layer of diode is nil and capacitance is high. As DC increases, less capacitance is maintained by tuning diode. At maximum voltage, capacitance decreases to about 8 pF.

To illustrate how a varactor behaves under changing voltage, we've shown its response curve in Fig. 6. This would apply to the diode used in the antenna circuit of Fig. 5(B), a varactor now being offered for replacement of the variable capacitor in AM radios. Highest capacitance of the varactor—nearly 200 pF—occurs when voltage is less than 2 VDC. Then, as the potentiometer is rotated, thereby applying higher voltage, capacity drops to less than 20 pF. This indicates a ratio of more than 10-to-1, adequate for the large capacity swing needed to cover the AM broadcast band.

**A Swinging Modulator.** Tuning a circuit isn't the only application for the varactor. It also works well as an FM modulator. Take the circuit shown in Fig. 7, a practical schematic that will produce voice signals in an FM broadcast receiver with amazingly few components. In operation, the transistor oscillator section seen at left generates a carrier between 88 and 108 MHz, depending on adjustment of the 5-80 pF tuning capacitor. The carrier is easily shifted in frequency in step with the voice by the modulator section at right.

The process begins by talking into the

microphone, which is a crystal type. It generates tiny audio voltages which are applied to the varactor. The audio is translated into capacity changes which are applied back to the oscillator, via the 10-pF coupling capacitor. Since the capacity swing is in step with

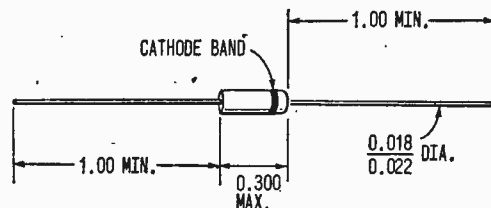

Above, varactor is shown actual size. In a circuit, lead with cathode band goes to positive DC source. Below are specs for "Epicaps"—low-frequency varactors made by Motorola. Capacitance ratings are for a bias of 2 VDC. Increasing the voltage ultimately reduces these values by a figure of 10 (i.e. tuning ratio equals 10).

### Specs of "Epicaps"— Low Frequency Varactors

Motorola Varactor	Typical Diode Capacitance (pF)			Figure of Merit (Q)
	Min.	Nom.	Max.	Min.
MV1403	140	175	210	200
MV1404	96	120	144	200
MV1405	200	250	300	200

the voice, the carrier commences to deviate and produce a conventional FM signal that can be detected by a receiver. A 10- $\mu$ H choke in the mike lead allows audio to reach the varactor, but prevents RF from backing up into the microphone.

If you know your way around a schematic, the circuit can be constructed and tested. Assemble it on a small piece of circuit board, keeping leads as short as possible. The varactor in this case is an inexpensive 1N60 diode. It's a good performer and generates

Fig. 7. Circuit of a small FM modulator reveals why a varactor's DC control voltage need not be steady. Here, a crystal mike controls DC that varies according to the audio signal. Since varactor capacitance changes as the DC changes, a shift in the frequency of the oscillator occurs. The FM signal can then be picked up by most any FM receiver.

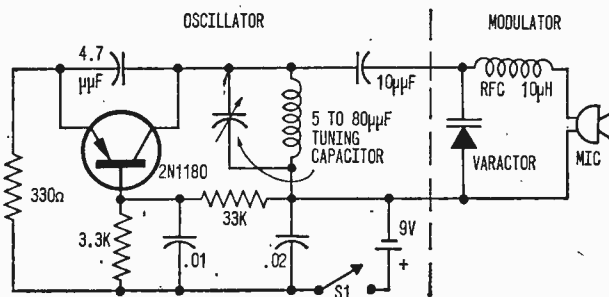

# e/e TUNING DIODES

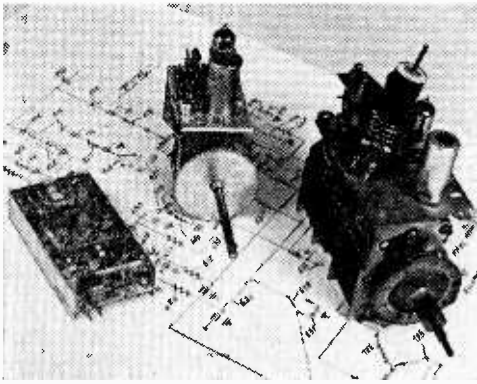

TV tuners over the last 15 years. Above at left is the first completely solid-state vhf tuner. It uses varactor diodes exclusively and is marketed by Standard Kollsman Industries of Syosset, N.Y. Varactor tuners are about 70% smaller than typical electron tube unit shown at center. This tuner must be mounted directly behind the channel selector (a varactor unit can go anywhere), and it has fixed elements that are switched in or out by contacts on a rotating turret (which are subject to wear). Finally, at right, is the older version which uses ganged IF plates to tune in various channels.

highly intelligible audio in a receiver. Tuning coil L is a 1-in.-diam. loop of hookup wire.

**Solid Color.** The varactor is responsible for the recent hoopla about automatic fine tuning (AFT) in color TV receivers. Though AFT is still found only in costly, top-of-the-line sets, it's expected to filter down to low-cost receivers. AFT is a welcome addition. Fine-tuning a color set is far more critical than in black-and-white. Unless the incoming signal plops perfectly into the receiver, the color image is only a sometime thing.

The varactor neatly solves this problem.

The AFT circuit in Fig. 8 is a typical arrangement now in use. The system is based on the fact that when a TV signal is properly tuned it will exist precisely on 45.75 MHz in the midsection of the receiver. (That's the video carrier frequency as it rides through the set's intermediate stages.) A tiny sampling of the signal is tapped off and applied to the detector. Here, the coils have been pre-set at the factory for response on 45.75 MHz.

If the signal is exactly on frequency it produces equal and opposite voltages across the two diodes in the detector. Voltage output is zero. But if drifting occurs, the diodes produce a DC voltage output that encodes the frequency error. The voltage may go positive or negative, depending on which way the signal has drifted, and increase according to the amount of drift.

The error voltage is fed to the varactor which is physically located in the receiver's front end. As a result, the varactor will produce corresponding changes in circuit capacity. Since the capacity is applied across the receiver's local oscillator, the oscillator is automatically retuned to the correct frequency. Once the desired 45.75-MHz frequency occurs—and the detector produces zero volts output—the system quiets down and awaits the next frequency drift. Such control duplicates grasping the fine-tuning control and manually adjusting for best picture. The AFT system works by itself and continues to monitor the tuning after you've returned to the easy chair.

Next time you purchase anything that smacks of automatic, "electric," or solid-state tuning, you can bet an old variable capacitor that a varactor is behind the claim. ■

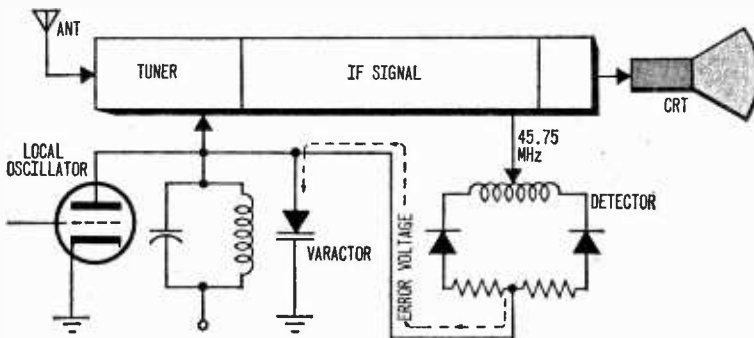

Fig. 8. Another type of variable DC is produced by the detector in the AFT circuit of a color TV set. The DC error voltage changes the varactor capacitance tuning the front end. The frequency shift will be proportional to the DC error voltage.



Pyrotechnic electronics is here!  
Build, see, and hear our...

# FLAME SPEAKER

Striking, stupendous, stunning—this  
is one project you'll never forget!

By Jorma Hyypia



**L**ine your speaker cabinet with asbestos before installing this hot-fi super-fidelity loudspeaker. Otherwise your audio system will be burned to a cinder because—believe it or not—the speaker is a high-temperature *gas flame!* We call it the *Flame Speaker*.

We don't seriously suggest that this revolutionary speaker should replace your present loudspeaker. But you will have to look long and hard to find a more spectacular audio experiment for a high school physics project, a science fair demonstration, or for simply astounding friends in your home.

The Flame Speaker is more than a far-out stunt. Its inventors already foresee many applications of the principles involved; they range from new communications systems to important new rocket design techniques, and from fire alarm systems to musical candles and fireplaces.

Credit for the original idea goes to researchers W. Babcock, A. G. Cattaneo and K. L. Baker who stumbled on the curious phenomenon while investigating methods of underwater sound generation at the United Technology Center at Sunnyvale, California. Using their original report as a guide, the author set up a similar system to find out how easily the Flame Speaker can be made

to work. The results were astonishing. Absurdly simple equipment can be used to demonstrate the principles involved; only slightly more sophisticated equipment is needed to produce sound of excellent quality.

The UTC researchers claim that high frequency response of the Flame Speaker is *better* than what can be obtained with the most expensive conventional loudspeakers now available. As a super-tweeter, the Flame Speaker probably has no peer.

Bass response starts to drop off around 2000 to 3000 Hz at a rate of 6 dB per octave, though there is some degree of response all the way down to DC. But, this is not believed to be an inherent shortcoming of the system; low-frequency response is expected to improve markedly with the use of larger flames.

**How It Works.** To make a musical flame, simply feed the output of a power amplifier (connected to a tuner, record player or tape recorder) to a step-up transformer and then to two electrodes positioned in the flame. A water solution of potassium nitrate must be fed into the flame to provide ionizable molecules for reasons that will become clear later.

This simple set-up will fill a large room with sound. Though there will be considerable distortion, the results will be so promis-

# e/e FLAME SPEAKER

ing that you won't be able to resist cleaning up the sound by adding a DC bias circuit. When that is done, you will feel amply rewarded for the effort; the music emanating from the flame will be astonishingly sweet and clear.

Though there is still much to be learned

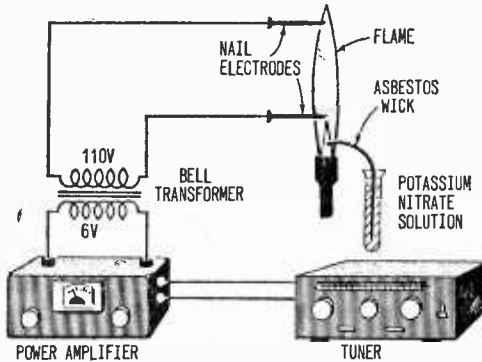

Simple setup utilizing bell transformer and nail electrodes produces loud sound. Lack of DC bias voltage, however, leads to considerable distortion.

about the Flame Speaker, it seems clear that the sound reproducing abilities of a flame are related to the formation of *plasma*—a gas made up of positively charged atoms and free electrons. The gas used to create the flame does not have enough ionizable molecules to form a good plasma; hence the easily-ionized potassium nitrate is needed.

When an oscillating electric field is applied to the flame by means of the two electrodes,

the free plasma electrons move toward the positive pole while the positive ions move toward the negative pole. Since positive ions are heavier than electrons, there is a net force in the direction of the negative pole. Thus the flame is bent by the electric field. This bending (vibration) of the flame is a function of the fluctuating electrical input. The flame remains electrically neutral because there are an equal number of plasma electrons and positive ions; the phenomenon is related only to the relative mobility of the electrons and positive ions.

We are so conditioned to think of sound generation in terms of vibrating *solids*—in particular the paper cone of a conventional loudspeaker—that it is at first difficult to imagine that a gaseous system might work in much the same way. For more than a century it has been known that flames can *respond* to sound waves, and can act as *amplifiers* of vibrations produced by other membranes. For the first time there is proof that a flame can also *generate* sound waves.

**Give Me Some Skin.** For some time scientists have speculated that flames, like liquids, exhibit a surface tension. We are all familiar with the surface tension "skin" on water that makes it possible to float a metal needle on water. The skin is not, of course, a physical entity that can be peeled off, like the skin of an onion. It only acts like a thin skin might act if it existed. The phenomenon results from molecular attractions that tend to pull the water into a shape consistent with the smallest possible volume.

The tapered shape of an undisturbed flame is probably due largely to this surface tension phenomenon. In fact, this flame speaker be-

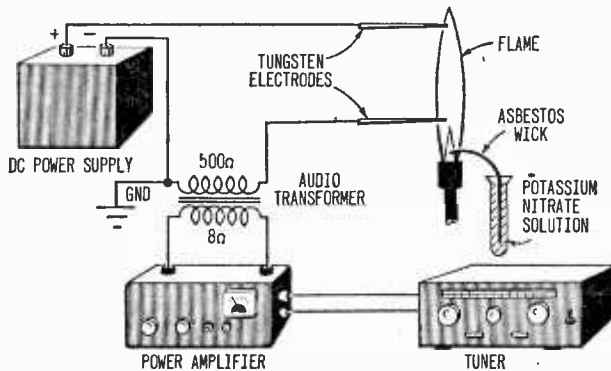

Elaborate version above ensures excellent sound quality. Addition of audio transformer and DC bias voltage gives flame a real boost in its ability to reproduce audio. At right, lower electrode goes just above inner cone of flame; upper electrode is positioned for best sound.

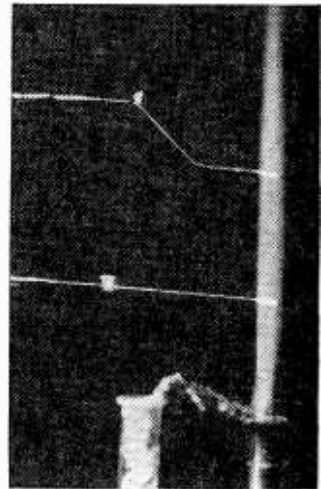

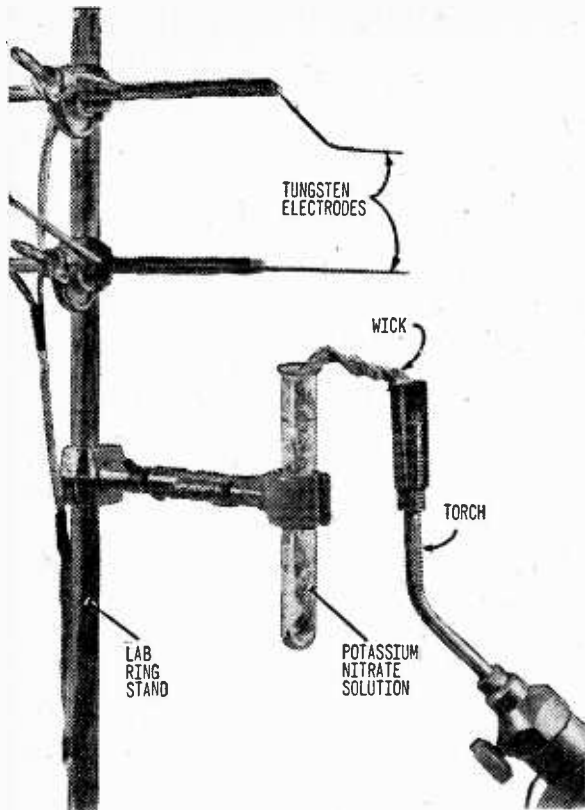

*Laboratory ring stand and clamps come in handy for holding tungsten electrodes and test tube. Bend upper electrode only when narrow gap is desirable.*

havior tends to confirm the flame "skin" notion.

We might now think of the flame "skin" as a sort of gaseous membrane that is in intimate contact with the surrounding air. As this skin vibrates, it moves the air in much the same way that a conventional speaker cone compresses and rarefies air to produce sound waves. However, the conventional speaker diaphragm is made of solid material that necessarily suffers from such factors as internal friction and mass inertia. No such diaphragm can ever be wholly efficient. On the other hand, a flame can be thought of as a virtually massless and frictionless membrane. It is able to vibrate much more freely than could any diaphragm made of solid material.

This explains why the flame is such an unusually efficient tweeter. Why doesn't it woof as well? Probably only because all experiments to date have been performed with rather small flames. A large flame might turn out to be a very efficient woofer—again, per-

haps far better than any conventional woofer.

How large would the flame have to be to be a good woofer? Only further experimentation will yield the answer. Meanwhile, we can't help but wonder what would happen if an intrepid audio bug were to stick electrodes into a burning oil well; he might succeed in woofing the Texans right off the map, or perhaps catalyze an earthquake.

**Hi Heat, Hot Fi.** It takes a lot of heat to jiggle electrons off atoms to create a really good plasma, so the UTC researchers used an oxy-acetylene welding torch in their experiments. Actually, even the 3000 degree temperature of such a torch produces at best a rather mediocre plasma, but one adequate for the purpose at hand.

In fact, you can get very good results even if a welding torch is not available. A bottled-gas shop torch (Bernz-O-Matic) serves well. Other flame sources worth trying include a plumber's blow torch, laboratory Bunsen burner, or an air-gas torch of the type used to blow glass in laboratories. As a matter of fact, the author managed to get a few low-fo squeaks using only the flame of a candle!

The potassium nitrate can be obtained from the local druggist or from a hobby shop selling chemicals for home experimentation. The solution strength is not critical; just dump a little into water and it will work.

The solution must be fed continually into the bottom portion of the flame so that the vaporized chemical streams upward past both electrodes; this is easy to see because the potassium colors the flame a faint lavender. Also, moving the wick end about on the burner helps because the sound volume will rise and fall abruptly as the vapor moves to and from the electrodes. Incidentally, move the wet wick only with a wooden stick or some other non-conductor; otherwise you

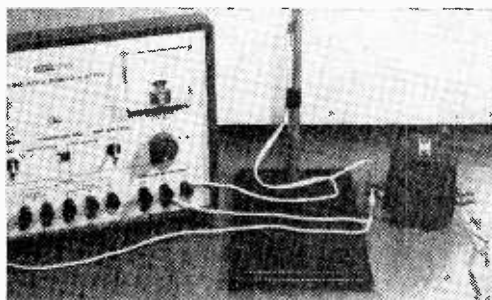

*Bias voltage (about 400 VDC) comes from regulated supply. Long wire in front of power unit is ground lead.*

# e/e FLAME SPEAKER

can get an uncomfortable shock because of the high voltage—especially if the DC bias circuit is operating.

The wick must be of some non-combustible material. Check the local heating supply shop for asbestos tape used to seal pipe joints in warm-air heating systems.

**Tungsten Electrodes.** The main reason for using electrodes made of tungsten wire is that they will last a long time without burning up in the intense heat. The author had some 2% thoriated tungsten electrodes, 0.04 inches in diameter, made by Sylvania. These proved excellent.

In lieu of tungsten, try nichrome or chromel wire used in electrical heating elements, or wire you can salvage from burned-out electric light bulbs. In a pinch, just use some sharpened 10-penny nails; they work quite well.

Mount the electrodes on wooden dowels after the wire leads have been attached. Wrap electrical tape around the wire and dowel to hold them together and to insulate the elec-

trodes. This is important. It not only prevents short circuits, but will protect you from shocks when you adjust the electrodes.

Mount the electrodes horizontally, one above the other, so that the lower electrode tip is just above the blue, inner cone of the flame. The upper electrode will be from two to four inches above the first, depending on the size of the flame used. The best position is found by *trial and error*. If the electrodes are too far apart, the sound will be weakened; if too close together, there will be undesirable flashing when peak surges of voltage pass between them.

**Step-Up Transformer.** The UTC scientists suggest the use of an 8-ohm/500-ohm step-up transformer between the power amplifier and electrodes. A 5-watt transformer having a 500 ohm primary, and 3.2 as well as 6-8 ohm secondary taps (Stancor A-8101) was used by the author. The low impedance winding (3.2-ohm) of the transformer connects to the amplifier's output terminals. The stepped up voltage from the 500-ohm winding connects to the electrodes. Oddly enough, polarity makes no difference.

This step-up transformer worked well when either of the low impedance taps was used. Theoretically, the 8-ohm transformer

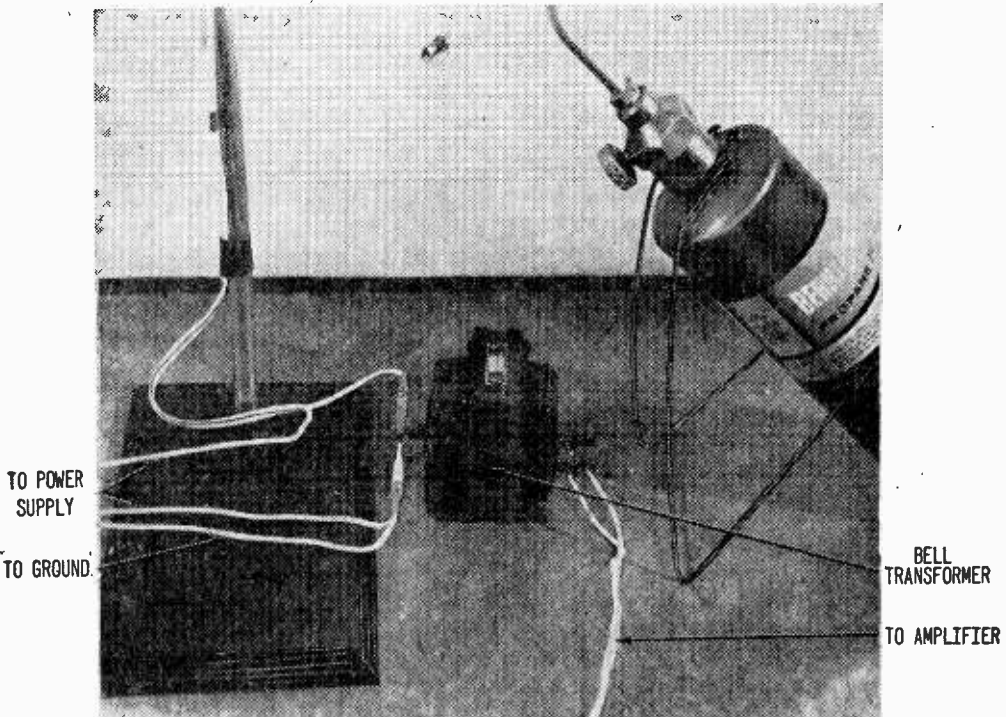

Coat-hanger supports torch in proper position. Electrode/bias leads go to 110-V terminal of transformer.

tap should be coupled to the 8-ohm output of the power amplifier. In practice, it made very little noticeable difference in sound quality when the 4, 8 and 16 ohm outputs of the amplifier were tried. The 5-watt transformer does not have quite enough power handling capacity; it tends to overheat on

ly. During normal performance, the Flame Speaker draws about 50 to 70 mA, with peaking at about 100 mA.

**Caution: Don't forget the ground wire; and keep fingers off exposed terminals, electrodes and the wet wick when the power is on!**

## Electronic experiments using flames were done 40 years ago!

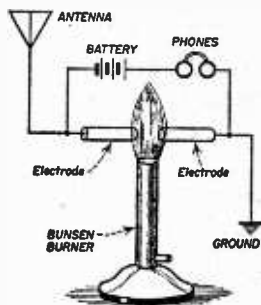

Flame replaced crystal detector in radio built by Lee DeForest in 1920s (see sketch above). Now scientists have done away with conventional speakers by exploiting flames that respond to audio signals.



prolonged use, especially when the high-voltage bias circuit is used.

Actually, the choice of transformer is not at all critical for general experimentation and demonstration purposes. An ordinary 6/110-volt AC bell transformer works very well when the power amplifier is hooked to the 6-volt terminals and the bias/electrode leads are connected to the 110 volt terminals. The resulting sound is clear and strong. Also, this heavy-duty transformer does not overheat even when shorted at the output.

**Bias for Beauty.** If no bias circuit is used, the sound will be loud but badly distorted. To clean it up and reveal the truly beautiful performance potentials of the flame speaker, the bias circuit must be added.

This calls for a DC power source with a 400 to 500 volt wallop. An EICO regulated power supply unit (Model 1030) can easily provide a usable voltage range from 0 to 400 VDC. As the bias voltage is gradually increased, both fidelity of reproduction and volume output improve dramatically. The maximum attainable voltage (400 VDC) is just barely enough to sweeten the music nice-

**Power Amplifier.** A small table radio or amateur tape recorder will not drive the flame speaker unless the signal is further amplified. The author used one channel of a Harman-Kardon Citation stereo amplifier rated at 60 watts per channel. With less power, be content to fill only a *small* room with sound.

**Fascinating Spectacle.** There is something downright eerie about the Flame Speaker when it is observed in action in a dark room. The tips of the electrodes glow and pulsate, and the light given off by the flame waxes and wanes in step with the music.

The UTC scientists have demonstrated that light emission reflects accurately the imposed modulations by optically beaming an image of the flame onto a photocell. The photocell output was amplified, and then fed to a conventional loudspeaker which recreated the original sound. This same optical system can be used to prove that even the weak flame of a candle has sound reproducing properties, albeit of low volume and fidelity.

*(Continued on page 106)*

e/e

HIGH-FIDELITY

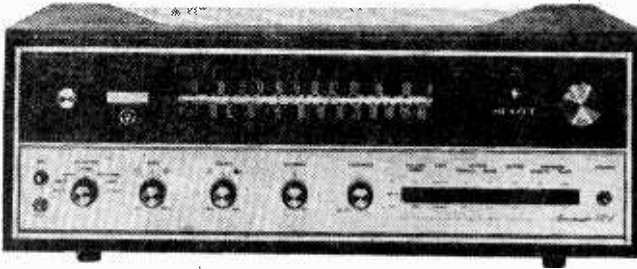

The Scott 388B is a luxury stereo tuner/amplifier that boasts latest innovations in solid-state circuitry

**C**ontrary to modern liberal thought, progress, *per se*, is not guaranteed by all-new innovations. Rather, progress is built on solid, proven foundations. It is therefore not surprising that Scott chose to utilize the advantages of integrated circuits ((ICs) in updating an already proven performer, their model 388 receiver. The new product is appropriately dubbed the 388B, and sports both IC IF amplifiers and an FET (field effect transistor) front end to minimize strong signal overload.

Featurewise, the 388B is loaded. In fact, its flexibility is more akin to the component system of separate tuner, control center, and power amplifier, than to the receiver that it is.

Though all solid-state, the 388B is no lightweight, and checks in at approximately 21 pounds. Overall size with the supplied leatherette metal cover is 17½ in. W x 15½ in. D x 5⅞ in. H. (An optional walnut finish wood cabinet is available.)

**Control Center.** A quick rundown of the major control features will give a good picture of what you can expect in the way of flexibility. The 388B tunes both AM, FM, and FM-stereo. A single signal-strength meter indicates proper tuning for both AM and FM stations. An input switch selects the desired input source: AM, FM, phono, microphone, and extra (auxiliary).

The phono preamp doubles as the mike

preamp; setting the input selector to *mic* removes the phono compensation from the preamp and mikes can be fed into front-panel jacks. The extra input can be used for any high-level sound source. A separate tape input is provided which is controlled by a separate front-panel switch, and provides simultaneous monitoring-when-recording with a three-head recorder.

A function switch determines the amplifier operation. It can be set up for mono, stereo, stereo reverse, left input to both channels, and right input to both channels. In addition, the function switch feeds both L and R inputs to the left channel *or* to the right channel for sound balancing. A second stereo/mono switch on the rear apron provides something we haven't seen before.

When the rear apron stereo/mono switch is in the stereo position, stereo can be fed either simultaneously or individually to local and remote speakers. When the rear apron switch is in the mono position the local speakers receive stereo while the remote speakers receive mono—an optimum convenience for sound distribution throughout the home.

Dual concentric, friction-clutched bass and treble tone controls allow the tone of each channel to be individually adjusted, or tracked together. A single volume level and balance controls are provided.

Seven push-on/push-off switches provide



for loudness tone compensation, tape monitor, rumble and noise filters, FM interstation noise muting, and main and remote speakers. A front-panel headphone jack and a stereo indicator lamp are provided.

**Pick Your Level.** A three-position phono sensitivity switch allows the gain of the phono channel to be equalized with the level from the tuner to avoid blasting sound levels when switching from radio to phono. Both a switched and a normally connected 117-VAC sockets are provided on the rear apron, as well as fuses for each amplifier's speaker output.

Incidentally, construction of the 388B is somewhat unique in that nearly every circuit is on its own independent printed circuit

measured as 0.4% at the tape output jack. Stereo distortion was also exceptionally low: 0.8%. The mono noise level was a good 60 dB down, with the stereo noise level 58 dB down (using a 1000  $\mu$ V standard reference signal).

No measurement was made of the AM tuner, since the accepted measurement technique is almost worthless. Compared against contemporary AM receiver sections the 388B's AM reception, in terms of sensitivity and selectivity, was judged good to excellent.

**Frequency Response.** The FM frequency response was measured at the tape output jack. For mono, the response was  $\pm 1$  dB, 50 to 14,000 Hz; for stereo R,  $\pm 1$  dB, 50 to 14,000 Hz. The stereo L channel fre-

Fig. 1. With tone controls flat, frequency response of amplifier in 388B at 1 W out was within  $\pm 1.5$  dB from 20 to 20,000 Hz.

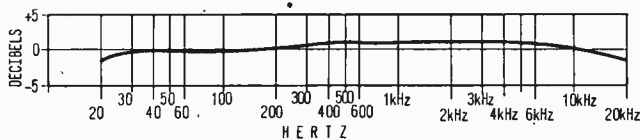
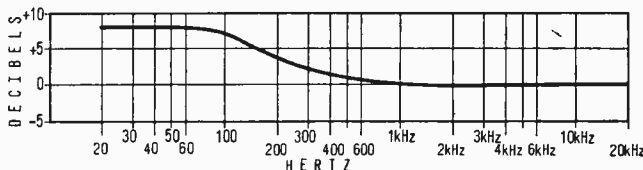

Fig. 2. Switching on volume compensation (loudness contour) switch boosts the bass response at least 5 dB. Here, loudness control is at mid-position; tone controls are flat.



board, individually mounted to the chassis. Though of no importance when the tuner is working properly, it should result in quicker and less expensive repairs should the receiver develop trouble, as it is easier to troubleshoot individual circuits. (The 388B is supplied with a comprehensive service manual.)

**The Front End.** By standard IHF measurement techniques the 388 B is one of the hottest FM receivers, with better than 2  $\mu$ V sensitivity at the bottom, middle, and top of the band for 30-dB signal-to-noise plus distortion reduction. Full limiting of 50-dB noise and distortion reduction was obtained with a 12  $\mu$ V input.

Mono distortion was exceptionally low,

frequency response was essentially identical to the right.

As shown in Fig. 1, the amplifier's frequency response was  $\pm 1.5$  dB, 20 to 20,000 Hz. (For clarity, only the right amplifier's characteristics are shown as the left amplifier is essentially identical.)

At the rated power output of 30 watts rms per channel (both channels driven), the distortion curve was almost ruler flat at 0.36%, 20 to 20,000 Hz. While the amplifier is rated at 50 watts rms per channel (one channel driven), we could not get better than 40 watts per channel before clipping. However, this is probably due to the wide variation common to transistor characteristics; then again, there is not much difference between

Fig. 3. Frequency response of 388B with both rumble and noise filters switched on shows extent of attenuation at both ends of curve. Response is down 18 dB at 25 Hz, and 3 dB at 4 kHz. Thus, while high-frequency attenuation is average, rumble filter may prove a mite too efficient at frequencies near 50 Hz.

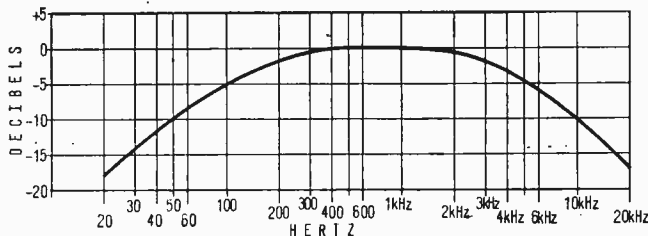

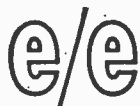

## HIGH-FIDELITY

40 and 50 watts—they both can cause pain.

The effect of the volume compensation (usually termed loudness contour) with the loudness (volume) control in the mid-position and the tone controls at the indicated flat position is shown in Fig. 2.

Figure 3 shows the effect of the rumble

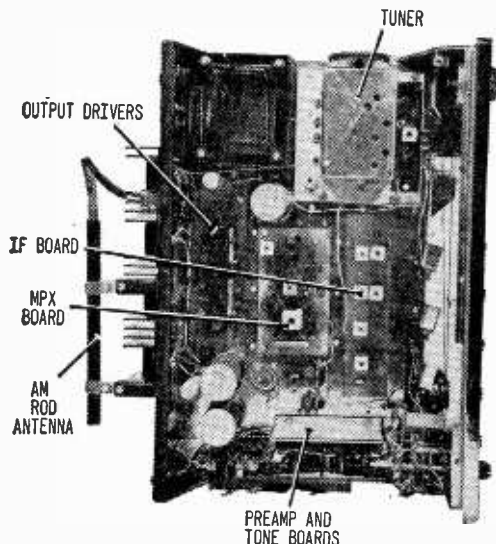

The 388B uses individual circuit boards. An external AM antenna can be substituted for the ferrite rod.

and noise filters. Note that the attenuation from 10 to 25 Hz, the rumble range, exceeds 18 dB. For some listeners, and with certain music, the 10-dB attenuation of the rumble filter at 50 Hz might prove too much, but the filter can be switched out. The noise filtering, also shown in Fig. 3, is about average, with the 3-dB down point at 4 kHz.

**FETs and ICs.** Unfortunately, standard measurements do not indicate the advantages obtained from the use of an FET front end and IC IF amplifiers. (Many early solid-

*Controls on 388B are well organized and extremely legible. Besides inputs for a pair of mikes and stereo headsets, seven push-on/push-off switches give listener control over numerous modes involved in stereo listening. Dual concentric, friction-clutched treble and bass controls allow tone of each channel to be adjusted individually, or tracked together.*

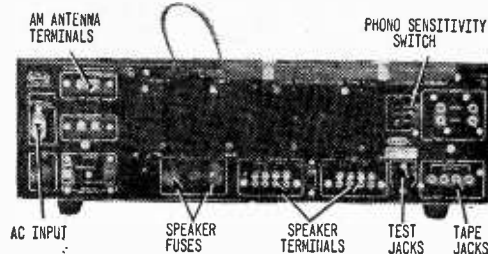

Rear apron on 388B is packed. Sensitivity switch equalizes phono volume with radio to avoid blasting.

state receivers with transistor front ends were prone to strong signal overload, with its resultant cross-modulation and spurious signals.) The 388B's front end is insensitive to overload, up to the 50,000  $\mu$ V limit of our signal generator. As for IC IF amplifiers, high sensitivity also means strong adjacent-channel interference to weak signals.

IC amplifiers, however, result in flat-topped, steep-sided IF selectivity, which produces a somewhat different tuning effect. Instead of being able to tune through a station from the carrier frequency to the distorted sidebands, the tuning "holds in" until the signal suddenly "drops off a cliff." This creates an advantage and a disadvantage.

The advantage is that you can often receive a weak signal very well with IC IF amplifiers, when the same signal—through a conventional IF amplifier—would be buried by a strong adjacent station. The disadvantage is that since the signal "holds" through a relatively large tuning range you can tune for clean sound and wind up with poor stereo separation. Since the 388B does not use AFC (it's not needed as the front end stability is excellent), the user must carefully tune for a combination of best sound quality and maximum stereo effect.

**Summing Up.** There's not much more we can say other than the 388B's performance easily justifies its price of \$539.95.

For additional information write to H. H. Scott, Inc., Dept. WG, 111 Powdermill Rd., Maynard, Mass. 01754. ■

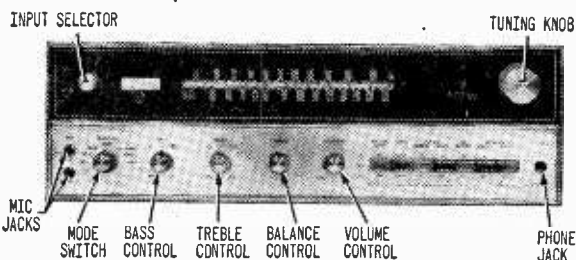

By Paul T. Judkins



# *the ABCs of QSLs*

Meet the challenge of active SWBC listening  
- learn how to get QSLs like the Pros

**D**ialing long distance is a chore that can give you a killing headache, and waiting for a hot piece of mail can be even worse. No wonder many beginning SWLs—like you—hesitate before sending for verifications from the stations they tune in. DX or not, they're usually a long way off.

These verifications (QSLs) are the heart of SW listening. And by passing them up, you're really just looking in, instead of looking out from inside the shack. An exciting hobby like shortwave radio demands a certain amount of dedication and skill. And taking the time to fill out a reception report accurately is just as important as learning how to get the most from your receiver. If you can do one, you should be able to do the other.

**The Why of the Game.** Basically, it's a matter of attitude. Developing good habits is half the battle for a beginning SWL. Whether your equipment is worth \$75 or \$575, if you don't have a method, you'll be staring at blank walls from first to last.

A wall covered with colorful and informative QSLs is an achievement—not just decoration. It means you know what you're after, and that you and your equipment are a one-person operation. Your hobby is an extension of *YOU*. So don't just sit there watching the dial light; make those numerals

on your receiver dial really mean something!

The majority of SWBC stations are happy to reply to reports they receive from their listeners. And it's not just a matter of good relations abroad, or at home. They're anxious to have accurate information about program transmissions to specific areas of the world. If your report is informative and accurate, you should receive a QSL card within a reasonable period of time. Having the patience to write the report and await an answer—that's the trick.

**First Things First.** Quite a number of things can happen after you drop your report in the mailbox before the time when, hopefully, the postman delivers that coveted QSL. The report can be lost in the mail, the address may be incomplete, wrong, or out of date. If it does reach its destination, it may be lost, ignored, or misplaced by someone who hasn't the slightest idea of what it is. The station manager or engineer may deem the report incomplete, inaccurate, or both, and not worthy of a QSL. And some stations have a simple "no verification" policy, no matter how good a report may be.

Let's first assume that a particular station is extremely selective in its dealings with reception reports. Obtaining a QSL from them is truly a task to be remembered. Some of the following suggestions will seem obvi-

ous to you,' but others may possibly indicate a more efficient way of writing up your report.

Your name and address should appear on every page of the report, and on the envelope. It is advisable to type or print carefully, as personal handwriting is often impossible to decipher.

Addressing your letter is no problem. The addresses of most stations can usually be found in the *World Radio-TV Handbook* (available at any radio supply store, or from Gilfer Associates, Box 239, Park Ridge, N. J. 07656). Club bulletins sometimes offer more recent information, and as a last resort a station's call, name, or slogan plus the city, province, state, country, and/or continent can sometimes do the job. Including a station's call provides more insurance that the report will reach its destination.

**Reporting in Detail.** Be sure to include the date and time, both yours and theirs. For example, it may be 10 p.m., June the 1st in New York, but it's 4 a.m., June the 2nd in

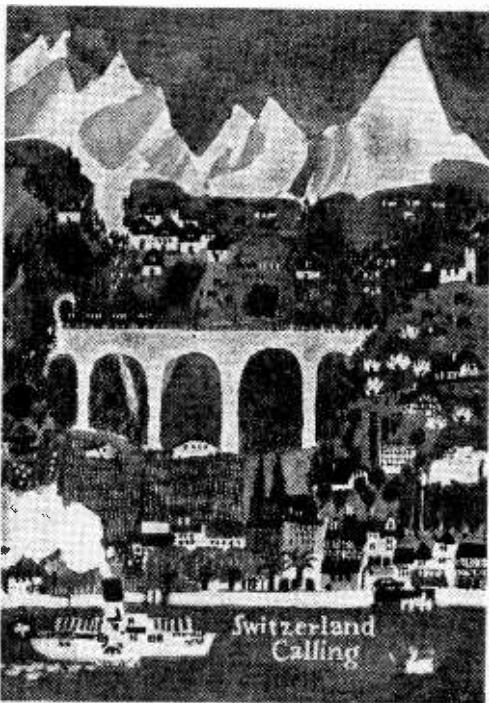

From the Alps comes a QSL of the Swiss Broadcasting Corp. Swiss offer many programs in English.

London, England. (This is, of course, only true in the winter. During the summer, the difference is 5 hours. British Standard Time —BST—is now the same as European Time and is 1 hour ahead of Greenwich Mean Time.) SWBC stations like to give time military-style. Instead of stopping at 1200 (say it, twelve hundred), they keep on counting to 2400. Thus, a program heard at 8 p.m. would be reported as having occurred at 2000 hours.

Most stations prefer the time listed in Greenwich Mean Time (GMT), which is simply the time at the Greenwich Observatory in England; it is 5 hours ahead of Eastern Standard Time (EST), and 4 hours

## Wavelength Versus Frequency

Basic equation is:

$$\lambda = \frac{300,000}{f}$$

where  $\lambda$  is the wavelength in meters, and  $f$  is the frequency in kilohertz (kHz). The higher the frequency, the shorter the wavelength. For instance, 4 megahertz (MHz) equals 4000 kHz. Therefore,

$$\lambda = \frac{300,000}{4000} = 75 \text{ meters.}$$

At 20 MHz, the wavelength is reduced to 15 meters.

ahead of EDT. Also, it is helpful to list the station's own local time, particularly in the case of smaller stations.

List the station's frequency in either kilo- or megaHertz (though it still doesn't hurt to use cycles), and also provide the wavelength in meters. Some SWBC stations prefer to use meters as a means of designating their spot on the dial! The wavelength can be found by dividing the frequency in kHz into 300,000 (see box). If the frequency you give is approximated, be sure to specify it as such in your report. When you list more than one frequency, the station's call will help indicate more clearly which frequency you were tuned to, as many stations have different calls for each frequency.

**On With the Show.** Try to include enough data to cover at least 25 minutes of program material, and make it as complete as possible. Include newscasts or bulletins, and should any technical trouble interrupt the program, include this information also. Mention any musical numbers you heard,

and should they be in a language other than English, indicate the type of music it was (Latin, Oriental, African, etc.) and how it was performed (female vocal, male vocal, instrumental, etc.).

If the broadcast is in English, try to determine the performing artist as well. Also try to get the station identification word for word. It is also advisable to check your clock or watch with one of the well-known time signals before you tackle a particular station. You should have your time report accurate to the nearest minute.

There are several excellent reporting codes, and by using this kind of shorthand, you enable station personnel to process your letter in a flash. Many stations seem to prefer the well-known SINPO code (see box for details). However, it is wise to also include a verbal description of the signal strength, interference, fading, etc., if you think those indications are important. If the station is transmitting on multiple frequencies, try to monitor at least two of them and give a comparison report. Catching a signal on a weaker frequency is the mark of a DXer who is out for bear.

**Show Off Your Station.** You can stimulate a good deal of interest if you give some information about your station. Explain the type of receiver you're using (communications, portable, etc.), give the manufacturer and model number, and also include information on the type of antenna being used. Tell whether it is an inverted L, a T type, or a long wire; also how high and long it is, and whether it is polarized vertically or horizontally.

Some personal details such as your age, occupation, and interests would help. And, if you have one handy, send a picture of yourself at the controls of your station. Other goodies to add to your report might be your

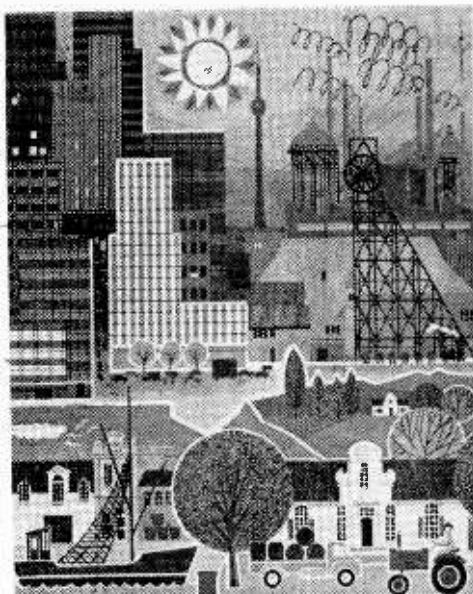

The QSL above is from Radio RSA, the Voice of South Africa. Broadcasts are made to 16 specific world areas.

exact location in terms of latitude and longitude, and the height above sea level. Also try to give the sunspot count at that particular time (available free of charge from Radio Nederland), and the prevailing band conditions. Band conditions are broadcast every 5 minutes from WWV, Ft. Collins, Colo. A letter to them will bring you information about this service.

**Getting Verifications.** When asking for a station's QSL, you should request, not demand, that they send you one. This is a mistake many SWLs make, and as a result they are blacklisted by certain stations. Remember that a QSL is a courtesy on the part of a station, not an obligation.

Unless you are sure that a station does not require return postage, always include at least one IRC (International Reply Cou-

#### SINPO CODE

S		I		N		P		O	
	Signal Strength		Interference		Noise (Atmospheric)		Propagation Disturbance		Overall Merit
5	Excellent	5	Nil	5	Nil	5	Nil	5	Excellent
4	Good	4	Slight	4	Slight	4	Slight	4	Good
3	Fair	3	Moderate	3	Moderate	3	Moderate	3	Fair
2	Poor	2	Severe	2	Severe	2	Severe	2	Poor
1	Barely audible	1	Extreme	1	Extreme	1	Extreme	1	Unusable

**Standard Bands For BC Stations**

Designation	Frequency (kHz)	Wavelength (m)
Long Wave	150-285	2000-1053
Medium Wave	525-1605	571-187
Short Wave (tropical)	2300-2495	120 meter band
	3200-3400	90
	4750-5060	60
Short Wave (high freq.)	3900-4000	75 meter band
	5950-6200	49
	7100-7300	41
	9500-9775	31
	11,700-11,975	25
	15,100-15,450	19
	17,700-17,900	16
	21,450-21,750	13
25,600-26,100	11	

pon). These can be obtained from your local post office for 15¢, and in most countries they are redeemable for enough postage to permit sending a reply by return surface mail. For air mail, you will have to provide several coupons.

**A Few Odds and Ends.** An excellent practice is to register your letter to ensure safe delivery. It may cost a bit more, but it's certainly worth the expense if you are a serious collector of verifications. If you don't get a reply to your report in about six months, try again. Be polite, and don't let the station think you are angry or upset because the first report wasn't answered (even if you are). Also remember, if you sent your report via surface mail, it sometimes takes up to a year to get a reply.

Another method of reporting is by tape

recording. However, this isn't completely accepted by the stations, as most still prefer the written report. Another disadvantage is that post offices now x-ray packages as an alternative to opening them for inspection. This will wipe all sound off the tape. And lastly, most SWLs don't have elaborate recording systems and use small transistor sets. These are usually below broadcast quality and do not offer a true picture of the original transmission.

Whatever method you use—letters, recording, or carrier pigeon—good luck for a bonanza QSL harvest!

From John P. Smith, Jr.  
160 Westlake Drive,  
Park Ridge, Illinois

To Radio Station  
Radio Nederland, Holland Identify National Anthem-3 Bars  
Wereldomroep

I AM PLEASED TO REPORT RECEPTION

Your verification (by card or letter) would be much appreciated

On April 16, 1967 on or about 9:25. local time (31.6 meters)

Time (local)	Time (GMT)	PROGRAM TRANSMISSION	S	I	N	P	D
<u>2000</u>	<u>0300</u>	<u>News Broadcast in English</u>	<u>4</u>	<u>3</u>	<u>4</u>	<u>4</u>	<u>4</u>
<u>2030</u>	<u>0330</u>	<u>Technical Information in German</u>	<u>4</u>	<u>4</u>	<u>5</u>	<u>4</u>	<u>4</u>
<u>2045</u>	<u>0345</u>	<u>Music Program - American</u>	<u>4</u>	<u>4</u>	<u>5</u>	<u>4</u>	<u>4</u>
<u>- 2130</u>	<u>2330</u>	<u>And European Jazz</u>					

You (have) (have no) interference on the frequency. If any, interference is on a (higher) (lower) (same) frequency from a (Broadcast) (radio/telephone) (CW) (FSK) station. Fading on your transmission was (Weak) (deep) (rapid). Receiving conditions were (good) (poor) (usual) (average).

My receiver is a Hollcrafters SX-100

My antenna is a Single wire (outdoor), 20'

Remarks Separation from BBC, London is sometimes  
difficult to maintain

I have interpreted the SINPO Code as follows

SIGNAL STRENGTH	I. INTERFERENCE	IMPEDANCE TO RX	PROPAGATION INTERFERENCE	OVERALL INDEX
5 Excellent	5 None	5 None	5 None	5 Excellent
4 Good	4 Slight	4 Slight	4 Slight	4 Good
3 Fair	3 Moderate	3 Moderate	3 Moderate	3 Fair
2 Poor	2 Severe	2 Severe	2 Severe	2 Poor
1 Barely Audible	1 Extreme	1 Extreme	1 Extreme	1 Unusable

Standard forms for reception reports are available from Gilfer Associates (see text for address). A hard-pressed editor filled this one out, but any SWL should be able to do better. Note overall layout.



## SUPERMARKET SUPER SELL

Shoppers in Britain are having their heads turned by more than high prices. At 100 selected Tesco food stores, closed circuit TV is used to catch customers just when they're in the mood to buy.

The trick is to show commercials while buyers are standing where goodies are on display. Ampex VR-7003 videotape recorders feed at least six monitors per store, and early reports indicate reception of the S9-plus variety. The facts: sales in some stores are up by a whopping 200%. ■



# Build HiBander ...a VHF police converter for your car!

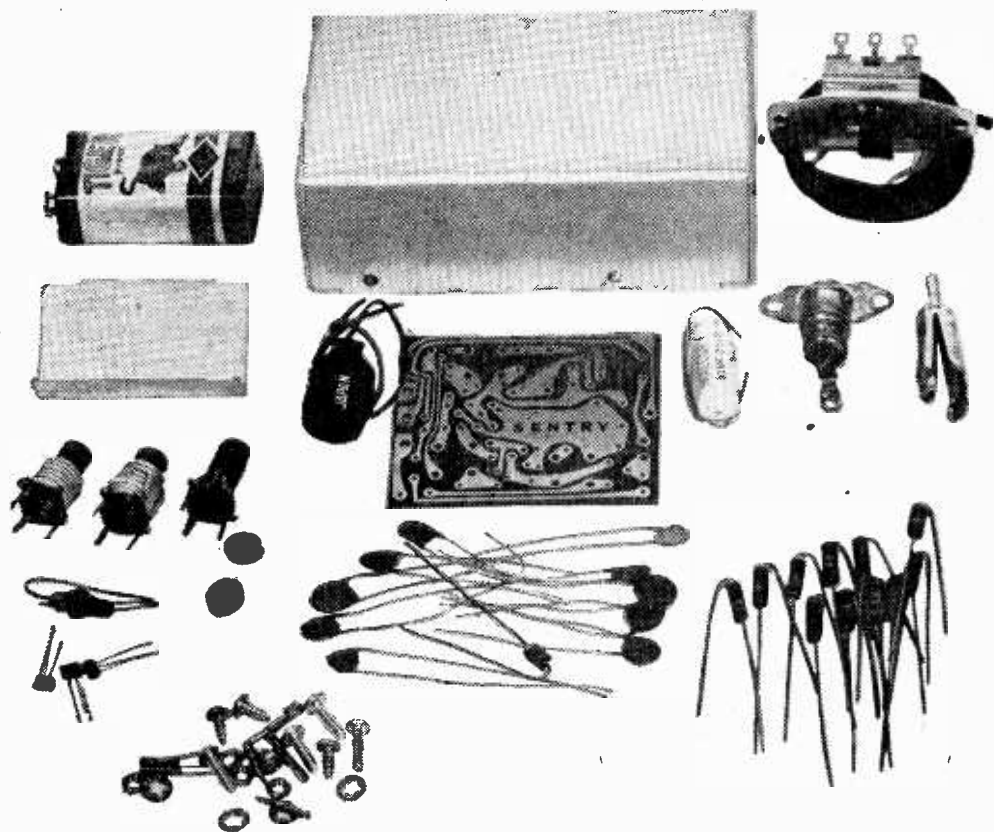

A printed circuit board for HiBander can be yours absolutely free, or you can order your board with a complete set of parts—see coupon

By the Editors of **ELEMENTARY ELECTRONICS**

**D**ay in and year out, the police radio frequencies make for some of the hottest "entertainment" in the radio spectrum. The reason isn't hard to find; it's the thrill of tagging along with the cops on what to them is routine business: robberies, murders—you name it!

All it takes to tune in on the cops is a battery-powered solid-state converter and a standard auto radio. Plug the Sentry converter into the radio and you get a choice of listening to either the standard broadcast band or the fuzz. And just in case you're not

thrilled by police broadcasts, there are always the other public-service stations such as the fire laddies or (in certain parts of the country) some of the best weather reports you are ever likely to hear.

**On . . . Or, Under.** An easy-to-build (and use) police converter is shown in the photographs. Measuring a mere  $2\frac{1}{4} \times 1\frac{1}{8} \times 4\frac{1}{8}$  in., it can be mounted just about anywhere on the dashboard of a car, or under the dash. To ensure absolute frequency stability, crystal-control is employed, and tuning is accomplished with the car radio rather than

# e/e HiBANDER

with the convertor. Here's how it's done.

The Sentry convertor plugs into the car radio's antenna socket and the car antenna plugs into the convertor. When the convertor's switch is in the *off* position, the convertor's internal 9-volt battery is disconnected. In addition, the car antenna is bypassed around the convertor directly into the radio. The result is that the radio functions as it normally does, receiving BC stations.

When the convertor's switch is set to *on*, however, power is applied to the convertor. Further, the car antenna is switched to the convertor's input while the convertor's output is connected to the radio's input. Since the entire antenna system from convertor to ra-

dio is shielded, no broadcast stations can leak through whenever the convertor is in use.

You might well ask: How can we tune in FM police signals with an AM car radio.

Don't we need an FM detector to hear FM signals? The answer is no. While it is true that Hi-Band signals are FM, they are narrow-band FM, less than 15-kHz wide. This means that they can be tuned in on an AM radio by using slope detection.

**On The Slope.** You simply tune the car radio very slightly past the carrier frequency so the signal is received on the slope of the IF curve, and you get fairly good FM detection. Since the detection—even though slope—is still AM, there is no automatic noise reduction as with an FM detector. But even so, you will get good, readable detection.

The convertor works by heterodyning the Hi-Band signal to a frequency which can be tuned by the car radio, say 1.0 MHz. Here's how it's done. The Hi-Band signal, assume

*HiBander schematic. Complete parts kit includes every component indicated, plus PC board and cabinet.*

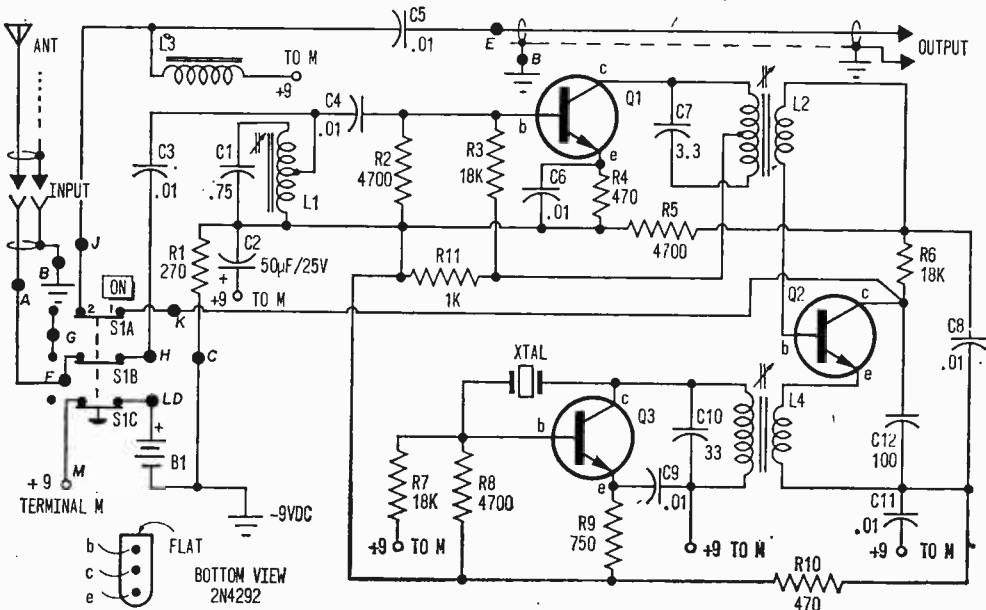

## PARTS LIST FOR THE SENTRY HiBANDER

- |  |   |
|--|---|
| B1—9-volt battery (Burgess 2U6 or equiv.)                          | R2, R5, R8—4700-ohm, 1/2-watt resistor  |
| C1—0.75-pF, 25-VDC tubular ceramic capacitor                       | R3, R6, R7—18,000-ohm, 1/2-watt resistor  |
| C2—50-uF, 25-VDC electrolytic capacitor                            | R4, R10—470-ohm, 1/2-watt resistor  |
| C3, C4, C5, C6, C8, C9, C11—0.01-uF, 25-VDC ceramic disc capacitor | R9—750-ohm, 1/2-watt resistor (5%)  |
| C7—3.3-pF, 25-VDC ceramic disc capacitor                           | R11—1000-ohm, 1/2-watt resistor   |
| C10—33-pF, 25-VDC ceramic disc capacitor                           | S1—3 p.d.t. slide switch (Continental-Wirt G-369 or equiv.)                     |
| C12—100-pF, 25-VDC ceramic disc capacitor                          | X1—Sentry type SGP-6 (see text)   |
| L1, L2, L3, L4—See text  | Misc.—Cabinet, antenna plug, antenna jack, Max Cab'e (RG-174/U), hardware, etc. |
| Q1, Q2, Q3—2N4292 transistor (see text)                            |   |
| R1—270-ohm, 1/2-watt resistor                                      |   |

156 MHz, is amplified by an RF amplifier (Q1) and fed to a mixer (Q2), where it is beat against the output from the crystal-controlled oscillator (Q3). If the crystal oscillator's output frequency is 155 MHz, the 155 MHz and 156 MHz beat together in the mixer, producing sum and difference frequencies. The difference between 156 MHz and 155 MHz is 1 MHz, a frequency just about in the center of the radio's dial.

When the 1-MHz output is fed from the convertor to the radio, the Hi-Band 156-MHz signal is "received" at 1 MHz on the car radio's dial. Since the car radio can tune a band approximately 1-MHz wide—from 600 to 1600 kHz—a single Hi-Band crystal allows reception of Hi-Band signals within a 1-MHz bandwidth. For example, with 155-MHz output from the oscillator, we could tune in a 155.4-MHz signal by setting the car radio's dial to 600 kHz, or a 156.6-MHz signal by tuning the car radio to 1600 kHz.

**Easy To Build.** The convertor shown in

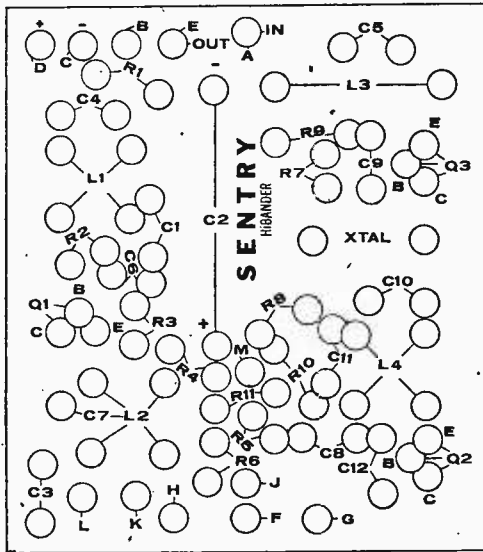

Constructing HiBander is a snap, since all holes in kit PC board are neatly labeled to show what goes where.

the photo is an easy-to-build, one-evening project, because a printed circuit board is used to ensure exact placement of the high-frequency components. There is no possibility your convertor won't work because of inexperience with high-frequency component layout; your convertor will be an exact duplicate of the one shown.

The printed circuit board is available absolutely free, without even a handling or postage charge. Simply send the coupon to

Sentry Manufacturing and you'll get your free PC board. Because high-frequency coils are often difficult to wind correctly, we have also made arrangements with Sentry to provide pre-wound coils at \$5.00 per set. In addition, Sentry will supply their SGP-6 crystal (X1) for \$4.75 (you specify frequency) and a package of three 2N4292 transistors for \$4.50.

To simplify obtaining components, you may order a complete set of components which includes cabinet, hardware, and push-pin terminals. Also worth noting is the fact that the PC board supplied with the complete kit comes plated for easy soldering and is pre-drilled. The free PC board, in contrast, is supplied unplated and undrilled.

**Construction.** If you are using the free PC board and your own components, the first step is to drill the holes in the board. The holes for the resistors and capacitors can be made with a #57 drill. The larger holes (for power/antenna switch S1, the crystal, and connecting leads) must match the components and wire you are using. If you have the complete component kit the holes have already been drilled the correct size. Before soldering to the free PC board, clean the printed wiring with a mild household cleanser such as Bon-Ami. Otherwise, it may be difficult to solder to the foil and you might use excess heat.

The printed wiring is very fine, and you must use a very thin soldering tip such as provided for Ungar soldering irons. You cannot solder to the foil with a standard size ¼ in. soldering tip, since the solder will splash to adjacent foil.

If you are using the kit PC board the component layout is printed on the top of the board and you simply plug the components into the matching holes. If you are using the free PC board follow the layout as shown in the illustration; the holes here exactly correspond to the top (non-foil) side of the PC board. Make certain you orient the board so it conforms with the illustration—don't try to work with the board sideways or upside down.

Bend up one (the bottom) set of horizontal S1 terminals, slide the PC board on the terminals so the top (non-foil) of the board faces up, and solder the terminals to the foil on the bottom of the board. The final position is shown in the photo. If the S1 terminals don't fit into the PC board's holes, use side-cutters to trim the width of S1's terminals.

(Continued overleaf)

Position the switch/board assembly so the front of the switch faces you. This done, fold the right-hand S1 terminal in the center row *down* to the terminal (hole G) directly underneath (the one soldered to the foil), and solder the two terminals together.

Next, install all components on the board except the crystal and transistors. It is best to mount all resistors first; then all capacitors (except C7), taking care to observe polarity on C2; and finally the coils. Capacitor C7 can be installed after the coils are mounted.

**Installing The Coils.** First mount choke L3. Then install L4, the coil made of fine wire. Note that L4 has two wires running from the top of the coil and two from the bottom. Position L4 so that the lugs with the wires from the top of the coil face Q2 and C8.

Examine the remaining two coils. Note that one coil (L2) is tapped and uses all four terminal lugs, while the other coil (L1) has connections to only *three* of the four coil-form terminal lugs. Mount L1 (the coil with three used lugs) so that the unused terminal faces R2. Now check L2; L2 should have connections to all four coil form terminals and a wire that sticks out by itself.

Position L2 so you are facing the top with the terminal lug connected to the coil center tap at the upper right. The terminal lug at the upper left should have but one wire, with the free wire sticking out to the left. If the upper left terminal has two wires and there is no free wire, cut the wire that comes from about two turns down from the top of the coil—this is the “free” wire. Now install L2 so the free wire faces C7.

The hole in the board directly under L2's free wire is for C7. Position C7 so its leads are vertical; install one lead in the hole in the board (with C7 against the board) and connect C7's free lead to the free wire from L2.

To avoid errors, reread the previous section on L2 and C7 before installing the components.

**Other Wiring.** Connect a short, direct wire from holes J and K to the S1 terminal directly above the holes. Connect a wire from hole L to the switch terminal directly above the terminal connected to hole K. Install an insulated wire from hole M to the top center C1 terminal.

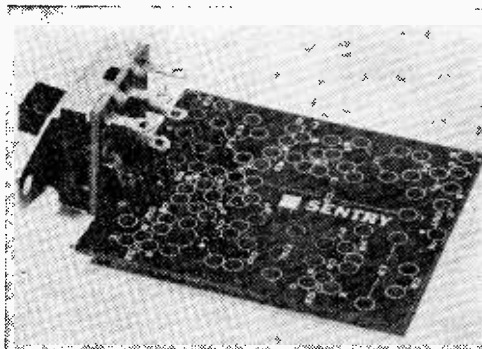

*First construction step is to mount PC board on bottom row of S1 terminals. Switch is biggest single component to appear on board.*

Now install transistors Q1, Q2, and Q3. Check the transistors very carefully against the sketch shown with the schematic. Note that one end is round and one is flat. The transistor lead closest to the flat end is the base (b), the one closest to the round end is the emitter (e), and the one in the center is the collector (c).

Match the leads to the corresponding holes in the PC board, but do not press the transistors flat against the board. Instead, use as much lead length as is possible; the transistor leads should stick through the foil side of the PC board no more than  $\frac{1}{8}$  in. Now mount the crystal and solder quickly.

Solder push-pin terminals to holes B, E, and A so the pins stick out the top of the PC board. Cut the pins in holes A and E flush with the copper side of the board so they do not short against the case. Leave the pin in hole B full length so it will act as a support for the back edge of the board. If you aren't using the component kit use a  $\frac{3}{4}$ -in. length of # 18 wire as push-pin terminals.

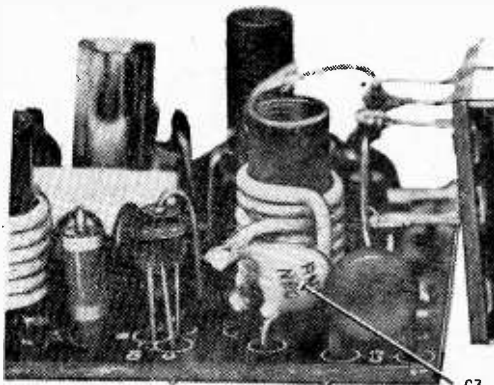

*Capacitor C7 is positioned so it stands on end between PC board and free wire from coil L2. Try to keep C7 as close to board as possible.*

Connect a set of battery terminals for a type 2U6 9-V battery to holes D and C. Hole D is for the positive (red) battery connection; hole C for the negative (black) battery connection.

The basic convertor is now completed. Check the board for unused holes; there should be none. If you find an unused hole you have left out a component or wire.

**Final Assembly.** If you have built the convertor with your own components the PC assembly can be mounted in a 3¼x2½x5-in. Minibox. Otherwise, you simply mount the PC assembly in the pre-drilled cabinet supplied.

Insert the antenna jack (standard auto antenna type) through the hole in the battery bracket and fasten the jack/bracket assembly to the back of the cabinet. (Don't forget to install the rubber grommets.) The battery bracket will be bent upwards; do not bend it down until you are ready to insert the battery. Solder a 2-in. bare wire to the antenna

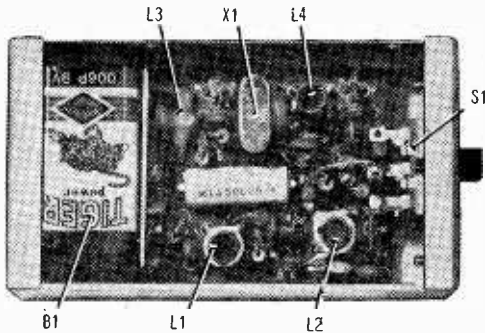

Completed Sentry HiBander, with all components (including battery B1) in their proper places. Unit is now ready to be checked out and instrument-aligned.



To align HiBander's oscillator, connect 0-10 DC mA meter in series with battery, adjust L4's slug (starting from full-out position) clockwise until meter peaks, then turn slug clockwise one more turn.

jack's center terminal and a 2-in. wire to the jack's frame (ground).

Now drop in the switch/PC board assembly and fasten the switch to the front panel. The board will be automatically positioned so the foil side does not contact the cabinet, but doublecheck anyway. Solder the wire from the antenna jack's center terminal to the push-pin at hole A. Next, pass a 12-in. length of 50-ohm subminiature coax cable through the right-hand cabinet hole and solder the center conductor to the push-pin at hole E.

Solder the coax ground and the wire from the antenna jack's frame to the push-pin at hole B. If desired, the wires to holes B and C can be soldered to clips which clamp to the push-pins. Solder to the free end of the coax cable an antenna plug that matches the antenna input of your car radio.

The convertor is now complete and ready for alignment.

**Alignment.** Temporarily clip the battery's negative terminal to the battery terminal from hole C (ground). Connect the positive terminal of an 0-10 DC mA (or higher) meter to the positive battery terminal, and connect the meter's negative lead to the battery ter-

## FREE PRINTED CIRCUIT BOARD OFFER

As a special service to readers, the Editors of ELEMENTARY ELECTRONICS have arranged for you to receive a Free VHF Police Converter PC Board from Sentry Manufacturing Company. Just fill out and mail the coupon on the next page so it's postmarked on or before September 1, 1968. Should you desire to purchase the complete parts-package, place an X in the appropriate box and include a check or money order for \$19.50 (price includes postage). Make checks payable to Sentry Mfg. Co. This free offer is invalid unless accompanied by the coupon on the following page.

The Editors  
ELEMENTARY ELECTRONICS

# HiBANDER

minal from hole D (positive). Using the proper alignment tool, back out L4's slug so it is flush with the top of the coil form. Set S1 to *on*, applying power; the meter should indicate anywhere up to about 6 or 7 mA.

The next step is to run L4's slug clockwise into the form until the meter indication peaks up a few mils (to about 8 mA). Then give another 1/8 clockwise rotation. But be careful—if the slug is run to the bottom of the form it will freeze and the form will be destroyed!

If no adjustment of L4 causes the meter to peak, there is either a wiring error or a defective component in the oscillator circuit. Also, the crystal may have been damaged by excess soldering heat.

**Using The Converter.** Remove the antenna plug from the car radio and connect the plug to the converter input jack. Connect the connector's output plug to the car radio input. Make certain S1 is *off*, turn on the car radio, and tune in a very weak station on

the high end of the BC band. Near the radio's antenna jack is a small trimmer capacitor shaft, or a hole through which a trimmer is accessible; adjust the trimmer for maximum signal in the radio.

Now turn on the converter (S1 automatically switches the antenna connections) and tune in the police frequency (or public-service station) on the car radio. (See special note below on how to select the proper crystal frequency.) If you hear nothing in the radio, don't worry; the public-service transmitters don't operate full time. When the signal comes on, adjust coil L1 and L2 for maximum signal strength (the tuning is broad). Then close up the converter's cabinet.

**Choosing The Crystal Frequency.** The basic crystal frequency of the police converter is in the 30-MHz range, and its fifth harmonic is used for the approximately 150-MHz oscillator output. When ordering the crystal specify the *exact frequency of the desired signals*—156.3 MHz, for example. Do not order crystals by their basic frequency.

If you later decide to change the converter's crystal to a new frequency, again specify the desired signal frequency. If you want the desired police frequency (or other public service frequency) to tune at exactly 1 kHz on the car radio, so specify in your order.

Since public service operating frequencies vary from area to area, check for the exact frequencies used in your locale. ■



*Simple U-bracket holds completed HiBander against dash. Before installing unit, take time to peak coils L1 and L2 for maximum signal in car radio.*

CUT HERE

## FREE PRINTED CIRCUIT BOARD: SENTRY HiBANDER

Sentry Manufacturing Co.  
Box 12322, Oklahoma City, Okla. 73112

Please send the Free Printed Circuit Board for the VHF Police Converter as described in the July/August 1968 issue of ELEMENTARY ELECTRONICS.

Please send the Sentry parts package and the Free Printed Circuit Board for the VHF Police Converter. I am enclosing a check or money order for the sum of exactly \$19.50, payable to Sentry Mfg. Co.

**THIS FREE OFFER IS NOT VALID UNLESS ACCOMPANIED BY THIS COUPON**  
Photostats, Xerox copies, etc., cannot be accepted!

Name \_\_\_\_\_

Address \_\_\_\_\_

City \_\_\_\_\_ State \_\_\_\_\_ Zip \_\_\_\_\_

Sorry, Free Offer expires September 1, 1968

When used with a VTVM,  
this handy probe  
will get you squared away  
with root-mean-square signals  
at megaHertz frequencies



# The RMS RFeR

By Bill Britton

**U**nless you're fortunate enough to own an RF voltmeter, your measurements of the RF output of a CB transceiver or RF drive voltages in a ham transmitter must be taken with a standard VTVM. This is equipped with an RF probe—a diode detector which converts the RF energy to a measurable DC value.

Unfortunately, many of the RF probes available, as well as the low-cost probe kits, simply indicate the RF voltage in terms of *peak* voltage (generally only the positive part of the waveform). The technician must go through the "rms equals 0.707 of the meter reading" routine before he can compare his measurements with the circuit's specified RF voltages—usually given in terms of rms.

**Why RMS?** AC and DC are basically two ways of delivering energy. Unlike DC, AC is fickle. AC values are constantly changing from zero to peak to zero, over each half-cycle. While the amplitude of a DC voltage remains constant, AC voltages are a series of instantaneous amplitudes which vary according to frequency.

When dealing with power and work (not electrical energy itself, but what it can do in a circuit), we have to measure a voltage that is steady. An ordinary power line may measure 24 V or 141 V at a particular in-

stant, but 117 V is the rated *effective* voltage that is generated at the power station. In other words, it is the steady AC equivalent to DC. It indicates the overall effect of the varying amplitudes.

This effective AC voltage (see Fig. 1) is a must for anyone working with AC circuitry. Peak voltages are important to know, because the components in a circuit must have large enough ratings (tolerances) to handle such high values. But when you are working with operating voltages, it is the effective (rms) voltage which must be measured. (The rms, or root-mean-square concept, is simply the mathematical way of dealing with power when you sum all the instantaneous AC amplitudes.)

While most VTVMs are calibrated to read rms values of low-frequency AC, RF signals are a different matter. The RF probes needed to rectify the high-frequency AC often do not give an indication of the effective (rms) AC input. Since it's just as easy to use a probe that directly indicates the rms value, you can skip the pencil-pushing needed for peak-to-rms conversions. In just an hour or so, you can build a professional rms RF probe that costs less than \$3.50.

**Looking Inside.** The rms RF probe consists of only three components, as shown



# e/e RMS RFer

in Fig. 2. Where's the filter capacitor? In the shielded cable going to the VTVM. The capacitance between the "hot" and shield conductors of a 3- to 5-ft. length of cable provides the filter capacitor.

The actual electrical circuit is shown in Fig. 3. Capacitor C1 serves to block any DC voltage that might be present in the circuit from appearing across diode D1. D1 rectifies the RF appearing across it, and R1 and the cable's capacity (that's C2) combine to filter the rectified RF to a smooth DC.

Normally, an RF filter of this type produces a charge across C2 equal to the peak value of the applied RF. However, R1's value has been selected so that it is part of the VTVM's input voltage divider; thus, the DC equivalent of the RF's rms value appears at the meter's input terminals and the meter indicates the rms value of the waveform.

The value of R1 given in the Parts List is valid only for an 11-megohm VTVM (10 megs in the meter divider and 1 meg in the DC probe). While R1's value is not the exact resistance required, it's an easily obtainable value and will result in 5% accuracy—which is close enough. (You cannot obtain the required 5.5 megohms.)

**Construction.** The RF probe shown is built in a Keystone model 1810 probe kit, which includes the housing, shield, perforated wiring board, terminals, and test prod.

Drive a terminal into the front end of the wiring-board strip—the end without the attached solder terminal, allowing sufficient area at the front end of the wiring board so that the entire body of capacitor C1 is against the board. Then, after adding two more terminals, install R1 and D1 between the terminals as shown. Diode D1 is shown with the usual probe polarity, the cathode "grounded" to produce a negative meter reading. If you prefer a positive voltage reading, simply reverse D1's connections.

The connecting cable should be three to five feet long. Ordinary shielded cable approximately 0.25-in. in diameter will do. Install a connecting plug to match the VTVM DC input jack on one end. Strip off about 2 in. of outer insulation from the free end, and pull the center conductor through the shield at the edge of the outer insulation.

Pass the shield through the hole in the

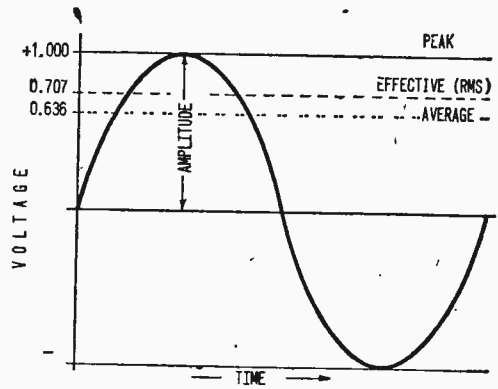

Fig. 1. Graph indicates relationship between average, effective, and peak values of AC as it goes through one-half of cycle. One ampere of rms AC will produce same heating effect in a load as one ampere of DC. Thus, rms AC value functions like steady DC current.

solder terminal attached to the wiring board, and solder. Connect the cable's insulated center conductor to R1. Then connect D1's grounded end to the solder lug.

If you are going to use the RF probe above 54 MHz, connect an 8- to 10-in. flexible ground lead to the solder lug. Then connect an alligator clip to the free end of the ground wire. If you have no need for measurements

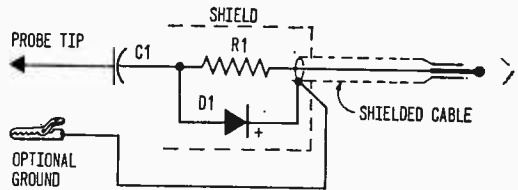

Fig. 2. RMS RFer is divided into three parts (C1, D1, and R1). Ground lead is for use above 54 MHz.

above 54 MHz, you can dispense with the ground wire and use the VTVM's regular ground test lead.

Before final assembly, check that the probe's case is on the cable between plug and the wiring board. It's OK? Then slip the shield over the wiring board, fold the solder terminal flat against the shield, and solder. Slide the probe case over the shield. Finally, slide the end cap with the test prod

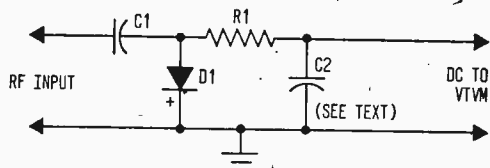
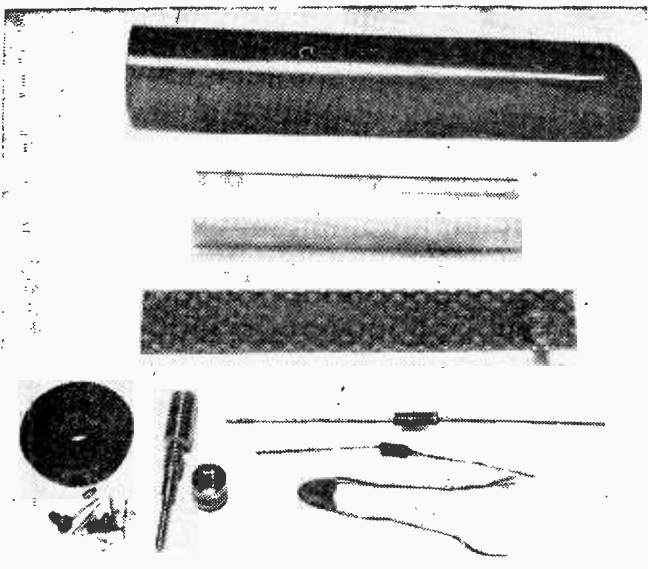

Fig. 3. Filter capacitor C2 is capacitance between connecting cable's center (hot) and shield conductors.



Since test probe kit includes all necessary hardware and materials, rms RF probe requires only the purchase of resistor, diode, and capacitor shown at lower right. Consult Parts List for the few extras relating to your VTVM.

**PARTS LIST FOR RMS RFER**

- C1—500-pF, 1-kV disc capacitor
- D1—Diode, 1N60 or 1N70A (see text)
- R1—5,100,000-ohm, 1/2-watt resistor (5%)
- I—Keystone model 1810 test-probe kit
- Misc.—Shielded cable, plug to match VTVM input, solder, wire, etc.

(The Keystone 1810 probe kit is available for \$2.00 prepaid from Custom Components, Box 352, Alden Manor, Elmont, N.Y. 11003. N.Y. State residents add appropriate sales tax.)

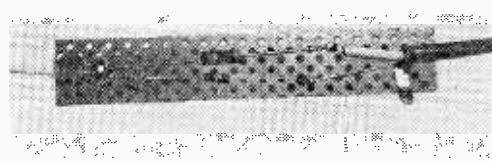

Completed detector, ready for application of shield and case. At least three terminals (plus solder terminal) should be used to tie down component leads.

in place over the free end of C1, and screw the test probe together.

**Using the RF Probe.** The RF probe can be used on any circuit containing DC up to the voltage rating of C1. If C1 is rated at 1 kV (the usual rating), you can place the probe across any DC circuit up to 1000 V. The maximum RF (AC) voltage will be de-

Slide shield over wiring board up to solder terminal, fold terminal flat against the shield, then solder it. Now you can slide probe case down over the whole assembly.

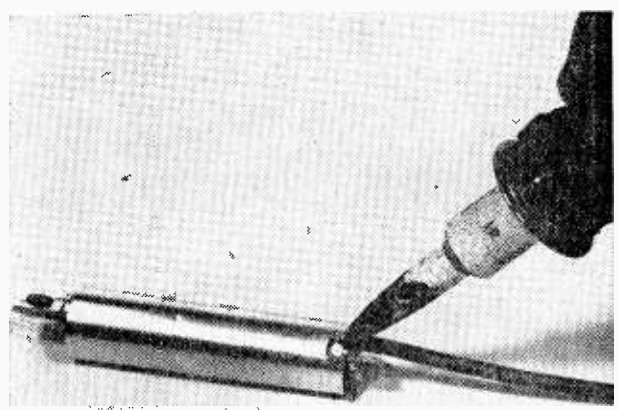

To complete probe, screw test prod into end cap that fastens to case with two machine screws. For snug connection, 3/8-in. grommet secures cable at other end.

termined by diode D1—25 V for a 1N60 and 100 V for a 1N70A.

To measure RF up to about 54 MHz, simply connect the probe to your VTVM's DC input jack and connect the VTVM's ground lead to the test circuit's ground. From 54 MHz on, use a probe ground as explained previously. The meter reading will be the rms value of the RF voltage. ■



## GET A FASTER START IN THE COURSE YOU CHOOSE WITH NRI'S REMARKABLE ACHIEVEMENT KIT

When you enroll with NRI we deliver to your door everything you need to make a significant start in the Electronics field of your choice. This remarkable, new starter kit is worth many times the small down payment required to start your training. And it is only the start . . . only the first example of NRI's unique ability to apply 50 years of home-study experience to the challenges of this Electronics Age. Start your training this exciting, rewarding way. No other school has anything like it. What do you get? The NRI Achievement Kit includes: your first set of easy-to-understand "bite-size" texts; a rich, vinyl desk folder to hold your training material in orderly fashion; the valuable NRI Radio-TV Electronics Dictionary; important reference texts; classroom tools like pencils, a ball-point pen, an engineer's ruler; special printed sheets for your lesson answers—even a supply of pre-addressed envelopes and your first postage stamp.

# ***Learning electronics at home is faster, easier, more interesting with new achievement kit***

Only NRI offers you this pioneering method of "3 Dimensional" home-study training in Electronics, TV-Radio . . . a remarkable teaching idea unlike anything you have ever encountered. Founded more than half a century ago—in the days of wireless—NRI pioneered the "learn-by-doing" method of home-study. Today, NRI is the oldest, largest home-study Electronics school. The NRI staff of more than 150 dedicated people has made course material entertaining and easy to grasp. NRI has simplified, organized and dramatized subject matter so that any ambitious man—regardless of his education—can effectively learn the Electronics course of his choice.

### **DISCOVER THE EXCITEMENT OF NRI TRAINING**

Whatever your reason for wanting knowledge of Electronics, you'll find the NRI "3 Dimensional" method makes learning exciting, fast. You build, test, experiment, explore. Investigate NRI training plans, find out about the NRI Achievement Kit. Fill in and mail the postage-free card. No salesman will call. NATIONAL RADIO INSTITUTE, Electronics Division, Washington, D. C. 20016

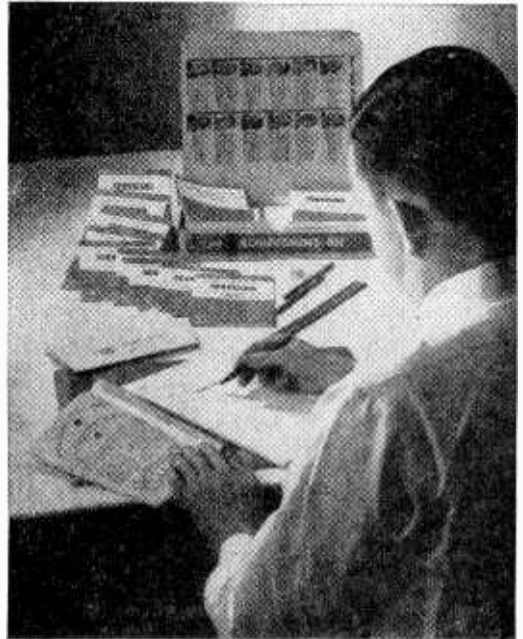

## **ELECTRONICS COMES ALIVE AS YOU LEARN BY DOING WITH CUSTOM TRAINING EQUIPMENT**

Nothing is as effective as learning by doing. That's why NRI puts so much emphasis on equipment, and why NRI invites comparison with equipment offered by any other school, at any price. NRI pioneered and perfected the use of special training kits to aid learning at home. You get your hands on actual parts like resistors, capacitors, tubes, condensers, wire, transistors and diodes. You build, experiment, explore, discover. You start right out building your own professional vacuum tube voltmeter with which you learn how to mount and solder parts, how to read schematic diagrams. Then, you progress to other experimental equipment until you ultimately build a TV set, an actual transmitter or a functioning computer unit (depending on the course you select). It's the practical, easy way to learn at home—the priceless “third dimension” in NRI's exclusive Electronic TV-Radio training method.

## **SIMPLIFIED, WELL-ILLUSTRATED “BITE-SIZE” LESSON TEXTS PROGRAM YOUR TRAINING**

Lesson texts are a necessary part of training, but only a part. NRI's “bite-size” texts are as simplified, direct and well-illustrated as half a century of teaching experience can make them. The amount of material in each text, the length and design, is precisely right for home-study. NRI texts are programmed with NRI training kits to make things you read come alive. As you learn, you'll experience all the excitement of original discovery. Texts and equipment vary with the course. Choose from major training programs in TV-Radio Servicing, Industrial Electronics and Complete Communications. Or select one of seven special courses to meet specific needs. Check the courses of most interest to you on the postage-free card and mail it today for your free catalog.

**Available Under  
NEW  
GI BILL**

If you served since  
January 31, 1955, or  
are in service, check GI  
line in postage-free card.

## ***custom training kits “bite-size” texts***

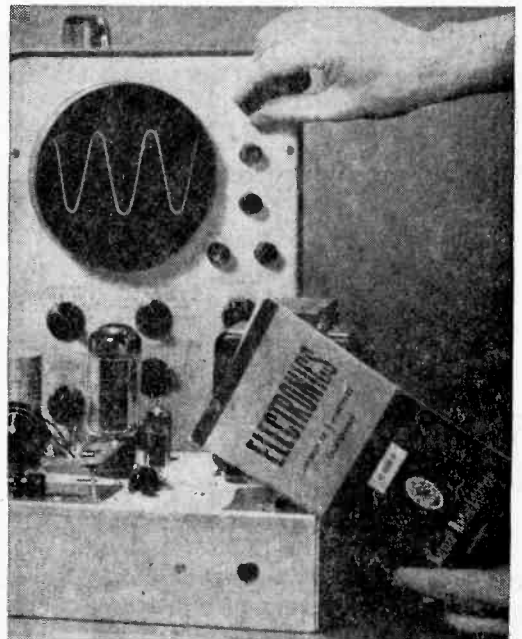

# SKIP SIGNALS

By Jack Schmidt

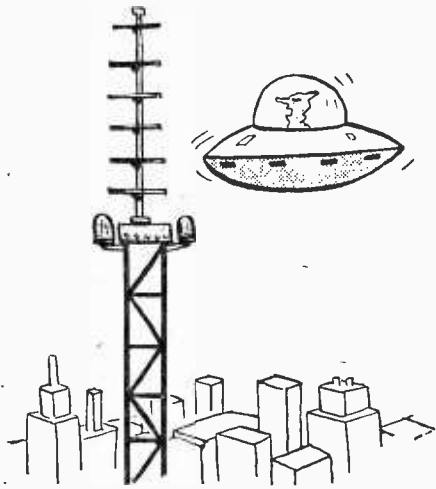

"I dare you to say that again!"



"... furthermore, I distinctly remember mailing my check . . ."



"Wha'da you mean, you thought it was something on your stereo?"

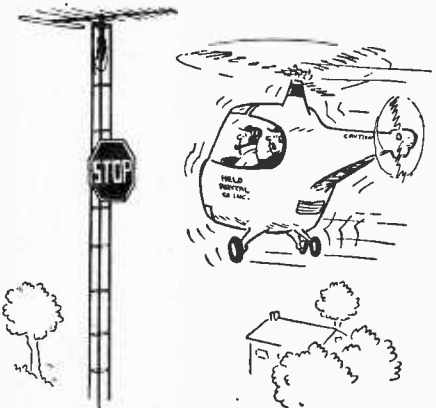

"This must be the guy who's complaining about interference."

# PUTTING THE IONOSPHERE TO WORK

Want to look over the horizon? The ionosphere can bend a signal and send it around the globe—just what the military wants most!

By Len Buckwalter, K1ODH

Wherever you're located on the globe, chances are that hundreds of radio signals are striking this page as you read it. (For proof, you need only a shortwave receiver that'll pick up the high-frequency band of 3 to 30 MHz.) Most of the incoming signals you'll hear won't be from local stations. Instead, they'll arrive from points around the earth—from hundreds of international broadcasters, a multitude of hams and CBers, and a myriad of military and communications services.

The invisible bridge supporting this volume of long-range radio traffic is the ionosphere. As detailed in an earlier article (see **ELEMENTARY ELECTRONICS**, May-June, 1968), it

shapes up as an umbrella of ionized gas that shrouds the earth with electrical layers that can bounce signals over great distances. Created and controlled by the sun, the ionosphere faithfully follows a daily and seasonal change—and also writhes with contortions during the 11-year sunspot cycle.

Libraries of information compiled over 50 years tell of its past behavior and predict its future. Yet there remains much that is mysterious about the ionosphere. So crucial is the region to communications on earth and in outer space that scientists assault the ionosphere daily to understand more of its curious action.

For years the (Continued overleaf)



# e/e THE IONOSPHERE

Most productive key method of probing the ionosphere has been the ionosonde. This device is a combined transmitter and receiver that fires a burst of radio energy skyward, then records the time of the returning echo. Working like radar, the ionosonde explores the ionosphere's profile, which emerges as a series of layers that begin about 50 miles up and continue to heights of about 250 miles.

Today, scientists are armed with a battery of new techniques. Orbiting satellites dip in and out of the ionosphere and report back their findings. Rockets arc through the lay-

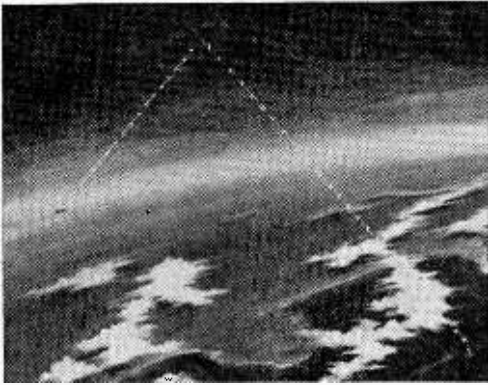

Fig. 1. In ship-to-shore transmission link, radio signal from ship bounces off ionized trail left by meteor.

ers, spraying them with chemicals or buffet-ing the region with high explosives. The result of all this activity is a picture of the ionosphere that's far more complex than the simple layer-cake concept contrived back in 1925. In this article we will examine the ionosphere's stranger behavior, and look at new theories that attempt to explain its action.

**The Scatter Matter.** Early investigators spent most of their time mapping the distinct electrified layers of the ionosphere. And we now have a reasonably clear picture of the three main regions—D, E, and F—which represent altitude levels where electrons, energized by the sun, tend to thicken in the upper atmosphere. They account for the reason signals in the high-frequency region of 3 to 30 MHz reach up skyward and deflect back to earth. A signal entering these levels is simply refracted, much like a ray of light passing through a lens.

As detailed in our earlier article, the angles

are often just right for signals to take off, bounce from a layer, then return to earth thousands of miles away. This action alone, however, could not explain why VHF signals—which lie between 30 and 300 MHz—would also take flight and propagate over great distances. It had been proved countless times that VHF signals normally penetrate the ionospheric layers with hardly a bend.

To explain this curious action, scientists theorized the existence of "scatter." Smooth, distinct layers certainly do bend high-frequency (HF) signals and scarcely affect VHF. But the ionosphere, as a physical reality, doesn't conform to that serene image. It is hit by turbulence from wind shear at its lower reaches and often attacked by debris from outer space.

These and other irregularities in the ionosphere hold the secret of returning VHF signals. Though the exact process is still unknown, somehow the signal smacks into an irregularity and "scatters." Most of the energy is absorbed, but a tiny portion wriggles back to earth. Despite this huge energy loss, two important communications systems are based on scatter techniques. The first one begins like a story on flying saucers.

**Visitors from Outer Space.** The ionosphere is so crowded these days that scientists were delighted to find they could literally hitch a ride on a falling star. It began back in World War II, when radar was in its infancy. Somehow, radar signals were bouncing from targets that didn't exist. The ionosphere couldn't be the culprit—since radar signals are extremely high in frequency, they supposedly penetrate the ionosphere in a fairly straight line. Yet no one could deny confusing signs on the radar screen. These signals were really from unearthly visitors.

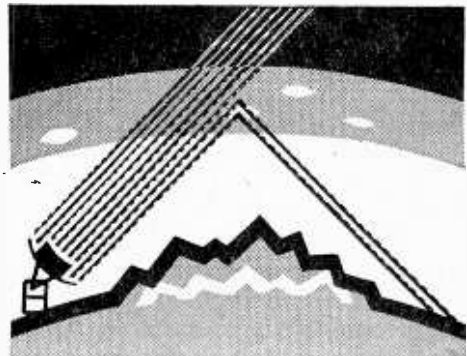
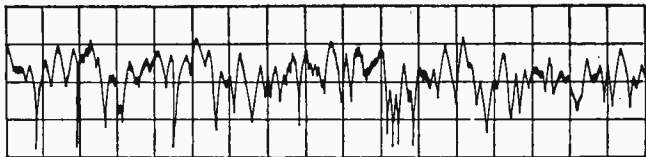

Fig. 2. With scatter, most of signal passes through ionosphere, irregularities return some signal to earth.



*Fig. 3. Recording of radio signal on single frequency over troposcatter link. The variations show clearly that fading can cause signal to drop to one one-thousandth of its former strength in a matter of seconds. Thickness indicates power.*



Millions of tiny meteors careen into the top of the earth's atmosphere every day. Searing friction ignites them into a fiery gas. As the meteors burn, they leave behind a miles-long trail of ionized gas. That trail of electrified particles can act as a temporary electrical mirror, able to bounce back VHF signals that normally penetrate the ionosphere.

Beyond 30 MHz, the electromagnetic wave penetrates the normal ionospheric layers with only rare bounce-back to earth. But a meteor trail, it was found, can return signals higher than 100 MHz. An artist's conception of how a meteor trail deflects the signal is shown in Fig. 1. The dabs of light at the top represent ionized trails that form at heights of about 60 miles above the earth's surface. (They share the same region with the ionosphere's E layer).

The life of the trail may be a fraction of a second, though some last more than a minute. The meteor gas is quickly dissipated by winds, and the electrified particles are rapidly absorbed in the ionosphere. This variability keeps meteor-trail communications in the category of a "weak-signal system." But since it opens a broad, new highway for long-range traffic outside the crowded high-frequency bands, researchers have worked out some remarkable innovations.

Boeing, for example, has done considerable work with meteor trails. Their tests prove that 50-MHz signals can be sent and received regularly at distances up to 1000 miles. Since such signals are relatively free from ionospheric disturbances, they're proving especially attractive for military communications.

In the practical meteor-trail system, the sky is first probed for a meteor "burst"—an electrically "hot" region. If the pathway seems promising, data is transmitted and received at high speed until conditions start to fail. It's a hit-and-run system, but one that averages out for reliable communications.

**Troposcattering.** Another scatter system now relieving traffic in the ionosphere uses the *troposphere*. Beginning at the earth's surface and rising to about 10 miles, it's the

"weather" layer of the earth. Though temperature, humidity, and air pressure hardly affect signals up to about 30 MHz, the picture changes at higher frequencies. As signal frequencies become higher, the transmissions are increasingly susceptible to climatic changes. The exact mechanism is not yet completely understood, but scientists suspect that the boundary existing between huge blobs of air which differ in density can "scatter" radio waves and return part of the en-

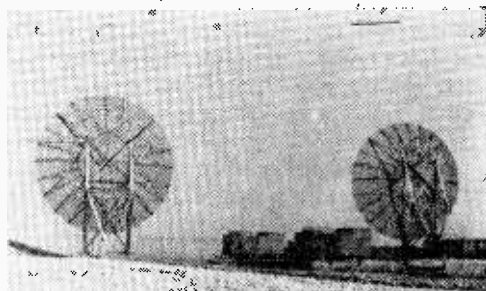

*Fig. 4. Relay station built by Navy Seabees at Chu Lai, South Vietnam has powerful dish antennas. They are a link to similar station at DaNang, 52 miles away.*

ergy to the ground (Fig. 2). This method has been exploited since the early 1950s to send and receive signals of extremely high frequency (microwaves) around the earth's curve. But troposcatter has its problems.

Fading is severe on a troposcatter link, as revealed in Fig. 3. The signal takes a roller-coaster dip in strength several times every second. In ten minutes of reception there may be 2000 fades and many instances where the signal is lost completely.

One solution has been to use brute force. The transmitter pours extremely high power into a highly directional antenna, so enough signal usually gets through to the receiving end. Navy Seabees recently built such a system in South Vietnam, using the powerful dish antennas shown in Fig. 4. That installation transmits signals through the troposphere to a similar station 52 miles away.

Troposcatter systems are operational, but they're heavy. Even a small system weighs about 2000 pounds. It hardly meets the demands of military services for a highly mo-

# e/e THE IONOSPHERE

bile instrument that can dart around a fast-changing battlefield. And flexible communications over a 35- to 150-mile range simply are not practical with telegraph lines (which can be cut), or with normal microwave signals (which can't follow the earth's curve).

A new Bell Aerosystems setup, though, trims size to where a small crew can set up a complete troposcatter link anywhere in less than an hour. It weighs under 500 pounds, including the antenna.

The trick to slash size is a kind of signal coding that dodges the fades. Let's say a word (about one second in duration) is spoken into the microphone. In the equipment, it's broken into some million electrical bits. The pieces are distributed over a number of different radio frequencies for transmission through the troposphere. Since different frequencies tend to fade at different rates, chances are that a fair number of pieces ultimately get through. The bits are then reconstructed (decoded) at the receiving end into the original word.

This system is reminiscent of "diversity" reception, where two antennas feed a single receiver. When the signal fades in one antenna, there's a good chance it's strong in the other. The receiver senses less net fading. The Bell Aerosystems troposcatter technique uses computer-type techniques to achieve a similar result.

**Watts Up?** Communication via scatter techniques is becoming so important that the U.S. Government continues to keep it under close scrutiny. A high-power radar installa-

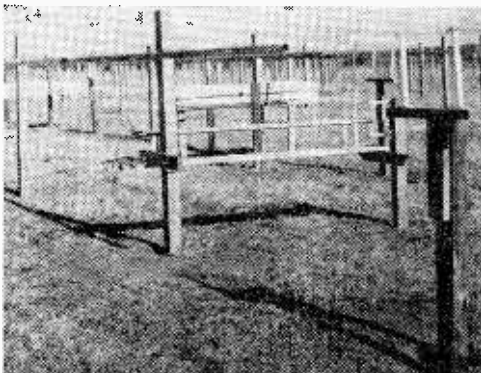

Fig. 5. Upper reaches of ionosphere are studied with antenna having 1024 dipoles. It is part of 4-acre array.

tion like the one in Fig. 5 has detected scattering effects as high as 400 miles up. The antenna system consists of more than 1000 dipoles fed by a transmitter capable of delivering 6 million watts of power at a frequency of 41 MHz. The returning echoes are measured by the ionosonde seen in Fig. 6.

The huge antenna array in Fig. 7 is designed to investigate the phenomenon of *backscattering*. Here the signal actually boomerangs from transmitter to receiving point and back to transmitter. Both irregularities in the ionosphere and scattering from the ground at the distant stations are responsible for the signal's round trip. In one experi-

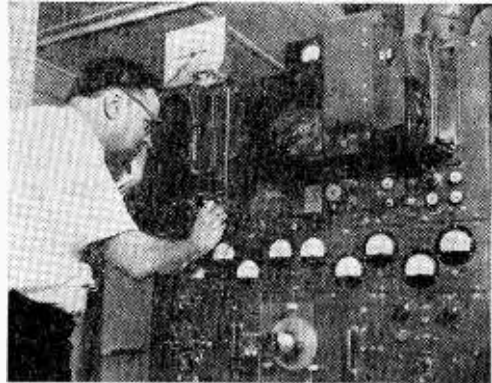

Fig. 6. Engineer prepares to place ionosonde in operation. Camera records ionograms to allow further study.

ment (Fig. 8), a signal burst is transmitted from a site in Colorado at a low angle toward the ionosphere. It scatters and returns to earth somewhere on the East Coast of the U.S. Then, the wave scatters back to the Colorado location.

Once such scattering signals are more completely understood, they'll be exploited for more than just communications. One application is a long-distance radar that can "see" over the horizon. Another is a method to map or explore a remote point on the earth by interpreting the echoes returned by the ground scattering effect.

**Topside Signals.** While ground-based investigation of the ionosphere continues, the *topside sounder* is coming into its own. Rockets and orbiting satellites provide a convenient platform for studying the ionosphere from above. By inserting a satellite into a highly eccentric orbit, it dips in and out of the ionosphere as it rotates about the earth. The procedure for a topside probe of the ionosphere is similar in many respects to

**Fig. 7. Antennas stacked on steel tower fire radar signals at low angles. Returning echoes permit study of scattering effects so crucial for operation of long-range radar systems. These radars look around the globe to detect foreign objects which might invade American air space. Future missile defense systems will depend on effectiveness of long-range scatter radars.**



using an ionosonde on the ground. The pulsed radio wave is directed downward, however, and the echo picked up by the satellite receiver. The data is then transmitted to antennas on the ground (Fig. 9).

These new probes are crucial to the coming exploration of interplanetary space. As we noted earlier, signals below 30 MHz are deflected by the ionosphere during long-range communications. The same effect would happen to signals arriving from a vehicle in outer space. Only now they'd bounce and return to space, never to be heard at ground stations.

To counteract this effect, a spacecraft could use VHF or higher-frequency signals to obtain ionospheric penetration. But there are limits here, too. Irregularities in the ionosphere might displace or scatter the signal far from the ground station. Further, extremely high-frequency signals might even be shielded from the ground by a heavy rainfall. These problems are now under study at elaborate radar installations, like the one in Fig. 10.

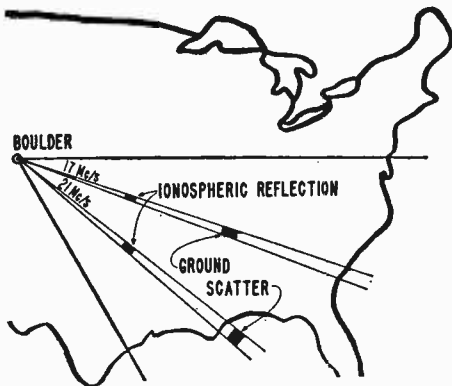

**Fig. 8. Backscatter effect in long-range radars depends on ping-pong-like bounce of over-the-horizon echoes.**

**Whispering Satellites.** Orbiting satellites are also checking out some weird effects long suspected to occur in the ionosphere. One is the *whispering gallery*. If you've visited the nation's capitol in Washington, you might have experienced a similar effect with sound waves. If two people whisper while standing inside the dome-shape structure, they can hear each other from opposite sides of the room. The weak sounds are carried

**Fig. 9. Satellites will turn the tables on us, and measure ionosphere from above. Here, a highly directional antenna at satellite ground station picks up signals containing information about the ionosphere above.**



around the circular walls with very little loss.

A similar effect happened recently between two orbiting satellites located half-way around the world from each other. Though their radio frequencies would not normally curve, somehow the signals were trapped by layers of the ionosphere and were forced to travel a circular route around the earth. The ionosphere apparently forms an electronic



**Fig. 10. Broadside antenna covers 25 acres near Lima, Peru. This radar probe uses a 6-megawatt transmitter.**

"duct" that some believe may eventually eliminate ground relay stations or prove useful when solar storms wipe out normal communications. Air Force scientists report that signals also leak out of the duct at various points and are heard by various ground stations. In one case, a satellite over the Indian Ocean was received by a ground station as far away as Massachusetts.

**Ethel, Fanny, Gilda, Karen, Martha.** One of the more dramatic efforts by scientists  
(Continued on page 106)



# BUS 57 Where are you?

*Key to new bus-identification system is special FM transmitter. Once installed in each and every bus, transmitter emits signal identifying bus, its location, and route it is traveling.*

*Roadside unit picks up signal whenever bus passes within 50 feet. Signal is then transmitted over ordinary telephone lines to computer control center where information can be displayed via teleprinter, wall panel, or video screen. Data can also be stored in computer for future reference.*

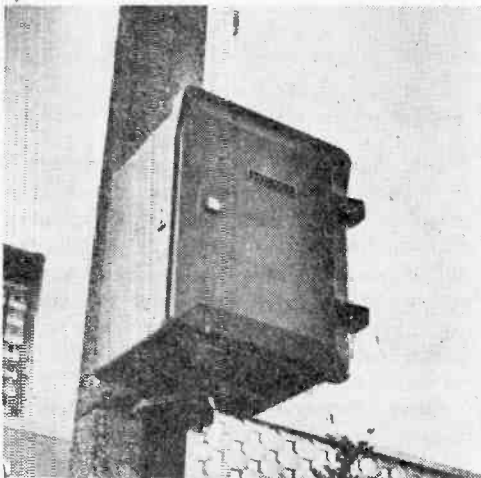

**K**eeping tabs on a bus as it meanders its weary way through congested city streets is the primary function of a versatile, all-electronic system developed by Sylvania Electric. Basically, the system calls for equipping each vehicle with a limited-range data transmitter operating on 200-210 kHz. As the bus travels its assigned route, it passes permanent wayside receivers mounted on utility poles or buildings. Information automatically sent to the receivers identifies the bus, its route, and its location.

Converted to digits and relayed to a "data concentrator," the signals are then passed to a centrally located computer, which is programmed to signal any variations from schedule which fall outside of predetermined tolerances. A wall map traces the course of each bus and, by means of different colored lights, indicates whether a bus is ahead of, behind, or smack on schedule.

What about emergencies? Simple. When an emergency occurs, a bus operator can call either supervisor or maintenance at the touch of a button (see photo above). And a police emergency beacon, activated by a hidden footswitch, is intended to take care of situations supervisors and maintenance personnel don't handle.

—Robert Levine ■

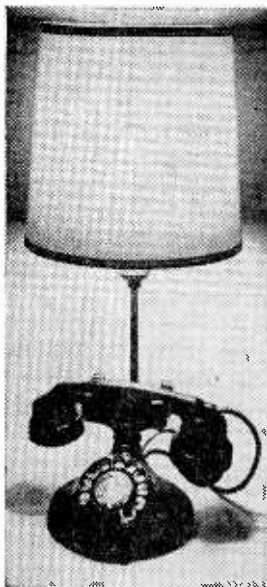

# DIAL-A-LIGHT TELEPHONE

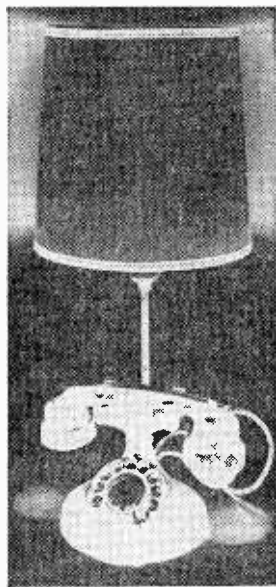

Rather dial than switch? Here's a telephone with a twist that'll really turn you on!

By Art Trauffer

**P**eople are constantly showing off new and unique ways to construct furniture. When browsing around in the rummage shops of the big city or in small country stores, they pick up odds and ends that later turn into the conversation pieces we all hear about.

Old steering wheels off long-forgotten boats are covered with glass, and *voila*—a cocktail table with more class than anything you can find at a Playboy Club. Old bottles become lamps, flower vases, or even radios.

With antique phones the latest craze (just don't let the phone company know you've installed one), here's a project that will put a light in your eye as well as on your favorite table. And if you're careful with the power cord, it won't get you in any trouble, either.

An elegant solution to your lighting problem is offered by our Dial-A-Light Telephone. Instead of having to listen to a noisy and irritating snap every time you reach for the switch, now you can grab your foot-candles by merely dialing a digit. And instead of getting the operator or a dial tone, you have a soft beam of light anxious to flatter every room in your house.

By turning the dial back to its starting point, you extinguish the glow and wish all a good night. And you do so with no noise, no bothersome click—just a natural motion that you do many times a day.

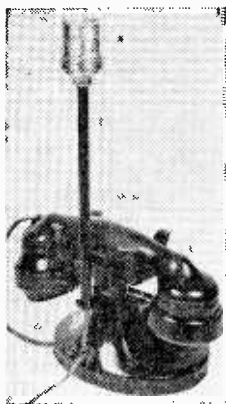

*Standard lamp socket (without switch) is mounted on pipe that is 8 in. long and has 1/8 NPT threads. After figure-8 bracket is made and clamped on phone, pipe is soldered into eye. Note extra hole for handset cord.*

# e/e DIAL-A-LIGHT

**French Touch.** Heart of the Dial-A-Light lamp is the Western Electric #202 French telephone. It has an oval base and came into use when the old, upright (candlestick) phones were phased out of operation. A partial list of dealers who sell these semi-antique phones is included in the Bill of Materials; our photos show how well this phone adapts to modifications.

Whereas previous projects have required that the receiver be lifted off the hook to turn on the lamp, the Dial-A-Light makes it easy. The lamp goes on when you dial number one, and goes off when you turn the dial counterclockwise.

To begin construction, first remove the two screws that hold the bottom cover to the base. Remove all the hardware and wiring not needed for your Dial-A-Light.

The photographs and first diagram show how the lamp support is secured to the

phone. Both the 8-in. length of pipe and the figure-8 bracket should be painted black to match the phone. The lamp socket needs no switch.

Mount the figure-8 bracket to the phone first. A ring-nut holds the phone cradle to the base, and this must be tightened securely when the bracket is mounted. Make sure the bracket is at a right angle to the base, and use plenty of solder when joining the pipe to the bracket.

**Decor Cord.** The headset cord is simply for decoration, but boring an extra hole for it is certainly worth the effort. Rubber grommets will ensure a snug fit for the cords, and, in the case of the power line, the grommet will ensure complete insulation from the metal body.

The last two diagrams show the wiring of your Dial-A-Light. One pull-apart power cord does the whole job. Measure a length of the cord carefully, so that you will have no trouble leading it from the lamp socket, through the pipe, and into the base of the phone. All connections are made in the base.

Note that the power cord goes through the

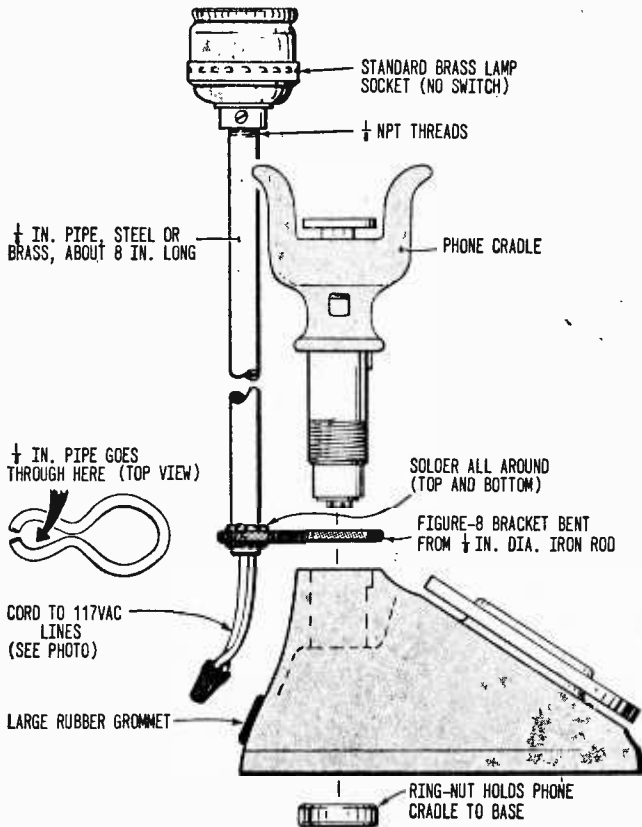

*Exploded view shows how to secure lamp support to phone. After painting the steel or brass pipe black to match phone, cover power cord with tape, run it through pipe, strip the leads, and attach to terminals of socket. Then screw socket to pipe. Make figure-8 bracket from iron rod (1/8 in. dia.) and mount it by screwing phone cradle down through large loop into base of phone, using ring-nut. The small eye should be aligned perpendicular to base; pipe is then soldered into eye.*

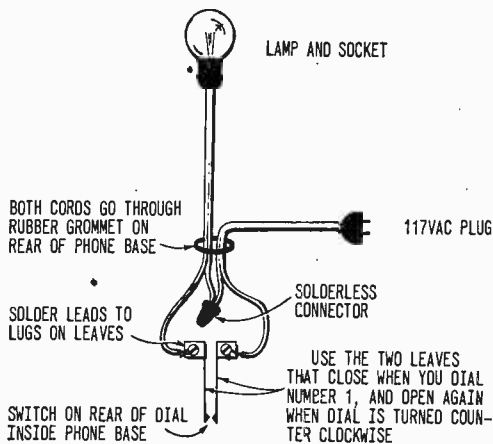

*Cut power cord so there is enough lead to reach from lamp socket to base. Solderless connector joins one lead from line cord and one from lamp; two remaining leads connect across dial switch.*

same grommet twice. One lead comes in from the terminals of the lamp socket, and the other is led out to a convenient wall outlet. Covering the leads inside the phone with extra insulation will guard against a

possible short-circuit inside the case.

The switch which is actuated by the dial is used to turn the lamp on and off. Select the two leaves of the switch that close when you dial number one and open when the dial is turned counterclockwise.

Solder your leads directly to the lugs on the leaves of the switch. And don't forget to use electrical tape to insulate them.

**On And Off.** Now for the \$64 question: when you dial number one to turn on the lamp, how do you make the dial stay there? The author solved the problem by cementing a small piece of felt under the finger-stop on the outside of the dial. This friction against the dial holds the dial until you push it counterclockwise to turn the lamp off.

This solution should work for you. Experiment for best results, and you may even figure out a better way of doing it. Also, you have a free hand when selecting the right shade to clip on to the lamp bulb.

If you prefer to finish the phone in some other color than black, do this before you start to make it into a lamp. Then watch the conversation start to fly. ■

*Interior of phone base shows how to make connections to dial. Leads are soldered directly to lugs on leaf of switch. Choose the two leaves which close when you dial number one and open when dial is returned to its original position. Felt or some other material placed under the finger-stop should keep dial from slipping back.*

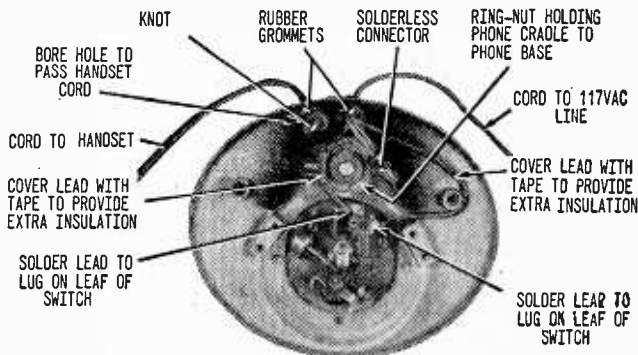

NOTE: REMOVE ALL OF THE ORIGINAL HARDWARE AND WIRING INSIDE THE BASE THAT IS NOT NEEDED.

#### BILL OF MATERIALS

- 1—Western Electric #202 French-style telephone (see listing at right)
- 1—Brass-shell standard lamp socket (without switch)
- 1—8-in. length of iron or brass pipe (1/8-in. dia.)
- 1—6-in. length of iron rod (1/8-in. dia.) for figure-8 bracket
- 1—Length of zip cord, with plug
- Misc.—Solderless connector, electrical tape, rubber grommets, lamp bulb, clip-on lamp shade, solder, etc.

#### WHERE TO GET WE #202 PHONES

- Billard, 21710 Regnart Rd., Cupertino, Calif. 95014
- Continental Telephone Supply Co., Inc., 49 W. 46th St., New York, N.Y. 10036
- Delta Electronics, Box 2262, Dallas, Texas
- Ora Nardacre, 555 S. Harbor Blvd., Anaheim, Calif. 92805
- Telephone Company, Turtle Lake, Wis. 54889
- Telephone Engineering Co., Lincoln Bldg., Simpson, Pa. 18407
- Telephone Repair & Supply Co., 1760 Lunt Ave., Rogers Park Sta., Chicago, Ill. 60626



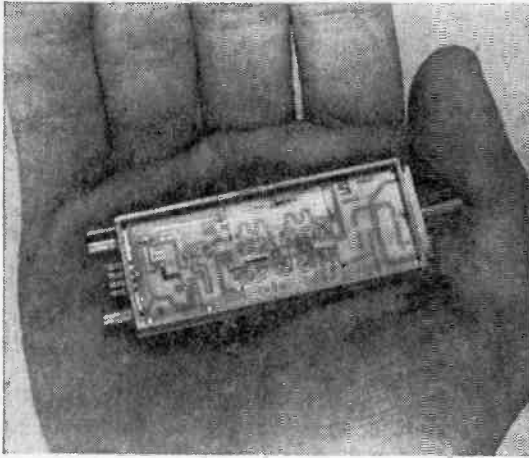

# World's Tiniest Radar

**P**ity the flight engineer who must dump some gunsights to make room for an airborne radar. But dump he does, for radar systems have long been overweight and oversized. Now the day of reckoning is here.

Up to now, not only did vacuum tubes and power supplies eat up space, but mechanical gizmos like motors and gears were needed to rotate heavy antennas. These have always spelled disaster; they break down with frightening regularity.

This size/weight barrier has now been overcome with the help of a miniature radar module developed by Texas Instruments. It's a solid-state 3 x 1 x ½-in. package that fits into the palm of your hand.

The module contains a transmitter, receiver, and antenna, so each unit is a radar set by itself. The shrinkage was made possible by using integrated circuits. In the midst of gold circuit paths, two tiny specks are responsible for the signals generated.

The big problem was to duplicate the scan of a moving antenna. TI solved the problem by hooking up 604 modules into a matrix that transmits signals according to a predetermined pattern. The matrix is called a *phased array*; it allows the radar to scan the horizon electronically.

This duplicates the effect of a rotating antenna, and makes for a radar that, next to a bat's, just might be the smallest ever. ■

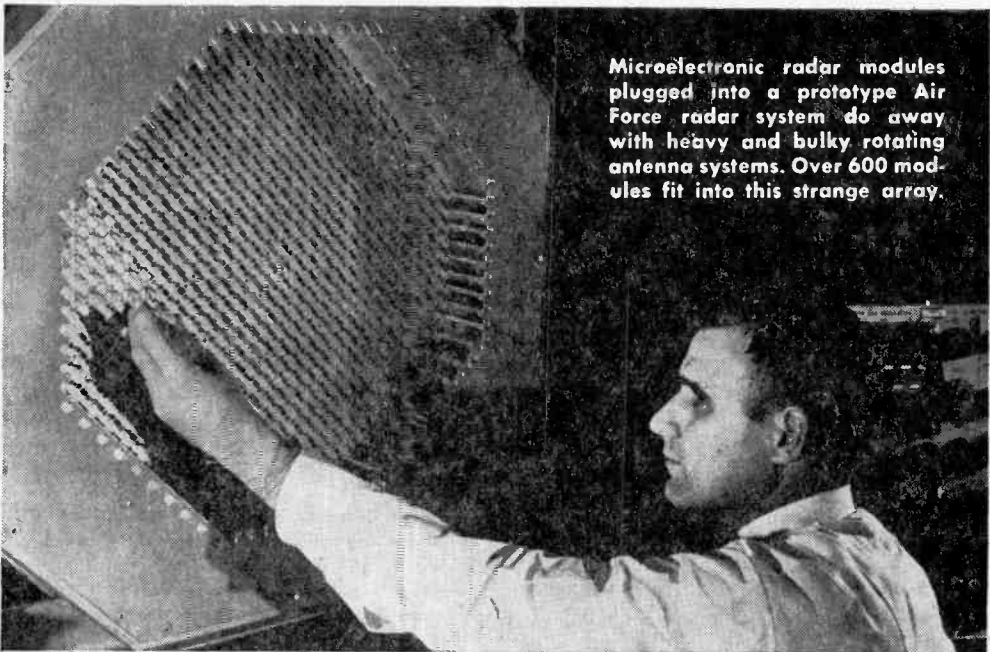

Microelectronic radar modules plugged into a prototype Air Force radar system do away with heavy and bulky rotating antenna systems. Over 600 modules fit into this strange array.

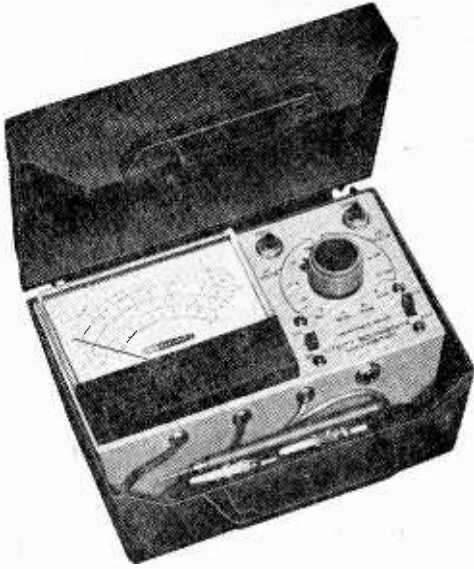

### HEATHKIT IM-17

Solid-State, High-Impedance

Volt-Ohm-Milliammeter

**T**he Heath IM-17 Solid-State Voltmeter is perhaps the first successful attempt to combine the high input impedance of the VTVM with the portability of a VOM at VOM prices. While there have been battery-powered VTVMs in the past, the battery death rate was very high simply because vacuum tubes were used. On the other hand, because the IM-17 is all solid-state, just two low-cost, more-or-less standard batteries provide several months of dependable service, even under heavy use.

The IM-17, priced at \$19.95, is what is termed a utility meter, meaning that its ranges and features are intended primarily for the handyman or experimenter, rather than for lab use. For example, four DC volt ranges cover 1 to 1000 volts full scale in a 1:10 decading. Since the meter scale can be read accurately down to 1/10 of the total scale, the minimum dependable DC voltage reading is 0.1 volt.

There are also four AC volt ranges, again with 1:10 decading. Lowest AC range is 1.2 volts, so lowest dependable AC volt reading is again 0.1 volt.

Four resistance ranges provide Rx1 ohm to Rx1 megohm, with 10 ohms at center scale.

**Four And Three.** A zero and ohms adjust are provided, as well as an on-off and probe polarity (+, —) reversal switches. Three test leads are provided: Common, AC-Ohms, and DC. When the meter is set to off, a short-circuit is connected across the meter movement to damp the meter, thereby preventing the pointer from swinging when the meter is transported. A plastic utility case is an integral part of the IM-17.

While the IM-17's DC input impedance is 11 megohms (the same as that of most VTVMs), its AC input impedance is 1 megohm—high, but not equal to that of a VTVM.

Heart of the IM-17 and the device that provides the 11-megohm input impedance is a Field Effect Transistor (FET), used as a source-follower input amplifier. Since the FET's input impedance is in the order of several thousands of megohms, the IM-17's DC input impedance is equal to the resistance of the 11 megohm DC voltage divider (selector switch). For AC measurements a diode is used ahead of the FET, and a different voltage divider comes into play—one with only 1 megohm total resistance.

**Unbalanced Bridge.** Figure 1 shows how the meter and FET works. The DC input is fed through a probe with a 1-megohm isolation resistor to a voltage divider. The output of the voltage divider is fed to the high-input impedance FET, which in turn drives a two-transistor meter bridge amplifier. Q2's bias is determined by Q1, the FET, while Q3's bias is a fixed value. Hence, a signal fed to Q1 changes the bias on Q2, thereby unbalancing the meter bridge, causing the meter pointer to rise upscale.

For AC voltage measurements, a voltage divider and a diode rectifier are connected ahead of the DC voltage divider. (The AC and DC dividers are ganged, so they are set as one.) The diode rectifier is a simple half-wave unit which rectifies only the positive



part of the AC waveform, and the meter is calibrated to indicate the rms value of sine-waveform. When complex waveform is applied, the meter reading is naturally inaccurate (as is that on other service grade meters). The ohmmeter is straightforward.

Fig. 1. Simplified circuit of Heath IM-17. Diode D1 rectifies AC input; diodes D2 and D3 protect FET from overload. In operation, DC voltage at Q1's gate changes bias on Q2, thereby unbalancing Q2/Q3 bridge. Degree of unbalance is read on M1.

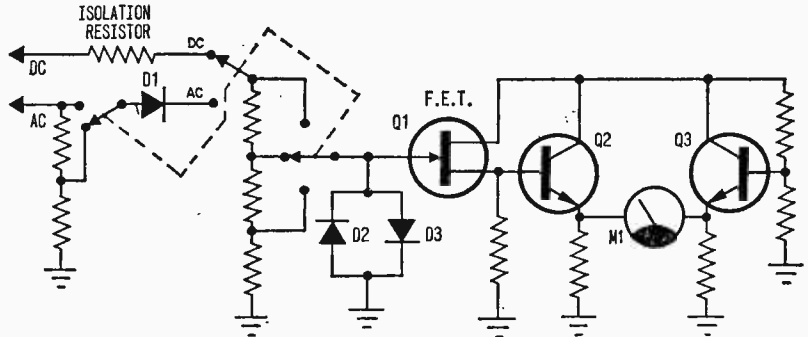

The IM-17's 4¾-in. meter scale has but four highly legible scales. The top scale is for resistance. The second scale (black) serves for all DC measurement. The third scale (red) is for all AC ranges except 1.2 volts. The last scale (also red) is for 1.2 VAC.

**Building The Kit.** The assembly is rather simple, and is at most a one- or two-evening project. Except for the meter, front-panel controls, and switches, all components mount on a small printed circuit board which has

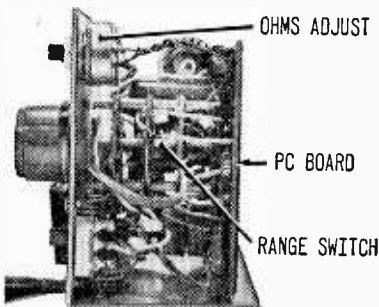

Bulk of IM-17's circuits are wired to PC board, which is then mounted on back of range switch. Switch and meter terminals support PC board.

an anti-solder-run coating. Somewhat unusual for kit PC boards, the printed circuit wiring is rather heavy, ensuring that the use of a high wattage soldering iron will not destroy the PC wiring. Even so, an iron rated at 50 watts or less is recommended.

While most of the final assembly wiring is easy, a few wires from the range switch are in a tight corner, so take care the soldering iron doesn't melt a few other wires.

**Calibration.** The user need make only three calibration adjustments: AC cal., DC cal., and bias. The DC and bias adjustment is made using the internal battery as the voltage reference; the AC adjustment uses the power line as the reference. The result is that calibration is a very easy procedure.

**Performance.** The IM-17 is phenomenally stable as far as zero set stability is concerned; it even exceeds that of some lab-grade solid-state VOMs we have used. Once

User makes only three adjustments: AC cal., DC cal., and bias.

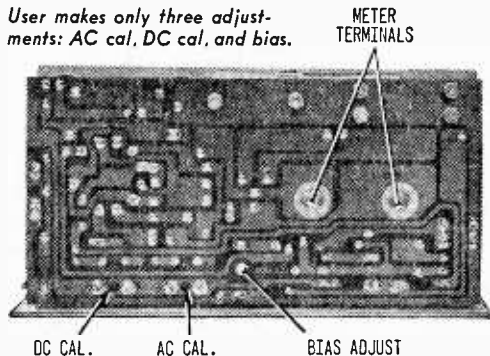

the zero pointer position is set the zero holds for all the AC, DC, and ohms ranges; you can switch from one function to another and never touch the zero-set control. The same holds true for the ohms adjustment; once set it holds for all resistance ranges.

The only area where you might find some problem is in the 1:10 decading of the voltage range switch. For while you can read 1 or 10 volts full scale, 1.5 volts must be read on the 10-volt scale. And unfortunately, the 1.5-volt point falls almost at the bottom of the scale. (Standard service grade instruments generally fill in the hole with a

*(Continued on page 108)*

# e/e's Basic Course in Electricity and Electronics\*

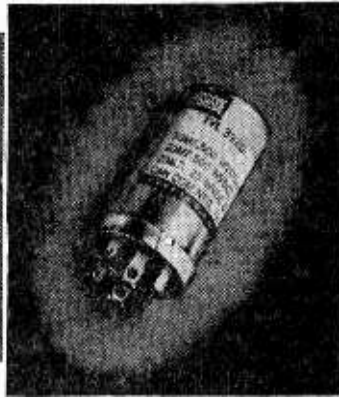

## PART III—UNDERSTANDING CAPACITORS

**W**HAT YOU WILL LEARN. A capacitor is another very basic but highly useful circuit component. Since it can regulate current, as do resistors and coils, the capacitor is used for this purpose in most electronic and many electrical circuits. Upon completing this chapter, you will understand what capacitors are, how they are used, and how they are connected in circuits.

### WHAT IS A CAPACITOR?

A capacitor has the ability to store electrical energy. Because it can do this, it is able to control the amount and the manner in which current will flow in a circuit.

Most electronic circuits consist of a combination of only three components—resistors, inductors, and capacitors. Each reacts in a different way to AC and DC voltage and current.

A *resistor*, as you recall, *controls* electricity by limiting the flow of current. This reaction is called *resistance*. It affects the flow of either AC or DC current.

\* This series is based on *Basic Electricity/Electronics*, Vol. 1, published by Howard W. Sams & Co., Inc.



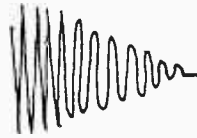

An *inductor* controls electricity by regulating the flow of AC current. The magnetic field in an inductor cuts its own coils, developing a voltage that opposes a change in current. This is called *inductance*.

A *capacitor* controls electricity by also regulating the flow of AC current. It stores an electrical *charge* which opposes any change in current. This property is called *capacitance*.

### HOW DOES A CAPACITOR WORK?

A capacitor, sometimes called a *condenser*, is manufactured in several shapes and sizes. A number of capacitors are shown below. You may recognize a few.

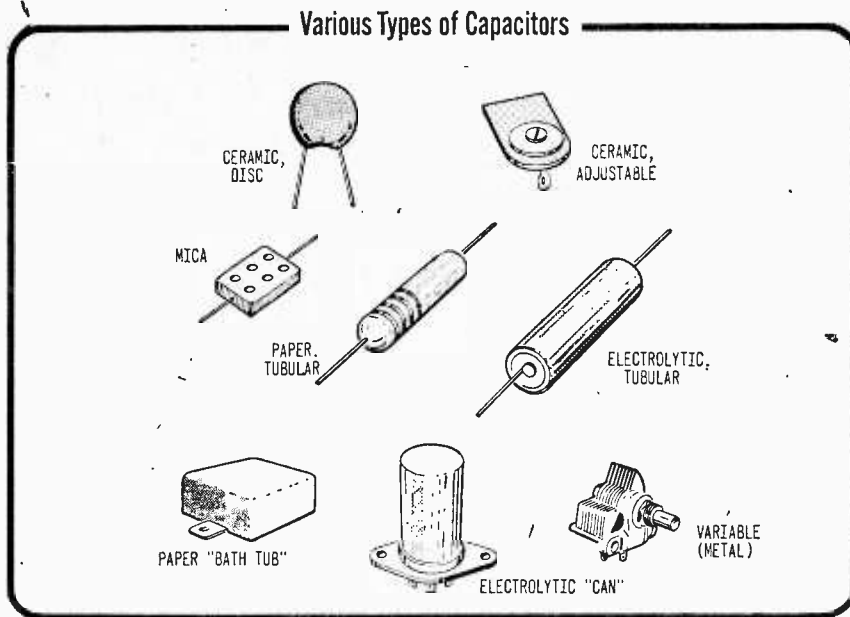

Several of each kind of capacitor are probably in your home. They can be found in radios, television receivers, intercoms, audio systems, and other electronic equipment. A capacitor is used with some electrical motors and even in the ignition systems of automobiles.

### Basic Construction

Every capacitor is constructed in the same basic manner. An insulating material, called a *dielectric*, is sandwiched between two conductors (usually a pair of metal plates). A wire is connected to each plate to form the leads or terminals of the capacitor. Details are shown at top of next page.

This basic principle is elaborated upon to produce the shapes shown in the box above. For example, the plates of the variable capacitor are curved

### Basic Capacitor Construction

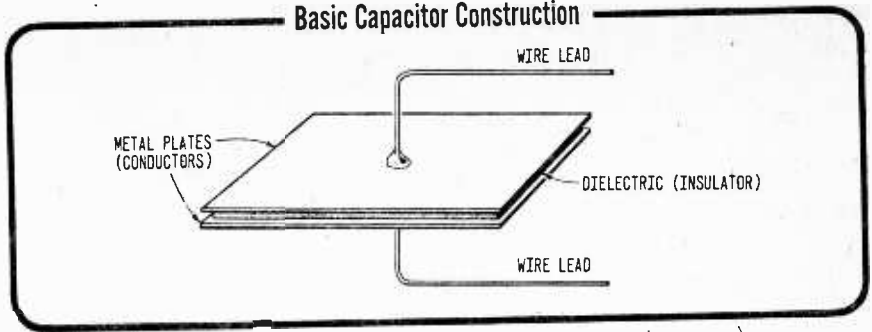

and exposed. Since air is an insulator, it forms the dielectric.

The tubular capacitor, as shown below, uses lengths of metal foil as the plates, which are separated by strips of treated paper to form a dielectric. Wire leads are connected to the exposed ends of the foil and the assembly is rolled into a tight spiral and placed in a case.

### A Tubular Capacitor

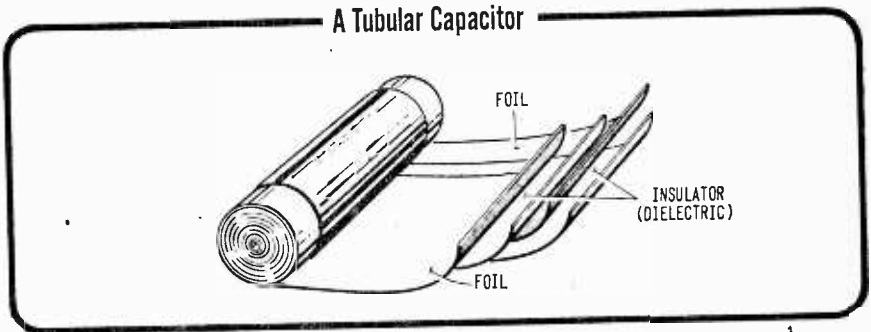

- Q1. The opposition to current flowing through the atomic structure of material is called - - - - - .
- Q2. The reaction of a changing magnetic field to current change is called - - - - - .
- Q3. The reaction of a stored electrical charge to current change is called - - - - - .

#### Your Answers Should Be:

- A1. The opposition to current flowing through the atomic structure of material is called *resistance*.
- A2. The reaction of a changing magnetic field to current change is called *inductance*.
- A3. The reaction of a stored electrical charge to current change is called *capacitance*.

### Electrical Principle

The structure of a capacitor obeys the fundamental principles of voltage and current as applied to conductors and insulators. Assume, as shown in the following diagram, that the plates of a capacitor are connected to a battery through a switch. An edge view of the plates is illustrated.

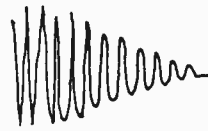
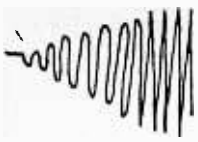

The open switch prevents the battery voltage from being applied across the capacitor. A voltmeter will show a zero voltage between the plates. This is normal, since all matter tends to seek a natural balance when no forces are applied.

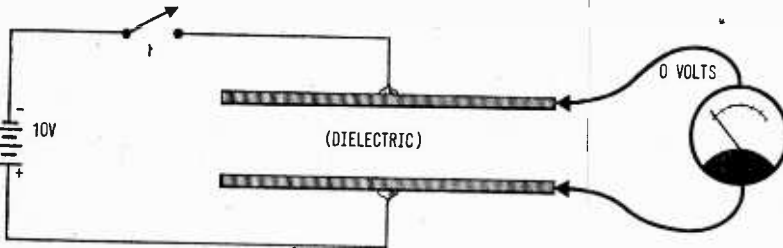

Suppose the switch is now closed. A first thought might be that no current would flow. Current does not flow through an insulator, and the dielectric is an insulator. Current will flow in the circuit, however.

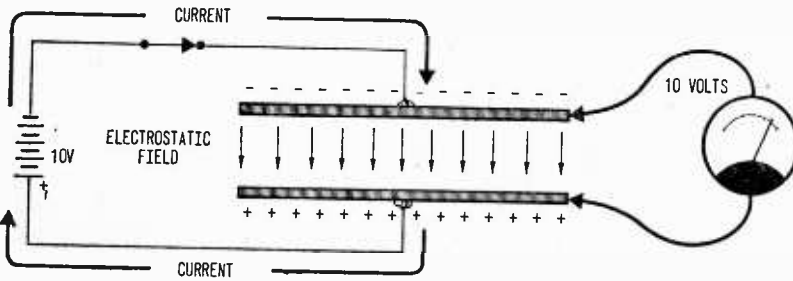

Current will flow until a charge (voltage) of 10 volts appears across the plates. The plates are conductors and therefore have electrons free to flow as current. Electrons have a negative charge. They are repelled (caused to move) by the negative pole of the battery and attracted by the positive pole. The positive terminal pulls electrons away from the bottom plate of the capacitor, and the negative terminal forces them to accumulate on the top plate.

A deficiency of electrons results in a positive *potential* (voltage) on the bottom plate, and an excess of electrons makes the upper plate negative. Current flows, rapidly at first, but more slowly as the voltage across the capacitor builds up to the same potential as the battery. When current ceases to flow, 10 volts will be across the capacitor.

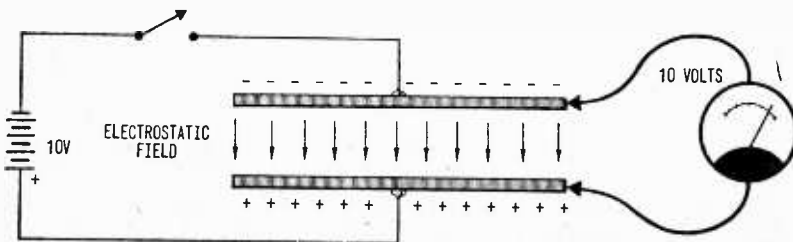



A field of force, equal to 10 volts, now exists between the two plates. This field is called an *electrostatic* force and has a direction as shown by the arrows—from negative to positive. The excess electrons are attracted to the positive plate, and it is this attraction that develops the force. Suppose the switch is now opened. Will the electrostatic force of 10 volts disappear?

! The voltage across the capacitor is still 10 volts, just as it was before the switch was opened. The excess electrons remain because there is no path for them to return to the positive plate (assuming the voltmeter has infinite internal resistance through which no electrons can travel).

Q4. Electrons leave the capacitor plate connected to the  
----- battery terminal.

Q5. Electrons are repelled by a ----- voltage.

Q6. The plate that has a(an) (excess, deficiency) of electrons has a negative charge.

Q7. A(an) ----- force is set up between the plates of a charged capacitor.

Q8. The insulating material through which the force lines extend is called a(an) ----- .

**Your Answers Should Be:**

A4. Electrons leave the capacitor plate connected to the *positive* battery terminal.

A5. Electrons are repelled by a *negative* voltage.

A6. The plate that has an *excess* of electrons has a negative charge.

A7. An *electrostatic* force is set up between the plates of a charged capacitor.

A8. The insulating material through which the force lines extend is called a *dielectric*.

**Capacitor Charge and Discharge**

*Charging* is the term used when a capacitor is acquiring a potential. In the example on the preceding page, the capacitor was charged to 10 volts.

Some capacitors can be charged to extremely high voltages and will retain this charge for long periods. The capacitor in the high-voltage section of a TV receiver builds up to 10,000 volts or more. So be careful when working around capacitors. A capacitor can be discharged either through normal operation of a circuit or by shorting the capacitor leads.

When the capacitor discharges, the excess electrons return to the positive

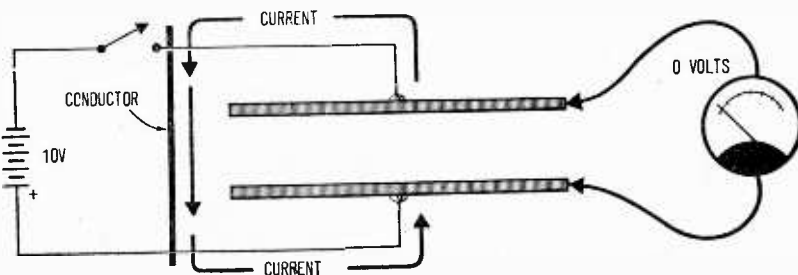



plate, the difference in potential (voltage) between the two plates becomes 0, and the electrostatic force disappears. As a matter of fact, the voltmeter constitutes a circuit between the plates of the capacitor, thus forming a path for the electrons to return to the positive plate. The high resistance of the meter, however, limits the current, resulting in a long discharge time. This can be seen by watching the meter pointer.

**Effect on DC Current**

As you have seen, a capacitor *blocks* the passage of DC current. Current flows only long enough to build up a charge equal to the source potential.

**Effect on AC Current**

You will often hear or read that AC *flows through* a capacitor. This is not true. As long as the dielectric retains its insulating quality (as long as the applied voltage does not become great enough to puncture a path through the dielectric), very few electrons will pass through.

With AC voltage applied, electrons accumulate first on one plate and then the other, as the voltage changes polarity. But this electron current does not change in phase (in step) with the voltage. The diagram shows the schematic symbol and letter designation for a capacitor, and a graph of the current and voltage relationships.

**Voltage and Current in a Capacitor**

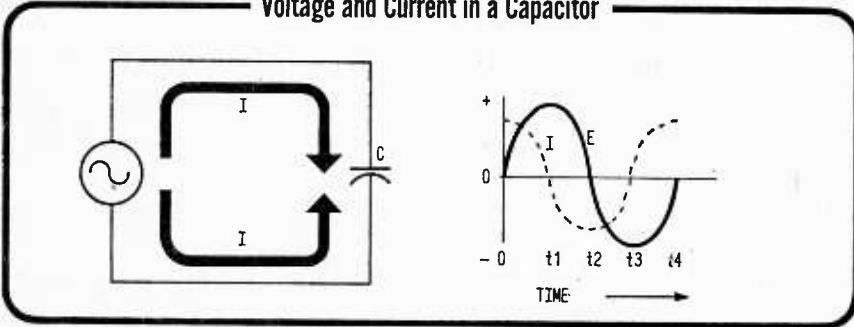

At time zero, the applied voltage starts to go positive. At that instant, current flow from one capacitor plate to the other is maximum. As the source voltage increases, I decreases because the charge on the capacitor is getting closer and closer to the applied E. When E reaches maximum positive (at time t1), the capacitor is charged to the same value. Current is zero. When source E decreases toward zero volts, capacitor E is greater and causes current to flow in the opposite direction. At zero source volts, current has become maximum negative (time t2). The difference and equality of the source voltage and the capacitor charge continue in the same time sequence for the next half cycle. As the graph shows, current is always a quarter of a cycle ahead of the source voltage.

**Q9. Current leads AC voltage by a(an) - - - - - cycle in a capacitor circuit.**

**Your Answer Should Be:**

**A9.** Current leads AC voltage by a *quarter* cycle in a capacitor circuit.

## CAPACITOR CHARACTERISTICS

Before circuits are shown that prove the effects of a capacitor on AC and DC current, you must learn a little more about capacitor characteristics.

### Units of Measurement

A capacitor is measured in terms of its capacitance, which is a definition of how many excess electrons it can store on one plate to develop a specific charge. A *Farad* is the unit of capacitance just as ohm is the unit of resistance.

However, when a Farad was first defined it was too large a unit for any practical purpose. Capacitors are either measured in micro-Farads (one-millionth of a Farad), abbreviated  $\mu\text{F}$ , or in micromicro-Farads, (one-millionth of a millionth of a Farad), abbreviated  $\mu\mu\text{F}$  (this is also called  $\text{pF}$ ).

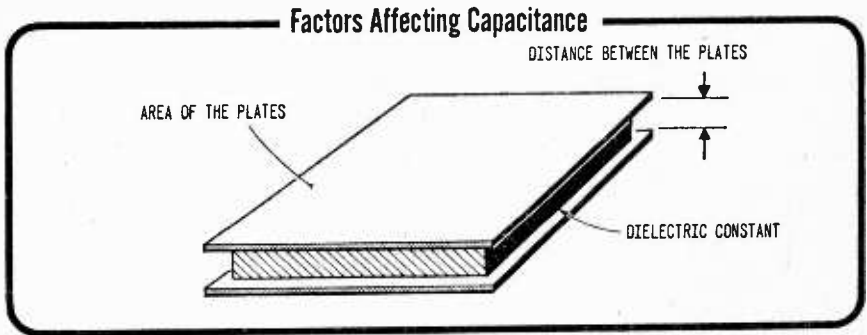

Capacitance (Farads) is determined by three factors:

1. Area of the plates. Larger area, greater capacitance.
2. Distance between the plates. The closer the plates, the greater the capacitance.
3. Dielectric constant (type of material). A higher constant, a larger capacitance. The constant for air is given as 1. Paraffin paper is 3.5; mica, 6; flint glass, 9.9. This means that a mica capacitor would have six times as much capacitance as a capacitor with air as a dielectric, all other things being equal.

### Voltage Rating

If the voltage applied across a capacitor is too large, the dielectric fails to maintain its insulating qualities. It breaks down under the stress of the electrostatic force and allows current to flow from one plate to the other.

Capacitors are given a *working-voltage* rating. This rating is the highest voltage that a capacitor can withstand without the possibility of creating a short-circuit through the dielectric. The type of material and thickness of the dielectric determines what the working voltage will be.

Since the distance between plates is one of the factors which determines the

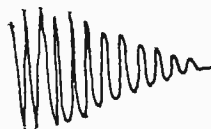
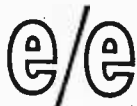
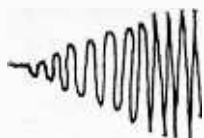

capacitance and working voltage, a capacitor having both a large capacitance and a high voltage rating will also have a large plate area.

A working-voltage rating pertains to a DC voltage or the *peak* value of AC. The peaks of an AC voltage wave are about 1.41 times its effective or working voltage. 115 volts DC and 115 volts AC are compared below.

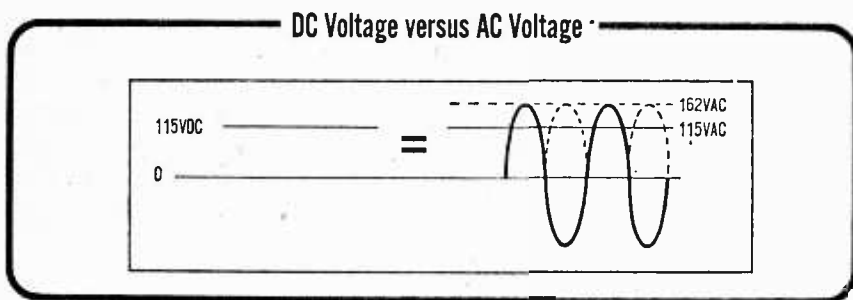

The peaks of 115 volts AC are actually 162 volts. A capacitor with a 150-volt rating will work well on 115 volts DC but not 115 volts AC. Standard practice is to use a capacitor with a working voltage about 50 percent higher than any voltage expected in the circuit.

**Q10.** A (thick, thin) dielectric allows more capacitance.

**Q11.** A small plate area develops (greater, less) capacitance than a larger area.

**Q12.** Glass is a (better, poorer) insulator than mica.

**Q13.** Working voltage is equal to the DC value or to the  
----- value of AC.

**Q14.** A higher working voltage will be possible with a (thicker, thinner) dielectric.

**Your Answers Should Be:**

**A10.** A *thin* dielectric gives more capacitance.

**A11.** A small plate area will develop *less* capacitance than a larger area.

**A12.** Glass is a *better* insulator than mica.

**A13.** Working voltage is equal to the DC value or to the *peak* value of AC.

**A14.** A higher working voltage will be possible with a *thicker* dielectric.

**A TIMING CIRCUIT**

A capacitor and a resistor can be placed in a circuit to operate as a timing device. If the values of R and C are carefully selected, the circuit can determine when an exact number of seconds has elapsed. This circuit contains com-

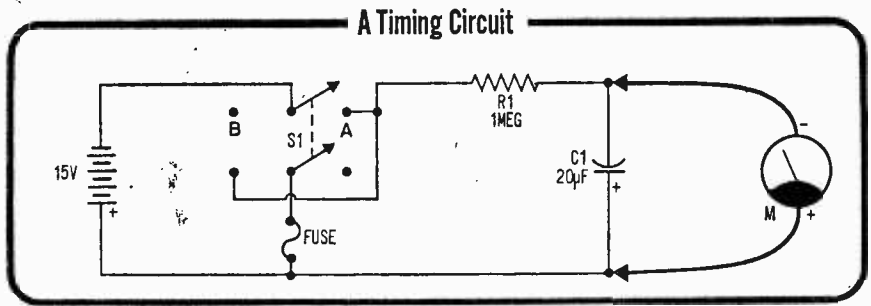

ponents from previous circuits—a 15-volt battery, a 1-megohm resistor, a DPDT switch, and a 20- $\mu$ F electrolytic capacitor (connected as shown).

The resistor limits the amount of current flow which charges C1. The values of R1 and C1 determine the charge time.

If you have constructed the circuit, you can see the build-up of the capacitor charge (voltage) by watching the voltmeter. At the instant S1 is moved to position A, the meter pointer begins to move quickly across the scale. As the capacitor increases its charge (in opposition to battery voltage), current starts to decrease. The pointer moves slower and slower. As it approaches 15 volts (full charge), its movement is almost impossible to see.

In an RC (resistance-capacitance) circuit, charge and discharge times are measured in RC seconds. Part A in the illustration below shows the rise of voltage across a capacitor during charge.

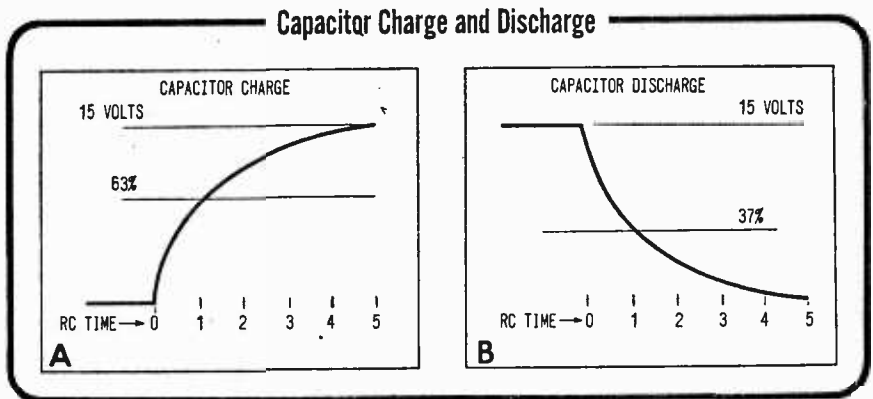

RC is a quantity obtained by multiplying R (ohms) by C (Farads). Any capacitor in an RC circuit (such as this one) charges to 63 percent (actually 63.2 percent) of its final value (battery voltage) in one RC second. In 5 RC seconds it reaches full value. The arithmetic statements are:

$$R \text{ (ohms)} \times C \text{ (Farads)} = \text{time (seconds)}$$

OR

$$R \text{ (megohms)} \times C \text{ (micro-Farads)} = \text{time (seconds)}$$

Since R is one megohm and C is 20 micro-Farads in the circuit on the

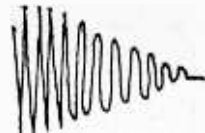

preceding page, the capacitor charges to 63 percent of its full charge in 20 seconds (63 percent of 15 volts is 9.45 volts). When the meter pointer reaches this value you know that 20 seconds have passed since moving S1 to position A.

If you move S1 to position B, the capacitor discharges at the rate shown in Part B (the exact reverse of Part A). The capacitor discharges to 37 percent of its full charge in one RC second, a value of 5.55 volts. The *RC time constant*, as it is called, holds true for any voltage.

- Q15.** How long does it take the capacitor in the circuit on the preceding page to charge to 15 volts?
- Q16.** If R1 were 10 megohms and C1 were 16 micro-Farads, how long would it take C1 to charge to 9.45 volts?
- Q17.** If a 50-volt battery were used, how many seconds would it take the capacitor to reach 63 percent of full charge. What would the voltage be at that time?

**Your Answers Should Be:**

- A15.** 100 seconds. (If one RC time is 20 seconds, 5 RC time constants equal 100 seconds.)
- A16.** 160 seconds. (9.45 volts is the 63 percent level with a 15-volt source.  $10(\text{megohms}) \times 16(\text{micro-Farads})$  is equal to 160 seconds.)
- A17.** 160 seconds. Regardless of the voltage, it will still take one RC time to reach 63 percent of full charge. 31.5 volts is the 63 percent level.

### DC BLOCKING

By alternately manipulating the two switches in the preceding circuit, you can simulate what the capacitor will do if AC voltage is applied. Closing one switch charges (increasing AC voltage) the capacitor, and closing the other switch (and opening the first switch at the same time) discharges (decreasing AC) the capacitor.

Whether DC or AC, current in the circuit did not pass through the capacitor. Instead, it flowed back and forth through the circuit, collecting first on one plate and then on the other. The effect is that of AC being passed through the capacitor. This characteristic of a capacitor is used in most electronic circuits where it is necessary to control alternating current, but yet allow it to flow through the circuit.

Transistors and vacuum tubes operate in electronic circuits with DC voltage applied to their elements. In nearly all such circuits, an AC signal is applied to the input of the circuit (to be amplified, for example). The AC must be allowed to pass through the amplifier, but the DC voltage must not. A capacitor can be used for this purpose—*blocking DC*. The circuit on the next page demonstrates how this is accomplished.

## DC Blocking Circuit

The circuit which follows uses a 15-volt battery, a 3000-ohm resistor, and a 20- $\mu$ F electrolytic capacitor.

How many volts would you expect to read with the meter probes connected to points A and C? An answer of 15 volts, the full battery voltage, is correct. Points A and C are directly connected to the battery. How many volts will appear between points B and C?

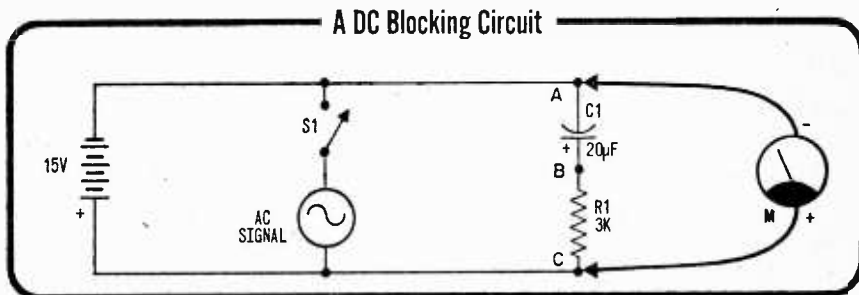

To develop a voltage across R1, current must flow through it. At the instant the circuit is connected, current flows from the lower plate of the capacitor through R1 and the battery to the upper plate. In 10 RC times, the capacitor is fully charged and current stops flowing.

Applying the voltmeter across R1 after this time gives a reading of zero volts. When current is not flowing through a resistor, a voltage drop is not present.

## Applying an AC Signal

Closing S1 applies an AC signal (voltage and current) across the same load. AC current flows back and forth from one plate of the capacitor to the other through the signal source. It also develops a voltage across R1 that corresponds to the changes of the AC signal. Connections from B and C to another circuit would apply the changing voltage to the input of the second circuit. And no DC would interfere with its proper operation.

**Q18.** In the above circuit (without AC applied), how long does it take C1 to charge to 63 percent of 15 volts?

**Q19.** The - - - - - terminal of an electrolytic capacitor must be connected to a negative voltage source.

**Q20.** After C1 is charged, - - will not flow through R1.

### Your Answers Should Be:

**A18.** 0.06 seconds. R1 is 0.003 megohm and when it is multiplied by 20 micro-Farads, one RC time is 0.06 second, or 60 milliseconds.

**A19.** The *negative* terminal of an electrolytic capacitor must be connected to a negative voltage source.

**A20.** After C1 is charged, *DC* will not flow through R1.



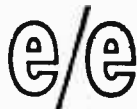
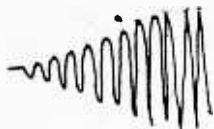

## WHAT YOU HAVE LEARNED

1. Capacitance controls the flow of AC current. However, AC current does not actually flow through a capacitor.
2. Capacitors are used in many electrical and electronic circuits. They are found in radios, television receivers, hi-fi systems, and almost every other type of electronic equipment.
3. A capacitor is a pair (or pairs) of plates separated by a dielectric. The dielectric, an insulator, does not pass current as long as the applied voltage is kept within the capacitor rating.
4. When a capacitor is connected to a voltage source, electrons move from one plate through the circuit and accumulate on the other plate. This charges the capacitor electrically and develops an electrostatic field between the plates. A capacitor discharges when the excess electrons on one plate return to the other plate.
5. DC current is blocked by a capacitor. AC appears to pass through by alternately charging and discharging the capacitor.
6. The effect of an electrostatic charge on AC is to cause current in a circuit to follow the AC wave pattern a quarter of a cycle in advance of the voltage.
7. A capacitor is measured in Farads, micro-Farads ( $\mu F$ ), and micromicro-Farads ( $uuF$ ); the larger the area of the plates and/or the closer their spacing, the greater the capacitance will be. It has a working-voltage rating that should not be exceeded.
8. Capacitors can be used in a timing circuit where charge and discharge time is measured in terms of an RC time constant. Another use for a capacitor is to block DC from those parts of a circuit where it is not desired.

### NEXT ISSUE: Part IV—Understanding Transformers

This series is based on material appearing in Vol. 1 of the 5-volume set, BASIC ELECTRICITY/ELECTRONICS, published by Howard W. Sams & Co., Inc. @ \$19.95. For information on the complete set, write the publisher at 4300 West 62nd St., Indianapolis, Ind. 46268.

## Secret Timetable

Continued from page 45

Comes the day when the thickening neck meets the closing rope, and *arggggh*—no more CB service!

Could it be, then, that the secret timetable calls for CB to undergo a slow but agonizing decay, leading, ultimately, to death? And could it be that the FCC will continue to tighten the reins—by, say, upping that license fee (once nonexistent) to \$80, maybe even \$160? And isn't it conceivable that the FCC will further reduce the number of

channels available to rank-and-file CBers—until, say, only *two* remain?

In short, is it not at this point the inescapable conclusion that that secret timetable calls for CB to die not with a bang, but with a *blaaaah*?

Motives? It could very well be that the CB service has gotten far too big for the FCC to handle, while simultaneously being far too big (in terms of manufacturers and operators) to be abruptly shut down. And if this is indeed the case, CB's every day is numbered. Given plenty of patience and a bit of legal maneuvering, it will all go away like the bad case of indigestion it has given the FCC. ■

## CBers Lose 39 Channels

Continued from page 45

home-made Class A CB rig can run from less than \$50 to more than \$100. It doesn't have to be a transmitter. You can build a transmitter, then rely on a converter and a BCB or SW receiver for receiving.

If you build your own transmitter, it must conform with Part 95 CB technical standards for Class A equipment. And before you use it, you've got to get FCC type acceptance. This requires conducting the tests specified in Part 2, FCC Rules and Regulations.

Most experimenters don't possess the equipment required for making the tests. However, almost every two-way radio service shop is set up to make the tests and prepare the reports the FCC requires.

A new or used 150-MHz band FM transmitter can be adapted for Class A CB use by using a converter ahead of it. Again, the whole ensemble must be type accepted by the FCC.

Snowed? Don't be. A Class A CB rig is much simpler than a TV set.

Only the future can tell whether the few

remaining UHF CB channels will be humming with activity soon—or whether the FCC will up and allocate them to some other service.

Let's face it. The space is up for grabs, and other services can be expected to put on plenty of pressure in order to get extra frequencies they think *they* need.

In any event, the loss of 93.7% of the CB spectrum within a decade is not to be passed off lightly. Let's not lose these 16 remaining Class A CB channels by ignoring them. In terms of spectrum space, they're a more valuable asset than the 23 Class D channels. ■

### CLASS A CB CHANNELS

Base and Mobile (MHz)		Mobile Only (MHz)	
462.550	462.650	467.550	462.650
462.575	462.675	467.575	462.675
462.600	462.700	467.600	462.700
462.625	462.725	462.625	462.725



"They said to stay off the air unless it's an emergency. We're interfering with the CBers."

## Flame Speaker

*Continued from page 59*

**Potential Applications.** The inventors of the Flame Speaker have applied for patents in the belief that there will be important commercial applications forthcoming.

UTC is in the business of developing and manufacturing rockets, propellants and propulsion systems. It is hoped that the principles of the Flame Speaker can be used to evaluate the combustion efficiencies of experimental liquid rocket engines.

It is also believed that the phenomenon may have "dramatic effect" on future developments in the design of super-fidelity loudspeakers, and of very high speed information transmission systems.

But when they talk about the possibility of making musical fireplaces or musical candles for use on the dinner table, imaginative amateur experimenters should react with special interest.

Consider the fireplace idea. Thin electrodes might be placed inconspicuously into a fireplace, and an ion-producing chemical could be thrown onto the hot coals. The rest of the system, including transformer, bias power pack and the basic audio system could be at some remote location, out of sight. You would then be ready to really mystify friends who would be hard put to explain how music can possibly come out of a roaring hot fireplace!

In any case, no matter how you choose to demonstrate your Flame Speaker, there will be no contesting the fact that yours is the hottest hi-fi system in the neighborhood. ■

## Ionosphere to Work

*Continued from page 85*

tists to understand the ionosphere occurred in Project Firefly. With a series of chemical releases and explosions at high altitudes, researchers introduced man-made disturbances into the ionosphere. Rocket launches (bearing the feminine names above) in 1962 carried the experimental materials aloft, while scientists on the ground transmitted radio signals to observe the effects on returning echoes. The chemical releases, designed to gather free electrons from the ionosphere, produced changes in the reflective ability of the ionosphere.

Shock waves from high explosives also rocked the layers with disturbances that proved to be similar to those caused by natural sources. Though Project Firefly hasn't unlocked any major secrets, it represents one of the first efforts to tinker with the complex chemical processes that mix air and outer-space radiation to create the ionosphere.

Despite frenzied research in the ionosphere, some say the end is in sight. For the past generation the ionosphere has carried a growing load of global communications, and the saturation point may have been reached. The communications satellite is expected to take over the role of international common carrier.

It is now possible to build a single satellite which can carry more messages, TV programs, and other data than all the regular radio stations and undersea cables combined. Explanation for this is that satellite transmissions have shorter wavelengths, so they can carry a far greater number of channels. Also, their point-to-point communications are not subject to atmospheric conditions. But so long as the volatile, turbulent ionosphere lies between earth and space, scientists won't rest until they've understood its behavior down to the last free electron. ■



# En Passant

Continued from page 26

Diagram for Surprise Move from page 26

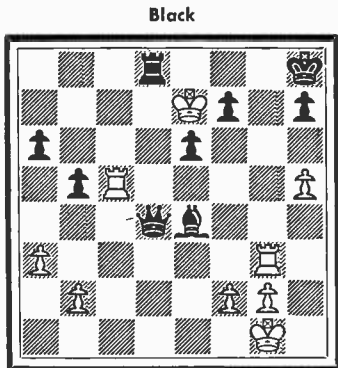

White

ing a performance of "The Marriage of Figaro," is an elegant gem which has always been a great favorite. An offhand partie, it is perhaps the best known game in chess literature.

Morphy had White and his titled opponents adopted Philidor's Defense.

- |         |       |         |      |
|---------|-------|---------|------|
| 1 P-K4  | P-K4  | 4 PxP   | BxN  |
| 2 N-KB3 | P-Q3  | 5 QxB   | PxP  |
| 3 P-Q4  | B-N5? | 6 B-QB4 | .... |

Threatening 7 QxP mate.

- |           |        |
|-----------|--------|
| 6 . . . . | N-KB3? |
| 7 Q-QN3   | Q-K2   |
| 8 N-B3    | ....   |

Morphy wants more than a Pawn. If 8 QxP, Q-N5# forces an exchange of Queens and blunts the attack.

- |           |      |
|-----------|------|
| 8 . . . . | P-B3 |
| 9 B-KN5   | P-N4 |
| 10 NxPI   | .... |

A piece for two Pawns and the attack.

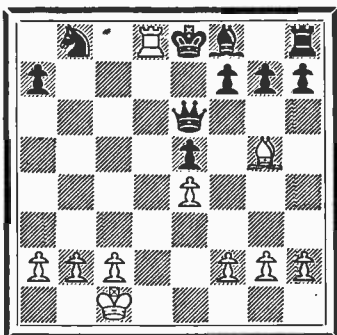

Position after 17 R-Q8 mate

- |            |       |              |      |
|------------|-------|--------------|------|
| 10 . . . . | PxN   | 14 R-Q1      | Q-K3 |
| 11 BxNP#   | QN-Q2 | 15 BxR#      | NxB  |
| 12 O-O-O!  | R-Q1  | 16 Q-N8#!    | NxQ  |
| 13 RxNI    | RxR   | 17 R-Q8 mate |      |

A delightful miniature, but it spoiled our "Why did Black Resign" format!

## Problem 13

By H. Bristow  
Scotland

Black

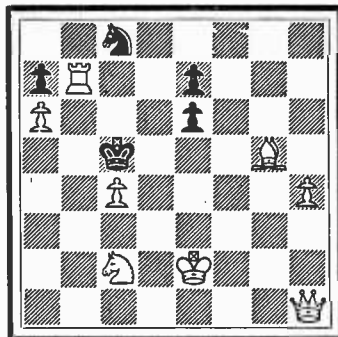

White

White to move and mate in two.  
Solution in next issue.

Solution to Problem 12: 1 P-K8=B

**News and Views.** Stein and Ivkov, 10½, tied for 1st and 2nd at Sarajevo. Benko (USA) and Savon, 10, finished 3rd and fourth, and R. Byrne (USA) and Ciric, 9½, were next.

Grandmaster Samuel Reshevsky of Spring Valley, N.Y., a six-time champion of the United States, tied at 4-4 (eight draws!) with Leonid Stein of the USSR and Vlastimil Hort of Czechoslovakia, in a three man qualifying tournament at Los Angeles. But Reshevsky was declared the winner on tie-breaking point (held over from the Interzonal in Sousse, Tunisia, last November) and will now compete in the Challenge Matches. The winner of those matches will then play Tigran Petrosian of the USSR for the Championship of the World.

**Learn by Reading.** "Chess Life" and "Chess Review" are the two top American magazines devoted to the Royal Game. Both cover all branches of the game, carry features by famous masters, run 32-34 pages, are published monthly, and cost 65¢ a copy ("Chess Life" annual subscription is \$6.50 and "Chess Review" is \$7.50). "Chess Life" is the official organ of the United States Chess Federation (479 Broadway, Newburgh, N.Y. 12550), and "Chess Review" (134 West 72nd St., New York, N.Y. 10023) is owned and edited by I. A. Horowitz. ■

## Hey, Look Me Over . . .

*Continued from page 32*

### Man's Cassette in His Own Castle

Harman-Kardon's new SC-2520 home music system is a complete FM/phonograph stereo music system and a cassette recorder/playback



*Harman-Kardon Model SC-2520 Home Music System*

cartridge. The SC-2520 will play stereo and mono music from pre-recorded tape cassettes and phonograph records and also permits stereo and mono recording on tape cassettes from record collections. FM radio, reel-to-reel tape, microphones and television. Using a Garrard 3000 record changer and two air-loaded speakers which feature a heavy-magnet 8-in. woofer, network and 3-in. wide-dispersion tweeter, the SC-2520 as a power output of 30 watts IHF at 8 ohms. Frequency response is  $\pm$  dB 20-30,000 Hz at 1 watt, with harmonic distortion less than 1%. Square wave rise time is better than 5 microseconds; usable FM sensitivity, 2.9 microvolts, IHF; image rejection better than 40 dB; multiplex separation 30 dB. The whole thing is wrapped in walnut, and the suggested list price is \$479. At distributors, or write to Harman-Kardon, Inc., Plainview, N.Y. 11803.

### Printed Circuit Stereo Amp

This 20-watt stereo amplifier, the Amperex PCA-6A-25, comes completely assembled and ready to use when connected to a sound source and speaker system. The amplifier provides 10 watts output per channel when driven by a ceramic phono cartridge. With its input sensitivity of 0.5 V you can also use it with a tuner. With four controls (volume, balance, bass, treble), the circuit has a 3-stage DC-coupled power amplifier with a thermistor for temperature stabil-

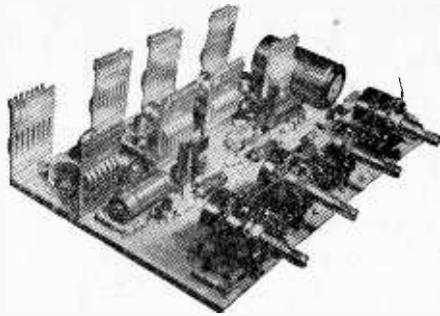

*Amperex PCA-6A-25 10-watt/Channel Amplifier*

ization. Each channel has a separate preamplifier stage with a low-noise transistor before the controls. Speaker load impedance is 8 ohms. Price of the PCA-6A-25 is \$22.60, and the manufacturer's address is Amperex Electronic Corp., Distributor Sales Dept., Hicksville, N.Y. 11802.

### Lab Check—Heathkit IM-17

*Continued from page 92*

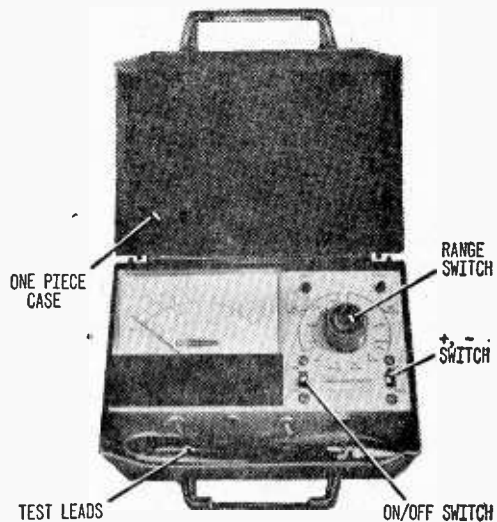

*One-piece plastic case is integral part of voltmeter. Test probes are permanently connected to instrument and store in bottom of case.*

3 or 5 volt range, so readings are always taken from the top two-thirds of the meter scale. But such simplified decading contributes to the IM-17's very low cost.)

**Summing Up.** If you need a general purpose meter for use around the house, the Heath IM-17 is, to date, the best buy.

For additional information write to the Heath Co., Dept. EB, Benton Harbor, Mich. 49022. ■

# CLASSIFIED Market Place

FOR BIGGER PROFITS! NEW CAREER OPPORTUNITIES!  
READ AND REPLY TO THESE CLASSIFIED ADS

Classified Ads 65¢ per word, each insertion, minimum 10 words, payable in advance. To be included in the next available issue of **ELEMENTARY-ELECTRONICS**, copy must be in our New York Office by July 10th. Address orders to C. D. Wilson, Manager, Classified Advertising, **ELEMENTARY ELECTRONICS**, 505 Park Ave., New York, N. Y. 10022.

## ADDITIONAL INCOME

**MONEY**—Spare Time Opportunity. We Pay Cash For Nothing but your opinions, written from home, about samples of our clients' products. Nothing to sell, canvass or learn. No Skills. No Experience. Just honesty. Details from: Research 669, Mineola, N.Y. 11501, Dept. 584-EE.

**COLLECT** Coins! Profitable! How, where to start, sell. Valuable coins listed. Detailed report \$1.00. Martin's, 503 E. Houk St., Ironwood, Mich. 49938.

**MAKE** Your Classified Ad Pay. Get "How To Write a Classified Ad That Pulls." Includes certificate worth \$2.00 towards classified ad in S & M. Send \$1.00 to C. D. Wilson, Science & Mechanics, 505 Park Ave., New York, N. Y. 10022.

## BOOKS & PERIODICALS

**TERRIFIC**, New Army Written Book. Basic Theory And Application of Transistors, \$1.40 Postpaid. Devices, Box 136B, Bronx, N. Y. 10463.

**CATALOG** of all Science & Mechanics Craftprints. Send 25¢ to cover postage and handling to Craftprint Div., Science & Mechanics, 505 Park Ave., New York 10022.

## BUSINESS OPPORTUNITIES

**I MADE \$40,000.00 Year by Mailorder!** Helped others make money! Start with \$10.00—Free Proof! Torrey, Box 318-T, Ypsilanti, Michigan 48197.

**AMAZINGLY Profitable Mailorder Business.** Free Details. Window, Box 148, Grandview, Mo. 64030.

**START Profitable Business** in spare time. Investigate many money-making opportunities. Send 25¢ for sample copy of Income Opportunities Magazine, 505 Park Ave., New York, N. Y. 10022, Dept. S.

## CAMPERS—CAMPING EQUIPMENT

**FOR** Consistent Fun, Excitement and Expert Advice, subscribe to "Camping Journal," America's Leading Camping Magazine. Only \$6.00 for 12 Issues. Write Camping Journal, 505 Park Ave., New York, N. Y. 10022.

## EARTHWORMS

**BIG** Money Raising Fishworms and Crickets. Free literature. Carter Farm-O. Plains, Georgia 31780.

## EDUCATION & INSTRUCTION

**B.S.C. Engineering. Management-Correspondence Course Prospectus \$1.00.** Canadian Institute of Science & Technology, 267J Adelaide St., W., Toronto.

**FCC License and Associate Degree** correspondence/residence courses. School bulletin free. Grantham Institute of Electronics, 1505 N. Western Ave., Hollywood, California 90027.

**MAKE** money in Radio, TV, Electronics. Free information. Write Steg, Amston, Connecticut 06231.

**EARN** Your Degree In Electronics Engineering. Highly Effective Home Study Courses In Electronics Engineering Technology And Electronics Engineering Mathematics. Free Literature. Cook's Institute Of Electronics Engineering, P. O. Box 36185, Houston, Texas 77036. (Established 1945.)

**PRACTICAL** tips for home, garden and workshop are in "1001 How-To Ideas." A high value reference for all craftsmen. Send \$1.00 for your copy includes Postage. 1001 How-To Ideas, 505 Park Ave., New York, N. Y. 10022.

## FARMS, ACREAGE & REAL ESTATE

**FLORIDA** 2½-Acre beautiful wooded Estates. Only \$995.00. Terms. Refund Guaranteed. High, dry, desirable community. Splendid roads. Free information. Owenwood, Pountain, Florida 32438. AD66LS151 (A-9)

## HYPNOTISM

**SELF-Hypnosis** for self-improvement. New Concept. Free literature. Smith-McKinley, Box 3038, San Bernardino, California 92404.

## IMPORT—EXPORT

**FREE CATALOG IMPORTED CUCKOO CLOCKS.** Write to John Kolacz, P.O. Box 10215-C, West Hartford, Conn. 06110.

## INVENTIONS WANTED

**WE** either sell your invention or pay cash bonus. Write for details. Universal Inventions, 298-3, Marlon, Ohio 43302.

## MAGNETS

**MAGNETS.** All types. Specials—20 disc magnets or 2 stick magnets, or 10 small bar magnets, or 8 assorted magnets, \$1.00. Maryland Magnet Company, 5412-D Gist, Baltimore, Md. 21215.

## OF INTEREST TO WOMEN

**LEARN FASCINATING HOME INTERIOR DECORATING**, custom drapes, slipcovers, bedspread ensembles. Turn sewing machine into money making machine by supplying Huge Demand for tastefully decorated homes, luxury drapes, etc. Delightful hobby too! Learn, earn, work at home. No experience needed. We Show You How! Fabrics wholesale—save big money on your own decorating & drapes. Write for Free four color decorating-drapery book today! Custom Drapery Institute, Box 555-FB, Orange, Calif. 92669.

## RADIO & TELEVISION

**CONVERT YOUR** table radio into a transmitter! Talk through nearby radios! Complete plans \$1.00. Catalog of other interesting plans 20¢. Franks Scientific Co., P.O. Box 156, Martelle, Iowa 52305.

**CRYSTAL, TRANSISTOR**, tube kit catalog—25¢, refundable. Laboratories, 12041-G Sheridan, Garden Grove, Calif. 92640.

**C.B. BUYERS' Guide**—A new magazine for the buyers of Citizen's Band Electronic Equipment. The Social Side of C.B.; FCC Regulations. Send \$1.25—includes Postage to C. B. Buyers' Guide, 505 Park Ave., New York, N. Y. 10022.

## START YOUR OWN BUSINESS

**START BIG-PAY** Business at home in spare time! No experience needed to operate little table-top machine for bronzing baby shoes. Make \$7.32 profit on every pair. Full particulars free. Send postcard to: Mason, 1512 Jarvis, Room C.-107-HO, Chicago, Ill. 60627.

## For Greater Classified Profits

WHY NOT TRY THIS NEW

## combined classified ad medium

Your classified ad will appear in **SCIENCE & MECHANICS MAGAZINE** as well as in a minimum of four other **SCIENCE & MECHANICS PUBLICATIONS**. Write now for information to C. D. Wilson, Manager, Classified Advertising, **SCIENCE & MECHANICS**, 505 Park Ave., New York, N. Y. 10022.

**Gene Frost was "stuck" in low-pay TV repair work. Then two co-workers suggested he take a CIE home study course in electronics. Today he's living in a new house, owns two good cars and a color TV set, and holds an important technical job at North American Aviation. If you'd like to get ahead the way he did, read his inspiring story here.**

**I**F YOU LIKE ELECTRONICS—and are trapped in a dull, low-paying job—the story of Eugene Frost's success can open your eyes to a good way to get ahead.

Back in 1957, Gene Frost was stalled in a low-pay TV repair job. Before that, he'd driven a cab, repaired washers, rebuilt electric motors, and been a furnace salesman. He'd turned to TV service work in hopes of a better future—but soon found he was stymied there too.

"I'd had lots of TV training," Frost recalls today, "including numerous factory schools and a semester of ad-

vanced TV at a college in Dayton. But even so, I was stuck at \$1.50 an hour."

Gene Frost's wife recalls those days all too well. "We were living in a rented double," she says, "at \$25 a month. And there were no modern conveniences."

"We were driving a six-year-old car," adds Mr. Frost, "but we had no choice. No matter what I did, there seemed to be no way to get ahead."

#### Learns of CIE

Then one day at the shop, Frost got to talking with two fellow workers who were taking CIE courses... pre-

paring for better jobs by studying electronics at home in their spare time. "They were so well satisfied," Mr. Frost relates, "that I decided to try the course myself."

He was not disappointed. "The lessons," he declares, "were wonderful—well presented and easy to understand. And I liked the relationship with my instructor. He made notes on the work I sent in, giving me a clear explanation of the areas where I had problems. It was even better than taking a course in person because I had plenty of time to read over his comments."

#### Studies at Night

"While taking the course from CIE," Mr. Frost continues, "I kept right on with my regular job and studied at night. After graduating, I went on with my TV repair work while looking for an opening where I could put my new training to use."

His opportunity wasn't long in coming. With his CIE training, he qualified for his 2nd Class FCC License, and soon afterward passed the entrance examination at North American Aviation. "You can imagine how I felt," says Mr. Frost. "My new job paid \$228 a month more!"

  
**"CIE training helped pay for my new house,"**

says Eugene Frost  
of Columbus, Ohio





Currently, Mr. Frost reports, he's an inspector of major electronic systems, checking the work of as many as 18 men. "I don't lift anything heavier than a pencil," he says. "It's pleasant work and work that I feel is important."

### Changes Standard of Living

Gene Frost's wife shares his enthusiasm. "CIE training has changed our standard of living completely," she says.

"Our new house is just one example," chimes in Mr. Frost. "We also have a color TV and two good cars instead of one old one. Now we can get out and enjoy life. Last summer we took a 5,000 mile trip through the West in our new air-conditioned Pontiac."

"No doubt about it," Gene Frost concludes. "My CIE electronics course has really paid off. Every minute and every dollar I spent on it was worth it."

### Why Training is Important

Gene Frost has discovered what many others never learn until it is too late: that to get ahead in electronics today, you need to know more than soldering connections, testing circuits, and

replacing components. You need to really know the fundamentals.

Without such knowledge, you're limited to "thinking with your hands" ... learning by taking things apart and putting them back together. You can never hope to be anything more than a serviceman. And in this kind of work, your pay will stay low because you're competing with every home handyman and part-time basement tinkerer.

But for men with training in the fundamentals of electronics, there are no such limitations. They think with their heads, not their hands. They're qualified for assignments that are far beyond the capacity of the "screw-driver and pliers" repairman.

The future for trained technicians is bright indeed. Thousands of men are desperately needed in virtually every field of electronics, from 2-way mobile radio to computer testing and troubleshooting. And with demands

like this, salaries have skyrocketed. Many technicians earn \$8,000, \$10,000, \$12,000 or more a year.

How can you get the training you need to cash in on this booming demand? Gene Frost found the answer in CIE. And so can you.

### Send for Free Book

Thousands who are advancing their electronics careers started by reading our famous book, "How To Succeed In Electronics." It tells of the many electronics careers open to men with the proper training. And it tells which courses of study best prepare you for the work you want.

If you'd like to get ahead the way Gene Frost did, let us send you this 40-page book free. With it we'll include our other helpful book, "How To Get A Commercial FCC License." Just fill out and mail the attached card. Or, if the card is missing, write to CIE at the address below.

  
**CIE**  
Cleveland Institute  
of Electronics  
1776 E. 17th St., Dept. EL-9  
Cleveland, Ohio 44114

Accredited Member National Home Study Council

### ENROLL UNDER G.I. BILL

All CIE courses are available under the new G.I. Bill. If you served on active duty since January 31, 1955, or are in service now, check box on reply card for G.I. Bill information.

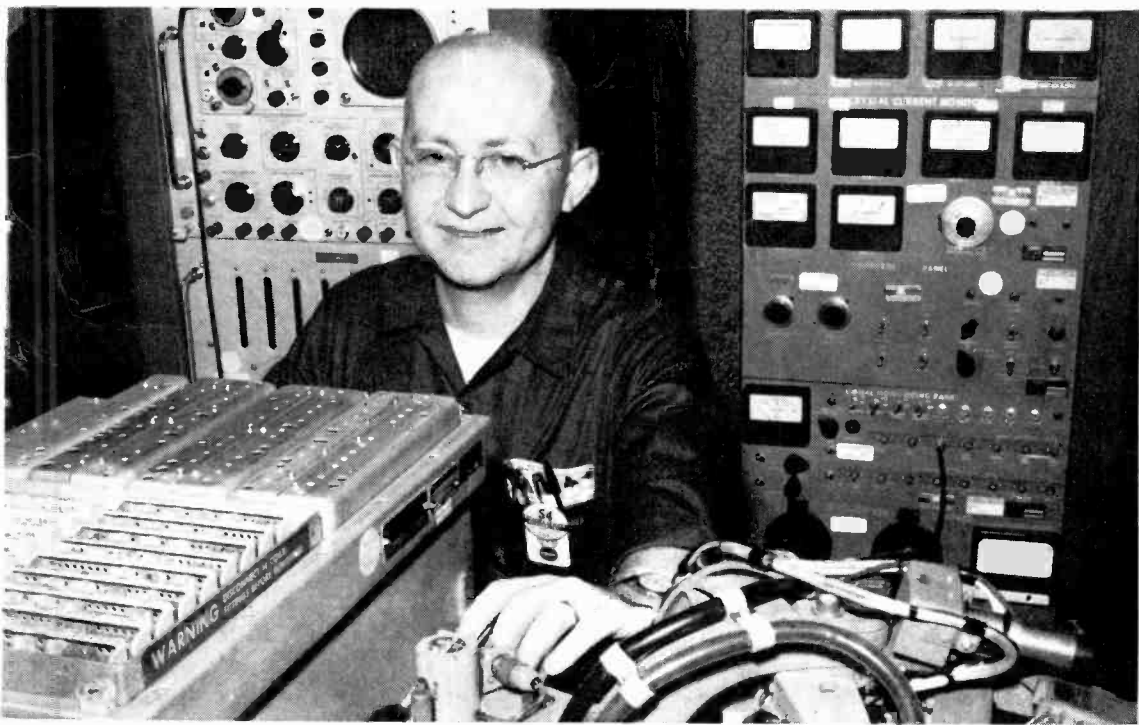

# BUILD YOUR OWN RADIO

**CIRCUITS AT HOME**  
with the New Improved  
**PROGRESSIVE RADIO "EDU-KIT"®**

only  
**\$26.95**



Reg. U. S.  
Pat. Off.

## A Practical Home Radio Course

### Now Includes

- ★ 12 RECEIVERS
- ★ 3 TRANSMITTERS
- ★ SQ. WAVE GENERATOR
- ★ SIGNAL TRACER
- ★ AMPLIFIER
- ★ SIGNAL INJECTOR
- ★ CODE OSCILLATOR

- ★ No Knowledge of Radio Necessary
- ★ No Additional Parts or Tools Needed
- ★ EXCELLENT BACKGROUND FOR TV
- ★ SCHOOL INQUIRIES INVITED
- ★ Sold In 79 Countries

Training Electronics Technicians Since 1946

## FREE EXTRAS

### SET OF TOOLS

- SOLDERING IRON
- ELECTRONICS TESTER
- PLIERS-CUTTERS
- VALUABLE DISCOUNT CARD
- CERTIFICATE OF MERIT
- TESTER INSTRUCTION MANUAL
- HIGH FIDELITY GUIDE • QUIZZES
- TELEVISION BOOK • RADIO TROUBLE-SHOOTING BOOK
- MEMBERSHIP IN RADIO-TV CLUB: CONSULTATION SERVICE, FCC AMATEUR LICENSE TRAINING
- PRINTED CIRCUITRY

## YOU DON'T HAVE TO SPEND HUNDREDS OF DOLLARS FOR A RADIO COURSE

The "Edu-Kit" offers you an outstanding PRACTICAL HOME RADIO COURSE at a rock-bottom price. Our Kit is designed to train Radio & Electronics Technicians, making use of the most modern methods of home training. You will learn radio theory, construction practice and servicing. THIS IS A COMPLETE RADIO COURSE IN EVERY DETAIL. You will learn how to build radios, using regular schematics; how to wire and solder in a professional manner; how to service radios. You will work with the standard type of punched metal chassis as well as the latest development of Printed Circuit chassis.

You will learn the basic principles of radio. You will construct, study and work with RF and AF amplifiers and detectors, rectifiers, test equipment. You will learn and practice code, using the Progressive Code Oscillator. You will learn and practice trouble-shooting, using the Progressive Signal Tracer, Progressive Signal Injector, Progressive Dynamic Radio & Electronics Tester, Square Wave Generator, and the accompanying instructional material.

You will receive training for the Novice, Technician and General Classes of F.C.C. Radio Amateur Licenses. You will build Receiver, Transmitter, Square Wave Generator, Code Oscillator, Signal Tracer and Signal Injector circuits, and learn how to operate them. You will receive an excellent background for television, Hi-Fi and Electronics. Absolutely no previous knowledge of radio or science is required. The "Edu-Kit" is the product of many years of teaching and engineering experience. The "Edu-Kit" will provide you with a basic education in Electronics and Radio, worth many times the low price you pay. The Signal Tracer alone is worth more than the price of the kit.

## THE KIT FOR EVERYONE

You do not need the slightest background in radio or science. Whether you are interested in Radio & Electronics because you want an interesting hobby, a well paying business or a job with a future, you will find the "Edu-Kit" a worth-while investment. Many thousands of individuals of all

ages and backgrounds have successfully used the "Edu-Kit" in more than 79 countries of the world. The "Edu-Kit" has been carefully designed, step by step, so that you cannot make a mistake. The "Edu-Kit" allows you to teach yourself at your own rate. No instructor is necessary.

## PROGRESSIVE TEACHING METHOD

The Progressive Radio "Edu-Kit" is the foremost educational radio kit in the world, and is universally accepted as the standard in the field of electronics training. The "Edu-Kit" uses the modern educational principle of "Learn by Doing." Therefore you construct, learn schematics, study theory, practice trouble-shooting—all in a closely integrated program designed to provide an easily-learned, thorough and interesting background in radio.

You begin by examining the various radio parts of the "Edu-Kit." You then learn the function, theory and wiring of these parts. Then you build a simple radio. With this first set you will enjoy listening to regular broadcast stations, learn theory, practice testing and trouble-shooting. Then you build a more advanced radio, learn more advanced theory and techniques. Gradually, in a professional manner, and at your own rate, you will find yourself constructing more advanced multi-tube radio circuits, and doing work like a professional Radio Technician.

Included in the "Edu-Kit" course are Receiver, Transmitter, Code Oscillator, Signal Tracer, Square Wave Generator and Signal Injector Circuits. These are not unprofessional "breadboard" experiments, but genuine radio circuits, constructed by means of professional wiring and soldering on metal chassis, plus the new method of radio construction known as "Printed Circuitry." These circuits operate on your regular AC or DC house current.

## THE "EDU-KIT" IS COMPLETE

You will receive all parts and instructions necessary to build twenty different radio and electronics circuits, each guaranteed to operate. Our Kits contain tubes, tube sockets, variable, electrolytic, mica, ceramic and paper dielectric condensers, resistors, tie strips, hardware, tubing, punched metal chassis, Instruction Manuals, hook-up wire, solder, selenium rectifiers, coils, volume controls and switches, etc.

In addition, you receive Printed Circuit materials, including Printed Circuit chassis, special tube sockets, hardware and instructions. You also receive a useful set of tools, a professional electric soldering iron, and a self-powered Dynamic Radio and Electronics Tester. The "Edu-Kit" also includes Code Instructions and the Progressive Code Oscillator, in addition to F.C.C. Radio Amateur License training. You will also receive lessons for servicing with the Progressive Signal Tracer and the Progressive Signal Injector, a High Fidelity Guide and a Membership in Radio-TV Club, Free Consultation Service, Certificate of Merit and Discount Privileges. You receive all parts, tools, instructions, etc. Everything is yours to keep.

Progressive "Edu-Kits" Inc., 1186 Broadway, Dept. 526DJ, Hewlett, N. Y. 11557

## UNCONDITIONAL MONEY-BACK GUARANTEE

Please rush my Progressive Radio "Edu-Kit" to me, as indicated below:

Check one box to indicate choice of model

- Regular model \$26.95.
- Deluxe model \$31.95 (same as regular model, except with superior parts and tools plus Radio & TV Parts Jackpot worth \$15.)

Check one box to indicate manner of payment

- I enclose full payment. Ship "Edu-Kit" post paid.
- Ship "Edu-Kit" C.O.D. I will pay postage.
- Send me FREE additional information describing "Edu-Kit."

Name

Address

## PROGRESSIVE "EDU-KITS" INC.

1186 Broadway, Dept. 526DJ, Hewlett, N. Y. 11557

## SERVICING LESSONS

You will learn trouble-shooting and servicing in a progressive manner. You will practice repairs on the sets that you construct. You will learn symptoms and causes of trouble in home, portable and car radios. You will learn how to use the professional Signal Tracer, the unique Signal Injector and the dynamic Radio & Electronics Tester. While you are learning in this practical way, you will be able to do many a repair job for your friends and neighbors, and charges fees which will far exceed the price of the "Edu-Kit." Our Consultation Service will help you with any technical problems you may have.

## FROM OUR MAIL BAG

J. Stataitis, of 25 Poplar Pl., Waterbury, Conn., writes: "I have repaired several sets for my friends, and made money. The "Edu-Kit" paid for itself. I was ready to spend \$240 for a Course, but found your ad and sent for your Kit."

Ben Valerio, P. O. Box 21, Magna, Utah: "The Edu-Kits are wonderful. Here I am sending you the questions and also the answers for five that I have been in Radio for the last seven years, but like to work with Radio Kits, and like to build Radio Testing Equipment. I enjoyed every minute I worked with the different kits; the Signal Tracer works fine. Also like to let you know that I feel proud of becoming a member of your Radio-TV Club."

Robert L. Shuff, 1534 Monroe Ave., Huntington, W. Va.: "Thought I would drop you a few lines to say that I received my Edu-Kit, and was really amazed that such a bargain can be had at such a low price. I have already started repairing radios and phonographs. My friends were really surprised to see me get into the swing of it so quickly. The Trouble-shooting Tester that comes with the kit is really a gem. I can find the trouble, there is any to be found."

## PRINTED CIRCUITRY

At no increase in price, the "Edu-Kit" now includes Printed Circuitry. You build a Printed Circuit Signal Injector, a unique servicing instrument that can detect many Radio and TV troubles. This revolutionary new technique of radio construction is now becoming popular in commercial radio and TV sets.

A Printed Circuit is a special insulated chassis on which has been deposited a conducting material which takes the place of wiring. The various parts are merely plugged in and soldered to terminals.

Printed Circuitry is the basis of modern Automatic Electronics, and the knowledge of this subject is a necessity today for anyone interested in Electronics.