

A 75c QUARTERLY

ELEMENTARY ELECTRONICS

FALL 1965

10 SILICON
CONTROL
RECTIFIER
EXPERIMENTS!

**Thermoelectric
DC Cold Plate!**

**PLUS RUNDOWN ON
NEW TE MODULES!**

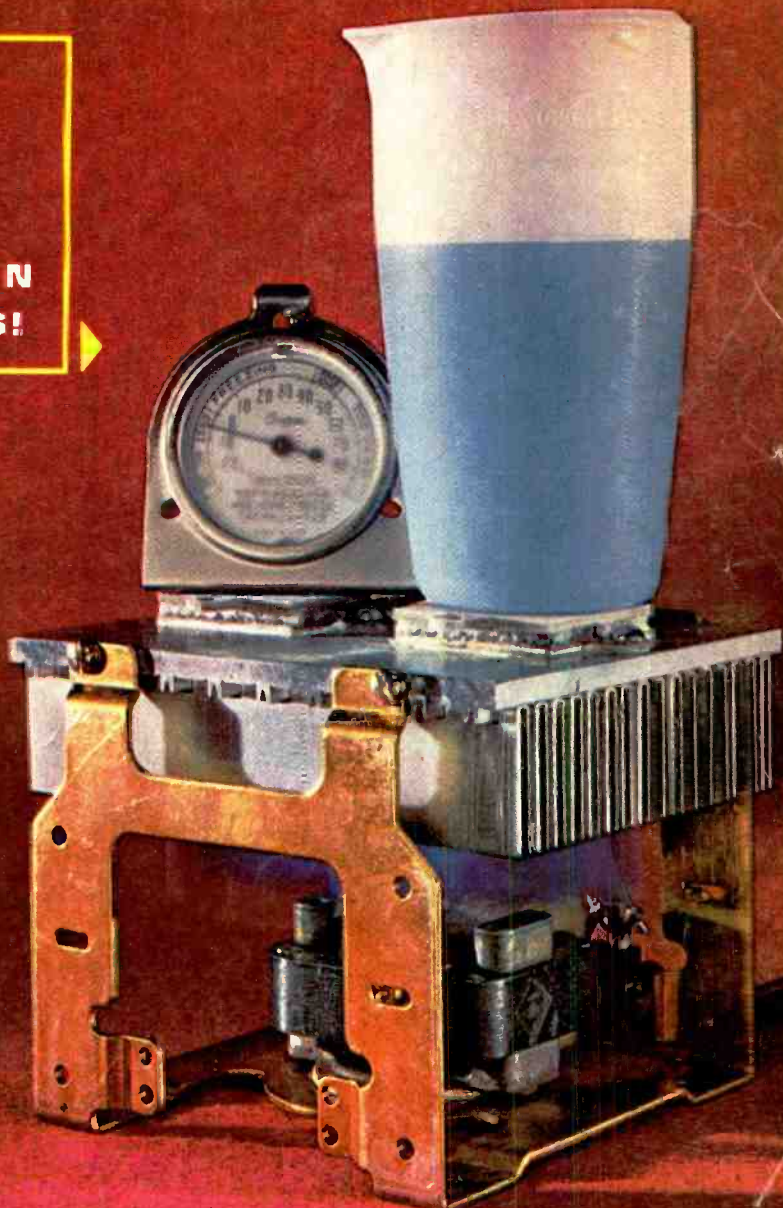

**CB's Frequency
Synthesis:**

RADIO'S RUBBER CRYSTALS!

**Novice Ham
License Guide!**

ANL AUTOMATIC
NOISE LIMITERS:
ADD ONE TO YOUR SET!



99-3027

LAFAYETTE SOLID-STATE 5-WATT C.B. TRANSCEIVER
Model HB-500 Small, Quiet, Powerful . . . only 3" High

- 139⁵⁰**
- Mechanical Filter for Razor Sharp Selectivity
 - 12 Crystal Transmit and Receive Positions
 - 23 Channel Tunable Receiver with Spotting Switch
 - Multi-Stage Automatic Noise Limiting Circuit
 - With Channel 12 Transmit and Receive Crystals, Push-to-Talk Dynamic Mike, Crystal for Dual Conversion Mobile Mounting Bracket.

THE WIDELY ACCLAIMED LAFAYETTE TAPE RECORDER Model RK-137A

- 89⁵⁰**
- Takes Full 7" Reel of Tape
 - 2 Speeds—3¾ and 7½ ips
 - Electronic Track Selector Switch
 - Features 4-Track Monaural Record/Playback
 - Adaptable to 4-Track Stereo Playback
 - With Lightweight Carrying Case, Dynamic Mike, Shielded Patch Cords, 7" Take-up Reel.



99-1511



99-3022

LAFAYETTE 12-TRANSISTOR C.B. WALKIE-TALKIE Model HE-100
with Noise Squelch

- 399⁵⁰**
2-for-78.88
- Separate Microphone and Speaker for Better Modulation, Increased Range
 - 12 Transistors, 1 Diode and 1 Thermistor
 - Superhet Circuit is Crystal Controlled on Transmit and Receive
 - Variable Squelch Reduces Background Noise
 - Optional Plug-in 117V AC Power Pack
 - Easy to Use and Lightweight
 - With Leather Case, Earphone, Telescoping Antenna, Batteries, Crystals for Channel 10.

LAFAYETTE 70-WATT COMPLETE AM-FM STEREO RECEIVER Model LR-800

- 199⁵⁰**
- Just Add Speakers and Enjoy FM, FM Stereo and High-Quality AM Reception
 - FM "Stereo Search" Circuit
 - Nuvistor "Front End"
 - Powerful 70-Watt Amplifier plus Complete Preamp plus AM Tuner plus FM Tuner plus FM Stereo Tuner on One Chassis



99-0005

FREE! LAFAYETTE Radio **ELECTRONICS**
1965 Catalog featuring
EVERYTHING IN ELECTRONICS FROM THE
"World's Hi-Fi & Electronics Center"

See the Latest in Low-Cost, Top Quality stereo Hi-Fi, Experimenter's Kits, Citizens Band Equipment, Tape Recorders, Ham Gear, Test Equipment, and much more.

Write today for your Free catalog!

LAFAYETTE Radio **ELECTRONICS**
Dept DEEJ-5, P.O. Box 10
Syosset, L. I., N. Y. 11791

AMERICAN BASIC SCIENCE CLUB'S **ELECTRONICS LAB and RADIO COURSE**

All the Equipment for 65 Exciting Projects, Including **\$17⁸⁰**
3 Tube Short Wave Radio, DC Power Supply,
Microphone and Audio Amplifier, Signal Tracer—only **COMPLETE LAB AND COURSE**



TROUBLE SHOOTING WITH THE SIGNAL TRACER

YOU GET A VALUABLE ELECTRONICS LAB

Containing parts by RCA, MALLORY, PYRAMID, GE, CENTRALAB, STACKPOLE, TRIM, CINCH and other reliable manufacturers. Retail value of parts alone is MORE THAN **25 DOLLARS**

PLUS A COMPLETE ELECTRONICS COURSE

You REALLY LEARN ELECTRONICS. The progressive "learn by doing" American Basic Science Club system is the **EASIEST, MOST THOROUGH and MOST EXCITING** way to a solid background in electronics. Basic enough for beginners . . . rewarding enough for experts. **NOWHERE ELSE** is a course of this scope available at this **LOW PRICE!**

ENTHUSIASTIC MEMBERS WRITE:

"basic principles unforgettably learned" . . .

It is only after having completed the experiments in your kits that I can say I have truly and unforgettably learned the basic principles of electronics. **JOHN R. KANIA**, 2 Berkeley Ave., Yonkers 5, N. Y.

"your kits are interesting and rewarding" . . .

I am an electronics student in the Air Force and find your kits interesting and rewarding. We have not covered anything in the school that you have not covered in the kits. **JOHN G. DILL**, Keesler Air Force Base, Biloxi, Miss.

"far ahead of friend taking another course" . . .

A friend of mine is taking a correspondence course in electronics, and I have learned more from your first two kits than he has in twenty lessons. **RAY P. BILODEAU**, 139 Exchange St., Leominster, Mass.

"the number of concepts presented is amazing" . . .

Your kits offer a range of experiments usually performed only in the better high school and college laboratories. The number of concepts presented, and the clarity and concreteness of their development is amazing. **R. M. HELM**, Professor of Physics, East Carolina College, Greenville, N. C.

Get it All in One Complete Shipment — or Divided into these 4 Monthly Kits

1st KIT — DC AND AC CIRCUITS

Equipment for 26 Projects Including:

- Electroscope • Electromagnetic Relay • Galvanometer
- AC Buzzer • Magnetizer and Demagnetizer • Solenoid Coin Tossor • Safety AC Power Supply with Isolation Transformer.

Subjects Covered:

- Electron Theory
- DC and AC
- Electro-Chemistry
- Transformer Principles
- Inductance

FREE with 1st Kit — Surprise "Mystery Box"

2nd KIT — RESISTANCE, CAPACITANCE AND RECTIFICATION

Equipment for 18 Projects Including:

- Strobe Light - variable pulse Neon Lamp "freezes" the motion of vibrating or rotating objects and checks RPM
- Thermocouple • Wheatstone Bridge (measures resistance)
- Extinction Voltmeter • DC Power Supply (Transformer, Vacuum Tube Rectifier and 20-20 mfd. Capacitor Filter Circuit.)

Subjects Covered:

- Ohm's Law
- Rectification
- Resistance
- Neon Glow Tubes
- Capacitance
- Filter Circuits

FREE with 2nd Kit — Electric Soldering Iron

3rd KIT — AMPLIFIERS AND OSCILLATORS

Equipment for 14 Projects Including:

- Two Stage Amplifier • Capacitance Burglar Alarm
- Proximity Detector • Variable Frequency Ripple Tank Wave Generator (Produces standing waves, nodal lines, etc. Invaluable in understanding wave theory) • Code Practice Oscillator.

Subjects Covered:

- Vacuum Tube Amplifiers
- Frequency and Wave Length
- Wave Theory
- Oscillator Circuits

FREE with 3rd Kit—"Steps to a Ham License" Manual

4th KIT — AUDIO AMPLIFICATION AND RADIO

Equipment for 7 Projects Including:

- Short Wave and Broadcast Radios (3-tube regenerative. Uses 115V AC house current. Complete with Headset) • Carbon Microphone and Two Stage Audio Amplifier • Radio Transmitter • Signal Tracer and Continuity Tester (valuable trouble-shooting tools).

Subjects Covered:

- Audio Amplifiers
- Radio Theory
- Regen. Circuits
- Tuning Circuits
- Signal Tracing

FREE with 4th Kit — Radio-TV Service Manual

ALL FOUR KITS IN ONE SHIPMENT ONLY \$17⁸⁰ POSTPAID

OR—YOU CAN GET THE FOUR KITS, ONE A MONTH

SEND **\$2⁰⁰** WITH COUPON ONLY PAY **\$3⁹⁵** PLUS COD POSTAGE ON RECEIPT OF EACH KIT

ALL SHIPMENTS ON 10 DAY APPROVAL. YOUR SATISFACTION OR YOUR MONEY BACK.

WE KNOW YOU WILL BE AMAZED AND DELIGHTED.

USE THIS "NO RISK" COUPON FOR EITHER PAID IN FULL OR MONTHLY PLAN

AMERICAN BASIC SCIENCE CLUB, Inc., 501 E. Crockett, San Antonio 6, Texas

Send me ABSClub's Electronics Lab in four kits — one a month. I enclose \$2.00 and will pay \$3.95 plus COD Postage on arrival of each kit. I understand that all kits will be on 10 day approval with full refund guaranteed and also that I may cancel unshipped kits at any time without obligation.

Send me ABSClub's Electronics Lab (all four kits) in one shipment. I enclose \$17.80 full payment, postage paid to me. I understand that this will be on a 10 day approval with full refund guaranteed.

NAME.....

ADDRESS.....

CITY and STATE.....



FALL 1965

Cover photo by Don Lothrop

ELEMENTARY ELECTRONICS

Theory Articles

NE-2—the Noble Neon Bulb.....	21
The Hows and Whys of Resonance.....	29
10 Simple SCR Experiments.....	39
Frequency Synthesis—CB's Rubber Crystals..	49
The Astounding TE Module (Cover Story).....	55
UHF Antenna Installation.....	61
After Ohm's Law—Node Voltage Method.....	65
Novice Hams License Guide.....	67
Noise Limiters	79

Construction Projects

Thermostat Relays	47
Thermoelectric Beer Cooler.....	59
Transistorized Inductance Bridge.....	75
Stereo Checker	87
Transiflash	91
The Little Beeper.....	93
Electronic Temperature Indicator.....	95
Build Your Own Batteries.....	98
FM and TV-Sound Eavesdropper.....	101

Departments

Ask Me Another.....	6
NewScan	10
Literature Library	106
Classified Ads	111

FACTORIES ARE TURNING OUT MILLIONS OF APPLIANCES DAILY . . . WHO WILL REPAIR THEM?

START YOUR OWN BUSINESS!

ELECTRICAL APPLIANCE REPAIRING



There are over 60,000,000 families in the United States. They average 15 or more appliances each, and every marriage means another 15 appliances. Billions of dollars are invested in appliances, yet every year more appliances appear on the market. Eventually they all need adjustment or repair — that is why Electrical Appliance Repairing is such a profitable business today and will go on paying big cash profits for years to come.

EARN WHILE YOU LEARN

Since 1935 Christy Trades School has been teaching mechanically-inclined men the profitable Electrical Appliance Repair business. You learn by working with your hands — testing and repairing. We send you kits to assemble and keep, including the valuable Christy Electronic Trouble Tracer. We show you how to find trouble in refrigerators, automatic washers, irons and everything electrical, how to fix it quickly. We tell you what to charge, how to solicit business, where to get spare parts wholesale. We also teach you how to build power tools from spare parts, and how to do welding, house wiring, and other profitable businesses.

MAKE MONEY RIGHT FROM THE START

Many of our students pay for their entire course before they have completed their training! How? Because right from the very beginning they are shown how to make actual repairs! Thousands of Electrical Appliance Technicians can testify that the CTS course is a practical course written in simple, easy-to-understand language, profusely illustrated with hundreds of photographs and detailed drawings.



ELECTRONIC TESTING KIT FURNISHED



SEND FOR FREE BOOK . . . tells you how to do it!

PAY-AS-YOU-LEARN PLAN. Send TODAY for FREE illustrated book and special form for paying from earnings made while learning. See how you can soon own your own money-making business!

USE YOUR OWN BASEMENT, garage, or kitchen. You don't need expensive equipment. Work full or spare time, as you wish.

\$6 to \$7 AN HOUR are the going rates for making ordinary repairs and doing routine appliance service work. Think of the things you could have if you had your share of this money!

AGE IS NO BARRIER, nor is a minor handicap. The work is light and pleasant. Work when you wish — you're the boss!

RETIRED MAN BUILDS BUSINESS. Mr. Marion A. Pippin, 1139 E. Lincoln Ave., Decatur, Ill., writes: "I am now in the phone book in 4 places in the yellow pages. My business is getting better all the time." Mr. Pippin, now in his sixties and retired, is building a real business with solid security in his fix-it shop. You can do the same with CTS training.

CHRISTY TRADES SCHOOL INC.

Dept. A-4Y, 3214 W. Lawrence Avenue, Chicago, Illinois 60625

Please RUSH FREE book on America's fastest growing industry, Electrical Appliance Repairing, and special form for paying from earnings while learning.

Name _____

Address _____

City _____ State _____

ELEMENTARY ELECTRONICS

No. 751

Fall 1965 Edition

"TAB", SILICON 750MA* DIODES
***NEWEST TYPE! LOW LEAKAGE** Factory Tested!

Piv/Rms 50/35 .05	Piv/Rms 100/70 .09	Piv/Rms 200/140 .12	Piv/Rms 300/210 .14
Piv/Rms 400/280 .15	Piv/Rms 500/350 .19	Piv/Rms 600/420 .23	Piv/Rms 700/490 .27
Piv/Rms 800/560 .35	Piv/Rms 900/630 .45	Piv/Rms 1000/700 .65	Piv/Rms 1100/770 Query

ALL TESTS AC & DC & FWD & LOAD!

1700Piv/1200Rms @ 750Ma \$1.20 @, 10 for \$10
 same 1100Piv/770Rms 75c @, 16 for \$11

SILICON POWER DIODES STUDES & P.F.**

D.C. Amps	50 Piv 35 Rms	100 Piv 70 Rms	150 Piv 105 Rms	200 Piv 140 Rms
3	.08	.14	.17	.24
12	.50	.55	.70	.85
25**	.20	.30	.50	.75
35	.70	2.05	1.35	1.50
100	1.65	1.00	2.50	3.15
240	3.75	4.75	5.75	8.75
D.C. Amps	300 Piv 210 Rms	400 Piv 280 Rms	500 Piv 350 Rms	600 Piv 420 Rms
3	.29	.30	0	.48
12	1.00	1.35	1.45	1.70
25**	1.00	1.00	Query	Query
35	2.15	2.45	2.75	3.33
100	3.75	4.60	5.50	8.00
240	11.70	19.80	27.90	43.33

Battery Charger 6 & 12 V Charges up to 5 Amp with Circuit Breaker \$8 @, 2 for \$15.
 D.C. Power Supply 115V/60 to 800 Cys. Output 330 & Tap 185V up to 150Ma \$5 @, 2 for \$9.
 3000Piv/2100Rms @ 200Ma \$1.80 @, 6 for \$10.
 6000Piv/4200Rms @ 200Ma \$4 @, 4 for \$15.
 12000Piv/8400Rms @ 200Ma \$10 @, 3 for \$25.
 5U4 Silicon Tube Repl. \$1.90 @, 6 for \$11.

"TAB" ★ SCR's ★ TRANSISTORS ★ DIODES!!!
 Full Leads Factory Tested & Gid! U.S.A. Mfg.

PNP/HiPower/15 Amp Round T036 Pckg! 2N441.
 442, 277, 278, D5501 up to 50 volts VCB0 \$1.25 @, 5 for \$5
 TN278, 443, 174 up to 80v @ 2 for \$5
 PNP Diamond/3A-2N155, 156, 235, 242, 254, 255.
 256, 257, 301, 351, 435 @, 4 for \$1
 PNP/Signal up to 350mW T05 c25 @, 6 for \$1
 NPN/Signal 1F, RF, OSC, T05, 0V5, c25 @, 6 for \$1
 PNP 2N670/300mW c35 @, 4 for \$1
 PNP 2N671/1 watt c50 @, 3 for \$1
 Power Heat Sink Finned 100 Sq \$1 @, 6 for \$5
 STABISTOR Diodes Fwd Regulators @, 1 watt 5 for \$1
 Zener Diodes up to One Watt 6 to 200v c70 @, 3 for \$2
 Zener Diodes Ten Watt 6 to 150v \$1.45 @, 4 for \$5



SiI Presfit 1BA up to 100 Piv..... 4 for \$1
 Micro or MuSwitch CSD 35 AMP/AC-DC..... 3 for \$1

"SCR" SILICON CONTROLLED RECTIFIERS!

PRV	7A	16A	25A	PRV	7A	16A	25A
25	.30	.50	.85	250	1.35	2.25	2.60
50	.50	.75	1.00	300	2.00	2.45	2.80
100	.90	1.35	1.60	400	2.50	2.90	3.35
150	1.00	1.65	2.00	500	3.25	3.60	4.00
200	1.30	1.90	2.30	600	3.50	4.35	4.60

"Volt-Tab" 600 watt "SCR" speed control 115 VAC
 \$4.50 @, 2 for \$8.00

"TAB" TERMS: Money Back Guarantee! Our 20th year. \$2 Min. order F.O.B. N.Y.C. Add shpg charges or for C.O.D. 25% Dep. Prices shown subject to change.
 111-M5 Liberty St., N. Y. 6, N. Y.
 SEND 25¢ Phone: Rector 2-6245 for CATALOG

\$

There's money to be made in the Stock Market and INVESTOR'S GUIDE points the way!

Read the professional advice on how you can cash in on the stock market boom!
Buy INVESTOR'S GUIDE at your newsstand for only \$1.
 Or write:
INVESTOR'S GUIDE #743A
 505 PARK AVE., N.Y., N.Y. 10022
Add 25¢ for postage and handling.

\$

Editor
JULIAN M. SIENKIEWICZ
 WA2CQL, KAIØ614

Associate Editor
WILLIAM HARTFORD
 KKD7432

Art Director
ANTHONY MACCARRONE

Assistant Art Director
JOSEPH DAVIS

Art Editor
VICTOR J. CLOSI

Art Associates
ALBERT DE QUERQUIS
LYNDA P. KALMAN

Advertising Director
ELLIOT S. KRANE

Advertising Manager
JIM CAPPELO

Production Director
LEONARD F. PINTO

Production Manager
CARL BARTEE

Assistant Production Manager
HELEN GOODSTEIN

Promotion Manager
RICHARD HOWE

Executive Editor
JOSEPH DAFFRON

President and Publisher
B. G. DAVIS

Executive Vice President and Assistant Publisher
JOEL DAVIS

Vice President and Editorial Director
HERB LEAVY

ELEMENTARY ELECTRONICS (No. 751) is published by SCIENCE & MECHANICS PUBLISHING CO., a subsidiary of Davis Publications, Inc. Editorial, business and subscription offices: 505 Park Ave., New York, N.Y. 10022. Advertising offices: New York, 505 Park Ave., PL-2-6200; Chicago: 520 N. Michigan Ave., 527-0330; Los Angeles: 6253 Hollywood Blvd., 213-463-5143; Atlanta: Pirnie & Brown, 3108 Piedmont Rd., N.E., 404-233-6729; Long Island: Len Osten, 9 Garden Street, Great Neck, N.Y., 516-487-3305.

EDITORIAL CONTRIBUTIONS must be accompanied by return postage and will be handled with reasonable care; however, publisher assumes no responsibility for return or safety of manuscripts, art work, or photographs. Contributions should be addressed to the Editor, Elementary Electronics, 505 Park Avenue, New York, New York 10022.

Copyright 1965 by Science & Mechanics Publishing Co.

SOMEONE SHOULD DEVELOP AN EASY WAY TO LEARN ELECTRONICS AT HOME

RCA INSTITUTES DID!

RCA Introduces new CAREER PROGRAMS—beginning with the student-proved "AUTOTEXT" Programmed Instruction Method—the faster, easier way to learn. You start to learn the field of your choice immediately. No previous training or experience needed.

Pick the career of your choice—and RCA Institutes will do the rest! RCA's new, revolutionary "Career Programs" help you go directly to the career you want! You waste no time learning things you'll never use on your job! Each Career Program is designed to get you into the kind of job you want in the fastest, easiest possible way!

SEPARATE COURSES

In addition, in order to meet specific needs, RCA Institutes offers a wide variety of separate courses which may be taken independently of the above Career Programs, on all subjects from Electronics Fundamentals to Computer Programming. Complete information about these courses will be sent with your other materials.

CHOOSE A CAREER PROGRAM NOW your first step to the job of your choice!

- Television Servicing
- Telecommunications
- FCC License Preparation
- Automation Electronics
- Automatic Controls
- Digital Techniques
- Industrial Electronics
- Nuclear Instrumentation
- Solid State Electronics
- Electronics Drafting

RCA INSTITUTES BONUS EXTRAS

Only RCA Institutes offers you a Liberal Tuition Plan, one of the most economical ways to learn. Plus, you get top quality equipment in all kits furnished to you with your courses—yours to keep and use on the job. And now, RCA's NEW PROGRAMMED ELECTRONIC BREADBOARD GIVES YOU LIMITLESS EXPERIMENTATION—scientific laboratory procedures right in your own home! You build a working signal generator, AM Receiver, Multi-meter, Oscilloscope, and other valuable

equipment—all as a part of your course! Get the facts today!

Classroom Training Also Available. Day and Evening Classes are available to you in New York City at RCA Institutes Resident School. You may be admitted without any previous technical training; prep courses are available if you haven't completed high school. Coeducational classes start four times a year.

SEND COUPON TODAY FOR COMPLETE INFORMATION. CHECK HOME STUDY OR CLASSROOM TRAINING.

RCA INSTITUTES, INC., EA-75

A Service of the Radio Corporation of America
350 West 4th St., New York City 10014

RCA Institutes, Inc. Dept. EA-75
350 West 4th St., New York, N.Y. 10014

Please rush me FREE illustrated book with information checked below. No obligation. No salesman will call.

Home Study Classroom Training
Name _____ Age _____
Address _____
City _____ Zone _____ State _____

CANADIANS: Take advantage of these same RCA Institutes Courses at no additional cost. No postage, no customs, no delay. Fill out coupon and send in envelope to: RCA Victor Ltd., 5581 Royalmount Ave., Montreal 9, Quebec.



THE MOST TRUSTED NAME IN ELECTRONICS

when it's time to think of college
you should read this

FREE CAREER BOOKLET

about electronics at

MSOE



**MILWAUKEE MS-237
SCHOOL OF ENGINEERING**

Dept. EE-65, 1025 N. Milwaukee Street
Milwaukee, Wisconsin 53201

Tell me about an engineering career through
residence study in:

Mechanical fields Electrical fields

Name.....Age.....

Address.....

City, State.....

AMAZING "X-RAY" VISION INSTANTLY!



A Hilarious
Laughingly Funny
Illusion!

See through fingers—
through skin—see yolk
of egg—see lead in pen-
cil. Many, many amaz-
ing, astounding, illusory
X-ray views yours to see
ALWAYS—when YOU
wear Slimline X-ray
Specs. Bring them to
parties, for real FUN.
GUARANTEED—They
give you a 3 dimensional
X-ray illusion—the
instant you put them
on. No real X-ray vision
"X-ray" vision so real

is obtained. But you get an illusion of
you will hardly believe your eyes. Full instructions of How To
Enjoy Them To The Fullest! Last For Years—Harmless—Requires
No Electricity Or Batteries—Comes Complete—Permanently Focused
—Nothing Else To Buy—Send \$1. plus 25¢ for postage and handling
or send \$2. for Deluxe model—Money Back If Not 100% Satisfied.

SLIMLINE CO., Dept. 479
285 Market St., P. O. Box 90, Newark, New Jersey

BUILD HIGH-QUALITY PRECISION KITS AT LOW COSTS!

**DECADE
RESISTANCE
BOX—\$24.95**

Can get any value
of resistance at 1%
accuracy.

**ALL-PURPOSE
SHOP
TACHOMETER
\$16.95**

This 3-range tach
belongs in the shop
of every electrician.

SCIENCE & MECHANICS

Kit Division

MONEY-BACK GUARANTEE.

505 Park Ave.

New York, N. Y. 10022

ask me another

By Leo G. Sands

Elementary Electronics brings the know-how of an electronics expert to its readers. Leo G. Sands, columnist for *Radio-TV Experimenter*, will be happy to answer your question. Just type or print your unsolved problem on the back of a 4¢ postal card and send it to "Ask Me Another," *Elementary Electronics*, 505 Park Avenue, New York, New York 10022. Leo will try to answer all your questions in the available space in upcoming issues of *Elementary Electronics*. Sorry, Leo will be unable to answer your questions by mail.

Neon Relaxes

How can I determine the frequency of a neon lamp relaxation oscillator? It is not $t = RC$ because different voltages produce different frequencies.

—E. S., Springfield, Ore.

The time constant of the circuit shown in the diagram, without the neon lamp, is equal to R in megohms times C in microfarads. If R is set to one megohm and C has a value of one microfarad, it will require one second for C to charge to 63% of the supply voltage.

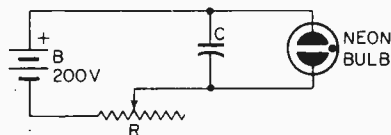

When the neon lamp is in the circuit, the supply voltage and the lamp characteristics have an effect on the period of the circuit. Suppose the neon lamp fires at 100 volts and extinguishes at 70 volts. If the supply potential (B) is 200 volts, C will not charge to 63 per cent of the supply voltage (126 volts) because the neon lamp will fire when the charge in C reaches 100 volts, which it does in about half the time required to reach 126 volts.

When the lamp fires, the capacitor discharges through it, but the charge only drops to 70 volts since the lamp goes out at this

point. Then, the cycle starts again, the charge in C rising exponentially from 70 volts (not from zero) to 100 volts and then dropping abruptly to 70 volts.

There are fairly complex equations for calculating the frequency of a neon lamp relaxation oscillator which are applicable when the characteristics of the lamp are known and the voltage source is stable. The easiest way is cut and try. It is extremely important for the voltage source to have excellent regulation in order to achieve frequency stability.

Local Oscillator Kaput!

My 5-tube AC-DC superheterodyne receiver will bring in stations near one end of the dial. The rest of the band is dead. What is the trouble?

—T. K., Long Island City, N. Y.

Either the tuning condenser plates are shorting or you probably are experiencing oscillator trouble. The oscillator may cease to function except over a limited frequency

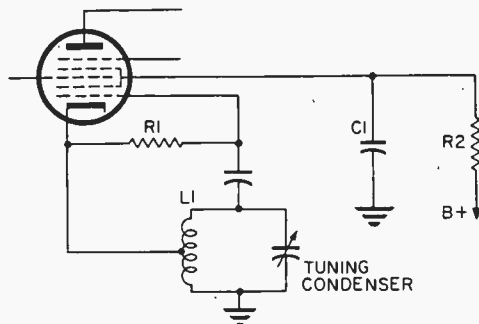

range. The trouble is usually due to a defective converter tube, change in the value of the oscillator grip leak (R1) or in the value of the screen voltage dropping resistor (R2). It could be that by-pass capacitor C1 may be leaky causing the screen voltage to drop. Try a new grid leak (R1) of the same value as the original. If that doesn't do it, change R2 and C1. Sometimes the oscillator coil (L1) absorbs moisture and its Q is lowered. Try drying it out by exposing it to an infrared lamp.

Radio Goes PA

How can I connect a microphone to an AC/DC radio so I can use its amplifier without using the radio circuit?

—A. S., Passaic, N. J.
(Continued on page 104)

COLOR CODED NUTDRIVER SETS

no fumbling..
you reach for
the right one
every time!



No. 17
HANDY
BENCH STAND

- 7 Most-used sizes — $\frac{3}{16}$ " thru $\frac{3}{4}$ " • High carbon steel, polished and plated • Precision fit case-hardened sockets
- Shockproof plastic handles (UL) • Large, readable size indexes

No. 127
SPACE-SAVING
WALL RACK
(lockable)



OTHER SETS, TOO:
hollow-shaft or mixed

PLUS A FULL RANGE OF
SEPARATE NUTDRIVERS:
 $\frac{3}{32}$ " thru $\frac{3}{4}$ " — Regular,
Stubby, Extra-long,
Midget (Pocket clip)

available through leading electronic distributors

XCELITE

XCELITE INC. • 80 BANK ST., ORCHARD PARK, N. Y.

Send free literature on nutdriver sets.

name _____

address _____

city _____ state & zone _____

BECOME A RADIO

Build 20 Radio and Electronic Circuits at Home

ALL GUARANTEED TO WORK!

YOU DON'T HAVE TO SPEND HUNDREDS OF DOLLARS FOR A RADIO COURSE

The "Edu-Kit" offers you an outstanding **PRACTICAL HOME RADIO COURSE** at a rock-bottom price. Our Kit is designed to train Radio & Electronics Technicians, making practice and servicing. **THIS IS A COMPLETE RADIO COURSE IN EVERY DETAIL.** In a professional manner: how to build radios, using regular schematics; how to wire and solder punched metal chassis as well as the latest development of Printed Circuit chassis. You will learn the basic principles of radio. You will construct, study and work with RF and AF amplifiers and oscillators, detectors, rectifiers, test equipment. You will learn troubleshooting, using the Progressive Signal Tracer, Oscillator. You will learn and practice Progressive Dynamic Radio & Electronics Tester, Square Wave Generator and the accompanying instructional material. You will receive training for the Novice, Technician and General Classes of F.C.C. Radio Amateur Licenses. You will build Receiver, Transmitter, Square Wave Generator, Code Oscillator, Signal Tracer and Signal Injector circuits, and learn how to operate them. You will receive an excellent background for television, Hi-Fi and Electronics. Absolutely no previous knowledge of radio or science is required. The "Edu-Kit" is the product of many years of teaching and engineering experience. The "Edu-Kit" will provide you with a basic education in Electronics and Radio, worth many times the complete price of \$26.95. The Signal Tracer alone is worth more than the price of the entire Kit.

THE KIT FOR EVERYONE

You do not need the slightest background in radio or science. Whether you are interested in Radio & Electronics because you find an interesting hobby, a well paying business or a job with a future, you will find the "Edu-Kit" a worth-while investment. Many thousands of individuals of all

ages and backgrounds have successfully used the "Edu-Kit" in more than 79 countries of the world. The "Edu-Kit" has been carefully designed, step by step, so that you cannot make a mistake. The "Edu-Kit" allows you to teach yourself at your own rate. No instructor is necessary.

PROGRESSIVE TEACHING METHOD

The Progressive Radio "Edu-Kit" is the foremost educational radio kit in the world, and is universally accepted as the standard in the field of electronics training. The "Edu-Kit" uses the modern educational principle of "Learn by Doing." Therefore you construct, learn schematics, study theory, practice trouble-shooting—all in a closely integrated program designed to provide an easily-learned, thorough and interesting background in radio. You begin by examining the various radio parts of the "Edu-Kit." You then learn the function, theory and wiring of these parts. Then you build a simple radio. With this first and trouble-shooting. Then you build a more advanced radio, learn more advanced theory and techniques. Gradually, in a progressive manner, and at your own rate, you will professional Radio Technician. Included in the "Edu-Kit" course are Receiver, Transmitter, Code Oscillator, Signal Tracer, Square Wave Generator and Signal Injector circuits. These are not unprofessional "breadboard" experiments, but genuine radio circuits, constructed by means of professional wiring and soldering on metal chassis. Plus, the new method of radio construction known as "Printed Circuitry." These circuits operate on your regular AC or DC house current.

THE "EDU-KIT" IS COMPLETE

You will receive all parts and instructions necessary to build 20 different radio and electronics circuits, each guaranteed to operate. Our Kits contain tubes, tube sockets, variable, electrolytic, mica, ceramic and paper dielectric condensers, resistors, tie strips, coils, hardware, tubing, punched metal chassis, Instruction Manuals, hook-up wire, solder, selenium rectifiers, volume controls and switches, etc. In addition, you receive Printed Circuit materials, including Printed Circuit chassis, special tube sockets, hardware and instructions. You also receive a useful set of tools, a professional electric soldering iron, and a self-powered Dynamic Radio and Electronics Tester. The "Edu-Kit" also includes Code Instructions and the Progressive Code Oscillator, in addition to F.C.C.-type Questions and Answers for Radio Amateur License training. You will also receive lessons for servicing with the Progressive Signal Tracer and the Progressive Signal Injector, a High Fidelity Guide and Quiz Book. You receive Membership in Radio-TV Club, Free Consultation Service, Certificate of Merit and Discount Privileges. You receive all parts, tools, instructions, etc. Everything is yours to keep.

SERVICING LESSONS

You will learn trouble-shooting and servicing in a progressive manner. You will practice repairs on the sets that you construct. You will learn symptoms and causes of trouble in home, portable and car radios. You will learn how to use the professional Signal Tracer, the unique Signal Injector and the dynamic Radio & Electronics Tester. While you are learning in this practical way, you will be able to do many a repair job for your friends and neighbors, and charge fees which will far exceed the price of the "Edu-Kit." Our Consultation Service will help you with any technical problems you may have.

J. Stataitis, of 25 Poplar Pl., Waterbury, Conn., writes: "I have repaired several sets for my friends, and made money. The "Edu-Kit" paid for itself. I was ready to spend \$240 for a Course, but I found your ad and sent for your Kit."

FROM OUR MAIL BAG

Ben Valerio, P. O. Box 21, Magna, Utah: "The Edu-Kits are wonderful. Here I am sending you the questions and also the answers for them. I have been in Radio for the last seven years, but like to work with Radio Kits, and like to build Radio Testing Equipment. I enjoyed every minute I worked with the different kits; the Signal Tracer works fine. Also like to let you know that I feel proud of becoming a member of your Radio-TV Club."

Robert L. Shuff, 1534 Monroe Ave., Huntington, W. Va.: "Thought I would drop you a few lines to say that I received my Edu-Kit, and was really amazed that such a bargain can be had at such a low price. I have already started repairing radios and phonographs. My friends were really surprised to see me get into the swing of it so quickly. The Trouble-shooting Tester that comes with the Kit is really swell, and finds the trouble, if there is any to be found."

PRINTED CIRCUITRY

At no increase in price, the "Edu-Kit" now induces Printed Circuitry. You build a Printed Circuit Signal Injector, a unique serving instrument that can detect many Radio and TV troubles. This revolutionary new technique of radio construction is now becoming popular in commercial radio and TV sets.

A Printed Circuit is a special insulated chassis on which has been deposited a conducting material which takes the place of wiring. The various parts are merely plugged in and soldered to terminals.

Printed Circuitry is the basis of modern Automation Electronics. A knowledge of this subject is a necessity today for anyone interested in Electronics.

NOW! TRAIN AT HOME

IN RADIO AND ELECTRONICS

ORDER DIRECT FROM AD . . . USE COUPON ON NEXT PAGE

RECEIVE FREE RADIO & TV PARTS JACKPOT

TECHNICIAN for only \$26⁹⁵

THE NEW IMPROVED DELUXE

Progressive Radio "Edu-Kit"®

is now ready

NOW INCLUDES

- ★ 12 RECEIVERS
- ★ 3 TRANSMITTERS
- ★ SQ. WAVE GENERATOR
- ★ AMPLIFIER
- ★ SIGNAL TRACER
- ★ SIGNAL INJECTOR
- ★ CODE OSCILLATOR

PRACTICAL
HOME
RADIO
COURSE

only
\$26⁹⁵



Reg. U.S.
Pat. Off.

TRAINING ELECTRONICS
TECHNICIANS SINCE 1946

FREE EXTRAS

- SET OF TOOLS
- SOLDERING IRON
- ELECTRONICS TESTER
- PLIERS-CUTTERS
- VALUABLE DISCOUNT CARD
- CERTIFICATE OF MERIT
- TESTER INSTRUCTION MANUAL
- HIGH FIDELITY GUIDE • QUIZZES
- TELEVISION BOOK • RADIO TROUBLE-SHOOTING BOOK
- MEMBERSHIP IN RADIO-TV CLUB; CONSULTATION SERVICE • FCC AMATEUR LICENSE TRAINING
- PRINTED CIRCUITRY

SCHOOL INQUIRIES INVITED

Unconditional Money-Back Guarantee

The Progressive Radio "Edu-Kit" has been sold to many thousands of individuals, schools and organizations, public and private, throughout the world. It is recognized internationally as the ideal radio course.

By popular demand, the Progressive Radio "Edu-Kit" is now available in Spanish as well as English.

It is understood and agreed that should the Progressive Radio "Edu-Kit" be returned to Progressive "Edu-Kits" Inc. for any reason whatever, the purchase price will be refunded in full, without quibble or question, and without delay.

The high recognition which Progressive "Edu-Kits" Inc. has earned through its many years of service to the public is due to its unconditional insistence upon the maintenance of perfect engineering, the highest instructional standards, and 100% adherence to its Unconditional Money-Back Guarantee. As a result, we do not have a single dissatisfied customer throughout the entire world.

You Will Find That The Progressive Radio "Edu-Kit" Is Perfect

- • • FOR anyone who wishes to learn more about radio construction, theory and servicing.
- • • FOR anyone who is looking for an interesting hobby.
- • • FOR anyone who would like to learn radio but does not have time to attend regular school hours.
- • • FOR anyone who wants to start studying for a high-paying radio job.
- • • FOR anyone who wishes to start in Television.

- Send "Edu-Kit" postpaid. I enclose full payment of \$26.95.
- Send "Edu-Kit" C.O.D. I will pay \$26.95 plus postage.
- Rush me FREE descriptive literature concerning "Edu-Kit."

Name

Address

PROGRESSIVE "EDU-KITS" INC.

(ATT: S. Goodman, M. S. in ED., Pres.)
1186 Broadway, Dept. 509-DJ, Hewlett, N. Y.

WORTH \$15.00

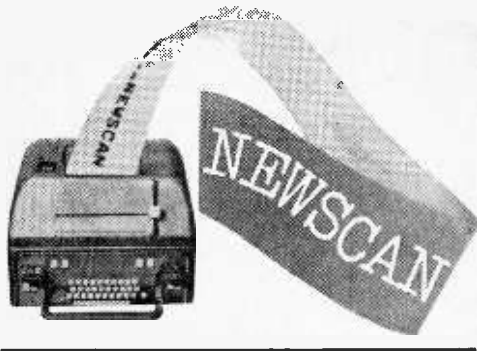

Lantern Batteries Go Nickel-Cadmium

A new rechargeable nickel-cadmium battery, designed for emergency lights, railroad lantern lamps and other small standby power systems, as well as for use by hobbyists, is being marketed by the Battery Division of Sonotone Corporation. The new nickel-cadmium battery package can be recharged hundreds of times. It's shockproof and will operate in wide temperature ranges—subzero to tropical heat. It's resistant to vibration and delivers a current at high, level discharge rates.

The battery is formed by a new packaging concept designed by Sonotone engineers. It has four cylindrical "F" size, 1.25-volt nickel-cadmium sealed cells, arranged 2 x 2, totaling a 5-volt battery pack (equivalent to a 6-volt dry cell lantern type battery). The cells are packaged between two lightweight nylon plates, one at the top and one at the bottom sandwich fashion). Each nylon plate is molded on the mating side to fit the diameters of the "F" size cells, with canal type grooves to run inter-cell jumpers. The cells are recessed 1/4" in each plate, making it completely insulated at the top and bottom. The sandwich of cells is held in place by a shaft, running through the middle of the package, which is threaded at each end for mating the top and bottom nylon plates. The top and bottom plates have provisions for probing individual cell voltages.

Since it is not a potted type package and completely open, air may circulate, protecting against shorting of battery cells due to humidity or condensation buildup. The battery can easily be serviced in the field and cells can be changed, if necessary.

The battery package using "F" size nickel-cadmium cells is also ideally suited for "D" size battery cells, since both the "F" and "D" are the same diameter, differing only in length. This provides for greater flexibility in battery packaging. For example, the "F" size battery package offers a nominal capacity (5-hour rate) of 5 1/2 ampere hours. A 4-cell battery using "D" size

cells offers a nominal capacity (5-hour rate) of 4 ampere hours. The "F" and "D" size nickel-cadmium battery cells used in this new battery package are designed with safety vents (as are all Sonotone sealed cells). The vent feature allows excessive internal pressure to escape in case of malfunction of charging equipment. If venting action should occur, this does not affect the performance of the Sonotone cell . . . it will continue to cycle for hundreds of times.

Both the "F" size package and the "D" size package are direct replacement for NEDA Nos. 908 and 916 lantern batteries. In actual field use, the new Sonotone 5-volt lantern battery, using "F" size cells, has operated at a constant drain for 10 hours with a PR-2 bulb and for 20 hours with a PR-6 bulb. When battery capacity is drained, the battery is restored to its original

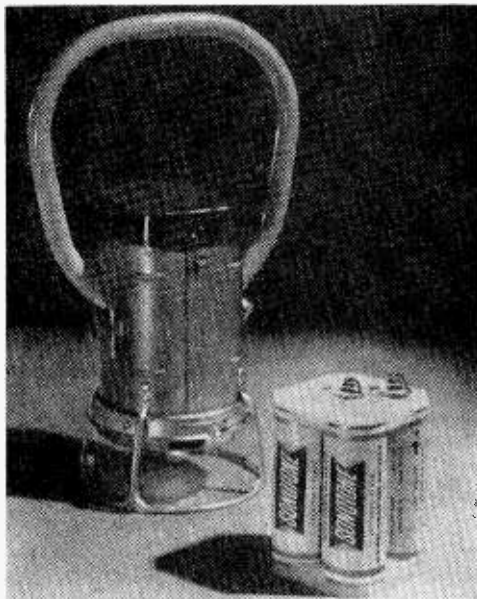

A new "sandwich" design by Sonotone has packaged this lightweight, flexible battery for emergency and standby battery power. The nickel-cadmium battery package is an assembly of 4 "F" sealed cells rated at 5 volts (equivalent to a 6-volt dry cell lantern type battery) and has a nominal drain of 5.5 ampere hours. This same package is also available with 4 "D" size cells. Both models are direct replacements for standard NEDA type batteries.

life by a 14-hour charge. If the battery is not in use, and requires shelf storage, it can be maintained by trickle charge with no harmful effects.

Complete data is available on Sonotone's new battery package. Write Battery Division, Dept. 51, Sonotone Corporation, Elmsford,

N. Y., for spec sheet BA-158, showing the battery, discharge curves, dimensions and physical and electric characteristics. Suggested charging circuits (spec sheet BA-160) are also available.

Miniature Probe for Peering Behind the Eardrum

A Chicago optics physicist told of his work in developing two miniature probes for insertion through the eardrum to examine the middle ear. He is Anatoli Brushenko of IIT Research Institute who spoke before the annual meeting of the Optical Society of America. In a paper he co-authored with another IITRI scientist, Donald A. Pontarelli, he said:

"The objective of our work was to develop two highly compact probes to be used by surgeons as diagnostic instruments for examination of

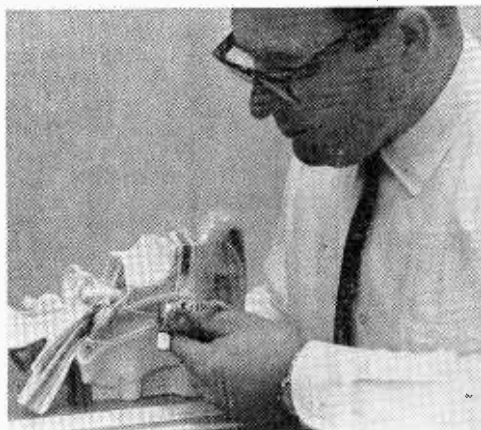

Miniature instruments for peering behind the eardrum have been developed at IIT Research Institute, Chicago. One of the developers, Anatoli Brushenko, IITRI optics physicist, shows how the devices, that use more than 10,000 tiny glass fibers, work. For clarity, a model ear quite a bit bigger than lifesize, is shown.

the middle ear—one device can be inserted immediately beyond the eardrum to view areas at right angles to the tip, and a second with a straight-ahead view that is equipped with a tiny electrode to measure miniscule electrical currents found in the ear."

Funding for the development came from part of a \$36,000 grant to the University of Illinois Medical Center in Chicago by the National Institute of Neurological Diseases and Blindness. University researchers experimenting with the devices are Dr. Bruce Mer and Arthur J. Derbyshire, Ph.D.

The right angle probe permits viewing of the



 **FREE**



Fill in coupon for a **FREE** One Year Subscription to **OLSON ELECTRONICS' Fantastic Value Packed Catalog—Unheard of LOW, LOW PRICES on Brand Name Speakers, Changers, Tubes, Tools, Stereo Amps, Tuners, CB, and other Values. Credit plan available.**

NAME _____
 ADDRESS _____
 CITY _____ ZONE _____ STATE _____

If you have a friend interested in electronics send his name and address for a **FREE** subscription also.

OLSON ELECTRONICS
 INCORPORATED

401 S. Forge Street Akron, Ohio 44308

ELECTRONICS

TELEVISION ELECTRICITY
 TECHNICIAN COURSES

ALSO
 Electronics
 Engineering
 Technology



COYNE ELECTRONICS INSTITUTE

Founded
 1899

Learn on a quarter of a million dollars worth of equipment for top salaries and an Exciting Career. Many special finance plans. Part time employment service while in school. Also free graduate employment service.



Use this coupon to get our **FREE BOOK "YOUR OPPORTUNITIES IN ELECTRONICS"**

COYNE ELECTRONICS INSTITUTE, Dept. of Electronics B5-F
 1501 W. Congress Parkway, Chicago, Illinois 60607

Name _____ Age _____

Address _____ Phone _____

City _____ Zone _____ State _____

Unlike most other schools, we do not employ salesmen
 I only want information on Home Study Courses

Do You Want More Miles-Per-Gallon?

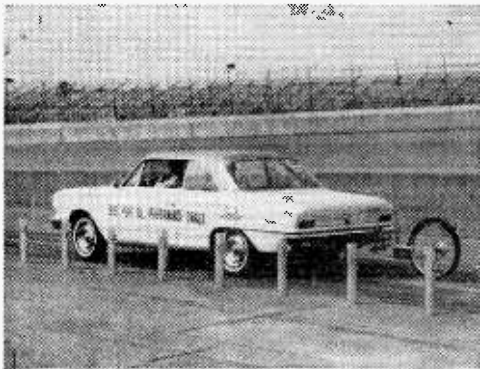

Of course — everyone does! And in the August S&M you'll read 17 tips from an expert on how to drive farther on less. The article is written by Les Viland, staff engineer for the American Motors Corp., who took First in his Class at the 1965 Pure Oil Economy & Performance Trials. Learn gas economy from a pro in the

AUGUST Science & Mechanics

on sale at all newsstands

NEWSCAN

series of bones which transmit vibrations from the eardrum to the inner ear where the vibrations are converted to electrical energy which may initiate the messages to the brain. The straight-viewing instrument with the electrode permits recording of the impulses of energy and viewing in an area called the round window, immediately behind the eardrum. Entry to the middle ear is made by making a small incision in the eardrum.

Key to the miniaturization of the probes is the use of more than 10,000 tiny glass fibers in each device, both to transmit images picked up and to send light down to the area to be viewed. The probes have a diameter of 2.5 mm and are attached to a surgical microscope.

Optics in the side-viewing instrument consist of a planoconvex lens, a prism, and fibers, Bru-shenko said. Light from a miniature bulb is "piped" down to the viewing area by five .015 inch diameter fibers which are bent 90 degrees to illuminate objects off the axis. Reflected light from the viewed objects is redirected by a prism, then is focused by a 2 mm focal length lens onto the end of a fiber bundle that conveys the image up to the microscope.

For focusing, the lens and bundle are mounted in a cam-driven tube which slides inside a 2½-inch-long barrel. An integral part of the probe is a 10X microscope objective which is focused on top of the fiber bundle. The microscope in combination with a 5X eyepiece produces 50X magnification.

However, total magnification varies with the distance of the object viewed. With the object 2mm away from the face of the prism, the total magnification is 50X, but with the object 15mm away total magnification drops to 7.5X. The same optics are used for the forward-looking device except that the prism is omitted. It uses a .005-inch diameter stainless steel electrode with a ball tip to pick up signals from the round window.

Cat's Eyes for G.I.'s

Light amplifying tubes that make it possible for soldiers to see in the dark without revealing their presence will be available to the U. S. Army. The image intensifier tubes permit soldiers to see objects hidden in light levels far below the threshold of normal human vision. Developed by the Machlett Laboratories, Inc., a subsidiary of Raytheon Company, the new tubes intensify the natural low level of night illumination to present a bright image, thus providing the soldier with fire power and mobility at night comparable to daylight activities.

Machlett, which produced the first commercial x-ray tubes in 1896, just one year after the discovery of x-rays, is the world's largest manufacturer of x-ray tubes. The firm also makes large area x-ray image intensifiers and a wide range of infrared image converter tubes for low light level and night viewing. Among other related products are high sensitivity vidicons in the near infrared and near ultraviolet regions for special purpose closed circuit television.



Image intensifier permits soldiers to see in the dark without revealing their presence. Photo shows unit mounted on rifle. Inset shows unit used for spying without rifle.

Looking at Water Through a Lead Wall

A method of taking television pictures through a lead wall and detect a stream of water flowing on the other side has been developed by The Rauland Corporation, a subsidiary of Zenith Radio Corporation, and the U. S. Atomic Energy Commission's Argonne National Laboratory. This new technique allows scientists to see neutron radiographs on a TV monitor screen and, because of its ability to resolve moving objects, opens up a whole new field of neutron radiograph motion pictures. Neutron radiography is a valuable research tool because absorption of thermal neutrons (neutrons that have been slowed down) is essentially the reverse of absorption of X-rays. Heavy elements such as lead, bismuth, and uranium are practically transparent to thermal neutrons, whereas they absorb X-rays strongly. Conversely, hydrogen, lithium, boron, and other light elements strongly absorb thermal neutrons but allow X-rays to pass freely. This is why neutron beam can "see" water, a hydrogen compound, while looking through lead.

In practice, neutron radiography formerly consisted of putting an object to be radiographed in front of an intense beam of thermal neutrons from a reactor. A thin screen of some material that could be made radioactive by the neutrons then was placed in back of the object and ex-

YOUR NEW COPY IS WAITING



FREE! For fun and pride in assembly, for long years of pleasure and performance, for new adventures in creative electronics mail the coupon below and get Conar's brand new catalog of quality do-it-yourself and assembled kits and equipment. Read about items from TV set kits to transistor radios . . . from VTVM's to scopes . . . from tube testers to tools. And *every* item in the Conar catalog is backed by a no-nonsense, no-loopholes, money-back guarantee! See for yourself why Conar, a division of National Radio Institute, is about the fastest growing entry in the quality kit and equipment business.

CONAR

MAIL THIS COUPON NOW

CONAR

GV5C

3939 Wisconsin Ave., Washington 16, D.C.

Please send me your new catalog.

Name _____

Address _____

City _____ State _____ Z-Code _____

Why Not Receive Every Copy

of **ELEMENTARY ELECTRONICS?**

**SEND IN THE SUBSCRIPTION
FORM TODAY!**

Each issue will arrive directly at your home to tell you everything that is going on in the world of basic electronics. And, importantly, it is written by professionals.

ELEMENTARY ELECTRONICS

is chock full of

- Theory Articles
- Features
- Build-It-Yourself Projects

Send in your order now. Join the many satisfied subscribers who never miss an issue.

ELEMENTARY ELECTRONICS EE-7
505 Park Ave., N.Y., N.Y. 10022

Please enter my subscription today.

I enclose \$3. Bill me.

name _____
(please print)

address _____

city _____

state _____ zip code _____

posed to the transmitted beam. This screen, with a radioactive but invisible image on it, then was placed in contact with a piece of photographic film. The radioactive atoms in the screen exposed the film which then was developed to show an image. Though useful to scientists, this technique was cumbersome and time consuming. Also, a very intense beam of neutrons was needed to obtain an intelligible image. Neutron radiographs could be made only at the sites of large reactors or particle accelerators.

A neutron radiography inspection system capable of observing motion was a particular requirement of Argonne scientists who used the technique. Berger and his associates discussed this problem with Dr. Wilfrid F. Niklas, Associate Director of Research of The Rauland Cor-

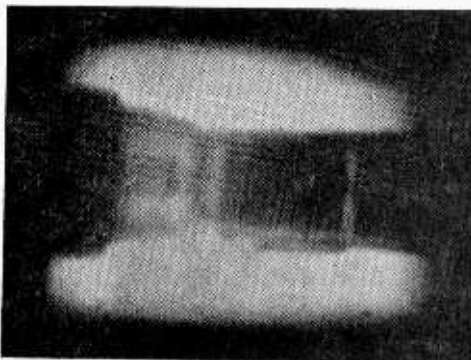

Neutron radiographs photographed from the screen of a closed-circuit television monitor located at the Juggernaut reactor at Argonne National Laboratory. Pictures were obtained through the use of a neutron image intensifier tube. Pictures show flashlight (top) and Masonite test object viewed through two inches of lead. Note holes in Masonite.

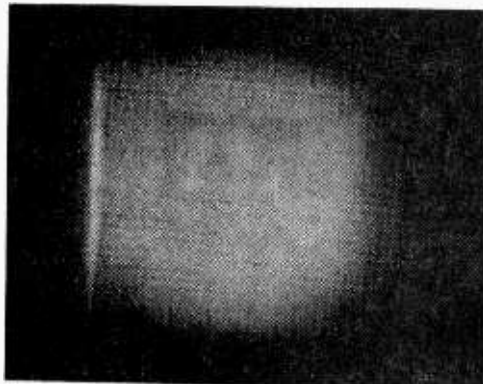

poration. Rauland, a leading producer of X-ray image intensifier tubes, agreed to cooperate in the development of a neutron image intensifier tube. Following an initial cooperative study to determine the best approach, a useful tube was assembled. The first tube, made by The Rauland Corporation and now in operation at Argonne, looks somewhat like a television picture tube but has "screens" on both ends. The screen on the input end contains a mixture of chemicals that glow faintly when exposed to neutrons. This small amount of light is sufficient to release a

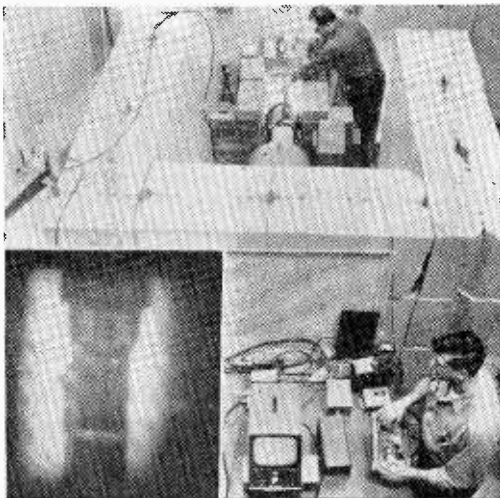

Scientists of Zenith Radio Corporation's cathode-ray tube-producing subsidiary, The Rauland Corp., and Argonne National Laboratory, have cooperated to develop a neutron image detector, using a new image intensifier tube with a neutron-sensitive screen. Shown in experimental use at Argonne, the tube produces a bright image that permits display of neutron images (similar to X-ray), on closed circuit TV and opens up a whole new field of neutron radiograph motion pictures. Inset shows neutron radiograph of flashlight.

certain number of electrons from a second layer behind the neutron-sensitive screen. These electrons then are accelerated to an energy of approximately 30,000 volts and focused on a small fluorescent screen on the other end of the tube.

Scientists view and photograph the neutron pictures on the screen of a closed-circuit television monitor located safely outside the radiation field of the reactor. A television camera picks up the images by viewing them on the output screen of the intensifier tube. With the new system, Argonne scientists have for the first time been able to obtain motion pictures of what happens to a piece of irradiated nuclear fuel when it is heated to high temperatures in a

COMING UP

in the next issue of

ELEMENTARY ELECTRONICS

**BUILD YOUR OWN
Decimal to binary
diode matrix converter**

Discover how computers convert numbers as we know them into "computer language" for rapid computations. Complete theory article precedes construction plans.

This and dozens of other new and informative features will be found in the next issue of ELEMENTARY ELECTRONICS. Be sure and buy your copy, starting October 14. Available at all newsstands for 75¢. Or send for your advance copy and add 25¢ for postage and handling.

ELEMENTARY ELECTRONICS

505 PARK AVENUE, N.Y., N.Y. 10022

New Magazines For Your Reference Library!

BOATCRAFT, Cruising Issue. (#749). 75¢.

Unusual ideas for all small craft owners. Of particular interest: "Formula For More Boating Fun."

FISHERMAN, Fishing & Tackle Show Issue. (#750). 75¢.

Large section features new tackle and equipment. Find out which new products are best for you.

Buy your copies of **BOATCRAFT** and **FISHERMAN** today at newsstands everywhere. Or write Davis Publications, 505 Park Avenue, New York, N. Y. 10022, adding 25¢ per copy to cover postage and handling. Be sure to specify the issue you want.

NEWSCAN

shielded container. In an experiment performed by W. Nelson Beck, an associate physicist in the Argonne Metallurgy Division, pictures were obtained of the fuel expanding and breaking through its protective metal cladding. According to Beck, pictures of this type—showing what may occur in an experimental fuel loading of an atomic reactor—should be of material assistance in the design of advanced reactor systems for making atomic power.

Way Out Weather

A satellite orbiting earth around the poles and measuring how starlight is bent by the high atmosphere would show air temperatures and pressures. This information could then be used within a few seconds to help make weather forecasts. The temperatures and pressures obtained from a polar-orbiting satellite would be at least as accurate as the readings taken now by radiosonde balloons, and possibly more so, for heights below 15 miles. They would also have the advantage of giving worldwide coverage, filling in the great gaps now existing over the oceans.

Star-tracking equipment is sufficiently accurate to allow the instrument to lock onto and track one star after another when the satellite is on the dark side of the earth. The star will be tracked from a height of about 25 miles above the earth's surface until its light is cut off either by clouds or by the earth itself. The atmosphere between the satellite and the star would bend the starlight, just as it bends the sun's light during a lunar eclipse to give the moon a coppery glow. The bending of starlight measured by a satellite gives the air's density directly, from which pressure and temperature can be calculated.

Each orbit would yield between 100 and 150 soundings of the atmosphere, covering the earth with some 1,600 observations daily, except in the polar area in sunlight. Key to the success of the method is the establishment of a mathematical connection between the refraction, or bending, of earth's atmosphere and its density. A speedy computer will translate the density measurements into temperatures and pressures within a few seconds.

Hot Ceiling

Families can now help keep their homes warm with a special plug-in "ceiling" that can be rolled on like wallpaper. The ceiling is a new electric heating system that emits waves of radiant energy, which is converted to heat when it contacts objects in the room—in much the same way as the sun's rays warm objects.

Called Sun-Glo, the system is a flexible "sandwich" consisting of two outer layers of thin vinyl and a filling of nylon net interwoven with thread-thin resistance wiring. It is installed in panels which are unrolled onto the ceiling and bonded with a special paste. The Sun-Glo, which operates on 240 volts with a heat output of about 17 watts per square foot, was developed by the Goodyear Tire and Rubber Company, Akron, Ohio.

Life Can Exist on Mars

Striking new evidence which indicates that life can exist on Mars and perhaps other planets has been discovered in experiments at the Union Carbide Research Institute near Tarrytown, N. Y. These findings were reported by Dr. Sanford M. Siegel, who heads up the Institute's research



The temperature of the soil for these small cactus plants has been lowered to that of liquid nitrogen ($-320^{\circ}\text{F}.$). The experiment conducted by Dr. Sanford M. Siegel of the Union Carbide Research Institute, was designed to test the plants' ability to tolerate cold. Actively growing plants did not survive; however it was found that dormant forms of life such as seeds and spores have a high tolerance for extreme cold.

program in extraterrestrial biology. A key discovery described by Dr. Siegel as "the turning point in our work" was the finding that the resistance of many plants and animals to freezing temperatures increases as the level of oxygen in the air is reduced. Mars has both low temperatures and little oxygen. (Turn page)

"The meter is a marvelously sensitive and accurate instrument." *U. S. Camera*

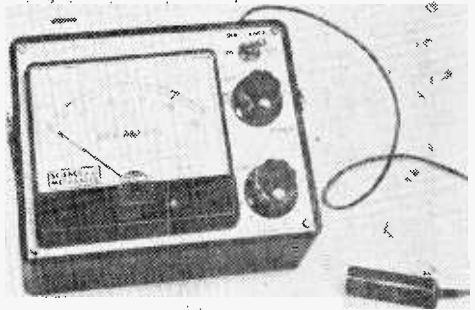

\$36.95 IN KIT FORM

Here is a precision instrument that meets the highest standards of any meter available today. The S&M A-3 uses the newest cadmium sulfide light cell to measure light levels from 0 to 10,000 foot lamberts at ASA speeds of 3 to 25,000. It is successfully used with movie or still cameras, microscope, telescope—as well as densitometer.

The computer gives F stops from .7 to 90 and lists exposure time from 1/15,000 sec. to 8 hours. 43° angle of acceptance, 4 range selection; EV-EVS-LV settings. Large (4½") illuminated meter, paper speed control knob for use with enlargers and now has a new battery test switch.



SCIENCE & MECHANICS — KIT DIVISION 78
505 Park Avenue / New York, N. Y. 10022 EE-75

Enclosed is \$_____. Please send me the Super-sensitive Darkroom Meter, as checked below. I understand that if I am not completely satisfied, I may return the meter within 10 days for a complete refund.

- No. A-3 in kit form — \$36.95 No. A-3 assembled — \$41.95
 A-3 Carrying Case — \$5.00

Add 10% for Canadian and foreign orders.
New York City residents add 4% for N.Y.C. sales tax.

NAME _____ (Please print)

ADDRESS _____

CITY _____ ZONE _____ STATE _____

NEWSCAN

The Union Carbide laboratory has been testing several hundred species and varieties of plants—both general and food types under simulated Martian conditions. "We believe," Dr. Siegel said, "that we are among the few laboratories working primarily with higher plant life. We have many different kinds of seeds under study, including beans, cereal grains, cucumbers, and cabbage. We have also carried out observations on the behavior of lower forms of animal life, such as insects, worms, and small shrimp." Molds, usually associated with dampness, showed surprising ability to thrive when deprived

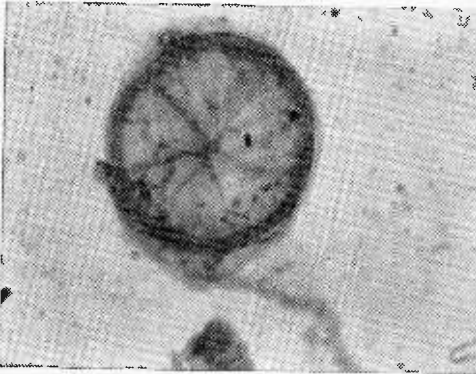

This strange micro-creature—only one five-thousandth of an inch in size -- was grown in an atmosphere of methane, ammonia, and oxygen, which resembles that of Jupiter and ancient earth. After its discovery, this organism remained on the unknown list for about six months until some clue as to its identity was found in a published article.

of water and oxygen. Dr. Siegel said this shows the vital importance of thorough sterilization for any interplanetary space probe. "If we contaminate Mars, our greatest opportunity to study life of independent origin could vanish virtually before our eyes," he said.

Discussing the meaning of these findings for life on other planets, Dr. Siegel said that this question involves the very early history of the planets. The primitive atmosphere of all the planets is believed to have been rich in methane, ammonia, and hydrogen. The Moon and Mars lost most of these gases because their gravitational pull was weak. The Earth's atmosphere was changed to its present oxygen-rich state by photosynthesis carried on by plants. As for Mars, Dr. Siegel said that despite its present aridity, it shows signs of a "history of abundant water and oxygen." He went on to state that "as a biolo-

gist, it is my conviction that if life got any foothold, it is likely to be there now. This is to say no more than that the process of natural selection is cosmic in character and that life, where it starts will be shaped by the action of its surroundings, no matter how exotic, and will transmit the capabilities for survival to its progeny."

In his concluding remarks, Dr. Siegel touched on the possibility of life on Jupiter, whose atmosphere, rich in ammonia, "is rather like the Earth and Mars before life began." A microbiological discovery by Dr. Siegel points out how tenacious living things can be. Soils are frequently used as sources of various microorganisms. An umbrella-shaped organism one five-thousandth of an inch in size was found in one such soil sample that was incubated in the laboratory in an atmosphere of methane, ammonia, and oxygen which resembles the atmosphere of Jupiter. At first, the organism bore no resemblance to any known to exist.

However, some clue as to its identity was found in an article published in the February 5, 1965 issue of *Science* by Elso S. Barghoorn, a Harvard paleobotanist, and Stanley A. Tyler, a professor in the department of geology at the University of Wisconsin, describing a fossil organism, "Kakabekia umbellata," which had been found in a Canadian chart deposit two billion years old. From photographs taken by Barghoorn, Dr. Siegel was able to show that the ancient fossil—the oldest yet found—was similar in shape and form to the micro-organism found in the Jupiter studies.

"So we ask," concluded Dr. Siegel, "can this be a genuine relic of the pre-cambrian era, when the primordial atmosphere was giving way to



In this chamber called Mars Simulator II, a variety of plants can be studied under conditions thought to exist on the planet Mars. The atmosphere in Mars Simulator II has no oxygen and so little water that a temperature of -76°F . would be required to freeze out whatever water vapor may exist.

modern air? If so, the endeavors begun here with oxygen physiology on the earth, and which have reached out toward life beyond the earth, may also have come full circle back to terrestrial origins."

Radar Checks on Einstein's Relativity

A new test to check on Einstein's general theory of relativity was proposed using radar waves reflected from the planets Mercury or Venus when they are on the far side of the sun from earth. The test would measure the time delay in the reflected radar waves caused by the sun's strong gravitational field. Einstein's theory predicts that light or radio waves passing near a high gravitational field will be bent. This has been verified by many experiments since 1919 in which the bending of light waves from distant stars by the sun's gravitation has been measured. Determining the slow-down of radio waves passing near the sun is another way of measuring this bending, or refraction, of light or radio waves by a source of strong gravitation in the vacuum of space.

The new test, which is still in the planning stage, will be possible because of recent improvements in radar equipment and techniques. It was proposed in *Physical Review Letters*, a publication of the American Physical Society, by Dr. Irwin I. Shapiro of Massachusetts Institute of Technology's Lincoln Laboratory. Dr. Shapiro suggests that the radar facility best suited for the test is the one called Haystack, developed by Lincoln Laboratory for the U. S. Air Force.

Besides the bending of light waves, two other tests have been made to verify Einstein's general theory of relativity: changes in the perihelion (point closest to the sun) of Mercury's orbit, and the reddening of spectral lines due to gravitational attraction. The time delay expected in the reflected radar waves is only one-fifth of a thousandth of a second, but the proposed new test could provide a check if the experiment is continued for several years.

To Build a Better Tape Measure

To reach the moon, rockets must travel 238,866.16 miles. This mean distance to the moon was measured by scientists at the Naval Research Laboratory here by bouncing radar waves from the lunar surface. The distance varies from 221,463 miles to 252,710, depending upon its position in orbit. Based on this distance, which is accurate within seven-tenths of a mile, the scientists find that the radius of the earth at the equator is 3,963.393 miles. The radar measurements were made during a period of several months by Drs. B. S. Yaplee, S. H. Knowles, A. Shapiro and K. J. Craig. Dr. Kirk Brouwer of Yale University Observatory collaborated in the research. ■

pick **UP** signals
from **ORBITING**
TRANSMITTERS!

*You can receive signals
from the Soviet space
band. Read about it in the
August-September
issue of*

**RADIO-TV
EXPERIMENTER.**

ON SALE
at all newsstands
JUNE 29

75 CENTS

*Or write for your copy
and add 25¢ for postage
and handling.*

**RADIO-TV
EXPERIMENTER.**

505 Park Ave., N. Y., N. Y. 10022

FREE!...Send Today

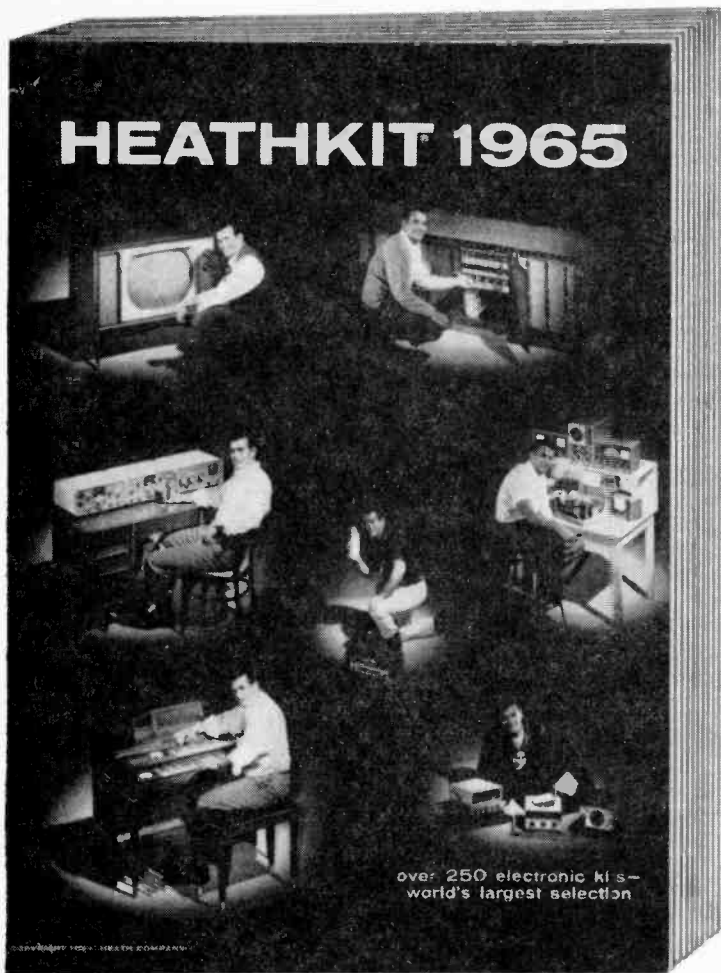

World's Largest Electronic Kit Catalog

Save 50% on:
Electronic Organs
Color TV
Stereo/Hi-Fi
Shortwave
Automotive
Amateur Radio
Citizen's Band
Education
Photography
Lab & Test
Marine

Over 250 Easy-To-Build Kits

Over 250 ways to add better quality and more fun to your hobby or profession... and save up to 50%! Convenient time-payment plan. Free help from our technical correspondents. Find out why Heath is the world's largest manufacturer of quality electronic kits. Send for your FREE 1965 Heathkit Catalog now!



HEATH COMPANY, Dept. 139-7
Benton Harbor, Michigan 49023
In Canada: Daystrom, Ltd., Cooksville, Ontario

Please send Free 1965 Heathkit Catalog.

Name _____
(Please Print)

Address _____

City _____ State _____ Zip _____

Prices & specifications subject to change without notice.

CL-202

NE-2

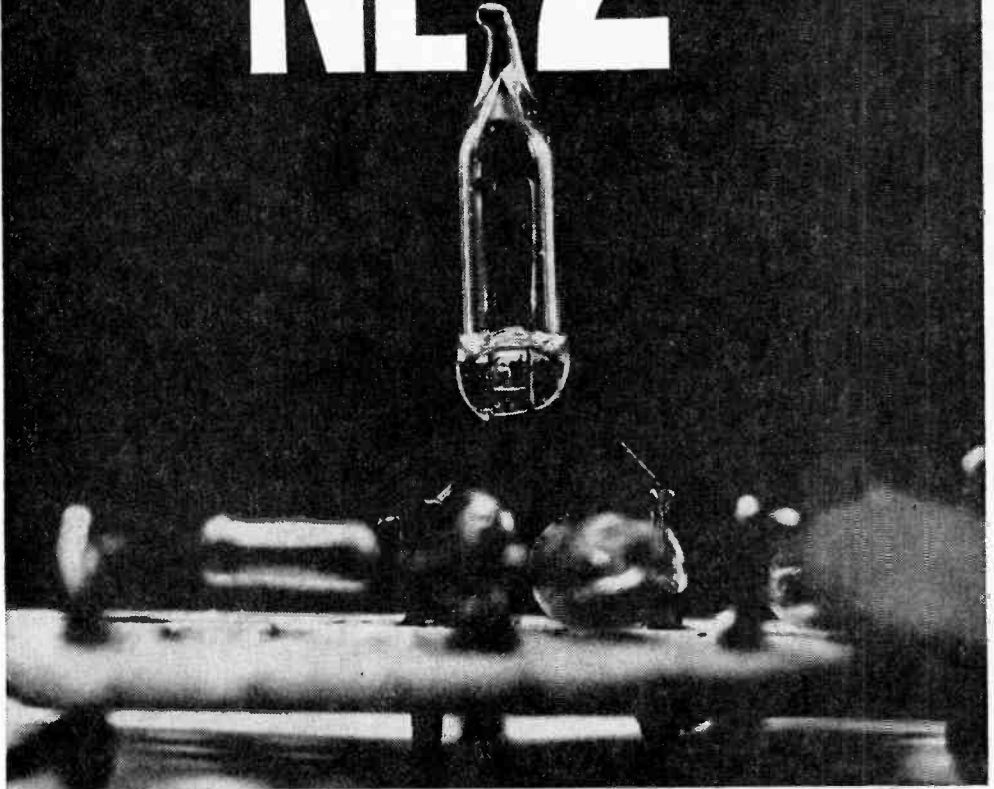

...the noble neon bulb

Verily there are 1001 uses for this electronic knight . . .

□ Four will fit into a thimble. One will cost you ten cents. Hook it to a few other parts and it'll provide enough different circuits to keep you busy at a breadboard for weeks. Some new breakthrough in electronics? Not at all. It's the homely old neon bulb, the NE-2. Long used as a cheap, low-power pilot lamp, the neon is getting a new lease on life. Now it's found in space-age instrumentation, test equipment and other exotic applications. Some remarkable characteristics make it every bit as glamorous as some of the newer semiconductor components. Let's see why.

Neon Vs. Filament Lamp. A regular pilot lamp has a filament. Feed voltage in and the filament grows hot, giving off light in the process. More voltage, more light—until the filament burns out from excessive current. The neon bulb does it differently. It has two electrodes, or metal pins, spaced about 1/8-inch apart. The only connection between them is neon gas, which fills the bulb. Nothing happens as the input voltage on the electrodes goes from 0 to about 80 volts. Then the gas "fires." What was a neutral, invisible vapor turns into charged ions to form an electrical bridge between

BY E. NORBERT SMITH

e/e NE-2 NEON BULB

the electrodes. The neon glows orange and current can flow.

But the novel feature is yet to follow. If the bulb is fired at 80 volts, it will continue to remain ionized, even as the voltage drops down to somewhere around 60 volts. (It needed the higher voltage as a "push" to get started.) And once the bulb is fired, it doggedly tries to keep the voltage within a narrow range. As we will see, this arises from the bulb's ability to convert part of the applied voltage into current flow.

What the Scope Shows. Before seeing a practical application of this, let's examine the basic action of voltage on the neon bulb, as shown in Fig. 1. Increasing voltage is seen along the horizontal line, while current flow in the bulb is represented by the vertical line. The bulb fires at point A (zero current) or just over 80 volts. Now the bulb conducts about 5 ma at 77 volts (point C). At lower voltage, say 61 volts (point B) the current is a mere 1/2 ma. The central idea shown is that a fairly small change in voltage causes a great swing in current through the lamp. This characteristic, as will be shown in a moment, can smooth out variations in

a power supply. The action between points B and C falls into an area of relatively constant voltage.

Power Supply Regulator. Shown in Fig. 2 is a 100-volt DC source. It's assumed that it varies considerably (it's unregulated) and is needed to power some device or load that requires 50 volts of constant DC (regulated). With no load on the supply, the voltage across the NE-2 would be 50 volts, with the other 50 volts dropped across the 10K resistor, R1. The bulb now draws 5 ma

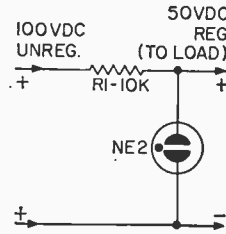

Fig. 2. Simple regulated power supply is attained by placing neon lamp across output.

of current. Now let's add a load of 25,000 ohms. Ohm's Law would indicate that a current flow of 2 ma. would flow through the load with 50 volts applied.

$$I = \frac{E}{R} = \frac{50}{25K} = 2 \text{ ma.}$$

The additional load current causes slightly

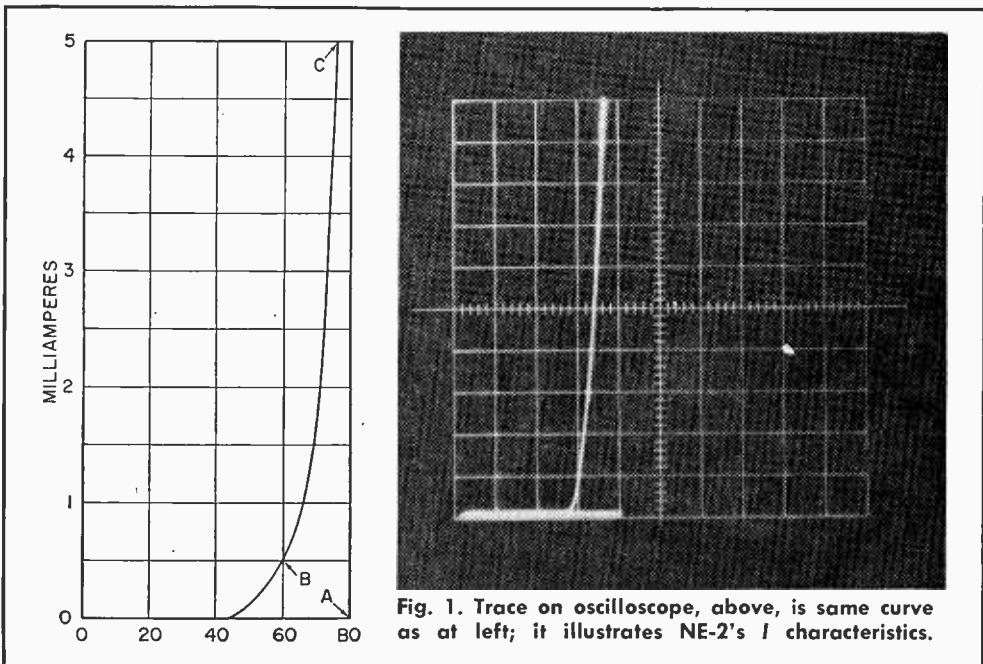

Fig. 1. Trace on oscilloscope, above, is same curve as at left; it illustrates NE-2's I characteristics.

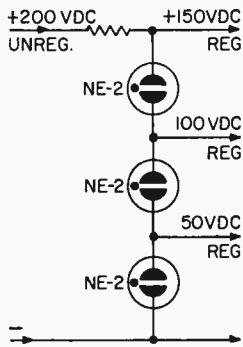

Fig. 3. NE-2's in series for 3 regulated voltages.

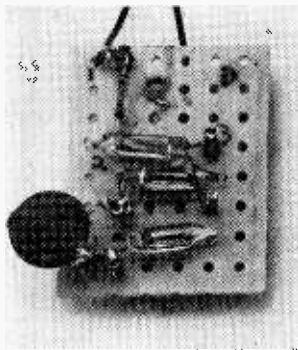
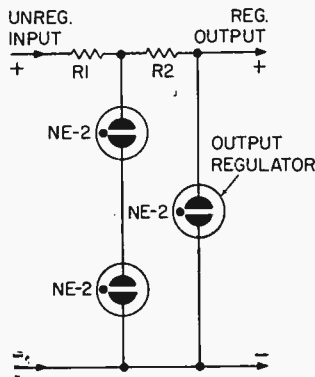

Fig. 4. NE-2's in cascade for high percent of regulation. Capacitor paralleled on breadboard circuit to reduce noise.



more voltage to drop across R1. Less voltage is now available to the NE-2, so it draws less current. But since a neon bulb has a large current change with small voltage changes, the NE-2 will have a rather large current decrease—from 5 ma. to 3 ma. in this case. This provides 2 additional ma. to the load and the original circuit conditions are re-

sistance we find

$$R = \frac{100 - 50}{5} = \frac{50}{5} = 10K.$$

The power rating of the resistor is found by $P = IE = (.005)(50) = .25W.$

A ¼-watt or larger resistor will work. The result is a regulated supply which can deliver 50 volts from 0 to 4.5 ma. (Note: 50 volts is typical; some NE-2's range from 45-80 volts. Under load, at least ½ ma. should flow through the NE-2 to maintain ionization.)

This circuit, which is actually varying parallel resistance to keep voltage constant, is exactly how the larger voltage regulator tubes—the OB2, OA2, OA3—operate. They are designed however, to handle currents from 5 to 40 ma. at voltages from 75 to 150 volts and usually use mercury vapor or other gas.

Using More Than One. Neon regulators can be placed in series for larger voltages or to provide several regulated voltages, simultaneously as in Fig. 3. The units can also be placed in parallel for added current handling capabilities. A disadvantage of the parallel hookup is that a resistor of from 100 to 1000 ohms is needed in series with each neon to equalize different starting voltages. Added resistance degrades the performance of the regulator.

A 5 ma. power supply is not the maximum that can be built with an NE-2. The bulb can be used in supplies of much greater current as long as the current *change* does not exceed 5 ma. It can, for example, work equally well with a load requiring from 98 to 102 ma. if at no time (such as tube warm-up), the load draws less than 98 ma. The only circuit change from Fig. 2 is a decrease in R1 resistance and an increase in its power

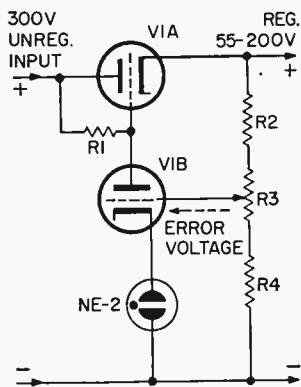

Fig. 5. NE-2 used in conjunction with vacuum tubes for an increased current swing.

stored. R1 still drops 50 volts and 50 volts appear across the load. The circuit therefore, is regulated by the give-and-take of current from the neon lamp.

R1 was computed by Ohm's Law for resistance:

$$R = \frac{E}{I}$$

with R in thousands of ohms; E the desired voltage dropped by the resistor (unregulated voltage minus the regulated voltage); and I the current in milliamperes. (For an NE-2, current should not exceed 5 ma. unless a constant load is present.) Solving for re-

e/g NE-2 NEON BULB

rating. Ohm's law, shown earlier, is used to figure the new values.

If better voltage regulation is required, several NE-2 bulbs can be used in a *cascade* arrangement. It can produce voltage regu-

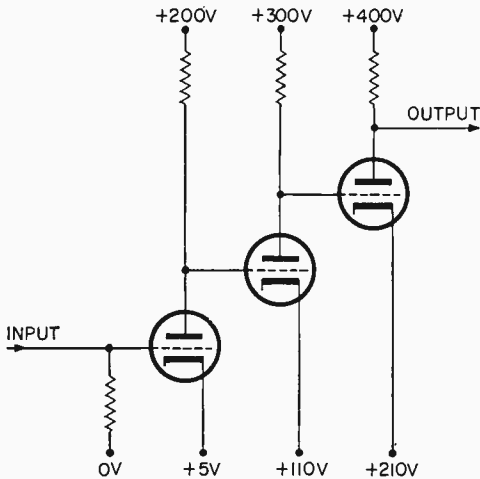

Fig. 6. Schematic of conventional direct-current amplifier; main problem is drift.

lation of better than one percent. (See Fig. 4.) By selecting the output regulator to maintain steady voltage of 50, 55, or 60 volts, an inexpensive and accurate voltage source can be obtained for calibrating test equipment. The NE-2 should be biased for 1 ma. of current for the most stable operation; done by adjusting the resistor values.

Working With Vacuum Tubes. If a larger current swing is desired, an electronically regulated supply is in order. Again we can use the NE-2, but this time in conjunction with a vacuum tube. Fig. 5 shows a supply capable of currents from 0 to 20 ma. It has the bonus of adjustable regulated voltage from 55 to 200. In this circuit the series resistor is a tube, V1A, which changes current flow to maintain constant output. The cathode voltage of V1B is held constant by the NE-2. The resistor string consisting of R2, R3, and R4 is a voltage divider which feeds an error, or sense, voltage to the grid of V1B. (R2 is also a limiting resistor to keep excessive voltage from the grid.) R3 is a variable resistor which determines voltage output by controlling current through V1A. R4 sets the lower limit.

Assume an increase in load current. This causes a small drop in output voltage and a part of this decrease appears at the tap of R3. This causes V1B to conduct less current, causing its plate voltage to increase greatly. This increase is fed to the grid of V1A. As this tube conducts more heavily, it brings the output voltage back to its desired point. Thus, a small change in output voltage, due to change in load current or fluctuating line voltage, is amplified by V1B. This causes V1A to change current flow to maintain constant output voltage. By replacing V1A with a larger triode or a power tetrode, currents of several hundred milliamperes can be regulated in this manner.

Direct-Coupled Amplifier. To attain very low-frequency response, even down to DC in some scientific recording instruments, amplifiers are direct-coupled. It eliminates coupling capacitors which block DC. But the

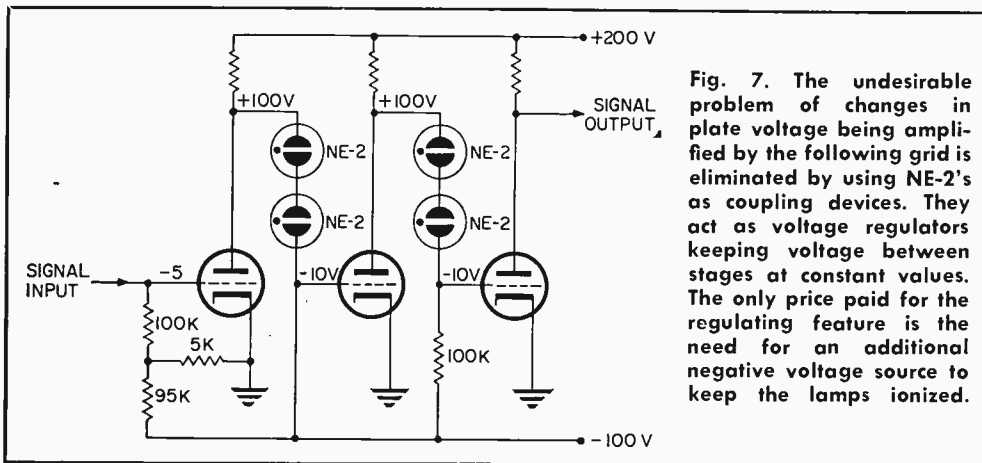

Fig. 7. The undesirable problem of changes in plate voltage being amplified by the following grid is eliminated by using NE-2's as coupling devices. They act as voltage regulators keeping voltage between stages at constant values. The only price paid for the regulating feature is the need for an additional negative voltage source to keep the lamps ionized.

big problem is drift; changes in plate voltage are amplified by the following grid (see Fig. 6) By using NE-2's as coupling devices, the problem is minimized, as shown in Fig. 7. Since the neon bulbs are voltage regulators, they hold the supply voltage from the plate of one stage to the grid of the next at constant values. The desired signal, however, passes through the neons with no regulating effect. They are low enough in level to prevent such action. One disadvantage of this circuit is that an additional negative voltage source must be provided to keep the neons ionized.

Indicators. New electronic equipment is using more neon indicators. The trend is well justified. The NE-2 and its more sophisticated cousins, such as the NE-17 and NE-21, are far more dependable than incandescent lamps. Life expectancy of neon glow lamps ranges from 10 to 25 thousand

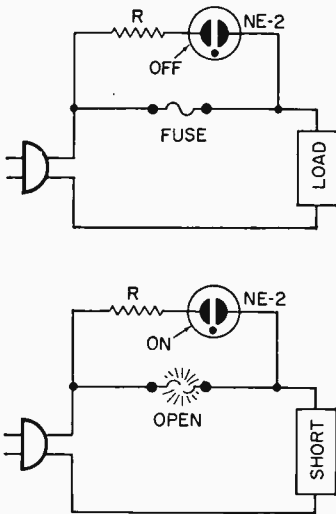

Fig. 8. Self-indicating fuse lights, thanks to NE-2, when a short in the circuit blows it.

hours as compared with only 1 to 5 thousand hours for incandescent bulbs. Another important feature occurs in low power equipment. Due to low power consumption, neons can operate from the AC line with only a small series resistor. With some transistor equipment a regular pilot lamp might draw more current than the rest of the circuit combined! Some manufacturers produce neon lamp sockets with built-in resistors for exclusive use with neon glow lamps, such as the NE-51.

Neon lamps are also widely used as blown-fuse indicators. (See Fig. 8.) How many

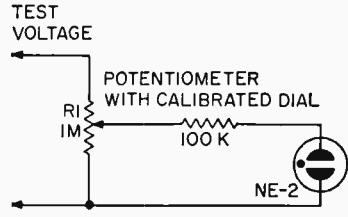

Fig. 9. Since firing voltage is constant for any given NE-2, it's a good voltage indicator.

times have you searched with ohmmeter in hand to find the malfunction to be just an open fuse? With a self-indicating fuse holder, you could have reached for the open fuse immediately. These fuse holders cost little more and are slightly larger than standard models but are frequently worth the investment in time saved.

Perhaps you have noticed that both electrodes of an NE-2 light on AC but only one glows with DC. This is because only the negative electrode glows. AC makes each electrode negative 60 times per second. The appearance of both electrodes simultaneously glowing on AC is due to persistence of vision in the human eye. Due to the neon bulb's ability to light many times a second, it is useful as a simple strobe light to stop fast motion. The strobe effect, for example, enables the audiophile to accurately check record-player or tape-recorder speed. Line voltage at 60 cps flashes the neon. Stripes on the disc or tape appear motionless if rpm are correctly synchronized.

Voltage Indicator. Since the firing voltage for any given NE-2 is almost constant, an inexpensive voltage-measuring device can be built with three or four components, as in Fig. 9. The voltmeter is used by adjusting variable resistor R1 so the neon bulb just lights. Then read the voltage opposite the

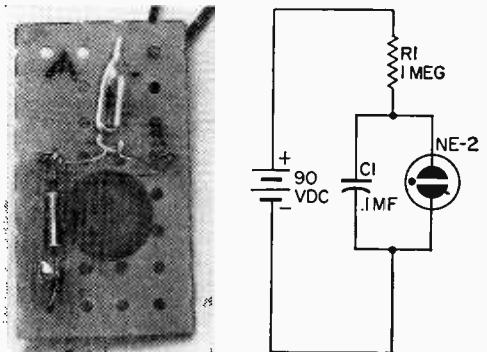

Fig. 10. NE-2 acts as heart of relaxation oscillator which is compactly breadboarded.

e/e NE-2 NEON BULB

pointer. The unit can be built in a small box with insulated alligator clip leads or an AC plug for detecting house current. (This is one way to tell 110 from 220 volts AC.) The variable resistor is first calibrated from a known voltage source at several points. Since one electrode glows on DC, the negative one, the neon can also determine polarity.

Modulation Monitor. Another use of the NE-2's constant firing potential is modulation monitoring in the CB or ham transmitter. The voltmeter circuit, Fig. 9, is used with the input leads going to the modulation transformer to detect audio level. With a 'scope or other modulation measuring system, adjust modulation for 100 percent and set pot R1 so the NE-2 just fires. Another NE-2 could be used for 75 and 50 percent modulation. The 50 and 75 percent lamps should flicker at normal speech levels as the 100 percent indicator just glows on speech

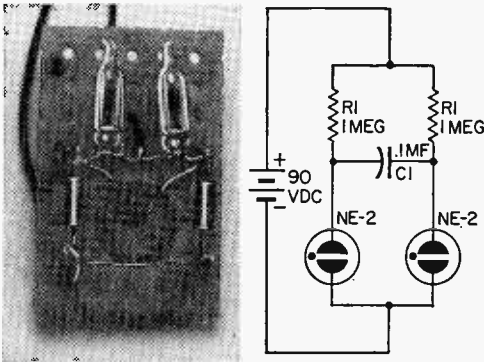

Fig. 11. Alternately blinking NE-2's can be breadboarded for a variety of applications.

peaks. (This system will need recalibrating if bands are changed or loading readjusted.) Properly adjusted, the flickering NE-2 gives assurance that you're modulating properly and its absence warns of lost modulation.

R.F. Indicator. A unique characteristic of the NE-2 is that it glows from electromagnetic radiation from a tank capacitor, coil or even a leaky transmission line. Place an NE-2 in a clear glass or plastic container. (A small vial works well.) Snip one lead off the NE-2 and splice a ground connection to the other lead. You can also hold the ground lead in your hand if the NE-2 is well-

insulated from any high voltage. By placing the probe near tuning capacitors and tank circuits you can check for RF energy by an orange or violet glow. TVI problems can frequently be found in this manner before the transmitter or final amplifier is placed on the air.

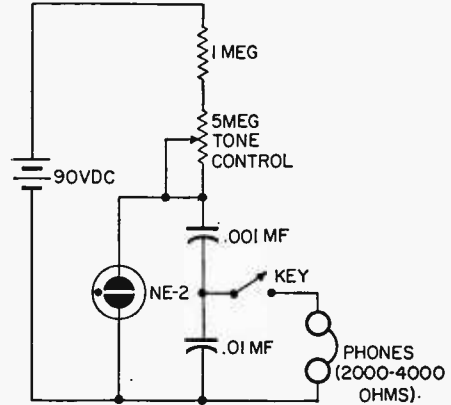

Fig. 12. Schematic diagram of NE-2 circuit wired for use as code practice oscillator.

Oscillators. The versatile neon bulb also makes a fine oscillator. Many oscilloscopes have used neons as time-base generators and some still do. The relaxation oscillator in Fig. 10 is one of the cheapest and simplest signal generating devices available. When voltage is applied, C1 begins to charge. Charging time is dependent on the resistance of R1 and the capacitance of C1. When the voltage across C1 is equal to the starting voltage of the NE-2, the gas ionizes, then quickly discharges the capacitor. The NE-2 ceases to conduct. The charging process now starts over. The action produces a wave

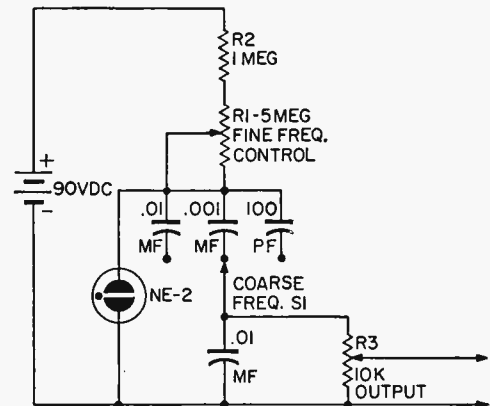

Fig. 13. A practical audio signal generator can be wired using but a single neon lamp.

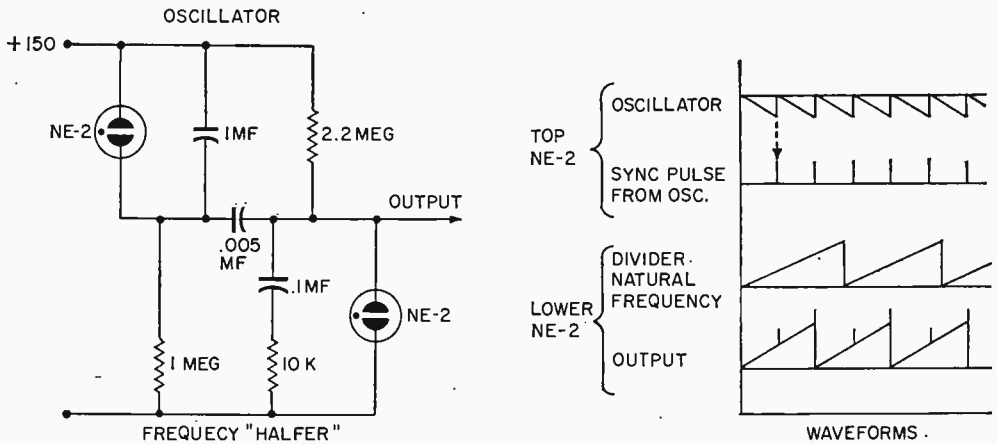

Fig. 14. Schematic diagram and waveforms illustrate method of dropping frequency of NE-2 relaxation oscillator by half.

which resembles a saw tooth.

The relaxation oscillator makes an attention-getting display if the repetition rate is about few cycles per second. It can also be used as a strobelight for "stopping" the motion of rotating machinery. When battery power is used battery life will be almost the same as normal shelf life due to extremely small current drawn.

Two NE-2's will blink alternately in the circuit shown in Fig. 11. It's an amusing novelty if the eyes of a stuffed animal are replaced by NE-2's and the circuits hidden inside the toy.

By adding a capacitor, key and earphones, the relaxation oscillator becomes a pleasant-sounding code practice oscillator for the future ham (Fig. 12.) R1 is replaced by a 5 megohm pot to make a variable-tone oscillator. A 1 megohm resistor is needed to

limit the current to a safe value. With this oscillator, high-impedance earphones, such as the crystal type, are preferred.

Fig. 13 illustrates a useful audio signal generator utilizing an NE-2 relaxation oscillator. S1 is the range switch for selecting the proper capacitor; R1 is the fine frequency adjustment. R3 adjusts the amplitude, or volume.

Frequency Dividing. A relaxation oscillator can also be synchronized to lock onto some submultiple of another signal. This can provide, for example, an output at half the oscillator frequency or some other division. Referring to Fig. 14, the oscillator is seen at the top and a frequency halver at the bottom. Let's say we want to convert 1000 cps from the top neon to 500 cps. Every other cycle generated by the top neon is used to trigger, or synchronize, the lower neon.

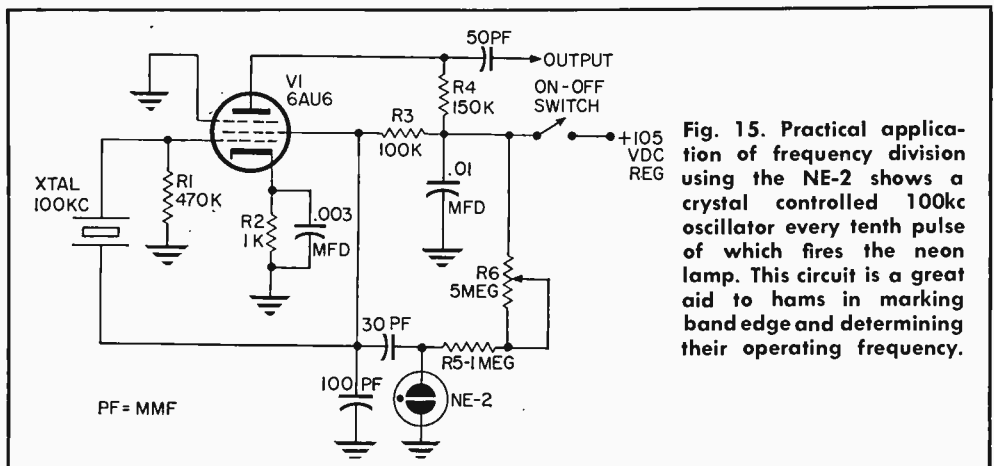

Fig. 15. Practical application of frequency division using the NE-2 shows a crystal controlled 100kc oscillator every tenth pulse of which fires the neon lamp. This circuit is a great aid to hams in marking band edge and determining their operating frequency.

e/e NE-2 NEON BULB

Note the waveform of the top NE-2 in Figure 14 ("oscillator"). When the first "sync" pulse occurs it isn't capable of turning on the lower NE-2 (through the .005 mf. capacitor). The voltage continues. The second sync pulse comes just before the lower neon bulb fires at its own, *unsynced* rate. Sufficient sync voltage is now available to make the lower neon fire prematurely, thus getting it in step with the top neon. Thus, synchronization occurs at half the frequency. A useful and practical application of this characteristic is shown in Fig. 15.

A 100 kc oscillator is a great aid in ham radio for marking band edges and determining operating frequency. But 100 kc signals on the low frequency band leaves some rather wide uncalibrated areas. With an NE-2 locked oscillator, 100 kc markers *and* 10 kc markers provide almost continuous calibrated coverage. The 10 kc markers are as accurate as the 100 kc markers. To aid in distinguishing between the two markers, a 5 megohm pot, R6, is used to reduce the 10 kc amplitude.

In this circuit an NE-2 fires on every tenth pulse from the 100 kc tube oscillator (6AU6). The 10 kc signal beats with 100 kc energy and both signals are electron coupled to the output, then radiated to the receiver.

Neon Logic. Although not used in commercial logic circuitry, the NE-2 is capable of many transistor or tube logic functions. These include the astable, or free running

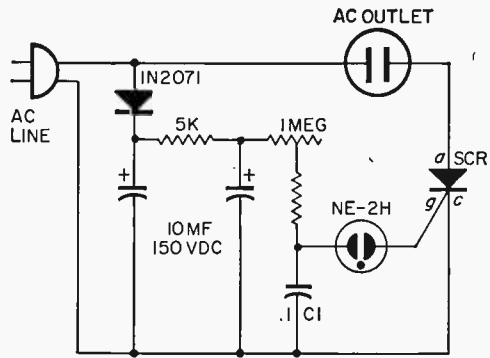

Fig. 17. The characteristics of the NE-2 neon lamp make it an excellent device for triggering the silicon controlled rectifier. In this circuit, capacitor C1 is charged until the neon lamp firing voltage is reached. Then the SCR begins to conduct until polarity reverses.

multivibrator, bistable and monostable multivibrator and gate circuit. The disadvantages that keep neons from more sophisticated devices are slow speed and no gain. They work nicely however, in logic demonstrations. Due to their light-giving characteristic they are self announcing. (See Fig. 16.)

SCR Trigger. The ability of the NE-2 to pass virtually no current until a certain voltage is reached, then to conduct heavily, makes it an ideal way to turn on a silicon-controlled rectifier. Fig. 17 shows a circuit that will repeatedly flicker a light bulb plugged into the AC outlet. Capacitor C1 charges until the NE-2 firing voltage is reached. Then the SCR is turned on, discharging C1 through its cathode. The SCR remains on until the 60-cycle AC reverses polarity to repeat the process.

(Continued on page 109)

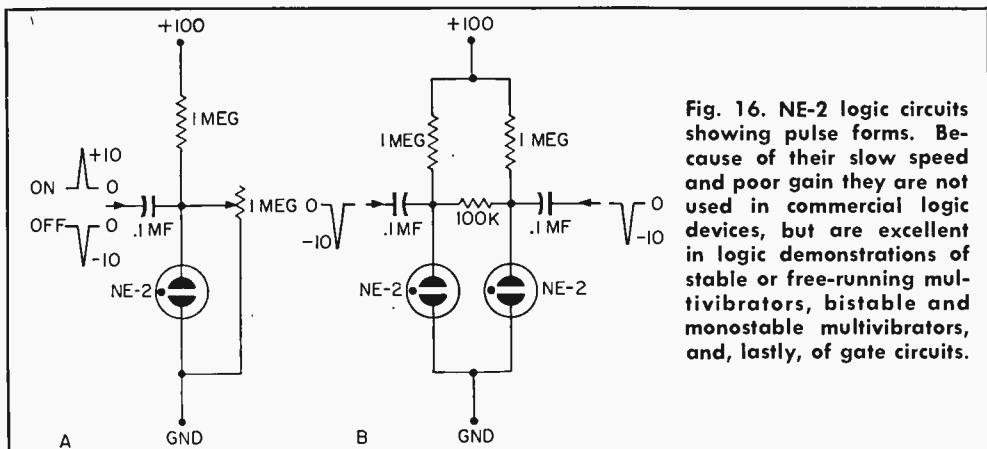
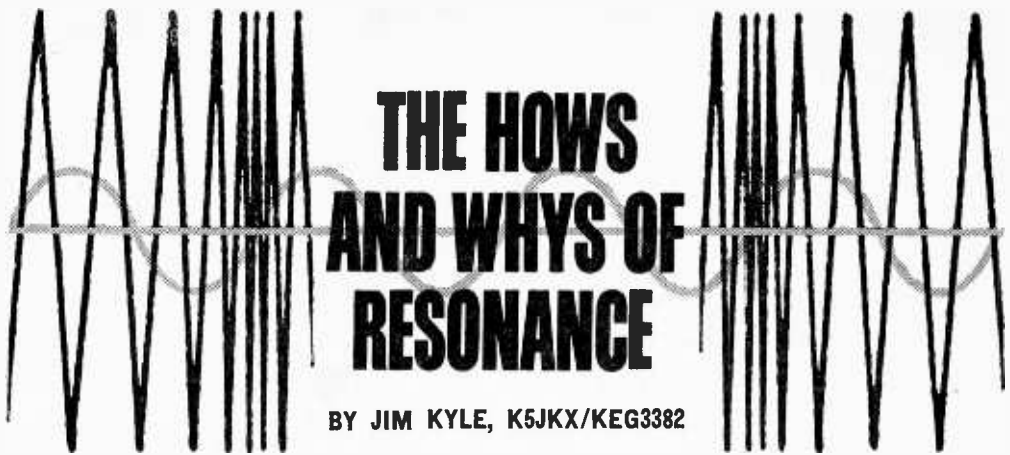

Fig. 16. NE-2 logic circuits showing pulse forms. Because of their slow speed and poor gain they are not used in commercial logic devices, but are excellent in logic demonstrations of stable or free-running multivibrators, bistable and monostable multivibrators, and, lastly, of gate circuits.



■ One of the most important phenomena involved in the “miracle” of radio is that known as *resonance*. Without the effect called resonance, it would be impossible to tune in a station, to transmit a coherent signal, or to amplify frequencies very much above the audio range.

Important though resonance is, however, few hobbyists have a clear idea of how it works, or why. While the “how” is simple enough, the “why” seems to get bogged down in higher mathematics—or ignored altogether.

Such a situation needn’t exist; the purpose of this article is to show you the *how* and the *why*. Then when you run into a discussion of “broadly tuned circuits” or “high-Q operation” you’ll know exactly what’s going on.

What resonance does. Before we get into the hows and whys of resonance, let’s take a brief look at what it does. The most familiar function of resonance in radio and electronic circuits is the tuning of a receiver.

Literally thousands of radio stations are transmitting at any minute throughout the day, and if a receiver had no means of separating these stations you could hear nothing but bedlam.

But each station operates on a specific frequency (or wavelength—the terms have

the same meaning). If the receiver has circuits which can select a single frequency out of the broad spectrum available, then you will hear only those stations transmitting on this frequency.

Resonance offers this ability. A resonant circuit will respond most strongly to signals of a specific frequency, and will hardly respond at all to signals far removed from this frequency. Its response to signals close to, but not exactly at, its “resonant frequency” is determined by some characteristics of the circuit itself which we’ll examine in detail as we go along.

While receiver tuning is probably the most familiar function of resonance, it’s far from the only one. The receiver gains its ability to separate closely-spaced stations through another application of resonance, and its ability to bring in the weak ones through still a third function of this phenomenon. The transmitters themselves are kept on their assigned frequencies by resonant circuits, and their signals are boosted to rated power by yet more applications of resonance. This thing called resonance is hard to escape, in radio!

So how does it work? To get into this, first we must take a look at the alternating-current waveform and find out a little more about it.

WIGGLE THE CURRENT, ADD L's AND C's, AND RESONANCE COMES ON THE SCENE

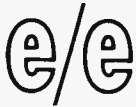

THE HOWS AND WHYS OF RESONANCE

The AC Waveform. Alternating current, or AC, is not quite so simple to deal with as is its cousin, direct current (DC). While DC always flows in the same direction, AC flows first one way and then the other. The most commonly used forms of AC reverse their direction at regular intervals.

Most AC, in addition, is always changing in strength. If we could hook a fast-response voltmeter to an AC source and actually watch the voltage as it changed through the cycle, we would find that the voltage regularly passes through zero, rises to a "positive peak" value in a smooth change, moves through this peak in an equally smooth manner, falls back through zero to a negative peak, then begins rising again. The time taken to move from one specific value to the next occurrence of this same value, with the change going in the same direction, is known as a cycle.

The instrument called an oscilloscope and more often known simply as a 'scope is such a "voltmeter," and will display a picture of the AC waveform on its screen. Fig. 1 shows such a waveform. The peak voltage values have been set arbitrarily at 10 volts.

Since the *instantaneous* voltage of AC is always changing, we normally specify voltage values for AC in terms of "effective" or rms voltage, which is 70.7 percent of the peak value. This value is determined by the heat produced by the AC, as compared to DC. That is, a 10-volt-peak AC wave will produce as much heat (if connected to a resistive heating element) as would 7.07

volts of DC. Unless otherwise specified, all AC meters are calibrated to show rms values.

In addition to the voltage present, DC has another important characteristic—polarity. If you've done any experimenting at all with transistors, you know that 6 volts positive is not at all the same thing as 6 volts negative!

Since AC is either positive or negative, depending on what part of the cycle you examine, it would appear to have no polarity. It does, however, have a corresponding characteristic, which is known as *phase*.

Phase. To talk about phase, we have to sidestep for a moment and talk about how AC is generated. One way to do it is with an alternator, which is a mechanical device much like a DC generator that rotates a magnetic field inside a fixed coil. As the field rotates, a varying voltage is induced in the fixed coil winding (which corresponds to the armature of the DC generator and is sometimes called by the same name).

In the alternator, one complete cycle of AC is produced every time the field makes one complete rotation. Because of this correspondence between *rotation* of the field (which can be measured in degrees, with 360 degrees being one full circle) and the *cycle* of AC, a full cycle of AC is said to contain 360 *electrical degrees*. The point at which the AC voltage passes through zero, going positive (the left-hand side of the waveform in Figure 1) is called the 0-degree point. The next zero-crossing, halfway through the cycle, is 180 degrees later. The positive peak point, halfway between zero crossings, is at 90 degrees, while the negative peak occurs at 270 degrees.

Now let's get back to phase. We said earlier that it corresponds to DC polarity,

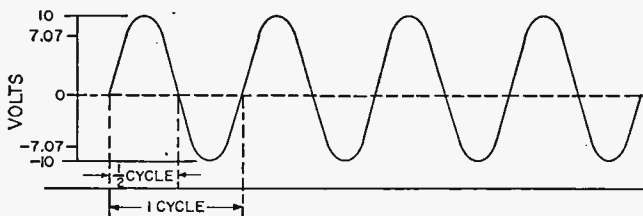
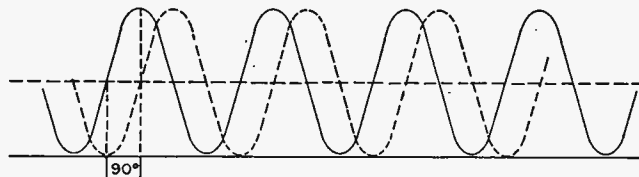

Fig. 1. Waveform of a pure, single-frequency alternating signal as displayed on an oscilloscope. Three cycles shown.

Fig. 2. These two voltage waveforms are 90 degrees out-of-phase with each other. Solid line signal is taken as reference to measure the phase difference of dashed signal.



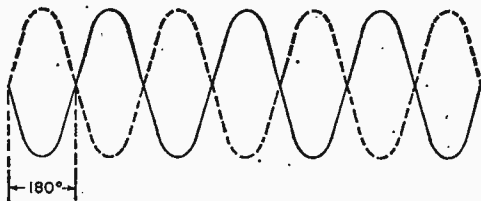

Fig. 3. Identical voltage waveforms 180 degrees out-of-phase with each other cancel out since minus and plus halves are equal.

but when dealing with AC we must have something to use as a reference. Phase has no meaning, then, unless at least two AC signals are being compared. Both must also be of the same frequency.

Fig. 2 shows just such a case. One of the signals, which we'll use as our reference, is shown in solid lines. The other is dashed.

Both, you can see, repeat themselves endlessly, though we've shown only a couple of cycles of each. As our reference point from which to measure things, we take the first zero-crossing of the solid-line signal, marked with a heavy dot. This is zero-degree phase.

The dashed-line signal is identical to the reference signal except that it is just a little bit behind the times. By the time this second signal gets to its zero-crossing point, the first one has reached positive peak and started down. When the second is at positive peak, the first is at zero again on its way toward negative peak, and so forth.

The voltage values of the two signals are the same, but the second one lags a quarter-cycle behind the first. So we can say that the second signal is of *lagging phase*, and since it lags a constant 90 degrees behind the first we say it has a phase lag of 90 degrees.

This is usually stated simply as "90 degrees lag." It could equally well be said that everything in the second signal happens 270 degrees *before* the first, if we were to take the second zero-crossing of the first signal as the reference. To eliminate this possible source of confusion, phase shifts are always read as amounts no greater than 180 degrees.

180 Degrees Out. So far, all this may sound as if it's very complicated and doesn't have much to do with resonance. However, we're almost ready to fit things into place a bit. First, let's see what happens if we have two signals present, but 180 degrees out of phase with each other (Fig. 3).

Whenever two signals are present in the

same place at the same time, the actual resulting signal is the total of both together. Thus, in the 90-degree-lag circuit of Fig. 2, the actual voltage at the 0-degree point would be equal to the negative-peak value of either signal (negative-peak of signal 2, plus 0 for signal 1) and at the 90-degree point would have been equal to positive-peak value (positive-peak for signal 1, zero for signal 2). In between, at 45 degrees, it would have been zero as the positive voltage of signal 1 and the equal but negative voltage of signal 2 would cancel out. The result, therefore, would be a *single* signal, of equal voltage, but lagging 45 degrees in phase from the original reference (signal 1).

Had the two voltages not been equal, this would not have worked out so simply. Try it for yourself, assuming that signal 1 is twice as strong as signal 2.

Now to Fig. 3. Here, the two signals are

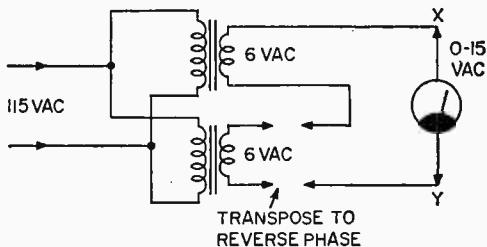

Fig. 4. This hookup demonstrates cancellation of equal but out-of-phase voltages.

180 degrees out of phase, and whenever one of them is positive the other is negative by exactly the same amount.

Proving It. The result is—you're right—that they cancel each other out completely, leaving no voltage at all.

Again, if one is a little stronger than the other, it won't be completely cancelled, and the final voltage will be the *difference* between the two.

This part of the theory is easy to check with a pair of filament transformers and an AC voltmeter. Hook the transformers up as shown in Fig. 4, with the primaries in parallel and connected to the AC line, and the secondaries in series. Measure the voltage across points X and Y. Now reverse the leads of *one* of the secondaries; this effectively reverses its phase, introducing a 180-degree change. Measure the voltage across X-Y again.

With one connection, you'll find the voltage across X and Y is equal to the *sum* of the secondary windings. With the other connec-

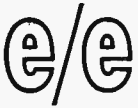

THE HOWS AND WHYS OF RESONANCE

tion you'll get only the *difference*. If the two transformers are identical, the difference reading will be virtually zero.

Disconnect the transformers but don't put them away just yet. We'll be using them both again before much longer, to check out some theory on reactance and impedance.

Reactance, Resistance, and Impedance.

AC, since it is so different from DC, has a few abilities which DC doesn't have. One of them is the ability to flow through a capacitor. Actually, the current doesn't really flow *through* the capacitor, but it produces the effect of going through—and it's the effect that counts.

You can prove this for yourself by taking one of the filament transformers, a No. 47 dial-light bulb, and a 10-microfarad AC capacitor. The easiest source for such a large AC capacitor is to take a dual-20-mfd 150-volt rated electrolytic unit, and use only its positive leads (ignore the negative or black lead). Another source is the military sur-

Parts List for Circuits

- 2—6.3-volt filament transformers, 600 ma. rating
- 1—10-mf AC capacitor, see text for details
- 1—0.7-henry inductor, 250-ma. rating
- 1—No. 47 pilot bulb (6-8 volts, 0.25 amperes)
- Hardware—Breadboard chassis, perforated Masonite approx. 6" x 8"; AC line cord; socket for bulb; hookup wire; solder; etc.
- Accessories—General purpose VOM

plus market, where 10-mfd. 600-volt oil-filled capacitors may be found for less than \$2 each. Hook things up as shown in Fig. 5A first, to see what the normal glow of the No. 47 bulb looks like. Then break one lead to the bulb and insert the capacitor in series, as shown in Fig. 5B.

You'll find that the bulb still glows, although at greatly reduced intensity. This proves that the effect of the AC supply is transmitted through the capacitor, although

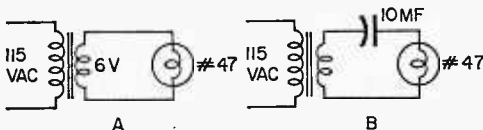

Fig. 5. Diagram A shows normal glow of bulb; B shows AC power flow "through" capacitor with dimmer, but visible, glow.

if you check the capacitor with an ohmmeter (first disconnecting it from the transformer!) you'll find it virtually open.

The dimming of the bulb when the capacitor was put into the circuit is due to *reactance* in the capacitor. This is an effect very similar to that of resistance in a DC circuit. To see how it works, we'll have to look at some more waveforms.

First, let's examine Fig. 6, which shows the waveforms of both voltage and current when AC is applied to a resistor or resistive load, such as the No. 47 bulb.

The No. 47 bulb is rated at 6 volts and 250 milliamperes, which are both rms values. Thus the peak value of voltage is approximately 8½ volts, and the peak value of current is about 350 milliams.

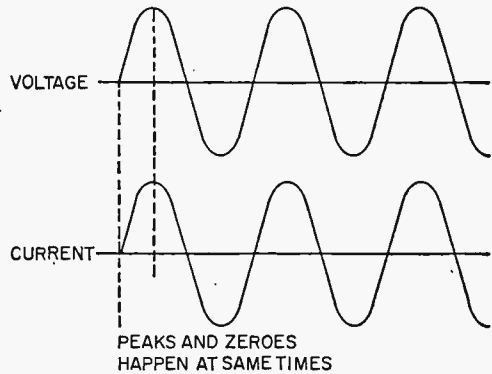

Fig. 6. These are the waveforms of voltage (top) and current (bottom) through a resistive circuit such as a lamp bulb or heater.

When the voltage is at zero (zero phase), the current is also at zero. As voltage rises toward +8½, the current rises with it, and reaches 350 ma. at the same instant the voltage reaches 8½. At every point during the cycle, the voltage and current are *in phase* with each other.

Now, let's move on to Fig. 7, which represents the voltage and current waveforms for an AC circuit in which a capacitor is in series with the load. Peak value of voltage is the same as in Fig. 6.

However, when voltage is applied now, the capacitor must charge before anything else can happen. If voltage is applied at a positive peak, the capacitor current will be zero at first but will tend to increase rapidly. Before it can increase, however, the voltage has begun to fall, which forces the capacitor current to go in the *negative* direction. So long as the voltage exists across the capaci-

tor, current will flow, and the smaller the voltage the smaller the current.

The voltage is continually falling, which means that the current is falling with it. This process continues until the voltage reaches zero. As voltage continues negative, the current flow in the capacitor is forced to reverse and begin moving in the positive direction.

By the time the voltage has reached the negative peak, the current has risen from its negative-peak value to zero. As voltage starts going positive, the current goes positive also, moving up from zero to its positive-peak value.

Thus, in a capacitor circuit, the current peaks are always separated from the voltage peaks by 90 degrees. Since the current peaks occur earlier, current is said to *lead voltage* by 90 degrees.

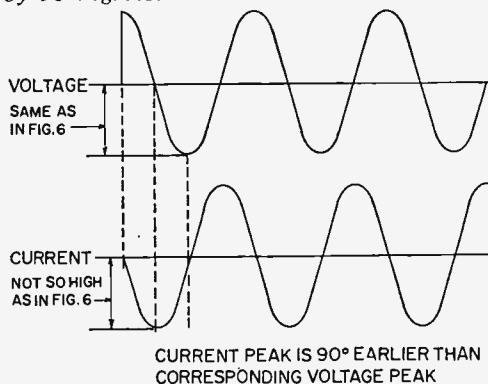

Fig. 7. Waveforms show what a capacitor does to the phase of current. Current peaks are 90 degrees earlier than voltage peaks.

The actual peak current value is determined both by the electrical size of the capacitor and by the duration of the cycle. The capacitor's charging is interrupted and reversed whenever the voltage goes through zero, which means that the current flow lasts for only half a cycle before being reversed. A large capacitor will require more current to charge to the same voltage than will a small one in the same time; similarly, for the same current and voltage, a small capacitor requires a shorter cycle time.

This limiting of the flow of current produces an automatic limiting of the power available for the rest of the circuit, although no power is dissipated in the capacitor itself. Such power limiting is called "reactance"; for a given frequency of AC, a large capacitor has less reactance than a small one, while for a given size of capacitor, its re-

actance is less at higher frequencies than at lower ones.

The power limiting was visible in the last experiment as a reduction of the glow from the bulb. The phase difference produced by the capacitor is difficult to show with inexpensive instruments—but its presence will be proved just a little farther along.

Inductors, too. Capacitors are not the only electrical components with reactance. Inductors also have reactance, but with some differences.

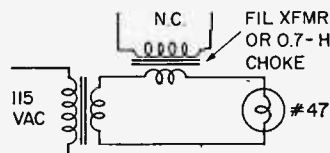

Fig. 8. This hookup shows the effect of inductance in an AC circuit; lamp glows dim.

To prove this, substitute an inductor (the secondary of the unused filament transformer is excellent) for the capacitor in the experimental hookup, as shown in Fig. 8. Note how the bulb dims in this case also, though it probably won't dim quite so much.

If you can locate a 0.7-henry inductor or filter choke, use it in place of the transformer secondary, and the dimming will be approxi-

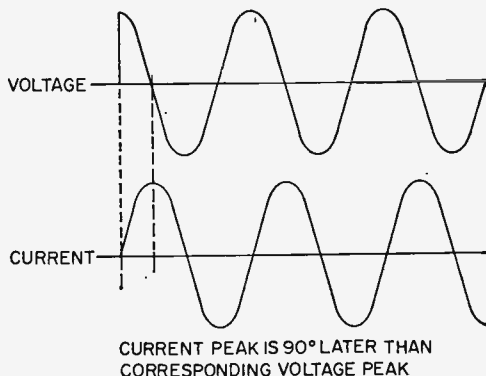

Fig. 9. Voltage and current waveforms of inductive circuit shown like those in Fig. 7; current lags 90 degrees behind the voltage.

mately the same. This value of inductance, at 60 cycles per second (power-line frequency), has approximately the same magnitude of reactance as does the 10-microfarad capacitor used previously.

Inductive reactance behaves a bit differently from that produced by capacitors, however. Fig. 9 shows the waveforms involved, and some of the reasons.

E/C THE HOWS AND WHYS OF RESONANCE

An inductor tends to maintain the value of current flow at a constant level, resisting any change. Thus, when voltage is first applied, the current flow remains at zero.

As time passes, current begins to flow, in the positive direction although the voltage is moving negatively, because the voltage is still greater than zero.

Current flow builds up rather rapidly, but as voltage moves through zero and becomes negative the current through the inductor is forced to reverse direction, which puts the current peak at the same point in time as the voltage zero.

So long as the voltage is negative the current is moving in the negative direction, but when the voltage becomes positive again after moving through zero on the way up, the

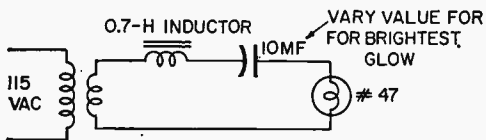

Fig. 10. By combining both inductor and capacitor in series, reactance effects cancel out and lamp glows as brightly as in Fig. 5A.

current reverses and begins going positive.

Thus, voltage and current in the inductive circuit are separated by 90 degrees just as in a capacitive circuit. The difference is that with an inductor, the current lags by 90 degrees instead of leading.

Reactance is produced by the same means—the limiting of current by the polarity change in the voltage—but it behaves differently as frequency is changed. The inductor prefers to handle direct current. As the duration becomes shorter and shorter, the current flow is limited more and more.

Whereas for a capacitor of fixed value, the reactance decreases as frequency of the signal goes up, for an inductor the reactance increases with frequency. This difference between inductive and capacitive reactance offers the possibility of making them cancel out at one specific frequency—and that's the secret of resonance.

The Series-Resonant Circuit. We'll start this off with an experiment, and work back to the reasons why it happens later. Hook up Fig. 10, with the exception of the capacitor. The bulb should light dimly.

Now connect in the capacitor. The bulb's glow should be noticeably brighter. If your inductor is exactly 0.7 henries in value and the capacitor is reasonably close to 10 microfarads, the bulb should glow every bit as brightly as if it had no reactances at all in series with it.

To check, use higher and lower values of capacitance. Parallel capacitors, one microfarad at a time, to increase the capacitance value. If values were exact to begin with, any change in capacitance will dim the glow. If your values were a wee bit off, you will find the glow gets brighter, then dims.

How does this work? We have to go back to the discussion of phase to show why. There, you remember, we showed how two voltages of different phase would combine to give a single voltage of in-between phase, and how two voltages exactly 180 degrees apart in phase would cancel each other out completely if they were of the same strength.

That's exactly what's happening here. We have four phases involved; one is of voltage, the other three are current. At the transformer (the source) voltage and current are exactly in phase. After the inductor, phase of the voltage is not changed but the current has been made to lag by 90 degrees, with resulting high reactance. The capacitor doesn't affect the voltage, but puts a 90-degree lead in the current phase, again with high reactance.

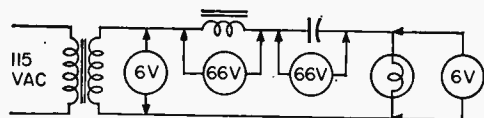

Fig. 11. When voltages in Fig. 10 are measured, voltage across capacitor or inductor is found to be greater than supply voltage.

But the 90-degree lead in current produced by the capacitance, together with the 90-degree lag produced by the inductor, add up to no phase change at all! The capacitor and the inductor have cancelled out each other's phase shifts, so that the full power of the source is available to light the bulb.

The cancellation can happen only when both reactance values are equal; if they were not equal, then either the lagging current of the inductor or the leading current of the capacitor would be too large to be completely cancelled by its counterpart. Since inductive reactance rises with frequency while capacitive reactance falls, for any specific combination of inductor and capacitor there

is only *one frequency* at which they will cancel.

This cancellation of reactance is what is known as resonance, and even if there were no other effects than the ability to separate one frequency out of the infinite number available it would be an important effect.

However, the benefits don't stop there. The resonant circuit can "amplify" its selected signal to as much as 100 times its original voltage, or more.

Using the circuit of Fig. 10, measure the voltages as shown in Fig. 11. Note that the transformer delivers only about 6 volts, and the bulb has about the same voltage across it. You would expect to find no voltage at all across either the resistor or the capacitor, since they are cancelling out each other's effects.

But when you measure the voltage across either of these components, be sure to set your voltmeter to its highest range first. If your parts values are exactly those shown in Fig. 10, the voltage across either the capacitor or the inductor will measure out to 66 volts, 11 times greater than either the source or the load!

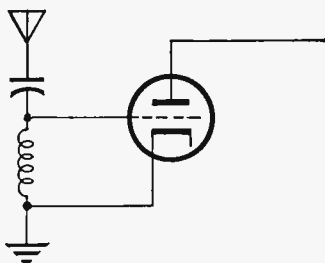

Fig. 12. A practical use for the multiplication effect is in the grid circuit of a receiver's RF stage; the coil is connected across grid.

How Voltage Multiplication Works.

How can such a seemingly simple circuit provide a more-than-10-time multiplication of voltage, without losing power?

The answer lies in the *phase* relationships inherent in AC flowing through capacitors and inductors. Remember that when AC flows through a capacitor, the current leads the voltage by 90 degrees. This is the same thing as saying the voltage is behind the current by 90 degrees—the separation is 90 degrees, and the current comes first.

The leading current effect of the capacitor, and its resulting limitation of total current flow in the circuit, has been cancelled out in the resonant circuit by an equal lagging-current effect of the inductor, so that the

current flow is limited only by the resistance in the circuit—the light bulb.

However, this *load current* still flows through the capacitor, which means that it *must* have associated with it a voltage which is 90 degrees behind it in phase. And this voltage must have the same strength in relation to the current that the 6-volt supply voltage had in relation to the limited current flow, before the circuit was made resonant.

Since the capacitor alone limited current flow to about 23 ma., with a 6-volt supply, the phase-shifted voltage produced by flow of the 250 ma. load current through the capacitor must be 250/23 times 6 volts, or about 66 volts.

The same load current flows through the inductor, where by an exactly similar process it produces another 66-volt phase-shifted voltage; this time, however, the voltage is 90 degrees ahead of the current in phase. With one voltage 90 degrees behind and the other 90 degrees ahead, the two voltages are 180 degrees apart in phase and so cancel each other out so far as either the source or the load are concerned.

However, the meter will measure the full voltage across either the capacitor or the inductor, since conventional meters are not sensitive to phase.

In A Radio. If the series resonant circuit is adjusted for resonance at some radio frequency, say 1,000 kc, rather than at the 60-cps power-line frequency we've been using in our experiments, and is connected in the grid circuit of a vacuum tube as shown in Fig. 12, then it will perform the dual function of selecting the desired frequency, and giving it a boost.

When radio waves strike the antenna, they cause a small current flow down the feed-line, through the capacitor, and through the coil to ground. If the signals are not at the resonant frequency, 1,000 kc, they will be greatly impeded by the reactance of the capacitor.

At resonance, however, they find almost no impedance at all in their path from antenna to ground, since the reactances of the capacitor and the coil cancel each other. A relatively large current flows.

This current flow develops a much larger voltage across the coil, so that the vacuum tube (connected to takes its input from the coil voltage only) obtains a relatively strong input signal.

The voltage multiplication effect is de-

e/e THE HOWS AND WHYS OF RESONANCE

terminated by the ratio of one *reactance* (either the capacitive or inductive one) to the total *resistance* of the circuit, and is so important that it is known as the "quality factor" of the circuit—usually abbreviated to "Q".

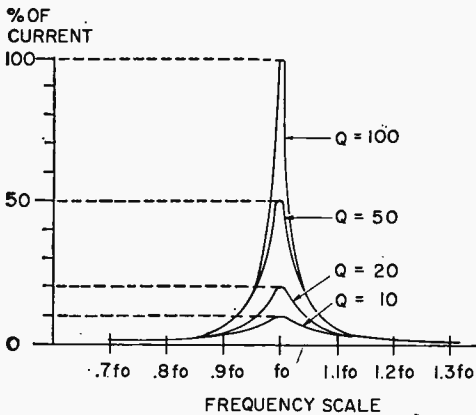

Fig. 13. Selectivity of high-Q circuits is due to great variation between current at the resonant frequency and all other frequencies.

The Significance of Q. While Q has as its strictest definition the measurement of quality of a resonant circuit, it is also applied in many other fields of electronics. By using the definition "ratio of reactance to resistance", the Q of a coil alone may be measured.

This comes about because all coils (and other components too, for that matter) have at least some built-in resistance, no matter how undesirable this may be. The higher the Q, the greater is the ratio of reactance to resistance, which means that the resistance is less significant. For this reason, high Q is

considered desirable in most applications.

Q is also a measure of a resonant circuit's ability to separate closely-spaced frequencies. Figure 13 shows the response of a number of resonant circuits, all of which are resonant at the same frequency and have the same values of capacitance and inductance. The only differences between them are the amounts of resistance present—or in other words, their Q's.

You can see that at frequencies far away from resonance, all the circuits have about the same response, which is very small compared to their response at the resonant frequency.

At resonance, however, the highest-Q circuit (the one with the least resistance) allows much greater current flow than does the low-Q circuit. This follows naturally, since at resonance the current flow is controlled only by the resistance. The less resistance, the more current, so that if resistance dropped to zero (which would make Q infinite) the current flow would also become infinite.

You can see from Fig. 13 that the *difference* in current flow at resonance and at far-removed frequencies is much greater for the high-Q circuits than for the low-Q ones.

Since the difference is much greater while the frequency spacing remains the same, this means that the *change of response* as resonance is approached must be greater for the high-Q circuits.

This change-of-response is the feature that allows separation of closely spaced stations. Fig. 14 shows how; these are response curves for two different circuits, both tuned to 1,000 kc. One circuit has a Q of 100, while the other has a Q of 10.

Both reject signals at 100 kc equally well. But when a potentially interfering station shows up at 950 kc, what happens?

With the Q-of-100 circuit, response at

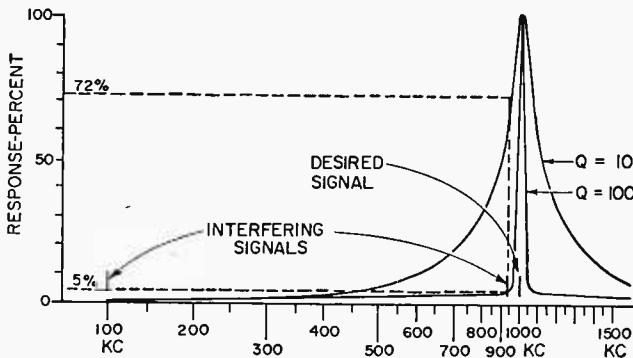

Fig. 14. The high-Q circuits reject stations near the desired frequency. Frequency of interfering signal nearest desired one is 950 kc. With Q of 10, this signal is 72% as strong as the desired one at 1000 kc. With Q of 100, it is only 5% as strong. Hence, the higher Q reduces interference.

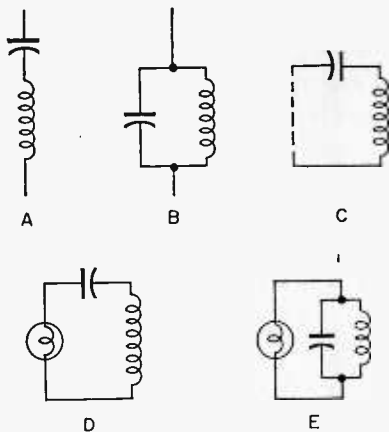

Fig. 15. Series-resonant circuit (A) and parallel-resonant variety (B) differ by only one connection, shown dotted at (C). Regardless of connections, circuit operates at series resonance if current is injected in series (D), and parallel resonance if current is injected in parallel (E). Most circuits which may appear to be parallel-resonant actually operate in the series-resonant mode.

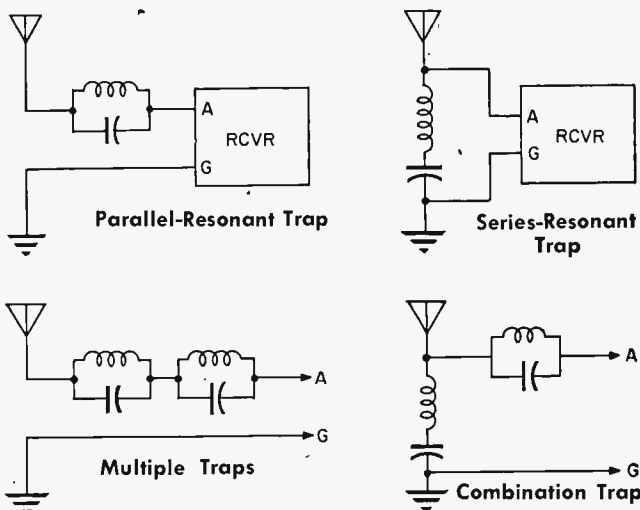

Fig. 16. Various ways to connect wavetraps are shown; multiple traps tune to different frequencies while the combination trap offers double rejection of only one frequency.

950 kc is only about 1/20 of that at 1,000 kc, and in addition the reactance cancellation effect is very small.

With the Q-of-10 circuit, however, response at 950 kc is 72 percent as great as that at 1000 kc. The interfering signal will come through almost as loud as if the circuit were resonant at 950 kc instead of at 1000 kc.

For an interfering signal to reach this 72-percent point in the Q-of-100 circuit, it would have to be a mere 5 kc away from 1000 kc. If it were this close, its modulation would interfere with the desired signal anyway and no amount of selectivity could help.

In practical receivers, the intermediate-frequency stages are fixed-tuned and employ high-Q coils, to obtain the desired selectivity. Each of these coils is tuned to resonance at the intermediate frequency.

The differences in shapes and response curves for resonant circuits having different values of Q can be related to the resonant frequencies of the circuits, and the result leads to some rules of thumb which offer additional definition of Q.

The most important of these is that the Q of a resonant circuit is equal to the resonant frequency of that circuit, divided by the spacing between the two points (one on either side of the resonant frequency) at which current flow is reduced to 70.7 percent of that resonance. Thus, with a resonant circuit tuned to 1,000 kc, if the distance between 70.7-percent points is 10 kc (5 kc up and another 5 kc down), then the Q is 1,000/10 or 100.

This rule makes it easy to measure the approximate Q of a tuned circuit, if you have a signal generator available. Simply tune through resonance and note the maximum current flow. Then measure how many cycles (or kc, or Mc) either side of this point you must go to reduce current flow to 71 percent of maximum, add the two distances together, divide into the resonant frequency, and the result is a rather surprisingly accurate measurement of the circuits' Q.

The Parallel Resonant Circuit. So far, all the resonant circuits we have been discussing look like that in Fig. 15A, in that they are series resonant. On the other hand, most schematic diagrams show the type of resonant circuit illustrated in Fig. 15B, the parallel resonant variety.

We aren't trying to confuse you. The series resonant circuit is easy to work with,

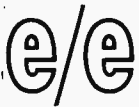

THE HOWS AND WHYS OF RESONANCE

to prove experimentally for yourself how these hookups work. The parallel resonant variety is not so easy.

However, even more important is the fact that *most* of the "parallel resonant" circuits employed in radio are actually, so far as circuit behavior is concerned, series resonant circuits instead.

The only real difference between a parallel and a series resonant circuit is shown in Fig. 15C. If the dotted connection is left out, the circuit is series resonant. If this connection is made, parallel resonance results.

Of course, the power source must be connected into the circuit by some means. In the series circuit, the source injects its current in series as shown by the generator symbol in Fig. 15D, while in the parallel circuit the current is injected across the circuit as at E.

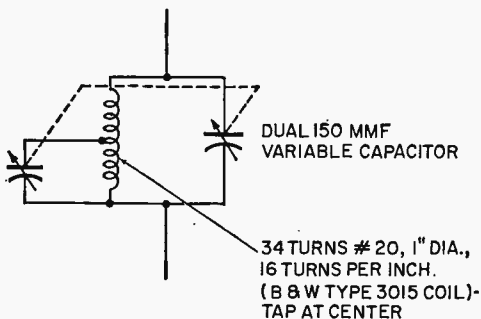

Fig. 17. Multiband tuner covers 3 to 30 mc. without switching; uses multiple resonances.

A *true* parallel-resonant circuit behaves in a manner that is almost the exact opposite of the series circuit. Where current flow from source to load is maximum at resonance in the series circuit, it is minimum at resonance in the parallel variety. This makes the parallel resonant circuit most useful as a wavetraps, to block current flow at a particular frequency. Such "trap" circuits are widely used in TV receivers, for instance, to remove video signals from audio circuits and to block audio signals from the picture.

Wavetraps. Both the series and parallel varieties of resonant circuits may be used as wavetraps. A parallel resonant circuit placed in series with a source such as the antenna will block signals near its resonance, but will have very little effect upon signals at

frequencies away from the resonant point.

The series resonant circuit, on the other hand, must be placed across the load to serve as a trap. In this location, it shorts out signals at its resonant frequency but has relatively little effect upon other signals.

Several wavetraps may be combined; each will have little effect upon the other. Thus an extremely strong broadcast station may be cut back in strength by use of a high-Q parallel-resonant wavetraps, so that you can hunt DX only a few kilocycles removed from the local-station frequency, and at the same time you can have a second trap circuit tuned to block signals coming from the ham next door, so that they won't overload your receiver. Various circuits are illustrated in Fig. 16.

Reactance Away From Resonance.

Earlier, we pointed out that complete cancellation of reactance by resonance can happen at only *one* specific frequency for any combination of capacitor and inductor. At all other frequencies, some reactance will remain in the circuit.

Since capacitive reactance increases and inductive reactance decreases as the frequency is lowered, at frequencies *below* resonance the capacitive reactance will be larger than the inductive reactance in the circuit, and the reactance left after all of the smaller reactance has been cancelled out will be capacitive in nature. Thus, below its tuned frequency, a resonant circuit appears to be simply a capacitor.

Above resonance, the reverse is true. The circuit now appears to be simply an inductor—the capacitive reactance was cancelled.

These facts can be useful, should you need a particular size of capacitor or inductor and find that you don't have one on hand. You can use either a larger or smaller value, and *tune* it to the electrical size you need by making it part of a resonant circuit, and adjusting the resonant frequency in relation to the actual frequency present so that the reactance left in the circuit is the same as would be produced by the component you wanted to use in the first place. In the VHF region, such tricks are necessary almost all the time because the actual values needed are too small to produce directly.

Multiple Resonances. Since a resonant circuit looks like a capacitor at frequencies below resonance, and like an inductor at higher frequencies, it follows that *two* res-

(Continued on page 105)



simple experiments show . . .

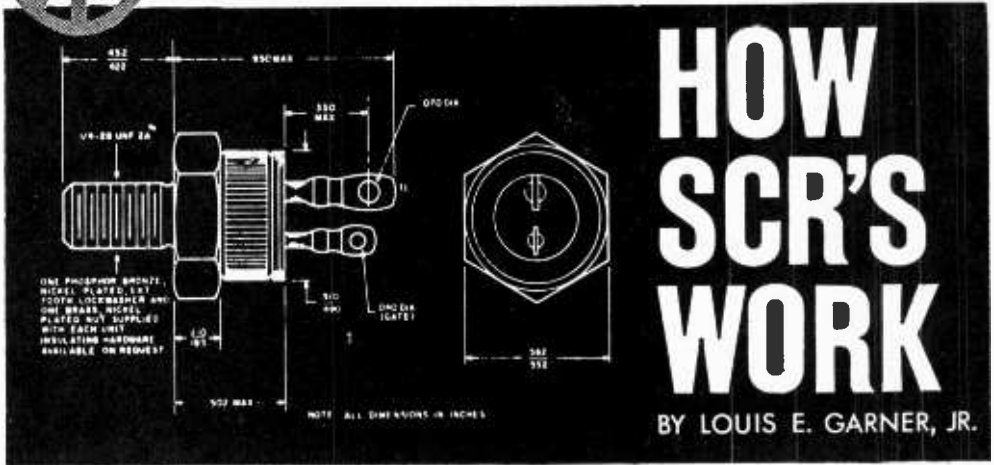

The silicon controlled rectifier is a versatile semiconductor that can be used in the shop to vary motor speed or in the living room to dim the lights

■ First introduced in 1958, nearly a full decade after the invention of the transistor, the silicon controlled rectifier is a “younger,” relatively speaking, as far as semiconductor devices are concerned. Within a few short years, however, it has been accepted wholeheartedly by industry and, today, is being used in increasing quantities by industrial and commercial equipment manufacturers. Its applications are legion—it has been used in light dimmers, motor speed controls, solenoid actuators, battery chargers, electromagnet controls, power supplies, electroplaters, welders, power inverters, automobile ignition systems, temperature regulators, and process controllers.

Although a three-terminal device, it is not, as the transistor, an amplifier. Nor is it a rectifier in the conventional sense of the word. Rather, it is a rectifier which “works” (or conducts) only on command. In other words, as its name implies, it is a *controlled* rectifier. When conducting, however, it behaves much as a familiar two-terminal rectifier, permitting current to pass in one direction but blocking reverse current flow.

What It Is. Generally identified by its initials *SCR*, the device is made up of four alternate layers of *p-type* and *n-type* semi-

conductor materials. Its schematic symbol is similar to the one used for a conventional diode rectifier, but with a third electrode added, as shown in Fig. 1(a). As in a standard diode, its two principal electrodes are its *anode (a)* and *cathode (c)*, while the third electrode is called a *gate (g)*.

SCR's are specified according to their forward and reverse breakdown voltages, maximum power dissipations, and maximum forward currents. Their control characteristics are identified in terms of gate voltages and currents for “firing” and *holding* current. The first two specifications indicate the voltages at which internal breakdown will occur when the device is biased in its forward and reverse directions, respectively. The unit's maximum power dissipation, given in watts, indicates the maximum electrical power which the device can dissipate as heat without damage. The gate voltage and current ratings indicate the control signal levels needed to “trigger” and operate the device. Finally, the holding current is the minimum forward current needed to maintain the device in a conducting state once “fired.”

There are other electrical specifications, of course, but these are primarily of interest to design engineers. Typically, they might

e/e HOW SCR'S WORK

include gate power dissipation, breakover voltage, forward voltage drop, forward (and reverse) leakage current, delay time, turn-off time, and the device's temperature characteristics.

Watt Size? Physically, SCRs are manufactured in a variety of sizes, styles and shapes with electrical specifications to meet virtually every circuit requirement. Low power units, capable of handling currents up to one or two amperes, may be mounted in small cases similar to those used for standard transistors. High power types, on the other hand, may be encased in a strong cartridge equipped with a heavy mounting stud and

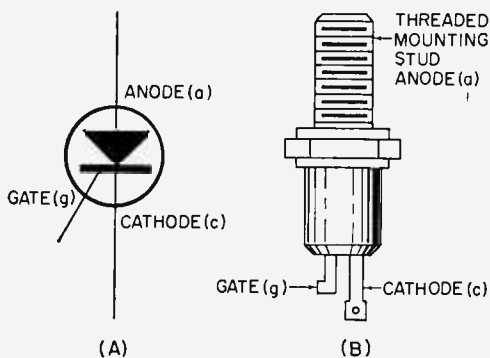

Fig. 1. Schematic symbol of SCR is shown at (A); electrodes are identified at (B).

sturdy electrode leads, as illustrated in outline form in Fig. 1(b). Maximum voltage ratings range from less than 25 volts to over 1,000 volts, depending on type, while maximum current ratings range from a fraction of an ampere to hundreds of amperes.

When first introduced, the SCR was a very expensive device. As the years have passed, however, increased industrial demand coupled with improved manufacturing techniques have brought prices lower and lower until, today, many types are priced within the budgets of hobbyists and home experimenters.

You Build It. The ten simple experiments described below, easily performed with instruments available in the average home electronics laboratory, will demonstrate how SCRs work and what they can do. As specified in the Parts List, relatively few components are needed—a simple power supply

made up of series-connected batteries, a low-cost SCR, a general purpose VOM, a few resistors, an isolation transformer, a couple of diodes, an experimental breadboard, and a few pieces of hardware are the basic items needed. All the items are readily available through both local and mail order parts distributors.

The author used a perforated *Masonite* board as an experimental "chassis," but a conventional metal chassis may be used if preferred by the individual experimenter. Size is not critical, but the chassis (or board) should be equipped with rubber feet to prevent damage to table or workbench tops. Major components and mounting brackets are attached to the board using small machine screws and nuts, while individual components and leads are soldered in place, except for the battery and meter leads.

When conducting the experiments, be sure to follow a few basic rules, both to insure accuracy and to avoid possible damage to your test instrument or components. Use a hot, well-tinned soldering iron (or gun) when making connections to the SCR, completing each connection as quickly as possible. Remember that all semiconductor devices can be damaged by excessive heat.

Always check your wiring and circuit polarities *before* applying power. Disconnect power when making circuit changes and between steps. When taking a voltage measurement, set your VOM to its highest range for the type of measurement needed, switching to lower ranges as necessary to obtain a satisfactory reading.

The experiments have been designed to

PARTS LIST

- R1—10,000-ohm, potentiometer
 - R2—1,000-ohm, 1-watt resistor
 - R3—1,000-ohm, 1/2-watt resistor
 - R4—1,500-ohm, 10-watt resistor
 - R5—5,600-ohm, 2-watt resistor
 - R6—1,000-ohm, potentiometer
 - D1, D2—Silicon diodes (International Rectifier type 5A4-D)
 - SCR—3.5-amp., 200 volt SCR (International Rectifier type SCR-02-C)
 - B1—27-volt battery (Three Burgess type 2N6 in series)
 - T1—100-volt isolation transformer (Lafayette No. NE-1948)
 - SO1—Line receptacle (Amphenol type 61-F1)
 - Misc.—Perforated *Masonite* breadboard chassis, approx. 6" x 7 3/4"; control knob; battery clips; line cord and plug; test leads; assorted L-brackets; (4) rubber feet; cable clamp; 2-point terminal strip; ground lugs; machine screws and nuts; wire, solder, etc.
- Accessory: General purpose VOM

require *voltage measurements only*, both to avoid the need for opening circuit connections (as is needed to take current measurements) and to reduce the chance of accidental damage to the VOM. Do not, however, expect *your* measurements to correspond *exactly* to the values obtained by the author and given in Tables A through I. Normal component tolerances will result in different readings, even where the specified parts are used. There is space provided in the tables for your readings to be recorded.

EXPERIMENT 1:

Determining an SCR's forward characteristics with gate open.

Any rectifier's "forward" electrical characteristics are those which indicate its performance when biased in its conducting direction; that is, with its anode positive and cathode negative. The circuit used for this experiment is diagrammed in Fig. 2, while a

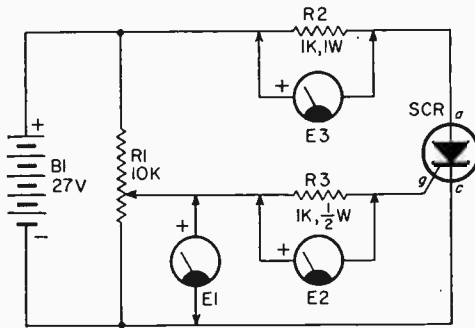

Fig. 2. Schematic diagram for circuit to determine the SCR's diode characteristics.

breadboarded version is shown in Fig. 3. The SCR and potentiometer (R1) are mounted on L-brackets, with the anode connection made through a soldering lug. Three 9-volt batteries are connected in series to supply a maximum of 27 volts.

Referring to the schematic diagram, R1 serves as a voltage control while series resistor R2 serves both as a current-limiting device and as a means for measuring anode current. With a 1,000 ohm resistor used here, the D.C. voltage drop across R2 (E2) is equal to the current through it in milliamperes.

With the experimental circuit wired as shown, adjust the applied voltage (E1) from zero (0) to the maximum available (27) in small steps, recording the applied voltage at each step and the corresponding voltage across R2 (E2) in Table A. Use steps of

3 or 6 volts, as preferred. The VOM's positive lead may be left connected to R1's center arm during the entire experiment, with only the negative lead transferred to obtain the two measurements, E1 and E2.

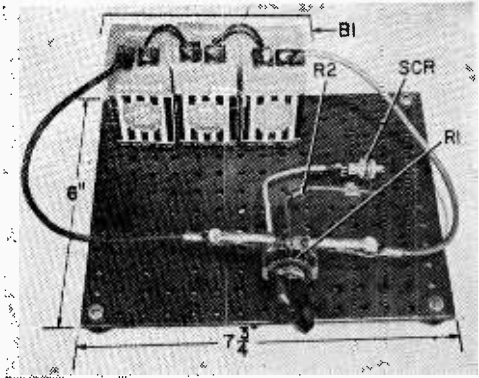

Fig. 3. Here the circuit shown in Fig. 2 is breadboarded using three 9-volt dry cells.

Your results should show that little or no current flows, even with maximum voltage applied. If a high enough forward bias is applied, of course, forward "breakdown" can occur, in which case the SCR will switch from its high resistance non-conducting state to a low-resistance state, acting as virtually a "short." The breakdown voltage of the SCR specified is greater than the maximum voltage available from our simple power supply, however.

TABLE A

Author's		Your's
E1	E2	E2
0	0	
6	0	
9	0	
15	0	
21	0	
27	0	

EXPERIMENT 2:

Determining an SCR's reverse characteristics with gate open.

A rectifier's "reverse" characteristics are those indicating its performance when biased in its high-resistance (non-conducting) direction—anode negative, cathode positive. The basic circuit used in this experiment is identical to that used in the previous experiment,

HOW SCR'S WORK

except that the battery (B1) lead connections are interchanged. Naturally, the VOM's test leads must be reversed as well.

As in the first experiment, change the applied voltage in small steps by adjusting R1, recording the applied voltage (E1) and voltage drop across the series resistor (E2) at each step in Table B. In this case, of course, the VOM's negative lead may be left connected to R1's center arm, with only the positive lead transferred to obtain the two measurements of each step.

TABLE B

Author's		Your's
E1	E2	E2
0	0	
6	0	
9	0	
15	0	
21	0	
27	0	

Again, your results should demonstrate that little or no current flows, even with maximum voltage applied. As before, however, internal breakdown can occur if the reverse bias is of sufficient amplitude, and the device, in such a case, will switch from a high resistance to a low resistance state.

EXPERIMENT 3:

Determining an SCR's conduction characteristics as gate voltage is increased.

In our first two experiments, we treated the SCR as if it were a conventional diode rectifier, ignoring its third (gate) electrode. Our tests demonstrated that the SCR *does not behave* as a conventional diode, however, for such a device conducts when biased in its forward direction and acts as an open circuit (or extremely high resistance) when reverse biased. The SCR *did not conduct* when biased in either its nominal "forward" or reverse directions.

Let us determine what happens when a DC control signal is applied to the SCR's gate, and whether this has any effect on its forward conduction characteristics. The

basic circuit for this experiment is given schematically in Fig. 4, while a typical bench setup for tests is shown in Fig. 5. B1, as before, serves as the power source; R1 is used as a voltage control and, in this case, permits an

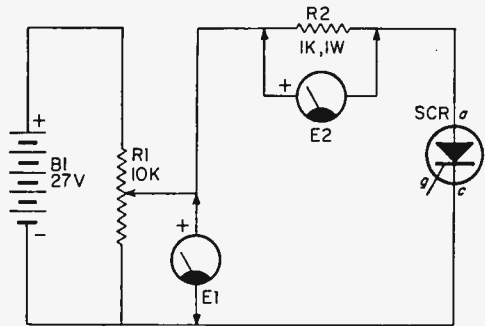

Fig. 4. This circuit is used to determine the effect of gate voltage on SCR operation.

adjustment of gate (g) bias; R2 serves to limit anode current while simplifying measurement of this value and R3 performs a similar function in the gate circuit.

Starting at zero (0), increase the applied gate voltage (E1) in, say, 3-volt steps, recording the corresponding voltage drops across R3 (E2) and R2 (E3) in Table C. Note that the applied anode voltage is the same as the supply voltage (B1), and that voltage drops E2 and E3 are equal, in milliamperes, to the currents through their respective resistors.

Your test results should indicate that the gate current (proportional to E2) increases as the applied gate voltage (E1) increases, but that the anode current (proportional to E3) remains virtually at zero until a specific gate voltage is reached, then increases

TABLE C

Author's			Your's	
E1	E2	E3	E2	E3
0	0	0		
3	2.6	0		
6	5.4	0		
9	8.2	0		
12	11	0		
15	13.9	1.5		
18	16.7	9.5		
21	19.5	24.5		
24	22.5	24.5		

quite rapidly, reaching a maximum and then remaining at that value thereafter, even with further increases in gate voltage. It is as if the SCR were an electrical switch, remaining "open" until "closed" by a specific value of gate voltage. The gate, in other words, serves to *trigger* the SCR into a conducting state. From a device specification viewpoint, the gate voltage needed to trigger the SCR under specified circuit conditions is some-

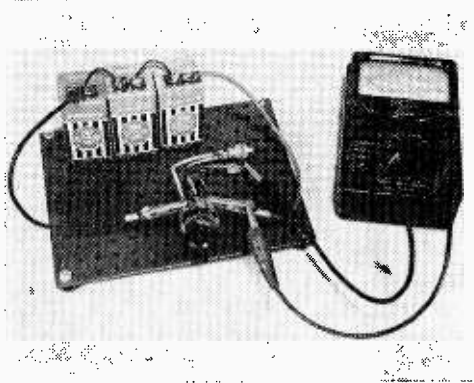

Fig. 5. Experiments 3, 4, 5, and 6 are performed using this breadboard and the meter.

times called the *gate firing voltage*. The name is derived from gas tube terminology, in which a given grid voltage "fires" a thyatron tube, causing it to switch from a high to a low resistance state.

EXPERIMENT 4:

Determining the approximate gate voltage required to trigger an SCR.

Our previous experiment indicated that the SCR can be switched to a conducting state in its forward direction by the application of a suitable gate voltage. The experiment was conducted using 3-volt steps (increments), however, and it may be that the actual gate firing voltage is somewhere between the test values used. In order to determine if this is true, repeat the previous experiment using *smaller* gate voltage increments.

First, disconnect all power to restore the circuit to normal and turn R1 back to its "zero voltage" position. With circuit power reapplied and the VOM connected to measure E3, adjust R1 until a small voltage is measured on the meter, indicating the start of anode current flow. Check E1 at this point. Next, increase E1 in small (1-volt) steps, checking E2 and E3 at each step and

recording the values in Table D. Continue until E3 reaches a steady, fixed value, indicating maximum anode current flow.

Examine your test results. Your measurements should demonstrate that the SCR's anode current (as indicated by E3) increases to a maximum quite rapidly at a specific applied gate voltage (E1). This value, less the voltage drop across R3 (E2), is the approximate *gate firing voltage* for your SCR under the test conditions used.

In commercial practice, the gate firing voltage is specified at a given anode voltage under known temperature conditions. Some firms, instead, specify Gate Voltage for Firing (V_{GF}), which is the gate voltage with gate current flowing, but just prior to the start of anode conduction. Equally important, however is the *gate current* required to fire an SCR under specified anode voltage and temperature conditions.

TABLE D

Author's			Your's	
E1	E2	E3	E2	E3
14	12.8	1.0		
15	13.9	1.5		
16	14.8	3.0		
17	15.8	5.5		
18	16.7	9.5		
19	17.5	24.5		
20	19	24.5		

EXPERIMENT 5:

Determining the effect of gate voltage on SCR operation after firing.

There are a few additional tests we can make using the circuit employed in the two previous experiments (Fig. 4). Disconnect B1, removing power, and return R1 to its "zero voltage" position. Reapply power by connecting B1 and, using your VOM, measure E1, E2 and E3, recording these values in Table E. All readings should be "O."

Next, adjust R1 for the gate firing voltage as determined in Experiment 4. Measure—and record—the values of E1, E2 and E3. Now, *without removing power*, return R1 to its "zero voltage" position. Check E1, E2 and E3 once again. Finally, momentarily open the anode lead and reconnect it. Check E1, E2 and E3 once more, recording the measured values.

Your test results, when finally tabulated,

e/e HOW SCR'S WORK

should indicate that anode current *continues to flow once the SCR has fired, even after the gate voltage is reduced to zero*, until the anode voltage is removed temporarily. In other words, once the SCR has been switched to its conducting state, the gate "loses control" until the device is switched back to its non-conducting (high resistance) state by an interruption of anode current flow.

TABLE E

CONDITION	Author's			Your's		
	E1	E2	E3	E1	E2	E3
Basic	0	0	0			
Adjust to fire	19	17.5	24.5			
Retrn g to 0	0	0	24.5			
Open a & close	0	0	0			

EXPERIMENT 6:

Determining SCR operation with reversed gate and anode voltages.

Thus far, we have found that the SCR does not behave as a conventional rectifier in that it will not conduct when its anode is biased in a forward direction *until* triggered by a suitable gate voltage. At this point, you might wonder if the SCR can conduct in *both* directions when a gate voltage is applied. Let's find out.

TABLE F

TABLE F			Your's	
E1	E2	E3	E2	E3
0	0	0		
6	2	0		
12	6.5	0		
18	11.3	0		
24	15.8	0		

Using the basic circuit illustrated in Fig. 4, interchange B1's connections, reversing D.C. polarity. Adjust R1 for increasing values of applied gate voltage (E1) in, say, 6-volt increments, recording E1, E2 and E3 in Table F. Don't forget to *reverse meter lead connections*.

When you analyze your test results, you

should find that there is some gate current flow, as indicated by the voltage drop across R3 (E2), but that anode current remains at zero, as shown by the voltage drop across R2 (E3). The measured gate current will be less than in the previous experiment. From this, you can conclude that the SCR does not conduct in its "reverse" direction (unless, of course, the applied voltage exceeds its breakdown rating) and thus can serve as a true rectifier under suitable operating conditions.

EXPERIMENT 7:

Determining an SCR's forward characteristics when its gate voltage is maintained above the firing point.

We'll use the circuit illustrated in Fig. 6 for this experiment. An adjustable voltage (E1) is applied to the SCR's anode while the gate voltage is maintained at a fixed value well above the firing voltage determined in your previous experiments.

With the circuit wired as shown in the diagram and R1 adjusted to its "zero voltage" position, apply power and measure E1, E2

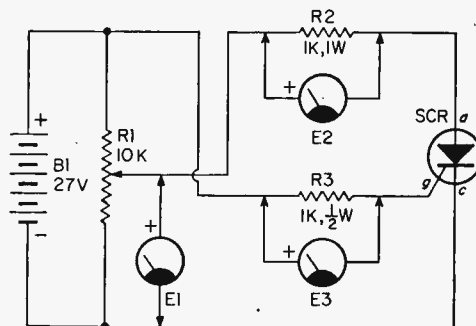

Fig. 6. Schematic of circuit used in the determination of SCR's forward characteristics.

and E3, recording the values in Table G. Increase E1 in, say, 3-volt increments, rechecking E2 and E3 and recording the measured values each time. You may find that the supply voltage (across B1) will drop slightly as you carry out the experiment, depending on the condition of your batteries, due to the circuit's (comparatively) heavy current requirements.

Your experimental results should indicate that the SCR's anode current (as indicated by E2) is directly proportional to the applied anode voltage (E1), doubling (approximately) each time the voltage is doubled. E2 will be only slightly less than E1 . . . in the

author's tests, E2 was about 1 volt less than E1, with the difference representing the fixed voltage drop across the SCR. A small "reverse" voltage may be measured across R2 when R1 is set for zero voltage. This is caused by a small leakage current from gate to anode.

On the basis of these tests, you can conclude that the SCR acts like a low value resistance when maintained in a conducting state and that, within limits, its anode-to-cathode voltage drop is a fixed value, regardless of anode current.

TABLE G

Author's			Your's	
E1	E2	E3	E2	E3
0	-0.25	24.5		
3	2.1	24.5		
6	5.1	24.5		
9	8.2	24.5		
12	11.1	24		
15	14.2	23.5		
18	17.2	23.5		
21	20.1	23.5		
24	23	23		

EXPERIMENT 8:

Determining an SCR's AC characteristics.

Our experiments have demonstrated that the SCR can perform much like a conventional rectifier under suitable operating conditions. It is logical to suppose, then, that the device can be operated by an AC (rather than DC) power source. Let's find out if this is true.

Use the circuit arrangement diagrammed in Fig. 7 and illustrated, in breadboard form, in Fig. 8. Referring to the schematic diagram, T1 is a standard AC isolation transformer, while R1 and R2 are the resistors

TABLE H

Author's		Your's
E1 (AC)	E2 (DC)	E2 (DC)
0	0	
6	0	
12	29	
18	39	

used in previous experiments. A 10-watt resistor (R4) is used in series with the anode rather than the 1-watt type used in earlier tests due to the higher anode voltages used

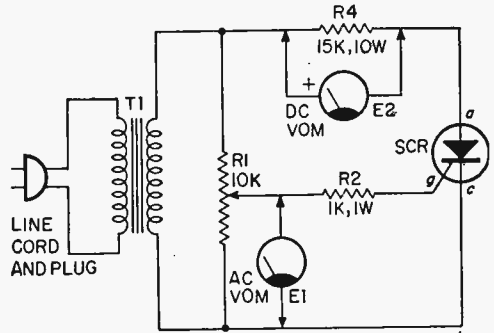

Fig. 7. The silicon controlled rectifier's AC characteristics are shown in this circuit.

here (and, therefore, larger currents).

Adjust R1 to its "zero voltage" position, apply power (by inserting the line plug in a suitable wall outlet), and measure E1 and E2, recording the values obtained in Table H. Use your VOM as an AC voltmeter when checking E1 each time and as a DC voltmeter for checking E2. Next, increase E1's value in, say, 6-volt steps by adjusting R1, checking and recording E2's value each time.

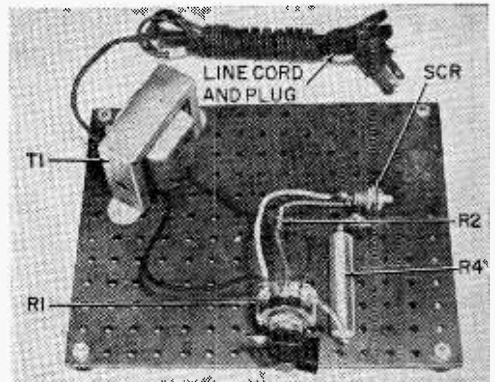

Fig. 8. Breadboarded version of circuit in Fig. 7 shows standard isolation transformer.

Important: Complete each test step as quickly as possible, removing power between steps, to avoid damage to R1. Do not increase E1 beyond 18 volts.

When you examine your test results, you'll find that the SCR's anode current remains essentially at zero (as indicated by E2) until the peak applied gate voltage approaches the applied (DC) gate voltage needed to

e/e HOW SCR'S WORK

"fire" the SCR in earlier experiments. The peak voltage is approximately 1.4 times the measured AC voltage (E1).

This experiment clearly demonstrates that the SCR retains its basic electrical characteristics when operated by an AC source. That is, it will not permit current flow in *either* direction until an adequate gate voltage is applied, at which time it behaves much like a conventional rectifier.

EXPERIMENT 9: Studying an SCR's AC characteristics with DC gate control.

Extremely versatile, the SCR's operation need not be confined *just* to AC or DC power sources. Both types of power may be used at the same time; one as the major (anode-

verses) at a periodic rate, permitting the gate to regain control at the end of each positive-going half-cycle. An experimental circuit featuring a DC gate control and an AC main power source is illustrated in Fig. 9, while a bench test set-up is shown in Fig. 10.

Referring to the schematic diagram, an AC anode-cathode voltage is supplied by isolation transformer T1. Gate voltage is furnished by B1, controlled by R1. Series resistors R3 and R4 serve as current limiting resistors in the gate and anode circuits, respectively.

TABLE I

Author's			Your's	
E1	E2	E3	E2	E3
0	0	0		
6	5.2	0		
12	11.1	0		
18	16.5	45		
24	22.5	45		
0	0	0		

cathode) power source, the other for control purposes. This technique is, in fact, quite useful in many applications for, as we learned in Experiment 5, the gate electrode loses control once the SCR has "fired" if a DC power source is used. With an AC source, the applied voltage drops to zero (and re-

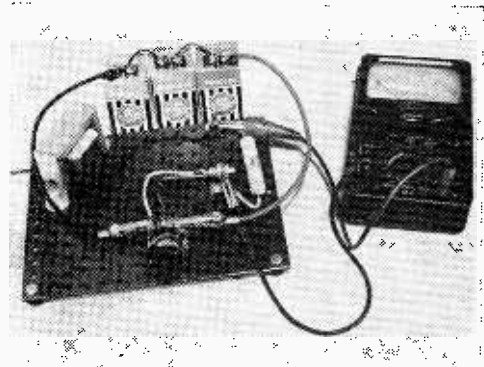

Fig. 10. Breadboard of Fig. 9 circuit shows transformer and batteries for AC and DC.

With a test circuit wired as shown, adjust R1 to its "zero voltage" position and apply power. Using the VOM as a DC Voltmeter, check E1, E2 and E3, recording these values in Table I. Next, increase E1's value in 6-volt steps by adjusting R1, recording the corresponding values measured for E2 and E3 each time. After reaching the maximum gate voltage, return E1 to zero without *disconnecting power*. Record the final measurements obtained for E2 and E3.

At this point, you should be able to predict
(Continued on page 108)

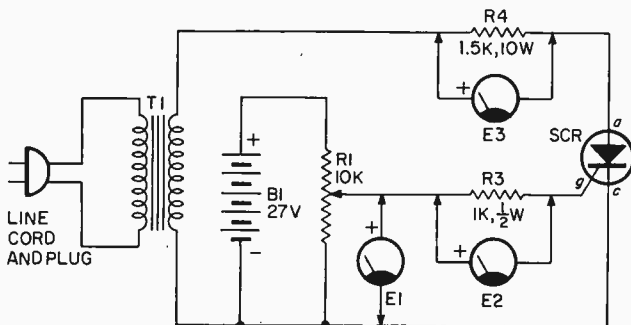
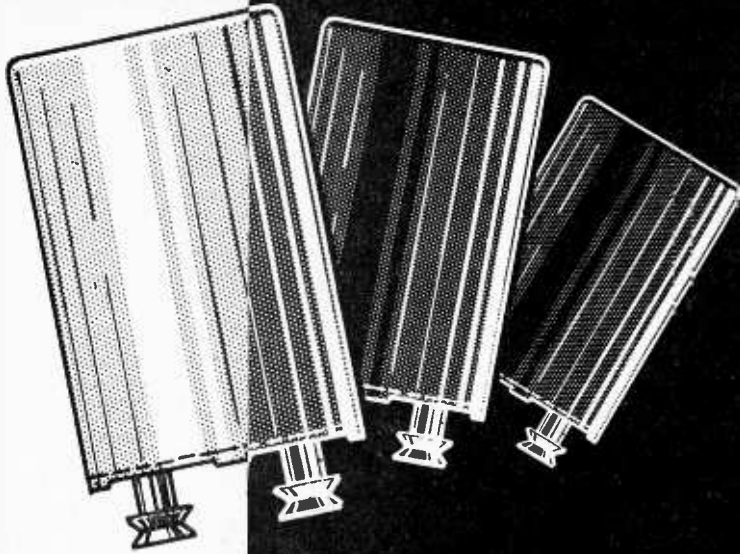

Fig. 9. Schematic diagram of circuit for studying the SCR's AC characteristics with DC gate control shows AC anode-cathode voltage supplied by isolation transformer T1. B1, a 27-volt DC supply provides gate voltage which is controlled by R1. In the experiment, R1 is used to adjust the readings of E1 in increments of six volts.



MAKE YOUR OWN THERMOSTAT RELAYS

Stop discarding those old starters and start making sensing elements

■ Electronic experimenters and radio amateurs often need a thermostatic switch to perform simple switching functions. One thermostatic relay suitable for many home brew applications can be made from the common fluorescent starter of the glow-bulb type used in the home. The bimetallic switch in the starter usually remains undamaged in defective units which are normally thrown away when no longer serviceable.

Inside the Starter. The typical inexpensive 115-volt AC fluorescent lamp circuit using a series ballast and cylindrical starter unit is shown in Fig. 1. When the switch is thrown, the DC resistance of the ballast coil is low and most of the line voltage appears across the open gap in the starter bulb (covered by the aluminum can). This bulb is filled with argon or neon gas at low pressure which ionizes at about 87 volts and glows, conducting the current in both directions across the gap. The glow quickly heats the curved thermostatic electrode, making it bend outward to touch the stationary electrode. As soon as the two electrodes make contact, the glow in the bulb is extinguished and a momentarily heavy AC current flows

through the ballast coil, building up full line voltage across the ballast with the current flowing through and heating the filaments in each end of the fluorescent lamp.

When the glow in the starter bulb (Fig. 2)

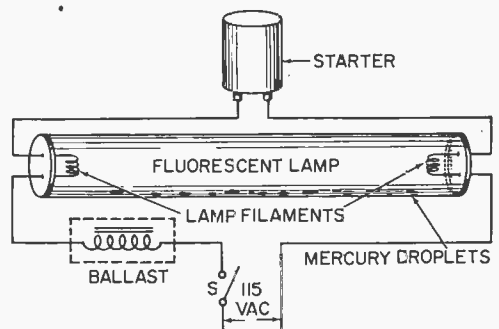

Fig. 1. A pictorial drawing of fluorescent lamp using ballast and glow-tube starter.

is shorted out, the bimetallic strip begins to cool and snaps away from the stationary electrode. This opens the circuit at the starter bulb and throws the line voltage across the gap between the filaments in the fluorescent lamp. When the lamp filaments are heated a



THERMOSTAT RELAYS

small amount of mercury in the lamp tube is vaporized. Mercury vapor conducts at a lower voltage than the neon gas in the starter, so the starter will not ionize as long as the mercury arc is maintained in the fluorescent lamp. Operation of the lamp keep the filaments hot, maintaining the electric arc inside the lamp, while the starter bulb remains inactive until again needed to start the lamp. The capacitor found inside the can with the starter bulb is needed to prevent arcing when the thermostat opens and usually will be found "shorted out" in a defective starter.

Thermostat Alarm System. For some high-temperature (150°-300°F) applications, the defective starter bulb may be used with-

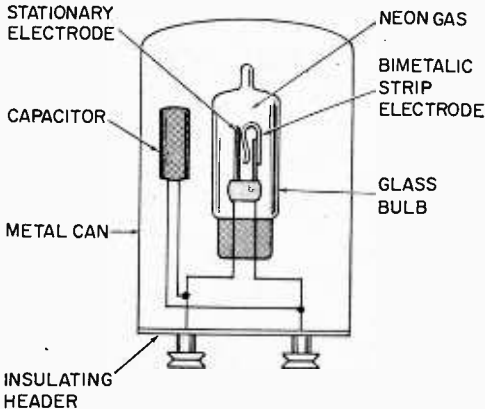

Fig. 2. Capacitor, most often paper, that is housed in starter can may be defective.

out breaking the glass by removing the outer metal can. Just cut off the capacitor if it is shorted and connect the two starter terminals in series with a low-voltage buzzer circuit (Fig. 3). To test the starter bulb for its operating temperature, enclose the bulb (externally connected to a buzzer circuit) with an oven thermometer and an incandescent lamp (to serve as a heating element) in a small asbestos-lined metal box. As soon as the buzzer sounds open the box and read the temperature. The incandescent lamp can then be turned off and the box allowed to cool until the buzzer stops. The temperature can then be read again, which should give the ON and OFF temperature limits.

If these temperature limits are not suitable for your application, or if the enclosing bulb makes the operation of the thermostat too sluggish, the glass bulb can be broken away,

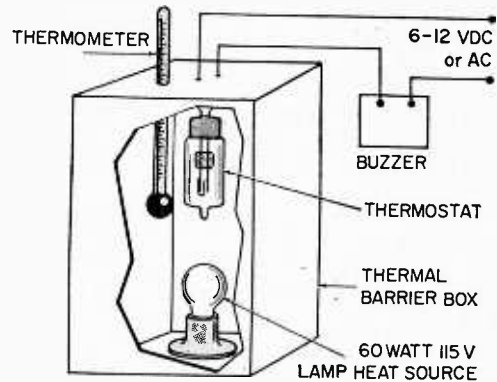

Fig. 3. Thermostat action of starter glow-tube can be checked using home-brew oven.

taking care not to crush the stem which holds the thermostat electrodes in place. The stationary electrode now can be bent to adjust the gap until the operating temperature, tested as before, is suitable for the desired application. The thermostat can be made to signal by closing the circuit on falling temperatures simply by positioning the stationary electrode on the inside of the curve (Fig. 4). If the capacitor is not defective, it can be left connected; or if short or open should be replaced with a .02 mf. 500-volt ceramic type to assure longer life for the thermostat contacts.

Other Applications. Thermostat alarm units of this type may be placed in locations

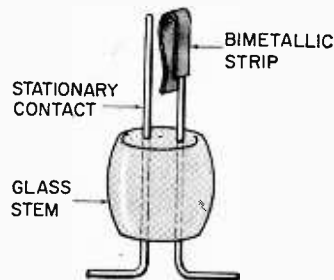

Fig. 4. Vertical contact must be bent inside curve to make contact as temperature falls.

favorable to detect an overheated furnace, machinery, or other electrical appliances; or used to regulate the sun's heat on seedling plants in a small hot-bed or cold frame. Hams
(Continued on page 104)

ONLY 11 CRYSTALS CONTROLLING 23 CB TRANSCEIVER CHANNELS!

■ Moments before landing a big jet aircraft, the pilot reaches for his radio. He's got to change channels fast. Does he fiddle around for the right frequency—like dialing in music on a table radio? Far from it. A quick flip of the tuning knob and the aircraft radio “ker-chunks” exactly on frequency. Or a CB operator is driving down the road at 50 mph. No need to fish around for the right channel. He can switch it in without taking his eyes off the road. Each of these examples points up the value of frequency synthesis; a circuit that adds two important benefits to 2-way radio equipment. For one, it takes all the guesswork out of tuning. Just as important, it slashes the number of crystals, (which do the actual tuning), to a mere fraction found in conventional circuits.

The term “frequency synthesis” nearly explains itself. It literally means putting together different signals to form one frequency. To examine it in detail, it's best to begin with a brief look at normal tuning methods in 2-way radio. Then the advantages of frequency synthesis should become apparent. Consider, first, why crystals are used in tuning. Two simple circuits are shown in Fig. 1. Both are oscillators and either can generate a radio signal for, say a transmitter. In Fig. 1a is the continuously-

tuned circuit, a type that might be found in a ham transmitter. A coil and capacitor control the frequency generated by the tube. As the ham turns the tuning capacitor he shifts his transmitter to any frequency in a particular band. This is convenient for ham operation, where any frequency within a band can be dialed at random, but it's unsatisfactory for other kinds of 2-way radio. To minimize interference and insure accuracy, the FCC assigns specific channels for most radio services. In CB there are 23 channels in the 27-mc band, and about 90 channels in the aircraft 118-135 mc band. This rules out the continuously-tuned oscillator for transmission.

Xtal Oscillator. The answer, the crystal-controlled oscillator, is shown in Fig. 1b. Instead of a coil-capacitor combination, a quartz crystal is the frequency-determining element. Extremely accurate and stable, it vibrates on one specific frequency. It's far less responsive to forces that cause frequency drift in the continuously-tuned oscillator—like heat, humidity and aging. And it can be switch-selected; the operator can instantly select one of the two channels shown with great precision. There's no hunting or guessing.

Price Isn't Right. But there's a big disad-

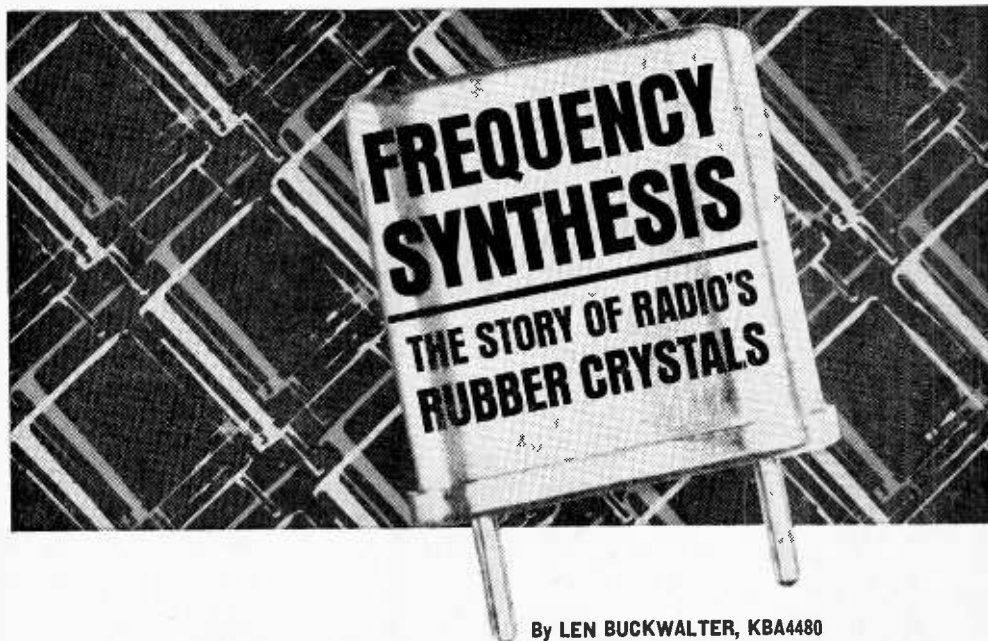

By LEN BUCKWALTER, KBA4480



FREQUENCY SYNTHESIS

vantage with crystals. Unlike the continuously-tuned oscillator, which can sweep across an entire band, a separate crystal is required for each channel. Its affect on equipment is significant. If one crystal costs \$3, a 23-channel CB rig would require \$69 in transmitter crystals alone. And to obtain

another channel, 27.5 for example, a 23.5-mc crystal is switched into the circuit. In this manner, the local oscillator always maintains that 4-mc spacing. The important point: a receive crystal is always spaced some distance from the transmitted frequency. With these relationships, it's now possible to see how frequency synthesis is applied.

How It's Done. In a word, frequency synthesis is a technique which utilizes relatively few crystals in dozens of different combinations to create all desired channels. Not only

Fig. 1. When you put two-way communications on wheels or wings, you don't have the time or attention to devote to continuously tuned rigs; you need quick convenience of crystals.

Fig. 2. By its very theory of operation, the superhet can't use same crystal on transmit and receive, transmit frequency is 27 mc; receiver oscillator is set for a 23 mc. frequency.

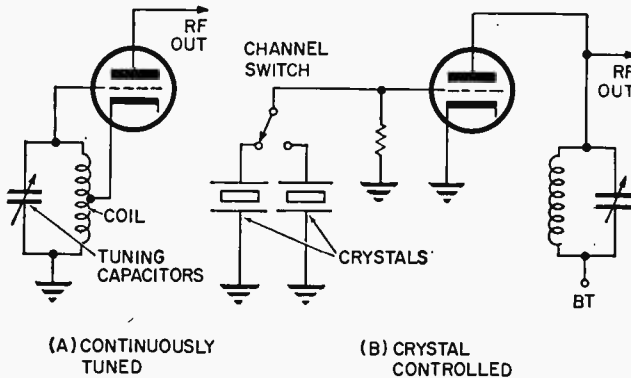

the same crystal-control benefits for receiver tuning, another \$69 in crystals would be needed. Add it up and you'll find that crystal cost alone totals \$138—about the price of some complete CB transceivers. In the case of the aircraft radio, crystal cost may not be as important. What is crucial, however, is space convenience. To cover 90 channels, an unwieldy 180 crystals would be needed to cover all transmit and receive channels.

Why not use the same crystal to control both transmitter and receiver on a given channel? A look at a standard receiver circuit reveals why it's not practical. Shown in the block diagram of Fig. 2 is a superhet receiver and the reason it requires a crystal different from the one in the transmitter. We'll assume the transmit channel is exactly 27 mc. For a superhet to reject interference, it converts the 27-mc frequency down to some low value; in this case, 4 mc. Operating at 4 mc, the receiver's intermediate-frequency amplifier (IF) can effectively strip away interference. Note in Fig. 2 that the incoming signal is converted in the Mixer stage. The Local Oscillator generates 23 mc to mix with the incoming 27 mc for a 4-mc difference frequency. For no-drift, switch-tuning, the Local Oscillator is crystal controlled. If the operator tunes his receiver to

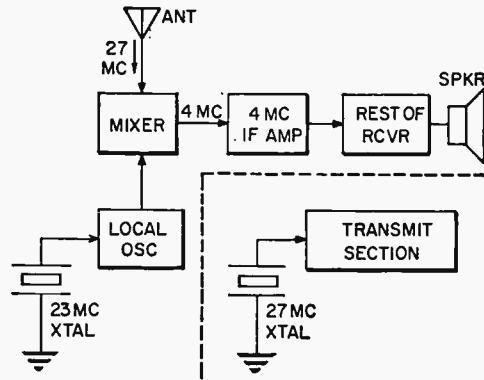

are the same crystals used for both transmit and receive, but the total number of crystals is reduced to about one-quarter the number needed in the basic circuits just described. Various combinations are created much like the local-oscillator action shown in Fig. 2. Signals are fed to mixer stages, where they combine (or heterodyne) to create new signals. In some instances, crystals add—in others they subtract.

How Poly-Comm Did It. Let's consider a practical example, found in the Poly-Comm 23 CB transceiver. Here, frequency synthesis is called "Spectramatic" tuning. This rig uses only 11 crystals to produce the

same result as 46 crystals in a standard circuit.

The schematic drawing in Fig. 3 illustrates what occurs during transmit. We'll assume that the desired transmit channel is precisely on 27 mc. As the operator turns the channel-selector switch, two crystals go into action simultaneously; one on 38 mc, the other on 5 mc. (You may recall that the conventional transmitter would have just one crystal on 27 mc, the operating frequency.) The first step in frequency synthesis occurs as the two crystal signals are applied to the Synthesizer stage. It is nothing more than a mixer. As 38- and 5-mc mix at this point, they generate a difference frequency on 33 mc. (There are other mixtures, but these are rejected by tuned circuits which accept only signals in the 33-mc range.)

Now the mixing process is repeated. As 33 mc enters the Converter (also a mixer stage) it commences to mix with energy from a crystal fixed on 6 mc. The difference emerging from this stage is 27 mc, the de-

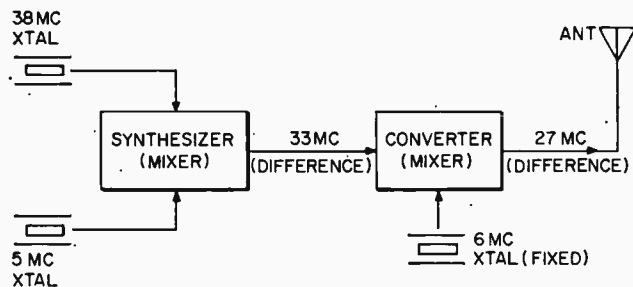

Fig. 4. The same two crystals as used in the transmit circuit can be used in the receiver circuit shown above. It's one advantage of frequency synthesis.

through the receiver's IF stages in normal superhet fashion.

Xtal Economy. But this is only part of the frequency synthesis operation. Up to this point, in fact, it has actually used more crystals than a conventional circuit; three where two would appear in a regular set (one receive, one transmit). The answer to this

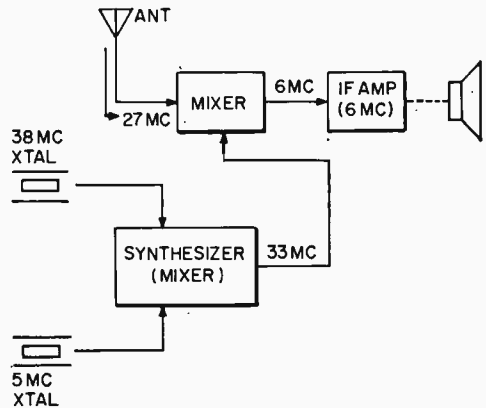

Fig. 3. With a frequency synthesis arrangement in the transmit circuit, the operating frequency of transmitter is difference of crystal frequencies.

sired operating frequency.

Getting 23 Channels. This circuit shown in Fig. 3 may seem to have a lot of unnecessary complication to produce 27 mc, but the value of frequency juggling should be clear when the receive function is considered. Crystals just used for transmit can also serve for receiving the same channel. The set-up for receiving 27 mc is shown in Fig. 4. Again 38- and 5-mc crystals mix in the Synthesizer to produce a difference on 33 mc. This is fed to the receiver's conventional mixer stage, similar to the one shown in Fig. 2. The object now will be to mix the incoming signal on 27 mc so it is converted down to the receiver's intermediate frequency—6 mc in the Poly-Comm circuit. If the numbers in Fig. 4 are checked, it is seen that the correct conditions occur; the synthesizer provides 33 mc, which mixes with 27 mc to create the 6-mc. The 6-mc signal proceeds

apparent contradiction is in Fig. 5. It illustrates something which is impossible in the conventional circuit; few crystals can be mixed in many combinations to generate the correct channels.

In Fig. 5 are the actual crystal frequencies of the Poly-Comm circuit. Note how they are arranged in two groups on the channel-selector switch. In turning the twitch, the CB operator is energizing one crystal from each group. With a total of just 10 crystals, the switch can combine them in various pairs to achieve all the necessary frequencies for full, 23-channel coverage.

This can be shown by an example; Let's say the CB operator wishes to operate on channel 23, which is 27.255 mc. To find which crystals in Fig. 5 are activated it is only necessary to examine each crystal group to see where the number 23 appears. In this case, it is the lowermost crystals in each



FREQUENCY SYNTHESIS

group—and the switch is shown on this position. It is also seen that the two active crystal frequencies are 4.595 mc (at left) and 37.850 mc. They mix in the Synthesizer to produce a difference on 33.255 mc. If the rig happens to be on transmit, that signal mixes again with the 6-mc oscillator (Fig. 3) and the difference is precisely on 27.255 mc, or the desired transmit channel. When the rig is on receive the Synthesizer feeds the same 33.255 signal to the receiver local oscillator where an incoming signal on channel 23 produces the required IF—6 mc.

Thus the circuits in frequency synthesis are somewhat more complex than for conventional units, but the number of required crystals is drastically reduced. Another difference concerns the matter of crystal tolerance. According to FCC regulation, CB transmitter crystals must remain within the range of .005 percent which means that crystal drift should not be greater than about 1300 cps. With three crystals operating at

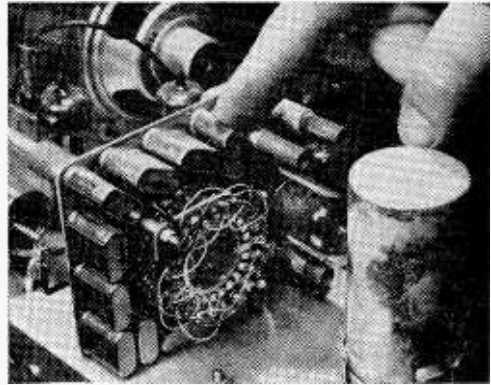

Frequency synthesis reduces the number of crystals needed in this rig from 46 to 11.

once in frequency synthesis, it is possible for their errors to add and spill outside the .005 percent ratings. For this reason, the selected crystals are five times more accurate; each is rated at .001 percent.

Another Application. Although frequency synthesis is usually designed for all-channel operation, some manufacturers use it to obtain other advantages. An example is found in a CB transceiver marketed by

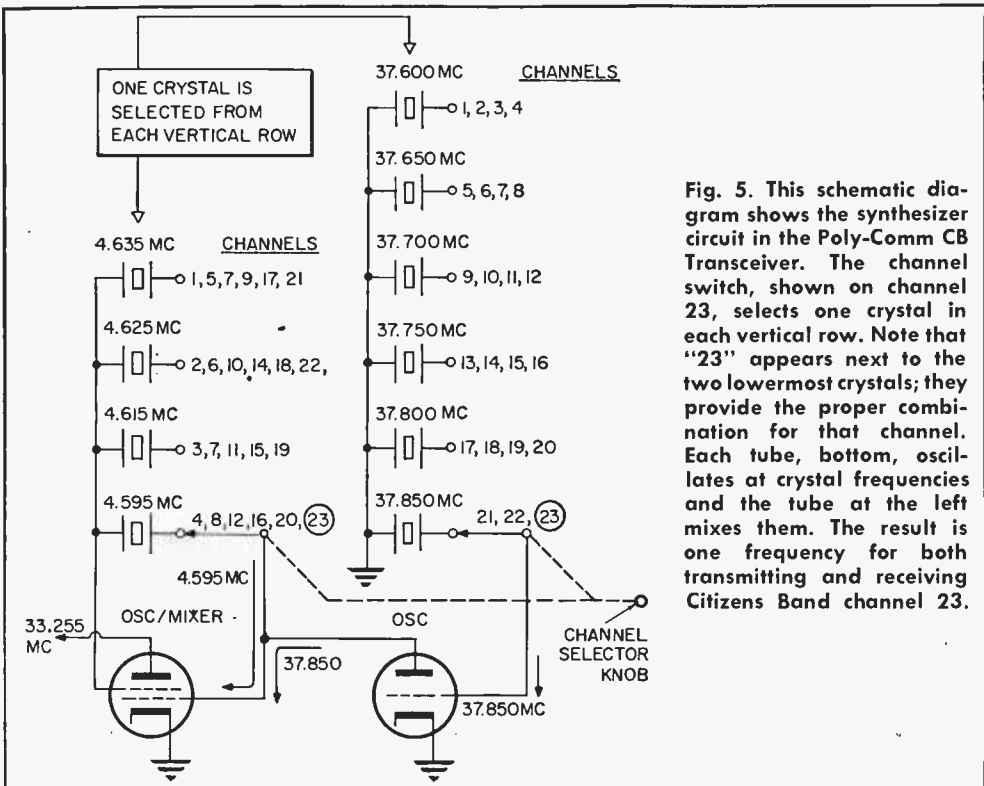

Fig. 5. This schematic diagram shows the synthesizer circuit in the Poly-Comm CB Transceiver. The channel switch, shown on channel 23, selects one crystal in each vertical row. Note that "23" appears next to the two lowermost crystals; they provide the proper combination for that channel. Each tube, bottom, oscillates at crystal frequencies and the tube at the left mixes them. The result is one frequency for both transmitting and receiving Citizens Band channel 23.



Frequency-synthesis crystal-controlled rig has fine tune for off-frequency incoming signals.

Regency. The unit is basically an 8-channel job, but it offers the operator one convenience not found in the standard rig. In normal operation, there's a channel switch for selecting any of seven crystal channels. One crystal socket, however, is brought out to the front panel. By inserting a single crystal into that socket the operator may set up the rig for a channel not already covered by the seven internal crystals. The novel feature is that only one crystal is required to control both receiver and transmitter. This is in contrast to standard sets where two are required.

How this type of frequency operates is shown in Fig. 6. The circuit is shown on

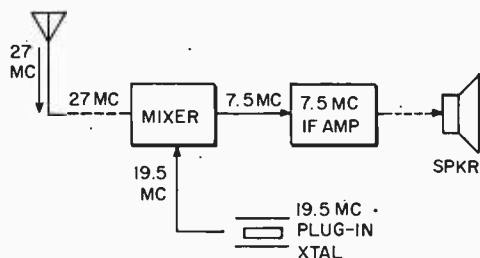

Fig. 6. Regency Transceiver uses front panel plug-in crystals for increasing the coverage.

receive. The plug-in crystal is approximately 19.5 mc (the exact frequency depends on the particular channel). It is fed to the receiver's Mixer and serves as the local oscillator in the standard superhet circuit. Thus, 19.5 mixes with the incoming signal and produces the difference—7.5 mc, the desired IF value.

An additional stage is activated when the circuit is on transmit, as illustrated in Fig. 7. The original 19.5-mc crystal now mixes with a fixed oscillator on 7.5 mc and the two

signals add in the Synthesizer. The output, therefore is on 27 mc, the desired transmit frequency. In this system, the Regency unit permits channels to be rapidly changed with just one crystal. (The 7.5-mc unit remains fixed throughout.)

Dial It. Another important application of frequency synthesis is found in the aircraft receiver. In one band that runs from 108 to 129.6 mc, there are usually individual channels spaced every 100 kc (.1 mc). This means the pilot might have to select from more than 200 possible channels in this band alone. And with conventional receiver circuits, 200 crystals would be needed to accurately control the local oscillator. The solution is digital tuning; a technique that not only reduces the number of crystals to a mere 29, but also simplifies the channel-selector switch. The circuit works something like an adding machine. The pilot first dials whole megacycles, then kilocycles. The basic

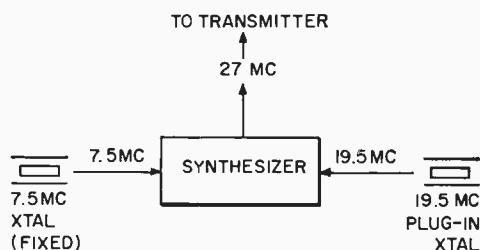
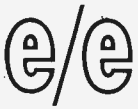

Fig. 7. With Regency Transceiver in transmit mode, an additional mixing stage is activated.

system is shown in Fig. 8. Its key feature is that one set of 19 crystals takes care of the megacycle steps. A second set of 10 crystals provide the 100-kc increases for any selected megacycle in the band. Let's consider how 108 mc is received.

Note the basic receiver shown in Fig. 8. It is a superhet of a *dual-conversion* type; that is, any received frequency is converted down in two steps. If we assume the pilot wishes to monitor 108 mc, the megacycle selector energizes the first local oscillator to produce 90.5 mc. The 1st Mixer combines this with the incoming 108 mc to produce the difference, or 17.5 mc. The next step-down in frequency occurs as the crystal controlled by the 100-kc knob produces 14.395 mc. Mixing reduces the signal to 3.105 mc, which is the final IF.

Now assume that the pilot wishes to hear 108.1 mc, just 100 kc higher. He does not have to move the megacycle selector. By turning the kilocycle knob one step, a new



FREQUENCY SYNTHESIS

crystal is activated in the 2nd Local Oscillator. Its frequency is 14.495. This again creates the desired IF on 3.105 mc.

A sidelight on this circuit is that any received signal between 108 to 109 mc can be stepped down to the first IF and reach the second mixer. The receiver in this part of the circuit is broad enough to accept them. Sharp selectivity only occurs at the low second IF. Megacycle tuning crystals can

be compared to coarse tuning, and the 100-kc crystals to fine tuning.

Summing Up. Thus, frequency synthesis provides valuable functions in 2-way equipment for more than one reason. Through an ability to mathematically manipulate crystal mixtures, it simplifies equipment operation or helps reduce cost where large numbers of accurate channels are needed. The future may hold even more sophisticated variations. Even now, one crystal manufacturer is toying with a technique for making a single crystal oscillate on two different frequencies. It might provide even further gains in tuning control for 2-way radio. ■

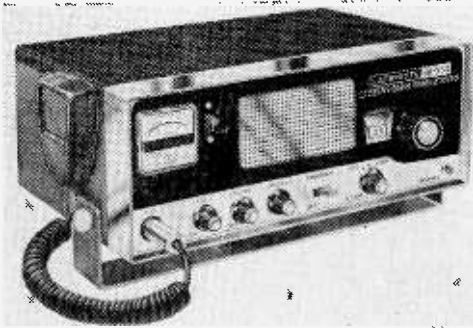

CB Rigs That Use Frequency Synthesis

Shown above is Lafayette's HB-333 23-channel frequency synthesis transceiver. Above right is Pearce-Simpson 23-channel transceiver which pops the channel number in a front panel window. Shown at the right, is ECI Courier 23, with 23 channels, naturally.

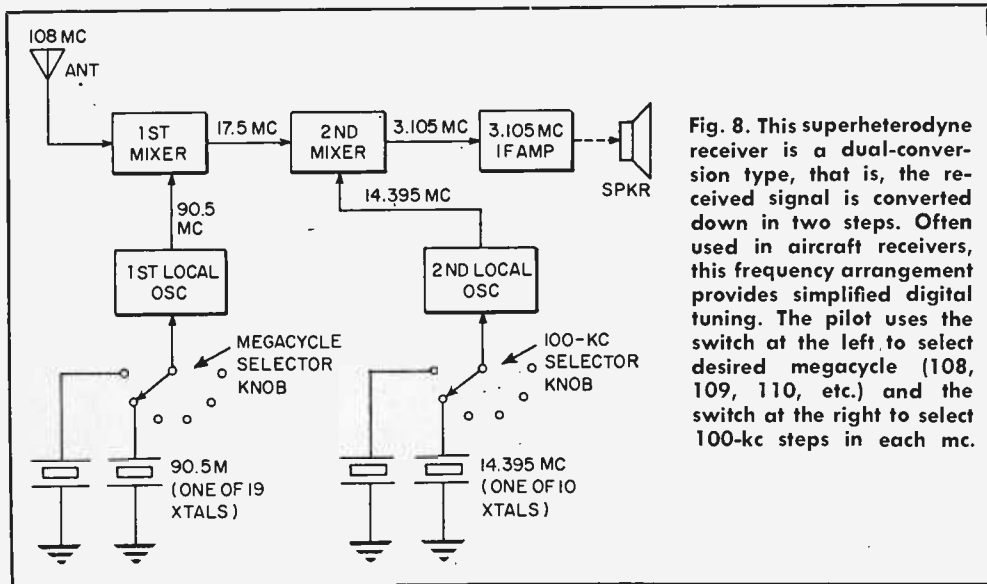

Fig. 8. This superheterodyne receiver is a dual-conversion type, that is, the received signal is converted down in two steps. Often used in aircraft receivers, this frequency arrangement provides simplified digital tuning. The pilot uses the switch at the left to select desired megacycle (108, 109, 110, etc.) and the switch at the right to select 100-kc steps in each mc.

The Astounding TE Module

■ The scientist looked at the object he had removed from the strange space ship. It was small, less than half the size of a package of cigarettes. It didn't rattle; there were no wheels, pulleys or other moving parts; no knobs, controls or levers; no dials; no projections of any kind. In fact, it looked like nothing more than a small slab of solid metal. But there were two heavy wires attached to one edge.

He connected a meter to the wires. Nothing. The object was not a battery. Pausing in thought, he laid the object against the cool metal top of his workbench, resting his warm hand on its upper surface.

Glancing at the meter, he shook his head in disbelief. There was a reading on the meter! The slab of solid metal was generating power!

(Turn page)

New horizons in thermoelectricity are now open to industry's design engineers as well as home experimenters due to the surge in semiconductor technology

BY LOUIS E. GARNER, JR.

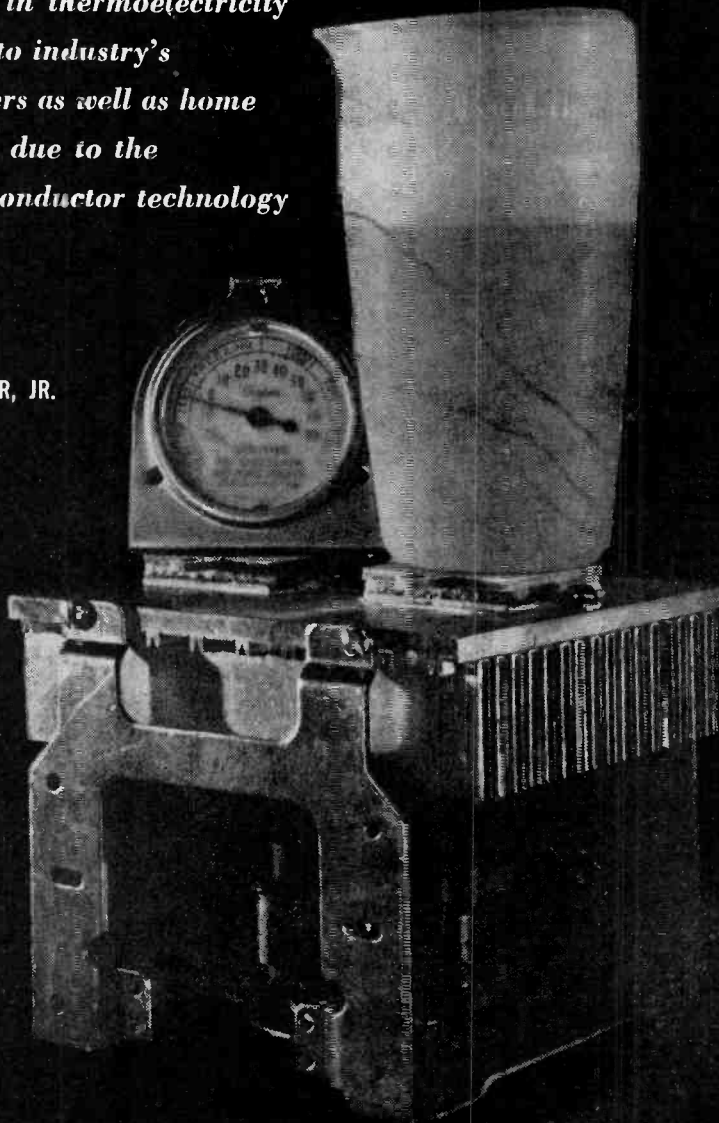

e/e ASTOUNDING TE MODULE

He removed his hand. The meter needle crept back to zero.

"I wonder," he said to himself.

He removed the meter and connected a battery to the object's wires, placing it back on the table. As he watched, a layer of frost started to form on the upper surface. It became thicker and thicker.

"Astounding," he thought to himself, "how can solid metal generate electrical power at one moment and absorb heat the next? What advanced race of alien creatures could develop such a device?"

It's Not Fiction. The scene described above *might* have appeared in a science-fiction story a few years ago . . . and *it is* fiction. But the fascinating, almost unbelievable, object which the scientist was examining *is not* fiction. It was an electrical component which is available today to the experimenter, a *thermoelectric* (or *TE*) *module*.

First cousin to the familiar crystal diode and the versatile transistor, the *TE* module is one of the newest members of the growing family of semiconductor devices. Yet the principles on which it is based are not new.

The phenomenon of thermoelectricity dates back to a discovery in Germany in 1821. Thomas Seebeck found that an electric current flows continuously in a closed circuit made up of two dissimilar metals as long as the junctions of the metals are maintained at different temperatures. Dubbed the *Seebeck effect* in honor of its discoverer, this phenomenon was utilized for over a century in low power devices known as *thermocouples*.

Over a decade later, in 1834, the French physicist Jean Peltier gave a partial explanation of the earlier discovery and went on to observe the opposite effect . . . that heat energy could be absorbed at one junction and liberated at the other whenever an electric current flows in such a circuit. The new discovery was called, appropriately enough, the *Peltier effect*.

Two more decades passed before the English physicist, Lord Kelvin, advanced the first detailed theoretical explanation of the Seebeck and Peltier effects.

For many years thereafter, however, the thermoelectric effect found its only practical application in temperature measurement.

The voltage generated by a thermocouple made up of such metals as, say, copper and constantan, was measured with a sensitive voltmeter. This voltage, a function of the temperature measured, is typically on the order of a few thousandths of a volt for a junction temperature difference of 100° F.

Efficiency Counts. Although many scientists and engineers studied the problem of converting heat energy into electricity over the next several decades, little progress was made. No known pair of metals permitted conversion efficiencies appreciably greater than 1 percent—too low for commercial or industrial applications. The thermocouple's

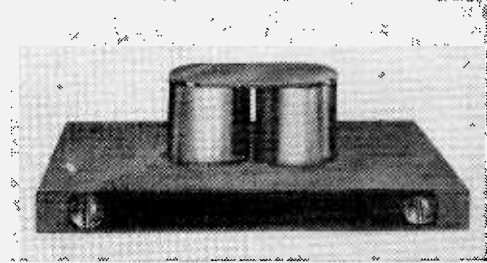

Fig. 1A. P- and N-type semiconductor material strapped together forms basic TE module.

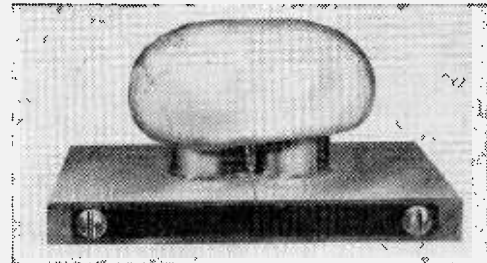

Fig. 1B. When power is applied to module, thick layer of frost forms in a short time.

uses were limited to temperature measurement and simple control functions, and no large-scale commercial applications were considered possible or even theoretically feasible.

The first important scientific breakthrough in the United States was made in 1937, when Dr. Maria Telkes of the *Westinghouse Research Laboratories* decided to try other than all-metal thermocouples. Using a zinc antimony and lead sulfide pair, she was able to observe a conversion efficiency of 7 percent in the temperature range of 70-800° F. Although this marked the advent of semiconductor materials for thermoelectric applications, these alloys were not recognized, at

the time, as belonging to a distinct class of materials.

Today, the basic TE module is made up of thick "slugs" of P-type and N-type semiconductor materials bonded together at one end with a heavy metal strap, with the other ends serving as the input (or output) electrodes. If power is applied to such a device, one side will become extremely cold as it absorbs heat, while the other will become quite warm. A thick layer of frost can be formed on the cold side, even at room temperatures, in a relatively short time, as shown in Fig. 1.

How They Work. A typical TE semiconductor module element is diagrammed in Fig. 2. The N and P-type slugs may be made up of a variety of semiconductor materials including, typically, bismuth telluride. The N-type material has an excess of negatively-charged free electrons and conducts, primarily, by means of these negative "current carriers." The P-type material, on the other hand, has a deficiency of electrons, with a resulting surplus of positively-charged "holes" in its crystalline structure; the positive holes, then, serve as its principal current carriers.

When external power is applied to the device by DC source B1 with the polarity shown, the electrons in the N-type material move towards the positive electrode, while the holes in the P-type material, transferring from molecule to molecule, migrate towards the negative electrode. In the meantime, new electrons are being freed at the junction end of the device, providing additional negative current carriers in the N-type material and creating new positive holes in the P-type material. As each electron is released, it absorbs thermal (heat) energy. There is, of course, a transfer of electrons from the P to the N-type material through the metal

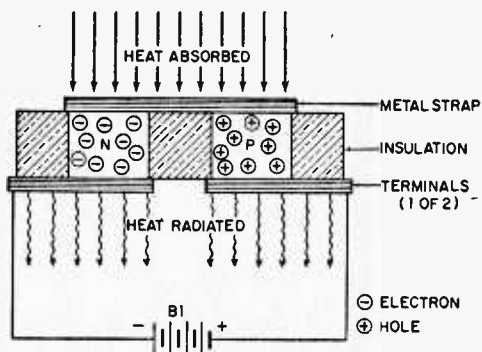

Fig. 2. Pictorial-schematic diagram shows how the TE module functions as a heat pump.

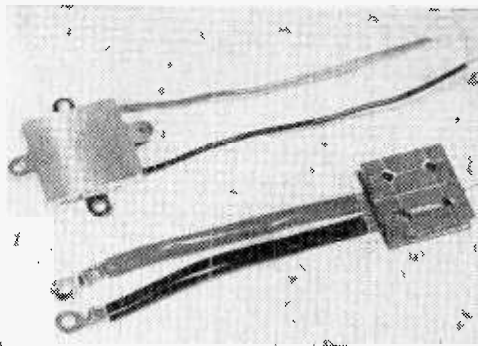

Fig. 3. TE modules produced by Cambridge Thermionics (L) and Ohio Semiconductor (R).

bonding strap at the junction end.

The net result of all of this activity is a transfer of heat energy from the junction side to the electrode side of the device. Heat is absorbed at the junction and generated at the electrodes. The element becomes, in effect, an electronic *heat pump*.

A single semiconductor TE element made up, as it is, of relatively thick sections, has

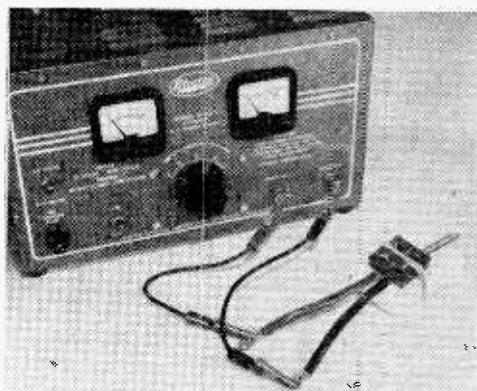

Fig. 4. Checking temperature of TE module as several amps of DC voltage are applied.

very low electrical resistance and, therefore, requires quite heavy currents at low voltages for operation. To offset this characteristic, commercial TE modules generally are made up of a number of series-connected elements. Typical units are illustrated in Fig. 3.

Science Fair Idea. The operation of a TE module as a heat pump may be demonstrated quite easily in the home or school electronics laboratory by using the technique illustrated in Fig. 4. The TE module is connected to a variable low-voltage DC source capable of supplying relatively high currents. A thermometer is held against one (or both)

e/e ASTOUNDING TE MODULE

side(s) of the module. As power is applied and current increased, the thermometer(s) will register a temperature change, with one side of the device becoming cool, the other warm. For maximum heat transfer, a suitable *heat sink* must be used on the warm side of the module to collect and dissipate both the "pumped" and the internally generated heat (the latter being developed due to the current movement through the device).

Heat to Watts. A semiconductor junction element also may be used as a power generator, converting heat into electrical energy. Its operation in this application is illustrated diagrammatically in Fig. 5. Here, an external load is connected across the ele-

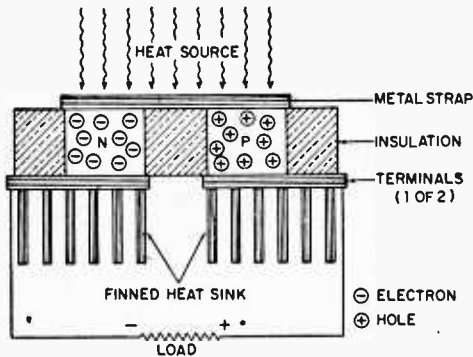

Fig. 5. Module operation is reversible; here it functions as electrical generator.

ment's electrodes. A suitable finned heat sink is mounted on the electrode side (although water, ice or other cooling means may be used) to dissipate heat energy. External heat is applied to the junction side.

In operation, the current carriers (electrons and holes) undergo thermal diffusion, migrating from the warm to the cool side of the module, and congregating near the electrodes. This surplus of current carriers, of course, develops a potential difference (voltage) between the two electrodes which can be used to drive current through the external load. The applied heat continues to free electrons on the junction side of the material, creating additional negative current carriers in the N-type material and holes in the P-type material. As each electron is freed, it absorbs energy from the heat source, and it is this thermal energy which is converted by

the current carrier movement into electrical energy. Power will continue to flow through the load as long as a suitable temperature differential is maintained between the junction and electrode sides of the module.

The conversion of heat energy into electricity can be demonstrated by using the same type of modules as are used for heat pumps. Simply connect the module to a milliammeter, as shown in Fig. 6, applying heat to one side while cooling the other side. An ice cube, "borrowed" from the refrigerator, may be used for cooling in place of a commercial heat sink, while the hand may be used as a heat source. An upscale meter reading will prove that electrical power has been generated.

Current TE Applications. Although semiconductor TE modules have not, as yet, been used extensively in consumer products, they have found widespread use in military, laboratory, industrial and commercial applications. Several firms, for example, are producing miniature TE coolers for power transistors, SCRs and similar semiconductor devices, while one firm has developed TE spot coolers for machine tool cutting bits.

The *Cambridge Thermionic Corporation* (Cambridge, Massachusetts) is manufacturing a TE "Coldplate" for laboratory and
(Continued on page 60)

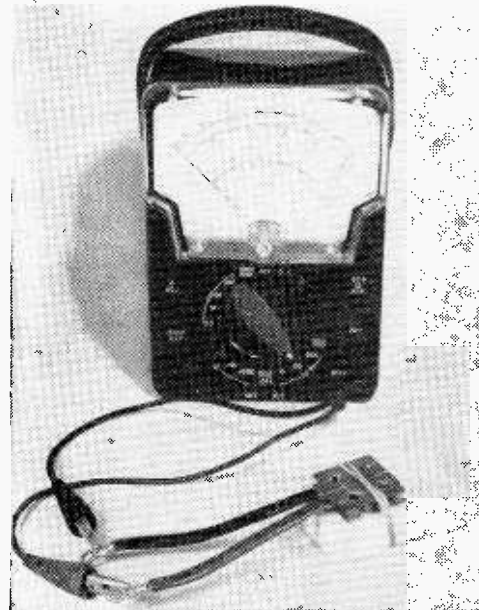
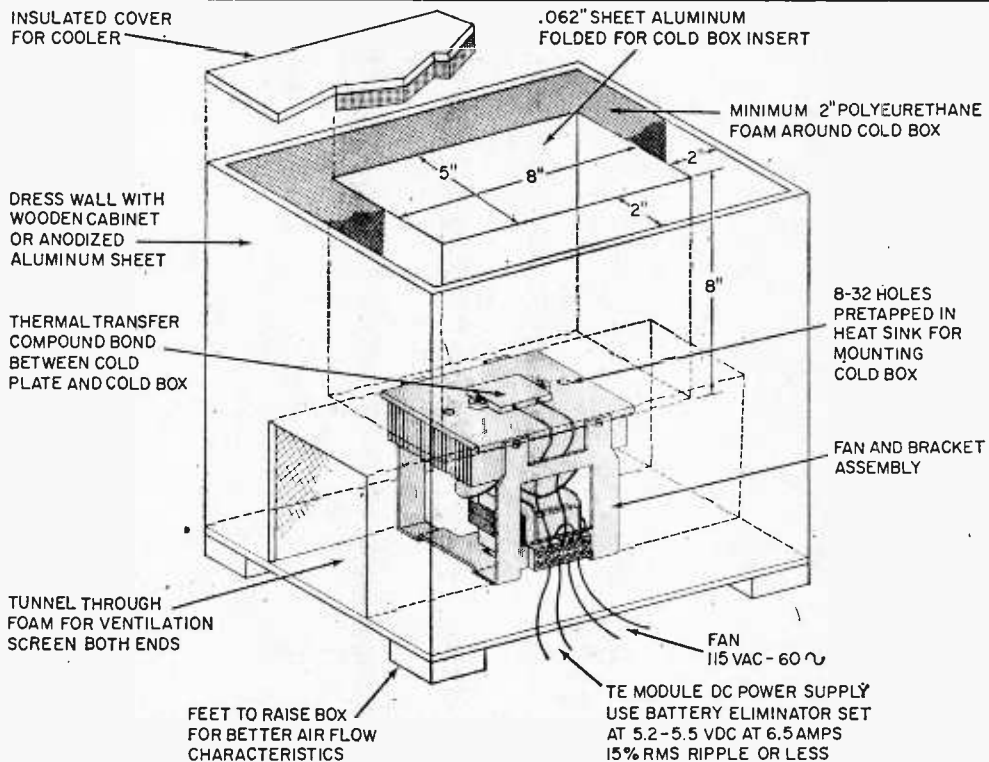

Fig. 6. Current supplied by module is measured as one side is heated and other cooled.

THERMOELECTRIC BEER COOLER

THIS ELECTRONIC 'FRIDGE WILL KEEP THAT SIX-PACK FROSTED EVEN ON SIZZLING 90° DAYS

1. Cut and fold a 21" x 24" sheet of .062" aluminum to the cold box insert shape indicated. Non-anodized aluminum may be used since thermoelectric (TE) module used is electrically isolated. Drill two holes in insert to align with pre-tapped 8-32 holes in heat sink.
2. Assemble the fan motor and bracket assembly to the aluminum heat sink.
3. Spread a thin layer of thermal transfer compound on the TE module cold plate and press cold box insert on the module with the mounting holes aligned.
4. Secure the cold box to the heat sink using two 8-32 x 1/2" or 3/4" nylon screws. Tighten uniformly only 1/4-turn past finger tight.
5. Prepare the polyurethane foam and (with the cold box upside down) foam the thermoelectric module in place. Tape the heat sink fins and fan motor to prevent foam from flowing between the grooves.
6. After the foam has been set for 45 minutes, trim the excess and cut a tunnel from the heat sink to each side of the foam structure.
7. Foam the structure to final shape and prepare a cover with a 5" x 8" foam boss 2" deep to seal the cold box.
8. The entire foam structure may be enclosed with attractive wooden cabinet or aluminum sheet. Screen each side of the ventilation tunnel and place feet on the cooler to improve air flow to the heat sink.



PARTS LIST FOR COOLER

- 1—Heat sink and thermoelectric module (Cambion ES7250-1: Cambridge Thermionic Corporation, 445 Concord Avenue, Cambridge, Mass. 02138: \$25.50.)
- 1—Fan motor and bracket assembly: includes terminal block, mounting hardware, rubber shocks, thermal heat-transfer compound (Cambion ES-7250-2: Cambridge Thermionic Corporation: Price \$11.50 or equiv.)
- 1—Package Polyurethane foam, 2- to 4-pound density (Order from Poly-Structures, 41 Montvale Avenue,

Stoneham, Mass., or make from solid insulating material or "rock-foam" insulation used in home construction.

- 1—DC power supply: capable of 6.5 amperes at 5.2 to 5.5 volts DC with 15% RMS ripple or less; battery eliminator with filtering will serve well.

1—21" x 24" x .062" aluminum sheet

Misc.—Line cord, wire (#12), screening, scrap for feet, paneling material, etc.

ASTOUNDING TE MODULE

research applications in chemistry, physics, biology, and medicine. Similar to the familiar Hotplate, except that it is designed to keep test samples cold, the unit operates on a standard 117 volt A.C. line and has a heat pumping capacity of 40 watts. Measuring 18" in length by a little under 8" in width, the instrument sells for under \$100.00.

Another firm, *Frigitronics, Inc.* (Bridgeport, Connecticut) is offering a portable, desk top, thermal test instrument for testing miniature parts, compounds and biological specimens. Capable of maintaining test temperatures from -115° F. to $+225^{\circ}$ F., the unit is ideal for checking the low (and high) temperature characteristics of microminiature integrated circuits as shown in Fig. 7.

Military applications are increasing by leaps and bounds. *RCA*, for example, recently delivered a thermoelectric air conditioner designed for submarine applications to the U. S. Navy Bureau of Ships. The unit, with a rated capacity of 9 tons, measures only 4 ft. long by 3 ft. high by 1 ft. thick. It uses almost 40,000 pairs of bismuth telluride semiconductor TE elements.

Commercially built, gas-fired TE generators are being used to supply power to remote radio relay stations, to radios in train cabooses, and for the cathodic protection of well casings and pipelines. Other units are being used as battery chargers and as emergency power supplies in remote field stations.

Future Applications. Looking to the future, governmental and industrial TE appli-

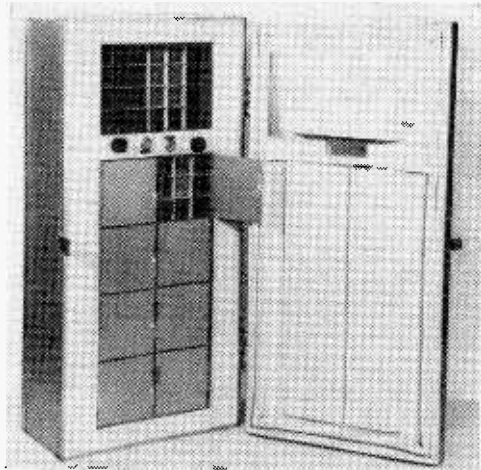

Fig. 8. Westinghouse compact TE refrigerator/freezer was developed for space use.

cations will continue to increase. *Westinghouse*, for example, has developed a number of TE operated devices for future space exploration, including a compact refrigerator/freezer (see Fig. 8) and an all-weather suit.

Nor will the average man be neglected. Manufacturers have designed and built prototype models for a wide variety of consumer products, including a bedside baby bottle cooler-warmer, hostess carts and hot/cold trivet plates, table top butter coolers, and a host of other items.

There is a good chance that the *most important* future application of TE modules is not yet on the drawing board, but in the mind of someone reading this magazine. The future, in fact, is wide open for the individual with an active imagination. ■

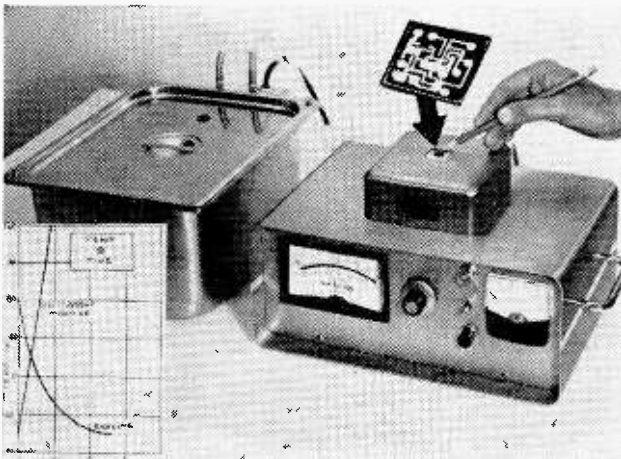

Fig. 7. Commercial applications of thermoelectric modules include this desk top, portable thermal test instrument manufactured by Frigitronics, Inc. Small plate on top of unit can be temperature controlled from -115 F. to $+225$ F. for checking high and low temperature characteristics of miniature parts, compounds, and microminiature integrated circuits as shown in the detail. Curves in the corner insert plot time versus temperature to illustrate quick response of the module in reaching the desired operating temperature for specific tests.

UHF ANTENNA INSTALLATION

By John Potter Shields

The FCC requirement that, as of March, 1964, all TV receivers intended for interstate shipment must be capable of receiving UHF channels, coupled with the cropping up of many new UHF stations in all areas of the country, indicate that UHF TV is finally here to stay. This boils down to the fact that in all probability UHF either has, or is about to be coming to your town. The question is . . . are you able, or will you be able to receive it? Even though you may have purchased a new TV receiver capable of receiving all 82 channels, or added a UHF converter to your present set, there is much more to receiving a good UHF signal than hanging a wire out the window or simply tying on to your present VHF antenna. UHF signals are a bit trickier to handle than the old familiar VHF. Let's take a look at why UHF is around in the first place, as well as at the UHF signal itself and how we may best capture it for feeding to the receiver.

Why UHF? Originally, when the 13 VHF TV channels were created, it was felt that they would provide adequate capacity for the TV market. It was subsequently found, that additional channels would be required to handle the desires of many areas for additional outlets. Another reason for UHF is that it permits two channels of the same frequency to operate relatively close together

. . . say in adjacent cities. This has been a problem with VHF; the advent of more powerful transmitters and more sensitive receivers has resulted in interference between like channels in relatively widely separated areas. Thus, in a nutshell, UHF permits: 1. a larger number of available channels, and 2. these channels may be spaced more closely together than in the case of VHF channels.

Now that we've seen why we have UHF, let's take a look at the basic UHF signal in order to get a better idea of how to handle it. The first and most obvious difference between the VHF and UHF signals is their frequency. Both VHF and UHF signals are high enough in frequency so as to travel in a straight line (like a searchlight beam) rather than following the curvature of the earth as do lower frequency signals. However, lower band VHF TV signals are susceptible to a phenomenon known as "skip" as shown by the sketch, Fig. 1. This "skip" occurs when the transmitted signals bounce off the ionosphere (a layer of charged particles encircling the earth) and return to a receiving point many miles from their point of origin. This "skip" explains some of those amazing TV-DX accounts we hear about.

This "skip" effect is non-existent at the UHF TV channels thus eliminating the chance of interference between widely sepa-

If your television receiver is capable of plucking out any of the 70 UHF-TV channels then it is high time for some top-level UHF thinking and installation on your roof!



e/e UHF ANTENNA INSTALLATION

rated channels. The UHF TV signals are more readily blocked by relatively small objects such as buildings, etc. due to the much shorter wavelengths involved. The cumulative effect of this again cuts down the range of UHF signals. Also, the radiated signal strength of UHF signals is generally lower than in the case of VHF signals . . . another factor is their reduced coverage when compared to VHF.

UHF signals are also more directional than lower frequency VHF signals, and as a result, ghosting due to multi-path signal reception is more of a problem with VHF signals.

Capturing the UHF Signal. The most logical starting place is at the antenna. UHF antennas pretty much follow the same basic types as found in VHF—the dipole, folded

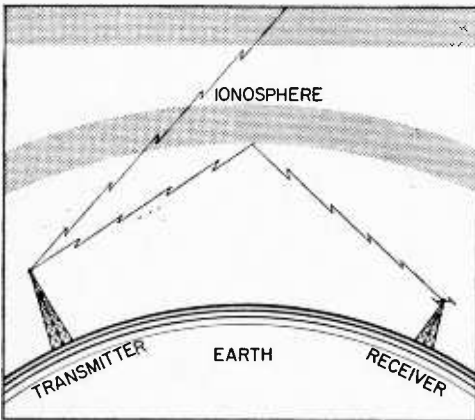

Fig. 1. VHF signals skip to distant receivers—UHF signals pass through ionosphere.

dipole, conical, yagi, etc. However, the physical construction of UHF antennas differ considerably from corresponding VHF types. For one thing, all UHF antennas are considerably smaller than their VHF counterparts. The reason for this, of course, is the shorted wavelengths up in the UHF spectrum. Remember, the element length(s) of any antenna, dipole, yagi, or what have you, is a direct function of the wavelength being received.

The smaller physical dimensions of the UHF antenna make possible many arrays not practical with the larger, more bulky, lower frequency VHF antennas. For ex-

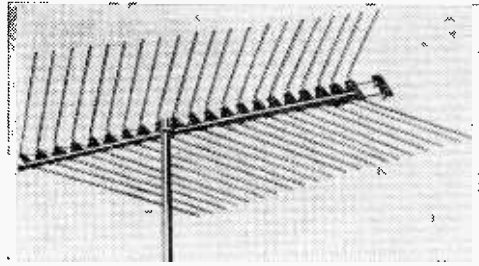

Fig. 2. A log periodic UHF antenna with 21 cells—good for working stations 80 miles.

ample, look at the log-periodic UHF antenna pictured in Fig. 2. The design of this type of antenna for VHF frequencies would be very difficult due to the considerably longer element lengths required as well as the greater spacing between elements. Maintaining structural strength would be extremely difficult, and the increased weight would also be a problem.

Fig. 3 is another example of the physical advantage gained with UHF antennas. A large number of individual bays are easily stacked for increased gain without taking up an unreasonable amount of space or becoming unwieldy or overly heavy.

The smaller dimensions of UHF antennas offer still another advantage . . . much better performance. As just mentioned, a fairly large number of arrays may be stacked by increased gain. It is also feasible to employ the parabolic antenna design (similar to those

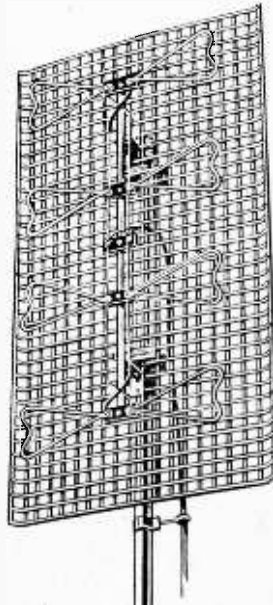

Fig. 3. Four individual bays are stacked one on top of the other for greater gain.

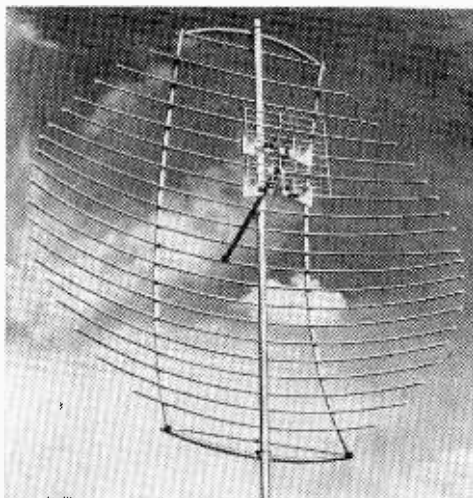

Fig. 4. UHF antenna using a parabolic reflector to gather in signal for high gain.

microwave dish antennas). This design, somewhat similar to using a reflector behind a searchlight to increase intensity . . . only in reverse, results in greatly increased antenna gain (sensitivity). Fig. 4 pictures an antenna using this approach. Note the curved reflector which resembles a section of a parabolic reflector. It's pretty obvious that this type of construction would be just about mechanically impossible with a VHF antenna.

Fig. 5 shows another type of UHF antenna construction. Actually, a dipole with reflector, this unit differs from the VHF dipole and reflector in that a number of

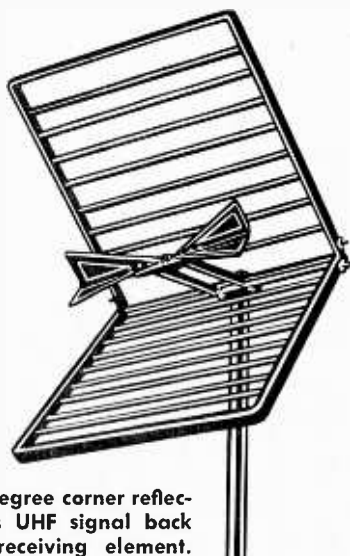

Fig. 5. 90-degree corner reflector bounces UHF signal back to dipole receiving element.

individual reflectors are used in place of a simple tubular rod reflector element. This screen improves antenna gain and sharpens its selectivity.

Besides providing increased gain, the "fancier" arrays possible with the smaller UHF antennas offer sharper pickup patterns. Just what this means is shown in Fig. 6. As we mentioned earlier, UHF signals are particularly prone to ghosting as a result of multiple path reflections. Notice that the sharp reception pattern of the multibay UHF antennas effectively reduced the pickup of multiple path reflections as well as signal pickup from its rear.

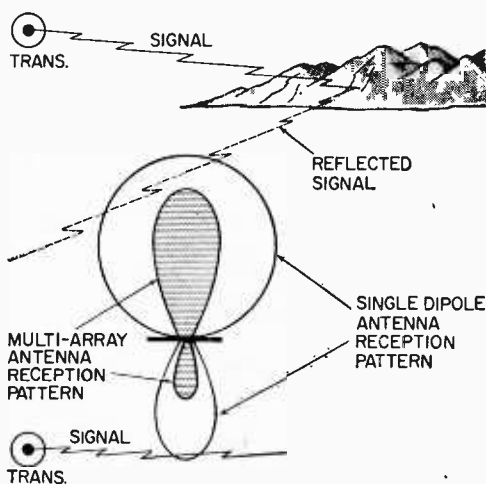

Fig. 6. Multi-array UHF antennas can eliminate ghosts caused by multi-reflections.

In areas where a strong UHF signal is present, "bowtie" UHF dipole antennas such as pictured in Fig. 7 will be satisfactory. Fig. 8 shows an indoor antenna of unusual shape, a UHF log periodic trapezoid.

The Antenna to Receiver Path. Although the installation of a UHF antenna is essentially the same as for a VHF, you still have to lug it up to the roof or up to the attic. There are also a number of differences that you should note:

For one thing, signal losses are much greater at UHF frequencies, as we mentioned before. This means that care must be taken to reduce or eliminate all sources of possible signal loss between the antenna and receiver, or converter, input terminals.

Beginning at the antenna itself, make sure that lead-in cable connections to the antenna terminals are tight and that the antenna terminals themselves are free from all corrosion. While in this area, don't overlook the

e/e UHF ANTENNA INSTALLATION

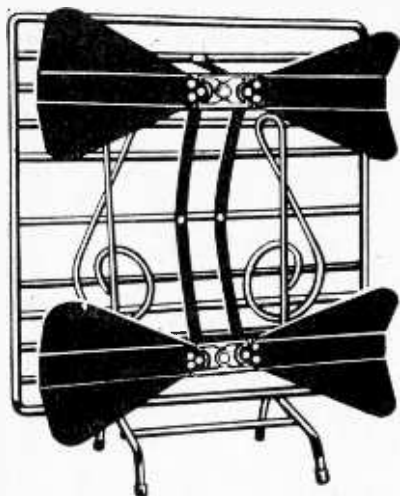

Fig. 7. TV top UHF antenna resembles its outdoor brother—works well in urban areas.

antenna terminal block and antenna insulators. Avoid getting any oil or grease on these parts, as these substances make excellent signal-killing dirt catchers.

The type and care of the lead-in wire or cable is especially important at UHF frequencies. A source of signal loss at VHF frequency, signal loss in the lead-in, is a considerably larger problem at UHF frequencies. The least "lossy" type of lead-in is the "open-wire" type such as shown in Fig. 9. As you can see, it consists of two parallel



Fig. 8. JFD's new UHF VU-Vista indoor antenna pulls in channels 14 through 83.

wires, separated at regular intervals by low-loss spacers. Due to air being the only dielectric between the wires, except for the widely spaced insulators, this lead-in has extremely low loss at UHF frequencies. The one disadvantage of this type of lead-in, however, is that it is more difficult to handle than the other types of lead-in.

The next least lossy type of lead-in is the tubular type. The advantage of the tubular lead-in as compared to the flat type is that, being circular, it provides a longer leakage path between conductors. One point though . . . be sure to seal the ends of tubular lead-in

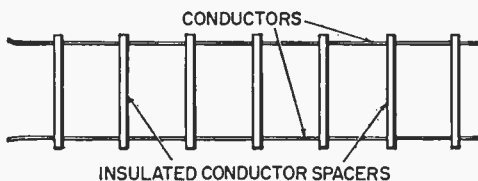

Fig. 9. Open-wire type TV lead-in is best when losses must be minimized. Spacers between conductors are made of porcelain glass.

with either a match flame or hot soldering iron after it has been installed to prevent any water from getting into it.

In areas where interference, such as automobile ignition noise, is a problem, shielded



Fig. 10. Typical UHF converter made by Jerold selects UHF channel and provides boost.

coaxial cable is your best bet. Since this cable is usually 75 ohms unbalanced line, a matching transformer will probably be needed at the antenna as most antennas have a nominal impedance of around 300 ohms. Similarly, a second transformer will be required if the converter or TV's input is rated at 300 ohms.

When installing the lead-in, it's of course important to keep it well away from other objects, especially metallic ones. Also, the length of lead-in from antenna to set should
(Continued on page 110)

after OHM'S LAW node-voltage method

When the circuit takes the right configuration, voltage nodal pairs permit computational short cuts

BY JAY COPELAND

■ If you haven't been following this series "After Ohm's Law", then now is the time to hop in. All you need to know is Ohm's law and possess the desire to learn.

Ohm's law applies to a single element in a circuit or many elements that can be combined into one resistive element for computational purposes. However, there exist circuits where the resistive elements cannot be grouped into a single convenient element. Also, there may be more than one voltage source to further the difficulty in applying Ohm's law. These circuits cannot be dealt without other basic laws, rules, or mathematical methods.

First Things First. Before we get into the *node-voltage method* of solving network problems, it will be best to look at the circuit in Fig. 1. Observe that I_1 enters the

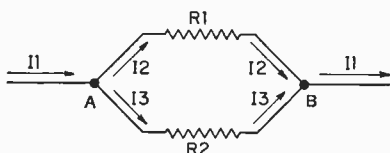

Fig. 1. Nodal pairs.

circuit at junction A and divides into 2 parts, I_2 and I_3 . Exactly how the currents are proportioned through the circuit is not important. The important thing to notice is that the two currents join at point B to sum up again to I_1 . This is not so overwhelming

since it follows Kirchhoff's current law which states *at any junction in a circuit the total current entering that junction is equal to the total current leaving that junction*. Kirchhoff's current law stated in equation form using the current symbols in Fig. 1, we get

$$I_1 = I_2 + I_3 \quad (1)$$

A Simple Problem. You are asked to determine the voltage drop across the junctions

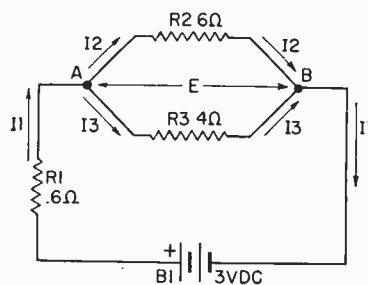

Fig. 2. Sample problem diagram.

A and B in Fig. 2 as quickly and easily as possible without any wasted effort. There are a few ways to go about it, but let us describe the technique that many amateur experimenters would use. They would compute the total resistance of the parallel pair R_2 and R_3 ; sum R_1 with this total; divide this total resistance into the battery voltage to find the current supplied to the circuit; compute voltage drop across R_1 ; and finally subtract the voltage drop across R_1 from

Ⓜ/Ⓜ AFTER OHM'S LAW NODE-VOLTAGE METHOD

the battery supply to find the voltage drop across the junctions A and B. You may know a simpler way—but can you do it with *one* equation using *one* unknown?

Node-Voltage Method. Solving network problems involving pairs of junctions in a circuit (known as *nodal pairs*) is commonly used by engineers as a shorthand method when it can be applied. For example, let's find the voltage drop across nodal pairs A and B in Fig. 2. First we write the current equation:

$$I_1 = I_2 + I_3 \quad (1)$$

Now, back to Ohm's law to recall that $I = E/R$, so we substitute equivalent values for I in equation (1) whenever possible using only E , the unknown voltage across the nodal pairs we are seeking, as the unknown quantity. Since I_2 flows through R_2 , $I_2 = E/6$ where E is the unknown voltage and 6 is the 6 ohms for R_2 . Now we insert this information into equation (1).

$$I_1 = E/6 + I_3 \quad (2)$$

The term I_3 is equal to $E/4$ for the same reason as the previous paragraph and we insert it into equation (2) for term I_3 .

$$I_1 = E/6 + E/4 \quad (3)$$

Now, to rid ourselves of I_1 ! The entire circuit has 3 volts across it. All of this voltage except for E is across R_1 . Therefore, the voltage drop across R_1 is $(3-E)$ volts; and, hence, $I_1 = (3-E)/6$ which we insert into equation (3) for term I_1 .

$$\frac{3-E}{6} = \frac{E}{6} + \frac{E}{4} \quad (4)$$

Now in equation (4) we have one equation with one unknown which is easy to solve. First, multiply each side of the equation by 12 to clear all fractions.

$$12 \left(\frac{3-E}{6} \right) = \frac{12E}{6} + \frac{12E}{4}$$

$$\frac{36}{6} - \frac{12E}{6} = \frac{12E}{6} + \frac{12E}{4}$$

$$60 - 20E = 2E + 3E$$

$$25E = 60$$

$$E = 2\% \text{ volts}$$

Now go back and review the entire nodal-voltage method. You will discover how easy it really is since no new principles were learned. Rather, the nodal-voltage method uses only Ohm's law and Kirchhoff's current law; both well known to the experimenter. (For a complete review of Kirchhoff's current law refer to *ELEMENTARY ELECTRONICS*, p. 65, *Spring, 1965 issue*.)

Problem 1. Find the nodal voltage across the nodal pairs A and B in Fig. 3, then find the current in the 8-ohm resistor.

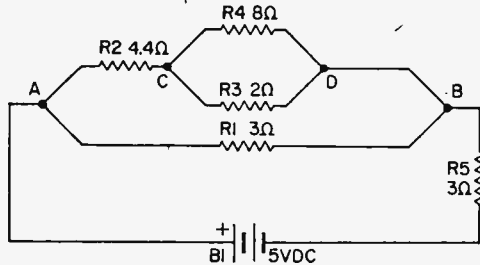

Fig. 3. Diagram for Problem 1.

ANSWERS TO PROBLEM 1: The voltage drop across nodal pairs A and B is exactly 2 volts. To find the current in the 8 ohm resistor it is necessary to use the node-voltage method again to find the voltage drop across nodal pairs C and D: 0.53 volt. Hence, power dissipated in 8-ohm resistor is E^2/R or 2.2 watts approximately.

Problem 2. Find the nodal voltage across nodal pairs A and B in Fig. 4, then compute the power dissipated in the 6-ohm resistor.

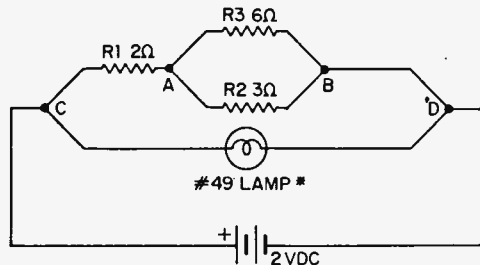

Fig. 4. Diagram for Problem 2.

ANSWERS TO PROBLEM 2: If you understand the nodal-voltage method you would not include the #49 lamp in your computations. It is only one leg in a parallel circuit and has no effect on the voltage across nodal pairs A and B. The nodal voltage across A and B is 1 volt. Power dissipated in 6-ohm resistor (E^2/R) is $\frac{1}{6}$ watt.

If you have been following "After Ohm's Law" in this and the previous two issues of *ELEMENTARY ELECTRONICS*, you have been (Continued on page 112)

HAM

NOVICE LICENSE GUIDE

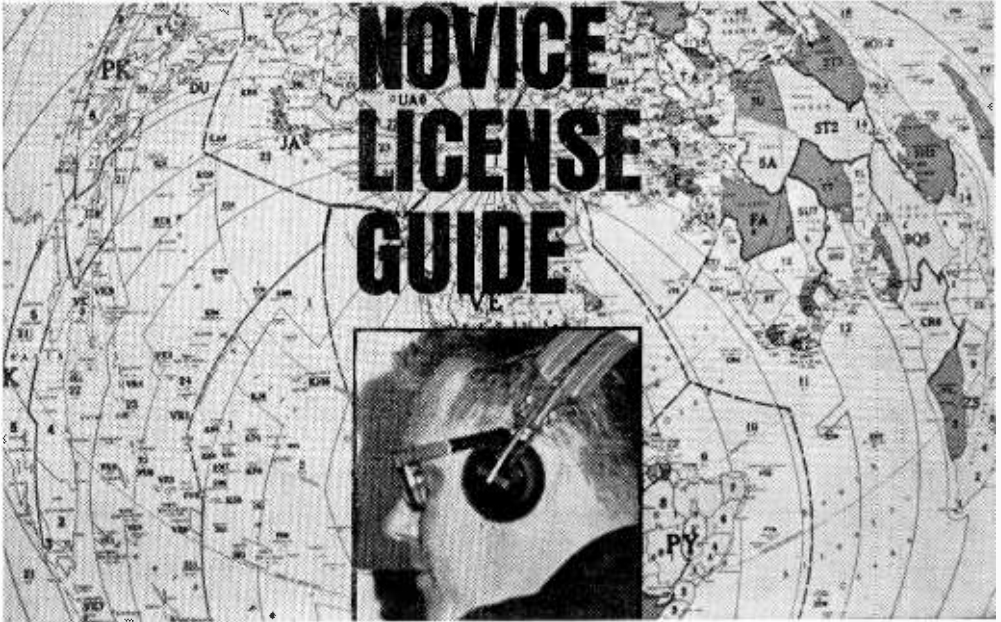

BY LEO G. SANDS

■ Countless CB enthusiasts faced with the newly tightened CB regulations imposed by the FCC would undoubtedly like to become hams but are afraid that they can't pass the code test and written examination. However, since these tests are so easy, the ham-to-be should not be apprehensive. In fact, they don't even have to go to an FCC office to take the test. The code test can be administered and the written examination conducted by a local licensed ham.

The first step is to get a copy of Volume VI, FCC Rules and Regulations.* This book contains Part 97 which covers the Amateur Radio Service. Also get a copy of FCC Form 610 from the Federal Communications Commission, Washington, D. C. 20554. Study the rules and locate a ham with a general license to give you the tests after you have mastered the code and believe you can answer the questions that the FCC will send to your volunteer examiner.

Learning the Code. The alphabet is easily mastered by small children. Anyone with

enough intelligence to read this magazine should be able to learn the International Morse code quickly. First of all try writing your name and address in code. It won't take long to translate letters and numbers into code characters. Then get a recorded code course, Sams, Rider, etc. They are available at radio parts stores and mail order houses. If you have a record player (or tape recorder), you can play the recordings, follow the instructions and start learning how to receive code.

Sending code is even easier. You need a telegraph key and a buzzer or code practice oscillator. Form dots by pressing the key for only a very short interval. Form dashes by holding the key down at least three times as long as for a dot. Allow space between each letter or number and a longer space between words.

Soon you will recognize entire words in code, instead of single letters or numbers, just as you recognize these printed words without having to read them letter-by-letter. Five words-per-minute is a very slow speed. Don't be afraid of the code test. You have

*Available from Supt. of Documents, Government Printing Office, Washington, D. C. 20402 for \$1.25.

Shake your CB shackles and start DX'ing on the ham bands



HAM NOVICE LICENSE GUIDE

to take the code test even if you plan to use voice radio communication only because the United States is a party to an international agreement which requires radio amateurs to have knowledge of the code.

Basic Law. You must have knowledge of basic radio laws in order to pass the written examination, as can be noted in the questions and answers contained in this article. But, you don't have to know much about them, only enough so you will know how to operate your ham rig lawfully.

Technical Examination. If you already understand receivers and amplifiers, it won't take you long to learn enough about transmitters to pass the novice license exam. A

transmitter is much like a receiver except that the signal level is higher in some circuits and the signal is modulated instead of demodulated.

Look over the list of questions and answers and put most effort on those that you can't answer off the top of your head. You must answer only 20 questions and get a grade of 74% or higher in the written exam which includes both the laws and technical matters. You don't have to phrase the answers in the same manner as shown in our Novice Quick Quiz near the end of this article.

It will be easier for you to answer the questions and you won't have to memorize the answers if you read on and soak in the information given below. Let's start out with a quick description of a transmitter before we get into more intricate details. Look at

CAPSULE INFORMATION

AF CHOKE	An inductance that resists passage of audio frequencies
AMMETER	Measures current
AMPERE	Voltage divided by resistance (in ohms)
AMPLIFICATION	Process for increasing power level or amplitude of a signal
AMPLIFIER	Device for increasing power level or amplitude of a signal
AMPLITUDE MODULATION (AM)	Radio signal modulated by varying its amplitude
ATTENUATION	Process for reducing power level or amplitude of a signal
AUDIO FREQUENCY (AF)	Signal in audible range (below 20 kc)
BLEEDER	Resistor across a capacitor which discharges capacitor when power is off
CRYSTAL	Quartz device for stabilizing frequency of an oscillator
CST, cst	Central Standard Time
CW	Continuous wave signal keyed on and off to transmit coded intelligence
DETECTION	Process for extracting intelligence from a modulated wave. (demodulation)
EST, est	Eastern Standard Time
FILTER	Device which passes or rejects signals within, above or below a specified band
FILTER CHOKE	An inductance used to smooth out the pulsating DC furnished from a rectifier
FREQUENCY	300,000,000 divided by wave length in meters
FREQUENCY MODULATION (FM)	Radio signal modulated by varying its frequency
GMT, gmt	Greenwich Meridian Time
HARMONIC	Exact multiple of a frequency
HARMONIC FILTER	Device used at output of a transmitter to reduce radiation of unwanted harmonics
INPUT POWER (watts)	Plate voltage times plate current (in amperes) at final RF stage of a transmitter
kc, Kc/s	Kilocycles per second
KEY CLICK	Interference caused by sparking of telegraph key contacts or transients
KEY CLICK FILTER	Device for suppressing key click interference
KILO	Times 1000
KILOWATT	1000 watts
LICENSE PERIOD	One year (novice)

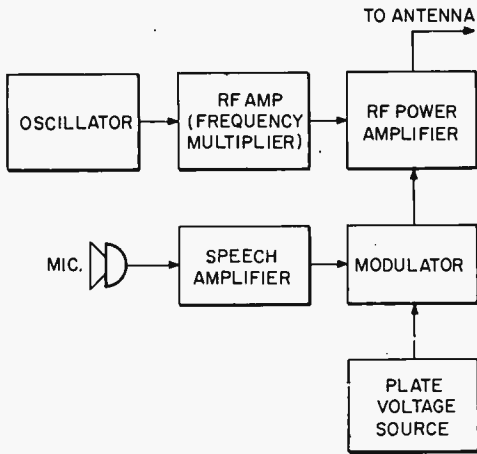
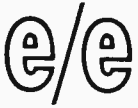

Fig. 1. Block diagram of a typical amplitude-modulated transmitter used by novice hams. Each stage has at least one tube.

the block diagram, Fig. 1, for the transmitter. The transmitter signal is generated, and its frequency is determined, by the *oscillator* which employs a quartz *crystal* to hold it on frequency. The oscillator signal is fed into an *RF amplifier* stage which, in this case, is a *frequency multiplier*. In this stage, the oscillator frequency is multiplied (twice or more) to a frequency that is a direct multiple of the oscillator frequency.

The multiplied frequency output of the frequency multiplier stage is fed to an *RF power amplifier* whose output is fed to the antenna. To transmit code, the RF power amplifier stage is turned on and off with a telegraph key. In some cases, all three stages are keyed on and off. Keying causes dots and dashes to be transmitted. The signal is known as CW (continuous wave) since the RF signal is not modulated.

LICENSE RENEWAL	Novice license may not be renewed
LOG	Record of station transmissions
LOG ENTRIES	Date, time, frequency band, power input, emission, location and call sign of station called or contacted
LOG RETENTION TIME	One year
mc, Mc/s	Megacycles per second
MEGA	Times 1,000,000
MICRO	One millionth
MILLI	One thousandth
MILLIAMPERE	0.001 ampere
MODULATION	Process for applying intelligence to a radio signal
MODULATION PERCENTAGE	Degree of modulation
MODULATOR	Device for modulating a radio signal
MTS, mts	Mountain Standard Time
NOVICE CW BANDS	3.7-3.75 mc (80-meter), 7.15-7.2 mc (40 meter), 21.1-21.25 mc (15-meter), and 145-147 mc (2-meter)
NOVICE PHONE BAND	145-147 mc (2-meter), FM or AM
OHM	Voltage divided by current (in amperes)
OHM'S LAW	$I = E/R$ (I in amperes, E in volts, R in ohms)
OVERMODULATION	Modulation in excess of 100%
PARASITIC OSCILLATIONS	Unwanted oscillations at other than the operating frequency
PENALTIES	For violations of FCC Rules: \$10,000 and/or two years imprisonment maximum, or \$500 per day
PST, pst	Pacific Standard Time
RADIO FREQUENCY (RF)	Signals at frequencies above 20 kc
RECTIFIER	A device for converting AC into pulsating DC
RF CHOKE	An inductance that resists passage of radio frequencies
SPURIOUS EMISSIONS	Signals radiated by a transmitter other than the carrier and its modulation
VOLTS	Resistance in ohms times current in amperes
VOLTMETER	Measures voltage
WATTS	Voltage times current in amperes
WATTMETER	Measures watts directly
WATT-HOUR METER	Measures watts consumed
WAVELENGTH (METERS)	300,000,000 divided by frequency in cycles per second



HAM NOVICE LICENSE GUIDE

Novice class hams may transmit only code in the 15-, 40- and 80-meter bands and voice or code in the 2-meter band. For voice transmission, a *modulator* is required (see block diagram). In an AM (amplitude modulation) transmitter, the modulator varies the plate voltage applied to the RF power amplifier stage causing the RF power output to vary. The modulator is usually fed by a speech amplifier which is fed by a microphone. The modulating system (speech amplifier and modulator) is simply an audio amplifier whose output signal is connected in series with the plate voltage fed by the RF power amplifier. Now, let us cover the points that are included in novice ham license examinations.

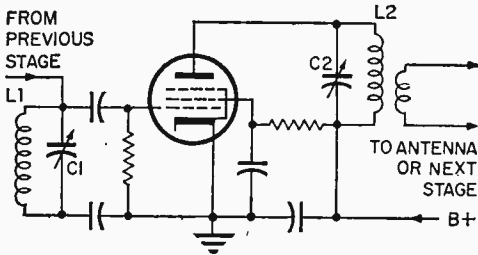

Fig. 2. Schematic diagram of a typical tuned-grid, tuned-plate RF amplifier. When C2 and L2 are tuned to a harmonic of input signal, stage becomes a frequency multiplier.

Amplifiers. An *amplifier* increases the power level or amplitude of an electrical wave. Different kinds of amplifiers are used for audio frequencies (AF) and radio frequencies (RF). An amplifier may consist of one or more stages using tubes or transistors.

In RF amplifiers, *parasitic oscillations* may occur. The RF amplifier in a transmitter is not supposed to oscillate. It simply amplifies the radio signal that is fed to it and is tuned to the frequency of the radio signal. However, the amplifier may also oscillate at a different frequency because a resonant circuit may be formed by the components and the tube. This is known as *parasitic oscillation* which may cause harmful interference and reduces the power of the transmitter since some power is consumed in generating the unwanted oscillations. See Fig. 2.

An RF amplifier may also be used as a *frequency multiplier*. The RF signal fed to it is at a lower frequency than the output signal. This is done by tuning the output circuit to a *harmonic* of the input signal. For example, if the input signal is at 73 mc and the output signal is at 146 mc, the amplifier functions as a *frequency doubler*. Or if the input signal is at 49 mc and the output is at 147 mc, the amplifier acts as a *frequency tripler*.

Modulation. Intelligence can be transmitted by radio by *modulating* the radio signal. In *amplitude modulation* (AM), the power output of the transmitter is varied. In *frequency modulation* (FM), the frequency of the radio signal is varied.

Most ham transmitters employ AM. A simplified schematic of an amplitude modulation system is given in Fig. 3. The RF power amplifier tube (V1) is driven by an unmodulated RF signal from an oscillator, frequency multiplier or buffer RF amplifier. When not modulated, the plate voltage at V1 (E3) is equal to the plate supply voltage (E1) minus the small DC voltage drop (E2) across L2, the modulation reactor.

When modulated, an audio voltage is developed across L2 which alternately changes polarity. At one instant E2 is in series-aiding with E1 causing E3 to rise. The V1 plate voltage is higher than when no modu-

INTERNATIONAL MORSE CODE

A	· —	N	— ·
B	— · · ·	O	— — — —
C	— · — ·	P	· — — ·
D	— · ·	Q	— — — ·
E	·	R	· — ·
F	· · ·	S	· · ·
G	— · —	T	—
H	· · · ·	U	— · ·
I	· ·	V	· · · —
J	· — — —	W	· — —
K	— · —	X	— · · —
L	· — · ·	Y	— — · —
M	— —	Z	— · · ·
1	· — — — —	6	— · · · ·
2	· · — — —	7	— · · · ·
3	· · · — —	8	— — · · ·
4	· · · · —	9	— · · · · ·
5	· · · · ·	0	— — — — —
Period	· · · · ·	?	· · · · ·
Comma	— · · · ·	Break	— · · · ·

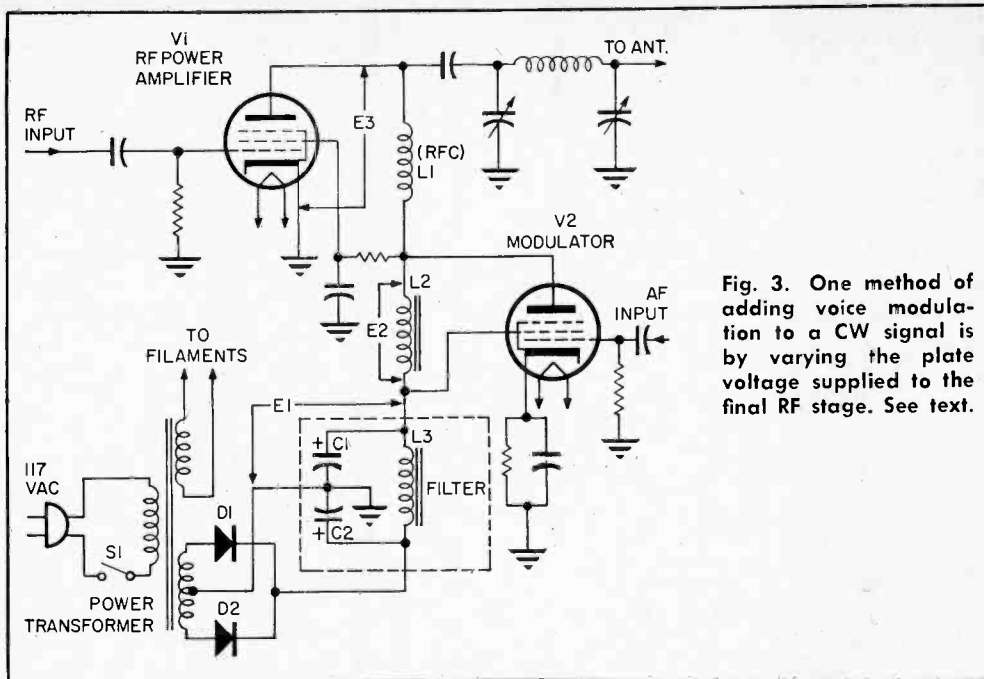

Fig. 3. One method of adding voice modulation to a CW signal is by varying the plate voltage supplied to the final RF stage. See text.

lation is present and, thus, the power output of the transmitter increases. At another instant, E2 is in series-opposing with E1 causing E3 to drop. The V1 plate voltage is therefore lower than when no modulation is present. Thus, the power output is alternately raised and lowered by the audio modulating signal.

Overmodulation would occur if the modulating signal E2 were to become so large that when it opposes E1 by more than the value of E1, E3 becomes negative. Overmodulation causes harmful interference and should never be allowed to take place. The degree of modulation is expressed in terms of *percentage of modulation* and should not exceed 100%.

Chokes. Fig. 1 shows us three different kinds of chokes. The plate of V1 is prevented from being grounded with respect to the RF signal by L1, an *RF choke* which resists passage of RF but easily passes DC. Modulation reactor L2 is an *AF choke* which resists passage of AF but passes DC. And, *filter choke* L3 resists changes in current and smooths the pulsating DC furnished by the rectifier diodes D1 and D2. Capacitors C1 and C2 in conjunction with L3 form a low-pass filter which *attenuates* the ripple frequency (120 cps when a full-wave rectifier is used, as shown).

It is required by the FCC that the power supply be well filtered in order to produce

a pure CW (code) signal or relatively hum-free radiotelephone signal.

Frequency. The frequency bands in which Novice hams are permitted to operate are listed in Table of Operating Frequencies. Novices may employ phone (radiotelephony) only in the 145-147 mc portion of the 144-148 mc, 2-meter band. Only CW (code) transmission is permitted in the other bands. These same restrictions are not imposed on Technicians, Conditional and General Class hams.

TABLE OF NOVICE OPERATING FREQUENCIES

Emission	Frequency Bands (mc)	Power Input (watts)
CW	3.70-3.75	75
CW	7.15-7.27	75
CW	21.10-21.25	75
AM/FM/CW	145-147	75

Hams may operate on *any frequency* within an authorized band. A ham does not have to maintain transmitter frequency at any given stability as in the case of CB, but must know how and have means for measuring transmitter frequency to determine that his signal is within the authorized band. This frequency measuring device must be separate from the transmitter. Even if the crystal is supposed to function at a specified frequency, this fact alone is not sufficient



HAM NOVICE LICENSE GUIDE

proof of being on the desired frequency.

Novice ham transmitters must be crystal controlled. The use of a VFO (variable frequency oscillator) is not permitted.

The *harmonics* of a radio signal are its direct multiples. For example, the first harmonic is the same as the fundamental frequency, the second harmonic is at a frequency that is twice the fundamental, the third is at three times the fundamental, and so on. An *overtone*, on the other hand, is different. The first *overtone* is equal to the second harmonic. Thus, a *third-overtone* crystal stabilizes an oscillator at the fourth harmonic of the crystal basic fundamental.

Radio frequencies are referred to in kc or Kc/s (kilocycles per second) and mc or Mc/s (megacycles per second), one megacycle being equal to 1000 kilocycles. The frequency of a radio wave is equal to 300,000,000 divided by the *wave length* of the signal in meters. The wave length is equal to 300,000,000 divided by the frequency in cycles per second (1000 cycles equals one kilocycle). The speed of radio waves is said to be 300,000,000 meters or 186,000 miles per second.

Emission. The transmitter should radiate

only the RF carrier and its modulation. However, transmitters may also radiate *spurious* signals caused by *parasitic oscillations*, leakage of signals from stages preceding the RF power amplifier and other factors. *Harmonics* of the transmitted signal frequency may also appear in the output of the transmitter. *Spurious emissions* can be

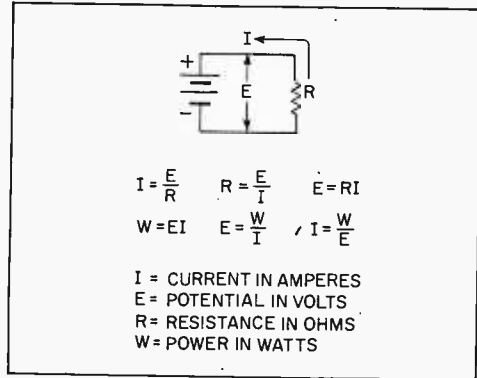

Fig. 4. Knowledge of Ohm's law and how to determine power is necessary for the exam.

minimized by proper transmitter design and by using a *low-pass filter* between the antenna and the transmitter.

Basic Electricity. The exam questions include Ohm's law which is used for calculation of voltage, current, resistance and power as shown in Fig. 4. The questions also

CHECK LIST OF TOPICS FOR STUDY

Topic	What You Should Know About It			
Amplifiers	<input type="checkbox"/> Function	<input type="checkbox"/> Parasitics	<input type="checkbox"/> Frequency multipliers	
Frequency	<input type="checkbox"/> Available to novice hams	<input type="checkbox"/> Measurement	<input type="checkbox"/> Crystal control	<input type="checkbox"/> Harmonics
Modulation	<input type="checkbox"/> Function	<input type="checkbox"/> Percentage	<input type="checkbox"/> Overmodulation	
Chokes	<input type="checkbox"/> Radio frequency	<input type="checkbox"/> Audio frequency	<input type="checkbox"/> Filter	
Emission	<input type="checkbox"/> Spurious	<input type="checkbox"/> Key clicks	<input type="checkbox"/> Purity	
Power	<input type="checkbox"/> Determination	<input type="checkbox"/> Maximum allowed		
Instruments	<input type="checkbox"/> Voltmeter	<input type="checkbox"/> Ammeter	<input type="checkbox"/> Watt meter	<input type="checkbox"/> Watt-hour meter
Calculations	<input type="checkbox"/> Ohm's law	<input type="checkbox"/> Frequency vs wavelength	<input type="checkbox"/> Power input	<input type="checkbox"/> Harmonics
License	<input type="checkbox"/> Kind required	<input type="checkbox"/> Renewals	<input type="checkbox"/> Re-examination	
Operation	<input type="checkbox"/> Identification	<input type="checkbox"/> Portable/mobile	<input type="checkbox"/> Language on the air	<input type="checkbox"/> Penalties
Safety	<input type="checkbox"/> Bleeders	<input type="checkbox"/> Grounding	<input type="checkbox"/> High voltage exposure	<input type="checkbox"/> Power on-off
Relationships	<input type="checkbox"/> Frequency to wavelength	<input type="checkbox"/> Current to voltage, etc.	<input type="checkbox"/> Watts to current, voltage	<input type="checkbox"/> Harmonics
Log	<input type="checkbox"/> Entries	<input type="checkbox"/> Retention		
Definitions	<input type="checkbox"/> Amplification	<input type="checkbox"/> Modulation	<input type="checkbox"/> Detection	<input type="checkbox"/> Attenuation
Functioning	<input type="checkbox"/> Modulator	<input type="checkbox"/> Amplifier	<input type="checkbox"/> Rectifier	<input type="checkbox"/> Filter
Abbreviations	<input type="checkbox"/> Frequency	<input type="checkbox"/> Time	<input type="checkbox"/> Modulation	

Every grade of ham license exam requires that the prospective operator know how to send and receive code (CW). Transistorized code practice oscillators, such as this one by Knight, are invaluable aids to learning. Usually, instructions for how to learn CW are included with the unit.



require definition of an *ammeter*, which is used for measuring current, a *voltmeter*, which is used for measuring electrical potential, a *watt meter*, which is used for measuring power, and a *watt-hour meter* which is used for measuring power consumption. One question requires definition of the term *detection*, which means demodulation of a radio signal in order to extract the intelligence, *attenuation*, which means reduction of a signal's amplitude, *amplification*, which is the process used to increase the power level or amplitude of an electrical signal, and *modulation*, which is the process used to apply intelligence to a wave by varying its amplitude, frequency or phase.

Also required is the definition of a *rectifier* which converts AC into pulsating DC, and *filter*, which smooths out the pulsating

DC furnished by a rectifier. Almost all electronic gear include rectifiers and filters.

The power input to a transmitter is said to be the number of watts of power consumed by the final RF amplifier stage of a transmitter when not modulated. This may be determined by measuring the plate current and the plate voltage and then multiplying volts times amperes to arrive at power in watts. For example, if the plate voltage is 600 volts and the plate current is 100 milliamperes (0.1 ampere), the power input is 60 watts.

Safety. The FCC also wants to know if a license applicant knows how to protect himself from shock hazard. For example, a *bleeder resistor* should be connected across all high voltage filter capacitors so they will be discharged when the power is turned

NOVICE QUICK QUIZ

Questions	Check the Correct Answers		
	A	B	C
1. The station call sign should be transmitted	every 15 minutes	beginning and end of each transmission	every 3 minutes
2. A novice license can be renewed	every year	for six months	never
3. The maximum penalty for rule violations is	\$100 per day	\$10,000 and/or 2 years in jail	Loss of License
4. 145 mc is equal to	145,000 cycles	145,000 kc	1.45 kc
5. When plate voltage is 300 volts and current is 40 milliamperes, power input is	12 watts	120 watts	75 watts
6. Overmodulation causes	interference	better voice quality	loss of power
7. Novice hams may transmit	FM in any band	AM in the 80-meter band	AM or FM in the 2-meter band
8. A novice station may be operated by a	novice only	general class or novice	technician
9. A log must be retained for	one year	three years	60 days
10. An RF choke	blocks DC	passes RF	blocks RF

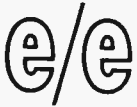

HAM NOVICE LICENSE GUIDE

off. All high voltage points should be covered or at least not exposed so that someone can touch them. The power should be turned off when working on high voltage circuits. And, when feasible, keep one hand behind your back when the other hand is near live high voltage points.

Operation. The station call sign should be transmitted at the beginning and end of each single transmission and at least once



Newcomers to amateur radio should do as much reading and studying as possible before taking their FCC exam. The American Radio Relay League (ARRL) publishes four soft cover books every prospective ham should purchase: *How to Become a Radio Amateur*—\$1.00, *Learning the Radiotelegraph Code*—50¢, *The Radio Amateur's License Manual*—50¢, and *Operating an Amateur Radio Station*—25¢. Each publication is bargain at twice the price and should be in every amateur's bookshelf. These ARRL books are available at radio parts stores, amateur suppliers, electronic mail order supply houses and book stores. The FCC will send you, free of charge, a general-information bulletin entitled *Amateur Radio Service*. All you do is write to the FCC, Washington, D. C. 20554.

every ten minutes during a sustained transmission. Profanity must not be used on the air. When operating a portable or mobile station in another radio district, the engineer in charge of the FCC field office in that district should be notified, if operation for more than 48 hours is contemplated.

Every amateur radio station must maintain a log and retain it for at least a year. The log must include (1) the date and time of transmission, (2) the call sign of the station contacted or called, (3) the frequency band used, (4) the type of emission used, (5) the input power, (6) the location of the station if not at its designated fixed location, and (7) the signature of the licensed operator and the name of any other person using the transmitter under the supervision of the licensed operator. Printed log books with blank spaces for insertion of this information are available.

The time may be inserted in the log as GMT (or gmt) for Greenwich Meridian Time or as local time (EST, est, CST, cst, MST, mst or PST, pst).

Start Now. It should not take long to learn enough here to pass the written examination. For convenience, the information you must have is summarized in table form—check list of topics for study. Test your knowledge with the Quick Quiz, but be prepared to answer the questions in prose. And, turn on that record player and listen to the code practice records. Soon, you should have that ham ticket and be free to talk as long as you please with any other ham without the inhibitions of the new CB rules. Who knows but you might be soon talking with General Curtiss LeMay, Herbert Hoover, Jr., Bob Moon, ex-Senator Barry

ANSWERS TO QUICK QUIZ

Question	Answer	Question	Answer
1	B	6	A
2	C	7	C
3	B	8	B
4	B	9	A
5	A	10	C

Goldwater or Stuart Meyer, who are among the many well known hams. And don't stop learning theory or code. Shoot for that General Class ticket where more bands are made available with less restrictions. All the fun is yours depending how hard you want to work for it now. So get busy now and we'll tune you in on the ham bands. ■



BUILD AN... INDUCTANCE BRIDGE

BY CHARLES GREEN, W31KH

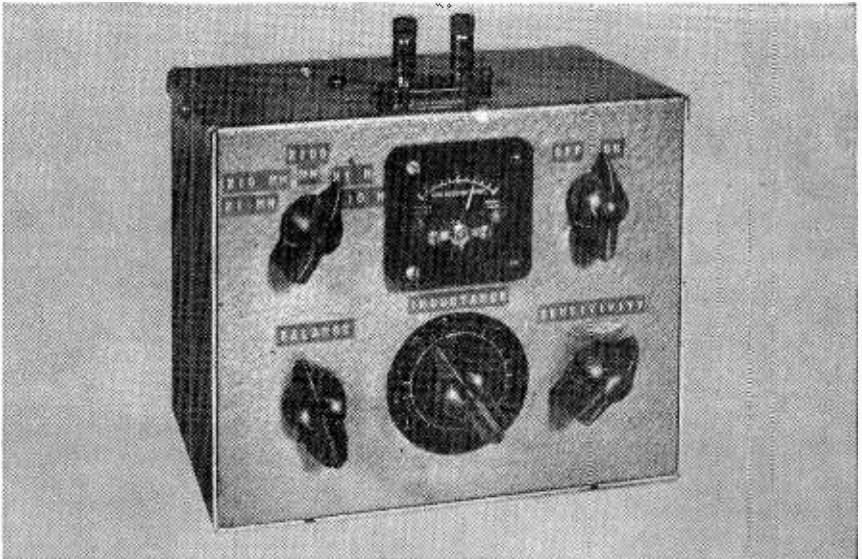

The combination of three basic circuits forms a compact unit for accurately measuring inductance

■ **You** can find the value of those unmarked surplus and commercial type inductances with this handy transistorized inductance bridge. This simplified, easy to build unit uses three inexpensive transistors in a battery powered circuit that will adequately determine inductance values of RF, audio and filter chokes from 1 millihenry to 100 henries.

The bridge is housed in a compact 4" x 5" x 6" aluminum utility box, with all components self-contained. A built-in meter and direct reading dials, indicate the inductance values.

How It Works. Approximately 1 kc is generated by the R-C phase shift oscillator circuit of Q3 and is connected via the Q2 emitter-follower circuit to the basic inductance bridge circuit.

The unknown inductance is connected across J1. Then the inductance control R2, and balance control R7 are adjusted to bal-

e/e INDUCTANCE BRIDGE

ance the bridge circuit for a minimum indication on meter M1. The inductance control, R2, is calibrated to read the inductance value, multiplied by range switch S1 setting.

The range resistors R3, R4, R5, and R6 are connected into the basic bridge circuit by range switch S1A, with the reference capacitors, C1-C2, switched by S1B for the ranges of 1 millihenry to 100 henries.

The 1 kc output of the bridge circuit is coupled via the Sensitivity control, R8, to Q1. This amplifier signal is then rectified by the detector circuit of D1, D2, D3, and D4. The dc output actuates M1, which indicates the balancing of the bridge circuit by a minimum reading (null).

S2 controls the battery power to the unit. Two 9 volt batteries are used to provide isolation between the oscillator and detector.

Construction. The wiring and layout are not critical, any parts placement and box size can be used. The author utilized a 4" x 5" x 6" aluminum chassis box with component layout as shown in the photos.

Meter M1 can be any type from 50 ua to 1 ma., the greater the sensitivity of the meter, the more accurate the adjustment of the Inductance control, R2, will be for balancing the bridge circuit. As the meter does not have to be calibrated, any type of meter scale can be used, such as the surplus one shown in the photo.

The scale for the Inductance control, R2, was made by painting an aluminum disc with black enamel and scratching the calibration markings. But a paper scale with ink notations can also be used.

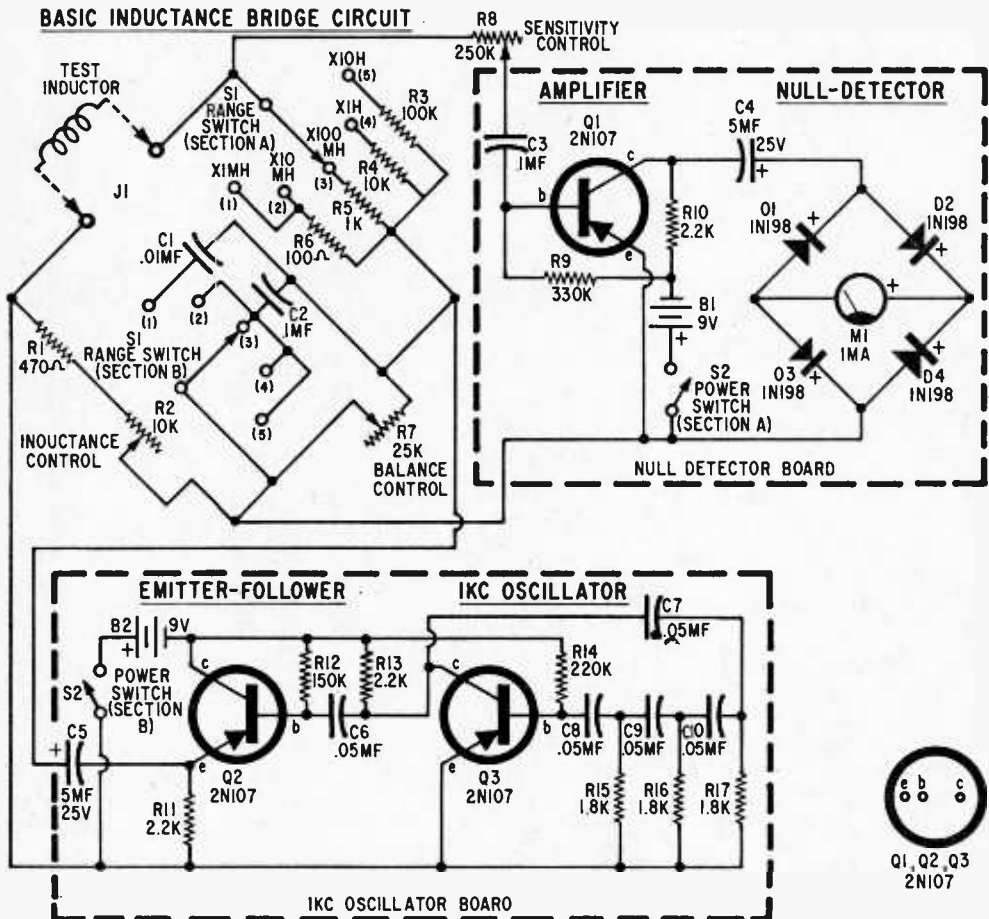

An inductance bridge circuit, 1 kc. oscillator and null detector comprise the test unit.

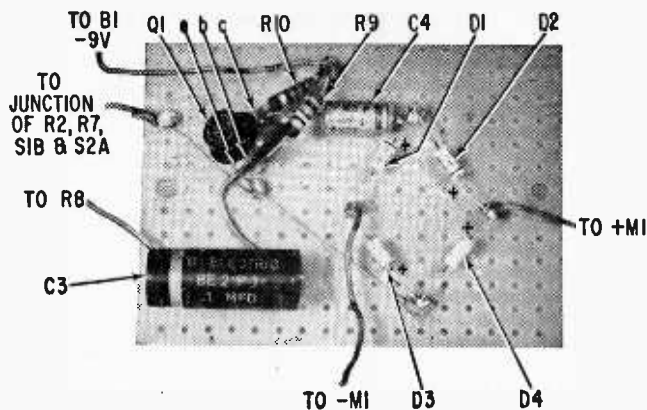

The author's phenolic board assemblies are shown for layout reference. Amplifier-null detector board is at top and 1 kc. oscillator board is shown below. It is suggested that novices follow the author's original layout very carefully.

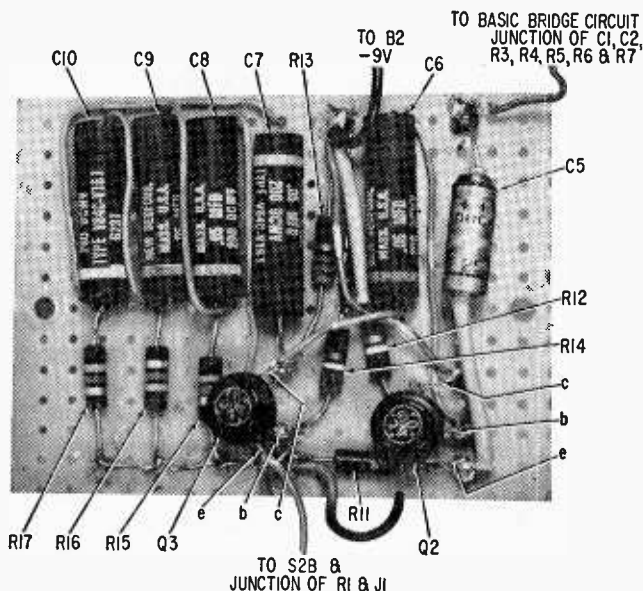

PARTS LIST

B1, B2—9 volt battery (Burgess 2U6 or equiv.)
 C1—.01 mf., 100-volt paper capacitor
 C2—.1 mf., 100-volt paper capacitor
 C3—.1 mf., 100-volt paper capacitor
 C4, C5—5mf., 25-volt miniature electrolytic capacitor
 C6—.05mf., 100-volt paper capacitor
 C7, C8, C9, C10—.05mf., 100-volt paper capacitor
 D1, D2, D3, D4—1N198 diode (1N34A or 1N60 can be used)
 J1—Dual binding post assembly (H. H. Smith type 209)
 M1—1-ma. DC meter (Emico RF-2C, Shurite 8300Z, or equiv.)
 Q1, Q2, Q3—2N107 transistor
 R1—470-ohm, 1/2-watt resistor
 R2—10,000-ohm, 5-watt, wire-wound potentiometer, linear taper
 R3—100,000-ohm, 1/2-watt resistor
 R4—10,000-ohm, 1/2-watt resistor

R5—1,000-ohm, 1/2-watt resistor
 R6—100-ohm, 1/2-watt resistor
 R7—25,000-ohm carbon potentiometer, linear taper
 R8—250,000-ohm carbon potentiometer
 R9—330,000-ohm, 1/2-watt resistor
 R10, R11, R13—2,200-ohm, 1/2-watt resistor
 R12—150,000-ohm, 1/2-watt resistor
 R14—220,000-ohm, 1/2-watt resistor
 R15, R16, R17—1.8K, 1/2-Watt, 10% carbon resistor
 S1—2-pole, 5-position rotary switch, non-shorting
 S2—2-pole, 2-position rotary switch, non-shorting
 1—4" x 5" x 6" aluminum box (LMB 142 or equiv.)
 Misc.—perforated boards, wire, hardware, etc.

Estimated cost: \$25.00

Estimated construction time: 8 hours

e/e INDUCTANCE BRIDGE

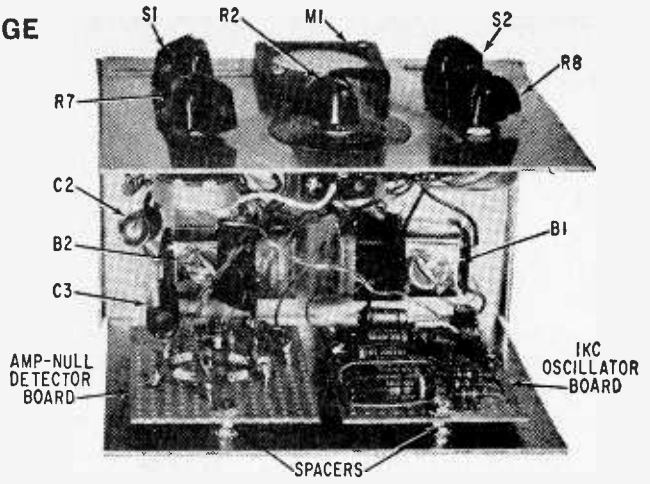

An inside view from the bottom of completed inductance bridge shows placement of circuit board assemblies and the easy access to all parts on the front and top panels.

The basic bridge components are mounted on the front panel of the box, using shake-proof washers to prevent movement. The amplifier-detector and the oscillator-emitter follower circuits are installed on two perforated boards. The wiring of the perforated boards can be made using "flea clips" or feeding the leads through the holes, bending the ends, and soldering. All of the wiring should be made on the side of the boards that the components are mounted on. This will simplify any possible troubleshooting after the boards are mounted in the box. Mount the perforated boards with a spacing nut on their mounting screws to make sure that the flea clips or soldered wiring does not short to the box side. Note: do not connect the wires to the arm of the Inductance control, R2, until after calibration.

Make battery mounting brackets out of sheet aluminum strips and cover them with a plastic tape, wrapping to insulate the batteries from the case.

The metal box is not electrically connected to the circuits. The author did not notice any hand capacity effects while operating the unit, but an external ground to the case can be used if required.

Calibration and Operation. Calibrate the inductance dial by hooking up an ohmmeter between the arm of the Inductance control, R2, and the terminal of J1 that connects to R1. Mark off on the dial every 500 ohm points on R2 to 10,000 ohms. Disconnect the ohmmeter and solder the wires to the arm of the Inductance control, R2.

Connect the batteries and turn S2 to on. No warm up time is necessary. Rotate the sensitivity switch until the meter indicates half scale. Connect an inductance (RF or

filter choke) to J1. Set the Range switch, S1, to an appropriate range. Adjust the Inductance control, R2, to mid-range and rotate the Balance control, R7, for a dip in the indication of M1. Then alternately adjust R2 and R7 until the meter is at a maximum dip (minimum current reading). Increase sensitivity as required with the Sensitivity control, R8, to achieve maximum meter dip. Multiply the reading of the Inductance control, R2, by the setting of Range switch, S1, to find the inductance value.

The author used 10% components because they are readily available through normal retail sources. If better components are available, they can be used in the same circuit for higher accuracy than 10%. ■

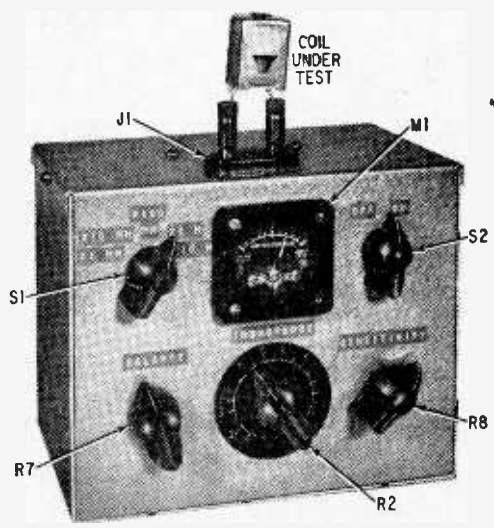

Complete unit showing location of front panel controls, the meter, M1, and jack, J1, at top.

Most good receivers have built-in circuits that mow down the ra-tat-tat of impulse noise spikes; if yours doesn't, add one!

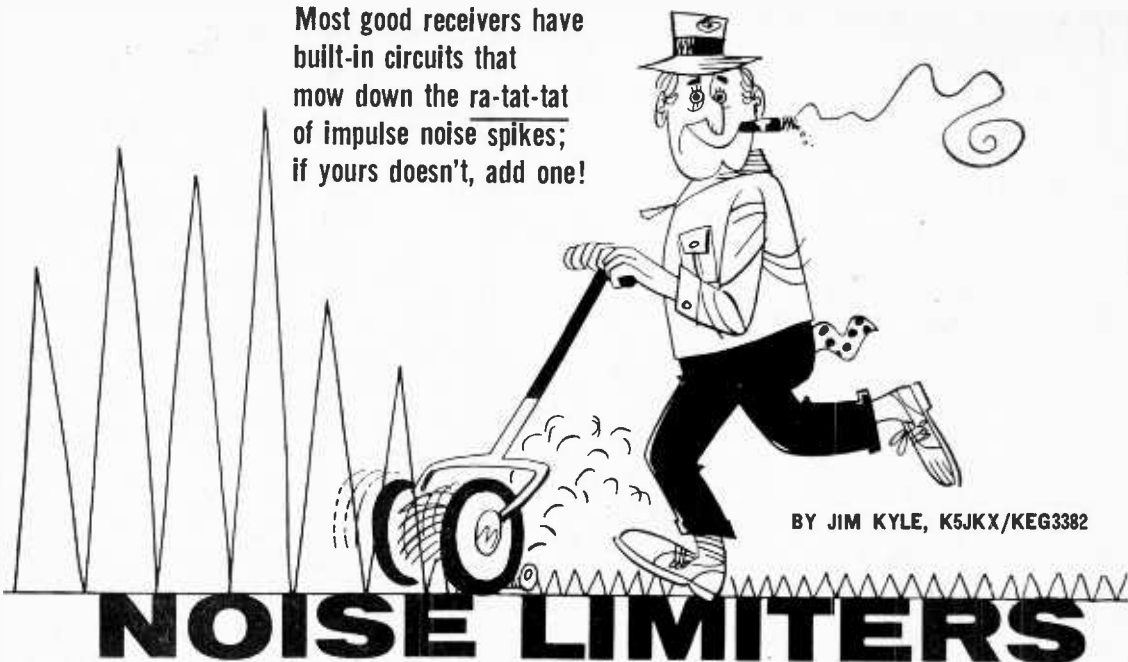

NOISE LIMITERS

How many times have you strained your ears for 45 minutes or more, digging out a signal you hope is rare DX? You hear the announcer quite clearly as he starts the station break, "You are listening to Radio Blat-at-at-at-at-at broadcasting from Blat-at-at-at-at-at in the overseas service of the Blat-at-at-at-at-at Broadcasting Company on the 19-meter band." All too late you realize where the burst of machine-gun-like noise which drowned out the precious identification came from. It issued from a heavy truck that happened to be passing by.

The staccato pops of ignition noise have long been the bane of high-frequency radio communication. So severe is this interference that a large variety of special noise limiter circuits have been developed to combat it.

If your receiver has a good noise limiter, you may not be troubled by the noise. But good noise limiters are not so common as many of us may believe. As a matter of fact many inexpensive receivers have no noise limiters at all!

Fortunately, such circuits are not particularly difficult to add to almost any piece of equipment. Before you can do it, though, you need to know how the noise limiter works. Even if you have a good one already, it's helpful to understand how it operates.

Basic Principles. Regardless of what name it goes under, a noise limiter is basic-

ly a fast-acting switch. Its purpose to *switch out* each individual noise pulse, while leaving normal signals alone. The difference between a good noise limiter and a not-so-good one is simply how well it does this job of switching.

The reason an electronic circuit is able to distinguish between *noise* and *signal* is that ignition-noise pulses have certain characteristics which normal signals do not have. Generally speaking, the noise pulse is: (1) much stronger than most received signals, (2) lasts for a much shorter period of time than any portion of a normal signal, and (3) causes audio signal voltage to change much faster than does any part of a normal signal.

These same three characteristics make the noise most damaging to signal. The extreme strength assures that the pulse will probably drown out all incoming signal so that the receiver can't hear it in the first place. The short duration causes a "ringing" effect in the receiver which makes the pulse *seem* to last much longer than it *does* (like the echoing of a Chinese gong after it has been struck). And the fast voltage change causes audio stages of the receiver to distort whatever signal does manage to get through in spite of the noise.

Since noise, in radio, is a word with many meanings, it might be well to pause at this point and define clearly just what we're talk-

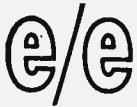

NOISE LIMITERS

ing about here. *Noise* can mean the frying hiss you get when you turn the volume all the way up with no station coming in. This is *thermal noise*, and no noise limiter can do much about it.

Noise can also mean the rumbles and crashes you hear when a thunderstorm is near, which are literally the electronic sounds of the thunderstorm. At certain times of the year and on certain bands in the short-wave region, this noise is virtually always present. It's called *atmospheric noise* or simply *sferics* (in older times, it was known as *static*), and again, the noise limiter doesn't do much good.

The third meaning of noise is the sharp pop of auto ignition, the click you hear when light switches are thrown on or off, and for that matter anything that interrupts the flow of current in a circuit. This *impulse noise* is the kind we mean when we use the word noise here, and it's the only kind the noise limiter is intended to combat. Fig. 1 shows the waveforms of the three kinds of noise, and details the characteristics of impulse noise which allow electronic circuits to distinguish it from signal.

It's worth mentioning that *some* kinds of signal are so similar to noise that the noise limiter can't tell the difference. One striking example is a particular kind of selective-calling accessory widely used by CB operators. It operates with several audio pulses which are spaced at precise intervals to form a *calling code*. These pulses are so similar to noise in their electrical appearance that a noise limiter can't tell the difference. It will go right ahead and remove them so the makers of equipment designed to be used with this accessory are forced to use less-than-perfect noise limiters. There's just no other way to be sure that their calling pulses will get through to the accessory!

In most cases, though, the differences between signal and noise are so marked that circuits have little difficulty determining which is which.

The Simplest Limiters. The basic operation of a noise limiter can be on one of two principles. One is based on a *series* switch, while the other is known as a *shunt* circuit and is based on a parallel-connected switch. Some limiters use one, some the

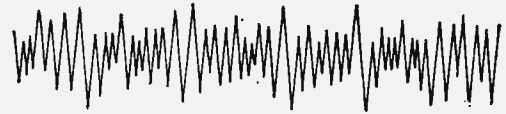

Visual representation of thermal noise. The strength and duration of each pulse is completely random and cannot be predicted.



Atmospheric noise is similar to a thermal noise but the pulse duration is much longer.



Impulse noise consists of regular, narrow, extremely strong pulses. An average signal waveform is shown at left for comparison.

Fig. 1. Different types of noise that plagues radio communications have different waveshapes. These are the typical waveshapes for three general classes of noise. Noise limiters work only on impulse noise which has narrow, strong pulses of energy. Atmospheric and thermal noise are similar to signal; circuits can't tell the difference.

other, and infrequently you may come across a circuit which uses both.

Fig. 2 shows the basic circuit of the series switch reduced to its simplest terms. The output of the receiver's detector circuit, containing both the desired signals and the undesired noise pulses, is routed through switch S1 to reach the audio circuits. Normally, this switch is closed (as shown) and the detector output gets through to the audio uninterrupted.

However, when a noise pulse comes along, the switch is opened. The path from detector to audio is then blocked, and no sound gets through. This results in the noise being stopped. When the pulse of noise is over, the switch is closed once again, and the audio passes through as before.

Since most noise pulses last for considerably less than 1/10,000 of a second, your ear can't hear the *hole* in the signal. The only way you know the limiter is doing anything is to disable it (in other words, leave the switch open), and listen to the noise come through.

Since nobody is fast enough to flick a switch on and off again in 1/10,000 of a second, this simplified circuit obviously can't be used exactly as shown. Electronic switches, though, can be made to operate this fast (or even much faster), and in practice the series noise limiter is an almost exact replica of Fig. 2. The only difference is that electronic switching circuitry has replaced the simple switch S1.

The other principle used in noise limiters is almost the exact opposite of the series switch. Fig. 3 shows this circuit reduced to simplest terms. Note that switch S1 has been moved so that it is no longer in *series* with the detector output. Instead, it is in parallel or *shunt* with it.

Normally, in this circuit, S1 is open, as shown. Output from the detector goes to the audio stages, and operation sounds normal. But when the noise pulses arrive, the switch

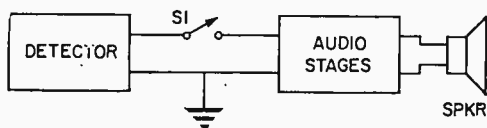

Fig. 2. A series switch noise limiter is shown in simplified form. Switch is normally closed, but opens for the duration of the noise pulse. Electronic switch circuit is used since an ordinary switch is too slow.

is closed for the duration of each pulse. This shorts out the audio stages, so that no signal or noise gets through to them. At the end of each pulse, the switch is opened once again, letting the audio pass through.

As with the series switch, practical shunt limiters use electronic circuits instead of the simple mechanical switch, for speed of operation.

The two basic circuits have a number of similarities, but they also have a few differences. It's theoretically possible to completely remove a noise pulse with the series circuit, since the path it must travel is completely opened. With the shunt circuit, however, at least a tiny bit of the pulse will always get through, since the "short circuit" can never be perfect. This isn't the drawback it might seem, however, since with practical components neither circuit is able to approach its theoretical performance capabilities.

The electronic switch used in the series circuit must perform considerably better than that in the shunt circuit. Semiconductor

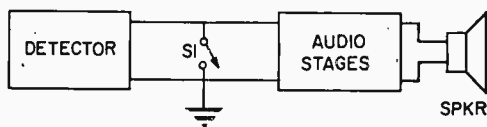

Fig. 3. Shunt switch noise limiter operates similar to a series switch circuit. Practical shunt circuits are not quite as efficient as the series switch limiter circuits, however.

diodes were, at one time, recommended for use only in shunt circuits since they simply were not capable of meeting the requirements for the series circuit. Modern diodes, however, function equally well in both types.

The Electronic Switches. The electronic switching circuits almost universally used in noise-limiters are simple diodes. Some circuits use vacuum diodes such as the type 6AL5 tube. Others employ semiconductor diodes such as the 1N54 high back-resistance germanium unit (especially designed for noise limiters) or the 1N459 silicon diode, which has a higher back resistance than many vacuum diodes.

The switching capability, an inherent property of the diode, can be understood by studying Fig. 4. Operation of the vacuum diode is shown in A and B, while that of the semiconductor diode is shown at C and D.

In the circuit of Fig. 4A, a 6-volt battery is connected to the plate of the diode, through a 1200-ohm current limiting resistor

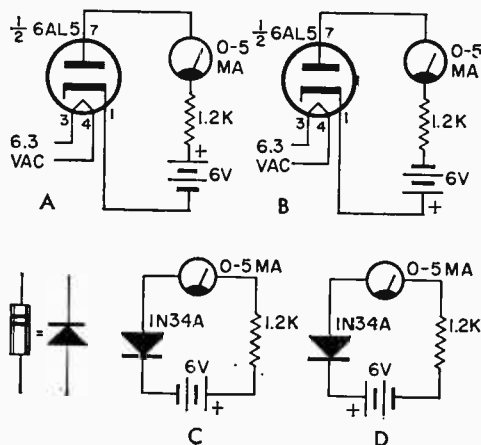
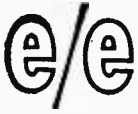

Fig. 4. These circuits show how a diode can be used as a switch. With forward bias, as in circuits A and C, the diode conducts as would a closed switch. With reverse bias, as in circuits B and D, current flow is blocked as with an open switch. You can prove this for yourself with these circuits.



NOISE LIMITERS

and a 0-5 milliammeter. The negative battery terminal is connected to the diode's cathode. All resistors in the schematics are $\frac{1}{2}$ -watt and all capacitor values are in microfarads unless otherwise noted.

With this hookup, the diode is said to be *forward biased* and current will flow through the resistor and the meter. The diode behaves just as though it were a closed switch, except that it does have some resistance of its own. In this hookup, the meter will probably indicate about 4.5 MA instead of the full 5 you would expect. This is because of the diode's *forward resistance*.

The circuit of Figure 4B is almost identical to that of the 4A. However, the battery has been reversed so that now the negative terminal connects to the resistor, meter, and diode plate, while the positive terminal connects to the cathode.

In this condition, the diode is said to be *reverse biased* and current flow is virtually blocked. The meter probably will not indicate any current flow at all.

In a sense, then, a reverse-biased diode is the same as an open switch. Similarly, the diode when forward-biased corresponds to a closed switch. This is an electronic switching circuit, because the polarity of bias applied to the diode can be controlled electronically rather than by actually taking out the battery and turning it around.

The major apparent difference between the semiconductor diode circuits of Fig. 4C and 4D, and the vacuum tube diode circuits of Figs. 4A and 4B, is that the semiconductor diode requires no source of heater power. Actually, there's a little more difference than this.

The built-in resistance of the diode in its *on* condition, mentioned a couple of paragraphs back, is considerably higher for the vacuum tube diode than for its semiconductor cousin. Where the vacuum tube diode may have a forward resistance of 200 to 300 ohms, the semiconductor is more likely to be in the 1-to-10 ohm region.

The reverse or *back* resistance, in the *off* condition, is also different, but here the vacuum tube diode has the advantage. Its back resistance is nearly infinite. Common semiconductor diodes have back resistances in the region of 5000 to 500,000 ohms, so they are

not perfect switches. Silicon junction diodes, however, are in the same operating region as tubes, with back resistances measured in the billions of ohms.

Thus, in Fig. 4C, the meter would indicate the full 5 MA you would expect. But the meter in 4D might register a small but not noticeable reading, instead of zero.

Employing the Switches. Now that we have our electronic switch circuit, let's see what can we do with it to get it into the basic hookups of Figs. 2 and 3.

Fig. 5 shows the starting point for employing a switching diode in the series-switch basic circuit. Capacitors C1 and C2 serve

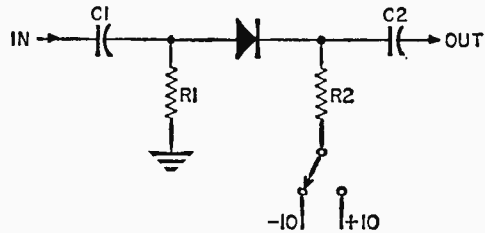

Fig. 5. A practical application of a diode switch in series hookup. While mechanical switch is still used at this stage, it only carries DC rather than the signal current.

merely to keep the DC used for diode switching out of the rest of the receiver. They also prevent any DC that may be on the audio line from detector to audio stages from affecting the switch.

Incoming signal from the detector appears across resistor R1, which is fairly large in value. This resistor serves the dual purpose of providing a ground return path for the switching voltage, and keeping the signals from being bypassed to ground.

Switching voltage, either positive or negative as selected by the SPDT switch, is applied to the cathode of the diode through resistor R2. This component serves the same purposes as R1 in routing signal and switching voltage through their separate paths.

When the switching voltage selected is negative the diode is forward biased and will conduct. The signal appearing across R1 passes through the diode and appears also across R2. It is coupled to the output through blocking capacitor C2. If positive voltage is applied to R2, the diode is reverse biased and cuts off. No signal can then get through.

The circuit of Fig. 6 shows how the diode switch is used in the shunt-switch limiter of Fig. 3. C1, C2, and R1 serve the same pur-

poses as in Fig. 5. When positive voltage is applied to the diode, as shown, the diode is *off* and the audio path from detector to audio stages isn't affected by presence of the limiter components.

However, if negative voltage is applied to the diode, it will go to its *on* or conducting state. It will then short out the signals so that none can get through to the output.

The circuits of Figs. 5 and 6 are still not usable as shown, because they still depend upon manual switching. However, the switch shown in these two circuits is handling only DC control voltage—not the signal itself as in Figs. 2 and 3. From here, it's only a step to the workable noise limiter in its basic form.

In fact, the step is already taken. In Fig. 5, for instance, the switch-control voltage is shown as being -10 volts. As long as the input signal appearing across R1 does not swing more negative than 10 volts, so that the DC voltage at the diode end of R1 is always more positive than -10 volts, the diode will be *on* and the circuit will operate as described.

If, however, the signal across R1 swings down to 20 volts negative, so that the "plate" or anode of the diode is more negative than is the cathode, the opposite will be true. The diode will then be reverse biased as long as the signal is larger than the bias, and the voltage at the junction of R2 and C2 cannot go more negative than 10 volts. The diode is, in effect, automatically switching from *on* to *off* whenever the input signal voltage is larger than the bias voltage.

As shown in Figs. 5 and 6, though, the limiter would be useful only for signals which never exceeded 10 volts, and also were never much weaker than this level. For more usability, the versions shown in Fig. 7 were developed. The *turn-off* bias supply isn't necessary, for the noise pulse itself provides the turn-off bias.

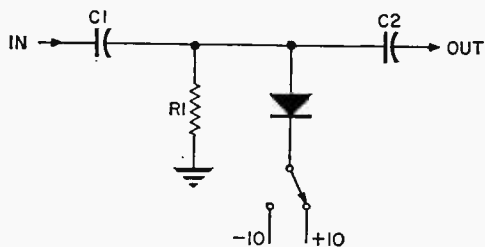

Fig. 6. Shunt version of circuit in Fig. 5. In both, switch is shown in normal position.

Fig. 7A shows the manually adjusted series noise limiter, while Fig. 7B shows the shunt version. Although semiconductor diodes are shown, vacuum tube diodes may be used interchangeably.

Operation of the circuit of Fig. 7A is the same as that of Fig. 5, except that potentiometer R3 is adjusted until the bias voltage applied to R2 is just equal to the peak voltage of the desired signal. In practice, this is done by adjusting R3 until the signal just begins to sound distorted or *mushy* as its peaks are clipped off. When so adjusted, the switching action of the diode will prevent the output voltage from ever going *higher* than the setting of R3.

When the diode switches *off*, the output voltage across R2 remains at the level set by R3 instead of dropping to zero. This means that the stump of the noise pulse will still remain in the output. However, the pulse has at least been trimmed down to be no stronger than the signal.

Because the human ear responds more readily to familiar sounds than to noise, a

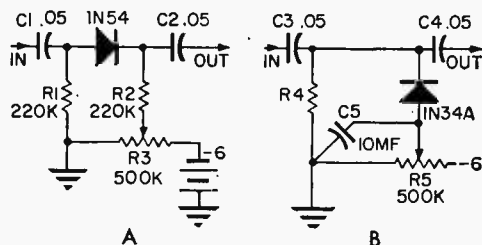

Fig. 7. Complete noise limiters with automatic switching. The series circuit is at A, and the shunt at B. Circuits can be installed in any receiver. See the text for a discussion of operation and adjustment of the circuits.

limiter of this type which leaves the noise pulse stumps in its output provides generally acceptable performance. Getting rid of the stumps requires considerably more exotic circuitry, which we'll look at a little later.

The shunt circuit of Fig. 7B is similar in many ways to its series equivalent. The diode has been reversed from the position shown in previous illustrations simply to allow a negative voltage to bias it *on*. Without noise, and with R5 adjusted so that the voltage applied to the diode's anode is just barely insufficient to cause forward bias on audio peaks, this limiter does nothing. But when a noise pulse appears, that is stronger than the peak value of the signal, its voltage will add

Ⓞ/Ⓞ NOISE LIMITERS

to the bias set by R5 and turn the diode on. This shorts the audio and the noise pulse to ground through C5. The capacitor is necessary to provide a low-impedance path to ground, regardless of the setting of R5.

Like the series limiter of Fig. 7A, this circuit leaves the stumps in. When the diode turns on, it clamps the output voltage at the level set by R5. The chief difference between the two limiters of Fig. 7 is that the shunt version can use an inexpensive general-purpose diode, while the series circuit requires a diode with high back resistance.

The need for high back resistance can be seen by looking at Fig. 8. This includes the effective parts of Fig. 7A, but shows the diode as a resistor with resistance equal to the diode's back resistance. This is the case whenever the diode is turned off by a pulse.

The complicated network of resistors at the left side of Fig. 8 can be combined, by adding series resistors together and combining values of parallel resistors, into the sim-

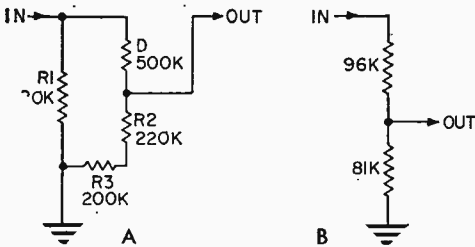

Fig. 8. High reverse resistance is necessary for diode used in series switch circuits. At left, 50,000-ohm resistance D is reverse resistance of the diode. When series resistors are added and parallel resistances are combined to get equivalent circuit, the one at B is the result. In B, only half as much voltage is at output as was applied to input although switch is at the off position.

ple voltage divider at the right. You can see that, by voltage-divider action, the output voltage of this network is almost half as large as its input.

Since this is the exact set of conditions during the off part of the limiter action, it means that a diode with back resistance of only 500,000 ohms would not inform well in the circuit of Fig. 7A. In fact, it would reduce the noise pulses only to half their

original strength, rather than cutting them down to be exactly equal to the signal peaks! For efficient action in the series circuits, then, diode back resistances must be in the many-megohm regions.

Automatic Bias. Although the circuits shown in Fig. 7 work excellently with steady signals, they fall far short when the incoming signals are fading. If R3 or R5 is adjusted when the signal is strongest, then as the signal fades the noise pulses still will not be clipped until they reach the level set by R3 or R5. Their level, unfortunately, will then be several times larger than the peak values of the signal.

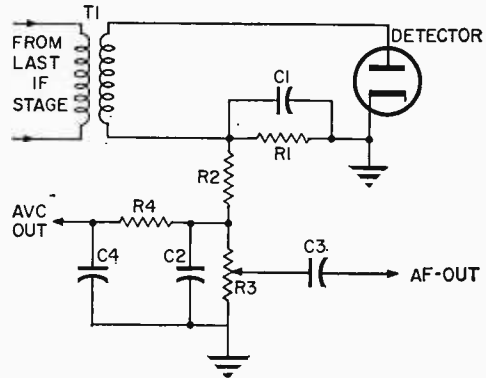
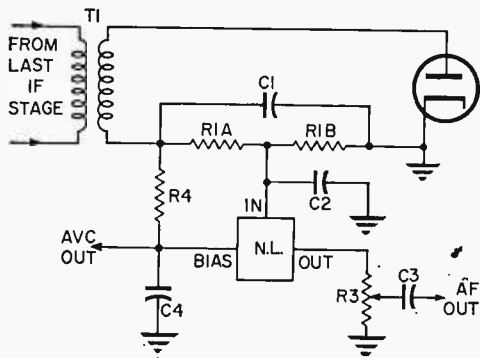

Fig. 9. Typical second-detector circuit of a radio receiver shows separation of the AVC control voltage and audio-frequency signal output. AVC voltage is DC making it suitable for use with a noise limiter, but some changes must be made in the existing circuit.

If, on the other hand, the potentiometer is set when the signal is weakest, then as the signal comes up, the signal peaks themselves will be clipped, causing extreme distortion.

The only way to employ these circuits on fading signals is to keep one hand on the control, continually readjusting it to keep step with the signal fade. While such operation is possible, it's not always practical—and definitely is far from the most desirable state of affairs!

What is needed is some method to change the diode bias voltage automatically, so that it will rise as the signal strength comes up and will fall with the signal as signals fade down. This is relatively easy to do, and virtually all noise limiters commercially available today include this feature as a matter of course. This automatic bias setting is why the circuit is known as an "automatic noise limit-



RIA + R1B = R1 OF FIGURE 9

Fig. 10. This circuit shows the changes necessary to get completely automatic operation of the noise limiter. The bias voltage comes from AVC line, but the signal input is reduced by the voltage divider network, R1A and R1B. See text for the full operation.

er" or ANL for short.

The major requirement to make the bias setting automatic is a source of DC voltage which varies in step with signal strength. This source is inherent in every receiver, since the detector circuit produces DC as well as the audio signal. Furthermore, the strength of the DC produced by the detector is directly related to the strength of the RF carrier.

This fact is already made use of in receivers which have automatic volume control (AVC), which includes most receivers on the market today. Fig. 9 shows how it works.

Incoming signals from IF transformer T1 are applied to the detector diode, in series with load resistor R1 and first filter capacitor C1 (in parallel with R1). The detected audio appears across R1, as does the rectified DC produced by the carrier.

C1, C2, and R2 are filter components, chosen to block any RF energy from the rest of the circuitry while allowing both the audio and the DC to pass. R3 is the volume control, while C3 blocks the DC from the following audio circuits. R4 and C4 are filter components chosen to block the audio from the AVC line, but permit the DC to pass. Thus the DC and the audio are routed to their respective destinations.

The AVC voltage is perfect for use in the noise limiter, but it introduces another limitation. The AVC voltage is always equal to approximately the peak voltage of the RF carrier at the detector. However, the audio peak voltage will vary from almost nothing at all up to two times the peak RF voltage,

depending upon the setting of the volume control.

To overcome this limitation, the audio applied to the noise limiter is taken off ahead of the volume control. Here, its peak value is two times that of the AVC voltage, for 100-percent modulated signals. Furthermore, the ratio of peak-audio to AVC voltage remains constant. Fig. 10 shows modifications to the circuit of Fig. 9 for inclusion of an automatic noise limiter.

By proper choice of values for resistors R1A and R1B in Fig. 10, the noise-clipping point may be placed anywhere from zero to several times the peak signal level. If R1A and R1B are equal, the clipping point will be at the peak signal level corresponding to 100-percent modulation. In this case, no distortion of audio can result.

If R1A is larger than R1B, the clipping point will be above peak signal for all modulation levels. Distortion cannot result, but the noise pulses will always be at least a little louder than the signal.

If R1A is smaller than R1B, the clipping point will move below the 100 percent point and noise pulses won't be so loud. Since average modulation level of signals is much closer to 30 percent than to 100 percent, many ANL's are set up for clipping at the 30

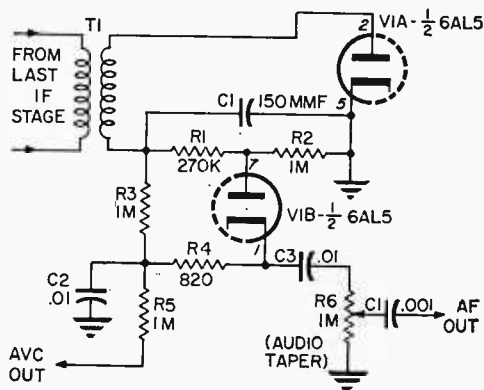

Fig. 11. Second-detector/AVC/ANL circuit of Johnson Messenger I CB transceiver shows typical commercial values of components in noise limiter circuit. It can be used in most receivers with very little change in parts.

to 50 percent level. The occasional signal distortion that results is considered simply as the price paid for less noise.

Practical ANL Circuits. By combining the circuits of Fig. 7A and Fig. 10, we get Fig. 11, which is the standard automatic noise

e/e NOISE LIMITERS

limiter circuit in use today. Its full name is the *half-wave series-gate automatic-impulse noise limiter*, but it's usually called merely the *series limiter* or even *ANL*. It's that common.

By now, operation of the circuit should be fairly easy to see despite the multiplicity of components and connections.

Incoming signals, in the form of a modulated carrier, are delivered through IF transformer T1. They are rectified by detector diode V1A, which converts the carrier to DC and detects the audio. Both DC and audio appear across R1 and R2 in series.

The DC is filtered by R3, C2, and R5 to remove all audio variations in its level and leave only the average voltage determined by incoming-signal strength. Meanwhile, a part of the audio (divided by the voltage-divider action of R1 and R2 in series) is applied to the plate of limiter diode V1B. The cathode of V1B receives negative voltage from the AVC filter, through R4. The purpose of R4 is to prevent any audio from being bypassed back into the AVC circuits, or to ground. C3 blocks the DC control voltages from volume control R6, while C4 is another blocking capacitor for R6 (volume controls tend to develop noise when operated in the presence of DC).

Limiter diode V1B is normally *on*, since its cathode receives the full voltage developed across R1 and R2 while its plate receives only a part of this voltage. Typical voltage measurements are 0.1 volt from pin 7 to ground (in absence of an incoming signal) and 0.3 volt from pin 1 to ground.

When a noise pulse arrives, however, the voltage at the cathode of V1B remains steady. This is because capacitor C2 filters the pulse out, while that at the plate goes strongly negative since it is not filtered. With the plate more negative than the cathode, V1B cuts off and the noise pulse is blocked.

At the end of the pulse, when the plate voltage of V1B again becomes less negative than the cathode voltage, V1B turns *on* again and allows audio to pass as before.

Resistor R1 corresponds to R1A in Fig. 10, while R2 corresponds to R1B of Fig. 10. Since R2 is nearly four times as large as R1, this RNL circuit clips at a point somewhat lower than the 100-percent modulation peak.

However, any resulting distortion is too small to be objectionable.

Incidentally, the values and circuit of Fig. 11 are those used in the Johnson Messenger I citizens-band transceiver's receiver section, one of the best for use in high-noise areas.

Full-wave Limiting. A variant of the half-wave series-gate circuit which offers improved action in high noise is the full-wave circuit shown in Fig. 12. This amounts to simply a pair of half-wave limiters, *back*

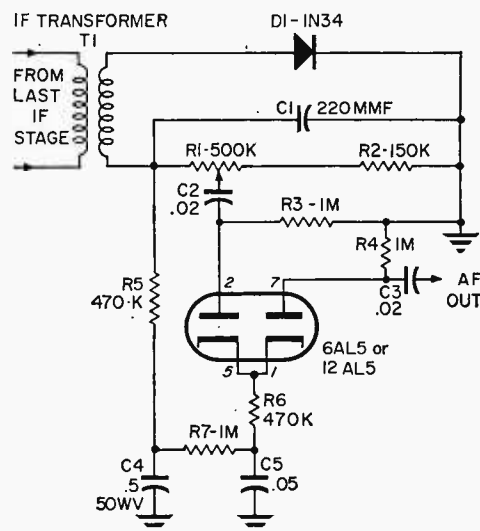

Fig. 12. Full-wave automatic noise limiter consists of two half-wave circuits back-to-back. R1 allows the adjustment of clipping level and need be set only once; the limiter bias follows signal strength automatically.

to back, so that both the positive and negative going halves of the noise pulses are clipped at the same point.

When the noise limiter is set up to clip at 100-percent modulation peaks, the full-wave circuit offers no advantage at all over the half-wave version. This is because the detector itself is an efficient noise limiter for positive-going pulses. However, when clipping is set for lower levels, as in Fig. 11, the negative-going noise pulses will be clipped as planned. Simultaneously, the positive-going pulses will go to the 100-percent level. Using the full-wave circuit makes both halves stop at the same point.

The full-wave circuit is found in a few high-priced communications receivers. Its widest use however, is as a part of a more complex noise-limiting device which has become almost a standard accessory in the

(Continued on page 102)

SO RIGHT CHANNEL KNOWS WHAT LEFT'S DOING, BUILD A . . .

Now you can check that stereo system from top to bottom with the Stereo Checker and shake loose from those audio/stereo bugs. Both right and left channels can be balanced at the same time; you can check signal from the stereo cartridge clear through the whole amplifier; and the left and right channel crystal will show up a defective or weak cartridge. Also, you can use the VU meters with a tape recorder or music distribution system. Last, but not least, the Stereo Checker will properly phase each stereo speaker.

Left and Right. The Stereo Checker consists of two VU meters with variable attenuators R5 and R6 as shown in the schematic diagram. A shorting or calibration switch inserts a resistance into the meter in-

put circuit. Selector switches S1 switches the left channel, right channel, to signal checking and balancing. Two sets of test clips insert into four banana jacks.

A push-pull transistor amplifier, inexpensively purchased from the hobbyist pages of a radio parts catalog, is used for signal tracing. Signal from the stereo cartridge and each amplifying stage can be checked stage by stage. If the stereo phonograph is way off balance to the left channel you can trace the signal until it drops. A three-inch PM speaker provides the audible sound while the gain will be measured on VU meter M2 when S3 is closed.

In the battery supply is a small speaker polarity circuit which will be described and discussed in the following pages.

BENCH TESTED

STEREO CHECKER

BY HOMER L. DAVIDSON

e/e STEREO CHECKER

Construction. Stereo Checker was built in a 5"x10"x3" aluminum chassis. Parts layout in the chassis is shown in the photographs. To prepare the chassis, first cut the speaker and meter holes with a circle cutter. Insert one of the meters into the meter holes and mark out the small mounting holes. Drill all of the small $\frac{1}{8}$ inch holes and then the $\frac{3}{8}$ inch holes. De-burr the back side of each hole with a larger drill bit to allow the parts to mount straight and clean.

On the top center of the chassis, drill a $\frac{3}{8}$ inch hole for S3. Drill two small $\frac{3}{32}$ holes for the metal handle. Center these holes both ways. At the bottom of the metal chassis drill holes to mount the rubber feet.

Mount the speaker with two homemade L brackets fabricated from aluminum if there are no mounting holes in the speaker frame. Place grille cloth or screen in front of the speaker. Under the right speaker mounting bolt, fasten a solder lug. Use this as a common ground terminal. Place a star washer under all controls to keep them from turning. Mount the VU meters after all front parts are in place. The transistor amplifier is not mounted until all other wiring is finished.

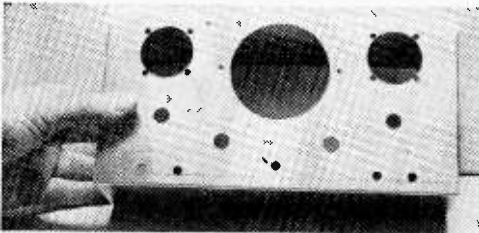

Preparing the chassis for parts mounting requires circle cutter and various drills.

Wiring. Start the wiring by soldering the left and right channel banana jacks to S1. Ground the black banana jacks to the common ground lug. Next wire up the indicator calibration switch, S4. Wire each attenuation control to each corresponding meter.

Now mount the transistor amplifier circuit board to the back of the chassis. Use $\frac{3}{8}$ -inch spacers to hold the board away from the metal chassis. There are two small mounting holes on the grounded side of the board that are used.

Run the green and black output trans-

PARTS LIST

- B1—9-volt battery (Eveready 216 or equiv.)
- C1, C2—.1-mf., 600-vdc capacitors
- J1 through J6—3 red, 3 black banana jacks
- M1, M2—VU panel meter; -20 to +3 VU and 0-100% ranges; ref. level 1mw in 600-ohm line, 3900-ohms internal resistance (Lafayette Radio 99G5024)
- R1—10-ohm, $\frac{1}{2}$ -watt resistor
- R2, R3—18,000-ohm, $\frac{1}{2}$ -watt resistors
- R4—500,000-ohm volume control with s.p.s.t. switch (Lafayette Radio 33G4346 and 33G4428 respectively, or equiv.)
- R5, R6—100,000-ohm linear taper controls (Lafayette Radio 33G4334 or equiv.)
- S1—2-gang, 4-position rotary switch
- S2—S.p.s.t. switch (see R4)
- S3—S.p.s.t. toggle switch
- S4—D.p.d.t. toggle switch
- 1—4-transistor subminiature push-pull audio amplifier, 100-mw output power (Lafayette Radio 99G9042 or equiv.)
- 1—8-10 ohm, 3-inch PM speaker
- 1—5" x 10" x 3" aluminum chassis (Premier ACH-401 or equiv.)
- 1—High fidelity stereo-monaural test record
- Misc.—Dial plates, pointer knobs, test leads, speaker grill, handle, panel markings, hardware, rubber feet, wire, solder, etc.

Estimated cost: \$24.00

Estimated construction time: 7 hours

former leads to the three-inch speaker. Ground the black lead. Tie a wire to the green lead and run to one side of S3. The other switch lead goes to the junction of R3 and R6.

Solder the green and black lead of the input circuit to the volume control. Run the two orange leads to S2 on the back of R4.

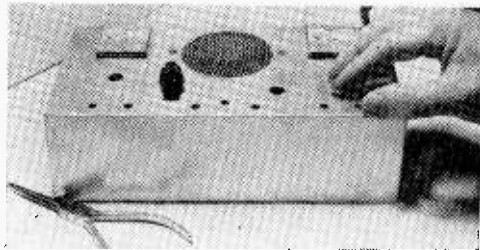

After de-burring-chassis holes, mount front panel meters, switches, pots, and speaker.

The two leads from the SPK-POL plugs go in series with a 10-ohm resistor and the 9-volt battery.

Balance Check. To check the balance on the left and right channel, turn S1 to BAL position. Clip the left channel test leads to the left channel speakers. Be sure the black

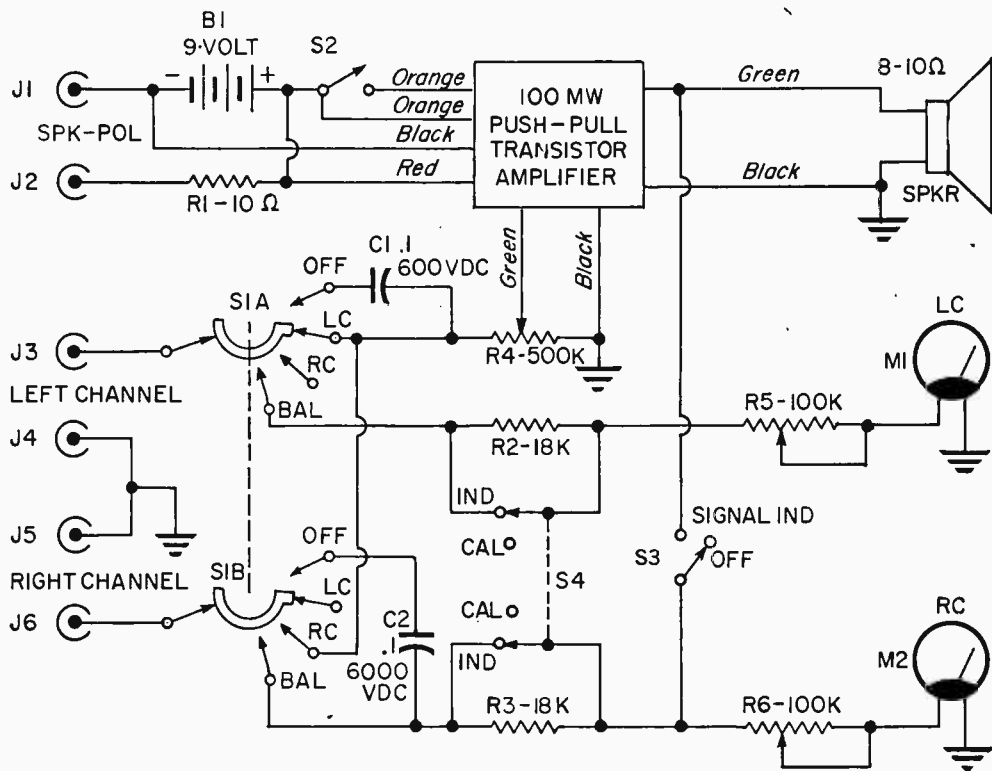

Ganged, dual-channel operation of the circuit is discerned in the overall schematic diagram.

lead is to ground or common terminal. Attach the right channel leads to the right channel speakers.

Set the balance control on the stereo phonograph to middle position. Load the turntable with a 1000-cycle test record. If the turntable is automatic, switch to manual position. Rotate the left channel attenuation control to 85 on the dial. Turn the volume up on the stereo until the VU meter reads *O Red* or 100%. A 1000-cycle note from an audio oscillator can also be used for this test.

Now check the right channel. Set the right channel attenuation control to 85 on the dial. Leave the volume control the same. If both channels are balanced, the reading will be the same. Let's say for instance, that the right channel reading is number 2 in the *red*. This means the right channel has more gain than the left channel. To balance these two channels perfectly, turn the balance control on the phonograph to read 1 on the right channel. Set the left channel attenuation control and right channel attenuation control to read zero on their respective meters. The reading on these two controls should be the same. If so, the stereo phono-

graph is properly balanced.

You will find that when your stereo phonograph has a few years on it, the balance control will usually be farther to one side than the other. Also, you will be quite surprised to find that many commercial stereo machines have poor balance when they come from the factory. Some of these balance controls act as a tone control instead of a perfect balance control. Five different makes were checked with the stereo checker and two of them had poor balance. The balance control had little effect on either side.

If both meters have a reading when the left or right channel is checked separately, the set has poor balance. Rotate the stereo balance indicator to either side and notice if there is a great degree of meter change. If you had this stereo checker to analyze the stereo unit before purchasing it, you'd really be in business.

Stereo Cartridge Check. Hook the left and right channel leads to the small wires coming from the crystal cartridge. On some chassis the crystal leads unplug, others are soldered in place. If there are only three wires, be sure the black lead goes to common or ground. Set the volume control on

STEREO CHECKER

the stereo phonograph to minimum. Place a 1000-cycle test record, that indicates left and right channels, on the turntable.

Set the phonograph changer to manual position and start the record. Rotate the selector switch to *LC* and turn up the *SIGNAL AMP* control. You will now hear the 1000-cycle note through the self-contained speaker. Set the dial pointer to *15*. The attenuation and VU meter used in this test is the right channel. Both crystals will be checked through the right channel. Take a look at the diagram and throw the *SIGNAL IND* switch, S3. You will note that this switches the green speaker lead output to the right meter.

Turn the attenuation dial pointer to *15*. Rotate the *SIGNAL-AMP* volume control until the meter reads zero. Use zero as a reference point.

To check the right channel crystal, turn the selector switch to *RC*. Leave the attenuation control set at *15* and the *SIGNAL-AMP* volume control right where they are. If the right channel crystal has a higher reading than the left channel, the left channel crystal is down. If the reading is the same, you are in business.

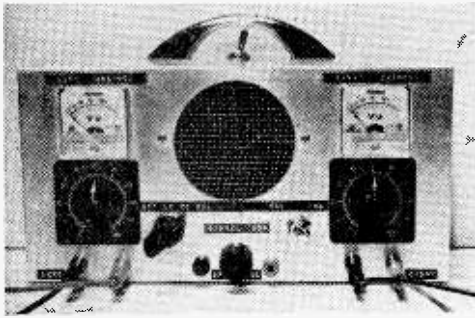

Symmetry of the Stereo Checker front panel contributes to easy and efficient operation.

The crystal cartridge will age with time. If one side has a lower reading than the other, it is defective. Say, for instance, there is a great difference in the two readings. From the low side you will hear distortion. If the music from the right channel is intermittent, the meter reading will be up and down. You can check both channels for balance and also locate the defective crystal. The stereo crystal output should be checked when the phonograph is new and recorded

for reference. Always keep the volume control on the *SIGNAL-AMP* as low as possible when making these tests.

Signal Tracing. The stereo checker can be used to check a weak, dead, or distorted amplifier. Simply set the selector switch to the *OFF* position and use the left channel test leads. This position switches in a coupling condenser when tests are made on circuits with a DC voltage. In checking low voltage transistor amplifiers, leave the selector switch set to *LC*. The right channel can be made for direct reading off plate circuits in high powered amplifiers.

SIGNAL-AMP control R4 will control the picked-up signal. Keep this control as low as possible. When you go through to the final stages the control must be turned way down.

Let's say, for example, we have checked both stereo crystals for gain and find they are good. The signal on the left channel

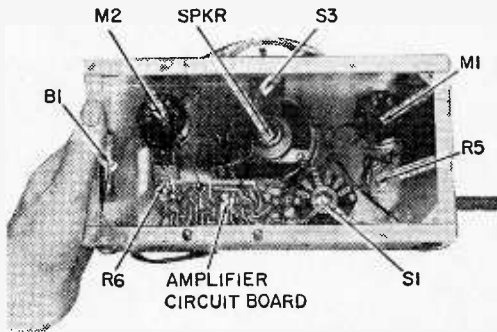

Back panel is removed showing component layout and wiring; and amplifier circuit board.

is very weak. All of the tubes have been checked and any bad ones replaced. Place the 1000-cycle note of the test record on the turntable or hook into the input of a small audio signal generator. Even a small harmonic audio generator can be used for signal tracing.

Use the left channel test leads and set the selector switch to *OFF* position. Now check the signal on the grid and plate of each tube until you find the weak spot. Always keep the volume control as low as possible. You can measure this signal on the meter by switching in the *SIGNAL IND* switch, S3. The *OFF* position of the selector switch is used when high DC voltages are present on the plate of a tube. Use the *LC* position when working on low voltages stages, such as transistor amplifiers. When checking the

(Continued on page 112)



the TRANSIFLASH

by Jim Kyle, K5. KZ

■ A supersensitive transistor switching circuit provides the punch to fire flash bulbs up to a quarter-mile from the camera with the Transiflash. And though results are spectacular, the circuit itself is extremely simple. Only a battery, a capacitor, a resistor, and two transistors are used.

■ **Construction.** A 1½ x 2 inch piece of perforated Bakelite or phenolic board forms the chassis of the Transiflash. A thin piece of plywood, plex plastic, or even heavy drafting cardboard would also serve.

■ Though all parts are mounted by passing their leads through perforations in the board, the 2N307 power transistor requires two extra mounting holes. They are ⅛ inch in diameter, to pass 4-36 by ⅜-inch machine screws.

Location of them is determined by passing the base and emitter terminals through existing perforations and using the transistor itself as a marking template for the extra holes.

■ The collector of the 2N307 is electrically connected to its case, so that the two mounting bolts serve as collector connections. Put a solder lug beneath one of the nuts for making the connections.

■ With the board drilled and the 2N307 in place, mount the 2N404 by passing its leads through three perforations and pulling the transistor up snugly. Be sure that no lead shorts to the metal case of the transistor in this process.

■ The emitter lead of the 2N404 must be insulated with plastic or cambric tubing to prevent its

shorting to the 2N307 collector; all other leads can remain bare.

■ The capacitor and resistor are mounted by passing their leads through appropriate holes as shown in the photos and bending the lead wires over tightly. Make all connections then, and solder.

■ To save both space and money, transistor sockets were omitted. This means that you must use heat sinks or grip the transistor leads between the joint and the transistor with long-nose pliers while soldering, to prevent heat damage. When soldering the 2N404 emitter lead to the 2N307 base, grip the 2N307 base terminal. The 2N404 emitter lead is long enough for safety if you work rapidly.

■ For all joints, a 37½-watt pencil-type iron with small tip is recommended; it is hot enough

SIMPLE TRANSISTOR CIRCUIT POPS OFF LIGHT SOURCES AT ¼ MILE

e/e THE TRANSIFLASH

to allow a quick job, yet small enough to handle easily. Soldering guns can damage transistors.

The battery is both connected to the circuit and held in place by short stiff wires soldered first to the battery terminals and then to the capacitor leads. Since average life of the battery is over two years, no battery holder was felt to be necessary. Leaving the battery off the board makes eventual replacement easier.

With all connections made according to the drawings and the photos, connect flexible wires to the shutter and bulb terminals and you're ready to try it out. Keep in mind that this is a power unit rather than a complete flashgun; the flashbulb wires can either be soldered to the socket of your present flashgun, or run to a connector which fits the plug of your extension flash units.

Of course, final housing and possible mounting of the Transiflash depends on your particular camera, how you plan to use it, and whether you just want a *working studio unit* or a *chic* addition to your equipment. A small aluminum chassis box outfitted with jacks for the shutter and flashbulb leads makes a neat package; neater yet when covered with leather or a simulated leather material to match your camera case.

(Continued on page 105)

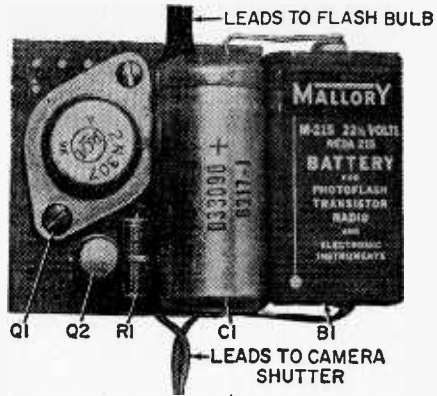

The handful of electronic parts that make up the Transiflash fit neatly on a 1 7/8 x 2-inch phenolic board as shown above. Dry cell battery (below) juts past board and is held in place by its leads. Entire unit can be potted with only the battery outside.

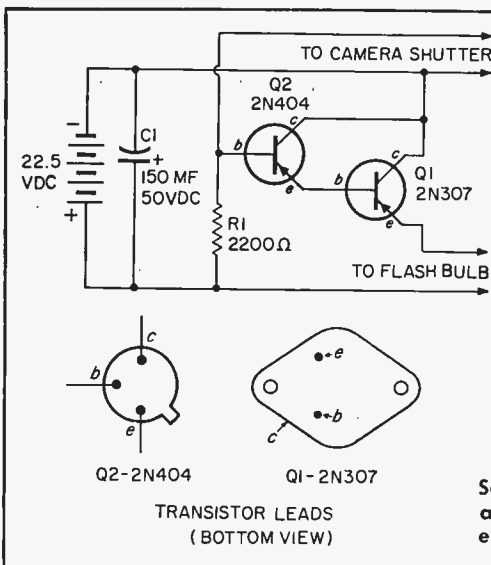
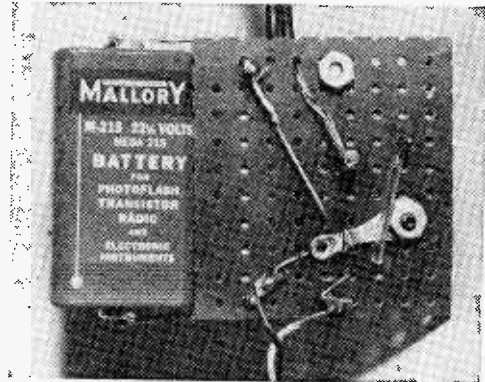

PARTS LIST

- B1—22.5-volt battery (Mallory M-215 or equiv.)
- C1—150mfd., 50vdc midget electrolytic capacitor
- Q1—2N307 medium-speed computer switching transistor
- Q2—2N404 medium-speed computer switching transistor
- R1—2200-ohm, 1-watt resistor
- 1—perforated phenolic board, 1 7/8 x 2 inches
- 1—Chassis box (see text)
- Misc.—Solder lugs; hookup wire; spaghetti; hardware; appropriate plugs, jacks and leads (see text); solder, etc.

Estimated cost: \$4.00

Estimated construction time: 1 1/2 hours

Schematic diagram shows that Q1 carries all of the current through its collector-emitter circuit and Q2 serves to fire Q1.



THE LITTLE BEEPER

BY JAMES A. FRED

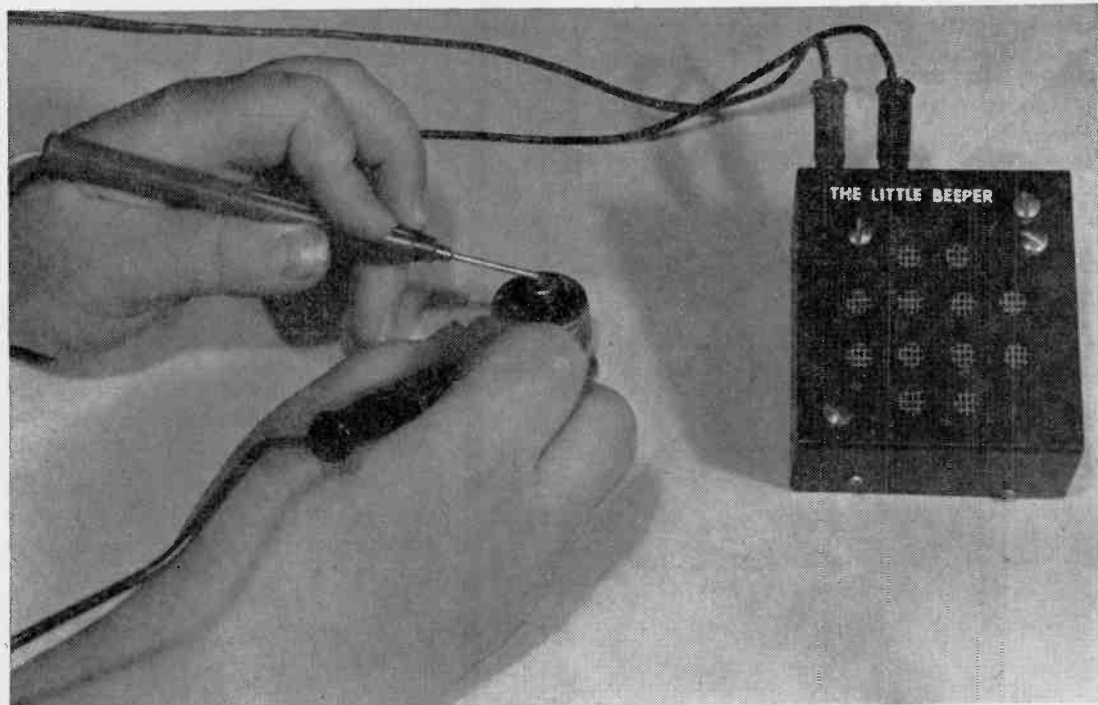

This oscillator voice box says *continuity* or *didahdit*

■ For a project that can be built for such a small cost you will probably never find a more useful or valuable item for your workshop as the Little Beeper. The Beeper is a transistorized continuity checker that is small enough to fit into your shirt pocket. It's only about 2x3x1¼ inches in size. It can also be used as a code practice oscillator, putting out enough volume for a table full of students. In addition it operates on one small 1.5-volt pen cell so that it is perfectly safe for the children to use or play with. The Little Beeper is completely self contained with its own two-inch speaker.

Low Current Draw. There are many advantages to this device, some of which are: low cost, small size, low power, audible instead of visible, and some indication of resistance can be had by the tone generated. No current is drawn from the battery unless the external circuit is closed, thus no on-off switch is needed. The current through the

test leads is only five milliamperes so even the most delicate tube filament will not be harmed. Those of you that build the Little Beeper will probably find many other uses for it.

The unit as shown was made from easily purchased parts except for the case which was made from scrap aluminum. A miniature chassis box can be used to house the unit if you desire. A parts list is included since most of us don't have transistor parts in our junk box.

Construction Details. The two-inch speaker is held in place by solder lugs fastened to the case with 6-32 screws and nuts. The output transformer mounting ears are soldered to the speaker frame. The battery holder is fastened to the case with 2-56 screws and nuts or it could be cemented into place with epoxy cement. The balance of the parts are mounted by their leads to a four-terminal strip before mounting it in the case.



LITTLE BEEPER

Resistor R1 can be a fixed or variable resistor. If a fixed resistor is used it will be necessary to determine its value. The value will depend on the tone desired and the transistor used. A variable resistor is connected into the circuit and adjusted for the desired tone. The variable resistor is then removed and the resistance of its setting carefully measured. The closest standard size is then soldered in place. The main advantage of the variable resistor is that it can be re-adjusted at a later date if any component changes makes it necessary.

The transistor is a *npn* type and almost any one will oscillate. The one shown was

one of four for 79¢ that was purchased from a mail order parts house. The small case is quite full of parts so the placement shown should be followed quite closely. Be careful when soldering the transistor so that heat does not ruin it. Be sure to follow the color coding shown for the transformer leads or the unit may not oscillate.

Put It To Use. After you have finished assembling, wiring, and testing the Little Beeper you are ready to put it to work. Some of the items that you can test for continuity are, fuses, light bulbs, vacuum tubes, electrical appliances and toys. It is perfectly safe for checking anything electrical and for anyone to use. It will also double as a code practice oscillator when it isn't otherwise being used. It will find a place at home or in industry and will fit the corner of a tool box or a shirt pocket. ■

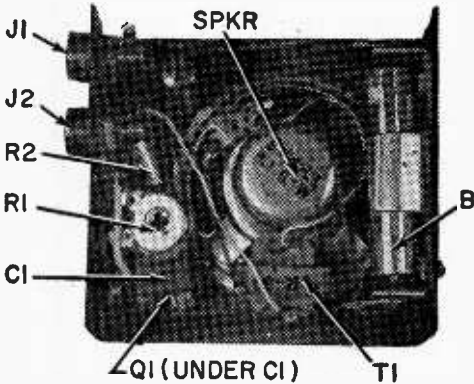

Components of the Beeper will fit into the smallest of chassis to form a compact unit.

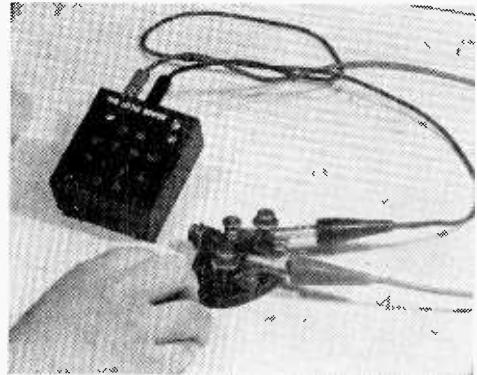

The Beeper is most readily used as a code practice oscillator with addition of a key.

Parts List

- B1—1½-volt pen cell battery (Eveready No. 912 or equiv.)
- C1—.1-mfd., 751 vdc ceramic capacitor
- J1, J2—Red and black nylon tip jacks
- Q1—PNP general purpose germanium transistor
- R1—Variable or fixed resistor, range between 5 and 10,000 ohms (see text)
- R2—470-ohm, ½-watt resistor
- T1—Audio-output transistor transformer; center-tapped, 500-ohm primary, 3.2-ohm secondary
- 1—3- to 8-ohm, 2-inch speaker
- 1—2¼" x 2½" x 1⅞" aluminum chassis box (Premier 1000 or equiv.)
- Misc.—Battery holder, terminal strip, speaker screen or cloth, test leads, hardware, wire, solder, etc.

Estimated cost: \$4.00

Estimated construction time: 2 hours

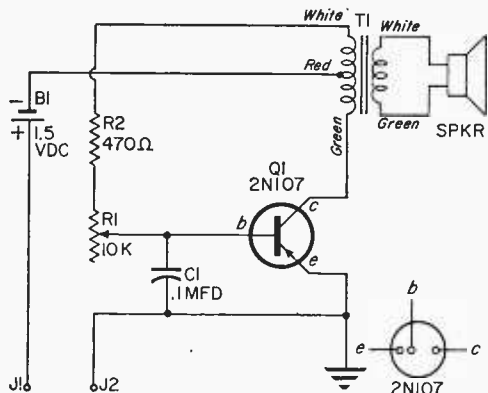

Use of a variable resistor for R1 will allow adjustment of the tone of the Beeper.

ELECTRONIC TEMPERATURE INDICATOR

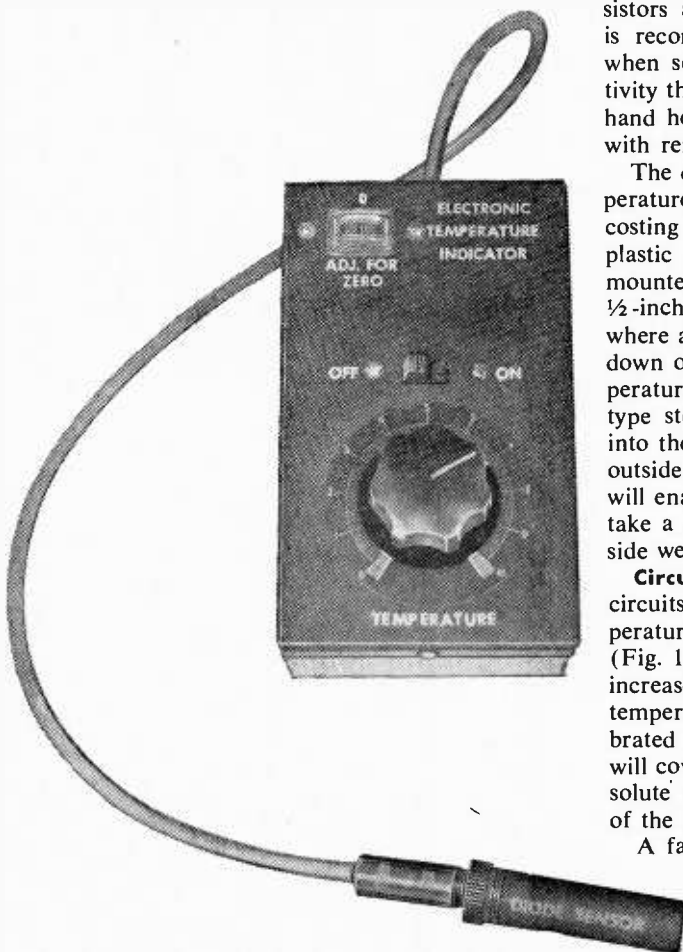

Combination of phone jack and temperature sensitive diode, housed in a small vial, comprises remote sensing element of this easy-to-build, easy-to-use semiconductor thermometer.

There are many ways to measure temperature. Some of these are with thermometers, thermocouple indicators, thermistors, and now temperature sensitive diodes, and transistors. We all know diodes and transistors are temperature sensitive because it is recommended that we use a heat sink when soldering them. It is this heat sensitivity that has led to the design of a portable hand held indicator working in conjunction with remote mounted sensing diodes.

The diodes used with the Electronic Temperature Indicator are quite inexpensive, costing only 50¢ each. They are mounted in plastic vials with a Switchcraft Tini-jax mounted in the end of the vial. The vial is ½-inch in diameter and can be mounted anywhere about the house or can merely be laid down on a chest or desk. For outside temperatures a hole can be bored in a wooden type storm window and the vial cemented into the hole with the diode exposed to the outside temperature while the jack inside will enable you to plug the indicator in and take a reading without exposure to the outside weather.

Circuit Variations. There are several circuits that can be used to measure temperatures with diodes. The simplest type (Fig. 1) is where a decrease in temperature increases the voltage across the diode. The temperature of the diode may then be calibrated as voltmeter readings. This circuit will cover the temperature range of near absolute zero to the upper temperature limit of the diode itself.

A far more practical circuit for our pur-

BY JAMES A. FRED

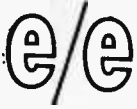

ELECTRONIC TEMPERATURE INDICATOR

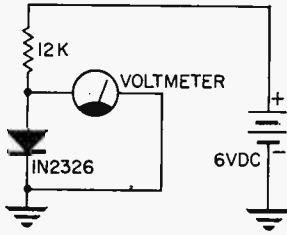

Fig. 1. Simplest circuit for measuring temperature from the voltage across the diode.

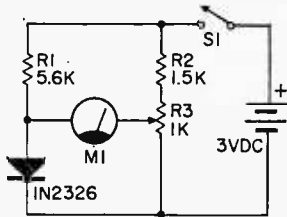

Fig. 2. A better temperature measuring circuit uses the diode in one leg of a bridge.

pose is shown in Fig. 2. This circuit is a bridge circuit with the diode as one leg of the bridge. As the resistance of the diode changes the bridge is brought into balance (zero reading on the microammeter) by a calibrated potentiometer in the other leg of the

the bridge. We can use a calibrated dial on the potentiometer or use a conversion chart to give us the relative temperature. We have chosen the circuit of Fig. 2 for the temperature indicator described here. This device will read the temperature over a range of -25 to 100 degrees Fahrenheit. This is the average temperature range over most of the United States and will allow you to read inside and outside temperatures in winter and summer in and around your home.

If you desire to cover a different temperature range you can experimentally determine new sizes for resistors R2, R3, and R4. The circuit as shown (Fig. 3) uses R4 as a calibration potentiometer that is used initially to set 100 degrees F at the 10 point on the dial. Later on as the battery voltage drops the accuracy of the indicator can be restored by setting the dial to the room temperature, as read on another thermometer, and the meter zeroed by R4. This allows you to reset and recalibrate your instrument with any available thermometer.

Packaging. All the components except the temperature sensitive diode are housed in an aluminum flange-lock box which is 5 1/4 x 3 x 1 1/2 inches in size. The box is just the right size to conveniently hold in your left hand while you zero in the meter with your right. However you may use any type metal box that you desire. (Fig. 4.)

The mercury battery was chosen because of its constant voltage discharge curve. With

PARTS LIST

- B1—1.35-volt battery (Mallory RM4R or equiv.)
- D1—1N2326 germanium compensating diode (Newark Electronics 20F7038)
- J1—2-conductor open circuit jack (Switchcraft type 41 or equiv.)
- M1—Balance and tuning panel meter, $\pm 100\mu\text{a}$ (Lafayette Radio 99G5034)
- P1—Phone plug (Switchcraft type 750 or equiv.)
- R1—2700-ohm, 1/2-watt fixed resistor
- R2—10,000-ohm, 1/2-watt fixed resistor
- R3—1500-ohm potentiometer (Mallory type SU-6 or equiv.)
- R4—500-ohm potentiometer (Mallory UA52L or equiv.)
- S1—S.p.s.t. slide switch (Lafayette 99G6189)
- 1—5 1/4 x 3 x 1 1/2 flange lock chassis box (LMB type 531EL or equiv.)
- Misc.—Battery holder, dial plate, plastic vial, microphone cable, rubber feet, hardware, wire, solder, etc.

Estimated cost: \$6.50

Estimated construction time: 4 hours

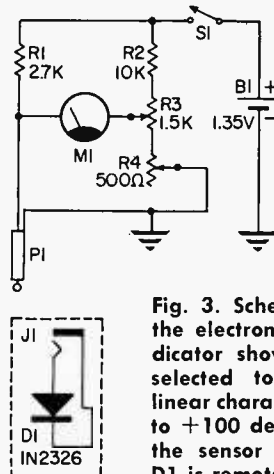

Fig. 3. Schematic diagram of the electronic temperature indicator shows resistor values selected to give essentially linear characteristics from -25 to +100 degrees F. Note that the sensor package, J1 and D1 is remote from chassis box for more versatile application. You can build any number of probes for many varied uses.

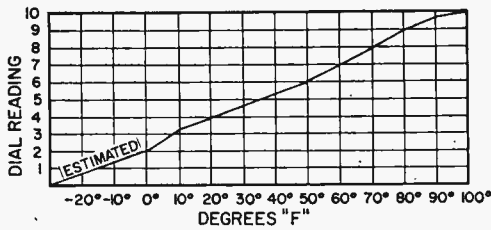

Fig. 5. Calibration curve for electronic temperature indicator is essentially quite linear.

only a few microamperes being drawn from the battery it should last for up to two years. The meter used is a center reading microammeter originally sold for use as an FM tuning meter. The rest of the components are standard and are listed in the parts list.

The temperature probe consists of an RCA diode 1N2326 and a miniature phone jack mounted in a plastic vial. Most drug stores package pills in vials of this type and you can get them there if you haven't any in your junk box. The vials I used were originally used to hold General Electric transistors. Put sleeving over the diode leads and carefully solder the lead near the red dot on the diode to the tip terminal on the jack. Solder the other lead to the ground terminal on the jack. Make a hole in the cover of the vial and fasten the jack inside securely. A metal washer inside the cover may make for a more secure mounting.

The diode floating in the plastic vial will not respond to temperature changes very rapidly. To insure a faster response fill the bottom of the vial with liquid aluminum paste and push the diode into it, but not far enough to cover the leads, because the aluminum will short out the diode terminals.

As mentioned before several probes can be made up and merely left in different places where it is desired to read the temperature. By carrying the temperature indicator in the left hand it can be plugged into the probes and the meter zeroed with the right hand. This will enable the readings to be taken quickly.

Calibration. After the probes and indicator are assembled it is necessary to calibrate the indicator. The easiest way to do this is with a glass of water and a photographic thermometer. Put some hot water into the glass along with the thermometer and a diode probe. Allow several minutes for temperatures to stabilize then drop in enough ice cubes if necessary until the thermometer reads 100 degrees F. Set the dial to 10, turn

on the indicator switch and adjust R4 for zero on the meter. Zero on the meter is in the center of the scale.

Now lower the temperature of the water 10 degrees at a time allowing at least five minutes at each step for the temperature to stabilize. Rezero the meter with the calibrated dial and carefully note the reading. You can use ice cubes to continue lowering the temperature to near 32 degrees. As the water level rises be sure that no water gets into the diode probe. After you reach 32 degrees you can put the thermometer and diode probe into your home freezer or refrigerator freezer compartment. Try to plot points every ten degrees until you reach zero degrees. This is usually as low as a home freezer will go. To reach minus 25 degrees you can extend the graph in a straight line from the last few readings. (Fig. 5.)

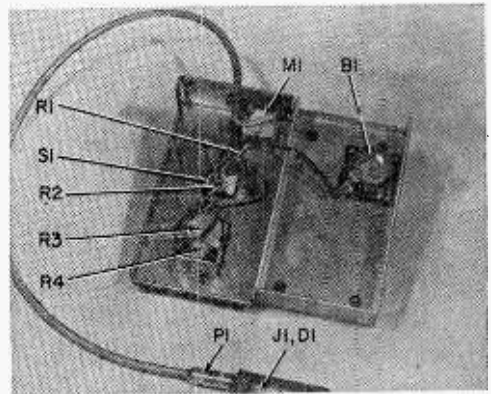

Fig. 4. Small aluminum flange-lock chassis box provides the best portable housing for the unit, and allows a convenient layout.

Of course if you build the temperature indicator in Alaska or in midwinter in the northern part of the United States you could go outside for this calibration. If you do go outside in the extreme cold do not let the battery get too cold as the accuracy of the instrument will be impaired. Once the calibration is finished you can merely make a graph as we have here or you may make a calibrated dial for the potentiometer.

Any time that you want to check your calibration just set the dial to the indicated value for the actual temperature as read on an accurate thermometer. If the meter doesn't read zero just reset R4 until the meter does read zero.

Now just put the indicator to work in any one of many ways. ■

BUILD YOUR OWN BATTERIES

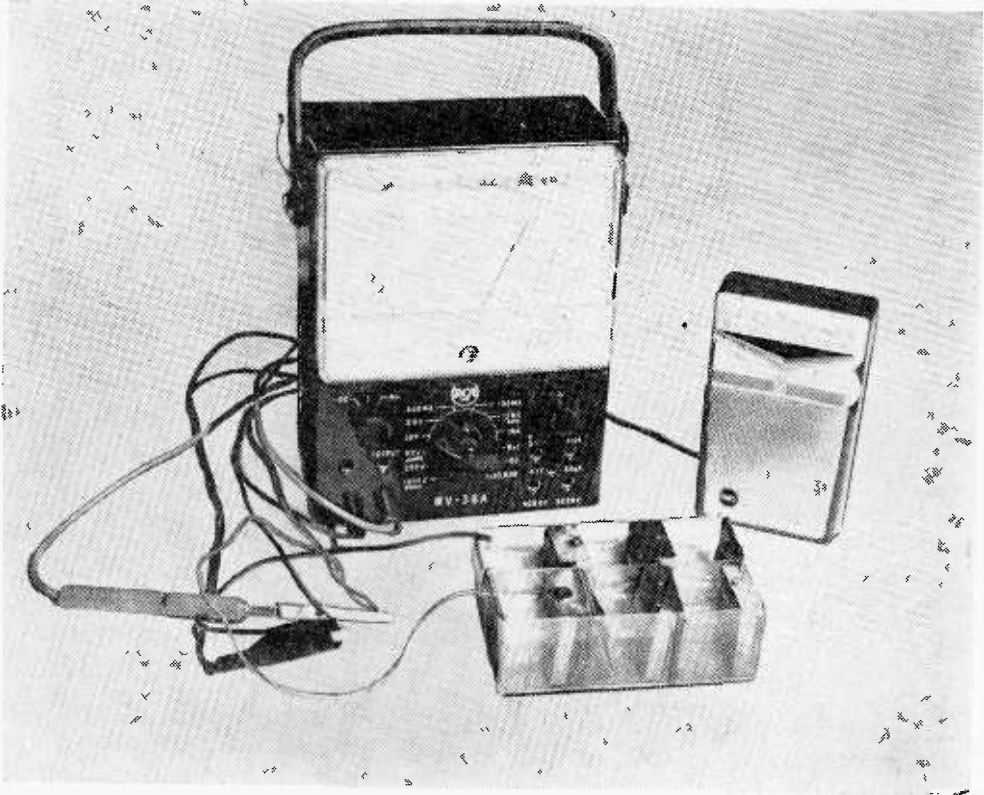

BY MARTIN H. PATRICK

You can have an ever ready voltage supply with just household Clorox and some workshop scraps

■ When Alessandro Volta built the first wet-cell battery sometime around the beginning of the 19th Century, little did he realize what could come out of his first simple experiments. He took two small metal discs, one of copper, the other of zinc and between them he placed a piece of paper soaked in salt water. He found that this unlikely combination would generate a small voltage. He then added many more discs of zinc, copper and salt-water soaked paper and built a battery so powerful that it could deliver an uncomfortable shock. The foot-high pile of

to the zinc in the next) and filled the cups with a dilute acid solution.

You can make your own demonstration version of Volta's *Crown of Cups*, and in fact even use it to operate a transistor radio. You'll need 15 strips of aluminum about 1¼" long and ½" wide. These are fastened with nuts and bolts to a disc of plexiglass about ⅛" thick and 4¼" in diameter. To each strip of aluminum there is attached a 2" length of #12 or #14 copper wire turned into a small circle right over the aluminum as shown. The aluminum and copper are so

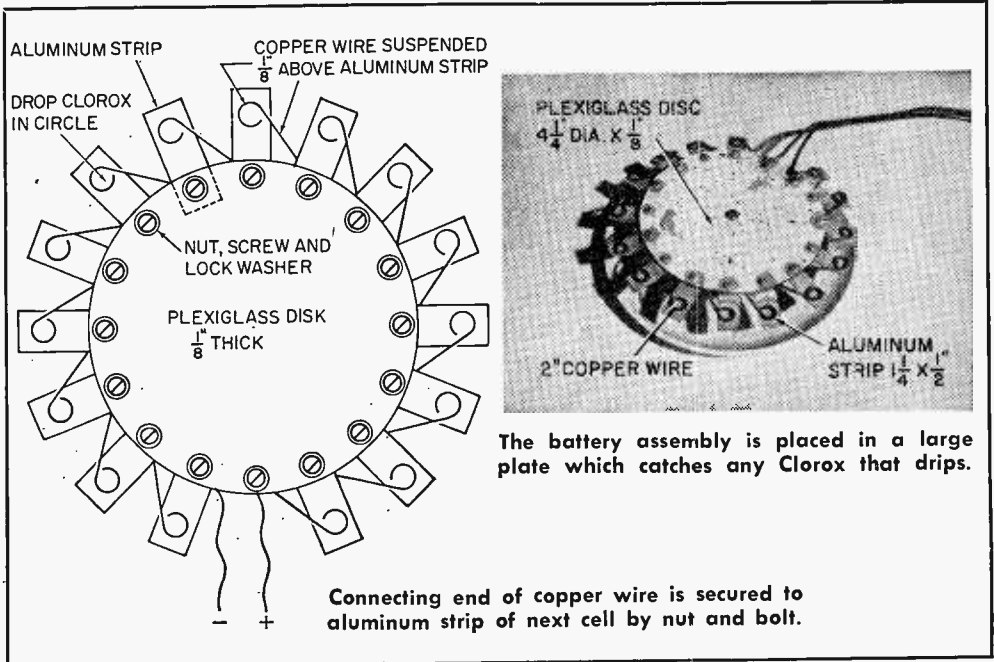

The battery assembly is placed in a large plate which catches any Clorox that drips.

Connecting end of copper wire is secured to aluminum strip of next cell by nut and bolt.

metal and paper that he had built became known as the *Voltic pile*—and as a matter of fact, the electrical term *volt* is derived from Alessandro Volta's name.

You can duplicate Volta's first cell with a penny and a nickel. Simply place a piece of salt-water soaked blotting paper between the two coins. You have made a wet cell—by touching the terminals of a pair of headphones to the nickel and penny you will hear a click caused by the current flow.

Crown of Cups. Volta continued his wet-cell experiments for many years and finally developed his most powerful battery called the "Crown of Cups." The battery had this odd name because of the way it was built. Volta placed pieces of copper and zinc in earthenware cups. He connected the cells in series (the copper in one cup connected

arranged as to form fifteen cells connected in series as shown in detail drawing. Each of the copper circles should be bent to be about ⅛" above the adjacent aluminum strip.

Use Clorox as the electrolyte and in order for the cells to work, there must be no seepage of the electrolyte between the metal strips. You can support the complete battery on a saucer to catch any overflow. Now drop some household Clorox into each copper ring so that it forms a puddle contacting both the copper and aluminum. Use just enough to prevent spilling. Your radio should go on immediately after the last cell receives its electrolyte and should operate for several minutes, before requiring replenishment of the Clorox. One drop of Clorox in each ring at a time should be sufficient. One word of caution—the aluminum and copper elec-

e/e BUILD YOUR BATTERIES

trodes have to be well cleaned with steelwool before they are used. In any case, it may take a little time before each cell reaches its maximum voltage output due primarily to the oxides on the electrodes.

Note that each cell will deliver approximately one volt under no-load conditions; the voltage drops considerably under a load such as a transistor radio. This is the reason that 15 cells must be connected in series to produce the 8 to 9 volts required by the radio.

Go for Power. The battery described above although it works well, is more of a novelty than a practical device. If you wish a veritable power-house, to keep as an emergency battery or perhaps to use to operate your radio around the house, build one in an ice cube tray. It is made of aluminum and copper electrodes installed in a six-section plastic box that can be cut from a plastic ice cube tray. The electrodes are cut to a size suitable for the plastic container. See detail drawing. In general, the larger the sections,

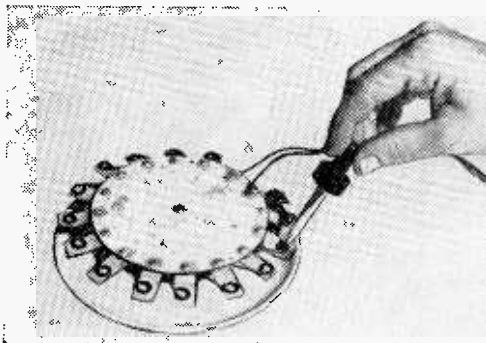

When final cell of battery is filled with electrolyte, 9 volts are ready to be used.

the greater will be the power delivered. Each cell should have only enough Clorox to cover about $\frac{1}{2}$ " of the electrode.

To condition the electrodes, you may short out each cell for a few seconds until a chemical action begins. When functioning properly, the battery should provide enough power to operate your transistor radio for several hours. It may be necessary periodically to lift the electrodes from the Clorox to get rid of the insulating bubbles that form as a result of the chemical action. When the battery power wears down, you need only to refill

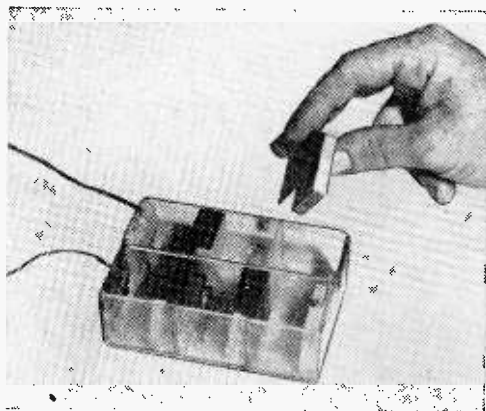

Heavy-duty, home-brew battery uses heavy plates that straddle the tray compartments.

each cell with fresh Clorox. If you use heavy-aluminum electrodes, your battery should last a long time. Since its power comes mostly from the chemical action wearing away the aluminum.

If you wish to save the battery for emergency use, be sure to clean the electrodes thoroughly before you store it away. When you are ready to use the battery, you need only to fill the cells with Clorox, and you have a ready battery. The storage time, or shelf life, will have no effect on the battery. A pint of Clorox should give you many hours of radio operation.

Avoid breathing the fumes generated by the battery and remember that Clorox will bleach most fabrics; so avoid spilling any on your clothing. ■

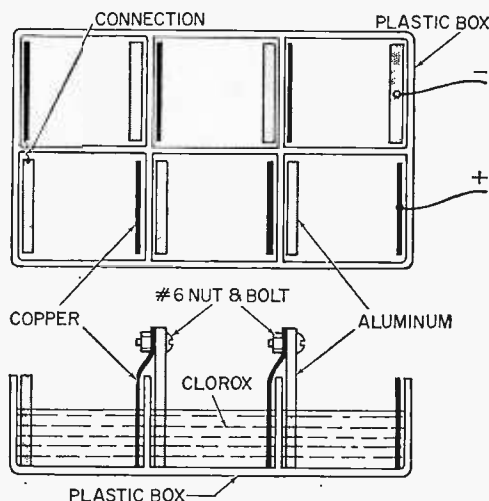

Detail of plastic-tray battery shows relative thickness of Cu and Al electrodes.

FM and TV SOUND EAVESDROPPER

By Art Trauffer

This simple and easily built receiver will let you listen to a near-by FM broadcast station, or to the sound channel of local TV stations. Being a simple crystal receiver with a loop antenna, this little receiver doesn't have the sensitivity and selectivity of multi-tube outfits, but it's fine for those who live close to an FM transmitter tower. Considering the large number of FM and TV stations in operation there ought to be plenty of experimenters living close to stations.

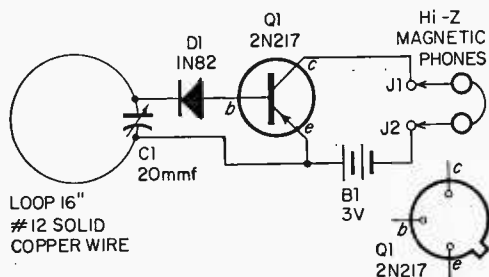

Schematic diagram shows how to interconnect the eavesdropper and serves as parts list.

Construction. The photos and schematic diagram show the simple construction and wiring. The loop, bent from a 16-inch length of #12 solid copper wire, is soldered directly to the rotor and stator lugs on a 20 mmf. midget variable capacitor. The 1N82 silicon diode and the 2N217 transistor are supported by their own leads. The diode lead to the variable capacitor should be short. Use a pair of long-nose pliers as a heat sink when soldering the diode and transistor leads. No battery switch is used—the circuit is opened by pulling out one of the phone cord tips when the receiver is not in use. A 1N34A germanium diode could be used instead of the 1N82, and any good *pnp* audio transistor could be used instead of the 2N217. If you use a *nnp* transistor reverse the battery polarity. You can try reversing the diode polarity to see which way gives best results

in your case. This receiver covers the FM broadcast band, but for picking up some of the lower frequency, and higher frequency, TV transmitters, you will have to use a larger or smaller loop.

Use a good pair of high-impedance magnetic earphones. You will find that volume (and sometimes fidelity) will vary when the receiver is placed in various positions and in different places in the room. For additional pickup, clip a three-foot length of wire onto the loop at the place where it gives best results. This pickup wire should be horizontal, and it is also directional. Experiment with different positions for best results. ■

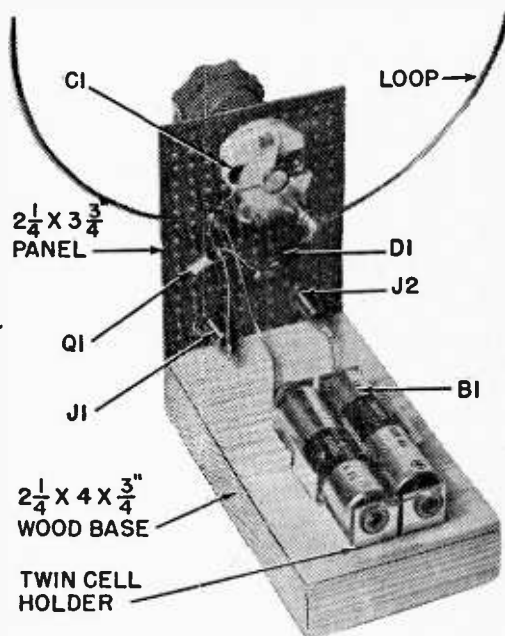

To keep construction costs down wood-block base and Bakelite front panel are used—great for RF insulation. Be ultra neat when wiring the unit to avoid losing any signal strength. Completed unit may be housed in a non-metallic (wood or plastic) case.

Noise Limiters

Continued from page 86

more-than-a-decade since its introduction.

This more complex circuit is the *Twin Noise Squelch* or TNS, first described in an amateur radio magazine in 1953. This device, the invention of Wil M. Scherer, W2AEF, combines both an efficient noise limiter and a squelch circuit. It has been marketed under many names, including *Noistop*, *Squelcher*, *Noise Filter*, and, of course, *TNS*. The circuit is shown complete in Fig. 13 and in simplified form in Fig. 14. Here's how it works.

An incoming signal develops voltage, both DC and audio, across the series resistor string made up of R1, R2, and R3. About 55 percent of this voltage is applied to the grid of V2A, while about 10 percent goes to the grid of V2B.

This difference in DC level between the voltages applied to the two grids causes an amplified difference in DC voltage at the plates of V2A and V2B. V2B's plate will be less positive than that of V2A.

The plate of V2B is connected directly to the cathode of V1A, while the plate of V1A

is connected to the cathode of V1B. The plate of V2A is connected to the plate of V1B through resistor R6.

Since V2A's plate is more positive than that of V2B, the voltage differences produce forward-bias conditions for both halves of V1. This allows the passage of audio signals.

The audio signals, like the DC voltage for control, come from the R1-R2-R3 string. However, C2 is connected from the plate of V2A to ground and effectively bypasses all audio at this point. As a result, the only audio signal which gets through is that from V2B. It passes from V2B's plate to V1A, through V1A so long as the diode is *on*, and out through C4.

When a noise pulse arrives, the voltage at the plate of V2A is held steady by C2. However, the voltage at the plate of V2B goes sharply negative because of the pulse. This cuts off both V1A and V1B, blocking passage of the pulse to the output. In addition, the full value of the pulse goes through C1 and R4 to the plate of V1B. This helps cancel out all traces of the stump left by clipping action in V1A.

Thus, as long as a signal is present, the circuit clips out any noise pulses, removes the stumps left by clipping, and lets the audio on through to be heard. When the signal

Fig. 13. Schematic diagram of the twin noise squelch circuit (TNS). It combines full-wave automatic noise limiting with efficient squelch action. To install the circuit in your receiver, wire as shown and remove the old diode load resistor from receiver as indicated.

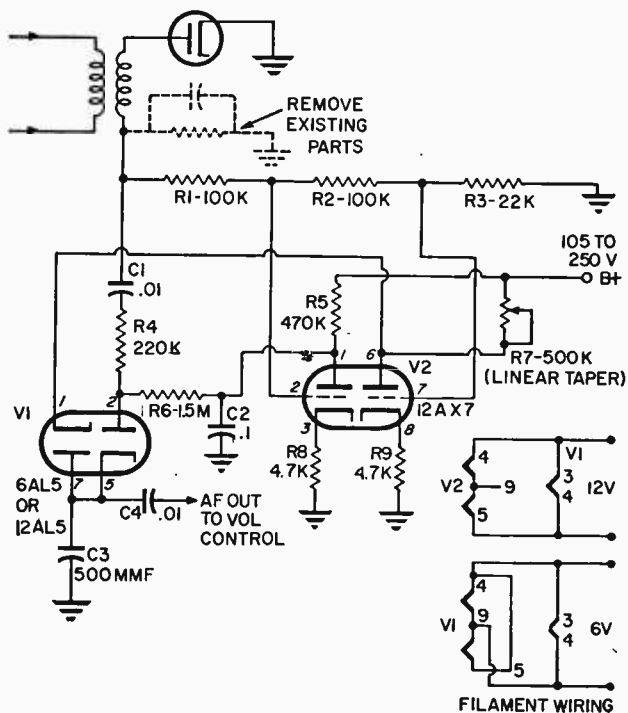

stops, no voltage appears across R1, R2, and R3. This puts the grids of V2A and V2B both at ground potential and removes the differences in plate voltage.

With no difference in voltage between the plate of V2A and that of V2B, there's nothing present to turn the two halves of V1 on. This means that no audio can get through. In practice, squelch control R7 is set so that in the absence of incoming signals, the plate of V2B is slightly more positive than that of V2A. V1 is definitely turned off as a result.

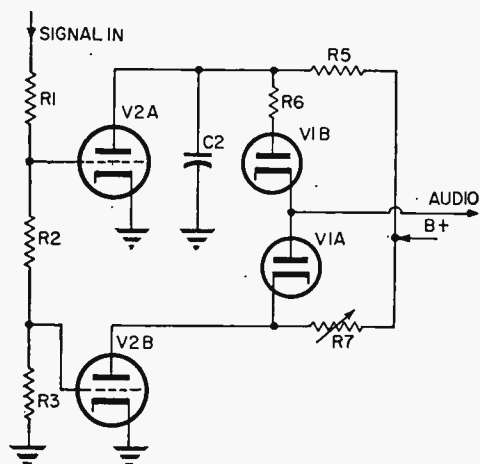

Fig. 14. Operation of TNS circuit is easier to understand with the simplified schematic that omits all components except those that are essential to the operation of the circuit.

The improved performance of the TNS, as compared to the standard series limiter, is due primarily to the amplification of control voltage made possible by use of two tubes. The cancellation of the stump, also, contributes greatly.

Squelch control R7 can be set so that signals must exceed a certain strength to *open the squelch*, without changing the clipping action for noise pulses. However, if R7 is set to its extremes, distortion may result. With proper setting of the control, the distortion contributed by the TNS is not measurable. This makes this circuit ideal for broadcast listening as well as for communications.

Adding A Limiter. For rapid and inexpensive addition of a noise limiter to an existing receiver without such a circuit, the arrangement shown in Fig. 15 probably cannot be surpassed. While its performance is not up to that of more complex circuits, it's hard to equal with any other three parts cost-

ing less than a dollar!

This is a shunt limiter circuit, using the diode, D1, as a parallel switch. The diode conducts until capacitor C1 charges to the average voltage set by the signal level. When C1 reaches this level, diode D1 moves into the transition region because the voltage difference across it is so minute. In this region, diode resistance is high although not high enough to be called an open circuit. The high resistance of diode D1 combines with the 10,000-ohm resistor, R1, to form a voltage divider, but normal audio signals pass through with very little loss.

A noise pulse turns diode D1 on, and low resistance of the diode together with the series resistance of the resistor combine to trim the noise to a very low value. As soon as the pulse passes, diode D1 moves back to transition region and normal operation resumes.

This circuit is particularly good for use with war-surplus command set receivers. This is because they are so cramped for room inside that no extensive modifications may be made unless additional chassis are

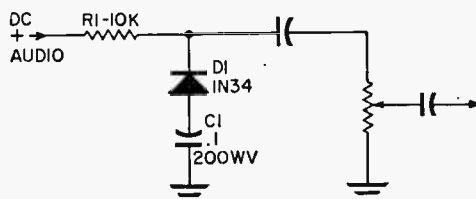

Fig. 15. The simplest ANL circuit of all is this shunt-switch circuit which requires only three parts and gives marked improvement in performance over sets without the noise limiter; it is not the best, but it's economical.

hung on the outsides of the units. But there is plenty of room for the three components of this hookup.

While many types of noise limiters not discussed here do exist, the principles set forth in this article apply to all. The other types are concerned mainly with removing the stumps left by clipped noise peaks, and with reducing audio loss and distortion which can result with the basic limiter circuits.

However, if you keep in mind the basic switching function of the limiter and the workings of the electronic switch, you shouldn't have trouble figuring out how even the most exotic ANL circuits work. And with any of them added to your receiver, you should never again completely miss a message because of excess ignition noise. ■

Thermostat Relays

Continued from page 48

could conjure up simple crystal ovens. See Fig. 5. For a fire-alarm signal system, all thermostats may be placed in parallel across a single alarm-bell buss or each can be con-

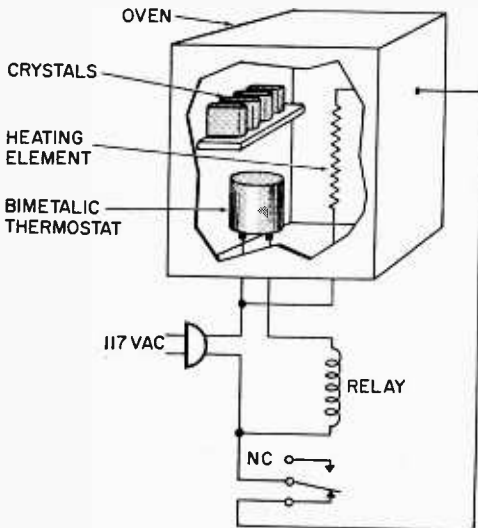

Fig. 5. A ham's crystal oven can be fabricated using starter as sensing element.

nected separately to an annunciator to show the location of the overheated condition. For automatic control of motors to open and close the window of a cold frame, two separate thermostats—one for the hot and one for the cold limit—are commonly used. ■



"Yeah, but we also have the clearest picture on the block!"

Ask Me Another

Continued from page 7

Since the amplifier may not have enough gain for a crystal, dynamic or ceramic microphone, you can use a carbon microphone as shown in the diagram. Install a d.p.d.t. toggle switch, S1, on the chassis or the set's rear cover. Mount microphone transformer T1, such as a Stancor A4705 on the chassis or rear cover, grounding transformer frame to chassis. Also install a battery holder (Lafayette 34G5005) on rear cover and slip a 1.5-volt battery (Burgess Z, Eveready 915, etc.) in the holder. Disconnect the "hot" volume control lead as indicated by "X" in the diagram. Wire the new parts into the circuit as shown, using the shortest possible leads (except microphone cord). Capacitor C1 may be an 0.01 mfd tubular.

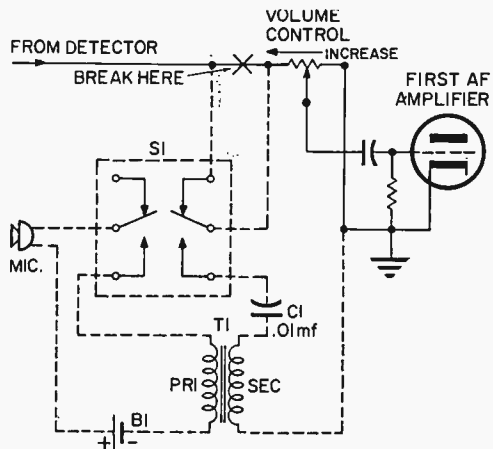

Throw the switch one way for normal radio reception, the other way to use the mike. The volume control works for both. If there isn't enough mike volume add more batteries. Using a telephone type carbon mike, you should get lots of sound.

An alternative is to use a Philmore Junior Microphone (Cat. No. 500) which can be connected directly to the plate and cathode prongs of the first AF amplifier tube by means of clips furnished with the mike. These are sold in many radio parts stores. Still another, and the safest way is to get a wireless broadcaster (Knight, Lafayette, etc.) which does not have to be connected to the set and does away with the shock hazard. ■

The Transiflash

Continued from page 92

The Circuit. Operation of the Transiflash depends on a phenomenon called *current multiplication*. This means that when a transistor is properly connected, the current in its emitter circuit is a multiple of that in the base; and if emitter current is limited, then the base current will be limited to only a fraction of that actually available.

In the Transiflash circuit, no current can flow from the capacitor or battery to bulb until the shutter contacts close, because of the high resistance of the 2N307 transistor.

When the contacts close, current passes into the 2N404 base circuit, and a larger current flows from the 2N404 emitter into the 2N307 base. This, in turn, saturates the 2N307, dumping the entire capacitor charge through it into the flash bulb.

But because of current multiplication, the current through the camera contacts is limited to only about $\frac{1}{1000}$ of that flowing through the bulb.

A dramatic demonstration of the minute amount of current required to fire the bulb is witnessed by touching the two shutter wires to the tip of your tongue. The bulb will fire—and you won't feel a thing. Don't try this with a conventional flashgun; the current jolt from an ordinary B-C flash will leave your tongue sore for hours!

Photographic Versatility. Since the capacitor stores up quite a jolt of energy, all of which dumps through the bulb, you can use extremely long wires from the Transiflash to the bulb. It has fired with the equivalent of 2400 feet of No. 18 wire in series with the bulb, which means the bulb could be a quarter-mile away (since *two* wires connect to the bulb, the bulb-to-Transiflash distance can be only half that of the total wire length). It can also fire 8 or more bulbs at one time, if all are connected in series so that the current jolt goes through them all.

Why bother with all this to fire a flashbulb? The popular B-C flash unit also charges up a capacitor to fire the bulb, but all the firing current (as much as 10 amps) must go through the delicate contacts inside your camera's shutter. With the Transiflash, only about $\frac{1}{1000}$ of the firing current must pass through the shutter. This means longer life for the camera, and more assurance for you, in your flash photos. ■

Resonance

Continued from page 38

onant circuits tuned to widely different frequencies can have, together, a third frequency of resonance, at which the capacitance left over from the higher-frequency circuit cancels with the inductance left over from the lower-frequency one.

The two resonant frequencies do not even have to be widely separated for this to happen. Its most common use is in "band-pass" circuitry, where it allows a more uniform response across a band than would simple single-resonant circuitry.

A more useful example of multiple resonance is the device known to hams as a "multiband tuner" which consists of two tunable resonant circuits in series with each other, as shown in Fig. 17.

In this case, for any single shaft position of the variable capacitor, one of the circuits is resonant at one frequency while the other is resonant at a different spot. So far as the higher-frequency circuit is concerned, the lower-frequency one is simply a small RF choke, while to the low-frequency circuit, the higher-frequency one looks like a bypass capacitor. These circuits respond to both frequencies equally well.

Summing Up. Now that you've come all this way through the not-too-simple subject of resonance, its hows, and its whys, it's time to sum it all up: With AC, phase is the equivalent of DC polarity. Capacitors and inductors in an AC line introduce 90-degree phase shifts between the voltage and the current, and in so doing limit the possible current flow. This limitation of current flow by 90-degree phase shift is called reactance. When both inductance and capacitance are present in the circuit and their reactances are equal at one frequency, the circuit is said to be resonant at that frequency.

At resonance, a large current flows *through* a series circuit, or circulates *around* a parallel circuit.

The voltage-multiplication effect is called the quality factor, or *Q*, of the circuit. The higher the *Q*, the more effective the circuit, in most cases.

Resonant circuits are used in all types of radio, both to select the desired signals from the larger number of signals on the air, and to reject undesired signals. It's possible to have multiple resonances. ■

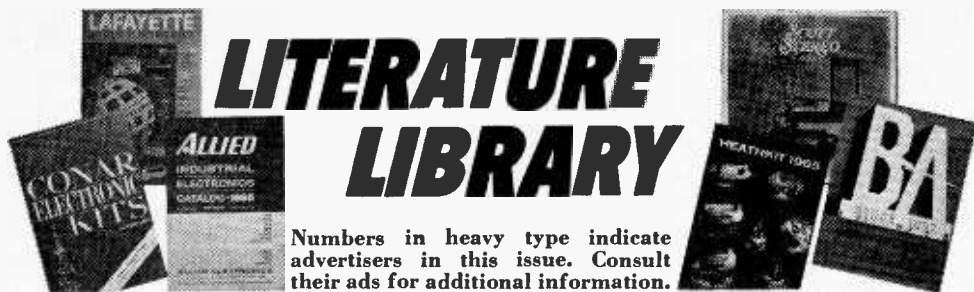

LITERATURE LIBRARY

Numbers in heavy type indicate advertisers in this issue. Consult their ads for additional information.

ELECTRONIC PARTS

1. This catalog is so widely used as a reference book, that it's regarded as a standard by people in the electronics industry. Don't you have the latest *Allied Radio* catalog? The surprising thing is that it's free!

2. The new 516-page 1965 edition of *Lafayette Radio's* multi-colored catalog is a perfect buyer's guide for hi-fiers, experimenters, kit builders, CB'ers and hams. Get your free copy, today!

3. *Progressive "Edu-Kits" Inc.* now has available their new 1965 catalog featuring hi-fi, CB, Amateur, test equipment in kit and wired form. Also lists books, parts, tools, etc.

4. We'll exert our influence to get you on the *Olson* mailing list. This catalog comes out regularly with lots of new and surplus items. If you find your name hidden in the pages, you win \$5 in free merchandise!

5. Unusual scientific, optical and mathematical values. That's what *Edmund Scientific* has. War surplus equipment as well as many other hard-to-get items are included in this new 148-page catalog.

6. Bargains galore, that's what's in store! *Poly-Paks Co.* will send you their latest eight-page flyer listing the latest in merchandise available, including a giant \$1 special sale.

7. Whether you buy surplus or new, you will be interested in *Fair Radio Sales Co.'s* latest catalog—chuck full of buys for every experimenter.

8. Want a colorful catalog of goodies? *John Meshna, Jr.* has one that covers everything from assemblies to zener diodes. Listed are government surplus radio, radar, parts, etc. All at unbelievable prices.

9. Are you still paying drugstore prices for tubes? *Nationwide Tube Co.* will send you their special bargain list of tubes. This will make you light up!

10. *Burstein-Applebee* offers a new giant catalog containing 100's of big pages crammed with savings including hundreds of bargains on hi-fi kits, power tools, tubes, and parts.

11. Now available from *EDI (Electronic Distributors, Inc.)* a catalog containing hundreds of electronic items. *EDI* will be happy to place you on their mailing list.

12. VHF listeners will want the latest catalog from *Kuhn Electronics*. All types and forms of complete receivers and converters.

23. No electronics bargain hunter should be caught without the latest copy of *Radio Shack's* catalog. Some equipment and kit offers are so low, they look like mis-prints. Buying is believing.

25. Unusual surplus and new equipment/parts are priced "way down" in a 32-page flyer from *Edlie Electronics*. Get one.

75. *Transistors Unlimited* has a brand new catalog listing hundreds of parts at exceptionally low prices. Don't miss these bargains!

HI-FI/AUDIO

13. Here's a beautifully presented brochure from *Altec Lansing Corp.* Studio-type mikes, two-way speaker components and other hi-fi products.

15. A name well-known in audio circles is *Acoustic Research*. Here's its booklet on the famous AR speakers and the new AR turntable.

16. *Garrard* has prepared a 32-page booklet on its full line of automatic turntables including the Lab 80, the first automatic transcription turntable. Accessories are detailed too.

17. Two brand new full-color booklets are being offered by *Electro-Voice, Inc.* that every audiophile should read. They are: "Guide to Outdoor High Fidelity" and "Guide to Compact Loudspeaker Systems."

19. A valuable 8-page brochure from *Empire Scientific Corp.* describes technical features of their record playback equipment. Also included are sections on basic facts and stereo record library.

20. Tape recorder heads wear out. After all, the head of a tape deck is like the stylus of a phonograph, and *Robins Industries* has a booklet showing exact replacements. Lots of good info on how the things are built, too.

22. A wide variety of loudspeakers and enclosures from *Utah Electronics* lists sizes shapes and prices. All types are covered in this heavily illustrated brochure.

24. Here's a complete catalog of high-styled speaker enclosures and loudspeaker components. *University* is one of the pioneers in the field that keeps things up to date.

26. When a manufacturer of high-quality high fidelity equipment produces a line of kits, you can just bet that they're going to be of the same high quality! *H. H. Scott, Inc.*, has a catalog showing you the full-color, behind-the-panel story.

27. An assortment of high fidelity components and cabinets are described in the *Sherwood* brochure. The cabinets can almost be designed to your requirements, as they use modules.

28. Very pretty, very efficient, that's the word for the new *Betacom* intercom. It's ideal for stores, offices, or just for use in the home, where it doubles as a baby-sitter.

30. Tone-arms, cartridges, hi-fi, and stereo preamps and replacement tape heads and conversions are listed in a complete *Shure Bros.* catalog.

TAPE RECORDERS AND TAPE

31. "All the Facts" about *Concord Electronics Corporation* tape recorders are yours for the asking in a free booklet. Portable battery operated to four-track, fully transistorized stereos cover every recording need.

32. "The Care and Feeding of Tape Recorders" is the title of a booklet that *Sarkes-Tarzian* will send you. It's 16-pages jam-packed with info for the home recording enthusiast. Includes a valuable table of recording times for various tapes.

33. Become the first to learn about *Norelco's* complete Carry-Corder 150 portable tape recorder outfit. Four-color booklet describes this new cartridge-tape unit.

34. The 1964 line of *Sony* tape recorders, microphones and accessories is illustrated in a new 16-page full color booklet just released by *Superscope, Inc.*, exclusive U.S. distributor.

35. If you are a serious tape audiophile, you will be interested in the new *Viking of Minneapolis* line—they carry both reel and cartridge recorders you should know about.

HI-FI ACCESSORIES

76. A new voice-activated tape recorder switch is now available from *Kinematix*. Send for information on this and other exciting products.

39. A 12-page catalog describing the audio accessories that make hi-fi living a bit easier is yours from *Switchcraft, Inc.* The cables, mike mixers, and junctions are essentials!

KITS

41. Here's a firm that makes everything from TV kits to a complete line of test equipment. *Conar* would like to send you their latest catalog—just ask for it.

42. Here's a 100-page catalog of a wide assortment of kits. They're high-styled, highly-versatile, and *Heath Co.* will happily add your name to the mailing list.

43. Want to learn about computers the easy way? Brochure from *Digication Electronics* describes its line of transistorized kits.

44. A new short-form catalog (pocket size) is yours for the asking from *EICO*. Includes hi-fi, test gear, CB rigs and amateur equipment—many kits are solid-state projects.

AMATEUR RADIO

45. Catering to hams for 29 years, *World Radio Laboratories* has a new FREE 1965 catalog which includes all products deserving space in any ham shack. Quarterly fliers, chock-full of electronic bargains are also available.

46. A long-time builder of ham equipment, *Hallcrafters, Inc.* will happily send you lots of info on the ham, CB and commercial radio-equipment.

CITIZENS BAND SHORT-WAVE RADIO

48. *Hy-Gain's* new 16-page CB antenna catalog is packed full of useful information and product data that every CB'er should know about. Get a copy.

49. Want to see the latest in communication receivers? *National Radio Co.* puts out a line of mighty fine ones and their catalog will tell you all about them.

50. Are you getting all you can from your Citizens Band radio equipment? *Cadre Industries* has a booklet that answers lots of the questions you may have.

52. If you're a bug on CB communications or like to listen in on VHF police, fire, emergency bands, then *Regency Electronics* would like to send you their latest specs on their receivers.

53. When private citizens group together for the mutual good, something big happens. *Hallcrafters, Inc.* is backing the CB React teams and if you're interested in CB, circle #53.

54. A catalog for CB'ers, hams and experimenters, with outstanding values. Terrific buys on antennas, mikes and accessories. Just circle #54 to get *Grove Electronics* free 1964 Catalog of Values.

55. Interested in CB or business-band radio? Then you will be interested in the catalogs and literature *Mosley Electronics* has to offer.

Also see Item 46.

SCHOOLS AND EDUCATIONAL

56. *Bailey Institute of Technology* offers courses in electronics, basic electricity and drafting as well as re-education. More information in their informative pamphlet.

57. *National Radio Institute*, a pioneer in home-study technical training, has a new book describing your opportunities in all branches of electronics. Unique training methods make learning as close to being fun as any school can make it.

68. Would you like to learn all about television servicing quickly at home? *Coyne Electronics Institute* would like to show you how easy it is, and at a low cost, too.

59. For a complete rundown on curriculum, lesson outlines, and full details from a leading electronic school, ask for this brochure from the *Indiana Home Study Institute*.

60. Facts on accredited curriculum in E. E. Technology is available from *Central Technical Institute* plus a 64-page catalog on modern practical electronics.

61. *ICS (International Correspondence Schools)* offers 236 courses including many in the fields of radio, TV, and electronics. Send for free booklet "It's Your Future."

ELECTRONIC PRODUCTS

62. Information on a new lab transistor kit is yours for the asking from *Arkay International*. Educational kit makes 20 projects.

64. If you can use 117-volts, 60-cycle power where no power is available, the *Terado Corp.* Trav-Electric 50-160 is for you. Specifications are for the asking.

66. Try instant lettering to mark control panels and component parts. *Datak's* booklets and sample show this easy dry transfer method.

77. Government surplus nickel cadmium cells can be yours at a fraction of original cost! Send for *Esse Radio's* 3-page flyer.

67. Get the most measurement value per dollar." That's what *Electronic Measurements Corp.* says. Looking through the catalogue they send out, they very well might be right!

TELEVISION

70. The first entry into the color-TV market in kit form comes from the *Heath Company*. A do-it-yourself money saver that all TV watchers should know about.

73. Attention, TV servicemen! *Barry Electronics* "Green Sheet" lists many TV tube, parts, and equipment buys worth while examining. Good values, sensible prices.

72. Get your 1964 catalog of *Cisin's* TV, radio, and hi-fi service books. Bonus—TV tube substitution guide and trouble-chaser chart is yours for the asking.

SLIDE RULE

74. Get your copy of *CIE's (Cleveland Institute of Electronics)* 2-color data sheet on their electronics slide rule and information on their free "Auto-Programmed" 4-lesson instruction course.

TOOLS

78. Do more jobs with fewer tools. *Xcelite* bulletin N563 describes double-duty midget-nut and screwdriver sets that have power and reach of standard drivers.

Elementary Electronics, Dept. LL-751
505 Park Avenue, New York, N. Y. 10022

Please arrange to have the literature whose numbers I have encircled sent to me as soon as possible. I am enclosing 25¢ (no stamps) to cover handling charges.

I am a subscriber

Indicate total number of booklets requested



	1	2	3	4	5	6	7	8	9	10	11	12	13
14	15	16	17	18	19	20	21	22	23	24	25	26	
27	28	29	30	31	32	33	34	35	36	37	38	39	
40	41	42	43	44	45	46	47	48	49	50	51	52	
53	54	55	56	57	58	59	60	61	62	63	64	65	
66	67	68	69	70	71	72	73	74	75	76	77	78	

NAME (Print clearly) _____

ADDRESS _____

CITY _____ STATE _____ ZIP CODE _____

How SCR's Work

Continued from page 46

the final results. Gate current (as indicated by E2) increases as the applied gate voltage is increased. There is no flow of anode current (as indicated by E3), however, until the gate firing voltage is reached, at which time anode current quickly reaches and remains at its maximum value. The *measured* DC voltage across R4 (E3) when the SCR is conducting will be considerably less than the applied AC voltage, for the meter indicates only the average value of a half-wave rectified pulse.

The last measurement (when the gate voltage is returned to zero) is of particular interest. Compare these measurements with those obtained in Experiment 5 (Table E) where a DC power source was used for the anode-cathode circuit. In the earlier experiment, the gate lost control and anode current remained at its maximum value. In this experiment, on the other hand, the anode current dropped to zero.

EXPERIMENT 10:

Assembling a "Universal" Motor Speed Control for small power tools.

Having learned that an SCR's gate voltage (and current) is one of the most important factors in establishing its operating characteristics, and that the device may be operated on an AC power source, we can take

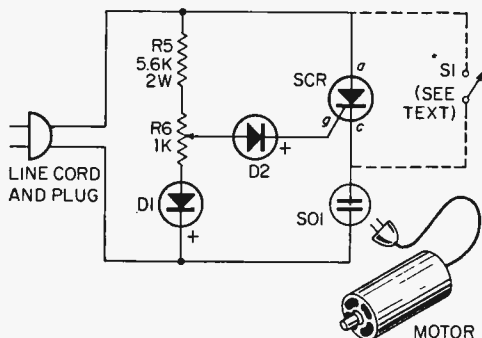

Fig. 11. Schematic diagram of practical circuit for controlling speed of small motors.

the next step—that of controlling the line power supplied to a practical load. A simple, but effective, speed control circuit suitable for use with "universal" (AC/DC) electric motors is shown in Fig. 11, while a wired

breadboard version of the control is illustrated in Fig 12. Universal motors are found in many small power tools (typically, electric drills, see Fig. 13) and in a number of home appliances.

Referring to Fig. 11, the SCR is connected in series with the external load through receptacle socket SO1. A pulsating DC voltage is obtained by means of diode D1, voltage dropping resistor R5 and control potentiometer R6, and is applied to the SCR's gate electrode through diode D2. In operation, the SCR can conduct only during positive half-cycles of the applied line voltage,

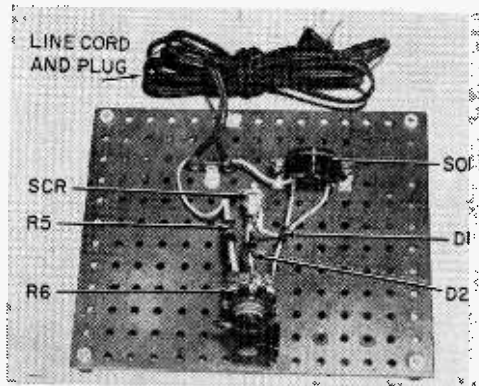

Fig. 12. Breadboarded motor speed control is initially set up for experimental use.

provided an adequate gate voltage is applied *at the same time*. Potentiometer R6 permits the amplitude of the gate voltage to be varied, changing the point at which the SCR "fires" and hence the period within each half cycle during which conduction can take place. This, in turn, varies the power delivered to the load.

Any of several construction techniques may be used for circuit assembly. Breadboard construction, as illustrated in Figs. 12 and 13, is preferred for experimental tests, but a more permanent type of assembly may be used if desired. The entire circuit may be wired in a small metal case or standard *Minibox*, provided an *insulated* finned heat sink measuring at least 3" square is provided for the SCR. In addition, a 3 ampere line fuse should be connected in series with one side of the power line and a SPST switch should be connected across the SCR (S1, as shown dotted in Fig. 11); the switch may be closed to short the SCR and apply *full power* to the load when needed.

The basic circuit may be used not only as a speed control for small motors but as an

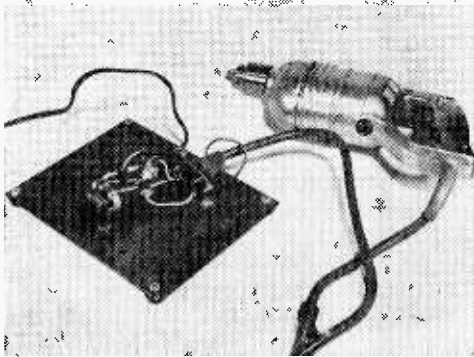

Fig. 13. Make motor speed control permanent part of shop by enclosing (see text).

electronic dimmer for incandescent lamps (up to 200 watts). As a speed control, it can be used effectively at moderately low to relatively high speeds, but can not be used at extremely low speeds, for the narrow pulses supplied by the SCR may cause unstable operation. In a similar fashion, when the circuit is used for lamp dimming, extremely low settings (of R6) may cause the lamp to flicker.

Conclusion. The experimental SCR circuits we've discussed were chosen to require a minimum of components and simple power sources, while the tests were designed so that a single general purpose VOM could be used for all measurements. As a result, the approach has not been as rigorous as might be used, say, in a class room. The VOM, for example, could act as a load in several of the tests (depending on the sensitivity of the

instrument used), resulting in voltage measurements which may not correspond exactly with component specifications. In addition, an oscilloscope, if available, would be extremely useful for studying circuit waveforms in Experiments 8, 9, and 10.

Readers who may wish to pursue the study of SCR's in greater detail will find the following manufacturer's publications useful. Many of these contain a number of practical circuits and construction projects.

- CONTROLLED RECTIFIER MANUAL, available through *General Electric*, Semiconductor Products Department, Syracuse 1, New York.
- SILICON CONTROLLED HOBBY MANUAL, available through *General Electric*, Rectifier Components Department, West Genesee Street, Auburn, New York.
- MOTOROLA SEMICONDUCTOR CIRCUITS MANUAL, available through *Motorola Semiconductor Products, Inc.*, Box 955, Phoenix, Arizona.
- SILICON CONTROLLED RECTIFIER DESIGNERS HANDBOOK, available through *Westinghouse Electric Corporation*, Semiconductor Division, Youngwood, Pennsylvania.
- THE CONTROLLED RECTIFIER—Volume 1, available through the *International Rectifier Corporation*, 233 Kansas Street, El Segundo, California.

Publication prices range from \$1.00 to \$2.50 per copy, and many are available through parts distributors as well as direct from the manufacturers. When writing to the above manufacturers, ask them about the other fine books they have to offer. ■

NE-2 Neon Bulb

Continued from page 28

Fig. 18 illustrates an electronic fence charger to keep livestock within an enclosure. Many manufacturers are switching from costly electro-mechanical methods to the more efficient SCR-NE-2 approach.

So you see, the little 10-cent NE-2 is far from obsolete. Even more ingenious applications should develop as designers continue to seek simpler ways to regulate, oscillate, indicate and trigger, functions necessary to a myriad of circuits. They're all possible with the noble little neon knight of 1001 uses. ■

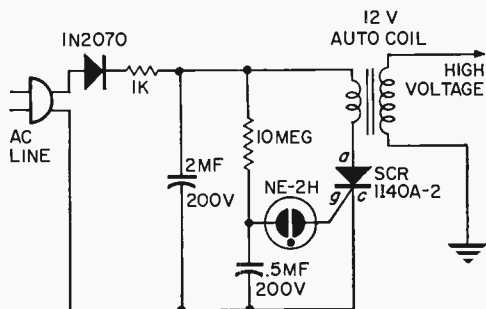

Fig. 18. This electronic fence charger represents the answer to the question, "how 'ya gonna keep 'em down on the farm?" Utilizing the same principle as SCR trigger in Fig. 17, NE-2 fires when .5mf capacitor reaches firing voltage, SCR conducts and shocks livestock.

UHF Antenna Installation

Continued from page 64

be kept as short as possible to minimize signal loss.

While still on the subject of signal loss, it's important to keep in mind that some types of lightning arrestors can cause severe signal loss at UHF frequencies. If, after completing your UHF installation, you find that you are losing signal, check the lightning arrestor. If the signal improves without it, replace with a higher quality unit.

Orienting the antenna for best picture is a bit trickier at UHF frequencies. Since the UHF signal bounces around more than VHF, careful orientation can be a bit touchy . . . only a change of a few degrees can make the difference between no picture and a good quality picture. Likewise, raising or lowering the antenna just a foot or so can make all the difference in the world. In some instances, it's possible to get a stronger signal from a reflected signal rather than the direct signal from the transmitter.

UHF Converters and Boosters. If your TV set is not equipped to receive UHF, then obviously you must obtain a UHF converter in order to be able to receive any UHF sta-

tions. One exception to this is if your receiver's tuner is of the type which will receive UHF strips. In this case, you simply obtain the strip for the desired UHF channel.

UHF converters come in all sizes, shapes, and forms nowadays . . . a typical unit being shown in Fig. 10. Some manufacturers offer transistorized converters which offer the advantages of low power consumption and cool operation. Converters are available which may be placed on top of, or near, the receiver. Others may be placed unobtrusively behind the set.

There are a few precautions to watch when installing a UHF converter. To prevent converter oscillation (indicated by either interference bars or excessive "snow" in the picture), keep the converter's input and output leads well separated. Also, keep the leads from the converter's output to receiver antenna terminals as short as possible.

Heat is an enemy of UHF converters . . . especially transistorized ones! To minimize converter drift due to excessive temperatures, keep the converter well isolated from such relatively high temperature spots as the rear of a TV that is placed smack against a wall.

UHF boosters are now available. Similar in results to VHF units, they give the UHF signal extra "oomph" before it reaches the converter or receiver. Fig. 11 shows two types of antenna mounted UHF boosters which amplify the signal before it is sent down the lead-in. This is an advantage as the stronger signal tends to override the noise and interference picked up by the antenna lead-in.

UHF "two-set" couplers are also available . . . a typical unit being pictured in Fig. 12. These couplers are designed for minimum signal loss at UHF frequencies.

Equipped now with the scoop on UHF and a *clear picture* of the reception process, you're ready to start pulling in those ultra-high frequency broadcasts. ■

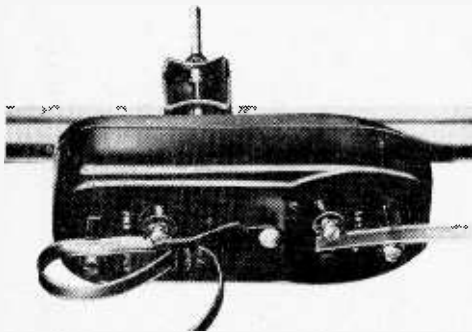

Fig. 11. Wide-band UHF signal boosters are mounted on antenna masts just under the UHF antenna. Tele-Amp unit is shown above and Jerold unit below. Power to units is supplied through TV lead-in wire from indoor supply.

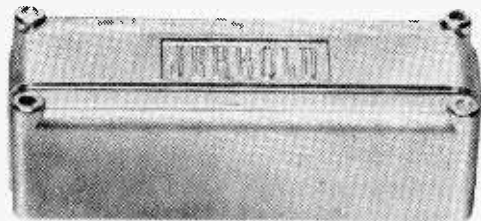

Fig. 12. Since anyone can splice wire, far too often two set couplers are eliminated in installations causing loss of signal, ghosts.



"Pulling Power Is Amazing"

Classified MARKET PLACE

Classified Ads only 55¢ per word, each insertion, minimum 10 words, payable in advance. For information on Classified ads—to be included in our next ELEMENTARY ELECTRONICS—write C. D. Wilson, Mgr., Classified Advertising, 505 Park Ave., New York, N. Y. 10022.

ADDITIONAL INCOME

MAKE Mail Order pay. Get "How To Write a Classified Ad That Pulls." Includes certificate worth \$2.00 toward classed in S & M. Send \$1.00 to C. D. Wilson, Science & Mechanics, 505 Park Ave., New York, N. Y. 10022.

AUTO TRAILERS & SUPPLIES

BUILD Expanding Eight Foot Trailer. Accommodates Five. Literature 10¢. Fra-Mar Company, Wilmington, Mass.

BATTERIES—GENERATORS

BATTERY Secret. Guaranteed Last 5-Years Longer. Write Joe's, Box 1115-SC, Modesto, Calif.

BIG MAIL

YOUR Name Listed with 1000 Malters, Publishers, Imprinters, etc. Our mailing each month \$1.00. Dixie Mailers, King, North Carolina.

BOATS, MOTORS & MARINE SUPPLIES

BOAT Kits! Factory molded fiberglass or pre-assembled plywood. 50 models. 12' to 30'. Free catalog. Luger, Dept. UC-65, 8200 Access Road, Minneapolis 31, Minn.

FULL size, cut-to-shape boat patterns, blueprints. Send 50¢ for big New illustrated "Build a Boat" catalog includes Fishing Boats, Garvies, Cruisers, Catamarans, Houseboats—Outboards, Inboards, Sailboats—7½ to 38". "How to Build a Boat" booklet \$2.50. Cleveland Boat Blueprint Co., Box 18250, Cleveland, Ohio.

CONVERT your present boat trailer winch to power. For complete instructions send \$1.00 to Winch, P.O. Box 642, Sheboygan, Wis.

EIGHT Foot Pram Kit \$39.95. Sailing Rigs available. Butler, X123, Marblehead, Massachusetts.

ELIMINATE Underwater corrosion any size boat. Box 823, So. Miami, Fla. 33143.

"FISHHOOK" Sunfish or similar type Boat, metal wall storage Boat Bracket. "Theft proof" requires no extra space. Mention if vertical or horizontal hanging. Can be installed on masonry, wood or tree. Send check or money order for \$14.95 each. To "Fishhook"—Franklin Lakes, New Jersey.

BOOKS & PERIODICALS

BOOKS for everyone. Catalogs mailed 15¢. Myers Books, Marquand, Mo. 63655.

BUSINESS OPPORTUNITIES

I MADE \$40,000.00 a Year by Mailorder. Helped others to make money! Start with \$10.00—Free Proof, Torrey, Box 3565-T, Oklahoma City 6, Okla.

FREE Book "990 Successful Little-Known Businesses." Fascinating! Work home! Plymouth-811-G, Brooklyn 4, N. Y.

CAMERAS & PHOTO SUPPLIES

FREE Illustrated photographic bargain book. Central Camera Co., Dept. 36-H, 230 So. Wabash, Chicago, Ill.

AT last! Build your own supersensitive light meter from complete kit with easy to follow instructions. Send \$19.95 to Kit Division, Science and Mechanics, 505 Park Ave., New York 22. Money completely refunded if Kit returned within ten days for any reason

CAMPERS, CAMPING EQUIPMENT & TENTS

CAMPER Units—Compact buses, vans—Build yourself—Plans, instructions, photographs. Set SM2 for Volkswagens SM4, for Econoliners, Dodges. \$2.00 set. Dot Campers, Box 67J, Saugus, Calif.

OUTDOORSMEN! You'll want to receive every issue of Camping Journal, written by pros for man-sized reading. Read what they say about equipment, food, rigs, first aid—all aspects from wilderness camping to firearms to gourmet camp cooking. Send \$4.50 for your 1-year subscription to Camping Journal, 505 Park Ave., New York, N. Y. 10022.

COINS, CURRENCY & TOKENS

UNCIRCULATED Mexican Silver 1 Peso 1962. Plus ten different foreign coins, \$1.45. McMahon, 2626 Westheimer, Houston, Texas 77008.

COINS Wanted—Top Dollar. Free list. Capo, 1030 Morris St., Philadelphia, Pennsylvania 19148.

EARTHWORMS

BIG Money Raising Fishworms and Crickets. Free literature. Carter Farm-O, Plains, Georgia.

EDUCATION & INSTRUCTION

"THE Real Atom" and "Elementary Particle Structure and Keys to the Universe." The beginning of Man's Final Picture of Material Reality. Price \$1.00 Postpaid. The Real Atom, P.O. Box 245, Claysville, Penna.

CATALOG of All Science & Mechanics Craftsprints. Send 25¢ to cover postage and handling to Craftsprint Div., Science & Mechanics, 505 Park Ave., New York, N. Y. 10022.

FISHING TACKLE, BAIT & LURES

GET Savage Bites! Patented Crippled-Minnow Lure Swims! Buzzes! Bleeds! All under own power. Details free. Post Mart, Box 475-E, Reseda, California 91336.

MORE Fun, Action. Fish With Three Way Fish Call Only \$14.95. Free Trial Offer—Lures with Order Now! E. G. Van Orman, P.O. Box 756, Alascadero, California 93422.

FLORIDA LAND

FLORIDA Water Wonderland—Home, cottage, Mobilsites. Established area, \$590.00 full price, \$9.00 a month. Swimming, fishing, boating. Write: Lake Weir, Box MK38, Silver Springs, Florida AD 6-1070 (F-1).

FOR INVENTORS

PATENT Searches—48 hour airmail service, \$6.00, including nearest patent copies. More than 200 registered patent attorneys have used my service. Free Invention Protection Forms. Write Miss Ann Hastings, Patent Searcher, P. O. Box 178, Washington 4, D. C.

GIFTS THAT PLEASE

1000 NAME and Address Labels \$1.00. LaParl, 1513 Springwells, Detroit, Mich. 48209.

HYPNOTISM

NEW concept teaches you self-hypnosis quickly! Free literature. Smith-McKinley, Box 3038, San Bernardino, Calif.

SLEEP-Learning—Hypnotism! Strange catalog free! Autosuggestion, Box 24-TV, Olympia, Washington.

INVENTIONS WANTED

INVENTORS! We will develop, sell your idea or invention patented or unpatented. Our national manufacturer-clients are urgently seeking new items for highest outright cash sale or royalties. Financial assistance available. 10 years proven performance. For free information, write Dept. 7, Wall Street Invention Brokerage, 79 Wall Street, New York 5, N. Y.

MAILING LISTS

YOUR Name listed with 1000 Malters, Publishers, Importers, etc. Our mailing each month \$1.00. Dixie Mailers, King, North Carolina.

MONEYMAKING OPPORTUNITIES

FOR Money Making Opportunities. Business Building Offers. Write Tojocar, 2807-A West 39th Place, Chicago, Ill. 60632.

OFFICE EQUIPMENT & SUPPLIES

YOUR Name Listed with 1000 Malters, Publishers, Importers, etc. Our mailing each month \$1.00. Dixie Mailers, King, North Carolina.

PATENT SERVICE

Patent Searches, \$6.00; For free "Invention Record" and "Important Information Inventors Need," write Miss Hayward, 1029-D Vermont, Washington 5, D. C.

PETS—DOGS, BIRDS, RABBITS, ETC.

MAKE big money raising rabbits for us. Information 25¢. Keeney Brothers, New Freedom, Penna.

PROFITABLE OCCUPATIONS

INVESTIGATE Accident. Earn \$750.00 to \$1,500.00 monthly. Car furnished. Expenses paid. No selling. No college education necessary. Pick own job location in U. S., Canada or overseas. Investigate full time. Or earn \$8.44 hour spare time. Men urgently needed now. Write for Free Information Absolutely no obligation. Universal, CMH, 6801 Hillcrest, Dallas 5, Texas.

RADIO & TELEVISION

RADIO & TV Tubes 33¢—Free List. Cornell, 4215-17 University, San Diego 5, California.

JAPAN & Hong Kong Electronics Directory. Products, components, supplies. 50 firms—Just \$1.00. Ippano Kaisha Ltd., Box 6266, Spokane, Wash. 99207.

SONGWRITERS

POEMS wanted for new songs. Send poems. Crown Music, 49-SC West 32, New York 1.

SPECIAL SERVICES

FACTS—Any Subject—Product. Send \$1.00 Today For "Copyright Plan," Reports, Surveys, Research. EM, Box 1431, Greenville, So. Carolina 29602.

TREASURE FINDERS—PROSPECTING EQUIPMENT

TREASURE Hunter's — Prospector's News. Sample 10¢. Exanlimor Press, Weeping Water, Nebr. 68463.

NEW supersensitive transistor locators detect buried gold, silver, coins. Kits assembled models, \$19.95 up. Free catalog, Relco-A30, Box 10563, Houston, Texas 77018.

Stereo Checker

Continued from page 90

output from the voice coil winding, be sure a speaker is hooked across these leads. If not, clip a 220-ohm resistor across the voice coil leads.

Level Indicator and Phasing. The stereo checker can be used as a level indicator on an amplifier or tape recorder. Switch the selector switch to *BAL* position. Use either the left or right channel test leads. Clip to the output speaker leads of the instrument to be checked. If the signal is strong, like that of a large amplifier, flip the *IND-CAL* switch to *CAL* position. Set the attenuation switch to 100% on the meter.

On tape recorders that have a neon indicator, flip the *IND-CAL* switch to *IND* position. Set the volume on the tape recorder where the neon bulb indicates on a regular recording. Adjust the attenuation control until the meter reads *O*. Leave the control

set at this position and watch the level meter as you record.

To check the phasing of a speaker or to phase a new speaker that may be installed, use the *SPK-POL* jacks. Do not leave the test leads plugged in the jacks when through with speaker phasing; they may be accidentally short and run down the small nine-volt battery.

Clip the black lead to one side of the speaker voice coil. Touch the red lead to the other speaker terminal and notice if the speaker cone goes in or out. Let's say, for instance, the cone goes in. Mark the red lead with a plus sign. Now check the other speaker the same way. When the speaker cone goes in, mark the red lead terminal positive. All positive terminals on the speakers will be connected together on side of the output transformer. All terminals not marked will go to the other side of the output transformer. Now, when program material is being played, all speaker cones will be going in and out at the same time or, in other words, are now in phase with each other. ■

Node-Voltage Method

Continued from page 66

armed with useful methods of attacking network problems you previously were unable to solve. It is best to reread the entire series once more as a "refresher". A little application and practice, and you'll be ready for more mathematical methods and theories. ■



"Hello, Doris. It's over, you're out!"

Solution to Last Month's Problem

The reader was asked to solve for the current flow and direction (up or down) through the 6-ohm resistor in the diagram below using Maxwell's cyclic method.

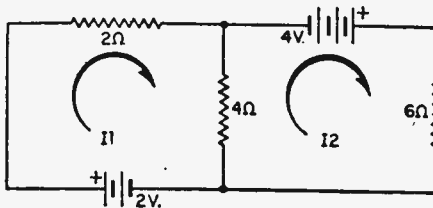

$$2 = 2I_1 + 4(I_1 - I_2) \quad (1)$$

$$4 = 6I_2 + 4(I_2 - I_1) \quad (2)$$

Simplifying equation (1) and (2)

$$1 = 3I_1 - 2I_2 \quad (3)$$

$$2 = -2I_1 + 5I_2 \quad (4)$$

Multiply equation (3) by 2 and equation by 3

$$2 = 6I_1 - 4I_2 \quad (5)$$

$$6 = -6I_1 + 15I_2 \quad (6)$$

Combine equations (5) and (6)

$$8 = 11I_2$$

$$I_2 = \frac{8}{11} \text{ amperes}$$

Substitute value for I_2 in equation (3)

$$1 = 3I_1 - 1\frac{5}{11}$$

$$I_1 = \frac{9}{11} \text{ amperes}$$

Current flowing down ($I_1 - I_2$) through 6-ohm resistor is

$$I_1 - I_2 = \frac{1}{11} \text{ amperes}$$

and since answer is positive, current is definitely flowing from top to bottom.

BUILD, EXPERIMENT, EXPLORE, DISCOVER WITH NRI CUSTOM-DESIGNED TRAINING KITS



BUILD YOUR OWN PHONE/CODE TRANSMITTER

This is just one of seven training kits programmed into NRI's Complete Communications course. You get actual practice in building your own crystal-controlled, phone/code transmitter and putting it on the air. You experiment with modulation, "clamping" circuits, key filters, other aspects of commercial transmitter operation. Can be put on the air simply by attaching an antenna and complies with FCC regulations. As with all NRI training kits, you get the most modern features and parts.

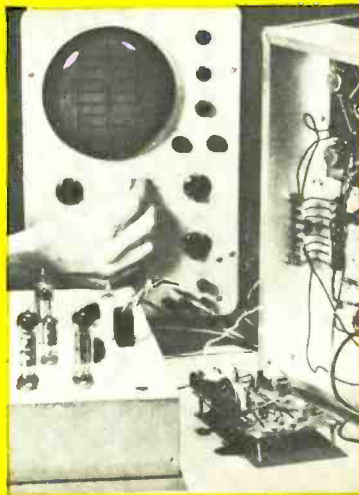

BUILD ACTUAL ANALOG COMPUTER CIRCUITS

Industry, business offices, the government and military all need trained Electronics Technicians. NRI's Industrial Electronics course prepares you. You progress through 10 carefully designed training kits, topping off your practical experience phase of training by experimenting with feedback control systems, analog computers and digital computer elements. You actually solve problems on this analog computer you build yourself. This is the practical, fast way to a good paying, career position.

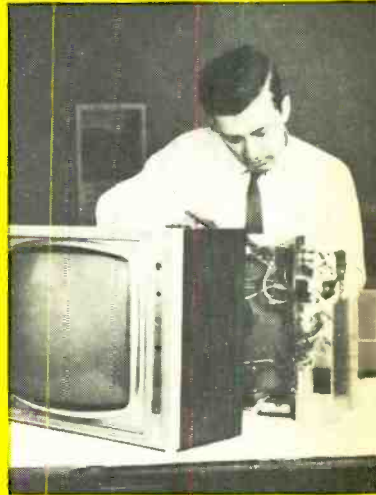

BUILD A CUSTOM-ENGINEERED TELEVISION RECEIVER

Want to earn \$3 to \$5 an hour in spare time? Want your own part-time or full-time business? In Radio-TV Servicing you learn to install, maintain, service radios, TV sets, hi-fi and stereo, other home Electronics equipment. In your training are eight training kits, including this complete, modern, slim-line TV receiver. You build it yourself, become familiar with components and circuits, learn servicing procedures... and earn extra money as you train. National Radio Institute, Washington, D.C.

Join the Thousands Who Gained Success with NRI



"I am Frequency Coordinator for the 11th Naval District. The course was priceless." J. J. JENKINS, San Diego, Calif.



"Many thanks to NRI. I hold FCC License, am master control engineer with KXIB-TV." R. L. WOOD, Fargo, N.D.



"I am a Senior Engineering Aide. Without NRI I would still be working in a factory at a lower standard of living." D. F. CONRAD, Reseda, Calif.



SEE OTHER SIDE ▶

FIRST CLASS
PERMIT
NO. 20-R
Washington, D.C.

BUSINESS REPLY MAIL

NO POSTAGE STAMP NECESSARY IF MAILED IN THE UNITED STATES

POSTAGE WILL BE PAID BY

NATIONAL RADIO INSTITUTE
3939 Wisconsin Avenue
Washington, D.C. 20016



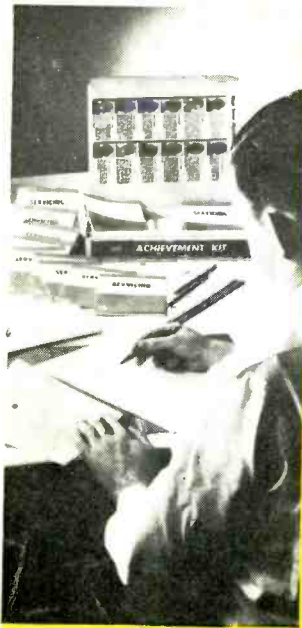

GET FAST START WITH NEW ACHIEVEMENT KIT

Delivered to your door—everything you need to make a significant start in the Electronics field of your choice. An outstanding, logical way to introduce you to home-study training. It includes your first set of lesson texts and all the "classroom tools" you need. No other school has anything like the new NRI Achievement Kit.



ELECTRONICS COMES ALIVE WITH NRI TRAINING KITS

Nothing is as effective as learning by doing . . . and NRI pioneered the "home lab" technique of training. NRI invites comparison with training equipment offered by any other school. Begin NOW this exciting program of practical learning. Make the skills of the finest Electronic Technicians your own. Mail card below.

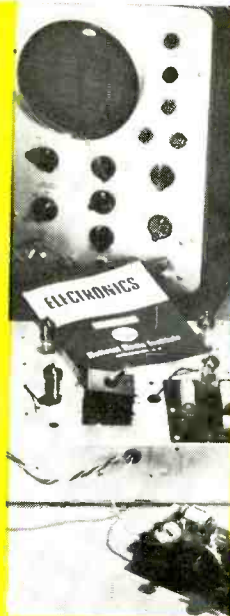

"BITE SIZE" TEXTS PROGRAM YOUR TRAINING

Certainly, lesson texts are necessary. NRI's programmed texts are as simple, direct and well illustrated as 50 years of teaching experience can make them. They are carefully programmed with NRI training kits to make the things you read about come alive. You experience all the excitement of original discovery.

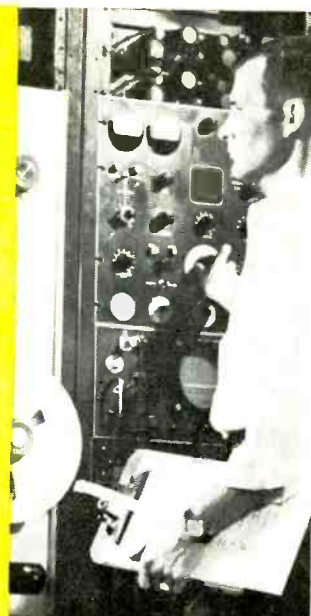

HOBBY? CAREER? MAIL CARD NOW TO NRI

Whatever your need . . . whatever your education . . . there's an NRI training plan to fit your requirements. Choose from three major courses or select one of seven special courses in particular Electronics subjects. Check the postage-free card below, fill in and mail. National Radio Institute, Washington, D.C.

DISCOVER THE EASE AND EXCITEMENT OF LEARNING ELECTRONICS THE NRI WAY

SEE OTHER SIDE

National Radio Institute, Electronics Div.
Washington, D.C. 20016 6-075

Please send me your catalog. I have checked the field(s) of most interest to me. (No salesman will call.)

- | | |
|--|---|
| <input type="checkbox"/> TV-Radio Servicing | <input type="checkbox"/> Basic Electronics |
| <input type="checkbox"/> Industrial Electronics | <input type="checkbox"/> Electronics for Automation |
| <input type="checkbox"/> Complete Communications | <input type="checkbox"/> Aviation Communications |
| <input type="checkbox"/> FCC License | <input type="checkbox"/> Marine Communications |
| <input type="checkbox"/> Math for Electronics | <input type="checkbox"/> Mobile Communications |

Name _____ Age _____

Address _____

City _____ State _____ Zip Code _____

Accredited Member National Home Study Council

PICK THE TRAINING PLAN OF YOUR CHOICE AND MAIL CARD FOR FREE CATALOG



OUR 50TH YEAR OF LEADERSHIP IN ELECTRONICS TRAINING

