

MAY 19, 1982

THE EE SHORTAGE: A SCATTERED DEMAND FOR SPECIALISTS/105

Built-in logic-block observers speed digital testing/ 164

Dual receiver-transmitter takes on 16-bit microprocessors/ 168

SIX DOLLARS A Mc GRAW-HILL PUBLICATION

Electronics®

A SPECIAL REPORT

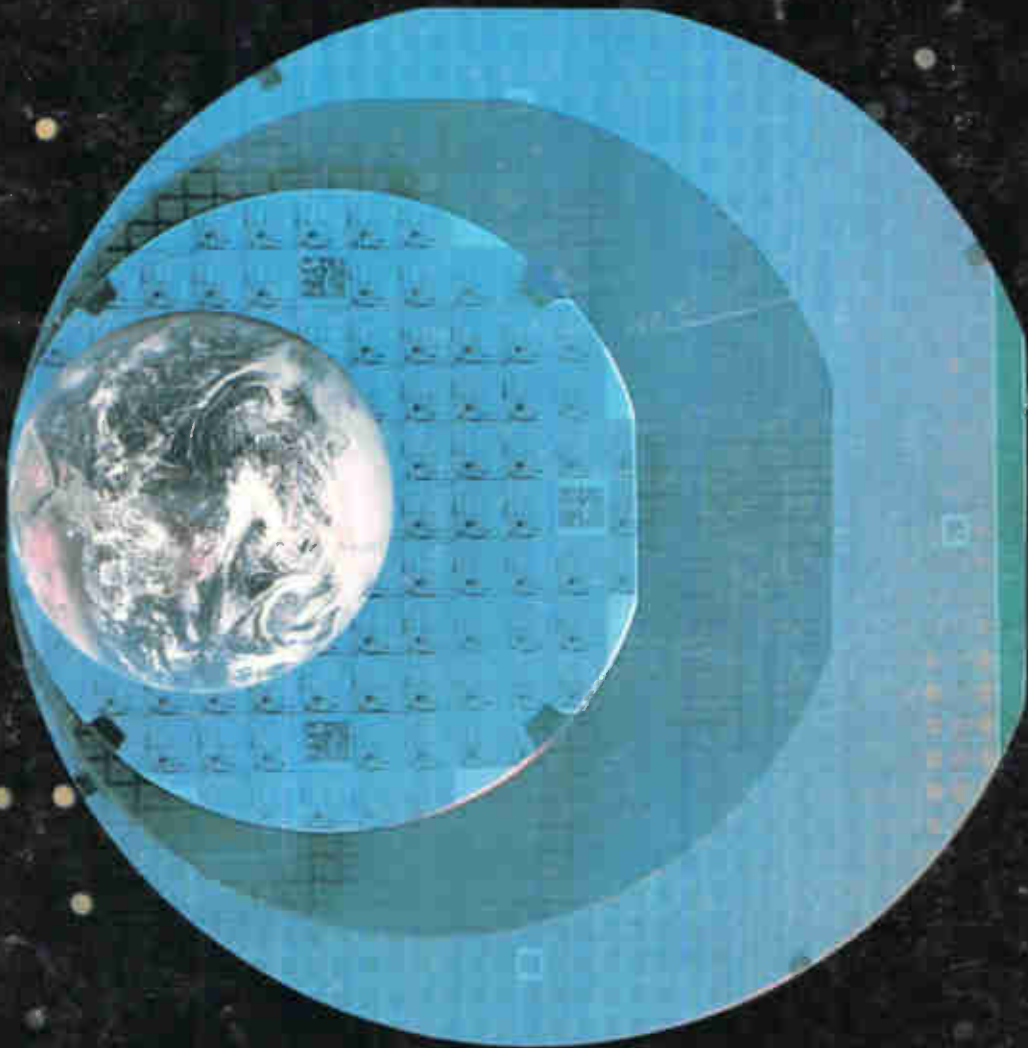

The Expanding World of Semiconductors

Advanced Technology Op Amps from a Proven Source.

In the Space-Age Arena of Linear Technology, Raytheon Stands Out with High Speed, Low Noise, High Performance, and Programmable Op Amps.

The Op Amp marketplace is a very competitive arena. To meet the challenge of supplying devices to your high performance requirements, Raytheon stands out as your champion.

Proven Source

You no longer have to shop around to fill your various Op Amp needs. Raytheon has the most complete line of high performance and standard devices available. Your most demanding requirements, as well as your standard device needs can be satisfied with only one phone call.

High-Reliability

All Raytheon Op Amps are available with full MIL-STD-883 processing as well as some available with 38510 qualification.

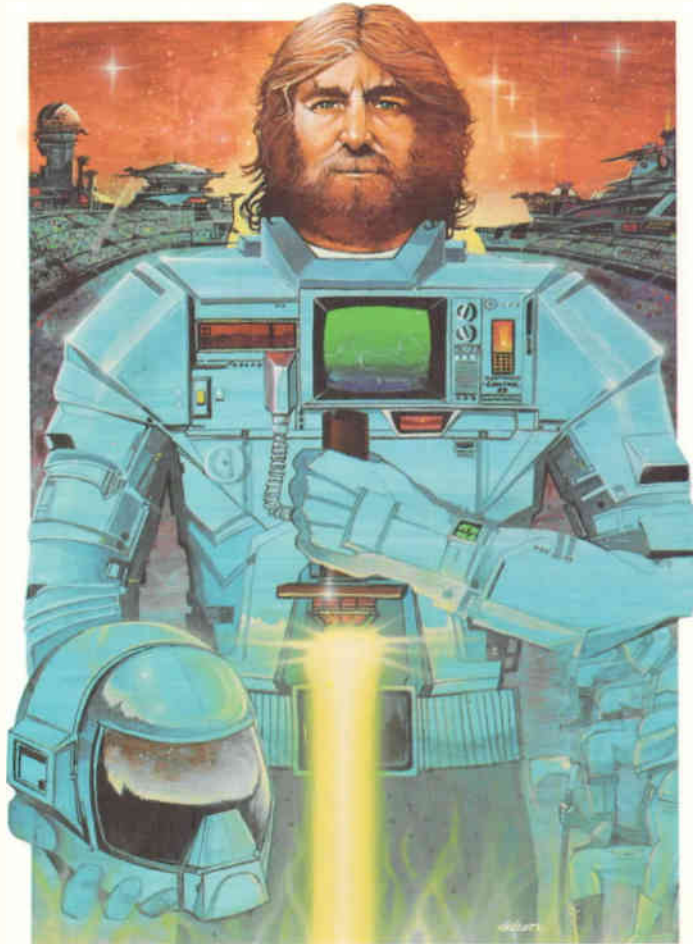

Guaranteed Specifications

We'll give you guaranteed maximum specifications, high performance, low noise, high speed and programmability.

Quads, Duals and Singles

Our Op Amp mix is made up of 50% quads, 20% duals and 30% singles. Some of the more popular device types are shown below.

Get out of the Op Amp arena of multiple sources. Call Raytheon and we'll send you our Op Amp Buyer's Guide.

Raytheon Company
Semiconductor Division
350 Ellis Street
Mountain View, CA 94042
(415) 968-9211

Popular Device Types

Quads	Duals	Singles	Programmable
RC4136	RC5532/A	RC725	LM346
RC4156*	RC4739	RC3078	RC4149
RC4157	RC4558	RC5534/A	RC4149-2
HA-4741	RC4559**	OP-07 Series	RC4149-3

*High Performance HA-4741

**High Performance RC4558



Semiconductor Division

Circle 900 on reader service card

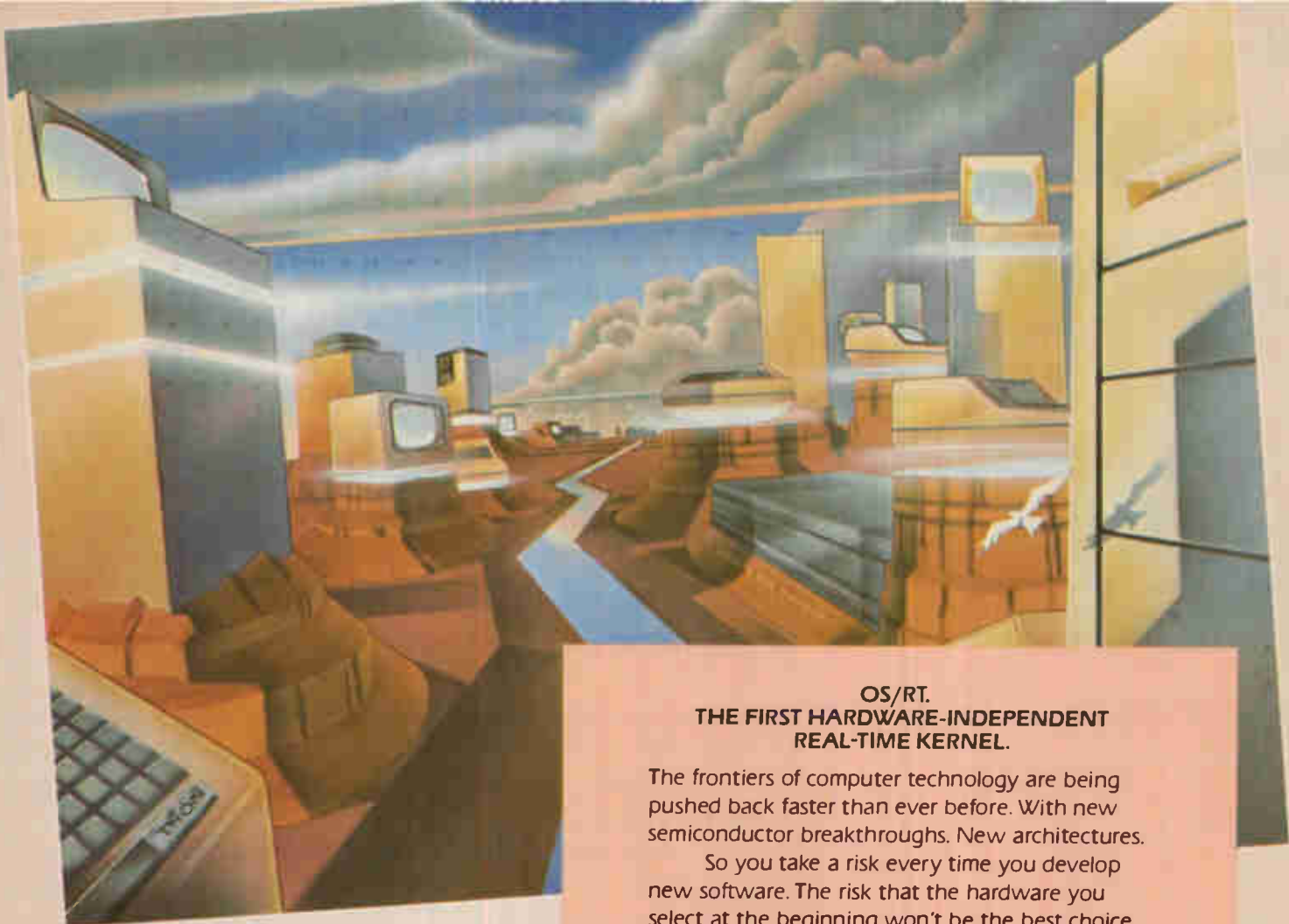

SOFTWARE FOR THE NEW FRONTIER.

OS/RT. THE FIRST HARDWARE-INDEPENDENT REAL-TIME KERNEL.

The frontiers of computer technology are being pushed back faster than ever before. With new semiconductor breakthroughs. New architectures.

So you take a risk every time you develop new software. The risk that the hardware you select at the beginning won't be the best choice when you finish.

OS/RT eliminates that risk by keeping your hardware options open all the way. Because the real time applications you build around OS/RT can be quickly and easily transported from processor to processor. Any processor with a "C" compiler.

OS/RT is the ideal kernel for your process control, instrumentation, simulation, electronic mail, and communications control applications. Along with the inherent efficiencies of "C," OS/RT offers dynamic resource allocation/sharing and asynchronous interrupt support.

With source code and unlimited binary rights for \$8,000, OS/RT pays for itself in development costs alone. Because now you can develop on low cost hardware and implement on larger systems.

OS/RT makes hardware-dependent operating system kernels obsolete. For full details, order our preliminary evaluation package — manual, applications notes, and users' reference list. We'll enclose an invoice for \$50 to cover our costs. Or circle the bingo card for a free data sheet. Call DESTEK at (415)968-4593 and ask for Craig Willison.

The DESTEK Group, 1923 Landings Drive, Mountain View, California 94043

DESTEK

WE BUILD ACCESS TO PRODUCTIVITY.

Circle 1 on reader service card

Electronics

The International Magazine of Electronic Technology and Business



Cover designed by Fred Sklenar and photographed by John G. Posa. Waters courtesy of National Semiconductor Corp.

The Cover Story

Special report: Economic, technological change reshapes semiconductor industry, 129

Merchant chip makers await recovery from the recession as competition from captive and Japanese firms increases. Very large-scale integrated-circuit designs shift their focus to user-defined functions.

Major New Developments

16-bit dual UART

A dual-channel universal asynchronous receiver-transmitter handles 16- as well as 8-bit microprocessors and offers self-testing, independently programmed bit-rate generators, and interrupt handling, 168

A better magnetic transistor

An improved understanding of how magnetic fields affect carriers in semiconductor pn junctions points the way to smaller, more sensitive magnetic transistors, 45

EE shortage?

After talking to employers, college deans, and other insiders across the country, Electronics has found that there is indeed a shortage of electrical engineers — but that its severity varies with specialty and location, 105

Semicon/West new products

Attendees of the May 25–27 production-equipment show in San Mateo, Calif., will witness the introduction of a direct-writing electron-beam machine, a reactive ion etching system, and other unique products, 191 and 200

NEWSLETTERS

Electronics, 41
Washington, 71
International, 79
Engineer's, 182
Products, 239

DEPARTMENTS

Highlights, 4
Publisher's letter, 6
Readers' comments, 8
Editorial, 12
People, 14
In my opinion, 24
Meetings, 26
News update, 32
Business activity, 35
Washington commentary, 72
New literature, 234
Career outlook, 240

SERVICES

Employment opportunities, 240
Reader service card, 249

Electronics Review**SOLID STATE**

New theory points to smaller, better magnetic transistors, 45
Magnetic transistors revisited, 46

SOFTWARE

Natural language targeted on small machines, 47

MICROCOMPUTERS

Chip makers guard against theft of programs, 48

INSTRUMENTS

Analyzer's color display highlights glitches, 48

PERSONAL COMPUTERS

DEC shoots for major market share, 50

SOLID STATE

Single wafer holds megabit memories, 53

PERIPHERALS

Chassis handles a range of disk drives, tape transports, 54

CONSUMER

Component television poised to take off, 54

NEWS BRIEFS: 56

Electronics International**GREAT BRITAIN**

Wide-area radio pager employs single chip, 89
A fresh look at direct frequency conversion, 90

JAPAN

Market gets new gallium and indium compounds, 90

WEST GERMANY

Associative memory takes 4 ms for 32 searches, 92
Big market seen for associative memory unit, 92

FRANCE

Amorphous silicon enlarges liquid-crystal displays, 94

WEST GERMANY

Glass fibers link CPUs, 96

Probing the News**CAREERS**

Electronics companies are still short of engineers, 105

DATA COMMUNICATIONS

Burroughs joins IBM in embracing token passing for local-network access control, 115

INSTRUMENTS

Disk-drive boom opens growing market for testers, 118

Technical Articles**SEMICONDUCTORS FACE****WORLDWIDE CHANGE:****A SPECIAL REPORT**

Introduction, 129

Recession appears to be ending, but some anxiety persists, 130

VLSI shifts its focus from fabrication to function, 141

SOFTWARE

Standard software interface boosts program portability, 157

DESIGNER'S CASEBOOK

Frequency comparator uses synchronous detection, 160

Conductive foam forms reliable pressure sensor, 161

Joining a PLL and VCO forms fractional frequency multiplier, 163

PACKAGING & PRODUCTION

Circuit module implements practical self-testing, 164

COMMUNICATIONS & MICROWAVE

16-bit UART manages two programmable signal paths, 168

PACKAGING & PRODUCTION

Back-contact resistor net pares wire count in ECL hybrids, 173

COMPUTERS & PERIPHERALS

Electromatrix printing reduces terminal noise, 175

ENGINEER'S NOTEBOOK

Single chip solves MC6809 timing problems, 178

Comparator, one-shot give servos pulse-width inversion, 179

OTAs and op amp form voltage-controlled equalizer, 181

New Products**IN THE SPOTLIGHT**

Electron-beam machine writes directly on 20 wafers/h, 191

900-MHz transistor trio puts out 30 W, 194

PACKAGING & PRODUCTION

Reactive ion etching system makes 0.5- μ m metal lines, 200

Hybrid mask aligner isolates stage to expose 1- μ m lines, 200

Gage controls lapping operation to new accuracy level, 202

Board-to-board connector puts up with vibration, 205

COMPOONENTS

COMPOONENTS

70-MHz op amp is stable over 1-to-40 gain range, 210

COMPUTERS & PERIPHERALS

Card gives Q bus RS-232-C and current-loop I/O, 215

MICROSYSTEMS

Enhanced operating system lets RAM emulate disk, 221

68000-based system runs in-house operating system, 221

INDUSTRIAL

13-slot STD-bus chassis has room for disk drives, 227

SOFTWARE

Spread sheet accepts input from data base, 228

INSTRUMENTS

Recorder is calibrated by internal microprocessor, 231

EDITOR-IN-CHIEF: Samuel Weber

SENIOR MANAGING EDITOR, *News*:
Arthur Erikson

MANAGING EDITOR, *Technical*:
Howard Bierman

ASSOCIATE MANAGING EDITORS:
Alfred Rosenblatt, Howard Wolff

ASSISTANT MANAGING EDITOR:
Margaret Eastman

SENIOR EDITORS: Ray Connolly, Kevin Smith

ART DIRECTOR: Fred Sklener

DEPARTMENT EDITORS

Aerospace/Military: Ray Connolly

Circuit Design: Ashok Bindra

Communications & Microwave:

Harvey J. Hindin

Components: Stephen Evanczuk

Computers & Peripherals: Tom Manuel

Industrial/Consumer: William E. Suydam

Microsystems: R. Colin Johnson

New Products: Jeremy Young, Steve Zollo

Packaging & Production: Jerry Lyman

Software: R. Colin Johnson

Solid State: Roderic Beresford

Systems Integration: George Sideris

Test, Measurement & Control:

Richard W. Comerford

CONTRIBUTING EDITOR: John G. Posa

STAFF WRITER: Jesse J. Leaf

CHIEF COPY EDITOR: Margaret Eastman

COPY EDITORS: Marilyn A. Harris, David Kach,
Erik L. Keller, Benjamin A. Mason

ART: Charles D. Ciatto, *Associate Director*
Sachiko Inagaki, *Assistant Director*

EDITORIAL ASSISTANT: Penny Reitman

ADMINISTRATIVE ASSISTANT: Kathleen Morgan

EDITORIAL SECRETARIES: Lorraine Gibbs,
Janice Jung, Josephine Ortiz

REGIONAL EDITORS

Boston: Linda Lowe (617) 262-1160

Chicago: Wesley R. Iversen (312) 751-3811

Costa Mesa: Terry Costlow (714) 557-6292

Dallas: J. Robert Lineback (214) 458-2400

Los Angeles: Larry Waller (213) 487-1160

Palo Alto: Stephen W. Fields (415) 968-2712

Washington: Ray Connolly (202) 624-7592

Frankfurt: John Gosch 72-5566

London: Kevin Smith 493-1451

Paris: Robert T. Gallagher 723-4656

Tokyo: Charles Cohen, Robert Neff 581-9816

McGRAW-HILL WORLD NEWS

Michael Johnson, *Director*; James Smith, *Brussels*

Lois Bolton, *Milan*; Alex Beam, *Moscow*

Robert Skole, *Stockholm*

PUBLISHER: Paul W. Reiss

GENERAL MANAGER, DIRECT MARKETING
OPERATIONS: Horace T. Howland

DIRECTOR OF CIRCULATION: Frederick J. Kostbar

RESEARCH MANAGER: Margery D. Sholes

PROMOTION MANAGER: Jane DeCourt

MARKETING ADMINISTRATION MANAGER:

Frances M. Vallone

BOOKS & SPECIAL PROJECTS MANAGER:

Janet Eyer

SPECIAL PROJECTS ASSOCIATE:

June A. Noto

Cover: Semiconductor industry girds for worldwide changes, 129

The protean semiconductor industry is entering a period of upheaval, as the shaping economic and technological forces themselves undergo profound changes. This worldwide special report assesses these changes in depth. An analysis of market prospects (p. 130) is followed by evaluations of the impact of the burgeoning captive integrated-circuit operations (p. 133) and of the flourishing Japanese IC producers (p. 136). An assessment of the technology appraises the new concern with functional definition of very large-scale ICs (p. 141), considering in particular memories and microprocessors (p. 145) and gate arrays (p. 148).

EE shortage shows no signs of abating, 105

Companies in every sector of the electronics industries in every area of the U. S. report personnel shortfalls. The supply of electrical engineers is lagging further and further behind exploding demand, they say, and regional and specialty considerations exacerbate the dilemma.

Standard interface adds compatibility to software, 157

A set of standard operating-system calls and shared code- and data-storage formats makes up a software core that enhances the compatibility of programs and improves their portability.

Circuit concept implements VLSI self-testing, 164

A register-based module facilitates self-testing, in the form of signature analysis, for combinatorial logic on very large-scale integrated circuits.

16-bit UART runs two independently programmable channels, 168

Independently programmable bit-rate generators permit a dual-channel universal asynchronous receiver-transmitter to manage each of its interrupt-driven self-testing signal paths separately.

ECL hybrids' wire count drops with resistor-net chip, 173

A dual-termination resistor network on a chip uses back-contact technology to reduce the number of wire bonds in emitter-coupled-logic hybrids.

Printer vaporizes aluminum film to form dot-matrix characters, 175

Forming characters by vaporizing a reflective aluminum layer over a black undercoat, the electromatrix printing terminal is quiet and compact. The nonimpact technique consumes little power.

In the next issue . . .

Automatic program generators: a special report . . . error-correction chips: two approaches . . . a 256-K read-only memory.

May 19, 1982 Volume 55 Number 10
105 001 copies of this issue printed

Electronics (ISSN 0013-5070) Published every other Wednesday except the issue of Tuesday Nov. 30 by McGraw-Hill, Inc. Founder: James H. McGraw 1860-1948. Publication office: 1221 Avenue of the Americas, N.Y., N.Y. 10020. Second class postage paid at New York, N.Y. and additional mailing offices.

Executive, editorial, circulation and advertising addresses: Electronics, McGraw-Hill Building, 1221 Avenue of the Americas, New York, N.Y. 10020. Telephone (212) 907-1221. Teletype 12-7960 TWX 710-581-4879. Cable address: MCGRAWHILL NEW YORK.

Subscriptions limited to professional persons with active responsibility in electronics technology. No subscriptions accepted without complete identification of subscriber name, title or job function, company or organization, and product manufactured or services performed. Based on information supplied the publisher reserves the right to reject non-qualified requests. Subscription rates in the United States and possessions: \$19 one year, \$32 two years, \$47 three years, company addresses and company libraries: \$24 one year, \$42 two years, \$59 three years. Canada and Mexico: \$30 one year, \$33 two years, \$48 three years. Europe: \$50 one year, \$85 two years, \$115 three years. Japan, Israel and Brazil: \$70 one year, \$115 two years, \$165 three years. Australia and New Zealand: \$35 one year, \$170 two years, \$240 three years, including air freight. All other countries: \$50 one year, \$85 two years, \$125 three years. Limited quota of subscriptions available at higher than basic rate for persons allied to field served. Check with publisher for these rates. Single copies: \$5.00. Please allow four to eight weeks for shipment.

Officers of McGraw-Hill Publications Company: Paul F. McPherson, President; Executive Vice Presidents: Daniel A. McMillan III, Gene W. Simpson; Senior Vice President-Editorial: Ralph R. Schult; Vice

President: Kemp Anderson; Business Systems Development: Robert B. Dill; Circulation: James E. Harlett; Controller: Eric B. Herr; Planning and Development: H. John Sweger; Marketing Officers of the Corporation: Harold W. McGraw Jr., Chairman and Chief Executive Officer; Joseph L. Donno, President and Chief Operating Officer; Robert N. Landes, Senior Vice President and Secretary; Ralph J. Webb, Treasurer.

The registered in U.S. Patent Office. Copyright © 1982 by McGraw-Hill, Inc. All rights reserved. The contents of this publication may not be reproduced in whole or in part without the consent of copyright owner.

Where necessary permission is granted by the copyright owner for libraries and others registered with the Copyright Clearance Center (CCC), 21 Congress Street, Salem, MA 01970, to photocopy any article herein for the base fee of \$0.50 per copy of the article plus \$0.25 per page. Payment should be sent directly to the CCC. Copying done for other than personal or internal reference use without the express permission of McGraw-Hill is prohibited. Requests for special permission or bulk orders should be addressed to the publisher: ISSN 0013-5070 8150 50-25.

Subscribers: The publisher upon written request to our New York office from any subscriber, agrees to refund that part of the subscription price applying to copies not yet mailed. Please send change-of-address notices or complaints to Fulfillment Manager, Subscription Order to Circulation Manager, Electronics at address below. Change-of-address notices should provide old as well as new address, including zip code. Attach address label from recent issue. Allow one month for change to become effective. Subscriber Service call (609) 448-8110 9 a.m. to 4 p.m. EST.

Postmaster: Please send form 3579 to Fulfillment Manager, Electronics, P.O. Box 430 Hightstown, N.J. 08520.



tough attenuators

from **\$11.95**
(1-49)

the world's lowest-priced coax attenuators
3, 6, 10 or 20 dB... from DC to 1500 MHz
one-piece design defies rough handling

Check these features:

- ✓ Solid one-piece tubular construction
- ✓ Available with BNC, N, SMA, TNC connectors
- ✓ Male/female connectors standard
- ✓ Connector series intermixing available
- ✓ 2 watts max. power (except 0.5W for SMA)
- ✓ Excellent temperature stability, .002 dB/°C
- ✓ Low-cost, only \$11.95 BNC (1-49 qty.)
attenuation values may be combined
- ✓ Delivery, from stock
- ✓ Exclusive one-year guarantee

Model	Attenuation, dB	Attenuation Tolerance	Frequency MHz	Attention Change over Frequency Range, MHz		VSWR Max. (50 ohms)	
				DC-1000	1000-1500	DC-1000	1000-1500
-AT-3	3	±0.2dB	DC-1500	0.6dB	1.0dB	1.3:1	1.5:1
-AT-6	6	±0.3dB	DC-1500	0.6dB	0.8dB	1.3:1	1.5:1
-AT-10	10	±0.3dB	DC-1500	0.6dB	0.8dB	1.3:1	1.5:1
-AT-20	20	±0.3dB	DC-1500	0.6dB	0.8dB	1.3:1	1.5:1

Add prefix **C** for BNC (\$11.95), **T** for TNC (\$12.95),
N for Type N (\$15.95), **S** for SMA (\$14.95)

finding new ways
setting higher standards

Mini-Circuits

A Division of Scientific Components Corporation
World's largest manufacturer of Double Balanced Mixers
2625 East 14th Street, Brooklyn, New York 11235 (212)769-0200
Domestic and International Telex 125460 International Telex 620156

Circle 5 on reader service card

Never before...

200 watts
of RF power with
incredible
versatility.

3200 L spans
250 kHz to 150 MHz.



Now there's a completely solid state power amplifier that provides 200 watts of linear power over a frequency range from 250 kHz to 120 MHz. And at 175 watts, the range extends to 150 MHz.

Imagine the wide range of applications you can cover with this single Class A linear unit. All you need is any standard signal or sweep generator and you have the ultimate in linear power for RFI/EMI testing, NMR, RF Transmission, and general laboratory applications.

And, like all ENI power amplifiers, the 3200 L features unconditional stability, instantaneous failsafe provisions, and absolute protection from overloads and transients.

The 3200 L represents a breakthrough in RF power versatility and packaging. Never before has there been anything like it commercially available anywhere!

Contact us for a demonstration of the 3200 L and our complete catalog on the other amplifiers in our wide line. ENI, 3000 Winton Road South, Rochester, NY 14623.

Call 716/473-6900, or Telex 97-8283 ENI ROC.

ENI



The advanced
design line of
power amplifiers

Publisher's letter

Yes, indeed, there is a shortage of engineers in the U. S., concluded seven *Electronics* field editors after roaming campuses, recruitment offices, and military and industrial firms for the Probing the News story that starts on page 105.

Terry Costlow, Tom Moran, and Larry Waller handled the West Coast assignment, Rob Lineback tracked the Southwest, Wes Iversen screened the Midwest, and Linda Lowe checked out New England. Wherever they went, the reaction was the same: there are just not enough electrical engineers around today. As a result, salaries are rising 10% and more each year—and company-paid advanced education is a popular fringe benefit, Terry adds. Graduate EEs with good grades from top schools can start as high as \$26,000, Larry notes, often with several offers from which to select.

As for employing foreign EEs, Intel vice chairman Robert Noyce told senior editor Ray Connolly over dinner that close to 25% of his company's Ph.D.s are foreign-born and that Intel would be "in deep trouble if they were sent back home."

More engineering undergraduates are clearly needed, but who will they be? Replies Leo Young, former president of the Institute of Electrical and Electronics Engineers and the Defense Department's director of research and technical information: "Women."

Perhaps the word that best typifies the chip business is "change." Even now, the semiconductor industry is shifting, pausing, taking stock, and planning its next move.

In the special report that begins on page 129, editors John Posa and Howard Bierman review the chang-

ing technological and business scene of very large-scale integrated circuits. While in Europe this spring for two weeks, John visited 17 firms to report on their activities. Despite vigorous U. S. and Japanese thrusts into the European industrial and consumer electronics markets, he observes: "Many European marketing and technical executives in IC firms believe they will not be easy victims. Instead, they intend to put up a strong struggle not only to survive but to increase their share of market."

American chip manufacturers are upset not just with Japan's growing share of the world semiconductor markets, Howard says, but with its different rules of competition. Altogether, over 80 executives were interviewed by him and by field editors in the U. S., Europe, and Japan, with Wes Iversen of the Chicago bureau deserving a special mention for his contribution on captive chip suppliers.

The consensus: "It's naive to believe that U. S. firms stand a chance of doing much business in Japan once its factories can deliver the same products." However, Howard notes, Japan's makers of 64-K random-access memories dislike the publicity their domination of the market is attracting and so are anxious for U. S. chip makers to get their 64-K RAMs into customers' products.

Wanted: a Business Trends editor

An opening on the New York editorial staff of *Electronics* offers a unique opportunity for a skilled communicator interested in the business side of technology. We seek an experienced business journalist with a good statistical or market research background in the electronics field. An EE or an MBA in market research or an economics degree would be eminently desirable. Send your résumé to the Editor-in-Chief, *Electronics*, 1221 Avenue of the Americas, New York, N. Y. 10020.

MODEL 1870 provides new functions that enable programming to FPLA and 64K-bit P-ROM's multi-job processing.



In the field of the logic, the LSI is marking revolutionary changes. Minato Electronics's "Model 1870" is a fully up-to-date achievement in a universal programmer. Designed for programming of logical devices such as FPLA. The "Model 1870" features a host of functions as a P-ROM programmer and offers easy operation. The replacement of the personality module permits not only programming of one MOS and bipolar device, but also easy and simultaneous gang-programming of 8 and 16 MOS devices. One of its significant features is that it permits the simultaneous gang-programming of 16 64K-bit P-ROMs, aiming at the anticipated 128K period. The "Model 1870" meets the current requirements as the P-ROM programmer, as well as the future requirements for LSI logic, by one unit. It responds to a wide variety of applications through its excellent performance, as a new-type universal programmer having great possibility.

- Very easy to operate
- Programs EP-ROMs, BIPOLAR PROMs, Single Chip Microcomputers, FPLA's, PAL's etc.
- Various kinds of personality modules (single-gang) and socket adapters
- 16K x 8 RAM standard—32 x 8 RAM optional
- Various test, check and protection functions for correct programming
- Various serial interface (option)
RS232C, 20mA current loop and TTL levels

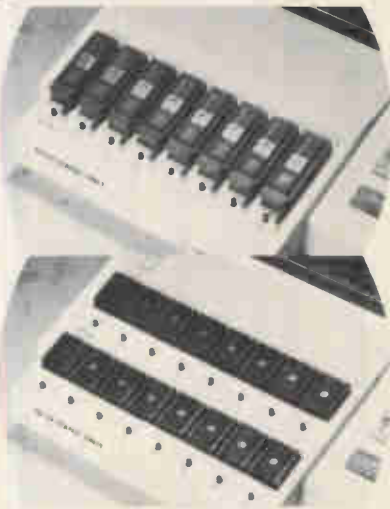

For further information, Please contact

- AUSTRIA
DES ELECTRONISCHE SYSTEM GMBH
A-1120 Wien, Fockygasse 51/3 Austria
Phone: 0222/83 01 91
- CANADA
CYBERNEX LTD.
Box 9086 Ottawa, Ontario Canada K1G 3T8
Phone: (613) 741-1540
- FRANCE
TEKELEC AIRTRONIC
Cite Des Bruyeres Rue Carle-Vernet 92310 Sevres
France
Phone: (1) 534-75-35

- FINLAND
PROFELEC OY
PL 67 00421 Helsinki 42
Phone: (90) 5664 477 Finland
- HONG KONG
SCHMIDT & CO. (H.K.) LTD.
28th Fl. Wing on Centre Hong Kong
Phone: 5-455644
- MALAYSIA
NIE ELECTRONIC (M) SDN. BHD.
P.O. Box 2167 Lor 2.22, Kompleks Selangor,
Jalan Sultan, Kuala Lumpur Malaysia
Phone: 03-24341
- SINGAPORE
LIM CHENG KOAN HOLDING PTE. LTD.
29, Hong Kong Street, Singapore, 0105.
Phone: 434626, 430358, 2243038
- SWEDEN
TELEINSTRUMENT AB
P.O. Box 4420 S-162 04 Valingby, Sweden
Phone: 08/380370
- SWITZERLAND
PRECITEK ELECTRONIC AG
Bahnhofstrasse 358b CH-8107 Buchs Zurich
Switzerland
Phone: 01-8442950
- TAIWAN
BURGEON INSTRUMENT CO., LTD
No. 90 Alley 83 Lane 211 Sec. 4 Nanking East Road
Taipei Republic of China
Phone: (02) 7646968, 7647017
- UNITED KINGDOM
MTL MICROTSTING LIMITED
Mill Lane, Alton, Hampshire GU34 2QG England
Phone: Alton (0420) 88022
- U.S.A.
OKURA & CO. (AMERICA), INC.
615 South Flower Street Suite No. 908 Los
Angeles, Calif. 90017 U.S.A.
Phone: (213) 624-8611



MINATO ELECTRONICS INC.

4105, Minami Yamada-cho, Kohoku-ku,
Yokohama, 223, Japan Phone: 045-591-5611
Cable: MINATOELEC YOKOHAMA
TELEX: 3822-244 MINATO J

Plastic Film Capacitors

Lead Spacing 5 mm

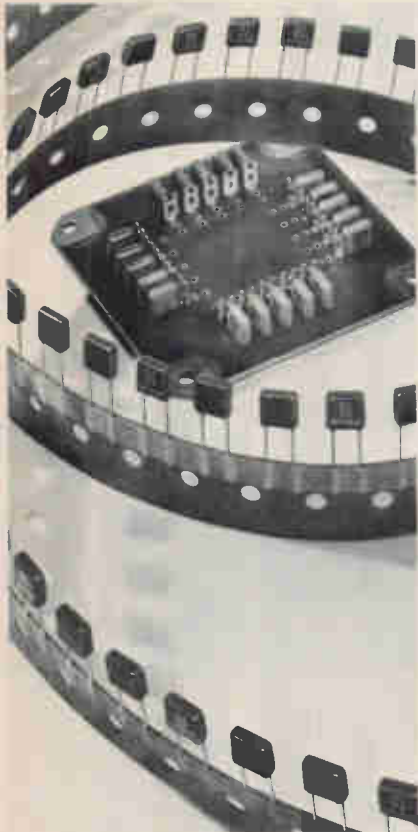

- Space saving design up to 1 μ F
- High capacitance/temperature stability
- Suitable for automatic insertion; available on tape for volume usage

WIMA MKS 2

Metallized polyester type providing extremely small dimensions at maximum capacitance/volume efficiency.

Ranges also include WIMA FKS 2/WIMA FKC 2/WIMA FKP 2: polyester/polycarbonate/polypropylene with metal foil electrodes.

WIMA PCM 5 mm Capacitors:

Tomorrow's technology!



WILHELM WESTERMANN

Spezialvertrieb elektronischer Bauelemente
P. O. Box 2345 · D-6800 Mannheim 1
Fed. Republic of Germany

THE INTER-TECHNICAL GROUP INC.
North Dearman Street · P. O. Box 23
Irvington · New York 10533
(914) 591-8822

TAW ELECTRONICS CO.
4215 W. Burbank Blvd., Burbank
California 91505 · (213) 846-3911

Readers' comments

Dodging the budget ax

To the Editor: It has been brought to my attention that *Electronics* has reported the imminent demise of "the National Bureau of Standards industrial robotics effort" due to budget cuts, a subject that was mentioned in passing in the article "DOD budget boosts dismay Congress" (Feb. 24, p. 89).

Though NBS does not have a formal program in robotics research as such, we do some work on robots in connection with a larger project to develop an Automated Manufacturing Research Facility (AMRF) for the study of such things as standardization problems facing automated machine shops. In particular, we have been and are studying interface standards and metrology for automated facilities involved in batch manufacturing.

In fiscal year 1982 we received a \$1.5 million increase. In fiscal 1983 the direct appropriation for the program was reduced by \$1 million. However, the program itself will not be curtailed because we will be able to obtain funds from other Government agencies and the private sector to replace the funds that have been cut out of our budget.

Michael Baum
National Bureau of Standards
Washington, D. C.

Cheap skills

To the Editor: The column by Irwin Feerst in your March 24 issue ["The Americanization of the IEEE," p. 24] was very interesting. Throughout human history, there have always been those who have attempted to gain power by selecting an easily identifiable subgroup of humanity and inciting members of that group to hostile action against others by appealing to the selfish interests of its members. In many cases, such attempts have been successful, particularly where the subgroup constituted a majority of the individuals concerned.

Mr. Feerst's contention that the growing number of alien engineers in this country, or their allegedly preferred treatment, represents in some way an injustice to us truly "Ameri-

can" engineers, is characteristic of this mentality. The whole notion of enlightened free enterprise centers around the concept that people should be free to do what they please, where they please, as long as doing so is not actively injurious to anyone else. Putting someone out of a job by doing more work for less money is not considered to be actively injuring them. Nationality has no more to do with the situation than sex has or race.

The sad experience of the automobile and steel industries in recent years is directly due to the selfish meddling with the laws of supply and demand on the part of those supposedly representing the work force. Lest the same fate befall the practitioners of engineering as a whole, let us not indulge ourselves by supposing that anything other than competence and productivity should be determining factors in the allocation of employment.

If a given human being can do more for less money than another, then let him. What difference does it make, which side of a particular arbitrary national boundary an individual was born on?

Timothy Stryker
Samurai Software
Pompano Beach, Fla.

Jingoist jangle

To the Editor: Having read Irwin Feerst's column in the March 24 issue, I must remark that I have never come across such narrow-mindedness in any issue of *Electronics* before.

The U. S. was built up and populated by immigrants or labor imported from abroad, and the author's ancestors must indeed have been among them. May I also remind the author that foreign-born employees are often harder-working and better trained than some of their American counterparts.

Author Feerst should also note that much of the technology of the U. S. was developed by immigrant scientists. The late Albert Einstein, for example, was not U. S. born.

Tarun Bikesh Roy
Pointe Claire, Que., Canada

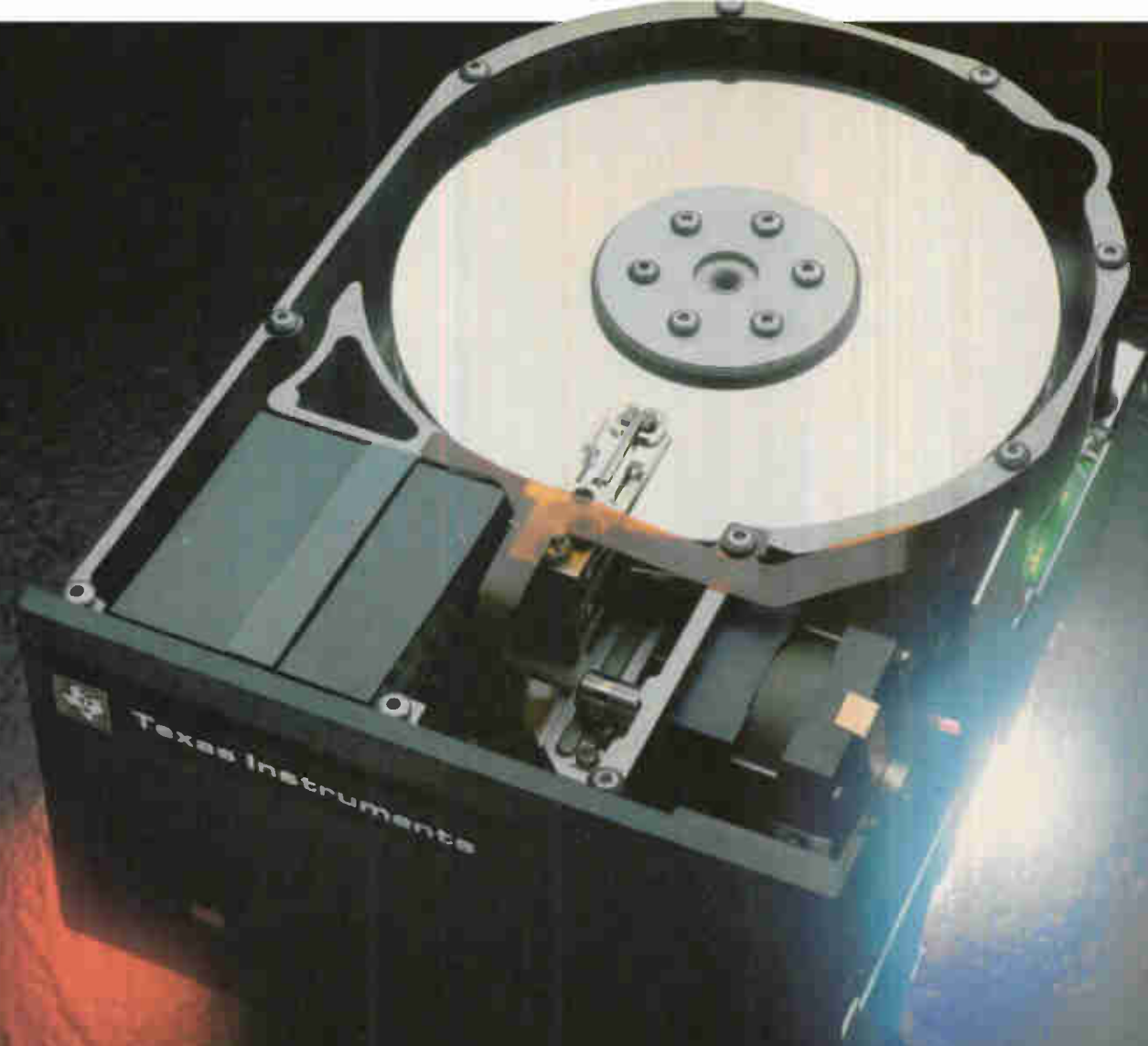

We deliver what the others promise.

The Texas Instruments 5¼" 6- and 12-Megabyte Winchester Disk Drive Family fits right into TI's tradition of perfecting our technology, production techniques and reliable performance.

That's why we can ship our disk drives in large production quantities just when you want them. This ability to deliver has made us a leader in the OEM marketplace.

It's really not surprising that TI's Winchester Disks actually do what all the others promise.

After all, we invented the integrated circuit, the microprocessor and microcomputer. They're the key components that make computers what they are today.

As always, our worldwide support and service are part of TI's

tradition of giving you more than you expect. For information write: Texas Instruments Incorporated, P.O. Box 202145, Dallas, Texas 75220. Better yet, call us today: 1-800-231-4717. In Texas: 1-800-392-2860.

TI invented the integrated circuit, the microprocessor and the microcomputer.



TEXAS INSTRUMENTS
INCORPORATED

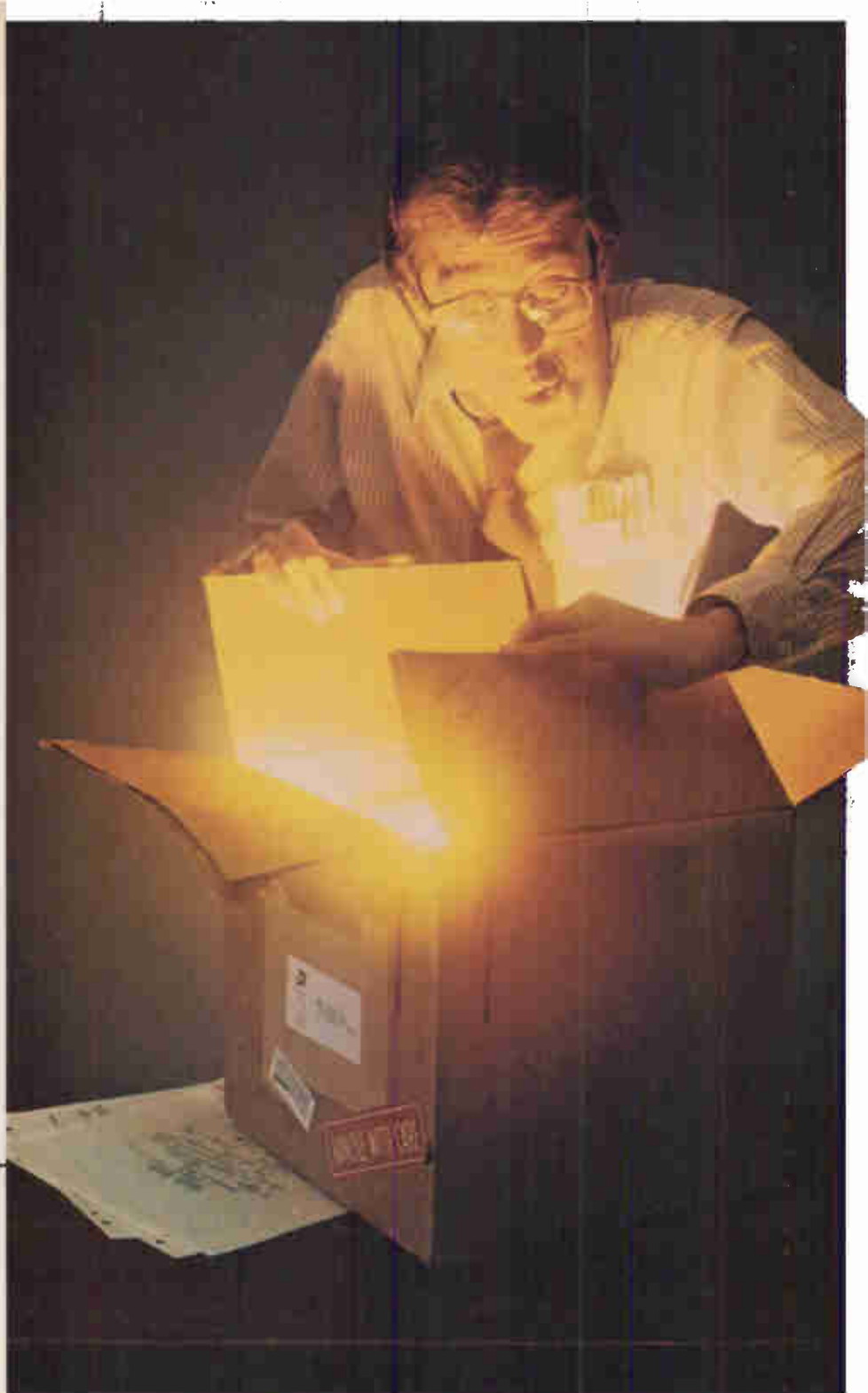

We've already shown you what IMOX™ can do for bipolar memories and digital signal processing chips.

Now, for the bit-slice processors. Two different slices, two different applications.

**FIRST, THERE'S
THE Am2901C.**

Thanks to IMOX, it's the first to break the 100ns micro-cycle barrier for 16-bit arithmetic. (That's worst case!) It's the fastest bipolar bit-slice

microprocessor ever made.

The Am2901C rips through arithmetic. It leaps through logic functions.

And, get this, there are over fifty high-performance

peripherals in the Am2900 Family and more on the way. Designing was never easier.

And, yes, it's available right now.

NEXT, THE Am29203.

The Am29203 will have a lot of features that make it

FAST ISN'T FAST ENOUGH ANYMORE.

faster for more complex functions.

Its dual I/O ports will allow twice as many data moves per cycle. Its 16 internal registers can be expanded indefinitely.

The single cycle BCD arithmetic will make the Am29203 the perfect choice for high-performance

small business computers.

And if all this sounds good, just wait until you see what AMD will be doing with IMOX in the future.

IMOX is our very advanced, ion-implanted, oxide-isolated process. It lets us make smaller, more complex devices than ever before.



IMOX lets us shrink the space between transistors, cut capacitance and decrease die size.

And IMOX isn't the only thing that nobody else offers. There's INT-STD-123.

Are you designing a high-performance system? Call or write AMD. We're a whole lot faster than fast.

The International Standard of Quality guarantees these electrical AQLs on all parameters over the operating temperature range: 0.1% on MOS RAMs & ROMs; 0.2% on Bipolar Logic & Interface; 0.3% on Linear, LSI Logic & other memories.

INT-STD-123

Advanced Micro Devices

901 Thompson Place, Sunnyvale, CA 94086 • (408) 732-2400
IMOX is a trademark of Advanced Micro Devices, Inc. ©1982 AMD

Circle 11 on reader service card

The shortage of EEs threatens the future

Is there a shortage of electronics engineers or isn't there? After *Electronics* editors around the country put that question and others to companies, colleges, and others deeply affected by the answer (see p. 105), the consensus is that the shortage is indeed real, though its severity varies with specialty, location, and, above all, the quality of any particular EE. Unfortunately, this conclusion lends comfort neither to the conspiracy theorists, who argue that shortfall rumors are concocted by companies plotting to keep salaries low, nor to those who counsel complacency because such conditions are cyclical in nature.

The truth appears to be that even though some engineers are out of work—after all, 100% employment even in heady times is unattainable—many firms of all sizes and in every sector of the electronics industries simply cannot find enough of the qualified professional personnel they need.

Electronics has become one of the nation's basic industries, taking its place beside autos and steel. Its insider jargon is now on the lips of the person in the street, who has created an almost insatiable demand for electronics products. More—and more sophisticated—designers and specialists in the technologies that make up electronics are needed to feed that demand.

This pervasiveness has spread its burden beyond industry to the academic community, already bludgeoned by increasing costs and losses in teaching ranks. Universities report there just is not enough money available to update sorely needed laboratory equipment; nor are there enough graduates willing to forgo the allure of industry salaries to enter the teaching profession.

Even more cause for concern is that

advanced electronic technology clearly points the way toward increased productivity, full employment, and the health of the general economy. It is, to reduce the equation to just two words, the future. By permitting shortages of the professionals needed and qualified to build that future, we are, in effect, short-circuiting it. That is why efforts such as the Semiconductor Research Cooperative of the Semiconductor Industry Association, which is being set up to funnel money to the universities to be spent for basic research, must be supported and expanded as quickly as possible—and so must the recently established grant program of the American Electronics Association.

What is needed also is a greater joint effort from two sectors—private and Government—to expand the inadequate programs in electronics engineering. Industry has recognized that merely to complain about inadequate supplies of EEs emerging from college is a disservice; to solve the problem it must contribute its know-how and money to provide enough of the right kind of people and equipment for the educators.

It is ironic that an Administration that is characterized by a "supply side" economic philosophy should fail to see the connection between the supply of engineers and the continuing leadership of this country in technology. Forcing reductions in aid to universities and to students is borrowing from the future to balance today's books. If there are not enough engineers to design the technology that the nation needs to maintain the pace of the innovative growth that has seen it become the world's technological leader, there will not be any trickle down in theory or reality.

When you can't get action out west...

COME EAST to CHERRY for CUSTOM ICs



We'll treat you like a CUSTOMER!

We're the "action now" people who take your custom IC needs as seriously as you do. We know your business can't afford delays. So we give you the prompt attention you expect.

With full custom IC capabilities and some of the most advanced technology anywhere, we can meet your design, production and delivery schedules for digital and linear bipolar circuits. Need both on the same chip? We've done it with I²L...successfully!

And, if a full custom design isn't quite what you need, one of our circuits that has been processed up to the point where it is ready for your interconnect mask can be finished to your specifications, saving design time and cost.

Call us today for ACTION! Dial (401) 885-3600 and ask for Custom IC Engineering Sales. Or write for this 12-page, full color brochure describing production of custom ICs the Cherry way.



CHERRY SEMICONDUCTOR

CHERRY SEMICONDUCTOR CORPORATION 2000 South County Trail, East Greenwich, RI 02818 / 401/885-3600

A wholly owned subsidiary of Cherry Electrical Products Corp., Waukegan, IL, U.S.A., 312 889 7700 • Worldwide affiliates and phone numbers: Cherry Mikroschalter GmbH, Auerbach, Germany, 09 643 181 • Cherry Electrical Products Ltd., Harpenden (Herts) England, (05827) 63100 • Chercu Brasil Industria E Comercio Ltda., Sao Paulo 55 (011) 246-4343 • Hirose Cherry Precision Co., Ltd., Kawasaki, Japan, 044 933 3511

Circle 13 on reader service card

**PIN GRID ARRAY
AREA GRID
PIN ARRAY
AREA ARRAY
BED of NAILS**

Regardless of what you call the packages, Textool probably has a ZIP (zero insertion pressure) socket to accommodate them.

If your requirements are strictly for test or burn-in, Textool's series of Grid Zip sockets (below right) are perfectly suited to your needs.

Should your needs include a production socket, Textool Area Array sockets (below left) will solve your problems.

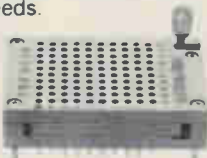

Lead configurations pose no real challenge to the unique flexibility of these Textool socket series (.100 x .100" grid). You see only the positions you need.

Simple mechanical action characteristic of all Textool ZIP sockets allows the user to literally "drop" a device into any of them. Close the cam and the device is

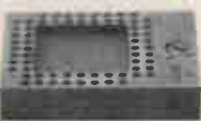

retained with a minimum of 100 grams pressure per lead. Release the cam and the device

may be removed with zero contact pressure, thus virtually eliminating mechanical rejects caused by bent or distorted leads. No longer is there a need to mount direct and run the risk of losing a multilayer PC board.

Detailed information on Textool's complete line of sockets/carriers for test, burn-in and production applications is available on request.

**Textool Products Department
Electronic Products Division/3M
1410 W Pioneer Dr., Irving, TX 75061
214/259-2676**



People

Szygenda and CGIS look up for computer-aided services

As an increasing number of firms scatter their operations across the land, it becomes more difficult for them to create an integrated network for computer-aided design, manufacturing, and tests. That's why Stephen A. Szygenda, president of Comsat General Integrated Systems Inc. in Austin, Texas, looks to the sky for the answer.

CGIS, which became a wholly owned subsidiary of Washington, D. C.-based Communications Satellite Corp. in January 1981, is now chartered to develop CAD/CAM/CAT systems that can be

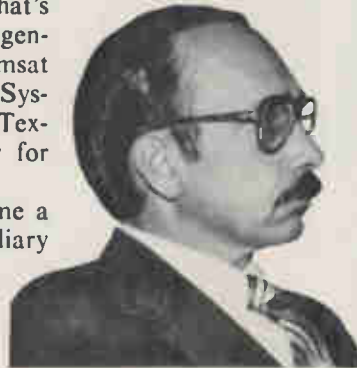

Sky net. Stephen A. Szygenda thinks the way to link scattered design operations is with satellites.

cost-effectively networked through a satellite. As products generally become more sophisticated, many manufacturers are having to delegate design responsibilities to a number of development laboratories—which, often because of acquisitions or the desire to be near various technology centers, are located in different cities.

These CAD/CAM/CAT satellite networks will allow designers states apart to work concurrently on the same projects, says the 43-year-old Pennsylvanian, who now enjoys raising cattle and quarter horses in central Texas. "A satellite network will allow utilization of very expensive resources in a cost-effective manner," he states. "You don't have to duplicate resources like data bases or other capabilities."

In many ways, the company is faced with those very same obstacles, since it has design centers in Palo Alto, Calif., as well as Austin. The operation is planning soon to link CAD/CAM capabilities over the Satellite Business Systems network with an economical transmission scheme that shares channels and uses a lower data rate than voice or video applications.

Szygenda, who founded the Austin software operation while teaching at the University of Texas in 1971, says, "All predictions indicate that the total CAD/CAM area will surpass \$1 billion in 1985, with the bulk of money going to software." But back when he started Comprehensive Computing Systems and Services (now Comsat General Integrated Systems) software was not high on the priority list of many businesses. However, that is beginning to change with dropping hardware prices and escalating software costs. "It's starting to gain the respectability that hardware had in the past," says Szygenda, who received his doctorate in computer engineering

at Northwestern University in Evanston, Ill., while working at Bell Laboratories in the late 1960s.

Now a part of Comsat, his operation is entering the total integrated-systems business from the software side—something that Szygenda believes gives his company a distinct advantage over firms with hardware expertise. "Experience and credibility are the keys in the software business. You must show that you've done it," he states. In general, he says, the industry is "just more knowledgeable in building hardware" and most are relatively inexperienced in software—especially when it comes to maintaining leading-edge software over the years.

Daniels, Forward Technology on bit-mapped graphics track

If the user is given a choice of similarly priced microsystems, Dennis Daniels maintains that he or she will invariably choose a bit-mapped graphics display over the alphanumeric displays that are the rule in the personal work stations now on the market. Moreover, the founder

Ohmite can help you select the right resistor for your application with capabilities unequaled by any other manufacturer. We make more types, in a wider range of wattages and resistances than anyone else. You can be sure that our recommendations will not be influenced by product line limitations.

Our resistors range from 1 watt up to 1500 watts and from 1 megohm down to 0.005 ohm in the coatings you need. We can even provide 0.005 ohm resistors with 1% tolerance—a variance of only ± 0.00005 ohm! For special needs, we can custom wind virtually any size or type.

Our applications engineering department is the industry's most experienced, and can help you determine what type and size resistor will best handle your demands. Unlike some other manufacturers, we offer both vitreous enamel and silicone coatings and can recommend what's really best for your needs.

For many special applications, our evaluation goes beyond power ratings, value and tolerance. For example, in circuits encountering brief power surges, the invisible differences between two types of 5 watt resistors can mean the difference between long-term reliability and premature failure. We can help you design-in reliability.

FOR IMMEDIATE DELIVERY of standard products contact your local Ohmite distributor. For application assistance call your Ohmite sales office.

A 60 page resistor catalog is available from Ohmite Manufacturing Co., 3601 Howard Street, Skokie, IL 60076, 312-675-2600.



OHMITE

A NORTH AMERICAN PHILIPS COMPANY

Circle 15 on reader service card

Which wirewound resistor is best for your application?

Ohmite has the right resistors and the right application advice.

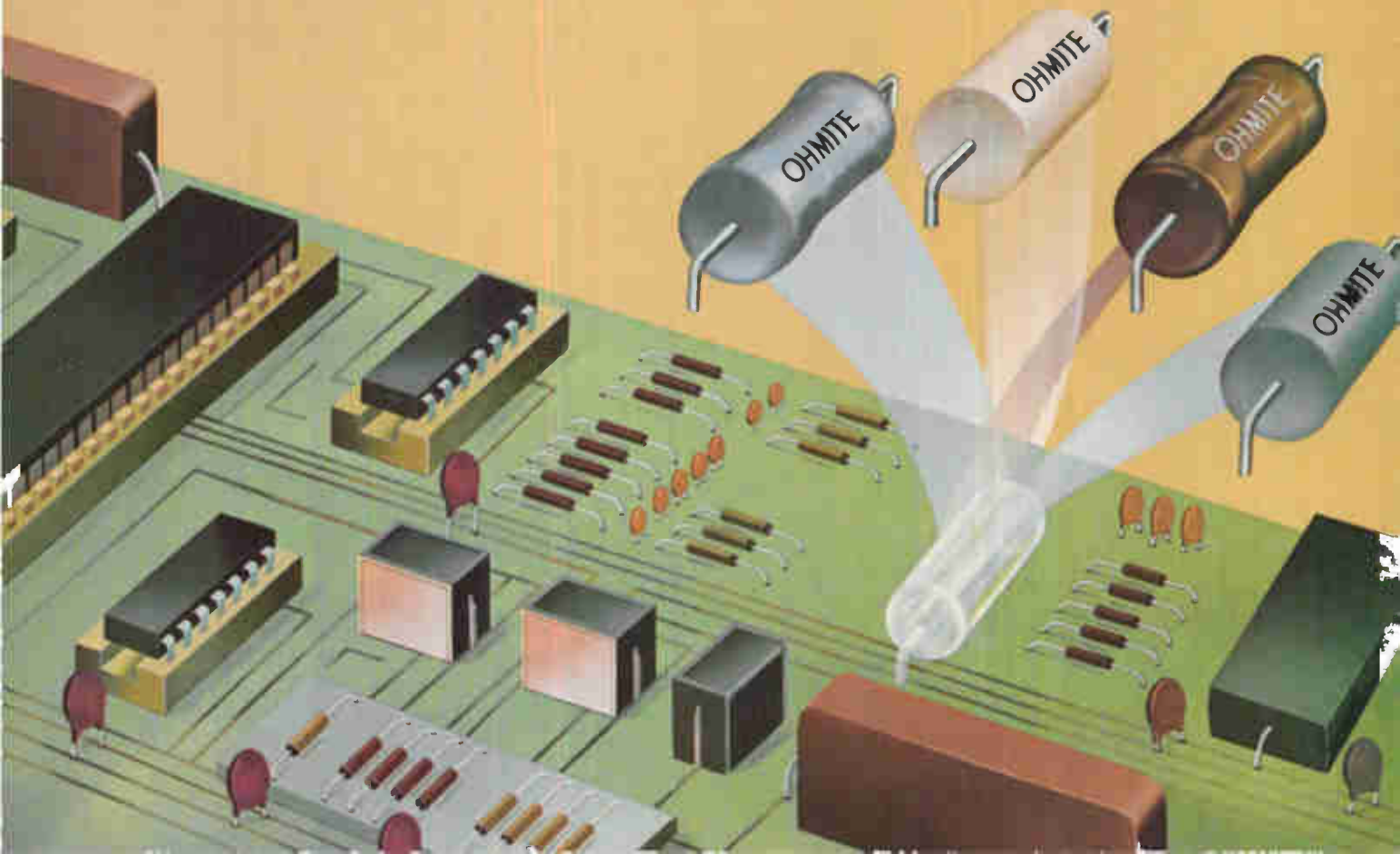

THE ZENDEX ZX-907 BUS TRACER Monitors Multibus* Operation

The ZX-907 represents a major advancement in Multibus development tools. This processor-based board, in conjunction with an external CRT, interprets Multibus events by monitoring address, data and control lines. The on-board memory will store up to 1024 bus events. The interpreted results are displayed on the CRT in the form of action, memory or I/O location, and data.

- 40 bit wide trace
- 1024 Bus Cycle Storage in on-board RAM
- On-board 8085A-2 Processor
- Menu driven software trace control
- Breakpoint can be preset on Address = , <, >
- 8 or 16 Bit Processor Compatibility

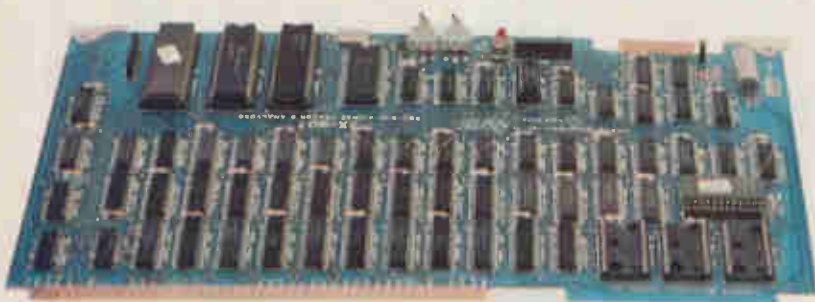

* TM INTEL Corp.

United Kingdom—Giltspur Microprocessor Systems
Tel (0635) 45406 Telex 848507
France—Tekelec Airtronic
Tel (1) 534-7535 Telex 204552F
West Germany—Allmos Elektronik
Tel (089) 857-2086; Telex 5215111



Zendex®

6644 Sierra Lane, Dublin, California 94566
Tel.: [415] 828-3000 TWX 910 389 4009

Circle 16 on reader service card

Keeping you ahead of the pack ...

You (and we) are in a quick-moving business. News breaks frequently. Change is the name of the game. Awareness is the way to win.

Give us one hour of your time every two weeks and we will keep you aware of what's going on around you and around the changing world of electronics technology.

Keep ahead of the pack. Send in one of the subscription cards in this issue.

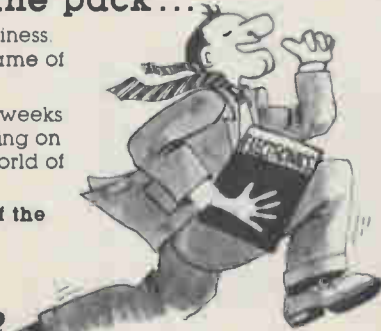

Electronics Magazine

People



An answer. Dennis Daniels says his boards give microcomputers mini-like muscle.

of newcomer Forward Technology Inc. believes that such systems are already entering the market thanks to the advent of the 16-bit microprocessor in packaged systems.

Daniels so strongly puts his faith in bit-mapped graphics, he left another company he helped found—intelligent-terminal manufacturer Zentec Corp. of Santa Clara, Calif.—and created Forward (also in Santa Clara) to manufacture the board-level designs that were prototyped as the Stanford University Network (SUN) work station.

For some time, “people have been looking for a microcomputer with enough power to provide true mini-computer functionality,” says Daniels. “They want sufficient address space, memory management, a sophisticated interrupt structure, and context switching.” He believes the Multibus-interfaced SUN board his firm provides, which includes a graphics board with 1,000 by 1,000 picture elements, a central-processing-unit board containing a Motorola 68000, and 256-K bytes of random-access memory, is the answer to those needs. “They are also looking for an engine to run Unix or Xenix.”

The 42-year-old Daniels’s marketing orientation at this point is almost instinctive, after 18 years in related positions. He studied at San Diego State University and the University of California, Los Angeles. When he joined Zentec in 1974, it was as vice president of marketing.

“I was always a classical entrepreneur,” observes Daniels. “I thought of a better way to do something and then did it. It happened that this idea [for the SUN boards] did not fit in with Zentec’s thrust; so I spun it out as Forward Technology.” □

Centigrad III

The world's first CMOS compatible EMR

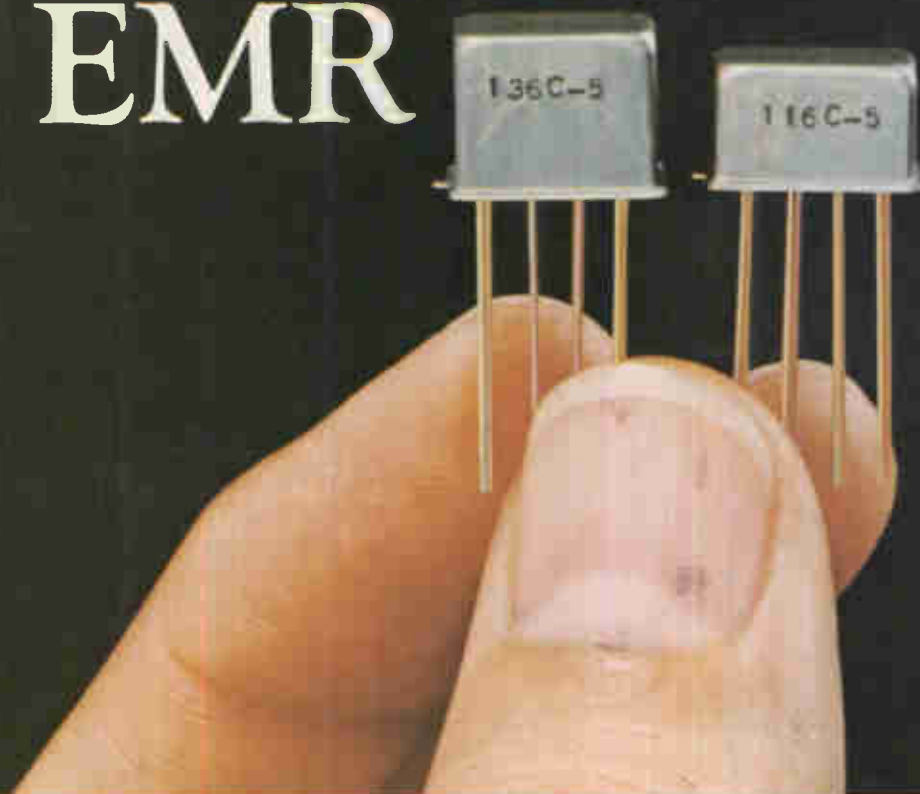

Now for the first time you can drive an electromechanical relay directly with the signals of most logic families—including CMOS. That means simpler board layout problems and reduced components counts for greater reliability.

The new Centigrad relay incorporates a power FET driver in the input to amplify the signal, protects it with a large Zener diode, and packs it all together with a DPDT relay and coil suppression diode in a tiny Centigrad

style can. And make no mistakes . . . it is a Centigrad relay designed to meet the requirements of MIL-R-28776. Its ruggedness and proven contact reliability are industry bywords.

Ultraminiature Centigrad relays have proven extremely effective in applications where high board density and close board spacing are critical. Low power requirements make them exceptionally valuable for battery operation, and they have excellent RF char-

acteristics up through UHF.

The new Centigrad is available in both general purpose (116C) and sensitive (136C) versions. Call or write today for complete information or applications ideas.

TELEDYNE RELAYS
The best little relays in the world.

12525 Daphne Ave., Hawthorne, California 90250 • (213) 777-0077
U.K. Sales Office: Heathrow House, Bath Rd., Cranford, Hounslow, Middlesex, TW 5 9QQ • 01-897-2501
European Hqtrs: Abraham Lincoln Strasse 38-42 • 62 Wiesbaden, W. Germany 6121-700811
Japan Sales Office: Nihon, Seimei Akasaka Building • 8-1-19 Akasaka, Minato-Ku Tokyo, 107 Japan (03) 403-8141

Circle 17 on reader service card

Our sockets don't fail under stress.

By design, AMP DIP sockets don't knuckle under to overstress—the number one reason for socket failure.

But that's not all. They're also competitively priced, delivered on time with our computer-linked regional inventory system.

What's more, they offer your design

engineers a broad range of features—and a choice of .175" or .160" profiles in solid or ladder housings. A number with MIL-S-83734 qualification. And all capable of machine insertion to increase your productivity.

Get the socket that won't fail under stress—or go over your budget.

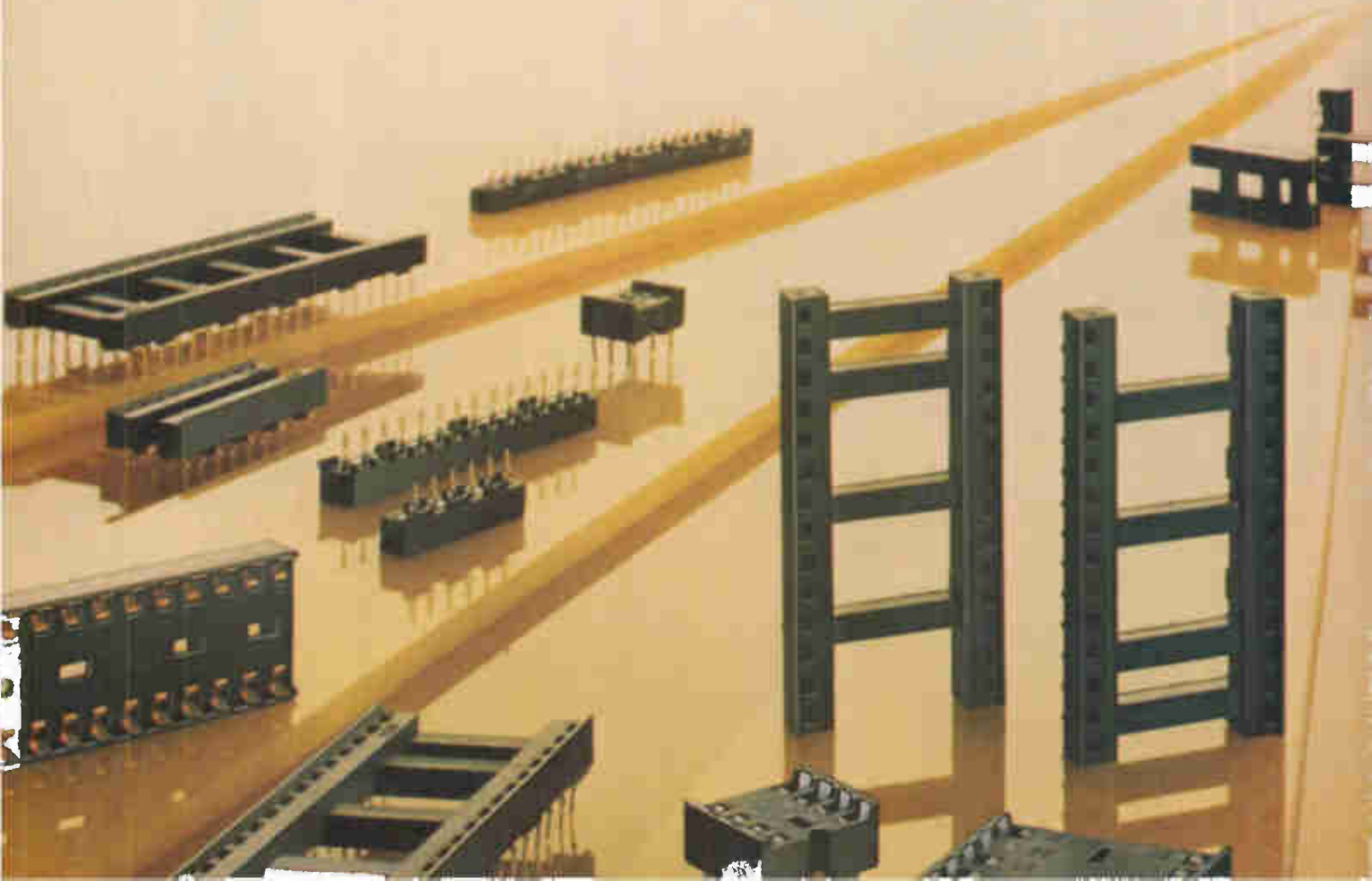

AMP Facts

DIPLOMATE SL Sockets

Sizes: 8 through 40 positions
Profile: .160"
Engaging force: 340 grams max.
Separating force: 25.5 grams min.

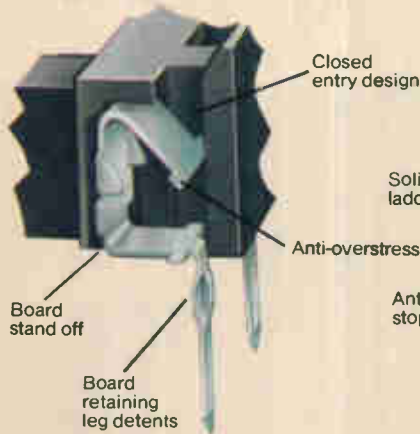

DIPLOMATE DL Sockets

Sizes: 6 through 40 positions
Profile: .175"
Engaging force: 340 grams max.
Separating force: 14 grams min.

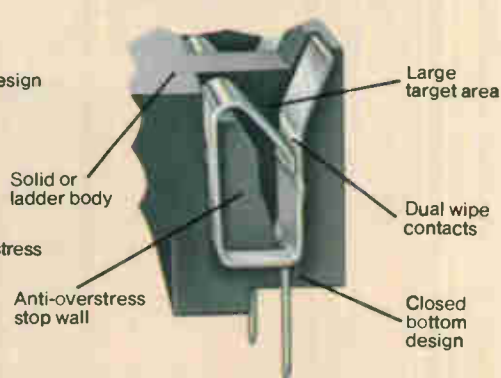

For full details, call the AMP DIP Socket Information Desk at (717) 780-8400.
AMP Incorporated, Harrisburg, PA 17105.

AMP and DIPLOMATE are trademarks of AMP Incorporated

AMP means productivity.

CIRCLE
NUMBER
125

WE KNOW PROGRAMMERS WHO' TO WORK FOR YOU.

There are about 37,000 microsystem software engineers in the world today.

80% of them are developing programs based on our 16-bit architecture.

So far, they've written nearly a billion lines of code for us — and for you.

Our software is one of the biggest reasons why. Because at Intel, we give you a lot more support than anybody else in the industry. Like our completely modular set of software building blocks. Which includes development tools. Utilities. Operating systems. High level languages. Complete documentation. And workshops.

We've even created a whole third-party software operation. To take the best work of those 30,000 programmers and make it available to you.

As a result, we can give you more operating systems and languages than any other microprocessor manufacturer. Five 8-bit languages. Five 16-bit languages: FORTRAN, Pascal, BASIC, PL/M, and COBOL. With JOVIAL and Ada on the way.

And we give you three operating systems to choose from: our own iRMX 86 and iRMX 88, plus CP/M*. Compare that to our closest competitor who can't even give you half the choices we do.

Impressive as all that sheer volume may be, we think it's even more important to give you real quality. So we've made sure that all the pieces work together, through well-defined standard interfaces. We even give you a direct connection to the future. Because all your applications in high-level languages are fully

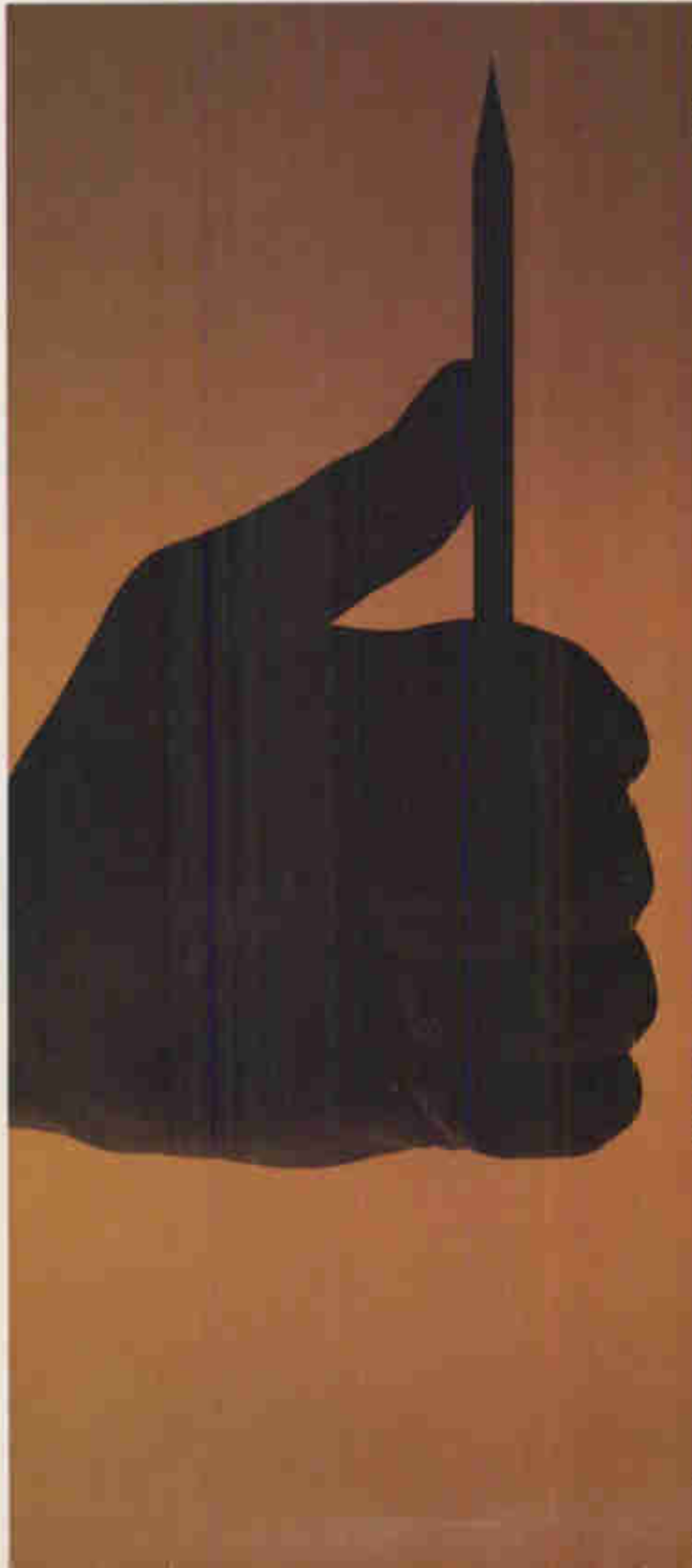

30,000 LL BE PERFECTLY GLAD OR AGAINST YOU.

portable to our next-generation iAPX 186 and iAPX 286 as well.

You'll see real quality in our field support, too. With our worldwide network of software support engineers, you can look for the best advice in the industry. And real help whenever you need it.

Finally, we'd like to remind you of another big reason why all those programmers started writing for the iAPX 86 in the first place.

Performance.

According to our latest benchmarks, when you combine an iAPX 86 CPU with one of our operating systems, one of our high-level languages, and an applications program, the result is a total solution that runs circles around any other microsystem combination of hardware and software.

We'd like to send you a new brochure that's full of detailed information about our software. About the quantity. The quality. And the performance.

Because we want you to see exactly how much help you get when you design with an Intel CPU.

And how much help your competition gets when you don't.

Just get in touch with your distributor. Or write: Intel Corporation, Attn. Literature Dept., 3065 Bowers Avenue, Santa Clara, CA 95051. (408) 987-8080.

intel[®] delivers
solutions

United States and Canadian Distributors: Alliance, Almac/Stroum, Arrow Electronics, Avnet Electronics, Component Specialties Inc., Hamilton/Avnet, Hamilton Electro Sales, Harvey Industrial Components Inc., L.A. Varah, Measurement Technology Inc., Mesa, Pioneer, Wyle Distribution Group. Zenitronics CP/M is a registered trademark of Digital Research, Inc.



Smart color from Tektronix: Performance and clarity you should see for yourself!

The 4113 combines a crisp, clear color display with true zoom and pan, local segments, and the many other performance extras of the Tektronix 4110 Series. To appreciate the significance of the 4113, you must see it for yourself. No other color terminal so successfully merges high information density with comfortable viewability, or offers such powerful local capabilities at such an affordable price.

You'll see exceptional sharpness and image stability engineered into the 4113's 483 mm (19-inch), 60 Hz non-interlaced display. You can address a 4096 x 4096 point matrix, then zoom and pan to magnify any detail on the 4113's 640 x 480 display. As a result, plots developed on the highest resolution Tektronix displays, such as the 4114, are easily transferred to the 4113 for color enhancement.

You'll see how easy it is to access any of 4096 colors, or to command local graphics, using a

minimum of host computer time. The Tektronix Color Standard makes color specification remarkably simple. Work with 8 colors on-screen at once or, with optional bit plane, as many as 16 colors.

Powerful, highly expandable local intelligence lets you retain pictures and picture segments in local memory, then redraw and manipulate with a short command from the host.

The 4113's operating system is wholly compatible with all other 4110 Series terminals, as is its optional, integral flexible disk mass storage. The 4113 is available in either pedestal or convenient workstation configuration. For fast start-up, easy maintenance, CPU and terminal independence, you can take advantage of the Tektronix PLOT 10 Interactive Graphics Library: the most popular implementation of the 1979 SIGGRAPH proposal for a computer graphics standard.

Ask your Tektronix Sales Engineer for a hands-on demonstration. Or call Tektronix today for more information.



U.S.A., Asia, Australia, Central
& South America, Japan
Tektronix, Inc.
P.O. Box 4828
Portland, OR 97208
Phone: 800/547-1512
Oregon only: 800/452-1877
Telex: 910-467-8708
Cable: TEKTRONIX

Europe, Africa, Middle East
Tektronix Europe B.V.
Postbox 827
1180 AV Amstelveen
The Netherlands
Telex: 18312

Canada
Tektronix Canada, Inc.
P.O. Box 6500
Barrie, Ontario L4M4V3
Phone: 705/737-2700

Tektronix
COMMITTED TO EXCELLENCE

Japanese investment in the U. S.

by Edson W. Spencer, *chairman, Honeywell Inc.*



Japan and the United States are inexorably driven together in matters of international trade and investment. We are the two leading users of petroleum, and between us we import half of all the exports of the oil-producing nations. We both, therefore,

have great need to maintain a free international environment for exports, imports, capital flows, and productive investments. Closed capital markets and discriminative policies against each other's products make for a course that will only lead to retaliation and disaster.

Competition between our industries, on the other hand, is healthy. It prevents our domestic manufacturing and service businesses from becoming fat, complacent, and unresponsive to customer needs. We are not afraid of Japanese competitors in our markets, and Japanese businessmen should not fear American competition in theirs. Of course, we have to be understanding of each other's national interest and domestic political problems. That is possible, however, while maintaining the industrial strength that competition engenders. The consumers in Japan and the U. S. will be the beneficiaries.

Helps exports. I believe Japan has arrived at the point where it must invest aggressively in worldwide markets. Foreign investments in manufacturing facilities will, in the long run, help increase the flow of Japanese exports into those countries where plants are established. Exports follow because components, parts, and assemblies are required for further fabrication and added value in the market being served. Exports are further enhanced by establishing a bigger and stronger presence in the market being served and hence the ability to sell all products in greater volume.

My experience tells me that in all countries, a competitor's market penetration is limited if his business in that country is confined to importing. Making capital investments in a foreign country is essential if the goal is maintaining and increasing market share.

The reasons for this are many. One has to do

with economies of scale, especially when selling to the U.S. market. This market's very size reduces the risks involved in undertaking U.S. manufacture of the product, and it increases the profit opportunity.

A second reason is the natural desire of any customer to favor a local product over an imported product—everything else being equal.

Another major factor that has to be considered by importing companies is the friction that may be created when local workers are put out of jobs because of imports.

Pressure point. In my own view, the Japanese automobile industry has been too late in recognizing this pressure point and too slow in moving into manufacturing in the U. S. and Europe. A company that has done just the opposite is Sony Corp. Sony invested in America before the American television industry began to ask for help under anti-dumping laws; before Congress began to look at the effect of declining jobs and displaced workers; before the pressure point was reached. I frankly do not think many Americans know whether Sony is a foreign company or not. As a result of the farsighted views of Sony's management, the "Made in USA" label diffuses protectionist concerns and allows Sony to perform as a strong and successful competitor in the U. S. market.

More of Japanese industry must follow Sony's example and be willing to take the risk of setting up manufacturing plants outside Japan, before the backlash against Japanese imports becomes an even stronger political pressure point in the major industrialized markets.

And we welcome Japanese businessmen who are willing to put capital into productive enterprise in our country. We also expect equal opportunity for American companies to invest in Japan. I would characterize Japan as a country in the process of opening its doors to foreign investment, but with a long way to go to match the openness of the U. S. market.

If Japan does not welcome the competition of investors in its market, and if Japan does not invest outside its borders, short-range gains can only be followed by long-range opportunities lost by Japanese industry to the more venture-some of its foreign competitors.

Electronics will periodically invite the expression of outside views on this page concerning issues of importance to the electronics industries.

A system housing as intelligently engineered as STD BUS itself.

Introducing the STD 701 μ Package . . . from the designers of the STD BUS.

When we designed our new STD BUS enclosure, every detail was analyzed to solve your system packaging problems before they happen.

First, the size. With 12- or 21-slot card cage on $\frac{3}{8}$ " centers, +5V and ± 12 V power supplies, fan and connector panel, it's still roomy enough for your custom equipment. Like signal conditioning, interface hardware, displays and connectors.

Then there's the easy access. The front panel disconnects easily so you can add or swap cards. And it's flat for simple installation of your custom keys, switches, lights or displays.

Our intake fan air flow system offers better cooling and cleaner operation than packages using an exhaust fan.

Converting the μ Package from rack-



mount to benchtop configuration is a simple matter of adding the optional decorative top and side panels.

We even thought of little things like spare panels for inexpensive replacement if you damage the original or change your mind about a design.

And we supply a vellum drawing kit for documenting custom areas.

Manufactured to Pro-Log's high quality standards.

The STD 701 μ Package was engineered to meet UL, FCC and CSA requirements, giving you a head-start on approval of your final

system design. It carries a limited two-year warranty.

Build a microcomputer with Pro-Log STD BUS cards.

Plug in your choice of Pro-Log STD BUS cards and you have a complete customized microcomputer for process control, data collection, ATE or development applications.

For more information, write or call Pro-Log Corporation, 2411 Garden Road, Monterey, CA 93940, phone (408) 372-4593. Outside California, call toll-free: (800) 538-9570.

Australia, Werner Electronic Industries, Telex AA88405; France, Yrel, Telex 842-696379; Germany, Spezial Electronic, Telex 971624; Italy, Techniron, Telex 68071; Japan, Syscon, Telex 2635496; Switzerland, Max Meier Elektronik, Telex 55448; United Kingdom, Technitron, Telex 858618.



VACTEC

OPTOELECTRONICS

DETECTORS

AND

EMITTERS

FOR

INFRARED

REMOTE CONTROL



DETECTORS

EMITTERS

DETECTORS—
PIN photodiodes;
NPN phototransistors

EMITTERS—Gallium
Arsenide LED's

PACKAGING—T-1 and
T-1 1/2 (3mm and 5mm)
plastic; TO-18, TO-5
ceramic, micro DIP

Call or write for Bulletins
VTTA-3 and VTD-1.



VACTEC, INC.

10900 Page Blvd.
St. Louis, Mo. 63132
(314) 423-4900
TWX 910-764-0811

Meetings

40th Annual Device Research Conference, IEEE (H. Craig Casey Jr., Duke University, Durham, N. C. 27706), Colorado State University, Fort Collins, June 21-23.

International Symposium on Information Theory, IEEE (Carl Helstron, Department of Electrical Engineering and Computer Sciences, Mail Code C-014, University of California, La Jolla, Calif. 92093), Les Arcs, France, June 21-25.

Circuit Expo West '82, Worldwide Convention Management Co. (Sheila Mors, Worldwide Convention Management Co., P. O. Box 159, Libertyville, Ill. 60048), Long Beach Convention Center, Long Beach, Calif., June 22-24.

Nepcon East '82, Cahners Exposition Group (222 West Adams St., Chicago, Ill.), New York Coliseum, June 22-24.

Comdex/Spring '82, The Interface Group (160 Speen St., P. O. Box 927, Framingham, Mass. 01701), Convention Hall, Atlantic City, N. J., June 28-30.

Videotex '82, Online Conferences Ltd. (Meeting Systems Inc., 286 Fifth Ave., Suite 809, New York, N. Y. 10001), New York Hilton, June 28-30.

Conference on Precision Electromagnetic Measurements, IEEE (Robert Kamper, National Bureau of Standards, Boulder, Colo. 80303), University of Colorado, Boulder, June 28-July 1.

9th International Power Electronics Conference and Exhibit, Power Concepts Inc. (Ronald Birdsall, P. O. Box 5226, Ventura, Calif. 93003), Hyatt Regency Crystal City, Washington, D. C., July 12-15.

Joint Intermag and Magnetism and Magnetic Materials Conference, IEEE (Prof. Arthur Yelon, Ecole Polytechnique, University of Montreal, Quebec, Canada), Montreal, July 20-23.

Siggraph '82—9th Annual Conference on Computer Graphics and Interactive Techniques, Association for Computing Machinery (Siggraph '82, Convention Services Department, 111 East Wacker Dr., Chicago, Ill. 60601), Hynes Auditorium, Boston, July 26-30.

6th International Conference on Computer Communication, International Council for Computer Communication (ICCC, P. O. Box 23, Northwood Hills HA6 1TT, Middlesex, England), Barbican Centre for Arts and Conferences, London, England, Sept. 7-10.

Wescon/82—Western Electronic Show and Convention, Electronic Conventions Inc. (999 North Sepulveda Blvd., El Segundo, Calif. 90245), Anaheim Center and Anaheim Marriott Hotel, Anaheim, Calif., Sept. 14-16.

6th International Fiber Optics and Communications Exposition, Information Gatekeepers Inc. (Ellen M. Bond, Information Gatekeepers Inc., 167 Corey Rd., Suite 111, Brookline, Mass 02146), Marriott Hotel, Los Angeles, Sept. 15-17.

Seminars

Design-Oriented Analysis and Measurement Techniques (for electronic-feedback control) and Basics of Power Electronics: Topologies, Magnetics, and Control will be presented in Boston in June, Miami Beach in July, and the San Francisco area in late August. For information on these three-day seminars, write Tesla Co., Educational Division, 490 South Rosemead Blvd., Suite No. 6, Pasadena, Calif. 91107 or call (213) 795-1699.

Spectrum of Solutions '82, an exhibition and conference on computer applications, is sponsored by Prime Computer Inc. (Prime Park, MS 15-60, Natick, Mass. 01760), McCormick Inn, Chicago, June 29-July 1. The same show will visit the New York and Dallas areas during this coming fall.

Available now... a family of high speed 16K static RAMs that meet MIL-STD-883B



Take your pick. A 16Kx1 organization with the IMS1400S-70M, or a 4Kx4 with the IMS1420S-70M. INMOS delivers both. They're fully processed and qualified by INMOS to MIL-STD-883B. This includes screening over the full -55°C to +125°C temperature range, as defined in Method 5004 Class B, and qualification to Method 5005 Class B.

Both RAMs give you 70ns chip enable access time and 660mW maximum active power dissipation (only 165mW maximum standby). They operate from a single 5V ($\pm 10\%$) power supply, are TTL compatible and come packaged in 20-pin, 300-mil ceramic DIPs with industry standard pinout.

Remember, you can get them now, off-the-shelf* from your local INMOS distributor. Because INMOS believes that meeting your delivery requirements is just as important as meeting the military standard.

* IMS1400S-70M



P.O. Box 18000 • Colorado Springs, Colorado 80935 • (303) 630-4000 • TWX 910/920-4904 • Burlington, Mass. (617) 273-5150 • Dayton, Ohio (513) 439-0988 • San Jose, Calif. (408) 298-1786 • Whitefriars • Lewins Mead • Bristol BS1 2NP • England • Phone Bristol 0272 290 861 • TLX 444723

inmos,  and IMS are trademarks of INMOS.

Circle 27 on reader service card

In the Microworld, Motorola and Intel CPU's

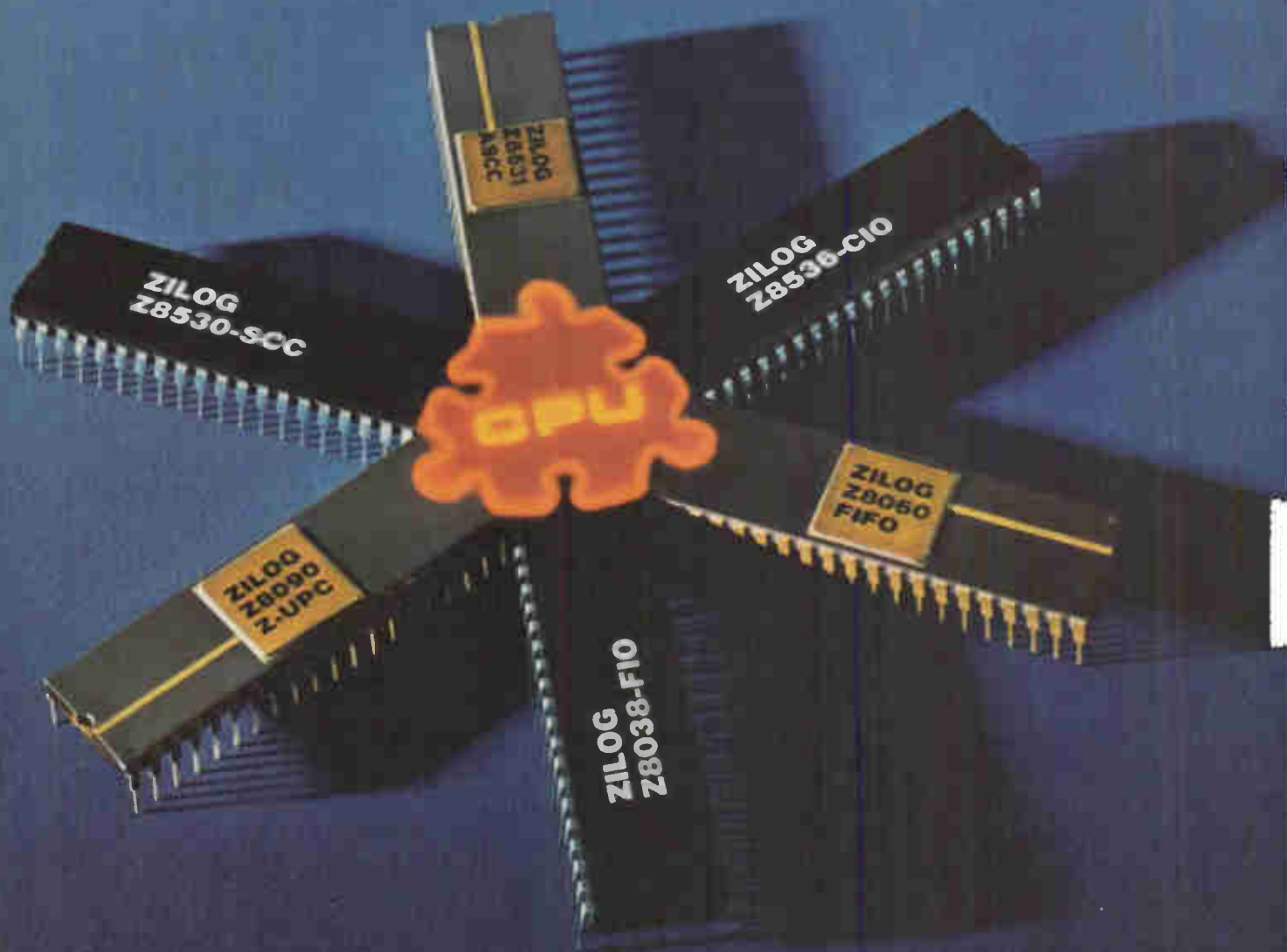

turn to Zilog peripherals for outside help

Now, no matter whose microprocessor you choose, you can design a better system by surrounding it with Zilog's architecturally-advanced universal peripherals.

We put more functions on every chip, so you need fewer parts and less space. For example, our CIO gives you three on-board 16-bit counters, 20 programmable I/O lines, and vector interrupt control.

Advanced architectural features sharply reduce CPU overhead and increase system throughput. The SCC, for example, includes most of the frame-level protocol implementation requirements for Bisync and SDLC, including SDLC Loop Mode. And, it's the only serial controller with on-chip clock recovery logic. For asynchronous-only applications, there is also Zilog's ASCC which offers all of the benefits of the SCC at lower cost.

We also have circuits that can simplify your multiprocessor designs. Our FIO provides an easy-to-use asynchronous FIFO interface between any two CPU buses. Our UPC gives you a complete single chip microcomputer with a built-in host bus interface for distributed processing applications.

Find out today how Zilog peripherals can make your product more competitive in the Microworld — no matter which CPU you've decided on. Call your nearest Zilog sales office or write Zilog, Inc., Components Marketing, 1315 Dell Avenue, Campbell, CA 95008.

In addition to working with Zilog's CPUs, Zilog peripherals help these processors.

Supplier	16-Bit	8-Bit	Single
Intel	8086/8088	8080/8085	8051
Motorola	68000	6800/6809	6801
Rockwell		6502	
Texas Instruments	9900/99000		

Zilog's Universal Peripherals are available now: SCC, Serial Communications Controller; ASCC, Asynchronous Serial Communications Controller; FIO, FIFO Input/Output Interface Unit; FIFO, FIFO Buffer Unit and FIO Expander; CIO, Counter/Timer and Parallel I/O Unit; UPC, Universal Peripheral Controller. The Z-SCC (Z8030), Z-ASCC (Z8031), Z-CIO (Z8036), Z-UPC (Z8090) work with multiplexed address and data bus CPUs. The SCC (Z8530), ASCC (Z8531), CIO (Z8536), UPC (Z8590) are non-multiplexed address and data bus versions. The FIO (Z8038) and the FIFO (Z8060) work with either bus versions.

Domestic
 Campbell, CA
 (408) 370-8120
 Irvine, CA
 (714) 549-2891
 Van Nuys, CA
 (213) 989-7484
 Clearwater, FL
 (813) 535-5571
 Schaumburg, IL
 (312) 885-8080
 Burlington, MA
 (617) 273-4222

Cedar Knolls, NJ
 (201) 540-1671
 Woodmere, OH
 (216) 831-7040
 Austin, TX
 (512) 453-3216
 Dallas, TX
 (214) 931-9090
 Bellevue, WA
 (206) 454-5597

International
 London
 England
 0628-39200
 Munich
 Germany
 8016-4035
 Paris
 France
 778-14-33
 Minato-ku
 Tokyo, Japan
 03-587-0528

Zilog *Pioneering the Microworld*

GOULD BIOMATION

A breakthrough in software/hardware integration.

Merging sophisticated software with complex hardware requires a new class of measuring instrument. And that means Gould Biomation.

The K101-D (48-channel) and K102-D (32-channel) logic analyzers offer unprecedented power in both data domain and time domain, enabling software and hardware engineers to solve elusive integration problems.

For software analysis, both instruments separate multi-system/multi-peripheral transactions. Debug loop and branch routines. Integrate long multiple subroutines. And selectively monitor system response to peripherals.

To aid the hardware designer, both instruments relentlessly track down complex timing skews, erratic signal relationships and other subtle hardware errors. Advanced high-performance hybrid probes capture glitches smaller than 5 ns.

To speed up software/hardware integration, mnemonic disassembly formatting saves time by correlating machine code to its source code.

Trace control revolutionizes monitoring of program flow.

More sophisticated than any classical triggering system, trace control allows you to isolate and capture widely-separated slices of program flow for review and comparison.

Sixteen separate selective trace control levels are available, each with 4 conditional commands and delay. By setting multiple breakpoints, you can determine cause-and-effect relationships between events that occur as much as weeks apart.

The K101-D or K102-D continuously monitors system activity, recording only the program segments you specify and ignoring irrelevant segments. You can not only advance to the next trace level, but jump to other levels to follow conditional branching across complex loops.

Individual trace level screen menus and keyboard controls make set-up simple. You can easily integrate the K101-D or K102-D

**FOR SLICING
TO THE HEART
OF A PROBLEM,
NO OTHER
LOGIC ANALYZER
COMES CLOSE.**



CLEARLY THE BEST.

into a computerized system for remote control via RS-232-C or GPIB interface.

Flexible clocking combinations

With either the K101-D or K102-D, you can keyboard-select virtually any conceivable clocking scheme in AND or OR combinations. This clocking flexibility allows you to accommodate virtually any system architecture. No need to waste time developing your own external circuitry to drive the clock input on your logic analyzer.

Level-sensitive ENABLE clocks permit easy capture of multiplexed information and act as a signal for demultiplexing.

Edge-sensitive SAMPLE clocks synchronize the logic analyzer to the target system at speeds to 50 MHz.

Mixed clocking mode allows precise and simultaneous capture of software execution and hardware timing characteristics, with timing speed to 100 MHz.

Uncompromising dedication to high performance.

The Gould Biomation philosophy dictates that every instrument we make be the best for the job it's designed to do.

The impressive performance of the K101-D and K102-D in software/hardware analysis is evidence of that commitment to excellence.

For a demonstration or product brochures, write Gould, Inc., Instruments Division, 4600 Old Ironsides Drive, Santa Clara, CA 95050-1279. Manufacturer of Gould Biomation products. For fastest response, call (408) 988-6800.



Circle #30 for further information on the K101-D
Circle #31 for further information on the K102-D



 **GOULD**
Electronics & Electrical Products

**Tough. Precise.
Totally self-contained.
Only Tektronix packs
so much into so little!**



The TEK 200 Series are battery-operated miniaturized scopes with performance that is full-scale Tektronix. A featherweight 3.7 pounds and less, all Tek 200 Series scopes are highly impact resistant and double insulated for floating measurements. You can select bandwidths to 5 MHz. Single or dual trace. DMM. Even storage. All while getting precise measurements from an easy-to-use go-anywhere package. Each scope includes rechargeable internal battery, viewing

hood, carrying case and convenient neck strap. You can keep both hands free to use the integral probes, or to steady yourself on ladders and catwalks, with the CRT clearly readable.

The 200 Series miniscopes: small wonder they were designed by Tektronix.

**CALL TOLL-FREE
1-800-547-1845
Ask for Dept. H0720**

to get more information or to place an order. (Oregon, Alaska and Hawaii, call 503-627-5402 collect.)

Tektronix
COMMITTED TO EXCELLENCE

News update

■ The current slump in air travel is setting up some turbulence for the otherwise climbing market for jet-air liner simulators.

In Atlanta, the Federal Aviation Administration's National Simulator Program Office reports a surge in requests for certification of computer-based systems designed to meet standards in the FAA's three-phase "total training" plan [*Electronics*, Oct. 6, 1981, p. 96]. Under the program, pilots who are already jet-qualified can acquire some take-off and landing credits in a Phase 1 simulator; copilots may move up to captain in a Phase 2 system; and Phase 3 affords total simulation training of pilots who are not jet-qualified.

A half year ago, only three flight simulators had been approved for Phase 2 training. Today, eight have passed and at least a half dozen more are awaiting approval, says James L. Copeland, technical adviser to the program manager.

This week, FAA officials are scheduled to travel to the United Airlines training center in Denver to conduct the program's first Phase 3 tests, which require full daylight visual scenes and enhanced motion and sound effects. United's 272 simulator uses a leading-edge computer graphics system developed by Rediffusion Simulation Inc. of Arlington, Texas—the firm that manufactured the first visual systems to win Phase 2 clearance last year.

However, the current airline slowdown is causing most carriers to move more cautiously into Phase 3, Copeland notes. "I think a lot may be waiting for someone to break the ice—and United has chosen to do just that," he says.

Some struggling airlines have delayed plans to press on with total simulation because they are no longer hiring new pilots. For example, Braniff Airlines—which pioneered the simulation route last year with the nation's first three Phase 2 systems—sees no need for Phase 3 at this time. Says Capt. D. R. (Dale) States, vice president of flight for Braniff, "Maybe four or five years down the road, we'll take another look."
—J. Robert Lineback

SYSTEM 720

the complete system for data acquisition/reduction

For the first time, demanding DAS users can obtain a complete, high-performance data acquisition system without going to a high priced, risky custom system. For critical measurements, these users need *speed, accuracy and reliability* . . . qualities long associated with the Neff System 620 family of data acquisition products. *Now, these same qualities are available in a fully integrated system.*

The use of System 620 instrumentation equips System 720 with the most powerful and flexible analog front end available. Consider these features: 50kHz throughput, 120dB CMRR, 15-bit resolution, signal conditioning, automatic computer controlled calibration and many other sophisticated options. Add a computer, carefully selected peripherals, complete DAS software and a FORTRAN development system and you have the *complete* System 720.

You'll be in control. No third-party hardware integration or software design . . . no interface worries . . . and future system expansion is as easy as plugging in cards.

System 720 is the result of Neff's 25 years experience in serving DAS users. *High performance, reliability and versatility are built into each system.* Find out more. Send for our System 720 brochure or, for immediate answers, call us toll free: (800) 423-7151; in California, (213) 357-7151 collect.



700 South Myrtle Ave., Monrovia, CA 91016
TWX 910-585-1833





A CLOSER LOOK
AT THE
FIRST CMOS
ELECTRICALLY
ERASABLE PROMS



HUGHES EEPROMS NOW IN VOLUME PRODUCTION!

HUGHES

HUGHES AIRCRAFT COMPANY

Solid State Products

500 Superior Avenue
Newport Beach, CA 92663
(714) 759-2942
TWX: 910-596-1374

In Europe

Hughes Microelectronics Ltd.

Clive House
12-18 Queens Road
Weybridge, Surrey KT 139XD
England
Telephone: 932-47262
Telex: 929727

Hughes EEPROMs, introduced in 1980, are gaining wide market acceptance in applications requiring electrically erasable non-volatile memory and low power operation. Production quantities are now being delivered for both the 4K and 8K bit versions.

Applications are divided into two general categories:

- convenient alternative to EPROMs
- in-circuit programming which offers new dimensions in innovative design techniques.

For example; Hughes has developed a digitally compensated crystal oscillator (DCXO) with temperature compensation using our HNVM 3008. The ROM code is not written until after the product is completely assembled, providing more accurate compensation, ease of manufacture, and subsequent recalibrations in the field. Other applications are emerging for postage meters, portable terminals, adaptive processors and many more.

The HNVM 3004 (512 x 8) and the HNVM 3008 (1024 x 8) EEPROMs can be written 10,000 times and retain information for 10 years at 125°C or 20 years at 70°C. Naturally, the Hughes HNVM 3000 series are compatible with all major logic families.

To respond to the EPROM market, Hughes is introducing the HNVM 3704 (512 x 8), our first product to provide a cost effective alternative to EPROMs with CMOS characteristics. This device can be programmed electrically in 1 millisecond and erased electrically in 100 microseconds.

It is time for you to consider Hughes EEPROMs. Programming is easy to accomplish either in-circuit or out-of-circuit. Parts are available now from Hughes distributors. For more information and your copy of our new EEPROM application notes contact your local Hughes Representative or Hughes—Solid State Products.

Hughes... A Leader in CMOS Technology.

Business activity

The electronics production index is a seasonally adjusted measure of the level of production activity among U. S. manufacturers of office and data-processing equipment, communications and radio-television equipment, instruments, and components. As a reference point, the 1977 yearly average = 100.

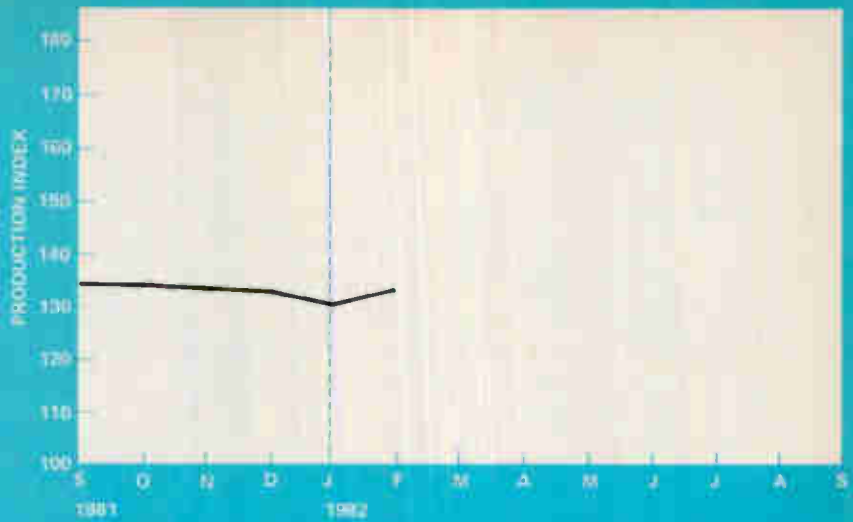

U. S. INDUSTRIAL PRODUCTION INDEX¹

	February	January	February 1981
Office and data-processing equipment	321.1	308.1	305.0
Communications equipment	168.0	162.7	157.6
Radio and TV equipment	85.1	79.8	102.0
Electronic and electrical instruments	256.2	258.5	250.3
Components	164.8	162.1	171.1

U. S. ELECTRONICS ECONOMIC INDICATORS

Production orders ² (thousands)	February	January	January 1981
Office and computing machines	189.3	187.3	182.0
Communications equipment	261.8	262.3	263.4
Radio and TV receiving equipment	68.7	71.7	76.7
Components	334.4	333.8	329.6

Shipments ³ (\$ billions)	March	February	March 1981
Communications equipment	3.279	3.400	3.050
Radio and TV receiving equipment	1.009	0.805	0.929
Electronic and electrical instruments	4.048	4.103	4.136
Components	2.295	3.350	3.326

U. S. GENERAL ECONOMIC INDICATORS

	March	February	March 1981
Index of leading economic indicators ⁴	124.4	125.0	135.8
Budgeted outlays of the Federal government ⁵ (\$ billions)	63.5	57.8	54.2
Budgeted outlays of the Department of Defense ⁵ (\$ billions)	16.4	14.6	13.6
Operating rate all industries ⁶ (% capacity)	67.9	68.6	77.7
Industrial-production index ¹	141.2	142.3	152.1
Total housing starts ³ (annual rate in thousands)	947	924	1,318

Sources:

¹Federal Reserve Board (1967 = 100) ²Bureau of Labor Statistics ³Bureau of the Census ⁴Department of Commerce (1967 = 100)
⁵Department of the Treasury ⁶McGraw-Hill Publications Co., Department of Economics

Business activity

Stock prices of electronic component and semiconductor manufacturers have been moving up sharply in the last month or so. In the six weeks since March 8, when the broad stock market averages reached a two-year low, the index for stocks of semiconductor and other electronic components companies has increased by more than 18%.

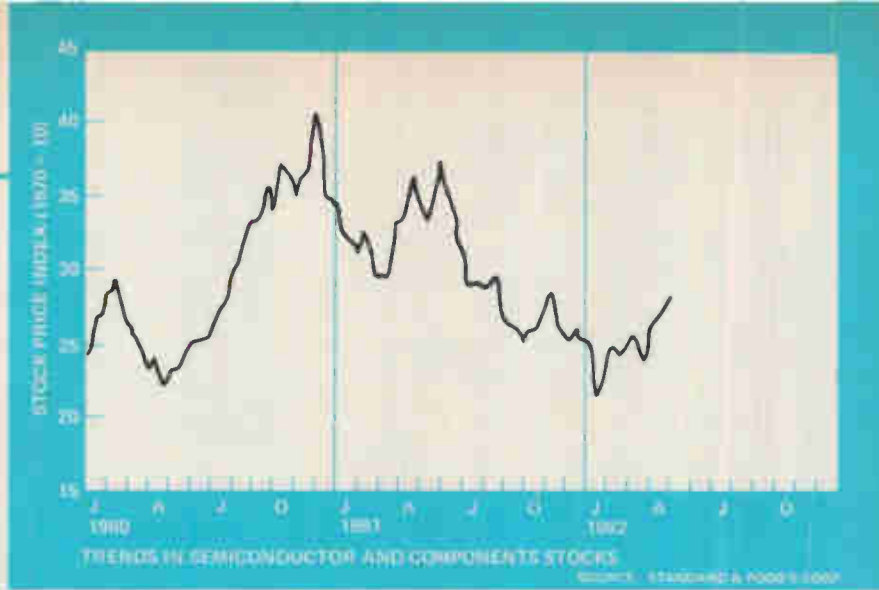

Although earnings remain under pressure for the components manufacturers, investors are taking a long-term view of the industry and are recognizing the potential for rapid growth. However, though the semiconductor industry should outperform most sectors of the economy through 1982, investors who expect these companies to achieve an earnings performance during 1982 in line with the record 1980 earnings level are likely to be disappointed.

The announcement that the gross national product declined at a 3.9% annual rate during the first three months of 1982 left little doubt as to the severity of the recession. However, within that report should be the seeds of recovery. The reason for such optimism in the face of the continued fall in the index of leading economic indicators is that virtually all of the decline in GNP was a result of inventory liquidation. As inventories reach low levels, any pickup in demand will almost immediately result in higher production levels. And the July 1st tax cut, combined with a Social Security cost of living increase, should be just what is needed to bring about a recovery.

The outlook for interest rates is far less favorable. The high levels of unemployment have inflated previous estimates for Federal budget deficits, and whatever compromise in the debate over the budget is finally reached, a Federal deficit of over \$100 billion now appears certain. This deficit will create a borrowing demand by the Federal government this fall that will crowd out a major part of private credit demands. As a result, any relief from the burden of high interest rates is probably a year away, leading to the belief that any recovery will be modest at best.

Finally, visible signs are appearing that the U. S. economy is in its first phase of recovery. Orders for durable goods, such as radios, television sets, and kitchen appliances, rose during February and March as housing started its upturn. In addition, electronics firms producing defense products are receiving new orders from various Government agencies. Semiconductor firms are enthusiastic about the first quarter's volume of new orders, which is at its highest level in two years. The latest figures from the Semiconductor Industry Association show the book-to-billing ratio rising sharply from 1.00:1 in January to 1.16:1 in March, probably a harbinger of good news. Europe's economy is also recovering, with increased sales ahead for U. S. component and equipment makers.

**"With
Fujitsu Microelectronics'
Fast Static RAMs
I can quadruple memory
without increasing power."**



That's design freedom!

Now, go from 4K density to 16K density — without compromising speed or power — in either 16K × 1 or 4K × 4 organizations. Chip select power-down and 20-pin LCC configurations are also available. Find out more: contact your Fujitsu Microelectronics sales office listed below.

MAXIMUM POWER DISSIPATION (mW)					
MAXIMUM ACCESS (ns)					
POWER SUPPLY (V)					
ORGANIZATION					
DEVICE NUMBER				Active	Standby
MB8167A-45	16K × 1	+5	45	660	137
MB8167A-55	16K × 1	+5	55	660	137
MB8168-55	4K × 4	+5	55	825	220
MB8168-70	4K × 4	+5	70	825	220

**FUJITSU
MICROELECTRONICS**

FUJITSU MICROELECTRONICS SALES OFFICES:
Boston 617/449-1603; Chicago 312/934-6400;
Dallas 214/669-1616; New York 516/273-6660;
Northern California 408/866-5600;
Southern California 714/547-9525.

***Creating New Horizons...
in RAMs.***

Circle 37 on reader service card

“These new systems combine accuracy and high volume. Quality testing has never cost less.”

*Dennis P. O'Connell, Vice President
Teradyne, Inc.*

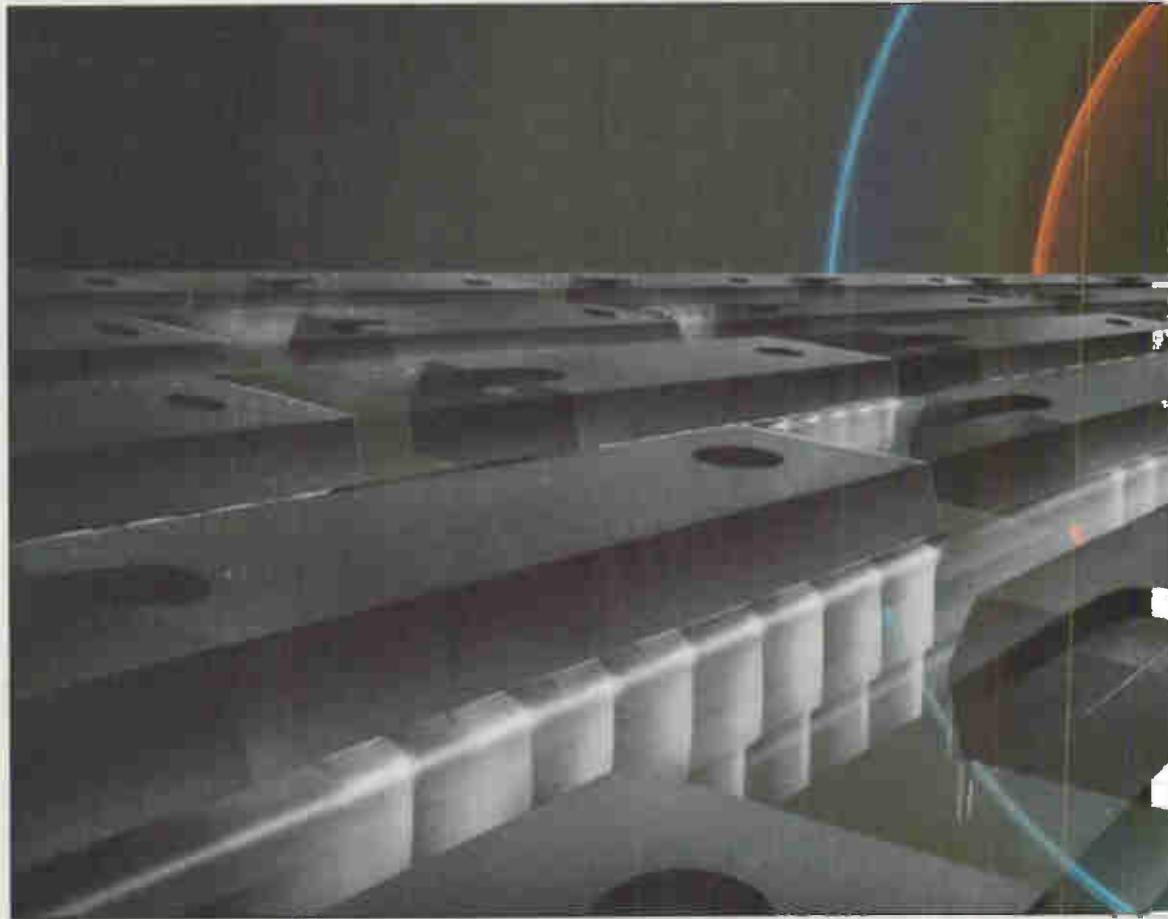

Recently, some customers came to us with a problem. They said our big test systems were ideal for development. But they needed that same quality testing at much less cost for the production of high volume devices.

So we rolled up our sleeves and designed two new low cost test systems. The A351 for industrial linear devices. And the J385A for dynamic RAMs up to 256k.

These new systems have the lowest testing costs in the industry. And both offer the same high accuracy as our larger systems.

The A351 and J385A are actually smaller versions of our field-proven A300 and J387A. We took out a lot of hardware in exchange for production floor efficiency and space economy.

What's more, software costs are minimal. Software developed for the A300 and J387A can be plugged into the smaller testers.

This assures identical test results in design and production. So any production problems will be found quickly. And better quality products will be shipped out.

Both the A351 and J385A easily accommodate automatic handlers and probers. The A351 has 4-way multiplexing which gives it the lowest capital cost and highest throughput in the industry. And the J385A accommodates

RAMs up to 256k, so it will be on line into the 1990's.

Our new low cost testers prove quality and economy aren't mutually exclusive.

At Teradyne, quality is *always* a matter of economy.

For more information write us at 183 Essex Street, Boston, MA 02111. Or call (617) 482-2700.



TERADYNE

We measure quality.

Eight pens for the price of one



We're offering our new eight pen plotters at a price well below that of competitive one pen plotters.



As a special introductory offer, through August 31, 1982, the all new eight pen model of the Houston Instrument CPS-20 will be available for only \$4,295*. Imagine it...plots up to 11" x 144". CPS-20 performance and flexibility, and eight microprocessor controlled pens for only \$4,295. Compare that to competitive continuous feed four pen plotters costing as much as \$8,500!

The Houston Instrument CPS-20 gives you the ultimate in plotter versatility. Our exclusive single board design enables the plotter to be interfaced with virtually any computer (RS-232-C, single or dual port, IEEE-488, Centronics® compatible, and

incremental). If you upgrade or change computers in the future, it's no problem. A simple change of the interface boards and the CPS-20 is ready to interface with the new computer.

Don't miss this unique opportunity. The special introductory offer ends August 31.

For complete details, contact Instruments and Systems Division, P.O. Box 15720, Austin, Texas 78761. (512) 835-0900. For rush literature requests, outside Texas call toll free 1-800-837-2820. For technical information, ask for Operator #5. In Europe, contact Instruments and Systems Division, Rochesterlaan 6, 8240 Gistel, Belgium. Phone 059/27-74-45.

INSTRUMENTS & SYSTEMS DIVISION
Together...we'll create tomorrow.

BAUSCH & LOMB 

* U.S. domestic price only

® Registered trademark of Centronics Data Corporation

Circle 40 on reader service card

Ethernet interfaces coming from DEC

Digital Equipment Corp., one of the three Ethernet sponsors, is dramatically expanding the horizons for the local network with a series of hardware and software interfaces scheduled for availability between late 1982 and 1984. The Maynard, Mass., firm plans by mid-1983 to start **linking its VAX and PDP-11 computers to Ethernet via a data-link-managing communications controller.** Based on the DEC T-11 microprocessor, the controller will support 1,024 addressable nodes. DEC also will offer an Ethernet transceiver, along with transceiver cables and a line of Ethernet coaxial cables, by the end of this year. The transceiver incorporates a noninvasive tap for easy linking of new nodes. Additional introductions throughout 1983 and 1984 will include Ethernet interfaces to the DECnet communications network and to DEC's new Professional 325 and 350 personal computers (see p. 50), gateways to remote X.25 packet-switching nets and IBM's SNA systems network architecture, and terminal-server units that route Ethernet messages.

Intel to introduce redesigned 64-K RAM

Running to catch a bigger piece of the expected 1985 \$1.5 billion market for 64-K dynamic random-access memories, Intel Corp. is about to announce its redesigned part, the 2164A. The Santa Clara, Calif., company calls the RAM a second-generation device and has built it with a **minimum access time of 150 ns, redundancy, and a higher cell capacitance than competing 64-K RAMs.** Intel, which, according to Dataquest Inc., shipped some 30,000 64-K RAMs last year, has tagged its 2164A with an introductory price of \$13.50 in 100-piece lots. The higher performance is not without premium, as some 90% of the chips from volume shippers Hitachi, Fujitsu, Mitsubishi, Nippon Electric, Motorola, and Texas Instruments are 200-ns versions selling for an average of less than \$10—although they also offer 150-ns speeds at higher prices. At the same time, Motorola Inc., right on schedule, has first silicon on its 256-K dynamic RAM chip [*Electronics*, March 10, p. 37], and the Austin, Texas, memory operation expects to start shipping samples in the fourth quarter.

Circuit detects, corrects 3 errors

Implementing a highly complex algorithm, an error-detecting and -correcting circuit that can handle up to three errors in a data word has been developed at the Electronic Systems operation of Bunker Ramo Corp. in Westlake Village, Calif. Devised by senior systems engineer Lawrence J. Rennie, the circuit is based on the Golay error-detection and -correction code, rather than the widely used Hamming code, which can detect two errors and correct one. **The scheme already is working: Rennie's former employer, Litton Data Systems in Van Nuys, Calif., uses it to provide a reliable interface between a variety of synchronous and asynchronous terminal equipment operating at many different data rates and a 32-kb/s synchronous data-communications network.**

Itoh enters market for fast printers

With Japanese printer manufacturers making inroads into the low-speed end of the U. S. market for dot-matrix printers, American manufacturers have kept one ear cocked, nervously waiting for the second shoe to drop. It has: **a Japanese maker is offering printers in the medium- to high-speed range.** One of the world's largest manufacturers of dot-matrix print heads, C. Itoh & Co., will sell the C. Itoh/Citizen line printer, which has selectable speeds from 72 to 300 lines per minute, 9-by-9- to 17-by-17-dot

upper- and lower-case characters, and an end-user price below \$5,000. It will be introduced next month at the National Computer Conference in Houston.

Zenith to show 16-bit family

Look for Zenith Data Systems, Glenview, Ill., to push into the 16-bit microsystems arena when it introduces the Z100 family of machines at the National Computer Conference. With four versions of the system to be initially available, the Z100 will run the MS/DOS operating system used by IBM's Personal Computer, as well as CP/M-86. **It will thus be positioned to capitalize on the growing software base for both of those popular 16-bit operating systems.** For now, the company will not identify the 16-bit microprocessor powering the new family, which includes color capabilities.

Also to be introduced at the computer show will be a family of computers from Four-Phase Systems Inc., Cupertino, Calif., designed for office automation in large, multilocation operations. The machines include a personal-computer option, touch-sensitive screen, and voice-message storage and forwarding. They accept up to 6 megabytes of main memory and 2.2 gigabytes of disk storage.

Supermarket scanner sales accelerating

Despite the recession, scanning-equipment sales to supermarkets are continuing at a heady pace, reports the Food Marketing Institute. U. S. installations of point-of-sale scanning systems totaled 1,782 during 1981 — **more than half again as many as the total installed base of 3,108 scanning systems at year-end 1980.** First-quarter installations this year amounted to 483 units, bringing the total number of U. S. grocery scanning installations to 5,228. The institute predicts that 10,000 stores will have scanning systems in place by 1985.

Genrad local net links bench testers

With what it terms the first local network for benchtop component-test systems, Genrad Inc. will begin linking its linear, digital, and passive component testers by the fourth quarter of this year. The Concord, Mass., firm says its Semiconductor Component Analysis Network (SCAN) gives component users **a means of qualifying vendors and characterizing devices at the incoming-test level** by performing data-logging and yield analyses, as well as off-line test-program generation.

Addenda

With the introduction of an information-delivery software package called Transfer and the announcement of a dedicated satellite network, **Tandem Computers Inc. of Cupertino, Calif., is jumping into the office-of-the-future market with both feet.** The Transfer package works with the company's Expand data-communications network to link up to 255 locations into a fault-tolerant network for text handling, electronic mail, and facsimile transmission. . . . For the first time, privately owned Hughes Aircraft Co., Culver City, Calif., has reported in some detail on its financial results, **which were led by a 27% jump in sales during 1981, to just over \$3.3 billion.** The Government accounted for 75% of the total sales, with foreign military customers taking 17% and commercial sales about 8%. Employment reached 59,000, largely in southern California.

WHY BUY THEIR CIRCUITS WHEN WE'LL BUILD YOURS?

Since you have some ideas about systems, you probably also have some ideas about IC's. And maybe your ideas include a wish list. Because nobody makes exactly the IC you need to optimize your system.

You can make do with standard parts, maybe three or four more than you think you really need. Or, you can call I.M.P. We're specialists in custom MOS. NMOS or CMOS. You design or we design. You design and we build. Or, we design and we build.

Custom MOS any way you want it. Prototyping or production quantities. 5 or 3 micron technology. But when we're finished, you own it. We don't. And neither does anybody else. Which means you can hold your jump on the market.

But why I.M.P.? One reason: A management team with experience. 91 years of it in all five critical areas of custom IC manufacture. Design. Production. Operations. Quality control. Customer liaison. And that's just our management team.

And we started with CAD. It isn't pasted on. It's built into our design and manufacturing operations. Which means we can deliver your designs or circuits on a schedule that fits your schedule.

And here's the clincher. In the long run, it is always cheaper and more efficient to build your own circuits than it is to buy theirs.

Planning a system? Call us. We'd like to work with you from initial concept through final production. And we can join you at any stage in between. With complete custom MOS facilities. Any way you want them.



EX 5-19

iMP COMMITTED TO
CUSTOM MOS

International Microelectronic Products
2830 North First Street
San Jose, CA 95134 (408) 262-9100

You build our circuits?
Tell me about your capabilities.

Name _____

Company _____

Address _____

City _____ State _____ Zip _____

I'm a prospect, call me at (_____) _____

I care about your business. That's why I put a tough guarantee on every instrument.

Good service and dependable delivery are important to me, because they are important to you. That's why I've put a tough guarantee on every instrument. Either we live up to our guarantee or you get 25% of your first month's rental fee back for that unit.

Here's what I promise:

1. The instrument will arrive on the day we say it will.
2. It will work properly, be calibrated and have everything you need right down to the operator's manual.

Choose from the industry's largest pool of general purpose test instruments.

USIR stocks more than a thousand models of instruments from more than one hundred leading manufacturers. We add more every day as new instruments are introduced. No one else offers you this much to choose from.

See what a difference caring makes.

Systems and computers don't solve your test and measurement problems. People do. At USIR we have people who are willing to try just a little harder to get you the instrument you need, when you need it. In short, we care.

Call or write for USIR's latest catalog today.

2988 Campus Drive
San Mateo, California
94403-2563
(415) 572-6600
(800) 227-6884



**United States
Instrument Rentals, Inc.**



A U.S. Leasing Company

Circle 44 on reader service card

**"GET THE TEST INSTRUMENTS YOU WANT.
ON TIME. OR GET MONEY BACK."**

—Anthony Schiavo, President.

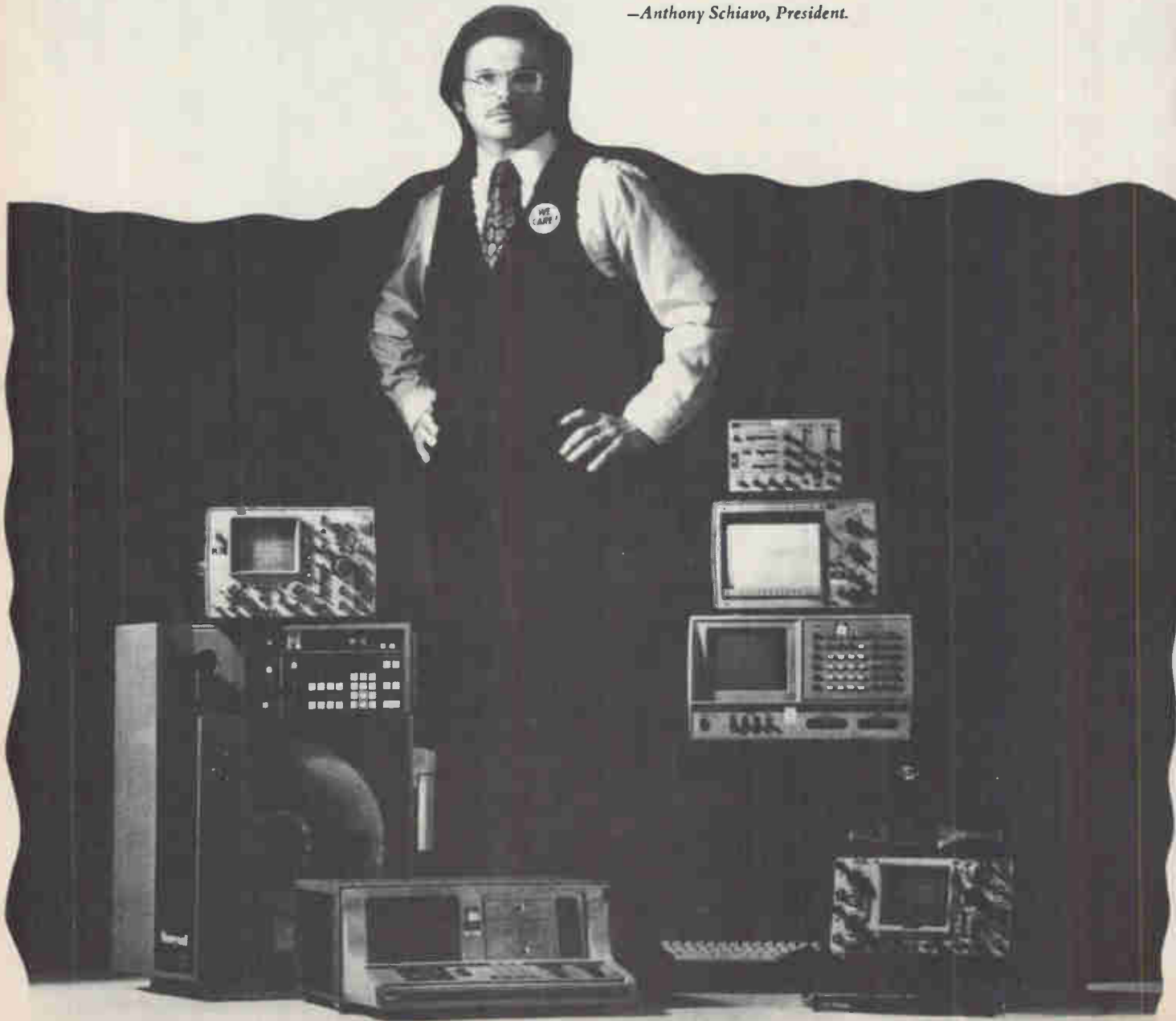

Magnetic transistors exploit new theory of carrier modulation

by Roderic Beresford, Solid State Editor

Differential voltages develop as magnetic field modulates, rather than deflects, carriers injected by biased emitter

For the most part, progress in semiconductor electronics builds on a foundation of widely known physics; even today, however, an occasional leap forward results from a basic discovery. In trying to improve semiconductor magnetic sensors, a researcher at International Business Machines Corp. has uncovered a flaw in the understanding of the underlying physics and has developed magnetic transistors smaller and more sensitive than previous versions.

"I built magnetic transistors that should not work at all according to accepted theory, but that actually perform better than any previous magnetic sensors," says Albert Vinal, who is a senior engineer at the company's System Communications division, located in Raleigh, N. C. Vinal discovered that a magnetic field in fact modulates the injection of carriers at a forward-biased pn junction. It is that mechanism, and not the deflection of the carriers as was believed previously, that is responsible for a transistor's sensitivity to the field (see "Magnetic transistors revisited," p. 46).

Sensitive. Armed with this understanding, he has produced experimental transistors with magnetic properties approaching the best achievable within the limits imposed by carrier mobility in silicon, according to a technical report distributed

within IBM last month. By tailoring device geometry and doping according to the new theory, Vinal has built magnetic-field-sensing transistors with sensitivity as high as 2 millivolts per gauss, and signal-to-noise ratios of about 10 per gauss, with a 1-megahertz bandwidth.

Comparable performance in the past has required transistors several times larger, says Vinal, making them too big for some key applications such as reading data on magnetic tapes and disks.

The optimized device is shown in cross section in the figure. The strongest response to a magnetic field occurs when the field is perpendicular to the direction of the injected carriers. This field is parallel to the flat bottom surface of the emitter—its direction is into the page.

By moving the base contacts away

from the emitter, vertical injection down from the bottom of the emitter (large arrows in the diagram) dominates even though the base current flow is primarily horizontal. Vinal says the lateral transistor is easier to fabricate than a vertical device. Because only the bottom surface of the emitter is sensitive to the magnetic field, the emitter is made shallow to reduce lateral injection and increase sensitivity.

The sensor responds to the difference in currents flowing to the left and right collectors. The stronger the magnetic field, the greater the difference.

Sensitivity also increases with the total emitter current. Thus, the smaller the load resistors on the collectors, the higher is the sensitivity. A smaller resistance also increases the bandwidth of the device, but it dissipates more power too. Also,

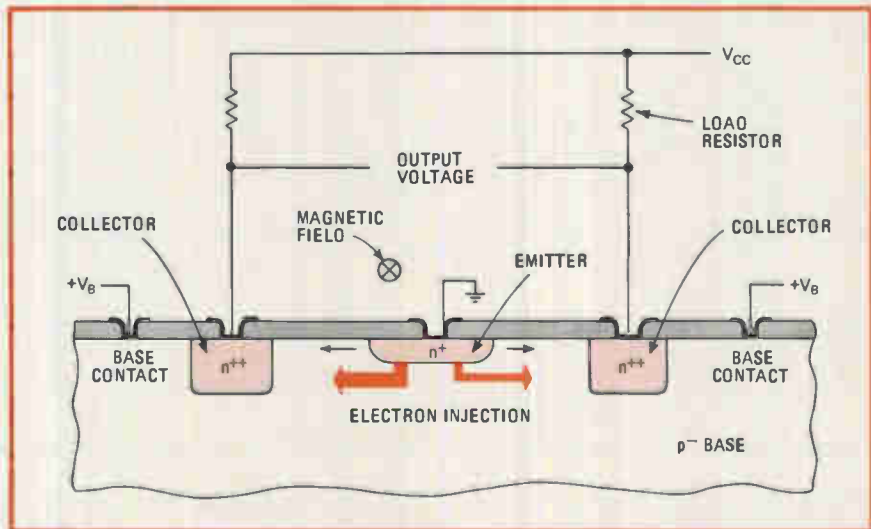

Injection. IBM's revised concept of magnetic-transistor fundamentals led to this design. The magnetic field modulates the emitter's injection of electrons, giving rise to a differential output voltage as base current flows laterally to the collectors.

Magnetic transistors revisited

Understanding how magnetic transistors work has rested on the explanation of the Hall effect. In Edwin Hall's experiment, first carried out in 1879 at Johns Hopkins University, Baltimore, a magnetic field perpendicular to a current flowing through a piece of gold foil resulted in a small transverse electric field across the third axis of the sample, that is, perpendicular to both the magnetic field and the current.

Since a magnetic field deflects a moving charge, it is thought that charge clouds are created at either side of the sample, setting up a transverse electric field that counterbalances the force of the magnetic deflection.

Deflection of carriers has been used to explain the magnetic transistor. The conventional transistor sensor in the figure below is a lateral npn device. In the presence of an external magnetic field in the direction shown, its base-emitter junction is forward biased and injects electrons into the transistor base.

The accepted view is that a magnetic field deflects the carriers horizontally as they flow in the base, so that one of the reverse-biased collectors receives more current than the other. This yields a differential output voltage that is proportional to the magnetic field strength.

But International Business Machines Corp.'s Albert Vinal, a researcher at the firm's Communications Systems facility in Raleigh, N. C., points out this explanation is

wrong. Once carriers are deflected, a transverse electric field is created that balances the magnetic deflection force. The consequence is that the carriers are not deflected but flow in a straight line.

His new explanation, as a result, postulates that because of the magnetic field the emitter injects more carriers on one side than on the other, so that current flow to the collectors is not the same. As is illustrated in the inset, the transverse electric field alters the forward bias on the base-emitter junction, in effect rotating the boundary of the depletion region.

Other experts agree with part of Vinal's theory. "He has clearly demonstrated that a transverse electric field modulates emitter injection and that this modulation, not carrier deflection, is the transduction mechanism in a magnetic transistor," says Nino Masnari, chairman of the electrical engineering department at North Carolina State University in Raleigh.

However, the source of that transverse electric field is apparently still controversial. Vinal backs the idea that a microscopic polarization of the semiconductor results from the magnetic field, something very difficult to prove, says Masnari. The older, accepted version of charge clouds separated by deflection in the magnetic field could still account for the transverse electric field that modulates emitter injection in Vinal's theory. **-Roderic Beresford**

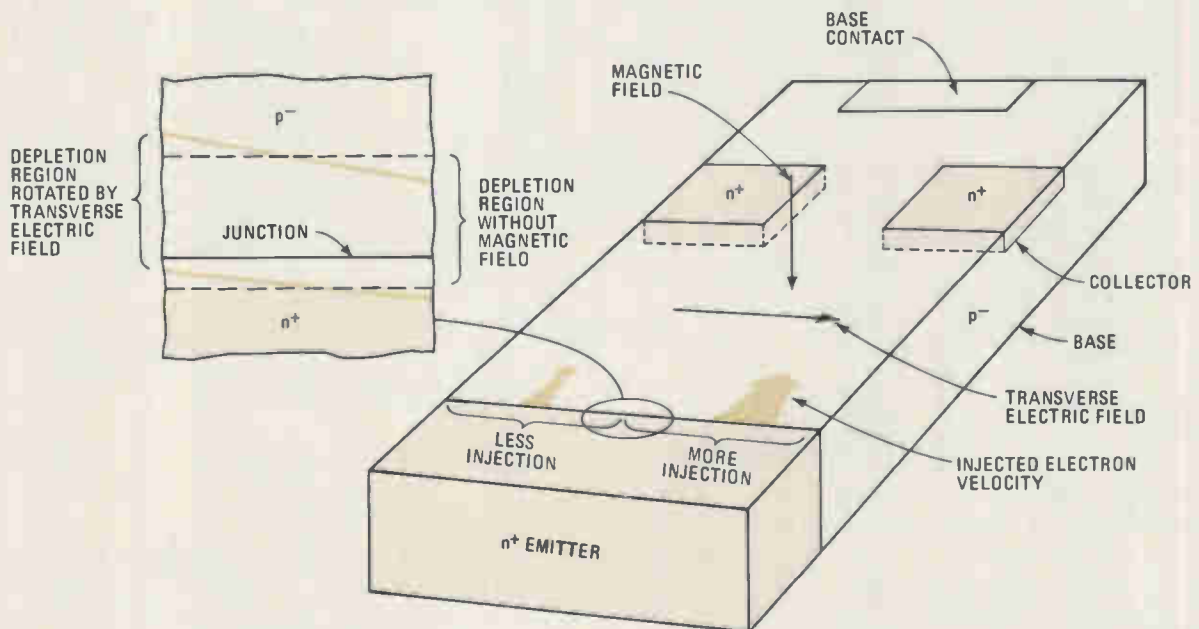

with a 6.8-kilohm load and a 25-milliampere emitter current, a device with a 30-micrometer basewidth shows a field sensitivity of more than 1.3 mV/G, an excellent result.

According to Vinal, the optimized sensor would not work at all if the carrier-deflection model were correct. The carriers flowing laterally to the left and right toward the collec-

tors would be deflected vertically by the magnetic field. Therefore, the two collectors would still receive the same current and give no differential signal.

Natural language migrates from mainframes to small machines

Because it is much easier to ask a computer "What is Mary's salary?" than to use computer jargon like "select salary from emp where name = Mary," natural languages are expected to be one of the keys to the office of the future. But first, the complex software systems needed to interpret more natural sentences must move from the large computers now used in laboratories and into the microcomputers that most office applications will demand.

As a start, an experimental system has been relocated from a mainframe-sized Digital Equipment Corp. system 20/60 computer to an Apple II personal computer by Symantec Inc. This new Sunnyvale, Calif., company is backed by Machine Intelligence Corp., also of Sunnyvale, which produces another type of artificial-intelligence machine—vision systems for industrial robots [*Electronics*, April 7, p. 89]. Symantec is headed by Gary G. Hendrix, a cofounder of Machine Intelligence, who previously headed natural-language research at SRI International in nearby Menlo Park.

Symantec will focus on office automation where, says Hendrix, the mass market for such systems lies. However, the system running on the Apple II is not ready to be moved out the door. Rather, the small computer represents the kind of machine at which his firm is aiming. It is currently being used as a test bed for natural-language tools the company is developing on another, larger machine.

Software semantics. Stored in the 8-bit microcomputer's 64-k memory is software code for breaking down a sentence and understanding its meaning. This involves three kinds of software: grammar rules, semantic routines, and a lexicon containing the meanings of words (see "Building a natural-language lexicon," right).

There is also a small relational data base to which natural-language commands are applied, and a graphics program that manipulates and displays the data in answer to the commands. The data base contains the personnel records of an imaginary small business, with names, positions, salaries, and other information about employees.

When given natural commands like: "list the salaries and ages of the Sunnyvale employees. Plot salary as a function of age. What is the average salary? What is the salary of the manager of the tallest employee over 40?," the system responds with tables and graphs of data. With a different data base it could answer questions like "What vendors make 25-amp power supplies costing less than 40 dollars?"

"What you see is the result of [software] code compression," says Hendrix, while colleague Norman Haas, a computer scientist also formerly of SRI International, puts the system through its paces. But he refuses to detail the compression technique because it is proprietary.

"The type of compression most important to us must account for a large variety of sentence types," explains Hendrix. "There are thousands of different sentence patterns that could be used to query the system. Rather than deal with these individually, his firm has isolated components of the patterns that are commonly used in the sentences. These are then shared by the software that interprets the individual sentences, to reduce the amount of software code that must be stored and run by the system."

The data base itself is not a conventional relational type, but one whose structure is optimized for natural-language systems, Hendrix adds, again mum on specifics.

Response. Besides shrinking the memory required, code compression speeds response, and the Apple II answers most questions immediately. It would interpret sentences just as fast with a larger data base stored on disk memory, although multipart questions requiring several searches and comparisons would take longer to execute after interpretation, Hendrix says. Actually, programs could be developed on the Apple II, with its Pascal language card, but a DEC VAX 11/780 computer equipped with the software tools is faster, says Hendrix.

The firm's four-person staff is also

Building a natural-language lexicon

Like other artificial-intelligence systems, natural-language systems are really quite stupid. But they can be programmed to ask questions, build up a lexicon, and thus be able to parse typical sentences. Here is an example of the way Symantec's microcomputer system becomes more intelligent:

- Q. Who is Mary?
A. Computer displays Mary's personnel file.
Q. What is Mary's weight?
A. Word weight is unknown to me.
Q. Mary has a weight of 115 [pounds].
A. What words are used for weight?
Q. What is X's weight? How heavy is Mary?
A. Understood.
Q. How heavy is Mary?
A. 115.
Q. Who is the heaviest employee?
A. Mary 115.

The last answer is a stupid one. But the system would identify the heaviest employee, just as it can now identify the highest-paid or tallest employee, if the weight column in the personnel data base were filled in. **-George Sideris**

working on other tools of the natural-language trade, such as languages for creating person-machine interfaces, grammar-rule editors and checkers, and parse-tree analyzers. The last are graphics systems that show the software's attempts to break up a query into its components and understand its meaning. There are no dates set for when these will be available.

-George Sideris

Microcomputers

Chip makers guard their PROMs

With software development costs spiraling upwards, equipment manufacturers are anxious to prevent the unwarranted copying of proprietary programs that reside in read-only memories. Often the success of microcomputer-based products—from video games to industrial controls—is influenced by the length of time the programs remain a secret of the companies that devised them.

Motorola Inc. and Seeq Technology Inc. are independently working on two different security schemes aimed at reducing piracy of software from the on-board memory of single-chip microcomputers. Both are developing security features for microcomputers with erasable programmable ROM, but the similarities end there.

In Austin, Texas, Motorola's Microprocessor division is designing an

8-bit device, the MC68705P5, that can block external access to its 1,804 bytes of E-PROM programs by the insertion of a single security bit. This bit is inserted over the external pin used to load and test the memory.

The pin does not go directly to the E-PROM but to control circuitry on the device. Motorola made changes to this circuitry to allow the security bit to block external access. After the software is debugged, this bit is activated in the mode option register, which is the final control byte, says Ed Peatrowsky, senior planning engineer for midrange microprocessors. Only the microcomputer's central processing unit can then read data out of the E-PROM over the internal data bus.

Once this protection is activated, the pin normally used to gain external access to the program over the data bus will read only 1s. The only way to disable the security bit is to expose the E-PROM to ultraviolet light, which will also destroy the entire program. Motorola is currently filing for a patent on the logic circuitry it is adding to the die.

Head start. Design of the new chip promises to be relatively simple because Motorola is starting with the layout of its existing MC69705P3 8-bit microcomputer, which is modular and already has E-PROM on board. The introduction of this new version of the high-density n-channel MOS part is expected this fall, with production quantities scheduled to follow by year-end.

The security bit is the result of requests from customers increasingly concerned about software theft as more microcomputers with E-PROMs go out into the field, says Peatrowsky. E-PROMs are desirable to use because they allow equipment to be upgraded with new software.

Elsewhere, in San Jose, Calif., Secq is working on an 8-bit unit that can block access to on-board electrically erasable PROMs [*Electronics*, Feb. 10, p. 121] that it is adding to a Z8 microcomputer. It is slated to be offered in sample quantities late this year, with production quantities available in the first half of 1983. Instead of an absolute-blocking bit, a special security algorithm can instruct Seeq's chip to give no response under certain conditions. This arrangement obviously involves more than a single bit change, says Larry Jordan, director of marketing.

He says the programmable feature will give the design wider flexibility. The central processing unit of the device will control access to the E-PROM program, providing the user with more control over his product, according to Jordan.

"Just cutting off the ability of all programs to go to the output might work in some applications, but may not be the best in others," he says.

-J. Robert Lineback

Instruments

Color timing display highlights glitches

Tektronix Inc. came up with a winner when it introduced its DAS 9100 digital logic analyzer late last summer. Running third in the \$200 million U.S. analyzer market at the time, the Beaverton, Ore., instruments maker bolted into first place within six months, according to the firm's market intelligencers.

Tektronix hopes to maintain that lead with a color version of the 9100 that adds \$2,900 to the first analyzer's typical price of \$17,000. The new 9120 comes hard on the heels of a feature-packed analyzer recently

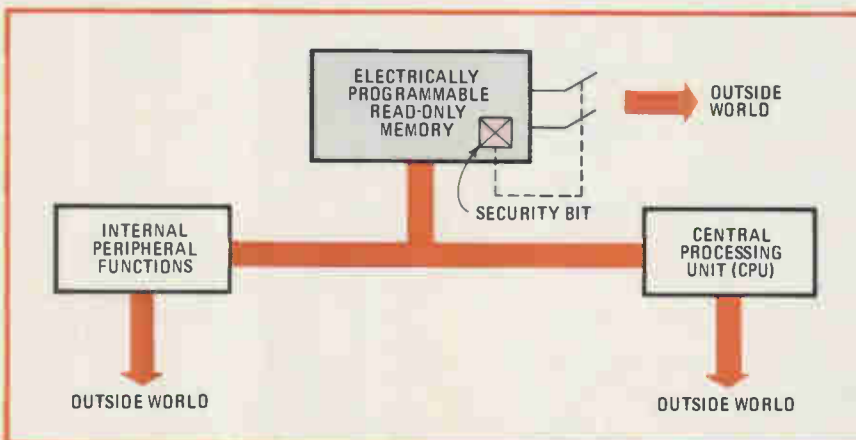

Isolated. When the security bit is loaded into the control-byte register, the E-PROM holding the control program can no longer be accessed from the outside world.

MarksmanChip

Our Gate Arrays Are Right On Target For Hi-Rel Applications.

If you're in the market for gate arrays that meet full Mil-spec, there's one overriding reason for specifying ours: experience.

We've designed gate arrays for a myriad of Hi-Rel products. Like digital signal processors. Health monitors. Real image processors. Data encryption equipment. Medical pacemakers. And more. We've been delivering our gate arrays since 1974... with complete confidence.

That's why today, every gate array we make is designed from scratch to meet the most stringent military reliability specifications. In fact, nearly half of our total production goes into programs with MIL-STD 883B requirements or even tougher.

Significant? You bet.

It means that when you specify one of our gate arrays for any application you automatically get the high reliability and extended performance you expect... at a cost that you might not expect. So you can design them into your application... quickly, cost-effectively and confidently. That's because we're a dedicated, full-service gate array house, with complete CAD capabilities, wafer-fab, packaging, burn-in and testing facilities, on premises, ready to serve you.

Want all the facts? Just write for our new brochure, "YOUR GATE ARRAY". Or call us. Or send us your logic drawing for a quick, confidential quote. Our gate array leadership will keep your Hi-Rel program on target.

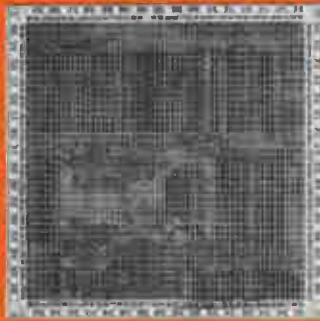

**INTERNATIONAL
MICROCIRCUITS
INCORPORATED**

Gate Array Leadership

3350 Scott Boulevard, Santa Clara, CA 95051
Tel: (408) 727-2280, TWX 910-338-2032

introduced by the traditional market leader in this field, Hewlett-Packard Co. [*Electronics*, April 7, p. 47].

A first. John Huber, marketing manager for the line, maintains the 9120 is the first general-purpose bench instrument to have a color cathode-ray tube. Huber also maintains that the three-color CRT, made especially for Tektronix by Nippon Electric Co. of Japan, is much more than a marketing gimmick. With timing diagrams in green, glitches in yellow, and cursors in red, for example, troubleshooters make accurate readings faster, thus enhancing their productivity, he claims.

Tektronix has assembled a good deal of experimental data to back up this claim. Under the aegis of Jerry Murch, director of the perceptual research group of the company's information display division, 44 Tektronix engineers and technicians were tested on a mock-up of the 9120 display.

In the tests, subjects—some of them color blind—were shown timing diagrams with several data- and address-line waveforms that had a glitch at some point. They were quizzed about the diagrams with questions like "What are the values of DAT3 and ADD2 during the glitch?" and would then respond by pressing one of four keys to signify correct values on the lines.

Spotting glitches. When the waveforms and glitches were color-coded, reading errors were one quarter those that occurred with black and white waveforms and gray-scale glitches. When blinking gray-scale glitches were encountered, eight times more errors occurred than for color-coded ones. The flashing glitches tended to distract subjects, Murch concluded. Similar results were obtained when conventional coding was compared with color for cursor readings.

The experiment, performed using as many as 16 different colors simultaneously, also showed that the number of hues dramatically affected operator performance. So the company settled on a three-color scheme—red, green, and yellow. Blue and violet were ruled out

because the eye perceives them as being at different distances than, say, red or yellow and therefore must refocus. Furthermore, the colors had to be "seen" as being of different intensity by color-blind troubleshooters to make the coding scheme benefit all users. As a result, Tektronix had NEC substitute a yellow phosphor for the blue one it normally uses.

—Richard W. Comerford

Personal computers

DEC plunges into personal computers

Traditionally, the population explosion in personal computers has taken place one machine at a time. But last week, Digital Equipment Corp., the pioneering heavy hitter in minicomputers, added a quartet of "professional-grade" systems to the ever-growing list of entries in the \$3.2 billion personal-computer market.

DEC, out to acquire a major share of this market before the Japanese computer makers make their own bid, is confident it can field the firepower needed to succeed against entrenched companies like Apple Computer, Tandy, IBM, Xerox, and

others. "We're doing everything we can think of to make DEC the most attractive choice for the full range of professional and office personal-computer applications," says Robert E. Montemerlo, manager of programmable terminals at the Maynard, Mass., firm.

Montemerlo says that DEC will offer high-end functionality at very aggressive prices, with quantity discounts of up to 35% on base prices that start at \$3,495. The firm's success in minicomputers stems largely from its ability to supply abundant software, and not surprisingly, its new entries are geared to run "the widest range of software"—both DEC-supplied and industry-standard packages—of any personal computer on the market, Montemerlo claims.

Stress on service. As an added sales argument, the company will support its systems with 90-day warranties and offer an array of servicing options that include a \$34-a-month contract for on-site maintenance, 160 walk-in service centers, and mobile service vans in major urban areas. For do-it-yourselfers, the computers feature simple self-diagnostics and systems boxes that can be opened up with just a ballpoint pen. All four entries have practically identical packaging—the

Switch hitter. DEC's Rainbow 100 personal computer has two processors and switches automatically from 8- to 16-bit application programs. Its base price is \$3,495.

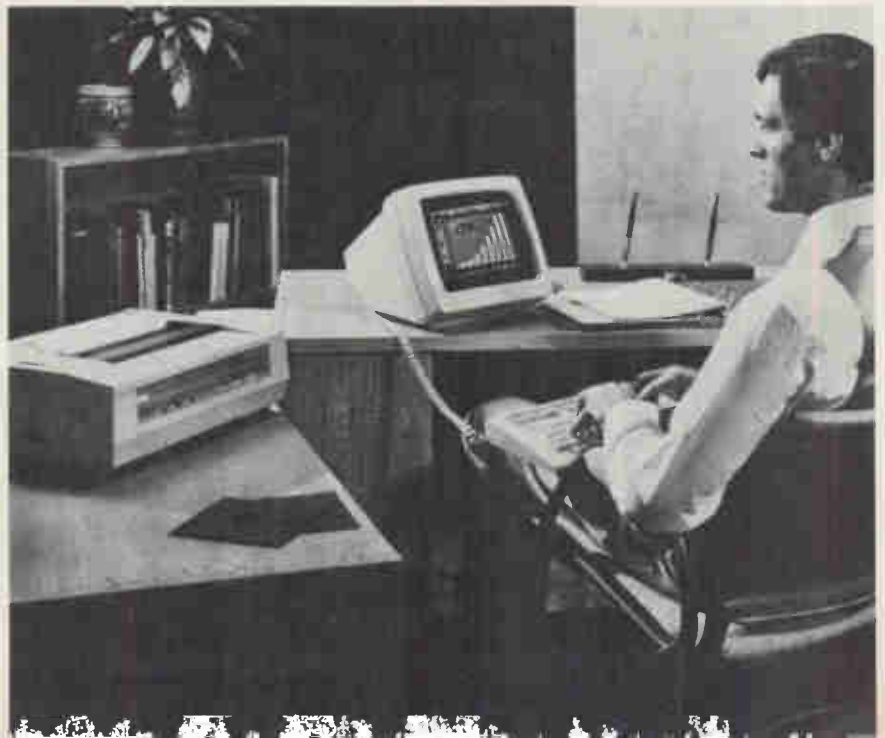

same keyboard, monitor, and system box (with one exception)—the difference lies in the microprocessor cards used.

DEC will market the systems "every way we know how," according to Montemerlo. Four different product-marketing teams under the direction of Andrew C. Knowles III, vice president and manager of DEC's small systems group, already are pushing the personal computers at original-equipment manufacturers. In addition, they are enticing independent customers through retail outlets like ComputerLand and the Hamilton-Avnet distribution network. "We'll be seeding the market through this fall," notes Montemerlo, who adds that full-volume deliveries will get under way by October of this year.

Heavy artillery. The big guns in DEC's offensive are the Professional 325 and the Professional 350, whose operating system makes possible menu-driven commands for more than 75 application-software packages. The P/OS system, says Montemerlo, "incorporates the guts of the RSX-11 real-time operating system for PDP-11s along with the file structure of the VAX-11's VMS operating system."

The 16-bit T-11 microprocessor, originally designed for the PDP-11/23 minicomputer, is the brains of both the 325 and 350 systems, both of which include 256-k bytes of random-access memory and can accommodate 800-k bytes of dual 5¼-inch floppy-disk storage. The 350 accepts an additional 5-megabyte 5¼-inch Winchester disk. The 325, intended as an auxiliary work station, has one user-available option slot, compared with the more versatile 350 version's four, and is base-priced at \$3,995 versus the 350's \$4,995 starting cost.

The entry-level machine in DEC's new line is the \$3,495 Rainbow 100. Its distinguishing characteristic is the ability to run either 8- or 16-bit software. The DEC-designed CP/M 80/86 operating system automatically identifies the program format and then calls up the appropriate microprocessor (the machine has two): a Zilog Z80 running at 4

MOS Switched Capacitor Filters.

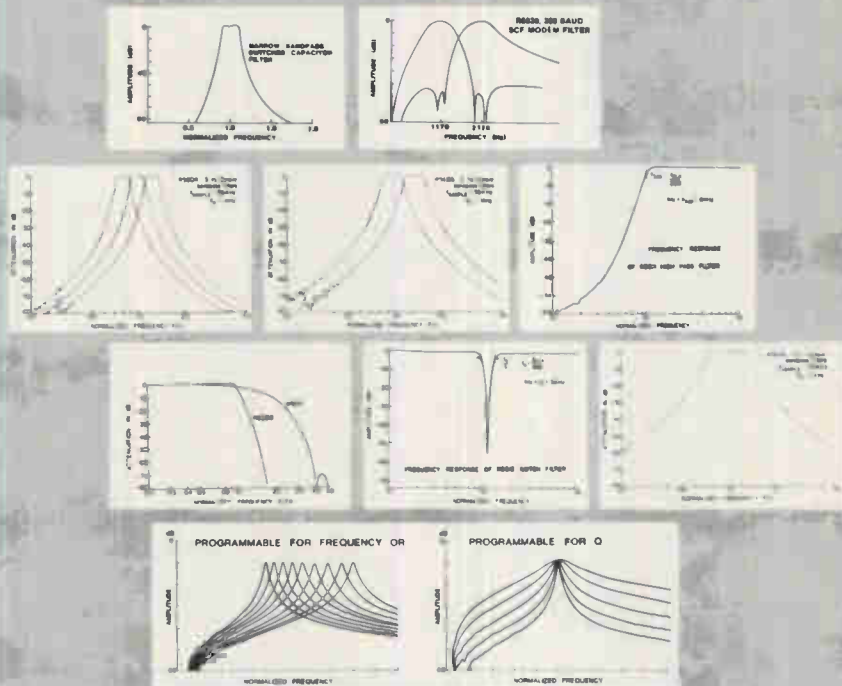

Standard Products by Reticon.*

RETICON offers the world's largest selection of standard switched capacitor filters for your various active filter requirements. These fully integrated MOS filters feature:

- Low cost
- Small size
- Continuous adjustability
- Simple implementation
- Low frequency operation
- Excellent temperature stability
- Multiple filters in one package
- Easily converted to custom spec's

*Reticon also has custom design and production capability.

For further information, call us at: (408) 738-4266 or: Boston (617) 745-7400, Chicago (312) 640-7713, Tokyo, Japan (03-343-4411, Wokingham, Berks, England (7034) 790772, Munich, Germany (089) 918 061.

EG&G Reticon • 345 Potrero Avenue • Sunnyvale, CA 94086



EG&G RETICON

NEW GRAYHILL SLIDE DIP SWITCHES: VISIBLY BETTER!

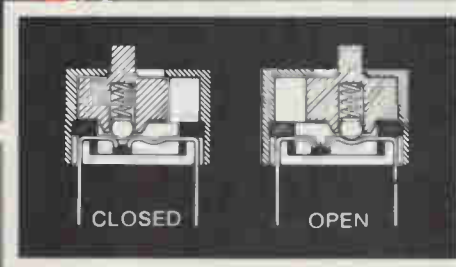
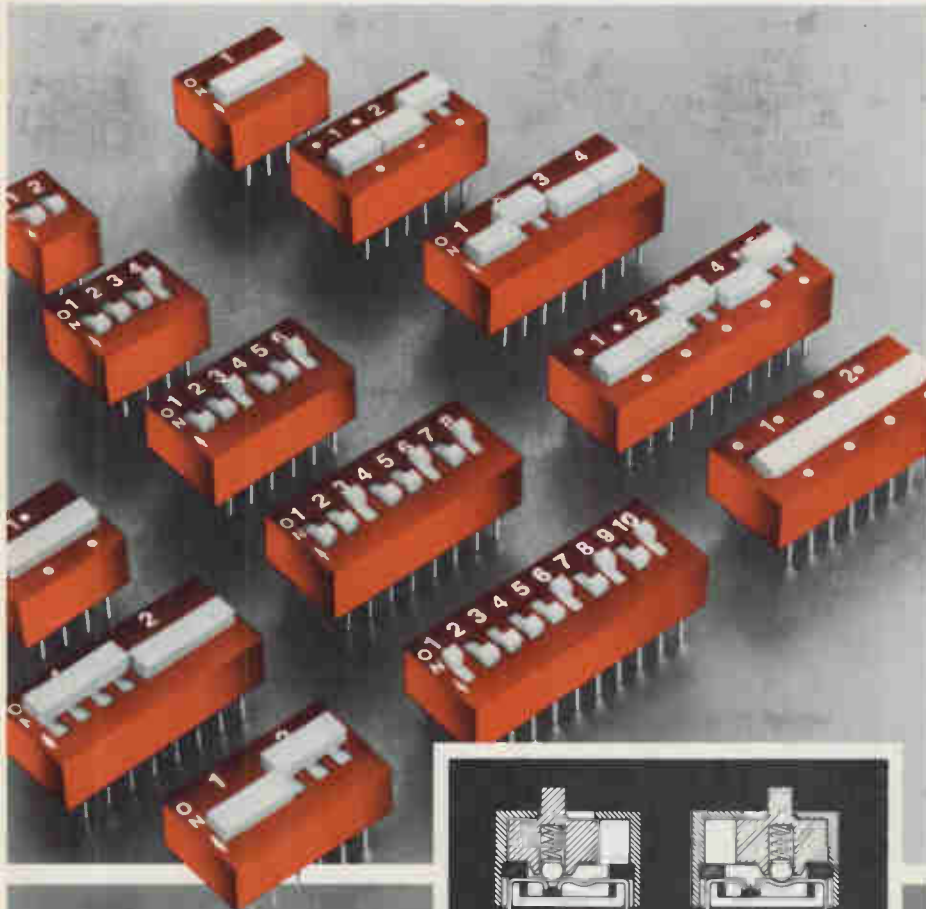

Visible position identification is one big plus the slide format DIP switch offers; the red color indicates a second visible advantage—it tells you it's a Grayhill slide DIP switch.

The new Grayhill 78 Series is not just another DIP switch variation. It is a completely new family of DIP switch products built on automated equipment (and at automated prices). Multi-pole and multi-throw switching is accomplished by means of an external snap-on plastic strap. The switches are "ganged" after completion, providing maximum flexibility in inventory management and allowing for many "non-standard" ganging arrangements.

The BIG PLUS features of the Grayhill Series 78 Slide DIP come along with all the other BIG PLUS features that have long made Grayhill's Different DIP Switch the favorite of engineers and buyers world-wide.

- **High contact pressure**
The famous Grayhill spring-and-ball contact system outperforms cantilever contacts, and provides an exceptional 30,000 cycle life.
- **Epoxy sealed base—**
as a standard feature
- **100% electrical inspection—**
as a standard feature
- **100% pin straightening**
- **Off-the-shelf distributor availability**
Procurement made simple—call Grayhill or your local distributor, for off-the-shelf delivery of most types. Only Grayhill offers you this purchasing convenience!

Available Circuitry

SINGLE THROW— All "On" Positions In-line



1PST, 2 - 10 stations.



2PST, 1 - 3 stations.

DOUBLE THROW— Alternating Side "On" Positions



2PDT, 1 - 8 stations.



1PST, 1 - 7 stations.



4PST, 1 or 2 stations.



2PDT, 1 or 2 stations.

Other combinations and specials available. Call Grayhill for more information.

Free on request... the most recent Grayhill DIP Switch Catalog.

Grayhill
INC.

the Difference Between Excellent and Adequate

561 Hillgrove Avenue • LaGrange, IL 60525 U S A
Phone: 312/354-1040 • TWX: 910-683-1850

GRAYHILL Switches are distributed by

ALABAMA
Huntsville
Powell Electronics

ARIZONA
Phoenix
Kachina Electronic Distr
Tempe
Fisher Brownell
Richey Electronics

ARKANSAS
Little Rock
Carlton-Bates

CALIFORNIA
Alhambra
Fisher Brownell
Anaheim
Glendale
R V Weatherford
Los Angeles
Electric Switches
Riverside
Electronic Supply
San Diego
Fisher Brownell
Richey Electronics
Santa Clara
Fisher Brownell
Sunnyvale
Powell Electronics
R V Weatherford
Sun Valley
Richey Electronics

COLORADO
Denver
Electronic Parts
CSID
Newark Electronics

CONNECTICUT
Bethel
Heiland Electronics
Greenwich
Wise Components
Wallingford
Midan Electronics

FLORIDA
Miami
Powell Electronics
Oakland Park
Peerless Radio
Orlando
Hammond Electronics

GEORGIA
Norcross
AA Electric

ILLINOIS
Chicago
Newark Electronics
Elk Grove Village
Pioneer Chicago
Northbrook
Classic Components Supply
Palatine
DHM Electronics
Peoria
Klaus Radio
Wheaton
Conectrix

INDIANA
Evansville
Hutch & Son
Fl Wayne
Graham Electronics
Indianapolis
Graham Electronics
Genesis Electronics
South Bend
Radio Distributing

IOWA
Cedar Rapids

DEACO

KANSAS
Wichita
LCDMP Inc

MARYLAND
Beltsville
Powell Electronics
Gaithersburg
Pioneer Washington
Kensington
Marine Air Supply Inc
Rockville
Capitol Radio Wholesalers

MASSACHUSETTS
Hingham
Sager Electric Supply
North Adams
Electronic Supply Center
Norwood
Gerber Electronics
Worcester
R M Electronics

MICHIGAN
Livonia
Pioneer Michigan
R S Electronics
Oak Park
Newark Detroit Electronics
St. Claire Shores
Spemco

MINNESOTA
Minneapolis
Newark Electronics
Stark Electronics
St. Paul
Gopher Electronics

MISSISSIPPI
Jackson
Ellington Electronic
Supply Inc

MISSOURI
Kansas City
LCDMP Inc
Maryland Heights
LCDMP Inc
St. Louis
Dixie Intrust Electronics

NEBRASKA
Lincoln
Scott Electronic Supply

NEW HAMPSHIRE
Hudson
Heiland Electronics

NEW JERSEY
East Hanover
State Electronics Parts Corp
Springfield
Federated Purchaser

NEW MEXICO
Albuquerque
International Electronics
Walker Radio Company

NEW YORK
Binghamton
ASI Electronics
Bohema
Car-Lac Electronic
Industrial Sales
Buffalo
Summit Distributors
Lynbrook
Peerless Radio
Rochester
Simcona Electronics
Rome
Rome Electronics
Vestal
Harvey/Federal Electronics

NORTH CAROLINA
Greensboro
Hammond Electronics
Pioneer Carolina
Raleigh
Southeastern Electronics

OHIO
Cincinnati
Hughes-Peters
URI Electronics
Cleveland
Pioneer Cleveland
Columbus
Hughes-Peters
Dayton
ESCO Electronics
Pioneer Dayton
Stotts Friedman Co

OKLAHOMA
Oklahoma City
Electro Enterprises
Tulsa
Oil Capitol Electronics

OREGON
Beaverton
Component Resources
Portland
United Radio Supply

PENNSYLVANIA
Erie
Rem Electronics
Harrisburg
Cumberland Electronics
Philadelphia
Almo Electronics
Herbach & Rademan
Powell Electronics
Pittsburgh
Cam/RPC
Pioneer Pittsburgh
Reading
George O Barbey

RHODE ISLAND
Warwick
Edwards Electronics

SOUTH CAROLINA
Columbia
Oixe Electronics
Greenville
Hammond Electronics

TEXAS
Dallas
Norvell Electronics
El Paso
International Electronics
Houston
Kent Electronics
Harrison Equipment
Irving
Solid State Electronics
Richardson
Fisher Brownell
Stafford
Southwest Electronics

UTAH
Salt Lake City
Standard Supply

VIRGINIA
Richmond
Sterling Electronics

WASHINGTON
Kent/Interface Electronics
Seattle
R V Weatherford

WISCONSIN
Milwaukee
Marsh Electronics

Electronics review

megahertz or an Intel 8088 running at 4.8 MHz. As for memory, 64-K bytes of main memory is standard, with expansion capabilities equalling those of the 325 and 350. The initial standard software packages DEC has in mind for the 100 are word-processing, a spread-sheet calculator, and M- and C-Basic compilers.

As for the fourth new entry, the DECmate II is based on a 12-bit microprocessor originally developed for the PDP 8 mini. About 1.5 times faster than the earlier DECmate system, the successor version—essentially a word processor—carries a base price of \$3,745. —Linda Lowe

Solid state

Single wafer holds megabit memories

Reconfigurable systems are highly prized commodities in spacecraft and remote equipment where repair or changeover for different tasks would otherwise be difficult, if not impossible. The concept is being pursued by McDonnell Douglas Astronautics Co. to develop a wafer loaded with components that will work as a single unit. The technique is called wafer-scale integration, and the company plans to create first megabit memories and then complete systems on a wafer.

Silicon machine. Work on a non-volatile n-channel MOS memory technology is still in development, with the first full wafer-scale devices expected by mid-1983. The first will probably consist of eight 1-megabit memories linked together.

But this will be only a beginning. The 10-person team researching the approach hopes it will lead to a "silicon machine," a wafer loaded with memories and processor units, by at least the end of the decade. Yukun Hsia, who originally headed the work at McDonnell Douglas's Huntington Beach, Calif., facility, says, "Memory is an intermediate step. It's the easiest to do." (Hsia recently left to become engineering technology manager at Fairchild Camera &

Instruments' Microprocessor division, Santa Clara, Calif.)

The work on reconfigurable wafer-scale integration, discussed at the Electronic Components Conference in San Diego last week, began in 1976. Actually, integration of systems on a single wafer had been attempted in the 1960s, but McDonnell Douglas took a new tack by adding reconfiguration capabilities. This approach did not impose a 100% yield on the full wafer, since "bad cells" could be simply bypassed.

Richard Rodgers, section chief, sees applications for new wafer systems in things like flight-data recorders for aircraft and, particularly, in places where bubbles are now being considered.

A recent comparison with a commercially available 8-megabit bubble memory showed access times of 320 microseconds for the wafer memory, as against 7 to 40 milliseconds for the bubble. Average data rates were 1.85 megabits per second versus 544 kilobits per second for the bubbles. Like bubbles, this memory requires external chips—in a configuration tying 32 memories together, four drivers and four decoders would be used. But Rodgers says the wafer memory will not only offer faster data rates but be smaller and lighter in weight as well.

Currently, the work centers on a square 1-megabit silicon slice packaged so that any number can be tied together to create memories of up to hundreds of megabytes, Rodgers says. The 1-megabit wafer will be trimmed to a 3.4-inch square and will "likely" be housed in a 31-pin ceramic package.

The memory arrays, which employ 4-micrometer geometries, are arranged in 14-row-by-16-column matrixes. Each of these arrays stores 8,192 bits. Total capacity is figured using an average of 50% good cells on each wafer. Arrays are linked together via interconnect lines that can be likened to bus lines. These buses all tie into an on-chip array controller, which stores the addresses of the cells in use and of spares.

During operation, the array con-

Grayhill
INC

troller powers up the cells and channels data to them. A bad cell can be electronically isolated so it will not interfere with functionality, and the data is channelled to a spare. The array controller handles this simply by disregarding the address of the faulty memory array. Power switches on each of the arrays only accept power when the addresses sent out by the array controller match.
-Terry Costlow

Peripherals

Chassis houses range of memory

Buyers of peripheral memory may be finding it tougher than they thought to design housings for the many different small Winchester and floppy-disk drives and cartridge-tape transports on the market. As a result, one manufacturer has developed what it calls a universal peripheral chassis, a 19-inch-wide box with room to spare for the power supplies, cooling fans, and mountings needed to support a pair—almost any pair—of peripherals.

Voltage requirements range, for example, from two to five levels, power dissipation runs between 50 and 260 watts, and dimensions of even the same kind of memory unit can vary by as much as an inch, points out Leslie G. Alberts, marketing vice president at Distributed Logic Corp., Garden Grove, Calif. "It's a surprise even to sophisticated OEMs," he says.

As a manufacturer of some 20

kinds of controllers that mate different peripherals with Digital Equipment Corp. computers, Alberts' company thought it had heard enough complaints to offer a box that, at \$1,700 in single units, is certainly not cheap. But Alberts maintains that the device, which will be shown at June's National Computer Conference, is well worth it, considering the engineering and manufacturing costs of a custom design.

Combinations. The chassis handles some 42 combinations of disk drives, along with the backup tape cassettes from a dozen manufacturers. Chassis for this purpose are available, and for only about \$300. But they are designed for a single manufacturers' memory and do not offer original-equipment manufacturers the flexibility of the universal chassis, Alberts says.

The chassis can hold any 8-in. Winchester drive, with the model 850 made by Shugart Associates, Sunnyvale, Calif., probably the most popular. Cartridge-tape drives include the 6450 unit from Kennedy Corp., Monrovia, Calif., and the model 401 from Qantex Corp., Sunnyvale. The most widely used 8-in. floppy-disk drives come from Shugart and from Tandon Corp., Chatsworth, Calif.

By far the toughest part of providing one all-purpose package, according to Alberts, lies in the power supplies. Voltages needed by similar types of units are fairly consistent, but floppy-disk drives need a linear supply not powerful enough for most 8-in. Winchester units.

So the firm designed its own hybrid supply to combine features of both linear and switching types. Its double-primary transformer winding permits selection of six input voltage and frequency combinations from 115 volts ac to 240 v ac at 50 or 60 hertz, and the user may choose between two (positive or negative) dc-to-dc converter modules.

Multiples. Some 42 combinations of Winchester-disk drives and cartridge-tape transports from 12 manufacturers can be handled by Distributed Logic's chassis.

Cooling fans able to draw 120 cubic feet of air a minute hold the chassis temperature to between 10° and 32°C. The cooling is enough to handle 260 watts—which is the worst-case power dissipation of a pair of Fujitsu model 2312 Winchester devices, the hottest-operating drives in the business, says Alberts.

One OEM that integrates equipment on a custom basis—Spectra Systems Inc. of Newbury Park, Calif.—definitely plans using the new chassis. "It's a good idea, very flexible for a variety of peripherals," says vice president George Teachout. He praises its cooling capabilities. "This is a critical factor often overlooked," he says.
-Larry Waller

Consumer

Component television poised to take off

Spurred by new video-program sources, which last year helped push U. S. color-television sales to an all-time record 11.2 million sets, component TV appears primed to hit the market in force.

Japan's Sony Corp. continued its pioneering tradition in quality TV last year when it went to market in America with its Profeel Trinitron component-TV line [*Electronics*, June 16, 1981, p. 44]. A number of manufacturers—among them Zenith Radio Corp. and three Japanese firms—will follow suit next month, timing their product introductions with the Consumer Electronics Show in Chicago.

The Video Hi-Tech Component TV line that Zenith in Glenview, Ill., unveiled to distributors in early May is typical of modular TV. It allows consumers to mix-and-match video components as their tastes dictate and their pocketbooks permit. Initial component offerings in the line include a 19-inch (diagonal) color monitor, a separate TV tuner, a 20-watt-per-channel stereo amplifier, two-way speakers, and a program-source selector box that is capable of handling up to six sources. The



Type T912 / T914 Ultra-Precision Resistor Networks from Caddock provide Ratio TCs to 2 PPM/°C and Ratio Tolerances to ±0.01% for precision analog designs.

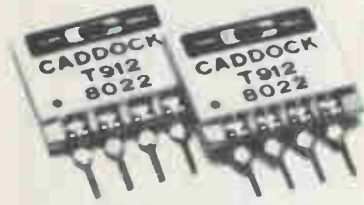

Type T912 Ultra-Precision Resistor Network 'Pairs'

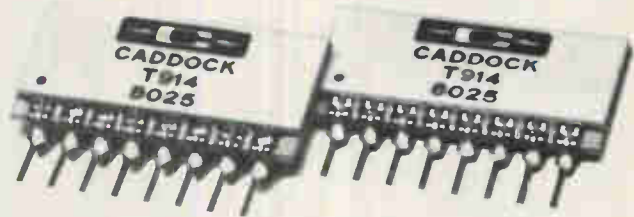

Type T914 Ultra-Precision Resistor Network 'Quads'

Type T912 / T914 Ultra-Precision Resistor Networks are constructed with Caddock's Tetrinox™ resistance films to achieve all of these high performance characteristics:

- Absolute Tolerance: 0.1% for all resistors.
- Ratio Tolerances: From ±0.1% to ±0.01%.
- Ratio Temperature Coefficients: From 10 PPM/°C to 2 PPM/°C.
- Absolute Temperature Coefficient: ±25 PPM/°C from 0° C to +70° C, referenced to +25° C.
- Ratio Stability of Resistance at Full Load for 2000 Hours: Within ±0.01%.
- Shelf Life Stability of Ratio for Six Months: Within ±0.005%.

This exceptional combination of performance specifications – and the compact, plug-in configuration of the Type T912/T914 precision resistor 'pairs' and 'quads' – provide the single-package

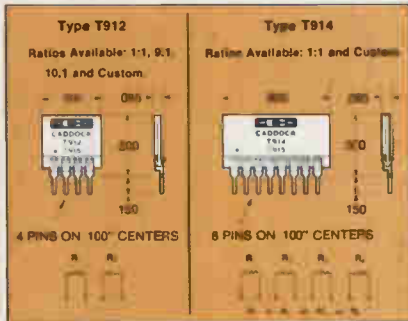

matched resistor characteristics and stability required by high-accuracy analog circuits, including –

- Precision analog amplifiers.
- Voltage reference circuits.
- Instrumentation bridge circuits.
- Voltage and current comparison circuits.

Standard models of Type T912 / T914 precision resistor 'pairs' and 'quads' include 14 off-the-shelf resistor values with a wide choice of Ratio Tolerances, Ratio TCs and Resistance Ratios:

This standard part number provides a selection of over 500 in-production models of Type T912/T914 precision resistor 'pairs' and 'quads':

T912 - A 1K - 010 - 10

Model Number: _____

Ratio Code Letter: _____

Ratio Temperature Track: (0° C to +70° C)
 -10 = 10PPM/°C -05 = 5PPM/°C
 -02 = 2PPM/°C

Ratio Tolerance:
 -100 = 0.1% -020 = 0.02%
 -050 = 0.05% -010 = 0.01%

Standard Resistance Values (R₁):
 1K 10K 40K 200K 500K
 2K 20K 50K 250K 1 Meg
 5K 25K 100K 400K

A - T912 with R₁ = 10R₂
 (Example 1K - 10K)
 B - T912 with R₁ = 9R₂
 (Example 1K - 9K)
 No Letter - T912 with R₁ = R₂
 No Letter - T914 with R₁ = R₂ = R₃ = R₄



As an example of the price/performance advantages of this advanced resistor technology, the Model T912-A1K-010-10 shown here provides a 1K-10K resistor 'pair' with a ratio tolerance of ±0.01% and a ratio temperature coefficient of 10 PPM/°C at a 1000-lot unit price under \$2.55. The same resistor 'pair' with a ratio tolerance of ±0.1% delivers at a 1000-lot unit price under \$1.50!

Type T1794 Custom Precision Resistor Networks meet special circuit and packaging requirements:

For medium- to high-volume applications, Type T1794 resistor networks provide all of the standard Type T912/T914 specifications, plus –

- From 2 to 15 resistors per assembly.
- Absolute tolerances from 1.0% to 0.01%.
- Custom voltage and power ratings.
- Resistance values from 500 ohms to 10 Megohms
- Absolute TC from 50 PPM/°C to 15 PPM/°C.
- Ratio TC from 50 PPM/°C to 2 PPM/°C.
- Variations in pin configurations and package size as required to meet performance and existing circuit-board arrangements.

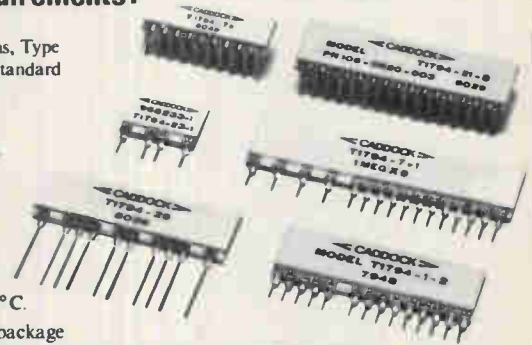

Caddock's advanced film resistor technology is the source of these outstanding advantages – advantages that are matched by a 20-year record of outstanding 'in-circuit' reliability.

Discover how easily these problem-solving resistors can improve the performance and reliability of your equipment, too. For your copy of the latest edition of the Caddock 24 page General Catalog, and specific technical data on any of the more than 150 models of the 13 standard types of Caddock High Performance Film Resistors and Precision Resistor Networks, just call or write to –

Caddock Electronics, Inc., 1717 Chicago Avenue, Riverside, California 92507 • Phone (714) 788-1700 • TWX: 910-332-6108

CADDOCK

HIGH PERFORMANCE FILM RESISTORS

Electronics review

choices include video cassettes and disks, games, a vhf/uhf antenna, a cable-TV converter, subscription-TV decoder, a microcomputer, and a home earth-station satellite receiver.

The system's model CV1950 monitor is equipped not only with base-band video and audio inputs but also has direct red, green, and blue inputs for high-resolution teletext or microcomputer applications, points out Carl A. Michelotti, vice president for color-TV engineering at Zenith.

Sober rise. Though the market "is not going to take off like a sky rocket," says Michelotti, he does expect component TV to become a significant business within the next two to three years, by which time the American public will have become more accustomed to the concept.

Raymond B. Penkola, assistant product manager for Teknika Electronics Corp. in New York agrees. Teknika, a joint venture of two Japanese firms, has been selling its ATV-19 and -25 component lines in the U. S. since last November. In Japan, where component TV has been available for three to four years, component systems now account for about 30% of all color-TV sales, says Penkola, who expects about the same rate of market penetration here.

Stereo sound on TV broadcasts in Japan has helped boost component system sales there, observes Don F. Sinsabaugh, a vice president with Bache Halsey Stuart Shields Inc. in New York. Though stereo broadcasting for TV has not yet started in the U. S., Sinsabaugh says that stereo sound on video-cassette and -disk systems, as well as performance features like high-resolution monitors, will help U. S. component-TV sales. The ability to tie video and stereo-audio signals into the same system is also important.

Price drops. As more competitors enter the market for component TV, the price will likely come down. The current price of a basic Sony Profeel system equipped with a 25-in.-monitor is about \$1,500. Systems having monitors with a higher resolutions than the current Sony Profeel line will be available within 18 months priced at less than \$1,000, predicts

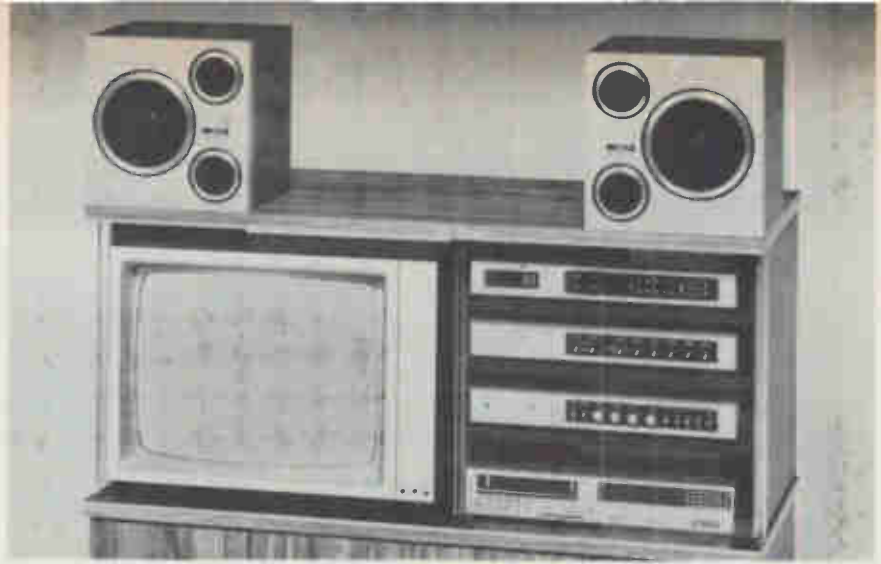

Mix and match. There is a rack of optional gear to go with the 19-inch monitor in Zenith's HI-Tech line. The selector box handles a half-dozen program sources.

James I. Magid, a vice president at L. F. Rothschild Unterberg Towbin in New York.

Among new systems coming on the market this year, the Zenith system carries a suggested retail price of \$1,170, which includes a 19-in. monitor, a tuner, a source selector, a stereo amplifier, and a pair of speakers. The new Pro-ponent Series from the U. S. subsidiary of Japan's Sanyo Electric will include a 19-in. monitor and TV tuner without stereo-

audio capability for about \$1,000.

For its part, Sony Corp. of America, New York, is taking aim at teletext, videotext, and computer applications with the addition of a new high-resolution 12-in. monitor to its Profeel line. The new model, the KX-1211HG, will be equipped with red, green, and blue inputs and an improved electron gun having smaller scanning-beam spots. Pricing and availability will be announced this fall.

-Wesley R. Iversen

News briefs

Motorola to have wholly owned plant in Japan

Motorola Inc. plans to purchase from its Japanese partner Toko KK the other 50% share of their MOS-manufacturing venture Aizu-Toko KK. The move will make Motorola the second U. S. chip maker—the other is Texas Instruments Inc.—to have a wholly owned manufacturing facility in Japan. Following completion of the deal, Motorola will rename the operation Nippon Motorola Seizo KK, which the firm says it plans to use as a base for present and future VLSI operations in Japan.

IBM chips away at size of 64-K dynamic RAM

International Business Machines Corp. has whittled its 64-K dynamic random-access memory to 62% the area of the original 64-K chip, the company's General Technology division announced early this month. Developed jointly by the Burlington, Vt., and Böblingen, West Germany, laboratories, the new chip measures 3.8 by 6.0 millimeters (35,300 square mils). Two-hundred forty of the new chips can fit on a 100-mm-diameter silicon wafer, compared with 145 for the earlier chip. IBM's new RAM is made using the firm's silicon and aluminum metal-oxide-semiconductor (Samos) technology.

Massachusetts proposes high-tech agency

Putting its chips on high technology as a way out of the current recession, the Commonwealth of Massachusetts wants to establish a \$40 million state corporation to train engineers and technicians. The corporation's first project would be the Massachusetts Microelectronics Center, a joint industry-university educational center containing design, fabrication, and testing facilities, as well as classrooms. Legislation authorizing a \$20 million state bond issue—which would have to be matched by industry contributions, equipment, and machinery—was filed in late April.

NATIONAL ANTHEM[®]

SEMICONDUCTOR NEWS FROM THE PRACTICAL WIZARDS OF SILICON VALLEY.

The world's first 32K CMOS EPROM.

NEW NMC27C32 IS THE LATEST IN NATIONAL'S
LONG LINE OF HIGH PERFORMANCE CMOS MEMORIES.

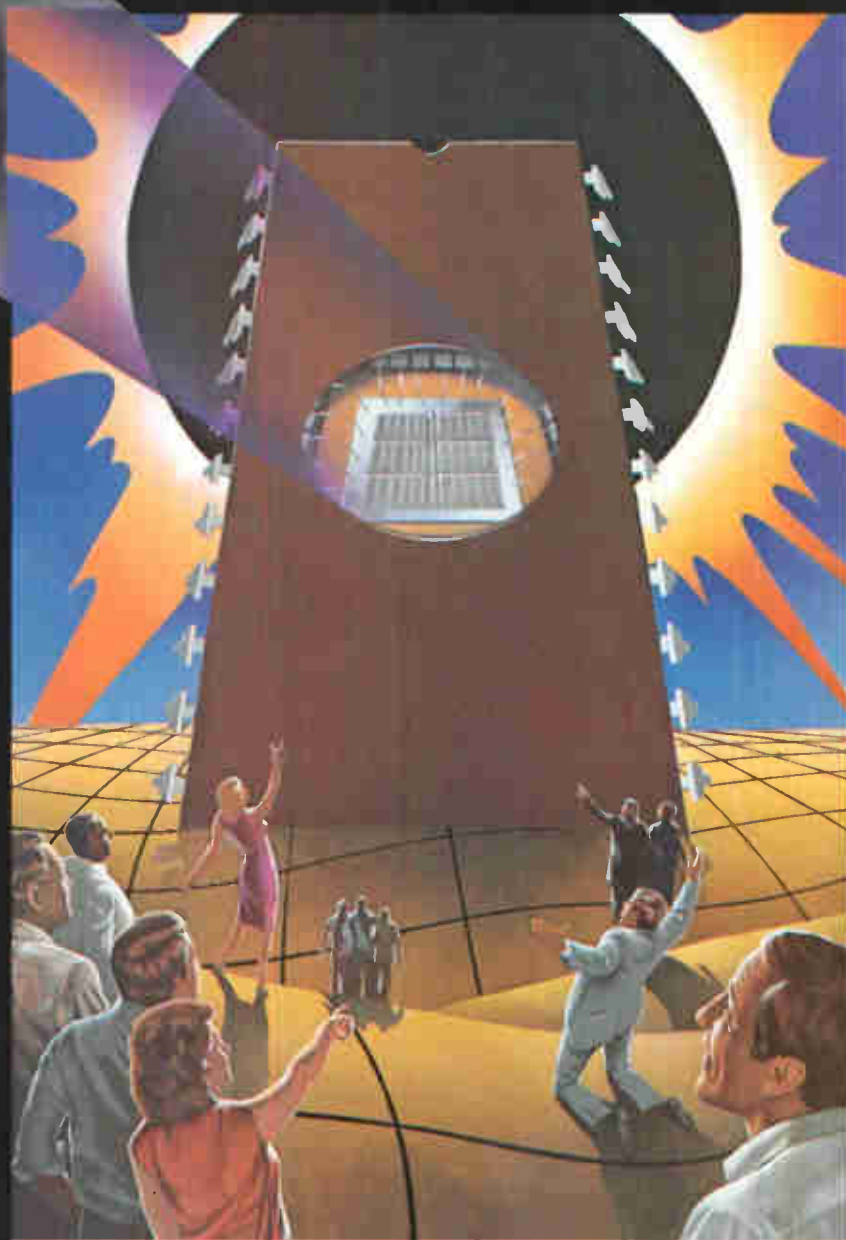

High speed
CMOS logic

Two new advanced
bipolar logic
families

NSC800-based
board-level
family

Transceivers
that stop
glitches cold

Powerful new COPS
microcontrollers

Special Report:
the full range of
CMOS μ P products

The reliability
of integrated
displays

The 1982 Linear
Data Book is here

How to get the
latest on MOS/LSI
reliability

Digitaltalker COPS Data Acquisition Logic Transistors Hybrids Linear Interface Fiber Optics
RAMS/ROMs/PROMs Transducer Displays Custom Circuits Optoelectronics

Memory Systems Microprocessors Microcomputer Systems Board Level Computers Modules Mil/Aero

NATIONAL ANTHEM

The world's first 32K CMOS EPROM.

National's new NMC27C32 offers CMOS power-savings with NMOS performance.

National advances the state of the art in high-density CMOS memories with their new NMC27C32 32K UV-erasable P²CMOS™ EPROM.

The device, the industry's first 32K CMOS design, offers engineers the opportunity to develop higher density CMOS memories with all the speed of conventional NMOS designs.

CMOS advantages with NMOS performance. The NMC27C32 has all the advantages of CMOS: low active (10mA max) and ultra low standby current (25μA max), exceptionally low noise, and higher component and system reliability.

It's an ideal pin-for-pin replacement for the n-channel 2732 EPROM in power-sensitive systems, dissipating 10 times less max active power and having 10,000 times less typical standby power.

Overall system costs can be cut using the NMC27C32, since its wide power supply operating range eliminates the need for an expensive voltage regulator.

With all those advantages, access times are still 350 ns.

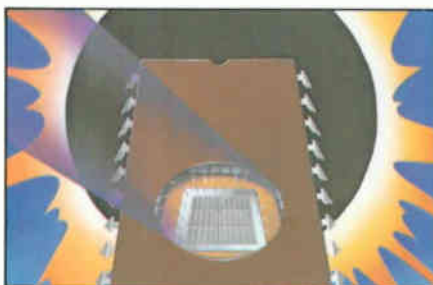

POWER DISSIPATION COMPARISON

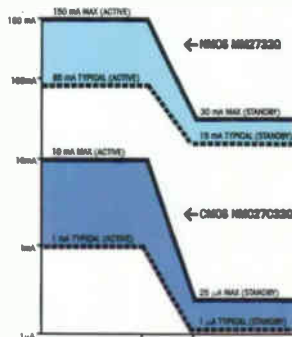

Without sacrificing system speed, the NMC27C32 offers a reduction in power dissipation of greater than four orders of magnitude over the MM2732.

Designing with the NMC27C32. By designing in the NMC27C32, expansion to 64K or 128K CMOS EPROMs will not increase the system's power consumption.

In addition, by replacing CMOS RAMs and batteries with the new device, system performance and reliability are improved.

Full programming support. The NMC27C32 comes with a transparent lid which allows the chip to be erased with ultraviolet light. Once erased, a new bit pattern can be programmed using National's STARPLEX™ development system with the optional Universal PROM Programmer.

The senior-ranking EPROM receives military standing. For their high-rel customers, National offers the NMC27C32 in MIL-STD-883. Mil/Aero applications can now take full advantage of this P²CMOS speed/power product in a 32K CEPROM.

To get more information on the industry's biggest CMOS EPROM, check box D7 on the National Archives coupon.

The NMC27C32 32K CMOS EPROM. Another CMOS hit from the Practical Wizards of Silicon Valley.

P²CMOS and STARPLEX are trademarks of National Semiconductor Corporation.

Speed: the missing piece in CMOS logic.

Introducing MM54HC/74HC: the new family of high performance CMOS logic circuits from National.

The Practical Wizards are proud to introduce a new family of high speed, low power, CMOS logic chips: the MM54HC/74HC family.

The new logic family is pin-out compatible with popular 7400 LS-TTL, but offers dramatic power savings with no reduction in speed. The family will include a wide range of small- and medium-scale CMOS logic devices that will make complete, high speed CMOS systems possible for the first time.

First with the best. The MM54HC/74HC family is the first broad, truly high speed logic family that offers all the advantages of CMOS: high noise immunity, power requirements below 1μW typical (static) 2V to 6V power supply operating range, and an extended commercial temperature range of -40°C to +85°C.

The key is National's advanced P²CMOS™ fabrication process. P²CMOS has been proven faster and less power-intensive



than conventional CMOS. A modification of this advanced process, optimized for producing high volume logic devices, is used to produce the MM54HC/74HC family.

Translated into system benefits, those features mean: less expensive and smaller

system power supplies, the elimination of fans, heat sinks, and cooling systems, higher density/lower cost PC boards, more compact systems, and a substantial increase in reliability.

Ideal for military service. Of course, the MM74HC will be available in full mil-spec versions (MM54HC) and with National's rigorously controlled A+ and B+ processing.

All versions feature the high quality that has made National one of the top suppliers to the MIL/AERO market.

National's new MM54HC/74HC logic family is another example of their commitment to low power, high performance technology. It's the logical next step toward the design solutions of the future.

A MM54HC/74HC databooklet is available which includes our sampling schedule. Just check box C9 on this Anthem's coupon.

The MM54HC/74HC family will be mutually sourced by Motorola, Inc.

P²CMOS is a trademark of National Semiconductor Corporation.

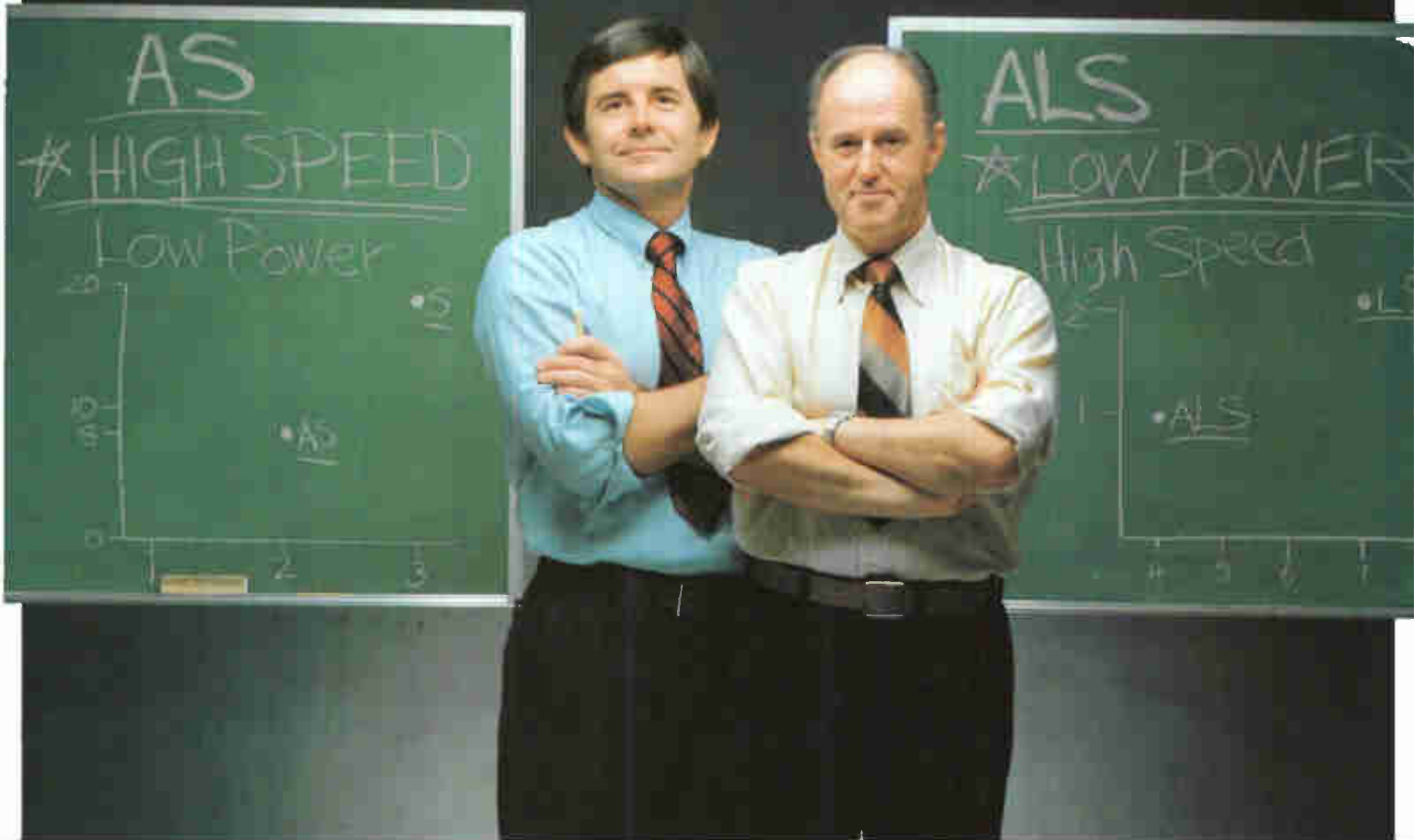

AS and ALS—two new logical choices for S and LS designs.

National's AS and ALS logic families bring lower power and faster speeds to next-generation S and LS applications.

National's logical line, already the world's largest with seven 74-series families, broadens even further with the addition of two new bipolar lines: the Advanced Low Power Schottky and the Advanced Schottky families.

The new families offer designers a choice of either the ultimate in low power dissipation or the ultimate speed for bipolar. The ALS family offers per-gate speeds of 4ns with power consumption of just 1mW. The AS family dissipates 8mW per gate, but features a speed of just 2ns, ideal for time-critical applications.

Plus, all of National's AS and ALS devices are specified at $\pm 10\% V_{CC}$, encom-

passing both the commercial and military voltage ranges.

The devices are pin-out compatible with other popular logic families, including LS, S, and TTL.

Two big families. The two families will include over 150 logic devices by the end of 1982. Octals, multiplexers, counters, latches, comparators, and many more products will be available.

Both families are mutually sourced by Texas Instruments.

Some logical applications. Because the new logic families offer substantial performance advantages over conventional bipolar logic, and yet are pin-for-pin and function compatible, they represent an excellent opportunity to design engineers to upgrade standard logic system designs.

Both families are designed to function well in a wide variety of applications: computers, communications equipment, terminals,

and most medium- to high-performance logic systems.

High volume production for lower cost.

To ensure that the new logic families will offer high quality at the lowest possible cost, the Practical Wizards are gearing up their efficient manufacturing operation for high volume production of both product lines.

Pricing for a typical ALS device like the DM74ALS00 in a plastic DIP package will be \$.40* in 100-up quantities. Pricing for a more complex device like the DM74ALS138 will be \$.80* in 100-up quantities.

To get more information on National's two new logic families, check box D5 on this issue's National Archives coupon.

The ultimate in speed or the ultimate in low power performance. The kind of logical choices customers have come to expect from the Practical Wizards. 

*U.S. prices only

SPECIAL REPORT

Broad range of high performance, low

National's selection of CMOS μ Ps, boards, and development support products gets low power systems up fast.

Now National can solve virtually any low power system design problem with a complete spectrum of processing capabilities.

National's CMOS line extends from efficient 4-bit COPS™ microcontrollers all the way to high performance board level systems. Highlighting their line of powerful CMOS processors are the NSC800™ and the NS80CX48.

These new P²CMOS™ processors not only greatly reduce power consumption in existing systems, but can also be used to develop new ultra-low power designs.

So now it's no longer necessary to choose between the advantages of CMOS and the performance of NMOS.

NS80CX48: extra features at no extra cost. Using their field-proven P²CMOS process, the NS80CX48 features the same speed of the industry standard 8048 Series, but

consumes a mere fraction of the power.

National offers both the standard NS80C48, plus the NS80CX48. The "X" represents an "Extra Features" register that allows—among other things—software control of its power consumption. And the price for the "X" version is the same as for the NS80C48.

NSC800: the most powerful CMOS μ P available. The popular NSC800 combines the multiplexed address/data bus of the 8085 with the sophisticated register structure and instruction set of the Z80®. Yet the NSC800 typically dissipates only 50mW operating at 5V at a 2.5MHz clock speed.

Watch for announcements of the new NSC800A version, which offers 4MHz Z80A computing speed with CMOS power.

Complete the design with the NSC810 RAM-I/O-Timer and the NSC830 ROM-I/O. These two circuits are packed with just the right amount of data and program storage memory, programmable input/output interface lines

and versatile timers to complete an efficient minimum system or the heart of a larger system.

In addition to supporting the NSC800 microprocessor, these two devices make excellent peripherals for NS80C48/NS80CX48 system expansion.

Drafted for military service. Because of its low power, high performance and proven reliability, the NSC800 Family is fast becoming the CMOS military standard for microprocessor applications. The NSC800DM/883 is processed to MIL STD 883B requirements and operates over the full -55°C to +125°C military temperature range. For high density packaging needs, select the NSC800ME/883B leadless chip carrier version.

A complete board level system for less than 5 watts.

The Practical Wizards have also designed a board line around their low power standard NSC800 P²CMOS microprocessor. So now the board level market can enjoy all the advantages of low power, high performance technology.

The CIMBUS™ CMOS Industrial Microcomputer (CIM™) boards use so little power that a fairly large system can be configured to draw less than 5 watts. Compare that to a typical NMOS CPU board which alone can

NS80CX48 EXTRA FEATURES COMPARISON		
	STANDARD 8048	NEW NS80CX48
PRESCALE VALUE	32	PRESCALE VALUES: 5, 10, 20, 40, 80, 100, 160, 200
MODULO OPTION	MUST USE MOV _T , A TO LOAD EACH TIME	AUTOMATICALLY LOADS SAME VALUE AT ROLL-OVER
GATE OPTION	N/A	GATES PRESCALER OUTPUT TO TIMER/CRT REGISTER INPUT
CONTINUE OPTION	LOW ON V _{CC} STOPS OSC, RESETS CPU	OPTION WITH LOW ON V _{CC} OF RUN OR IDLE
ENABLE I/O OPTION	LOW ON V _{CC} SETS ALL LINES TO UNDEFINED STATES	OPTION WITH LOW ON V _{CC} OF TRI-STATE® OR ENABLED I/O



power processing from National.

CONSERVING POWER IS A NATIONAL ACHIEVEMENT

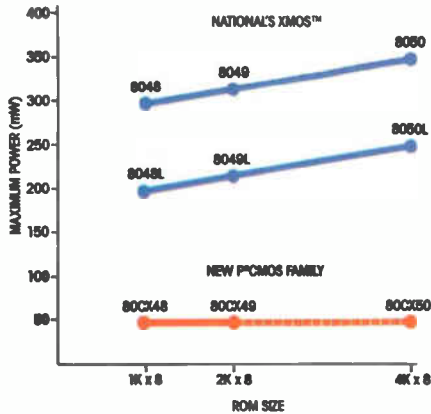

National's P²CMOS NS80CX48 family draws only 10mA max at full 6MHz operating speed. Watch for announcements of the P²CMOS NS80CX49 and NS80CX50 with larger memory on board.

draw 15-30 watts.

The new boards offer all the inherent benefits of low power dissipation—higher reliability, portability, battery operation, sealed enclosures, smaller systems, and lower system costs—with speed that can handle the most demanding industrial applications.

A complete performance family. There are 19 CIMBUS products, a complete family for all system needs (with still more on the way).

The family already includes three CPUs, memory expansion boards, discrete I/O interfaces, A/D and D/A boards, card cages, a voltage regulator, a battery charger, a firmware monitor, plus extender and prototyping boards. The BLMX-80 real-time multitasking operating system is also available.

Built for the harsh environment. CIMBUS boards are designed to thrive in environments that conventional boards can't take. Ambient operating temperatures can be as low as -40°C or as high as +85°C.

Smaller systems, higher reliability, lower costs. The series also offers the smallest form factor around—3.9" x 6.3" (100mm x 160mm). That's 69% smaller than Multibus™ and 15% smaller than Std. Bus. So many systems can be made smaller and for less total system cost.

Every CIMBUS board comes with a 12-month warranty and the built-in reliability that goes into every National product.

Complete development support, prototyping, evaluation, and documentation.

STARPLEX II™, National's highly interactive development system, supports and speeds the overall development effort for both the 8048 and NSC800 families of μ Ps. With real-time In-System Emulation (ISE™), engineers can develop, test, analyze and debug prototype software and hardware with ease. In fact, National offers the only 11 MHz emulator for the 8048.

Aside from real time In-System Emulation, the upgraded STARPLEX II offers high

level languages, including PL/M, PASCAL, BASIC, and FORTRAN. Cross-assemblers are already available for all supported products, and other system enhancements are on the way.

In addition, National's NS87P50 (for up to 4K emulation) and their new CMOS NS87PC48 "piggyback" μ Ps greatly simplify design prototyping.

NSC800 evaluation made easy. Immediate evaluation of the NSC800 family of products is made easy and inexpensive with NSC888 Evaluation Board. The fully assembled board includes the NSC800 CPU plus memory, timers, I/O, wire-wrap area, an RS232 interface plus complete documentation. An on-board monitor provides the necessary tools to write, modify, and execute NSC800 programs.

COPS microcontroller development products. The COP400-PDS is a low-cost concept-to-product tool designed to expedite every phase of COPS microcontroller system design.

National's STARPLEX system also provides the same capability when equipped with the COPS ISE.

How to get all the details. To receive all the specifics on National's high performance CMOS microprocessors and board level systems and their powerful development tools, simply check boxes E1 and E2 on this issue's National Archives coupon.

It's the best way to start putting high performance, low power processing to work today.

COPS, NSC800, P²CMOS, X8000, CIMBUS, CIM, STARPLEX II, ISE, and TRI-STATE are trademarks of National Semiconductor Corporation.

Z80 is a registered trademark of Zilog Corporation.

Multibus is a trademark of Intel Corporation.

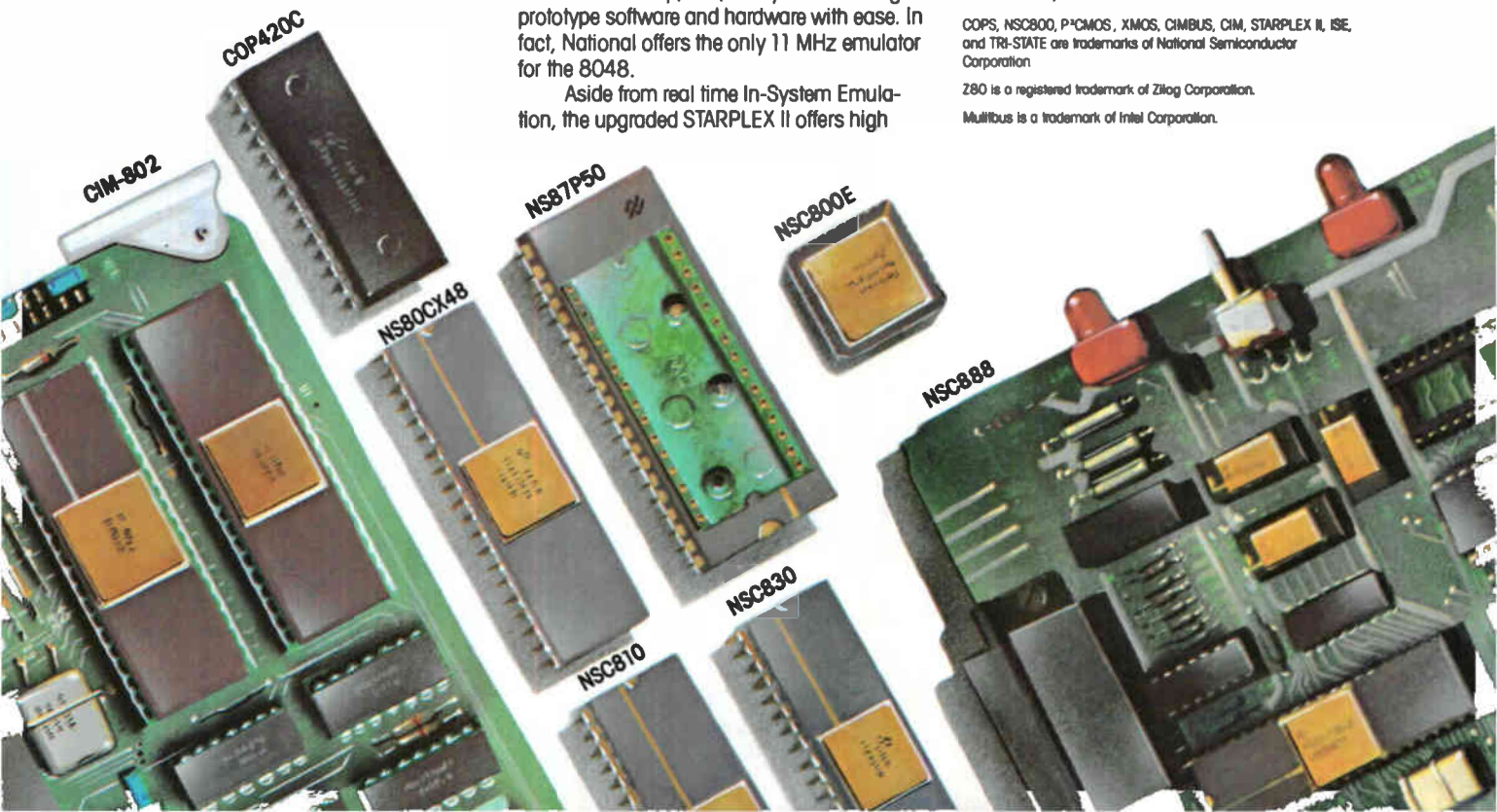

NATIONAL ANTHEM

A complete board level system for less than 5 watts.

New NSC800™-based board line offers NMOS performance in a CMOS environment.

The Practical Wizards have done it again. This time they've designed a board line around their low power standard NSC800 CMOS microprocessor to bring the advantages of low power, high performance technology to the board level market.

The CIMBUS™ boards are designed to complement the characteristics of CMOS technology. They use so little power that a fairly large system can be configured to draw less than 5 watts. Compare that to a typical NMOS CPU board which alone can draw 15-30 watts.

The new boards offer all the inherent benefits of low power dissipation—higher reliability, portability, battery operation, sealed enclosures, smaller systems, and lower system costs—with speeds that can handle the most demanding industrial applications.

A complete performance family. There are 19 CIMBUS CMOS Industrial Microcomputer (CIM™) products, a complete family for all system needs (with still more on the way).
CIM-801—CPU with 1MHz NSC800
CIM-802—CPU with 2MHz NSC800
CIM-804—CPU with 4MHz NSC800
CIM-100—16KB RAM/PROM Expansion

Board with OKB RAM installed
CIM-104—16KB RAM/PROM Expansion Board with 8KB RAM installed
CIM-108—16KB RAM/PROM Expansion Board with 16KB RAM installed
CIM-201—Serial I/O Board
CIM-230—Distributed I/O Bus (DIB™) Interface Board
CIM-311—OPTO 22 SSR Rack Interface
CIM-411—A/D Board
CIM-421—D/A Board
CIM-602—9.5-inch Card Cage (10 slots)
CIM-604—19-inch Card Cage (21 slots)
CIM-610—Voltage Regulator
CIM-611—Battery Charger
CIM-630—Prototyping Board
CIM-640—Extender Board
CIM-660—Firmware monitor
BLMX-80—Real-time Multitasking Operating System

Built for the harsh environment. CIMBUS boards are designed to thrive in environments that conventional boards can't take. Ambient operating temperatures can be as low as -40°C or as high as +85°C.

High noise environments are no problem either. The boards' immunity to noise makes them ideal for heavy industrial control applications.

And positive contact DIN connectors, instead of card-edge connectors, substan-

tially improve resistance to vibration and corrosion.

Smaller systems, higher reliability, lower costs. The series also offers the smallest form factor around—3.9" x 6.3" (100mm x 160mm). That's 69% smaller than Multibus™ and 15% smaller than Std. Bus. So many systems can be made smaller and for less total system cost.



Every CIMBUS board comes with a 12-month warranty and the built-in reliability that goes into every National product. For more information, check box DO on this issue's coupon.

Multibus is a trademark of Intel Corporation.
DIB, CIM, CIMBUS and NSC800 are trademarks of National Semiconductor Corporation.

New 488/GPIB transceiver family stops glitches.

Eliminating power up/down glitches from IEEE-488 buses.

National's new family of octal bi-directional transceivers were designed with a unique feature: all bus outputs are provided with power up/down protection circuitry for glitch-free operation.

The new family meets IEEE-488/GPIB standards, and is pin-compatible with the SN75160A, SN75161A, and SN75162A, but provides better performance than those devices.

Family features. All chips in the family provide pin-selectable totem-pole/open collector outputs on the data pins to optimize system speed. On-chip bus terminators with active turn-off provide high impedance under power down, allowing over 15 devices to be connected to the bus, with up to 15 being active at any one time.

Meet the family. The family members include: the DS75160A Data Buffer, which handles 8 channels of data, the DS75161A



Management Buffer, which handles 8 channels of management signals in a single controller system, and the DS75162A Management Buffer, which can handle management signals from either single or multi-controller systems.

Combining data and management signals. The family also includes the DS3666 transceiver, a combination data/management buffer unique to National. The DS3666 handles four data and four management signals, all in a 0.3" skinny DIP.

Two DS3666's can take care of the data

and management channels for a single or multi-controller system, reducing inventory part count to a single device type, which is not possible with two- or three-chip solutions.

Receive more information. The transceiver family also features high impedance PNP inputs on the drivers and 500mV (typical) hysteresis at the receiver inputs (for added noise margin).

For more information on the only 488 transceiver family that can prevent glitches, check box D8 on this issue's National Archives coupon.

More powerful microcontrollers for more flexible designs.

Capable COP440 series gives designers additional freedom.

Engineers designing dedicated control applications should look carefully at National's new COP440 microcontroller family before resorting to a conventional discrete logic approach.

In most cases, the COPS™ distributed intelligence approach represents an excellent compromise between cheap, but inflexible, discrete designs and expensive micro-processor solutions.

The 440 family. The COP440 operates on a single 5V supply and comes in 24-, 28-, and 40-pin versions. So systems can be tailored to specific I/O requirements.

This reduces system costs, especially when coupled with COPS' distributed intelligence and the MICROWIRE™ peripheral interface. (MICROWIRE is a low-cost, three-wire serial link designed exclusively for the COPS family.)

What is distributed intelligence?

The entire COPS family provides a unique approach to microcontroller applications. Each peripheral in the family has sufficient intelligence to execute its own instruction set. This distribution of intelligence spreads the processing workload, optimizing efficiency and cost.

Intelligence runs in the COPS family.

COP440 family members offer greater capabilities than most conventional micro-controllers. Their high performance features include:

- High efficiency instruction set

THE DISTRIBUTED INTELLIGENCE APPROACH TO MICROCONTROLLER APPLICATIONS.

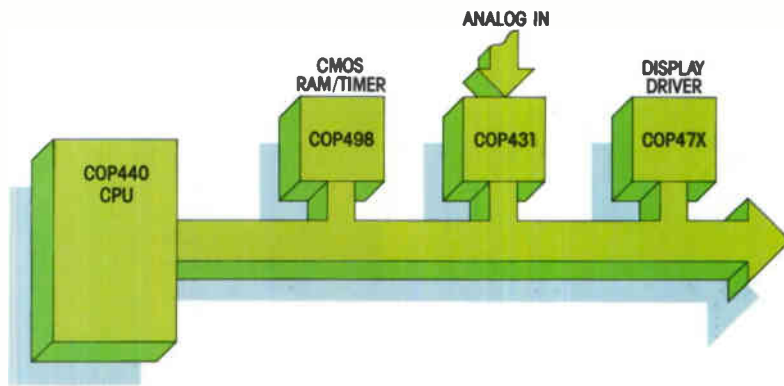

The illustrated system uses a COP498 CMOS RAM/Timer to switch the COPS controller off and on between instructions so its power consumption approaches that of a CMOS device, but for less money. The COP431 adds A/D conversion with up to 8 multiplexed input channels from various analog signals. Choosing the COP470 or COP472 adds VF or LCD display drive.

- Most instructions are single-byte for 4 μ s execution
- 4 selectable interrupt sources
- 4 levels of stack
- Interrupt/subroutine stack in RAM
- Settable/readable timer
- On-chip zero crossing detector with hysteresis

The family also offers 2Kx8 ROM, 160x4 RAM, software-selectable interrupt and event counter options, keyboard input, display output, and data manipulation capabilities.

Full field and development support. The

entire COPS family has a common instruction set and is fully supported by the STARPLEX™ system with real-time ISE™ as well as the COPS Product Development System (PDS™).

Plus, National's field support team is always available to ease design-in.

To find out more about the new COPS family, check box D6 on this issue's National Archives coupon.

Helping add flexibility to system design is a National priority.

COPS, MICROWIRE, PDS, ISE and STARPLEX are trademarks of National Semiconductor Corporation.

Integrated displays increase reliability.

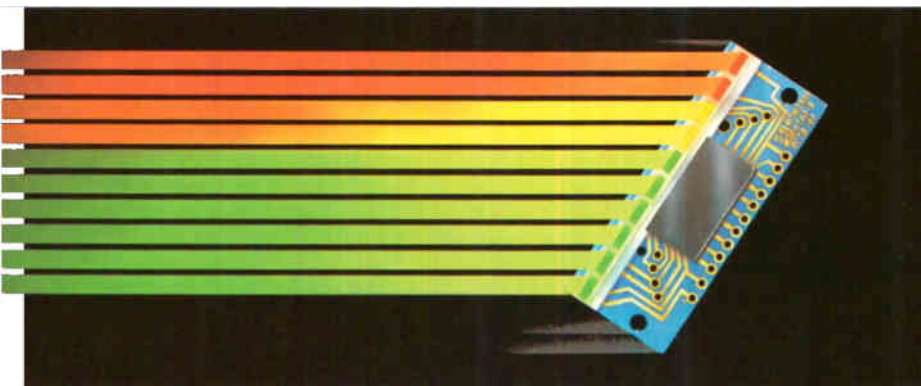

An on-board driver chip minimizes system interconnects to enhance reliability while cutting design-in and manufacturing costs.

Now engineers designing analog instruments such as panel meters, temperature

control systems, thermometers and speedometers can save space and increase instrument reliability by using integrated bargraph displays.

Rugged reliability, curtailed costs. Due to their single-unit construction, the NSM3900 Series LEDs are considerably more reliable

and resistant to shock than the traditional models with separate driver and display.

The NSM3900 Series of self-contained bargraph displays—which combine a 10-element linear array with a monolithic driver circuit—measure only 2" X .85". The series includes models for linear, logarithmic, and VU meter applications.

The advantage of single-unit construction also provides significant reductions—up to 25%—in stocking and development costs.

Practical versatility in all color combinations. The NSM3900 Series bargraphs are end-stackable and can be cascaded to 10 arrays (100 bargraph elements).

What's more, they're available in all combinations of red, yellow and green in linear, logarithmic and VU meter functions.

Yet another first in reliability and savings from the Practical Wizards.

For more information on the NSM3900 Series bargraph displays, check box B4 on this Anthem's coupon.

The 1982 Linear Databook has arrived.



Get the lowdown on National's long linear line.

The 1982 edition of National's Linear Databook is out. And it's the most comprehensive ever. Over 2000 pages of complete specs on our advanced linear products.

The source for all linear knowledge. The new Databook contains applications, technical descriptions, full features, and comprehensive diagrams.

It also includes detailed sections on voltage regulators, references, comparators, op

amps and buffers, instrumentation amps, analog switches, sample and hold circuits, A/Ds, D/As, telecommunications circuits, industrial building blocks, audio, radio and TV circuits and DIGITALKER™ speech synthesis technology.

The 1982 Linear Databook is now available for only \$12.00.* To order, check box D9 on the coupon below and include a check or money order for the appropriate amount (see directions on the coupon).

*U.S. price only.

DIGITALKER is a trademark of National Semiconductor Corporation.

Get the MOS/LSI reliability update.

The new report on the reliability of MOS/LSI microcircuits is out.

National's newest NMOS reliability update, "Reliability of N-Channel Metal Gate MOS/LSI Microcircuits" is now available.

The update is the best way to find out the latest on National's extensive investigation and test results on their NMOS products.

Reliable facts on reliability. The report

includes the results of exhaustive tests conducted on National NMOS parts since 1979. Test results are identified by part type for the following tests: Operating Life, Storage Life, Temperature-Humidity-Bias, Temperature Cycling, and Autoclave.

A summary of test results is given as well as the full details.

To get the new MOS/LSI Reliability update, check box EO on the coupon below.

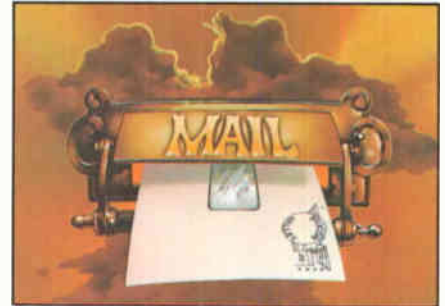

What's new from the National Archives?

- | | | | |
|--|---|--|--|
| 52 <input type="checkbox"/> Data Update—Latest New Product Information | C6 <input type="checkbox"/> Hybrid Products Data Book (\$7.00)* | D0 <input type="checkbox"/> CIMBUS Board Level Information | D8 <input type="checkbox"/> GPIB 488 Transceiver Data Sheets |
| 61 <input type="checkbox"/> CMOS Data Book (\$6.00)* | C7 <input type="checkbox"/> 1982 Voltage Regulator Handbook (\$7.00)* | D5 <input type="checkbox"/> Advanced Bipolar Logic Data Book (\$5.00)* | D9 <input type="checkbox"/> 1982 Linear Data Book (\$12.00)* |
| B4 <input type="checkbox"/> NSM3900 Series Bar-graph Data Sheets | C8 <input type="checkbox"/> PAL Data Book (\$6.00)* | D6 <input type="checkbox"/> COPS Data Book (\$6.00)* | E0 <input type="checkbox"/> MOS/LSI Reliability Update |
| | C9 <input type="checkbox"/> MM54HC/74HC Databooklet | D7 <input type="checkbox"/> NMC27C32 CEPROM Data Sheet | E1 <input type="checkbox"/> CMOS Microprocessor Information |
| | | | E2 <input type="checkbox"/> NSC800 Information |

*Enclose check or money order based upon appropriate currency. U.S. residents may use VISA or MasterCard (all information must be supplied). Make checks payable to NS Publications. All prices shown are U.S. prices only. California residents add applicable state and local sales tax. Allow 4-6 weeks for delivery. This coupon expires on July 31, 1982.

For desired information, mail coupon to:

National Semiconductor Corporation
P.O. Box 70818
Sunnyvale, CA 94086

 **National Semiconductor**
The Practical Wizards
of Silicon Valley

NAME _____

TITLE _____ PHONE _____

COMPANY _____

ADDRESS _____

CITY _____ STATE _____ ZIP _____

M.C. VISA # _____ EXPIRES _____

SIGNATURE _____

ACCT ADDRESS _____

E

NA 41

WHATEVER YOUR LOGGING PROBLEM ORION HAS THE ANSWER.

A SIGNIFICANT CLAIM FROM SOLARTRON

Orion measures thermocouples, resistance bulbs, strain gauges, flow meters, status switches, event inputs, binary and BCD data, and provides energisation and conditioning for virtually any type of transducer or input.

Easy to use menu selected facilities include standard and user defined conversion equations, limit, threshold and significant change alarms, max/min, mean and standard deviation statistics.

Up to 600 channels and scan speeds to 500 points/second can be configured to carry out eight independent logging activities – or they can be inter-related to provide powerful event driven logging and control functions.

The integral magnetic tape cartridge and strip printer, together with GPIB, RS232 and RS422 interface options, make Orion ideal for stand-alone or computer linked systems for both laboratory and plant operation.

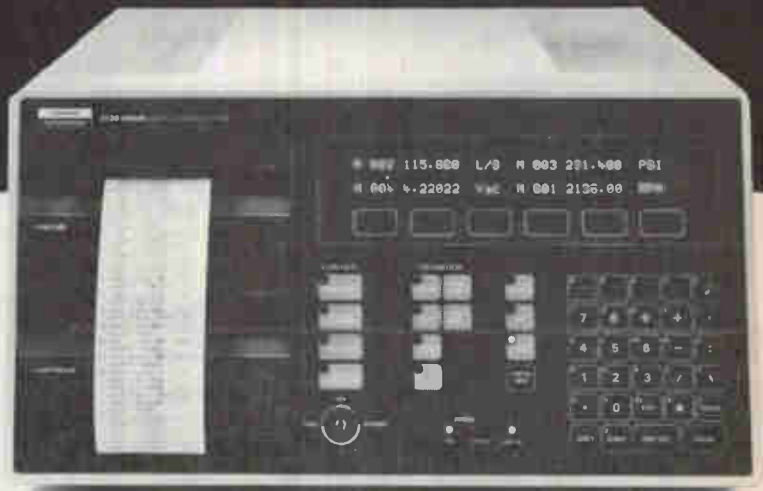

And for all this performance Orion is still extremely competitively priced.

To find out more, phone or write to the address below.

The Solartron Electronic Group

USA:— 17972 Sky Park Circle, Irvine, Cal. 92714
Tel: 7146417137

UK:— Farnborough, Hampshire, GU14 7PW Tel: 0252 44433

GERMANY:— AM Kirchoezl, 15 8032 Graefelfing, Munchen
Tel: 89-854-3071

FRANCE:— 1, Rue Nieuport, 78140 Velizy-Villacoublay
Tel: 9469650

SWEDEN:— Vesslevagen, 2-4, Box 944, 5-18, Lidingsö 9
Tel: 4687652855



SIGNIFICANTLY FROM SOLARTRON



Circle 65 on reader service card

*The limits of performance
are barriers only
to the unimaginative.*

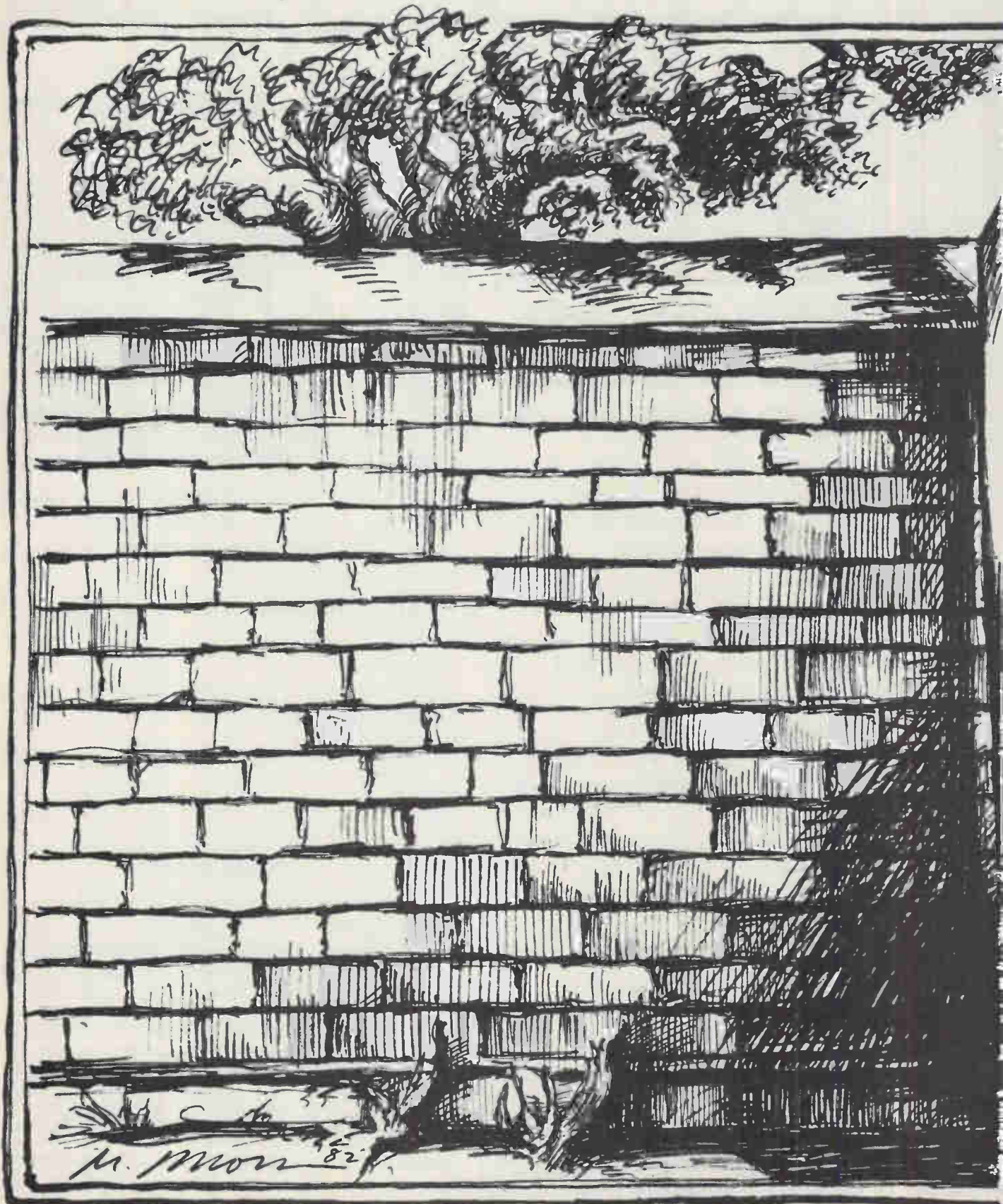

Illustration by Geoffrey Moss, © 1982.



PAL is a registered trademark of Monolithic Memories, Inc.

*Imagine.
The fastest system.
Packed with the smallest chips.
Running on the power it takes to
generate a thought.
That's where Monolithic Memories
is going.*

*We began by developing the bipolar
PROM and now offer a complete
family of some of the fastest, lowest
power PROMs available.*

*To bring the same kind of advan-
tages to logic, we invented the PAL[®],
and likewise, now market the fastest,
lowest power, greatest density PALs.*

*Along with the fastest FIFOs. The
fastest multipliers. The world's first
multiplier/divider. And more.*

With still more to come.

*Because nobody knows your design
better than you do, we concentrate
on programmable solutions. To help
cut your costs. Save you space.
Enhance the performance of your
system. And give you exactly what
you had in mind.*

*If the progress of the semiconductor
industry has proven anything, it's
that the limits of semiconductor per-
formance are not limitations. But
merely milestones on the road to
the future.*

Come with us.

*Your imagination can take you
anywhere.*

And we know the way.

*For more information, write us.
Monolithic Memories, Inc., 1165 East
Arques Avenue, Sunnyvale, CA 94086
(408) 739-3535.*

Pushing The Limits.

Monolithic Memories 

Circle 67 on reader service card

Unitrode linear ICs let you design to the same old standards.

REGULATING PULSE WIDTH MODULATORS

Unitrode Part No.	Max. Output Voltage	Output Current	Operating Temp. Range	Package Type (TO-116)	Features
UC1524	40V	100mA	-55°C to +125°C	16 Pin Ceramic	Uncommitted dual alternating outputs.
UC2524	40V	100mA	-25°C to +85°C	16 Pin Ceramic/Plastic	
UC3524	40V	100mA	0°C to +70°C	16 Pin Ceramic/Plastic	
UC1525A	40V	500mA	-55°C to +125°C	16 Pin Ceramic	Dual source/sink outputs (NOR logic).
UC2525A	40V	500mA	-25°C to +85°C	16 Pin Ceramic/Plastic	
UC3525A	40V	500mA	0°C to +70°C	16 Pin Ceramic/Plastic	
UC1527A	40V	500mA	-55°C to +125°C	16 Pin Ceramic	Dual source/sink outputs (OR logic).
UC2527A	40V	500mA	-25°C to +85°C	16 Pin Ceramic/Plastic	
UC3527A	40V	500mA	0°C to +70°C	16 Pin Ceramic/Plastic	
UC1524A	60V	200mA	-55°C to +125°C	16 Pin Ceramic	Improved performance over UC1524/2524/3524.
UC2524A	60V	200mA	-25°C to +85°C	16 Pin Ceramic/Plastic	
UC3524A	60V	200mA	0°C to +70°C	16 Pin Ceramic/Plastic	

THREE TERMINAL FIXED VOLTAGE REGULATORS

Unitrode Part No.	Output Polarity	Output Current	Operating Temp. Range	Nom. Reg. Output Volt.	Present Output Volt. Tolerance	Package Types
UC7800	Positive	1.0A	-55°C to +150°C	5, 12, 15V	±4%	TO-3,
UC7800C	Positive	1.0A	0°C to +125°C	5, 12, 15V	±4%	TO-3, TO-220
UC7800A	Positive	1.0A	-55°C to +150°C	5, 12, 15V	±1%	TO-3
UC7800AC	Positive	1.0A	0°C to +125°C	5, 12, 15V	±1%	TO-3, TO-220
UC7900	Negative	1.0A	-55°C to +150°C	-5, -12, -15V	±4%	TO-3
UC7900C	Negative	1.0A	0°C to +125°C	-5, -12, -15V	±4%	TO-3, TO-220
UC7900A	Negative	1.0A	-55°C to +150°C	-5, -12, -15V	±1%	TO-3
UC7900AC	Negative	1.0A	0°C to +125°C	-5, -12, -15V	±1%	TO-3, TO-220

THREE TERMINAL ADJUSTABLE VOLTAGE REGULATORS

Unitrode Part No.	Output Polarity	Output Current	Operating Temp. Range	Output Volt. Range	Line Regulation	Package Types
UC150	Positive	3.0A	-55°C to +150°C	1.2 to 33V	0.005%/V	TO-3
UC250	Positive	3.0A	-25°C to +150°C	1.2 to 33V	0.005%/V	TO-3
UC350	Positive	3.0A	0°C to +125°C	1.2 to 33V	0.005%/V	TO-3
UC117	Positive	1.5A	-55°C to +150°C	1.2 to 37V	0.01%/V	TO-3
UC217	Positive	1.5A	-25°C to +150°C	1.2 to 37V	0.01%/V	TO-3
UC317	Positive	1.5A	0°C to +125°C	1.2 to 37V	0.01%/V	TO-3, TO-220
UC137	Negative	1.5A	-55°C to +150°C	-1.2 to -37V	0.01%/V	TO-3
UC237	Negative	1.5A	-25°C to +150°C	-1.2 to -37V	0.01%/V	TO-3
UC337	Negative	1.5A	0°C to +125°C	-1.2 to -37V	0.01%/V	TO-3, TO-220

Unitrode Representatives

Alabama: Conley & Associates, Inc. 205-882-0316 Arizona: Compass Marketing & Sales, Inc. 602-266-5400 California: (Northern) I², Inc. 408-988-3400 (Southern) Bestronics, Inc. 213-870-9191; Bestronics, Inc. (Irvine) 714-979-9910; Bestronics, Inc. (San Diego) 714-452-5500 Colorado: Component Sales, Inc. 303-759-1666 Connecticut: Kanan Associates 203-265-2404 Florida: Conley & Associates, Inc. (Oviedo) 305-365-3283; Conley & Associates, Inc. (Boca Raton) 305-395-6108; Conley & Associates, Inc. 813-885-7658 Georgia: Conley & Associates, Inc. 404-447-6992 Illinois: (Northern) Oasis Sales Corp. 312-640-1850 Indiana: Oasis

Sales Corp. 317-848-5265 Kansas: Rush & West Associates 913-764-2700 Maryland: New Era Sales, Inc. 301-544-4100 Massachusetts: Byrne Associates (DEC only) 617-897-3131; Kanan Associates 617-944-8484 Michigan: Miltimore Sales, Inc. 313-349-0260; Miltimore Sales, Inc. 616-942-9721 Minnesota: Electronic Innovators 612-941-0830 Missouri: Rush & West Associates 314-394-7271 New Jersey: Technical Application & Marketing, Inc. 201-575-4390 New Mexico: Reptonix, Ltd. 505-881-8001 New York: Reagan/Compar Albany, Inc. 518-489-7408; Reagan/Compar Albany, Inc. 315-732-3775; Reagan/Compar Albany, Inc. 716-271-2230; Reagan/Compar Albany, Inc.

(Endwell) 607-723-8743/754-8946 North Carolina: Conley & Associates, Inc. 919-876-9862 Ohio: Baehr, Greenleaf & Associates, Inc. (Cincinnati) 513-891-3826; Baehr, Greenleaf & Associates, Inc. (Dayton) 513-439-0724; Baehr, Greenleaf & Associates, Inc. 614-486-4046; Baehr, Greenleaf & Associates, Inc. 216-221-9030 Oregon: Vantage Corporation 503-297-1714 Pennsylvania: (Eastern) Omni Sales 215-233-4600 Tennessee: Conley & Associates, Inc. 615-639-3139 Texas: Sundance Sales, Inc. 214-699-0451; Sundance Sales, Inc. 512-250-0320; Sundance Sales, Inc. 713-668-8923 Utah: Components Sales, Inc. 801-466-8623 Washington: Vantage Corporation 206-455-3460

Wisconsin: Oasis Sales Corp. 414-782-6660 Canada: Kaytronics Limited 514-367-0101; Kaytronics Limited 416-669-2262 British Columbia: Kaytronics Limited 604-581-7611

Unitrode Distributors

Arrow Electronics, Inc.: all locations; Capsco: (capacitors) California; Components Plus: California, New York, Texas; Future Electronics, Inc.: (Canada only) all locations; Hall-Mark: all locations; Hamilton/Avnet: all locations; Industrial Components, Inc.: Minnesota; Lenert Co., Inc.: Texas; Lionex Corporation: all locations; Pioneer: Indiana, Michigan, Ohio, Pennsylvania; Taylor Electric Co.: Wisconsin; Wyle Distribution Group: all locations

Or set new ones.

~~3524~~
3524A

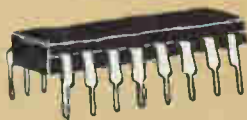

REGULATING PULSE WIDTH MODULATORS

Unitrode Part No.	UC3524A	UC2524A	UC1524A
Max. Output Voltage	60V	60V	60V
Output Current	200mA	200mA	200mA
Operating Temp. Range	0°C to +70°C	-25°C to 85°C	-55°C to 125°C
Package Type (TO-116)	16 Pin Ceramic/Plastic	16 Pin Ceramic/Plastic	16 Pin Ceramic

We couldn't stop with industry standard parts. So we re-designed the 3524 Series to eliminate all its weaknesses. Unitrode's new UC3524A increases the output voltage range to 60V; reduces the reference voltage tolerance from $\pm 4\%$ to $\pm 1\%$; doubles the output current to 200mA; provides faster, more accurate current limiting; offers a new under-voltage lockout feature to protect power supply output stages; and includes a standby current of 4mA. And it's pin-compatible with the standard 3524—which we also make. The 3524A is just what you'd expect from a company that specializes in power supply components.

All our ICs are available in volume right now, with full applications support. Just contact the Unitrode representative or distributor near you.

Unitrode Corporation, 5 Forbes Road,
Lexington, MA 02173, U.S.A. Telex: 95-1064.
TWX: 710-326-6509.

UNITRODE

How did AMCC build a higher performance TTL array than TI, Fujitsu, or Motorola?

We cheated.

Our Q700 System Array™ isn't all TTL. It's a unique integration of TTL I/O and bipolar ECL in a single logic array. This bit of technological cheating results in a 100% compatible 74S, 74LS, ALS, or ECL 10K replacement. One that performs reliably at clock rates up to 80 MHz. Minimum.

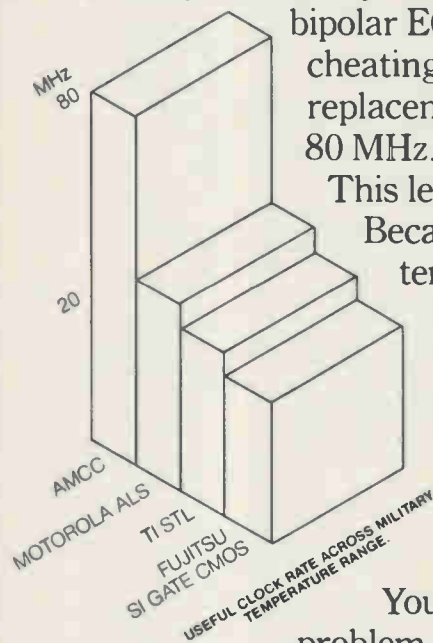

This lets you put your competitors at a terrible disadvantage.

Because while they spend weeks debugging noise and temperature sensitive TTL-ECL interfaces, you can be implementing signal processors, Winchester disk controllers, high speed CPUs, and real-time systems with the ease of any other TTL design.

While capitalizing on the other advantages of System Arrays. Like parts reductions of up to 50 to 1. Power consumption equivalent to LS logic. Military range performance. And complete second sourcing.

You'll also have the edge in solving a major system timing problem. Time to market.

Every step in the design of a Q700 is performed under control of our advanced, interactive CAD system. So every step is guaranteed error free.

That means we can go from circuit design to mask design in days. Put in-house manufactured prototypes in your hands weeks faster. And give you a big jump in getting your product out the door. Ahead of your competition.

All of which means the Q700 is more than a system design tool. It's a powerful competitive tool as well. One that can give you an almost unfair advantage.

Something to consider when you design your next high performance system.

Especially if you're like us. And don't mind listening to the competition cry foul.

For more information on the Q700 System Array, or to order a System Array design kit, write AMCC, 21040 Homestead Road, Cupertino, California 95014. Or call (408) 749-8844 or (714) 268-0097.

AMCC
SYSTEM ARRAYS

Engineers top job-growth list

The number of jobs for engineers, technicians, and systems analysts will increase much more rapidly in the 1980-90 time frame than for other U. S. occupations. Exacerbating the current shortfall (see p. 105), **openings for electronics, computer, and aerospace engineers will lead that growth**, according to new Federal forecasts. Similarly, demand for teachers of those disciplines in U. S. colleges and universities, as well as for secondary-school mathematics and science teachers, will also grow despite an overall decline in faculty jobs, according to the Bureau of Labor Statistics study of about 250 job categories. The data estimates 1980 job totals (and percentage growth ranges by 1990) as follows: aerospace engineers at 68,000 (43% to 52%); systems analysts at 205,000 (68% to 80%); engineering and science technicians at 885,000 (24% to 33%); computer service technicians at 83,000 (94% to 112%); and computer operators at 558,000 (22% to 30%).

SBS proposes economy service

Satellite Business Systems Inc. wants to begin a lower-cost medium-to-high-speed data service for smaller customers in the first quarter of 1983. The McLean, Va., firm proposes seven data speeds—56, 112, 224, 448, and 896 kb/s, plus 1.344 and 1.544 Mb/s, for one-way, two-way, or broadcast transmissions using low-cost earth stations. Called Data Network Service, **it would operate in the Ku bands of 14 and 12 GHz** without interfering with existing radio-frequency systems, says SBS. Ground stations will use antennas 3.6 m in diameter for the most part, with some 4.7-m units, and will have time-division multiple-access controllers.

Four seek to build satellites for pay-TV direct broadcast

Satellite Television Corp. says it now has proposals from four U. S. manufacturers **to build two satellites for its proposed pay-TV direct-broadcast system** to serve the eastern U. S. time zone with three channels. Although STC, a Washington, D. C., subsidiary of Communications Satellite Corp., can make no awards for the operational bird and its spare until the Federal Communications Commission acts, it says it has bids from Ford Aerospace & Communications, GE, Hughes Aircraft, and RCA Astro-Electronics. The satellite-to-home service could start in late 1985 or early 1986, if the FCC approves the December 1980 application.

Addenda

The American Electronics Association is backing two new bills by Sen. Lloyd Bentsen (D., Texas) to expand corporate tax benefits for aid to education. The Scientific Research and Education Act (S. 2474) would broaden last year's 25% tax credit for university research and development to include funds for faculty salaries and graduate assistantships in engineering and science. **All funds would be eligible for the tax break, rather than just 65% of a company's increase in R&D outlays.** The Scientific and Technical Equipment Act (S. 2475) would expand deductions to cover equipment used for teaching, instead of just for research, and used equipment up to three years old. . . . The Electronic Industries Association proposal to encourage joint corporate research **by making it exempt from civil antitrust actions, as it is now exempt from Federal suits** [*Electronics*, March 10, p. 66], has been introduced in the House as H.R. 6262.

Telecommunications bogs down in Congress

The Federal legislative process can become a morass, especially in the summer of an election year when legislators' thoughts turn to the campaign at home. President Reagan has discovered the problem as he watches his deficit-swollen budget sink slowly into the congressional swamp. So has Rep. Timothy Wirth, the Colorado democrat who chairs the telecommunications subcommittee. Wirth's H. R. 5158, designed to encourage telecommunications competition through controlled deregulation also appears close to suffocation.

American Telephone & Telegraph Co.'s multimillion-dollar lobbying blitz against the Wirth bill may be less a factor in its failure than the more recent defection of some AT&T competitors who supported Wirth earlier. Notable among them are MCI Telecommunications Corp., based in Washington, and the Ad hoc Committee for Competitive Telecommunications, whose nine member companies include MCI as well as other long-distance competitors for voice, data, video, and hard-copy services. Among the better-known are Graphnet, RCA Americom, and Satellite Business Systems.

The numbers game

MCI chairman William McGowan appears to believe that his company and others may now get a better shake from U. S. District Court Judge Harold Greene, who is handling the AT&T antitrust settlement with the Justice Department. Under that agreement, AT&T will be able to compete in any field of telecommunications after divestiture of its local Bell operating companies [*Electronics*, Jan. 27, p. 73]. McGowan now argues that H. R. 5158 "would overturn crucial aspects of the proposed settlement . . . before the court has a chance to approve it and before the details of the AT&T reorganization are known." More important to MCI, the bill "would impose heavy, highly visible overcharges on all users of long-distance service on the theory that the proceeds would be used to subsidize local telephone rates." In short, MCI finds the Wirth subcommittee staff's arithmetic suspect in the area of cost allocations between local and long-distance services.

The Ad hoc Committee's executive vice president, Herbert N. Jasper, puts it more bluntly. When it comes to AT&T's long-standing contention that long-distance revenues subsidize local business and residential costs, as well as defining specific AT&T costs of terminal equipment and private-line and toll services, he says, "no one—neither the state commissioners nor

AT&T—knows what the actual costs of these services are. Furthermore, no one, including AT&T, can say what the amount of any subsidy from long-distance revenues to local telephone companies is, if any."

Telecommunications equipment makers, increasingly anxious about passage of legislation so they can begin selling in the enormous marketplace that AT&T has long dominated, find themselves in a different part of the morass. If legislation is put on hold until Judge Greene accepts or modifies the antitrust settlement, independent equipment suppliers could wait through years of appeals. If, on the other hand, the Wirth bill is as imperfect as AT&T's service competitors say it is, then the mess may never be untangled to everyone's satisfaction.

Betting on Judge Greene

Finally, there is the judge himself, who must review the more than 600 comments received on the antitrust settlement. These run close to 9,000 pages, according to the Justice Department, and identify more than 30 general issues.

One of the more troublesome issues facing the court is the interest of the individual states. Attorneys General for 23 of them warned Greene that "state public utility commissions are effectively vested with unassailable authority to veto many of the crucial steps of the settlement insofar as they occur within their respective jurisdictions." That power "could, if exercised by some and not by others, result in a balkanized scheme of telecommunications service and effectively frustrate the pro-competitive intent of the proposed settlement."

When Judge Greene finally rules, any attempt by him to send AT&T and the Justice Department back to the bargaining table or to propose significant modifications to the settlement on his own is sure to be challenged by AT&T and possibly the Government. Overstepping his authority is likely to be one challenge in any appeal. AT&T might also fall back on its old contention that jurisdiction belongs to the New Jersey court where the settlement was first taken and AT&T got its 1956 consent decree.

The betting in Washington now is that Judge Greene will climb out of the bog more quickly than will Congress. If he comes out clean, it may be because he applied the maxim of Oliver Wendell Holmes to many of the complaints of the special interests. "When the ignorant are taught to doubt," wrote the late U. S. Chief Justice, "they do not know what they safely may believe."

-Ray Connolly

DIRECT HIT ON MIL-STD-883



Sprague Interface Drivers Zero-In On Military/Aerospace IC Requirements

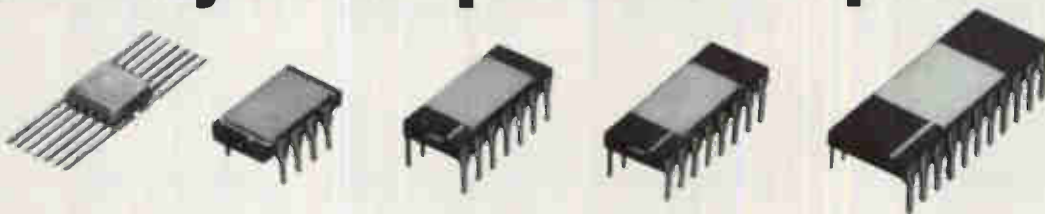

For interface ICs to MIL-STD-883, set your sights on Sprague, a major supplier of high-reliability devices in hermetic packages.

For the engineering bulletins of interest to you, write to: *Technical Literature Service, Sprague Electric Co., 35 Marshall St., North Adams, Mass. 01247.*

For application engineering assistance, write or call *Walter Sullivan or Mark Heisig, Sprague Electric Company, Semiconductor Div., 115 Northeast Cutoff, Worcester, Mass. 01606. Telephone 617/853-5000.*

For the name of your nearest Sprague Semiconductor Distributor, write or call *Sprague Products Co. Div., North Adams, Mass. 01247. Tel. 413/664-4481.*

Device	Series	Max. V _{OUT}	Max. I _{OUT}	Eng. Bulletin
Quad Power Drivers	UHC/UHD-400	40V	500mA	29300.1
	UHC/UHD-400-1	70V	500mA	
	UHC/UHD-500	100V	500mA	
7-Channel Darlington Arrays	ULS-2000H	50V	500mA	29304.1
	ULS-2010H	50V	600mA	
	ULS-2020H	95V	500mA	
Quad Darlington Switches	ULS-2064H to 77H	50-80V	1.5A	29305.1
8-Channel Darlington Arrays	ULS-2800H	50V	500mA	29304.4
	ULS-2810H	50V	600mA	
	ULS-2820H	95V	500mA	
8-Channel Source Drivers	UDS-2980H	50-80V	-500mA	29310.1
Dual Power Drivers	UDS-3610H	80V	600mA	29308.1
Quad Power Drivers	UDS-5700H	80V	600mA	29306.1
Dual Power Drivers	UDS-5710H	80V	600mA	29307.1
Quad PIN Diode Drivers	UDS-5790/91H	120V	500mA	29315.1

FOR FAST INFORMATION, CALL YOUR NEAREST SPRAGUE SALES OFFICE:

ALABAMA, Sprague Electric Co. 205-883-0520, Electronic Marketing Associates 205-837-7363 • ARIZONA, Sprague Electric Co. 602-831-6762 602-244-0154 • CALIFORNIA, Sprague Electric Co. 213-649-2600 714-549-9913, R. David Miner Inc. 714-267-3900, W. J. Purdy Co. 415-347-7701 • COLORADO, W. J. Purdy Co. 303-777-1411 • CONNECTICUT, Sprague Electric Co. 203-261-2551 • DIST. OF COLUMBIA, Sprague Electric Co. (Govt. sales only), 202-337-7820 • FLORIDA, Sprague Electric Co. 305-831-3636 305-979-1440 • GEORGIA, Electronic Marketing Associates 404-448-1215 • ILLINOIS, Sprague Electric Co. 312-296-6620, 312-635-4020 • INDIANA, Sprague Electric Co. 317-253-4247, Ruit-Paetow, 219-432-9502 • MARYLAND, Sprague Electric Co., 301-792-4890, 301-953-1717 • MASSACHUSETTS, Sprague Electric Co. 617-875-3200, 413-664-4411, Ray Perron & Co., Inc. 617-969-8100 • MICHIGAN, Sprague Electric Co. 517-787-3934, Mareco, Inc. 517-263-1333 • MINNESOTA, HMR, Inc. 612-831-7400 • MISSOURI, EPI Inc., 314-821-4090 • NEW HAMPSHIRE, Ray Perron & Co., Inc. 603-742-2321 • NEW JERSEY, Sprague Electric Co. 609-795-2299, 201-696-8200, Trinkle Sales Inc. 609-795-4200 • NEW MEXICO, W. J. Purdy Co. 505-266-7959 • NEW YORK, Sprague Electric Co. 516-234-8700, 914-834-4439, 315-437-7311, William Ruit, Inc., 914-834-8555, Paston-Hunter Co., Inc. 315-437-2843 • NORTH CAROLINA, Electronic Marketing Associates, 919-722-5151 • PENNSYLVANIA, Sprague Electric Co., 215-467-5252 • OHIO, Sprague Electric Co. 513-435-1678, Electronic Salesmasters, Inc. 216-831-9555 • SOUTH CAROLINA, Electronic Marketing Associates, 803-233-4637 • TEXAS, Sprague Electric Co. 512-459-3336 214-235-1256 • UTAH, W. J. Purdy Co. 801-486-8557 • VIRGINIA, Sprague Electric Co. 703-463-9161 • WASHINGTON, Sprague Electric Co. 206-632-7761 • CANADA, Sprague Electric of Canada, Ltd. 416-766-6123 613-238-2542

45S-1140R2



a subsidiary of **GK Technologies**

an operational

Circle 73 on reader service card

NOBODY'S

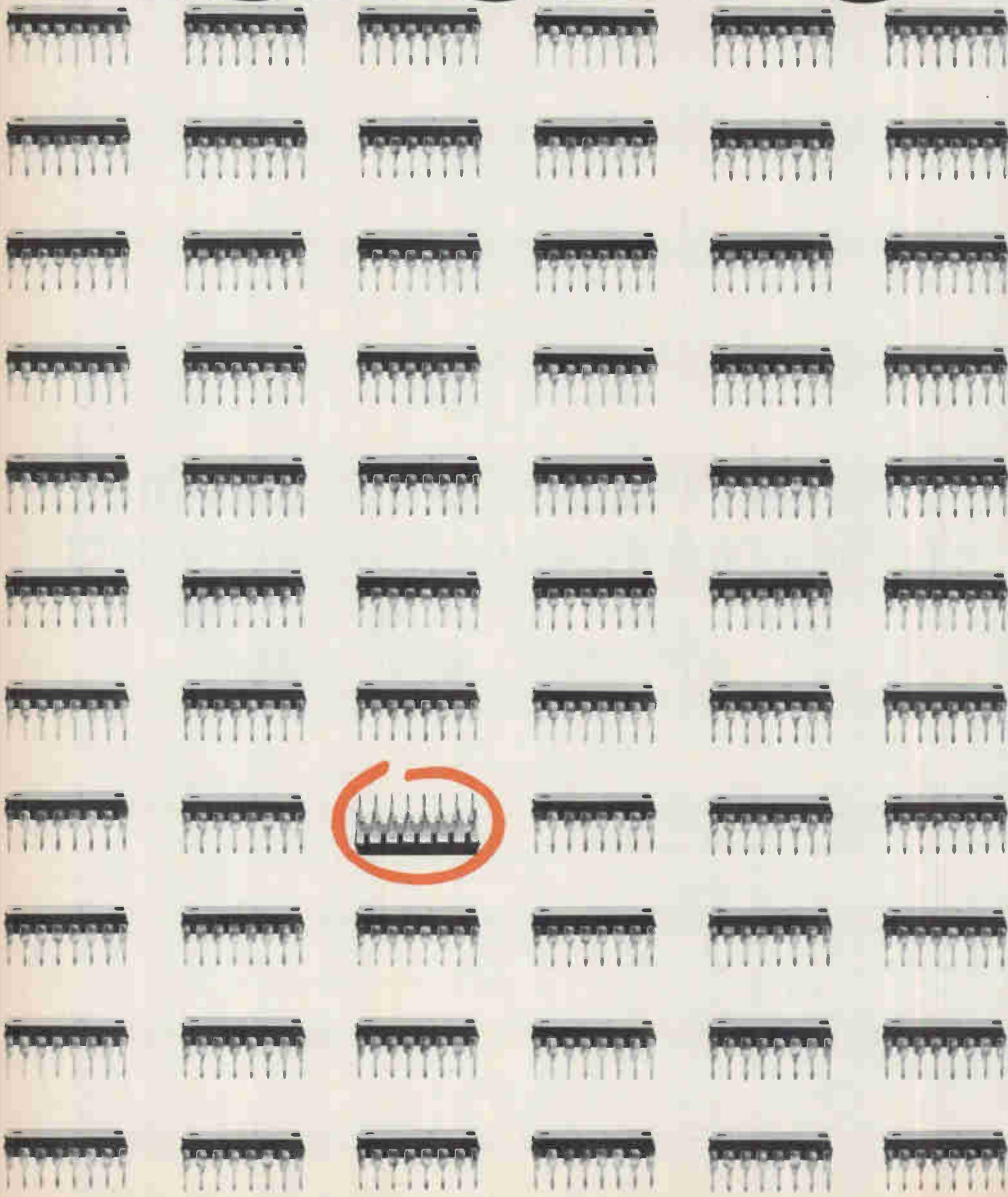

PERFECT

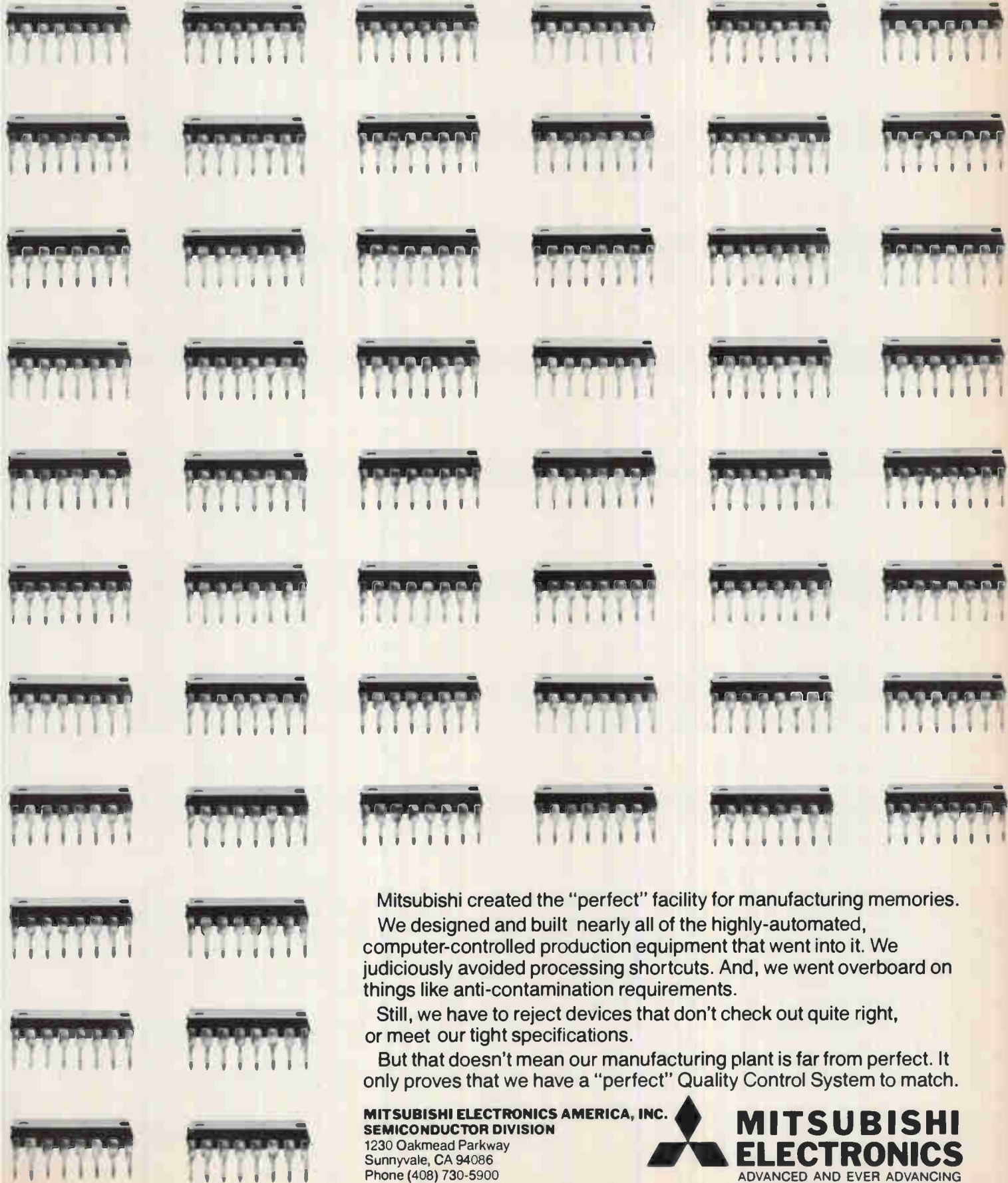

Mitsubishi created the "perfect" facility for manufacturing memories. We designed and built nearly all of the highly-automated, computer-controlled production equipment that went into it. We judiciously avoided processing shortcuts. And, we went overboard on things like anti-contamination requirements.

Still, we have to reject devices that don't check out quite right, or meet our tight specifications.

But that doesn't mean our manufacturing plant is far from perfect. It only proves that we have a "perfect" Quality Control System to match.

MITSUBISHI ELECTRONICS AMERICA, INC.
SEMICONDUCTOR DIVISION
1230 Oakmead Parkway
Sunnyvale, CA 94086
Phone (408) 730-5900



**MITSUBISHI
ELECTRONICS**
ADVANCED AND EVER ADVANCING

Circle 75 on reader service card

We sell more magazines worldwide than our competitors give away free.

International Circulation (in thousands)

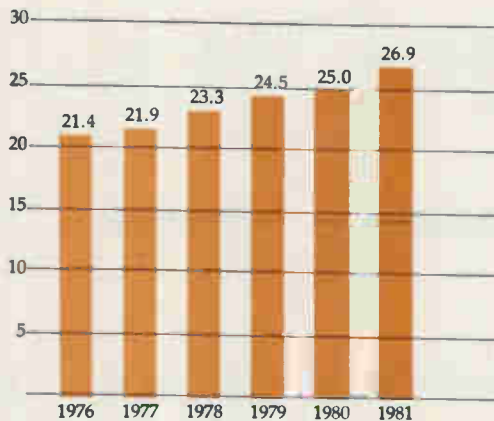

International Advertising Pages

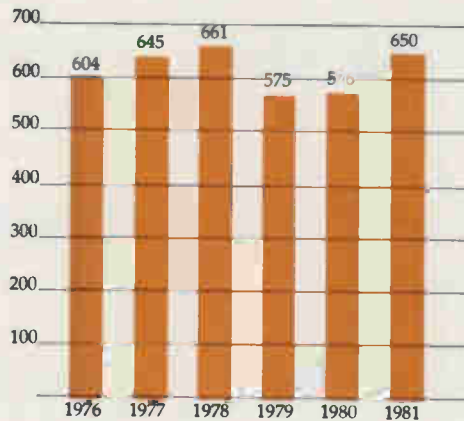

1. Largest international circulation:
Electronics magazine sells more subscriptions around the world than its competitors give away free . . . 26,923 in 127 countries.

2. Largest reader response:
Electronics magazine generates more advertising inquiries from more countries throughout the world than any other electronics publication.

3. Greatest advertiser acceptance:
Electronics magazine carries more than twice the number of international advertising pages as its nearest U.S. competitor.

4. Most international editorial published:
Electronics magazine publishes twice the amount of original editorial from outside the U.S. as any other electronics publication.

5. Incomparable international reporting:
Electronics magazine is the only U.S. electronics publication with full-time resident editors in Paris, London, Frankfurt, and Tokyo (2). Electronics also has the services of full-time resident World News editors in Bonn, Sao Paulo, Brussels, Milan, Singapore, Stockholm and Moscow.

6. Highest rated magazine:
Electronics magazine is rated best over its competitors in editorial importance and quality.

- Reports most timely international business and technical developments
- Most authoritative
- Reports most timely business and technical news
- Best state-of-the-art coverage
- Best at assessing the most important developments
- The only publication read most thoroughly
- "Must" reading upon receipt
- Preferred by advertisers for promoting company's capabilities
- Preferred by innovators as the place to publish their articles

Source: Crossley Surveys, Inc.

Largest worldwide audience: 331,072.

Electronics magazine has the largest readership by important people in the worldwide electronics technology marketplace.

Electronics

Where important people
read important editorial



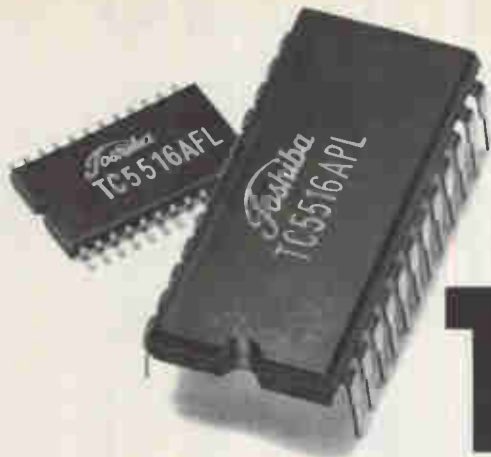

TOSHIBA'S 16K CMOS RAM uses only 5 nanoamps.

Toshiba's new 2K x 8 CMOS static RAM needs only 5 nanoamps (Typ) for data retention.

This means battery requirements are minimal. Which means space, weight, and cost requirements are also minimal.

Phone or write today, and we'll send you complete technical information on our new 16K CMOS RAM.

Toshiba also supplies the reliable 1K CMOS RAM, single chip microcomputers, and CMOS logic circuits.

In fact, we're the world's largest supplier of 4K CMOS RAMs.

Toshiba is a world leader in CMOS technology. We're constantly introducing new products that represent a significant advance in the state of the art.

Our new ultra low power 16K CMOS RAM is a good example.

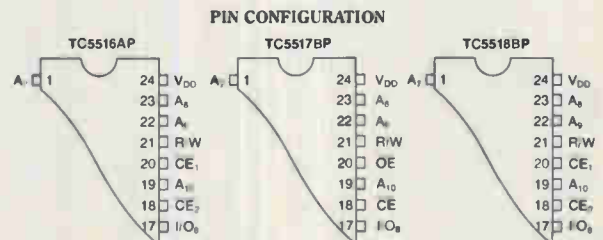

TOSHIBA AMERICA, INC.
Nobody makes CMOS better

Western Sales Office: Newport Beach, CA (714) 752-0373, Eastern Sales Office: Boston, MA (617) 742-2040, Central Sales Office: Minneapolis, MN (612) 831-2566

Oliver Germanium: The Great Rectifier.

"If you look at the forward voltage curves" says Oliver O Ward, President of GPD and often known as Oliver Germanium, "you will see that we are making a line of Germanium Rectifiers which offers many advantages over even the most up-to-date Silicon types including Schottkys.

"Our DO-8 200Amp rectifier, for example, has a forward voltage drop of only 0.42 Volts at 100A and 75°C, which is so much better than the published Schottky figures of around 0.5V at 175°C, let alone 0.63V at 25°C.

"In many applications, and battery-operated computer-standby inverters come to mind, the ambient temperature will of course be more like 50° or 55°C, and our Germanium in that instance is at least 12% more efficient than the best Silicon.

"Power supplies, where you want maximum efficiency and minimum heat dissipation, provide another good example.

GPD Germanium Rectifiers come in DO-4, DO-5, DO-8, DO-9 and DO-13 packages; telephone for information on prices, current ratings and thermal resistances; not forgetting that GPD also has a catalogue full of other Germanium devices, from 125mW to 200A."

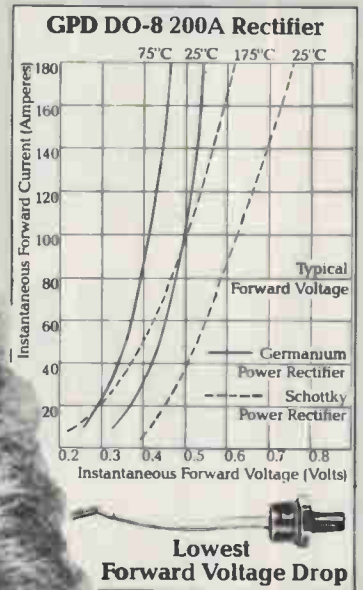

Germanium Power Devices
Corporation

Austria Rieger GmbH, Marzergasse 10, A-1030 Wien 3 Tel: 0222-73 46 84 Tlx: 131087 rieger a/Omni Ray GmbH, Vertriebsbüro Wien, Prinz Eugen-Strasse 36, A-1040 Wien Tel: 0222-65 64 31 Tlx: 132712 omray a
Benelux BV DIODE Laboratorium Voor Electronentechniek, Hollantlaan 22, 3526 AM Utrecht, Holland Tel: 030-894214, Tlx: 47308/Ruc Picard Str 202, 1020 Bruxelles, Belgium Tel: 02-4285105 Tlx: 259013, Denmark E V Johansen Elektronik A/S, Titangade 15, DK 2200 Copenhagen N Tel: 0451-83 90 22 Tlx: 16522, France Davum, Dept TMC, 11 Rue Ruene, PO Box 28, 93121 La Courneuve Tel: 836-84-01 Tlx: 210311F (PUBLI), West Germany Solcomp Elektronik GmbH, Mondstrasse 10, 80000 Munich 90 Tel: 089-66 10 27 Tlx: 05-22870, India Kirloskar Electric Co Ltd, Bangalore 560 055 Tel: 366771-4 (Marketing) 35311-8 (other depts), Tlx: 0845-230 & 0845-790, Italy Syscom Electronica Spa, Via Gran Sasso 35, 20092 Cinisello Balsamo, Milano Tel: 02-6 189 159 and 02-6 189 251 Tlx: 330118 /Eurelectronica Srl, Sede, 20145 Milano, Via Mascheroni 19, Tel: 049-81 851 Tlx: 39102 THOMELEC, Norway Nordisk Elektronik (Norge) A/S, Mustadvei 1, Postboks 91-Lilleaker, Oslo 2 Tel: 0752-13880, Tlx: 856-16963 (AJCO NM), Portugal Ditrax Componentes Electronica, Lda, Av. Miguel Bombarda 133, 1 D, 1000 Lisboa, Tel: 54 53 13, Republic of South Africa L'Electron (Pty) Ltd, 704 Main Pretoria Road/Hoofweg Wynberg PO Box 10544, Johannesburg 2000 Tel: 406 290 Tlx: 8-2333, Spain Kontron SA, Costa Brava, 13, Edificio Mirasierra, Madrid-34, Tel: 734 84 13 Tlx: 23382, Sweden Satt Electronics AB, Agency Sales Division, PO Box 3200b, S-126 11 Stockholm Tel: 08/81 01 00, Tlx: 10884, Switzerland Omni Ray AG, 8008 Zurich, Dufourstrasse 56, Tel: (01) 478200, Tlx: 53239, UK Representative Wintronics, 71 Tunnel Road, Tunbridge Wells, Kent TN1 2BX, Tel: 0892-44811 Tlx: 957567, UK Agents Jermyn Industries, Sevenoaks, Kent, Tel: 0732-50144, Tlx: 95142, /C onsort Electronics Ltd, Rosebank Parade, Reading Road, Yateley, Camberley, Surrey Tel: 0252-871717 Tlx: 858800/

GPD Box 65, Shawsheen Village Station, Andover, Mass 01810.

Circle 78 on reader service card

Telephone: (617) 475-5982. Telex: 94-7150 GPD Andr

Data-flow computer getting up to speed

Manchester University's data-flow computer, whose architecture portends much more powerful machines than are available today, now has 5 of its full complement of 20 arithmetic units operational. Data-flow machines have no single central processing unit, but use a processing section with tens or even thousands of processing units [*Electronics*, May 24, 1979, p. 132]. The British computer's 24-bit arithmetic unit, built from bit-slice chips, can handle 32-bit floating-point operations fed from a pipeline bus operating at 300 ns. **When fully commissioned, it will execute around 3.3 million instructions/s**—roughly equivalent to a top-end minicomputer. The university wants to use it to design computers faster—performing logic-simulation and routing tasks, both multipath problems with a high degree of parallelism well-suited to a data-flow computer.

Olivetti seeks strength in U. S. through mergers

Ing. C. Olivetti & Co. SpA, the Ivrea, Italy, company with international ambitions, continues to reinforce its American connection with two new operations—one designed to mend its losing ways in the U. S. and the other to block Japanese competition. Calling it “our decision to be American in America,” Carlo de Benedetti, Olivetti vice chairman and chief executive officer, announced that his company's \$37.5 million U. S. subsidiary, Olivetti Corp., New York, and the \$40 million Docutel Corp. would merge into a new company, Docutel Olivetti. **Olivetti, which has not turned a profit in the U. S. for several years, will hold a controlling 47.8% interest.** Docutel, of Irving, Texas, makes bank-automation equipment.

The Docutel merger was followed by an accord with the Allen-Bradley Co. of Milwaukee, Wis., a major U. S. producer of electronic controls for machine tools. The two companies, whose production is complementary, are expected to make reciprocal licensing and sales agreements. An Olivetti spokesman said that the merger was essential in the face of sharper competition from the Japanese in the machine tool market.

Hitachi offering two optical-fiber networks

Hitachi Ltd. has announced two optical-fiber communications networks somewhat resembling Nippon Electric Co.'s C&C Optonet [*Electronics*, May 5, p. 78]. The Sigma network, aimed at office-automation applications, puts a maximum of 64 link controllers in the loop, each of which can be shared by up to 64 word processors, computers, data terminals, telephones, or facsimile machines. Deliveries will start early next year at about \$21,370 for 10 circuits and a link controller. **The Tokyo company's H-8644 loop network uses packet switching to link large computer systems.** Designed for production control and laboratory and office-automation systems with a central computer, it can handle up to 1,000 stations and terminal control units hooked to as many as 125 node processors on the loop. Deliveries start in October at a minimum monthly rental of about \$2,140. Both networks are compatible with virtually any hardware and offer a host of protocols.

West Germany's computer market healthier this year

After a downturn during the second half of 1981, West Germany's data-processing-equipment market, Europe's biggest, is on the rise again. This is the finding of a study conducted by Frankfurt-based Diebold Deutschland GmbH, an affiliate of the U. S. computer consulting firm. The upswing comes after a period during which incoming orders shrank by 22% and exports rose only 1.1%. **It results in part from the recent rise in**

International newsletter

the value of the U.S. dollar, reduced equipment costs, and lower-than-expected wage hikes, the last leaving more money for investments. Although the market for large computers is still stagnant, that for small office machines, desktop systems, and terminals is flourishing. Orders rose 26% in January and 18.4% in February over those months last year.

Ultrafast facsimile terminal readied

With a view toward things to come, Standard Elektrik Lorenz AG, the West German affiliate of International Telephone & Telegraph Corp., has developed a prototype facsimile terminal for 64-kb/s transmissions. At that speed, **the information on a standard-sized sheet of paper can be transmitted over a digital network in 8 s**, in contrast to the current 2 or 3 min for facsimile transmissions over regular lines. The unit could go into service in a few years when 64-kb/s digital transmissions become a reality in West Germany and elsewhere. Prime features of the Stuttgart company's prototype are a 4-s scan time, resolution of 8 lines/mm vertically, 1,728 picture elements per line horizontally, and display of the called party's number before start of transmission.

Japanese skirmish on low-end word processors

Competition in low-end Japanese word processors is getting rough, with two new products crashing the magic ¥1 million (\$4,300) barrier for the first time. First Fujitsu Ltd. announced its My Oasys, a "personal" word processor, priced at what some observers termed a drastically low \$3,200. With one 5¼-in. floppy-disk drive, 9-in. screen, standard kana keyboard and 15-character/s dot-matrix printer, it weighs a scant 42 lb. **Four days later, Nippon Electric Co. answered with its NWP-10N two-model series**, the cheaper of which lists at ¥998,000 (\$4,283). In contrast to Fujitsu's unit, NEC's has a 20% larger dictionary of 60,000 words, two 8-in. floppy-disk drives, a 12-in. screen, 40-character/s printer, and calculation functions. Both products ~~convert kana syllabary into Chinese characters~~ and boast the same character set. Fujitsu started shipping May 6, with NEC to follow in October.

Fiber optics to link local net, PBX

A private branch exchange and local network may unite in a fiber-optic system, if the development plans of London-based Xionics Ltd. come to fruition. **It claims its test system—capable of handling an unprecedented 16,000 internal telephone, text, and data channels—could be in production by 1984.** The prototype is based on a fiber version of the company's Xinct local network, a duplicated ring-based system that offers low latency and wide bandwidth by using a bus structure 10 bits wide. This bus is at present fabricated from 10 twisted-pair cables each clocked at 1 Mb/s, but a faster fiber-optic version has been planned for some time, says the company. To exploit the full market potential of its prototype system, the UK start-up may have to team with a larger firm, it says.

Israel gets first digital phone exchange

Israel has installed its first digital telephone exchange, built by Telrad Ltd., a subsidiary of Koor Industries, the country's largest industrial concern. **Competition for hundreds of millions of dollars worth of additional digital electronic exchanges** now being planned appears to be among three Israeli companies—Telrad, Tadiran Ltd. and American Electronic Laboratories, owned by the U.S. company of the same name.

IS LEGAL TENDER
PUBLIC AND PRIVATE

WD27



02



WASH



SERIES
279X



Via
Gen
Pro

WASHINGTON

ONE DOLLAR

No other
floppy disk
controller gives
you so little
for your
money.

Making the leading edge work for you.

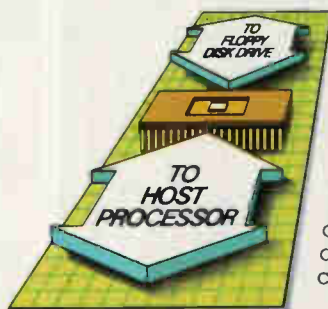

At Western Digital, getting less for your money makes good sense. Any way you look at it.

Because our new WD 279X is the first floppy disk controller that gives you everything on just one chip.

And we do mean everything.

Fact is, our incomparable new WD 279X packs all standard control functions for both 5¼" and 8" drives on a single, solitary +5V chip.

And all data separation and write precompensation functions are included on chip.

It's simply amazing. And so are the savings. The WD 279X will cut your design time, simplify system integration, conserve PCB real estate, cut component count and save hours of board assembly and testing.

What's more, the WD 279X comes in four different versions to accommodate both true and inverted data bus applications, as well as single and double-sided designs. And it's fully compatible with our industry standard WD 179X floppy disk controller family and Winchester disk controllers.

You can't buy a more cost-effective floppy controller.

But prove it to yourself. Just drop us a note on your letterhead and we'll make sure you get an evaluation unit.

Absolutely free.

No other disk controller can offer you more for less.

WESTERN DIGITAL
C O R P O R A T I O N

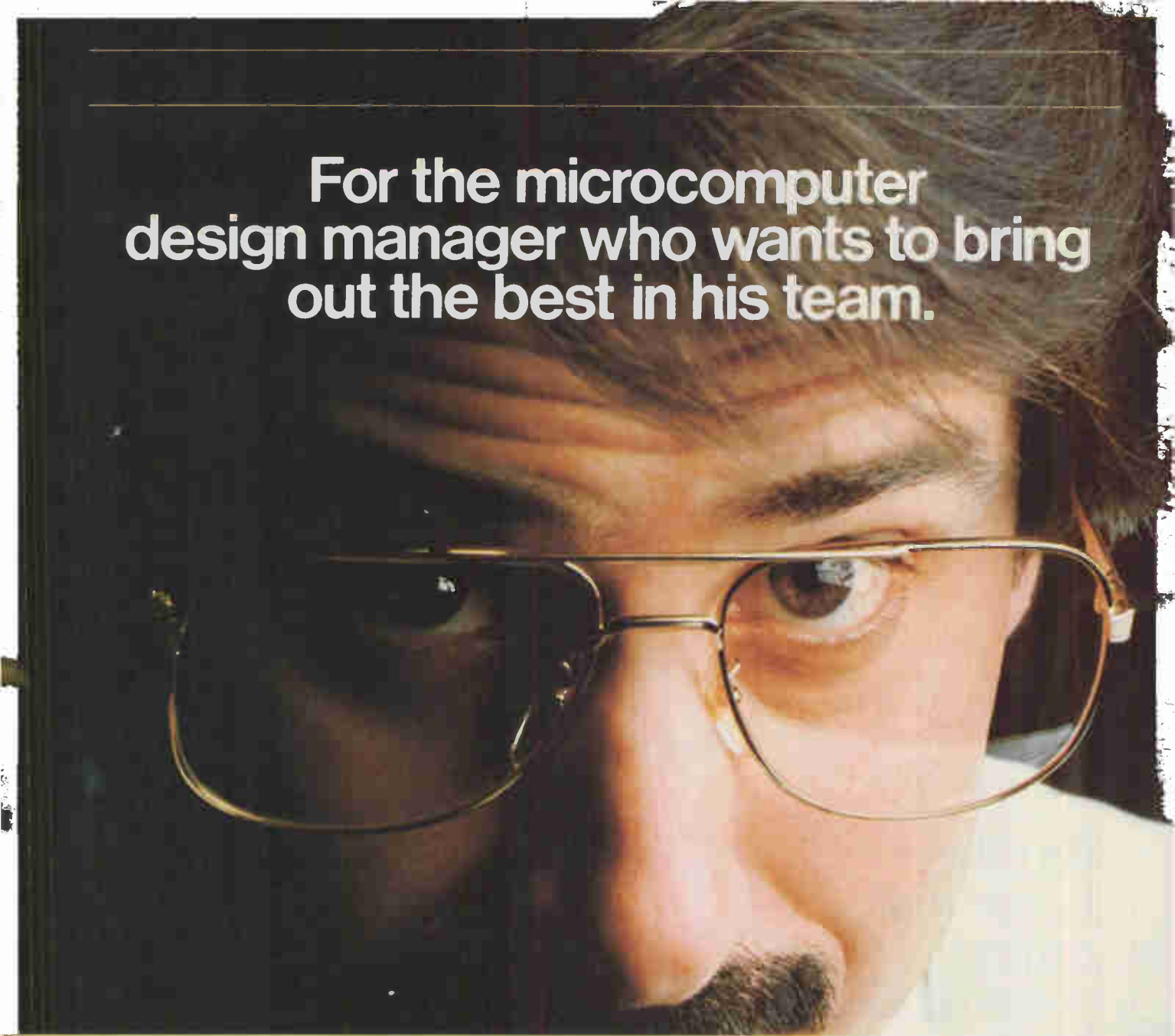

**For the microcomputer
design manager who wants to bring
out the best in his team.**

Tek introduces the 8560.

To help his people work as a team, a design manager's got to pull together every designer. But he can't do it alone.

Code volumes are heading toward the megabyte range. Soon, a single project may require designers to develop and

debug hundreds of modules — all against ever tightening production schedules.

As microcomputer design becomes this demanding, only a team working tightly together can be successful.

But not until now has a micro-

computer development system been dedicated specifically to the needs of a team of designers.

Not until the Tek 8560 Multi-User Software Development Unit. **The 8560 is targeted directly at the team effort.**

For openers, the 8560 sup-

ports up to eight workstations. With each station configurable as either a software development

by project, in sub-directories. So you can quickly locate any file: yours or your team-members'.

TYPICAL 8560 SYSTEM CONFIGURATION

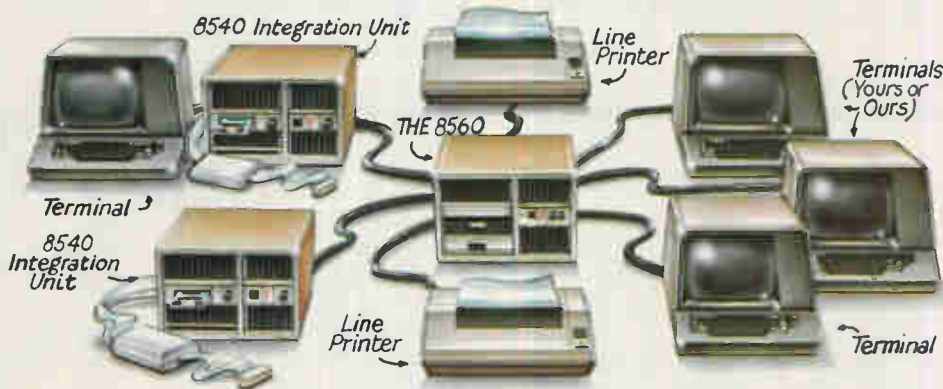

terminal or a hardware/software integration site.

You get all the standard tools you'd expect from a high-performance development system: editors, language translators, loaders, linkers, spooling line printers and hard disc mass storage.

But that's just the start. The 8560 goes on to organize these tools specifically for use in a closely knit team effort. One that channels individual efforts into a workable, synergistic whole.

All through TNIX*.

TNIX ties the team together.

TNIX, an operating system derived directly from Bell Laboratories' UNIX** V.7 operating system, runs the 8560. Refined specifically for microcomputer development, TNIX includes a multitude of features that enhance the team effort.

The 8560 Supports:

68000	6800	8035
Z8001	6801	8748
Z8002	6802	8049
8086	6809	8021
8088	Z80A	8041A
8080A	8048	8022
8085A	8039	

A hierarchical filing system allows you to organize your files

Plus multi-level read/write protection that lets users' files become more accessible as they become more complete.

Text processing keeps team members well informed by facilitating timely documentation. All design specifications are easily updated working documents.

With the number of code modules running into the hundreds, the integration of different "versions" of source modules from multiple team members can result in very bothersome program bugs. TNIX provides a powerful solution through "make", a utility which tracks dependencies between source and object modules, and insures that only up-to-date object modules are included in the final program.

TNIX extends to hardware/software integration as well.

For hardware/software integration, the 8560 uses the Tek-

tronix 8540 Integration Unit as an intelligent subsystem. The 8540 employs Real-Time Emulation for fast, efficient debugging. And for tracing real-time program execution, an optional Trigger Trace Analyzer allows highly selective acquisition of bus transactions and other prototype logic events.

And because the 8540's debug commands are fully integrated into TNIX, you have unprecedented power to process debug data. For instance, a few simple commands provide the capability to sift through debug trace data and produce a frequency distribution of all sub-routine calls as executed by the prototype program.

Put the 8560 on your team.

For more information, contact your nearest Tektronix Sales Engineer about buying or renting the 8560. Or contact us at any of the addresses listed below.

-- 8560 GUIDE --

- 1) Introduction to GUIDE
- 2) Select prompting level
- 3) File Manipulation Menu
- 4) Program Processing Menu (compilers, assemblers, etc.)
- 5) Program Debugging Menu (with 8540/8550 only)
- 6) Other System Operations Menu
- 7) System Maintenance Menu (must be "superuser")
- 8) Terminate GUIDE
- 9) Temporary escape to command language

Select by entering a number from 1 to 9: █

GUIDE, a friendly user interface, provides a menu-driven path through system operations, while allowing a return to the conventional TNIX command interface at any time.

U.S.A., Asia, Australia, Central & South America, Japan
Tektronix, Inc. PO Box 4828 Portland OR 97208 For additional literature, or the address and phone number of the Tektronix Sales Office nearest you contact Phone 800 547-1512 Oregon only 800 452-1877 Telex 910-467-8708 Cable TEKTRONIX

Europe, Africa, Middle East
Tektronix Europe B.V.
European Headquarters, Postbox 827, 1180 AV Amstelveen, The Netherlands Telex 18312
Canada, Tektronix Canada Inc., PO Box 6500, Barrie, Ontario L4M 4V3, Phone 705 737-2700

*TNIX is a trademark of Tektronix **UNIX is a trademark of Bell Laboratories

Tektronix

COMMITTED TO EXCELLENCE

Circle 82 for Literature
Circle 83 for Sales Contact

To boost capacity and yield while reducing Combine HP's Circuit Test

Boost your manufacturing productivity with effective testing throughout the production cycle. Automated testing with HP's 3060A Circuit Test System can help you meet this objective.

Increase yield and reduce final product test and repair costs by combining the flexibility of HP's 3060A Circuit Test System with HP's family of programmable instruments. For example, the HP 1980A/B Oscilloscope Measurement System gives you the versatility of a programmable oscilloscope with automatic set-up, data collection and analysis.

Obtain rapid start up, software development assistance, ongoing technical applications support and reliable service. HP's worldwide System Engineering Organization and network of service centers offer these services at modest cost to help you get the highest returns from your HP 3060A solution.

Achieve higher throughput. HP's 3060A supports custom dual fixturing in high volume applications.

Minimize your software development and troubleshooting costs via the HP 3060A's flexible, easy-to-use controller and high-level software development tools. The HP 3060A's Board Test Language and automatic program generation features help you get tests up and running quickly.



HP-IB: Not just IEEE-488, but the hardware, documentation and support that delivers the shortest path to a measurement system.

work-in-process and costs...

Systems with an effective test strategy.

Productivity '82 shows will be held through June in the following cities:

- Atlanta March 2-3
- Philadelphia March 16-17
- New York April 6-8
- Washington, D.C. April 14-15
- Cleveland April 21-22
- Toronto May 12-13
- Chicago June 2-3
- Denver June 15-16
- Seattle June 29-30

Measure and optimize your manufacturing processes through datalogging and factory network solutions. The HP 3060A system provides automatic datalogging and analysis. And HP offers a variety of networking solutions, such as the HP 9845C Computer, which is shown receiving and processing board test data from the HP 3060A in this application.



Increasing productivity is the challenge of the eighties. And Automatic Circuit Test Equipment is required to meet this challenge. But selecting automated equipment is just part of the solution. Of equal importance is having an integrated manufacturing test strategy...one that reflects screening, diagnosis and control needs throughout the manufacturing process — from incoming inspection to final assembly testing.

For the electronics manufacturer, the critical point is board testing. Board testing effectively locates component faults that slip through incoming inspection, plus process faults that surface in assembly. Furthermore, end product testing and troubleshooting problems are reduced by in-circuit and functional testing at the board level.

So when you consider a board tester, be sure to carefully assess its integration into your entire manufacturing process... both before and after board test. HP's 3060A Circuit Test System, in the application shown here, is a good example of combining system features, flexibility and support into a total manufacturing strategy.

Learn how you can increase productivity, using an HP 3060A solution, by attending one of HP's Productivity '82 Seminars. You'll see the HP 3060A as well as other production test and control solutions in operation. And by attending HP's technical seminars during Productivity '82 you can learn more about production test strategies for electronic manufacturing. To attend Productivity '82, call TOLL-FREE 800-453-9500 for free registration and location information. Or, write Hewlett-Packard, 1820 Embarcadero Road, Palo Alto, CA 94303.

09115



When performance must
be measured by results



**HEWLETT
PACKARD**



INTRODUCING WAFERTRAC® II.

When we first introduced Wafertrac®, it was the best wafer processing system available. Now we've built a second generation Wafertrac. And again, it's number one.

The secret? Simple: Simplicity of design.

Wafertrac® II has fewer moving parts than any comparable in-line wafer processing system. So there's less to go wrong. Which means more reliability, more uptime, and more high-yield processing.

Also, all process modules are

smaller than ever; most are just 9" x 9". And each module is self-contained, has its own microprocessor, and literally plugs into the mainframe. So a module can be replaced on-line, fast, by anyone in the clean room. And it can be done with virtually no downtime at all.

These smaller modules have some big features. For example, our revolutionary Hotplate Bake Module processes in soft and hard bake applications in under 45 seconds with less than 1°C variation across a

125mm wafer. And our new Ultrasonic Cleaner Module, which does its job in under a minute, offers the most complete removal of particulate and organic contaminants of any system available.

All of the modules in Wafertrac II communicate with each other. They also communicate with a host computer that can be used for off-line development of process programs, and monitoring and troubleshooting of multiple systems, single systems, or modules.



**A STEP
AHEAD.**

IT'S STILL NUMBER 1.

For all its features, Wafertrac II takes 30-50% less floor space than comparable systems. And it's clearly the most contamination-free in-line wafer processing system available today.

For more on Wafertrac II, the number one system of its kind, write to us at one of these addresses: GCA/California Operations, 217 Humboldt Court, Sunnyvale, CA 94086. Tel: (408) 732-5330. Sumisho Electronic Systems, Inc., Tokyo, Japan. Tel: (03) 234-6211. Or GCA International,

Kreuzlingen, Switzerland. Tel: 41-072-71-1585.

1. Ultrasonic Cleaner Module removes particulate and organic contaminants faster and more completely than any other system.
2. Wafertrac II is smaller, simpler, more reliable, and more productive than any wafer processing system available.
3. Hotplate Bake Module, for soft and hard bake applications in under 45 seconds with less than 1°C variation across a 125mm wafer.
4. Local controller provides process information.

5. Temperature controlled positive developer gives excellent critical dimension control. Developer and rinse solutions dispensed via single pressure-fit nozzle.

6. Powerful host computer can monitor and troubleshoot a single module or multiple systems. It can also be used for training, R&D, and development of process programs.



GCA CORPORATION
IC Systems Group
Wafertrac® Products
217 Humboldt Court
Sunnyvale, CA 94086

SPRINGS, CO 303-598-2208 • F-01210 FERNEY-VOLTAIRE FRANCE 50-406850 • LANGHORNE, PA 215-757-0460 • PORTLAND, OR 503-638-8040
602-894-9831 • UNDERHILL, VT 802-899-3096 • 2950 VEDBAECK, DENMARK 2-890668 • WEYBRIDGE, SURREY ENGLAND 09322-27388

See us at the Semicon West Show, booth #335-346.

Circle 87 on reader service card



GOULD BIOMATION 4500

Stop guessing at accuracy.

Introducing the world's most accurate 100 MHz digital oscilloscope.

The only scope with specified performance across the entire frequency range.

All measurement instruments have their performance limitations, but until now the precise margin for error was anybody's guess. The Gould Biomation 4500 is the first digital scope to specify and guarantee dynamic performance, so that you can make measurements based on specifications, not assumptions.

Among conventional analog scopes, a well-calibrated unit is rarely capable of better than 2% to 3% accuracy. And they don't stay calibrated long.

Most digital oscilloscopes do better than analog scopes at very low frequencies. However, they are less accurate at high frequencies, due to a degradation of dynamic resolution in the analog-to-digital converter section and non-linearities in the front-end section.

With a revolutionary design of both the analog-to-digital converter and front-end sections, plus microprocessor-controlled autocalibration, the 4500 is two to ten times more precise than its closest competitors. It tracks waveforms that have been difficult to

measure in the past— even those with full-scale risetimes as fast as 20 ns.

With a maximum digitizing rate of 100 MHz, the 4500 gives you better than 7-bit resolution at 1 MHz, more than 6 bits at 10 MHz and more than 5 bits at 35 MHz.

Benchtop or systems operation.

For electronic, industrial and scientific R&D, production testing, product design and other applications, digital storage makes benchtop viewing of signals easy. Raster scan displays are crisp and precise. On-line comparisons can be made against stored reference signals. And a floppy disk option allows storage of 30 waveforms—so you can capture data at the bench or in the field for later analysis.



For automatic test systems use, the 4500's GPIB, RS-232-C and high-speed memory output option card allow complete I/O interfacing to a GPIB controller or a minicomputer. It can even be left to "babysit" an experiment and capture events which occur at random times and elude conventional oscilloscopes.

Designed for ease of use.

You don't have to be a computer whiz to take full advantage of the microprocessor-based 4500. It has scope-like controls for easy operation by anyone familiar with an ordinary oscilloscope. A self-test routine checks the 4500's operation at power-up, and a user-evoked diagnostics set allows for detailed troubleshooting. The simple keyed menu selection guides you each step of the way.

Find out more about accuracy today.

For application notes and product brochure on the Gould Biomation 4500 digital oscilloscope, write Gould Inc., Instruments Division, Santa Clara Operation, 4600 Old Ironsides Drive, Santa Clara, CA 95050. Or call the Digital Oscilloscope people at (408) 988-6800.

Wide-area radio pager uses single chip

by Kevin Smith, Senior Editor

Direct frequency conversion and monolithic construction provide for small size and excellent sensitivity

Radio communications systems have been the last to enjoy the full benefits of large-scale integration because of the difficulty of integrating inductor and capacitor elements on a chip. But by adopting and adapting a long-forgotten idea—direct frequency conversion—Britain's Standard Telephones & Cables Ltd. has successfully packaged an entire very high-frequency receiver on a single silicon chip.

The technology is being used in the company's recently introduced Wide Area Radio Pager, a miniature unit measuring only 3/4 by 1 1/4 inches. The pager antenna simply connects to one pin of the bipolar chip, and fully demodulated, filtered data is produced at another. A second complementary-MOS chip decodes the incoming selective-call address. The data rate is 500 bits a second.

The technique has many advantages. Adjacent channel rejection is a high 65 decibels, and sensitivity is exceptionally good at 10 microvolts per meter. Both are vital for a radio pager whose miniature antenna is poorly matched for the rf signal—a problem made worse by its closeness to the body. "It can perform better than a standard superheterodyne receiver unit with a standard crystal filter," says Ian A. Vance. He heads the team at Standard Telecommunication Laboratories Ltd., in Harlow,

Essex, that worked out a modern form of direct frequency conversion and implemented it in silicon.

Rare technique. Though the radio pioneers of the early 1920s knew about direct frequency conversion, the technique is infrequently used. The reason is that a direct-frequency receiver needs two matched channels to restore lost phase information and establish whether the instantaneous frequency is above or below the carrier. With modern very large-scale integrated-circuit technology, both channels can be accurately matched on a single chip at little extra cost (see "A fresh look at direct frequency conversion," p. 90).

Vance's team began modernizing the technique in 1976, first producing a monolithic voice communications receiver. Quite independently, Plessey Electronic Systems Ltd. was moving in the same direction and in 1978 announced Groundsat, a single-frequency military repeater using the technology [*Electronics*, Oct. 12, 1978, p. 70; Nov. 6, 1980, p. 73].

Like Plessey, Standard Telephones had its eye on a military market—but it also foresaw professional applications. British Telecom's nationwide radio paging system was just getting under way and promised a boom in pocket-pager sales. STC wanted a slice of the action, so it commissioned Standard Telecommunication Laboratories to develop a single-chip bipolar receiver optimized for use with British Telecom's Post Office Code Standardization

Beep. This miniature pager is literally a vhf radio on a chip. It has four separate tone patterns for different sources and can record calls silently for later playback.

Advisory Group selective calling scheme. Based on frequency-shift-keying principles, the Pocsag scheme is being considered as an International Consultative Committee for Telegraphy and Telephony standard.

Smallest. Plessey Semiconductors Ltd., Swindon, Wilts., implemented STC's design in its high-performance bipolar process. When the new pager was introduced on the market, it was easily the smallest around. British Telecom immediately placed an order for 5,000 while STC began work on a more advanced version capable of storing and displaying short text messages on a liquid-crystal display.

Other pager manufacturers have begun to follow suit. London-based Multitone Electronics PLC, for one, has followed with its own single-chip system. It, too, is using Plessey Semiconductors to manufacture its chip and has granted the company



world marketing rights. "We purposely set up separate design teams to work on the two projects and maintain customer confidentiality," says Paul Mathews, marketing manager for Plessey's communications ICs.

Plessey's plans to market the Multitone chip were stalled while all three companies cleared the patent position. That hurdle has been overcome, and Mathews expects a commercial product to be launched within weeks for wide-ranging military, telemetry and security applications.

Japan

Market gets new Ga, In compounds

The world's leading producer of III-IV compound semiconductor materials this month becomes the first company to bring to market high-purity, single-crystal gallium antimonide and indium arsenide wafers of substantial size (35- to 50-millimeter diameter) for special optoelec-

tronic, microwave, and transducer applications.

Officials at Sumitomo Electric Industries Ltd. of Osaka say that, although the substances are less versatile than gallium arsenide, their key advantage is their narrower bandgap and the resulting longer-wavelength optical emission. Multi-epitaxial layers of gallium aluminum antimonide and gallium aluminum arsenic antimonide on a GaSb substrate emit infrared waves of 1.2 to 1.6 micrometers, as against 0.7 to 0.8 μm by aluminum gallium arsenide on a GaAs substrate. The longer-wavelength emitters are highly desirable for low-loss optical-fiber communications.

Fewer defects. The specifications of GaSb closely resemble those of indium phosphide, but the far fewer dislocation defects of GaSb give it a longer life as a light emitter and higher yields. Takashi Suzuki, manager of the company's Semiconductor Materials division, expects two major immediate applications to be in optical communications and pressure transducers and a later one to be in very high-speed microwave equipment when that technology is developed.

Sumitomo worked on its indium arsenide in cooperation with an unnamed U.S. company. InAs mobility of at least 2×10^4 square centimeters per volt-second is faster than indium antimonide's, and the substance is superior to InSb and GaAs in high-output electromagnetic transducer applications.

The company also claims that InAs infrared sensors can detect wavelengths of at least 3.5 μm and are faster, simpler, and ultimately cheaper than the common mercury-cadmium-telluride variety. It adds that composition control is much easier than with the InAs and indium gallium arsenic phosphide materials heretofore used in long-wave light-emitting and laser diodes, so dispersion and yields are better.

Sumitomo grows the crystals with a liquid-encapsulated Czochralski pulling technique developed by Nippon Telegraph & Telephone Public Corp. Takashi Suzuki says doping is

A fresh look at direct frequency conversion

In a direct frequency conversion system, the modulating signal is extracted from its carrier in a single operation by matching the local receiver oscillator to the carrier frequency. Instantaneous frequency deviations in the carrier signal immediately appear as a low frequency-difference signal in each of the receiver's two mixer channels. Since the LC-tuned intermediate-frequency stage of a conventional superheterodyne receiver is eliminated, the direct frequency conversion receiver can readily be integrated on a single chip.

The technique can be applied to data as well as voice. For example, the new pager chip from Britain's Standard Telephones & Cables Ltd. will decode frequency-shift-keyed data signals. A logical 0, or space, is represented by a frequency of, say, 4.5 kilohertz above the carrier, while a logical 1, or mark, is represented by the same frequency below the carrier.

For either state, 4.5-kHz sine waves appear at the output of the two separate mixer channels. By itself, neither output indicates whether the deviation is above or below the carrier. To accomplish this, one of the signals is first phase-shifted 90° with respect to the other. The output of the local oscillator applied to one of the mixers is merely phase-shifted 90° before application to the mixer.

Before demodulation, however, the two channels' signals are first low-pass-filtered to provide channel selectivity. Then the signal level is boosted to a point where the final output stage overloads. This produces a squared-off sine-wave output suitable for driving the following digital demodulator.

The demodulator is a D-type flip-flop, or edge-triggered device, whose output remains constant despite subsequent input state changes. One 4.5-kHz square wave is applied to the D pin while the quadrature channel signal is applied to the clock pin.

If the D-type is positive-edge-clocked and the relative quadrature condition is as shown in the figure, the output will be a constant logical 1 when the instantaneous frequency is 4.5 kHz above the carrier. When it is 4.5 kHz below the carrier, the relative phase change at the flip-flops shifts a full 180°, from 90° lag to 90° lead, and the Q output is now a continuous 0. This result is due to mixing from the high instead of the low side.

-Kevin Smith

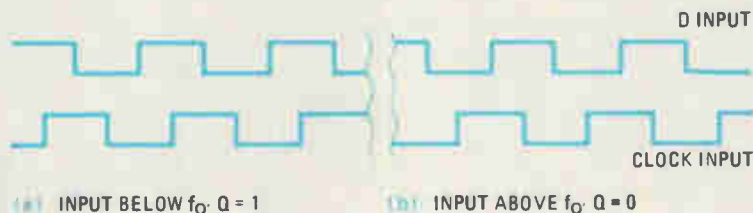



New Cromemco System One shown with our high-capability terminal and printer.

A new small computer that won't limit you tomorrow

Here's a low-priced computer that won't run out of memory capacity or expandability halfway through your project.

Typically, computer usage tends to grow, requiring more capability, more memory, more storage. Without a lot of capability and expandability, your computer can be obsolete from the start.

The new System One is a real building-block machine. It has capability and expandability by the carload.

Look at these features:

- Z80-A processor
- 64K of RAM
- 780K of disk storage
- CRT and printer interfaces
- Eight S-100 card slots, allowing expansion with
 - color graphics
 - additional memory
 - additional interfaces for telecommunications, data acquisition, etc.
- Small size

GENEROUS DISK STORAGE

The 780K of disk storage in the System One Model CS-1 is much greater than what is typically available in small com-

puters. But here, too, you have a choice since a second version, Model CS-1H, has a 5" Winchester drive that gives you 5 megabytes of disk storage.

MULTI-USER, MULTI-TASKING CAPABILITY

Believe it or not, this new computer even offers multi-user capability when used with our advanced CROMIX* operating system option. Not only does this outstanding O/S support multiple users on this computer but does so with powerful features like multiple directories, file protection and record level lock. CROMIX lets you run multiple jobs as well.

In addition to our highly-acclaimed CROMIX, there is our CDOS*. This is an enhanced CP/M† type system designed for single-user applications. CP/M and a wealth of CP/M-compatible software are also available for the new System One through third-party vendors.

COLOR GRAPHICS/WORD PROCESSING

This small computer even gives you the option of outstanding high-resolution color graphics with our Model SDI interface and two-port RAM cards.

Then there's our tremendously wide range of Cromemco software including packages for word processing, business, and much more, all usable with the new System One.

ANTI-OBSOLESCENCE/LOW-PRICED

As you can see, the new One offers you a lot of performance. It's obviously designed with anti-obsolescence in mind.

What's more, it's priced at only \$3,995. That's considerably less than many machines with much less capability. And it's not that much more than many machines that have little or nothing in the way of expandability.

Physically, the One is small — 7" high. And it's all-metal in construction. It's only 14 1/8" wide, ideal for desk top use. A rack mount option is also available.

CONTACT YOUR REP NOW

Get all the details on this important building-block computer. Get in touch with your Cromemco rep now. He'll show you how the new System One can grow with your task.

*CROMIX and CDOS are trademarks of Cromemco Inc.
†CP/M is a trademark of Digital Research

 **Cromemco**™
Incorporated
280 BERNARDO AVE., MOUNTAIN VIEW, CA 94040 • (415) 964-7400

Tomorrow's computers today

Circle 91 on reader service card

much more uniform in a (100) orientation than in (111), where distribution of impurities is extremely uneven. For its (100) crystals, Sumitomo uses a charge weighing 1,567 grams and comprising 45% gallium and 55% antimony. Sixty grams of sodium chloride or potassium chloride serve as the encapsulant, and tellurium is the dopant. The pulling rate is 3 to 7 mm an hour.

The resulting carrier concentration at room temperature varies from $[2.12 (\pm 0.08) \times 10^{17}] / \text{cm}^3$ at the top of the crystal down to $[1.82 (\pm 0.03) \times 10^{17}] / \text{cm}^3$ at the bottom. Electron mobility correspondingly ranges from 3,540 to 2,920 $\text{cm}^2 / \text{V}\text{-second}$. Etch-pit density, which reveals structural defects, is a very low 1 to 10/ cm^2 . All three specifications outdo those for (111) crystals.

The InAs is sulphur-doped, with a carrier concentration of at least $1 \times 10^{17} / \text{cm}^3$ and a resistivity of at least $3.5 \times 10^{-3} \Omega / \text{cm}$. Sumitomo uses liquid epitaxy now but has plans for molecular beam epitaxy or metal-organic chemical vapor deposition for device fabrication. —Robert Neff

West Germany

Memory takes 4 ms for 32 searches

Content-addressable, or associative, memory has intrigued computer makers for years because by using the content of an item of data rather than the fixed address, the approach vastly speeds the storage and retrieval of information. But the high cost of implementing such memory has limited its use to a few military and highly professional applications.

Now, employing a U.S.-originated associative-processing concept, West Germany's AEG-Telefunken is about to go to market with a peripheral memory unit that for the first time turns any minicomputer or small computer into an intelligent data bank. "We are putting data bank functions right at the computer user's work station instead of at a remote site," says Erdmann Thiele,

vice president for marketing and sales in the Frankfurt-based company's Information Systems Equipment Group.

The heart of the Synfobase unit is the recognition memory, or REM. This type of associative memory was first described in 1978 by Sydney Lamb, a linguistics professor at Rice University, Houston, Texas, and was implemented at Semionics Associates, then in Berkeley, Calif., and now in Houston. AEG-Telefunken secured the exclusive rights from Lamb to build and use the REM against heavy international competition, notably from Japan.

Besides providing fast data search and giving small-system users on-the-spot data-bank functions, Synfo-

base lets users generate their own search and sorting criteria without having to write new programs for complex searches. If the memory contains, for example, data on a company's employees, complete with name, sex, length of service, and so on, and if the user is searching for all male employees with 10 years of service, he or she simply keys into the computer the words, "Show employee name when years equals 10 and sex equals male" to get the information desired. Significantly, search queries may be entered into the computer in the user's native language.

Measuring 18 by 60 by 45 centimeters and weighing about 44 pounds, Synfobase is a compact unit built for tabletop use. In its minimal

Big market seen for associative memory unit

AEG-Telefunken foresees big sales opportunities for its Synfobase memory unit. By its estimate, the number of computers the unit could serve—small business, desktop, and minicomputer systems for professional applications—is at present between 60,000 and 100,000 in West Germany alone. Worldwide, the firm puts the number at over 1 million. Installations of such systems should rise at an annual average of 25% for some time to come, according to company analysts.

To cash in on that market, AEG-Telefunken is gearing up production lines at its Information Systems Equipment Group in Constance, West Germany, and the first units are slated to come out this fall. A highly integrated recognition-memory module (REM) is now in development at the company's Ulm custom-design center and will be fabricated at the firm's semiconductor facilities in Heilbronn. The 1983 production target for Synfobase systems is set at 10,000 units.

Synfobase sales will be primarily to makers of small business computers. "But," says a company official, "we won't neglect the end user market." The unit price to end users will be in the range of \$8,000. That figure should come down, though, as sales pick up.

Serving as a basis for sales outside West Europe will be Corem International Inc., a firm established in McLean, Va., earlier this year. Corem is 90% owned by AEG-Telefunken and 10% by Semionics Associates, Houston, in which REM inventor Sydney Lamb is a partner. Corem will also serve as the main software development center for the Synfobase unit. —John Gosch



MULTIFACETED CAPABILITY: THOMSON-CSF COMPONENTS



An international dimension

- 14,000 employees ● 32 production facilities
- Sales: \$650 million

A vast range

- Electron tubes ● Semiconductors: discrete -IC's
- Microwave components ● Piezoelectric components
- Passive components ● Hybrids ● Interconnection products

State-of-the-art technology through ongoing R & D

Quality to the highest standards

A commitment to service

 **THOMSON-CSF**
COMPONENTS

THOMSON-CSF DIRECTION DU GROUPE COMPOSANTS ET TUBES ELECTRONIQUES
101, BOULEVARD MURAT - 75781 PARIS CEDEX 16 / FRANCE - TEL. : (1) 743.96.40.

AUSTRIA
THOMSON CSF ELEKTRONISCHE
ANLAGEN GMBH
VIENNA 222 34 42 91 / 34 25 57

BELGIUM
THOMSON SA NV
BRUSSELS 2 648 64 85

BRAZIL
THOMSON CSF COMPONENTES
DO BRAZIL
SAO PAULO 11 542 47 22

CANADA
THOMSON CSF COMPONENTES
TORONTO 416 493 4442

FAR EAST ASIA
THOMSON CSF FAR EAST LTD
HONG KONG (3) 721 96 82

FEDERAL REPUBLIC OF GERMANY
THOMSON CSF BAUELEMENTE GMBH
MÜNCHEN (89) 76 75 1

ITALY
THOMSON CSF COMPONENTI
MILAN 21 607 37 61

JAPAN
THOMSON CSF JAPAN K.K.
TOKYO 3 264 63 4442

SOUTHEAST ASIA
THOMSON CSF SOUTHEAST ASIA
PTE. LTD.
SINGAPORE (65) 295 31 24

SPAIN
COMPONENTES ELECTRONICOS S A
BARCELONA (3) 373 30 11
THOMSON CSF COMPONENTES
Y TUBOS S A
MADRID (1) 419 85 37

SWEDEN
THOMSON CSF KOMPONENTER
SÖDERTELEFON AB
STOCKHOLM (08) 72 26 15

UNITED KINGDOM AND IRELAND
THOMSON CSF COMPONENTS
AND MATERIALS LTD
BASINGSTOKE (256) 29155

UNITED STATES
THOMSON CSF COMPONENTS
CORPORATION
RUTHERFORD (201) 438 2300

OTHER COUNTRIES
THOMSON CSF COMPONENTS
EXPORT
BRUSSELS 2 648 64 85

configuration, it contains the REM module plus a Z80 8-bit microprocessor, 64-K bytes of random-access memory, a 5¼-inch Winchester drive with an unformatted capacity of 6 megabytes, and an RS-232-C interface for connecting the unit to the host computer. Operable at either 115 or 220 volts, it consumes roughly 130 watts.

According to Anton Kresser, the group's head of product planning and Synfobase project manager, the Lamb-conceived REM is an 8-K-byte memory module organized into 8-bit words and 32 data sets, or superwords, each 256 bytes long—enough for most of the data records that would be put into the REM. The Winchester drive loads data in chunks of 32 superwords into the REM at rates of between 150 and 200 kilobytes per second.

The software also uses the REM to achieve data compression, so that records longer than 256 bytes can be stored within one superword. This compression considerably increases the effectiveness of transfer of data from the disk.

Instantaneous. Simultaneous with the movement of the disk head to the next track, the 32 superwords are queried in parallel fashion as to their contents in 4 microseconds. The results are virtually instantaneously at hand. Then, another 32 superwords are loaded into the REM for the subsequent search cycle, and so on. The 64-K byte RAM in the system contains the software, and the Z80 processor performs systems control. Data is sent to the host computer through the RS-232-C interface at up to 19,200 bits/s, according to the information systems group.

In its present form, the REM module is made up of 16 off-the-shelf 4-K RAMs. Associated with each superword is a comparison logic circuit, at present distributed over a number of separate chips. "But we are now working to reduce the components count by using large-scale integrated-circuit techniques," Kresser explains. The comparison circuits perform various operations, including several types of recognition. Besides the exact match, there

are quantitative comparisons like "greater than", "greater than or equal to", "less than", "less than or equal to", and so on.

Every superword has associated with it a tag bit that holds the results of comparisons. At the beginning of a comparison, which typically would involve a string of bytes, all tag bits are set true. Then, any failure to meet a recognition criterion causes the tag bit for the failing superword to be set false. At the end of all operations upon whatever bytes are selected, any true tag bits mark the superwords that have satisfied all the recognition criteria. These are called responders.

-John Gosch

France

Amorphous silicon enlarges LCDs

The basic limitation of liquid-crystal-display devices addressed directly by a MOS field-effect-transistor array is the relatively small size and high cost of single-crystal silicon substrates. To solve this problem, the Centre National d'Etudes des Télécommunications research laboratories in Lannion, France, is preparing a matrix of more than 100,000 transistors by depositing amorphous silicon on an ordinary glass substrate to control a flat, high-resolution liquid-crystal screen.

CNET hopes to have a working prototype sometime this summer, after which it will move on to an

even more ambitious project—an identical screen with all of the shift-register circuitry integrated on the same substrate as the display matrix's analog switches.

Recrystallized. Each point of the 320-by-320-element matrix will be controlled by a single thin-film amorphous-silicon transistor. Key to the eventual complete integration of the screen is a process to recrystallize the film on the periphery of the substrate into polycrystalline silicon in order to take advantage of its higher carrier mobility—the amorphous transistors are too slow for the shift-register logic circuits. This recrystallization is impossible using conventional amorphous silicon.

"When we tried to recrystallize hydrogenated amorphous silicon, there were always flaws like bubbles and cracks that we thought were probably caused by its high hydrogen level—up to 15%," explains Joseph Richard, one of the engineers working on the project. "Our solution was to decompose silicon at 500°C instead of 300°C, giving amorphous silicon with only about 1% hydrogen. Then the films can be rehydrogenated after annealing."

Because the shift register for the first matrix to be produced will be controlled by external circuitry, the matrix will be made with standard hydrogenated amorphous silicon deposited at about 300°C instead of the 500°C required for the post-hydrogenated type. Otherwise, fabrication of the transistors is almost identical.

After a transparent indium-tin-oxide electrode has been deposited

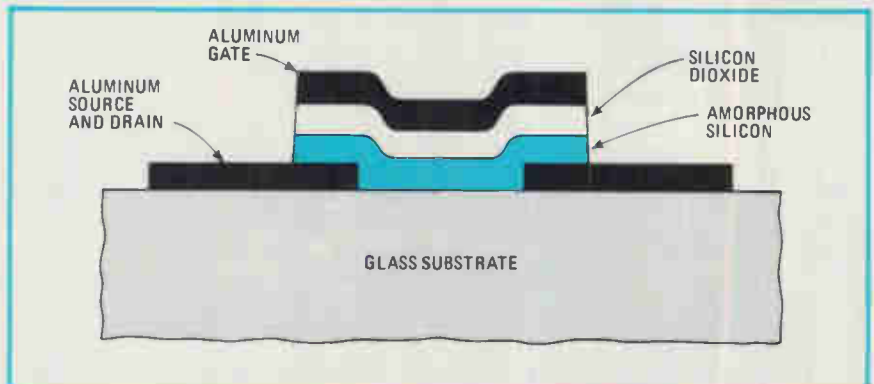

Sandwich. Layers of amorphous silicon, silicon dioxide, and aluminum gates are patterned in a single lithographic step, which makes for a better yield and lower cost.

Technological leadership.

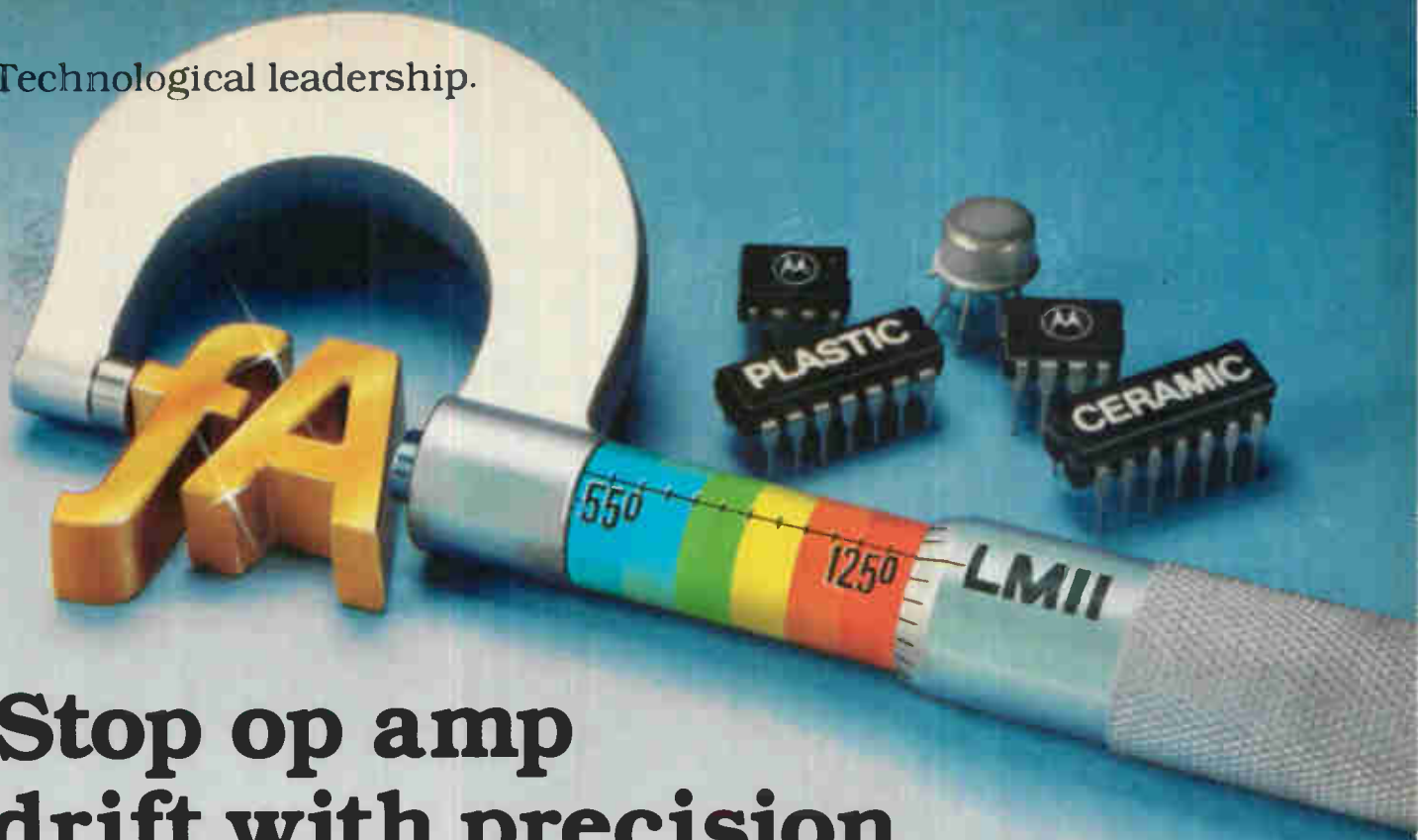

Stop op amp drift with precision, low-cost LM11s.

Sure. Bifets sound good. But you pay dearly for accuracy and never get temperature stability.

Of course. LM108s provide low-cost, nanoamp offset and bias currents. But you can do a lot better for just a little more.

Yes, that's right... the new LM11 bipolar op amp provides the best advantages of both and beats the parameters out of them where you need it most for the majority of applications. And over a full operating temperature range, not just 25°C.

Femtoamps. New delta standard.

Twenty quadrillionths of an ampere (20 Femtoamps) $\Delta I_{IO}/\Delta T$ over the entire -55° to 125° C range. An astounding LM11 spec 25 times better than the 108... 5000 times better than Bifets!

$\Delta V_{IO}/\Delta T$ is nearly twice as good as both, too. And our Super Beta design reduces input bias currents 10 times or more over the 108 and equals the best Bifets at 25°C. Unlike Bifets, LM11 bias currents do not double every 10°C nor do they increase with increased common mode input voltage at room temperature.

They're solid, stable, and virtually drift-free no matter what the ambients.

LM11-designed equipment turns on immediately because the low, 0.6 mA LM11 supply current eliminates long warmup times. And bandwidth and bias currents are consistent, device to device. It's internally compensated but external compensation can easily be added for even more stability. V_{IO} can be balanced with a single, external pot.

The LM11 is ideal for analog memories, temperature controllers, low frequency active filters, light meters and log amps, as a design-in or replacement.

Price. Precisely low.

8-pin plastic prices start as low as \$1.60, 100 up... 15-25% lower than others. Two temperature and five

package choices, including the exclusive 8-pin ceramic unit, suitable for automatic insertion, are factory and distributor-available.

OP AMPS AT A GLANCE

	LM108A	LFI55A	LM11
V_{IO} Max	0.5 mV	2 mV	0.3 mV
I_{IO} Max	200 pA	10 pA	10 pA
I_{IB} Max	2 nA	50 pA	50 pA
$\Delta V_{IO}/\Delta T$ Max	5 μ V/°C	5 μ V/°C	3 μ V/°C
$\Delta I_{IO}/\Delta T$ Typ	0.5 pA/°C	100 pA/°C	20 fA/°C
$\Delta I_{IB}/\Delta T$ Typ	10 pA/°C Typ	250 pA/°C	0.5 pA/°C

Make your own LM11 op amp comparison — then contact Motorola Semiconductor Products, Inc., P.O. Box 20912, Phoenix, AZ 85036 for data.

We're ready with precision linear ICs for

**Innovative systems
through silicon**



MOTOROLA INC.

TO: Motorola Semiconductor Products Inc., P.O. Box 20912, Phoenix, AZ 85036.

Please send me more information on LM11s.

123 ELEX 5/19/82

Name _____

Title _____

Tel.: (____) _____

Company _____

Address _____

City _____

State _____

ZIP _____

on the glass substrate by sputtering, aluminum source and drain contacts are patterned by photolithography. Then comes a layer of amorphous silicon 3,000 to 5,000 angstroms thick. Pulsed laser annealing at 300°C to 330°C raises the mobility of the amorphous silicon without crystallizing it.

Integrated. At this point, for a completely integrated screen, the periphery of the substrate is recrystallized using either argon laser or xenon flash-lamp annealing, and then the entire surface is post-hydrogenated in low-power hydrogen plasma. The transistor's gate insulator is formed by a 1,000-Å-thick silicon dioxide layer, and aluminum 2,000 Å thick provides gate contacts. The principal advantage of this method is that it requires only a single masking step for patterning the amorphous silicon, the gate insulator, and the gate contact, thus significantly raising the yield.

The matrix, which has a resolution of 4 lines per millimeter, will take up an 8-by-8-centimeter area on a 10-by-10-cm glass substrate. The remainder of the substrate area will be employed at a later date for the integration of the phase-shift-register function.

-Robert T. Gallagher

West Germany

Glass fibers link CPUs to each other

Fiber-optic technology is now being used in the computer field to couple central processing units not just to peripherals but to each other. West Germany's Siemens AG, Munich, is readying for market a glass-fiber-based data-transmission system, the 3962L, that ties together the CPUs of its 300 family of process and commercial computers, those of the Siemens 6000 family of office machines, or a member of one of these families to the other.

Able to bridge distances up to 2 kilometers without intermediate equipment like optical amplifiers, the two-fiber cable replaces a con-

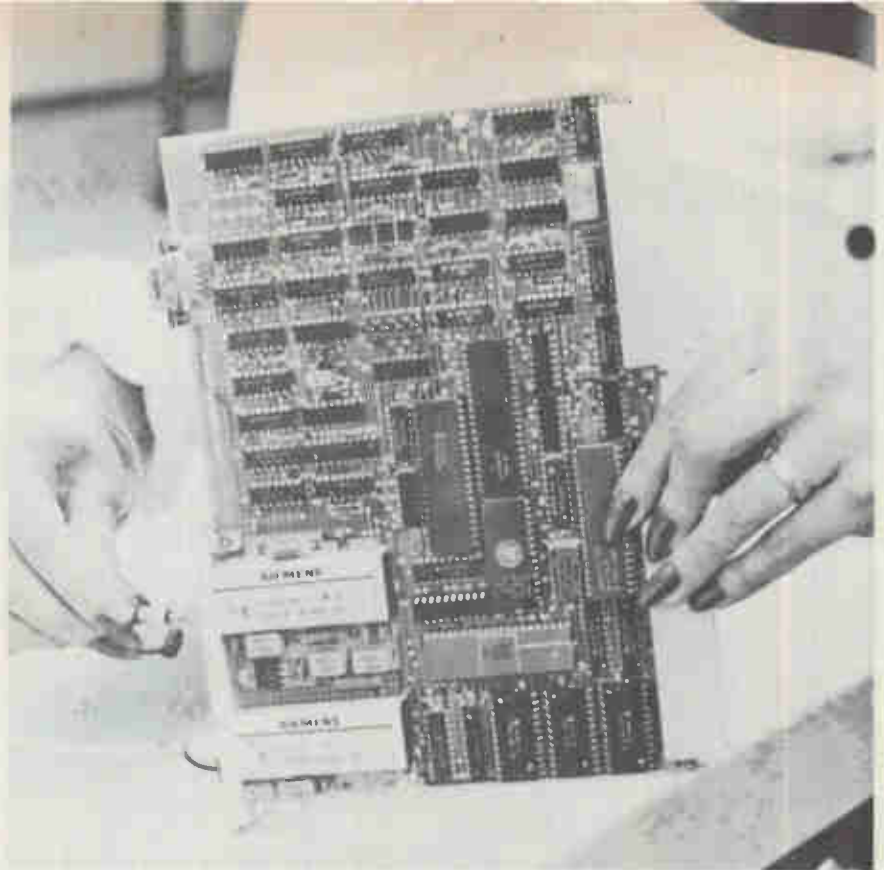

Connection. A glass-fiber cable section is plugged into the receiver of a 3962L data-transmission system, linking the central processing units. The transmitter is below.

ventional cable with 48 copper wires and can handle a data-transmission rate as high as 1.5 megabits a second. This makes the system suitable for both commercial applications with high data rates and for use with minicomputers in rough industrial environments.

The controller (see photograph), one at each end of the link, converts electrical into optical signals and *vice versa*, monitors the data transmission, and replaces dropped bits. A microprocessor in the unit controls data transfer, thus relieving the CPU of handling the transmission procedure. At both controllers of a link, a full-duplex high-level data-link control procedure is executed for point-to-point communications.

The glass fibers used are a product of Siecor, a Siemens/Corning Glass venture located in Munich and Hickory, N. C. Multimode types, they are either 200 or 100 micrometers in diameter. The larger fiber has an attenuation equal to or less than 50 decibels per kilometer and the thinner one an attenuation no greater than 7 dB/km.

Unique. Siemens knows of no computer maker that is offering such glass-fiber systems as a standard

piece of equipment for directly coupling computer CPUs. To be sure, some multiplexer makers have developed systems with optical fibers between their multiplexers [*Electronics*, Jan. 27, 1981, p. 149]. The latter, in turn, tie in to computers via conventional low-rate (64-K or so) cables, so this scheme does not entail direct coupling.

Besides, only the multiplexer-to-multiplexer portion is glass fiber. With the Siemens system, however, high-speed glass-fiber links the CPUs directly, giving optical transmission's inherent high speed all the way.

Only now are glass fibers and high-reliability long-life optocouplers, optical transmitters, and receivers dropping in price to levels at which they can be offered as components in standard systems to the general user with perhaps a limited budget. (Postal authorities, communications houses, and so on are generally less cost-conscious.)

The 3962L controller is expected to sell for around \$2,920 on the German market. The two-fiber cable with the larger-diameter fibers will probably go for \$2.10 per meter, and one with the smaller-diameter fibers for roughly \$6.25/m. -John Gosch



New Design # 14,395

INTRODUCING BUSSMANN QUALITY IN THE WORLD'S SMALLEST FUSE.

Now Buss reliability is in the world's smallest fuse

— Tinitron. And it has an axial pull-strength of 10 pounds, plenty strong for tape and reel lead forming and automatic insertion into printed circuit boards.

Available in ratings from 1/16th amp through 15 amps, 120 volts or 32 volts, delivered in reel pack, loose bulk or ten-packs.

Buss sub-minis are available with clear body and printed ratings, Tinitron II or color coding, Tinitron III. Tinitron is the third generation sub-mini from Bussmann. Each unit is tested twice before it leaves the

ACTUAL SIZE



factory so you know you've got Bussmann reliability. You can get Buss fuse No. 14,395 from any Bussmann distributor. Call today.

Bussmann Division, McGraw-Edison Co., P.O. Box 14460, St. Louis, MO 63178.

McGRAW-EDISON

Bussmann

"WHAT HAVE WE DONE FOR YOU LATELY?"

For semi-custom or custom ICs, Exar's the best of the bunch.



More semi-custom and custom experience.

It's not just Exar's ten years of experience in cost-effective IC processing. Or our expertise in a wide variety of applications and industries. It's not just the fact that we've built more standard products, phase-locked loops and function generators than our competition. There's more.



More reliable IC production.

Take our CAD systems. They allow us to complete your designs more quickly—and with far greater accuracy. For extra control, our in-house burn-in facilities save having to use outside testing labs. So we not only save you money—we save you valuable testing time. And our full MIL-STD-883 screening means we'll process your ICs to space-qualifiable levels.

More flexible IC service.

When you've got special process requirements, they're no problem for Exar. Our extensive fab facilities enable us to modify a process quickly and easily. We even offer extras like chip carriers, a variety of special packages and fast turnaround for all your prototypes. Exar's personalized service and engineering expertise are all you could ask for, too. But best of all, Exar is more cost-effective than the competition.

When *your* ICs need to be the best of the bunch, call Exar. Or send this coupon for more information.

Tell me more, Exar.

Please send me a copy of:

- Custom and Semi-Custom Product Guide.
- Standard Product Guide.
- Please have a sales engineer call me.

Name _____

Title _____

Company _____

Street _____

City _____ State _____

Zip _____ Phone (____) _____

My application is: _____

Exar, 750 Palomar Ave., Sunnyvale, CA 94086
(408) 732-7970

ELEC 5/19/82

EXAR

For semi-custom, custom or standard ICs . . . **Exar has the answer.**

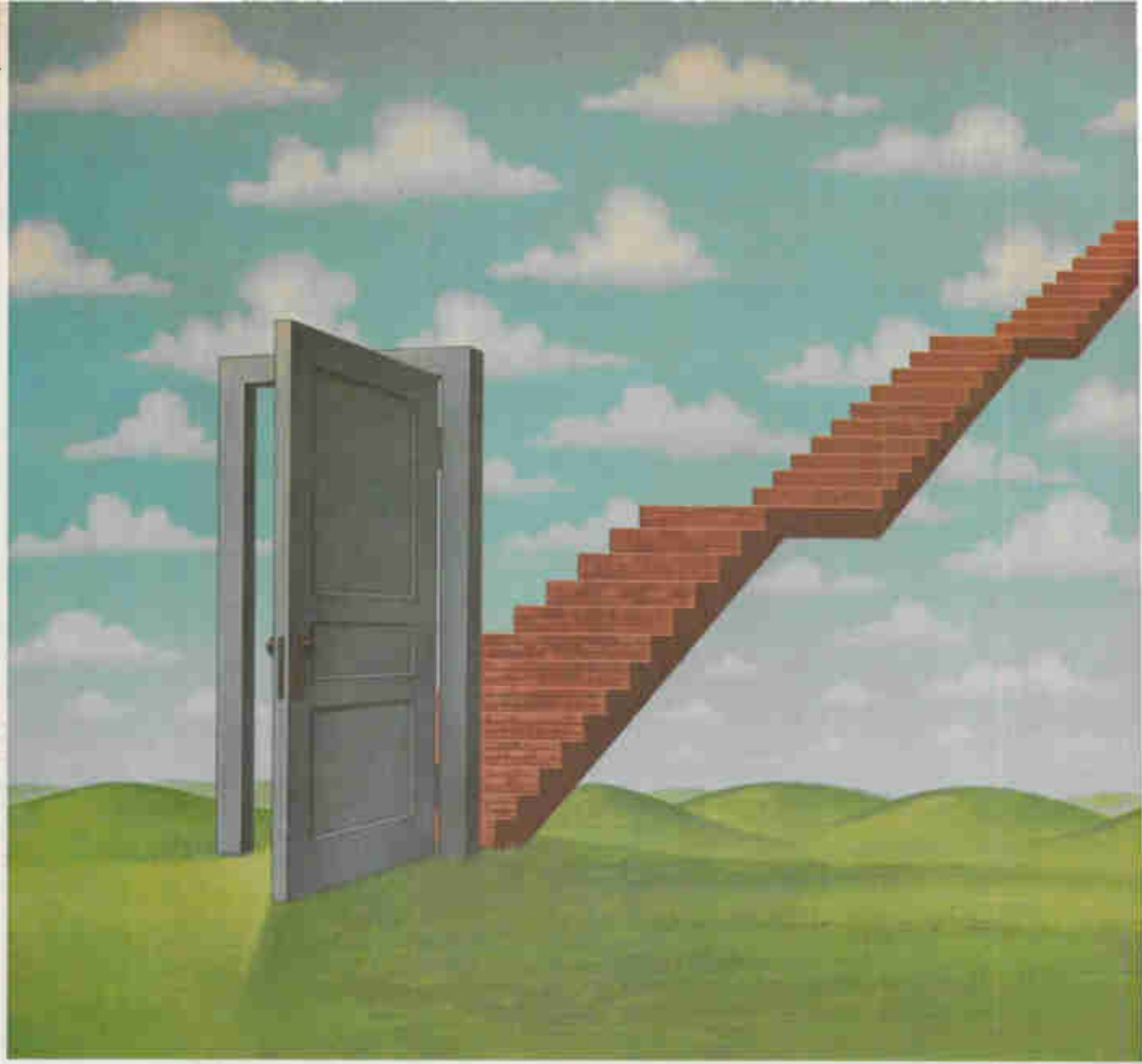

ONWARD AND UPWARD.



THE NEW SERIES 21 VLSI TEST SOLUTION



FAIRCHILD

A Schlumberger Company

The new Series 21 is Fairchild's most advanced, most accurate VLSI test solution to date. And, as an important part of our carefully planned pathway to the factory of the future, the new Series 21 is simply the best overall VLSI characterization test solution available.

ACCURATE, DELIVERABLE TEST SOLUTION.

Capable of 20 MHz test speeds (up to 40 MHz in multiplex mode), the new Series 21 offers guaranteed overall system accuracy of 1 ns, allowing you to test high-speed VLSI devices much more precisely.

Series 21 also features real auto deskew. Programmable hybrid delay lines control driver leading and trailing edges, automatically adjusting to any combination of timing generators and/or pins.

Series 21 provides both hardware and software solutions to high-speed testing. Hardware delay lines and auto-calibration routines are handled under software control. Now total testhead calibration can be run in less than 15 minutes per day. Once the values are determined, vectors are set automatically, programming the delay lines to the specified values.

Series 21 also features "strobe anywhere" Zero Strobe Inhibit Region for complete, flexible high-speed testing without restrictions.

And, for added capability, Series 21 options include the new Serial Test Module (STM) for serial

scanning of complex VLSI devices. A Pattern Processor Module (PPM) for testing large-scale memories. A double-density disk with fast access for test program/truth table storage. CPU memory expandability to 256K words. And SAGE (System Analytical Graphics Enhancement), a program development tool that converts test programs into graphic waveform displays, cutting debug time in half.

Most importantly, the new Series 21 is available today. It uses the same device programs and performance boards as the Series 20 and Fairchild Sentry systems. And it's backed by a service, support and training program second to none.

KEEPING YOU ON THE RIGHT PATH.

In the weeks and months to come, you'll be seeing and hearing about the new Test Area Manager (TAM), as well as other future-minded program development tools compatible with the new Series 21. All are part of our ongoing commitment to provide you with products designed for greater return on your investment with Fairchild.

For more about the new Series 21 VLSI characterization test solution, call or write: Fairchild Test Systems Group, 1601 Technology Drive, San Jose, CA 95115, (408) 998-0123, Ext. 2296. Fairchild Camera and Instrument Corporation.

Cost.

Forward Current Amps	Reverse Voltage Volts	Forward Voltage Drop Volts	Package	Part No.
1.0	20, 30, 40 50, 60, 80	.45-.70	Axial DO15	SB120-SB180 IN5817, 18, 19
3.0	20, 30, 40 50, 60, 80	.50-.75	Axial DO201AD	SB320-SB380 IN5820, 21, 22
5.0	20, 30, 40 50, 60, 80	.42-.70	Axial DO201AD	SB520-SB580 GI5823, 24, 25
8.0	20, 30, 40 50, 60, 80	.65-.75	TO-220	SB820-SB880
10.0	20, 35, 45	.84	TO-220	SB1020-SB1045
16.0	20, 30, 40 50, 60, 80	.65-.75	TO-220CT	SB1620-SB1680
30.0	20, 30, 40 50, 60, 80	.65-.75	TO-3CT	SB3020-SB3080

Time was when Schottky rectifiers were too expensive for any application that wasn't a power supply.

Well, times have changed. And General Instrument has lowered Schottky rectifier prices to a fraction of what they were. Low enough to make them a cost-effective consideration for virtually any application you can imagine where recovery times and low forward voltages are critical. Like automotive circuits, telecommunications devices, computer equipment and, of course, power supplies.

General Instrument Schottky rectifiers are available from 1 to 30 amps; 20 to 80 volts. With forward voltages as low as .42V. In three packages—axials, TO-220's and TO-3's. The axial and TO-220 packages are encapsulated in UL listed, flame retardant epoxy. The TO-3 is hermetically sealed in a metal package.

You can specify General Instrument with confidence. We're the world's largest rectifier manufacturer. And now we've broken the Schottky price barrier, too.

For immediate delivery, technical data or a complete catalog, contact your nearest General Instrument Discrete Semiconductor Division distributor, or General Instrument Discrete Semiconductor Division, 600 West John Street, Hicksville, NY 11801. Telephone: (516) 733-3333.

GENERAL INSTRUMENT

LSI-11 System Boxes and Box Systems

• **Functionality** • **Versatility** • **Reliability** • **Cost Effective**

MDB makes the difference!

No compromise! You can get the LSI-11 system building blocks you need, from a system box to a box system, for fast, efficient system configuration. All with plenty of board space in the box for system applications that require specific user selected modules.

No matter what kind of system you're building, from support for battery back-up to core memory and everything in between, it doesn't pay to start with less than a no compromise enclosure.

By no compromise we mean:

- System boxes from 8 to 32 dual slots, (8 to 16 quad), you select what you need.
- Triple output (+5V, +12V, -12V) cool running, efficient, light weight regulated switching power supplies with up to 50 amps capability at +5V.
- Integral 22 bit addressing, with built-in bus termination.
- Multilayer motherboard backplane for the cleanest possible signal paths.
- Built-in power sequencing and line time clock.
- No rewire for 115V 60Hz to 230V 50Hz operation.
- Front or rear loading configurations.

MDB has more experience building box configurations than any other manufacturer. In fact we offer thirteen.

By starting with the most functional system boxes available, MDB also builds the most versatile box systems you can buy.

Systems which include the LSI-11/23 CPU, 22 bit addressing memory, Q-Bus 8 or 16 line multiplexors, high speed synchronous communications interfaces and the complete line of MDB interfaces.

With MDB box systems, you don't buy any board you don't need. And you pay less for the system than you would for the individual modules. All products are warranted for 1 year and can be purchased under GSA #GS-OOC-02851. You win no matter how you stack it with MDB! Let MDB make the difference.



MDB 1995 N. Batavia Street
Orange, California 92665
714-998-6900
SYSTEMS INC. TWX: 910-593-1339

Circle 104 for more information.

"See us at NCC Booth #2015-16"

Companies still short of EEs

Certain specialties and some locations lead the list;
new graduates find themselves in driver's seat

by Ray Connolly, Senior Editor

The cry of engineer shortage has been raised for many months, only to be countered by the claim that any shortfall is ephemeral and that too many are out of work. Around the country, however, the people who hire and train engineers say they cannot fill their needs; likewise, new graduates find themselves being courted by many companies.

For electrical engineers, "it is the best time ever," says one Californian, and most corporate recruiters across the country sadly agree. For them, the Reagan recession and its continuing high costs of housing and mortgage money is limiting the mobility of experienced engineering talent. The result: salary levels are increasing at a rate of 10% or more annually, and benefits—notably company-paid advanced-education programs—are improving, too.

"From what I hear," says one Department of Labor official, "the mobility problem ranks right up there with companies' complaints about high capital costs. Reports of layoffs get more press coverage, of course, but no manufacturer is laying off its good engineers. The operative word there is 'good.'"

For the EE who considers himself a good one but is out on the street nevertheless, the Californian's euphoria seems unreal and provides no solace. Such euphoria demonstrates the problem of generalities: they cannot be applied in all cases.

The shortage has aspects that relate to geography and the specialties of engineers and technicians, as well as economics. Other elements include faculty shortages in the nation's universities, their antiquated laboratory facilities and the short-

age of funds to upgrade them (much less pay higher faculty salaries), plus the acknowledged decline in the country's secondary-school curriculums and the shortage of good teachers at that level. "What they all have in common is money—or the lack of it," says John W. Geils, the American Telephone & Telegraph Co. executive on loan to the American Society for Engineering Education in Washington, D. C. for a two-year study of academic issues.

For the near term, corporate managers in California say they are hardest hit by the shortage, notably in the southern part of the state with its heavy concentration of military-electronics manufacturers gearing up for President Reagan's defense buildup. However, other weapons makers like Raytheon Co. in Lexington, Mass., Harris Corp. in Melbourne, Fla., and the growing complex that surrounds the nation's capital in Maryland and Virginia also are feeling the pinch.

The fact that many companies have restored the bounty system of the 1960s—paying a bonus to employees for each person who is hired after the worker's recommendation—is evidence of the tightening market. Burroughs Corp.'s Rancho Bernardo, Calif., plant, for exam-

ple, pays \$700. Atlantic Research Corp., Alexandria, Va., a producer of small missiles that also does military research, pays up to \$1,000 a body, with winners of top prize money eligible for a drawing to win a trip to the Caribbean.

Top skills. Computer hardware and software specialists are clearly the most sought-after EEs across the country, in view of the need for such talent by both commercial- and military-systems makers. Not far behind, however, are those trained in telecommunications and test-equipment work—specialties that can also be applied in both the commercial and Government markets. Also, some producers of semiconductors seem to be rebounding from the recession, and, like Silicon Valley's Intel Corp., say they are hiring again.

The nation's crop of new electronics and electrical engineering gradu-

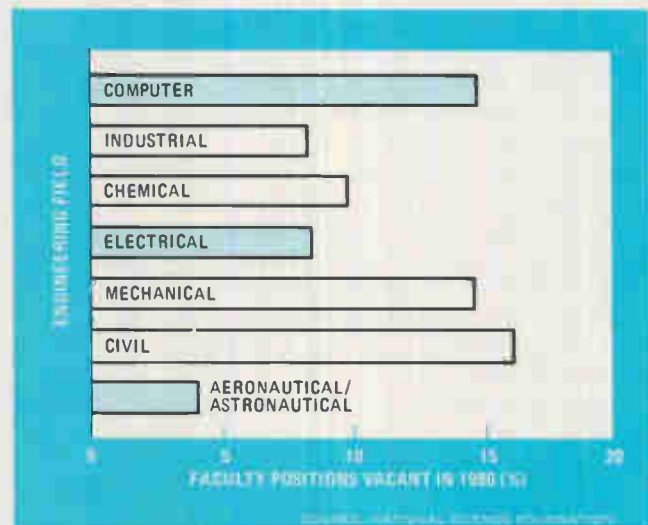

Help wanted. The roots of the shorgage of engineers have been traced back to a shortage of instructors in universities.

ates is unquestionably the biggest beneficiary of the ongoing talent shortage because most of them do not have the housing or family constraints of their older colleagues. Moreover, leaders in the corporate and academic communities agree that the quality of newly hired graduates generally is superior to anything they have seen in some time.

At Data Control Corp. in Minneapolis, Minn., Peter Michalowski, manager of college relations, attributes the higher quality levels to the fact that the tight economy permits employers to be more selective. New hires, he says, are "better rounded and more capable, not only technically but also in their communications skills and in their general knowledge of the company."

That positive image of new graduates is widely held, with concurrence coming from such divergent corporate interests as California's commercial semiconductor producers in the north like Intel, military electronics manufacturers in the south like Hughes Aircraft and TRW, as well as Data General Corp., the Westboro, Mass.-based computer maker, to name a few.

Some decrease. Most manufacturers except weapons producers concede that while the recession may have dampened the demand for EES, the economic downturn has not eased the shortage. Data General's Jonathan Lane, a personnel director, notes that the shortage is no less real because new graduates may be getting only five job offers instead of 10 this year. The fact that engineering schools, now operating at capacity, are turning away applicants, plus the widening demand for engineers as both end users and producers of commercial products move to enlarge staffs in competition with weapons makers, are seen as warnings that the talent shortage could get worse.

Equally concerned are the nation's schools of engineering, where more than 1,600 faculty positions—some 10% of the total—are unfilled. Almost half of those posts have been vacant for more than a year, says the American Council on Education.

AEA sees shortage growing

An awareness that the electronics industries were having troubles filling engineering slots had been building for months, but one document can be singled out as the one that caused awareness to increase sharply. That was the American Electronics Association's report of its membership survey on the subject. Joyce Lekas, vice president for communications, says, "Among the association's membership, which is now 1,800 to 1,900 companies, the consensus is emerging that the engineer shortage is real and growing. And the reason underlying it is that the engineering faculty shortage is not being alleviated rapidly enough."

However, Irwin Feerst, the indefatigable and sometimes abrasive founder and staff of the Committee of Concerned EEs, an organization dedicated to reforming the Institute of Electrical and Electronics Engineers and improving the lot of the EE, is not convinced. Feerst, a Massapequa Park, N. Y., consulting engineer, says flatly, "I don't think there's a shortage of engineers. They're lying. It's their [company executives] duty to reduce costs" by encouraging more people to become engineers and flood the job market. "If they would offer new graduates \$32,000 a year, the kids would be beating down their doors."

That, as Feerst sees it, is the crux of the matter: salaries. "Pay in constant [1969] dollars has been going down. If there were a genuine shortage of, say, strawberries then their price in constant dollars would rise. Why isn't that the case for EES?" Another point Feerst makes is that recent layoffs at Texas Instruments Inc. and General Electric Co. and that forced furloughs in California's Silicon Valley have created a surplus of engineers. In line with this belief, Feerst last winter told a Senate committee that foreign-born engineers are taking jobs that could be filled by Americans. His testimony helped lead to inclusion of a provision in the Immigration Reform and Control Act now before the Congress (S. 2222 and H. R. 5872) that would force foreigners to return to their native countries for two years after receiving engineering degrees. The AEA opposes that section because, says Lekas, "in some colleges the only pool of instructors is foreign Ph.D. graduates. U. S. citizens are grabbed by the aerospace and defense industries because they are required by law to hire citizens. All that is left for the small, entrepreneurial companies is foreigners."

-Howard Wolff

The shortage is so severe, says the council, that it would not be filled even if all the resident engineering doctoral candidates opted for faculty jobs. Schools find themselves with salaries and benefits that do not begin to match those of industry. Compounding the problem for schools, however, is the in-house political issue of tenure, says ASEE's Geils, with its built-in constraints on advancement for young faculty members.

Money is the fundamental issue nonetheless. In the past four years, the differential between industry starting salaries and the average engineering faculty salary "has widened from 22% to 33%," says the National Engineering Action Conference, a small group of leaders from academia, Government, and industry. "Even in these recessionary times," says the group, "a young baccalaureate engineer can com-

mand a higher salary in industry than the average engineering assistant professor with a Ph.D."

One consequence is that more than 20 major universities, already bursting at the seams with engineering students, have put caps on enrollments. They range from California's campuses at Berkeley and Los Angeles to New York's Cornell and Rensselaer Polytechnic Institute to the Georgia Institute of Technology. Others in between include the universities of Illinois, Maryland, and Michigan, plus Notre Dame, Purdue, and Michigan State, Ohio State, and Penn State. The caps came because faculty left, while the 1980 freshman engineering class of 110,000 was the largest ever by far, producing a total undergraduate enrollment of some 365,000—a 58% increase from 1975.

If the long-term outlook for employers is dim, it is grim for the

Why sacrifice accuracy when buying a fast system DMM.

Making the decision on which Digital Multimeter to use in your next system isn't simple. Some vendors would have you sacrifice accuracy for speed. But with the Fluke 8520A and 8522A Digital Multimeters, you don't have to sacrifice performance for your high speed systems applications. **No accuracy trade-off with Fluke System DMM's**

When integrated into your automated test system, the 8520A System DMM is able to deliver 5½ digits at 0.005% accuracy up to 240 readings per second.

For speeds of 240 to 520 readings per second, the 8520A gives you 4½ digits of 0.01% accuracy.

The 8520A is ideal in applications like aerospace and advanced research/development where you need to make a variety of different precision measurements very quickly.

Put a window around your transient signals

The 8520A DMM also features a pre-trigger memory that allows you to view data *before* and after a specific event. Leave the meter alone and it can record up to 400

readings prior to a transient event, giving you a better picture of how your UUT is performing.

High-Performance for Non IEEE-488 Systems

Fluke has just introduced the new 8522A. Its performance matches the 8520A, but with Parallel and BCD Interfaces as standard equipment. The 8522A also emulates the interface of our earlier system DMM's found in many ATE systems. So you can easily incorporate the advantage of high-speed modern measurement technology into your existing BCD or Parallel systems with minimum software changes.

Standard DMM Features

For maximum versatility, both meters include

- VDC
- VAC true RMS
- VAC + DC
- 2- and 4-wire ohms
- 50 Readings Memory
- 7 standard math programs

The standard 8520A is priced at \$2995 and the 8522A is priced at \$3995.

The 7 additional math programs and 400 readings memory option is only \$500 extra.

Call 1-800-426-0361 or write for more information on how you can step up to high speed performance for your next automated test and measurement system.

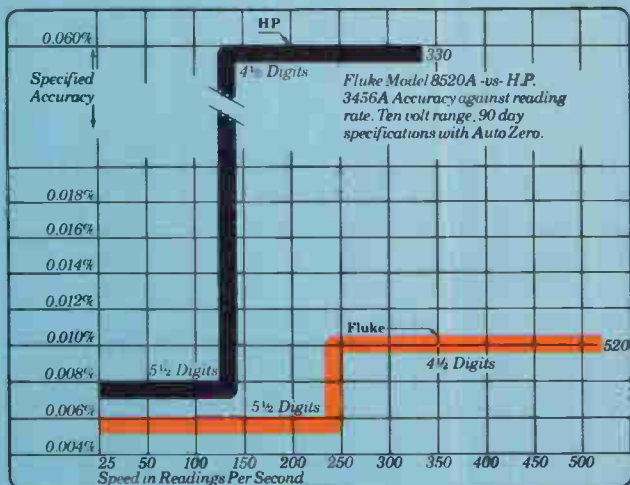

IN THE U.S. AND NON-EUROPEAN COUNTRIES: **John Fluke Mfg. Co., Inc.**
P.O. Box C9090, M/S 250C
Everett, WA 98206
(206) 356-5400, Tlx: 152662

IN EUROPE: **Fluke (Holland) B.V.**
P.O. Box 5053, 5004 EB
Tilburg, The Netherlands
(013) 673973, Tlx: 52237

Send information on 8520A/8522A
 Send information on 2205A Switch Controller

Name _____
 Title _____ MS
 Company _____
 Address _____
 City _____ State _____ Zip _____
 Telephone () _____ Ext. _____

Probing the news

short term. Again, the issue revolves around engineering quality, rather than quantities. "Historically, people are reluctant to switch jobs during bad times," says Nicolet Instrument Corp.'s Robert Lovely, personnel chief for the Madison, Wis., company's oscilloscope, analytical, and biomedical instrument divisions. "Over the last six months, I have seen a marked decrease in the number of quality applicants" who have at least three years' experience and can move quickly into place.

From northern California, Intel's vice-chairman Robert Noyce believes that enlightened management in the electronics industries can best cope with the engineering shortage by "going where the people are." Citing Intel's expansion of operations into such areas as Austin, Texas, Albuquerque, N. M., Phoenix, Ariz., and Portland, Ore., Noyce sees possible future opportunities in places like Baltimore and Boston. But those opportunities will remain no more than that, he adds, until the cost of capital comes down.

The hottest markets for relocating engineers are in the South, says Scott R. Hall, president of Corporate Staffing Consultants Inc., a Northbrook, Ill., recruiter. "The major problems we face right now relate to the economy," he acknowledges, citing high mortgage interest rates and relocation costs that make some engineers reluctant to move, particularly to California.

In the past 18 months, Hall says,

some employers have been beefing up their relocation benefits in recognition of this. By his estimate, salaries for EEs and computer scientists with at least two years' experience has been rising at a 20% to 25% annual rate over the past two years, roughly double that of the 1972-79 period.

Hall sees future demand outpacing supply, making these specialties "strongly marketable for the next to 10 to 15 years at least." In Detroit, Burroughs corporate employment director, Keith J. Horngren, supports this view, as do other manufacturers in every region of the nation.

California shortage. Los Angeles recruiter J. Paul Sutton of Gemini Management Resources supports the California shortage argument. "None of my clients can get enough engineers now and see no breakthroughs coming" in the aerospace market. Although there is a critical lack of "the creative design types," who Sutton says often leave the most heavily recruited jobs, the shortage is especially acute for EEs with 5 to 10 years' experience.

San Diego's Megatek Corp., now a part of United Technologies, is trying to resolve its staffing shortage by rethinking its management approach, says Donald Ledbetter, personnel director. "There are a lot of tasks that don't require an engineer, but companies hire engineers for them," he contends. "Instead of having an engineer spend half his time doing paperwork, upgrade someone else to do it."

Hughes Aircraft Co., California's largest employer with more than 60,000 workers, may be an exception to the engineer-undersupply rule. Donald Diers, corporate manager for employment programs and human resources, concedes it will "be tough to hire experienced people" as more military contracts are awarded.

Yet the company's in-house training program coupled with on-site

courses given in cooperation with universities for engineering advancement has kept talent turnover low. Hughes' manager of college relations, John Wilhite, adds that these benefits, plus the fact the recession seems to have made campus recruiting less competitive, made it possible last year for the Culver City company to hire 344 EEs overall out of a total of 2,127 engineers and scientists.

Quality of new graduates is excellent, says Wilhite, noting that the company makes offers only to those with a 3.0 grade average (4.0 is the top) or higher, and looks for well-rounded types. Top BSEEs can command about \$26,000, with salaries rising about 10% annually. Hughes may be unusual, however, in that it does not expect immediate productivity from new graduates, but trains them for one or two years in such fields as radar, microwave, analog, and radio-frequency technologies.

Texas Instruments Inc. in Dallas, the subject of much-publicized recent layoffs, sees no immediate shortage of EEs, but expects that to change "in the next five to ten years," says Ralph Doshier Jr., manager of training and education. While Doshier is among those who praise the better work attitudes of new graduates, he notes that TI's training programs are "aimed directly at the middle- and lower-level people," who tend to fall behind the state of the art rather quickly. In addition to internal programs bringing those staff members up to speed, Doshier also says TI pays its engineers' tuition for advanced-degree work—the first \$300 each semester and 80% after that.

The survey by *Electronics* embraced engineering employers in Government and companies large and small—from Analog Devices Inc. in Norwood, Mass., to TRW Inc.'s operations in California—as well as makers of commercial, industrial, and military electronics, plus professional recruiters and academic leaders. The pattern of responses was that there is an engineering shortage, with the degree of severity dependent, as noted, on the engineering specialties sought by employers and location of plants. Also, there is unanimous agreement by all parties



Listening in. Aimed at easing the shortage, a House bill would provide aid to train technicians. Reps. Pete Stark (D., Calif.) and George Miller (D., Calif.) conduct hearings.



No Competition.

Now a monolithic 9-bit 40 nsec A/D converter. Just \$585.

TRW presents the state of the art.

Now, there's a monolithic 9-bit 40 nsec A/D converter for only \$585 in hundreds. TRW technology gives you the edge: Up to 10-1 power reduction over other video-speed A/D converters, and more than 2/3 size reduction; conversion up to 25 megasamples per second; highest reliability and stability; wide temperature range performance.

Using the TDC1019J is simplicity itself. A convert signal strobes 511 comparators, encodes all their binary outputs into a 9-bit word, and stores the word in an output latch. Unlike other types, our converter needs no sample-and-hold circuit. It works as a *flash converter*, and doesn't depend on tedious successive-approximation techniques. (And it's ECL compatible.)

Our new A/D converter is also available on its own standard 100 mm x 160 mm evaluation board (TDC1019EC). It's fully assembled and tested, equipped with a universal 64-pin edge connector. Using -5.2V and $\pm 15V$ power supplies,



the board accepts and digitizes a 1-volt peak-to-peak signal from 75-ohm source at up to 25 megasamples per second. (Soon to be available in IC form.)

Price for converter and evaluation board is \$885. In hundreds, just \$685. (Converter only, \$785. In hundreds, \$585. If you order only the converter, we'll enclose the pertinent data sheet/application notes to help you evaluate it on your own.) Prices are U.S. prices only.

Any way you order, you can order

with confidence and the knowledge that TRW has more experience than any other company in the design and production of high speed monolithic A/D and D/A products. (Remember our 8-bit converter? It was revolutionary then. It's now the industry standard.)

Give yourself and your company the TRW edge. Order the no-competition TDC1019J. On the board or by itself. Now in stock at Arrow Electronics and Hamilton/Avnet.

For immediate information, call 714-457-1000, or send in coupon, or just attach your business card to this ad and mail it to us.

TRW LSI Products P.O. Box 2472, La Jolla, CA 92038

E-5

Please send data sheets on the TDC1019EC and TDC1019J 9-bit A/D converter.

Name Company

Div./Dept. Mail Code

Address

City State Zip

TRW keeps you ahead in video speed data conversion.

TRW LSI PRODUCTS
An Electronic Components Division of TRW Inc.

Circle 109 on reader service card

on one point: the long-term outlook for expanding the pool of U. S. engineering talent is bleak.

Dollars and cents. The 10% shortage in engineering faculties for all disciplines is seen as worsening by everyone questioned. The median salary for an assistant professor with a Ph.D. stands at \$19,250, according to mid-1980 data assembled by the ASEE. Because BSEEs can command nearly \$26,000 to start in industry, more teachers are defecting to the commercial world with its better perquisites and research facilities. With a high-quality Ph.D. getting \$45,000 to \$50,000 in industry today, "people don't stay around," says George Turin, chairman of electrical engineering and computer sciences at the University of California at Berkeley. Moreover, fewer BSEEs are going on to get doctorates because "there is just no cost-benefit rationale."

Turin's counterparts at other universities agree. The Massachusetts Institute of Technology in Cambridge has been "trying for a year or so to recruit an assistant professor for our very large-scale integrated-circuit program, and we're just not having any luck," says Richard B. Adler, an associate department head for electrical engineering and computer science. Although Adler concedes that, by and large, MIT has been getting the faculty it needs, "finding and keeping people for non-faculty research positions" is a greater problem. Again, the academic nemeses are companies that "siphon off researchers."

Not affordable. Continuing high costs for capital as well as the faculty shortage seems to preclude any expansion of U. S. engineering schools. Deans say they not only cannot afford the investment—in part because of Reagan administration cutbacks in support of education. They also question the need for expansion because there are fewer secondary school graduates.

The last factor, also a product of a tight economy, is a result of a declining birthrate, as more wives work to make ends meet. Expansion at the University of Southern California in

Sometimes it takes 300 résumés

In the year after John D. Garcia sold his interest in Systems Engineering Enterprises of Rockville, Md., he sent out 300 résumés. "The purely technical jobs were much harder to get than they had been," he says now. "The opportunities seemed to be primarily in administration and sales." Eventually, Garcia received response to his massive mailing effort. "I got several job offers, primarily in electronics, and some in biomedicine and related technical fields that use a lot of electronic instrumentation. Virtually everyone who expressed interest was interested in my microcomputer background, so that was an important feature for every field, not just electronics fields."

Garcia has a background in applied mathematics, systems designs and engineering, and mathematical statistics, but he says, "Those skills were not nearly as useful as just straight knowledge of microcomputer technology." He advises the job-seeking engineer to "be flexible and consider other skills besides your primary ones, and look for an opportunity to apply your skills in other fields, including administration and sales or some combination of the two." Garcia adds, "Electronics is the one area that has an engineering shortage, especially in computers and telecommunications. Instrumentation and process control are probably not quite as much in demand. In production and quality control, it's very hard to compete with the Japanese, so jobs are being exported—especially in the area of consumer electronics." In his new job as director of development for Friends-Amis of San Francisco, Garcia designs hardware and software.

-Tom Moran, San Francisco regional bureau

Los Angeles is "out of the question," says William Sieier, chairman of the EE-electro-physics department.

Where will new engineering undergraduates come from? "Women," says Leo Young, the Defense Department's director of research and technical information. Young, a former president of the Institute of Electrical and Electronics Engineers, also notes that the Pentagon has earmarked \$30 million a year for the next five years to upgrade university research equipment—although academics argue that this and other Federal grants are far below the estimated \$1 billion or more that is believed to be needed.

Meanwhile, among the most delicate issues in academia, Government, and industry is that of foreign students. USC's Mel Gurstein, interim dean of engineering, sees the school's 40% foreign enrollment as a strength. They "serve a valuable purpose in research," he says, "and it cements good relationships with their native countries when they go home."

Stay on. The fact that a greater proportion of foreign students go on for engineering doctorates than do U. S. students, plus the fact that many of the foreign Ph.D.s stay on in the U. S. to teach, is an issue that divides some industry leaders. For

example, Intel's Noyce says that perhaps 25% of his company's Ph.D. engineers are foreign-born, and that Intel would be "in deep trouble" without them.

Companies and schools working on contracts with military applications or potentials point out that Federal laws prevent them from using aliens on these efforts. Indeed, IEEE gadfly Irwin Feerst says he has induced Congress to consider an amendment to legislation that would require foreign-born students to return to their homeland for at least two years after graduation to prevent them from undercutting the market for Americans seeking jobs (see "AEA sees shortage growing," p. 106).

However, Stanford University's William Kays, dean of engineering, notes that about half of his school's foreign students go on for doctorates, and that a large percentage of these stay to teach, ameliorating the faculty shortage.

More Japanese Ph.D.s are staying in the U. S. than formerly, Kays adds, but most still return home, "usually to a company that funded them." European and Middle East students also tend to return home. □

Reporting for this article was provided by Terry Costlow, Wesley R. Iversen, J. Robert Lineback, Linda Lowe, Tom Moran, and Larry Waller.



Stephen Coan
Corporate Interface Engineering
Tektronix, Inc.
Beaverton, Oregon

"If there's a better GPIB chip than TI's 9914A, we haven't found it."

Tektronix evaluated many IEEE-488 GPIB chips before specifying Texas Instruments TMS9914A General Purpose Interface Bus Adapter.

Their choice proved correct. "The TMS9914A has no known problems," Mr. Coan reports.

Saves money and space

The TMS9914A provides talker, listener, and controller all on one chip. And all for the price of an ordinary talker/listener. A mere \$16.*

"Another nice plus is that the TMS9914A can be used as a direct replacement for the TMS9914," says Mr. Coan. "No changes are required in its programming."

The TMS9914A also saves board space. It and TI's GPIB linear drivers — SN75160A and SN75161A — can be laid out with only 0.2 of an inch between them.

Versatile and fast

Ideal for use with all popular microprocessors and instrumentation applications, the TMS9914A provides a flexible unambiguous interrupt structure which separately latches all interrupts. No lost interrupts. No spurious interrupts at the end of an operation.

"The TMS9914A also is faster on the bus," Mr. Coan states. Data rates as high as 500K bytes per second are

possible using the TMS9914A.

Meets IEEE-488

IEEE Standard 488-1975, 1978, and 1980 revisions all can be met with the TMS9914A from the company that invented the integrated circuit, microprocessor and microcomputer.

With all these advantages, it's easy to see why Tektronix chose the TMS9914A.

For more information, call your nearest authorized TI distributor.

Or write to
Texas Instruments,
P.O. Box 202129,
Dallas, Texas 75220.



TEXAS INSTRUMENTS
INCORPORATED

*100-piece U.S. price,
subject to change without notice

© 1982 TI
87225

Circle 111 on reader service card

GOULD MILLENNIUM

High-performance real time emulation?

No Competition.

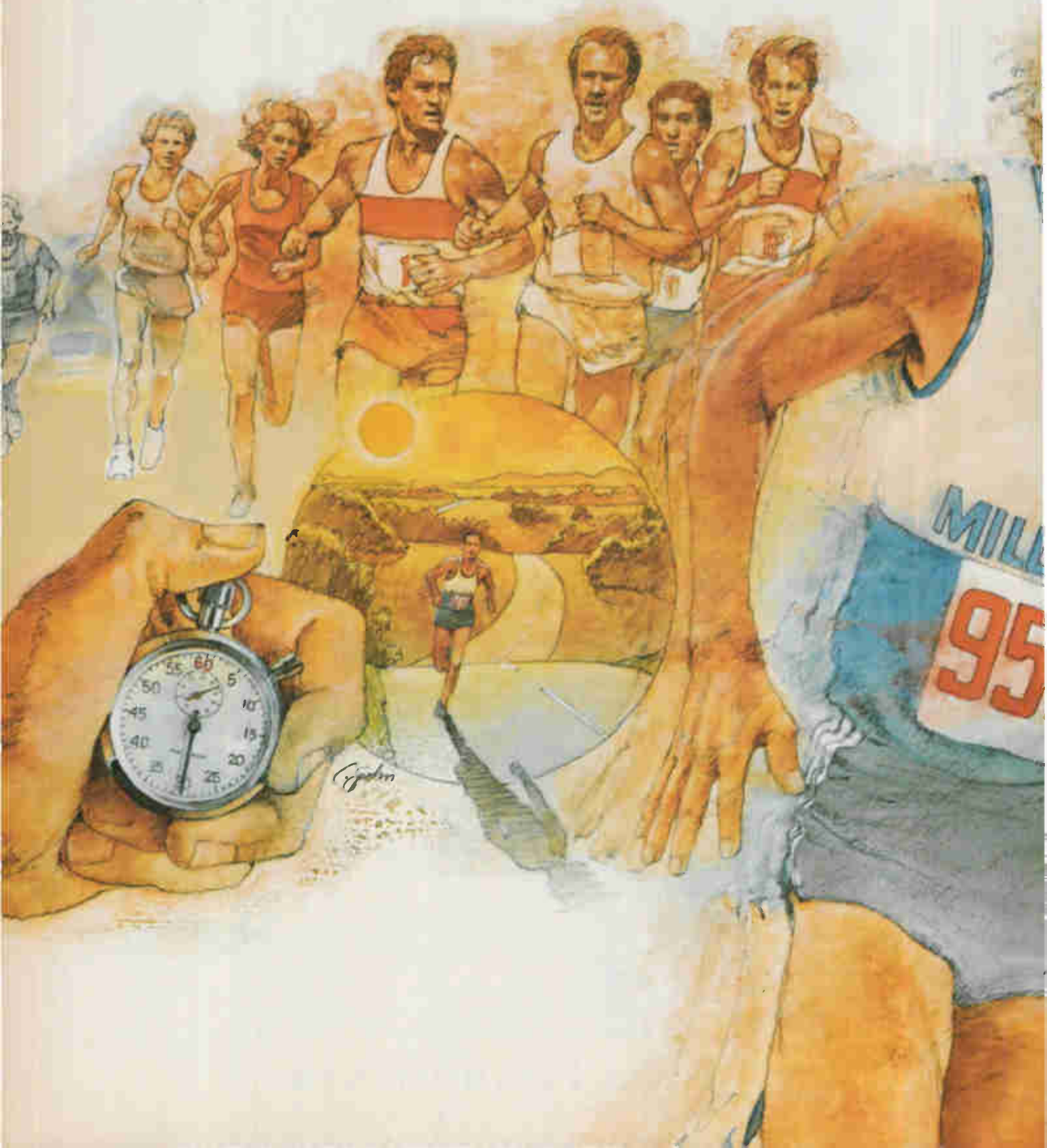

When it comes to stand-alone Multi-ICE,* Millennium's 9500 family of development tools sets the pace.

The proven winner in universal in-circuit emulation.

There are some other big names in the field, but Millennium has quietly established its undeniable leadership in universal emulation. We introduced the first universal ICE, and since then we've designed and built more types of emulators than anyone else in the business. So it shouldn't be too surprising that our 9516 integration system is leading the way as the technology moves firmly into 16-bit emulation—and beyond. After all, quality and innovation are part of Millennium's long established winning tradition.

The speed and efficiency of real-time Multi-ICE.

Just think of it. No more "wait states." We're the only company offering real-time universal emulation *all the time*. Whether or not the memory is mapped. That's one good reason no one can catch us. Here's another. Millennium's 9516 allows you to emulate up to four different 8 or 16-bit microprocessors simultaneously. That means debugging systems is a lot quicker. And most major microprocessors are fully supported with cross-software and emulators:
Z8001/02, 8086, 8088, 68000,**
8048/49, 8021/41, 8080, 8085,
8051**, Z80A, 6800, 6802,
6801/03, 68B09, 68B09E.

Powerful stand-alone analysis tools.

When it comes to analysis capability, we really sprint ahead of the pack. Our

**available soon

*ICE is a trademark of Intel Corporation, PDP-11 and VAX are trademarks of Digital Equipment Corporation.

9516 offers unlimited software breakpoints, and the extent of our capabilities in simple, complex, super and global breakpoints leaves the others in the dust. And Millennium provides so much more trace capacity and proficiency, well, it's just no contest. What's more, all of this analysis capability can be applied to up to four microprocessors at once. Without giving up a thing.

No-strain operation.

Millennium's 9500 family of development tools is the easiest to use and the easiest to learn on the market. That's no accident. We designed them with the operator's real-live needs and environment in mind. Aside from the advantages of universal, real-time, stand-alone emulation, there are some pretty impressive features that make a design engineer's life easier. Features like: soft keys and extensive human interface qualities—including a guided menu tree, full structured language capabilities and an on-line user's manual. It's easy to see how our 9508 and 9516 have won their reputation as the most user-friendly systems around.

CHALLENGE US.

We'd love the chance to show you what our 9508 and 9516 integration stations can do. Team up with your PDP-11,* VAX,* minicomputer or development system. Or better yet, let us show you head-to-head just how we outdistance the competition. We're only a phone call away: (800) 538-9320 Toll Free. (800) 662-9231 in California. Gould Inc., Millennium Instruments Division, 19050 Pruneridge Avenue, Cupertino, CA 95014.

GOULD MILLENNIUM

The standard by which everyone else measures universal emulation.



GOULD

Electronics & Electrical Products



Circle 113 on reader service card

Innovative circuit design and advanced laser wafer trimming bring you the first monotonic, monolithic 16-bit DAC.

We made it first!

Our new AD7546 is a 16-bit, voltage output D/A converter that's monotonic to 16 bits over temperature.

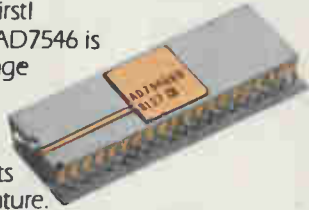

It features fast settling time ($10\mu\text{s}$ to $1/2\text{LSB}$), unipolar and bipolar operation, and low power consumption (50mW). It has an on-chip latch for easy μP interface, and even an output deglitching switch synchronized to the latch-enable signal.

And we can deliver it!

By using a novel circuit design and our exclusive laser wafer trimming technology—the only proven way to cost-effectively manufacture ADCs and DACs—we've also made the AD7546 a real high-volume production component.

If you want the high reliability, compact size, and low cost (as low as \$19 in 100's) of a true monolithic 16-bit DAC, you want it from the recognized leader in IC converter technology.

For more information and the full specifications on this advanced new DAC, contact Don Travers or Doug Grant at (617) 935-5565, or write Analog Devices, Inc., P.O. Box 280, Norwood, MA 02062.



**The AD7546.
The First Monolithic
16-Bit DAC.**

**Analog.
At the cutting edge
of technology.**

Data communications

Burroughs embraces token passing

Joining IBM in touting such local-network access control, the company calls its scheme the same but different from rival's

by Harvey J. Hindin, Communications & Microwave Editor

Burroughs Corp. has joined International Business Machines Corp. on the side of token passing as a local-network access-control scheme. With that move, the two top earners in the computer mainframe industry during 1981 have now lined up behind token passing, although Burroughs, like IBM, whose preference was made known by key personnel, has not yet officially announced its endorsement.

The Burroughs scheme, to be described at Electro/82 in Boston next week, spices the race among mainframe houses to serve the large user demanding that its data-generating and -receiving equipment, often supplied by more than one vendor, be accommodated by a local network. Also, it is imperative for computer makers like Burroughs and IBM to offer a local network to establish positions in office automation and data communications.

Robert M. Grow, manager of networks engineering at Burroughs' Danbury, Conn., operation, will tell his Electro audience that the company's patented "timed-token" approach "is entirely the same but totally different" from the IBM technique [*Electronics*, April 7, p. 37]. Though different in implementation, the two schemes are alike, he explains, because the two companies have similar needs and desires. "We are both targeted to the same basic requirement, which is the ability to efficiently integrate voice, data, facsimile and all those other things on a local network," Grow says.

The Burroughs protocol, like IBM's, is adaptable to either a physical ring network or its logical and electrical equivalent. Moreover, ac-

cording to Grow, certain portions of the Burroughs protocol are being included as options in the Institute of Electrical and Electronics Engineers Local Network Standards Committee's token bus protocol, as well as in the token ring protocol.

Like IBM, Burroughs is concerned with accommodating both voice and data on its network and makes provision for different service classes. For Burroughs, this means three classes of service with a priority relationship among them. The reason for three classes is to guarantee bandwidth when it is needed, say, simultaneously handling 64-kilobit voice service and either interactive or batch processing. All this is accomplished by adjusting the load that the network's work stations can put on the network at any instant. In this approach, transmission is controlled by the class of service that the user's work station has and the network's observation of how long the token is taking to rotate.

Since there already are a variety of ways to set up the details of a token-passing protocol [*Electronics*, May 5, p. 151], only some of which have been tested or simu-

lated in software form, it is no surprise that Burroughs and IBM part company at the implementation level. "The networks differ in what areas they are more deterministic," Grow says. "Theirs tends to be more preemptive in bandwidth, while ours is, as the IBM people describe it, more the reservation type." The basis for either the preemptive or reservation approach to bandwidth allocation is simply the problem of limiting demand so voice can be efficiently carried by the digital data packets that destroy speech continuity as they bounce around the ring.

Burroughs, IBM, and Xerox Corp., with its local network based on a collision-detection access procedure, have spent a lot of time figuring out

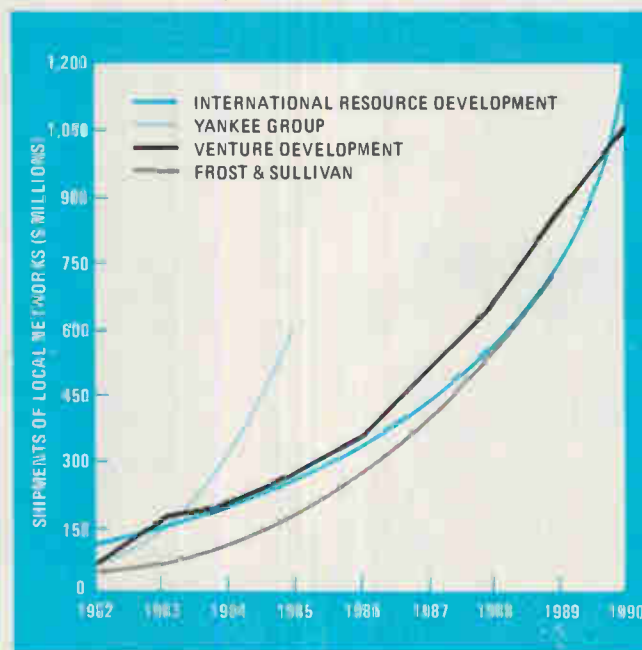

Growth galore. Though they use different criteria, four major market research firms agree that local networks—some of which will use a form of token passing—will be a big business in the next eight years.

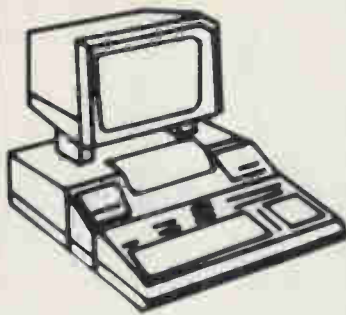

HEWLETT PACKARD

Desktop & Mini
Computer Products

SAVINGS ALL MODELS

9845B/C 9836A HP1000L
9835A/B 9826A w/Winchesters

CALL OR WRITE
FOR FREE CATALOG

digital resources Inc.

Box 23051 Portland, OR 97223 USA
503-246-0202
International Sales Telex 360-143

NEW TELEPHONE COUPLING TRANSFORMERS

NOW AVAILABLE TO
COMPLY WITH NEW
FCC PART 68



Low Profile
PC
Construction

DESIGNED FOR
VOICE/DATA
TELECOMMUNICATIONS

Request Engineering Bulletin F232 and
Complete Catalog on your Letterhead

Complete line of
AUDIO · POWER
COMMERCIAL · MIL
Transformers

IMMEDIATE DELIVERY
FROM DISTRIBUTORS



MICROTRAN

COMPANY INC

145 E. Mineola Ave. Valley Stream, N.Y. 11582

Probing the news

how to accommodate voice. Xerox has gone public with its thoughts on this subject [*Electronics*, Dec. 15, 1981, p. 44] but IBM has only talked informally about "a central box which does allocation of circuits for voice," according to Grow. Simply put, both Burroughs and IBM need to be able to throttle the synchronous or voice calls as necessary. This will be done much the way a private branch exchange does the job—using a technique known as blocking so that a call simply cannot be made.

The operation of the Burroughs timed-token protocol has been neatly summed up by Thomas J. Harrison, manager of advanced software engineering technology at IBM in Boca Raton, Fla., in his *Electro/82* paper on the progress of the IEEE committee. A set of stations on the ring is guaranteed a certain percentage of the maximum number of bytes that can be transmitted on a rotation of the token around the ring. Moreover, due to the presence of what is known as a token-holding timer on the ring, the maximum rotation time (maximum bytes allowed per rotation) is fixed. The maximum number of bytes allowed is equivalent to the bandwidth of the ring. As Burroughs has it, one synchronous and two different asynchronous classes of service—number of bytes that can be transmitted in a given time—are allowed.

A synchronous station (the most important priority) may transmit up to a predetermined number of bytes whenever it has the token. By knowing the maximum number of such stations and their limitations on bytes that are allowed to be transmitted, as compared to the bandwidth, a minimum bandwidth percentage can be guaranteed and shared by each station.

Sharing leftovers. Any remaining system bandwidth, plus any that the synchronous stations are not using, is shared by stations in the two asynchronous classes. This allocation is based on a simple assignment and counting scheme—the station can transmit only if there is a space for transmission in its byte quota.

According to Harrison, the differ-

ence between the two asynchronous classes is one of priority. Thus, under heavy transmission loads, some asynchronous stations may not receive a fair share of what is nominally assigned to them. This depends on their position in the logical ring. But, again according to Harrison, short-changes are not much of a problem since the service requirement for this lowest class of service is defined to be noncritical.

Harrison will also say that "broadband transmission schemes are not applicable to the ring token-passing network." It is no wonder then that the 4-megabit-per-second IBM token-passing network is a base-band scheme, as Burroughs' first product will be. According to the proposals now before the IEEE committee, such a network could be implemented in a 150-ohm shielded twisted-pair cable or a 75- Ω coaxial cable system.

Unlike IBM, which has published test results showing that its token scheme can function at 4, 8, or 16 Mb/s, Burroughs has released no test data. It will only say, in Grow's words, that the protocol "is suitable for implementation over a broad range of speeds." It seems clear, however, that once a product is forthcoming from Burroughs, it is likely that the speeds accommodated will be similar to those that IBM can handle. IBM feels that 4 Mb/s is quite enough for now and, as mentioned earlier, both companies are looking at the same market.

There is yet another development to come. The reliability of a token-passing protocol is always open to question since the all-important token recovery in the event of a crash is difficult. For its part, IBM has made much of its protocol reliability and has spent much time verifying its software at the IBM Zurich Research Laboratories in Switzerland. By contrast, Grow would not comment when asked what has been done to check the behavior of the Burroughs protocol. He did say that recovering from the loss of the token "is a simple procedure involving what amounts to each station on the ring bidding for the token." In this approach, the station with the highest address simply generates the new token. □

Technological leadership.

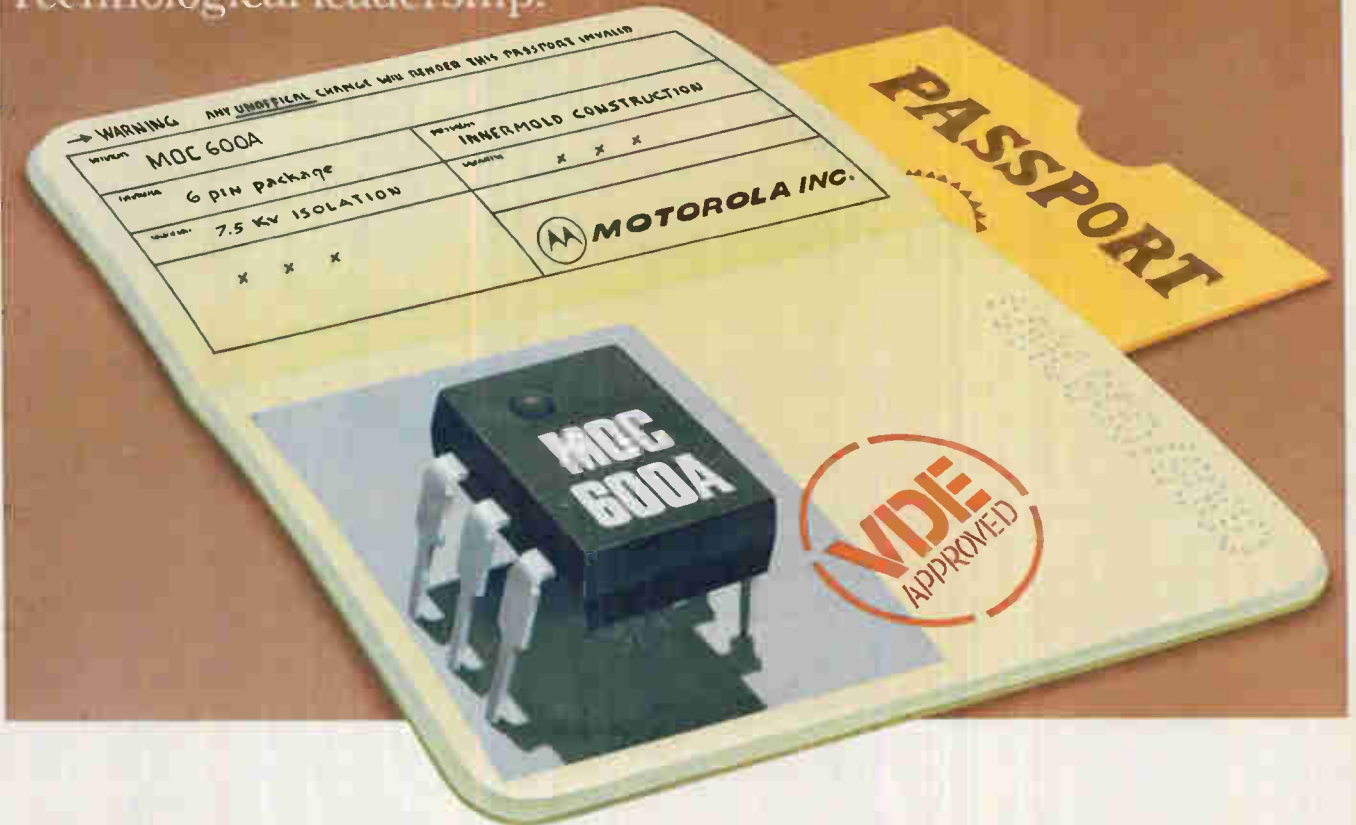

Open up European applications with Motorola VDE-approved optocouplers.

If you've been production-stymied by lack of optocouplers specifically designed for European import — Motorola now has the answer. The MOC600A series that meets creepage and clearance distances in VDE specs.

This much-sought-after designation, similar to the USA's UL stamp, demands that stringent acceptance criteria in coupler construction, materials, conductor separation and environmental testing be met before approval is granted.

Motorola has a 6-pin DIP package that meets a variety of VDE safety classifications from appliances to alarms... radios, TV, games, organs, manufacturing/processing machines, electrical

trains, electromedical and telecommunication equipment, railroad signals, fire and burglar alarms.

The MOC600A series fills the needs for European design in the same, standard package that contains our other leading-edge coupler technology — Triac drivers with and without zero-crossing, 7.5 kV isolation, UL-recognition, and unique, electrically and mechanically-stable innermolds.

Contact Motorola Semiconductor Products, Inc., P.O. Box 20912, Phoenix, AZ 85036 for data on couplers with more for European

*Innovative systems
through silicon.*

Series	CTR %	BV _{CEO} Volts
Transistor Output		
MOC601A	10	30
MOC602A	20	30
MOC603A	50	30
MOC604A	100	30
Darlington Output		
MOC622A	100	30
MOC623A	300	30
MOC624A	500	30
MOC625A	1000	30
Series	I _{FT} mA	V _{DRM} Volts
Triac Driver Output		
MOC633A	30	400
MOC634A	15	400
MOC635A	10	400
Zero-Crossing Triac Driver Output		
MOC640A	30	400
MOC641A	15	400



MOTOROLA INC.

TO: Motorola Semiconductor Products Inc., P.O. Box 20912, Phoenix, AZ 85036.

Please send me information on VDE-approved couplers.

119 ELEX 5/19/82

Name _____

Title _____ Tel.: (____) _____

Company _____

Address _____

City _____

State _____ ZIP _____

Instruments

Disk-drive boom opens new market

New companies lead the way in development of testers that perform a variety of checks semiautomatically

by Terry Costlow, Costa Mesa bureau

With disk-drive sales soaring and no end in sight, a number of small companies are betting their futures that testing these drives will be a lucrative way to ride the coattails of the boom. Testing floppy- and Winchester-disk drives has always been a narrow niche for a few firms, and now they are broadening their marketing and product lines. At the same time, new companies and research and development houses are looking to cash in.

The increasing interest stems from several factors. The sheer number of drives already in the field and being shipped obviously means more breakdowns. A heavier emphasis on reliability, coupled with the elevating cost of shipping and reworking faulty devices, makes testing a cost-effective way to prevent defective units from leaving the factory. "The value of drive testing increases directly with the number of drives in the field," notes Steve Mattos, who heads testing at Seagate Technology, Scotts Valley, Calif.

In past years, manufacturers have relied on in-house equipment and simple drive exercisers and oscilloscopes, equipment also used by many systems houses and original-equipment manufacturers for incoming tests. The new firms say they offer a cheaper way to handle these operations with a minimum investment also of time, offering quicker auditing with more complete results.

Everyone has his own version of the difference between dumb exercisers,

which have been around for years, and automatic testers. However, most agree that the new generation of testers consists of microprocessor-based equipment designed to perform a wider variety of tests with a minimum of user intervention.

The systems check tasks like seek, read, write, and head movement. In the read section, common tests may include alternate reads, read-after-write recovery time, and read with a pattern. Criteria in such tests include timing and accuracy.

While all the firms in the market obviously feel it will be lucrative, they are leery about estimating total market value, although \$10 million is generally considered a generous total for 1981. In contrast, seven-month-old Qubex Associates Inc. of Santa Clara, Calif., predicts \$15 million for 1983.

"Our original analysis told us not to get into the market," recalls Robert Koontz, president of Cambrian Systems Inc., a Westlake Village, Calif., firm that, despite the warning, stepped in to broaden its product line of equipment for the disk indus-

try. "But in the first 60 days, we exceeded our first two years' sales projections." Two years after that initial entry, the firm is still trying to figure out how to analyze the market potential of what has to be ranked a primary product.

One of the first companies to enter the field was Applied Data Communications, Tustin, Calif., which came out with a desk-sized setup for testing floppy-disk drives in 1974. Applied Data's entry was unplanned. "We backed into it because we had no way to test our own floppies," remembers president Pat Kane. Now the line is the hallmark of the \$5 million company's sales.

More carefully. New firms across California are now entering less haphazardly. The first product from Brikon Inc. in Laguna Hills was a Z80-based family of portable floppy-disk-drive testers priced between \$1,980 and \$3,650, whereas Qubex Associates is targeting Winchester-disk drives with its new 30-pound box—a \$10,950 unit with five microprocessors [*Electronics*, April 7, p. 239]. Pioneer Research Inc. of Santa Monica has made a variety of equipment for disk manufacturers, but moved into intelligent testers with its \$3,795 Qualifier early this year. Applied Circuit Technology, a Brea R&D house that designed Seagate's equipment, has recruited a marketing staff and plans to sell its equipment to other manufacturers.

With the exception of Applied Circuit Technology, all those companies feel their products fit the needs of a variety of users. Qubex president Donald Kelley estimates the breakdown for his products is about 25% to drive manufacturers, 60% to

Looking ahead. At Qubex Inc., founded by Donald W. Kelley, left, Michael Juliff, and C. T. Cheng, not shown, the prediction is for a market worth \$15 million next year.



Perfection

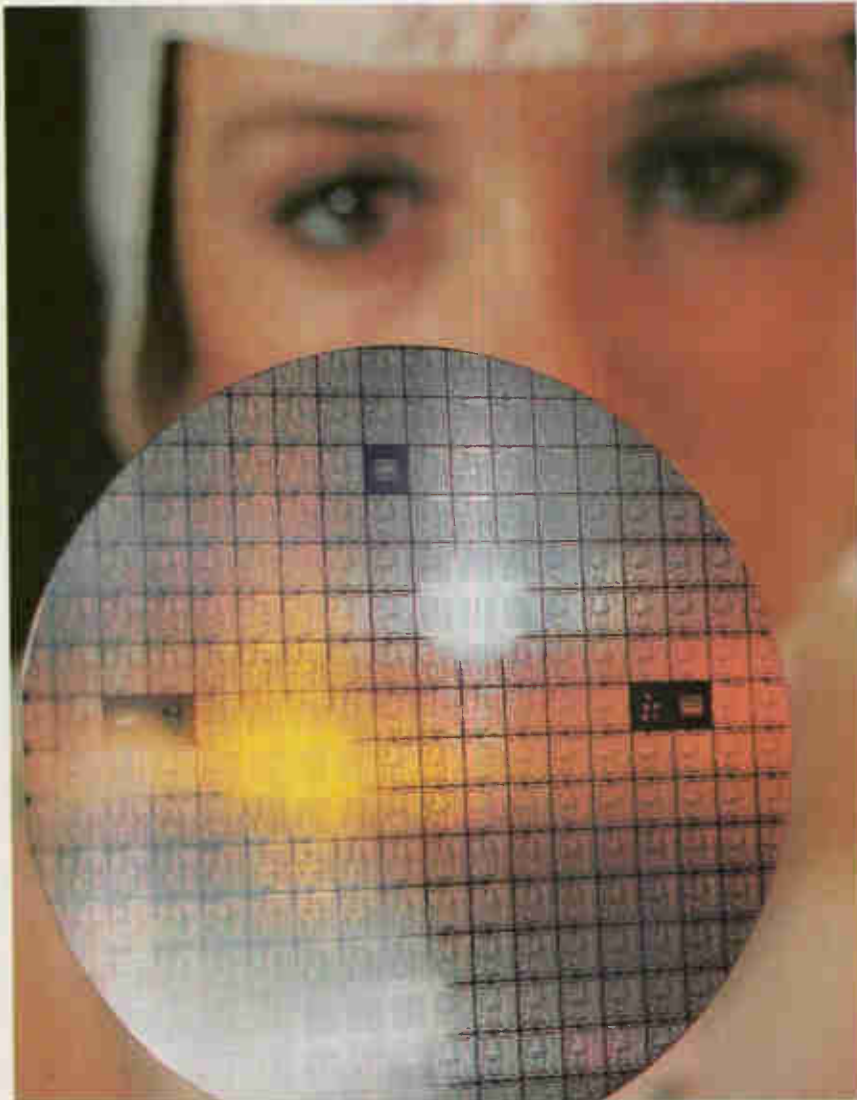

...That's what you can expect from our ROM family.

Uncompromising attention to detail, including quality levels of 650 PPM, plus state-of-the-art technology give General Instrument 16K, 32K and 64K ROMs the reliability and service that proves itself with every performance.

What's more, our QTP (Quick Turn-around Production) program guarantees "volume production" in 4 to 6 weeks, a service made possible by the size and scope of our world-wide facilities.

Naturally, as the industry's largest manufacturer of masked ROMs, we can afford to be price-competitive. In other words, our ROMs will give you quality and service at low cost. Isn't that the name of the game?

The RO-3-9364 64K ROM, very latest in our memory family, is ideally suited for CPU memory applications. Fabricated in our advanced silicon gate process, it provides the best combination of high performance, large bit storage and simple interfacing. It's edge-activated, allowing a maximum access time of 300ns with low power dissipation. And it's compatible with the MK 36000.

It makes good sense (and dollars, too) to use General Instrument ROMs. Consider the advantages — quality, service, price and don't forget our ROMs are pin-compatible replacements for your EPROMs too! Call the Microelectronics Division, office nearest you for more information and assistance.



GENERAL INSTRUMENT

Sales Offices USA: CA, 213-322-7745 or 408-496-0844; FL, 813-577-4024;
GA, 404-588-1375; IL, 312-981-0040; IN, 317-872-7740 or 219-291-0585;
MI, 313-391-4070; MD, 301-269-6250; NH, 603-424-3303; NY, 516-733-3107; TX, 214-934-1654;
EUROPE: London, 01-439-1895; Munchen, (089) 27 24 049; Paris, (1) 365 72 50;
ASIA: Hong Kong, (5) 434360; Tokyo, (03) 473-0281.

**We help you
compete.®**

Circle 119 on reader service card

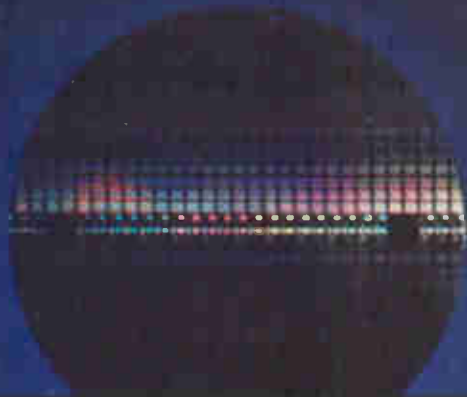

CMOS Gate Array and Bipolar Master Slice Technology

STC Microtechnology offers rapid product development cycles, simplified design methods and competitive pricing structures for semi-custom LSI.

CMOS Gate Array

- Advanced silicon gate two-level-metal technology
- 300-block & 960-block configurations
- Totally automatic placement and routing

Bipolar Master Slice

- 'Macro Cell' design approach (Op Amp, VCO, Comp Macros available)
- High-speed technology
- Easy-to-use design layout sheets

Take advantage of Microtechnology's total in-house capability---from design through final testing---for fast engineering turn-around time.

For more information, call Lori Hiatt at STC Microtechnology; (303) 673-4307. She can help you put CMOS gate array or bipolar master slice in your products.



MICROTECHNOLOGY

A Subsidiary of Storage Technology Corporation

2270 South 88th Street / Mail Drop G1
Louisville, Colorado 80027

Probing the news

OEMs and systems houses, and 15% to field-service companies.

Systems houses agree that they are prime targets. One system integrator, which goes through 500 floppy- and 300 Winchester-disk drives each month, says incoming testing is mandatory. "At this volume, it will pay for itself in just one or two months," says an official of that company describing his \$14,000 automatic tester from Applied Data.

Look afield. Testing outfits are also eyeing the increasingly important field-service market [*Electronics*, April 7, p. 110]. Although Applied Data and Cambrian believe their units are best suited to depot-level work, the others note that portability of their testers permits field work as well. A recent wrinkle now common to most products, which should be a big plus, is a single tester that checks a variety of drives using the same interface.

Even though these two areas of demand appear to be ready for quick and simple machines to audit quality, some drive manufacturers are hesitant to embrace commercially available units. Those who have developed their own systems did so to get around the slower throughput they claim they have experienced with the systems produced by the independents, most of which test drives sequentially rather than in parallel. Other drive makers claim the commercial units are simply not reliable enough to test the output of two daily shifts over the long haul.

Maker's response. The vendors counter that their products will hold up, but as for parallel testers, Applied Data's chief engineer, Jerry Ruoff, notes they will inevitably cost more. "We can get multiple data paths [for parallel operation], but it will double the complexity of the system, and it takes more complex programming, too," he explains.

The relatively costly system used by Seagate bears this out. A basic system listing for \$150,000 will test 10 drives at once, with easy expansion to 100. Applied Circuit Technology feels this product will fit the manufacturers' needs better than a number of lower-priced units. □

THANKS TO US, IT'S CLEVER.

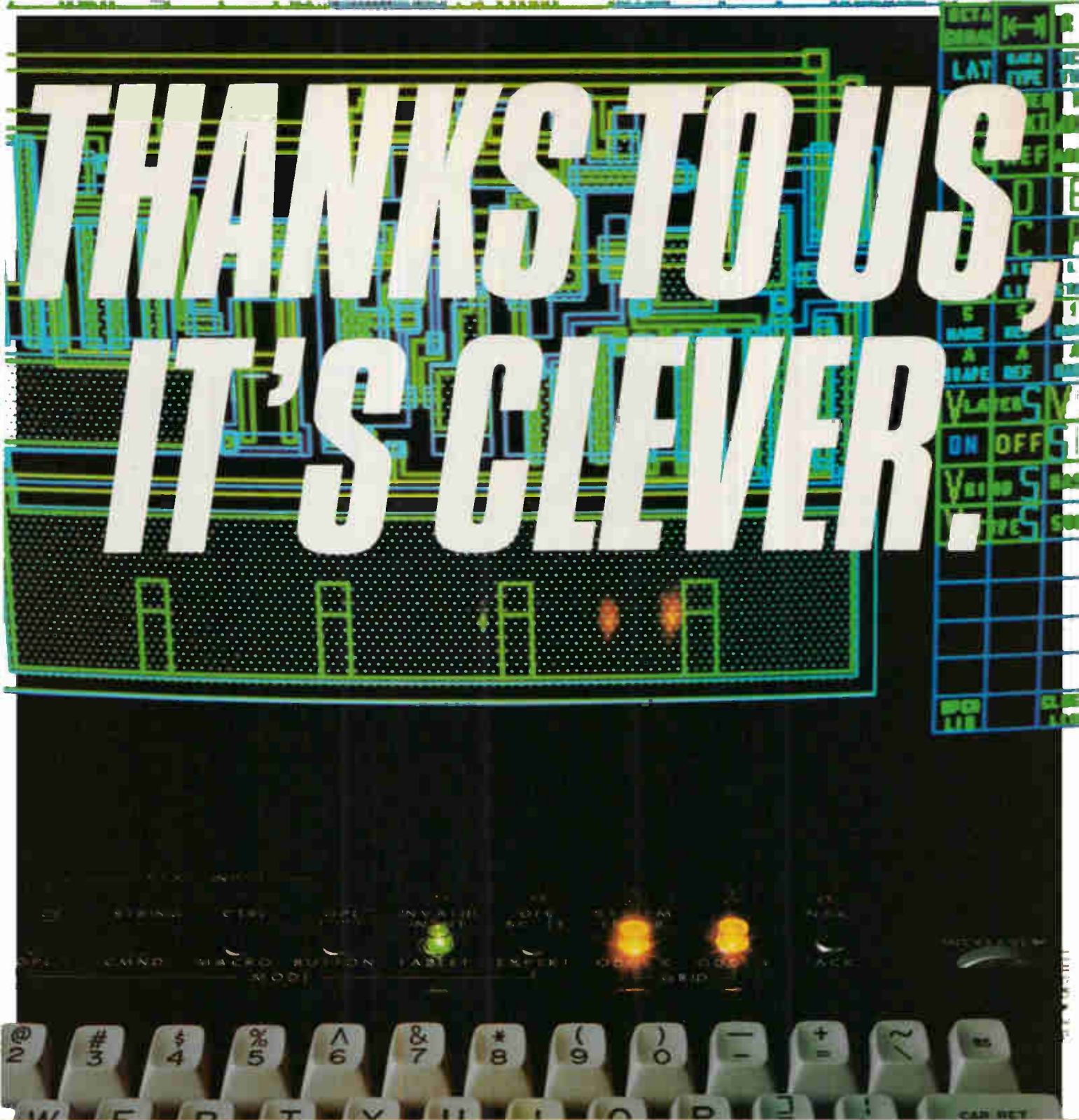

Memories, microcomputers, microcontrollers, microprocessors —for aerospace, military, automotive, data processing, office of the future, telecommunications...Technology: MOS/CMOS—VLSI.

EUROTECHNIQUE 
Progress takes dedication

For further information, please contact : International and french Sales Offices : 3 place Gustave Eiffel — Silic 209 — 94518 RUNGIS CEDEX — FRANCE — (1) 687.23.03 / Eurotechnique Sales Offices : WEST GERMANY — Munich — TEL : 89.50.50.88 / U.K. — Romford (Essex) — TEL : 708.27.488 / Distributors : FRANCE-ALMEX (Antony) (1) 666.21.12 / COMPOSANTS S.A. (Pessac) (56) 36.40.40 — (Toulouse) (61) 20.82.38 — (Poitiers) (49) 88.60.50 — (Rennes) (99) 54.01.53 / DISCOM (Aix-en-Provence) (42) 60.01.77 / ISNARD-DEBELLE (Seyssinet) (76) 49.14.49 / R.T.F. DIFFUSION (Paris) (1) 531.16.50 / SANELEC (Marq-en-Barœul) (20) 98.92.13 / S.C.A.I.B. (Rungis) (1) 687.23.13 / BELGIUM — J.P. LEMAIRE (Brussels) (2) 478.48.47 / CANADA — FUTURE ELECTRONICS (Pointe Claire, Quebec) (514) 694.77.10 / DENMARK — E.V. JOHANSEN ELECTRONIK A.S. (Copenhagen) (1) 83.90.22 / SPAIN — SEIESA S.A. (Madrid) (1) 456.11.61 / FINLAND — NABLA ELECTRONIikka OT (Tapiola) (90) 46.28.29 / ISRAEL — M.R.B.D. (Ramat Gan) (3) 73.98.65 — 72.23.62 — 72.19.18 / ITALY — EMESA S.A. (Milan) (2) 86.03.07 — 87.91.55 — 86.90.616 / NETHERLANDS — DIODE B.V. (Utrecht) (030) 88.42.14 / SWEDEN — BEXAB ELEKTRONIK AB (Taby) (08) 768.05.60 / SWITZERLAND — ROMOS ELEKTRONIK A.G. (61) 98.22.54 / U.K. — BEAM COMPONENTS LTD (Rochester, Kent) 634.79.821 — CAMPBELL-COLLINS (Stevenage, Hertfordshire) 438.69.466 — STEATITE INSULATION LTD (Birmingham) (21) 454.69.61 / U.S.A. — FUTURE ELECTRONICS (Boston, Massachusetts) (617) 366.24.00 / WEST GERMANY — ELECTRONIC 2000 (Munich) (89) 43.40.61 / Headquarters and Factory : Eurotechnique — B.P. N° 2 — 13790 ROUSSET — FRANCE — TEL. : (42) 23.98.01 tlx : 440.306 F

Circle 121 on reader service card

Standard-B INTELSAT earth station at Cancun, Mexico

STANDARD-B EARTH STATION COMPLETED WITHIN TWO MONTHS

Only two months were allotted for the construction of the Standard-B INTELSAT earth station at Cancun, Mexico. NEC met this tight schedule and helped the Mexican telecommunications authority prepare for the "North-South Summit" held in October, 1981.

Although Mexico already had two Standard-A INTELSAT earth stations—also supplied by NEC—the new station was needed to handle the large volume of communications traffic generated by the conference, which was attended by over twenty heads of state.

NEC is the world's No.1 supplier of INTELSAT earth station systems, with 156 supplied on a total plus partial system supply basis as of November 30, 1981. When DOMSAT, TVRO, IN-MARSAT/MARISAT, higher frequency, transportable and mobile stations are also included, the total supply figure is 513 on a total plus partial system supply basis.

Satellites and onboard equipment have also been manufactured by NEC. Among these are most of Japan's applications satellites and all scientific satellites and, in collaboration with the Hughes Aircraft Company, the transponders of the INTELSAT IV and IV-A satellites now in orbit. Moreover, a recent NEC achievement, 20/30GHz and 30/35GHz transponders, promises to relieve the frequency congestion that exists in lower frequency satellite communications.

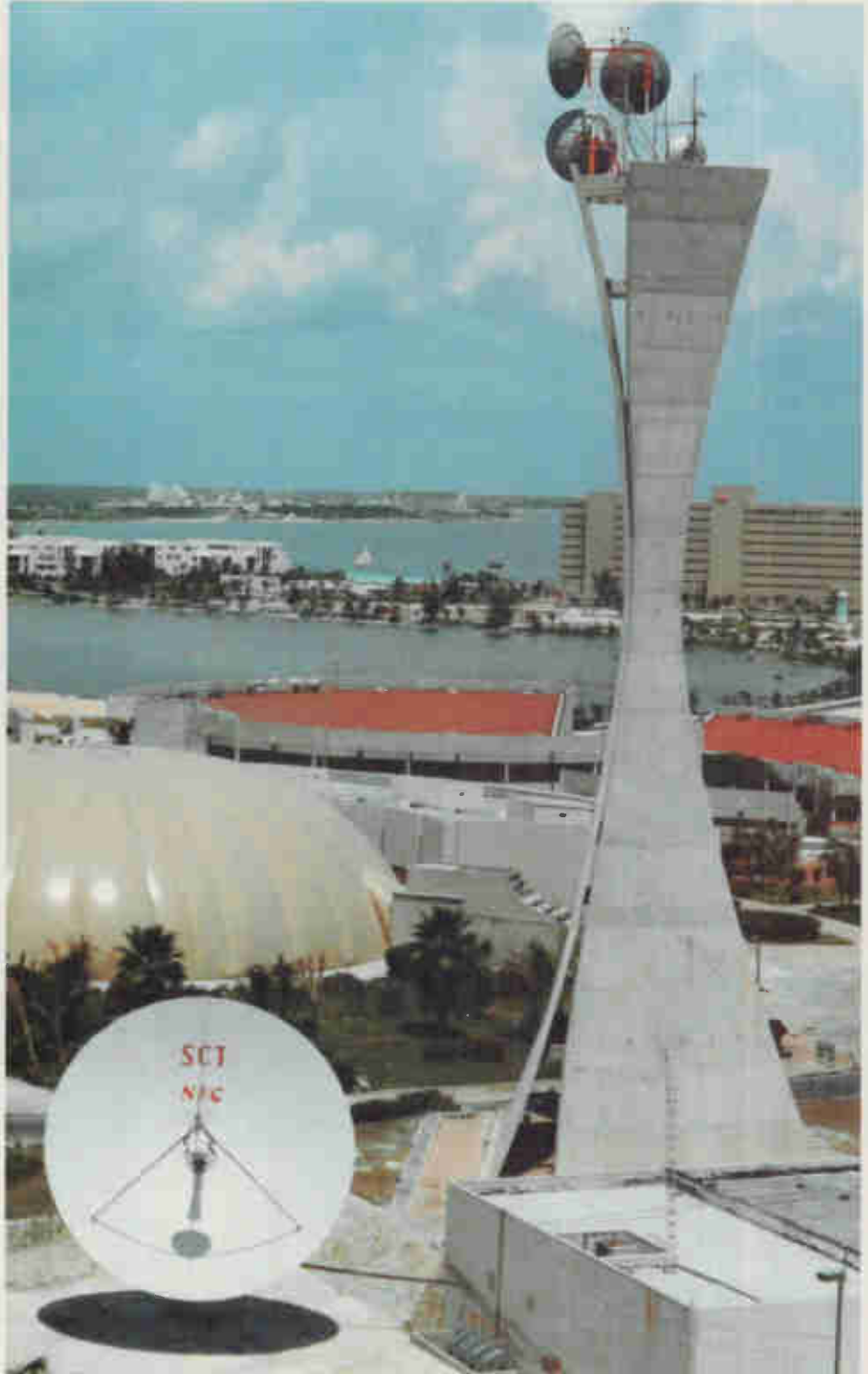

NEC-EQUIPPED CRAFT DIVES TO RECORD DEPTH

By reaching a depth of 2,008 meters, a deep submergence vehicle has set a new Japanese diving record.

The Shinkai 2000, built for the Japan Marine Science and Technology Center, is 9.3 meters long, 3 meters wide, and weighs 24 tons. Its globular pressure hull is made of 3 cm thick super-high tensile strength steel to protect two pilots, one researcher, and electronic equipment from extreme water pressure.

NEC was responsible for integrating the control console of the Shinkai 2000. NEC also supplied underwater telephones, altitude/depth sonar, forward obstacle avoidance sonar, acoustic direction finders, a transponder and an emergency pinger.

The 1,553-ton support ship was also NEC equipped, with a precision depth echo sounder, high resolution side-scan sonar, and underwater telephones.



The Shinkai 2000 will be used to collect data for prediction of underwater earthquakes, to study deep sea plants and animal life in Japanese waters, and to explore for mineral resources within the deep sea bed.

NEW STAND-ALONE 8-BIT MICROCOMPUTER USES LESS POWER

A new CMOS stand-alone 8-bit microcomputer contains all the necessary functional blocks: 1 k byte ROM, 64 byte RAM, 27 I/O lines, on-chip 8-bit timer/event counter, and clock generator.

Compatible with industry standard NMOS 8048 and 8748 products, the CMOS μ PD80C48 reduces power consumption significantly. And its "Halt" and "Stop" modes further augment power conservation.

In the "Halt" mode, internal clocks and logic operations are discontinued. The oscillator, however, continues to function and all internal logic and

control status prior to "Halt" mode engagement are maintained. Power consumption under this mode is less than 10% of that during normal operation and less than 1% of the power needed for the 8048 operation.

The "Stop" mode saves even more power by discontinuing oscillator operation and retaining only the contents of the RAM.

The μ PD80C48 may also be employed together with other CMOS devices including I/O expander μ PD82C43 and memories.

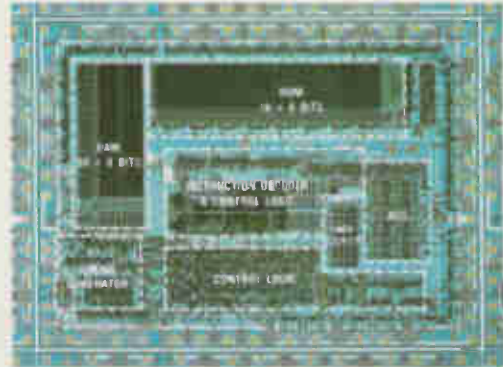

TELECONFERENCES GO BETTER WITH NETEC-X1

Enhanced teleconferencing is promised by NETEC-X1, a television interframe codec that converts NTSC color television signals with audio into low bit rate digital signals of 1.544Mbps.

NEC's new product has a data compression ratio as high as 1/40th of the conventional rate, so transmission cost is greatly reduced. In spite of this, NETEC-X1 reproduces pictures with excellent quality. The essential feature of the system is that it transmits only the difference between two

picture frames through a unique interframe coding.

On the audio side, the system uses a broader band for signal transmission than that of telephones, so that subtle vocal nuances can be discerned.

The NETEC-X1 can also be connected with coaxial PCM transmission links, terrestrial digital microwave links and TDMA satellite links.

NETEC-X1 applications other than teleconferencing include educational television, traffic or security control and remote medical diagnosis.

NEC

Nippon Electric Co., Ltd.
P.O. Box 1, Takanawa, Tokyo, Japan

“I believe the CRT 9007 VPAC™ is one of the most important developments in CRT system design in the last decade.”

Paul Richman, President, Standard Microsystems Corporation



The next generation of IC video processor/controllers for CRT systems is here. The new MOS/MSI Video Processor and Controller (VPAC™) from Standard Microsystems provides the most powerful CRT Controller available, reducing both the hardware and software required for video control.

The CRT 9007 VPAC™ represents an evolution in display-system design.

It provides a long list of distinguishing features:

Versatile software implementations to help ease the processor software burden.

- Variable speed partial page smooth scroll operation in both directions.
- Double height/double width data row display.
- Multiple memory contention schemes permitting an efficient tradeoff between processor and display system access to memory.
- Flexible attribute handling.
- Flexible video timing circuitry to enable operation with a wide variety of CRT monitors.
- Split screen operation.



These represent only seven of the over twenty functions the CRT 9007 VPAC™ performs within the CRT system. For a complete list and detailed technical data on this important

development and how it can help put you ahead of your competition, call or write us today. We're Standard Microsystems,  the one to watch.

STANDARD MICROSYSTEMS

35 Marcus Boulevard, Hauppauge, NY 11788/516-273-3100

SLASH SYSTEM POWER



SUPPLY COSTS BY HALF

USE MITEL ISO-CMOS™ MD74SC... OCTAL INTERFACE SERIES AND REMEDY THOSE POWER DISSIPATION HEADACHES.

Mitel 74SC... Octal Interface series brings enormous cost savings to your application by slashing power dissipation right down to the bone. Reduced dissipation allows smaller, low cost power supplies, increased packing density, and the elimination of fans and cooling systems.

Mitel ISO-CMOS Octal Interface circuits give an immediate plug-in advantage. Each replacement

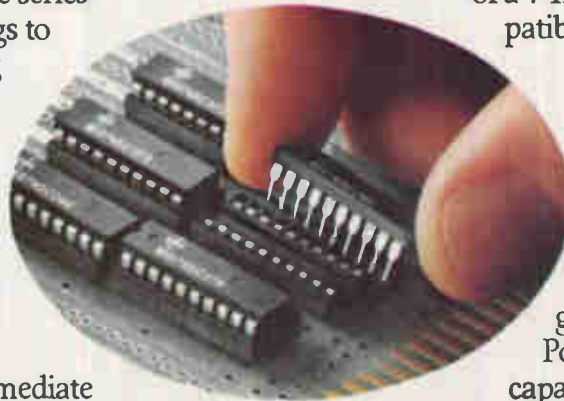

of a 74LS device with a TTL compatible MD74SC series component dramatically reduces quiescent dissipation, from hundreds of milliwatts to micro-watts. Mitel ISO-CMOS technology allows this power saving, while maintaining propagation delays similar to Low Power Schottky with outputs capable of driving in excess of 5 standard TTL loads.

A wide selection of functions combined with a choice of pinouts are available to suit your design needs. For bus oriented designs, MD74SC5.. types offer pinouts which simplify board layout.

MD 74 SC 137 1 of 8 Inverting Decoder with input latches
MD 74 SC 138 1 of 8 Inverting Decoder
MD 74 SC 139 Dual 1 of 4 Inverting Decoder
MD 74 SC 237 1 of 8 Decoder with input latches
MD 74 SC 238 1 of 8 Decoder
MD 74 SC 239 Dual 1 of 4 Decoder
MD 74 SC 240 Octal Inverting Buffer
MD 74 SC 241 Octal Buffer
MD 74 SC 244 Octal Buffer
MD 74 SC 245 Octal Transceiver
MD 74 SC 373 Octal Transparent Latch

MD 74 SC 374 Octal D-Type Flip Flop
MD 74 SC 533 Octal Inverted Output, Transparent Latch
MD 74 SC 534 Octal Inverted Output, D-Type Flip Flop
MD 74 SC 540 Octal Buffer
MD 74 SC 541 Octal Buffer
MD 74 SC 545 Octal Inverted Output, Transceiver
MD 74 SC 563 Octal Inverted Output Transparent Latch
MD 74 SC 564 Octal Inverted Output, D-Type Flip Flop
MD 74 SC 573 Octal Transparent Latch
MD 74 SC 574 Octal D-Type Flip Flop

When you specify Mitel MD74SC... Octal Interface Series, you get the world-wide service of stocking distributors backed up by Mitel sales and application support. Ready availability is ensured by licenced second sources. Get in on the savings. Contact your local Mitel sales office.



MITEL SEMICONDUCTOR

United States: 2321 Morena Blvd., San Diego, California, 92110.
Telephone (714) 276-3421. TWX: 910-335-1242.
1223 Westchester Pike, Haver town, Pennsylvania, 19083.
Telephone (215) 449-5556. TWX: 510-662-6653.
14330 Midway Rd., Dallas, Texas, 75234.
Telephone (214) 387-5581. TWX: 910-860-9263.

Canada: P.O. Box 13320, 360 Legget Drive, Kanata, Ontario, K2K 1X5.
Telephone (613) 592-5630. TLX: 053-3221.

TM Trademark of Mitel Corporation
Copyright 1982 Mitel Corporation

Europe: 33/37 Queen St., Maidenhead, Berkshire, England SL6 1NB
Telephone 0628-72821. Telex: 51-849-808.
Bredgade 65A, 2nd Floor, 1260 Copenhagen K, Denmark
Telephone (01) 134712. Telex: 19502.

Asia: Young Ya Industrial Building,
Block A&C, 16th Floor,
381-389 Sha Tsui Rd., Tsuen Wan, Hong Kong,
Telephone 0-463641-6. TLX: 34235.

BUILDING BETTER COMMUNICATIONS

Circle 127 on reader service card

"Old Reliable" introduces a powerful new microprocessor.

RCA's new 1805 gives you all the 1802 features plus a whole lot more.

The CDP1805 microprocessor uses the register-based architecture of the most popular CMOS microprocessor in history: the 1802.

It's a direct plug-in replacement for the 1802 and 1802A, but its design enhancements give you even better performance. You get a 64-byte RAM for program instructions or data, 22 additional instructions, an 8-bit pre-

settable down-counter with a division by 32 prescaler, event counter mode and pulse width mode.

Our other new microprocessor, the CDP1806, has everything except the RAM. Both are capable of 4 MHz clock, while using less than 25 mW from a 5V supply.

You'll achieve significant chip count reductions, and save execution time and memory space.

For example, the call and return instructions execute four times faster than the routines on the 1802A. And

four new instructions provide direct 16-bit data transfer between internal registers and external memory.

These new microprocessors are supported by a large and growing family of I/O devices, RAMs, ROMs, high-level languages and development systems. Plus full technical support from the people at "Old Reliable." And remember, we're the people who invented CMOS.

For more information, contact any RCA Solid State sales office or appointed distributor.

RCA Solid State headquarters Somerville, NJ Brussels Sao Paulo Hong Kong

Circle 128 on reader service card

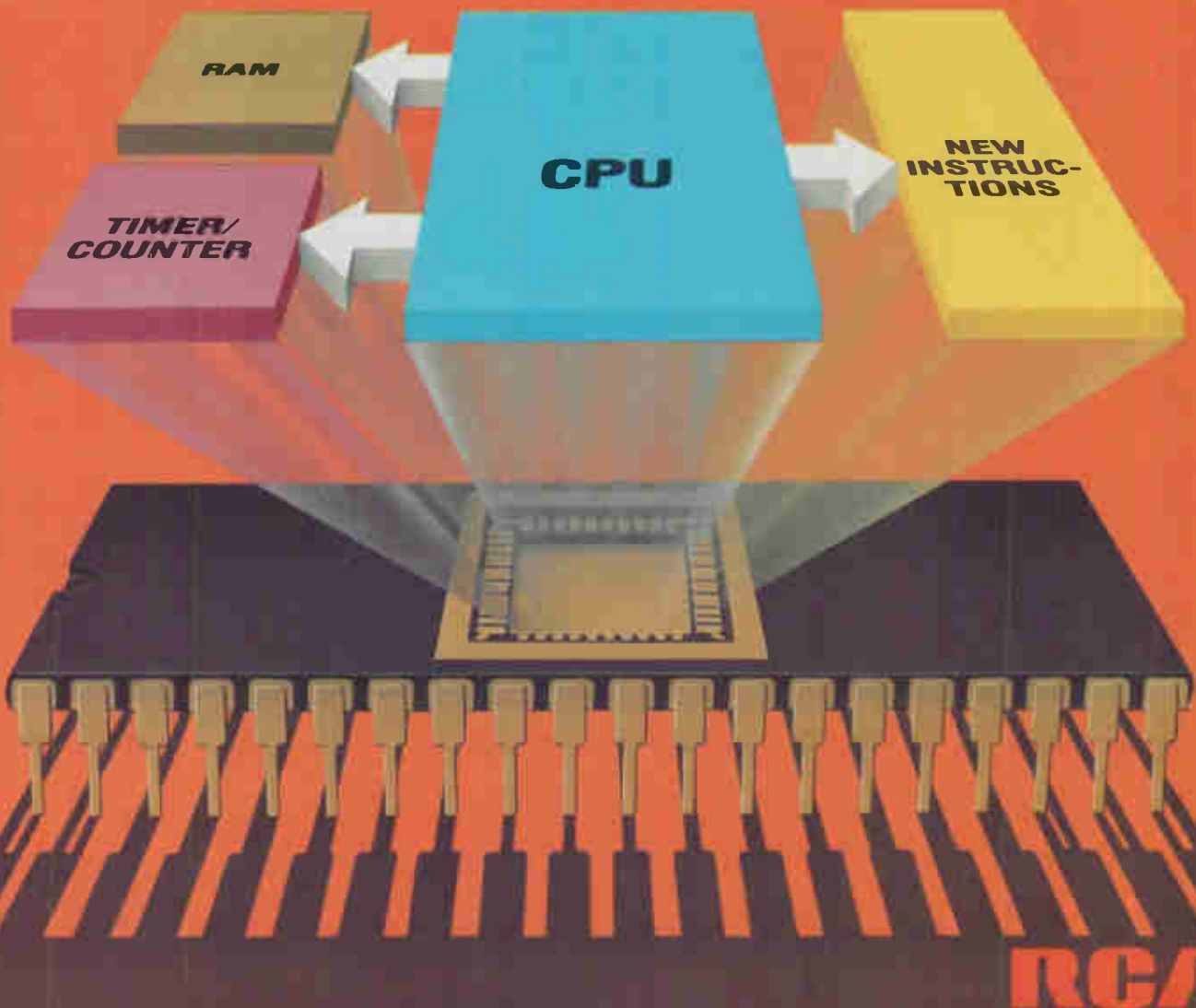

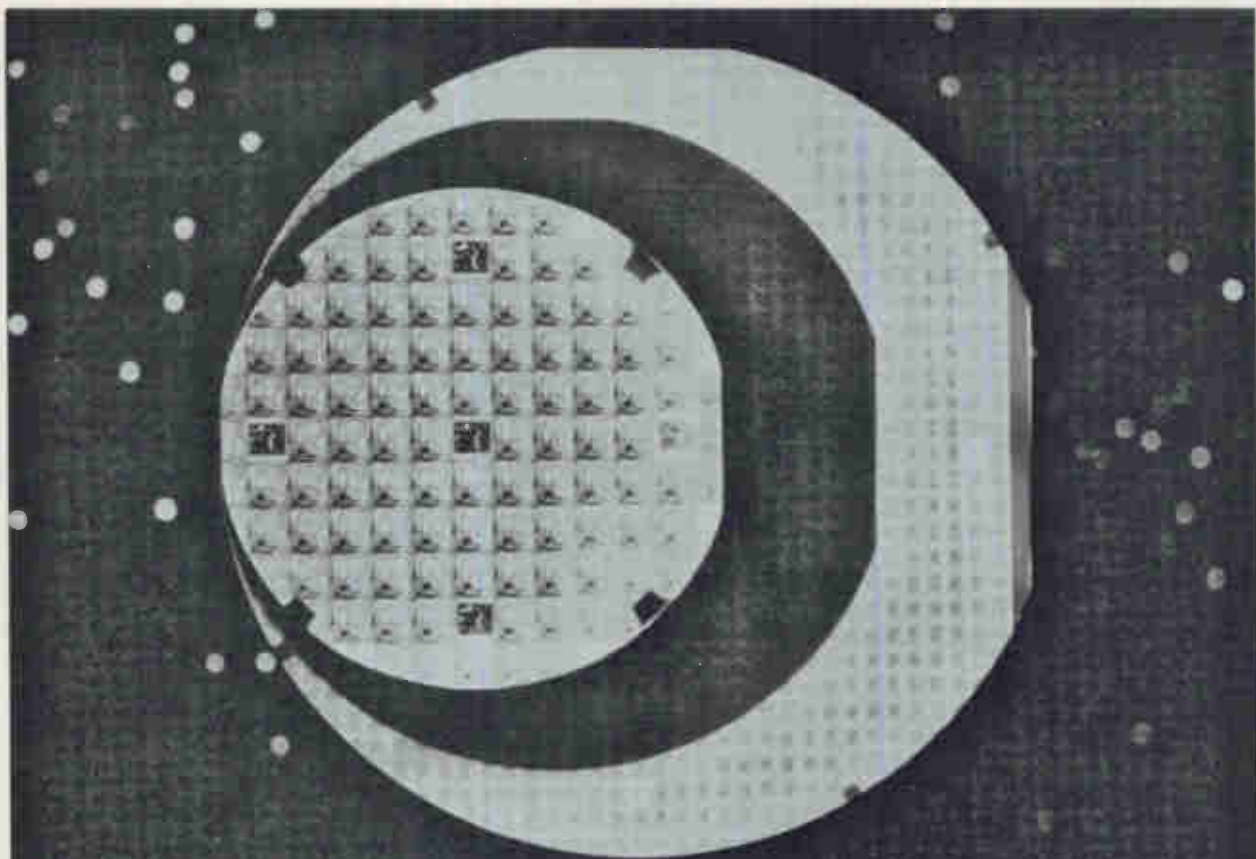

A SPECIAL REPORT

Semiconductors face worldwide change

When, back in 1980, Jerry Sanders, chairman of the board of Advanced Micro Devices, coined his now-famous metaphor, "Semiconductors are the crude oil of the '80s," presumably he meant that those who controlled the production of semiconductor technology could wield immense power over the industrial destiny of the world, just as OPEC held a vise-like grip on the industrialized nations of the West.

It was said at a heady time, when semiconductors were riding high, vanquishing traditional mechanical technologies one by one and seeming to grow at a rate that was accelerating and limitless.

But then semiconductors ran into rough economic seas. Buffeted by a prolonged recession, wracked by international battles for market share, restrained by

high interest rates and ever-expanding capital costs, over the last year and a half the industry has been marked by dwindling profits, shifts in competitive lineups, and consolidation by merger and acquisition.

But the eternal optimism and faith in the future of the industry has not gone away. Recent economic signs indicate that the worst of the recession may be over. And the number of new start-ups that continue to spring up attests to the firm belief of the industry's entrepreneurs in its future growth.

Thus, 1982 will be remembered as a watershed year for the semiconductor industry. There are technological, economic, and political forces at work that will bring many changes. There may be shakeouts and realignments, but as this special report shows, Sanders' description is still appropriate.

SPECIAL REPORT

Recession appears to be ending, but some anxiety persists

Semiconductor industry analysts see sharp gains, but top managers face recession woes and competition from captives and Japanese giants

by Howard Bierman, *Managing Editor, Technical*



Although the semiconductor industry has suffered through a tough year, prospects for the future are bright and brisk. Estimates by market analysts at Merrill Lynch and Motorola indicate worldwide sales this year will grow by 12% in contrast with last year's 5% drop; the Rosen

Electronics Letter predicts a

25% rise in U.S. and European semiconductor shipments during the 1982-83 period; and Dataquest's researchers foresee worldwide semiconductor sales soaring from \$14.1 billion in 1980 to over \$58 billion by 1990 (see figure on opposite page). There's substantial growth ahead—but for whom?

In the coming year, companies in the U.S.—and still more so in Western Europe—face a number of serious challenges to their continued growth and even existence. Is the recession ending, or will the second half of 1982 repeat last year's dismal showing? At the end of 1981, semiconductor equipment manufacturers noted that their 1981 sales would have collapsed without orders from U.S. captive firms and Japanese semiconductor houses. With their additional capacity, how much business will captive suppliers withdraw from merchant vendors? The Scottsdale, Ariz., market research firm, Integrated Circuit Engineering Corp., reports that captive IC production in the U.S. will grow by 12% in 1982 to reach \$3.3 billion while merchant IC sales will rise about 7.5% compared with its pre-1981 22% annual boosts. It also bothers merchant suppliers that the captives could join them on the open market.

Also, of course, the growing threat of Japanese competition is on the mind of every U.S. semiconductor executive as Japan races ahead with its plant expansions at home and in the U.S. Further, with its domestic market softening and sales of its consumer products and small computers sagging, Japan will aim harder at its export targets in Europe. American firms are also concerned that price erosion, which plagued the memory market, could occur in logic and microprocessor chip sales and blight their long-awaited return on their investment.

But perhaps the greatest challenges to U.S. semiconductor manufacturers lie in the areas of money and manpower. Capital costs for increasingly sophisticated semiconductor fabrication and test equipment are soaring, while, at the same time, interest rates on the neces-

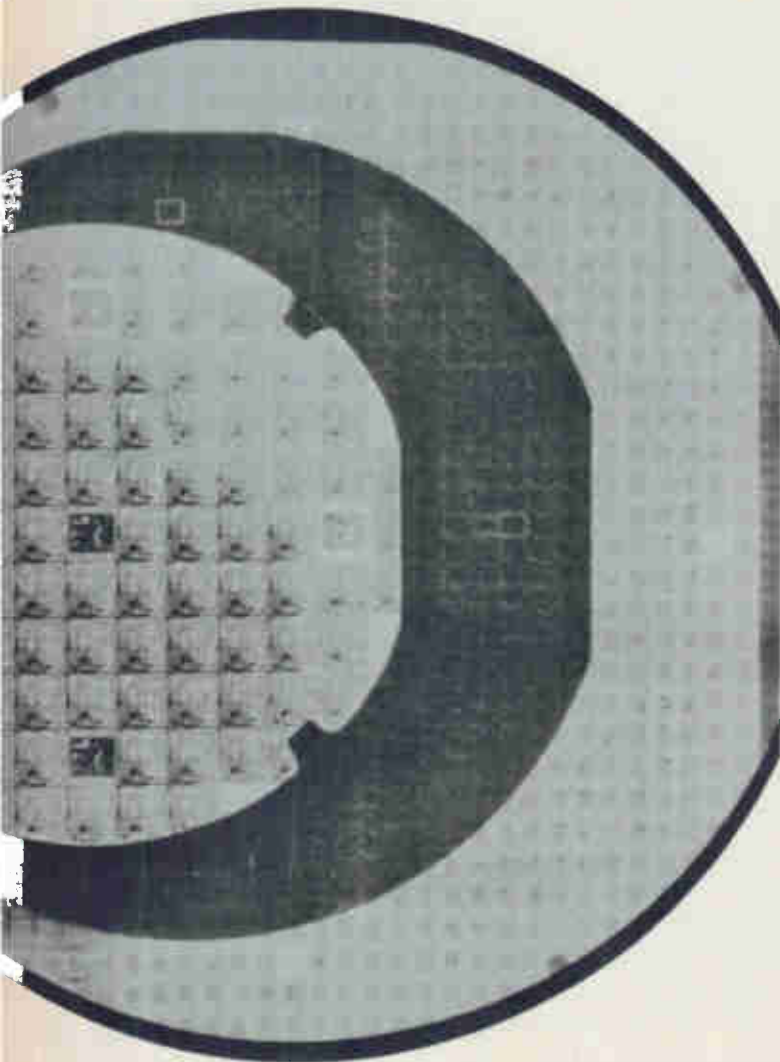

sary loans are not diminishing. Today, for instance, it takes around \$60 million to set up a 64-K random-access-memory manufacturing facility—and all for a product at this point barely verging on profitability.

Finding experienced, competent semiconductor designers and production help to staff such a facility is the other great difficulty. Indeed, the current scarcity of engineering and technical talent, when coupled with the current cutbacks in research and development expenditures, could tumble North American semiconductor technology from its long-held position as world leader.

Uncertain recovery

“Ask three semiconductor marketing managers if the recession is over and you’ll probably get three different answers,” claims James Bagley, senior vice president of Applied Materials Inc., Santa Clara, Calif. Bagley, who travels widely and is in daily contact with prospective buyers of Applied Materials’ semiconductor manufacturing equipment, explains that some will argue that little change will occur before early 1983, others see the nation’s economy as well as the semiconductor industry picking up in a few months, and the most optimistic believe the recession is already over.

“The semiconductor recession is not a stand-alone event,” points out Irwin Federman, president of Monolithic Memories Inc. of Sunnyvale, Calif. “It is related to the global economy. We have reason to believe that 1983 will be a reasonably good year.”

Everyone wants to see an upturn soon, asserts Harold L. Ergott Jr., president and chief executive officer of Mostek Corp., Carrollton, Texas (now owned by United Technologies, Hartford, Conn.). But in his opinion, it will probably be the first half of 1983 before the demand finally builds to the point where he will be ready to declare the slump “officially over.” He claims, however, that Mostek is still spending as it had planned to do for R&D since “we’ve decided a recession is not the time to slacken off.”

Also among the least hopeful is Robert Penn, president of American Microsystems Inc. of Santa Clara, Calif. (now owned by Gould Inc.). “I haven’t seen any signs that the semiconductor market will solidify soon,” he states. “We are saying that the end of the recession will come at the end of 1982.”

Skepticism even about the positive market indicators is widespread. A marketing vice president of a major semiconductor firm (who requested anonymity) commented, “Yes, orders are up and book-to-bill ratio has been improving. But when I go home at night and turn on the news, I can’t figure out why. There is no real improvement in the economy and therefore no real reason for our business to be up unless customers are finally running out of product and being forced to reorder. But this does not mean an end to the recession.”

Similar doubts are expressed by John R. Finch, vice president and general manager of National Semiconductor Corp., also of Santa Clara. “We’ve seen some signs of the market awakening, but I can’t tell whether they are real or not,” he says. “Lead times on some products are moving out and distribution has picked up nicely—partly due to inventory corrections and partly to an

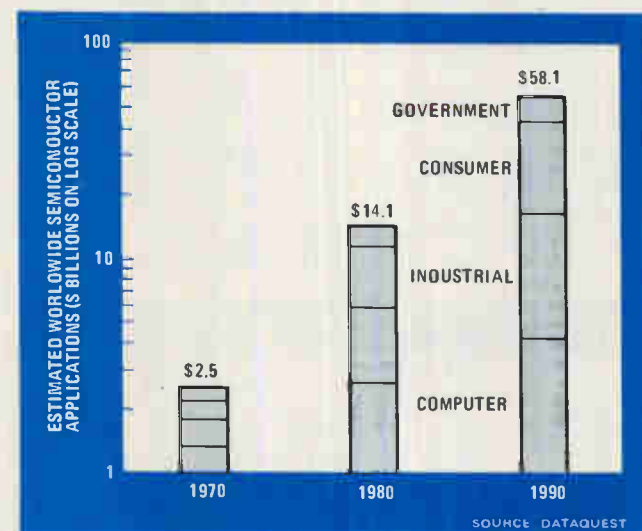
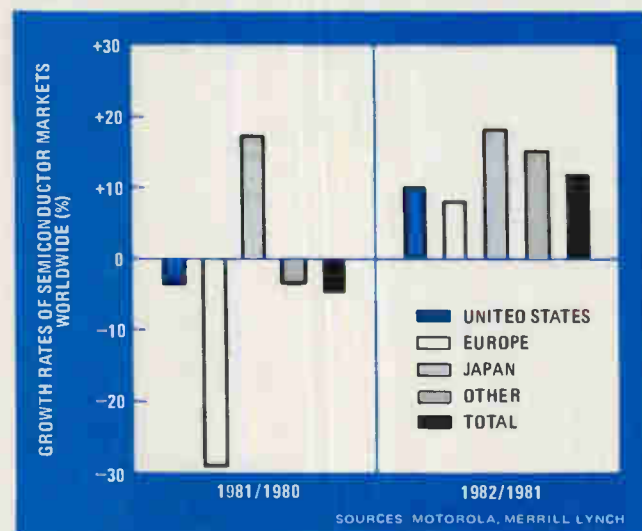
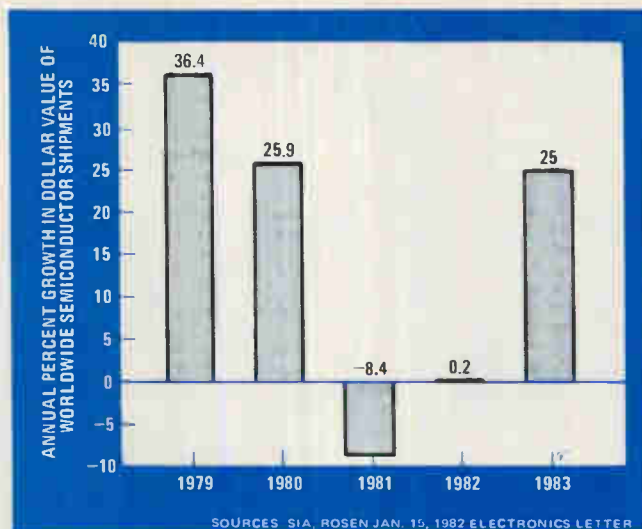

Blooming prospects. Semiconductor industry analysts predict that the 1981–82 slump will give way to a healthy long-lasting rebound. Motorola and Merrill Lynch forecast a 12% increase this year (top), the January Rosen Electronics Letter foresaw a 25% rise during 1983 (middle), while Dataquest looks far ahead with the prediction that worldwide sales will exceed \$58 billion by 1990.



Recession ending. Observes Irwin Federman, president of Monolithic Memories: "The semiconductor recession is not a stand-alone event, it is related to the economy. We have reason to believe that 1983 will be a reasonably good year."

increase in sales. But, on the other hand, some big customers are pulling in their horns."

Others are a shade more hopeful. Says Ralph J. Kaplan, sales vice president at Harris Semiconductor in Melbourne, Fla., "I think we're all bouncing on the bottom, but at Harris we're just now beginning to see lead times stretching out and prices beginning to stabilize. I think we'll see a turnaround by mid- or late summer—I'm uncertain of that upturn, however."

Moderate expectations

A similar timetable is suggested by Ray Stata, president of Analog Devices Inc., Norwood, Mass., who comments, "My company has seen some recovery in recent months, and I expect to see moderate growth by this summer. As for real vitality, all cylinders firing again, I think that should be happening by the end of this year."

Confident that 1982 will be a strong year, Charles

(Chuck) E. Thompson, world marketing vice president at Motorola Inc.'s Semiconductor Sector in Phoenix, Ariz., argues, "The recession bottomed in the fourth quarter of 1981 and once you're at the bottom, things can only get better." Thompson is convinced 1982 will be stronger than most predict because the three major contributors to a tough 1981 will all improve—memory prices, the U. S. economy, and the exchange rate of the dollar, which affects imports.

The bright side

Equally optimistic is Charles C. Harwood, president of Signetics Corp. of Sunnyvale, Calif. "I have controlled optimism that the recession is over," he says, "and the recession has been essentially an inventory correction that has taken two years. Now we are starting back up the ladder."

As vice president of international sales and corporate marketing at Advanced Micro Devices Inc., Sunnyvale, Calif., Ben Anixter is pleased that "bookings are definitely up, and the up trend has been sustained since January. Our customers have used up their inventory and are reordering." He sees AMD's short-term backlog going up with some price firming and reports a substantial comeback in Europe since last summer.

Distributors are carefully watching incoming orders and are trying to evaluate whether the recession is really ending or whether customers are just replenishing their low inventories. Because of tight money and high interest rates, major firms such as the Harvey Group Inc. of Woodbury, N. Y., and Kierulff Electronics Inc., Los Angeles, are concerned with keeping inventories in line with current sales trends but are also worried about being caught short in the event a rapid turnaround in demand takes place.

As yet, no one at the distributor level seems convinced the recession has run its course. Optimists hope orders will continue on the increase, while the pessimists foresee a slow summer with the solid upturn happening towards the end of the year. Hamilton/Avnet, Culver City, Calif., and Hall-Mark Electronics Corp. in Dallas report solid semiconductor bookings while other distributors, such as Apollo Electronics in Cambridge, Mass., have not seen an upturn as yet.

There are mixed emotions about Japan's fierce battle for increased market share in Europe. "Now the U. S. is facing the same dilemma Europe had to face some time

TABLE 1: THE EUROPEAN SEMICONDUCTOR MARKET BY MARKET SEGMENT (\$ MILLIONS)

	Years		Growth rate
	1981	1986	1986/81
	Consumer	\$ 480	\$ 570
Distribution	570	940	10.5%
Industrial	400	1,370	28.0%
Data processing	540	950	12.0%
Telecom	500	1,550	25.0%
Automotive	120	270	18.0%
Total	\$2,600	\$5,650	17.0%

SOURCES: MOTOROLA, MERRILL LYNCH

TABLE 2: EUROPEAN SEMICONDUCTOR MARKETS (\$ MILLIONS)

	Year			Growth rate	
	1980	1981	1982*	1981/80	1982/81
W. Germany	\$1,240	\$ 760	\$ 855	-39%	12%
UK	670	530	580	-21%	10%
France	580	520	520	-10%	0%
Italy	350	240	250	-31%	4%
Scandinavia	290	240	265	-17%	10%
Others	410	310	340	-24%	10%
Total	\$3,540	\$2,600	\$2,810	-26%	8%

*Estimated. SOURCES: MOTOROLA, MERRILL LYNCH



Picking up. Claims John R. Finch, vice president and general manager of National Semiconductor: "Lead times on some products are moving out and distribution has picked up nicely—partly due to inventory corrections and partly to an increase in sales."

ago," points out D. W. Larkin, managing director of Plessey Co.'s Solid State division in Swindon, UK. "For once, you in the U. S. are up against somebody who doesn't care about profits but rather market share."

On the subject of protectionism, Daniel Leveille-Nizerolle, head of RTC's-La Radiotechnique Compélec semiconductor division in Paris, France, strongly states, "Protectionism is warranted against Japanese chip makers to permit you to fight by the same rules." Further, Nizerolle argues, "tariffs mean nothing because the Japanese dump . . . the only prevention is to limit imports."

A different view of the Japanese marketing strategy is expressed by Gernot J. Oswald, marketing director of the Munich-based Semiconductor Components Group of West Germany's Siemens AG, who simply states, "You can set your watch on when the Japanese will deliver orders they promise to expedite. Furthermore, when we had a problem, they were in the next day."

"Recession is not an unhealthy period," philosophizes Lubo Micic, managing director of ITT Semiconductors Worldwide in Freiberg, West Germany. "You have an opportunity to do some necessary cleanup. To show good results in a boom period is only good marketing . . . to do well in poor times demands good management. You clean your product line during boom periods and clean up your customer mix during a recession." Tables 1 and 2 portray the West European markets.

Captive semiconductor facilities are gearing up to compete against established merchant suppliers



ust when U. S. merchant semiconductor manufacturers have their hands full with the challenge from Japan, another long-term competitive threat may be materializing in their own backyard. Many U. S. computer and equipment houses are gearing up to produce more of their own chips for internal use (see

Table 3). And while there is widespread disagreement over the significance of the buildup, some industry watchers believe it could eventually take its toll of the merchant suppliers' business. Numerous large expansion programs at the captive semiconductor operations of firms such as General Electric, NCR, and Tektronix "could provide enough additional capacity that the open-market industry might be faced with a noticeable decrease in demand, especially for custom and semicustom components," says the recently published report from Integrated Circuit Engineering Corp.

In addition, the number of captive start-ups surged

last year to nine from only one or two per year previously, according to the report, which is titled "Status 1982." It predicts captive producers will account for about 40% of all U. S. chip production by mid-decade, up from 33% last year (see figure on p. 134). By 1990, it adds, captive in-house production should equal open-market sales.

There are several reasons for the new emphasis on in-house chip design and production by the systems houses. With very large-scale integration literally putting entire systems on a chip, many equipment makers see the need to develop and protect proprietary device designs. "If all the computer companies continue to buy all their logic devices from the merchants, the uniqueness of the computer products would disappear," observes Peter R. Tierney, senior professional consultant with Sperry Univac's two-year-old semiconductor division in Eagan, Minn.

Variety versus volume

In addition, as VLSI allows system-level chips to be customized to specific applications, the number of device types needed will rise dramatically, but volumes on each individual chip design will be low. As a result, some systems houses want an increased captive chip capability in order to ensure a timely supply of devices.

"The demand in the future is going to be for applica-

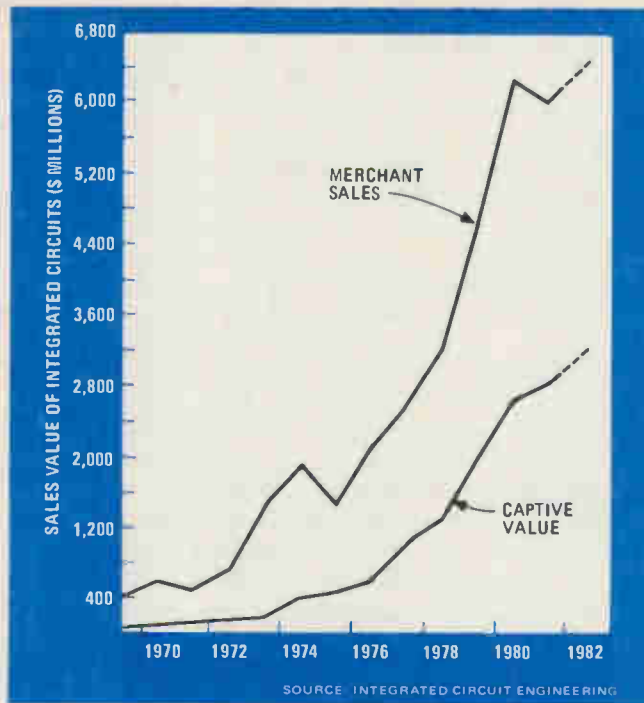

Captive clutch. Captive producers will account for 40% of U. S. IC production by the mid-1980s, predicts Integrated Circuit Engineering. Further, the market-research company also suggests that in-house production value will equal open-market sales by 1990.

tion-dedicated equipment, and while the computer makers will continue to depend on the merchant vendors for commodities such as dynamic RAMs, they don't think they can necessarily depend on the merchants to make one [logic] chip for a banking terminal, another chip for an airline terminal, another chip for a factory terminal, and so on," explains Stephen T. McClellan, vice president and computer industry analyst with Salomon Brothers Inc., New York.

Systems manufacturers confirm the scenario. At Honeywell Inc.'s captive Solid State Electronics division in Plymouth, Minn., for example, the number of chips designed for internal use will rise from about 200 per year currently to about 1,500 annually by 1985, says K. C. Nomura, vice president and general manager.

Meanwhile, at Sperry, a new \$50 million, 2,400,000-square-foot semiconductor plant set to come on line in Eagan this fall is designed specifically with an eye toward production of large numbers of device types in low-volume runs—in many cases, as few as 1,000 devices of a particular design. Sperry expects better flexibility and faster turnaround times than would be possible from a traditional merchant vendor operation geared to high-volume runs. Tierney says, "I don't think the merchant would be capable of managing all of these different devices that are coming into being."

Both Honeywell and Sperry, as well as other captive manufacturers, will rely on gate array devices in the short term to meet a portion of their needs. But many foresee fully custom chips displacing gate arrays later as more sophisticated computer-aided-design tools become available.

Despite the recent captive buildup, not all are con-

vinced that the captives will gain market share at the merchants' expense. At Smith Barney, Harris Upham & Co. in New York, research vice president James L. Barlage points out that traditional merchant vendors are beginning to pursue the custom and semicustom business more aggressively. Intel's recently established foundry operation is a prime example, he says, while a number of recent semiconductor start-ups are also aiming at the same kind of market.

"The captives are not particularly anxious to spend money on the semiconductor business—they're only doing it because they can't buy what they want on the outside," contends Howard Bogert, director of technology at Dataquest Inc., the Cupertino, Calif., market research firm. The key question now, he says, is whether the merchants will provide the necessary flexibility and service orientation for the nonstandard chip market, so that the captives will not be forced to continue their own capacity expansion to meet internal chip needs.

The stakes are high. About 29% of the U. S. semiconductor market today is in custom devices, about two thirds of which are supplied by the captives, Bogert says. But by 1990, some expect customer business to explode to as much as half the total projected \$30 billion U. S. semiconductor market. "That means \$15 billion," Bogert points out. "Will the captives maintain their share and get two thirds of that, or will the merchants get it?" he asks. "It's a \$5 billion issue."

The Dataquest official says he personally is betting on the merchants: "We've seen a lot of rethinking lately by the merchants in terms of how to best serve the custom business." In addition, Bogert notes that half of 22 semiconductor merchant start-ups since 1977 are aimed at nonstandard products. U. S. captives' share of the worldwide semiconductor market rose from about 13% in 1980 to about 15% last year, he says. But because of the rising merchant emphasis on nonstandard devices, he sees the captives' share remaining relatively flat over the next five years.

The state of the art

Another part of the debate involves the ability—doubted by some observers—of captive makers to stay at the forefront of device process and production technology. "With the exception of IBM and Western Electric, which have been very successful, most captive operations in the past have either degenerated into design shops with low production expertise or focused on manufacturing efficiencies and ended up being very proficient producers of old technology, because their design doesn't keep up with the state of the art," contends Thomas P. Kurlak, vice president of technology research at Merrill Lynch, Pierce, Fenner & Smith Inc., New York.

At Control Data Corp.'s captive operation in Bloomington, Minn., "the technologies we have chosen are not super-performance state of the art," allows Lloyd M. Thorndyke, senior vice president of research. A major function of CDC's captive operation is to build older device types that may have been phased out by the merchants, he indicates. CDC does produce some LSI chips, notably integrated-injection-logic devices for use in CDC computer peripherals. But because of the high



Captive success. James H. Van Tassel, vice president of the Microelectronics division of NCR Corp., says: "I'm quite satisfied with our merchant-market penetration to date . . . we've significantly exceeded our 1981 sales predictions."

cost of staying at the leading edge, CDC's philosophy is to allow a device technology to mature a bit before cranking it up for the production line.

Not surprisingly, Thorndyke favors a cooperative approach similar to those proposed by top CDC officials earlier. Industry discussions are continuing on CDC chairman William C. Norris's February proposal for a multifirm R&D consortium [*Electronics*, March 10, 1982, p. 97], following suggestions last year by CDC president Robert M. Price that U. S. companies cooperate on chip production as well as R&D. "You can easily put in \$50 million to \$100 million trying to be vertical supplier," Thorndyke observes, adding that "vertical cooperation" makes a lot more sense from the computer makers' standpoint. "Over a period of time, as some form of cooperative effort comes on stream, some U. S. computer houses will wonder why they invested so much now for internal chip production capability," the CDC official predicts.

Estimates vary as to the minimum amount of equipment business necessary to support a minimum captive semiconductor operation. Dataquest puts the figure at about \$600 million, down from about \$1 billion in 1970.

Honeywell—whose Synertek subsidiary is already in the merchant business—is in fact planning the entry of its captive operation into certain niches of the merchant market, says Nomura [*Electronics*, April 7, 1982, p. 34].

TABLE 3: TOP 10 U.S.-BASED CAPTIVE SUPPLIERS OF INTEGRATED CIRCUITS

Company	Estimated number of employees		Estimated IC production (sales in \$ millions)	
	1981	1981	1981	1982
IBM*	35,000	1,870	1,870	2,100
Western Electric	5,500	350	350	385
Delco	1,500	180	180	185
Hewlett-Packard	1,400	140	140	160
NCR	1,100	60	60	70
Honeywell**	1,100	60	60	70
DEC	900	50	50	60
Burroughs	650	40	40	40
Data General	500	25	25	30
Tektronix	350	20	20	25
Total	48,000	2,795	2,795	3,125

*Worldwide production and employees involved in design and manufacture of ICs.
**Excludes Synertek.

SOURCE: INTEGRATED CIRCUIT ENGINEERING

But he emphasizes that a "good strategy" is essential to success for a captive selling to the open market. "The main reason for doing it should be because there's an opportunity," he says, "not because you have a surplus of capacity."

NCR Corp., Dayton, Ohio, surprised a lot of people last year when it announced plans to enter the merchant chip market [*Electronics*, July 14, 1981, p. 48]. Although some observers publicly doubted the wisdom of the move, NCR's Microelectronics division vice president James H. Van Tassel says he is generally "quite satisfied" with the company's merchant-market penetration to date. Though he will not supply figures, Van Tassel contends that nonvolatile memory and foundry business sales throughout last year "significantly exceeded our predictions."

The NCR official concedes, however, that the company's semicustom logic offerings have been "awfully slow getting off the ground." Indeed, as of late in the first quarter of this year, the firm had not yet signed a single customer for that business. Despite the current soft IC market, Van Tassel expects NCR's merchant business will do well, thanks to a strategy of supplying products to niche markets expected to grow faster than the semiconductor industry as a whole. The company recently added read-only memory devices to its merchant bag of chips [*Electronics*, April 7, 1982, p. 239].

Some skepticism

Some, however, remain unconvinced. As far as captive houses now competing or likely to compete on the open market are concerned, "the only one I'd really fear if I were a merchant would be Western Electric," says Smith Barney's Barlage. Given the division's high volume and "leading-edge production" capabilities, a move into the merchant high-density-memory business would be "a natural" for Western Electric Co. following parent American Telephone & Telegraph Co. deregulation, Barlage believes.

Others, on the other hand, are doubtful that Western could profit by entering the cyclical and extremely price-competitive merchant memory business. For the compa-

ny's part, a Western Electric spokesman says it is too early to speculate on its intentions.

Though there is no clear industry consensus on the extent to which stepped-up captive production will affect the traditional merchant chip vendors, there is agreement by many that the trend to consolidation of the semiconductor industry will continue. The smaller semiconductor merchants "are all being bought by bigger companies that have their own axes to grind and their own products to make. They'll still be selling to the street, but they're going to be making more for home consumption, too," predicts Integrated Circuit Engineering's William I. Strauss.

With the exception of the largest independent chip makers—those about the size of Intel Corp. or bigger—the economics of the business will dictate the scenario, Strauss states: "Any little semiconductor house that is not already spoken for soon will be, because they can't stay up with the state of the art unless they continue to invest in equipment." Since returns in the merchant market are insufficient for the kind of investments required, remaining small chip makers "are going to seek ownership by a big daddy," he predicts. "We just

don't see any small merchant semiconductor houses left without a parent by mid-decade."

Others agree, though some to a lesser extent. "I think there are going to be lots of acquisitions, but I hesitate to predict the total death of the independent people," says Dataquest's Bogert.

For the merchant vendors not gobbled up by larger firms, most industry watchers project migration more toward the systems business, with the chip makers devoting a growing percentage of their semiconductor capacity to internal needs. Intel is cited as a prime example of this development.

Thus, as the decade unfolds, the picture that some experts project is for a U. S. semiconductor industry in which merchants will continue to play an important role. But in character, many think the U. S. industry will begin to more closely resemble the industry structures seen in Europe and Japan, where neither pure merchant nor pure captive vendors are common.

The foregoing section on the rise of captive semiconductor makers in the U. S. was contributed by Wesley I. Iversen of Electronics' Chicago bureau.

Clamor for action increases as U. S. chip makers charge the Japanese with unfair competition

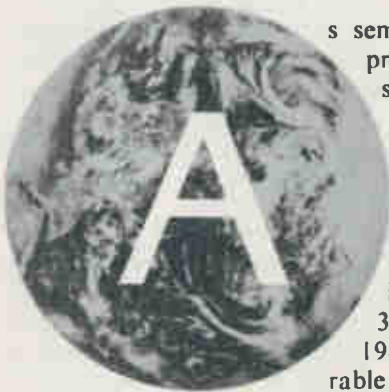

As semiconductor sales and profits continue their slump, U. S. manufacturers are warily eyeing Japan's increasing share of the Free World market in the devices—up from 23% in 1980 to 27% in 1981 and probably 34% by the end of 1982. Since the comparable U. S. figures go from 59.4% to 54.8%, the fear is that Japan will eventually dominate the world semiconductor market. That apprehension explains much of the fuss over the 64-K dynamic RAM, 70% of whose market last year fell to the Japanese. For although only \$100 million worth of the devices were sold, the prediction is that by 1985 they might well represent \$1.5 billion in sales. As yet, few 64-K RAM manufacturers, if any, are making any profits because 64-K RAM prices have been eroding steadily, from \$20 in 1980 to \$9 in mid-1981 to \$5 this year. Currently only two U. S. firms, Texas Instruments Inc. and Motorola Inc., both with facilities in Japan, are actually delivering 64-K RAMs. All other U. S. companies are behind schedule, and some, with embarrassing earnings to report to their stockholders in 1981, may well be feeling reluctant to stay in the expensive race, even though dropouts will risk losing out on the technological expertise crucial to their eventual survival in the logic

arena. Meanwhile, Nippon Electric Co. and Hitachi Ltd. have already announced plans to deliver 256-K chips within a year.

The rest of the 64-K RAM uproar, however, stems from a deeper concern—the realization that for the Japanese this chip is not the end, but the means to a more ambitious goal: complex systems development and dominance of the worldwide computer market. Semiconductors and computers are tightly interwound, and superiority in semiconductor product development, production proficiency, and device quality will determine the leader in computer hardware.

Last year, Japan exported about \$900 million worth of semiconductors worldwide, says Robert H. Silin, a Bank of America vice president, in his recently completed report on "The Japanese Semiconductor Industry 1981-1983." This year, under heavy pressure from U. S. industry and Government to decrease their country's overall \$18 billion trade imbalance, Japanese semiconductor companies plan to increase their share of the world market via their U. S. plants, rather than by exports from their home factories, says the report. The percentage of their production exported will probably be held to the 30% mark, it adds, but this will not include anticipated sales from NEC's, Hitachi's, and Fujitsu's U. S. factories.

The same study also indicates that U. S. firms will face even greater resistance to the marketing of their integrated circuits in Japan since the Japanese firms are now geared up to satisfy most of the domestic demand. In 1980, it estimates, 18% of the Japanese semiconduc-

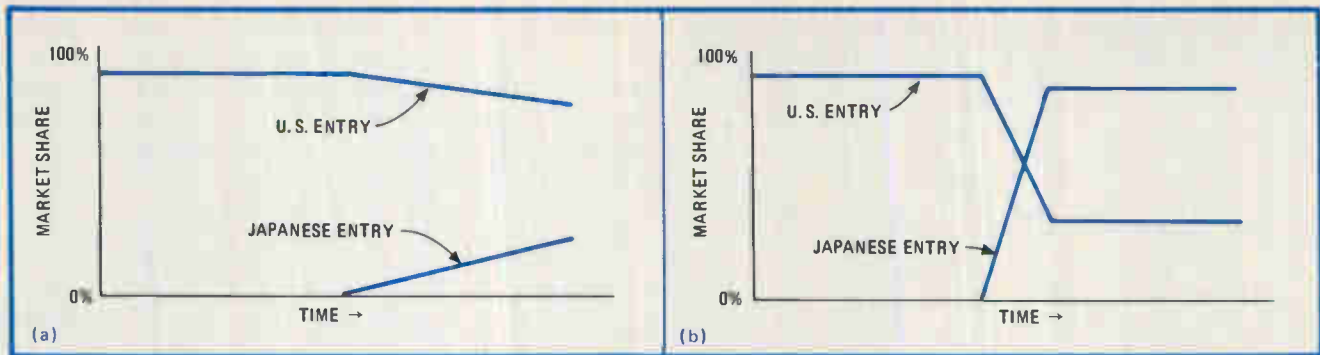

Open or closed? In an open market (a), the initial entry (foreign) loses market share gradually as competitors (domestic) enter; in a closed market (b), imports drop sharply in favor of domestically produced parts. U. S. chip makers say Japan's is a closed market.

tor needs were satisfied by U. S. imports; this figure dropped to 14.5% in 1981 and is projected to dwindle to 10% during the next few years.

A major reason for declining U. S. chip sales in Japan is a general business slowdown there, claims Stephen L. Levy, senior vice president of Japanese operations at Motorola Inc. But he also admits that "the Japanese market is more closed" and that Japanese chip makers have been made more proficient by the VLSI program sponsored by the Ministry of International Trade and Industry.

A matter of policy

As is well known, it is such Japanese government support, as well as private industrial arrangements, that have created intense market pressure on American electronics firms. The availability of funds for expansion, guaranteed by the Japanese government at low interest rates, plus a closed-market policy, has not only expedited the advance of IC technology and production in Japan, but is similarly aiding progress in computers and telecommunications systems.

Japanese policy, until 1978, was to manipulate access to its semiconductor market by forcing American companies to sell or license their patents and production techniques; otherwise, no production or marketing of U. S. components was permitted. Thus Japanese firms were enabled to gain a significant semiconductor technology education in a short space of time.

Subsequently, as formal restrictions were lifted, access to the Japanese market barely changed. Japan's six largest captive producers—NEC, Hitachi, Fujitsu, Toshiba, Mitsubishi, and Matsushita—specialize in different product areas, the first three in computer and communications devices and the latter three in industrial and consumer parts. Since the firms are major producers of large systems, extensive trade among them gives them a strong base from which to compete with the rest of the world, besides in effect subsidizing chip development and also making the best use of their production capacity. Table 4 lists the leading Japanese IC makers.

With this closed-market arrangement, only the most sophisticated devices were and are imported from the U. S. until the domestic suppliers master the production know-how; at that point, imports are dramatically dropped in favor of the domestic products. In an open market, in contrast, American firms would face only a

slow decline of market share when the domestic suppliers were able to deliver. An open- and closed-trade pattern is shown in the figure above.

Motorola's Levy is not the only U. S. semiconductor company executive to be skeptical that the Japanese market is really open for sales of their products.

"By no stretch of the imagination do the Japanese have an open market, and no one in our industry is so naive as to believe it," declares AMD's Anixter.

Similarly, John R. Finch of National Semiconductor says, "I don't think the Japanese are willing to use any product from foreign competitors, U. S. or European. They have a different mode of doing business, and they protect themselves. We need Government help to tell the Japanese that they have to open up—we have to force concessions." But, Finch also cautions, the Japanese have done a good job and they have good products, and "if we are to compete, we have to be efficient manufacturers—we need to automate wafer fabrication, make the best use of CAD/CAM [computer-aided design and manufacturing], and get yields up, especially with VLSI."

W. J. (Jerry) Sanders III, chairman of AMD, is an outspoken critic of the Japanese competitive approach. In a recent full-page advertisement in the New York Times, he stated, "I just don't want to pretend that I'm in a fair fight. I'm not . . . Let me tell you the truth. Do you know how the Japanese got the dynamic RAM business? They bought it. They pay 6%, maybe 7% for capital. I pay 18% on a good day. They pay their employees about 75% of what I pay mine. And then their parts arrive here in a flood. Are they dumping? I think so. It sure looks like dumping . . . it's way past time to take a tough, self-interested look at the business practices on both sides of the Pacific."

"Japan is feasting off our table," declares Eric Lidow, president of International Rectifier Corp., El Segundo, Calif. "The threat to the U. S. semiconductor industry is really dangerous, and unless Congress puts through some tough legislation pretty soon, the semiconductor industry here will follow the auto and steel industry."

Japan's reply

Japanese officials at MITI and its subsidiary, the Japan External Trade Organization (Jetro), argue that U. S. semiconductor executives are unfair in their criticism that the country is a closed market. They point to 1981 figures prepared by Japan's Ministry of Finance that

TABLE 4: JAPAN'S TOP 10 INTEGRATED-CIRCUIT SUPPLIERS (MILLIONS OF YEN)

Company	1979	1980
NEC	448	550
Hitachi	316	405
Toshiba	250	360
Fujitsu	122	220
Mitsubishi	122	150
Matsushita	113	135
Tokyo Sanyo	90	105
Sharp	57	80
Oki	38	60
Sony	28	50
Total	1,584	2,115

*Conversion rate: ¥ 212 = \$1

SOURCES: JEJ
INTEGRATED CIRCUIT ENGINEERING

show Japan buying 70.5 billion yen of ICs and chips from the U. S. while selling the U. S. similar products valued at 71.2 billion ¥ (see figure on opposite page). During 1980, Japan bought 69.6 billion ¥ and exported 72.4 billion ¥ in U. S. trade. Thus, the argument goes, there has been only a slight 1.7% decrease in exports coupled with a 1.3% increase in their imports. Since the value of the U. S. dollar falls from 227 ¥ in 1980 to 219 ¥ in 1981, these figures translate into about a 2% rise in the dollar value of Japan's exports to the U. S. from 1980 to 1981 and a 5% increase in the dollar value of its imports from the U. S.

These figures cause Kazuyuki Wakasone, director of MITI's Industrial Electronics division in Tokyo, to comment, "I can't find any points that are unfair—many people are complaining about unfairness, but I don't know why." In addition, he believes, "It's actually a very favorable situation with several U. S. firms manufacturing, testing, and designing ICs in Japan while Japanese firms are doing the same in the U. S."

Wakasone believes the real U. S. complaint centers around the 64-K dynamic-RAM segment of the market and predicts the 70% share of it attributed to Japan will soon change as TI, Motorola, and six other U. S. manufacturers (including National Semiconductor, Intel, Mostek, and Fairchild) start producing the 64-K chips in large quantities. Beyond 1982, therefore, Japanese exports of 64-K RAMs to the U. S. could drop, and the balance of trade in semiconductors could swing further back in favor of the U. S.

Finally, insists Wakasone, "if the U. S. does launch an investigation of U. S.-Japanese IC trade and does it fairly, there will be no trouble or barriers as a result."

Academic analysis

The outline for just such a study was prepared for the Joint Economic Committee of Congress. Called "International Competition in Advanced Industrial Sectors," it starts with the problem of how to define a closed market quantitatively. Monitoring is the key, it claims. Somehow someone should monitor how advanced semiconductor products sell in Japan and then taper off (or fail to) with Japanese end users as local companies offer their wares. That person or organization should also check whether rumors are true that state-of-the-art Japanese

semiconductor manufacturing equipment is not made available to U. S. firms and should closely eye the strategies and methods used by Japanese chip makers as they introduce their new devices into the U. S. market. Furthermore, the study insists, the same monitoring should be applied to the markets in semiconductor end products such as computers and telecommunications gear.

Though the study's charges about unfair Japanese competition are pointed and direct, its recommendations for solutions are rather general and vague. American policy should be directed toward sustaining and enhancing the competitiveness of the domestic sector, the report urges, to ensure technological manpower and financial resources. In addition, policies should be devised to permit small and medium-sized firms to weather economic downturns.

The Department of Defense's funding of the Very High-Speed Integrated Circuits program offers an excellent vehicle for the development of advanced circuits for military applications, the study points out. So why not establish a civilian application program to fund consumer electronics product development? The difficulty, as the study admits, is the necessity for decision making as to which civilian goods merit Government funding and which companies should get tapped to participate. In short, nowhere does the study make clear just how the policies it recommends should be implemented and under whose direction.

Some remedies

Given that the closed-versus-open market debate cannot be settled objectively, what other course or courses of action should U. S. semiconductor firms pursue?

The imposition of trade restrictions on Japan has already been mooted by National's Finch. And they have the firm support of Lidow of International Rectifier, which has a joint-venture operation in Japan. In his view, high trade tariffs should be immediately imposed on high-technology products and, if this step fails, an embargo should be threatened until the Japanese really open up their markets. He insists that the Japanese will do what they think they have to do and are currently offering only token mention of open trade with the U. S.

However, trade restrictions are not favored by Fred Adler, a well-known venture capitalist who has been heavily involved in many start-ups in the electronics business. But he does believe a detailed study should be conducted to see whether the Japanese are dumping (selling below the prices they charge in Japan) or competing unfairly (selling below cost). They should be bounced out if guilty, he urges. He also is not bothered over U. S. firms matching quality with Japan—that furor is over, he believes, and he considers it more important for U. S. chip suppliers to regain the customer confidence they lost a few years ago.

"U. S. semiconductor firms will win back many of their U. S. customers from Japanese suppliers when they act more like they are running a business," he says sharply. In his view, U. S. chip houses are suffering now from broken commitments made to U. S. computer and instrument makers during 1979 and 1980 when memory parts were scarce. Japanese companies, Adler claims,



Expansion into Japan. Says Stephen L. Levy, senior vice president for Japanese operations, Motorola Inc.'s Semiconductor Sector: "Anyone who believes he can do as well servicing a customer from 6,000 miles away as he could by manufacturing in Japan is naive."

stuck by their promises, whereas American firms squeezed their customers on price and delivery. But he adds, U. S. firms will win back their lost business.

AMD's Ben Anixter would agree with that last point. "Computer companies understand the game," he remarks, "and be sure of this, something will happen." In other words, U. S. computer companies are facing a similar closed market and out of sympathy will start buying American instead of Japanese semiconductors, such as 64-K RAMs, as soon as U. S. firms build up capacity and production.

Robert Noyce, vice chairman of Intel Corp. in Santa Clara, Calif., and president of the Semiconductor Industry Association, expects the same thing to happen, but for different reasons. He sees Japanese manufacturers becoming a declining threat as U. S. high-technology semiconductor firms gear up to crack the U. S. computer makers. Japanese IC makers, he believes, are not as good at competing in fast-moving areas such as logic ICs as they are in established mass markets such as circuits for television sets, watches, and calculators—except for NEC, he hastens to add.

"Innovation is the key," also says Mostek's Ergott. "I think what we need to do is to have ways of obsoleting their capacity by the time they move on line."

Speculating on Japan's economic advantages over the U. S., Intel's Noyce put them at 10% in the cost of capital, 10% in labor costs, and another 10% due to an undervalued yen in today's world markets. Also, he adds, U. S. military market requirements account for 20% of U. S. semiconductor firms' output while Japan's government market takes only a 10% slice, leaving a larger share of the country's IC production available for domestic use and export sales. He believes that the cost of capital formation in the U. S. will have to "get down to

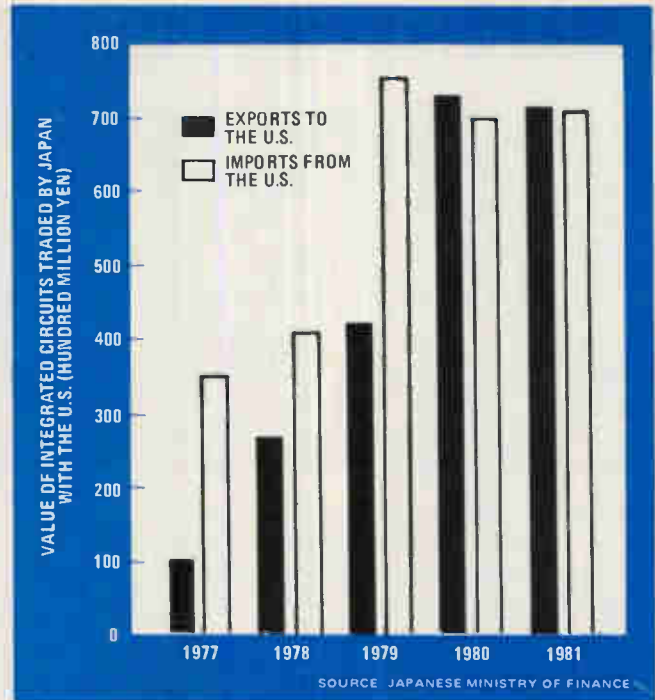

Japan's retort. Officials at Japan's Ministry of International Trade and Industry argue that a trade balance favorable to the U. S. still exists in IC shipments. Their 1981 data indicates that the dollar value of their exports dropped by 1.7% while imports rose 1.3%.

the 6% to 7% level" before it can compete economically with Japan.

One of the most concrete recommendations came from several sources: set up plants in Japan. That is the advice the Bank of America study offers foreign firms anxious for two-way trade and some piece of the domestic market there.

Similarly, though not quite advising other U. S. companies that they, too, have to go to Japan to penetrate its markets, Motorola's Levy insists that "in order to be a major factor in any market, you've got to be pretty close to the customer and provide him with the level of service he expects and deserves—anyone who believes he can do as well from 6,000 miles away as he could by manufacturing in Japan is naive."

Establishing a joint venture for entering the closed Japanese market is also advocated by David Simpson, president and chief operating officer of Gould Inc., Rolling Meadows, Ill. "U. S. firms can build more ventures in Japan," he suggests, "since the Japanese are great entrepreneurs and there's always somebody willing to venture with you to leverage his position." Simpson should know, because Gould recently became involved in a Japanese venture for production of copper foil for printed-circuit boards and "Japan is way behind the U. S. on CAD/CAM and would love to get in bed with people who would share it with them." He concludes, "I'd prefer to see this approach rather than trade barriers erected in the U. S."

Concern mounts among U. S. semiconductor and computer manufacturers that the Japanese will soon focus their attention on product lines other than memories, with microprocessors a strong first choice. And fully

East-West conflict

The U. S.-Japanese relationship has become pretty heated. Recently, U. S. House Speaker Thomas P. (Tip) O'Neill Jr. commented, "If I were President, I'd fix the Japanese like they've never been fixed. I think they've been extremely unfair with us and I don't think we've acted harshly enough against them." And U. S. Chamber of Commerce president Donald Kendall insists that Japanese trade negotiations "have been making suckers out of us for years."

At almost the same time, Akio Morita, chairman of Sony Corp., stated, "Americans never admit they're wrong, even when they know they are wrong. That's the way they were reared. Even if an American causes an accident, he

doesn't say he's sorry. Just such a spirit is directed towards the rest of the world today." Going further, he added, "Japan is a friend. If Japan's industrial power were to be switched to the other side of the Communist Bloc, the balance of world power would be altered."

Why the emotional flare-up on both sides? This is an election year and, the Japanese believe, the U. S.-Japan trade issue, coupled with high unemployment and the continuing recession in the U. S., makes Japan an easy target for those troubled about the American economy. Further, the Japanese are angered that their recent trade concessions were viewed as an admission of previous wrongdoing rather than as a gesture of goodwill.

conscious of the Japanese strategy to sacrifice profits to attain market share, U. S. firms fear another potential area for price erosion that would affect their ability to recover from the current recession.

With U. S. chip makers accounting for only 5% of the Japanese market, pressures are being applied to limit further Japanese competition in the U. S. The President is being urged to impose reciprocity legislation to counter unfair trade barriers. Failing this strong step, the Government could impose such nontariff barriers as temporary quotas or additional testing procedures to drive import prices up. A dramatic measure would be the limitation of 64-K RAM imports from Japan on the basis that national security might be at stake since semiconductors are important components of U. S. military systems. The Government is also considering a step to restrict the licensing of U. S. high technology, which would effectively slow down the rate of Japanese product introduction.

Cooperation pays

U. S. firms angrily denounce MITI's role in allocating R&D programs among Japanese firms, generally organized into small teams, and MITI's ability to arrange financial backing through low-interest loans by friendly banks. Japanese officials express surprise that U. S. firms do not follow the same path. Thus, despite the intense competition among American semiconductor firms since the early days of the transistor, the time has come for a more organized, team-oriented plan, U. S. executives have decided. Two separate joint ventures have been initiated—one among U. S. semiconductor firms and universities and a second between U. S. semiconductor and computer manufacturers.

The joint venture between industry and universities is the Semiconductor Industry Association's Semiconductor Research Cooperative [*Electronics*, April 21, 1982, p. 40]. Initial funding will be about \$6 million from 13 participating companies this year, with up to \$18 million expected next year. The goal of the research effort is to develop next-generation VLSI and state-of-the-art semiconductor devices.

Among the charter members are Intel, Digital Equipment Corp., Signetics, Fairchild Camera & Instrument, Motorola, AMD, Hewlett-Packard, Rockwell Interna-

tional, and National Semiconductor. The nonprofit organization, created to fund long-term semiconductor research at universities, will open its membership to foreign manufacturers. However, there are two provisos—the foreign company must pay a fee reflecting its IC production or consumption, and it must also offer other members the right to participate in similar cooperative programs in their country. Japanese firms are not expected to join since they would have to share their R&D gains with their U. S. competitors.

Another effort

To challenge the Japanese threat to dominate the world computer and semiconductor markets with their fifth-generation computer project, 16 major U. S. electronics firms met in late February to formulate a joint R&D venture [*Electronics*, March 10, 1982, p. 97]. The meeting, provoked by Japan's onslaught of the U. S. memory market, proposed a consortium composed only of U. S. companies involved in semiconductor fabrication, manufacturers of semiconductor production and test equipment, and computer manufacturers.

The venture, to be called Microelectronics & Computer Technology Enterprises (MCE Inc.), parallels Japan's arrangement of combining and assigning research efforts among members rather than allowing individual firms to each seek separate paths and consequently dissipate talent and budgets.

Despite the fact that the joint venture will not make anything—its charter is to research such areas as materials, quality control, and processing—obtaining antitrust clearance will be an issue. With investment capital scarce, interest rates soaring, and engineering personnel overworked, cooperation among MCE members would yield enormous benefits at a most opportune time. CDC's chairman, William C. Norris, who organized the meeting, firmly believes that "if the U. S. doesn't move forward successfully, it will suffer irreparable losses in both domestic and international microelectronics and computer markets."

Jerry Sanders of AMD considers the MCE venture a self-help operation that will allow more research activity per dollar invested than any individual company could yield. Charles E. Sporck, National's president, looks for MCE to provide "more bang for a buck."

SPECIAL REPORT

VLSI shifts its focus from fabrication to function



semiconductor technology is undergoing a gradual but nonetheless profound transformation. The era of very large-scale integration is shifting the focus of integrated-circuit makers from the processes by which the ICs are made to the functions users want them to perform. This transformation is worldwide, as

VLSI takes hold in Europe as it has in the U.S. and Japan. Fueled by advances in design automation, chip makers will move to take full advantage of the system-level integration possible with VLSI technology. Under the microscope, the circuits of the future will look more or less like those of today—smaller dimensions, to be sure, but with the transistors and other devices behaving no differently. When the microscope is pushed away, however, the naked eye will see a layout characteristic of a new design philosophy, one developed to cope with the awesome ability to integrate an entire system on a single chip. Successful companies will necessarily concentrate on functional IC definition, customer interaction, and applications, rather than on lithographic shrinks and processing tricks.

Not all industry observers believe that chip makers will be able to exploit the capabilities of VLSI fully. Prominent among them is Gordon E. Moore, chairman and chief executive officer of Intel Corp., Santa Clara, Calif., who once said that, beyond memories and microprocessors, he could think of no obvious use for VLSI. He still holds that view today.

“When you get to the million-transistor-on-a-chip level, it’s very hard to define what a circuit should do,” he says. “You can always make a bigger memory or add more memory to a microprocessor, but to define a circuit with 500,000 transistors takes a tremendous amount of time.”

Will Moore prove right? The betting is that chip makers will find uses for VLSI beyond memories and microprocessors, once the design emphasis on functionality takes hold. However, commodity random-access and read-only memories will continue to be reliant on leading-edge process technology.

Changes in commodity memories will occur, causing one manufacturer to outdo another, but such changes will likely be process-related, rather than on the systems level—denser cells, for instance. The functional trend for

Now that the process technology has matured, the industry needs to discover more good uses for very large-scale integration

by John G. Posa, *Contributing Editor*

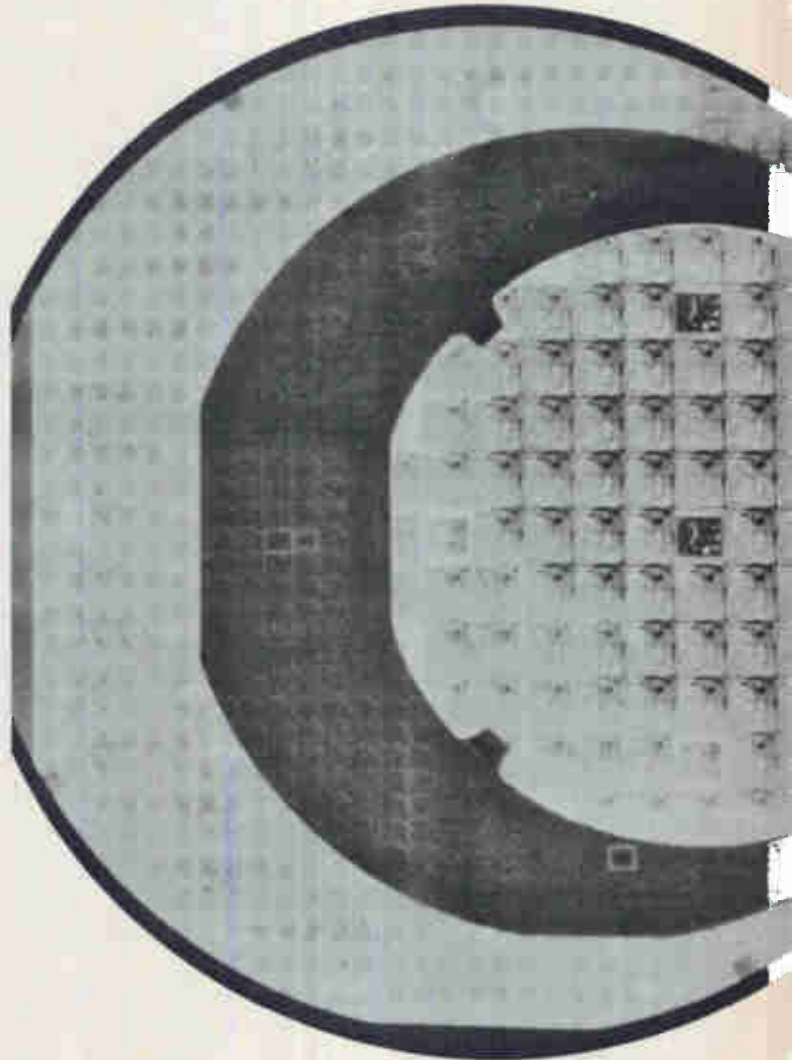



Devil's advocate. Intel Corp.'s chairman Gordon E. Moore still thinks it's going to be difficult to fully exercise the potential of very large-scale integration. It is always possible to make a bigger memory, but to define a 500,000-gate chip takes tremendous time.

these memories more or less has been established: squeezing more bits onto a chip.

The course in functional specification of logic components has hardly been set, however. At lower levels of integration, components were general enough to appeal to a broad customer base. Users could select a basic logic engine, such as a microprocessor, and build up a system by adding memories, support devices, and various "glue" chips. Such a method continues to be the most effective approach to system integration. With VLSI, however, the microprocessor, peripheral devices and glue chips—even memories and software programs, in some cases—may be integrated onto a single chip.

Users would still benefit from increasing levels of integration—that much has not changed. However, this subsystem integration means that the combination of the various functions must be implemented by the IC manufacturer, rather than the user. Somehow, then, logic, memory, and input/output functions must be selected and embedded onto a chip that will appeal to a wide audience.

In some respects, the evolution of the single-chip microcomputer illustrates the trend toward greater integration. Central processing unit, memories, and I/O sections have been packaged by the IC maker with much success.

But even with more refinements, the single-chip microcomputers of the future still should be standard components. They will not be exactly what the doctor ordered, but with some added specialized components and custom programs, they will suffice—or will they? After all, IC users have been forced to put up with standard components because they have traditionally offered the lowest cost per function.

VLSI, on the other hand, in conjunction with a comprehensive design-automation system, offers the possibility of integrating a user's entire system onto silicon—not

just the microcomputer, but all the specialized I/O drivers, even analog portions. Software routines, too, could be built right in or even replaced with faster, hard-wired logic at little added cost. Such a capability is nearly in place, but the IC maker must find out exactly which functions the user needs and how to profit from very low volumes of user-specific chips.

Chip makers will find out what users need by getting them more involved in the design cycle or by getting into the systems business themselves, thereby becoming their own customers. To produce the small lots of application-specific chips, they will increasingly turn to computer-aided design in order to maintain profitability. By collecting descriptions of standard functions in CAD circuit libraries, chip makers will be able to offer particular solutions to problems that would not have been economically inviting in the past. One result will be a diverse new breed of quasi-standard components, brought to the market more quickly than in the past.

In addition, IC makers will use semicustom logic like gate arrays to accommodate a number of differing application requests. The logic-array business has already gotten off to a healthy start, and some predict that it will account for up to 10% of the world semiconductor business in just a few years. Such a serious endorsement of logic arrays would prove that the industry is becoming less concerned with process technology, for already as much as one fifth of some arrays go unused in the implementation of a customer's design.

Diversify, diversify

Logic arrays will grow more diverse, with some versions including dedicated memory and even CPU subsections. Thus they will grow to resemble single-chip microcomputers, with the customer creating all but the most basic modules. In addition, more of the array-definition software will be put in the hands of the user through remote terminals, easing the manufacturer's burden.

Some observers envision the day when IC users will be able to design their own custom chips from the top down. After all, once they gain access to IC design tools via work stations, there is no telling how far they will take their design capability. Perhaps the same function libraries used by chip makers to configure standard components will ultimately be at the disposal of the users, or perhaps they will build up their own cell libraries.

No matter how the design responsibility is shared, CAD capability does not necessarily demand in-house process expertise. Design data could be shipped off to a silicon foundry for processing. Such a facility would possess the most advanced lithography and other manufacturing equipment, saving the IC designer the expense and worry of remaining competitive in wafer processing.

As a result, process technology will not drive the market, as it so often has in the past decade, when "anybody bringing out anything new had a fantastic impact on the market," recalls Francis Carassic, director of commercial semiconductors for CIT-Alcatel in Paris. "Each time a company made a technological change, they turned over 30%. If they switched from metal gates to silicon gates, they increased their business 40%."

But the market configuration is changing, Carassic

Quality and reliability: how the West caught up

Some two years ago, Richard Anderson, then general manager of Hewlett-Packard Co.'s Computer Systems division in Cupertino, Calif., announced that testing of 300,000 16-K random-access memories from three of U. S. and three Japanese vendors had turned up higher incoming and field-failure rates for the American components. That statement has become the shot that began the so-called U.S.-Japan quality and reliability war. The reaction to Anderson's indictment was in three phases: outrage, then quiet admission, and finally hard work to correct any Q&R problems that might, in fact, have existed. The hard work paid off—in only seven months, Anderson could say the gap about halved [*Electronics*, Nov. 6, 1980, p. 46].

The issue has faded, but the need for high quality and reliability has not. Indeed, these characteristics have been added to a semiconductor's list of qualifiers, along with its speed and power-dissipation range. It is also felt that with very large-scale integrated circuit parts—particularly custom and semicustom ICs—even more work will be required to maintain present high Q&R levels.

Actually, some never believed that the Japanese were capable of higher quality, and still do not feel they are. Intel's chairman Gordon E. Moore does not think there was ever a gap between the U. S. and Japan in terms of quality and reliability. "The differences in incoming quality from week to week at any single vendor were greater than the differences from nation to nation. There was no U.S.-Japan quality issue; there was a lot-to-lot quality issue and the industry as a whole has made much improvement."

Some Europeans echo Moore in their view of the relative quality of their parts *vis à vis* the Japanese offerings. For example, Lubo Micic, who is managing director for International Telephone & Telegraph Corp.'s Semiconductors Group in Freiburg, West Germany, says, "I don't think we have a quality and reliability problem. I think it's a problem of correlation between vendor and user testers. . . . We

need more outgoing inspection—like testing two or three times."

Though quality and reliability mean different things, they are related; a higher-quality device will likely last longer in the field. Quality is likewise related to device yield; painstaking care during fabrication results in the obvious: more good chips. Merrill W. Brooksby, manager of corporate design aids for Hewlett-Packard Co. in Palo Alto, Calif., believes "yield, not lithography, is the biggest technological problem facing IC vendors. In most cases, U. S. vendors don't even believe the reliability and yield numbers coming out of Japan—or they don't comprehend those numbers. In my opinion, those yields are there."

Also in agreement that Japanese quality levels have been superior is Fred Blum, president of newly formed Gigabit Logic in Culver City, Calif. However, he adds, others have caught up. "If the Japanese hadn't come along, we'd have had to invent them. Their standards in semiconductors are far higher. We must stick with this quality level now that we've come up to it."

Most non-Japanese IC producers agree with Blum that U. S. and European companies have done a remarkable job of raising the quality and reliability of their components to the high levels reached in the Far East. Intel's Moore feels that "the quality and reliability issue has almost retreated to a nonissue." The challenge now is to retain the levels of quality reached or even to surpass those of foreign competitors.

Jean-Paul Meyer, corporate procurement strategy manager for mainframe maker CII-Honeywell Bull in Paris, says, "We have a large number of sites and we would have had to change our maintenance policy if there had not been an increase in quality at the component level. The Japanese have been leaders in that area. But some U. S. plans have succeeded already, and that is putting more pressure on all vendors. We can almost avoid testing some lots now coming in."

says. "Now we're in the industrial phase." He characterizes this phase: "The 8080 [microprocessor] is now used like 7400 [-series TTL] logic, and nobody cares except the purchasing department; engineers are no longer involved with the decision to buy even some very complex devices." He cites three generations of electronic components: TTL, from 1965 to 1970; large-scale integration in the early 1970s; the microprocessors and memories from the mid-1970s to the present. "Now we are repackaging third-generation stuff or developing systems with semicustom logic. Intel reached \$800 million, but now what can they invent for a 30% increase?"

A change in focus

What Intel is doing is to put a new emphasis on system-level design (it may well be that Gordon Moore is acting as devil's advocate in his comments on the application of VLSI). Certainly the company is not alone, and leading technologists around the world are already assessing the impact of the change in focus from fabrication to function.

Tadaaki Tarui, chief engineer for the semiconductor division of Toshiba Corp. in Tokyo, says, "Our definition

of VLSI is [simply] more than 10,000 devices. From our viewpoint it is an evolution; but from the viewpoint of the user, it is a revolution."

"VLSI is a natural evolution if you look at die size and feature size," remarks Sven E. Simonsen, vice president and technical director of Advanced Micro Devices Inc., Sunnyvale, Calif. "But there is a quantum step regarding how much of a system you can put on a chip—this is not evolution."

As for processes, "it is not like the mid-1970s where semiconductor manufacturers were fine-tuning what they had," says Raphael Klein, president of the nonvolatile-memory start-up Xicor Inc. of Milpitas, Calif. "This is no longer an IC business," contends Irwin Federman, president and chief executive officer of Monolithic Memories of Sunnyvale, Calif. "It's an integrated service business."

The consensus among chip makers is that the timely application of semiconductor technology is now as important—if not more critical—than the processing of silicon. The most pressing need now is to understand users' needs and get them more involved in the design process. In some cases, this means semicustom approach-



Industrial phase. Francis Carassic, director of commercial semiconductors for CIT-Alcatel in Paris, France, says the industry is now in the industrial phase. "Now we are repackaging third-generation stuff or developing systems with semicustom logic."

es to chip design; in all cases, it means a heavy reliance on design automation.

"I'm convinced that the key to VLSI design is CAD capability," says William O'Meara, vice president of marketing for LSI Logic Corp., Milpitas, Calif. "The fab line is a second-order priority. Now, in high-production fields like 64-K RAMs, fabrication is important; but on VLSI chips where volumes might be 10,000 per year, timely design will be much more critical."

This view is echoed by Howard W. Cotterman, vice president for microcomputer products at Rockwell International Corp.'s Electronic Devices division in Anaheim, Calif. "In the next few years, we'll be more limited in our ability to provide products by the time to market than by design problems. CAD will be a key factor."

The complexity of the designs is the stumbling block, believes Douglas Fairbairn, director of VLSI technology at VLSI Technology Inc. of Santa Clara. "VLSI is not a simple extrapolation from previous design," he says. "When you change a problem by factor of 10, it becomes a qualitatively different problem. We need different [CAD] tools."

Process changes continue

Of course, fabrication technology will always be important, but advanced lithography and processing are increasingly seen as requisites for remaining in the business, rather than as the keys to a competitive edge. Technical achievements at the silicon level will come, but in the mid-1980s and beyond they will arrive occasionally, rather than continuously as they did in the last decade. For instance, the switch away from optical lithography to a more advanced form of exposure will take place, but it will not happen as rapidly as once predicted (and it will also probably be in the direction of



Micic's law. Lubo Micic, director of ITT Semiconductors in Freiburg, West Germany, uses this diagram to distinguish semiconductor companies. Devices built with advanced technology that create a new market (upper right), have the highest average selling price.

X-ray, rather than electron-beam, techniques).

Gallium arsenide will no doubt be exploited for faster commercial LSI and VLSI chips, but the delay that GaAs has already experienced en route to the merchant market is due as much to functional uncertainty as it is to processing roadblocks. Indeed, it is the same situation—in terms of the function crisis—that silicon is facing: what to put on the advanced new ICs.

After all, maximizing yields is still a pressing problem for silicon VLSI chips. The controversy over higher levels of quality and reliability in Japanese dynamic RAMs died down. However, it is on its way to becoming moot, as U. S. semiconductor manufacturers refine their production expertise. (see "Quality and reliability: how the West caught up," p. 143).

A mature process

That even smaller semiconductor companies can now master multiple-mask MOS and bipolar technologies is indicative of a maturation of silicon processing. Denis McGreivy, semiconductor department manager of the market research firm Gnostic Concepts Inc. of Menlo Park, Calif., cites four reasons why "the manufacturing technology of silicon chips is beginning to show signs of approaching middle age."

For one, the cost of polished silicon wafers has essentially bottomed out, preventing manufacturers from saving very much money on basic materials. In addition, trends toward larger-diameter wafers will cause the total number of wafers processed to flatten around 1983 and remain relatively constant throughout the rest of the decade. Problems with die flatness and power dissipation will soon limit chip size and raise packaging complexity and cost; and finally, on-chip interconnection impedance and crosstalk between conductors will impose a limit on

the speed and complexity characteristics of conventional ICs some time early in the next decade.

"The saturation in these four basic IC manufacturing parameters" is affecting the way chips are designed, fabricated, packaged, and tested, McGreivy holds. For example, the efficiency of design tools must be raised, he says, from the current 50 to 100 transistors per day to a staggering daily rate of 10,000 devices by 1990. In addition, there will be a shift away from batch-mode wafer processing to single-wafer processing. These demands, plus assembly and circuit-evaluation complexities, will result in "a major shift toward fully automated approaches in all phases of IC manufacturing."

With processing technology capable of producing systems on chips, semiconductor makers are being chal-

lenged to become systems designers. "The cost of VLSI chip development is now half the cost of system design. Five years ago it was only 10%," says Lubo Micic, managing director of International Telephone & Telegraph Corp.'s Semiconductors Group, based in Freiburg, West Germany.

As a result, "the day of the supplier designing the chip is passing—now it's the customer who makes the definitions," adds LSI Logic's O'Meara. Thus, "designers of products must have access to [IC] technology. Survival dictates that they will, and the urgency of this need has recently become more widely recognized," says Carver Mead, the professor at California Institute of Technology in Pasadena who has been an outspoken proponent of a more structured IC design methodology.

Standard components still cry for the finest features; application-specific memories, microprocessors are coming



One change already apparent from the impact of VLSI technology is the diversification in IC offerings across all product lines, including memories and microprocessors. With modern memories capable of storing tens of thousands of bits and more, on-chip intelligence simply no longer

presents the overhead problem that it once did. Some chip makers already are moving to provide certain memories with features to make them more versatile, economical, or easier to use. Standard microprocessors have become accepted to the point of there being a shakeout at the 16-bit level. However, a new generation of specialized single-chip microcomputers is springing up for jobs like digital signal processing. New designs intended to ease the man-machine interface through architectural novelty have also been promised for this decade.

New cell and circuit designs have raised the density of electrically erasable programmable ROMs, opening up new applications and entrepreneurial opportunities, as well. The current crop of EE-PROMs is adding nonmemory circuits for easier interfacing, such as charge pumps for 5-volt-only operations and latches and timers that allow storage locations to be automatically altered upon receipt of an address and data.

In addition, manufacturers have already begun to put their EE-PROM cells and support circuits into nonvolatile RAMs—or shadow RAMs. Soon system designers will be able to choose from a variety of fast, static-looking RAMs that remember their data *sans* power supply.

With circuitry for self-refreshing and bus arbitration, a dynamic RAM, too, can be made to appear static—but

at a much lower cost per bit than a fully static part. This cost savings is, of course, the reason behind the interest in the part called the pseudostatic RAM.

Some observers foresee a merger of pseudostatic techniques and EE-PROM technology. One result might be an almost ideal nonvolatile RAM. With dynamic RAM cells, it would exhibit a low cost per bit; the self-refreshing would make it appear fully static; and the EE-PROM elements for each cell would result in nonvolatility.

Intel's Moore has another idea: "With the present complexity of memory components, you could build an on-chip tester. Memories today have up to 500,000 transistors; if you could add only 10%, you would have 50,000 transistors, and with 50,000 transistors you could build a pretty good tester."

"Already the issue of intelligent memories is popping up," says Walden C. "Wally" Rhines, advanced development manager and assistant vice president of Texas Instruments Inc.'s Semiconductor Group in Dallas. He believes that TI is selling a lot of memory in the form of TMS1000 and TMS7000 single-chip microcomputers. "People buy them for the kinds of things you buy a memory for; but instead of using them as just a ROM, they will use them for intelligent functions, too."

Stay in commodities

In addition, smart memories may also give manufacturers relief from the pricing pressures of commodity memories. However, the desire to pull out of price-eroded high-volume memories is tempting but dangerous. To stay on top in technology, the IC supplier of the 1970s often used a commodity component like the dynamic RAM to shake the bugs out. Dynamic parts most strongly present the conflicting requirements for the highest volume and the tiniest features; thus, if a chip maker could succeed in the RAM business, it could make just about anything else profitably.

Some companies still contend that success in the high-volume RAM business is necessary to retain a technologi-

Smart part. One direction for memory technology is to incorporate circuits to make the device more economical or easier to use. One such intelligent memory is the self-refreshing integrated RAM, or iRAM, from Intel Corp. It offers a low cost per bit but interfaces like a static RAM.

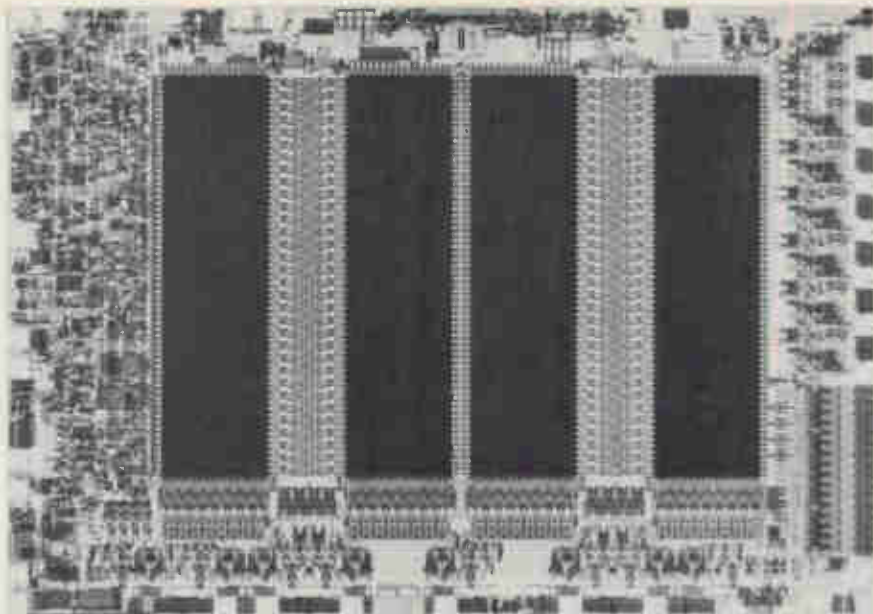

cal lead; others say that relinquishing such products will not necessarily have harmful effects. Gernot J. Oswald, director of semiconductor components marketing at Siemens AG in Munich, West Germany, says of the 64-K dynamic RAM: "We probably won't make much money on the device. But that's not the reason to stay in the business. It's a technology leader and a volume leader."

Regarding firms that are pulling out of the dynamic RAM business because of the fierce competition, Oswald says, "We would be willing to break even in terms of revenues in order to master the technology" of the 64-K RAM. His boss, E. h. Ulrich Haier, executive vice president of Siemens's Components Group, adds that "in a very short time, you will have a 64-K RAM as part of a more complex chip. It's a good thing to have in your library. I think we can do it. I think we should do it."

Some industry leaders believe that ICs other than memories and microprocessors can be used to fine-tune a company's process technology. "Sure, you need high-volume parts, but telecommunications and automotive devices are high enough in volume," says Paul Mirat, chairman and president of France's Thomson-EFCIS.

"Dynamic RAMs, as a technology developer, apply only to n-channel MOS, and leave out 70% of the market," comments W. C. J. van 't Hoff, senior managing director of the Electronic Components and Materials division (Elcoma) of NV Philips Gloeilampenfabrieken in Eindhoven, the Netherlands.

"Companies who believe success is hinged on technology keep getting burned—especially in Europe," states Rüdiger Karnatzki, director of IC operations at ITT's Intermetall division in Freiburg, West Germany. "There is no need to be in the forefront, because there is still much to be done with existing technology. Take the digital TV." ITT is now perfecting a chip set that will implement the signal-processing sections of a digital television receiver [*Electronics*, Aug. 11, 1981, p. 97]. "The chips use 3-micrometer technology—with the possibility of shrinking—but it's not the forefront," Karnatzki says. "Three-micron technology was ready three

years ago, but this product would have been too early."

Recent microprocessor and single-chip microcomputer innovations also seem to stress specialized architectures to solve specific problems—ITT's digital TV is only one of many examples. Although standard high-performance microprocessor families are taking firmer root, a batch of specialized signal processors is on the way for speech I/O, image recognition, and other computation-intensive applications. At the 32-bit level, data-flow architectures, rather than the standard von Neumann partition into CPU and memory, and machines designed for parallel processing and networking are also expected.

Major 16-bit microprocessor families have already become so established that the success of a new, proprietary architecture appears doubtful. Some even foresee the demotion of the Z8000 to the second tier, leaving Intel and Motorola to battle it out with their 8086 and MC68000 machines, respectively. Even though National's NSC16000 microprocessor has recognized advantages, such as true virtual-memory support and exceptionally easy programming, it also will have a tough row to hoe.

The 16000 should get a fresh start in the 32-bit generation, though, which promises a new wave of architectural diversity. Besides 32-bit extended versions of the conventional architectures to be marketed by Motorola, Intel, Zilog, and other major chip vendors, specialized object-oriented and parallel-processing machines will vie for the attention of prospective users. As the chip manufacturers scale up the sophistication of their designs and support them with software and services, the anticipated clash between IC makers and systems houses will attain a new degree of significance.

The investment in software for a particular microprocessor family is forming ever-stronger bonds between chip makers and OEMs. "When you choose a microprocessor, you choose a microprocessor family and a company," says Jean-Paul Meyer, corporate procurement strategy manager for CII-Honeywell Bull, Saint Ouen, France. "Now we're talking about a CPU in the form of a



Transputer maker. Ian Barron, cofounder of Inmos Corp., believes that new architectural approaches to microcomputer design can ease the programmer's burden more than embedding software routines in silicon would. So his company is building what it calls a transputer for networks of processors.

chip, and the high development costs sort of preclude choosing more than one CPU. Also, compatibility with your older machines means that you have to choose the microprocessor that programs most easily for you."

Intel's chairman Moore believes that it is now next to impossible to introduce a new microprocessor family. "We have our 8086 family and the 432 [32-bit object processor], Motorola has its 68000, and the others are outside looking in," he says flatly. The mere presence of the object-oriented iAPX432 shows that microprocessor makers are looking to architectures other than those of minicomputers and mainframes to reap all the benefits of being able to put wide-word systems onto silicon.

Other semiconductor manufacturers such as Texas Instruments are also identifying problem areas in need of dedicated CPUs. Indeed, TI's Rhines maintains that there will be more microprocessor device families—not fewer. "We are going to have specialized architectures for special applications, and people will very quickly move through—or even around—the general-purpose 16- and 32-bit microprocessors," he says.

Interestingly, at least one Japanese executive—from Nippon Electric Co., Tokyo—sees things in much the same way as Rhines and other U.S. managers. "The 4-bit versions have been standardized, but 32-bit models should be custom because of individual applications in telecommunications and data processing," says Tomihiro Matsumura, senior associate vice president. "We will have to prepare a completely different 32-bit microprocessor for each use—it will be difficult to prepare one standard component."

Enter digital signal processors

European companies have had little success designing proprietary microprocessors, whereas some Japanese companies have been successful with their own 4-bit single-chip microcomputers. NEC and Matsushita Electronics Corp., Kawasaki, Japan, have even designed proprietary 16-bit machines—albeit with limited commercial success outside Japan. However, digital signal pro-

cessing is a niche where some European companies will have new chance to stake a claim. Companies like Philips and Intermetall already lead the way with digital signal-processor chips that have been designed for TV applications.

Digital signal processors have long been valuable for military applications such as radar and tracking. Their utility is increasing, in fact, as evidenced by the large number of contracts for them awarded under the Department of Defense's Very High-Speed Integrated Circuits (VHSIC) program. Commercial applications are expanding also, because of the current boom in speech processing, image recognition and generation, and robotics. A likely development is a generalized architecture—perhaps with on-chip conversion from and to analog signals—though demanding applications will continue to warrant dedicated hardware.

Unlike conventional microprocessors, which evolved from the world of logic replacement into general-purpose functional controllers, signal processors are necessarily more computation-intensive. After sampling an analog signal at high speed, the digital counterparts of analog signal manipulations like filtering, correlation, and various transformations can be performed in real time with a high and consistent accuracy, much more immunity to temperature and component aging, and so on.

To perform such functions, these processors must be able to carry out numerous wide-word multiplications and additions each second. Thus an expanded arithmetic and logic unit must be coupled with a direct, pipelined architecture and a method of programming that minimizes execution time and software bottlenecks.

Competition in signal processing should be healthy in the coming years. Besides NEC, TI, and the emerging Europeans, American Microsystems Inc. of Santa Clara, Calif., Western Electric Corp., TRW Electronics Systems of Redondo Beach, Calif., Hewlett-Packard Co.'s, Cupertino, Calif., facility and Matsushita have so far reported on VLSI solutions to digital signal processing.

At Analog Devices Inc., Norwood, Mass., "we're now

putting together a digital signal-processing capability and expect first products from that facility by this summer," reports Heinrich F. Krabbe, vice president of new product development. "The emphasis here is on designing digital front ends to offload computers in functions like filtering and fast Fourier transforms."

Analog processing will not disappear because of digital processing techniques, however. "VLSI is making it possible to substitute digital signal processing—with its built-in accuracy—for many analog functions," notes Krabbe, "but analog will always be there, and simpler, custom linear ICs will continue to fill market needs so well that VLSI won't make a dent in that area."

Functional revision

In considering VLSI's ability to integrate an entire system onto silicon, forward-looking companies in the microprocessor business believe that data processing should be reassessed to determine if a different functional partitioning will increase throughput or ease the programmer's burden.

"In the mid-1960s," recalls Intel's Moore, "mainframe makers tried to cut a computer apart into sections. They defined many blocks, each with lots of pins. We [the semiconductor industry] came up with standard parts like memories and microprocessors that enabled more people to build computer-based systems, but we didn't solve the mainframe maker's problem. The poor guy still has to go his own way."

Inmos's Colorado Springs, Colo.-based chairman

Richard Petritz believes that "microprocessor makers have really taken minicomputer architectures and put them on chips and in so doing have not arrived at a useful system building block. In fact, this is why many of these companies are finding that they are getting into the systems business themselves."

Inmos is therefore working on what it calls a transputer: a microprocessor that should ease coding problems by the nature of its new I/O-intensive architecture. "With the present level of integration, we can exploit the scale of complexity by finding quantitatively different levels of interfaces with the programmer," states Inmos cofounder Ian Barron, who works out of the company's Bristol, UK, offices.

Intel's 432 is another attempt to design a system building block that relieves programmers of time-consuming coding problems. The chip set embodies operating-system and executive-software constructs that are intended to simplify interprocessor communications. In addition, it allows high-level language execution to circumvent the confusion of machine- or assembly-language programming.

However, Inmos is taking "an entirely different philosophy than [Intel did] on the 432," Barron explains. "In the design of a microprocessor, you have to distinguish between complexity and complications." The former has to do with transistor count and the latter, with how hard a part is to use. "Complexity comes from software design, so embedding software constructs into silicon can only complicate things."

Logic arrays ease the interface between the IC makers and users; semicustom logic may yield to wholly user-defined VLSI



learly, VLSI and the integration levels beyond will unleash unprecedented data- and signal-processing power on a single chip or chip set. Many industry leaders see a quantum change in the works that represents a sharp break with past design philosophies.

"Up to now we have been building only sequential systems—systems in which only one or a very few things happen at the same time," says Cal Tech's Mead. "It is clear, however, that sequential systems will not be adequate in the future. The reason is that there are an additional four orders of magnitude in computational capability available through concurrent systems. VLSI technology can replicate an enormous number of processors at low cost. Pretending that everything placed on one chip must be one sequential activity is insanity."

"It's our opinion that the LSI level was not a high enough level of integration to produce useful new system building blocks—with the exception of memory," remarks Inmos's Petritz. "VLSI really involves the creation of new building blocks for systems."

"The device count of VLSI is not used just to achieve functional addition of things that were on other chips or to increase performance," adds TI's Rhines. "You are putting in architectural sophistication that increases ease of use and enhances reliability and testability."

"Take a look at some of the telecommunications products we are coming out with, like the modem or codec-filter," says AMD's Simonsen. "They require a lot more front-end engineering—more mathematical modeling and emulation to check the design. With the modem, it took a lot more work to prove out the concept than we've been used to before. It took almost 10 man-years before we got to the schematic level on the modem—and that's with extensive computer help. The ratio of product-definition engineers to circuit designers is changing; we have many more product-definition engineers now."

A VLSI chip presents a huge design task, and it is truly difficult to utilize its functional capacity and still retain mass-market appeal. Thus the notion of a new genera-

tion of standard parts gives some industry leaders pause—but many others expect high-volume ICs to continue to be key products.

“As the complexity of chips increases, the complexity of the overall system will increase as well,” says Gerald P. Dinneen, corporate vice president of science and technology at Honeywell Inc. in Bloomington, Minn. “As long as the one is greater than the other, merchant manufacturers will be able to supply the lower tier with standard VLSI chips.”

Jeffrey C. Kalb, leader of Digital Equipment Corp.’s LSI group in Hudson, Mass., comments, “We’re seeing a lot of activity in innovation and experimentation with design for semicustom systems. I think over time we’ll have a shakeout, and new standard parts will emerge. It’s always been difficult to define standard chips with wide appeal.”

“The thrust of the industry is, and will remain, with high-volume parts,” maintains Inmos’s Barron. “Recent efforts underscore this. The wafer-stepper is not appropriate for low-volume production. Our aim is to make absolute standard components that can be programmed for various environments.” For this reason, Inmos has no plans to get into the logic-array business. Indeed, chairman Petritz contends that “the semicustom business will be reduced greatly with the introduction of the new breed of system components—like the transputer.”

The future of logic arrays

The future of the semicustom business is a hot topic, with controversy raging particularly about the significance of the logic-array business and the impact that it might have upon the semiconductor industry. Some simply write off the whole concept as a last-ditch effort for those companies unable to compete in the standard parts business. Others claim that logic arrays herald a fourth component revolution (after discrete semiconductors, medium-scale integration, and microprocessors) that should develop into a multibillion dollar market. Still others predict that logic arrays and the semicustom business will give way to a dramatic rebirth in the demand for custom chips once CAD tools are in place.

The advantages of arrays are well known, but now their drawbacks are being felt. They do allow a semiconductor manufacturer to process numerous wafers for a variety of applications in almost the same way, leading to high yield and to low-cost chips. On the consumer’s side, the arrays can be customized for a particular application, enabling a system designer to replace boards full of random logic in some cases, thereby saving considerable area and power.

But the hard part, and the part that will separate the successful from the not-so-successful, is the ability to turn the customer’s idea or logic diagram or schematic—or whatever—into one or more customizing masks. Merchant IC manufacturers see how well some computer companies apply logic-array technology, and they think that they can easily tap into that market. However, there is much more to the array business than hardware.

Paul Low, International Business Machines Corp.’s vice president and general manager of its East Fishkill, N. Y., plant notes that “arrays are absolutely essential

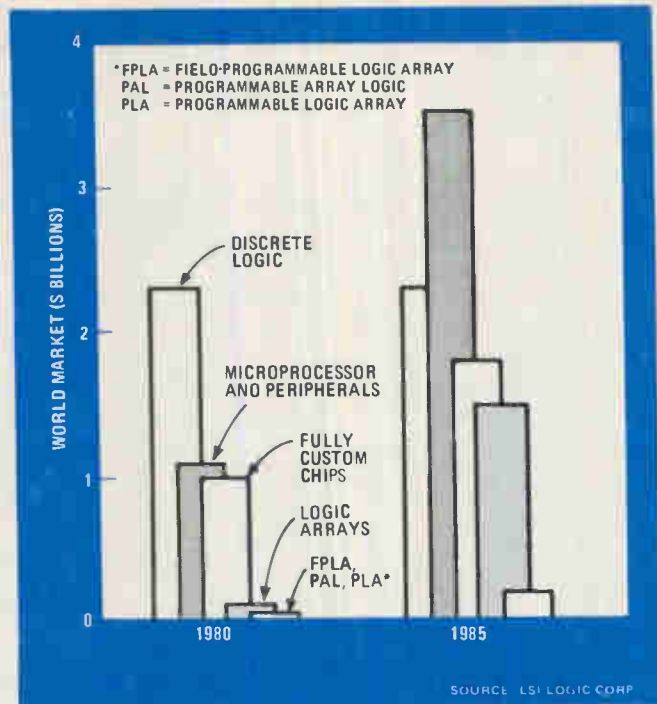

Arrays to the rescue. There is disagreement as to the effect that logic arrays will have on the semiconductor industry, but LSI Logic Corp. of Santa Clara, Calif., believes the market will be huge. Starting from today’s tiny base, it says they will reach \$1.5 billion by 1985.

and vital” to a computer company. However, he adds, merchant suppliers fail to appreciate the sophistication necessary to meet the design-automation and packaging requirements of the arrays.

IBM designers can ship the description of an entire logic system via satellite to East Fishkill, where the plant’s CAD facility will automatically partition the system into arrays, multilayer ceramic modules, and multilayer printed-circuit boards and then automatically derive wiring patterns and test programs for all of them. As for packaging, the latest IBM ceramic chip-carrier, 28 layers thick, can carry 133 ICs.

“People who think they can take advantage of gate arrays have not been successful in the standard parts business—they can’t apply today’s technology,” says ITT’s Karnatzki. “An intelligent and cost-competitive application of a uncommitted logic array requires a transfer from hardware cost to software cost.” In his opinion, only those original-equipment manufacturers that need the security against copying that is offered by a custom-wired chip will really benefit from the logic-array approach.

“There are 30 companies in it [the gate-array area] already,” sighs Intel’s chairman Moore. “I don’t feel a need to rush in. We’ve done some internal work on it, but we don’t have any unique advantage. One report I’ve seen [from England’s Mackintosh International] says gate arrays will be 40% of the semiconductor business. My personal opinion is that it will be more like 4%.”

O’Meara of LSI Logic holds the opposite view—undoubtedly because his company is banking on the array business. “From 1982 to 1985—and perhaps beyond—gate arrays will be the single most important

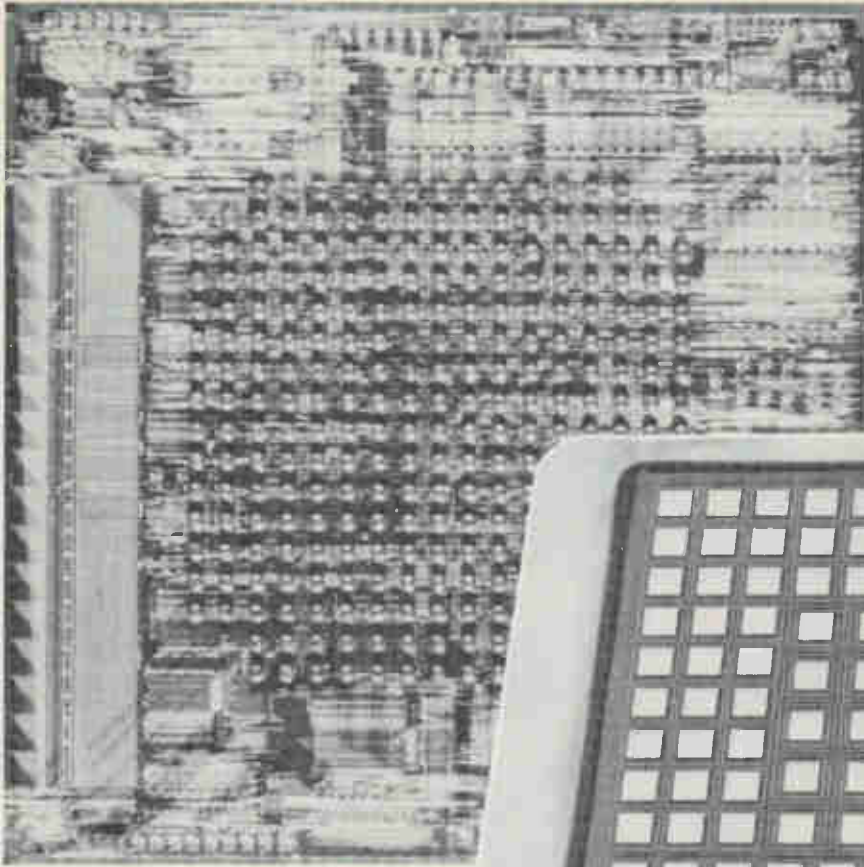

Populated. Paul Low, general manager of IBM Corp.'s East Fishkill, N. Y., facility warns that, unless VLSI chip makers master advanced packaging techniques, systems integration will be slowed. One of IBM's latest multilayer ceramic carriers can accommodate up to 133 VLSI chips.

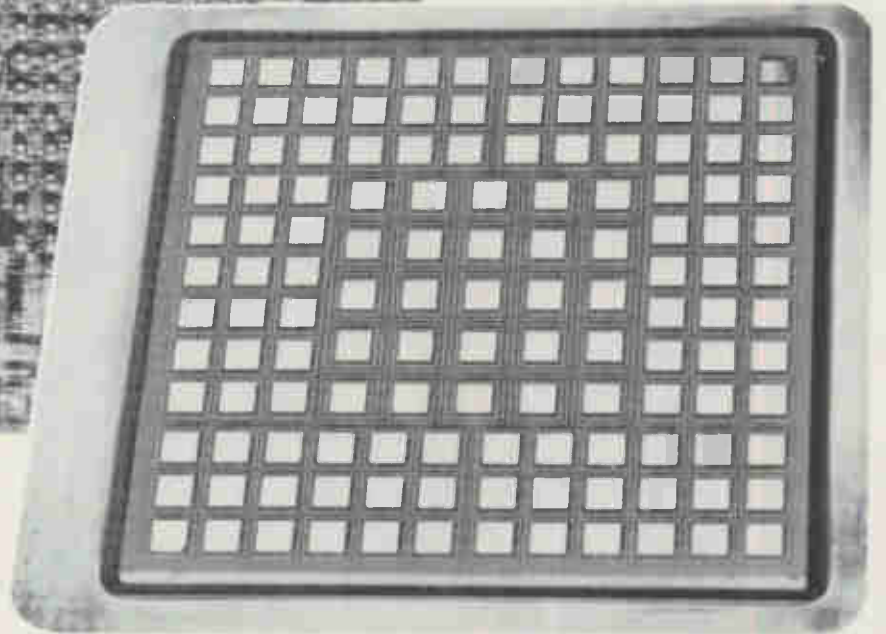

VLSI product," he says. "I expect the market for gate array to be greater than \$1.5 billion by 1985." Dataquest Inc., an industry-analyst group located in Cupertino, Calif., predicts that the gate-array business will account for 5.9% of the 1985 world IC market.

The UK's Ferranti Ltd. has been a merchant logic-array supplier longer and more consistently than perhaps any other chip maker. Brian Down, the company's marketing director in Oldham, Lancs., sees "semicustom on its way to becoming a mainstream business. We have been able to show a profit over the past seven years where others [not in the array sector] have showed a loss. If we were in the memory business, we'd be out of business right now."

Undeterred by any skepticism, numerous companies around the world are jumping on the gate-array bandwagon, and, as a result, "there will certainly be a shakeout in arrays," Down believes. He cites three qualifications for success in the business. The first is possession of wafer-fabrication facilities so that yields can be closely monitored.

A second requirement, one that is less obvious but nonetheless important, is flexibility: the ability to be accommodating to win over a customer. If Ferranti finds that the complexity of a user's circuit happens to fall in

between two of its standard arrays, it can easily create an intermediate array by adding or subtracting cells. The final criterion for success in the array business, according to Down, is a CAD capability that matches the complexity of the array product line.

Ian M. Mackintosh, chairman of industry analyst Mackintosh International Ltd., Luton, Beds., UK, is now winding up a report on logic arrays around the world. He says arrays have mushroomed in popularity for two reasons: the industry can now reliably make multilevel interconnections, and the chips can be wired effectively via CAD techniques.

Mackintosh says arrays are now changing the complexion of the semiconductor industry and that Europe stands to do well in the array business. "They've been clever on the software side—on the design side. Whereas the odds against Europe achieving world parity in the IC business are about 10 to 1, in the array business, they are more like 6 to 4."

Knowing that a flood of competition is on the way, European array makers have some highly ambitious programs to remain competitive. Ferranti has set some of the highest goals for itself, perhaps because the UK is already crowded with companies counting on the semicustom business. David Grundy, Ferranti's technical

Digital-TV man. Digital television, says Rüdiger Karnatzki, director of IC operations at ITT Intermetall, shows how technology can be used for new markets. ITT's digital-TV chip set would have been too early, had it been built when 3- μ m rules first became possible.

director for ICs, hopes to be "in production of 120,000-gate arrays by 1985. They will be about four tenths of an inch on a side," he says. Since today's biggest arrays comprise only a few thousand gates, Ferranti is talking about a whole new level of achievement in this area of semicustom design.

New applications for arrays

Some say that it will be difficult for Ferranti to pinpoint applications sophisticated enough to warrant such a huge matrix of gates, but Grundy feels that applications like Japan's fifth-generation computers project [*Electronics*, Nov. 17, 1981, p. 83] will call for the complex arrays. Moreover, "We've got a guy right now kicking our door down for a 10-K gate array in high volume," he says. Brian Proctor, head of the medium systems technology centre product development group for ICL Ltd. in West Gorton, Manchester, UK, says, "We could use a 10-K gate array right now. We already have a peripheral controller that uses an entire 8-K gate array."

Early opinion regarding Japanese competition in gate arrays held that it would be difficult for them to make significant inroads in the business because it requires a more intimate link between chip maker and user than Japanese plants enjoy with foreign OEMs. Since then, however, NEC has begun construction of a much-publicized multimillion-dollar fabrication facility in Roseville, Calif., that will be used to build "ROMs, microprocessors and single-chippers, and gate arrays," according to Keiske Yawata, newly appointed president of NEC Electronics USA. Moves like this are forcing array manufacturers to brace themselves for competition from the Far East. "The Japanese will be successful in logic arrays," states Mackintosh, "—no question about it."

When asked if the Japanese will have any luck in the logic-array business, Hervé M. Lhomme, director of sales for Philips's French subsidiary RTC-La Radiotechnique-Compélec, replies, "What? Are you kidding? They now compete in the pc-board business, and that's a custom business. Gate arrays are going to a worldwide business. What is a gate array but a pc board on silicon?"

"Gate arrays are a commodity," says Philips's IC marketing director Theo Holtwijk. "In fact, they are a replacement for boards on which commodity components are put. They will have tremendous growth, but before people know how to take full advantage of them, they may become obsolete."

By obsolete, Holtwijk means that other device types—be they standard or custom—may emerge as more economically attractive than gate arrays. Gordon A. Campbell, president of Seeq Technology Inc., a recent San Jose, Calif., start-up, sees a trend toward what he terms "soft custom": using a microprocessor and an EE-PROM to get the job done." The primary advantage of gate



arrays, he says, is a truncated development cycle and a quicker time to market. "But you could have EE-PROM logic arrays that could be programmed by the customer—this is the decade of programmability, and the trend is to nonvolatility."

Rockwell's Cotterman recognizes a similar trend. "In each generation, everybody has said we must go into custom, but a neat solution comes along. Custom won't be a panacea, but there will always be a place for custom. A big factor now will be EE-PROMS. They can be embedded into the architecture, so the user can configure his own system."

Rhines of TI explains that "our TMS7000 microcomputer family offers custom microcodes because people want an enhanced level of customizability beyond just writing a program into ROM. They want to go in and play with the architecture, and that customization is going to increase."

Some industry leaders hold that demands for customization by IC users will grow even more intense; that, with a good enough algorithm for automated gate placement



No doubt. Some think the close cooperation between users and makers of semicustom chips will thwart foreign intervention. Keiske Yawata, president of NEC Electronics USA, disagrees. NEC is putting together a multimillion-dollar U. S. plant that will wire gate arrays.

and wiring, fully custom chips—those whose entire mask set is unique—should become as economical as semicustom chips like gate arrays. “A very, very effective design automation system could displace the gate array,” maintains Honeywell’s Dinneen.

If this happens, silicon foundries might flourish as outlets to process small runs of specialized VLSI chips from various users. The current rise in captive semiconductor production can be construed as a demand for more custom chips; the systems companies building up or acquiring in-house fabrication facilities are just making sure they will have their own foundry for the upcoming era of user-designed VLSI.

One of the few direct formulas for equipping chip users with the tools to build VLSI circuits is the proposal by Cal Tech’s Mead and Lynn Conway of Xerox’s Palo Alto (Calif.) Research Center [*Electronics*, Oct. 20, 1981, p. 102]. Their push for a change in emphasis—away from silicon processing and toward functional IC design—has been termed a hierarchical or topdown approach.

Such a concept is not new. Software designers and even some chip makers are already using this approach, but some designers of IC hardware had never heard of it until recently. Mead and Conway explored, publicized, and legitimized hierarchical IC design as a foundation for a future standard.

The mature electronics industry will have a service component dedicated only to fabrication, according to Mead. It will have foundries that will fabricate chips, starting either with masks, pattern-generation tapes, or

higher-level commonly accepted descriptions of circuits. Their fabrication technology will be state-of-the-art, but they will be less expensive to use than to buy, maintain, and update proprietary facilities. Even firms with large internal production capabilities will benefit by going outside occasionally to keep both the fabrication and the design groups honest.

One of the first companies formed to preach the Mead-Conway design style is VLSI Technology Inc. Its Douglas Fairbairn acknowledges “confusion about what Mead-Conway is and what it is not. I see it as the method which allows systems engineers to participate in the [IC] design process. When you grow the number of transistors by a factor of 10, you grow the interrelations by a factor of 100 or 1,000. VLSI represents the tyranny of numbers.”

Indeed, some go so far to place layout philosophy above design automation—for example, Merrill W. Brooksby, manager of corporate design aids at Hewlett-Packard Co. in Palo Alto. “CAD tools are not the critical factor in VLSI design,” he says. “The critical factor is coming up with a good, consistent design strategy. You can spend a lot of time and money and not get to VLSI unless you have a good design strategy.” Interestingly, he feels that “with the gate-array approach, for example, you just can’t get there.”

Design strategy—the process used to go from an idea to an IC—is perhaps the outstanding consideration facing VLSI technology. If applications truly scale up in sophistication, then chip manufacturers will continue to recognize standard functions and turn them into high-volume circuits.

If users really must do their own designing, semicustom logic will undoubtedly increase in popularity. If that happens, the possibility does exist that OEMs will go on to create their own custom designs. Once the tools to automate and regiment the design process are in their place, more systems makers will be set to join the VLSI design parade.

Design automation aids are on the way, too, in the form of creative new layout methodologies, software packages for simulation and test-vector generation, and turnkey graphics work stations. But apart from radically different tools, existing ones must be employed more effectively. For example, the use of symbolic layout with available interactive graphics systems can greatly expand productivity. This kind of layout is easy to set up and does not require new software as it is strictly a design methodology.

Moreover, when a design tool is endowed with human-like attributes, conversation becomes natural, expressive, and stimulating. It encourages a designer to think of new possibilities and inspires him or her to explore. This kind of harmony should go beyond machine helping man to man helping machine, as there are tasks at which each individually excels. □

Contributions to the technology part of this special report were received from all Electronics’ field bureaus in the U. S. and overseas.

Reprints will be available at \$6.00 each. Write to *Electronics* Reprint Dept., P. O. Box 669, Hightstown, N. J. 08520. Copyright 1982, *Electronics*, a McGraw-Hill magazine.

MOTION AND ACTION.

From its inception, INTERSIL INSIGHT has provided news and information that is timely and important to IC users and specifiers. We've shown you Intersil's leadership position in linear CMOS devices, in power MOSFETs, in data acquisition circuits and low-power displays and drivers. We've told you about the incredible ICL7650 CMOS op amp, the ubiquitous ICL7660 voltage converter, and the world's only fault-protected multiplexer, the IH5108. We rarely confuse motion with action at Intersil, and in future issues of INTERSIL INSIGHT we'll continue to bring you news of new state-of-the-art semiconductor devices. And copies of back issues of INSIGHT are available, in case you missed them. For instance, check #9-A for INSIGHT 7 or #9-B for INSIGHT 8.

ULTRA LOW POWER 16K CMOS ROM PERFECT FOR MICROPROCESSORS

Our 2k x 8 IM6316 CMOS ROM is perfect for use with all CMOS microprocessors (both ours and theirs). It uses less power than any other 16k ROM—maximum 100 μ A standby and 10mA active—and its synchronous design saves an external latch whenever data and addresses are multiplexed, thereby keeping board space and component count to a minimum.

Anything else? The IM6316 replaces any of our popular CMOS EPROMs—the IM6654 (4k), IM6658 (8k), and the soon-to-be-introduced IM6716 (16k), for less than the price of the 4k. Also available is a 10 Volt version, for special voltage and battery applications. Access time is 450ns maximum, equal to the NMOS counterparts. And fast turnaround on phototypes too! For a data sheet on the IM6316 check #9-C.

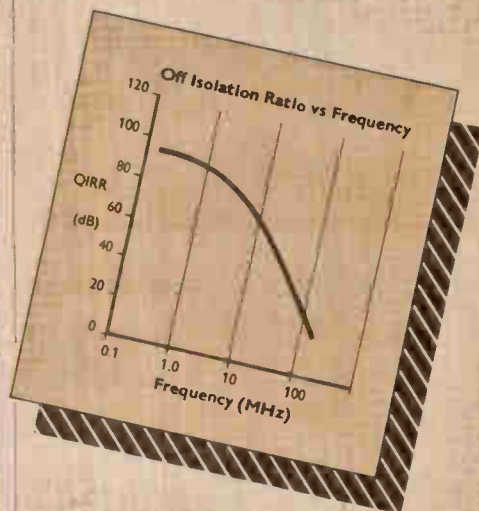

CMOS R.F./ VIDEO SWITCH: 70dB OFF ISOLATION

Meet our new IH5341 monolithic CMOS rf/video switch. This high-speed dual SPST switch (80/150ns typical) uses a unique series shunt T-switch configuration for good OFF isolation (70dB @ 10 MHz) while maintaining good frequency response in the ON condition. $r_{DS(on)} < 75\Omega$ from DC to 100MHz. Power supply current drain is typically less than 10nA, so you'll have design freedom in building remote and portable video equipment intended for operation under extended battery life conditions. T0-100 type packages are available for both industrial and military temperature ranges, with 100-unit quantity prices beginning at \$6.00. Check #9-E for additional information.

"Never confuse
motion with
action."

For our
Ben Franklin
poster,
check # 9-D.



Here's the World's Best 3½ Digit A/D Converter!

Here's backup for that somewhat immodest claim: The new Intersil ICL7136 does everything our Industry Standard ICL7106 and ICL7126 do—plus instant recovery from overrange resistance, current or voltage measurements in digital multimeters. The meter will display proper readings in only one conversion rather than the 1 to 5 second overrange recovery time range associated with previous DMM's. What's more, the ICL7136 can help improve the noise performance of your DMM design. With the ICL7136, you

can increase the auto-zero capacitance up to 1.0 μ F without undesirable side effects and it's an easy retrofit to ICL7106/ICL7126 sockets. The ICL7136 reduces maximum supply current to only 100 μ A, 18 times better than the ICL7106. Advanced CMOS construction means meter operation in excess of 8000 hours... nearly a year... on a single 9V battery.

Price for this little jewel: \$11.30 in 100-unit quantities. Just check # 9-F for more information.

EASY DIGITAL THERMOMETER

Build this simple digital thermometer. All the parts you need are a battery, a one-chip A/D converter, a display, and one of Intersil's new ICL8073/8074 temperature transducers. Use the ICL8073 for direct readings in degrees Centigrade, or the 8074 for direct readings in degrees Fahrenheit.

Each temperature sensor has three outputs. The first is proportional to absolute

temperature, in $^{\circ}$ K. The second provides the constant offset needed for conversion to the $^{\circ}$ C or $^{\circ}$ F scale. The third output is a reference voltage for A/D conversion in a ratiometric system, such as Intersil's popular new ICL7136 ADCs.

Your completed digital thermometer will run on a 9V transistor battery, with useful system life of at least six months.

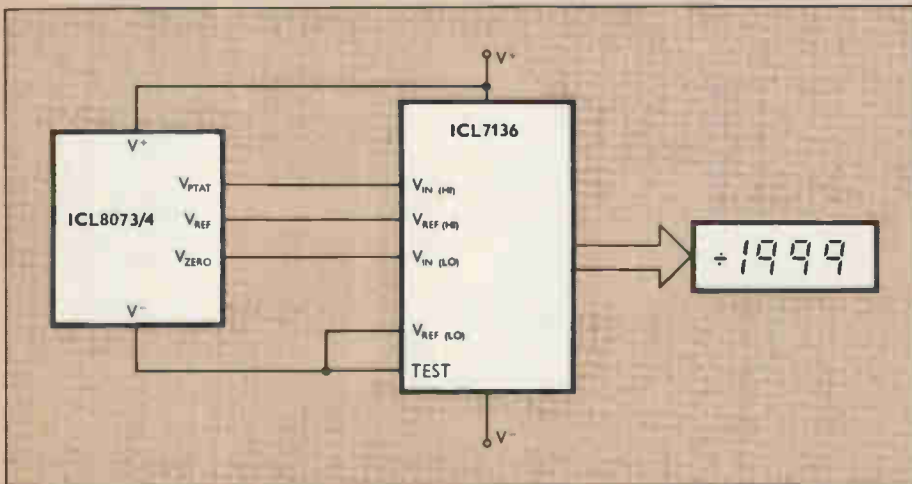

14-BIT MDAC WITHOUT LASER TRIMMING!

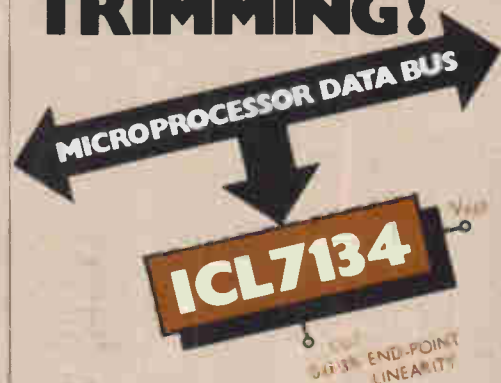

More than a 14-bit resolution Multiplying D/A Converter. This device combines a conventional DAC using thin film resistors and CMOS circuitry with an on-chip PROM-controlled correction circuit. Which means you get both 14-bit resolution and true 14-bit linearity without laser trimming. No gain adjustment needed. Plus, microprocessor compatibility with double-buffered inputs. All from Intersil in our new ICL7134.

Just look at these specs:

Non-linearity to 0.003% FSR max.

Non-linearity temp. coefficient:
1 ppm/ $^{\circ}$ C

Gain error to 0.006% FSR max.

Gain error temp. coefficient
5 ppm/ $^{\circ}$ C

Output current settling time:
900 ns

Plus it requires only 2mA supply current from +5V. Provides full four-quadrant multiplication.

Available in 3 low non-linearity versions:

J .01% max.

K .006% max.

L .003% max.

For unipolar applications, use the ICL7134U; for bipolar, the ICL7134B. Prices start at \$19.95, with the premium 14-bit device at \$35 each in 100-quantities. Check # 9-G.

**ROM HOTLINE
(408) 996-3116**

**ROM Prototypes
in Four Weeks!**

That's right! We guarantee that we'll deliver sample ROMs for prototyping within four weeks after we verify your codes of 8K, 16K, 32K or 64K devices. Code input can be punch cards, paper tape, mag tape, diskette or actual PROM/EPROM parts. Our HMOS 82HM181 and 82HM191 are direct replacements for bipolar 8K and 16K PROMS and the HMOS IM7332 and IM7364 are 32K and 64K devices with industry-standard access times, pinouts and power requirements. They're all price competitive, so call your nearest Intersil sales office or dial our ROM Hot Line phone number for a quote. For data sheets on all Intersil ROMs—high-density HMOS or low-power CMOS—check # 9-H.

**FIRST 8-CHARACTER
ALPHANUMERIC LED
DECODER/DRIVER**

The new ICM7243 monolithic LED display drivers are the first to feature 14/16 segment alphanumeric 8-character display capability. The ICM7243 has the award-winning features you'd expect from Intersil. An on-board ROM for generation of 64 characters...you won't need an external ROM or PROM. Full microprocessor compatibility, accepting the popular six-bit ASCII input. Multiplexed displays can be directly driven, eliminating external components. And you can cascade up to 16 or 24 characters without additional hardware. All latching, timing and decoding are performed on the chip, dramatically reducing software overhead. The ICM7243 is manufactured with power-saving CMOS technology, for lower operating current and higher reliability and all for \$8.25 each in 100-unit quantities. Check # 9-I for additional details.

**CHIPS
FOR SALE**

Whether you design hybrids, black boxes or subsystems, chances are that we can supply unpackaged Intersil die which will match your exact needs. We have hundreds of standard parts in our product lines, and virtually every one...discrete device or integrated circuit...is available in die form. Our dice are easy to handle, and have very long shelf life: Each die is protected by surface planar passivation, with additional surface glassivation. They can materially cut your assembly costs; they're packaged in individual carrier packages, 100% electrically probed and visually sorted with all rejects removed. IC chips are available with length and width dimensions controlled to ± 2 mils, and we inspect to MIL-883 for military dice. Dice are supplied to AQL levels of 2% visual, 1% functional electrical test, 4% parametric DC testing and 10% on untested parameters. You're probably missing a bet if you haven't checked into using Intersil dice for your individual design requirement. Contact your Intersil sales representative for more information.

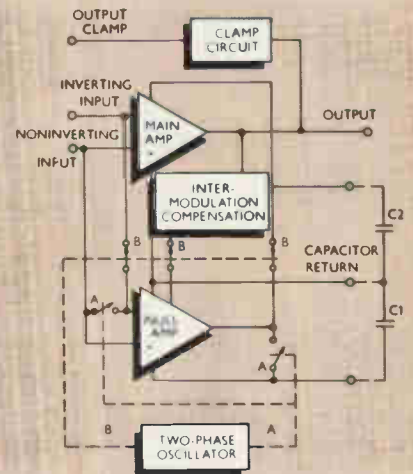

**OP AMP
WITH
 $V_{os} = 1 \mu V$
AT \$2.75**

An incredible price for an "almost ideal" chopper-stabilized Op Amp. Our ICL7650 boasts a low offset voltage of $1 \mu V$ and thermal drift of $0.01 \mu V / ^\circ C$ over the entire operating temperature range. In addition, it has a low input bias current ($10 pA$), low long-term stability ($100 \text{ nv}/\sqrt{\text{month}}$) and no chopping spikes at either input or output. Yet it features a high slew rate of $2.5V/\mu S$; high gain, CMRR and PSRR of 120 dB; and 2MHz gain bandwidth product. This new design approach eliminates the need for trimming potentiometers—only two low-cost external capacitors are required. Put it another way—it's an ideal replacement for any conventional hybrid, modular or other precision monolithic op-amp, but at an ultra-low cost—only \$2.75 in 100-up for the plastic DIP package. Also available in Cerdip and metal can. Check #9-J for all the scoop on this high performance CMOS Op Amp.

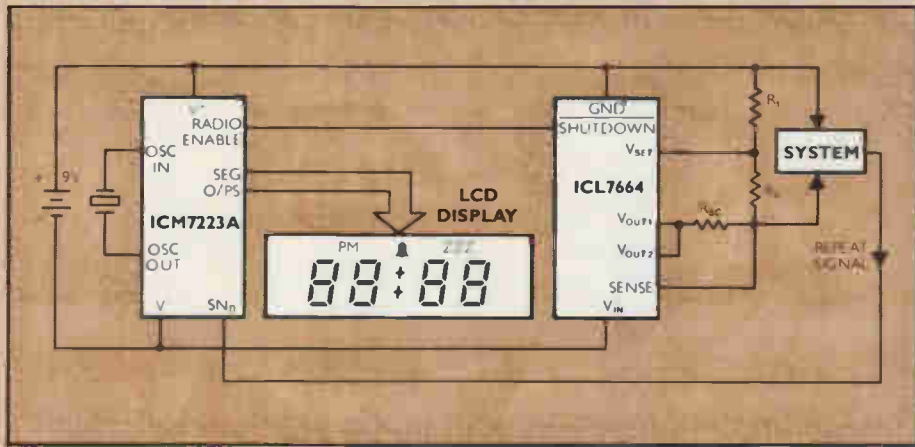

ONCE-A-DAY PRESET TIMER

The ICM7223 LCD alarm clock circuit can be used to turn on a low-quiescent-current ICL7664 voltage regulator for one minute at a preset time each day. The whole system draws about 20 μ A when idling, giving a several year battery life on a single 9V radio battery. ON time can be extended by using the "snooze" and sleep-

time features of the clock circuit or can be reduced by using the ALARM OFF pin. The system, driven by the regulator, can draw up to 40mA while ON and will receive a regulated supply so long as the battery voltage is 50-100mV above the regulated level.

For more details, check # 9-K.

INTERSIL

YOU GOT ME!

VOL. 9

Please send me data on the following:

- | | | |
|------------------------------|------------------------------|------------------------------|
| <input type="checkbox"/> 9-A | <input type="checkbox"/> 9-E | <input type="checkbox"/> 9-I |
| <input type="checkbox"/> 9-B | <input type="checkbox"/> 9-F | <input type="checkbox"/> 9-J |
| <input type="checkbox"/> 9-C | <input type="checkbox"/> 9-G | <input type="checkbox"/> 9-K |
| <input type="checkbox"/> 9-D | <input type="checkbox"/> 9-H | <input type="checkbox"/> 9-L |
| | | <input type="checkbox"/> 9-M |

Name _____

Title _____

Company _____

Address _____

City _____ State _____ Zip _____

Phone _____

For more information, just check the appropriate box, then clip and mail!

InterSight
Marketing Services
10710 No. Tantau Ave.
Cupertino, CA 95014

Tel: (408) 996-5000
TWX: 910-338-0171
Outside California (800) 538-7930

E51982

Hot New Lit!

You'll want our new 16-page four-color brochure on REMDACS II, Intersil's exciting new board-level concept in advanced remote data acquisition and control systems. REMDACS II blends the latest semiconductor technology and innovative systems design to provide a family of easy-to-use low-cost cards, each ideally suited to a specific data acquisition or control task. The combination gives you the accuracy and utility to meet today's demanding instrumentation and control requirements. REMDACS II is a modular system which employs pre-programmed microcomputer-controlled cards placed close to the signal source or control point. The remote cards are linked to a central receiver/transmitter card through a single twisted pair of wires in a party-line multiplex configuration, PROVIDING ENORMOUS SAVINGS IN INSTALLATION COST. For more information, check #9-L.

Precision Single-Chip $\pm 4\frac{1}{2}$ Digit A/D

NEW—our ICL7135 precision $\pm 4\frac{1}{2}$ digit A/D converter with multiplexed BCD output. Combines dual slope conversion reliability with 1 count in $\pm 20,000$ accuracy. You also get auto-zero to $<10\mu$ V, zero drift $<1\mu$ V/ $^{\circ}$ C, input bias current of 10pA Max. and rollover <1 count. Then there's auto polarity, true ratiometric operation, almost-ideal differential linearity and true differential signal input. With this CMOS chip, you need only a single reference voltage and display driver. Auxiliary input/outputs also available for easy interface with UARTs, μ P, and other complex circuitry. 100-up price: \$15.00 each in plastic. Check # 9-M.

Standard software interface boosts program portability

With stock operating-system routines and formats, programs may be easily fitted to new applications

by Al Hartman, Intel Corp., Santa Clara, Calif.

□ The patchwork era of microsystem software is ending, as the programming philosophy of compatibility gains strength. Among the standardization techniques that will write *finis* to software incompatibility is the concept of a standard software interface (see figure).

Such an interface, consisting of standard system calls and shared code- and data-storage formats, allows conforming operating systems and user programs simply to plug into new hardware configurations. In fact, with the intervention of an adapter program, even nonstandard operating systems can be used, as can any compiler, assembler, utility, or application that uses the standard interface or that can be adapted to it.

No longer will writing a program that is to run under several distinct operating systems require a maddening duplication of effort involving subtle and arbitrary differences in handling similar items. Rather, such file-, memory-, and device-management operations will be standardized for true software compatibility.

A standard software interface tends to increase the available software base from which users may choose. The portability of operating systems, system software, and application programs is increased, lowering software development costs. Adoption of a software-interface

standard creates a ready market in which software producers and consumers alike can participate to their mutual benefit.

With the Intel family of microprocessors, software writers are encouraged to use the software interface component called the Universal Development Interface (See Table 1). The UDI may be implemented for any microprocessor, since it is not specific to any one instruction set. In fact, the set of UDI primitives has been adapted by one customer to the VAX minicomputer from Digital Equipment Corp. However Intel's major thrust is in the proliferation of software for the already large base of 8088, 8086, iAPX-186, and iAPX-286 users.

Freedom in standardization

Designers conforming to UDI are free to choose operating systems, system software, or application programs provided by any source that conforms to that software interface. The chaotic custom-software marketplace, which spawned a cottage industry almost overnight, sometimes cannot meet the cost, functionality, and reliability requirements for newer microprocessors. With UDI, quality software for all common applications is becoming available, because proven programs can be

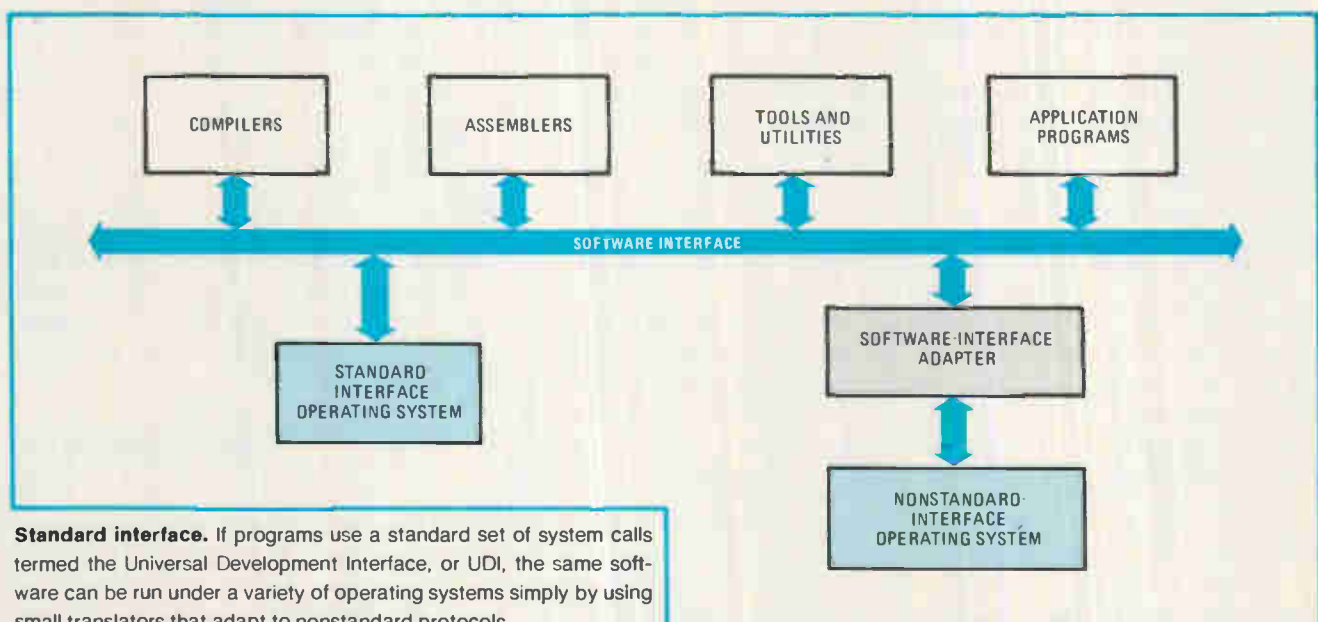

Standard interface. If programs use a standard set of system calls termed the Universal Development Interface, or UDI, the same software can be run under a variety of operating systems simply by using small translators that adapt to nonstandard protocols.

TABLE 1. SOFTWARE COMPATIBLE WITH UNIVERSAL DEVELOPMENT INTERFACE

Operating systems	High level languages
Isis	Pascal
iRMX 86	Fortran
CP/M 86	Basic
MP/M-86	C
MP/NET-86	Cobol
Xenix	PL/M
MS/DOS	Jovial
Oasis*	Ada**

*under negotiation **under development

quickly transferred from one processor type to another.

The UDI consists of 27 primitives (see Table 2) for memory and file management, input/output operations, exception handling, and command interpretation, as well as some miscellaneous functions. These primitives provide a standard interface with sequential programs and can be implemented for single- or multitasking operating systems. Few assumptions are made about the form of the user's command language, and virtually any style of command syntax is possible when the UDI is implemented. Almost any operating system can be adapted to this interface. In addition, a standard format for 8086 object-code modules allows interchangeability regardless of the source of the modules.

As one of the memory-management services, a free block of memory can be obtained for a task using the Allocate primitive, with the desired size as an argument. The Free primitive returns a block of memory to the available pool, and the Get-size primitive provides the actual size of a given memory segment. As with all of the operating-system primitives, the memory-management primitives return an exception code to the caller indicating either no exception or one of several error conditions.

Managing the files

For file management, primitives exist to create or delete connections to files, to attach or detach files to and from a program, and to open or close files for input, output, or updating. Also, files may be renamed and have their type and status changed.

The Attach operation searches a directory for a file, verifies file-access privileges, creates a file control block, and returns an internal pointer for future file references. The Open operation verifies access for write or update privileges and allocates file buffers. The Detach operation scratches the pointer indicating the location of a file, and the Close operation deallocates the file buffers and removes its name from the list of open files kept by the operating system.

I/O and positioning operations on an open file include Read, Write, Seek, and Truncate primitives. A simple byte-stream I/O model is assumed in the design of the UDI rather than using built-in block-moving operations. A Read or Write request specifies the number of bytes to be manipulated. A Seek operation specifies a byte displacement from the current file position or from the

TABLE 2. STANDARD PRIMITIVES OF THE UNIVERSAL DEVELOPMENT INTERFACE

Name	Type of service
Allocate Free Get size	Memory management
Delete Rename Change extension Attach Create Open Close Detach Get status	File management
Read Write Seek Truncate	Input/output operations
Trap exception Get exception handler Decode exception	Exception handling
Trap control-C Special Get argument Switch buffer	Command interpretation
Exit Get time Get system ID Overlay	Miscellaneous

beginning or end of the file. And the Truncate operation cuts off the file at the current position.

The exception-handling primitives are Trap exception, Get exception handler, and Decode exception. The Trap exception designates user routines to gain control if the operating system detects an exception. The Get-exception-handler primitive returns a pointer to the current exception handler. To aid in providing user diagnostic information, the Decode-exception operation translates an exception code into an error message for display at the terminal or in a listing file.

Other aids to user interaction are the command-interpretation primitives. The Trap-control-C primitive establishes a user routine that will gain control when the user types "control-C." What is called the Special primitive selects terminal input in either a line-edited mode (where the program system interprets editing characters, such as delete or rubout) or in a transparent mode (where the program interprets editing characters its own way). This choice allows free usage of editing characters according to the conventions of different operating systems or application programs.

No particular command syntax is enforced, but the first word of a command is frequently the file name of the invoked program. Arguments following this may be read using the Get-argument primitive, which allows any reasonable argument delimiter, including blanks. By use of the Switch-buffer primitive, the command interpreter may be used to read commands that are found in

The virtues of standardized system software

Not too long ago most computer-systems makers viewed software standardization as detrimental to sales. The software base available for a machine differentiated it from its competitors and therefore was the driving force behind hardware selection. However, the lure of incompatibility is largely *passé*. Even at the mainframe level, the emergence of plug-compatible machines has thrown cold water on the attempt to differentiate a computer system by the software offered for it.

Nowadays the pressure of user demand for more application software has turned the tide. At least at the micro-system level, compatibility is the issue. An increasing number of vendors is choosing an already established software base for their new systems. For example, International Business Machines Corp.'s Personal Computer runs the CP/M operating system, as well as the MS/DOS look-alike, and the UCSD p-System. In fact, IBM, the champion of incompatibility, did not write a single line of code for the machine—nor does it intend to.

In a nutshell, the advantage of standardization is that the wheel does not have to be reinvented for every new computer system. Intel's Universal Development Interface and standard object-module format are attempts to alle-

viate just this problem. "When we started work on our series III microprocessor development system, we realized that it would be much easier to reuse this software for all of our development systems, as well as computers such as the 86/330" explains Stuart Vannerson, software product manager at Intel Corp. in Santa Clara, Calif.

"UDI and standardized OMFs were the result of a great deal of forethought at Intel. In fact it was this degree of standardization that allowed the Grid Systems Corp. briefcase computer to access Intel's software base with a mere 4 months of work." The Grid computer [*Electronics*, April 7, 1982, p. 182] is a full-feature computer system using the 8086 processor and 8087 numeric coprocessor with 256-K bytes of main memory and a like amount of nonvolatile bubble memory. All its application software is written in Intel's high-level languages. The IEEE-855 microprocessor standards committee is working on just such software compatibility problems. Both Intel with its UDI and OMFs and Texas Instruments Inc. with its layered approach to operating systems have seats on this committee. An industry-wide standard may emerge to help avert the software generation crisis that plagues the further proliferation of computer systems.

-R. Colin Johnson

locations other than in the standard console input file.

UDI also provides several miscellaneous primitives. Exit relinquishes control to the operating system, while providing it with a completion code for the program. Get time provides a data and time message for a console display or file stamping. The Get-system-ID primitive provides an operating-system identification message, also for a console or listing display. Finally, to support overlaid programs, the Overlay primitive loads an overlay from a one-level overlay program. An overlaid program is a single program file containing an overlay directory at its beginning.

Representing information

Object-module formats are standard ways of representing the binary information that will be executed on a processor. Intel has versions for the 8086, 286, 8085, and 8051 microprocessors, because different types of information need to be represented for each.

First of all, OMFs are a way of representing the interdependency between the modules that need to be linked together to form an executable program. Having a standard way of representing data objects that will be passed among procedures and standard ways of calling them is a necessity for modern languages that allow separate compilation of modules.

One common approach is to follow program compilation with what is called a linking loader. Using a standard format allows the language translator to produce the same type of modules that are produced by the linkage utilities. In this way, standard libraries of modules can be built up, any one of which may be passed to a linker, loader, debugger or other system utility in a compatible fashion.

What is more, debugging information like data types and symbolic names can be stored in object-module

formats by each of the system utilities and used by any of them. Thus debugging can be much more sophisticated than would otherwise be possible. For instance, whenever the linker resolves variable references between modules, it can perform type checking to make sure that both modules are using the same type of data. This check can flush out errors that would be very difficult to find at debugging or execution time.

Also, memory-segment information is included so that modules can be assigned to the same segments whenever possible. This arrangement can speed up the execution of programs to the point where they will run faster than equivalent programs written on a machine with linear addressing, such as the 68000.

For the 286 with on-chip memory management, the protection information (read-only, system-only, and so on) is stored in an OMF so that it is accessible to the operating-system language translators, linkers, loaders, and debuggers, and to other system-level tools. Because this protection information is easily accessible to the system software, it can be well hidden from the application programmer, thereby eliminating the need to understand the underlying architecture.

Also, the object-module format makes it easy to add new features without introducing incompatibilities, because the specific storage mechanisms are very flexible. For instance, when the 8087 numeric coprocessor was introduced, a new data type—the 80-bit long-real—was easily integrated into the object-module format. Also, the PL/M-86 compiler has recently been updated to produce the same kinds of debugging information that the Pascal-86 compiler does, without introducing incompatibilities. Thus access to PL/M is opened to debuggers such as Intel's new Pscope, which allows debugging within the high-level language itself rather than resorting to assembly language. □

Frequency comparator uses synchronous detection

by Israel Yuval
Video Logic Corp., Sunnyvale, Calif.

There are many different ways to monitor a frequency but most have the disadvantage that they also detect any noise inherent in the circuit along with the desired waveform. This circuit circumvents the noise problem through the use of a technique that samples the unknown frequency at the rate of the reference signal and then averages the measured waveform with a low-pass filter.

If the input frequency f_{in} is equal to the reference f_{ref} , a nonzero average results at the output. However, if $f_{in} \neq f_{ref}$, the average of the samples is zero. In addition, the circuit is immune to noise and works well between 100 hertz and 100 kilohertz.

Comparator U_2 (a) determines the sampling frequency that is derived from reference input signal V_{ref} .

Resistor R_2 determines the duration of the sample pulse. The output of U_2 turns switch Q_1 on and off at the rate f_{ref} . The input signal, which is compared with the reference signal, is amplified by U_1 whose gain is set by R_1 . Capacitor C_1 blocks any dc component of V_{in} . The cutoff frequency of the low-pass filter is determined by R_3 and C_3 and is given by the equation $f_c = 1/2\pi R_3 C_3$.

The output of the filter (b) keeps comparator U_3 in the high state as long as $|f_{in} - f_{ref}| < f_c$. The output of U_3 turns low otherwise. The response time of the circuit is determined by time constant $R_3 C_3$. To satisfy the response time and the frequency accuracy, the designer must appropriately select values for R_3 and C_3 .

The harmonics of f_{ref} will also result in a nonzero average and therefore must be attenuated by adding a low-pass filter with a cutoff frequency less than $2f_{ref}$ at the input. Also, the phase delay between $V_{in}(t)$ and $V_{ref}(t)$ must not equal 90° because it will result in a zero average even when $f_{in} = f_{ref}$. Adding a phase delay to either signal will eliminate this problem. The circuit assumes that the phase difference between V_{in} and V_{ref} is less than $\pm 90^\circ$. If no such certainty is guaranteed, a window comparator should replace U_3 . □

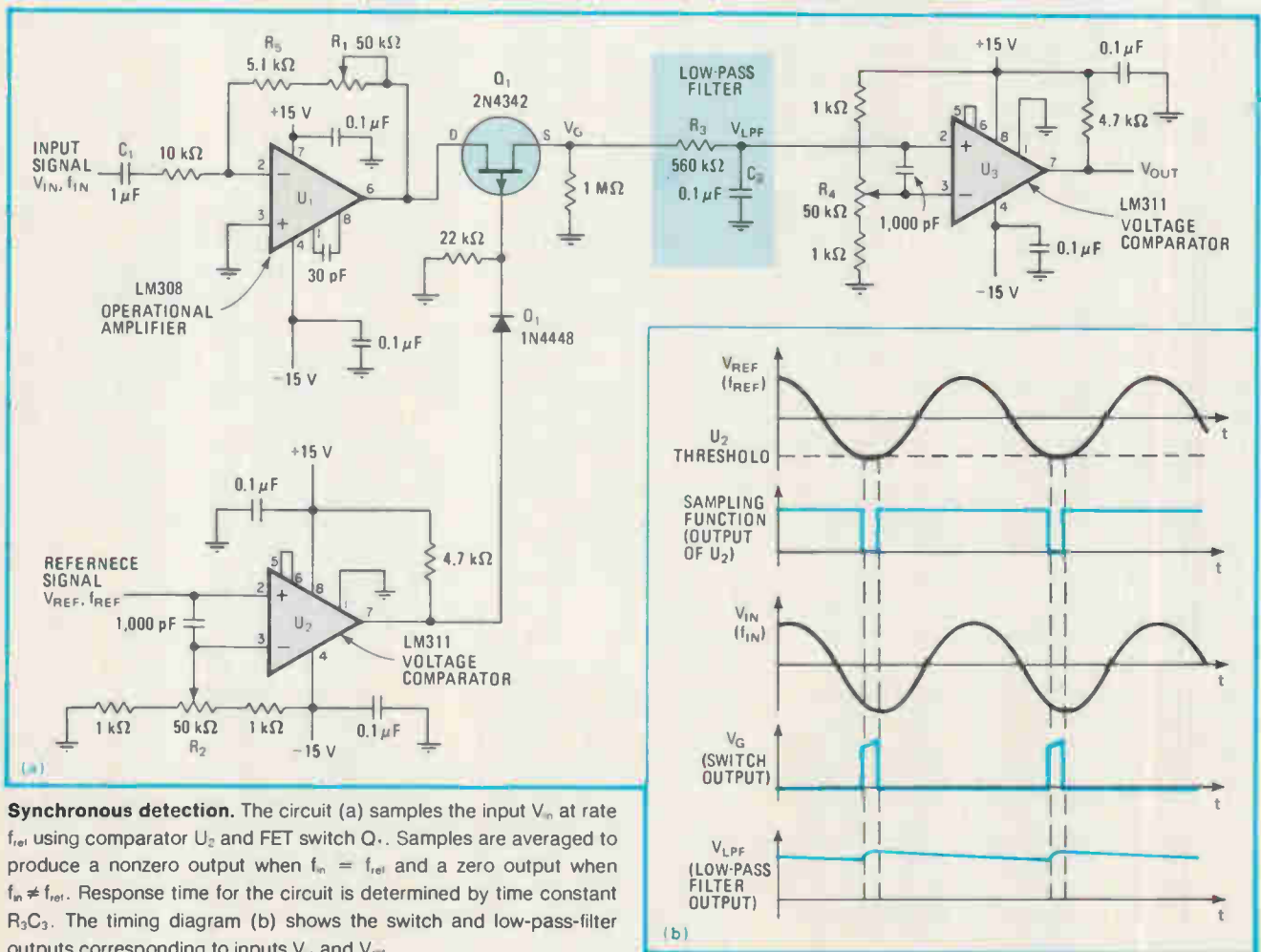

Synchronous detection. The circuit (a) samples the input V_{in} at rate f_{ref} using comparator U_2 and FET switch Q_1 . Samples are averaged to produce a nonzero output when $f_{in} = f_{ref}$ and a zero output when $f_{in} \neq f_{ref}$. Response time for the circuit is determined by time constant $R_3 C_3$. The timing diagram (b) shows the switch and low-pass-filter outputs corresponding to inputs V_{in} and V_{ref} .

Conductive foam forms reliable pressure sensor

by Thomas Henry
Transonic Laboratories, Mankato, Minn.

Pressure-sensitive resistors made with conductive foam usually suffer from mechanical and electrical reliability problems—the electrodes of the unit are prone to short, and its sensor rarely returns to its initial value once the pressure is released. However, this circuit, which uses a low-cost electronic pressure sensor, overcomes these problems and provides additional control voltages.

The electronic pressure sensor (a) comprises a conductive foam that is sandwiched between two copper-clad boards that act as electrodes. This configuration creates a pressure-sensitive resistor that has a high resistance in an uncompressed state. Its value drops considerably under pressure; when compressed, the sensor's high resistance value of 10 to 50 kilohms drops to several hundred ohms.

Sensor. This pressure-sensitive resistor (a) together with the circuit (b) provides a reliable electronic pressure sensor. Conductive foam that is sandwiched between two electrodes forms the pressure sensor. Ordinary insulating foam rubber, surrounding the conductive layer, is placed within the sandwich to prevent the boards from shorting. The output from the sensor is sensed by op amp A_1 .

The insulating foam rubber placed in the sandwich prevents the electrodes from shorting and also evens out the action of the sensor. Common integrated-circuit packaging foam is used as the conductive material.

Operational amplifier A_1 senses the output generated by voltage divider R_6 and the pressure sensor (b). Any noise in the system is grounded by capacitor C_1 . In addition, C_3 functions as a low-pass filter to provide a smooth voltage at the output of A_1 . When the pressure sensor has a nominal uncompressed resistance of 10 k Ω , the voltage at pin 3 of A_1 is about -5 volts when the sensor is uncompressed and -15 v when compressed. This voltage swing is offset by a fixed value of +7.5 v,

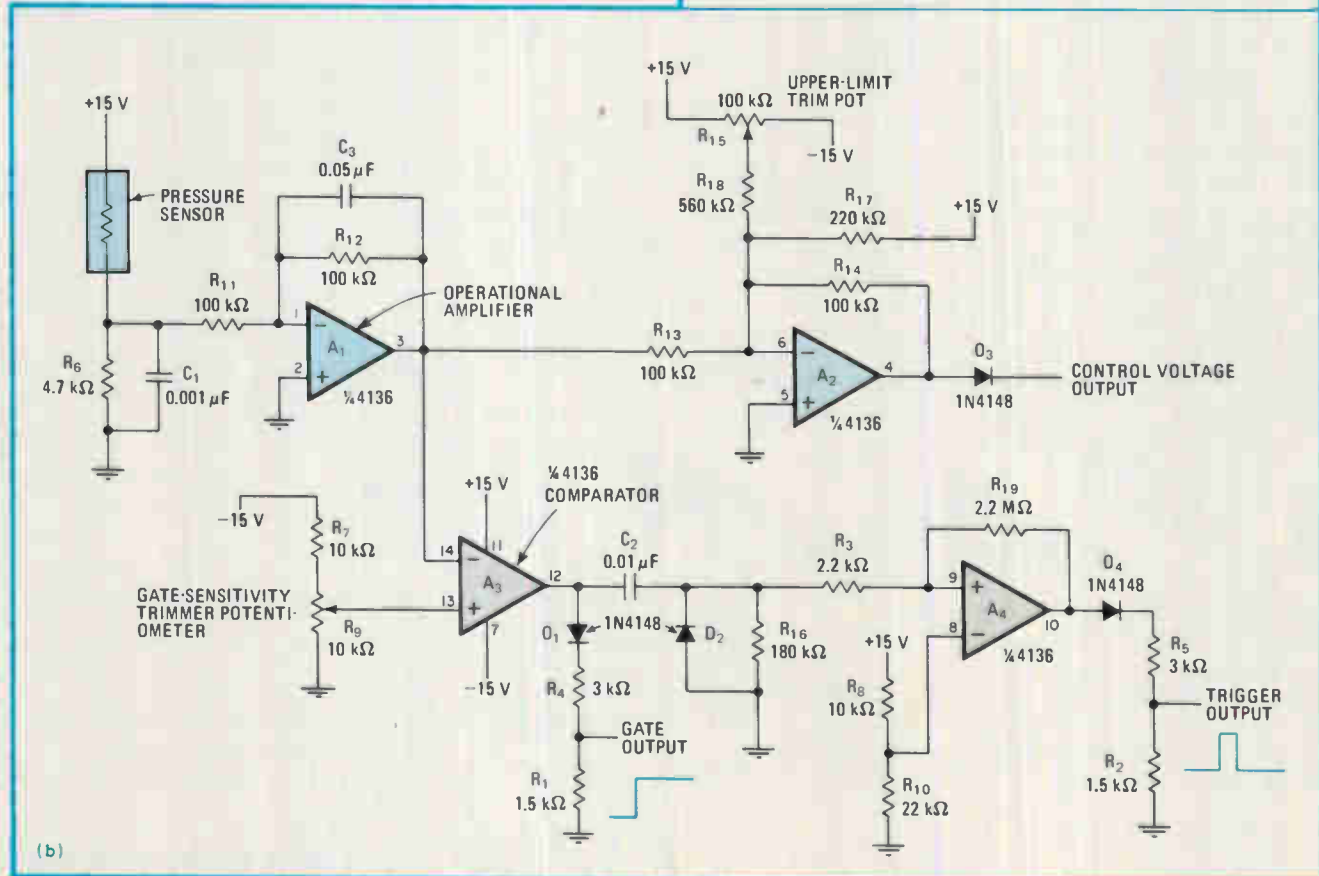
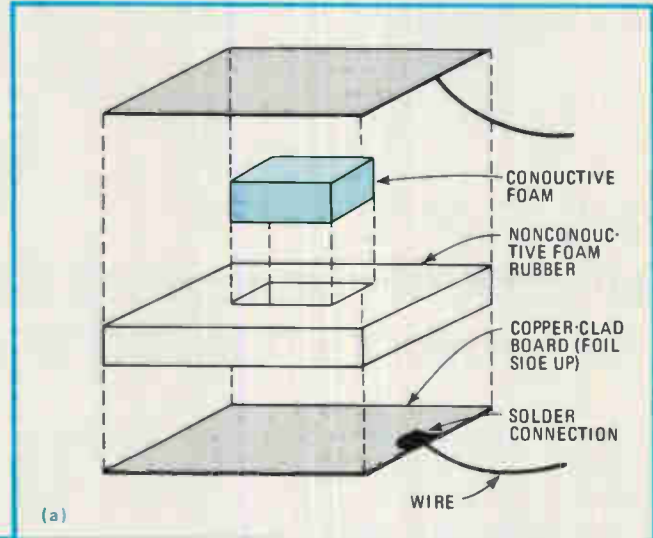

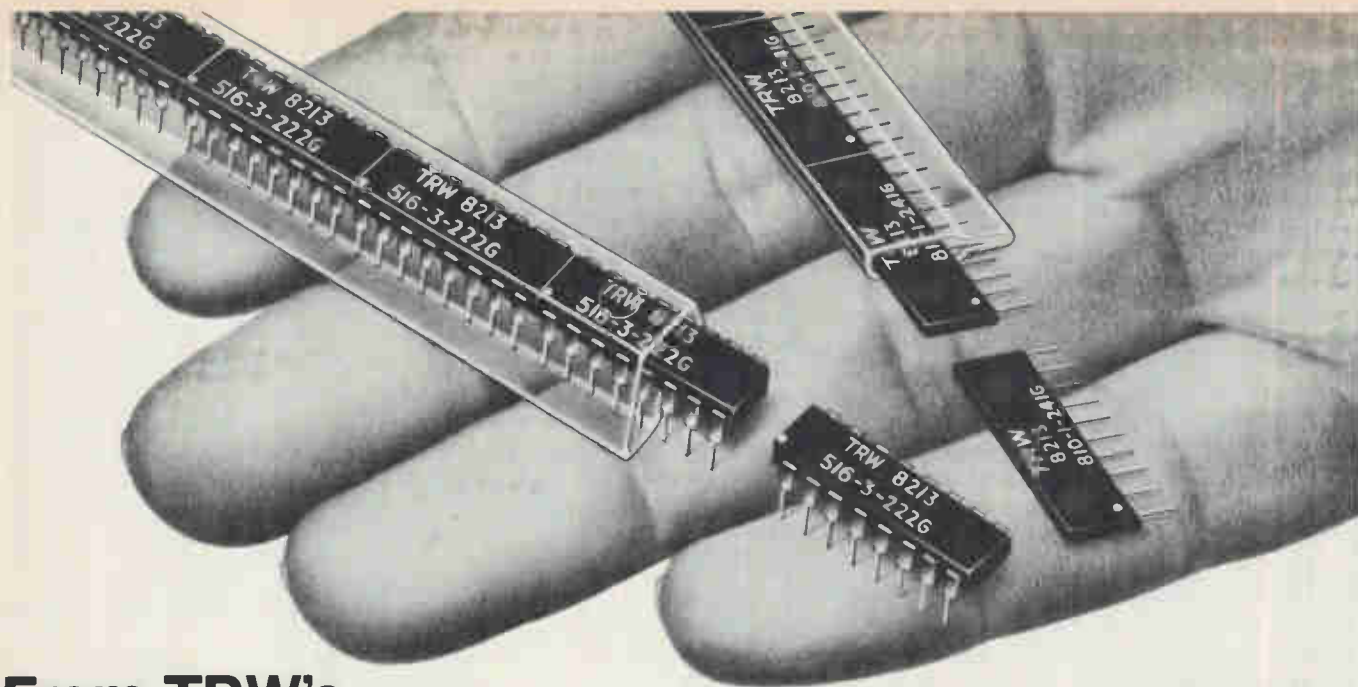

From TRW's vast experience in thick film resistors, the only networks not tied to precious metals.

TRW formulates its own thick film materials.

Composed of base metal resistors and copper conductors in a glass matrix, TRW thick film resistors deliver a noble performance with non-noble materials. These unusual networks are proven to be rugged and reliable in applications from standard pull up/pull down networks to 25 KV bleeder/divider circuits.

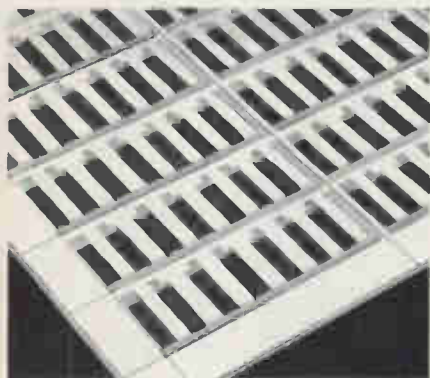

Performance specifications are equivalent to MIL-R-83401.

Performance like discrete metal film resistors. Plus excellent tracking between elements, (as low as ± 50 ppm), and substantial space savings over discretives.

Resistance Range*	22 Ω –1 Meg Ω
Resistance Tolerance	$\pm 2\%$, $\pm 5\%$
Temperature Coefficient	$\leq \pm 150$ ppm/ $^{\circ}\text{C}$
Package Power Rating	1.5 to 2.7 Watts
1000 Hr. Load Life ΔR	$\pm 1\%$
*Max. 150 K Ω on low profile SIP	

1000 $^{\circ}\text{C}$ N₂ firing produces rugged cermet element fused to alumina substrate.

After screen printing on ceramic plates, the TRW materials are fired in inert N₂ covering gas. Temperature profiles reach 1000 $^{\circ}\text{C}$, several hundred degrees higher than air fired

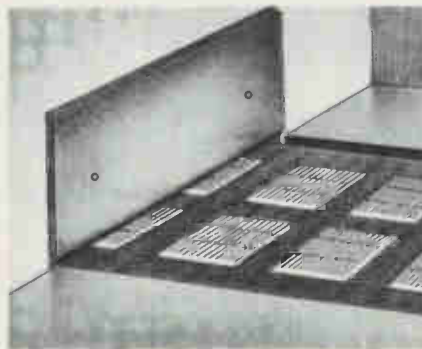

precious metals. Subsequent laser trimming adjusts resistance to desired tolerance.

Available in 6-, 8-, 10-pin single-in-line, 8-pin low profile and 14-16 pin dual-in-line molded construction.

Epoxy based transfer molding provides excellent dimensional uniformity and mechanic strength. And all TRW thick film resistor networks are ideally suited to automatic machine insertion from IC carrier tubes.

Standard Circuits

(Resistors all same value)

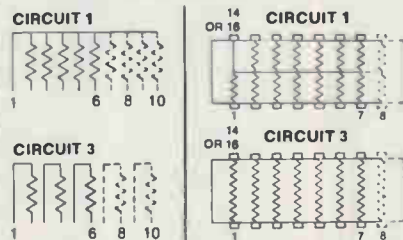

Dual terminator and custom circuits available.

Call your local TRW/IRC distributor. Or Fixed Resistor Distributor Operation, 215-923-8230. For technical information call 704-264-8861, or write: TRW/IRC, P.O. Box 1860, Greenway Road, Boone, NC 28607.

TRW IRC RESISTORS

Another product of a company called TRW.

produced by R_{17} , and the sum is inverted by A_2 whose output then swings from -2.5 v to $+7.5$ v. In addition, this output is further truncated by diode D_3 to provide a range of 0 to $+7$ v. As a result, the sensor will always indicate a return to a constant value.

Comparator A_3 generates a gate output that is based on the amount of pressure exerted on the pad, which is set by trimmer potentiometer R_9 . The comparator output is differentiated by A_4 to provide a 1-millisecond, 5-v trigger pulse.

This circuit is designed to control an electronic-music

synthesizer. The control-voltage output of the circuit controls the voltage-controlled oscillator while the gate and trigger pulses fire the envelope generator of the synthesizer. Thus one transducer is used to control several parameters of a design simultaneously.

Though the circuit provides a reliable uncompressed and compressed voltage output, there is no guarantee that the voltages between these two extremes follow a linear progression. The plot of the voltages depends both on the physics of the sensor and the voltage drop across diode D_3 . □

Joining a PLL and VCO forms fractional frequency multiplier

by S. K. Seth, S. K. Roy, R. Dattagupta, and D. K. Basu
Jadavpur University, Calcutta, India

Most frequency multipliers are hampered by the fact that they can multiply frequencies only in integer amounts. As a result, if a certain output frequency is desired, the input frequency must be carefully selected. Such exact choosing is no longer needed because this circuit can multiply pulse frequencies by any real number through the simple adjustment of two potentiometers. In addition, it operates over a wide input-frequency range and has a more stable output than do conventional multipliers.

This design combines a phase-locked-loop frequency-to-voltage converter and an external voltage-controlled oscillator for pulse-frequency multiplication. However, conventional multiplication circuits employing PLLs use either harmonic locking or a frequency divider between its VCO and phase comparator. Thus, the output is only an integer multiple of the input.

A PLL connected as a frequency demodulator, generates voltage V_d that is related to the input frequency by

$V_d = kf_{in}$, where k is a constant and f_{in} is the frequency of the input signal. In addition, the input frequency of the internal VCO (contained in the PLL) is $f_{in} = V_d/VR_1C_1$, where R_1 and C_1 are the frequency-determining components of the internal VCO and V is the supply voltage.

Demodulated voltage V_d is fed to the control-voltage input of the external VCO whose output frequency is $f_{out} = V_d/VR_2C_2$, where R_2 and C_2 are frequency-determining components of the external VCO. Solving for the output frequency: $f_{out} = f_{in}R_1C_1/R_2C_2$ and thus $n = (R_1C_1)/(R_2C_2)$. The multiplication factor n is only determined by the externally connected resistors and capacitors and therefore can be chosen for any value.

The circuit (a) uses National Semiconductor's general-purpose PLL LM565 and VCO LM566. Operational amplifier $\mu A741$ serves as the buffer between the two.

The multiplication factor for this particular circuit is 6.15, and its input-frequency range is 2 to 6 kilohertz. The oscilloscope display (b) shows the input and output waveforms for an input frequency of 4 kHz and multiplication factor of 6.15. For stable circuit operation, R_1 and C_1 should be selected according to the input frequency, and R_2 and C_2 should be chosen to generate the desired multiplication factor. □

Designer's casebook is a regular feature in *Electronics*. We invite readers to submit original and unpublished circuit ideas and solutions to design problems. Explain briefly but thoroughly the circuit's operating principle and purpose. We'll pay \$75 for each item published.

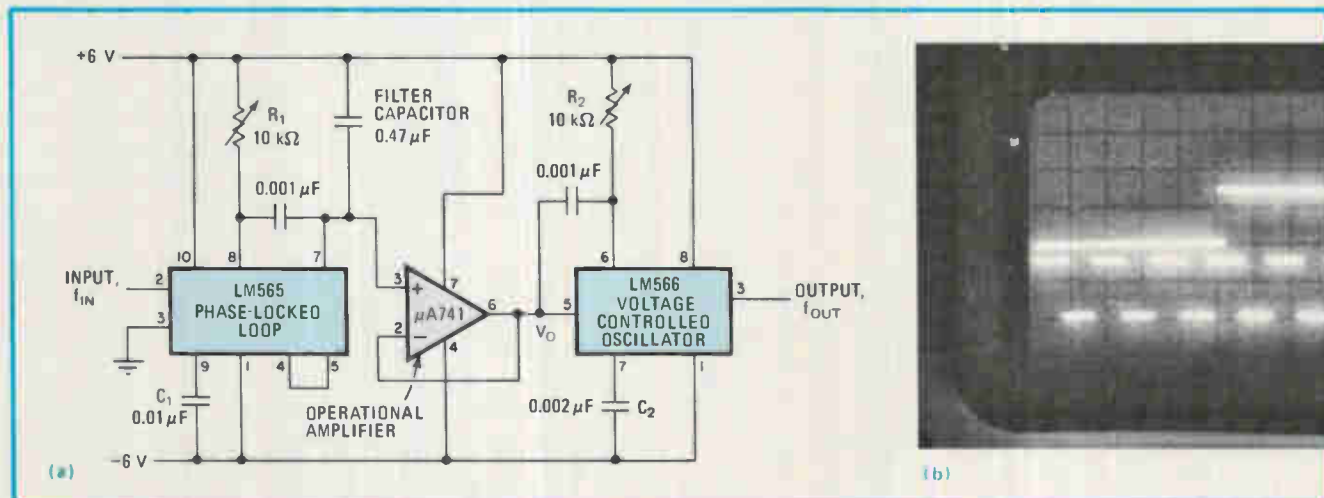

Multiplier. The circuit (a) uses a phase-locked loop, an external voltage-controlled oscillator, and a buffer. The oscilloscope display (b) shows the input and output waveform for an input frequency of 4 kHz and a multiplication factor of 6.15.

Circuit module implements practical self-testing

Simple circuitry could perform signature analysis automatically on the boards in a system

by Patrick P. Fasang, *Siemens Corp., Cherry Hill, N. J.*

□ Self-testing very large-scale integrated circuits are by now more than a blue-sky notion, but they still await practical realization. A strong candidate for this role is a simple circuit called a built-in logic-block observer. Two Bilbos, together with some additional circuitry, make up an experimental module that could bring signature analysis to the chip level.

Called a built-in digital-circuit observer, the module could easily be reduced to a single chip that can check out highly complex VLSI circuitry—not completely, as will be made clear below, but the Bidco might be enhanced in future developments. Certainly the basic Bilbo, originated by Bernd Koenemann of the Institute for Theoretical Technology in Aachen, West Germany, could be included on a VLSI chip.

The Bidco (Fig. 1) includes a pseudorandom number source (Bilbo A), the circuit under test, a signature register (Bilbo B) that processes information from the circuit under test and compresses it into a unique signature, and a decoder capable of deciding whether the circuit being checked meets the test criteria. Suitable status indicators reporting whether the circuit under test is good or bad are also part of the Bidco.

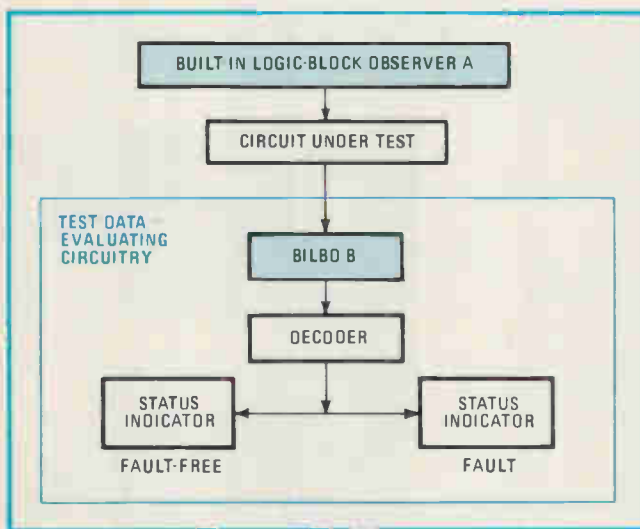

1. Building blocks. A built-in digital-circuit observer (Bidco) is a self-testing method. It is based on the use of two identical circuits called Bilbos (built-in logic-block observers) configured as a pseudorandom number generator and as a signature register, respectively.

In general, there are two types of self-testing—on-line and off-line. On-line testing takes place while a system is performing its designated function, that is, testing is done in the background mode. Off-line, on the other hand, means that the system can be in one of two mutually exclusive modes—operational and testing.

There are advantages and disadvantages to both of those techniques. Although the on-line approach may seem attractive in that it does not entail system downtime, it also may be more expensive because all testing circuitry may be devoted strictly to testing. The off-line approach, though requiring a halt to the regular system operation, may permit use of the self-testing circuitry as a part of the functional system.

On the chip level—assuming that self-testing can be done by grounding one or two pins, applying power to the chip, and getting a simple output (for example, 0 or 1) at some other pin—the testing is a straightforward go-no-go test. Actually, there is no need for any diagnostics here: if a chip is bad, it is replaced.

On the system level, some degree of diagnostics is desirable. Here, a simple indication of which board is bad (by a light-emitting diode mounted on it) might be sufficient, speeding field troubleshooting and repair.

Testing circuits

Such a check may be performed by a Bidco, which has a relatively simple configuration, as the more detailed block diagram of Fig. 2 makes clear. The master-clock and reset circuit supplies clock pulses to the Bilbos and to the control and timing circuits. It resets all flip-flops and registers, including those in the circuit under test (if present). The control circuit provides a controlled series of clock pulses and also a load pulse for loading the bias word into Bilbo A. A bias word is the initial number loaded into the Bilbo to trigger the generation of a pseudorandom number. The timing circuit is simply a counter that counts from 0 to 255. It contains two stages, the first counting from 0 to 15. When pulse No. 16 arrives, a carry is generated and sent to the second stage. When 256 pulses have been observed, the second stage generates a carry, which ends the test cycle. The clock-end circuit inhibits the clock's pulse train and loads the output of the decoder into the status indicators.

A Bilbo essentially is a four-function general-purpose register. In this circuit, Bilbo A is configured as a

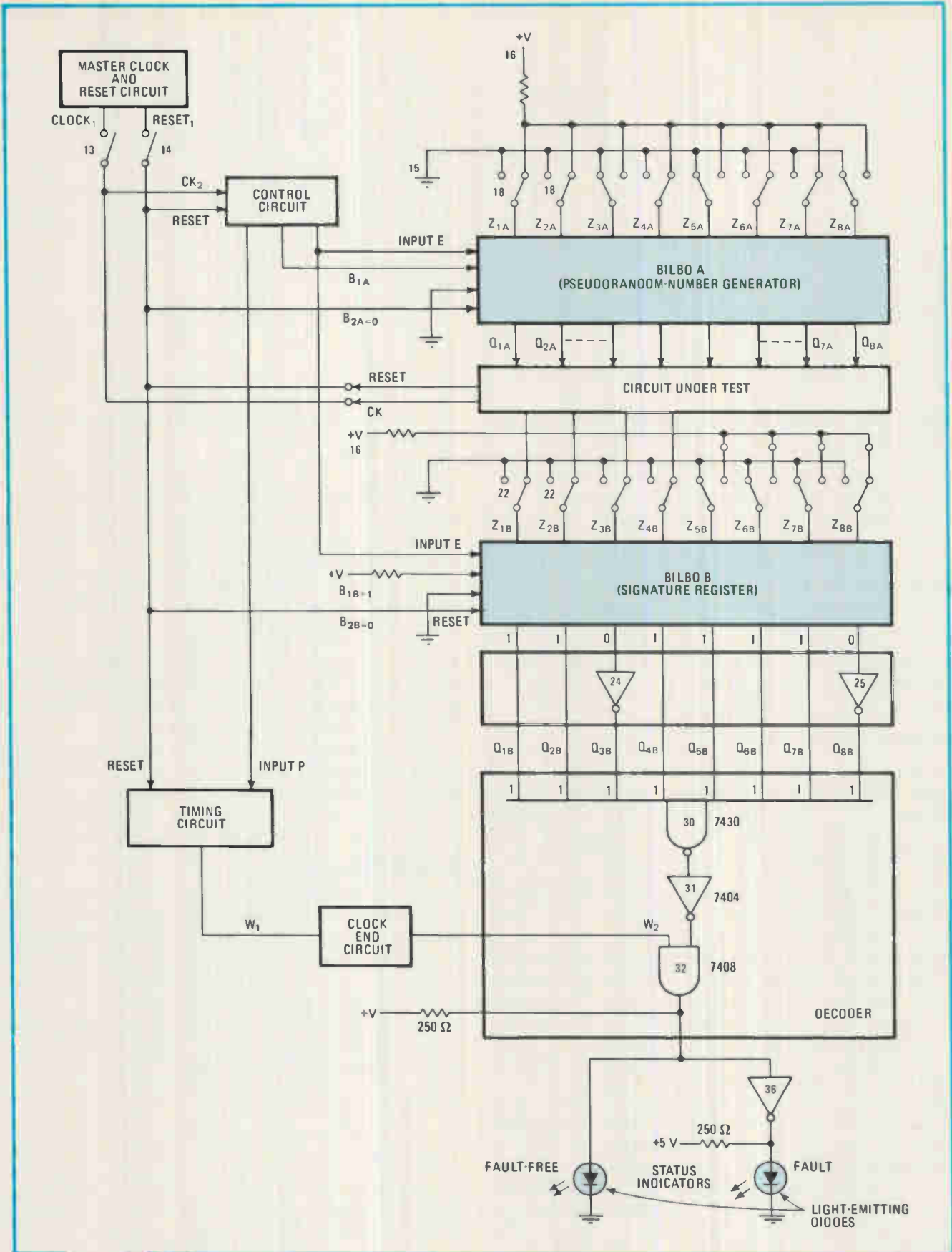

2. Go no-go. In a Bidco, the master clock, control circuit, timing circuit, decoder, and status indicators are only for testing. The two Bilbos are for testing, but can play a role in the operational mode where they could be used as standard shift registers.

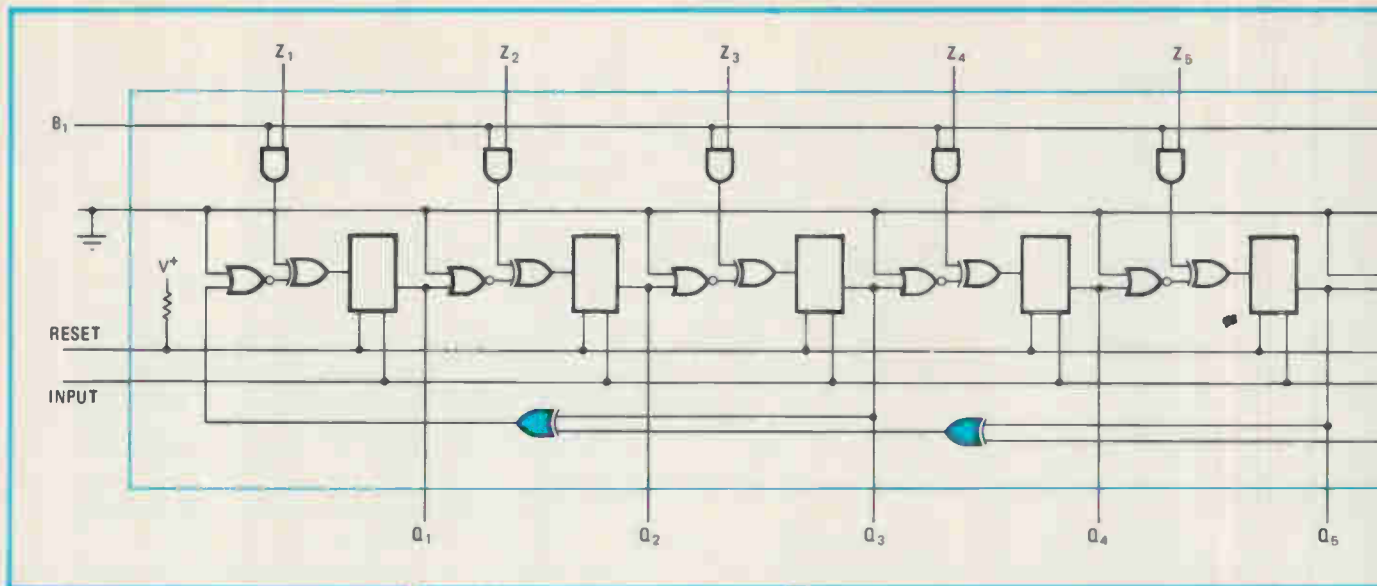

3. Bilbo innards. A Bilbo is a four-function linear feedback register with eight flip-flops and three feedback paths. Depending on the logic state of the control line, B_1 , the circuit can serve as either a pseudorandom generator or as a signature register in a Bidco.

pseudorandom pattern generator whose output serves as a stimulus to the circuit under test. Bilbo B is configured as a parallel signature register.

The decoder in the Bidco is basically an input AND gate with appropriate inverters at its eight inputs. Presence or absence of these input inverters depends upon the nature of the circuit under test: they must invert the input combination so that for a given good circuit under test, the decoder output will be 1. Status indicators can be suitable LEDs—one indicating faults, the other to show a fault-free performance.

Testing combinations

In general, the Bidco technique can be used to test all combinatorial circuits. Sequential circuits can also be tested if they can be partitioned suitably. In those cases when both combinatorial and sequential circuits are present, the Bidco can perform testing if the two parts can be separated. Also, the Bilbos can be made up with part of the sequential circuitry in the operational mode. Finally, if there are flip-flops in the circuit under test, they must be resettable.

It should also be noted that this approach does not require any special flip-flops, as is the case with another approach known as the level-sensitive scan. The requirement of level-sensitive flip-flops demands custom-designed chips if that testing approach is adopted.

The Bilbo four-function linear-feedback register has eight flip-flops and three feedback paths. Only two of the functions are of interest in the Bidco: pseudorandom pattern generation and parallel signature registration. Because these functions are provided by the same circuit design, it makes for a simpler testing architecture.

As Fig. 3 shows, the state of the control line, B_1 , determines whether the circuit will serve as a pseudorandom pattern generator or as a signature register. The operating principle of this circuit is described by the following conditions.

Initially the register is set by the reset input to

initialize all of the flop-flops to 0. Then an initial bias number is loaded into the register through the eight inputs. The circuit is then clocked through input E to cause the state of the register to change.

Feedback data flows through the three lower exclusive-OR devices to the input flip-flop. The feedback data is processed together with the present state of the circuit to produce the next state when the register is clocked. This continues as additional pulses are applied, producing a series of pseudorandom numbers at the Q outputs. If 256 clock pulses are applied to the register, a sequence of 256 pseudorandom numbers is generated.

If, in addition to the data from the feedback loop, inputs from a circuit under test are applied to the inputs and the register is clocked, data compression is performed. If this process continues for 256 clock pulses, a final signature is formed at the end of the 256th pulse.

A signature

In effect, the 256 bytes of data are compressed into a unique signature. Because of the sequential nature of the circuit, a deviation in any of the input words would produce a difference signature. This property makes the signature-register Bilbo a useful circuit for detecting any aberration or fault in the circuit under test.

A Bilbo is defined quantitatively by means of a set of state equations derived for each of the Q outputs:

$$Q_1 = [Q_3 \oplus (Q_5 \oplus [Q_7 \oplus Q_8])] \oplus Z_1$$

where \oplus = exclusive-OR, and

$$Q_j = Q_{j-1} \oplus Z_j$$

where $j = 2 \dots 8$

These equations describe the behavior of a Bilbo. A Fortran program was written to generate the 256 pseudorandom numbers for a particular bias number.

Among the biggest advantages of the Bidco approach to self-testing is the ability to perform checks—both in the factory and field—without external equipment. Thus

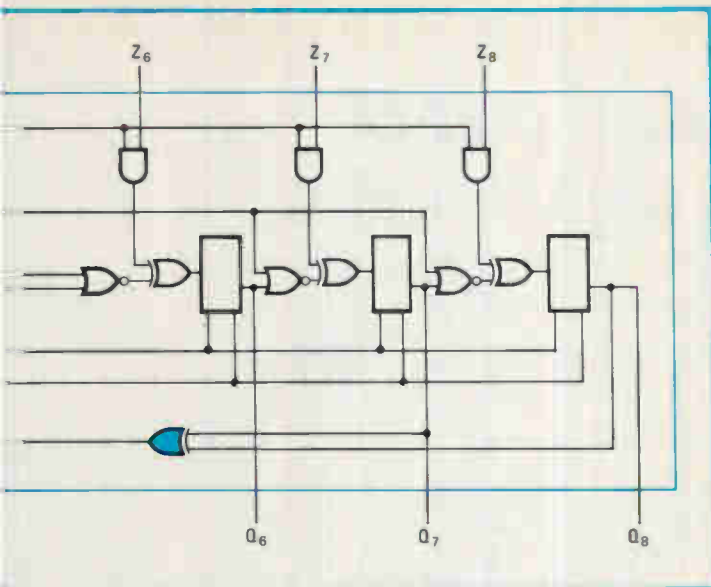

it is possible to save considerable sums: after all, quotes for automated test equipment amounting to \$1.5 million or so are not uncommon.

The high equipment cost, however, is not the whole story—a programmer is needed to write and maintain the ATE software, which, of course, adds to the overhead. Finally, when equipment goes down in the field, the serviceman might not have an ATE setup in his vehicle. Rather, he must work through tedious test procedures outlined in manuals several inches thick.

Add customer downtime and aggravation to this, and the ability to test and identify faults quickly and decisively will become valuable. Such a capability can be achieved quite readily if suitable built-in test devices and status indicators are provided, as mentioned earlier.

Among the biggest limitations of the Bidco approach is that it gives no fault-isolation information as far as the combinatorial elements are concerned (unless the technique is extended in future developments). For the sequential elements, fault isolation is possible if the scan technique is also used.

It might be added here that Bidco testing can be made as fast as the speed of its clock. In an experimental Bidco with a 120-kilohertz clock, for instance, testing time was about 2 milliseconds per test.

Testing the self-tester

While all preliminary evaluations point to tangible benefits that can be obtained through the application of the Bidco concept to practical circuits, only laboratory circuitry has actually been tested. Figure 4 depicts a circuit built to check the Bidco idea. Thirty-six faults were inserted into the circuit, and they were all detected.

As the Bilbos themselves can be tested quite simply by first resetting all of the flip-flops, then applying a known input to each Bilbo and clocking both of them 256 times. The signatures of both Bilbos should be identical and should be equal to a known-good answer that can be determined analytically.

In addition to tests performed with the circuit of Fig. 4, there also has been some laboratory testing involving

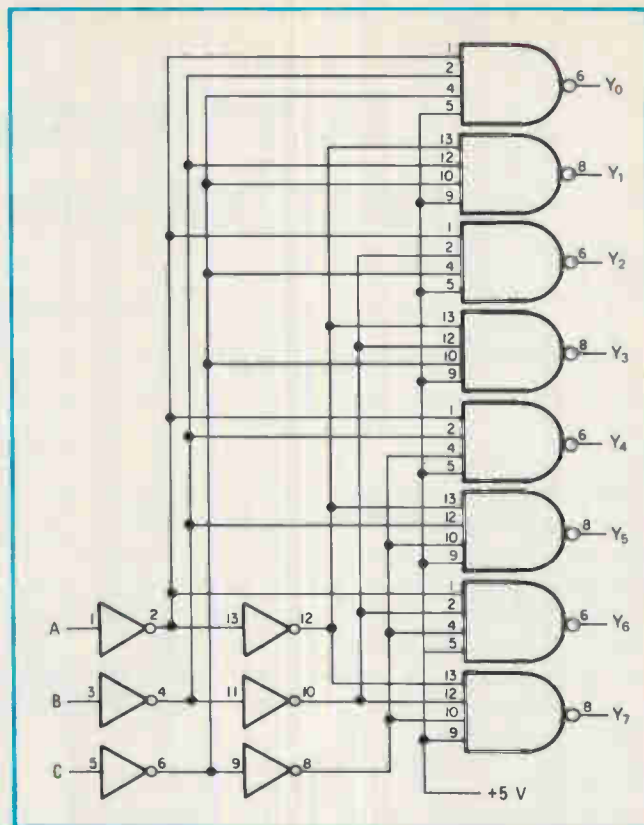

4. Combinations. This TTL combinatorial circuit was tested to demonstrate the Bidco principle. Thirty-six faults (typically "stuck-at" faults and shorts to ground, or V_{cc}) were inserted, and all were detected. All gates are 7420s, and all inverters are 7404s.

microprocessors. Although the results of these tests are incomplete, the preliminary data looks promising.

In anticipating practical applications of the technique, it should be pointed out that, so far, all work was done with 8-bit devices. But, in the case of larger systems, suitable partitioning could divide the overall system into manageable pieces.

Another question facing future Bidco designers is how self-testing modules should be packaged. Should they be combined on a single chip, spread over several chips, or, perhaps, become on-chip elements of large-scale and VLSI circuits? In order to save space, it would appear that putting all of the Bidco functions on a single chip would be the preferred way. Besides the Bilbos, the chip would hold the clock, reset, and timing circuits and the control circuit.

The go-no-go nature of the present Bidco technique can be extended by providing a certain amount of diagnostic capability. Even an indication of which board has a fault is a step in the right direction. Obviously, some means of identifying the individual chip that caused the fault would greatly simplify subsequent troubleshooting and repair (in spite of the fact that such repair would most likely be performed in a central shop equipped with adequate testing and repair instruments).

Other future improvements could include raising the Bidco operating speed. Since it is based on standard circuitry, there is no reason why it cannot operate considerably faster than the 120 kHz cited earlier. □

Duart manages a pair of programmable signal paths

Dual universal asynchronous receiver-transmitter boasts independent bit-rate generators for its interrupt-driven, self-testing channels

by Alex Goldberger, *Signetics Corp., Sunnyvale, Calif.*

□ Even the most skilled juggler would have his hands full maneuvering three or four differently shaped and weighted objects, yet the tasks routinely required of a receiver-transmitter in a home computer or multi-terminal system are not dissimilar. Especially dextrous handling and the ability to juggle bits of information coming in and going out at different speeds are the forte of Signetics' new dual-channel universal asynchronous receiver-transmitter, which, unlike its predecessors, performs as capably for 16- as for 8-bit microprocessors.

The SC2681 goes several more steps better than its UART competitors, whether single- or dual-channel. Besides its two asynchronous data channels, it offers independently programmed bit-rate generators (BRGs), self-testing, and interrupt handling, obviating costly external components. Moreover, the unit can be used in both polled and interrupt-driven systems, as is elaborated in the table.

Each channel's operating mode—full-duplex, half-duplex, loopback, or autoecho—and data format—including bits per character or number of stop bits—are independently programmable. For example, an internal BRG operating directly from a crystal or from an external timing source allows each transmitter or receiver a choice of 18 fixed bit rates. Alternatively, the rate can be programmed either as the output from an internal programmable counter-timer or as an external $1 \times$ or $16 \times$ clock.

Each receiver of the Duart (Fig. 1) includes a 3-byte first-in, first-out memory to hold received characters. Together with the receiver shift register, the FIFO provides four character time periods of buffering between

the Duart and the microprocessor, doubly benefiting the user. For one, in a polled system, the time between polls for received data can be lengthened without risking overrun, that is, the chance that a previously received character will be overwritten by a new character. Addi-

	Dual-channel		
	Signetics 2681 ¹	Western Digital WD2123	Zilog Z80-DART
Number of pins	40/28/24	40	40
Power supplies	+5 V	+5 V	+5 V
Bit-rate generation	independent bit rate for Tx and Rx of each channel	same bit rate for Tx and Rx of each channel	no
Maximum data-transfer rate	1 X -1 Mb/s 16 X -125 kb/s	1 X -500 kb/s 16 X -37.5 kb/s	1 X -0.8 Mb/s 16 X -156 kb/s
Self-test modes	local and remote	local	no
Autoecho mode	yes	no	no
Full-duplex channels	2	2	2
Stop-bit-length programming	9/16 to 2 bits in 1/16-bit increments	1, 1-1/2, 2	1, 1-1/2, 2
Modem control lines	2/channel	2/channel	4/channel
General-purpose input line	7 lines	none	none
General-purpose output lines	8 lines	none	none
Programmable counter-timer	yes	no	no
Maskable interrupt output	yes	no	yes
On-chip crystal oscillator	yes	yes	no
Receiver buffer	4	2	4
Transmitter buffer	2	2	2
Checking status in character or block mode	yes	no	no
Automatic wake-up mode	yes	no	no
Change-of-state detection on input pins	yes	no	no
Deactivating request-to-send on receive or transmit	yes	no	no
Start or end of break gives interrupt and status bits	yes	no	no
Detecting break that originated in the middle of the character	yes	no	yes
Interrupt on a character or 3-character mode	yes	no	no

¹ Comparison applies to 40-pin version.

tionally, in an interrupt-driven system, the interrupt overhead is minimized because three characters can be transferred during each interrupt instead of only one.

The Duart's programmable counter-timer can also be used as a BRG, if the selection of fixed bit rates provided does not meet the user's requirements. Alternatively, it can undertake other general-purpose counting or timing functions. Also provided on the SC2681 are a multipurpose 8-bit output port and a 7-bit input port, which can serve as general-purpose I/O ports or, under program control, undertake such specific functions as clock inputs or status or interrupt outputs.

The unit is available in three package configurations (40, 28, and 24 pins), each offering different levels of I/O capability to satisfy various system requirements. A 24-pin version, optimized for interfacing with SC68000-microprocessor-based systems, is designated the SC68681. This Duart supplies the asynchronous bus handshake signals that are required by the 68000 as well as an interrupt vector in response to receipt of an interrupt-acknowledge input.

Whatever its package, the Duart has eight sections: besides the data-bus buffer, there are operation and timing controls, two communications channels, input and output ports, and interrupt control (Fig. 2).

Internal architecture

The data-bus buffer of the Duart functions as the interface between the external and internal data buses. It is controlled by the operation-control block to allow read and write operations to take place between the controlling central processing unit and the Duart.

The operation of the Duart itself is programmed by writing control words into internal registers. Operational feedback derives from status registers that can be read by the CPU in control. For fully independent operation and control, each channel has its own modes and command, clock-select, and status registers.

The operation-control logic receives operating commands from the CPU and generates appropriate signals to internal Duart sections to control the Duart's operation. The Duart also contains address-decoding and read

COMPARISON OF SINGLE AND DUAL CHANNEL UNIVERSAL ASYNCHRONOUS RECEIVER TRANSMITTER CHIPS

Single-channel

	Western Digital TR1863 ²	Western Digital WD1983	National INS8250	Motorola MC6850	Synertek 5551	T1 TMS9902
	40	28	40	24	28	16
	+5 V	+5 V	+5 V	+5 V	+5 V	+5 V
	no	no	same bit rate for Tx-Rx	no	same bit rate for Tx-Rx	independent bit rate for transmitting and receiving
	16 x -218.75 kb/s	1 x -56 kb/s 16 x -9.6 kb/s	16 x -56 kb/s	1 x -500 kb/s 16 x -31.25 kb/s	16 x -125 kb/s	550 kb/s (2 x clock)
	no	no	local	no	no	local
	no	no	no	no	no	no
	1	1	1	1	1	1
	1, 1½, 2	1, 1½, 2	1, 1½, 2	1, 2	1, 1½, 2	1, 1½, 2
	none	4	6	3	5	3
	none	none	none	none	none	none
	none	none	2	none	none	none
	no	no	no	no	no	yes
	no	no	yes	no	no	yes
	no	no	yes	no	yes	no
	2	2	2	2	2	2
	2	2	2	2	2	2
	no	no	no	no	no	no
	no	no	no	no	no	no
	no	no	yes	no	no	no
	no	no	no	no	no	no
	no	no	no	no	no	no
	no	no	no	no	no	no
	no	no	no	no	no	no
	no	no	no	no	no	no

²TR1402, TR1602 are the same as TR1863 with dual power supply. TMS6011, COM1863, 8018, 2502, 2017, 8017, 8502 are similar to TR1863.

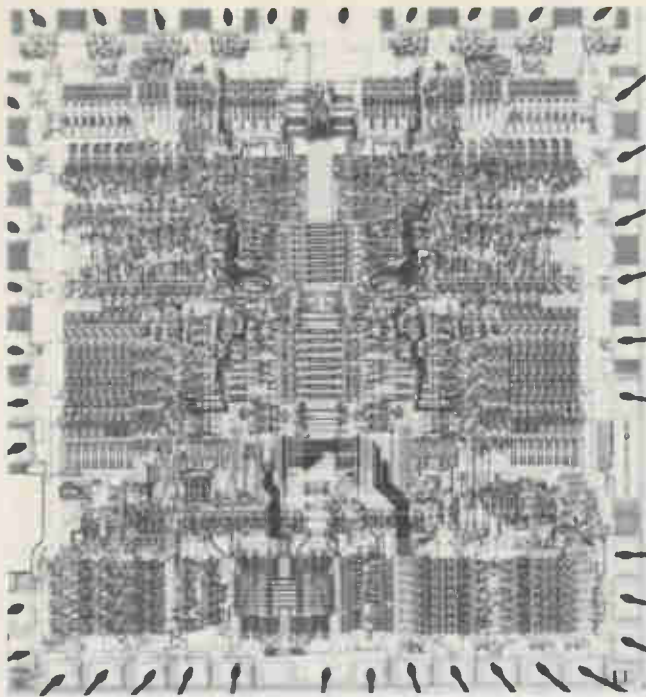

1. **Versatile.** The Signetics 2681 dual-channel asynchronous receiver-transmitter needs but one 5-volt power supply. Its maximum data-transfer rate is 1 megabit per second, and it can perform local and remote self-testing as well as autoechoing.

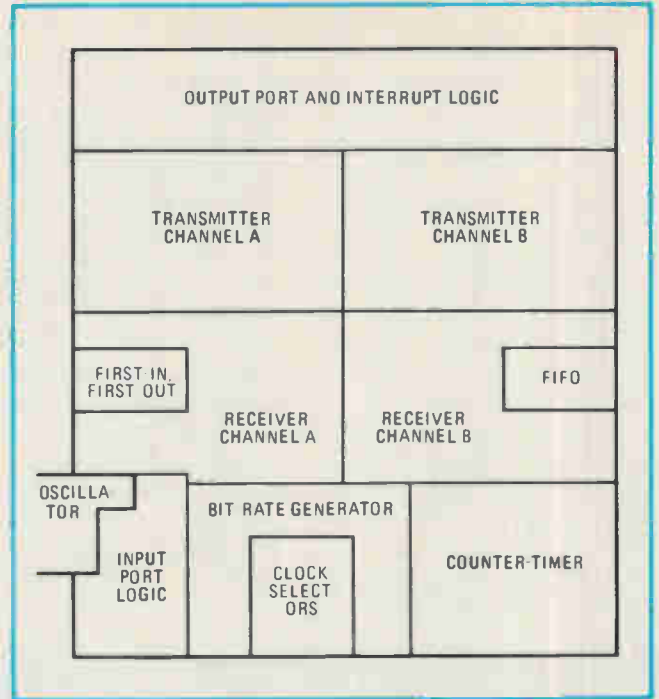

and write circuits for communicating with the microprocessor over the data-bus buffer.

The timing block of the 2681 consists of a crystal oscillator, a BRG, a programmable 16-bit counter-timer, and four clock selectors. The crystal oscillator operates directly from a 3.6864-megahertz crystal connected across the X1/CLK and X2 inputs. If an external clock of the appropriate frequency is available, it may be connected to the X1/CLK pin.

The BRG operates from the oscillator or external clock input, selecting from 18 commonly used data-communications rates ranging from 50 bits to 38.4 kilobits per second. The clock outputs from the BRG are 16 times the actual bit rate. The counter-timer can be used in the timer mode to produce a 16 \times clock for any other bit rate by counting down either the crystal clock or an external clock. Any of these rates or an external timing signal can be independently assigned to each receiver and transmitter by means of the four clock selectors.

Double-barrelled

In operation, the Duart indicates to the CPU that it is ready to accept a character by setting the transmitter-ready (TXRDY) bit in the status register or by asserting an equivalent interrupt request. The controlling CPU responds to this condition by loading the next character to be transmitted into the transmit holding register (THR). Data is transferred from the holding register to the transmit shift register when it is idle or has completed transmission of a previously supplied character. The TXRDY conditions are then reasserted. This means that one full character time of buffering is provided.

The transmitter converts the parallel data from the CPU into a serial bit stream on the TXD output pin. In accordance with the asynchronous data-transmission for-

mat, it automatically sends a start bit followed by the programmed number of data bits, an optional parity bit, and the programmed number of stop bits. Following the transmission of the stop bits, if a new character is not available in the THR, the TXD output remains high, and the transmit-empty (TXEMT) bit in the status register will be set to 1. When the CPU loads a new character into the THR, transmission resumes and the TXEMT bit is cleared. If the transmitter is disabled, it continues operating until the character currently being transmitted is completely sent out. The transmitter can be forced to send a continuous-low condition; this is done by issuing a send-break command.

The operation of the transmitter can be programmed to be under the direction of an external input, derived, for example, from a computer. In this mode, the clear-to-send, or CTSN, input must be low in order for a character to be transmitted. If it goes high in the middle of a transmission, the character in the shift register is sent, and TXD then remains in the marking state until CTSN goes low again. Only then does normal operation resume. This feature can be used by an external device such as a printer to ensure that characters arrive at the rate they can be accepted.

At a glance

The receiver looks at the received data (RXD) for the high-to-low (mark-to-space) transition of the start bit that precedes each asynchronous format character. When the transition is detected, the state of the receiver input is sampled either each 16 \times clock for 7½ clocks if in the 16 \times clock mode or at the next rising edge of the bit-time clock if in the 1 \times clock mode. In the case where the input is sampled high, the start bit is invalid—most likely because of noise on the line—and subsequently the

search for a valid start bit resumes.

If the input remains low, a valid start bit is assumed and the receiver continues to sample the input at 1-bit theoretical time intervals, at the time center of each bit, until the proper number of data bits and the parity bit (if any) have been assembled and one stop bit has been detected. The receiver checks for parity error, framing error (a missing stop bit), and received break state (a continuously low input) and then transfers the data and the status conditions to the receive FIFO.

Ins and outs

The inputs to the unlatched 7-bit input port can be read by the CPU. The pins of this port may also serve as auxiliary inputs to certain portions of the Duart logic. Change-of-state detectors associated with four inputs can be used to indicate any changes in control inputs from a modem.

A high-to-low or low-to-high transition of these inputs will set the corresponding bit in the input-port change register. The bits are cleared when the register is read by the CPU. Any change of state can also be programmed to generate an interrupt to the CPU.

The 8-bit multipurpose output port can serve as a general-purpose output port, or, alternatively, outputs can be individually assigned specific functions by appropriately programming the internal registers.

A single active-low interrupt output (INTRN) is activated when any of eight internal events occurs. Associated with the interrupt system are the interrupt mask register (IMR) and the interrupt status register (ISR). The former may be programmed to select only certain conditions to cause INTRN to be asserted. When read by the CPU, the ISR shows all currently active interrupting conditions.

In order to assign priority to the interrupts, five pins of the output port can be programmed to generate discrete interrupt outputs to the transmitters, the receivers, and the counter-timer. These, together with the normal interrupt output, can then be applied to an external interrupt-priority resolver to set up their relative priorities as required by the system design.

The SC68681 version of the Duart includes an interrupt-acknowledge (IACKN) input. When the CPU asserts this input in response to the interrupt request, the Duart places the contents of its interrupt vector register on the data bus. The CPU uses this vector to perform an automatic jump to the appropriate interrupt service routine.

A many-splendored thing

Because the operating speeds of the Duart's receiver and transmitter can be programmed independently, the unit is particularly handy in dual-speed channel applications. For example, a small computer or a word-processor system handling eight asynchronous terminals each needs fast transmission from the computer to the terminal to respond to an operator's request for a page of data. A speed of 19.2 kb/s will provide a worst-case time of approximately 8 s, which is derived from a transmission rate of 1,920 characters/s, 80 by 24 characters per display, and eight displays to be updated.

If the terminals sent data back to the computer at the

same speed, the computer would need to receive, in the worst case, where all terminals transmit simultaneously, (1,920×8) characters in 1 s, or one character every 65 microseconds. Demands like these are tough on both hardware and software. A reduction in the transmission speed from the terminal to the CPU down to, say, a more reasonable 2.4 kb/s translates into a worst-case rate of one character every 530 μ s.

To bring about such a reduction, however, implies that the transceiver must receive and transmit at different speeds. Moreover, it requires that multiple timing sources be provided both in the CPU and at each terminal, the most common (though undesirable) means being the addition of external components. The Duart can in fact solve the predicament on its own by assigning speeds for the receiver and transmitter of each channel from its internal BRG.

A situation even more conducive to the use of the Duart would be a similar multiterminal system that also incorporates a printer. Printers usually have a limited-capacity input buffer to store the characters to be printed and provide a "buffer full" output signal—most often one or two characters before the buffer is actually full—to stop the transmitting device from sending more characters. Accordingly, the CPU in this setup samples this signal before sending each character. The SC2681's capability to stop transmitting (at the next character boundary) when the CTSN input is negated eliminates the additional hardware and software that otherwise would be the most likely solution.

Even less of a problem

If a Duart were used at the receiver, or printer, end of the system, the task could be made even simpler. The receiver can be programmed to control automatically the negation of its request-to-send (RTSN) output pin. If so programmed, the RTSN output will be negated when a valid start bit is received and the FIFO is full.

When a FIFO position opens up, the RTSN output will automatically be reasserted. Thus when its buffer fills up, the printer's microprocessor merely stops reading data from the Duart's FIFO. When the FIFO fills, the RTSN output is negated. Because this output is connected to the CTSN input of the Duart at the computer, it automatically stops the transmitter from sending any more characters, preventing a data overrun. When the printer buffer becomes emptied, normal operation resumes. Such a sequence makes for totally automated flow control between the CPU and the printer without extra hardware or software.

In applications requiring timing information to be transmitted, asynchronous systems are outdone by their synchronous counterparts. Because the former cannot transmit this kind of information, their transmitting speed may be higher than the speed expected by the receiver (although still within the receiver's acceptable limits). Internal character buffering is needed when the receiver must in turn retransmit the data, as in a code or protocol converter.

One way around this need for buffering is to set the retransmitting bit rate slightly higher than the fastest expected receiving speed. But there is a price to pay, in

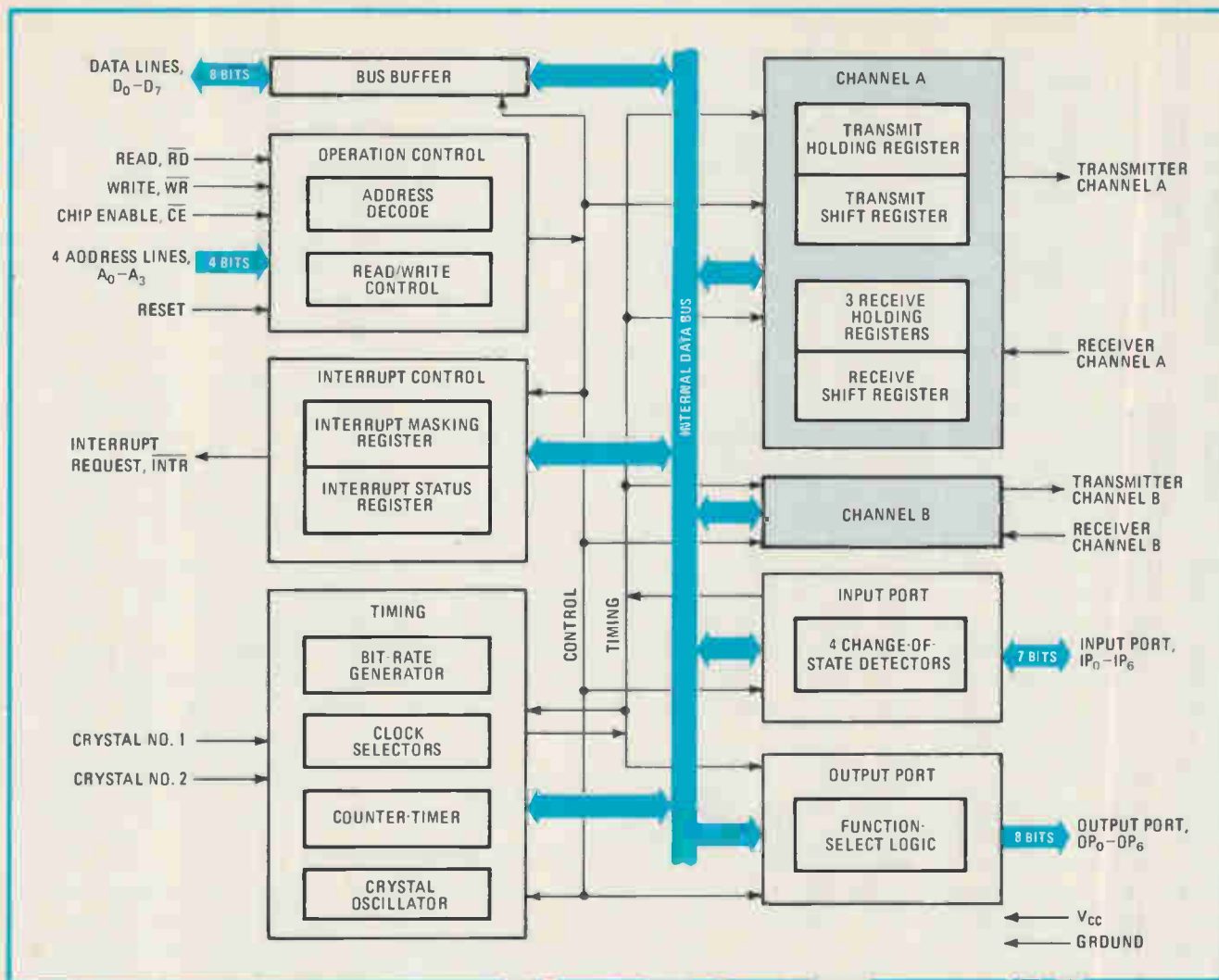

2. Two channels. The block diagram of Signetics' Duart illustrates its two independently programmable receiver-transmitter channels. Three packages of this configuration allow the user to select the best pinout for his application.

that this normally would require two separate timing sources. Moreover, if the process must be repeated farther down the line, an even more tangled web is woven. To unsnarl the jam, the Duart steps in with what is known as "stop-bit shaving."

Stop-bit shaving involves programming the length of the stop bit at the end of each transmitted character in increments of one sixteenth of a bit time instead of the full or half-bit increments most common with a UART. A stop bit slightly shorter than its normal length can provide the required time compression without resorting to separate clocks. The receiver accepts this message as usual because it samples the stop bit only at the center of the bit time and then immediately starts looking for the next start bit.

The SC2681 finds still other shortcuts around a high system price tag. For example, in master-slave communications systems, a multidrop configuration would be preferable to a point-to-point scheme because its associated cabling costs are considerably lower. But to require each slave station on the line to monitor each character of the data stream in order to detect messages addressed to it, as the multipoint regime commands, may

keep the slave's CPU from performing other tasks not associated with the data-communications process. The Duart is equipped with what is known as a wake-up mode intended specifically for these applications.

In the wake-up mode, the master transmits an address character followed by data characters for the addressed slave. A transmitted character consists of a start bit, the programmed number of data bits, an address/data (Λ/D) bit, and the programmed number of stop bits. The polarity of the transmitted Λ/D bit is selected by the master's CPU by programming a bit in a control register. A 0 in the Λ/D -bit position identifies the corresponding data bits as data, and a 1 indicates that the corresponding data bits are an address.

To perform its chores in the wake-up mode, the Duart receiver at each slave station continuously looks at the received data stream to determine whether it is enabled or disabled. If it is disabled, the Duart sets the $RXRDY$ status bit and loads the character into the receiver FIFO if the received Λ/D bit is a 1, or address tag. But it discards the received character if the received Λ/D bit is a 0, or data tag. If the stream is enabled, the receiver transfers all received characters to the CPU. □

Back-contact resistor network pares wire count in ECL hybrids

Thin-film tantalum-nitride resistor chip eliminates four interior wire bonds with a common back contact

by Dieter Walter, *Semi-films Division, National Micronetics Inc., West Hurlay, N. Y.*, and Loyd Searle, *High Tech Promotions, Woburn, Mass.*

□ Emitter-coupled-logic integrated circuits require dual-resistive-termination networks no matter how they are packaged. For some time now, printed-circuit users have been able to save space and simplify interconnections by availing themselves of the dual-termination networks built into single and dual in-line packages.

Hybrid manufacturers, on the other hand, have not had a chip component functionally similar to the DIP-based dual-terminator network. Now, a unique thin-film process has been designed exclusively for hybrid manufacturers, which emulates the simplicity of resistive networks in DIPs.

The dual-terminator back-contact resistor network for ECL hybrids is made from tantalum nitride, a resistor material that is self-passivating and impervious to moisture. The thin-film substrate is single-crystal silicon to ensure the best possible power dissipation characteristics. Back-contact technology reduces the number of bonding pads necessary and also obviates the need for interior wire bonding. Four ECL lines can be terminated with five bonds—a savings of four interior wire bonds.

All logic circuit interconnections are, inadvertently, transmission lines. As logic speeds and wiring lengths increase, reflections from the ends of the logic lines are more likely to interfere with the desired signals. The termination of a logic line with an appropriate resistive load, however, reduces these reflections.

A resistive divider consisting of two series resistors, R_H and R_L , forms a very practical terminator for ECL. The divider is connected between the positive and negative supply lines, and the logic line is connected to the divider output. Since the supply lines are electrically common to ac signals, the input impedance at the divider output is R_H in parallel with R_L . In addition, the divider functions like a pull-up or pull-down resistor. These terminators are called dual-terminating networks.

Wired at the back

The dual-terminator network sits on a 50-by-90-mil chip containing four terminator pairs (Fig. 1). Normally, four terminator chips with three pads each would have 12 pads requiring 12 wire bonds. Using common positive and negative buses on the chip would reduce the number of wire bonds to six, but would not significantly reduce the size of the chip. Also, all pads could not be located at the periphery of the chip. A more practical solution to

the layout problem was achieved here by using back-contact technology.

Back-contact technology employs the silicon body of the chip as a circuit node. Heavily doped low-resistivity silicon is used to minimize parasitic resistances. The back of the wafer, and hence each chip, is metalized with gold. Electrical connections are made from the tantalum nitride film to the silicon body through etched windows in a silicon oxide layer. This technique has been used for many years to make single-resistor chips. With it, the user need make only one wire bond; the other connections are made through the die bond to the substrate.

The final design has one bus for the positive connections. This bus, employing aluminum metalization, runs along one edge of the chip (Fig. 2). It widens at four places to form bonding pads, any of which may be used. Along the opposite edge are located the four bonding pads for the logic lines. The metalization covering the back-contact windows appears as four "pads" in the interior of the chip. They are not intended for wire bonding since this bus is the back contact, which is bonded to a conductive pad on the final hybrid substrate.

Each resistor is of composite design—that is, each consists of several trimmable elements in series. This arrangement allows for wide trim ranges (up to 2:1), with a trim resolution of $\leq 2\%$, while limiting power

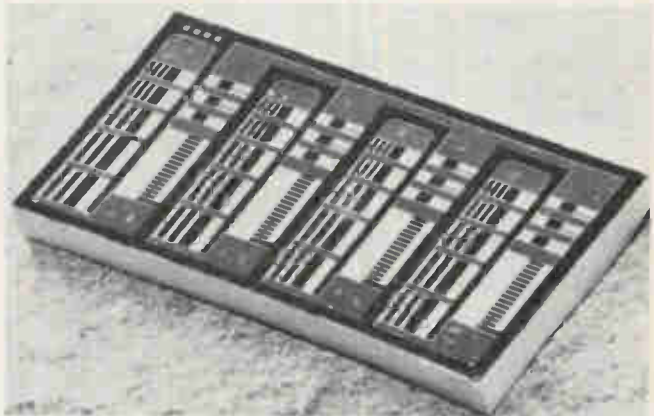

1. Back contact. A scanning electron microphotograph of the dual terminator for emitter-coupled-logic hybrid circuits shows the tantalum nitride resistors (the white areas) on a silicon substrate. The back contact of the chip is metalized with gold and connects to the resistors through windows in an insulating silicon dioxide layer.

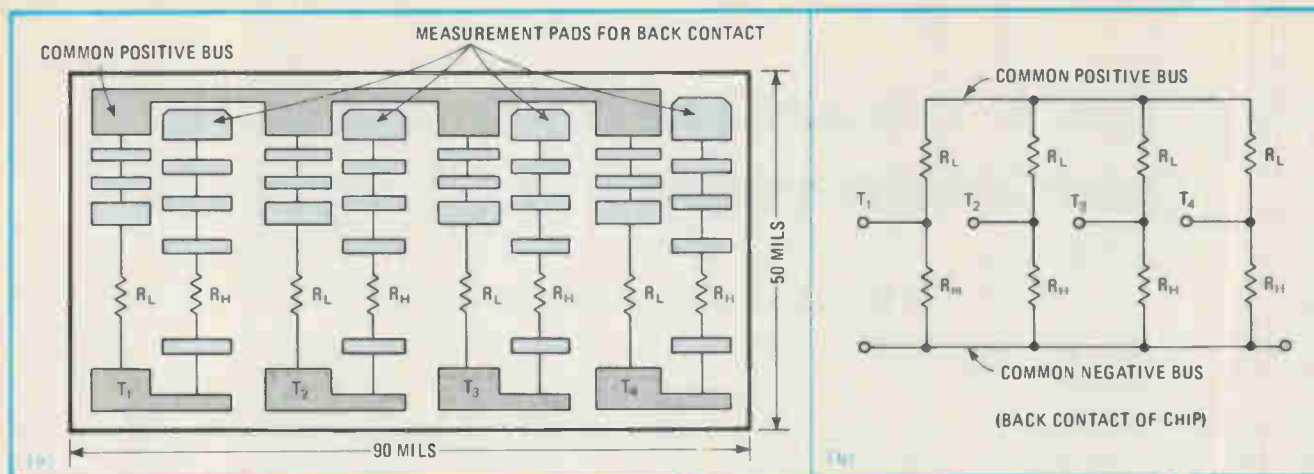

2. **Savings bonds.** Chip layout (a) and the equivalent circuit (b) of the emitter-coupled-logic terminator are depicted above. T_1 , T_2 , T_3 , and T_4 are bonding pads for resistor junctions. The metalization of the chip's back forms the negative bus through the chip substrate.

dissipation density to 5,000 watts per square inch at any point in the film under worst-case conditions. The metalization bars separating the elements of each resistor contribute to the unique appearance of the chip.

On the wafer

In wafer form, direct electrical contact to the silicon body is not readily achieved. Instead, probes are placed on the back-contact pads as well as on the bonding pads. The equivalent circuits of the structure thus tested contain the eight desired tantalum nitride resistors, four undesired back-contact window resistances, and three resistances resulting from the bulk resistivity of the silicon. These 15 resistors are arranged in a circuit with three independent loops.

The parasitic resistances associated with the back contacts are low—several ohms or less—compared with 81Ω and up for the terminator resistors. Each network must be tested to verify that the resistances are low enough. In wafer form, this is done by measuring the resistance between back-contact pads. However, because of low values, separate current and voltage probes must be used. Three of the four contact pads are too small to accept more than one probe. A solution is to use one probe for current and sense the voltage through one of the terminator resistors.

An additional complication arises from the fact that the terminator resistors shunt the parasitic resistances. The sensed voltage is therefore attenuated, and a true-ohms reading is not obtained. Nevertheless, it can be shown mathematically that a sufficiently accurate result is obtained by these measurements.

Multiple measurements

Measurement of the eight terminator resistors in closed-loop configuration is achieved by using an active guarding option available on the laser trimmer. This standard technique has to be slightly modified, again because of the inability to place more than one probe on the back-contact pad of the silicon wafer.

All the resistor networks on the chip are functionally tested in the same manner as any integrated circuit component. First, the chip is bonded to a conductive

surface (ground) using conductive epoxy. The bus on the chip is then shorted to the ground surface, and the resistance measured between each logic terminator pad and ground. In this manner, dc measurements are used to predict ac operation. The standard tolerance on the impedance is $\pm 2\%$ and has been readily achieved by laser trimming with the previously discussed techniques.

Other samples are used to test for the output voltage, that is, the ratio $R_{II}/(R_L + R_{II})$. Again, the chips are bonded to a conductive surface. Two probes are used to apply a dc potential between the bus on the chip and the ground plane, and separate probes are used to measure the output voltage ratio. The 2% tolerance on the output voltage has been easily met by the manufacturing techniques described. The logic terminator chip is called upon to dissipate substantial power. For example, as a 50- Ω terminator for Signetics ECL II logic, the chip dissipated 636 milliwatts with nominal values and logical 1s applied.

Old reliable

Using tantalum nitride improves reliability; absolute resistance shift of the material $\Delta R/R$ is less than $\pm 0.5\%$, after being tested to MIL-STD-202, Method 106 (moisture resistance). This is more representative of microelectronic operating environments than MIL-R-55342, since a bias is applied under high relative humidity. Method 106 consists of ten 16-hour cycles during which relative humidity and temperature are ramped up to 98% at 65°C and a bias equal to the working voltage is applied during the first 2 h of each 8-h half-cycle. In addition, absolute resistance stability over 5,000 h at 125°C in air is $\pm 0.2\%$ maximum $\Delta R/R$, while noise, tested to MIL-STD-202, Method 308, is rated at -35 decibels maximum. Under worst-case conditions, power dissipation is limited to 5,000 w/in.²

Experience with tantalum nitride's stability was used to select a conservative stability specification of less than 2% change in 1,000 h under load with a chip temperature not to exceed 125°C . Additional specifications, including temperature coefficient of resistance, high-temperature exposure, and thermal shock and moisture resistance, are par for tantalum nitride chip resistors. \square

Electromatrix printing reduces terminal noise

Low-energy printing technology leads to small fast terminals that require no adjustments and very little service

by Humberto Cordero Jr., IBM Corp., General Technology Division, Endicott, N. Y.

□ A half millennium or so since he revolutionized printing, Johann Gutenberg would be hard-pressed to recognize the technology his latter-day electronics-engineering counterparts have devised. A new process for character formation reverses the traditional deposition of dark material on a lighter background by removing light-reflecting aluminum from a black underlayer, quickly, quietly, and at low cost—ideal for desktop terminals and printers (Fig. 1). The old printers' devils cringing and scurrying at barked commands have given way to several microprocessors programmed by microcode to set uncomplainingly and efficiently about their tasks.

Electromatrix printing, as the process is known, yields

a dense array of dots at high speed and with low energy consumption. It involves the selective removal of portions of a very thin (0.1 micrometer) layer of aluminum that overlays a black undercoat, 5 μm thick, atop paper. The basic concept is that, since so much of the visible spectrum is reflected off a metal layer whose thickness is less than the light's wavelength, the surface appears white. In contrast, the black layer, with a thickness orders of magnitude greater than the wavelength, absorbs the light very efficiently.

The characters are formed by a print head consisting of 18 circuit wires that form an array of electrodes nine high by two wide (Fig. 2). As this array passes horizon-

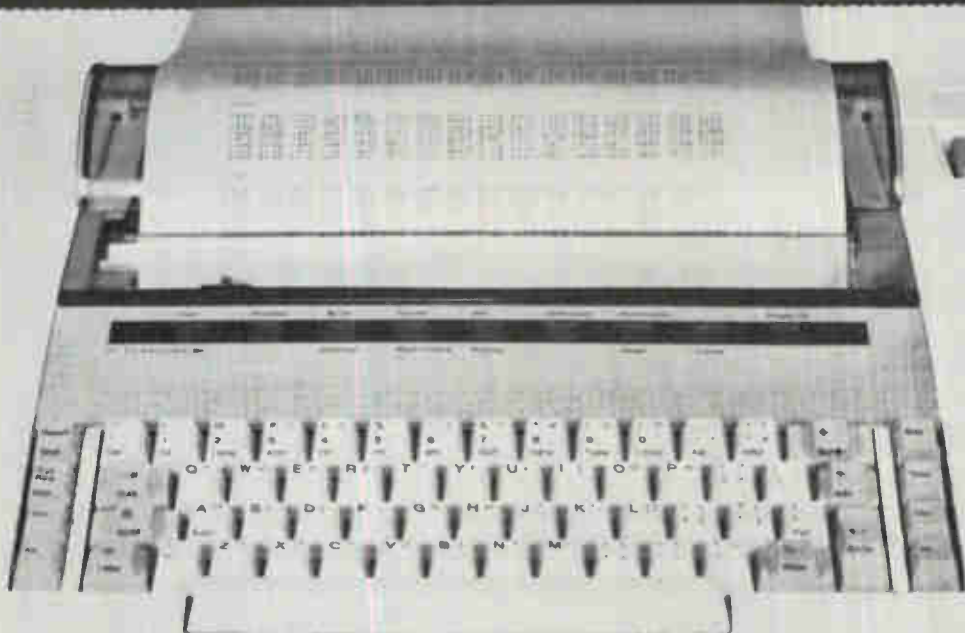

1. Hush, hush. The 3232 electromatrix printing terminal is very quiet because of the nonimpact, low-energy printing process. It is also small, fast, and reliable, thanks to the overall simplicity of the process and the company's no-adjustment design philosophy.

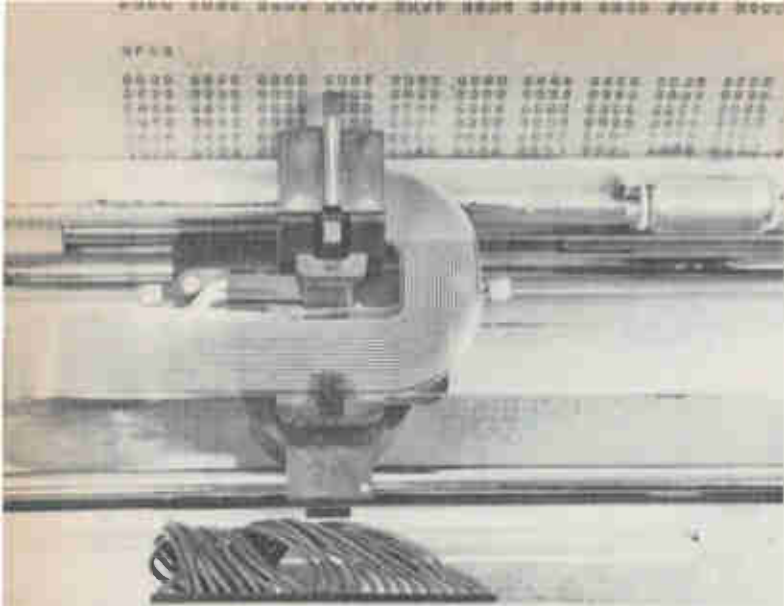

2. Quick as a cobra. The simple, lightweight print head used in electromatrix printing can move across the paper very rapidly and print in both directions. The head can be easily replaced by the customer and, what's more, involves no messy ribbons.

tally across the paper, an electrical pulse is sent through each wire to produce a diminutive dot.

Specifically, a high electrical current is passed from the wire tip through the metallic layer of the paper to a ground roll whose area is much larger than the cross section of the wire. As the high current momentarily passes through the metalized layer, the heat it generates vaporizes a small spot of aluminum, emitting various gases and particles (see "Testing electromatrix printing's gaseous and particulate byproducts"). Primarily because each spot is so minuscule, the procedure consumes little energy.

Printer's devils

All the control functions are contained in the printer package, which mechanically is quite simple. For example, the vertical array of wires forming the printing element is mounted in a single print head that can be replaced by the user. Because the compact head moves swiftly and accelerates easily, no mechanical acceleration or deceleration compensation is needed at either end of the line. Also in the printer are two microprocessors that obey programmed microcode to perform almost all the control functions, including self-diagnostics. A third microprocessor, which is located in the keyboard, controls its operation. All three microprocessors communicate with each other.

One of the printer's microprocessors interfaces with the host system and processes all the communications protocol and the basic data manipulation. It also handles the operator-panel keyboard and the reliability and service functions.

The companion printer microprocessor controls all the unique functions of the printing mechanism, reducing the printer's hardware to a minor interface. It also sets variable line spacing of three, four, six, or eight lines per inch and gets the character definitions from read-only memory.

Another benefit of the dual-processor design is that it permits data to be received and processed at the same

time other data is being printed. This pipeline allows the mechanical part of the printer to keep running as fast as it can.

Testing electromatrix printing's

The development of the IBM electromatrix printer prompted a series of tests to determine the composition and quantity of the gases and particles dispersed into the immediate environment by the electromatrix printing process, which involves the selective removal of light-reflecting aluminum from atop a black undercoat on paper.

Initial investigation and review indicated that at least three separate tests would be required to provide adequate data on the three broad classes of air pollutants—organic and inorganic gases, and particles.

Organic-gas analysis was performed by a combination of chromatography and mass spectrometry, which together are able to measure almost all the organic gases. The chromatography portion of the apparatus separated the 21 different gases to be detected, after which the spectrometry helped establish the chemical structures. This sensitive technique is able to detect 20×10^{-9} grams (20 nanograms) of material. In comparison, the mass of a grain of sand is approximately 1,000 times heavier.

The analysis of inorganic gases is laborious because a separate technique is required for each gas, meaning it is necessary to identify which gases are most likely to be given off. However, an examination of the materials in the black undercoat determined the likely candidates. Accordingly, appropriate tests were made for sulphur dioxide, chlorine, ozone, total sulfur, hydrogen sulfide, nitrous oxide, and carbon monoxide.

Step by step. The size and quantity of the airborne particles were measured by a Climet Particle Analyzer, an optical instrument for counting and sizing particles as small as 0.3 micrometer in diameter.

In the initial step, the particles were trapped on acetone-soluble filters and analyzed with polarized light and transmission electron microscopy. The particles that settled out of the air were collected on acetone-soluble sticky tape. Residual particles were also brushed from the inside of the machine under test and then collected.

In addition, the printer being tested had to be isolated to ensure that the contaminants analyzed were only the evolved printing products and did not include any contaminants from the environment.

Precision flow controllers were used to monitor the flow rates and to ensure that a small positive air pressure was maintained on the aluminum box that held the printer being tested. Surgical-grade stainless-steel tubing and only ultrapure compressed air were used throughout the test apparatus. In order to minimize the pressure of ultrapure air, a vacuum pump was used to draw the samples through the analyzer.

The substantial effort expended to develop this sampling system proved its worth, because tested samples taken without a printer in the box contained no contaminating background gases and particles.

Good news. Tests were made and the results analyzed to represent a hypothetical application in a worst-case situation. The concentrations of gases and particles found after eight hours of continuous printing were compared against the Occupational Safety and Health Administration's (OSHA) Threshold Limit Values (TLVs). The TLVs

The printer contains three major sections of microcode. Their mutual communication takes place through an interface called the program-control block by means

of the printer common microcode, which serves as the link to the host system and executes the operator panel and keyboard functions.

gaseous and particulate byproducts

are considered the average concentration to which a person may be exposed for an 8-h day, over many days, with no harmful effect. These figures are usually established by the American Conference of Governmental Industrial Hygienists.

The established test conditions represented a printer being used continuously in an 8-by-8-by-6-foot unventilated room without air changes, considered worst-case because:

- Most rooms of this type normally have 100% air exchange at least 10 times per day.
- A room this small permits perhaps only slightly more space than is taken up by a desk and chair.
- It is unusual for printing to be done continuously.
- The concentrations measured were peak concentrations at the end of the 8 h, in contrast to OSHA's basis of an average taken over the same period.

The analysis indicated that the concentrations of gases and particles fell significantly below the TLVs. The results shown in the table are for evolved gases that have threshold values established by the Government. The particle tests resulted in counts of airborne particles of 0.4127 million and 0.002 million particles larger than 0.5 μm per cubic foot respectively for continuous printing and operation without a print head.

The OSHA TLV for particles is set at 15 million per cubic foot. All the data in these results indicate concentration below the OSHA limits. **-R. C. Lasky and E. J. Vytlačil,**
IBM Corp., General Technology Division, Endicott, N. Y.

Another section of microcode, the printer mechanism-adaptor code, handles such mechanical printing functions as the initial printing request and setup, print-head sensing, testing for paper alignment and margin locations, and sensing the size of the paper roll.

The third major section, the reliability and serviceability microcode, tests the hardware and software operations before printing. It also scrutinizes the performance of the operator panel and keyboard and directs the storage of the basic operating parameters that are located in the host memory. In the event an error or failure occurs, the on-line diagnostics detect it and convey the message to the operator by means of eight panel lights. This error information provides guidance for servicing the equipment.

Bright lines

The printer was designed with the consumer in mind—the bright line was “no adjustments.” Consequently, the final product had to measure up to high standards of reliability, ease of manufacture, simple installation, and self-diagnostics for ready identification of malfunctions.

The only moving parts are in the print head and the paper-feeding mechanism. Driven by a cable, the head travels up to 35 in. per second and prints bidirectionally. Built to need no adjustments during manufacture or afterward, its working parts cannot be improperly aligned during assembly and so should remain within working tolerances during the product's lifetime.

Also free of adjustment is the optical emitter and receiver system that guides the displacement, velocity, and direction needed to move the print head. Two pickups provide dual-pulse trains employed by the microprocessors' microcode to control the head.

Similarly, a special spring-loaded mechanism prevents improper belt tension in the belt that, driven by a stepper motor, in turn drives the friction roll for paper spacing, with the help of reduction pulleys. Other special mounting and positioning techniques also contribute to the insurance provided by the “no adjustment” watchword.

The unit's packaging also reflects consideration for the end user. For example, one of the models boasts a 64-key keyboard that provides the operator with positive tactile feedback. Character graphics are clearly legible on the left side of the keys' tops, and control functions are scribed on their fronts. The operator's view of the last line printed is unobstructed, thanks to the thin, low-profile print head. Character impressions are highlighted by the electromatrix technology's stark contrasts, and the dense dot matrix forms bold characters. Further, the actual printing is much quieter than with the more common impact method, and at only 30 pounds and 20.9 by 19.2 by 5.9 in. in size, the terminal is light, compact, and portable.

The entire printer is housed in a two-piece enclosure surrounding a planar-type electronic package that contains most of the electrical components. Forced air flows through the cover and serves to cool the assembly. □

AMOUNTS OF EVOLVED GASES RELEASED BY PRINTER

	Printer on	Printing	Threshold limit value set by OSHA**
	(ppm volume/volume)*		
Organic			
Benzene	—	0.007	10
Napthalene	0.0002	0.0009	10
Cyclohexanone	0.03	0.06	50
Trichloroethylene	0.002	0.004	100
Tetrachloroethylene	0.0005	0.004	100
Xylene	0.003	0.005	100
2-ethoxy ethyl acetate	0.007	0.01	100
N-butyl acetate	0.003	0.0003	150
Toluene	0.002	0.006	200
4-me-2-pentanone	0.006	0.003	200
Ethyl acetate	0.003	0.03	400
Inorganic			
Total sulphur	0.0001	0.0002	—
Sulphur dioxide	0.0001	0.0002	5
Ozone and chlorine	<0.0001	0.0004	O ₃ —0.1 Cl ₂ —1
Nitrogen monoxide	<0.0002	<0.0002	25
Nitrogen dioxide	<0.0002	<0.0002	5
Carbon monoxide	0.5	4.6	50

* Within a factor of 5.

** Occupational Safety and Health Administration's approximate value.

Single chip solves MC6809 timing problems

by Kim A. Crane
Arizona State University, Mesa, Ariz.

Microprocessor-based systems often have several levels of peripheral decoding. Propagation delays due to these decoding schemes make the bus-timing parameters critical. As a result, they are difficult to keep within specifications from a worst-case-analysis point of view and introduce a timing fault TF.

TF is the amount of time by which the last opportunity to read or write valid data has been missed. However,

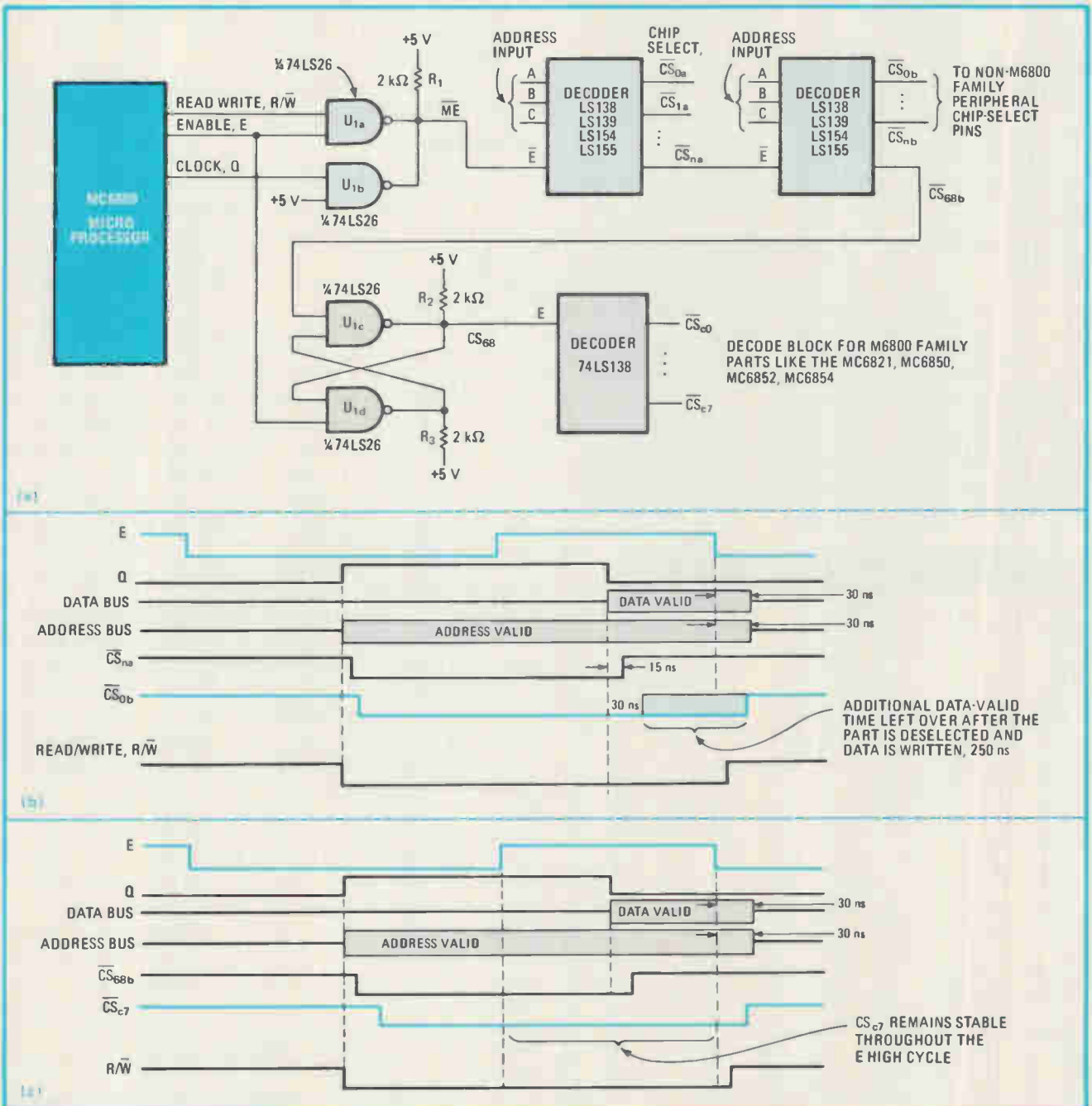

Delay. The circuit (a) ends decoder bus-timing problems on the MC6809 processor when it is being interfaced with M6800 and non-M6800 parts. Diagram (b) shows that a string of 18 74LS138 decoders can be used with this scheme without any timing-delay problems. For interfacing with some M6800 parts, logic extends the chip-select low during a write cycle (c) to the falling edge of E.

this configuration uses only one chip and three resistors to eliminate this timing problem for the MC6809 processor when it is being interfaced with either M6800 or non-M6800 family parts.

The circuit (a) takes advantage of quadrature clock Q that is included in the MC6809 chip. The rising edge of this clock indicates that the address bus is valid, and its falling edge indicates that the data bus is valid. In addition, the read-cycle access time is extended by about 250 nanoseconds through enabling the decoders on the rising edge of this clock.

However, the main advantage lies in the write-cycle timing. On the falling edge of Q, during a write-cycle, the decoders that drive the appropriate chip-select high while enable E is only partially through its high cycle are disabled, causing the data to be written. Also, the data is valid until the falling edge of E occurs. This provides the

chip-deselect signal with an additional 250 ns to propagate through the various decoding levels and still remain within worst-case timing margins. With this method, no timing faults will occur for up to 18 levels of LS type decoders connected in series (b).

Unfortunately, this write-cycle technique is not suitable for some M6800 family parts because of the fact that the data is written into these parts on the falling edge of E and not the rising edge of chip-select. Therefore, additional hardware is required for these parts. NAND gates U_{1c} and U_{1d} and resistors R_2 and R_3 solve this problem by extending the chip-select low during a write cycle to the falling edge of E without affecting the already correct read-cycle timing (c). □

Engineer's notebook is a regular feature in *Electronics*. We invite readers to submit original design shortcuts, calculation aids, measurement and test techniques, and other ideas for saving engineering time or cost. We'll pay \$75 for each item published.

Comparator, one-shot produce pulse-width inversion for servos

by John Karasz
Norden Systems, Norwalk, Conn.

Frequencies usually trigger movements of servo-actuators within radio-controlled vehicles. However, these transmitted waves are difficult to produce and are noisy. This design overcomes both problems by employing pulse control with a comparator, two monostable multivibrators, and a pair of NOR gates. Although the circuit produces only three pulses, or three servo positions, more comparators and NOR gates may be added to create an n-position control.

The circuit compares the width of the input pulse with that of a reference. A reference pulse of 1.5 milliseconds is selected for the circuit through the RC network connected to one-shot U_{1a} . As a result, pulse durations of 1.0 ms and 2.0 ms produce servo-output positions of $+45^\circ$ and -45° , respectively.

The reference pulse is triggered by the leading edge of the input pulse. The trailing edge of this pulse triggers U_{1b} to generate output Q_2 , which is equal in duration to its input. When the width of the input pulse is equal to the reference pulse, output Q_2 passes through the NOR gates and is unchanged. Under this condition, no contributions are made by the comparator outputs.

However, when the width of the input pulse is greater than the reference pulse, the trailing edge of Q_1 triggers U_{1b} and comparator U_2 produces a high output at pin 5 ($A > B$). This pulse starts at the trailing edge of the reference pulse and ends at the falling edge of the input

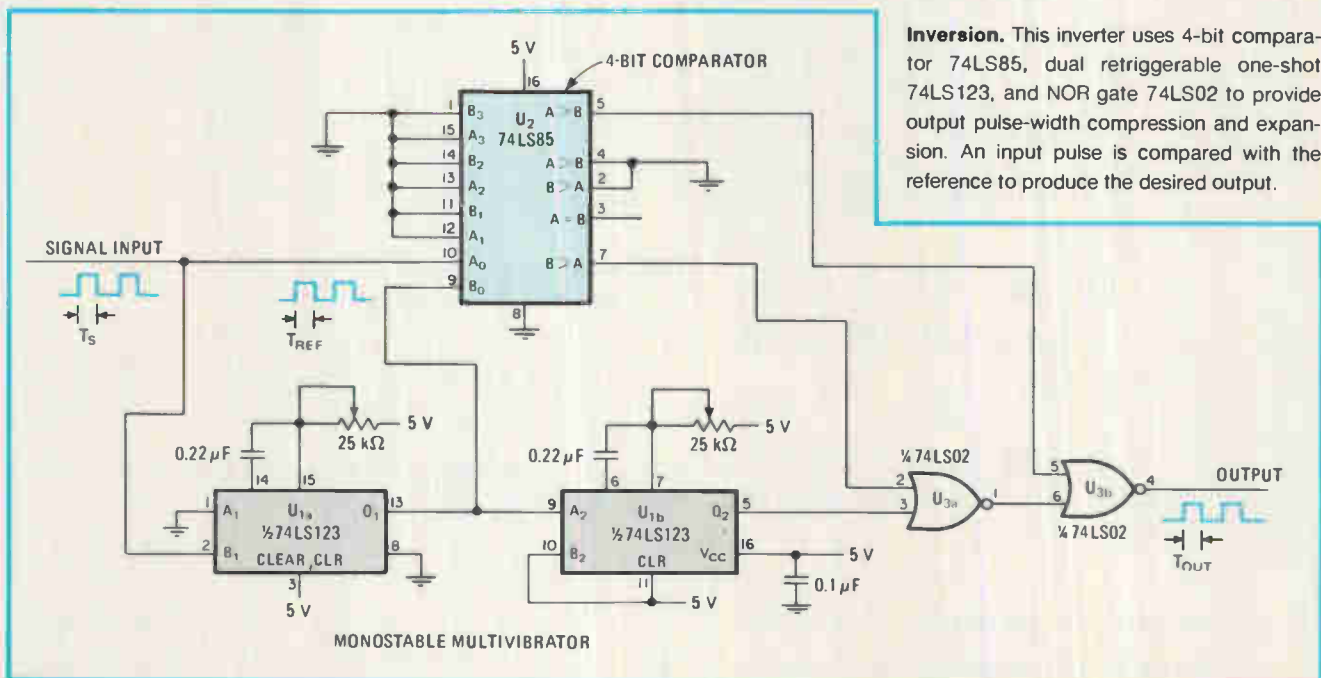

Suddenly your last year's Electronics Buyers' Guide is as outdated as last year's phone book

Just published: 1982 Electronics Buyers' Guide. Completely new listings of catalogs, new phone numbers, new addresses, new manufacturers, sales reps, and distributors! The total market in a book—four directories in one!

1.

Directory of products.
Over 4,000 products, over
5,000 manufacturers.

2.

Directory of catalogs.
Includes six post-paid
catalog inquiry cards for
10-second ordering.

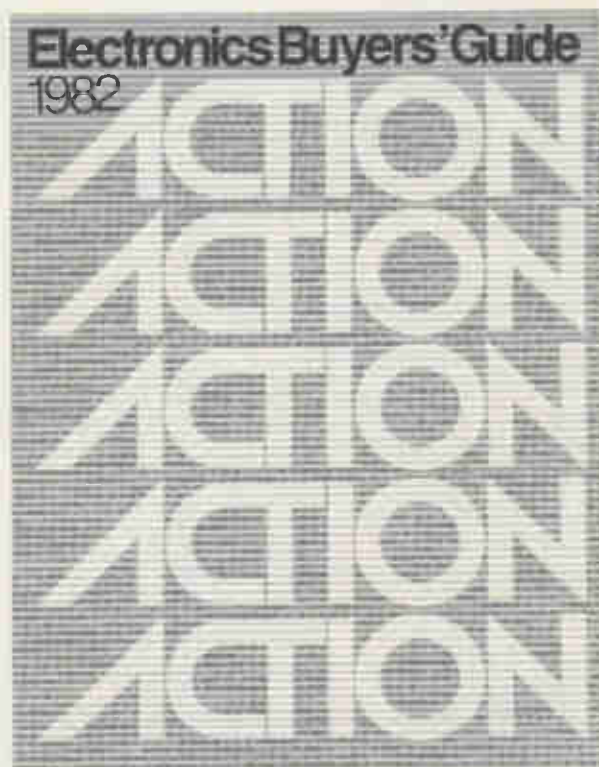

3.

Directory of
manufacturers. Local
sales offices, reps, and
distributors, with phone
numbers. Number of
employees and engineers,
dollar volume, name of
company contact.

4.

Directory of trade names
of products and their
manufacturers. You can
trace a product by its
trade name only.

**The only book of its
kind in the field.**

**If you haven't got it,
you're not in the market.**

**To insure prompt delivery
enclose your check now.**

Write to:

Regina Hera
Electronics Buyers' Guide
1221 Avenue of the Americas
New York, New York 10020
(212) 997-2544

Enclose check for: • \$35 for each copy delivered in
U.S. and Canada.

• \$45 for each copy delivered
elsewhere.

• \$57 for each copy sent airmail
outside of U.S. and Canada.

Standard for high-speed, C-MOS logic enters formative stage . . .

To accelerate the acceptance and growth of high-speed silicon-gate complementary-MOS logic, the Joint Electron Device Engineering Council's JC-40.2 committee has begun work on a standard that will include well over 100 device types. Tentatively titled "Standard Specification for 54/74 HC/HCT/HCU High-Speed Si-gate C-MOS Logic," it will cover buffered (HC) and unbuffered (HCU) C-MOS-compatible logic as well as buffered TTL-compatible (HCT) logic. **The committee, chaired by Richard Funk of RCA Corp. and including representatives of Fairchild, Motorola, National Semiconductor, Texas Instruments, and Toshiba, held its first meeting in March in Phoenix, Ariz. Two further meetings are planned this year to finalize dc and ac specifications. Engineers wishing to participate in the effort should contact Richard Funk at RCA, Rte. 202, Somerville, N. J. 08876, or call (201) 685-6916.**

. . . as 256-K RAM standard leaves EIA

The Electronics Industry Association has just published the new Jeduc standard for the pin configuration of 256-K-by-1-bit dynamic random-access memories. It covers address-multiplexed devices in dual in-line packages 0.300 in. wide with 16 pins. **Also covered are 24-pin, byte-wide bipolar programmable read-only memories in 0.600-in. DIPs with one or two enable modes.** Those wishing to obtain a copy of this Addendum No. 2 to Jeduc Standard 21 may do so by contacting the EIA Engineering Department, 2001 Eye St., N. W., Washington, D. C. 20006. Its phone number is (202) 457-4981.

How to mate chips to the right substrate

One of the biggest problems facing the packaging designer today is making a choice of the correct substrate or board for the wide variety of integrated-circuit packages—chip-carriers of all sorts, pin-grid arrays, dual in-line packages on 100- and 50-mil centers, small-outline packages, and even tape automated bonding types—that are available today. Further confounding the choice are the facts that some of the packages mount on the substrate surface and others use through-hole mounts, while some can be socketed and others cannot. To ease the headache, D. Brown Associates, in association with consultant J. W. Balde, is conducting a multiclient study entitled "VLSI and the Substrate Connection—the Technological Tradeoffs of the Package-Board Interface." **The study will also provide answers to marketing questions about the packaging options.**

Due out early in December of this year, the study will be priced at \$3,900; a \$400 discount is available to companies that subscribe before June 15. For further information, contact Don Brown, P. O. Box 404, Willow Grove, Pa. 19090, or call (215) 657-4717/3814.

Do your own market analysis of home computers

For all the bubbling excitement of the personal computer market, few solid statistics have been available on the purchasers and applications of the systems. Now Future Computing Inc. of Richardson, Texas, is taking a bottom-up approach to such a study, offering **the actual data obtained from a survey of 400 personal computer retailers**, so that users can draw their own conclusions with the aid of software from Software Publishing Corp. of Mountain View, Calif. The cost of Future Computing's raw data is \$12,000. More information can be obtained from Future Computing's Pam Inserra at (214) 783-9375 or Software Publishing's Fred Gibbons at (415) 962-8910.

-Richard W. Comerford

Signal Generators from Marconi. They will change your way of thinking.

Think about testing receivers quickly. Wouldn't it speed your operations if all your signal generators gave the same answers and if your operators could recall complete test settings at the touch of a button even after the instrument had been switched off. Or when setting up a GPIB system, wouldn't you like your controller to be able to learn the settings of the generator.

Think about maintaining your signal generator easily. How much down time could microprocessor assisted fault diagnosis and recalibration from the GPIB or front panel save you? Wouldn't you like the reliability of a cool-running instrument, with no noisy fan to maintain.

Think about cost... would

2018 and 2019 Well Worth Thinking About

80kHz to 520MHz or 80kHz to 1040MHz frequency coverage

Non-volatile memory	Save operator time – recall up to 50 settings at any time – even after switch off
RF Level offset	Save arguments – standardise your microvolt and compensate for cable losses
GPIB Talker facility	Save program preparation time – let the GPIB controller learn the instrument settings
Reverse Power Protection	Save maintenance costs – no more burnt out attenuators to repair
Recalibration via Keyboard or GPIB	Save recalibration costs – adjust r.f. level and f.m. deviation calibration without removing the covers
Fully programmable	Save measurement time – automate your testing

a quality signal generator giving all this with wide frequency coverage and 10Hz resolution really cost more than you can afford? Marconi have a pleasant surprise for you!

Contact Marconi today – they will change your way of thinking.

Circle 183 on reader service card

marconi instruments

100 Stonehurst Court
Northvale, New Jersey 07647
Telephone: (201) 767-7250
Telex: 710-991-9752
(West): Telephone: (714) 857-2326
UK: Telephone: 0727 59292
FRANCE: Telephone: (1) 687-36-25
GERMANY: Telephone: (089) 84 50 85



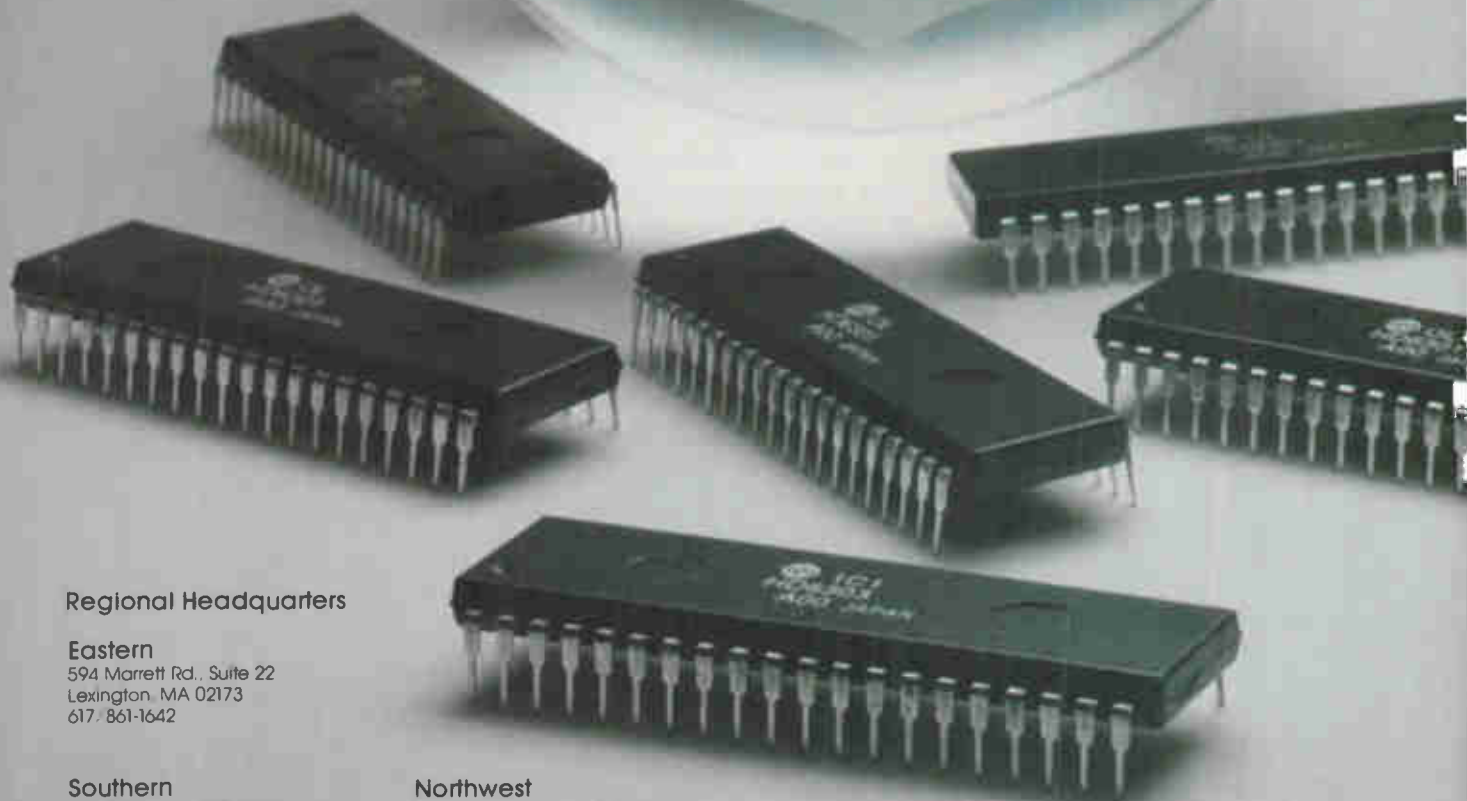

Regional Headquarters

Eastern

594 Marrett Rd., Suite 22
Lexington, MA 02173
617/861-1642

Southern

6200 Savoy Dr., Suite 704
Houston, TX 77036
713/974-0534

North Central

500 Park Blvd., Suite 415
Itasca, IL 60143
312/773-4864

Northwest

9700 Reseda Blvd., Suite 208
Northridge, CA 91324
213/701-6606

Southwest

9700 Reseda Blvd., Suite 208
Northridge, CA 91324
213/701-6606

Stocking Distributors

Active Component Technology • CAM/IPC • Cetec •
Classic Components • Combined Technology •
Cronin • Diplomat • Future • Gerber • Jaco •
Marshall • Milgray • RC Components • Resco •
RM Electronics • Ryno • SAI • Semiconductor Specialties •
Sterling • Time • Western Micro Technology •

CMOS MICROCOMPUTER SUPERSTARS!

No Other 8-Bit, Single-Chip Microcomputer Offers Higher Speed, Lower Power Consumption, or More Design Features than the Hitachi HD6301 Family. Here's Proof:

- Exclusive 3-micron "HI-CMOS" process yields extremely low-power consumption
- Unique parallel pipelined microcoded architecture provides unmatched execution speed
- The HD63B01 and HD63B03 with speeds of 0.5 μ s at 60mW – **twice the speed of HMOS at 1/10th the power**
- Abundant on-chip resources – the HD6301 has 4K ROM (HD6301 only), 128 bytes RAM, 64K external memory addressability, 29 parallel I/O lines, 16-bit timer, 2 external and 6 internal interrupts, plus serial communications interface
- VCC operation from 3V to 6V enhances immunity to voltage variations
- Unmatched execution speed and external memory addressability allow for complex data/information algorithms and storage
- 10.0mW sleep mode allows the HD6301 to perform a variety of functions at 1/6th active power without disrupting internal registers and RAM contents
- A full complement of development tools to support your design needs are available
- Upward compatible with the 6800 and 6801 families
- **The HD6303 ROMless version can be used with EPROMs or EEPROMs if you are not ready to commit to a 6301 ROM pattern**
- **HD6303 (ROMless) is available now from your Hitachi distributor**
- Famous Hitachi Quality Control, including 100% dynamic high-temperature burn-in on every unit sold
- The HD6301... the first of many innovative Hitachi high-density, high-performance microcomputers designed for low-power applications

Learn More About the Revolutionary Hitachi HD6301 and 6303 8-Bit Microcomputers Today. This ad presents just some of the highlights of the performance and reliability found in these new 8-bit microcomputers. For full technical information, return coupon or call your local Hitachi Representative or distributor sales office.



HD68SD5 Development System



HITACHI

A World Leader in Technology

Hitachi America, Ltd.
Semiconductor and IC Sales and
Service Division
1800 Bering Drive, San Jose, CA 95112
(408) 292-6404

YES, I am interested in receiving further information about the new Hitachi HD6301/6303 8-Bit Microcomputers.

Send technical data on the 6301.

Send technical data on the HD6303 ROMless version.

Send data on development system.

Have my Hitachi Representative call.

Name _____

Company _____

Title _____

Address _____

City _____

State _____ Zip _____

Phone (____) _____

Send to: Hitachi America, Ltd.
1800 Bering Drive
San Jose, CA 95112

EL51982-HLN-045

AMI gets you into production



before your market slips away.

You know the advantages of custom circuits. Superior performance. Reduced component count. Less power consumption. Proprietary protection. And lower costs in production. But you're concerned about development time.

Well, don't be.

AMI delivers more custom approaches than anyone else. And one of them is just right for getting you to market quickly.

The right solution. AMI has a full spectrum of custom solutions. Like semi-custom logic arrays. Computer drawn standard cells. Computer-aided designs. Hand drawn design. Or we can teach you how to design your own circuits and fabricate for you.

One of these options is the right one to replace your standard logic and get you to market at the lowest possible cost, in the shortest possible time. No matter what stage your project is in—masks, design, or blue sky.

Solutions on time. What's more, AMI has more experience than any other

company in delivering these custom solutions. More experience in evaluation. Specification. Logic design. Layout. Prototype. Production. And our process technologies—NMOS, CMOS, or PMOS—are ready when you are, whether your designs are digital or analog.

Quality you can depend on. With over 15 years experience in MOS/LSI technology, with more custom circuit designs in use than anyone else, with more expertise, technology, and facilities at our disposal, no one can offer you more than AMI. Proven, reliable circuits, inspected and tested to our 0.1% AQL or your custom specifications.

And no one can deliver them more quickly.

Outpace your competition.

To find out more about what we do and how fast we can do it for you, just call Custom Marketing at (408) 554-2150. Or send in the coupon below.

After all, if you're going to put some distance between yourself and the rest of the pack, don't wait any longer.



AMI

American Microsystems, Inc.

The most natural solutions in MOS.

I want to know more. And I want to know it fast!

- Send me your capabilities brochure, "The AMI Spectrum of Custom Solutions."
- Send me your most amazing custom circuits' case histories.
- Have a field engineer call me.

Name _____ Title _____

Company _____ Phone () _____

Address _____ M/S _____

City _____ State _____ Zip _____

Send to: AMI Custom, 3800 Homestead Road,
Santa Clara, CA 95051

L5-19

**Wavetek believes
you've been paying too much for
programmable function generators.**

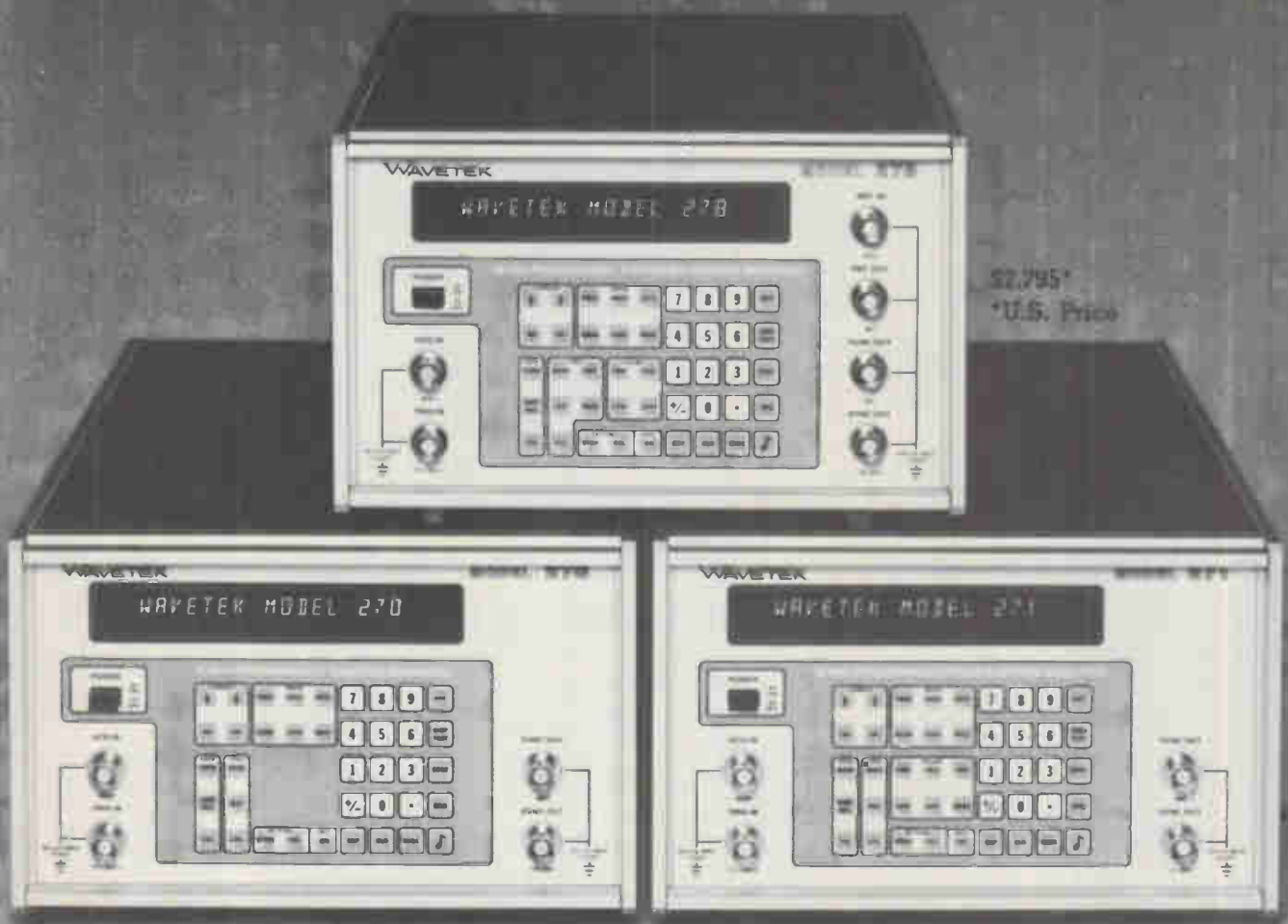

\$2,795*
*U.S. Price

\$2,195*

\$2,795*

Introducing the Wavetek 270 Series.

270 Programmable Function Generator	271 Programmable Function Pulse Generator	278 Synthesized Function Generator
<ul style="list-style-type: none"> • 0.01 Hz to 12 MHz Range • 0.01 to 10 V_{p-p} into 50Ω • Stored Calibration Procedure • Stored Settings Standard • Output Protection • GPIB (IEEE-488) Standard 	<ul style="list-style-type: none"> • 0.01 Hz to 12 MHz Range • 0.01 to 10 V_{p-p} into 50Ω • Burst count—1 to 1,048,200 • Pulse width control • Variable time delay • Plus all Model 270 features 	<ul style="list-style-type: none"> • 0.01 Hz to 12 MHz Range, with 5-digit resolution, 0.005% accuracy • 0.01 to 10 V_{p-p} into 50Ω • Variable pulse widths • Burst count—1,048,200 • Plus all 270 features

You've been paying too much, because you've been getting too much.

A lot of you simply don't need the frequency ranges, the specifications or the features that the other manufacturers have been offering.

And that's what the 270 Series is all about.

The Wavetek 270 Programmable Function Generator.

The 270 is a microprocessor-based, fully programmable signal source of precision sine, square and triangle waveforms. It is equally useful for benchtop or systems applications.

Three-digit amplitude resolution controls output levels. Up to $\pm 5V$ dc offset may be combined with any waveform or alone as a dc source. Mode selection provides continuous, triggered or gated operation. Frequency can be controlled by external voltage for sweep or FM. Programmable trigger level and slope control are also provided.

Free-format programming allows numeric entries to be made in fixed-point, floating-point or scientific notation.

Parameter entry can be made for a single parameter or a complete instrument setting, with one execute command. This flexibility eliminates errors and unwanted intermediate waveforms, when reprogramming to a new test condition. GPIB address is selectable by an internal switch or front-panel entry. Command Recall mode can be used to verify programming string content via the front-panel alphanumeric display.

The Wavetek 271 Programmable Function Pulse Generator.

The 271 delivers all the performance of the 270, plus pulse and burst.

When in the pulse mode, the 271 provides variable pulse delay and width control from 50 nanoseconds to 0.1 second. Pulse rise and fall times are less than 15 nanoseconds at full amplitude.

In the burst mode, burst counts from 1 to 1,048,200 may be programmed.

Output protection, standard in all three models, guards against the injection of external over-voltages and short circuits.

The Wavetek 278 Synthesized Function Generator.

The 278 is a synthesized 270.

It uses phase lock loop techniques to add synthesis to the main generator, providing five digits of programming resolution with an accuracy of 0.005%. When the synthesized mode of the 278 isn't being used, the phase lock loop circuit is converted to an independent oscillator, which can be used to trigger or gate the main generator to generate variable width pulses.

A step-by-step calibration procedure, common to all three models, is stored in memory to speed up performance verification and recalibration when needed.

The 278 even includes burst and stored settings as standard features.

We believe you'd like a 270 Series brochure.

Write Wavetek, 9045 Balboa Ave., San Diego, CA 92123. Or give us a call, (714) 279-2200. TWX 910-335-2007. We'll send you complete information on the 270 Series.

It'll make a believer out of you.

WAVETEK®

THE NEW DATA I/O 121A PUTS EPROM PRODUCTION PROGRAMMING BACK ON SCHEDULE.

If you're programming more EPROMs than ever before, and anticipate even higher volumes in the future, the 121A will deliver the throughput and yields your schedules demand.

The 121A is a smart, sophisticated production tool. It can duplicate 20 devices at once, or program complete sets of EPROMs simultaneously up to 20 devices per set, each with a different data pattern.

121A is all business:

- It programs more than 50 different 24 or 28 pin EPROMs without changing hardware.
- It has the stamina to operate continuously, shift after shift, because of its heavy duty power supply and cooling systems.
- It lets you program with confidence because of extensive device testing and verification. The 121A uses approved programming algorithms.

Complete flexibility

The 121A can operate as a stand alone programmer or as part of a complete production programming station on line to a computer or Data I/O Data Control Unit (DCU). The Data I/O DCU enables you to access data patterns directly from a diskette and load them into RAM without the nuisance of papertape or master devices, and supports Data I/O systems for high volume bipolar programming.

Two models available

If your production needs don't include programming complete EPROM sets, the new Data I/O 120A Gang Programmer is an economical alternative. The 120A offers the throughput of the 121A without set programming or editing capabilities.

Another innovation from Data I/O, your productivity partner.



Data I/O Corporation, 10525 Willows Road N.E., C 46, Redmond, Washington 98052. For immediate action, contact us directly, CALL TOLL FREE 800-426-1045. In Washington, Alaska and Hawaii, call 206-881-6445. Europe Vondelstraat 50-52, GE, Amsterdam, The Netherlands, Tele (20) 186855. Japan. Sankei Building 1-8, Sarugaku-cho, 2-Chome, Chiyoda-Ku Tokyo 101, Japan, Tel (03) 295-2656

DATA I/O

Electron beam writes on 20 wafers/h

Commercial direct-writing electron-beam unit has throughput of 5 to 20 4-in. wafers/h at geometries of 0.25 to 2.0 μm

by Terry Costlow, Costa Mesa bureau

Direct-writing electron-beam lithography equipment has been developed for internal use at such firms as IBM, Bell Laboratories, Texas Instruments, and Hewlett-Packard, but commercially available systems have been limited to low-throughput systems requiring specialized processes. At the Semicon/West conference later this month, Electron Beam Corp. plans to change that with the introduction of its Waferwriter.

The Waferwriter is a vector-scan system that writes patterns directly onto wafers using standard resists and boasts throughput ranging from 5 to 20 4-in. wafers per hour. Although throughputs are not high enough for high-volume production runs, mask development and other time-consuming steps are eliminated, giving much quicker turnaround. Marketing vice president Ron Felker feels the system will be employed at custom-chip houses and at standard semiconductor houses for prototypes and low-volume runs. The use of standard resists ensures prototypes will exhibit the same characteristics as production units, Felker notes.

The system will also write a variety of patterns on the same wafer. This lets users mix several chips on a single wafer rather than one pattern on each wafer, meaning that a bad wafer will not destroy the entire lot of a short-run product. In prototyping, several versions of the same chip can be run on a single wafer, to guarantee uniformity.

The system is designed to work with 2- μm geometries so that it will fit into current processes. It will go down to 0.25 μm , but throughput drops a lot below 0.5 μm .

The key to relatively high throughput with standard resists is a high-intensity beam, putting out more than 1,000 A/cm^2 . This intensity is achieved by using a zirconium-coated tungsten thermal-field emitter. The intensity also permits precise alignment accuracy of $\pm 0.05 \mu\text{m}$, with $\pm 100\text{-\AA}$ sensitivity.

The electron column the beam travels through is kept small and simple. The Waferwriter uses only two large lenses, compared with four or five on other units. Scan fields are addressed by both magnetic and electrostatic deflection fields.

Each subsystem has its own microprocessor that ties into a central processing unit, a PDP-11/24. Two subsystems, the pattern computer and die memory, work together to store about 6 million geometries, each consisting of a discrete feature like a via hole or short line segment. A data-compression scheme developed by Electron Beam lets the system transfer this data to the pattern processor at a rate of 30 megabytes/s. There, data is expanded to write at 10 million geometries per second. The unit accepts data directly from computer-aided-design systems, using the Caltech intermediate format.

For high-density chores like writing metalization patterns, throughput is approximately 11 wafers an

hour. For low-density tasks like writing vias, speed increases to about 20 wafers/h. Average throughput should be around 13 wafers/h, according to Felker. In the submicrometer range, such as for parts with 0.5- μm geometries for the Very High-Speed Integrated-Circuits (VHSIC) program, throughput drops to 6 wafers/h.

Direct writing offers enhanced yields, says Felker. The reasons for this are the elimination of reticle and mask, and better overlay accuracy, scaling, process bias control, and wafer-topography tolerance.

The unit is priced at approximately \$2.3 million. Initial deliveries will be made early next year. After that, deliveries are expected to take 10 to 12 months.

Electron Beam Corp., 9747 Business Park Ave., San Diego, Calif. 92131. Phone (714) 566-0852



Digital's new 16-bit Falcon. Fierce competition for 8-bit SBC's.

You don't have to sacrifice size or affordability anymore to step up to 16-bit performance for your ROM-based application. Because now you can buy Digital's new ultra-small 16-bit Falcon for just \$521.*

Never has so much microcomputer been packaged in so little space. At just 8.5" x 5.2," Falcon is by far the smallest 16-bit SBC on the market—smaller, even, than most 8-bit SBC's.

Yet astonishingly, the tiny Falcon is a full-power LSI-11, executing the same proven PDP-11 instruction set that has made our micros the world sales leader.

On one board, the SBC-11/21 Falcon packs 4Kb RAM, sockets for up to 32Kb PROM or additional RAM, 2 serial I/O lines, 24 lines of parallel I/O, and 50, 60 or 800 Hz Line Time Clock. And Falcon's LSI-11 Bus Interface lets you use other I/O interfaces from Digital's large family of I/O modules.

However you measure performance—power, functionality or size—Falcon is fierce competition for 8-bit SBC's.

For complete details, fill out the coupon or contact the Hamilton/Avnet, Harvey Electronics, Pioneer/Standard, Pioneer/Washington or Wyle distributor near you.

Or simply call toll-free (800) 225-9222 and ask us to send Falcon Information Package # N-190. In MA, HI, AK and Canada call (617) 568-5707.

*In quantities of 100. Single unit price is \$790. Domestic U.S. prices only.



Please rush your Falcon Application Information Package to me at once. My application is:

- Laboratory/Scientific
- Data Communications
- Industrial Controls (please specify) _____

Other (please specify) _____

Name _____

Title _____

Company _____

Street _____

City _____

State _____ Zip _____ Tel. (____) _____

Digital Equipment Corporation
Microcomputer Products Group, HL2-2/E10,
77 Reed Rd., Hudson, MA 01749.

N-5-19-82
Dec-C-190

digital

**We change the way
people work.**

900-MHz transistor trio puts out 30 W

Fully characterized 24-V npn silicon devices together amplify 100-mW signal in cellular radiotelephone base station

by Harvey J. Hindin, Communications & Microwave Editor

In what it says makes up the industry's first standard line geared toward the burgeoning field of cellular radiotelephone base stations, Motorola is introducing three 24-v 900-MHz power transistors. The MRF 890 predriver is a 2.0-w device with 9.0-dB minimum gain, the 14-w model -892 driver has a gain of 8.5 dB, and the -894 is a 30-w final amplifier that produces a gain of 7.0 dB. The three npn silicon transistors can be linked in a chain and driven by a 100-mW signal over the frequency range of 804 to 960 MHz.

Each of the transistors can withstand a voltage standing-wave ratio mismatch of 30:1 for their output loads at full rated voltage and power levels. Interstage matching should be no problem, however, because these devices are designed specifically for 900-MHz operation, in contrast to devices originally designed to operate at microwave frequencies and then pressed into service in the lower

radiotelephone band. The transistors' features are oriented toward the large-signal common-base amplifiers found in the industrial and commercial fm radiotelephone equipment recently approved by the Federal Communications Commission [*Electronics*, Jan. 13, p. 97].

Motorola has paid particular attention to reliability in this series, says a spokesman for the semiconductor products operation in Phoenix, Ariz. For example, all-gold metallization and emitter ballasting is used for both ruggedness and reliability. Furthermore, the transistors are passivated with silicon nitride to increase lifetimes.

The devices are so trustworthy

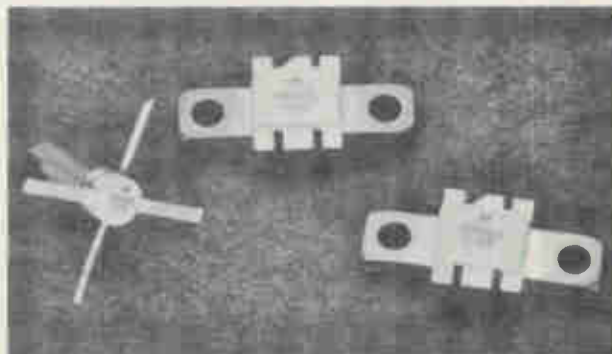

that Motorola can characterize them fully and guarantee both gain performance and a collector efficiency of at least 55%. Thus the system designer is able to specify power-supply capacity with little waste.

Full documentation. The complete characterization of the series is extensively documented. Smith charts show the input and output impedances as a function of frequency. Curves are provided plotting output power versus input power and supply voltage as a function of both frequency and input power.

Motorola also publishes charts of output power versus frequency as a function of input power and data showing typical power gain, input standing-wave ratio, and collector efficiency versus frequency. As a final touch, Motorola furnishes schematics for test circuits in addition to the usual maximum ratings and thermal characteristics.

Prices in quantities of 100 to 499 are \$10.00 each for the -890, \$19.55 for the -892, and \$30.60 for the -894. Samples of the device can be delivered in 8 to 12 weeks.

Motorola Semiconductor Products Inc., P. O. Box 20912, Phoenix, Ariz. 85036. Phone (602) 244-6399 [339]

Techniques suppress static

Designers working on 30-W radiotelephone base-station transmitters may also be involved in the design of the mobile receivers at the other end of the communications link. Receivers, of course, must perform far from the transmitter, making the most of a weak signal—mobile receivers in particular must be able to pull this signal out of radio-frequency interference produced very close to the antenna by the vehicle's ignition system, electric motors, and other moving parts.

The National Bureau of Standards has just come out with a report entitled "Methods of Suppressing Automotive Interference," which can be helpful to both designers and users of mobile receivers. It concentrates on rfi in fm communications in the 900-MHz band. It discusses both classic methods (resistive spark plugs and grounding straps) and modern techniques such as fan-belt discharge reduction. The report also explains a simple procedure for measuring receiver rfi. Designers of automobile broadcast-band radios and television sets should be interested in the report. It is available for \$6 from the National Technical Information Service, Springfield, Va. 22161, as publication No. 82-165259.

-H. J. H.

AND NOW... A WORD ABOUT HEXFET[®] QUALITY: PHENOMENAL!

The more you know about quality the more you'll want to design with HEXFETs[™], today's most advanced, available and affordable power MOSFETs.

All HEXFETs are tested and shipped to an AQL of 0.1%! If you're familiar with lot sampling testing, you'll recognize this as phenomenally tight quality.

This quality level is achieved through high technology in design, structure and manufacturing, plus rigid production standards that include pre-cap visual inspection.

The result is quality which can be easily translated into high reliability.

You'll get the same high quality in every HEXFET whether it's a higher current TO-3 or lower current TO-39 hermetically sealed unit, a plastic TO-220AB, or one of the new dual in-line, low power HEXDIPs.

What's more, IR is committed to make HEXFETs the most reliable semiconductor devices ever!

Contact the factory for details on HEXFETs to JAN, JANTX and JANTXV specifications.

Write on your letterhead and we'll send you complete data on HEXFETs and the 224 Page HEXFET DATABOOK.



HEXFETs are available off-the-shelf from an IR Distributor near you.

INTERNATIONAL RECTIFIER

WORLD HEADQUARTERS: 230 KANAWA DRIVE, RICHMOND, CALIFORNIA 94804 (310) 706-7000, TWX: 910-348-2091, TELEFAX: 910-348-2092

EUROPEAN HEADQUARTERS: 11, RUE FRAENKEL, D-22111 BURKEL, FR-966, ENGLAND, TELEPHONE: 01823 73111, TELEFAX: 01823 73112

Manufacturing, Warehouses, Sales Offices, Representatives, Agents and Distributors Throughout the World



Circle 195 on reader service card



Introducing the Zehntel 810.

It doesn't just test boards.

It keeps them moving.

Test complex boards faster.

Speed. With today's larger, denser boards, it's more than a crucial requirement for an in-circuit tester. It's the path to greater productivity. Faster test speed, improved program generation speed, wider bandwidth—the new Zehntel 810™ has them all. So you can increase your board test throughput and keep your board production moving.

Advanced LSI functional testing.

DATA DIRECTOR,™ Zehntel's powerful LSI testing system, is standard on the Zehntel 810. DATA DIRECTOR is a universal emulator that mimics the native environment of an LSI device.

With DATA DIRECTOR, you can test a chip, an entire board, or part of a board—functionally and in-circuit.

The Zehntel 810 also features coaxial fixture receiver wiring to reduce crosstalk—essential in testing LSI devices. New pin electronics test CMOS and clocked devices faster. Concurrent sense and direct tri-state measurement make digital testing even more thorough and efficient.

Multi-user productivity.

The Zehntel 810 features the new Gemini™ computer, a unique dual-processor system that permits multiple users to access the tester without interrupting the flow of production testing.

Overcome your production plan pressures with simultaneous program generation, data analysis, even computer-aided board reworking.

With its advanced UNIX*-based operating system and NETCOMM™ communications software, the Zehntel 810 can manipulate test data and transfer it throughout the manufacturing environment to improve overall productivity.

Speed dollars to your bottom line.

You'll profit from improved test productivity with faster ROI, lower WIP, more shipments, fewer field returns.

The Zehntel 810 is the first of our new Test Information products—modular hardware and software designed to increase your manufacturing productivity.

For full technical and financial details, write Zehntel, Inc., 2625 Shadelands Drive, Walnut Creek, CA 94598, or call 415 932-6900.



Zehntel

a PLANTRONICS company

™ Zehntel 810, DATA DIRECTOR, Gemini computer, and NETCOMM are trademarks of Zehntel, Inc.
*UNIX is a trademark of Bell Laboratories, a division of Western Electric Company.

Circle 197 on reader service card

THE DSD 880 WINCHESTER SYSTEM.

MADE THE WAY
DIGITAL WOULD MAKE IT.

EXCEPT DIGITAL
DOESN'T MAKE IT.



HyperDiagnostics, HyperService and Rapid Module Exchange are trademarks of Data Systems Design, Inc.
PDP is a registered trademark of Digital Equipment Corp.

★ "OEMS: Don't miss the new 700 Series of Multibus
Winchesters at NCC booth #A549, Astroarena, Houston."

The people at Digital are a pretty smart bunch. They make some of the finest small computers in the world. So we like to think that if they were to make a new storage system like our 880 Winchester/Floppy, they'd do it the same way we did.

First of all, they'd make it extremely reliable with extensive testing and by using one of the most reliable storage technologies known, the Winchester.

Next, they'd offer it in different capacities, like 7.8, 20.8, and 31.2 megabytes, with a choice of .5 or 1 Mb floppy back-up, or none at all.

These different configurations would, of course, be fully compatible with Digital's LSI-11 and PDP®-11 computers.

And the whole package would be extremely compact, just 5¼ inches high, so it would save space and fit in almost anywhere.

They might even add some on-board self-diagnostics, similar to our exclusive HyperDiagnostics™, so you could test, exercise, and debug without a CPU. And cut down on your service costs at the same time.

Maybe they'd even institute a module swap program, something like our Rapid Module Exchange™, which would be designed to get you

back up and running within twenty-four hours.

Finally, since this system would be so dependable, they'd be able to offer their extended service at a much lower price—much like we do with our own HyperService™, which goes into effect when the 90-day warranty expires and covers everything.

And then, as if it weren't good enough already, they'd offer this remarkable storage system at a lower cost per megabyte than any comparable system.

The fact is, though, Digital doesn't make anything like this.

Which is why we make the DSD 880 Winchester system to go with your Digital computer. And, why we make it the way we do.

Corporate Headquarters: 2241 Lundy Avenue, San Jose, CA 95131. Eastern Region Sales and Service: Norwood, MA, 617 769-7620. Central Region Sales: Dallas, TX, 214 980-4884. Western Region Sales: Santa Clara, CA, 408 727-3163.

DATA SYSTEMS DESIGN

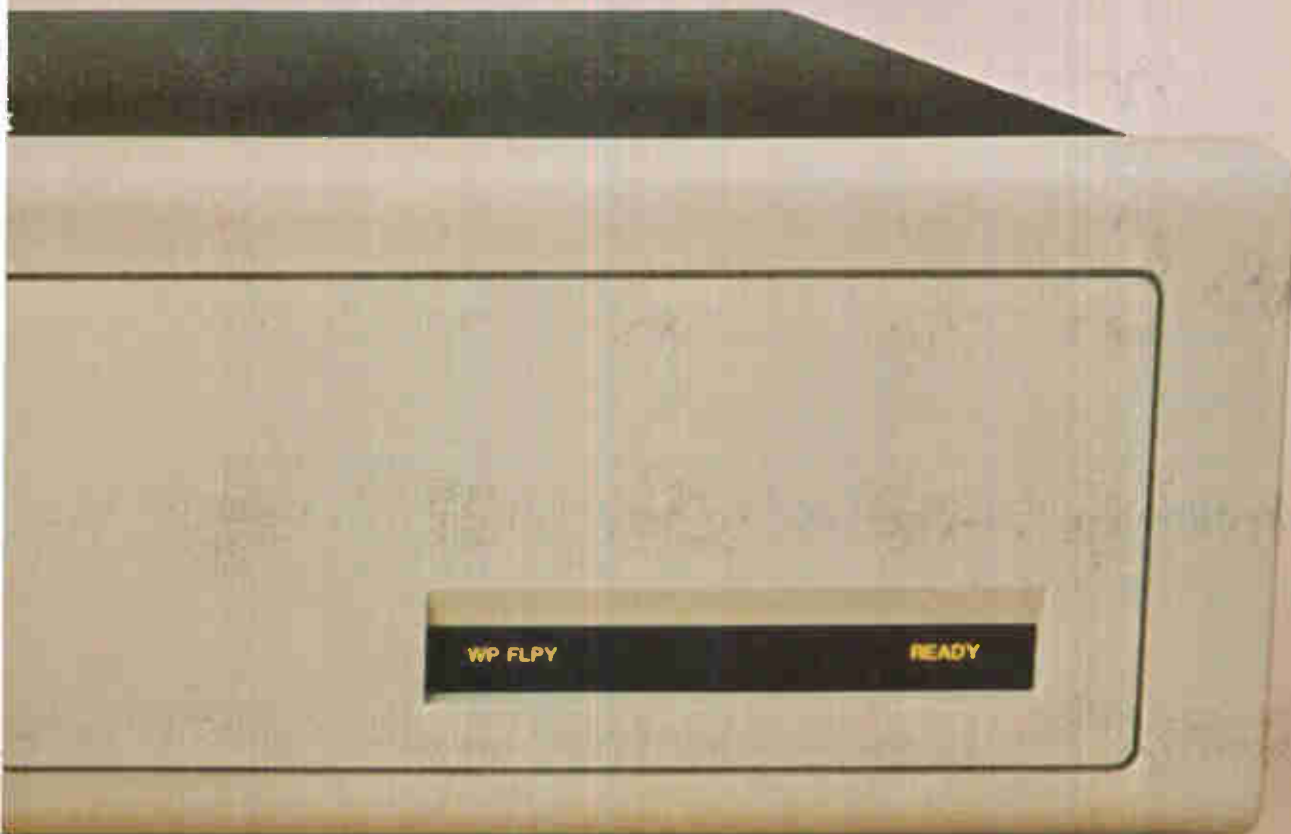

INTERNATIONAL SALES: Australia 03/544-3444, Belgium and Luxembourg 02/7209038; Canada 416/625-1907; Central and South America (office in U.S.A.) 415/967-8818; Denmark 01/83 34 00; Finland 90/88 50 11; France 03/956 81 42; Israel 03/298783; Italy 02/4047648; Japan 06/323-1707; Netherlands 020/45 87 55; New Zealand 4/693-008; Norway 02/78 94 60; Spain 34/433-2412; Sweden 08/38 03 70; Switzerland 01/730 48 48; United Kingdom 44/7073/34774; West Germany and Austria 089/1204-0; Yugoslavia 61/263-261.

New products

Packaging & production

Machine etches fine metal lines

Reactive ion etching system reduces undercutting to make aluminum lines $0.5\ \mu\text{m}$ wide

With the geometries of very large-scale integrated circuits approaching the submicrometer region, semiconductor manufacturers have turned to dry plasma etching systems, which offer tighter control in oxide, nitride, and polysilicon etching. But the size of many VLSI devices is determined by the metal interconnections, which are wet-etched and must be made wide enough for the acid etching not to completely undercut them.

A new system from Technics West Inc. promises to solve this problem with reactive ion etching [*Electronics*, April 21, p. 33]. With this technique, metal lines can be produced that are $0.5\ \mu\text{m}$ wide on $0.5\text{-}\mu\text{m}$ spacing, with a height of $1\ \mu\text{m}$.

Reactive ion etching combines the characteristics of two established wafer-processing techniques—plasma etching and ion milling. As in plasma etching, reactive chemicals in a gas plasma are employed, but the plasma's ions are accelerated in a collimated beam, as in ion milling. The beam strikes the bottom of the etch pattern and not the sidewalls,

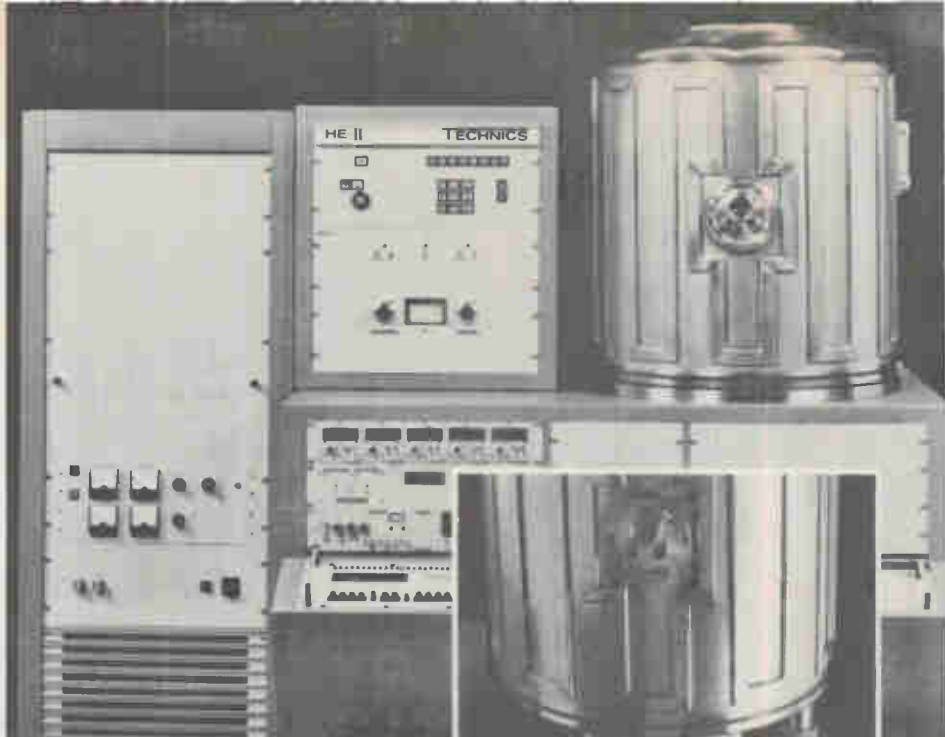

greatly reducing undercutting and allowing narrower metal lines.

The reactive ion etching takes place in a chamber where the cathode is a hexagonal aluminum column on which the wafers are mounted. The anode is a stainless steel bell jar. Four wafers (3, 4, or 5 in. in diameter) are mounted on each of the six surfaces. A complete etching cycle takes 40 minutes, so the system, called the HE-II, has a throughput of 36 wafers per hour.

Technics West has been building plasma etching and ion milling systems for about 10 years. The HE-II, which is based on a process developed and licensed by Western Electric's Bell Laboratories, will be shown for the first time at Semicon/West, the semiconductor production-equipment trade show held in San Mateo, Calif., May 25-28.



The HE-II will sell for about \$250,000, depending on configuration. Delivery is in six months.

In addition to the ion etching system, Technics West has developed a wafer loader that automatically takes wafers from standard cassettes and loads them onto the special carriers that mount on each of the six processing surfaces. Pricing for the loader has not yet been set.

Technics West Inc., 2305 Paragon Dr., San Jose, Calif. 95131. Phone (408) 946-8700 [435]

Hybrid aligner exposes fine lines

Mask aligner's critical stage is pneumatically isolated to achieve $1\text{-}\mu\text{m}$ line widths

The key to aligning geometries with dimensions of around $1\ \mu\text{m}$ on thin-film hybrids, flat-screen displays, microwave hybrids, and other fine-

line devices is a vibration-free system that enables an operator to view the mask and substrate clearly at high magnifications. Optical Associates Inc. has designed its new series 500 mask aligner so that its mask-to-substrate alignment stage is located on a vibration-free pneumatically isolated exposure platform. The Hybralign 500 system, a successor to the proven 400 series, can accommodate substrates up to 4 in. on a side and rectangular masks with a diagonal dimension of 7 in.

At higher magnifications (up to

$\times 400$) it is essential that the substrate surface remain in focus as the microscope is moved along any axis during the alignment phase. To achieve this, the aligner first brings the substrate surface into contact with the mask. When separated, the system keeps the mask and surface parallel, compensating for any substrate-wedge error.

Selection of microscopes. Another key feature of the 500 aligner is its wide microscope adaptability. The user can select from a variety of split-field metallurgical microscopes

senitron

One Step Ahead of Your Mature MOS Requirements.

At Senitron, we stay ahead of your mature MOS requirements by keeping a few paces back in the semiconductor race. Our sole business is the production of mature PMOS, NMOS and CMOS products, left behind in an industry that outgrows technology every few years.

Whether you're a semiconductor company searching for a way to fulfill ongoing requirements of your customers, or an OEM looking for hard-to-find MOS products, Senitron can provide you with a permanent supply.

Best of all, our fast turn-around time delivers the product you want when you want it. At a price you'll like. Write or call us at: Senitron, 3883 N. 28th Avenue, Phoenix, AZ 85017, (602) 277-3481.



senitron

Moving Ahead By Staying Behind.
Circle 203 on reader service card

New products

with a bright- and dark-field capability or units operating on Nomarski interference-contrast principles, which are especially valuable when lining up a feature to a metal edge.

The mask-to-substrate alignment stage is supplied with differential micrometers that provide fine vernier control of X- and Y-axis movements of the substrate holder. In addition, the microscope joystick has finger-tip-operated X- and Y-axis brakes. Another valuable feature is simple, direct operator control of the pneumatically powered stage positioning for the alignment and expo-

sure steps. In the off-load, on-load phase, there is unobstructed access to the entire mask-to-substrate alignment stage.

Other features of the system, which is priced at approximately \$25,000, are constant intensity control at the substrate surface and a shutter timer. Light sources for the unit are available with collimating lenses up to 7 in.



in diameter and with lamp ratings of up to 500 w.

Optical Associates Inc., 3300 Edward Ave., Santa Clara, Calif. 95050. Phone (408) 988-6900 [436]

Gage controls lapping to 0.5 μm

Quartz crystal is lapped with wafers; its resonance is used to monitor progress

Thickness is a parameter that must be carefully controlled in the process of lapping metals, semiconductors, or insulators. A new piezoelectric gage from Transat Corp. employs a low-cost, disposable quartz sensor disk to monitor the thickness of work pieces during lapping to an accuracy of 0.5 μm and terminate the process

automatically when the work pieces reach a preset thickness.

The measurement, twice as accurate as those of existing instruments used for this purpose, is independent of lap-plate wear—it indicates the thickness of the machined pieces, not the distance between the lap plate and a fixed reference surface.

The gage consists of a control unit and a base unit. The control unit contains the thickness display and a key pad for entering the desired control parameters. It can be located near the operator or mounted in the control panel of the lap machine. The base unit contains the main electronics and can be remotely located.

The gage measures the oscillation

frequency of the quartz monitor disk in two modes, from 1 to 40 MHz. The control unit translates frequency into thickness. Normally the gage uses the frequency constant of AT-cut quartz monitors ($k = 1.66 \times 10^9 \mu\text{m-Hz}$), but other constants can be entered through the keyboard. The thickness dimension can be read out in micrometers or mils. Furthermore, an offset can be entered to account for the added thickness of a spacer on which the monitor can be mounted. With the standard frequency constant, thickness can be measured from 1,660 down to 41.5 μm . With the addition of a spacer, greater thicknesses can be measured.

In an actual lapping operation, a small quartz monitor blank is inserted into the center of one or more wafer carriers. An electrode is mounted in the lap plate, its face flush with the lap surface and positioned so that it meets the quartz monitor once each revolution. A variable-frequency sweep signal is applied to the electrode from the gage. The signal flows through the quartz monitor and then back to the electrode.

Target resonance. The monitor oscillates, responding strongly when its mechanical resonance frequency coincides with the signal frequency. The resonant frequency is sensed and compared with a target frequency. When the resonant frequency of the monitor equals the target value, the lapping motor is stopped by a relay. Thickness equals the frequen-



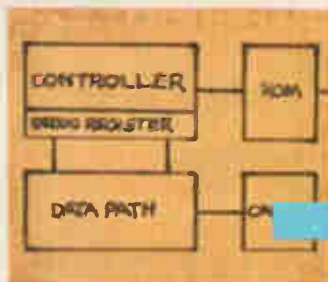

Choosing an architecture appropriate to LSI is important.

1



"Stick diagrams" are used to describe basic building blocks.

2

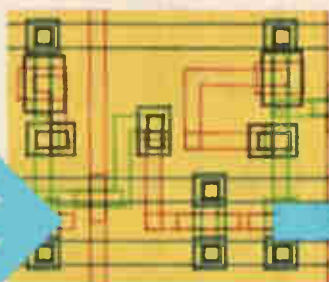

Computer-aided design helps generate final layout file.

3



Final designs may be fabricated and packaged for testing.

4

LEARN VLSI DESIGN!

If you want to take part in LSI/VLSI design—and understand what this technology means to you, your company, and your career—you can't sit back and watch. **Join the design revolution of the '80's!** Learn VLSI design!

And that's what this new **video tape course** from VLSI Technology, Inc. is all about—actually "doing LSI/VLSI". Filmed before a class of managers, engineers, and CAD specialists from Hewlett-Packard, this 21 hour video

Designing complete systems on a few chips is now possible.

5



Berkeley. Similar courses based on the Mead/Conway design methodology are now being taught at **DEC, Xerox, Varian, Bell Labs, and Hewlett-Packard**, as well as at over 30 major

universities in the U.S. and Europe.

Now you and your company have the opportunity to take part in this valuable course at your own plant or office. A modest programming or digital design background are the prerequisites.

Managers, engineers, programmers, and CAD specialists can all benefit. This new course will allow you and your company to become a participant in the LSI/VLSI design revolution. You will be able to make more accurate technology tradeoffs, take part in proprietary chip-design programs, and develop CAD tools more attuned to the design and testing problems of your company.

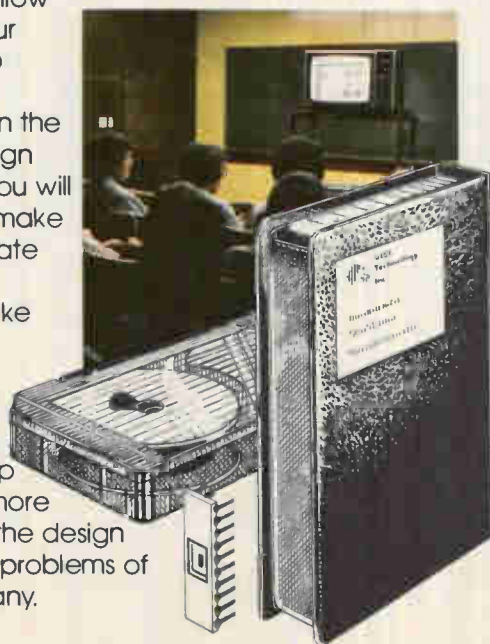

Hands-on experience ■ Important to the learning process

This exciting video tape series focuses on the following critical areas ■

- Architectural design for VLSI
- nMOS logic and basic building blocks
- Chip planning and layout
- Performance evaluation
- System timing and simulation
- Computer-aided design techniques
- Case studies in LSI design.



Checkplot of an impressive student design project



tape series teaches you how to **architect, design, and layout your own proprietary chips**. Homework assignments are provided so you can learn by doing. Some of you may actually fabricate your first designs.

The instructors for this course have debugged the material over the past two years while teaching LSI/VLSI design courses at M.I.T., Caltech, Stanford, and U.C.



VLSI Technology, Inc.
1401 McKay Drive
San Jose, CA 95131
408-942-1890

VLSI Technology, Inc. is a new high-technology semiconductor company that will specialize in fast-turnaround fabrication of custom and semi-custom LSI/VLSI and silicon foundry services. We will continue to offer a range of educational services for this fast-moving field.

Our name is on the keyboard, but your name is on the line.



When your design team chooses a keyboard for your new business-computer, word-processor or other new application, you know your products' success will be based in large part on that keyboard . . . how it feels, how it looks, its functions, features and reliability.

That's why so many companies specify Digitran's capacitive switch technology.

People tell us that the "tactile feel" of our keyboards beats anything they've ever used. Effortless, but positive.

Digitran keyboards make your product look better because we make everything (except the IC's) in house. We control the color, the finish and the aesthetic appeal for maximum marketing impact.

Specifications? Yours. Custom or standard. We'll design to U.S. specs or the new European DIN specs. We can provide any function you specify and many features you may not be aware of. If your specifications call for a standard application keyboard, we have those, too.

Application by application the Digitran keyboard has built a proven record of field-tested reliability.

You may already be using Digitran keyboards. If you aren't, remember: Your product is only as good as its keyboard. Is your product as good as it could be? If you aren't sure talk to your design team. Then write or call: Director of Marketing, Keyboard Division.

DIGITRANTM

The Digitran Company, a division of Becton, Dickinson and Company

855 South Arroyo Parkway • Pasadena, California 91105 • Phone: (213) 449-3110 • TWX 910-588-3794, TELEX 67-5485

New products

cy constant, k , divided by the resonant frequency. For quartz, k is precise within about 1 part per million. The monitor, which costs about 15¢, is lapped down with the lap load and

discarded after the process.

The gage has been evaluated by a major lapping-machine manufacturer, and several are currently being installed at integrated-circuit firms.

It is priced at about \$8,000 and can be delivered in eight weeks.

Transat Corp., 3713 Lee Rd., Shaker Heights, Ohio 44120. Phone (216) 991-7300 [437]

Dense connector takes vibration

Stacking connector uses wires bonded to elastomer to link boards despite knocks

The stacked or board-to-board connector has evolved into an attractive alternative to the backplane. Present metallic-contact board-to-board connectors are adequate for most applications but are limited to relatively low-density interconnections and, in addition, are susceptible to failure due to shock and vibration.

Tecknit has developed a high-density, low-resistance elastomeric connector assembly for board-to-board applications where center-to-center contact spacing is less than 50 mils and where the system must withstand a certain amount of vibration.

The assembly consists of a low-resistance Zebra series 7000 elastomeric connector inserted into the slot of a plastic dielectric holder, which is held in position between a pair of printed-circuit boards with two screws. The holder is designed to align the pc boards and also acts as a controlled deflection stop.

The elastomeric connector element is a D-shaped low-durometer silicone elastomeric core around which run flat metal conductors. Parallel rows of these wires are vulcanized to the surface of the silicone and become part of the composite material.

When the con-

connector is deflected by vibration between the pc boards, there is no danger of the wires coming loose since the bond between the wires and rubber is stronger than the rubber itself. The elastomer also provides excellent shock and vibration damping and forms a gas-tight seal where it contacts the board.

At the extreme top and bottom of the D configuration, the tips of the flat wires flare upwards so point contact can be achieved. This contact penetrates any surface oxides or other contaminants present on the surface of the contact pads, ensuring a reliable electrical connection in addition to the connection through the flat surface of the element. The flat wires of the elastomeric insert are on 15-mil centers and typically have a contact resistance of 20 m Ω when connected to a pad 35 mils wide.

The new connector offers a pressure-type connection that eliminates problems associated with soldering and lead straightening and allows for rapid assembly and disassembly of interconnected boards. A plastic holder and connecting element 2 1/4 in. long sell for about \$3 in lots of over 20,000. Deliveries are in about three weeks.

Tecknit, 129 Dermody St., Cranford, N. J. 07016. Phone (201) 272-5500 [438]

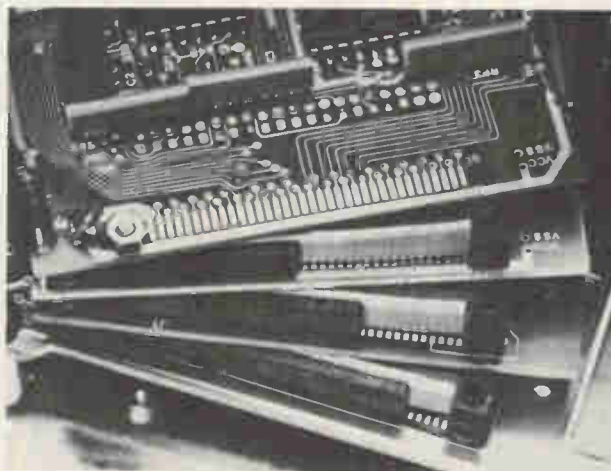

Chip sorter permits chip inspection

A programmable chip sorter enables users to categorize integrated-circuit chips and diodes and simultaneously moves them from film-mounted sawed wafers to waffle packs and from waffle packs to substrates, hybrid circuits, or other packages.

The KTC Placement System can load the chips in up to four separate waffle packs. The operator visually determines the chip's category and then presses the appropriate output button (labeled A through D), causing the chips to be automatically placed in the designated chip tray.

The chips are picked up from the input table by a dual-tip 180° transfer head and transferred to the output table. Both 4-by-4-in. tables are microprocessor-controlled with programmable read-only and random-access memory and have several optional tooling holders.

The KTC Placement System is available with a closed-circuit television monitoring system that is used to align and inspect chips transferred from film through a die-elevator device and sells for \$34,500. With a stereo microscope monitoring system used for high-quality inspection, it sells for \$32,500. Delivery takes eight to ten weeks.

Keller Technology Corp., P. O. Box 103, Buffalo, N. Y. 14217. Phone (716) 693-3840 [393]

Multipole connectors work in hostile environments

A line of multipole connectors with die-cast aluminum housings resist dirt, grease, oil, vibration, and water. They are commonly used on heavy-duty machine tools, indu-

QUALITY PROBLEMS?

We Can Find Failures Before Your Customers Do

Thermotron has been solving quality problems for 20 years for the aerospace industry with environmental simulation stress screening.

Call Us 616-392-1492

Ask for Stress Screening Consultant

We Can

- Save you money
- Improve your product's image

We Have

- Largest design and application engineering staff in the industry
- Largest product support organization to provide "after sale service"

ERMOTRON

es, Inc., Kollen Park Drive, Holland, Michigan 49423

BSIDIARY OF WEHR CORPORATION

New products

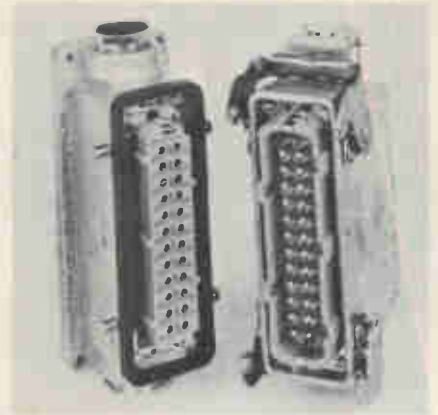

machinery and processing equipment, electronic medical equipment, transport and recreational vehicles, and outdoor advertising and communications equipment.

The environmentally protected connectors comply with DIN 40050 standards and are VDE rated. Their positive-locking latch comes in zinc-plated steel or stainless steel, and the neoprene gasket seal is resistant to aging.

Available with either screw-, solder-, or crimp-type terminations, the multipole connectors are priced at \$38 each. Delivery takes eight to ten weeks after receipt of order.

Electrovert Inc., Components Division, 399 Executive Blvd., Elmsford, N. Y. 10523. Phone (914) 592-7322 [394]

Desoldering unit removes components from pc boards

In the offing is a desoldering system, the printed-circuit-board reflow module, which can remove bad multi-lead components quickly and easily from printed-circuit boards in about 5 seconds. The component to be removed is positioned so that a predetermined amount of solder flows against the lead pattern of the component. The flowing solder transmits enough heat to cause solder in all lead holes to melt for instant removal of the component. The operator need not be experienced to operate the system because the only thing that touches the board is the flowing solder.

With the printed-circuit board

th
sts
sea
for
trial

205

ader service card

Electronics/May 19, 1982

CMOS Power At Bipolar Speed. A Stroke Of Genius.

The latest available technology for custom IC's. Truly a stroke of genius from Synertek.

You get the best of both worlds. Low power consumption. High speed – up to a 20MHz clock. That's HCMOS – high-performance CMOS. And we're the first custom IC manufacturer to offer this advanced technology to the custom marketplace.

High-speed, high-performance, cost-effective custom IC's. Tough to do. And we did it first. That tells you something about Synertek custom.

Because when you commit your product's success to the successful design and manufacture of a custom IC, you want a custom house that performs. And delivers. You need to know that the best options are available to you. So that you can get the best circuit possible for your particular requirement.

For design engineers, HCMOS – the dominant technology of the 80's – can be the answer, and Synertek

does it with state-of-the-art 3-micron design rules. From hand-crafted maximum performance designs to semi-automated cell-library designs. Plus flexibility. Plus experience. All molded by a team of professionals dedicated solely to custom work. And all this backed by the resources of one of the largest and most innovative custom MOS manufacturers today. Synertek.

We've been designing and manufacturing custom IC's since day one. For HCMOS (and

HCMOS or industry standard NMOS) now is the right time for you to tap the genius at Synertek. The artisans of technology.

Synertek Custom HCMOS*

Propagation Delay	2ns
Threshold Voltage	V_{TP} -0.9V V_{TN} 0.7V
Supply Voltage	1.5–5.5V
Channel Length	3 μ

*Values are typical values. Actual circuit performance will depend on particular circuit needs and components.

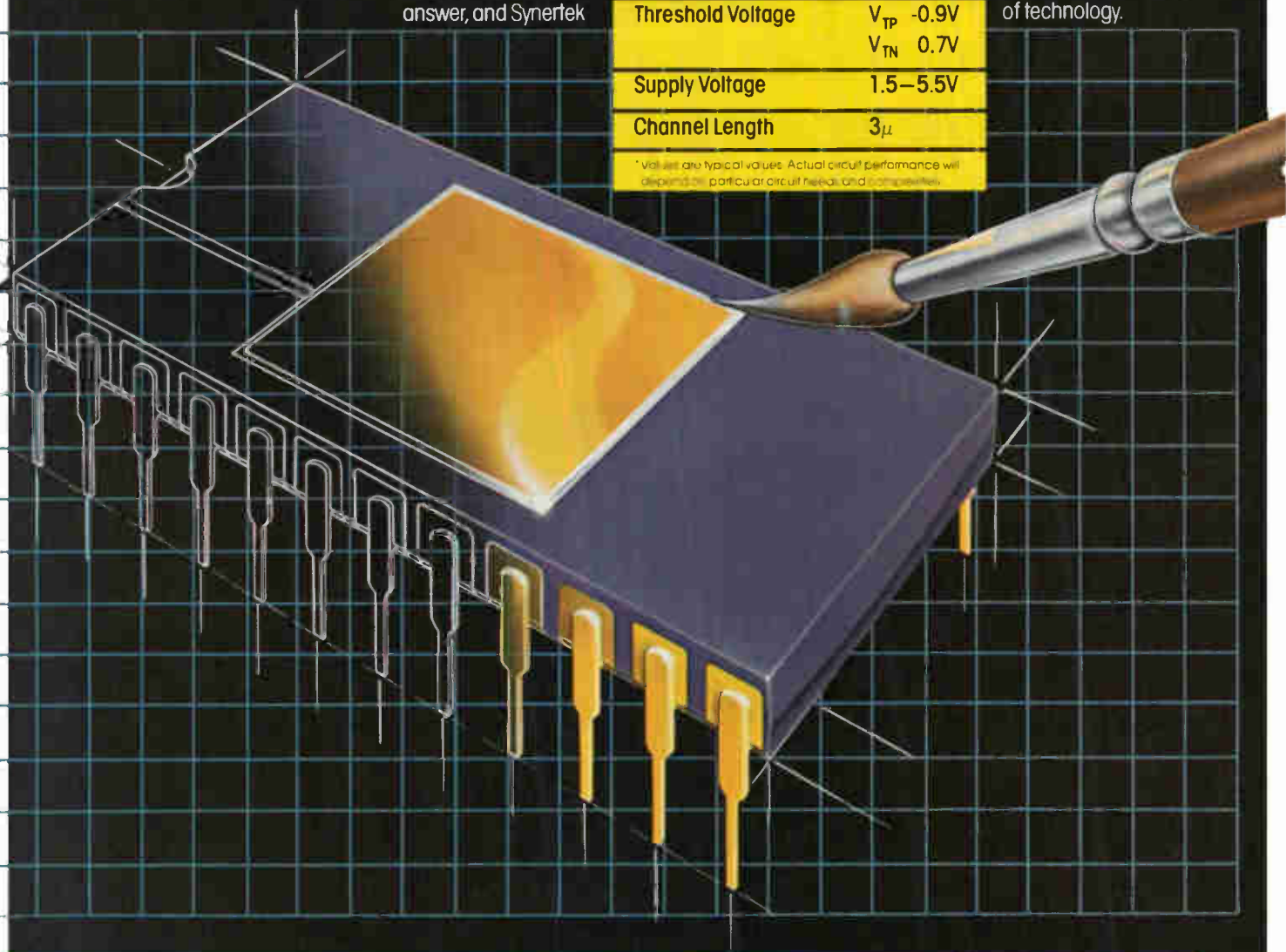

Send for your Custom MOS/LSI brochure (M/S 57). Or call (408) 748-7070.

E519

Name, program and application

Name _____ Title _____

Telephone _____ Ext. _____

Company _____ M/S _____

Address _____

State _____

Zip _____



SYNERTEK

A Subsidiary of Honeywell
3001 Stender Way, P.O. Box 552
Santa Clara, California 95052
(408) 988-5600
Telex 9-0338-0135



Fairchild Gold. Tough probes for your toughest tests.

Even in the toughest applications, user reports and our own tests show the Fairchild probe tip, plated with 50 millionths of gold, to have a consistent pattern of superior performance compared to other types of probe tips. We give you the largest diameter spring in the industry for dependable electrical contact and longer spring life. You get the closest possible tolerance between each component of the probe-receptacle set, and the receptacle will handle repeated probe replacements while retaining its tight fit to insure reliable continuity during testing.

Fairchild Test Systems / Mechanical Division

FAIRCHILD One Fairchild Sq.
Clifton Park
New York 12065
A Schlumberger Company 518-877-7042

Make your own tests with Fairchild's free samples. Send your request on your company letterhead and we'll send you our sampler pack which includes every tip style. You can request rhodium-tip samples, too. Go for the gold.



Circle 208 on reader service card

WORLDWIDE ELECTRONICS MARKETS

Electronics' highly respected 24th annual market forecast has been expanded to provide a 65-page in-depth look at the current and future demand for more than 800 electronic component and equipment products in the USA, Western Europe, and Japan — including 23 additional pages of market-estimate and growth-rate tables. Order today for immediate delivery of the *Electronics 1982 World Markets Forecast Data Book!*



Payment of \$150 (USA orders add local tax) must accompany order to:

New products

reflow module, faulty assemblies can be economically repaired, and valuable components can be salvaged from nonfunctional boards, thus reducing the cost of replacement, according to its maker.

The desoldering system is available as a table-top model or as a console station with adjustable board carriers, a target locator, and temperature and speed controls. It is framed in an acrylic-polyvinyl-chloride housing and is priced at \$3,900. Delivery takes six weeks.

Air-Vac Engineering Co., 100 Gulf St., Milford, Conn. 06450. Phone (203) 874-2541 [395]

Pc-board cleaning systems
sell for under \$10,000

Two aqueous cleaning systems, the Aquamatic I and II, wash, rinse, and dry printed-circuit boards. They incorporate features normally found in only the much larger systems but have a base price starting at under \$10,000—lower than any comparable system in the industry, its maker claims.

The Aquamatic I is a modular system with a series of seven basic modules that can be added or subtracted according to the user's needs. The Aquamatic II is a self-contained unit incorporating three basic stations. Both are available with a variety of options and accessories for custom-designed systems. The Aquamatic I, for example, comes with an optional clear window for inspection of the cleaning operation. A nonpolluting and economical cleaning stage that uses water to eliminate constant dumping and monitoring is common to both systems.

The Aquamatic I and II can handle pc boards up to 12 in. wide and can be used in line with larger systems, including soldering systems, without costly modifications. Delivery is estimated at eight to 10 weeks after receipt of order.

The John Treiber Co., 18120 Mount Washington St., Fountain Valley, Calif. 92708. Phone (714) 557-1821 [398]

THE UNSCOPE!



HUNTRON TRACKER

NOT AN OSCILLOSCOPE! NOT A CURVE TRACER!

TESTS SOLID STATE DEVICES . . . IN-CIRCUIT . . . WITH NO CIRCUIT POWER APPLIED!

This amazing instrument will help you reduce troubleshooting costs and speed repair to a degree that will surprise you. Easy to operate, HUNTRON TRACKER locates defective devices FAST. NOT A LOGIC TESTER! The TRACKER locates shorts, opens and leaky components of all kinds. LED's diodes, bipolars, FET's, J-FET's, MOS and CMOS IC's, electrolytics, memories of all types, special purpose devices like diac triggers and integrated voltage regulators.

FAST, LOW-COST REPAIRS WITH . . . HUNTRON TRACKER!

HUNTRON INSTRUMENTS

15123 Highway 99 North, Lynnwood, Washington 98036

(800) 426-9265

AUSTRALIA
CANADA
FRANCE
GERMANY
NORWAY/DENMARK
SWEDEN/FINLAND
SWITZERLAND
UNITED KINGDOM

ECO ELECTRONICS
CYPRUS PRODUCTS, INC.
MB ELECTRONIQUE
INSTRUMATIC ELECTRONIC GMBH
WESTRON A/S
SATT ELEKTRONIK A/B
INSTRUMATIC AG
M.T.L. MICROTESTING LTD.

QUEENSLAND, AUSTRALIA 4068
VANCOUVER, B.C.
B.P. 31-78530 BUC, FRANCE
MUNICH, GERMANY
OLSO 4, NORWAY
S-126 STOCKHOLM, SWEDEN
8803 RUSCHLIKON, SWITZERLAND
HAMPSHIRE GU342QG, UNITED KINGDOM

TEL: 07-376-5677
TEL: (604) 327-8814
TEL: (3) 956.81.31
TEL: (089) 85 20 63
TEL: (02) 155500
TEL: (08) 81 01 00
TEL: (01) 724 1410
TEL: ALTON (0420) 88022

Components

Hybrid op amp runs at 70 MHz

High-speed unit's performance is stable without compensation over gain range of 1 to 40

Comlinear Corp. is offering a hybrid operational amplifier of exceptional performance. It has, says David A. Nelson, president, a gain-phase response that is flat from dc to 100 MHz and an unconditional stability not requiring external components.

The CLC103's typical small-sig-

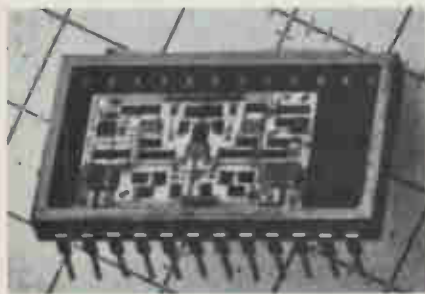

nal 3-dB bandwidth is 150 MHz, and the minimum full-power (an output of 20 v peak to peak) 3-dB bandwidth is 70 MHz for noninverting applications or 75 MHz when the input is inverted. These minimums hold over a range of transfer gains (V_{out}/V_{in}) of 1 to 40. The typical slew rate is greater than 6 v/ns.

For a 10-v output step, typical settling time to within 0.4% of final value is 5 ns and to within 0.2% is 10 ns. Maximum settling times at a transfer gain of 20 are 8 ns to within 0.4% of a 10-v step and 15 ns to 0.2%. Phase linearity from dc to half the bandwidth is within 1°.

Stable performance at this high level is maintained by a proprietary design that keeps the op amp's closed-loop gain constant as transfer gain is varied by a single external resistor from 1 to 40, says Nelson. With closed-loop gain held constant, no change in internal compensation is required as transfer gain is varied.

Unlike conventional op amp designs where the optimum gain-bandwidth product is achieved at high gain, minimum settling time occurs at a gain of -1, and the minimum slew rate is found at a gain of +1, the year-old-firm's device is consistent in almost all aspects of performance over its entire gain range.

The hybrid's high stability at all gain settings "means that no compensating capacitors or resistors are needed to maintain stable gain and high-fidelity pulse response," says Nelson. "This eliminates the expense of adjustable capacitors and the labor of a trained technician to adjust them."

Uses. Comlinear is targeting the CLC103 for use with 100-MHz flash analog-to-digital and digital-to-analog converters, as preamplifiers for high-speed fiber-optic detectors and photomultiplier tubes, as high-performance low-cost output amplifiers for function and pulse generators, and for baseband video communications in such applications as satellite earth stations.

Group delay for the CLC103 is typically 2.2 ns at a transfer gain of 4, 2.9 ns at a gain of 20, and 3.5 ns at a gain of 40. Overshoot for a 1-ns input rise time and a 20-v output step is typically 3% at gains of 20 and 40 and 12% for a gain of 4. For a 5-v step, overshoot is only 2% at a gain of 20. The part's high linearity is typified by a minimum third-order intermodulation intercept of 40 dBm at 20 MHz. At 50 MHz, 1-dB gain compression occurs at 20 v peak-to-peak output.

Input offset voltage is typically less than 30 mv and drifts less than 50 $\mu\text{V}/^\circ\text{C}$. The unit draws 27 mA from a $\pm 15\text{-v}$ supply—supply levels may range from ± 9 to ± 16 v. The two bipolar output transistors will put out ± 200 mA at 12 v peak.

In a 24-pin ceramic dual in-line package, the CLC103 is priced at \$150 each in small quantities. For orders of 1,000 pieces or more, the price is under \$100; production quantities will be available this month. The operating temperature range is -25° to $+85^\circ\text{C}$. Comlinear is also offering a version that meets

MIL-STD-883B, operating at from -55° to $+125^\circ\text{C}$.

Comlinear Corp., 2468 East Ninth St., Loveland, Colo. 80537. Phone (303) 669-9433 [341]

Instrumentation filter and amplifier eliminate aliasing

The PDF-106 instrumentation amplifier and filter conditions signals and eliminates aliasing by limiting the input-signal bandwidth. The -106 combines a programmable, high-performance instrumentation amplifier and a low-pass, six-pole Butterworth filter that is housed in a thick-film hybrid circuit, hermetically sealed in a 24-pin dual in-line package.

Amplifier gain is from 0.1 to 1,000, amplifier offset is $\pm 100\%$, and the filter cutoff is between 5 Hz and 5 kHz. All values are determined by external resistors. The amplifier-filter combination has floating differential inputs, an input range of ± 10 v, and a high common-mode rejection ratio—110 dB minimum for a gain of 1,000. The device's gain stability is within 2% between -35° and $+85^\circ\text{C}$.

The -106 is approximately \$200, with delivery from stock.

Aydin Vector Division, P. O. Box 328, Newtown, Pa. 18940. Phone (215) 968-4271 [343]

Digital attenuators operate over dc-to-400-MHz range

A line of TTL-programmable digital attenuators spans the frequency range of dc to 400 MHz, with a maximum attenuation to 127 dB. These miniature components are capable of providing attenuation with a preci-



Let's talk silicon value...

Monsanto now offers two families of silicon products—MQS™ and YIELD MAX™.

These products, coupled with our yield analysis program, are designed to help fab engineers achieve higher device yields and lower device costs.

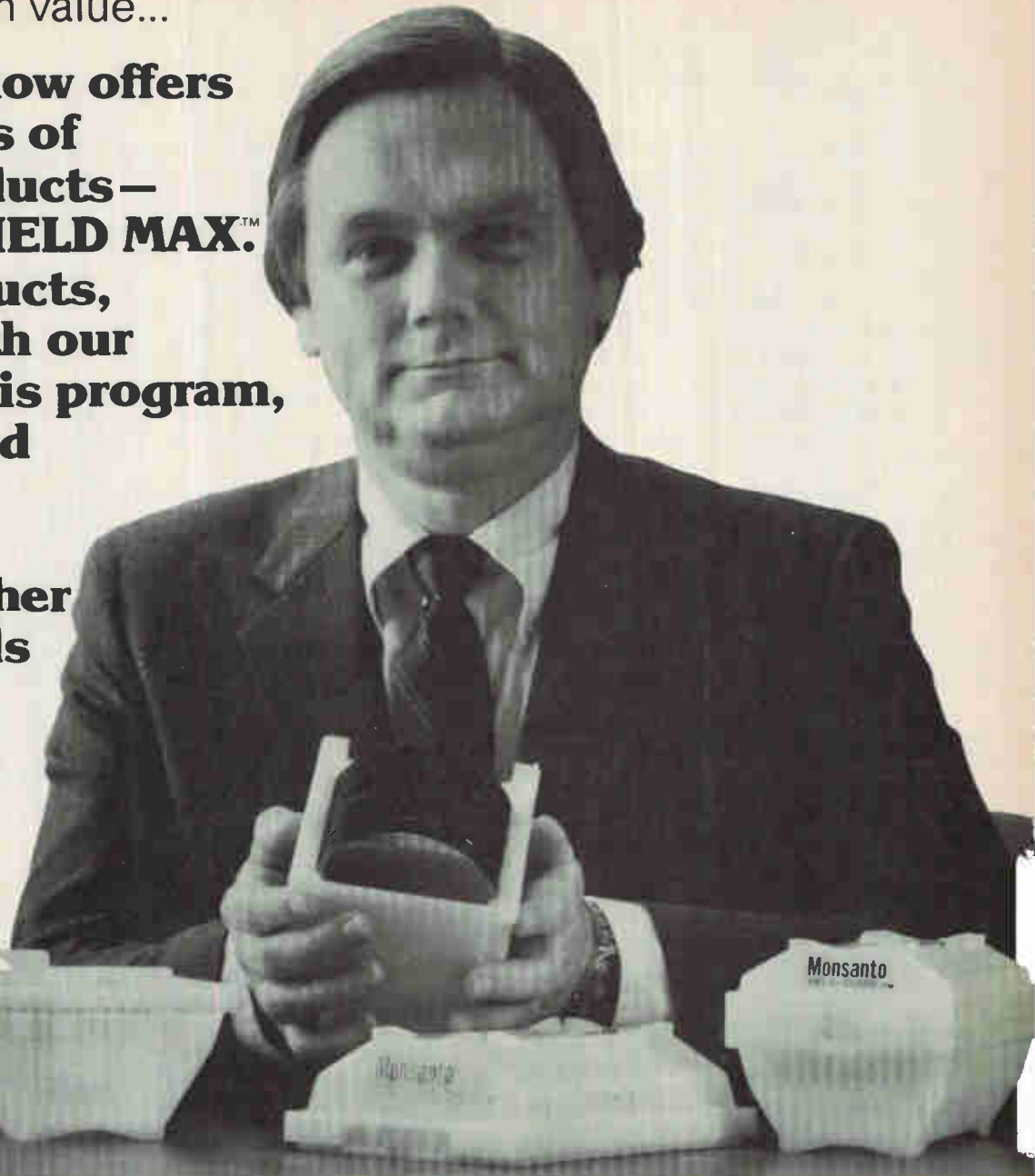

Haskell Waddle
Director, Marketing

MQS and YIELD MAX products deliver improved device yields by:

- **Matching wafer characteristics to specific I.C. process requirements.**
- **Consistently delivering wafers to stringent quality standards.**



To learn more about the Monsanto silicon program, send for our product offering and Silicon Story.

Monsanto Electronics Division
Attn: B.G. Marchetta
755 Page Mill Road
P.O. Box 10123
Palo Alto, California 94303
Phone: (415) 493-3300

Name _____
Title _____
Company _____
Address _____
City _____ State _____ Zip _____
Telephone (_____) _____

Monsanto

Circle 211 on reader service card

New products

sion normally associated with mechanical step attenuators.

The DA-600 series covers the 1.0 to-35-MHz range with a balanced configuration that reduces switching transients to extremely low levels, while the -700 series covers the 20-to-400-MHz range with attenuation in 1-dB steps to 127 dB. A third series, the -800, uses miniature electromechanical devices to cover the dc-to-35-MHz range with negligible switching transients and distortion.

The series is available in a variety of binary or binary-coded-decimal sequences, including single-bit units suitable for interspersion in signal paths where gain-attenuation profiles require critical control. Switching times are 200 ns for the -600 series, 2 μ s for the -700 series, and 3.0 ms for the -800 series.

The devices range in price from \$460 to \$1,995 each. Delivery takes 60 days and longer.

Lorch Electronics Corp., 105 Cedar La., Englewood, N. J. 07631. Phone (201) 569-8282 [344]

Pulsed laser diode works at wavelengths of 870 to 904 nm

The PLD-10, a high-performance, military-grade laser diode, is a gallium-aluminum-arsenide laser designed for pulsed operation. The laser has a mirror-coated, multi-layer, heterojunction design and operates on a low threshold current. The device's output power is typically 10 w.

The laser diode is available at peak wavelengths of 870 to 904 nm. Each laser is factory tested for 24 continuous hours before shipment. The pulsed laser diode, packaged in an optically centered, hermetically



sealed case, can be used in a variety of military systems including laser range finders, proximity devices, and target designators. Available for immediate delivery, the -10 sells for approximately \$150 each.

Laseron, 655 Concord St., Suite 1, Framingham, Mass. 01701. Phone (617) 872-9870 [345]

Resistor networks in plastic packages meet military specs

Housed in plastic 8-, 14-, and 16-pin dual in-line packages with a 99.5% alumina substrate and 0.100-in. lead spacings are the F08, F14, and F16 series, respectively, thin-film precision resistor networks that meet the specifications of characteristic V of MIL-R-83401. Automatically insertable, the devices have standard resistor tolerances of $\pm 0.1\%$, $\pm 0.5\%$, and $\pm 1\%$ absolute, respectively. Their temperature coefficient of resistance is 50 ppm/ $^{\circ}$ C, and their operating temperature range checks in at -55° to $+125^{\circ}$ C.

Suitable for replacing discrete precision resistors, the resistor networks' applications include matched pairs, pull-up resistor arrays for unused TTL gates, parallel high-speed circuitry, wire-OR gate configurations, and TTL-MOS interfacing.

In 1,000-unit lots the devices sell for 95¢ each, with delivery taking eight weeks.

Allen-Bradley Co., Electronics Division, 1201 South Second St., Milwaukee, Wis. 53204. Phone (414) 671-2000 [346]

Full-travel keyboard has ergonomic features

A full-travel membrane-type keyboard, called Screened-Contact, for wired-only keyboard requirements is designed to replace more expensive and less reliable gold-contact switches.

The keyboard, which will be exhibited at the National Computer Conference next month, meets all of the new ergonomic standards, in-



cluding the German DIN requirements. Each switch is 19 mm high and has a lifetime of over 50 million operations.

The board is mounted on a rigid frame, and stepped or sculptured keytops are available—a nonglare keytop finish is standard. The 53-station keyboard with a wired-only, X-Y matrix termination will be delivered from stock for \$76.07 each in lots of 1 to 9 and \$52.90 each in quantities over 50.

In addition, the firm has introduced an off-the-shelf enclosed keyboard, model P2492, that includes an 83-station microprocessor-encoded capacitance keyboard with serial ASCII output. This keyboard will be available from stock for \$149.63 without an enclosure and \$212.63 with one for 1 to 9 units.

Key Tronic Corp., P. O. Box 14687, Spokane, Wash. 99214. Phone (509) 928-8000 [347]

Membrane-telephone keypad costs as little as 45¢ each

Added to the Kriket series of silicone elastomer keypads is a standard telephone-array membrane keypad. The units are guaranteed for 3 million cycles and have typical contact resistances of less than 200 Ω . Center-to-center spacing, in both directions, is 17.5 mm.

The keypad is configured in the standard three-by-four-key array, but customers can use multiple pads to make larger arrays. Available from stock, the keypads sell for \$1.25 each in the 50-piece minimum order and for as low as 45¢ each in quantities over 10,000.

Conductive Rubber Technology, Olive Mill Plaza, 1230 Coast Village Circle, Santa Barbara, Calif. 93108. Phone (805) 969-5807 [348]

ISAAC™ turns Apples into laboratory computers...



...and data acquisition costs tumble!

ISAAC teams with the Apple Computer to give you automated control of laboratory instruments, data acquisition, electronic test, process control and front end processing for centralized systems.

Its LABSOFT extended BASIC language makes ISAAC easy to use wherever real time signals must be recorded, manipulated, related, analyzed, stored, displayed or printed out. Color charts and graphs are a breeze.

Major ISAAC Hardware Features:

- 16-channel, 12-bit A/D converter
- 4-channel, 12-bit D/A converter
- 16 binary inputs
- 16 binary outputs
- 16 bit timer
- 8 channel counter
- Real-time clock
- RS-232C and IEEE 488 (optional)
- 4 programmable Schmitt triggers
- Expansion cards for additional analog and binary channels.

Typical Applications:

CHEMISTRY

- Spectroscopy ● Chromatography ● Electrochemistry

ENGINEERING

- Bioengineering ● Electronic test ● Materials testing

PSYCHOLOGY

- Biofeedback ● Stimulus response ● Cognitive learning

PHYSIOLOGY

- Human performance testing ● Neurological waveform analysis

PROCESS CONTROL

- Flow, pressure and temperature measurements
- Current and voltage measurements

ISAAC plus Apple. A lot of technical computing power for a little money. For complete information, circle reader service number, or call us toll free at 1 (800) 343-4494.



Circle 213 on reader service card

Cyborg Corporation, 55 Chapel Street, Newton, MA 02158 (617) 964-9020

Apple is a trademark of Apple Computer. ISAAC, LABSOFT and CYBORG are trademarks of Cyborg Corporation.

Throw away your resistors.

Replace them with the unique RCA programmable dual 4-bit logic terminator and save space and power.

RCA's new CD40117B is the industry's first low-current data terminator.

Consisting of two 4-bit terminators, it can be used to terminate a data bus to a high or low logic state. Or to terminate any open or unused CMOS logic input to the last driven logic state with 3-state logic or during power down.

Each IC will replace 8 power-hungry pull-up or pull-down resistors. So you save power while improving board density. Ideal for any battery-operated or battery back-up data bus application.

In addition to saving space and power, you can program your 8-bit data bus using the strobe and data inputs. And the CD40117B

remembers the last logic state of the data bus.

Available in 14-lead hermetic or plastic packages.

Another CMOS logic innovation from the people who invented CMOS.

For more information, contact any RCA Solid State sales office or appointed distributor.

RCA Solid State headquarters: Somerville, NJ, Brussels, Sao Paulo, Hong Kong. Circle 214 on reader service card.



“Old Reliable”...

RCA

New products

Computers & peripherals

Q-bus card links to current loop

Communications card also offers RS-232-C link, lets Unibus code run on LSI-11

The world is opening up to Digital Equipment Corp. LSI-11 users who can now choose between current-loop and RS-232-C interfaces, and now Unibus *aficionados* will be able to bring their software to the LSI-11 environment—all because MDB Systems Inc. has expanded its line of DEC-compatible boards with a system communication module that is a multifunction board.

The MLSI-SCM11 offers a variety of features that are not available on the comparable DEC board, the MXV11RC, according to MDB design engineer Sandy Traylor. Foremost among these is the ability to interface with both current-loop and RS-232-C peripherals. The single port on the board accepts either, letting users switch equipment easily without worrying about compatibility, she notes.

Two features permit users to carry over Unibus software. The -SCM11 offers support for four-level interrupt schemes, so Unibus packages can be brought to it without modification. A clock-programmable interrupt capability is another aspect that makes it easy to maintain Unibus software. The board provides for the timed interrupts needed for Unibus programs that are not a feature of the LSI-11. When Unibus software runs, the LSI-11 ignores the interrupts, obviating code rewriting.

A selector on the front of the board lets users manually change transmission rates when devices of different speeds are used. This quick conversion method eliminates special software packages needed on some systems for rate alteration or the powering down of the system for hardware conversions required on

others, says Traylor. Rates from 110 b/s to 38.4 kb/s are standard.

As a troubleshooting aid, the -SCM11 has two light-emitting diodes that show whether the board is transmitting or receiving data. This feature, common to many of MDB's recent introductions, makes it simpler to determine whether the terminal or board is malfunctioning by indicating data flow.

The board lists for \$450 in single quantities, with the price dropping to \$360 in 100-quantity orders. Delivery is 30 days after receipt of order.

MDB Systems Inc. 1995 North Batavia St., Orange, Calif. 92665. Phone (714) 989-6900 [411]

Spate of CAD/CAM hardware heads toward market

Developers of computer-aided design and manufacturing systems are aiming at a new level of system integration based on a common data base accessible to both engineering and manufacturing organizations and maintained by a 32-bit computer. This key feature is found on the most recent CAD/CAM entries from Applicon, Sperry Univac, Graftek, and Auto-trol Technology Corp.

Applicon's series 4000 (see photo below) is built around three new Graphics Processing Facilities based on Digital Equipment Corp. minicomputers. The series 4000 features a Distributed Graphics Network package and a data-base manage-

ment system. The network package allows users to establish graphics data networks. The data-base management package provides the multidisciplinary access to engineering and design data necessary to see a product through the entire development cycle. Says Applicon president Donald W. Feddersen, "The series 4000 provides more than basic documentation and drafting capabilities. It offers engineering, manufacturing, and data-management capabilities not typically found in today's CAD/CAM systems."

Data base with network. The 4275 graphics processing facility offered with the top-of-the-line series 4000 system represents a major innovation for Applicon. Based on a DEC VAX-11/751 processor, this facility is supplied with 1 megabyte of main memory (which can be upgraded to 2 megabytes) and supports as many as four dual-density tape drives and four hard-disk drives. Starting at less than \$320,000, this system combines networking and data-base capabilities with the fast number crunching that is necessary for many advanced applications.

The VMS operating system and virtual-memory architecture help to keep data-base management swift and efficient. The data-base manager sees to it that access to data is protected. The system can be set up so that manufacturing personnel cannot change the original design to make it easier to manufacture without notifying the engineers and designers responsible for the original



New products

development of the product.

Besides its top-of-the-line system, Applicon offers entry-level systems based on the 16-bit PDP-11/34 processors. These graphics processing facilities, dubbed the 4225 and 4245, include the RSX-11M operating system. A system including hardware, software, and a work station can be bought for less than \$100,000 and is upwardly compatible with other Applicon systems to protect the user's initial investment.

Unifying thread. Joel N. Orr, chairman of Orr Associates Inc. of Danbury, Conn., and a CAD/CAM expert, notes that "the unifying thread running through all the operations of the automated factory is the geometric description of the part." Sperry Univac has designed its UNIS*CAD system with that thought in mind. Seeking to build a system with drafting and design capabilities and analysis software that operates directly on the design model, Sperry included a direct connection with production scheduling and control operations, as well as numerical-control capabilities.

The most recent addition to Sperry Univac's UNIS series of systems executing manufacturing planning, scheduling, and control software, UNIS*CAD (see photo above) uses both a Sperry Univac 1100 series 32-bit mainframe and a Sperry Univac V77 minicomputer in a distributed architecture. The V77 handles design, drafting, numerical control, and mesh generation, freeing the mainframe to run large analysis programs, perform the detailed calculations required for solid modeling, maintain the data base, and perform business functions. The V77 is in turn offloaded by the graphics terminals, which store display lists; zoom, pan, and rotate display figures; and communicate with the designer via the data-tablet interface. The graphics software packages provided by Sperry Univac support the Megatek 7200 and the Adage 4177 terminals.

Graphics Technology Corp., also known as Graftek, is adding to the spectrum of available hardware a high-resolution-color work station to be used with its 32-bit turnkey



CAD/CAM system. The new high-performance display will feature a 19-in. raster-scanning color cathode-ray tube with flicker-free 60-Hz non-interlaced operation. Capable of displaying 1024 by 768 picture elements in eight colors, the terminal has 27 programmable-function keys and screen-overlay capabilities.

But the element that promises to make the new color work station truly unique is its voice-input option. Slated to be available in September, this option recognizes 100 words or phrases up to 1.2 seconds in length. Extra words can be added to the recognizable vocabulary in under 15 seconds.

Full-featured. The color terminal alone will be available in July for \$45,000. It is designed to work with Graftek's series 32 CAD/CAM system, which has a relational data base specifically designed to handle engineering and scientific data. The series 32 is a full-featured system including provisions for mechanical design, numerical control, production drafting, electrical-power wiring work, solid-geometric and finite-element modeling, flat-pattern development, and plastic injection molding. Graftek first began shipping the system, which is built around Gould's SEL 32-bit computer, in May of 1981. A complete turnkey system including four work stations is available for \$425,000.

Another 32-bit-based system designed to be an integrated product-development tool was recently announced by Auto-trol Technology Corp. Auto-trol's GS-32 engineering and manufacturing system also uses the DEC VAX series of 32-bit minicomputers. The minicomputer sup-

ports the user's work stations, with all functions—from tooling design and flat-pattern development to numerical-control and product assembly programs—running on the same computer. Turnkey systems, including the processor, start at \$80,000.

Applicon, 32 Second Ave., Burlington, Mass. 01803. Phone (617) 272-7070 [476]

Auto-trol Technology Corp., 12500 North Washington St., Denver, Colo. 80233, Phone (303) 452-4919 [477]

Graphics Technology Corp., 1777 Conestoga St., Boulder, Colo. 80301. Phone (303) 449-1138 [478]

Sperry Corp., Sperry Univac Division, P. O. Box 500, Blue Bell, Pa. 19424. Phone (215) 542-4213 [479]

\$895 daisy-wheel printer runs at 12 characters/s

The cost of letter-quality printing for small computer and word-processing systems takes a big step down with the announcement of the TP-I daisy-wheel printer from Smith-Corona. Its suggested retail price is only \$895, and glass-reinforced nylon daisy wheels for various type fonts are only \$5 each.

The unit prints at speeds between 12 and 15 characters/s on paper up to 13 in. wide. The 10-character/in. version can print 105 characters a line, and the 12-character/in. version 126 a line. The initial unit has a friction paper-feed scheme—a tractor-feed mechanism is due out during the first half of the year, according to the firm.

The TP-I comes with either a Centronics-compatible parallel interface or an RS-232-C serial interface. The latter can be strapped to operate from 50 to 19,200 b/s. Character length and parity can also be strapped. Margins are under program control.

Printing is unidirectional at 6, 4, or 3 lines/in. Impression force is controlled with a five-position switch so that up to five carbon copies may be produced. Print wheels are said to have a 2-million-character life and are easily replaceable. Three types of ribbon are available in convenient

UNCANNY.



Introducing the TRW-61 Metallized Polyester Capacitor. Now you get better performance for medium-current switching power supplies . . . at a competitive price.

Unlike electrolytic capacitors which are can-shaped, our new TRW-61 capacitors are flat. So, lying down or standing up, they take less space on the PC board. Giving you more design flexibility.

But that's only the second best thing about our metallized film capacitors.

The best thing is, unlike electrolytic capacitors, the TRW-61 exhibits little or no capacitance roll-off with

increasing frequency. So now you get superior performance over electrolytic capacitors. At a competitive price.

Designed specifically for SPS applications requiring low ESR and current capability up to 4 amps, the TRW-61 is used for input filtering, high frequency transformer DC blocking, and output filtering.

Rated for 20 through 60 kHz usage, there's negligible shift in capacitance due to aging, long exposure to humidity, or temperature cycling. And our insulation resistance, surge rating and dissipation factor are all superior to the can-shaped variety.

How does the TRW-61 capacitor deliver such great performance at such a sensible price?

It's positively uncanny.

Send in coupon or call us at (308) 284-3611.

TRW Capacitors	E-5
301 W O Street, Ogallala, Nebraska 69153	
Yes, I want better performance for my lower switching power supplies	
Please send data on your TRW-61 Capacitors.	
Name _____	
Company _____	
Div / Dept _____	Mail Code _____
Address _____	
City _____	State _____ Zip _____

TRW CAPACITORS

AN OPERATION OF TRW CAPACITORS DIVISION

Circle 217 on reader service card

New products

snap-on cassettes—one-time film for the highest contrast (57,000 characters a cassette) and reusable Mylar and nylon-fabric ribbons, each having a life of about 250,000 characters. The TP-1 measures 6.4 by 19.5 by 12.5 in. and is currently being shipped to dealers.

Smith-Corona, 65 Locust Ave., New Canaan, Conn. 06840 [403]

Low-cost hard-disk kit adds 5 megabytes to Apples

For only \$1,299, programmers can add 5 megabytes of Winchester-disk storage capacity to their Apple II computers. Aimed at both the hobbyist and system integrator, the Hard Disk Kit is offered in component form to be assembled by the purchaser. Assembly requires only a few simple connections that can be performed in less than 10 minutes and no technical expertise, the manufacturer claims.

Included in the kit are an Apple II host-adaptor personality card that currently supports both DOS and CP/M software and will soon support Pascal, a 115/230-v power module, cable set, cabinet, DOS or CP/M software, and installation instructions and documentation. The components may be purchased separately.

At the heart of the disk system is the Intelligent Disk Assembly, which consists of a 5¼-in., 5-megabyte Winchester technology disk drive and the S-1410 intelligent disk controller [*Electronics*, Sept. 22, 1981 p. 236]. The disk system features up to 22-bit error detection and up to 11-bit error correction, a full-sector data buffer, and single command disk initialization. The Hard Disk Kit can be delivered now.

Xebec, 432 Lakeside Dr., Sunnyvale, Calif. 94086. Phone (408) 735-1340 [404]

Intelligent terminal has dumb terminal price

Bowing at dumb-terminal prices is a smart editing terminal, the View-

point/60, which features extensive screen editing, fine-line business graphics, and five operating modes: local, conversational, page, message, and forms. Priced at \$895 each in single units, the terminal has a 12-in. screen and displays 25 lines including a status line. The unit is a full 80-character/line terminal with both upper- and lower-case characters.

The Viewpoint/60's ergonomic features include a detachable keyboard with keys that have a selectable audible click, a tilt mechanism to adjust the display to the user's preferred viewing angle, and eight programmable function keys. It has a variety of transmission rates ranging from 110 to 19,200 b/s and three interfaces—RS-232-C, RS-422, and current-loop.

The terminal, to be shown at the National Computer Conference in Houston next month, is designed for both end users and original-equipment manufacturers.

Applied Digital Data Systems Inc., 100 Marcus Blvd., Hauppauge, N. Y. 11787. Phone (516) 231-5400 [383]

5¼-in. removable Winchester drive holds 5 megabytes

Using the proposed ANSI standard disk cartridge is the Micro-Magnum 5, a removable 5¼-in. Winchester-



technology disk drive with 6.7 megabytes of unformatted storage, 5 megabytes formatted. The Micro-Magnum 5 employs the same basic technology as the company's Micro-Magnum 5/5 fixed-and-removable 5¼-in. drive [*Electronics*, April 21, p. 112].

The drive has a 40-ms average

access time, a 5-Mb/s data transfer rate, and a 5-megabyte copy time of under 90 s. Recording density is 8,600 bits/in.

Typical applications for the unit are in small computer systems for business, local networks, and word processing. For these uses, the Micro-Magnum 5 may be used as backup for 5¼-in. fixed-disk Winchester and as an input/output device. Used as a multiple drive system, it provides mass storage, I/O, and backup.

In large quantities, the Micro-Magnum 5 sells for \$995 and the removable cartridges go for \$85 each. Both drive and cartridge are available in evaluation quantities.

DMA Systems Corp., 325 Chapala St., Santa Barbara, Calif. 93101. Phone (805) 965-7059 [384]

Smart 12-megabyte drive does its own housekeeping

With the intelligence provided by a built-in controller compatible with the Shugart Associates standard interface, the D145 intelligent disk drive, combining 12 megabytes of hard disk storage and 12 megabytes of disk-to-disk backup, does many of the housekeeping functions associated with disk drives in the drive itself, rather than using the central processing unit.

Using the processing power of the controller, the D145 performs all error handling and protocol interface functions without separate hardware interfacing or applications software changes. Also, all seeks, verifications, error recovery, disk control, and data transactions are automatically handled in the drive.

The drive offers a unique 10½-in. technology, including patented embedded servo positioning, 3,330 ramp-load heads, and linear voice-coil activator.

In quantities of 100, the D145 is priced at \$3,390 and is available in 90 days.

Cynthia Peripheral Corp., 3606 West Bayshore Rd., Palo Alto, Calif. 94303. Phone (415) 856-8181 [385]

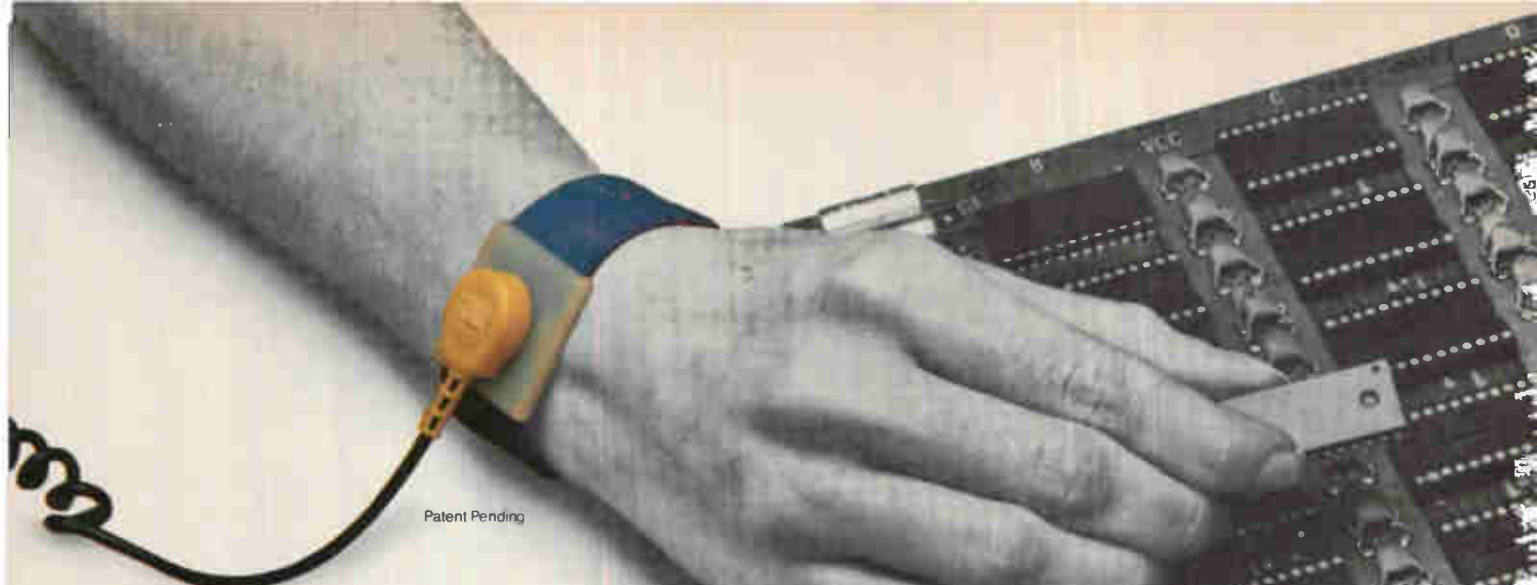

Patent Pending

This new Charge-Guard™ wrist strap comes attached to a total static control program.

To encourage your employees to use wrist straps properly, we've added all the comfort and convenience features shown at right.

Our new *Charge-Guard* Wrist Strap is an elastic band with interwoven stainless steel fibers. Soft, airy and as washable as cotton. Yet it offers 360° conductive contact inside, plus an insulative outside for worker safety.

Its coiled cord stays out of the way and can be detached at a swiveled snap.

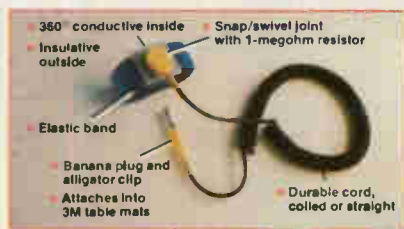

Charge-Guard Wrist Straps — but on our Total Static Control Program as well.

The first line of defense against static

Equipping personnel at each of your static-safe work areas with *Charge-Guard* Wrist Straps helps fulfill one of 2 basic rules of static control —

- (1) Handle all static-sensitive components at static safeguarded work areas
- (2) Transport all static-sensitive components in static shielding packages or containers.

Because building a program around these basic rules can be the most profitable step your company has ever taken, we'd like to send you more information — not just on

The management approach to static control

Developed to help the electronics manufacturer establish, implement and maintain a comprehensive plan, the Total Static Control Program offers —

- Seminars to focus the attention of your key personnel — in planning, purchasing, receiving, production, shipping, maintenance and field service — on the realities of static damage.
- Surveys to explore the scope of static problems in your plants.
- Educational and awareness-building materials such as films,

literature, posters and labels to help you manage the human element.

- And a full line of products to safeguard your static-sensitive components at workstations, during transport, and in the field.

Just send the coupon and you'll receive a packet with all the details — including special literature on the *Charge-Guard* Wrist Strap.

3M: Please send information on:
 Charge-Guard Wrist Strap
 Total Static Control Program

NAME _____

TITLE _____ PHONE _____

COMPANY _____

ADDRESS _____

CITY, STATE, ZIP _____

Send to: Static Control Systems/3M, Dept. ETC-032, 225-4S, 3M Center, St. Paul, MN 55144
 Or call toll-free: 1-800-328-1684 (in Minnesota: 1-800-792-1072).

Total control of the static in your business

3M Hears You...



Circle 219 on reader service card

The challenge: conformance to VDE and international standards

The solution: AIRPAX IPG and SNAPAK[®] magnetic circuit breakers.

For the export market, your product must conform to international and VDE specifications. AIRPAX engineers designed the IPG and SNAPAK to comply with the spacing requirements of VDE 0730, IEC 380, and IEC 435 standards.

You now have the benefits of precision magnetic "stand alone" protection—with choices of handle actuation, colors, illumination, terminals, and hardware. Also, the IPG will mount in any equipment that currently uses the UPG and UPL style breakers.

"Hotline" delivery is assured for prototype requirements. Find out how we can help you meet the challenge of international standards with positive, reliable circuit switching and protection.

Specifications are in our new catalog. Write or call AIRPAX/North American Philips Controls Corp., Cambridge Division, Woods Road, Cambridge, MD 21613, telephone (301) 228-4600.

The Intelligent Choice.



AIRPAX[®]

NORTH AMERICAN PHILIPS CONTROLS CORP

Cambridge Division

New products

Microcomputers & systems

Enhanced OS lets RAM emulate disk

Version of operating system for IBM Personal Computer speeds I/O-intensive tasks

Microsoft, the company that developed the primary disk operating system for IBM's Personal Computer, has come up with an expandable random-access-memory card with a difference: it comes with a modified version of the PC-DOS that allows a portion of main memory to be used as if it were a disk drive. Because programs written in the Personal Computer's Basic language can only use 64-K bytes of the potentially large semiconductor memory as work space, long programs may be forced to keep subroutines and data on disk. Transferring them to and from floppy-disk storage can slow

execution down radically, and this is where the RAMDrive feature of the RAMcard, as it is called, steps in.

"Programs aren't bottlenecked while the disk drive is clicking and whirring," says David Woodruff, product marketing manager. Emulating the disk with the RAMcard achieves much higher input/output rates and is particularly valuable to programs requiring repeated disk access. Large-scale business programs, sophisticated graphics programs, and major development tasks are made feasible.

The card comes in 64-, 128-, 192-, and 256-K-byte configurations ranging in price from \$495 to \$1,095. The smaller versions can be upgraded in \$200 64-K-byte increments. Three cards, placed in any available expansion slots, add up to 576-K bytes of usable memory. Address-decoding switches let the user assemble programs anywhere in the user memory map.

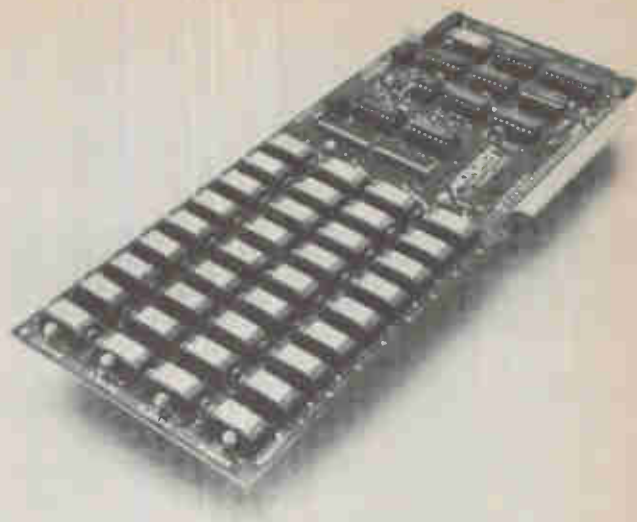

With a utility called Config, the user may assign a disk-drive letter to a portion of the main memory. Another utility, Memtest, can isolate bad memory to the chip level.

The card has odd parity checking and two light-emitting diodes, one indicating that parity checking has been disabled and the other that the board has been selected. The fully loaded card draws 600 mA from the 5-v supply when accessed, 525 mA when idle. It will be available this month at retail stores.

Microsoft Corp., 10700 Northup Way, Bellevue, Wash. 98004. Phone (206) 828-8080 [371]

68000-based unit runs in-house OS

Proprietary operating system is user-friendly, supports body of tested application programs

The Motorola 68000 is fast growing in popularity for small-business systems, and most of the recent 68000-based entries offer system software employing *de facto* industry standards, such as Bell Laboratories' Unix. Alpha Microsystems is taking a different tack with its AM 1000

entry-level system: it has designed the hardware around the 68000 specifically to run the firm's user-friendly AMOS (for Alpha Microsystems operating system).

Implementing the multiuser multitasking operating system and revising the Alphabasic compiler for the generation of 68000 code allows the AM 1000 to run tested application software written during the last five years with a minimum of code modification, says Robert Currier, director, future systems. In addition, users who develop programs on the AM 1000 will be able to maintain them as they move to larger systems. Alpha Microsystems will continue to support the custom central process-

ing unit that it first made available in 1977 even though it is currently updating all its hardware to 68000-based units.

The system is designed for first-time users and comes with a variety of built-in mass-storage options that use the Shugart Associates standard interface. A low-end version will have two 5¼-in. double-density floppy-disk drives, each with an unformatted capacity of 1 megabyte. Another model substitutes a 10-megabyte Winchester disk drive for one of the floppy-disk drives. A third version includes the Winchester drive and an interface that allows the hard disk to be backed up with a video cassette recorder, using a technique unveiled last year [*Electronics*, Nov. 17, 1981, p. 40].

The AM 1000 comes with a maximum of 16-K bytes of read-only memory and a main memory 128- to 512-K bytes in size. Three RS-232-C ports are provided.

Distributor pricing is not yet set

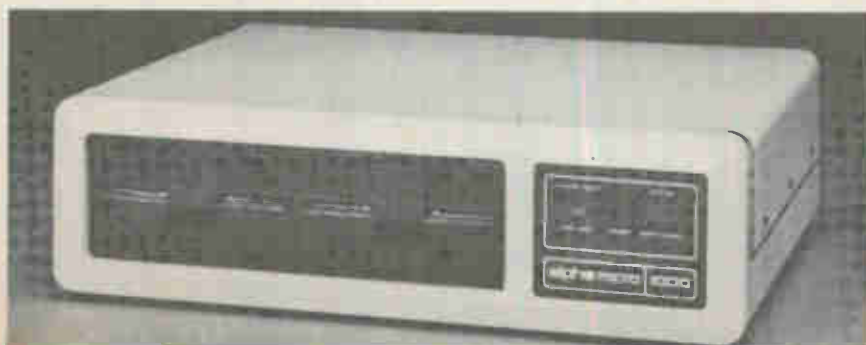

New products

for the AM 1000, but the system will sell to the end user for under \$10,000, the company says. Deliveries are in 30 days.

Alpha Microsystems, 17881 Sky Park North, Irvine, Calif. 92713. Phone (714) 957-1404 [372]

S-100 voice unit lets users vary quality of speech

With its selectable bit rates of 1.25-, 2-, 3-, and 4-k bytes per second of speech, the CompuCorder, an S-100-bus-compatible speech-storage circuit card, lets the user determine the tradeoff between computer memory requirements and speech quality to suit individual applications.

The unit can produce high-quality speech in any language, from any voice, male or female. Vocabulary for the CompuCorder is prepared by the user by simply speaking into a microphone. The voice is digitized using a hardware-based data-compression technique. The resulting speech data is stored in computer memory, then replayed under software control.

When combined with a disk, the unit becomes a high-speed, random-access tape recorder, suitable for applications such as voice store-and-forward systems, paging systems, automatic announcement systems, ham-radio repeaters, and computer-aided instruction.

Available now, the CompuCorder is priced at \$295.

Computalk Consultants, 1730 21st St., Santa Monica, Calif. 90404. Phone (213) 828-6546 [373]

Low-cost video controller is aimed at smart terminals

Built on a 3-by-7-in. iSBX Multimodule board, the iSBX 270 video display controller provides low-cost, eight-color display-terminal control for all 8- or 16-bit Multibus and iSBX-compatible systems.

The board can interface with either color or black and white dis-

play monitors at a 50- or 60-Hz frame rate. Up to 256 characters are contained in erasable programmable read-only memory, reprogrammable by the user for custom applications.

Three types of character font displays are supported by the iSBX 270 in matrixes of seven by nine, five by seven, or six by eight dots. A keyboard and light-pen interface are also on board to simplify the design of intelligent terminals. Rounding out the controller's features are cursor control, reverse video, blinking and underline, and scrolling.

The iSBX 270 contains a software package in its on-board 8741A microcomputer that initializes and monitors the various on-board very large-scale integrated circuits, maintaining constant video display without the intervention of the system's central processing unit. The device is available now for \$750.

Intel Corp., 5200 N. E. Elam Young Parkway, Hillsboro, Ore. 97123. Phone (503) 640-7147 [374]

Boards make IEEE-488 bus respond to serial, parallel data

The models 4825 and 4828 interface cards allow IEEE-488 bus control from any standard serial or 8-bit parallel data source, respectively. Both are Eurocard-sized plug-in boards intended for the original-equipment-manufacturer market.

The 4825 accepts command data in serial format from any RS-232-C or RS-422 serial-data source com-



puter input/output port or modem and interprets it to control IEEE-488 bus operations. The 4828, on the other hand, accepts command data in parallel format from any standard 8-bit Z80- or 8080-type micropro-

cessor bus and interprets that data for bus control.

No special interface software need be written. Each board contains all the logic and intelligence necessary to let it operate as a full-featured controller, and each accepts high-level commands, generating all the control signals and character codes necessary to command bus operations. Each card can address any device connected to the bus as well as transfer data from devices on the bus back to the command source.

In small quantities, the 4825 sells for \$550 each, the 4828 for \$525. Delivery takes 45 days.

ICS Electronics Corp., 1620 Zanker Rd., San Jose, Calif. 95122. Phone (408) 298-4844 [378]

Package brings CP/M to SS50-bus computers

A combination hardware and software package called the Z809 Softboard System enables users of SS50-bus computers to run commercial CP/M application programs. In addition, a large quantity of public-domain software is available from the CP/M User Group.

The Z809 board contains a Z80A microprocessor that runs at 4 MHz when installed on a 2-MHz SS50 system. It will execute Z80 and 8080 object code. Minimum memory requirements are 25-k bytes, but the system can accommodate as much as 56-k bytes. It also supports up to four disk controller boards and up to 16 disk drives.

Included with the Z809 are the CP/M 2.2 operating system, the console command processor, the file manager, and a collection of nonresident commands and utility programs. The Z809 Softboard System, which is to sell for \$595, will be demonstrated at the National Computer Conference next month. In addition to the 50-pin processor board and CP/M, it includes an editor, assembler, and debugger.

Meta Lab, 2888 Bluff St., Suite 106, Box 1559, Boulder, Colo. 80306. Phone (303) 499-4236 [376]

Here's a new line of Miniature ROTARIES PLUS a whole lot more...

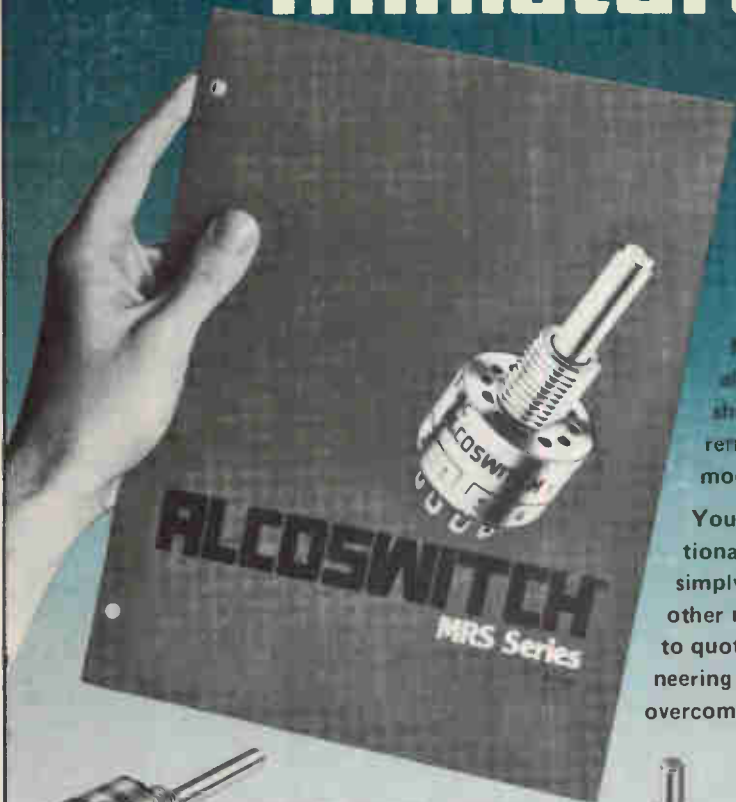

Make ALCOSWITCH your one stop supply source for all miniature rotary switch requirements. The brief list shown will provide an idea as to the extent of our current line. In the works are also many options and custom modifications to meet many of your exact requirements.

You can start by calling ALCOSWITCH and ask for additional information on one or more specific series. Or, simply request a copy of our new catalog which includes other miniature switch products. ALCOSWITCH is prepared to quote on any custom design switch products. Our engineering department is trained to work with your designers to overcome any technical problems or space limitations.

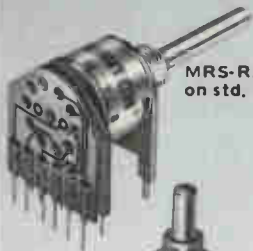

MRS-RA Series right angle mounting on std. 0.1" centers.

MRS Series miniature rotary switches with solder lug or PC terminals. Choice of two shaft lengths, with adjustable stop feature.



MRSB Series is a programmable rotary for PC applications. Terminals are molded in DAP base. Features full environmental seals. Excellent for flow soldering & auto-cleaning.



MRSE Series is splash-proof. Internal & external "O" Ring Seal shaft & or bushing.



MRC Series have adjustable-stops with molded-in terminals.

MRJ Series are PC rotaries with maximum positions in minimum space, 30° index.



Command Series selector switch offers 1 amp rating @ 125 VAC, 2 or 3 positions.

MRJE Series have splashproof seal on shaft & bushing for added protection.



MRCE Series feature splashproof "O" Ring Seals between the bushing, shaft & panel.

DRS Series dual-in-line mounting. Available as BCD or 1, 2 or 3 pole 4, 6, or 12 positions.

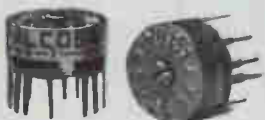

MRJB Series has screwdriver slot adjustment. All MRJ versions are break-before-make.

AUGAT® **ALCOSWITCH®**
QUALITY AND INNOVATION

ALCO ELECTRONIC PRODUCTS, INC.
1551 Osgood Street, North Andover, MA 01845 USA Tel: 617/685-4371

Canada: Augat Electronics Inc., Suite 103, 6205 Airport Rd., Mississauga, Ontario, Canada, L4V 1E1
Europe: Augat France SA (Z.I. Sofilic) B.P. 440-CEDEX 94263 Fresnes, France

"Of course we advertise..."

Many electronics executives do not have good, sharply-focused, measurable objectives for their advertising. This general aimlessness is perhaps the biggest single cause of wasted advertising dollars.

The purpose of this ad is to remind you that advertising is too efficient and powerful to be thrown away on vague objectives. Only you can set the specific tasks that will make your advertising investments pay off, but we hope this ad will serve you as a general checklist of possibilities.

1. Market coverage and brand recognition.

They can't buy from you if they don't know about you. Conversely, the more people who recognize you as a competent supplier, the more companies you will be able to sell to. It is beyond controversy that brand recognition and brand preference are the essential predecessors of sales. It is also beyond controversy that the only efficient tool for establishing broad market recognition is publication advertising. The Electronics Technology Market is getting bigger and broader, and the only way to cover it is to advertise. Don't fall into the trap of believing that the market knows you and is thinking about you. Research will tell you how much recognition you have now. Decide how much more you want, set that increase as the objective for your advertising, invest to achieve it, and measure the return on that investment.

2. Positioning.

Positioning is simply deciding what you most want the market to remember about your company and its products, and then saying those

things in your advertising. Do you want to be remembered most for quality, value, low price, service, dependability, research, technology, software support, delivery, or something else? Whatever you select, a good positioning statement can be very powerful. It can make your company easy or safe to buy from. It can preempt your competitors, forcing them into a "me too" position. Research can help guide you to the selection of the optimum available "position" and can measure your progress through the years as you advertise to make that position stick in the marketplace.

3. Ride the trends.

This is a flexible form of positioning. You figure out how your product or service offerings tie in with current market trends and then advertise to put those tie-ins into the prospect's mind. For example, you advertise to show how your products can contribute to microprocessor-based systems, or how they can increase productivity, or how reliable they are in under-the-hood environments. The important technology and market trends are there for all to see.

4. Reach unknown or inaccessible buying influences.

Traditionally, advertising has been seen as a sales support function — "calling on" customers when the salesman is calling someplace else. Electronics technology purchases have become more complex and more critical. The buying decisions have moved up in the organizational hierarchy where the salesman has difficulty making calls. As you define your market coverage objectives,

but I'm not sure why."

make sure your advertising is reaching the important people your salesmen cannot see. Make sure your message is of interest to these kinds of people. If it is, *they will reach you*—even if your salesmen cannot reach them.

5. Product differentiation.

When your products are viewed as commodities, price and availability become your only real competitive weapons. And your profit margins are under constant pressure. The only way out of this "commodity trap" is to differentiate your products from those of your competitors. Pick some product differences and drive them home in your advertising. There almost always are saleable differences in apparently identical products. If there aren't any in yours, *don't advertise*. Save the money and put it into price and inventory for quick delivery.

6. Increase or maintain market share.

If you already have a good share of market and are willing to keep building brand recognition and preference, advertising will make it awfully tough for your competitors to make a run at you. The important thing is to do the research to learn what your share of recognition and share of preference are. Then invest whatever advertising is required to maintain or increase the lead over your competitors. There's also a message here for market trailers: If old number one in your market is letting his advertising slip, your advertising will help you close that gap faster than any other investment you can make.

7. Increase market size.

Suppose you already have the lion's share of a product market? Your strategy as the dominant supplier should be to increase the market size. Maybe this means going into new geographical areas where you have not competed before, like Japan, South America, Eastern and Western Europe, Australia, or Israel. Or maybe it means creating new applications for your products. Advertising worldwide in an international magazine will pave the way.

The surest way to expand a market is to educate potential customers. The surest medium of product education is advertising.

8. Sponsor change.

Change is what creates sales opportunity—change gives you the chance to get business you don't presently have.

Use your advertising to sponsor change. Show the prospect how your product will improve his system, cut his costs, increase his own sales, lower his inventories, let him extend his warranties. Become known as the supplier who can deal with change. Then, when your customers need a change, they'll come to you.

9. Control your message.

Good publications won't let you manage or control the news in their editorial columns, but you can do it in your advertising pages. Advertising is an ideal "announcement" medium. You can tell your story to the whole

worldwide market, at one time, and in your own words, for very modest expense. When you have something to announce, advertise. Then set up a system to measure how the message got across.

10. Make the customer ask.

How many times have you seen a salesman hand a prospect a sample, or a brochure, or something else that the prospect had not yet requested? This is a faulty selling technique. The sample will only be meaningful to the prospect if the prospect wants it. The salesman should make the prospect ask for something. Your advertising can make the prospect ask. Use advertising to get the prospect to request a sample or demonstration. Then the sample or demo will mean something to him and will be more likely to lead to a sale.

11. What about media?

Now that you have good advertisements based on objectives that you can measure—run them in *Electronics*. It's read by important people all around the world, and most read only *Electronics*. In fact, more important people keep ahead of technology and business developments with *Electronics* than any other magazine—331,072 to be exact. Your share of market will grow with your advertising in *Electronics*.

Electronics

Where important people
read important editorial 

This is the second in a series of advertisements on important marketing and advertising objectives for the 1980's. Your comments are welcome.
Electronics Magazine, 1221 Avenue of the Americas, New York, N.Y. 10020

The TRE 800SLR wafer stepper[™] has proven that there are no alternatives to its superiority! Here's why..

Industry's highest wafer throughput

The TRE 800SLR Wafer Stepper has the highest demonstrable throughput of any stepper on a production floor today. At 0.2 micron and 2σ registration, the 800SLR provides a guaranteed global throughput of 55 wafers per hour on 4" wafers, on a 10X configuration. The 5X provides a guaranteed global throughput of 90 wafers per hour on 4" wafers.

Ask the competition to demonstrate comparable figures; TRE's throughput can't be beaten.

Machine interchangeability— a new industry standard

TRE Semi manufactures all their steppers to a factory standard of $\pm 0.3 \mu\text{m}$ and uses system characterization software to monitor their performance.

There's nothing else like it. In less than 20 minutes, 484 location points per wafer are calibrated and the data reduced and presented in a numerical and graphic printout.

This production line characterization technique has set the standard for the industry. It should be setting the standards for your production floor.

Industry's most advanced stepper

The TRE 800SLR Stepper is the technological leader; the industry's most advanced, fully-automated system.

It's features include:

- automatic field-by-field alignment
- automatic reticle changing, alignment and masking
- automatic wafer handling (3", 4" and 5")
- automatic reticle-to-wafer alignment
- automatic wafer alignment in less than 0.25 second with 0.2 micron precision at 2σ
- built-in environmental control

Maximum yields through automatic alignment

The TRE 800SLR stepper system uses the industry's state-of-the-art automatic wafer-to-reticle alignment system which eliminates the effects of wafer distortion and continental drift errors introduced through the IC manufacturing process.

This results in increased yield, providing more net good die per hour than any other system.

The sensitivity of the system guarantees fast precision overlays on each chip level within $0.2 \mu\text{m}$ at 2σ and is capable of aligning to a target in the first level oxide through all subsequent layers. This is not compromised by different resists, surfaces, or topographies. The benefits are substantially increased yield, chip reliability and tighter design rules.

TRE technology— your competitive edge in IC production

TRE Semi has pioneered many firsts in microlithography. Like vacuum air bearings. And the laser-controlled stage. Environmental chambers. Computer control. Automatic air gauge focus. Automatic reticle align. Criss cross. Automatic reticle and wafer handling. And automatic die-by-die alignment.

And we originated the concept of interchangeable lens systems which permit the user to alter his machine configuration to address his product mix without additional capital expenditures.

TRE Semi's present 24-hour-interchangeable 5X/10X system configurations are the continuation of this company philosophy... and the prelude of technologies to come.

What other stepper companies have only been promising for the last two years, TRE Semi delivers. Today.

Industry's highest uptime record

With TRE 800SLR steppers, it's a field-proven fact that when our systems come up, they stay up, consistently registering 95+% uptime.

And they're up, because we build them that way. TRE Semi is the only stepper manufacturer who does a full three weeks of reliability testing prior to source inspection. So any problems are found in our factory, not on your production floor.

Plus, we ship fully-assembled systems. So they're shooting wafers within 8 hours of applying power in 90% of the installations. Shipping sub-assemblies in boxes like some manufacturers do, virtually guarantees problems.

Cost-effective production requires reliability. Our reliability is built in, not serviced in.

TRE worldwide service and support

TRE Semi has the industry's highest commitment to service and support. No other stepper manufacturer can top the breadth of experience or manpower put behind every system we build.

- 4-Hour Response Time—Internationally, within 24 hours.
- 24-Hour Hotline—(800) 423-5327; in CA, (800) 382-3373.
- 14 Service Centers—on three continents with fully-trained, experienced field engineers.
- Process Engineers—with extensive resist background and fab line experience.
- Development Lab—supports production and is open to customers.

**We'll demonstrate
the difference!**

TRE Semiconductor
Equipment
Corporation

6109 De Soto Ave., Woodland Hills, CA 91367 (213) 884-5050

2 and 4 Avenue de l'Europe, 78140 Velizy, France 946-59-58

Radix House, Central Trading Estate, Staines, Middlesex, England 44-784-51444

TEL, 1-26-2 Nishi-Shinjuku, Shinjuku-ku, Tokyo 160, Japan 03-343-4411

Industrial

STD-bus chassis holds disk drives

13-slot chassis carries four-output switching supply, two 1.6-megabyte drives

More than 50 manufacturers are now creating function cards for the STD bus, but the original-equipment manufacturer who wishes to integrate all this functionality into systems has had to supply his own chassis or select Pro-Log's model 701, a 12- or 21-slot card cage with a linear power supply. Pro-Log's latest addition to the STD-bus effort goes the model 701 one better in making systems easier to integrate.

Model 702 improves upon model 701 by using a four-voltage switching power supply and adding two thin-line 8-in. double-sided double-density floppy-disk drives to a chassis with 13 slots on 1/2-in centers. "Users previously either had to buy two separate boxes to get a mass-storage STD-bus system, or they had to design their own package," notes Charles Cech, Pro-Log's director of product marketing.

The thin-line floppy drives have capacities of 1.6 megabytes each and are made by Tandon Magnetics and an as-yet unnamed second source. The drives are guaranteed for one year, and the remainder of the 702 carries a two-year guarantee. The all-metal model 702 uses forced-air cooling and meets Federal Communications Commission and Underwriters' Laboratories requirements. It fits into a standard 19-in. rack, with optional side and top panels for forming a tabletop unit. The 702 will be priced at about \$5,000, and it will be available in September.

A full deck. According to Pro-Log president Edward Lee, the total market for STD cards alone is now about \$50 million. "That figure doesn't include the STD cards that users have manufactured for themselves," notes

Lee. The STD bus has caught on primarily in industrial control and instrumentation applications. Such systems are also used in telecommunications, medical applications, traffic control, oil exploration and logging, and elevator control.

"The STD bus is now over 20% of the industrial pc-card marketplace," observes Lee. It is basically an 8-bit microcomputer bus, as evidenced by the availability of STD central-processing-unit cards containing all 6800 family members, as well as the Z80, 8080, 8085, 8088, RCA's 1802, and National Semiconductor's NSC 800. The STD function cards also include disk controllers, random-access memory, and input/output cards among the primary functions.

The three types of dc power made available to bus cards by the 702's switching power supply include +5 v at 15 A, +12 v at 5 A, and -12 v at 1.5 A. Its rear-panel controls include an ac power switch, two switched auxiliary outlets and a power-line filter. The dimensions of the system, either rack-mounting or tabletop, are 22 by 19 by 7 in., and the unit weighs 46 lb. The front panel can tilt down 180°, or it can be removed by activating two spring-loaded pins. A 3-in. space between the front panel and card cage allows components to be mounted on the panel and cables to be connected to the front of the STD-bus cards.

Pro-Log Corp., 2411 Garden Rd., Monterey, Calif. 93940. Phone (408) 372-4593 [411]

Meter measures fluid flow using ultrasonic transducers

The Sonic-1010 velocity-averaging ultrasonic flowmeter uses the Doppler effect to measure the flow of a fluid in a pipe. A transmitting

transducer injects an ultrasonic signal into the pipe; shifts in the frequency of the signal reaching the receiving transducer are translated into a flow rate indicated on a meter and by a linear 4-to-20-mA current-loop output. Measurement repeatability is better than 1% of full scale.

The non-invasive twin-transducer design works with most pipe materials and measures the flow of slurry-like fluids, among others. The unit's nickel-plated aluminum sensors operate at -20° to +130°C, and the instrument itself operates at 0° to 70°C. Its electronics are on epoxy-coated modules with gold-plated contacts. Dual-alarm and integrating totalizing modules can be installed in the field.

The Sonic-1010 flowmeter comes in a 12-by-10-by-5-in. steel case and runs from a 120-v 60-Hz line. The basic unit is warranted for five years and priced at \$2,400. Quantity discounts are available, and delivery is immediate.

Pacific Meter Inc., P. O. Box 1011, Station A, Delta, B. C. V4M 3T2, Canada. Phone (604) 943-8315 [416]

P. O. Box 145, Point Roberts, Wash. 98281 [417]

Solar panel produces power for remote installations

Photowatt International has introduced the largest silicon cell in a solar panel to date. Designed to produce electricity economically for remote industrial applications, the model ML7010 solar panel consists of 36 5-in.-diameter silicon cells that will produce 55 w peak under optimum conditions (3.3 A at 16.5 v).

The cells can be wired in either series or parallel to meet specific voltage requirements. Some of the applications powered by the panel include navigational aids for off-shore platforms and buoys, railroad signaling, remote communications, telemetry, and pumping stations.

The ML7010 sells from stock for \$575 in small lots.

Photowatt International Inc., 2414 West 14th St., Tempe, Ariz. 85281 [415]

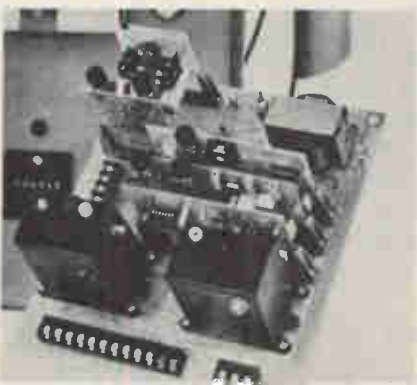

New products

Software

Spread sheet is large, versatile

Financial modeling package for Prime computers accepts initial input from data base

A versatile financial-modeling package called Cybil is available from Software Management Systems to run on Prime Information systems. It is a spread sheet program set up to perform profit and loss analysis and forecasting, cost studies, market planning and sales forecasting, tax planning, and cash-flow management. Up to 702 columns and any number of rows can be maintained.

Paging, scrolling, and moves to a specific location are possible with positioning commands. Columns and rows can be inserted, copied, and deleted; column width and the number of decimal places displayed can be changed. A spread sheet can be initialized from a data base using English-like sentence fragments that invoke any number of files and attributes. Status lines display the current location's definition and position, calculation mode, and whether recalculation is required.

Cybil prints out a report using any number of columns or rows. A spread sheet may be saved on disk under a user-assigned name. Time, date, and the name of the user saving it are recorded, and it can be protected against overwriting.

Calculations can be done automatically, or external Basic subroutines can be called for complex custom calculations. In addition to standard arithmetic, transcendental algebraic and trigonometric functions are included; the program computes averages, maximums and minimums, and the results of relational expressions. Cybil's price is \$5,000; the program is available now.

Software Management Systems, 84 Inverness Circle East, Englewood, Colo. 80122. Phone (303) 741-3179 [361]

UCSD p-System runs on Altos hardware

A multiuser UCSD p-System, a program-development and execution-environment aid, is now available for the Altos 5 $\frac{1}{4}$ -, 8-, and 14-in. Winchester-disk microcomputer systems. This package is compatible with the UCSD p-System and provides it with full output support, including a high-speed interpreter, buffered disk, and input/output terminal.

The UCSD p-System can handle up to four terminals and three printers simultaneously and will also run existing single-user programs without modifications. Full memory is available for each user with a random-access-memory disk. In addition, the system offers hard-disk mapping and user privacy protection with interuser communication and resource sharing. With an automatic-start utility, the system can be easily installed.

Future enhancements for the version IV.0 package include networking, data communication, extended memory support for large code pools, and extended filing systems. Single system costs are \$495 for a turnkey implementation and \$925 for full-system implementation.

Dynamic Control Systems, 13662 104A Ave., Surrey, B. C. V3T 1Y8, Canada. Phone (604) 585-0655 [363]

Spelling checker proofs

10,000 words in under 2 min

A tool appreciated by writers, editors, and business people that can not only proofread 10,000 words of text in less than 2 minutes but can automatically correct any errors found throughout the entire document is Word Plus. In addition, Word Plus will visually display the misspelled word and will look up possible correct spellings of the word it has found in its 45,000-word literal vocabulary.

An enhanced version of a spelling checker called the Word, Word Plus includes programs that will automatically hyphenate words within the text, tell not only how many words there are in a given text, but also how many different words there are, what they are, and how many times each was used. Also, it will help locate rhyming words and solves crossword puzzles and anagrams.

Word Plus is compatible with almost every CP/M editor commercially available and will run under CP/M 1.4 and 2.2, CDOS, and others. It comes in a variety of formats including 8-in. single-density; 5 $\frac{1}{4}$ -in. double-density for North Star, Superbrain, and Osborne; and 5 $\frac{1}{4}$ -in. single-density for Apple CP/M and Osborne. Complete with a 50-page instruction manual, Word Plus is

available for immediate delivery at a price of \$150.

Oasis Systems, 2765 Reynard Way, San Diego, Calif. 92103. Phone (714) 291-9489 [368]

Ada-to-Pascal translator aids in learning Ada

Available now from SofTech is an Ada-to-Pascal source-to-source translation tool that also enables the programmer to gain experience with Ada. Designed to be used in the interim until production of the company's Ada compilers and related tools are available, the translation tool recognizes and translates features from the Pascal subset of Ada into the VAX/VMS version of standard Pascal.

The translator includes a standard 9-track tape with the translator's Digital Equipment Corp. Pascal source code, VMS command files for compiling and using the translator, and an installation verification program. It is currently available for the VAX-11/780 and -11/750.

This package is available for a one-time license fee of \$4,000 for each central processing unit. Delivery takes 15 days after receipt of a completed license agreement.

SofTech Inc., Ada Products Manager, 460 Totten Pond Rd., Waltham, Mass. 02154. Phone (617) 890-6900 [366]



SUWA SEIKOSHA

A Specialist in CMOS LSI

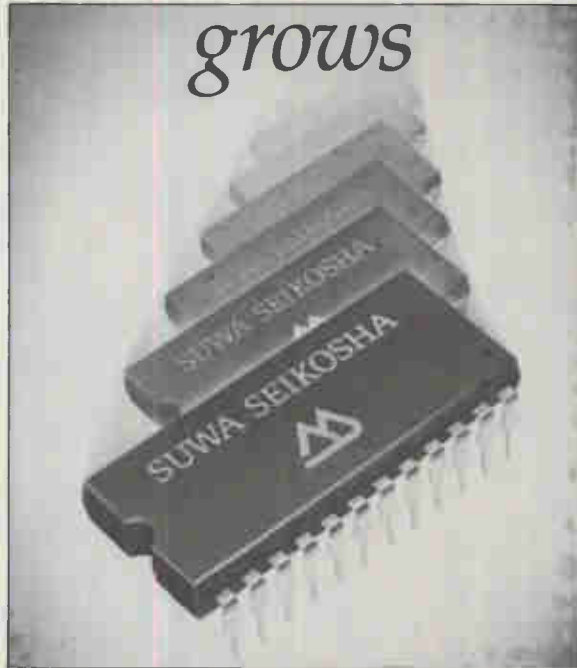

Suwa Seikosha, a major manufacturer of the famous SEIKO watches, is now producing new Static RAMs, Mask ROMs, Microcomputers, Voice Synthesizers and a host of other new products not yet released. As a pioneer of quartz watch technology, the company consistently developed and manufactured its own miniature electronic parts and IC's. Now a recognized specialist in the broad field of CMOS LSI, Suwa Seikosha is working aggressively to extend its

position as a major-source supplier of Microcomputer Chips, Memories, Time Standard ICs, Voice Synthesizers, LCD Drivers, CMOS LSIs for Watches and Clocks, and Custom LSIs. OEMs are invited to contact Suwa Seikosha regarding new or existing products in these fields. Further-

more, inquiries are solicited regarding requirements in other fields that might benefit from Suwa Seikosha's most-advanced CMOS LSI technology. *Suwa Seikosha is a growing specialist in CMOS LSI.*

CMOS LSI FOR USE IN LOW POWER SYSTEMS

- | | | | |
|---|---|---|--|
| <ul style="list-style-type: none"> • STATIC RAM SRM 2016 (2k×8) SRM 2017 (2k×8) SRM 2018 (2k×8) SRM 2114 (1k×4) SRM 6504 (4k×1) SRM 6514 (1k×4) | <ul style="list-style-type: none"> • MASK ROM SMM 2364 (8k×8) SMM 2365 (8k×8) SMM 2325 (32k×8) SMM 2326 (32k×8) | <ul style="list-style-type: none"> • MICROCOMPUTER SMC 1102, SMC 1112
(one chip 4-bit Micro-computer, built-in Driver) | <ul style="list-style-type: none"> • MELODY IC 7910 7920 7930 SVM 7940 SVM 7950 SVM 7970 SVM 7990 |
| <ul style="list-style-type: none"> • VOICE SYNTHESIZER SVM 9300 | <ul style="list-style-type: none"> • LCD DRIVER | <ul style="list-style-type: none"> • TIME STANDARD IC (Programmable Clock Pulse Generator) 8640 8650 8651 | <ul style="list-style-type: none"> • HIGHLY COMPACT MELODY MODULE SEK7 Series |
| | <ul style="list-style-type: none"> • CMOS LSI for Watch and Clock | | |
| | <ul style="list-style-type: none"> • CUSTOM LSIs | | |

Semiconductor Operation Division (Fujimi Plant)
281, Fujimi, Fujimi-machi, Suwa-gun, Nagano-ken,
399-02 JAPAN
Phone: (02666) 2-4112 Telex: 3362-432 S SEIKF I
Fax: UF520 III (02666)2-5393

SUWA SEIKOSHA CO., LTD.

SUBSIDIARIES

Epson America, Inc.
Semiconductor Marketing
3415 Kashiwa St.
Torrance, CA 90505 U.S.A.
Phone (213) 534-0360
Telex (230) 182412

Epson U.K. Ltd.
Sherwood House
176 Northolt Road
South Harrow, HA2 OEB, U.K.
Phone 01-422-5612 Telex (51)8814169

Epson Electronics Trading Ltd.
Tsim Sha Tsui Centre, Room 411
East Wing No. 6
Ching Yee Road, Tsim Sha Tsui,
Kowloon, Hong Kong
Phone 3-694343/4 Telex (802)64714

AUTHORIZED AGENTS

W. Moor AG
8105 Regensdorf-Zurich
Bahnstrasse 58, Switzerland
Phone 01-840-6644 Telex (45)52042

W. Moor GmbH
1150 Wein XV
Stochengasse 1/1/1, Austria
Phone 0222-858646
Telex 135701

Technoprojekt GmbH
Heinrich-Baumann-STR 30
7000 Stuttgart
West Germany
Phone 0711-561712 Telex 721437

Charming Industrial Co., Ltd.
51-5 Sec. 2, Chang Ar Road, East
Taipei 104, Taiwan, R.O.C.
Phone 02-522-1566
Telex 22279

For timeless architecture... the R6500/1.

Build in Rockwell's proven microcomputer family. And build out business risks.

When you take advantage of the computer history lessons we've learned, you'll find you're managing your business risks better.

Get off the instruction-set treadmill.

At Rockwell, we think systems, not just devices. That's why we made the R6500/1 truly object-code compatible throughout the family, along with its well-established predecessors. And we've maintained architectural compatibility with our powerful new 16-bit microprocessor, the R68000.

Get high performance through "less time" architecture.

The real measure of data throughput is the time it takes to execute an instruction. That we deliver in 1 μ sec at 4 MHz. While others push all the way up to 11 MHz trying, we haven't even begun to crank up the clock.

And you get this performance distilled onto one remarkable chip. One that offers the industry's smallest and fastest CPU, On-board RAM and ROM. Thirty-two I/O ports. And the most versatile counter/timer made to date. Plus the R6500/1 family offers virtually endless expansion opportunities with low-cost peripheral chips—the most complete family in the business.

Minimize your costs and time-to-market.

The real power of our 8- and 16-bit families lies in the fact that their efficiency and design capabilities are

intended for your convenience, not ours. This makes them easy to learn and easy to use, allowing you to get your product to market faster—without destroying your investment in training and software.

Your investment in development support can be minimal, too. Let us show you how to utilize your current development system to design the R6500/1 into your product. Or, we can supply a complete set of economical support tools and application aids. Even applications engineers, if you need them.

Build timeless reliability into your designs.

Best of all, Rockwell's microprocessors have a history of high-volume, high-reliability use. That means the R6500/1 will be manufactured and delivered on time. And in the quantities you need.

So before you commit to a part for your next generation product, look at the only one that will endure the test of time—the R6500/1. Call Rockwell at (714) 632-3698. For complete technical literature, call (800) 854-8099, or (800) 422-4230 in California. In Europe, telex 0571/2650. In the Far East, telex J22198.



Rockwell International
...where science gets down to business

Circle 230 on reader service card

Instruments

Smart recorder calibrates itself

Microprocessor in recorder equalizes and calibrates it for a wide range of tasks

For its reentry into the market of wideband instrumentation recorders, Racal Recorders Ltd. is introducing a high-performance 42-track tape recorder that sets itself up. Calibration and equalization tasks are assigned to a microprocessor, thus reducing an operation that can take several hours to about three minutes. The microprocessor also drives a small built-in cathode-ray-tube display through which matching characteristics and recorder performance can be monitored.

Racal has set out to cover the widest market spectrum possible with a single multipurpose chassis. It is useful in applications representing 28% of the total world recorder market, says David Kempson, managing director of Racal. Storehorse, as it is called, can be used in any combination of the three standard data record-replay formats: direct recording, frequency modulation, and high-density digital-data recording.

The machine works with 1/2- or 1-in. tapes. A user can start small with a 14-track intermediate-frequency-band recorder. Subsequently he can change heads and add a signal board for a 28-track wideband recorder. Expanding to a full 42 tracks, however, requires the addition of an external clip-on housing.

Marketing gamble. The firm's bid to squeeze a laboratory-style data recorder into a portable package is a marketing gamble. Usually laboratory-performance instruments are large rack-mounted affairs with coplanar tape transports. But the company has managed to keep Storehorse lean—it weighs around 100 lb and can be transported by a car.

For compactness, a coaxial-spool

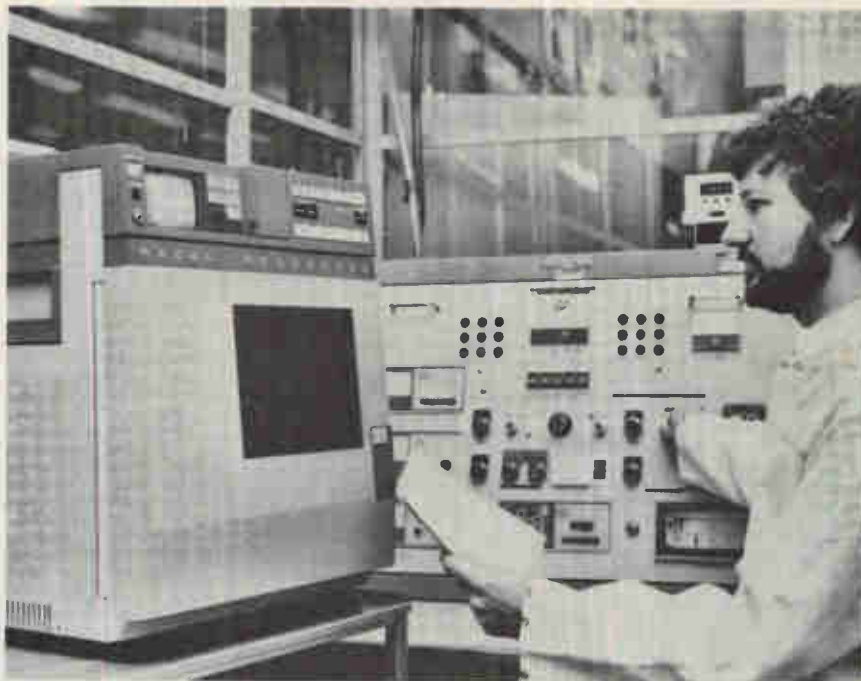

layout has been adopted. This arrangement puts one 15-in. spool behind another but may be harder on the tape than the usual coplanar feed, argue competitors. Users, they claim, may wish to use a lighter 14-track recorder, playing the tape back later on a laboratory machine.

The extensive use of microprocessor technology eases the construction and increases the reliability of recorders by permitting the elimination of the usual arrays of potentiometers. Also new is the use of a digital tracking filter. Changing tape playback speed can alter the apparent signal frequency, so ideally any filter in the playback chain should track the tape speed, adjusting its filter characteristics accordingly.

Use of such a tracking filter allows Racal to offer many tape speeds without additional complexity or compromise in performance. For example, the tape speed is adjustable from 15/32 in./s to 120 in./s. In many recorders, speeds can be incremented by a factor of two, but in the Racal recorder there is also a facility for dividing tape speed by 6, 10, or 60. This feature is extremely valuable for minutes-to-seconds time compression or expansion.

Racal uses a microprocessor to calibrate the recording circuitry for

biasing and recording level and to equalize the replay circuitry across its full bandwidth. Equalization of the replay circuitry is performed using test signals laid down as a preamble when the tape is recorded. Storehorse records these signals automatically. When used as a playback machine for tapes recorded on other machines, these signals are not available, but the company is also offering an accessory that will allow any of its instrumentation recording systems to lay down the necessary preamble signals.

The microprocessor and cathode-ray-tube display monitors the system for fault analysis or diagnosis. For example, all input or output channels can be monitored simultaneously on a bar-graph display. By switching between inputs and outputs, the user can look for any channel that is not functioning correctly. Signal overload is indicated whenever the input or output channel exceeds defined limits.

Other display pages indicate tape position as well as attenuator settings, machine status, trace sequence, tape shuttle, and an index of stored calibration settings. In the event of a system fault during power up or tape loading, a full page will interrupt the display to indicate the



Now, you can draw on NCR's semiconductor experience – coast to coast and year after year. Consider the facts.

1. NCR pioneered MNOS and, now, SNOS

With twenty-one MNOS patents since 1972, NCR has designed and developed seventeen non-volatile memory devices. From our MNOS products to our exciting new n-channel SNOS (Silicon Nitride Oxide Silicon) 4K NV-RAM, you can count on NCR innovation. And our 5V-only SNOS E²PROMs are coming soon (see memory guide).

2. We're in the merchant market to stay

NCR's commitment to the merchant market is long term. We're spending \$155 million on the expansion of existing chip making facilities. That's because we're thinking about the future—as you are—and preparing for it.



3. Experienced technical representatives coast to coast

Over one hundred representatives in North America are trained and ready to support your requirements—from technical applications to prompt customer service. Of course, they're backed by NCR Microelectronics expertise if and when needed.

4. NCR semiconductors—quality you can count on

Our ten years of experience as a manufacturer of semiconductors has taught us quality and reliability are essential elements of any chip. It's no

wonder we're one of the world's leading manufacturers of MNOS non-volatile memories.

NCR—NV MEMORY GUIDE

Device No	Organization	Type
2051	32x16	WAROM
2055	64x8	WAROM
7033	21x16	WAROM
1400	100x14	WAROM
3400	1024x4	WAROM
2811	2048x4	EAROM
2168	2048x8	EAROM
2161	2048x8	WAROM
4485	512x8	NVRAM
52801*	16x16	E ² PROM
52817*	2048x8	E ² PROM
52832*	4096x8	E ² PROM

*Industrial and Military temperature ranges available
Future product

For more information, call your local NCR Microelectronics representative. Or contact Dave Major at NCR Microelectronics Division, Box 606, Dayton, Ohio 45401. Our toll free number is (800) 543-5618, in Ohio (513) 866-7217.

NCR
Microelectronics Division

NCR Microelectronics Technical Representatives

- 1a N.R. Schultz Company
Bellevue, WA 206/454-0300
- 1b N.R. Schultz Company
Beaverton, OR 503/643-1644
- 1c N.R. Schultz Company
Boise, ID 208/377-8686
- 2 Costar, Inc.
Cupertino, CA 408/446-9339
- 3a Orion Sales, Inc.
Glendale, CA 213/240-3151
- 3b Orion Sales, Inc.
Tustin, CA 714/832-9687
- 4 Wescom Marketing, Inc.
Broomfield, CO 303/465-2234
- 5 B.H.&B. Sales, Inc.
Phoenix, AZ 602/269-7069
- 6a Oeler & Menelaides, Inc.
Dallas, TX 214/361-8876
- 6b Oeler & Menelaides, Inc.
Houston, TX 713/772-0730
- 6c Oeler & Menelaides, Inc.
Austin, TX 512/453-0275
- 7a Electronic Marketing Associates, Inc.
Atlanta, GA 404/448-1215
- 7b Electronic Marketing Associates, Inc.
Huntsville, AL 205/837-7363
- 8a Hutto-Hawkins-Peregoy, Inc.
Maitland, FL 305/831-2474
- 8b Hutto-Hawkins-Peregoy, Inc.
Fort Lauderdale, FL 305/971-5750
- 8c Hutto-Hawkins-Peregoy, Inc.
Clearwater, FL 813/797-4447
- 9a Zucker Associates, Inc.
Raleigh, NC 919/782-8433
- 9b Component Sales, Inc.
Baltimore, MD 301/484-3647
- 9c Component Sales, Inc.
Richmond, VA 804/270-9470
- 10a Rich Electronic Marketing, Inc.
Carmel, IN 317/844-8462
- 10b Rich Electronic Marketing, Inc.
Fort Wayne, IN 219/432-5553
- 10c Rich Electronic Marketing, Inc.
Louisville, KY 502/499-7808
- 10d Rich Electronic Marketing, Inc.
Dayton, OH 513/237-9422
- 10e Rich Electronic Marketing, Inc.
Cleveland, OH 216/468-0583
- 11a Rush & West Associates, Inc.
Olathe, KS 913/764-2700
- 11b Rush & West Associates, Inc.
Ballwin, MO 314/394-7271
- 12 Sieger Associates
Bloomington, MN 612/884-7788
- 13 Sieger Associates
Rolling Meadows, IL 312/991-6161
- 14a Precision Sales Company
Liverpool, NY 315/451-3480
- 14b Precision Sales Company
Pittsford, NY 716/381-2820
- 14c Precision Sales Company
Binghamton, NY 607/648-8833
- 14d Precision Sales Company
Pleasant Valley, NY 914/635-3233
- 15 REP Associates Corporation
Marion, IA 319/393-0231
- 16 Tritex Sales, Inc.
Haddonfield, NJ 609/429-1551
- 17 Tri-Tek Associates
Wantagh, NY 516/221-7600
- 18a New England Technical Sales
Corporation
Burlington, MA 617/272-0434
- 18b New England Technical Sales
Corporation
Menden, CT 203/237-8827
- 18c Nets Limited
Malahide Co. Dublin
Republic of Ireland 450-635
- 19a Cantec Representatives, Inc.
Ottawa, Ontario, Canada
613/725-3704
- 19b Cantec Representatives, Inc.
Brampton, Ontario, Canada
416/791-5922
- 19c Cantec Representatives, Inc.
Quebec, Canada 514/683-6131
- 20 Enco Marketing, Inc.
Bloomfield Hills, MI 313/642-0203
- 21 Rocky Mountain High, Inc.
Albuquerque, NM 505/292-3360

New products

type of fault and its location.

In the direct-recording mode, Storehorse can operate in an intermediate frequency band to 600 kHz and in the wideband mode to 2 MHz. Fm recording covers an intermediate frequency band to 40 kHz and wideband to either 80 or 500 kHz. High-density digital-data recording is at up to 36,000 b/in. using delay modulation, biphasic L or nonreturn-to-zero codes.

Racal Recorders Ltd., Hythe, Southampton, Hants. S04 6ZH, England. Phone 0703-843265 [359]

Racal Recorders Inc., 3830 Bee Ridge Rd., Suite 100, Sarasota, Fla. 33583. Phone (813) 921-6662 [360]

Four-channel analyzer superimposes waveforms

Contained in a 25-lb package, the Smartscope II is an integrated hardware-software system with built-in disk storage for waveform analysis of time- and frequency-domain data. The unit uses a 16-bit microprocessor and is a complete system for the acquisition, storage, analysis, processing, and display of waveforms.

For ease of use, front-panel knobs,



controls, and switches have been replaced by a calculator-style keypad. Menu selections and screen prompts aid in the unit's use. Every function is programmable and the test setups and programs can be stored on disk.

Models come with two or four independent channels of acquisition, with or without signal averaging, with up to a 500,000 Hz sampling rate, a 12-bit resolution, and sweep

times as slow as 1,500 s/point. Users can display up to four channels on the screen with up to four waveforms superimposed per channel. Included are IEEE-488 and RS-232-C interface ports.

Prices start at \$10,500, with delivery taking 30 days.

T. G. Branden Corp., 5565 Southeast International Way, Portland, Ore. 97222. Phone (503) 659-9366 [354]

VLSI test system

operates at up to 60 MHz

Production testing, inspection, and quality assurance may be had with the series 21, a general-purpose very large-scale integrated-circuit test system. It has an accuracy of 1 ns (500 ps for inputs and 500 ps for outputs), offers test rates of up to 40 MHz in a variety of pin counts, and has automatic timing deskewing and calibration.

The system's automatic deskew feature uses programmable hybrid delay lines for automatic adjustment for any combination of timing generators and pins. A deskew load board, containing a 50-Ω matrix, allows the series 21 to be automatically calibrated in less than 15 minutes. It is available with high-speed or -voltage test heads with 60, 90, or 120 pins and uses 10K and 100K emitter-coupled logic throughout all formats, timing paths, pipelines, and local memory sections.

The series 21 has a free-running clock that is used for asynchronous testing and allows the user to force clock bursts out to the device under test at frequencies up to 60 MHz. Because it uses the same operating system as the rest of Fairchild's general-purpose LSI testers, the operator can use the company's library of utility and device programs. It is available with a variety of options to further enhance its capabilities.

The series 21 base configuration is priced around \$450,000 with delivery taking 120 days.

Fairchild, Test Systems Group, 1601 Technology Dr., San Jose, Calif. 95110. Phone (408) 998-0213 [356]

The designers' choice for MULTIBUS compatible data acquisition systems.

The ADAC 700 series of data acquisition systems plug directly into the same card cage as computers from Intel and National. Mounted on a single PC board, the 700 series includes both high and low level analog to digital systems and DAC boards.

710 Series Low Level A/D

- Withstands common mode voltage to 250 V
- Digitizes outputs from bridges, thermocouples, and other low level transducers
- Gain amplifier with system cold junction compensation can be programmed channel to channel
- 8 or 16 differential inputs per card
- 12 bit resolution

735 Series High Level A/D

- 16 to 64 single ended or pseudo differential inputs
- Jumper selectable for 8, 16 or 32 differential analog inputs
- 12 bit high speed analog to digital converter
- Up to 2 channels of 12 bit digital to analog converters
- Bus interface includes software choice of programmers control or interrupt

735 DAC Series

- Up to 4 channels of 12 bit DACs
- 2 scope/recorder per control circuit
- 8 discrete digital outputs with 8 current sinks
- 8 discrete digital inputs

Send for full technical data to:



70 Tower Office Park • Woburn, MA 01801, 617-935-6668

New literature

Thin-film primer. The 1982 "Book of Basics," an expanded second edition, serves as a primer on the fundamental sciences required for thin-film technology. It contains five technical papers covering the basics of plasmas, materials, thin films, sputtering, and plasma etching. Illustrated with photos, graphs, and charts, the 214-page book is available for \$50 a copy from Materials Research Corp., Route 303, Orangeburg, N. Y. 10962 at (914) 359-4200. Circle reader service number 421.

VIC-20 aid. Designed for use by computer novices as well as experienced programmers, the "VIC-20 Programmers Reference Guide" provides complete information about the programming of Commodore Business Machines' popular low-cost VIC-20 computer. Nearly 300 pages long, the \$16.95 guide includes illustrations, instructions, charts, and programs as well as a schematic diagram of the computer. For a copy, write to Commodore Business Machines Inc., 681 Moore Rd., King of Prussia, Pa. 19406 or call (215) 337-7100. [422]

Phosphors and filters. For use as a design guide by manufacturers of equipment with visual displays, an engineering bulletin provides design data and specifications for nonglare, contrast-enhancement cathode-ray-tube display filters. The bulletin lists the most commonly used phosphors and the Homalite shade that meets specific light-transmission requirements for those phosphors. The publication is available free from SGL Homalite, 11 Brookside Dr., Wilmington, Del. 19804 at (302) 652-3686. [423]

Software plus service. Lifeboat Associates' catalog No. 22, called the "Software Desk Reference," includes listings for 26 new products; a special section detailing the company's original-equipment-manufacturer services and products; a new minicomputer systems section; and for the first time, a list of 16-bit software programs including information about the IBM Personal

WHY NEW YORK IS A SOLID STATE FOR THE ELECTRONICS INDUSTRY.



Look at what New York State offers the electronics industry, and you'll agree: It's more profitable to do business in New York State.

It costs less to do business in New York State locations than in San Jose, California. And we can prove it.

An independent study analyzed the four critical costs of taxes, wages, power and construction for a model new electronics firm. It showed that New York State offers locations where these costs are less than they are for choice electronics industry locations around the country.

For example, these costs would total \$7.6 million annually in San Jose, versus only \$6.4 million in, say, Brookhaven, New York.

New York has the best business advantages in America.

New York State is committed to a big, broad business-boosting program to create private sector jobs.

Our costs are lower because we have the best tax incentives and credits. We have on-the-job training and job incentive programs. Long-term, low-cost financing. And, we've cut personal and busi-

ness taxes by over \$2 billion annually.

Our labor force is #1 in productivity.

New York ranks #1 in electronic components productivity (value added per production wage dollar) among the locations analyzed. And in the past five years, New York's number of idle man-days due to work stoppages was half that of the national average.

We graduate more electronics engineers than any other state.

Thanks to universities like RPI and Cornell—and dozens of other fine colleges and universities—more electronics engineers are graduated each year in New York State than in any other state including California or Massachusetts. And since many of the largest electronics firms are already doing business here—GE, IBM, to name only a couple—our graduates are quickly turned into seasoned professionals.

When you look into New York, you'll love New York.

We have an abundance of electric power. Lots of affordable housing for your employees. And our 30 million acres include thou-

sands of available plant sites. And some of the most magnificent outdoors and year-round recreation on the American continent.

Tell me more about why New York is a solid state for business. I am particularly interested in information on:

- Electronic Components
- Small Computers
- Semiconductors

George G. Dempster, Commissioner
New York State Dept. of Commerce
99 Washington Avenue
Albany, New York 12245

Name _____

Title _____

Company Name _____

Product/Service _____

Employees _____

Address _____

City _____

State _____ Zip _____

MSEX

NEW YORK STATE VOTES "YES" FOR BUSINESS.

Circle 235 on reader service card

A/D CONVERTER

15 BITS 2 μ SEC

Not a dream, not in the planning stage, but a reality now! Phoenix Data's ADC 1215 H is a reliable, proven performer that has been used successfully by several customers for over a year.



Now, you can count on a true 15 bit A/D Converter that has a maximum conversion time of 2 μ sec. . . all this on a single P.C. Board measuring 5.5" x 4.5" x 0.5" high!

Optional Features:

- A -55°C to 125°C temperature range is available.
- A high reliability version is available.
- An encased version will be available.

For additional information contact: Srinil Iyer



Phoenix Data, Inc.

3384 WEST OSBORN ROAD, PHOENIX, ARIZONA 85017 - PHONE 602/278-8528

Circle 236 on reader service card

New Multi-Turn Pots

Wide
selection...
high resolution

Series 2200 multi-turn potentiometers offer a wide selection of high resolution wirewound units for precise set-point or level adjustments. Models are available in 1, 2, 3, 5 and 10 turn configuration as well as 2 gang versions. Units have molded plastic housings, stainless steel shafts and are O-ring sealed. Call (617) 358-2777 or fill out reader service card.



**WATERS
MANUFACTURING, INC.**

Longfellow Center, Wayland, MA 01778 / (617) 358-2777 • Telex: 948441

236 Circle 256 on reader service card

New Literature

Computer DOS. The catalog is available free by writing Lifeboat Associates, Catalog Department, 1651 Third Ave., New York, N. Y. 10028 or calling (212) 860-0300. [424]

DEC directory. Based on a six-volume reference set originally developed for consultants, a publication and supporting service, designated the Digital Equipment Corp. Reference Service, describes the entire range of the company's products and services and is intended for original-equipment manufacturers, volume users, Government agencies, software houses, and consultants. The \$295 annual charge for the service includes six basic volumes, four quarterly updates, and newsletters. For more information write to Digital Equipment Corp. Reference Service, Mail Stop PK3-1/K21, 129 Parker St., Maynard, Mass. 01754. [425]

Competitive analysis. "The Detailed Analysis of the Data General MV/8000," a comparative evaluation of 32-bit minicomputer systems released earlier this year, has been expanded to evaluate the MV's newer real-time capabilities and to discuss a new contender from Perkin-Elmer. The report examines the Data General superminicomputer and compares it in detail with its most popular competitors. It features in-depth discussions of the MV/8000 architecture, software, and hardware, and includes current pricing and budgeting information. For more information contact the Computer Consultants' Consortium, 48 Dewey Ave., Mechanicville, N. Y. 12118. [426]

Software directory. The two-volume "International Software Directory" is now available on line through Lockheed Dialog. As with the hard copy, it is fully searchable by machine, operating system, subject, vendor, and price, but in addition, with the on-line service, it has full-text searching by key words in any or all fields. For more information or to order a directory, contact Imprint Editions, 1520 South College, Fort Collins, Colo. 80524 at (303) 482-5574. [428]

EDAC'S WORLD

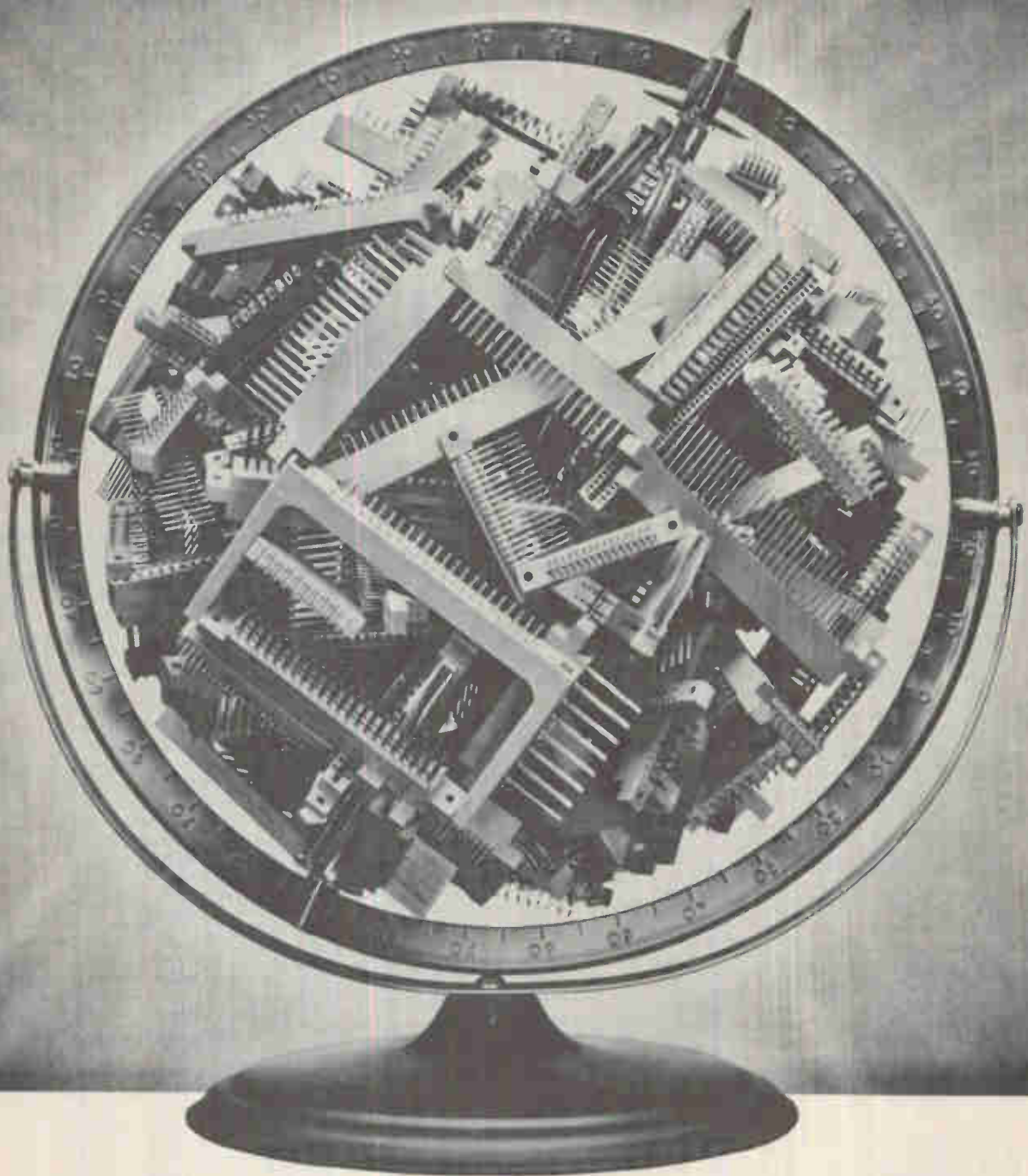

There are over 700,000 excellent reasons why more and more companies are coming to EDAC for their card-edge connector needs.

When you add up all the series of card edge connectors, the full magnitude of contact sizes, single and dual readouts, the myriad of available contact spacing, plating choices and material, insulator materials, available card guides and termination styles, you will be pleasantly surprised to learn that it comes to over 700,000 choices available to your company. Impressive!

What is equally impressive is the kind of company EDAC is. The Chairman of the

Board still reads all the orders as they come in. So does the President. And they both still get a "kick" out of doing that.

It is, therefore, not so surprising to learn that EDAC probably offers the fastest delivery time and quick turnaround. It also has the desire and ability to manufacture to custom specifications efficiently and with justifiable pride. We believe you will find it a pleasure to do business with a Company that has not forgotten all the

good reasons that made it grow.

For more detailed information and your free comprehensive catalogue, please contact EDAC, today.

The EDAC logo consists of the letters "EDAC" in a bold, green, sans-serif font. To the right of the letters is a small, stylized globe icon.

EDAC INC. 20 Rainside Road,
Don Mills (Toronto) Ontario M3A 1A4
Tel. 416-445-2292 TWX. 610-492-1398

EDAC Connectors are C.S.A. and U.L. approved and are available throughout the major countries of the world.

Circle 237 on reader service card

Published by Electronics Magazine . . .

Books of special interest to our readers



Circuits for Electronics Engineers
 Almost 350 diagrammed circuits arranged by 51 of the most useful functions for designers. Taken from the popular "Designer's Casebook" of *Electronics*, these circuits have been designed by engineers for the achievement of specific engineering objectives. Pub. 1977, 396 pages, softcover.
 Order No. R-711, \$17.95.

Electronic Circuits Notebook
 Contains 268 completely illustrated electronic circuits conveniently arranged by 39 vital functions, including amplifiers, audio circuits, control circuits, detectors, converters, display circuits, power supplies and voltage regulators, function generators, memory circuits, microprocessors, and many others, as published in *Electronics* magazine 1977-1980. Companion volume to *Circuits for Electronics Engineers*. Pub. 1981, 344 pages, softcover.
 Order No. R-026, \$17.95.

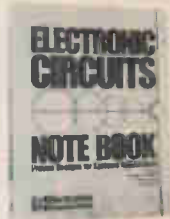

Microprocessors and Microcomputers: One-chip Controllers to High-end Systems
 Practical orientation to all aspects of microprocessors and microcomputers in 95 articles from *Electronics* covering low-end microcontrollers, mid-range microprocessors, high-performance 16-bit microprocessors, high-speed bipolar processors, peripheral support chips, signal processors, board-level microcomputers, software and applications. Pub. 1980, 482 pages, softcover.
 Order No. R-011, \$18.95.

Design Techniques for Electronics Engineers
 Expert guidance at every point in the development of an engineering project — making measurements, interpreting data, making calculations, choosing materials, controlling environment, laying out and purchasing components, and interconnecting them swiftly and accurately. Nearly 300 articles from *Electronics*' "Engineer's Notebook," with more than 500 diagrams and tables. Pub. 1977, 370 pages, softcover.
 Order No. R-726, \$17.95.



Designer's Casebook No. 1
 Design solutions from *Electronics* magazine cover controls, filters, logic, power supplies, signal conversion, and signal sources. Pub. 1976, 106 pages, softcover.
 Order No. R-31D, \$10.95.

Basics of Data Communications
 This compilation of essential articles from *Data Communications* magazine includes chapters on terminals, acoustic couplers and modems, communications processors, networking, channel performance, data link controls, network diagnostics, interfaces, and regulations and policy. Pub. 1976, 303 pages, softcover.
 Order No. R-608, \$15.95.



Personal Computing: Hardware and Software Basics
 More than 50 articles from leading publications provide information on personal computing hardware, software, theory and applications. Pub. 1979, 266 pages, softcover.
 Order No. R-903, \$15.95.

Practical Applications of Data Communications
 Selected articles from *Data Communications* magazine cover architecture and protocols, data-link performance, distributed data processing, software, data security, testing and diagnostics, communications processors, and digitized-voice and data-plus-voice. Pub. 1980, 424 pages, softcover.
 Order No. R-005, \$17.95.



Active Filters
 Covers the theory and practical implementation of filter networks built with active elements. Includes design tables and computer/calculator programs, as published in *Electronics*. Pub. 1980, 133 pages, softcover.
 Order No. R-003, \$11.95.

An Age of Innovation: The World of Electronics 1930-2000
 The editorial edition of *Electronics* 50th Anniversary issue of April 17, 1980, casebound with four-color jacket. A comprehensive look at past and future developments in electronics, researched and written by the editors of *Electronics*. 300 illustrations, many in color. 274 pages.
 Order No. R-013, \$18.50.



Microelectronics Interconnection and Packaging
 Articles from *Electronics* include sections on lithography and processing for integrated circuits, thick- and thin-film hybrids, printed-circuit-board technology, automatic wiring technology, IC packages and connectors, environmental factors affecting interconnections and packages, computer-aided design, and automatic testing. Pub. 1980, 321 pages, softcover.
 Order No. R-927, \$15.95.

ELECTRONICS MAGAZINE BOOKS
 1221 Ave. of the Americas
 New York, N.Y. 10020
 (Telephone 212/997-2996)

McGraw-Hill Intl. Publications Co.
 European Circulation Center
 Maidenhead, Berks. SL6 2QL, UK
 (Tel. 106281)23431; Telex 848640)

Order #	Qty	Price
R-	_____	\$ _____
R-	_____	\$ _____
R-	_____	\$ _____
R-	_____	\$ _____
R-	_____	\$ _____

Name _____

Title _____

Company _____

Street/PO address _____

City/State/Zip (Outside USA: City/postal code/country) _____

Payment enclosed (Payment must accompany orders under \$25. USA residents add applicable local tax.)

Bill my company (or attach company Purchase Order)

Bill me

Ten-day money-back guarantee applies on all books.



Full-duplex modem has 2,400-b/s channel

Racal-Vadic of Sunnyvale, Calif., will introduce a four-channel originate-and-answer modem at the National Computer Conference to be held in Houston, Texas, June 7-10. The unit is the first available of its kind: its full-duplex 2,400-b/s channel communicates over telephone lines in synchronous or asynchronous modes, implementing 16-level phase-shift-keying quadrature amplitude modulation. The only other 2,400-b/s equipment available is a large box geared to cryptographic applications made by Motorola's Codex Corp. In contrast, **eight of the Quadruple modems, as they are called, will fit into a 7-in.-high rack-mountable enclosure.** Each modem consists of two printed-circuit boards.

A microprocessor in the modem acts as a signal processor to do digitally what is generally done with analog filters and discriminators. The modem also has equalizers that adapt it automatically to a variety of telephone-line conditions. The direct-connect unit includes a 300-b/s asynchronous channel and two 1,200-b/s channels for synchronous or asynchronous operation. One possible market for the modem is computer installations, such as those of Telenet's time-sharing service, with 2,400-b/s ports that are not used because of the lack of suitable hardware.

Finnish supermini executes Ada code

Nokia Electronics of Helsinki, Finland (the U.S. arm, Nokia Inc., is in Sunnyvale, Calif.), is soon to introduce a very compact 32-bit super-minicomputer, the MPS 10. **It has an object-oriented architecture with extended stack organization** and is designed to execute Ada programs. The initial compiler is a nearly complete subset, and a full version of Ada is due out next year.

The fault-tolerant machine has a **40-bit virtual-memory address space and built-in relational data-base management.** The bit-slice TTL central processing unit will come with 0.5 to 4 megabytes of main memory; it is said to perform in the range of a VAX-11/780 from Digital Equipment Corp. Its local network, which links it to intelligent workstations and a gateway processor for interfacing with other networks, will at first be a 500-kb/s subset of Ethernet supporting up to 30 nodes but will later be a full Ethernet implementation. An entry-level system with a 1/2-megabyte main memory and a Winchester drive and streaming-tape backup each of 45-megabyte capacity will sell for under \$30,000 in the U. S.

64-K RAM chip is redesigned

Motorola is placing its redesigned 64-K dynamic random-access memory, the MC6664A, on the market in 150- and 200-ns versions. **Changes in the RAM [Electronics, Oct. 20, 1981, p. 39] increase speeds and are transparent to users of the earlier design.** Available now in sample form in ceramic dual in-line packages, the 150-ns chip is priced at \$17 each in lots of 100. The 200-ns part sells for \$13.60 each, also in lots of 100.

Interface with IBM channel is modified to speed transfers

Auscom Inc. is upgrading its 8900 series of programmable IBM-channel interfaces to increase the throughput rate during data transfers. The Auscom series gives **non-IBM peripherals a direct interface with the mainframe channels.** To enhance the performance of the interfaces, the Austin, Texas, firm has reconfigured the input/output registers. The new series is priced the same as existing models: \$4,995 each in single quantities for the model 8900A card set and \$14,995 for the 8911A box configuration. Auscom is also offering upgrade kits for the earlier version.

S.W. & SUNBELT

Circuits	Micro
Systems	Software
Product	Hardware
CAD	Optics

\$25,000 to \$50,000

Specialists placing EEs/MEs in data acquisition, peripheral and instrument development companies across the Sunbelt. 100% company Fee Paid. Send resume geographic preference, salary and salary requirements to:

J. Robert Thompson Companies, Inc.
Management & Employment
Consultants
2200 West Loop South, Suite 800-E
Houston, Texas 77027
(713)827-1940

POSITIONS VACANT

South? Technical / Professional Placement Network — fee paid. Murkett Associates, Box 527 (E), Montgomery, AL 36101

Electronics Technology Instructor for two year degree program. Masters in EE preferred, minimum of 5 years field and/or teaching experience. Basic electronics plus communications, digital systems, microprocessing processors and instrumentation. Start August 19, 1982 \$14,414 to \$32,299 (81 82 schedule). Inquire V P Academic Services, Lincoln Land Community College, Springfield, IL 62708 EOE (217) 786 2267

FACULTY POSITIONS VACANT

Electronics Instructor — Black Hawk College. Tenure position begins August 15, 1982 for a Technology Instructor in a 2-year Associate Degree program in Electronics / Instrumentation & Process Control BS or equivalent experience in EE or EET preferred. Minimum of 2 year's industrial work experience is desired with some teaching experience. Basic circuit analysis, industrial controls, and instrumentation courses. Send application to Dr. Richard J. Henry, Director IRT Division, Black Hawk College, 6600 34th Avenue, Moline, IL 61265

POSITIONS WANTED

Seeking permanent position that involves microcomputer design. Experience includes designing microcomputers from ground up from hardware concept to assembly language programming. Experience also includes A/D and D/A conversion and interfacing transducers. PW-6062, Electronics.

Microcomputer Expert for hire. Contract or per diem. Programming, products with a brain, circuitry. Mr. Masel, 212-476-1516.

RESUMES

Resumes — Complete instructions and examples \$4. Consultants, Box 567 — J. Bergenfield N J 07621

Career outlook

Educators get together

In the continuing controversy, a growing number of observers now trace whatever shortage of electronics engineers may exist to a shortage of engineering faculty in the colleges. It is against that background—and that challenge—that the American Society for Engineering Education is preparing for its 90th annual conference. Thus it seems entirely appropriate that the ASEE will gather from June 20 through 24 at the country's largest engineering school, Texas A&M University in College Station.

For the educators finding their way to the central Texas campus of Texas A&M, which is an hour by air from Dallas-Fort Worth and 30 minutes from Houston, the program for the meeting offers such a dizzying array of mini-plenaries, workshops, and meetings of boards, councils, and divisions that only one steeped in the arcana of academia could feel comfortable. No detail is overlooked—the program, some 98 pages of listings, directions, and ads, even explains that the native greeting is "Howdy."

In any case, what will the instructors, working the kinks of a just-completed teaching year out of their muscles, seek to accomplish that affects the working EE? At first glance, the conference is top heavy with subjects concerning teaching itself. But for today's engineering faculty, the campus is no ivory-towered sanctuary: scattered throughout the week at Texas A&M are forums and discussions—the mini-plenaries—that will grapple with the realities of shortage versus surplus in these days of an uncertain economy.

In the areas of interest to the EE, there is evidence that help is on the way—although that will be cold comfort to the out-of-work engineer. Still, the educators are worried about catching up with the state of the art, as evidenced by sessions like "Electronics in the '80s." There, guided by C. R. Visvanathan, professor and chairman of the EE depart-

ment of the University of California, Los Angeles, three panelists will wonder out loud about who will teach electronics, what the curriculum should contain, a philosophy of education for very large-scale integration, computer architecture, and the like. The panelists will be Rajinder Khotla, who heads the solid-state laboratory at Eastman Kodak Co. in Rochester, N. Y.; Dennis McGreivy of Gnostic Concepts Inc. in Menlo Park, Calif.; and Edward Kinnen of the University of Rochester (N. Y.).

Another discussion, or mini-plenary session, that deals directly with the faculty shortage is "Status Report on the Engineering Faculty Shortage Project." Robert P. Stambaugh of Union Carbide Corp., New York, will moderate a panel of experts including John W. Geils, who heads the industry-funded ASEE study and will describe the accomplishments of the first year of the project; Paul E. Torgersen of Virginia Polytechnic Institute, Blacksburg, who will view the project from the university's vantage point; and Robert K. Armstrong of Du Pont, who will describe how it looks from the industry side.

Nitty gritty. On the more basic level, J. J. Jonsson of Brigham Young University, Provo, Utah, who is program chairman for electrical engineering, points out that a lecture on the first day will look at the role of electromagnetic fields in "Field Theory—a Bushel or a Peck?" Gayle Miner of Brigham Young will ask "Who Needs Electro- and Magneto-Statics?" Alexander B. Bereskin of the University of Cincinnati will cover "Microwave Course Content." And Fred J. Young and C. John Mole of Westinghouse Corp.'s Research Laboratories in Pittsburgh will discuss the role of "Electronic Fields and Industrial Research."

The conference, whose theme is "Productivity through engineering," is a big, sprawling affair—much like the state in which it will take place—and will provide proof that the academic community is working hard to keep pace with technological progress. **-Howard Wolff**

engineers

Projects like the ring laser gyro for the Tomahawk-2 mean even more career paths at Kearfott.

Like our on-going JTIDS terminal project and many other key awards, our new contract for the inertial sensor for the MRASM (medium-range, air-to-surface) Cruise Missiles clearly demonstrates our record of success in solving strategic systems problems.

As a recognized leader in dozens of aerospace technologies, we offer a broad spectrum of inertial guidance, navigation, communications and airborne computer programs that are as challenging as they are professionally stimulating.

Whether your strength is in staff engineering, project engineering, or project management, you'll find ample opportunities to choose your own career path with Kearfott. And to move along it rapidly. If you're impatient with your current prospects, and have at least a BS degree, let us show you in realistic terms where proven innovative ability in any one of the following areas can take you.

- Digital Signal Processing
- Communication Systems Analysis
- Navigation Systems Analysis
- Digital Logic Design
- RF Communications
- Computerized Avionics
- Microwave Circuitry
- Realtime Computer Systems
- Power Supply Design
- Advanced Manufacturing
- Electro Optics

Find out about the sustained growth environment at Kearfott, and about our excellent on-site Masters Degree program which further supports your career progress. Send your resume, along with salary history and requirements, to: Mr. F. DeGennaro, Singer Company, Kearfott Division, 1150 McBride Avenue, Little Falls, NJ 07424.

An equal opportunity employer, m/f, who creates opportunities.

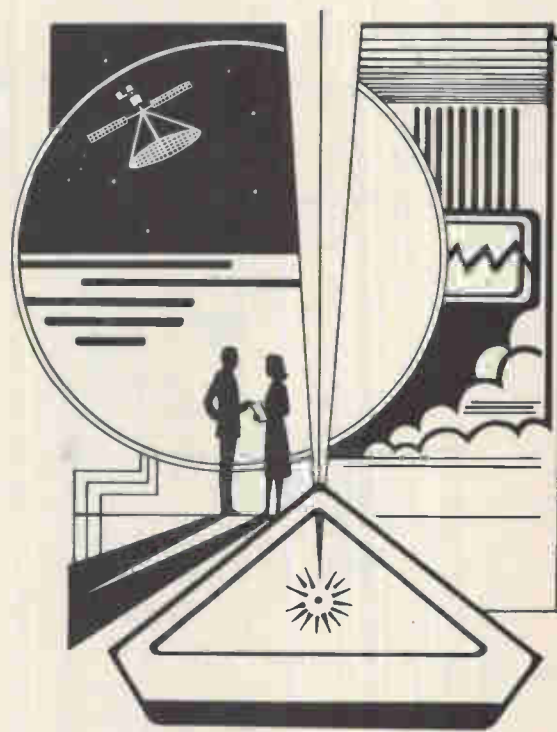

Kearfott

a division of The SINGER Company

TOMORROW'S TECHNOLOGY TODAY

The engineering leadership of Computing Devices Company in advanced acoustic signal processing, military command & control, and security sensor systems, has created career opportunities with challenge and growth prospects. We have immediate openings for:

ELECTRONIC ENGINEERS – RELIABILITY AND MAINTAINABILITY

Applicants must be able to contribute actively to the frontend design process, and must have an ability to communicate effectively with government/customer representatives.

Reliability/Parts Engineers: Duties include planning and management of reliability and parts control programs, responsibility for associated analyses and test phases, and supervision of parts application/specification activities.

Maintainability/ILS Engineers: Duties include planning, analysis, and test phase activities in the areas of Maintainability, Human Engineering, and Logistics Support.

Qualifications: Several years of experience in the electronics development or support environment, including familiarity with relevant military specifications and standards.



GD COMPUTING DEVICES COMPANY
a Control Data Company

EMPLOYMENT OR TERM-CONTRACT

Applications for full-time employment, or for work on a term-contract basis, are both welcome.

We offer attractive financial and professional rewards with the additional benefits of the Company's location in the beautiful National Capital area. For career opportunities in the forefront of the high technology industry contact Joyce Kincade at (613) 596-7066 or write to: Computing Devices Company, P.O. Box 8508, Ottawa, Ontario, Canada K1G 3M9.

Electronic Engineering/Data Processing Professionals

CONSIDER TEACHING, THE STANDOUT CAREER

That Offers Satisfaction, Recognition and The Opportunity to Keep Up with the Latest

STATE OF THE ART

Find yourself performing with assembly line enthusiasm, wondering if anybody is listening? Turn to teaching! Your abilities to respond to problems will be challenged as YOU MANAGE the flow of knowledge to an attentive audience. Leading as a teacher exchanges the anonymity of project teams and large departments for highly motivated students looking up to you for direction!

- **TEACHING BACKGROUND IS NOT REQUIRED!**
BSEE or MSEE and at least 2 years post-degree experience required.
- **CREATIVITY IS ENCOURAGED!**
Experiment a little with the freedom to think again . . . ON YOUR OWN!
- **ATTRACTIVE SALARIES, OUTSTANDING BENEFITS!**
4 weeks vacation, sabbatical programs, tuition reimbursement plus the involvement in the advances inherent in teaching. BHEG Institutes are accredited by the North Central Association. The electronics degree programs are accredited by TAC/ABET.



If you're ready to redefine your career goals, let's exchange information. (1) Send a letter or resume, (2) Call our Toll Free Number 800/323-4253, (3) In Illinois call 312/328-8100, or (4) Fill out enclosed coupon, mail to:

Attention: E. Cabot, Dept. E

BELLE HOWELL
EDUCATION GROUP INC

2201 W. Howard St., Evanston, Illinois 60202
312/328-8100

An Equal Opportunity Employer M/F/H

Name _____
Address _____
City _____ State _____ Zip _____
Phone (daytime) _____ Please: Send information
Preferred Location: _____ Contact me now
Kansas City Atlanta Dallas Phoenix
Columbus, OH Chicago Woodbridge, NJ
Toronto, Canada



GTE & PHOENIX... a winning team

GTE Automatic Electric Laboratories has been a leader in the telecommunications industry since 1892, and our future never looked better!

In this exciting and rapidly changing industry, GTE is meeting the challenges and opportunities of the future by developing advanced digital telecommunications systems today. Our new design and development laboratory in Phoenix will help us maintain our edge in advanced systems design technology.

If you're looking for technical challenge, growth opportunity and would like to be a part of our rapidly growing organization...if you're looking for the quality of life offered in this vibrant, emerging technological center, make the move to GTE.

A degree in Electrical Engineering, Computer Science, Computer Engineering or related field

and experience in one of the following will qualify you for a position with our winning team.

SYSTEMS ENGINEERS - APPLIED RESEARCH

SYSTEMS TEST ENGINEERS

SOFTWARE DEVELOPMENT ENGINEERS

Send your resume in complete confidence today. GTE Automatic Electric Laboratories, Manager of Manpower, Dept. T 519, 2500 W. Utopia Road, Phoenix, AZ 85027.

GTE Automatic Electric Laboratories

GTE Research &
Development

An Equal Opportunity Employer M/F/H

INTERNATIONAL OPPORTUNITY AUDIO VISUAL

The King Faisal Specialist Hospital and Research Centre in Riyadh, Saudi Arabia has current openings in its Audio Visual Department. The AV Department is responsible for the educational and television needs of the employees and dependents of the 250 bed acute care referral facility.

The following positions are available:

CHIEF TV ENGINEER: BSEE, 8 yrs. related experience (2 as supervisor) in the design and maintenance of CCTV systems and other AV equipment.

TV ENGINEER: BSEE, 5 yrs. experience in maintenance and repair of TV or Video systems. Must be familiar with TV cameras, monitor systems, video tape recorders and cable.

TV TECHNICIAN: AA Electronics or 2 yrs. trade school or military equivalent plus 5 yrs relevant experience—at least 2 of those years maintaining and repairing TV and video systems. (Single Status)

Benefit package includes attractive salary, 30 day annual leave, free transportation, furnished lodging, free medical care, bonus pay and bonus leave. Two year contract.

For further information, please send resume to: Kathleen Langan, Personnel Consultant, Hospital Corporation of America-International Division, P.O. Box 550, Nashville, TN. 37202.

HCA International Division

Engineers

- Design
- Development
- Project
- Software

\$20,000-\$50,000

Riddick Associates Engineering Division specializes in placement of electrical and electronics engineers with top companies on the East Coast and throughout the U.S. We provide advice on careers, resumes and interviews for a position tailored to your skills. Client companies pay all fees. For details call or send resume in strict confidence to Phil Riddick, President.

**Riddick
Associates, Ltd.**

13 Koger Executive Center
Norfolk, VA 23502
Area 804-461-3994

TO ANSWER BOX
NUMBER ADS
Address separate en-
velopes (smaller than 11" x
5" for each reply to:

Box Number
(As indicated)
Electronics
Box 900, NY 10020

**MCGRAW-
HILL'S
ELECTRONIC
BOOKSHELF
IS ON THE
AIR!**

Ask your computer
to call 212/997-
2488 for the latest
info on our com-
puter and electron-
ics books. The
system is up daily
from 6 pm to 8 am
and 24 hours on
weekends.

NOTICE TO EMPLOYERS :

Why we can recommend our readers for the top jobs

The subscribers to this magazine have qualified professionally to receive it. They are also paid subscribers—interested enough in the technological content to have paid a minimum of \$19 for a subscription.

As subscribers to ELECTRONICS, our readers have told you several things about themselves. They are ambitious. They are interested in expanding their knowledge in specific areas of the technology. And they are sophisticated in their need for and use of business and technology information.

Our readers are now in senior engineering or engineering management, or they are on the road toward those levels. In either case, they are prime applicants for the top jobs in almost any area.

If you are interested in recruiting the best people in electronics, these pages are open to you for your recruitment advertising.

Our readers are not "job-hoppers". To interest them you will have to combine present reward with challenge and opportunity for future career advancement.

**The cost of recruitment advertising on
these pages is \$119 per ad-
vertising inch. For information call or write:**

Electronics

Post Office Box 900, New York, NY 10020
Phone 212/997-2556

ADAC	234	■ Hewlett Packard	84,85	‡ Senitron	201
* Adret Electronique	10E	‡ Hitachi America Ltd.	184,185	* SGE Bosari	18E
Advanced Micro Devices	10,11	Hughes Aircraft Company Solid State Products	34	* SGS Ates	1E-4E
Airpax Cambridge	220	* Hughes Microelectronics	19E	* Siemens AG, Munchen	15E
■ Alco Electronic Products	223	Huntron Sales, Inc.	209	Silvar Lisco	247
AMCC	70	Inmos	27	Solartron	65
American Microsystems, Inc.	186,187	Intel Corporation DSO	20,21	* Solartron Membrain	184,185
■ Amp, Inc.	18,19	International Microelectronic Products	43	Sprague Electric	73
* Ampex Corporate	12E	International Microcircuits	49	Standard Microsystems	124,125
Analog Devices	114	International Rectifier Division Semi	195	STC Microtechnology	120
□ Bank of America	120A 120D	Interall	153-156	Syntertek	207
Bausch & Lomb Houston Instrument Division	40	* Israel Export Institute	18E	* TEAC Corporation	10E
■ Beckman Instruments EPG	3rdC	* ITT Capacitors	26E	* Techmasheport	24E
* Burr Brown Research Corporation	203	Kojima Electric Manufacturing Company Ltd.	248	Tektronix	22,23,32,82,83
■ Bussman Division, McGraw Edison Company	97	* Leader Instrument	11E	* Telecontrolli	204
Caddock Electronics, Inc.	55	* Lear Siegler, Inc.	27E	■ Teledyne Relays	17
Cambion Division Midland Ross Corporation	248	■ 3M Static Control Systems	219	Teradyne, Inc.	38,39
■ Cherry Electrical Products	13	Marconi Instruments	183	Texas Instruments Digital Systems	9
■ Clairex Electronics	4thC	MDB Systems	104	Texas Instruments, Inc. Semiconductor	111
Cromemco	91	■ Microtran	116	Textool Products/3M	14
Cyborg Corporation	213	Miller Technology	248	Thermotron	206
Daini Seikosa Co., Ltd.	247	Minato Electronics, Inc.	7	Thomson CSF/GCT	93
Data I/O Corporation	190	■ Mini-Circuits Laboratory	5	‡ Toshiba America	77
Data Systems Design	198,199	Mitel Corporation	126,127	TRE Semiconductor Equipment Corporation	226
The Destek Group	1	Mitsubishi Electronics America, Inc.	68,69	TRW/Capacitors	217
Digital Equipment Corporation	116	Monolithic Memories	66,67	TRW/IRC Resistors	162
Digital Equipment Corporation Microcomputer	192,193	Monsanto Industrial Chemicals	211	TRW/LSI Products	109
‡ Digitran Company	204	Motorola Semiconductor Products	95,117	Unitrode Corporation	74,75
EDAC Connectors	237	* Murata Manufacturing Company, Ltd.	20E	‡ US Instrument Rentals	44
* Efcis (Thomson)	17E	National Semiconductor	57-64	■ Vactec, Inc.	26
EG&G Reticon	51	NCR Corporation	232,233	■,* Vectron Laboratories	22E
■ Electronic Navigation Industries	6	□ NEC Italia	24B	‡ V T I	203
Epson America/Suwa Seikosa	229	Neff Instrument Corporation	33	* Wandel un Goltermann	21E
Eurotechnique	121	New York State Department of Commerce	235	Waters Manufacturing	236
Exar	98,99	* Nippon Electric Company Ltd.	27E,122,123	Wavetek San Diego	188,189
Fairchild Mechanical Division	208	* Northern Ireland Department of Commerce	201	Western Digital	81
Fairchild Test Systems	100,101	Ohmite	15	Wilhelm Westermann	8
John Fluke Manufacturing Company	107	□ Panduit Italia	24A	Zendex Corporation	16
* Fujitsu Ltd.	6E,7E 180	* Phillips CMSD	8E,9E	Zilog	28,29
Fujitsu Microelectronics	37	Phoenix Data, Inc.	236		
GCA Corporation	86,87	Plantronics Zehntel	196,197		
General Instrument Corporation Discrete Semi Division	102,103	* Plessey Semiconductor	44		
General Instrument Microelectronics	119	■ Pro-Log	25		
Germanium Power Devices	78	Raytheon Company Semiconductor Division	2ndC		
Gould Inc. Instrument Division SC Operations	30,31,88	RCA Solid State	128,214		
Gould Millenium	112,113	Rockwell International (Electronic Devices)	230		
■ Grayhill, Inc.	52,53	* Rohde & Schwarz	19E		
		* S.E.C.I. S.p.A.	28E		

Classified and employment advertising
 Bell & Howell Education Group Inc. 242
 Computing Devices Company 242
 GTE Automatic Electric Laboratories 243
 Hospital Corporation of America, International Division 244
 J. Robert Thompson Companies, Inc. 240
 Kearfott, a division of Singer Company 241
 Riddick Associates, Ltd. 244

■ For more information of complete product line see advertisement in the latest Electronics Buyers Guide
 * Advertisers in Electronics International
 ‡ Advertisers in Electronics domestic edition
 □ Advertisers in regional issue

Data Communications Books.

Basics of Data Communications

This compilation of essential articles from *Data Communications* magazine includes chapters on terminals, acoustic couplers and modems, communications processors, networking, channel performance, data link controls, network diagnostics, interfaces, and regulations and policy. Pub. 1976, 303 pages, softcover.
Order No. R-608, \$15.95.



Data Communications Procurement Manual

The information you need to turn data communications procurement into a smoothly running, cost-effective operation. Includes sample solicitation clauses and forms, specification checklists on 38 devices, and 8 useful appendices. By Gilbert Held. Pub. 1979, 150 pages, clothbound.
Order No. R-925, \$24.50.



Fiber Optics and Lightwave Communications Vocabulary

The basic reference document on fiber optic and lightwave communications for those who design, develop, operate, use, manage, or manufacture data communications or data processing equipment and components. 1400 entries, with inversions and cross-references, and index of terms. Edited by Dennis Bodson. Pub. 1981, 149 pages, softcover.
Order No. R-030, \$12.95.



McGraw-Hill's Compilation of Data Communications Standards

Presents verbatim reprints of all 123 interface protocol data communications standards promulgated by International Telegraph and Telephone Consultative Committee (CCITT), International Organization for Standardization (ISO), European Computer Manufacturers Association (ECMA), Electronic Industries Association (EIA), American National Standards Institute (ANSI), and U.S. Government (NCS and NBS). Special feature for easy access to applicable standards: cross-reference tables of standards produced by each of these groups corresponding to similar standards published by the others. Edited by Harold C. Folts. Pub. 1981, 1923 pages, clothbound.
Order No. R-100, \$250.00.



Practical Applications of Data Communications

Selected articles from *Data Communications* magazine cover architecture and protocols, data-link performance, distributed data processing, software, data security, testing and diagnostics, communications processors, and digitized-voice and data-plus-voice. Pub. 1980, 424 pages, softcover.
Order No. R-005, \$17.95.

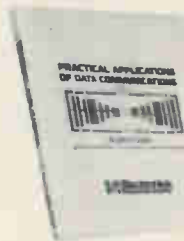

Advertising Sales Staff

Advertising sales manager: Norman Rosen
3200 Wilshire Blvd., South Tower
Los Angeles Calif. 90010 [213] 487-1160

Market managers:

Computers & Peripherals: Frank Mitchell, Boston
Test & Measurement: Don Farris, San Francisco
Semiconductors: Norman Rosen, Los Angeles

Atlanta, Ga. 30309: John J. Uphues
100 Colony Square, 1175 Peachtree St., N.E.
[404] 892-2868

Boston, Mass. 02118: Frank Mitchell
Paul F. McPherson, Jr.
607 Boylston St., [617] 262-1160

Cleveland, Ohio 44113: William J. Higgins III
[312] 751-3738

Fort Lauderdale, Fla. 33306: John J. Uphues
3000 N.E. 30th Place, Suite #400
[305] 563-9111

New York, N.Y. 10020
Matthew T. Reseska [212] 997-3617
Albert J. Liedel [212] 997-3616
1221 Avenue of the Americas

Philadelphia, Pa. 19102: Joseph Milroy
Three Parkway, [215] 496-3800

Pittsburgh, Pa. 15222: Joseph Milroy
4 Gateway Center, [215] 496-3800

Chicago, Ill. 60611
Jack Anderson [312] 751-3739

William J. Higgins III [312] 751-3738
645 North Michigan Avenue

Southfield, Michigan 48075: Jack Anderson
4000 Town Center, Suite 770, Tower 2
[313] 352-9760

Dallas, Texas 75201: John J. Uphues
2001 Bryan Tower, Suite 1070
[214] 742-1747

Denver, Colo. 80203: Harry B. Doyle, Jr.
655 Broadway, Suite 325
[303] 825-6731

Houston, Texas 77040: John J. Uphues
7600 West Tidwell, Suite 500
[713] 462-0757

Los Angeles, Calif. 90010: Chuck Crowe
3200 Wilshire Blvd., South Tower
[213] 487-1160

Coast Mesa, Calif. 92626: Edward E. Callahan
3001 Red Hill Ave. Bldg. #1 Suite 222
[714] 557-6292

Palo Alto, Calif. 94303: Don Farris,
Larry Goldstein, Lauren Scott
1000 Elwell Court, [415] 968-0280

Paris: Michael Sales
17 Rue-Georges Bizet, 75116 Paris, France
Tel: 720-16-80

United Kingdom: Simon Smith
34 Dover Street, London W1
Tel: 01-493-1451

Scandinavia: Andrew Karnig and Assoc.
and Simon Smith
Kungsholmsgatan 10
112 27 Stockholm, Sweden

Tel: 08-51-68-70 Telex: 179-51

Milan: Ferruccio Silvera and Elio Gonzaga
1 via Baracchini, Italy
Tel: 86-90-656

Brussels:
23 Chaussee de Wavre
Brussels 1040, Belgium
Tel: 513-73-95

Frankfurt/Main: Fritz Krusebecker
Liebigstrasse 27c, Germany
Tel: 72-01-81

Tokyo: Akio Saijo
McGraw-Hill Publications Overseas Corporation,
Kasumigaseki Building 2-5, 3-chome,
Kasumigaseki, Chiyoda-Ku, Tokyo, Japan
[581] 9811

Business Department

Thomas M. Egan
Production Director
[212] 997-3140

Carol Gallagher
Production Manager
[212] 997-2045

Betty Preis
Production Manager Domestic
[212] 997-2908

Evelyn Dillon
Production Manager Related Products
[212] 997-2044

Sharon Wheeler
Production Assistant
[212] 997-2843

Frances Vallone
Reader Service Manager
[212] 997-6058

Electronics Buyers' Guide

H.T. Howland, General Manager
[212] 997-6642

Regina Hera, Directory Manager
[212] 997-2544

Classified and Employment Advertising

[212] 997-2897

ELECTRONICS MAGAZINE BOOKS

1221 Ave. of the Americas
New York, N.Y. 10020
(Telephone 212/997-2996)

McGraw-Hill Intl. Publications Co.
European Circulation Center
Maidenhead, Berks. SL6 2QL, UK
(Tel. [0628] 23431; Telex 848640)

Order #	Qty	Price
R- _____	_____	\$ _____
R- _____	_____	\$ _____
R- _____	_____	\$ _____
R- _____	_____	\$ _____
R- _____	_____	\$ _____

Name _____

Title _____

Company _____

Street/PO address _____

City/State/Zip (Outside USA: City/postal code/country) _____

Payment enclosed (Payment must accompany orders under \$25. USA residents add applicable local tax.)

Bill my company (or attach company Purchase Order)

Bill me

Ten-day money-back guarantee applies on all books.



CAD TOOLS FOR CUSTOM IC DESIGN

- Schematic entry
- Hierarchical design support
- Automatic layout of standard cell IC's
- Automatic layout of gate arrays
- Mixed mode simulation
- Switched capacitor network simulation
- Interfaces to logic simulators
- Interactive color graphics support
- Integrated portable software system available on Apollo, DEC VAX, IBM and Prime

An integrated set of tools for gate array design.
Full Customer support in U.S., and Europe.

For more information call or write our Marketing Department.



SILVAR-LISCO

3172 Porter Drive, Palo Alto, CA 94304 (415) 856-2525
34 Abdijstraat, B3030 Leuven, Belgium (016) 20 00 16

Circle 247 on reader service card

this publication is available in microform



Please send me additional information.

University Microfilms International

300 North Zeeb Road
Dept. P.R.
Ann Arbor, MI 48106
U.S.A.

18 Bedford Row
Dept. P.R.
London, WC1R 4EJ
England

Name _____

Institution _____

Street _____

City _____

State _____ Zip _____

Electronics / May 19, 1982

Applicable To Many Uses

Liquid Crystal Displays

■ SP-203 (For calculators)



■ SP-202 (For measuring instruments etc)



■ SP-102 (For games and large instruments)

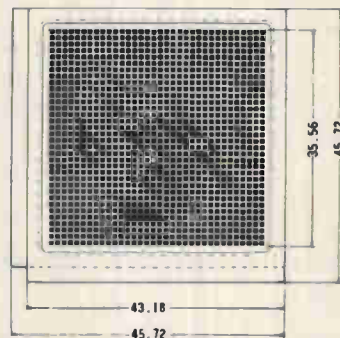

Unit(m/m)

Daini Seikosha is one of the world-renowned watch makers which started commercial production of quartz watches first in the world. The Company now is ready to make great strides to become a manufacturer of precision components using precision processing techniques and experiences obtained and accumulated in quartz watch manufacturing. Here we introduce to you our liquid crystal display panels specially designed and developed for calculators, instruments and games applications.

[Features]

- The organic panel construction guarantees clearer contrast and wider viewing angle.
- High multiplex properties.
- Diverse reflectors are to be provided.

* We try to meet every customer's needs regardless of the volume of the order.

SEIKO GROUP DAINI SEIKOSHA CO., LTD.

Sales Division: 31-1, 6-chome, Kameido, Koto-ku, Tokyo, 136, Japan.

Phone: Tokyo 684-2010 Telex: 2622410 DSEIKO J

Seiko Instruments U.S.A. Inc. 2990W. Lomita Blvd., Torrance Calif., 90505

Phone: 213-530-8777 Telex: 9103477307

Frankfurt Representative Office: Arabella Center 13 OG Lyoner Strasse 44-48, 6000

Frankfurt/Main 71 W. Germany. Phone: 0611-666971-2, Telex: 413045 DSFM D

Precision Engineering LTD. Sales Division: Peninsula Centre.

Room 1114, East Tsim Sha Tsui, Kowloon, Hongkong.

Phone: 3-676485, 683160, 683169, 697593 Telex: 40211 PELSD HX

Circle 252 on reader service card

247

MORE POWER, MEMORY, I/O CAPABILITY AND PERFORMANCE

Introducing the MCPU-800 one year anniversary.

For over a year now, Miller Technology has been delivering a little single board microcomputer with some pretty big features.

- 4 MHz Z80A CPU
- 64K or 16K bytes RAM
- 4 ROM sockets hold up to 32K bytes ROM or EPROM (2K, 4K or 8K)
- 32 Parallel I/O bits
- Fully programmable serial port
- Software control of memory configuration on 16K boundaries
- IOEXP line under software control, MEMEX and MCSYNC fully supported

- Completely STD bus compatible
- Single +5 supply
- Low power: 5 w typical
- Software support:

MONITOR

2K BASIC

8K BASIC

Both Basics support ROM-able code.

CP/M compatible—ask for tech note #8102

- Optional RS-232 interface +5 only

Shipped Only After 100 Hour Burn-in.

We've got 'em ready to ship — allow 2 weeks for delivery on small quantity orders.

For information on the only no frills, pure

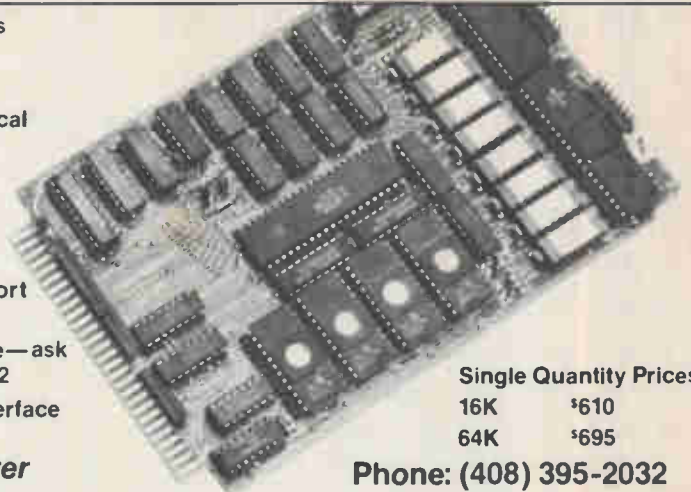

Single Quantity Prices

16K \$610

64K \$695

Phone: (408) 395-2032

647 N. Santa Cruz Ave.
Los Gatos, CA 95030

© Trademark of Digital Research

**MILLER
Technology**

**performance
single board
microcomputer
get in touch with
Miller Technology
today.**

Circle 248 on reader service card

SUNLIT

Quartz
Noiseless

INVERTER & U.P.S. WITH BATTERY

"Noiseless" Series
INVERTER

50~500VA Miniature U.P.S.
with "GS" Sealed-gel Battery



SPECIFICATIONS OF INVERTER

Output	50VA	100VA	200VA	300VA	500VA	1000VA
Model	DA50	DA100	DAX200	DAX300	DAX500	DAX1000
Input Voltage	DC12V 11~15V	DC24V 22~30V	DC48V 44~58V	DC22~30V	DC44~98V	
Freq. Stability	50/60Hz Less than ±1Hz		50/60Hz or 400Hz	Less than 1X/10		
Output Voltage	AC100V · 115V · 200V or 230V Less than ±5% 0~Full Load					
Distortion	Less than 10% (Special Order Minimum 1% or More)					
Dimension mm	176X114X213	176X153X213	176X183X262	176X183X393	210X350X350	248X430X470
Weight kg	5.0	5.6	7.5	12.0	29.0	36.0

Note: available for use with other rated output voltage and variable frequency.

**U.S.A.
SUNLITPOWER INC.**

2931 South Main St., Suite C, Santa Ana, Calif. 92707 U.S.A.
Phone: (714) 641-3013 TWX: 910-595-2697 Cable: SUNLITE

**NETERLAND
OKAMOTO ELECTRONICS CORP.**

© Osaka Merchandise Center, Schiekade 189 Rotterdam 3004,
The Netherlands Phone: 010-123117

KOJIMA ELECTRIC MFG. CO., LTD.

Main Office: No. 26-8, 2-chome, Minamikaneden, Suita-shi, Osaka 564
Japan Phone: 06-385-3523 Telex: 5136627 KOJIMA J
Tokyo Branch: Toyotama Bldg. No. 15-3, 3-chome, Toyotamakita
Nerimaku, Tokyo 176, Japan Phone: 03-948-4312

248 Circle 249 on reader service card



REQUIRED READING FOR ELECTRONIC DESIGN ENGINEERS: CAMBION CATALOG 800

When it comes down to selecting the definitive design reference source in the electronic components field, get Cambion's Catalog 800 listing over 23,000 different components—connectors, terminals, inductive products, handles, and much more associated hardware. Cambion's reputation for high quality, reliability, and worldwide off-the-shelf availability, plus our special attention to custom-designs have made us a near-legend in our own time. The Catalog 800—designed to make your design concept a design reality. Get your copy today!

CAMBION
The Right Connection.

Midland-Ross Corporation

Cambion Division

445 Concord Avenue

Cambridge, MA 02238

Tel: (617) 491-5400

Telex: 92-1480

TWX: (710) 320-6399

MIDLAND ROSS

See Us In Booth # 102, Electro '82

Circle 251 on reader service card

Fast Relief.

For fast relief from slow electronic component delivery, just consult your nearby Beckman distributor.

You'll get quick response because Beckman's world-wide sales, service and distributor network specializes in delivering what you need, when you need it.

Beckman is committed to serving the electronics industry with superior quality, competitive prices, and reliable delivery. To meet this commitment, Beckman continues to invest in new product development and production facilities expansion.

For example, Beckman's new computerized production control system provides on-line, real-time status of product availability and delivery information. Within a matter of minutes, you'll have a

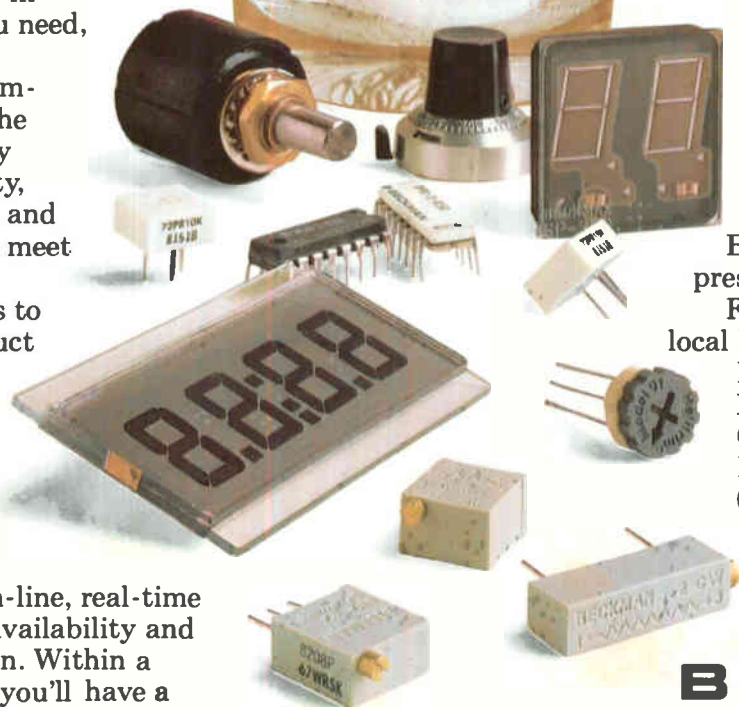

delivery date you can depend on.

And Beckman's new displays facility in Fullerton, California is now on-line, delivering a complete line of liquid crystal and planar gas discharge displays.

Remember, for just about any ailment associated with displays, as well as precision pots and dials, trimmers, digital multimeters, precision resistor networks, and hybrid microcircuits, Beckman has the right prescription.

For timely relief see your local Beckman distributor today. Beckman Instruments Inc., Electronic Technologies Group, 2500 Harbor Blvd., Fullerton, CA 92634. Or call (714) 773-8441.

**The best medicine
in electronics.**

BECKMAN

PHOTOVOLTAIC DIODES

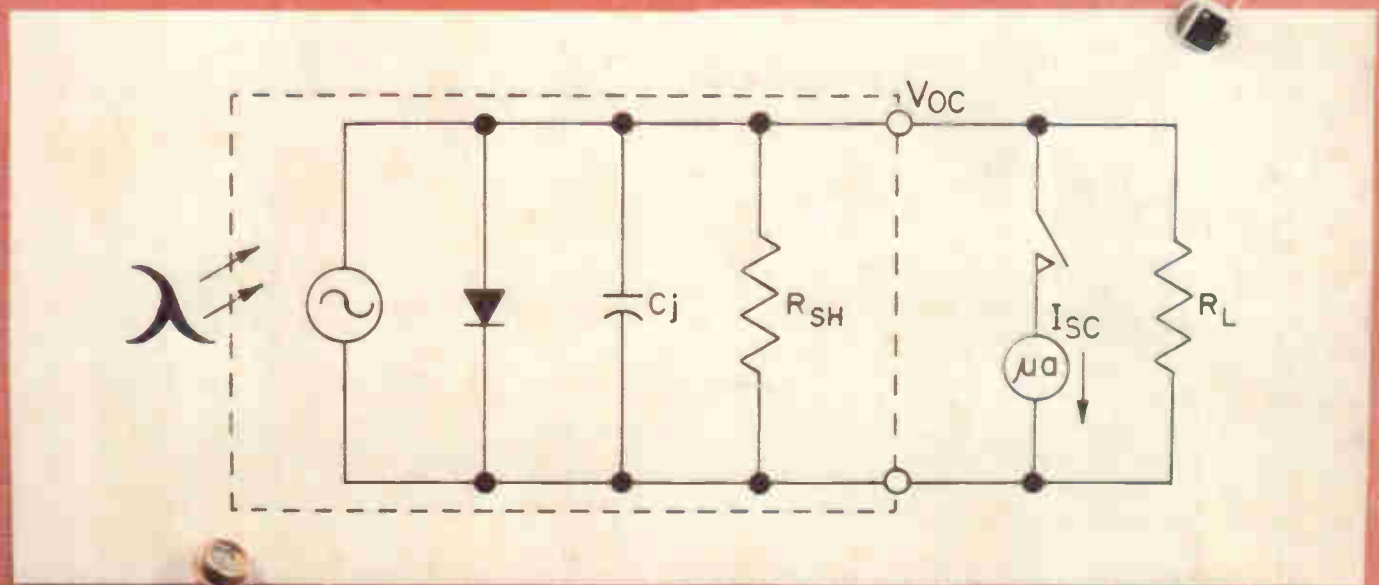

from Clairex

with tight specifications and 100% tested... twice

Clairex photodiodes of the CLD series are designed to optimize the photovoltaic characteristics of silicon and maintain tight specifications on all significant parameters.

The four silicon PN planar diodes presently available all offer high linearity, low dark current and fast response for use in critical measurement applications. Three hermetically sealed types are available for

use in hostile environments and one epoxy encapsulated type for lower cost applications.

And, as is the case with all Clairex optoelectronic devices, these photodiodes are 100% tested twice.

Try Clairex photodiodes. Call (914) 664-6602 or write Clairex® 560 South Third Avenue, Mount Vernon, New York 10550.

CLAIREX ELECTRONICS

A Division of Clairex Corporation

Circle 902 on Reader Service Card