

DECEMBER 15, 1981

SYSTEMS ON CHIPS STAR AT ISSCC/97

Ethernet controller links Unix-based machines/ 133

Solving the complex problems of ECL board testing/ 146

SIX DOLLARS A Mc GRAW-HILL PUBLICATION

International

Electronics[®]

EXECUTIVE OUTLOOK

HOW INDUSTRY LEADERS SEE THE ROAD AHEAD



CIRCUIT BOARD TESTING: SHOULD IT BEGIN IN PRODUCTION OR IN THE LAB?

Some successful companies charge production with the responsibility for developing test procedures. Others give the job to the design lab. And with many it's a shared responsibility.

However, if these methods were decided by the standards of yesterday's technology, you may increase today's productivity with a different approach. Consider these points:

Testing options begin in the lab.

With today's product designs using microprocessors, memory and other LSI circuits, the question "How to test?" will arise long before a design is released to production. When asked in the hardware/software definition phase, electronic manufacturers can opt for one of three approaches: 1) Not to design for testability, thus leaving test development responsibility to production. 2) Design for go/no-go self test, covering a "critical" subset of board functions, and leaving fault isolation to skilled technicians in production as well as the field. 3) Design for thorough self test, including diagnostics, which facilitate fault isolation, thus providing a total test solution for R&D, production and field service.

Can you afford to design for testability?

Let's take a look at the trade-offs. Option 1 appears to offer the shortest design cycle. However, the designer

will probably take longer than planned in design turn-on. And design follow-up with production often takes more effort than expected. Longer production test development time is also likely to delay shipments.

Designing in a go/no-go self test (option 2) solves some of the problems associated with option 1. However, a limited self test may still lead to failures at system turn-on. And without fault isolation, expensive technician time will be needed in production and field service.

At first glance, option 3 may seem to require too much of the designer's time. However, the payback can be significant in reduced debugging time and enhanced test effectiveness. After all, the designer best understands the product structure and critical aspects of its operation. And the designer has the tools and the opportunity to implement design features often required for high fault-coverage testing of complex LSI circuitry.

A decision that impacts production most.

Whatever the decision, production will feel its effect most. A balance must be found between design time and a viable board test solution. HP provides that balance with the 3060A Board Test System. Equipped with the High Speed Digital Functional Test Option (HSDFT), it delivers the flexibility to solve your μ P and LSI board testing problems whether you design for testability or not.

For example, the 3060A can activate μ P-based, designed-in stimulus

firmware and measure the dynamic board response using Signature Analysis. If self-stimulus isn't available you can use the HSDFT programmable stimulus capability (Figure 1).

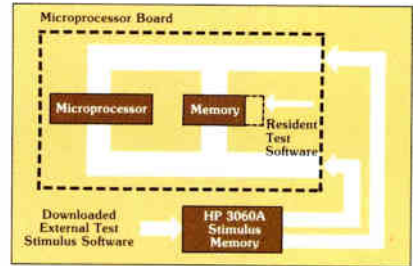

Figure 1 — The 3060A can activate resident test stimulus software or provide that stimulus from its own RAM.

Test stimulus software developed for design turn-on can even be leveraged for production test by downloading from your design system (such as the HP 64000) into 3060A stimulus RAM. Or, alternatively, HP's 3060A Digital Functional Test software provides easy-to-use stimulus and measurement programming procedures.

For fault isolation, the 3060A HSDFT software provides automatic backtracking via in-circuit visibility on the basis of a topological description of the board. And, these procedures can be used as the basis for effective field service repair using HP Signature Analysis instrumentation (HP's 5005A).

The bottom line? Rapid software development, thorough testing, high throughput and efficient field troubleshooting — the complete solution. That's worth investigating.

For more information.

Let HP help you optimize your investment in design, test and service. Write Hewlett-Packard, 1820 Embarcadero Road, Palo Alto, CA 94303. Or call the HP regional office nearest you: East (201) 265-5000, West (213) 970-7500, Midwest (312) 255-9800, South (404) 955-1500, Canada (416) 678-9430.

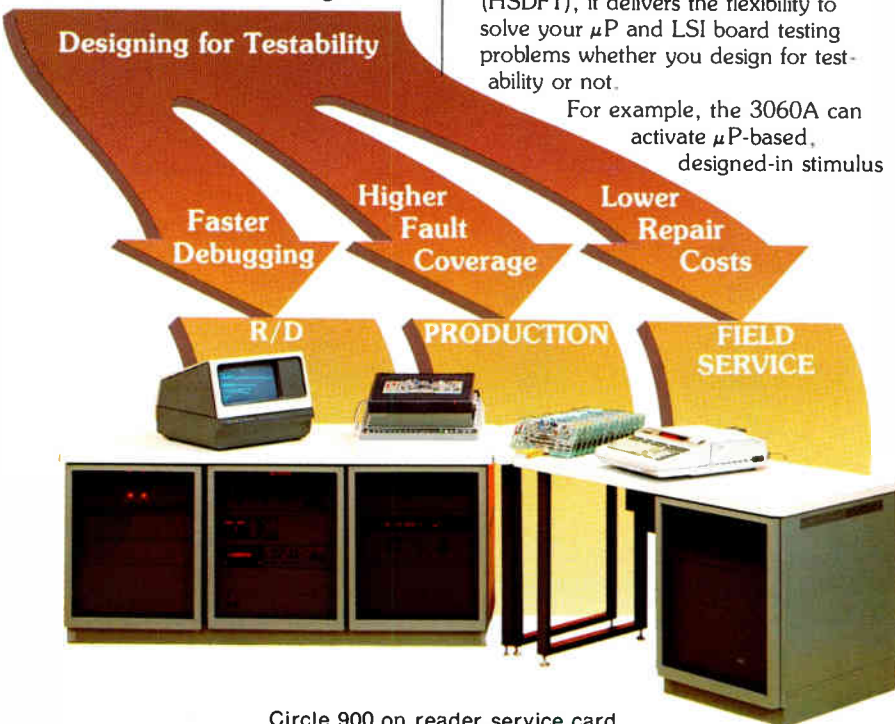

Circle 900 on reader service card

World Radio History

HP Circuit Testers—
The Right Decision

 **HEWLETT
PACKARD**

VISIT US AT ATE,
BOOTH #801-806

SURPRISE!

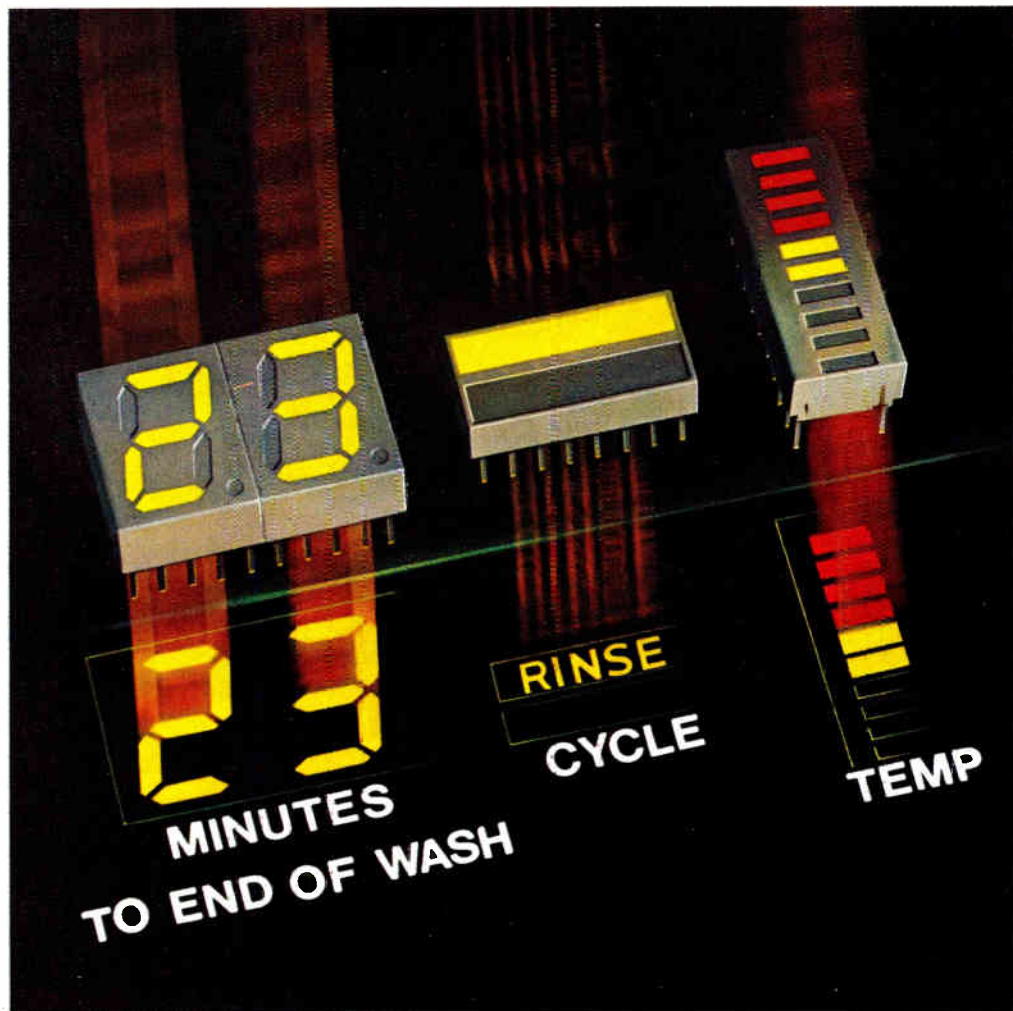

Light up your message with HP's LED products.

With HP's broad and versatile family of seven-segment displays, light bars, and 10-element bar graphs, your displays can be designed with ease. Use HP's digital displays, annunciate function light bars and analog bar graphs in any combination to conveniently display complete information in compact, attractive packages. For example, look at the effective combination of HP's HDSP-5701, 14.1mm (0.56 inch) seven-segment display, with the HLMP-2735 light bar and HDSP-48X0 series bar graph array.

All displays are TTL compatible, eliminating the need for extra power supplies in your display system. All offer HP's proven reliability and quality.

For HP's whole colorful story on LED products, or immediate delivery, call your local HP components distributor.

In the U.S., contact Hall-Mark, Hamilton/Avnet, Pioneer Standard, Schweber, and the Wyle Distribution Group.

In Canada, call Hamilton/Avnet or Zentronics, Ltd.



**HEWLETT
PACKARD**

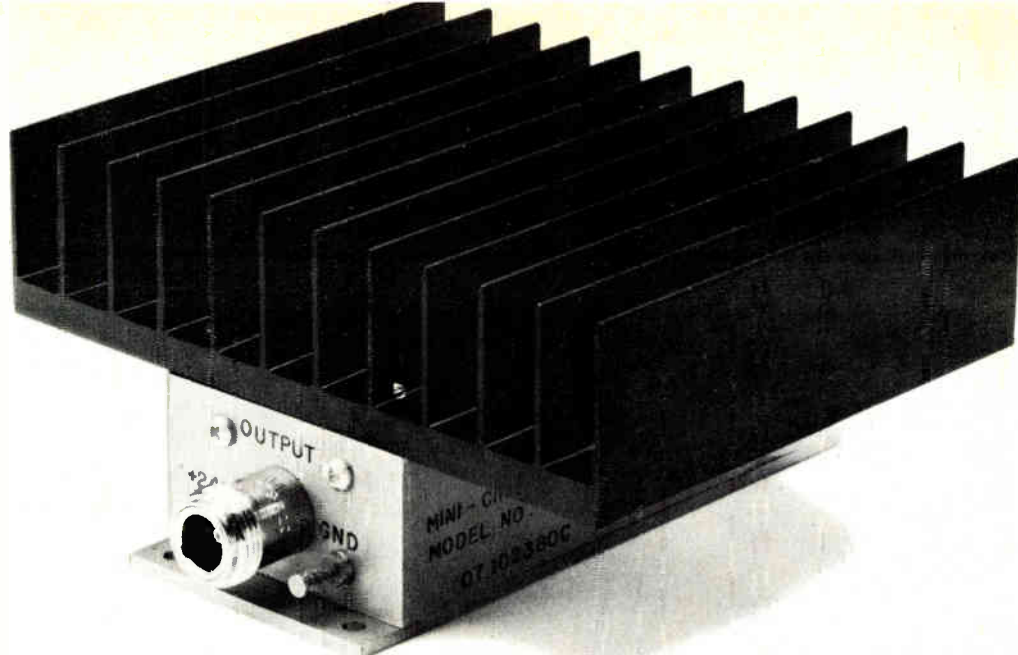

power amplifiers

1 Watt and now... 2 Watts linear output from 50KHz to 1200 MHz from \$199

If your application requires up to 2 watts for intermodulation testing of components... broadband isolation... flat gain over a wide bandwidth... or much higher output from your frequency synthesizer or signal/sweep generator... Mini-Circuits' ZHL power amplifiers will meet your needs, at surprisingly low prices. Seven models are available, offering a selection of bandwidth and gain.

Using an ultra-linear Class A design, the ZHL is unconditionally stable and can be connected to any load impedance without amplifier damage or oscillation. The ZHL is housed in a rugged 1/8 inch thick aluminum case, with a self-contained hefty heat sink.

Of course, our one-year guarantee applies to each amplifier.

So from the table below, select the ZHL model for your particular application... we'll ship within one week!

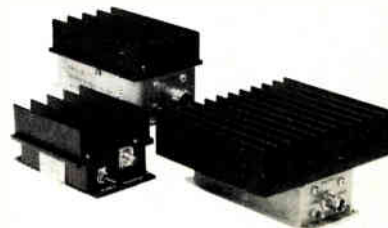

* Model No.	Freq. MHz	Gain dB	Gain Flatness dB	Max. Power Output dBm 1-dB Compression	Noise Figure dB	Intercept Point 3rd Order dBm	DC Power Voltage	Current	Price \$ Ea.	Qty.
ZHL-32A	0.05-130	25 Min.	±1.0 Max.	+29 Min.	10 Typ.	+38 Typ.	+24V	0.6A	199.00	(1-9)
ZHL-3A	0.4-150	24 Min.	±1.0 Max.	+29.5 Min.	11 Typ.	+38 Typ.	+24V	0.6A	199.00	(1-9)
ZHL-1A	2-500	16 Min.	±1.0 Max.	-28 Min.	11 Typ.	+38 Typ.	+24V	0.6A	199.00	(1-9)
ZHL-2	10-1000	15 Min.	±1.0 Max.	-29 Min.	18 Typ.	+38 Typ.	+24V	0.6A	349.00	(1-9)
ZHL-2-8	10-1000	27 Min.	±1.0 Max.	+29 Min.	10 Typ.	+38 Typ.	+24V	0.65A	449.00	(1-9)
ZHL-2-12	10-1200	24 Min.	±1.0 Max.	-29 Min.*	10 Typ.	+38 Typ.	+24V	0.75A	524.00	(1-9)
ZHL-1-2W	5-500	29 Min.	±1.0 Max.	-33 Min.	12 Typ.	+44 Typ.	+24V	0.9A	495.00	(1-9)

Total safe input power +20 dBm, operating temperature 0° C to +60° C, storage temperature -55° C to +100° C, 50 ohm impedance, input and output VSWR 2.1 max. +28.5 dBm from 1000-1200 MHz

For detailed specs and curves, refer to 1980/81 MicroWaves Product Data Directory, Gold Book, or EEM.

* BNC connectors are supplied; however, SMA, TNC and Type N connectors are also available.

Mini-Circuits

A Division of Scientific Components Corporation

World's largest manufacturer of Double Balanced Mixers

2625 East 14th Street, Brooklyn, New York 11235 (212)769-0200
Domestic and International Telex 125460 International Telex 620156

Circle 2 on reader service card

122 Technical Articles

EXECUTIVE OUTLOOK

Industry leaders see 1982 turnaround, disagree on recession's depth, 122

COMMUNICATIONS & MICROWAVE

Software pack and controller link DEC computers in an Ethernet, 133

SOLID STATE

C-MOS support logic helps build unified, high-speed systems, 137

TEST & MEASUREMENT

Board testing meets the challenges of ECL, 146

COMPUTERS & PERIPHERALS

Custom video control delivers advanced font graphics, 151

DESIGNER'S CASEBOOK: 142

ENGINEER'S NOTEBOOK: 156

37 Electronics Review

SOLID STATE: Infrared camera relies on large monolithic silicon array with platinum silicide detectors, 37

COMMUNICATIONS: AT&T to offer dial-up 56-kilobit-a-second data service, 38

Bell's value-added service born again, 39

PRODUCTION: Hopes brighten for silver bromide as multipurpose resist, 39

SOFTWARE: CP/M house plans rapid expansion, 40

Intel covers its operating-system bets, 40

Price cut makes Unix stronger contender, 42

FIBER OPTICS: Separated signals aim at gigabit rate, 42

NEWS BRIEFS: 46

PHOTOVOLTAICS: Solar storage cell is looking still better, 46

OFFICE AUTOMATION: Copier marketer adds word-processing equipment, 57

PERIPHERALS: Optical tape holds 50,000 megabytes, 57

69 Electronics International

FRANCE: Gallium arsenide chip sets speed record at room temperature, 81

GREAT BRITAIN: Continuous computing systems catch on with Western European hardware makers, 82

CAD revision packs logic tightly on chips, 82

WEST GERMANY: Siemens tests implanted injector that meters insulin to diabetics, 86

INTERNATIONAL NEW PRODUCTS: 7E

97 Probing the News

SOLID STATE: ISSCC shows that VLSI is starting to earn its keep, 97

COMPUTERS: West is wary of Japan's fifth-generation computer effort, 102

COMPONENTS: Industry warms to high-temp R&D, 106

MICROSYSTEMS: Self-testing processors cut costs, 110

169 New Products

IN THE SPOTLIGHT: 9.6-kb/s asynchronous data modem cuts cost of broadband networking, 169

INSTRUMENTS: Calculator-sized field-service terminal has modem, 176

MICROCOMPUTERS & SYSTEMS: S-100 speech-synthesis card attains special audio effects, 193

COMPONENTS: 125-V voltage regulator combines bipolar and D-MOS technologies, 210

SEMICONDUCTORS: 2 nA holds data in 64-K static random-access memory, 224

C-MOS arrays boast 2-ns gates, 224

INDUSTRIAL: 8085-based single-loop temperature and flow controller is accurate to within $\pm 1^\circ\text{F}$, 237

Departments

Highlights, 4

Publisher's letter, 6

Readers' comments, 8

News update, 12

People, 14

Editorial, 24

Meetings, 26

Electronics newsletter, 33

Washington newsletter, 63

Washington commentary, 64

International newsletter, 71

Engineer's newsletter, 160

New literature, 246

Products newsletter, 257

Career outlook, 261

Services

Reader service card, 13E

Employment opportunities, 262

EDITOR-IN-CHIEF: Samuel Weber

SENIOR MANAGING EDITOR *News*:
Arthur Erikson
MANAGING EDITOR *Technical*:
Raymond P. Capece

ASSOCIATE MANAGING EDITORS:
Alfred Rosenblatt, Howard Wolf

ASSISTANT MANAGING EDITOR:
Margaret Eastman

SENIOR EDITORS: Ray Connolly, John G. Posa

ART DIRECTOR: Fred Sklenar

BUSINESS TRENDS EDITOR: Howard Bierman

DEPARTMENT EDITORS
Aerospace/Military: Ray Connolly
Circuit Design: Ashok Bindra
Communications & Microwave:
Harvey J. Hindin
Components: Roderic Beresford
Computers & Peripherals: Tom Manuel
Microsystems: R. Colin Johnson
New Products: Jeremy Young, Steve Zollo
Packaging & Production: Jerry Lyman
Software: R. Colin Johnson
Solid State: John G. Posa
Test, Measurement & Control:
Richard W. Comerford

STAFF WRITER: Jesse J. Leaf

CHIEF COPY EDITOR: Margaret Eastman

COPY EDITORS: Marilyn A. Harris, David Kach,
Erik L. Keller, Benjamin A. Mason

ART: Charles D. Ciatto, *Associate Director*
Sachiko Inagaki, *Assistant Director*

EDITORIAL ASSISTANT: Penny Reitman

ADMINISTRATIVE ASSISTANT: Kathleen Morgan

EDITORIAL SECRETARIES: Janice Jung,
Josephine Ortiz, Dawn Ramsay

REGIONAL EDITORS

Boston: James B. Brinton,

Linda Lowe (617) 262-1160

Chicago: Wesley R. Iversen (312) 751-3811

Costa Mesa: Terry Costlow (714) 557-6292

Dallas: J. Robert Lineback (214) 742-1747

Los Angeles: Larry Waller (213) 487-1160

Palo Alto: Martin Marshall (415) 968-2712

Washington: Ray Connolly (202) 624-7592

Frankfurt: John Gosch 72-5566

London: Kevin Smith 493-1451

Paris: Robert T. Gallagher 723-4656

Tokyo: Charles Cohen,
Robert Neff 581-9816

McGRAW-HILL WORLD NEWS

Michael Johnson, *Editor*; James Smith, *Brussels*

Lois Bolton, *Milan*; Alex Beam, *Moscow*

Robert Skole, *Stockholm*

PUBLISHER: Paul W. Reiss

GENERAL MANAGER, DIRECT MARKETING
OPERATIONS: Horace T. Howland

DIRECTOR OF CIRCULATION: Frederick J. Kostbar

RESEARCH MANAGER: Margery D. Sholes

PROMOTION MANAGER: Jane DeCourt

MARKETING ADMINISTRATION MANAGER:
Frances M. Vallone

BOOKS & SPECIAL PROJECTS MANAGER:
Janet Eyler

SERVICE REVENUE ASSOCIATE:
June A. Noto

Cover: Industry leaders see recovery, but a tough year, 122

In its worldwide survey for the annual Executive Outlook on economic conditions, *Electronics* finds a general expectation of a turnaround in 1982, but disagreement on the timing. The Reagan Administration's long-range economic plans also wins praise from many, and competing in world markets is getting renewed attention from executives in every country.

The cover design is by Art Director Fred Sklenar; the photograph is by Jim Lukoski.

Circuits conference marks maturing of VLSI, 97

Next February's International Solid State Circuits Conference will include papers on a broad spectrum of very large-scale integrated circuits, indicating beyond question that VLSI technology is now the mainstream of solid-state design around the world.

Controller plus software add up to Ethernet link, 133

New interconnection tools, notably a network controller and software, make it possible to link Digital Equipment Corp. computers with the Unix operating system into an Ethernet.

C-MOS gate packages help build high-speed systems, 137

A family of high-speed complementary-MOS logic circuits fills the requirement for low-power interface chips to link the new fast C-MOS memories and microprocessors. The gate propagation delays of the new series come close to those of low-power Schottky-TTL packages.

In-circuit testers take on emitter-coupled logic, 146

Testing emitter-coupled logic is more than a question of chasing after its speed, and a series of in-circuit test systems is designed to cope with the test problems posed by ECL-based systems. These problems include the lower voltage levels, exacting resistance requirements, and nodes that handle both wired-OR and complementary outputs.

Character-oriented display incorporates bit-map capabilities, 151

A multifunction work station includes a video subsystem that adapts to the user's design needs with add-on options that give it such bit-map display characteristics as graphics, subscripts and superscripts, and boldface and double-width and -height characters. Also, its character fonts may be modified through software changes.

. . . and in the next issue

Packaging very large-scale integrated circuits: a special report . . . the state of the art in electrochromic displays . . . test strategies for the 1980s: a new series.

December 15, 1981 Volume 54, Number 24
106,431 copies of this issue printed

Electronics (ISSN 0013-5070). Published every other Tuesday except the issue of Monday, Nov. 30, by McGraw-Hill, Inc. Founder James H. McGraw 1860-1948. Publication office 1221 Avenue of the Americas, N.Y., N.Y. 10020; second class postage paid at New York, N.Y. and additional mailing offices.

Executive, editorial, circulation and advertising addresses: *Electronics*, McGraw-Hill Building, 1221 Avenue of the Americas, New York, N.Y. 10020. Telephone (612) 997-1221. Teletype 12-7960 TWX 710-581-4879. Cable address: MCGRAWHILLNEWYORK.

Subscriptions limited to professional persons with active responsibility in electronics technology. No subscriptions accepted without complete identification of subscriber name, title or job function, company or organization, and product manufactured or services performed. Based on information supplied, the publisher reserves the right to reject non-qualified requests. Subscription rates in the United States and possessions: \$19 one year, \$32 two years, \$47 three years; company addressed and company libraries \$24 one year, \$42 two years, \$59 three years; Canada and Mexico \$20 one year, \$33 two years, \$48 three years; Japan, Israel and Brazil \$70 one year, \$115 two years, \$165 three years; Australia and New Zealand \$95 one year, \$170 two years, \$240 three years, including air freight, all other countries \$50 one year, \$85 two years, \$125 three years. Limited quota of subscriptions available at higher-than-basic rate for persons allied to field served. Check with publisher for these rates. Single copies \$6.00. Please allow four to eight weeks for shipment.

Officers of McGraw-Hill Publications Company: Paul F. McPherson, President; Executive Vice Presidents Daniel A. McMillan, III, Gene W.

Simpson; Senior Vice President Editorial Ralph R. Schulz; Vice Presidents: Kemp Anderson, Business Systems Development; Robert B. Doll, Circulation; James E. Hackett, Controller; Eric B. Herr, Planning and Development; H. John Sweger, Marketing.

Officers of the Corporation: Harold W. McGraw, Jr., Chairman and Chief Executive Officer; Joseph L. Dionne, President and Chief Operating Officer; Robert N. Landes, Senior Vice President and Secretary; Ralph J. Webb, Treasurer.

Title registered in U.S. Patent Office. Copyright © 1981 by McGraw-Hill, Inc. All rights reserved. The contents of this publication may not be reproduced in whole or in part without the consent of copyright owner.

Where necessary, permission is granted by the copyright owner for libraries and others registered with the Copyright Clearance Center (CCC), 21 Congress Street, Salem, MA 01970, to photocopy any article herein for the base fee of \$0.50 per copy of the article plus \$0.25 per page. Payment should be sent directly to the CCC. Copying done for other than personal or internal reference use without the express permission of McGraw-Hill is prohibited. Requests for special permission or bulk orders should be addressed to the publisher. ISSN 0013-5070/81\$0.50+25.

Subscribers: The publisher, upon written request to our New York office from any subscriber, agrees to refund that part of the subscription price applying to copies not yet mailed. Please send change-of-address notices or complaints to Fulfillment Manager, subscription orders to Circulation Manager *Electronics* at address below. Change-of-address notices should provide old as well as new address, including zip codes. Attach address label from recent issue. Allow one month for change to become effective. Subscriber Service: call (609) 448-8110, 9 a.m. to 4 p.m. EST.

Postmaster: Please send form 3579 to Fulfillment Manager, *Electronics*, P.O. Box 430, Hightstown, N.J. 08520.

The plot may be complicated,

but this new programmable arbitrary waveform/function generator makes the resolution clear

Any waveform you can draw can be entered directly in volts on the new 5910 generator by means of a 1024 x 4000 matrix. Or instead of manually plotting the points, set the Autoprogrammer to rapidly create any waveshape that can be expressed using loops that involve basic arithmetic functions. Either way, your waveforms can be reproduced repetitively, at any amplitude, with excellent waveform resolution.

By adding this arbitrary waveform capability to our popular GPIB-compatible 5900 function generator, Krohn-Hite offers you double function for

your dollar. You have at your fingertips the versatility of a function generator with a bank of nine Storage Registers and an Autoprogrammer with self-contained memory for storing up to 360 steps. Or you can select ARB and produce your own waves digitized to 12-bit resolution.

Easy — that's what they're saying about the 5910. Easy to operate and easy on the budget. Now you can have an arbitrary waveform generator AND a programmable function generator in a single unit.



KH KROHN-HITE CORPORATION

Avon Industrial Park, Avon, MA 02322
(617) 580-1660 TWX 710 345 0831

Krohn-Hite... Benchmark of Quality in Programmable Instruments

OVERSEAS SALES OFFICES:

Arab Republic of Egypt, 860819-963989; Argentina, 52-3185; Austria, 42-23-58, 43-52-87; Australia, 3567333, (07) 52-7255, 03 699 4999, 643 1711/648-1381; Belgium, 02.35.21.35; Denmark, (02) 80-42-00, (45) 6 19 09 77; England, (0734) 861-287; Finland, (90) 742-133; France, 956-81-31; Germany, 0-89/7-14-40-65; Holland, 070-996360; India, 53-30-76; Israel, 72 73 17, 72 87 16; Italy, (02) 34.52.071; Japan, (03) 6675945; New Zealand, TWX, FF7913824; Norway, (02) 78-94-60; Portugal, 57-19-61; Singapore, 637944; So. Africa, (2711) 786-3647; Spain, 257-62-00, 258-09-07; Sweden, 08/38-03-70; Switzerland, 01/734/4171; Taiwan, TWX, 78523855

Never before...

200 watts of RF power with incredible versatility

3200 L spans
250 kHz to 150 MHz.



Now there's a completely solid state power amplifier that provides 200 watts of linear power over a frequency range from 250 kHz to 120 MHz. And at 175 watts, the range extends to 150 MHz.

Imagine the wide range of applications you can cover with this single Class A linear unit. All you need is any standard signal or sweep generator and you have the ultimate in linear power for RFI/EMI testing, NMR, RF Transmission, and general laboratory applications.

And, like all ENI power amplifiers, the 3200 L features unconditional stability, instantaneous failsafe provisions, and absolute protection from overloads and transients.

The 3200 L represents a breakthrough in RF power versatility and packaging. Never before has there been anything like it commercially available anywhere!

Contact us for a demonstration of the 3200 L and our complete catalog on the other amplifiers in our wide line. ENI, 3000 Winton Road South, Rochester, NY 14623.

Call 716/473-6900, or Telex 97-8283 ENI ROC.

ENI



The advanced
design line of
power amplifiers

Publisher's letter

Back in the winter of 1971, the editors of *Electronics* decided that they needed a strong news feature to complement the magazine's highly respected annual world markets survey and forecast. One of them came up with the idea of polling a representative group of chief executives about what concerned them most about the coming year. Thus, the first executive outlook story appeared in the Jan. 3, 1972, issue of *Electronics*. It has since become a year-end tradition that with this issue embarks on its second decade.

Many things have changed in the 10 years since that story idea was broached. There have been recessions and inflation, administrations have changed in Washington, D. C., and some of the editors and writers who worked on that initial outlook piece, along with the executives they first spoke with, have moved on. But there are some concerns that never seem to change. For example, even then there was some worry about trade with Japan as well as about the shrinking technological advantage enjoyed by U. S. electronics firms. And there was some concern about the handling of the economy by the (Nixon) Government.

But one change in the scope of the annual coverage has mirrored that of the electronics industries themselves: the gradual strengthening of what has become a worldwide outlook. Take the executive outlook in this issue (p. 122). Of the 19 industry leaders who were interviewed, six are from outside the U. S. and a seventh heads the U. S. arm of a Japanese company. What's more, there has been a corresponding convergence of concerns.

Associate managing editor Ho-

ward Wolff, who coordinated the effort in New York, says, "It's interesting to note that, while the Americans, French, English, and Germans all are worried about their Japanese competitors, the Japanese themselves express a grave concern over what they euphemistically label trade friction: that is, the growing consensus by other governments that Japanese domination of their domestic markets must be somehow kept under control." Aside from that, there is universal concern about recession, inflation, personnel shortages, and the like.

Another interesting facet of the executive outlook article, as Howard points out, is that it focuses the attention of those questioned by the magazine's editors around the world on a list of a half dozen or so major issues selected by the magazine. Thus, the reader is assured of learning about the universal concerns that are getting the attention of the top executives rather than those that are of interest only to each of the companies individually.

In any event, the executive outlook has grown into a traditional event that now appears in an issue of its own, separate from the markets survey. And nowadays, with the globe having shrunk considerably from the way it was 10 years ago, it can truly be said that there is a single international executive outlook in the electronics industries.

Wanted: a consumer/industrial editor

Electronics has open a challenging editorial position for an electronics engineer with a bent for journalism. Right now, we're looking for someone who can write and edit articles on the latest trends in the areas of consumer and industrial electronics, which include video, audio, speech synthesis, and personal computing in the former and robotics and energy management in the latter. A bachelor's degree and experience in design are desirable. We offer excellent salary and benefits. Write a letter telling us about yourself to the Managing Editor (Technical) at *Electronics*, 1221 Avenue of the Americas, New York, N. Y. 10020.

If nine to five finds you between 1 MHz and 1 GHz, we just made your job a lot easier. Because your new partner, the Wavetek Model 1080 Sweep Generator, is a real workhorse.

It sweeps from 1 to 1000 MHz without a band change. That's in the full sweep mode, where you have a continuously adjustable marker. The other modes are CW and ΔF , where you have a variable sweep width centered around the

marker frequency. Output is also continuously adjustable, from +13 to -70 dBm. And the sweep rates go from 10 milliseconds to 100 seconds.

You'll find Model 1080 easy to understand. There are digital readouts for frequency and output power level. Plus a simplified control panel.

Model 1080 is ready to go to work the moment it's out of the box. No mainframe to mess with, just plug it into the wall.

And it's inexpensive. Just \$1995 including 1, 10 and 100 MHz harmonic comb markers.

To get better acquainted with the Model 1080 Sweep Generator, contact: Wavetek Indiana, Inc., 5808 Churchman, P.O. Box 190, Beech Grove, IN 46107. Phone Toll Free 800-428-4424. In Indiana (317) 787-3332. TWX 810-341-3226.

WAVETEK[®]

Circle #7 for demonstration

Circle #265 for literature

Great news for anyone who sweeps for a living!



When you have a static problem

**Can you locate
and measure it?**

Can you eliminate it?

Analytical Chemical Laboratories can provide the materials, instruments and consulting services to answer these questions.

Staticide™

... a unique topical anti-stat that eliminates static for long periods of time on any material. It is especially useful where non-conductive surfaces and continuous static generation occurs.

Staticide is an easily applied coating that is widely used to eliminate static on electronic components, subassemblies, equipment and environmental surfaces. Product packaging, production assembly and data processing areas can be rendered static-free with Staticide.

Only Staticide brand anti-stat complies with the electrostatic decay requirements of MIL-B-81705B and NFPA-56A. It is non-toxic, non-flammable, biodegradable, EPA registered, inexpensive and performance guaranteed.

Instrumentation

A full line of static measurement and detection devices, from hand-held types to continuous monitoring systems are produced.

Consulting

... Internationally recognized authorities in static control are available to analyze your problem and propose the best solutions.

Write or call for information on how Staticide can solve your static problems.

Analytical Chemical Laboratories

1960 Devon Avenue
Elk Grove Village, IL 60007
312/981-9212

Readers' comments

Of scenarios and sophists

To the Editor: It is unbelievable to me that the American Electronics Association continues to make headlines with its "projection" that the number of electrical engineering graduates must triple in five years ("U. S. asked to help produce EEs," Nov. 17, p. 96). Here's another projection using the AEA approach but different premises.

The number of graduates (in engineering) has approximately doubled since 1973—about a 9% annual rate of increase. The Wall Street Journal (Nov. 17, p. 1) reports that employment of engineers among 164 employers fell 8% since March. That amounts to an 8% drop in seven months, or an annual rate of 14%. Projecting this figure over five years would mean that about half the present engineers will be out of work and there will be no jobs for the new graduates who will number 54% more than now. This is about as believable as the AEA's predictions.

Back in the real world, the engineer's purchasing power is decreasing. In 1960, I started at \$7,200. The consumer price index has since increased by a factor of 3.15, making an equivalent starting salary today \$22,600. With today's higher taxes, it can be seen that the 1960 graduate was better off than 1981's.

Shortage? The data indicates otherwise.

Richard G. Wiley
Syracuse Research Corp.
Syracuse, N. Y.

A good hobby

To the Editor: It's been a long time since I've honestly felt there was a shortage of skilled people in the electronics industry.

In recent years, I've been recommending that young career-seekers avoid electrical engineering. It's a good hobby but a poor livelihood. The classifieds tell the story. Nobody seriously needs engineers. The headhunters want to stuff their filing cabinets, but that's about it.

I'm sure your Career Outlook column and editorial articles take the shortage attitude for a reason: engineers, uncertain of their positions,

want to read that their skills are in demand. There may be more sinister reasons, but the flavor of your verbiage is probably the result of more simple and direct motives.

I'd like to see articles that more realistically reflect the serious problems seasoned engineers have when they want to make a change. I contend the majority of your readers have a far more accurate picture of the EE career field than your magazine presents. As mature problem solvers, they'd like to study the situation from a factual source.

Floyd G. Carle
Garden City, Kansas

Remedial electronics

To the Editor: Congratulations on your editorial in the Oct. 20 issue ("Opportunity, not license," p. 26) in which you excoriated the University of the District of Columbia for its high-pressure advertisement in The Washington Post. Surely, UDC's claim of a "high quality" engineering education is at odds with the fact that 90% of its freshmen cannot read at the ninth grade level.

There is, however, another point that was overlooked. How did UDC receive its accreditation from the Accrediting Board for Engineering and Technology in the first place? ABET is the successor to the discredited Engineers Council for Professional Development, which was accused of being much too lenient in granting accreditation. Clearly, ABET is following the same route.

Part of the problem is the "you scratch my back and I'll scratch yours" attitude on the part of the college professors who comprise the accrediting teams. These teams—IEEE calls them the Boards of Visitors—are appointed by the various engineering societies. Care is taken to ensure that no whistle-blowers or boat-rockers are included.

I have formally requested that ABET initiate an immediate reaccreditation of UDC, and I have volunteered to be a part of the team. Would anyone care to bet on the outcome?

Irwin Feerst
Massapequa Park, N. Y.

Interested in higher performance software?

The Mark Williams Company announces **COHERENT**™ a state of the art, third generation operating system. **COHERENT** is a totally independent development of The Mark Williams Company. **COHERENT** contains a number of software innovations not available elsewhere, while maintaining compatibility with UNIX*. The primary goal of **COHERENT** is to provide a friendly environment for program development. The intent is to provide the user with a wide range of software building blocks from which he can select programs and utilities to solve his problems in the most straightforward manner.

COHERENT and all of its associated software are written totally in the high-level programming language **C**. Using **C** as the primary implementation language yields a high degree of reliability, portability, and ease of modification with no noticeable performance penalty.

Features

COHERENT provides **C** language source compatibility with programs written to run under Seventh Edition UNIX, enabling the large base of software written to run under UNIX (from numerous sources) to be available to the **COHERENT** user. The system design is based on a number of fundamental concepts. Central to this design is the unified structure of i/o with respect to ordinary files, external devices, and interprocess communication (pipes). At the same time, a great deal of attention has been paid to system performance so that the machine's resources are used in the most efficient way. The major features of **COHERENT** include:

- multiuser and multi-tasking facilities,
- running processes in foreground and background,
- compatible mechanisms for file, device, and interprocess i/o facilities,
- the shell command interpreter—modifiable for particular applications,
- distributed file system with tree-structured, hierarchical design,
- pipes and multiplexed channels for interprocess communication,
- asynchronous software interrupts,
- generalized segmentation (shared data, writeable instruction spaces),
- ability to lock processes in memory for real-time applications,
- fast swapping with swap storage cache,
- minimal interrupt lockout time for real-

*UNIX is a trademark of Bell Labs

time applications,

- reliable power failure recovery facilities,
- fast disc accesses through disc buffer cache,
- loadable device drivers,
- process timing, profiling and debugging trace features.

Software Tools

In addition to the standard commands for manipulating processes, files, and the like, in its initial release **COHERENT** will include the following major software components: **SHELL**, the command interpreter; **STDIO**, a portable, standard i/o library plus run-time support routines; **AS**, an assembler for the host machine; **CROSS**, a number of cross-assemblers for other machines with compatible object format with 'AS' above; **DB**, a symbolic debugger for **C**, Pascal, Fortran, and assembler; **ED**, a context-oriented text editor with regular expression patterns; **SED**, a stream editor (used in filters) fashioned after 'ED'; **GREP**, a pattern matching filter; **AWK**, a pattern scanning and processing language; **LEX**, a lexical analyzer generator; **YACC**, an advanced parser generator language; **NROFF**, an Nroff-compatible text formatter; **LEARN**, computer-aided instruction about computers; **DC**, a desk calculator; **QUOTA**, a package of accounting programs to control filespace and processor use; and **MAIL**, an electronic personal message system.

Of course, **COHERENT** will have an ever-expanding number of programming and language tools and basic commands in future releases.

Language Support

The realm of language support is one of the major strengths of **COHERENT**. The following language processors will be supported initially:

- **C** a portable compiler for the language **C**, including stricter type enforcement in the manner of **LINT**.
- **FORTRAN** portable compiler supporting the full ANS Fortran 77 standard.
- **PASCAL** portable implementation of the complete ISO standard Pascal.

- **XYBASIC**™ a state of the art Basic compiler with the interactive features of an interpreter.

The unified design philosophy underlying the implementation of these languages has contributed significantly to the ease of their portability. In particular, the existence of a generalized code generator is such that with a minimal effort (about one man-month) all of the above language processors can be made to run on a new machine. The net result is that the compilers running under **COHERENT** produce extremely tight code very closely rivaling that produced by an experienced assembler programmer. Finally, the unified coder and conformable calling sequences permit the intermixture of these languages in a single program.

Operating System

In part because of the language portability discussed above, and in part because of a substantial effort in achieving a greater degree of machine-independence in the design and implementation of the **COHERENT** operating system, only a small effort need be invested to port the whole system to a new machine. Because of this, an investment in **COHERENT** software is not tied to a single processor. Applications can move with the entire system to a new processor with about two man months of effort.

The initial version of **COHERENT** is available for the Digital Equipment Corporation PDP-11 computers with memory-mapping, such as the PDP 11/34. Machines which will be supported in the coming months are the Intel 8086, Zilog Z8000, and Motorola 68000. Machines for which ports are being considered are the DEC VAX 11/780 and the IBM 370, among others.

Because **COHERENT** has been developed independently, the pricing is exceptionally attractive. Of course **COHERENT** is completely supported by its developer. To get more information about **COHERENT** contact us today.



1430 W. Wrightwood Ave., Chicago, IL 60614
TEL: 312-472-6659 TWX: 910-221-1182

OUR CMOS EPROM WE'VE GOT YOUR



COLLECTION: SIZE AND PRICE.

TREND-SETTING EPROMS.

Intersil is the CMOS EPROM trend-setter. First in 4K, and now in 8K too. Adding to our lead in the fashionable technology for the '80s.

Whether you're in program development or volume production, try on our 8K IM6657/58 (2048x4 and 1024x8, respectively) for size. They're compatible with the CMOS ROMs you're now using, including our IM6316 16K ROM, and with our IM6653/54 4K CMOS EPROMs.

LOW ACTIVE OPERATING POWER.

When it comes to low current requirements, our EPROMs are a cut above the rest. Only 100 μ A standby, and active current that decreases with lower operating frequencies. So battery life can increase 100-fold in your low-power applications.

FASHIONABLY FAST.

Our EPROMs meet and surpass NMOS EPROM speeds, while adding the CMOS advantages of low power, increased reliability, and lower system cost. At 5V, access time is a 1MHz-compatible 450ns. And if you need speed at higher system voltages, our 10V "A" version gives you a 300ns access.

WE'VE GOT YOUR STYLE.

Choose our industrial line, with a temperature range of -40°C to $+85^{\circ}\text{C}$. Or we can tailor your order to military specifications. With 883B processing and full temperature range of -55°C to $+125^{\circ}\text{C}$.

EASY TO PROGRAM.

All our CMOS EPROMs can be programmed by any standard EPROM programmer with the proper personality module. Or, you can get a dedicated 6920 CMOS EPROM programmer from us. After all, we're the leader in CMOS EPROMs.

AVAILABLE NOW. OFF THE RACK.

The new 8K CMOS EPROM dramatically expands Intersil's EPROM production. Both 4K and 8K CMOS EPROMs are in stock. Call or write for our EPROM data sheets and a delivery quotation. Whatever your CMOS ROM or EPROM needs, chances are we've got your size.



INTERNATIONAL OFFICES:

Northern and European headquarters:
Intersil Datel (UK) Ltd., 9th Floor, Snamprogetti House, Basing View, Basingstoke, Hants, RG21 2YS, England. Tel: (0256) 57361. TLX: 858041 INTRSLG.

Central European headquarters:
Intersil GmbH, 8000 Munchen 2, Bavariaring 8, West Germany. Tel: 89/539271. TLX: 5215736 INSL D.

Southern European headquarters: Intersil, Inc., Bureau de Liaison, 217, Bureaux de la Colline, Batiment D (2E Etage) 92213 Saint-Cloud Cedex, France. Tel: (1) 602.58.98. TLX: DATELEM 204280 F.

Far East headquarters (except Japan):
Intersil, Datel (Hong Kong) Ltd., Rm. 1603, Perfect Commercial Bldg., 20 Austin Avenue, Tsim Sha Tsui, Kowloon, Hong Kong. Tel: 3-7214286-7. TLX: 39979 INTDL HX. *Japan representative:*
Internix, Inc., Shinjuku Hamada Bldg. (7th Floor), 7-4-7 Nishi Shinjuku, Shinjuku-Ku, Tokyo 160, Japan. Tel: (03) 369-1101. TLX: INTERNIX J26733.

INTERSIL

Intersil Datel (UK) Ltd.
9th Floor, Snamprogetti House,
Basing View, Basingstoke, Hants,
RG21 2YS, England.
Tel: (0256) 57361
TLX: 858041 INTRSL G.

Dear Intersil:

_____ Dress me in style. Rush me data sheets on
your _____ IM 6653/54 4K EPROMs

_____ IM 6657/58 8K EPROMs.

My annual EPROM usage is
approx. _____ units.

My EPROM application is _____.

Name _____

Company _____

Address _____

City/State/Zip _____

Phone _____

E121581

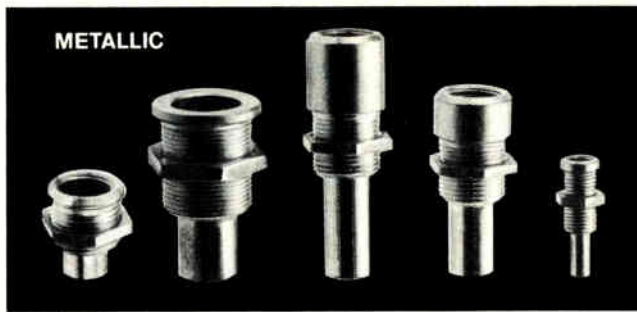

METALLIC



INDUCTIVE/CAPACITIVE

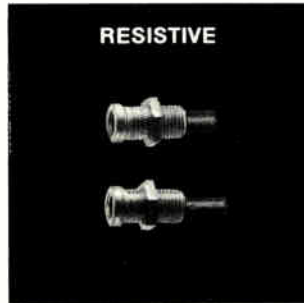

RESISTIVE

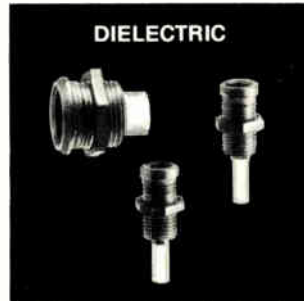

DIELECTRIC

Johanson can tune your waves.

Microwave tuning elements are a unique money saving means of introducing a variable reactance into waveguides, cavities and other microwave structures. They are excellent for applications requiring precision, low loss high resolution tuning. The self-locking, constant torque drive mechanism (U.S. Patent No. Re30,406) eliminates the need for locking nuts and assures stable, noise free adjustment in applications from L to W band.

Electronic Accuracy through Mechanical Precision



Manufacturing Corporation

400 Rockaway Valley Road Boonton, New Jersey 07005
201-334-2676 TWX 710-987-8367

News update

■ Twice-jilted Gould Inc. finally may be about to acquire a semiconductor manufacturer. From its Rolling Meadows, Ill., headquarters, the electronics and electrical products conglomerate late last month announced an agreement with American Microsystems Inc. by which the Santa Clara, Calif., firm would become a wholly owned Gould subsidiary. The proposed deal involves an exchange of stock valued at about \$200 million.

Previous Gould attempts to acquire a chip maker were thwarted when the unwilling targets were snatched up by other bidders. Schlumberger Ltd. got Fairchild Camera & Instrument Corp. [*Electronics*, June 7, 1979, p. 42]. And Mostek Corp., another Gould target, found its white knight in United Technologies Corp. [*Electronics*, Oct. 11, 1979, p. 100].

But this time, there are smiles on both sides of the table. Gould, with sales in 1980 of around \$2.2 billion, has promised autonomous operation for AMI, whose sales that year were \$129.4 million. And AMI board chairman and president Glenn E. Penisten says he is "optimistic" about the marriage.

C-MOS. Gould was particularly attracted to AMI's complementary-MOS lines, says Gould's investor relations director John W. Gannon. C-MOS is the most frequently mentioned technology in Gould's internal surveys of future process-technology needs, he says. Though Gould will be "just another customer" for AMI, "it will gradually expect to get a larger percentage of their sales," Gannon adds. The company currently purchases from \$25 million to \$30 million in semiconductor devices annually.

Gould already has some circuit-design capability internally and now AMI provides the needed production complement. Some 60% of AMI's integrated-circuit output is in custom or semicustom devices, with 25% to 30% of current chip production in C-MOS. The firm now devotes about 25% of its chip output to p-channel MOS devices, with the rest n-channel MOS. **-Wesley I. Iversen**



The keyboard switch with a heart of gold

...keeps your product WORKING year after year...after year.

In your keyboard or ours, Cherry key switches just don't fail. The knife-edge contact area is so small (9 millionths of a square inch)... the contact pressure so great (about 5,000 psi) ... the gold alloy so pure and film-free ... that you are assured of positive contact every time. For 50 million operations and beyond. (Which is probably beyond the life expectancy of your product!)

Cherry "heart of gold" keyboard switches are available individually or with two-shot molded keycaps. Hopefully, you want keycaps. Because, *we have keycaps* ... in more legends, sizes, type faces than you're likely to find anywhere else. Sculptured keycaps? We've got 'em. Gloss or matte finish? We've got *both*. Colors? Lighted? Specials? Sure! Some "off the shelf"... all at prices that make it obvious why the *Cherry way* is the *economical way* to put a heart of gold in any keyboard

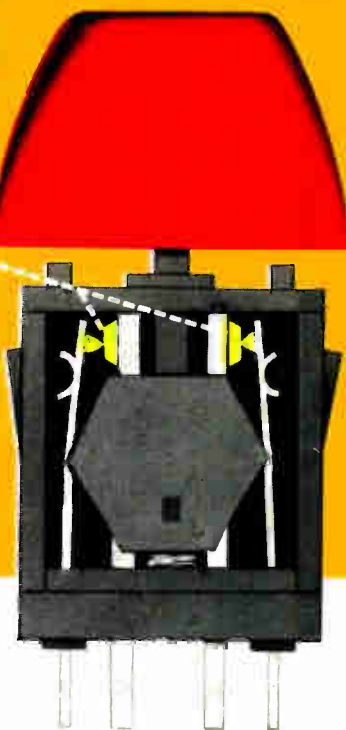

Get this 32 page, full color catalog of Cherry keyboards, keyboard switches and keycaps. Yours free for the asking.

Cherry switches now available locally from distributors.



CHERRY ELECTRICAL PRODUCTS CORP., 3608 Sunset Avenue, Waukegan, IL 60085

Circle 13 on reader service card



TRW Optron OPTICALLY COUPLED ISOLATORS

NEW JAN 4N22A SERIES
OFFERS
HIGHEST RELIABILITY

You can't buy a more reliable optically coupled isolator than one of TRW Optron's new JAN 4N22A series. The popular JAN 4N22A, 4N23A and 4N24A all feature fully qualified JANTX AND JANTXV ratings.

These new TRW Optron isolators consist of a high efficiency, solution grown gallium arsenide LED and a silicon N-P-N phototransistor in a hermetically sealed 6-pin TO-5 package. Minimum input-to-output isolation voltage for the series is 1000 volts and minimum current transfer ratios range from 25% for the 4N22A to 100% for the 4N24A.

New "A" version TRW Optron isolators are a significant improvement over the older 4N22 series since the case is isolated from the sensor and LED to eliminate the need for an insulating spacer in many applications.

TRW Optron also offers a new JEDEC registered series of high reliability isolators in a 4-pin TO-18 package. The 3N243 series includes three devices with the same reliability and similar characteristics as the JAN 4N22A TO-5 series, yet in a smaller package.



3N243

TRW Optron's complete line of optically coupled isolators includes other immediately available standard devices in high-rel metal cans and low cost DIP and other plastic configurations for almost every application.

Detailed technical information on optically coupled isolators and other TRW Optron optoelectronic products... chips, discrete components, reflective transducers, and interrupter assemblies... is available from your nearest TRW Optron sales representative or the factory direct.

TRW OPTRON
A DIVISION OF TRW INC.

1201 Tappan Circle
Carrollton, Texas 75006, U.S.A.
TWX-910-860-5958
214/242-6571



People

TI's McDonnell leads revolution in the hills of East Tennessee

On the surface, Johnson City, Tenn., may appear to be an unlikely site for an up-and-coming Texas Instruments Inc. division, but don't be fooled by the rustic mountain terrain. Although the East Tennessee location is miles away from traditional technology hubs, TI's corporate fathers have plans to make the Electronic Controls division a star performer in the 1980s, explains Millard McDonnell, manager of the operation.

The division, not quite two years old, is part of a quiet, ongoing evaluation—an industrial-

automation revolution. It is rapidly arming factories around the world with solid-state programmable controllers, which are replacing traditional mechanical relay switches and boosting plant productivity with the flexibility of digital technology.

McDonnell says that bringing microelectronics to the industrial world has been no small task for controller manufacturers, which include the likes of Gould Inc.'s Modicon division and Allen-Bradley Co. But TI learned early on that the key to replacing relays is "keeping it user-friendly," notes the West Texas native, who graduated from Rice University in Houston with a five-year degree in electrical engineering.

McDonnell, who joined TI in 1958, hastens to add that "reliability is the way to stay in the factory once you get there. Features and prices are important in this business, but in the long run, reliability is the most important—it must run and run and run."

The next major challenge facing programmable-controller makers is local networks in the factory area, which, like office networks, will

allow distribution of intelligence and communication between machines. Because manufacturing controls are crucial to safety and profits, the reliability of these factory networks must be much higher than in the office of the future.

"It's very, very different from office networks," McDonnell says. "If a word processor misses a bit,



Friendly. TI's Millard McDonnell says the secret of getting industrial firms to use microelectronics is user friendliness.

then what you've got is a mad secretary. If a factory network fails, then you may end up with 50,000 gallons of milk on the floor, or, even worse, a fatal accident."

Jackson looks for Altos to triple sales in 1982

In 1977, when David Jackson started Altos Computer Systems, the buzzword was bus-oriented systems. But Jackson had a different idea: rather than make a microsystem that could be everything to everybody through a wealth of plug-in boards, why not make a single-board computer that was most things to most people?

"If you build a machine with the best price-performance ratio in its field, you don't have to define your market, it defines itself," claims Jackson—a statement that departs widely from the old established marketing philosophies.

His idea worked, since today Altos is one of the largest microsystem manufacturers, shipping at a rate that should mean a gross of \$65 mil-

PDP-11[®] and LSI-11[®] TAPE and DISK CONTROLLERS



AUTHORIZED EMULEX DISTRIBUTOR
First Computer Corporation, the world's leading DEC computer system integrator now distributes the complete spectrum of EMULEX Tape and Disk controllers for the PDP-11 and LSI-11 family of computers.

HARDWARE / SOFTWARE TRANSPARENCY

These microprogrammed, emulating Tape and Disk Controllers are fully software transparent to both the PDP-11 hardware and software. The use of these controllers protects you from the impact of future versions of the operating system software. They are so compatible you can plug them into your system and be up and running the standard DEC diagnostics and operating systems in minutes.

ADDED FEATURES

These controllers provide you with added features such as automatic self-testing, onboard pack formatting, and programmable bandwidth control at no additional cost.

® Registered trademark of Emulex Corporation
® Registered trademark of Digital Equipment Corporation
™ Trademark First Computer Corporation

BROAD RANGE OF DEVICES SUPPORTED

It makes no difference which of the DEC PDP-11 or LSI-11 family you are using or which type of storage device is required for your application. We can support 59 different drives from 13 different manufacturers.

HIGHEST QUALITY AND SUPER RELIABILITY

You can be assured of the quality and reliability of these Tape and Disk Controllers because First Computer Corporation specializes in PDP-11 and LSI-11 computer systems, components, and peripherals. Over the years our reputation was built on the quality and reliability of the products we sell. We continue to protect this reputation by selling only the very best.

SUPER FAST SERVICE

Because we are the largest system integrator specializing in PDP-11 and LSI-11 systems, components, and peripherals, First Computer Corporation can satisfy most of your Tape and Disk Controller requirements directly from our stock.

GUARANTEED SATISFACTION

Your satisfaction is fully guaranteed by First Computer Corporation. We believe in every product we sell. If for any reason these Tape and Disk Controllers do not meet your expectations, simply return them freight prepaid and insured, within 10 days of receipt and we will refund your money in full. First Computer Corporation backs each of these products with a full one year warranty.

AUTHORIZED REPRESENTATIVES AND DEALERS

Authorized EMULEX Sales Representatives earn full commissions for orders filled by First Computer Corporation. Attractive Dealer discounts are available to all Authorized EMULEX Dealers.

PRICE AND PERFORMANCE

You pay no more for First Computer Corporation service. Write or call today for our free EMULEX Buyer's Guide.



First computer corporation

645 BLACKHAWK DRIVE / WESTMONT, ILLINOIS 60559 (312) 920-1050

TWX NUMBER 910-651-1916

CE3

SOUTHERN REGION
Houston, TX (713) 960-1050

WESTERN REGION
California (To be announced)

NORTH CENTRAL REGION
Chicago, IL (312) 920-1050

Circle 15 on reader service card

Monosil. The original semiconductor foundry.

The semiconductor foundry business is not a new idea at Monosil. In fact, we've been building wafers, chips and packaged devices for over seven years using a variety of processes including metal gate CMOS, PMOS, NMOS, silicon gate CMOS, PMOS, NMOS, I²L, ISO-C-MOS, bipolar, linear bipolar, and dielectric isolation.

We can work from your mask, PG tape or composite design. And... because we also do custom IC work, we understand the importance of immediate response. Our foundry programs are specifically designed for cost-effective product evaluation as well as fast prototype delivery.

Monosil also maintains a complete line of gate arrays and special 4-bit microprocessors. If you have questions about custom IC development of any kind, give us a call.

Monosil.
We were there at the beginning.

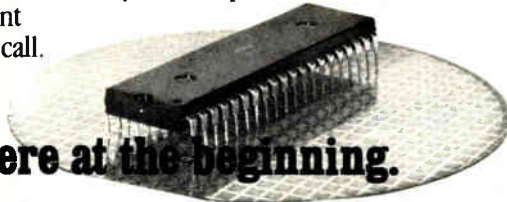

Yes, Monosil! Please tell me more about your

- | | |
|---|--|
| <input type="checkbox"/> Wafer foundry | <input type="checkbox"/> Special microprocessors |
| <input type="checkbox"/> Complete line of gate arrays | <input type="checkbox"/> Other _____ |
| <input type="checkbox"/> Custom ICs | |

Name _____

Title _____

Company _____

Address _____

City _____ State _____ Zip _____

Telephone () _____

Simply clip out this coupon and send it to Monosil, 3060 Raymond Street, Santa Clara, CA 95050. Or call us at (408) 727-6562. TWX 9103380540.

Monosil, Inc.
3060 Raymond Street
Santa Clara, CA 95050
(408) 727-6562 TWX 9103380540



European Office
In Brussels:
2-268.41.29
TLX 25387

lion next year after \$20 million for 1981. Jackson's long-term goal for Altos is "to join the ranks of Prime and DEC," hoping for sales in excess of \$500 million in five years.

The 44-year-old Jackson came to the U. S. in 1963 from London with a London University degree in math and physics. Subsequently, he worked as an engineer on a variety of digital-computer-related projects at several established firms. However, Jackson's aspiration was always to run his own company.

In 1969 he made his first attempt, starting Peripheral Technology with \$40,000 he had made in the stock market and \$500,000 that he acquired in venture capital. About a year later, it became clear that the company was not going to be the lifelong project that Altos is and he bailed out, selling the company to Pertec Computer Corp. for a profit of about \$100,000.

"In 1971, when Intel invented the microprocessor, that started me



Paying off. David Jackson has parlayed his single-board idea into a top industry spot.

thinking. I spent the next five years working for computer firms in non-engineering capacities, finally with DEC, refining my ideas." And in 1977, it all came together with the Z80-based single-board microsystem that has made Altos so successful.

"We've always been technology-driven, and we intend to stay that way," notes Jackson. For the immediate future, Altos is preparing to ship its eight-user microsystem, an 8086-based affair that sells for \$10,500, with a choice of MP/M-86, Unix, or Oasis operating systems. □

FRIENDLINESS.

Informative HP manuals, helpful error messages, and automatic syntax checking make BASIC language programming easy.

EXPANDABILITY.

Just plug in the HP interface bus (HP-IB) and add up to 14 peripherals without disassembly.

FULL-SCREEN EDITING.

Edit the easy way – without retyping entire statements. Insert, change, or delete characters at the touch of a key.

12-DIGIT ACCURACY.

(Not just 9!) Thanks to BCD math capability.

HP SOFTWARE.

Powerful, time-saving solutions to your everyday problems.

PORTABILITY.

Keyboard, CRT, printer and storage – all in a 20-lb. package. So you'll have computing power wherever you need it... office, lab, field, or home.

INTEGRATED GRAPHICS.

Analyze a better way – with graphics. Document your results with hard-copy plots.



Hewlett-Packard put it all together.



The HP-85 personal computing system.

Leave it to Hewlett-Packard to put a lot of power in a little package. Plus flexibility, portability, and all the other features you'd expect to find in a personal, professional, integrated computing system.

Turn it on and the HP-85 is ready to go. You're off and running using HP software or creating your own programming solutions. There's no bootstrapping. And since the operating system and powerful BASIC language exist in ROM, they use almost none of the available RAM.

If you've been looking for a friendly, integrated

computer with power and dependability, look at the HP-85.

We put it all together for you!

For further information, phone toll-free, 800-547-3400, Dept. 214N, except Alaska/Hawaii. In Oregon, call 758-1010. Or, write Hewlett-Packard, Corvallis, OR 97330, Dept. 214N.

611/22

When performance must be measured by results.



**HEWLETT
PACKARD**

**SINCE 1976,
ONE FAMILY
HAS
QUIETLY
CONTROLLED
THE WORLD.**

Think about it for a minute.

There are all kinds of microcontrollers on the market today. Handling literally billions of control functions all over the world. In everything from toys to terminals to satellites.

But when it comes to performance, flexibility, and quality, there's one family that's taken control right from the very beginning. And set all the standards.

Our 8048 family of microcontrollers.

Because ever since we introduced the 8048 five years ago, it's quietly established itself as the World Standard in every way.

With more customers, more design wins, and more second sources than any other microcontroller. All of which makes our 8048 family a very attractive choice. No matter what you're designing.

Because of the obvious benefits of our learning curve. High volume, lower cost, higher reliability.

Because of the worldwide acceptance of the 8048 architecture. So you can look forward to a long life. And so you can hit the ground running with new applications, cutting both development costs and time to market.

Because the 8048 family is still in the earlier stages of its life cycle. Which means you'll be able to grow right along with it, whether you're

upgrading from 4-bit or looking for an easy path for future expansion.

And because we give you pin-compatible EPROM versions for even faster design cycles. Plus a complete package of hardware and software development support. A whole variety of products based on the 8048 architecture, to fit your exact application. And a huge network of factory and field applications engineers to give you the support you need.

With all this going for us, it's easy to see why the 8048 has become the world's best-selling 8-bit microcontroller. And we're fully committed to keeping it that way. You can count on us to deliver the volume you need. When and where you need it.

We'd like to tell you more. About applications. About customer training. And about all the 8048 family. Including our new high-performance 8051. Our new 8749 and 8751 EPROM microcontrollers. And our brand new low-power CHMOS versions, too.

Just get in touch with your local Intel distributor. Or write Intel Corporation, 3065 Bowers Avenue, Santa Clara, CA 95051. (408) 987-8080. We'll send you complete information.

And help you quietly take control of a nice big share of your own market.

intel® delivers solutions



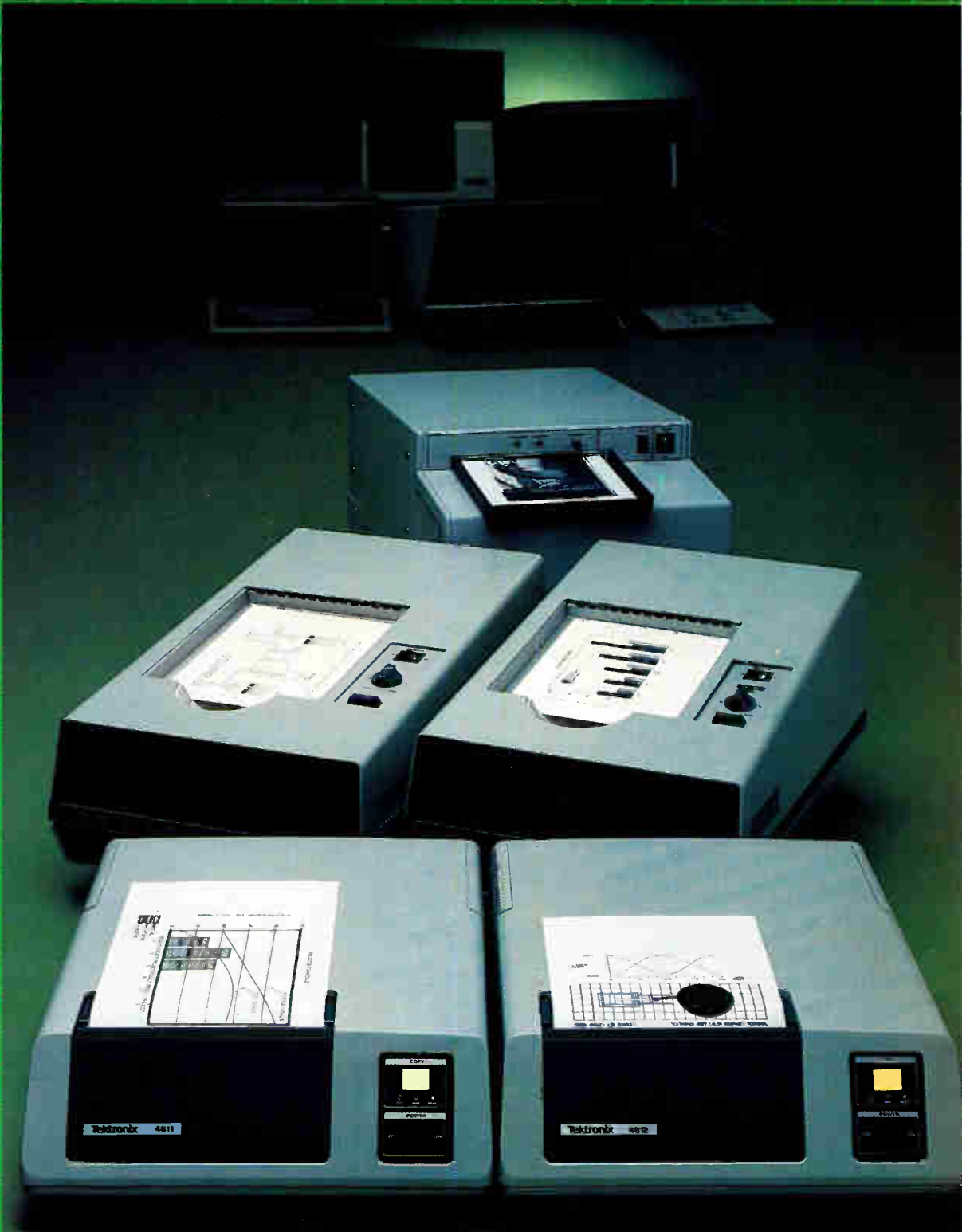

Copyright ©1981, Tektronix, Inc. All rights reserved. OEM quotations available on request. 103-1

Fast copies. Raster scan or storage tube. It's easy to get attached to a Tektronix CRT copier.

The fine art of quick CRT copies: no one has mastered it better, for more kinds of terminals, than Tektronix. Owners of Tektronix terminals aren't the only ones to take advantage of our leading hard copier expertise. Far from it: our copiers are plug-compatible with both storage tube and a wide variety of raster scan terminals. They can copy the most detailed monochrome and continuous tone images, and provide economical gray-scale reproductions of color displays.

For precision's sake: a complete line of fiber optics copiers. Compact, quiet, reliable, our extensive 4630 fiber optics series is designed for the sharpest of copies. No toner or chemicals are ever required. The 4630 Series is your best choice for the most exacting reproductions, for gray scale working copies of color video displays, or for photographic-quality images from either single page or continuous roll feed copiers.

For practicality's sake: our electrostatic devices offer an extra measure

of economy, without shortchanging you on quality. Our 4610 Series introduces an electrostatic process that's economical, and that produces darker, smoother lines than ever before. The copiers are light weight, use a new easy-loading dry toner, and provide the perfect solution to everyday CRT copier requirements.

However your needs evolve, you'll develop a lasting attachment to Tektronix. You can multiplex as many as four workstations to one Tektronix copier. Clean, dry results come out in seconds, at a cost of just pennies a page. Of course, fast service is available, if you ever need it, from expert Tektronix service people around the world.

You can also get attached to Tektronix as a prompt resource for copier supplies, including the highest quality dry silver and electrostatic paper; toner; and interconnecting cables of various lengths.

For additional literature, or the address and phone number of the Sales Office nearest you, contact Tektronix.



U.S.A., Asia, Australia, Central & South America, Japan
Tektronix, Inc.
P.O. Box 4828
Portland, OR 97208
Phone: 800/547-1512
Oregon only: 800/644-9051
Telex: 910-467-8708
Cable: TEKTRONIX

Europe, Africa, Middle East
Tektronix Europe B.V.
Postbox 827
1180 AV Amstelveen
The Netherlands
Telex: 18312

Canada
Tektronix Canada, Inc.
P.O. Box 6500
Barrie, Ontario L4M4V3
Phone: 705/737-2700

Tektronix
COMMITTED TO EXCELLENCE

Circle 21 on reader service card



A processor and a 2500 gate controller that shatter the sub-100ns microcycle barrier. A 50ns 16 x 16 multiplier. A 16K PROM with a 35ns access time.

And that's just a preview of what our new process lets us do.



Ever since we started the bipolar LSI business with

the Am2901 back in 1975, we've been making everything in our 2900 family faster and denser. Now, thanks to IMOX™, we're doing it even better than before.

IMOX is our advanced,

ion implanted, oxide isolated process. It gives us smaller chips; faster, more complex devices.

And because IMOX lets us use ECL internal structures with TTL I/O, you get all this unbelievable speed without any interface problems.

Advanced Micro Devices • **Austria:** Kontron Ges. m. b. H., A-2345 Brunn am Gebirge. Tel: (02236) 8 66 31. Telex: 79337 **Belgium:** AMD Overseas Corporation, B-1150 Bruxelles. Tel: (02) 771 99 93. Télex: 61028. • **MCA Tronix S.P.R.L.**, B-4200 Ougree. Tél: (041) 36 27.80 Télex: 42052 **Denmark:** Advanced Electronic of Denmark Aps. DK-2000 Copenhagen F. Tel: (01) 19 44 33. Telex: 22 431 **Finland:** Komdel OY, SF-02271 Espoo. Tel: (0) 885 011. Telex: 12 1926 **France:** AMD, S.A., F-945E8 Rungis Cedex. Tél: (01) 686 91.86. Télex: 202053. **Germany:** AMD GmbH, D-8000 München 80. Tel: (089) 40 19 76. Telex: 523883 • **AMD GmbH**, D-7024 Filderstadt 3. Tel: (07158) 3060. Telex: 721211. **Italy:** AMD, S.r.l., I-20090 MI2-Segrate (MI). Tel: (02) 215 4913-4-5. Telex: 315286 **Israel:** Talviton Electronics Ltd., Tel-Aviv. Tel: (03) 444572. Telex: 03-3400. **Japan:** AMD, K.K., Tokyo 168. Tel: (03) 329-2751. Telex: 2324064. • **AMD, K.K.**, Osaka 564. Tel: (06) 386-9161. **Netherlands:** Arcobel BV, NL-5342 PX Oss. Tel: (04120) 30335. Telex: 37489. **Norway:** A.S. Kjell Bakke, N-2011 Strømmen. Tel: (02) 71 53 50. Telex: 19407. **South Africa:** South Continental Devices (Pty.) Ltd., 2123 Pinegowrie. Tel: (011) 789-2400. Telex: 4-24849. **Spain:** Sagitron S.A., Madrid-1. Tel: (01) 275-4824. Telex: 43819. **Sweden:** AMD AB, S-172 07 Sundbyberg. Tel: (08) 98 12 35. Telex: 11602 • **Svensk Teleindustri AB**, S-162 05 Vällingby. Tel: (08) 89 04 35. Telex: 13033 **Switzerland:** Kurt Hirt AG, CH-8050 Zürich. Tel: (01) 302 21 21. Telex: 53461 **United Kingdom:** AMD (U.K.) Ltd, Woking, Surrey GU21 1JT. Tel: (04862) 22121. Telex: 859103

ON MAY 4, 1980, AMD DISCOVERED A NEW WAY TO MAKE HIGH PERFORMANCE ICs.

TAKE THE NEW 2901 C.

It's half the size, one-third the price, and more than twice the speed of the Am2901.

And we're making high-speed VLSI devices right now that are going to replace three whole PC boards of FAST or AS MSI. That's

about 200 fewer chips—200 fewer ways to use power, spend money and waste time.

FOUR BIG, HAPPY FAMILIES.

You can come to AMD for total design solutions, not just a part here and there.

We've got high performance IMOX LSI families

for signal processors, controllers, CPUs, plus all the interface and support you're ever going to need. Not only that, we're using IMOX to make the fastest, most complex proms ever.

And all of them come with a quality guarantee you can't get from anybody else.

If you want the newest, the fastest, the most complete families of high performance LSI, call AMD. We'll show you the light.

The International Standard of Quality guarantees these electrical AQLs on all parameters over the operating temperature range: 0.1% on MOS RAMs & ROMs; 0.2% on Bipolar Logic & Interfaces; 0.3% on Linear, LSI Logic & other memories.

INTSTD-25

Advanced Micro Devices

For more information, call one of our distributors or write the words "IMOX Family" on your letterhead and mail it to Advanced Micro Devices Mail Operation, P.O. Box 4, Westbury-on-Trym, Bristol BS9 3DS, United Kingdom.

Universities' fear of R&D bills is misplaced

A piece of legislation whose passage is of vital and immediate concern to the high-technology community in the United States has up till now been moving smoothly through the Congress. However, its critics have begun to make headway with their lobbying such that they could derail the measure.

At stake are two bills, one in each house. They would redress, if only to a small degree, the egregious imbalance that now exists between the amount of research and development money that flows from the Federal government to small businesses and the grants to other recipients, principally the colleges and universities. It is estimated that small businesses now receive a mere 4% of the \$40 billion annual Government R&D dispensation. But it is well known that these same small businesses engender far more than their share of technological innovations.

Enter the colleges. Understandably worried that any funds to someone else would eat into their pot, they have mounted a campaign against the bills, which were introduced in the Senate by freshman Republican Warren Rudman of Vermont and in the House by Democrat John J. LaFalce of New York. The college administrators, academic scientists, and Government research officials explain that every little cut smarts in these days of vast slashes in basic science budgets.

Rudman's bill has 86 cosponsors in the Senate, and the House bill carries close to 100 names. Ordinarily, support like this would guarantee passage. But now the House Committee on Science and Technology and the House Committee on Energy and Commerce have both asked for a shot at the LaFalce bill before it gets to the floor. Both committees are viewed by Capitol Hill observers as sympathetic to the universities' side.

Rudman's bill would require Federal agencies with annual R&D budgets over \$100 mil-

lion to establish small-business innovation research programs. Those programs would receive at least 1% of the funds the agencies allot to outside R&D.

The LaFalce bill in the House differs from Rudman's mainly in that the amount to be diverted to small businesses would be at least 3%. However, Rudman's bill exempts grants and contracts from other sources while LaFalce's are not. In both bills, the percentages mandated are minimums.

The universities claim they do not object to spreading Federal seed money among small businesses so much as they are opposed to the rigid quotas. Some spokesmen for the academic science establishment suggest that the SBIR programs should compete for agency funds just like other programs.

To respond, first of all, the growth rates of small businesses generally outstrip those of large corporations, generating more new jobs than other segments of the society. Certainly, in a time of climbing unemployment, any enterprise that adds jobs to the economy should be encouraged.

Secondly, the amount of money involved here is relatively paltry by Government standards—the LaFalce version in its present form would provide but \$1.2 billion a year.

Most of all, the critics' suggestion that small businesses should throw their lot in with big business is cynical, to say the least. The small entrepreneur has neither the time nor the resources to lobby for Federal funds. Under the system now in effect, small high-tech firms have received next to nothing—what is to say they will do better in the future?

The Rudman and LaFalce bills deserve to be passed, and without further delay. A clear signal from the Government that it encourages small business is imperative.

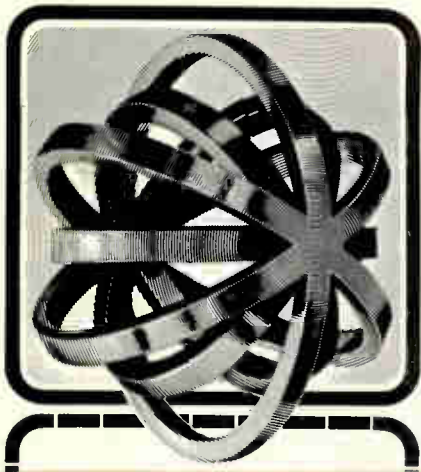

Meetings

International Winter Consumer Electronics Show, EIA (2001 Eye St., N. W., Washington, D. C. 20006), Convention Center, Las Vegas, Nev., Jan. 7-10, 1982

Symposium on Silicon Processing, National Bureau of Standards (Elaine Cohen, A308 Technology Building, NBS, Washington, D. C. 20234), Le Baron Hotel, San Jose, Calif., Jan. 19-21.

Internecon/Semiconductor International Data and Telecommunication show, Cahners Exposition Group (222 West Adams St., Chicago, Ill.

necticut Path, Framingham, Mass. 01701), South Padre Hilton Resort, Brownsville, Texas, Feb. 3-5.

16th Annual Television Conference, Society of Motion Picture and Television Engineers (Lynne Robinson, 862 Scarsdale Ave., Scarsdale, N. Y. 10583), Opryland Hotel, Nashville, Tenn., Feb. 5-6.

5th European Exhibition and Congress for Telecommunications, Online GmbH (Postfach 10 08 66, D-5620 Velbert 1, West Germany), Düsseldorf Fairgrounds, West Germany, Feb. 8-11.

Make the most of your host with the lowest cost development tool available.

It's called RADIUS*. By using one with a host computer (any host †), you can develop Z80 and 3870 applications for a lot less than ever before. In fact, at \$2995, plus an emulation module, RADIUS is the most inexpensive microprocessor/microcomputer development station available. Yet it's fast, powerful and reliable.

Why? Because RADIUS lets you take full advantage of the host's speed and power to develop the application software. Once completed, the software is downloaded to the RADIUS (using a link-error-tolerant protocol). Then, using only the RADIUS with the appropriate emulation module, you can perform the full range of real-time, in-circuit emulation and debug needed for hardware development and software integration.

A very friendly user interface makes it all possible. Local or remote (with a MODEM) emulation capability makes it very practical as well. Because at the price we're offering RADIUS, the idea of multiple development stations is more affordable than ever.

In a multi-user environment, for example, you can connect several RADIUS units to an appropriate host and operate them simultaneously to perform entirely separate jobs. This configuration also supports the development of multiple microprocessors and microcomputers.

A SMART WAY TO DEVELOP PLANS FOR THE FUTURE.

In addition to Z80 and 3870 emulation capability, RADIUS will also accept the forthcoming emulation module for the MK68000, our new



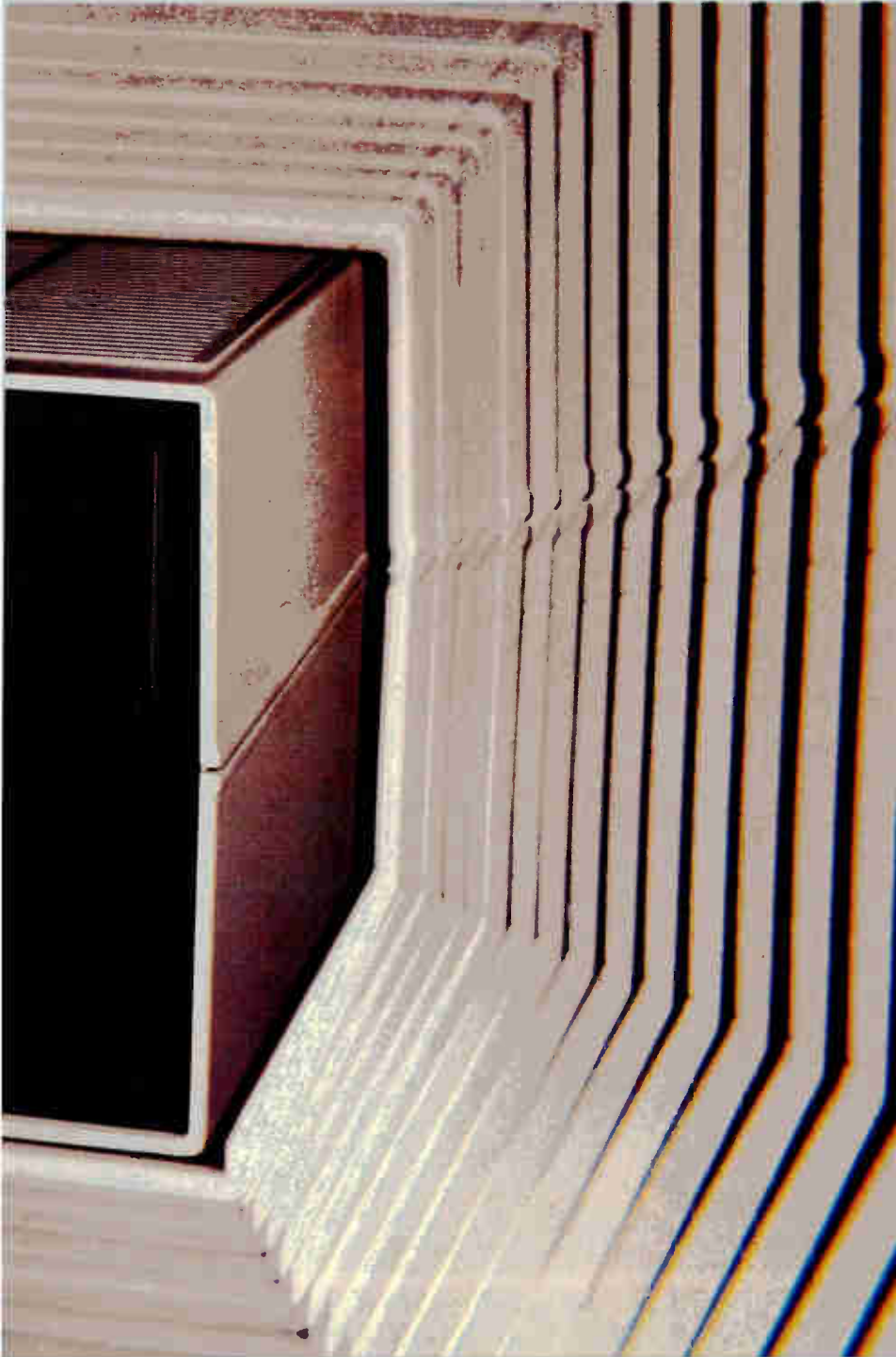

16-bit microprocessor. So no matter which way you're going or plan to go, 8-bit or 16-bit, RADIUS can help you get there. For less.

Find out more by contacting Mostek, 1215 West Crosby Road, Carrollton, Texas 75006 (214) 323-1801. In Europe, contact Mostek International at (32)(02) 762.18.80. In the Far East, Mostek Japan KK (03) 404-7261.

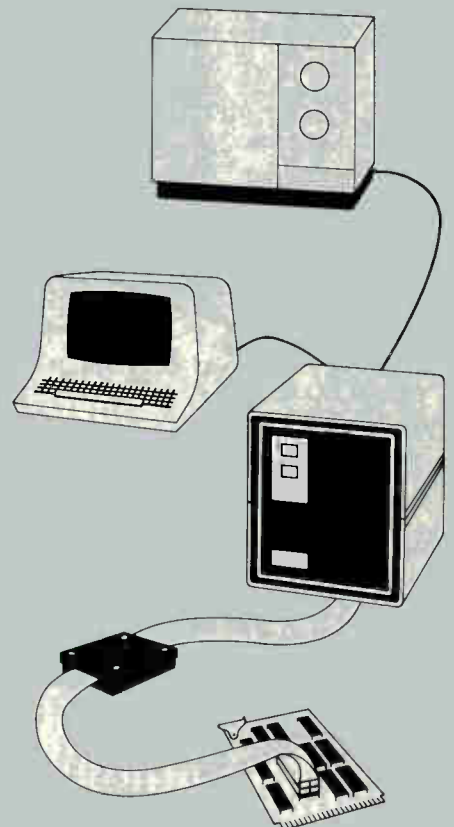

*RADIUS is a trademark of Mostek Corporation

†Handshake software packages available for DEC. PDP-11 and VAX. More will be available soon. For others, Mostek will provide source code and compatibility conversion instructions. (DEC. PDP-11 and VAX are trademarks of Digital Equipment Corporation).

©1981 Mostek Corporation

Circle 29 on reader service card

GOULD BIOMATION K100-D

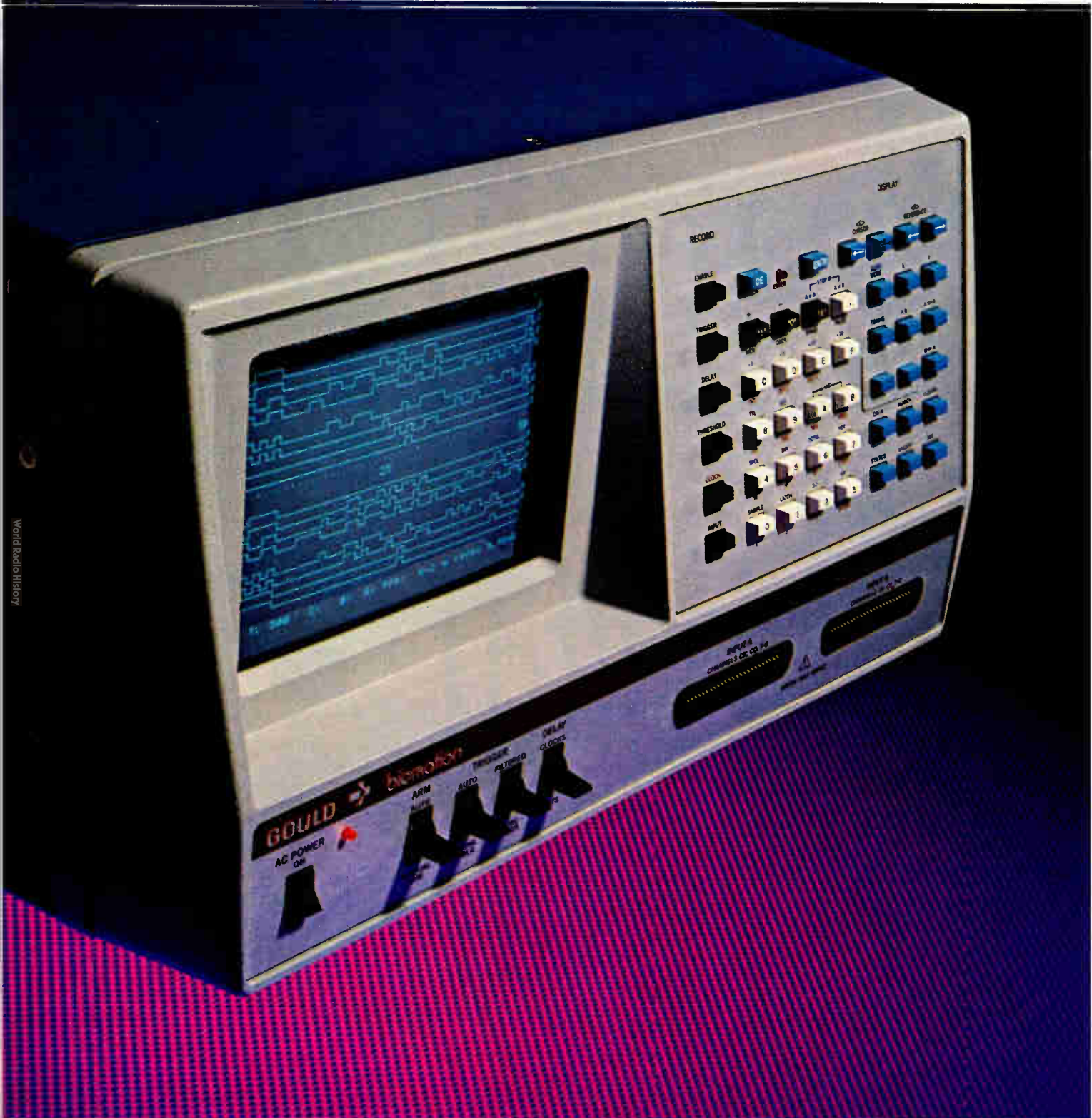

World Radio History

7 reasons why the K100-D is now the world's best-selling logic analyzer.

How the general-purpose K100-D beat out H-P to become #1.

Not so long ago, Hewlett-Packard logic analyzers were the industry standard. We asked digital designers to compare the K100-D with H-P's popular 1610B and 1615A logic analyzers before making any buying decision.

In head-to-head comparison, the K100-D came out looking so good, it's now the best-selling logic analyzer in the world. Here's why:

1. It's easy to systematize.

For automated troubleshooting and production ATE, the K100-D features a fully-programmable GPIB interface.

To help you support a wide variety of bus-oriented systems, there are standard high-performance probes, specialized probing accessories and detailed application notes available on all the popular microprocessor systems currently in use.

2. It's concise.

The K100-D monitors 16 channels in time domain, 32 in data domain, so you can probe enough points to pin down problems at their source.

3. It's fast.

A 100 MHz clock rate resolves signals to 10 nanoseconds. The front end is also sensitive enough to capture glitches as narrow as 4 ns.

4. It's deep.

1024 words deep in memory—for faster, more accurate debugging. The K100-D extends the length of data you can trap from your system at any one time.

5. It's clear.

The K100-D has a large keyboard and interactive video display, a comprehensive status menu, highly useful time domain display, and data domain readout in user-specifiable hexadecimal, octal, binary or ASCII.

6. It has remote diagnostics.

A new T-12 communications interface option lets your field troubleshooters share their system observations with the best engineers back at headquarters. Remote diagnostics provide faster debugging and save a lot of time and travel for your most valuable people.

7. It's well supported.

You get full applications support from the experts in logic analysis.

For a free copy of our "Logic Analyzer Comparison Guide," request card for microprocessor system application notes, and T-12 Communicator information, just circle the appropriate reader service numbers. Or contact Gould, Inc., Instruments Division, Santa Clara Operation, 4600 Old Ironsides Drive, Santa Clara, CA 95050, phone (408) 988-6800.

The T-12 "top hat" for the K100-D provides logic analyzer remote diagnostic capability. Other options include the GPIB Analyzer and RS232 Serial Data Analyzer.



 **GOULD**
Electronics & Electrical Products

Circle 30 for Comparison Guide
Circle 31 for APP Note request form
Circle 32 for T-12 communicator data
World Radio History

No other oscilloscope offers this much in one package.

Large 16K Memory

See things you've never seen before with a time resolution of up to 16,000:1 and a dynamic range of up to 32,000:1. Zoom in on the smallest signal detail with expansion up to x256 on both axes. By using subsections of memory, you can display up to 32 stored waveforms simultaneously.

4-Channel Operation

Capture, store and display four signals simultaneously using two plug-ins operating on the same, or totally independent, timebase and trigger. Compare live and stored waveforms in real time. Even compare interactive variables such as voltage/current or stress/strain using X-Y display of either live or stored signals.

Pre- and Post-Trigger Delay

Look into the past or future with a pre-trigger delay from 500 nano-seconds to 37 days or a post-trigger delay up to 106 years. Avoid accidental triggering by checking the threshold and sensitivity using the trigger-view mode.

Signal Averaging

Extract repetitive signals from noise using sweep averaging. Even smooth those slow, noisy, one-shot signals by using the unique point-averaging mode.

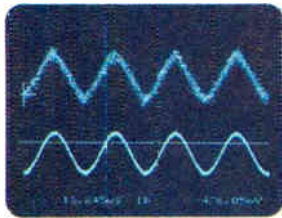

Alphanumeric Display

Get absolute or relative measurements from any portion of the waveform using the cursor-interactive time and voltage readout. The numerics include a channel identifier to eliminate errors even on multiple trace displays.

Data Manipulation

As with all Nicolet scopes, manipulate stored data using the pushbutton functions of add, subtract or invert. With the 4094, continue to expand this capability with disk-extended functions of multiply, integrate, smooth, RMS and much more.

Permanent Data Storage

Store waveforms at the touch of a button on the optional floppy disk or capture and store automatically using the autocycle feature. Get report ready hardcopy records using the standard X-Y or Y-T recorder outputs, or obtain fully annotated plots automatically with the optional digital plotter.

IEEE-488 and RS-232 I/O

Integrate the 4094 into your digital measurement system with the fully bi-directional GP-IB and RS-232 digital I/O option.

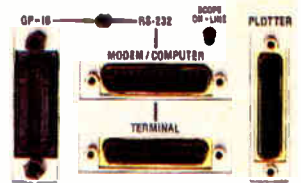

One of a Family

Nicolet is the world's leading manufacturer of high resolution digital oscilloscopes. In addition to the 4094, Nicolet offers the 2090 range of 2-channel digital oscilloscopes with many advanced features including high-resolution, disk storage and digital I/O.

Find out how Nicolet can bring digital precision to your analog measurements. For more information, call 608/271-3333. Or write: Nicolet Instrument Corporation, Oscilloscope Division, 5225 Verona Road, Madison, WI 53711.

In Canada: call 416/625-8302.



Sales and Service Offices Worldwide

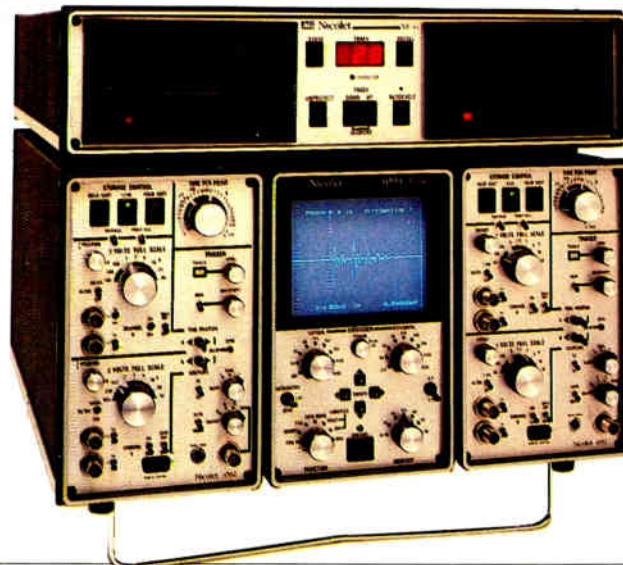

The Nicolet 4094.

High-power TWT has multi-octave span

By placing very small T-shaped segments along the length of the tube, Varian Associates has developed the world's first multi-octave traveling-wave tube that combines high power and continuous-wave operation. The segments supply negative dispersion control, which synchronizes the tube's electron beam with its propagating electromagnetic field. Researchers at Varian's Microwave Tube division in Palo Alto, Calif., report that **their tube covers the 6:1 frequency ratio from 3 to 18 GHz; models designed over the past 30 years did little better than 2:1.** The helix tube is targeted for the power stage of military electronic-countermeasure systems, such as jammers, and can generate about 250 W (+54 dBm). Harmonic output of the tube was kept below 5 dB—an exceptional figure compared with the 3 dB usually obtained in 2:1-ratio versions. The efficiency ranges from 5% to 12.5%. The work is sponsored by the U. S. Naval Research Laboratory in Washington, D. C., which also has awarded Varian another contract for a 2-to-18-GHz design.

Thin-film GaAs sheets form huge solar arrays

On the heels of their success in growing thin single-crystal layers of gallium arsenide with the Cleft approach [*Electronics*, May 19, p. 38], researchers at the Massachusetts Institute of Technology's Lincoln Laboratory, Lexington, Mass., are now mapping a scaled-up Cleft process aimed at producing monolithic solar-cell arrays up to 4 ft on a side. **If successful, the effort would result in the largest-area single-crystal semiconductors to date.** In the plan, large master panels of ceramic would be placed in an epitaxial reactor and coated with single-crystal GaAs. The 2-by-4-ft GaAs sheet then would have front contacts and an antireflection coating applied and only then would be separated from its master panel. The system would cut costs drastically by offering huge economies of scale and by side-stepping several fabrication, encapsulation, and packaging phases. Cleft-built solar cells already have shown 21% efficiency in tests.

Processor from National to use Eurocard format

A new board line based on its P²C-MOS NSC800 chip set is expected to emerge from National Semiconductor Corp.'s Microcomputer Systems division in the second quarter of 1982. The line will not be based on Intel's Multibus as its predecessors were. **It will use a single-width Eurocard 100-by-160-mm format designed solely for complementary-MOS devices.** The target market of the Santa Clara, Calif., division is primarily users seeking more speed and power than they are getting from their RCA 1802s.

DEC adds triple CPUs to mainframe line

Digital Equipment Corp. is unveiling new hardware and software for its DECsystem-10 and -20 mainframe computers. Most eye-catching is a triply redundant multiprocessor system, called SMP, or symmetric multiprocessing, by the Maynard, Mass., firm. The new capacity **uses three DECsystem-1091 central processing units with at least 1 million 36-bit words of memory.** DEC expects many of the triple-CPU systems to be retrofitted to existing mainframes. The firm also is marketing a more powerful version of its DBMS software, plus enhanced Fortran and Cobol compilers. Depending on the application, the new software may be from 18% to 100% more powerful than older versions. Finally, the company is

making its RPO7 high-density disk memory available for DECsystem use; the 498-megabyte drive will have a data-transfer rate of 2.2 megabytes/s.

NCR to introduce denser n-MOS, C-MOS cell libraries

Look for NCR Corp. to expand its semicustom logic line next year with two new standard-cell libraries for customer use. Scheduled for first-quarter availability is an improved version of NCR's original silicon-gate n-channel MOS semicustom offering, brought out when the Dayton, Ohio, company entered the merchant semiconductor market earlier this year [*Electronics*, July 14, p. 48]. The new n-MOS cell library will **expedite customer designs that employ 4- μ m minimum geometries and perhaps up to 3,000 gates per device.** In comparison, NCR's original semicustom line involved a 6- μ m process and a maximum of about 1,000 gates per chip. Also in the works is a standard-cell library for designs using a complementary-MOS process, expected to be ready for customer use during the second quarter.

Hydroplaning could yield smoother IC wafers

A new polishing technique for semiconductor materials promises very smooth surfaces free of mechanical defects, faster polishing, and, by implication, improved yield and throughput. Called hydroplane polishing by its developers at the Massachusetts Institute of Technology's Lincoln Laboratory in Lexington, Mass., the system may beat today's mechanical and chemical polishing approaches. **So far used on gallium arsenide and indium phosphide, the technique removes material at up to 30 μ m per minute,** as much as 60 times faster than other methods, and the surfaces produced are flat to within 0.3 μ m and free of mechanical damage. In the new process, semiconductor wafers are mechanically suspended about 125 μ m above the surface of a smooth, spinning disk coated with continually replenished etchant solution; the wafers thus hydroplane just above the disk's surface. The new method was developed to satisfy the stringent surface-quality requirements of molecular-beam epitaxy.

Nestar net to add CP/M capability

A significant increase in capability is coming for Nestar System Inc.'s local network. The Palo Alto, Calif., firm will shortly offer CP/M compatibility, enabling users to store, retrieve, and share CP/M files and programs. **Now Nestar users can ship only Apple-DOS and assembly-language files and programs around the net.** With the new version, they can switch among the various operating systems while staying on the network.

Addenda

Kenneth Olson, president of Digital Equipment Corp., has been named winner of the 1982 medal of achievement awarded by the American Electronics Association. **The medal, given annually since 1959, recognizes significant contributions to electronics.** Olson was honored because, in the words of the citation, "he is generally credited with launching the minicomputer industry when he founded DEC in 1957." . . . RCA Corp. plans to have a **stereophonic sound version of its SelectaVision VideoDisc player on the market in June 1982.** By the end of the coming year, 20 stereo disks will be available, says Thomas G. Kuhn, vice president of the VideoDisc division.

Let's talk silicon value...

"The Monsanto Certificate of Conformance guarantees the quality of your wafers."



Hubert Dohmen
Director,
Quality Assurance

Tom Ray
Manager, Quality Systems

Andy Taylor
Manager, Quality
Assurance Specifi-
cations Center

Jerry Gayer
Manager, Quality
Assurance Operations

Monsanto's quality program is designed to deliver the highest quality wafers consistently, to reduce incoming wafer inspection costs, and to contribute to the worldwide semiconductor quality leadership of our customers.

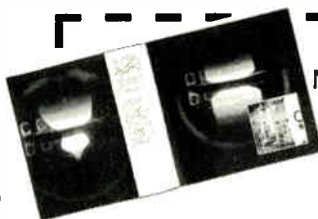

For more information about Monsanto's quality program, send for the Silicon Story.

Monsanto Electronics Division
Attn: B. G. Marchetta
755 Page Mill Road
Palo Alto, California 94304
Phone: (415) 493-3300

Name _____
Title _____
Company _____
Address _____
City _____ State _____ Zip _____
Telephone (_____) _____

EL

Monsanto

Circle 35 on reader service card

The Associate Producer.

820 RO Receive-Only Printer

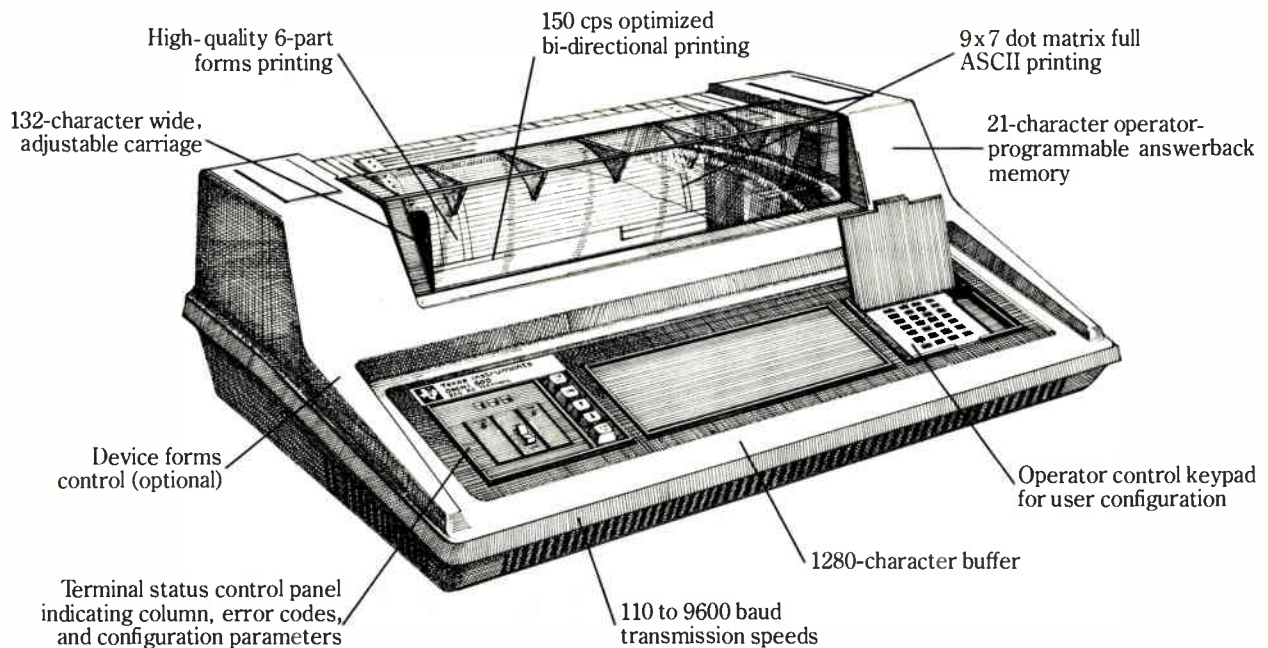

The Omni 800* Model 820 RO Printer has the same designed reliability as its associate, the 810 RO. With more standard features and options like expanded and compressed printing, the 820 RO offers greater flexibility for additional applications. And, should application needs change, the 820 RO is easily upgraded to a KSR model for a modest cost. The productive 820 RO Printer has all the quality and performance you asso-

ciate with the OMNI 800 Family.

TI is dedicated to producing quality, innovative products like the Model 820 RO Printer. TI's hundreds of thousands of data terminals shipped worldwide are backed by the technology and reliability that come from 50 years of experience, and are supported by our worldwide organization of factory-trained sales and service representatives.

For more information on the

820 RO, contact the TI sales office nearest you. In Europe, write Texas Instruments, M/S 74, B.P.5, Villeneuve-Loubet, 06270, France, or phone (93) 20 01 01. In Asia Pacific, write Texas Instruments Asia Ltd., 990 Bendeemer Rd., Singapore 1233. Telex RS 21399, or phone 258 1122.

TI invented the integrated circuit, the microprocessor and the microcomputer.



TEXAS INSTRUMENTS
INCORPORATED

*Trademark of Texas Instruments Copyright © 1981, Texas Instruments Incorporated

291113 I

Circle 37 on reader service card

Infrared camera relies on large monolithic array

by Roderic Beresford, Components Editor

Sensitive platinum silicide detectors are fabricated in array made mostly using n-channel MOS technology

Why struggle with compound semiconductors if silicon can do the same—or better—job? That is the question RCA Corp. is asking, now that it has demonstrated an infrared TV camera based on platinum silicide detectors that can resolve temperatures to within a fraction of a degree.

The sensitive picture-sensing elements are readily fabricated on the same chip with a charge-coupled-

device readout array. This combination promises thermal-imaging systems at a much lower cost than those based, for example, on mercury-cadmium-telluride sensors that cannot be fabricated monolithically.

The military has been using exotic materials like mercury-cadmium-telluride for years because of their high conversion efficiencies for wavelengths of 3 to 6 micrometers—a must for arrays with relatively few elements to be scanned across the scene. However, because its array is stationary, RCA can use a detector with a much lower efficiency in a staring focal plane array, as it is commonly called.

The 64-by-128-element array [*Electronics*, Nov. 30, p. 33] is the

largest staring IR imager ever reported—the sensor chip is over 350 mils a side. Its quantum efficiency of a few percent at 3- μm wavelengths marks an order of magnitude improvement over the first Schottky-barrier-diode PtSi detectors developed by RCA two years ago at its Princeton, N. J., research laboratories with support from the Air Force Systems Command's Electronics Systems division, Hanscom Air Force Base, Mass. RCA Automated Systems division, Burlington, Mass., developed the camera.

Conventional process. Except for the PtSi detectors, the imager is fabricated on a 3-inch wafer with a conventional double-polysilicon n-channel MOS process that produces the transfer gates and an interline-transfer buried-channel CCD array for reading out the photogenerated charges (see figure).

The key to fabricating the detec-

Hot shots. An experimental infrared RCA camera detects heat variations of a fraction of a degree C. Its 64-by-128-element sensing array, housed in a Dewar flask, is immune to blooming when a hot object is in focus. Closeup shows the detail obtainable.

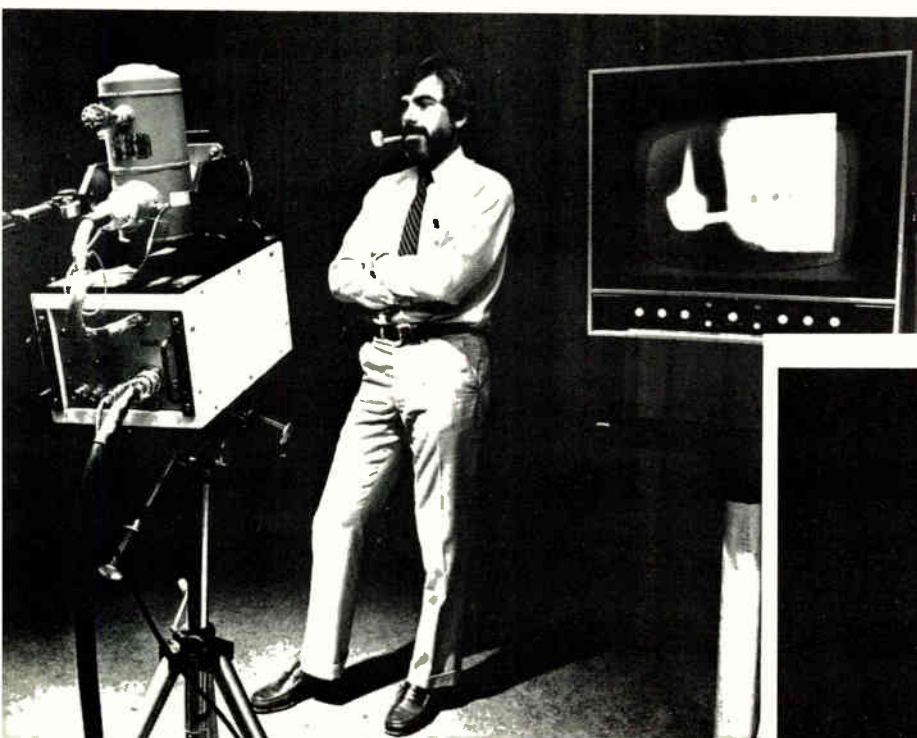

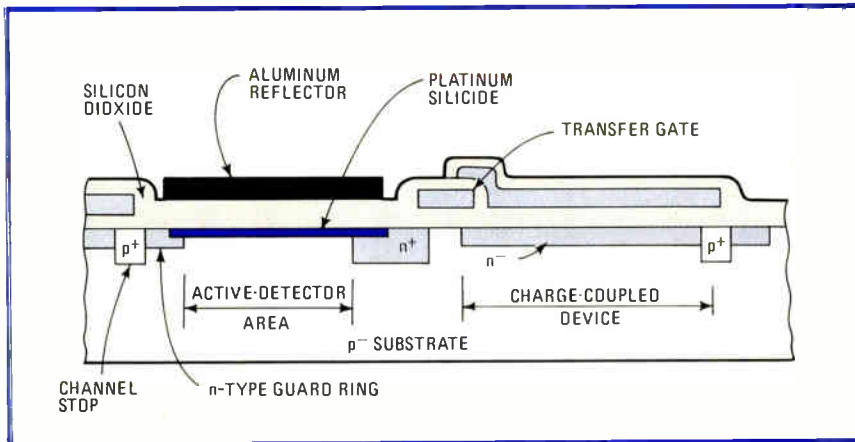

IR sensor. A platinum silicide Schottky-barrier detector is formed on a silicon substrate containing n-channel MOS gating and charge-coupled-device read-out electronics. The aluminum layer reflects infrared energy back into the active detector area.

tors is the precisely controlled deposition of platinum on the same silicon surface, points out Walter F. Kosonocky, a Fellow on the technical staff in Princeton who directed the effort. Uniformly thin layers of the pure metal—between 20 and 200 angstroms thick—are vacuum-evaporated, sintered to form PtSi, and then etched to remove the unreacted metal.

The response of the detectors is so uniform—less than 0.5% root-mean-square variation—that minimal processing is needed to generate the video signal for a television monitor. This precision is in sharp contrast to compound-semiconductor sensors whose properties are much harder to control.

RCA's PtSi detectors operate by internal photoemission from the silicide itself. Incident photons with energies above the Schottky barrier height and below the silicon bandgap level generate charge pairs in the thin metal layer. The charges drift apart under the influence of the Schottky barrier's reverse-bias field.

No blooming. Under high illumination, the diode becomes slightly forward-biased, and the photocurrent saturates—additional excess carriers will not contribute to the signal. As a result, the imager does not suffer from blooming. Furthermore, because the diode does not store minority carriers, it can recover quickly from an optical overload.

To operate the camera, the sensor

chip must be cooled down to about 80 K, the temperature of liquid nitrogen, to reduce the dark current. The laboratory prototype uses a liquid-air filled Dewar flask, but for portable applications, a microrefrigerator could be fitted to the 1/2-in. package housing the chip. A germanium lens focuses the incident radiation onto the sensor array.

According to Kosonocky, RCA will soon have a 200-by-200-element array, and TV-like resolution will follow. The company is researching the market potential for the camera and says that a product could be out in 18 months.

Besides the military applications that originally motivated the project, a low-cost IR imager is expected to be widely used in medical and industrial settings. RCA's can, for example, image the veins of a person's body.

Communications

AT&T to offer dial-up 56-kb/s data service

Moving toward the long-term goal of establishing nationwide service on a completely digital network, American Telephone & Telephone Co., New York, announced it is readying its dial-up system to handle digital data at a 56-kilobit-a-second rate. Though this service for its business

customers will not be available before 1983, on January 1 of the new year AT&T will make public the input specifications for the network-channel terminating equipment that it will supply for the digital hookup.

If there are no regulatory hitches, then AT&T will offer purely a transmission capability, unlike its unregulated subsidiary which will offer data processing as well (see "Bell's value-added service born again," opposite). It will also offer access to proprietary packet-switching networks.

Currently, AT&T transmits data through its Digital Data Service. This service can operate as high as 56 kb/s, but special, dedicated lines must be used and the service is not switchable. Other companies' services—Tymshare Inc.'s Tymnet and General Telephone & Electronics Corp.'s Telenet—also offer data transmission through a packet-switching network, usually at a 9.6-kb/s rate with higher speeds available. According to estimates, the 56-kb/s rate could satisfy as much as 90% of the needs of business for long-haul data transmission.

Full duplex. Sending 56 kb/s over the two-wire lines connecting the telephone to the switching office was not the problem; this and higher data rates can be easily handled over the typical distances involved. Rather, the problem was to obtain the full-duplex transmission. Half-duplex is easier, and this is what Bell engineers will rely on with time-compression multiplexing.

Using a burst mode of transmission, the line is operated half-duplex at 144 kb/s. This is twice the 56-kb/s rate, plus additional overhead bits. With buffering, each end of the data conversation may control the line during the burst or remain silent. The result is equivalent to full-duplex transmission at 56 kb/s.

Existing long-haul facilities already have a substantial amount of digital capability, but some analog facilities are being replaced. With echo cancellers and other such bit-distorting gear removed, the lines are suited for the new service.

So are the Bell Systems' existing

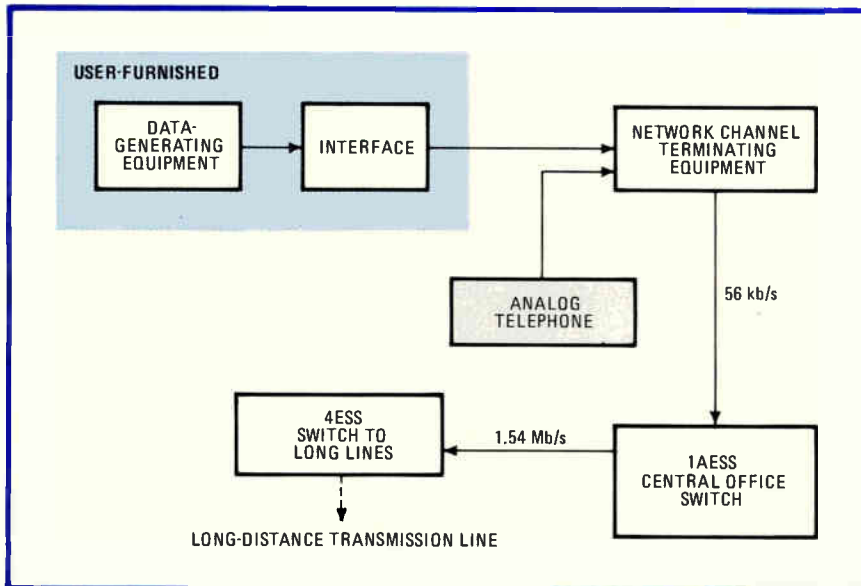

Dial up. An interface added on the user's premises gives access to the dial-up digital data service being readied by AT&T that will use much of its existing facilities.

central-office switches. The No. 4ESS switch is already a time-division-multiplexing digital switch which handles 64-kb/s digitized voice signals. It can be readily modified for digital data at 56 kb/s.

A bigger problem lies in modifying the No. 1AESS. It is a space-division-multiplexing switch, usually used with analog voice signals. It can handle 56-kb/s baseband digital signals with modifications added on cir-

cuit boards. These boards provide, among other functions, the balance for hybrid conversion circuits, as well as interfaces to adjust impedance and voltage levels. The No. 1AESS also needs software to operate in the 56-kb/s data mode and to perform loop-back tests to the customer's standard interface.

Access. Ac-powered terminating equipment will be installed on the customer's premises. It will include two analog voice lines that allow a data call to be initiated with a voice hookup. This procedure is required by AT&T's electronic switches. The box's eight external wires also include four for digital data and two for control. Actually, its interface is similar to the one used with Bell's own present DDS.

The box performs "a basic minimum number of functions and does not require that much intelligence," according to Gary J. Handler, AT&T's manager of network planning. It has a Bell Laboratories-developed microprocessor but needs neither signal processors nor software control. It also has buffering and some custom large-scale integrated circuits for its time-compression-multiplexing mode.

AT&T described its channel-terminating equipment at the National Telecommunications Conference in New Orleans on December 1. It is not the first to come up with the idea of an end-to-end switched data service on the public network. A similar 56-kb/s service in Japan uses special dedicated switches, and Canada has a switched data service at 9.6 kb/s. There are also services of limited geographic extent in Germany and Scandinavia. **-Harvey J. Hindin**

Bell's value-added service born again

While American Telephone & Telegraph Inc.'s regulated operations prepare to transmit 56-kilobit-a-second data directly over phone lines, the company also filed in late November with the Federal Communications Commission a plan to offer by January 1, 1983, data-processing capabilities through its Advanced Communications Service. The plan, in compliance with the FCC's Computer Inquiry II ruling, also calls for the formation of a fully separate affiliate on or before June 1, 1982, to handle the service.

ACS will be a packet-switching network with computing power permitting data-generating and -receiving equipment with diverse protocols to communicate with each other. It will have storage and communications-processing capabilities and will manage data networks as well as transport data. First promised almost three years ago, ACS encountered software problems, which have only recently been ironed out or may not yet be fully resolved. This situation may also limit the kinds of services to be offered initially.

ACS would start with \$3 million in cash and \$56 million in assets from AT&T and Bell Laboratories. The affiliate would issue equity shares to be held by its parent. Up to \$434 million would also be supplied over a four-year period to support the new venture until it is on its own. Bell competitors are unhappy at this arrangement since the new organization would not have to go to the usual sources of money and pay market rates.

AT&T sources, pointing out that its filing with the FCC concerns financial not technical matters, will not say what kind of services ACS will provide. Nor will it speculate on data rates and equipment to be accommodated.

The new service will affect the business of many suppliers of value-added communications services, however. These companies provide packet-switched services to their customers using, in many cases, AT&T telephone lines. Just how Bell will allocate the hard-to-get lines for long-distance packet switching among these companies and its affiliate remains to be seen. **-H.H.**

Production

Hopes brighten for silver-bromide resist

As engineers strive for finer integrated-circuit geometries and greater throughput, they sometimes find these two goals mutually exclusive. Electron-beam lithography, for ex-

ample, achieves the fine geometries, but often requires more exposure time than the relatively less precise optical techniques.

One answer to this problem would be more sensitive—and thus faster—photoresists, and it would be even more helpful if such resists were sensitive to the three most popular exposure media—light, electron beams, and X rays.

Now a group at the GCA Corp., led by senior scientist Jerome M. Lavine and Joseph I. Masters, manager of the Bedford, Mass., firm's photo-materials research department, has devised a resist technique that can boast all these advantages. Moreover, it may be only a year or two away from the marketplace, according to GCA, which is best known in semiconductor circles for its success with step-and-repeat optical lithography systems.

The basic material is one of the oldest photosensitive materials in current use, silver bromide. It has been a main ingredient for more than 20 years in emulsions for high-resolution photomasks. But until now, it has been unsuccessful as an on-wafer resist because of problems with contamination of the emulsion and coating defects such as pinholing.

Emulsion banished. GCA's answer was to eliminate the emulsion. Instead of applying the usual kind of emulsion resist and then curing and exposing it, a user first would lay down a polymer layer that produces a smooth surface for the photosensitive material. A coating of silver bromide is then evaporated atop it. The typical layers of silver bromide are about 2,000 angstroms thick, but the thickness of the polymer layer can be varied to suit the development and etch needs of the process line.

Not only are there no emulsion defects like pinholes, but the deposition process takes place in a vacuum chamber and is almost totally free of particulates. Lavine says that silver bromide is "from tens to thousands of times more sensitive" than common resist materials. So its shorter exposure times would translate directly into greater productivity.

Further, because the material is sensitive to a variety of wavelengths, users could combine exposure modes in the same resist step, thus allowing X-ray or electron-beam systems to expose finer features while also exposing the larger geometries with ultraviolet light. With the present technology, such multiple exposures entail multiple resist steps, and this slows production.

Under the UV light, at wavelengths from 2,600 to 3,000 Å, silver bromide has a sensitivity of about 50 microjoules per square centimeter, said to be more than a tenfold improvement over polymer resists. At the usual 7-Å X-ray wavelength, sensitivity is at least as good as in the UV spectrum and is nearing electron-beam sensitivity of 10^{-9} to 10^{-10} coulombs/cm.²

Lavine says that next year's work will concentrate on optimizing sensitivity and resolution, as well as improving edge acuity. Two approaches are being considered.

First, the company will experiment with silver bromide applied in very thin layers in order to eliminate diffraction as a source of fuzzy edges. The second approach will be to dope the silver bromide with other elements or compounds, a technique Lavine expects will reduce grain size and help control sensitivity.

Another group studying a resist for more than one type of lithography is Sperry Corp.'s Research Center in Sudbury, Mass. It has successfully combined electron-beam and UV lithography using Shipley Co.'s 300-series resist [*Electronics*, Nov. 30, p. 40]. —James B. Brinton

Software

CP/M house plans rapid expansion through marketing change and money

From \$6 million this year to \$20 million next would not be bad growth for any company, but it is positively stunning for one specializing in software, a field noted for having many small shops each turn-

Intel spreads its operating-system reach

Unwilling to put all its eggs in one or even two baskets, Intel Corp., Santa Clara, Calif., will be backing all the currently popular operating systems for its 16-bit 8086 microprocessor. It has contracts with Digital Research for its CP/M- and the multiuser MP/M-86 and with Microsoft for MS-DOS. It also is after Bell Laboratories' Unix and is negotiating with Microsoft for its version of Unix, called Xenix.

In addition, Intel is pushing its own real-time operating system, iRMX-86, most recently by embarking on a joint venture with Lifeboat Associates—already the largest 8-bit software distributor—to form a users' group called iRUG Corp. The first meeting is to take place during the National Computer Conference in June. New York-based Lifeboat will manage the program, with Intel supplying the money and equipment to kick it off.

Lifeboat itself will be using Intel's new 86/330 8086-based minicomputer to start making its programs compatible with iRMX-86. "We are going to our OEMs and contracting with them to write software for iRMX-86 and expect to print our first catalog in 1982," says Tony Gold, Lifeboat's president. Microsoft has already promised to bring up its languages under iRMX-86.

Intel's software distribution operation [*Electronics*, Sept. 8, p. 39] will sell Digital Research's CP/M- and MP/M-86 line of operating systems and languages. It is also putting CP/M-86 on a chip—in fact, the same chip that houses its iRMX-86 operating system, the 80130, only with a reprogrammed read-only memory. And Intel is likely to commit the other operating systems it is backing to silicon in the near future.

—R. Colin Johnson

The talk of the town!

General Instrument's new VSM2032 has made speech synthesis the talk of the town. In fact it speaks so well we named it Orator.™

The VSM2032, a complete speech system, is immediately available. It needs only a power source and speaker to start talking...in less than an hour you can hear it speak, fluently, with a 32 word calculator/clock vocabulary that combines to form over one billion phrases.

You can use the Orator module as a stand alone voice system or interface it with industrial equipment, vending machines, instrumentation, arcade games, computers or warning devices.

More than the spoken word. With Orator you get a lot more than talk. General Instrument's state-of-the-art technology utilizes Linear Predictive Coding (LPC) for speech data compression with minimum ROM support. And to obtain truly natural speech, a 12 pole cascade filter is used to implement a mathematical model of the human vocal tract so that Aunt Mary sounds exactly like Aunt Mary and not like Uncle Walter.

Now. Talk's cheap.

Simplified digital interfacing... immediate availability...high voice quality...low price...make Orator VSM2032 an attractive and feasible way to make your product speak. At a cost of \$99 (signifi-

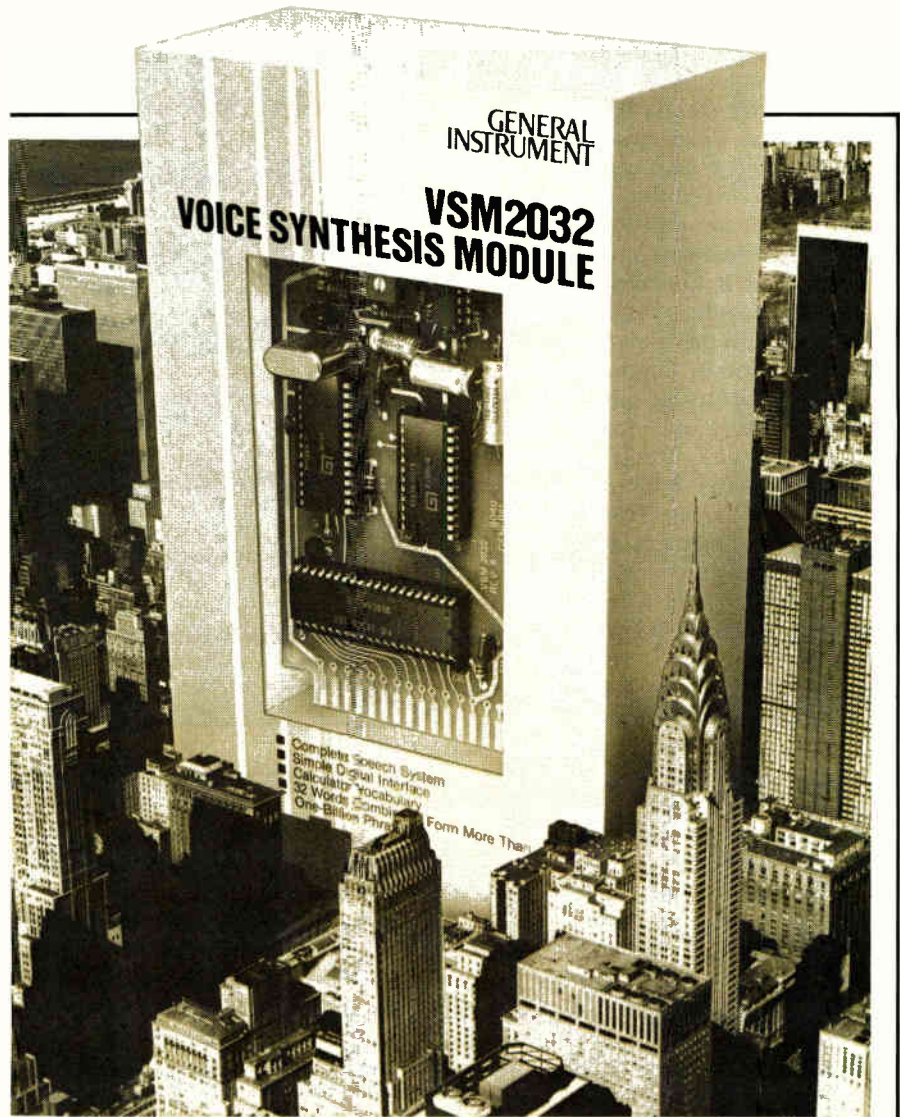

cantly less in production quantities), you can't afford not to hear Orator! And you can choose from standard vocabularies or your own vocabulary for orders of 250 or more modules.

The final word is up to you. The VSM2032 is available *now* from these distributors, Advent, Anthem,

Arrow, Diplomat, Future, Hallmark, Pioneer and VSI. Or write Module Products Dept., Microelectronics Division, General Instrument Corporation, 600 West John St., Hicksville, New York 11802.

We help you compete.®

GENERAL INSTRUMENT

Sales Offices USA: CA, 213-322-7745 or 408-496-0844; FL, 813-577-4024; GA, 404-588-1375; IL, 312-981-0040; IN, 317-872-7740 or 219-291-0585; MI, 313-391-4070; MD, 301-730-8992; NH, 603-424-3303; NY, 516-733-3107; TX, 214-934-1654; EUROPE: London, 01-439-1895; Munchen, (089) 27 24 049; Paris, (1) 365 72 50; ASIA: Hong Kong, (5) 434360; Tokyo (03) 473-0281.

"Hear it like it is" at Winter CES, Las Vegas.

ing out a few products.

Nevertheless, this is the leap in sales predicted by company president Gary Kildall for Digital Research Inc., the Pacific Grove, Calif., software house that authored CP/M, the industry-standard 8-bit operating system. The boom is coming about largely because of a drastic change in marketing strategy coupled with the infusion of a hefty amount of venture capital.

All of it is aimed at establishing for six-year-old Digital Research, which is still privately held, a dominant position in the marketplace for software for 16-bit microprocessors. The company was forced to these moves because it lost its longtime partner in the 8-bit arena. Microsoft Inc., Bellevue, Wash., which has high-level languages for CP/M, developed its own operating system for the IBM Personal Computer, based on the 16-bit 8088 microprocessor, and does not plan to support CP/M-86 [*Electronics*, Oct. 6, p. 37]. Moreover, Lifeboat Associates, the New York publisher that is the major distributor of 8-bit software, joined forces with Microsoft and declined to distribute 16-bit software from Digital Research.

Kildall plans to use the venture capital to buy the high-level languages he needs. "OEMs want a total language environment for 16-bit machines," he points out. In September, Digital Research bought Compiler Systems Inc., Sierra Madre, Calif., authors of the popular C-Basic for business applications. And in November, it agreed to acquire M.T. Microsystems Inc., Carlsbad, Calif., authors of Pascal/MT. Digital and these companies have about \$11 million in sales this year.

With acquired languages added to Digital Research's own PL/1, Kildall is already off to a pretty good start, and he is looking to fill out his in-house 16-bit catalog by buying companies offering high-level languages such as Cobol and Fortran. Possibilities include CIS-Cobol from Micro Focus, APL/86 from Vanguard Systems Corp., Forth from Stack Works, Lisp from The Soft Warehouse, and C from three differ-

Price cut makes Unix stronger contender

As Digital Research with its CP/M operating system squared off against Microsoft's MS-DOS, a suddenly much cheaper version of Unix, Bell Laboratories' popular operating system for mainframes and minicomputers, acquired a new dimension in the 16-bit microprocessor world. Western Electric in November announced it was dropping the price on Unix, which is a multitasking system, such that it will be much more competitive with Digital Research's multitasking MP/M-86 for microprocessor systems. The new price means systems can be sold with as little as \$1,000 tagged on for the license fee. Previously, the manufacturer of a multiuser computer system would have had to charge several thousand dollars for Unix.

Western Electric's announcement detailed what is called the Unix system 3, a new version of the Unix version 7 system, and is supplied with the Programmer's Workbench—a set of program development tools—as well as a source-code control system. The previous arrangement was one in which Western Electric required an OEM to prepay \$50,000 toward future billings of \$750 for the first user on a single processor and \$250 for each additional and simultaneous user on the same processor. The package that Western Electric now offers asks the original-equipment manufacturer to pay a flat fee of \$25,000 for the system 3 license plus \$100 per processor for single-user systems and \$250 per processor (not per user) for systems that are designed for anywhere from 2 to 16 users.

Bell has gone even further with high-volume OEMs. It reduced the single-user price to \$70 and the price for from 2 to 16 users to \$125, for vendors who purchase \$1 million worth of Unix. If a vendor purchases over \$2.5 million worth, the price sinks even more, to \$40 for a single-user system and \$50 for a 2-to-16-user system.

-Martin Marshall

ent companies. Application programs will be developed further by expanding the training and support of both original-equipment manufacturers and end users.

New distributor. As for distribution, "we are shifting our emphasis on who we want to reach from a large number of small OEMs to a small number of large OEMs," says Kildall. Accordingly, Digital Research recently signed up Hamilton-Avnet, one of the largest electronics distributors, to stock its software. The large OEMs Kildall has in mind include IBM Corp., for whose Personal Computer Digital Research has configured its CP/M-86. A version for IBM's Displaywriter is scheduled to be shipped this month.

Kildall is counting on making inroads into IBM's Personal Computer market, even though IBM itself is backing Microsoft's MS-DOS with its software publishing operation. Many features of the Unix operating system are incorporated into MP/M-86, Kildall explains, which should make it attractive. Moreover, the multitasking system that allows sev-

eral jobs like edit, compile, and print to be run simultaneously is available, while a similar version of MS-DOS is still being developed. Kildall hopes that the convenience of using MP/M-86, as has been reported by Digital Research's 20 OEMs and 3,000 end users, might persuade IBM to offer it, too.

-R. Colin Johnson

Fiber optics

Separated signals aim at gigabit rate

Challenged to top the hundreds of megahertz data rates that can be obtained from step-index optical fibers, experimenters at ITT's Electro-Optical Products division and the Stevens Institute of Technology have devised a new multiplexing scheme designed to give fiber-optic communication networks gigabit data rates. Unlike wavelength-division multiplexers, an older technique that uses input signals at different wavelengths, the new approach funnels

SMART PLANT MANAGER DISCOVERS TWO NEW OFF-THE-SHELF SOLUTIONS FOR REPAIR AND ASSEMBLY PROBLEMS.

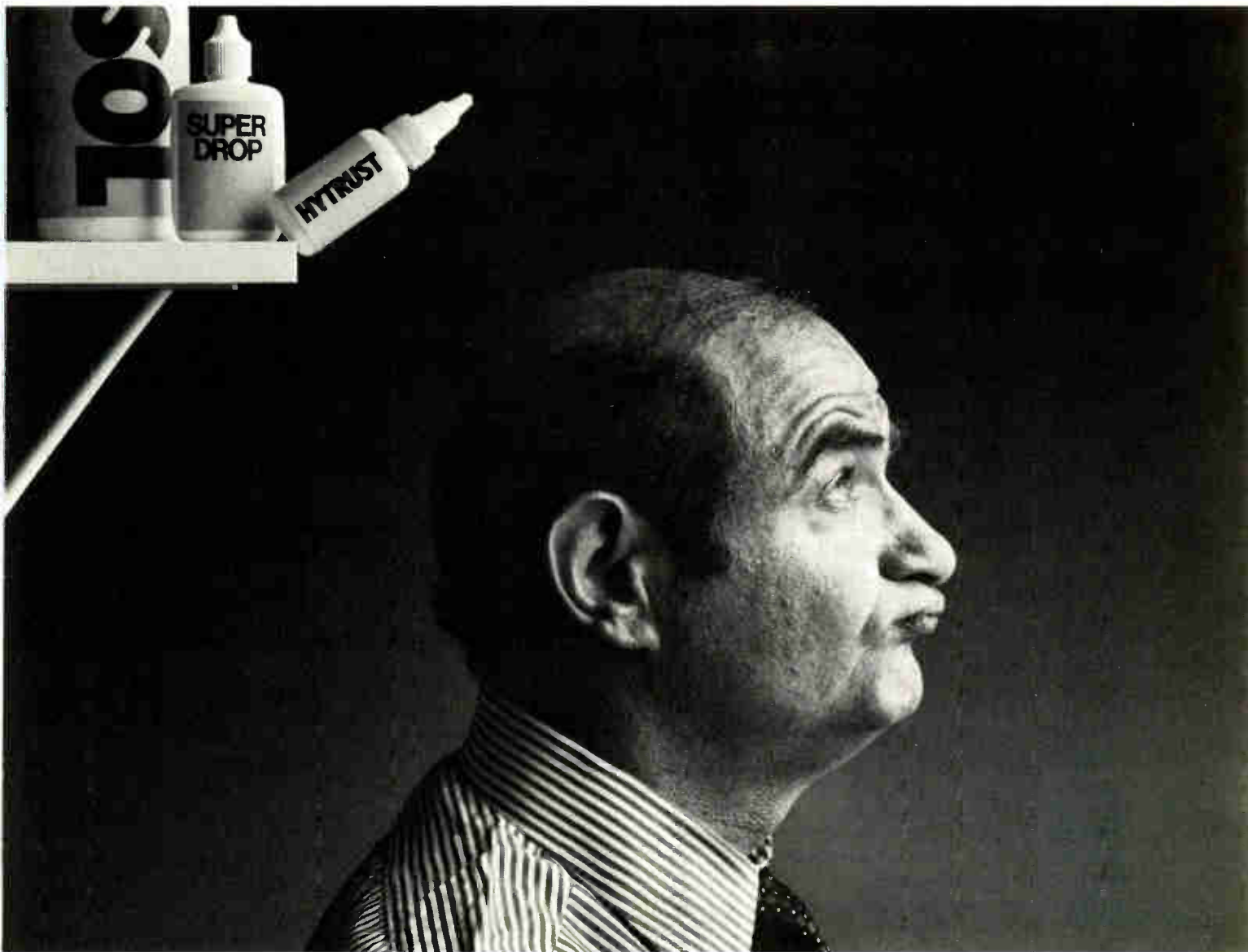

Now Dexter Hysol gives you *two* new ways to assemble even better products.

Hytrust™ modified acrylic adhesives and Super Drop® cyanoacrylate adhesives.

On the production line, both replace old-fashioned fastening methods like riveting, welding and brazing. So you can assemble products faster — and at less cost.

Meanwhile, these versatile Hysol adhesives

are great for general plant repairs and maintenance. Fixing worn and broken machinery, bolts, valves, pipes and switches.

So your production line won't come to a halt while you wait for a repairman or replacement part.

Our *Hytrust* modified acrylics are the most practical way to bond practically any surface. They cure quickly at room temperature. And resist just about any solvent, including moisture.

Our *Super Drop* cyanoacrylates are more

than the fastest curing line of adhesives on the market—they offer two new, advanced generations of instant bonding technology. With unique characteristics for unsurpassed performance. No matter what the application.

To find out more about Super Drop cyanoacrylates or Hytrust modified acrylics for assembly and repair, just write or call Dexter Hysol today.

Don't wait for the idea to hit you on the head.

HYSOL DIVISION
THE DEXTER CORPORATION

2850 Willow Pass Road,
Pittsburg, CA 94565.
(415) 687-4201.

DEXTER
HYSOL

Circle 43 on reader service card

separate signals of the same wavelength down the fiber.

Playing the angles. Key to the new technique, says Gerald J. Herskowitz, professor of electrical engineering at Stevens in Hoboken, N. J., is the fact that the plane-wave angle incident to the fiber's axis, as it is reflected at the core-cladding interface, is constant as the wave propagates down the fiber. Thus, if several plane waves of the same frequency are sent on their way at different propagating angles, and if these different waves can be separated at the receiving end, a multiplexing scheme is automatic. Herskowitz, George A. Gasparian at ITT in Roanoke, Va., and their co-workers have taken the first steps to do this.

Classic lenses. A classical biconvex lens is used to focus two separate input waves into the test fiber at different angles. At the end of the fiber, the two beams, tagged with different modulation frequencies, are separated by another well-known device, a fresnel lens.

The bulk of the energy in the waves comes out of the fiber in concentric rings and the fresnel lens focuses these rings into separate spots. The optical power in each spot is then detected and displayed by the spectrum analyzer. One important parameter of the multiplexing system, the crosstalk, is determined by the ratio of the detected powers at the modulating frequencies.

Herskowitz and Gasparian did their work in cooperation with scientists at the U. S. Army Communications Research and Development Command at Fort Monmouth, N. J. Much must yet be done to ready the technique for practical application. For one thing, the crosstalk, which depends on the fiber used, is around -10 decibels to -15 dB or some 15 to 20 dB worse than theory predicts.

A more accurate model of the system is needed. Also, both the input and output coupling lenses must be improved. What results are obtained also depends on things like the roughness of the core-cladding interface, the fiber's refractive-index uniformity, and any microbends in the fiber itself.

-Harvey J. Hindin

Local networks

Voice studied for Ethernet network

Convinced that Ethernet, the local network it is backing, must transmit voice, Intel Corp. of Santa Clara, Calif., rolled out a report last month that in effect says to prospective network customers, "Don't worry, we're looking into it, and it looks feasible."

Some two years of studying the problems involved with adding voice to the packet-switched network were described by Intel's Donald K. Melvin at the National Telecommunications Conference in New Orleans. The project's aim is to make Ethernet competitive with other upcoming local networks—like those of Wang Laboratories—that will handle voice transmissions.

Melvin's feasibility study showed that a combination of voice and data could use Ethernet's standard contention-access, baseband digital transmission over its coaxial cable. In the study, he relied on experimental voice-transmission circuits on breadboards and a computer synthesis of key critical factors like traffic loading, transmission delay, and the mix of voice and data on the network. (Actually, Intel will not disclose any timetable for developing

chips to do the job. Interface chips for the data-only Ethernet are first due next year.)

Results. For a network used exclusively for voice traffic that accepts a 50-millisecond round-trip maximum delay, Melvin concludes that up to 100 simultaneous conversions may occur during traffic peaks. If only one third of the telephones are busy at the peaks, then 300 phones may be connected.

In the case where 35% of the network's bandwidth is devoted to data and the allowable round-trip delay is a (still acceptable) 100 ms, then Melvin says 78 simultaneous calls may take place. He believes that both these scenarios could yield effective service.

To combine voice and data, Intel will have to build new interface modules for telephones on the public network, as well as for work stations on Ethernet alone. There could also be gateways to private automatic branch exchanges and the public telephone network.

A typical telephone-net interface module, shown in the figure, would provide the usual line-interface functions such as ringing and two-to-four-wire conversion, as well as digital buffering for eliminating packet jitter. Also included are packet assembly and disassembly, signaling and control, Ethernet media access, and transceiver and codec functions,

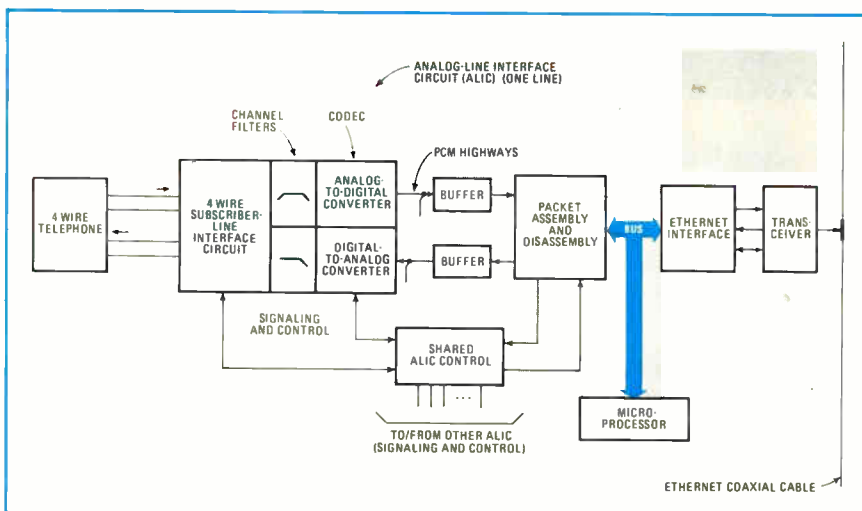

Interface. The telephone network interface module studied by Intel shows the usual telephone-subscriber-line interface and codec functions, as well as the functions involved with placing packetized voice and data onto the Ethernet coaxial cable.

How to boost the productivity of your wire bonding and probing operations...

Operator eye fatigue is a major cause of low productivity – and of lost profits. That's why companies interested in a quick return on investment choose Wild. Wild human-engineered stereomicroscopes dramatically reduce eye-fatigue because they use parallel rather than covering beam paths. Even after many hours of use operators' eyes are relaxed and unstrained.

The result is fewer errors, high production rates and higher yields that contribute to high return on investment. Wild Stereomicroscopes have been designed on the modular principle with a broad range of accessories to meet the most difficult challenges. Adapters are available for mounting on bonders, probers and other machinery. Find out how you can adapt the Wild Stereomicroscope to your existing equipment – and how to assure higher productivity on new equipment by insisting that it be equipped with a Wild Stereomicroscope. Send for literature today. ■

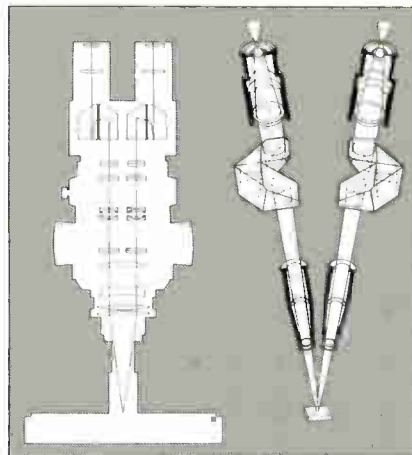

The common main objective system of the Wild stereomicroscope, left, offers the advantage over the Greenough system, right, in that the intermediate image planes are parallel to the object plane and there is no tilt between them.

Wild Heerbrugg and Leitz Wetzlar: World leaders in macroscopy and microscopy

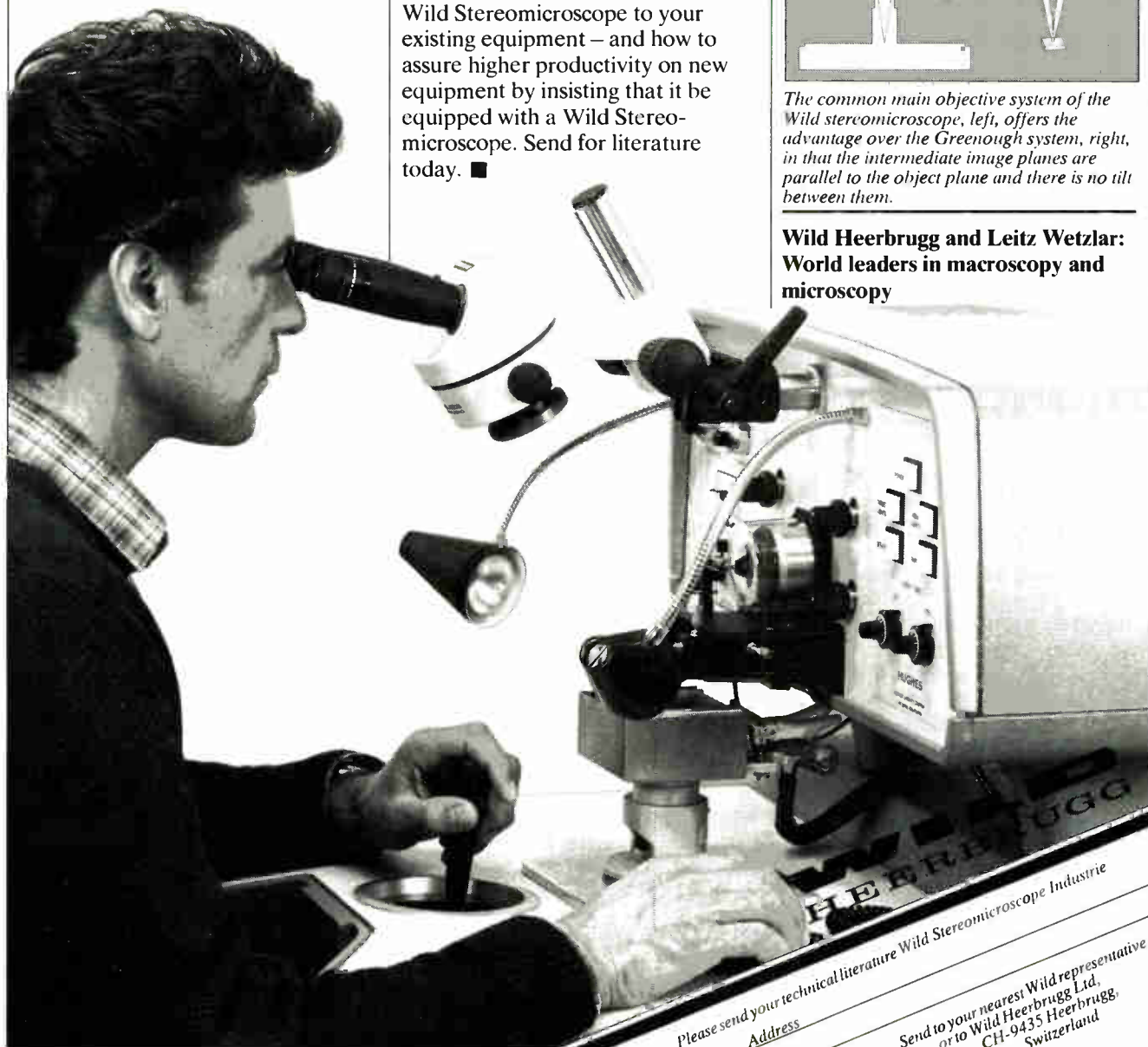

Please send your technical literature Wild Stereomicroscope Industrie
 Address

Send to your nearest Wild representative
 or to Wild Heerbrugg Ltd,
 CH-9435 Heerbrugg,
 Switzerland

all under microprocessor control.

The PABX gateway would provide similar functions but also converts packetized voice into analog or pulse-code-modulated digital signals for connection to the public network.

Problems. Intel has concentrated its first investigations on echo and delay, which are the primary determinants of voice quality. Delays in gaining access to an Ethernet cable vary from moment to moment because of the network-access contention and arbitration scheme.

Packet buffering can only do so much; moreover, it and its memory management are expensive, and too much buffering is disconcerting to the user. What is needed is to optimize the number of packets transmitted and their length, a problem Intel continues to study.

Intel is also looking into the snags variable delays cause for both PABXs and telephone central-office switches. The best solution to the delay and echo problem is to minimize the number of telephones connected to the Ethernet. To make this number as large as possible, however, Intel has been looking at various schemes that could allow up to 10% of the transmitted packets to be lost without voice-path impairment, Melvin says.

The amount of echo and delay that can exist before the user is bothered depends on the architecture of the system. Thus, two- or four-wire hybrid design, the kinds of modules present, the use of echo cancelers, and the like, are all relevant to the network capacity problem, says Melvin. Other factors Intel is considering include the mix of voice and data and also the bandwidth of the system's data terminals.

Obviously, if Ethernet is to be used with telephones, the grade of service would have to be planned in advance, based in part on usage habits, traffic peaks, and densities. "Additional research, experimentation, field trials, and performance standardization are necessary before these systems can be widely used—especially when there is access to the public switched network," Melvin says.

-Harvey J. Hindin

News briefs

IBM realigns all U. S. marketing

The promised second phase of its marketing reorganization was announced by IBM Corp. To segment its U. S. market by customer instead of by product type, IBM will be combining the resources of the Data Processing, General Systems, and Office Products divisions into two new marketing divisions. To start up next month, each will market IBM's full product line to its assigned customer groups. The National Marketing division, headquartered in Atlanta, will sell to small, medium-sized, and some large customers. The National Accounts division of White Plains, N. Y., will serve selected large customers having complex information processing needs, such as the Fortune 500 companies and the large financial institutions. Both divisions are part of the Information Systems Group created last fall.

Glass transmits across entire infrared spectrum

A new infrared-transmissive glass is searching for applications. It is the first amorphous material that transmits as well as or better than other materials across the entire 1-to-11-micrometer wavelength range of the IR spectrum, according to Barnes Engineering Co. in Stamford, Conn. Until now, transmission media covered this spectrum in sections. For example, silica- or fluoride-based glasses would cut off at about 4 and 8 μm , respectively; some crystalline materials transmit in the 10-to-11- μm range. Barnes is looking to license the manufacture of the material, which it declines to describe for publication, to whoever has any ideas for its use. It may also enter into joint ventures. Possible applications include lasers, lenses, IR domes, thin-film dielectrics, and in medium-loss fiber optics.

U. S. production systems to be made in Japan

A joint venture, GCA Sumitomo Shoji Japan Ltd., established by GCA Corp. of Bedford, Mass., and Sumitomo Corp. of Tokyo, should begin manufacturing GCA's DSW 4800 wafer stepper-lithography and its Wafertrac wafer-processing systems in Japan early next year. The move anticipates a switch by Japanese integrated-circuit makers from 1:1 projection aligners (like Perkin-Elmer's Micralign systems) to steppers for next-generation 64-K and 256-K memory chips, says GCA. Sumitomo currently markets GCA's capital equipment products through its Sumisho Electronic Systems Inc. division.

Xerox releases higher-level Ethernet protocols

Details of the higher-level protocols used in its Ethernet-related products have been released by Xerox, hoping to encourage others to develop equipment for the local network. The documents, "The Internet Transport Protocols" and "Courier: The Remote Procedure Call Protocol," are available from Xerox Corp., Office Products Division, Network Systems Administration Office, 333 Coyote Hill Rd., Palo Alto, Calif. 94304.

Photovoltaics

Solar storage cell looking still better

Three years after receiving a Federal government contract to develop an inexpensive solar-energy technique combining silicon photovoltaics and fuel cells, Texas Instruments Inc. reports "all major milestones have been met." However, the Dallas firm cautions that it considers the project

"a high-risk proposition" because of the need to conduct more tests to prove reliability.

The novel solar energy concept combines conversion and storage functions [*Electronics*, Nov. 6, 1980, p. 39]. Its prime investigator, E. L. "Pete" Johnson at TI, says it should provide electricity at nearly the same cost as residential utility rates.

Tiny silicon spheres, immersed in a hydrobromic-acid electrolyte, create a current that splits the aqueous solution into liquid bromide and hydrogen gas. These elements are

MEMORIES

from Texas Instruments

Read-and-File Guide to TI Semiconductor Memories

Here are the densities and performance features — the advanced technologies — that will help you design the best possible, most cost-effective systems.

A broad choice in both MOS and bipolar: DRAMs. EPROMs. ROMs. SRAMs. PROMs. All from Texas Instruments. All of proven quality and reliability.

Included are the industry's first 32K and 64K EPROMs. The fastest of the fast statics. The widest selection in PROMs. And a pacesetter 64K DRAM.

Read and file this convenient guide. It's worth a lot of mileage in helping you save time and money.



DRAMs

from Texas Instruments

PART NO.	ORGANIZATION	ACCESS	CYCLE	MAX. POWER		PACKAGE
				OPER.	STBY.	
TMS4116-15	16K × 1	150 ns	375 ns	462 mW	20 mW	NL-Plastic
TMS4116-20	16K × 1	200 ns	375 ns	462 mW	20 mW	NL-Plastic
TMS4116-25	16K × 1	250 ns	410 ns	425 mW	20 mW	NL-Plastic
TMS4164-15	64K × 1	150 ns	280 ns	200 mW	27 mW	NL-Plastic JDL-Sidebrazed
TMS4164-20	64K × 1	200 ns	350 ns	200 mW	27 mW	NL-Plastic JDL-Sidebrazed
TMS4164-25	64K × 1	250 ns	410 ns	200 mW	27 mW	NL-Plastic JDL-Sidebrazed

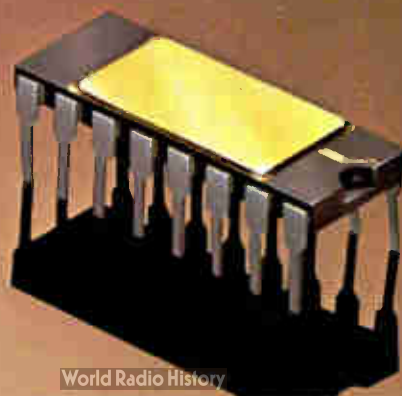

Major performance improvements at lower costs

Readily available, TI's new TMS4164 64K DRAM brings higher system performance at lower overall system cost to your new designs and upgrades.

Best speed/power combination — In all the world, only the new TMS4164-15 offers 150-ns access time and 280-ns cycle time coupled with the lowest power dissipation for such a device. Only 140 mW typical — a 50% reduction compared to 16Ks.

And, our 200- and 250-ns versions have even lower typical power dissipations — 125 and 105 mW — ideal for small systems demanding low active power.

Faster cycle times also mean refresh overhead is reduced from 2.4% to 1.8%.

"Elegant" chip design — In addition to lowering power requirements, TI's unique epitaxial silicon technology virtually eliminates the effects of substrate noise and dramatically increases operating margins. And, this innovative design also results in a 64K chip that's the smallest in production.

Overall economies — Having 64K bits in a single package substantially boosts system capability and reduces system costs.

Compared to four 16Ks, the single 300-mil, 16-pin package saves board space and eases layout. As does the single +5-V power supply — normally you would need three.

System operating margins are improved. As is reliability. Interconnects and system test are reduced. As are cooling requirements.

The TMS4164 is in distributor stocks ready for off-the-shelf delivery. It is supported down-the-line by knowledgeable, accessible field sales engineers in TI's 50 sales offices across the nation. Help, whenever you need it, is only a phone call away.

TI's TMS4164. It gives you the best possible performance improvement obtainable today at an extremely cost-effective price.

Coming soon:

- An even faster TMS4164
- A new 64K especially for microprocessor systems
- A controller to simplify DRAM design

Leadership 16K DRAM — For designs where larger memory capacity is not required, TI continues to offer the low-cost TMS4116 16K device. The popular choice for present high-volume applications, the TMS4116 offers outstanding — and thoroughly proven — quality, performance, and reliability. The result of five years of production experience, the TMS4116 represents TI's on-going commitment to MOS memories.

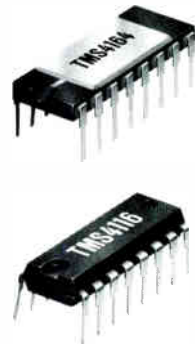

EPROMs

from Texas Instruments

PART NO.	ORGANIZATION	ACCESS		MAX. POWER		PACKAGE
		FROM ADDR.	FROM C/S	OPER.	STBY.	
TMS2708-35	1K × 8 3 power supplies	350 ns	120 ns	800 mW	—	JL-Ceramic JDL-Sidebraze
TMS2708-45	1K × 8 3 power supplies	450 ns	120 ns	800 mW	—	JL-Ceramic JDL-Sidebraze
TMS27L08-45	1K × 8 3 power supplies	450 ns	120 ns	580 mW	—	JL-Ceramic JDL-Sidebraze
TMS2716-30	2K × 8 3 power supplies	300 ns	120 ns	720 mW	—	JL-Ceramic JDL-Sidebraze
TMS2716-45	2K × 8 3 power supplies	450 ns	120 ns	720 mW	—	JL-Ceramic JDL-Sidebraze
TMS2516-25	2K × 8	250 ns	120 ns	525 mW	131 mW	JL-Ceramic JDL-Sidebraze
TMS2516-35	2K × 8	350 ns	120 ns	525 mW	131 mW	JL-Ceramic JDL-Sidebraze
TMS2516-45	2K × 8	450 ns	120 ns	525 mW	131 mW	JL-Ceramic JDL-Sidebraze
TMS2532-30	4K × 8	300 ns	—	840 mW	131 mW	JL-Ceramic JDL-Sidebraze
TMS2532-35	4K × 8	350 ns	—	840 mW	131 mW	JL-Ceramic JDL-Sidebraze
TMS2532-45	4K × 8	450 ns	—	840 mW	131 mW	JL-Ceramic JDL-Sidebraze
TMS25L32-45	4K × 8	450 ns	—	500 mW	131 mW	JL-Ceramic JDL-Sidebraze
TMS2564-45	8K × 8	450 ns	120 ns	840 mW	158 mW	JDL-Sidebraze

ROMS						
TMS4732	4K × 8	300 ns	120 ns	440 mW	110 mW	JL-Ceramic NL-Plastic
TMS4764	8K × 8	300 ns	120 ns	440 mW	110 mW	JL-Ceramic NL-Plastic



The broad choice for optimum system performance

From the workhorse 16K to the industry's first 64K, TI offers 5-V, fully-static EPROMs to fit your every design need. With high performance, and access times as fast as 250 ns. For today's new systems and upgrades. Preparing for what is to come.

Use TI's TMS2500 family for program and fixed parameter storage during system development and prototyping where you need to change data quickly and easily. Check out their cost effectiveness for use in initial production when you are in a hurry to get to the marketplace.

Maximum compatibility — The pinouts for TI EPROMs are derived from popular industry-standard ROMs so that all members of the family are plug-compatible with each other. And will be with those that are on the way. Which makes upgrading a simple design task, and prolongs product life.

Easy programming — You avoid mask charges by programming TI EPROMs yourself using widely available programmers and a single TTL-level pulse. You program in any order — individually, in blocks, at random. Erasing is only a matter of ultra-violet.

The result is that whatever EPROM type you choose, it can be used for many different programs. You lower inventory costs and eliminate write-off costs when programs need updating.

From TI, you have the choice and the performances to achieve optimum system performance. At especially attractive prices. With prompt delivery from distributor stocks.

Coming soon:

- A new EPROM family with very fast access times
- A high-density 128K EPROM for tomorrow's systems

Economical, high-density ROMs — When your programming will not change or need to be updated, using large-capacity ROMs in large numbers can achieve the lowest cost of any semiconductor memory. TI offers two high-density ROMs tailored for the job — the 32K TMS4732 and the 64K TMS4764.

Both are high performance memories with low power dissipations, typically less than 400 mW. Maximum access and minimum cycle times are 300 ns. They are fully static — no clocks — and require only a single 5-V power supply. Reliability is enhanced by the use of N-channel silicon gate technology during fabrication, and all outputs are TTL compatible.

These ROMs are plug-compatible with TI's 32K and 64K EPROMs. After you have defined your programming using TI EPROMs with their inherent savings, you can switch to TI ROMs for the economies of volume production. A system designed with appropriate memory addressing can utilize TI's 32K or 64K EPROMs or TI's 32K or 64K ROMs on the same printed circuit boards in the same 24- or 28-pin sockets.

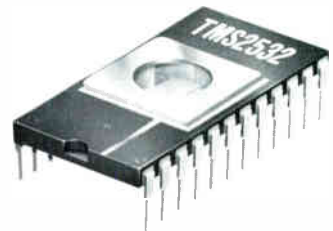
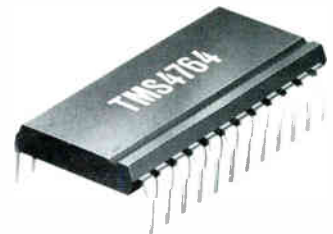
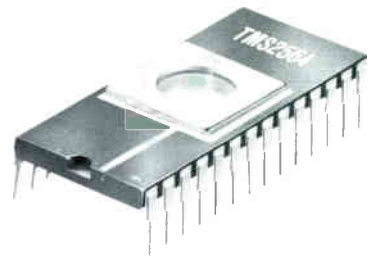

SRAMs

from
Texas Instruments

PART NO.	ORGANIZATION	ACCESS		MAX. POWER		PACKAGE
		FROM ADDR	FROM C-S	OPER.	STBY.	
TMS2114-15	1K × 4	150 ns	70 ns	330 mW	120 mW	NL-Plastic
TMS2114-20	1K × 4	200 ns	85 ns	330 mW	120 mW	NL-Plastic
TMS2114-25	1K × 4	250 ns	100 ns	330 mW	120 mW	NL-Plastic
TMS2114-45	1K × 4	450 ns	120 ns	330 mW	120 mW	NL-Plastic
TMS2114L-15	1K × 4	150 ns	70 ns	248 mW	72 mW	NL-Plastic
TMS2114L-20	1K × 4	200 ns	85 ns	248 mW	72 mW	NL-Plastic
TMS2114L-25	1K × 4	250 ns	100 ns	248 mW	72 mW	NL-Plastic
TMS2114L-45	1K × 4	450 ns	120 ns	248 mW	72 mW	NL-Plastic
TMS4044-12	4K × 1	120 ns	70 ns	303 mW	108 mW	NL-Plastic
TMS4044-20	4K × 1	200 ns	70 ns	303 mW	108 mW	NL-Plastic
TMS4044-25	4K × 1	250 ns	70 ns	303 mW	108 mW	NL-Plastic
TMS4044-45	4K × 1	450 ns	100 ns	303 mW	108 mW	NL-Plastic
TMS40L44-12	4K × 1	120 ns	70 ns	220 mW	60 mW	NL-Plastic
TMS40L44-20	4K × 1	200 ns	70 ns	220 mW	60 mW	NL-Plastic
TMS40L44-25	4K × 1	250 ns	70 ns	220 mW	60 mW	NL-Plastic
TMS40L44-45	4K × 1	450 ns	100 ns	220 mW	60 mW	NL-Plastic
TMS2147H-3	4K × 1	35 ns	35 ns	660 mW	165 mW	NL-Plastic JL-Ceramic
TMS2147H-4	4K × 1	45 ns	45 ns	660 mW	165 mW	NL-Plastic JL-Ceramic
TMS2147H-5	4K × 1	55 ns	55 ns	660 mW	165 mW	NL-Plastic JL-Ceramic
TMS2147H-7	4K × 1	70 ns	70 ns	660 mW	165 mW	NL-Plastic JL-Ceramic
TMS2149-3	1K × 4	35 ns	15 ns	660 mW	—	NL-Plastic JL-Ceramic
TMS2149-4	1K × 4	45 ns	20 ns	660 mW	—	NL-Plastic JL-Ceramic
TMS2149-5	1K × 4	55 ns	25 ns	660 mW	—	NL-Plastic JL-Ceramic
TMS2149-7	1K × 4	70 ns	30 ns	660 mW	—	NL-Plastic JL-Ceramic

Speed demons and other performance leaders

Where speed is the top priority in storing variable data, TI's fast SRAMs win hands down. Two new memories from TI — TMS2147H and TMS2149 — offer an access time from address of a scant 35 ns. Access time from chip select can be a lightning-fast 15 ns. Yet maximum operating power is only 660 mW.

They are just the ticket for use in cache, control store, and high-speed buffer applications.

High performance TMS2147H — Organized 4K × 1, this new SRAM offers access times from address or chip select of 35, 45, 55, and 70 ns, and has a chip select, power down feature. Maximum operating power is 660 mW, with standby power at 165 mW.

High performance TMS2149 — This new SRAM is organized 1K × 4, and has an access time from chip select as fast as 15 ns. Allowing you to take full advantage of system decoding delays and get the performance you expect. Access time from address is 35, 45, 55, and 70 ns.

Because of TI's low power, both memories come in space-saving 18-pin, 300-mil ceramic and plastic packages. And, both are ready for delivery now.

If your system calls for slower speeds but you still want high performance, check our new 4K TMS4044 and TMS2114 static RAMs. The 4K × 1 and 1K × 4 offer 120 ns and 150 ns access times respectively, with maximum operating power only 220 mW and 248 mW on the low-power versions. Both represent a dependable, reliable solution to simplify your microprocessor system design.

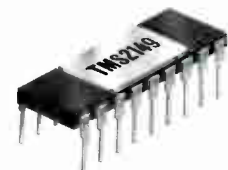

Coming soon:

- A new 2K × 8 static RAM with 120 ns access times
- A high-density, high-performance 16K × 1 static RAM
- A MOS memory subsystem for cache memory design

PROMs from Texas Instruments

PART NO.	SIZE	ORGANIZATION	TYPICAL ADDRESS ACCESS TIME	TYPICAL POWER DISSIPATION
TBP18S030 TBP18SA030	256 Bits 256 Bits	32W × 8B	25 ns	400 mW
TBP24S10 TBP24SA10	1K Bits 1K Bits	256W × 4B	35 ns	375 mW
TBP28L22 TBP28LA22	2K Bits 2K Bits	256W × 8B	45 ns	375 mW
TBP28S42 TBP28SA42	4K Bits 4K Bits	512W × 8B	35 ns	500 mW
TBP28S46 TBP28SA46	4K Bits 4K Bits	512W × 8B	35 ns	500 mW
TBP24S41 TBP24SA41	4K Bits 4K Bits	1024W × 4B	40 ns	475 mW
TBP28S86-60 TBP28SA86-60	8K Bits 8K Bits	1024W × 8B	35 ns	625 mW
TBP28S86 TBP28SA86	8K Bits 8K Bits	1024W × 8B	45 ns	625 mW
TBP28L86	8K Bits	1024W × 8B	65 ns	275 mW
TBP24S81-55 TBP24SA81-55	8K Bits 8K Bits	2048W × 4B	35 ns	625 mW
TBP24S81 TBP24SA81	8K Bits 8K Bits	2048W × 4B	45 ns	625 mW
TBP28S166-55 TBP28S166	16K Bits 16K Bits	2048W × 8B 2048W × 8B	35 ns 45 ns	675 mW 675 mW

A = OPEN COLLECTOR; L = LOW POWER

Top performers across the board

Name your design needs in bipolar PROMs. Fill them quickly from the industry's broadest choice. At Texas Instruments.

Low densities to high — Your choice ranges from a 256-bit PROM — often needed but difficult to find — to a new high-performance 16K device. You can choose from by-4 and by-8 organizations. With maximum address access times as much as 20 ns faster than data sheet specifications thanks to speed screening.

Better heat dissipation — Many TI PROMs in plastic packages now incorporate advanced copper-clad stainless steel leadframes which improve thermal characteristics by 20% to 25%. Result: Lower operating temperatures in the circuit which boost product reliability.

Convenient programming — TI's PROMs eliminate many programming problems and reduce programming costs. A single specification programs all members from 1K through 16K, using any of the popular programmers on the market. Or for no fallout whatever, you can have TI program, symbolize, and ship your PROMs to you (200-piece minimum order per program per scheduled delivery).

Space-saving packages — You can order many TI PROMs in 300-mil wide packages that save 50% in board space. The 600-mil package is also available — both widths in plastic or ceramic.

More advantages — All TI PROMs incorporate titanium-tungsten fuse lengths. All have low current PNP inputs to permit easy interfacing with MOS and bipolar microprocessors. All are Schottky-clamped for the best speed/power combinations.

Coming soon:

- Registered PROMs ideally suited for microprogrammed pipeline systems

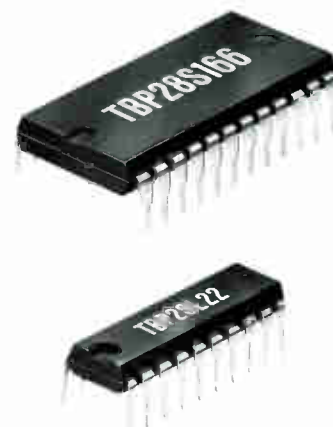

Read and file this guide. As a quick reference to TI's broad selection of semiconductor memories, it can quickly put you on the right track to solutions for design problems.

For more detailed information on any of TI's semiconductor memories, call your authorized TI distributor:

TI Distributors

ALABAMA: Huntsville, Hall-Mark (205) 837-8700.

ARIZONA: Phoenix, Kierulff (602) 243-4101; R.V. Weatherford (602) 272-7144; Tempe, Marshall (602) 968-6181; Tucson, Kierulff (602) 624-9986.

CALIFORNIA: Anaheim, R.V. Weatherford (714) 634-9600; Buena Park, RPS (213) 744-0355; Canoga Park, Marshall (213) 999-5001; Chatsworth, JACO (213) 998-2200; El Monte, Marshall (213) 686-0141; Glendale, R.V. Weatherford (213) 849-3451; Goleta, RPS (805) 964-6823; Irvine, JACO (714) 540-5600; Marshall (714) 556-6400; Los Angeles, Kierulff (213) 725-0325; Newport Beach, Arrow; Northridge, Arrow (213) 701-7500; Palo Alto, Kierulff (415) 968-6292; Pomona, R.V. Weatherford (714) 623-1261; San Diego, Arrow (714) 565-4800; Kierulff (714) 278-2112; Marshall (714) 578-9600; R.V. Weatherford (714) 695-1700; Santa Barbara, R.V. Weatherford (805) 465-8551; Santa Clara, United Components (408) 496-6900; Sunnyvale, Arrow (408) 745-6600; Marshall (408) 732-1100; Time (408) 734-9888; United Components (408) 496-6900; Torrance, Time (213) 320-0880; Tustin, Kierulff (714) 731-5711.

COLORADO: Denver, Arrow (303) 758-2100; Diplomat (303) 740-8300; Kierulff (303) 371-6500; Englewood, R.V. Weatherford (303) 428-6900.

CONNECTICUT: Orange, Milgray (203) 795-0714; Wallingford, Arrow (203) 265-7741; Marshall (203) 265-3822; Kierulff (203) 265-1115.

FLORIDA: Clearwater, Diplomat (813) 443-4514; Ft. Lauderdale, Arrow (305) 973-8502; Diplomat (305) 971-7160; Hall-Mark (305) 971-9280; Orlando, Hall-Mark (305) 855-4020; Palm Bay, Arrow (305) 725-1480; Diplomat (305) 725-4520; St. Petersburg, Kierulff (813) 576-1966; Winter Park, Milgray (305) 647-5747.

GEORGIA: Norcross, Arrow (404) 449-8252; Hall-Mark (404) 447-8000; Marshall (404) 923-5750.

ILLINOIS: Bensonville, Diplomat (312) 595-1000; Hall-Mark (312) 860-3800; Elk Grove Village, Kierulff (312) 640-0200; Chicago, Newark (312) 638-4411; Schaumburg, Arrow (312) 893-9420.

INDIANA: Ft. Wayne, Graham (219) 423-3422; Indianapolis, Graham (317) 634-8202; Arrow (317) 243-9353.

IOWA: Cedar Rapids, Arrow (319) 395-7230; Deeco (319) 365-7551.

KANSAS: Lenexa, Component Specialties (913) 492-3555; Shawnee Mission, Hall-Mark (913) 888-4747; Wichita, LCOMP (316) 265-9507.

MARYLAND: Baltimore, Arrow (202) 737-1700; (301) 247-5200; Hall-Mark (301) 796-9300; Columbia, Diplomat (301) 995-1226; Rockville, Milgray (301) 468-6400.

MASSACHUSETTS: Billerica, Kierulff (617) 667-8331; Burlington, Marshall (617) 272-8200; Holliston, Diplomat (617) 429-4120; Woburn, Arrow (617) 933-8130; Time (617) 935-8080.

MICHIGAN: Ann Arbor, Arrow (313) 971-8200; Oak Park, Newark (313) 967-0600; Farmington, Diplomat (313) 477-3200; Grand Rapids, Newark (616) 241-6681.

MINNESOTA: Bloomington, Hall-Mark (612) 854-3223; Edina, Arrow (612) 830-1800; Kierulff (612) 941-7500; Minneapolis, Diplomat (612) 788-8601.

MISSOURI: Earth City, Hall-Mark (314) 291-5350; Kansas City, LCDMP (816) 221-2400; St. Louis, Arrow (314) 567-6888; LCDMP (314) 291-6200; Kierulff (314) 739-0855.

NEW HAMPSHIRE: Manchester, Arrow (603) 668-6968.

NEW JERSEY: Camden, General Radio Supply (609) 964-8560; Cherry Hill, Hall-Mark (609) 424-0880; Clifton, JACO (201) 778-4722; Marshall (201) 340-1900; Fairfield, Kierulff (201) 575-6750; Marlton, Milgray (609) 424-1300; Moorestown, Arrow (609) 235-1900; Saddlebrook, Arrow (201) 797-5800; Totowa, Diplomat (201) 785-1830.

NEW MEXICO: Albuquerque, Arrow (505) 243-4566; International Electronics (505) 345-8127; United Components (505) 345-9981.

NEW YORK: Endwell, Marshall (607) 754-1570; Freeport, Milgray (516) 546-5600; N.J. (800) 645-3986; Hauppauge, Arrow (516) 231-1000; JACO (516) 273-5500; Liverpool, Arrow (315) 652-1000; Diplomat (315) 652-5000; Melville, Diplomat (516) 454-6400; Rochester, Arrow (716) 275-0300; Rochester Radio Supply (716) 454-7800; Marshall (716) 235-7620; Ronkonkoma, QPL (516) 467-1200.

NORTH CAROLINA: Greensboro, Kierulff (919) 852-6261; Raleigh, Arrow (919) 876-3132; Hall-Mark (919) 832-4465; Winston-Salem, Arrow (919) 725-8711.

OHIO: Beachwood, Kierulff (216) 587-6558; Centerville, Arrow (513) 435-5563; Cincinnati, Graham (513) 732-1661; Columbus, Hall-Mark (614) 846-1882; Dayton, ESCO (513) 226-1133; Marshall (513) 236-8088; Highland Heights, Hall-Mark (216) 473-2907; Solon, Arrow (216) 248-3990.

OKLAHOMA: Tulsa, Component Specialties (918) 664-2820; Hall-Mark (918) 835-8458; Kierulff (918) 252-7537.

OREGON: Beaverton, Almac Stroum (503) 641-9070; Portland, Kierulff (503) 641-9150.

PENNSYLVANIA: Pittsburgh, Arrow (412) 856-7000.

TEXAS: Austin, Component Specialties (512) 837-8922; Hall-Mark (512) 258-8848; Harrison Equipment (512) 458-3555; Kierulff (512) 835-2090; Dallas, Component Specialties (214) 357-6511; Hall-Mark (214) 341-1147; International Electronics (214) 233-9323; Kierulff (214) 343-2400; El Paso, International Electronics (915) 778-9761; Houston, Component Specialties (713) 771-7237; Hall-Mark (713) 781-6100; Harrison Equipment (713) 652-4700; Kierulff (713) 530-7030.

UTAH: Salt Lake City, Diplomat (801) 486-4134; Kierulff (801) 973-6913.

WASHINGTON: Redmond, United Components (206) 643-7444; Seattle, Almac/Stroum (206) 643-9992; Kierulff (206) 575-4420; Tukwila, Arrow (206) 575-0907.

WISCONSIN: Oak Creek, Arrow (414) 764-6600; Hall-Mark (414) 761-3000; Waukesha, Kierulff (414) 784-8160.

CANADA: Calgary, Cam Gard Supply (403) 287-0520; Future (403) 259-6408; Varah (403) 230-1235; Downsview, CESCO (416) 661-0220; Edmonton, Cam Gard Supply (403) 426-1805; Halifax, Cam Gard Supply (902) 454-8581; Hamilton, Varah (416) 561-9311; Kamloops, Cam Gard Supply (604) 372-3338; Moncton, Cam Gard Supply (506) 855-2200; Montreal, CESCO (514) 735-5511; Future (514) 694-7710; Ottawa, CESCO (613) 729-5118; Future (613) 820-8313; Quebec City, CESCO (418) 687-4231; Regina, Cam Gard Supply (306) 525-1317; Saskatoon, Cam Gard Supply (306) 652-6424; Toronto, Future (416) 663-5563; Vancouver, Cam Gard Supply (604) 291-1441; Future (604) 438-5545; Varah (604) 873-3211; Winnipeg, Cam Gard Supply (204) 786-8481; Varah (204) 633-6190. AF

Outside the United States and Canada:

Argentina 748-1141; Australia (02) 887-1122; Belgique/Belgique (02) 720.80.00; Brasil 518423; Deutschland 08161/801; France (3) 946 97 12; Italia (0748) 69034; Japan 03-498-2111; Mexico 567-9200; Nederland 020-473391; Schweiz/Suisse 01 740 22 20; Sverige (08) 23.54.80; United Kingdom (0234) 223000

Texas Instruments invented the integrated circuit, microprocessor and microcomputer. Being first is our tradition.

TEXAS INSTRUMENTS
INCORPORATED

"Now you know me. But do you know my company?"

Fred Molinari, President

Ads like these have made me pretty well-known in the world of analog I/O.

But there's more to Data Translation than Fred Molinari.

DEC LSI-11, UNIBUS®, MULTIBUS®, and STD bus. You'll find we have the widest line of microcomputer analog I/O boards anywhere.

In the last two years alone we have developed the very first Intelligent Analog Peripheral. The MIDAX family of industrial measurement and control systems. LAB-DATAX, the highest performance laboratory data acquisition system in the business. And the dual-port 250 KHz A/D system and dual-port RAM board for the DEC LSI-11.

We also designed DTLIB and DTFIRM, outstanding software packages for data acquisition.

So even though we still offer the broadest variety of modules and boards, there's no denying we are a systems supplier now.



For a copy of our 288 pg. catalog call Data Translation. Or turn to Volume III of the Gold Book.

"Why design a data acquisition function? We stock a wonderful variety of high performance modules. And they're all compatible."

Designing microcomputer DAS is a woolly business. But we have a simple solution to your problems. High performance modules you simply plug in. We offer a broad variety of data



"How did we manage to be first with intelligent analog peripherals? By working like madmen."

We worked days and nights, weekends

Fred Molinari, President

"With this catalog, these analog I/O boards, and our guaranteed five-day delivery, we're something of a freak in this business."

Fred Molinari, President

In this business, being good means being unusual.

For instance, we guarantee to deliver analog I/O for your microcomputer within five days. That's unusual.

But more to the point, we offer an unusually broad and technically advanced selection of high accuracy, high resolution data acquisition systems (DAS) modules and boards.

Data Translation was the first to put DMA on a board, and the first with 16-bit DAS. We were the first to put isolated DAS modules on a board, and the first with a DAS software library. Whether your application is laboratory or industrial, you will benefit by our unusually thorough approach.

Each of our boards and modules comes with free diagnostics and documentation. Each module is subjected to rigorous testing, including a three-day burn-in.

Our modular concept allows us to provide the widest range of products. More important, it offers you



to upgrade your system quickly and easily. We can deliver compatible DAS from Intel or National, and at lower prices, all height systems for LSI-11 and quant size systems with the others. We have hex-height PDP-11 Unibus™ systems performance is unmatched. LSI-11 and PDP-11

ies, at lower

I/O systems

With this

choose,

well

DATA TRANSLATION

This catalog enables you to get the microcomputer analog I/O you need in 5 days or less. Send for your working today.

DATA TRANSLATION

DATA TRANSLATION



have brought high-speed low-end computers. And, we are the first

madmen has its advantage. You'll let us work like

located at 100 Locke Drive, 752. Telex: 951646. 7-481-3700. In Europe: Ltd., Rockwell House, Slough, Berkshire/England RG2 861. Telex: 849862.

DATA TRANSLATION

Data Translation has grown quickly. Today we are big enough for *anyone* to do business with. We are unmatched in applying advanced data acquisition technology to real-world problems.

In the months to come I plan to tell you more about Data Translation and its products. If you want the facts now, call for our catalog. Data Translation is a company that merits your attention.

DATA TRANSLATION

World Headquarters: Data Translation, Inc., 100 Locke Dr., Marlboro, MA 01752 (617) 481-3700 Tlx 951-646

European Headquarters: Data Translation, Ltd., 430 Bath Rd., Slough Berkshire SL1 6BB England (06286) 3412 Tlx 849-862

MULTIBUS is a trademark of Intel Corp. UNIBUS and LSI-11 are trademarks of Digital Equipment Corp.

World Radio History

Circle 47 on reader service card

stored separately and, when electricity is needed, are recombined in a hydrogen bromide fuel cell. The acid solution is then returned to the solar chemical converter for use again.

An important milestone recently attained is that TI has been able to store the hydrogen safely, using a

technique that combines the gas with a powdered alloy of calcium and nickel, says Johnson. He discussed the closed-loop system at this month's International Electron Devices Meeting in Washington, D. C.

Converting the hydride compound back into gas and the alloy requires

less pressure and lower temperatures than if other alloys, such as iron and titanium, were used, he says. Heat from the liquid-bromide storage unit is enough to store and release the hydrogen.

New ground. Johnson also announced that TI's Central Research Laboratory in Dallas has also "plowed new ground" in developing an efficient hydrogen bromide fuel cell that meets the program's power goal of 300 peak watts output. "Most practical devices have been limited to several other chemicals—like hydrogen-oxygen, which received wide application in space programs," Johnson explains.

"In changing the feed stock, you have to address a whole new set of technology problems, like corrosion, material technology, design and construction," Johnson continues. "So from a materials standpoint, it's like starting over."

With less than a year left on the

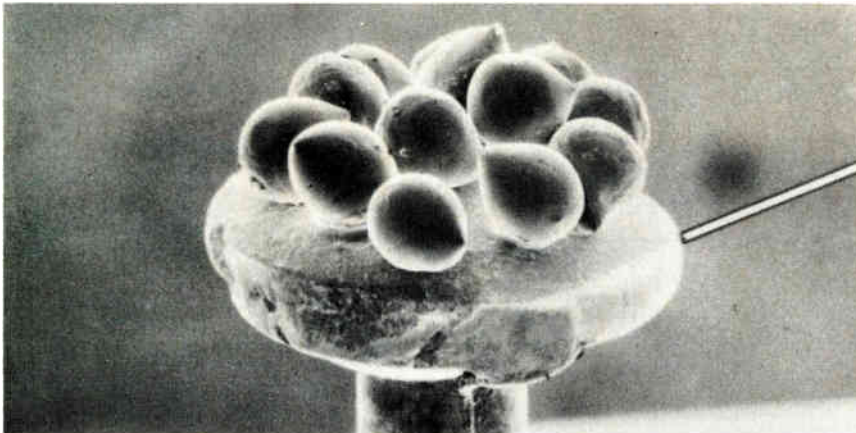

Tiny cells. Microphotograph shows TI's spherical silicon solar cells, 10 to 15 mils in diameter. The spheres, cast in a glass matrix, offer a conversion efficiency of 13%.

Something missing?

If your colleague has already filed TI's comprehensive guide to its family of

SEMICONDUCTOR MEMORIES, circle the number given below in the Reader Service Card.

We'll send you your own Read-and-File Guide to TI's broad choice in DRAMs, EPROMs, ROMs, SRAMs and PROMs.



Texas Instruments invented the integrated circuit, microprocessor and microcomputer. Being first is our tradition.

TEXAS INSTRUMENTS
INCORPORATED

©1981 Texas Instruments Incorporated

An advertisement for Texas Instruments memories. The top half features the word "MEMORIES" in large, bold, white letters against a black background, with "from Texas Instruments" in smaller white text below it. The background of the advertisement is a photograph of several memory chips, likely DRAMs, arranged in rows. In the lower right quadrant, there is a small white rectangular box with a black border. The box contains the text: "Read-and-File Guide to TI Semiconductor Memories. Here are the details and performance features — the advanced technologies — that will help you design the best possible, most cost-effective systems. A broad choice in both 1M16 and bipolar: DRAMs, EPROMs, ROMs, SRAMs, PROMs. All from Texas Instruments. All of proven quality and reliability. Included are the industry's first 228 and 618 EPROMs. The fastest of the fast statics. The smallest section in 1M16s. And a pioneering 816 DRAM. Read and file this convenient guide. It's worth a lot of mileage in helping you save time and money." To the right of the text in the box is a small version of the Texas Instruments logo.

83966

Electronics review

Department of Energy pact, most of the remaining work has to do with reliability of the system. Corrosion remains a major concern, Johnson indicates. TI continues to offer no timetable on possible commercial products, only saying it is targeting its work toward residential applications.

-J. Robert Lineback

Office automation

Copier marketer adds word processing

Savin Corp. is hardly a household word, but thousands of office workers know the company through its copiers. Now it aims to make its brand even more common in offices by introducing two families of work stations that integrate word-processing, data-processing, and communications capabilities.

The Valhalla, N. Y., firm is counting on its reputation in copiers to bolster sales of its new systems, which sell for as little as \$7,800. Such a price is comparable with bottom-of-the-line equipment from major suppliers like Wang Laboratories Inc. and Digital Equipment Corp.

Says company vice president Abraham Ostrovsky, "Customers know that Savin understands office operations and can respond to the users' requirements." He is convinced the firm can sell around several thousand work stations over the first year of sales. Deliveries will start at year end.

Enhanced. To create the two families, each of which has four members, Savin added its own software and some hardware enhancements to Convergent Technologies Corp.'s three-piece work stations that feature a high-resolution video-display terminal (see p. 151).

Savin has enhanced the detachable keyboard with interchangeable front-panel strips that express functions as simple English words like "bold" or "underline." Thus users can perform complex functions simply by a single touch rather than through memorized keystroke codes.

Each customer gets a custom data-processing software package under Savin's approach. The customer describes how his business works, then goes through a detailed question and answer session with Savin programmers who then design an appropriate software package. This approach allows data collected by a company for one application be used for other applications.

Savin is not the first to use Convergent Technologies 8088- and 8086-based series of work stations. In November, NCR Corp. Dayton, Ohio, announced its WorkSaver systems, to be delivered in April of 1982 for \$7,795. Early in the second quarter of 1982, Burroughs Corp. of Detroit, Mich., will also be introducing a small business system based on Convergent's hardware, the B20.

Savin's top-of-the-line IS 2000 uses a 5-megahertz 8086 processor, 256-k bytes of random-access memory, and 8-k bytes of read-only memory. Its mass store contains an 8-in. floppy-disk drive with 0.5 megabyte of formatted storage and a 20-megabyte Winchester-technology disk drive.

-Steve Zollo

Peripherals

Optical storage tape holds 50 gigabytes

The supremacy of magnetic tape as for low-cost archival storage may be challenged in the near future by a new medium that promises bit densities that are orders of magnitude greater and cost much less per bit. The medium is optical tape, which stores bits of information not as magnetic flux units, but as the presence or absence of small holes drilled into its surface.

The holes are drilled by using a laser beam to melt the highly reflective, silvered surface of the tape, exposing areas of low reflectivity. Bits are read by detecting the reflective scattering of laser light from the tape. The result is a medium that, though not erasable like magnetic tape, is a permanent one suitable for

12 Weeks
From This

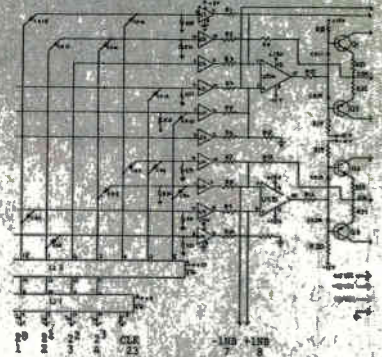

To This

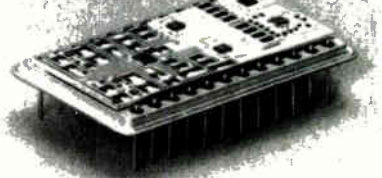

Custom Hybrids Aerospace Military Medical

Crystalonics can deliver prototype quantities of custom hybrid circuits in less than 12 weeks from the time you present your debugged design. Our people have been designing and building devices and circuits exclusively for high reliability applications for twenty years. Our engineers have sharpened their skills in teamwork with designers of aerospace, military and medical projects, such as F15, Hawk, Viking Mars, Intelsat and implantable pacemakers. We can ease you quickly and confidently through the transition from schematic to finished hybrid package. Utilize the hybrid's advantages of space, weight, reliability and cost by calling on our experience: (617) 491-1670.

 **TELEDYNE
CRYSTALONICS**
147 Sherman Street
Cambridge, MA 02140
Tel: (617) 491-1670
TWX 710-320-1196

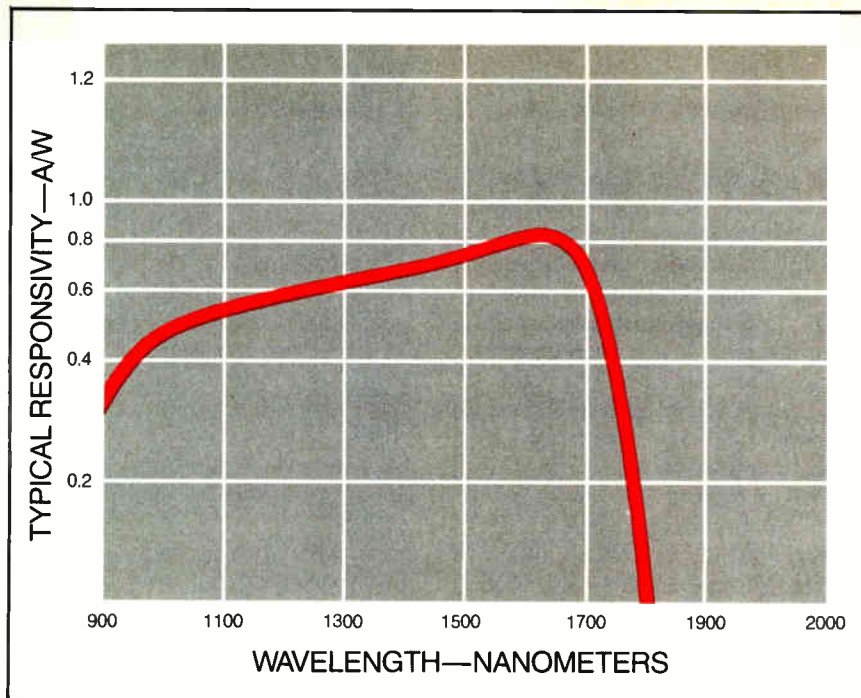

Typical spectral responsivity characteristic.

New fiber optics photodetector optimized for 1300 and 1550 nm sources.

RCA's new InGaAs photodiode can help you explore the "second window" in fiber optics communications.

If you're investigating fiber optics communications systems in the so-called "second window" beyond the 950 nm peak, we'd like to acquaint you with our new C30979E Indium Gallium Arsenide photodiode.

This is a high-speed photodiode fabricated with the use of vapor-phase epitaxial techniques. The structure provides high-speed responsivity between 900 and 1650 nm and is optimized for detection of 1300 and 1550 nm sources.

The C30979E has high quantum efficiency (60% typical at 1300 and 1550 nm) and extremely fast response

(rise and fall times are typically less than 1.0 ns). The device is equipped with a removable cap which permits optimum coupling of the fiber to the photosensitive surface of the detector.

For further information, and applications assistance, please contact your RCA Sales Office or write to RCA Photodetector Marketing, Ste. Anne de Bellevue, Quebec, Canada H9X 3L3. Telephone: 514-457-9000.

RCA Brussels, Belgium. Sao Paulo, Brazil. Sunbury-on-Thames, Middlesex, England. Paris, France. Munich, W. Germany. Hong Kong. Mexico 16 D.F., Mexico.



RCA

purposes of archival storage.

Drexler Technology Corp., Mountain View, Calif., is developing the tape using its own Drexon laser-recording material usually applied to optical disks. While acknowledging that it may be well into 1983 before production quantities of the tape—and the read/write mechanisms to go with it—are available, company president Jerome Drexler notes that his company has developed a prototype tape that it will make available to researchers in sample quantities.

Many bits. "Right now, we are using 5-micrometer holes, but there would be no problem in going to 2.5- μ m holes," Drexler asserts. He points out that a 2,400-foot tape 70 millimeters wide could store 50,000 megabytes using 5- μ m holes. To original-equipment makers, price of the tape is expected to be under \$5,000 per 2,400-ft reel—a cost of 10¢ per megabyte. Using 2.5- μ m holes would permit 200,000 megabytes to be stored at a cost of 2.5¢ per megabyte. By contrast, magnetic-tape storage costs about 15¢ per megabyte.

The tape could be used in an open-reel configuration with a 50-mil-thick-coating applied to the reflective surface to prevent dust particles from interfering with the recording process. But Drexler envisions another way. "I see it sealed in a cassette, and a 50-mil window in the package would replace the coating on the tape," he says.

Uses. A long reel of 35- or 70-mm optical tape could be used in recording satellite transmissions or retaining geophysical data for oil and gas exploration, computer and document archives, and off-line tape libraries, Drexler says. He also sees smaller optical cassettes with tape about 3 mm wide and 50 ft long and capacities of about 25 megabytes. These could be used with personal and business computers.

At present, Drexler has developed only a prototype reader/writer that handles small strips. At least one of its customers is at work on a commercial version. Its introduction is expected before the second quarter of 1982.

-Martin Marshall

Are you sowing the seeds of success?

VMOS—the Vertical D MOSFET technology from Ferranti—has blossomed so effectively that more and more successes are being reported every day in telecommunications, military and industrial applications.

For microprocessors and display drivers through to switching power supplies, VMOS offers the fastest switching, highest input impedance, highest gain and greatest reliability in performance.

You can get the rugged, reliable VMOS in the widest of varieties: N-channel and P-channel. Voltages up to 650V. Currents up to 16A continuous, 32A pulsed. You can get switching times as low as 5nSec, ON-resistances as low as 0.1ohms . . . and as wide a range of packages as you'll ever need.

Ferranti Electronics Limited,
Discrete Component Marketing,
Fields New Road, Chadderton, Oldham OL9 8NP
Telephone: 061-624 0515 Telex: 668038

FERRANTI Semiconductors

FERRANTI
VMOS

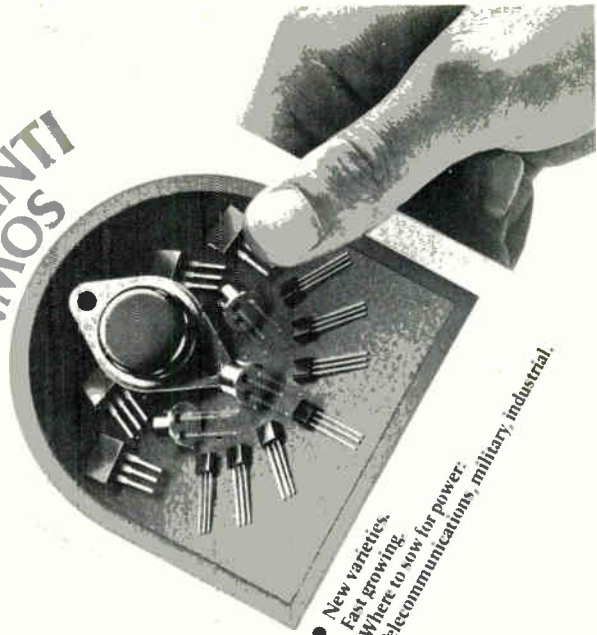

• New varieties
• Easy growing
• Where to sow for power:
Telecommunications, military, industrial.



Ferranti Electronics Limited, Fields New Road,
Chadderton, Oldham, England, OL9 8NP
Tel: 061-624 0515 Telex: 668038

Ferranti GmbH, Widenmayerstrasse 5,
D8000- Munich-22, West Germany
Tel: 089-293871 Telex: 523980

Ferranti Electric Inc., 87 Modular Avenue,
Commack, N.Y. 11725, U.S.A.
Tel: 516-543 0200 Telex: 510 226 1490

ELO3/06/101

Circle 133 on reader service card

Simple, better, low cost

N coax connectors for data communication systems

With their new commercial N-series AUTOMATIC CONNECTOR INC., a subsidiary of the Swiss ASUAG group, developed a series of unique coax connectors. Their simple, superior design not only reduces their prices but increases their electrical and mechanical performance at the same time. These low cost connectors will satisfy requirements in data communication systems like Ethernet and equivalent systems, as well as in Satellite TV applications. They are weatherproof and available in 2 versions: with solderable center contact and with solder-free quick mounting for rugged cables. Frequency 0... 11GHz. Impedance 50 ohms. V.S.W.R. 1.30:1 maximum. Meets MIL specifications.



TH 214 CO 81

AUTOMATIC
Connector, Inc.

P.O. Box 297, 1860 Aigle, Switzerland
Tel. 025 - 26 55 33, Telex 456 138

ASU

COMPONENTS Ltd.

A subsidiary of the Swiss ASUAG group

Electronics/December 15, 1981

Circle 134 on reader service card

59

Meet the little thermal with the big



printers
difference

...the electronics come built in.

Control electronics... interface electronics... power-supply electronics... **all** the electronics come built right into Datel-Intersil's panel printers. No more of the do-it-yourself hassles of print-mechanism-only panel printers. No more space problems.

You get many other convenience features, too. Like whisper-quiet thermal printing (no ink, no ribbons, no hammers, no noise, no mess!). There are models with full alphanumeric printing... parallel or serial input capability... inverted printing for text (TTY) or lister applications... and much more. All in pint-sized packages one-third smaller (and lighter) than other panel printers.

Datel-Intersil also gives you plenty of choice. It's the broadest line of its kind anywhere.

To learn more about Datel-Intersil's hassle-free, cost-saving, got-everything mini-printers — and how they can simplify printer applications for you, call or write any sales office in the U.S. or overseas.

Model DPP-Q7 Parallel. Seven-column numeric printer. Two hundred forty lines/min. Selectable positive or negative TTL full-parallel BCD input plus input storage register. Same size, shape and interfaces of digital panel meters. Only 4.4 pounds. Selection of printout formats. 115/230 VAC power.

Model APP-20 Parallel. Twenty-column, 96-character ASCII alphanumeric printer. Seventy-two lines/min. TTL bit-parallel, 7-bit character — serial, selectable positive or negative true. Input storage register. Programmable control. Tall characters. Selected inverted text printing. Single-character printing. 115/230 VAC power (DC-powered models also available). Same compact dimensions as DPP-Q7.

Model APP-20 Serial. Similar to alphanumeric APP-20 Parallel model, but designed for full serial 20mA optoisolated and RS-232-C data input. Seventy-five to 9600 baud data rate. Needs only two wires to interface. Can be remotely located from hazardous data source. Tall characters. Selectable inverted text/lister printing.

Model APP-48 Serial. Forty-eight column, 96-character alphanumeric printer with second 96-character set of special figures, currency symbols, etc., European characters, Greek letters, others. Seventy-two lines/min. Full serial 20mA optoisolated and RS-232-C data input. 115, 100 or 230 VAC or 12 Vdc power. Selectable inverted text printing.



11 CABOT BOULEVARD, MANSFIELD, MA 02048/TEL. (617) 339-9341/TWX 710-346-1953/TLX 951340 • SANTA ANA, (714) 835-2751 • SUNNYVALE, CA (408) 733-2424 • HOUSTON, (713) 781-8886 • DALLAS, TX (214) 241-0651 • OVERSEAS: INTERSIL DATEL (UK) LTD — TEL: BASINGSTOKE (0256) 57361 • INTERSIL DATEL SARL 602-57-11 • INTERSIL DATEL GmbH (089) 77-60-95 • DATEL KK TOKYO 793-1031

Call us on our Instant-Info-Hot-Line • 617-339-9341 Ext. (100)

"DELIVERY FROM STOCK"

Circle 61 on reader service card

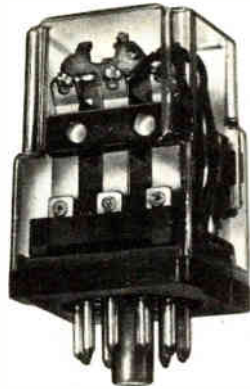

Our KRP has finally got some tough, low-cost competition. Our KRPA.

The new KRPA is designed to give you the long, trouble-free life that has made the KRP the industry standard in general-purpose, medium-power relays. And it's available in the same popular 5 and 10 amp multi-contact configurations. But for about 15% less cost. Without compromising performance, we made design improvements that permit simplified assembly procedures and greater use

of automated manufacturing processes. And like all Potter & Brumfield components, KRPA's are available off-the-shelf from leading distributors backed by P&B's sizable factory inventory. Potter & Brumfield Division AMF Incorporated, 200 Richland Creek Drive, Princeton, IN 47671. 812/386-1000.



AMF

Potter & Brumfield

**We're demanding so
you don't have to be.**

Potter & Brumfield

Washington newsletter

Postal Service gears for electronic mail

The U. S. Postal Service and four telecommunications carriers have signed agreements to provide transmission links between volume mailers of computer-generated mail and the Post Office's electronic mail service, known as E-Com. The four firms are TRT Communications, ITT World Communications, Network, and Taipan Industries. **Also, 25 major mailers have applied for technical certification as of Dec. 1 to use E-Com.** Three other companies, Dialcom, Western Union International, and Graphnet, have applied for E-Com access and are evaluating the interconnection agreements. Slated to begin Jan. 4, E-Com will allow volume mailers to transmit their messages through the telecommunications carriers to 25 serving post offices where they will be mailed.

FCC ponders allocation of transponders

The issue of allocating transponders on communications satellites is heating up. The Federal Communications Commission currently has three inquiries under way that are expected to result in decisions by early next year. Whatever the FCC decides, however, the matter is almost certain to end up in court. **One controversy is whether satellite owners may take the auction-lease route, as RCA did in November,** to determine which companies would get to lease seven transponders, with the right to lease going to the highest bidder. That squeezed out companies that had been expecting a first-come, first-served allocation. Another dispute involves outright sales of transponders. Hughes has sold 18 for a total of \$201 million on a satellite to be launched in May 1983, and RCA has also sold two transponders. The third issue before the commission is a proposal to completely deregulate domestic communications satellites.

Support grows for 'right-to-tape' law

Support for what is called right-to-tape legislation is growing in response to the U. S. Court of Appeals decision making it illegal to videotape copyrighted TV programs for noncommercial use. Bills have been introduced in the House and Senate with the Senate version moving very quickly. **Backers of the Senate bill include Sony Corp., the National Association of Retail Dealers of America, the National Citizens' Committee for Broadcasting, and 3M Corp.** The bill, which has 30 cosponsors, would permit home recording for private use. Testifying before the Senate Judiciary Committee on the bill, Joseph Lagore, president of the Sony Consumer Products division, argued that "to ban this equipment would surely have a dangerously negative impact on technological innovation and development of any kind in this country. Why would someone spend billions of dollars needed to create new technology in the fashion we have here only to have it banned or recalled a decade and a half later?"

Navy wins approval for LAMPS production

After several weeks of agonizing over rising costs of the LAMPS Mark III SH-60B antisubmarine warfare helicopter, the Defense Department has finally approved the Navy's request to put the electronics-crammed choppers into production in the current fiscal year (see p. 64). A memo from Deputy Defense Secretary Frank C. Carlucci to the Navy approved limited initial production of the system—**18 helicopters and the backfitting of 10 ships to accommodate them**—in fiscal 1982, at an estimated cost of about \$700 million. Carlucci also authorized the Navy to initiate advance procurement of 48 LAMPS helicopters in fiscal 1983, for which the Pentagon will request \$970 million.

The Navy's skewed priorities for antisubmarine warfare

Christmas will not be very merry this year at Lockheed-California Co. in Burbank, Calif. The reason: the Department of Defense's decision to support Navy Secretary John F. Lehman's plan to cancel production of Lockheed's P-3C Orion aircraft, which are used for antisubmarine warfare patrols. After deciding to proceed in fiscal 1983 with the production of 60 Orions at the rate of a dozen a year, the Navy secretary reversed himself upon listening to his carrier admirals.

The infighting for funds is becoming increasingly competitive, and the admirals argue that they can make better use of the money by buying more Harriers and F-18Ss, while relying on IBM Light Airborne Multipurpose System shipboard helicopters for antisubmarine defense. Lehman proposes to stop P-3C production for five years and then restart the line in 1988. In reality that decision will kill the program.

Lockheed's grim picture

This cancellation, coupled with the company's termination of the unsuccessful L-1011 commercial jet transport, leaves Lockheed-California with only the low-volume line of the TR-1 high-altitude reconnaissance plane, a variant of its U-2R, and a handful of other classified efforts at its Skunk Works, formally known as Advanced Development Projects. As a result, as Lockheed Corp. president and chief executive Larry Kitchen put it in a mid-November letter to Lehman, "The viability of Lockheed-California Co. would be in great jeopardy." If it folds, Kitchen warned, it will represent the loss of "the only existing integration and production capability for airborne antisubmarine warfare in the free world."

The P-3, with its 10,000 pounds of avionics, has done well for Lockheed. When sales to foreign allies are included, the company has turned out 523 of the four-engined Orions, although only 40% of these are the latest C models. To shut down production now, disband the team of contractors, and then restart a cold production line in five years would more than double the plane's unit cost of \$34.5 million to nearly \$75 million, when an annual inflation factor of 7% is included. Of course, Lehman is unlikely to have to face that problem in five years, as he well knows.

Other Navy options for the P-3 are available under the awkward acronym of SLEP/Cilop—for service life extension program and conversion in lieu of procurement. By Lockheed's estimate, Cilop would cost nearly \$4.38 billion over

eight years. That covers upgrading 182 planes at \$23.8 million each plus nonrecurring costs. The figure is based on upgrading 36 planes each year after a three-year lead time. Lockheed, of course, would rather build new ones.

Loss of foreign military sales dollars to the U. S. is another argument advanced by Lockheed's Kitchen. The Netherlands, for example, uses older P-3As for the most part, but is scheduled to take delivery of three more P-3Cs in fiscal 1983 concurrent with the Navy purchase. Australia, which has P-3Bs it plans to upgrade, had planned to buy 10 P-3Cs in the fiscal 1984-86 timeframe. Japan, says Kitchen, "is accelerating its license production and is planning to extend its production quantity from 45 to 90 or 100" planes, while France and West Germany are interested in the Orion for their antisubmarine warfare aircraft needs of 40 and 20 planes respectively.

Whether Lockheed-California lives or dies is far less critical to the country than maintenance of its long-range antisubmarine warfare capability—although the first, unfortunately, may be inextricably interwoven with the second.

Range is the name of the game in airborne antisubmarine warfare for the Navy today. It will be more so in the years ahead as the Soviet Union increases its undersea fleet and builds on its existing ability to stand off from a task force and use cruise missiles launched under water from distances of more than 250 miles. Fleet air defense, however crucial, will be of little help in such circumstances.

When the Pentagon distributed its fearful 100-page assessment of Soviet military power earlier this year to rationalize its escalating spending program to a questioning Congress and its constituents, it ranked the growth of Russia's submarine fleet near the top of its threat list. "Over the past 10 years," the Pentagon maintains, "the Soviets introduced two new versions of the Victor nuclear-powered attack submarine (SSN) and developed the Alfa high-technology attack submarine. In 1980, the Soviets produced Oscar, the prototype of a new class of nuclear-powered cruise-missile attack submarine (SSGN), which is about twice the size of any previous SSGN. High priority is being devoted to antisubmarine sensor technology applicable against ballistic-missile submarines."

If that is the case, then Lehman's priorities for airborne antisubmarine warfare require a great deal more explanation. Lockheed Corp., for one, is determined to see that Congress seeks it out.

-Ray Connolly

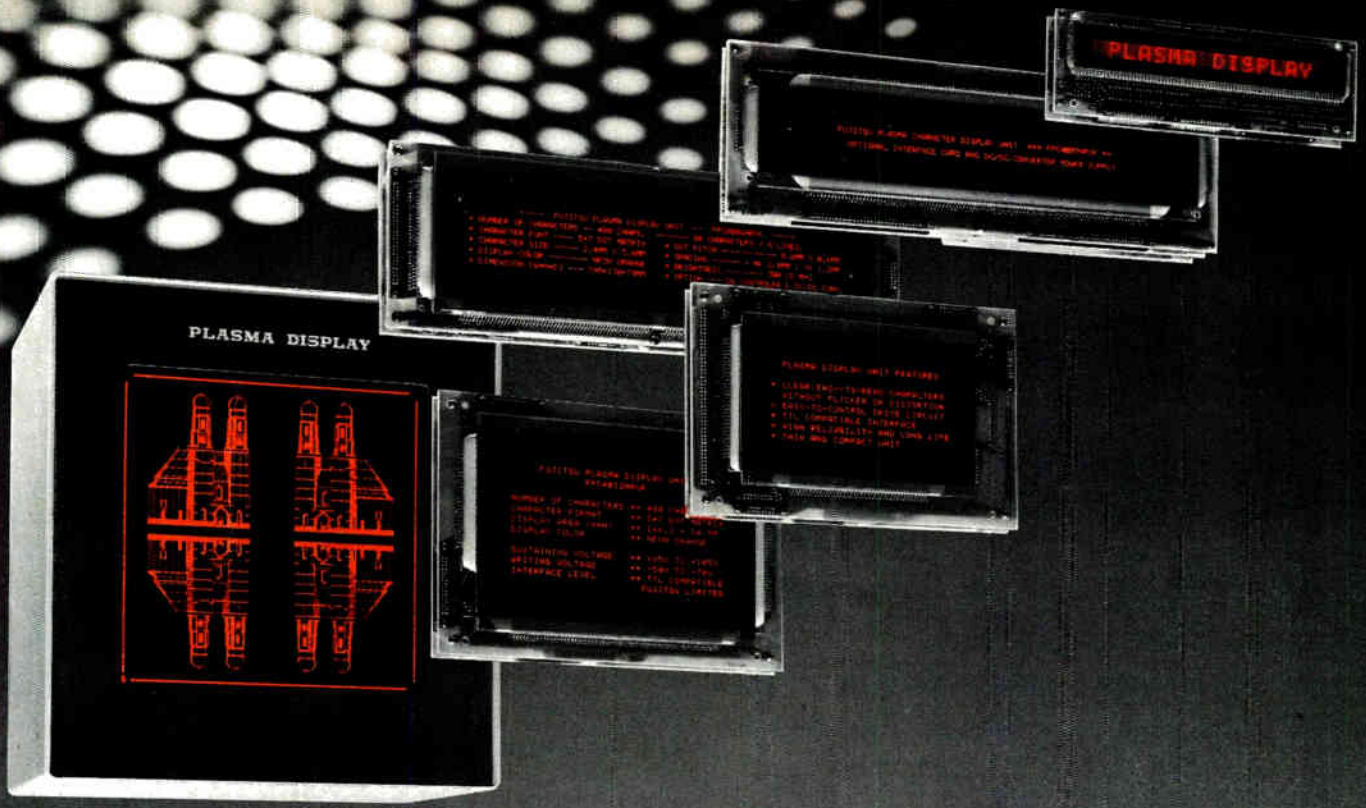

The Separable 5V/12V Plasma Display Unit Take It All Or Take A Part It's Your Choice

Three new features in Fujitsu's character plasma display units will save you money and streamline your operations:

- direct power compatibility as the world's first 5V/12V character plasma display unit,
- cost-saving flexibility which lets you select the entire assembly: panel and panel drive – control – 5V/12V power source – or any one of the individual parts,
- all 5 x 7 dot matrices which present a clear, crisp display while reducing your costs.

In addition, Fujitsu's character and graphic display units are smaller and thinner, with the same screen size, because Fujitsu has redesigned the circuits to reduce the size of the units. There's also a new look on the screen. Clear, highly visible characters and graphics against a darker background give you a more distinct image which is easier to read both straight on and well off to the side.

Of course AC drive and inherent memory are still features of the full lineup. And you can choose from a wide variety of designs to suit any application, including measuring instruments, computer peripheral and terminal equipment, and graphic design units. The result is the most advanced plasma display unit available today. At Fujitsu Component Europe, B.V., which started in November, an experienced staff is on hand to give you full details.

Fujitsu Component Europe, B.V.

Rijnkade 19B, 1382 GS, Weesp, The Netherlands Phone: 02940-18748 Telex: 11966 FUJCENT

CHARACTER UNITS (For units with character generator control)

Model	No. of Characters	Character Format	Character Size (mm)	Power Source
FPC1601NRCA*	16 (16 chars. x 1 row)	5 x 7 dot matrix	8.0 x 10.2	V _{CC} =+5V V _{GG} =+12V
FPC3201NRCK	32 (32 chars. x 1 row)		4.0 x 5.6	
FPC4002NRCK	80 (40 chars. x 2 rows)		3.1 x 4.4	
FPC3208NRCK	256 (32 chars. x 8 rows)		3.0 x 4.2	
FPC4012NRCK	480 (40 chars. x 12 rows)		3.0 x 4.2	
FPC8002NRCK	160 (80 chars. x 2 rows)		3.0 x 4.2	
FPC8006NRCK	480 (80 chars. x 6 rows)		3.0 x 4.2	
FPC8012NRCK	960 (80 chars. x 12 rows)		3.0 x 4.2	

* Also includes V_{sub} = -5V

GRAPHIC UNITS (For units with graphic generator control)

Model	Effective Display Area		No. of Effective Lines		Dot Pitch (mm)	Power Source
	D(mm)	W(mm)	D	W		
FPG0707NRUC	78	78	128	128	0.6	V _{CC} =+5V V _S =+80V~+110V V _W =+140V~+160V
FPG0805NRUA	18.6	153	32	256	0.6	V _{CC} =+5V V _S =+85V~+105V V _W =-55V~-75V
FPG0909HFUA	217	217	512	512	0.423	V _{CC} =+5V V _S =+85V~+105V V _W =-55V~-75V

Character and graphic color: neon orange



Fujitsu Limited, Tokyo, Japan

THERE IS NO EQUIVALENT R & D.

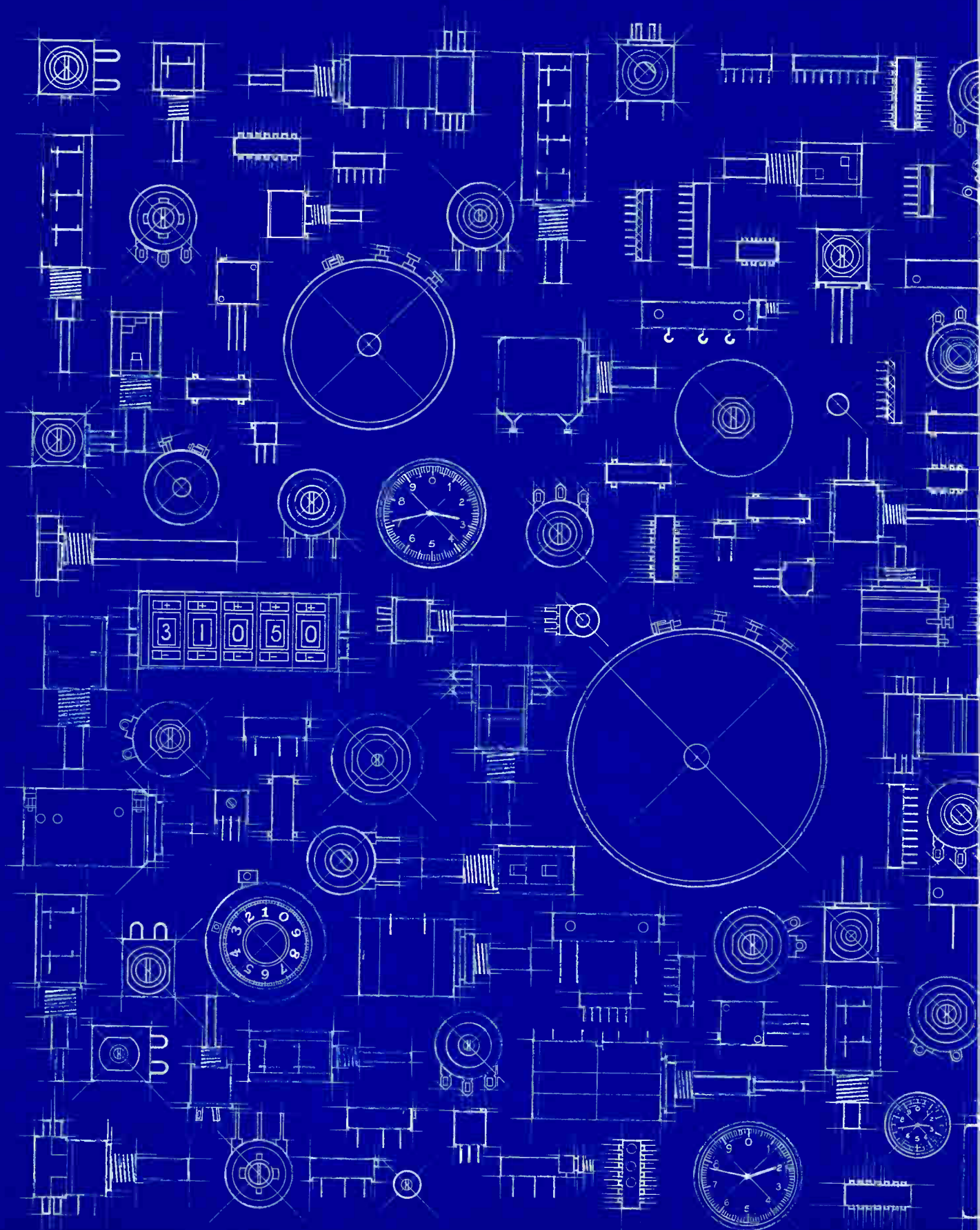

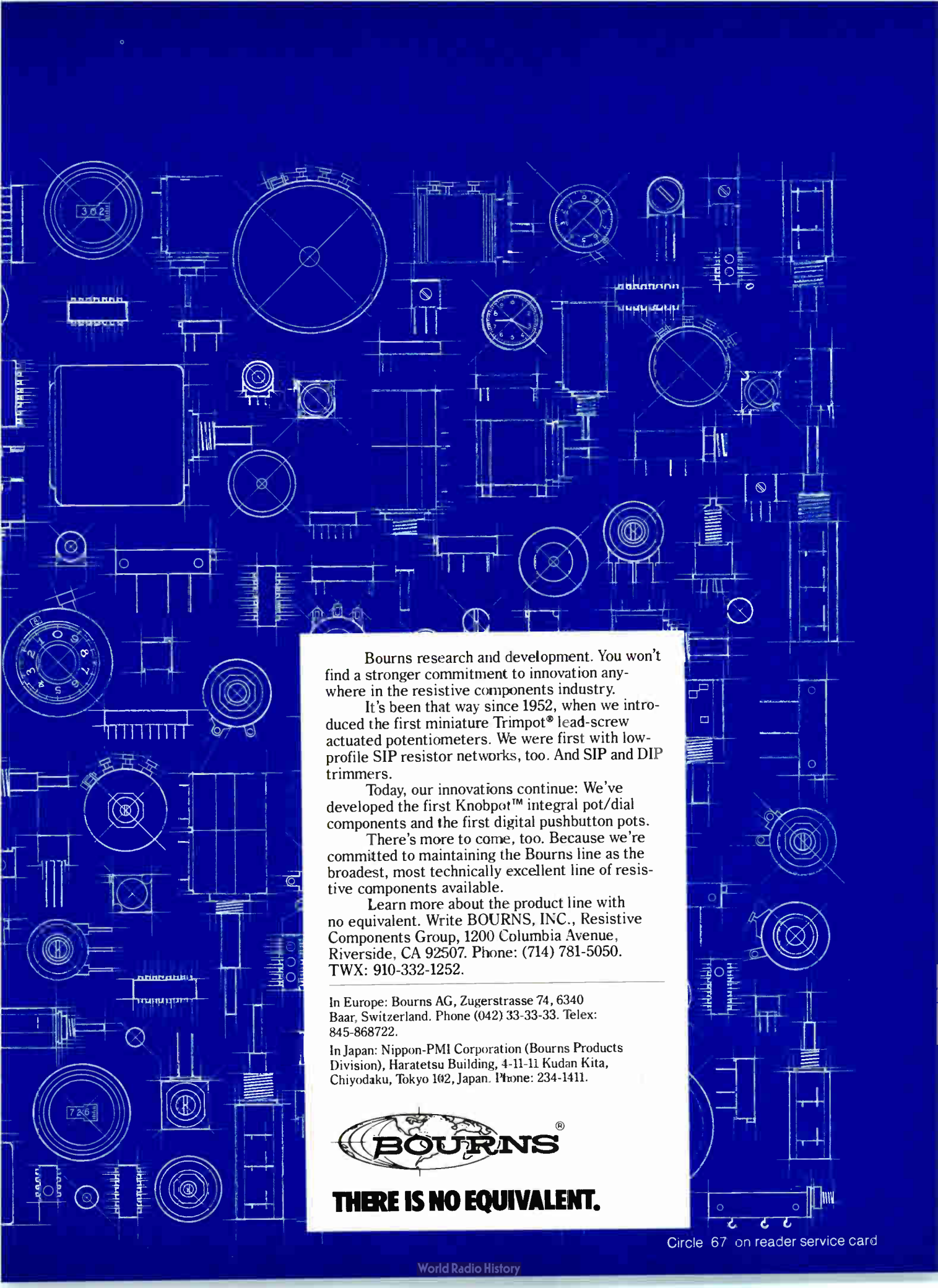

Bourns research and development. You won't find a stronger commitment to innovation anywhere in the resistive components industry.

It's been that way since 1952, when we introduced the first miniature Trimpot® lead-screw actuated potentiometers. We were first with low-profile SIP resistor networks, too. And SIP and DIP trimmers.

Today, our innovations continue: We've developed the first Knobpot™ integral pot/dial components and the first digital pushbutton pots.

There's more to come, too. Because we're committed to maintaining the Bourns line as the broadest, most technically excellent line of resistive components available.

Learn more about the product line with no equivalent. Write BOURNS, INC., Resistive Components Group, 1200 Columbia Avenue, Riverside, CA 92507. Phone: (714) 781-5050. TWX: 910-332-1252.

In Europe: Bourns AG, Zugerstrasse 74, 6340 Baar, Switzerland. Phone (042) 33-33-33. Telex: 845-868722.

In Japan: Nippon-PMI Corporation (Bourns Products Division), Haratetsu Building, 4-11-11 Kudan Kita, Chiyodaku, Tokyo 102, Japan. Phone: 234-1411.



THERE IS NO EQUIVALENT.

Circle 67 on reader service card

A FULL RANGE OF PRODUCTS... A NAME TO RELY ON!

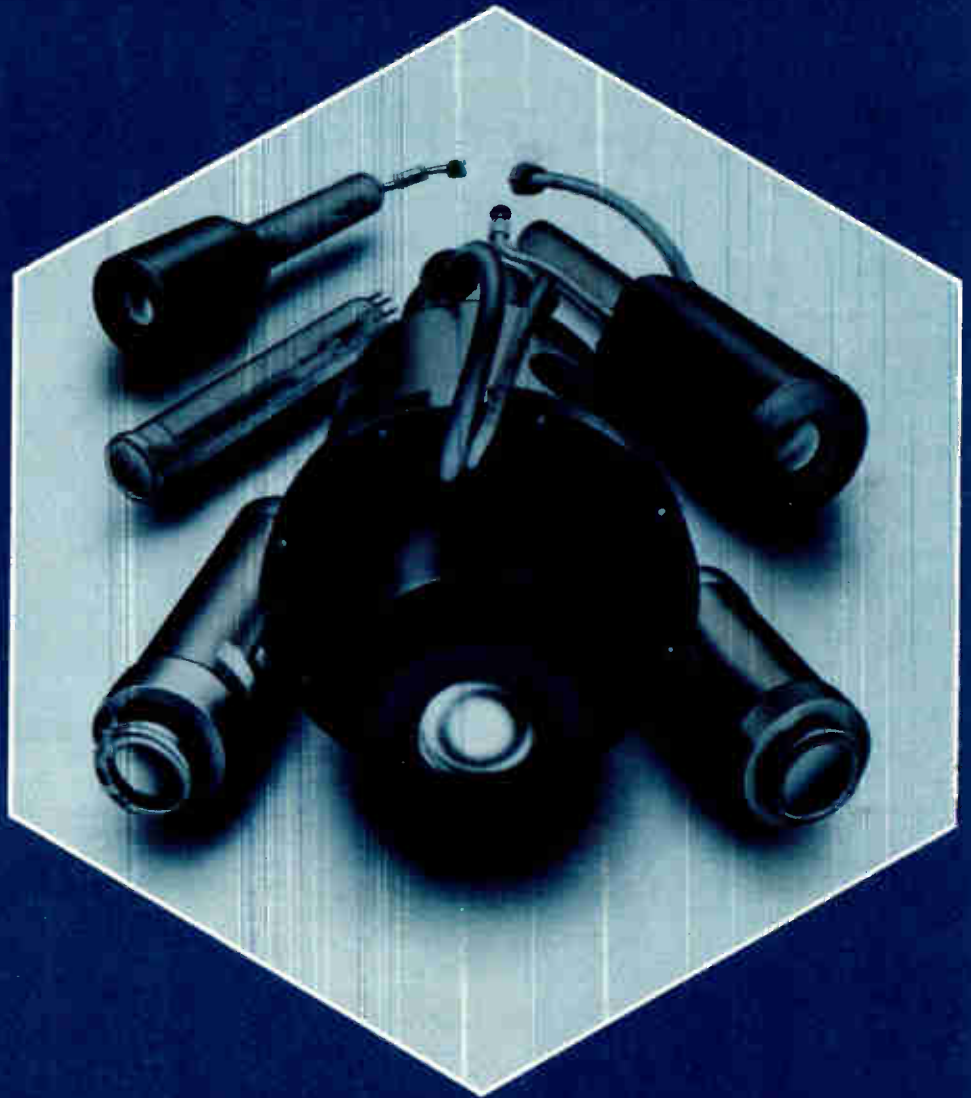

Daytime - Night-time - Thermal imaging

- Vidicons ● Silicon-target vidicons ● Pyroelectric-target vidicons
 - Nocticon® L3 TV tubes ● Supernocticon® L3 TV tubes.
- Potted, integral-coil, and ruggedized models available.

 **THOMSON-CSF**
COMPONENTS

THOMSON-CSF DIVISION TUBES ELECTRONIQUES

38 RUE VAUTHIER / BP 305 / 92102 BOULOGNE-BILLANCOURT CEDEX / FRANCE / TEL. : (33.1) 604 81 75

USA
THOMSON-CSF
COMPONENTS CORPORATION
CLIFTON NJ (201) 779.10.04

BRAZIL
THOMSON-CSF
COMPONENTES DO
BRASIL Ltda
SAO-PAULO (11) 542.47.22

GERMANY
THOMSON-CSF
BAUELEMENTE GmbH
MÜNCHEN (89) 75.10.84

UNITED KINGDOM
THOMSON-CSF
COMPONENTS AND
MATERIALS Ltd
BASINGSTOKE (256) 29.155

ITALY
THOMSON-CSF
COMPONENTI
ROMA (6) 638.114.58

SPAIN
THOMSON-CSF
COMPONENTES
Y TUBOS S.A.
MADRID (1) 419.88.42

SWEDEN
THOMSON-CSF
KOMPONENTER
& ELEKTRONRÖR AB
STOCKHOLM (8) 22.58.15

JAPAN
THOMSON-CSF
JAPAN K.K.
TOKYO (3) 264.63.46

Circle 135 on reader service card

Dec. 15, 1981

Electronics

International®

World's fastest IC can get
faster still: page 81

Designer checks a mask layout that owes its unusual density to a revised version of Gaelic computer-aided design software: page 82

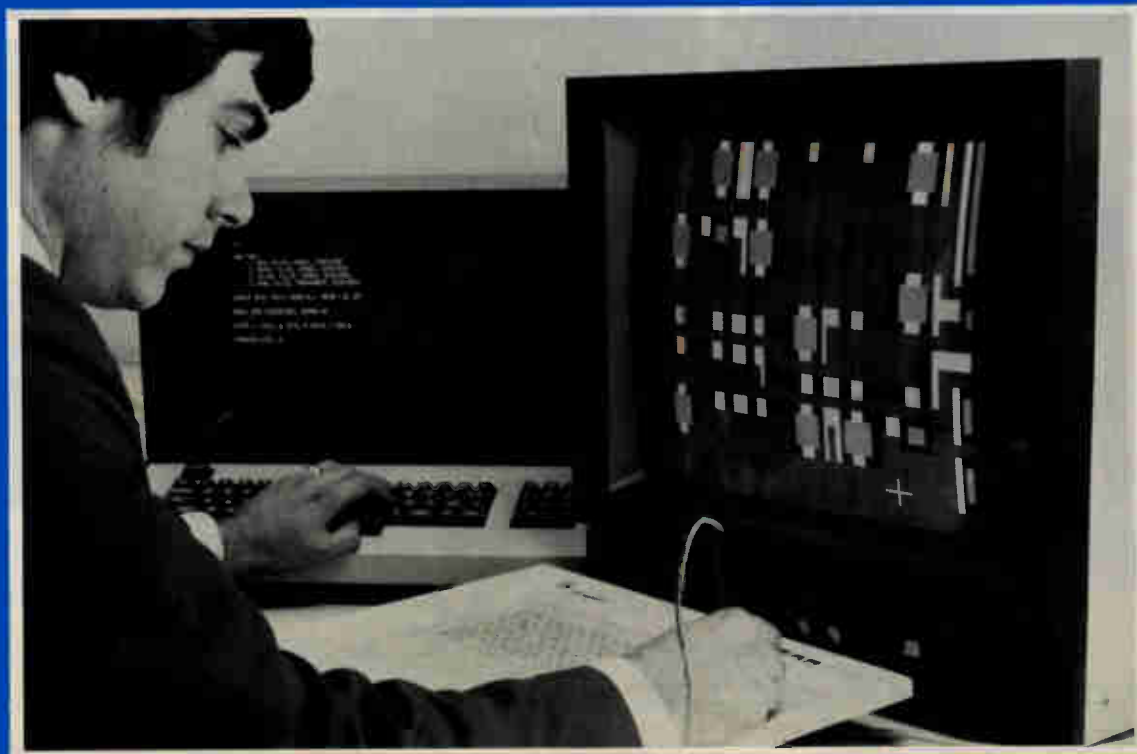

NEC, too, to make gate arrays

Nippon Electric Co. has followed Fujitsu, Oki Electric, Hitachi, and Toshiba into the gate array business. Initial products will include TTL devices with 1,000, 550, and 250 gates and complementary-MOS devices with 2,100, 1,300, and 800 gates. The TTL devices will have an internal propagation delay of 2 ns for a fanout of 3 and a 3-mm lead length. The C-MOS devices will have a 12-ns delay for the same fanout and lead length. By the end of next year the firm expects to be able to offer TTL devices with 3,000 gates, C-MOS devices with 10,000 gates, and emitter-coupled-logic devices with 2,000 gates.

Real-time holography analyzes stresses

A system using holography in real time to analyze stresses in materials has been developed at the Thomson-CSF central research laboratory in the Paris suburb of Corbeville. Using bismuth silicate crystal [*Electronics*, July 19, 1979, p. 72], the unit displays the deformations of vibrating objects up to 20 mm square directly on a video monitor and thus **avoids the need for photography**. Based on an argon laser with a wavelength of 514 nm, the system could include signal digitization in future versions to facilitate measurement of the deformations.

Japan plans cut in computer tariff

Japan will cut its computer import tariff next spring to roughly 7% from a current 9.1% as part of a **new effort to ease trade friction with the West**. Computers are among 2,000 items for which Japan will speed up by two years tariff reductions already agreed to in the Tokyo round of the multilateral trade negotiations. Last May, Japan agreed to slash semiconductor tariffs next spring to 4.2% from 10.1%, five years ahead of schedule.

Addenda

Britain's ICL is now producing software for the Sinclair ZX81 home computer, **over 250,000 of which have now been produced worldwide** in either the \$150 wired-up form or the \$100 kit form. According to Sinclair Ltd., it is the industry's fastest-selling computer. . . . Videlec AG, in Lenzburg, Switzerland, a joint venture of Brown, Boveri & Cie in Baden and Philips of the Netherlands, is **giving up production of smaller liquid-crystal displays—mostly used in watches**—but will continue to manufacture larger LCDs. The low cost of small units from Japan on the world market has made Swiss production uneconomic. . . . Siemens AG is delivering 10,000 teletypewriters to Saudi Arabia. These, plus the 17,000 the West German company has already installed there, will give the country a Telex network **as dense as that of many highly industrialized nations**. . . . Matra-Harris Semiconducteurs SA of Paris and Intel Corp. of Santa Clara, Calif., are jointly funding Cimatel, a center for the **design of n-channel MOS devices for European and other markets**. Circuits designed by Cimatel, to be based in Paris and Nantes, France, will be manufactured by both companies. . . . An agreement on laying a phone cable **directly between Israel and Egypt and on helping Egypt establish a communications link with the Sinai** has been signed by the two countries. West Germany's Siemens is to supply the necessary equipment within the next six months. . . . Thorn Consumer Electronics Ltd. in the UK and Japan's Mitsubishi Electric Corp. will **share technical information relating to television technology** in such areas as chassis development, production technology and quality control.

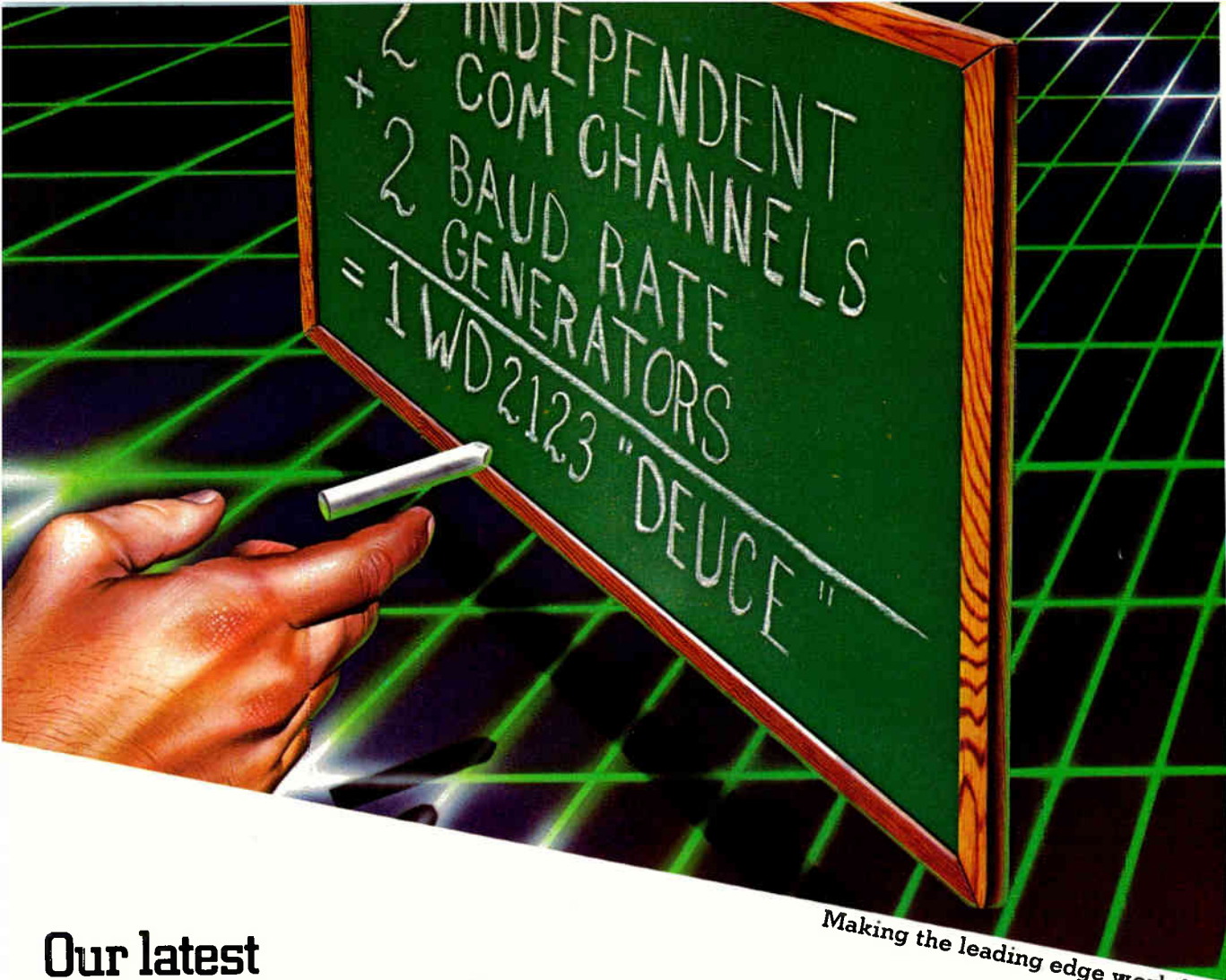

Making the leading edge work for you.

**Our latest
async breakthrough
was simply a matter
of putting
two and two
together.**



The WD 2123 Deuce's numbers speak for themselves: 2 independent async com channels. 2 baud rate generators. Even a crystal oscillator.

All in a brand-new, single-chip package. From Western Digital.

It all adds up to instant savings, too. In hardware costs, assembly costs and board space. Because now, one device does the work of four.

But then, Western Digital's written the book on Async Solutions.

The WD 8250 Ace, for example, was the very first single-chip Async Com Element to provide an on-board programmable baud rate generator.

And the world's smallest bus-oriented async com device is our WD 1983. A glitch-free, 8-bit design that's also Intel and NEC 8251A compatible.

Fact is, we even invented the UART. And our TR 1863/1865's at 3.5 Mb/s are far and away the fastest 5-volt-only UARTs on the market.

So before your async problems multiply, contact Western Digital.

We'll make sure the numbers always come out in your favor.

WESTERN DIGITAL
C O R P O R A T I O N

Telecommunications Division, 2445 McCabe Way, Irvine, CA 92714, (714) 557-3550.

So advanced

Tek 2213. \$1100



Performance

BANDWIDTH
Two channels, dc — 60 MHz to 20 mV/div, 50 MHz to 2 mV/div.

LIGHT WEIGHT
6.1 kg (13½ lbs.), 6.8 kg (15.0 lbs.) with cover, and pouch.

SWEEP SPEEDS
Sweeps from 0.5 s to 0.05 μs (to 5 ns/div with X10 magnification).

SENSITIVITY
Scale factors from 100 V/div (10X probe) to 2 mV/div (1X probe). Accurate to ±3%. Ac or dc coupling.

MEASUREMENT CONVENIENCE
Automatic intensity, automatic focus, beam finder for off-screen signals, full 8x10-cm CRT.

Tektronix tradition for excellence in designing and manufacturing oscilloscopes is recognized around the world. But, rather than rest on past laurels, we've veered dramatically from the traditional design path we ourselves established.

With the 2213 and the 2215, an entirely new form of scope is on the scene. Most remarkable about these new scopes is that their major design advances deliver full range capabilities at prices significantly below what you would expect to pay.

How has this been accomplished?

First, the number of mechanical parts in these new scopes has been reduced by 65%. Saving parts cost and ultimately improving reliability.

Makes sense. The fewer the parts, the less likely something will go wrong. And the less often something goes wrong, the more hours spent being productive.

Next, board construction was designed with the ultimate sophistication: simplicity. High performance is

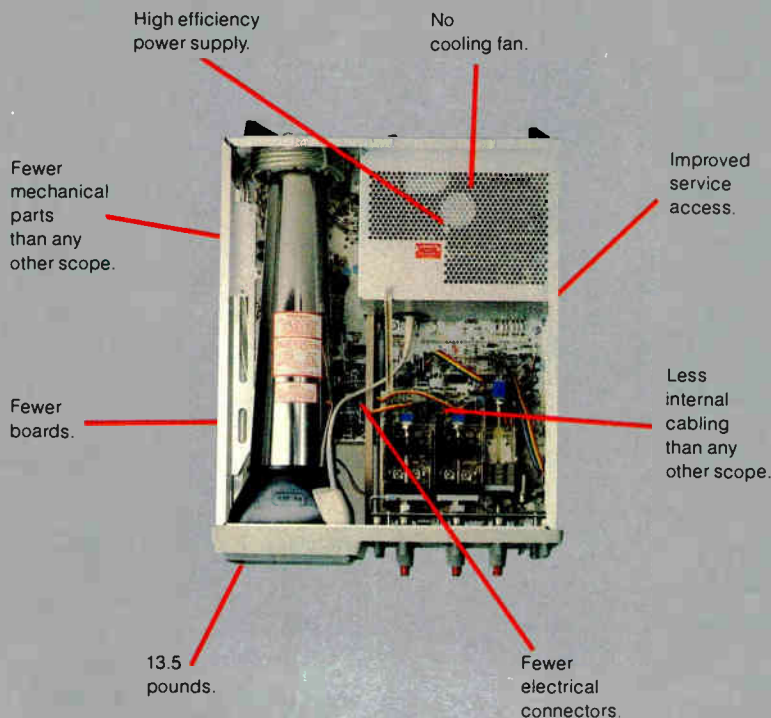

* FOB Beaverton, OR.
U.S. Prices.

they cost you less.

Specifications

Tek 2215. \$1400

DELAYED SWEEP MEASUREMENTS

2213: standard sweep, intensified after delay, and delayed; delay times from 0.5 μ s to 4 ms. 2215: increased delayed measurement accuracy to $\pm 1.5\%$; A only, B only, or A and B alternately with A intensified by B; B sweeps run after delay or separate trigger.

COMPLETE TRIGGER SYSTEM

Modes include TV field, normal, vertical mode, and automatic; internal, external, and line sources; variable holdoff; separate B sweep trigger on 2215.

NEW P6120 PROBES

High performance, positive attachment, 60 MHz and 10-14 pF at probe tip; light weight, flexible cables; new Grabber tips for ICs and other small diameter components.



achieved with fewer boards. (The 2213 has only one). Board electrical connectors are reduced in number — virtually eliminated in the 2213 — and cabling cut an amazing 90%.

Fewer components and fewer boards mean fewer steps in assembly, less testing, less likelihood of testing errors.

These are the direct efficiencies that keep prices low and reliability high.

The 2213 and 2215 also feature a high efficiency power supply and power-saving circuitry.

These innovations eliminate the need for a cooling fan and help make the scopes smaller, lighter and cleaner.

In addition, the power supply works all over the world (90-250 Vac, 48-62 Hz) without needing a line switch or a bulky line transformer. This special power supply also regulates fluctuations in line voltage, to assure calibrated measurements.

These are just some of the innovations built into the 2213 and 2215 to

reduce costs and improve performance.

Performance that's written all over the front panels.

The bandwidth for digital and high-speed analog circuits. The sensitivity for low signal measurements. The sweep speeds for fast logic families. And delayed sweep for fast, accurate timing measurements.

The advanced trigger system features a vertical mode for true alternate triggering on both channels. It even has a convenient signal-seeking auto mode. And it also triggers on either TV lines or fields at any sweep speed for video service.

These scopes have it all. They're lightweight for field work. They've got a bright, easy to view display. Automatic CRT focus and intensity. Beam finder. And the operating simplicity to fit a wide range of operator skills.

These are the advances in performance, cost savings and convenience that break tradition. But other traditions remain. Like fast, reliable ser-

vice support. Nearly 1300 people around the world to service Tektronix products exclusively. Plus the customer documentation, training programs and applications assistance that help to make Tek service the most comprehensive in the industry. And make your 2200 scope an even greater value.

For full information on the 2213 and 2215, contact the Tek office nearest you. Or have your technical questions answered or place your order via our new telephone sales service. Call 800-547-1845. From Alaska, Hawaii or Oregon, call collect 503-627-5402.

You just can't buy a more advanced scope, for anything less.

For further information, contact:

U.S.A.
Tektronix, Inc.
Delivery Station 19-100
P.O. Box 500
Beaverton, OR 97077
Phone: 800/547-1845
From Alaska, Hawaii
or Oregon call collect:
503/627-5402
Telex: 910-467-8708
Cable: TEKTRONIX

Canada
Tektronix Canada Inc
P.O. Box 6500
Barrie, Ontario L4M 4V3
Phone: 705/737-2700

**Asia, Australia,
Latin America, Japan**
Tektronix, Inc.
Americas Pacific Marketing
P.O. Box 500
Beaverton, OR 97077
Telex: 910-467-8708

**Europe, Africa,
Middle East**
Tektronix International, Inc.
European Marketing Centre
Postbox 827
1180 AV Amstelveen
The Netherlands
Telex: 18312

Tektronix
COMMITTED TO EXCELLENCE

Technological leadership.

Motorola's new 150ns 64K DRAM

Electronics review

Market-share scramble sires faster versions of 64-K dynamic RAMs

By J. Robert Moore, Staff Writer

Memory makers feel that 64-K DRAMs will be a key to success in the microprocessor market.

The race for market share in the 64-K dynamic random access memory (DRAM) market is heating up. Motorola, Intel, and other manufacturers are competing to produce faster versions of the 64-K DRAM. Motorola's new 150ns 64-K DRAM is a key example of this competition.

Intel Corp. and Intel Corp. will soon be the market with faster versions of their 64-K DRAM. Motorola is a strong contender at the moment. Intel's new 150ns 64-K DRAM is a key example of this competition.

Motorola's new 150ns 64-K DRAM is a key example of this competition. It is a 64-K DRAM with a 150ns access time. This is a significant improvement over previous versions. Motorola's new 150ns 64-K DRAM is a key example of this competition.

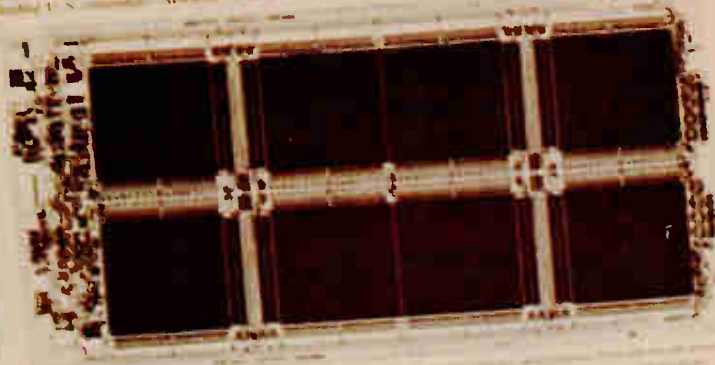

Better halves

Electronics

Reprinted from
ELECTRONICS, OCTOBER 20, 1981.
Copyright 1981 McGraw-Hill Inc. All rights reserved.

OCTOBER 20, 1981
ANNUAL TECHNOLOGY UPDATE ISSUE
Program the U.S. for the future
Engineering strategies in production, test, and equipment supply

Electronics



1981 AWARD FOR
ACHIEVEMENT
LYNN CONWAY - CARVER MEAD

“...is less susceptible to soft errors, and in fact none occurred during tests totaling more than 2 million device hours.”

The first volume supplier of +5 V 64K dynamic RAMs is now first with volume quantities of second-generation parts. They not only give you 150ns speed but greater reliability as well: system soft error tests indicate a rate well below 0.1%/1,000 hours, as specified on the data sheet.

In fact, as *Electronics* reported October 20th, no soft errors took place in the first two million-plus life-test hours.

Coupled with lower prices resulting from higher yields and a new five-inch wafer line, Motorola's second-generation single +5 V MCM6664A (pin 1 refresh) and MCM6665A now take you beyond the price-per-bit crossover point with industry-standard (and pin-compatible) 16Ks. Lower system costs are yours with one-fourth the parts, only one

power supply, faster CAS access times, lower input capacitance and wider operating margins. And a choice of 120, 150 or 200ns devices.

For production-run availability, contact the nearest Motorola sales office or off-the-shelf-service distributor. Reliable Motorola 64K DRAMs are the answer for your

Innovative systems through silicon.



MOTOROLA INC.

TO: Motorola Semiconductor Products Inc., P.O. Box 20912, Phoenix, AZ 85036.

Please send me information on 64K DRAMs.

112 ELEX 12 15 81

Name _____

Title _____ Tel.: (____) _____

Company _____

Address _____ Mail Drop _____

City _____

State _____ ZIP _____

The Lexidata System 3400 Display Processor and full line of interactive peripheral devices are designed specifically for OEMs and sophisticated end-users. The System 3400, rapidly becoming the leader, with over 1,000 units shipped to date, possesses the product characteristics required by this demanding customer group.

- System 3400 *performance* is truly outstanding. Only the System 3400 offers 1280x1024 resolution at 60Hz non-interlaced black-and-white and grayscale capability, or 880x704 resolution at 60Hz non-interlaced color. Our programmable lookup tables are the industry standard of performance. Double buffered memories or multiple lookup tables with bank switchable

memories and processor features, such as pan/zoom and 4K WCS, are available.

- System 3400 *quality* satisfies the requirements of Fortune 500 companies, the leading CAD/CAM systems vendors and military and government contractors. We continue to focus on quality because we believe that quality and cost effectiveness are closely related.
- System 3400 *flexibility* ensures a configuration to meet the exact requirements of each customer. The System 3400 offers a complete range of OEM configurations, starting from \$7,540, including monitor.
- System 3400 *software* provides a high-level language user-interface to

execute graphics and imaging functions. The powerful subroutine library streamlines application software development and facilitates user interaction.

- System 3400 *cost effectiveness* enables even price-sensitive OEMs to configure a highly competitive product. You will be able to maximize your value-added contribution and optimize your overall system performance.

For more details, call (617) 663-8550 or write to us at 755 Middlesex Turnpike, Billerica, MA 01865. TWX 710-347-1574.

 **LEXIDATA CORPORATION**

Circle 80 on reader service card

LEXIDATA



RASTER DISPLAYS...
FOR THOSE WHO DEMAND PERFORMANCE.

GaAs chip sets speed record at room temperature

by Robert T. Gallagher, Paris bureau manager

Planar enhancement-mode switching transistors and ungated load transistors achieve 19-ps delay

Researchers at Thomson-CSF have developed what they claim is the world's fastest circuit at room temperature, while leaving themselves room to beat their own record. The 11-stage ring oscillator uses gallium arsenide of only normal mobility, a standard gate length, and complex logic to achieve an announced 22-picosecond propagation delay at 25°C [*Electronics*, Nov. 30, p. 55]. Mounting the test circuit in a laboratory package has trimmed this figure to 19 ps.

The basis for the circuit's speed is electron confinement at its gallium-aluminum-arsenide and GaAs heterojunctions, as it is for a similar device developed at Fujitsu Labora-

tories Ltd. [*Electronics*, Oct. 20, p. 73]. The basic difference between the two is that, while Fujitsu uses recessed-gate technology, the Thomson circuit is based on planar enhancement-mode switching transistors and ungated load transistors. The Japanese company claims a propagation delay of 17.1 ps at liquid nitrogen temperature.

The technology is based on an experiment to determine the effect of the thickness of epitaxy on the transistors built on it. On a chromium-doped substrate, an undoped p-type GaAs layer 1 micrometer thick, an undoped GaAlAs layer 60 angstroms thick, and a silicon-doped GaAlAs layer 700 Å thick were deposited in turn by molecular beam epitaxy.

Next step. The wafer was then cut into two equal parts, with the first left intact. The other received chemi-

cal etching to remove 200 Å. Both halves were then treated identically: gold over germanium nitride was deposited and annealed to form source and drain contacts, and then an aluminum gate was deposited directly on the top epitaxy layer without any recess.

As a result, all tested transistors on the first half of the wafer were depletion-mode, whereas those on the second half were enhancement-mode. Tested at 10 gigahertz, both types of transistor showed a minimum noise figure of 2.3 decibels.

The first improvement in the circuit's speed will derive from simplifying its logic. "Our objective is to get down to 10 ps at room temperature before we start working at 77 K," says Nuyen Linh, manager of the microstructures section at the company's central research laboratory located in the Paris suburb of

Proof positive. Oscilloscope screen (left) shows the output waveform of the 11-stage ring oscillator from Thomson-CSF. Right microphotograph shows two of the devices.

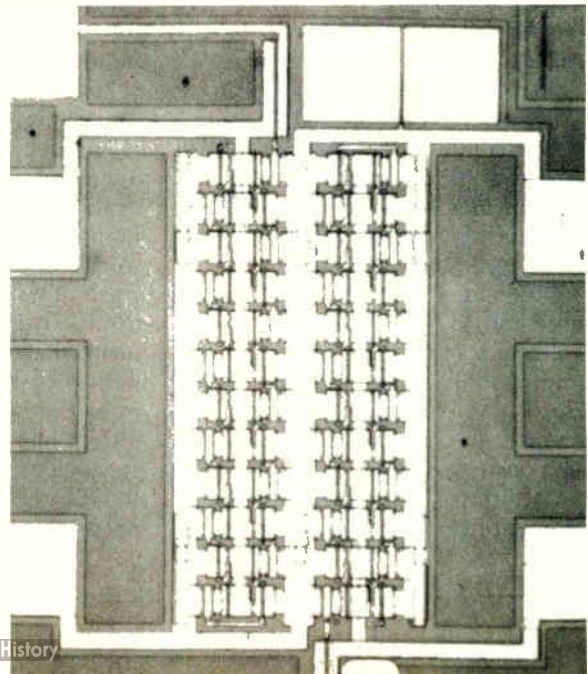
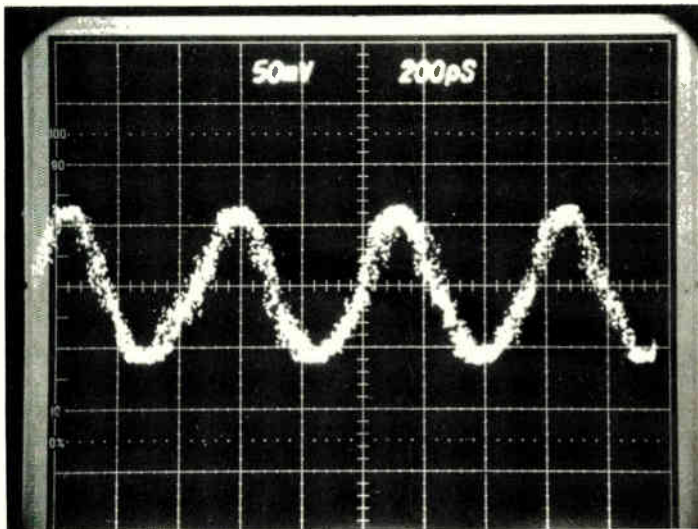

Corbeville. "I feel that we can do that simply by changing the logic from field-effect-transistor logic with low pinch-off voltage to direct-coupled FET logic. Other improvements we can make are the use of higher-mobility materials and a change in the geometry to shorten the gate length. When we go to liquid nitrogen temperature, that will

improve speed and heat dissipation."

The present circuit exhibits an electron mobility of 4,000 square centimeters per volt per second, works off a 3.5-v power supply, and consumes a hefty 6.6 milliwatts per stage though both the power supply and consumption will be dramatically reduced by the conversion to direct-coupled FET logic.

Great Britain

Continuous computing systems catch on with Western European hardware makers

Resilient computer systems, capable of quickly recovering from a hardware or software fault, are assuming an increased significance as computer terminals move into the general office and more and more office staff become dependent on them. Tandem Computers in the U. S. was first to the market with a resilient dual-computer system and has rapidly built a \$200 million business with it. Now other manufacturers are joining in and still more will be forced to follow. Within the last month alone the entries have been:

- Britain's Computer Technology Ltd. launched Momentum, its answer to data protection.
- International Computers Ltd. revealed how it will exploit the dual-processor architecture of its newly launched 2988 to improve the resilience of its system.
- A U. S. start-up, Stratus Computers Inc., announced the Stratus/32 Continuous Processing System [*Electronics*, Nov. 3, p. 167].
- In a continuing effort, the Danish electronics company, Christian Roving in Copenhagen, is building a reputation for duplicated high-reliability systems.

Different. Computer Technology's approach to resilience differs from Tandem's in several respects. According to its managing director Bob Finch, CTL wants to move nonstop computing down market from the high-cost specialist defense and public utilities sector and has aimed Momentum at the small-systems

market—the segment starting from \$77,000 and extending to, say, \$144,000 for a system supporting 100 terminals. To begin with, the company, headquartered in Hemel Hempstead, Herts., offers a range of graded options so that a customer, as his business becomes more integrated with large numbers of computer terminals, can progressively add protection to the firm's series 8000 16-bit computers.

Momentum comprises a range of hardware and software options, some already well proven. Added to the series 8000 data-base management system, for example, Momentum copies every transaction in progress, throwing away the copies after each update. Then, if a transaction fails, the system falls back to the last valid checkpoint and tries again. To guard against disk-head crashes, data can be read to paired disks so that the failure of one causes an automatic changeover to the other, with no break in on-line service.

Next, a single processor can be upgraded to a dual-processor configuration to guard against a processor failure, the two processors sharing workload and disks. When one processor goes down, the other can pick up its workload. A data-management map of all current transactions—at the file level—is preserved in both processors and is updated by a data link between the two processors operating at 1 or 2 megabits per second. Tandem, by contrast, connects processors over a high-band-

width data-base, using it to copy data rather than just file locations. Connected terminals can be switched manually, though CTL has plans for automatic changeover.

Though CTL can offer only dual processing (Tandem can run up to 16 processors in harness), the company hints that Momentum could be extended to larger multiprocessor configurations connected by a local network, a technique that squares well with the parent group's office automation strategy.

CTL marketers concede that they may not be offering the same level of uninterrupted operation as Tandem, but they are confident that they can meet the requirements of large sectors of commercial environment at a far lower cost.

Connect. For London-based ICL, resilience will flow from its fast-evolving multiprocessor architecture in which two or four processors can be linked without a significant loss of performance. By more tightly segregating jobs, so that interprocessor communication and, hence, overheads are minimized, ICL is achieving performance factors of between 1.7 and 1.9 for its dual machines.

Basic to the new system resilience—which is slated to give uninterrupted service for periods in excess of three shift years, or 7,500 operating hours—is a continuous-control software facility that lets one dual processor monitor the other. Then, if a failure or error occurs, one mode will diagnose the problems and reconfigure the system after removing the doubtful element. The process is carried out without operator intervention and will be completed within three minutes. Continuous control, says ICL, will be released in phases.

-Kevin Smith

CAD revision packs logic tightly on chips

No computer program can yet match a skilled integrated-circuit designer's ability to pack the maximum number of logic functions onto a chip, but Compeda Ltd.'s latest

Cutting the high cost of micro-system service.

“There’s only one micro-system tester that pays for itself from the day it arrives.”

“Microprocessors are both a blessing and a curse. The same technology that keeps driving down the cost of electronic equipment has made repairing it more costly and complex. At Fluke we’re attacking this critical service problem head on, with a whole new class of instruments: the 9000 Series Micro-System Troubleshooters. Starting with the 9010A, which is available now, these testers are inexpensive, easy to operate, and start returning your investment from the very first day. Here’s how:”

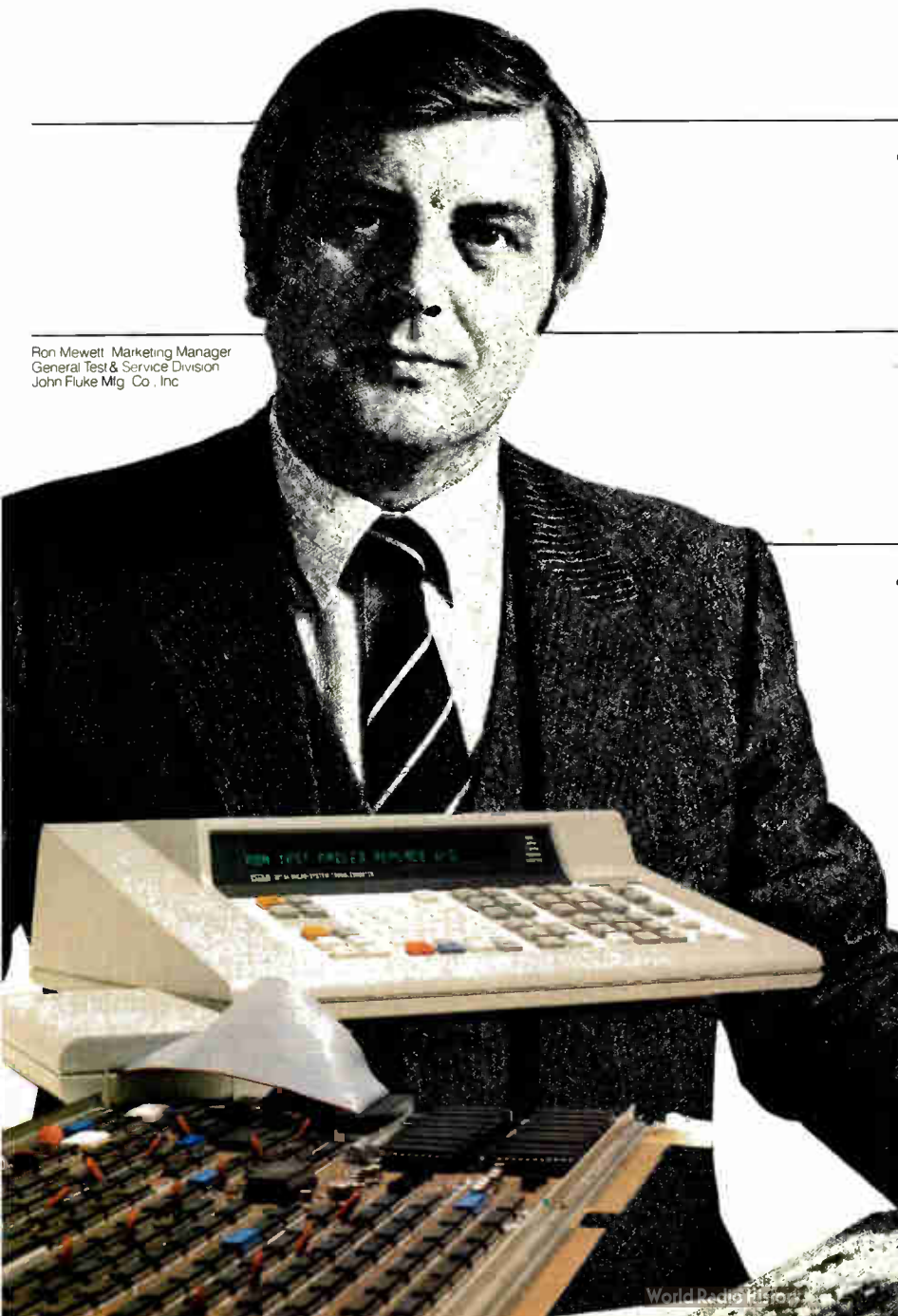

Ron Mewett, Marketing Manager
General Test & Service Division
John Fluke Mfg. Co., Inc.

Productivity without programming:

“Automated functional tests and powerful troubleshooting aids are built in—no costly software to develop. Saves months of programming labor and lead time. With the 9010A, testing starts the day you plug it in.”

Fault isolation is fast and foolproof:

“Simple, straightforward operating characteristics mean no lengthy training is needed for effective troubleshooting. Our tests have shown that the 9010A reduces average micro-system board service-time by 80%. Savings like that mean a payback period of days instead of years.”

Helps reduce board float and test time:

“Affordable enough for local service depots, the 9010A lets you bring board repair closer to customers helping to reduce your organization’s share of the estimated 9 billion dollars of board float existing today. 9000 Series models are also available for factory and field service applications.”

For more information:

“Use the coupon below or call our toll-free hotline, **1-800-426-0361**. We’ll help you control runaway service costs.”



Fast Response Coupon

In the U.S. and Non-European Countries: John Fluke Mfg. Co., Inc. P. O. Box C9090, M/S 250C Everett, WA 98206 (206) 356-5400 Tlx 152662	In Europe: Fluke (Holland) B.V. E1 12/81 P. O. Box 5053, 5004 EB Tilburg, The Netherlands (013) 673 973 Tlx 52237 1069-4/9000
---	--

- Please send me 9000 Series product information and cost justification data.
- My service organization would like a demonstration, Please contact me.

Name _____

Title _____ Mail Stop _____

Company _____

Address _____

City _____ State _____ Zip _____

Telephone () _____ Ext _____

© 1981 John Fluke Mfg. Co., Inc. All rights reserved.
For technical data circle no. 82

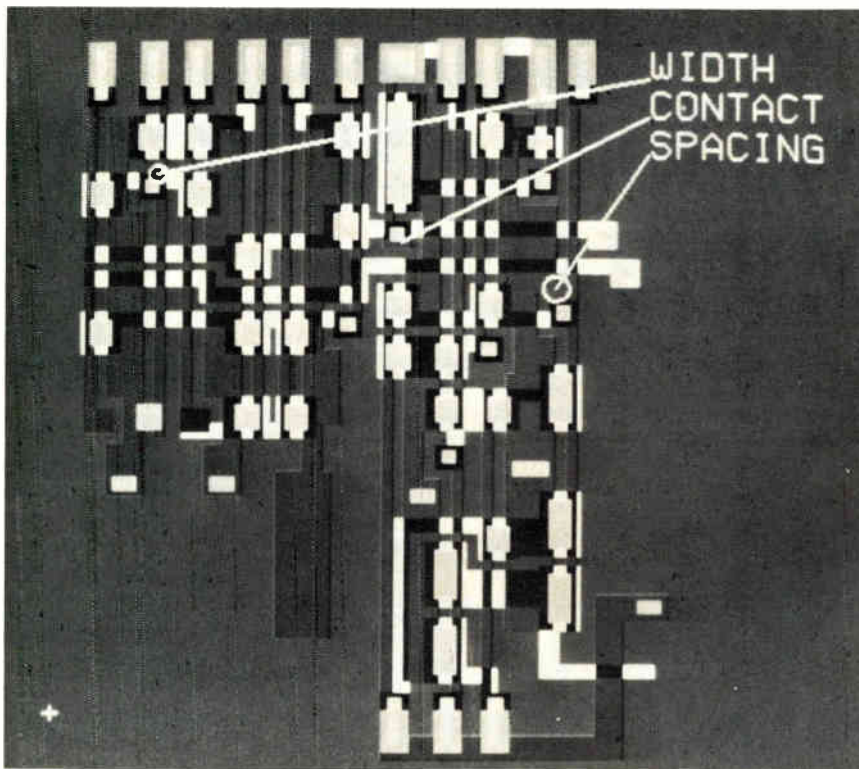

Errors checked. This color graphics terminal output resulting from Gaelic CAD software highlights design rule violations over an entire very large-scale integrated-circuit layout.

version of its Gaelic circuit-design package is much closer to that ideal.

Developed by Edinburgh University, Gaelic's great strength as a commercial system is its ability to automatically place and route assorted sizes of logic blocks chosen from a standard cell library [*Electronics*, March 30, 1978, p. 62]—a technique of crucial importance in the design of very large-scale ICs. The package was picked up by Compeda Ltd., Stevenage, England, a three-year-old computer-aided-design company established by Britain's National Research and Development Corporation (now merged with the National Enterprise Board) to commercialize software developed in British universities.

Slow beginning. The first version of Gaelic—though it has had successes like a prestige sale to General Electric Co. in the U.S.—had annual sales of only \$1 million, proving it far from an out-and-out winner. But with software sales of over \$5 million a year, Compeda itself is accounted a success. One reason, says Kenneth Baker, Compeda's

commercial manager, was that Gaelic was little more than a language for conveniently representing and manipulating geometric shapes. Also its 32-bit orientation was ahead of the market and was economic only on large, multiuser installations. Today, however, Gaelic will run on industry-standard Digital Equipment, Prime, IBM, and other 32-bit computers. Typically, a three-workstation system would cost in the region of \$320,000. Alternatively, users already committed to a CAD system can buy the software separately for around \$20,000 a year, for a minimum of three years on a three-workstation system.

Today, Gaelic incorporates a set of modules to assist the designer at every stage in the design process, among them: automatic layout and mask making, color editing, schematic preparation, design-rule checking, and logic simulation. These are all interconnected by a software communications highway so that the output from one module is immediately available to the next. A management highway module

tracks the design process, and a gate-array-routing package is in the offing.

In its new version, Gaelic's most striking feature remains its automatic layout capability. Initially chip layouts were between 30% and 50% larger than handcrafted designs, but with the latest version of Gaelic, now being benchmarked, the chips run anywhere from the same size to 30% larger than their manual counterparts, according to Baker.

The starting point of the program is a global placement routine whose function is to reduce routing runs between cells and bonding pads to a minimum. Compeda engineers, in common with others, use a model in which connections are represented by stretched rubber bands, causing cells with a high connectivity to be pulled closer together. Time-critical signal tracks can be assigned additional weighting.

Layering. From this initial placement, the program works much like a stonemason packing a dry stone wall—placing first the large cells and then filling in with smaller cells. After each layer has been placed, the global placement routine is repeated. A battery of algorithms is available to optimize placement by different routines. "It's rather like turning up the skill factor in a game of computer chess," says Ken Loosemore, a Compeda software expert.

The placement routine also takes care of routing. It connects up ground and supply in a single metalization-masking stage, interdigitating the two supply lines from opposite ends of the chip. Another facility is the ability to vary the width of power-bus tracks so that, as the current in a particular track section drops, the width of the track automatically shrinks as well.

Gaelic's color graphics and bit-pad facility makes the different mask layers easy to identify. In fact, the Gaelic package can handle three layers of interconnection. Also, its schematics-preparation module helps an engineer turn his rough notes for a logic diagram into drawing-office documentation.

The design-rule-checking facility

Important editorial



SIR JOHN CLARK
chairman and chief executive
Plessey Co.

Clark's foremost worry—and all pangs—is the industrial policy of the British government. Prime Minister Margaret Thatcher's government came to power a year ago with the most radical "Conservative" policy since the war, he says. Its cure for Britain's ills involves a number of

practices of the government's non-interventionist stance in a modern capital-intensive society dominated by technology. "Interventionism is a word based on dogma, and there is no place for dogma in government, only pragmatism. Government support has a proper place in the sup-

Concern for the economy tempers industry leaders' overall optimism for 1981

Government's attitude toward business, deepening shortage of professionals, and sharp competition for world markets also loom as obstacles

JOHN W. ZEVENBERGEN
president
John Fluke Manufacturing Co.

The economy, the shortage of engineers, Government action—these top the list of concerns for a majority of electronics executives looking ahead to 1981, and Zevenbergen is no exception. "I don't see the U.S. economy straightening out until April," he says. "And the European economy is still headed downward, which will slow the instrumentation industry's recovery." But Zevenbergen does anticipate a boom after



KAZUO IWAMA
president, Sony Corp.

If only there were enough engineers to go around, Iwama would be a man without a care in the world. Sony plans to hire 400 engineers and scientists next spring, but has difficulties in recruiting them because of competition from such other technology areas as the machine tool, office machine, and auto-innovative industries. "Iwama considers himself fortunate that Sony has no plans for large-scale software development in 1981 because software engineers are in even shorter supply. Still, he points out, there has been such a shortage for about 10 years, and Sony still has managed to develop new products and increase sales on old ones in that period.

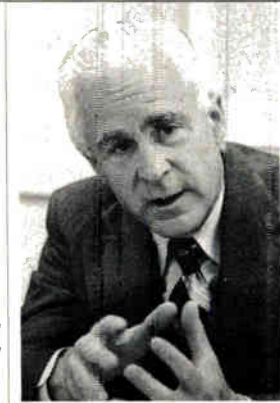

WILLIAM R. THURSTON
president, GenRad

My chief concern is uncertain demand. Electronics has traditionally lagged behind other sectors in the economy.

world markets. Another unsettling factor that creeps in the relative scarcity of top-tier science personnel: electric engineers and programmers. Iwama calls this a "chronic problem all sectors concern" pointing to the number of U.S. graduating engineers in Japan compared with the U.S. Not only are the Japanese graduating about 50% more yearly, but number is even more impressive when viewed as a proportion of nation also. Japanese engineers are highly motivated, productive and capable of high-quality work as good as ours. If forced to choose, he would spend his time boosting the skill of U.S. engineering rather than ductility. Productivity is a difficult measure to measure, he says. "What counts for a company is not share, what counts for a client is world market share, and the quality that sets. I think I could be convinced to sacrifice part of my interest in productivity to gain a better improvement in quality. As for the shortage of engineers, he says that it is being addressed through no too many. "Out-of-class are growing larger. He and there is increasing interest between industry and the schools. More academicians recognize our needs, and more managers are going to help supply colleges and universities with the money and equipment that they need to meet the needs. Through 1981 and beyond, Thurston says the shortage of engineers will grow as rapidly as it has in the past. "I'm basically optimistic and I see growing opportunity in there and hope that our sector's managers will increase in and

Electronics worldwide editorial breaks all important technical and business news.

Take Sir John Clark...

"The private sector in England is being slaughtered. Government support? I would place the French ahead of everybody."

Or GenRad's William R. Thurston...

"What counts for a company is market share, what counts for a country is world market share."

Or Kazuo Iwama of Sony...

"Japan has more consumer electronics engineers than any other nation, making it strong in both development and production technology."

Or Pasquale Pistorio of SGS Componenti Elettronici...

"Semiconductor growth is so strong and people so cautious that demand and supply will be rebalanced in 1982."

Or Hughes Aircraft's John H. Richardson...

"Suppliers view the defense marketplace as a less attractive place to do business than other market sectors."

Or Unitrode's George M. Berman...

"The Europeans and Japanese are tough rivals, and that's good. We don't need protection from them. We need wider markets."

Such concerns as the economy, the shortage of engineers, government action, international economics, are addressed by top management in electronics companies throughout the world each December in Electronics Annual Executive Outlook.

These personal opinions are important information from important people all over the world, to important readers all over the world.

Electronics magazine is where important people become important editorial.

is read by important people.

Not everyone in the electronics technology marketplace is important to you. Not all the engineers, not all the managers.

However, the people who read Electronics are important to you. They are the people who make the important technology and business decisions. They are the planners. They set standards. They supervise design engi-

neering. They are directly accountable for their company's profits. They are buyers.

Most don't read direct mail. But they all read Electronics magazine—four out of ten read no other.

These important people are hard to see. Salesmen often miss them. They travel extensively on company business.

Let us introduce you to these important people. Call Norm Rosen, National Sales Manager at: 213-487-1160, and he'll arrange a conclusive demonstration in your office. Or call your local Electronics salesperson.

Electronics
Where important people read important editorial



VACTEC SILICON PHOTOVOLTAIC DETECTORS

VACTEC photovoltaic cells are large area detectors, available in **BLUE ENHANCED, LOW CAPACITANCE AND SOLAR** processes. Characterized for **I_a, I_t and max. capacitance for LOW CAPACITANCE** series.

VACTEC BLUE ENHANCED detectors with high radiometric sensitivity in the uv as low as 200nm with .16 typical and .1A/W minimum at 365nm. These large area devices (up to .8X.8 inch) are ideal for low level color separators, spectrophotometers and colorimeters. Vactec's care in processing provides stability in the uv (below 400nm) normally only found in small junction photodiodes.

VACTEC LOW CAPACITANCE cells have fast response. A .2X.2 inch cell, operating in the photovoltaic mode has rise/fall times less than 15 μ s with a 10K Ω load. For optical encoders, remote control and optical communications, smoke detectors, laser surveying and presence detectors.

VACTEC SOLAR process cells have high V_{oc} at low light levels. At 1.0fc (.05mW/cm²) typical V_{oc} is 200mV.

VACTEC Photovoltaic detectors are available as chips, with flying leads, mounted or in custom assemblies to your specifications. Single cells, duals and multiple cells in many standard sizes up to 1.25 inch diameter. Request Bulletin VTS4000.

**VACTEC,
INC.**

18000 Page Blvd.
St. Louis, MO 63132
(314) 473-4800
TWX 910-764-0811

Electronics international

is now particularly easy to use. Violations of track width and spacing rules, or contact transgressions, are clearly indicated on both the graphics terminal and the printout. Also, the user can apply different design rules in different sectors of the chip. A regular random-access-memory structure, for example, could thus be designed with the tightest rules.

The logic simulator automatically generates logic-timing diagrams of all output signals for any specified logic block and specified set of input

signals. Baker accepts that many potential customers will be more familiar with other simulation packages such as Spice or Tegas and points out that these can readily be interfaced with the Gaelic system.

The end product, says Baker, allows a high degree of optimization and, if desired, operator intervention, achieving a finished design in days rather than months. Gaelic, he believes, is now poised for a rapid takeoff in a field that right now has no market leaders. **-Kevin Smith**

West Germany

Siemens tests implanted injector that meters insulin to diabetics

Electronically controlled insulin dosage units have, for the first time, been implanted in a number of diabetic patients in Europe. Developed at Siemens AG, the implant holds a four-week supply of insulin and may be remotely programmed by an external hand-held device to pump insulin into the body at set rates.

One patient has been wearing his unit since April of this year. On two others, the implants have been in place since August and September. No complications have been reported thus far, says Manfred Franetzki, who heads the system's development at Siemens's medical-engineering group in Erlangen.

Although the ongoing tests have been successful so far, Siemens considers its system still in the research stage. "Commercial devices and routine implantations are still several years away," Franetzki cautions.

Companies and medical institutions on both sides of the Atlantic are working on implantable injectors. In the U. S., the Sandia National Laboratories in Albuquerque, N. M., implanted a similar device earlier this year. But according to Franetzki, its insulin reservoir requires refilling every two days, and the supply tubing between the reservoir and the dosage unit, both internal, poses problems.

The Siemens device, in contrast,

needs refills only once every four weeks. Also, the reservoir and pump are integrated into one unit, eliminating the need for extra tubing. The company is now weighing whether to offer a trial unit to medical experts in the U. S. for evaluation. The present version contains a peristaltic pump, control electronics, a lithium battery, an insulin reservoir, and a septum for replenishing the reservoir. All components are hermetically encapsulated in a titanium pacemaker casing, a metal that the body readily accepts.

Size and weight. Weighing about 170 grams with a full reservoir and roughly the size of a pack of cigarettes, the unit is connected to a catheter with an opening that is 0.3 millimeter in diameter. The reservoir—it holds about 10 milliliters of insulin—is refilled through an injection needle through the skin. Refilling is usually done by a physician. The battery, rated at 3.2 volts, lasts at least a year for daily injections of 50 insulin units. The average diabetic, Franetzki explains, needs about 40 units a day.

The system's programming unit, about the size of a pocket calculator, has both programming and monitoring functions. Powered by a 5.6-v battery, it programs the implant's insulin pump for any one of 12 basic injection rates and any of 12 demand

Logic Analysis System

The *PI-540* packs virtually every measurement function you'll need in a single, easy-to-use instrument.



Measurement Section
Up to 40 channels. Display data in hex, octal, decimal, binary and ASCII. Includes powerful qualification features, branch analysis, and 16 levels of triggering.

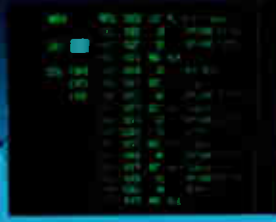

Measurement Section
Dedicated CPU probes with disassembly simplify software development tasks. *PI-540* can accommodate 3 resident disassemblers.

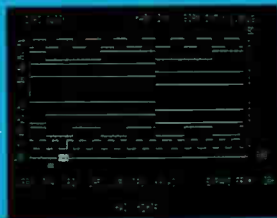

50 MHz Timing Section
Independent, 8-channel, 1000-word timing analyzer with 5 ns glitch capture. Also provides 5 state display formats.



Performance Monitoring
100 MHz counter/timer measures hardware and software execution times. Includes industry standard signature analyzer.

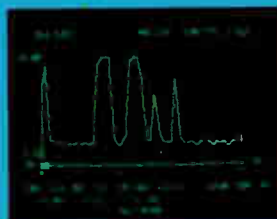

Waveform Recording Section
50 MHz and 1000 samples. Waveform can be linked to other analysis sections for tracing analog and digital interactions.



RS-232 Serial Testing
Model 70 probe converts *PI-540* into powerful serial communications analyzer. Receive, edit, and transmit messages at rates up to 19.2 K b.

Want a closer look? Call 800-538-9713 (outside California) or 408-263-2252. TWX: 910-338-0201

PARATRONICS INC.
2140 Bering Drive San Jose, California 95131

Leading the Way in Analysis Technology



The *PI-540* resides in the expandable System 5000 mainframe. RS-232 and IEEE-488 interfaces are available.

FOR ADDITIONAL INFORMATION CIRCLE 340
FOR A DEMONSTRATION CIRCLE 405

Looking for a faster processor-to-processor communications link?

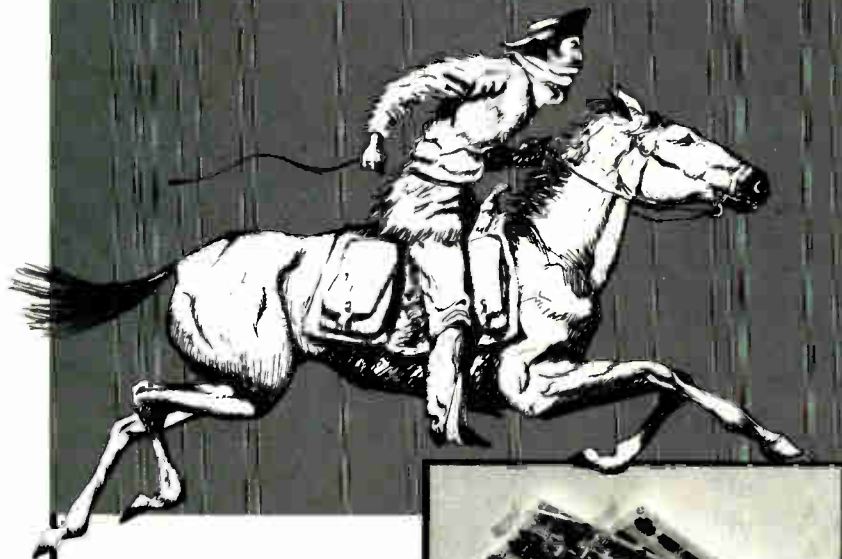

Use Megalink™ for 1 Megabit/sec DMA transfer between as many as 255 DEC and Intel processors on local networks up to 32,000 feet long.

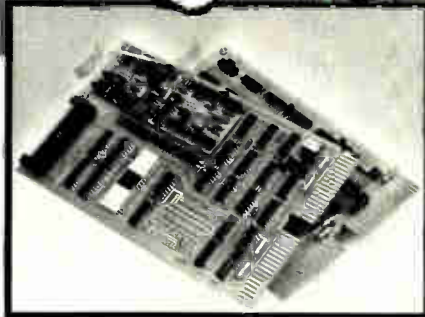

- Q bus, Unibus, and Multibus compatible units plug directly into DEC and Intel backplanes.*
- Multidrop operation of different processors on single coaxial cable for distributed networks.
- Integral 1 Megabit/sec FSK modem is immune to baseband noise.
- Software compatible drivers available.
- HDLC protocol implemented in hardware.
- Polled, token pass, or CSMA contention networks possible.

Call Garry Stephens today at (203) 544-9371, or write now for specifications of Megalink DMA Interface Units

computrol

15 Ethan Allen Highway
Ridgefield, CT 06877
(203) 544-9371

*DEC, Q bus, and Unibus are trademarks of the Digital Equipment Corporation. Intel and Multibus are trademarks of the Intel Corporation.

Electronics international

doses—the patient sets the rate and dose on the programmer and holds the device near the implant, no more than 15 centimeters away.

Coded rate and dose information is then inductively coupled from the programmer's transmitting coil through the body tissue to the implant's receiving coil. For sending monitoring information from the implant to the programmer, the motor coil of the pump is also used as a transmitter.

Because a malfunctioning implant could be disastrous to the patient, the Siemens designers have gone to great lengths to implement safety measures. One is keeping the interior of the implant at less than atmospheric pressure. That way, neither a leak of the pump nor a leak of the reservoir or the filling septum can lead to an uncontrolled release of insulin into the body. Further, the reservoir is made of a special compound-foil plastic material. The catheter is made of durable polyethylene and, for protection and long life, is surrounded with a silicone rubber sleeve. In the case of overdosing as a result of faults in the electronic circuitry, the pump automatically shuts itself off.

For proprietary reasons, Siemens is not disclosing a detailed description of the unit's electronics at present. But it will say that an encoder in the programmer codes both the basic rate and demand dose in the form of pulses, the pulse spacing representing the code.

The pulses are modulated onto a 25-kHz carrier that is inductively coupled from the transmitting coil to the receiving coil in the implant. There the carrier is demodulated, and the pulses are used to operate the pump motor.

For low current consumption, the implant's circuitry is designed around a complementary-MOS device. The other components in the circuit are discrete. Eventually, the circuit will be hybridized, Franetzki says, "and one day it may pay to use integrated-circuit techniques." Continuing work is aimed at reducing the size of the implants and increase reservoir refill intervals. **-John Gosch**



Microelectronics starts with "Z." As in Zeltron.

Founded in 1977 as an entrepreneurial effort within the ZANUSSI group, ZELTRON quickly established a reputation in Europe as a firm providing reliable and innovative products and services in microelectronics. From our three development laboratories in Northern Italy, we serve both the Zanussi group and other clients throughout Europe with special services and products:

- Microprocessor-based product development
- Component testing & qualification
- Automatic test equipment
- Production automation systems
- Sensor & transducer development
- Custom designed IC's
- Real-time software.

For reliability and innovation in microelectronics, start with "Z."
Start with ZELTRON.

ZELTRON

ISTITUTO ZANUSSI PER L'ELETTRONICA SpA

33030 Campofornido (UD) ITALY - Via Principe di Udine, 66 - Tel. 0432/69652-3 - Telex: 450365 - 20122 Milan, Viale Bianca Maria, 45 - Tel. 02/709176-795802.

World Radio History

Circle 361 on reader service card

ZANUSSI

Who gives you wide microcomputer plus multi-emulation capability... plus constant system extension...?



8085



Z80



2650



support...

PMDS – Philips Microcomputer Development System – lets you get to work immediately with today's most important chips, thanks to a range of quickly interchangeable, plug-in MABs (Microcomputer Adapter Boxes). And that range is continually being updated to cover new μ Ps coming onto the market.

Available now is full support for 8085, Z80, 2650, 6809, 6500 family and 6500/1. To be added in the coming months are 6800, 6802, 6808, 68000, 8048 family and 8400 family. So PMDS is a highly versatile system, that keeps pace with your changing demands. In addition, PMDS has a powerful multi-emulation capability that allows simultaneous emulation of up to 4 different microprocessors to debug complex systems using synchronized or inter-related breakpoints, giving a complete picture of overall system performance.



Multi-emulation in a 2-microprocessor system.

Other powerful PMDS development tools include: **PASCAL** for simple programming of 8085, Z80 and 6809 with extensive debug facilities; **real-time emulation** for testing and debugging at true system speed – up to 5 MHz for 8085-A2, 4 MHz for Z80A, 2 MHz for 68B09 etc.; step-by-step **logic analysis** with a 255-word, 48-bit wide trace memory to show you events in program and external history using pre-selected breakpoints; **symbolic debugging** with automatic cross-referencing of symbolic values to absolute hexadecimal values; and **I/O simulation** using built-in software commands to specify PMDS system elements.

And with PMDS, these tools are easy-to-use, thanks to interactive software that gives full operator guidance. To find out more about PMDS' comprehensive development tools, wide micro-computer coverage and programmed system extension, contact Philips Industries, Test & Measuring Dept., TQIII-4-62, 5600 MD Eindhoven, The Netherlands.

...Philips, of course!

PHILIPS

How many amps? What voltage? ...



Electronic
Components
and Materials

How fast? No problem!

Switch on fast to a new world of power devices ... devices that are easy to drive from ICs and μ Ps ... devices like our unique GTO switches that turn off fast - in less than a microsecond ... devices that are ideal for this digital decade.

See Philips first when you've got a power problem. We cover the technology and application spectrum with these and other exciting devices. Our advice is therefore objective and our concern is with making sure you get optimum design results.

POWERMOS

POWERMOS is Philips' shorthand for Power MOS FETs. Features include:

Direct drive from TTL/LSI plus μ C output ports. Controls up to 30 A from a few volts and almost no drive power.

Fast switching. Several times faster than bipolar, even an order of magnitude for certain types.

Optimum reliability via outstanding SOAR characteristics.

No secondary breakdown: as device heats up, resistance increases and current goes down. Therefore no hot spots or current hogging and automatic equalisation throughout chip.

Easy parallel operation. Devices share current evenly. Those that heat up will increase in on-resistance and shift current to another branch.

High power amplification. Typically, an order of magnitude higher than bipolar.

These features make POWERMOS ideal for inductive load switching, switched-mode power supplies (SMPS) and motor control. For SMPS they allow frequencies to be more than doubled, bringing further reductions in system size and weight.

Get your answer to the question of how many amps ... how fast ... and what voltage by sending today for our new brochure 'Power at your Command'. It gives full details of GTO and POWERMOS devices, plus the rest of our comprehensive range.

Philips Industries,
Electronic Components and Materials Division,
Eindhoven, The Netherlands

GTO

GTO ... standing for Gate Turn-Off ... is the nearest thing yet to the perfect semiconductor switch. Like the thyristor, it can be turned on by positive gate drive and like high-voltage transistors, it can be turned off by negative gate drive. The features of both devices combine to give the best of both worlds, for example:

High blocking voltage.
Up to 1500 V.

Excellent overvoltage/current capability. Includes simple fuse protection.

No commutation problems. GTOs can handle dV/dt rates of up to 10 kV/ μ s.

Controllable anode currents.
Well in excess of average ratings.

Easy drive. Low gate trigger currents allow direct drive from ICs.

Fast turn-off. GTOs can be switched off in less than 1 μ s. These last two features are typical for bipolar devices, but GTO figures are considerably superior. The overall combination of high current and voltage handling, easy gate drive, fast switching and rugged construction therefore make GTO devices ideal for a very wide range of applications.

POWER-MOS	Main Applications	GTO
●	Automotive	
	Light ballast (TL)	●
●	Telephony/EDP printers	
	Domestic appliances (washers; microwave ovens; cookers)	●
●	Low-power motor control (500 W typical)	
	Medium/high-power motor control	●
●	SMPS (switched-mode power supplies)	
	SRPS (series-resonance power supplies)	●
	CRT deflection	●

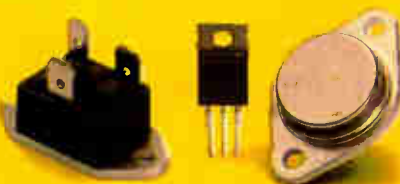

GTOs are available in isolated TO-238 and plastic TO-220 encapsulations. POWERMOS switches come in metal TO-3 and TO-220.

We'll keep you well powered

PHILIPS

Circle 363 on reader service card

Catch & Compare

Digital storage on the PM 3310 combines easy signal capture with sophisticated signal comparison and analysis. Here's how:

- 50 MHz clock rate (fastest yet in a portable scope) retains signal detail for fast, single-shot phenomena.
- 4 memories and 2 channels give multiple display modes over a 60 MHz bandwidth.
- A trigger delay of -9 to + 9999 divisions that effectively

stretches memory capacity and provides pre-/post-triggering.

- IEEE/IEC-Bus for systems operation and further signal analysis.
- Multiple single-shot mode for capture of successive transients.
- Plus TV triggering, X-t recorder type roll mode and X-Y recorder output.



PM 3310 sets a new standard in digital storage

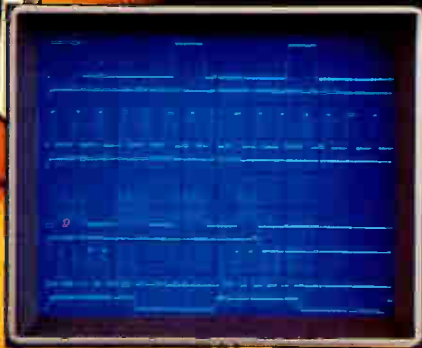

Two input channels and four memories allow eight traces to be displayed for detailed analysis and comparison. The in-house developed Profiled Peristaltic Charge Coupled Device (P² CCD) allows 50 MHz data to be sampled in a cost-effective manner.



Easy operation is another big PM 3310 plus. Parameter settings, for example, are stored with the relevant signals and can be recalled for display.

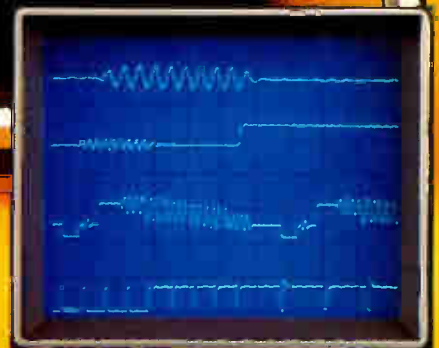

An accurate -9 to + 9999 division trigger delay extends the basic benefits of A/D conversion. This facility is used here to pick out a particular TV colour burst.

Philips Industries, TQ III-4-62, Eindhoven, The Netherlands.

From Philips, of course



Test & Measuring Instruments

PHILIPS

Circle 364 on reader service card

Plotter, processor, and software join to draw graphs

by Robert Neff, Tokyo bureau

Packaged unit also has CRT, keyboard, and diskette drive; interactive graphics language can be learned in one day

Computer graph generation traditionally has required, in addition to a computer, a separate plotter and software package, usually in Basic. The Graphwriter, which Yokogawa Electric Works Ltd. will start delivering this month, combines everything into one stand-alone unit for the first time. It uses a proprietary language called Sing that Yokogawa says is far more friendly than Basic.

The Graphwriter is a follow-on to Yokogawa's Graphmate, which went on sale a year ago. It is the instrument maker's third office-automation product entry. The new unit is far more powerful than Graphmate, which lacks the Graphwriter's full alphanumeric and kana keyboard, cathode-ray-tube monitor, on-board optional floppy-disk drive, and Sing (for super-interactive new graphics).

Capable of automatically drawing on three axes with two pens to provide contrasting thicknesses or colors, the Graphwriter can turn out a host of graph designs in any pattern, including histograms, radar charts, and donut graphs, from data that is keyed in. It also writes numerals, letters, and a limited set of kanji characters and symbols in any size. Axis scales may be either linear or logarithmic. The Graphwriter can add lines and columns in numerical charts and bar graphs, compare data, accumulate, and compute moving averages.

So simply does Sing guide the user through the screen-displayed menu and operating steps that someone with no computer experience can master the Graphwriter in one day, says Hiroshi Shibuya, manager of the product marketing department at Yokogawa's instrumentation and medical-systems division.

Shibuya describes Sing as belonging to the category of "super-easy" languages, more simple than Visicalc and Sord Computer Systems' Pips. He states that this is a big advantage in Japan, at least, where only 0.6% of the population can program with Basic.

The Graphwriter, priced at \$5,715 in Japan, is built around a Z80A central processing unit and boasts 44-K bytes of read-only memory and 18-K bytes of random-access memory, including 4-K bytes of user area. RAM can be extended by another 16-K bytes in a model that also packs a floppy-disk drive for data files and is priced at \$7,512.

The floppy disk, a more universally accepted standard than the Graphmate's external microdisk unit, allows users to save data and formats for future processing or revision. The display is a 7-in. monochrome flat-face CRT. The Graphmate has only a single-line 16-digit display.

Color plots. The plotter element can hold 420-by-297-mm paper or overhead-projector film, either of which can be fixed electrostatically for maximum security. The pens, available in four colors and in water- or oil-based fiber or ceramic construction, move at up to 20 cm/s at a resolution of 0.05 mm. Data may be keyed in while previously entered

data is being plotted.

The Graphwriter measures 355 by 574 by 740 mm and weighs about 25 kg without the optional disk drive. Yokogawa plans initial monthly production of 50 to 100 Graphwriters, with exports to start after a year of domestic marketing experience.

Shibuya expects the product's market to diverge initially into two major categories. Perhaps 75% of the Graphwriter's purchasers will use it for sales management and marketing reporting functions, Shibuya guesses, and the other 25% will use it to make photographic masters for offset printing plates. But Yokogawa is also planning additional application software packages to



New products international

extend the Graphwriter's market to other as yet unspecified areas.

With existing software, the Graphwriter may be used for a variety of purposes, including technology management and patent applications, arrangement of research results, planning, and quality control. Shibuya argues that the Graphwriter makes sense even for users of the big computers that usually lack graphics-software flexibility. In fact, he maintains that because such users buy many Graphmates, they are bound to flock to the Graphwriter.

Yokogawa Electric Works Ltd., 9-32, Naka-cho, 2-Chome, Musashino-shi, Tokyo 180, Japan. Phone (0422)-54-1111 [441]

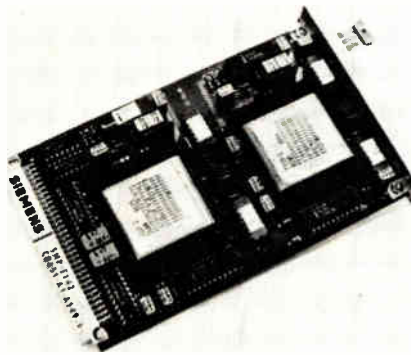

Magnetic-bubble-memory banks with 128-K to 1-megabit capacities are continued in the Siemens Microcomputer Expansion Boards SMP-E140 (controller), -E141 (128-K), and -E142 (256-K). Siemens AG, Zentralstelle fuer Information, Postfach 103, D-8000 Munich 1, West Germany [444]

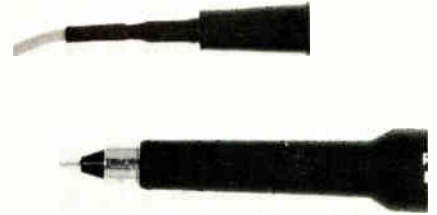

A 4-in. probe accessory explores wire-wrapped terminals on edge and multiway connectors. It has an adaptor that fits the 88 series of probe tips. A socket on its free end can be joined to a 0.025-in. wire-wrapped post Greenpar Connectors Ltd., P. O. Box 15, Harlow, Essex CM20, 2ER, UK [447]



The 2018 and 2019 signal generators have a frequency range of 80 kHz to 520 MHz and 80 kHz to 1,040 MHz, respectively, and a 10-Hz resolution. They can store up to 50 settings in a nonvolatile memory. Marconi Instruments Ltd., Longacres, St. Albans, Herts. AL4 0JN, England [442]

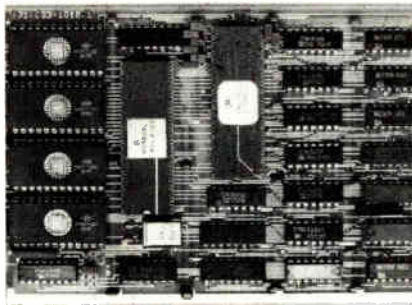

The MC6809 microprocessor and MC6844 direct-memory-access controller are on this printed-circuit board. The 2716/2732 erasable programmable read-only memories may also be placed on the board. PEP GmbH, Gutenbergstr. 9 b, D-8950 Kaufbeuren, West Germany [445]



The Frequency Decade ND 1M has a frequency range of 10 Hz to 1 MHz and a resolution of 0.01 Hz. Frequency is keyed in and shown on an eight-digit display. The output voltage is adjustable in 10-, 1-, or 0.1-dB steps. Schomandl, Ingolstaedter Str. 68d, [448] Munich 46, West Germany

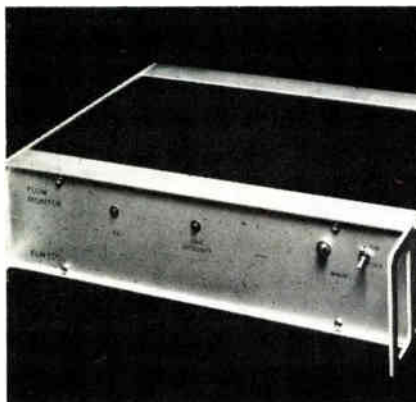

A fiber-optic cable is used by the FLM 135 to carry a modulated optical signal that measures flow in hazardous areas at distances up to 1,500 m from monitoring gear. An alarm is sounded if the fiber breaks. Optronics Ltd., Cambridge Science Park, Milton Road, Cambridge CB4 4BH, UK [443]

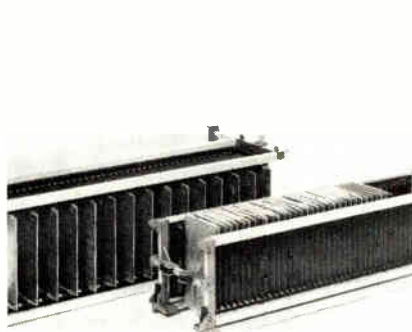

Up to 43 sizes of printed-circuit boards and double Eurocards, measuring 160 by 233 mm and held with cam-type clamps, may be stored and transported in these racks. Imhof-Bedco Standards Products Ltd., Ashley Road, Uxbridge, Middlesex UB8 2SQ, England [446]



Temperatures from -50° to $+999^{\circ}\text{C}$ are measured with the AT3 digital thermometer, which uses type K thermocouple sensors. The AT4 and AT5, with permanently attached probes, measure temperatures from -55° to $+125^{\circ}\text{C}$. Avo Ltd., Archcliffe Road, Dover, Kent CT17 9EN, UK [450]

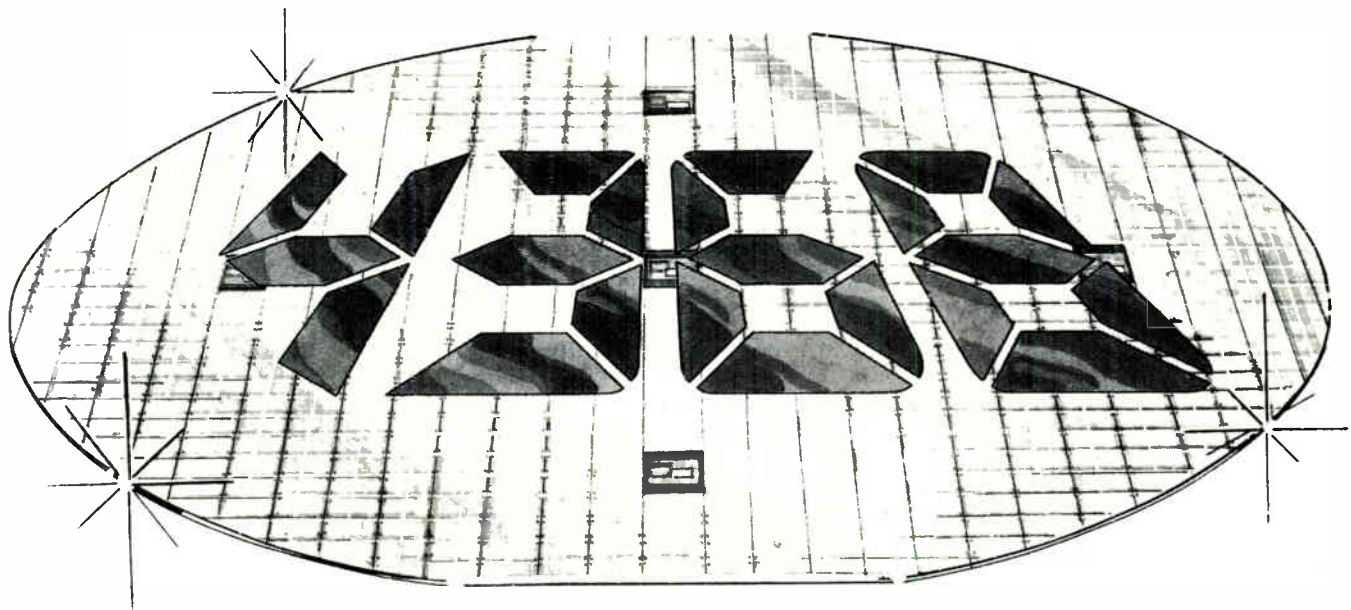

FASTER OCTALS AND PUSHY DRIVERS

No less than twenty-one new Plessey CMOS MSI devices for buffering, decoding, interfacing and selection in high speed/low power microprocessor and memory subsystems. And fast. Like 25ns typical tpd.

Then, eleven new driver and interface circuits. Latched HEX and BCD LED drivers guaranteed to 20mA for a really bright display. 30 and 32 bit shift registers with parallel outputs for driving LCD

displays. And a high-speed 5V to 12V level shifter.

Like most Plessey CMOS circuits, they are in volume production using the highest performance 5-micron process worldwide – ISO-CMOS. And they're multi-sourcable too.

Full data available direct from your nearest Plessey office or through the reader information service.

MORE GREAT CMOS DEALS FROM PLESSEY



Plessey Semiconductors Limited, Kembrey Park, Swindon, Wiltshire SN2 6BA, United Kingdom. Tel: (0793) 694994 Tx: 449637
Plessey Semiconductors, 1641 Kaiser Avenue, Irvine, California 92714, USA. Tel: 714 540 9979 TWX 910 595 1930

In Europe:

Belgium Plessey Semiconductors, Avenue de Tervuren 149, Boite 2, Brussels 1150. Tel. (02) 733 97 30 Tx: 22100

France Plessey France SA, 74-80, Rue Foque de F'lol, 92800 Puteaux. Tel. (1) 776 41 46 Tx: 620789F

Italy Plessey Italia SpA, Corso Garibaldi 70/72, 20121 Milan. Tel. (02) 345 20 81 Tx: 331347

Netherlands Plessey Fabrieken BV, Van de Mortelstraat 6, PO Box 46, Noordwijk. Tel. (01719) 19207 Tx: 32088

Spain Plessey Spain, Calle Martires de Alcala 41, 3ª derecha, Madrid 8. Tel. (1) 248 12 18/248 3882 Tx: 42701

Sweden Svenska Plessey AB, Kemistvaegen 10 A, Box 509, S-183 25 Taby. Tel. (08) 756 02 55 Tx: 12800

West Germany Plessey GmbH, Altheimer Eck 10, 8000 München 2. Tel. (089) 23 62 1 Tx: 5215322

with local distributors and agents in most countries throughout the world.

0628 2 0035

WELL-PROVEN IN EUROPA

Miniature relays series M
Small dimensions for better use of printed circuit space. Guaranteed by SEV, VDE, SEMKO, NEMKO, DEMKO, FEMKO approval and by their conformity with insulation classes of VDE 0110 standards. Suitable for various applications in automation, thermostatic controls for industry and home, alarm and antitheft systems, output of optoelectronic systems, electronic timers and industrial controls. High sensitivity as little as 200 mW. Switching from low levels up to 16A/220V with alternating current. Version with high insulation up to 4 kV-8 mm.

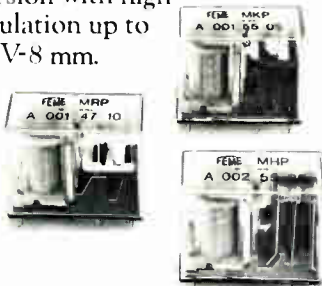

means reliability

20149 Milano
Viale Certosa, 1-ITALY
Tel. 390.021-Telex 331217



advertteam

New products international



This Servogor 430 is a one-to-three-channel vertical recorder used in the laboratory, out in the field, and for general service. Recordings are made on 120-mm wide paper at from 3 cm/h to 60 cm/min. Metrawatt GmbH, Thomas-Mann-Str. 16-20, D-8500 Nuremberg, West Germany [451]

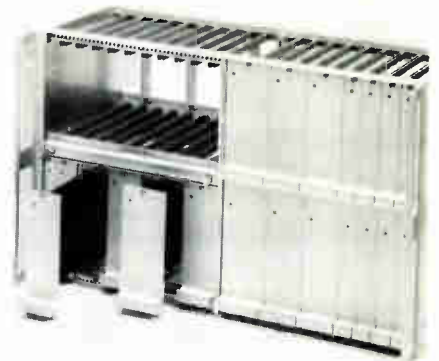

Printed-circuit boards with nominal depths of 100, 160, or 200 mm may be accommodated in the type 21 rack. Profiled aluminum rails with threaded holes in the back make for precise and easy connector mounting. AKA Mayr AG, CH-8635 Duernten ZH, Switzerland [456]



The type 622 power supply is used for satellite communications at unmanned earth stations. It was developed for traveling-wave tubes with an upper limit of about 400 W of continuous-wave power. Mean time before failure is 3,200 h. Microtest Ltd., 18 Normandy Way, Bodmin, Cornwall, UK [452]



The VAC ACE desoldering unit has a power unit incorporating a vacuum pump and desoldering gun with a ceramic heater. The gun may be grounded when used on sensitive components. Light Soldering Developments Ltd., Spencer Place, 97/99 Gloucester Rd., Croydon CR0 2DN, UK [458]



The FSU 800 is a very portable, compact unit that can fusion-splice optical fibers 125 to 300 μ m in diameter in approximately 15 minutes. It operates from an outlet supply or battery and has an attenuation loss around 0.2 dB. Sieverts Kabelverk, S-172 87 Sundbyberg, Sweden [453]

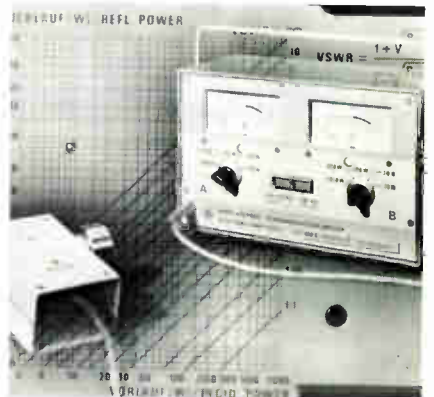

The 240-W NAUS5 and 1,100-W NAUS6 directional power meters are suitable for power and voltage standing-wave-ratio measurements on modulated and unmodulated power stages in the 25-to-1,000-MHz range. Rohde & Schwarz, P.O. Box 801469, D-8000 Munich 80, West Germany [459]

TEAC FD-50 Series 5 1/4" Floppy Disk Drives—A Wide Choice of Features

50F NEW 1 MEGABYTE

Our newest 5-1/4" floppy, the FD-50F, features a big 1 megabyte of data storage capacity. It has a double-sided, double-track-density configuration with MFM and formats both supported. Like all drives in this series, the FD-50F has a super-long-life, noiseless, brushless DC motor that is so reliable (lifetime 10,000 hours) that we let it run continuously.

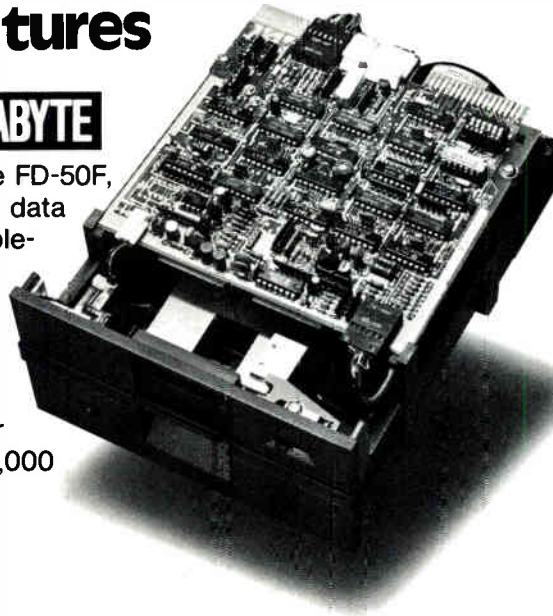

50A

- Single density, 48 tpi, 40/35 tracks
- Compatible with SA-400 in 35-track mode
- Daisy-chain up to 4 drives

50B

- Double sided, single density, 48 tpi, 40/35 tracks/side
- Twice the data capacity of the FD-50A

50C

- Double track density, 100 tpi, 77 tracks
- Compatible with the Micropolis 1015
- MFM/FM recording formats

50E

- Double track density, 96 tpi, 80/70 tracks
- Industry standard format
- MFM/FM recording formats

TEAC

TEAC CORPORATION: 3-7-3 Naka-cho, Musashino, Tokyo, Japan Tel: (0422) 53-1111 Fax: 2822451, 2822551

• U.S.A. TEAC Corporation of America, Tel: (213) 726-0303 • Canada R.H. Nichols Co., Ltd., Tel: (416) 661-3190 • Hongkong Dah Chong Hong Ltd., Tel: 5-261111, 5-226258
 • New Zealand W. & K. McLean Information Technology Ltd., Tel: 587-037 • Australia Jacoby Mitchell Pty Ltd., Tel: 267-2622 • South Africa Mayfair Sales (Pty) Ltd., Tel: (011) 29-2921 • United Kingdom Tekdata Limited, Tel: 0782 813631 • West Germany nbn Elektronik GmbH Tel: 08152/390 • Holland Simac Electronics B.V., Tel: 040-533725 • Belgium & Luxemburg Simac Electronics, Tel: 02-219.24.53 • France Tekelec Airtronic S.A., Tel: (1) 534-75-35 • Italy A.E.S.E.S.P.A., Tel: 54.64.741-2-3
 • Spain Atajo Ingenieros S.A., Tel: 733 3700 • Switzerland Wenger Datentechnik, Tel: 061/50 84 84 • Denmark Danbit, Tel: (03) 662020 • Sweden Scantel AB, Tel: 08-24 58 25 • Finland HAVULINA Instrumentarium Oy, Tel: +3580 799 711

* If no distributor is listed above in your area, please contact us directly for further details about our products.

Circle 367 on reader service card

VACOMAX[®]

**Permanent Magnets make your devices
smaller and more efficient**

VAC
VACUUMSCHMELZE

VACOMAX is a permanent magnet alloy of cobalt and rare earth-metals. It is characterized by a very high energy product and a particularly high coercive field strength, combined with high saturation and good temperature stability (up to +250°C).

The smallest by comparison

VACOMAX is particularly advantageous if high fields close to the magnet are required. It is not only the magnet volume which becomes smaller, but the whole system can be miniaturized. The high coercive field strength practically excludes demagnetization by opposing fields, which is very important in motor design and elsewhere.

Form of product as required

We usually supply magnets according to customers drawings, or mounted components (e.g. magnet plus return-path) in either magnetized or non magnetized condition. Parts of various shapes and dimensions are available as samples within short.

For further details see our Company Leaflet M 040.

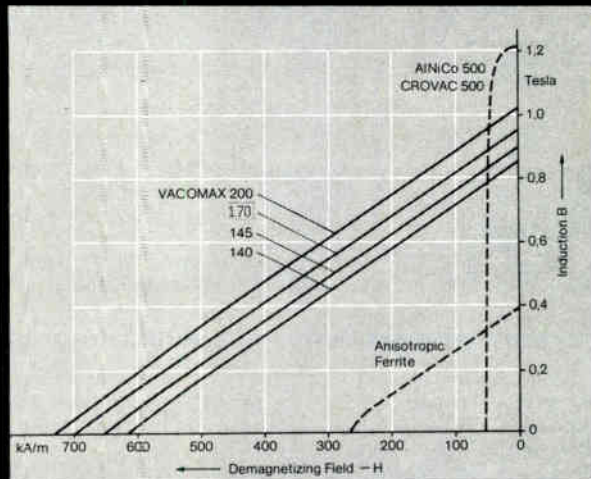

Characteristic curves of **VACOMAX** (in comparison with other permanent magnet materials).

VACUUMSCHMELZE GMBH

Grüner Weg 37, D-6450 Hanau
Cable: Vacuum Hanau

Telex: 04 184 863
Phone: (06 181) 362-1



M-2e

ULTRA-LOW THERMAL EMF REED RELAYS

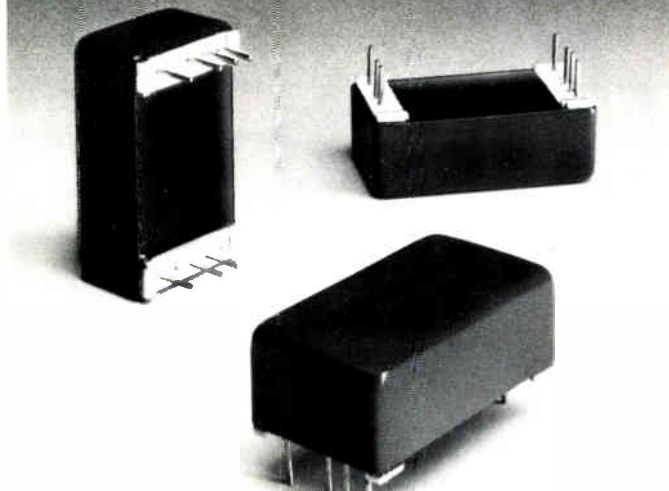

New from Coto — series CR-3400 ultra low thermal EMF reed relays. Standard features: 500 nanovolt thermals (other offset ratings available); as low as 50 nanovolt stability; complete electrostatic and magnetic shielding; full encapsulation; I.R. $> 10^{12} \Omega$; excellent reed contact stability; 100% dynamic testing. Perfect for low level switching applications such as data acquisition systems, process controllers, data scanners, etc.

Contact: European Agent,
RHOPOINT LTD

Delta House, 118 Station Road East, Oxted, Surrey RH8 0HG, England
Tel: (08833) 7988 Telex: 957094

Circle 369 on reader service card

The NEW Electronics Buyers' Guide is now available!

1.

Directory of products. Over 4,000 products, over 5,000 manufacturers.

2.

Directory of catalogs. Includes six post-paid catalog inquiry cards for 10-second ordering.

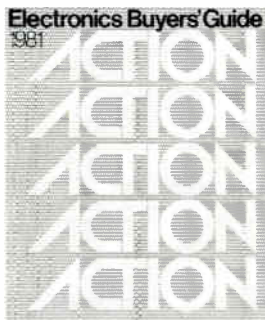

3.

Directory of manufacturers. Local sales offices, reps, and distributors, with phone numbers. Number of employees and engineers, dollar volume, name of company contact.

4.

Directory of trade names of products and their manufacturers. You can trace a product by its trade name only.

To insure prompt delivery enclose your check with coupon.

Yes, please send me _____ copies of 1981 EBG.

I've enclosed \$30 per copy delivered in USA or Canada. Address: EBG, 1221 Avenue of the Americas, New York, N.Y. 10020.

I've enclosed \$52 for air delivery elsewhere. Address: EBG, Shoppenhangers Road, Maidenhead, Berkshire S16, 2Q1 England.

Name _____

Company _____

Street _____

City _____

State _____

Zip _____

Country _____

New products international

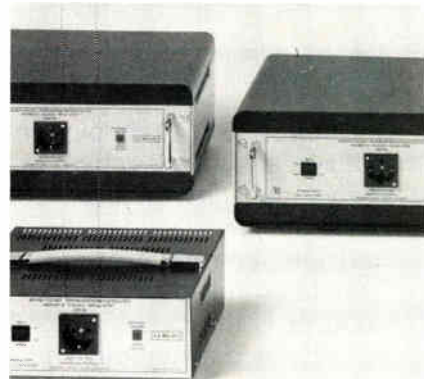

Designed to handle 250, 500, and 1,000 VA respectively, the EA-MS 603, 605, and 610 magnetic voltage regulators operate from 160 to 250 V. In addition, they have a frequency of 50 Hz and an output voltage of $220 V \pm 3\%$. Eltronix GmbH, D-7770 Ueberlingen, West Germany [460]

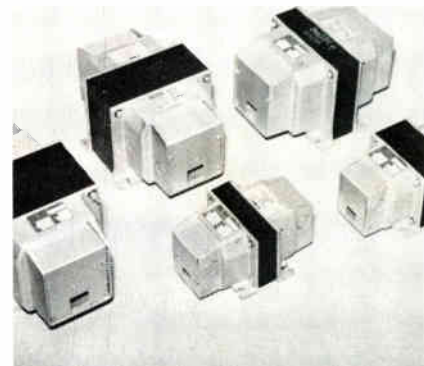

Transient noise is killed in data systems with the Deltac DT super-isolation transformers. They provide a common-mode noise-rejection ratio of 140 dB and have ratings of 250 VA single phase to 15 kVA three phase. Gould Power Conversion, Rhosymedre, Wrexham, Clwyd. LL14 3YR, UK [461]



Computer-aided design and drawing has a new high-resolution graphic-display system in the Picture Interaction Computer System (PIC) 1000. It has a flicker-free color monitor that displays clear pictures at 50 frames a second. Bosch GmbH, Bosch-Str. 7, D-6100 Darmstadt, West Germany [465]

Electronics

Reader Service

For additional information on products advertised, new products or new literature, use these business reply cards.

Complete entire card.

Please print or type.

Circle the number on the Reader Service postcard that corresponds to the number at the bottom of the advertisement, new product item, or new literature in which you are interested.

To aid the manufacturer in filling your request, please answer the three questions.

All inquiries from outside the U.S. that cannot reach Electronics before the expiration date noted on the Reader Service postcard must be mailed directly to the manufacturer. The manufacturer assumes all responsibilities for responding to inquiries.

Subscriptions & Renewals

Fill in the subscription card adjoining this card. Electronics will bill you at the address indicated on the card.

Electronics

December 15, 1981

This reader service card expires March 15, 1982

NAME _____ TITLE _____

PHONE (_____) _____ COMPANY _____

STREET ADDRESS (Company or home check one) _____

CITY _____ COUNTRY _____

Was This Magazine Personally Addressed to You? Yes No

Industry classification (check one):

- a** Computer & Related Equipment
- b** Communications Equipment & Systems
- c** Navigation, Guidance or Control Systems
- d** Aerospace, Underseas Ground Support
- e** Test & Measuring Equipment
- f** Consumer Products
- g** Industrial Controls & Equipment
- h** Components & Subassemblies

8 Source of Inquiry—All Other INT'L.

- j** Independent R&D Organizations
- k** Government

Your design function (check each letter that applies):

- x** I do electronic design or development engineering work.
- y** I supervise electronic design or development engineering work.
- z** I set standards for, or evaluate electronic components, systems and materials.

Your principal job responsibility (check one)

- t** Management
- v** Engineering Management
- r** Engineering

Estimate number of employees (at this location): 1. under 20 2. 20-99 3. 100-999 4. over 1000

1 16 31 46	61 76 91 106	121 136 151 166	181 196 211 226	241 256 271 348	363 378 393 408	423 438 453 468	483 498 703 718
2 17 32 47	62 77 92 107	122 137 152 167	182 197 212 227	242 257 272 349	364 379 394 409	424 439 454 469	484 499 704 719
3 18 33 48	63 78 93 108	123 138 153 168	183 198 213 228	243 258 273 350	365 380 395 410	425 440 455 470	485 500 705 720
4 19 34 49	64 79 94 109	124 139 154 169	184 199 214 229	244 259 274 351	366 381 396 411	426 441 456 471	486 501 706 900
5 20 35 50	65 80 95 110	125 140 155 170	185 200 215 230	245 260 275 352	367 382 397 412	427 442 457 472	487 502 707 901
6 21 36 51	66 81 96 111	126 141 156 171	186 201 216 231	246 261 338 353	368 383 398 413	428 443 458 473	488 503 708 902
7 22 37 52	67 82 97 112	127 142 157 172	187 202 217 232	247 262 339 354	369 384 399 414	429 444 459 474	489 504 709 951
8 23 38 53	68 83 98 113	128 143 158 173	188 203 218 233	248 263 340 355	370 385 400 415	430 445 460 475	490 505 710 952
9 24 39 54	69 84 99 114	129 144 159 174	189 204 219 234	249 264 341 356	371 386 401 416	431 446 461 476	491 506 711 953
10 25 40 55	70 85 100 115	130 145 160 175	190 205 220 235	250 265 342 357	372 387 402 417	432 447 462 477	492 507 712 954
11 26 41 56	71 86 101 116	131 146 161 176	191 206 221 236	251 266 343 358	373 388 403 418	433 448 463 478	493 508 713 956
12 27 42 57	72 87 102 117	132 147 162 177	192 207 222 237	252 267 344 359	374 389 404 419	434 449 464 479	494 509 714 957
13 28 43 58	73 88 103 118	133 148 163 178	193 208 223 238	253 268 345 360	375 390 405 420	435 450 465 480	495 510 715 958
14 29 44 59	74 89 104 119	134 149 164 179	194 209 224 239	254 269 346 361	376 391 406 421	436 451 466 481	496 701 716 959
15 30 45 60	75 90 105 120	135 150 165 180	195 210 225 240	255 270 347 362	377 392 407 422	437 452 467 482	497 702 717 960

Electronics

December 15, 1981

This reader service card expires March 15, 1982

NAME _____ TITLE _____

PHONE (_____) _____ COMPANY _____

STREET ADDRESS (Company or home check one) _____

CITY _____ COUNTRY _____

Was This Magazine Personally Addressed to You? Yes No

Industry classification (check one):

- a** Computer & Related Equipment
- b** Communications Equipment & Systems
- c** Navigation, Guidance or Control Systems
- d** Aerospace, Underseas Ground Support
- e** Test & Measuring Equipment
- f** Consumer Products
- g** Industrial Controls & Equipment
- h** Components & Subassemblies

8 Source of Inquiry—All Other INT'L.

- j** Independent R&D Organizations
- k** Government

Your design function (check each letter that applies):

- x** I do electronic design or development engineering work.
- y** I supervise electronic design or development engineering work.
- z** I set standards for, or evaluate electronic components, systems and materials.

Your principal job responsibility (check one)

- t** Management
- v** Engineering Management
- r** Engineering

Estimate number of employees (at this location): 1. under 20 2. 20-99 3. 100-999 4. over 1000

1 16 31 46	61 76 91 106	121 136 151 166	181 196 211 226	241 256 271 348	363 378 393 408	423 438 453 468	483 498 703 718
2 17 32 47	62 77 92 107	122 137 152 167	182 197 212 227	242 257 272 349	364 379 394 409	424 439 454 469	484 499 704 719
3 18 33 48	63 78 93 108	123 138 153 168	183 198 213 228	243 258 273 350	365 380 395 410	425 440 455 470	485 500 705 720
4 19 34 49	64 79 94 109	124 139 154 169	184 199 214 229	244 259 274 351	366 381 396 411	426 441 456 471	486 501 706 900
5 20 35 50	65 80 95 110	125 140 155 170	185 200 215 230	245 260 275 352	367 382 397 412	427 442 457 472	487 502 707 901
6 21 36 51	66 81 96 111	126 141 156 171	186 201 216 231	246 261 338 353	368 383 398 413	428 443 458 473	488 503 708 902
7 22 37 52	67 82 97 112	127 142 157 172	187 202 217 232	247 262 339 354	369 384 399 414	429 444 459 474	489 504 709 951
8 23 38 53	68 83 98 113	128 143 158 173	188 203 218 233	248 263 340 355	370 385 400 415	430 445 460 475	490 505 710 952
9 24 39 54	69 84 99 114	129 144 159 174	189 204 219 234	249 264 341 356	371 386 401 416	431 446 461 476	491 506 711 953
10 25 40 55	70 85 100 115	130 145 160 175	190 205 220 235	250 265 342 357	372 387 402 417	432 447 462 477	492 507 712 954
11 26 41 56	71 86 101 116	131 146 161 176	191 206 221 236	251 266 343 358	373 388 403 418	433 448 463 478	493 508 713 956
12 27 42 57	72 87 102 117	132 147 162 177	192 207 222 237	252 267 344 359	374 389 404 419	434 449 464 479	494 509 714 957
13 28 43 58	73 88 103 118	133 148 163 178	193 208 223 238	253 268 345 360	375 390 405 420	435 450 465 480	495 510 715 958
14 29 44 59	74 89 104 119	134 149 164 179	194 209 224 239	254 269 346 361	376 391 406 421	436 451 466 481	496 701 716 959
15 30 45 60	75 90 105 120	135 150 165 180	195 210 225 240	255 270 347 362	377 392 407 422	437 452 467 482	497 702 717 960

Electronics Reader Service

If the cards below have already been used,
you may obtain the needed information
by writing directly to the manufacturer,
or by sending your name and address,
plus the Reader Service number and issue date,
to Electronics Reader Service Department,
P.O. Box No. 2530, Clinton, Iowa 52734, U.S.A.

Place correct airmail
postage here ... for
faster service.

Electronics

P.O. Box No. 2530
Clinton, Iowa 52735
U.S.A.

Place correct airmail
postage here ... for
faster service.

Electronics

P.O. Box No. 2530
Clinton, Iowa 52735
U.S.A.

BASICPAC™

A New Concept in Industrial Measurement and Control Systems

TEN/10
Calculating Datalogger/
Control System



TEN/5
General Purpose Datalogger



Introducing the Autodata TEN/50

~~process monitors~~

~~measurement and control systems~~

calculating dataloggers

data acquisition systems

low cost dataloggers

- Friendly Operator Interface
- Computer Power with Instrument Simplicity
- BASICPAC™ plus Menu for Quick Startup
- Software programmable Operator Interface
- On Board Tape Storage
- Simplified Graphics and Report Formatting

The A-TEN/50 is a unique new Measurement and Control System which provides the accuracy and high noise rejection you need plus computer processing power. Unlike many "computer" systems, our BASICPAC™ program gets you up and running fast. Menu programming lets you measure and record data without specialized

programming. Then create your own custom program in BASIC, and you're on line to your solution. With RS-232, pulse, thermocouples, RTD, 4-20 mA and BCD inputs plus on board tape, we are sure you will find a solution in the TEN/50.

Give us a call and let us help you solve your next Measurement and Control problem.

 **ACUREX
Corporation**

Autodata Division
485 Clyde Ave., Mt. View, CA 94042
(415) 964-3200 Telex: 34-6391

At Exar, you call the shots on custom IC development.



We bend our rules to meet your needs.

Some big custom IC houses lose interest if your custom requirements don't fit their rules. At Exar, we don't have rigid rules. You tell us what you need and we help you get it. Period.

How many custom ICs do you need?

At Exar, there's no minimum volume requirement. Even if your current volume is too small to make full custom cost-effective right now, we'll help you get started with semi-custom ICs. When your product matures and the numbers get big, we'll help you convert to full custom.

How soon do you need prototypes?

We'll work out a schedule you can live with. At Exar, typical turnaround time is half that of most big custom houses.

How much do you want to do yourself?

We can do all or any part of the custom development cycle. We'll design and build your custom circuit from your specs. Or convert your semi-custom design to full custom to reduce unit cost. Or fabricate wafers from your design and tooling. We'll even second-source a custom circuit designed for

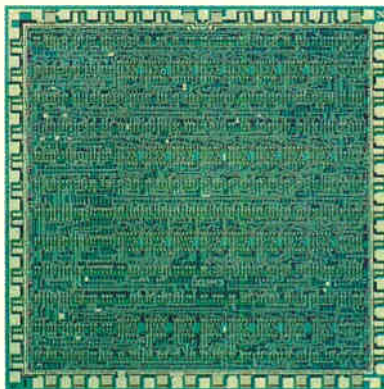

you elsewhere. Any way you call it—CMOS, I²L, or bipolar gate arrays—you'll get personal attention and guidance every step of the way from our custom IC experts.

What kind of packaging?

Choose from plastic or ceramic DIPs, molded flat packs, chip carriers, tab power packages, or your own custom packaging. Or specify delivery in wafer or dice form.

How about cost?

We're committed to providing the highest-quality custom ICs in the industry at a competitive price. We're even flexible about upfront money and contract agreements, because we know how important these can be to you.

Call Exar for full custom and call your own shots.

We've been providing custom ICs for companies large and small for over 10 years. Our experienced people, CAD design capabilities, modern processing facilities and rigorous quality control programs assure you custom circuits that meet your product needs.

- Please send me your Custom & Semi-Custom Product Guide.
- Please have an Exar representative call me.

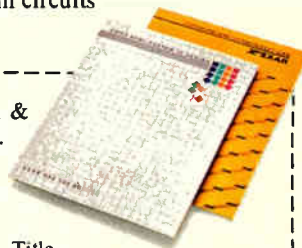

Name _____ Title _____

Company _____

Street _____

City/State/Zip _____ Phone _____

My application is: _____

Exar, 750 Palomar Avenue, Sunnyvale, CA 94086
(408) 732-7970

ELEC 12/15/81

EXAR

For custom, semi-custom or standard integrated circuits ...

Exar has the answer.

“Quality? Teradyne and General Electric are on the same wavelength.”

*Paul McLean, Advance QC Manager
General Electric Mobile Communications Division*

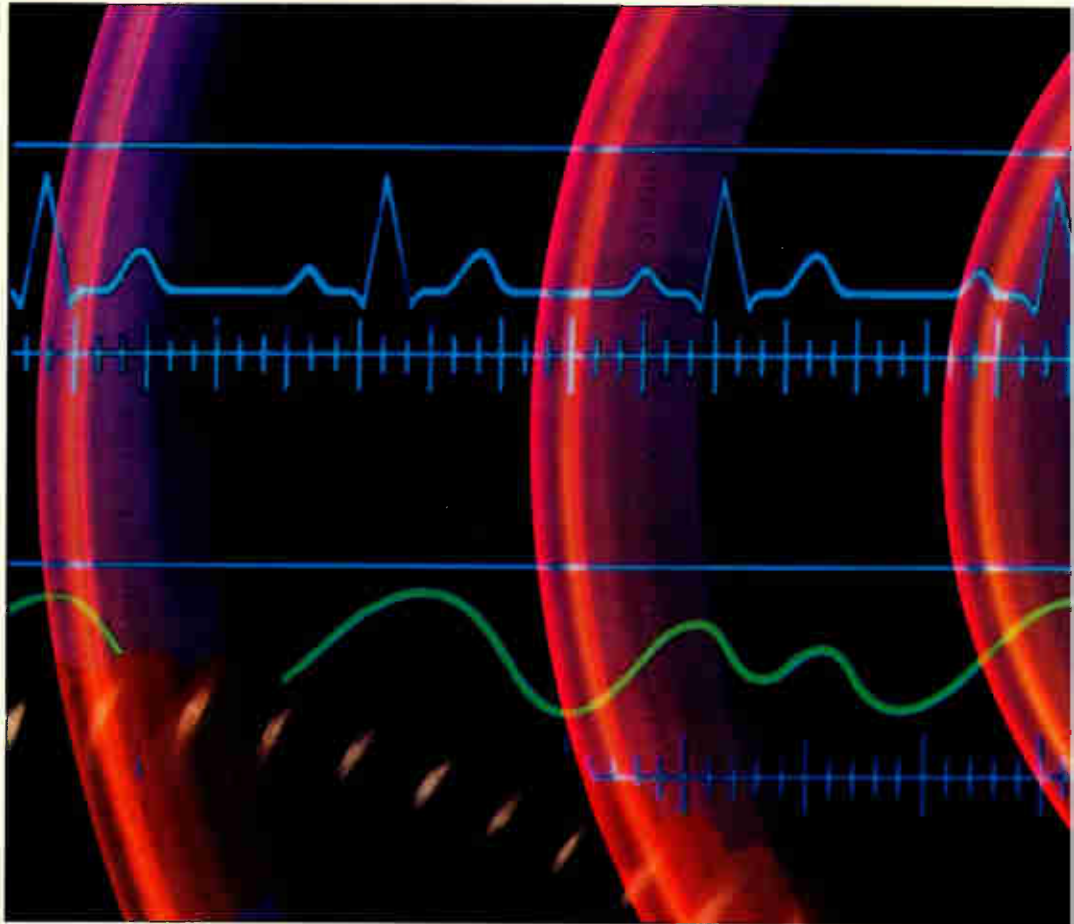

General Electric's mobile radios are among the most reliable built. And it's easy to see why.

Recognizing the link between testing and quality, General Electric has instituted an extraordinarily rigorous product evaluation program.

In the words of Advance QC Manager Paul

McLean, "We believe in 100% testing – in incoming inspection, subassembly, and final assembly."

At General Electric's Mobile Communications Business Division, a large and well orchestrated network of automatic test systems is used to improve quality.

Every SSI and MSI digital IC is tested on a Teradyne system. Every linear IC. Every transistor. Every memory. Every analog LSI device.

Why such extensive testing? "Because," says Paul McLean, "testing gives us the information we need to know where we are, where we're going, and how to get there. Our test systems zero in on all the subtleties, and we can believe what they tell us."

For General Electric, where every product must be "better than the best," one message has always come through loud and clear:

If you can measure it, you can improve it.

TERADYNE

We measure quality.



Announcing 23 new Microboard products.

Now there are over 70
Microboard problem-solvers
from "Old Reliable".

The first color Microboard Computer
Development System.



New Opto 22* I/O interface Microboard.

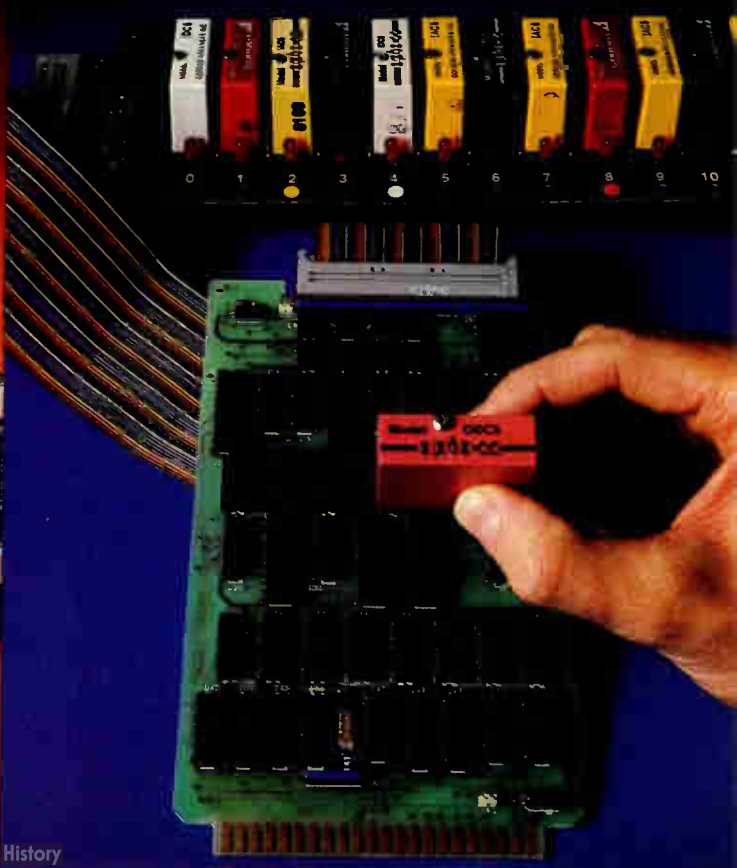

These new products will help you to use the power of board-level computers to solve many more of your application problems.

Color development system.

The first color development system for 1802-series microprocessors. Ideal for developing your own 1802 microprocessor, Microboard, or color video applications.

Software development and screen editing made easy by colors that distinguish your inputs from computer responses. Unique cursor, prompt, and background color identify Monitor and Program Development modes. Expandable with any RCA memory or I/O Microboard. Firmware includes floating-point BASIC3, ROM-based assembler/editor, and monitor.

The CDP18S695V1 comes complete with color monitor, full keyboard and promprogrammer for only \$1499.** Other models as low as \$499** at that price the system is an ideal BASIC language controller.

New I/O interface.

Opto 22* module interface Microboard CDP18S662 provides 24 bi-directional parallel I/O lines. Solves your power problems by interfacing directly with industry-standard optically isolated plug-in modules and racks.

Unique circuit design enables you to select the direction of each signal line. No Microboard changes or programming required.

Innovative built-in interrupt structure can be programmed to generate an interrupt in response to a change in one or more signal lines.

Five new Microboard computers.

Based on the new 1805 microprocessors with built-in counter/timers. The new counter/timer features include real-time event counter, pulse-duration timer and program decrement counter.

And these new microprocessors have 22 additional powerful instructions, including one-instruction call and return, and 4 instructions to load and store 16-bit words.

We've put these features of the 1805 to work for you on five new Microboards. Each is a complete computer system, with read-write memory, parallel and serial I/O ports (available on 4 of the 5), power-on reset, expansion interface and ROM sockets.

Ideal for solving your 1805 or 1806 microprocessor prototyping needs, or for systems requiring timers and counters.

Industrial chassis series.

Designed to stand up to tough industrial environments. Seven sizes, from 4 to 25 slots. Built-in Universal Backplane accepts all Microboards.

Mounting methods almost unlimited: 19" rack, NEMA enclosure, backwall mounting and even desk-top models.

Every industrial packaging problem known to us was carefully considered,

resulting in a really useful small, compact, front access, protected family.

Two initial optional modules make these chassis even more versatile: A self-contained, plug-in power supply that will accept 110-volt or 220-volt AC input to provide all logic and analog supplies needed for Microboard cards.

And a Microboard I/O module card which mounts into a 4-slot segment of the chassis, and holds up to 8 industry-standard optically isolated power modules in any mix of AC or DC input or output signals. Complete with mating 4-slot cover with barrier strips for power connections.

These new products are part of our ongoing commitment (39 new products in 1981) to develop and produce the devices you need to put the flexibility and power of board-level computers to work solving your problems.

And of course, our Microboards give you the bonus of CMOS low power and -40°C to $+85^{\circ}\text{C}$ operating temperature range at no additional cost.

For more information, contact any RCA Solid State sales office, representative or distributor.

Or call (800) 526-3862.

Circle 95 on reader service card

RCA

*Trademark of Opto 22. **Optional U.S. distributor resale. RCA Solid State headquarters: Somerville, NJ. Brussels. Sao Paulo. Hong Kong

Five new Microboard computers with 1805 microprocessors and counter/timers.

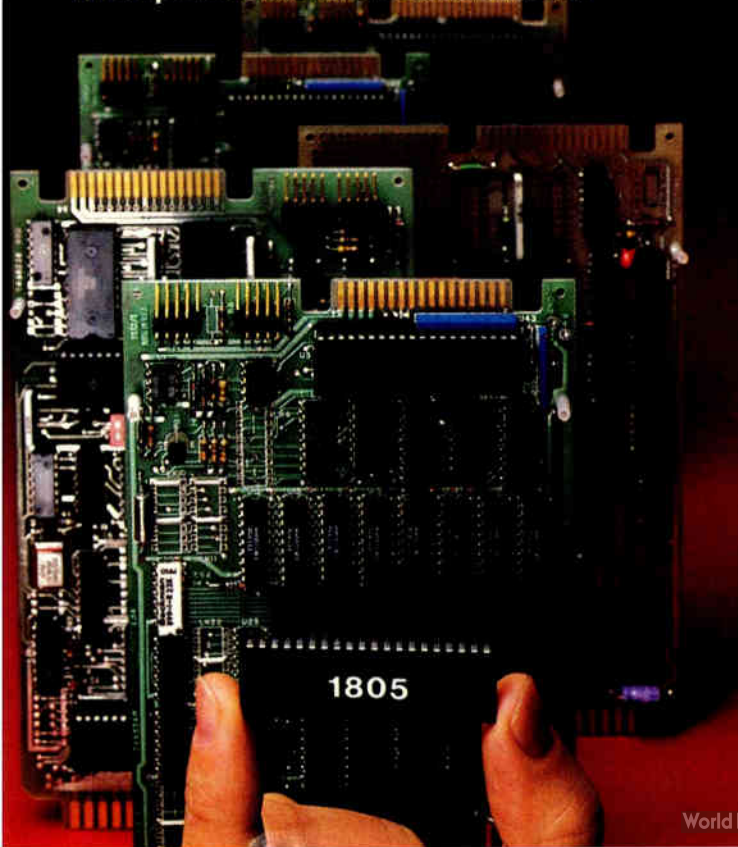

Rugged, versatile family of 16 industrial chassis and signal-conditioning Microboards.

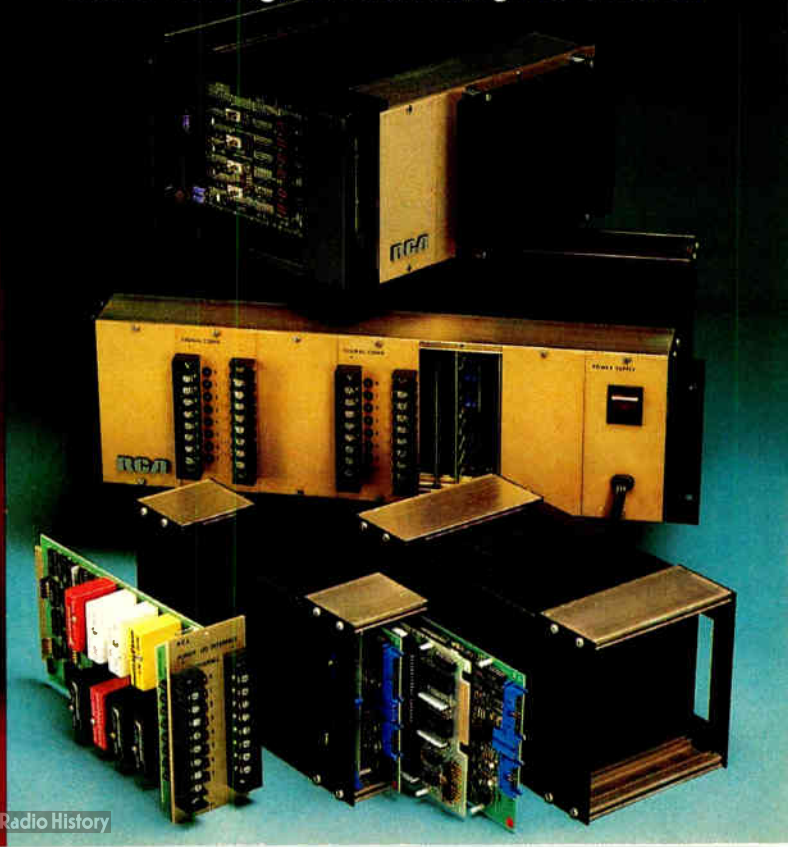

FIVE OF A KIND

LOW POWER ★ LOW PRICED ★ LINE POWERED MODEMS



202S LP

auto-answer
1200 bps

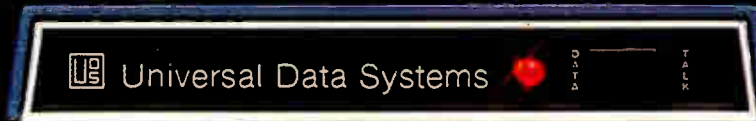

\$295
(quantity one)

202 LP

1200 bps

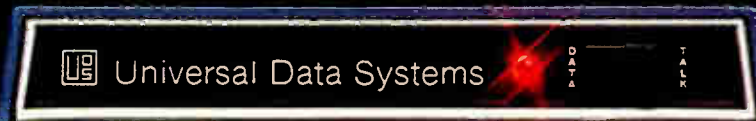

\$245
(quantity one)

103J LP

originate/answer
auto-answer
300 bps

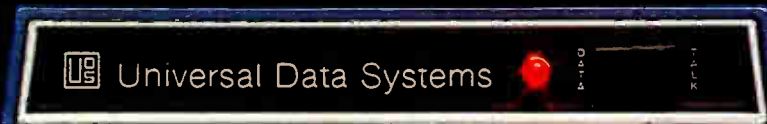

\$245
(quantity one)

103 LP

originate/answer
300 bps

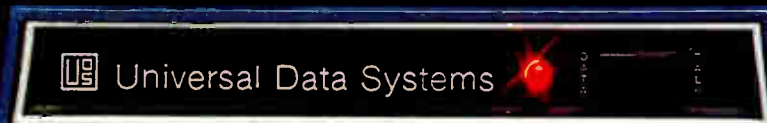

\$195
(quantity one)

103 LP

originate only
300 bps

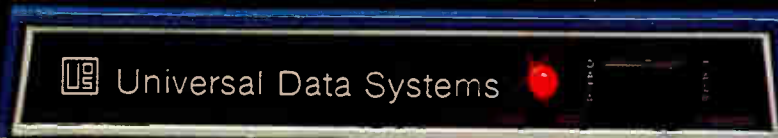

\$185
(quantity one)

All UDS LP modems are FCC-certified for direct connection to the telephone network and require no AC power connection. For details, contact Universal Data Systems, 5000 Bradford Drive, Huntsville, AL 35805. Phone: 205/837-8100.

"Confidence in Communications"

Universal Data Systems



Member
IDCMA

DISTRICT OFFICES: Summit, NJ, 301/522-0025 • Blue Bell, PA, 215/643-2336 • Atlanta, 404/998-2715 • Chicago, 312/441-7450 • Columbus, OH, 614/846-7478 • Dallas, 214/385-0426 • Englewood, CO, 303/694-6043 • Santa Ana, 714/972-4619 • Sunnyvale, 408/738-0433 • Boston, 617/875-8868.

Circle 96 on reader service card

Created by Dayner/Hall, Inc. Winter Park, FL



ISSCC: VLSI earning its keep

1982 circuits conference, a cornucopia of papers and panels, shows spread of very large-scale integration

No one topic grabs the spotlight at the 1982 International Solid State Circuits Conference—they all will. From Feb. 10 to 12, San Francisco's Hilton Hotel will be the stage for over 300 authors and more than 100 panelists to explain and debate topics ranging from 1-micrometer circuit patterning to single-chip systems comprising hundreds of thousands of devices.

The diversity of the circuits makes global trends trickier to spot, but one thing is clear: chip designers have settled down to business with very large-scale integration. For the huge memories that have resulted, laser-based redundancy seems to be the technique of choice for improving yield. For the complex logic and processing units that have also come about, design automation is growing in significance as designs strive for shorter turnaround times.

Downscaling is speeding up n-channel MOS, complementary-MOS, and gallium arsenide circuits alike. A raft of communications chips will be found in next year's proceedings, including single-chip systems to process data and synthetic speech. A larger number of monolithic microwave components will soon make possible integrated transmitters and receivers, as well.

Notwithstanding the preeminence of static and nonvolatile memories at the 1982 conference, innovation in

dynamic random-access memories has not been relinquished to Japanese manufacturers by U.S. firms. Besides a byte-wide 288-k chip made by IBM Corp. with a 2- μm n-MOS process, late papers on 256-k chips employing laser redundancy are expected from both Bell Laboratories and Motorola Inc.

Soft errors. Among the problems facing any attempts to build such large memories, soft errors induced by alpha particles promise to rear their troublesome heads anew with the scaled-down geometries. IBM reports effective control of soft errors for 2.5- μm geometries using a buried n-type layer. However, Monte Carlo simulations at the firm's Yorktown Heights, N. Y., laboratories show that dynamic RAMs with 1- μm features will not find significant relief from the particles, even if epitaxial layers, buried implants, or Hi-C (high-capacitance) structures are employed.

Mitsubishi Electric Corp. will offer a novel dynamic RAM architecture. Word-line delay is reduced by storing the logic-1 level as 1.7 times the supply voltage—without using boosted clocks.

Intel Corp. will be sharing the spotlight with several Japanese firms in the ISSCC session on static RAMs. Not unexpectedly, scaled-down double-polysilicon MOS processes are now yielding 64-k devices. Hitachi

Ltd.'s HI-C-MOS-II memory checks in with a 65-nanosecond access time and 200-milliwatt power dissipation; again, laser programming of polysilicon links is employed to boost yields. Toshiba Corp., too, opted for a fault-tolerant C-MOS design, and the six-transistor cell in its chip holds power dissipation down to 15 mW. Besides showing its 50-ns n-MOS 64-k static RAM, Intel will discuss laser redundancy for 16- and 32-k chips and a novel static RAM compatible with emitter-coupled logic.

Hints of future improvements in static RAM speed and density are also evident in Intel's preview of H-MOS-III. The process features 1- μm electrical channel lengths and refractory metal contacts for holding down parasitic resistances in the next round of memory capacities.

A diverse collection of nonvolatile memories—most from domestic makers—will surface in session 9. These range from a Fujitsu Ltd. 2-k part that exploits a nitride barrier up to Intel's 128-k erasable chip complete with redundant rows and polysilicon fuses. Highlights between those extremes include an RCA Corp. 8-k C-MOS-on-sapphire electrically erasable memory with an access time under 40 ns and a 64-k programmable chip that Harris Semiconductor Group made in its junction-isolated bipolar process.

Reflecting the importance of logic

Probing the news

arrays for automating the design of very large-scale ICs are several papers covering technologies ranging from C-MOS to ECL. Testing fast logic at its rated speeds is one likely use for the gallium arsenide chips developed jointly by Hewlett-Packard Co., Stanford University, and Podell Associates of Palo Alto, Calif. They will report on circuits for generating and detecting random bit streams at 2.5 gigabits a second.

It seems that ECL will accompany GaAs into this subnanosecond realm, as will be demonstrated by Motorola with a 2,500-gate master-slice chip that includes on-chip diagnostics. The slice's oxide-isolated walled-emitter gates switch 1-milliampere currents in 250 picoseconds. Toshiba claims that C-MOS can do that too; it will present a 6,000-gate array with propagation delays well below a nanosecond.

In linear and data-conversion circuits, bipolar processes are forging the path to 16-bit accuracy, with MOS switched-capacitor techniques following close behind. Notable among the latter's successes is an instrumentation amplifier with 12-bit linearity and 120-decibel common-mode rejection from the University of California at Berkeley.

Glimpses of the bright future for bipolar technology in data conversion will come in the form of Harris's monolithic 16-bit digital-to-analog converter built with dielectric isolation and a 14-bit dual-slope con-

MEMORIES		
Session	Description	Source
18.1	A 20-ns 4-K static random-access memory, built with complementary-MOS, is compatible with 10K emitter-coupled logic.	Intel
7.1	Word-line delays in dynamic RAMs are reduced by charging the storage plate to 1.7 times the supply voltage.	Mitsubishi
7.2	A 288-K dynamic RAM with byte-wide read and write operations is fabricated with 2- μ m ground rules.	IBM
1.5	Monte Carlo simulations of soft-error rates in dynamic RAMs with 1- μ m features show that buried layers and Hi-C structures are poor defenses against alpha particles.	IBM
9.1	32-K electrically erasable programmable read-only memory gives a 90-ns access time plus erasure by word, subpage, full page, or bulk.	Motorola
9.4	Four fuse-selected redundant rows go into a 128-K erasable programmable ROM with access time under 200 ns.	Intel
18.4	Scaled-down n-MOS processing packs static cells into 0.5 mil ² for a 50-ns 64-K RAM.	Intel
18.6	Fault-tolerant 64-K C-MOS RAM consumes only 15 mW in operation; access time is 70 ns.	Toshiba

verter from Signetics Corp. with an on-chip precision sample-and-hold amplifier.

Tell and trig. Telephony and trigonometry are still challenging analog designers. Intel will be showing off its family of n-MOS switched-capacitor circuits for coder-decoder and filter applications. Among the eye-openers is a universal generator from Analog Devices Inc. that synthesizes all of the trigonometric functions to accuracies within 0.04%.

Session 2, on digital signal processors, is dominated by 32-bit arithmetic processors, but there will be one 64-bit model there, too. Four of the 32-bit models will be described.

Perhaps the most specialized of the mathematics processors is the 32-point fast-Fourier-transform C-MOS processor from the Electronic Systems division of TRW Inc. It oper-

ates on 32 complex data samples simultaneously, computing 32 complete Fourier coefficients.

Texas Instruments Inc., for its part, will describe a 32-bit single-chip microcomputer that is ideal for signal processing, but also will fit nicely into any high-speed mathematics application. It exhibits a 200-ns cycle time, a 32-bit adder-subtractor, and a 16-bit multiplier. It also includes a 144-by-16-bit data memory and a 1,536-by-16-bit program memory.

HP will detail a high-speed math chip set that performs 64-bit floating-point operations. It adds, subtracts, multiplies, and divides at speeds of up to 1 million operations per second.

The other two chips, to be described by Motorola and Matsushita Electronics Corp., are much more specialized. The first performs error correction for the National Aeronautics and Space Administration's 30-gigahertz systems using convolution, whereas the second implements a 14,400-bit-per-second digital modem.

In session 10, Nippon Electric Co. will show off its single-chip Winchester-technology disk controller, and TI will demonstrate how a 152-bit horizontal control read-only memory with 256 states can be reduced using a compression algorithm to require less than 10,000 ROM cells.

Microwave ICs. Monolithic integrated circuits for the microwave region of the spectrum have been a

GALLIUM ARSENIDE AND OPTICAL CIRCUITS		
Session	Description	Source
14.1	Gallium arsenide circuits generate and detect random bit streams at 2.5 Gb/s, 8-bit words at 5 Gb/s.	HP, Stanford, Podell Associates
11.3	Four-stage monolithic GaAs field-effect-transistor amplifier for satellite communications in 7.25-to-7.75-GHz band has 1-W output, 33-dB gain.	TI
11.4	Monolithic 8.8-to-10-GHz GaAs voltage-controlled oscillator combines metal-semiconductor FET, tuning varactor, tuning inductors, and bypass capacitors and resistors.	TI
11.5	10-GHz three-stage amplifier owes 29.7-dB gain and 4.0-dB noise figure to three identical 0.5- μ m common-source FETs.	TI
13.3	Bipolar chip for selection, biasing, and 100-MHz modulation of a group of diode lasers includes failure-detection and power-limiting circuits.	Bell
13.4	Optically coupled bipolar amplifier achieves 160-dB isolation, uses optical feedback for 0.05% nonlinearity.	Burr-Brown

DMOS regulator shatters 40-V barrier. And a few hallowed traditions. TL783. New from Texas Instruments.

Remember when 40 V was the highest that adjustable, three-terminal regulators in single-chip form could produce? Forget it. TI's new positive-output TL783, in a TO-220 package, handles an I/O differential voltage up to 125 V. The maximum output current is 0.7 A.

Now power supply designs for a wide variety of high-voltage applications, including plasma displays, CRT-biasing circuits in TVs and computer video displays, and telephone communications equipment, can benefit from the space-saving, improved reliability, and reduced cost features that their lower voltage counterparts enjoy.

Line regulation for the TL783 is 0.02%/V. Load regulation, 0.5%. Typical temperature coefficient of 0.4% and an initial accuracy of $\pm 4\%$ are significant operating characteristics.

Because TL783's reference terminal can float free above ground and draws less than 0.1 mA, it can be configured into a highly versatile, adjustable precision current regulator. The TL783

can start with 100 V, instead of the previous 40-V maximum, to produce a better regulated current output, 0.02%,

TL783 (DMOS) vs LM317 (BIPOLAR)		
CHARACTERISTICS	TL783	LM317
I/O differential	125 V	40 V
Max. output current	0.7 A	1.5 A
Initial accuracy	$\pm 4\%$	$\pm 4\%$
Temp. coefficient	+0.4% (typ)	$\pm 1\%$ (typ)
Line regulation	0.02%/V	0.04%/V
Load regulation	0.5%	0.5%
Dropout voltage	10 V at 400 mA	3 V at 1.5 A
Failure modes	No comparable failure mechanisms	Prone to thermal runaway, secondary breakdown, and current hogging

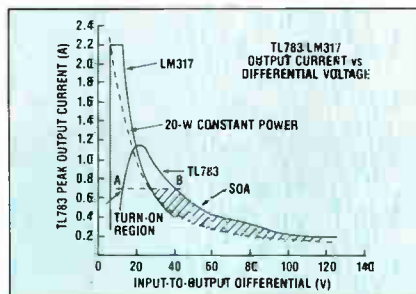

over a larger range of load resistances, even at low-mA currents.

Now, about tradition. We're doing it in DMOS because, for high-voltage capability, it's better than bipolar.

Reliable performance is further enhanced by the DMOS output transistor's SOA (Safe Operating Area) characteristics — no secondary breakdown — no thermal runaway. Some of the TL783's protection circuitry is internal thermal shutdown with a zener temperature sensor and a current limiting circuit. The thermal shutdown circuitry automatically turns the regulator off above 165°C, and back on when it cools. The current limiting circuit adjusts the output current so that the voltage-current product does not exceed 20 W.

Forget 40 V. For more information on the new TL783, contact your nearest authorized distributor, or write Texas Instruments Incorporated, P.O. Box 202129, Dallas, Texas, 75220.



Texas Instruments invented the integrated circuit, microprocessor and microcomputer. Being first is our tradition.

©1981 Texas Instruments Incorporated

TEXAS INSTRUMENTS

822091

ARGENTINA 748-1141 • AUSTRALIA (02) 887-1122 • BELGIE/BELGIQUE (02) 720.80.00 • BRASIL 518423 • DEUTSCHLAND 08161/801 • FRANCE (3) 946 97 12 • ITALIA (0746) 69034
JAPAN 03-498-2111 • MEXICO 567-9200 • NEDERLAND 020-473391 • SCHWEIZ/SUISSE 01 740 22 20 • SVERIGE (08) 23.54.80 • UNITED KINGDOM (0234) 223000

World Radio History

Circle 98 on reader service card

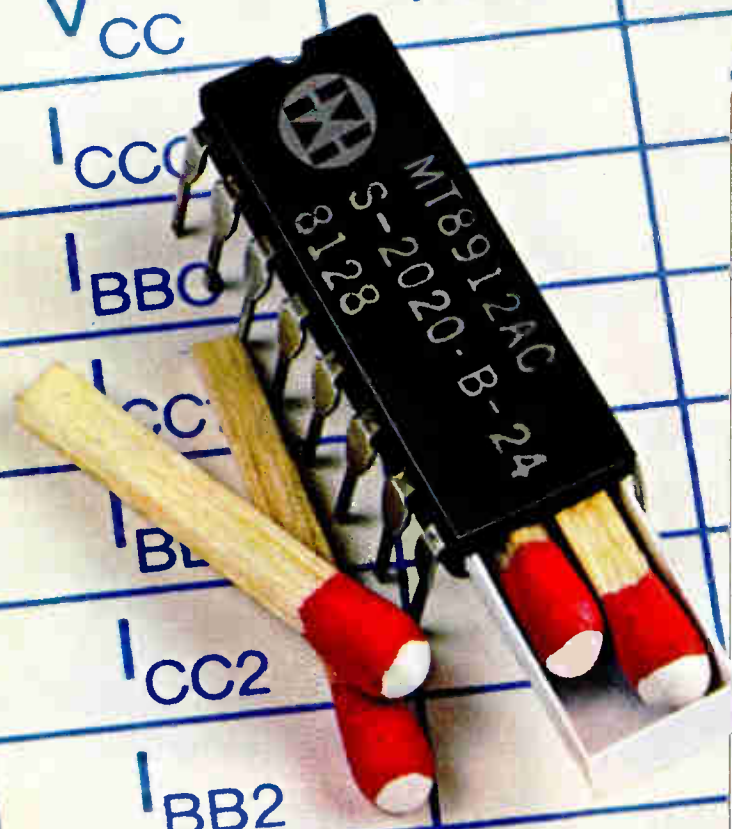

HOT SPECS: THE MT8912 ISO²-CMOS PCM FILTER.

When the specs are examined, it's clear that the Mitel MT8912 PCM Transmit/Receive filter can offer your application significant advantages.

Low power consumption is just one such advantage. The MT8912 operates at a mere **20 mW** typical without power amps. Other units come in at as much as 280 mW.

Idle channel noise. With the MT8912, it's extraordinarily low—typically **6dBnc0** total C message noise at output.

Consider too the MT8912's **power supply rejection ratio: 40 dB** at 1kHz. In addition, the Mitel MT8912 is pin for pin compatible with the Intel I 2912. It meets AT&T D3/D4 and CCITT G712 specifications. The receive filter includes sinx/x correction and there is external gain adjustment of both transmit and receive filters.

All in all, it's a case of hot specs guaranteeing you hot performance.

Find out more about what the Mitel MT8912 can do for your application by contacting your local Mitel sales office.

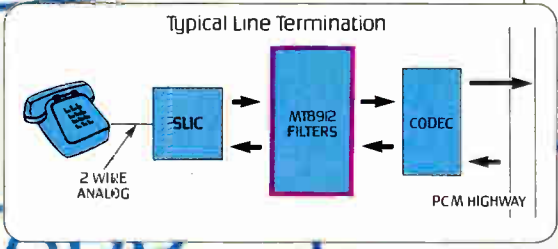
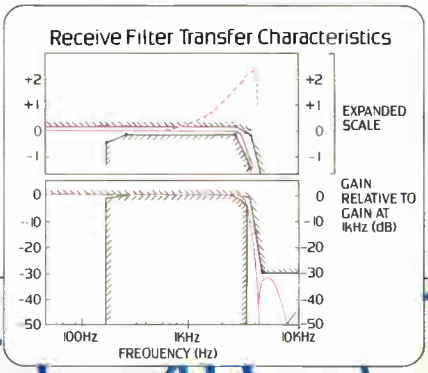
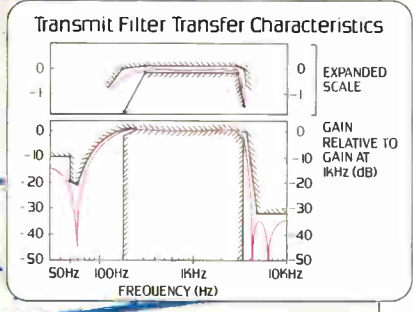

MITEL SEMICONDUCTOR

United States: 2321 Morena Blvd., Suite M, San Diego, California, U.S.A. 92110.
Telephone (714) 276-3421, TWX: 910-335-1242.
P.O. Box 17170, 600 West Service Road,
Dulles International Airport, Washington, D.C., U.S.A. 20041.
Telephone (703) 661-8600, TWX: 710-833-0865.

Europe: 33/37 Queen St., Maidenhead, Berkshire, England SL6 1NB
Telephone 0628 72821, Telex: 849-808.
Bredgade 65A, 2nd Floor, 1260 Copenhagen K, Denmark
Telephone (01) 134712, Telex: 19502.

Canada: P.O. Box 13089, Kanata, Ontario, Canada K2K 1X3.
Telephone (613) 592-5630, Telex: 053-3221, TWX: 610-562-8529.

Asia: TST P.O. Box 98577, Kowloon, Hong Kong.
Telephone 3-318256, Telex: 34235.

Copyright 1981 Mitel Corporation

BUILDING BETTER COMMUNICATIONS

Circle 100 on reader service card

Probing the news

long time coming because of the unique circuit-design problems that reign at frequencies of thousands of megahertz. Silicon technology at lower frequencies had the computer as a market, but there is as yet no mass market for microwave ICs.

Although many possibilities are now under investigation, the components to be described at the ISSCC focus on the range of separate parts

needed to put together monolithic microwave receivers. It is still too early for a cost-effective complete monolithic receiver; in fact, the optimal process technology has yet to be selected.

While GaAs is clearly favored, researchers at General Electric Co. will report they have made large-gate-width metal-semiconductor field-effect transistors on sapphire that operate at 3 GHz, as experimental devices. Further work will be needed before the practicality of the

units is demonstrated.

The big push is in monolithic GaAs parts because they can be made to have better electrical specification than SOS devices. For example, TI researchers, practically dominating the GaAs sessions with four papers, have designed a four-stage power FET with a 1-watt output and 33-dB gain in the 7.25-to-7.75-GHz frequency range. It is designed for active-antenna-array applications.

Other work at TI's Dallas facility has produced an 8.8-to-10.0-GHz GaAs FET voltage-controlled oscillator with all its associated parts on a 1.1-by-1.2-millimeter chip—an unheard-of small size. Adding to the list of parts needed for a complete receiver, a 10-GHz, three-stage amplifier with a 4.0-dB noise figure and 29.7-dB gain has been built. Such state-of-the-art specifications for a low-noise amplifier are achieved through a common-source configuration of three identical FETs having 300-by-0.5- μm gates.

Lower numbers. Apart from all the work on monolithic microwave ICs, the needs of designers interested in data and voice communications at lower frequencies are not being ignored. Modem manufacturers will want to look at Berkeley's n-MOS 16-tap adaptive transversal filter, which provides 50 dB of echo suppression at data rates of 80 kilobits per second.

They will also want to hear the results of a collaboration between NEC and the Musashino Laboratories of Nippon Telegraph & Telephone Public Corp. to develop a single-chip, n-MOS analog front end for modems. It contains all the front end's filters, equalizers, zero-crossing detectors, and a-d and d-a converters on a 7.14-by-6.51-mm chip.

Designers of private branch exchanges and digital switches will be pleased to learn about the 256-channel cross-point array developed jointly by Plessey Ltd. and Stentor AS in Norway. The nonblocking design, for use in European 32-channel, 2.048-MHz, pulse-code-modulated systems, is similar to one recently developed VLSI chip has a power consumption of only 200 mW. □

GENERAL-PURPOSE AND DEDICATED PROCESSORS

Session	Description	Source
6.1	Automated design yields a 32-bit complementary-MOS processor with 17,000 gates of random logic and a 2-K random-access memory.	NTT
2.5	Single-chip 32-bit microcomputer integrates a 16-by-16-bit multiplier, 32-bit arithmetic and logic unit, and memories for data and programs.	TI
10.5	32-bit processor chip set embodies over 660,000 1- μm n-MOS transistors on six very large-scale integrated circuits.	HP
19.6	A 16-bit C-MOS systolic array processor performs pattern matching for speech recognition at 25,000 words per second.	Bell Laboratories
10.2	Single-chip adaptive array processor incorporates eight 8-bit parallel processors using 81,000 transistors.	NTT Musashino Laboratory
2.2	A 2- μm C-MOS process spawns a 32-point fast-Fourier-transform processor.	TRW
10.1	Compression technique fits a wide horizontal microcontrol read-only memory into the same space that a vertical format would allow.	TI
2.1	Floating-point arithmetic processor chip set adds, subtracts, multiplies, and divides 64-bit quantities.	HP

LOGIC ARRAYS AND SINGLE-CHIP SYSTEMS

Session	Description	Source
14.4	Three-level metalization, oxide isolation, and walled-emitter transistors join forces for an emitter-coupled-logic master slice array having 2,500 250-ps gates.	Motorola
6.3	Layout generator varies programmable-logic-array sizes in an automated very large-scale integrated-circuit design system.	IBM
6.4	Self-testing PLA finds all of its own stuck faults and shorts by addressing each transistor with shift registers.	Siemens
3.4	Monolithic generator of trigonometric functions, even the arctangent, synthesizes them with accuracies as close as $\pm 0.02\%$.	Analog Devices
8.2	Differential switched-capacitor techniques bring 12-bit accuracy and 1-mV offsets to MOS amplifiers.	University of California at Berkeley
8.5	Monolithic digital-to-analog converter holds 16 bits monotonically over 0° to 70°C thanks to dielectrically isolated bipolar process.	Harris
10.4	Winchester-disk controller on a single chip can handle 1.5-megabyte-per-second data rates.	NEC
2.4	Single-chip digital modem runs at either 9,600 or 14,400 b/s.	Matsushita
2.3	Error-correction chip supports 30-GHz data rates and features on-chip convolution.	Motorola
19.4	N-MOS audio synthesis chip packs in 64-K of read-only memory for up to 90 seconds of voice, music, or sound effects.	NEC
12.2	Analog n-MOS front-end for modems crams filters, equalizers, zero-crossing detector and data converters onto a single chip.	NEC and NTT
16.3	One 5- μm n-MOS 256-channel cross-point array handles 32-channel 2.048-MHz pulse-code-modulation switches yet consumes only 200 mW.	Plessey and Stentor

This report was prepared by Roderic Beresford, Harvey J. Hindin, R. Colin Johnson, and John G. Posa.

Computers

West wary of Japan's computer plan

University and industry experts agree that fifth-generation effort is a giant step but predict that it can be done

by Tom Manuel, Computers & Peripherals Editor

U.S. and European academicians and computer company executives generally agree that the Japanese have bitten off a very large piece to chew on indeed with their proposed fifth-generation computer project [*Electronics*, Nov. 17, p. 83], but that they may succeed. Moreover, it would be a big mistake to underestimate what Japan will be able to do, the experts warn.

Jonathan Allen, professor of electrical engineering and computer science and director of the research laboratory for electronics at the Massachusetts Institute of Technology in Cambridge, says, "We have good reason to be very, very concerned." Another academic leader in computer science, Bruce H. McCormick, director of the integrated systems laboratory and professor of information engineering and bioengineering at the University of Illinois at Chicago, says, "I think they're dedicated to go get it. . . . [The U.S.] shouldn't fold up its tent, but it's going to be tough competition."

McCormick points out that the fifth-generation project is only one of several that the Japanese have going at present. Other separate programs exist in areas such as robotics, personal computers, and supercomputers. But "in a way," he says, "this one is the scariest."

The project, planned as a 10-year joint effort by Japanese industry and universities and coordinated and partially funded by the government, is considered to be extremely ambitious. However, computer executives seem to be taking the announcement of the project rather calmly—they do not appear to be as concerned as the academicians.

"The Japanese are quite good and there is always the possibility that they could capture leadership," says John R. Opel, president and chief executive officer of IBM Corp. But he is also quick to point out that he does not consider that a very strong likelihood. "I don't think they'll surpass IBM," he says.

"There is no doubt that by 1990 there will be enormous advances in computer architectures," he adds. But it is his opinion that the fifth-generation talk "has more of a public-relations flair to it than reality."

A senior director in the data-processing division of Siemens AG in Munich says, "If that project turns out to be successful, then the Japanese will be out front in computer technology. But it is a big if, and we doubt that they can pull it off. The goals are almost utopian."

The kinds of knowledge-based and -inferring computers conceived by the fifth-generation project have not been built anywhere—only some basic research on several concepts has been done. Because the project is aimed at moving into areas that are

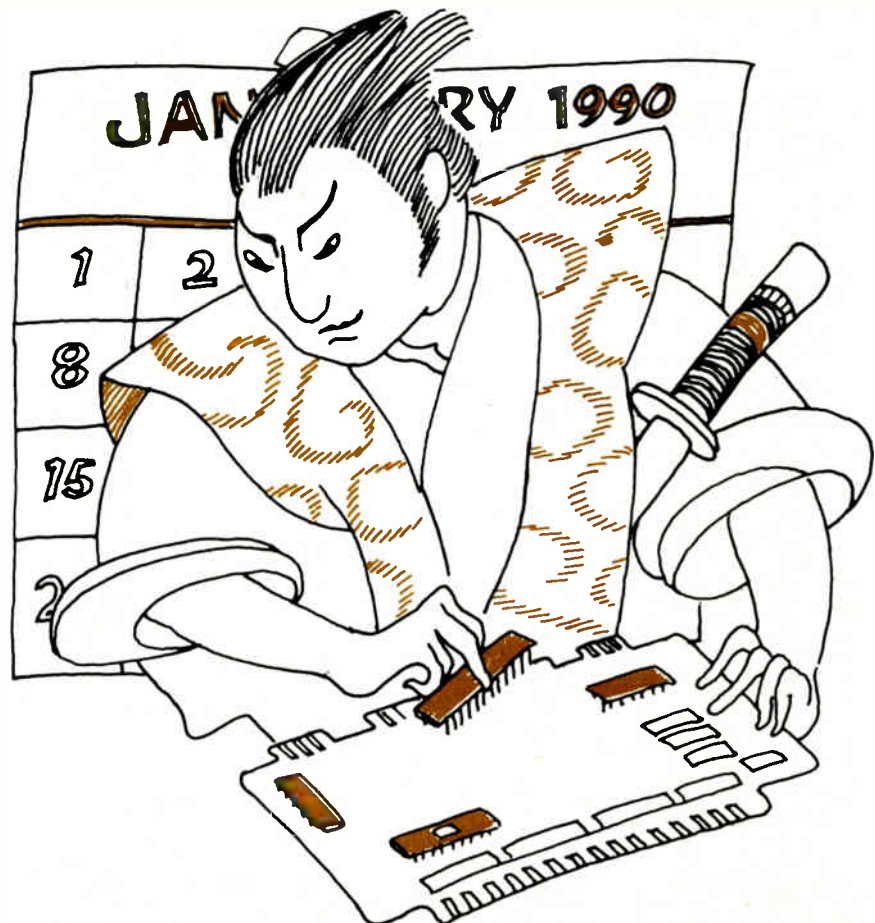

Dolch.

advanced logic analysis

à la carte

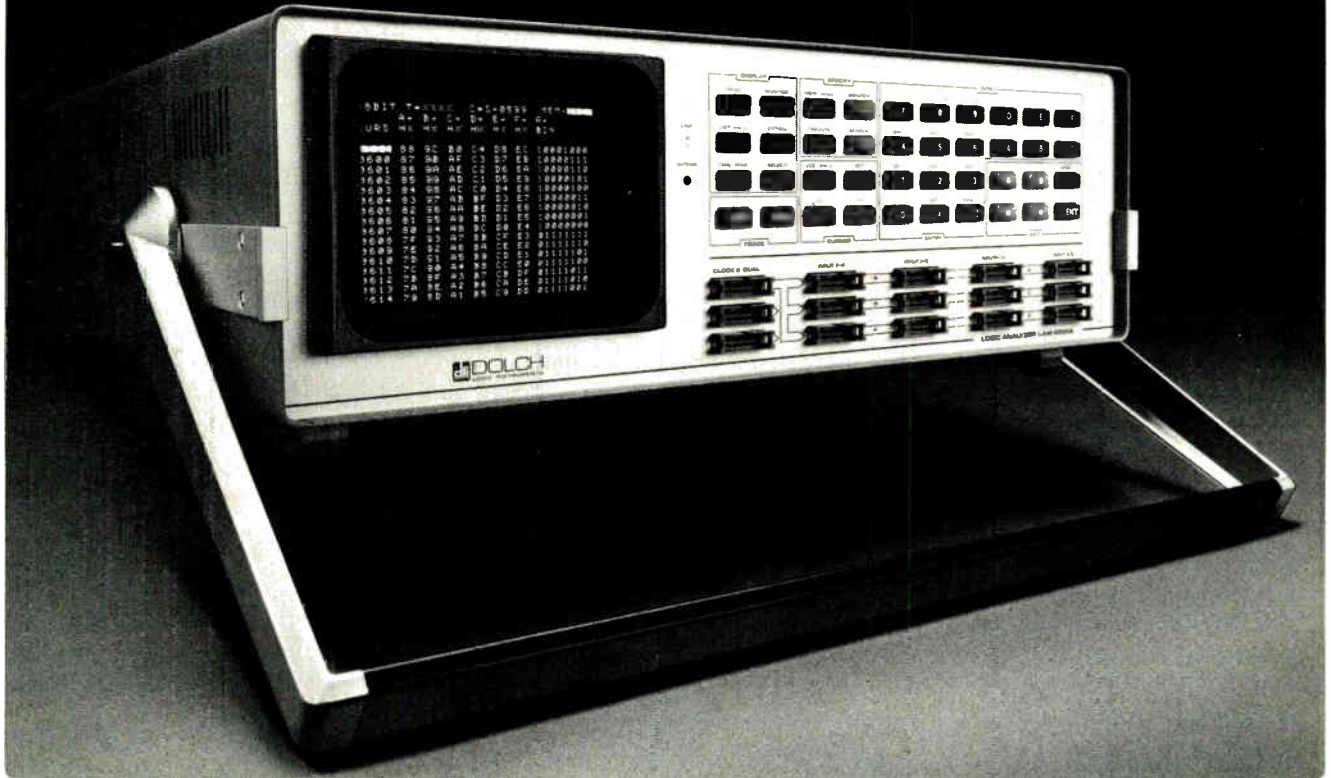

48 to 96 Channels, 300 MHz, plus Mnemonics

Order up your parameters. Dolch's LAM 4850A logic analyzer makes it easy with a new key — Monitor. Monitor gives you status information and comments on menu setups, and can be called up at any time to interpret each parameter, its range, and its interaction with the current setup. And, you can store your setups for three months without power, eliminating the need to reprogram.

Zero in fast. The LAM 4850A disassembles your code into Mnemonics and gives you the channels you need to trace data, address, port and control lines. And for future needs, you can expand to 64, or even 96, channels.

Circle 273 for demonstration

Hook up fast, too. Dolch personality probes clip right over your CPU chips so you don't waste time connecting dozens of individual hooks. And the probe takes care of clock, timing and signal interfacing — no need to worry about signal conditions.

300 MHz sampling across 16 channels. A revolutionary option gives you the ultimate in sampling resolution — 3.3 ns — to help you solve the toughest timing and phase related problems. A unique memory overlay configuration provides simultaneous dual asynchronous recording across 16 channels without compromising any of the LAM 4850A features.

Don't settle for less than Dolch. The basic LAM 4850A is truly a universal logic analyzer system with 50 MHz sampling rate, 1000 bits per channel source and reference memories, and sophisticated sequential trigger and multilevel clocking.

For details on the Dolch LAM 4850A, or any of our other troubleshooting tools, write: Dolch Logic Instruments, Inc., 230 Devcon Drive, San Jose, CA 95112. Or call toll free: (800) 538-7506; in California call (408) 998-5730.

di DOLCH
LOGIC INSTRUMENTS

Circle 103 for more information

Probing the news

essentially uncharted in the marketplace, "it is not going to be easy [for the U.S.] to respond," explains McCormick.

He was one of the three U.S. researchers invited to give guest lectures at the Tokyo conference where the proposals were presented—the other two were Allen of MIT and Edward A. Feigenbaum, head of the artificial intelligence laboratory at the Stanford University Computer Science department in Palo Alto, Calif. In addition, there were three invited lecturers from Europe—Wolfgang Bibel of the Technische Universität of Munich; Giles Kahn of France's national computer and automation research institute in Rocquencourt, and Philip Treleven of the University of Newcastle-upon-Tyne, England.

Great Britain sent a seven-man team of computer academics to the Tokyo conference; and the team was impressed with what it heard, but found some of the plan's premises not yet proven. For example, "Knowledge systems or so-called expert systems in which a computer can make inferences from a limited set of data have only been demonstrated in one or two specific applications like medical diagnosis" says a member of the UK team. "The Japanese want to turn it [knowledge

information processing] into a generalized computer tool, but it's not yet obvious that you can do that," says a UK researcher.

Even if the complete project fails to reach its goals, it is agreed that there will be many successful results from the subgoals. Another attendee at the conference who works for a major U.S. computer company says, "The key issue is the many worthwhile results that the Japanese computer industry will gain as fallout."

He goes on to say, "At first sight, some of the overall goals seem unattainable. However, there are checkpoints in the project every three or four years where the goals can be changed and adjusted to reality—the Japanese have shown an ability to shift targets" in other of their long-range projects.

Yet the feeling is that it is not a good idea for U.S. computer industry to get too complacent about this Japanese project. It need only remember how Japan took leadership positions in steelmaking and consumer electronics and recall its growing predominance in automobiles and semiconductor components, notably 16- and 64-K memory chips. As many observers note, the Japanese are very good at planning, engineering, and working together on large, long-term projects.

"It's a false comfort to think the Japanese have no talent for creativity, and that the U.S. has a corner on

innovative ideas," Allen says. "In fact, the U.S. industry gets so enamored with the big idea that it neglects the kind of nitty-gritty details at which the Japanese excel—the ability to grab an idea, assess it, follow up alternatives in a systematic way, select the best alternative, and push it to a good solid product."

Culture gap. The U.S. is not doing anything now in the form of a national, cooperative effort. And, it is not likely to, either, according to a number of experts.

John H. Clippenger, president of Brattle Research Corp., Boston, views U.S. response to the Japanese project as much a problem of culture as of technology. "When I saw how the Japanese are breaking the technology down, I realized that in each area, the U.S. has already done significant work, and that all that is needed in many cases is development or engineering," he says.

Significant research in artificial intelligence and knowledge-based systems has been in progress for many years in the U.S. and Europe, as well as some in Japan. The Japanese project will be building on work done at MIT, Stanford, and Carnegie-Mellon University in the U.S., and the universities of Newcastle and Edinburgh in Great Britain, for example. Also, several U.S. companies are currently doing some development in this area [*Electronics*, Sept. 11, 1980, p. 93].

At this point, for example, Hewlett-Packard Co. is doing work in applying artificial-intelligence research in the areas of expert systems, natural language, novice user interaction with systems, programmer environments, and speech recognition. Texas Instruments Inc. and Schlumberger Ltd. are working on speech recognition and artificial intelligence as well. According to Clippenger, "the foundations of a fifth-generation computer capability already exist in the U.S."

In addition to the companies noted, he says, for example, that Bell Labs is strong in voice recognition, natural-language processing, and transparent systems. Much the same is true for IBM, he feels. But he is pessimistic about any chance for a coordinated effort in the U.S. □

Can Europe form a common policy?

The Japanese fifth-generation computer effort has focused growing attention on the latest European Economic Commission attempt to forge a European computer policy that will enable firms to catch up both with the U.S. and the Japanese. The Battelle Memorial Institute and other consulting firms are in the second year of a three-year study aimed at identifying long-lead-time research and development needs centered largely on data processing. But the inability of nationalistic governments and competing firms to agree on cooperating in the commercial area stalled earlier Common Market efforts in the computer field. A senior director in the data-processing division of Siemens AG in Munich says that the long-lead-time project could provide a basis for a coordinated effort in Europe, "but that presupposes that the various countries identify themselves with the need for a combined effort and that different companies cooperate."

Though EEC experts say the Japanese fifth-generation project is still only a series of proposed objectives for the future aimed largely at U.S. firms including IBM, they concede the Japanese have previously demonstrated their ability to move forward in the computer area. This is bad news for European firms, "many of whom are managing to stay profitable only by technical linkups with the Japanese. But this is dangerous for the future of European industry," a Common Market official observes.



BIPOLAR LSI: COMPLETE SOLUTIONS TO HIGH PERFORMANCE SYSTEMS DESIGN.

Am2900 SEMINAR: PART II

If you want to learn more about high performance systems solutions, come to Part II of Advanced Micro Devices' Bipolar LSI Seminar.

Bipolar LSI offers you the highest performance and the lowest package count of any design solution. Not to mention incredibly high flexibility and the lowest costs around.

MEET THE FAMILY.

The microprogrammable Am2900 Family has almost everything you'll need for high performance systems design. Just take a look at our "Program of Technical Topics." These products are now being upgraded with AMD's proprietary IMOX™ oxide-isolated process and advanced circuit design techniques. And we're adding new functions all the time.

In fact, Am2900-based designs are already the industry standard for all kinds of applications from minicomputers, peripherals, business systems and graphic displays to modems, PBX's, programmable controllers, and array processors.

GO TO THE HEAD OF THE CLASS.

One seminar with AMD and you'll know what's new for the 80's in Am2900 Family products. You'll learn about the System 29/10 with trace—the complete microprogrammable development system for all Am2900 designs. You'll also find out about some selected MOS peripherals that can enhance overall systems performance. And finally, you'll go home with a small library of AMD technical literature and a copy of the McGraw-Hill, "Bit-Slice Microprocessor Design."

CITIES AND DATES

For information regarding exact locations, starting times and registration fees, contact the office nearest you.

- 18.1.82 ROMA:
AMD Milano, (02) 215 4913-4-5
- 20.1.82 MILANO: AMD Milano, (as above)
- 22.1.82 OSS (NL): Arcobel BV, (04120) 30335,
- 27.1.82 PARIS: AMD Rungis, (01) 68736.66
- 1.2.82 OSLO: A. S Kjell Bakke, (02) 71 18 72
- 3.2.82 STOCKHOLM:
AMD Sundbyberg, (08) 98 12 35
- 5.2.82 COPENHAGEN:
Advanced Electronic, (01) 19 44 33
- 8.2.82 ANTWERP:
MCA Tronix, (041) 36.27.80/36.27.95
- 9.2.82 HANNOVER:
AMD München, (089) 40 19 76
- 11.2.82 LONDON:
AMD Woking, (04862) 22121
- 11.2.82 ZÜRICH: Kurt Hirt AG, (01) 302 21 21
or Kontron Elektronik, (01) 62 82 82
- 16.2.82 STUTTGART:
AMD München, (089) 40 19 76
- 18.2.82 MÜNCHEN: AMD München (as above)

PROGRAM OF TECHNICAL TOPICS.

- PROCESSOR PRODUCTS New high-speed bit-slice microprocessors, sequencers and peripheral products.
- CONTROLLER PRODUCTS 16-bit, 100ns Am29116 microprogrammable controller, burst error processor, interruptable sequencer and support products.
- DIGITAL SIGNAL PROCESSING PRODUCTS 16x16 multipliers, microprogrammable signal processor, FFT address sequencer.
- MEMORY SUPPORT PRODUCTS Am2960 series error detection and correction, 64K dynamic memory controller, and MOS drivers.
- INTERFACE PRODUCTS Data communications interface, microprocessor support and new 24-pin bus interface family.
- BIPOLAR MEMORY PRODUCTS RAMs, PROMs and registered PROMs.
- Am2900 SYSTEMS SUPPORT PRODUCTS AmSYS29/10 microprogrammable development system with trace capability.

Please accept my reservation for the Am2900 Seminar Part II. In _____ (City) on _____ (Date).

Name _____ Position _____

Company _____

Street Address _____

Postal Code/City _____ Tel _____

Additional participants from my company:

Name _____ Position _____ Tel _____

Name _____ Position _____ Tel _____

Enclosed is my check for _____ at DM98/SwFr87 per person.

Advanced Micro Devices

Offices in Brussels, London, Milan, Munich, Paris, Stockholm and Stuttgart.

Components

Industry warms to high-temp R&D

Government program's semiconductor know-how fuels commercial developments aimed at oil and gas firms

by Roderic Beresford, Components Editor, and Linda Lowe, Boston bureau

A major Government-funded research and development program in high-temperature semiconductor devices has just slid into the lap of industry. Work at Sandia National Laboratories has shown the feasibility of fabricating a wide range of semiconductors that can be used in environments where temperatures commonly reach 300°C or more.

Oil- and gas-producing companies probably have the greatest interest in such technology because their deep-well exploratory operations can reduce the risk of drilling a dry hole if they use electronic parts that can withstand high temperatures. Because of this need, firms like Schlumberger Ltd., Gearhart Industries Inc., and Dresser Industries Inc. are beginning to increase their commitment to high-temperature-electronics development and design,

says Anthony F. Veneruso, former director of the Sandia program in Albuquerque, N. M.

This information transferral occurred during the High-Temperature Electronics and Instrumentation Conference in Houston, held Dec. 7 and 8, where papers describing Sandia's geothermal logging instrumentation development program were delivered to companies with a commercial stake in such devices.

Veneruso himself is an example of the increased commercial commitment. He recently moved to Gearhart, where his duties as manager of the Houston development laboratory include supervising work on high-temperature logging instruments.

"The Sandia program was a catalyst," says Veneruso. "It raised the awareness about the potential of high-temperature electronics in an

industry relatively unfamiliar with it and showed these firms what kinds of expertise they needed to continue research on their own." Although developments in the near future will rely on silicon-device technology, the eventual commercialization of gallium phosphide, or other wide-band-gap semiconducting materials, promises operating temperatures higher than those that are possible with silicon.

GaP widens. Junction leakage currents—a central problem in integrated-circuit design for high temperatures—depend on thermally generated carriers, whose numbers drop with increasing bandgap. Recent work at Sandia documents the advantages to be expected from GaP, a material with a wider band-gap than silicon.

Diodes and transistors fabricated with GaP operate reliably between 300° and 400°C, and a 500°C capability is in sight. These devices are made in magnesium-doped epitaxially grown layers.

Sandia's approach encouraged not only oil and gas firms, but also component companies to jump into the high-temperature-electronics business. Sandia contracts already have permitted heat-resistant hybrid circuits, complementary-MOS parts, and instruments to be developed by firms like Teledyne Philbrick, Harris Corp.'s Semiconductor Group, and General Electric Co.'s Space Systems division [*Electronics*, Aug. 14, 1980, p. 41]. Others with high-temperature-electronics programs include Burr-Brown Research Corp., Micro Networks Co., and MicroPac Industries Inc.

"I think the work Sandia started

HIGH-TEMPERATURE MATERIALS TECHNOLOGY: STATE OF THE ART AT A GLANCE							
Process	Materials						
	GaAs	GaP	SiC	AlGaAs	AlGaP	InGaP	Si
Substrate formation							
Crystal growth	●	●					●
Semi-insulating	●	●					●
Impurity introduction							
Diffusion	●	●	●				●
Ion implantation	●	●	●				●
Epitaxy							
Liquid phase	●	●	●	●	●	●	●
Vapor phase	●	●		●			●
Molecular beam	●	●		●			●
Region formation							
Native oxide			●				●
Chemical etching	●	●	●	●	●	●	●
Deep-level isolation	●	●		●			
Metalization							
Contacts	●	●	●	●	●	●	●

● Excellent ● Good ● Poor

SOURCE: SANDIA LABORATORIES

T/Maker II:™ it does a number on VisiCalc!™

T/Maker II does more. And does it on your computer.

VisiCalc is a fine aid for the computation of numerical problems. But it does have two major limitations: it is available only for a small number of systems, and its use is limited strictly to numbers, not words. To overcome these substantial limitations, Lifeboat Associates introduces T/Maker II.

Unlike VisiCalc, T/Maker II is designed to run on most business computers with SB-80™ or other CP/M-80® compatible operating systems.

Available now for UNIX™. And soon there will be T/Maker II versions for RT-11™ and other systems as well.

Works with words as well as numbers. Like VisiCalc, T/Maker II reduces the manual tasks involved in computing and calculating financial documents. But since most business problems and reports involve words as well as numbers, T/Maker II also functions as a full-screen text editor for word processing.

T/Maker II is the most advanced aid for the analysis and presentation of numerical data and text material. In a matter of minutes, an entire document — including all edited text, all figures and all calculations — is created, reviewed on your screen and reported in printed form.

T/Maker II turns your small business computer into a powerful, sophisticated and convenient tool. A tool that will save you money, time and energy, and eliminate the need for costly time-sharing.

With T-Maker II you can easily perform an unlimited number of analytical and reporting tasks which integrate numerical and text processing. You'll find T/Maker II perfect for such things as:

- Financial Statements
- Statistics
- Profitability Reports
- Revenue and Expense Analyses
- Portfolio Evaluations
- Price Lists
- Rate Structures
- Expense Accounts
- Cash Flow Projections
- Checking Account Reconciliations
- ... and much, much more.

Easy to learn and use. You don't have to be a programmer to operate T/Maker II. Just follow T/Maker II's easily understood and ordered instructions, set up your data in

rows and columns, define the relationships and T/Maker II will do the rest: it will perform the computations and formatting necessary to prepare your document. When you're finished you can analyze your report on your screen or store it on a diskette. Or, you can have the report printed with presentation quality.

And when any changes have to be made, simply enter the new figure or relationship and tell T/Maker II to adjust and recalculate all the new results.

Editing capabilities. As a full-screen editor for word processing, T/Maker II handles text up to 255 characters wide. It includes features like text formatting and justification, centered titles, a text buffer for block moves and repeated inserts, global search and replace commands for printing your letters, reports and documents. Wide documents are supported by horizontal scrolling.

Low cost. The cost of T/Maker II is miniscule when you consider all the time, energy and money it saves. T/Maker II is brought to you exclusively and supported completely by Lifeboat Associates, world's largest computer software publisher. For more information send us the coupon below.

Mail coupon to: Lifeboat Associates,
1651 Third Ave., NY, NY 10028. Or call (212) 860-0300.

- Please send me more information on T/Maker II.
- Please send me a free Lifeboat Catalog featuring over 200 programs.

Dealer, Distributor and OEM inquiries invited.

Name _____
Title _____
Company _____
Street _____
City _____
State _____ Zip _____
5201

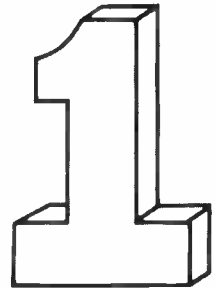

Software With Full Support

T/Maker II is a TM of P. Roizen. VisiCalc is a TM of Personal Software, Inc.
SB-80 is a TM of Lifeboat Associates. UNIX is a TM of Bell Laboratories.
CP/M 80 is a reg. TM of Digital Research, Inc. RT-11 is a TM of Digital Equipment Corp.

As an example of what T/Maker II can do, see the chart below. The operator entered only the data shown in boldface. T/Maker II calculated and reported all the other values.

	— Actual —			Growth Rate	Average	Total (000's)	— Projected —		
	1978	1979	1980				1981	1982 *	1985
Item A	42,323	51,891	65,123	24.04	53,112	159.34	80,782	100,206	191,262
Item B	45,671	46,128	49,088	3.67	46,962	140.89	50,891	52,761	58,791
Total	87,994	98,019	114,211	13.93	100,075	300.22	131,673	152,966	250,053
% Item	48.10	52.94	57.02	8.88	52.69	158.1	61.35	65.51	76.49
% Item	51.90	47.06	42.98	-9.00	47.31	141.9	38.65	34.49	23.51
Total	100.00	100.00	100.00	—	100.00	300.0	100.00	100.00	100.00

*Two intervening years not shown.

LIFEBOAT WORLDWIDE offers you the world's largest library of software. Contact your nearest dealer or Lifeboat.

Lifeboat Associates
1651 Third Ave.
New York, N.Y. 10028
Tel: (212) 860-0300
Telex: 640693 (LBSOFT NYK)
TWX: 710-581-2524 (LBSOFT NYK)

Lifeboat Inc.
OK Bldg., 5F
1-2-8, Shiba-Daimon
Minato-ku, Tokyo 105, Japan
Tel: 03-437-3901
Telex: 2423296 (LBJTYO)

Lifeboat Associates, Ltd.
PO Box 125
London WC2H 9LU, England
Tel: 01-836-9028
Telex: 893709 (LBSOFTG)



Lifeboat Associates GmbH
Hinterbergstrasse
Postfach 251
6330 Cham, Switzerland
Tel: 042/36 8686
Telex: 865265 (MICO CH)

InfoSoft GmbH
Schlossgartenweg 5
D-8045 Ismaning, W. Germany
Tel: 089-966-444
Telex: 5213643 (ISOFDI)

Lifeboat Associates, SARL
10, Grande Rue Charles de Gaulle
92600 Asnieres, France
Tel: 1-733-08-04
Telex: 250303 (PUBLIC X PARIS)

Lifeboat Associates

World's foremost software source

Probing the news

gave a lot of impetus to small, 'Lone Ranger' research operations buried in many companies," Veneruso comments. Agreeing with him is Paul L. Sinclair, manager of Schlumberger's Microelectronics Systems group in Houston. "We've been building electronic components for down-hole exploration for decades, but development of high-temperature-circuit prototypes only got under way in 1980. It's still a relatively small program, but it's going to grow fast."

The Schlumberger group will concentrate on developing circuit designs, Sinclair adds. "We're scouting for components houses to build the parts for us."

Needed now. The time is ripe for high-temperature electronics because of dwindling supplies of gas and oil from traditional sources, Sinclair maintains. "Every developed country is scrambling for new sources; the last five years have seen phenomenal growth in geophysical well-logging operations, which I'd estimate have been growing at a rate of roughly 33% a year."

Probing deeper and deeper past many strata for fuel, drillers encounter steadily rising temperatures, which at the bottom of a well can reach a peak of 275°C. In addition, a promising new oil-recovery method, using steam injection, must deal with temperatures that can reach a point around 250°C.

So the need for all types of heat-resistant parts—sensors, amplifiers, signal conditioners, converters, and digital-processing and -transmission equipment—is increasing dramatically. "I anticipate that this will become the dominant technology for our industry in the next 10 years," Sinclair asserts.

"We're rather constrained by what chips the semiconductor makers can produce for us," he adds. "Although there are definite benefits to be gained from GaP, it is going to be years before we get our hands on this material in commercial ICs."

In the meantime, making do with silicon will soon be a lot easier, because Harris Semiconductor in Melbourne, Fla., is about to make generally available its dielectrically

isolated C-MOS parts, which are specified for 350°C. The group will base its product plans on the sentiments of the narrow market.

"There is not enough demand to warrant an entire high-temperature edition of the 4000-series logic family," points out Harris's Scott Falater, an analog product designer, "although we now have that capability. We are looking at universal gate chips, in which specific configurations could be selectively powered up by pin programming."

Dielectric isolation clears up two common failure modes in junction-isolated chips—latch-up and parasitic device formation. Otherwise, the fabrication process is not so different from conventional room-temperature C-MOS. However, circuit designs must consider device behavior at high temperatures.

For example, forward-biased diodes drop only about 100 millivolts at 300°C, so biasing schemes based on diode strings are ruled out. Furthermore, leakage currents from a transistor's collector-base junction get so large that the net base-current flow reverses, requiring bias circuits that can source and sink current.

Work needed. Although much of the Harris effort has been focused on circuit design "there is still much process refinement to be done," says Falater. A major stumbling block is electromigration—the rupturing of metal interconnects by current flow that is aggravated as the temperature rises.

In addition to this problem, the stability of metal layers is a prime concern for hybrid-circuit makers. Thin-film processes for passive components have demonstrated excellent performance in the temperature range of 350° to 500°C [*Electronics*, Jan. 3, 1980, p. 39].

Interconnection with the thick-film components, however, requires a special treatment. The usual gold-to-aluminum bonds that connect chip pads to wires and then to the thick-film conductors last only about 100 hours at 200°C. Burr-Brown gets up to 1,000 hours of operation by using an aluminum-composition bond wire and doping the gold films with platinum and palladium. The formula helps minimize the bond's intermetallic phases. □

Message from MDB:

"MDB is on your side! We want to serve you with superior product quality, innovative features, better than competitive prices, short delivery times and with responsive sales personnel located conveniently to you. Call your MDB salesperson today."

Bill Wollam,
MDB Sales Manager

MDB Direct Sales Offices

Central Northeast 216/247-2630	NY/NJ/Eastern Pennsylvania 516/324-3698
Northern California 408/733-3950	Mid-Western 312/980-8929
Mid-Atlantic 703/893-0753	Southwest Central 713/376-3973 214/559-3890
New England 617/444-1800	So. California/ Arizona 714/998-6900
Southeastern 305/275-5898	

Authorized Manufacturers' Representatives

Pacific Northwest E. S. Chase Co. 206/453-0759 503/641-4111	New Mexico Sota Rep. 505/523-4480
Hawaii The Thorson Co. 808/524-8633	Rocky Mountain Area Electrodyne Inc. 303/695-8903

For Fast Response on literature requests call MDB's new TOLL FREE number. In California call 800-852-7777; other states call 800-824-7888.

For technical information and pricing call
714/998-6900

MDB
SYSTEMS INC.

1995 N. Batavia Street
Orange, California 92665
714-998-6900
TWX: 910-593-1339

The most complete line of Interface Products for PDP*-11, LSI-11
and VAX* Computers with features you can't get anywhere else

For DEC users... MDB makes the difference!

You *can* have it all! Along with the benefits of your DEC computer, you can get interface products that significantly extend the capability, flexibility and economy of DEC systems. MDB makes more DEC system boards than any independent manufacturer—some with plain vanilla compatibility; others with plain incredible performance boosting features. For example—

- Line printer controllers for every major line printer, with complete self-testing capability and optional RS-422 "long lines."
- Peripheral device controllers for card readers, X-Y plotters, electrostatic printer/plotters and paper tape readers/punches.
- DZ11 compatible multiplexors for LSI-11 and PDP-11 users; some combine RS-232 and current loop or RS-422 with a single board.
- High speed synchronous serial interfaces; one DUP-11 compatible model has all bit and byte protocols even for LSI plus X.25 capability.
- Inter processor links between Unibus computers or between Unibus and Q-bus.
- System modules including DMA modules with RS-422, general purpose parallel and digital I/O interfaces, an IEEE 488 bus

- controller and a programmable real time clock.
- PROM memory modules, some with an on-board PROM programmer.
- General purpose interface and bus foundation modules.
- LSI-11 based subsystems and systems with capabilities like TU-58 cartridge storage and memory management.
- LSI-11 system boxes with 22-bit addressing and switching power supplies.

In addition to the DEC compatible products, MDB also manufactures comparable interfaces for Data General, Perkin-Elmer, Intel and IBM Series/1 computers. All MDB products are available under GSA contract #GS-00C-02851.

Give your DEC system *all* the benefits. Discover the difference MDB interface products can make.

*Trademark Digital Equipment Corp.

MDB
SYSTEMS INC.

1995 N. Batavia Street
Orange, California 92665
714-998-6900
TWX: 910-593-1339

Circle 109 for more information.

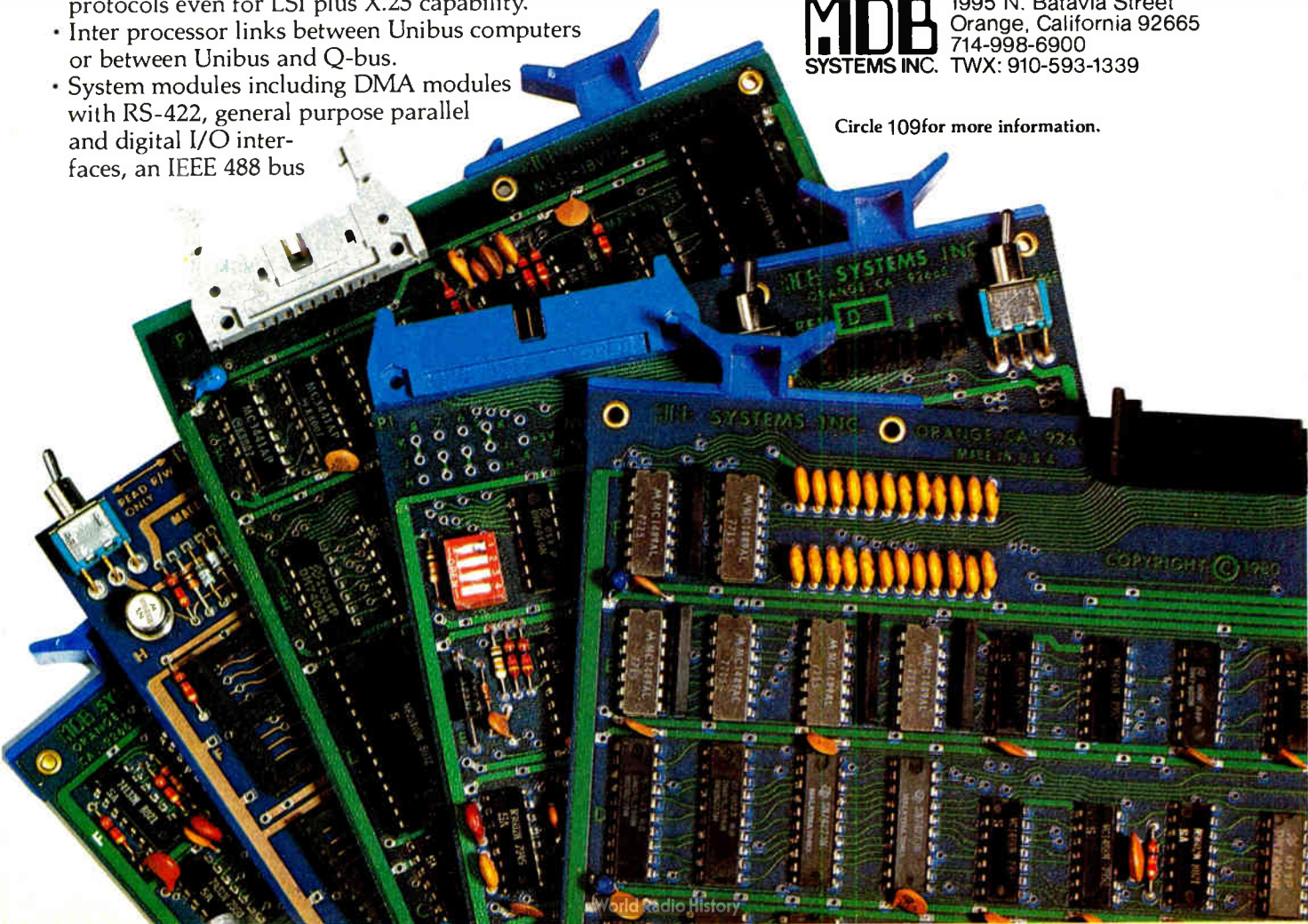

Microsystems

Self-testing processors cut costs

Manufacturers, happy with technique, are considering larger chips to house diagnostics—Motorola adds 2% more silicon

by J. Robert Lineback, Dallas bureau

Adding on-chip microprocessor hardware and new testing techniques that examine blocks of circuitry independently of each other appears to be a promising way of reducing production costs on future high-density devices. Already, it is clear that using hardware to execute production tests has distinct speed advantages over software diagnostic schemes. As microprocessor volumes continue to build and prices slide, the time that it takes to weed out defects in semiconductors at the factory becomes an increasingly critical cost factor. At the same time, manufacturers must avoid the pitfalls of reducing test coverage and risking a costly drop in quality and a rise in angry customers.

To expedite functional testing, many designers are now considering using slightly larger dice to house special self-test hardware. In most cases, this diagnostic silicon will be completely transparent to customers and will be used strictly in house. The issue simply comes down to a tradeoff—yield vs test time—and it appears that manufacturers are becoming more willing to settle for fewer parts per wafer in order to reduce test times, which are rapidly growing as circuit complexity increases.

Motorola Inc. has been highly successful in reducing production test times on its 68000 16-bit microprocessor through the use of an extra 2% of silicon on the die and a unique partitioning test method. The extra real estate, which has been on the device since the firm first began offering 68000s more than two years ago, contains diagnostic hardware that causes the microsequencer to quickly exercise its own internal instructions.

At the same time, the extra hardware isolates the microsequencer from the rest of the chip's data and

address registers—essentially dividing the microprocessor in half, explains Mike Spak, staff engineer in Motorola's MOS microcomputer design operation in Austin, Texas. "Another way of saying it is that we tried to separate the control part of the information from the data-handling part of the chip," he says. "So, we try to first guarantee the control part, which is the microsequencer.

"I think the key to understanding the philosophy is that we are not attacking the problem from just a single-chip 'black box' perspective. We are really cutting it down and

doing the same kind of thing that used to be done with pc [printed-circuit] boards," Spak states. "We test certain pieces of it independently to guarantee that the whole thing works together. I think it [partitioning of the tested blocks] will be there more and more as systems get larger and technologies get denser."

2% solution. Although he declines to discuss the impact on yields, Spak says the extra 2% silicon has significantly saved time in volume testing. "There have been no dollar figures placed on it, but it does cut the time down from what would have been a matter of several minutes to several seconds," he adds. Be-

Test map. The outline indicates the silicon added by Motorola to its 68000 microprocessor for self-testing. The company says the addition saves time.

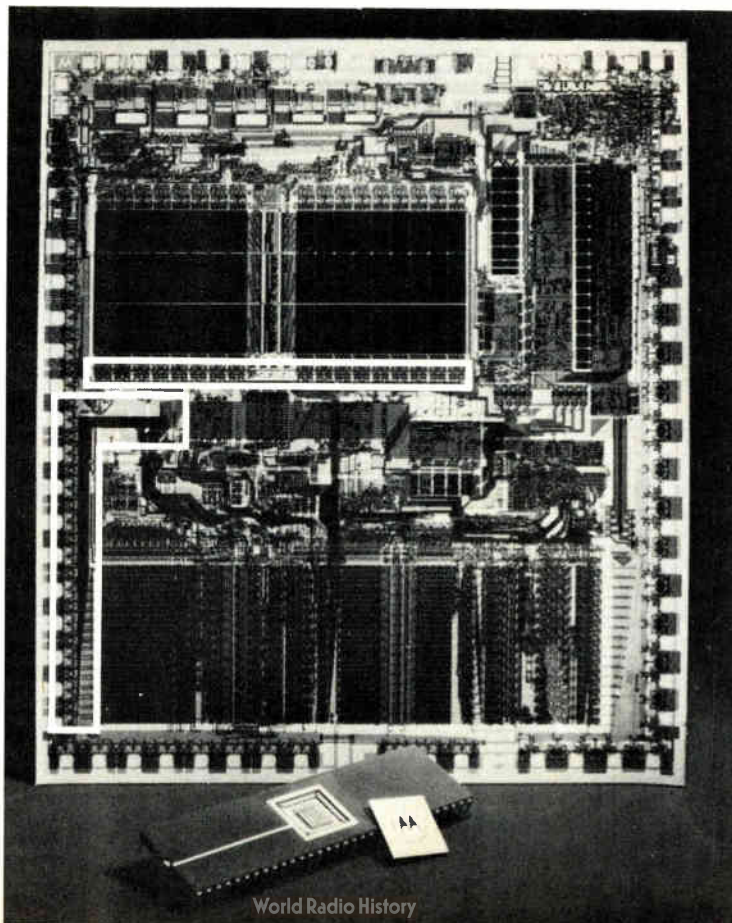

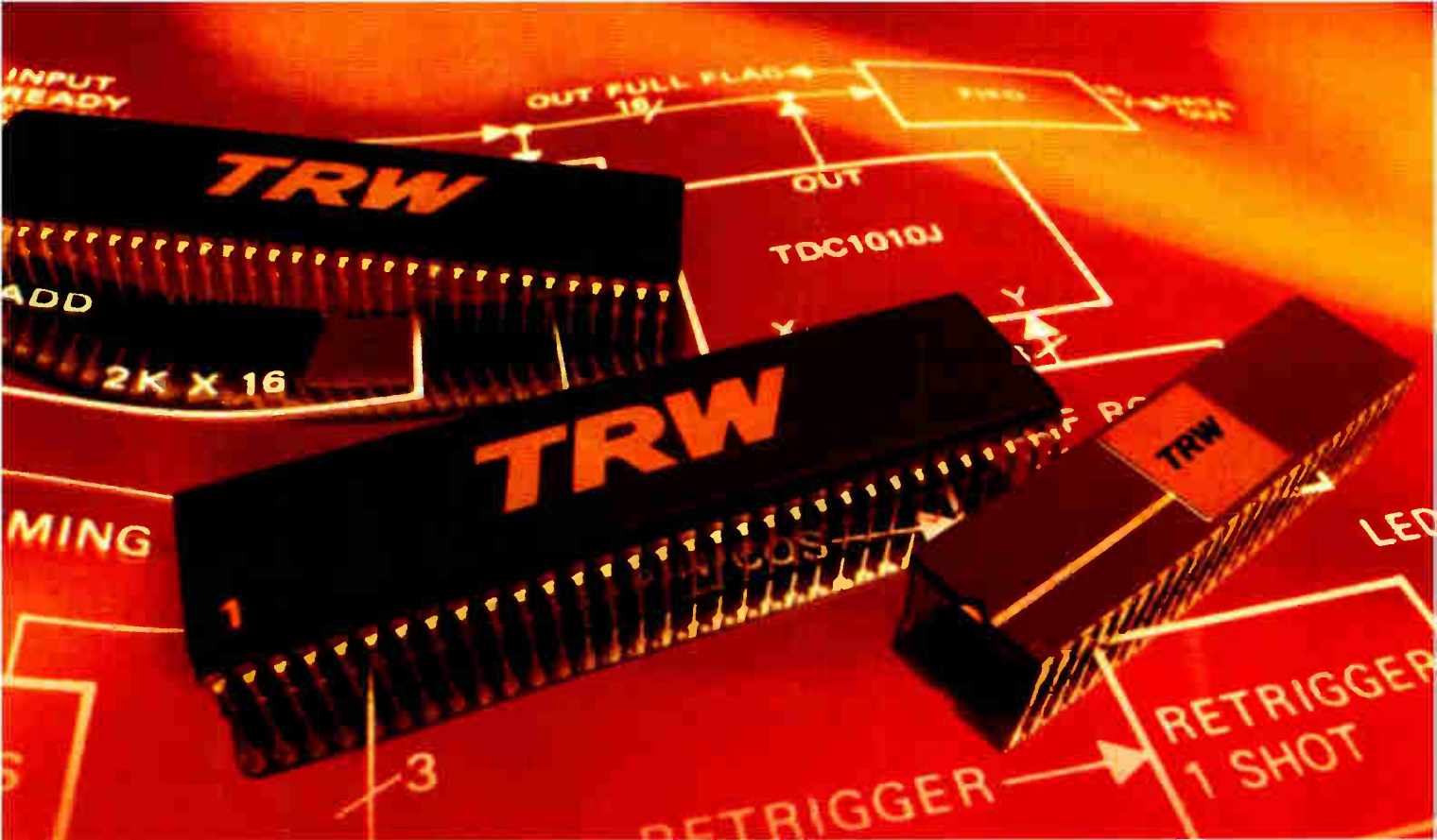

16x16-bit multiplication and 35-bit accumulation in 115 nsec

(From a single chip.)

The easiest way to boost the number crunching ability of a microprocessor... or to build a high speed, low cost digital signal processor... is to use one of our MACs.

These bipolar, monolithic multiplier/accumulators give you dramatic savings in hardware and dollars. And their power demands are much lower than alternative devices.

The MACs are ideal building blocks for digital signal processing, particularly complex multipliers, filters, and FFT's. If you'd like to extend the capability of your micro/minicomputer, or if you're designing small yet potent signal processors for voice processing,

video processing, communications, or data analysis, look what we have for you:

- On-chip input and output registers with 3-state outputs.
- Subtract, as well as add, in the accumulator.
- Double precision arithmetic.
- Two's complement or unsigned magnitude.
- TTL compatible.
- Ability to operate as conventional n-by-n bit multipliers.
- Single power supply, + 5V.

For immediate information, call your nearest TRW International Sales Office:

- ARGENTINA**, Buenos Aires 304132
- AUSTRALIA**, Moorabbin 5555-1566
- AUSTRIA**, See Germany
- BELGIUM**, 5117089
- BRAZIL**, Sao Paulo 2409211
- DENMARK**, (02) 842000
- FINLAND**, Helsinki 90-6926022
- FRANCE**, Paris 7581111
- GERMANY**, Munich 7146065
- HONG KONG**, Kowloon 3856199
- INDIA**, Bombay 27385
- ISRAEL**, Tel Aviv 444572
- ITALY**, Monza 360021 Rome, 318026
- JAPAN**, Tokyo 4615121
- NETHERLANDS**, Den Haag 210101
- NEW ZEALAND**, Wellington 64437049
- NORWAY**, Oslo 786210
- SOUTH AFRICA**, Capetown 21-215350
Johannesburg 011-6181027
- SPAIN**, Madrid 2425204
- SWEDEN**, Vallingby, Stockholm 8635040
- SWITZERLAND**, Zurich 429900
- TAIWAN**, Taipei 7512062
- UNITED KINGDOM**, Middlesex 9025941

Multiplier/ Accumulator	Word Size (Bits)	Sum (Bits)	Speed (nsec)	Power (Watts)	Unit Price (100s)**
TDC1010J*	16x16	35	115	3.5	\$205
TDC1009J*	12x12	27	95	2.5	\$120
TDC1008J*	8x8	19	70	1.2	\$ 70

*Guaranteed operation over $T_c = -55^\circ\text{C}$ to $+125^\circ\text{C}$ available for military applications.

**U.S. Prices

TRW keeps you ahead in digital signal processing

TRW LSI PRODUCTS

An Electronic Components Division of TRW Inc.

Circle 110 on reader service card

SOFTWARE DEVELOPMENT TOOLS FOR INDUSTRY

CP/M CROSS-ASSEMBLERS

Fast, comprehensive cross-assemblers to run under CP/M.* Extensive pseudos include full listing control, nested conditionals, mnemonic synonyms, and inclusion of external source files. Generate object file, assembly listing, and symbol table from source code for nine popular microprocessor families.

XASM05	6805
XASM09	6809
XASM18	1802
XASM48	8048/8041
XASM51	8051
XASM65	6502
XASM68	6800/6801
XASMf8	F8/3870
XASM400	COP400

Assemblers ... \$200.00 each
Manual only ... \$ 25.00

8048 DEVELOPMENT PACKAGE

Now you can use the 8048 family of single-chip microcomputers without buying expensive equipment. Develop 8048 software with the XASM48 cross-assembler. Then plug our EPR-48 board into your S-100 system to program the 8748 EPROM version.

8048 Development Package ... \$574.00
EPR-48 alone \$449.00

EPROM SIMULATOR BOARD

Debug dedicated systems quickly. Our PSB-100 PROM Emulator is an S-100 board with up to 8K of RAM. Cable with 24-pin plug replaces 2708 or 2716 EPROM(s) in your target system for instant program testing

PSB-100 EPROM Simulator ... \$445.00
w/2K RAM

*Trademark of Digital Research

avocet
systems inc.

804 SOUTH STATE ST.
DOVER, DEL. 19901
302-734-0151

Visa and Mastercharge accepted. We ship 8" single-density and Softcard+ 5.25" diskettes. Ask us about other formats. OEM AND DEALER INQUIRES INVITED.

+ Trademark of Microsoft

Probing the news

cause the task of checking the sensitivity of the 68000 microsequencer's instructions is time-consuming, the control block is first tested by itself. This lets Motorola ensure that the individual instructions are not sensitive to one another.

One failure does it. A Fairchild tester monitors the microsequencer's performance at the data and address buses. If the microsequencer misses a single bit, the part is rejected. But if it passes, the rest of the 68000's 17 data and address registers are tested along with the "proven" microsequencer. Using this special hardware and partitioning of the chip lets Motorola execute a thorough program of production tests in the shortest time.

At Zilog Inc., microprocessors are not partitioned during testing, but it may be only a matter of time before design complexity gives the technique a clear advantage, says Bernard L. Peuto, director of component production development. "I see a trend developing for two reasons," Peuto states. "One, the hardware is getting more and more complex. You may have more engineers working on it, in which case they have to have an agreement on how their pieces fit together.

"Also, as the hardware gets more complex, from a logical standpoint you really have more and more blocks that can be isolated and treated independently of any other blocks, which is one way to reduce the complexity of the [testing] task," says Peuto.

Software's role. Although Zilog is using on-chip hardware to test its 8-bit microprocessors in production, the Cupertino, Calif., firm is not using self-diagnostic features to monitor its Z8000 16-bit in manufacturing testing. "There were some features put on it when we were debugging it, but they are not used in production," he explains.

Instead, Zilog uses software to test the Z8000 because it is not micro-coded. Peuto believes the use of special on-chip hardware will increase a manufacturer's functional wafer tests, but software will continue to play the major role in parametric

evaluations, which are often used by customers for incoming inspection.

Meanwhile, at Texas Instruments Inc., Karl M. Gutttag, who headed development of TI's 99000 16-bit microprocessor architecture and logic, agrees that complexity is the key issue in determining whether to use self-testing circuitry on chip in volume production operations. TI considered a partitioning scheme in the early design stages of its 99000, says Gutttag, but decided it would give no testing advantage.

Because the part operates at seven times the speed of TI's older 9900 16-bit unit, it can run seven times more test software, Gutttag states. In addition, the simple architecture of the microprocessor also makes it easier to "tell what's going on inside the machine.

"I would agree that as processors get more complex, there may be an advantage to partitioning," he says. "Right now, I see that happening in kind of a parallel sense, which would let you check out two or three things at the same time. We are not doing that, but we are investigating it."

Two strikes. Intel Corp. agrees with that view. It believes the tradeoffs currently do not weigh in favor of dedicated on-chip test hardware because of the cost of large dice and the burden of proving that the test circuitry itself is in working order. Intel is using software along with the microprocessor's general circuitry to check the chip, which is designed for ease of testability.

"There are three important things to consider in weighing the completeness of your test coverage," notes Joseph Louie, product engineering manager for microprocessors and peripherals. "First, do you exercise every node and how do you exercise every node? Then, have you tested for sequence sensitivity for the operating code? And third, what about timing coverage and something like asynchronous testing?"

But that does not mean the Santa Clara, Calif., firm is not currently considering special test hardware for its future chips. "Time is where the tradeoff comes in," Louie notes. "Do you want to put in some test circuitry to reduce that test time? And what's most economical? That's the real question." □

Zilog's Z80[®] family: The industry's number one choice.

Because there's so much more to choose from with the Zilog Z80. More than any other eight-bit family on the market. More power, more instructions. More speed options, package types and peripherals.

The Z80's dual registers permit high-speed context switching and efficient interrupt processing. On-chip refresh logic allows easy interface to dynamic RAM's. And, of course you can choose your CPU's and all peripherals in plastic, cerdip or side-braced packages.

Choose the ultrafast Z80B, at low

volume prices. For a 6 MHz clock rate that can lower your instruction execution time to .5 microseconds. Whichever Z80 you choose, MIL-STD-883 screening comes as standard equipment, at no extra charge.

No wonder the Z80 family remains number one. The favorite eight-bit microprocessor for system designers all over the world!

For prototype or production quantities, call your nearby Zilog sales office or distributor. For more information, write Zilog, Components Marketing, 10460 Bubb Rd., Cupertino, CA 95014.

**Zilog
makes it happen
for you!**



Zilog

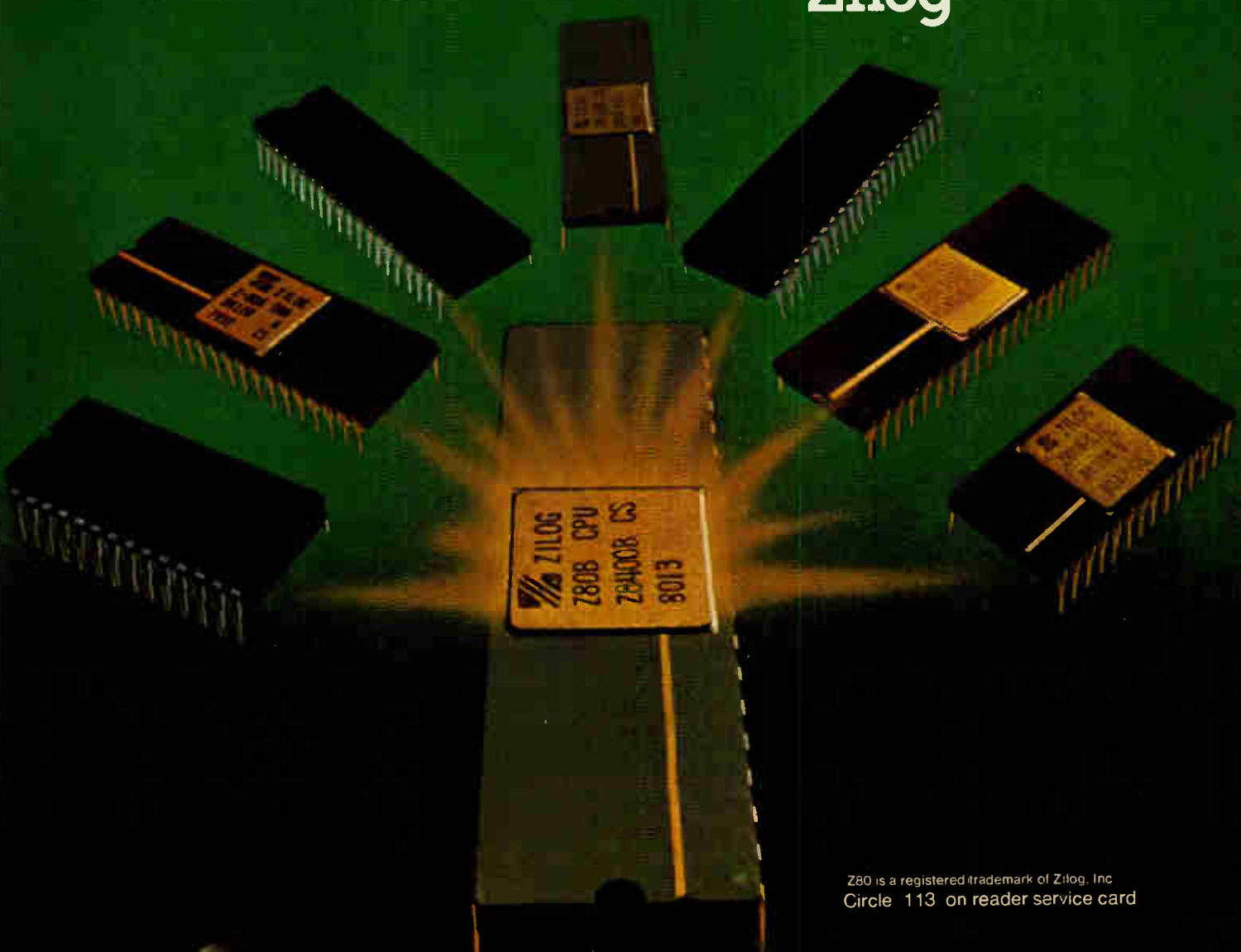

Z80 is a registered trademark of Zilog, Inc.
Circle 113 on reader service card

Circle #114 for literature

Circle #115 for sales contact

Authorized Motorola Semiconductor Distributors

ALABAMA, Huntsville	Hall-Mark Electronics	(205) 837-8700
ALABAMA, Huntsville	Hamilton/Avnet Electronics	(205) 837-2110
ALABAMA, Huntsville	Pioneer/Standard	(205) 837-5300
ARIZONA, Phoenix	Kierulff	(602) 243-4101
ARIZONA, Phoenix	Wyle Distribution Group	(602) 248-2232
ARIZONA, Tempe	Hamilton/Avnet Electronics	(602) 231-5100
CALIFORNIA, Anaheim	Zeus West	(714) 532-6880
CALIFORNIA, Costa Mesa	Avnet	(714) 755-8155
CALIFORNIA, Costa Mesa		(213) 558-2345
CALIFORNIA, Culver City	Hamilton Electro Sales	(714) 841-4111
CALIFORNIA, Culver City	Hamilton Electro Sales/L.A.	(213) 556-2000
CALIFORNIA, Culver City	Corporate Headquarters	(213) 558-2000
CALIFORNIA, Irvine	Schweber Electronics	(714) 556-3880
CALIFORNIA, Irvine	Wyle Distribution Group	(714) 641-1600
CALIFORNIA, Los Angeles	Wyle Distribution Group	(213) 322-8100
CALIFORNIA, Palo Alto	Kierulff Electronics, Inc.	(415) 968-6292
CALIFORNIA, Palo Alto	Semi Disc North	(415) 967-4392
CALIFORNIA, San Diego	Hamilton/Avnet Electronics	(714) 571-2510
CALIFORNIA, San Diego	Kierulff Electronics	(714) 278-2118
CALIFORNIA, San Diego	Wyle Distribution Group	(714) 565-9171
CALIFORNIA, Santa Clara	Schweber Electronics	(408) 498-0200
CALIFORNIA, Santa Clara	Wyle Distribution Group	(408) 727-2500
CALIFORNIA, Sunnyvale	Bell Industries	(408) 734-8570
CALIFORNIA, Sunnyvale	Hamilton/Avnet Electronics	(408) 743-3300
COLORADO, Denver	Hamilton/Avnet Electronics	(303) 740-1017
COLORADO, Denver	Kierulff Electronics	(303) 371-6500
COLORADO, Denver	Wyle Distribution Group	(303) 457-5700
CONNECTICUT, Danbury	Hamilton/Avnet Electronics	(203) 797-2800
CONNECTICUT, Danbury	Schweber Electronics	(203) 792-3500
CONNECTICUT, Norwalk	Harvey Electronics	(203) 853-1515
FLORIDA, Ft. Lauderdale	Hall-Mark Electronics	(305) 971-9280
FLORIDA, Ft. Lauderdale	Hamilton/Avnet Electronics	(305) 971-2900
FLORIDA, Hollywood	Schweber Electronics	(313) 322-8111
FLORIDA, Orlando	Hall-Mark Electronics	(305) 855-4020
FLORIDA, Orlando	Pioneer/Orlando	(305) 856-3600
FLORIDA, St. Petersburg	Hamilton/Avnet Electronics	(813) 376-3600
FLORIDA, St. Petersburg	Kierulff Electronics Inc.	(813) 576-1966
GEORGIA, Atlanta	Schweber Electronics	(404) 449-9170
GEORGIA, Norcross	Hamilton/Avnet Electronics	(404) 447-6023
ILLINOIS, Bensenville	Hall-Mark Electronics	(312) 860-3800
ILLINOIS, Chicago	Bell Ind.	(312) 982-9210
ILLINOIS, Chicago	Newark Electronics Corp.	(312) 848-4411
ILLINOIS, Elk Grove Village	Kierulff	(312) 640-0200
ILLINOIS, Elk Grove Village	Pioneer/Standard	(312) 437-9680
ILLINOIS, Elk Grove Village	Schweber Electronics	(312) 384-3750
ILLINOIS, Elmhurst Industrial Park	Semiconductor Specialists, Inc./Chicago	(312) 279-1000
ILLINOIS, Schiller Park	Hamilton/Avnet Electronics	(312) 871-5000
INDIANA, Indianapolis	Graham Electronics Supply, Inc.	(317) 634-8202
INDIANA, Indianapolis	Hamilton/Avnet Electronics	(317) 844-9333
INDIANA, Indianapolis	Pioneer/Standard	(317) 849-7300
KANSAS, Overland Park	Hamilton/Avnet Electronics	(913) 888-6900
KANSAS, Shawnee Mission	Hall-Mark Electronics	(913) 888-4747
MARYLAND, Baltimore	Hall-Mark Electronics	(301) 795-9300
MARYLAND, Gaithersburg	Pioneer/Standard	(301) 548-0710
MARYLAND, Gaithersburg	Schweber Electronics	(301) 840-5900
MARYLAND, Hanover	Hamilton/Avnet Electronics	(301) 827-4110
MARYLAND, Savage	Pytronic Industries, Inc.	(301) 792-0780
MASSACHUSETTS, Bedford	Schweber Electronics	(617) 275-5100
MASSACHUSETTS, Boston	Kierulff Electronics	(617) 861-3231
MASSACHUSETTS, Boston	Lionex Corporation	(617) 272-9400
MASSACHUSETTS, Burlington	Zeus Components	(617) 273-0750
MASSACHUSETTS, Lexington	Harvey Electronics	(617) 861-9200
MASSACHUSETTS, Needham	Impact Sales Co., Inc.	(617) 444-3971
MASSACHUSETTS, Wakefield	Massachusetts Components, Inc.	(617) 245-5967
MASSACHUSETTS, Woburn	Hamilton/Avnet Electronics	(617) 935-9700
MICHIGAN, Livonia	Hamilton/Avnet Electronics	(313) 522-4700
MICHIGAN, Livonia	Pioneer/Standard Electronics	(313) 525-1600
MICHIGAN, Livonia	R S Electronics	(313) 528-1155
MICHIGAN, Livonia	Schweber Electronics	(313) 528-8100
MINNESOTA, Bloomington	Hall-Mark Electronics	(612) 925-2223
MINNESOTA, Eden Prairie	Schweber Electronics	(612) 941-5280
MINNESOTA, Edina	Kierulff Electronics	(612) 941-7500
MINNESOTA, Edina	Hamilton/Avnet Electronics	(612) 925-0264
MISSOURI, Earth City	Hall-Mark Electronics	(314) 291-5350
MISSOURI, Earth City	Hamilton/Avnet Electronics	(314) 344-1200
NEW JERSEY, Fairfield	Hamilton/Avnet Electronics	(201) 575-3300
NEW JERSEY, Fairfield	Schweber Electronics	(201) 227-7880
NEW JERSEY, Cherry Hill	Hall-Mark Electronics	(609) 424-0880
NEW JERSEY, Cherry Hill	Hamilton/Avnet Electronics	(609) 424-0110
NEW JERSEY, Cherry Hill		(215) 925-6900
NEW JERSEY, Pinebrook	Harvey Electronics	(201) 575-2510
NEW MEXICO, Albuquerque	Alliance Electronics	(505) 262-3260
NEW MEXICO, Albuquerque	Hamilton/Avnet Electronics	(505) 765-1500
NEW YORK, East Syracuse	Hamilton/Avnet Electronics	(315) 437-2641
NEW YORK, Elmford	Zeus Components	(914) 748-7400
NEW YORK, Fairport	Harvey Electronics	(716) 381-7070
NEW YORK, Farmingdale	Harison Radio Corporation	(516) 293-7990
NEW YORK, Hauppauge	JACO Electronics	(516) 273-4500
NEW YORK, Melville, LI	Hamilton/Avnet Electronics	(516) 454-6000
NEW YORK, Rochester	Hamilton/Avnet Electronics	(716) 475-9130
NEW YORK, Rochester	Schweber Electronics	(716) 424-2222
NEW YORK, Vestal	Harvey Electronics	(607) 748-8211
NEW YORK, Westbury, LI	Schweber Electronics	(516) 334-7474
NEW YORK, Westbury, LI	Harvey Radio	(516) 332-8700
NORTH CAROLINA, Greensboro	Pioneer/Carolina	(919) 273-4441
NORTH CAROLINA, Raleigh	Hall-Mark Electronics	(919) 832-4465
NORTH CAROLINA, Raleigh	Hamilton/Avnet Electronics	(919) 834-8200
OHIO, Beachwood	Schweber Electronics	(216) 464-2970
OHIO, Centerville	Hamilton/Avnet Electronics	(513) 433-0610
OHIO, Cleveland	Hall-Mark Electronics	(216) 473-2907
OHIO, Cleveland	Pioneer/Standard	(216) 587-3600
OHIO, Cleveland	Hamilton/Avnet Electronics	(216) 831-3500
OHIO, Dayton	Pioneer/Standard	(513) 238-9900
OHIO, Worthington	Hall-Mark Electronics	(614) 846-1882
OKLAHOMA, Tulsa	Hall-Mark Electronics	(918) 835-8458
OKLAHOMA, Tulsa	Radio Inc.	(918) 587-9123
OREGON, Beaverton	Almac/Stroum Electronics	(503) 641-9070
OREGON, Lake Oswego	Hamilton/Avnet Electronics	(503) 635-8831
PENNSYLVANIA, Horsham	Pioneer/Delaware Valley	(215) 374-4000
PENNSYLVANIA, Horsham	Schweber Electronics	(215) 441-0600
PENNSYLVANIA, Monroemeryville	Pytronic Industries, Inc.	(215) 643-2850
PENNSYLVANIA, Pittsburgh	Pioneer/Standard	(412) 782-2300
TEXAS, Austin	Hall-Mark Electronics	(512) 258-8848
TEXAS, Austin	Hamilton/Avnet Electronics	(512) 837-8911
TEXAS, Dallas	Hall-Mark Electronics	(214) 341-1147
TEXAS, Dallas	Hall-Mark Corporate	(214) 343-5000
TEXAS, Dallas	Schweber Electronics	(214) 661-5010
TEXAS, Dallas	Treviso Electronics, Inc.	(214) 358-2418
TEXAS, Houston	Hall-Mark Electronics	(713) 781-6100
TEXAS, Houston	Hamilton/Avnet Electronics	(713) 780-1771
TEXAS, Houston	Schweber Electronics	(713) 784-3600
TEXAS, Irving	Hamilton/Avnet Electronics	(214) 381-9651
UTAH, Salt Lake City	Bell Industries	(801) 972-6969
UTAH, Salt Lake City	Hamilton/Avnet Electronics	(801) 972-4300
WASHINGTON, Bellevue	Hamilton/Avnet Electronics	(206) 648-3950
WASHINGTON, Seattle	Wyle Distribution Group	(206) 453-8300
WASHINGTON, Seattle	Almac/Stroum Electronics	(206) 763-2300
WISCONSIN, New Berlin	Hamilton/Avnet Electronics	(414) 784-4510
WISCONSIN, Oak Creek	Hall-Mark Electronics	(414) 761-3000
CANADA		
ALBERTA, Calgary	L A Varah Ltd.	(403) 276-8818
ALBERTA, Calgary	Zentronics, Ltd.	(403) 230-1422
ALBERTA, Edmonton	Intex Electronics, Ltd.	(403) 437-2755
B.C., Vancouver	Intex Electronics, Ltd.	(604) 224-8831
B.C., Vancouver	L A Varah, Ltd.	(604) 873-3211
B.C., Vancouver	Zentronics, Ltd.	(604) 325-3292
MANITOBA, Winnipeg	Zentronics, Ltd.	(204) 775-8651
ONTARIO, Hamilton	L A Varah, Ltd.	(416) 561-9311
ONTARIO, London	C.M. Peterson Co., Ltd.	(519) 434-3204
ONTARIO, Mississauga	Hamilton/Avnet Int'l Canada Ltd	(416) 673-2332
ONTARIO, Mississauga	Zentronics, Ltd.	(416) 876-9000
ONTARIO, Ottawa	Hamilton/Avnet Int'l Canada Ltd	(613) 228-1700
ONTARIO, Ottawa	Zentronics, Ltd.	(613) 848-9431
ONTARIO, Willowdale	Electro Sonic, Inc.	(416) 494-1555
QUEBEC, Montreal	Cesco Electronics Ltd.	(514) 735-6511
QUEBEC, Montreal	Zentronics, Ltd.	(514) 784-5361
QUEBEC, Quebec City	Cesco Electronics, Ltd.	(418) 524-4641
QUEBEC, St. Laurent	Hamilton/Avnet Int'l Canada Ltd.	(514) 331-8443
*Military, Power and RF Products		
†Authorized for all Components, Except System Products		
‡Chips, SOTs Only		



Technological leadership.

More EPROM available now,

Motorola's four different 8-bit EPROM MCUs are all in volume production and available off-the-shelf at precedent shattering low prices. They also have the largest amounts of EPROM.

You get design flexibility you've never had before, on-the-spot code-change capability, economy, confidence in delivery and quality, and streamlined inventories. Each EPROM MCU is pin and functionally compatible with mask-ROM versions for appropriate high-volume situations.

From the least expensive MC68705P3 to the high-end MC68701, these MCUs are characterized by large EPROM space and special features.

The single-chip EPROM MCUs are actually excellent emulation tools for ROM during system development and prototyping. They provide real-time evaluation of system performance, noise conditions, timing, loading and so on, both in the lab and in the field.

Prototyping is enhanced by the ease and quickness of code modification compared to ROM cycle

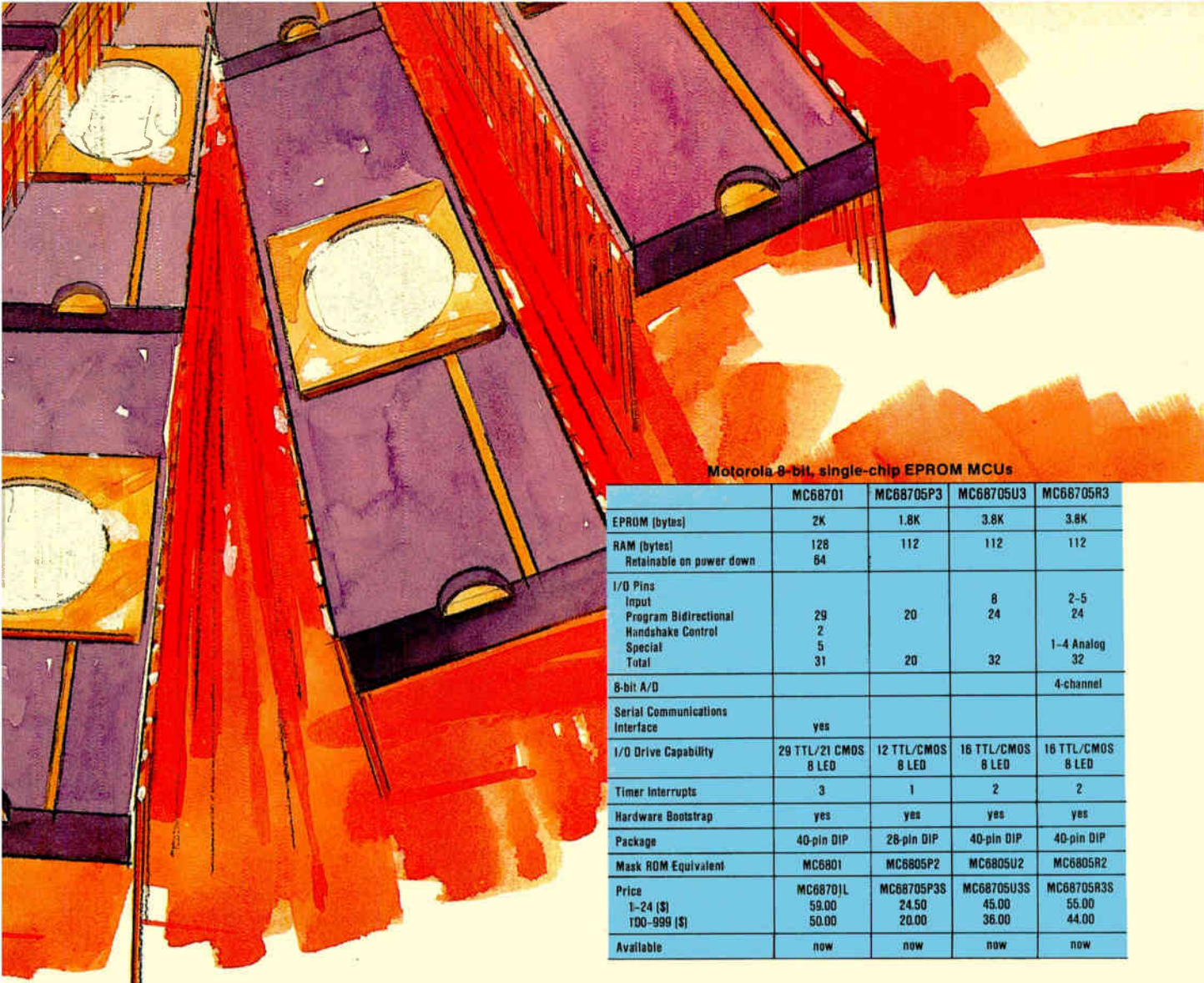

Motorola 8-bit, single-chip EPROM MCUs

	MC68701	MC68705P3	MC68705U3	MC68705R3
EPROM (bytes)	2K	1.8K	3.8K	3.8K
RAM (bytes)	128	112	112	112
Retainable on power down	64			
I/O Pins				
Input			8	2-5
Program Bidirectional	29	20	24	24
Handshake Control	2			
Special	5			1-4 Analog
Total	31	20	32	32
8-bit A/D				4-channel
Serial Communications Interface	yes			
I/O Drive Capability	29 TTL/21 CMOS 8 LED	12 TTL/CMOS 8 LED	16 TTL/CMOS 8 LED	16 TTL/CMOS 8 LED
Timer Interrupts	3	1	2	2
Hardware Bootstrap	yes	yes	yes	yes
Package	40-pin DIP	28-pin DIP	40-pin DIP	40-pin DIP
Mask ROM Equivalent	MC6801	MC6805P2	MC6805U2	MC6805R2
Price	MC68701L	MC68705P3S	MC68705U3S	MC68705R3S
1-24 (\$)	59.00	24.50	45.00	55.00
100-999 (\$)	50.00	20.00	36.00	44.00
Available	now	now	now	now

MCUs with larger EPROM are in volume production, priced low.

times. And, EPROM MCUs add to system flexibility by allowing easy product customization.

Dramatically reduced prices have resulted from a continued program for packaging and processing technology advancements and increased volume-production. EPROM MCUs are now more desirable for higher-volume applications. They're no longer only for prototyping and low-volume applications requiring end-user reprogramming.

In addition to the obvious inventory advantages, your designs can get to market faster without waiting for factory-programmed ROMs.

Software and hardware development for the M6805 and M6801 family EPROM MCUs are supported by the MEX6805 and MEX6801 emulator systems. They are fully compatible with both the MC6800 and MC6809-based EXORcisers®. The EXORterm™ development system also provides software support. An inexpensive PROM Programmer is available.

Find out more about Motorola's EPROM MCUs

by sending your information request to Motorola Semiconductor Products Inc., P.O. Box 20912, Phoenix, AZ 85036. Use them for an adventure in

Innovative systems through silicon.



MOTOROLA INC.

TO: Motorola Semiconductor Products Inc., P.O. Box 20912, Phoenix, AZ 85036.
Please send me information on EPROM MCUs for development and production.
 113 Elex 12/15/81 M6805 Family M6801 Family

Name _____
 Title _____ Tel.: (____) _____
 Company _____
 Address _____ Mail Drop _____
 City _____
 State _____ ZIP _____

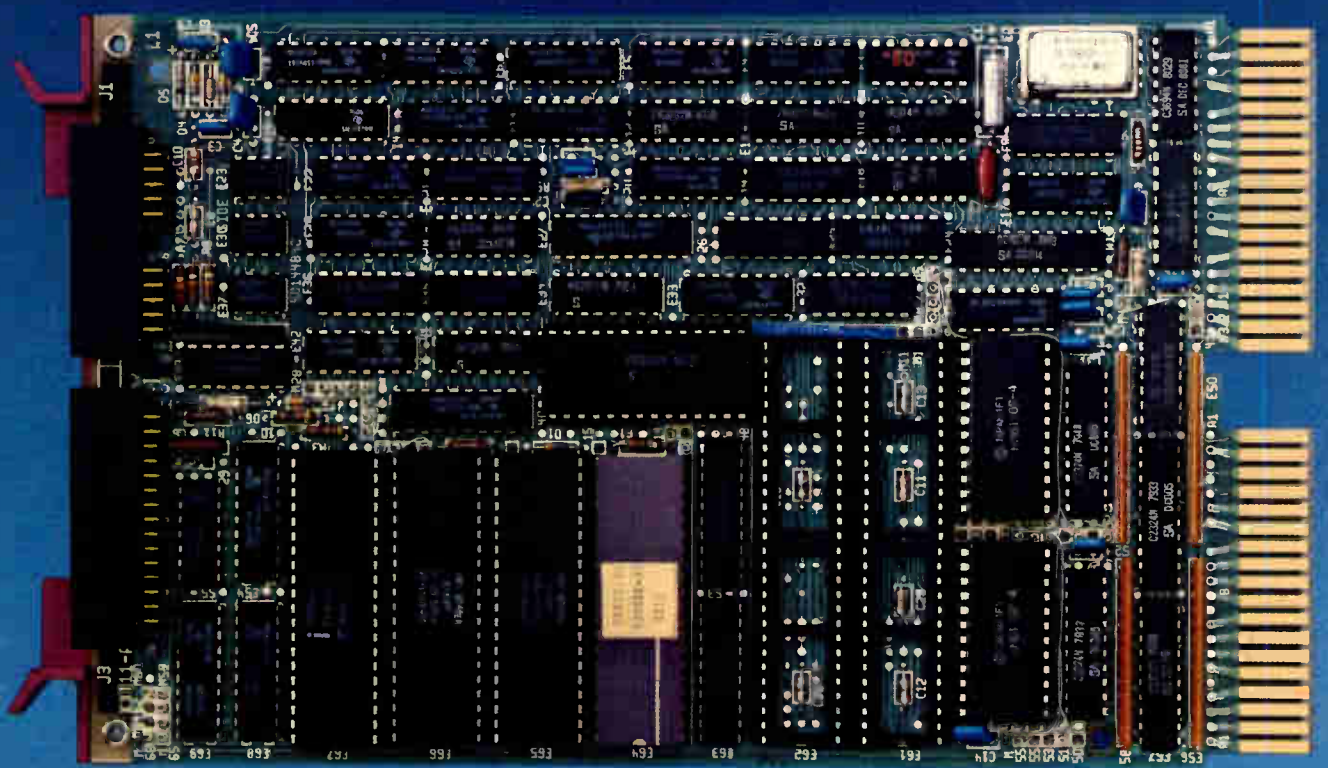

Digital's new 16-bit Falcon. Fierce competition for 8-bit SBC's.

You don't have to sacrifice size or affordability anymore to step up to 16-bit performance for your ROM-based application. Because now you can buy Digital's new ultra-small 16-bit Falcon for just \$521.*

Never has so much microcomputer been packaged in so little space. At just 8.5" x 5.2", Falcon is by far the smallest 16-bit SBC on the market—smaller, even, than most 8-bit SBC's.

Yet astonishingly, the tiny Falcon is a full-power LSI-11, executing the same proven PDP-11 instruction set that has made our micros the world sales leader.

On one board, the SBC-11/21 Falcon packs 4Kb RAM, sockets for up to 32Kb PROM or additional RAM, 2 serial I/O lines, 24 lines of parallel I/O, and 50, 60 or 800 Hz Line Time Clock. And Falcon's LSI-11 Bus Interface lets you use other I/O interfaces from Digital's large family of I/O modules.

However you measure performance—power, functionality or size—Falcon is fierce competition for 8-bit SBC's.

For complete details, fill out the coupon or contact the Hamilton/Avnet, Harvey Electronics, Pioneer/Standard, Pioneer/Washington or Wyle distributor near you.

Or simply call toll-free (800) 225-9222 and ask us to send Falcon Information Package # N-190. In MA, HI, AK and Canada call (617) 568-5707.

*In quantities of 100. Single unit price is \$790. Domestic U.S. prices only.



Please rush your Falcon Application Information Package to me at once. My application is:

- Laboratory/Scientific
- Data Communications
- Industrial Controls (please specify) _____

Other (please specify) _____

Name _____

Title _____

Company _____

Street _____

City _____

State _____ Zip _____ Tel. (____) _____

Digital Equipment Corporation
Microcomputer Products Group, HL2-2/E10,
77 Reed Rd., Hudson, MA 01749.

N12-15-1
Dec-C-190

digital

**We change the way
people work.**

Industry leaders see turnaround in 1982 but disagree on length and depth of the recession



Initiatives by the Reagan Administration designed to help business draw applause from top executives even as they wait for interest rates to start downward and keep a watchful eye on foreign competition and the world market situation

MILTON GREENBERG

president, GCA Corp.

Optimism is the order of the day at the Bedford, Mass., headquarters of the semiconductor-manufacturing-equipment maker Greenberg leads. "I think we'll see an economic upturn early in 1982, at least by the second quarter," he says. An easing of interest rates, which he expects will decline steadily through mid-summer next year, will help. The real spark igniting the recovery, however, should come from the brightening expectations of businessmen both in electronics and in industry at large.

"There's nothing consciously willed about this, no cabal meeting behind closed doors and voting to be optimistic this quarter, but I see glimmers of a gathering consensus that 1982 will be a better year." The psychological impact of such a consensus, he says, will be a powerful, if intangible, factor in any upswing.

Chief among the more tangible spurs to recovery will be "a more generous level of investments" due to falling interest rates, the specter of both domestic and foreign competition, and improved industry-government relations. "The Reagan Administration is on the right track economically, and there's a growing appreciation of high-technology industry as the instrument of choice in bettering our balance of trade. But there's still a long way to go on both those fronts."

Industry leaders can do more to foster government support, Greenberg stresses. "In this state, you already see executives getting more politically active: our Massachusetts High Technology Council is a strong lobby for government measures that enhance the climate for business."

Easing tax and bureaucratic burdens on companies, rather than a proliferation of protective legislation,



is the course he prefers to see government take. "I want a helper, not a protector. We live in an international marketplace where the distinction between foreign and domestic competitors is an artificial one."

Corporate planning and invest-

ment scenarios at GCA during 1982 will reflect his optimism, he says. "Our research and development budget, for instance, which grew from around \$11 million to over \$16 million in 1981, will get a similar increase this year."



ROBERT S. PEPPER

vice president and general manager, Solid State division, RCA Corp.

"We all understand the long-term outlook very well," says Pepper, "but 1982 is the toughest year I ever faced in terms of finalizing the numbers." The near-term concerns faced by business center around the uncertain outcome of the Reagan economic program. "We don't have a track record of operating in a high-interest-rate economy. Our ability to forecast might be suspect."

The interest-rate problem is twofold for RCA, because the company must fund capital for new developments like the video disk, and the cost of capital puts a heavy burden on the profit-and-loss picture. The problem also affects RCA's customers' ability to sell to their customers. High interest rates are a depressant that causes delay in placing orders.

As a result, inventories are leaner, and moving product becomes highly dependent on contractors supplying what is needed on schedule. "This requires close control, and makes it a lot tougher to run a business."

Longer term, however, he is optimistic. "Pervasiveness of the electronic technology is with us. Growth will occur, but we must position our resources for the long term. This is difficult for this country because traditionally we have tended to look shorter term than competitors."

Pepper worries over what he considers the U. S. failure to come to

grips with the changing world competitive picture. The ground rules have changed, he holds, from a world where all the resources the country needs were under its control and where the competition was basically domestic.

As a result of the failure to adjust to the new rules, U. S. imports and exports are way out of balance. In contrast, "the Japanese have targeted and supported businesses that look promising for export and dropped weaker businesses. They really encourage exports, and that is the name of the game."

Long-term survival may depend upon a lot more cooperation among government, management, and labor, he believes. "In management-labor relations we need interaction on problem solving, not a contest in which there are winners and losers. We've got to produce a desire on both sides to do an understanding job. They will either succeed or fail together—they're not separable."

His scenario for 1982 shows modest growth in dollars with continued severe price pressures and significant excess worldwide capacity. He expects a gradual ("on the high side of modest") upturn to occur but no earlier than the second half of 1982. Even then, it will not be spectacular. "The industry won't be sold out in the third quarter, believe me."



MICHAEL C. J. COWPLAND

president, Mitel Corp.

The economy fills the foreground of Cowpland's view from Kanata, Ont., a suburb of Ottawa, Canada's capital city. But somewhat surprisingly in this period of a troubled worldwide economy, his outlook for North America is strictly upbeat.

He bases his optimism on the presence of Ronald Reagan in the White House. The Administration's overall program, he believes, "will save the world economic position of the U. S. I'm encouraged by his record to date. In 6 to 12 months, things will start to look rosy."

On the prospects of the semiconductor industry, he is equally optimistic. "It will be out of the slump by the end of 1982 and back to the old growth rates. What we have now is just a hiccough in the industry of the future. The chip people give too much value for the money for it to be otherwise. Don't worry about the Japanese in the long run; the trend line is up, and they won't stop it."

The keys to all this? For Cowpland, they are improved productivity and reliability. "The productivity of semiconductor-industry labor will go up, and the reliability issue will disappear very shortly as the U. S. addresses both problems."



R. W. KLUCKMAN
president, Zenith Radio Corp.

Despite predictions that the recession could persist into 1982, Kluckman is optimistic and expects continued overall strength next year in the market for color television receivers. The industry "has been surprisingly strong during the past couple of years," running counter to trends of previous years in which color TV sales had a tendency to track automobile sales.

"During the past recession, the consumer made his decision to purchase color TV and consumer electronics instead of going on vacation and buying automobiles, and there's no reason to believe that should change during 1982," he observes. Also contributing to his optimism are new opportunities for color TV sales, given the growth of cable and subscription TV services.

The first half of 1981 was stronger than the second half, but in the aggregate, the color TV industry "will have a very good year in terms of unit volume," says the Zenith executive. The coming year—though equally strong overall—should reverse that trend, showing more relative strength during the second half after a slower period during the first six months of 1982.

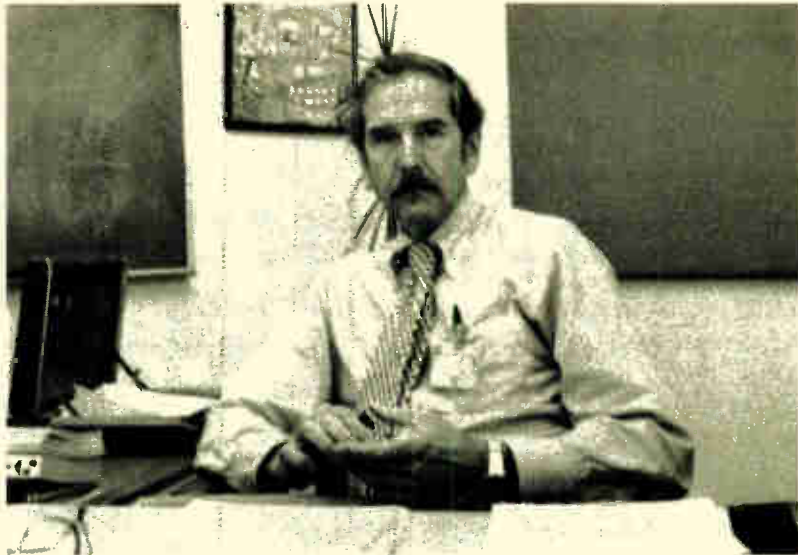

CHARLES E. SPORCK
president, National Semiconductor Corp.

The economy is first on Sporck's worry list, as it is for many executives. "We won't see the turnaround in semiconductors until the general economy turns around, and that won't happen until there are major changes in the interest rates. Instead of asking when the turnaround will occur, maybe we should be asking whether we have seen the bottom of the recession."

The forecasts released by the Semiconductor Industry Association are too optimistic, he thinks. "Those forecasts were created a few months ago, and from what we've seen since then, we believe that the growth will be less than that cited by the SIA."

He has no objections to the association's projections beyond 1982. But for next year, he suggests that the percentage growth figure could be down 50% from the SIA's worldwide prediction of 16.9% for solid-state devices and 20.4% in total integrated-circuit dollar volume.

He does not believe that the high interest rates will be a limiting factor on capital expenditures. "What influences us most is the demand for products and the anticipated demand for products." The semiconductor industry in general, and National in particular, have enough bricks and mortar in place to take care of capacity requirements in an upturn, but the limiting factor will be

manpower, in Sporck's view.

The fluctuation of the dollar in Europe also has an effect. "We are selling in local currencies and have local competitors. That means that U. S. vendors have to sell at about the same price as local competition, and it means a decline of about 25% in the U. S. dollar price. The impact is on profitability, not volume." In general, Europe's business is down, and he expects the European upswing to trail the American recovery.

The Government-business relationship has been improving over the past few years, in that the Government has begun to realize the importance of a strong industrial base, he believes. "The industry is beginning to feel that it can talk to government," he says. "They are encouraged by examples such as the Government's insistence that the Japanese bring in their new tariff rates in April 1982 instead of 1987."

In a broader sense, he wants the Government "to establish an environment which places us on a competitive footing with the Japanese. There must be some principle of equivalency." The key to that effort, he feels, is the acknowledgement that U. S. manufacturers "are in a restricted trade environment, not a total free-enterprise system. We as a government must recognize that and plan accordingly."

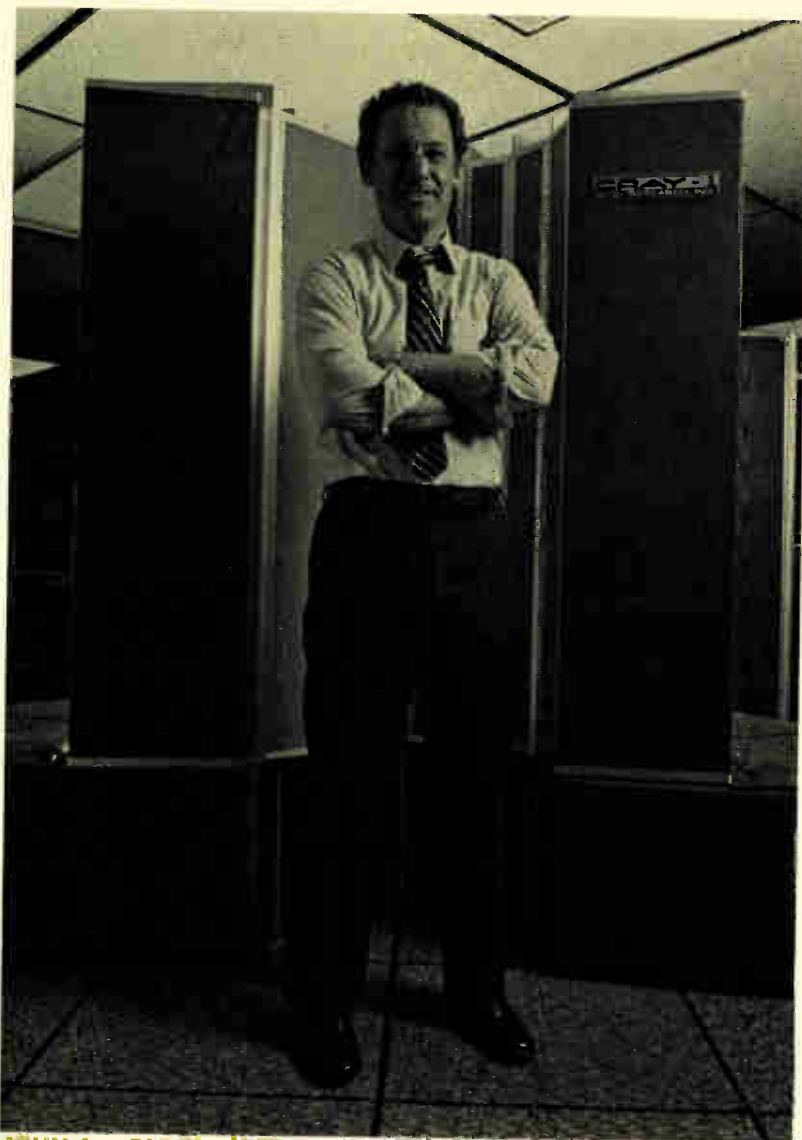

JOHN A. ROLLWAGEN
chairman, Cray Research Inc.

Maintaining internal corporate growth and technology leadership at his Mendota Heights, Minn., super-computer maker concerns Rollwagen more than the general economy. "The Japanese have specifically stated that they intend to build a computer that is 67 times more powerful than the Cray I by 1990. Our only defense against them is to do it first," he says.

Cray continues to purchase "a significant portion" of some types of components from Japan—particularly 4-K bipolar memory devices. Though the balance could swing even further in the short term, Rollwagen sees that trend reversing in

the long run. U. S. semiconductor suppliers are reacting to the Japanese threat by actively installing reliability and quality-control programs of their own, he notes.

He has few complaints about Reagan Administration policies, though he would in some cases like to see regulatory agencies "make decisions more quickly and openly about export licenses." From a personal viewpoint, he supports the Reagan approach for turning the economy around. "The trouble is, it's not going to work very fast." He worries that some—particularly Congress—may give up too soon on the Reagan economic program.

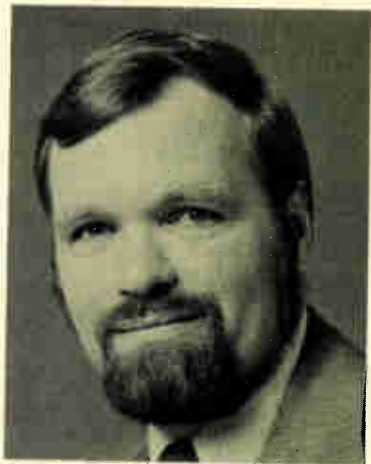

R. W. MILLER
general manager, LSI Products division, TRW Inc.

The lack of qualified design personnel is No. 1 on Miller's list of concerns for the future. "I think it will continue to get worse," he says. The lack of trained personnel is one factor, as is the difficulty in attracting engineers, due to the housing problems around the division's headquarters in La Jolla, Calif.

In the long term, he sees industry's proposed support of university technical departments helping alleviate the crunch. But for more immediate answers, TRW is looking outside the U. S. "We're continuing to look at offshore satellite design centers in the Far East. Some cultures there encourage people to become professionals, but local economies can't support them, making foreign investment welcome."

Looking at the uncertainty of the economy, Miller's main concern is predicting its effects. "We have great difficulty forecasting when customers will take programs which have slid and firm them up," he explains. Eighteen months ago, new-product programs were active, "but since then a vast majority of them are on the skids."

This poses a looming problem for semiconductor makers that have recently boosted their capacity. "Looking to 1983, should we be developing broader markets?" Unless the demand rises to meet the increased output, "there will be a pricing effect until that capacity starts to get used."



KEISKE YAWATA

president, NEC Electronics USA Inc.

If nothing else, Yawata finds himself in a unique position from which to look at 1982: "We are a U. S. company, even though our financing comes from Japan." While most of the firm's activities concern marketing products from its Japanese parent, its Electronic Arrays division in Mountain View, Calif., is expanding its U. S. manufacturing operations.

Taking a look at the subject that nearly universally tops this year's list of major concerns, the economy, he believes it is too soon to assess the impact of the Reagan Administration's policies. However, he says, the moves are in the right direction.

As for the current recession, Yawata believes the semiconductor industry will turn around in the fourth quarter of next year. "The turnaround will very quickly create shortages. The big surge will not come until 1983."

One development that concerns him is the recent court decision holding the vendors of video-cassette recorders liable for consumers' copyright infringements of material such as old movies. "This may lead to a surcharge upon the initial sale of the VCR to cover copyright licensing" and affect the market, he says.

The consumer sector in general will rate as moderately strong in the U. S. next year and show particular strength in Japan. But for real strength, watch office automation. "It is the hottest thing in Japan, along with personal computers and minicomputer-based systems."



GEORGES PEBEREAU

managing director, CIT-Alcatel

Though Pebereau's preoccupations for 1982 are predictable enough—the generally poor state of the world economy, the depressed condition of the market, and high interest rates—the change to a Socialist government in France with a massive nationalization program and plans to reinflate the economy to create jobs set the country apart from its monetarist-dominated neighbors. Indeed, CIT-Alcatel's parent Compagnie Générale d'Electricité is on top of the list of those to be nationalized.

"As the state takes over control of the CGE it will, thus, take a majority interest in CIT-Alcatel," he notes. So the relationship of the state to the company will be that of any majority shareholder to a company.

"Exactly what difference that will make to us is not for me to say, but there are two specific things worth noting. First, the government has already publicly expressed its desire not to change for the sake of change. Second, the stated technological priorities of the government—telecommunications and data processing, for example—coincide with what have been the priorities of CIT-Alcatel for a long time."

On the international level, Pebereau hopes that next year world standards will be set for the Télématique communications-oriented data-processing program. "One of our principal priorities for next year is to make inroads into the American market, particularly in the field of telecommunications," he says.



LUBO MICIC

*managing director,
ITT Semiconductors Group*

The view from Micic's office in Freiburg, West Germany, is dominated by the sluggish economy. He sees the Western European semiconductor industry as having hit bottom, a position it will maintain for some time, "giving little hope for some recovery in the near term."

A concomitant concern is high interest rates, a condition that will stifle investment in new technologies. Tight money is also creating the need for a new type of executive, he notes, one with a good understanding of cash management. "It's no longer enough just to have good designers, good technologists, and good production engineers."

For the further development of microelectronics, much capital will be needed, "and it must be invested at the right time and in the right spot," he says. Among the companies that can handle this best are those that are part of a large corporation, like ITT, that operates worldwide and that embodies a rich pool of know-how and resources. As for selling to the Japanese, it need not be a problem, says Micic. If a semiconductor maker adopts their quality concepts, sells at reasonable prices, and offers good service, it can do good business with them.

But productivity can be a problem if a company does not keep working at it. Increasing productivity requires a continuous effort and the kind of diligence that has helped the Japanese on their road to success.

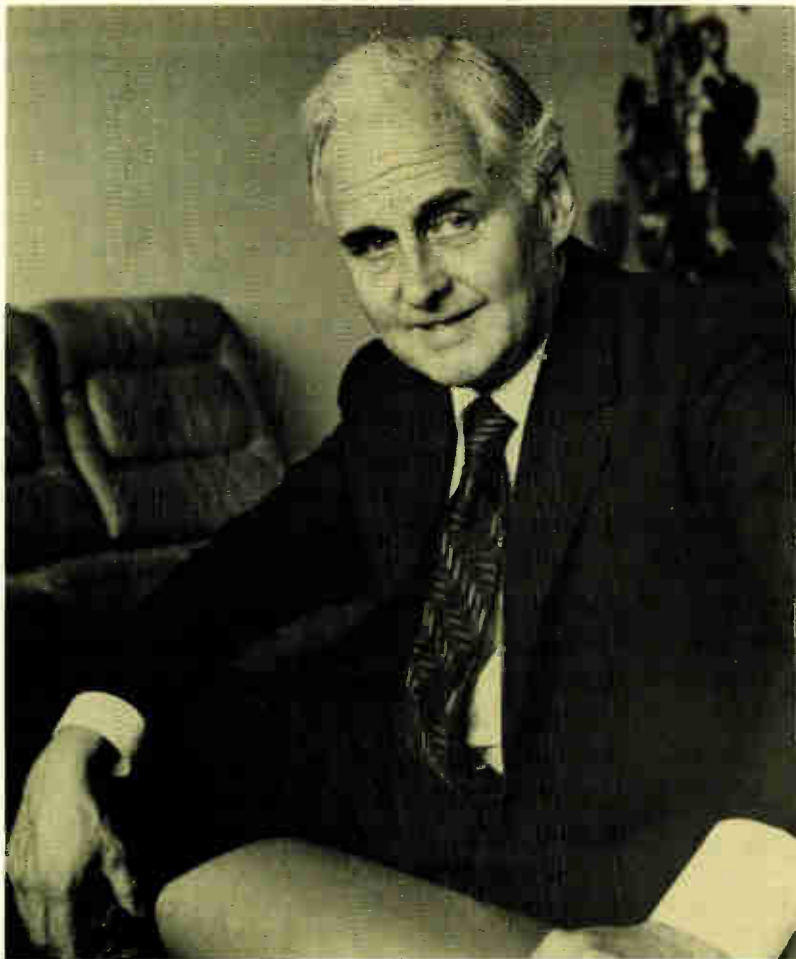

SIR WILLIAM BARLOW
chairman, engineering group, Thorn EMI plc

The British economy is still bumping along, so the prime concerns now are how to prime the pump and how to push industry away from the older declining sectors into newer high-growth sectors exploiting cheap microcircuit technology. Not too surprisingly, Barlow believes that telecommunications should play a key role in showing the way.

In fact, his advocacy of the need to invest in a modern telephone network at a time of economic stringency eventually led to his resignation as chairman of the post office organization last year. Belatedly he appears to have made his point: the government is now formulating plans to raise additional finance from the private sector—something that France was doing 15 years ago, as he points out. But he would like to see at least double the \$300 million being mooted.

Sir William is more positive about other government initiatives. He welcomes the relaxation of the post office monopoly, as competition both improves performance and provides a check to union power. Indeed, he is widely credited with turning the BPO's successor, British Telecom, from a stodgy civil service organization into a surprisingly aggressive commercial enterprise.

He also welcomes the formation of the new Ministry of Information Technology. At long last, he says, government policy is developing a clear focus.

But British industry must take much of the blame for its poor competitive situation. "We spend only half as much as the Japanese and Americans on product design and development," he says. "There's not enough evidence that companies are prepared to pump in money."

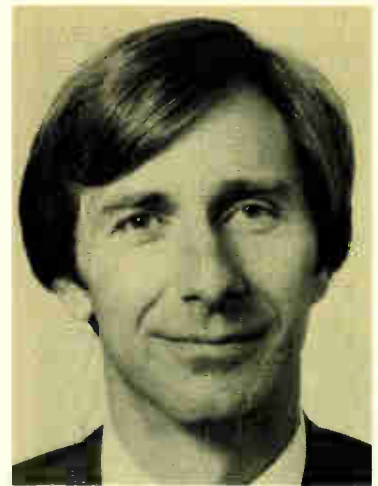

WILLIAM E. FOSTER
president, Stratus Computer Inc.

The concerns of the chief executive officer of a new computer firm are not all that different from those of an established company's leader. For example, Foster is concerned about component availability, particularly 64-K random-access memories.

"Till now, we have had no trouble getting 64-K parts. But we are surprised that so few major users have adopted 64-K RAMs so far, and wonder whether in 1982 there might be a great increase in demand. If there is, allocations could be a possibility" that would affect his Natick, Mass., company. However, "most of the major computer vendors' older products can't deal effectively with the 4- and 8-megabyte main memories 64-K RAMs make possible," eliminating retrofits.

Foster wonders whether high-margin memory may not be helping pay for some of the increasing costs of software development. "Software still is relatively cheap in comparison to its value, and it used to be given away almost free. The market doesn't yet reflect the real cost or value of software, and until pricing policies are rationalized, computer makers may be tempted to keep margins and prices up."

To attract money, start-ups will need unique products. "There is less new money coming into venture capital now than a year ago, and fewer new funds are being formed. Venture houses are going to be increasingly selective as 1982 wears on."



KENT W. BLACK

president, Commercial Electronics Operations, Rockwell International Corp.

For anyone in the avionics business, it is necessary to keep a wary eye on factors affecting the sales of planes. The two biggest current impediments are the air controllers' strike and the rising cost of fuel, which have caused airlines to delay purchases for about two years until new models of fuel-effective craft reach the market. By that time, the controller force should be restaffed.

Thus Black sees a hazy short term. "I think 1982 and '83 will be years of transition in the avionics industry. There's a very bright outlook if you look ahead two years, but it's mixed over the short term."

Fuel costs also knocked small-plane buyers out of the marketplace to a large degree, but that setback was offset by increased sales of business jets and twin-engine planes to operators that moved in when trunk carriers stopped serving smaller cities following deregulation. "Then the controller strike put that into a tailspin," he says.

When things do turn around, Black sees little foreign competition, since the Japanese, his major concern, have shown little interest in avionics. However, in telecommunications, the story is different. "NEC, Fujitsu, and a number of other suppliers to NTT are already showing strength here."

He sees mostly good things coming from the new Administration. "I believe in them. I've seen a lot of progress in the removal of 'export disincentives' and less interference from agencies like OSHA."



TAIYU KOBAYASHI

chairman, Fujitsu Ltd.

Overseas problems in 1982 will cause more knitted brows than will domestic problems in Japan. Everybody is keeping an eagle eye on the moves of Japanese companies, Kobayashi says, and there are apt to be repercussions.

Thus the company will enter the U. S. market for personal and small computers through Fujitsu-TRW as inconspicuously as possible—so he does not anticipate any problems. But he fears that other computer and peripheral-equipment manufacturers may opt for much more rapid entry into the American market, the largest one available.

The chance of new friction being generated is great, he fears. Fujitsu would like to try to reduce that heat by expanding the territorial range of its exports, but Kobayashi feels that the prospects are not good. Neither developing countries without oil, the

Eastern Bloc, nor China has money, so exports are not possible without international help.

His pessimism extends to the current slump, which he does not think will end next year. At present, social security costs are rising and higher wages lead to higher taxes because of bracket creep. These factors combine to squash hopes for additional discretionary spending. There is no hope for an improvement without a decrease in Japan's taxes, he says, though the government is trying to reduce expenditures.

Fujitsu's chief also believes that not much business can be expected from Nippon Telegraph & Telephone Public Corp.—although 20% of Fujitsu's sales are to NTT, that figure will drop. Kobayashi says the reason is that, while Fujitsu overall is growing at a 15% rate, sales to NTT are growing at about 5% at best.



KATSUSHIGE MITA
president, Hitachi Ltd.

Like his fellow executives in Japan, Mita is worried about trade friction. For example, limitations on the export of automobiles to the U. S. affect the firm's sales of automobile components. Now, exports of video-cassette recorders are especially high, leading Mita to wonder what sort of heat that might cause.

As for the domestic economy, the high cost of oil precludes a significant upturn next year, he feels. The sluggishness results in good sales for such products as computers and large-scale integrated circuits and poor results for products such as motors. Thus there is a need to re-design poorly selling items to improve their chances, meaning that Hitachi must maintain its research and development budget at about 6% of sales, or about \$565 million, as it endeavors to upgrade the old offerings while developing new ones.

Meanwhile, the firm must arrange capital investment for expansion and modernization of plants. In the past, it was able to generate the necessary funds through depreciation and profits, but next year it will have to go to the equity markets.

Engineers are in short supply, and it is exceedingly difficult for Hitachi to hire more. One solution is to start up engineering subsidiaries because they can operate with less stringent personnel rules—for example, they can recruit at the less prestigious universities. Also, this year there were about 100 women among the 1,000 college-trained engineers and technical persons hired by Hitachi.



FREDERICK A. WANG
vice president of market planning and development, Wang Laboratories Inc.

"The recession will either lessen in 1982—or we'll just get used to it." If that outlook makes Wang appear a fatalist, he hastens to add that his attitude is an optimistic one. He believes that companies, even small ones that delayed major purchases in 1981, will perceive capital outlays as a necessity rather than a mere cash drain and will be investing in computer products like those his Lowell, Mass., company makes.

So he sees more of a business-as-usual year ahead for high-technology companies. "I do think that interest rates can't go on at the levels they hit this year; they have to decline." More importantly, he counts on the pressure for increased productivity and for aggressive innovation to spur industry recovery from the effects of the recession.

Demand for technological solutions to productivity problems, which in recent years lagged behind the technology actually available, is beginning to catch up as a result of recessionary problems, he observes.

U. S. industry's need to stay competitive with foreign rivals also makes recovery likely in 1982. "America still has the most stimulating environment for innovation," and that, says Wang, is the key to competing successfully, as well as to a high level of industry spending over the coming year. "The Japanese have very cost-effective, well-thought-out products, but I don't see them producing the next-generation technologies."



EARL J. ROGERS
chairman, Precision Monolithics Inc.

The semiconductor industry will not see a turnaround before the fourth quarter of next year, and that is causing some concern in the Santa Clara, Calif., headquarters of PMI. However, Rogers is quick to point out his firm's business, linear integrated circuits, does not track the rest of the semiconductor industry. "We haven't seen the crunch that others have. For us, a recession means a flat line, not a down one."

He does see some silver lining showing. "During a recession, the yields go up because the operators work more diligently. In addition, companies usually make process improvements during a recession.

"The net result is that, while the wafer line slows up, we get better-yielding wafers and sometimes get the same number of good dice out of the system." He adds that the industry is currently using about 30% of its fabrication capacity.

Turning to the American work force and economy in general, Rogers says it is too early to see if the Reagan economic program will work. "It took the Great Society programs 20 years to get us into this mess, and we should give Reagan half that time to reverse it."

The Government, he believes, "should restore the work ethic to the populace. It could, for example, reduce payments to the unemployed, so that people will want to go back to work." He is not sure that there are personnel shortages. "There is, right down the line, a shortage of people who want to work."



PAUL MIRAT
president, Thomson-EFCIS

Generally pessimistic about the economic outlook for 1982, Mirat nevertheless feels that in the semiconductor industry there will be opportunities for companies strong enough to withstand the shock of the world recession. "I really cannot see us coming out of the current economic dip before the end of 1982," he states.

"Worldwide, most semiconductor companies are at a more or less equal level of technology, but I don't see this as the area for investment. My strategy would be to invest in design and software, to weather the storm of the recession, and be ready for the upswing with a new generation of standard, rather than custom, integrated circuits."

For Mirat, the structure of a company is essential to its ability to be innovative and to grow. "The companies that are organized vertically with a semiconductor division and then divisions producing manufactured goods using the semiconductor division's products: these are the companies that have enough depth to invest, even when times are difficult next year."

For any European firm to successfully take advantage of this sort of structure, he is convinced that it must establish itself outside Western Europe. "The European market represents just 20% of the world. It is impossible to restrict yourself to this portion and to be a real innovator, and the production of original products and new components to build them around is not a follower's business," he says.



JOHN V. ROACH
president, Tandy Corp.

The consumer electronics market may be ailing, but Roach has a prescription for what he considers the right medicine: high technology. Without new state-of-the-art products, consumer-electronics manufacturers may find sales susceptible to severe slumps during recessions.

But one thing that does not worry him is a consumer-electronics recession in 1982. "Certainly, history has shown that consumers will continue to buy interesting, innovative new electronic products regardless of the general economic environment," he says. For Tandy, that meant a 1981 that lived up to expectations—including a 57% earnings increase in the third quarter.

The key is always to have an arsenal of innovative products, whether the economy is hot or cold. "Companies recognize this and will continue to push very hard on new-product developments independent of any temporary market condi-

tions." In fact, he adds, advances in consumer electronics may accelerate during tough times as highly competitive retailers seize on innovations to help slug it out.

One area on which Roach is keeping his eye is the personal-computer market. An example of the consumer-technology blitz, the personal-computer picture shows Tandy as the volume leader with its TRS-80 line. But 1981 saw a flood of competitors enter the market—among them such giants as IBM, Xerox, and Hewlett-Packard. "I guess 1982 will be the year that we see just how those competitors stack up," he says with a grin.

In addition to healthy computer activity, he sees a promising year for telephone and video products, which are also experiencing great strides in technology. 1982 also will be a personal landmark for Tandy's president and chief executive office: in July, he will become chairman.

EXORMACS[®] 'USERS

What about 8 bits

You can use every software you have already running on an Exorciser[®] under MDOS[®]
You can use all the Motorola 680X support software for designing 8 Bits on your mono or multi-users EXORMACS[®].



Please contact soon
for the nearest distributor :

DATA SUD SYSTEMES FRANCE, 22 RUE DE CLARET, 34000 MONTPELLIER FRANCE
Télex 490-425

Circle 132 on reader service card

MDOS[®], EXORCISER[®] and EXORMACS[®] are trademarks of Motorola inc.

World Radio History

Software pack and controller link DEC computers in an Ethernet

Machines running under Unix operating system can communicate with one another in local network

by Ronald C. Crane, 3Com Corp., Mountain View, Calif.

□ Designers of data-generating and -receiving equipment now have some useful interconnection tools with which to realize the well-publicized Ethernet approach to a local network. A newly introduced Ethernet controller and Ethernet-related software will link Digital Equipment Corp. computers that use Bell Laboratories' Unix operating system. The controller can also be used with other available software drivers to provide link-level communications between machines with DEC's own operating systems; that is, it provides the physical and data links of the International Standards Organization's reference model for open-systems interconnections.

Ethernet and Unix look to be two emerging *de facto* standards, so it was an obvious choice to design network software that could be used with Unix and an Ethernet

controller. 3Com's Unet software implements software layers of the ISO's reference model.

Combining Unet and the controller eliminates the need for users of Unix-based DEC computers to write the software needed for communication between two or more machines over Ethernet. Only the ISO session layer is not accounted for, but its functions are taken up by the other layers. The Ethernet specifications, as published by DEC, Intel, and Xerox, take care of the physical and data-link levels of a local network's layered hardware and software architecture. These are necessary but not sufficient to connect equipment, since they ignore higher-level software problems.

The Defense Advanced Research Projects Agency's internet and transmission-control protocols were chosen

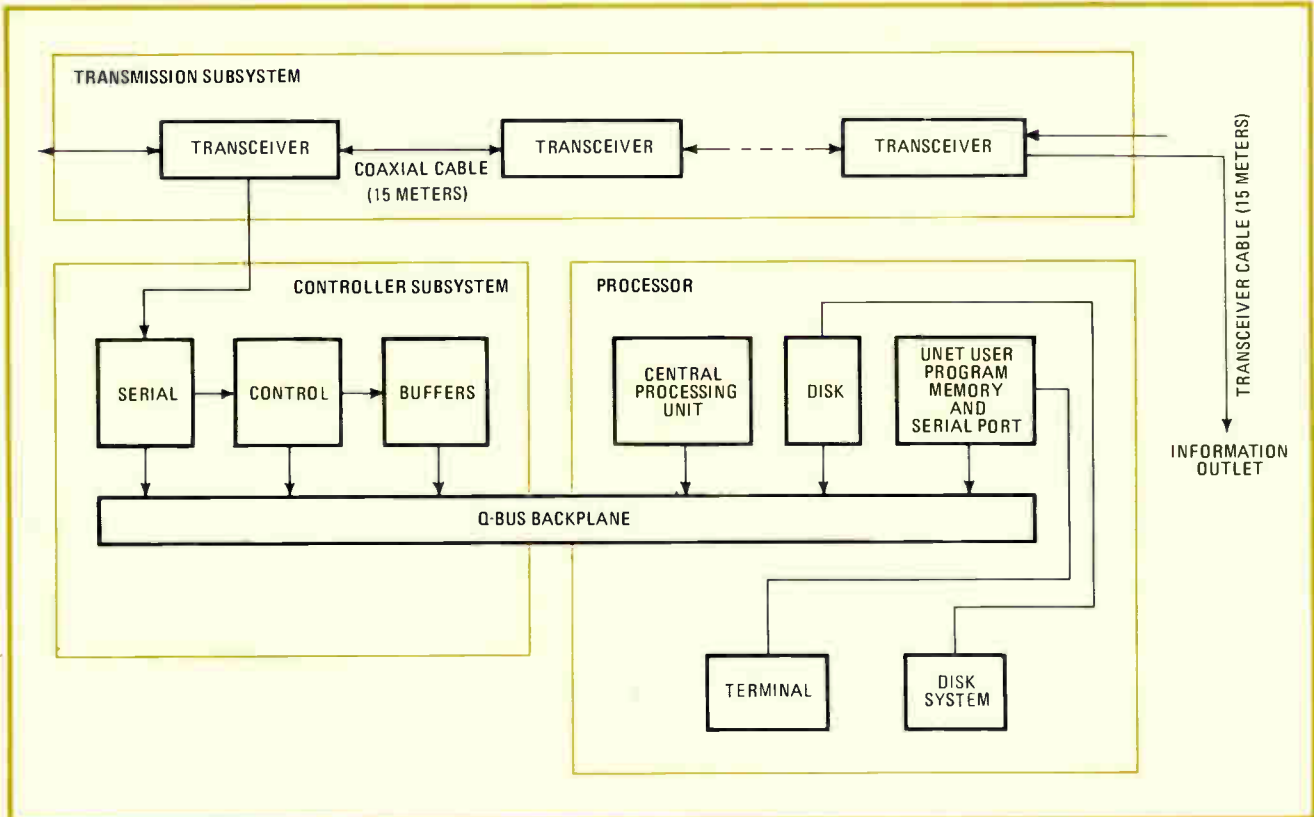

1. **Three boards.** The 3Com Ethernet controller for DEC computers using the Unix operating system comprises three printed-circuit boards that plug into the Q-bus backplane. The transceiver, Unet software, and other components are also 3Com designs.

to implement the network and transport layers because they were available standards. The end-user capabilities, such as mail and file transfers, are provided by a 3Com-designed presentation and application layer.

A complete Ethernet local computer network for the LSI-11 Q-bus processor can be constructed from available components (Fig. 1). These include the Ethernet transceivers (introduced early this year) and Q-bus controller (just introduced as the QE model, or the 3C200). What's more, with last month's introduction of a Unibus controller, any PDP-11 or VAX machine can have an Ethernet capability.

It is important to note that participation in Ethernet communications is not limited to DEC products. Any Unix-based machine with Unet and either a parallel or serial port can make use of a low-cost LSI-11 and a gateway to make the connection. For example, 3Com makes use of this approach to connect an Onyx machine running Unix to an Ethernet.

Inside the controller

The QE controller has the chore of interfacing the Ethernet transceiver with the internal bus of the LSI-11 processor. Directed by Unet or other driver software resident on the LSI-11, it performs buffering, cyclic redundancy generation and checking, flag and address recognition, phase encoding and decoding, and serial-to-parallel and parallel-to-serial conversion (Fig. 2). The input/output structure and speed of the LSI-11 determine how these functions are partitioned between hardware, software, and microcode.

For example, the amount of buffering in the controller is determined by the latency and speed of the I/O system. Clearly, the buffer size must exceed the product of the data rate and I/O latency. Since I/O systems may have transfer rates less than the network bandwidth, the QE controller has full-packet buffers to keep up with the network bit rate.

The controller checks the data passing through it by means of a cyclic redundancy code. The Ethernet CRC is the 32-bit polynomial from the Autodin II military packet-communications system and is implemented in hardware on the QE controller.

In an Ethernet system, the controller must watch every packet that passes to determine whether to accept it. Full-packet buffers can greatly speed this recognition process for the system.

With partial buffers, the host processor must check the address upon the arrival of the first part of the packet. It can reject the packet, but many unwanted bits may funnel through the buffer to the processor, wasting I/O system cycles. With one or more full-packet buffers, the packet remains in the buffer until it is accepted by the software, thereby saving I/O cycles. Using a full-packet buffer and software address recognition minimizes the hardware content of the QE controller.

Standard Manchester encoding and decoding with a 50% duty cycle is used for data transmission (see "Inside Ethernet," p. 136). Assigning the encoding and decoding functions to the QE controller simplifies the interconnection to the transceiver by reducing the number of wires.

Together with an Ethernet transceiver, the QE control-

ler can both transmit and receive packets through a common coaxial cable. It has no on-board intelligence; instead it is controlled through registers in the I/O space of the LSI-11 by the Unet software resident on that machine. The two registers are the transmitting control register and the receiving control register.

The controller provides 32-K bytes of memory, which can be any 32-K byte boundary in the LSI-11's memory, and data transfer takes place via memory-mapped I/O. For the controller's purposes, this memory is viewed as sixteen 2-K-byte packet buffers. Any space not used as packet buffers can serve general system use.

Code is necessary for address recognition and for implementing the random retransmission time period, as well as for loading and unloading the buffers. This code can be interrupt-driven and requires three vector locations when operated in that mode.

The QE controller has independent receiving and transmitting sections, but they operate similarly, so to explain the transmitting section is to explain both. This section has two first-in, first-out memories, which are 4 bits wide and 16 words deep. One FIFO keeps the numbers of the buffers awaiting transmission, and the other keeps those that have completed successful transmission.

When the software wants to transmit a packet, it writes its buffer number in the pending FIFO. When the controller transmits a buffer's contents, it removes the buffer number from the pending FIFO, copies it into the completed FIFO, and sets the done bit. The software removes a buffer's pointer from the completed FIFO by clearing the done bit.

The low-order 4 bits of the control word go into the pending FIFO when the XWBN (transmit write buffer number) signal is on. While these bits are being read from the control register, the contents of the done FIFO appear in the buffer's number field. Before it is transmitted, the packet is aligned in the buffer so that its last byte of data coincides with the last byte of the buffer.

The first word in each buffer is called the header and contains the address of the first byte of the packet. The controller transmits the buffer contents pointed to by the header of the pending FIFO. If the FIFO contains more than one packet, the controller transmits them back to back over the network.

Handling collisions

Ethernet's binary exponential back-off algorithm is implemented by the controller's software. When the controller detects a collision, the software must delay (back off) an appropriate length of time before attempting retransmission.

The length of the time that the software delays must be an integral multiple of a packet slot time (512 bit times, or 51.2 microseconds). The integral multiple is chosen as a uniformly distributed random integer greater than or equal to 0 and less than 2^K where K is either the number of retransmission attempts for the packet being transmitted or 10, whichever is less. If the number of retransmission attempts exceeds 16, then something is wrong or the network is very heavily loaded, and error reporting to higher-level Unet software occurs.

When the controller detects a collision, it sets the JAM

status bit. Any other packets in the pending FIFO remain undisturbed. When the time comes to retransmit, the software merely sets a JCLR signal. If another collision results, JAM comes back on. The software then waits a random amount of time before setting JCLR again.

When the transmission finally succeeds, the controller sets XDONE, alerting the software to a successful transmission. If the FIFO contains pointers to other packets waiting for transmission, the controller waits for the minimum interframe spacing time and transmits the next packet without processor intervention.

In the QE controller, all received packets begin at the same place in each buffer: 528 bytes from the beginning. This spacing leaves exactly enough room in the buffer for a packet of maximum size, plus 4 frame-check-sequence bytes and 2 guard bytes. After receiving a packet, the header points to the first free byte past the end of the packet and the FCS.

If the header is zero or points to the odd guard byte, the received packet has exceeded the legal size. This procedure ensures that oversized packets are rejected. The sign bit of the header, when on, indicates an FCS error. The packet, as received with the offending FCS, remains in the buffer.

The controller receives packets and writes them into the buffer specified by the contents of the head of the FIFO. If the receiving FIFO is empty, the controller ignores packets passing by on the network. After receiving a packet, the controller sets the RDONE signal.

If there are other entries in the receiving FIFO, the

controller can receive other packets without processor intervention. The software then clears RDONE and removes the head entry from the FIFO by setting RCLR. This memory-mapped approach is particularly attractive for small, stand-alone systems whose software can make use of the 16 packet buffers directly without incurring any bus cycles for data transfers to memory outside the controller's 32-K-byte buffer area.

Operational experience

In the Ethernet system implemented by the QE controller, all packets, regardless of their destination, are written into available receiving buffers. Controller software compares the destination address of each packet with the Ethernet address of the processor.

Each uninteresting packet consumes about 85 μ s of LSI-11/23 time to start an interrupt, compare the destination address, resubmit the buffer, and return from the interrupt. To determine how much of the processor resources will be necessary to perform these address-recognition chores, the time it takes to recognize software addresses must be calculated.

An Ethernet packet has a 64-bit preamble, 48-bit destination and source addresses, a 16-bit data-type word, 368 to 12,000 bits of data, a 32-bit CRC word, and a 96-bit packet gap. Thus a packet can range in length from 672 to 12,304 bits. Statistical experience at Xerox indicates that roughly 80% of the packets will be minimal and 20% will be maximal in size. The average packet length for these conditions is therefore about

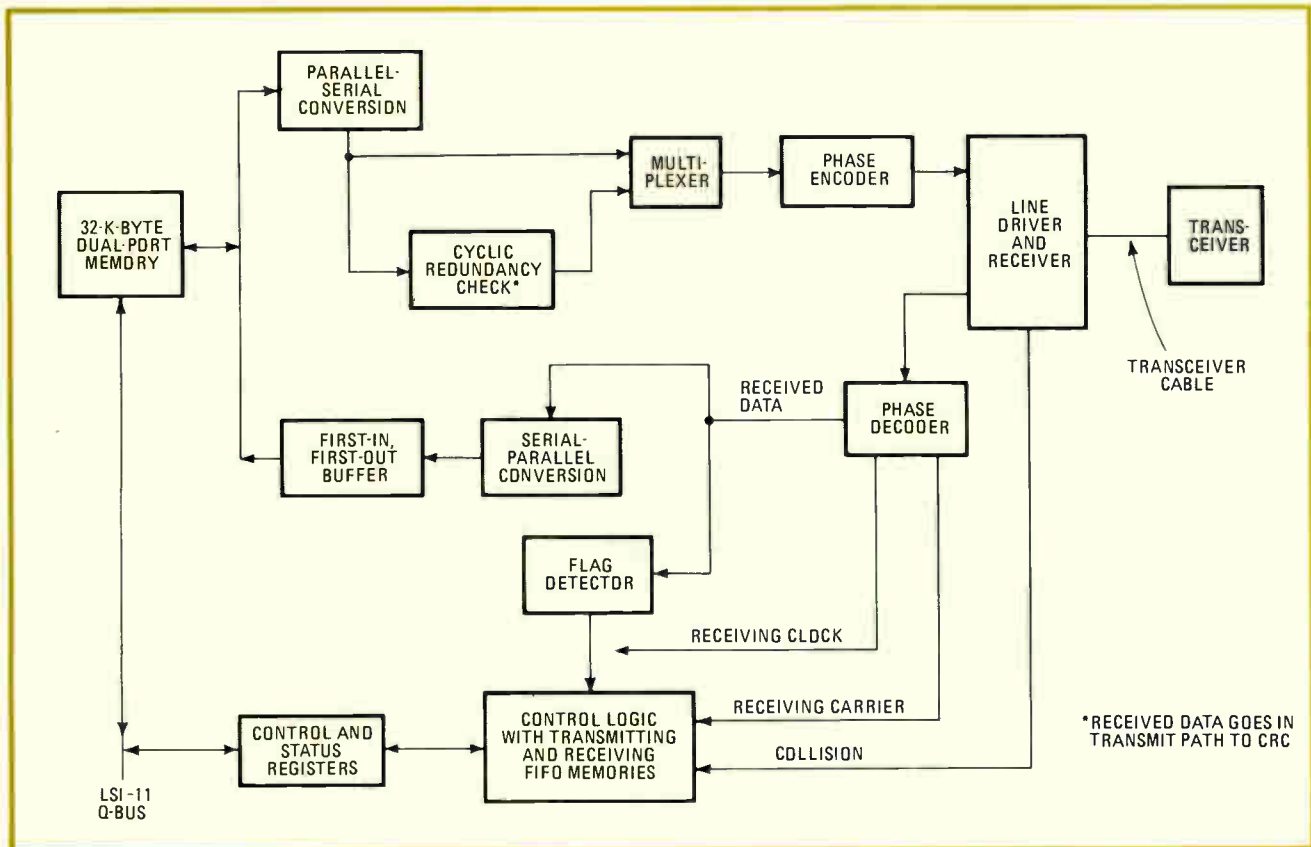

2. What's inside. The Q-bus controller performs a variety of communication functions without microprocessor control. These include line driving and receiving, phase encoding and decoding, cyclic redundancy checking, buffering, and memory management.

Inside Ethernet

Ethernet is a bus-oriented communications system providing 10-megabit-per-second bandwidth and supporting up to 100 stations using 50-ohm coaxial cable as its bus. The Ethernet specification calls for a carrier-sensing, multiple-access transmission system with collision detection. This means that in order to transmit a packet, a station must wait for quiet on the network and then start to transmit. During the transmission, the station also watches for collisions with other transmitters.

If a collision does occur, the station transmits 4 to 6 additional bytes of jamming data and then aborts the packet. The extra bytes ensure that any other participant in the collision is sure to see it. The station then waits a random amount of time before attempting to retransmit. At the end of this period, it tries to transmit at the earliest opportunity, deferring to packets in transit.

The Ethernet transceiver makes a high-impedance connection to the common coaxial cable and provides electrical isolation between the cable and the twisted pair going to the controller. The transceiver cable carries the signals and all necessary power. Its signaling uses balanced differential signals, typically from emitter-coupled-logic drivers operating between ground and +5 volts.

Tracing the signal and timing waveforms through the

interface points of an Ethernet system is the easiest way to understand this local network's operation. The figure illustrates the signal flow through an Ethernet system from the clock and data signal present in the controller before phase encoding, through the transceiver, coaxial cable, receiving transceiver, and finally, the receiving controller.

As the network specifications require, clock and data are exclusive-ORed together to produce a Manchester-encoded data stream. To maintain a 50% duty cycle, each bit cell of the encoded data is divided into halves. The first half of the bit cell contains the complement of the data bit and the second half contains the bit. The line driver in the controller sends this Manchester-encoded data to the transceiver.

The transceiver converts the signal on the transceiver cable, which is equivalent to a differential drive, into a unipolar drive on the coaxial cable. It also limits the minimum rise and fall times of the waveform to minimize noise-producing reflections in the cable system. Since the signal undergoes attenuation and distortion as it travels through the coaxial cable, the transceiver provides equalization for the cable distortion and restores a balanced signal for the transceiver cable to send to the receiving controller, confirming a successful transmission.

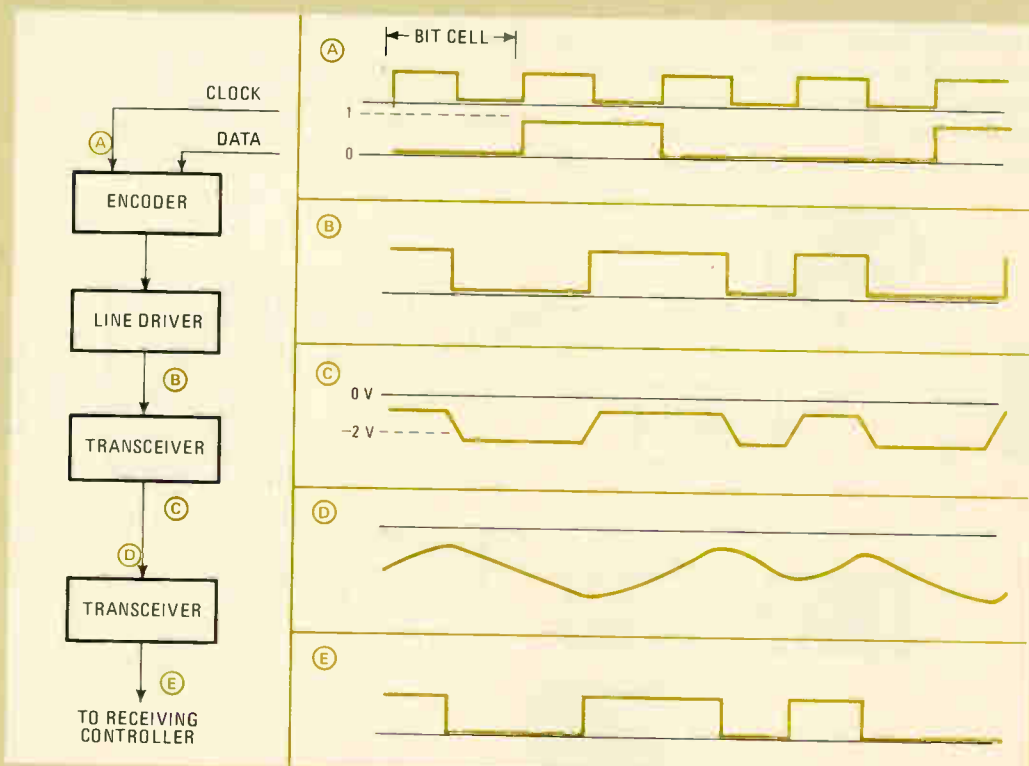

3,000 bits. Since the Ethernet data rate is 10 megabits per second, the average packet duration is 300 μ s.

With the 85- μ s time it takes an LSI-11/23 to recognize an address, a very heavily loaded Ethernet (that is, 37% of the net's equipment on line) would keep busy 11% of all the LSI 11/23s attached. It is a simple matter, given what is known as the Ethernet offered-load percentage, to calculate the percentage of processor time

dedicated to address recognition: $P = L \times 85/300$.

Studies of experimental Ethernets at Xerox indicate that a typical load is 1%. During shorter periods, however, maximum utilization in the busiest interval is much higher. About 3.6% over the busiest hour, 17% over the busiest minute, and 37% in the busiest second are typical. For any of these figures, the capacity of the QE controller is more than adequate. \square

C-MOS support logic helps build unified, high-speed systems

High-speed process gives gates low-power Schottky TTL speed while retaining the advantages of metal-gate C-MOS units

by Ken Karakotsios and Larry Wakeman, National Semiconductor Corp., Santa Clara, Calif.

□ Scaling down and enhanced processing have dramatically raised the speed of complementary-MOS circuits, producing fast memories and microprocessors that draw little current. But the absence of low-power interface devices has created a need for C-MOS chips to glue these components together. After all, the full benefits of C-MOS's low-power diet are realized only when the entire system is built from the one technology.

The HC series of high-speed C-MOS gate packages, to be supplied by National Semiconductor and also Motorola Inc. of Phoenix, Ariz., are designed precisely for this role. This family, which incorporates both 74HC commercial and 54HC military versions, operates at Schottky TTL speeds but retains the attractive dc electrical characteristics of the metal-gate CD4000B and 54C/74C C-MOS families. In addition, internal circuitry has been added or improved for more symmetrical switching behavior and also for greater protection against static discharge.

Good mixers

The devices are easily mixed with components from other logic families, even bipolar ones. Some HC devices are further able to accept the higher logic-1 voltage levels delivered by older C-MOS gates, truncating them to the HC's 5-volt operating levels.

The short propagation delays of HC logic are attained through a single-polysilicon C-MOS process, similar to the double-polysilicon process (P²C-MOS) used by National for its NSC800 microprocessor [*Electronics*, Nov. 22, 1979, p. 111]. Optimized for 5-v operation, it features a recessed-oxide structure to reduce parasitic capacitances and increase transistor gains, so that gate-propagation delays are an order of magnitude shorter than in metal-gate C-MOS circuits.

Designed to meet the dc electrical characteristics of standard C-MOS logic, all devices in the family conform to standard input and output specifications. In addition to the attractively low power and near-zero input current characteristic of all C-MOS circuits, members retain the high input-noise immunity usually associated with C-MOS logic. Standardized output buffers allow symmetrical current sourcing and sinking for equal output rise and fall times, thus simplifying system design.

The family will begin with about 100 devices, with more types to be added at a later date. A wide assort-

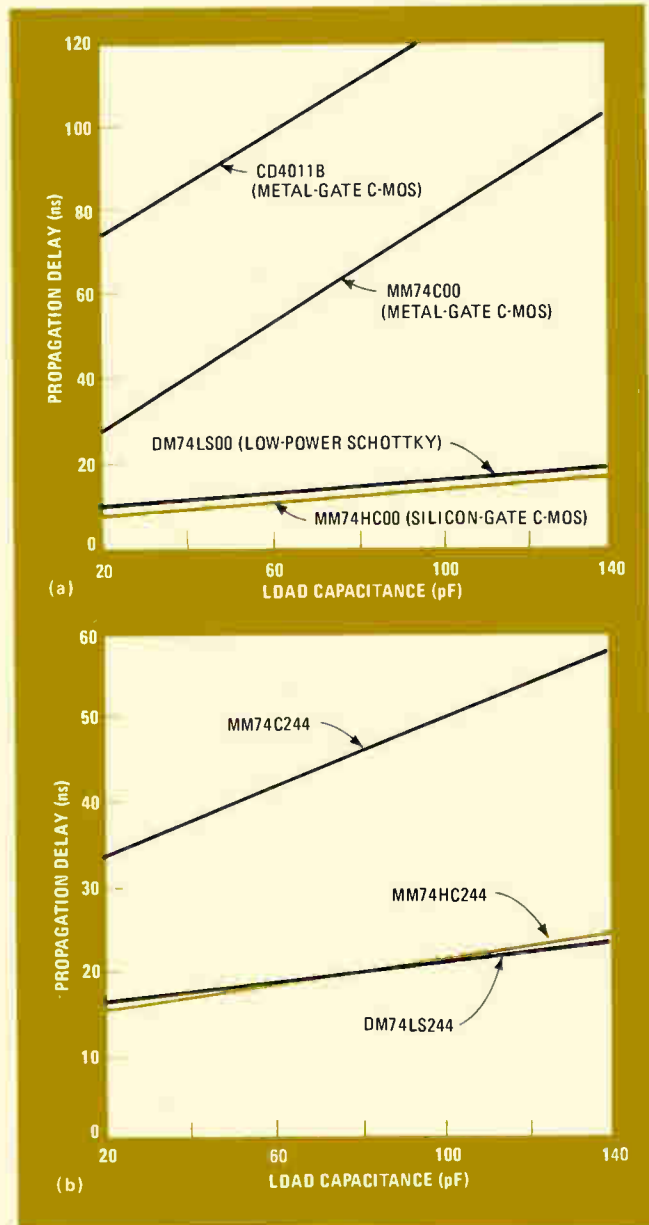

1. LS-TTL-like. The propagation delays of HC-type complementary-MOS standard (a) and bus-buffer (b) gates are nearly equal to those of low-power Schottky TTL packages. Because of high current-driving capabilities, speed varies little with loading, unlike older parts.

TABLE 1: A COMPARISON OF LOGIC FAMILIES

Family type	Low input voltage, V_{IL} (V) ^a	High input voltage, V_{IH} (V) ^a	Low output current, I_{OL} ^{a,b}	High output current, I_{OH} ^a	Supply range (V)
74HC (silicon-gate C-MOS)	1.0	3.5	4 mA	-4 mA at $V_{out} = 4.2$ V	3.0 - 6.0
74C (metal-gate C-MOS)	1.5	3.5	360 μ A	-360 μ A at $V_{out} = 2.4$ V	3.0 - 15.0
CD4000 (metal-gate C-MOS)	1.5	3.5	360 μ A	-120 μ A at $V_{out} = 4.6$ V	3.0 - 15.0
74LS (low-power Schottky)	0.8	2.0	4 mA	-400 μ A at $V_{out} = 2.7$ V	4.75 - 5.25

^a $V_{CC} = 5$ V ^b $V_{out} = 0.4$ V

TABLE 2: THE FAN-OUT CAPABILITIES OF HC DEVICES*

Device type	Buffer type	Output current (mA)	Low-power Schottky TTL fan-out
54 HC	standard	± 3.4	8
	bus driver	± 5.1	12
74 HC	standard	± 4.0	10
	bus driver	± 6.0	15

* $V_{out} = 0.4$ V or 4.2 V, $V_{CC} = 5$ V. All values are guaranteed across the entire recommended operating temperature range.

ment of small- and medium-scale integrated-circuit packages is being offered, most of which are pin-for-pin and logically equivalent to their low-power Schottky TTL counterparts. Additionally, several functions that are uniquely implemented in the RCA Corp.'s CD4000B series of C-MOS logic are provided.

Beating low-power Schottky

A typical HC gate delay, about 10 ns, is similar to LS-TTL but far faster than the 4-to-5-megahertz rate specified for metal-gate C-MOS parts. As with other C-MOS logic, the speed of HC parts is determined by loading: as fan-out and load capacitance are increased, device propagation delay increases. Like LS-TTL, HC logic offers standard and bus-driver outputs. Figure 1 shows some of the typical propagation-delay versus output-capacitance curves for a standard output device (the 74HC00) and a bus-driving device (the 74HC244), plotted along with their LS-TTL and metal-gate C-MOS equivalents.

The metal-gate 74C00 and CD4011B exhibit a larger initial delay and a greater delay variation with load than the 74HC00 and 74LS00. The HC and LS-TTL devices have similar output impedances, so that their speed variations are nearly the same. The 74HC244 bus driver has the same delays as the 74LS244 at small loads, but exhibits a slightly larger variation in delay due to the increased impedance of its output buffer. Except where

these circuits must drive very large loads or where every nanosecond counts, such minor differences in speed can be reconciled by adjusting the specified delays.

Temperature variations also affect propagation delay and can be an important design consideration. In C-MOS, this variation stems from changes in the gain of n- and p-channel transistors due to differences in carrier mobility. The propagation delays of both the 74C00 and the 74HC00 increase about 0.3% per °C. Bipolar circuits are affected by a different set of internal parameters, the factor that accounts for the slightly different temperature variation of LS-TTL.

Family dc characteristics

Standard-output 74HC devices can source and sink 4 milliamperes of current, whereas the bus-driver versions can drive 6 mA. A logical-low input voltage (V_{IL}) may be as high as 20% of V_{cc} , and a logical-high one (V_{IH}) may range from V_{cc} down to 70% of V_{cc} . These input levels are specified over the entire 3-to-6-v supply range.

Table 1 compares the 74HC, 74C, CD4000, and 74LS logic families. The 74HC family has input levels comparable to those of other C-MOS logic families, but with the current drive of the LS-TTL. Moreover, 74HC current driving is typically symmetrical—unlike LS-TTL outputs, which usually source less than they sink.

The HC logic family has the very low quiescent power dissipation of standard C-MOS ICs, which is several orders of magnitude below that of LS-TTL. Figure 2 charts supply current as a function of frequency for a NAND gate and flip-flop from each logic family.

A drastic difference in current requirement can be seen between the C-MOS and LS-TTL devices at frequencies below 1 MHz because the bipolar devices consume direct current, even when not switching. The 74HC devices draw slightly more current than other C-MOS parts because their low-impedance output buffers must source and sink LS-TTL-level currents.

Figure 2 shows the current required by a single gate when it is switching; however, all gates in a package draw dc current. Thus, the bipolar 74LS200 package will draw four times the current of one gate (at 10 kilohertz). But if only one C-MOS gate is switching, then only one gate will draw power.

If the quiescent current consumed by all gates is counted in, the current used by the C-MOS packages remains as shown in the graphs. This puts the power crossover frequency—the point at which a C-MOS package draws more power than its counterpart in LS-TTL—at about 10 MHz.

Surprising crossover effect

It might seem that as the complexity of a C-MOS component rises, the power crossover frequency should get lower. But, in fact, the opposite will most likely occur. For instance, if a counter is operating at the power crossover frequency of a NAND gate, each subsequent counter stage switches at half the frequency of the previous stage. In a C-MOS circuit, this means that each stage will use half the power of the stage before it, one fourth of the current in the third stage, and so on.

But in a TTL circuit, every stage will draw a similar amount of direct current overall—therefore, the C-MOS device will consume much less power than will an equiv-

alent circuit built with LS-TTL technology.

As with any MOS circuits, HC logic gates must be protected against damage from the excessive electrostatic discharges that can occur during assembly and handling. So a new input-protection mechanism, working in conjunction with output parasitic-drain diodes, is used to clamp these voltages to a reasonable level, minimizing a chip's susceptibility to damage.

Figure 3 shows a schematic of the input-protection network employed. It consists of three elements: a polysilicon resistor, a diode connected to V_{cc} , and a distributed resistor-diode device connected to ground.

The polysilicon resistor, connected to the input pad, is used to slow down fast input transients and dissipate some of their energy. This resistor is connected to the two diodes, which clamp incoming spikes and prevent large voltages from appearing across the two transistors' gates. These diodes were made larger than those used in metal-gate C-MOS parts to enable greater current shunting and to render them less susceptible to damage. More-

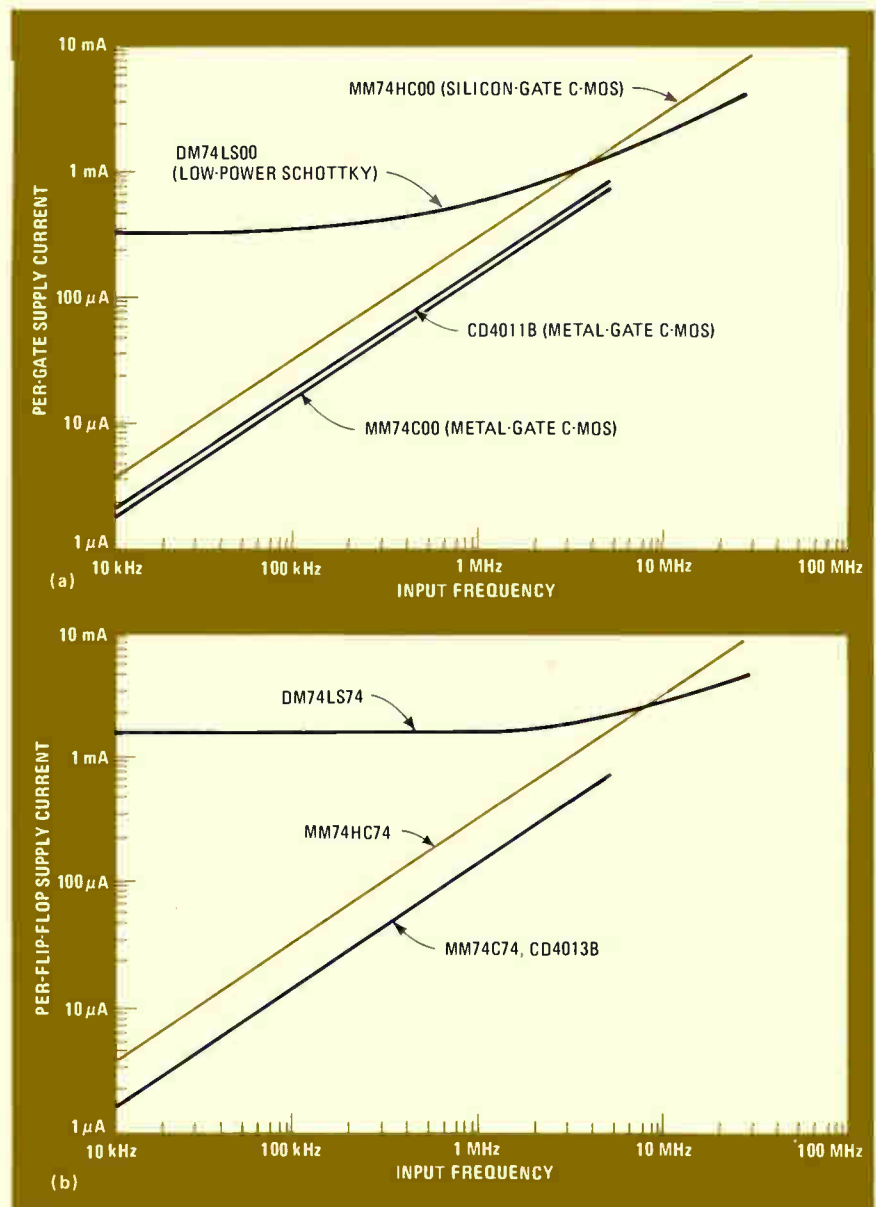

2. Extended crossover. A marked difference in the power usage of C-MOS and LS-TTL devices can be noted at frequencies below 1 megahertz because the bipolar devices consume direct current, even when not switching. The power crossover point marks the frequency at which the C-MOS device begins to draw more current than its bipolar counterpart. The power crossover point for both gates (a) and flip-flops (b) is approximately 10 MHz.

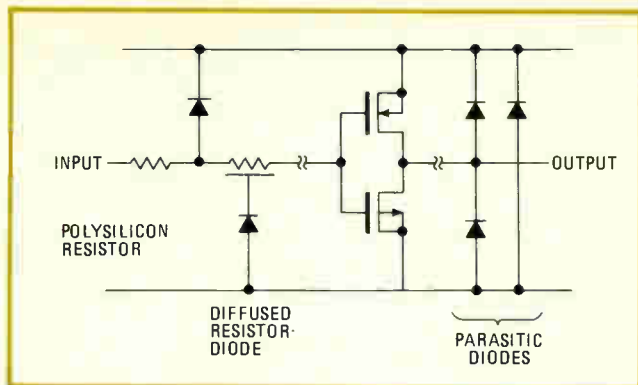

3. Static control. To clamp static voltages, a polysilicon resistor, a diode, and a diffused-resistor-diode device is used at each input pad. At each output, parasitic diodes perform the same function. These drain diodes are also ringed by supply and ground regions.

over, the parasitic diodes that connect the drains of the output transistor to the substrate also prevent damage by clamping static voltages. Both the p- and n-channel drain diodes are ringed by regions tied to V_{cc} and ground so as to lower substrate resistance and currents.

The HC logic family, being C-MOS, retains many of the design rules that apply to CD4000B or Motorola's 54C/74C parts. Input voltages leading to HC circuits should not exceed V_{cc} or become less than ground. The devices should not be powered down while their inputs are left active.

In harsh environments, where there is a lot of power-supply or input-transient noise, inputs should have additional protection in the form of a series resistor or clamp diodes or both. The choice of the resistor can be critical since it will add some delay to the circuit.

Output rules for HC gates are again similar to those for metal-gate C-MOS devices; but because of the larger output drive of HC gates, more care must be exercised not to overdrive their outputs. The output voltage also should not exceed V_{cc} or become less than ground.

Whenever driving resistive loads, power dissipation per package should be calculated at the rated ambient temperature to ensure that the maximum dissipation is not exceeded. The steady-state output current should not be greater than 25 mA per output (37 mA for bus-driving outputs), to avoid short circuits and excessive currents. For the same reason, the total supply current should not exceed 50 mA (75 mA for the bus-driving devices).

Power-supply layout, including capacitor placement, is more critical than for metal-gate devices because switching-transient currents are much larger and also briefer. The inductance and resistance of power buses are more important. Although layout requirements are not as critical as those of TTL, careful power-bus routing and an increased use of bypass capacitors near the gate packages will maximize noise immunity.

Lowering power consumption

To reduce system power consumption, supply and switching currents should be minimized in accordance with some simple guidelines. Switching currents are related to the amount of capacitance on signal lines and to the frequency at which these signals switch. Reduc-

tion of circuit interconnection capacitances—by keeping printed-circuit-board traces short and by decreasing coupling between signal lines—will minimize switching currents. Accordingly, related high-frequency gates should be grouped to shorten printed-circuit-board traces on critical hf paths.

A second cause of excessive power in C-MOS circuits is through currents, as they are called. These flow through both the p- and n-channel transistors when a gate's input is making the transition between logic levels. Thus, the time spent between input logic levels should be kept to a minimum. In systems based on LS-TTL or C-MOS logic, waveform rise times are ordinarily sharp enough to minimize power consumption. Any slow-rising waveforms should be squared up to reduce transition times.

Low-frequency oscillators tend to have slowly rising resistor-capacitor timing waveforms that cause through currents. So in these applications, it is sometimes better to employ standard 54C/74C or CD4000B series parts. An alternative solution would be to use a Schmitt-trigger oscillator, since its internal positive feedback can be used to keep the circuit out of the transition region.

Besides shortening transition times, maintaining solid input-logic levels will also reduce unnecessary internal currents. This demand is automatically met when a C-MOS device drives another C-MOS device, because its outputs will be close to the supply voltage or ground. If the input-logic voltages are not kept close to the supply voltage, input transistors may actually conduct a slight amount of current. The device will still function correctly, so long as minimum logic levels are maintained, but an excess supply current will result.

In many designs, HC logic may be mixed with other C-MOS logic or TTL types. HC logic-level specifications are not quite compatible with TTL output specifications, however. If an LS-TTL device drives a C-MOS device, and if the TTL gate's output high level is around 4 V, the input p-channel transistor of the C-MOS gate will be slightly on, causing internal currents to flow. To increase compatibility between the two logic families, pull-up resistors from the inputs to V_{cc} can be used.

In addition, several members of the high-speed C-MOS family have been designed to have TTL-compatible inputs. Some of the latches and buffers have input levels specified at 2.0 V and 0.8 V to ease interfacing and to eliminate the extra pc-board space required by the pull-up resistors. Interfacing HC outputs with TTL gates requires no extra circuitry, since they can handle a fan-out of 10 LS-TTL loads (eight loads for the 54HC).

When 54HC/74HC, 54C/74C, or CD4000B logic families share a common power supply, no logic-level translation is needed—all three C-MOS families are input- and output-compatible. However, if CD4000B or 54C/74C devices are operating from a 10-V or 15-V supply, a logic-level conversion down to the 5-V 54HC/74HC supply is necessary. This purpose is supplied by the 54HC4049/74HC4050 circuits. These inverters and buffers are high-speed versions of the CD4049 and CD4050B devices. Their upper input-protection diode has been omitted, enabling the input voltage to exceed the supply. Thus, for operation at 5 V, input logic levels up to 15 V will be translated. □

Model 178 produces some really memorable pictures—triggers, gates, tone bursts and lin/log sweeps, for example. And it gives you a full complement of synthesized functions, including ramps, haversines and pulses. So even though we call it a waveform synthesizer, Model 178 is also a sweeper, function generator, pulse generator, and general-purpose signal source.

Also memorable are the instrument's eight digits of resolution, 0.0005% accuracy over the entire 1 μ Hz to 50 MHz frequency range—plus 20V peak to peak output into 50 Ω .

Optically isolated GPIB programming is standard. And with the free format, you can give the Model 178 instructions in any order—the dual microprocessors handle everything—in milliseconds.

More than anything else,

remember that it's a Wavetek, which means value and performance far beyond its very reasonable price. For more information, contact:

Wavetek San Diego,
P.O. Box 651,
9045 Balboa Ave.,
San Diego, CA 92112.
Tel (714) 279-2200;
TWX 910-335-2007.

WAVETEK®

Circle #140 for demonstration

Circle #141 for literature

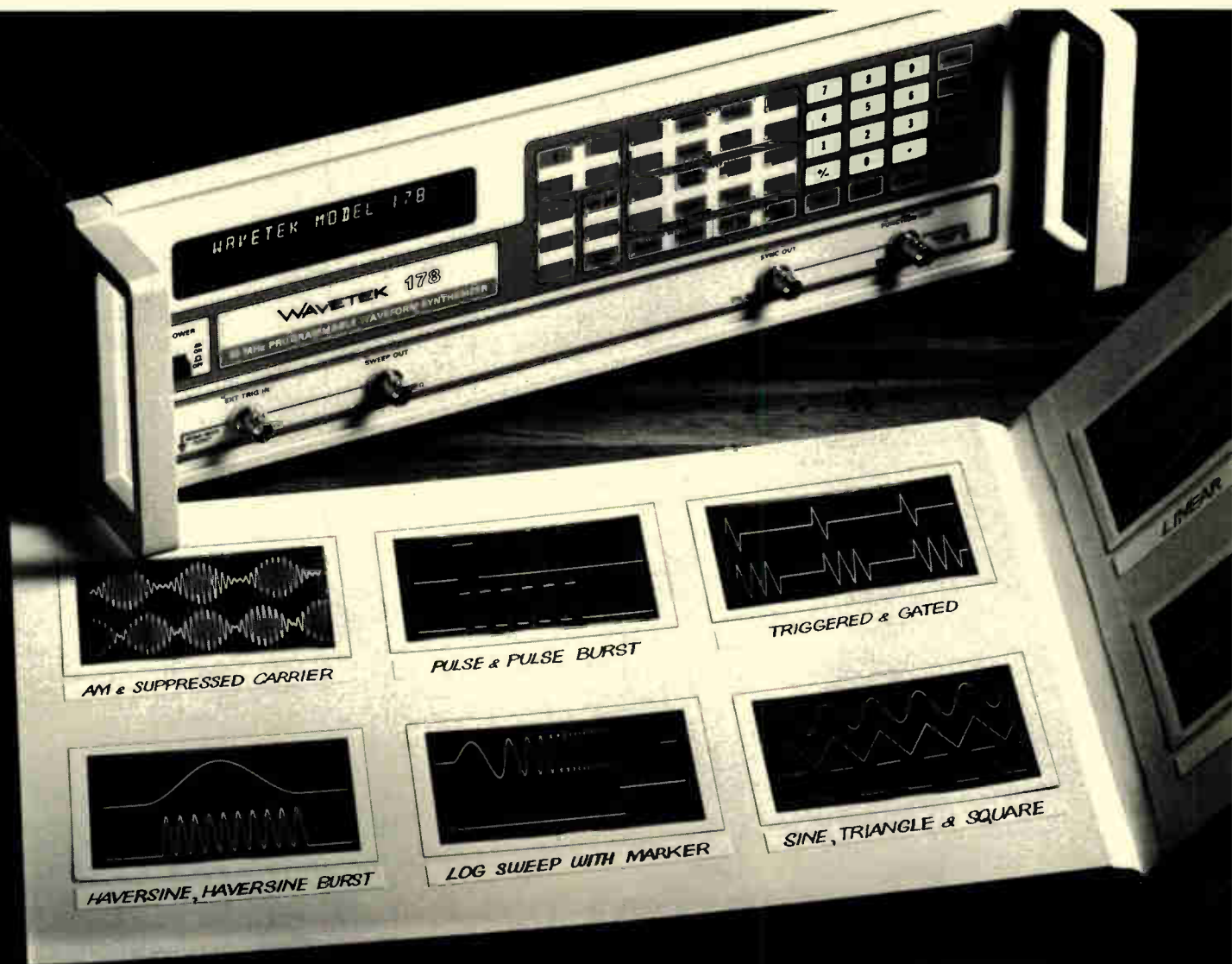

**A few shots to remember from our
50 MHz programmable waveform synthesizer.**

High-frequency sweep oscillator uses discrete components

by Charles A. Walton
Walton Electronics, Los Gatos, Calif.

Offering a wide frequency range and low distortion, this high-frequency sweep oscillator uses discrete components to deliver a clean sine wave of 0.3 to 70 megahertz with a control voltage of 0.5 to 2.5 volts. The oscillator's total harmonic distortion factor is less than 3%.

The circuit (a) uses a triple-stage inverter. It has an overall positive feedback at a frequency where each stage has a phase lag of 60° in addition to an inversion lag of 180° , resulting in a total phase lag of 720° . The oscillator frequency is varied by controlling the collector's supply voltage and current—a higher collector supply voltage

results in a higher frequency of oscillation.

By using complementary npn and pnp transistors, symmetrical rise and fall times are generated for each stage, thereby eliminating even harmonics. In addition, diode clamps in each stage prevent saturation and minimize odd harmonics. The third harmonic generated is 360° out of phase in successive stages (b).

The oscillator output is taken from a pair of successive stages and subtracted with a differential amplifier, thus canceling the third harmonic. The fifth harmonic is damped by the bandwidth limitation of each stage. Moderate decoupling between stages using 100-ohm resistors avoids parasitic oscillation. As a result, the overall low harmonic distortion allows a good-quality sine wave to be created.

The signal amplitude is 0.5 v peak to peak at 3 MHz, 0.7 v at 10 MHz, and 0.8 v at 15 MHz. The differential-amplifier stage is a convenient point to shape the amplitude versus frequency characteristic.

The high-frequency sweep oscillator, used in a proxim-

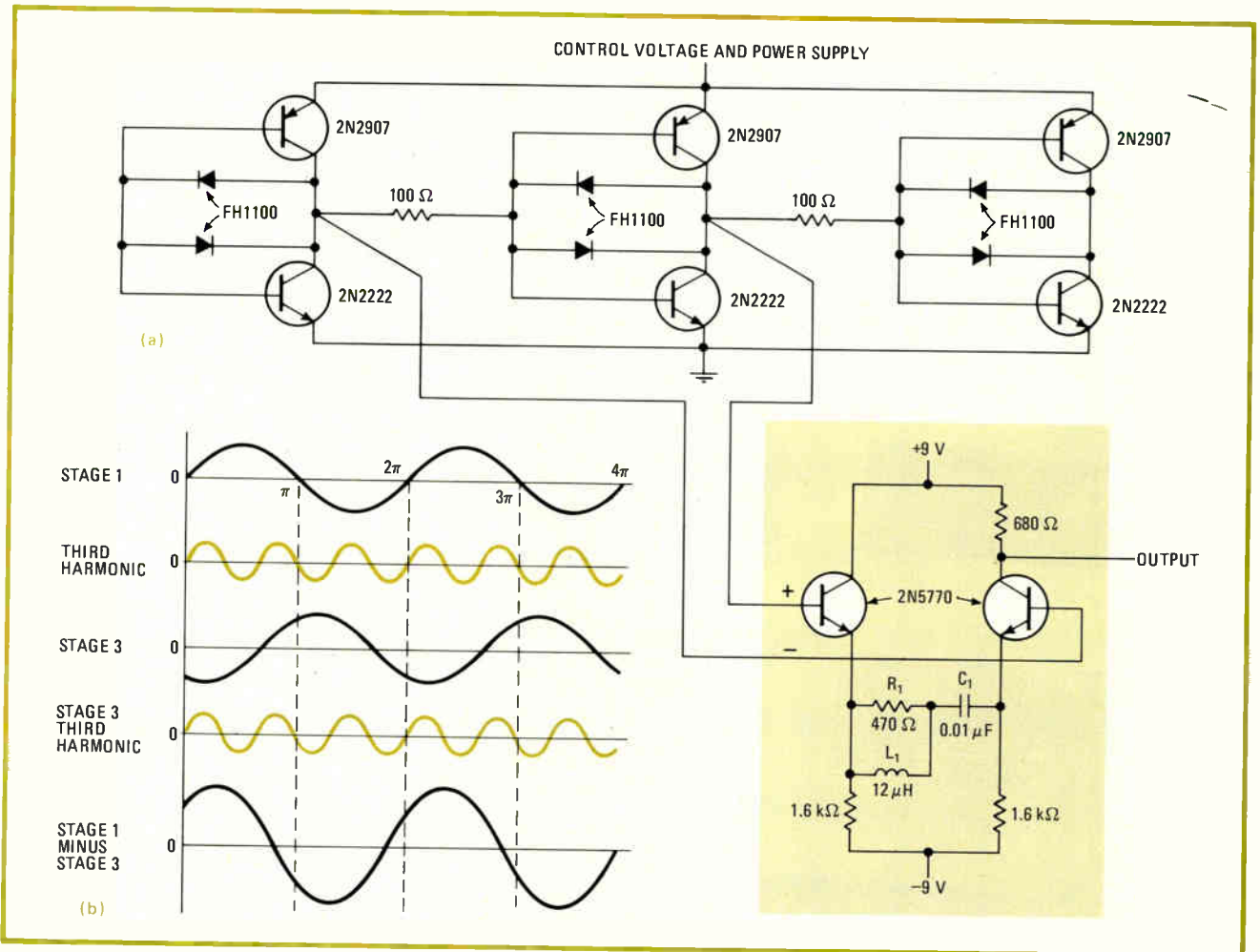

Sweeping oscillator. Increasing the supply voltage of this oscillator (a) reduces the stage-time delay, thus increasing the frequency of oscillation. Also, harmonic distortion is low due to the use of complementary npn and pnp transistors and the diodes. R_1 , L_1 , and C_1 shape the high-frequency envelope. The differential-amplifier output cancels third harmonic (b). Signal amplitude is 0.8 V peak to peak at 15 MHz.

ity electronic access system for control and identification, drives a sensing coil and searches through the high-frequency spectrum (3 to 30 MHz) for resonances in a credit-card key. The resonances, once they are found,

are used to determine the identity of the bearer. □

Designer's casebook is a regular feature in *Electronics*. We invite readers to submit original and unpublished circuit ideas and solutions to design problems. Explain briefly but thoroughly the circuit's operating principle and purpose. We'll pay \$75 for each item published.

Phase compensation stabilizes pulse-width-modulator system

by Christopher S. Tocci
Clarkson College of Technology, Potsdam, N. Y.

Unlike conventional modulation circuits, this phase-compensated pulse-width modulator employs negative feedback to improve system linearity under varying load conditions—without adding excessive cost to the system. This technique may be used when the average value of the modulator's output is the controlled variable.

The system (Fig. 1) produces a pulse-width-modulated form from an analog input by using a converter to make a differential comparison of that input and a triangular waveform. This information is fed into a fast switching comparator (power driver) having a small amount of hysteresis. The output then feeds back through the phase-shift network comprising a low-pass filter and phase compensator (an all-pass filter).

The phase-shifting properties of the filters and the feedback are shown in Fig. 2. A net phase shift of 180° indicates that together the low- and all-pass filters form an inverting amplifier in terms of the averaged output

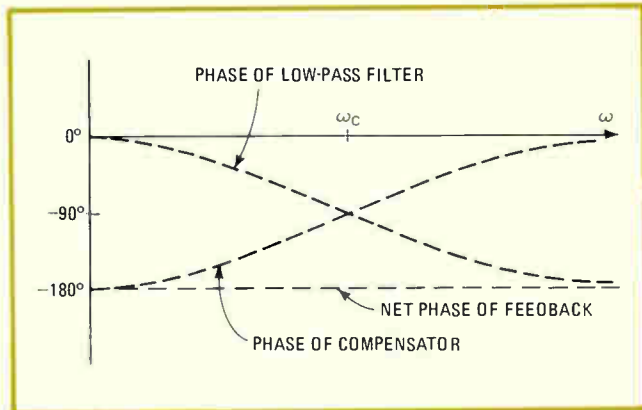

2. Phase. The figure shows the individual phase versus frequency characteristics of a second-order low-pass filter, first-order phase compensator, and the feedback network. The feedback network provides a constant 180° phase shift with respect to the input.

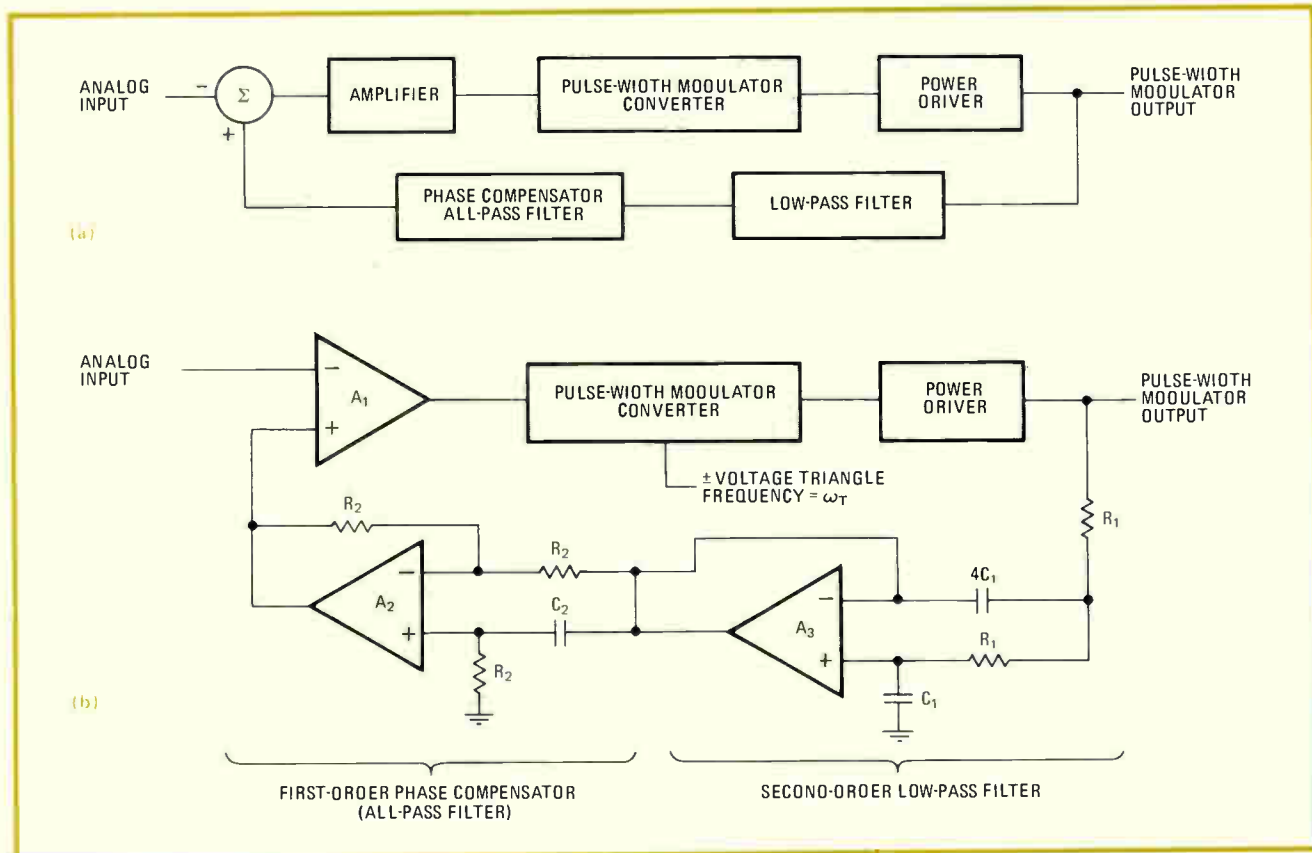

1. Stable. A phase-compensation technique (a) used in this system provides negative feedback and enhances system stability under varying load conditions. Hardware implementation of the system (b) uses a second-order Butterworth low-pass filter and a first-order phase compensator for a constant 180° phase shift of the feedback information.

Ich bin ein Berliner.

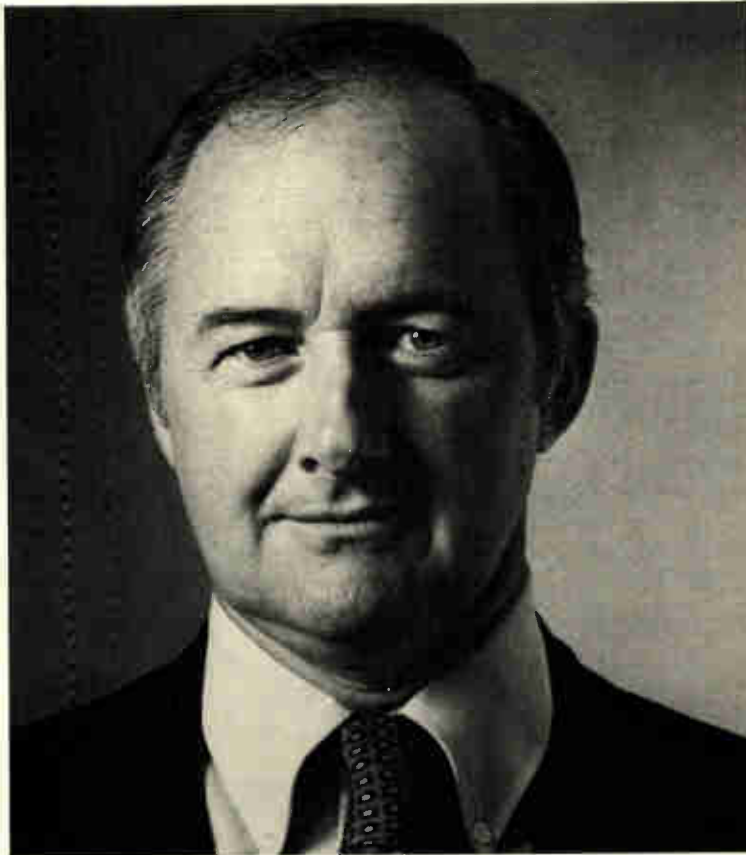

Many American companies proudly can make this statement: Ford, GM, Gillette, IBM, United Technologies, ITT, Philip Morris, Warner Lambert. Why? Because...

Berlin is high tech.

Our technical university graduates over 3,000 every year. Three recently established chairs in micro-electronics. 185 technical and R&D institutes employing 30,000, and such German technological giants as Siemens, Nixdorf, AEG-Telefunken, Mercedes Benz and Schering. In short, a technological climate and infrastructure second to none.

Berlin is quality and reliability.

An economically and politically stable city that hasn't had a major industrial strike in 35 years. 3,000 supplier companies. Unrestricted access.

Berlin is good business.

- Tax-free investment grants averaging 25% of the capital requirements for plant, machinery and equipment.
- Ten-year fixed rate loans at 7.5-9.5%.
- Our unique turnover tax rebate which adds up to 10.2% of sales to the bottom line, annually. Up to 14.2% for software and other service companies.
- Substantially reduced corporate and personal income tax rates, 75% depreciation in year one, 50-year leases of land at 3% of appraised value p.a., and more...

If you are planning to expand in Europe, you owe it to yourself and your stockholders to consider Berlin.

For more information contact: Mr. Wolfe J. Frankl, the North American Representative, (212) 980-1545. Or fill in the coupon.

Economic Development		E 1215
BERLIN		
Please send me more details about Berlin's business incentives.		
Name	_____	
Title	_____	
Company	_____	
Address	_____	
City	_____	
State	_____	
Zip	_____	Tel. _____
Mail to: W.J. Frankl, Berlin Economic Development Corporation, 767 Third Avenue, New York, N.Y. 10017-2079		

Wolfe J. Frankl, 767 Third Avenue, New York, N. Y., is registered under the Foreign Agents Registration Act as an agent of the Berlin Economic Development Corporation, Budapeststrasse 1, Berlin 30, West Germany. This material is filed with the Department of Justice, where the required registration statement is available for public inspection. Registration does not indicate approval of the contents of this document by the U.S. Government.

with respect to the input analog signal.

The low-pass filter by itself must be an even-order part to obtain a constant 180° phase difference with respect to the input. If the amplifier has the typical first-order roll-off at 10 hertz (LM741), then the net

phase differential will approach -90° at the summing input with respect to the feedback.

The filters have equal cutoff frequencies. If the switching frequency ω_T is suppressed by 40 decibels ($\omega_C \approx \omega_T/10$), the circuit's feedback error is reduced. □

Quad op amp helps reconstruct sampled data

by Kamil Kraus
Rokycany, Czechoslovakia

Analog waveforms for digital data systems may be reconstructed with this signal processor. It uses a quad operational amplifier that serves both as a sample-and-hold module and filter.

Transistors Q_1 and Q_2 , and operational amplifier A_1 make up the sample-and-hold circuit shown. Its input is TTL-compatible. The low-ripple (<0.5 decibel), fifth-order elliptical filter that follows recovers the analog waveform. The passband insertion loss is less than 0.5 dB, and the circuit's stop-band attenuation is greater than 55 dB. A standard communications bandwidth of 3.4 kilohertz is achieved by using a sampling frequency

of 8 kHz and a popular elliptical (Cauer) low-pass filter.

Op amps A_2 to A_4 depict the practical implementation of two twin-T networks and an integrator, which comprise the elliptical filter. The normalized transfer function of a single twin-T network is given by $F_1(s) = k_1(s^2 + d)/(s^2 + bs + a)$ where k_1 , a , b , and d are constants that are related to the filter's component values by $d = 1/c_1^2$, $a = 1/c_1^2(1 + 2m)$, $b = 2(2 + m - k)/c_1(1 + 2m)$, $m = c/c_1$, $k = (R_2 + R_3)/R_2$, $k_1 = k/(1 + 2m)$, c and c_1 are normalized capacitances, and R_1 whose value is 10 kilohms is normalized to equal 1 ohm. Thus, the normalized transfer function of this entire filter is:

$$F(s) = \frac{-17.6(s^2 + 1/0.02)(s^2 + 1/0.06)}{(s^2 + 0.32s + 1.27)(s^2 + 1.01s + 0.83)(s + 0.70)}$$

and it may be varied by appropriately selecting filter elements. Practical values of C_1 may be obtained from $C_1 = c_1/2\pi f_p R_1$, where f_p is the cutoff frequency.

The overall gain of the circuit is 17.6. The circuit's sample-and-hold will track a 5-volt input signal at 0.5 v/microsecond and hold the signal for up to 100 μ s. □

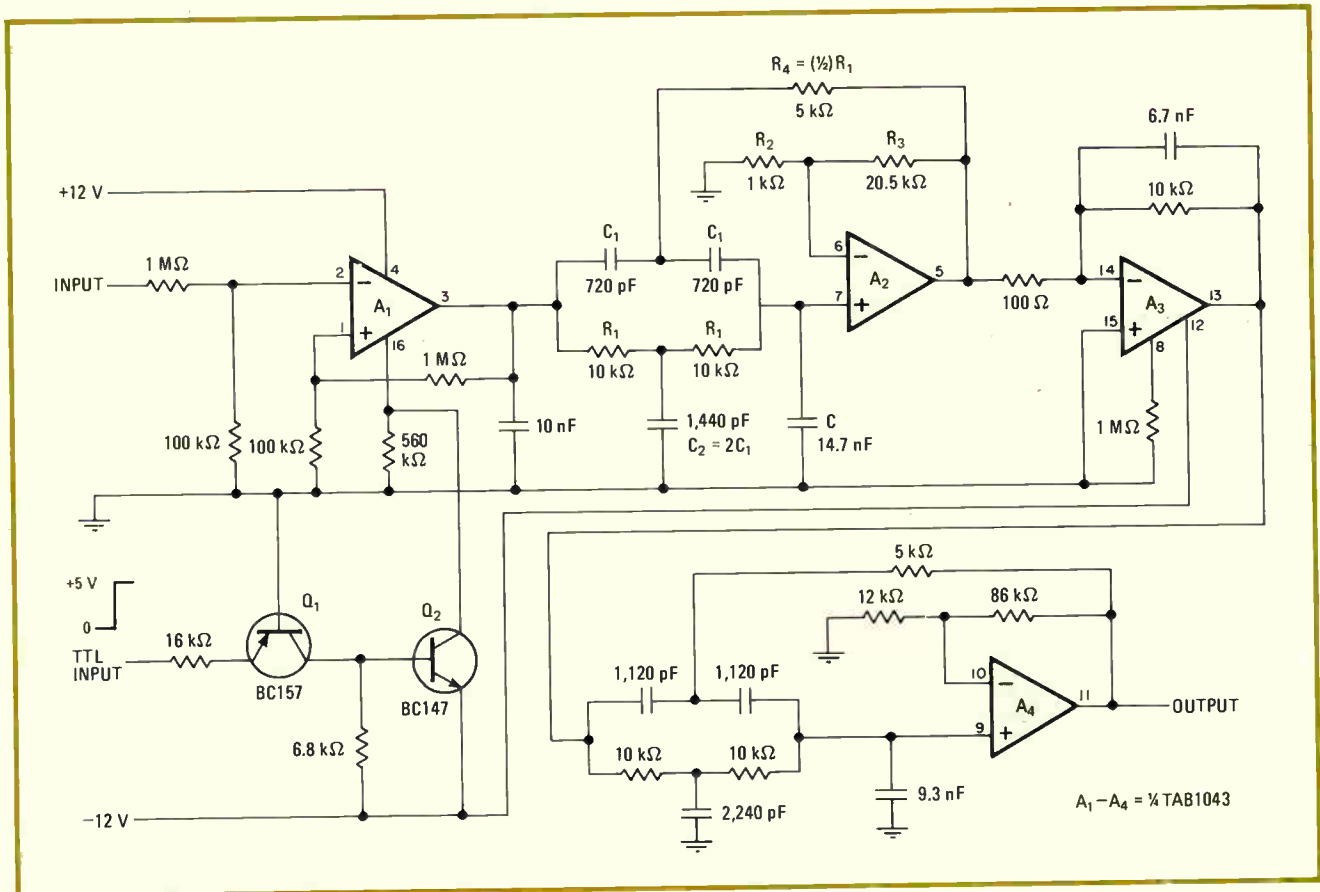

Recovery. This simple circuit built with one operational-amplifier chip derives analog information from its 8-kHz digital-equivalent input. An elliptical filter employed to recover the waveform in a 3.4-kHz baseband uses two symmetrical twin-T networks and an integrator whose characteristics may be varied by selecting the appropriate filter elements. The unit costs around \$5.

Board testing meets the challenges of ECL

ECL's negative voltages, terminator requirements, and design opportunities present special test problems in the production arena

by Joe Prang, GenRad Inc., Concord, Mass.

□ Emitter-coupled logic is proving a boon to system designers who need faster digital signal processing than TTL can provide. But for test engineers and production managers, these high-speed bipolar circuits present a whole new set of board-test problems.

Some of the difficulties arise out of the characteristics of ECL itself. Because it relies on lower voltages and smaller voltage swings to transmit data at high speeds, the instrumentation used for testing ECL-based boards must be able to both source and sense different voltages more precisely than is the case for other types of logic.

Other problems are due to the fact that ECL both constrains and frees the designer in certain areas. On the one hand, its speed—to 200 megahertz in some instances—dictates use of transmission-line-quality ter-

minators on signal paths so that data can be communicated without degradation. But then the resistive elements on such boards must be tested with greater accuracy than before.

On the other hand, ECL allows the designer to use wired-OR as well as complementary outputs. Thus the outputs of different components are often wired to the same node, with the result that each component must be activated or deactivated independently for faults to be diagnosed down to the component level.

Another freedom designers working with ECL have is the ability to use it in conjunction with TTL, letting ECL handle only those tasks demanding the highest speed and thus using less of this more costly logic. These mixed-logic designs require instrumentation that can, say, drive

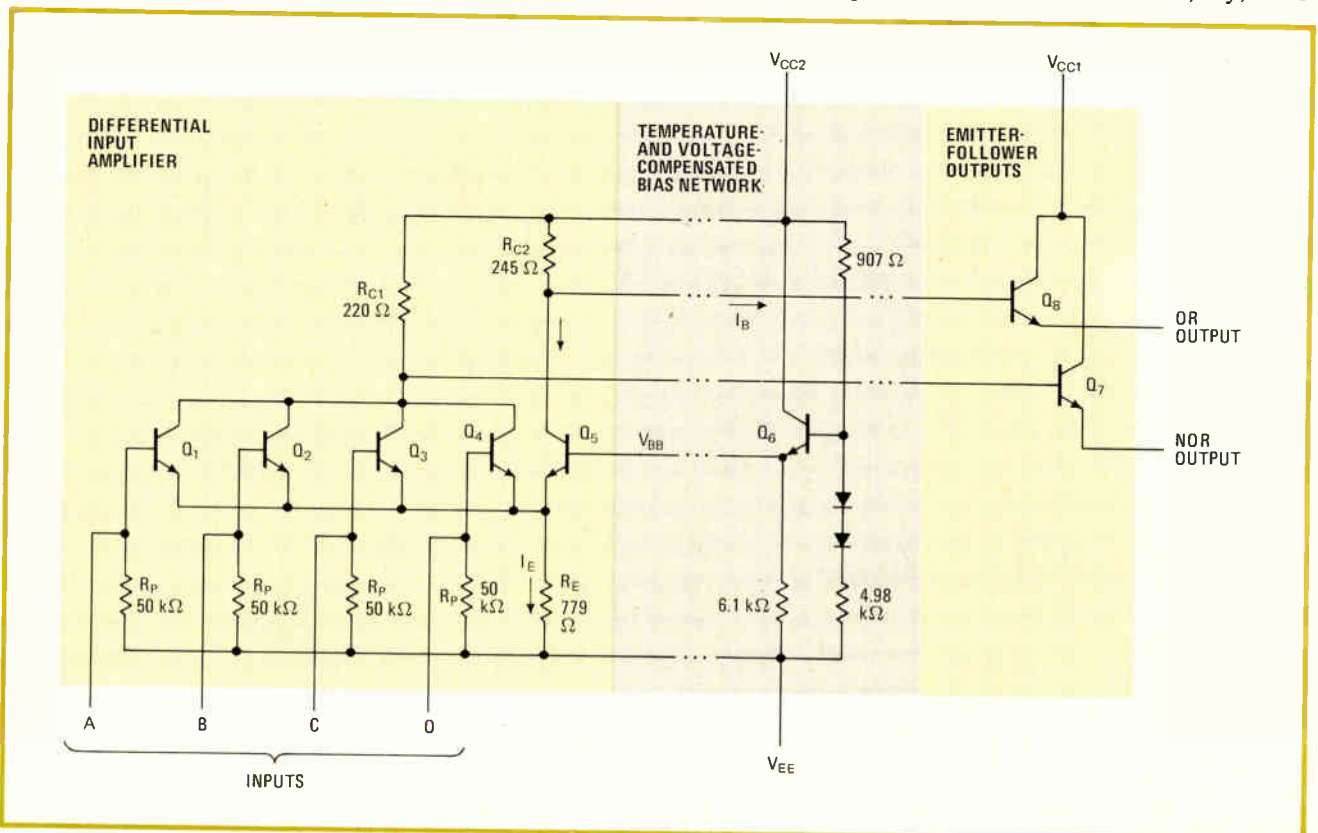

1. Challenger. The generic ECL part above shows some of the reasons this logic requires special testing. Its low collector resistances (R_{C1} and R_{C2}) make logic swings narrow and output currents significant. Outputs can be wire-ORed, making testing tougher.

circuits at one type of logic level and sense at another. Further, such instrumentation must be extremely flexible so that changes in design or boards of different designs can be accommodated without extensive and costly overhaul of the tester.

These observations derive from a comprehensive study of ECL and ECL designs that led to the creation of the 227X family of in-circuit test systems. In this family, the basic in-circuit approach has been expanded by improvements in both hardware and software in order to make ECL testing as straightforward as that of any other logic family.

To check the logical functioning of any individual component using an in-circuit approach, the test system must take command of the device's input so as to control the state of its output. This is done by sourcing or sinking enough current at the device's input to override the output of any device that may be driving it, a process that is usually referred to as back-driving.

To back-drive an ECL device like the one in Fig. 1 from a logic high (-0.8 volt) to a logic low (-1.69 v), the tester must sink an amount of current that is dependent on the value of the base-biasing resistor (R_{C1} or R_{C2}

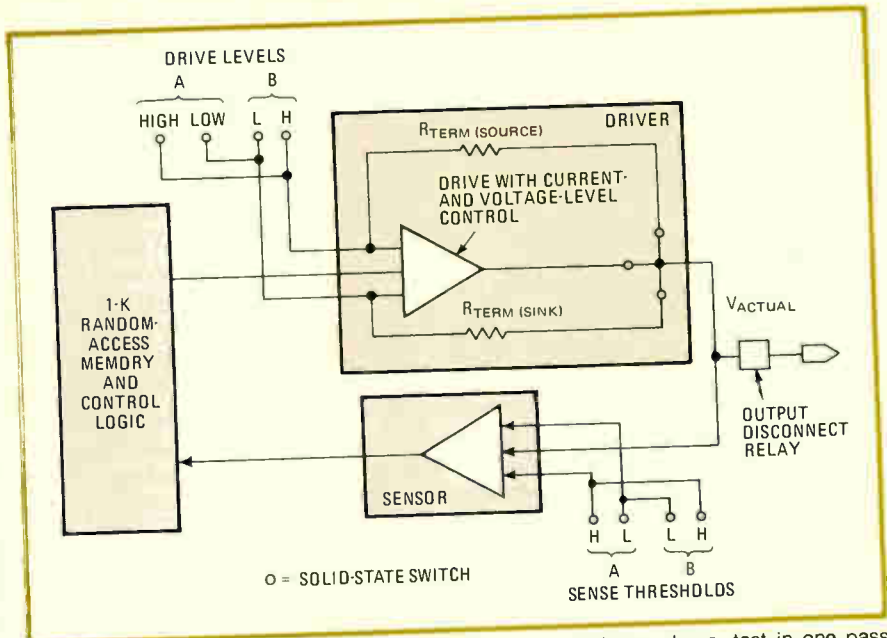

3. Smart pins. In the 227X, pins backed by memory, as shown above, test in one pass without having to hold a back-drive level while fetching instructions. The R_{TERM} resistors let devices be checked even if on-board terminators are missing.

in Fig. 1), the output-transistor gain, and the base-emitter voltage drop of the output transistor. For typical values of 220 ohms, 20-, and -0.7 v, respectively, that current works out at 90 milliamperes using a saturated-transistor model. The actual value is lower—typically 67 mA—because the external circuit usually includes a terminating resistor that sinks about 23 mA from the node.

Though this current may not seem large, manufacturers' ratings for ECL devices make it significant. Typical ratings for surge, continuous, and normal output source currents are 100, 50, and 22 mA respectively. Thus, if a tester is sinking enough current to override a logic high, it must do so for a very short time so that the 67 mA falls into the area of the output surge current. Research data for ECL devices (Fig. 2) indicates that, if a test is executed in a subsecond time-frame, the junction temperature rise caused by back-driving does not exceed the manufacturer's specified limit of 125°C and thus there is no short- or long-term degradation of the integrated circuit. Actual experience with ECL testing over several years has confirmed this data.

Back-driving an ECL device from logic low to logic high requires the tester to source less current and does not subject the device to a high current. The sourcing current needed is determined by taking the difference between the reference voltage, 2 v, and the logic high level and dividing by the external terminator resistance, typically 47 Ω . Thus the tester need typically supply only 23 mA to override a logic low.

Sourcing is thus easier for the tester and does not require the ECL device to supply high currents. Moreover, while the 227X family can handle the currents needed in either back-drive situation, its special circuit-analysis software, trademarked INHIBITS, can determine how to set a preceding layer of logic so that the tester need only override logic lows.

The 227X's driver-sensor hardware (Fig. 3) is also

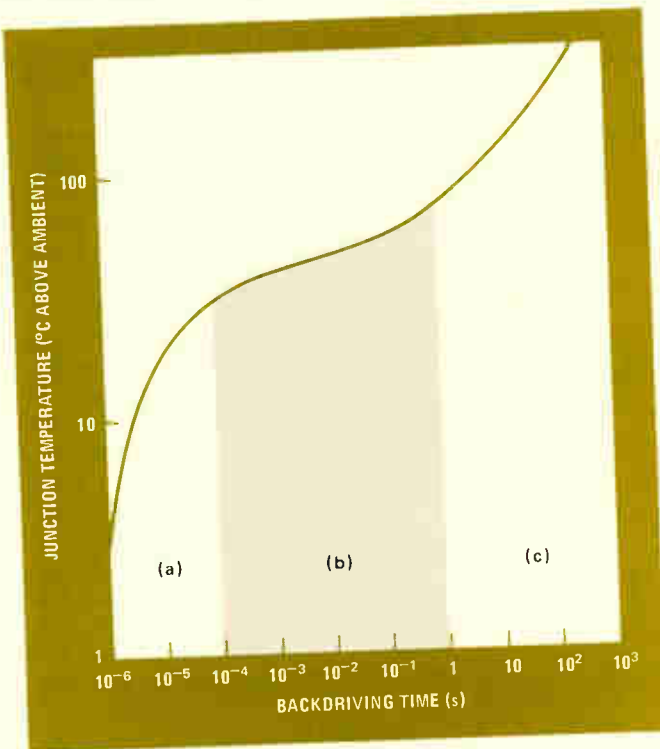

2. Heat transfer. For ECL devices in dual in-line packages, temperature rises at the output transistor junction, as shown for a back-drive sink current. In (a) the sharp rise is due to dissipation at the junction alone, while in (b) heat spreads to the header, case and leads. When they can dissipate no more (c), the rise speeds up.

designed to minimize test duration and protect against excessive back-drive currents. This is done by using dedicated memory behind each driver-sensor pair to minimize test duration. Testers without such memory must intersperse loading and execution, maintaining the state of devices while detecting faults and thus increasing back-drive time.

In addition, a parallel pin controller compares the actual with the expected logic states. Thus back-drive time is independent of the number of device inputs and outputs. If parallel sensing is not used in a tester, test sequences must be repeated for each output pin, or time must be taken to scan each sensor at each test step. In either case, test and back-drive time increases.

To control back-drive current at each driver pin, local feedback monitors unique to the 227X family are employed (Fig. 4a). The monitors automatically shut down the driver when a high back-drive current has been present for the maximum allowable time.

Accurate drive levels

Once a sufficient but controllable back-drive current is generated, control of the resultant logic voltage is important. The specified voltage ranges for ECL can have very small swings, as little as 370 millivolts in the worst case. Accurate drive levels to meet such stringent specifications are achieved in the in-circuit back-drive situation by providing local voltage-monitoring and compensation circuitry at each driver.

The circuitry in Fig. 4a has several key aspects to its design. The driver reference-voltage source, controlled by software in the user test program, is independent of the driver back-drive current supplies. (Independent back-drive sources ensure that the reference does not

vary when the back-driving loads of the device under test change.) The feedback circuit compares the actual voltage at the driver output with the reference-voltage source. Each driver has its own monitor or compensation circuit to make adjustments on a driver-by-driver basis.

In a "rail" driver design (Fig. 4b), the back-drive-current supplies also serve as the reference voltage (V_{high} and V_{low}). Any change in loading can cause the supply (reference) to vary up and down; hence the driver output voltage is not stable. Monitoring the driver voltage at its output compensates for changes in the voltage level of the back-drive current supplies, as well as the voltage drop across transistors Q_H and Q_L .

The rail driver can have voltage drops in the hundreds of millivolts across its output transistors, and these vary depending on loading. Maintaining a voltage in the specified range across all pins is difficult. The use of compensation at every 227X driver ensures that the effects of varying loads are handled directly at the individual driver without being propagated to other drivers. Isolating the operation of a driver is difficult in the rail design because noise is coupled by the back-drive supply from driver to driver.

To ensure that this accurate drive voltage is present when all outputs of the device under test are sensed, the sensor associated with each driver is strobed at each test step. Thus, when testing or debugging an ECL board, the system has direct access to both the outputs and inputs of the device being tested.

Achieving accurate drive and sense levels for ECL's negative logic voltages is not sufficient to thoroughly test a board that contains logic conversion to and from TTL. To stimulate and verify inputs at one logic level and sense outputs at another requires dual references for drivers and/or sensors.

Independent pin-level-programmable drive levels and sense thresholds for 227X testers are shown in Fig. 3. The drivers used to block feedback may be in a TTL area while the inputs of the device under test are in an ECL area. Thus, drivers to both positive and negative voltages may also be required simultaneously.

Maintaining a stable ground reference point for the device and tester also helps to create precise logic levels. As a comparison, TTL has a noise margin of approximately 1 v, whereas ECL has approximately only 0.5 v. Noise must be minimized because any fluctuations in the ground are directly coupled to the output. To counteract noise problems, ECL device designers often provide multiple

4. Controlled drive. The 227X family's driver (a) not only monitors current, but also uses a separate programmed voltage (the switched high or low voltage seen in Fig. 3) to control the pin voltage. Rail driver configurations (b) lack these dual controls.

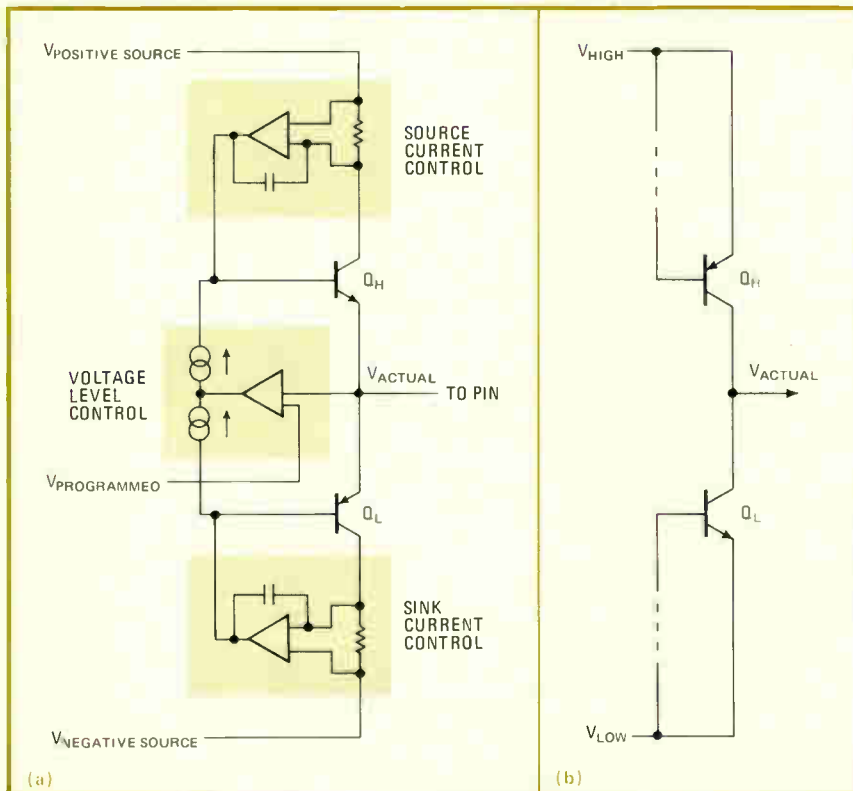

IC ground pins so a high output load current can be provided while the ground is stable.

To minimize noise, the 227X testers provide logic levels programmable from +16 v to -8 v. This eliminates the need to float the printed-circuit board in order to produce negative voltages from a positive-voltage-only driver. Driver signals are routed to the bed-of-nails fixture in cables with parallel ground-return lines to minimize any coupling. Finally, the fixture itself includes a ground plate directly beneath the board under test. This plate helps minimize coupling and provides a low-impedance ground-return path.

Terminating ECL signal lines

Pull-up resistors on TTL bus lines provide a current return to a power supply to create the proper reference voltage. In ECL designs, however, termination resistors ensure proper impedance matching of the communications lines between devices. In addition, because of ECL's open-emitter outputs, the time constant formed by the load capacitance and the terminator resistor must be precisely correct to maintain a signal's transmission time. Thus, unlike TTL pull-ups, the wrong-value terminator slows down an ECL circuit at high frequencies and creates mismatches that cause reflections and ringing.

The method of termination is typically a series resistor to a -2-v reference, which reduces power dissipation more than would parallel resistors between, say, -5.2 v and ground, another ECL termination method. The value of the termination depends on the characteristic impedance of the communications path, with circuit-board etch being typically 100 Ω and cabling being 50 Ω .

The importance of the termination value means that tests that merely verify the presence or absence of a resistor are not accurate enough for ECL. Therefore, all 227X testers include true analog test instrumentation,

with 14-bit accuracy available to each pin. A four-line matrix provides both access to source and measurement instruments and the use of extended guarding.

Extended guarding ensures that current cannot flow through parallel paths to the measurement node, and thus it isolates the terminator being tested from the effects of connected ICs and terminators.

A typical application of guarding is to a pair of parallel termination resistors between -5.2 v and ground. In this situation the parallel path is through the other resistor in the pair and any coupling capacitors or internal IC impedances between -5.2 v and ground. The use of guarding and precision instrumentation is often not available on high-pin-count testers, where analog test capability has been removed to allow more digital pins. In these designs the digital driver typically supplies the test source voltage. The inaccuracies of using a digital driver, due to the varying back-drive transistor voltage drops described previously, severely compromise the testing of the terminator.

Ensuring the presence of a terminator resistor when testing the digital IC connected to it is as important as testing for the correct value during the analog test. Terminators are typically located at the end of the signal path in good transmission design. Thus, in a multiboard system the ICs driving the outputs of a board may not have terminators on that board. Rather than force the user to customize each test fixture with switchable load resistors, the test system has internal termination resistors for each driver/sensor.

The resistors are used to terminate automatically all open-emitter outputs (perhaps every node on the board) as a protection against typical manufacturing faults like missing or misinserted terminators. Since these faults are unpredictable, the user of a system without internal terminators must either create program flow control to

The speed myth about ECL testing

A widespread misconception about emitter-coupled-logic board testing is that the test system must be able to check the devices at their rated speed.

At-speed testing is really needed only for two reasons: to check a device's parameters and to test a device whose functionality is speed-dependent.

In-circuit testing of logic devices is intended to check functionality, not ac and dc parameters. The most cost-effective way to ensure parametric compliance is to check the individual devices at incoming inspection or perhaps to have them checked by an independent semiconductor testing house. Handling devices during board assembly will not change these parameters.

Unlike many MOS and TTL devices, ECL devices do not have minimum operating speed requirements. Dynamic n-channel MOS random-access memories, for example, have a mini-

mum keep-alive rate—the frequency with which charge that has leaked off bit-storing capacitors must be replenished, or refreshed. Since ECL devices store bits in cross-coupled transistor flip-flops which will not change with time, they are fully static, and as such, they do not have keep-alive rates as many MOS devices do.

TTL devices can be subject to double-triggering—switching twice for a single logic transition. The phenomenon occurs because real digital waveforms are often not ideal and because TTL devices trigger at a single level, as

indicated below. ECL devices operate internally in a master-slave mode—transitions must first be latched by a master before they can be transferred to the slave that controls the device output—and the master and slave have different trigger levels. The separation between levels makes double-triggering of ECL virtually impossible.

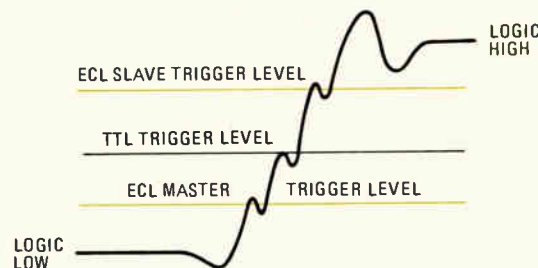

SOFTWARE MODEL FOR A 10102 DEVICE	
Listing	Comment
.HEAD; .SIZE 16; .INPUT (4 6 10 12=A, 5 7 11 13=B); .OPENE (2 3 14 15=NX, 0 0 0 9=X); .DL (4, 5, 6, 7, 10, 11, 12, 13); .END HEAD;	description of pin functions
.DISAB (X) IL (A, B); .HOLD (A, B); .END DISAB; .DISAB (NX); PH1 (A, B,); .HOLD (A, B); .END DISAB;	output disable
.INH (X, NX); PH1 (A, B,); .HOLD (A, B); .END INH;	input inhibit
.HFORCE (NX); IL (A, B); .END HFORCE; .HFORCE (X); IH (A); .END HFORCE; .HFORCE (X); IH (B); .END HFORCE;	beyond-the- node bus diagnostic (Busbust)
.MAIN; SSP (X, NX); IC (A, B) OS (X,NX) OH (NX) OL (X); IH (A) OL (NX) OH (X); IH (B) IL (A); IH (A); SPN (X, NX); ID (A, B) OI (X, NX); .END MAIN;	truth-table test

skip all ICs that missing terminators make untestable or replace and retest misdiagnosed ICs.

Much has been said about the problems of automatically generating tests for bus-structured TTL circuit boards. ECL boards compound this problem several times because every output can be wire-ORed with others. Thus automatic test generation (ATG) must:

- Identify the presence of the bus node (that is, a node driven by two or more outputs) and which are the devices that drive it.
- Determine how each device can be disabled from driving the bus.
- Generate an all-devices-disabled, go/no-go bus test before individual devices are tested.
- Perform beyond-the-node diagnostics should the go/no-go test fail.

To achieve all this, the 227X ATG process adds two unique tools to the basic techniques of generating in-circuit tests. First, ATG software analyzes the circuitry that surrounds the device under test, in addition to simply matching models with devices. Second, the models for devices provide more information than just the appropriate truth-table test. The analysis of the sur-

rounding circuits, described in the user's topology description file, identifies what components are connected to the device under test. Pin functionality descriptions in the models help distinguish what devices in addition to the test one are driving an output node.

The model 10102 ECL device is described in the tester model seen at left. In the program, the Head section describes pins as INPUT, OPENE, and so on, to allow the ATG process to identify where devices with multiple open-emitter (OPENE) outputs are wired-ORed to form a bus. Once the bus has been identified as present, disable procedures called DISAB are extracted from the models for all devices driving the bus. By putting these procedures together, ATG automatically creates a go/no-go test for the bus that ensures that no contention exists. Should this test be passed, then individual devices on the bus can be tested with the assurance that detected failures are due to some defect in them and not others. The disable function is also needed in these individual device tests to guarantee that only the test device is communicating with the bus.

Should a go/no-go bus test fail, individual devices on the bus cannot be tested in an isolated manner due to the contention problem. To ensure that component-level diagnostics are maintained without operator intervention, ATG automatically creates test procedure BUSBUST to handle these "beyond-the-node" diagnostics. Once again, information is extracted from the models—HFORCE and LFORCE—to identify the contribution of each device to parametric measurements being made at the bus node. The faulty device(s) can thus be isolated from the good ones driving the bus.

Completing isolation

Controlled back-driving and automatic bus disabling are two ways the 227X extends the basic in-circuit technique to ensure test isolation of components that drive the device under test or share a common bus with it. A third and equally important effect occurs because the circuit board is powered and stimuli are applied to various nodes during tests, which can create feedback.

Feedback paths in the board design may affect the static state of the devices driving the test one. Glitches and instability result, causing an intermittent test of an IC. The best solution is to prevent changes in the state of the logic driving the device under test.

Circuit analysis and the model for each device can once again be combined to solve this problem. In this case, the analysis attempts to locate what drives the device. This function, trademarked INHIBITS, can use the pin functionality data in a model to determine which devices with an output type of pin share a node with an input-type pin on the device being tested. The actual procedure (.INH in the model) is extracted from the model and included in the truth-table test for the device being tested. The inhibit function prevents any change in the output state for a change at either input due to feedback, noise, and so on, by choosing from the truth table the output state least sensitive to a change on the input pins. Thus, the node where back-driving is taking place is protected. In a similar way, INHIBITS can set the logic states for low-current back-driving. □

Custom video control delivers advanced font graphics

Video subsystem in multifunction work station adapts to user's design needs with add-on options, software-modifiable fonts

by Mike Ramsay and Theodore A. Shaffer, *Convergent Technologies, Santa Clara, Calif.*

□ The most important person-to-computer interaction in an information system is through the terminal. The computer's face to the world is usually a video display and, in designing a system, the display screen, the video logic behind it, and the display-driving software should be given special attention. This was done in the design of the video subsystem for the Convergent Technologies' Integrated Work Station (IWS). The result is an innovative video-display system that is easy to look at, simple to understand, and comfortable to work with. It can also be easily adapted by a system builder to specific applications.

The IWS has a custom-designed character-oriented display; but with its high-performance row-buffer architecture and available add-on extensions, it achieves some capabilities of bit-map displays—graphics; double-width, double-height, and boldface characters; and subscripts and superscripts—while preserving the speed and display dynamics of character displays.

The display system has a character font that can be modified by software, so changes are quick and easy. An interactive font-design program is provided (see "An interactive font designer," p. 154) so that system builders can design their own character fonts.

Ergonomic (human engineering) issues played a strong role in the overall system design because users of the IWS are expected to spend large amounts of time—possibly most of their working day—in front of the display. Thus, physical features such as high resolution, highly legible characters, an antiglare screen, and a tilt-and-swivel display are included. Also, the ergonomics of the system's software proved equally as important.

The IWS multifunction work station, which has the capability of a small minicomputer, uses the Intel 8086 microprocessor, high-density random-access memory, and the custom-designed video display packaged in three units—central processing unit, display, and keyboard—for a compact desk top configuration (above). Systems can be configured either as single-user, display-based

minicomputers with up to 1 megabyte of RAM and 60 megabytes of Winchester-drive disk storage, or a cluster of up to 16 work stations that share mass-storage resources. In the cluster configuration, all the work stations remain computers with their own operating systems, making possible fast response when running user application programs.

In order to produce high-quality characters and graphics, custom video logic was designed with speeds that exceeded those of commercially available large-scale integrated video chips. The system was also designed to give the system builder flexibility in tailoring the display's features for specific applications.

Another requirement determined from prospective users was the option of either 80 or 132 characters per row. A wider row is required for previewing line-printer output in traditional data-processing applications and displaying 12-month tables in financial modeling.

Character density on the display also proved crucial to the design. With too few characters, not enough information is available at a single glance; with too many characters, legibility will be poor. On the 15-inch screen that was chosen, a good compromise between high density and legibility was achieved with 34 lines of characters.

The size of each character cell was established at 10 dots wide by 15 scan lines high. With 34 information-character lines and one retrace character line, the total number of scan lines is 35×15 , or 525—the same as the RS-170 standard for TV scanning, except the IWS display is refreshed at 60 hertz noninterlaced instead of the standard 30 Hz interlaced, making the display flicker-free. Still, the IWS can be interfaced with RS-170-compatible projectors, monitors, and video printers.

With these design criteria, the video display capabilities achieved can be summarized as follows:

- Thirty-four lines of 80 or 132 characters a line.
- A character generator, called a font RAM, for storing up to 256 user-defined characters and graphics.
- Four standard character attributes usable in all 16



possible combinations of underline, reverse video, half-bright, and blink functions.

- Facilities for adding double-height, double-width, boldface, subscript, and superscript capabilities to the display's character attributes.
- A 10-by-15-dot character cell.
- Separate whole-screen attributes: characters per row, reverse video, half-bright, and blank.
- Expandability of the font RAM to 512 characters.
- Provisions for including line attributes.

These capabilities are implemented in the video subsystem, which consists of a 10-by-12-in. logic board in the CPU card cage, the display, and an interconnecting cable up to 12 feet long.

The implementation of row buffer architecture to achieve the performance required became a technical challenge, although the architecture itself is not unique. Figure 1 includes a block diagram of the video control board. The row buffers are made of high-speed bipolar RAMs. They can contain up to 256 8-bit character codes and 4-bit attribute codes, though only 132 are used. The attribute codes go to the character-attribute logic. The character codes pick up 4 bits of scan-line address, representing each of the 15 scan lines of the character cell on their way to the font RAM, where they form a

12-bit address. The font RAM, implemented in 10 4-K-by-1-bit static H-MOS (high-speed MOS) chips, contains 15 10-bit data words for each of the 256 characters represented by the 8-bit code from the row buffers.

All 150 locations of the character cell are user-definable and can be loaded from the system memory over the local data bus through a direct-memory-address transfer. DMA is also used to transfer character and attribute data from system memory into the pair of high-speed RAM row buffers. While one is being loaded, the other is being read for refreshing the screen.

The DMA transfers consist of short, three-word blocks. After each block is transferred, the local data bus is available to the CPU or other DMA channels. A succession of three-word transfers is required for each character row. The time during which the video control occupies the bus depends on the number of lines displayed and the number of characters per line. In the worst case, it holds the bus approximately 20% of the time.

The data out of the font RAM is first loaded into a 10-bit emitter-coupled-logic output shift register and then serially shifted out through the output logic and becomes the data stream to the display. The 4-bit character-attribute codes are decoded in the character-attribute logic, and then used to modify the output video

1. Block and board. The large board is the basic video control board for the integrated work station. Riding on top is the advanced features option board. The block diagram of the main video control board in the work station shows the dual row-buffer architecture with the font RAM implemented in high-speed semiconductor memory to provide a high-performance character-oriented display.

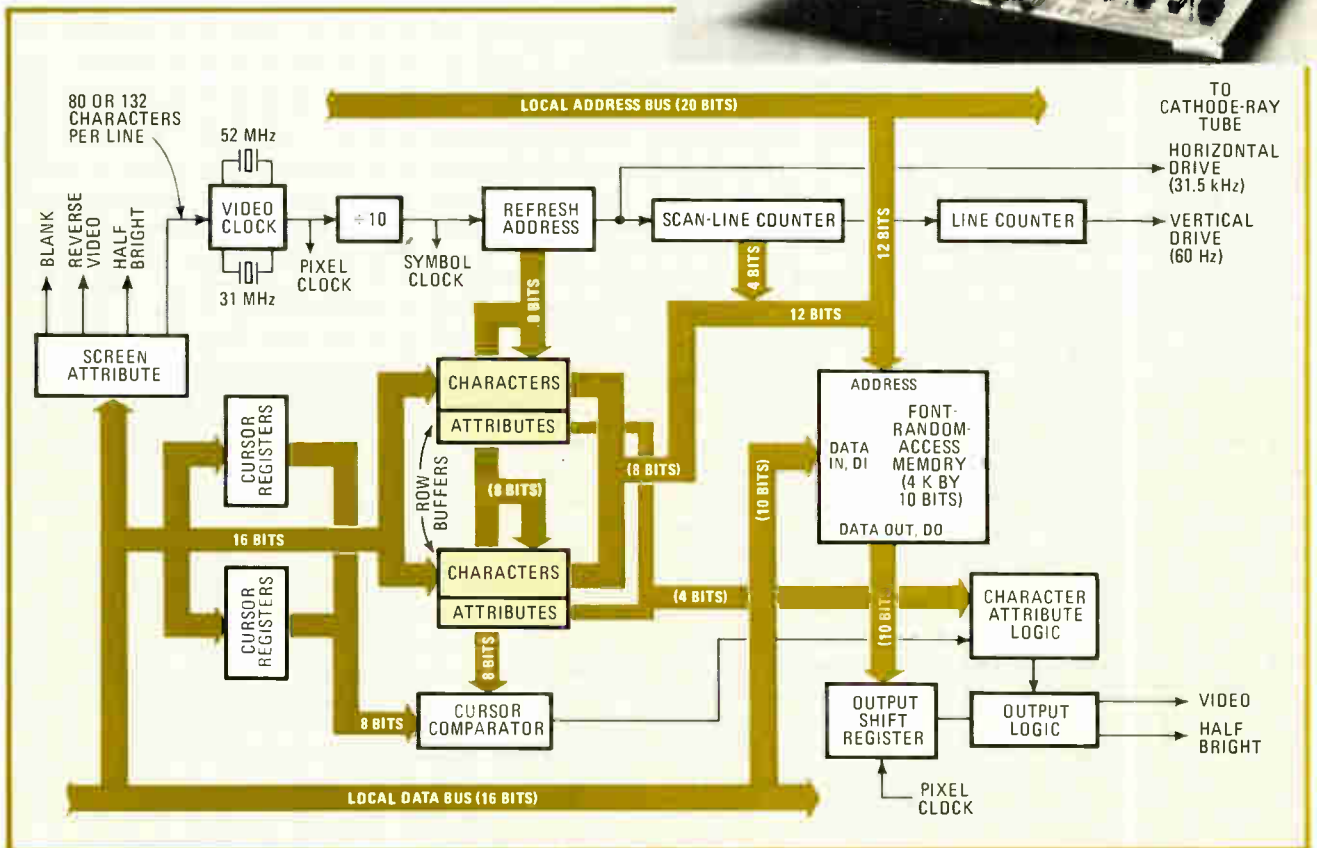
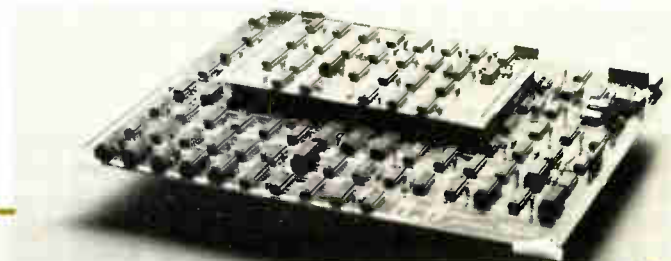

stream going through the output logic. Cursor registers are provided with each row buffer. These are loaded at the beginning of each character row and specify the cursor position, if any, for that row. The video clock, output shift register, and output logic are all implemented using Motorola's Inc.'s 10000 series logic.

Frosting on the cake

The capabilities of the basic video subsystem can be extended with an add-on expansion board. Word- and document-processing are areas in which the functional capabilities of the work station and enhanced video capabilities can be well-utilized. A study of the functional requirements of these areas indicated the need for several desirable add-on features.

First, the character attributes are expanded from four to ten to add superscripts and subscripts with controllable offset, boldface characters, double underline for accounting, and cursor selection on a character-by-character basis. Line attributes are added for double-height and double-width characters. Two other extensions are a 10-by-15-dot matrix cell for a user-definable cursor character and expansion of the font RAM to 512 characters for quick alternation of character sets.

These features are implemented through character manipulation rather than with specialized character sets. Thus the 512-character set is maintained independent of the attributes invoked.

The hardware implementation consists of a second printed-circuit board called the advanced video control board mounted on top of the video control board. Two 40-pin connectors join the two boards. All the additional

features, except the font RAM expansion, are implemented on a single add-on board. An additional add-on board is dedicated to the 256-character expansion of the font RAM. Thus the option permits either attribute or font expansion.

Expansions of the character attributes—superscripts, subscripts, offset, double underline, cursor-select, and boldface—are accomplished with attribute-mapping executed in what is called a style RAM that is mounted on the add-on board on top of the main video control board. This RAM has as its address the 4-bit character attribute codes from the row buffers.

Data can be loaded into the style RAM with a DMA transfer from system memory. Data coming out of the RAM consists of a single bit for each of the 10 implemented attributes—the six new ones enumerated above and the four standard ones.

For a given loading of the style RAM, up to 16 combinations of the 10 attributes can be invoked. Figure 2 shows the style RAM on the add-on board and how the attribute codes are rerouted to the address input of the style RAM. Data out of the RAM corresponding to the four standard attributes is passed back to the main video control board for decoding in the attribute logic. The six additional attributes are processed on the add-on board and then are routed to the output logic on the main video control board.

Character attributes for superscript or subscript are displayed by causing the characters to be offset higher or lower within the character cell. The amount of offset is determined by the offset attribute. For superscript and subscript with no offset, the character is moved by two scan lines in the desired direction. With the offset set, the character is moved by four scan lines, and two scan lines are removed from within the character cell, truncating the character height. The font is reduced in this manner in order to retain maximum character legibility.

The relative position of the character within the cell is determined by the scan-line counter-address input to the font RAM. Usually, this counter addresses the low-order 4 bits of the font RAM in the range 1 to 15, corresponding to the 15 scan lines in each character cell. By altering this addressing sequence, character offset is achieved.

For double-height characters (a line attribute), the scan-line count is simply incremented every other scan line. The point at which the row buffers are transferred is delayed by

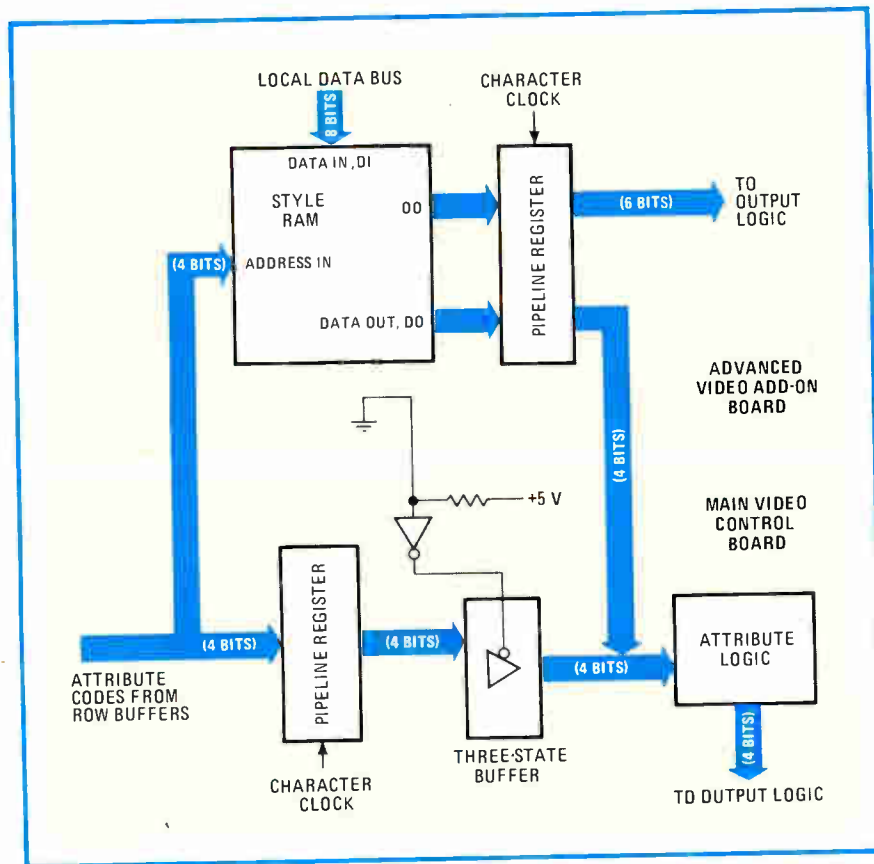

2. Add-on. A style RAM and pipeline register on the advanced video add-on board add six character attributes. These, plus other circuitry on the add-on board, create a video controller that gives the display features similar to that of bit-map displays.

An interactive font designer

The Convergent Technologies font designer is a software product that is used interactively to design character sets. Whereas most computer systems have what are termed hard read-only-memory-based character sets, the 256 characters in this system are called soft because they can be modified using software. A standard character set is supplied, but a user can develop a customized character set to replace it or define multiple character sets that can be called up dynamically by application programs.

The font designer screen, as shown in the figure, is divided into six windows, called frames—the scaled-character frame, the character frame, the character-code frame, the work-area frame, the sample-text frame, and the sample-text character-code frame.

While the character frame displays the character being edited in true size, the scaled-character frame above it displays a greatly enlarged version that is easier to work with. The character-code frame contains the two-digit hexadecimal code of the character being edited.

To modify a character, the user either types the character into the character frame or types the hexadecimal code into the character-code frame. At this point, the enlargement appears in the scaled-character frame. Each cell in the scaled character frame represents one pixel in the 10-by-15-dot matrix of the character. Editing consists of positioning the cursor at individual cells, which are turned on or off with function keys on the keyboard. As the pixels are modified in the scaled-character

frame, the character frame is concurrently updated to reflect those changes. More advanced editing features allow blocks of pixels to be turned off or on or moved from one area to another.

Characters can be edited in the work-area frame as well. The advantage of this frame is its 40-pixel (4-character) width, which can be used to draw multicell symbols or to examine the relationships between characters when they are adjacent. Blocks of pixels can be moved or copied back and forth between the scaled character frame and the work-area frame.

The sample-text frame displays three rows of 40 actual-size character cells each so that a representative sample portion of the font currently being worked on is also visible. As the user types into this frame, characters are displayed as they appear in this font.

Characters may also be entered into the sample-text character-code frame in the form of hexadecimal codes vertically arranged. As the codes are typed into this frame, the characters, in the current-font, are displayed in the corresponding position in the sample-text frame.

Several input and output commands are available to merge fonts. The read-font command is used to read part or all of a font file into the current-font memory. The write-font command does the opposite—writing from the current-font memory into a file. The read-text command reads from an ASCII-coded file into the sample-text frame for judging different fonts using the same sample text.

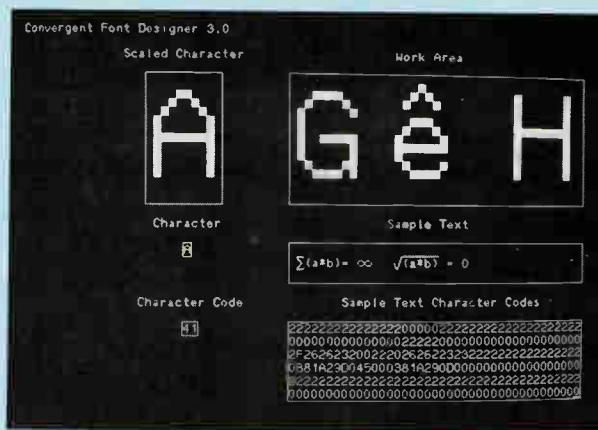

the appropriate amount. Superscript and subscript in conjunction with double-height characters result in the display of single-height characters offset to either the top or bottom half of the double height row.

The implementation of these line and character attributes is also accomplished with circuitry on the advanced video add-on board. An alternate line counter is synchronized to the main video control board counter. Output from this alternate line counter, in conjunction with the appropriate character and line attributes, address a programmable ROM. The output from the PROM is passed back to the main video control board to become the low-order address bit to the font RAM. The PROM is programmed to do the scan-line manipulations needed.

Double-width characters are implemented by loading every other character from the row buffer into the output shift register on the main video control board and clocking the register at half the normal rate. Thus every other character in the row buffer is displayed.

Boldface characters are generated by stretching every illuminated dot in the character cell to two dots in the horizontal direction. All vertical lines thus become wider. A single OR gate is required on the add-on board

which, when selected by the bold-enable line from the style RAM, gates the serial video stream with a 1-bit delayed version of itself.

User definition of cursor shape is accomplished through the use of a dedicated 10-by-15-bit RAM on the add-on board. This RAM is loaded by a DMA across the local data bus and contains the bit pattern for the user-defined cursor character. The RAM is addressed from the scan-line counter. The 10-bit output is loaded into a shift register and then output serially and exclusive-ORed with the main video stream. The standard cursor is disabled but the 2-Hz blink rate is superimposed on the new cursor in the output logic.

An additional 256 characters are added to the font RAM by parallel connection of another 256-character RAM. Each chip has three-state outputs and can be selectively enabled. This is accomplished by dedicating an additional style RAM output to character set selection. Thus, either font can be selected on a character-by-character basis. Either font RAM is loaded and read with a DMA transfer across the local data bus. The character set selection for loading is made by a dedicated bit in the screen attribute register. □

INTERCONNECTION CITY NEWS

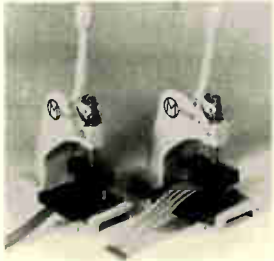

NEW Flat cable notcher and multiple terminator, hand press or optional power press.

Circle 146 on reader service card



NEW, in line "JAGUAR" IDC series of mass termination .100" and .156" center connectors for wire-to-board discrete wire or ribbon cable applications.

Circle 147 on reader service card

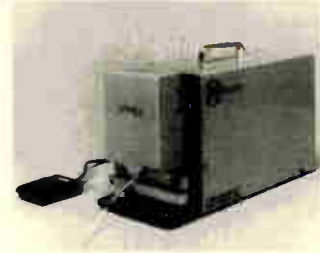

NEW Model JT-1 semi-automatic self indexing all electric I.D.C. Terminator.

Circle 148 on reader service card

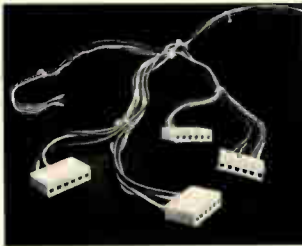

Custom discrete wire or cable harnesses. Simple or complex... available to customer specifications.

Circle 149 on reader service card



"JAGUAR" ...
Methode's name
for high speed mass
termination with I.D.C.
connectors and application
tooling.



NEW card edge connector with insulation displacement contacts for mass termination. Fits .062" PC boards, 4 thru 15 positions.

Circle 150 on reader service card

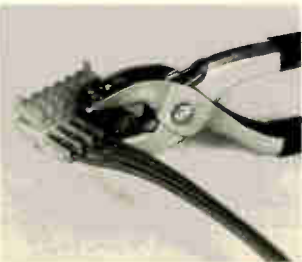

NEW Simple pliers for field terminating Series 2300 power connector.

Circle 151 on reader service card

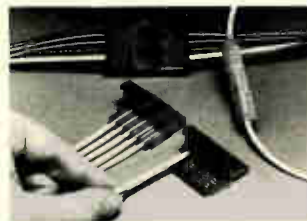

NEW Series 2300, 1-6 circuit power connector insulation displacement termination. Saves crimping & stuffing contacts. Hermaphroditic housing saves handling & inventory.

Circle 152 on reader service card



NEW Self-indexing hand held terminating gun for low volume or field termination of "JAGUAR" connectors.

Circle 153 on reader service card



NEW Self indexing arbor press for terminating Series 2300 power connector.

Circle 154 on reader service card



Model JT-7—fully automatic high speed production harness fabricator — multiple options.

Circle 155 on reader service card

Methode offers a full line of interconnect products. For complete product data, just circle the reader service number.

Methode Electronics, Inc.

INTERCONNECT PRODUCTS DIVISION
1700 HICKS ROAD
ROLLING MEADOWS, IL 60008
(312) 392-3500 TWX 910-687-0760

In Europe

Methode International, Inc.

P. O. BOX 93 BERKHAMSTED
HERTS HP4 2AT U.K.
TELEPHONE 04427 75536
TELEX 8267 15

Program pinch calls editor and assembler at random

by P. R. Ramraj
ISRO Satellite Centre, Bangalore, India

As software is developed, it usually needs to be able to call quickly on its editor and assembler from paper tape, magnetic tape, a floppy disk, or a semiconductor memory. This program pinch transfers editor or assembler programs at random from erasable programmable read-only to random-access memory.

The RCA Cosmac development system (CDS-II) has a resident editor and assembler (level-I) on paper tape.

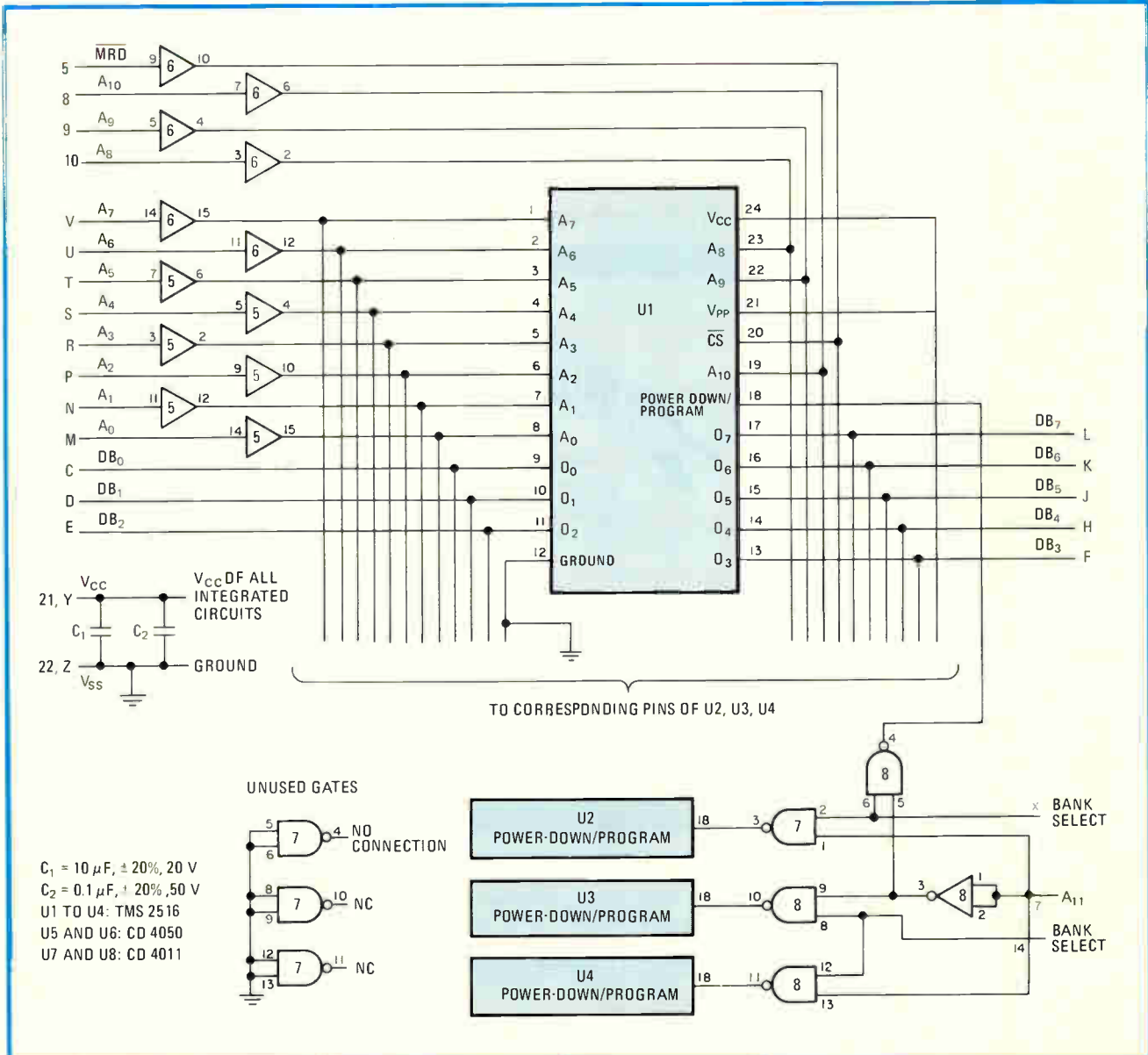

No.	FROM		TO		Remarks
	Module-slot No.	Pin No.	Module-slot No.	Pin No.	
1	Memory module-slot No. 5	X	Address latch and decoder/slot No. 10	5	Bank A for 4-K-byte erasable programmable read-only memory
2	Memory module-slot No. 5	14	Address latch and decoder/slot No. 10	4	Bank B for 4-K-byte E-PROM

Memory bank. CDS-II provides unused space for memory banks (slot 1 to 7). Slot 5 is selected to accommodate an 8-K-byte E-PROM card that will hold the assembler and editor. Banks A and B, which are allotted for an assembler and editor, each have a 4-K-byte E-PROM, and a program pinch is appended with each of them.

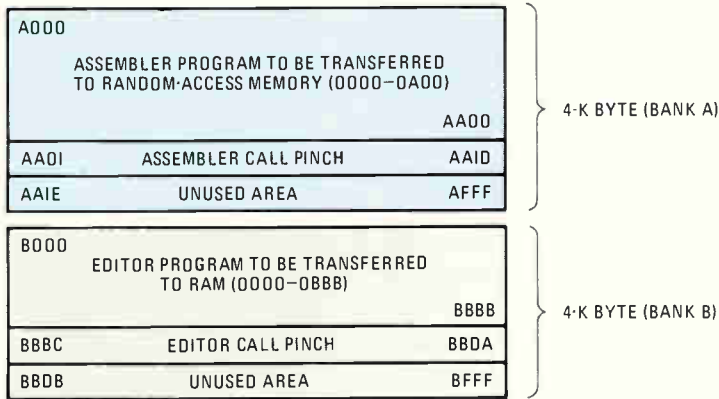

MEMORY MAP
FOR ADDED 8-K-BYTE
ERASABLE PROGRAMMABLE
READ-ONLY MEMORY

FLOW CHART FOR ASSEMBLER CALL PINCH

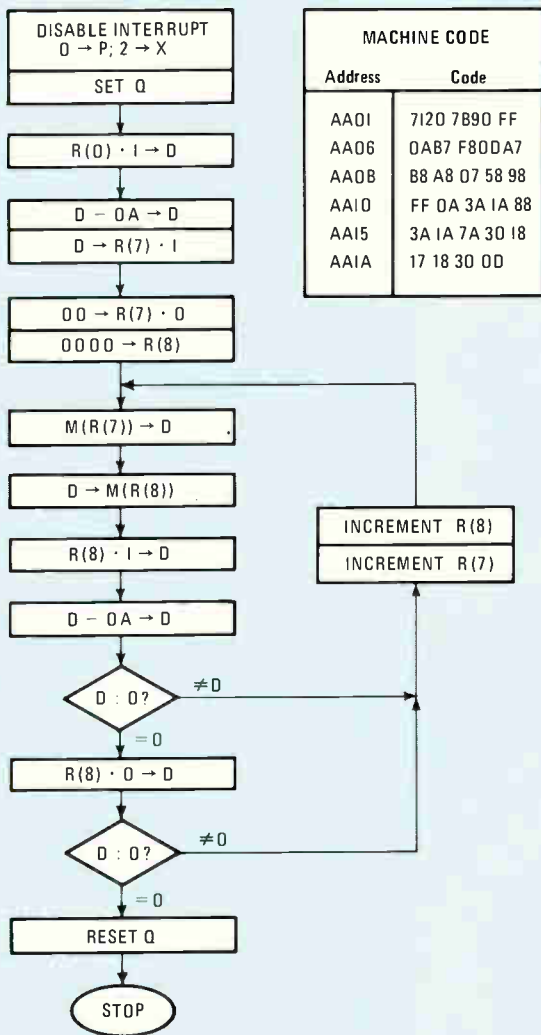

FLOW CHART FOR EDITOR CALL PINCH

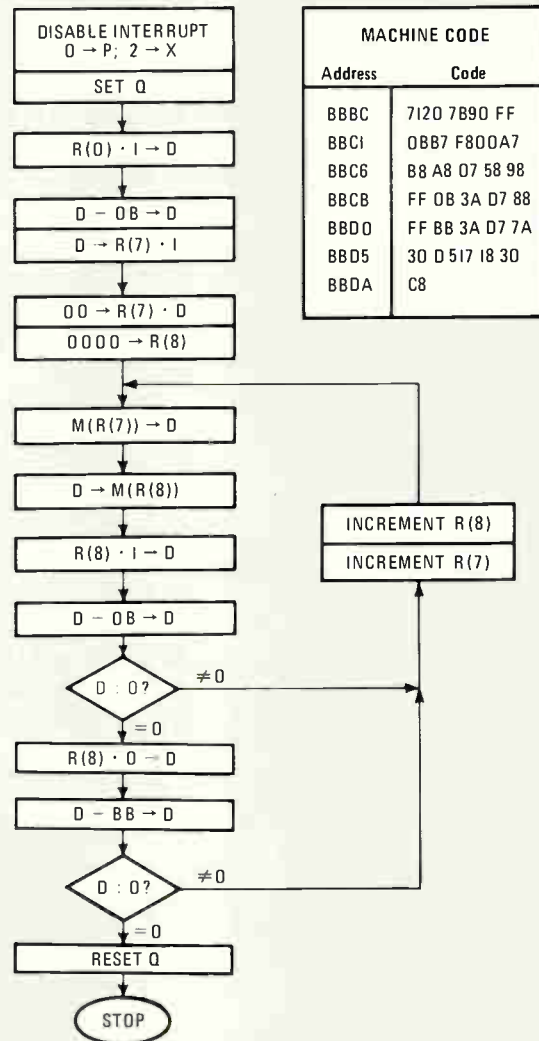

During program development, the UT20 command temporarily transfers the editor (3,004 bytes) and the assembler (2,561 bytes) to a RAM, beginning at the 0000 location. The calling time for the program is about 3 minutes and tends to increase if the user wishes to switch

from assembler to editor or vice versa.

The flow chart, memory map, and machine code for the program pinch presented in the table are designed to aid the CDS-II software development. Banks A and B are allotted for an assembler and editor in ROM respec-

MIL-C-28840. SEAWORTHY IN ANY WEATHER.

For hostile environments, you need a tough connector. At sea, that means our new MIL-C-28840 threaded circular connector. It's rugged, reliable and ready for the roughest sea duty.

Our MIL-C-28840 is scoop proof, has a multiple keying arrangement to prevent mismatching, and a conductive finish on the shells that withstands a 500-hour salt spray test. It can survive random vibrations of 150 Gs and can continue in service after exposure to high shock testing. Connectors can be supplied in shell sizes 13 through 33, from 12 to 155 contacts and 6 shell styles.

So when you need a connector that's seaworthy in any weather, look to the hostile-environment specialists at ITT Cannon Electric Canada.

For more information on our MIL-C-28840, contact ITT Cannon Electric Canada, A Division of ITT Industries of Canada Limited, Four Cannon Court, Whitby, Ontario, Canada, L1N 5V8. (416) 668-8881. TELEX: 06-0981357.



CANNON ITT

You can always connect with Cannon.

Circle 158 on reader service card

tively, and the appropriate program pinch is applied to each of them.

The added 8-K-byte E-PROM card hardware and modifications are shown in the figure. AA01 and BBBC are the starting locations for the assembler call pinch and editor call pinch. The assembler and editor programs are transferred to RAM using locations 0000 through 0A00 and 0000 through 0BBB.

Both programs test RAM availability by starting from 8000 and decrementing down with successive write-read

operations. Initiating a program pinch using command UT20 and specifying the starting location automatically sets the data pointer to the respective program to be transferred to 0000, after disabling the interrupt.

A Q flip-flop is set to give an indication of transfer (on the control/display panel) and then, once the transfer is over, reset, so that the user can proceed with program development. The length of the program pinch is less than 32 bytes, and the call for any software aid hardly takes 0.2 second at the clock rate of megahertz. □

Computer notes

Pocket computer scales computer-generated plots

by Cass R. Lewart
System Development Corp., Eatontown, N. J.

Every good plotting program should be able to calculate scales for the X, Y, or Z axes automatically because users cannot always anticipate the scales they will need for computer-generated plots. Linear scale values for such plots may be generated with this program, written in Basic for the Radio Shack pocket computer, given the minimum and maximum values of a variable's range. In addition, it may easily be modified for other Basic computers or translated into other languages.

The scale values are integer multiples of the interval value, which is a product of an integer power of 10 and 1, 2, or 5. Therefore, values like -0.5, 0.0, 0.5, 1.0 . . . , 1.24, 1.26, 1.28 . . . , and 100, 200, 300 . . . are allowed, but not -1, 4, 9 . . . , 1.2, 1.31, 1.42 . . . , and 0, 4, 8 Given the minimum (MIN) and maximum (MAX) values of the array to be plotted and the approximate number of scale intervals (N), the program computes four parameters: a new minimum (MINP), a new maximum (MAXP), the interval size (DIST), and the number of scale intervals (NP) that best fit the plot. These parameters satisfy the following:

```
SCALE-VALUES PROGRAM FOR COMPUTER-GENERATED PLOTS

5 "Z" PAUSE "SCALE BY C.R. LEWART"
10 INPUT "MIN? "; X
15 INPUT "MAX? "; Y
20 INPUT "# INTERVALS? "; N
25 IF (X < Y) * (N > 0) GOTO35
30 BEEP 2: GOTO10
35 D = (Y - X) / N: J = D / 10 ^ 7: E = INT LOG D
40 F = D / 10 ^ E: V = 10
45 IF F < √50 LET V = 5
50 IF F < √10 LET V = 2
55 IF F < √2 LET V = 1
60 C = V * 10 ^ E: G = INT (X/C)
65 IF (ABS (G + 1 - X/C) < J) LET G = G + 1
70 H = INT (Y/C) + 1
75 IF (ABS (Y/C + 1 - H) < J) LET H = H - 1
80 BEEP 1
85 PRINT "NEW MIN = ", CG
90 PRINT "NEW MAX = ", CH
95 PRINT "NEW INTERVAL = ", C
100 PRINT "# INTERVALS = ", H - G: GOTO 10
```

$$(MIN - DIST) < MINP \leq MIN,$$

$$MAX \leq MAXP < (MAX + DIST), \text{ and}$$

$$N / (2.5)^{1/2} < NP < [N(2.5)^{1/2} + 2]$$

The program avoids having an unnecessarily large range between MINP and MAXP by introducing a narrow gate ±J (line 35) around the MIN and MAX values. It also provides for prompting and input error trapping. □

Engineer's notebook is a regular feature in *Electronics*. We invite readers to submit original design shortcuts, calculation aids, measurement and test techniques, and other ideas for saving engineering time or cost. We'll pay \$75 for each item published.

SCALE PROGRAM EXAMPLES		
Key entry	Display	Remarks
SHIFT Z	SCALE BY C.R. LEWART	Start program
	MIN?	First example:
-3.1 ENTER	MAX?	
11.1 ENTER	# INTERVALS?	
5 ENTER	NEW MIN = -4	Beeps when ready
ENTER	NEW MAX = 12	
ENTER	NEW INTERVAL = 2	Resulting scale:
ENTER	# INTERVALS = 8	-4, -2, 0, . . . 12
ENTER	MIN?	Second example:
75 ENTER	MAX?	
2,000 ENTER	# INTERVALS?	
40 ENTER	NEW MIN = 50	Beeps when ready
ENTER	NEW MAX = 2,000	
ENTER	NEW INTERVAL = 50	Resulting scale:
ENTER	# INTERVALS = 39	50, 100, . . . 2,000.

Test service reveals soft errors in RAMs

Burn-in tests to detect soft-error sensitivity in 16- and 64-K random-access memories are desirable to ensure highly reliable parts. But RAM users have not had an independent testing laboratory that offers such service. Sensing a market—even for 256-K RAMs, it claims—Reliability Inc. of Houston has set up its Interception service to do the job. **Its test sequence comprises four phases: initialization, multipattern test, burn-in stress, and cool-down.** Initialization, performed at 25°C, checks for proper board operation, and then the multipattern test at 70°C runs testing patterns through the RAMs. The burn-in sequence, run at 125°C, also checks the RAMs with various testing patterns, and the cool-down is performed under bias. Further information on these and custom test sequences is available from the company at P. O. Box 218370, or call (713) 492-0550.

A no-cost way of ending ringing

The ringing that occurs when a high-speed signal travels along a wire or printed-circuit-board etch is a classic design problem: since there can be ambiguity as to whether the ringing signal is a 1 or a 0, latch elements may be set in the wrong state. John DeFalco, manager of LSI design at Honeywell Information Systems Inc. in Billerica, Mass., points out that many MOS circuits, unlike Schottky TTL, have inadequate clamping to stop this ringing. His simple solution is not to use an expensive discrete-diode clamp, but instead the diodes already present in a spare TTL part. **He simply places the TTL diode's input near the end of the transmission line.** If this chip is grounded but not powered up, only the diode is used—no extra load current is required.

How to interface data with phone system

Engineers responsible for designing equipment to interface with American Telephone & Telegraph Co.'s **new 56-kb/s switched-data service** will want a copy of Technical Reference PUB 61310. Available for \$21 from the Publisher's Data Center, Box C738, Pratt Street Station, Brooklyn, N. Y. 11205, it describes the interface's specifications.

Group to purvey videotex news

Because opportunities in the videotex industry have grown so rapidly, a grass-roots movement is under way for an association to apprise manufacturers of hardware and software, information providers, data banks, and potential users of videotex services as to what is going on. **The U. S. Videotex Industry Association, as it is known, is an educational, not a lobbying group,** says spokesman Jack O'Grady of John Adams Associates in Washington, D. C. Interested parties should contact O'Grady at 1825 K Street N. W. or call him at (202) 466-8320. Future meetings are planned to establish bylaws and a clearinghouse for videotex information.

Standard aids mobile-radio makers

One of the problems plaguing manufacturers of mobile radio equipment is the lack of standards for measuring the spurious emissions conducted by antenna terminals. These are particularly important in mobile radio because the available spectrum is so congested that **spurious emissions are almost sure to cause interference problems.** This measurement problem has now been addressed by the International Electrotechnical Commission. Its standards publication 489-3A describes how to make the measurements and can be had for 17 Swiss francs from 1, rue de Varembe, 1211 Geneva 20, Switzerland.

-Harvey J. Hindin

FUJITSU: READILY AVAILABLE



World famous for design and quality, these Fujitsu components are available now.

And through our national network of distribution. This means the most popular configurations are in stock and as near as your telephone. You'll find that Fujitsu com-

ponents not only have the reliability others can only hope to attain but that they are competitively priced as well. Just contact your local distributor. Should you need technical help, don't hesitate to call on Fujitsu direct.

You'll quickly see why Fujitsu has the products, quality and the service that is known around the world as the finest.



FUJITSU
AMERICA, INC.

COMPONENT SALES DIVISION
910 SHERWOOD DRIVE-23 LAKE BLUFF ILLINOIS 60044 TEL (312) 295-2610 TELEX 706196

OND CAPACITORS AND KEYBOARDS AND

Circle 161 on reader service card



World Pacific History

If you're still looking for the best 5 1/4"



rigid disk drive, you haven't found us yet.

Hard to believe, perhaps, but our 5¼" rigid drives rank among the highest in storage capacity. No one ships as many 5¼" floppy drives. No one knows more about high-volume, high-quality electromechanics. And no one else designs and produces their own head from start to finish. In fact, no one, but no one, builds as much of their own product. You see, at Tandon, we simply make more of what we make. Tandon. 20320 Prairie, Chatsworth, CA 91311, (213) 993-6644.

Tandon

The most successful disk drive company you never heard of.

World Radio History

Circle 163 on reader service card

SIEMENS

From Siemens... the world's most complete optoelectronics line.

The Siemens line of **Litronix** optoelectronics offers you the broadest product choice in the industry... ready now for prompt delivery, quality performance and highly competitive pricing!

Siemens, a world leader in electronics, offers you through its Litronix Division what well may be the broadest, most complete line of optoelectronic products available anywhere. This means the Litronix product line can be your one source for virtually all your optoelectronic needs.

Count on prompt service and competitive pricing whether your needs are for LED lamps, displays, IR diodes, photo-detectors or state-of-the-art Intelligent Displays™ up to 32 characters.

Siemens has one of the world's most advanced high volume automated facilities. That's why we can deliver virtually any size order fast. For further information on our complete line of Litronix optoelectronics, or applications engineering assistance, contact Siemens Corporation Litronix Division, 19000 Homestead Road, Cupertino, California 95014, Telephone (408) 257-7910.



Alphanumeric LED Intelligent Displays™
4 and 8 character LED Display modules with 16, 17 or 22 segment font and on board CMOS integrated circuit. The CMOS chip provides segment decoding, drivers, multiplexing and memory for easy interfacing to most microprocessors. Also available mounted on boards in 16 and 32 character assemblies.

Specify Siemens and be secure.



Alphanumeric LED Displays
 Character sizes from .16" to .68" in 14 and 16 segment and 5 x 7 Dot Matrix configurations. Single character encapsulated and four character magnified monolithic packages. 5 types. 5 types.

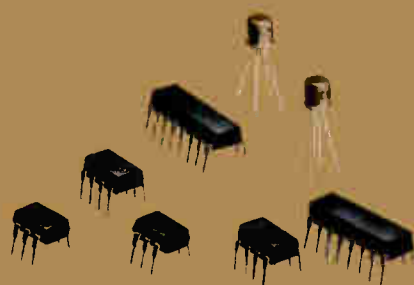

Optoisolators
 One, two and four channel optoisolators. Current transfer ratios up to 500%. Isolation voltages up to 5300 V. Premium quality VDE approved. Transmission rates as high as 4 megabits/sec. Reflective sensor. 9 jedec type. 52 types in all.

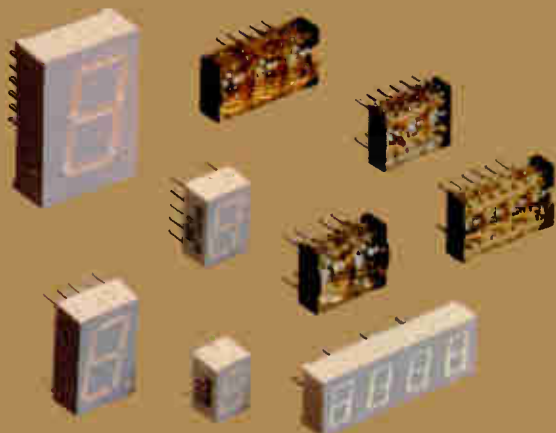

Numeric LED Displays
 Digit sizes from .11" to .15" in 2, 3 and 4 digit magnified monolithic packages. Digit sizes from .28" (in world's smallest package, single and four digits) to .80" encapsulated filled reflector packages. 72 types.



Infrared Emitting Diodes
 From medium to very high power. Beam widths from 6° to 60°. Hermetic and non-hermetic TO-18 size, T1 and T1 1/4 plastic packages. Miniature single chip and arrays of 2 to 10 emitters. 46 types.



LED Lamps
 Red, high efficiency red, yellow and green lamps. T1 1/4, T1 and miniature axial packages. Arrow, triangle, cylinder, rectangle and square shapes. Arrays of 2 to 10 lamps, lamps that flash on/off. Constant current lamps, multicolor lamps. 228 types.



Photodetectors
 Phototransistors and photodiodes with acceptance angles from 6° to 75° hermetic and non-hermetic TO-18 size, T1 and T1 1/4 plastic packages. Plastic packages with solder tabs. Miniature single chip and arrays of 2 to 10 detectors. 64 types.

Return this coupon now for our 424-page optoelectronics catalog.

OPTOELECTRONICS CATALOG 1982



Siemens Corporation, Box 1000, Iselin, NJ 08830
 Please send your optoelectronics catalog.

Name _____
 Firm _____
 Address _____
 City _____
 State _____
 Zip _____

Circle 165 on reader service card

FASTEST

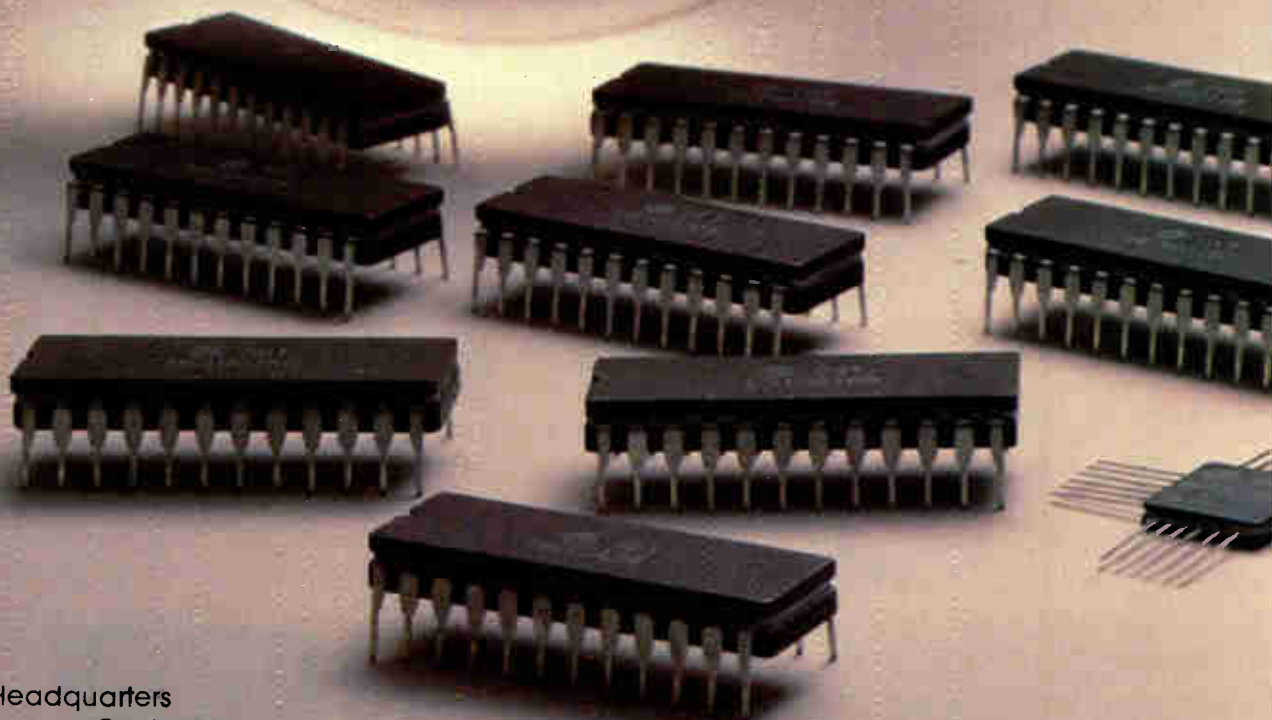
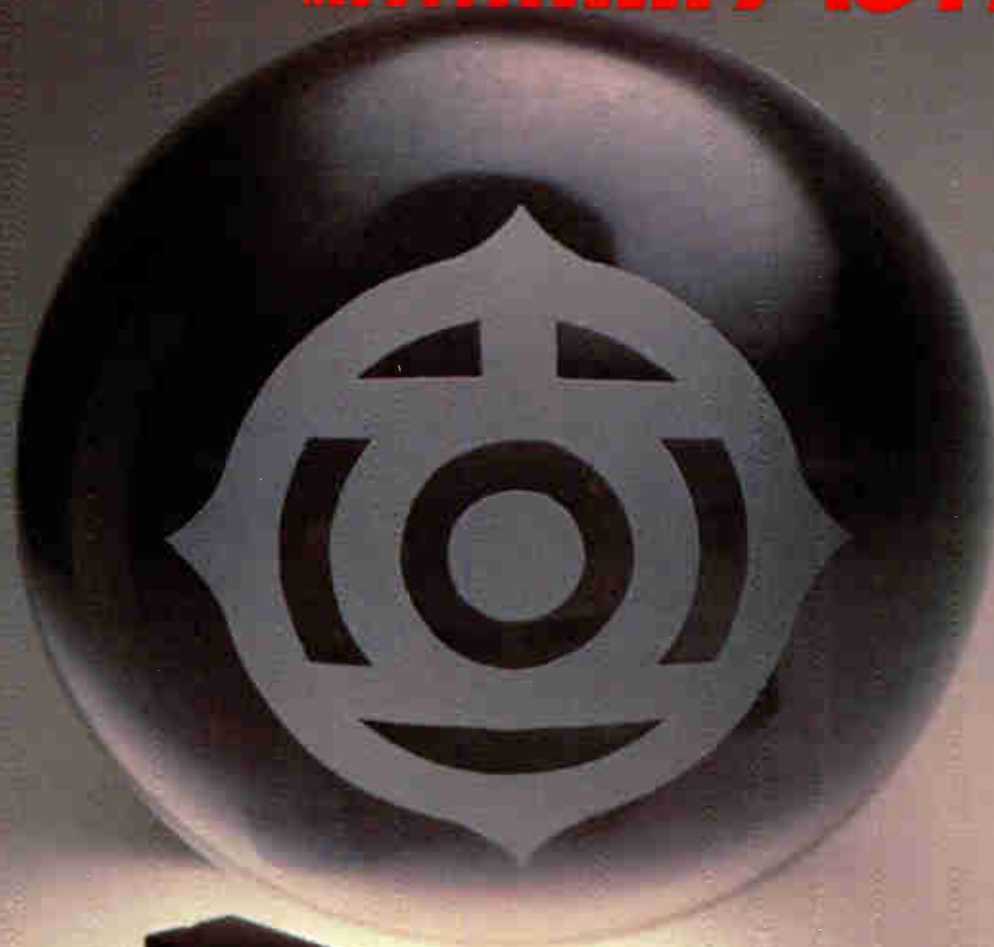

Regional Headquarters

Western

9700 Reseda Blvd.
Suite 208
Northridge, CA 91324
(213) 701-6606

Central

6200 Savoy Drive, Suite 704
Houston, TX 77036
(713) 974-8534
TWX 910-881-7043

Eastern

594 Marrett Road, Suite 22
Lexington, MA 02173
(617) 861-1642
TWX 710-326-1413

Stocking Distributors

Active Component Technology • Anthem •
CAM/RPC • Cetec • Classic Components • Cronin •
Diplomat • Future • Gerber • Jaco • Marshall • Milgray •
RC Components • Resco • RM Electronics •
Semiconductor Specialists • Sterling • Summit • Time •
Western Micro Technology

Bipolar in the World!

Hitachi has just added a new dimension to bipolar speed.

World's Fastest ECL Memories!

Hitachi offers the broadest line of bipolar memories in the industry. The Hitachi bipolar family tree includes both ECL and TTL RAMs, including 10K and 100K ECL compatible versions. All are PIQ* coated for alpha particle immunity and added reliability. All 100K compatible memories are available in DIP and flatpack ceramic packages. And, of course, all Hitachi ECL memories are complemented by a full line of 100K ECL logic.

*Polyimide isoindroquinazoline-dione

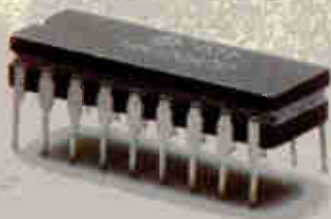
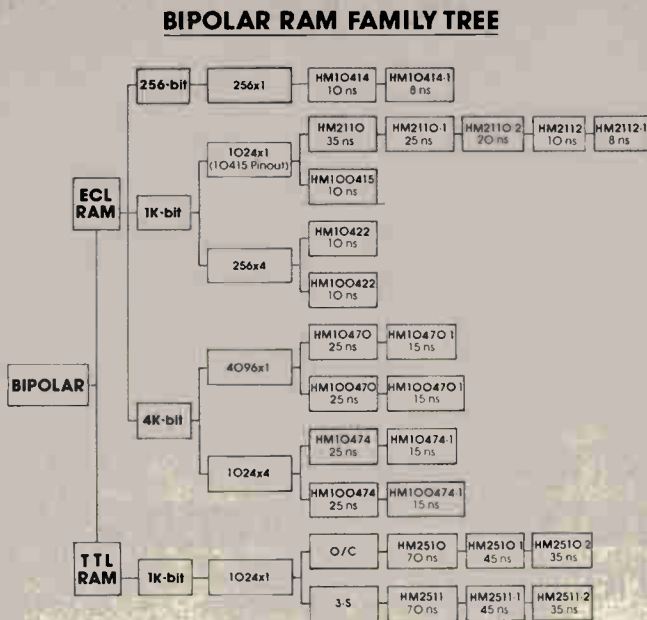

HITACHI

Hitachi America, Ltd.
Semiconductor and IC Sales and Service Division
1800 Bering Drive, San Jose, CA 95112
(408) 292-6404

Symbol of Semiconductor Quality, Worldwide

World's Fastest ECL Logic!

Talk about speed: Hitachi's complete 35-device ECL logic family features subnanosecond performance (750 ps gate delays), as well as voltage and temperature compensation. This entire family of industry standard 100K ECL functions and pinouts is available in both ceramic DIP and flatpack.

ECL LOGIC FAMILY

HD100101	HD100131	HD100164
HD100102	HD100136	HD100165
HD100107	HD100141	HD100166
HD100112	HD100142	HD100170
HD100114	HD100145	HD100171
HD100117	HD100150	HD100179
HD100118	HD100151	HD100180
HD100122	HD100155	HD100181
HD100123	HD100156	HD100182
HD100124	HD100158	HD100183
HD100125	HD100160	HD100194
HD100130	HD100163	

In Stock, Ready For Immediate Delivery!

YES, I want to know more about Hitachi ECL products. I'm interested in:

- Bipolar Memories ECL Logic
 Send detailed product literature.
 Have my Hitachi Representative call.

Name _____

Title _____

Company _____

Address _____

City _____

State _____ Zip _____

Phone (_____) _____

Send to: Hitachi America, Ltd.
1800 Bering Drive
San Jose, CA 95112

E 121581-380

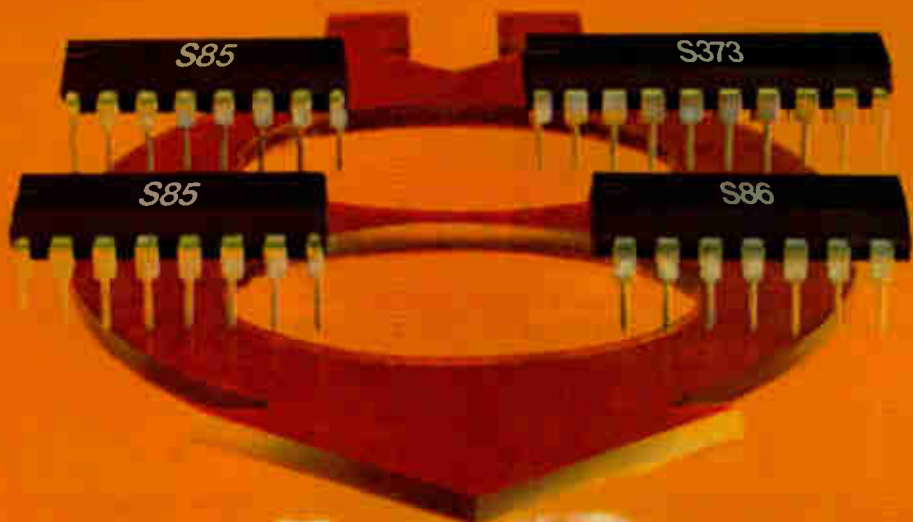

 **AS885**

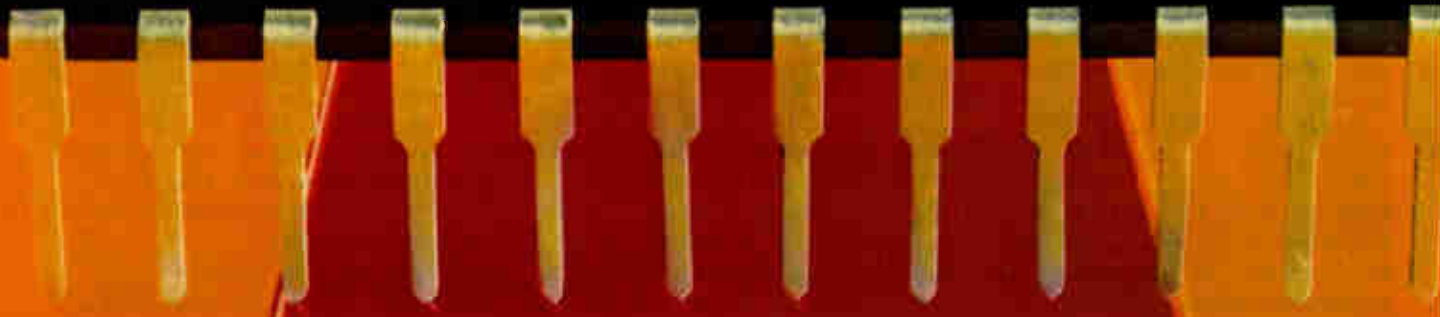

The next generation: TI's Advanced Schottky magnitude comparator.

One single device—TI's new SN54/74AS885—is now all you need to compare two parallel 8-bit binary words. You would need four standard Schottky parts to equal the functional capability of the AS885. The saving is obvious. The performance outstanding. With TI's Advanced Schottky technology, the next generation of TTL logic is here today.

Speedy and small

The AS885 is more than twice as fast as the standard Schottky arrangement. Typical propagation delay is only 12 ns vs 28 ns (see table).

Contained in a 24-pin, 300-mil package, the AS885 occupies just 0.4 sq. in. of board space instead of 1.0 sq. in. This compact design includes an octal on-chip latch to store one 8-bit input data word.

As for power, consumption is substantially reduced—650 mW compared to 1500 mW.

The AS885 performs a binary 2's complement magnitude comparison of two 8-bit numbers. With a choice of logical or arithmetic routines built right into your system. And, they can be cascaded to any length.

Advanced technology

The new AS885 is the newest member of the growing Advanced Schottky (AS) Series from Texas Instruments.

As the historical leader in Schottky technology, TI has constantly refined the process until, across the line, the AS Series sets new performance standards. Featuring a typical 1.5-ns SSI gate delay and higher-density MSI, the Series is—typically—twice as fast as the original Schottky family.

In addition, there's an Advanced Low-Power Schottky (ALS) Series that's more than two times faster than today's popular 74LS family—at half the power.

And both the AS and ALS devices can be designed-in as simply as you do with TI's popular Low-Power Schottky (54/74LS) and Schottky (74/54S) TTL series.

Figure the savings

Ideal for high-speed processors and microprocessor/microcomputer-based systems, the AS885 produces real bottom-line results. Fewer components, reduced power consumption, greater performance—they add up to savings in design time, board space, production and operating costs.

Initial quantities of the AS885 are available now. Check with your local authorized TI distributor or TI field sales office.

For more information on TI's Advanced Schottky magnitude comparator, simply fill out and return the coupon today.

Savings with the new Advanced Schottky

	SN54AS885	Standard STTL SN74AS885 Configuration	Your Savings
Packages	1	4	3 packages
Package Area	0.4 sq. in.	1.0 sq. in.	0.6 sq. in.
Pins	24	66	42 pins
Performance (t_{pd})	12 ns	28 ns	16 ns
Power	650 mW	1500 mW	850 mW

Check one:

EL7

- Please send me more information on your new Advanced Schottky AS885.
- You've convinced me. Send me a sample.

Name _____

Title _____

Company _____

Address _____

City _____ State _____ Zip _____

Texas Instruments
P. O. Box 202129
Dallas, Texas 75220



Texas Instruments invented the integrated circuit, microprocessor and microcomputer. Being first is our tradition.

TEXAS INSTRUMENTS
INCORPORATED



BIPOLAR

PACKAGES

CMOS/NMOS

PRODUCTION

SPECIALTIES

MATERIALS

MOM
Linear
812
COMPONENTS

MOE
LINEAR
More than
3,000,000
Sold

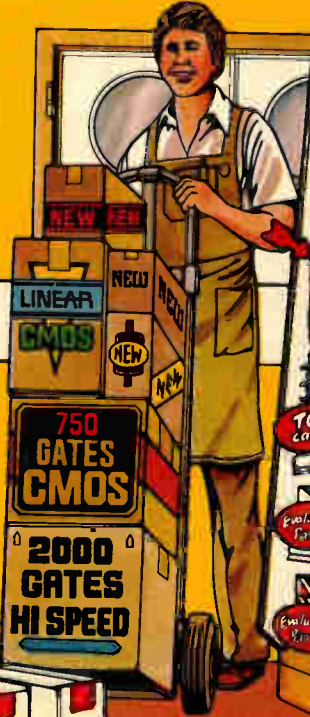

Linear Interdesign

AT
THE GATE ARRAY SUPERMARKET.

A FERRANTI COMPANY

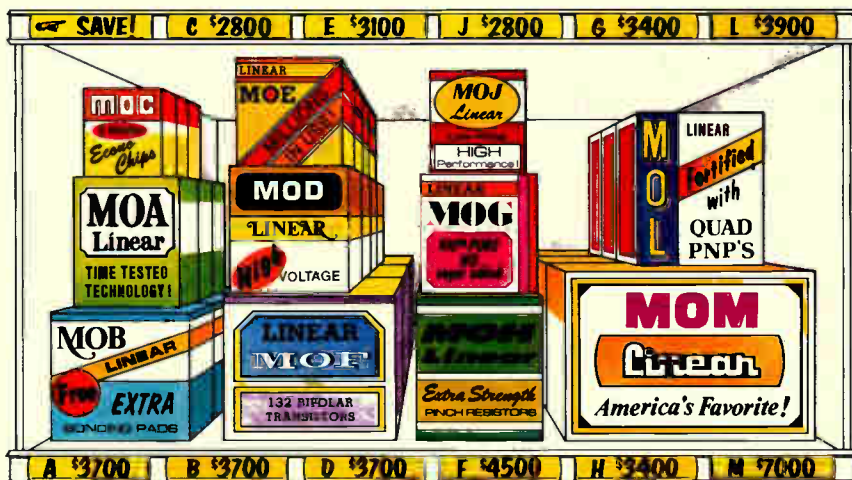

MOK DESIGN KIT

The MOK contains everything you need to design your own custom IC. Priced at \$59., it includes process technology, more than 200 pre-designed linear circuits, component characteristics, breadboard parts, and 200X layout sheets. As a purchaser, you're also entitled to free, expert applications assistance.

Start Saving Today!

Purchase an MOK design kit and complete your design, breadboard, and IC layout. If you submit your package by April 30, 1982, we'll deduct \$250. from the standard integration cost. Shortly thereafter, we'll deliver prototypes and production IC's and you can start manufacturing your new products with low cost Monochips. To order the MOK, call or write:

Interdesign, Inc.
1255 Reamwood Ave.
Sunnyvale, CA 94086

MONOCHIPS™

If you need a semi-custom linear IC, chances are that Interdesign is the only place you'll need to shop. With more than 1200 circuits integrated to date, our IC's are performing in the field in automotive, telecommunications, consumer, computer, aerospace, and industrial products. We

have the arrays, the components, the design aids, and the applications experience to help you convert discrete transistor or IC designs to compact, cost-effective linear Monochips.

Monochip linear arrays range in size from 110 to 812 components with up to 28 bonding pads. Many useful components are offered including a variety of NPN's, vertical and horizontal PNP's, diodes, and resistors. Integration charges vary from \$2800 to \$7000 depending on chip size.

CHUPON VALID ONLY AT INTERDESIGN

\$250 OFF ANY LINEAR INTEGRATION

RESERVATIONS SUGGESTED
CALL 408-734-8666 TODAY!

LIMIT ONE COUPON PER PURCHASE - EXPIRES APRIL 30, 1982



**This symbol
means faster
measurement
system
development. . .**

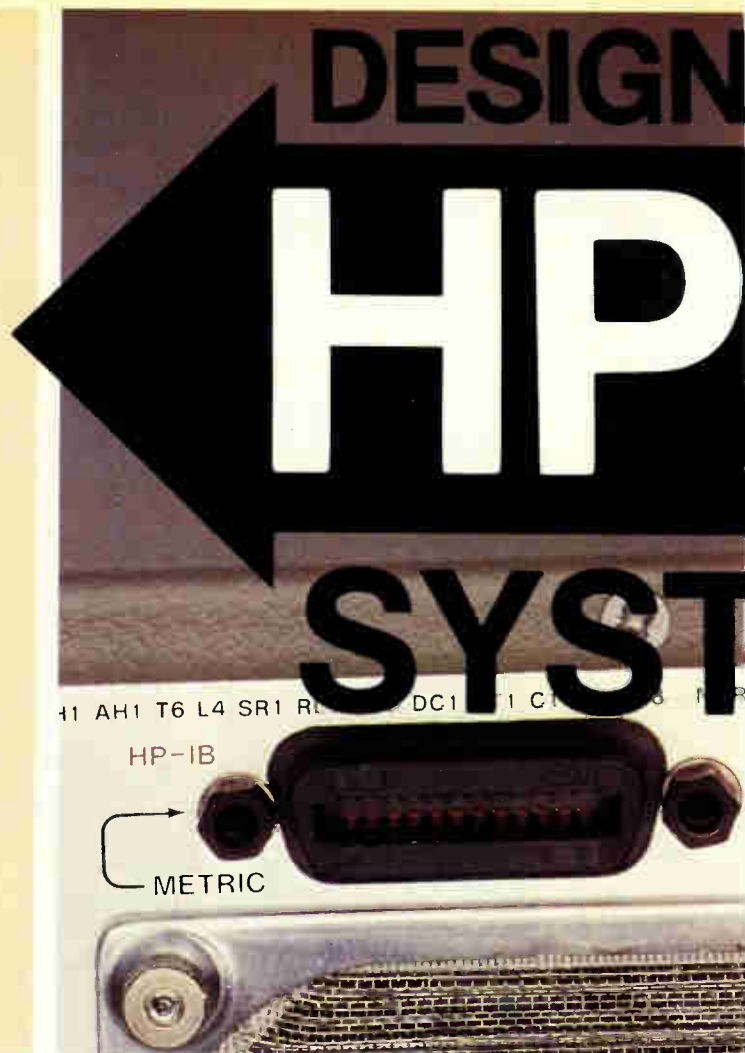

The familiar HP-IB (Hewlett-Packard Interface Bus) symbol is HP's way of identifying instruments and computers that conform to the IEEE-488 standard. But it means much more than just bus architecture and system compatibility. The HP-IB symbol also stands for the documentation and support that helps you get a measurement system operational in weeks instead of months.

Five reasons why you'll save time and effort.

Choose HP when you need a measurement system

and you get these advantages: 1) All devices and all documentation come from a single source which means consistency in design and documentation. 2) Every member of the HP-IB family of instruments and computers — over 140 in all — is designed for and tested to rigid HP-IB standards of compatibility.

3) Just as important, every HP-IB device comes with complete and comprehensive documentation that's easy to follow and consistent in its approach to implementation. You'll receive service manuals and operating manuals that typically include a guide to the implementation of computer based systems. 4) You



can choose from more than 100 HP application notes. Many of these will teach you how to accomplish specific measurements in conjunction with the controlling computer. Software examples are included in a number of these to help you get to a solution even faster. In fact, one of these examples may be just what you need for your exact application. And many HP application notes list the results of performance tests to help you verify proper system operation. 5) HP also offers training, system engineering support and on-site service . . . assistance from start to finish. But these aren't the only reasons HP is the logical choice for measurement system development.

Over ten years of experience to call on.

When you design and build a measurement system, you can have the confidence of working with the company that was there when the need for a standard was realized. HP invented the 3-wire handshake technique and ever since then we've been designing and building HP-IB compatible components. By choosing an HP instrument or computer, you get the benefit of over 10 years experience in interface bus architecture, and how it can best be implemented.

Choose from a wide variety of computers.

With more than 140 different HP-IB instruments and computers to choose from, you can configure the measurement system that's just right for your application.

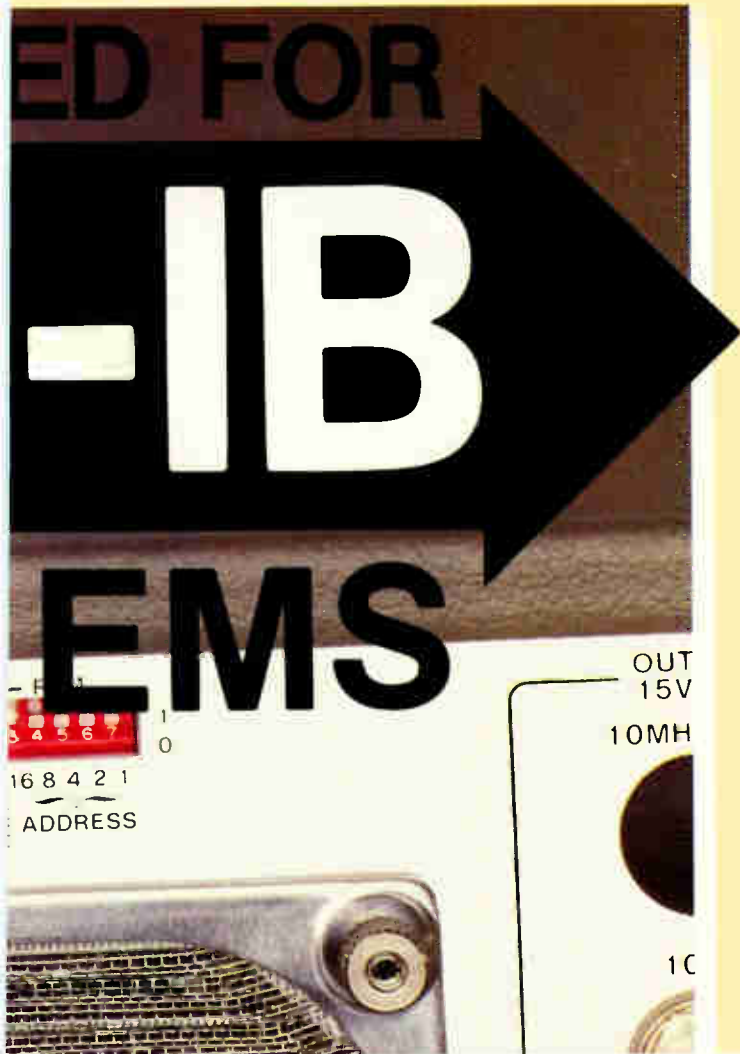

because it stands for system documentation and support on more than 140 HP-IB instruments and computers.

For your computing controller, you can choose from among the seven members of HP's powerful, flexible 1000 series family. Or you can select one of five friendly and flexible desktop computers. All HP computers have powerful, high-level languages that make it easy for you to write application programs.

Sticking with you.

HP offers all "Designed for Systems" devices with post-warranty support you can count on. You can continue this beyond the normal warranty period with an HP Maintenance Agreement. That means you'll enjoy yearly fixed cost, regularly scheduled preventive maintenance, priority response, and even more.

Meet the HP-IB family.

To find out how HP-IB compatible instruments and controllers can speed you to a faster system solution, send for our free brochure, "Do your own system design in weeks, instead of months." Just write: Hewlett-Packard, 1507 Page Mill Road, Palo Alto, CA 94304. Or call the HP regional office nearest you: East (201) 265-5000, West (213) 970-7500, Midwest (312) 255-9800, South (404) 955-1500, Canada (416) 678-9430.



HP-IB: Not just a standard, but a decade of experience.



Instruments

Tiny terminal aids field service

Calculator-sized unit has built-in modem for two-way communications with host

A small company called Pinetree Systems Inc. is tackling two of the biggest problems in today's field-service industry—getting good service data and providing on-site help to field technicians. It is doing so with an inexpensive handheld terminal, called the model DP2002, that puts field-service people in two-way communication with the home-office computer over telephone lines, radios, and satellite links.

The Z80A-based terminal, which measures 6 by 3¼ by 1¼ in. and weighs 11 oz., "makes it more likely that the field technician will file an accurate report," according to Rufus Coomer, vice president and director of marketing for the three-year-old company. That opinion is backed by the company's experience with an earlier one-way model, the DP2001.

In operation. The information to be reported—such as travel time, time to repair, parts used, and so

forth—can be specified by the purchaser. Pinetree will set up the system software, which is stored in 8-K bytes of read-only memory, to give prompts on its 16-character light-emitting-diode display, so that the field technician will supply the appropriate alphanumeric information. Entered data is stored in 2-K bytes of random-access memory, more than enough to store a full day's service calls. Reports can thus be filed in a burst mode, as well as one at a time.

At the home office, the reports are accepted by the model DPR1004, a benchtop receiver designed originally for use with the DP2001. The data receiver provides an interface between two to four separate lines and the host computer.

The unit automatically receives data, checks it, and responds to the sender, acknowledging receipt or asking for retransmission. The receiver can translate the information into computer-compatible form, as well as transmit data from the computer to the user.

In the latter mode, the receiver is able to provide the DP2002-equipped field technician with support. The technician can enter a code that describes the type of fault encountered, and the computer will find the appropriate repair action stored in its data base.

The receiver will then transmit this information to the DP2002, which can store consecutive steps in its internal RAM. Coomer notes that the DP2002's memory is expandable; and when 64-K chips are readily available, they can be used to replace the current RAM.

Given a customer's requirements, Pinetree can set up a system in six to eight weeks. Key to that flexibility is the fact that the DP2002 terminal is

a software-intensive unit.

"Most people, for instance, use a hardware chip to generate tones," Coomer says, "whereas we do it in software to have more flexibility in setting up communications protocols." The unit is programmed in assembly language, and its message checking is also done in software. Messages can be encrypted, and its self-diagnostics can isolate faults to a chip and in some cases to a pin.

The DP2002 is priced between \$500 and \$600, depending on the software required. The DPR1004 is priced at \$4,000 to \$4,800.

Pinetree Systems Inc., 734 Greenview Dr., Grand Prairie, Texas 75050. Phone (214) 641-7500 [35-1]

Signal generators serve radar, communications uses

Solid-state technology combined with the spectral purity of cavity tuning produces the high-performance test signals of the HP 8683A/B and HP 8684A/B microwave signal generators for communications and radar applications. Instead of klystrons, the active oscillator elements are bipolar transistors for the 8683 and gallium arsenide field-effect transistors for the 8684.

A key component in each is the mechanically tuned cavity, which provides high stability and nonspurious signals. The microprocessor corrects for the inherently nonlinear cavity tuning.

Communications applications are covered in two frequency bands: 2.3 to 6.5 GHz in the 8683A and 5.4 to 12.5 GHz in the 8684A. These units feature 0 to -130 dBm power output, calibrated low-distortion frequency modulation with ±5 MHz peak deviation at rates from dc to 10 MHz, and calibrated and metered amplitude modulation with 0% to 70% modulation depths at rates from dc to 10 kHz.

For radar and military applications, the 8683B, with a range of 2.3 to 6.5 GHz, and the 8684B, with its range of 5.4 to 12.5 GHz, are used. These units have an increased power



ROMs

MOS STATIC ROMs (+ 5 Volts)

Character Generators³

Organization	Part Number	Access Time (ns max)	No. of Pins
128 x (7 x 5)	MCM6670P	350	18
128 x (7 x 5)	MCM6674P	350	18
128 x (9 x 7)	MCM66700P	350	24
128 x (9 x 7)	MCM66710P	350	24
128 x (9 x 7)	MCM66714P	350	24
128 x (9 x 7)	MCM66720P	350	24
128 x (9 x 7)	MCM66730P	350	24
128 x (9 x 7)	MCM66734P	350	24
128 x (9 x 7)	MCM66740P	350	24
128 x (9 x 7)	MCM66750P	350	24
128 x (9 x 7)	MCM66760P	350	24
128 x (9 x 7)	MCM66770P	350	24
128 x (9 x 7)	MCM66780P	350	24
128 x (9 x 7)	MCM66790P	350	24

Binary ROMs (+ 5 Volts)

Organization	Part Number	Access Time (ns max)	No. of Pins
1024 x 8	MCM68A308P	350	24
1024 x 8	MCM68A308P7 ⁴	350	24
1024 x 8	MCM68B308P	250	24
2048 x 8	MCM68A316AP	350	24
2048 x 8	MCM68A316EP	350	24
2048 x 8	MCM68A316EP91 ⁴	350	24
4096 x 8	MCM68A332P	350	24
4096 x 8	MCM68A332P2 ⁴	350	24
8192 x 8	MCM68A364P	350	24
8192 x 8	MCM68A364P3 ⁴	350	24
8192 x 8	MCM68B364P	250	24
8192 x 8	MCM68365P25	250	24
8192 x 8	MCM68365P35	350	24
8192 x 8	MCM68366P25	250	24
8192 x 8	MCM68366P35	350	24

CMOS ROMs (+ 5 Volts)

Organization	Part Number	Access Time (ns max)	No. of Pins
256 x 4	MCM14524	1200	16
2048 x 8	MCM65516P43	430	18
2048 x 8	MCM65516P43M ⁴	430	18
2048 x 8	MCM65516P55	550	18

³Character generators include shifted and unshifted characters, ASCII alphanumeric control, math, Japanese, British, German, European and French symbols.

⁴Standard Patterns for MOS ROMs:

MCM68A308P7 — MC6800 MIKbug/MINIBug ROM
 MCM68A316EP91 — Universal Code Converter and Character Generator
 MCM68A332P2 — Sine/Cosine Look-Up Table
 MCM68A364P3 — Log/Antilog Look-Up Table
 MCM65516P43M — MC146805 Monitor Program

PROMs

ECL PROMs

Organization	Part Number	Access Time (ns max)	No. of Pins
32 x 8	MCM10139	20	16
256 x 4	MCM10149	25	16

TTL PROMs

Organization	Part Number	Access Time (ns max)	Output	No. of Pins
512 x 8	MCM7641*	70	3-State	24
1024 x 4	MCM7643	70	3-State	18
1024 x 8	MCM7681	70	3-State	24
2048 x 4	MCM7685	70	3-State	18
2048 x 4	MCM7689	—	3-State with Registers	20
2048 x 8	MCM76161*	80	3-State	24

Not all package options are listed.

Operating temperature ranges:

MOS — 0°C to 70°C

ECL — Consult individual data sheets

TTL — Military — 55°C to +125°C, Commercial 0°C to 70°C

MOTOROLA MEMORIES

Motorola has developed a very broad range of reliable MOS and bipolar memories for virtually any digital data processing system application. And for those whose requirements go beyond individual components, Motorola also supplies Memory Systems and Micromodules.

New Motorola memories are being introduced continually. This selector guide lists all those available as of December 1981. For later releases, additional technical information or pricing, contact your nearest authorized Motorola distributor or Motorola sales office.

Data sheets may be obtained from your in-plant VSMF Data Center, distributors, Motorola sales office or by writing to:

Literature Distribution Center
 Motorola Semiconductor Products Inc.
 P.O. Box 20912
 Phoenix, AZ 85036.

MOTOROLA MEMORIES Selector Guide

RAMs ROMs PROMs EPROMs EEPROMs

December 1981



MOTOROLA

RAMs

MOS DYNAMIC RAMs

Organization	Part Number	Access Time (ns max)	Power Supplies	No. of Pins
4096 x 1	MCM4027AC-2	150	+ 12, ± 5 V	16
4096 x 1	MCM4027AC-3	200	+ 12, ± 5 V	16
4096 x 1	MCM4027AC-4	250	+ 12, ± 5 V	16
16384 x 1	MCM41168P15	150	+ 12, ± 5 V	16
16384 x 1	MCM41168P20	200	+ 12, ± 5 V	16
16384 x 1	MCM41168P25	250	+ 12, ± 5 V	16
16384 x 1	MCM4517P10	100	+ 5 V	16
16384 x 1	MCM4517P12	120	+ 5 V	16
16384 x 1	MCM4517P15	150	+ 5 V	16
16384 x 1	MCM4517P20	200	+ 5 V	16
32768 x 1	MCM6632L15 ¹	150	+ 5 V	16
32768 x 1	MCM6632L20 ¹	200	+ 5 V	16
32768 x 1	MCM6632L25 ¹	250	+ 5 V	16
32768 x 1	MCM6633L15	150	+ 5 V	16
32768 x 1	MCM6633L20	200	+ 5 V	16
32768 x 1	MCM6633L25	250	+ 5 V	16
65536 x 1	MCM6664AL12 ^{1*}	120	+ 5 V	16
65536 x 1	MCM6664L15 ¹	150	+ 5 V	16
65536 x 1	MCM6664AL15 ^{1*}	150	+ 5 V	16
65536 x 1	MCM6664L20 ¹	200	+ 5 V	16
65536 x 1	MCM6664L25 ¹	250	+ 5 V	16
65536 x 1	MCM6665AL12 [*]	120	+ 5 V	16
65536 x 1	MCM6665L15	150	+ 5 V	16
65536 x 1	MCM6665AL15 [*]	150	+ 5 V	16
65536 x 1	MCM6665L20	200	+ 5 V	16
65536 x 1	MCM6665L25	250	+ 5 V	16

TTL BIPOLAR RAMs

Organization	Part Number	Access Time (ns max)	Output	No. of Pins
256 x 4	MCM93422	45	3-State	22
256 x 4	MCM93L422*	60	3-State	22
256 x 9	MCM93478*	60	3-State With Latches	22
256 x 9	MCM93479*	45	3-State	22
1024 x 1	MCM93415	45	Open Collector	16
1024 x 1	MCM93425	45	3-State	16

* To be introduced.

¹Motorola's innovative pin #1 refresh

²All MOS memory outputs are three-state except the open collector MCM2115A series.

MOS STATIC RAMs (+ 5 Volts)

Organization	Part Number	Access Time (ns max)	No. of Pins
128 x 8	MCM6810	450	24
128 x 8	MCM68A10	360	24
128 x 8	MCM68B10	250	24
1024 x 4	MCM2114P20	200	18
1024 x 4	MCM2114P25	250	18
1024 x 4	MCM2114P30	300	18
1024 x 4	MCM2114P45	450	18
1024 x 4	MCM21L14P20	200	18
1024 x 4	MCM21L14P25	250	18
1024 x 4	MCM21L14P30	300	18
1024 x 4	MCM21L14P45	450	18
1024 x 1	MCM2115AC45 ²	45	16
1024 x 1	MCM2115AC55 ²	55	16
1024 x 1	MCM2115AC70 ²	70	16
1024 x 1	MCM21L15AC45 ²	45	16
1024 x 1	MCM21L15AC70 ²	70	16
1024 x 1	MCM2125AC45	45	16
1024 x 1	MCM2125AC55	55	16
1024 x 1	MCM2125AC70	70	16
1024 x 1	MCM21L25AC45	45	16
1024 x 1	MCM21L25AC70	70	16
4096 x 1	MCM6641P20	200	18
4096 x 1	MCM6641P25	250	18
4096 x 1	MCM6641P30	300	18
4096 x 1	MCM6641P45	450	18
4096 x 1	MCM66L41P20	200	18
4096 x 1	MCM66L41P25	250	18
4096 x 1	MCM66L41P30	300	18
4096 x 1	MCM66L41P45	450	18
4096 x 1	MCM2147C55	55	18
4096 x 1	MCM2147C70	70	18
4096 x 1	MCM2147C85	85	18

CMOS STATIC RAMs (+ 5 Volts)

Organization	Part Number	Access Time (ns max)	No. of Pins
256 x 4	MCM5101P65	650	22
256 x 4	MCM5101P80	800	22
256 x 4	MCM51L01P45	450	22
256 x 4	MCM51L01P65	650	22

ECL BIPOLAR RAMs

Organization	Part Number	Access Time (ns max)	No. of Pins
8 x 2	MCM10143	15	24
256 x 1	MCM10144	26	16
16 x 4	MCM10145	15	16
1024 x 1	MCM10146	29	16
1024 x 1	MCM10146A*	10	16
128 x 1	MCM10147	15	16
64 x 1	MCM10148	15	16
256 x 1	MCM10152	15	16
256 x 4	MCM10422*	15	24
4096 x 1	MCM10470*	35	18
1024 x 4	MCM10474*	25	24

EPROMs

MOS EPROMs

Organization	Part Number	Access Time (ns max)	Power Supplies	No. of Pins
1,024 x 8	MCM2708C	450	+ 12, ± 5 V	24
1024 x 8	MCM27A08C	300	+ 12, ± 5 V	24
2048 x 8	TMS2716C	450	+ 12, ± 5 V	24
2048 x 8	TMS27A16C	300	+ 12, ± 5 V	24
2048 x 8	MCM2716C	450	+ 5 V	24
2048 x 8	MCM2716C35	350	+ 5 V	24
4096 x 8	MCM2532C	450	+ 5 V	24
B192 x 8	MCM68764L	450	+ 5 V	24
B192 x 8	MCM68766L	450	+ 5 V	24
B192 x 8	MCM68766L35	350	+ 5 V	24

EEPROMs

MOS EEPROMs

Organization	Part Number	Access Time (ns max)	Power Supplies	No. of Pins
16 x 16	MCM2801P	10 μs	+ 5 V	14
32 x 32	MCM2802P*	15 μs	+ 5 V	14

EPROM/ROM COMPARISON

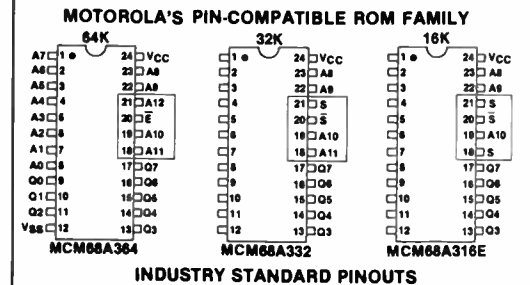
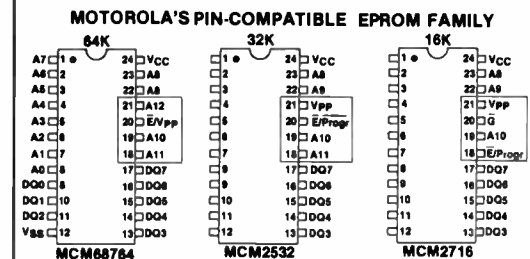

New products

output of 10 dBm and a pulse modulator and generator with rates from 10 Hz to 1 MHz in five ranges. The A models sell for \$12,000 and the B models run \$15,000. Delivery takes 12 weeks.

Hewlett-Packard, 1820 Embarcadero Rd., Palo Alto, Calif. 94303 [354]



Analyzer traces 64 channels to memory 4,096 words deep

Giving flexibility to the KLA logic analyzer is a floppy-disk drive that stores front-panel setups, known-good-response reference information, and the instrument's operating software. Three analyzers are available: 32-, 48-, and 64-channel versions, models KLA-32, -48, and -64, respectively.

Each has asynchronous clock speeds of up to 100 MHz and 2,048 or, optionally, 4,096 words of memory. The instrument can record simultaneously with up to four clocks and 12 clock qualifiers, which helps track down faults in multiplexed systems. Glitches as short as 5 ns are latched and stored in a memory separate from data so that the unit can be triggered on glitches. For easy recognition, glitches are displayed as half-height lines on the 9-in. screen.

Data can be displayed in timing-diagram, hexadecimal, decimal, octal, binary, ASCII, or EBCDIC formats, with optional disassemblers to display microprocessor programs in the device's memory. Personality probes for 8- and 16-bit microprocessors are also available as options. Prices start at \$15,000, \$17,000, and

Ceramic Filters for Age of High Selectivity

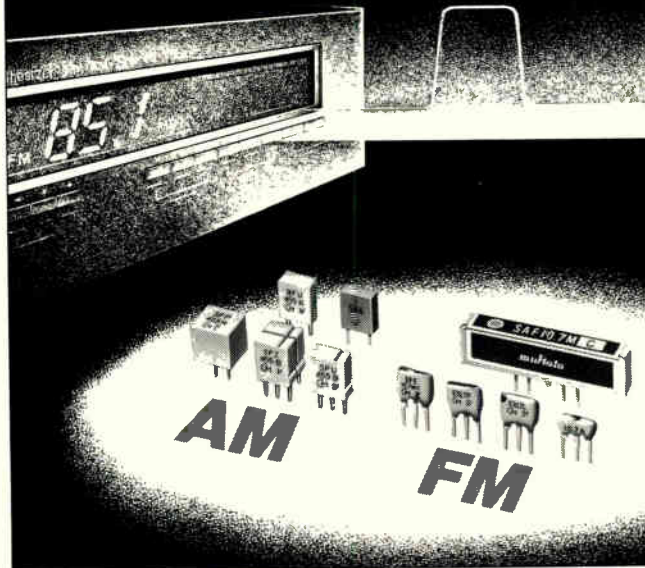

CERAMIC FILTER

Responding to the Requirements of the Age of Synthesizers With Soft Technology

The epochal advancement of LSI technology has permitted audio equipment to enter the age of frequency synthesizers with one-touch channel selection, long a dream of many audio equipment users. The high quality and stability of filters support the channel selection performance and sound quality of audio equipment.

In response to this technological trend, MURATA has placed on the market a series of ceramic filters and ceramic discriminators for AM and FM applications, boasting a stable channel selection of electronically-tuned radios by fully utilizing the ceramic filter technology at its disposal. MURATA's miniature and high-selectivity ceramic filters, which fully match the packaging requirements for printed boards together with ICs, assure their users of a reduced number of components and devices to be packaged and labor saving, as adjustments are not necessary.

MURATA delivers high-quality electronic components to you, components that satisfy an age when importance is attached to the sound quality of AM and when the number of FM broadcasting stations, signifying new trends for the 1980s, is increasing.



MURATA MFG. CO., LTD.

HEADQUARTERS Nagakakyō-shi, Kyoto 617, Japan	Phone 075 921 9111 Telex 64270 MURH J
MURATA CORPORATION OF AMERICA	Phone 404 952 9777 Telex 0542329 MURATA AT1
MURATA ERIE ELECTRONIK GMBH (West Germany)	Phone 0911 46065 Telex 623763 MFGN D
MURATA ERIE ELECTRONIQUE, S.A. (France)	Phone 558 0901 Telex 204520 ERITRON PARI5
MURATA ERIE ELETTRONICA S.R.L. (Italy)	Phone 658 4833/4835 Telex 330375 FRIF M11
MURATA ELECTRONICS SINGAPORE (PTE.) LTD.	Phone 2564233, 2564023 Telex 2127 MURASIN
MURATA COMPANY, LIMITED (Hong Kong)	Phone K306291-2 Telex 86208 HKMRT HX
TAIWAN MURATA ELECTRONICS CO., LTD.	Phone 042 31 4151-2 Telex 51249
MURATA MFG. CO., LTD. Seoul Branch (Korea)	Phone 776 2783 Telex K25858 MURASUL



LARGEST RADAR INVENTORY IN THE WORLD

SYSTEMS & SPARES

AN/ALT-67-8
 AN-APG-33
 AN/APG-51
 AN/APN-69
 AN/APN-102
 AN/APN-169
 AN/APQ-50
 AN/APQ-55
 AN/APS-20
 AN/APS-31A
 AN/APS-42-45
 AN/APS-64
 AN/ASB-4/9
 AN/CPS-6B
 AN/CPS-9
 AN/DPN-32
 AN/FPS-6-8
 AN/FPS-14-18
 AN/FPS-20-75
 AN/FRC-39
 AN/FRT-15
 AN/GPA-30
 AN/GPA-126
 AN/MPQ-4A-10
 AN/MPQ-29
 AN/MP-19
 AN/MPX-7
 AN/MSQ-1A
 AN/SPA-4A
 AN/SPA-8
 AN/SPN-5
 AN/SPS-5B
 AN/SPS-6C
 AN/SRW-4C
 AN/TPN-12/17
 AN/TPS-1D,E
 AN/TPS-10D
 AN/TPS-28
 AN/TPS-34B
 AN/TPS-37
 AN/TPX-21
 AN/UPA-25-35
 AN/UPX-4-6
 AN/UPX-14
 HIPAR
 MK-25
 Nike Ajax
 Nike Hercules
 SCR-584

AUTOTRACK ANTENNA SCR-584 RADAR SYSTEM

360 deg AZ 210 deg EL. 1 mil. accuracy. Missile vel. accel. and slew rates. Amplitude control. Handle up to 20 ft. dish. Compl. control chassis. ALSO in stock 10 cm. van mounted rad. system. Conical scan. PPI. 6 ft. dish. 300 pg. instr. bk. on radar. \$50.

RF SOURCES

17-27 KHz 200 W CW
 125-450 KHz 4 KW CW
 2-30 MHz 3 KW CW
 4-21 MHz 40 KW CW
 24-350 MHz 100 W CW
 80-240 MHz 500 W 2-5 uS
 175-225 MHz 300 KW 1, 20 uS
 200-2000 MHz 40 W CW
 210-225 MHz 1 MW 5 uS
 385-575 MHz 1.5 KW CW
 400-700 MHz 1 KW .03 DC
 950-1500 MHz 1 KW .06 DC
 900-1040 MHz 5-10 KW .006 DC
 1.2-1.35 GHz 500 KW 2 uS
 1.5-9.0 GHz 150 W CW
 3.2-3.3 GHz 10 KW .002 DC
 2.7-2.9 GHz 1 MW 1 uS
 3.1-3.5 GHz 1 MW 1.3 uS
 2.7-2.9 GHz 5 MW 2-3 uS
 4.4-5.0 GHz 1 KW CW
 5.4-5.9 GHz 5 MW .001 DC
 6 GHz 1 MW 1 uS
 6.2-6.6 GHz 200 KW .37 uS
 8.5-11 GHz 200 W CW
 9.375 GHz 40 KW .5-1-2 uS
 8.5-9.6 GHz 250 KW .0013 DC
 15.5-17.5 GHz 135 KW .33-1-3 uS
 24 GHz 40 KW .15 uS
 35 GHz 50 KW .1 uS

MODULATORS

25 KW 5.5 KV 4.5 A; .0025 DC
 144 KW 12 KV 12 A; .001 DC
 250 KW 16 KV 16 A; .002 DC
 405 KW 20 KV 20 A; .1 DC
 500 KW 22 KV 28 A; .001 DC
 1 MW 25 KV 40 A; .002 DC
 3 MW 50 KV 60 A; 30 uS
 10 MW 76 KV 135 A; .001 DC
 66 MW 160 KV 400 A; .00

TRACKING SYSTEMS

K BAND MONOPULSE 40 KW E-34
 X BAND NIKE AJAX/HERCULES
 X BAND HI-RES MONOPULSE MOD IV
 X BAND GCA PAR II
 X BAND FIRE CONTROL 250 KW M-33
 X BAND MOBILE 40 KW AN/MPQ-29
 X BAND BEACON 100 W AN/DPN-52
 S BAND 10' DISH 500 KW AN/MPQ-18
 S BAND 250 KW AN/MPQ-10A
 S BAND 250 KW AN/MPQ-9
 X BAND HAWK MPQ-34
 X BAND HAWK MPQ-33
 C BAND 1.5 MW MPS-19(C)
 S BAND 14' DISH PRELORT

SEARCH SYSTEMS

KU BAND AIRBORNE 135 KW B-58
 X BAND WEATHER 250 KW AN/CPS-9
 X BAND WEATHER 40 KW AN/SPN-5
 X BAND 7 KW AN/TPS-21
 X BAND CW DOPPLER AN/PPS-9/12
 C BAND HGT FDR 1 MW TPS-37
 C BAND 285 KW AN/SPS-5B/D
 S BAND HGT FINDER 5 MW AN/FPS-6
 S BAND COHERENT 1 MW AN/FPS-18
 S BAND 1 MW NIKE AJAX/HERC
 L BAND 40' ANT 500 KW AN/FPS-75
 L BAND 500 KW AN/TPS-1D/GSS-1
 UHF 1 MW HELIHUT TPS-28

C BAND TRACKER

Pwr: 1.5 MW Range: 250 miles
 Recv: param Display 5" "A" scopes,
 10' dish w/linear or circ. polarization.

NIKE HERCULES SPARES/MAINTENANCE

Over 10,000 major components in stock w/repairs and overhaul facilities incl: SHOP 1 & 2 MAINTENANCE VANS.

SEND FOR FREE 24 PAGE CATALOG



Radio Research Instrument Co., Inc.

2 Lake Avenue Ext., Danbury, CT 06810
 (203) 792-6666 • Telex 962444

Circle 180 on reader service card

Need a Real-Time Multi-Tasking Executive for 8080 and Z80?

AMIX

- Faultless operation proven in world wide use
- Truly hardware independent
- Optimized for fast interrupt response
- Minimal memory requirements
- ROMable for control applications
- Terminal Handler is CP/M BDOS compatible
- Console Driver supports Intel iSBC boards
- SYSGEN speeds user system configuring
- Program in PL/M, Fortran, Pascal or Assembler
- Source code included (Intel or Zilog mnemonics)
- Unlimited use licence agreement
- Complete documentation (available separately)
- Low cost



KADAK Products Ltd.

206-1847 West Broadway Avenue
 Vancouver, B.C., Canada V6J 1Y5
 Telephone (604) 734-2796

Dealer enquiries invited

CP/M is a trademark of Digital Research Corp.; RMX/80, iSBC are trademarks of Intel Corp.

180 Circle 267 on reader service card

New products

\$19,000 for the 32-, 48-, and 64-channel versions.

Kontron Electronics Inc., 630 Price Ave., Redwood City, Calif. Phone (415) 361-1012 [353]

Dual-furnace scanning unit measures directly in calories

Easy to use, but under 6800-control, the model DSC-4 differential scanning calorimeter can operate unattended for such quality control applications as materials composition, purity additive levels, and thermal or oxidation degradation levels.

The calorimeter employs dual furnaces with a power compensation method that permits measurement of samples directly in calories. Multi-step programming in the program mode allows up to four sequential steps to be selected for automatic operation, thereby permitting not only automatic sample analysis but also complete recycling of the DSC-4 for the start of the next analysis. An automatic setup routine guides the operator through the proper sequence for entering parameters.

When coupled to the thermal analysis data station, the DSC-4 has an interactive video-screen display, a wide selection of programs, and facilities for writing programs in Basic. Available immediately, the DSC-4 sells for \$15,000.

Perkin-Elmer Corp., Main Avenue, Norwalk, Conn. 06856. Phone (203) 762-1000 [355]

Data logger converts into front-end terminal

The portable Cyber I data logger has both an integrating digital voltmeter for 60-Hz rejection and a high-speed analog-to-digital converter, as well as a peak-hold feature.

The 10½-in.-high logger packs 16 multiplexer channels per card for a total of 384 sensor channels. Its turnkey read-only memory software includes rosette analysis, thermocouple linearization, cold junction compensation, tape-cartridge re-

"Old Reliable" cuts military minicomputers down to size.

New 8-bit slice CMOS chip set allows you to reduce system size dramatically...without writing any new software.

Our new High-Rel EPIC (Emulation and Programmable IC) chip set includes an 8-bit slice general processor unit.

Plus, a full family of RAMs, ROMs and logic gate arrays in leadless packages to support your application.

You can use EPIC to emulate

almost any minicomputer. Or to create original computer architecture.

You'll achieve excellent throughput and tremendous savings in space and power. Most important, you'll be able to use your existing software. So you'll save countless thousands of dollars in development costs.

Developed under contract for the U.S. Air Force and other agencies, and built to the demanding standards of Mil-Std-883, EPIC has already proved its value in sophisticated

military applications.

The chip set has been used to emulate the AN-UJK minicomputers and Air Force 1750 instruction set. It is also a key element in the NAVSTAR Global Positioning System and several aerospace projects.

Write to us on your letterhead today to find out how you can get all the benefits of CMOS technology without re-writing your software.

RCA Solid State (Attention: Dick Glicksman or Sy Dansky), MS 442, Route 202, Somerville, NJ 08876.

RCA Solid State headquarters: Somerville, NJ, Brussels, Sao Paulo, Hong Kong **Circle 181** on reader service card

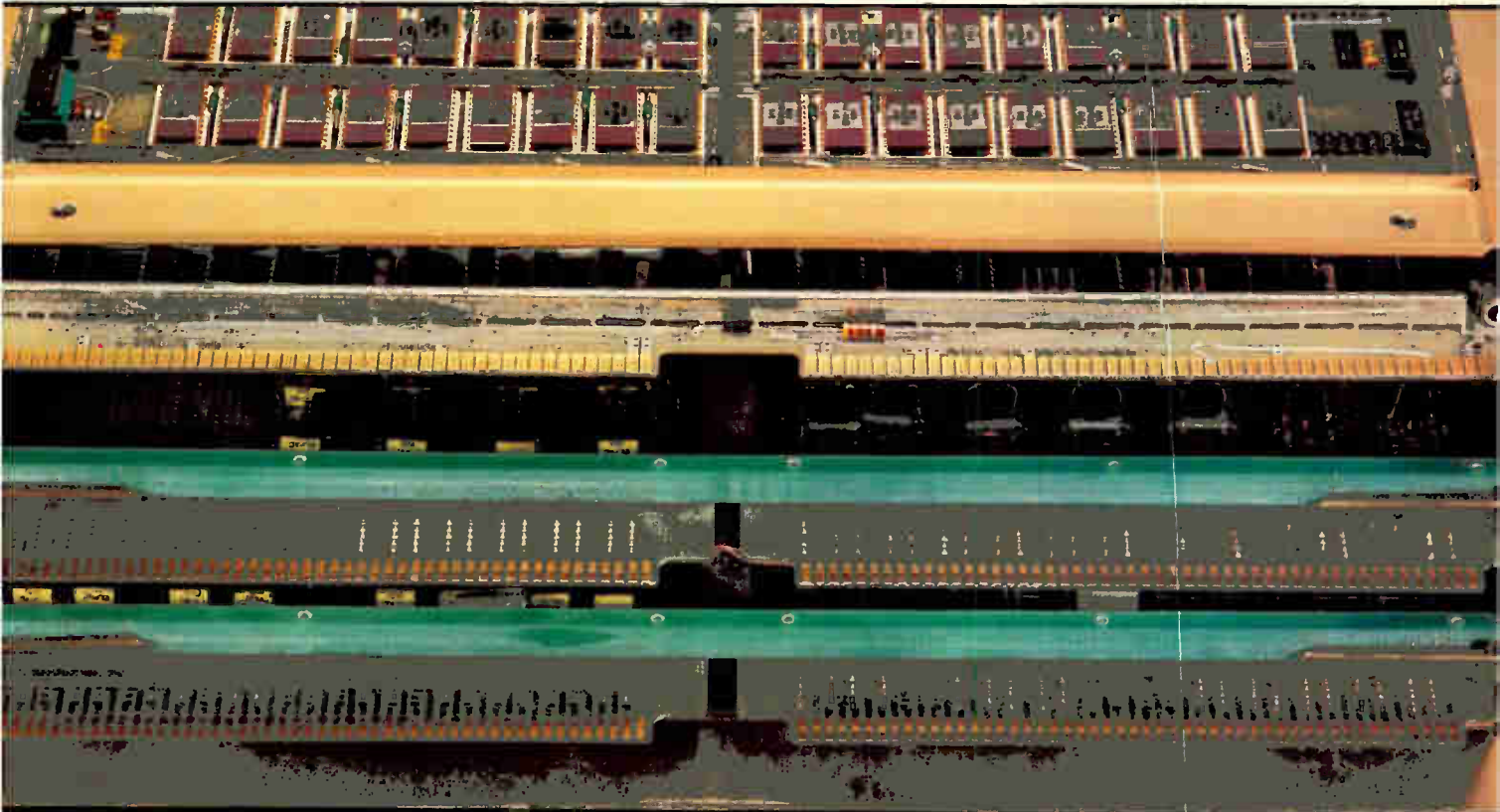

Before

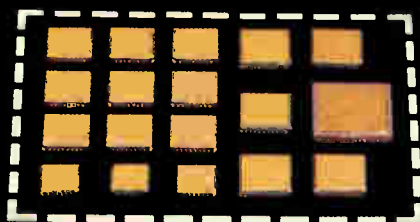

After

EPIC GPU
chip set

RCA

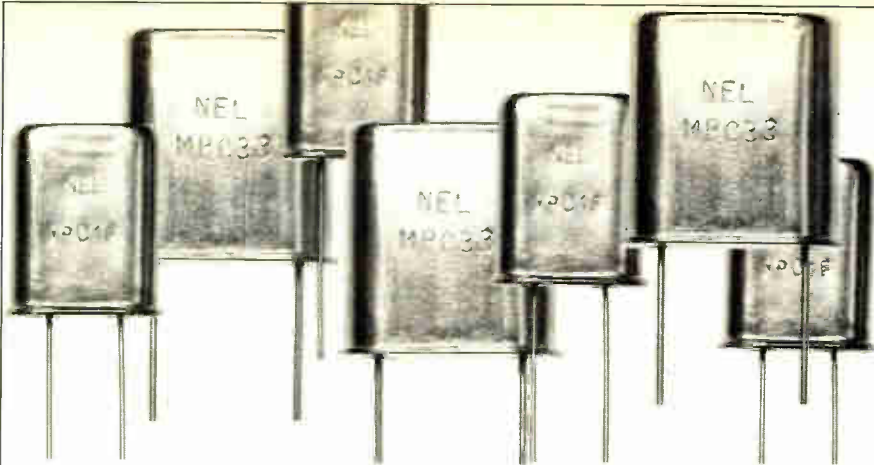

Microprocessor Crystals

IN STOCK Microprocessor crystals in all the popular frequencies are stocked in production quantities at the factory and by local distributors. All crystals are hermetically sealed in metal HC-33 HC-18 packages to insure product integrity.

Quality Crystals At Competitive Prices NEL's 27 years as a major manufacturer of frequency control devices can work for you. Volume production capabilities, dedicated to quality and service, are available to meet your needs at competitive pricing.

For design assistance, the name of your nearest NEL distributor, samples and quotes, or your FREE copy of *Microprocessor Crystals Stock Catalog 8109-C*, contact:

Midland-Ross Corporation
NEL Unit
 357 Beloit Street
 Burlington, WI 53105
 Phone 414 763-3591
 TWX 910-278-2450

MIDLAND ROSS

Circle 182 on reader service card

Reliable DIP switches at reasonable costs.

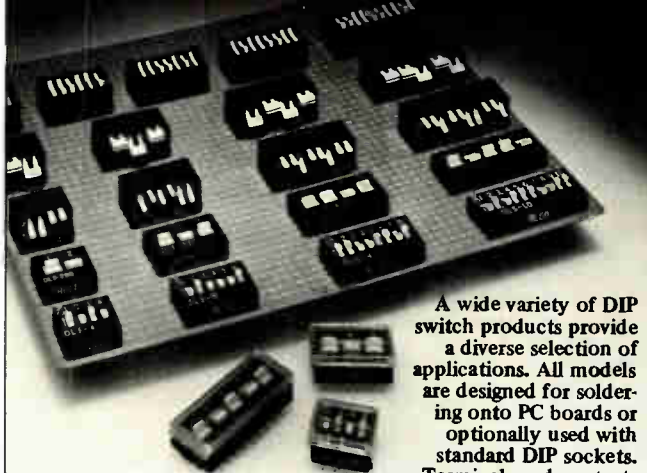

A wide variety of DIP switch products provide a diverse selection of applications. All models are designed for soldering onto PC boards or optionally used with standard DIP sockets. Terminals and contacts

are gold plated. Protective covers available with exclusive "actuator-lock" feature. We also have totally sealed types with tape seal. Our DIP switches are 100% compatible and are in stock for immediate delivery or through our stocking distributors in your area. Call or write ALCO for more detailed information.

AUGAT ALCOSWITCH

ALCO ELECTRONIC PRODUCTS, INC.
 1551 Osgood St., No. Andover Ma 01845 USA
 Tel: (617) 685-4371 TWX: 710 342-0552

Canada: **ALCOELECTRONICS**, 375 Norman St. Ville St. Pierre, Que. H8R 1A3
 Europe: **AUGAT France SA** (Z.I. Sofille) B.P. 440-CEDEX 94263 Fresnes, France



182 Circle 268 on reader service card

New products

ording, and RS-232-C communications-link handlers.

The table-driven software lets the user mix scan rates, channel sequence, transducer types, channels for results, and calculation units at will, to fit the needs of a test. Once defined, test parameters are saved on a tape for instant reloading.

The peak-hold feature, also in ROM, has general appeal but is designed for peak-load measurements in static and fatigue testing. The Cyber I meets stand-alone logger needs, but it can act as a distributed-system front end, gathering data at 20,000 channels/s. Burst memory allows 20,000-channel/s operation for short periods in the stand-alone mode. With delivery to start in the first quarter of 1982, the data logger will sell for below \$25,000 with signal conditioning for 64 channels.

Cyber Systems Inc., 2031 East Cerritos, Anaheim, Calif. 92806. Phone (714) 772-2051 [356]



Programmable pulser works in three modes

Programmable in three modes—frequency, time, or constant output—the Power Pulser provides direct operation of relays, solenoids, valves, motors, and numerous other electrical, electronic, and electromechanical devices. The pulser can be set from 0.2 to 16 V dc at currents of up to 3 A. From a keyboard, the operator can program pulse frequencies from 0.00005 Hz to 5 kHz, pulse duty cycles of 0.1% to 100%, and quantities of 1 to 99,999,999 cycles. The operator can enter pulse on and off times of 0.0001 to 999.999 s, as

Electronics/December 15, 1981

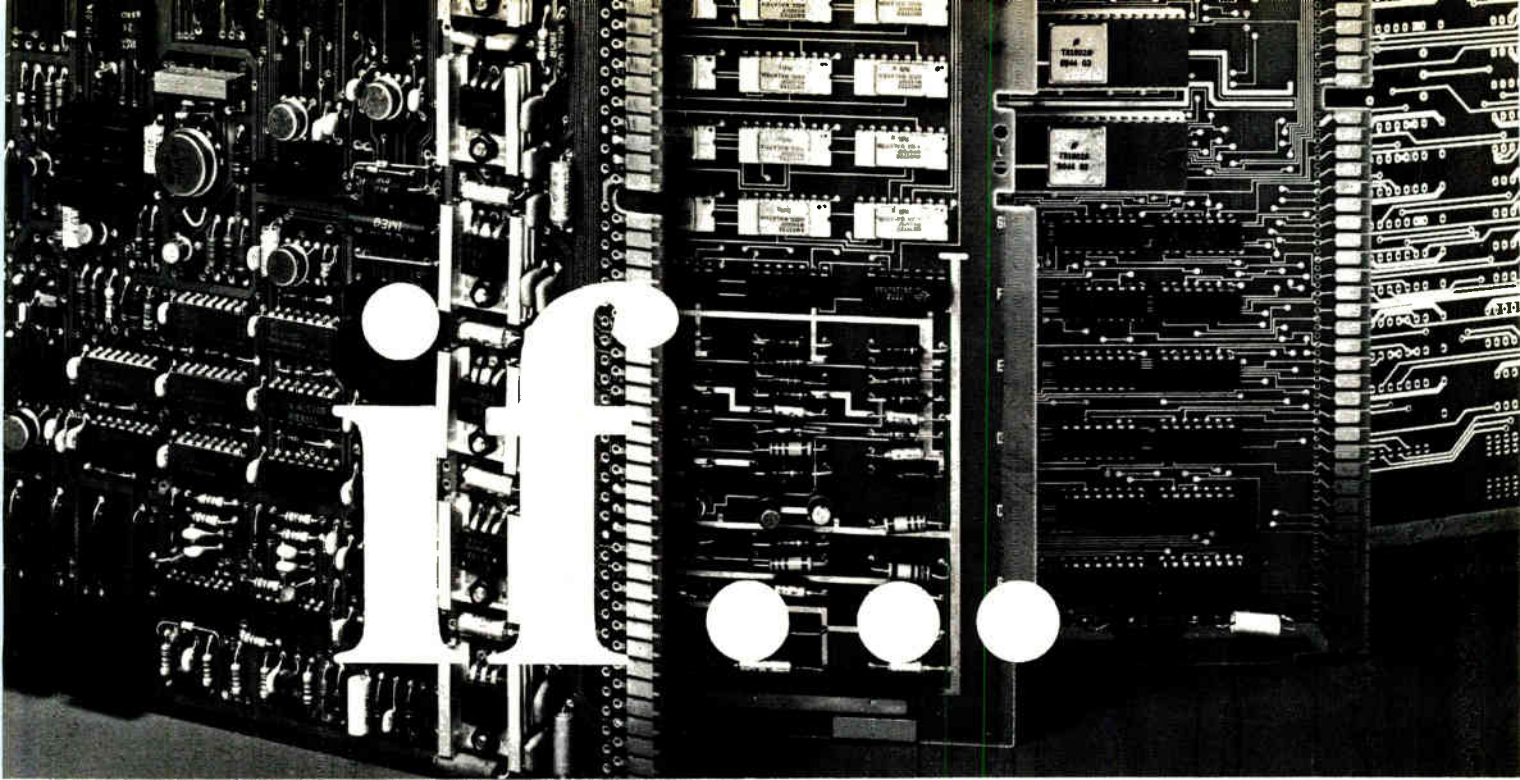

if

... you are considering ATE ...you are not satisfied with your existing ATE ...you are experiencing testing problems ...you are hoping to improve your testing activities you will find our experience invaluable.

Our experience is based on: 20 years advanced electronic production; annual production of 3 millions boards; annual servicing of 1/2 million boards; years of investment in R & D. Our range of test equipment goes from first production stages to field servicing.



WPV 60, wire pattern verifier, can test in a few seconds: ● a bare single or multi-layered board ● the same board fully

assembled ● back planes and cable harnesses ● 25.000 discrete test points on a single board.

ICT 80, in-circuit tester can, in 20 seconds:

● locate up to 98% of all board faults ● test 400 analogue components in a single board test ● test 80 digital compo-



nents including microprocessors. DTS 60 functional board tester provides: ● functional tests in real

time ● functional tests on boards which contain microprocessors ● testing in the same high level language as the microprocessors under test.

MIT 3 field service tester offers:

● simple and speedy fault diagnosis in field servicing ● reduction in down time of equipment ● reduction in the use of highly-skilled technicians ● reduction in spares holding.



We are ready to discuss at any time your board testing problems.

**olivetti
tecnost**

Circle 157 on reader service card

OLIVETTI TECNOST S.p.A. - VIA JERVIS, 77 - 10015 IVREA - ITALY - TEL. (0125) 525 - TELEX 210030/175 OLTEC
 U.K.: OLIVETTI TECNOST CHILTEE MANOR CHASE, HASLEMERE ROAD LIPHOOK - HAMPSHIRE - TEL. (0428) 722844 - TELEX 858926 TECNOS G
 FRANCE: C.I.V.A. - 6, RUE GAUTHERIN - 78120 RAMBOUILLET - TEL. (03) 4832831 - TELEX 698430
 WEST GERMANY: SYNTEL SYSTEMELEKTRONIK GmbH - MÜNCHNERSTRASSE, 60-8025 UNTERHACHING - TEL. (089) 619027 - TELEX 524373
 SWEDEN - MACROTEK AB - VÄLLINGBYVÄGEN 212 - BOX 43 - 162 11 VÄLLINGBY - TEL. 08-879490 - TELEX 12543

TOTAL FREQUENCY CONTROL FROM ERIE

HIGH FREQUENCY AT CRYSTALS



Erie AT Crystals are used over the frequency spectrum from 950 kHz to 200 MHz. Low temperature coefficient, extremely high Q, economical. Used in TCXO and VCXO oscillators, temperature controlled and, non-controlled oscillators, and filter applications. All size cans.

LOW FREQUENCY CRYSTALS



Low frequency crystals are available from 1 kHz to 1MHz in a broad variety of crystal holders and mounting configurations. Erie is a leading source for all types of high quality, Low Frequency Crystals.

CRYSTAL OSCILLATORS



Erie offers a broad range of economical as well as highly sophisticated Crystal Oscillators. These small size oscillators are available in a wide range of frequencies. Hermetically sealed crystals assure long term stability. Design assistance available.

CRYSTAL FILTERS

Erie quartz crystal filters are specified for use in communications receivers ... as well as for radar, sonar and space applications.



Write for brochure describing Erie Crystals, Filters, Oscillators and Ovens.

MURATA ERIE

MURATA ERIE NORTH AMERICA, INC.

ERIE FREQUENCY CONTROL

Carlisle, Pa. 17013
717/249-2232

New products

well as run times of 1 s to 9,999 h and 59 min. Alternatively, the unit can serve as a programmable dc power supply.

The data and test status are automatically calculated, converted to the other program mode, and quickly recalled by push button and light-emitting-diode display. Guaranteed for one year, Power Pulser is approximately \$1,000 and available for immediate shipment.

Signals and Systems Inc., 333 Park St., Troy, Mich. 48084. Phone (313) 585-0600 [357]



Unit distinguishes between analog and digital traces

Computer technology gives the Di-anagraph chart recorder the visual advantage of analog recording with the accuracy of digital print-out.

Analog and digital records for up to 12 inputs can both be printed side by side on fanfold computer paper. The analog records are identified by a number inserted into the traces every 5 in., while digital columns are identified at the top of each page.

The printer's use of standard typewriter-style ribbon eliminates the chore of cleaning the pen. Carbon-interleaved fanfold paper can be used to make duplicate records.

Models with 5 and 12 channels are available. Options available include a calculation and control package for analyzing and modifying data, a fast mode for such high-speed data input as electroencephalographs and electrocardiographs, cassette storage, and a computer interface. The Di-anagraph starts at \$4,900, with delivery taking six weeks after receipt of order.

Bailey Instruments Inc., 515 Victor St., Saddle Brook, N. J. 07662. Phone (201) 845-7252 [358]

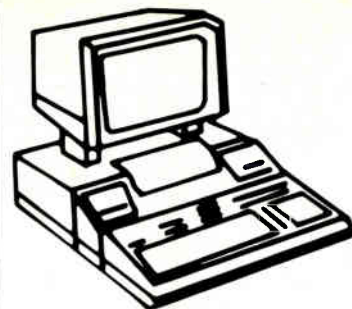

HEWLETT PACKARD

Desktop & Mini
Computer Products

SAVINGS ALL MODELS

98458/C HP85 HP1000L
9835A/8 9826A w/Winchesters
CALL OR WRITE FOR FREE CATALOG
Call Now Toll Free—Ask For Opr. #554
U.S.—800-824-7888
Calif. only—800-852-7777
Alaska/Hawaii—800-824-7919

digital resources inc.

Box 23051 Portland, OR 97223 USA
503-246-0202
International Sales Telex 360-143

Circle 269 on reader service card

FIBER OPTICS VOCABULARY



The basic reference document on fiber optic and lightwave communications for those who design, develop, operate, use, manage, or manufacture communications or data processing equipment and components.

- 1400 entries, with
- inversions and cross-references
- index of terms

Order your copies today!

\$12.95 each, discounts of 10% on orders of more than 10.



Electronics Magazine Books
1221 Ave. of the Americas
New York, NY 10020
Tel. (212) 997-2996

Wouldn't it be great if every kind of keyboard had our kind of performance?

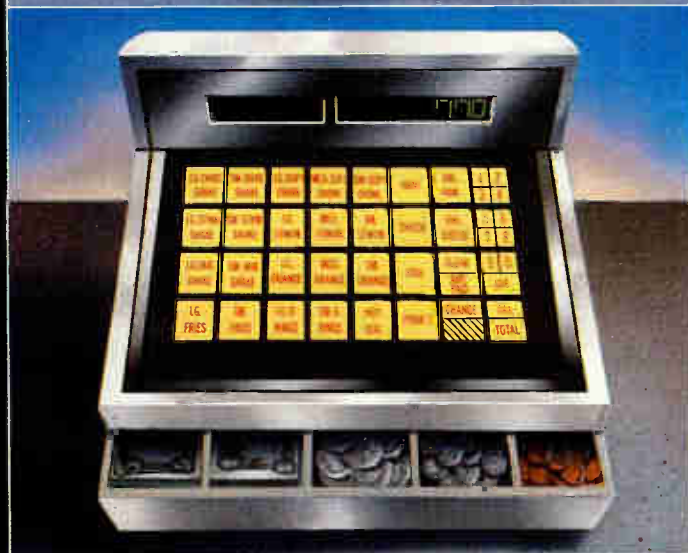



SC Series Capacitance Membrane Keyboard



KD Series Touch Panel Keyboard



SD Series Hall Effect Keyboard



CT Series Contact Membrane Keyboard

Now they do.

Until now, getting a keyboard at the price you needed could have meant giving up the kind of performance you wanted.

But not anymore.

Because, with the introduction of three new membrane keyboards, MICRO SWITCH has become the world's only full-line supplier of reliable keyboards. We offer a high-performance and cost-effective solution for virtually any application.

Now, in addition to our time-proven Hall effect offerings, you can specify MICRO SWITCH SC Series full-travel capacitance membrane or CT Series contact membrane keyboards, and KD Series touch panel membrane keyboards.

Whatever type of seal you need, all you have to do is ask. The capacitance membrane units are the world's only capacitance keyboards with all the benefits of membrane sealing. And we're the first to solve the venting problems associated with previous membrane designs. Both our capacitance membranes and contact membranes are internally vented

to maintain their seal while preventing switch collapse due to air pressure or temperature changes. And for especially severe environments, the touch panel keyboards give the added feature of panel sealing.

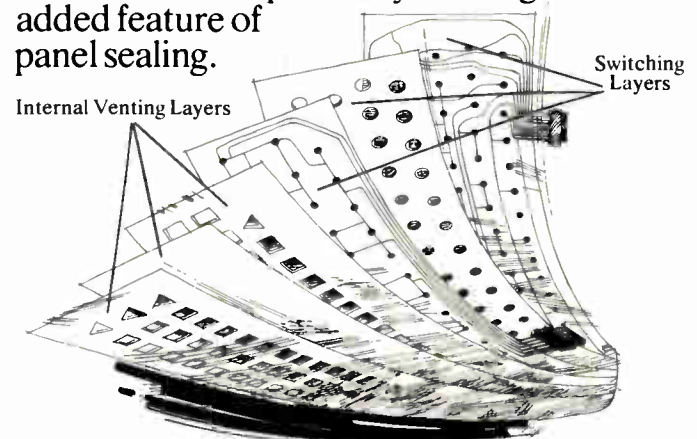

It's those features, among others, that make these new keyboards more reliable than other capacitance and hard-contact designs.

And because all three new keyboards have been designed with traditional MICRO SWITCH quality and reliability, each carries a 1% Acceptable Quality Level and 2-year warranty.

Now any combination of keyboard features you can name can have the MICRO SWITCH name on it.

Now your keyboard specifications are only limited by what you want. Not by what you can get.

Our full-travel series, for example, are available in a wide variety of keyboard configurations, with a choice of over 40,000 legends.

Because legends are screened on our touch panel designs, the graphic possibilities are endless. And, we can combine full-travel and touch panel actuation in a single assembly, featuring either capacitive or hard contact technology.

We make it easier to comply with European standards, because our full-travel membrane designs are available in low-profile versions to meet world requirements.

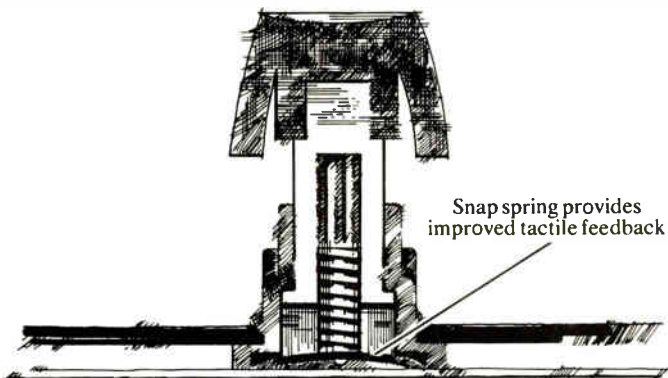

And, the actuator module for the full-travel membrane keyboards helps achieve new levels of tactile feedback and operator satisfaction.

So you can come to MICRO SWITCH for the keyboard technology, travel, actuation, sealing, appearance, profile, electronics, and special features you need.

And get them all—backed with the experience and full application support that's been a MICRO SWITCH tradition.

Being able to design a keyboard to fit any application is important. But doing it to fit any operator is imperative.

It's important to understand that half of any keyboard application is a human being. There's probably no keyboard manufacturer who understands that better than MICRO SWITCH.

Our unique human factors research—an intensive, on-going program for over 20 years

—has given us the tools to develop industry standards for key speeds and multi-key roll-over; tactile, visual, and audible feedback; and various keytop shapes, spacing, configurations and travel. We're continually improving the man/machine interface.

This human factors research is part of



what makes our keyboards unique. And it's part of every keyboard we make.

Instead of resting on our laurels, we're relying on our research.

Being able to add state-of-the-art capacitance membrane, contact membrane, and touch panel keyboard types to our Hall effect offerings is the result of extensive planning, research and testing.

But it's only the beginning.

Each of these keyboard types will be continually subjected to the refinements growing from our human factors research, customer feedback, and our unmatched R&D facilities which include backup by our Honeywell corporate facilities.

Also, every keyboard customer benefits from a manufacturing capability that stands unmatched: it's large enough to handle the most extensive order; responsive enough to give the modest order the same kind of intensive, individualized and quality-conscious attention.

All of these efforts are to make sure that, as your keyboard needs change and grow, you'll always have the choice of a progressive alternative with one unchanging feature: the MICRO SWITCH name. With all the performance that name implies.

For more information on our keyboard technologies, call 815-235-6600. Or write, MICRO SWITCH, the Keyboard Consultants, **MICRO SWITCH** Freeport, IL 61032. a Honeywell Division

Bridging the generation gap.

How Fairchild makes past and future come together.

Since 1965, Fairchild Test Systems has tried to make each new product generation compatible with its predecessor. It's just a more efficient way of doing business.

And we've been doing business longer than anybody else.

It all started with our Series 500. A precursor of the Sentry® series, the 500 used discrete transistors and vacuum tubes. The same year also saw the Series 4000, our first IC tester. Then came the 5000, the first computer-controlled tester.

That's a lot of firsts. Industry firsts. That's why we're The First



Series 20

Family of ATE.

And Fairchild's Series 20 carries on the tradition.

This state-of-the-art LSI/VLSI tester will solve just about any testing or characterization problem you have. Today or tomorrow. You can

test MOS and bipolar microprocessors, gate arrays and memories up to 20 MHz. Plus bit-slice microprocessors and peripheral and memory devices beyond 20 MHz.

And when it comes to compatibility, the device performance boards on your existing Fairchild test equipment are totally compatible with the Series 20.

If you're interested in just production testing, you still need a system that keeps pace with future technology. And won't obsolete your existing equipment.





Series 10

Our new Series 10 production tester is compatible with Sentry and Series 20 systems, thanks to our new, standard M³ operating software.

And the Series 10 is designed to be flexible, yet affordable. You can increase CPU memory from 128K to 256K words. Plus, we're developing options like enhanced timing, algorithmic pattern generation and 120-pin VLSI capability.

Speaking of options, SAGE, our new program debugging tool, combines intelligent color graphics and FRIENDLY™ software. It provides a menu of options to debug any problem, so you don't have to depend on complex computer language.

Compatible with our Sentry and Series 20 systems, SAGE displays all programmed stimulus and response to and from the device under test. And offers you the ability to modify the program stimulus in-

teractively. With SAGE, you'll spend less time debugging. And have more time for actual device testing.

To tie all our systems together, there's Integrator. A powerful host computer that helps you get the most out of your test equipment.

Integrator can control, manage and communicate with up to eight remote test systems, whether you're using our engineering or production testers. It can interpret, analyze and modify device test results and programs. With Integrator, your test sys-



SAGE

tems can be completely dedicated to testing.

Fairchild continues to bridge the generation gap. And as today's



Integrator

technology becomes more complex, we'll continue to be modular, expandable and compatible. So you won't have to worry about obsolescence.

That's the simple solution.

But we've been doing that for years.

For more information, contact Fairchild Test Systems Group, 1601 Technology Drive, San Jose, California 95115, (408) 998-0123, Ext. 2732. Fairchild Camera and Instrument Corporation.

Circle 189 on reader service card

FAIRCHILD

A Schlumberger Company

**The
First Family
of ATE.**

EXIT



TEST
ENGINEERING
VLSI
DEPARTMENT
201



1981
OCTOBER



RS 232 and RS 449, bring them together with our subminiature Ds. It's easy.

Save your systems from obsolescence. Bring them up to the standard with AMPLIMITE subminiature D adapters.

They interface RS 232 with the new RS 449 cable-to-cable or directly to your equipment. One way or the other, you save the cost of major redesign.

Our subminiature Ds also give you the widest choice. Metal shell and



all-plastic connectors. Filtered assemblies. Mass termination styles. Standard, high density and MIL-C-24308 versions. And the most complete selection of accessories made.

You bring a lot together with our AMPLIMITE connector system.



AMP Facts

Plated-through hole damage is avoided with ACTION PIN contacts. Gas-tight connection without soldering is also assured.

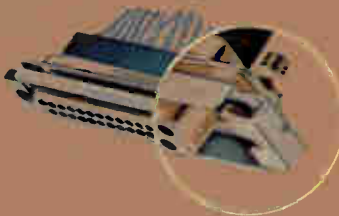
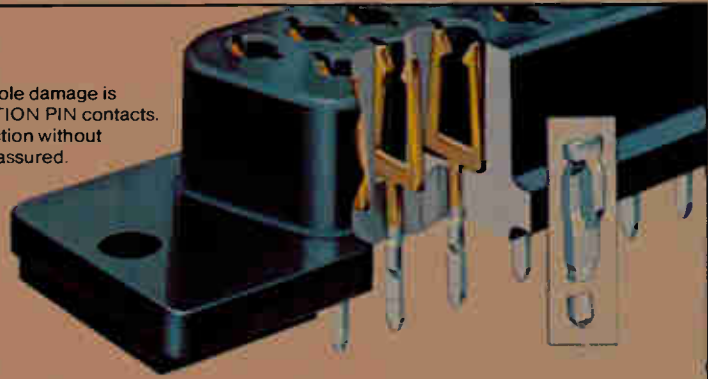

Two styles of slide latch clips simplify plug and receptacle mating.



Metal-shelled shielded connector provides EMI protection.



Spring latch assembly allows easy harness hook-up to RS 449 standards.

For more information, call the AMPLIMITE Connector Desk at (717) 780-8400.

AMP Incorporated, Harrisburg, PA 17105.

AMP, AMPLIMITE and ACTION PIN are trademarks of AMP Incorporated.

AMP means productivity.

CIRCLE
NUMBER
125



We'll deliver MIL-C-24308 connectors faster than anyone else.

No ifs, ands, or buts.

This covers our MIL-spec AMPLIMITE pin and socket connectors with 9-50 contact positions. And our unique high-density series with 15-104 positions.

MIL-C-39029 contacts come in continuous strip for our semi-automatic stripper crimper and our fully automatic lead maker. Also, in loose piece for hand tool application.

We even have the widest selection of accessories, including mounting hardware, spring latches and cable clamps. So we can deliver the application versatility you need.

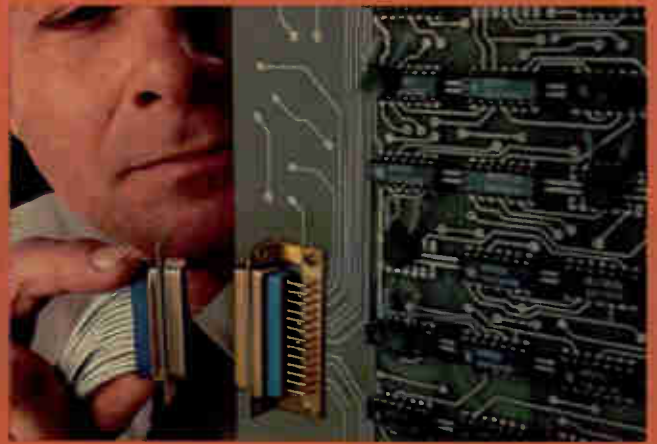

AMP Facts

- Right angle pc board headers are designed to meet the requirements of MIL-C-24308.

Shells can be specified in non-magnetic material.

- Connectors are intermateable with industry standards.

- New housing design for mixed coax and crimp snap-in signal contacts.

For more information,
call the AMPLIMITE
Pin and Socket Connector
Desk at (717) 780-8400.

AMP Incorporated, Harrisburg, PA 17105.

AMP and AMPLIMITE are trademarks of AMP Incorporated

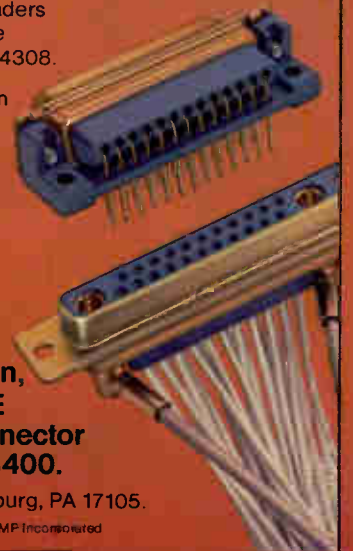

AMP means productivity.

CIRCLE
NUMBER
126



New products

Microcomputers & systems

Talking board mixes in effects

S-100 speech synthesis card
uses d-a converter and mixer
to add special audio effects

Speech, sound, or a combination of the two can emanate from a computer equipped with the Synthetalker, an S-100 compatible speech synthesis board. Using the Votrax SC-01 synthesizer, with its 64 phonemes, four inflection levels, and automatic phoneme timing, the Synthetalker has both preset and program control over the speech pitch. A trimmer potentiometer sets the preset pitch or an on-board 8-bit digital-to-analog converter can be used to vary the pitch by controlling the SC-01's oscillator. In addition, this combination yields tremelo, multiple voices, or other special effects.

Operation of the talking board is straightforward. The words and or phrases to be synthesized are first broken down into phonemes. Their corresponding codes are then selected from a table and sent to the Synthetalker one at a time as the SC-01 requests them at a rate averaging 70 b/s. The SC-01 ready line may be

polled or configured to generate an interrupt when the SC-01 is ready for the next phoneme.

The sound of software. Sounds have more diverse origins. They may be created from the SC-01 phonemes, by waveform synthesis with the d-a converter, or by a combination of both. Sound effects can be generated along with speech by mixing the outputs of the SC-01 and the d-a converter, or sounds may be mixed with speech by sending waveform values to the d-a converter at an audio rate. Speech and sound can also be mixed with an external audio signal; an external audio line input is provided. The mixing of the d-a converter and external input with the speech is under program control.

A digitally controlled attenuator on the output of the mixer permits software control of the Synthetalker's volume. The output of the attenuator is processed by a fourth-order Butterworth low-pass filter to minimize the speech- and sound-generation aliasing frequencies and is available as an audio line-output. An on-board audio amplifier also provides a 250 mW signal to an 8- Ω load. All audio inputs and outputs are on RCA-type phone jacks, allowing easy interconnection to audio systems with shielded cables.

Two 8-bit ports, one for input and the other for output, are provided with ribbon-cable connectors. Each port includes a program-controlled

strobe line and two jumper-controlled control/status lines. The input port can support an extra keyboard or joystick circuitry.

As a bare board, Synthetalker will be available in three weeks for \$64.95. Pricing and availability of kit or assembled-and-tested boards are expected in six weeks.

Ackerman Digital Systems Inc., 110 N. York Rd., Suite 208, Elmhurst, Ill. 60126. Phone (312) 530-8992 [371]

128-K-byte memory emulates Apple II disk drive

For \$750, Apple II owners can buy a 128-K-byte random-access-memory card that emulates a floppy-disk drive. Called the 128KDE Soft Disk, the card has access times 300 times shorter than a floppy disk and thus prevents the Apple from bogging down in disk-intensive tasks.

The 128KDE, which uses sixteen 64-K RAM chips, can be placed in any slot and can be accessed with the standard Apple DOS 3.3 commands. Its software supports three cards and thus three fast-access disk drives.

A Mount command enables users to store the contents of a floppy disk in one emulated disk drive, and an Update command copies the contents of the emulated disk back onto a floppy disk in 18 s. The software also supports Integer or Applesoft firmware cards.

The board is delivered from stock. Legend Industries Ltd., P. O. Box 112, Pontiac, Mich. 48056. Phone (313) 674-0953 [373]

Memory card expands SBC 86/12A systems

Designed to augment the Intel Intellec SBC 86/12A microcomputer, the CI-8086 memory module is available in 32-K- to 512-K-by-9 bits. The CI-8086 is compatible with both 8- and 16-bit Multibus-based systems.

A single board, the memory plugs directly into the backplane of any Multibus-compatible system. It gen-

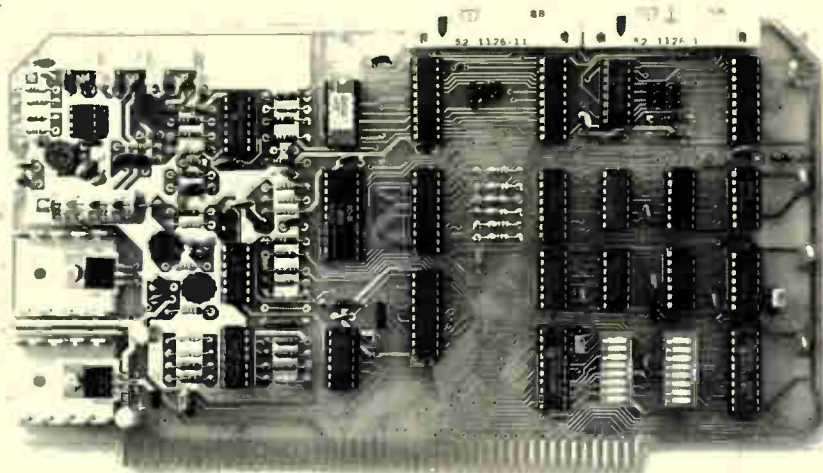

IMPROVE YOUR PRODUCT'S ENERGY EFFICIENCY



Model 4612 microprocessor-controlled analyzer tells you what you have to know if your product is to meet the energy-efficiency demands of today's marketplace. It tests the power consumption of virtually any electrical appliance or device, and its integrating capability lets you measure average usage over any desired period of time. It gives simultaneous readouts of true RMS amps, volts, watts, with typical accuracy better than .5 percent. Many other advanced features. Request detailed brochure today.

see our catalog in
THOMCAT
or call us toll-free at
800-828-7844
(except New York State)



MAGTROL, INC.

70 GARDENVILLE PARKWAY WEST
BUFFALO, NEW YORK 14224 716-668-5555

Circle 194 on reader service card

New products

crates and checks even parity with selectable interrupt on parity errors. On-board refresh-control logic allows maximum processor throughput. Data access time is 270 ns; cycle time is 400 ns.

The memory is addressable in 16-K increments for up to 16 megabytes of storage. The board measures 6.75 by 12 in. and consumes under 8 w. The CI-8086 sells for \$795 as a 128-K-by-9 board and for \$1,995 as a 512-K-by-9 module. Delivery is from stock.

Chrislin Industries Inc., Computer Products Division, 31352 Via Colinas, Westlake Village, Calif. 91362. Phone (213) 991-2254 (374)

NEC offers Multibus card using its version of 8086

Using its own μ PD8086 16-bit chip as a central processing unit, NEC has constructed a Multibus-compatible single-board computer. The BP-0186 has 32-K bytes of high-speed random-access memory, with sockets for up to 32-K bytes of read-only memory or programmable ROM. System memory can be expanded to a total of 1 megabyte.

In addition, a serial RS-232-C synchronous-asynchronous interface with software-selectable bit rates and 24 buffered, programmable, parallel input/output lines enhance the system.

The heart of the BP-0186, the μ PD8086, can directly address 1 megabyte of memory over its 20-bit address bus. It features fourteen 16-bit registers accessed by 24 operand-addressing modes for complex data handling and flexible memory addressing. The optional 8087 floating-point coprocessor may be installed to add over 60 numerical instructions and hardware support for multiple-precision-integer and floating-point data types.

For applications that require additional processing capacity, the BP-0186 has multimaster capabilities, allowing multiple CPUs or intelligent controllers to share the system bus. Available for immediate delivery,

"SURGE FREE" SURGE ABSORBABLE DISCHARGE TUBE (FOR CIRCUIT PROTECTION)

● POINT

- (1) Usable at wider ambient condition, especially good under high humidity
- (2) Visibility for operation
- (3) Compact and easy assembly
- (4) Stable characteristics

● APPLICATION

Computer circuit
Communication equipment
Home Appliance
Aircraft and Automobiles

● TYPE

Type	Breakdown Voltage (V) dc	Insulation Resistance (Ω)	Minimum Surge Current (8 \times 20 μ s) KA	Life Times at 500A
SA-80SS	80 \pm 10%	10 ⁷ min	0.7	3000
SA-200SS	200 \pm 10%	10 ⁷ min	0.7	3000
SA-80	80 \pm 10%	10 ¹⁰ min	1.5	3000
SA-140	140 \pm 10%	10 ¹⁰ min	1.5	3000
SA-200	200 \pm 10%	10 ¹⁰ min	1.5	3000
SA-250	250 \pm 10%	10 ¹⁰ min	1.5	3000
SA-300	300 \pm 10%	10 ¹⁰ min	1.5	3000
SA-7K	7000 \pm 1000V	10 ¹⁰ min	—	5000
SA-10K	10000 \pm 1000V	10 ¹⁰ min	—	5000

Change of Ez by cycling discharge

(Model) SA-80

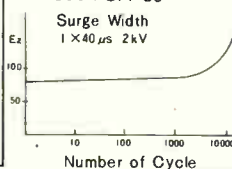

● MAIN PRODUCT

NEON GLOW LAMP, XENON FLASH LAMP, RARE GAS, DISCHARGE LAMP.
MINIATURE : BLACK-LIGHT, UV-LIGHT, FLUORESCENT COLOR-LIGHT.

ELEVAM ELECTRONIC TUBE CO., LTD.

NO. 17-8CHOU 2-CHOME OTA-KU, TOKYO JAPAN
TELEPHONE : 03(774) 1231~5 TELEX : 246-8855 ELEVAM

AN INNOVATIVE 20 MHz OSCILLOSCOPE THAT EMPHASIZES OPERABILITY

The SS-5702 has flexibility and power which make it ideal for the maintenance and troubleshooting of TVs, VTRs, audio equipment and a wide range of other electronic systems by hobbyist as well as professionals. At the top of its class, the SS-5702 uses a 6-inch rectangular, parallax-free CRT.

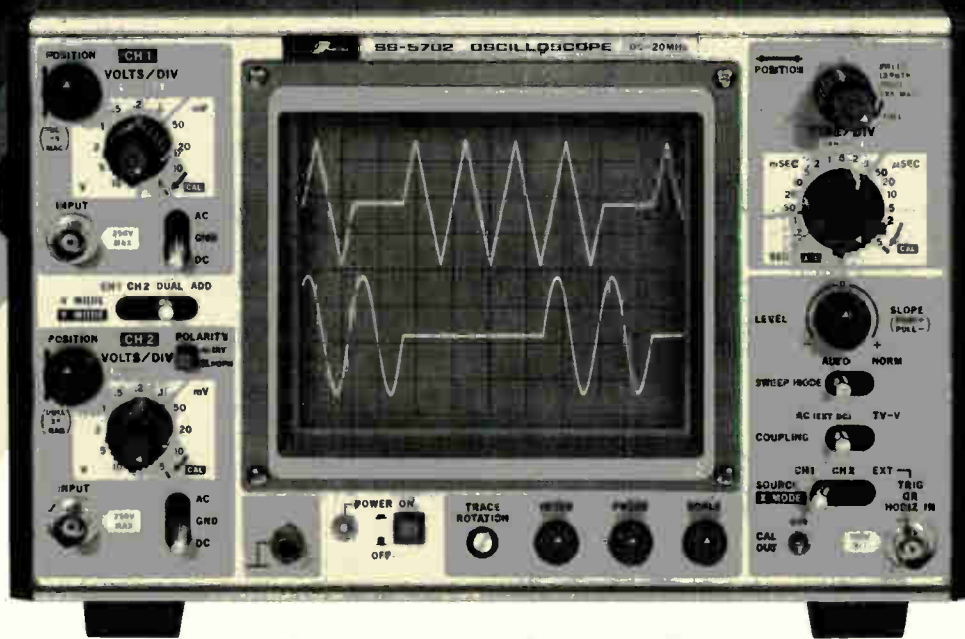

IWATSU SS-5702 DC-20 MHz OSCILLOSCOPE

IWATSU makes more than 20 oscilloscopes as well as an impressive lineup of other instruments including logic analyzers and digital memory scopes. The fastest oscilloscope has a maximum frequency of 350 MHz. And the same technological expertise and product quality that make this super high-frequency oscilloscope possible are incorporated in the SS-5702.

- 6-inch rectangular, parallax-free CRT
- TV-V trigger
- Variable sweep length
- Double Lissajous figure
- 1 mV/div to 10 V/div sensitivity
- 100 ns/div to 0.2 s/div sweep
- Differential input with ADD mode
- DC operation (optional)



IWATSU ELECTRIC CO., LTD.

ASAHISEIMEI BLDG., 2-1-3 NIHONBASHI, CHUO-KU, TOKYO, 103 JAPAN TELEX: J24225 TELEIWA

- Austria: Universal Elektronik Import GmbH 54 15 38
- Canada: Associated Test Equipment Ltd. (416) 497-2208
- Chile: Importadora Janssen Y Cia. Ltda. 72 3956
- Denmark: Danstrumment aps (03) 28 34 31
- England: ITT Instrument Services 0279 29522
- Finland: Oy Etra AB 780 122
- Italy: Radiel Spl (02) 213.30.56
- Netherlands: Klaasing Electronics BV 01620-51400
- New Zealand: G.T.S. Engineering Ltd. 546-745
- Norway: Solberg & Andersen A/S (02) 19 10 00
- S. Africa: Ultra Instruments (Pty) Ltd. (011) 37-7860/1
- Sweden: Teleinstrument AB 08/38 03 70
- Switzerland: Traco Electronic AG. 01 201 07 11
- West Germany: NBN Elektronik GmbH (0 81 52) 390

LIQUID CRYSTAL DISPLAYS

(Unit : mm)

■For watches
SP-04D



SP-12



■For calculators
SP-203



■For clocks and measuring instruments
SP-201

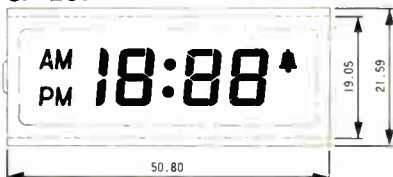

■For games and large instruments
SP-101

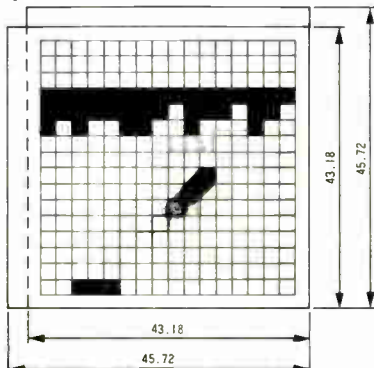

[Characteristics]

(1) High contrast and wide viewing angle.

Special organic panel construction provides excellent contrast and wide viewing angle.

(2) Color display.

Color polarizer type and guest-host type.

(3) Excellent multiplexing characteristics.

(4) Wide variety of glass thickness.

(5) Various reflector.

Color, transfective, patterned, etc.

SEIKO GROUP
DAINI SEIKOSHA CO., LTD.

Sales Division: 31-1, 6-chome, Kameido, Koto-ku, Tokyo, 136, Japan.

Phone: Tokyo 684-2010 Telex: 2622410 DSEIKO J

Frankfurt Representative Office: Arabella Center 13 OG Lyoner Strasse 44-48, 6000

Frankfurt/Main 71 W. Germany. Phone: 0611-666971-2, Telex: 413045 DSFM D

Seiko Instruments U.S.A. Inc. 2990W. Lomita Blvd., Torrance Calif., 90505

Phone: 213-530-3400 Telex: 9103477307

Precision Engineering LTD. Sales Division: 1F, 37, Hillwood Road Kowloon,

Hongkong. Phone: 3-676485, 3-675902 Telex: 40211 PELSD HX

New products



the BP-0186 is priced at \$2,100 each.

NEC Electronics USA Inc., Microcomputer Division, 1 Natick Executive Park, Natick, Mass. 01760. Phone (617) 655-8833 [375]

Desktop unit processes data and runs instruments

The model 48 puts not only data-processing but also General-Purpose Interface-Bus control capabilities into a desktop unit. The heart of the system is a four-layer, single-board GPIB controller that features two independent GPIB ports, each with a bus transfer rate of over 14-K bytes/s. The controller also includes an RS-232-C serial port and two parallel data ports.

A 12-in. cathode-ray-tube terminal with a full 80-by-24-character display has scrolling capability and features a 25th line for displaying system status, as well as the time and date. A Qwerty keyboard is used for manual entry of data, and a \$1,500 impact dot-matrix printer produces hard copy 132 columns wide.

The model 48 is supplied with the CP/M operating system, as well as a text editor, assembler, and debugging software. An enhanced Basic, called GPIBasic provides direct GPIB commands. Each command, such as IEEEOUT, takes the place of the multiple commands that would be needed if straight Basic were used.

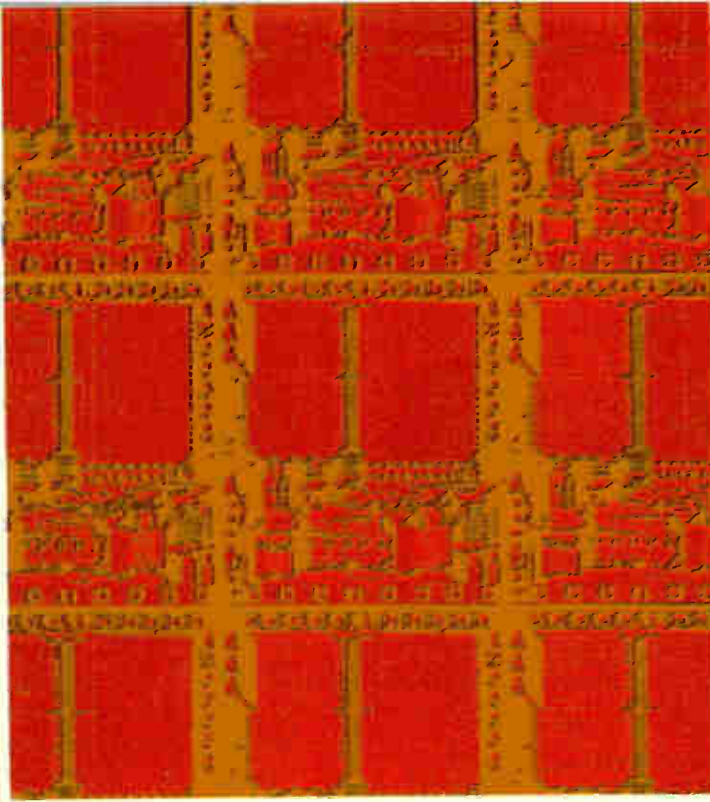

TMS1000 products give your products microcomputer performance. At the lowest possible cost.

TI's TMS1000 Family can give your products the benefits of microcomputer intelligence at a very low cost.

More than 60 million TMS1000 4-bit microcomputers are at work in many diverse applications — radios, home appliances, air conditioners, toys, clocks, microwave ovens, scales, POS terminals, smart thermometers and metering functions.

Enhance your product

With microcomputer intelligence, your product can respond or take action from a sensor or user input. A telephone that dials a preset number on command. A scale that weighs, then calculates the price. TMS1000-enhanced products are faster. More efficient. More accurate. More reliable. And more cost-effective.

Like your product, most TMS1000 applications must be highly reliable. TMS1000 has an attained failure rate of 0.048%/1000 hours, based on 5 years and millions of device-hours of operation. Also, using TMS1000 instead of standard logic greatly

reduces system connections, a major source of malfunctions.

New TMS1000 Products For Temperature Control
The TMS2372 Climate Controller can sense and control the temperature of 1 or 2 areas according to user-programmed schedules.

For Telecom/Hand Held Low Power Applications
The TMS1100C CMOS microcomputer is a 4-bit device with 2K bytes ROM and 512 bits RAM. It uses only 5 mW typical power.

Design Flexibility
The TMS1000 Family provides technology and output options to closely match your application. Choose CMOS for very low power applications, or PMOS. On-chip memory from 1K to 4K bytes of ROM, 128 to 512 bits of RAM. Standard or low (9V) voltage can be specified.

Development Support

Let TI develop and test software for your application, or develop your own using TI development boards, systems and software. Our Regional Technology Centers provide courses in software and hardware design as well as design support.

For more information on TMS1000 Family microcomputer solutions, call the factory direct at (214) 995-6023, send in the coupon, or call your nearest TI sales office or authorized distributor.



TI Literature Response Center		EL-4
P.O. Box 202129		
Dallas, Texas 75220		
Please tell me more about the advantages of the TMS1000 4-bit, single chip microcomputer family.		
MY APPLICATION IS _____		
NAME	TITLE	
COMPANY _____		
ADDRESS _____		
CITY	STATE	ZIP
PHONE _____		

Texas Instruments invented the integrated circuit, microprocessor and microcomputer. Being first is our tradition.

*Trademark of Texas Instruments
© 1981 Texas Instruments Incorporated

TEXAS INSTRUMENTS

85323C

ARGENTINA 748-1141 • AUSTRALIA (02) 887-1122 • BELGIE/BELGIQUE (02) 720.80.00 • BRASIL 518423 • DEUTSCHLAND 08161/831 • FRANCE (3) 946 97 12 • ITALIA (0746) 69034
JAPAN 03-498-2111 • MEXICO 567-9200 • NEDERLAND 020-473391 • SCHWEIZ/SUISSE 01 740 22 20 • SVERIGE (08) 23.54.80 • UNITED KINGDOM (0234) 223000

World Radio History

Circle 49 on reader service card

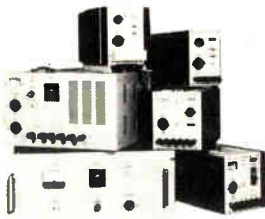
SUNLITQuarts
Noiseless**INVERTER & U.P.S.**
& FREQUENCY CONVERTER WITH BATTERY"Noiseless" Series
INVERTER50~500VA Miniature U.P.S.
with "GS" Sealed-gel Battery

SPECIFICATIONS OF INVERTER

Output	50VA	100VA	200VA	300VA	500VA	1000VA
Model	DA50	DA100	DAX200	DAX300	DAX500	DAX1000
Input Voltage	DC12V(11~15V)		DC24V(22~30V)		DC48V(44~58V)	
Freq. Stability	50/60Hz Less than ±1Hz		50/60Hz or 400Hz Less than 1X10 ⁻⁷			
Output Voltage	AC100V · 115V · 200V or 230V Less than ±5% (0~Full Load)					
Distortion	Less than 10% (Special Order Minimum 1% or More)					
Dimensions(mm)	176X114X213	176X153X213	176X183X262	176X183X393	220X350X350	248X430X470
Weight (kg)	5.0	5.6	7.5	12.0	29.0	36.0

Note: available for use with other input output voltage and variable frequency.

U.S.A.
SUNLITPOWER INC.2931 South Main St., Suite C, Santa Ana, Calif. 92707 U.S.A.
Phone: (714) 641-4021NETRELAND
OKAMOTO ELECTRONICS CORP.C/O Osaka Merchandise Center, Schiekade 189, Rotterdam 3004,
The Netherlands Phone: 010-123117

KOJIMA ELECTRIC MFG. CO., LTD.

Main Office : No. 26-B, 2-chome, Minamikaneden, Suita-shi, Osaka 564,
Japan Phone: (06) 385-3523 Telex: 5236627 KOJIMA-J
Tokyo Branch: Toyotama Bldg. No. 15-3, 3-chome, Toyotamakita
Nerimaku, Tokyo 176, Japan Phone: (03) 948-4312

Circle 198 on reader service card

**IN THE MARKET FOR
FERRITE
FABRICATION?**

✓ Check out **PERMAG**
... your one-stop shopping mart
for sophisticated magnetic materials

"In the Magnetic Field, PERMAG is No. 1"

ALL ACROSS THE COUNTRY

PERMAG

ATLANTA • BOSTON
CHICAGO • DALLAS
LOS ANGELES
MINNEAPOLIS/ST. PAUL
NEW YORK • SAN FRANCISCO
TOLEDO

Consult Yellow Pages for
the PERMAG near you.

Permanent Magnets
Flexible Rubber
Magnets
New Rare Magnets
Linear Ferrites &
Hardware
Ceramic Magnets
Audio Magnets
Beryllia/Technical
Ceramics
Shielding Materials

PERMAG CORP., 400 Karin Lane, Hicksville, N.Y. 11801
Send me your catalog.

Name _____
Address _____
City _____
State _____ Zip _____

198 Circle 50 on reader service card

New products

The model 48 IEEE-488 bus controller and computer system is priced at \$5,500, with shipment 30 days after receipt of order.

Systel Computers Inc., 538 Oakmead Parkway, Sunnyvale, Calif. 94086. Phone (408) 746-2901 [377]

Q-bus controller handles
IBM's OEM Winchester drive

The Quad 3000 is a single-board Q-bus controller that supports IBM's 680, a recently introduced 64.5-megabyte Winchester disk drive for original-equipment manufacturers. It has an aggregate data-input rate of over 2 megabytes/s and a 4-K-byte on-board high-speed buffer.

The Quad 3000 incorporates National's proprietary controller micro-engine, the transfer processing unit (XPU), which implements a 4-bit-wide microword architecture with bit-slice components. The unit's architecture is identical to that of the Hex 3000 Unibus multidevice controller, the company says.

Large OEMs can use the model 680 controllers simply by changing the form factor and bus interface; the microengine, device-interface hardware, and microcode remain the same. Delivery will begin in the second quarter of 1982, and the unit will sell for under \$3,000.

National Semiconductor, 2900 Semiconductor Dr., Santa Clara, Calif. 95051. Phone (408) 737-5000 [376]

Controller runs 1/4-in.
tape drives at 192 kb/s

The Pico-mate 1/4-in. cartridge-tape interface adapter controls one or two Kennedy Corp. model 6450 1/4-in. cartridge-tape drives, yielding up to 46 megabytes of unformatted storage. A parameter block interface lets the Pico-mate be incorporated into any Multibus system, appearing as a 1/2-in. magnetic tape, an alternate Winchester back-up device. The Pico-mate is a full direct-memory-access bus master, with a typical

Electronics/December 15, 1981

examine...

a worldwide perspective.

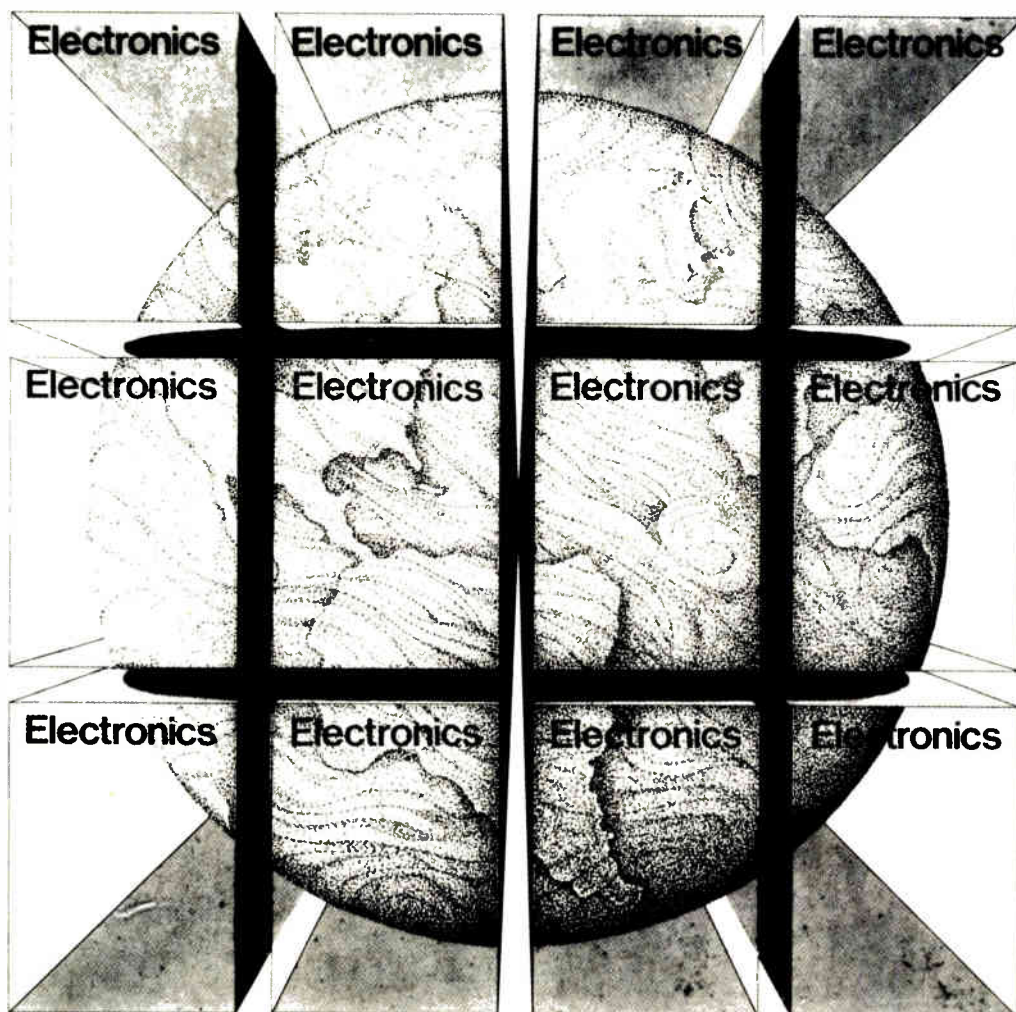

Wherever you are in this world, whatever your specialty...ELECTRONICS magazine's exclusive worldwide, international coverage of electronic technology and business guarantees that our subscribers are the first to know precisely what's happening...when it's happening...regardless of where it's happening.

From San Francisco to Tokyo, Moscow to Tel Aviv, only ELECTRONICS covers the fast-paced changes taking place in today's world of electronic technology. Our overseas editors don't travel to where the news is breaking, they live and work there. They examine and interpret every significant technological and business development on the international electronics

scene to make sure our subscribers not only keep pace...but keep on top.

You owe it to yourself and to your career to find out why nearly 100,000 of your professional colleagues in 127 different countries explore the world of Electronics on a regular basis. Devote one hour of your reading time every two weeks and we'll broaden your dimensions in ways that no one else can. We'll keep you current on what's going on in the technology.

To start your subscription to ELECTRONICS send in the subscription card found in this magazine. Or, write directly to Subscription Department, ELECTRONICS, McGraw-Hill, 1221 Avenue of the Americas, New York, N.Y. 10020.

Electronics Magazine



**Superb Performance
Broad Frequency Range**



CUSTOM ENGINEERED OSCILLATORS

PIEZO SYSTEMS manufactures a wide range of oscillators and specializes in custom engineered oscillators to meet your specifications.

The heart of a PIEZO SYSTEMS oscillator is a PIEZO CRYSTAL COMPANY high stability stress compensated crystal. Some of the unique advantages of a PIEZO SYSTEMS oscillator are . . .

- Frequencies to 600 MHz
- Low Phase Noise, up to -160 dbc/Hz Noise Floor
- Fast Warm-up, to 5×10^{-9} within 10 minutes
- Aging Rates Less Than 3×10^{-10} per day

PIEZO has been the leader in frequency control technology since 1936. We maintain that lead by providing high quality products, personalized service, and prompt delivery to our customers. You are guaranteed first rate performance every time, both from our personnel and our products.

Write or call today for our complete catalog and a no obligation estimate tailored to your needs.



An Affiliate of PIEZO Crystal Company

100 K Street • P.O. Box 619 •
Carlisle, PA 17013

Tel. (717) 249-2151 • TWX 510-650-2280

New products

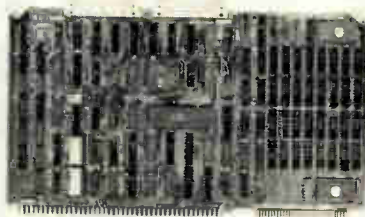

data-transfer rate of 192 kb/s.

The Pico-mate executes 31 commands, including buffered and direct data-transfer operations. Direct commands transfer data between system memory and a moving tape, with a 64-byte first-in, first-out buffer easing bus conflicts. Buffered transfers use on-board static random-access memory (of 2- to 16-K bytes) to buffer each block of data while data integrity is verified.

The unit, which imports popular operating systems, is programmable for 8- or 16-bit data systems and can address 16 megabytes (24 address bits). The price in original-equipment-manufacturer quantities is \$1,081, with delivery 30 to 45 days after receipt of order.

Computer Products Corp., 2415 Annapolis Lane, Plymouth, Minn. 55441. Phone (612) 559-2034 [378]

Controller drives motors rated up to 5 A/phase

Carrying on-board stepper motor logic, the ST60 Stepping Motor Controller is Std-Bus-compatible and provides four independent dc output-driver circuits that can operate motors rated up to 5.0 A/phase at up to 60 v dc. For heavier loads it can be used in parallel.

The high-power driver card comes with the logic to generate full- or half-step sequences, fully isolated inputs and outputs, and three signal inputs for limit switches or general-purpose use.

The controller sells for \$275 each in lots of 10.

Standard National Corp., 212 Main St., North Reading, Mass. 01864. Phone (617) 942-0514 [379]

NEW From TL Industries The MIKUL™ 500 series STD BUS Compatible Boards

Mix and Match

Get large card performance in a high density board with STD BUS MIKUL boards in your Z80 and 6809 based systems. Call TL Industries to add our decade of experience in reliable micro-processors and industrial applications to your project.

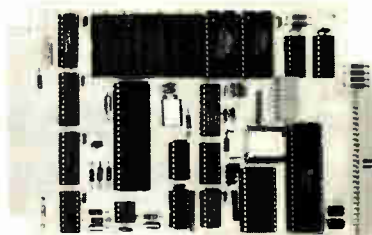

MIKUL™ 500 SERIES STD BUS COMPATIBLE BOARDS

- 580 Monocard Microcomputer Z80 CPU, two 8-Bit I/O Ports, four Counter/Timers, 2K RAM, sockets for 8K EPROM
- 509 Monocard Microcomputer 6809 CPU, two 8-Bit I/O Ports, two Counter Timers, RS-422, 4K RAM, sockets for 12K EPROM
- 514 Alpha/Graphic Display Interface 16 Rows of 32 Characters, two 8-Bit I/O Ports
- 519 4K Electrically Erasable ROM
- 501 Dual 12-Bit D/A Converter High power and low power
- 576 256 Channel A/D Converter and 7 Channel D/A Converter
- 500 8 Channel SPDT Relay Output, 5 Amp contacts, LED Indicators
- 598 4 and 8 Card Racks

6000 Series EXORciser* Bus and 900 Series TM 990 Bus compatible boards in stock

Turnkey systems and custom design services

*Trademark of Motorola Inc.



Industries Inc.

2573 TRACY RD., NORTHWOOD, OH., 43619
(419) 666-8144

CMOS picks up speed.

The RCA 1802, fastest-selling CMOS microprocessor in history, is now 30 percent faster.

In 1980 alone, we shipped more than a million 1802 CMOS Microprocessors. But we think our new 1802A will be even more popular.

Here's why:

The 1802A is faster. 3.2 MHz @ 5V, compared to 2.5 MHz for the 1802. And it costs only \$3.98.*

It's volume-proven for reliability, so there's minimal user risk.

And it's available for immediate delivery in volume.

This new CMOS microprocessor is ideal for applications where portable operation, noise immunity, or wide temperature range operation (-40°C to +85°C) is important.

And it's supported by one of the most comprehensive lines of CMOS support devices in the industry, including I/Os, RAMs and ROMs. High-level programming languages

include BASIC 1, 2 and 3, Micro Concurrent PASCAL, PLM-1800 and a Macro Assembler. Plus, a full line of Microboards and development systems.

For you, this means ease of system development and flexibility.

So, if you're looking for a proven, reliable, high-speed, low-cost CMOS microprocessor, look no further. The 1802A is here.

For more information, contact any RCA Solid State sales office or appointed distributor.

*Optional U.S. distributor resale, 1000+ price.

RCA Solid State headquarters: Somerville, NJ. Brussels. Sao Paulo. Hong Kong.



RCA

Circle 201 on reader service card

World Radio History

The ZyP™ The First Comprehensive CAD VLSI

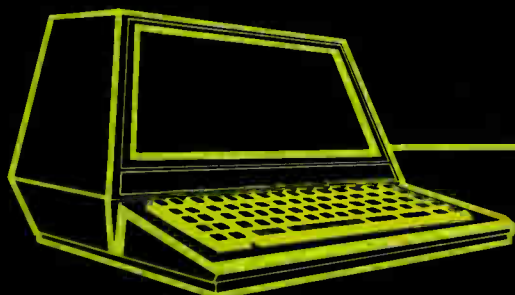

Customer Logic Input

ZyP™ Transform

Design custom MOS even if you've

ZyP™ puts you in control.

Now you or your company's logic engineers can design full custom MOS circuitry without any specialized training in silicon device physics or IC topological design. With the fully automated ZyP™ design system, you define your system logic by inputting a logic network listing into an alphanumeric terminal right in your office. The ZyP™ Transform incorporates a logic simulator which allows you to simultaneously verify logic functionality and system timing. After verification, your logic network listing is input to a software module which routes your circuit and produces computer graphics information used to make photo masks. Then your logic simulation files are automatically transformed into a test program. You input your logic requirements — and the ZyP™ Transform does the work.

Everything you need available today.

The ZyP™ design is based on standard cells — logic building blocks that are linked together in the pattern of your choosing to form custom circuits. The ZyP™ standard cell library is the most extensive of its kind commercially available. There are three libraries, one for NMOS, Si Gate CMOS and Metal Gate CMOS processes. Over 500 elements are available in each library with more being added all the time. ZyMOS supplies you with the complete documentation necessary to design even the most complex VLSI circuitry.

Prototype circuits in as little as eight weeks.

The ZyP™ design system gives your logic engineers the tools, flexibility, and control to design exactly what you need in custom circuitry on your time schedule. Once you have the network files you can have the performance, low power consumption, high reliability, propriety and low production costs of a custom circuit in as little as eight weeks.

Transform Design System For Logic Engineers

Photo Masks

Wafer Fabrication



Packaged Circuitry

never worked with silicon before.

The ZyP™ design system gives you the benefits of full custom while getting your products to market ahead of the competition.

ZyMOS offers total support.

ZyMOS guarantees production of all ZyP™ design system circuits in our ultra modern Silicon Valley fabrication facility. A variety of packaging options are offered. In addition to the ZyP™ design system, ZyMOS offers traditional full custom design and wafer fabrication services. Our total commitment to quality custom MOS is reflected in our new 30,000 square foot headquarters which houses the latest fabrication and test equipment. ZyMOS' highly qualified personnel are on hand to help you with design and discuss your needs. Send the attached coupon to 477 N. Mathilda Avenue, Sunnyvale, CA 94088 or call ZyMOS Marketing: (408) 730-8800.

ZyMOS

Where Silicon Solutions Are Custom Made.

YES, I want to ZyP™ from logic input to packaged circuitry on my schedule!

- Send me more literature!
- Have a ZyMOS representative call on me!
- I'm interested in attending a 1-day seminar on ZyP™ please contact me!

Name _____ Title _____

Company _____ Application _____

Address _____ City _____

State _____ Zip _____ Phone _____

ZyP™ is a trademark of ZyMOS Corporation.

Circle 203 on reader service card

World Radio History

Rockwell International know-how: A transportation system that puts space to work for mankind.

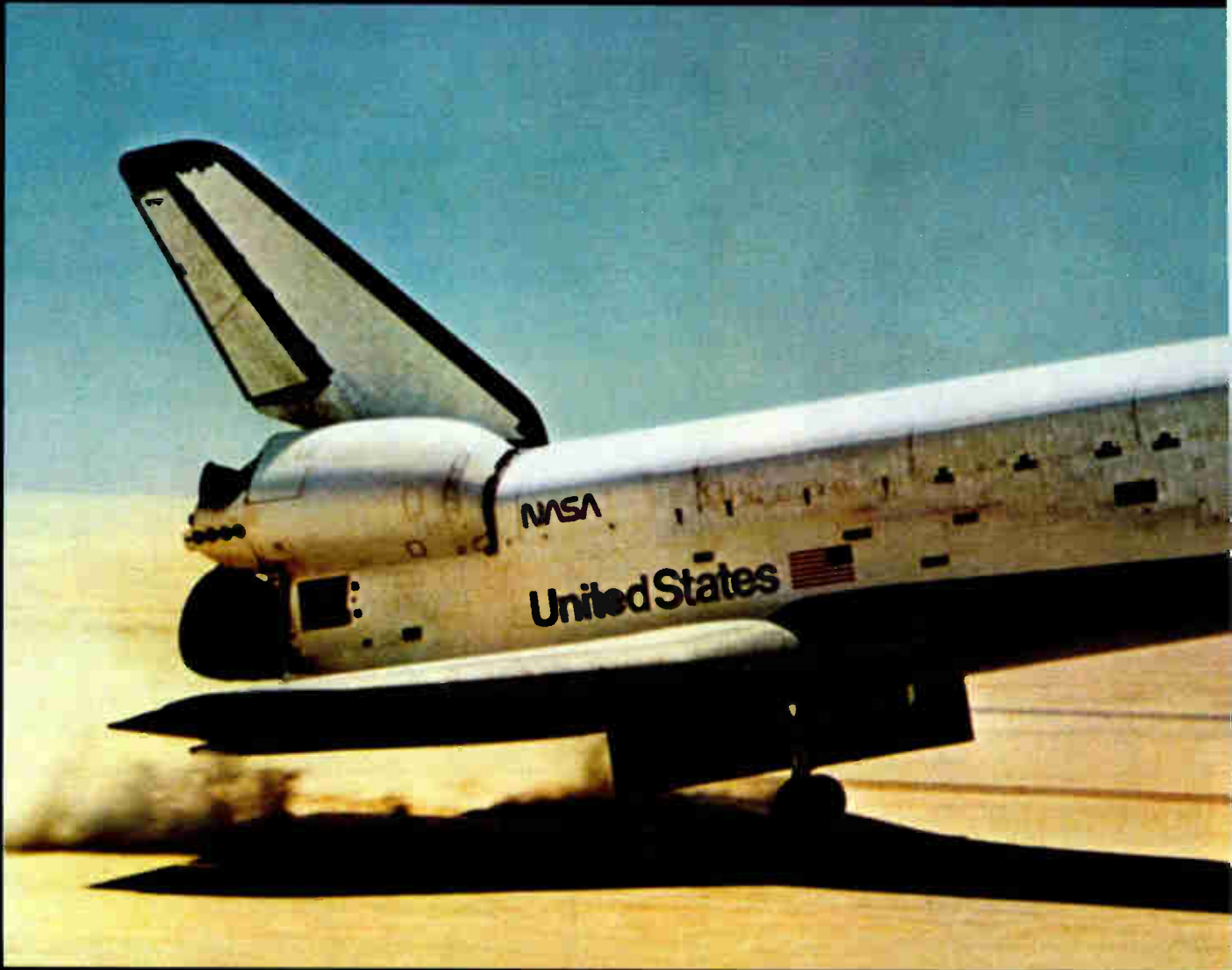

The vast resources of space are now within our reach. And Rockwell International is playing the leading industrial role in the new era of space utilization.

In our Aerospace Operations, our Space Division is prime contractor to the National Aeronautics and Space Administration for the reusable Shuttle Orbiter — the most complex flying machine ever built. Our Rocketdyne Division builds the main engines — the first reusable engines to go

into space. And we assist NASA in the integration of the entire Space Transportation System.

Through the Aerospace Operations, Rockwell has a major role in the development of the Department of Defense NAVSTAR Global Positioning System. We're a major supplier of aircraft assemblies for the new Boeing 757 jetliners.

Aerospace is one of the vital businesses at Rockwell International, a \$7 billion worldwide, multi-industry company. We're at the leading edge

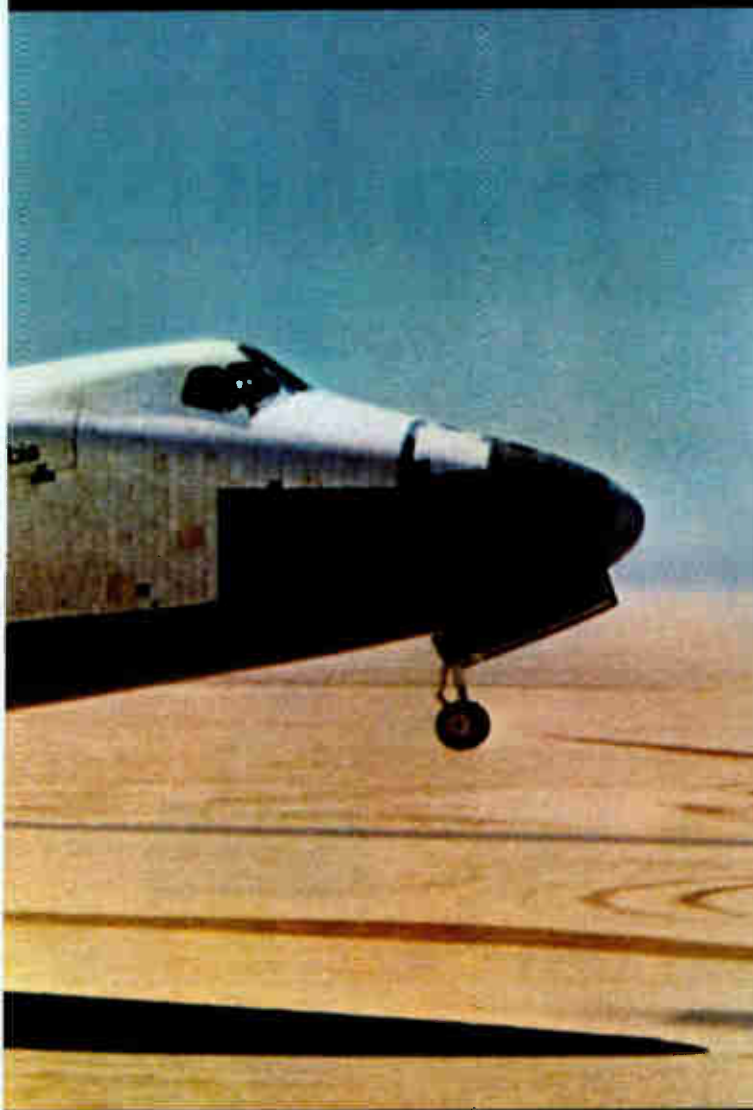

Our Collins color weather radar is another product of the technology that has made us a leader in avionics.

An advanced-technology air disc brake for the '80s: lightweight, durable, easy to maintain. More than half the heavy-duty trucks in America stop with our brakes.

Goss Metroliner® offset newspaper production systems are among the most sophisticated and technologically advanced in the world.



of technology in our other principal businesses as well: Automotive, Electronics and General Industries.

Furthermore, to manage these technologies, we've developed systems that are as advanced as the technologies themselves.

We've put the right engineering and manufacturing teams together with the right management to meet many of the world's unprecedented challenges.

To learn more about us and our products or if you are interested in an engineering career, write: Rockwell International, Department 815G-1, 600 Grant Street, Pittsburgh, PA 15219.



Rockwell International

... where science gets down to business

Automotive / Aerospace
Electronics / General Industries

Circle 205 on reader service card

Untype 60 words per minute.



The IBM Electronic 75 Typewriter can erase faster than some people can type.

At the touch of a button, it can automatically lift a character, a word, or an entire line clean off a page.

But not only does the IBM Electronic 75 offer you automatic erasing, it also offers you automatic indents, centering, underlining and column layout.

As well as a memory that can store up to 7,500 characters.



(With optional memory: 15,500.)

So if you're interested in saving time, consider the

IBM Electronic 75 Typewriter.

You'll be surprised how fast your typing gets done.

And undone.

To order call *IBM Direct* at the toll-free numbers below.

Or, for a free demonstration call your local IBM Office Products Division Representative.

Free demonstration

For a free demonstration of the IBM Electronic 75 Typewriter, write today to: IBM Office Products Division, 400 Parson's Pond Drive/Dept. 804 L, Franklin Lakes, N.J. 07417.

NAME _____

TITLE _____

COMPANY _____

STREET ADDRESS _____

CITY _____

STATE _____ ZIP _____

BUSINESS PHONE _____



Office Products Division

135-12-81

Call *IBM Direct* 800-631-5582 Ext. 135. In New Jersey 800-352-4960 Ext. 135.
In Hawaii/Alaska 800-526-2484 Ext. 135.

Circle 206 on reader service card

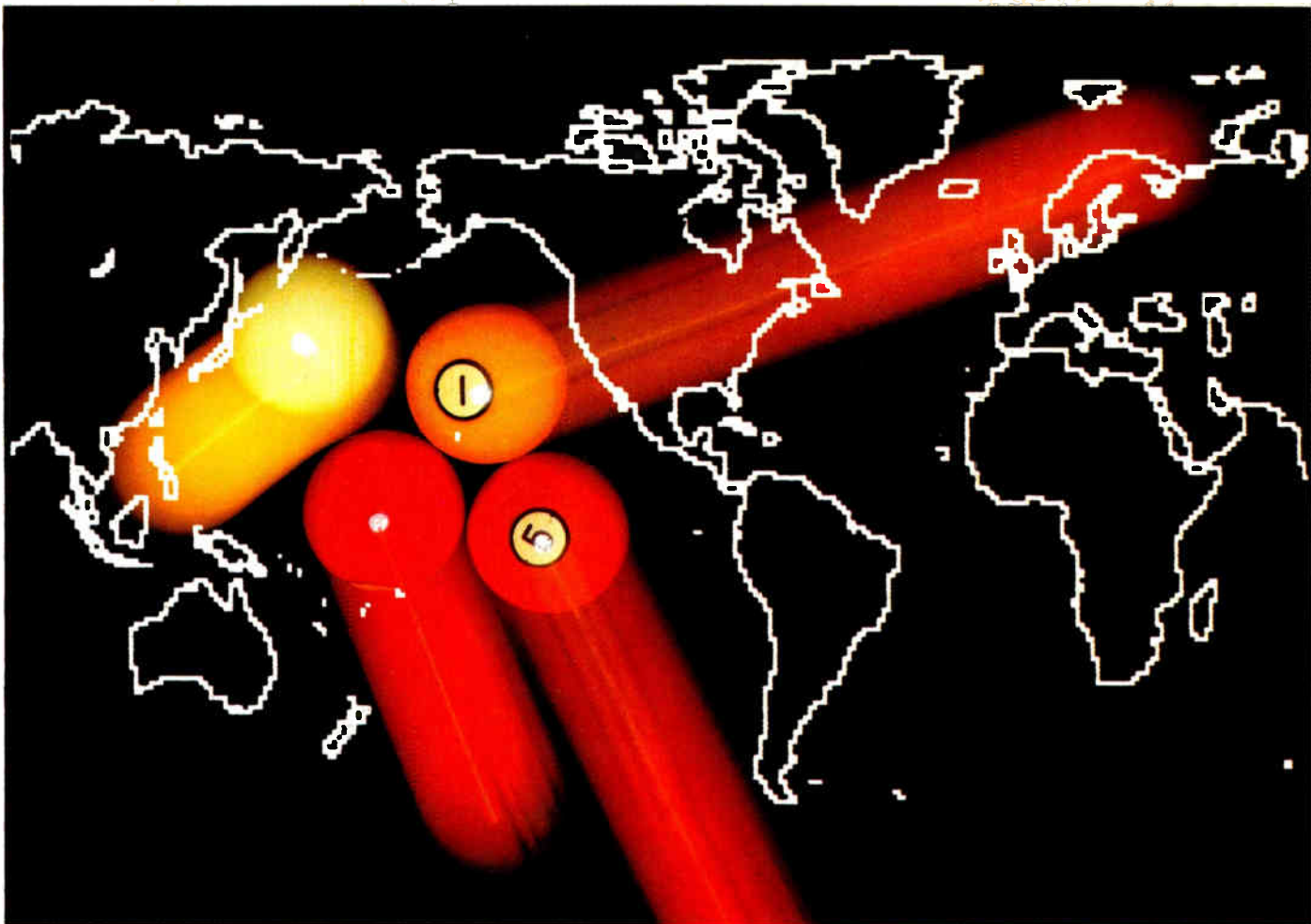

RESHAPING THE WAY PEOPLE THINK

You can probably name the world's largest maker of computers, or of automobiles. But what about printers? Stumped? The answer is "Epson". You're probably acquainted with our dot-matrix printers for small businesses, as they've become well known because of their features, reliability, and high cost performance. But you may not have realized that we've been selling vast quantities of printing mechanisms all over the world for

years. This is because most of our products have been incorporated into other manufacturer's calculators, electronic cash registers, and measuring instruments, instead of appearing under the Epson name. With our small-business printers, though, we're taking advantage of the chance to put our name nice and big on every unit. Just remember that behind this name is the experience of the world's largest manufacturer of printers.



MX-80

- 80 cps printing speed
- Full 96-character ASCII set with descenders
- Correspondence-quality printing



MX-80F/T

- 3-way paper handling
- Correspondence-quality printing
- Versatile interface options



MX-100

- Wide 15" carriage
- Bit Image printing
- Full 96-character ASCII set with descenders

EPSON

SHINSHU SEIKI CO., LTD.

HEAD OFFICE & PLANT: 80 Hirooka, Shiojiri-City, Nagano, 399-07 Japan. Tel: 02635-2-2552 Telex: 0334-2214 (SHINH J)

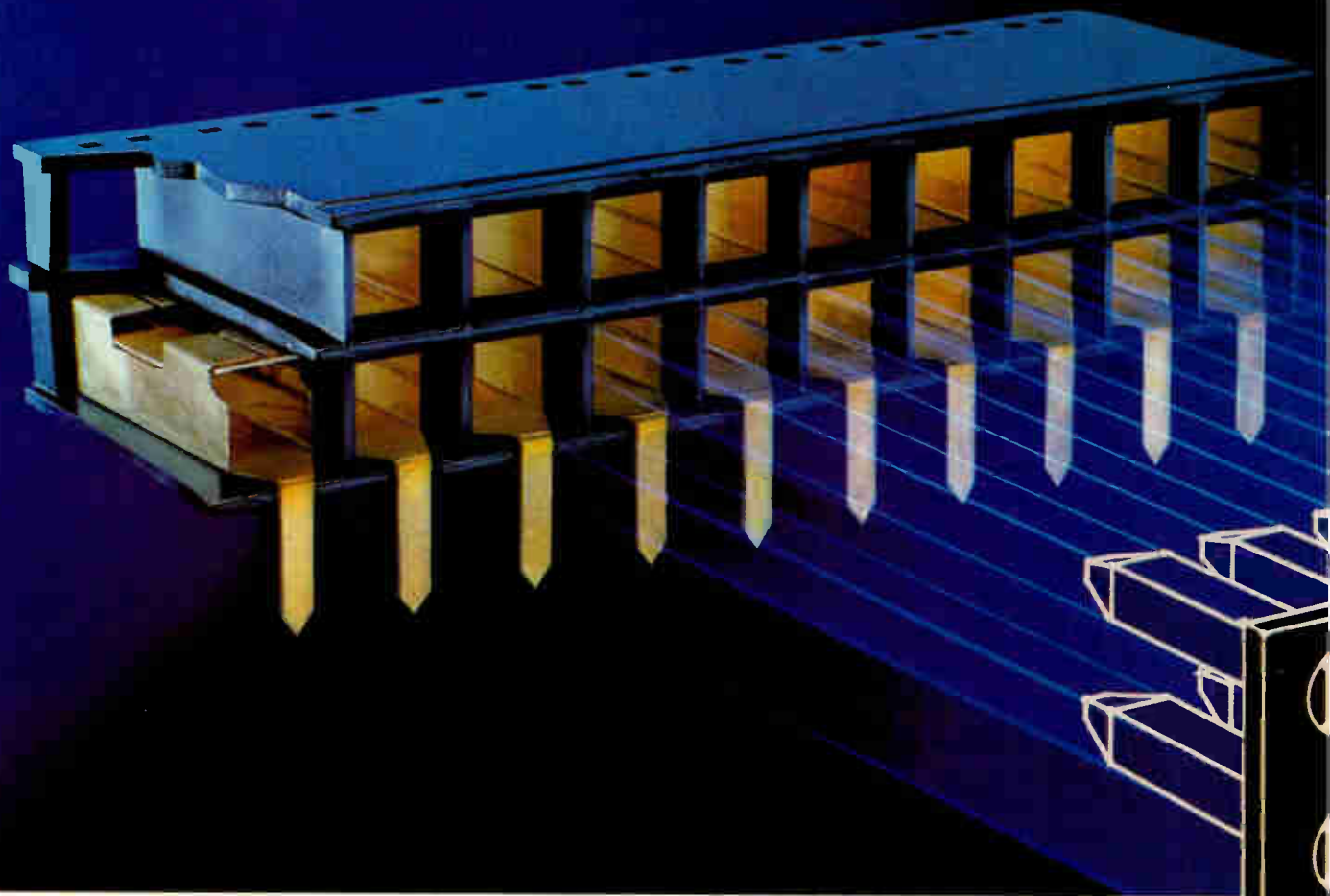

Only Berg's card connectors are made with the patented 2-piece dual-metal "PV"[™] receptacle for low contact resistance, lasting retention and exceptional cycle life.

The secret is in the spring. Most female receptacles are stamped from a single strip of metal. The "PV" receptacle is unique: a brass body combined with a heat-treated beryllium copper spring (see the drawing).

Constant mechanical pressure is exerted

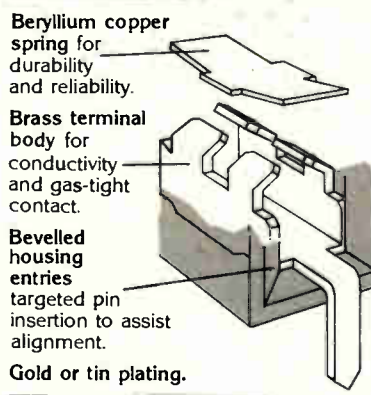

on the pins by this all-important spring. And that pressure remains . . . even after repeated cycling. The spring also will absorb stress from a misaligned insertion and continues to apply strong, perpendicular retention force

Berg "PV"™ Card Connectors Make Solid Contact. Over and Over Again.

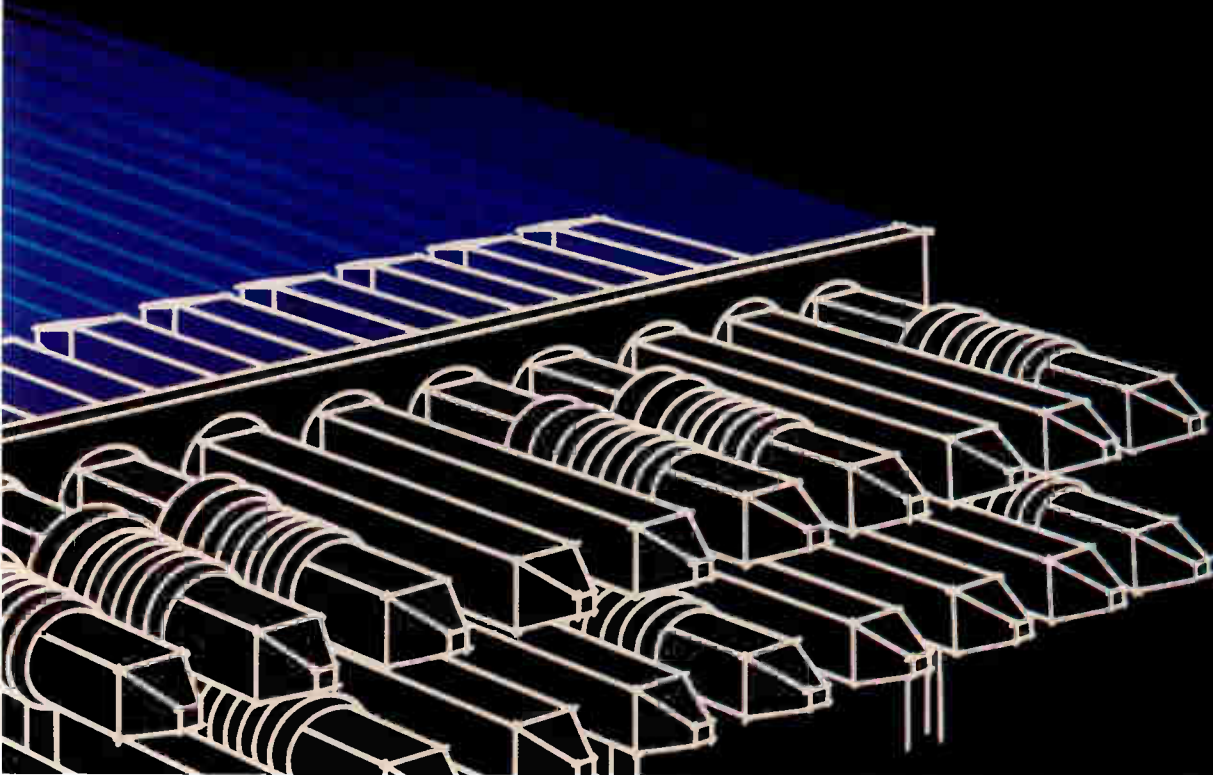

to the inserted 0.64mm (0.025") square pin.

Excellent electrical conductivity is achieved by the receptacle's high normal force. It creates a wiping action that cleans the contact surface of oxides during insertion and withdrawal. Berg "PV" card connectors come in selectively loaded single and double rows. So you pay only for the positions you need. They conform to MIL C-55302-127/128 and are available for delivery in only 4 to 6 weeks.

Find out more about the Berg "PV" card connector and the entire BergCon system that solves the majority of board-to-board, board-to-wire and wire-to-wire interconnection problems.

For details, call us for Bulletin 700 at 800-233-1450. (In PA. 717-975-2000)
The Du Pont Company, Berg Electronics,
Camp Hill, PA 17011.

An electronics company.





ASCII Encoded Keyboards.

Where can you buy as much keyboard for as little as \$49?*

Feature for feature, no keyboards offer you more value and durability for the money than the RCA VP-600 series.

58-key typewriter format, or typewriter plus 16-key calculator-type keypad. Both versions available with parallel or serial output. These keyboards are particularly suitable for hostile environments.

- Spillproof, dustproof, unitized keyboards.
- Flexible membrane switches with contact life rated at greater than 10 million operations.
- Finger-positioning overlay and positive keypress.
- Two-key rollover circuitry.
- Aural keypress feedback with adjustable volume.
- High noise immunity CMOS circuitry.
- Low power, 5V DC operation.
- Three serial output modes: RS-232C, 20 mA current loop and TTL.

For more information, write RCA MicroComputer Marketing, New Holland Avenue, Lancaster, PA 17604, or call 717-291-5848. To order, call toll-free, 800-233-0094.

*OEM quantity price, Model VP-601 (parallel output).

RCA

Circle 210 on reader service card

New products

Components

Bipolar regulator has D-MOS output

Technologies combined in 125-V part that imposes own safe-operating-area limits

Combining bipolar and double-diffused MOS technologies, Texas Instruments Inc. is unveiling a three-terminal voltage regulator capable of handling an input-to-output differential of up to 125 v. Designated the TL783, the regulator is housed in a TO-220 package and sells for \$1.73 each in quantities of 100. It is available for delivery now.

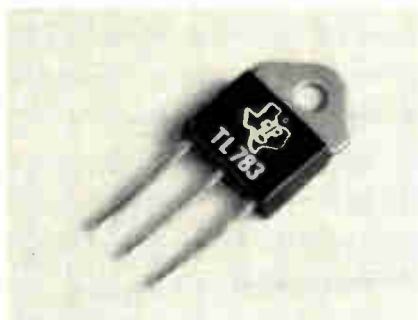

TI is targeting the positive-output, adjustable regulator at applications involving high voltage differentials, like power supplies for plasma displays. The bipolar and D-MOS combination came out of work in TI's telecommunications operation, explains Delbert Whitaker, division manager of linear functions.

Although the TL783's differential rating has been set at 125 v, Whitaker indicates that the bipolar-D-MOS technology promises to be able to achieve 200 v in the foreseeable future. The D-MOS output transistor carries the regulator's high-voltage burden without secondary breakdown and thermal-runaway effects. The D-MOS process also increases switching speeds.

The TL783 delivers a maximum of 0.7 A and is limited automatically by a special circuit to an output of

about 20 w. The part also features line regulation of 0.2%, load regulation of 0.5%, a typical temperature coefficient of 0.4%, and an initial accuracy of $\pm 4\%$.

The unit has an internal thermal shutdown using a zener temperature sensor. It is automatically turned off above 165°C, and on again when it cools. A current-limiting circuit also adjusts the output to 20 w.

The thermal cut-off and 20-w roll-off features—along with a stack of zener diodes in a safe-operating-area circuit—confines the part's operation within a self-imposed safe operating area over its total input-output differential voltage range of 10 to 125 v.

The TL783 can also provide good current regulation at low current since its quiescent current is less than 0.1 mA.

Texas Instruments Inc., Central Literature Response Center (SC-138), P. O. Box 202129, Dallas, Texas 75220. Phone (214) 995-5900 [341]

30-kHz isolation amp slews at 0.05 V/ μ s

Boasting a 30-kHz bandwidth and a 0.05-v/ μ s slew rate, the IA194 magnetic isolation amplifier has the frequency range and slew rate of an optical amplifier but the stability inherent in magnetic devices. Isolation in three ports—input, output, and power—is 3 kv dc.

The device has a 100- μ s settling time, a 90-dB common-mode rejection ratio, and an externally programmable gain of 1,000:1. Its 0.1% linearity ensures its compatibility with 10-bit data-acquisition systems.

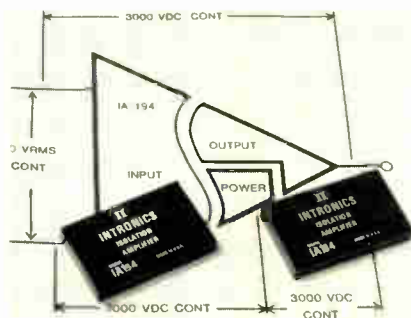

Electronics / December 15, 1981

Although input noise is held to 3 μ v in the 10-Hz-to-1-kHz range, its maximum current noise in the same range is 40 pA.

Taking into account the effects of offset, temperature, and linearity, the accuracy of the IA194 is $\pm 0.5\%$ over the full range of 0° to 80°C. In quantities under 10, the amplifier is priced at \$119 each. Delivery is from stock to six weeks.

Intronics, 57 Chapel St., Newton, Mass. 02158. Phone (617) 332-7350 [343]

Schottky devices serve as output rectifiers, catch diodes

Joining the USD 800 and 900 series of power Schottky rectifiers are the 600 and 700 families of single- and dual-chip rectifiers, rated at 6 to 16 A.

The single-chip 600 series and dual-chip 600C series feature peak

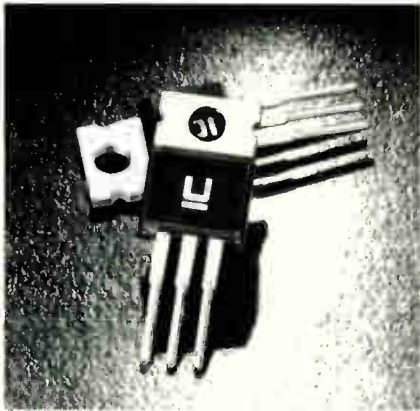

reverse-voltage ratings of 20, 35, 40, and 45 v. The current rating for the single-chip versions is 6 A, while the dual-chip models' center tap is 12 A. Forward voltage for either series is 0.55 v at 8 A per diode.

The two 700 series have identical peak-voltage ratings. Current ratings are 8 and 16 A for single- and dual-chip versions, respectively, and forward voltage for either series is 0.55 v at 8 A per diode. The devices, housed in TO-220 packages, are suitable for output rectifiers and catch diodes in high-performance, fast-switching power supplies. Prices for the 600 series are \$1.10 and

\$1.81 for 1,000-piece lots. The 700 series bears tags of \$1.37 and \$2.26 in like quantities. Delivery is from stock.

Unitrode Corp., 5 Forbes Rd., Lexington, Mass. 02173. Phone (617) 861-6540 [344]

Fast power MOS FET has 800-V breakdown voltage

Extending Hitachi's line of power MOS field-effect transistors [*Electronics*, May 19, p. 81] is the 2SK351, a device with a breakdown voltage of 800 v and a 80-ns switching time. It is suitable as a switching power device for equipment using an ac line voltage of more than 200 v.

MOS FETs have an advantage over bipolar parts in these applications because bipolars suffer large power losses at switching, break down more easily at high temperatures or under surge currents, and cannot easily be used in parallel operation to handle large power loads. Computer-aided design and structural analysis help the 2SK351 attain its high breakdown voltage by giving the part stability and uniformity in the electrical field distribution.

Other specifications include a drain current of 5 A, a 125-w maximum channel dissipation, and an on-resistance of 3 Ω , 1.7 Ω typically. The triple-diffused MOS isolation arm, housed in a TO-3 container, sells for \$19 in lots of 1,000.

Hitachi Information Service, 77 Water St., 22nd floor, New York, N. Y. 10005. Phone (212) 425-4845 [345]

LED array substitutes for mechanical meters

As an alternative to mechanical meters in instruments and status- or position-indicator panels in process-control systems, the HDSP-8820 10.58-cm light-emitting-diode graph array offers 101 red elements, each 1.52 mm wide.

Package and drive requirements make the array easy to design into a



Interactive Data Terminals.

Where can you buy as much terminal for as little as \$249?*

Versatility and durability at a low price... you'll find all that and more in RCA's rugged VP-3300 series Interactive Data Terminals. Computer applications include data entry, data and graphic display, process control and time-sharing. And they are compact. Perfect for use as remote or portable terminals.

- RF or Video output. Designed to work with standard TV sets or monitors.
- Unique color-locking circuitry for sharp color graphics and rainbow-free characters.
- 128 resident and dynamically redefinable character set.
- 20- and 40- character formats.
- Selectable data rates up to 19.2 kilobaud.
- Standard ASCII encoding with RS-232C and 20 mA current loop interfaces.
- LSI video and microprocessor control.
- Spillproof, dustproof unitized keyboards.

Plus much more.

For more information write RCA MicroComputer Marketing, New Holland Avenue, Lancaster, PA 17604, or call 717-291-5848. To order, call toll-free, 800-233-0094.

*OEM quantity price, Model VP-3301 (video/audio output).

RCA

Circle 211 on reader service card

NEW COTO CR-7000 SERIES RELAYS

**High Reliability.
Premium Quality.**

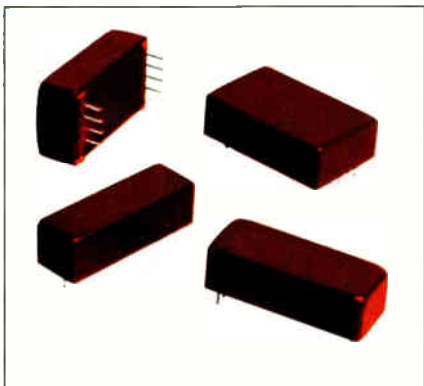

Coto's new 'No Compromise' series of relays has been designed for reliable, low-level switching and high insulation resistance.

Ideal for accurate current/voltage measurement applications found in Test Instrumentation, ATE, Medical Instrumentation or anywhere precision and reliability are imperative.

STANDARD FEATURES

- New contact plating material eliminates "sticking" and unstable contact resistance. Standard on all CR-7100 relays.
- Fully encapsulated; Magnetically shielding steel shell coated with a bright, chemically-resistant and insulating epoxy.
- Reed switch and coil connections coated with silicone to provide stress-free encapsulation.
- Reeds are dry-buzzed and Coto Dynamic Contact Resistance Tested.
- Each isolated pin checked against all others for insulation resistance at rated breakdown voltage.
- Series includes dry standard (CR-7100); mercury-wetted (CR-7200); and high voltage (CR-7300).

Contact: Coto Corporation,
65 Pavilion Avenue,
Providence, RI 02905
Tel.: (401) 467-4777
TWX: 710-381-8016

COTO
CORPORATION

New products

system or instrument. It has a single in-line-package configuration for standard sockets and printed-circuit boards. The common-cathode LED arrangement simplifies interfacing with a microprocessor.

The array has $\pm 1\%$ resolution and consumes typically 140 mW. In quantities of 249, the HDSP-8820 sells for \$40. Delivery is from stock. Hewlett-Packard Co., 1820 Embarcadero Rd., Palo Alto, Calif 94303. [346]



**60-MHz op amp is stable
at closed-loop gains over 10**

With a gain-bandwidth product of 60 MHz and a 50-V/ μ s slew rate, the AM-411 operational amplifier serves those applications that require high-frequency capabilities and excellent dc input characteristics, such as analog-to-digital converter input buffering, digital-to-analog converter output amplification, active filters, and sample-and-hold circuits.

The device's input characteristics include maximum bias and offset currents of 50 pA and a common-mode rejection ratio of 80 dB. Its input offset voltage is a maximum ± 1.0 mV and offset voltage drift is typically 5 μ V/ $^{\circ}$ C.

The AM-411 settles in 1 μ s to 1%. It is an uncompensated device that is stable at closed-loop gains of greater

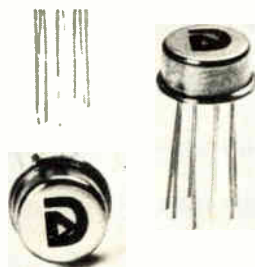

than 10 without external compensation. Its output drive capability is ± 12 V at a minimum ± 10 mA.

Housed in an eight-lead hermetically-sealed TO-99 case, the AM-411 operates over two ranges: the 0 $^{\circ}$ -to-+70 $^{\circ}$ C range or the military range of -55 $^{\circ}$ to +125 $^{\circ}$ C. In quantities up to 24, the military version sells for \$32.50 each, while the other offering costs \$10.50 each. Delivery is from stock to 10 weeks.

Datel Intersil, 11 Cabot Blvd., Mansfield, Mass. 02048. Phone (617) 339-9341 [347]

**\$20 5-A, 30-V op amp
has 2.6-V/ μ s slew rate**

Giving high voltage and current at low prices, the PA01 operational amplifier costs \$20 each in 100-unit lots. It is rated for supplies up to ± 30 V; its output current is ± 5 A.

To achieve these ratings, the PA01 has a tracking junction and thermistor-compensated class AB biased emitter-follower output stage, rather than the class C output stage of other economy power op amps;

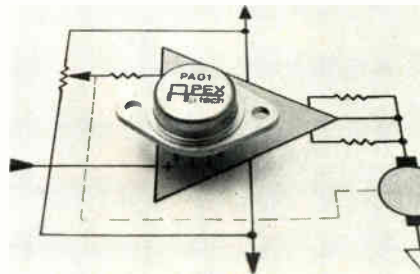

class C stages exhibit higher crossover distortion.

Additional characteristics include a 2.6-V/ μ s slew rate, a 110-dB common-mode rejection ratio, and an initial input bias current of 50 nA maximum. At full load, its open-loop gain is a minimum of 91. Output power is a function of case temperature and load characteristics; at 25 $^{\circ}$ C it can be as high as 115 W into resistive dc loads or 50 W into ac transducers. Delivery is from stock.

Apex Microtechnology Corp., 1130 East Pennsylvania St., Tucson, Ariz. 85714. Phone (602) 624-0273 [348]

Amphenol® 17D subminiature. New arrivals. New answers. Worldwide.



Meet the expanded family of Amphenol 17D subminiature connectors—all with non-rotating contacts.

They come in five shell sizes, a variety of contact arrangements, dielectric materials and terminations. And, since they are compatible with other D subminiature connectors *and* available worldwide, you can be assured of design integrity with Amphenol replacements whenever they're

needed. Certain of the 17D Series conform to either MIL-C-24308 or EIA Standards RS 232C and RS 449.

Find anything you need, anywhere you are, for data processing, telecommunications, instrumentation and military applications. Choose from a complete line of accessories and tools.

For more information, contact the office nearest you.



An  ALLIED Company

AMPHENOL INTERNATIONAL LTD.

Amphenol International Ltd., 900 Commerce Drive, Oak Brook, IL 60521, USA—Tel: (312) 986-2700—Telex: 206-054

EUROPE: Austria—Amphenol Ges.m.b.H., Tautenhayngasse 22, A-1151 Wien (Vienna), Tel: (0222) 95 15 11 • England—Amphenol Limited, Thanet Way, Whitstable, Kent CT5 3JF, Tel: 02 27-26 44 11 • France—UMD Amphenol, Avenue de Gray, 21 Chemin Du Défois, 39100 Dole, Tel: (84) 72 81 13 • W. Germany—Amphenol-Tuchel Electronics GmbH, August-Häusser-Str. 10, 7100 Heilbronn/N., Tel: (07131) 486-1 • Italy—Amphenol Italia S.R.L., Via Plinio 43, 20129 Milano, Tel: (02) 28 70 061 • Sweden—Amphenol Scandinavia AB, Kanalvaegen 1, S194 61 Upplands Vaesby, Tel: 46-8-760-88-035

FAR EAST: Hong Kong—Amphenol International Limited, Room 521-22, New World Centre Office Bldg., Tsingshatsui, Kowloon, Tel: 3-681-283 • India—Amphetrionix Ltd., Plot No. 105, Bhosari Industrial Area, P.B. No. 1 Poona, 411026, Tel: 83363 • Japan—Dai-Ichi Denshi Kogyo K.K., Shinjuku Bldg. 7-12, 2-Chome, Yoyogi, Shibuya-Ku, Tokyo, Japan 151, Tel: (03) 379-2111

Capability is what puts it ahead today.



The Fairchild Series 30/333 H

For comprehensive fault isolation, no other system comes close.

The new Fairchild 333 In-Circuit Test System is the most advanced system ever developed for isolating faults on large, complex, analog, digital and hybrid PCBs.

It offers an expanded 2,207 digital test point capability—each point with its own driver, and an analog test section with 959 test points. It can test LSI and VLSI IC's on boards with advanced, bus-oriented designs, and it can also fully test mixed logic boards such as ECL/TTL.

The 333 also includes such innovative design features as FAULTS™, WIREGEN™, and our new Datalogging Analysis Program—the most powerful management analysis package available today. And our new Testing Diagnostic Center provides all the tools to quickly isolate faults—

including BUSPROBE™, which tracks bus-oriented failures right to the IC.

You get both functional and in-circuit capabilities in one economical system.

Key to the increase in fault isolation capability is the 333's new high-speed digital test section. Called FAST-TEST™, this optional 256 pin high-speed section uses Fairchild's own FAST™ semiconductor technology. It not only allows you to test dynamic parts with parallel patterns at speeds up to 2MHz, but permits high-speed functional exercise of strategic LSI devices, giving you both digital capabilities in one economical in-circuit system. And because FAST-TEST comes with its own built-in sequence processor, initializing devices is far easier and overall test efficiency is maximized.

Fairchild's HI-CURRENT™ testing power supplies enable the 333 to deliver more digital test capability than any other in-circuit test system available today, allowing even very large PCBs to be fully exercised.

Along with an expanded analog test section, the 333 also provides enhanced guarding techniques for more accurate component measurements. And a wide selection of software-controlled IEEE instruments is also available.

Improved software makes every test easier.

The 333's software is designed not only to improve in-circuit testing performance, but to significantly reduce test program preparation and maintenance times. The FAST-TEST device library is included with the CHIPS LSI Test Program Compiler. FAULTS, our automatic test program generator, has been improved with digital testing

Compatibility is what keeps it ahead tomorrow.



Hybrid In-Circuit Test System.

routines including bus-disable and feedback loop disable techniques, as well as initialization problem detection software and automatic program generation. And a special editor facilitates fast keyboard control of the entire package.

WIREGEN, the new automatic fixture wiring program, uses program input data to develop a fixture-wiring scheme. UUT circuit designs and the system's test pin matrix are matched during wire assignment. The result—a fixture efficiently wired, and one that speeds program optimization and simplifies future wiring changes.

Our new Datalogging Analysis Program lets you review and track board and component failure histories, using any one of a variety of output formats. And operator analysis and yield analysis programs offer a new level of visibility to in-circuit test site management.

System compatibility—the unique Fairchild advantage.

While other ATE companies are developing “one-of-a-kind” systems, Fairchild has designed the 333 with a full range of compatible features that make it your most cost-effective ATE investment. Because the fixturing, test programs and software on the new 333 are compatible with other Series 30 in-circuit test systems (the models 303S and 323), you save time, money and the maintenance problems common to competitive systems. In addition, compatibility makes training and operation far easier, and system users maintain their valuable expertise from one Fairchild system to another.

System compatibility is perhaps the single most important consideration in terms of “total cost of ownership.” And it's an advantage that Fairchild is committed to today and tomorrow.

For more information on the new Series 30/333 for large, complex, analog, digital and hybrid boards, write or call Fairchild Test Systems, 299 Old Niskayuna Rd., Latham, NY 12110; (518) 783-3600.

FAIRCHILD

A Schlumberger Company

**The
First Family
of ATE.**

CLICK

Scotchflex® interfaces with a positive

“Click” is the sound of decisive socket-to-header interface in Scotchflex® Brand connectors from 3M, The Source for premium mass termination systems. Sockets and headers have important design features for easier assembly and greater mechanical dependability than ever before.



First, Scotchflex headers (.100" x .100" grid series) now have built-in retainer/ejector latches (1).

② They snap up to lock sockets firmly in place. They snap down to disconnect sockets quickly and easily . . . good news where density makes access tough.

Second, mating socket connectors have designed-in metal spring clips (2) that lock the covers to the bodies for maximum cover retention. The clips double cover retention strength, and let the connector be disassembled and reused if necessary.

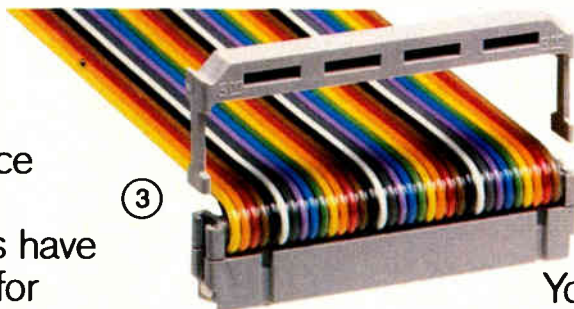

Third, one-piece strain relief clips (3) take fewer steps to assemble.

You get higher productivity and lower inventory costs since you need only one type of socket and a supply of efficient, inexpensive clips.

Fourth, connectors snap into polarized headers with an audible “click” without pin loss, for the lowest possible cost per line. The unique 3M keying system (4)



provides positive electrical polarization, prevents even a partial mismatch, and helps reduce equipment damage and field maintenance.

CLICK AND EASY.

sound for 6-way better assembly.

Fifth, 3M's patented U-contact is ultra-simple. But it's superbly functional, proven reliable in thousands of applications.

Sixth, Scotchflex Brand sockets and headers in this grid range include 10, 14, 16, 20, 26, 34, 40, 50, and 60-pin sizes. They give you the same dependable mechanical and electrical performance as other 3M components.



**NOW QPL APPROVED
MIL-C-83503**

Long service life is a prime measurement as well; only Scotchflex products have successfully passed 40-year life-cycle testing. (Test data available on request.)

④ Click and Easy: words that describe these products' capabilities right down to the pins. Combine with off-the-shelf availability (from our



established national distributor network) and superlative technical assistance, and you can see why 3M is The Source for the very best mass termination has to offer the electronic

designer. And there's one more thing.

The Sourcebook—Free

All the technical data you'll need for Scotchflex Brand mass termination products is in our complete Scotchflex catalog. It's yours free. Ask your 3M Scotchflex distributor, or write Electronic Products Division/3M, Building 225-4S, 3M Center, St. Paul, MN 55144.



"Scotchflex" is a registered trademark of 3M.

SPECIFY THE SOURCE

3M Hears You...

3M

Circle 217 on reader service card

A world of infinite possibilities—from concept through wafer production to tested finished devices—is yours when you choose MCE to assist in your custom and semi-custom IC development programs. MCE also can offer you a wide range of technical services, including: design, layout, integration, wafer fabrication, and both electrical and environmental testing.

MCE  MICRO-CIRCUIT™

Design it

1.



MCE design aids and tools speed the economical development of your ICs by: providing the Uniray concept which contains a large number of uncommitted components on each array... offering Bipolar Linear and CMOS Gate Arrays that provide many functions... supplying convenient layout worksheets for each array... giving instructions about interconnecting components... and including kit parts and data sheets.

2.



MCE can integrate your IC designs in the shortest time possible by: providing the UniDES™ board (MCE's powerful new circuit development and evaluation system) to evaluate circuit performance, to determine interconnect errors and judge performance... circuit simulation by computer models before generating production masks... and computer-aided mask design.

MCE's basic philosophy lets you become involved in a joint IC development program to whatever extent you desire. Our "universal array" (Uniray™) concept for semi-custom circuits gives you most of the advantages of full custom IC integration — at a fraction of the cost and turnaround. And our full custom design programs offer the lowest possible unit cost due to optimum die utilization. We're ready to serve you throughout the development and production cycle of your Bipolar and CMOS ICs, whether they're custom or semi-custom.

Youself.

3.

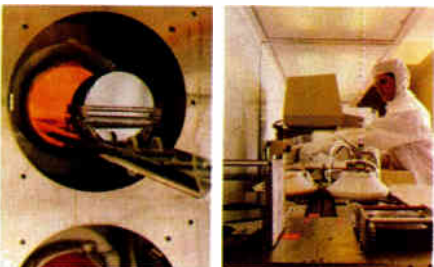

MCE's full IC production manufacturing facilities can support you with: all the steps necessary to produce highest quality ICs. . . computer-aided circuit simulation, artwork and layout services. . . technologies for producing a wide range of products for both analog and digital functions. . . a variety of packaging. . . laser trimming on all wafers. . . AC and DC final unit testing. . . and environmental testing as required.

Circle 219 on reader service card

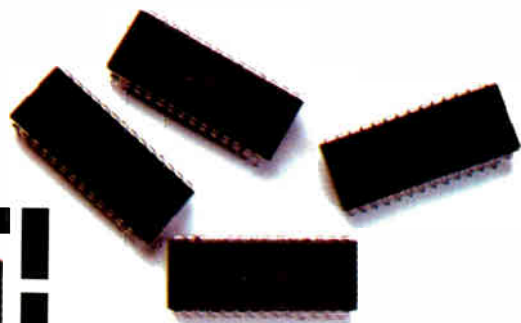

Gentlemen: I'm very interested in how you might be able to support and assist me in developing my integrated circuits. Please send me a copy of your new capabilities brochure "A World of Possibilities."

Name _____
 Position _____
 Company _____
 Address _____
 City _____ State _____ Zip _____
 Phone () _____

MCE Design, Applications and Marketing Centers

Micro-Circuit Engineering Inc., 1111 Fairfield Drive, West Palm Beach, FL 33407. Telephone (305) 845-2837, Telex 513463 (MCE NPAB).

Micro-Circuit Electronics, 1270 Oakmead Parkway, Suite 101, Sunnyvale, CA 94086. Telephone (408) 732-6090, Telex 171895 (M CELECTR SUVL).

Micro-Circuit Engineering Vertr. GmbH, Pirckheimer Str. 124, D-8500, Nürnberg, W. Germany. Telephone 0911-533993, Telex 06-22748 (SVOLKD).

Micro-Circuit Engineering Vertr. GmbH, Blumenstr. 9A, D-8013, Haar/München, W. Germany. Telephone 089-463085, Telex 05-212965 (MCEMD).

World Radio History

LOOK TO LEXAN[®] RESIN FOR THE DESIGN EDGE

Whether it's new designs or design modifications, we can help all the way. Help turn parts into systems. Help utilize solid injection molding to produce large finished parts as well as small ones. Help minimize costs while maximizing performance. Help choose the right grade, develop working prototypes, secure agency approvals. In short, we've got the experience and resources to help you see the way design can be. Call us at (413) 494-4837. Or send for our free design brochure:

LEXAN Products Division,
Dept. 492, General Electric
Company, One Plastics Ave.,
Pittsfield, MA 01201.

We bring good things to life.

GENERAL  ELECTRIC



LEXAN resin's superb strength and durability mean slender snap-fit arms that resist snap-offs.



With LEXAN resin, parts that locate, align or hold components can be designed-in rather than added on.



By designing-in ribs, fillets and radiused corners, rigidity and strength are optimized while weight and costs are minimized.

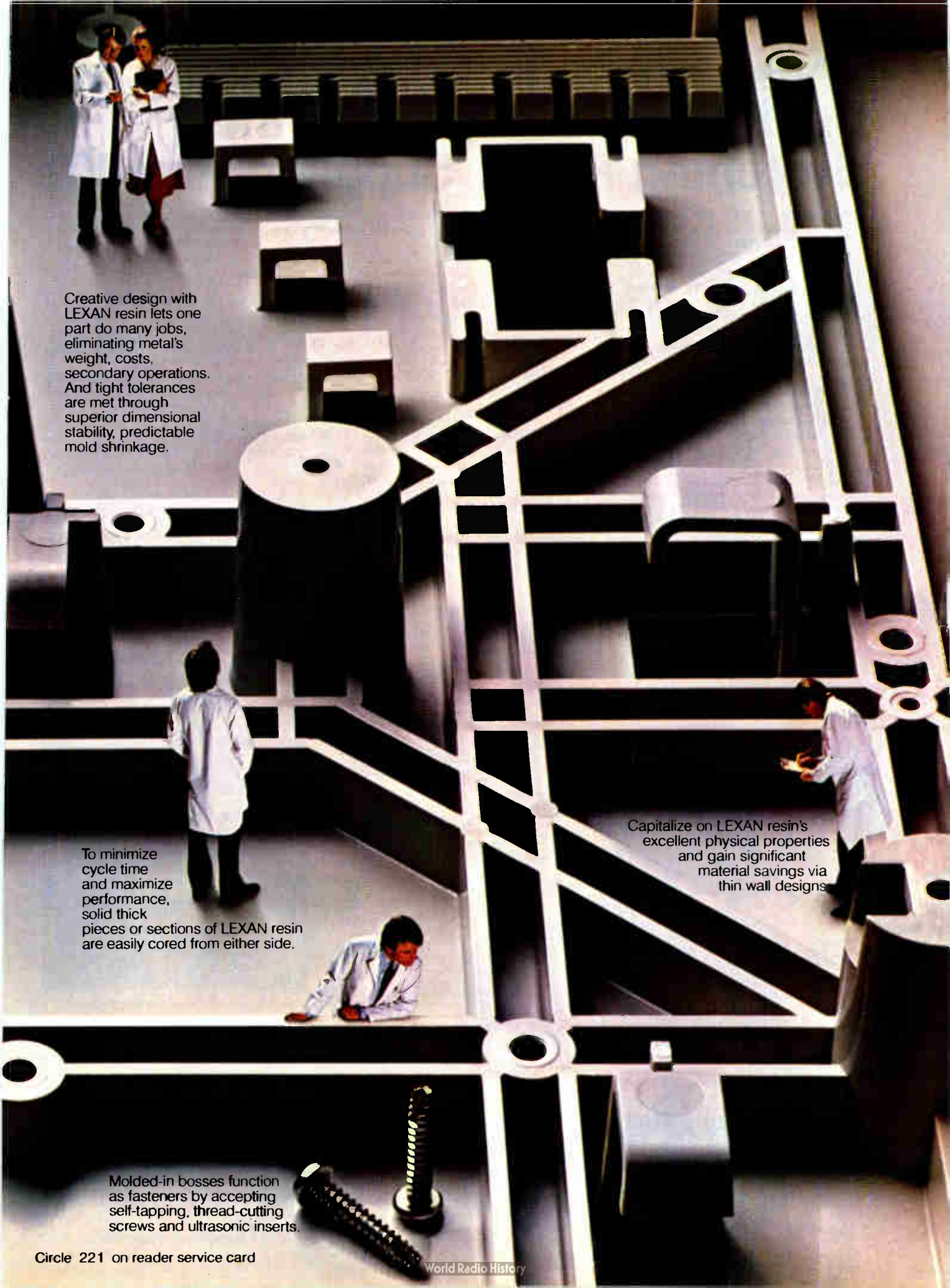

Creative design with LEXAN resin lets one part do many jobs, eliminating metal's weight, costs, secondary operations. And tight tolerances are met through superior dimensional stability, predictable mold shrinkage.

To minimize cycle time and maximize performance, solid thick pieces or sections of LEXAN resin are easily cored from either side.

Capitalize on LEXAN resin's excellent physical properties and gain significant material savings via thin wall designs.

Molded-in bosses function as fasteners by accepting self-tapping, thread-cutting screws and ultrasonic inserts.



Three Interconnecting modules, no hard wiring and you get the Switching Power Supply of the 80's

Customer: What's the significance of the 3 modules?

ACDC Salesman: In the past, everybody including ACDC produced specific switchers for given applications. You know, assemble the components in a box, wire them and then tweak and test and trim, etc. In our RS/RT switchers, we produce large quantities of three basic modules, and then test the daylights out of them, followed by full load, high temp burn-in.

Customer: What modules are you talking about and how do they work?

ACDC Salesman: O.K., we produce input modules, converter modules and output modules. We have 16 different board modules that make up 50 different power supplies. We take various combinations out of stock and assemble them in a chassis, interconnecting them through a mother board. It's fast, reliable, and it eliminates hard wiring.

Customer: I see, you can make up most

any switcher I could want right out of stock. You say no hard wiring...what's wrong with wiring?

ACDC Salesman: Harnesses are a point of potential failure. There are possible cold solder joints vulnerable to everything including shipping vibration, not to mention noise considerations in how the harnesses are placed throughout. No one has ever successfully introduced a switching supply without hard wiring until our RS/RT Series.

Customer: When you say you test the daylights out of them, give me some details.

ACDC Salesman: O.K. First, all of our active devices are 100% screened. We stable bake, temperature cycle, and then 100% electrical test. All to MIL-STD-883B. The modules themselves are computer tested. When we assemble them into the final unit, we first Auto-Test, then burn-in for 48 hours at 50°C under full load, cycled, Auto-Test again with com-

puter print out-serialized. You get one copy of the hard test data and we keep a copy. In other words we all know exactly what you're getting.

Customer: Everything sounds good, but what about the cost?

ACDC Salesman: Simple. We save you money because instead of building a hundred of these and fifty of those, etc., we continuously build thousands of the same modules each month. That saves us, and you, money. We test everything thoroughly and that eliminates warranty returns, reworks and all those costly problems. Believe me, if you've ever seen the production of power supplies, you'd know we have a uniquely superior product here...and, at a fantastically low price.

Customer: It sounds to me like you've brought power supply technology up to date.

ACDC Salesman: Thanks...we think our RS/RT Series are the switchers of the 80's.

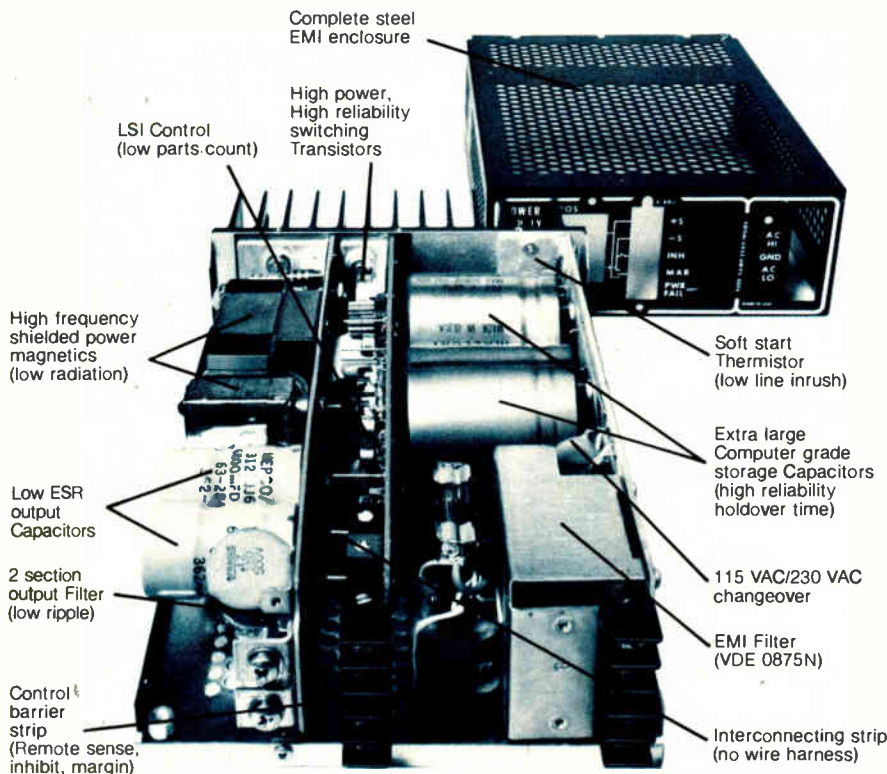

RS Series/Single Output

OUTPUT VOLTS	OUTPUT CURRENT				
	RS50	RS100	RS150	RS300	RSF375
2	10.0	20.0	30.0	60.0	—
5	10.0	20.0	30.0	60.0	75
6	8.0	9.0	25.0	50.0	—
12	4.5	9.0	13.5	27.0	31
15	3.6	7.2	10.8	21.0	25
18	3.0	6.0	9.0	18.0	—
24	2.5	4.5	7.0	13.0	15
28	2.0	4.0	6.0	11.5	—

RT Series/Triple Output

	MULTIPLE OUTPUT			
	TRIPLE			QUAD
	RT100	RT150	RT300	RQ300
MAIN OUTPUT	5V 20A	5V 30A	5V 60A	5V 30A
AUXILIARY OUTPUTS	12V 2A	12V 5A	12V 5A	12V 5A
	15V 2A	15V 4A	15V 4A	15V 4A
		5V 5A	5V 5A	5V 5A
			24V 2A	24V 4A
MAX. POWER	100W	150W	300W	300W

These Power Supplies are shipped with the industries most complete instruction manual.



SEND FOR COMPLETE CATALOG

acdc

electronics

401 Jones Road, Oceanside, California 92054
Telephone 714/757-1880

NEW EDITION

Complete and Unabridged American and International

DATA COMMUNICATIONS STANDARDS

All standards are new, revised, or reaffirmed since the previous edition

Presents all 123 interface protocol standards set by:

- International Telegraph and Telephone Consultative Committee (CCITT)
- International Organization for Standardization (ISO)
- European Computer Manufacturers Association (ECMA)
- American National Standards Institute (ANSI)
- Electronic Industries Association (EIA)
- U.S. Government (NBS and NCS)

Special feature for instant access:

Cross-reference tables of the similar and interfacing standards of each group corresponding to those published by the others.

An essential reference for designers, planners, operations managers, and all organizations exploring, developing, manufacturing, or using data communications equipment or networks.

Don't waste time and effort! With this landmark resource you can quickly and accurately determine exactly which standards apply to the project at hand, and speedily integrate those standards into your own data communications equipment or network plan.

Order your copy today!

Data Communications Standards II
Electronics Magazine Books
1221 Ave. of the Americas, Fl. 42
New York, NY 10020 USA
212/997-2996

Send me _____ copy (copies) of **DATA COMMUNICATIONS STANDARDS EDITION II** at \$250. U.S. orders please add local tax. McGraw-Hill pays regular shipping and handling charges on prepaid orders. Ten-day money-back guarantee applies.

Check enclosed. Bill me. Bill my company. Company Purchase Order enclosed.

American Express Visa MasterCard _____ Interbank No.

Credit Card Number _____

Expiration Date _____

Name _____

Title _____

Company _____

Address _____

City _____

State/Zip (U.S.) _____

Country (outside U.S.) _____

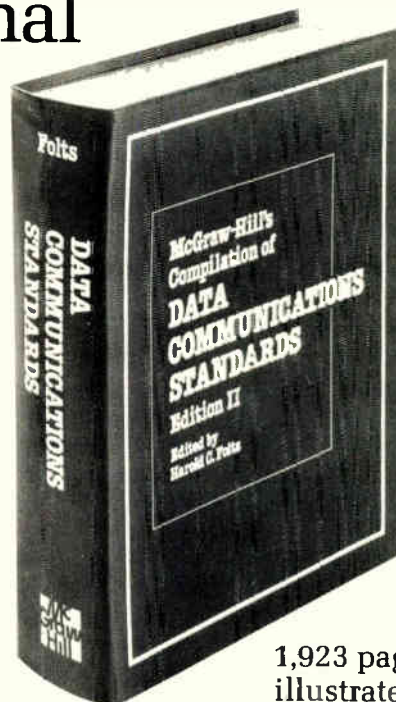

**1,923 pages
illustrated**

Edited by Harold C. Folts, the leading consultant on data communications standards and an active participant in the development of U.S. and international standards.

Published jointly by *Data Communications* and *Electronics* magazines.



EL1

Semiconductors

2 nA holds data in 64-K static RAM

C-MOS device's companion has n-MOS array; competitive pricing is two years away

Samples of 64-K static random-access-memory chips with as many transistors as the upcoming generation of 256-K dynamic RAMs will be available in Japan in March. Toshiba Corp. says that it expects to be able to deliver the first production shipments of its two new types of 8-K-by-8-bit complementary-MOS devices toward the end of 1982.

One, the TC5564P, is a true C-MOS device. The other, the TC5565P, incorporates an n-channel MOS memory matrix in a p-well with C-MOS peripheral circuits.

Both devices are made in a double-level polysilicon process with minimum line widths and spacings between lines of 2 μm , using 10:1-reduction direct-step-on-wafer projection lithography. They also share the same 100-ns maximum access time, 100-ns minimum cycle time, and Jedec type B 28-pin dual-in-line package.

C-MOS arrays boast 2-ns gates

2,000- and 6,000-gate arrays compatible with 74LS parts use double-metal process

A double-layer-metal complementary-MOS silicon-gate process that National Semiconductor is calling M²C-MOS adding speed to the firm's thrust into C-MOS gate-arrays. The first two parts made with the process, the 2,000-gate SLX 6320 and the 6,000-gate SLX 6360, have

Also common to both is the use of redundancy to increase yield, although the full C-MOS part incorporates an extra two rows and one column, whereas the n- and C-MOS RAM only has two columns. Laser programming of the extra rows or columns is used.

Seishi Okamoto, semiconductors application group manager, foresees the market for the high-priced pure C-MOS model in equipment that must retain memory with battery backup for months. Typical products include cash registers, pocket computers, and numerical- and industrial-control equipment.

Devices that require the n- and C-MOS chip include equipment that must only retain memory on battery backup for at most a few days and equipment where the added cost over a straight n-MOS device is warranted by the lower power consumption. Many applications using earlier 4- and 16-K static memories have been very price-sensitive and generated a huge market for n-MOS RAMs.

However, Okamoto says that he is unable to predict the breakdown of the market for 64-K devices. Increased emphasis on low-power designs may increase the premium that manufacturers are willing to pay for C-MOS parts.

The fully C-MOS version with six transistors per cell is fabricated on a 5.92-by-7.49-mm chip, with each

cell measuring 19 by 22 μm . Typical standby current is a mere 2 nA; operating current is 2 mA/MHz with a 5-v power supply. This low-power level has been achieved by careful system design rather than by using dynamic circuits. Some use of bootstrap circuits is made for high speed, and sensitive flip-flops are used as sense amplifiers. Data is retained over a range of 2 to 5 v.

The n- and C-MOS RAM incorporates high-resistivity polysilicon-load resistors for the memory cells in the second polysilicon layer. This permits a decrease in cell size to 15 by 19 μm , and a corresponding reduction in chip size to 4.97 by 7.22 mm. The standby current for this model is increased to 1 μA , but the operating current is the same 2 mA/MHz as the fully C-MOS version.

Initially, samples will be available only in Japan at 60,000 yen (about \$280) for the fully C-MOS chip and 50,000 yen for the n- and C-MOS part. Pricing for samples sold in the U. S. is not yet set. Toshiba sources say that the price per bit is expected to cross that for 16-K RAMs in 1984. (The price of a 16-K C-MOS parts in Japan today is 2,000 yen and falling.) These RAMs will also be available in flatpacks for use in applications where the user does not replace individual chips.

Toshiba Corp., 72 Horikawacho, Saiwaiiku, Kawasaki 210, Japan [419]

3- μm geometries and typical gate delays of 2 ns.

The 2-ns typical gate-delay specification is a real one. Notes Dick Hunt, director of data-processing industry marketing for semiconductor products at National, "We specify that figure using a fan-out of three to four devices driving 100 mils of metal each." With C-MOS technology the arrays can be power misers, too. Each gate dissipates 20 μW per megahertz of switching frequency; with a typical switching frequency of about 5 MHz, the 2,000-gate and 6,000-gate arrays would draw 200 mW and 600 mW, respectively.

The arrays employ n-well technology, which is to their advantage,

according to Hunt. "All of the scaling, lithography, and feature-size-reduction techniques that have been developed for other parts are applicable to our n-well C-MOS efforts," he says.

The SLX family maintains full compatibility with the 74LS family of parts. "Both ac and dc characteristics have been designed to match those of 74LS," says Hunt. For example, the output buffer's current and capacitive drive characteristics match those of the 74LS family, and the arrays' input buffer improves on the comparable 74LS characteristic. The propagation delay of the SLX family output buffer driving 50 pF is 8 ns typically; the family's TTL input

RACAL-VADIC MAKES C.C.I.T.T. COMPLIANT MODEM SELECTION AS SIMPLE AS...

1
V.2

300 bps Full Duplex

Racal-Vadic makes low speed communicating simple with the VI3021, a microprocessor-controlled 300 bps full duplex modem that provides asynchronous operation over 2-wire dial-up (PSTN) or leased telephone lines, in full compliance with CCITT V.21 recommendations.

This compact modem is packaged on a single PC board which can be housed in a 2½" high desk top cabinet for remote terminal use, or in a 19" rack mounting card nest for central computer sites. Up to 14 of these front loading modems can be mounted in the 8¾" high card nest along with power supply. Another plus, V.21, V.22 and V.23 modems can be freely intermixed.

When you add features such as Auto Answer, which enables a called modem to automatically connect itself on receipt of a ringing signal, and powerful diagnostics including self-test, analog loopback and digital loopback, you won't find a more versatile 300 bps modem at any price.

2
V.2

1200 bps Full Duplex

The VI1222 is a V.22 compliant modem which operates full duplex at 1200 bps over 2-wire dial-up or leased lines. It offers all three V.22 alternatives: A, B and C. The inclusion of alternative C means the VI1222 can operate with any terminal at all standard asynchronous speeds to 1200 bps plus split speed and overspeed.

Now, terminal users who were limited by a 300 bps modem can instantly transmit and receive data four times faster, with no change in protocol, merely by replacing their V.21 modem with the Racal-Vadic VI1222.

Packaging is versatile. The VI1222 comes in a compact desk top cabinet for remote use. For central computer sites, up to seven VI1222 modems can be housed in the 8¾" high rack mounted card nest including power supply module and powerful displays and diagnostics.

3
V.2

1200 bps Half Duplex

The VI1223, which conforms to CCITT V.23 recommendations, is a very flexible microprocessor-controlled modem, providing 1200 bps half duplex transmission over 2-wire switched or leased lines, and full duplex operation over 4 wire leased circuits. 16 versions of the VI1223 can be configured using the 3 unique plug-in adapters: *Switched Network Adapter* which converts the basic leased line modem for use on 2-wire dial-up lines. *Backward Channel Adapter* which adds switch selectable 75/150 bps reverse channel to 2- and 4-wire units and forward channel to the 4-wire version. *Synchronous Adapter* which provides synchronous operation at 600 and 1200 bps. A single VI1223 can be contained in the attractive table top cabinet, or up to 14 VI1223's can be housed in the 19" rack mount front loading card nest.



VI1600 Table Top Cabinet

VI1614 Rack Mount Chassis

Racal-Vadic **RACAL**

Australasia and Latin America, Contact:
Racal-Vadic Inc.
222 Caspian Drive • Sunnyvale, California 94086 U.S.A.
Telephone: (408) 744-0810 • Telex: 910-339-9297

Europe, Middle East and Africa, Contact:
Racal-Milgo Limited
Richmond Court • 309 Fleet Road, Fleet, Hampshire, England GU13 8BU
Telephone: Fleet (02514) 22144 • Telex: 858294

Circle 191 on reader service card

BAUSCH & LOMB ACCURACY

For critical circuit design, photomask, and photoresist inspections, the Bausch & Lomb BALPLAN® Incident Light Microscopes with a magnification range up to 1500X and the versatility of six incident light illumination modes leave nothing to chance or misinterpretation.

True color rendition and contrast from high quality optics result in the edge-to-edge sharpness necessary for detailed inspections. And the wide 20mm field of view offers no image drop off. Six types of illumination permit your technicians to match illumination mode to inspection application. They can't inspect it, if they can't see it!

The latest in photomicrographic and CCTV accessories, of course, are available.

Write or call today for detailed literature or a demonstration.

For quality, performance, and accuracy... THINK BAUSCH & LOMB.

BAUSCH & LOMB 
Scientific Optical Products Division

Rochester, New York 14602 USA

716-338-6000, TWX 510-253-6189 TELEEX 97-8231, CABLE: Bausch & Lomb

Regional Offices SOPD International CANADA Bausch & Lomb Canada Ltd., Don Mills, Ontario. **EUROPE** Bausch & Lomb GmbH, Muenchen, Germany. Bausch & Lomb France S.A., Versailles, France. Bausch & Lomb U.K. Ltd., Epson Downs, Surrey. Bausch & Lomb Italiana S.P.A. 00198 Rome, Italy. **FAR EAST** Bausch & Lomb (Hong Kong) Ltd. Shaukeiwan and Singapore. BLJ Co. Ltd. Tokyo.



"Contamination defects at 300X found during wafer inspection"

Bausch & Lomb
BALPLAN® Incident Light
scope Model
MBTA3A with
Lazy Susan



Circle 139 on reader service card

Flying an aircraft is an exacting job HUD will help

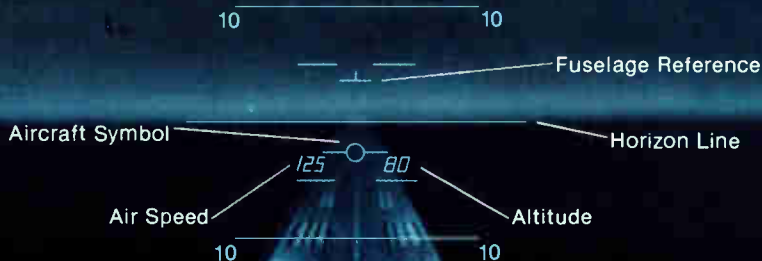

We supply deflection yokes to the major manufacturers of Head-up (HUD) display systems for aircraft, including the DC-9 Super 80. These displays enable pilots to focus attention straight ahead, and to see computerized flight information without looking away toward indicators and digital readouts for

airspeed, fuel consumption, altitude, etc.

Syntronic also designs and makes precision yokes and focus coils for navigation systems, weather radar, weapon systems and other CRTs used on most aircraft flying today.



Head-up display with flight symbols and digital information...



is visible to pilot through half-silvered mirror...



from CRT display below pilot's field of view...



Syntronic yoke provides sharp resolution at high brightness.



Precision yokes for exacting displays

Syntronic Instruments, Inc., 100 Industrial Road, Addison, IL 60101 (312) 543-6444

Circle 227 on reader service card

New products

buffer has a typical propagation delay of 4 ns, faster than that of the 74LS family.

Samples of the SLX 6320 and 6360 will be available in the first and second halves of 1982, respectively. Fujitsu has announced a similar product, but the typical gate delays of the devices are on the order of 4 ns. Motorola is expected to announce a competing product, but its gate delays are as yet unknown.

National plans to support the SLX family with an integrated computer-aided design system that is accessible from remote locations. The system is to include routines for logic simulation, test generation and grading, and automatic placement and routing. Hunt says this system will make turnaround times of only 12 to 14 weeks a reality.

National Semiconductor Corp., 2900 Semiconductor Dr., Santa Clara, Calif. 05051 [411]

Customized gate arrays can replace 80 devices

Designers will be able to use two integrated Schottky TTL semicustom gate arrays in logic-replacement applications requiring higher input/output or gate count. With gate delays of 4 ns, the devices can take over from standard low-power Schottky devices.

The 8A1260 has 1,200 gates and 60 I/O pins and substitutes for up to 65 low-power Schottky devices. The 8A1542 has 1,500 gates and 42 I/O pins for replacing more than 80 devices. Both dissipate 168 μ W per gate and operate over the -55° -to- $+125^{\circ}$ C temperature range.

The customer designs the gate arrays by simulating the required logic function with the Signetics time-shared Tegsim program, submitting the result with a logic diagram. Signetics completes the chip design using computer-aided design to ensure 99% first-pass success.

The arrays are available in plastic and ceramic dual in-line packages and leadless chip-carriers. In 5,000-piece lots, the 8A1260 ranges in

price from \$28 to \$40, and the 8A1542 runs \$26 to \$36, depending on package type and pin count.

Signetics, 811 East Arques Ave., P. O. Box 409, Sunnyvale, Calif. 94086. Phone (408) 739-7700 [413]

Static RAM can be accessed in 35 ns

Organized into 1,024-K words by 4 bits, the TMS2149 static random-access memory benefits from Texas Instruments' scaled n-channel MOS silicon-gate technology. The 4-K-device offers a worst-case access time from address of 35 ns—its access time from chip-select is just 15 ns. In addition, its maximum operating power is 660 mW, leading to a speed-power product of 23,500 pJ. The RAM operates from a single 5-V power supply.

With speed ranges of 35 to 70 ns, the TMS2149 is offered in both ceramic and plastic 300-mil, 18-pin dual in-line packages. The device is available immediately for \$8.45 each in 100-piece quantities.

Texas Instruments Inc., P. O. Box 202129, Dallas, Texas 75220 [417]

256-K dynamic RAM takes up 0.46-in.²

Occupying 0.46 in.², or just slightly more board space than a standard 16-pin dual in-line package, the EDH-4256 256-K-by-1-bit dynamic random-access memory may interface directly with high-performance logic families like Schottky TTL. It has on-chip address and data registers and two chip-select methods.

On a 22-pin single in-line package, the device uses four 64-K RAMs in leadless chip-carriers and two 0.1- μ F decoupling capacitors. Operating from a single +5-V supply, it dissipates only 540 mW when active and 110 mW on standby. Its input-noise immunity minimizes false triggering of the inputs.

The compact memory is suitable for applications that require error

checking or in systems using unorthodox bit counts—for example, in word processors, single-board computers, test equipment, and military electronics.

Two versions are available, a device with 150-ns access time for \$123 in 100-unit lots and one with 200-ns access time for \$112 in like quantities.

Electronic Designs Inc., 230 Eliot St., Ashland, Mass. 01721. Phone (617) 881-5244 [415]

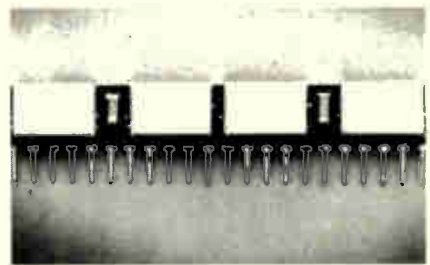

4-K C-MOS RAMs are radiation-hardened

Two 4-K complementary-MOS static random-access memories are constructed using radiation-hardened, self-aligned silicon-gate technology for such applications as satellites, nuclear instrumentation, and tactical and strategic weapons systems.

The HS-6504RH is a 4,096-by-1-bit RAM, and the HS-6514RH is a 1,024-by-4-bit version. Typical access time for both is under 250 ns. They consume 8 mW/MHz typically, 25 mW/MHz at worst, and 500 μ W on standby. Both memory devices have a total dose capability of 5×10^9 rad silicon and also latch-up-free operation of greater than 5×10^{11} rad silicon/s.

A 64-K version, the HS-6564RH, can be constructed using 16 of either of the two devices mounted on a ceramic substrate and screened to MIL-STD-883-B. Both the HS-6504RH and 6514RH are available in either dual in-line packages or leadless chip-carriers for \$400 each in 100-piece quantities.

Harris Corp., Programs Division, P. O. Box 883, Melbourne, Fla., 32901. Phone (305) 724-7800 [414]

DOUBLE TROUBLE FOR ALIASES

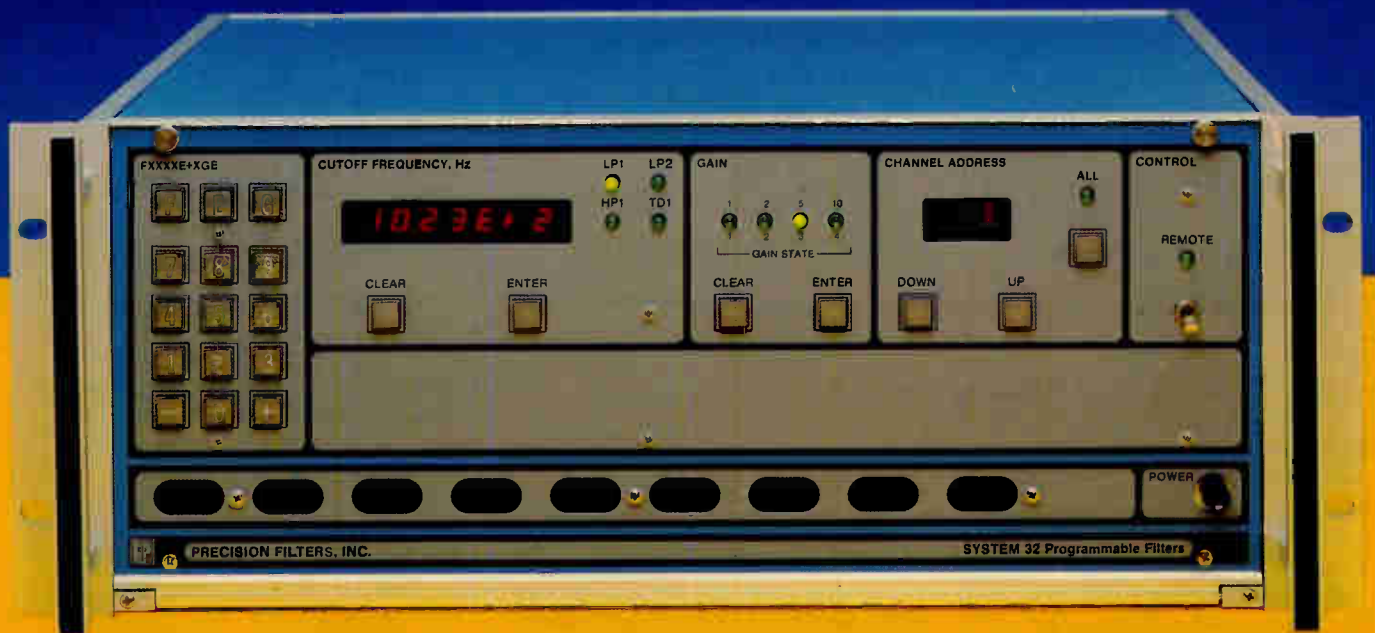

Twice the channels. Twice the density. Half the cost per channel.

The new Precision System 32 packs 32 programmable channels into the same 7 inches of rack space previously needed for 16.

You get more than 2 digit resolution, with 2047 programmable cut-off frequencies. Time delay filters are superior to Bessel. Elliptics afford 80 dB/octave attenuation. Phase match is within 1°. Interfaces with mini, micro or GPIB.

Savings can run nearly 50% per channel compared with competitive 16 channel units. Fixed frequency and third octave filters available at greater savings. It's a new reason to buy rather than build.

Call Mike Stewart at 607-277-3550 or write for complete specifications.



PRECISION FILTERS, INC.

240 Cherry Street, Ithaca, New York 14850

Circle 228 on reader service card

World Radio History

Introducing... The all NEW Printer from Digitec®

6400 SERIES features:

Low Cost - \$299 in 100 Quantities
Expanded Warranty - 1 Full Year
Compact Size - 7.38"W x 3.08"H x 6.12"D. WT 3-1/2 LBS

- Selectable serial RS-232-C/20 mA current loop or 8-bit parallel interface
- Selectable baud rates 110, 300, 600 or 1200
- Parallel-data rates in excess of 2000 characters per second
- 21 characters per line (optional 32 characters)
- 36 character input buffer
- Electrosensitive or thermal printing
- 5 x 7 Dot Matrix, 64 character ASCII Code
- Boldface characters for emphasis

\$299

in 100 quantities
\$399 list



Digitec

**UNITED
SYSTEMS
CORPORATION**

918 Woodley Road, Dayton, Ohio 45403
(513) 254-6251, TWX (810) 459-1728

Circle #52 for information only

Circle #230 for demonstration only

NEW EDITION Complete and Unabridged American and International

DATA COMMUNICATIONS STANDARDS

All standards are new, revised, or reaffirmed
since the previous edition

Presents all 123 interface protocol standards set by:

- International Telegraph and Telephone Consultative Committee (CCITT) • International Organization for Standardization (ISO) • European Computer Manufacturers Association (ECMA) • American National Standards Institute (ANSI) • Electronic Industries Association (EIA) • U.S. Government (NBS and NCS)

Special feature for instant access:

Cross-reference tables of the standards of each group corresponding to those published by the others.

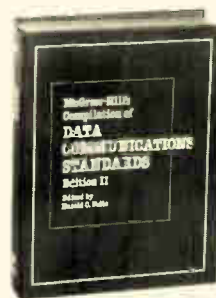

1,923 pages
illustrated

Edited by Harold C. Folts

Data Communications Standards II

Electronics Magazine Books
1221 Ave. of the Americas, Fl. 42
New York, NY 10020 USA
212/997-2996

Name _____

Title _____

Company _____

Address _____

City _____ State/Zip (U.S.) _____

Country (outside U.S.) _____

Send me _____ copy (copies) of DATA COMMUNICATIONS STANDARDS EDITION II at \$250. U.S. orders please add local tax. McGraw-Hill pays regular shipping and handling charges on prepaid orders. Ten-day money-back guarantee applies.

Check enclosed. Bill me. Bill my company. Company Purchase Order enclosed.

American Express Visa MasterCard _____ Interbank No. _____

Credit Card Number _____ Expiration Date _____



ELH

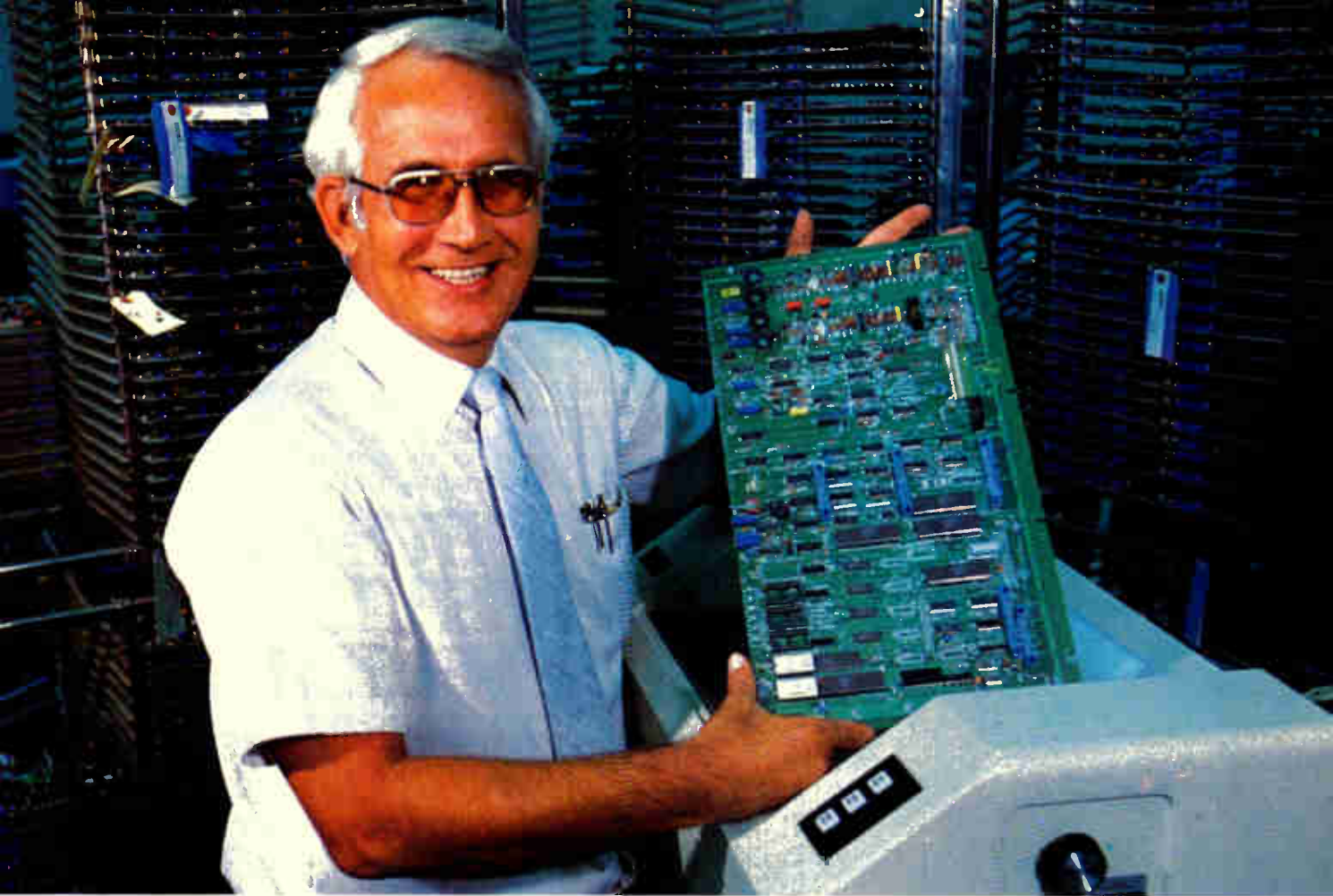

Computer Peripherals doubles production with Universal Automatic Insertion Equipment.

Luther "Duke" Galloway, manufacturing engineer of Computer Peripherals, Inc., Campton, KY, analyzed the company's printed circuit board production and concluded that they could save a quarter million dollars per year by automating circuit board component insertion with Universal Instruments equipment. He also concluded that production could be more than doubled on one shift.

Corporate management gave the go-ahead and Duke ordered a Universal Multi-Module[®] DIP Insertion Machine (3600/hr), a Dual-Head VCD Axial Lead Insertion Machine (25,000/hr) and a 60-Station Component Sequencing Machine

to provide component reels for the VCD machine. The System is controlled by a Satellite Controller[®] computer-based system. A Program Generation System was also ordered to allow fast, easy and highly accurate insertion pattern program generation.

In theory, these insertion rates are equal to the average production of 17 people. In actuality, the increased production made possible by the Universal Instruments automatic insertion system, also has increased Computer Peripherals productivity dramatically. Through the use of the Universal automatic insertion equipment, production schedules can handle even periods of peak demand. Even more, Computer Peripherals is tak-

ing on more work from other Control Data divisions, some of whom were buying their circuits from outside vendors.

Board reject rates have dropped because, with automatic insertion equipment, as Duke Galloway comments, Computer Peripherals has increased quality and reliability at lower cost. "It has been possible for us to build in quality from the beginning. You are as accurate as your program tapes are. We know that by developing good programs, we increase the reliability and quality of the boards, as we lower cost and increase production. Good tape programs mean good boards."

These benefits can make sense to you too. Ask your Universal sales engineer or send for literature.

Circle 231 on reader service card

Subsidiary of **DOVER CORPORATION**

Universal[®]

Universal Instruments Corporation ■ Box 825, Binghamton, New York 13902 ■ Tel: 607/772/7522 ■ TWX: 510/252/1990

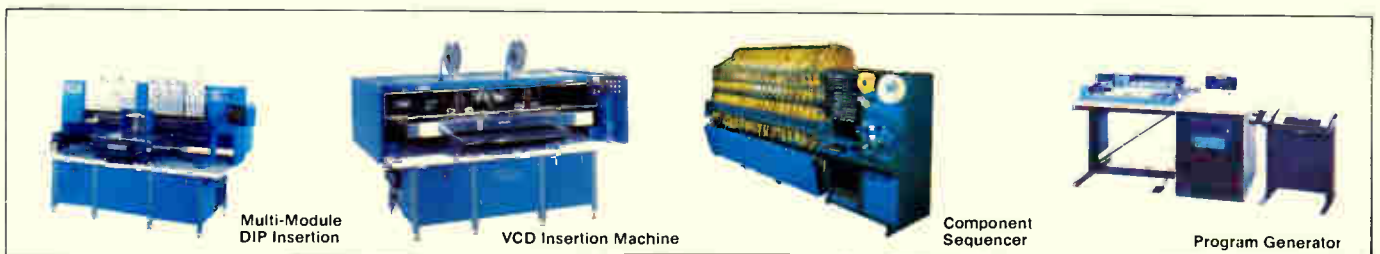

Multi-Module
DIP Insertion



VCD Insertion Machine



Component
Sequencer

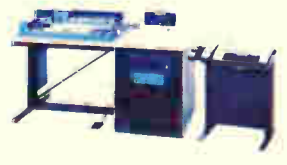

Program Generator

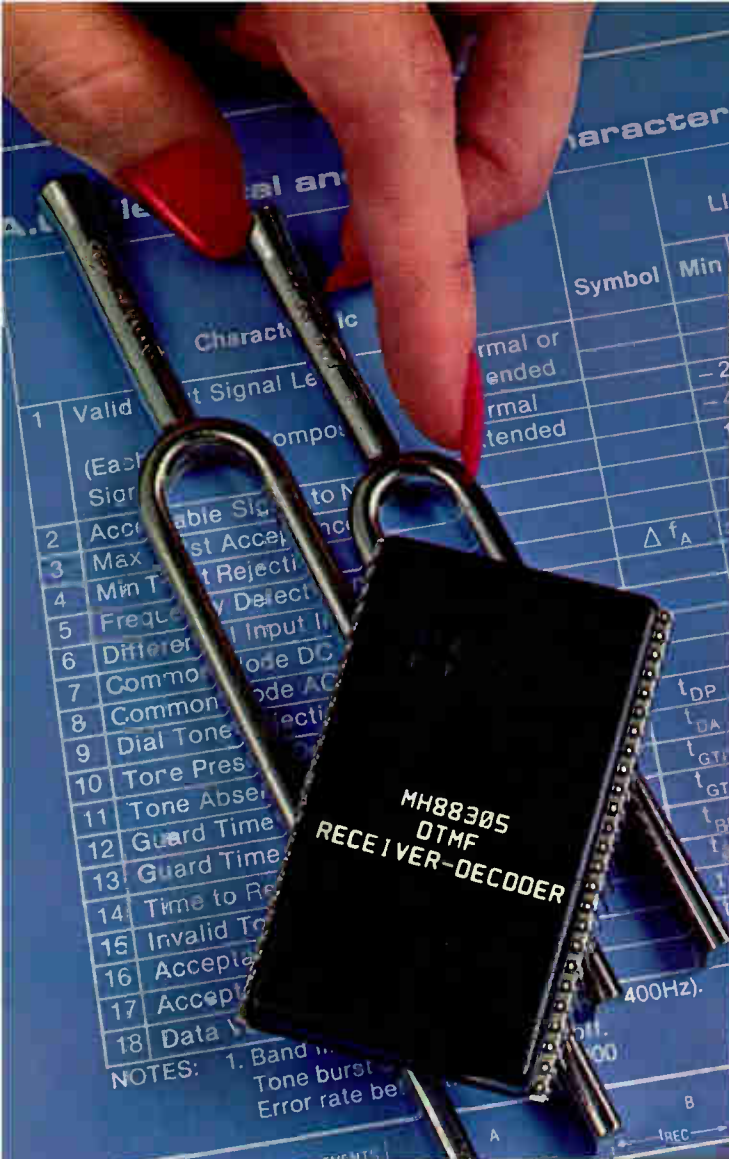

Test Conditions
unless otherwise specified
 $T_A = 25^\circ\text{C}, V_A = 5\text{V or } 12\text{V}$
 $V_B = V_{EE} = 0\text{V}$

Look no further than the Mitel MH88305 when you're looking for a DTMF Receiver that combines exceptional dynamic range, good talk-off immunity and excellent signal-to-noise performance in one compact module.

The MH88305 is excellent for such demanding applications as central office, end to end signalling, mobile radio and PABX.

This hybrid device is a direct replacement for the first generation MH88205, but offers enhanced performance and lower cost.

A PITCH FOR EXCEPTIONAL SENSITIVITY:- THE MH88305 DTMF RECEIVER.

The key features of the MH88305 are:

- Up to 55dB dynamic range.
- 14dB acceptable signal to noise ratio.
- 60dB Dial Tone Rejection.
- Acquisition time adjustment down to 10 ms.
- One external component adjusts: input sensitivity, guard time, twist accept/reject limit.
- 5V or 12V operation.
- Error rate better than 1 in 100,000 tones.

The swept in-band 3rd tone tolerance is measured as A-16 dBm and, in this case, total receiver performance conforms to the CEPT recommendations.

The Mitel MH88305 DTMF Receiver. It gives you exceptional sensitivity right down the line.

Find out more about this and other related Mitel products. Contact your local Mitel sales office.

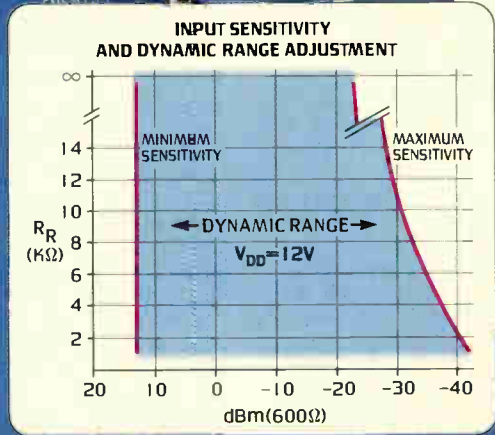

MITEL SEMICONDUCTOR

United States: 2321 Morena Blvd., Suite M, San Diego, California, U.S.A. 92110.
Telephone (714) 276-3421, TWX: 910-335 1242.
P.O. Box 17170, 600 West Service Road,
Dulles International Airport, Washington, D.C., U.S.A. 20041.
Telephone (703) 661-8600, TWX: 710-833-0865.

Canada: P.O. Box 13089, Kanata, Ontario, Canada K2K 1X3.
Telephone (613) 592-5630, Telex: 053-3221, TWX: 610-562-8529.

Europe: 33/37 Queen St., Maidenhead, Berkshire, England SL6 1NB
Telephone 0628 72821, Telex: 849-808.
Bredgade 65A, 2nd Floor, 1260 Copenhagen K, Denmark
Telephone (01) 134712, Telex: 19502.

Asia: TST P.O. Box 98577, Kowloon, Hong Kong.
Telephone 3-318256, Telex: 34235.

Copyright 1981 Mitel Corporation

BUILDING BETTER COMMUNICATIONS

Circle 232 on reader service card

WHY NEW YORK IS A SOLID STATE FOR THE ELECTRONICS INDUSTRY.

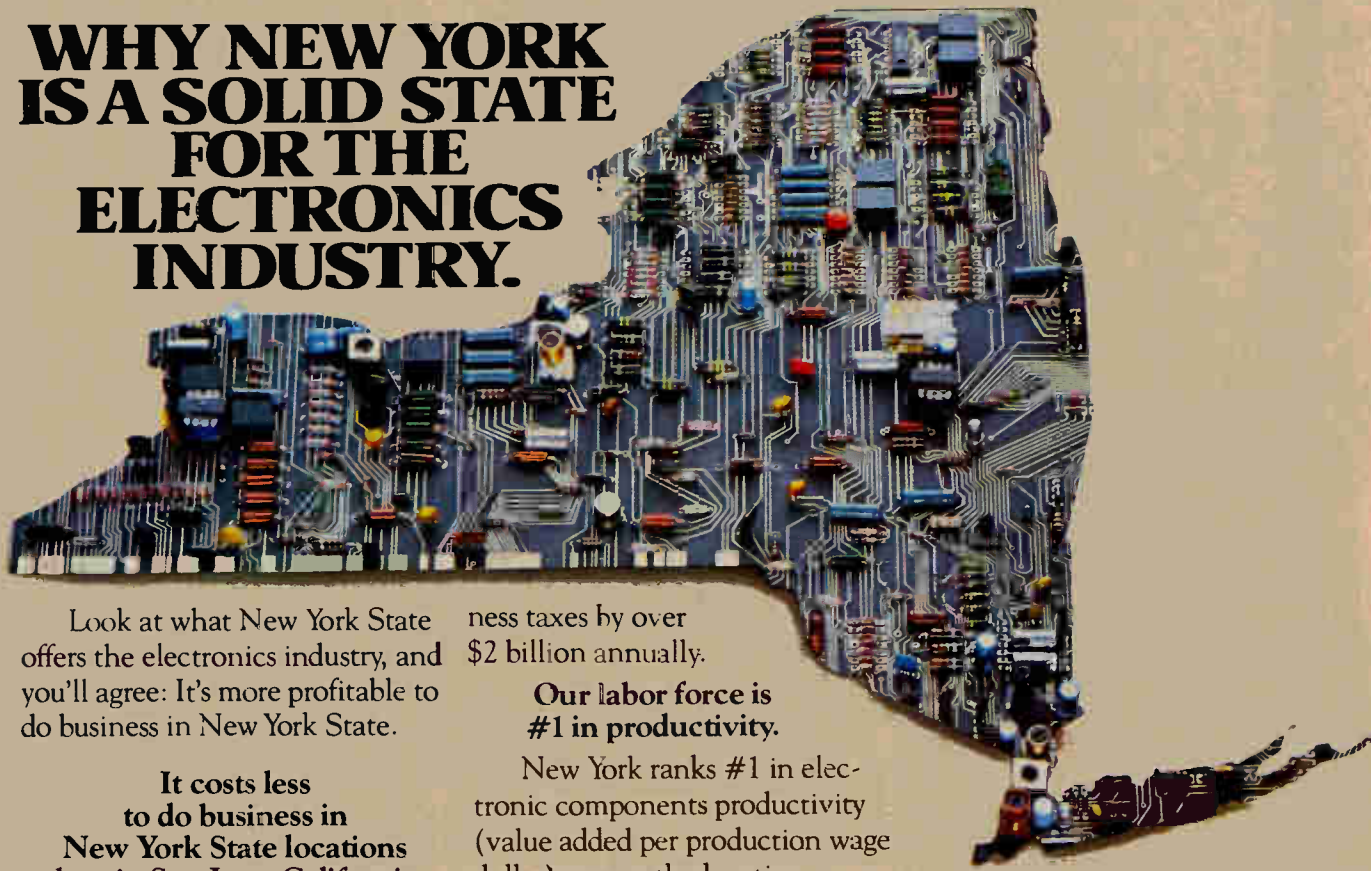

Look at what New York State offers the electronics industry, and you'll agree: It's more profitable to do business in New York State.

It costs less to do business in New York State locations than in San Jose, California. And we can prove it.

An independent study analyzed the four critical costs of taxes, wages, power and construction for a model new electronics firm. It showed that New York State offers locations where these costs are less than they are for choice electronics industry locations around the country.

For example, these costs would total \$7.6 million annually in San Jose, versus only \$6.4 million in, say, Brookhaven, New York.

New York has the best business advantages in America.

New York State is committed to a big, broad business-boosting program to create private sector jobs.

Our costs are lower because we have the best tax incentives and credits. We have on-the-job training and job incentive programs. Long-term, low-cost financing. And, we've cut personal and busi-

ness taxes by over \$2 billion annually.

Our labor force is #1 in productivity.

New York ranks #1 in electronic components productivity (value added per production wage dollar) among the locations analyzed. And in the past five years, New York's number of idle man-days due to work stoppages was half that of the national average.

We graduate more electronics engineers than any other state.

Thanks to universities like RPI and Cornell—and dozens of other fine colleges and universities—more electronics engineers are graduated each year in New York State than in any other state including California or Massachusetts. And since many of the largest electronics firms are already doing business here—GE, IBM, to name only a couple—our graduates are quickly turned into seasoned professionals.

When you look into New York, you'll love New York.

We have an abundance of electric power. Lots of affordable housing for your employees. And our 30 million acres include thou-

sands of available plant sites. And some of the most magnificent outdoors and year-round recreation on the American continent.

Tell me more about why New York is a solid state for business. I am particularly interested in information on:

- Electronic Components
- Small Computers
- Semiconductors

George G. Dempster, Commissioner
New York State Dept. of Commerce
99 Washington Avenue
Albany, New York 12245

Name _____
 Title _____
 Company Name _____
 Product/Service _____
 # Employees _____
 Address _____
 City _____
 State _____ Zip _____

MSER

NEW YORK STATE VOTES "YES" FOR BUSINESS.

Circle 233 on reader service card



**Our
message
is clear!**

We're dedicated to innovative CRT display design, quality production standards and complete customer satisfaction. Whatever your display needs, we have the experience and talent to design it, or improve it. Contact us today!

Designed, engineered and manufactured by
AUDIOTRONICS
 7428 Bellaire Avenue • North Hollywood, CA 91605 • (213) 765-2645 • Telex: 69-1241
 EUROPE—Sherwood House, 176 Northolt Road • South Harrow, Middlesex HA2 0EL England • 01-423 0866 • Telex: 89-3473

Circle 234 on reader service card

Your Choice!

Microprocessor Compatible 20 Column Alphanumeric Thermal Printers from Memodyne Corporation

Parallel Input Model MAP-20P

- 8 Bit TTL parallel data input
- Accepts rates up to 2000 characters per second

Programmable controls for:

- Text or lister printing
- Character size—normal or extended

Price: \$625.00 each in single quantities

Serial Input Model MAP-20S

- Simple 2 wire data input
- Isolated 20 mA current loop and RS232C interface
- Baud rates from 75 to 9600
- Internal/External Baud Clock
- Programmable controls for:
 - Text or lister printing
 - Character size—normal or extended
 - Baud rate

Price \$725.00 each in single quantities.

Common Characteristics of Both Models

- 96 Character print set
- Print rate of 2 lines per second
- Internal self test program of all characters and printing modes
- Complete with microprocessor electronics and AC power supply
- Small size measures 4.4" W x 2.75" H
- Fits in panel 4.5" W x 2.78" H
- Weighs 4.2 lbs.

Write for our complete 8 page color brochure.



Memodyne CORPORATION
 220 Reservoir St.,
 Needham Heights, MA 02194
 (617) 444-7000 Telex: 92-2537

234 Circle 51 on reader service card

Electronics / December 15, 1981

**Write for this important booklet.
It could be your most cost-effective idea today.**

**Designing
High Density
Printed Circuit Boards
Cost Effectively**



This 16-page Du Pont publication explores in depth many of today's high-density printed circuit board design challenges, including:

- Reducing circuit size
- Placing more circuits in the board area
- Standardizing the board for modular application
- Developing more effective conductor routing and more economical production techniques

What's more, you get plenty of solutions . . . from the manufacturers of RISTON® Photopolymer Dry Film Resist and VACREL™ Dry Film Solder Mask. New components . . . new materials . . . cost effective results—they're all here. For your copy, fill out and mail the coupon.

Du Pont Company
Marketing Communications Department
RISTON® Products Division, Room N-2526 D
Wilmington, DE 19898

Please send me a copy of "Designing High Density Printed Circuit Boards Cost Effectively."

Name _____ Title _____
Company _____ Phone _____
Address _____
City _____ State _____ Zip _____
Type of boards being designed _____
For use in _____

VISIT THE DU PONT BOOTH
AT NEPCON WEST, ANAHEIM, CA,
FEBRUARY 23-25, 1982.

An electronics company.



Circle 235 on reader service card



The guiding light.

From the beginning, we've been the fiber optic industry's guiding force. Its leader.

We did it by putting together the broadest and most reliable product line available. And by designing each part with a total system solution in mind. From our

state-of-the-art Sweet Spot™ Components to our advanced Masterslice Optical Circuits.

Today, our challenge is to continue developing and manufacturing new fiber optic components and systems to that same industry-standard level of excellence. We're meeting that challenge.

Find out how by calling any of our worldwide distributors today. Or contact Honeywell Optoelectronics, 830 East Arapaho Road, Richardson, Texas 75081; (214) 234-4271.

At Honeywell Optoelectronics, we'll be lighting the way for years to come.

Honeywell

Industrial

Loop controller has $\pm 1^\circ$ accuracy

8085-based single-loop temperature or flow controller can interface with computer

An 8085 is at the heart of a versatile modular process controller from Honeywell—the UDC 500, for universal digital controller. This single-loop temperature and flow controller is intended for furnace or boiler lead-lag control, temperature control in ovens, air-fuel ratio and other flow-ratio control, multizone kiln and distillation-column control,

need to control simple machines and to make them work together can use this feature. Honeywell sees these users as a large segment of the industrial control market.

The UDC 500 also justifies its price with a very high level of functionality combined with simple operation. During normal operation with the front panel door closed and locked, the operator sees two four-digit light-emitting-diode displays, nine indicator LEDs, and four buttons. The top digital display is dedicated to one process-variable input value; it can be set to read temperature in degrees Fahrenheit or Celsius and to show tenths of a degree or not, as required.

The lower digital display can read out the setpoint or the output value for one of the two possible outputs. The four buttons allow the operator to select what is shown on the lower display and to change the displayed value manually if necessary. LEDs indicate status (automatic operation or manual), tell the operator what's on the bottom display, and light up if one of two possible alarms has been tripped.

The front panel door when opened reveals several data-entry keys used in setting up the control loop. For security, a switch on one of the circuit boards must be accessed to change the basic algorithm used by the microprocessor or to change alarm or control-output action. Data is stored for 10 years or more in electrically erasable programmable read-only memory from General Instrument, thus preventing data loss on power failure without need for battery backup. Standard ROM contains routines for the unit's power-up self-test, automatic tuning, and calculation of such as integral square root and ratio bias adjustment.

Two alarms can be set to monitor two independent events each, for a

total of four events. The event can be a high or a low on either the process variable, the deviation, or the output. Optional relays can activate external equipment when alarm setpoints are exceeded.

The control output can be an analog signal that is current-, time-, or position-proportioning. It may also be set for on-off, on-off duplex, and three-position step control. The controller can accept two inputs, which can be different variables. Analog input is scaled, filtered, and sampled at 3 Hz. The sampled signal is amplified and converted into digital form; it then passes through isolation to the microprocessor.

The UDC 500 accepts thermocouple signals directly, without the need for a temperature transmitter and its associated power supply. The controller is compatible with most standard sensors, pressure transmitters, and final control devices. It occupies 3.62 by 5.39 in. in a panel.

Honeywell Process Control Division, Dept. 436, 1100 Virginia Dr., Fort Washington, Pa. 19034 [381]

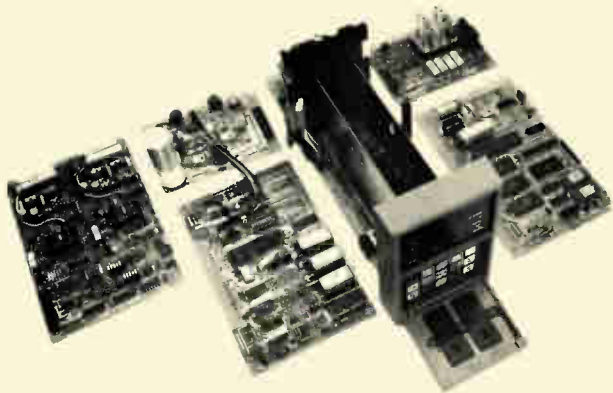

among other things. At any point on the temperature scale for types J, K, and T thermocouples, the UDC 500's accuracy is to within $\pm 1^\circ\text{F}$. This high accuracy can help a furnace pass stringent inspections, aid in saving fuel, and result in high product consistency.

At \$1,400 for the basic unit with one input and one output (it can be equipped with an extra one of each), the UDC 500 is not inexpensive compared with the less sophisticated controllers it seeks to replace. But the addition of an RS-422 interface card permits it to be connected to a computer network using the High-level Data-Link Control protocol, opening up numerous possibilities at the system level. Customers with the

Unit brings 16-bit power to industrial control system

The Macsym 10 measurement and control system operates in harsh process-control and manufacturing environments. It features a rugged package suitable for rack mounting with NEMA-12 enclosures, an operating temperature range of $+5^\circ$ to $+50^\circ\text{C}$, dust immunity, an operator's keylock for security, and a solid-state memory eliminating moving parts that are found in tape-cartridge units or floppy-disk drives.

The Macsym 10 is available with 27 input/output cards for up to 512 I/O connections. Up to 8,000 connections can be made by adding an expansion chassis. It is programmable in an enhanced form of Basic optimized for measurement and control applications called Macbasic. It includes a 16-bit central-processing unit with floating-point firmware; a 96-K-byte random-access memory (expandable to 128-K bytes); an ana-

High-clarity. One way itron fluorescents will brighten your displays' future.

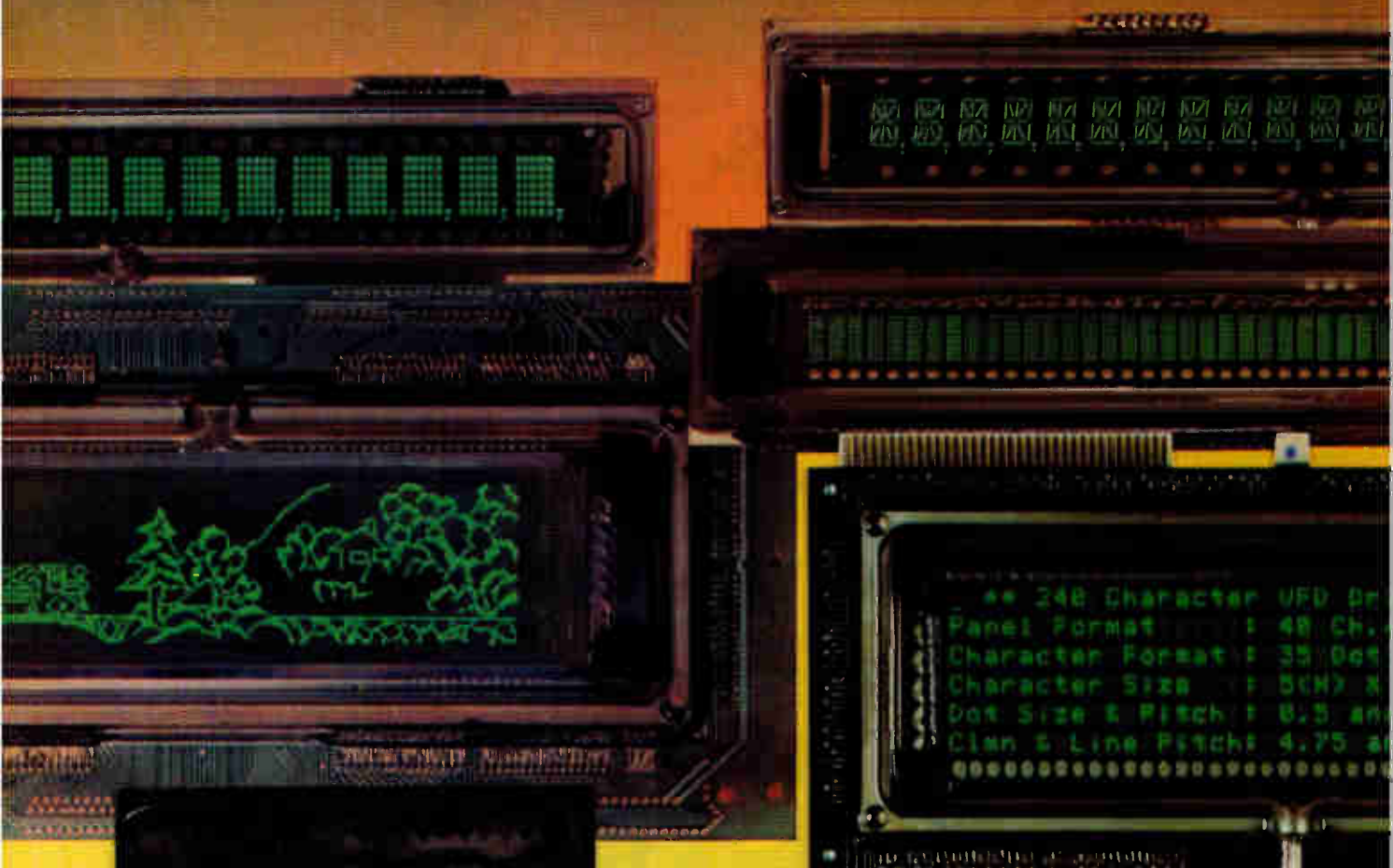

The brilliance and conciseness of our new high density 128 x 128 and 256 x 64 dot matrix display panels—made possible by our advanced double-matrix structure—exemplify the wealth of benefits afforded by "itron" fluorescent units. Let's enumerate some of the other reasons they'll enhance your designs' future.

Take alphanumerics. As the inventors of fluorescent technology, we naturally offer the widest selection of 14-segment and dot matrix arrays—from 5mm to 15mm in character heights, and packages ranging from 14-segment 8-character mini-units to complete 240 character 5x7 dot matrix plug-in panels, and everywhere in-between.

Their proven performance record, combine with cost-conscious pricing and ease of installation to make for time and money savings. And, their easy readability—even under high ambient light conditions and at extreme viewing angles—as well as low power requirements, are other good reasons why "itron" fluorescent displays will embellish your equipments' capabilities. As there're many more things to be said for "itron" fluorescent displays, contact us for particulars.

itron[®]

FLUORESCENT DISPLAYS
Patented and Manufactured by
ISE ELECTRONICS CORP.

INTERNATIONAL REPRESENTATIVES

WEST GERMANY: Neumuller GmbH, Eschenstr. 2, 8021, Taufkirchen, Munich. Phone: 089/6118-245. Telex: 522106

FRANCE: Europavia France, 5 Avenue Leon Harmel 92167 Antony Cedex. Phone: 666-21-10. Telex: 422043ii

UNITED KINGDOM: ITT Meridian, West Road, Harlow, Essex CM20 2BP. Phone: 0279-35351. Telex: 817202

SWEDEN: AB Nordqvist & Berg, Box 9145 S 10272, Stockholm. Phone: 08-690490. Telex: 10407

DENMARK: E. V. Johannessens Elektronik A-S, T Jagade 15-2200, Copenhagen. Phone: 01/839022. Telex: 16522

HONG KONG: Phone: 5-232420. TAPEI: Phone: 351-0243

Circle 258 for Sales Contact

NORITAKE ELECTRONICS, INC.

EASTERN OFFICE: 41 Madison Avenue, New York, NY 10010 • (212) 481-3440 • Telex: 12-5469

CENTRAL OFFICE: 1822 Brummel Drive, Elk Grove Village, IL 60007 • (312) 439-9020

WESTERN OFFICE: 22410 Hawthorne Blvd., Torrance, CA 90505 • (213) 373-6704 • Telex: 67-4910

NORITAKE COMPANY, LIMITED

JAPAN: 1 - 1, Noritake-Shinmachi, Nishiku, Nagoya-Shi • (052) 562-0336 • Telex: J59738

EUROPE: Burotel Belgium SA, Rue de la Presse 3-5, 1000 Bruxelles • (02) 217-83-60 • Telex: 4626962

World Radio History

Circle 259 for Literature Only



Spectrum's EMC technology— making computers compatible with radios.

Let us help you design your computing device to meet the FCC Docket #20780—to be compatible with communications.

Spectrum's engineers will work directly with you to identify, isolate, analyze, and solve any EMC problem at any stage of your system's development.

In addition, we perform testing in accordance with FCC, VDE, CISPR, CSA and MIL-461. Including the latest EMI/EMC requirements established by FCC Docket #20780 for Class A and Class B equipment. Our completely equipped, fully-shielded testing facilities include both mobile and fixed-location (Anechoic Chamber) enclosures.

And our computerized data base contains over 57,000 different product variations for EMI control. One may already fit your needs.

Spectrum's interference control components include: EMI/RFI filters, ceramic capacitors, shielding, gaskets, air ventilator panels, viewing windows, filtered connectors and more. All manufactured under the watchful eyes of a computer-controlled quality control system. And we serve all facets of industry from military and consumer to commercial and industrial.

For information about Spectrum Control and EMC technology, write: Spectrum Control, Inc., 8061 Avonia Rd., Fairview, PA 16415. Call: 814-474-1571.



SPECTRUM CONTROL INC.

Making technology compatible with technology.

Circle 128 on reader service card

"My own IBM computer. Imagine that."

One nice thing about having your own IBM Personal Computer is that it's *yours*. For your business, your project, your department, your class, your family and, indeed, for yourself.

Of course, you might have thought owning a computer was too expensive. But now you can relax.

The IBM Personal Computer starts at less than \$1,600[†] for a system that, with the addition of one simple device, hooks up to your home TV and uses your audio cassette recorder.

You might also have thought running a computer was too difficult. But you can relax again.

Getting started is easier than you might think, because IBM has structured the learning process for you. Our literature is in *your* language, not in "computerese." Our software *involves* you, the system *interacts* with you as if it was made to—and it was.

That's why you can be running programs in just one day. Maybe even writing your *own* programs in a matter of weeks.

For ease of use, flexibility and performance, no other personal computer offers as many advanced capabilities. (See the box.)

But what makes the IBM Personal Computer a truly useful tool are software programs selected by IBM's Personal Computer Software Publishing Department. You can have programs in business, professional, word processing, computer language, personal and entertainment categories.

You can see the system and the software in action at any ComputerLand[®] store or Sears Business Systems Center. Or try it out at one of our IBM Product Centers. The IBM Data Processing Division will serve those customers who want to purchase in quantity.

Your IBM Personal Computer. Once you start working with it, you'll discover more than the answers and solutions you seek: you'll discover that getting there is half the fun. Imagine that.

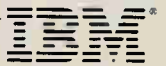

IBM PERSONAL COMPUTER SPECIFICATIONS *ADVANCED FEATURES FOR PERSONAL COMPUTERS

User Memory 16K - 256K bytes*	Display Screen High-resolution (720h x 350v)* 80 characters x 25 lines Upper and lower case Green phosphor screen*	Color/Graphics <i>Text mode:</i> 16 colors* 256 characters and symbols in ROM* <i>Graphics mode:</i> 4-color resolution: 320h x 200v* Black & white resolution: 640h x 200v* Simultaneous graphics & text capability*
Permanent Memory (ROM) 40K bytes*	Diagnostics Power-on self testing* Parity checking*	Communications RS 232-C interface Asynchronous (start/stop) protocol Up to 9600 bits per second
Microprocessor High speed, 8088*	Languages BASIC, Pascal	
Auxiliary Memory 2 optional internal diskette drives, 5¼", 160K bytes per diskette	Printer Bidirectional* 80 characters/second 12 character styles, up to 132 characters/line* 9 x 9 character matrix*	
Keyboard 83 keys, 6 ft. cord attaches to system unit* 10 function keys* 10-key numeric pad Tactile feedback*		

The IBM Personal Computer and me.



[†]This price applies to IBM Product Centers. Prices may vary at other stores.

For the IBM Personal Computer dealer nearest you, call (800) 447-4700. In Illinois, (800) 322-4400. In Alaska or Hawaii, (800) 417-0890.

A smart approach to containing costs and boosting productivity.

Now, more than ever before, a Chicago Laser trim system is the smart way to lower overhead and boost productivity. From the moment you order a CLS-33 laser trim system, you're holding the line on inflation with a powerful weapon that costs less and outperforms competitive systems. Its design is advanced, yet not extravagant; not wasteful—just what you'd expect for the state-of-the-art in laser trim systems. It is sophisticated yet practical.

The CLS-33 also costs less to operate. Designed as "the smart laser trim system," its microcomputer is backed by the industry's most intelligent software operating system. So easy and fast to program, an unskilled worker can learn to program the CLS-33 in just days.

Every Chicago Laser Systems trimmer must meet rigid quality-control standards, passing extensive performance and burn-in tests. The chances of downtime are further reduced by the ease of maintaining the system. Should a fault occur, it can be rapidly isolated with the systematic diagnostic programs provided.

Above all, the CLS-33 is a high volume production system that will increase worker productivity and trim the cost of laser trimming. With an available air-bearing step and repeat handler, it trims over 100,000 resistors per hour. An automatic stack load/unload station is also available.

For a detailed appraisal of how the Smart Laser Trim System can fill your needs, contact Chicago Laser Systems.



Circle 262 on reader service card



Chicago Laser Systems Inc.

4034 N. Nestville Ave., Chicago, IL 60634 • Phone 312-282-2718 Telex: 296-647

Trim the cost of laser trimming.





UNTIL NOW, LOCAL AREA NETWORKS WEREN'T REALLY A FACT. EVEN IN FANTASY.

Local area networking is an idea whose time has come. Almost. Massive investments of time and talent have created the concept — and the cable — to connect the network's stations. But so far only lip service has been paid to the interconnection of incompatible devices.

Some companies seem to believe the problem will eventually solve itself. Others feel that by ignoring it, it may go away. Still other companies, motivated largely by self-interest, have set out to create proprietary networking systems.

AT INTERLAN, WE'VE CHANGED ALL THAT.

Interlan is a new company that believes local area networking is not just desirable, it's inevitable.

That's why we have produced the hardware and software technology needed to connect almost any make of computer to today's networks. And we're already developing the equipment to make full use of tomorrow's networks.

For OEM's, Interlan means that compatibility — and more value — can be built directly into products, simply and inexpensively.

For end users, Interlan means greatly increased computing and data communications capabilities without greatly increased budgets.

DEDICATED TO SOLVING LOCAL AREA NETWORKING PROBLEMS.

At Interlan, we see the growth of networking as a tremendous business opportunity. But we also see it as our responsibility to turn tomorrow's ideas into hardworking realities. And we will.

To find out how Interlan can make local area networking a reality for you today, call or write.

INTERLAN

WE MAKE NETWORKS WORK.

160 Turrapike Road, Chelmsford, MA 01824
617-256-5888 (TWX) 95-1909

Better Alternative

STRIPSWITCH™ For Code Versatility, Simplicity, Reliability.

The better alternative to the printed circuit board mounted thumbwheel switch, EECO's STRIPSWITCH™ makes selecting coded outputs for digital circuits easy and economical.

CODE VERSATILITY. Available in a wide variety of codes, including 10- and 16-position switch modules, STRIPSWITCH can be used alone, or in combination. Mounted side by side on your PC board, they team up to let you mix and match codes in one space-saving assembly.

SIMPLICITY. Simple to design in and simple to use, STRIPSWITCH requires a minimum of PC board space and eliminates costly wiring. They can be mounted horizontally or vertically on either side of the board without hardware. Adjustments are even easy, since their design allows mounting on the card edge to provide accessibility without pulling the card. Plus, STRIPSWITCH' low profile permits close card spacing.

Two legend locations and ten orientations provide readability and adaptability, while a finger adjustable thumbwheel, screwdriver slot or optional extended shaft makes actuation a breeze. Topping off this simply designed and functional switch is a finished bezel attractive enough for front panel mounting.

RELIABILITY. Introduced by EECO in 1975, STRIPSWITCH remains first in sales and first in reliability. This means positive detent action, legible markings and consistent codes. Both the 2100 Series and the low profile, standard bottom sealed 2600 Series offer years of quality performance.

EECO's exclusive one-piece terminal board holds 2100 Series STRIPSWITCH modules firmly in place. One part number designates the number of stations in the strip – up to four – and helps make your manufacturing and parts inventory easier.

And as the only manufacturer of this type switch with a distributor value added program, EECO also means reliable service – fast delivery and competitive prices. Our distributor value added program can reduce lead times from several weeks to a few days.

Specify EECO code versatility, simplicity and reliability in your design, specify the better alternative – STRIPSWITCH. For detailed information, write: EECO Incorporated, 1601 E. Chestnut Ave., P.O. Box 659, Santa Ana, CA 92702-0659, or call 714/835-6000.

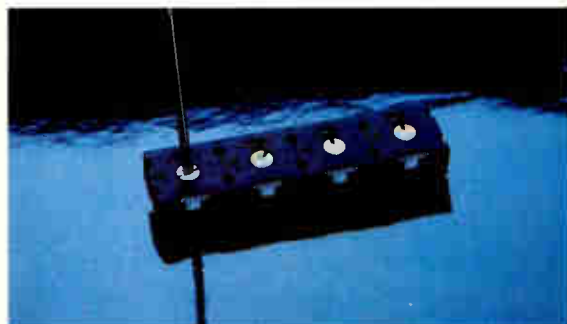
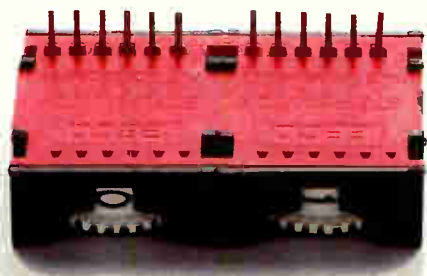
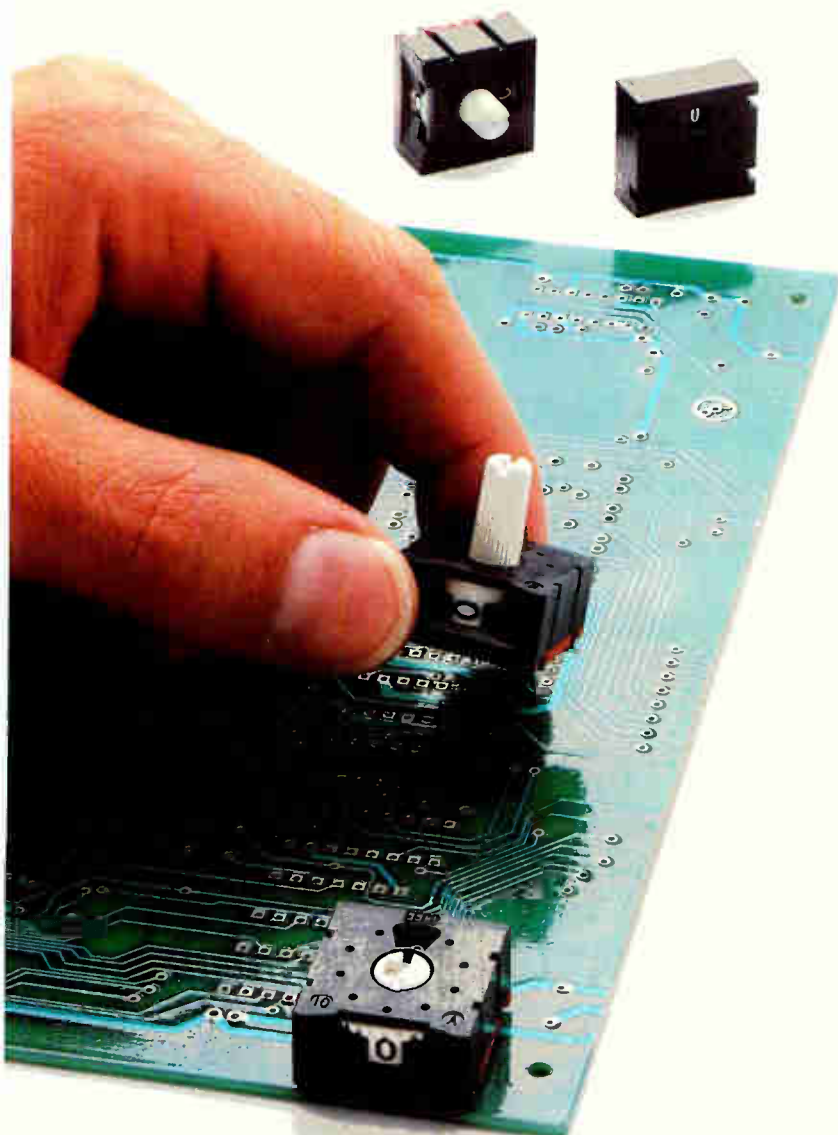

EECO
Incorporated

New literature

Programming a 16-bit chip. "The 68000: Principles and Programming" by Lee J. Scanlon, describes the 68000 16-bit microprocessor and how to program it. In its nine chapters, the book discusses Motorola's Cross Macro Assembler 14 addressing modes and 56 instruction sets capable of handling everything from integer arithmetic to bit manipulation. The book summarizes the support circuits that can be interfaced with the 68000, as well as the fundamental input/output operations, and provides a survey of the hardware and software support products currently available. The book (No. 21853) sells for \$14.95 plus \$1 for shipping and handling and 4% sales tax for Virginia residents. Visa and Mastercharge cards are accepted. For purchasing and further information, contact Group Technology Ltd. at P. O. Box 87, Check, Va. 24072 or phone (703) 651-3153. Circle reader service number 421.

Voice data entry. A four-page brochure entitled "Trends in Data Entry by Voice" reports on major advancements in the capabilities of voice-data entry systems that will improve productivity in manufacturing, quality-control, materials-handling, and numerical-control programming applications. The brochure includes reports on market projections, the economics and efficiencies of voice data entry, and it describes the hardware and software systems for both original-equipment manufacturers and end users. Threshold Technology Inc., 1829 Underwood Blvd., Delran, N. J. 08075. Phone (609) 461-9200 [422]

Wafer fabrication. A series of technical application notes have been issued by the Electronics division of Monsanto Co. for the wafer fabrication industry. The issues, which concentrate on determining wafer needs and optimizing yield, include "Backside Damage," "Flatness Characterization of Silicon Wafers," "Controlled Oxygen," "Revealing Denuded Zones in Silicon," "Flat Location Consequences," and "Ultra Flat Wafers." These application

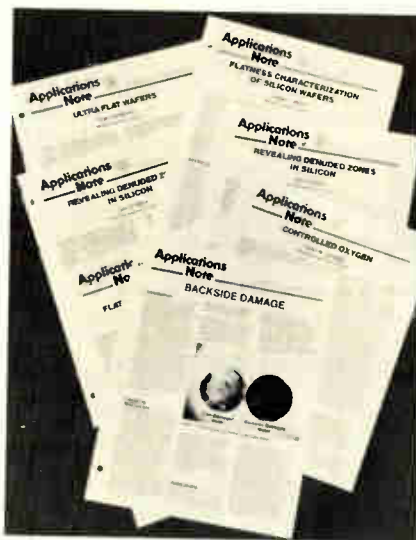

notes can be obtained by writing to B. G. Marchetta at Monsanto Electronics, P. O. Box 8, St. Peters, Mo. 63376. [423]

Apple computer references. Two publications are now available for the Apple user. "The Micro/Apple," Vols. 1 and 2, edited by Ford Cavallari, contains articles on the Apple computer and comes with a floppy disk of the microcomputer programs listed in the articles. Both volumes sell for \$24.95 including the floppy disk. "What's Where in the Apple," by William F. Luebbert, describes Apple II firmware and hardware. It contains an atlas and a gazetteer that provides over 2,000 locations of peeks, pokes, and calls. The names and locations of various Monitor, DOS, Integer Basic, and Applesoft routines are listed. It sells for \$14.95. Micro Ink Inc., 34 Chelmsford St., P. O. Box 6502, Chelmsford, Mass. 01824 [424]

Temperature measurements. The 1981/82 edition of the "Temperature Measurement Handbook" contains over 220 pages of products and technical articles on sensors and accessories such as indicators, controllers, and extension wires for applications ranging from cryogenic temperatures to over 2,200°C. For a free copy write to Gregory C. Nanihan at Nanmac Corp., 9-11 Mayhew St., Framingham Center, Mass. 01701. [430]

Logic-array design. A manual from Applied Micro Circuits Corp. shows logic and system designers how to implement logic functions on monolithic integrated circuits by using the Q700 high-speed logic-array series. The book contains procedures and rules to interconnect a library of pre-designed logic elements—macros—such as gates, flip-flops, and multiplexers; directions for entering the time-shared data base for simulation and net-list generation; and specifications on the production of these high-performance very large-scale integrated chips. The manual is available on a registered subscription basis for \$300 for the first year. This fee is credited to customers when ordering their first Q700 Quickchip. For a copy of the manual, contact Applied Micro Circuits Corp., 10626 Bandlely Dr., Cupertino, Calif. 95014. Phone (408) 257-4030 [425]

Data-conversion products. Application notes AN-13, -14, and -15 contain information on three design ideas for Teledyne Semiconductor's data-conversion product line. With the AN-13, the user can build a remote-control, dual-range analog-to-digital converter using Teledyne's 7106/7107 a-d converter. The AN-14 describes a way to modify a digital multimeter to measure frequency using Teledyne's 9400 frequency-to-voltage converter. The AN-15 details a simple way to use the 7106/7107 a-d converter to measure its own power supply. All three notes are available upon request from the advertising department of Teledyne Semiconductor, 1300 Terra Bella Ave., Mountain View, Calif. 94043. Phone (415) 968-9241, ext. 451 [426]

Capacitors. The Passive Components division of Thomson-CSF has published a brochure comparing its IRD capacitors made from metalized polyester film with the NPO, X7R, and Z5U monolithic ceramic capacitors. Charts and graphs compare the two in operating-temperature range, temperature characteristics, dc voltage coefficient, dissipation factor, insulation resistance, aging rate,

WANTED:

**Rectifiers with 25ns reverse recovery time,
from 1 to 30 amps, and forward voltage
as low as .82 volts.**



FOUND:

**Fast Epitaxial Rectifiers that give the
highest performance at the lowest price.**

At last, power supply and circuit designers have a single source for a complete range of high-reliability, low-cost Fast Epitaxial Rectifiers.

It's General Instrument Discrete Semiconductor Division.

No other manufacturer can match our combination of Superectifier® reliability, superior performance and low cost.

We've a broad range of product, too. From 1 to 30 amps; 50, 100,

150 and 200 volts. In three different packages — Axial-leaded, TO-220 and TO-3.

Axial-leaded Fast Epitaxial Rectifiers are from 1 to 6 amps in both Glass-Amp II® and Superectifier® configurations. Leads and junction are brazed at greater than 600°C. The junction is opaque-glass passivated. And each Superectifier® is then encapsulated with UL-listed, flame-retardant epoxy.

The TO-220 and TO-3 packages also have glass passivated junctions. The TO-220 is epoxy encapsulated. The TO-3 is hermetically sealed in a metal can.

For immediate product delivery, complete technical data or our latest catalog, call your authorized distributor or General Instrument Discrete Semiconductor Division, 600 West John Street, Hicksville, New York 11801. (516) 733-3333.

GENERAL INSTRUMENT

THE SOURCE OF AC/DC V-A

Model 828 accurately and effectively calibrates analog and digital meters and is suitable for production line, laboratory or field use.

- **Wide Range:**
1 millivolt to 1100 volts.
1 microampere to 5 amperes.
- **Accuracy:**
DC voltage $\pm 0.05\%$ of setting
 $\pm 0.05\%$ of range.
AC voltage $\pm 0.05\%$ of setting
 $\pm 0.10\%$ of range.
AC/DC current $\pm 0.10\%$ of
setting $\pm 0.10\%$ of range.
- **Direct reading percent deviation of output control.**
- **Output frequency:**
50, 60, 400 Hz and DC.
- **High burden and compliance.**

MODEL 828



RFL Industries, Inc.

INSTRUMENTATION DIVISION

Boonton, New Jersey 07005 • Tel.: (201) 334-3100

TWX: 710-957-8352/Cable: RADAIRCO, N.J.

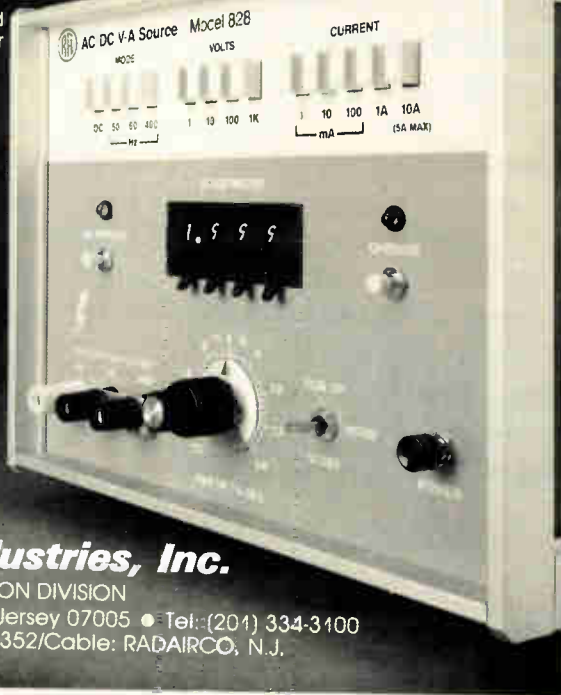

Circle 248 on reader service card

LCD'S ANY WAY YOU WANT THEM.

LCD's your way. Off the shelf or custom. As small as a lady's wrist-watch or as large as 7" x 7". Today, Commodore is one of the world's largest suppliers of LCD's. That means we can offer some of the world's most competitive pricing.

Fast delivery. Standard watch and clock displays virtually overnight. Custom LCD's in prototyping quantities within days of receiving your spec sheet.

Call for action. If you need LCD's fast, call us. Small quantities. Large quantities. Custom LCD's. All to highest quality standards. All at highly competitive prices.

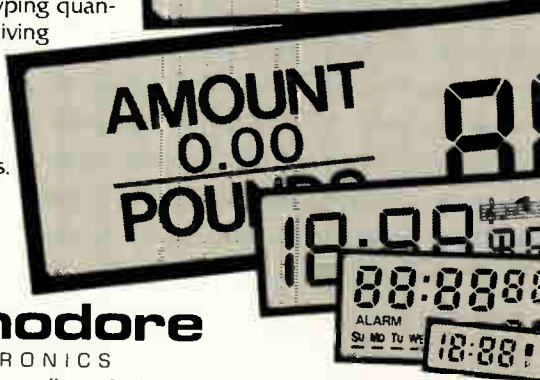

commodore
OPTOELECTRONICS

4350 Beltwood Parkway South
Dallas, TX 75234
(214) 387-0006
TLX 730-969

Eastern Regional Office
950 Rittenhouse Rd.
Norristown, PA 19103
(800) 345-6386
TWX 5106604168

Western Regional Office
3330 Scott Blvd.
Santa Clara, CA 95050
(408) 727-1130
TLX 171-141

248 Circle 272 on reader service card

New literature

standard capacitor tolerances, electrode construction, size, lead spacing, capacitor range, and typical pricing. The brochure is free from Thomson-CSF Components Corp., 6660 Variel Ave., Canoga Park, Calif. 91303. [427]

Interfacing streaming-tape drives. Design factors relating to interfacing Data Electronics Inc.'s streaming 1/4-in. digital cartridge-tape drive, the Streamer, are discussed in a 60-page manual. The book summarizes specifications, input/output signal requirements, timing diagrams, and streamer formats, and describes the drive's modes of operation. For further information and copies of the manual, contact Data Electronics Inc., 10150 Sorrento Valley Rd., San Diego, Calif. 92121. Phone (714) 452-7840 [428]

STREAMER INTERFACE



DEI DATA
ELECTRONICS
INC.

Latest Motorgram issue. The current issue of Motorgram contains an article on the "Recovery of Silver Lost in Film Processing" that presents the history of the Prospector 624, an automatic electrolytic silver-recovery machine. The issue also contains a section entitled "From the Chief Engineer's Handbook" that provides data on the design, operating characteristics, and advantages and disadvantages of permanent magnet synchronous motors. For a copy of this issue, Vol. 61, No. 3, write to Bodine Electric Co., 2500 West Bradley Place, Chicago, Ill. 60618. [429]

Electronics/December 15, 1981

SUPER TEX

RINGS SCHOTTKY'S BELL

© 1981 SUPERTEX

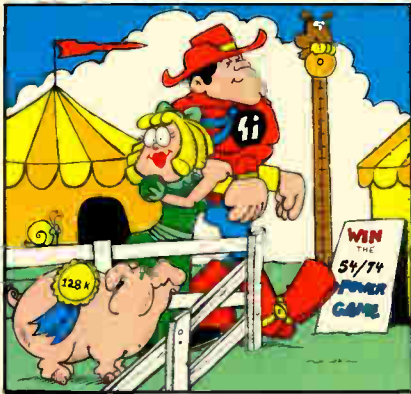

Super Tex and Margie Monolith are visiting the State Fair. **SUPER!**



The Villian using Bipolar TTL is trying to ring the bell and win a prize. **BOOI!**

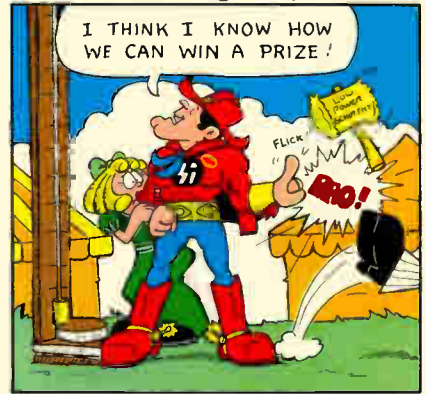

Super Tex with his super powers quickly analyzes the situation and knows how to win. **YEA!**



Knowing how to achieve results with low power consumption, Super Tex selects the CMOS hammer. **HUZZA!**



Right over might. **GONG!**

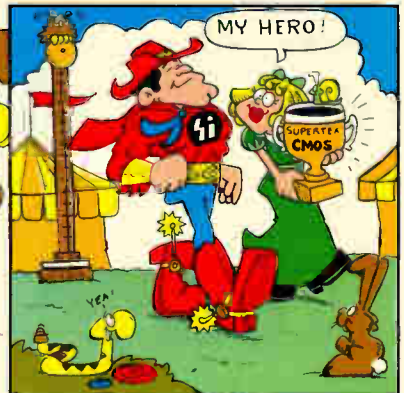
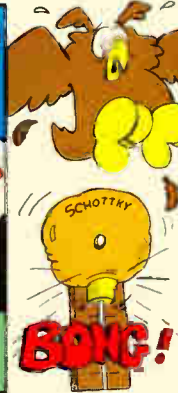

Super Tex explains to Margie that by using Supertex CMOS hammers, TTL interface can be done at low power. **VICTORY!**

(To know how Super Tex did it, see the specs below.)

High Performance CMOS Octal Interface Family Bipolar Performance with CMOS Power

By utilizing state of the art, oxide isolated, Silicon Gate CMOS technology combined with HMOS scaling techniques, Supertex offers a family of CMOS interface circuits with the highest performance available today. This new family of circuits meets LSTTL speed specifications at less than 1% of the power consumption.

Features

- Pin and Functionally Compatible with 54/74LS Series Circuits
- All Octal Arrangements to Fit μP Applications
- Low Power Consumption - Less than 1% of Bipolar TTL
- Input Hysteresis Improves Noise Margins
- 3-State Outputs Drive Bus Directly
- Full TTL and CMOS Compatibility
- Capable of Operating Over 4V to 6V Range
- Available in Commercial, Industrial and Military Temperature Ranges
- High Speed Silicon Gate CMOS Technology
- Ideal for battery back up applications.

Device No.	Description	Device No.	Description
54/74SC137	1 of 8 Decoders with Latched Address	54/74SC244	Octal Buffer
54/74SC138	1 of 8 Decoders	54/74SC245	Octal Bus Transceiver
54/74SC139	Dual 1 of 4 Decoders	54/74SC373	Transparent Latch
54/74SC237	1 of 8 Decoders with Latched Address	54/74SC374	D-Type Flip-Flop
54/74SC238	1 of 8 Decoders	54/74SC533	Transparent Latch
54/74SC239	Dual 1 of 4 Decoders	54/74SC534	D-Type Flip-Flop
54/74SC240	Octal Buffer	54/74SC540	Octal Buffer
54/74SC241	Octal Buffer	54/74SC541	Octal Buffer
54/74SC242	Quadruple Bus Transceivers	54/74SC563	Transparent Latch
54/74SC243	Quadruple Bus Transceivers	54/74SC564	D-Type Flip-Flop
		54/74SC573	Transparent Latch
		54/74SC574	D-Type Flip-Flop

Call, clip the coupon, or circle the bingo, but start today on your evaluation of SuperCMOS Interface. We will send you a catalog by return mail

- Send me a Super Tex poster Have a salesman call me

I am interested in the following part number(s)

My μP is _____ (Model #)

Name _____

Company _____

Address _____

City _____ State _____ Zip _____

Supertex

1225 Bordeaux Drive, Sunnyvale, CA 94086
(408) 744-0100 TWX 910-339-9388

Important editorial



Electronics review

Air Force working on single language for its computers

Jointly based language will be used for weapons R&D and support...
 for users developers...
 Editor Development...
 Editor Development...

Ada's modularity sparks interest for civilian uses

Language multiplexer for OS...
 program development...
 Microcode by...

Ada's father speaks many languages



Special report: Ada, the ultimate language?

Software components so portable that they would...
 use hardware modules... can customize Ada for any...
 Editor Development...
 Editor Development...



Electronics worldwide editorial announces and interprets all important technological developments.

Take Colin Johnson and the Countess of Lovelace...

Similar backgrounds. Colin Johnson is a computer engineer who earned an MS from the University of Michigan and taught microprocessors at Wisconsin School of Electronics. He's also our software editor. The Countess of Lovelace was a computer expert, too, and the world's first programmer as evidenced by her work on Babbage's Difference Machine in the 1840's. Their paths would cross in Minneapolis on

December 2, 1980. The catalyst would be Electronics. The result would be technology interpretation in its highest form.

The rendezvous. After a decade of development, through the foresight and funding of the Department of Defense, a new computer language was formed in 1980. It would be the answer to the Pentagon's demand for a single, tactical systems language that would reduce software costs. It was named *Ada*, because of the early programming contributions of Augusta Ada Byron, the *Countess of Lovelace*. Characteristically, Electronics had related *Ada's* progress during its military/industrial development, but it was now up to Colin to interpret its significance and importance to engineers and managers throughout the world. *What better way to interpret than to learn the language itself?* Colin learned that *Ada's* prime archi-

tect, Honeywell, was planning a three-day industry-only seminar in Minneapolis given by *Ada's* author, Jean Ichbiah. After a great deal of persistence (plus \$3000 in attendance fees), Colin was introduced to *Ada* as the only journalist/participant at the seminar. The rest is history. Colin immediately embraced *Ada* and produced the exclusive, in-depth report which appeared in Electronics' February 10, 1981 issue.

Epilogue. *Ada* remains Colin's favorite, as he believes that *Ada* will become the international standard computer language. The story of Colin and the Countess typifies Electronics' editorial commitment to first-hand reporting and interpretation. In Electronics, important technology *becomes* important editorial.

is read by important people.

Not everyone in the electronics technology marketplace is important to you. Not *all* the engineers, not *all* the managers.

However, the people who read Electronics *are* important to you. They are the people who make the important technology and business decisions. They are the planners. They set standards. They supervise design engi-

neering. They are directly accountable for their company's profits. They are *buyers*.

Most don't read direct mail. But they all read Electronics magazine—four out of ten read no other.

These important people are hard to see. Salesmen often miss them. They travel extensively on company business.

Let us introduce you to these important people. Call Norm Rosen, National Sales Manager at 213-487-1160, and he'll arrange a conclusive demonstration *in your office*. Or call your local Electronics salesperson.

Electronics
 Where important people read important editorial





Check the Osborne Books You Want

Assembly Language Program Series

by Lance Leventhal and co-authors
 You needn't know anything about assembly language to use these books. Each one is a straightforward, self-teaching textbook that is both precise and easy to understand.

NEW

- 68000..... #62-4, \$16.99
- 6809..... #35-7, \$16.99
- 6502..... #27-6, \$16.99
- Z80..... #21-7, \$16.99
- Z8000..... #36-5, \$19.99
- 6800..... #12-8, \$15.99
- 8080A/8085..... #10-1, \$15.99

The 8086 Book

by Russell Rector and George Alexy
 Part assembly language text and part hardware reference, this book covers all of the 8086's most important features.
 #29-2, \$16.99

Interface

NEW

Interfacing to S-100 (IEEE 696) Microcomputers

by Sol Libes and Mark Garetz
 Describes the S-100 Bus with unmatched precision. Covers mechanical and electrical design, logical and electrical relationships, bus interconnections, and much more.
 #37-3, \$15.00

NEW

Microprocessors for Measurement and Control

by D.M. Auslander and P. Sagues
 Learn to design mechanical and process equipment using microprocessor based "real-time" computer systems. This book allows readers (even those unfamiliar with machine or assembly language) to initiate projects.
 #57-8, \$15.99

PET and the IEEE 488 Bus (GPIB)

by E. Fisher and C.W. Jensen
 Provides chapters on all aspects of the General Purpose Interface Bus. Includes lines, signals, specifications, and much more.
 #31-4, \$15.99

Microelectronic References

Osborne 4 & 8 Bit Microprocessor Handbook

by Adam Osborne and Gerry Kane
 The one source for complete, objective and accurate information on 4 and 8 bit microprocessors. This book describes virtually every 4 and 8 bit microprocessor on the market today, and allows you to evaluate any device or combination of devices.
 #42-X, \$19.95

Osborne 16-Bit Microprocessor Handbook

by Gerry Kane and Adam Osborne
 A total reference book on virtually every 16-Bit microprocessor, this book permits objective evaluation and comparison of these new devices.
 #43-8, \$19.95

An Introduction to Microcomputers: Volume 3 - Some Real Support Devices

by Gerry Kane and Adam Osborne
 Available with or without 3-ring binder or updates. Each device is described in detail, including an analysis of the best uses for that device.
 Book - #18-7, \$15.00
 Binder - #19-5, \$6.99
 Six Updates - #98, \$25.00

Handbooks

68000 Microprocessor Handbook

by Gerry Kane
 This handbook offers more information about the 68000 than the manufacturer's data sheets.
 #41-1, \$6.99

CRT Controller Handbook

by Gerry Kane
 Describes five devices in the same thorough detail you'll find in Volume 3. Contains 13 tables and 149 separate illustrations.
 #45-4, \$6.99

8089 I/O Processor Handbook

by Adam Osborne
 A complete presentation of the 8089. The 8289 Bus Arbiter is also described with the same careful attention to design and application.
 #39-X, \$6.99

Osborne/McGraw-Hill
 630 Bancroft Way, Berkeley, CA 94710

Call Toll Free: 800-227-2895
 in California (415) 548-2805
 Dept. E32

Book#, Price: _____

Name _____
 Address _____
 City/State/Zip _____
 Plus: .75/item 4th class \$1.50/item UPS \$2.50/item Air Mail \$10.00/item Overseas
 (California residents add applicable tax.)
 Total amount enclosed \$ _____ or charge my Visa Mastercharge
 Card# _____ Expiration Date _____

Electronics is read most thoroughly by important people 2 to 1.

An important study by Crossley Surveys, Inc. shows that important engineers, engineering managers, and corporate managers read Electronics more thoroughly by 2 to 1 over its major competitors.

These important people make the important buying decisions. They authorize expenditures, determine need, select the company, choose the brands and approve the vendors.

These important people rate Electronics editorial the best—the best in state-of-the-art coverage plus nine other important editorial attributes.

Let us show you why Electronics is rated best. Why our readers are important to you. Call Norman Rosen, National Sales Manager, at: (213) 487-1160, and he'll arrange a conclusive demonstration *in your office*. Or, call your local Electronics salesperson.

Advertise in
Electronics.
It's rated best by
important people
who make
important buying
decisions
worldwide.

Electronics

Where important people
read important editorial



One Source. Every critical step of the way.

Announcing the Model 300... another dividend on your Micralign® investment.

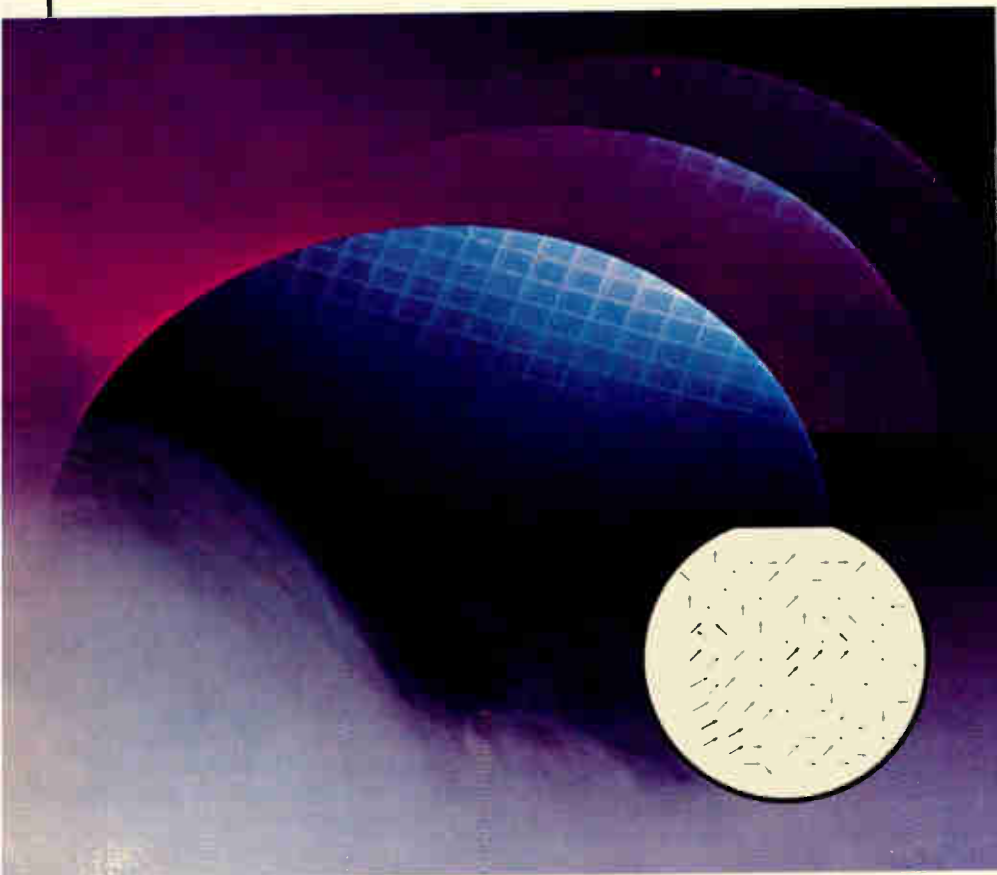

OVERLAY SCALE

—
0.50 μm

The inset shows a vector map of the Model 300 overlay performance measured against a contact-printed, first-level using electrical patterns distributed over a four inch wafer. Combined magnification/distortion and alignment errors are measured using this technique.

Perkin-Elmer now offers a cost effective route to higher packing densities, higher yields, greater production economies ... utilizing the same process, the same floor space, the same personnel, the same spare parts and the same tooling.

It's all made possible by the new Micralign Model 300 with a specified overlay accuracy of $0.5\mu\text{m}$, machine stability of $0.25\mu\text{m}$ and resolution of $1\frac{1}{8}\mu\text{m}$ at 300nm .

Dramatic improvements in optical fabrication techniques

are incorporated in the Model 300. To take full advantage of this, the 300 also incorporates improved optical mounting techniques, vibration isolation, air flow and internal temperature control, wafer-cassette protective cover, and pellicle protected mask capability.

These improvements provide overall stability measured in months, not days.

To find out what else the Micralign Model 300 can do for you, and to take advantage of equipment trade-in policies

and Model 200 to Model 300 retrofits, contact Perkin-Elmer, Semiconductor Operations, 50 Danbury Road, Wilton, Connecticut 06897.



PERKIN-ELMER

You know how an airplane simplifies business travel. Find out how Beech simplifies owning an airplane.

A company airplane simplifies business travel, many ways.

By freeing you from airline schedules that don't match your schedules.

By providing direct flights to everywhere the airlines go, plus literally thousands of places they don't.

By allowing your scarcest resource, qualified management, to be there, when and where they're needed.

You may know dozens of other ways. But you may not know how Beech simplifies airplane ownership and operation.

It starts with the comprehensive information in your free *Management Guide to Business Aviation* that helps you decide whether a Beechcraft can, indeed, be a profitable investment.

It extends throughout the network of Beechcraft Aviation

The Beechcraft Super King Air gives first class accommodations for 8-15 passengers at near jet speeds for over 2000 miles.



The Pressurized Beechcraft Duke carries six in cabin class comfort and quiet at over 280 mph.

Centers, where aviation professionals can help in every aspect of airplane purchase and operation.

And once you have purchased a Beechcraft, this same organization can teach you to fly or find you a qualified pilot. They can manage your maintenance. They've even gone so far as to operate a customer's airplane for him. Flying it, scheduling it, maintaining it, because that's what the customer wanted.

And finally, simple, reliable operation and fuel-efficiency comes standard with every Beechcraft business airplane. In its uncompromising quality, you find the reason why

Beechcraft owners experience minimum maintenance, low depreciation and a ready resale market.

If you would like to find out more, simply let us know.

Send for your free 1981 kit.

Write us on your company letterhead, and we'll send you everything you need to make an initial decision on the profitable use of a Beechcraft in your company. Write to: Beech Aircraft Corporation, Dept. MND, Wichita, Kansas 67201. If you'd rather call, call collect and ask for Del Chitwood, 316-681-8219.



EL 12

Member General Aviation Manufacturers Association

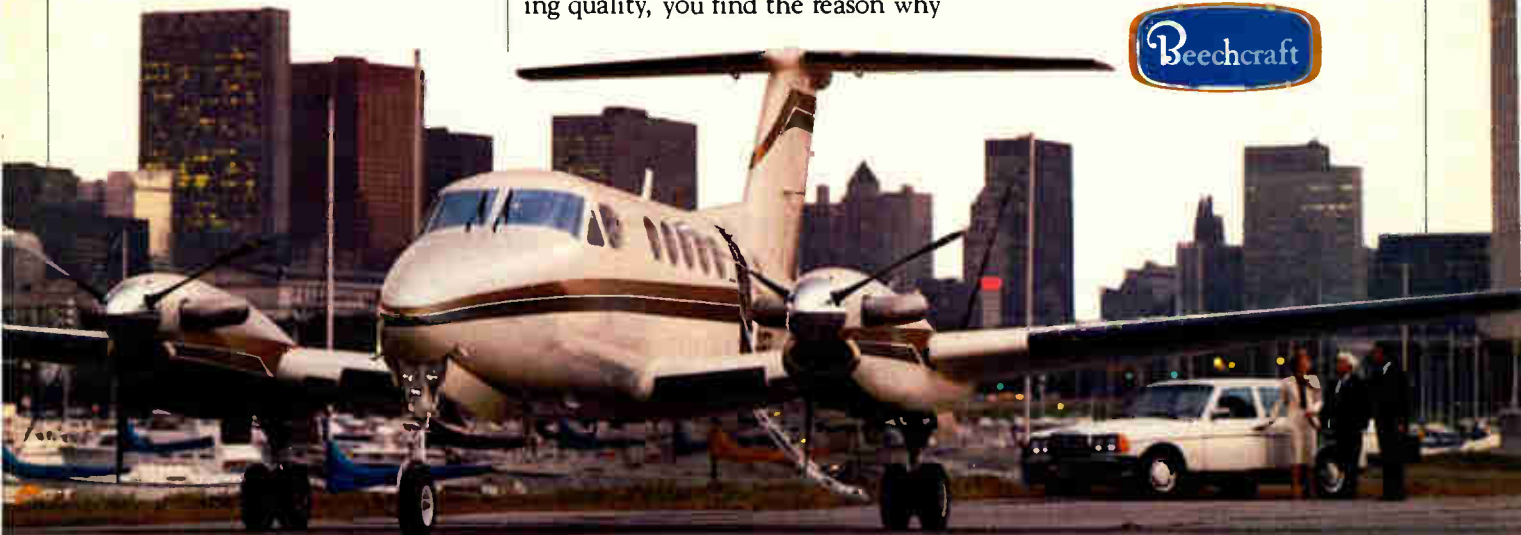

A Raytheon Company

For free information on learning to fly or upgrading your flying skills, plus the location of your nearest Beech Aero Center, call 1-800-331-1750 in the contiguous U.S. (In Oklahoma 1-800-722-3600). ASK FOR OPERATOR 701.

Introducing the new HP-11C.

The whole is greater than the sum of its parts.



Extensive programming capability



Horizontal design with LCD display



Rugged slim-line case

Leave it to Hewlett-Packard to assemble an ingenious combination of features and functions—in one calculator.

Computer-like programming.

The HP-11C offers over 200 lines of program memory, insert/delete editing, subroutines, indirect addressing, flags—all these powerful programming tools, plus an extensive set of built-in scientific/engineering functions.

Fits easily in your pocket.

The HP-11C's rugged slim-line case fits easily in your pocket. And its horizontal design with LCD display makes it easy to read even in bright sunlight.

Continuous memory.

The HP-11C's Continuous Memory remembers your programs and data even when your calculator is turned off. The calculator is powered by standard, disposable long-life batteries, making it both portable and convenient to operate.

Only from Hewlett-Packard.

Sure, other calculators may offer you some of these features. But Hewlett-Packard gives you all of them in a beautiful slim line design. The new HP-11C is built to the exacting standards of quality and reliability that you've come to expect from Hewlett-Packard.

To see the HP-11C in action, visit your nearest Hewlett-Packard dealer. For the address of the dealer in your area, call toll free: **800-547-3400**, Dept. 288L except Hawaii & Alaska. In Oregon, call 758-1010. Or write Hewlett-Packard, Corvallis, OR 97330, Dept. 288L.

Suggested retail price, \$135, excluding applicable state and local taxes—Continental U.S.A., Alaska, and Hawaii. 611/09

 **HEWLETT
PACKARD**

Circle 255 on reader service card

It's evolutionary, my dear Watson. The Synertek solution in Read Only Memories.

It's no mystery. Not here at Synertek. Because when it comes to Read Only Memories, no one services the needs of the ROM market place better than we do.

And no one offers a more compatible family of 16K, 32K and 64K ROMs. They're pinout compatible for easy upgrading to higher densities. And compatible with their respective EPROMs to make the move from EPROM prototyping to volume ROM production with no board layout or timing changes.

All with JEDEC approved pin-outs. And available in both major ROM pinout options.

Only a single additional address is required to upgrade the SY2316B to either the SY2332 or SY2333. Or to upgrade the SY2332 to the SY2364. It's that simple.

To upgrade from the SY2333, we offer the SY2365, the first of a new generation of 28-pin ROMs. The

2764 EPROM compatible SY2365 is the forerunner of this JEDEC approved 28-pin ROM family, leading to the 128K and 256K ROMs of the future.

The "A" in both the 24-pin SY2364A and the 28-pin SY2365A means Automatic Power Down for systems level power savings of up to 90 percent. And both offer the new standard in performance, 200nsec, thanks to our advanced scaled NMOS process.

As your needs grow, Synertek is the solution. Call Memory Product Marketing direct at (408) 988-5611. Or contact your area Synertek representative.

Synertek is a major MOS supplier of high volume parts with advanced technologies and techniques behind everything we make. ROMs. Static RAMs. Custom circuits. Single-chip Microcomputers. Systems. 6500 Microprocessors and Peripherals.

Part	Speeds	Package	Organization
SY2316B	200/300/450ns	24-pin	2048x8
SY2332	300/450ns	24-pin	4096x8
SY2333	300/450ns	24-pin	4096x8
SY2364/A	200/300/450ns	24-pin	8192x8
SY2365/A	200/300/450ns	28-pin	8192x8

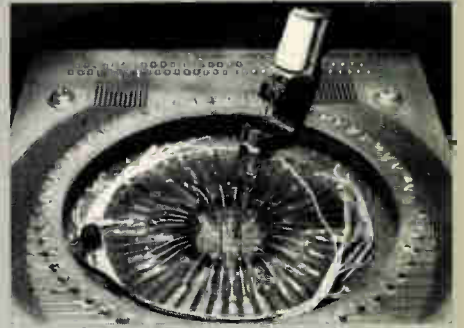

S SYNERTEK

3001 Stender Way, P.O. Box 552
Santa Clara, California 95052
(408) 988-5600
TWX: 910-338-0135

Circle 256 on reader service card

Read Only Memories

Total Capability

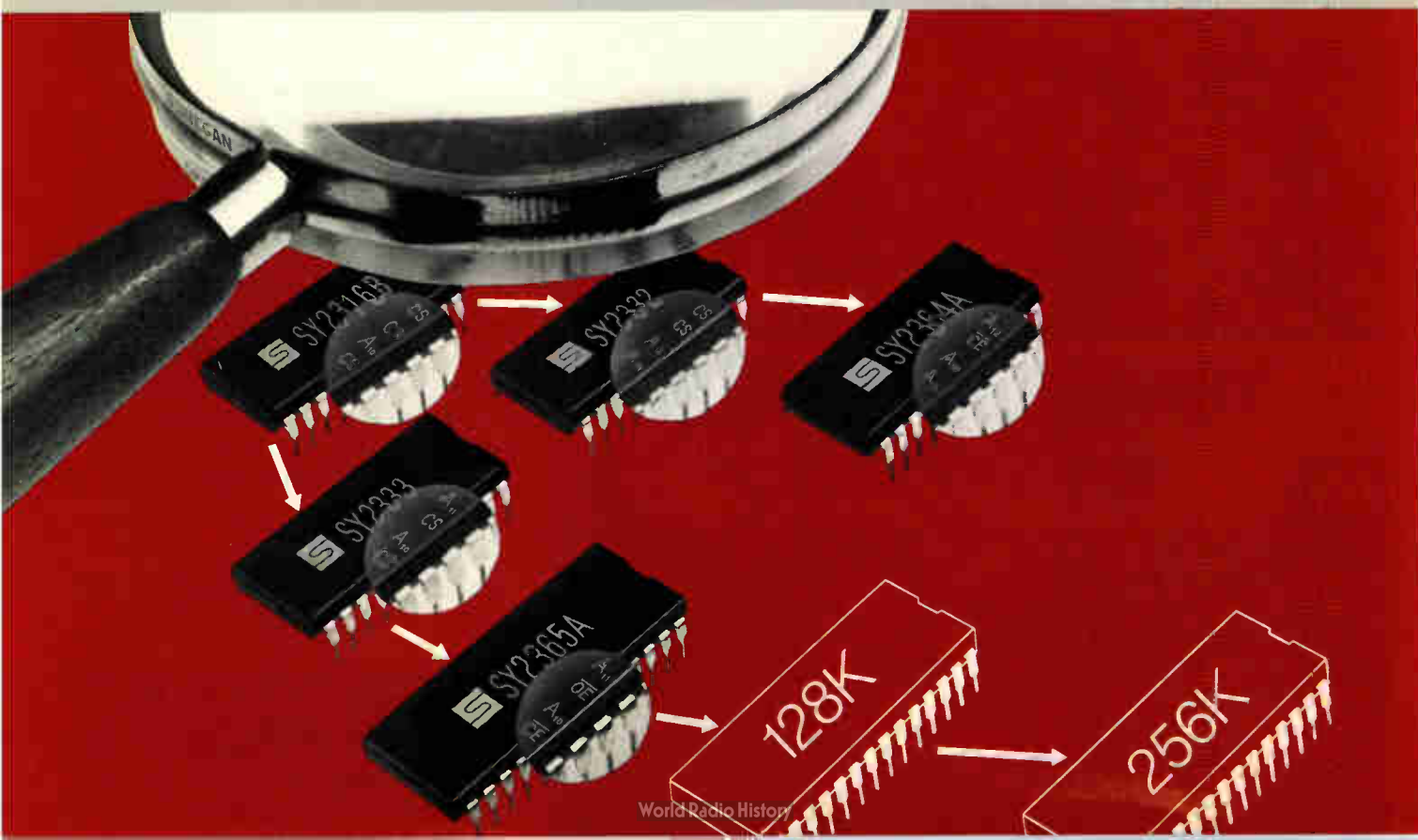

Height of 8-in. floppy shrinks to 2 in.

Claiming an ambitious hard-error rate of one reading error in 10^{12} , Micro Peripherals Inc. of Chatsworth Calif., has introduced the first 2-in.-high 8-in. floppy-disk drive. The slim-line design allows the drives to be mounted under a keyboard or **to be stuffed two abreast into a single standard-width 8-in. form factor.** With both single- and double-sided and single- and double-density versions, the drives, labeled models 41 and 42, have capacities of from 400-K bytes to 1.6 megabytes. Pricing is \$300 for the model 41 and \$400 for the model 42 in large quantities. The units have an average access time of 83 ms and consume 28 W.

Triac drivers employ GaAlAs LEDs

Using gallium aluminum arsenide, as opposed to gallium arsenide in its infrared light-emitting diodes, TRW Optron is expanding its line of 110-V ac triac drivers to include components with threshold trigger-current ratings of 5 mA. Existing versions rated at 30, 15, and 10 mA use GaAs LEDs. The Carrollton, Texas, facility of Electronic Components Group of TRW Inc. is also unveiling its **first 220-V ac triac drivers: OPI-3020, 3021, 3022, and 3023, which are designed for trigger ratings of 30, 15, 10, and 5 mA, respectively.** The 10- and 5-mA versions use the GaAlAs LEDs, and the 30- and 15-mA units use GaAs LEDs. In addition, look for TRW to add four zero-voltage crossing parts with identical ratings, in which the 10- and 5-mA models will also employ GaAlAs LEDs.

Color terminal bows at under \$1,000

Made possible through single-board construction, product volume, and a price breakthrough in usually costly analog cathode-ray-tube driver circuitry is the IS 2048 color-capable intelligent terminal costing less than \$1,000. **Priced at \$995 each in 600-unit lots, Intelligent Systems Corp.'s unit is said to offer features found on units two to three times as costly:** a total of 16 colors, a 13-in.-diagonal CRT, RS-232-C communications at selectable rates up to 9,600 b/s, 72-key ASCII keyboard, and editing commands. Delivery from the Norcross, Ga., firm begins in January.

Personal computer network links IBM, Xerox entries

Joining other Corvus Systems Corp. 5-megabyte Winchester-technology disk drives developed for Apple, Tandy, Cromemco, Intertec, Dynabyte, North Star, Vector Graphic, and Altos computers are 5¼-in. Winchesters for the IBM and Xerox 820 personal computers. At the same time, the San Jose, Calif., firm announced that the Xerox 820, the IBM Personal Computer, and the Apple II have been interfaced with the Corvus Omninet network, which is based on twisted-pair transmission. **The 5-megabyte drives are priced at \$3,750 for single units** and will be available in mid-January. The Corvus mass-storage systems are based on the plated-disk IMI 5007 drive, which has a 96-ms average access time and a 960-kilobyte/s transfer rate. The system includes a Z80-based controller card, an intelligent interface card with firmware, and a 5¼-in. floppy-disk form factor.

ROM simulator hastens designs

Design times of read-only memory-based systems can be reduced with the Romsim-1A ROM simulator because the S-100-compatible board **eliminates the repeated downloading and burning of programmable-ROMs during firmware development.** Instead, a host S-100 computer loads code in the random-access memory of Inner Access Corp.'s board and cables

from the Romsim to a destination board allow complete simulation of a programmed PROM. Thus ROM-stored code can be checked for compatibility with its associated hardware and software before a single PROM is burned. The Belmont, Calif., firm's Romsim emulates the 2758, 2798, 2716, 2516, 2732, 2532, 2764, and 2564. The \$495 package includes software support in the Basic and Forth languages; delivery is immediate.

Digital attenuator exceeds 88 dB

Designed for communications and communications-test applications, as well as digitally controlled automatic gain control, Analog Devices Inc.'s new AD7111 **accepts 8-bit parallel inputs, latches them, and uses the code to set the attenuation of analog signals in 0.375-dB steps** to a maximum of 88.5 dB. The Norwood, Mass., firm specifies a frequency range of dc to several hundred kHz for the unit. Its total harmonic distortion is said to be -91 dB with output noise limited to 70 nV/Hz^{1/2}. In hundreds it sells for as little as \$16.

Hardware, software make system fail-safe

Citing twin achievements in automated software development and fail-safe hardware architecture, DOSC Inc., of Albertson, N. Y., unveiled the DOSC FailSafe distributed processing system. Such software achievements as automated structured programming, reduced program maintenance, and lowered software down-time, are coupled with **a hardware architecture that provides redundancy, prevents loss of the data base, and eliminates long response times**. The basic \$79,400 system includes two each of 80-megabyte disks, 16-megabyte disk cartridges, data-base manager computers, data-base-controller computers, and 200-character/s printers.

Drafting system costs under \$100,000

The new CDA system from Data Technology Inc., Woburn, Mass., approaches computer-aided drafting from the draftman's point of view. **The system displays commonly used drafting terms and symbols** on its cathode-ray-tube terminal rather than using specially designed and often unfamiliar ones. The menu-driven system operates through a Digital Equipment Corp. LSI-11 microcomputer with a 5-megabyte disk and a Tektronix 4014 display and also a coordinate digitizer and automatic drafting plotter. The basic system includes software and is priced just below \$100,000.

Militarized parts invade market

Claiming an industry first, Analog Devices Inc.'s Computer Laboratories division in Greensboro, N. C., has unveiled its MOD-1205MB, a militarized analog-to-digital converter capable of 12-bit conversions at rates up to 5 MHz. **Aimed at signal-processing applications, the unit has a signal-to-noise ratio of 63 dB**. The converter is packaged on a 5-by-5.43-by-0.5-in. board and includes track-and-hold amplifiers with 25-ps aperture uncertainty, an encoder, and output registers. It sells for \$4,995.

Meanwhile, for an extra 10% (or 20¢, whichever is greater) Precision Monolithics Inc., Santa Clara, Calif., will provide infant-mortality testing for all its devices. Any PMI part may now be ordered with burn-in to MIL-STD-883, method 1015, condition B. A marking of BI identifies these devices, which have been tested at PMI's option for either 160 hours at $+125^{\circ}\text{C}$ or 80 hours at $+150^{\circ}\text{C}$.

We give you one thing other car rental companies don't. Everything.

Guaranteed pricing.

There are no surprises at Hertz. Just ask us and we'll tell you in writing what your final rental charges are before you go.*



Special deals on vacation wheels.

Whether you're going to Florida, California or anywhere in the world, Hertz has special deals to make your vacation dollars go farther.



No charge for mileage.

At Hertz, we give you free, unlimited mileage—any car, anywhere, round-trip or one-way.*

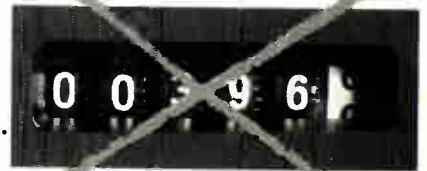

Fast take-offs from airports. When you reserve your Hertz car, ask for our #1 Express Service™ and you can go right from your plane to your car without stopping at the rental counter. (Available at most major airports.)



More help to help.

Hertz has more friendly people ready to help you than anyone. So call 1-800-654-3131 for reservations and we'll take it from there.

The world's largest fleet. With a fleet of cars big enough to stretch from Detroit to New York, chances are we've got the car you want—when you want it.



*Guaranteed Pricing available at all Hertz corporate and participating licensee locations in the U.S. Refueling charges and state and local taxes are not included. On some one-way there may be a drop-off charge.

#1 For Everyone.

Hertz rents Fords and other fine cars.

The NEW Electronics Buyers' Guide is now available!

The 1981 EBG is only a postage stamp away! Completely new listings of catalogs, new phone numbers, new addresses, new manufacturers, sales reps, and distributors! The total market in a book—four directories in one!

1.

Directory of products. Over 4,000 products, over 5,000 manufacturers.

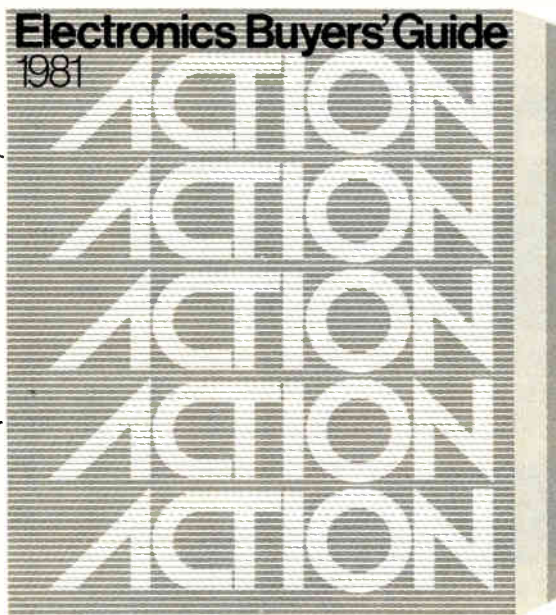

3.

Directory of manufacturers. Local sales offices, reps, and distributors, with phone numbers. Number of employees and engineers, dollar volume, name of company contact.

2.

Directory of catalogs. Includes six post-paid catalog inquiry cards for 10-second ordering.

4.

Directory of trade names of products and their manufacturers. You can trace a product by its trade name only.

**The only book of its
kind in the field.**

**If you haven't got it,
you're not in the market.**

**To insure prompt delivery
enclose your check with the
coupon now.**

Yes, please send me _____ copies of 1980 EBG.

I've enclosed \$30 per copy delivered in USA or Canada. Address: EBG, 1221 Avenue of the Americas, New York, N.Y. 10020.

I've enclosed \$52 for air delivery elsewhere. Address: EBG, Shoppenhangers Road, Maidenhead, Berkshire S16, 2Q1 England.

Name _____

Company _____

Street _____

City _____

State _____ Zip _____ Country _____

Career outlook

WIGS class of '82

The first graduates of the Wang Institute of Graduate Studies in Tyngsboro, Mass., will receive their master's degrees in software engineering next August. For about 25 of the students, that diploma will represent a two-year investment, during which they balanced a part-time academic schedule with their regular jobs in local computer companies. For another five full-time students, hailing from as far away as Colorado and California, the cost of the degree includes giving up a year's worth of paychecks.

The return on the investment, however, could be considerable. The program aims at turning out an elite corps whose software-engineering skills, buttressed by planning, managerial, and human-resource talents, suit them for positions as first-line project leaders and as high-level software architects [*Electronics*, Aug. 14, p. 92].

Funded by a private grant from An Wang, president of Wang Laboratories Inc., and his family, the institute recently received degree-granting authority from the state.

It expects a wait of about three years for review and accreditation by the New England Association of Schools and Colleges. WIGS had no trouble meeting its first-year enrollment goals, but will move carefully in its future growth, says Nancy Martin, professor of information technology. "Our first priority is a quality program; we currently have three faculty members, and I expect that number must double before we double the student-body size." Martin reports that WIGS hopes to have three more professors on board by next fall.

The part-time students at the institute are employed by about 15 local high-technology firms; WIGS is currently working with about 15 firms across the country on joint agreements by which the companies would grant paid leaves of absence to employees pursuing the one-year full-time degree program.

Additionally, a gift from the Wang corporate fund will allow 10

future full-time students to receive research assistantships. This program would pay students a small monthly salary for working on research projects at the institute, in addition to paying for their academic fees and books—tuition and fees total nearly \$8,000 for the full degree program.

Applications for admission to the institute now come from all over the country. While WIGS is expanding its outreach efforts, the emphasis is on explaining the nature of the WIGS program, which differs from most university-based degree programs in its stress on industry-oriented course work and research projects. Although all the applications for next fall's entrants will not be in until next February, Martin projects that WIGS probably will be able to accept only about a third of those applying for places.

Work required. Admissions standards also differ from university programs. They include a minimum of two years' work experience in a software-related field and specific expertise in computer-science and mathematics disciplines. WIGS also requires strong written and oral communications skills.

WIGS prides itself on its orientation to the needs and realities of industry, and starting in January, the class of '82 will get to sink its teeth into a major problem-solving project similar to those they will encounter on the job. WIGS hopes that in the future companies will suggest such projects, work with students on their completion, and even award grades for work performance. However, Martin notes, such projects cannot be confidential but must be in the public domain.

The first work project will be assigned by the WIGS faculty, and will lead within a year to a specific software product that WIGS will distribute to industry. WIGS also decided recently to publish an annual technical report, detailing curriculum and training methods and relating the programs and results of students' work projects. The first reports should be out by the end of this year. **-Linda Lowe**

MICROWAVE (FIELD) SALES ENGINEER

Precision Tube Company, the originators of the semi-rigid coaxial cable, requires an individual with expertise in the application of coaxial cable for MicroWave Transmission.

The person we are seeking must be capable of providing designers with application support and have the ability to sell a prospective cable buyer on the merits of Precision Coaxitube.®

The territory to be covered is world wide and the base of operation will be from our facilities in North Wales, PA. The applicant for this position must be prepared to travel more than 50% of their time.

Forward resume to A. J. Zuercher, President, Precision Tube Company, Inc., Wissahickon Ave., North Wales, PA 19454.

Engineers

- Design
- Development
- Project
- Software

\$20,000-\$50,000

Riddick Associates Engineering Division specializes in placement of electrical and electronics engineers with top companies on the East Coast and throughout the U.S. We provide advice on careers, resumes and interviews for a position tailored to your skills. Client companies pay all fees. For details call or send resume in strict confidence to Phil Riddick, President.

Riddick Associates, Ltd.
9 Koger Executive Center
Norfolk, VA 23502
Area 804-461-3994

ELECTRONIC ENGINEERS

Hardware/Software

Our high-tech. client firms in New England & nationwide have openings in hardware & software design, digital circuits, tele-comm., CAD/CAM, microwave, optics, RF, warfare systems, etc. MINI-APPLICATIONS. Send resume in confidence to Fred Raiser.

Search Incorporated
144 Westminster St.
Providence, RI 02903
(401) 272-2250

ADVERTISERS

Send all new copy, film or changes to:

ELECTRONICS
CLASSIFIED
ADVERTISING CENTER
POST OFFICE BOX 900
NEW YORK, NY 10020

Litton

NEW ORLEANS

is using the latest
CAD System equipment
to design and develop
AIR DEFENSE ELECTRONICS
at its New

COMMUNICATION SYSTEMS DESIGN CENTER

in suburban New Orleans
the Sun Belt's developing
electronics area

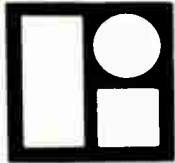

Litton
NEW ORLEANS

Immediate Openings for

CARD TEST ENGINEER- PROGRAMMERS

Conceptual and detail design, development, implementation, training and use of card tester programs for GenRad or equivalent card testers. Hardware design experience, in addition to software experience, with knowledge of assembly language required.

R/M ENGINEER (Reliability- Maintainability)

Reliability-maintainability engineer to support C3 systems design, test and delivery including FMEA's/MIL Standard 785, MTBF's per MIL HDBK 217 and MIL Standard 781 reliability demo's and to perform maintainability studies/analyses per MIL Standard 470 to assure equipment/system compliance.

Excellent fringe benefits including full relocation

Enjoy challenging work and the benefits of an area noted for its low cost-of-living, close-in commuting, public transit, excellent universities, gourmet restaurants, cultural attractions and year 'round out-of-doors recreation.

**For interview,
CALL COLLECT
Bob Taylor,
504-254-4530**

**between 8 a.m. and 4:30 p.m.,
Mon. Thru Fri.
or send resume,
in confidence, to:
R.H. Taylor,
Litton Data Systems
4200 Michoud Blvd.,
New Orleans, LA 70129**

An
Equal
Opportunity
Employer
M/F/H
•
A
Leader
in
Affirmative
Action

ACOUSTICS/VIBRATION ENGINEERS

Maximize your potential and work with "top-of-the-line" technology.

If you are a strongly motivated engineer with a proven track record in engineering and/or sales of high-technology products and have a BS degree in E.E., M.E. or Physics, this position offers you great potential for personal growth.

Bruel & Kjaer markets a broad "top-of-the-line" range of sophisticated sound and vibration data analysis instrumentation. We are growing rapidly and need ambitious sales and application engineers to work in the field and office with our customers in Seattle, San Francisco, Los Angeles, Milwaukee, Dallas, New Orleans, Houston, Washington, D.C., Chicago, New Jersey, Marlborough and Detroit. Responsibilities are wide and range from analyzing and developing sales opportunities, technical problem solving, seminars and the maintenance of good customer relationships. You will be fully supported by our highly competent technical and administrative staff.

We offer a generous salary and excellent fringe benefits including company-paid insurance programs.

For a chance to grow with us, send your resume to our Personnel Department.



**Bruel & Kjaer
Instruments, Inc.**

185 Forest St.
Marlborough, MA 01752
(617) 481-7000

Equal Opportunity Employer

In sonics or phonics, why electronics?

Because in these and hundreds of other fields, electronics applications are taking over. If your firm is looking for smart new electronics engineering graduates, you'll find them—and all other technical disciplines—through McGraw-Hill's **Graduating Engineer**.

Graduating Engineer is editorially planned to serve the career needs of soon-to-graduate engineers in civil, chemical, nuclear, industrial, electrical/electronic, aeronautical, mechanical, mining and petroleum fields, and computer sciences. Complimentary, all-request circulation puts your recruitment advertising before a guaranteed 75,000 senior level engineering students in every major engineering school in the U.S.—nearly 500 institutions in all! And a unique student resume forwarding plan, at no charge, supplies basic personnel information, as well as putting advertisers in touch with graduating engineers interested in *their* companies.

For full information on **Graduating Engineer**, call or write the Classified Representative at your nearest McGraw-Hill Regional Office. Or call (212) 997-2556.

GRADUATING ENGINEER

McGraw-Hill Publications Company
1221 Avenue of the Americas, New York, N.Y. 10020



ATTENTION HARDWARE ENGINEERS:
**YOU'VE EARNED
YOUR SPURS.**



You've put in at least 3 years of practical, on-the-job experience. And now, you've earned your spurs. You've earned the Texas sunshine and you've earned the chance to join the team at E-Systems Garland Division. You'll need your spurs, too, because some of the toughest high-technology electronics problems you can face are solved every day at E-Systems.

**OPPORTUNITIES FOR
HARDWARE ENGINEERS:**

- wide range of jobs:
 - systems analysis, design, development, test and integration in the following areas: computer-based intelligence and reconnaissance systems, command and control systems, electronic warfare, communications systems, digital image processing

- state-of-the-art technology:
 - high-speed digital logic and signal processing
 - communications theory, digital and analog design, and filter design
 - antenna/arrays for precision direction-finding systems
 - RF & IF processors & microwave integrated circuitry
 - microprocessor bit-slice, and high-speed, parallel pipeline processors utilizing MOS, TTL & ECL
 - high probability of intercept receivers

PUT ON YOUR SPURS

Don't miss out on this Texas size opportunity. We are planning to be in the following cities with some of our top technical people to talk with you. Send your resume today for professional review and priority attention:

Atlanta
Bethesda
Boston
Chicago
Dayton
Los Angeles
Melbourne/
Orlando
Minneapolis

Newark
Philadelphia
Phoenix
Pittsburgh
San Diego
San Jose
Seattle
St. Louis

If you have a degree and 3 or more years of experience, grab hold of this opportunity — don't delay — send your resume to: Professional Placement, E-Systems, Inc., Garland Division, P.O. Box 226118, Dept. ES29, Dallas, Texas 75266.



E-SYSTEMS

Garland Division

The problem solvers.

SCHOOL OF APPLIED SCIENCES UNIVERSITI SAINS MALAYSIA

APPLICATIONS are invited for the post of PROFESSOR, ASSOCIATE PROFESSOR and LECTURER in the field of Electronics/Computer Science and Technology with specialization in one of the following areas: (i) Computer Science/Engineering (Hardware techniques and or software methods) (ii) Micro-processors and Mini Computers and (iii) Television Engineering/High Frequency Engineering.

- A. QUALIFICATIONS/EXPERIENCE:** Candidates for the post of PROFESSOR/ASSOCIATE PROFESSOR should have a Ph.D./Masters degree with wide experience in teaching and research. They should also have some outstanding publications to their credit. Candidates for the post of LECTURER should have Ph.D./Masters degree with interest in undergraduate teaching and research.
- B. EMOLUMENTS:** PROFESSOR from M\$41,520 to M\$46,920; ASSOCIATE PROFESSOR from M\$35,040 to M\$39,720 and LECTURER from M\$17,040 to M\$33,240 per annum.
- C. OTHER ALLOWANCES PER ANNUM:** (i) Housing: ±M\$4,200 to ±M\$12,000; (ii) Entertainment: ±M\$6,600 to ±M\$12,000. For Lecturers, only those drawing a salary of M\$31,800 p.a. and above will be paid the two allowances.
- D. OTHER BENEFITS:** Return passage, excess baggage assistance, paid annual leave, free medical benefits for staff and family and gratuity at 17½% (tax free) of total monthly salary and car loan facilities.
- E. TENURE:** On contract for 3 years renewable if necessary. Apply to Registrar (Establishment Section) Universiti Sains Malaysia, Minden, Penang, Malaysia. Enclose curriculum vitae and references (3) before January 1, 1981.

POSITIONS VACANT

Electrical Engineer — Design, purchase, tooling and evaluation of production test equipment for emission control parts plant. Also performs design and evaluation for electrical system in plant, especially with regard to microcomputers and other electronic equipment. 40 hours per week; \$412 per week. Education: B.S.E.E. (electrical engineering). No training required. One year experience required. Must have knowledge of microcomputers and courses in electronics, digital and analog systems. Send resume to: Mr. Allan M. VanDeMark, Illinois Job Service, 2323 East Lincolnway, Sterling, IL 61081.

FACULTY POSITIONS VACANT

Faculty and Research Staff Positions. Massachusetts Institute of Technology. The Department of Electrical Engineering and Computer Science seeks candidates for faculty and research staff positions starting in September, 1982. Assistant Professor appointments are available, in the areas described below, for individuals who are completing or who have recently completed a doctorate. Faculty duties include teaching at both the graduate and undergraduate levels, research, and supervision of theses. Computer Systems. As part of a continuing effort in computer systems, a new faculty member would be expected to conduct experimental research in such topics as distributed systems, linguistic primitives for distributed applications, and networks of personal computers, with attention to such issues as robustness, authenticity, and atomicity. Robotics and Artificial Intelligence. We seek to expand our program in robotics, productivity technology, and related aspects of artificial intelligence. Included are such research areas as tele-operators and manipulator design and control, innovative mechanical hand and sensor design, spatial reasoning, force exploitation, and learning. Natural Language Understanding. We intend to expand our program in natural language understanding by computer. A new faculty member would complement ongoing work in speech production and recognition and in knowledge representation. Communications Systems. As part of an expanding effort in communications systems, a new faculty member would be expected to conduct experimental research in such topics as high-bandwidth local networks, packet radio networks, and high fidelity teleconferencing systems. Integrated Circuit/Systems Technology and Design. As part of an expanding M.I.T. program in microsystems, a new faculty member will be expected to contribute to research in design technologies for devices and integrated circuits and the development of novel devices, integrated circuits and integrated systems, both analog and digital. Applicants should have interest in working with groups that seek to develop integrated systems for a wide range of disciplines. Research Associate positions may be available in the above areas. Research staff devote their time principally to research, with opportunities for teaching or thesis

FACULTY POSITIONS VACANT

supervision when appropriate. A doctorate or equivalent experience is required. Research Associate salaries range from \$22,000 to \$35,000, depending on background and experience. We also anticipate the possibility of making a senior faculty appointment in computer science. All candidates should write to the address below, describing their professional interests and goals and indicating for which of the above positions they are applying. Applications should include a curriculum vitae and the names and addresses of three or more references. Additional material describing the applicant's work, such as papers or technical reports, would also be helpful. All candidates should indicate citizenship and, in the case of non-US citizens, describe their visa status. Although primarily interested in appointments in the specific technical areas described above, we will also consider exceptionally strong junior or intermediate level candidates with interests in other fields of electrical engineering and computer science. Opportunities for such appointments are very limited. Individuals wishing to be considered in this category should so state and should arrange to have three letters of recommendation sent directly to the address below. (Applications in this category will not be considered until three letters of recommendation are in hand.) Send all applications to: Prof. F. C. Hennie, Room 38-435, Massachusetts Institute of Technology, Cambridge, MA 02139. M.I.T. is an equal opportunity/affirmative action employer.

Electronics — Opening for Electronics Instructor to teach in community college electronics technology program. Duties include coordinating a proposed computer-repair curriculum and teaching Fundamental Electronics, Minicomputer Architecture, Programming, and peripheral service courses. Full-time, 10-month tenure track position. Master's required; teaching and experience in electronics service preferred. Salary \$16,000 to \$30,000. Application deadline January 12, 1982. Send resume to: Personnel Office, Catonsville Community College, 800 South Rolling Road, Baltimore, Maryland 21228. AA/EOE.

EMPLOYMENT SERVICES

International Placement Services — Specializing in engineering personnel. The EPMC Group has offices located in the United Kingdom, Europe, Australia, South Africa, United States. Contact Charles R. Christian, Director, Electronics Personnel and Management Consultants (USA), 1328 King Street, Wilmington, Delaware 19801, (302) 656-6110.

**CALL IN
YOUR
CLASSIFIED ADS
212/997-2556**

S.W. & SUNBELT

- Circuits
- Systems
- Product
- CAD
- Micro
- Software
- Hardware
- Optics

\$25,000 to \$50,000

Specialists placing EE's/ME's in data acquisition, peripheral and instrument development companies across the Sunbelt. 100% company Fee Paid. Send resume, geographic preference, salary and salary requirements to:

J. Robert Thompson Companies, Inc.
Management & Employment
Consultants
2200 West Loop South, Suite 800
Houston, Texas 77027
(713) 627-1940

FLORIDA ELECTRONICS ENGINEERS, \$18,000-\$40,000. Hardware & Software design. Entry thru management. Many choice positions. PROF. PERSONNEL CONSULTANTS, 1211 N. Westshore Blvd, Suite 314, Tampa, FL 33607 (813/877-7008).

DESIGN ENGINEERS to \$38K. Central Penna. & nationwide. Design connectors / terminals, microprocessors, controls. Reply in confidence to Z. A. Goglewski, MECK ASSOC. PERSONNEL, 1517 Cedar Cliff, Camp Hill, PA 17011 (717/761-4777).

npc NATIONAL PERSONNEL CONSULTANTS

SUNBELT OPPORTUNITIES

Our 14 SE offices cover many Manufacturing Firms which seek experienced degreed Electronic Engineers as well as Entry Levels. Microprocessor/Computer Applications — Hardware/Software, etc. Fee Paid. Confidential Treatment. BEALL ASSOC. Personnel, Box 8915E Greensboro, NC 27419

MCGRAW- HILL'S ELECTRONIC BOOKSHELF IS ON THE AIR!

Ask your computer to call 212/997-2488 for the latest info on our computer and electronics books. The system is up daily from 6 pm to 8 am and 24 hours on weekends.

Discover the secrets of Arizona's past while you develop the missile systems of the future at Hughes.

The rich cultural heritage of Tucson, Arizona is nowhere more evident than in the classic Spanish missions that dot the landscape of this year-long vacationland.



So whether historic sightseeing, golf, tennis, backpacking or skiing are included in your interests, you will find them here. Come join us at the Tucson Engineering Labs and help develop and produce the most advanced missile systems in the world.

We have successfully been breaking ground in military electronic technology for 30 years. That's why we've grown into one of Tucson's largest employers and continue to hold our position of technological leadership. So, discover the "secret" of our success AND be a part of it. The following development and production support openings await your interest:

- **Microwave Engineering**
(Devices, Components, Subsystems)
- **Circuit Design**
(Analog, Digital, Hybrid)
- **Missile System**
(Analysis, Design, Test)
- **Missile System**
(Test Equipment, Test Software Design)

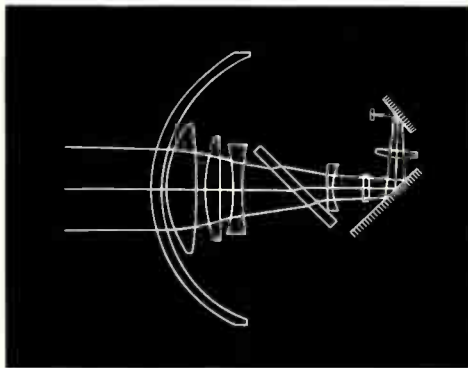

Applicants should have accredited degrees at the BS or MS level in appropriate disciplines and some experience in one or more of the above fields.

The many other advantages to a career with Hughes include an average of 13 paid holidays, with a year-end Christmas shut-down, and 2 weeks vacation per year (3 weeks after 5 years); company-paid medical, dental and vision care insurance, life insurance, retirement plan, a company-matching savings plan, credit union facilities, continuing education plans as well as relocation assistance.

Send your resume to R.W. Kelly, Hughes Aircraft Company, Professional Employment, Dept. No. TE-103A-E, P.O. Box 11337, Tucson, Arizona 85734. You can also call COLLECT at (602) 746-8266.

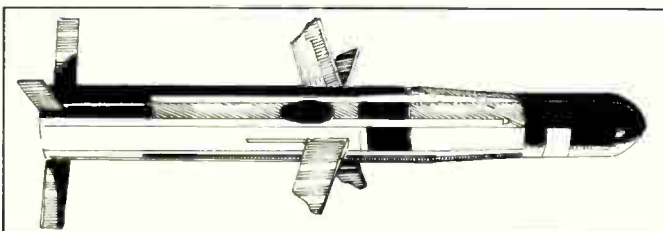
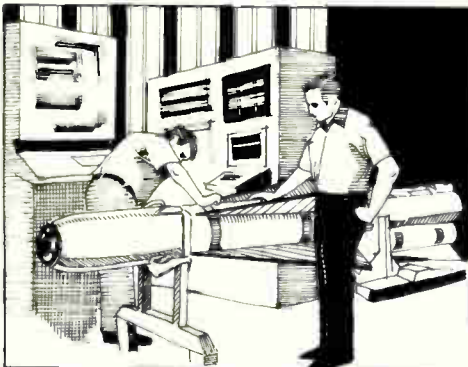

HUGHES

HUGHES AIRCRAFT COMPANY

MISSILE DEVELOPMENT DIVISION-TUCSON

U.S. Citizenship Required
Equal Opportunity Employer

MARKETING PROFESSIONALS

New semiconductor technologies and 10 years experience make NCR a powerful factor in merchant markets.

The same things that are contributing to our rapid rise as a marketer of custom logic and memory devices will contribute to yours.

1. New product development at NCR Microelectronics is using advanced SNOS technology to create 4K NVRAM's. Let us tell you about other industry firsts.
2. NCR is committed to achieving a leadership position. Our marketing drive is distinct from our own-use activities—not just a subsidiary or supplement. (But standing toe-to-toe with the smartest people in semiconductors will help keep us on our mettle.)
3. Since pioneering our first MOS-based terminal in 1971, we've developed 3 full-scale semiconductor fabrication facilities. We are able to produce, stock and quickly deliver high quality devices to almost any manufacturer's specifications.
4. This is where you come in... if you have a BSEE (MSEE preferred) and at least 3 years of solid experience in technical semiconductor sales or marketing.

As one of our **Product Marketing Engineers** you'll be studying and analyzing both competitive markets and business trends. And supporting sales via forecasting, product definition, promotion, presentations, and customer negotiation.

As an **Applications Engineer** you'll be evaluating new circuit technology for customer application. Assess applications potential, prepare product specifications and application reports, and become involved in new product strategies.

Not only will we position you strategically within the industry, and reward your achievements, but our comprehensive benefits include full relocation to Miamisburg, on the outskirts of Dayton—one of the midwest's most attractive and affordable areas. Learn more. Please send resume and salary history to: **Ms. Marcia S. Laderman, Dept. C-78, NCR Corporation, Microelectronics, 8181 Byers Road, Miamisburg, Ohio 45342.**

NCR

Complete Computer Systems

An equal opportunity employer

XEROX 400 TELECOPIER

To enable you to get your Classified Advertising type-written copy into this section at the last possible minute, we've installed a XEROX 400 TELECOPIER (which also receives copy from other makes) in our New York home office.

If you have a telecopier, just call the number below to see if your equipment is compatible. If you don't have a telecopier, call and we'll help you locate the nearest one. It could even be in your own firm or building.

NOTE: The Xerox 400 cannot accept photos or art, but as always, there is no charge for typesetting and layout service.

CALL (212) 997-6800

RADAR SYSTEMS ENGINEERS

RADAR AT NORDEN

...extending its reach extends your growth opportunity

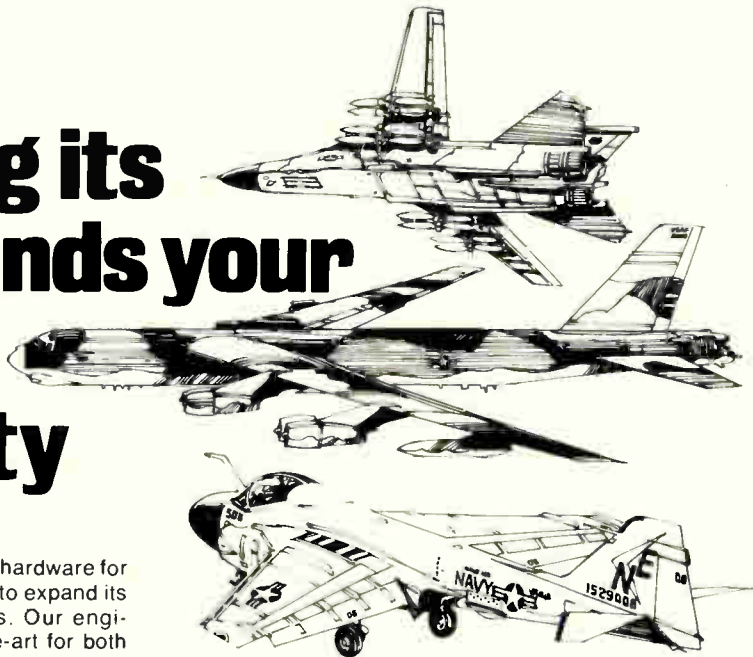

A leading developer of radar concepts and hardware for over 30 years, Norden Systems continues to expand its expertise and contractual commitments. Our engineers, setting the pace in the state-of-the-art for both air and seaborne systems, have opportunity to impact every project phase from concept and proposal through delivery—and to grow with advancing technologies. Today more than ever, Norden responds to your need for ongoing professional development through challenging assignments like these:

- B-52 Radar Modernization
- Target Acquisition/Weapon Delivery System (Synthetic Aperture Radar)
- Radar Guided Weapon System (Synthetic Aperture)
- A6-E advanced radar development (SAR/MTI)
- Millimeter Radar Programs
- Radar R&D Projects
- ECM Programs

Advanced Systems Engineers

To provide engineering leadership on advanced systems/technology including concept development, customer interface and proposal management.

Systems Engineers

Requires progressively responsible experience in advanced radar systems, including analysis, simulation, system trade-off, implementation, and signal processing.

Radar Project Engineers

Experience in airborne radar project engineering from proposal through design, development and test of both preproduction and production equipment. Responsibilities include planning, schedule/cost control and direction of an engineering development team.

Radar Signal Processing Design Engineers

Experience in digital signal processing techniques, signal processing algorithms and application of mini/micro computer and array processors. Working knowledge of software development procedures including the use of Assembly and higher order languages. Responsibilities include concept formulation, technical proposals, direction of software development, etc.

Call COLLECT to arrange appointment
William MacDougall at (203) 852-5408.

If not convenient to call, please send your resume to: William MacDougall, Norden Systems, Inc., 308 Norden Place, P. O. Box 5300, Norwalk, Connecticut 06856. An Equal Opportunity Employer.

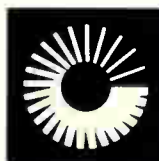

**UNITED
TECHNOLOGIES
NORDEN
SYSTEMS**

Abbott Transistor Labs	27	Fairchild Test Systems	188, 189, 214, 215	■ Mini-Circuits Laboratory	2
Able Computer Technology	239	* FEME S.P.A.	10E	■ 3M Company Scotchflex	216, 217
ACDC Electronics	222	■* Ferranti Electronics, Ltd.	59	■ Mitel Corporation	100, 233
Acurex Corporation	89	■ First Computer Corporation	15	■ Monosil, Inc.	16
• Advanced Micro Devices	22, 23, 105	■ John Fluke Mfg. Co.	83	■ Monsanto Industrial Chemicals	35
■ Alco Electronic Products	182	‡ Fujitsu America, Inc.	161	■ Mos Technology, Inc.	229, 248
AMF/Potter & Brumfield	62	• Fujitsu Limited	65	■ Mostek Corporation	28, 29
■ Amp Incorporated	190, 191, 192	■ General Electric Lexan	220, 221	■ Motorola Semiconductor Products	76, 77, 118, 119, 177, 178,
• Ampex Corporate	164, 165	■ General Instrument Microelectronics	41	• Murata Manufacturing Co., Ltd	179
■ Amphenol N. America Oak Brook	213	■ General Instrument Corp Discrete Semi Div	247	■ NEL Unit/Midtex Division Midland Ross	182
■ Analytical Chemical Laboratories	8	■ Gould Incorporated Instrument Div SC Operations	30, 31	■ New York State Department of Commerce	232
• ASU Components, Ltd.	59	■ Hamilton/Avnet Electronics	4th	■ Nocolet Instrument Corporation	32
Audiotronics Video Display Division	234	■ Hertz Corporation, The	259	■ Nippon Electric Company, Ltd.	78, 79
Avocet Systems	112	■ Hewlett Peckard	2nd C, 1, 17, 116, 117, 174, 175, 255, 175	■ Noritake Electronics, Inc.	240
Bausch & Lomb Scientific Optical Products	226	‡ Hitachi America Limited	166, 167	• Northern Ireland Dept of Commerce	167
Beech Aircraft Corp.	254	■ Honeywell Optoelectronics Div.	235	• Olivetti Technost	183
Berg Electronics	208, 209	■ Hysol	43	■ Osborne & Associates, Inc.	251
Berlin Economic Development	144	■ IBM	206, 242	‡ Panasonic	59
Bourne, Inc.	66, 67	■ Intel MCO	18, 19	■ Paratronics Incorporated	87
■ Cherry Electrical Products	13	■ Interdesign Incorporated	172, 173	■ Perkin-Elmer Semiconductor Operations	253
■ Chicago Laser Systems Incorporated	243	■ Interlan	244	■ Permag Corporation	198
■ Computrol Corporation	88	■ Intersil	10, 11	• Phillips Elcoma Market Promotion	4E & 5E
■ Coto Corporation	212	• Iakra Commerce Marketing	161	• Phillips T&M	2E, 3E, 9E
‡ CTS Corporation/Berne Div	168	■ ITT Cannon Electric	158	■ Piezo Crystal	200
■ Daini Seikosha Co., Ltd.	196	• Italtel/SIT	168	‡* Plessey Semiconductors	6E, 45, 70,
■ Data Sud Systems France	132	• Iwatsu Electric Co., Ltd.	195	■ Precision Filters	228
■ Data Translation	47	■ Johanson Manufacturing Corporation	12	■ Recal-Vadic	225
■ Datel-Intersil	60, 61	■ Kodak Products Limited	180	■ Radio Research Instrument Company	180
■ Digital Equipment Corp Microcomputer	120, 121	■ Kojima Electric Mfg Co. Ltd.	198	■ RCA Electro Optics	58
■ Digital Resources	184	■ Kontron Electronics Incorporated	85	■ RCA/OEM	210, 211
■ Dolch Logic Instruments	103	■ Krohn-Hite Corporation	5	■ RCA Solid State	94, 95, 181, 201
■ Dupont Riston	236	‡ Leader Instruments Corporation	183	■ RFL Industries Incorporated	248
‡ East Kilbride Development Corporation	207	■ Lexidata	80	• Rhopoint	12E
‡ Eaton Corporation, Cutler Hammer	199	■ Lifeboat	107	■ Rockwell International	204, 205
■ EECO Incorporated	245	■ Magtrol	194	■ S.D.S.A.	26
■ Electronic Navigation Industries	3C, 6	■ MDB Systems, Inc.	108, 109	• SEPA S.P.A.	166
■ Elevam Electronic Tube Co., Ltd.	194	■ Memodyne Corporation	234	• Shinshu Seiki Co.	207
□ EMM	72A-72B	■ Methode Electronics	155	‡ Siecor/Optical Cable	105
■ Erie Technological Products	184	■ Microcircuit Engineering	218, 219	‡ Siemens Corporation	164, 165, 185
EXAR	90, 91	■ Microswitch Division of Honeywell	185-187	‡ South Carolina State Development Board	223

How To Comply With The New Copyright Law

Spectrum Control	24
‡ STC Microtechnology	179
Supertex, Inc.	247
■ Syntronic Instruments, Inc.	226
Synertek	246
‡ Taiyo Yuden (USA) Incorporated	65
Tandon Corporation	162, 163
* TEAC Corporation	70, 11E
Tektronix	20, 21, 74, 75
Tektronix Design Automation Division	114, 115
Teledyne Crystallonics	57
Teradyne Incorporated	92, 93
Texas Instruments Digital Systems	36
Texas Instruments Incorporated (Semiconductor)	49-56, 170, 171, 99, 48, 197
* Thomson CSF Div D.T.E.	68
TL Industries	200
‡ Toshiba America	68, 69
Transwave Corporation	25
■ TRW LSI Products	111
■ TRW Optron	14
United Systems Corporation	230
Universal Data Systems	96
Universal Instruments	231
■ Vactec Incorporated	86
* Vacuumschmelze	11E
■ Wavetek Indiana	7
Wavetek San Diego	141
Western Digital	73
* Wild Heerbrugg	45
Mark Williams Company	9
* Zetron Istituto Zanussi per L'Elettronica	1E
Zilog	113
■ Zymos	202, 203

Classified and employment advertising

Beall Associates	264
Bruel & Kjaer Instruments	262
E- Systems, Garland	262
Hughes Aircraft	265
Litton Data Systems	262
National Personnel Consult. Inc.	264
NCR Corp.	266
Precision Lube Co., Inc.	261
Riddick Associates, Ltd.	261
Sains Malaysia University	264
Search Inc.	261
Thompson, Robert J. Co., Inc.	264
United Technologies, Norden Systems	267

- For more information of complete product line see advertisement in the latest Electronics Buyers Guide
- * Advertisers in Electronics International
- ‡ Advertisers in Electronics domestic edition
- Advertisers in regional issue

Libraries everywhere have found the easy way to fill photocopy requests legally and instantly, without the need to seek permissions, from this and over 3000 other key publications in business, science, humanities, and social science.

Participation in the Copyright Clearance Center (CCC) assures you of legal photocopying at the moment of need. You can:

Fill requests for multiple copies, interlibrary loan (beyond the CONTU guidelines), and reserve desk without fear of copyright infringement.

Supply copies simply and easily from registered publications. The CCC's flexible reporting system accepts photocopying reports and returns an itemized invoice. You need not keep any records, our computer will do it for you.

The Copyright Clearance Center is your one-stop place for on-the-spot clearance to photocopy for internal use. You will never have to decline a photocopy request or wonder about compliance with the law for any publication registered with the CCC.

For more information, just contact:



Copyright Clearance Center
 21 Congress Street
 Salem, Massachusetts 01970
 (617) 744-3350
 a not-for-profit corporation

NAME TITLE

ORGANIZATION

ADDRESS

CITY STATE ZIP

COUNTRY TELEPHONE

The NEW Electronics Buyers' Guide is now available!

Completely new listings of catalogs, new phone numbers, new addresses, new manufacturers, sales reps, and distributors! The total market in a book—four directories in one!

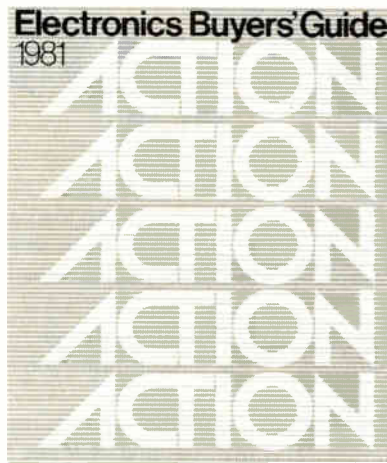

The only book of its kind in the field.

If you haven't got it, you're not in the market.

To insure prompt delivery enclose your check with the coupon now.

Yes, please send me _____ copies of 1981 EBG.

I've enclosed \$30 per copy delivered in USA or Canada. Address: EBG, 1221 Avenue of the Americas, New York, N.Y. 10020.

I've enclosed \$52 for air delivery elsewhere. Address: EBG, Shoppenhangers Road, Maidenhead, Berkshire S16, 2Q1 England.

Name _____

Company _____

Street _____

City _____

State _____

Zip _____

Country _____

Advertising Sales Staff

Advertising sales manager: Norman Rosen
3200 Wilshire Blvd., South Tower
Los Angeles Calif. 90010 [213] 487-1160

Market managers:

Computers & Peripherals: Frank Mitchell, Boston
Test & Measurement: Don Farris, San Francisco
Semiconductors: Norman Rosen, Los Angeles

Atlanta, Ga. 30309: John J. Uphues
100 Colony Square, 1175 Peachtree St., N.E.
[404] 892-2868

Boston, Mass. 02118: Frank Mitchell
Paul F. McPherson, Jr.
607 Boylston St., [617] 262-1160

Cleveland, Ohio 44113: William J. Higgins III
[312] 751-3738

Fort Lauderdale, Fla. 33306: John J. Uphues
3000 N.E. 30th Place, Suite #400
[305] 563-9111

New York, N.Y. 10020
1221 Avenue of the Americas
Barry Hakala [212] 997-3616
Matthew T. Reseska [212] 997-3617

Philadelphia, Pa. 19102: Joseph Milroy
Three Parkway, [215] 496-3800

Pittsburgh, Pa. 15222: Joseph Milroy
4 Gateway Center, [215] 496-3800

Chicago, Ill. 60611
645 North Michigan Avenue
Jack Anderson [312] 751-3739
William J. Higgins III [312] 751-3738
Southfield, Michigan 48075: Jack Anderson
4000 Town Center, Suite 770, Tower 2
[313] 352-9760

Dallas, Texas 75201: John J. Uphues
2001 Bryan Tower, Suite 1070
[214] 742-1747

Denver, Colo. 80203: Harry B. Doyle, Jr.
655 Broadway, Suite 325
[303] 825-6731

Houston, Texas 77040: John J. Uphues
7600 West Tidwell, Suite 500
[713] 462-0757

Los Angeles, Calif. 90010: Chuck Crowe
3200 Wilshire Blvd., South Tower
[213] 487-1160

Costa Mesa, Calif. 92626: Edward E. Callahan
3001 Red Hill Ave. Bldg. #1 Suite 222
[714] 557-6292

Palo Alto, Calif. 94303: Don Farris,
Larry Goldstein, Lauren Scott
1000 Elwell Court, [415] 968-0280

Paris: Michael Sales
17 Rue-Georges Bizet, 75116 Paris, France
Tel: 720-16-80

United Kingdom: Simon Smith
34 Dover Street, London W1
Tel: 01-493-1451

Scandinavia: Andrew Karnig and Assoc.
and Simon Smith
Kungsholmsgatan 10
112 27 Stockholm, Sweden

Tel: 08-51-68-70 Telex: 179-51

Milan: Ferruccio Silvera and Elio Gonzaga
1 via Baracchini, Italy
Tel: 86-90-656

Brussels:
23 Chaussee de Wavre
Brussels 1040, Belgium
Tel: 513-73-95

Frankfurt / Main: Fritz Krusebecker
Liebigstrasse 27c, Germany
Tel: 72-01-81

Tokyo: Akio Saijo and Hirokazu Nakamura
McGraw-Hill Publications Overseas Corporation,
Kasumigaseki Building 2-5, 3-chome,
Kasumigaseki, Chiyoda-Ku, Tokyo, Japan
[581] 9811

Business Department

Thomas M. Egan
Production Director
[212] 997-3140

Carol Gallagher
Production Manager
[212] 997-2045

Betty Preis
Production Manager Domestic
[212] 997-2908

Thomas Kazich
Production Manager Related Products
[212] 997-2044

Sharon Wheeler
Production Assistant
[212] 997-2843

Frances Vallone
Reader Service Manager
[212] 997-6058

Electronics Buyers' Guide

H.T. Howland, General Manager
[212] 997-6642

Regina Hera, Directory Manager
[212] 997-2544

Classified and Employment Advertising

Gerry F. Moss, Manager
[212] 997-2897

The advanced design line of RF power amplifiers... ENI.

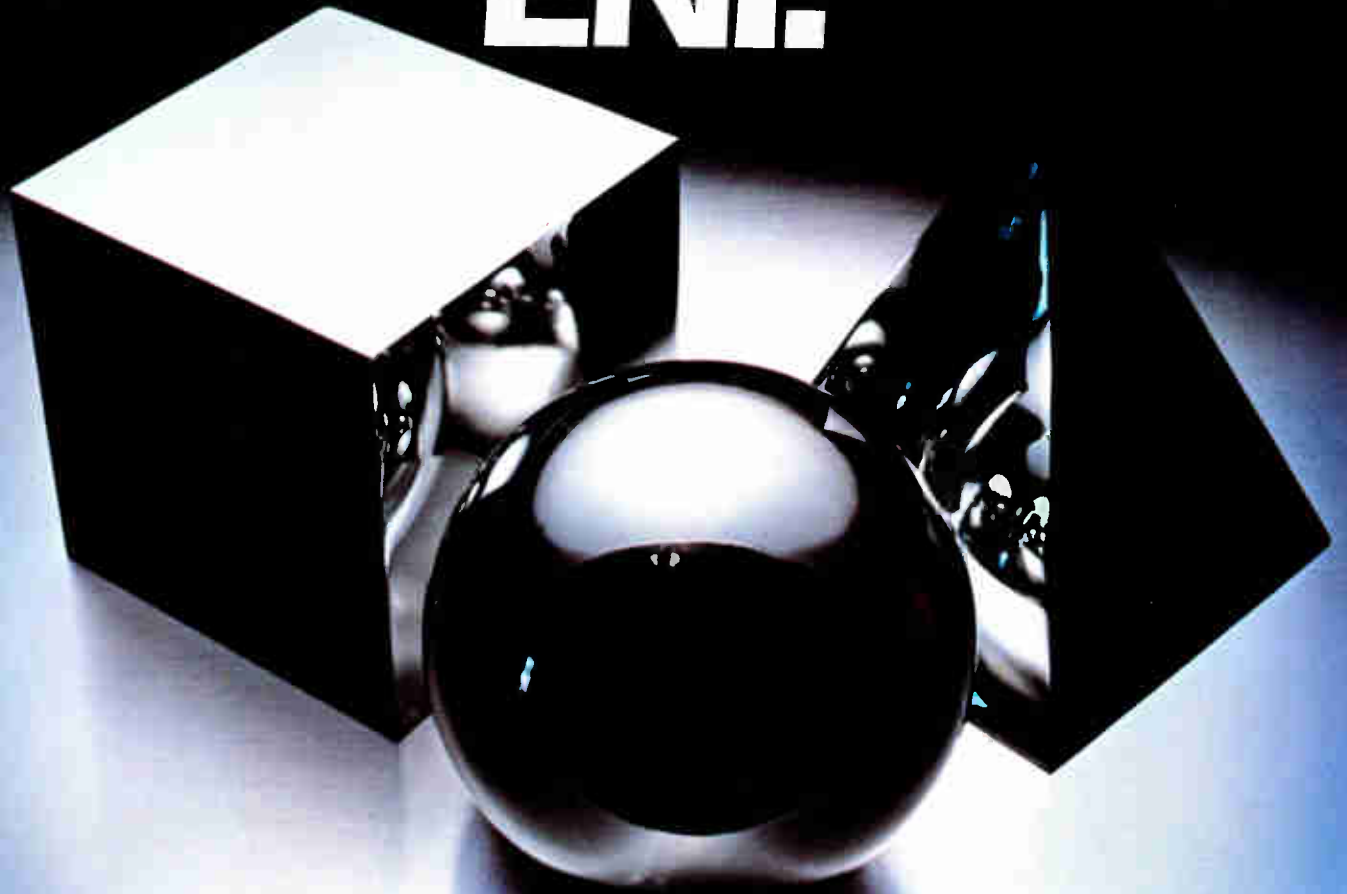

You can't claim to be "the world's leader in power amplifiers" unless you are. And being the world's leader means giving customers the ultimate in RF power flexibility with a clearly advanced design. That's the reputation we've earned with our product line because there's simply nothing finer in all the world.

And our instrumentation can meet all of your applications, for RF signal generator amplification, RFI/EMI testing, signal distribution, RF or data transmission, NMR/ENDOR ultrasonics and more.

ENI's selection of solid state Class A power amplifiers is unsurpassed,



combining a frequency spectrum of 10 kHz to 1 GHz with power outputs that range from 300 milliwatts to over 4,000 watts. Rugged, compact, and versatile, these units can be driven by virtually any signal source. They're completely broadband and untuned, amplifying inputs of AM,

FM, TV, SSB, and pulse modulations with minimum distortion. Their unconditional stability and failsafe design make them impervious to severe mismatch conditions, and capable of delivering rated power to any load impedance from an open to a short circuit.

Clearly, when it comes to meeting your power amplification needs, you'll get the utmost in flexibility from the advanced design of RF power amplifiers... ENI.

ENI

ENI products available through ENI Power Systems, Ltd., 23 Old Park Road, Hitchin, Hertfordshire, England SG52JS, Tel: Hitchin 51711, TELEX 825153
ENI UK G. And: **AUSTRALIA:** Elmeasco Instruments Pty Ltd., Concord N.S.W. Australia, Tel: 939-7944 **BELGIUM:** MCR Electronics Marketing, 1420 Braine
L'Alleud, Belgium, Tel: 02/384.80.62 **DENMARK:** Instrutek, 8700 Horsens, Tel: 05-611100 **EGYPT:** Electronic Precision Instrument Co., P.O. Box 1262, Cairo,
Arab Republic of Egypt, Tel: 860819 **FRANCE:** Comsatec, 92300 Levallois-Perret, France, Tel: 758.59.10 **GERMANY, AUSTRIA:** Kontron Elektronik GmbH,
8057 Eching/Munich 1, Germany, Tel: 89-3188-1 **ISRAEL:** RDT Electronics Engineering Ltd., Tel Aviv 61210, Israel, Tel: 483211-5 **ITALY:** Vianello S.p.A.,
I-20121 Milano, Italy, Tel: 34.52.071 **JAPAN:** Astech Corporation, Shinjuku-ku, Tokyo 160, Japan, Tel: Tokyo 343-0601 **NETHERLANDS:** Koning en Hartman
Elektrotechniek B.V., The Hague 2040, Netherlands, Tel: 70-678380 **SOUTH AFRICA:** Associated Electronics (Pty.), Ltd., Johannesburg, South Africa,
Tel: 724-5396 **SWEDEN:** Saven AB, S-18500 Vaxholm, Sweden, Tel: 0764/31580 **SWITZERLAND:** Kontron Electronic AG, 8048 Zurich, Switzerland,
Tel: 01 62 82 82 **UNITED KINGDOM:** Dale Electronics, Ltd., Frimley Green, Camberley, Surrey, England, Tel: Deepcut (02516) 5094

Circle 250 on reader service card

World's largest
local distributor
with 44 locations
stocking the finest
lines of electronic
components and
computer products

ALABAMA
Huntsville (205) 837-7210

ARIZONA
Phoenix (602) 231-5100

CALIFORNIA
Avnet, L.A. (213) 558-2345
Avnet, O.C. (714) 754-6111
Hamilton, L.A. (213) 558-2121
Hamilton, O.C. (714) 641-4100
San Diego (714) 571-7510
San Francisco (408) 743-3355

COLORADO
Denver (303) 779-9998

CONNECTICUT
Danbury (203) 797-2800

FLORIDA
St. Petersburg (813) 576-3930
Miami (305) 971-2900

GEORGIA
Atlanta (404) 447-7507

ILLINOIS
Chicago (312) 860-7700

INDIANA
Indianapolis (317) 844-9333

KANSAS
Kansas City (913) 888-8900

MARYLAND
Baltimore (301) 995-3500

MASSACHUSETTS
Boston (617) 273-7500

MICHIGAN
Detroit (313) 522-4700
Grand Rapids (616) 243-8805

MINNESOTA
Minneapolis (612) 932-0600

MISSOURI
St. Louis (314) 344-1200

NEW JERSEY
Fairfield (201) 575-3390
Cherry Hill (609) 424-0100

NEW MEXICO
Albuquerque (505) 765-1500

NEW YORK
Long Island (516) 454-6060
Syracuse (315) 437-2641
Rochester (716) 475-9130

NORTH CAROLINA
Raleigh (919) 829-8030

OHIO
Cleveland (216) 831-3500
Dayton (513) 433-0610

OREGON
Portland (503) 635-8831

TEXAS
Dallas (214) 659-4111
Houston (713) 780-1771
Austin (512) 837-8911

UTAH
Salt Lake City (801) 972-2800

WASHINGTON
Seattle (206) 453-5844

WISCONSIN
Milwaukee (414) 784-4510

INTERNATIONAL
Telex 66-4329
Telephone (213) 558-2441

CANADA
Toronto (416) 677-7432
Montreal (514) 331-6443
Ottawa (613) 226-1700
Calgary (403) 230-3586

JAPAN
Tokyo (03) 662-9911
Osaka (06) 533-5855

MOTOROLA AND HAMILTON/AVNET ANSWER THE 64,000 BIT QUESTION.

64K

MOTOROLA from HAMILTON/AVNET

With 16K prices at an all-time low, you're probably asking, "Is it economically feasible to start designing in 64K RAM devices?" It's the 64,000 bit question, and the answer is a resounding YES! With Motorola's 5 Volt dynamic MCM6664 (pin 1 refresh) and MCM6665, it is now practical, even preferable, to cross over to 64K. Because while 16K prices have been decreasing, so too has the cost of Motorola's 64K RAMs. And when you consider the savings in PC board real estate and reduced power supply requirements, you've got a rather convincing cost argument.

Of course other factors weigh heavily on

the decision to go the 64K route. Like performance, reliability, and availability. On all counts, Motorola is an industry leader. They're shipping hundreds of thousands of units monthly—more than any other U.S. supplier,—in fact, more than just about all manufacturers. And with Hamilton/Avnet's in-depth local inventory, you're assured of prompt delivery to meet your increasing production demands.

If you've been pondering the 64,000 bit question, call any of our 44 locations for more information on Motorola's 64K dynamic RAMs. Together, Motorola and Hamilton/Avnet have answered the 64,000 bit question!



Hamilton Avnet
ELECTRONICS  A DIV. OF AVNET, INC.

A commitment to stock and serve your local market!

Circle 902 on reader service card
World Radio History