

NOVEMBER 17, 1981

JAPANESE MAP STRATEGY FOR FIFTH-GENERATION COMPUTERS/83

Low-cost MES FET receivers capture satellite TV for home/ 125

Data-base management comes to microcomputers/ 129

SIX DOLLARS

A Mc GRAW-HILL PUBLICATION

International

Electronics[®]

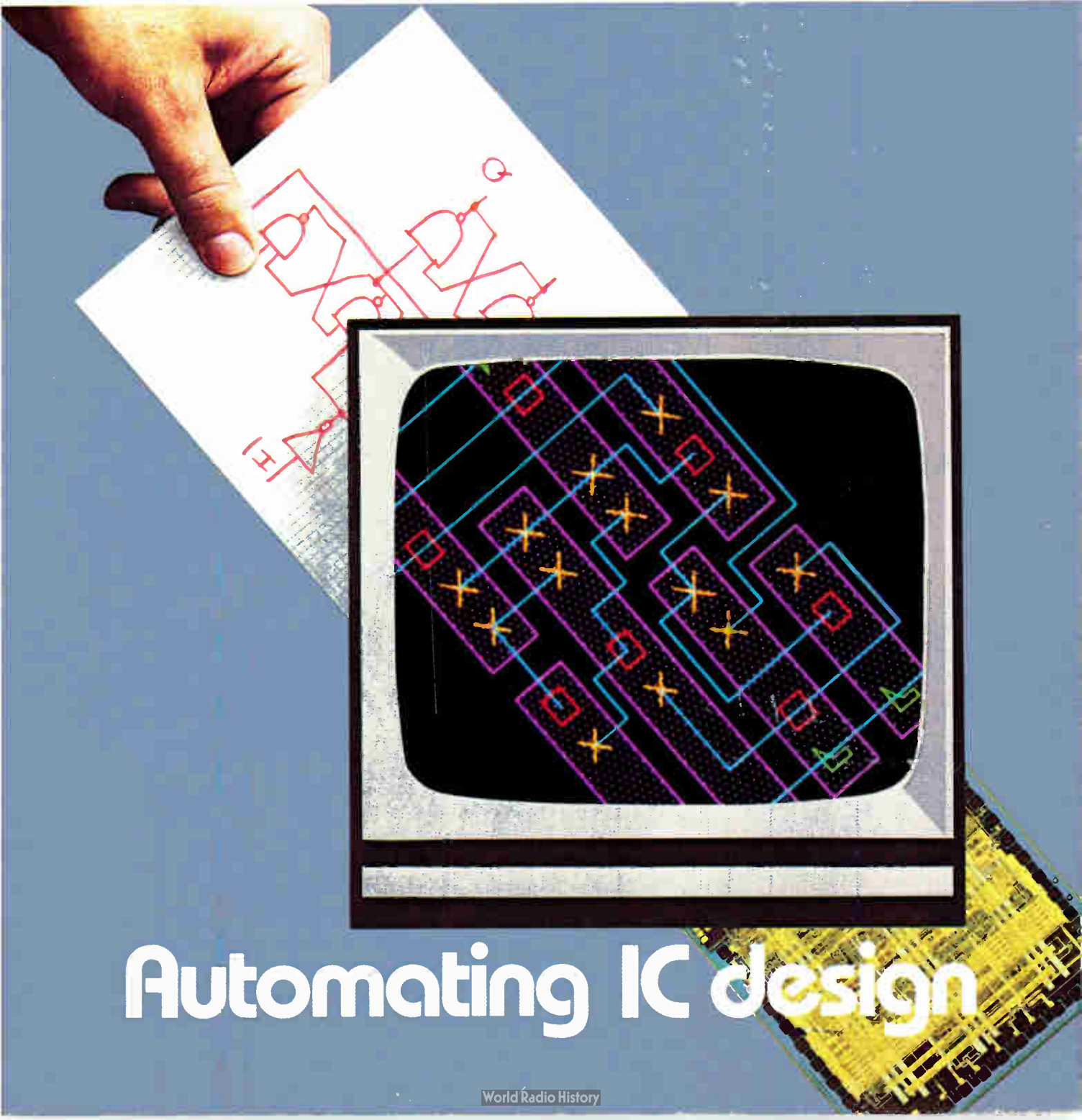

Automating IC design

CIRCUIT BOARD TESTING: SHOULD IT BEGIN IN PRODUCTION OR IN THE LAB?

Some successful companies charge production with the responsibility for developing test procedures. Others give the job to the design lab. And with many it's a shared responsibility.

However, if these methods were decided by the standards of yesterday's technology, you may increase today's productivity with a different approach. Consider these points:

Testing options begin in the lab.

With today's product designs using microprocessors, memory and other LSI circuits, the question "How to test?" will arise long before a design is released to production. When asked in the hardware/software definition phase, electronic manufacturers can opt for one of three approaches: 1) Not to design for testability, thus leaving test development responsibility to production. 2) Design for go/no-go self test, covering a "critical" subset of board functions, and leaving fault isolation to skilled technicians in production as well as the field. 3) Design for thorough self test, including diagnostics, which facilitate fault isolation, thus providing a total test solution for R&D, production and field service.

Can you afford to design for testability?

Let's take a look at the trade-offs. Option 1 appears to offer the shortest design cycle. However, the designer

will probably take longer than planned in design turn-on. And design follow-up with production often takes more effort than expected. Longer production test development time is also likely to delay shipments.

Designing in a go/no-go self test (option 2) solves some of the problems associated with option 1. However, a limited self test may still lead to failures at system turn-on. And without fault isolation, expensive technician time will be needed in production and field service.

At first glance, option 3 may seem to require too much of the designer's time. However, the payback can be significant in reduced debugging time and enhanced test effectiveness. After all, the designer best understands the product structure and critical aspects of its operation. And the designer has the tools and the opportunity to implement design features often required for high fault-coverage testing of complex LSI circuitry.

A decision that impacts production most.

Whatever the decision, production will feel its effect most. A balance must be found between design time and a viable board test solution. HP provides that balance with the 3060A Board Test System. Equipped with the High Speed Digital Functional Test Option (HSDFT), it delivers the flexibility to solve your μ P and LSI board testing problems whether you design for testability or not.

For example, the 3060A can activate μ P-based, designed-in stimulus

firmware and measure the dynamic board response using Signature Analysis. If self-stimulus isn't available you can use the HSDFT programmable stimulus capability (Figure 1).

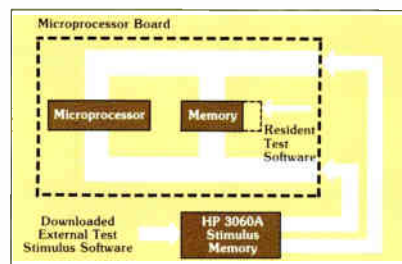

Figure 1 — The 3060A can activate resident test stimulus software or provide that stimulus from its own RAM.

Test stimulus software developed for design turn-on can even be leveraged for production test by downloading from your design system (such as the HP 64000) into 3060A stimulus RAM. Or, alternatively, HP's 3060A Digital Functional Test software provides easy-to-use stimulus and measurement programming procedures.

For fault isolation, the 3060A HSDFT software provides automatic backtracking via in-circuit visibility on the basis of a topological description of the board. And, these procedures can be used as the basis for effective field service repair using HP Signature Analysis instrumentation (HP's 5005A).

The bottom line? Rapid software development, thorough testing, high throughput and efficient field troubleshooting — the complete solution. That's worth investigating.

For more information.

Let HP help you optimize your investment in design, test and service. Write Hewlett-Packard, 1820 Embarcadero Road, Palo Alto, CA 94303. Or call the HP regional office nearest you: East (201) 265-5000, West (213) 970-7500, Midwest (312) 255-9800, South (404) 955-1500, Canada (416) 678-9430.

**HP Circuit Testers—
The Right Decision**

 **HEWLETT
PACKARD**

VISIT US AT ATE,
BOOTH #801-806

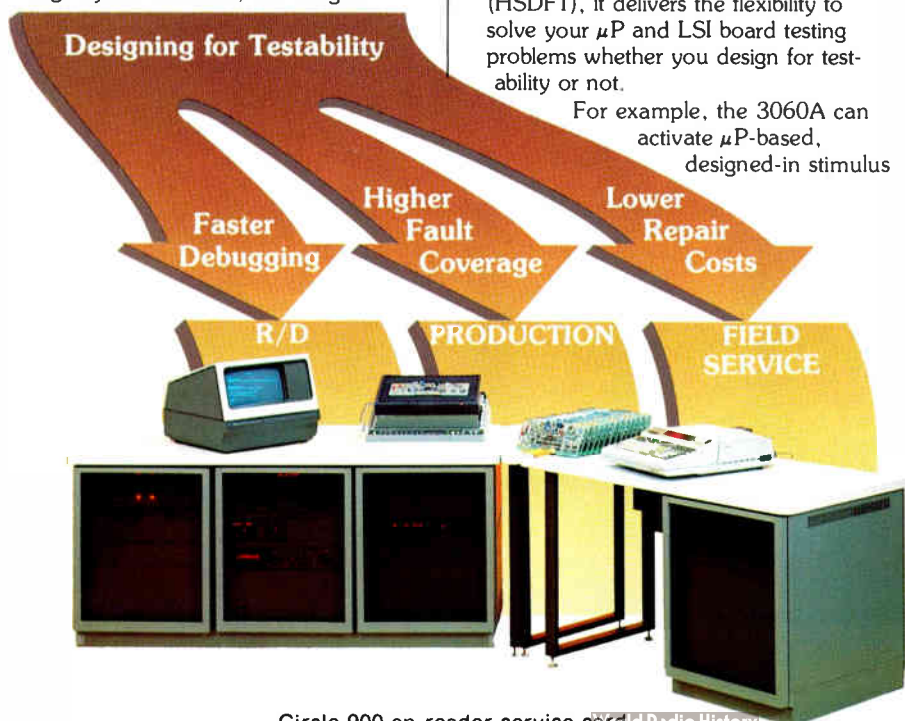

SURPRISE!

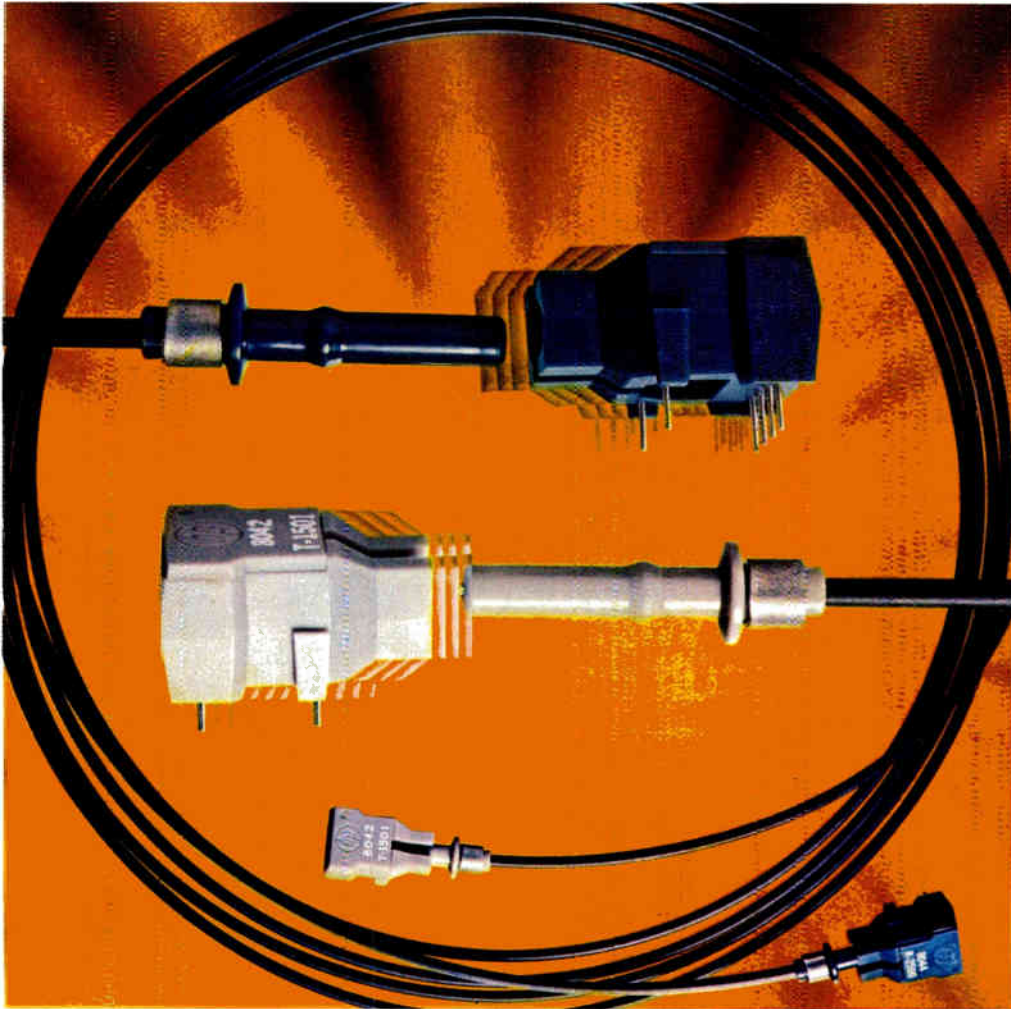

HP's New \$55 Link Makes Fiber Optics a Real Snap.

Now you can afford to use fiber optics. For just \$55.00* HP's new Snap-In Fiber Optic Kit, the HFBR-0500, gives you an LED transmitter module, an integrated TTL output receiver, 5 metres of connected plastic fiber cable, 2 spare connectors, polishing tool, and technical literature.

The cabled connectors simply snap-in to each of the modules. It's that easy! No special tools or epoxy are needed for installation.

If you're cost conscious, the HFBR-0500 kit is an affordable solution for your short distance applications.

Performance is guaranteed up to 10 Mbaud for cable lengths up to 5 metres. Longer distances are possible at lower data rates.

For more information or immediate off-the-shelf delivery, call your nearest HP components authorized distributor. In the U.S., contact Hall-Mark, Hamilton/Avnet, Pioneer Standard, Schweber, or the Wyle Distribution Group. In Canada, call Hamilton/Avnet or Zentronics, Ltd.



TEK S-3275 SEMICONDUCTOR TEST SYSTEM

We handle difficult personalities.

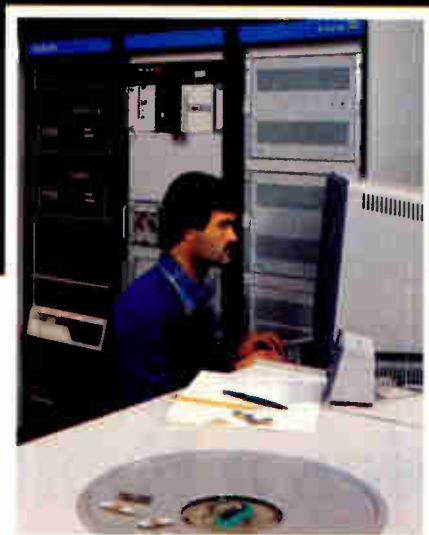

When it comes to characterization, many LSI/VLSI devices can be difficult little creatures. Normal evaluation procedures just won't work.

Like hybrids that present many simultaneous digital and analog operations. Or chips that require both algorithmic *and* random pattern testing. Plus the ability to change from one to the other on the fly.

There's only one test system that thrives on truly difficult personalities. The Tektronix S-3275. The more complex the device, the more you appreciate what the S-3275 can do.

Why? Because only the S-3275 combines all the right features into a single, powerful package. One that gives you the flexibility demanded by a growing versatility in device design and function.

A system that optimizes design engineering productivity.

With 128 channels at 20 MHz, the S-3275's state-of-the-art pattern processor combines the functions of pattern processing and algorithmic pattern generation. The clock system provides 125 pS resolution on each of 16 phases. Plus the S-3275 has a waveform digitizer to provide FFT and THD analysis.

With the S-3275, you get more than just sophisticated hardware. You get TEKTEST III™, an operating system that allows up to four concurrent tasks.

So when you've got some difficult LSI/VLSI devices to handle, ask us. We know what to do with those kind of personalities.

For more information about the S-3275, contact your Tek Sales Engineer.

U.S.A., Asia, Australia, Central & South America, Japan
Tektronix, Inc.
P.O. Box 4828
Portland, OR 97208
Phone: 800/547-6711
Oregon only 800/452-6773
Telex: 910-467-8708
Cable: TEKTRONIX

Canada
Tektronix Canada Inc.
P.O. Box 6500
Barrie, Ontario L4M 4V3
Phone: 705 737-2700

Europe, Africa, Middle East
Tektronix International, Inc.
European Marketing Centre
Postbox 827
1180 AV Amstelveen
The Netherlands
Telex: 18312

Tektronix
COMMITTED TO EXCELLENCE

106 Technical Articles

SPECIAL REPORT: COMPUTER-AIDED DESIGN

Introduction, 106

CAD tools must change to meet the needs of VLSI, 108

Multi-MOS structure speeds layout of VLSI chips, 111

Multiuser IC cell library buys custom densities at gate-array prices, 114

Structured logic-design system is fast and affordable, 117

COMMUNICATIONS & MICROWAVES

Low-cost 12-GHz receiver heralds satellite-to-home TV, 125

MICROSYSTEMS & SOFTWARE

Data-base manager fits microsystems, is application-independent, 129

TEST & MEASUREMENT

Rf level meter quashes errors from internal noise, 132

DESIGNER'S CASEBOOK: 122

ENGINEER'S NOTEBOOK: 137

37 Electronics Review

SOLID STATE: Superfast MOS outdoes gallium arsenide in switching speed, 37

Commercialization of GaAs is at hand, 38

SPEECH SYNTHESIS: Development systems add in-house voice, 38

RADAR: Former freighter sails off with the latest in phased arrays, 39

PERIPHERALS: Video recorders set to back up Winchester disk drives, 40

LOCAL NETWORKS: Interfaces let users mix gear, 40

MEDICAL: Computerized tomographic body scanners get new entries, 42

NEWS BRIEFS: 44

MILITARY: R&D for Stealth aircraft moves ahead, 44

PACKAGING: Pin count hits 40 in small-outline IC package, 46

PERIPHERALS: Dot-matrix printer 'hues' the line, 47

55 Electronics International

FRANCE: Cobalt over chrome outclasses oxides for magnetic disks, 67

JAPAN: 1.5-micrometer laser operates at room temperature, 68

WEST GERMANY: Barometer calls fair or foul, 70

GREAT BRITAIN: Computer and telecommunications-gear makers rush into office-automation market, 72

NEW PRODUCTS INTERNATIONAL: 9E

83 Probing the News

COMPUTERS: Japanese map domination with fifth-generation systems, 83

DATA COMMUNICATIONS: Encryption chips find a new use as message authenticators, 87

COMPONENTS: Chip resistors gain support, 90

CAREERS: U. S. asked to help turn out more EEs, 96

149 New Products

IN THE SPOTLIGHT: Small firmware-oriented controller board uses PDP-11 chip, 149

Net gets color graphics, laser printer, 154

SEMICONDUCTORS: 55-ns C-MOS 4-K RAM stands by on 100 μ A, 162

Chip's four diodes are isolated to 1 kV, 162

COMPONENTS: Bi-FET op amp has multiplexed inputs and programmable gain, 172

Long multiple-tap capacitors distribute power, 172

SOFTWARE: Graphics library joins p-System, 182

Report generator processes data, 182

COMPUTERS & PERIPHERALS: 125-in./s streamer has capstan for fast starting and stopping at 45 in./s, 188

Departments

Highlights, 4

Publisher's letter, 6

Readers' comments, 8

News update, 12

People, 14

Editorial, 24

Meetings, 26

Electronics newsletter, 33

Washington newsletter, 51

Washington commentary, 52

International newsletter, 57

Engineer's newsletter, 140

Products newsletter, 195

Career outlook, 196

Services

Reader service card, 29E

Employment opportunities, 197

EDITOR-IN-CHIEF: Samuel Weber

SENIOR MANAGING EDITOR *News*:

Arthur Erikson

MANAGING EDITOR *Technical*:

Raymond P. Capece

ASSOCIATE MANAGING EDITORS:

Alfred Rosenblatt, Howard Wolff

ASSISTANT MANAGING EDITOR:

Margaret Eastman

SENIOR EDITORS: Ray Connolly, John G. Posa

ART DIRECTOR: Fred Sklenar

BUSINESS TRENDS EDITOR: Howard Bierman

DEPARTMENT EDITORS

Aerospace/Military: Ray Connolly

Circuit Design: Ashok Bindra

Communications & Microwave:

Harvey J. Hindin

Components: Roderic Beresford

Computers & Peripherals: Tom Manuel

Microsystems & Software: R. Colin Johnson

New Products: Jeremy Young, Steve Zollo

Packaging & Production: Jerry Lyman

Solid State: John G. Posa

Test, Measurement & Control:

Richard W. Comerford

CHIEF COPY EDITOR: Margaret Eastman

COPY EDITORS: Marilyn A. Harris, David Kach,

Erik L. Keller, Benjamin A. Mason

ART: Charles D. Ciatto, *Associate Director*

Sachiko Inagaki, *Assistant Director*

EDITORIAL ASSISTANT: Penny Reitman

ADMINISTRATIVE ASSISTANT: Kathleen Morgan

EDITORIAL SECRETARIES: Janice Jung,

Josephine Ortiz, Dawn Ramsay

REGIONAL EDITORS

Boston: James B. Brinton,

Linda Lowe (617) 262-1160

Chicago: Wesley R. Iversen (312) 751-3811

Costa Mesa: Terry Costlow (714) 557-6292

Dallas: J. Robert Lineback (214) 742-1747

Los Angeles: Larry Waller (213) 487-1160

Palo Alto: Martin Marshall (415) 968-2712

Washington: Ray Connolly (202) 624-7592

Frankfurt: John Gosch 72-5566

London: Kevin Smith 493-1451

Paris: Robert T. Gallagher 723-4656

Tokyo: Charles Cohen,

Robert Neff 581-9816

McGraw-Hill WORLD NEWS

Michael Johnson, *Editor*; James Smith, *Brussels*

Lois Bolton, *Milan*; Alex Beam, *Moscow*

Robert Skole, *Stockholm*

PUBLISHER: Paul W. Reiss

GENERAL MANAGER, DIRECT MARKETING

OPERATIONS: Horace T. Howland

DIRECTOR OF CIRCULATION: Frederick J. Kostbar

RESEARCH MANAGER: Margery D. Sholes

PROMOTION MANAGER: Jane De Court

MARKETING ADMINISTRATION MANAGER:

Frances M. Vallone

BOOKS & SPECIAL PROJECTS MANAGER:

Janet Eyer

SERVICE REVENUE ASSOCIATE:

June A. Noto

Cover: Design automation facilitates VLSI efforts, 106

When it became clear that process technology could produce very large-scale integrated circuits, designers found they could not handle their complexity without new automated tools. Now these tools are appearing in full force, and their importance warrants a close look. The following four articles are the first in a series that will do just that; more will follow in future issues.

The cover illustration is by Art Director Fred Sklenar

■ **108.** The rash of new computer-aided design tools is only the beginning; useful as they are, greater effort must go into enhancing man-machine cooperation, as the history of VLSI design discloses.

■ **111.** One way to capitalize on CAD's advantages is a new basic logic cell—the Multi-MOS structure—that lends itself better to symbolic layout than do present cell architectures.

■ **114.** A library of standard cells that can be combined into semicustom ICs can provide designs with custom densities at gate-array prices.

■ **117.** Hierarchical structure of the logic-design task, plus separation of logic and timing validation, gives faster design with less computing power.

Japanese outline plans for fifth generation of computers, 83

What amounts to a sweeping master plan for the research and development necessary for a fifth computer generation has been unveiled by Japan. It would create machines with problem-solving, inferential capabilities.

Low-cost home receiver handles satellite TV signals, 125

Future television signals may travel via 12-gigahertz satellites, and a low-noise microwave receiver based on gallium arsenide metal-semiconductor field-effect transistors may make direct home reception possible.

Data-base management comes to microsystems, 129

More powerful microprocessors can support data-base management, but the missing ingredient has been the software to do it. A set of software tools fills this need and works with many operating systems and high-level languages.

Rf level meter boosts accuracy by damping internal-error noise, 132

Testing of radio-frequency equipment with greater precision and less operator input is possible with a new rf level meter. Controllable over an IEEE-488 bus, it boosts accuracy with special noise-cancellation and calibration circuits.

In the next issue . . .

A 16-bit microprocessor for peripheral-control functions . . . a preview of the International Electron Devices Meeting . . . more on VLSI CAD . . . packaging VLSI parts: a special report.

November 17, 1981 Volume 54, Number 23
105,919 copies of this issue printed

Electronics (ISSN 0013-5070). Published every other Tuesday except the issue of Monday, Nov. 30, by McGraw-Hill, Inc. Founder: James H. McGraw 1860-1948. Publication office 1221 Avenue of the Americas, N.Y., N.Y. 10020; second class postage paid at New York, N.Y. and additional mailing offices.

Executive, editorial, circulation and advertising addresses: Electronics, McGraw-Hill Building, 1221 Avenue of the Americas, New York, N.Y. 10020. Telephone (212) 597-1221. Teletype 12-7960 TWX 710-581-4879. Cable address: MCGRAW HILL NEW YORK.

Subscriptions limited to professional persons with active responsibility in electronics technology. No subscriptions accepted without complete identification of subscriber name, title or job function, company or organization, and product manufactured or services performed. Based on information supplied, the publisher reserves the right to reject non-qualified requests. Subscription rates: in the United States and possessions \$19 one year, \$32 two years, \$47 three years; company addressed and company libraries \$24 one year, \$42 two years, \$59 three years; Canada and Mexico \$20 one year, \$33 two years, \$48 three years; Europe \$50 one year, \$85 two years, \$115 three years; Japan, Israel and Brazil \$70 one year, \$115 two years, \$165 three years; Australia and New Zealand \$95 one year, \$170 two years, \$240 three years, including air freight; all other countries \$50 one year, \$85 two years, \$125 three years. Limited quota of subscriptions available at higher-than-basic rate for persons allied to field served. Check with publisher for these rates. Single copies: \$6.00. Please allow four to eight weeks for shipment.

Officers of McGraw-Hill Publications Company: Paul F. McPherson, President; Executive Vice Presidents: James E. Boddorf, Gene W. Simpson; Group Vice President: Daniel A. McMillan; Senior Vice President:

Editorial: Ralph R. Schulz; Vice Presidents: Kemp Anderson, Business Systems Development; Robert B. Doll, Circulation; James E. Hackett, Controller; Eric B. Herr, Planning and Development; H. John Sweger, Marketing

Officers of the Corporation: Harold W. McGraw, Jr., Chairman and Chief Executive Officer; Joseph L. Dionne, President and Chief Operating Officer; Robert N. Landes, Senior Vice President and Secretary; Ralph J. Webb, Treasurer.

Title registered in U.S. Patent Office; Copyright © 1981 by McGraw-Hill, Inc. All rights reserved. The contents of this publication may not be reproduced in whole or in part without the consent of copyright owner.

Where necessary, permission is granted by the copyright owner for libraries and others registered with the Copyright Clearance Center (CCC), 21 Congress Street, Salem, MA 01970, to photocopy any article herein for the base fee of \$0.50 per copy of the article plus \$0.25 per page. Payment should be sent directly to the CCC. Copying done for other than personal or internal reference use without the express permission of McGraw-Hill is prohibited. Requests for special permission or bulk orders should be addressed to the publisher. ISSN 0013-5070/81\$0.50+.25.

Subscribers: The publisher, upon written request to our New York office from any subscriber, agrees to refund that part of the subscription price applying to copies not yet mailed. Please send change-of-address notices and complaints to Fulfillment Manager; subscription orders to Circulation Manager, Electronics, at address below. Change-of-address notices should provide old as well as new address, including zip codes. Attach address label from recent issue. Allow one month for change to become effective. Subscriber Service: call (609) 448-8110, 9 a.m. to 4 p.m. EST.

Postmaster: Please send form 3579 to Fulfillment Manager, Electronics, P.O. Box 430, Hightstown, N.J. 08520.

RF transformers

the world's widest selection of matching ratios
10KHz-800MHz...balanced, DC isolated, center-tapped
 46 off-the-shelf models from Mini-Circuits from \$2⁹⁵

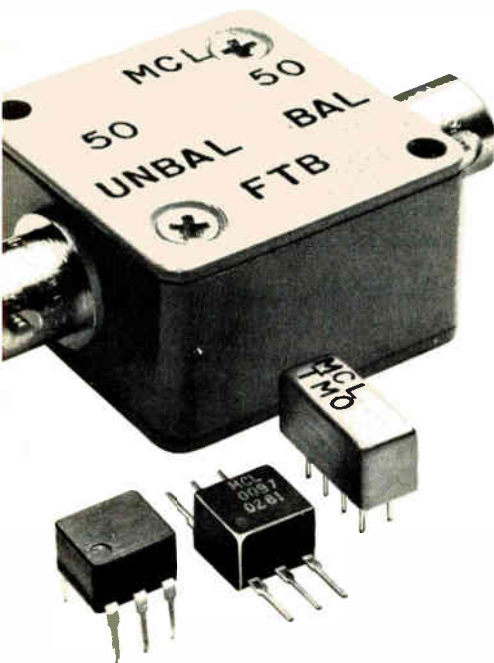

Bent Lead version,
 please specify

Select from the economical, microminiature T-series (plastic case) or TMO series (hermetically-sealed metal case) covering 10 KHz to 800 MHz. These models operate from 12.5 to 800 ohms with insertion loss typically less than 0.5 dB.

For large dynamic range applications, specify the T-H series which can handle up to 100 mA primary current without saturation or distortion.

Need a connector version? Select from the FT or FTB series, available with unbalanced or balanced outputs. Connector choices are female (BNC, Isolated BNC, and Type N) and male (BNC and Type N). These units operate from 10 KHz to 500 MHz with impedances of 50 and 75 ohms.

Of course, Mini-Circuits' one-year guarantee is included.

DC ISOLATED PRIMARY & SECONDARY



	T1-1	T1-1H	T1.5-1	T2.5-6	T4-6	T9-1	T9-1H	T16-1	T16-1H
Model No.	TMO1-1		TMO1.5-1	TMO2.5-6	TMO4-6	TMO9-1		TMO16-1	
Imped. Ratio	1	1	1.5	2.5	4	9	9	16	16
Freq. (MHz)	.15-400	8-300	.1-300	.01-100	.02-200	.15-200	2-90	.3-120	7-85
T Model (10-49)	\$2.95	\$4.95	\$3.95	\$3.95	\$3.95	\$3.45	\$5.45	\$3.95	\$5.95
TMO model (10-49)	\$4.95		\$6.75	\$6.45	\$6.45	\$6.45		\$6.45	

CENTER-TAPPED DC ISOLATED PRIMARY & SECONDARY



	T1-1T	T2-1T	T2.5-6T	T3-1T	T4-1	T4-1H	T5-1T	T13-1T
Model No.	TMO1-1T	TMO2-1T	TMO2.5-6T	TMO3-1T	TMO4-1		TMO5-1T	TMO13-1T
Imped. Ratio	1	2	2.5	3	4	4	5	13
Freq. (MHz)	.05-200	.07-200	.01-100	.05-250	.2-350	8-350	.3-300	.3-120
T Model (10-49)	\$3.95	\$4.25	\$4.25	\$3.95	\$2.95	\$4.95	\$4.25	\$4.25
TMO model (10-49)	\$6.45	\$6.75	\$6.75	\$6.45	\$4.95		\$6.75	\$6.75

UNBALANCED PRIMARY & SECONDARY



	T2-1	T3-1	T4-2	T8-1	T14-1
Model No.	TMO2-1	TMO3-1	TMO4-2	TMO8-1	TMO14-1
Imped. Ratio	2	3	4	8	14
Freq. (MHz)	.025-600	.5-800	.2-600	15-250	2-150
T model (10-49)	\$3.45	\$4.25	\$3.45	\$3.45	\$4.25
TMO Model (10-49)	\$5.95	\$6.95	\$5.95	\$5.95	\$6.75

FT FTB

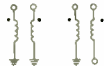

	FT1.5-1	FTB1-1	FTB1-6	FTB1-1-75
Model No.				
Imped. Ratio	1.5	1	1	1
Freq. (MHz)	1-400	.2-500	.01-200	.5-500
(1-4)	\$29.95	\$29.95	\$29.95	\$29.95

Mini-Circuits

A Division of Scientific Components Corp.

World's largest manufacturer of Double Balanced Mixers
 2625 East 14th Street, Brooklyn, New York 11235 (212)769-0200
 Domestic and International Telex 125460 International Telex 620156

Never before...

200 watts of RF power with incredible versatility.

3200 L spans
250 kHz to 150 MHz.



Now there's a completely solid state power amplifier that provides 200 watts of linear power over a frequency range from 250 kHz to 120 MHz. And at 175 watts, the range extends to 150 MHz.

Imagine the wide range of applications you can cover with this single Class A linear unit. All you need is any standard signal or sweep generator and you have the ultimate in linear power for RFI/EMI testing, NMR, RF Transmission, and general laboratory applications.

And, like all ENI power amplifiers, the 3200 L features unconditional stability, instantaneous failsafe provisions, and absolute protection from overloads and transients.

The 3200 L represents a breakthrough in RF power versatility and packaging. Never before has there been anything like it commercially available anywhere!

Contact us for a demonstration of the 3200 L and our complete catalog on the other amplifiers in our wide line. ENI, 3000 Winton Road South, Rochester, NY 14623.

Call 716/473-6900, or Telex 97-8283 ENI ROC.

ENI



The advanced
design line of
power amplifiers

Publisher's letter

This issue launches a series of articles on design automation—the rapidly exploding technology that industry is embracing to deal with the vast complexity of very large-scale integrated circuits. The series, which will run into the next issue and beyond, actually was born as a result of the incisive Inside the News story that was reported over a year ago [*Electronics*, July 31, 1980, p. 73] by West Coast editors Marty Marshall and Larry Waller. Even then, the importance and timeliness of the subject landed it on our cover.

But even before that article was put to bed, the scope of activity in computer-aided design—or design automation as it is increasingly being called—at companies ranging from American Microsystems Inc. to Zymos Corp. made our editors on both coasts realize there was much more going on than a single article could encompass. So articles were solicited from some of the people who were interviewed in the original story and the lineup was bolstered by other major contributors to the design-automation field. Senior editor John Posa was put in charge of implementing the project.

"The articles in this series are a good beginning," says John, "but by next year we could probably produce another special with a whole new set of authors writing about a whole new set of techniques. Things are moving that quickly."

John sees a similarity now between higher-level software languages and the new methods used to design chips. "Both are hierarchical in nature and allow the user to come up with a global solution. Just as a Fortran program will not produce the most compact machine code,

hierarchically designed chips will not be as dense as hand-crafted ones," he observes. "But the issue here is not perfection—it's productivity."

While some in the field favor the term computer-aided design, the name design automation appears to be gaining among the participants. "I think it has to do with the extent of the computer's involvement in the task," John comments. "Computer-aided design connotes a computer helping a person to solve a problem, whereas with design automation the person merely guides the machine while it does most of the work."

The scope of the report required a joint effort between bureau editors and staff editors, many not usually involved with IC layout principles. From this wide participation, an appreciation for the new techniques evolved that, in turn, was instrumental in the selection of Carver Mead and Lynn Conway—proponents of hierarchical system design—as 1981 achievement award winners [*Electronics*, Oct. 20, p. 102].

"The work in design automation is exciting, and I'm pleased with its rapid industry acceptance," says John. "I agree with Ben Lee [author of the article that starts on p. 108] that IC design is beginning to cost more than IC processing. That means the microelectronics industry is facing an entirely new set of economic considerations."

Wanted: a Silicon Valley editor

Electronics has a key editorial position open for a journalist who can cover business and technology developments in semiconductors, test and measuring instruments, and computers. Based in our Palo Alto, Calif., bureau, the job requires a newperson who can build a beat and turn out sprightly copy. A background in engineering or science is desirable, but not mandatory; more important is a desire to report on and write original stories about high technology. We pay competitive salaries with excellent fringe benefits. Write, telling why you are the person for the job, to the Managing Editor (News), at *Electronics*, 1221 Ave. of the Americas, New York, N. Y. 10020.

The plot may be complicated,

but this new programmable arbitrary waveform/function generator makes the resolution clear

Any waveform you can draw can be entered directly in volts on the new 5910 generator by means of a 1024 x 4000 matrix. Or instead of manually plotting the points, set the Autoprogrammer to rapidly create any waveshape that can be expressed using loops that involve basic arithmetic functions. Either way, your waveforms can be reproduced repetitively, at any amplitude, with excellent waveform resolution.

By adding this arbitrary waveform capability to our popular GPIB-compatible 5900 function generator, Krohn-Hite offers you double function for

your dollar. You have at your fingertips the versatility of a function generator with a bank of nine Storage Registers and an Autoprogrammer with self-contained memory for storing up to 360 steps. Or you can select ARB and produce your own waves digitized to 12-bit resolution.

Easy — that's what they're saying about the 5910. Easy to operate and easy on the budget. Now you can have an arbitrary waveform generator AND a programmable function generator in a single unit.



KH KROHN-HITE CORPORATION

Avon Industrial Park, Avon, MA 02322
(617) 580-1660 TWX 710 345 0831

Krohn-Hite ... Benchmark of Quality in Programmable Instruments

OVERSEAS SALES OFFICES:

Arab Republic of Egypt, 860819-963989; Argentina, 52-3185; Austria, 42-23-58, 43-52-87; Australia, 3567333, (07) 52-7255, 03 699 4999, 648 1711/648-1381; Belgium, 02-35.21.35; Denmark, (02) 80-42-00, (45) 6 19 09 77; England, (0734) 861-287; Finland, (90) 742-133; France, 956-81-31; Germany, 0-89/7-14-40-65; Holland, 070-996360; India, 53-30-76; Israel, 72 73 17, 72 87 16; Italy, (02) 34.52.071; Japan, (03) 6675945; New Zealand, TWX, FF7913824; Norway, (02) 78-94-60; Portugal, 57-19-61; Singapore, 637944; So. Africa, (2711) 786-3647; Spain, 257-62-00, 258-09-07; Sweden, 08/38-03-70; Switzerland, 01/734/4171; Taiwan, TWX, 78523855

Circle 195 on reader service card

TOUGH LITTLE TAPE SYSTEM

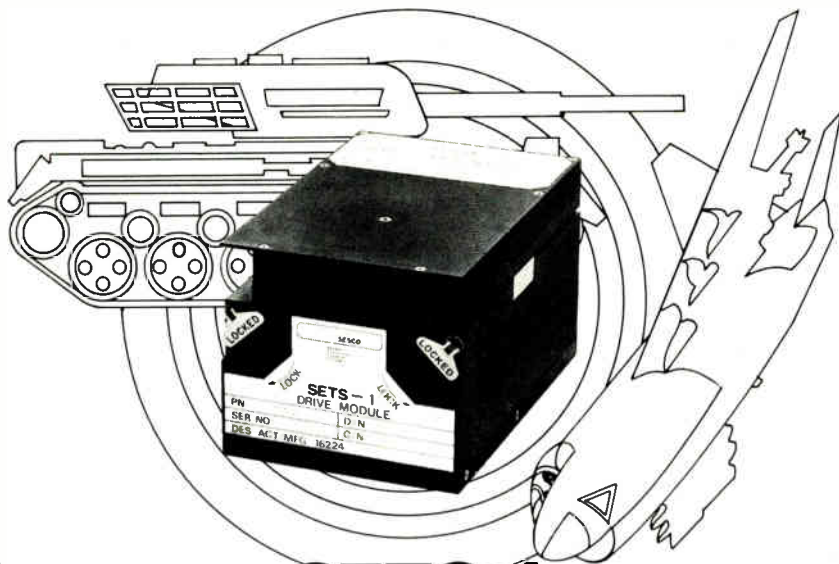

SETS-1

A 23-megabit digital tape system for airborne and other severe environments

Meeting MIL-E-16400, 5400 and 4158, SETS-1 is a compact digital tape system which stores 23 megabits of data at 1600 bits per inch on 300 feet of 1/4-inch magnetic tape. It has bidirectional read/write on 4 tracks with a 192K bit-per-second transfer rate.

SETS-1 consists of a compact drive module coupled to a removable, hermetically sealed tape module. It's being used right now by the Army and Air Force for bulk storage and data gathering from tanks, aircraft and remote sites. Also as a data entry device for mission loaders, communications and fire control systems.

Phone or write for details today.



Severe Environment Systems Company
A Subsidiary of Electronic Memories & Magnetic Corporation

P.O. Box 668 • Chatsworth, CA 91311 • Telephone: (213) 998-9090 • TELEX 69-1404



Circle 8 on reader service card



Electronics[®] IN-PLANT TRAINING SEMINARS

Our programs, conducted by skilled seminar leaders with extensive practical experience, can be presented at your location for ten or more attendees at significantly reduced costs.

For further information, call Mary Anderson at (212) 687-0243. Or write to her at the McGraw-Hill Seminar Center, Room 3112, 305 Madison Avenue, New York, NY 10017

Readers' comments

Pipeline precedents

To the Editor: With reference to the International Newsletter item on page 62 in the Oct. 6 issue ["C-MOS version of the 6801 arrives"], the complementary-MOS version of the 6801 designed at Hitachi is not the first 8-bit microprocessor to use pipeline control. The 6502, designed at Commodore's MOS Technology division, and its single-chip version, the 6500/1, were the first to use pipelining. Both are 8-bit processors.

G. Venkatesh

Commodore Semiconductor Group
Norristown, Pa.

Out of print

To the Editor: We have recently received inquiries indicating that reference was made on page 160 of *Electronics* magazine for Sept. 22 to Media Bulletin No. 2006 (1969), issued by the National Better Business Bureau on the subject of flash-light batteries.

We regret to inform your readers that the bulletin is not available and copies cannot be provided to anyone. Since it was prepared by the former National Better Business Bureau nearly 12 years ago, we could not attest to its accuracy today.

J. K. Orr, vice president
Industry Standards Division
Council of Better Business Bureaus

Corrections

In "Cool-running 16-K RAM rivals n-channel MOS performance" (Oct. 6, p. 121), several items in the panel entitled "Closing the price gap" had incorrect labels. The chart on the left should be credited to Integrated Circuit Engineering Corp., the one at the top right should be labeled C-MOS static RAMs, and the Y axis of the bottom right chart should reflect millions of units. Finally, in "IEDM entries continue to push limits" (Sept. 22, p. 97), Bell Laboratories was cited as having reduced the effect of alpha radiation using a buried n-type grid when the correct affiliation was IBM Corp.'s Thomas J. Watson Research Center, as noted in the table on page 99.

Interested in higher performance software?

The Mark Williams Company announces **COHERENT**[™], a state of the art, third generation operating system. **COHERENT** is a totally independent development of The Mark Williams Company. **COHERENT** contains a number of software innovations not available elsewhere, while maintaining compatibility with UNIX*. The primary goal of **COHERENT** is to provide a friendly environment for program development. The intent is to provide the user with a wide range of software building blocks from which he can select programs and utilities to solve his problems in the most straightforward manner.

COHERENT and all of its associated software are written totally in the high-level programming language **C**. Using **C** as the primary implementation language yields a high degree of reliability, portability, and ease of modification with no noticeable performance penalty.

Features

COHERENT provides **C** language source compatibility with programs written to run under Seventh Edition UNIX, enabling the large base of software written to run under UNIX (from numerous sources) to be available to the **COHERENT** user. The system design is based on a number of fundamental concepts. Central to this design is the unified structure of i/o with respect to ordinary files, external devices, and interprocess communication (pipes). At the same time, a great deal of attention has been paid to system performance so that the machine's resources are used in the most efficient way. The major features of **COHERENT** include:

- multiuser and multi-tasking facilities,
- running processes in foreground and background,
- compatible mechanisms for file, device, and interprocess i/o facilities,
- the shell command interpreter—modifiable for particular applications,
- distributed file system with tree-structured, hierarchical design,
- pipes and multiplexed channels for interprocess communication,
- asynchronous software interrupts,
- generalized segmentation (shared data, writable instruction spaces),
- ability to lock processes in memory for real-time applications,
- fast swapping with swap storage cache,
- minimal interrupt lockout time for real-

*UNIX is a trademark of Bell Labs

time applications,

- reliable power failure recovery facilities,
- fast disc accesses through disc buffer cache,
- loadable device drivers,
- process timing, profiling and debugging trace features.

Software Tools

In addition to the standard commands for manipulating processes, files, and the like, in its initial release **COHERENT** will include the following major software components: **SHELL**, the command interpreter; **STDIO**, a portable, standard i/o library plus run-time support routines; **AS**, an assembler for the host machine; **CROSS**, a number of cross-assemblers for other machines with compatible object format with 'AS' above; **DB**, a symbolic debugger for **C**, Pascal, Fortran, and assembler; **ED**, a context-oriented text editor with regular expression patterns; **SED**, a stream editor (used in filters) fashioned after 'ED'; **GREP**, a pattern matching filter; **AWK**, a pattern scanning and processing language; **LEX**, a lexical analyzer generator; **YACC**, an advanced parser generator language; **NROFF**, an Nroff-compatible text formatter; **LEARN**, computer-aided instruction about computers; **DC**, a desk calculator; **QUOTA**, a package of accounting programs to control filespace and processor use; and **MAIL**, an electronic personal message system.

Of course, **COHERENT** will have an ever-expanding number of programming and language tools and basic commands in future releases.

Language Support

The realm of language support is one of the major strengths of **COHERENT**. The following language processors will be supported initially:

- **C** a portable compiler for the language **C**, including stricter type enforcement in the manner of **LINT**.
- **FORTRAN** portable compiler supporting the full ANS Fortran 77 standard.
- **PASCAL** portable implementation of the complete ISO standard Pascal.

- **XYBASIC**[™] a state of the art Basic compiler with the interactive features of an interpreter.

The unified design philosophy underlying the implementation of these languages has contributed significantly to the ease of their portability. In particular, the existence of a generalized code generator is such that with a minimal effort (about one man-month) all of the above language processors can be made to run on a new machine. The net result is that the compilers running under **COHERENT** produce extremely tight code very closely rivaling that produced by an experienced assembler programmer. Finally, the unified coder and conformable calling sequences permit the intermixture of these languages in a single program.

Operating System

In part because of the language portability discussed above, and in part because of a substantial effort in achieving a greater degree of machine-independence in the design and implementation of the **COHERENT** operating system, only a small effort need be invested to port the whole system to a new machine. Because of this, an investment in **COHERENT** software is not tied to a single processor. Applications can move with the entire system to a new processor with about two man months of effort.

The initial version of **COHERENT** is available for the Digital Equipment Corporation PDP-11 computers with memory-mapping, such as the PDP 11/34. Machines which will be supported in the coming months are the Intel 8086, Ziilog Z8000, and Motorola 68000. Machines for which ports are being considered are the DEC VAX 11/780 and the IBM 370, among others.

Because **COHERENT** has been developed independently, the pricing is exceptionally attractive. Of course **COHERENT** is completely supported by its developer. To get more information about **COHERENT** contact us today.



1430 W. Wrightwood Ave., Chicago, IL 60614
TEL: 312-472-6659 TWX: 910-221-1182

A 14-BIT DAC AT

0.003%
LINEARITY-
4 TIMES THE ACCURACY

INTERSIL

ICL7134

14-BIT DAC

FEATURING ON-BOARD PROMS
FOR LINEARITY AND
FULL SCALE CORRECTION.

A 12-BIT PRICE.

Now you can get the Digital-to-Analog conversion accuracy you require.

At a price you can afford. Intersil's new ICL7134 is the world's first monolithic microprocessor-compatible DAC with true 14-bit accuracy. And prices start at what you'd expect to pay for a 12-bit DAC: an incredibly low \$19.95 (in 100's).

TECHNOLOGY BREAKTHROUGH PROVIDES TRUE 14-BIT ACCURACY.

The ICL7134 is the first DAC to replace conventional, costly laser trimming techniques with on-board PROMs for linearity and full-scale correction. The result? True 14-bit endpoint linearity (.003% max.). And an ideal DAC for applications in CRT display systems, process control, instrumentation, telephony, communications, and digital audio.

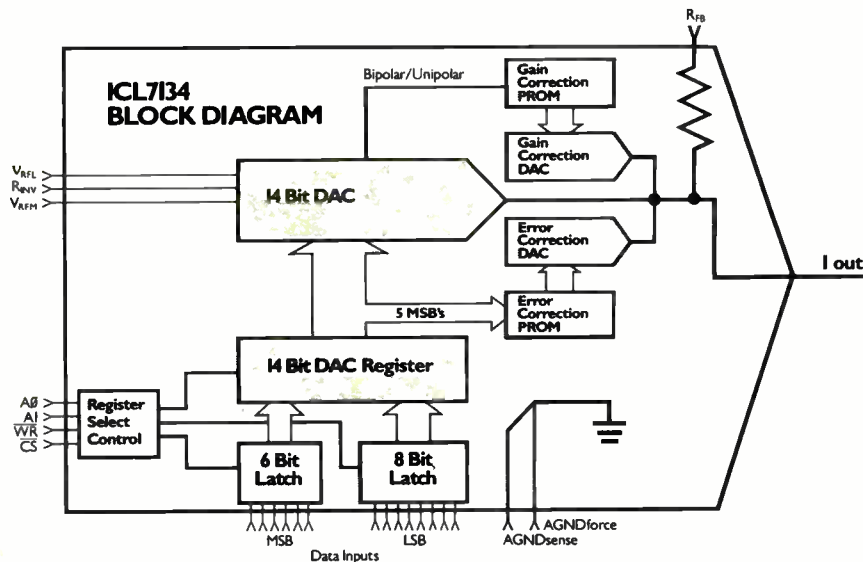

DIRECT MICROPROCESSOR INTERFACE.

Double buffered inputs provide a direct interface between the ICL7134 and standard 8- and 16-bit microprocessor buses. Data can be latched in as a single 14-bit byte or dual bytes, or go directly to the output switches under software control.

PRE-ADJUSTED FULL SCALE.

Say goodbye to costly, time-consuming full-scale tweaking. The ICL7134 is factory set to 0.006% max. An on-board PROM corrects full-scale, eliminating trimming potentiometers. So labor is reduced, reliability is increased, and long-term accuracy assured.

LOW POWER CMOS TECHNOLOGY. AND MORE.

The ICL7134 uses the low-power CMOS technology (10mW typical) that you've come to expect from Intersil. Its other specs are impressive, too: an extremely fast settling time (typically 900 ns.), extraordinarily low temperature drift

(5 ppm/°C), full four-quadrant multiplying capability, and a single +5 volt power supply. It all adds up to the best price/performance DAC you can buy.

NOW IN VOLUME PRODUCTION.

Now you can give your DAC applications the accuracy they deserve. Call your nearest Intersil sales office or franchised distributor, or send the coupon for full details and delivery information. The CMOS innovators at Intersil are making it a 14-bit DAC world. At a price you can't resist.

INTERNATIONAL OFFICES:

Northern and European headquarters: Intersil Datel (UK) Ltd., 9th Floor, Snamprogetti House, Basing View, Basingstoke, Hants, RG21 2YS, England. Tel: (0256) 57361. TLX: 858041 INTRSL G.

Central European headquarters: Intersil GmbH, 8000 Munchen 2, Bavariaring 8, West Germany. Tel: 89/539271. TLX: 5215736 INSL D.

Southern European headquarters: Intersil, Inc., Bureau de Liaison, 217, Bureaux de la Colline, Batiment D (2E Etage) 92213 Saint-Cloud Cedex, France. Tel: (1) 602.58.98. TLX: DATELEM 204280 F.

Far East headquarters (except Japan): Intersil, Datel (Hong Kong) Ltd., Rm. 1603, Perfect Commercial Bldg., 20 Austin Avenue, Tsim Sha Tsui, Kowloon, Hong Kong. Tel: 3-7214286-7. TLX: 39979 INTDL HX.

Japan representative: Internix, Inc., Shinjuku Hamada Bldg. (7th Floor), 7-4-7 Nishi Shinjuku, Shinjuku-Ku, Tokyo 160, Japan. Tel: (03) 369-1101. TLX: INTERNIX J26733.

INTERSIL

Intersil Datel (UK) Ltd.
9th Floor, Snamprogetti House,
Basing View, Basingstoke, Hants,
RG21 2YS, England.
Tel: (0256) 57361
TLX: 858041 INTRSL G.

E111781

Dear Intersil:

I'm ready for 14-bit DAC accuracy.

____ Please rush me your data sheet on the ICL7134.

Name _____

Company _____

Address _____

City/State/Zip _____

Phone _____

8 arc second accuracy for an astronaut's elbow

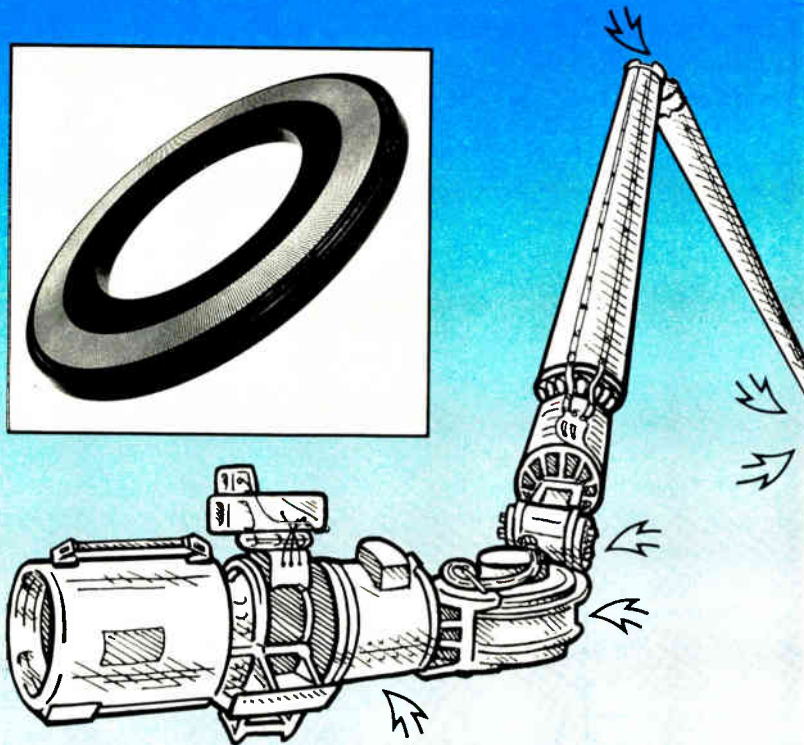

Six 2 inch diameter rotary Inductosyn® transducers are used in the shoulder, elbow, and wrist joints of the Remote Manipulator System* (RMS) arm installed in the cargo hold of the space shuttle to provide ± 8 arc second accuracy for precise servo control.

Inductosyn position transducers are unaffected by dust, oil films, sea water, hard vacuum, light, temperature variations, ionizing radiation, extreme pressure, and other hostile environments. They have operated at full accuracy for extended intervals in space, immersed in liquid nitrogen, and immersed in 600 feet of sea water. Noncontacting Inductosyn data elements have zero wear, never need lubrication. Single and multispeed units; 360 pole, 1024 pole, and others, accuracy to ± 0.5 arc second.

Call (914) 761-2600 today or write for down-to-earth information about Inductosyn rotary position transducers for applications from undersea to outer space.

**Built by Spar Aerospace Limited, Toronto, Canada,
under contract to the National Research Council of Canada.*

FARRAND CONTROLS

Division of Farrand Industries, Inc.
99 Wall Street Valhalla, NY 10595
(914) 761-2600 Telex: 646640

News update

■ Only six months ago, ECS Telecommunications Inc. of Richardson, Texas, had all to itself the market for electronic store-and-forward voice messaging [*Electronics*, April 21, p. 99]. Since then, however, a half-dozen firms—including IBM Corp.—have unveiled competing products. The systems cut the time wasted when office workers call someone but fail to reach the person they want.

Companies now offering voice-mail systems include: IBM in Armonk, N. Y.; Wang Laboratories Inc. of Lowell, Mass.; Delphi Communications Corp. of Los Angeles; Voice & Data Systems Inc. of Chicago; CXC Corp. of Irvine, Calif.; and Televoice International Corp. of Santa Clara, Calif.

Like ECS's voice-message exchange (VMX), which has been on the market for some 18 months, all these products are high-speed digital systems that are capable of storing, retrieving, and delivering verbal messages, much like text systems. But instead of using video-display terminals, voice systems generally employ push-button phones. Some equipment suppliers also lease voice "mailboxes" to users whose traffic does not justify a private system.

Stimulus. Like others in the industry, ECS believes the recent wave of entries—especially IBM's audio distribution system—will boost the market for voice-messaging equipment as well as increase competition. "Whenever IBM enters a market, it legitimizes it," says Kenneth G. Bosomworth, president of International Resources Development Inc. of Norwalk, Conn. "Because we know IBM is big and well-managed, we know from a corporate strategy standpoint that it wouldn't choose to enter a market unless it might be big. . . . it's clear IBM sees this as a market that will yield hundreds of millions of dollars."

Bosomworth, who has long followed developments in this area, has confidence in the prediction. He estimates that the entire voice-messaging market, both for businesses and consumers, will hit \$3.155 billion by 1990.

-J. Robert Lineback

You don't need a lot of lettuce to get a Cherry

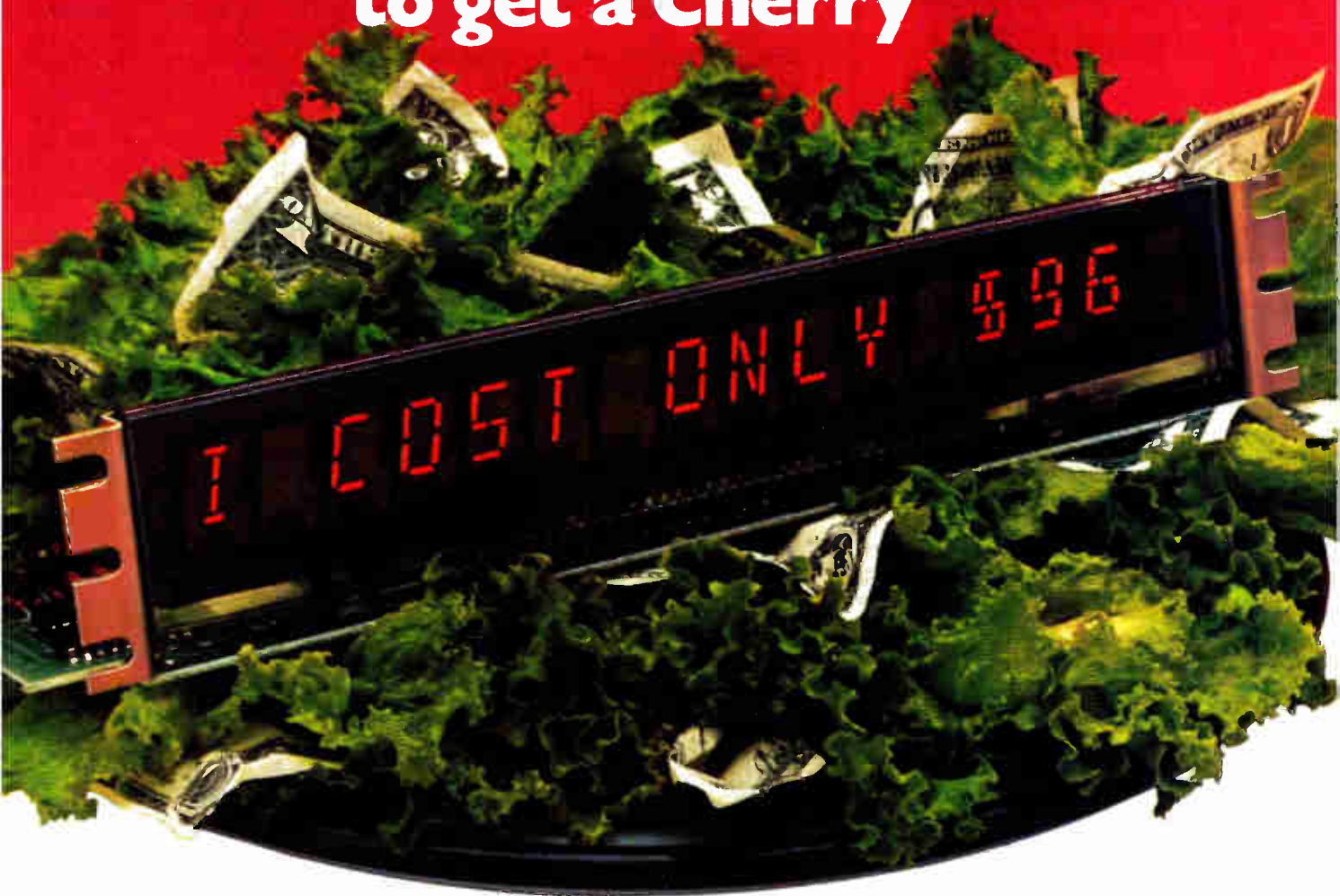

16 character display system for the OEM

The Cherry W416-1050 16 alphanumeric gas discharge display system is a lot more than "bare bones" even though it's priced at just \$96 in lots of 5,000. It is equipped with microprocessor controlled circuitry including drivers, character generator, refresh memory and provides 19 control functions at a price so low it's ideal for OEM product applications.

Easy-to-read half inch high 14 segment characters, 7-bit ASCII input, adjustable brightness, fully addressable cursor, and flashing display are but a few of many outstanding features found in this display

system. Comes complete with metal mounting bracket to facilitate installation. Works indoors or out from 0° C to 55° C. Best of all this bright new display system is available off-the-shelf.

FREE! Yours for the asking:
Complete information on the full line of Cherry 16, 20 and 24 character alphanumeric displays and display systems.



CHERRY

GAS DISCHARGE DISPLAYS

CHERRY ELECTRICAL PRODUCTS CORP. 3608 Sunset Avenue, Waukegan, IL 60085—312/689-7700

Worldwide affiliates and phone numbers: Cherry Semiconductor Corp., East Greenwich, RI, U.S.A., 401-885-3600 • Cherry Mikroschalter GmbH, Auerbach, Germany, 09 643 181 • Cherry Electrical Products Ltd., Harpenden (Herts) England, (05827) 63100 • Chercro Brasil Industria E. Comercio Ltda., São Paulo, Brazil, 55 (011) 246-4343 • Hirose Cherry Precision Co., Ltd., Kawasaki, Japan, 044 933 3511

World Radio History

Circle 13 on reader service card

SOFTWARE DEVELOPMENT TOOLS FOR INDUSTRY

CP/M CROSS-ASSEMBLERS

Fast, comprehensive cross-assemblers to run under CP/M.* Extensive pseudo-ops include full listing control, nested conditionals, mnemonic synonyms, and inclusion of external source files. Generate object file, assembly listing, and symbol table from source code for nine popular microprocessor families.

XASM05	6805
XASM09	6809
XASM18	1802
XASM48	8048/8041
XASM51	8051
XASM65	6502
XASM68	6800/6801
XASMF8	F8/3870
XASM400	COP400

Assemblers... \$200.00 each
Manual only... \$ 25.00

8048 DEVELOPMENT PACKAGE

Now you can use the 8048 family of single-chip microcomputers without buying expensive equipment. Develop 8048 software with the XASM48 cross-assembler. Then plug our EPR-48 board into your S-100 system to program the 8748 EPROM version.

8048 Development Package ... \$574.00
EPR-48 alone \$449.00

EPROM SIMULATOR BOARD

Debug dedicated systems quickly. Our PSB-100 PROM Emulator is an S-100 board with up to 8K of RAM. Cable with 24-pin plug replaces 2708 or 2716 EPROM(s) in your target system for instant program testing

PSB-100 EPROM Simulator ... \$445.00
w/2K RAM

*Trademark of Digital Research

avocet
systems inc.

804 SOUTH STATE ST.
DOVER, DEL. 19901
302-734-0151

Visa and Mastercharge accepted. We ship 8" single-density and Softcard+ 5.25" diskettes. Ask us about other formats. OEM AND DEALER INQUIRES INVITED.

+ Trademark of Microsoft

People

Market virtually untapped, says Young of Summit CAD

Working hard for what he wants is old hat to Gregg W. Young, co-founder and chief executive officer of Summit CAD Corp. of Houston, Texas. Just as he designed circuit boards to earn money for his electrical engineering degree from the University of Texas, Young's company has offered a design service to fund its own development of a stand-alone computer-aided design system that features a color-raster cathode-ray-tube display, a voice-input microphone, and a laser photoplotter.

Some of the troubles plaguing early CAD or design-automation systems, like complicated operating procedures and vulnerability to system crashes, initiated the firm's effort "to determine if a design of a stand-alone system would be feasible," says the 33-year-old Young. "We thought the market, because of our direct experiences, would accept a stand-alone system.

"When we started the design service, our goal was to produce a system. Although both were initiated at the same time, the design service paid our way."

Thus owing no debt to either the public or venture capitalists, the Kansas-born (but Texas-bred) entrepreneur is seeking the low end of the design market for his Pathfinder system. Nevertheless, Pathfinder, which is priced at \$60,000, can be worked easily into a large system supporting up to 60 users.

Believing that the major players, such as IBM, Prime Computer, and Hewlett-Packard, see design automation only as a way of moving hardware, Young says, "I don't think hardware people will have a major effect on the market. It's my prediction that the low-end systems will have a greater effect on the market than people are predicting."

Identifying potential sales of \$2

billion, Young expects to top \$25 million in the next 18 months and agrees with the industry consensus that the market is only 5% or 6% penetrated. He describes the target of his company as "the user who needs the sophistication and throughput of the large systems, but doesn't have it in his budget to start out with a commitment of several hundred thousand dollars."

Young cites some estimates that at the end of the decade there will be only 20% or 25% penetration. "If that is correct, that is a striking fact," he says.

Meanwhile, the company's design service has captured a respectable \$200,000-per-

month share of an estimated \$45-million annual market, numbering among its customers IBM, Teledyne, Xerox, Motorola, HP, and local Houston oilfield service people. Young intends Pathfinder to be equally—if not more—successful.



Do it yourself. Gregg Young's company funded development of computer-assisted design system.

Collmeyer relishes challenge of heading start-up Weitek

Weitek Inc., a company that recently started in Silicon Valley, is in the business of integrating algorithms into silicon, a business made possible through very large-scale integration and its ability to put systems on chips. And after seven years at Calma Co., a manufacturer of computer-aided design equipment that, like Weitek, is based in Santa Clara, Calif., Arthur J. Collmeyer has accepted the challenge of becoming Weitek's first president and chief executive officer.

"I was attracted by Weitek's people," comments the 40-year-old Collmeyer, who took a pay cut when he changed jobs. Begun last year by three technical staff members from

LSI 11/2[®] LSI 11/23[®] COMPONENT PRODUCTS

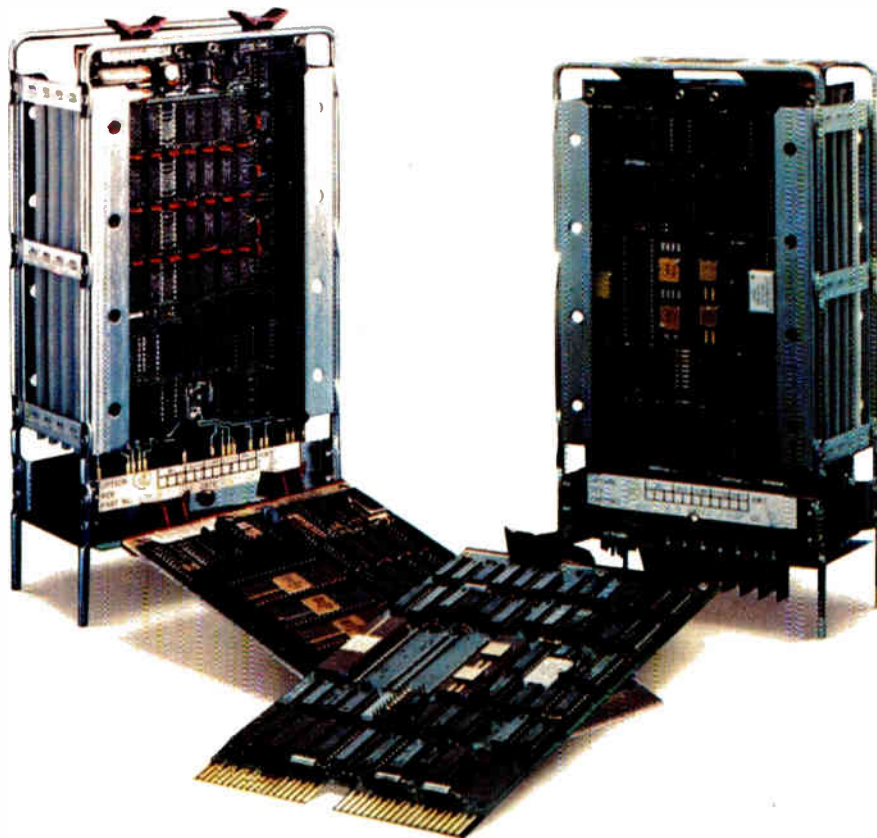

WHY IS FIRST COMPUTER YOUR BEST SOURCE FOR DEC'S LSI-11/2 and LSI-11/23 MICROCOMPUTER PRODUCTS?

FIRST COMPUTER IS THE WORLD'S LARGEST SPECIALIZED DISTRIBUTOR FOR LSI-11 and LSI-23 MICROCOMPUTER PRODUCTS.

No—we don't sell capacitors or resistors! We only sell products manufactured by Digital Equipment Corporation and other leading manufacturers which enhance the LSI-11/2 and LSI-11/23 Microcomputer Products.

FIRST COMPUTER SAVES YOU VALUABLE DOLLARS!

Because of our volume purchasing power we can acquire the products at the lowest possible cost. These savings enable us to offer the best price available anywhere. Before you buy, investigate our price and save dollars.

FIRST COMPUTER SAVES YOU VALUABLE TIME!

Because of our large inventory we can provide you with off-the-shelf delivery on the complete line of Digital Equipment Corporation's factory fresh Microcomputer Products. We are just a phone call away, or if you prefer you can TWX us your order. With pre-approved credit we can ship anywhere in the United States or Canada within 24 hours.

FREE TECHNICAL AND APPLICATION ASSISTANCE.

Because we specialize in LSI-11/2 and LSI-11/23s we can provide you with technical assistance to help you determine the products which best meet your application requirements. We utilize these products every day in our Commercial, Laboratory, Array Processor, and Image Processing Systems. Our application experience can help you avoid costly mistakes.

FULL MANUFACTURER'S WARRANTY.

When you purchase your LSI-11/2 and LSI-11/23 products from FIRST COMPUTER you receive the full manufacturer's Return to Factory warranty. All warranty claims will be handled by First Computer with courtesy & dispatch. FIRST COMPUTER stands behind each of the products we sell.

WE ARE A RECOGNIZED LEADER IN THE DISTRIBUTION OF LSI-11/2 and LSI-11/23 PRODUCTS.

No wonder so many people are turning to FIRST COMPUTER to provide them with their Microcomputer requirements. You owe it to yourself to investigate what FIRST COMPUTER can do for you! We stand ready to serve you. You can bank on us.

® Registered trademark of Digital Equipment Corporation
™ Trademark First Computer Corporation

C4

SOUTHERN REGION
Houston, TX (713) 960-1050

First™

computer corporation

645 BLACKHAWK DRIVE / WESTMONT, ILLINOIS 60559 (312) 920-1050

WESTERN REGION
California (To be announced)

NORTH CENTRAL REGION
Chicago, IL (312) 920-1050

Call us for sale prices

World Radio History

Circle 15 on reader service card

Give Your Present CPU Video I/O Capability

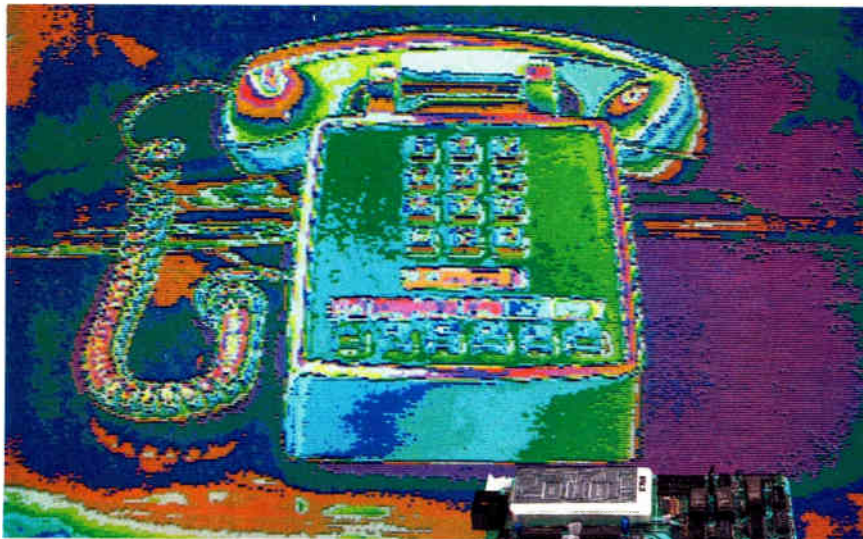

This Board Makes Real Time Digitized Imaging Possible... Economically

Put sight in your present system by mating your computer with our VG-120 Video Graphics Boards that can digitize and display information from standard video cameras for Intel's MULTIBUS™ and DEC'S Q-BUS™ systems.

A VG-120 couples easily to your display. Inputs and outputs are RS-170 compatible, with up to 8 bits flash A/D inputs. It stores up to 768 H x 512 V x 16 bits in black-and-white or pseudo-color.

For as little as \$3,000, you can bring sight to your system. Call today for details.



In 17 msec. the image above was viewed by a camera, stored in memory, retrieved, and displayed in pseudo-color. This VG-120 board made it possible.



Datacube

INCORPORATED
670 Main St., Reading, MA 01867
Telephone: (617) 944-4600 TWX 710-393-0144

Circle 16 on reader service card

Electronics

Seminar Catalogue

For Managers & Professionals: FREE Seminar Catalogue

Dollar-oriented, intensive practical programs developed specifically for the industry.

This catalogue is a complete reference guide to our seminar programs. It contains detailed outlines of each seminar, a biography of each instructor, and a listing of the dates and locations where each seminar will be held. Use this catalogue to select the program that will best help you to improve your professional skills. And to improve your company's profitability.

Send for your free copy NOW. But hurry—supplies are limited. Send coupon below or call Mary Andrews at McGraw-Hill Seminar Center, (212) 687-0243.

Mary Andrews
McGraw-Hill Seminar Center
Room 3112, 305 Madison Ave.
New York, NY 10017



Name _____
Company _____
Street _____
City _____ State _____ ZIP _____

16 Circle 245 on reader service card

People

the Palo Alto, Calif., advanced integrated-circuit laboratories of Hewlett-Packard Co., Weitek now has 14 employees, including Collmeyer.

His performance at Calma certainly makes Collmeyer a credible candidate to run a start-up like Weitek. He hired on at Calma as head of research and development, where he was also responsible for product engineering and production, before working his way up to general manager of its Microelectronics division.

"Calma grew about 60% per year for my seven years there," Collmeyer notes proudly. "It was at \$3.6 million when I started, and it should do about \$100 million for 1980."

Before that, Collmeyer put in stints as manager of Information Sciences at Xerox Corp., Stamford, Conn., and manager of system development at Scientific Data Systems of El Segundo, Calif., which was acquired by Xerox in 1969.

He wants to help shape Weitek into "a place where bright people can work on challenging problems and see the evidence of their work all



Challenge. Arthur Collmeyer wants to help shape start-up company Weitek Inc.

around them. If the solution to a problem is understood, you can put it into silicon," he says, "VLSI makes this possible. The formula for prosperous growth is different now; the game has different rules. The chip business is no longer driven by process technology, it has become a systems business." □

Did you know Mepco//Electra has the broadest Mil. Spec. Qualified Tantalum Capacitor line?

There's a lot you should know about Mepco/Electra, because we know "reliability"! And we've got the Mil. Specs to prove it; **Mil-C-39003, Mil-C-39006, and Mil-C-55365** with most styles qualified to the "S" Failure Rate. Nobody has more. **Tantalum Foil** Mil-C-3965 Style CL20, CL21, CL22, CL23, CL24, CL25, CL26, CL27, CL30, CL31, CL32, CL33, CL34, CL35, CL36, CL51, CL52, CL53, CL54, CL70, CL71, CL72, CL73; Mil-C-39006 Style CLR25, CLR27, CLR35, CLR37, CLR71, CLR73; **Sintered Anode Wet Electrolyte** Mil-C-3965 Style CL14, CL16, CL17, CL18, CL55, CL64, CL65, CL66, CL67; Mil-C-39006 Style CLR10, CLR14, CLR17, CLR65,

CLR79*: **Sintered Anode Solid Electrolyte** Mil-C-26655 Style CS12, CS13 and Mil-C-39003 Style CSR09, CSR13, CSR23, CSR33, CSR91; **Chip** Mil-C-55365 Style CWR06.

And Mepco/Electra has clients like you in mind with our **expanded production capacity** on these popular models; **CSR 13, CLR 65, CLR 79** and **CWR 06**.

Plus Mepco/Electra has a wide range of industrial tantalum capacitors available including: dipped & molded radial leaded and industrial versions of all our mil qualified devices.

Advanced technology in a **broad** range, that's Mepco/Electra! Check our specs! Check our prices, we're competitive! For your com-

plete Tantalum Capacitor needs backed up by quality service call: our Columbia, SC facility at (803) 772-2500 for wet slug & foil or our West Palm Beach facility at (305) 842-3201 for solids & chips.

Mepco/Electra: your resistor/capacitor company with tomorrow's technology today.



Corporate Headquarters
Columbia Road
Morristown, New Jersey 07960
(201) 539-2000
TWX: 710/986/7437

*Pending MIL Qualification Approval

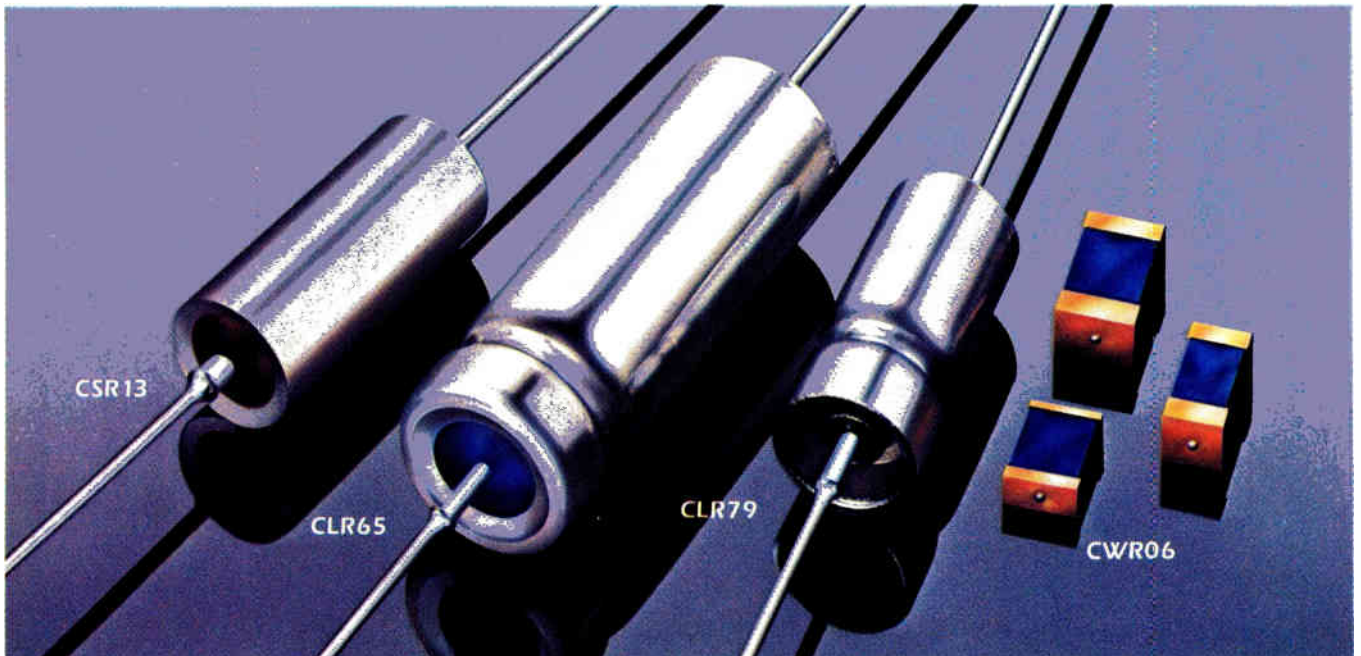

© Copyright, 1981 Mepco/Electra, Inc.

Now you do!

Circle 17 on reader service card

**SINCE 1976,
ONE FAMILY
HAS
QUIETLY
CONTROLLED
THE WORLD.**

Think about it for a minute.

There are all kinds of microcontrollers on the market today. Handling literally billions of control functions all over the world. In everything from toys to terminals to satellites.

But when it comes to performance, flexibility, and quality, there's one family that's taken control right from the very beginning. And set all the standards.

Our 8048 family of microcontrollers.

Because ever since we introduced the 8048 five years ago, it's quietly established itself as the World Standard in every way.

With more customers, more design wins, and more second sources than any other microcontroller. All of which makes our 8048 family a very attractive choice. No matter what you're designing.

Because of the obvious benefits of our learning curve. High volume, lower cost, higher reliability.

Because of the worldwide acceptance of the 8048 architecture. So you can look forward to a long life. And so you can hit the ground running with new applications, cutting both development costs and time to market.

Because the 8048 family is still in the earlier stages of its life cycle. Which means you'll be able to grow right along with it, whether you're

upgrading from 4-bit or looking for an easy path for future expansion.

And because we give you pin-compatible EPROM versions for even faster design cycles. Plus a complete package of hardware and software development support. A whole variety of products based on the 8048 architecture, to fit your exact application. And a huge network of factory and field applications engineers to give you the support you need.

With all this going for us, it's easy to see why the 8048 has become the world's best-selling 8-bit microcontroller. And we're fully committed to keeping it that way. You can count on us to deliver the volume you need. When and where you need it.

We'd like to tell you more. About applications. About customer training. And about all the 8048 family. Including our new high-performance 8051. Our new 8749 and 8751 EPROM microcontrollers. And our brand new low-power CHMOS versions, too.

Just get in touch with your local Intel distributor. Or write Intel Corporation, 3065 Bowers Avenue, Santa Clara, CA 95051. (408) 987-8080. We'll send you complete information.

And help you quietly take control of a nice big share of your own market.

intel® delivers solutions





WORLDWIDE BANK TO USE NEDIX-510F PACKET SWITCHING SYSTEMS

The Sumitomo Bank, Limited will use four NEDIX-510F packet switching systems to enhance their telephone, facsimile, teletype and on-line computer operations. The systems are being installed in New York, Tokyo, Hong Kong and London.

Designed to be the core of NEC's Integrated Voice/Data Communications Systems, the NEDIX-510F can packetize digital data (including voice data from

digital telephones), then multiplex and transmit them over leased or dedicated lines—or a switched telephone or telex network—at speeds from 50bps to 64kbps. For optimal use of transmission lines the system provides both real-time and store-and-forward switching.

Packet terminals, non-packet terminals, host computers of different speeds and protocols—all can be linked to communicate with each other

through the NEDIX-510F. Each packet terminal can communicate with up to 1,024 other terminals simultaneously over one physical line. Modular hardware and software and a wide range of network components simplify the building of a network structure according to user requirements.

The NEDIX-510F meets CCITT Recommendations and fully complies with other international and national standards. It is a prime example of how NEC integrates computer and communications (C & C) technologies to create a comprehensive information network.

SINGLE-CHIP MICROCOMPUTER HAS BUILT-IN A/D CONVERTER

For the first time ever, a micro-computer incorporates counters, timers, a serial interface, an A/D converter, a 4K-byte ROM and a 256-byte RAM on a single chip.

NEC's new μ COM-87AD μ PD7811G) is an 8-bit single-chip microcomputer with a built-in analog-digital converter for such applications as process control, copying machines, and automobiles. When used in automobiles, for instance, it can convert eight kinds of analog information such as temperature, pressure, and power supply) into digital information for further processing by the on-chip A/D converter.

The μ COM-87AD offers a high speed conversion rate of 50μ s. And use of the "successive approximation technique" gives it better cost-performance.

Another outstanding feature is its ability to perform pulse width measurement and frequency counting as well as programmable rectangular waveform output without need of complicated software. This makes it ideal for real-time control applications.

Other features include: Software performance 1.5 to 5 times higher than most other 8-bit single-chip microcomputers; A unique double-buffered serial interface which makes possible a multiprocessor system configuration; Direct addressability of external ROMs and RAMs up to a total of 60K bytes.

NEW MODEMS OFFER THE FASTEST POLLING RESPONSE TIME

Two new polling modems from NEC offer the world's fastest polling response time.

The 9,600bps data modem SP9600 FAST and the 4,800bps data modem SP4800 FAST incorporate a unique equalizer to offer a response time of 15msec. Even if synchronism is lost

during data transmission (due to temporary circuit malfunction) this automatic equalizer quickly recovers without training signals because of a retrain-on-data function. And these two models are only about 1/3 the size of competing products thanks to extensive use of LSIs.

Another new model, the 2,400bps data modem SP2400 FAST, is about half the size of comparable modems. It has a polling response time of 7msec, and is designed to meet CCITT's V.26 and V.26 bis recommendations.

All three modems can be used over leased circuits or the public switched telephone network.

NEW GENERATION 12GHz TVROs

With an antenna diameter of only 1.8m, NEC's 861 Series TVROs are economical and easy to install. They are designed to offer excellent reception

of OTS-2 and future systems (such as ANIK-C), and are ideal for CATV stations, rebroadcasting and community reception.

Featuring an impressive G/T of 18.7 dB/K, the 861 Series can pull in clear

signals even from relatively low power satellites. And NEC TVROs can access any polarization of satellites without extra cost. The outdoor units have an advanced but simple design that will permit easy manual change-over

when satellites convert from linear to circular polarization in the future.

The 861 Series has a wide-band antenna—11.50 to 12.75GHz.

The low noise converter, based on an



NEC-developed GaAs FET, is rated at 360 degrees K. With full 24-channel reception, dual polarization capability and multi-channel reception, the 861 Series provides outstanding performance

in a compact and economical package.

NEC is the world's No. 1 supplier of INTELSAT earth station systems, and has been accumulating expertise in direct TV reception from Ku-band satellites since 1973.

NEC

Nippon Electric Co., Ltd.
P.O. Box 1, Takanawa, Tokyo, Japan.



A processor and a 2500 gate controller that shatter the sub-100ns microcycle barrier. A 50ns 16x16 multiplier. A 16K PROM with a 35ns access time.

And that's just a preview of what our new process lets us do.



Ever since we started the bipolar LSI business with

the Am2901 back in 1975, we've been making everything in our 2900 family faster and denser. Now, thanks to IMOX™, we're doing it even better than before.

IMOX is our advanced,

ion implanted, oxide isolated process. It gives us smaller chips; faster, more complex devices.

And because IMOX lets us use ECL internal structures with TTL I/O, you get all this unbelievable speed without any interface problems.

Advanced Micro Devices • **Austria:** Kontron Ges. m. b. H., A-2345 Brunn am Gebirge Tel: (02236) 8 66 31 Telex: 79337 **Belgium:** AMD Overseas Corporation, B-1150 Bruxelles Tél (02) 771 99 93. Télex 61028. • **MCA Tronix S.P.R.L.**, B-4200 Ougree. Tél: (041) 36 27 80 Télex: 42052 **Denmark:** Advanced Electronic of Denmark Aps, DK-2000 Copenhagen F. Tel (01) 19 44 33. Telex: 22 431 **Finland:** Komdel OY, SF-02271 Espoo 27 Tel: (0) 885 011. Telex: 12 1926 **France:** AMD S.A., F-94588 Rungis Cedex. Tél: (01) 686 91 86. Télex: 202053 **Germany:** AMD GmbH, D-8000 München 80. Tel: (089) 40 19 76. Telex: 523883 • AMD GmbH, D-7024 Filderstadt 3 Tel: (07158) 3060 Telex: 721211 **Italy:** AMD, S.r.l., I-20090 MI2-Segrate (MI). Tel: (02) 215 4913-4-5. Telex: 315286 **Israel:** Talviton Electronics Ltd., Tel-Aviv Tel: (03) 444572 Telex: 03-3400 **Japan:** AMD, K.K., Tokyo 168 Tel: (03) 329 2751. Telex: 2324064. • AMD, K.K., Osaka 564. Tel: (06) 386-9161. **Netherlands:** Arcobel BV, NL-5342 PX Oss. Tel: (04120) 30335 Telex: 37489 **Norway:** A S Kjell Bakke, N-2011 Strømmen Tel: (02) 71 53 50. Telex: 19407 **South Africa:** South Continental Devices (Pty.) Ltd., 2123 Pinegowrie. Tel: (011) 789-2400 Telex: 4-24849 **Spain:** Sagitrón S.A., Madrid-1 Tel: (01) 275-4824. Telex: 43819 **Sweden:** AMD AB, S-172 07 Sundbyberg. Tel: (08) 98 12 35 Telex: 11602 • Svensk Teleindustri AB, S-162 05 Vällingby Tel: (08) 89 04 35 Telex: 13033 **Switzerland:** Kurt Hirt AG, CH-8050 Zürich Tel: (01) 302 21 21. Telex: 53461 **United Kingdom:** AMD (U.K.) Ltd, Woking, Surrey GU21 1JT Tel: (04862) 22121 Telex: 859103

ON MAY 4, 1980, AMD DISCOVERED A NEW WAY TO MAKE HIGH PERFORMANCE ICs.

TAKE THE NEW 2901 C.

It's half the size, one-third the price, and more than twice the speed of the Am2901.

And we're making high-speed VLSI devices right now that are going to replace three whole PC boards of FAST or AS MSI. That's

about 200 fewer chips — 200 fewer ways to use power, spend money and waste time.

FOUR BIG, HAPPY FAMILIES.

You can come to AMD for total design solutions, not just a part here and there.

We've got high performance IMOX LSI families

for signal processors, controllers, CPUs, plus all the interface and support you're ever going to need. Not only that, we're using IMOX to make the fastest, most complex proms ever.

And all of them come with a quality guarantee you can't get from anybody else.

If you want the newest, the fastest, the most complete families of high performance LSI, call AMD. We'll show you the light.

The International Standard of Quality guarantees these electrical AQLs on all parameters over the operating temperature range: 0.1% on MOS RAMs & ROMs; 0.2% on Bipolar Logic & Interface; 0.3% on Linear, LSI Logic & other memories.

INTSTD-123

Advanced Micro Devices

For more information, call one of our distributors or write the words "IMOX Family" on your letterhead and mail it to Advanced Micro Devices Mail Operation, P.O. Box 4, Westbury-on-Trym, Bristol BS9 3DS, United Kingdom.

A warning that is not just an empty threat

Nobody can say the world wasn't warned. Last month at the International Conference on Fifth-Generation Computer Systems, the Japanese unveiled a master plan for the development of computers to meet the needs of the 1990s. The plan is not just another exercise in computer-science esoterica; in fact, it is a mobilization on a national scale that is aimed at the domination of the world computer market.

At the conference, attendees received an 89-page preliminary report outlining the ambitious scope of the plan, including detailed research and development strategies and projections of applications and their effects on society. The summary at the beginning of the report is an intriguing mixture of altruism and self-interest, citing the use of information-processing systems to increase productivity, contribute toward international cooperation, save energy, and cope with a (Japanese) society that is aging rapidly (and thus requires advanced health-management and education systems).

Technical details of the plan are described on page 83, but just as interesting and perhaps more ominous are other comments that dot the report. For example:

"Japan has come to be considered an 'economic power' by the other countries of the world. Thus, if we consider the direction in which our industries proceed, it becomes clear that we no longer need chase the more developed countries, but instead should begin to set goals of leadership and creativity in research and development and to pioneer the promotions of such a project throughout the world." *Translation: "We've learned all we can from the U. S., now let's move in and beat the pants off it."*

As to the effects of the project, the report

goes on to say: "This effort will not only help our computer industry foster more creative technology, but will also provide our country with a means of bargaining power." *Translation: "We can use our technology to gain a favorable trade position for the natural resources we lack."*

The steering committee is well aware of the unease and suspicion with which the U. S. and European computer industry will view this project, so near the start it pays lip service to international benefits and cooperation. "The project must be an internationally oriented one," it says early on. But, only a few pages later, the report says: "For a number of reasons, it is difficult to make this an international project. Instead, it is desirable to execute it as a national project with Japan having the liberty to decide its course."

What does seem likely is the fulfillment of another recommendation of the committee: "Emphasis must be placed on the importance of public relations activities to avert misconceptions about this project in countries abroad and instead to stimulate enthusiasm in the different countries about its progress." *Translation: "We can't let them think we're going to do to computers what we did to consumer electronics, automobiles, and memories."*

The challenge is there—out in the open for all to see. The plan is an impressively comprehensive blueprint of government-directed, long-range industrial policy, something the U. S. sadly lacks. Given the scope, organization, and muscle the Japanese are putting behind this project, it looks as if U. S. leadership in computer technology will be in for a serious challenge. We had better respond before it is too late.

Pick the application software package that can save you a bundle.



It's the one in the microcomputer on the left. That's right. Completed application software imbedded in a 40-pin DIP. Available off-the-shelf from your nearest Mostek distributor.

We call it the MK95103 Serial Control Unit (SCU20*). It's an 8-bit single-chip microcomputer, preprogrammed with the software routines and communications protocol needed for most remote serial applications. Other features include three 8-bit I/O ports to interface with the outside world. On-chip memory for real-time data logging and event counting. Plus a hardware UART (baud rate up to 9600) to

communicate with a host computer. As a result, you can network up to 255 of them on a single serial link.

But the real beauty of the SCU20 is that with it, you can trim development time by as much as 70%, depending on the application.

Equally impressive, it's ideal for a wide range of distributed processing applications such as commercial building energy management. Process control in all types of industries, from wineries to textile mills. Data gathering and control for offshore oil rigs. Or standardized communications between office

machines. In fact, the list of networking opportunities is nearly endless.

Saving yourself a bundle of time. And money. Both advantages are yours when you specify application software that's packaged the way it should be—inside a circuit, ready for use. With the SCU20, it already is. To find out more, write Mostek, 1215 West Crosby Road, MS507, Carrollton, Texas 75006 (214) 323-1801. In Europe, contact Mostek International at (32) (02) 762.18.80. In the Far East, Mostek Japan KK (03) 404-7261.

*SCU20 is a trademark of Mostek Corporation
© 1981 Mostek Corporation

Circle 25 on reader service card

Can you spot the real



It's me! How can you be sure? Well, who else could come up with over 156,000 solenoids? Only a *real* Guardian Angel. Because of me you can get solenoids in just about any size and shape... pull or push. AC or DC. Tubular in traditional or long life versions. Box frame, laminated and U-frame. And I can even go back to my miracle drawing board and come up with one designed just for you. So why even look at those other phoney angels? You can see it's *me*.

Circle No. 196 for more information on Guardian Solenoids

No, it's me! I'm the one who inspired those Guardian engineers to develop the relays you need. Like my power and open relays. How do you want them? Large, small... miniature or "mini." AC or DC. You name it... I make it. Want another miracle?... OK. How about Guardian dependability. I build it right in. On every relay. How 'bout that? You want the *real* Guardian Angel? Then stop right here. It's *me*.

Circle No. 197 for more information on Guardian Open & Power Relays



GUARDIAN®

GUARDIAN ELECTRIC MANUFACTURING COMPANY

1550 W. Carroll Avenue, Chicago, IL 60607 • 312/243-1100

Pick the application software package that can save you a bundle.



It's the one in the microcomputer on the left. That's right. Completed application software imbedded in a 40-pin DIP. Available off-the-shelf from your nearest Mostek distributor.

We call it the MK95103 Serial Control Unit (SCU20*). It's an 8-bit single-chip microcomputer, preprogrammed with the software routines and communications protocol needed for most remote serial applications. Other features include three 8-bit I/O ports to interface with the outside world. On-chip memory for real-time data logging and event counting. Plus a hardware UART (baud rate up to 9600) to

communicate with a host computer. As a result, you can network up to 255 of them on a single serial link.

But the real beauty of the SCU20 is that with it, you can trim development time by as much as 70%, depending on the application.

Equally impressive, it's ideal for a wide range of distributed processing applications such as commercial building energy management. Process control in all types of industries, from wineries to textile mills. Data gathering and control for off-shore oil rigs. Or standardized communications between office

machines. In fact, the list of networking opportunities is nearly endless.

Saving yourself a bundle of time. And money. Both advantages are yours when you specify application software that's packaged the way it should be—inside a circuit, ready for use. With the SCU20, it already is. To find out more, write Mostek, 1215 West Crosby Road, MS507, Carrollton, Texas 75006 (214) 323-1801. In Europe, contact Mostek International at (32) (02) 762.18.80. In the Far East, Mostek Japan KK (03) 404-7261.

*SCU20 is a trademark of Mostek Corporation
© 1981 Mostek Corporation

Circle 25 on reader service card

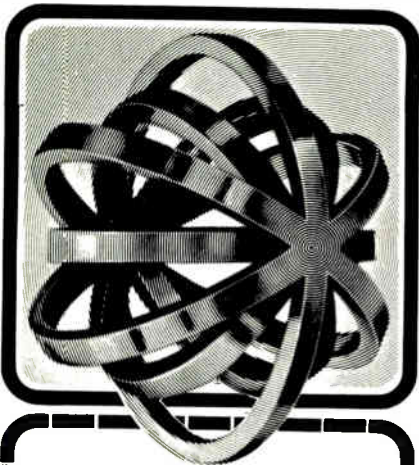

further information and invitation card
on request: S.D.S.A. 20, rue Hamelin,
F 75116 Paris ☎ 505.13.17 ☐ 630 400 F
In U.S.A.: International Trade Exhibitions
in France, Inc. - 8 West 40th Street
New York, N.Y. 10018 ☎ (212) 869.17.20
☐ 427 563 Fishows

salon international des
composants électroniques 82
PARIS avril 1-7 closed on sunday 4

Please send me an invitation card and full information

Name _____
Position _____
Address _____
Company _____

Meetings

International Electron Devices Meeting, IEEE (Melissa Widerkehr, Courtesy Associates, 1629 K St., N. W., Washington, D. C. 20006), Washington Hilton Hotel, Washington, D. C., Dec. 7-9.

Infrared and Millimeter Waves Conference and Exhibition, IEEE (K. J. Button, Massachusetts Institute of Technology, National Magnet Laboratory, Cambridge, Mass. 01239), Carillon Hotel, Miami Beach, Fla., Dec. 7-11.

6th Meeting on Integrated and Guided-Wave Optics, Optical Society of America and IEEE (OSA, 1816 Jefferson Pl., N. W., Washington, D. C. 20036), Asilomar Conference Center, Pacific Grove, Calif., Jan. 6-8, 1982.

5th Los Angeles Technical Symposium, International Society for Optical Engineering (SPIE, P. O. Box 10, Bellingham, Wash. 98227), Los Angeles Marriott Hotel, Los Angeles, Jan. 25-29.

First Spacecraft Electronics Conference, EIA (Frank A. Mitchell, EIA, 2001 Eye St., N. W., Washington, D. C. 20006), Hyatt Hotel, Los Angeles, Jan. 26-28.

Advanced Semiconductor Equipment Exposition and Conference, Electronic Representatives Association and Carlidge & Associates Inc. (CAI, 491 Macara Ave., Sunnyvale, Calif. 94086), Convention Center, San Jose, Calif., Jan. 26-28.

Annual Reliability and Maintainability Symposium, American Society for Quality Control, IEEE et al (H. C. Jones, Westinghouse, MS 3608, P. O. Box 1521, Baltimore, Md. 21203), Biltmore Hotel, Los Angeles, Jan. 26-28.

First Military Computers and Software Seminar, American Defense Preparedness Association (ADPA, 900 Rosslyn Center, 170 North Moore St., Arlington, Va. 22209), Sheraton National Hotel, Arlington, Va., Jan. 27-28.

Workshop On Reliability of Local Networks, IEEE (Robert S. Swarz, Prime Computer, Inc., 500 Old Connecticut Path, Framingham, Mass. 01701), South Padre Hilton Resort, Brownsville, Texas, Feb. 3-5.

16th Annual Television Conference, Society of Motion Picture and Television Engineers (Lynne Robinson, 862 Scarsdale Ave., Scarsdale, N. Y. 10583), Opryland Hotel, Nashville, Tenn., Feb. 5-6.

5th European Exhibition and Congress and Exhibition for Telecommunications, Online GmbH (Postfach 10 08 66, D-5620 Velbert 1, West Germany), Düsseldorf fairgrounds, W. Germany, Feb. 8-11.

Aerospace and Electronic Systems Winter Convention, IEEE (Tom S. Schuler, Rockwell International, P. O. Box 3105, Anaheim, Calif. 92803), Sheraton-Universal Hotel, Hollywood, Calif., Feb. 9-11.

International Solid State Circuits Conference, Institute of Electrical and Electronics Engineers (L. Winner, 301 Almeria Ave., Coral Gables, Fla. 33134), Hilton Hotel, San Francisco, Feb. 10-12.

Aerospace Applications Conference, IEEE (Russel Gaspari, Hughes Aircraft Co., MS S12/V305, P. O. Box 92919, Los Angeles, Calif. 90009), Woodbridge Conference Center, Snowmass, Colo., Feb. 21-28.

Nepcon '82 West, Cahners Exposition Group (222 West Adams St., Suite 999, Chicago, Ill. 60606), Anaheim Convention Center, Anaheim, Calif., Feb. 23-25.

Compcon Spring, Institute of Electrical and Electronics Engineers (Harry Hayman, P. O. Box 639, Silver Spring, Md. 20901), Jack Tar Hotel, San Francisco, Feb. 26-28.

Robots VI Conference and Exposition, Society of Manufacturing Engineers (1 SME Dr., P. O. Box 930, Dearborn, Mich. 48128), Cobo Hall, Detroit, March 1-4.

Introducing the new TRW Optron Automatic Brightness Controller.

It's the first time that ambient light sensing and automatic brightness control functions have been integrated on a single chip.

Pulse width modulation is the key. The output duty cycle varies proportionately with the ambient light level so that the brightness of vacuum fluorescent, LED, incandescent and other types of displays and display drivers can be varied from 0% to 100%. An analog output, which varies linearly with ambient light, is provided for simultaneous or separate operation. Sensitivity can be adjusted externally and independent of ambient light.

Imagine the applications! Stereos, television displays and screens, test equipment, aircraft instrument displays, industrial light

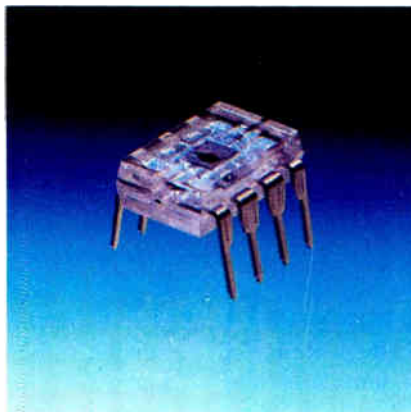

levels, appliances, gasoline pumps, automobile dash displays... the list is virtually endless.

The new TRW Optron Automatic Brightness Controller (OPL100) is incredibly versatile. It can operate

from supply voltages of 4.5V to 24V, and offers totem pole output to sink 20 mA or source 50 mA. And it will operate in synchronous or asynchronous modes. It is also available in a hermetically sealed TO-5 eight pin package (OPL105).

This technical innovation from TRW Optron means that for the first time with a single chip, you have the capability of precise automatic control over the brightness of your light source, independent of its non-linearities and sensitivity.

Let us tell you more. For a comprehensive data sheet and application note, ask for Product Bulletin 2091 and Application Bulletin 115. **Contact TRW Optron, 1201 Tappan Circle, Carrollton, Texas 75006, (214) 323-2200.**

TRW OPTRON

An Electronic Components Division of TRW Inc.

Can you spot the real



It's me! How can you be sure? Well, who else could come up with over 156,000 solenoids? Only a *real* Guardian Angel. Because of me you can get solenoids in just about any size and shape... pull or push. AC or DC. Tubular in traditional or long life versions. Box frame, laminated and U-frame. And I can even go back to my miracle drawing board and come up with one designed just for you. So why even look at those other phoney angels? You can see it's *me*.

Circle No. 196 for more information on Guardian Solenoids

No, it's me! I'm the one who inspired those Guardian engineers to develop the relays you need. Like my power and open relays. How do you want them? Large, small... miniature or "mini" AC or DC. You name it... I make it. Want another miracle?... OK. How about Guardian dependability. I build it right in. On every relay. How 'bout that? You want the *real* Guardian Angel? Then stop right here. It's *me*.

Circle No. 197 for more information on Guardian Open & Power Relays



GUARDIAN®

GUARDIAN ELECTRIC MANUFACTURING COMPANY

1550 W. Carroll Avenue, Chicago, IL 60607 • 312/243-1100

Guardian Angel®?



Don't listen to them! You want a real Guardian Angel? Then watch this. Enclosed relays. AC or DC. Size is no problem. I have mini. I have miniature. I have large and small. Plug-in or printed circuit termination. Some even have built-in test lamp and push-to-test. Mating sockets with solder lug or printed circuit terminals, too. Mechanical life. Those are miracles in themselves. Angel? No foolin' ... *I'm* the one.

Circle No. 198 for more information on Guardian Enclosed Relays

You know it's me! Prove it, you say ... okay ... you want a *solid* miracle? How about Solid State? Like my relays and I/O modules that perform the function of electro-mechanical relays with photo-isolation between control circuit and switching output. Let those others even try to *say* that. And I can do it right off-the-shelf or in custom designs. If you want the real thing you'll pick me. Not an imitation. I'm handing you a reliable relay line.

Circle No. 29 for more information on Guardian Solid State Controls

HERE'S THE ANSWER...

She's *all* of the above. They're all Guardian Angels. You see, ever since the Guardian Angel became our symbol, different models (and you thought she was real) have played the part.

FREE 1982 GUARDIAN ANGEL CALENDAR. Send your request—on your company letterhead, please—to: The Guardian Angel, c/o Guardian Electric Manufacturing Company.



GOULD BIOMATION K100-D



7 reasons why the K100-D is now the world's best-selling logic analyzer.

How the general-purpose K100-D beat out H-P to become #1.

Not so long ago, Hewlett-Packard logic analyzers were the industry standard. We asked digital designers to compare the K100-D with H-P's popular 1610B and 1615A logic analyzers before making any buying decision.

In head-to-head comparison, the K100-D came out looking so good, it's now the best-selling logic analyzer in the world. Here's why:

1. It's easy to systematize.

For automated troubleshooting and production ATE, the K100-D features a fully-programmable GPIB interface.

To help you support a wide variety of bus-oriented systems, there are standard high-performance probes, specialized probing accessories and detailed application notes available on all the popular microprocessor systems currently in use.

2. It's concise.

The K100-D monitors 16 channels in time domain, 32 in data domain, so you can probe enough points to pin down problems at their source.

3. It's fast.

A 100 MHz clock rate resolves signals to 10 nanoseconds. The front end is also sensitive enough to capture glitches as narrow as 4 ns.

4. It's deep.

1024 words deep in memory—for faster, more accurate debugging. The K100-D extends the length of data you can trap from your system at any one time.

5. It's clear.

The K100-D has a large keyboard and interactive video display, a comprehensive status menu, highly useful time domain display, and data domain readout in user-specifiable hexadecimal, octal, binary or ASCII.

6. It has remote diagnostics.

A new T-12 communications interface option lets your field troubleshooters share their system observations with the best engineers back at headquarters. Remote diagnostics provide faster debugging and save a lot of time and travel for your most valuable people.

7. It's well supported.

You get full applications support from the experts in logic analysis.

For a free copy of our "Logic Analyzer Comparison Guide," request card for microprocessor system application notes, and T-12 Communicator information, just circle the appropriate reader service numbers. Or contact Gould, Inc., Instruments Division, Santa Clara Operation, 4600 Old Ironsides Drive, Santa Clara, CA 95050, phone (408) 988-6800.

The T-12 "top hat" for the K100-D provides logic analyzer remote diagnostic capability. Other options include the GPIB Analyzer and RS232 Serial Data Analyzer.

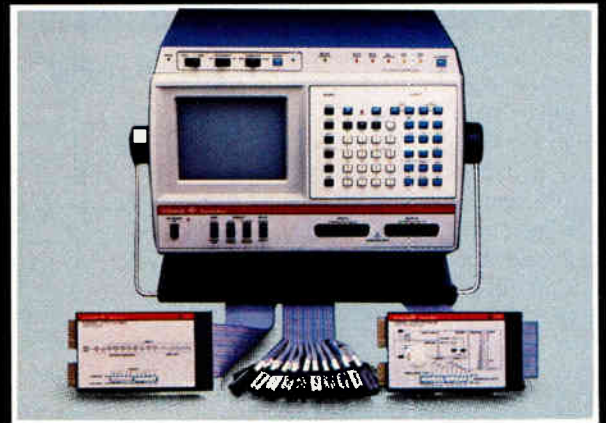

 **GOULD**
Electronics & Electrical Products

Circle 199 for Comparison Guide
Circle 200 for App Note request form
Circle 31 for T-12 communicator data

World Radio History

No other oscilloscope offers this much in one package.

Large 16K Memory

See things you've never seen before with a time resolution of up to 16,000:1 and a dynamic range of up to 32,000:1. Zoom in on the smallest signal detail with expansion up to x256 on both axes. By using subsections of memory, you can display up to 32 stored waveforms simultaneously.

4-Channel Operation

Capture, store and display four signals simultaneously using two plug-ins operating on the same, or totally independent, timebase and trigger. Compare live and stored waveforms in real time. Even compare interactive variables such as voltage/current or stress/strain using X-Y display of either live or stored signals.

Pre- and Post-Trigger Delay

Look into the past or future with a pre-trigger delay from 500 nano-seconds to 37 days or a post-trigger delay up to 106 years. Avoid accidental triggering by checking the threshold and sensitivity using the trigger-view mode.

Signal Averaging

Extract repetitive signals from noise using sweep averaging. Even smooth those slow, noisy, one-shot signals by using the unique point-averaging mode.

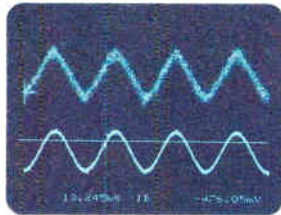

Alphanumeric Display

Get absolute or relative measurements from any portion of the waveform using the cursor-interactive time and voltage readout. The numerics include a channel identifier to eliminate errors even on multiple trace displays.

Data Manipulation

As with all Nicolet scopes, manipulate stored data using the pushbutton functions of add, subtract or invert. With the 4094, continue to expand this capability with disk-extended functions of multiply, integrate, smooth, RMS and much more.

Permanent Data Storage

Store waveforms at the touch of a button on the optional floppy disk or capture and store automatically using the autocycle feature. Get report ready hardcopy records using the standard X-Y or Y-T recorder outputs, or obtain fully annotated plots automatically with the optional digital plotter.

IEEE-488 and RS-232 I/O

Integrate the 4094 into your digital measurement system with the fully bi-directional GP-IB and RS-232 digital I/O option.

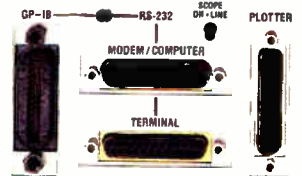

One of a Family

Nicolet is the world's leading manufacturer of high resolution digital oscilloscopes. In addition to the 4094, Nicolet offers the 2090 range of 2-channel digital oscilloscopes with many advanced features including high-resolution, disk storage and digital I/O.

Find out how Nicolet can bring digital precision to your analog measurements. For more information, call 608/271-3333. Or write: Nicolet Instrument Corporation, Oscilloscope Division, 5225 Verona Road, Madison, WI 53711.

In Canada: call 416/625-8302.

NICOLET INSTRUMENT CORPORATION
OSCILLOSCOPE DIVISION

Sales and Service Offices
Worldwide

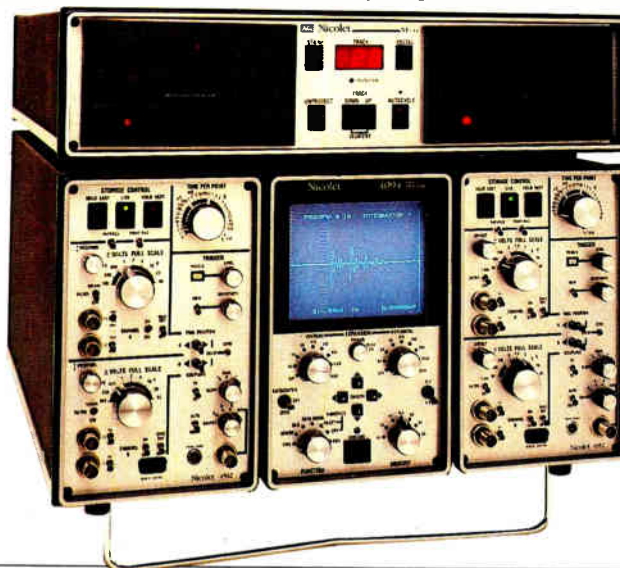

The Nicolet 4094.

Electronics newsletter

Mostek closes its E-PROM line

Faced with drastic worldwide price erosion on electrically programmable read-only memories, Mostek Corp. has shut down its E-PROM fabrication line in Carrollton, Texas. Company officials also are deciding whether to bring the MK2764 8-K-by-8-bit E-PROM to market. The fully static device, to have been available last June, has 25% redundancy—much more than competitive parts.

At Data General, CEO is office systems . . .

From now on at Data General Corp., CEO will stand for comprehensive electronic office systems, as the Westboro, Mass., firm becomes the **fourth major minicomputer maker in a month to announce a major thrust into office automation** [*Electronics*, Nov. 3, pp. 42, 106, and 110]. The new offering integrates word-, graphics-, and data-processing functions, includes electronic-mail and local-network capabilities, and sports a “decision support” facility called Present. Though some of the new programs grow out of existing software, each appears to have been significantly enhanced for this effort. The new CEO system operates with Data General’s 16- and 32-bit Eclipse processors and will make all office-automation functions available at a single terminal: either a Dasher G300, D400, or D450. The company says it will be shipping the entire package within 90 to 120 days—“and we mean *all* of it,” says a source.

. . . and NCR enters market with word processor

NCR Corp. of Dayton, Ohio, is also jumping into the office-automation market with a word-processing system known as the NCR WorkSaver. Using software known as WordReady, developed by the company’s nine-month-old Office Systems division, the WorkSaver system **relies upon a line of 16-bit multifunction work stations** supplied by Convergent Technologies Inc. of Santa Clara, Calif. Printers and mass-storage units are also part of the system package, which features user-friendly functions and configurability ranging from stand-alone to clustered work stations.

GE gears up factory automation, plans joint venture

Bent on becoming a major force in factory automation, General Electric Co. has introduced an electronic-vision system and has formed a joint venture to market what it calls computer-aided engineering software. The PN2304 Optomation II vision system **employs a distributed multiprocessor architecture and modular software to provide capabilities** that go beyond those offered by GE’s 1978-vintage PN2303 Optomation I. The new system handles randomly positioned parts on a conveyor; its predecessor requires parts to be positioned carefully and is programmed with control switches. GE’s Optoelectronic Systems Operation in Syracuse, N. Y., offers the 2304 for about \$50,000, twice the price of the 2303. The joint venture, General Electric CAE International Inc. of Milford, Ohio, will sell software for mechanical design and stress analysis. GE’s partner is Structural Dynamics Research Corp.

Superfast computer to use data-flow matrix

Designed for fail-safe operation in ultrahigh-throughput scientific applications, a new computer design from Isotropic Nexus Systems Inc., Seattle, Wash., **should be capable of executing as many as 1 billion 32- or 64-bit instructions per second.** The system would use a form of data-flow architecture [*Electronics*, April 26, 1979, p. 92] with multiple arithmetic and logic units made from off-the-shelf array-processor technology. Task

Electronics newsletter

partitioning and data routing would be handled by multiple microprocessors in the highly parallel machine. The modular system would grow upward from units performing 4 million instructions a second by adding array processors. Initial deliveries are scheduled for mid-1984.

Smart CRT terminal costs under \$1,100

Prices of smart cathode-ray-tube terminals continue to fall. The latest price breaker, listing for less than \$1,100 in single quantities, is a new member of the Viewpoint family of terminals from Applied Digital Data Systems Inc. Unveiled this week by the Hauppauge, N. Y., company at Comdex in Las Vegas, the Viewpoint 90 **may be customized from the keyboard or host computer by using software.** This addition to the product line—known for its ergonomic features and reliability at a low price—can emulate many of today's popular terminals.

32-bit 8086 version in works at Intel

Intel Corp. in Santa Clara, Calif., is working on a 32-bit version of the 8086 microprocessor dubbed the iAPX-386. Unlike the iAPX-432, **it will have an instruction set compatible with the 8086, but will have 32-bit data paths.** It will compete with the 32-bit models of Motorola's 68000 and Zilog's Z8000, though none of the three is likely to see silicon before 1983. At the same time, Intel is trying to make certain it will offer the leader in 16-bit operating systems by signing with Digital Research Inc. of Monterey, Calif., for CP/M-86, a version of the *de facto* standard for 8-bit microsystems, and with Microsoft for MS-DOS, the operating system used with IBM's new 8088-based Personal Computer.

Sperry turns out rugged Josephson parts in lab

New processing techniques for superconducting Josephson logic circuits promise higher yields of extremely rugged parts, reports Sperry Research Center in Sudbury, Mass. Using all-refractory materials like niobium film and amorphous-silicon barriers, rather than standard lead alloys and oxide barriers, produces Josephson parts **immune to the performance-degrading effects of thermal cycling.** The first small-scale logic parts thus fabricated show very uniform, reproducible junctions with capacitances as low or lower as those of present Josephson parts, says the Sperry Corp. division.

Ada compiler to sell for \$1,500

Vying for the front runner's spot in Ada software, Western Digital Corp. of Irvine, Calif., this week is unveiling MicroAda, a proper subset of the Department of Defense language. The enhanced compiler, priced at \$1,500, is **an introductory tool that can be traded in for full value** when a final version of Ada is completed in June. Work on the subset was performed at the company's System Technology Center in Pittsburgh, which opens formally this week.

Addenda

The first compiler for the Modula-2 language—the brainchild of Niklaus Wirth, author of Pascal—comes from Volition Systems of San Diego, Calif. **The language is the answer to Pascal's inability to handle real-time programming problems and compile procedures separately** for increased programmer productivity. . . . Apple Computer Inc.'s Apple III is **finally ready for mid-December delivery**, and the Cupertino, Calif., company also has introduced a 5-megabyte, 5½-in. Winchester disk drive.

NEW OSCILLOSCOPE TUBE

STORES VERY FAST TRANSIENT SIGNALS



THOMSON-CSF presents its new high performance TH 8911 tube.

This half-tone direct-view storage tube features:

- 10 x 12 cm flat screen ● illuminable graticule
- high writing speed:
 - 10 m/ μ s for dark screens
 - up to 30 m/ μ s for luminous screens
- 100 MHz bandwidth
- two mode operation, storage and normal.

This tube is particularly well adapted for the observation of very fast spikes, impulses and a variety of other transients.

 **THOMSON-CSF**
COMPONENTS

THOMSON-CSF COMPONENTS CORPORATION ELECTRON TUBES DIVISION
750 BLOOMFIELD AVENUE - CLIFTON NJ 07015 - TEL. : (1.201) 779.10.04 - TWX : 710 989.7149

BRAZIL
SAO-PAULO
THOMSON-CSF
COMPONENTES DO BRASIL LTDA
TEL. : (11) 542.47.22

FRANCE
BOULOGNE-BILLANCOURT
THOMSON-CSF
DIVISION TUBES ELECTRONIQUES
TEL. : (1) 604.81.75

GERMANY
MÜNCHEN
THOMSON-CSF BAUELEMENTE
TEL. : (89) 75.10.84

UNITED KINGDOM
BASINGSTOKE
THOMSON-CSF
COMPONENTS
AND MATERIALS LTD
TEL. : (256) 29.155

ITALY
ROMA
THOMSON-CSF COMPONENTI
TEL. : (6) 638.14.58

SPAIN
MADRID
THOMSON-CSF
COMPONENTES Y TUBOS S.A.
TEL. : (1) 419.88.42

SWEDEN
STOCKHOLM
THOMSON-CSF
KOMPONENTER &
ELEKTRONRÖR AB
TEL. : (8) 22.58.15

JAPAN
TOKYO
THOMSON-CSF
JAPAN K.K.
TEL. : (3) 264.63.46

Circle 35 on reader service card

Information Specialist.

767 KSR Bubble Memory Data Terminal

EIA RS-232-C
Synchronous/
asynchronous
interface

3780 error checking
and TTY communication
protocols

40K standard
characters
of nonvolatile
bubble memory

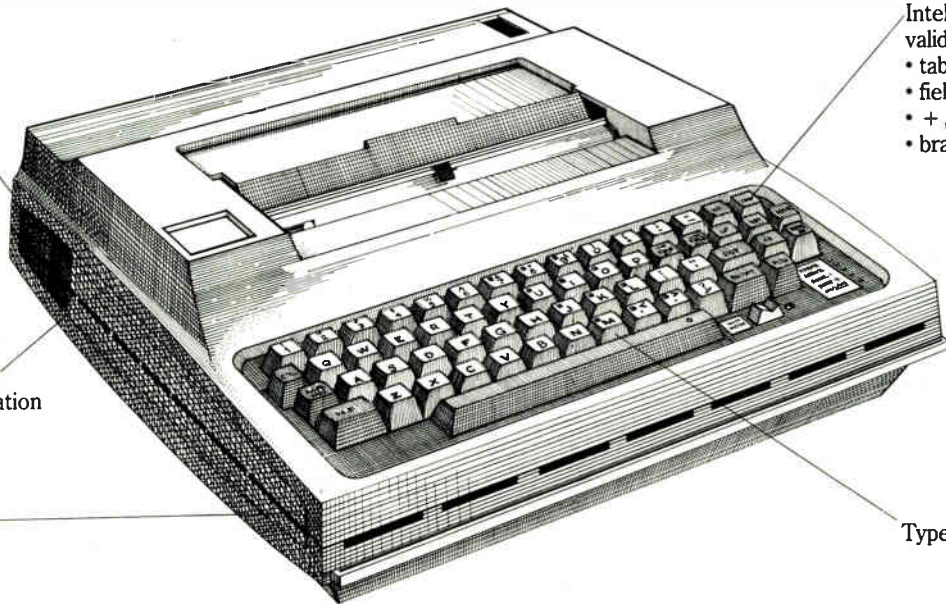

Intelligent data entry
validation (standard)

- table look-ups
- field validation
- +, -, ×, ÷ functions
- branching

Typewriter-like keyboard

TI's *Silent 700** Model 767 Electronic Data Terminal is ideal for remote data entry applications—especially those where data integrity is essential. The versatile 767 offers the advantage of high-speed batch synchronous communications with integrated nonvolatile bubble memory data storage for reduced connect time and communications costs. Featuring TI's Data Entry Validation and 3780 pro-

col capabilities, the 767 easily accommodates integration into new or existing distributed data entry networks.

TI is dedicated to producing quality, innovative products like the Model 767 Electronic Data Terminal. And TI's hundreds of thousands of data terminals shipped worldwide are backed by the technology and reliability that come from 50 years of

experience.

For more information on the Model 767; contact the TI sales office nearest you, or write Texas Instruments Incorporated, P. O. Box 202145, Dallas, Texas 75220, or phone (713) 373-1050.

TI invented the integrated circuit, the microprocessor and the microcomputer.



TEXAS INSTRUMENTS
INCORPORATED

In Canada, write Texas Instruments Incorporated, 41 Shelley Rd., Richmond Hill, Ontario L4C 5G4, (416) 884-9181. In Europe, write Texas Instruments, M/S 74, B. P. 5, Villeneuve-Loubet, 06270, France, (93) 20 01 01. In Asia Pacific, write Texas Instruments Asia Ltd., 990 Bendeemer Rd., Singapore 1233. Telex RS 21399, or phone 2581122.

*Trademark of Texas Instruments Copyright © 1981, Texas Instruments Incorporated

Superfast MOS outdoes GaAs in switching speed

by John G. Posa, Solid State Editor

X-ray lithography, advanced processing yield transistors with 0.25- μm channel length that switch in picoseconds

Some of the most sensational improvements in MOS technology are taking place over 3,000 miles from the fabled Silicon Valley in California. At Bell Laboratories, Murray Hill, N. J., researchers using X-ray lithography and other advanced processing techniques have fashioned MOS transistors with 0.25-micrometer channel lengths that switch in a matter of picoseconds—over an order of magnitude faster than those based on today's high-performance MOS technology.

What is more, Bell is on the verge of using the ultrafast MOS switches in very large-scale integrated circuits—one to control a new electron-beam lithography machine, another comprising an entire 40,000-transistor speech-processing system.

Bell's latest accomplishments and plans for its MOS technology were detailed at the 1981 Gallium Arsenide IC Symposium held late last month in San Diego, Calif. Martin P. Lepselter, director of Bell's advanced-development laboratory, was asked to speak at the conference on behalf of silicon technology.

Bell's lightning-fast MOS devices look just like conventional field-effect transistors, except they are much smaller. Heavy use of two-dimensional computer simulations ensures that parasitic influences will not degrade performance. To resolve the 0.25- μm features, Lepselter's

group has constructed a complete X-ray lithography system, including a compound mask and fast-acting triple-level resist to minimize radiation backscattering. The machine's latest improvement is an automatic wafer-feeding mechanism.

By paying particular attention to doping profiles, Lepselter and his colleagues have been able to fabricate MOS FETs that do not suffer from short-channel effects such as punch-through—a debilitating side effect to which such scaled-down devices are prone.

Ultrafast. With their 0.25- μm channels, the FETs switch in a remarkable 20 ps, a value that Lepselter contends will soon be halved. Whereas firms like Intel Corp. are producing commercial chips based on H-MOS-II (high-performance MOS) technology, Lepselter says his transistors "are around H-MOS-V." In fact, his calculations indicate that with theoretically perfect processing, the 0.25- μm FETs could switch in 4 ps—as fast as Josephson junctions.

Lepselter's comments raised considerable skepticism. Proponents of the GaAs technology submitted that his numbers were unrealistic because fan-out loading was not taken into account. Even with loading, however, Bell's FETs will switch in well below 0.5 nanosecond—more like 100 to 200 ps—says Lepselter, adding that with Bell's geometries, delay is so much a function of scattering-limited velocity that the choice of material—silicon or GaAs—is a

GaAs' bane. Bell Labs uses x rays and reactive sputter-etching to make picosecond MOS circuits. The 1- μm metal stripes above rest on oxide and polysilicon.

moot point indeed, in his opinion.

The very fastest GaAs devices, the high-electron-mobility transistors built by Japan's Fujitsu Ltd., switch at room temperature in 30 ps with a fan-out of 1 [*Electronics*, Oct. 20, p. 73]. They run faster than Bell's silicon MOS FETs only when supercooled—and in Lepselter's opinion, supercooling is impractical for commercial VLSI chips.

Armed with their silicon picocircuits, the Bell researchers are now in the process of laying out VLSI chips. The speech processor will perform well enough for both synthesis and recognition functions.

Also slated is a VLSI circuit that will handle all control and processing in Bell's EBES-IV scanning-electron-beam lithography system. The chip will measure 1,150 square mils and dissipate about 1.5 watts. It will include a 5-bit digital-to-analog con-

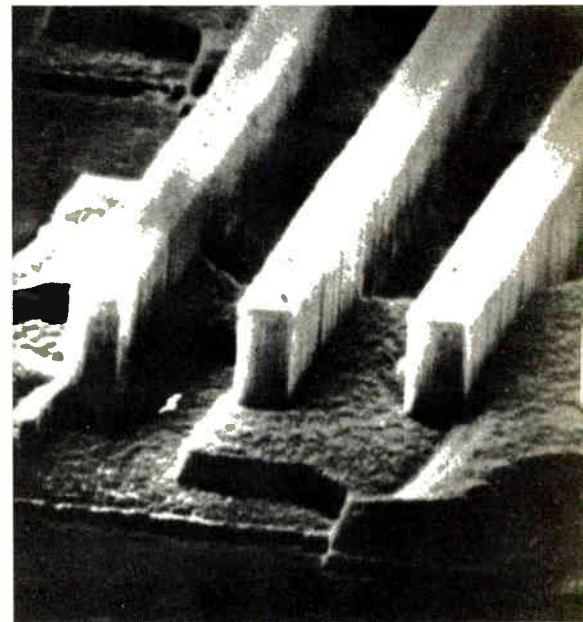

Commercialization of GaAs is at hand

Gallium arsenide now promises to be a very profitable niche for a semiconductor house that delves into the technology, according to Fred A. Blum, founder of Gigabit Logic Inc., Culver City, Calif., a company dedicated to GaAs products. Moreover, he believes products can be produced in high volume quite soon.

"We have to stop talking about it and start doing something," he told the recent gallium arsenide symposium in San Diego. Blum's company intends to sell gate arrays, memories, and monolithic microwave GaAs circuits to computer, communications, and instrumentation equipment makers willing to pay extra for the higher-speed chips.

"Any one of these producers will gladly switch to GaAs devices to obtain a competitive edge," he declares. One maker of high-speed scientific computers he knows about, supplying some two dozen machines per year, could use about \$45 million worth of high-speed digital chips, he says. Another \$10-million market could develop for very-high-frequency marine radios, he continues. As many as 20,000 such radios are manufactured annually, each requiring from 4 to 10 90-megahertz, variable-modulus frequency dividers at about \$50 each. That adds up to from 40,000 to 200,000 devices, or an annual market ranging between \$2 million and \$10 million. Altogether he foresees a \$200 million market for GaAs integrated circuits by 1985.

Chips required for this market should not be difficult to produce, Blum says. He calculates a requirement of 60,000 processed 3-inch GaAs wafers per year and an average selling price per GaAs circuit of \$50. This works out to 4 million devices.

If end-to-end yield is a conservative 10%, then 40 million dice must be manufactured. Further, assuming an average die size of 10,000 mil², 60,000 will have to be processed. Blum submits that this is a paltry number compared to silicon-chip volumes, leaving no excuse for the tardy commercialization of GaAs chips.

—John G. Posa

verter that can sample data at rates of 700 megahertz to 1.0 gigahertz with a nonlinearity less than 1.5%, resulting in a beam retrace time of less than 1 ns. Gates in the chip will operate from a 4-volt power supply and exhibit delays of 500 ps when driving 25-ohm loads.

Speech synthesis

Development systems add in-house voice

Buyers of voice chips and systems will soon be able to talk about how much easier it is to build electronic equipment that speaks for itself. Their suppliers are introducing development systems that allow them to produce the vocabulary for speech units in house, rather than outside at the vendors' speech development centers.

Last week, Texas Instruments Inc.

announced a new development system, and another major speech-chip vendor, General Instrument Corp., promises one for December. In addition, shipments have started for a development tool from Centigram Corp., a speech-system vendor.

There is a desire for such systems because of the proprietary nature of products and vocabularies, says Sharon B. Crook, product strategy manager for TI's speech-technology operation, Midland, Texas.

This idea is echoed by Murray Duffin, vice president of product management at GI's Microelectronics division, Hicksville, N. Y. "We are now finding that flexibility and the ability to paddle their own canoe are major concerns," he says.

In addition, some users are concerned that speech-chip vendors will be unable to handle vocabulary development once business surges.

Both ways. TI is unveiling for its major speech-chip customers what appears to be, in both price and

capabilities, the Rolls-Royce of development systems: it can generate vocabularies from either keyed-in text or a human voice. Other systems handle one or the other.

The system generates the parameters that can be stored in erasable programmable read-only memories, needed to drive TI's TMS5100 and TMS5200 families of speech-synthesis processors, which rely on linear-predictive-coding (LPC) techniques. Inputs are converted into phonemes and then into allophones before being converted into LPC parameters. Phonemes are basic speech sounds; allophones are a larger set of basic sounds that take into account things like position and emphasis in a word.

Sophisticated users—and TI expects many of its customers to hire linguists for the job—can enter and edit phonemes and allophones directly. In effect, the speech can be tweaked to sound even better as it moves from text to LPC.

TI's basic development system has two parts. One is the minicomputer-based Multiamplus development system that TI has offered for years. The other part is new—a data-collection processor that is an intelligent slave to the minicomputer and provides the analog interface required to collect and play back speech. TI quotes a total system price of \$97,930.

Coming soon. In addition, GI will bring out software and an emulator based on random-access memory for its speech-chip customers this December. Initially, the software package will be compatible with the HP 1000 and Digital Equipment VAX computers, but GI plans to expand this list early next year.

For GI's system, after a human voice has been compressed and placed on a disk, the host computer analyzes the data and produces the speech code that is downloaded into the emulator box. After speech has been edited and is of acceptable quality, the vocabulary can be burned into E-PROMs.

These E-PROMs can then be plugged into GI's new \$200 Speech Field Development 2000 board,

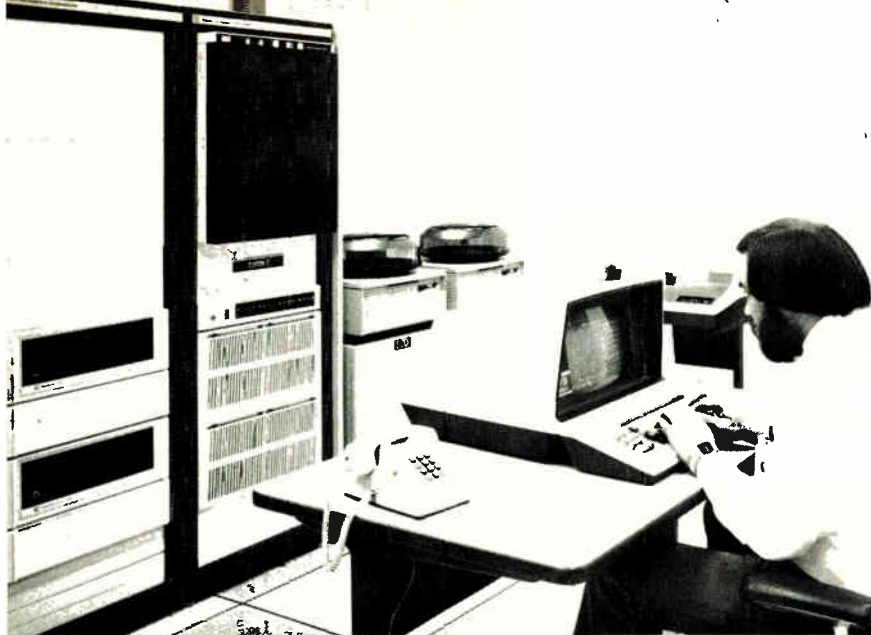

Speech maker. The development system from TI includes magnetic tape and 50-megabyte disk drives, a 256-K core memory plus an interface to collect and play back speech.

which emulates its SP256 speech system—the chip set the customer will eventually use. Hardware alone will cost about \$3,000; for software, a figure is yet to be set.

LISA. Centigram's speech development system, VoiceWare, helps develop vocabulary for its LISA (logically integrated speech annunciator) voice-synthesis terminal. The Sunnyvale, Calif., firm began shipping it last June. The \$30,000 system includes a cathode-ray-tube terminal with a floppy disk and a 5-megabyte 5¼-in. Winchester disk drive, a voice digitizer, and a board version

of the LISA terminal. Customers can digitize and compress human speech in real time using LPC and parametric waveform coding. By the end of the first quarter of 1982, Centigram president Gerard Currie expects to add personality modules to VoiceWare to support various makers' speech-chip sets.

Another voice-system vendor, the Votrax division of Federal Screw Works, Troy, Mich., reports that sales are brisk for its CDS II text-conversion development system [*Electronics*, Feb. 10, p. 118], and the CDS III. **-J. Robert Lineback**

Radar

Former Navy freighter sails off with the latest in phased arrays

A 30-year-old former U. S. Navy freighter is getting a new lease on life as a platform for the latest in operational phased-array radar. To be operated by Raytheon Corp., the Observation Island will sail for the western Pacific later this year to put the Cobra Judy (AN/SPQ-11) radar system on station.

The ship is unarmed and will make no attempt to hide its mission, which is to help monitor Soviet ballistic-missile flights in connection with the strategic arms limitation agreements. Cobra Judy will operate in conjunction with another Air

Force phased array, the Aleutians-based Cobra Dane radar.

Cobra Dane, in operation since 1977, is best situated to watch for missiles during their initial and intermediate launch phases. The curvature of the earth prevents it from monitoring the final flight stages and this is where Cobra Judy, specially designed for tracking re-entering space vehicles, comes in.

A project of the Air Force's Electronic Systems division, Hanscom Air Force Base, Mass., Cobra Judy sits in a 250-ton turret that can rotate 270°. The four-story-high tur-

ret contains all the equipment for the high-power S-band radar, including the waveguide and coaxial equipment in the microwave portion of the system that handles many kilowatts.

Phase-shifting the array's 12,288 elements is accomplished with programmable 8-bit p-i-n diode phase shifters. These shifters can tailor both rows and columns in the array and shift phase in 45° increments.

Classic microwave component design was used for Cobra Judy. For example, duplexing is performed by passive-waveguide magic tees, 30 years old in concept, instead of by newer semiconductor devices. In addition, water-cooled traveling-wave tubes energize the 22.5-foot-diameter antenna that can be stabilized independently of the ship's motion.

Processing. A digital signal-processing system generates some of the information to help radiate, steer, and shape the beam to maximize the returned information and analyze the returns, says Richard Daly, signal-processing department manager of Raytheon's Radar Systems Laboratory, Wayland, Mass.

The digital system provides the filtering and fast Fourier transforms for maximizing the signal-to-noise ratio and remove interference. It also helps the radar system to determine the number of missiles, their velocity, range, and bearing.

According to Daly, the processor system's design is state-of-the-art as of 1979, and getting it into operation in only two years "is a notable achievement. A lot of the Cobra Dane work helped us on the Cobra Judy project," he says.

Hardwired. The signal-processing system is hardwired although it is under control of the overall Cobra Judy computer. Resident program software-controlled processors were not sufficiently developed to be included at the time the design was frozen, Daly explains.

Typical of the system's signal-processing paths is one with a 50-megahertz radio-frequency bandwidth that accommodates a two-channel stream of information. The coherent channels in phase quadra-

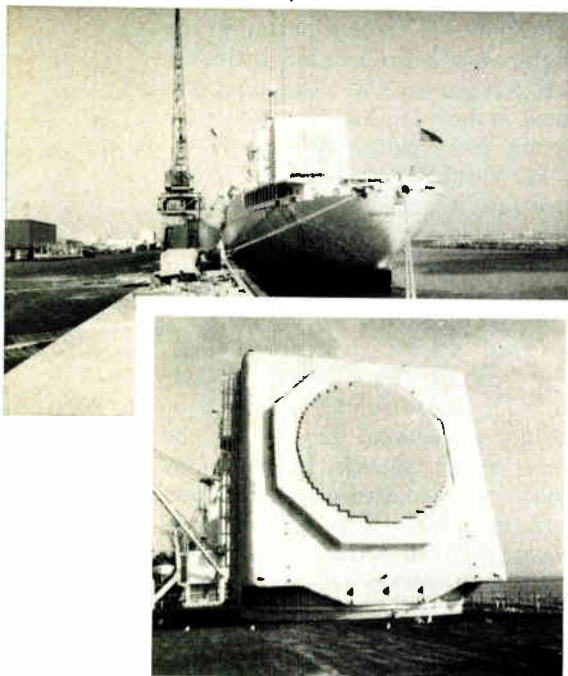

ture are converted to digital data streams with a 20-bit precision.

In actual processing, a digital FFT capability can handle up to 8,000 points in a single transform calculation. Calculations are done in a pipeline mode for maximum speed by a series of 13 two-point transform modules in series. They multiply complex numbers using parallel 5-MHz multiplier chips from TRW.

The analog-to-digital conversion is performed at the system's intermediate frequency, and the quadrature channels generated are detected by phase-matched detectors. The whole Cobra Judy show is run by a Cyber computer from Control Data Corp. with assembly-language software from the IBM Federal Systems division.

-Harvey J. Hindin

Peripherals

Video recorders set to back Winchester

Despite its high storage capacity, the video-cassette recorder is not widely accepted as a backup for Winchester-disk drives because of a high error rate. But by recording data redundantly, Alpha Microsystems

Watch out. The 22.5-ft.-diameter antenna of Cobra Judy's phased-array radar (close-up) dominates the stern of an ex-freighter, the Observation Island.

hopes to overcome that obstacle and popularize the VCRs' use.

The Irvine, Calif., maker of small-business systems will formally unveil its AM-610 VCR-interface controller board this week at the Comdex data-processing-equipment show in Las Vegas. With the 610, which has been under development for three years, users can store 100 megabytes on a four-hour cartridge using nearly any standard VCR.

Alpha Microsystems claims that by recording each block of data six times, the error rate is comparable with that of a Winchester, about 1 in 10^{-13} reads. Data is recorded in blocks, with six copies of block 1 followed by six of block 2, six of block 3, and so on, rather than a full recording of the entire file followed by another full recording.

Low cost. One of the hopes for the unit's success is based on its price. VCRs cost about \$500 to \$600 and the firm's controller lists for \$600 to \$1,000, putting the total cost slightly below $\frac{1}{4}$ -inch cartridge streamers with only 20-megabyte capacity. Additionally, the media sells for \$15 to \$20, also slightly less than streamer cartridges, the firm says.

The 610 is Z80-based with 4-K bytes of static random-access memory and 2-K bytes of programmable read-only memory, which holds the microcode. The microcode handles data retrieval and checks for errorless blocks of data using a cyclic redundancy check.

The transfer rate from disk to tape is 600 kilobits per second. But for both recording and playback, the tape requires its specified time from start to finish—four hours to completely fill a four-hour tape. Since this is a relatively slow transfer rate during which the computer must be dedicated to the task, Alpha Micro advises setting the timer on the unit to the system's internal clock and performing the backup at night when the system is unused.

In the event of disk problems,

retrieval of the data is also time-consuming. Operating at the VCR's standard speed, it could take four hours to locate a file near the end of a tape. The firm is currently revising its software to take advantage of fast-forward found on most VCRs.

Product manager Rich Oliva feels "people will come over in droves once they see that it works." He predicts that 70% to 80% of the firm's small-business-system sales will include the VCR as a backup device next year.

Detractors. Ray Freeman of Freeman Associates, a Santa Barbara, Calif., research firm specializing in disk and tape products thinks otherwise. "Our conclusion is that the VCR is not well-suited to backup requirements. It's too big and the transfer rate is too slow."

Actually, Alpha Micro is not first with a VCR as a disk backup. Corvus Systems Inc., San Jose, Calif., introduced in late 1979 as its second product the \$750 Mirror, a similar controller for VCRs. The firm now sells VCR backups for about 40% of its disk subsystems and recommends four redundant tapings.

Corvus finds acceptance is as yet lacking. "We still have to prove its reliability, even though it has been successful," says chief engineer Bruce Eisenhard. -Terry Costlow

Local networks

Interfaces let users mix network gear

Some of the first hardware that lets equipment from different manufacturers be interconnected on a local network will also be shown this week at Comdex in Las Vegas by a company called the Destek Group. Usually, local network hardware is developed by equipment makers for their own equipment, but several firms have announced they are developing so-called universal interfaces that cut across proprietary lines [*Electronics*, July 28, p. 97].

Destek says any combination of up to nine processors and peripherals

TO SEE OR NOT TO SEE...



That is the night viewing question,
answered with THOMSON-CSF's complete range of high-
performance image intensifiers.
Sturdily built and compact, these tubes offer high luminance gain up
to 25,000 cd/m²/lux with extended sensitivity in the near infrared.
With THOMSON-CSF,
to see or not to see at night is no longer a question.



THOMSON-CSF
COMPONENTS

THOMSON-CSF DIVISION TUBES ELECTRONIQUES

38 RUE VAUTHIER / BP 305 / 92102 BOULOGNE-BILLANCOURT CEDEX / FRANCE / TEL.: (33.1) 604 81 75

USA
THOMSON-CSF
COMPONENTS CORPORATION
CLIFTON NJ (201) 779.10.04

BRAZIL
THOMSON-CSF
COMPONENTES DO
BRASIL Ltda
SAO-PAULO (11) 542.47.22

GERMANY
THOMSON-CSF
BAUELEMENTE GmbH
MÜNCHEN (89) 75.10.84

UNITED KINGDOM
THOMSON-CSF
COMPONENTS AND
MATERIALS Ltd
BASINGSTOKE (256) 29.155

ITALY
THOMSON-CSF
COMPONENTI
ROMA (6) 638.14.58

SPAIN
THOMSON-CSF
COMPONENTES
Y TUBOS S.A.
MADRID (1) 419.88.42

SWEDEN
THOMSON-CSF
KOMPONENTER
& ELEKTRONRÖR AB
STOCKHOLM (8) 22.58.15

JAPAN
THOMSON-CSF
JAPAN K.K.
TOKYO (3) 264.63.46

Electronics review

can be tied into any of the four popular interconnection media—coaxial or twisted-pair baseband, rf-modulated broadband, fiber-optic, or conventional telephone lines. The job is done for each device with a combination of custom software packages and a Z80-based interconnect board that sells for \$795. Up to nine such boards plug into a \$1,500 switching box that supplies power and ties into the network. The boards can also plug directly into an S-100 computer backplane.

More boards. Destek's initial interconnect board in what it calls its NIB-1000 family is designed for the S-100 bus, but boards for other buses are planned. Up to 4,608 devices can be connected to a network. The speed of the network can range from 2 megabits per second for the baseband media up to 20 Mb/s for the fiber-optic.

The system will support a range of interconnect protocols, including asynchronous schemes (like Ethernet, for example), Synchronous Data-Link Control (SDLC), High-Level Data-Link Control (HDLC), and Advanced Data-Communications Control Procedure (ADCCP).

Destek, in Mountain View, Calif., was formed in 1980 primarily to develop software products for microsystems. It is working on systems software that allows existing software bases, like Bell Laboratories' Unix or Digital Research's CP/M, to execute on all the popular microsystems, instead of on just those designed to use them. Thus, eventually, Z80 code developed in a CP/M environment could execute on an 8086 microprocessor running under Unix.

-R. Colin Johnson

Medical

Body scanners get new entries

Though sluggish for the past four years, the U.S. market for computerized-tomographic scanners is attracting new product entries, including one from a company just starting

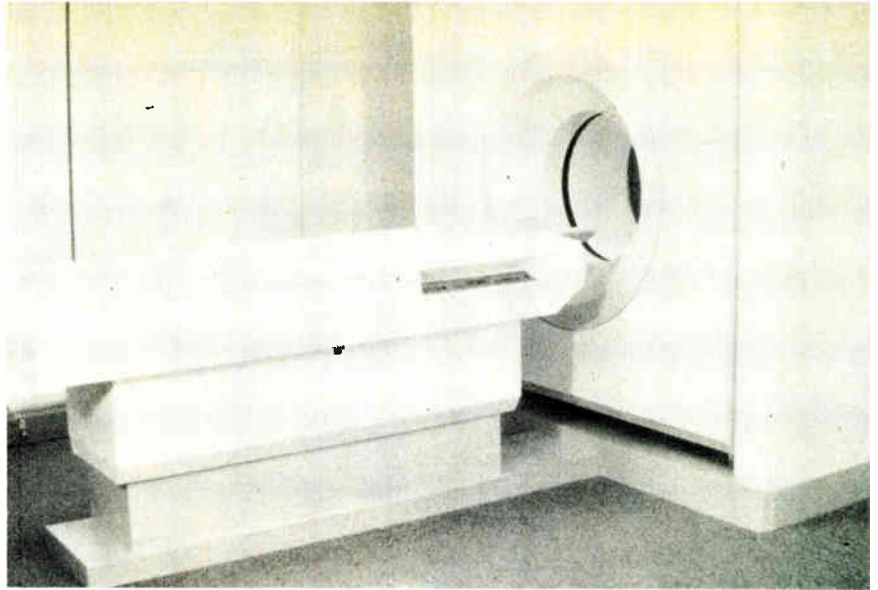

Radiator. A computerized-tomographic body scanner being readied for market by Interad Systems rotates X-ray tubes and detectors (in vertical housing) around patient.

up in the business. The design team at Interad Systems Inc., Schaumburg, Ill., comes replete with experience gained at companies that did not survive the recent CT makers' shakeout—Searle CT Systems and the company that acquired it and was later acquired in turn, EMI Ltd.

But with tailor-made knowledge and lower overhead than its larger, established competitors, Interad comes to market with a much cheaper body-scanning system. According to company president G. H. (Bill) Williams, his new entry matches the performance of top-of-the-line systems like the CT/T 8800 from General Electric Medical Systems and the Somatom II from Siemens, yet sells for \$475,000, some 30% to 50% less. The machine offers a choice of 3-, 6-, or 12-second scan times and resolution of 1 millimeter.

Rotation. Like most other high-performance systems, the Interad system employs a rotate-rotate design in which the X-ray tubes and detectors are fixed in the same assembly and rotate in unison around the patient. The relatively low cost, says engineering vice president David Peerenboom, was achieved by "designing out a lot of the extra costs that have been in CT scanners in the past."

For example, the Interad system architecture delegates its data-processing tasks to a 32-bit array processor and employs its central processing unit only as a data and device manager, Peerenboom notes. This design permits an LSI-11/2

microcomputer to be used as the system's chief processor instead of the more costly general-purpose minicomputer used in traditional scanner designs that typically split processing tasks among the CPU, the array processor, and a dedicated subsystem known as the back projector.

New array. The MSP-3000 array processor used in the Interad system is a new product supplied by Computer Design & Applications Inc., Newton, Mass. It contains a built-in display processor as well as an operator keyboard, eliminating the need to purchase these components separately, Peerenboom points out.

In addition, the Interad system uses an 80-megabyte, 8-inch Winchester disk drive from Scientific Microsystems Inc., Mountain View, Calif., a less costly alternative than the removable hard-disk peripherals typically employed. In all, Peerenboom estimates, the Interad approach allows about \$40,000 worth of computing power to do the job of a more traditional architecture with about a \$90,000 price tag.

Other significant cost savings were made by simplifying the mechanical gantry and patient-handling systems. Scheduling first deliveries for 1982's first quarter, Interad is aiming at smaller hospitals and clinics that have not been able to justify the \$800,000-to-\$1-million cost of current high-performance scanners.

Interad intends to control the cost of its service operation initially by clustering its early scanner sales in

SHARP

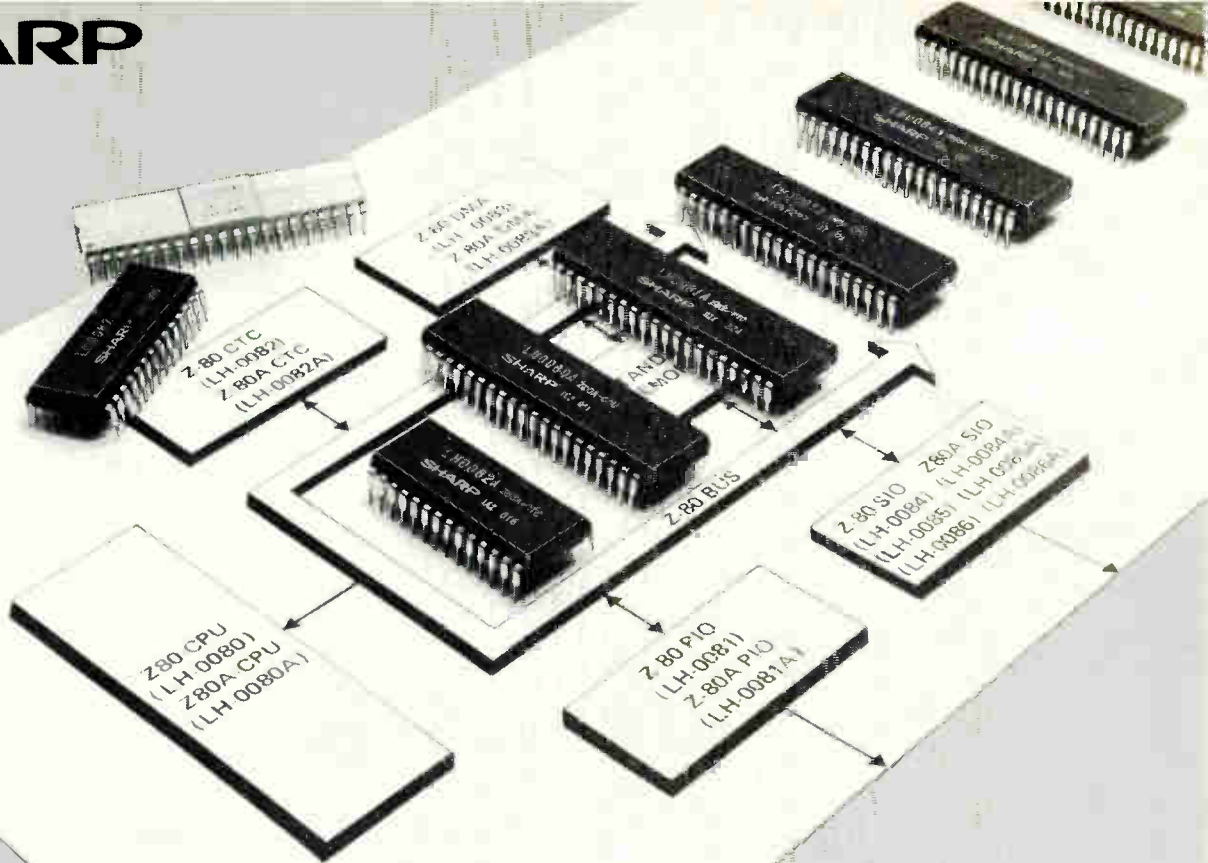

Now may be the best time ever to review suppliers for Z-80/Z-80A !!

• Z-80/Z-80(A) SERIES

Z I/O LOG	SHARP Type No.	Features	Package
Z-80 CPU Z-80A CPU	LH-0080 LH-0080A	• 158 instructions — includes all 78 of the 8080A instructions • Three modes of maskable interrupt plus a non-maskable interrupt • 22 internal resistors • •	40 DIP
Z-80 PIO Z-80A PIO	LH-0081 LH-0081A	• Two independent bidirectional ports • Any one of the following modes of operation may be selected for either port: Byte input/output, 8-bit bidirectional bus, Bit Mode • •	40 DIP
Z-80 CTC Z-80A CTC	LH-0082 LH-0082A	• Four independent programmable 8-bit counter/16-bit timer channels • Single phase clock • •	28 DIP
Z-80 DMA Z-80A DMA	LH-0083 LH-0083A	• Single channel 2 port • Three classes of operation • 3 Modes of operation • Up to 1.25M8 search rate • •	40 DIP
Z-80 SIO/0 Z-80 SIO/1 Z-80 SIO/2	LH-0084 OH-0085 LH-0086	• Two full duplex channels • Asynchronous operation • Binary synchronous operation • HDLC 18M SDLC Mode • 0 ~ 550k bits/Sec • •	40 DIP
Z-80A SIO/0 Z-80A SIO/1 Z-80A SIO/2	LH-0084A LH-0085A LH-0086A		

Vcc (V): +5 • Z-80: clock frequency 2.5MHz Z-80A: clock frequency 4MHz

SHARP can provide this full line with high quality and excellent reliability. Ceramic package types also available!

We have a versatile line of 4-bit to 8-bit microcomputers to meet various demands: Our Z-80/Z-80A series (CPU, PIO, CTC, DMA, SIO/0-2) are manufactured for controllers and terminals requiring complex processing while the SM series (4-bit 1-chip) are suitable for consumer product appliance.

• SM SERIES

Model No.	SM 4A	SM 5A	SM 510	SM 520	SM 570	SM 611
Plots	CMOS	MOS	MOS	CMOS	CMOS	CMOS
Power Supply Voltage	-3.2 Typ	4V Typ	4V Typ	5V Typ	1.5V Typ	1.5V Typ
ROM Capacity	2K x 8 bit	18.7 x 8 bit	272 x 8 bit	3072 x 10 bit	2016 x 8 bit	1260 x 8 bit
RAM Capacity	9 x 4 bit	6 x 4 bit	26 x 4 bit	160 x 4 bit	88 x 4 bit	27 x 4 bit
Instruction	4	51	49	53	47	48
Instruction Cycle Time	61ns	61ns	61ns	11ns	31.6ns	91.6ns
Remarks	PCD Direct Drive	CD Direct Drive	Fluorescent Display Driver	Fluorescent Display Driver	Fluorescent Display Driver	LCD Direct Drive

SHARP CORPORATION
International Division
Electronic Components Sales Dept.
22-22, Nagaiki-cho, Abeno-ku, Osaka 545, JAPAN
Phone: (06) 621-1221 Cable: LABOMET OSAKA
Telex: J63428 Attn: OSKPA (LABOMET A-D)

U.S.A. : SHARP ELECTRONICS CORPORATION
Sharp Plaza, Paramus, New Jersey 07652
Tel: (201) 265 5600 For further information, Contact: Mr. M. Miyagawa

EUROPE: SHARP ELECTRONICS (EUROPE) GMBH
Sonnenstraße 3, 2000 Hamburg 1, F.R. Germany
Tel: (040) 28511 Attention: Mr. Y. Goto

the Midwest near the firm's Schaumburg offices, Williams says. Plans call for third-party service organizations elsewhere later.

Another. Interad unveils its scanner this week at the Radiological Society of North America's 67th annual meeting in Chicago. Also dropping price at the meeting is Toshiba Medical Systems' TCT-80A, which was introduced this June at a Brussels trade show.

With a base price of \$650,000 that includes a multiformat camera for putting cathode-ray-tube images on hard-copy film, the TCT-80A undercuts the price of the company's 2½-year-old TCT-65A by some \$200,000.

Given the extensive history of firms that have tried and failed in the CT-scanner business, few observers are willing to place much hope in Interad's chances for success. But most do agree that the small-hospital sector is potentially fertile ground.

Out of some 7,200 U. S. hospitals, about 5,800 maintain fewer than 300 beds, says Kenneth W. Marich, senior health-industry consultant for SRI International, a Menlo Park, Calif., a research and consulting firm. These smaller hospitals, together with about 4,400 U. S. medical clinics and group practices with over three doctors, could all be potential buyers. **-Wesley R. Iversen**

Military

Stealth R&D moves ahead

The Air Force is proceeding with a program to develop radar-absorbing materials and radar-absorbing structures, called RAM/RAS, for its Advanced Technology Bomber that is popularly known as Stealth. Meanwhile, debate within the service and the Congress continues over whether the nation can simultaneously fund the advanced bomber-fighter for the 1990s as well as Rockwell International's near-term B-1B.

Northrop Corp. has been named

News briefs

Personal-computer maker undergoes change

With a name change and new business strategy, Ohio Scientific Co., acquired a year ago by M/A-Com Inc., is signaling a major thrust at the small-business computer market. Soon to be renamed M/A-Com Office Systems Inc., the company under William Chalmers, who became president last July, is organizing its product line in ranges that include the C100, a personal computer retailing for about \$3,400; the C200, a family of three systems aimed at single-user small-business applications priced between \$4,000 and \$8,000; and, at the top, the C300, with three machines based on a Winchester disk drive offering multiple-user and full-networking capabilities priced between \$10,000 and \$20,000.

One of the earliest personal-computer manufacturers in the field, OSI is now being positioned to serve the microcomputer market, with major emphasis on value-added systems makers as major customers. According to Chalmers, future plans include single-user office work stations for connection to office- and business-communications networks, such as Macomnet, a wideband digital-communications network for voice, data, and video being developed by M/A-Com. The network uses satellite, microwave, coaxial-cable or fiber-optic links to provide intracompany communications or access to data banks.

Major growth measured in factory sales last year

U. S. shipments of electronic equipment, systems, and components totaled approximately \$104 billion in 1980, representing a growth rate of 18.5% over 1979's \$81 billion, according to data released in the Electronic Industries Association's 1981 Market Data Book. The data book also reports that more than 1.5 million U. S. residents were employed in electronics manufacturing in 1980, and employment in U. S. electronics industries grew by an estimated 7%. This growth compares with a rate of 0.5% for overall U. S. nonagricultural employment.

R&D laboratory established by Sony in U. S.

Sony Corp. of America will establish a consumer-electronics laboratory to concentrate on future product development and adaptation. Sony Consumer Electronics Laboratories, Paramus, N. J., will be a division of Sony Corp. Kenji Tamiya, executive vice president of the parent company, says the lab will conduct research, development, and design work with particular emphasis on technology emerging in the U. S. Included will be cable-TV systems and terminals, receivers for direct satellite broadcasts, and home-information systems and terminals. Products that are developed will be sold in the U. S. and abroad.

Transponders sold on upcoming Comsat by auction

In an approach yet to gain Federal Communications Commission approval, RCA American Communications Inc., Princeton, N. J., auctioned off seven transponders on its yet-to-be-launched communications satellite for a total of \$90.1 million. More than 50 bidders participated in the sale at New York City's Parke-Bernet Galleries, better known for auctioning art works than electronics.

The event marked the first time that leases for transponders on a communications satellite—in this case, RCA Americom's Cable Net 2 Satellite, Satcom IV, to be launched Jan. 12—were offered by auction. Bids ranged from \$14.4 million down to \$10.7 million. They will be applied monthly against lease payments for the transponders beginning April 1982 and continuing through 1988. Full bid payments must be made in mid-January and will represent some \$20 million more than RCA Americom could have gained under rate schedules now in effect. Andrew F. Inglis, president of RCA Americom, notes that the auction reduces the opportunity for speculators to obtain transponder rights, then resell them for substantial profit. The bidding underscores the current heavy demand for transponders.



5 x 7 DOT MATRIX ALPHA-NUMERIC

- Clear Characters • Wider Variations
 - Reliability under stringent temperature ranges.
 - Compatible interface with TTL and CMOS
 - CMOS-level Compatible, consequently 8-bit parallel outputs from a microcomputer can be easily connected.
 - 128 row characters can be on display.
 - +5V ~ 7V single power supply.
- Now SHARP makes the readout easier to see and greater versatility available by adding 40 and 80 alpha-numeric Dot Matrix Display unit with 5 x 7 dot.

LM-24102



LM-40201

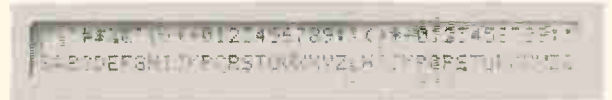

LM-80101



SHARP'S 5x7 DOT MATRIX LCD UNIT

Driver ICs also available.



LH-5001
LH-5002
LH-5003
LH-5004

Parameter	Character number (character x line)	Unit outline WxHxD (mm)	Character size WxHxD (mm)	Supply Voltage (V)
* LM-06151	6 Character. 1 Line	60x40 x14.5	4.8x7.5	+5
* LM-14151	14 Character. 1 Line	93x47 x13.5	2.65x3.75	+5
LM-24102	24 Character. 1 Line	175x46 x12	3.3x5.05	+5, -5
* LM-24151	24 Character. 1 Line	174x51 x13.5	3.3x5.05	+5
LM-40101	40 Character. 1 Line	175x45.4x15	2.32x3.28	+5, -5
* LM-40151	40 Character. 1 Line	177x46 x13.5	2.32x3.28	+5, -5
LM-40201	40 Character. 2 Line	230x50 x15	3.4x4.8	+5, -5
LM-80101	80 Character. 1 Line	310x90 x12	2.32x3.28	7V-13.5V

- * Select the character combination appropriate for the number of lines required for the read out.
- All types (except LM-06151) can display cursor line (5 dots)

SHARP CORPORATION
International Division
Electronic Components Sales Dept.
22-22, Nagaike-cho, Abeno-ku, Osaka 545, JAPAN
Phone: (06) 621-1221 Cable: LABOMET OSAKA
Telex: J63428 Attn: OSKPA (LABOMET A-D)

U.S.A.: SHARP ELECTRONICS CORPORATION

Sharp Plaza, Paramus, New Jersey 07652
Tel: (201) 265-5600 For further information,
Contact: Mr. M. Miyagawa

EUROPE: SHARP ELECTRONICS (EUROPE) GMBH

Sonninstrasse 3, 2000 Hamburg 1, F.R. Germany
Tel: (040) 28511 Attention: Mr. Y. Goto

512×512High Resolution.
Image Frame Memory Unit.

IMU6000

Series

&

Single Board Computer

EA9256-FD

ASSEMBLED TESTED

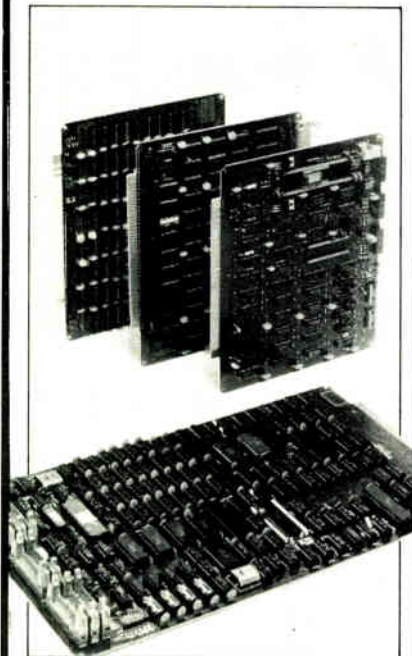

IMU6000Series

Frame Composition : 512×480Pixels
Level : 4bit 6bit 8bit
Sampling Time : 1/30sec
Input Output Video Signal : NTSC com-
posite Video Signal 1.4Vp-p
Input Output Impedance : 75Ω

EA9256-FD

CPU : MC6809
CLOCK : 1MHz
ROM : 4K Bytes(2716×2)
RAM : 64K to 256K Bytes
SERIAL INTERFACE : RS-232C×4
FLOPPY INTERFACE : Centronics type
FLOPPY DISK INTERFACE
SOFT WARES

* FLEX[®] DOS Modifications to run on our
EA9256-FD Computer Board is available.

* FLEX[®] is a Trade mark of Technical Systems Consultants Inc.

AMUST COMPUTER CORP.

ZENIYA BLDG. 1-8-4 SOTO-KANDA,
CHIYODA-KU, TOKYO 101, JAPAN
TELEPHONE: (03)257-1366
CABLE ADDRESS:
AMUSTCPTR TOKYO
TELEX 02228327
AMUST J

WANTED
DISTRIBUTORS.



Electronics review

prime contractor for the ATB if the bomber is produced. Lockheed Aircraft is working on a fighter version using Stealth technology and called AFT. Yet another, lower-cost concept is surfacing from Grumman.

The Air Force's Wright Aeronautical Laboratories' Materials section in Dayton, Ohio, says it wants responses by Nov. 22 from potential RAM/RAS developers for two independent efforts. One calls for developing weaving techniques for the materials similar to those used for textiles and incorporating epoxy composites locally for use in RAS.

The other effort seeks design and fabrication concepts for the leading-edge structures that balance the attenuation of radar signals with such mechanical requirements as structural efficiency, damage tolerance, and resistance to lightning strikes and weather erosion.

Costs. Present Air Force cost estimates for the Stealth program put its development at more than \$10 billion. Based on projected deployment beginning in 1989, production costs for the bomber alone could raise the total to more than \$25 billion in current dollars. Production costs for 100 of Rockwell's B-1B, exclusive of weapons and life-cycle support, are now projected at \$35 billion to nearly \$40 billion by the Congressional Budget Office. The latest escalation is far above the \$12 billion estimate the Air Force got from the contractor early this year and the source of concern as to whether the nation can afford both programs.

Compounding the dispute over two-bomber economics was the reputed leak by Grumman Corp., Bethpage, N. Y., that it is exploring a low-altitude ATB concept that purportedly would be more cost-effective than Lockheed's high-altitude approach. Long regarded as a Navy aircraft supplier, Grumman reportedly employs a delta wing mounted above the fuselage with two tail fins canted outward at 42° from the vertical. Missiles mounted internally would be launched from an opened housing atop the rear of the fuselage, thereby eliminating radar detection

of externally mounted munitions.

Radar-absorbent graphite epoxy composites would also help shield the engine inlet mounted flush under the fuselage. A synthetic-aperture radar, mounted forward in the fuselage and covered by a movable shield of radar-absorbent material, could be uncovered for target acquisition and terrain-following maneuvers.

The Air Force made no official comment on Grumman's plan. One source described it as "a company sending out a signal to see if it gets any response."
-Ray Connolly

Packaging

Pin count hits 40 in small package

The Dutch seem to be taking up the slack from U. S. companies when it comes to upping the pin count in the relatively new small-outline integrated-circuit (SOIC) packages. Philips Industries' Electronic Components and Materials division, Eindhoven, the Netherlands, is now supplying devices in 24-, 28- and 40-pin configurations.

Such packages offer considerably more pins than those being supplied by Signetics and Motorola [*Electronics*, Sept. 22, p. 39]. These companies supply devices in 8-, 14-, and 16-pin packages, relegating 20-pin types to the "under consideration" department. Most American companies take the view that at above 20 pins, plastic chip-carriers with leads on 50-mil centers make more effi-

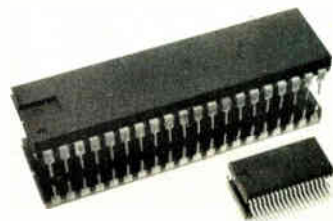

Mighty mite. Philips' 40-pin small-outline integrated-circuit package, with leads on 30-mil centers, has 85% less surface area than the standard 40-pin dual in-line package.

cient use of space than the rectangular SOIC shape.

Philips also supplies ICs with the smaller numbers of pinouts. Normal lead spacing is 50 mils, but the SO-40, which is the same size as the 24-pin SO-24, has its leads on 30-mil centers. Its size— 0.610 by 0.300 inch—offers a reduction in surface area of 85% compared to the common 40-pin dual in-line package, which measures 2 by 0.600 in. (see photograph, p. 46).

Philips has willingly sacrificed standardization in lead spacing to reduce the overall length of the SOIC package. It should be suited to thick-film hybrid circuitry, although designers used to the 100-mil grid of printed-circuit boards will not be overjoyed with its 30-mil spacing.

Philips, whose SOIC-packaged products are marketed in the U. S. by Signetics in Sunnyvale, Calif., already uses the new packages for several complementary-MOS large-scale integrated products. In the SO-28, Philips has a C-MOS liquid-crystal-display duplex driver for a 40-segment LCD. In the SO-40s, there are duplex drivers for 60- and 64-segment LCDs and a four-digit LCD automobile-clock. —**Jerry Lyman**

Peripherals

Dot-matrix printer 'hues' the line

Color and graphics from a dot-matrix printer listing for less than \$2000? Formerly unheard of, say spokesmen for Integral Data Systems Inc.—but unheard of no longer with the Milford, N. H., firm's forthcoming Prism printer.

The new system will not only produce normal black-on-white alphanumerics but four-color output and graphics, too. Further, IDS says that it will have shipped tens of thousands of them by February. Ink-jet color printers in this market have generally sold at prices ranging from \$5,000 to \$9,000.

Prism is the first of a new, modular, dot-matrix printer line to emerge

Have we got eyes for you.

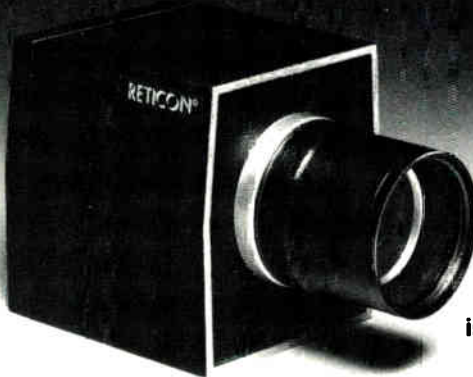

100 X 100 MATRIX CAMERA

When you need high speed geometrically accurate grey scale image data, the Reticon MC520 is the camera to use.

It can "see" 10,000 points in the chosen field of view and transmit the corresponding data with up to 256 grey levels to your equipment. Together with the RS520 controller, it offers the reliable high performance system you are looking for in your process control, non-contact inspection, surveillance, or robotics application.

- 100% solid-state construction
- Wide dynamic range
- High reliability environmentally sealed enclosure
- 25 to 500 frames per second
- Remote operation of camera head up to 75 feet from controller
- Bi-level threshold
- Optional 6 or 8 bit analog to digital conversion

We also offer a wide selection of line scan cameras with resolution from 64 to 2048 elements.

With all cameras, EG&G Reticon offers an accessory package that makes it the most versatile system to meet your needs, including: Interfaces to microprocessors, intelligent support electronics, light sources, and a variety of optical accessories.

Call us to discuss your application.

 **EG&G RETICON**

345 POTRERO AVENUE
SUNNYVALE, CA 94086
TWX: 910-339-9343

For assistance call: Boston (617) 745-7400, Chicago (312) 640-7713,
San Francisco (408) 738-4266, Tokyo, Japan 03-343-4411,
Wokingham, Berks, England (0734) 790772

World's broadest family of smallest PCB switches.

ALCO designed and engineered the TT Series primarily for PC applications. Their small size allows placement between PCB's on 1/2" centers. All terminals and mounts fall into a 0.1" grid.



Your choice of toggles, pushbuttons, slides, rockers and LED lighted types in 1, 2 or 4 poles. Right angle types are our specialty and wire wraps too! Gold plated contacts are standard for low-level switching. Silver provides a 3 amp rating and is U.L. listed. A variety of panel mounted types also available.

We pride ourselves by stocking hundreds of standard types, many in production quantities to service your immediate needs. However, our engineers and production group can also provide literally thousands of custom types promptly and economically. We urge you to call or write Customer Service for 160-page ALCOSWITCH catalog and free sample.

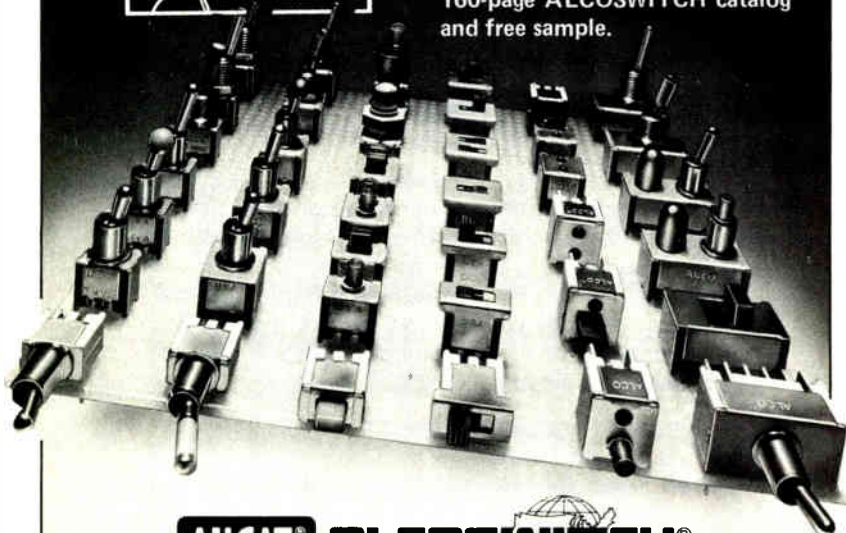

AUGAT ALCOSWITCH®

ALCO ELECTRONIC PRODUCTS, INC.
1551 Osgood St., No. Andover Ma 01845 USA
Tel: (617) 685-4371 TWX: 710 342-0552

Canada: Kaytronics, 375 Norman St. Ville St. Pierre, Qué, H8R 1A3
Europe: Augat France SA (Z.I. Sofilic) B.P. 440-CEDEX 94263 Fresnes, France

Circle 48 on reader service card

Keeping you ahead of the pack...

You (and we) are in a quick-moving business. News breaks frequently. Change is the name of the game. Awareness is the way to win.

Give us one hour of your time every two weeks and we will keep you aware of what's going on around you and around the changing world of electronics technology.

Keep ahead of the pack. Send in one of the subscription cards in this issue.



Electronics Magazine

Electronics review

from IDS, which plans to market it aggressively through retail outlets. Not only will it have the usual RS-232-C and "Centronics-compatible" parallel inputs, but special graphics and driver modules will be offered to give specific personal computers, like the Apple II and III, color and graphics capability. One also is due for IBM's Personal Computer.

Stripes. The Prism simply takes the old idea of a red-black typewriter ribbon and divides it up into four stripes of color—a choice of cyan, magenta, yellow, and black, or of red, blue, yellow, and black. Substituting one ribbon for the other—they are being produced especially for IDS—varies the tints and shades.

In operation, the ribbon is positioned with the desired color stripe between the print head and the paper. Several high-speed passes back and forth across the paper will generate the colors. The approach is similar to the method used for printing color in newspapers, although resolution is far higher.

The printer's standard features include proportional spacing, bold-face, and character densities of 10, 12, or 16.7 characters/inch. At 10 characters/in., the system prints out 132 columns on standard 15-in.-wide paper; the other pitches yield up to 220 columns per page. Four different character sets can be stored in read-only memory.

Prism also includes a high-speed capability allowing printouts at speeds exceeding 200 characters/second; in its normal, or correspondence-quality mode, speed is 150 character/s with the system printing bidirectionally.

It will be possible next year to buy the Prism one module at a time, starting with either an 80- or 132-column basic black-on-white printer, and adding capabilities as time and budget allow. Modules will add a graphics capability, higher print speed, higher resolution, buffer memory, and color. The prices for starter printers still would be higher than those for many of IDS's current products, at just under \$1,000 and \$1,300 for 80- and 132-column models respectively. **-James B. Brinton**

SSC-155™

SUPERSILVERCOPPER

WHEN YOU NEED MORE THAN COPPER

MORE THAN COPPER?

We identify SSC-155 SuperSilverCopper as a material that deserves your consideration when you need more than copper. Granted, we may be setting the stage for endless semantic arguments . . . or meta-physical arguments for those who want to debate on a loftier level. Is SSC-155 copper or isn't it?

Yes, it is copper. But it is a silver bearing copper to which magnesium and phosphorous have been

added. The result is a material with a combination of properties so dramatically elevated over ordinary copper that it could well be considered an entirely different material.

In product bulletins like this one, we will periodically present information about SSC-155, what is currently being achieved with it, and what could be achieved with it.

Chemical Composition

One atom of silver to 5,000 of copper make the big distinction in silver-bearing copper. In SSC-155 it's ten ounces of silver per ton of material that create the SilverCopper matrix to which stoichiometrically determined amounts of magnesium and phosphorous are added.

Element	Nominal Weight %	Range Weight %
Cu+Ag	99.80	99.75 min.
Ag	0.034	0.027-0.10
P	0.058	0.040-0.080
Mg	0.11	0.080-0.13

A Unique Combo

There is an adage in marketing that cautions, "Tell me less of how it came to be, and more of what it will do for me." With that in mind we'll simply state that SSC-155 was developed after extensive research by Copper Range Company, and it delivers to the user this combination of properties unmatched by any other material:

STRENGTH

Strain-hardenable to a range of 40,000 to 80,000 psi (276 to 552 MPa)

THERMAL SOFTENING RESISTANCE

Resistance to softening superior to any commercially-available copper with conductivity better than 80% IACS

ELECTRICAL CONDUCTIVITY

94% IACS; 94-86% IACS depending on temper

THERMAL CONDUCTIVITY

Superlative Thermal Conductivity of 0.83/cal/cm²/cm/sec/°C

DUCTILITY

Extremely formable by drawing, bending, stamping and other operations

VALUE INDEX

Highest combination of mechanical strength and electrical conductivity at a lower cost than all commercially-available coppers and copper alloys

Physical Properties

Electrical Conductivity	94% IACS; 86% minimum guaranteed
	0.504 Megmho-cm @ 20 C
Thermal Conductivity	0.83 cal/cm ² /cm sec/C
	200 Btu/sq ft/ft/hr/F (@ 68F)
Coefficient of Thermal Expansion	20C to 100C—17.7 x 10 ⁻⁶ /°C
	68F to 212F—9.8 x 10 ⁻⁶ /°F
Density	8.91 g/cm ³ (0.322 lbs./in ³)
Specific Heat	0.092 cal/g/°C (@ 20C)
	0.092 Btu/lb/°F (@ 68F)
Liquidus	1980F (1082C)
Magnetic Permeability	Less than 1.002 gauss/oersted
Modulus of Elasticity	11.7 x 10 ⁴ MPa
	17.0 x 10 ⁶ psi
Modulus of Rigidity	4.4 x 10 ⁴ MPa
	6.4 x 10 ⁶ psi

Excellent Ductility

The fine-grained structure of SSC-155 lends excellent formability during drawing, stamping, bending and other tests of ductility, shown here in graphs and in the type of folded "airplane" made by bored students and office workers.

The oxygen-free nature of SSC-155 also permits processing of formed parts in hydrogen or other reducing atmosphere without degradation. And parts can be readily plated when desirable, without poisoning the bath.

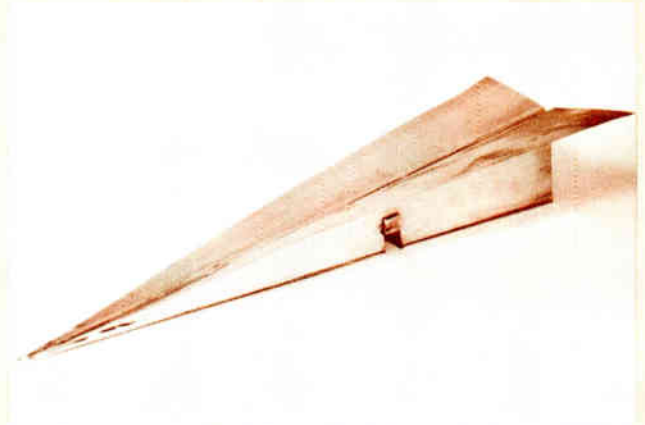

Multiple-Bend Requirements

The combination of excellent ductility and fine-grained structure makes SSC-155 an ideal material for complying with the most demanding multiple bend requirements, especially for electronic lead frames.

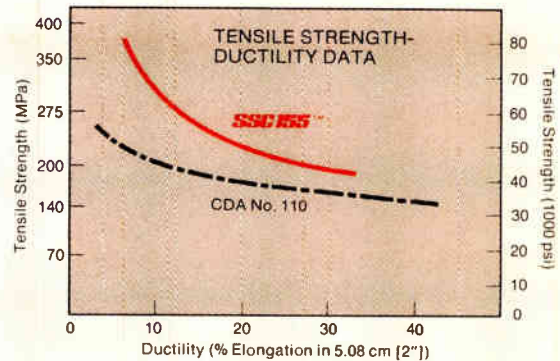
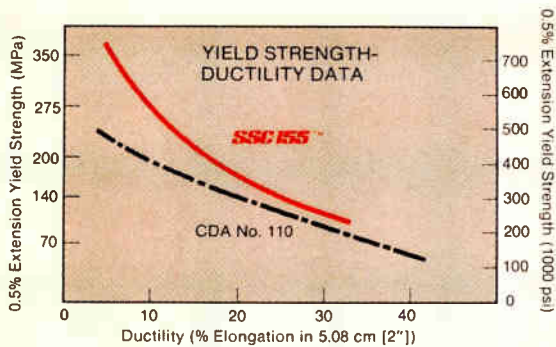

Product Applications

Electronic

The 24 pin Dual-Incline Package illustrated is used in a variety of computer-on-a-chip modules, resistor arrays, capacitor networks and other demanding functions.

Hussey's SSC-155 provides strength/stiffness for automatic insertion requirements, the ductility for multiple bend requirements and the thermal/electrical conductivity needed for highest performance.



component miniaturization resulting in highest performance at maximum cost efficiencies.

An example of Hussey's SSC-155 versatility is the contact switch and clip parts illustrated below. These parts are incorporated in automotive cruise control where consistent performance is a must.



Contact Hussey:

If you'd like additional information or samples of Hussey SSC-155 or you'd like to discuss your application with a Hussey Representative, call Jim Michel at (412) 766-5101, or write to Hussey/Copper Range, Leetsdale, PA 15056.

HUSSEY / COPPER RANGE

Hussey Metals Division/Copper Range Company
Leetsdale, PA 15056 (412) 766-5101 • (412) 266-8430

SALES OFFICES: Atlanta • Chicago • Cincinnati • Cleveland • Dallas • New York • Philadelphia • Pittsburgh • Phoenix • Seattle • St. Louis

WAREHOUSES: Chicago, Cincinnati, Cleveland, New York, Philadelphia, Pittsburgh

20% fewer engineering schools accredited . . .

Contributing to engineering manpower problems is a drop of 20% in the number of fully accredited college and university programs at the end of the last academic year—to about 50% from the prior year's 70% approval rate. Disclosure of the decline in programs accredited for a full six years by the New York-based Accreditation Board for Engineering and Technology came during **congressional hearings by the Joint Economic Committee on the U. S. engineering shortage** (see p. 96). ABET, an autonomous organization supported by the nation's major professional societies, does not deny the previously unpublished report but had no immediate formal comment on its latest findings. They were made known to the Congress by Southern Methodist University's F. Karl Willenbrock while testifying on behalf of the American Electronics Association in early November.

. . . as faculty shortages spur industry action

A four-pronged program to alleviate the growing shortage of U. S. engineering faculty is beginning at the American Society of Engineering Education **using funds provided by eight major corporations**—American Telephone & Telegraph, DuPont, Exxon, General Electric, General Motors, General Telephone & Electronics, International Business Machines, and Union Carbide. Project director is John W. Geils, an AT&T engineering director who is on loan to the ASEE for the first year of the two-year effort, funded at about \$100,000 a year. Goals of the program are to (1) collect relevant data to build an accurate and adequate data base on the faculty shortage; (2) develop with industry a viable plan of action for a solution; (3) work with industry, Government, and universities to implement the plan; (4) coordinate the activities of other industrial and association efforts toward that solution.

World trade system for components to start Jan. 1

A new international quality-assessment system that could affect \$40 billion in annual world markets for electronic components will go operational on Jan. 1, 1982, the Electronic Industries Association reports. Known as IECQ, for International Electrotechnical Commission Quality Assessment System, it currently has 21 countries participating in it and is **designed to promote world trade in components by giving purchasers the option of relying on IECQ certification** that a product meets a design specification [*Electronics*, Nov. 10, 1977, p. 50]. By U. S. Commerce Department estimates, \$26 billion of the 1980 market of \$40 billion was in international trade. The EIA, the driving U. S. force in the 10-year development of the IECQ system, says U. S. participation will be managed by the Electronic Components Certification Board, which has scheduled a series of seminars on the system for Washington, D. C., on Dec. 1; Chicago on Dec. 2; and San Francisco on Dec. 4.

Cost growth of 380% leads to death of tactical-radar project

Projected unit cost increases of more than 380% over the past year are what led to the House-Senate conference on the fiscal 1982 defense authorization to kill Sotas, the stand-off target-acquisition system being developed for the Army Electronic Research and Development Command by Motorola's Government Electronics division, Scottsdale, Ariz. Costs for the helicopter-mounted, all-weather radar system for detection of air and ground targets beyond the forward battle line **soared to \$2.45 billion for 16 division systems from earlier estimates of \$969 million for 24 systems**, the conferees report.

ITT Multilayer Ceramics. The ultimate decouplers.

You'll find ITT multilayer ceramic capacitors almost everywhere. In sophisticated aerospace communications equipment; the new generation of digital telephone exchanges; home and business electronic gadgetry. All with one thing in common - the need for reliable decoupling capacitors.

ITT Capacitors pioneered multilayer technology and have continued to develop materials and processes to give product performance to match today's IC requirements. Low impedance and low inductance at high frequency are an

integral design feature together with the high volumetric efficiency associated with multilayer ceramics.

We are already moving ahead with tomorrow's product. With the design of improved dielectric constants and electrode systems, building on our total control of production processes, from raw material selection to final product.

Multilayer ceramics from ITT are available worldwide, in all the usual styles and values. So couple your requirement with our expertise - it's the ultimate combination.

ITT CAPACITORS

South Denes, Great Yarmouth,
Norfolk NR30 3PX.



Nov. 17, 1981

Electronics

International®

Cobalt-chrome magnetic disks
pack in more data: page 67

In automated UK offices, people will annotate documents with
voicegrams instead of scribbling notes in the margin: page 72

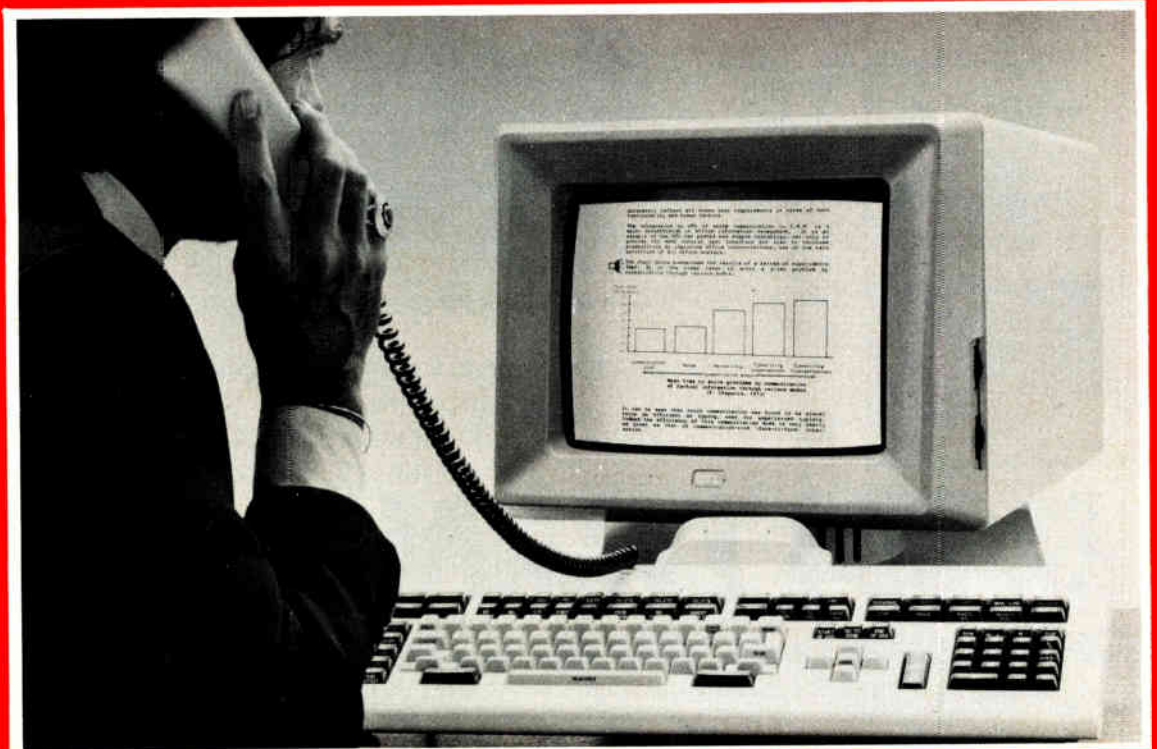

"Now you know me. But do you know my company?"

Fred Molinari, President

Ads like these have made me pretty well-known in the world of analog I/O.

But there's more to Data Translation than Fred Molinari.

DEC LSI-11, UNIBUS®, MULTIBUS®, and STD bus. You'll find we have the widest line of microcomputer analog I/O boards anywhere.

In the last two years alone we have developed the very first intelligent Analog Peripheral. The MIDAX family of industrial measurement and control systems. LAB-DATAX, the highest performance laboratory data acquisition system in the business. And the dual-port 250 KHz A/D system and dual-port RAM board for the DEC LSI-11.

We also designed DTLIB and DTFIRM, outstanding software packages for data acquisition.

So even though we still offer the broadest variety of modules and boards, there's no denying we are a systems supplier now.

Data Translation has grown quickly.

Today we are big enough for *anyone* to do business with. We are unmatched in applying advanced data acquisition technology to real-world problems.

In the months to come I plan to tell you more about Data Translation and its products.

If you want the facts now, call for our catalog. Data Translation is a company that merits your attention.

For a copy of our 288 pg. catalog call Data Translation. Or turn to Volume III of the Gold Book.



"Why design a data acquisition function? We stock a wonderful variety of high performance modules. And they're all compatible."
(Left to Right) Fred Molinari, President

Designing microcomputer DAS is a woolly business. But we have a simple solution to your problems. High performance modules you simply plug in. We offer a broad variety of data acquisition modules.

"How did we manage to be first with intelligent analog peripherals? By working like madmen."
We worked days and nights, weekends
 Fred Molinari, President

"With this catalog, these analog I/O boards, and our guaranteed five-day delivery, we're something of a freak in this business."
 Fred Molinari, President

In this business, being good means being unusual. For instance, we guarantee to deliver analog I/O for your microcomputer within five days. That's unusual. But more to the point, we offer an unusually broad and technically advanced selection of high accuracy, high resolution data acquisition system (DAS) modules and boards. Data Translation was the first to put DMA on a board, and the first with 16-bit DAS. We were the first to put isolated DAS modules on a board, and the first with a DAS software library. Whether your application is laboratory or industrial, you will benefit by our unusually thorough approach. Each of our boards and modules comes with free diagnostics and documentation. Each module is subjected to rigorous testing, including a three-day burn-in. Our modular concept allows us to provide the widest range of products. More important, it offers you the ability to upgrade your system quickly and easily. We can deliver compatible DAS than Intel or National, and at lower prices. We have the highest PDP-11 Unibus® systems performance is unmatched. LSI-11 and PDP-11 systems, at lower prices. I/O systems with this choice, you'll find the best. This catalog enables you to get the microcomputer board of I/O you need in 5 days or less. Send for your copy today.

DATA TRANSLATION

have brought high-speed low-end computers, and we are the first madmen has its advantage'll let us work like

located at 100 Locke Drive, 752, Telex: 951546, 7-481-3700. In Europe: Ltd., Rockwell House, Slough, Berkshire/England 622613412. Telex: 849862.

DATA TRANSLATION

DATA TRANSLATION

World Headquarters: Data Translation, Inc., 100 Locke Dr., Marlboro, MA 01752 (617) 481-3700 Tlx 951-646
 European Headquarters: Data Translation, Ltd., 430 Bath Rd., Slough Berkshire SL1 6BB England (06286) 3412 Tlx 849-862
 MULTIBUS is a trademark of Intel Corp. UNIBUS and LSI-11 are trademarks of Digital Equipment Corp.

Circle 56 on reader service card

World Radio History

British Telecom to offer data service

Competition from impending digital data services, such as Cable & Wireless's national fiber-optic network, has brought a sharp response from British Telecom, to the effect that it will offer business users end-to-end digital data links over leased lines by 1982. Its Kilostream service will send data to small and medium-sized customers some four times faster than is possible with conventional modem links, for it **pipes a single 64-kb/s channel direct to the customer's premises over two conventional twisted-pair cables.** At the exchange up to 31 similar data-only channels are multiplexed to form a 2-Mb/s supergroup that interfaces directly with British Telecom's growing pulse-code-modulated network. Data-circuit termination and exchange equipment will be produced by Marconi Communications Ltd. under a contract likely to be worth about \$14 million.

Digital standard in sight for world's TV studios

The multiplicity of analog standards at television studios around the world will give way to a single norm when TV production goes digital. A draft standard worked out by the International Radio Consultative Committee (CCIR) of the International Telecommunications Union should be adopted early next year at the CCIR's plenary session. The standard calls for **uniformly quantized pulse-code modulation of TV signals with 8-bit precision,** similar to the approach used for digital telephone transmission. The standard applies to studios only and will not affect transmitting stations or home receivers.

Two satellites to transmit to home TV sets in Europe

The European Space Agency's decision to implement its \$423 million L-Sat project means that about 1986 two rival European satellites could be sending TV broadcasts directly to home antennas. First up in 1984-85 should be the Franco-German TV-Sat in fully operational form, whereas ESA's L-Sat, primarily an Anglo-Italian venture with participation from six European countries and Canada, will be a preoperational satellite.

L-Sat aims to explore such advanced techniques as **on-board switching between several spot beams**—one of which is steerable—and combining direct-broadcast and telecommunication transponders. Britain's \$140 million share—announced this month—buys the British Aerospace group of companies a leading role, with Marconi Space & Defense Systems Ltd. in Portsmouth supplying the electronic payload. In its fully developed 7-kw form (the first bird will be 3-kw), it could handle five TV channels or one quarter of a million telephone channels. British Aerospace sees a market for 120 such systems by the end of the century.

NTT develops chips for computer systems

Sample chip sets for two 32-bit computer systems have been designed and fabricated at the Musashino Electrical Communication Laboratory of the Nippon Telegraph & Telephone Public Corp. Using p-well complementary-MOS technology on bulk silicon, the devices attain an average propagation delay time per gate of just 2 ns. The largest, which has 20,000 gates and dissipates 0.75 w, measures 1.2 cm square and is **sealed in a 208-pin square ceramic package 4.3 cm on a side.** It and two other chips will serve in a computer designed for NTT's on-line data-processing utility services, while another trio will be used in a multiprocessor electronic exchange. Tests of commercial systems of both kinds will start around the end of 1983.

Display processor for Antiope goes monolithic

Testing of the first samples of the single-chip video-display processor that Texas Instruments France is developing for Antiope, the French teletext system, is under way at the company's factory in Nice. The 11,000-transistor n-channel MOS chip is to go into production next year. **The third and last in the three-chip teletext set** for which TI France received research and development money from the French government, the display processor is designed to be driven by TI's 7040 8-bit microcomputer. Company officials boast that the device is fully compatible not only with the new European standard for alpha-mosaic videotex, but also with higher-quality alpha-geometric videotex systems such as the one being developed in the U. S. by AT&T. The former type addresses squares on the screen, the latter addresses points.

X.22 Interface standard attracts wide attention

X.22, the new interface standard for meshing data terminals with data-communications equipment announced by the International Consultative Committee on Telegraphy and Telephony (CCITT), is being closely examined for use in circuit-switched data networks by the Swedish and West German postal and telecommunications authorities. Though no commercial products yet exist, telephone companies elsewhere around the world are also starting to explore X.22, which **allows up to 48 kb/s of multiplexed data to be sent over a single- or multi-point configuration** and which handles data terminal demultiplexing by framing information passed across the interface. Circuit switching of data is an alternative approach to packet switching, which is governed by the CCITT's X.25 standard adopted just this year by IBM and AT&T in the U. S.

NEC extending software services

Nippon Electric Co. is adding five new software subsidiaries to the five it already has. Two in Nagoya and Fukuoka will **make applications services more widely available** to general mainframe users. The other three will supply software for aerospace and radio communications, telecommunications systems, and new technology.

Racal makes bugs for British Army

High technology is being used by the British Army to snoop on out-of-sight troop and vehicle movements. The smart new bugs, developed by Racal-SES Ltd. in Windsor in collaboration with the Royal Signals and Research Establishment, Malvern, use seismic or infrared detectors to **distinguish between personnel, tracked, and wheeled vehicle movements** before transmitting their findings back to the base receiver in a brief 30-ms tone-coded burst. First deliveries to the British Army against a \$1.5 million contract are for the Classic (for covert local-area sensor system for intruder classification) System.

Addenda

AEG-Telefunken has negotiated a licensing deal with Sydney Lamb, the American inventor of **associative memories, giving the West German company the right to manufacture and market them** on a worldwide scale. . . . Swiss watchmaker Omega of Biel will start manufacturing the **sophisticated optical step-and-repeat aligner developed by Censor AG** of Vaduz, Lichtenstein. Annual production of the Censor SRA-100 is targeted at 60 machines in the first year and a projected maximum of some 400 by 1985, each selling for \$700,000 to \$900,000.

ENHANCED VIDEO CONTROLLERS

Can Eliminate $\frac{2}{3}$ of your CRT Board

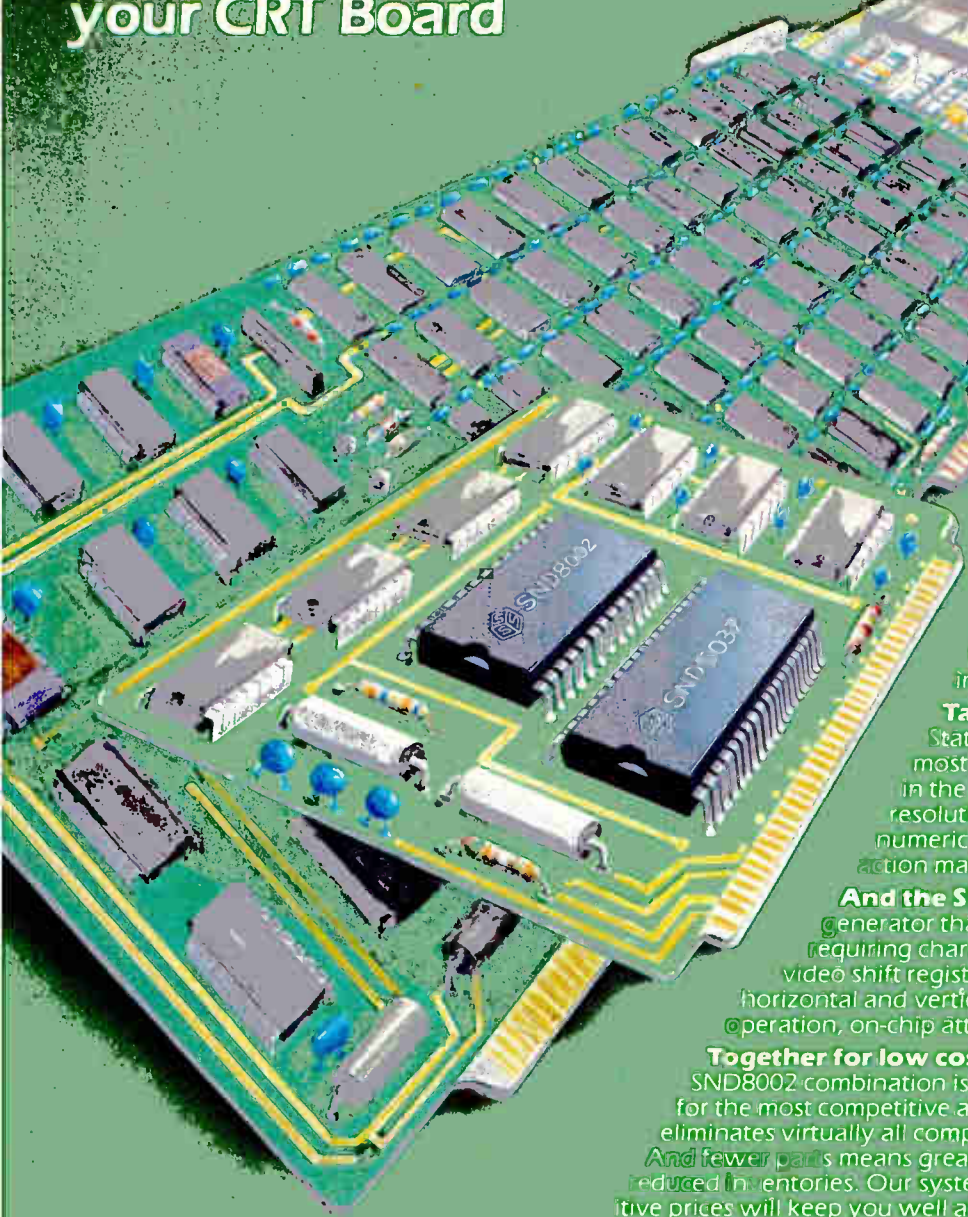
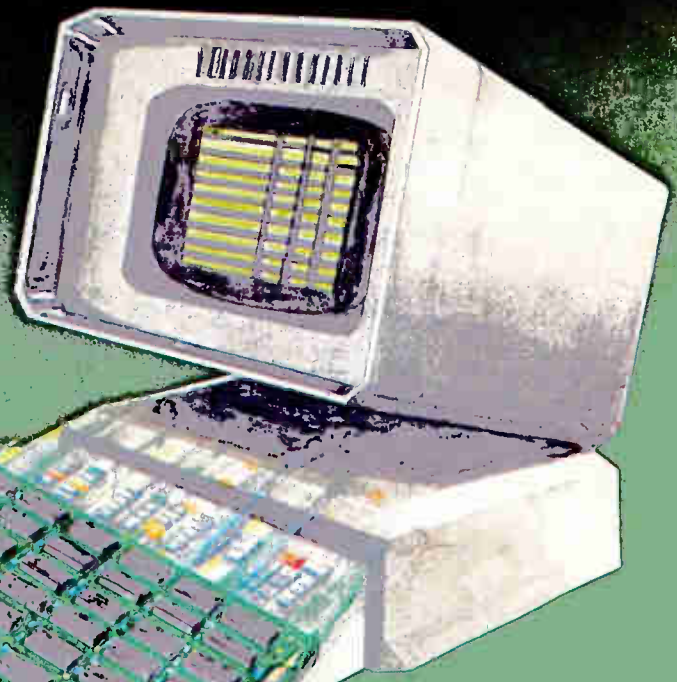

Today's word processing challenge. The Solid State Scientific SND5037/SND8002-CRT Controller System is the alternative for cost-effective CRT circuitry. The alternative that drastically reduces part count and offers extended capabilities as a totally user-programmable system. Together the SND5037 and SND8002 drive a wide variety of monitors to meet today's information processing challenge.

Take a look at the SND5037. The Solid State Scientific SND5037 is one of the fastest, most flexible, programmable, CRT controllers in the industry. The SND5037 provides the resolution needed in applications such as alpha-numeric terminals, point-of-sale systems, transaction machines and PBX consoles.

And the SND8002 is the popular character generator that can be used in virtually all applications requiring character display. Features include an on-chip video shift register (various frequencies available), on-chip horizontal and vertical retrace, video blanking, four modes of operation, on-chip attributes and four on-chip cursor modes.

Together for low cost, versatile CRTs. The SND5037 and SND8002 combination is practically indispensable in today's quest for the most competitive and capable CRT terminal. This system eliminates virtually all complex logic required in other CRT displays. And fewer parts means greater reliability, reduced labor costs and reduced inventories. Our system's enhanced capabilities and competitive prices will keep you well ahead of the competition.

Put the SND5037/SND8002 CRT Controller System to work for you today by calling your local Solid State Scientific sales office. Application support is available by writing to our Applications Department, Solid State Scientific, Montgomeryville, PA 18936 or by calling Marketing at (215) 855-8400.



Solid State Scientific

Circle 5 on reader service card

Make the most of your host with the lowest cost development tool available.

It's called RADIUS*. By using one with a host computer (any host †), you can develop Z80 and 3870 applications for a lot less than ever before. In fact, at \$2995, plus an emulation module, RADIUS is the most inexpensive microprocessor/ microcomputer development station available. Yet it's fast, powerful and reliable.

Why? Because RADIUS lets you take full advantage of the host's speed and power to develop the application software. Once completed, the software is downloaded to the RADIUS (using a link-error-tolerant protocol). Then, using only the RADIUS with the appropriate emulation module, you can perform the full range of real-time, in-circuit emulation and debug needed for hardware development and software integration.

A very friendly user interface makes it all possible. Local or remote (with a MODEM) emulation capability makes it very practical as well. Because at the price we're offering RADIUS, the idea of multiple development stations is more affordable than ever.

In a multi-user environment, for example, you can connect several RADIUS units to an appropriate host and operate them simultaneously to perform entirely separate jobs. This configuration also supports the development of multiple microprocessors and microcomputers.

**A SMART WAY TO DEVELOP
PLANS FOR THE FUTURE.**

In addition to Z80 and 3870 emulation capability, RADIUS will also accept the forthcoming emulation module for the MK68000, our new



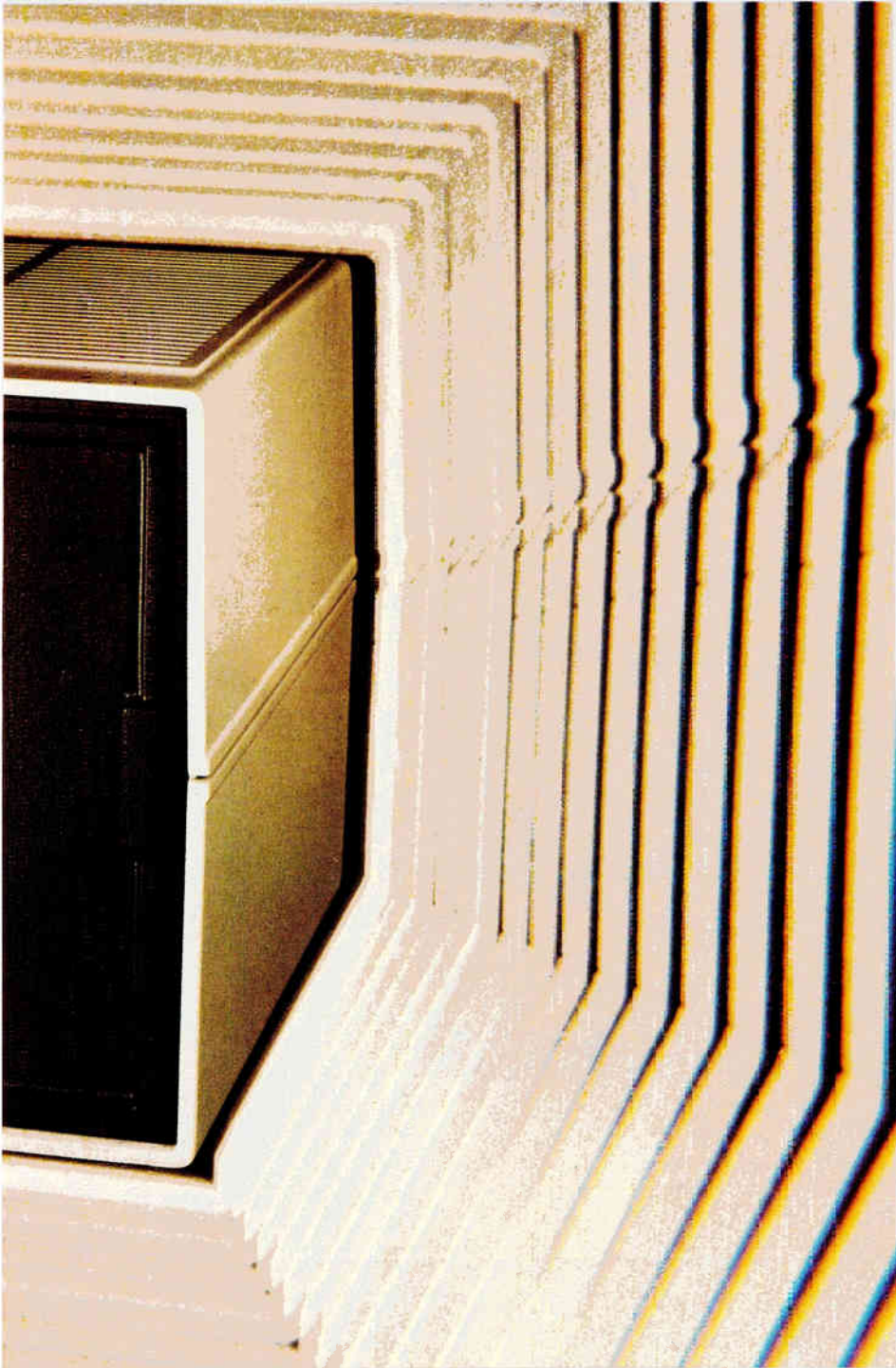

16-bit microprocessor. So no matter which way you're going or plan to go, 8-bit or 16-bit, RADIUS can help you get there. For less.

Find out more by contacting Mostek, 1215 West Crosby Road, Carrollton, Texas 75006 (214) 323-1801. In Europe, contact Mostek International at (32)(02) 762.18.80. In the Far East, Mostek Japan KK (03) 404-7261.

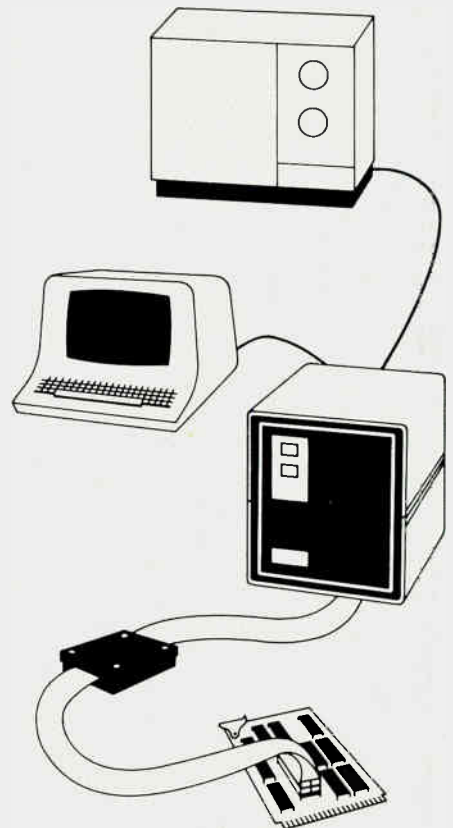

*RADIUS is a trademark of Mostek Corporation

†Handshake software packages available for DEC, PDP-11 and VAX. More will be available soon. For others, Mostek will provide source code and compatibility conversion instructions. (DEC, PDP-11 and VAX are trademarks of Digital Equipment Corporation).

©1981 Mostek Corporation

Circle 61 on reader service card

A MASTERPIECE IN ALUMINUM ETCHING



Al+2% Si+4% Cu ETCHED ON A DEVICE
WAFER WITH NO RESIDUE AND NO WET
DIP REQUIRED.

FROM A NEW ARTIST, THE APPLIED MATERIALS AME 8130 ALUMINUM ETCH SYSTEM



Applied Materials introduced its AME 8100 Series Plasma Etch Systems by showing customers the first plasma etch test results suitable for framing. Rapid industry acceptance proved the need for true masterpieces of the kind created by the

AME 8110 for oxides and the AME 8120 for polysilicon etch.

Now we can unveil the first masterpiece in aluminum etching from our new artist, the AME 8130. No other etcher on the market can achieve results like these in the etching of aluminum. The 8130 very cleanly etches all aluminum alloys anisotropically or with controlled profile, with no residues and with high selectivity to PSG and silicon. And with the 8130 there is no after-etch corrosion of aluminum.

The 8130 uses the same revolutionary technology as the 8110 and the 8120. That's why we offer *guaranteed* etch rate, uniformity, selectivity and uptime just as we did when we announced the AME 8100 Series. As before, you get an autoloader to automatically change wafer batches while you are processing 24

3-inch or 100mm wafers, or 18 125mm wafers.

Call your local Applied Materials sales office or Dave Sponseller at (408) 727-2300, for a demonstration of aluminum etching with the AME 8130. And if your taste is for masterpieces in oxide or polysilicon etching, we'll also demonstrate the 8110 and the 8120.

Find out why the artistry of Applied Materials' plasma etch systems is truly the *art nouveau* for state-of-the-art semiconductors.

GUARANTEED SPECIFICATIONS FOR BATCH ALUMINUM ETCHING OF 24-100mm WAFERS

MATERIAL	SUBSTRATE	ETCH* RATE (Å/minute)	SELEC- TIVITY*
Aluminum	PSG	1500	15:1
Al + 4% Cu + 2% Si	PSG	700	8:1

Line width loss using a typical (i.e. HPR 204 or AZ 1470) positive photoresist is less than 0.5µm.

*Exact etch rate and selectivity depend on the properties of the Al alloy film and substrate.

 **Applied Materials**[®]

COBILT DIVISION

3050 BOWERS AVENUE
SANTA CLARA, CALIFORNIA 95051
(408) 727-5555.

© APPLIED MATERIALS 1981

“Quality? Teradyne and General Electric are on the same wavelength.”

Paul McLean, Advance QC Manager
General Electric Mobile Communications Division

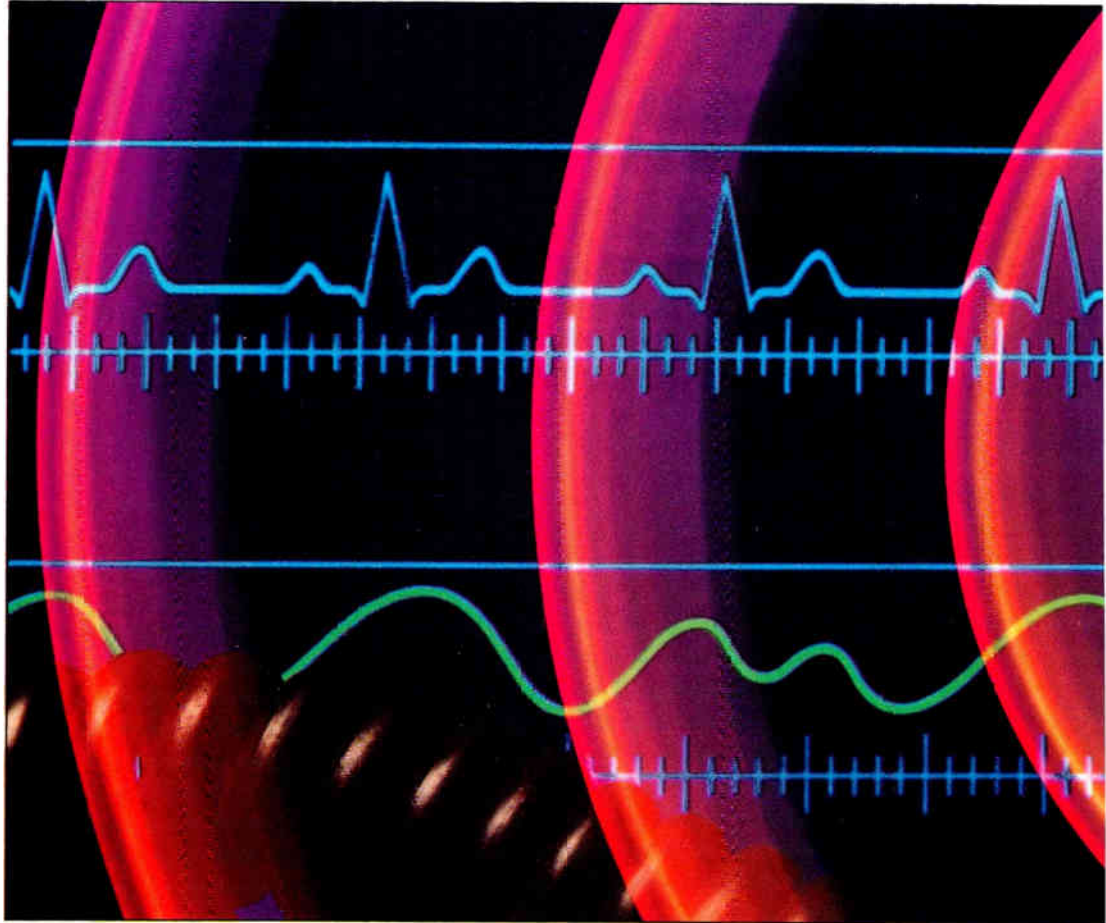

General Electric's mobile radios are among the most reliable built. And it's easy to see why.

Recognizing the link between testing and quality, General Electric has instituted an extraordinarily rigorous product evaluation program.

In the words of Advance QC Manager Paul McLean, "We believe in 100% testing—in incoming inspection, subassembly, and final assembly."

At General Electric's Mobile Communications Business Division, a large and well orchestrated network of automatic test systems is used to improve quality.

Every SSI and MSI digital IC is tested on a Teradyne system. Every linear IC. Every transistor. Every memory. Every analog LSI device.

Why such extensive testing? "Because," says Paul McLean, "testing gives us the information we need to know where we are, where we're going, and how to get there. Our test systems zero in on all the subtleties, and we can believe what they tell us."

For General Electric, where every product must be "better than the best," one message has always come through loud and clear:

If you can measure it, you can improve it.

TERADYNE

We measure quality.



OMNIBYTE OB68K1®

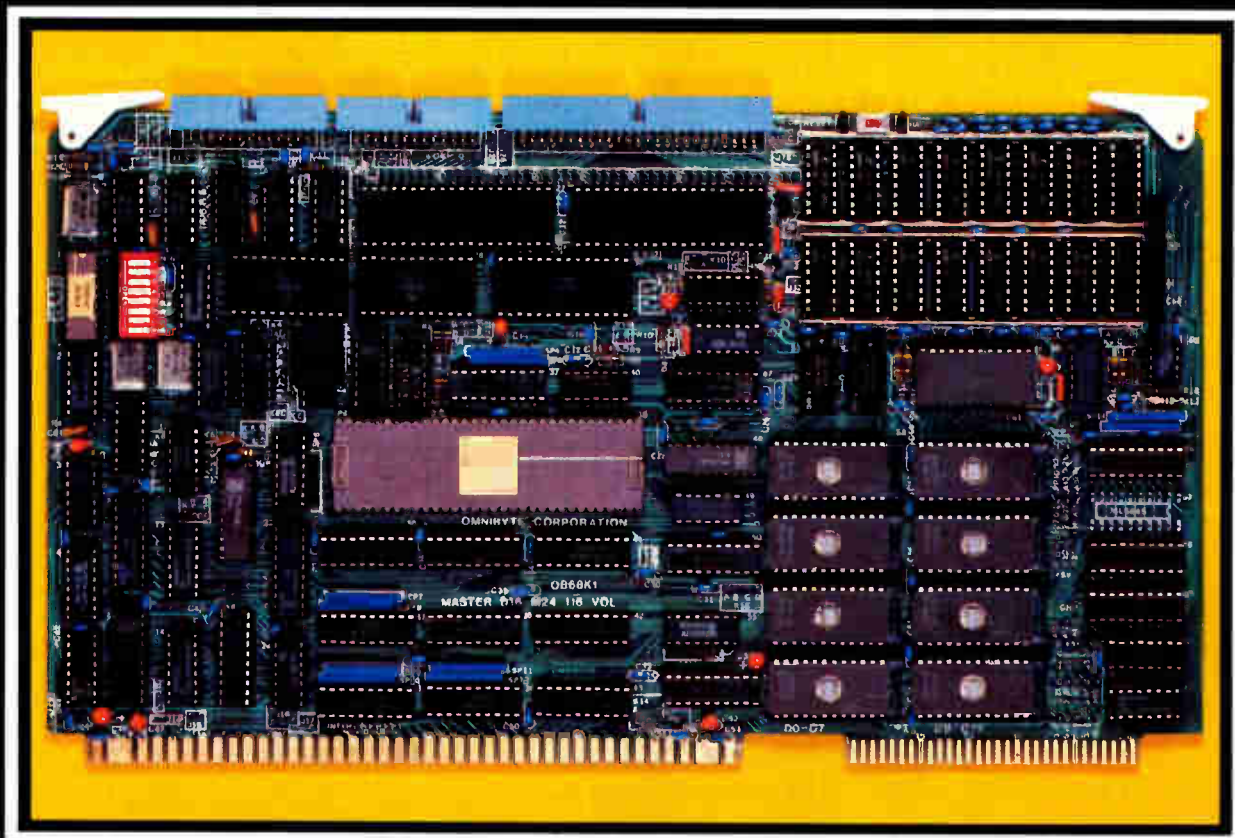

MC68000 CPU — MULTIBUS®/IEEE 796 BUS

The Multibus just got **A LOT** more powerful

The OB68K1 is a powerful, highly versatile single board computer capable of functioning as a stand-alone system, or as the central processor in a large microcomputer system. It features:

- ★ Motorola's MC68000 CPU
- ★ MULTIBUS/IEEE P796 compatibility
- ★ sockets for up to 64K bytes of ROM
- ★ 32K or 128K bytes of RAM
- ★ 8MHz processor speed
- ★ (7) prioritized-vectored interrupts
- ★ (2) RS232C serial ports
- ★ (2) 16-BIT parallel ports
- ★ triple 16-BIT timer/counter
- ★ user programmable memory mapping PROMs

- ★ crystal controlled baud rate generator with 16 standard rates

MULTI-PROCESSOR CAPABILITY

The OB68K1 is designed to function in either a single or a multi-processor environment. All onboard memory is protected from access by other processors and devices, permitting multiple boards to run concurrently. Since the OB68K1 will address up to 16 megabytes of total memory, it is possible for several boards to access a common pool of memory and I/O devices within a shared bus system.

SOFTWARE SUPPORT

Because the board is configured with the same I/O arrangement as Motorola's MEX68KDM design module, any software developed for the KDM module, including the MACSBUS® monitor/debugger, will operate on the OB68K1. An off-the-shelf operating system is

currently available from Hemenway Corporation (Boston, MA) and high level languages are reported to be available from several major software houses by early fall.

For more information about the OB68K1, ask for our free summary sheet or send \$10 for a detailed technical manual. Contact Randy Cochran, Marketing Manager.



OMNIBYTE CORPORATION

245 W. Roosevelt Rd.
West Chicago, IL 60185
(312) 231-6880

OB68K1® is a trademark of Omnibyte Corporation
MACSBUS® is a trademark of Motorola, Inc.
MULTIBUS® is a trademark of Intel Corporation

Cobalt over chrome outclasses oxides for magnetic disks

by Robert T. Gallagher, Paris bureau manager

Glass substrates enhance superb magnetic properties of cobalt-chrome, boosting bit density for computer disks

Although cobalt can be magnetized to extremely high levels, it has a very low coercivity and thus can be demagnetized so easily that it has long been considered useless for magnetic recording. The time for reconsideration has come, say engineers at the CII-Honeywell Bull research center in the Paris suburb of Les Clayes sous Bois.

They have found a way to increase the coercivity by as much as 30 times, pointing the way to disk memories much denser than those currently in use. What is more, these denser disks should be cheaper because their substrates are glass and not machined aluminum.

Hexagonal. Key to the new disks is the discovery that cobalt deposited on chrome crystallizes hexagonally, which dramatically alters its magnetic properties (ordinarily the crystal structure is cubic). "It is just one of those lucky accidents of nature that cobalt crystallizes in this way on chrome," says Jean-Pierre Lazzari, general manager of the research center's technology division.

"The chrome is useful in another way, too," he adds. "It gives strength to the glass substrate, and it also assures excellent adhesion."

The higher magnetization of cobalt makes for two major advantages over conventional magnetic-oxide recording media. The recording density can be regulated by changing the

temperature at which the cobalt layer is deposited and by varying its thickness. In addition, the chrome-cobalt combination boasts a magnetic hysteresis loop that is almost square, further enhancing its recording qualities.

The glass substrates, despite what at first might seem a fatal fragility, add their own advantages. Unlike the aluminum substrates, which undergo meticulous milling and polishing processes, the glass is used as received from the supplier. Indeed, the surface of the glass is so smooth that its surface roughness can scarcely be measured. The only constraint is to use glass of high-enough quality to withstand the rotation and shock to which a disk is subject.

Automatic pilot. The manufacture of the disks, which is in the pilot stage at CII-HB, is automatic. First

the glass substrates are chemically washed and then ionically cleaned. Then a 3,000-to-5,000-angstrom layer of chrome is deposited on the surface.

A layer of less than 1,000 Å of cobalt is deposited on the chrome and, finally, a hard protective coating is put on the cobalt to prevent oxidation. The layers are deposited under vacuum at a temperature of 400°C.

Disks made in this way have a surface so flat that the recording head is no longer required to fly over the surface but can make contact with it. For practical purposes, contact is a clearance of about 1,000 Å.

Although the state-of-the-art of disk reading is not advanced enough to take full advantage of these chrome-cobalt disks, Lazzari maintains that 12-centimeter disks made

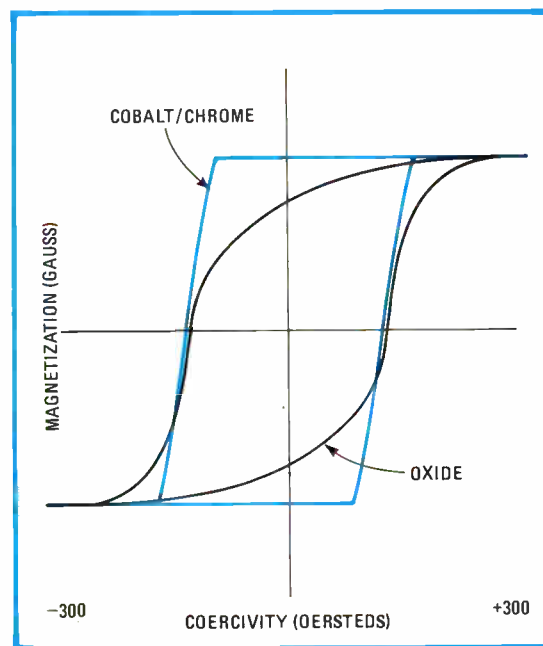

On the square. Cobalt over chrome magnetizes and demagnetizes in a near-perfect rectangular hysteresis loop. Used for computer disks, its threshold for reacting to write pulses becomes much sharper and helps make possible higher packing densities—up to 1,000 bits/mm—than are possible with conventional oxide coatings.

in this way initially will have a capacity of from 25 to 30 megabytes per face. They should be on the market by 1985, he expects.

With an improvement in the electronics of disk reading, the density could be as much as doubled. The surface of the disk could easily accept narrower tracks, but the signal would be too weak to be read by current hardware. To fully exploit the disks, a low-noise integrated amplifier close to the reading head will be needed.

The end result of the new disks, Lazzari says, will be smaller memories with higher capacity. One of the few disadvantages is a preconception of some users.

"Many people have a real psychological block against using glass disks," explains Lazzari. "Nonetheless they are not really more fragile or less reliable. To make doubly certain, we are going to make them to standards of operation and vibration very close to those used by the military."

-Robert T. Gallagher

Japan

1.5- μm laser operates at 23°C

A team at the Musashino Electric Communication Laboratory of the Nippon Telegraph & Telephone Public Corp. is the first in the world to develop a single longitudinal-mode room-temperature laser for the 1.5-micrometer band, the wavelength around which optical fibers have their lowest losses.

The task was difficult. Lasers using the usual Fabry-Perot cavity with a length several hundred times that of the generated wavelength may have gain-bandwidth characteristics that cause them to oscillate every 10 angstroms over a range of 100 Å. Under dc operation, the strongest mode will prevail. However, during the transient conditions of pulse modulation, unwanted multiple modes exist.

Devices built by other groups, including those at the Tokyo Insti-

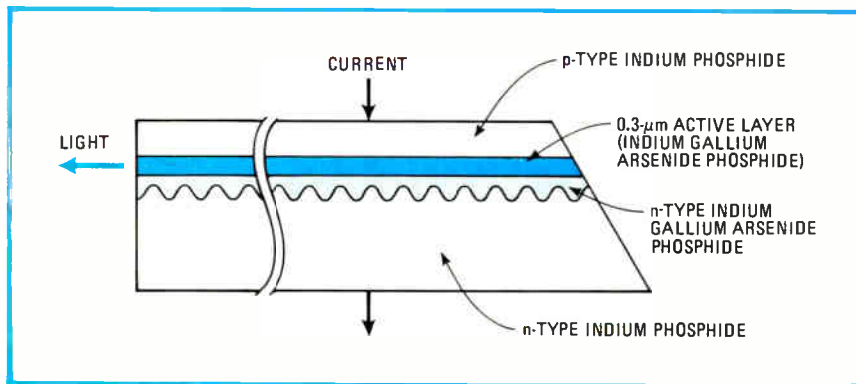

Corrugated action. Tuning and mode purity of NTT laser is achieved by using a matched-pitch refraction grating between an indium phosphide substrate and the active layer.

tute of Technology and at the Central Research Laboratory of Hitachi Ltd., have high threshold currents caused by low gain. Operation at room temperature is impossible; the devices would burn up if they were not cooled.

Buried. The device developed at the NTT lab is a buried-stripe, double-heterojunction laser with a distributed feedback that generates a beam at a wavelength between 1.51 and 1.54 μm . Tests indicate a negligible degradation of mode purity for pulse-code modulation at rates up to 400 megabits per second, the speed of the fastest modulator available.

Tetsuhiko Ikegami, head of the optical-device section, is confident that the device will operate at even higher modulation rates. He predicts that the new laser will open the way to fiber-optic communication systems with repeaters spaced up to 100 kilometers. It might also point the way even further in the future toward coherent systems [*Electronics*, Nov. 20, 1980, p. 73].

Ikegami expects his group to continue development of the device for roughly two years. Then it should be possible to transfer the technology to communications-equipment manufacturers for 1.5-gigahertz communications systems.

Substrate. The laser is fabricated on an n-type indium-phosphide substrate. Tuning and mode parity are achieved by scattering the laser beam from a corrugated surface atop the substrate, as shown in the figure. The 0.45- μm pitch of the corrugations, together with the 3.4 index of

refraction of the laser's active layer determines the wavelength of the laser beam, which is 1.5 μm in air.

Only one mode can survive the scattering from the distributed corrugations, which eliminate multi-mode operation and mode hopping. The technique resembles the method being used by Aerospace Corp. of El Segundo, Calif., in developing phased arrays of tuned lasers, [*Electronics*, Oct. 20, p. 42].

Index of refraction changes with temperature variations cause a slight change in wavelength, but it is limited to less than 1 Å/°C. Even that small effect is minimized by keeping threshold current, and the associated heating of the device, low.

Interference. The substrate of the laser is patterned by using a standard integrated-circuit photoresist but without a mask. The beam from an argon laser is split and then combined at an angle to form an interference pattern whose pitch, and thus that of the corrugations, depends only on the angle at which the beams are combined. Development and etching processes are standard.

A low-temperature liquid-phase epitaxial process at about 600°C is required so as not to disturb the corrugations during growth of an n-type indium gallium arsenide phosphide layer that is 0.3 μm thick. (At the usual liquid-epitaxial growth temperature of about 640°C, the corrugations would melt.)

A thin undoped active layer of indium gallium arsenide phosphide followed by a 1- μm -thick layer of p-type indium gallium arsenide

Smart enough to make ATE system control as easy as plugging in a cable.

Here's one instrument controller that gives you advanced system control and the smarts to make programming easier than you ever thought possible. How? Ingenious system interface capabilities and superior CPU intelligence. Together, they make the 1720A easy to program, easy to operate, and easy to integrate into your present system. Now that's smart.

A better match for your interface needs.

Since there are three primary interfaces, shouldn't a smart instrument controller easily handle all three? You bet it should. That's why we equipped the 1720A with two IEEE-488 and RS-232 ports—both standard. And you won't find that anywhere else. Plus, we've added a new

bit-parallel interface capability.

So now, whether your instruments are old or new, hardware integration is about as easy as plugging in the cables. Which means flexible system design that has you up-and-running-fast.

Minicomputer smarts give you easy programming and operating too.

Productivity isn't working harder. It's working smarter. The 1720A's minicomputer intelligence gives programmers smart tools—like enhanced BASIC and

Assembler software with special commands like RBYTE, WBYTE, RBIN and WBIN for faster, more efficient data bus manipulation.

For operators, our exclusive touch-sensitive display lets even unskilled operators perform complex test routines quickly and easily.

Does all this mean a big unwieldy package? Look again. The 1720A slides into a standard 19-inch rack.

A shared commitment to better, easier in-house ATE.

We're working with you to make ATE less time-consuming and costly through the IEEE-488 standard interface. Proof is our 36 different IEEE-488 compatible products—with more on the way.

If you're ready for the best in ATE system control, let us show you how we can make it easy. Write, or call toll free 1-800-426-0361 for a demonstration. Or send for our Instrument Controller Comparison Guide.



For technical data circle no. 69

---(fast response coupon)---

1039-7/1720 E2 11/81

IN THE U.S. AND NON-EUROPEAN COUNTRIES:

John Fluke Mfg. Co., Inc.
P.O. Box C9090, M/S 250C
Everett, WA 98206
(206) 356-5100, Tlx: 152662

IN EUROPE:

Fluke (Holland) B.V.
P.O. Box 5053, 5004 EB
Tilburg, The Netherlands
(013) 673973, Tlx: 52237

- Send 1720A Instrument Controller Comparison Guide
- Have sales representative call for demo

Name _____

Title _____ Mail Stop _____

Company _____

Address _____

City _____ State _____ Zip _____

Telephone () _____ Ext. _____

phosphide completes the basic structure. The active layer has a low-phosphorus content to give a band-gap energy that is equivalent to the 1.5- μm wavelength. The two layers that sandwich the active layer have more phosphorus for a bandgap energy equivalent of about 1.2 μm for the n-type indium gallium arsenide phosphide and 0.9 μm for the indium phosphide.

The laser is completed fairly conventionally by defining the stripe, etching away material on both sides, and then growing indium phosphide layers on both sides that protect the junctions. Completed, the laser has a strip of 3 μm wide and about 300 μm long.

Amplification. In operation, electrons are injected into the active layer from the n-type layer just above the corrugations. Light generated in the active region is amplified. The layers with a low index of refraction that are sandwiching the active layer form a waveguide at their interfaces with the active layer and confine the light.

However, a small amount of light does leak into the layer above the corrugations. This slight leakage serves as the source of the distributed feedback that tunes the laser. Because of its lower bandgap energy, the layer immediately above the corrugations is transparent to the 1.5- μm light.

-Charles Cohen

West Germany

Electronic barometer calls fair or foul

If the people who promote semiconductor pressure sensors for Siemens AG have their way, the household aneroid barometer with its moving parts will be consigned to the curiosity shop, supplanted by an electronic barometer.

Designers at the Components division of the Munich-based firm have put together a notebook-sized demonstration model of a solid-state barometer that measures air pressure once every minute and shows

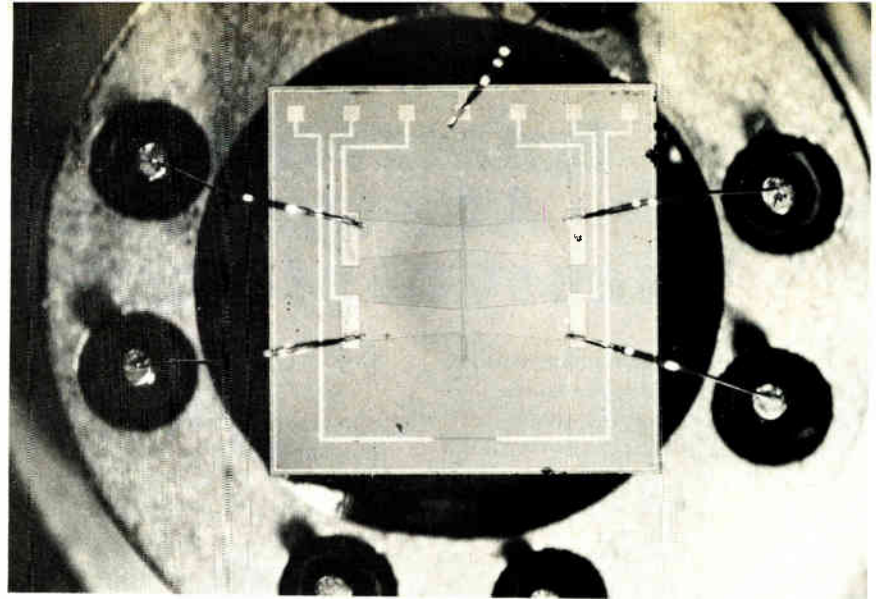

Under pressure. Four resistors diffused into a thin silicon membrane form a bridge whose resistance varies when the membrane flexes because of changes in atmospheric pressure.

the result, to the nearest millibar, on a 1-centimeter-high liquid-crystal display. The barometer will run for at least two years off a power supply of four 1.5-volt batteries.

Siemens is not the first to turn a semiconductor pressure sensor into a barometer. Industrial versions already exist, company designers point out, but these measure air pressure continuously and so draw too much power to operate off batteries. The requisite line-power supply for the industrial model makes for a fairly bulky and heavy instrument.

Demonstration model. Nonetheless, Siemens' development does not signal the company's entry into the barometer business. "Our device is only a model, to show barometer makers that using solid-state techniques in their instruments can result in a number of advantages," says Rudolf Knauer, who headed the project. Along with the battery-powered barometer's advantages in weight and size, its digital output permits an easy interface with computers should it be used in industrial applications.

Knauer figures that production versions of the barometer could be made for about \$35 in quantities of 100,000 a year. The device has already piqued the interest of an Italian firm, for shipboard use.

The Siemens model consists essentially of four circuit groups: the pressure sensor and its amplifiers; an analog-to-digital converter; an LCD module, and clock-signal circuitry. All the parts mount on a 140-by-

75-millimeter printed-circuit board.

In use, the KTY 10 semiconductor sensor, made by Siemens, delivers a voltage, proportional to absolute air pressure, of 70 microvolts per millibar when the supply is 6 v. This signal, which is temperature-compensated and boosted several times in a multistage integrated-circuit amplifier, goes to the integrated a-d converter.

Because of its relatively high current consumption of 2 milliamperes, the converter is activated for only half a second every minute. During this half-second, the air-pressure measurement is sampled, controlled by the clock-generating circuitry, which is based on complementary-MOS gates. The LCM 1011 liquid-crystal module contains memory and driver circuits that service the four-digit display.

As for the pressure sensor itself, it basically is a bridge circuit whose four 7-kilohm resistors are diffused into a thin silicon membrane. On one side of the membrane is a vacuum cell, on the other a small metal tube open at the top to the influence of atmospheric pressure. As the pressure rises or falls, the degree of membrane deflection away or towards the vacuum cell changes. Piezoresistive effects cause the resistance in the bridge to change, which, in turn, results in the pressure-proportional signal.

The barometer circuitry can be calibrated with a reference voltage so that the millibar value shown on the display corresponds to the pres-

Fluke 6070A and 6071A synthesized signal generators. The new generation.

For two decades Fluke has produced RF equipment including a full line of signal sources, counter/timers, and RF voltmeters — quality products that users have specified with confidence.

We're now introducing the new generation of sophisticated instruments in the Fluke RF family: the 6070A and 6071A, two general purpose synthesized signal generators that offer unmatched price/performance value in the market.

Most-wanted features through innovative design.

Both instruments feature a large output dynamic range — the 6070A covers frequencies from 200 kHz to 520 MHz; the 6071A range extends to 1040 MHz — and also deliver a high degree of spectral purity. Fluke engineers have developed a number of unique synthesis techniques resulting in noise performance that equals or exceeds that of the best cavity-tuned generators you can buy. Versatile AM, FM and θ M —

internal or external, simultaneous or separate — give these new synthesizers the flexibility for wide-ranging applications.

All the brains of 16-bit microprocessor control.

An integral 16-bit microprocessor makes these new generators incredibly easy to operate. Convenience features include simplified keyboard data entry, digital frequency sweep, digital spin knob tuning for pinpoint frequency control, a learn mode memory, self-diagnostics and error code flagging plus other special functions only advanced digital technology can provide.

Full programmability for automated test systems.

The 6070A and 6071A are equipped with an IEEE-488 bus interface as a standard feature for systems applications and all necessary front panel functions are remotely programmable. Complete status information can be supplied back to an instrument controller such as the Fluke 1720A. Both "teach" and "learn" modes are provided.

A full line of RF accessories is available to extend the capabilities of the 6070A and 6071A, making them excellent tools for the designer, bench user or laboratory technician.

For more information on the 6070A/6071A and other RF instruments from Fluke, call toll free 800-426-0361, use the coupon below or contact your nearest Fluke sales office.

With 20 years experience in RF instrumentation, we've used advanced technology and engineering excellence to produce the 6070A and 6071A.

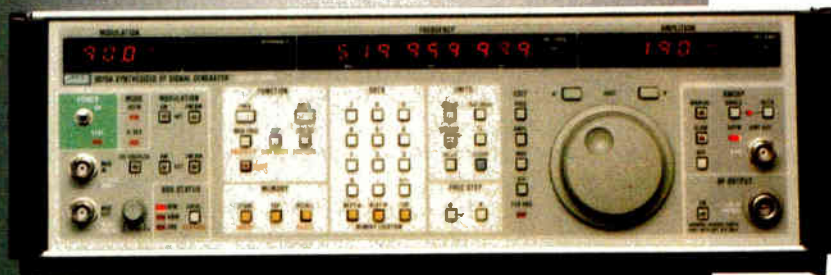

Fast-Response Coupon
 IN THE U.S. AND NON-EUROPEAN COUNTRIES: John Fluke Mfg. Co., Inc. P.O. Box C9090, M/S 250C Everett, WA 98206 (206) 356-5400 Telex: 152662
 IN EUROPE: 1040-5/6070 E2 11/81 Fluke (Holland) B.V. P.O. Box 5053, 5004 EB Tilburg, The Netherlands (013) 673 973 Telex: 52237

- Please send me complete 6070A specifications and applications literature.
- Send information on other IEEE products.
- Have a Sales Engineer contact me for a demonstration.

Name _____

Title _____ Mail Stop _____

Company _____

Address _____

City _____ State _____ Zip _____

Telephone () _____ Ext. _____

For technical data circle no. 71

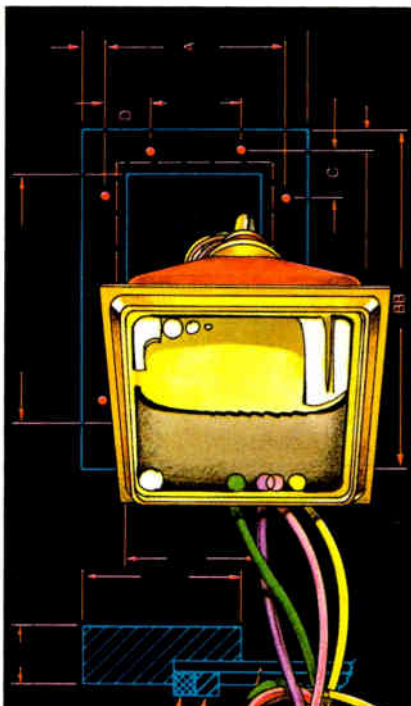

Our EMC viewing windows keep interference under glass.

When the cathode ray tube on a computer terminal was emitting electromagnetic interference (EMI), Spectrum Control, Inc. was called in. Spectrum is a full-service company that provides professional electromagnetic compatibility (EMC) testing, consulting, manufacturing and design. Our experts solved this EMI problem by installing a shielded viewing window* over the CRT. A window that kept internal emissions harmlessly inside the equipment.

Spectrum also designs and manufactures EMI/RFI suppression filters, gaskets, capacitors and many other custom and standard interference control devices. Our computer database contains over 57,000 product variations to help us solve any EMC problem you may encounter at any stage of your system's development. And our testing facilities include a completely equipped Anechoic Chamber and open field sites.**

So contact us about your EMI problem. Write: Spectrum Control, Inc., 8061 Avonia Rd., Fairview, PA 16415. Or call: 814-474-1571.

*See Engineering Bulletin 27-0027-41.
**Spectrum's testing facilities meet all FCC, VDE, CISPR, CSA and MIL-STD 461 A/B requirements.



SPECTRUM CONTROL INC.

Making technology compatible with technology.

Electronics International

sure at the point of measurement. For a pressure referenced to sea level, an offset voltage can be added that varies with the geographic location. Moreover, Knauer points out,

the barometer circuitry can be modified so that it compares air pressures over several hours. Thus, the barometer would show whether it were rising or falling. **-John Gosch**

Great Britain

Computer and communications-gear makers rush into office automation market

British Prime Minister Margaret Thatcher intends to campaign for office automation by doing as well as by preaching. Early next year, she'll be issuing memos, summoning ministers to her side at Number 10 Downing St., or asking for their comments on draft cabinet documents, all with the aid of a local network that will handle both text and data.

Before mid-1982, the \$500,000 prestige installation, the work of a small, new London company called Xionics Ltd., will have voice facilities added to it; encryption will follow in 1983. For voice messages, the system digitizes speech, compresses the data, and stores it on disks. These "voicegrams" then can be forwarded selectively to any users of the net or to all of them.

Show biz. In part, the No. 10 Downing St. voicegram network is an exercise in showmanship—like the electronic office at the White House in Washington—designed to promote the Thatcher government's Information Technology Year. But even before the promotion started, a lot of firms that produce hardware for telecommunications, for data processing, and for obsolescent offices had decided the office automation show must go on. In recent weeks, several have raised the curtain on their new acts.

■ Britain's ICL, largest of the native computer makers, has teamed with the Canadian telecommunications producer Mitel Inc. to market systems tied together by Mitel's Super-switch digital private automated branch exchange. At the same time, ICL is hedging its bets with a variety of local networks.

■ Plessey Office Systems Ltd. responded to ICL's incursion into the PABX sector by revealing the broad outlines of its electronic office strategy. Plessey's long-brewing plans call for a mid-1982 launch of a product line based on its best-selling digital PABX, which in effect provides a ready-made 64-kilobit/second (the digitized voice rate for the exchange) channel for each user. The PABX will serve as a concentrator and gateway for services like telex, teletex, electronic mail, and data processing with interfaces for ICL and IBM mainframes.

■ Gestetner Ltd., an old established duplicator manufacturer in bad need of new technology, hopes to move front stage by buying Nexos Ltd., the state-backed office equipment company that's now up for sale.

However, the established companies like ICL, Plessey, and Gestetner are not alone in the quest for market share. Xionics has already sold more than \$2 million worth of its local net hardware since it started up in January, 1979. To insure reliability of its networks, Xionics transmits 10 bits of parallel data over twisted-wire pairs and duplicates all the interfaces.

And the first UK company to get on the market with a second-generation office system integrating word-processing and voicegram facilities is Office Technology Ltd. of Winchester, a break-away group formed by four IBM office-equipment specialists in January, 1980. The company is part of the Information Technology Ltd. group of companies run by entrepreneur Tony Davies.

Office Technology believes that "few companies can afford specula-

"We asked for a high frequency counter that measures accurately in tough RF environments. We weren't disappointed."

"Measuring frequencies on-site can be a difficult job. Signals from nearby transmitters can interfere with the frequency we're monitoring. But Fluke has packed all the features we need for high frequency

measurements into their new 7220A Frequency Counter, and then some."

"A full 10 Hz to 1300 MHz bandwidth through 2 input channels, and 5 mV rms basic sensitivity give us the full frequency coverage we

need. The 7220A's X1 to X100 variable attenuator, effective overload protection, and 100 kHz low-pass filter on the Channel A input help us take clean, stable readings of audio signals with RF contamination. And an integral stainless steel RF shield surrounds this counter."

"We take accuracy with us."

"An optional battery pack combines with a choice of ovenized oscillators for high-accuracy, no-warm-up readings – even in the field."

"And because the 7220A is a member of Fluke's Portable Test Instrument (PTI) family, this counter quickly stacks-and-latches to any PTI Instrument. With the Fluke 1120A Translator, we can even assemble an inexpensive, transportable IEEE-488 system."

Convincing Evidence.

Communications specialists everywhere are finding that the new Fluke 7220A makes their tough frequency measurements on the bench or in the field. For more information on Fluke Counters, call toll free 800-426-0361, use the coupon below, or contact your Fluke Sales Office or Representative.



Fast-Response Coupon

IN THE U.S. AND NON-EUROPEAN COUNTRIES:
John Fluke Mfg. Co., Inc.
P.O. Box C9090, M/S 250C
Everett, WA 98206
(206) 356-5400
Telex: 152862

1041-3/7220 E2 11/81
IN EUROPE:
Fluke (Holland) B.V.
P.O. Box 5053, 5004 EB
Tilburg, The Netherlands
(013) 673 973
Telex: 52237

- Please send me the 7220A Brochure.
 Please have a Sales Engineer contact me.

Name _____
Title _____ Mail Stop _____
Company _____
Address _____
City _____ State _____ Zip _____
Telephone () _____ Ext. _____

For technical data circle no. 201

NEW NICKEL FLAKE OUTSTANDING FOR RFI-EMI SHIELDING.

**NOVAMET* Ni-HCA-1 Nickel Flake Pigment Newly
Developed for Electronics Applications**

Ni-HCA-1 is especially suited for RFI-EMI shielding as well as conductive adhesives. Specially developed for electronic applications, this new nickel flake pigment has been treated to yield metal-filled epoxy, acrylic and urethane paint and adhesive formulation with low surface resistance (1-3 ohms/sq).

Due to the high aspect ratio of the flake morphology (33:1 average) equivalent electrical or shielding performance can be obtained with lower pigment loadings of Ni-HCA-1 than conventional powders. This means

easier handling and improved application characteristics of the coating or adhesive system.

NOVAMET Ni-HCA-1 flake gives you outstanding environmental stability. You also gain significant economies over silver filled coatings.

You can take advantage of lower pigment loadings than conventional powder with Ni-HCA-1 and still maintain equivalent electrical or shielding performance. This is the result of Ni-HCA-1's high aspect ratio of flake morphology (33:1 average). And lower pigment loadings mean easier handling and application characteristics for both coating and adhesive systems.

You should know more about NOVAMET's new nickel flake pigment. Call Sharon Perkins at (201) 891-7978. Or write to Sharon Perkins, NOVAMET 7, 681 Lawlins Road, Wyckoff, N.J. 07481

Typical Properties of NOVAMET Ni-HCA-1	
Specular Reflectance (R _g)	>40%
Average Flake Thickness	1.2 microns
Typical Size Distribution:	
- 44 μm (- 325 mesh)	97%
- 30 μm	90%
- 20 μm	80%
- 10 μm	35%
Approx. Bulk Value	.033 gal/lb
Approx. Specific Gravity	3.66
Approx. Apparent Density	1.30 g/cc

*TM of an INCO Company

Circle 74 on reader service card

NOVAMET

DIV OF MPDTECH CORP

Electronics international

tive investment in untried office technology". So OTL has developed a high-performance cluster word-processing system to which voice facilities and other enhancements can be added when the customer is ready.

As a word processor, for example, the star-connected cluster can support up to 32 workstations and printers from a central disk file of up to 640 megabytes capacity. Each workstation displays black-on-white proportionally spaced text and scrolls it both horizontally and vertically. An 80-hertz refresh rate keeps the screen flicker-free.

Two roles. Hooks are provided within this system to expand its capability progressively. "It's a good vehicle for pilot office systems," says Bob Remington, an industrial psychologist and one of the four founder-directors of OTL. Foremost of these enhancements is what is termed its voice capability. This has two basic roles: first, to avoid telephone ping-pong by storing and automatically forwarding short verbal messages; second, to provide an alternative to scribbled notes in the margin of internal documents.

In the firm's information management system, annotation is readily accomplished with the aid of the display cursor and a set of voice-related keys similar in function to the controls of a cassette recorder. Once a document has been annotated, a loudspeaker symbol in the margin alerts addressees to any voicegrams stored alongside the text.

Other planned enhancements include the addition of auxiliary processors to the central controller—which currently uses two Intel 8086 16-bit microprocessors—to provide additional document processing plus statistics and heavy mathematics. Also promised are a local and remote networking gateway, as well as a facility for twinning the central controllers to achieve a high level of resilience. At home, OTL will market the system itself; in the United States it will be marketed through agents. In the UK, a six-station system sells for the equivalent of about \$12,700 per station. **-Kevin Smith**

McGraw-Hill's Electronic Bookshelf™ is on the Air!

Ask your computer to call (212) 997-2488 for the latest info on our computer and electronics books. The system is up daily from 6 pm to 8 am and 24 hours on weekends.

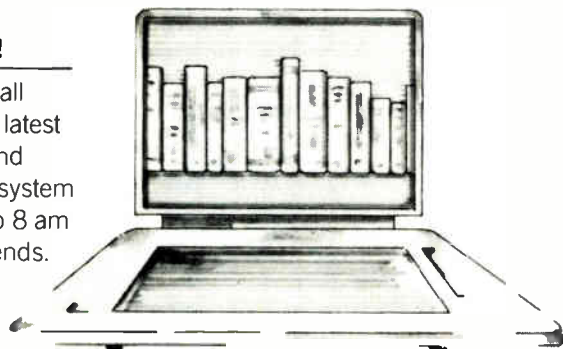

Modulation Analyzer FAM



All-round modulation analysis, manually or automatically, in the carrier-frequency range 55 kHz to 1.36 GHz

Special features:

- Residual FM < 1 Hz (CCITT weighted)
- Residual AM < 0.01 % (CCITT weighted)
- thus superior for spurious-modulation measurements

Excellent amplitude and phase linearity with stereo crosstalk attenuation of > 50 dB, distortion < 0.1 %

IEC-bus interface for use in automatic test systems

Compact design (12 kg) and low power needs

Easy to operate, ergonomic styling

The FAM is five instruments in one:

- modulation meter
- RF counter
- AF counter
- distortion meter
- psophometer

Versatile AF evaluation facilities:

- AF-level measurement
- weighting filters CCIR and CCITT
- distortion measurement

Indication of measured results by:

- three digital displays, one quasi-analog display

Ask for more information

Modulation analyzer FAM

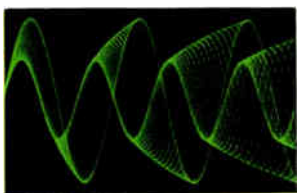

AM + FM

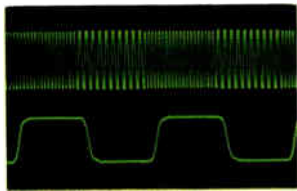

FSK



STEREO

Rohde & Schwarz GmbH & Co. KG
Postfach 80 14 69
D-8000 München 80
Federal Republic of Germany

Telex 523 703 (rus d)
Phone internat. +(4989) 4129-1
Independent concern
(established 1933)
represented in 80 countries



ROHDE & SCHWARZ

Electronic measurements · Broadcasting
Radio communications and monitoring

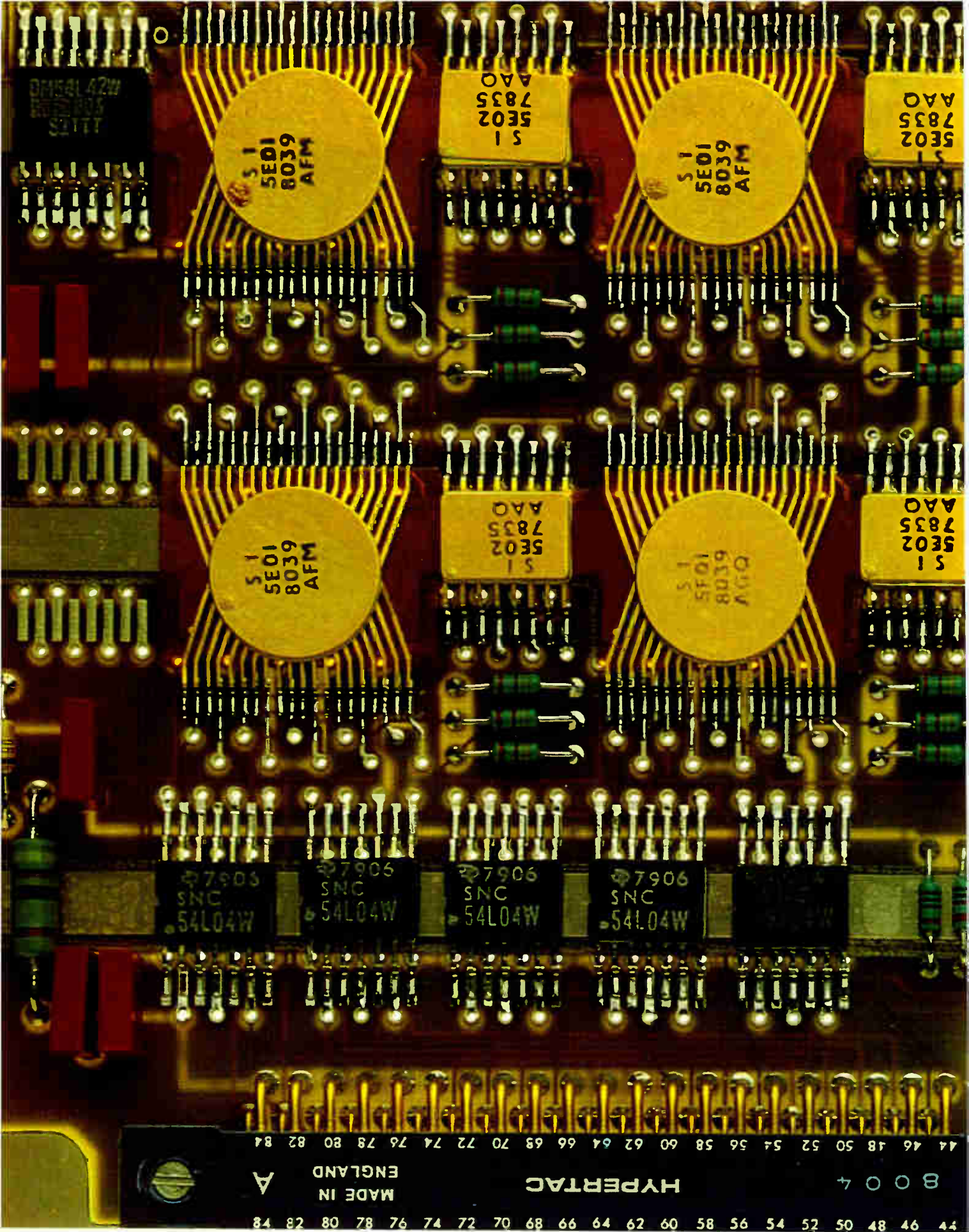

WARNING: CUSTOM LSI CAN SE

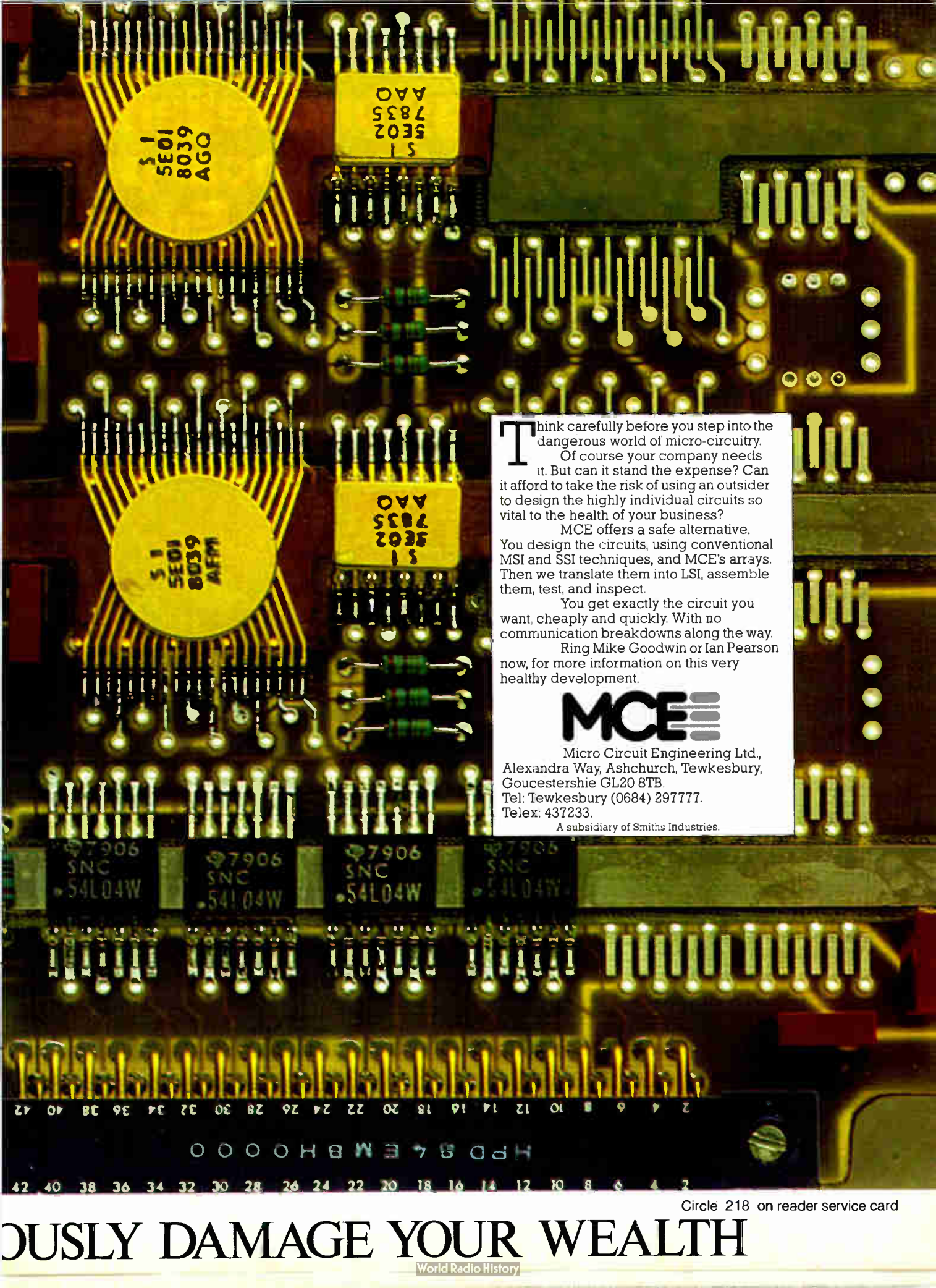

Think carefully before you step into the dangerous world of micro-circuitry. Of course your company needs it. But can it stand the expense? Can it afford to take the risk of using an outsider to design the highly individual circuits so vital to the health of your business?

MCE offers a safe alternative. You design the circuits, using conventional MSI and SSI techniques, and MCE's arrays. Then we translate them into LSI, assemble them, test, and inspect.

You get exactly the circuit you want, cheaply and quickly. With no communication breakdowns along the way.

Ring Mike Goodwin or Ian Pearson now, for more information on this very healthy development.

MCE

Micro Circuit Engineering Ltd.,
 Alexandra Way, Ashchurch, Tewkesbury,
 Gloucestershire GL20 8TB.
 Tel: Tewkesbury (0684) 297777.
 Telex: 437233.
 A subsidiary of Smiths Industries.

Circle 218 on reader service card

DOUSLY DAMAGE YOUR WEALTH

From home-computer memory chips



```
DATA A HEX      CLOCK EXTJ CQ X  DELAY  500 CLOCKS  
250 8A98 757 3210  
480 D727      T 500 D729      520 DF28
```



to guidance systems for aerospace ships.

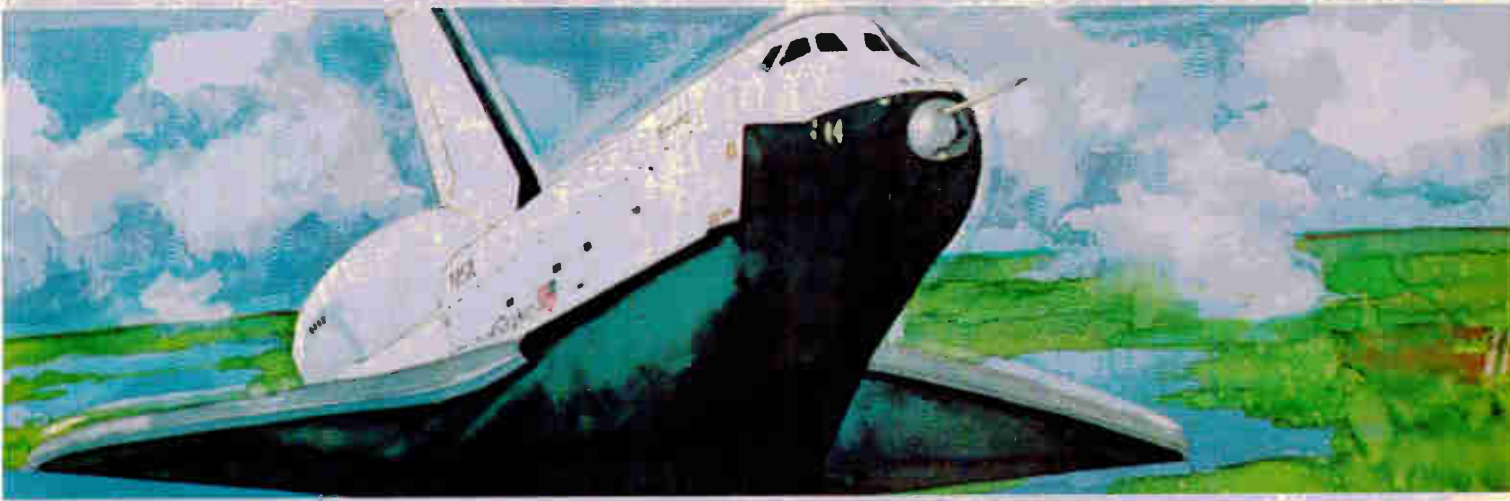

More and more people trust Gould instrumentation.

Gould logic analyzers troubleshoot and service the complex digital circuitry in computers and micro-processor-based equipment. They can diagnose problems that might arise in anything from a single memory chip to the complex guidance system that pilots America's shuttles through the intricacies of space.

Our Instruments Division pioneered the development of logic analyzers. And today we offer a full line of these powerful diagnostic tools. They are uniquely capable of testing both hardware and software, and offer unsurpassed speed and data capacity to business, industry and research facilities.

Gould logic analyzers. Part of our rugged family of high



quality, high performance instruments that measure, display, store or record data. A family that includes digital storage scopes and direct writing recorders. Electrostatic and thermal array recorders. X-Y and strip chart recorders. Biophysical recorders. And a full range of signal



conditioners. For more information, call or write Gould Inc., Instruments Division. Operations in Santa Clara, California; London, England; Paris, France; and Frankfurt, Germany. Headquarters at 3631 Perkins Avenue, Cleveland, OH 44114. 216/361-3315.



Electronics & Electrical Products
Circle 220 on reader service card

Multiple choice test.

Philips now gives you a wider choice in low frequency oscilloscopes, so you can better tailor the scope to your application.

Need a 25MHz/single time base scope? Choose the PM3212. A 25MHz with delayed time base? Choose the PM3214.

If your application requires a higher bandwidth and shorter rise time, choose one of the new 35MHz scopes from Philips.

Our PM3216 has a single time base; the PM3218 has delayed time base. Both have a maximum sweep speed of 10ns/div. and a trigger hold-off facility that eliminates double triggering on digital signals, making it unnecessary to use the time base in the uncalibrated mode.

All four oscilloscopes feature trigger selection from either channel, line, external source or composite triggering for asynchronous signals. The alternate time base displays of the PM3214 & 18 allow them to do the work of much more expensive instruments. Just press delayed time base and main time base simultaneously and both time base sweeps are displayed for one or both channels.

In addition, all four feature wide trigger bandwidth plus 10kV CRT for high light output and excellent resolution. Of course they are strong, rugged and lightweight.

Now, more than ever, Philips wants to make *your* next scope. And your next Logic Analyzer. And your Microcomputer Development System. We're going to give you a better multiple choice so you'll buy from us.

For more information contact the Philips organisation in your country or write to Philips Industries, Test & Measuring Instruments, TQ III-2, 5600 MD Eindhoven, The Netherlands.

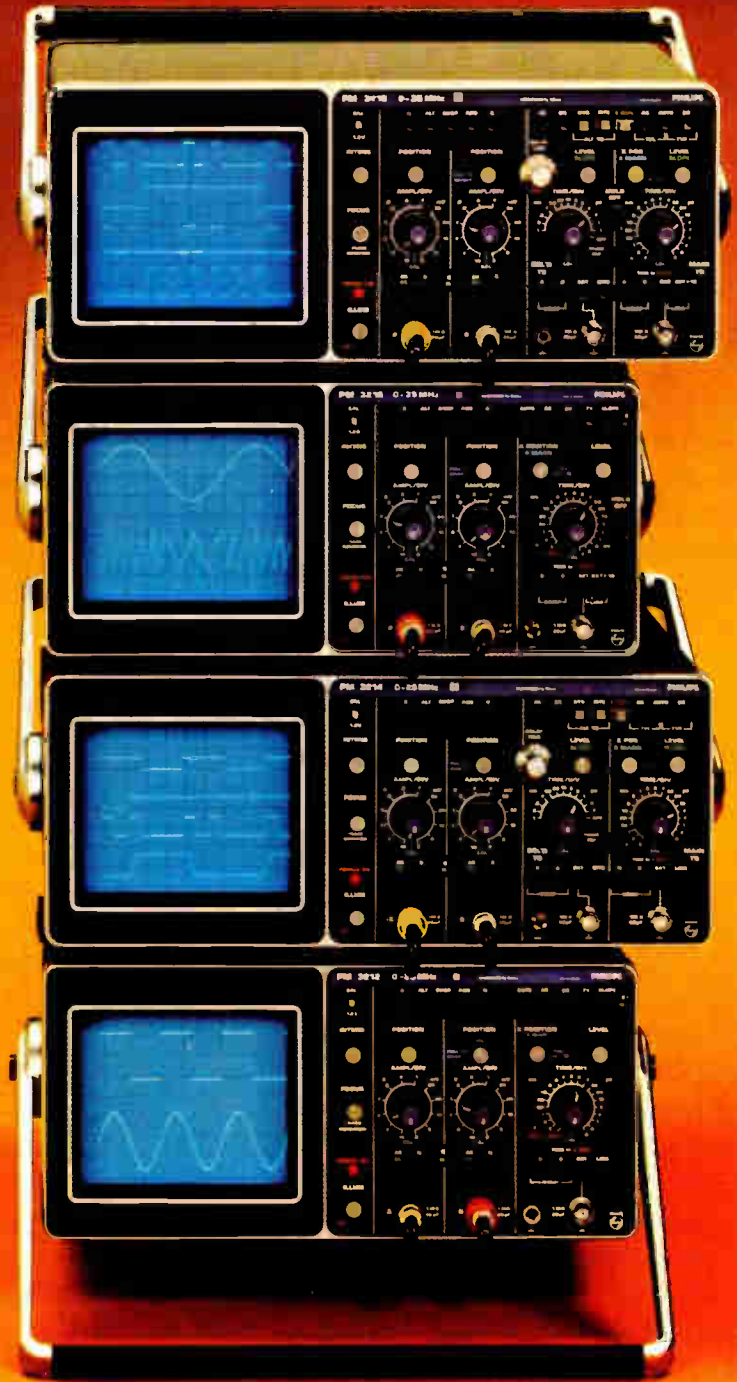

From Philips, of course.



Test & Measuring
Instruments

PHILIPS

Resonant ceramics lower microwave oscillator cost

by Robert Gallagher, Paris bureau

Dielectric ceramics based on zirconium, titanium, and tin have resonant-frequency stability comparable to Invar's

In what could drastically reduce the price of microwave oscillators and filters for certain applications, the Microwave Components division of Thomson-CSF is about to begin marketing a line of dielectric ceramics comparable in stability to Invar. In addition, the company will be selling two dielectrically stabilized oscillators based on the materials.

The ceramics are based on the ability of dielectric samples to exhibit electromagnetic resonances when the wavelength is shorter than the sample size. Because their resonant frequency is stable over time and temperature, they present an alternative to, say, Invar in waveguide filters.

The Thomson line consists of six ceramics, all of which are based on zirconium, tin, and titanium. They differ from each other in stability over temperature as a result of different ratios of zirconium to tin. Their common characteristics are a density of 5.2 ± 0.1 , an expansion coefficient of 3 ± 2 , a dielectric loss of 3×10^{-4} , and permittivity of 36 ± 1 . The E2036, E2336, E2636, E2936, E1336, and E36 ceramics, have resonant-frequency stabilities from -20° to $+80^\circ\text{C}$ of

0 ± 2 , 3 ± 2 , 6 ± 2 , 9 ± 2 , -3 ± 2 , and ± 10 ppm, respectively.

"There are very few such materials available, but one is a barium-based ceramic developed at Bell Laboratories," points out William Simonet, an engineer at Thomson's central research laboratory who worked on the materials' development. "This material can be very good indeed if it is well made, but it has the disadvantage of being manufactured at a temperature very close to its fusion temperature. Also, there are some stages at which it is water-soluble."

Thomson has developed two oscillators using the materials and plans to add substantially to that line. The TH 5129 and TH 5130 dielectrically stabilized oscillators operate at from

8 to 12.4 and 13 to 17 GHz, respectively, over a temperature range of -40° to $+80^\circ\text{C}$. They both feature very low fm noise (-100 and -80 dB/Hz, respectively), and come with an integrated voltage regulator. Pulling for the oscillators is 10^{-4} and output is 10 mW. Short-term instability is 10^{-7} .

The price of one of these oscillators is about \$1,250 in small quantities or as little as \$785 in large orders. The materials are priced according to the form in which they are purchased: blocks, as they come from firing; cylinders to be cut and finished by the customer; or already finished to specifications. "To make a 10-GHz resonant cavity with Invar could cost as much as \$2,000," explains Simonet. "With these ce-

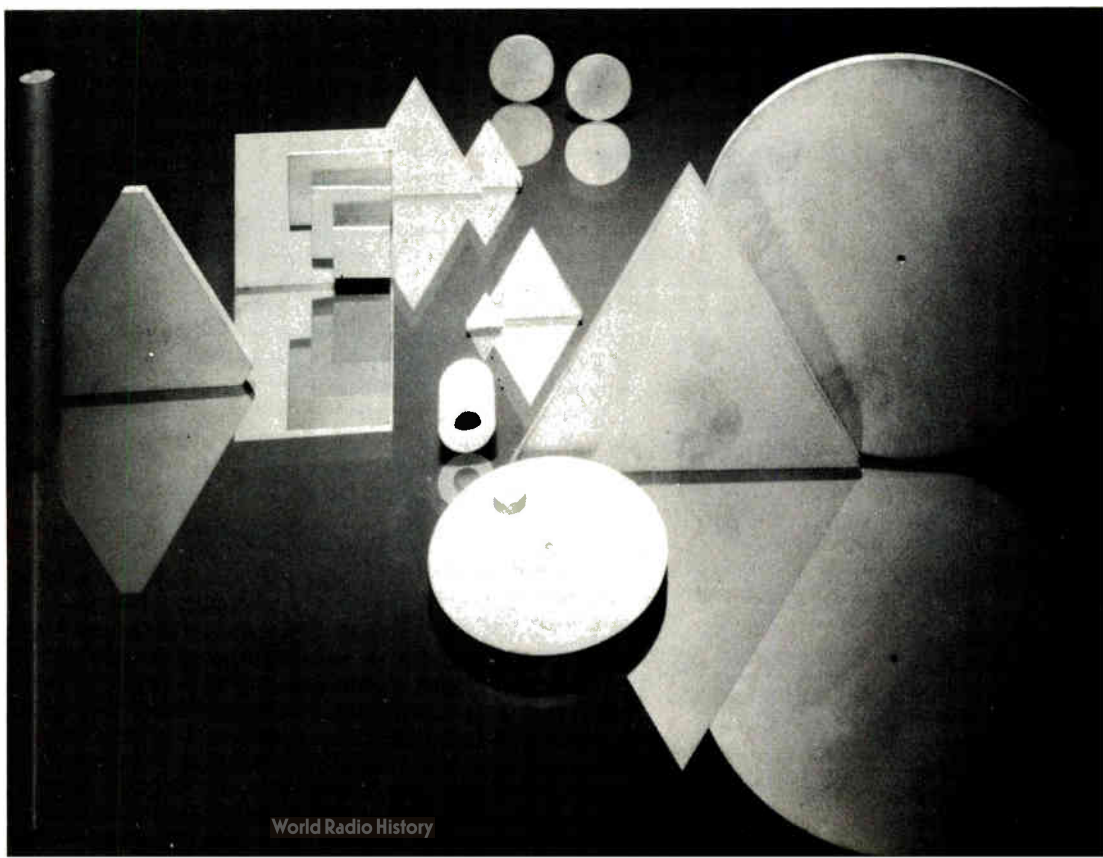

New products international



ramics we are talking more in the area of \$50 to do the same job."

Thomson-CSF Microwave Components Division, 101 Blvd. Murat, 7581, Paris Cedex 16, France [441]

Line of 100-in./s streamers backs up Winchester drives

Winchester-drive disk storage will find a complement in a line of streaming magnetic-tape drives from SE Labs (EMI) Ltd., the Thorn EMI

group's computer-peripherals company. SE Labs markets Fujitsu Ltd.'s range of Winchester-technology drives according to a recent agreement.

The 1/2-in. Emistreamers range in capacity from 15 to 61 megabytes unformatted and all stream at 100 in./s. The IBM/ECMA 1,600 b/in. phase-encoded format for 1/2-in. tape is used; models in the line share an industry-standard interface.

The top of the line is the 8900, which runs at 50 in./s in conventional start-stop operation in addition to streaming. It is based on the successful model 8800 tape transport, which can be upgraded in the field to 8900 specifications.

With the automatic threading and front loading of models 9900 and 9800, reels become as easy to handle as floppy disks. The two drives have a capstanless tape path that contacts the oxide at only the head and a sapphire cleaner. Without a capstan, these drives cannot match the 8900's 8-ms start-stop time. And their start-

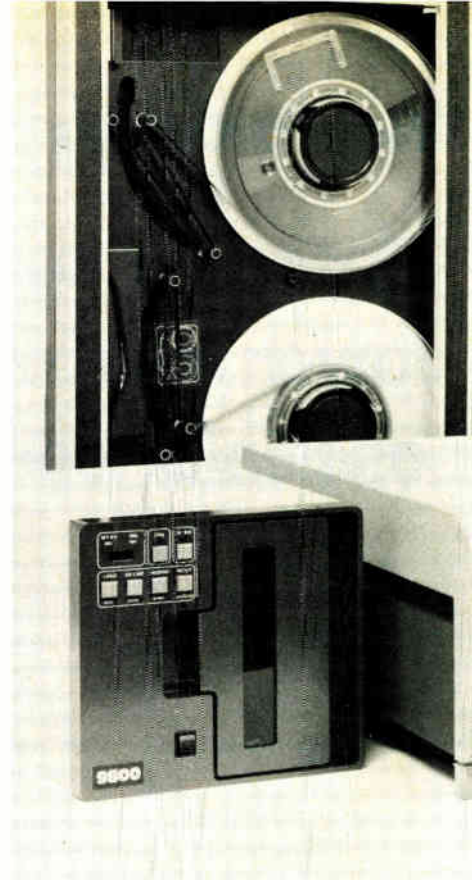

stop operation is at only 25 in./s. Nominal access time for the 9900 is 29 ms at 25 in./s and 176 ms at 100

ECONOMICAL.

When it comes to smart terminals, Lear Siegler has just what you need. In two versions.

ADM 31. LOADED WITH FEATURES.

The ADM 31 Intermediate Terminal™ comes standard with: full editing and formatting, two pages of memory (a total of 48 display lines), printer port and a complete range of visual attributes.

That wasn't enough for us, however. It also features a high resolution monitor with a choice of white or green display. Built-in numeric keypad. Function keys. Block mode transmission. Modifiable personality that lets you choose any



combination of terminal operations (transmit carriage return, line feed at end of every line instead of CR

code, etc.). Polling for more efficient use of computer time and transmission lines.

Business graphics. And for a mere \$50 extra, we'll throw in programmable function keys, 25th status line and smooth scroll.

ADM 32. EVEN MORE FEATURES.

The ADM 32 Ergonomic IT™ has all that, and is engineered to make you even more comfortable. Because comfort and ease increase productivity. So, in addition to the ADM 31's attributes,

\$1095.

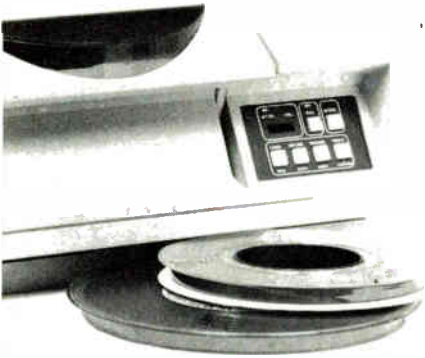

at 100 in./s. The larger drives take reels up to 10½ in. in diameter with standard IBM hubs.

The low-cost 9800 comes with a power supply and a formatter in a package the size of two 8-in. floppy-disk drives. A 7-in. reel of 1-mil tape stores 15 megabytes; the capacities of Mark II versions of this unit are expected to top 50 megabytes.

All three ½-in. drives have built-in self-diagnostics. A four-character alphanumeric display on the front panel conveys diagnostic messages as well as an indication of operational status. Six registers are allocated for error-logging, status, and diagnostic data, which can be displayed to the operator or transmitted over the drive's interface.

The firm is also offering a ¼-in. tape drive, the Streamer 9700, as part of a deal with Data Electronics Inc. of San Diego, Calif. The 30- and 90-in./s unit stores 10 or 20 megabytes on a 3M-type cartridge.

SE Labs offers interfaces, controllers, and host adapters for its tape

and disk drives. Apple and Pet microcomputers are supported, as well as minicomputers from Hewlett-Packard, Digital Equipment Corp., and Data General.

SE Labs (EMI) Ltd., Data Products Division, Spur Road, Feltham, Middlesex TW14 0TD, England [475]



The ZRA4025 solid-state relay incorporates snubber circuits and features zero-voltage switching. It blocks 420 V and carries 25 A or a single surge of 225 A. Control is at 3 to 32 V, and input impedance is 1,500 Ω. FR Electronics, Wimborne, Dorset BH21 2BJ, England [442]

in./s. The small 9800, accepting only 7-in. reels, has a nominal access time at 25 in./s of 80 ms and of 320 ms

ERGONOMICAL.

the ADM 32 gives you as standard equipment a detachable keyboard, and a non-glare 12" or optional 15" screen with optional tilt.

As if that wasn't enough, you can pick up the ADM 31 for an unheard of \$1095, and the ADM 32 for a very comfortable \$1295.

And if those aren't two smart ideas, we're not Lear Siegler.

Contact your local authorized Lear Siegler distributor or: Lear Siegler Data Products Ltd., Orchard House, Connaught Road, Brookwood, Surrey GU24 0AT, United Kingdom Tel: Brookwood (048 67) 80666 Telex: 859415



NOW AVAILABLE WITH INTEGRAL MODEM

\$1295.

Lear Siegler Authorized Distributors: AUSTRIA: Austria Electronic Data Products, Vienna, Austria; BENELUX: Benelux Data Products, Leuven, Belgium; DENMARK: Data Products, Copenhagen, Denmark; FINLAND: Data Products, Helsinki, Finland; FRANCE: Data Products, Paris, France; GERMANY: Data Products, Frankfurt, Germany; GREAT BRITAIN: Lear Siegler Data Products Ltd., Brookwood, Surrey, UK; GREECE: Data Products, Athens, Greece; ICELAND: Data Products, Reykjavik, Iceland; ISRAEL: Data Products, Tel Aviv, Israel; ITALY: Data Products, Milan, Italy; NORWAY: Data Products, Oslo, Norway; PORTUGAL: Data Products, Lisbon, Portugal; REPUBLIC OF IRELAND: Data Products, Dublin, Ireland; SOUTH AFRICA: Data Products, Johannesburg, South Africa; SWEDEN: Data Products, Stockholm, Sweden; SWITZERLAND: Data Products, Zurich, Switzerland; SWITZERLAND: Data Products, Zurich, Switzerland; LEBANON: Data Products, Beirut, Lebanon; SAUDI ARABIA: Data Products, Riyadh, Saudi Arabia; SYRIA: Data Products, Damascus, Syria.

**SMART TERMINALS.
SMART BUYS.**



LEAR SIEGLER, DATA PRODUCTS LIMITED
Intermediate Terminal and IT are trademarks of Lear Siegler, Inc.
Quotations in U.S. Dollars

New products international

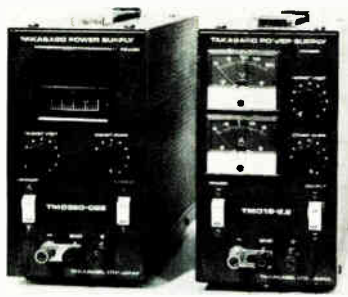

Constant-voltage or constant-current dc power supplies have outputs of 0 to 70 V for the TMD series and 0 to 360 V for the TM series at 0 to 5 A. They are used in factories for experimental, inspection, and production-line jobs. Takasago Ltd., 662 Futako, Takatsu-ku, Kawasaki 213, Japan [443]

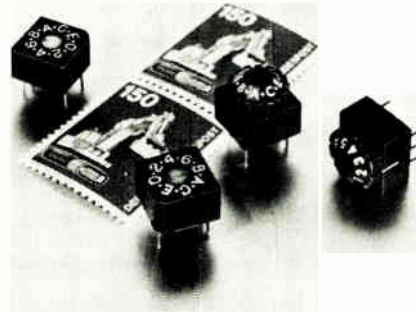

The series KDS code switches can be soldered or plugged into dual in-line sockets. They have 10-position binary-coded decimal or 16-position hexadecimal coding. Maximum contact resistance is 50 mΩ. Spezial Electronic, P. O. Box 1308, D-Bueckeberg, West Germany [446]

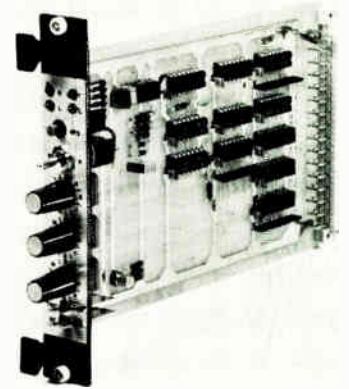

The test and service module KUAX 653 traces the logic states of programmable controls and indicates these states with light-emitting diodes. The addresses of the appropriate inputs, outputs, and clocks of the controls are preset by switches. Kuhnke GmbH, D-2427 Malente, West Germany [449]



The SP110 preamplifier for the ES1000 electrostatic recorder has a guarded floating input that operates up to 500 V above ground and a 6-kHz frequency response for an amplitude of 50 mm. Gould Instruments Division, Roebuck Road, Hainault, Essex IG6 3UE, UK [444]



The 218HF optical chopper produces 100% modulation up to 20 kHz in optical beams almost 25 mm in diameter. It consists of a compact chopping head, cable, and control unit for lock-in amplifiers. Bentham Instruments Ltd., 14 Arkwright Rd., Reading, Berks. RG2 0LU, UK [447]

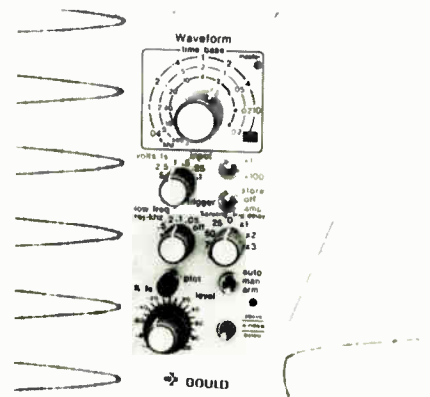

The model 13-4616-10 functions as a waveform-storage module and high-frequency dc amplifier. It produces hard-copy waveforms at frequencies up to 20 kHz on the Gould 2000 and 200 series direct-writing recorders. Gould Instruments Division, Roebuck Road, Hainault, Essex IG6 3UE, England [450]

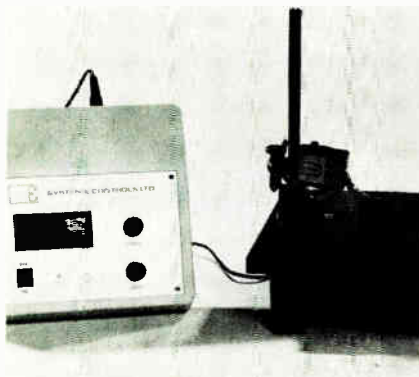

This portable digital meter gauge operates from a battery or main supply, has two imperial and metric magnification ranges from $\pm 200 \mu\text{m}$ to $\pm 0.200 \text{ in.}$, and works with the firm's half-bridge transducers. Systems E Controls Ltd., 1 New St., Leamington Spa, Warwickshire CV31 1HP, UK [445]



Micromat drills printed-circuit boards in a 315-by-470-mm pattern. It has insert and delete functions, subroutines, step and repeat, and a user-friendly control panel. It can drill at up to 60,000 rpm. Dorniver Ltd., The Green, Wellingborough Road, Rushden, Northants. NN10 9YN, UK [448]

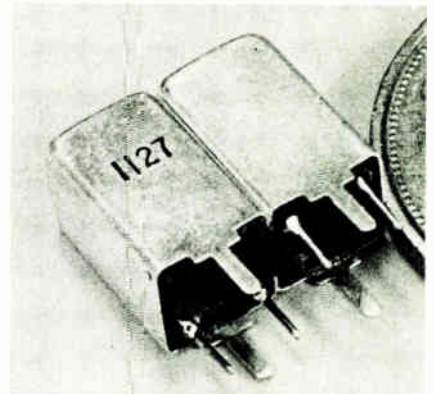

Toko's 7HW series of miniature helical filters is used in ultra high-frequency receivers and portable paging equipment. They have an insertion loss of better than 4 dB and cover the 380-to-500-MHz range. Ambit International, 200 North Service Rd., Brentwood, Essex CM14 4SG, England [452]

Polyskop SWOB 5 with extra capability

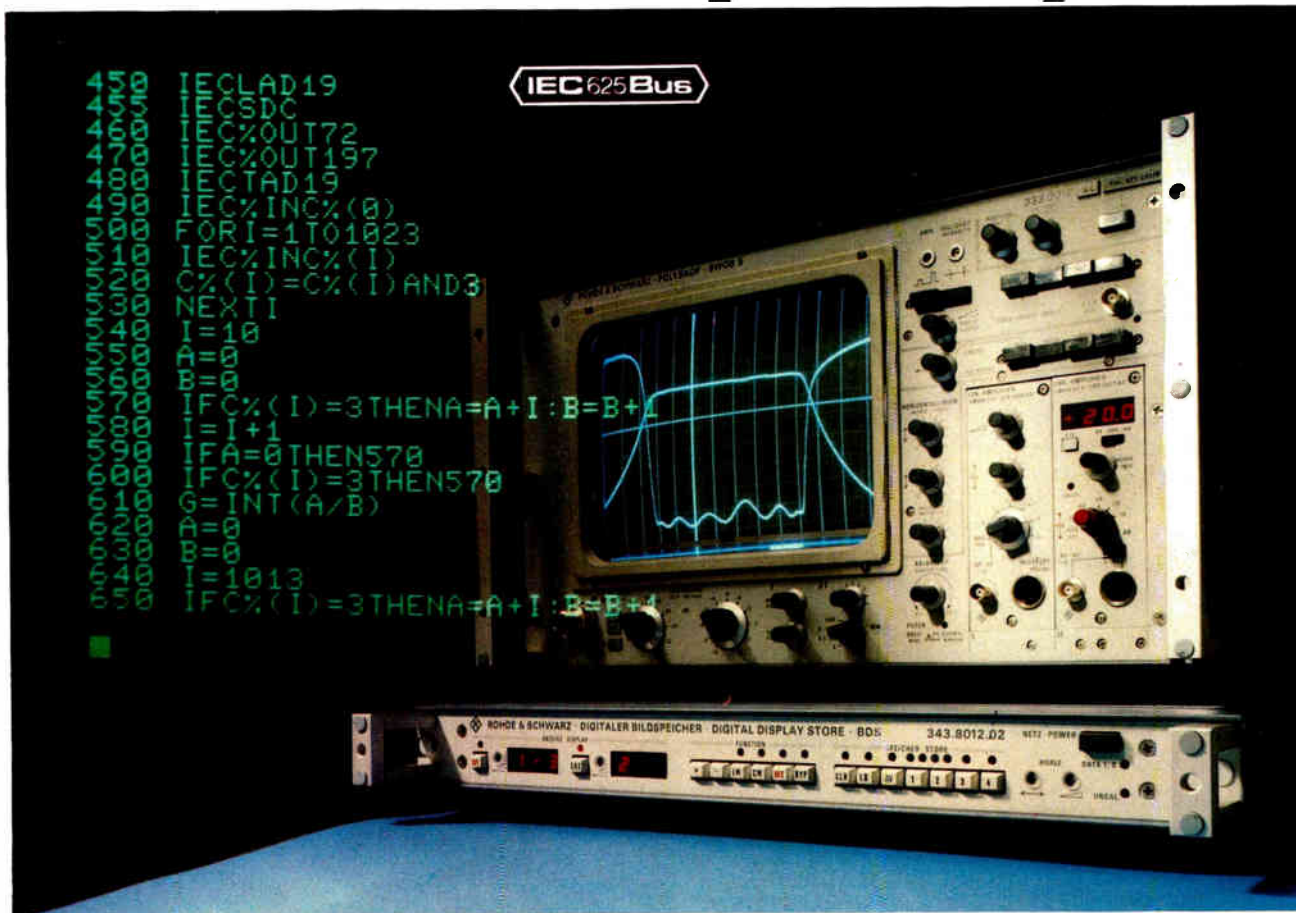

The operating ease and performance of the compact sweep tester Polyskop SWOB 5 (now up to 1.3 GHz) have been enhanced even more through a new digital display store and a log-amplifier plug-in.

Digital display store BDS

Even at slow sweep rates the BDS permits simultaneous, flicker-free display of two test curves plus associated information like frequency markers and level lines. Storage of four sweep curves is possible, and the contents of any two memories can be added and subtracted, thus enabling compensation of frequency-response errors for instance. The optional **average-value memory** averages 4, 8 or 16 successive sweeps, making it possible to suppress random interference on the sweep curve (e. g. noise). If the BDS is used with its optional **IEC-bus interface**, the contents of all memories can be read out, converted and read in again by a desktop controller.

The log amplifier SWOB 5-E3 (right in the photo) has a digital level display and the following new features:

- AF input for test items with built-in rectifier
- automatic setting of reference levels
- signalling of excessive interfering-signal levels
- gain of active demodulator taken into account in level measurements

The measured value indicated can be absolute in dB (V) and mV (with auto-ranging) or relative in dB, and for relative measurements the reference level can be set anywhere between 0 and -100 dB (V).

Ask for the new data sheets SWOB 5 and BDS

Rohde & Schwarz GmbH & Co. KG
Postfach 80 14 69
D-8000 München 80
Federal Republic of Germany

Telex 523 703 (rus d)
Phone internat. + (4989) 4129-1
Independent concern
(established 1933)
represented in 80 countries



ROHDE & SCHWARZ
SCHWARZ

World Radio History

Electronic measurements · Broadcasting
Radio communications · Radiomonitoring

Circle 223 on reader service card

TEAC TOOK OUT BRUSHES TO BUILD IN RELIABILITY.

Unique Long Life Brushless DC Motor
So reliable (lifetime 10,000 hours) that we let it run continuously. No motor start-up time. No electrical noise to bother CRT displays either.

Controlled Frame Expansion
We matched the thermal expansion rate of the frame to that of the media. Head misalignment is greatly reduced.

Choice of 2 Recording Methods: MFM/FM
Data capacity can be doubled using MFM. No write precompensation is necessary.

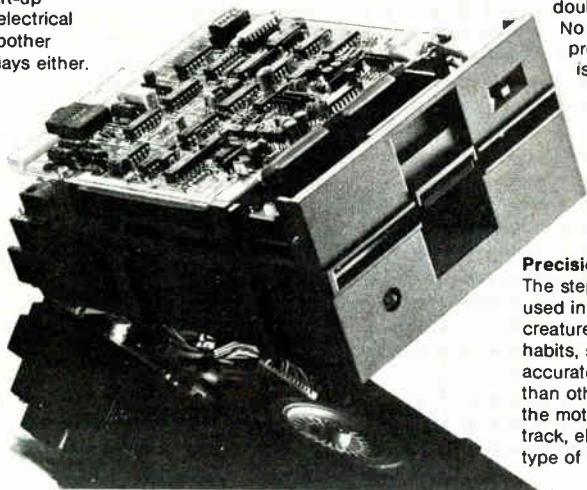

Precision Head Seek
The stepping motors used in floppy disks are creatures of strange habits, stopping more accurately at some steps than others. TEAC steps the motor 4 times per track, eliminating this type of error.

The super-reliable brushless DC motor used in our FD-50 series 5 1/4 Floppy Disk Drives lasts 10,000 hours.

3 Models FD-50A/50C/50E, 3 Formats

The FD-50A is a single-density, 48 tpi, 40/35 track model. In 35-track mode it is fully compatible with the Shugart SA-400. The FD-50C is a double-track-density, 100 tpi, 77 track model, and compatible with the Micropolis 1015. The FD-50E is an industry-standard double-track-density 96 tpi, 80/70 track model.



TEAC CORPORATION; 3-7-3 Naka-cho, Musashino, Tokyo, Japan Tel: (0422) 53-1111 Tlx: 2822451, 2822551

• U.S.A. TEAC Corporation of America, Tel: (213) 726-0303 • Canada R.H. Nichols Co. Ltd., Tel: (416) 661-3190 • Hongkong Dah Chong Hong Ltd., Tel: 5-261111, 5-26258 • New Zealand W. & K. McLean Ltd., Tel: 587-037 • Australia Jacoby Mitchell Pty. Ltd., Tel: (02) 26 2675 • South Africa Mayfar Sales (Pty) Ltd., Tel: (011) 29-2921 • United Kingdom Tekdata Electronics Limited Tel: 0782 813631 • West Germany nbn Elektronik GmbH, Tel: 08152/390 • Holland Simac Electronics B.V., Tel: 40-533725 • Belgium & Luxemburg Simac Electronics, Tel: 02-219.24.53 • France Tekelec Airtronic S.A. Tel: (1) 534-75-35 • Italy A.E.S.S.E.S.P.A., Tel: 54.64.741-2-3 • Spain Atlas Ingenieros S.A., Tel: 733 0562, 733 3700 • Switzerland Wenger Datentechnik, Tel: 061/50 84 84 • Denmark Danbit, Tel: (03) 141515 • Sweden Scantele AB, Tel: 08-24 58 25

* If no distributor is listed above in your area, please contact us directly for further details about our products

Circle 224 on reader service card

NEW 1981 Electronics Buyers' Guide

The only book of its kind in the field. If you haven't got it, you're not in the market.

To insure prompt delivery enclose your check with this coupon.

Yes, please send me _____ copies of 1981 EBG.

I've enclosed \$30 per copy delivered in USA or Canada. Address: EBG, 1221 Avenue of the Americas, New York, N.Y. 10020.

I've enclosed \$52 for air delivery elsewhere. Address: EBG, Shoppenhangers Road, Maidenhead, Berkshire S16, 2Q1 England.

Name _____

Company _____

Street _____

City _____

State _____

Zip _____

Country _____

New products international

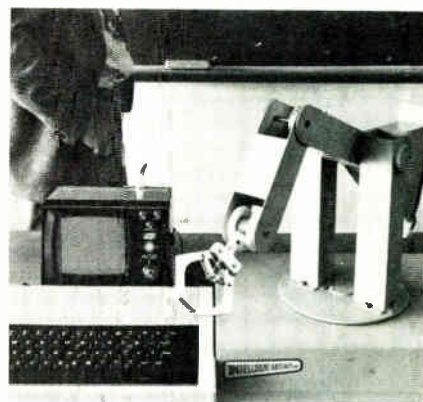

The Small Arm Robot uses six stepping motors and a solenoid controlled by a micro-computer-compatible card. It has a reach of 0.45 m and placement accuracy within 1 mm; it can lift 250 g. Sands Whiteley Research & Development Ltd., Cambridge Road, Orwell, Royston, Herts., England [453]



Micro-Professor is a Z80-based microcomputer learning set with a 2-K-byte read-only-memory monitor, 2-K-byte random-access memory 24 parallel input/output lines, system clock, and user's manual. Multitech Industrial Corp., 977 Min Shen E. Rd., Taipei 105, Taiwan, Republic of China [454]

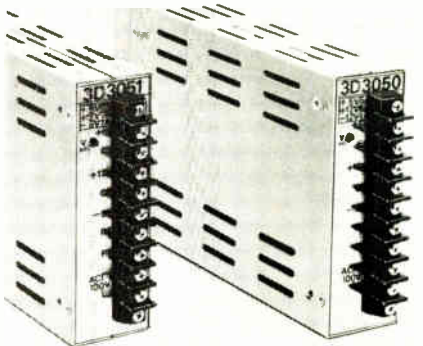

The Series 3D switching regulated power supplies come in single-, double-, triple-, and quad-output versions rated at 30 to 150 W. They have over-voltage protection, in-rush current suppression, and remote sensing and control. Delpak Electronics Ltd., 13 Hazelbury Crescent, Luton LU1 1DF, UK [455]

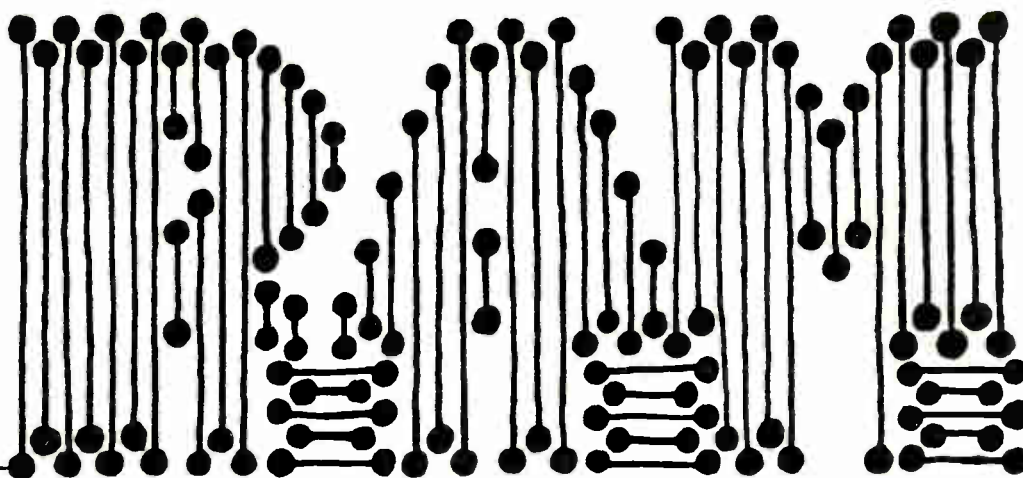

ALTERNATIVE PROCESSING METHOD FOR INDUSTRY AND ELECTRONICS



Lith development is not always strictly necessary, for example in industry or in electronics, when carrying out the preparatory photographic work. Or when using an exposure system producing needle-sharp results, for instance on the high-quality Copyline HDU films by means of a photo plotter.

In these cases you may use the R.A.M. method (Rapid Access Metal-hydroquinone processing). From dry to dry in 90 seconds. A welcome gain of time! High transport speed and therefore a large throughput. With R.A.M. no need for replenishment! Your solutions will remain stable for a long time.

Our assortment is truly complete: small, medium and large processors, films and papers for every conceivable application, processing solutions, accessories, etc.

Ask for more information on the Rapid Access Metal method.

AGFA-GEVAERT N.V.
B-2510 Mortsel-Belgium



AGFA-GEVAERT - your go-ahead partner!



Microelectronics starts with "Z." As in Zeltron.

Founded in 1977 as an entrepreneurial effort within the ZANUSSI group, ZELTRON quickly established a reputation in Europe as a firm providing reliable and innovative products and services in microelectronics. From our three development laboratories in Northern Italy, we serve both the Zanussi group and other clients throughout Europe with special services and products:

- Microprocessor-based product development - Component testing & qualification
- Automatic test equipment - Production automation systems
- Sensor & transducer development - Custom designed IC's - Real-time software.

For reliability and innovation in microelectronics, start with "Z."
Start with ZELTRON.

ZELTRON

ISTITUTO ZANUSSI PER L'ELETTRONICA SpA

33030 Campofornido (UD) ITALY - Via Principe di Udine, 66 - Tel. 0432/69652-3 - Telex: 450365 - 20122 Milan, Viale Bianca Maria, 45 - Tel. 02/709176-795802.

Circle 226 on reader service card

World Radio History



ZANUSSI

New products international



The model 117B precision noise figure meter measures noise in amplifiers and receivers from 0 to 30 dB in six ranges. It covers frequencies from 5 MHz to 40 GHz when used with various noise sources. Magnetic AB, Gardsfogdevägen 18 A, Box 20036, S-161 20 Bromma, Sweden [456]

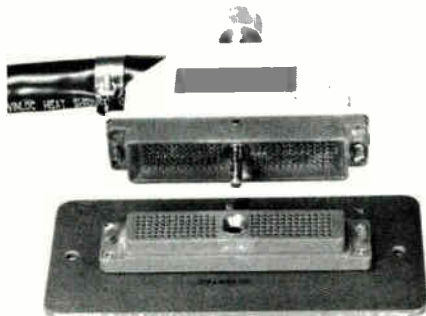

The Hypertac HDL connector incorporates 128 low-insertion force contacts, central latching, and an optional cable hood. It is compatible with the Cannon 156-way DL zero-insertion force connector. Hypertac Connectors, Chronos Works, North Circular Road, London NW2 7JT, England [457]



These drawer units are for free standing and 19-in. rack mounting of a variety of micro-processor boards, plug-in Eurocards, and Vero logic boards. They are available in one-, two-, and three-Eurocard versions. Vero Electronics Ltd., Industrial Estate, Chandler's Ford, Hampshire S05 3ZR, England [459]

Has Ceramics Become Close to the Human Voice?

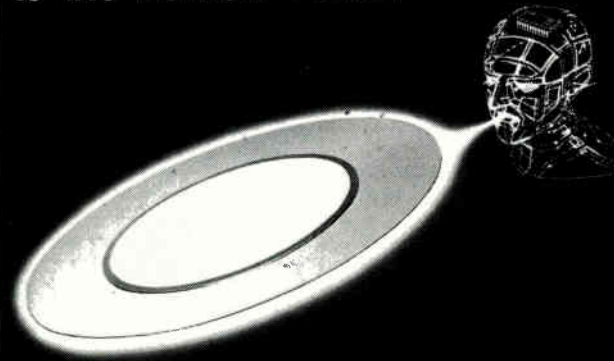

PIEZO SPEAKER

Coping with the Age of Voice Synthesis

It has been a everlasting dream for human being to communicate with electronic devices. Now, the age of so-called speaking electronic device is about to come thanks to the rapid progress of voice synthesizing technique of IC and LSI.

In order to meet the demand in the market, MURATA has developed an epoch-making product, PIEZO SPEAKER, which drastically changed the concept of the conventional buzzer as a communication signal. MURATA fully employed not only the latest technique of developing new material and thinning technique corresponding to the trend of low frequency range but also various techniques accumulated through long positive achievements for the purpose of developing PIEZO SPEAKER. MURATA's PIEZO SPEAKER guarantees high sound pressure and clear sound, which is ideal for melody or synthesized voice.

■ Piezo speaker for synthesized voice

● Frequency Range: 500Hz~20KHz ● Capacitance: 140nF at 120Hz
● Impedance: 1.2kΩ at 1KHz ● Input Volt.: 30Vp-p max.

Frequency Char.

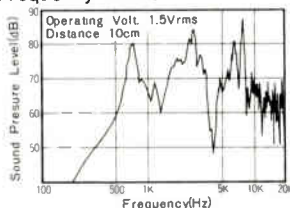

VSB-41D25-D7AR

MURATA

MURATA MFG.CO.,LTD.

HEADQUARTERS Nagatsuta-cho, Kyoto 617, Japan Phone 075-921-8111 Telex MURATA J 6427D
MURATA CORPORATION OF AMERICA Phone 404-952-9777 Telex 0542329 MURATA ATL
MURATA ERIE NORTH AMERICA INC. Phone 404-952-9777 Telex 0542329 MURATA ATL
MURATA ERIE ELECTRONIK GMBH (West Germany) Phone 0911-66065 Telex 623763 MEGN D
MURATA ERIE ELECTRONIQUE S.A. (France) Phone 558 0901 Telex 204520 ERITRON PARIS
MURATA ERIE ELETTRONICA S.R.L. (Italy) Phone 668-4833/4835 Telex 330385 ERIE M/L
MURATA ELECTRONICS SINGAPORE (PTE.) LTD. Phone 2564233 2554023 Telex 21127 MURASIN
MURATA COMPANY, LIMITED (Hong Kong) Phone K306291-2 Telex 86208 HKMRT H
TAIWAN MURATA ELECTRONICS CO., LTD. Phone 042 31 4151-2 Telex 51249
MURATA MFG. CO., LTD. Seoul Branch (Korea) Phone 776 2283 Telex K25858 MURASUL

QUALITY MONOCRYSTALS

for microelectronics,
laser electronics,
computer hardware,
optics, medicine,
other scientific
and applied arts

EFFICIENTLY GROWN IN "SAPFIR-1M" UNIT

- "SAPFIR-1M" • high-melting single crystals grown by the directed crystallization technique in vacuum or noble gases
- "SAPFIR-1M" • plate- or chip-shaped sapphire monocrystals can be grown
- "SAPFIR-1M" • uses any type of initial material for its charge: powders, ceramics, crystal production and working waste
- "SAPFIR-1M" • performs additional purification of the initial substance in the course of crystallization, due to high temperatures, vacuum and developed melt surface
- "SAPFIR-1M" • turns out highly homogeneous crystals requiring no specific heat annealing, owing to the optimized configuration of the heat-protection field yielded by the heater-screen system

WAFER SIZES, mm:	
DISCS — dia.	100
thickness	200–300
PLATES (CHIPS) —	
length	200
width	100
thickness	25
POWER CONSUMED, kVA	
	40
DIMENSIONS, mm	
	2,000 x 1,400 x 1,500
WEIGHT, kg	
	2,000



TECHMASHEXPORT

35 Mosfilmovskaya Ul. 117330 Moscow, USSR. Tel. 143-86-60.
Telex 411068 TEHEX SU 411228 TECEX SU

New products international

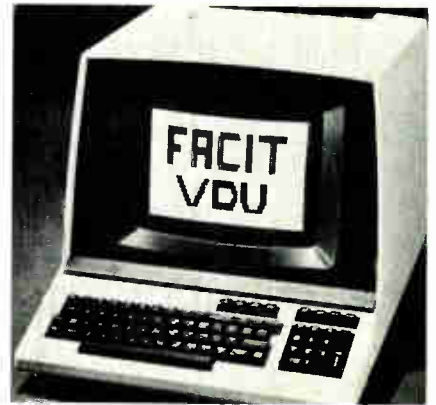

The 4411 video terminal has a European character set, full editing and format-handling functions, and semigraphics. It is intended for small businesses, computer-aided design and manufacturing, laboratories, and storerooms. Facit Data Products, S-105, 45 Stockholm, Sweden [460]

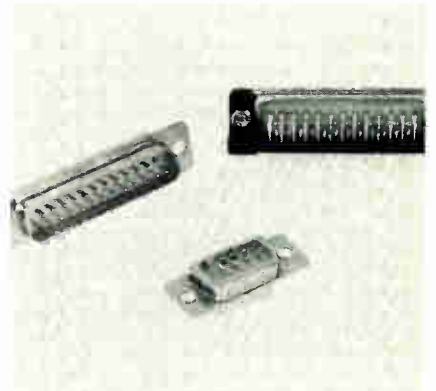

These D subminiature connectors have 9, 15, 25, 37, or 50 contacts and come in solder-bucket and supported right-angle versions. They are compatible with Greenpar's insulation-displacement D-style connectors. Greenpar Connectors Ltd., P. O. Box 15, Harlow, Essex CM20 2ER, England [461]

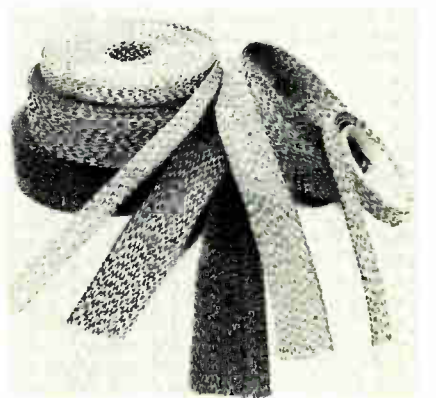

The 361 series of cables operate at from -50° to 260° C and are insulated to withstand 250 or 500 V. They resist solvents and are color coded. Wire sizes range from 30 to 20 American Wire Gauge. Tekdata Ltd., Westport Lake, Canal Lane, Tunstall, Stoke-on-Trent ST6 4PA, UK [462]

'Our optical know-how now also belongs to you.'

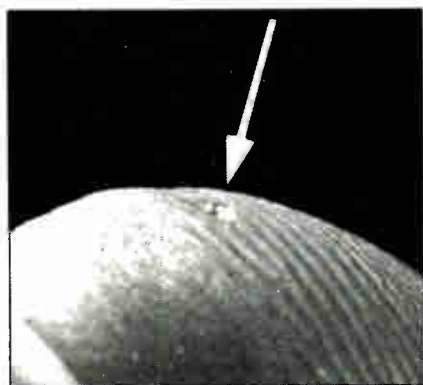

Example 1:

This is one of the world's smallest lenses

The accuracy and precision of the way we work at Wild Heerbrugg is demonstrated by the fact that this is where one of the world's smallest lenses was ground and polished. It has a spherical radius of only 0.515 mm. ■

These three Wild specialists want to show you something of what they mean by modern optics technology and what it can also do for you.

*K. Wasner,
Wild optics computing specialist*

*Dr. B. Gaechter,
Wild physicist*

*J. Behringer,
Wild optics production technician*



Example 2:

Wild lens systems determine satellite tracks

For the survey photographs used to determine the flight paths of satellites and to establish the global geodetic network for tracking them, the US Coast and Geodetic Survey and NASA required ground-based metric cameras made by Wild Heerbrugg. The high-performance lens systems used in these were developed and manufactured in Heerbrugg. ■

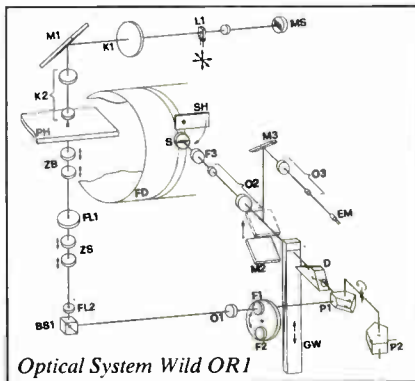

Optical System Wild OR1

Example 3:

Wild Heerbrugg develops unique zoom system

The skill of Wild specialists is documented by the optical image-transmission and rectification system used in the Wild OR1 orthophoto instrument. For this instrument, a zoom system was developed with a 1:56 spread factor whilst maintaining colour fidelity and geometrical accuracy. See for yourself what this know-how of our optics specialists can do to improve the performance of your products with Wild optics. That's top performance in optical technology which can only be achieved by specialists and receives recognition world-wide. That's know-how and potential for your own products, too. ■



Your Systems Partner

**WILD
HEERBRUGG**

Please send your technical literature on 'optics'
Address

Send to your nearest Wild representative
or to Wild Heerbrugg Ltd,
CH-9435 Heerbrugg,
Switzerland.

Sbb 11-1

*In Celebration
of the 50TH Anniversary of
Electronics Magazine...*

The most exhilarating, comprehensible look at past and future developments in electronics that has ever been published.

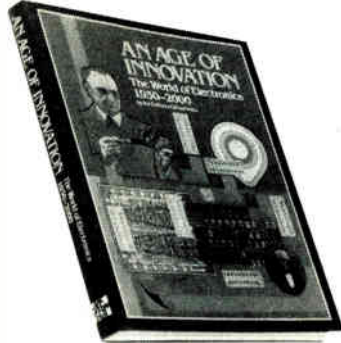

AN AGE OF INNOVATION
The World of Electronics 1930-2000
by the Editors of *Electronics*

The editorial edition of *Electronics'* 50th Anniversary issue of April 17, 1980, beautifully clothbound and jacketed for your permanent pleasure. 300 illustrations, many in full color. 274 pages, \$18.50

Painstakingly researched and written, AN AGE OF INNOVATION gives you an unforgettable overview of electronics. Everything from the individuals whose foresight and daring led to the great advances... to the origin of specific technological breakthroughs you use in your own work and home... to the challenges and discoveries we will face tomorrow.

Order your copy today!

Electronics Magazine Books
P.O. Box 669
Hightstown, NJ 08520
Tel. (609) 448-1700, ext. 5494



Please send me _____ copies of AN AGE OF INNOVATION @ \$18.50

Name _____

Company _____

Address _____

City/state/zip _____

McGraw-Hill pays regular shipping and handling on pre-paid orders.
Ten-day money-back guarantee on all books.

ELV

New products international

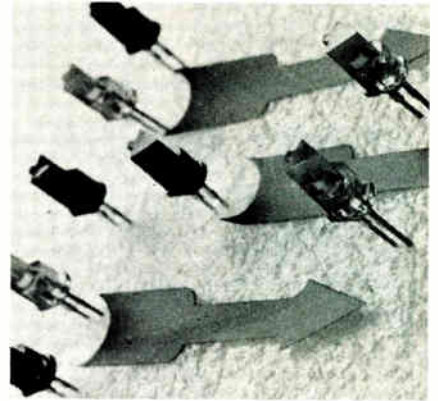

The Pic light-emitting diode comes in 15 versions with rectangular, round, square, triangular, and arrow-shaped planar surfaces. They are available in red, green, and yellow with a light intensity at 20 mA of at least 0.63 millicandelas. Siemens AG, P. O. Box 103, D-8000 Munich 1, West Germany [463]

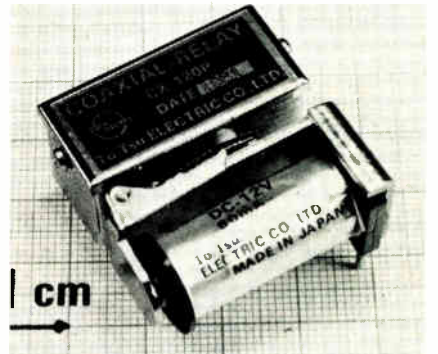

The CX-120P relay for coaxial-cable switching mounts on printed-circuit boards. It has a low-voltage standing-wave ratio to over 1 GHz and an insertion loss of only 0.2 dB at 2.5 GHz. Toyo Tsusho Co., 3F Daini Azuma Bldg., 1-14 Kanda-Sakuma-cho, Chiyoda-ku, Tokyo 101, Japan [464]



The D611 digital thermometer measures temperatures from -43° to 120°C with an accuracy within $\pm 0.1^{\circ}\text{C} \pm 1$ count. It can measure the difference of two temperatures and temperature change over time. Takara Thermistor Instruments Co., 2-12-13 Shibuya, Shibuya-ku, Tokyo 150, Japan [465]

NOW YOU CAN TEST 16 BITS

ATE SHOW
STAND
No. 729

A SIGNIFICANT FIRST FROM SOLARTRON



The 7201 Locator

For testing microprocessor systems, LOCATOR is the only tester to give you the combination of Signature Analysis, unique Trace-Analysis for feedback loop testing, in-circuit emulation stimulus and 14 other indispensable measurement functions.

This adds up to a test pack that can diagnose faults on all your system circuits — not just around the micro-computer bus.

With the new 72501 micropod you can fully test 8086 systems.

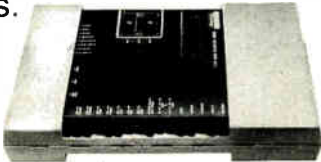

We already provide test solutions for a wide range of 8-bit processors: 6800, 6802, 6809, 8080, 8085, Z80, 6502, 2650 and others.

Now we have applied that experience to be first with 8086 testing.

To find out more, phone or write to the address below.

SIGNIFICANTLY FROM SOLARTRON

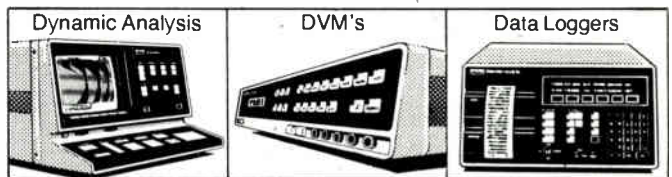

SOLARTRON
Schlumberger

The Solartron Electronic Group Ltd.,

UK:— Farnborough, Hampshire, GU14 7PW
Tel: 0252 44433

Germany:— AM Kirchoezl, 15, 8032 Graefelfing, Munchen
Tel: 89-854-3071

France:— Enertec, 1, Rue Nieuport, 78140 Velizy-Villacoublay
Tel: 9469650

USA:— Sangamo Weston Inc., 17972 Sky Park Circle, Irvine, Cal. 92714
Tel: 7146417137

Sweden:— Vesslevagen, 2-4, Box 944, 5-18, Lidingo 9
Tel: 4687652855

Meeting heavy demands for lightwave transmission

The promise that emerging lightwave communications technology offered just a few short years ago is about to be fulfilled as telecommunications authorities the world over upgrade or expand their networks with optical fibre systems. And Philips technology has contributed much to this state-of-the-art.

For example, Philips originated and developed the plasma-activated chemical vapour deposition (PCVD) method of manufacturing high quality fibre possessing a refractive index profile closely approx-

imating the theoretically desired parabolic form.

Unlike other CVD methods, PCVD employs a non-isothermal microwave plasma to stimulate low-temperature reaction of the gases SiCl_4 , GeCl_4 and O_2 within a tube of pure silica glass. The plasma reaction zone is produced by a microwave resonator that passes to-and-fro along the entire length of the tube, a very even and thin layer of oxides being deposited at each pass. In this way many hundreds of layers can be deposited to achieve a graded index fibre profile that

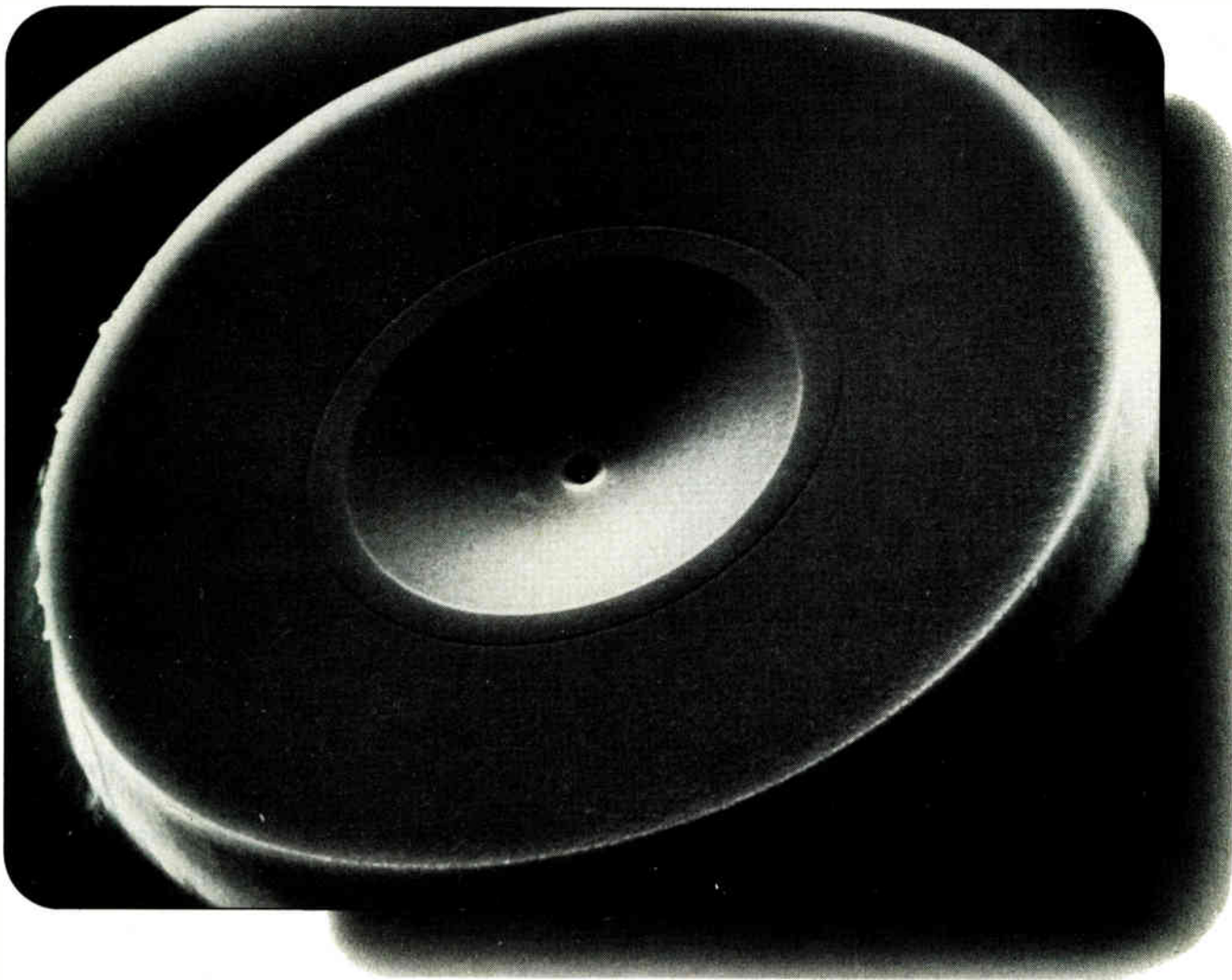

An enlargement of the etched surface of an optical graded index fibre (50 μ core and 125 μ cladding diameter).

PHILIPS

very closely resembles the ideal parabola.

Exceptionally high bandwidth measurements are obtained on continuous production runs of these fibres, typically 850MHz per kilometer at 850nm wavelength, with a lowest value of approximately 600 MHz.Km, and a top value of 1200-1300 MHz.Km.

Philips also achieved a major breakthrough in the complex PCVD manufacturing process by speeding up deposition of the layers without any loss in fibre quality. Instead of the standard deposition speed of 0.2

gramme/ minute, new techniques enable speeds up to one gramme/ minute to be reached, thus reducing the time taken to prepare silica glass preforms from 25 minutes to only five minutes per fibre-kilometer.

Increasing optical fibre quality at lower production costs is one of the many ways in which Philips technology is helping to meet the heavy demands for lightwave transmission. Here are some of the practical applications.



Overhead optical fibre cable now provides a cost-effective solution to the problems of television and FM radio reception in mountainous regions. A six-core NKF optical fibre cable system has been installed on a 2.8 kilometer pole-route to connect the villages of Aste and Beon, in the French Pyrenees, into the local CATV network. One of the first overhead optical fibre routes in the world, it provides the population of this remote area with FM audio reception and a choice of four colour television channels.

Circle 231 on reader service card

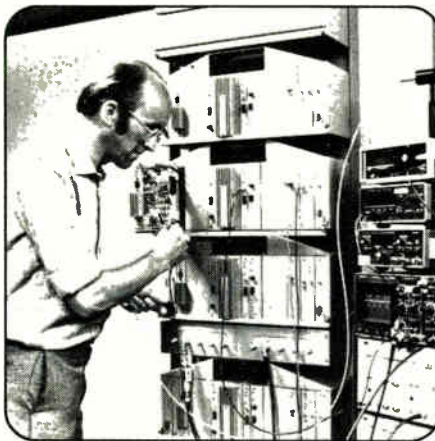

Lightwave telephone transmission. In addition to Philips all digital PRX/D exchanges, Saudi Arabia has ordered 140M/bits optical fibre systems to be integrated into the existing 2M/bits PCM networks in the Jeddah and Riyadh multi-exchange areas. Six-fibre cables, with a capacity of 1920 calls per fibre, will be used in the repeaterless routes, which total some 45 system kilometers. When completed it will be one of the first operational 140M/bits optical fibre transmission systems in the world. Circle 232



Optical fibre detection. The Philips SEM505 scanning electron microscope employs a unique optical fibre detection system within the specimen chamber. In the backscattered-electron mode, the system achieves the highest possible detection efficiency for highlighting topographic and/or atomic number contrast. When used for cathodoluminescence detection, a light-gathering lens focuses the signal on the fibre bundle. Light impulses from the detectors are routed to photomultiplier/-preamplifier combinations via optical switches. The system provides an exceptionally high degree of flexibility as well as a very fast reaction time. This ensures that TV-rate images can be obtained, even at low accelerating voltages, in all detection modes. Circle 233 on reader service card

Write for more information to your local Philips organization or to Philips, C.M.S.D.-Marketing Communications, VOp, Room 22, Eindhoven, Holland.

Or telex:
35000-PHTC-NL/CMSD-Marketing Communications, Eindhoven, Holland.

I would like more information on:

- _____
- _____
- _____
- _____

298



Philips working on advanced technology

New Edition Available NOW!

Instant Access to American
and International

DATA COMMUNICATIONS STANDARDS

All standards are new, revised, or reaffirmed
since the previous sell-out edition.

All 123 complete and unabridged
interface protocol standards set by:

- International Telegraph and Telephone Consultative Committee (CCITT)
- International Organization for Standardization (ISO)
- European Computer Manufacturers Association (ECMA)
- American National Standards Institute (ANSI)
- Electronic Industries Association (EIA)
- U.S. Government (NBS and NCS)

Special feature

Cross-reference tables of the similar and interfacing standards of each group corresponding to those published by the other activities.

An essential reference for

All organizations exploring, planning, developing, manufacturing, or using data communications equipment or networks, and

Designers

Find the specifications you need instantly

Planners

Determine which standards apply to your current and future network needs

Operations Managers

Learn whether the equipment you're buying will adhere to all the standards it should

Reduces a job that used to take days, even weeks, to minutes

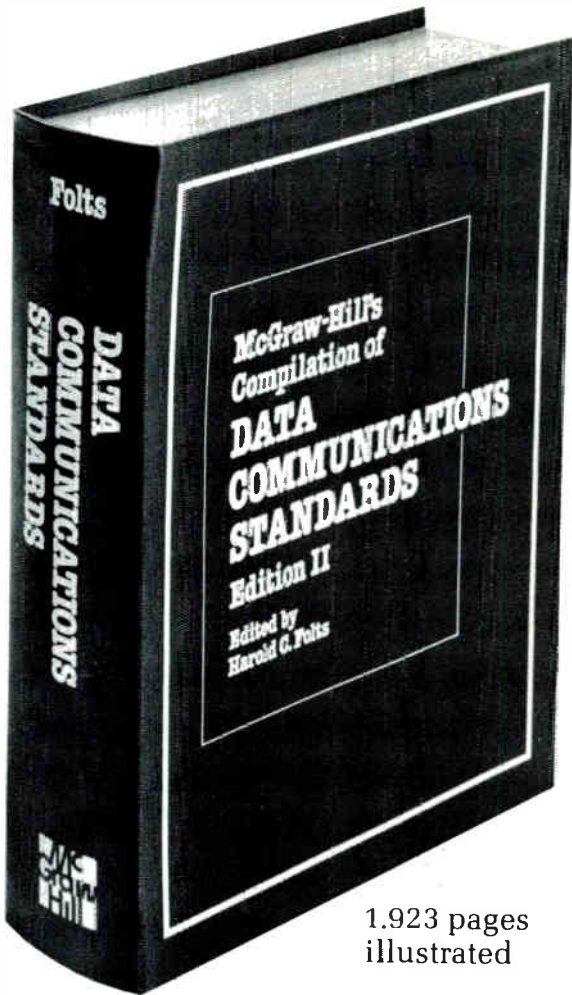

1,923 pages
illustrated

Edited by Harold C. Folts, the leading consultant on data communications standards and an active participant in the development of U.S. and international standards.

Published jointly by *Data Communications* and *Electronics* magazines.

NEW! UPDATED! EXPANDED!

With this landmark resource, you can quickly and accurately determine exactly which standards apply to the project at hand, and speedily integrate those standards into your own data communications equipment or network plan.

Among the important standards new to this edition

- The crucial CCITT X.25 Recommendation on the interface between data terminal equipment (DTE) and data circuit-terminating equipment (DCE) for terminals operating in the packet mode on public data networks
- A look at the Open System Interconnection (OSI) Reference Model (ISO 7498) and how it will serve as the foundation for future data communications standards activities
- The unique ECMA Transport Protocol
- ISO's series of High-level Data Link Control (HDLC) procedures
- ANSI X3.66 for Advanced Data Communications Control Procedures (ADCCP)

Order your copy today!

Data Communications Standards II
Electronics Magazine Books
1221 Ave. of the Americas, Fl. 42
New York, NY 10020 USA
212/997-2996

Send me _____ copy (copies) of **DATA COMMUNICATIONS STANDARDS EDITION II** at \$250. U.S. orders please add local tax. McGraw-Hill pays regular shipping and handling charges on prepaid orders. Ten-day money-back guarantee applies.

- Check enclosed. Bill me. Bill my company. Company Purchase Order enclosed.
 American Express Visa MasterCard _____ Interbank No.

Credit Card Number _____

Expiration Date _____



Name _____

Title _____

Company _____

Address _____

City _____ State/Zip (U.S.) _____

Country (outside U.S.) _____

EL2

A New Page has been Added to 100MHz Oscilloscope History!

NEW

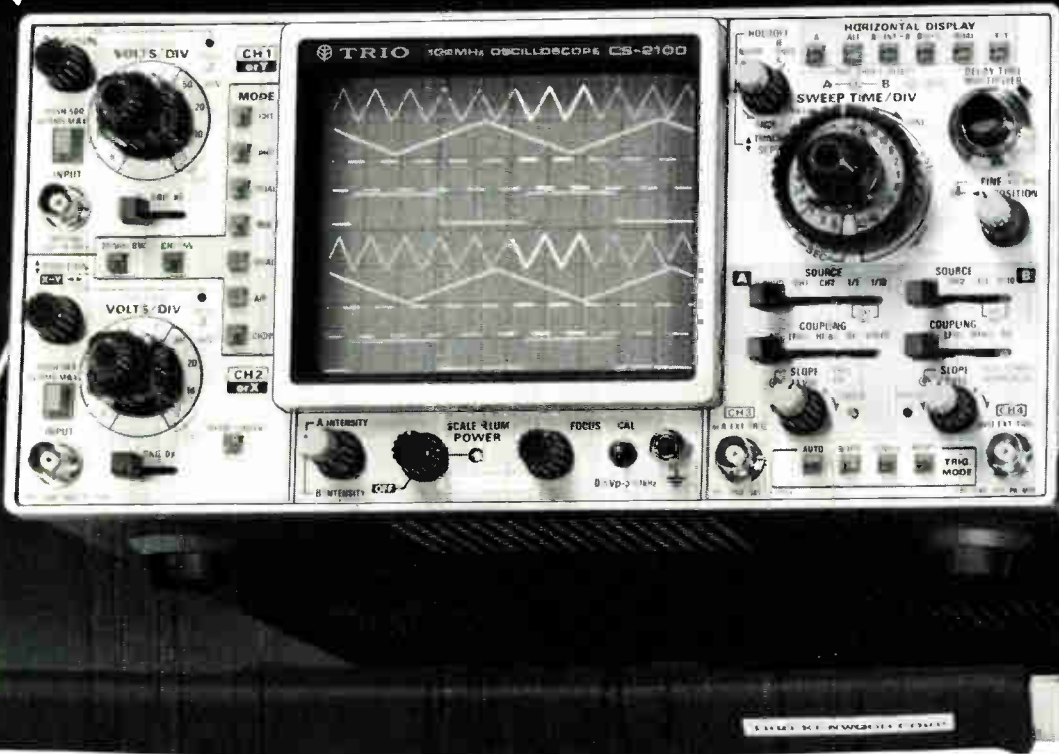

4 Channel 8 Trace Display

100MHz 4 Channel Oscilloscope

CS-2100

Trio, known throughout the world for its responsiveness to the tough demands of oscilloscope users, has developed a 100MHz scope that is destined to change your thinking about 100MHz oscilloscopes.

The compact, 100MHz CS-2100 offers 4 Channel/8 Trace display capability to solve even your trickiest display problems. The CS-2100 is the successful culmination of a development effort which sought to provide all the high frequency response and sensitivity demanded by today's state-of-the-art circuitry as well as a variety of features such as delayed, alternate and dual sweep display. The result of this effort is a full-feature 100MHz scope with designed-in solutions to your toughest problems.

- Up to 1 mV/DIV sensitivity usable all the way to 100MHz.
- Sweep times to 2ns/DIV with x10 magnification for easy viewing of the fastest signals.
- Unique 4 Channel/8 Trace display.
- Indispensable Delayed Sweep feature allows simultaneous viewing of the delayed sweep and the main sweep.
- Completely independent A and B Sweeps for easy viewing of signals of widely different frequencies.
- 50Ω input impedance is selectable for observing fast pulses or signals on 50Ω lines without the need for bothersome terminations.
- Independently adjustable main and delayed sweep intensity.
- 16kV of accelerating potential and Auto-focus for a clear bright display.
- Electronic switching and panel set-up memory.
- Compact 28.4cm(W) x 13.8cm(H) x 40.0cm(D) package weighs only 7.4kg for true portability.
- Power saving circuit requires only 56W and needs no cooling fan.

TRIO-KENWOOD CORPORATION

Producer of world-renowned KENWOOD brand audio equipment.

TEST INSTRUMENT DIV.: SHIONOGI SHIBUYA BLDG., 17-5, 2-CHOME SHIBUYA SHIBUYA-KU, TOKYO 150, JAPAN
CABLE: TRIOINSTRUMENT TOKYO TELEX: 242-3446 TRITES

The most economic way to high density packaging is Stitch-Wiring by computer!

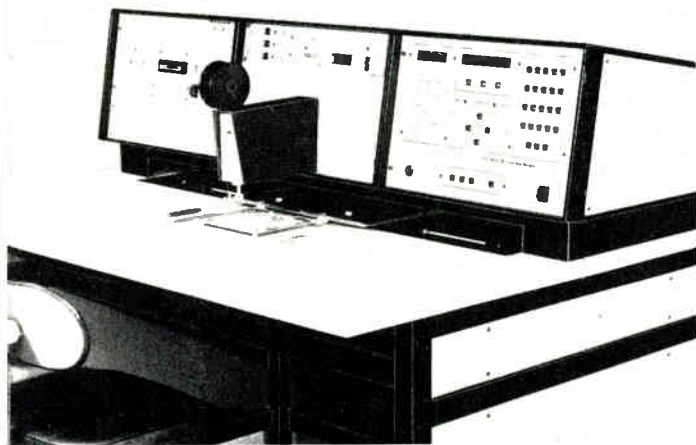

This low profile wiring technique allows, on standardized PC boards, packaging densities comparable with 6 to 8 layer boards. Compared to other techniques, the cost advantages at small or medium series and custom tailored circuit productions for military or industrial requirements are very substantial. The high economy and flexibility that this wiring technique offers, explains its great success. The new CNC85 computer controlled wiring machine now adds further economy to circuit productions. For full details call or write to ASU.

Th-213 SW 81

P.O. Box 297, 1860 Aigle, Switzerland
Tel. 025 - 26 55 33, Telex 456 138

ASU

COMPONENTS Ltd.

A subsidiary of the Swiss ASUAG group

Circle 236 on reader service card

EFFECTIVE COMMUNICATIONS ARE VITAL...

Effective communications are vital to the efficiency of every organisation. The easiest way to see and compare the whole range of electronic communications systems is to visit **Communications 82**, the world's leading international exposition of communications equipment and systems. It will be the sixth in a biennial series and will comprise a major international exhibition and conference, plus a programme of social events with guest speakers of international stature.

Communications 82 will be of direct interest to all communications users as it crosses the boundaries between civil and military, public and private, industry and commerce, fixed and mobile, in the same way as do the technologies involved.

So whatever you need – however specialised – you'll find the latest equipment at **Communications 82**, ranging from the simplest mobile radio equipment to tropospheric scatter; from public or private digital telephone exchanges to telephone handsets; and from data communications and information technology systems generally to fibre optics and power supplies.

Communications 82 enjoys unique and continuing support from national and international authorities, including

- International Telecommunication Union
- British Government – through the Home Office and the Department of Industry
- British Telecom

and the two leading UK trade associations

- Electronic Engineering Association
- Telecommunication Engineering and Manufacturing Association

The **Communications 82** Conference is again organised by the Institution of Electrical Engineers, in association with the IEEE Communications Society, IEEE UK/RI Section, Institution of Electronic and Radio Engineers, British Computer Society, Institute of Mathematics and its Applications, and Institute of Physics.

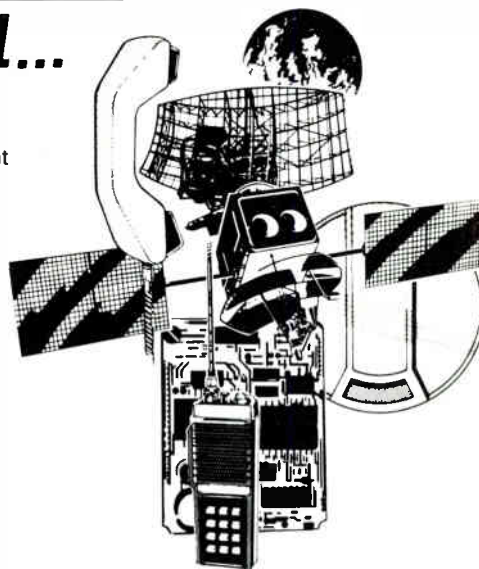

Communications



Communications Equipment and Systems
National Exhibition Centre, Birmingham, England
20-23 April 1982

Communications 82 is organised by Industrial and Trade Fairs Limited
Radcliffe House, Blenheim Court, Solihull, West Midlands, England
Tel: 021-705 6707 Telex: 337073 for Tony Davies Communications.



To: Print Services Dept, Communications 82
Industrial and Trade Fairs Limited, Radcliffe House
Blenheim Court, Solihull, West Midlands B91 2BG, England

021

Please send me details of **Communications 82***

Exhibition Conference

Name

Position

Company

Address

Number of admission tickets required *Please indicate as appropriate

Bryans proudly announce the birth of a new recording artist

Superbly styled, ruggedly designed and bearing all the traditional hallmarks of precision engineering that you'd expect from Bryans, our new Series 60000 XY Analogue Recorders achieve formidable recording standards at an extremely attractive price.

Incorporating the very latest technological advances in mechanical design and component performance, there's hardly an area of science or industry that would not benefit from the series 60000 mid range coverage.

Features include:

- Wide sensitivity ranges— $50\mu\text{V}/\text{cm}$ to $20\text{V}/\text{cm}$.
- Electrostatic paper hold down.
- Mute facilities—on both axes.
- Lockable controls.
- Time base included as standard.
- Personality module available as an option.
- Systems and OEM versions available.

We at Bryans are confident that this new series will follow our other technologically advanced systems and achieve a unique position in the market place.

Series 60000 XY recorder



For a full colour brochure on the new series 60000 X-Y Recorder please write to
Bryans Southern Instruments Limited,
Willow Lane, Mitcham, Surrey CR4 4UL,
England. Tel: 01-640 3490. Telex: 946097.





Making the leading edge work for you.

A Western Digital logic array is simply the shortest distance between two points.



When it comes to integrating your digital design into LSI, there are basically two ways to go.

The Western Digital way. And, the long way. Go with Western Digital and what you get is, in a word, simplicity.

For example, take our Logic Array Design Kit. It makes designing your own LSI circuits almost as easy as a connect-the-dots puzzle.

And as soon as you've finished your design, we digitize it, qualify it, test it and quickly transform it into a high-quality, semi-custom chip.

So, you get your prototypes in 4 to 6 weeks. Not months.

With Western Digital you also get a balanced complement of gates and flip-flops, greater reliability and a significant savings in board space. All for a price that makes good sense. Whether you need 1,000 or 10,000.

Western Digital eliminates plenty of headaches, too. Like plenty of complex transistor-level circuits, and costly computer-aided design. And plenty of waiting.

Like up to 6 months just for prototypes.

The choice is yours. But for the shortest, most practical route to market, contact the logic array experts at Western Digital.

All you've got to lose is a long wait.

WESTERN DIGITAL
C O R P O R A T I O N

Computer Products Division, 2445 McCabe Way, Irvine, CA 92714, (714) 557-3550.

WHILE OTHER VLSI SYSTEMS TESTED

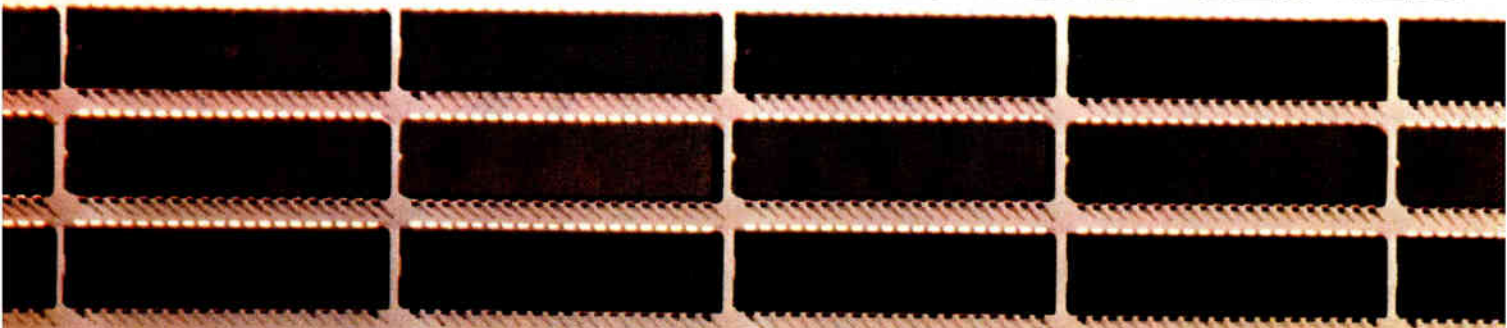

THESE DEVICES,

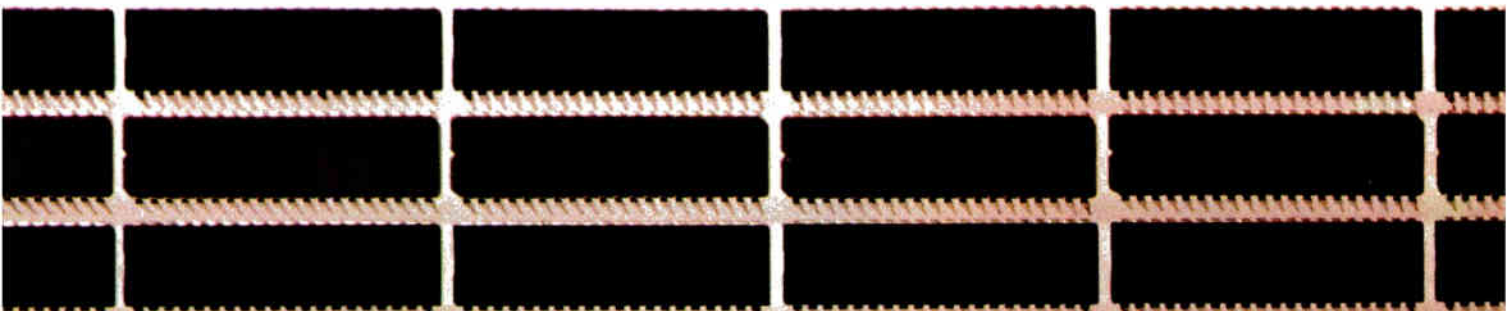

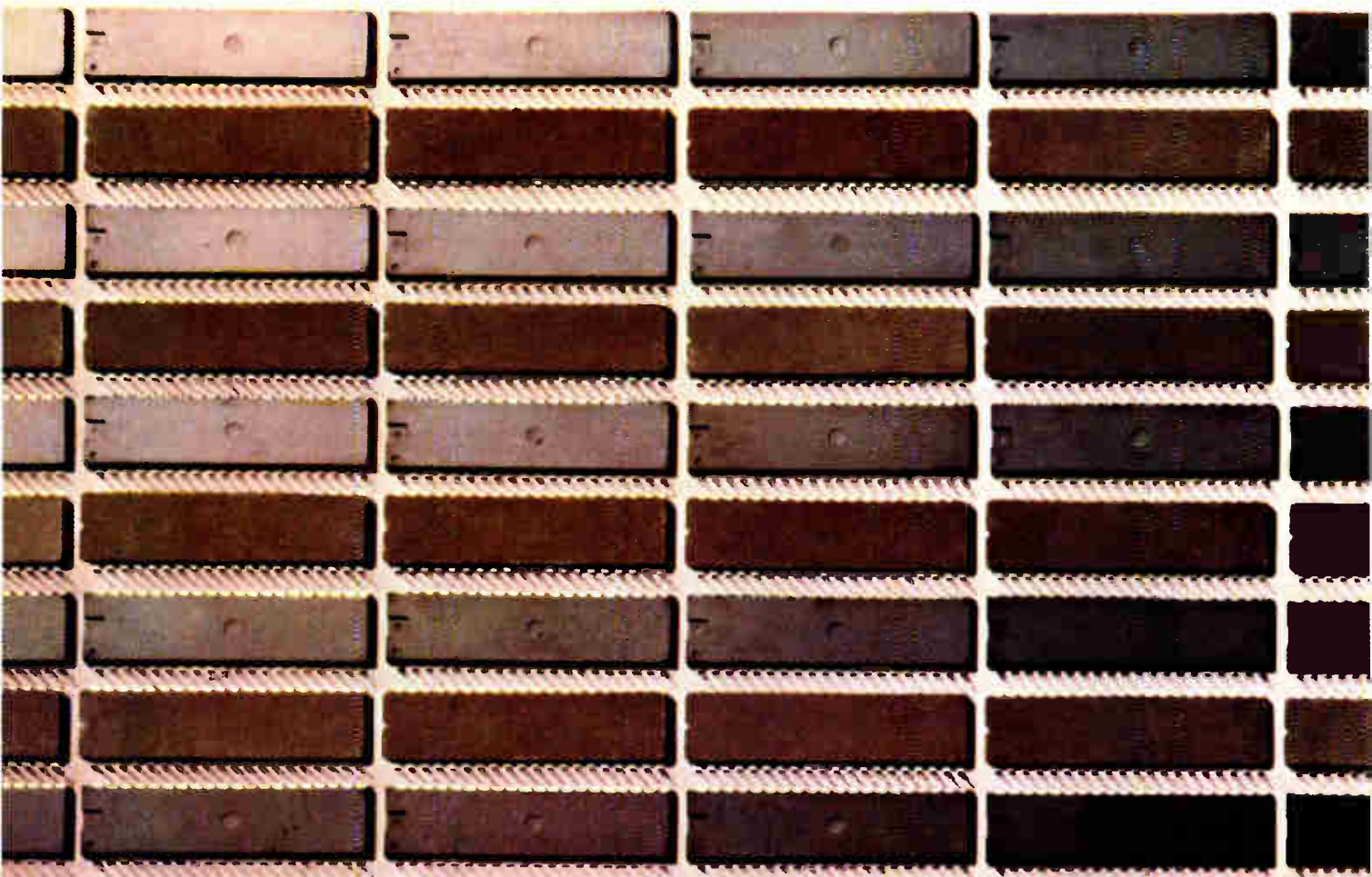

TERADYNE'S NEW J900
TESTED THESE.

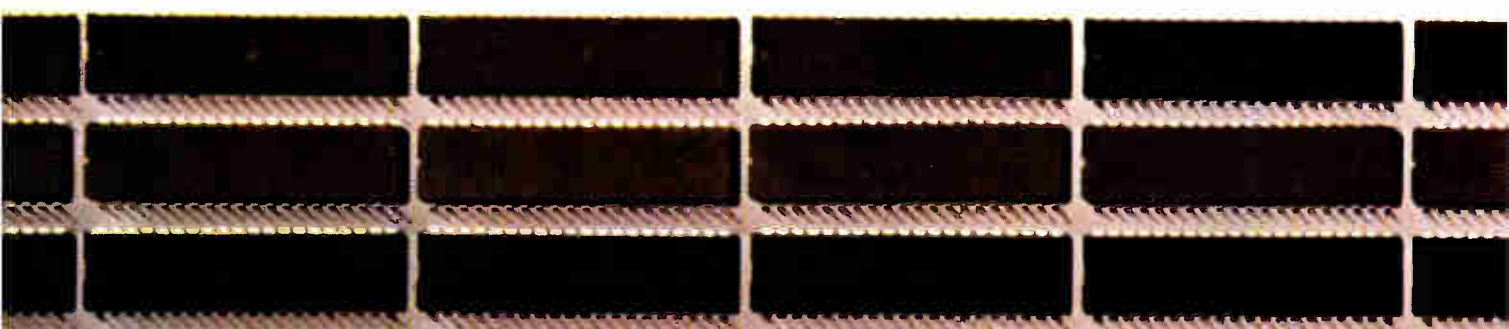



The J900 gives you the performance and flexibility you need to test the full range of VLSI devices, with capacity enough to let you test more devices per hour than any VLSI system on the market. We put 72K of high speed memory behind every pin on the J900 so long patterns can run without dead cycles, saving you valuable test time.

Automatic Edge Lock™, Teradyne's proven automated calibration technique, guarantees timing integrity so your devices are tested right the first time, every time.

Our powerful test language is easy to use, allowing you to generate programs faster and further reduce your cost of test. The result is a new standard in VLSI testing. Teradyne's J900 gives you the advantage in both quality and productivity by making every nanosecond count.

For more information write Teradyne, Logic Products Group, 21255 Califa Street, Woodland Hills, CA 91367. Or contact your nearest Teradyne Sales Office.

TERADYNE



Shown from top to bottom: CM 16/DS2 Multiprocessor System; CMT 68000 CPU; CM 16/DS2 Storage Subsystem.

CMS Series 16

The Complete Family Of 68000 Systems And Products.

CM Technologies presents a complete family of Multibus*-compatible computer products and systems based on the Motorola 68000. From our CMT 68000 16-bit single board computer to the CMS Series 16 Multiprocessor Systems, you can choose the state-of-the-art solution to increase your system performance and reduce development time and risks.

The CMT 68000 CPU board provides system designers with a high-performance 68000-based single board computer including 64K of dual ported RAM. The CMT 68000 CPU is also available set in an industry-standard 19" chassis, 9-slot Multibus card cage with serial I/O ports and power supply. Either way, you get the most powerful 16-bit microprocessor available today in the popular Multibus standard which will help speed your product to market.

For software development, CM Technologies offers a range of options. Using the CMS 16/DS1, software may be developed on any DEC** PDP-11** and the finished program downloaded to and debugged on the CMT 68000 CPU. The top of the line is the CMS 16/DS2 Multi-

processor System, a powerful CP/M based computer system with dual processors, which functions as a stand alone, real-time development system. A Z80 CPU functions as an I/O controller or a bus master to run CP/M application software. A CMT 68000 CPU runs the main program and is the execution vehicle for developing custom applications. For storage, the CMS 16/DS2 provides a built-in 11 Megabyte Winchester drive and a dual-sided, double-density floppy disk.

When you add it all up, CM Technologies delivers the family of state-of-the-art products you need for product development. Best of all, they're available now, so you can start designing today.

*Multibus is a registered trademark of Intel Corporation.

**DEC and PDP are registered trademarks of Digital Equipment Corporation.

For more information, call or write:



CM Technologies
525 University Avenue
Palo Alto, CA 94301 415/326-9150
Telex: 334417 Cable: CHIMINGCO

No noise is good noise.

When it comes to accurate test systems, no noise is good noise. And Fairchild's new Series 80 Analog Test System generates practically no noise at all.

With true 16-bit resolution, the Series 80 allows you to test to a tighter spec. That means reliable and repeatable measurement. So you throw out fewer components, because you can reduce your guardbands. It also means that you can test low-current parts without special rigging. All this means greater profitability.

It's simple. We solved the noise problem by considering the physics of noise, and scientifically determining signal/cable routing and RFI/EMI shielding.



We're the only ones who do.

And we know what we're talking about, because the accuracy of our measuring system is within .005%.

So, if you've got op amps, voltage regulators, comparators, AD/DA converters or telecommunications devices to be tested, you can't beat this system for quality performance.

Because this new standard of the industry is genuine good news. And not just a lot of noise.

For more information, contact Fairchild Test Systems Group, 1601 Technology Drive, San Jose, California 95115, (408) 998-0123, Ext. 2294. Fairchild Camera and Instrument Corporation.

FAIRCHILD

A Schlumberger Company

**The
First Family
of ATE.**

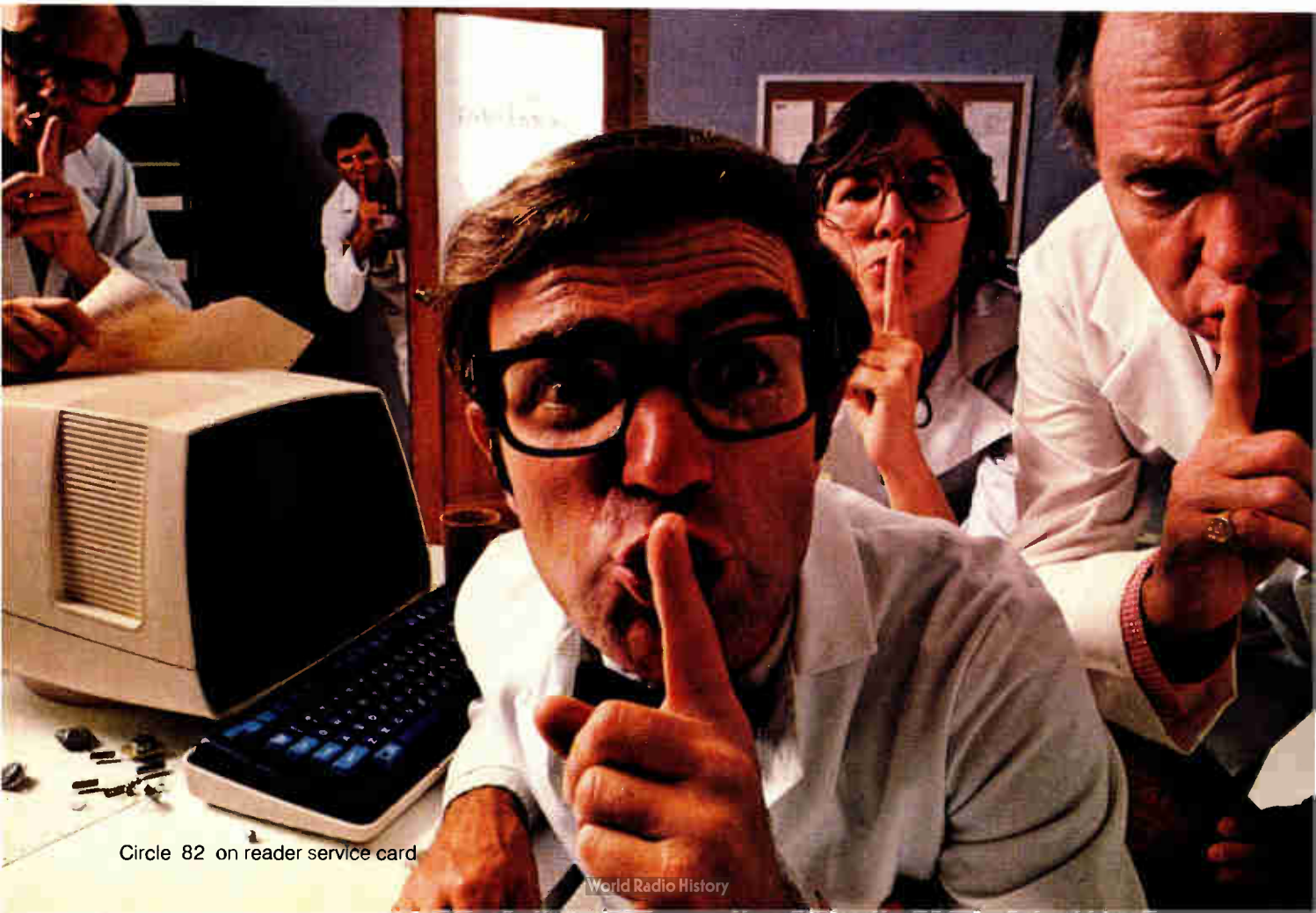

Circle 82 on reader service card

World Radio History

Japanese map computer domination

Ten-year R&D effort leading to fifth-generation systems for the 1990s is aimed at leapfrogging U. S. technology

by Tom Manuel, Computers & Peripherals Editor

The Japanese have set out to leapfrog U.S. computer technology and become the world's leading suppliers of advanced computer systems. After two years of study and research, the Japanese Information Processing Development Center—Jipdec—has hammered out a body of ideas, plans, and recommendations for projects that will culminate in what it calls a fifth-generation system by 1990.

The plan for research and development during the coming decade neatly integrates many of the innovative ideas from researchers in the U.S., Japan, and the rest of the world, extending and fitting them into the new system [*Electronics*, Nov. 3, p. 71].

What makes the goal entirely believable is the Japanese ability to turn such efforts into a national project. That gives them, in effect, a national computer policy that is concentrated, organized, and possibly government-backed in a way that other countries cannot match.

Problem solver. To meet Japan's needs, the computer of the future, in addition to having a higher performance at lower cost, must be able to handle many more general problem-solving tasks than today's machines. In addition, the systems must be as natural for people to use as it is for them to speak. Access is to be through natural language, everyday speech, and pictures. The system that will perform this feat is being called the intelligent-interface machine (see figure).

Another of its three basic functions will be the system's ability to learn, associate, and infer, just like people. The computer will be able to

clarify even vague requests and then, by using its vast store of information or that available from other computers, make judgments that will enhance the thinking capacity of its human masters.

In other words, the computer

could carry on an intelligent question-and-answer session with a person. The basic function that will perform this feat is called the problem-solving and inference system, with a separate machine to implement it.

The third basic capability will be

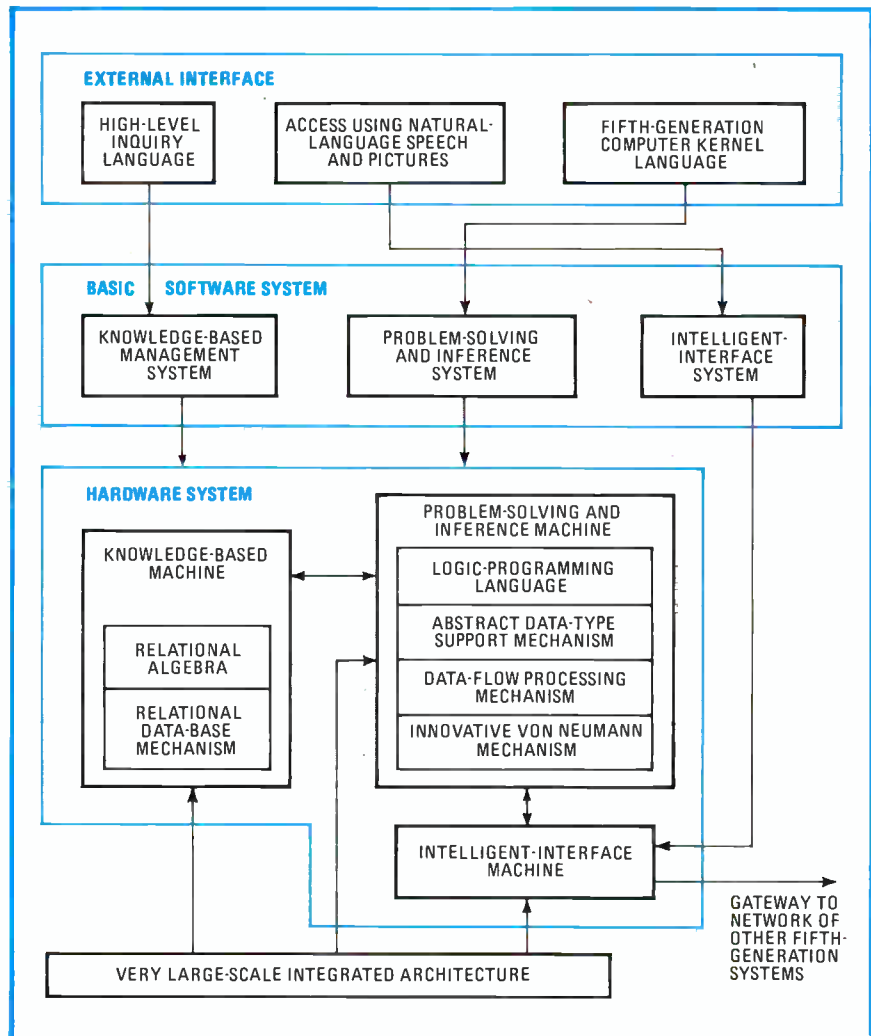

Planned system. The intelligent-interface machine will offer natural-language access, the ability to learn and infer, and an understanding of the data it is storing.

Probing the news

the ability to use stored information—the computer will be able to understand the contents of the data base instead of just being able to store it, retrieve it, and pass it on. These knowledge bases—as opposed to data bases—will feed the problem-solving function.

This part of the tripartite brain will be called the knowledge-based management system. It too will have its own specialized machine, like the other two, to use advanced very large-scale integration.

In all sizes. Fifth-generation computers are slated to come in sizes ranging from small personal to large mainframe computers. It should be no surprise that they will be interconnected with local and global networks. Some new techniques to be used are new architectures like data-flow machines, artificial-intelligence concepts, and languages such as Lisp and Prolog along with machines optimized for them.

Jipdec has recommended 26 R&D themes, each with several projects. The themes are grouped into seven categories (see table). Each theme has target specifications.

For example, a personal work station would be required to perform 2 million instructions per second, have from 0.5 to 5 megabytes of memory, and include 100 megabytes of disk storage with an average access of 1 millisecond. Other specifications include what is referred to as a super high-speed processor to perform from 1 billion to 100 billion floating-point operations per second and have a memory capacity of 8 to 160 megabytes.

Big numbers. Designers hope to create the problem-solving and inference function so it will have a performance of 100 million to 1 billion logical-inference operations per second (one logical inference equals 100 to 1,000 instructions). Another example is the specifications for a natural-language processing system. In addition, the knowledge-based management function should retrieve a unit of knowledge in several seconds from a knowledge base of 100 to 1,000 gigabytes.

VLSI technologies, first with 1 mil-

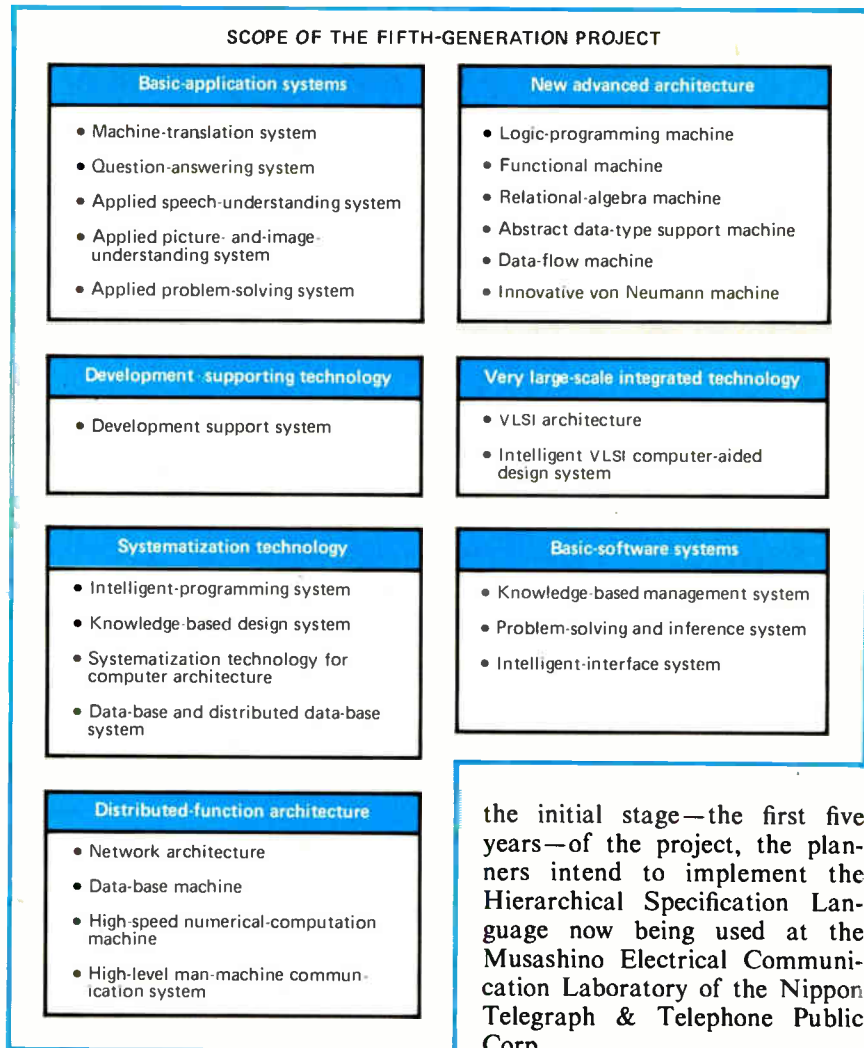

lion transistors per chip and then up to more than 10 million, are to be used. A design-automation system for these integrated circuits will also be developed.

Newer high-speed device technologies such as gallium arsenide and Josephson junctions are excluded from the program because the researchers believe that such devices will not be ready for general use by 1990. However, they do maintain that the progress of these devices will be closely watched so that they can be incorporated into the project at some intermediate stage should they prove sufficiently practical and capable of superior performance.

The design-automation system is to consist of three parts: the software for automated design of VLSI, a computer system to run it—called System 5G—and the 5G personal computer that will be a logic-programming work station for designers. In

The HSL system has several modules that are integrated into a total design system. It contains a language for describing a circuit, compiler, data base, timing simulator, logic simulator, circuit simulator, test-pattern generator, placement and routing program, and design-rule checker.

Logic designer. Also part of the design-automation project is the development of the logic-programming work station. No existing personal computer satisfies the requirements of high-speed processing of voice, graphic, and digitized image input and of performance as a personal inference machine using languages like Lisp or Prolog. One of the fastest conventional general-purpose computers—one capable of 40 million instructions per second—is planned to be the host computer for the design automation system until the first models of fifth-generation computers are available. □

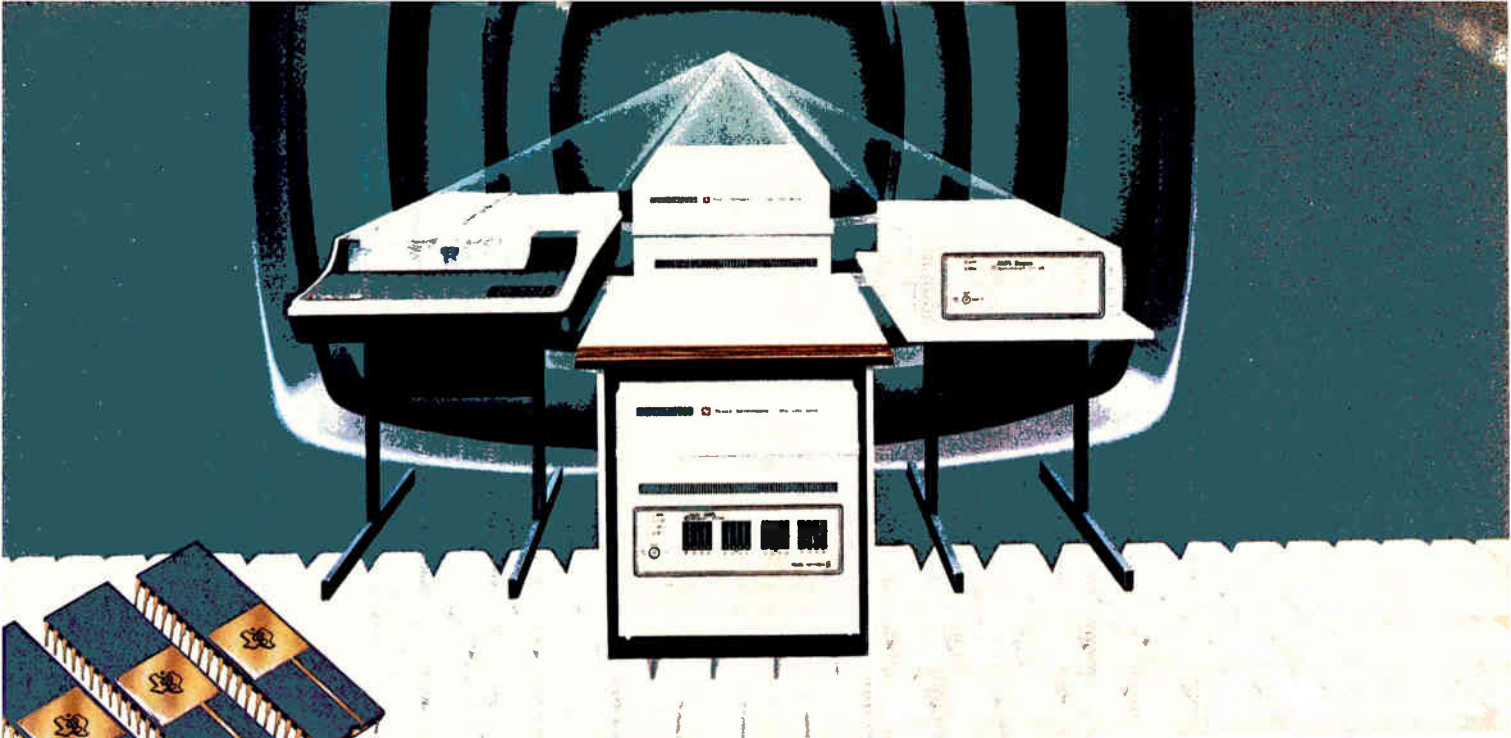

Speeding μ P designs into production. Saving time. And money. AMPL Development Systems from TI.

AMPL* hard disk and floppy systems to maximize software productivity.

You've read about it in the electronics press. TMS9995 — TI's enhanced performance member of the 16-bit 9900 Family, and TI's third generation 16-bit Family, and TMS7000—a new 8-bit microcomputer Series.

But there's more to our microprocessor story. There are the innovative hardware and software tools that support the design of these products and fulfill the promise of the future now with packaged AMPL systems.

Teamwork — yours and ours

Multi-AMPL*—a complete set of hardware and software development tools to help you get your designs into production faster at lower cost. A wide selection of systems featuring: Microprocessor Pascal high-level language; Component Software with Rx Real-time Executive; AMPL Debug HLL full-speed emulators; Logic state trace analyzer for up to four simultaneous AMPL Stations*; Debugging for hardware and software through emulation.

As many as eight program designers can work concurrently using hard-disk minicomputer throughput — maintaining a single data base, sharing CPU,

memory and peripherals, Multi-AMPL cuts development time while achieving the lowest cost per user.

Support, support, support

Expert assistance for installation and system generation. A network of engineers manning special "hotlines" at TI's

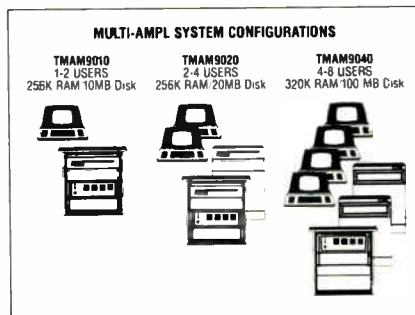

In addition to the configurations shown above, be sure and ask about TMAM9000, our new single-user floppy disk system with 64 KB RAM and more than 2 MB storage capacity.

Regional Technology Centers to provide immediate design and applications remedies or schedule service calls.

Good today. Good tomorrow.

TI AMPL systems support all of TI's leadership microprocessor and microcomputer module families. This com-

patibility means your investment in the system today will be valid tomorrow. That the code you write today will be valid tomorrow. And the latest developments in microprocessor technology will continue to be supported by a total capability development system.

For ordering information, contact your local TI field sales office or authorized Distributor System Center, or call TI at (713) 778-6549.

For details, send us the coupon and we'll send you a copy of our new brochure. Free.



Texas Instruments Incorporated
Microcomputer Marketing, M/S 6404
P.O. Box 1443, Houston, Texas 77001

Please send me your free Multi-AMPL brochure, CL-599, and more information on:

Hard disk systems: **New, single-user floppy disk system:**

- TMAM9010 TMAM9000
 TMAM9020 Have a representative call
 TMAM9040

Name _____ Title _____
Company _____
Address _____
City _____ State _____ Zip _____
Bus. Phone _____

Texas Instruments invented the integrated circuit, microprocessor and microcomputer. Being first is our tradition.

*Trademark of Texas Instruments
© 1981 Texas Instruments Incorporated

TEXAS INSTRUMENTS

856821

ARGENTINA 748-1141 • AUSTRALIA (02) 887-1122 • BELGIE/BELGIQUE (02) 720.80.00 • BRASIL 518423 • DEUTSCHLAND 08161/801 • FRANCE (3) 946 97 12 • ITALIA (0746) 69034
JAPAN 03-498-2111 • MEXICO 567-9200 • NEDERLAND 020-473391 • SCHWEIZ/SUISSE 01 740 22 20 • SVERIGE (08) 23.54.80 • UNITED KINGDOM (0234) 223000

World Radio History

Circle 84 on reader service card

ISO-CMOS™ When we developed the ISO-CMOS process at **THE HIGH SPEED**, Mitel we also developed a **LOW POWER** way of thinking. We ensured that **REVOLUTION** applications for the technology were kept foremost in mind—every step of the way.

Design Philosophy? Right from the start we made sure that our integrated circuit designers were exposed to the system environment, not just the component environment. In developing worldleading PABXs this perspective allowed Mitel Semiconductor to develop integrated circuits with well thought out general purpose interface capability.

Quality and Reliability? Our ISO-CMOS production technique and our quality assurance screens are based on MIL Standard 883 Test Methods and Procedures. Every ISO-CMOS device is hermetically packaged and 100 percent burned in. So ISO-CMOS quality and reliability is built in at the start of the process and is maintained through to completion.

Availability and Capacity? Mitel Semiconductor products are being marketed world-wide, with a supporting network of sales offices and distributors. In addition to a continuing expansion of manufacturing capacity by Mitel Semiconductor, Mitel ISO-CMOS devices are now sourced under licence by three major manufacturers, making our products and process the number one multi-sourced choice for new designs.

ISO-CMOS. It has created a revolution in the telephone, PABX and digital logic markets based on a capability for high speed, low power and high density. The continuing evolution of this superior technology is assured by the ongoing commitment by Mitel to the process.

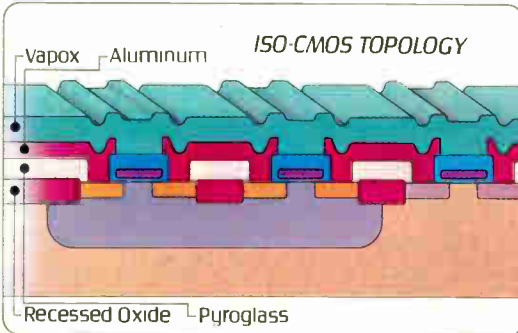

Discover what Mitel Semiconductor can do for you, by contacting your local Mitel sales office.

Shown here is a section of the MT8865 DTMF Filter magnified 1,300 times.



MITEL SEMICONDUCTOR

United States: 2321 Morena Blvd., Suite M, San Diego, California, U.S.A. 92110.
Telephone (714) 276 3421, TWX: 910-335-1242.
P.O. Box 17170, 600 West Service Road,
Dulles International Airport, Washington, D.C., U.S.A. 20041
Telephone (703) 661 8600, TWX: 710 833 0865.

Canada: P.O. Box 13089, Kanata, Ontario, Canada K2K 1X3.
Telephone (613) 592 5630, Telex: 053 3221, TWX: 610 562 8529.

Europe: 33 37 Queen St., Maidenhead, Berkshire, England SL6 1NB
Telephone 0628 72821, Telex: 849 808
Bredgade 65A, 2nd Floor, 1260 Copenhagen K, Denmark
Telephone (01) 134712, Telex: 19502.

Asia: TST P.O. Box 98577, Kowloon, Hong Kong.
Telephone 3 318256, Telex: 34235.

TM Trademark of Mitel Corporation
Copyright 1981 Mitel Corporation

BUILDING BETTER COMMUNICATIONS

Data communications

DES chips find a new niche

Authentication of messages may provide more sales for manufacturers of digital encryption-standard devices

by Wesley R. Iversen, Chicago bureau

When the National Bureau of Standards published the data encryption standard (DES) in early 1977, at least eight semiconductor manufacturers leaped to produce dedicated DES chips or chip sets. Additional vendors jumped in at the system level, with black boxes designed to capitalize on what all agreed was to become a booming market for DES chips and equipment.

Unfortunately, that estimation turned out to be grossly in error. Despite the vendors' best efforts, few commercial data-processing managers were convinced of the need to encrypt their data messages, and the expected DES market explosion never materialized. "Two or three years ago, we were predicting that the total market would be in the hundreds of millions of dollars by now. But I'd guess now that it's only a million-dollar business, if that," laments Jack J. Hill, privacy products manager for Rockwell International Corp.'s Collins Telecommunications Products division in Cedar Rapids, Iowa.

According to International Resource Development Inc., a Norwalk, Conn., research firm, the market for data, facsimile, and text encryption equipment will amount to just \$18 million this year, rising to only \$44.9 million by 1991. Instead of the broad mass market envisioned, DES chip and equipment manufacturers will have to be satisfied with "niche markets" for their products, declares International Resource.

Ironically, the next market niche to develop for DES chips may be spurred by the enactment soon of a different standard. The proposed standard developed by the X9.E8

working group of the American National Standards Institute covers the "authentication" of funds-transfer wire messages and other communications in the wholesale banking business. Expected to receive final approval within the next six months, the so-called "financial institution message authentication standard" specifically calls for use of the DES algorithm as part of its methods.

No coding. Data authentication differs from encryption in that it does not involve encoding of the message itself. Instead, authentication is used in applications where the sender and receiver are not concerned with the secrecy of the message *per*

se, but rather with assuring that the message is not altered during transmission. An additional concern is that bogus messages sent by unauthorized parties be not accepted as authentic. Though sophisticated authentication schemes have been used in military applications for some time, they have not found wide use in the commercial sector.

In the proposed ANSI standard, the DES algorithm is to be used in the generation of a message authentication code, or MAC, that is unique to the message being sent. An eight-digit number in hexadecimal format, the MAC is derived by passing the message or portions of the message

How the DES works

The data encryption standard can provide user authentication, data authentication, and data security in many ways. Some devices meet one or two of these objectives while others meet them all. While data security has been the major use of the DES until now, "no great practical or theoretical advances are needed to apply it to user or data authentication," says Carl M. Campbell, president of Transaction Security Products Inc., a consulting firm in Newton Square, Pa.

What are known as nonreversible transformation techniques provide only user authentication. In this approach each authorized user of a system is given a code word. Each terminal in the network using the authentication system has DES capability and transforms the user's code word into another code word. The system's host processor stores each user's transformed word. A simple comparison is thus sufficient to authenticate the user.

For data authentication that can also provide user authentication but no data secrecy, DES check digits are convenient. In this approach a check field is added to the message by the sender and verified by the recipient. The appended digits are generated by a DES key known only to the sender and recipient.

In one implementation of this approach, Campbell says, "each group of data bits is passed through the DES algorithm after being combined with the output of the previous pass." The final DES output (the check field) is a residue that is a cryptographic function of the entire message. This technique cannot prevent the repetition or deletion of a message. One way to solve this problem is to include a DES—protected sequence number with each message.

-Harvey J. Hindin



Snap-on

*** COLOR
CODED
NUT
DRIVERS**

Ideal for electrical work, these drivers have famous "Flank Drive" wrench openings for better grip, longer nut life. 9 sizes — 1/4 to 3/8 inch. Each size has a different color shank for easy size identification. Also available in metric sizes. Depression on handle top provides extra comfort and control. Call your nearest branch or write us. Snap-on Tools Corporation, 8051K 28th Ave., Kenosha, Wis. 53140.

Snap-on and Flank Drive are registered trade marks of Snap-on Tools Corporation.

Snap-on Tools

552

Circle 88 on reader service card

FREE CATALOG ELECTRONIC COMPONENTS & HARDWARE

'81-'82 EDITION

NEW PRODUCTS

- BINDING POSTS
- ALLIGATOR CLIPS
- TEST JACKS
- TIP JACKS & PLUGS

ALSO FROM STOCK:

Standoffs & Spacers • Battery Holders • Terminal Boards • Transistor Sockets • Printed Circuit Components

This new 60 page illustrated catalog features over 3000 standardized electronic components & hardware. All products are described and shown with drawings and photos with specifications.

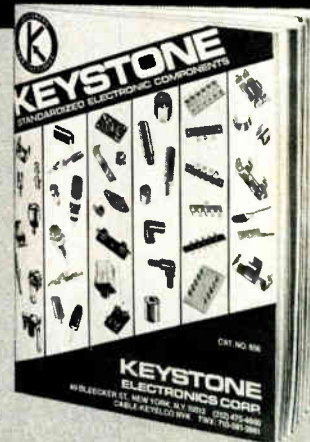

Send for your new free catalog or contact your local distributor.



KEYSTONE

ELECTRONICS CORP.

TWX 710-581-2861 CABLE-KEYELCO

49 BLEECKER STREET, NEW YORK, N.Y. 10012 212-475-4600

Circle 202 on reader service card

In celebration of the 50th anniversary of Electronics Magazine ...

The most exhilarating, comprehensible look at past and future developments in electronics that has ever been published.

Painstakingly researched and written, AN AGE OF INNOVATION gives you an unforgettable overview of electronics. Everything from the individuals whose foresight and daring led to the great advances ... to the origin of specific technological breakthroughs you use in your own work and home ... to the challenges and discoveries we will face tomorrow.

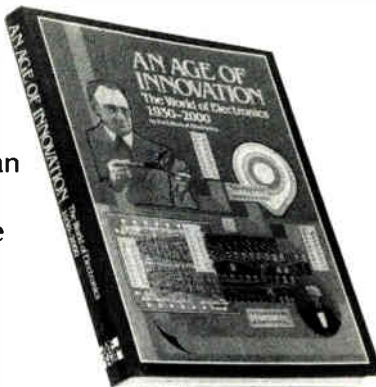

The editorial edition of Electronics' 50th Anniversary issue of April 17, 1980, beautifully clothbound and jacketed for your permanent pleasure. 300 illustrations, many in full color. 274 pages, \$18.50

AN AGE OF INNOVATION

The World of Electronics
1930-2000

by the Editors of *Electronics*

Order your copy today!

Electronics Magazine Books
P.O. Box 669, Hightstown, NJ 08520
Tel. 609/448-1700, ext. 5494



Send me _____ copies of *An Age of Innovation* @ \$18.50 plus applicable sales tax. McGraw-Hill pays regular shipping and handling charges on pre-paid orders.

Quantity discounts available. Ten-day money-back guarantee applies on all books.

- Payment enclosed Bill firm Bill me
Charge to my credit card: American Express
 Diners Club Visa MasterCard

Acct. No. _____ Date Exp. _____

On MasterCard only, first numbers above name _____

Name _____

Company _____

Street _____

City _____ State _____ Zip _____

Signature _____

ELH

Probing the news

to be sent through the DES algorithm with a secret 56-bit key that is agreed upon by the sender and the receiver. Either the DES-cipher-feed-back or cipher-block-chaining mode may be used.

Once the MAC has been calculated by the sender, it is appended to the message and transmitted with the message to the receiver. Upon receipt of the message, the receiver recalculates the MAC using the agreed-upon secret key. If the result is identical to the MAC received with the message, then the message is accepted as authentic. If the MACs do not match, then the message is rejected as having been altered or sent by someone using the wrong key. Since only the sender and the receiver share knowledge of the secret key, the MAC serves as an electronic signature of sorts.

Asking for DES. Since the proposed standard specifies use of the DES algorithm, the manufacturers of DES encryption equipment are cautiously eyeing the potential market for bank authentication gear. Motorola Inc., Scottsdale, Ariz., for example, will develop prototype equipment "by the end of next year or sooner" designed to implement the ANSI authentication standard, says Jerry J. Hogg, system development manager for the firm's Info-Guard 4100 product line. With firmware modifications, some of Motorola's 4100 DES encryption equipment could be used for authentication applications. But Hogg notes that bankers are also looking for new types of devices such as dedicated, low-cost handheld or desktop authentication terminals that could be used by smaller correspondent banks or bank customers. However, Motorola is mindful of the disappointing performance of the DES encryption market and will likely go slowly in introducing products.

One company that plans to go after funds-transfer authentication business in a big way is Atalla Corp., a 10-year-old San Jose, Calif., firm that currently supplies a variety of security hardware devices to the banking industry. At next month's Bank Administration Institute mon-

ey-transfer development conference in New York, Atalla plans to formally unveil a new version of its TRAC (transfer authentication code) system that is designed to implement the proposed ANSI standard. The system includes small authentication terminals priced at \$950 each for remote use as well as a \$16,000 wire-room security module that would be used at bank headquarters, interfacing with a bank's main computer, says chairman John M. Atalla.

The small TRAC terminals will rely upon Intel Corp.'s 8294—a DES peripheral chip designed for low-speed encryption requirements—under control of an Intel microprocessor. Equipped with a 10-key pad and an 8-digit display, the terminal will allow users to employ a MAC manually by keying in appropriate portions of the message to be sent together with the secret key. For automated MAC generation and comparison, the TRAC wire room security module will employ faster DES chips supplied by Western Digital Corp., Newport Beach, Calif., and by Motorola, Atalla says.

More uses. Though the wholesale banking business may offer the nearest-term potential, other applications may also crop up. In retail banking, a different ANSI group is working on an authentication standard covering automated teller machines and other consumer devices. And at the NBS, encryption specialist Miles E. Smid points out that authentication could also be useful for ensuring software integrity. For example, a MAC calculated on the basis of information contained in a particular file could be periodically recalculated to ensure that the file had not been tampered with. Authentication techniques could also be used to ensure that an operating system or other program had not been altered.

Authentication may also find uses in local area networking. Xerox Corp.'s Office Systems division, for one, is known to be working on a device referred to as an "authentication server." Though officials at the Dallas division are close-mouthed about the project or a potential product introduction date, the unit could eventually be offered to provide a message-authentication function on Ethernet systems. □

Power Op Amps

INDUSTRY'S LARGEST SELECTION

± 50V/15A



NEW -55 to +125°C

± 150V/75mA



SECONDSOURCEABLE

DRIVE:
Transducers
Actuators
Heaters
Syncros
Motors
Valves
Coils
CRTs

APEX
μtech

APEX MICROT TECHNOLOGY CORP.
1130 East Pennsylvania Street
Tucson, Arizona 85714
TEL: (602) 624-0273
TWX: 910 952 1176

Components

Chip resistors gain support

U. S. companies gear up to make the small, light thick-film devices, as a second domestic maker introduces an automatic insertion system

by Roderic Beresford, Components Editor

Against the backdrop of a thriving Japanese market for general-purpose thick-film resistors, American firms are preparing to turn out the tiny leadless components. In Milwaukee, Allen-Bradley Co. has announced its first chip resistors, manufactured on an automated production line and destined for high-volume applications in automotive and consumer electronics.

At the same time, and perhaps not coincidentally, the Dyna/Pert division of Emhart Corp. in Beverly, Mass., has made public its CHPS automatic insertion machine, the result of a several-year development program designed to come up with a

tool geared especially to handle leadless components. It joins the Onserter system from Universal Instruments Corp. of Binghamton, N. Y., on the domestic equipment front, and with other sources of the components likely here before long, the domestic market is a good bet to put in a strong showing.

Marriage. The thick-film technology for chip resistors is essentially the same used for many years in high-reliability hybrid circuits. The projected heavy use of these chips will represent a marriage of these proven techniques with automated mass production to establish a component with prices closer to carbon-

film resistors, but with greater reliability. The small, light chips are well-suited to automatic placement and wave-soldering onto printed-circuit boards, implying many indirect savings over leaded components.

Indeed, such a market is already geared up in Japan. About 1.8 billion units were sold last year, with Matsushita Electric Industrial Co. and R-Ohm Corp. the major suppliers. According to a report from Sal Guastella, product manager at Panasonic Co., the U. S. marketing and distribution arm of Matsushita, worldwide demand for general-purpose chip resistors is likely to top 7 billion units in 1985.

Embryonic. At Allen-Bradley, director of marketing Chet Grimsley paints a similar picture. He notes that "the chip resistor market is now in its embryonic stage in this country. By the end of the decade, we expect chips will be the largest-volume resistive component, totaling some 7 to 8 billion units."

Some, if not most, of this growth will be at the expense of discrete carbon-film or carbon-composition products that are larger and less reliable. Allen-Bradley does see the low-end carbon-composition resistors—for which it is now the only domestic source—as still viable for some time to come. One reason is that chip resistors today typically cost a few cents, compared with fractions of a penny for carbon types.

Still, the move toward chip resistors is more evidence that the domestic resistor industry is in something of a transitional period. TRW Inc. is scheduled to close its carbon-composition facility in Philadelphia in December and, perhaps not surpris-

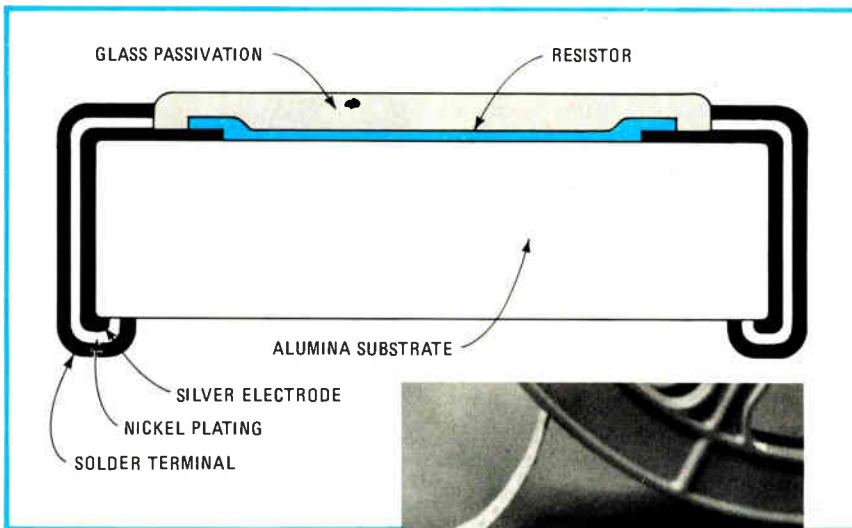

Tiny and leadless. Chip resistors borrow from hybrid-circuit fabrication: thick resistive pastes are screened onto a substrate and trimmed by laser. They are typically supplied in 8-mm reels for use with automatic-insertion equipment. The outline is 1.6 by 3.2 by 0.6 mm.

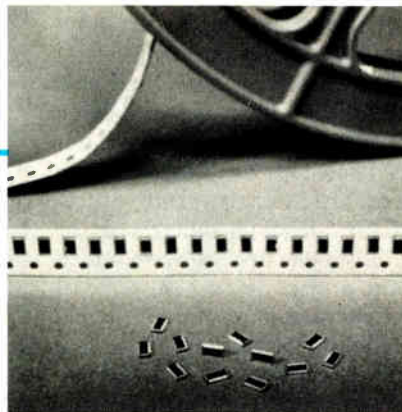

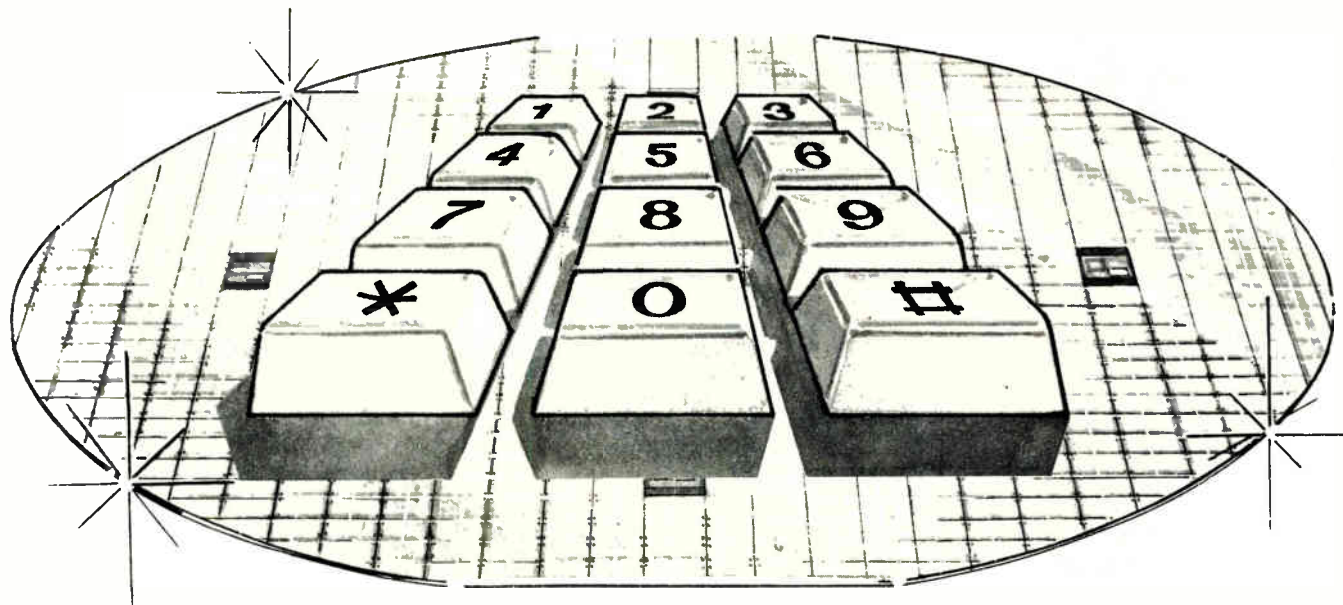

TELEPHONE KEYPAD LOGIC THAT'S VERSATILE BUT MEAN

A whole family of pulse dialler and DTMF circuits in fact, that combine outstanding performance with exceptionally low power dissipation.

The pulse diallers (MV4320 – MV4326) have all the logic for loop-disconnect push-button telephones.

For DTMF or MF4, there is a range of decoders and filters (MV88XX) that offers the designer a variety of output codes and

excellent voice talk-off performance – together with low power and wide supply tolerance. Compatible tone generators too!

Like all the Plessey CMOS circuits, they are in volume production using the highest performance 5-micron process worldwide – ISO-CMOS. And they're multi-sourcable.

Full data available direct from your nearest Plessey office or through the reader information service.

MORE GREAT CMOS DEALS FROM PLESSEY



Plessey Semiconductors Limited, Kembrey Park, Swindon, Wiltshire SN2 6BA, United Kingdom. Tel: (0793) 694994 Tx: 449637
Plessey Semiconductors, 1641 Kaiser Avenue, Irvine, California 92714, USA. Tel: 714 540 9979 TWX 910 595 1930

In Europe:

Belgium Plessey Semiconductors, Avenue de Tervuren 149, Boîte 2, Brussels 1150. Tel: 02 733 97 30 Tx: 22100

France Plessey France SA, 74-80, Rue Roque de Fillol, 92800 Puteaux. Tel: (1) 776 41 06 Tx: 620789F

Italy Plessey Italia SpA, Corso Garibaldi 70/72, 20121 Milan. Tel: (02) 345 20 81 Tx: 331347

Netherlands Plessey Fabrieken BV, Van de Mortelstraat 6, PO Box 46, Noordwijk. Tel: (01719) 19207 Tx: 32088

Spain Plessey Spain, Calle Martires de Alcala 41g 3ª derecha, Madrid 8. Tel: (1) 248 12 18/248 38 82 Tx: 42701

Sweden Svenska Plessey AB, Alströmergatan 39, 4tr, S-112 47 Stockholm 49; Postal address: Box 49023, S-100 28 Stockholm 49. Tel: (08) 23 55 40 Tx: 10558

West Germany Plessey GmbH, Altheimer Eck 10, 8000 München 2. Tel: (089) 23 62 1 Tx: 5215322

with local distributors and agents in most countries throughout the world.

 0628 2 0029

How To Comply With The New Copyright Law

Libraries everywhere have found the easy way to fill photocopy requests legally and instantly, without the need to seek permissions, from this and over 3000 other key publications in business, science, humanities, and social science.

Participation in the Copyright Clearance Center (CCC) assures you of legal photocopying at the moment of need. You can:

Fill requests for multiple copies, interlibrary loan (beyond the CONTU guidelines), and reserve desk without fear of copyright infringement.

Supply copies simply and easily from registered publications. The CCC's flexible reporting system accepts photocopying reports and returns an itemized invoice. You need not keep any records, our computer will do it for you.

The Copyright Clearance Center is your one-stop place for on-the-spot clearance to photocopy for internal use. You will never have to decline a photocopy request or wonder about compliance with the law for any publication registered with the CCC.

For more information, just contact:



Copyright Clearance Center

21 Congress Street
Salem, Massachusetts 01970
(617) 744-3350

a not-for-profit corporation

NAME

TITLE

ORGANIZATION

ADDRESS

CITY

STATE

ZIP

COUNTRY

TELEPHONE

Probing the news

ingly, last month announced a joint venture with Koa Denko Co. of Ina City, Japan, calling for manufacture in Japan of resistor networks and other thick-film components.

Back in this country, TRW appears to be the next major supplier that will enter the leadless-component business. At its Boone, N. C., plant, limited production is under way of leadless versions of the ceramic-metal resistors that TRW has for years supplied in discrete form.

As John MacWilliams, marketing manager for the company's Resistive Products division, says about the market, "Leadless components represent such a revision of present circuit-board assembly techniques that they are unlikely to catch on as quickly as some would think. Tremendous capital investments and long equipment lead times are necessarily involved in this move."

For high-volume users, this is likely to be less of a drawback. "The automotive companies, especially Delco, are very interested in reducing board sizes under the hood," Allen-Bradley's Grimsley says. "Even today, smaller-volume applications could be using chips, since there is some insertion equipment available in the range of \$25,000." In any case, chips have several compelling advantages for manufacturers.

Small and neat. The first thing that chip resistors offer is a very small and regular outline. The present standard is 1.6 by 3.2 by 0.6 millimeter, and the payoff is increased component densities on boards.

Even now, further improvements are in the works. Panasonic will introduce chips half this size early next year. The regularity of their structures is also a boon to automated design because standard rectangular shapes are more convenient in computer-aided layout.

The second attraction of these tiny chips is reliability. This is no surprise, with the technology so close to that conventionally employed by hybrid circuit makers (see figure).

The resistors are built on high-purity alumina substrates by screening on resistive paste, which is laser-

Important editorial



SIR JOHN CLARK
chairman and chief executive,
Plessey Co.

Clark's foremost worry—and pet peeve—is the industrial policy of the British government. Prime Minister Margaret Thatcher's government came to power a year ago with the most radical "Conservative" policy since the war, he says. Its cures for Britain's ills include a curbs on

prateness of the government's non-interventionist stance in a modern capital-intensive society dominated by technology. "Interventionism is a word based on dogma, and there is no place for dogma in government, only pragmatism. Government support has a proper place in the suc-

Concern for the economy tempers industry leaders' overall optimism for 1981

Government's attitude toward business, deepening shortage of professionals, and sharp competition for world markets also loom as obstacles

JOHN W. ZEVENBERGEN
president,
John Fluke Manufacturing Co.

The economy, the shortage of engineers, Government action—these top the list of concerns for a majority of electronics executives looking ahead to 1981, and Zevenbergen is no exception. "I don't see the U.S. economy straightening out until April," he says. "And the European economy is still headed downward, which will slow the instrumentation industry's recovery." But Zevenbergen does anticipate a boom after



KAZUO IWAMA
president, Sony Corp.

If only there were enough engineers to go around, Iwama would be a man without a care in the world. Sony plans to hire 400 engineers and scientists next spring, but has difficulties in recruiting them because of competition from such other technology areas as the machine tool, office machine, and automotive industries.

Iwama considers himself fortunate that Sony has no plans to large-scale software development in 1981 because software engineers are in even shorter supply. Still, he points out, there has been such a shortage for about 10 years, and Sony still has managed to develop new products and increase sales on old ones in that period.

On the bright side, sales forecasts in



WILLIAM R. THURSTON
president, GenRad Inc.

My chief concern is uncertain demand. Electronics traditionally is a seasonal group sector of the economy.

Thurston is as worried about management reactions to a slowdown as he is about the slow turn itself—es-

world markets.
Another unerring factor that cites is the relative scarcity of computer science personnel. Iwama engineers and programmers he calls this a "chronic problem in acute concern," pointing to the number of EEs producing each in Japan compared with the U.S. Not only are the Japanese graduating about 50% more yearly, but number of own-made instruments when viewed as a proportion of sales. "Japanese engineers are highly motivated, disciplined and capable of high-quality work as good as ours."
If forced to choose, he would spend his time boosting the level of U.S. engineering rather than industry. "Productivity is almost impossible to measure," he says. "What counts for a company is to get share, what counts for a country is world market share, and that quality that sells. I think I could convince to sacrifice quality for near productivity to gain a net improvement in quality."
As for the shortage of engineers, he feels that it is being addressed though not too widely. "Classical classes are growing larger," he says, and there is increasing interest between industry and the schools. More academics recognize our needs, and more managers are trying to help supply colleges and universities with the money and equipment that they need to meet the needs.
Through 1981 and beyond, Thurston hopes the industry is making talents grow as rapidly as its own business. "The basic supply and demand and see growing opportunity in there and hope that our senior managers' skills increase in prod-

Electronics worldwide editorial breaks all important technical and business news.

Take Sir John Clark...

"The private sector in England is being slaughtered. Government support? I would place the French ahead of everybody."

Or GenRad's William R. Thurston...

"What counts for a company is market share, what counts for a country is world market share."

Or Kazuo Iwama of Sony...

"Japan has more consumer electronics engineers than any other nation, making it strong in both development and production technology."

Or Pasquale Pistorio of SGS Componenti Elettronici...

"Semiconductor growth is so strong and people so cautious that demand and supply will be rebalanced in 1982."

Or Hughes Aircraft's John H. Richardson...

"Suppliers view the defense marketplace as a less attractive place to do business than other market sectors."

Or Unitrode's George M. Berman...

"The Europeans and Japanese are tough rivals, and that's good. We don't need protection from them. We need wider markets."

Such concerns as the economy, the shortage of engineers, government action, international economics, are addressed by top management in electronics companies throughout the world each December in Electronics Annual Executive Outlook.

These personal opinions are important information from important people all over the world, to important readers all over the world.

Electronics magazine is where important people become important editorial.

is read by important people.

Not everyone in the electronics technology marketplace is important to you. Not all the engineers, not all the managers.

However, the people who read Electronics are important to you. They are the people who make the important technology and business decisions. They are the planners. They set standards. They supervise design engi-

neering. They are directly accountable for their company's profits. They are buyers.

Most don't read direct mail. But they all read Electronics magazine—four out of ten read no other.

These important people are hard to see. Salesmen often miss them. They travel extensively on company business.

Let us introduce you to these important people. Call Norm Rosen, National Sales Manager at: 213-487-1160, and he'll arrange a conclusive demonstration in your office. Or call your local Electronics salesperson.

Electronics
Where important people read important editorial



Need a Real-Time Multi-Tasking Executive for 8080 and Z80?

CP/M®
Interface
Also Available

AMIX

- Faultless operation proven in world wide use
- Truly hardware independent
- Optimized for fast interrupt response
- Minimal memory requirements
- ROMable for control applications
- Terminal Handler is CP/M BDOS compatible
- Console Driver supports Intel iSBC boards
- SYSGEN speeds user system configuring
- Program in PL/M, Fortran, Pascal or Assembler
- Source code included (Intel or Zilog mnemonics)
- Unlimited use licence agreement
- Complete documentation (available separately)
- Low cost



KADAK Products Ltd.

206-1847 West Broadway Avenue
Vancouver, B.C., Canada V6J 1Y5
Telephone (604) 734-2796

Dealer enquiries invited

CP/M is a trademark of Digital Research Corp; RMX/80, iSBC are trademarks of Intel Corp.

Circle 94 on reader service card



**NEW
IERC ZIF
RETAINERS
CAN TAKE
IT...AND
DISH IT OUT!**

Now you can get a true zero-insertion force retainer that can take your PC boards and dish out their heat! You get...

- Ultra-efficient heat transfer!
- Shock and vibration protection even in the most severe military uses!
- 5 Mounting options!
- 7 Standard lengths!
- 5 Board thicknesses!

Call your IERC representative. Get ZIF retainers that can take it and dish it out!



INTERNATIONAL ELECTRONIC RESEARCH CORPORATION A SUBSIDIARY OF DYNAMICS CORPORATION OF AMERICA 135 WEST MAGNOLIA BLVD BURBANK CA 91502

94 Circle 205 on reader service card

Probing the news

trimmed to the required value. Wraparound edge terminals and a glass passivation layer are applied, completing the sealed, leadless assembly. The components have low parasitic inductance and also hold the potential for good accuracy and temperature-drift specifications.

Allen-Bradley's introduction, designated type BC, claims 1% tolerances and drifts of 100 parts per million/°C. Thus, the successful transfer of sophisticated thick-film techniques to mass production may eventually lead to chips displacing some precision discrete resistors.

Automation the key. But the clincher is automated pc-board assembly of leadless components. The high-volume users have been waiting for the automatic-insertion equipment that can handle the chips, whether they are supplied in tape reels or in bulk. Although several Japanese companies have been marketing such machines, Dyna/Pert's recent introduction is the second from a major U. S. supplier.

Universal Instruments began offering the Onserter—insertion equipment to handle leadless components—last May. According to Robert Groening, program manager for hybrid processing equipment, "as far as sources in this country, Universal and Dyna/Pert are it."

Dyna/Pert's CHPS system was shown to a group of component manufacturers last spring and to the public at Productronika in Munich last week. With up to six placement heads per X-Y table, the machine can place the leadless, rectangular, or cylindrical components at rates up to 60,000 per hour. What's more, the machine can store up to 600 different component values.

"The transport mechanism was a major design hurdle that we carefully protected with patents," says Neil McLean, marketing manager at Dyna/Pert. "The basic requirement is to move a tiny component over some feet of track at speeds around 100 miles per hour and decelerate it safely into the placement head." The system is expected to cost less than several less sophisticated units but have the same throughput. □

Electronics/November 17, 1981

Performance

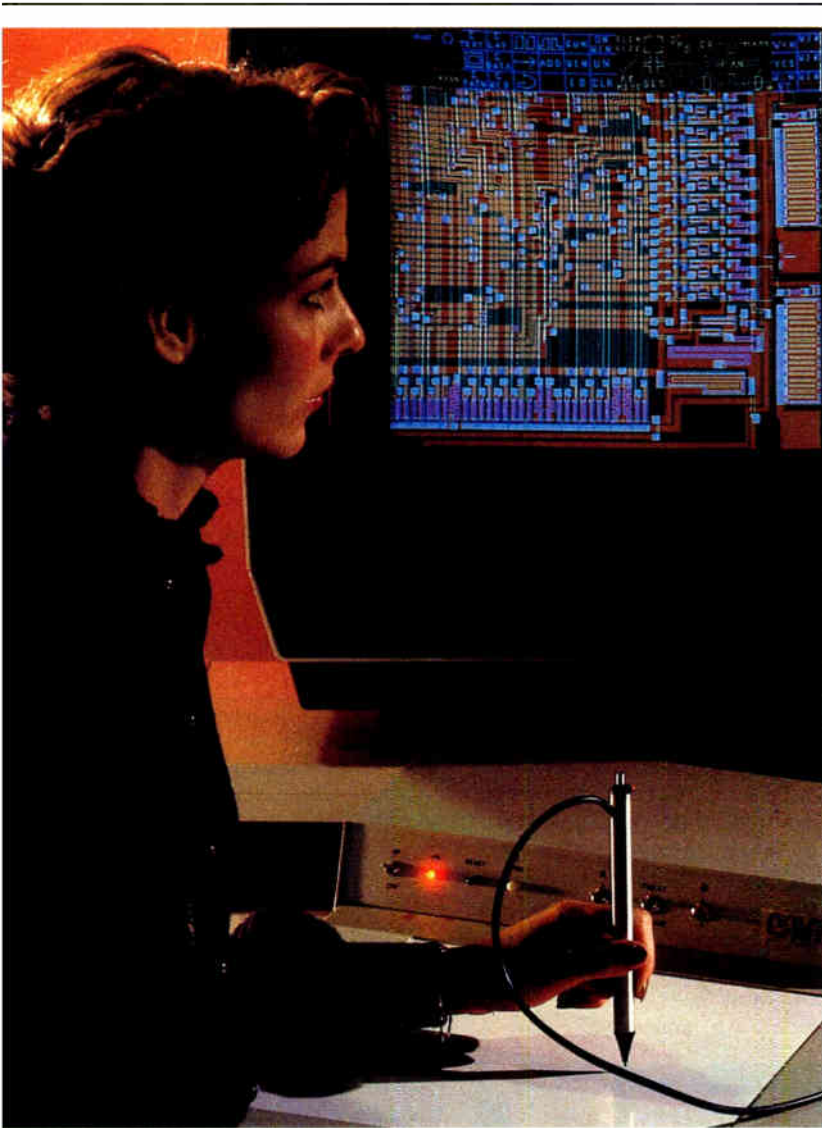

...Guaranteed from General Instrument's growing family of Electrically Alterable Non-Volatile Memories.

**New Generation:
Stand Alone Reprogramming**

System flexibility is a primary benefit of the ER4201, first in our new family of N-Channel EAROMs. Featuring automatic in-circuit, stand alone reprogramming, the ER4201 lets you cut system costs with independent operation and minimal interface circuitry requirement. Word alterable, the ER4201 has a maximum access time of 600ns, is organized 128 x 8 with 5V read operation. Samples available now. Hi-Rel options available soon.

16K EEPROMs

Next in our new family of N-Channel Electrically Alterable Non-Volatile Memories are two EEPROMs: the bulk erasable ER5716 and the ER5816 which is word alterable and features 5V only operation. Utilizing the latest Si-Gate Technology, both will have less than 300ns access time. The ER5716 is interchangeable with the popular 2716 EPROM.

Proven Performance

General Instrument has shipped over 10-million EAROMs including the popular 4K ER3400 and the widely used ER1400 which demonstrates our ability to make Electrically Alterable Non-Volatile Memories a reality for today, rather than a promise for tomorrow.

Contact your local Microelectronics Division office for more information and assistance.

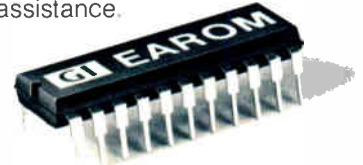

GENERAL INSTRUMENT

**We help you
compete.®**

Sales Offices USA: CA, 213-322-7745 or 408-496-0844; FL, 813-577-4024;

GA, 404-588-1375; IL, 312-981-0040. IN, 317-872-7740 or 219-291-0585;

MI, 313-391-4070; MD, 301-730-8992; NH, 603-424-3303; NY, 516-733-3107; TX, 214-934-1654;

EUROPE: London, 01-439-1895; Munchen, (089) 27 24 049; Paris, 365 72 50;

ASIA: Hong Kong, (5) 434360; Tokyo (03) 473-0281.

Careers

U. S. asked to help produce more EEs

AEA tells Congress that Government should join industry to help alleviate shortage of teachers and graduates

by Ray Connolly, Senior Editor

Some electronics engineers and computer scientists forced to look for new jobs because of the national economic downturn find it hard to comprehend manufacturers who claim there is a continuing shortage of electronics engineers and computer scientists—and that it will become more severe each year through 1985.

Nevertheless, that is the case that the American Electronics Association is bringing to Washington.

On the premise that sometime next year President Reagan's economic policies will produce an end to the existing recession, the AEA is pushing the Congress and the White House to develop a national education program to produce more electronics engineers and computer scientists. The association hopes this will offset the shortfall it says will number 129,000 by 1985, or about 25,000 annually [*Electronics*, June 30, p. 24].

The AEA, one of the more vocal disseminators of the shortage scenario, first made its case earlier this

month before the Joint Economic Committee with testimony by Southern Methodist University's F. Karl Willenbrock. He is a former president of the Institute of Electrical and Electronics Engineers, member of the National Academy of Engineering, and one of the 12 members of the AEA's blue-ribbon committee on engineering education. The following week, the full AEA committee met in Washington to prepare for a meeting with George Keyworth, the science adviser to the President.

Countering those moves, however, is a two-day session on manpower by the IEEE scheduled to begin Nov. 16 in Washington. In a classic example of the opposing views of management and labor, IEEE officials were preparing for their sessions with some members averring that the shortages of professional manpower are overstated. The depth of the job pool of available EEs is not completely clear at this point, but unemployment does exist.

"Engineering shortages pose a

particular dilemma for defense contractors," Willenbrock told the congressional hearing. "When the President was asked recently by reporters where companies would find technical workers if the defense budget passes, his optimistic reply was 'Give industry the money and it will find the people.'"

Willenbrock clearly dissents from that view, noting that "to win defense dollars, company proposals must demonstrate that competent technical talent is already on board or 'at hand.' A lack of engineers prevents many companies from bidding altogether."

Surplus students. What distresses Willenbrock and his AEA associates is that the nation's engineering schools "have far more applicants today than they can accommodate, and the quality of those candidates is probably superior to any that we ever had." Supporting Willenbrock's contention is an AEA study by Pat Hill Hubbard, engineering education manager for the association, which cites a National Opinion Research Center survey showing that, after business schools, "engineering is the second most-favored career choice of today's high-school seniors."

A severe shortage of engineering and computer-science faculty in the nation's schools is the crux of the problem that will continue to hold down the number of new engineering graduates, argues the AEA (see table). While engineering-faculty vacancy rates average 10% to 15%, forcing many schools to admit only one of every three applicants, the problem is even more serious in electronics education. Faculty shortages in solid-state electronics, computer

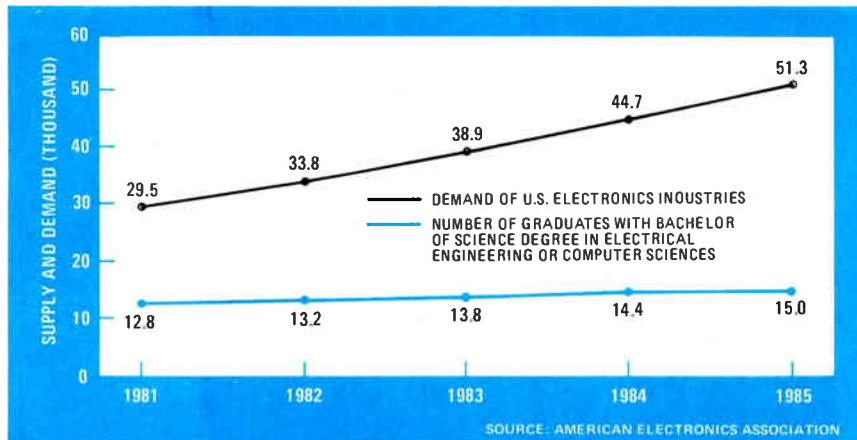

Diverging lines. The AEA projects that colleges will supply only 43% of the 1981 demand for new graduates in the electronics industries. The figures on needs are from 671 companies.

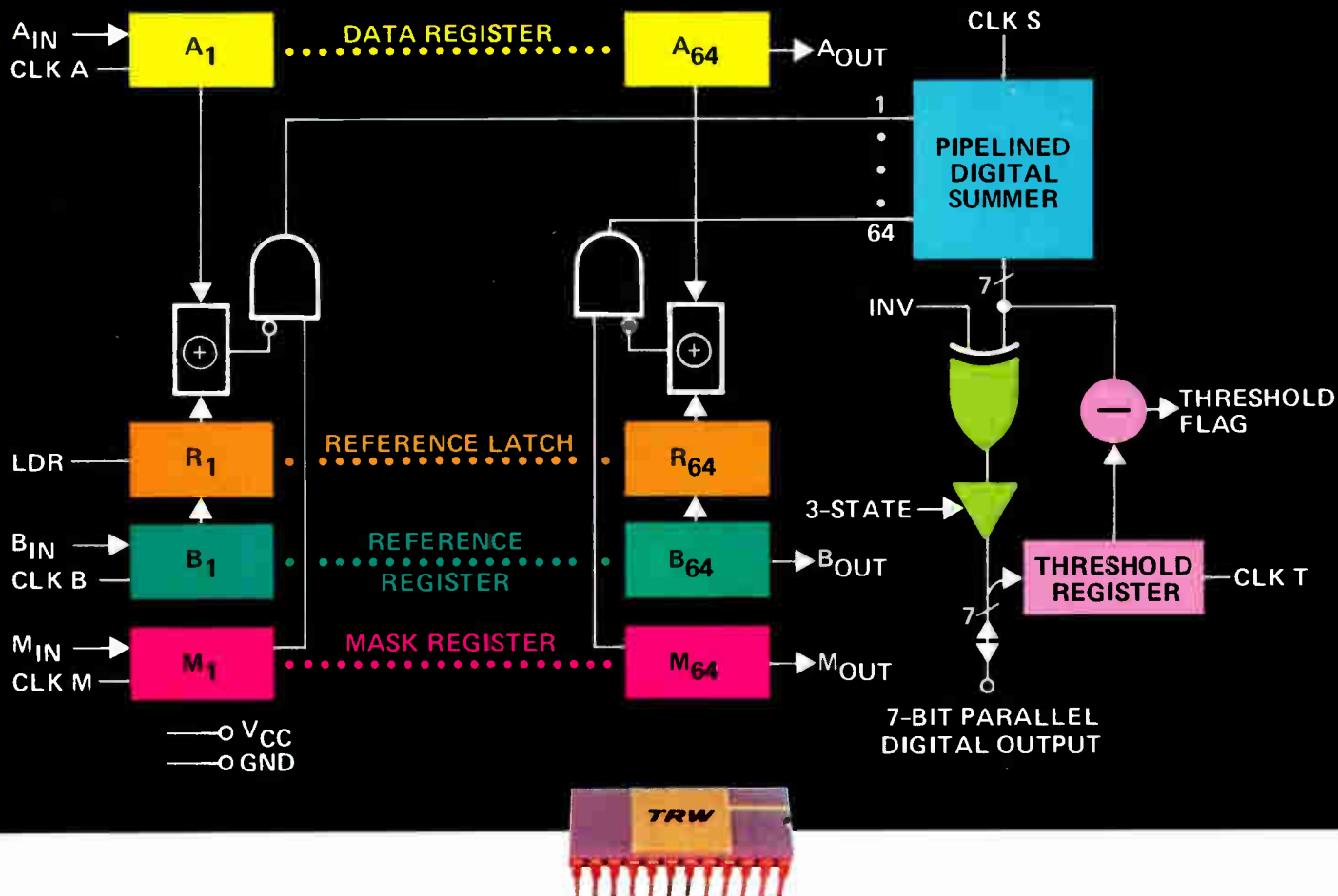

Now! A 64-bit, 20 MHz All Digital Correlator.

(On a single chip.)

Our TDC1023J correlator chip gives you the ability to detect a desired signal in the presence of other signals or noise. It can recognize and compare signal patterns. It may be used to measure time delays through various mediums such as materials, the body, RF paths, electronic circuits. It's ideal for the digital design engineer working in these areas:

- Convolution
- Error detection and correction
- Noise reduction in communications
- Pattern and image recognition
- Signal synchronization
- Signature analysis

And just take a look at these key features:

- Separate buffer register -- speeds processing, reduces external components
- Threshold register -- enables flag at preset correlation level
- Mask register -- permits adjustable compare lengths
- 20 MHz correlation rate

- +5V supply; TTL compatible
- 24 pin ceramic DIP package
- Only \$85 in 100's

Prices quoted are U.S. prices.

For complete information on our all new digital correlator, call your nearest TRW International Sales office and ask for our new 32 page brochure, "Correlation — a powerful technique for digital signal processing."

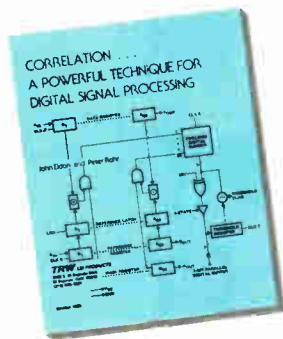

- ARGENTINA**, Buenos Aires 304132
- AUSTRALIA**, Moorabbin 5559566
- AUSTRIA**, See Germany
- BELGIUM**, See France
- BRAZIL**, Sao Paulo 2409211
- DENMARK**, Herlev 842000
- FINLAND**, Helsinki 6926022
- FRANCE**, Paris 7581111
- GERMANY**, Munich 7146065
- HONG KONG**, Kowloon 3856199
- ISRAEL**, Tel Aviv 444572
- ITALY**, Monza 360021
- JAPAN**, Tokyo 4615121
- NETHERLANDS**, Den Haag 210101
- NEW ZEALAND**, Wellington 851279
- NORWAY**, Oslo 786210
- SOUTH AFRICA**, Capetown 21-215350
- SPAIN**, Madrid 2425204
- SWEDEN**, Vallingby, Stockholm 8635040
- SWITZERLAND**, Zurich 429900
- TAIWAN**, Taipei 7512062
- UNITED KINGDOM**, London 9025941

TRW keeps you ahead in digital signal processing

TRW LSI PRODUCTS

An Electronic Components Division of TRW Inc.

Circle 206 on reader service card

SUNRISE® SUNRISE presents full line batteries for a great variety of electrical equipment.



- Manganese batteries
- Alkaline batteries
- Mercury batteries
- Silver oxide batteries
- Lithium batteries
- Solar batteries
- Nickel cadmium batteries
- Paper batteries
- Sealed lead-acid batteries
- Car batteries
- Battery operated appliances

With more than 60 years manufacturing experience

ASAHI DRY BATTERY CO., LTD.

1, MATSUSHITA CHO, MORIGUCHI, OSAKA 570, JAPAN TLX: 5297239 MATBAT J

Circle 98 on reader service card

CAMBION V-LP* IC SOCKETS

Now available in 2 different styles and in 8- to 64-pin positions, are Cambion's new, *Very-Low-Profile (.093") Series 703-43XX IC Sockets:

- **ROUND-PIN, SOLDER TAB VERSION** for mounting flush to PC boards. Use also as PROM carriers. Adhesive fit.
- **SQUARE-EDGE, WIRE-WRAPPABLE VERSION** orients each leaf of the 4-leaf Beryllium Copper spring contact to engage the sides and edges of IC leads for increased reliability! Press mount.

Machined body provides rigidity for pin alignment and for IC insertion/extraction. Ask for evaluation samples and the new IC Socket Catalog! Cambridge Thermionic Corp., 445 Concord Avenue, Cambridge, MA 02238, Tel: (617) 491-5400, Telex: 92-1480, TWX: (710) 320-6399.

CAMBION
design engineering guide
& IC Socket Catalog



CAMBION
The Right Connection.

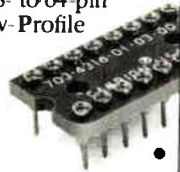

98 Circle 207 on reader service card

Probing the news

engineering, and digital systems are close to 50%, estimates one National Science Foundation official.

Lure of the dollar. Industry's high entry-level salaries—\$20,000 to \$24,000 annually for graduates with baccalaureates—are the principal disincentive for them to continue working for a doctorate and enter teaching, where a full professor averages \$33,295 per academic year. New graduates can earn far more in industry than the \$15,900 average for instructors.

In the face of this, it is no surprise to the AEA's Hubbard that only 8% of Stanford University's new Ph.D.s chose to enter teaching last year, compared with 50% a decade earlier. "Faculty salaries are the most serious problem," she says, "and need to be addressed immediately."

Further compounding the problem of the shrinking pool of doctoral students in engineering schools, the association adds, is the number of EE doctorates being awarded to foreign students. They received one third of the 523 Ph.D. EE degrees awarded in the U. S. last year, according to NSF figures. Of these 171 recipients, some 66% were on student visas and are likely to return home.

The AEA and its blue-ribbon panel, chaired by William J. Perry, former under secretary of defense and now partner in the California firm of Hambrecht & Quist, now await the outcome of their parley with the President's science advisor. First estimates on Capitol Hill are that industry will get a sympathetic audience but not much more from an Administration that is already cutting sharply Federal aid to education programs.

Nevertheless, SMU's Willenbrock sees one possible solution at the Federal level through an industrial alliance with NSF. "The NSF does have a lot of clout, and there is no reason why it should not work closely with industry."

Additionally, Willenbrock looks favorably on the prospect of greater support for education from the Department of Defense, as well as closer linkage between industry and the nation's universities. □

BOSCHERT. STAYING POWER IN SMART TERMINALS.

**INTRODUCING TWO NEW
POWER SUPPLIES THAT
STAY WITH YOU IN LOW-COST,
LOW-POWER APPLICATIONS.**

When you're in today's competitive smart terminal marketplace, you have to choose power supplies carefully. You need performance and low cost, but you want it from a source you can count on. Now Boschert delivers two new multiple-output switching power supplies designed to give you the cost, performance, and reliability you need today, including VDE 0730.

For low-power applications, use our 40-watt, XL51 supply; for higher-power applications, the new 60-watt XL53 is ideal. Both provide cool, efficient power in Boschert's field-proven, open frame design. And both give you the economy you need in today's cost-sensitive environment. You can build in either of our XL supplies for a cost of only about \$1 per watt, depending on quantity. Of course, custom variations are available.

In fact, you can count on Boschert for your full spectrum of switching power supply requirements. From 25 to 1500 watts, from prototype to volume production, Boschert's a world leader.

For more information on our new, low-cost CRT series or switching power supplies of any specification, write Boschert Inc., 384 Santa Trinita Ave., Sunnyvale, CA 94086. Or call (408) 732-2440.



B
Boschert
SWITCHING POWER

Circle 99 on reader service card

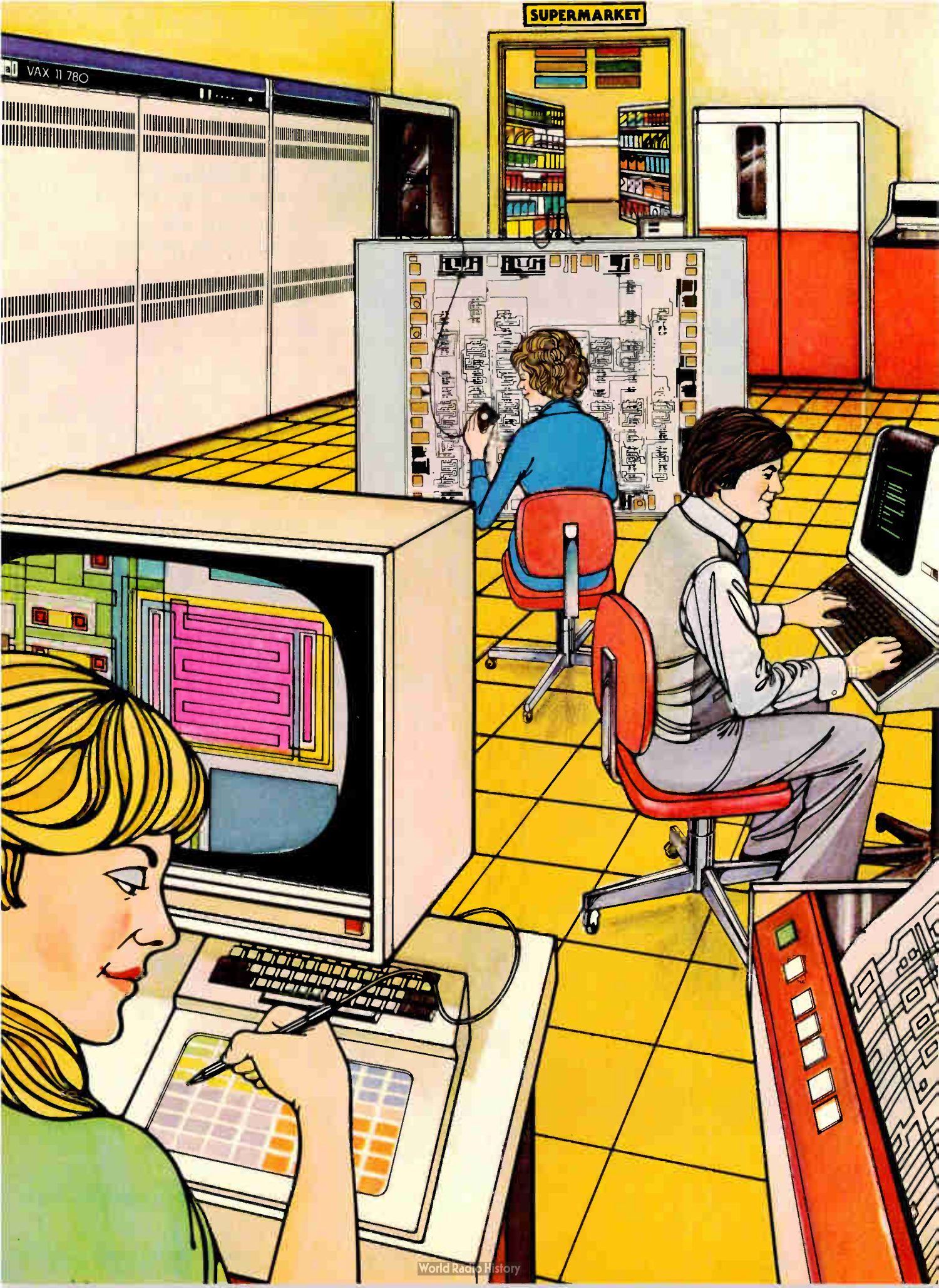

VAX 11 780

SUPERMARKET

CAD

Interdesign

A FERRANTI COMPANY

AT

THE GATE ARRAY SUPERMARKET.

There's a buzz in the backroom at the Gate Array Supermarket. To complement the Industry's largest variety of MOS and bipolar gate arrays, we've added a sophisticated computer aided design center and staffed it with some of Silicon Valley's finest talent.

HARDWARE

At the heart of the system is the Appicon graphic system linked with the DEC VAX 11/780 computer. Peripherals include design stations, engineering terminals, high speed printers, a 42" electrostatic plotter and a pattern generator. The hardware is designed to handle arrays of VLSI complexity.

SOFTWARE

Building on the Appicon 860 Super VLSI foundation, Interdesign has added powerful software developed specifically

for gate arrays. For verifying layout versus logic automatically, there's the **InterCheck™** software. Truth tables are converted to test programs and translated to test equipment format with the **InterTest™** software. Circuit and test program verification are accomplished through interaction between the **InterSim™** software and the digitized logic diagram. And, in development, is **InterLink™**, the software tool needed to convert logic diagrams to I.C. layouts automatically.

USER BENEFITS

As a gate array user, look forward to some real benefits from our CAD center. Faster turnaround results from increased engineering productivity and fewer circuit, tooling, and test errors. Design verification and better test coverage catch subtle problems prior to circuit integration. Confirmed manufacturing and test documentation mean a smooth transition from prototype acceptance to production quantities.

And forward looking system planning means arrays to 5000 gates and interaction with remote customer CAD terminals will be near term realities.

8-WEEK DELIVERY

With the CAD in the backroom, we can now turn your circuit design into an I.C. in just 8 weeks. Send us your logic diagram, circuit description, test inputs, and pencil connected layout and we'll do the rest. Clear, easy-to-understand design manuals show you how to prepare your materials for a fast, economical integration. Write or call today to discuss your circuit or to order your CMOS, CML, or Linear Design Kit.

Interdesign, Inc.
1255 Reamwood Ave.
Sunnyvale, CA 94086
Tel: 408/734-8666



COUPON VALID ONLY AT INTERDESIGN

\$250 **\$250.00 OFF** **\$250** ANY CML INTEGRATION

	WAS	NOW
MSA - 20MHz - 450 GATES	\$4500.00	\$4250.00
MSB - 20MHz - 880 GATES	\$7800.00	\$7550.00

LIMIT ONE COUPON PER PURCHASE - EXPIRES FEBRUARY 26, 1982

\$250 **\$250**

Circle 101 on reader service card

Inspiration strikes regularly at “Old Reliable.”

Seven of the new CMOS logic parts
RCA has introduced this year:



High-speed 8-bit Bi-directional
CMOS/TTL Interface Level Converter.

Dual 4-bit Terminator.



Quad “D” Flip-Flop.

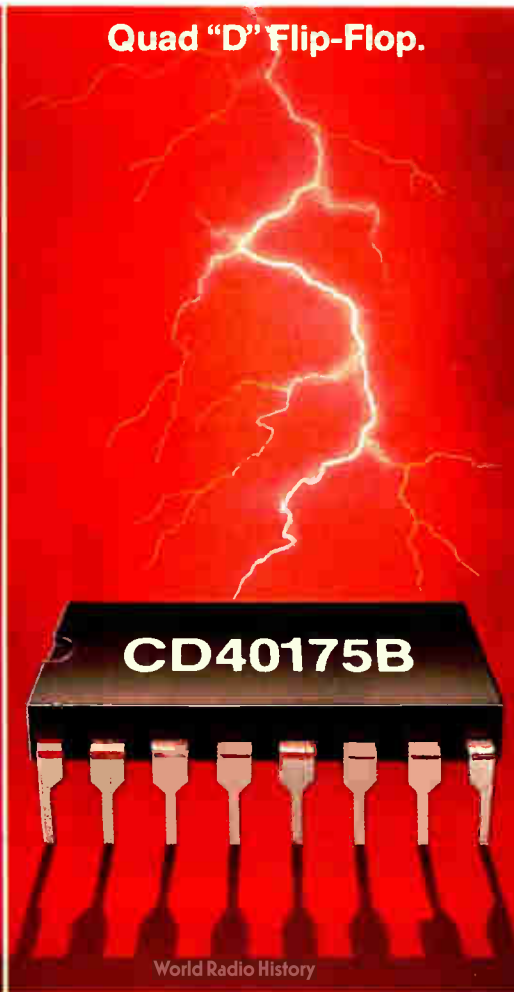

Dual Precision
Monostable Multivibrator.

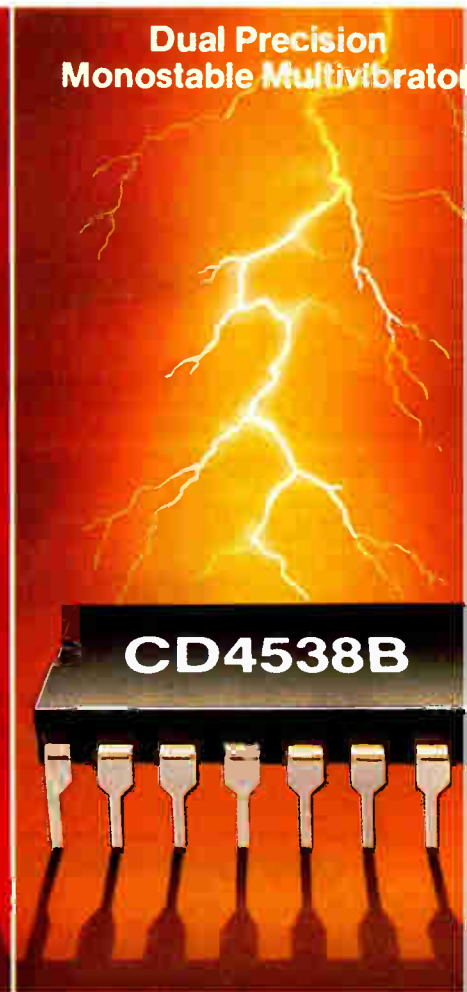

More and more people are switching to CMOS. And "Old Reliable" is supporting them with a steady stream of new CMOS devices.

CMOS/TTL High-speed Interface.

8-bit bi-directional circuit. Interfaces 5V to 12V CMOS microprocessors with TTL memories and peripheral devices—at very high speeds. Or interfaces between and within systems that combine CMOS and TTL (uses worst case TTL voltage levels).

CMOS/TTL conversion time, 15 ns typical; TTL/CMOS conversion, 30 ns typical.

Dual 4-bit Logic Terminator.

Unique. Replaces power hungry resistors with low-power pull-up and pull-down functions. Remembers last logic state of a data bus.

Power savings make it a must for battery-operated (or backed-up) data-bus applications.

Quad "D" Flip-Flop.

Q and \bar{Q} outputs on each of the Quad "D" Flip-Flops. Same pin-out as equivalent TTL device.

Dual Precision Monostable Multivibrator.

Pin-for-pin replacement for Motorola MC14538, and National CD4538. Can be triggered from either edge and is accurate to $\pm 1/2\%$, device-to-device over the entire temperature range. Circuits are completely independent, except for supply voltage.

HDB-3 Transcoder.

Operates at speeds up to 8.5 MBS at 5V and uses low power. Designed for bit stream encoding/decoding and error detection in AMI/HDB-3 formatted transmission line systems.

LCD Latch Decoder.

Ultra-low quiescent current. Can also interface with LED, fluorescent and other displays.

DTMF Tone Generator.

Ideal for telephone dialing systems and other tone encoding applications. Operates on telephone loop current, regulated DC or battery power from 2.5V to 10V.

Availability.

All of the above parts are available today. And they provide the CMOS advantages of low power consumption, low heat generation, and high noise immunity.

From "Old Reliable," the inventor—and the innovator—in CMOS logic.

For more information, contact any RCA Solid State sales office or appointed distributor.

Circle 103 on reader service card

RCA Solid State headquarters: Somerville, NJ. Brussels. Sao Paulo. Hong Kong.

HDB-3 Transcoder.

CD22103

LCD Latch Decoder Driver BCD-to-7 Segments.

CD4543B

DTMF Tone Generator.

CD22859

For letters and reports that really matter, you can't beat our D-50. With its superfast hammer and a resolution twice as fine as other daisy wheel printers (over 11,000 points per square inch), the D-50 prints the sharpest characters and clearest graphics in the business.

It's available in KSR (Keyboard/Send/Receive) terminal and RO (Receive Only) printer and terminal models.

Minimum maintenance, maximum productivity.

Thanks to a simplified printing mechanism, the D-50 is extremely reliable. It's designed to operate without adjustments, lubrication or preventive maintenance (other than routine cleaning).

The D-50 features long lasting reel to reel ribbon. You can complete lengthy jobs without an operator having to change it.

You'll save on ribbon replacement costs, too.

We have your type.

The D-50 uses standard 96 character plastic daisy wheels. They're available in a wide range of type styles, including international sets.

The print wheel motor tilts so you can change the wheel quickly, without removing the ribbon.

Dataproducts' Daisy Wheel Printer. When you have to make the best impression.



GREAT MOMENTS

A name you can trust.

Dataproducts is the world's largest independent printer manufacturer. For over 18 years, we've built printers for the biggest OEMs in the business, putting their names on our machines. These customers make sure our printers live up to some pretty tough standards.

30 day delivery.

Often we can deliver a partial order

even faster. If time is a problem, give us a call.

We're ready to help.

We'd love to show you how D-50 Daisy Wheel Printers and Terminals can help you look sharp with your customers. Call for more information. Or write our Marketing Department at 6200 Canoga Avenue, Woodland Hills, CA 91365. Telephone: (213) 887-8451

European Marketing Headquarters:
Egham, Surrey, England,
Tel: Egham 31161, Telex: 298562.



YS IN PRINTING

Design AUTOMATION

□ Profound changes are occurring in the microelectronics industry. More and more people are becoming involved in integrated-circuit design. Besides the usual IC houses—the Intels, the Motorolas, the TIs—users of chips, such as system companies, are increasingly seeing the need to design and build their own devices. Everywhere, the number of people required to design, lay out, and check logic masks and electrical performance is soaring.

The challenge is to put entire systems, consisting of thousands of transistors, onto silicon. In the view of many, a decent level of productivity in developing very large-scale ICs will be attained only with computer-aided design or, as some prefer to call it, design automation.

Design automation aids are on the way, too, in the form of creative new layout methodologies, software packages for simulation and test-vector generation, and turnkey graphics work stations. The articles in this series detail some of the newest of these tools, most of which hail from companies recently formed with specific solutions for the VLSI designer in mind.

The article from Calma Co. that kicks off the series on page 108 is a bit different. It explains how VLSI happened and what attitudes will be needed to keep it going. In particular, it states that chip design has begun to cost more than production.

At the standard-parts houses, numerous technical people are needed to deal with the incredible complexity of the VLSI circuits once they are defined—not to mention the teams

required to dream up new ones. Also the difficulty in creating new VLSI chips is being exacerbated by their application-specific nature, which stems from their being entire systems (see figure).

Though these specialized VLSI circuits represent production volumes that are unattractive to the vendor of volume parts, original-equipment manufacturers need the economies afforded by integration. To remain competitive, in fact, systems companies need their ICs faster than ever. This speedy turnaround is possible only through design automation.

Common thread

Design automation is the common denominator of the production of semicustom logic such as gate arrays, silicon foundries, and the IC structuring principles espoused by Carver Mead of the California Institute of Technology in Pasadena and Lynn Conway of Xerox Corp.'s Palo Alto, Calif., Research Center [*Electronics*, Oct. 20, 1981, p. 102]. Gate arrays aid design automation by making an IC's physical characteristics a foregone conclusion: only the last layers are personalized with application-specific wiring.

The unique advantages of gate arrays have nurtured a burgeoning demand [*Electronics*, Sept. 25, 1980, p. 145; Oct. 20, 1981, p. 116]. LSI Logic Corp., a Silicon Valley start-up that will provide gate-array designers with a new level of design automation, predicts that the market for semicustom logic will grow from the \$90 million of 1980 to \$1.5 billion by 1985. An exclusive article on

its entry-level offering—the LDS-I interactive development system—will appear in the next issue of *Electronics* as the series continues.

Gate arrays or standard cells

Some feel that arrays may ultimately be supplanted by custom ICs as design automation equalizes the two approaches' modes of logic entry and as silicon foundries become a reality. Some sophisticated arrays already demand personalization of three interconnection levels, inflating the number of custom masks toward that needed for a fully custom IC.

Standard cells are used to automate the design of custom chips. These cells are drawn from a database library and arranged on a die for a more compact layout than arrays can provide. Two new commercially available standard cell systems will be described in this series. One, from Zymos of Sunnyvale, Calif., begins on page 114; the other, from Alphasat of Cupertino, Calif., will appear in the next issue.

Standard cells run the gamut from gate arrays to fully custom chips. Some, like the polycells developed by Bell Laboratories, demand strict placement of power buses and also cells of a particular height. Other systems require areas to be reserved for wiring channels.

Whereas these approaches have gate-array-like features, other standard-cell systems place no restrictions on cell placement and in a few cases will even massage a cell's shape to fit into a given area. In the Gaelic VLSI design system from

The enormous complexity of very large-scale integrated chips is mandating the switch from manual design to computer aids. With VLSI systems, a top-down approach is required to organize their layout, simulation, and testing. Such a hierarchical approach is not a nicety; it is a necessity for continued productivity in the IC industry

by John G. Posa, *Senior Editor*

Compeda Ltd. of Stevenage, Herts., England, cells can have a mixture of sizes—that may or may not abut—and connections can be made from any cell point to any other.

The ease with which the design of a custom IC can be automated depends, in part, on process technology. For example, integrated injection logic can be laid out in a far more regular fashion than emitter-coupled logic can. This observation led the Centre National d'Etudes des Télécommunications of Paris to invent multi-drain MOS: with its I²L-like topology, multi-MOS technology formed the basis for the layout system described on page 111.

In designers' hands

Mead and Conway believe, along with a growing community of others in the IC industry, that automation is not yet really in the hands of the chip designer. Some believe that the current crop of CAD equipment from such well-known firms as Computer-ision, Applicon, and Calma is essentially drafting equipment. David Ryan, vice president of the Gerber Scientific Inc., a Hartford, Conn., maker of low-cost CAD systems for printed-circuit design, says that today's large, expensive, and overly general CAD systems will be obsolete in five years.

The producers of the CAD equipment are bending to change such impressions. Many are upgrading their host processors to 32 bits to handle more data and more distributed work stations. Calma is taking a bold step with its Sticks package, a dynamic symbolic system that allows

gridless, hierarchical layout and automatic circuit compaction [*Electronics*, Nov. 3, 1981, p. 41].

The general trend toward distributed computing is fueling the drive to decentralize design automation. The system from Valid Data Systems of Sunnyvale (p. 117), includes a logic simulator that separates logic verification from timing analysis, allowing VLSI designs to be handled on smaller computers than mainframes.

Avera Corp., a new company located in Scotts Valley, Calif., partitions the design of a VLSI circuit into individual tasks so that it can be distributed among a group of engineers. Its approach will be explained in the next issue of *Electronics*. Other novel design stations include one

from Daisy Systems Corp. of Santa Clara, Calif., [*Electronics*, Nov. 3, 1981, p. 176] and another due from Cadtec Corp. of Palo Alto, Calif.

Metheus Corp., a new Hillsboro, Ore., company made up of engineers from Intel and Tektronix, is also committed to VLSI design-automation tools for the product engineer. Its entry system, due next year, will include software routines for chip testing as well as for design. These will indeed be an accomplishment, for test-vector generation is still viewed as a black art and is often left for the circuit designer to develop empirically. Help is on the way, however, as the article in the next issue from Fairchild Camera & Instrument Corp.'s San Jose, Calif., facility will explain. □

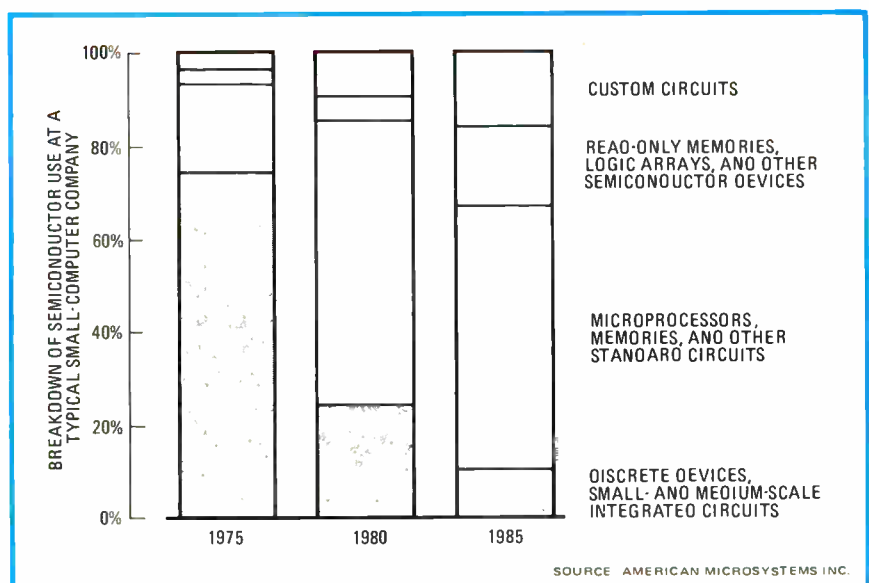

Going custom. Just a few years back, standard circuits made up the bulk of the electronics in applications like small computers. Custom and semicustom chips are catching up.

CAD tools must change to meet the needs of VLSI

Application-specific chips demand greater man-machine interaction

by Benjamin K. Lee and Casey Jones, *Calma Co., Santa Clara, Calif.*

□ Very large-scale integrated circuitry has arrived only two decades after the birth of the IC. It evolved from the techniques used to design and produce the medium- and large-scale ICs of the 1960s and 1970s, when manufacturing costs were, by and large, the semiconductor industry's greatest burden.

In recent years, however, the costs of circuit design and layout have come to dominate (see "The decline of standard components," opposite), and chip design can only become more difficult in the current decade. Now more than ever, the industry needs cost-effective design tools that address the type of design and the needs of the designer. Only the computer can handle the level of complexity involved, and in fact new computer-aided design tools are already coming to the rescue.

Dull tools

The design of VLSI parts not only requires many steps—from problem definition to final testing—but within each step, also, the amount of information involved is so staggering that today's tools cannot handle its complexity. They are specialized equipment, concentrating on a limited aspect of the design process, and as they are not integrated, they prohibit the exploration of global tradeoffs. Moreover, few available tools encourage man-machine cooperation in a meaningful way.

The lack of coordination results from the historical division of the IC design effort into separate steps, with narrowly focused tools and designers assigned to each. For instance, functional simulators were once at the disposal of only the system designers, and test-generation software was available only to the test engineers.

Dividing the problem, however, was not enough to conquer it. Worse yet, the division has blindered designers, forcing them to attempt optimization without regard to its impact on the overall circuit. Some of them speak in terms of instruction sets, others in terms of design rules. Layout designers often do not know the impact of

parasitics on circuit performance, just as logic designers often do not create testable circuits. Global strategies that take both computer architecture and chip layout into account are too few and far between.

Even if designers have a wish to collaborate, lack of a common data base may curtail it. The reason is that design tools were developed by programmers, and their offspring speak only their parents' language. Written in different languages, the tools usually run on different computers. Incompatible data may make it impossible to determine if, say, the circuit simulated with the logic simulator is in fact the same circuit simulated via the circuit simulator.

In the early days of CAD, not only was a design divided among engineers, but man and machine were viewed as two very different types of problem solvers. People and computers think differently, so tasks were divided into these mutually exclusive domains as well. Awed by the capabilities of computing machinery, manufacturers did not know quite how to utilize its power.

Will man meet machine?

This isolationist attitude derived, in part, from the traditional separation of personnel from computers. The computer resided in the computing center, the engineers in offices. Communication was awkward, as messages were punched into cards and submitted to a receiving window in the computer center for processing. The computer responded via reams of printouts, returned through the same window. Where this setup still exists, frustrated engineers can also be found, their creativity inhibited by the lengthy iterations needed to complete a design.

Even the most current design tools reflect these past technologies and market trends. Computer-aided design stations, with their attendant graphics terminals, are a case in point. Prior to their introduction, designers did their layout on Mylar sheets and checked it manually. Rubylith was then cut and checked again, only for new

AUTOMATION AUTOMATION AUTOMATIO

errors to be introduced as the old ones were corrected. In short, the manual checking provided no assurance that a circuit would work. As fine geometries spawned larger dice, the shortcomings of this method became ever more apparent to designers.

CAD graphics systems were originally designed to produce the patterns on an IC mask, with the computer capturing the data to drive a pattern generator. Handling data in this way did provide many advantages over manual methods. The data could easily be massaged through interactive editing commands, and design-rule checking could be automated. The tremendous success of these systems is evidenced by their rapid proliferation.

Engaging with complexity

However, times have changed to the point where much of this equipment is woefully inadequate for VLSI. With circuits comprising millions of rectangular regions, laying down each rectangle by hand is no longer practical. Design tools have not kept pace with semiconductor technology. The strengths of yesterday's equipment have turned into weaknesses, and past weaknesses have turned into major stumbling blocks.

To deal with the complexity of VLSI, the industry

needs to redirect its emphasis. Higher density and shorter design times must go hand in hand. Though automatic placement and routing algorithms fail to minimize chip area, the payoff is a shorter design cycle. Procedural design—after the manner of silicon compilers—will become a workhorse. This approach promises a VLSI circuit in an afternoon.

Using the tools

Apart from radically new tools, existing ones must be used more effectively. For example, the use of static symbolic layout with available interactive graphics systems can greatly expand productivity. This kind of layout is easy to set up and does not require new software as it is strictly a design methodology. American Microsystems Inc.'s symbolic interactive drawing system, SIDS, is a well-known static symbolic system.

The ASAP, or advanced symbolic artwork preparation, method developed at Hewlett-Packard Co. is another example of the improved productivity possible with present tools. Applying symbolic methods to a 10-year-old in-house system, HP reported a tenfold increase in layout efficiency without sacrificing chip density.

Even more optimistically, in viewing the totality of IC

The decline of standard components

The standard integrated circuit is no longer viable. Universal functions provided by logic gates, memories, and microprocessors, with their wide appeal and mass-market outlet, were ideal jellybean parts. Though the semiconductor industry possesses the technology to build almost any circuit that the mind can conjure up, it is unable to identify any universal very large-scale integrated circuit beyond the microprocessor.

No longer can semiconductor development costs be recovered solely by producing circuits in quantities. Economy will now be found in quality: the value added to a final product via proprietary circuits. Although these circuits will be the specialized components of an end product, their design must not impede product introduction. In today's market, product life cycles are shorter. Timing to hit a market window is no longer merely a desire; it is a necessity. Thus, VLSI tools must streamline designs to maximize the economic impact of the technology.

Still, the fact that economy is no longer strictly with quantity does not spell death to all jellybeans. A new type—the consumer circuit—has been introduced. Fabricated in relatively high volumes, it is more application-specific than standard components. Examples are digital watch chips and ICs for automobiles.

But beyond the consumer circuit, VLSI components will become increasingly specialized. Among the new VLSI designers, even consumer-circuit engineers will become a minority. Most future designs will be tailored so closely for specific systems that only those who are intimate with the end application will be able to identify the needs, justify

the economics, and design the circuits. These low-volume chips will definitely not be jellybean components.

There are two types of low-volume designs. Typically designed by computer companies for their own computers, the first type emphasizes high density. Hewlett-Packard Co.'s silicon-on-sapphire chip set for its HP3000 computer system is a good example. The market, in units, for HP's computers is certainly smaller than the one for the digital watches made by Casio.

A second kind of low-volume IC puts more stress on the quick turnaround required for timely market entry. Logic arrays and chips based upon polycells are examples here. Although these design alternatives have been around for years, it took fine-line lithography and its ability to crowd a die with logic to make them economical.

With arrays and polycells, plus automated placement and routing, a major part of the design cycle is reduced. In the case of logic arrays, prefabrication and the stockpiling of the preprocessed wafers further reduces manufacturing time and amortizes the manufacturing cost. The upshot is timely market entry, more than offsetting the cost of low-volume production.

Even though engineering costs are not amortized by low-volume circuits, the value they add to the end product justifies their existence. In view of the number of functions that designers are now able to put on a chip, the printed-circuit alternative would be altogether more expensive. Besides, custom ICs improve on electrical performance and dramatically reduce physical dimensions, making certain products possible.

OMATION AUTOMATION AUTOMATION

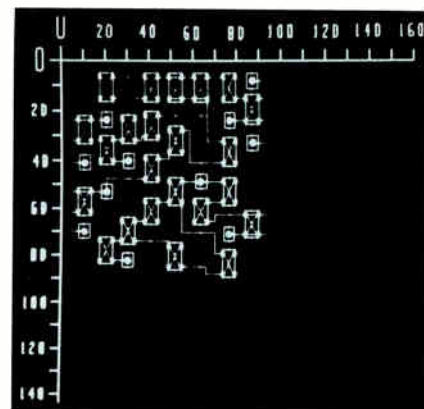
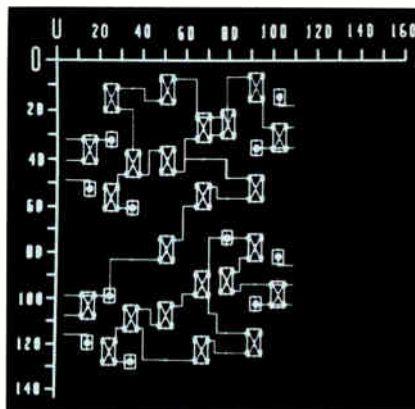
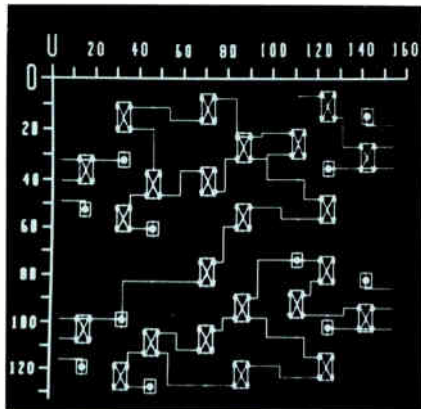

Design by computer. Even with the wealth of computer-aided design equipment available today, powerful tools are just now reaching the hands of designers. This sequence shows how a circuit entered with Calma's new Sticks package is automatically compacted.

design, researchers at the California Institute of Technology feel there is an underlying structural pattern to VLSI circuit layouts. So they are developing new design equipment that exploits this concept. One of these, a silicon compiler called Bristle Block, also makes tremendous strides in providing a compatible computing environment and data base to span much of the IC design spectrum. The tool allows a designer to deal with both computer architecture and chip layout, facilitating global tradeoffs between them.

Natural languages

These and other new tools are more expressive and natural to use. After all, designers, engineers, layout people, and programmers should feel comfortable with their own system involvement. Engineers think in terms of symbols: logic symbols, circuit symbols, and stick diagrams. They are concerned with drawing circuits at a very high level of abstraction, which does not mesh well and ought not to be bogged down with the rules of construction and manufacturing. Symbolic layout systems speak the engineers' language.

Programmers, on the other hand, can relate to silicon compilers and the compilers for programmable logic arrays that are already in widespread use. They, too, will be designing VLSI circuits and will be more comfortable compiling their written programs into finished layouts.

Layout people think in terms of the materials that make up the masks: metal, polysilicon, and diffused areas. Modern CAD graphics systems do allow users to tailor their language to reflect layout, but many designers continue willy-nilly to employ programming terms that are alien to their craft. For instance, to draw a metal line, the designer should be able to indicate "metal"—not "layer 5."

When a design tool is endowed with humanlike attributes, conversation becomes natural, expressive, and stimulating. It encourages a designer to think of new possibilities and inspires him or her to explore. Sticks, a

dynamic symbolic layout system from Calma, is such a tool (see figure). As with a static system, it understands symbols, but Sticks does more [*Electronics*, Nov. 3, 1981, p. 41]. When a designer wishes to connect one symbol to another, he need only place the interconnection within a visual tolerance for the system to automatically attach the wire to the intended symbol. He need not worry about the precise size of the spacing between symbols, either, as the program will correct the spacing later—but not on the designer's time. Because of a concept called spacing synthesis, design-rule errors no longer exist. Sticks removes the tedium from design and encourages the designer to explore.

This kind of harmony should go beyond machine helping man to include man helping machine. There are some circuit-design problems that are uniquely suited for people to solve, such as pattern recognition, which involves spatial relationships.

A well-crafted tool for cell placement and routing allows the designer to help the machine interactively. Placement and routing problems belong to a class of complexity known as nondeterministic-polynomial hard, or NP-hard. To prevent the exponential expansion of the time spent in computation, heuristic techniques are used. An interactive algorithm allows man to supply the heuristics, to guide the problem-solving process so as to arrive quickly at a more nearly optimum solution.

Can VLSI be saved?

VLSI is in trouble, and only computer-aided design can save it. It can be used to its fullest only when tools are devised that truly deal with its complexity, treat the entire design spectrum comprehensively and cohesively, and make optimum use of man and machine.

The tools will come from those who understand, those who make it their business, and those who can rally corporate resources. Moreover, the future clearly belongs to those designers who can remove the barrier between imagination and reality. □

Multi-MOS structure speeds layout of VLSI chips

Concept expedites design by using symbolic gates with multiple outputs; basic layout can be digitized and manipulated in graphic form

by Jacques Majos and Marie Josée Martin, *Centre National d'Etudes des Télécommunications, Paris, France*

□ The design of very large-scale integrated circuits need not be as formidably complex as it usually is. Though increasing cell densities are a contributing factor, the basic problem lies with the fundamental cells used to build up a circuit: they are too complicated, making layout tedious and design-rule violations inevitable.

The simplification of VLSI circuit layout depends on the use of a more manageable basic logic cell, so that it may be easily digitized and manipulated by computer to produce an entire design from the layout of a small number of cells. Some such methods already proposed [*Electronics*, July 31, 1980, p. 73] are based on a library of standard cells that have symbolized input and output signal points. Other approaches attempt to symbolize at the silicon level, with shapes that represent diffusions, polysilicon areas, and metal patterns. Programs for these usually ensure minimum spacing between elements.

The multi-MOS, or M²L, approach draws upon both these ideas by using a very regular symbolic gate having multiple outputs. Design-rule requirements are automatically met and the symbolic representation resembles a standard logic diagram. In contrast to conventional structures, gate load currents may be adjusted by the designer without changing the shape of the cells or their placement. This means that highly capacitive nodes encountered after interconnections are made can be handled without a new layout.

Multi-MOS technology

The M²L approach, an extension of multidrain MOS [*Electronics*, June 5, 1980, p. 73], is ideally suited to symbolic layout. The M²L structure consists of multiple n-channel MOS driver transistors, with common gates loaded by a depletion-mode n-MOS transistor (Fig. 1). The number of enhancement-mode driver transistors depends on fan-out. Their sources (here, the B input) are connected either to the substrate or to a logic signal.

The outputs of the M²L gate are available on the

drains of the driver transistors, but the function of the gate depends on the potential of the B input. If B is not connected to the grounded substrate, the multiple outputs of the M²L gate are equal to $\bar{A} + B$. When $B = 0$, the M²L gate is an inverter. It is possible to realize any logic function by connecting the outputs of M²L gates.

Attractive features of the M²L structure are its high packing density and high-speed performance. The table lists these properties for a fan-out of 2. The high packing density results from the common gate, which allows the drains to be tightly packed, and from the elimination of individual source contacts for each gate. In addition, the driver transistors are in parallel and their gate width is

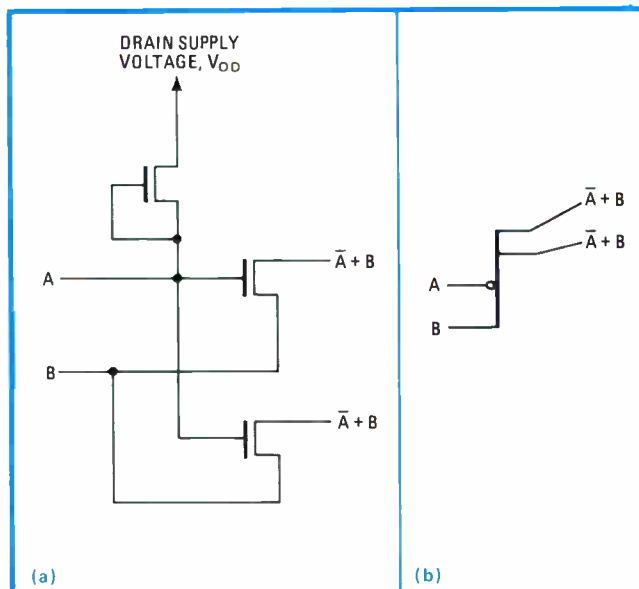

1. Great for CAD. The symbolic layout system makes use of a multidrain MOS structure that is ideally suited for computer-aided design. The basic gate (a) has two inputs; when one is grounded, the gate is turned into an inverter. A simplified schematic is shown in (b).

THE SPEED AND DENSITY OF M ² L GATES*			
Design rules (μm)	6	5	4
Maximum/typical density (gates/ mm^2)	310/220	450/320	700/500
Speed (ns)	5	3.5	2
Speed-power product (pJ)	1.3	1.0	0.6

*Fan-out = 2.

constant. Minimum drain capacitance and a high current-sinking capability due to a high gate width-to-length ratio permit the high speed.

With conventional n-MOS silicon-gate technology, the MOS drivers are connected in series, and this poses a difficult problem for the integrated-circuit designer. When implementing a NAND gate, for example, the designer does not usually know the load capacitance and therefore cannot predict load current. Besides the load capacitance to get a particular propagation delay time, the width of the driver transistor must be varied for the proper low-level output voltage.

Controlling capacitances

When load capacitance is not known, the designer must draw upon experience to adjust the width of the MOS driver transistor and load current. Unfortunately, if the load capacitance is larger than that supposed, it can have disastrous effects on the surrounding layout. When the capacitance increases, load current also increases and the width of the MOS driver must be increased to obtain a correct low-level output voltage. This means the packing density decreases with high frequencies.

The M²L gate avoids such drawbacks because the MOS drivers are never connected in series for any logic function. If the elementary MOS driver can support the maximum current generated by the load device, then for any interconnection diagram, the low output voltage will be correct. With 6- μm design rules, load current ranges from 10 to 180 microamperes; but the designer can, at any time, change the current value without also being obliged to make area modifications.

2. Topology. The gates represented by the schematic of Fig. 1 are here shown in symbolic and mask-level forms. With two inputs to the gate, (a) is used. Load current is easily adjusted by varying the gate width of the MOS driver transistors (b).

When speed is not critical, the current value generally used is 25 μA or less. However, the MOS drivers must be able to drive 180 μA to make the low output level consistently equal to 0.4 volt. To make that possible, the width of the MOS drivers is set to 24 micrometers, and the closed polysilicon structure in Fig. 2 is used to minimize silicon area.

Since the closed structure increases input capacitance and degrades the speed-power product, the width of the MOS drivers is equal to 12 μm when the high current is not required. This width is obtained by using only half of the polysilicon structure for a maximum drive current of 90 μA ; but in both cases, the same silicon area is used. When a load current in excess of 180 μA is necessary to drive a very high load capacitance, one or more M²L gates can be easily cascaded.

Symbolic layout and design

The geometry of the M²L gate facilitates a quick and easy symbolic layout. Because of the constant gate width and the position of the drains along the same axis, the overall width of the logic gate is also held constant. Length depends on the number of outputs and inputs.

Layout is done on an X-Y grid, the steps of which represent the design rule in micrometers. The rectangular symbolic gate is placed on the grid with the distance between the axis of two neighboring M²L gates equal to two grid steps.

The rectangle contains symbols representing that gate's inputs and outputs. In Fig. 2, the symbol placed at the top of the cell represents the position of the V_{DD} supply. The two grid steps below this symbol are occu-

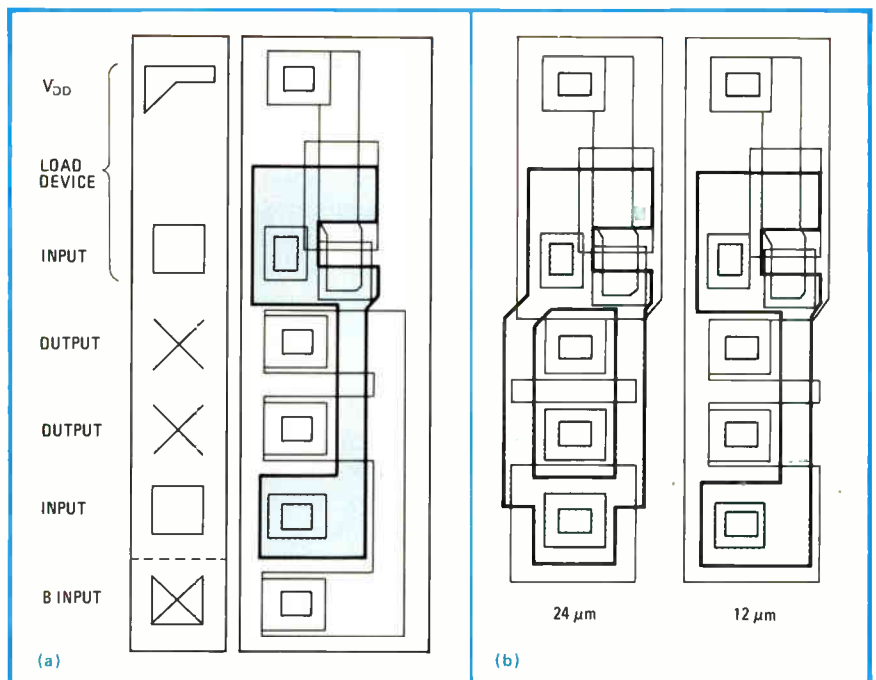

ATION AUTOMATION AUTOMATION

plied by the depletion-mode n-channel transistor. A square is used to symbolize the gate's input. It can be placed at any point along the longitudinal axis of the M²L cell, from the origin (the lowest grid point) to the point just below the V_{DD} symbol.

Since the polysilicon gate is common to an M²L cell, two or more may be made available by simply adding squares at any point on the grid. This property is particularly attractive for implementing logic functions; it permits a cell to be used as a polysilicon interconnection.

A cross is the symbolic representation of a drain (or output). Outputs can be placed at any point on the grid except the two grid steps occupied by the load device. If the M²L rectangle includes n grid points from the origin (point 0) to the V_{DD} position (point n), an output can reside at any position from 0 up to position n-3. Again, the number of drains depends on the fan-out.

When the M²L gate is used with source regions not equal to 0 V, a different symbol for the source contact is used and it is placed at the origin of the M²L rectangle. With these symbols, the position of the cell's inputs and outputs depends only on cell-to-cell connections.

CAD implementation

The M²L structure permits complex circuits to be designed quickly. The total number of M²L gates will be equivalent to the number of standard NAND and NOR gates. The first task of the designer is to transform the logic function into the M²L form, then implement the symbolic layout. The design rules are automatically satisfied, as are load-current requirements. This leaves only the problem of interconnection, meaning the designer can concentrate entirely on wiring.

When implementing the symbolic layout, the designer may use two interesting properties of the M²L structure. As mentioned, an M²L gate can be used as an intercon-

nection, thanks to the multiple gate contacts possible. Secondly, the designer may divide an M²L gate into two or more other gates whose inputs are wired together.

Once the symbolic layout satisfies the designer—that is to say, when a good packing density and a good interconnection arrangement have been obtained—the symbolic layout can then be digitized. With input and output symbols available on a menu, the designer points to a gate's origin and places the first symbol there. The second symbol may be placed along the X or Y axis. The relative position of the two first symbols automatically computes the orientation of that M²L gate.

After choosing the V_{DD} symbol, the symbolic contour of the M²L structure is automatically drawn. The designer then specifies the value of the load current and goes on to digitize another M²L gate. After a block of about 100 gates (and their interconnections) has been digitized, the designer asks the machine to draw the full mask layout; this task, too, is automatically carried out.

The M²L structure is an attractive tool for the IC designer, compared with traditional layout methods. Besides having excellent speed and packing density, the structure has many advantages, such as a symbolic representation that looks like a logic diagram that is independent of the design rules. When the design rules change, the symbolic data remains unchanged and can be compiled according to the new rules. In fact, the task of the designer is so easy that IC specialists are not required to implement or digitize the layout.

These advantages make the implementation of an n-MOS IC very similar to that of a printed-circuit board. The approach further offers very low cost and a fast implementation time. With the M²L structure, one man-year may be all that is needed for a 10,000-transistor chip, including the transformation of a logic diagram into the M²L scheme, the layout, and debugging. □

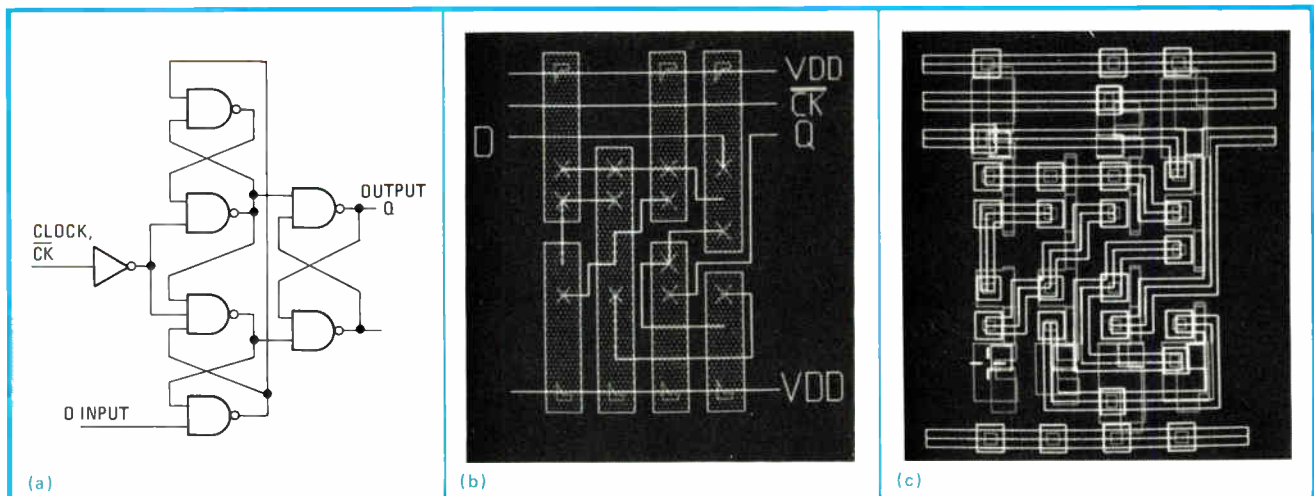

3. CAD implementation. This is how a logic diagram winds up as a mask layout using the multi-MOS system. A schematic (a) is converted into an M²L diagram, then digitized for the cleaner representation in (b), and from there transformed into mask data (c).

Multiuser IC cell library buys custom densities at gate-array prices

Use of standard circuit blocks for chip design apportions development costs, trims turnaround times

by William Loesch and Alex Young, *ZyMOS, Sunnyvale, Calif.*

□ Computer-aided design can produce integrated circuits that promise to provide the benefits of custom design—improved performance, smaller size, higher reliability—at a cost and convenience much closer to standard circuitry. One such CAD setup is the system to be trademarked as ZyP. Available to subscribing designers, it is based on a library of standard MOS cells and offers cost savings over gate-array and fully custom approaches, as well as a low risk of design iterations and testing delays.

What's more, the system eases the design job: an engineer trained in board-level design needs no knowledge of device technology to fashion chips with custom circuit blocks. Its operation is analogous to a mathematical transformation that maps parameters from one coordinate system to another: a description of logical functions is transformed into lithography masks. Access is through an international timesharing communications network, or the design system may be installed in a computer at the customer's facility.

One of the primary advantages is the control the engineer has over the design schedule. The user need not depend upon the availability of in-house IC design engineers or the willingness of a particular vendor to undertake his project. Once the chip is designed with the CAD system, ZyMOS can provide prototypes within eight weeks.

Most importantly, this system does not require massive in-house investments in graphic-design aids, IC designers, or wafer-fabrication and test facilities to obtain the benefits of custom chip design and manufacturing capabilities. Instead, many users share these costs.

At the heart of the system are libraries of standard functions, or cells, that can be interconnected to form systems of any desired complexity—limited only by economics: the more cells added, the more the chip will cost to produce. Over 500 functions are available in the standard cell libraries that continue to be expanded and

refined. There are three libraries, with cell designs optimized for silicon-gate n-channel and complementary-MOS and metal-gate C-MOS processing.

Many functions available in the libraries cannot be implemented with gate arrays: for example, memories, specialized input/output circuits, and analog building blocks such as operational amplifiers and comparators. Moreover, all of the cells in the standard libraries are

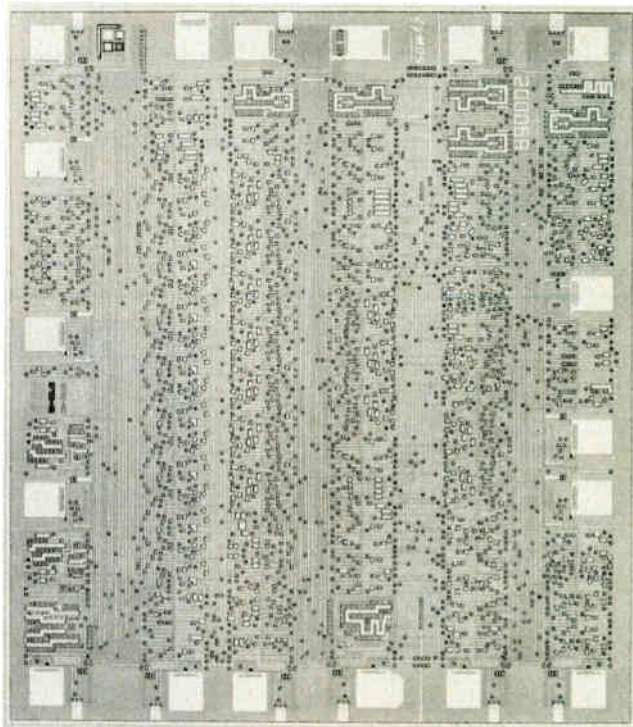

From the library. Board-level designers create semicustom ICs like this one by drawing logic functions from a collection of standard cells and specifying their placement. The hand-drawn cells let chips come close to the density and speed of fully custom layouts.

AUTOMATION AUTOMATION AUTOMATIO

constructed to exploit a given IC process for the maximum possible performance.

Most cells allow a choice from a range of different transistor sizes so that speed can be traded for lower power when such a course of action is desirable. Users can also specify new cell designs to meet the performance requirements of their applications.

Cell libraries

The Zyp design system is a combination of existing CAD tools, original software, and cell libraries linked together to form a comprehensive and friendly design tool (Fig. 1). The key is the libraries that currently include inverters, buffers, gates, flip-flops, latches, binary comparators, and random-access and read-only memory cells. Also, several analog building blocks have been incorporated into the libraries, including op amps, comparators, and voltage references. Several cell types, such as shift registers, counters, RAM, and ROM may be expanded to the size required.

In addition, a novel logic building block, called a core microprocessor, is included in the cell library. It is a 4-bit central processing unit stripped of all RAM, ROM, and I/O. Its instruction set is very similar to the 8048's. With this cell, an engineer can build a custom microcomputer with user-defined RAM, ROM, and I/O functions, giving a programmable chip that has the optimal architecture for a given application.

Every cell has three different representations stored in a common data base for each library: device-level and logic-level simulation models and digitized artwork. In addition, every standard cell is described in a data sheet that gives the designer information about the logic func-

tion performed, the area consumed, the input capacitance, the intrinsic and load-dependent components of the cell delay, output current-driving characteristics (for buffer cells), and the proper syntax to access the logic simulation model.

Circuit design begins with a definition of the system logic, in the form of a logic diagram or a written specification. Based on the information in the data sheets, standard cells from the libraries are selected to implement all the logic functions in the system.

This process is similar to selecting standard 4000- or 7400-series parts from a data book to build a breadboard of a system design. If there is a logic function or linear building block that is required by the system and is not in the library, Zymos will design and characterize it and add it to the library. In addition, users with IC expertise may design proprietary cells.

Once cells have been selected, the user submits to the computer a network listing that specifies the desired interconnections among the cells. This design task is analogous to wire-wrapping a breadboard of standard C-MOS or TTL parts.

Simulating delays

At this stage, the engineer verifies the design with the logic simulator, which runs both zero-delay and accurate time-delay simulations of any network. Initially, zero-delay simulations might be needed to debug the logic design. This effort is similar to running a TTL or C-MOS breadboard at low speeds, where gate delays are negligible compared with the clock rate.

After the logic design has been checked, the logic simulator will provide an accurate timing simulation

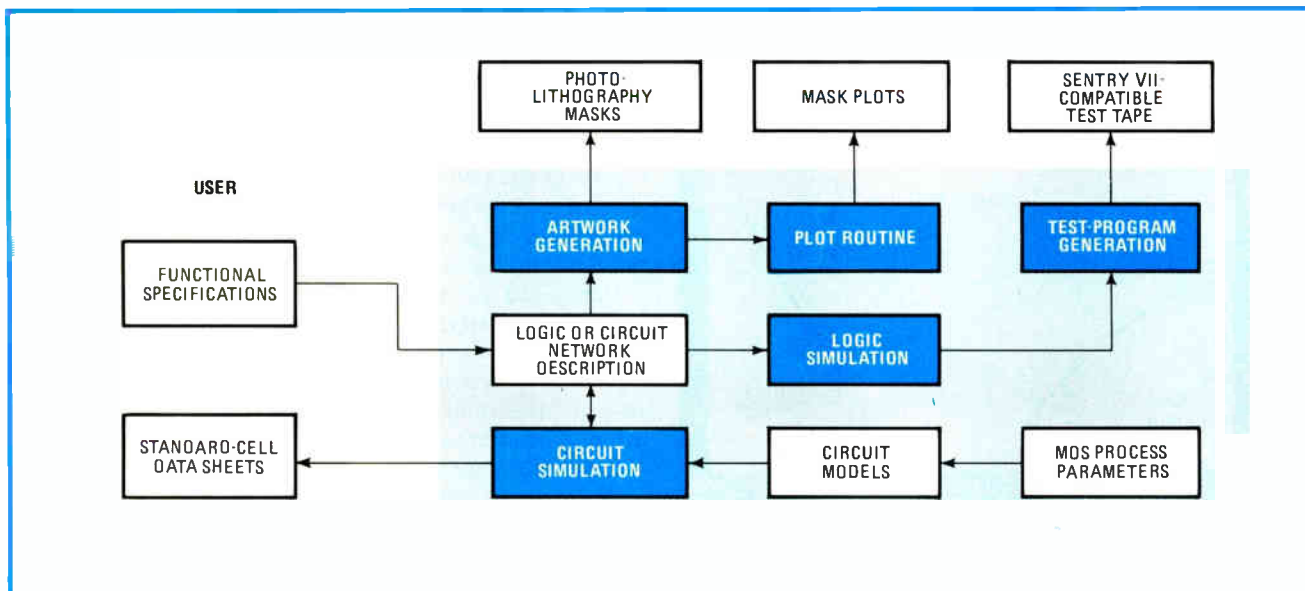

1. All bets covered. The Zyp design system transforms logic descriptions from the user into masks for wafer fabrication. The software modules (color) are combinations of original programs and existing CAD tools. In addition to photomasks, the system provides test tapes.

OMATION AUTOMATION AUTOMATION

based on the characteristics of the actual silicon implementation of the standard cell network. The net delay of each cell is modeled as the sum of an intrinsic delay and a load-dependent delay.

The intrinsic delay of a cell depends on its design and the temperature and voltage of operation, but not on the way the cell is interconnected in the network. The load-dependent delay accounts for capacitive loading and varies with the design, temperature, and voltage.

Initially, the logic simulator calculates the total capacitance at a given node in the network by adding the input capacitances of all the cells driven by that node, without regard for parasitic wiring capacitance. After the artwork has been generated, the interconnection capacitance at each node can be calculated and fed back to the logic simulator for a final check.

The logic simulator adds the load-dependent and intrinsic delay components at 25°C and 5 volts to find the nominal total delay. By using derating curves, this delay can be adjusted to predict performance at other ambient temperatures and power-supply voltages. Correlation studies show that the timing simulations and actual measured delays agree within about $\pm 10\%$ over a wide range of ambient temperatures (-55° to 125°C) and supply voltages (2 to 10 v).

Generating artwork

Once the system designer is satisfied with the network of standard cells, the network listing goes to the artwork-generation software. The initial output from this software is a cell-placement and routing diagram.

A Zymos technician works with this diagram on a computer to adjust the placement of certain cells, to specify the chip's aspect ratio for improvement of area efficiency or to fit the chip to a given package, and to

minimize the interconnection capacitance on a given node to meet speed objectives. The artwork-generation software accepts each of these constraints and generates new placement and routing diagrams. Once placement and routing are set, a data-base tape is automatically prepared, from which masks are fabricated.

As mask tooling and prototype circuits are being fabricated, the output from the logic simulator is processed by software that creates a test pattern compatible with the Fairchild Sentry VII tester.

Favorable economics

The direct development costs of a custom circuit using the Zyp system are much less than for a fully custom design and only slightly more than for a gate-array design. The indirect cost of turnaround time is substantially less than for the other approaches.

Zymos will deliver packaged, tested prototype circuits eight weeks after the user submits a verified logic description to the system. Assuming one month for verification of the design by the user, this system approach takes no longer than the 12 to 15 weeks specified for gate-array designs and is far faster than the 22 to 30 weeks required to turn a logic diagram into a fully custom chip.

Furthermore, because the circuit is built from well-characterized cells, the risk of a design iteration is greatly reduced. Because the system automatically generates a test program along with the mask tooling, another source of production delays is eliminated.

To minimize unit production costs, a design must minimize the area required for each transistor in the circuit. Since hand-drawn fully custom circuits offer the most efficient use of chip area for a given set of design rules, each standard cell in the design system is hand-drawn, giving the minimum possible area per transistor.

The Zyp system reserves space for interconnecting the cells and does not permit transistor placements there, so its ICs typically require from 10% to 20% more area per transistor than do fully custom designs. Still, this margin is substantially better than with the gate-array method, which usually gives 50% to 100% larger designs than a fully custom layout does.

Compared on the basis of production volume and circuit complexity, gate arrays and semicustom and fully custom designs each can make economic sense (Fig. 3). Gate arrays become more expensive than Zyp-designed systems as circuit complexity increases. The inefficient use of silicon area and associated high production costs of a complex gate array are the reasons.

As circuit complexity increases, the Zyp system becomes more economical than fully custom designs for an increasingly wide range of production volumes. The cost of designing a fully custom circuit goes up approximately exponentially with increasing complexity whereas the Zyp cost increases approximately linearly. □

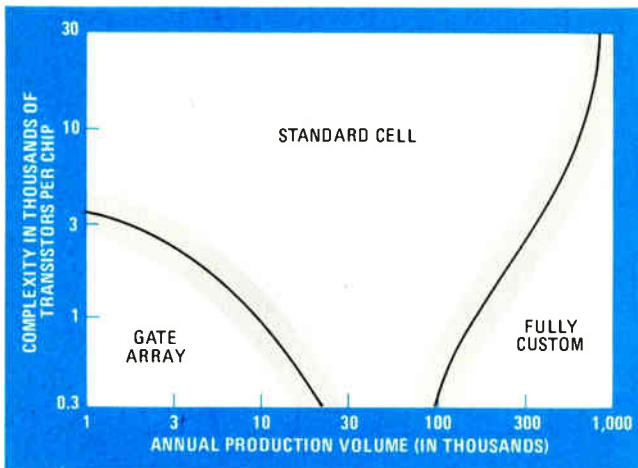

2. Best buys. The semicustom approach pays off for a wide range of production volumes when chip complexity increases. Gate arrays are least expensive only for simpler chips at low production volumes, and fully custom designs are justified only for the highest volumes.

Structured logic-design system is fast and affordable

Early simulation separate from timing verification speeds design; structuring the task hierarchically pares computing power needed

by Dean Miller and Jeff Rubin, *Valid Logic Systems Inc., Sunnyvale, Calif.*

□ Separating timing verification from logic simulation and providing support for structured design methodology makes possible a fast, affordable set of computer-aided design tools for logic. More than 50% of the effort involved in the design of digital systems is devoted to this task, but CAD tools so far have been used primarily for hardware design. The CAD logic tools available have not fully satisfied the needs of the designer, and they have been relatively expensive to use because of the computing power they require.

The Scald (for structured computer-aided logic design) system can run on a variety of computers, as can the new CAD hardware tools. Because it permits full validation of the logic design before hardware implementation, it makes possible the building of more reliable integrated-circuit and board-level systems faster and cheaper than before.

Many benefits

A validation technique that will exercise circuits throughout the design process permits detection and correction of errors at an early stage. This reduces the time and cost required to develop a product and increases the likelihood that field units will be error-free.

In one application, the Scald system uses a VAX-11/780 to simulate a typical system of 25,000 gate equivalents at a rate of four cycles a second. Using a larger IBM 370 or equivalent, the simulation speed is several times faster.

Logic simulation at this speed makes it practical to model large systems for relatively long periods of operation and hence to debug complex microcode as well as hardware. Debugging microcode during hardware design is important, since it may become necessary to make hardware changes to solve problems found in the code. Though design-automation tools potentially save development money by catching errors, they must not cost too much in time and money themselves.

The Scald system, to be available early next year, will facilitate a structured approach to design, in which the task is broken down into distinct modules. It will separate logic simulation and timing validation as part of a complete logic design package (Fig. 1) with a graphics editor for entry of schematic drawings and on-going interactive editing for design refinement, a compiler for expanding schematics in terms of device libraries, and a postprocessor for creating a data base for layout of either printed-circuit boards or ICs.

Logic simulation, as it is being done today, is relatively expensive and difficult to use. Large mainframe computers, and even supercomputers, are run for long periods to simulate reasonably large systems at great cost in computer time. Creating and maintaining the simulator models is often cumbersome, and simulators, in general, are batch-processing oriented, lacking the flexibility of interactive systems.

The Scald system attacks these problems on many fronts. For example, the logic simulator is event-driven. Instead of evaluating the entire system design at small

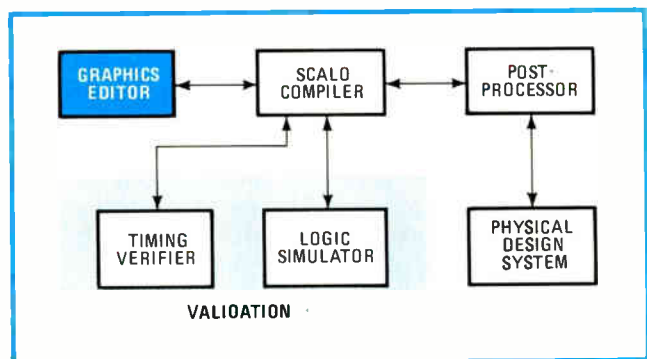

1. Logic tool. The Scald design-automation system for logic design reduces the cost of building digital systems. Validation has been separated into two independent functions, simulation and timing verification, providing better results in less time.

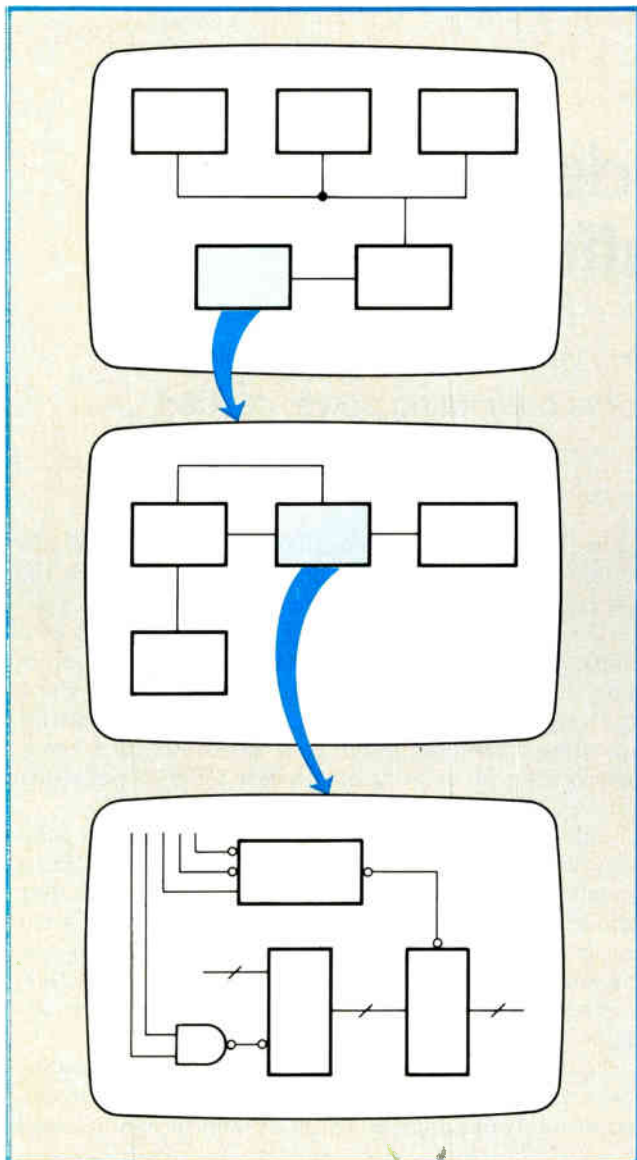

2. Structured. Systems may be represented by a hierarchy of schematics starting with a top-level block diagram. Each module is defined by a schematic at a lower level. The result is a complex system with only necessary detail shown on any one drawing.

fixed time intervals, it repeatedly advances time by the appropriate amount to reach the next signal change. Event-driven simulators are inherently faster than fixed-interval units and take much less computing power.

The system allows designers to design at many different levels of complexity using a structured design approach. A structured logic design, like a structured program, consists of easy-to-understand hierarchically organized modules that communicate through well-defined interfaces. Modules are defined once and may be used many times throughout the design.

Hierarchy is a fundamental part of structured logic design—a hierarchical design is one in which each module is defined in terms of a set of lower-level modules (Fig. 2). Complexity can be reduced by designing a system from the top down, and lower-level modules can be designed and verified by several designers working more or less independently.

The front end of the system is the graphics editor. The designer enters schematics on a high-resolution cathode-ray-tube terminal by using a keyboard and a graphics tablet. Since the system supports hierarchical design, the first schematic entered actually may be a block diagram of the system and may refer to many modules yet to be defined. The designer then draws each of these modules and continues refining them until the design is expressed entirely in terms of components that can extend down to the device level.

Graphical language

The graphical input language lets the designer refer to multi-bit-wide components and buses as single entities. In one small example, to construct a 32-bit-wide register using four 74LS273 octal flip-flop chips, the designer simply draws one D-type flip-flop and marks it to be 32 bits wide (Fig. 3a). The system automatically ties together the clock and clear inputs and treats the data input and output lines as 32-bit buses. The schematic in Fig. 3b is what the designer would have had to enter if the system did not have the multiplying capabilities.

The compiler expands the design to form a data base that shows the interconnection of the components, drawn from a component library. It iteratively substitutes the appropriate module definition for each module referenced in the schematic until the design is expressed entirely in terms of components from the library. During the expansion, the compiler checks to see that module interface conventions are used consistently.

The postprocessor uses the expanded design to generate a data base for use by existing layout design systems that may handle a wide range of technologies. It can turn out interconnection and layout data for a pc-board design or an IC mask maker.

Even during the early design stages, the system user can validate the design by independently using the timing verifier and the logic simulator. Traditionally, logic simulation has been used to detect both timing and logic errors, and this eats up computer time.

Timing verification neatly separates the problem of verifying timing behavior from that of verifying logic behavior and consequently greatly enhances the logic simulator's efficiency. A timing error exists in a clocked digital system when, for example, a data signal does not have time to settle before a clock pulse occurs. In timing verification, it is primarily the timing, rather than the values, of the data signals that is of interest.

The timing verifier provides a complete check of the

Using the simulator

A simple logic simulation would be the circuit in the figure, a 4-bit Fibonacci-number generator. It generates numbers in the Fibonacci series; that is, **numbers** whose values are the sums of the preceding **two numbers**. The first two numbers in the series are defined to be 0 and 1, so the subsequent numbers should be 1, 2, 3, 5, and so on.

The purpose of the zero detector module is to generate a logic 1 on the Z output for use as a carry signal to the adder when all bits on both inputs are 0. The implementation details of the zero detector are not shown at this level.

The circuit is initialized with the value of each output signal set to 0. Then the user tells the logic simulator which signals are to be displayed and for how long simulated time is to be advanced. The signals of interest are: FIB (the current value of the Fibonacci series) and EARLY FIB (the value that will become FIB one clock later). For this simulation, only these two signals are selected for display. The clock period (specified on another schematic) is 200 nanoseconds, and the user wishes to examine the state after each period. So the step is set to 200 ns.

The table shows the results of the simulation after several clock periods. Initially, both FIB and EARLY FIB were 0 and therefore the zero detector generated a carry input to the 4-bit adder.

After one clock period (at 200 ns), the first number in the series appears on FIB and the second appears on EARLY FIB. Since both inputs to the zero detector are no longer 0, the carry into the adder is set to 0. On each successive cycle, the value of FIB will be the sum of the preceding two values.

Time (ns)	FIB	EARLY FIB
0	0	0
200	0	1
400	1	1
600	1	2
800	2	3
1,000	3	5

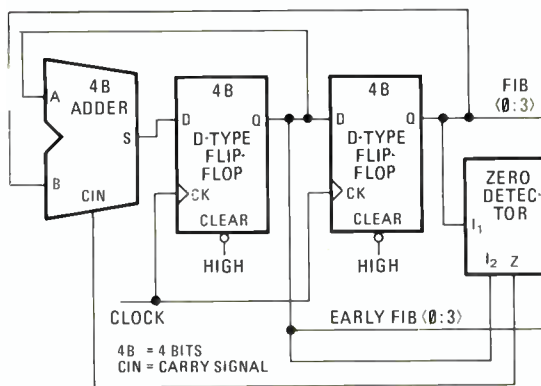

timing behavior of a clocked digital system based on timing specifications of components in the library. It ensures that the design is free of race conditions, setup and hold-time errors, pulse-width errors, and clock glitches. It easily verifies incomplete designs, providing continuous feedback about timing problems as the design progresses.

Working from libraries that define ranges of possible device delays in schematic form and from an optional data base that defines interconnection delays, the verifier checks the timing behavior of a design for all possible sets of delays. A design that verifies correctly has no possibility whatever of including any timing error—regardless of which devices or batches of devices will be used in the system—as long as every component used meets its library specifications.

This validation approach capitalizes on the independence of timing and logic verification. A circuit is determined free from timing errors for all possible input conditions, not just for some small set of cases selected by the designer or forced by the initial state of the digital system. Simulators that combine timing verification and logic simulation must contend with a much longer testing process because the entire logic-simulation sequence

must be rerun each time a timing change is made.

After the timing is verified, the only question that the logic simulator need answer is whether the logical behavior is correct for one set of delays. The logic simulator efficiently simulates designs, expressed as schematics in the common data base, using models that are natural for the designer. It provides an interactive user interface that helps locate logic errors quickly.

Interaction

The interactiveness of the simulator gives the designer the power to change the debugging plan dynamically in response to new information. It eliminates the need to devise a complete scenario for the simulation run before its initiation and avoids much superfluous output since the designer can restrict the display to contain just the signals of current interest.

The level of detail of the simulator building blocks greatly affects both simulation speed and ease of use. The Scald system simulates at the component or device level, which is an appropriate level for the simulation of large system designs.

In this approach, the building blocks used by the simulator are roughly at the same level as those used by

INFORMATION AUTOMATION AUTOMATION

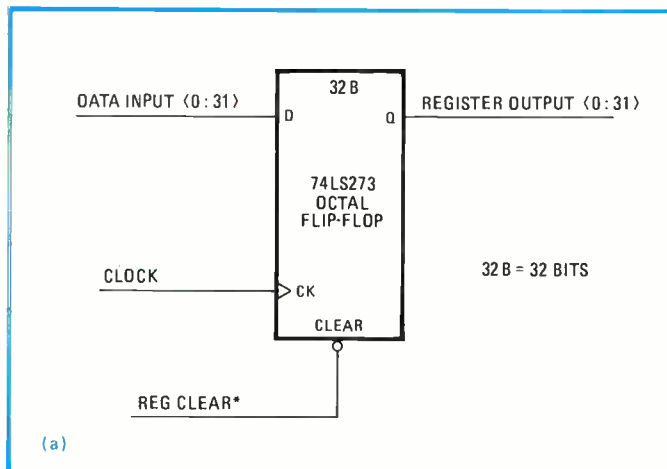

3. Simplicity. The design system permits the designer to draw a device once and simply indicate the bit width required exactly as shown in (a). Otherwise, each component and wire would have to be drawn in full detail, as shown in (b).

the designer in his schematics. The simulation primitives might be gates, flip-flops, gate-array macrocells, multiplexers, or adders, and may range up to arithmetic and logic units or even random-access memories. Component-level simulation permits a device like a 4-bit bidirectional universal shift register to be modeled by only two building blocks rather than as more than 60 gates.

Component-level simulation uses models that are simpler and easier to understand than procedural models of high-level modules, such as caches, register files, or ALUs. Also, it is much faster than simulation performed at the gate or analog device level.

The logic simulator first initializes the system being simulated to a fixed state and waits for a command from the user. Typically, the design contains some memory so the user initializes its contents by directing the logic simulator to load memory-image files, which might be produced by a microassembler. After loading the memory files, any other initialization may be done by specifying individual buses to change. Then, simulated time can advance one event at a time for as long as desired.

It is frequently necessary to provide an external stimulus to a design—a simulated disk data stream, for example. This may be done by the operator, through a command file, or in many cases by simulating an additional circuit specially drawn to provide a stimulus. There is no need to manufacture the stimulus circuit; it is there only during simulation to drive the main design.

Command files may also be used to exercise a design in a way that is analogous to a diagnostic program. The files provide the circuit stimulus and check certain signals for correct values. This capability allows the designer to verify that previously checked-out circuits are still working correctly after design modifications, because command files are stored for repeated use. □

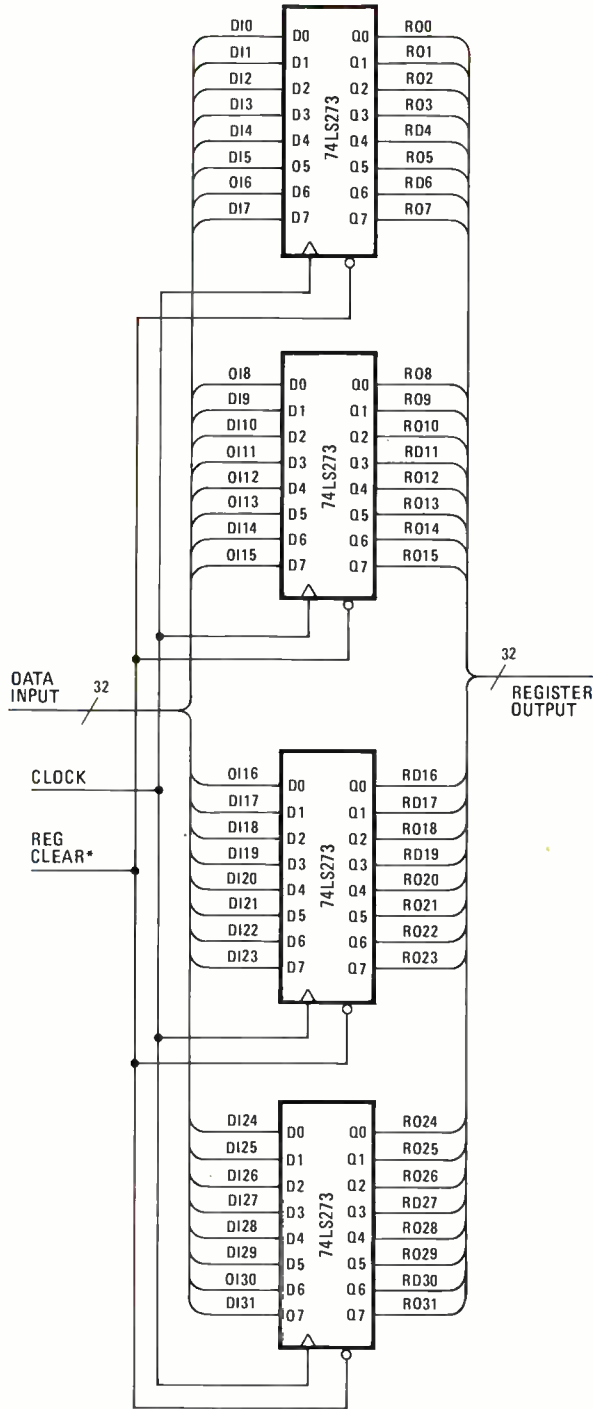

M-OV advance on 3 fronts!



Smaller

Now M-OV magnetrons are even smaller than ever.

This magnetron proves that solid-state devices must now compete with magnetrons on size as well as performance!

The M-OV E3469 for example (pictured here) gives 400 watts peak power from a unit that is only 10 cubic centimetres and weighs 50 grams.

The E3469 is small, but it certainly isn't weak.

A resonant frequency of 15kHz gives it excellent vibration performance, not to mention the pounding each magnetron gets in tests *before* it leaves the factory. Ruggedness is built in.

Brighter

M-OV's range of high resolution CRT's for military surveillance use includes this 1 inch diameter tube with 1,000 lines resolution and remarkable visual clarity, thanks to M-OV's rigorous technical development.

Electrostatically deflected, it gives a performance comparable with electromagnetic tubes but of course does not use coils. Infra-red facilities can be attached.

The tube is small and light so it is especially suitable for battlefield man-pack surveillance roles, and scores on costs too! Get in touch with M-OV to find out more.

Faster

The severe danger that exists to military systems from potential EMP is well known and requires very high technology to combat it.

That's why this tiny, but very very fast surge arrester is essential to security forces. This metal-ceramic protector reacts within nano-seconds without the high capacitance penalty of semiconductors. Get to know more from M-OV.

This new brochure on M-OV Magnetrons, CRT's and Surge Arresters is available from M-OV at Hammersmith. Send for your copy now.



M-OV

A MEMBER OF THE GEC GROUP

S&C

THE M-O VALVE CO LTD, HAMMERSMITH, LONDON W6 7PE, ENGLAND. TEL 01-603 3431. TELEX 23435. GRAMSTHERMIONIC LONDON

S.744

Circle 122 on reader service card

Bi-FETs expand applications for general-purpose op amps

by Jim Williams
National Semiconductor Corp., Santa Clara, Calif.

With their excellent low-power consumption and low drift, bipolar field-effect-transistor operational amplifiers easily outperform general-purpose (741-type) op amps in a variety of applications [*Electronics*, Nov. 3, 1981, p. 134]. A low-power voltage-to-frequency converter, a battery-powered strip-chart preamplifier, and a high-efficiency crystal-oven controller can also benefit from those qualities of the 441 op amp.

The voltage-to-frequency converter (Fig. 1a) provides linearity to within 1% over the range of 1 hertz to 1 kilohertz. What is more, it does not need an integrator-resetting network using an FET switch, and its current drain is only 1 milliamper.

Integrator A_1 generates a ramp whose slope is proportional to the current into the amplifier's summing junction.

The ramp's amplitude is then compared with the 1.2-volt reference at A_2 , which serves as a current-summing comparator.

When the instantaneous amplitude of the ramp exceeds -1.2 v, A_2 's output goes low, thereby pulling current from A_1 's summing junction. This pulling, aided by diode D_1 , causes A_1 's output to drop quickly to zero. D_2 biases A_1 's noninverting input, providing temperature compensation for the amplifier. These diodes and D_3 are 1N4148 parts.

The 2-picofarad capacitor at A_2 ensures that the output of the amplifier will remain high long enough to completely discharge the 0.01-microfarad capacitor at A_1 , thus doing the job of the integrator-reset mechanism. As for calibration, the output is easily adjusted with the 1-megohm potentiometer for a 1-kHz output that is given an input voltage of 10 v.

The 441's low-bias current and its low-power consumption can also yield a simple and flexible preamplifier for strip-chart recorders (Fig. 1b). The circuit is powered by two standard 9-v batteries and may be plugged directly into the recorder's input. As a result, common-mode and ground-loop difficulties are minimized. The gain is variable from 1 to 100, and the time

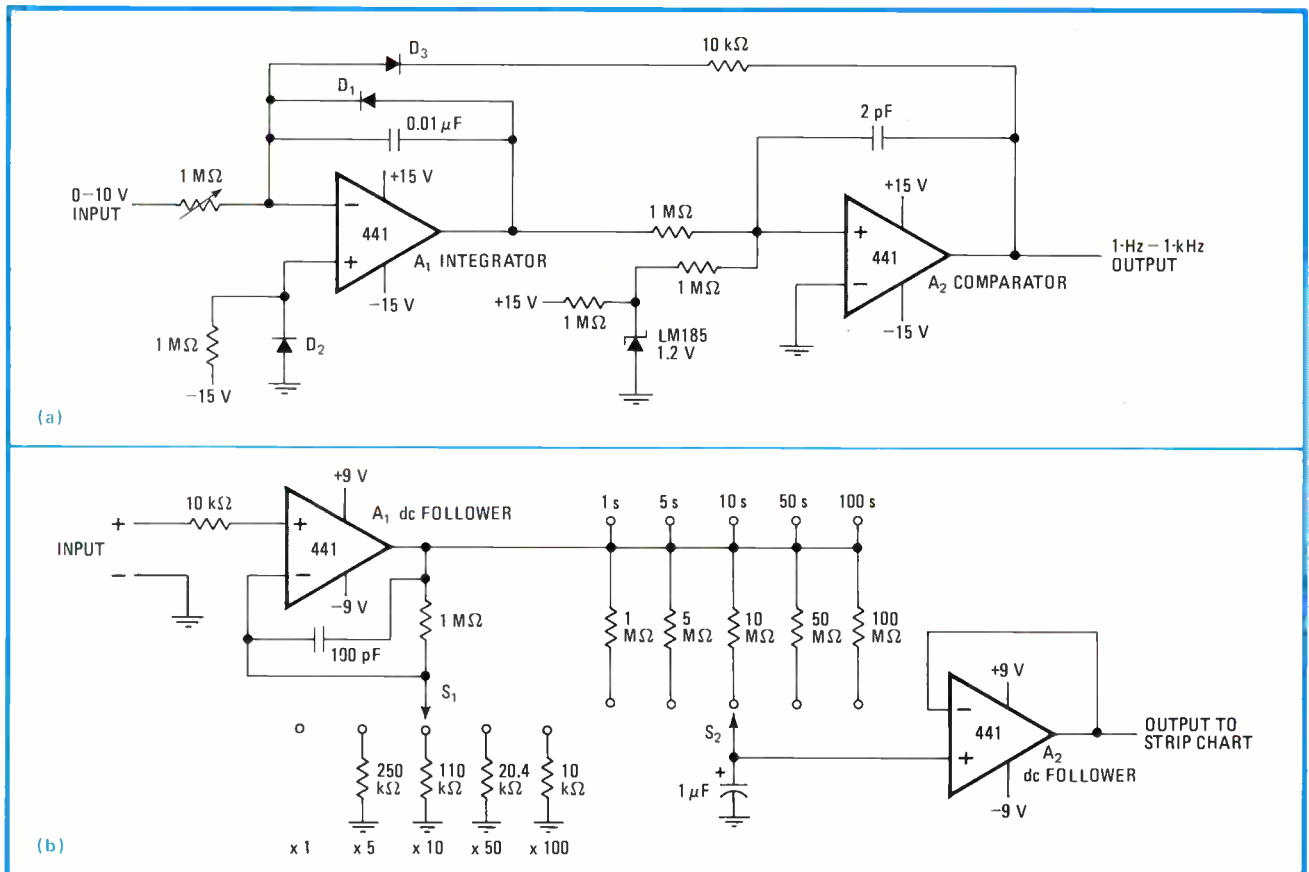

1. Low current, low cost. A voltage-to-frequency converter and preamplifier for strip-chart recorders may be built with the 441 bi-FET op amp. Converter (a), which is easily reset by a capacitor at A_2 , provides linearity within 1% over a 0-to-1-kilohertz range and draws only 1 milliamper. A battery-powered preamplifier (b) has an adjustable gain and time constant. The circuit draws less than 500 microamperes.

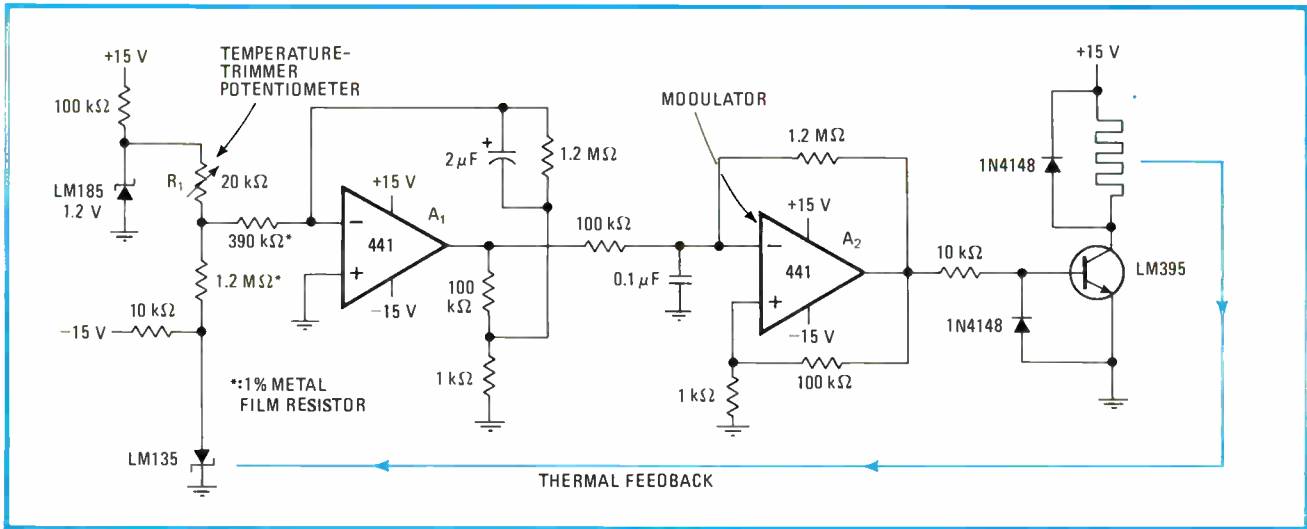

2. Heat switch. This feedback-type controller, using a switching modulator to conserve power, maintains the crystal temperature at about 75°C. Temperature, which may be trimmed over a 4°C range with potentiometer R₁, can be held to within ±0.1°C for a long time.

constant is adjustable from 1 to 100 seconds.

Input amplifier A₁ operates as a dc follower with gain. The gain has five ranges and is selected by S₁. The operational amplifier's input impedance is extremely high (10¹² ohms) and consequently bias-current loading at the input is around 50 picoamperes. The 10-kilohm resistor in the input line provides current limiting under fault (overloaded input) conditions.

A₂, a second dc follower, buffers the RC filter composed of five resistors and a capacitor. The time constant is selected by switch S₂. This circuit draws less than 500 microamperes, ensuring long battery life.

The efficiency of the crystal-oven controller circuit (Fig. 2) is improved by having power switched across the heater element, instead of using a conventional linear-control arrangement. Oven temperature is sensed by the LM135 temperature sensor, whose output varies 10 mil-

ivolts/°C; thus its output will be 2.98 v at 25°C. This signal, converted into current as it flows through the 1.2-MΩ resistor, is then summed with a current derived from the LM185 voltage reference.

A₁ amplifies the difference between these two currents and drives A₂, a free-running duty-cycle modulator, over several kilohertz of frequency to power the output transistor and the heater.

Generally, when power is applied to the circuit, A₁ attains a negative saturation, forcing A₂'s output to a positive one. The LM395 then turns on and the oven warms. When the oven is within 1°C of the desired setting, A₂ becomes unsaturated and runs at a duty cycle dependent upon A₁'s output voltage. The duty cycle is determined by the temperature difference between the oven and the setpoint. For the given values, the circuit will maintain an oven temperature at 75°C, ±0.1°C. □

Swapable fiber-optic parts ease isolation problems

by Jim Herman
Motorola Semiconductor Sector, Phoenix, Ariz.

Assembling opto-isolators from their component parts to meet various high-voltage, high-frequency applications is now simplified with the introduction of interchangeable fiber-optic emitters and detectors. These devices can be built at a lower cost than conventional hybrids.

Therefore, systems such as a simple and effective 25-megahertz analog transmission channel and a 20-megabit-a-second emitter-coupled-logic data-handling system, which provide ac and dc isolation up to 50,000 volts, may be easily constructed.

A light-emitting diode and an optically-coupled photosensitive detector make up the basic optical isolator (Fig.

la, p. 124). The plastic cable-splice bushing and plastic retainer caps housing the ferruled emitters and detectors are manufactured by AMP Inc., Harrisburg, Pa. When assembled, the components form an isolator that measures 0.75 inch long and 0.5 in. wide.

Characteristics of the isolator are determined by the selected emitter and detector. In particular, the interchangeable detectors provide the designer with several options that include interfacing with TTL or ECL loads, wide bandwidths, and analog or digital formats. The isolation voltage of the device is directly related to the separation between the LED and the detector, the package material, its size and shape, and the value of the parasitic capacity (C_c). This capacity determines the amount of ac protection.

The actual isolation (breakdown) voltage may easily be determined by measuring the voltage potential across the isolator from input to output at a prespecified leakage current such as 80 microamperes.

The coupler (1b) contains light pipes that provide efficient coupling while maintaining a large separation

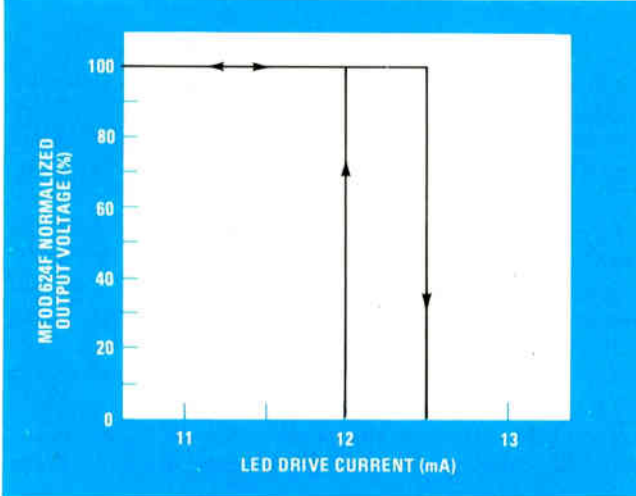
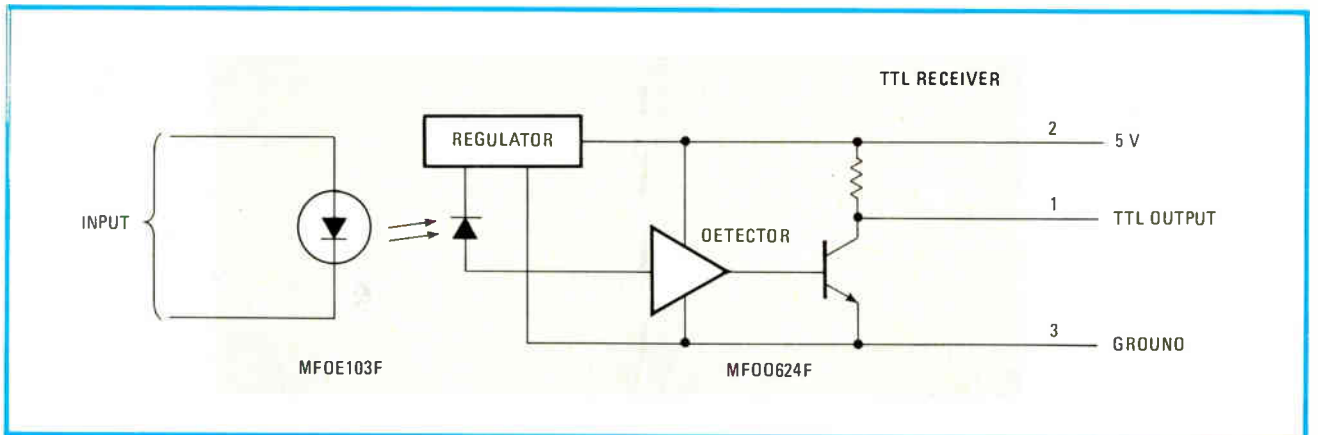
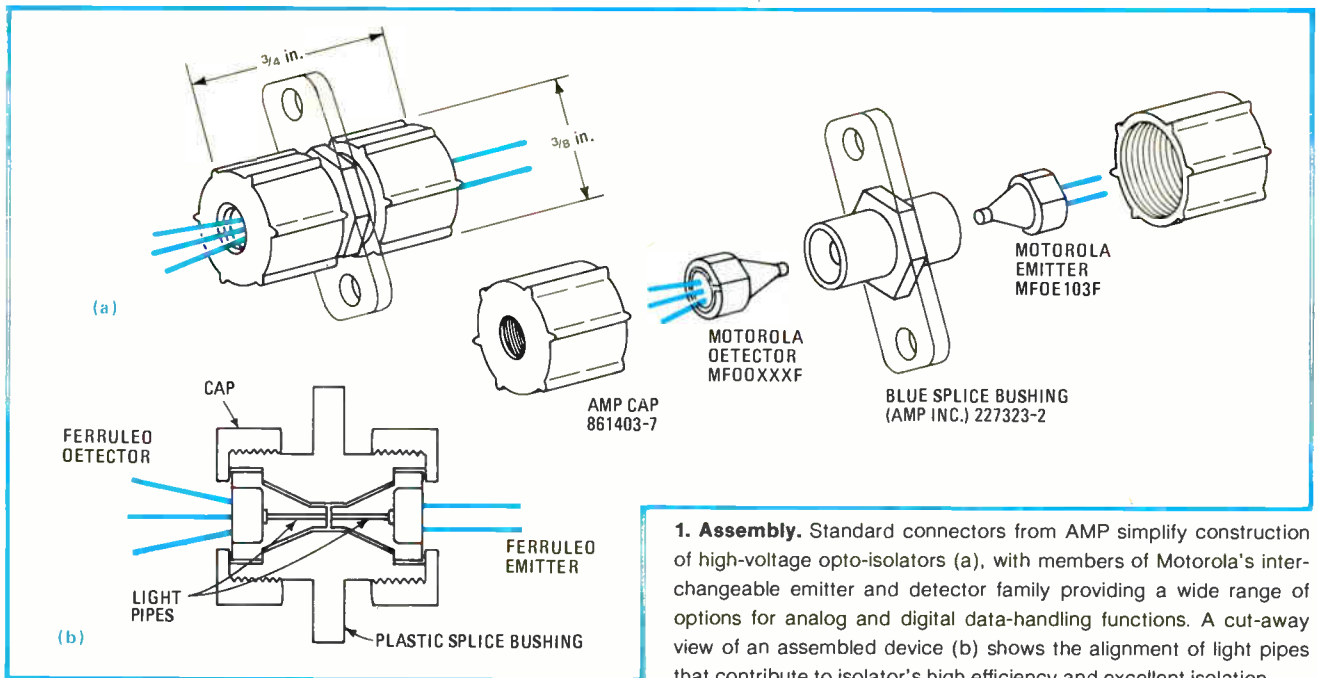

2. Applications. An isolator that can handle 500-kb/s data rates for TTL loads is configured with the MFOE103F emitter and MFO0624F detector. The device's transfer function is also very sharp. Replacing the receiver with a 404F detector converts the unit to one that delivers a 10-Mb/s data rate. When the MFOC600 receiver is added, an isolator will provide 20-Mb/s data rates to ECL loads.

between the emitter and detector. As a result, the input and output have excellent ac and dc isolation. A wide selection of emitters and detectors are available.

Among the devices that may be readily assembled is a 25-MHz analog isolator built with the MFOE103F emitter and the MFO0104F pin detector. The transfer function of this device will be linear, providing a 0-to-20- μ A pin-diode output for a 0-to-75-milliampere LED driving current.

Similarly, a 500-kilobit TTL isolator, Fig. 2, is easily built with the MFOE103F emitter and the MFO0624F integrated receiver. For wider bandwidths, the MFO0404F integrated detector preamplifier and the MFOC600 receiver circuit may be used. This combination will provide 10-Mb/s data rates for driving TTL loads or 20-Mb/s rates for driving ECL loads. In addition to high-voltage optical isolation, this isolator will also provide automatic gain control to stabilize output signals and an analog output port for status monitoring. □

Designer's casebook is a regular feature in *Electronics*. We invite readers to submit original and unpublished circuit ideas and solutions to design problems. Explain briefly but thoroughly the circuit's operating principle and purpose. We'll pay \$75 for each item published.

Low-cost 12-GHz receiver heralds satellite-to-home TV

Gallium arsenide MES FETs are basic to a low-noise unit that requires an antenna only 1 meter in diameter

by Peter Harrop, Paul Lesartre, and Christos Tsironis, *Laboratoires d'Electronique et de Physique Appliquée, Limeil-Brévannes, France*

□ Home television sets could soon be picking up broadcasts directly from satellites. Scientists in France have designed a low-cost microwave receiver that will need only a low-cost 1-meter antenna to be commercially feasible. The research effort was stimulated by experiments with the European Orbiting Test Station and the Japanese satellite Yuri, which confirmed that high-power geostationary craft transmitting at 12 gigahertz could provide sufficient signal-to-noise ratio for a quality picture. To gather further data on the concept, France and Germany plan a joint 1984 launch of two preoperational 12-GHz satellites.

The envisioned system will comprise outdoor and indoor units, according to the design from the Laboratoires d'Electronique et de Physique Appliquée in Limeil-Brévannes, near Paris. The heart of the outdoor unit is an amplifier—actually a gallium arsenide metal-semiconductor field-effect transistor—that is not only state-

of-the-art but by now is also practical for the consumer market. The design and operation of this amplifier is best understood in the context of the requirements of the outdoor system.

Outdoor requirements

The outdoor unit is typically fixed at the focal point of the antenna and converts the 12-GHz input signal into a 1-GHz intermediate-frequency signal that is then transmitted to the viewer's indoor unit. GaAs MES FET technology is particularly suitable for the outdoor unit because it can simultaneously operate with low noise, high frequency, and high amplification. To bring the satellite signals to the viewer, the indoor unit receives the fm-modulated signal from the downconverter, selects a channel, and demodulates it. At that point, the signal may either be converted into a-m in the band for the antenna socket of the TV set or be directly injected into

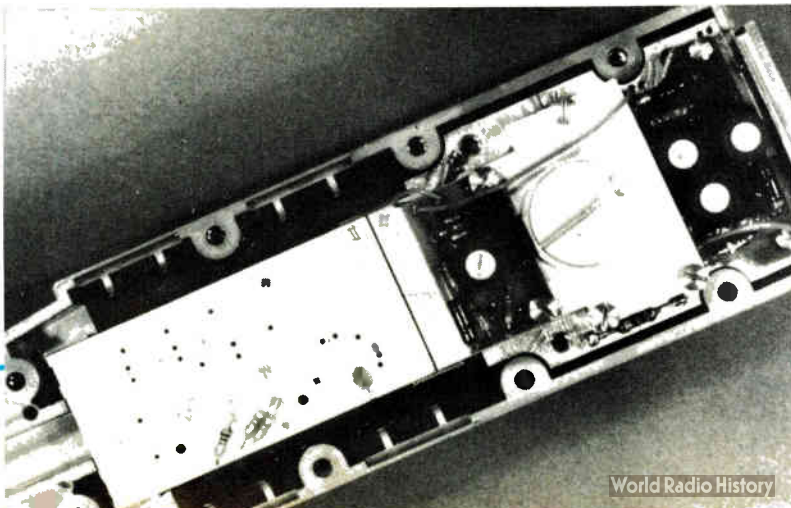
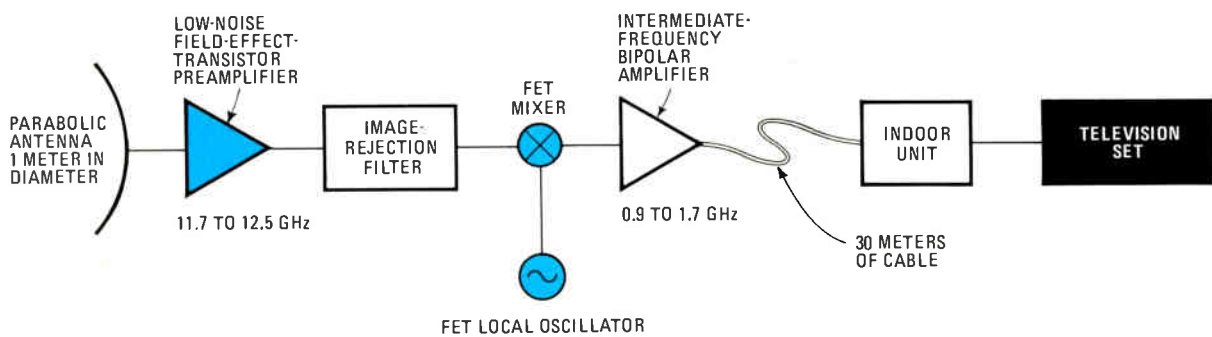

1. Multipurpose. In the Philips satellite-to-home receiver-downconverter, the MES FET plays a major role. Here it performs the functions of low-noise 12-gigahertz preamplification, downconversion from 12 to 1 GHz, and 11-GHz oscillation.

the receiver's standard video and audio circuitry.

The implementation of the outdoor unit is suited to the map of Europe, crowded with countries that look small at the range of a geostationary satellite. The frequency allocations created by this particular geography will no doubt markedly affect the next decade of innovation in satellite-to-home TV systems.

In 1977, the World Administrative Radio Conference allocated five 27-megahertz channels to each European country in one of the two subbands of 11.7 to 12.1 GHz and 12.1 to 12.5 GHz. It specified that the TV signals in these bands will be fm-modulated but may include more than one sound channel for different languages. (These channels may also be digitally coded.) The overlapping frequencies due to Europe's geography will cause spillover of satellite radiation patterns onto neighboring countries. Thus, viewers in closely adjoining areas will be able to receive not only their own five national programs, but also programs from neighboring countries.

2. Transitions. The receiver-downconverter is housed in a metalized plastic case and requires no temperature control. A waveguide-to-microstrip transition passes the 12-gigahertz input signal to the MES FET amplifier mounted on an alumina substrate measuring 2 inches by 1 in. The MES FET oscillator can either be electrically tuned or mechanically adjusted using the screw shown.

Regardless of the country or frequency band, it is likely that three reception systems will exist simultaneously to meet the European requirements. The first system is planned for community reception, whereby one ground station feeds a large number of houses. The second will operate with a collective reception scheme whereby one ground station supplies a block of houses or a small residential area. And finally, individual reception will be set up, each house equipped with its own antenna.

The specification the WARC recommends for the first two systems is an overall figure of merit of 14 decibels per Kelvin, derived by dividing the antenna's gain by the total system noise temperature (G/T). Individual systems will be required to have a G/T of 6 dB/K. All of these specifications can be met by a system based on a GaAs MES FET.

Interference reduced

In all these systems, since some channels overlap in frequency, circular-polarization microwave receivers must be employed to minimize potential interference problems. The second major source of interference comes about because proposed satellites, situated in one of four orbital positions, will transmit at a relatively high power. In fact, the effective radiated power per channel is about 60 dBW. Thus, the high-cost, high-technology requirements have been designed into the satellite side of the link, so that the specifications on the receiver end are relaxed—cutting the consumer's cost considerably.

Although cost counts, the absolute measure of any receiver is its capacity to present high-quality TV pictures on a standard TV set. Subjective as this criterion may be, it can in fact be defined in terms of a measurable signal-to-noise ratio at the TV receiver's input, which, by transposition up the receiver chain, may be specified in terms of the overall receiver's figure of merit—16 dB. Consequently, the minimization of the noise figure of any 12-GHz downconverter is fundamental to the receiver's performance.

There are four basic functions performed in the receiver's front end. These are 12-GHz filtering and low-noise

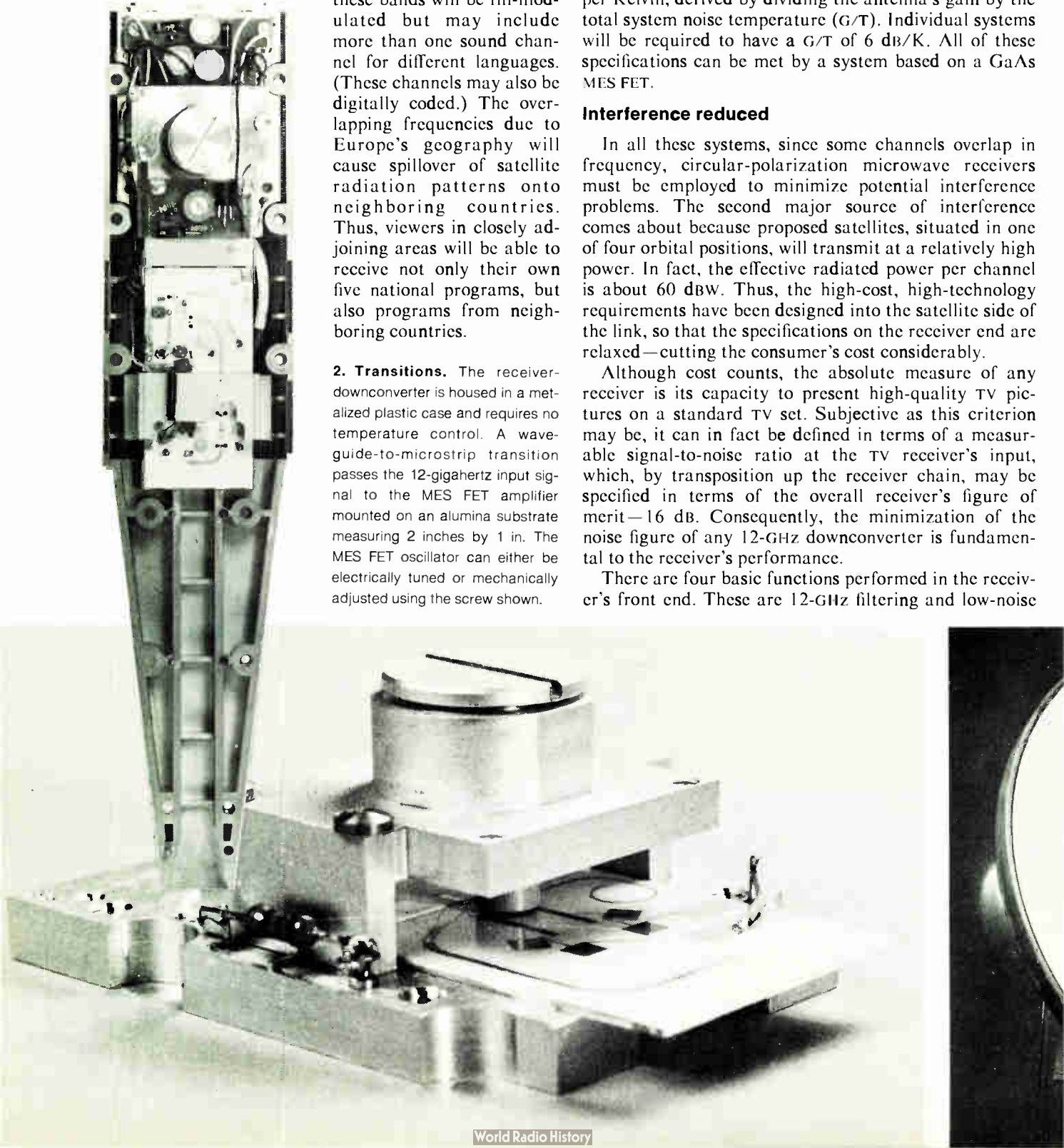

amplification (which is optional), 11-GHz stable oscillation, conversion from 12 GHz to 1 GHz, and 1-GHz i-f amplification. One system-design option involves the use of the same active component to perform all three radio-frequency functions. This is the solution LEP has proposed for the Philips industrial groups (Fig. 1).

In the Philips systems, MES FETs are used in the low-noise amplifier, the mixer, and the local oscillator. In each function, the single-gate MES FET presents particular advantages. It offers low noise in the amplifier stage, conversion gain in the mixer, and excellent temperature stability in the local oscillator.

The local oscillator is particularly steady when it is stabilized with a barium titanate dielectric resonator with the added compensating technique of voltage-controlled output power. The unit (Fig. 2) is housed in a molded, metalized plastic shell. The molding approach was adopted to minimize the hardware's price and remains relatively simple since no temperature control is necessary inside the front end. A bandpass filter is included to prevent all unwanted, out-of-band signals from impinging on the input stage.

Image rejection

A waveguide-to-microstrip transition passes the 12-GHz signal to the input of the two-stage MES FET amplifier mounted on one of two alumina substrates measuring 2 inches by 1 in. Image rejection between the amplifier and the mixer is achieved by means of a printed-circuit-board bandstop filter of the spurline type. Both the 12-GHz signal and the 11-GHz local-oscillator signal are coupled into the gate of the MES FET mixer by a directional filter. The high conversion gain of the mixer (5 dB) enables the use of an inexpensive 1-GHz bipolar amplifier, which is included on the same alumina circuit as the mixer. The local oscillator is mounted on a second substrate and its power fed through similar microstrip-waveguide-microstrip transitions, the waveguide section forming an integral part of the metalized plastic housing.

The oscillator itself uses another MES FET as the active component and its own barium titanate dielectric resona-

tor as the frequency stabilizer. It can deliver 20 mw of output power, which along with frequency is easily adjusted by varying the MES FET drain voltage. Frequency stability is better than $3 \times 10^{-6}/^{\circ}\text{C}$ (from -25° to $+55^{\circ}\text{C}$) and the pushing factor is less than 1 MHz for a 10-dB variation in output power. Frequency can also be mechanically tuned over a 50-MHz range simply by adjusting a screw over the resonator. The characteristics of the oscillator remain unchanged.

The spectral quality of the oscillator is equivalent to that of a free-running Gunn oscillator. This means that the fm noise is 1 hertz root mean square per hertz at 50 kHz from the carrier in a double-sideband measurement. This is sufficient for this application because of the relatively high i-f. The efficiency is 18% at $+25^{\circ}\text{C}$ for an output power of 22 mw.

The complete outdoor unit is mounted at the focal point of a 1-m parabola (Fig. 3). Its overall gain is 30 dB and its noise figure is 3.8 dB from 11.7 to 12.5 GHz. Over the temperature range -20° to $+55^{\circ}\text{C}$, the noise figure increases monotonically at 0.12 dB/ 10°C . One such front end has now successfully completed field trials with Yuri and the OTS and has confirmed its capacity to furnish high-quality TV pictures in extreme weather conditions. The link budget for the future French system (using the data of an all-FET front end) indicates a minimum signal-to-noise ratio of 21.5 dB, a figure high enough to ensure a clear picture.

Alternative solutions

Recent progress in MES FETs has led to the introduction of a family of devices with two Schottky-barrier gates. Indeed, these dual-gate devices are capable of simplifying many of the functions that are currently performed with single-gate MES FETs. For example, LEP has demonstrated the use of a device with two Schottky-barrier gates as a dielectric-resonator-stabilized oscillator at 11 GHz and even as a self-oscillating mixer. As an oscillator, the most recent device has loaded quality factors (Q_s) in excess of 2,000 when it is stabilized by a barium titanate dielectric resonator.

When used in the self-oscillating mixer mode, the dual-gate FET replaces both the oscillator and the mixer devices in Fig. 1, an exchange that considerably simplifies the microwave circuits in the receiver front end. In this operating mode, the device's second gate can be coupled to a dielectric resonator, while the first gate serves as the 12-GHz input.

Current front-end receiver research, at LEP and elsewhere, is directed toward a monolithic version of the FET front end where all the active components and some rf circuitry will be integrated on the same GaAs chip. This greatly reduces mounting and adjustment time and eliminates other time-consuming assembly operations. This approach is conceivable today because of progress in Czochralski GaAs growth techniques and localized ion-implantation procedures that can create large and reproducible GaAs wafers. However, the cost and material limitations of high-Q circuits, temperature-stable material, GaAs real estate costs, and production yield are considerations that ultimately will determine the degree of monolithic integration. □



3. Not obtrusive.

The outdoor receiver-downconverter is mounted at the focal point of a 1-meter diameter parabolic antenna that will be acceptable to consumers. A 30-decibel gain and 3.8-dB noise figure is achieved from 11.7 to 12.5 gigahertz.

“When are you going to get yours?”

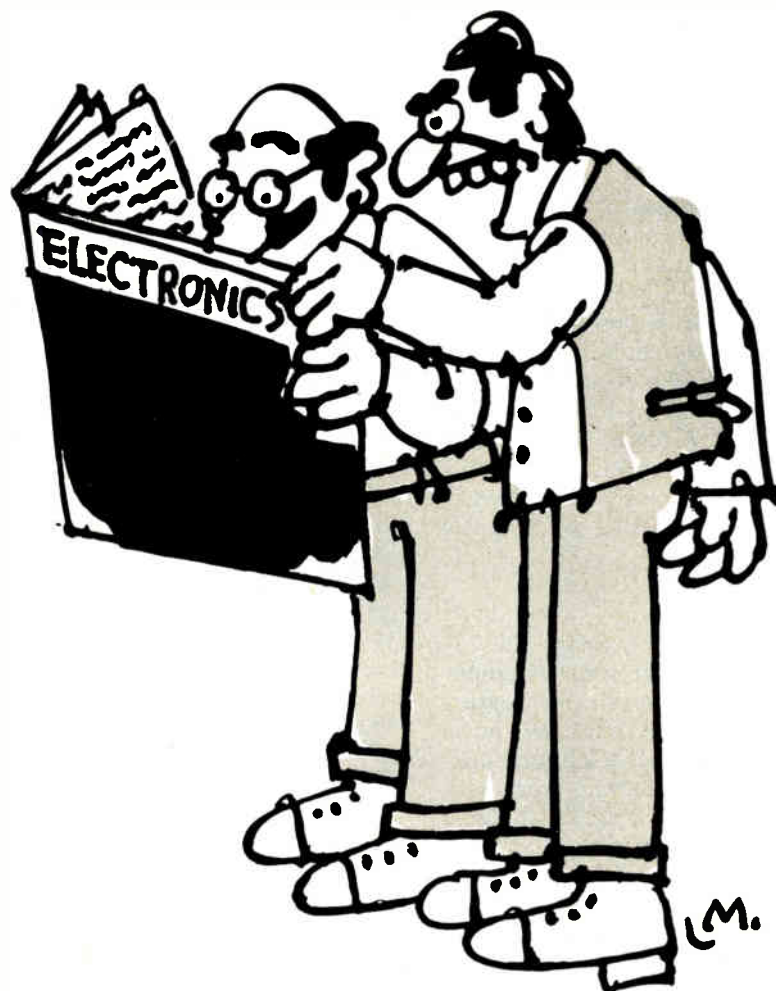

When are you going to get your very own, personal subscription to Electronics?

It could be very important to you. And we're not just referring to your status in the office hierarchy.

You (and we) are in a quick-moving business. News breaks frequently. Change is the name of the game. Awareness is the way to win.

You've got to follow what's going on beyond your specialty. Your career may have to last longer than your specialty.

If change is the game, obsolescence is the penalty for losing. Obsolescence of products, of technology and, unfortunately, of people. We can't change this fact. But we can help you cope with it.

Give us one hour of reading time every two weeks and we will keep you aware of what's going on around you and around the changing world of electronics technology.

Move up. Fill out one of the subscription postcards in this issue.

Electronics Magazine. The one worth paying for.

Data-base manager fits microsystems, avoids application dependency

Set of software tools organizes information flow, facilitates representation of data relationships, works with many operating systems, high-level languages

by Mike Gagle and Gary Koehler, *Micro Data Base Systems, Lafayette, Ind.*, and Andrew Whinston, *Purdue University, Lafayette, Ind.*

□ Data-base management systems have been reserved for mainframe computers and minicomputers, but microprocessor-based systems are ready to crash the club. Hardware advances and associated cost reductions, notably in high-capacity disk systems, can combine with the computing power offered by the new 16-bit microprocessors or with the currently popular 8-bit machines to provide microcomputer systems that can manage data as effectively as can minicomputers.

However, the missing ingredient has been the software to organize data-base management on microcomputer systems. Such programs are now available, in the form of the MDBS III data-base manager.

Unified collection

The purpose of data-base management is to provide a unified collection of software tools to store and retrieve information in a systematic manner, often in an on-line environment. A good data-base manager represents multiple, complex relationships among data items with little or no redundancy. It should also be independent of any particular application program and the specific physical representation of the data items. Of course, it should also provide a convenient and efficient means for the user to add, delete, or retrieve data and data relationships.

File management was the forerunner of data-base management. A common form of file management is the index sequential-access method (ISAM), which combines sequential-access file methods with direct-access file methods.

A sequentially organized file consists of a collection of records in which each one is stored in a sequential order based upon a criterion, such as alphabetical order. Sequential access means that a file's records can be quickly processed in the order in which they occur within the file.

A direct-access file, on the other hand, is a collection of records from which each one can be retrieved by specifying the data value of one of its fields. The time that is required to

locate a particular record is largely independent of that record's position in such a file.

An ISAM file manager uses a sequential file organization in which records can be processed in both a sequential and a random order; it also permits a certain amount of record insertion without reorganization. The file is initially created by loading the records in a sequential manner. These records must be in order, sorted by the key criterion to be used for later access (Fig. 1).

While the records are being loaded, an index is generated to permit direct access to the file. The system permits the addition of new records to the file by maintaining overflow areas. When the number of records in the overflow area becomes large, the file must be reorganized, which involves the same process used when the file was created.

A more elaborate approach

In contrast, the network data model developed by a task group of the Conference on Data Systems and Language (Codasyl) is a data-base management system. Unlike ISAM, it allows named relationships to be specified between different types of records. Each relationship has owner and member record types. Owners specify the

	NAME	KEY WORD	OVERFLOW LINK
	A TALE OF TWO CITIES	ENGLISH	
	CATCHER IN THE RYE	AMERICAN	
	CRIME AND PUNISHMENT	RUSSIAN	
	⋮		
	WAR AND PEACE	RUSSIAN	
	END OF FILE	∅	
	BILLY BUDD	AMERICAN	
	⋮		

OVERFLOW AREA

1. Sequential setup. The ISAM data-management model puts records in a single sequential order, in this case alphabetical. However, in order to find the books having a particular key word, a time-wasting exhaustive search of the entire file is required.

categories into which members may be classified.

A member can be accessed by specifying its owner, as well as a data value of one of its fields. In this way, records of one type that are related to records of another type can be easily processed. Moreover, a data base can grow and shrink without the need for the reorganization required for ISAM.

In Codasyl specifications, the relationship between owner and member record types is said to be "one-to-many." This means that a given member can be associated with only one owner, so that a many-to-many relationship has to be implemented by two one-to-many sets involving the usage of a dummy intermediate record. (Fig. 2).

The MDBS system developed by Micro Data Base Systems goes beyond Codasyl by representing the many-to-many relationships directly, and therefore eliminating the need for a dummy record to represent the many-to-many relationship (Fig. 3). Other features that greatly increase the efficiency and flexibility of this offering include the area declaration and location modes.

An area is a logical partition of the data base with a name that specifies which record types are included in it. Therefore, it allows the user to have control over the placement of the records. Security can be obtained by isolating highly sensitive data in a separate area and then imposing special control over that area. Cost can be reduced by maintaining frequently used data on high-speed devices and other data on lower speed, less costly devices.

A location mode is also definable for each record type to designate any special strategy for initial record placement in an area. One location mode, called calc, implements an address calculation scheme called hashing, which uses a key value called the calc key to store each new record.

Hashing is a way of choosing a storage address for a data item by means of a randomizing function. For instance, the first four characters in the data identifier could be treated as numbers and divided by a constant, and the result of that operation would then be used as the storage address. In this way, new data items are inserted in locations that are unlikely to be occupied. The record can be retrieved easily through specifying its calc key as its address. The use of the scheme yields high performance when specific records are desired quickly.

A second location mode is clustering. This allows efficiency to be further increased by physically clustering those records that are often accessed jointly. The MDBS location mode allows the user to choose the most appropriate storage method.

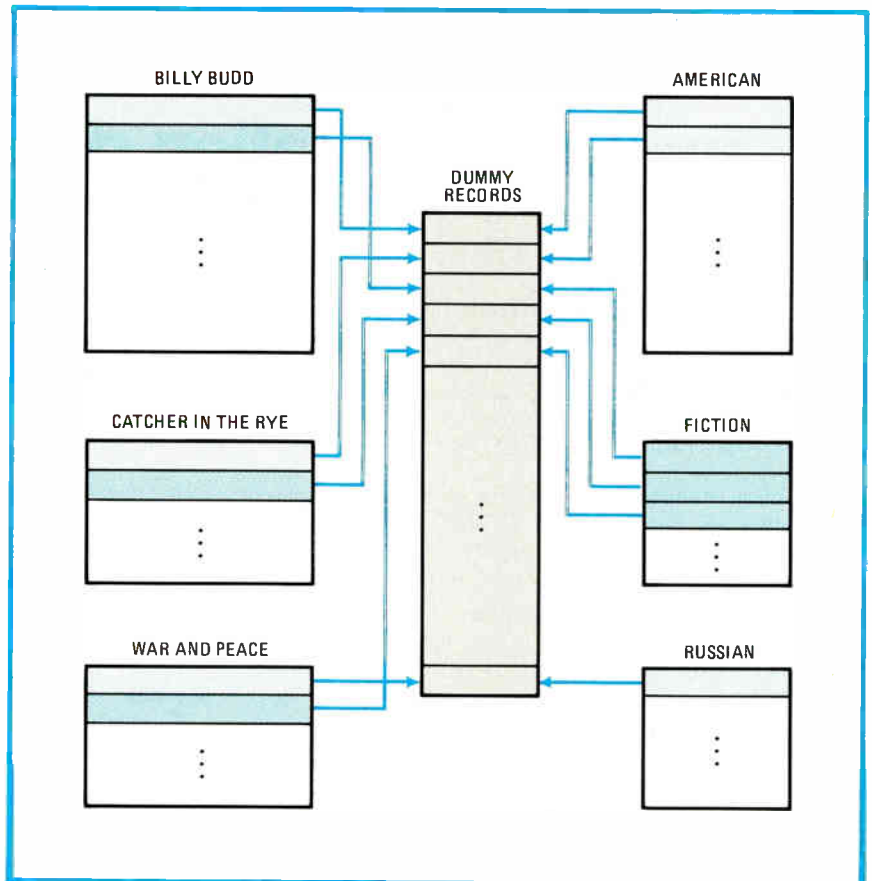

2. Pointing to data. The Codasyl data manager associates a group of pointers with each data item, allowing many different orderings to be simultaneously available. However, to access these multiple orderings, a memory-wasting dummy file must be set up.

Because of the variety of languages and language processors available for microcomputers and the number of operating systems in use, MDBS is divided into three logically distinct components: the operating-system interface, the host-language interface, and the data-base control (which is the bulk of the system). This design philosophy has greatly simplified the task of modifying the system software for various combinations of operating system and host language.

Op-sys link

The operating-system interface consists of a series of routines that emulate an ideal random-file input/output handler. Each operating system has its own conventions for file naming, parameter passing, and error detection, so this interface can be quite different in makeup for each operating system.

The data-base control system issues requests to the interface to open and close the data base, as well as to perform random I/O operations on it. Since it expects a full data-base page to be read or written on each I/O call, the interface must map from the operating system's disk-sector size (for example, 128 bytes on a CP/M system, and 256 or 512 bytes on a Northstar DOS system) to the user-specified page size for the data base (some multiple of 256) and then issue the appropriate I/O calls.

The host-language interface is more complex, since

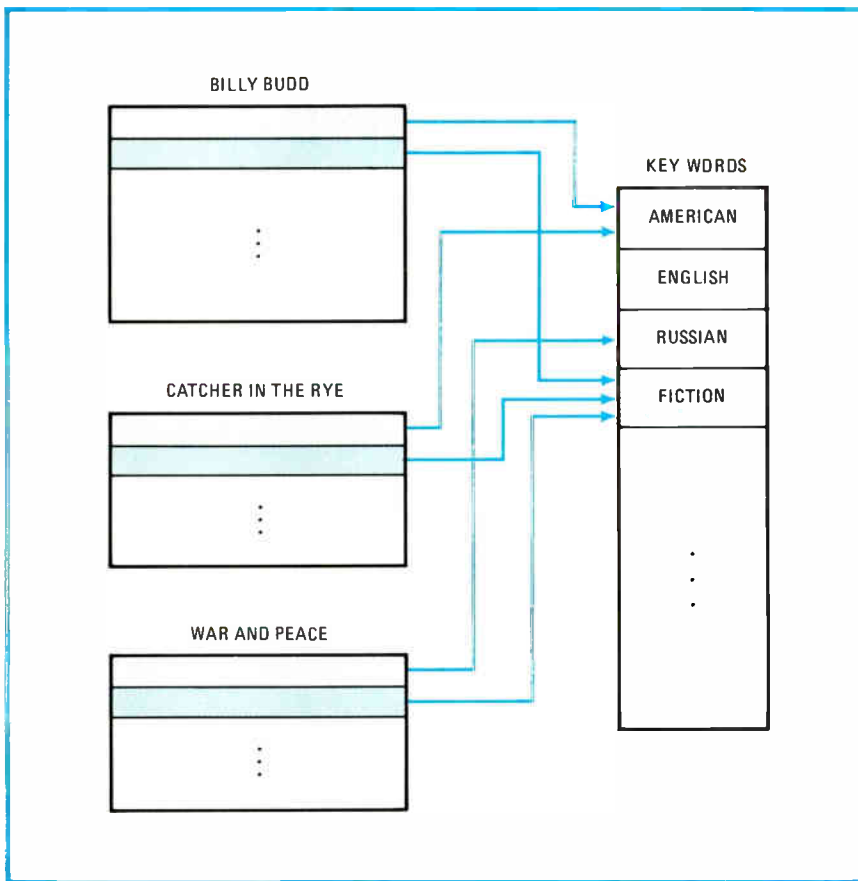

3. Handling multiplicity. The MDBS data-base manager can represent many-to-many relationships directly, thereby saving memory while still allowing quick retrieval of records. The arrows do not depict actual pointers; they indicate the logical relationships.

each host language has its own conventions for internally representing data. For example, integer and real values are not differentiated in Northstar Basic; Cobol has internal decimal and external decimal formats for numeric quantities; and Microsoft's Cobol has five possible representations of external decimal quantities.

For speed, MDBS is written in the assembly language of the target processor; for example, it fits into 18-K of main memory in Z80-based computers. In the micro-computer environment it is often quite critical to be able to organize the usage of main memory in a highly efficient manner. Accordingly MDBS can be placed anywhere in memory and can dynamically allocate buffers and tables of variable lengths.

Fine tuning

The system also can take advantage of any unused memory to increase buffer areas and hence to minimize disk paging. The page size is selected by the user to accommodate the requirements of the data base, realizing the tradeoff between page size and number of page buffers that may be resident in available memory. This choice is usually made to minimize the access time for a given data-base request.

An effective data-base management system should also minimize the amount of overhead (pointers, tables, etc.) stored in a data base, while still providing the user with fast retrieval and flexible data structures. Space-

management routines are smart enough to recover holes left by deleted records, to minimize the occurrence of spaces too small to contain a data record, and to provide for the judicious placement of records to facilitate fast access by the user.

As well as having these attributes, MDBS can work effectively with a variety of disks, including mini- and full-sized floppy disks and hard disks. Given the storage limitations of many forms of floppy disks it is usually imperative that a data base be able to spread across several drives. The operating systems for microcomputers usually do not automatically support such logical files, and so the MDBS handles a segmented data base.

The system can support a data base spread over eight drives and theoretically will manage over 4 billion bytes of information. The approximate amount of system overhead can be computed by some simple linear equations. Also, space management routines recover and coalesce space dynamically and allocate new memory in an intelligent manner. What is more, the judicious use of operating-system facilities make the MDBS independent of the type of disk units used, whether they

be mini- or full-sized floppy disks or hard disks.

The speed of access to a required record is, of course, one of the most important aspects of a data-base management system. If many data-base pages are kept in a primary memory buffer, the chance that a required page is already in the computer is greater.

For a reasonably defined data structure, the MDBS data manager can randomly retrieve a record from a sorted set of 10,000 records with a worst-case performance of less than 15 disk accesses. On a single-density mini-floppy disk, this performance would translate into a worst case of 8 seconds delay.

Of course, high-density media as well as full-sized floppy disks are commonly employed. A typical Winchester hard disk would result in a worst-case access of 0.75 s. Because of caching and several heuristics in the search procedure and the physical location of records and pointer arrays, average access is usually much better than the worst-case performance.

A data-base management system is typically invoked from a user-oriented language. This may be from a high-level language such as Cobol by using a data-manipulation or a English-like query language. MDBS is currently callable from Basic, Fortran, Cobol, Pascal, C, PL/1, and machine language. It currently runs on the 8080, 8085, 8086, Z80, Z8000, LSI-11, and 6502 microprocessors and on the Northstar, CP/M, Oasis, Newdos, Trsdos, and Apple DOS operating systems. □

Rf level meter quashes errors from internal noise

IEEE-488-compatible instrument also provides interchangeable sampling heads; liquid-crystal display includes analog readout for nulling

by Malcolm Sizmur and David Brewerton, *Racal-Dana Instruments Ltd., Maidenhead, Berkshire, England*

□ Loaded with measurement capabilities, a new radio-frequency level meter is ready to take on the production testing of rf equipment with greater precision and less operator input than earlier models. As well as speeding up equipment checks for any operator, the model 9303 meter is a boon to users unfamiliar with rf measurement techniques, and it can fit into a computer-controlled measurement system.

The microprocessor-based instrument uses the basic measurement principles first seen in the 9301A, but goes beyond its predecessor in being able to communicate and be controlled over the IEEE-488 bus. Also, it can achieve higher overall accuracy through special sampling, noise-cancellation, and automatic-calibration circuitry. Among the computing functions it performs are power-ratio, gain or attenuation, and percentage-difference measurements, as well as a null function.

Functionally, the 9303 [*Electronics*, May 19, 1981, p. 204] can be divided into the blocks shown in Fig. 1. The input selector can accept signals from one of two input sources or from the internal-calibration generator, which emulates an input Tee head with a known, accurate, and stable signal applied to it. The instrument can call on this generator periodically to verify the accuracy of internal-measurement circuits automatically.

This calibration technique cannot, of course, take into account inaccuracies in the Tee head itself, since this would require a known signal to be applied to the head. So an additional external-calibration source in the 9303 provides a standard signal at an output socket. The user may connect the Tee head to be used to this socket and can initiate a full self-calibration simply by pressing a front-panel button.

Head sampler

The sampling circuit for downconversion of high-frequency signals is contained within the Tee head. The input signal is sampled as it passes along a 50-ohm stripline in the head so that in-line measurements may be made at any point within a 50-Ω system.

The low-frequency output from the sampler, together with its drive signal and power inputs, are transmitted along a 1-meter multiconductor cable that joins the head to the main instrument. An extender cable is available so that the Tee head can be used up to 2 m from the 9303.

Using sample-and-hold circuits to convert signals from a high frequency to a lower one is a well-known technique. Provided the sampling frequency is not a subharmonic of the input frequency, a replica of the input waveform is built up at the output of the sample-and-hold circuit. Since the shape of the output is the same as that of the input, its root-mean-square value, assuming unity gain, will be the same as that of the input, neglecting quantization errors.

Because the rms value of the whole is equal to the square root of the sum of the squares of the individual sample values, the final value will be unaffected if the order of the samples is jumbled. In other words, the samples can be taken in a random manner, provided that all sampling intervals are evenly distributed. What's more, the same results can be achieved by linearly sweeping the sampling frequency.

In the 9303, the sampler circuitry comprises a 50-Ω stripline assembly, a hot-carrier diode bridge, a step-

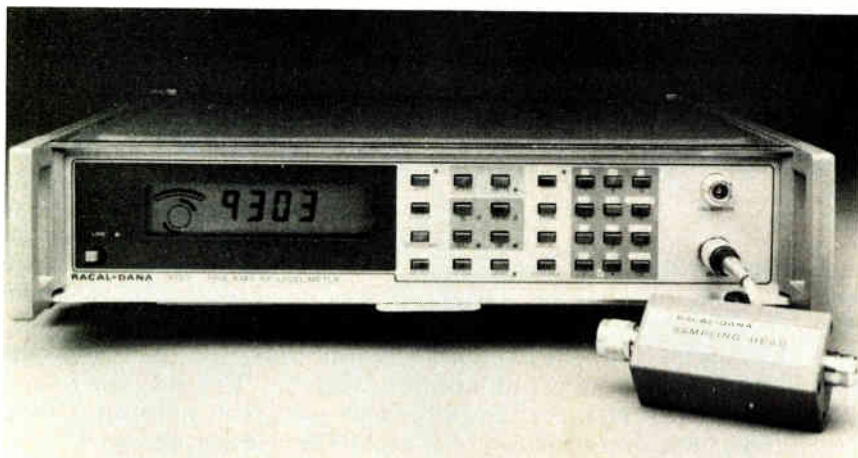

Cleaner. The 9303 rf level meter measures more accurately than its predecessors by noting internally generated noise before each measurement and subtracting it from the reading. Its specially designed liquid-crystal display (on the left of the front panel) is both analog and digital, giving users the choice of qualitative or quantitative information.

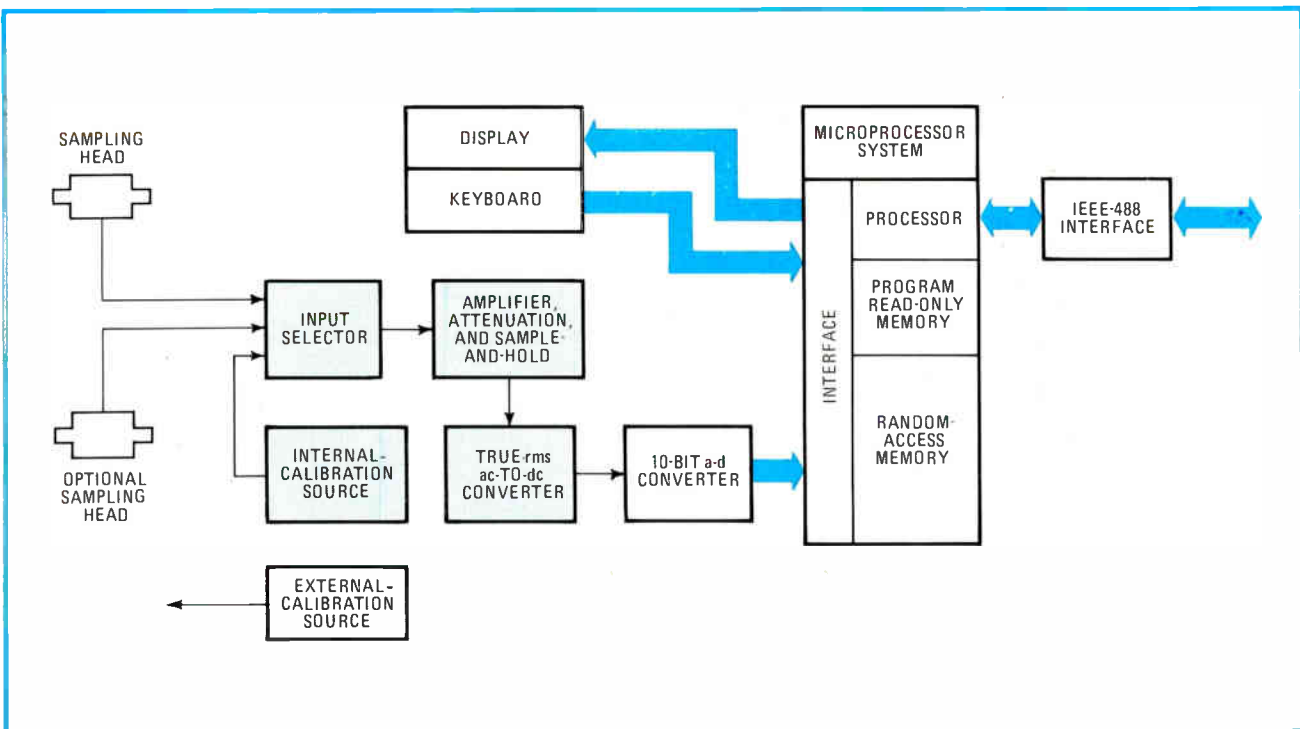

1. Analog emphasis. More digital than its predecessors, the 9303 relies on microprocessor control and communicates via the IEEE-488 bus, seen at right in the functional diagram above. But the art of its design is in its analog sections and sampling in-line heads seen at left.

recovery-diode pulse generator, and a field-effect-transistor buffer amplifier (Fig. 2). The diode bridge is usually reverse-biased by resistors R_1 and R_2 . A fast pulse from the step-recovery-diode pulse generator turns the diodes on for about 100 picoseconds, and the signal level at the stripline is transferred onto capacitor C .

This pulse is amplified by the subsequent amplifiers, resampled, and held for rms detection. The resistor R_3 discharges C , ensuring that each pulse starts from zero. Immediately prior to the second sampling action, the noise output from the system is checked by the second sample-and-hold circuit and held for analysis.

The 9303 has input sockets on both front and rear panels with internal electronic switching between these two controlled by a front-panel button or IEEE-488 bus command. Thus two Tee heads may be connected and measurements taken from either as required. Tee heads can be interchanged without recalibrating the system, and each carries its own calibration curve for frequency-response corrections.

Signals from the input selector are amplified to the required level by the amplifier and attenuator section. Four microprocessor-controlled attenuator pads give an 80-decibel attenuation range in 10-dB steps, a corresponding full-scale input range of 300 microvolts to 3 volts rms.

Signals from the amplifier are fed to the true-rms ac-to-dc converter. A noise-canceling feature in the converter does not require front-panel adjustment, since it measures the input noise directly during an auto-zero period and performs a true-power subtraction with all subsequent input signals.

The noise at the input to the converter is predominant-ly that of the buffer amplifier and sampler output resist-

or and is monitored by a separate channel. If this value is represented by N , then the channel output is $S + N$, where S is the signal value. In the rms converter, these two signals are squared and subtracted, and the difference is averaged and its square root taken. Hence, the noise component is removed and the output is proportional to the input signal only.

The use of this technique requires that the rms converter be of the type that separates the squaring, averaging, and square-root functions, which means that thermal converters are unsuitable. In the 9301A, a diode log-antilog system was used, but its frequency response is inadequate for the higher sampling frequencies in the 9303. Instead, a circuit based on a transconductance multiplier block provides both the squaring and square-root functions, its dc output being proportional to the rms value of the signal input.

The dc output from the rms converter is digitized by an analog-to-digital converter interfaced with the microprocessor system. The data fed to the microprocessor is corrected for gain and offset variations occurring in the analog measuring circuits before undergoing any necessary mathematical manipulation.

Calibration ins and outs

An instrument with so much analog signal processing inevitably suffers from gain drift with time and temperature. To overcome this, the automatic-calibration and external-calibration circuits were included.

The automatic-calibration source, an internal function, provides a reference square wave for calibrating the amplifier and attenuator chain and is internally connected to the amplifier input when required. The level of this reference is arranged to be identical between one 9303

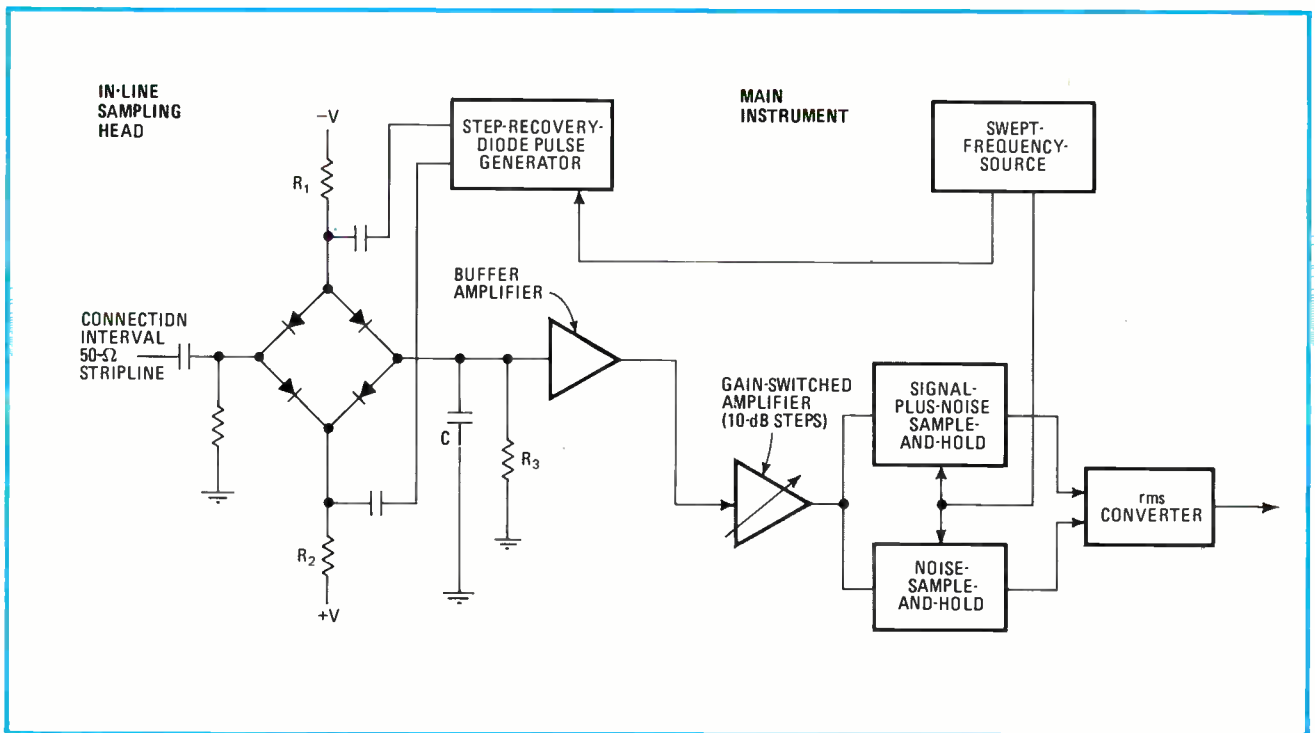

2. Sampling at the source. In the 9303's sampling in-line Tee head, signals are picked off a 50-Ω stripline. Samples are taken when the diode bridge is set by a pulse from the generator, stored on capacitor C, and transmitted via the buffer amplifier to the main instrument.

unit and any other to ensure that sampling heads are completely interchangeable. This source uses a swept-frequency-pulse train at 50 to 100 kilohertz to generate the sampling drive, which is divided by two to provide a mark-space ratio of exactly unity at half the frequency for the output.

The external-calibration source generates a square wave at approximately 500 KHz, which runs asynchronously with the sampling drive for head calibration. A 1-megahertz TTL oscillator is followed by a divide-by-two stage to ensure unity mark-space at 500 KHz. The output level is 0 dBm into 50 Ω.

The operation of both calibration sources is essentially the same. Both derive their reference from a precision bandgap-reference integrated circuit having a time stability of ± 10 parts per million per 1,000 hours and drift of less than 0.1% over the instrument's operating temperature range. As seen in Fig. 3, a fraction of the reference voltage is summed with the output square wave using an integrator within a dc feedback loop. This approach locks the mean value of the output square wave to the reference current. The use of exact square waves in the 9303 ensures that the rms values of the calibration outputs are accurately controlled.

Within the feedback loop, the integrator sets the output of a current source, which is fed to the load or shunted to ground by a parallel pair of transistors driven from the appropriate frequency source to produce the square-wave output. The calibration outputs are accurately set during manufacture; in the case of the external-calibration output, the setup is a precision 50-Ω load and a thermal transfer standard.

The external output has a 50-Ω source impedance, and so any subsequent load error will be halved in effect. The

only other sources of error after initial setting are the initial-setting error itself and the stability of the source components. Inaccuracy due to drift over a 1-year period and temperature variations is less than 0.5%.

Internal-calibration sequences are initiated by the instrument itself and require no response from the user. The sequence takes approximately 5 seconds, during which time measurements cannot be made. This sequence verifies the accuracy of the main instrument only, not of the Tee head. The first internal-calibration sequence occurs at turn-on and thereafter at intervals of 2.4 minutes and then every 8 min. Special functions are provided that let the user inhibit internal calibration altogether or initiate one immediately.

External-calibration sequences may be initiated by the user and require the Tee head to be connected to a stable 0-dBm signal (223.6 millivolts or 1 milliwatt). A suitable signal is available from the calibrator output connectors on the front and rear panels. Users may choose a different calibration source with the same frequency as the signal to be measured, thereby eliminating frequency-response errors from the measurement.

The sequence takes approximately 20 s to complete, the first 5 s being devoted to an internal-calibration cycle. Then the instrument measures the input to the head in use and computes a correction factor that it applies to future readings from that head.

A fixed attenuator in front of the head during high-level measurement may be left in place during the external-calibration sequence, and the instrument then adjusts all future readings to allow for the precise value of the attenuator. Full measurement accuracy is achieved when the Tee head is either terminated with a 50-Ω load (one is supplied) or used within an accurate

50-Ω system. A poor voltage-standing-wave ratio of the load used will adversely affect the accuracy, particularly when making in-line measurements.

A conventional 10× passive-divider oscilloscope probe may be connected to the head with a suitable adaptor since, with the 50-Ω load removed, the input impedance of the head is approximately 100 kilohm + 20 picofarads, as compared with 1 megohm + 20 pf for a typical scope. The different input resistance will cause errors in the extreme low-frequency response (10 to 100 KHZ) only, as the input capacitance is the dominant factor at the frequencies of interest here. The capacitance trimmer provided on the scope probe is set to midrange, and the microprocessor system, making use of the external calibration facility, automatically compensates for the 20-dB attenuation in the probe.

The calibrator outputs provided on the front and rear panels give a nominal 1 mW into a 50-Ω load, but only one output may be used at a time. The waveform is a 500-KHZ square wave and is switched on only during an external-calibration sequence (automatically), although a special-function routine is available to switch this on and off under user direction.

Accurate to a Tee

Each Tee head carries a calibration label on its side showing frequency-response corrections over the 0-to-2-gigahertz range. The corrections are shown as a scaling factor and may be entered into the instrument to eliminate frequency-response error at any frequency. The instrument powers up with a value of 1.000 in the calibration factor store, which may be displayed and changed with IEEE-488 commands or keyboard sequences. If the value set is anything other than 1.000, then the legend CF will appear on the display to remind the user that he has disturbed the calibration.

The factor entered applies to the measured voltage. If computed power is being displayed, then the correction is

squared by the instrument. The instrument computes power by squaring the voltage reading and dividing by the value in the ohms reference store. The value in this reference store may be displayed and changed with a keyboard sequence.

The 9303 computes the power factor before performing such calculations as power ratio, gain or attenuation in decibels, percentage difference, or null, so that these functions can be applied also to power values. An example is determining the ratio function, which displays the input reading divided by the stored ratio value. If the watts mode is selected before the ratio mode, both numbers are converted to equivalent power before the division is performed.

The ratio store contains a reference value held in volts. If the instrument is in the power mode, then this value is converted to power using the current ohms reference-storage value before being used in a calculation or displayed. The ratio store may be loaded either from an input reading or directly from the keyboard. The power-up value for the ratio store is 1 volt.

Decibels, percentage difference, and null are computed functions that operate in the same way as the ratio function. All four of these functions are mutually exclusive; only one can be called at a time.

Each computed function maintains its own independent reference store. Each store can be set up either in volts or watts, although in the latter case the instrument will convert the entered value to volts before it is stored. If the instrument is in the power mode when a store value is recalled, then a volts-to-watts conversion will be done before it is displayed.

After computation, the results of these functions are displayed. In all cases except the decibel function, both readings and stored values are converted to watts, if appropriate, before the computation.

One operational difference between the null function and any of the others is that whenever this function is

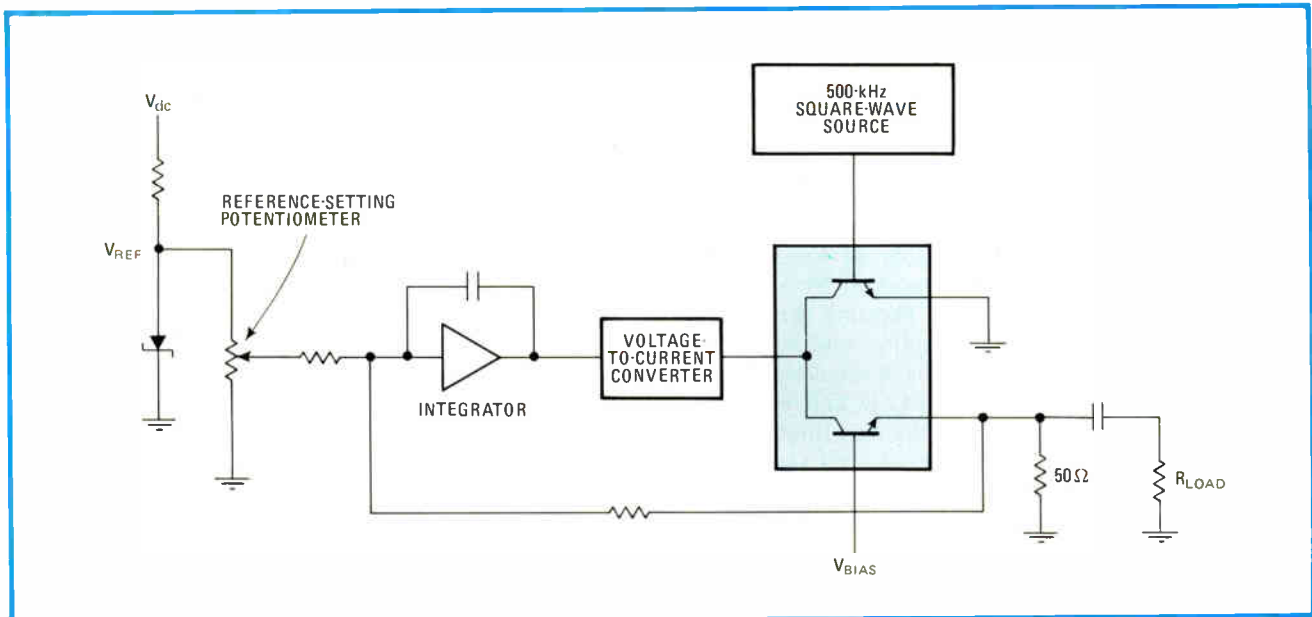

3. Calibration source. For a stable external calibration source the 9303 uses a bandgap reference diode (left). The integrator within the dc feedback loop sums a portion of this reference voltage with the output of the square-wave generator to lock the mean output to the reference.

A different display

A common application for radio-frequency level meters is in finding peaks and null points in a system's bandwidth. A tuned circuit, filter, or trap circuit all require adjustment at some stage, with a coil or trimmer being tweaked to maximize or minimize the output. With a purely digital display, spotting the point at which the maximum or minimum actually occurs is much more difficult than with an analog display, and hence most rf instruments still rely on the less accurate and more costly d'Arsonval movement for measurement presentation.

For the 9303, a simple bar-graph liquid-crystal display for analog readings was first considered, but to achieve resolution comparable to an analog meter would require 100 bars, which meant 100 connections to the display (multiplexing in an LCD causes very narrow viewing angles

and contrast problems). So the decision was to build a novel LCD with both digital and analog segments. The analog portion consists of an arc and a circle.

The arc is ten segments long with each segment representing 10% of full scale. The circle also has 10 segments, with each segment representing 1% of full scale. As the input to the instrument increases, the segments in the circle are addressed in a clockwise manner. For each complete trip around the circle, an additional segment of the arc is addressed.

When the input peaks, the circle's segments begin to be addressed in a decreasing manner and the circle rotates in a counterclockwise direction as the input falls. Thus the LCD provides analog relational information which is much easier for the user to interpret.

called, the null store will be automatically updated to the current reading. Thus the initial result will be zero.

The decibel function is probably the most frequently used of the four. The instrument powers up with 223.6 mV (1 mW into 50 Ω) in the decibel reference store and so will indicate dBm directly when called. This display will indicate dBm (as opposed to decibels) if the reference is equivalent to 1 mW.

The value of internal computing

Other standard reference values such as 1 V or 1 μ V may be entered with a few keystrokes. For measuring frequency response or gain or attenuation, the reference store would be set up from an input reading taken at the reference frequency or input to a device. After this, the instrument would show variations relative to this standard level directly. This feature is most useful when checking test specifications that set relative limits, because there is no need to set the signal level to any particular value before starting the test.

The percentage-difference function is also of value when testing between limits. Where a specification calls for 1 V \pm 5%, for example, 1 V can be entered into the percentage store directly, and the instrument will show deviations directly. Frequency-response checks may also be done in the percentage-difference mode.

The null function is particularly useful in the power mode, since it can mask the effect of noncoherent noise or interfering signals. It is possible to measure, for example, the background noise produced by a receiver front end (with no signal present). Pressing the null key would automatically store this reading and subtract it from all future readings—thus the immediate display would be zero. Applying a signal to the unit under test would now produce a reading for the true intermediate-frequency output power at the signal level (conversion efficiency) corrected for spurious signals such as noise and local-oscillator breakthrough. The same technique can be used to measure modulation sidebands in the presence of a carrier frequency and other fixed outputs from a transmitter.

The ratio function is virtually a linear version of the decibel feature and is mainly useful where high resolu-

tion is required. The setting procedure for the attenuators of the 9303 itself illustrates this: storing a signal level of about 1 V, then entering the ratio mode, increasing input power 10 dB, and stepping up to the next range will set the attenuator trimmer for a reading of 10.00 (10 dB in the power mode).

The 9303 is prone to jitter in the readings, and some form of selectable smoothing is desirable to achieve compromises between fast response and steady readings. Averaging is performed on the digitized signal over a set period and the display updated with the result at the end of that period. The range of averaging period allowable is 0.1 to 99.0 s in 0.1-s steps. The effective reading rate is the reciprocal of this time (not to be confused with the digitizing rate of the microprocessor system, which is a fixed 100 conversions per second).

Storing front-panel settings

When stepping through a test sequence repeatedly, it is obviously helpful to be able to recall complete front-panel settings and store values from a previous test. The 9303 facilitates entry, storage, and recall by accommodating as many as 10 complete front-panel settings. Recalling will set the instrument to its power-up state.

The current panel settings are held in the nonvolatile memory when power is removed. The unit powers up to a predetermined state—volts measured, automatic range, 50- Ω , 1-s averaging. The previous settings are obtained by keying in 99.

The analog meter, together with digital display of results in engineering units is only feasible with a liquid-crystal display (See "A different display," above). These features, when combined with the single-function-entry keyboard, result in an instrument that is very easily operated manually, yet one that has adequate computer power for systems use. The incorporation of the microprocessor has enabled improvements in accuracy to be achieved and maintained between longer calibration periods than previously. The sampling head is very rugged and immune to shock and can withstand indefinite overloads up to 1 watt on any range. All of these factors combine to give a reduced cost of ownership to the customer. \square

Stepper checks state of E-PROM's memory

by Steven Bennett
Harris Semiconductor, Melbourne, Fla.

Too often, ultraviolet-light-erasable programmable read-only memories have their contents blindly destroyed by users who cannot determine whether the memory contains valuable information or is totally blank. However, this circuit can scan each E-PROM location with a binary counter and so will distinguish memories that contain data from those that do not—all at a cost of around \$8.

In use, the memory device is placed into the test socket

and the momentary contact switch, S_1 , is pressed. If as little as 1 bit of memory is stored in any of the E-PROM's locations (logic 0 for an E-PROM), the light-emitting diode will light.

A 2-kilohertz clock signal for the 12-bit binary counter, B_1 , is generated by oscillator and buffer A_1 , so that the addresses will cycle through the 2716 2-K-by-8-bit E-PROM in about 1 second. (Although this circuit was designed for the 2716, it may also be adapted for any type of memory, bipolar or MOS.)

If any bits in a given location are low, then a pulse will be generated at the E-PROM's output and will drive the 4068 NAND gate high. This pulse, which is generated at the NAND output, is stretched to 2 s by one-shot and buffer A_2 to drive the LED. □

Engineer's notebook is a regular feature in *Electronics*. We invite readers to submit original design shortcuts, calculation aids, measurement and test techniques, and other ideas for saving engineering time or cost. We'll pay \$75 for each item published.

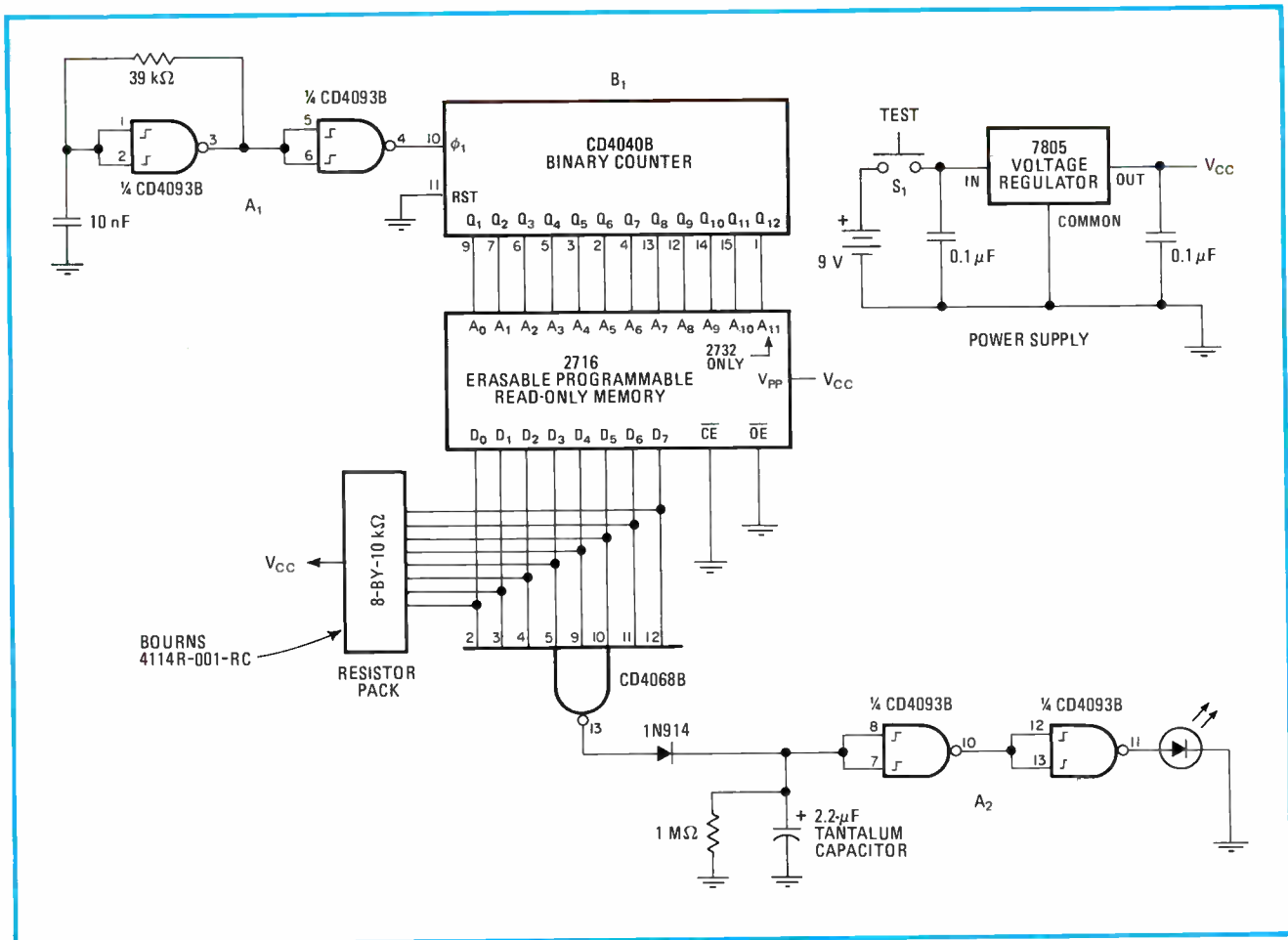

Seeing is believing Using a 12-bit binary counter, a tester of ultraviolet-light-erasable PROMs inspects each location of the device to determine if it contains data or is blank, thereby saving contents from accidental erasure. For a 2-K-by-8-bit E-PROM, the test takes about 1 second, with a light-emitting diode turning on if any memory location contains a data bit.

Two-chip ammeter measures currents down to picoamperes

by Douglas Modlin
Electrical Engineering Department, Stanford University, Stanford, Calif.

An ammeter circuit that can measure currents ranging from picoamperes to amperes may be built with two operational amplifiers, one having a low input bias current and offset voltage and the second having a high output-current capability. The accuracy of the meter is within 1%.

The basic configuration of the circuit (a) establishes A_1 as a field-effect-transistor input device that is internally compensated and A_2 as the power stage. The feedback arrangement of the circuit is technically possible but not practical because A_2 's gain-bandwidth product is much less than that of A_1 . This factor is due to A_2 's high-output capacity. As a consequence, the circuit is unstable and oscillates near the unity-gain crossover point of A_2 , because of a phase-shift around the feedback loop exceeding 360° .

Converting A_1 into an integrating comparator (b) stabilizes the circuit, thereby increasing the op amp's response time without introducing an additional phase shift to the feedback loop. Input current I_{in} flowing to the noninverting terminal of A_1 produces a positive voltage at its output and across integrating capacitor C_1 . A_2 , serving as an inverting, unity-gain amplifier, then raises its output to a voltage that causes I_f to equal I_{in} .

As a result, the output voltage corresponding to this input current is $V_o = I_{in}R_f$. The circuit accuracy is determined strictly by the tolerance of R_f . The input offset voltage of A_1 (1 millivolt maximum) and its correspondingly low offset current (0.15 picoampere maximum) have virtually no adverse effect on circuit accuracy. As for A_2 's output offset voltage, which is a maximum of 6 mV, it is canceled in the feedback loop. In order to maintain a virtual short at its input, A_1 develops a voltage across C_1 . When this voltage is applied to A_2 through R_2 , A_2 's offset voltage is canceled. This cancellation effect is independent of the second stage gain given by $A = -R_3/R_2$.

Feedback resistor R_f sets the cur-

rent range. To measure currents in the region of 1 pA for display on a 3½-digit digital voltmeter (resolution is 1 mV), R_f should be 10^9 ohms and be proportionally lower for higher currents. The circuit's input port A_1 , should be protected against leakage currents by Teflon standoffs or otherwise be guarded. This measure also holds true for mounting the selectable resistor R_f .

The picovoltmeter in (c) is much the same as in (b), but is configured as a low-input bias current, low-offset buffer amplifier whose gain is established by $A = R_3/R_2$. This circuit takes advantage of the best features of both op amps but suppresses their limitations. Including resistor R_o in the circuit will stabilize the amplifier for capacitive loads. Incidentally, the LH0041 allows a user to select current limiting. The circuits discussed are not limited to the op amps listed in the figures. Any device with similar characteristics may be used. □

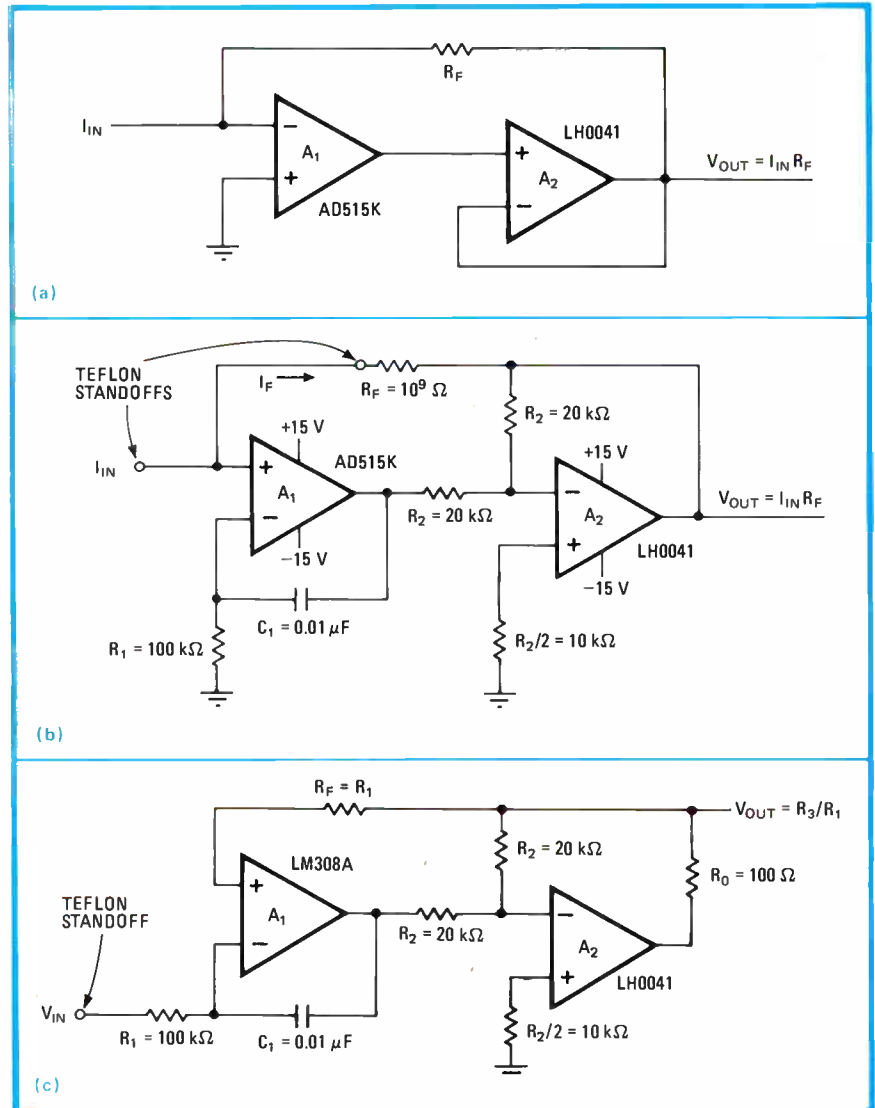

Infinitesimal. This ammeter, using one op amp having a low offset and another with a high-output driver, measures current from 1 pA to 1 A. Feedback resistor R_f determines the range of measurement. Based on the rudimentary circuit of (a), ammeter (b) is self-compensating and stable, providing accuracy to within 1%. Test currents are converted to corresponding voltage for display by 3½-digit digital voltmeter. A version for measuring low potentials (c) is similar. The LH0041 op amp allows users to select current limiting.

Meter measures processor's dynamic utilization capacity

by Henryk Napiatek
Lacznosci Institute, Gdansk, Poland

An ordinary milliammeter, calibrated in percentages, plays a key role in this simple one-chip, one-transistor indicator of the fractional utilization of a microcomputer's central processing unit in a real-time environment. As a result, the circuit (see figure) will be useful in optimizing system performance and debugging random process routines that typically occur in telephone- and vehicular-traffic applications.

The degree of utilization in processing data and handling interrupts versus the time the machine executes the scheduler's idle loop is simply measured by firing a monostable multivibrator with an output signal derived from the operating system's idle loop. The one-shot's pulse width is set equal to the execution time of the scheduler's idle loop, which generates one pulse for each loop's pass. The scheduler's idle loop is executed only if the processor does not process any data or handle any interrupts. The scheduler's idle-loop execution time is about 50 microseconds. Interrupts cause the processor to execute program routines concerning traffic changes.

The integrated output signal of the one-shot thus represents a fraction of the total time the CPU is not being used. This fraction will be indicated by a drop in the

reading of the milliammeter that is connected to the inverting output circuit of an npn transistor.

A register-enable pulse or similar signal leaving the output bus of the appropriate system peripheral is applied to the 74123's input. This signal is essentially an idle CPU mark that is derived from the sample idle-loop routine of the scheduler and is written in macro-11 assembly language for the PDP-11/34 minicomputer (see program).

The pulses from the one-shot's output are amplified by transistor Q_1 and integrated by capacitor C_1 and the milliammeter's resistance and distributed inductance. The meter's reading thus reflects the difference between the circuit's 5-volt output limit, which represents 100%

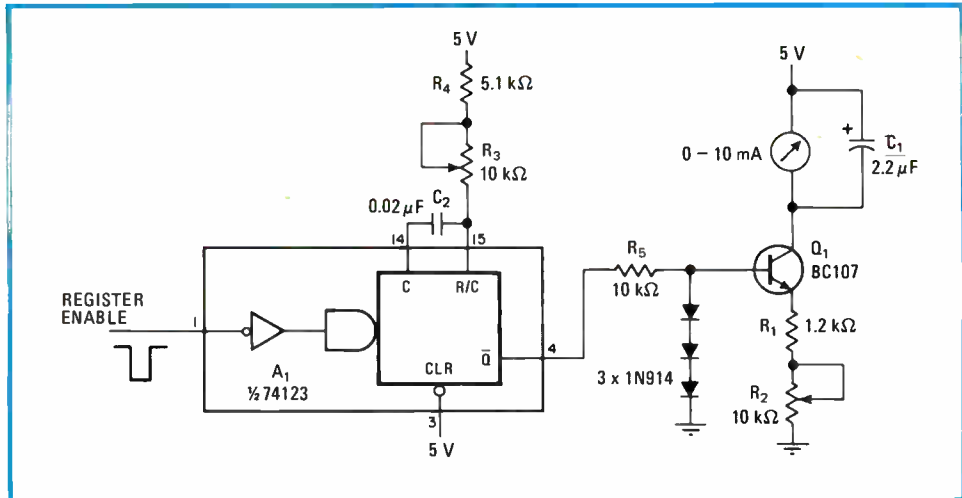

Indexing interrupts. This simple circuit determines the percentage of time the microcomputer's central processing unit is working on processing data and handling interrupts, thus serving as a low-cost optimization and debugging tool. A meter, calibrated directly from 0% to 100%, has typically a 2- μ s integration time for rapidly following dynamic changes in machine capacity. The one-shot timer's pulse width is equal to the execution time of the scheduler's idle loop.

CPU utilization, and the total interrupt time, to yield an index of the CPU's actual use.

The circuit is calibrated by adjusting potentiometers R_2 and R_3 . To calibrate the meter at full scale, the CPU's idle loop is halted (no input pulses) and R_2 is adjusted for a 100% meter reading. All external interrupts in the idle loop are then disabled (for example, the instruction CLR@#IDLESR should be replaced by the instruction CLR@#LIGHTS) and the routine run. The milliammeter is zeroed by adjusting R_3 for 0% processor utilization. In this case, the processor executes only the scheduler's idle loop. This design can be modified in hardware and software to accommodate indicators other than the milliammeter that can measure other parameters related to real-time operating systems. □

IDLE LOOP OF PDP-11'S SCHEDULER USED FOR CIRCUIT CALIBRATION

ETEXDS W.01/E.04 OPERATING SYSTEM

```

LIGHTS = 177570 ; LIGHTS REGISTER
IDLESR = 160224 ; REGISTER IN SPECIAL INPUT/OUTPUT DEVICE
PSW = 177776 ; CENTRAL PROCESSING UNIT STATUS WORD
PR7 = 340 ; PRIORITY 7
R3 = %3 ; CPU'S REGISTER 3
;
1S: MOV = PR7+1, @ = PSW ; EXTERNAL INTERRUPTS DISABLED, BIT C = 1
    MOV = IDLCNT, R3 ; ADDRESS OF IDLCNT 3-WORD VECTOR
    ADC /R3,+ ; BIT C+IDLCNT
    ADC /R3/+
    ADC /R3/+
    CLR @ = IDLESR ; COUNTING OF IDLE LOOPS IN IDLCNT VECTOR
    CLR @ = PSW ; ONE-SHOT TIMER STIMULI
    BR 1S ; EXTERNAL INTERRUPTS ENABLED
; TO NEXT IDLE LOOP
IDLCNT: .WORD 0, 0, 0 ; IDLE LOOP VECTOR COUNTER
    
```

New standard updates specs for signal quality

Data communications specification RS-334 has been updated by the Electronic Industries Association. Now known as RS-334-A, "Signal Quality At Interface Between Data Terminal Equipment and Synchronous Data Circuit-Terminating Equipment for Serial Data Transmission," the revised standard provides **a basis of agreement on the signal quality when timing signals are exchanged across the interface between the data terminal and the data-communications equipment in synchronous serial systems.** There is also a section on the significance of distortion in frequency measurements, and terminology has been revised to be consistent with that used in documents of the International Consultative Committee for Telegraphy and Telephony. Copies of RS-334-A may be obtained for \$6 each from the Standards Sales Office, Electronic Industries Association, 2001 Eye Street, N. W., Washington, D. C. 20006.

Another way to guard against voltage spikes

Henry Simon, general manager of the Polyswitch products group of Raychem Corporation in Menlo Park, Calif., says that Alex Kisin [*Electronics*, Sept. 8, p. 153] and Peter Schwartz [*Electronics*, Oct. 6, p. 150] have overlooked a cost-effective method of improving the performance of the series-resistor- and shunting-diode techniques for the protection of analog measurement devices at the input stage. According to Simon, by replacing the series resistor in the simple resistor-diode circuit with a low-ohm PolySwitch protector device [*Electronics*, Jan. 13, p. 159], **a much lower value of resistance can be used to limit surge currents.** As illustrated in Fig. 4 of the Jan. 13 article, a PolySwitch protector as low as 25 Ω in resistance—such as Raychem part number C24T002H—can effectively protect diodes from damage due to voltage spikes as high as 240 v root mean square. This amount of series resistance adds very little to the propagation delay of the analog data.

Reflectance sensor scans to digitize continuous-line graphs

What with the near-ubiquity of digital technology, it sometimes is necessary to digitize continuous-line graphs. For James A. Blackburn of the physics department of Wilfrid Laurier University in Waterloo, Ont., and his colleague H. J. T. Smith of the physics department of the University of Waterloo, Hewlett-Packard Corp.'s new high-resolution reflectance sensor (HEDS-1000) is the key to such digitizing. They use a Tektronix 4052 desktop computer programmed to control an HP 7225A digital plotter so that **the pen executes a scan of the plotter surface on which the graph of interest has been placed.** The line sensor is mounted within a special housing machined to the same dimensions as a standard plotter pen. As the scan proceeds, any line crossings result in a signal being sent from the HEDS-1000 to the controlling computer, which then stores the corresponding coordinates.

Satellite box score ranks birds, tracks launches

Engineers and managers in the aerospace industry, the military, or other Government agencies who want **to keep track of world-wide satellite launches** should obtain the just-published Space Log, vol. 18, from TRW Defense and Space Systems Group at 1 Space Park, Redondo Beach, Calif. 90278. The 100-page paperbound book has details on the latest birds as well as on past satellites. There is also a handy box score listing the leaders in the different satellite categories. Write to the company on a letterhead for your copy.

-Harvey J. Hindin



Look no further than the Mitel MH88305 when you're looking for a DTMF Receiver that combines exceptional dynamic range, good talk-off immunity and excellent signal-to-noise performance in one compact module.

The MH88305 is excellent for such demanding applications as central office, end to end signalling, mobile radio and PABX.

This hybrid device is a direct replacement for the first generation MH88205, but offers enhanced performance and lower cost.

A PITCH FOR EXCEPTIONAL SENSITIVITY: THE MH88305 DTMF RECEIVER.

The key features of the MH88305 are:

- Up to 55dB dynamic range.
- 14dB acceptable signal to noise ratio.
- 60dB Dial Tone Rejection.
- Acquisition time adjustment down to 10 ms.
- One external component adjusts: input sensitivity, guard time, twist accept/reject limit.
- 5V or 12V operation.
- Error rate better than 1 in 100,000 tones.

The swept in-band 3rd tone tolerance is measured as A-16 dBm and, in this case, total receiver performance conforms to the CEPT recommendations.

The Mitel MH88305 DTMF Receiver.

It gives you exceptional sensitivity right down the line.

Find out more about this and other related Mitel products. Contact your local Mitel sales office.

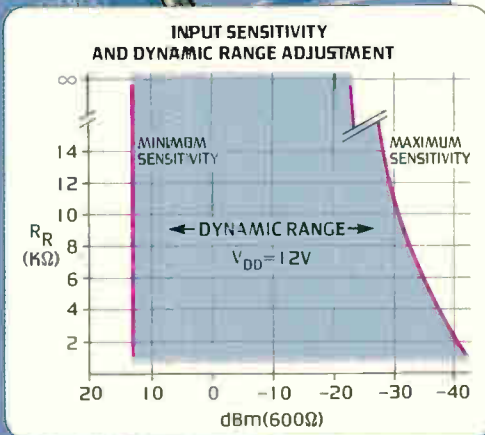

MITEL SEMICONDUCTOR

United States: 2321 Morena Blvd., Suite M, San Diego, California, U.S.A. 92101.
Telephone (714) 276 3421. TWX: 910 335 1242.
P.O. Box 17170 600 West Service Road,
Dulles International Airport, Washington D.C. U.S.A. 20041.
Telephone (703) 661 8600. TWX: 710 833-0865.

Canada: P.O. Box 13089, Kanata, Ontario, Canada K2K 1X3.
Telephone (613) 592 5630. Telex: 053 3221. TWX: 610 562 8529.

Europe: 33/37 Queen St., Maidenhead Berkshire, England SL6 1NB
Telephone 0628 72821. Telex: 849 808.
Bredgade 65A, 2nd Floor, 1260 Copenhagen K, Denmark
Telephone (01) 134712. Telex: 19502.

Asia: TST P.O. Box 98577, Kowloon, Hong Kong.
Telephone 3 318256. Telex: 34235

Copyright 1981 Mitel Corporation

BUILDING BETTER COMMUNICATIONS

Circle 141 on reader service card

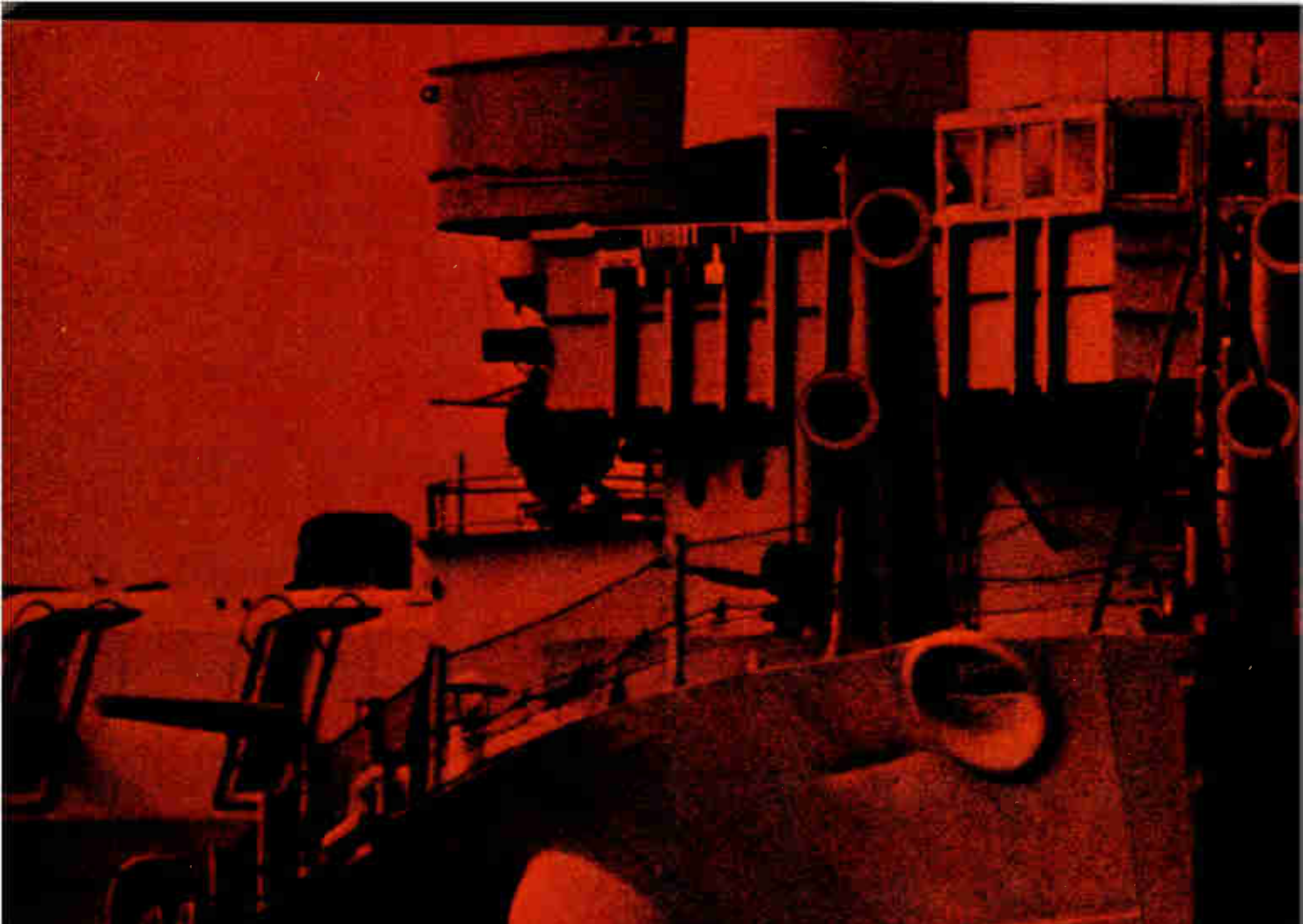

WE'RE ABOUT TO

We'd like to introduce you to the ultimate weapon in the battle to improve the quality of your printed circuit boards.

The GenRad 2272 Circuit Board Test System.

A test system so powerful, so fast, and so deadly accurate at finding and eliminating board problems, we call it The Destroyer.

The 2272 can take on bigger missions than any other system (up to 3584 pins, to be exact). But unless you've been locked below deck for a decade or so, you're bound to recognize that the easy way to give you that kind of fire power is to make some tradeoffs in the quality of your tests.

We refused to knuckle under.

Instead, we came up with a nifty multiplexing technique that lets us do more rigorous testing than any other in-circuit system—with exceptional



speed and no sacrifice in performance. (We should also note that our idea holds down the cost per pin and keeps our 2272 from getting as big as an aircraft carrier.)

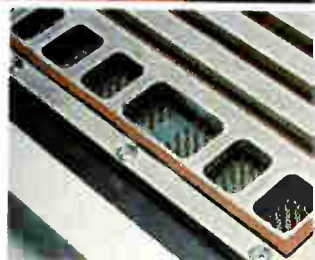

The 2272 can handle up to 3584 pins—all hybrid.

What kind of performance are we talking about?

Well, for starters, you get full hybrid capability, with total access to digital or analog instrumentation from every pin. Imagine what that could do for you. You get parallel drive and sense and local pin memory for drivers to give you absolutely meticulous testing accuracy.

You're armed with the most extensive library of ECL, TTL, and LSI/VLSI devices in the industry. You have an arsenal of

LAUNCH THE 2272.

features no one else has, such as automatic bus disable to "zero in" on the device under test; automatic feedback squelch, to defend against glitches and other intruders; and automatic component wiring compensation to protect you from devious wiring constraints. And you have our exclusive Scratchprobing™ method and Bus Busting™ beyond-the-node diagnostics at your command, as well.

In fact, we can safely say our new 2272 Circuit Board Test System gives you the fastest program development, the easiest debug and the most comprehensive, thorough testing of any in-circuit system you can buy.

The 2272. It'll destroy a lot of the illusions you have about what an in-circuit test system can do.

For a test cruise, just call your nearest GenRad office. Or write GenRad, 300 Baker Ave., Concord, MA 01742. Tel: (617) 369-4400.



GenRad

THE BEST IN TEST.



The Destroyer. Our 2272 Circuit Board Test System.

I'd like to see The Destroyer in action.

- Set up a demo.
 Have a salesperson call.
 Just send literature.

- I test small and medium-size boards. Send me information on your 2270 and 2271 Circuit Board Test Systems.

E1117

Name _____

Title _____

Company _____

Address _____

City _____ State _____ Zip _____

Telephone _____

My need is: Now! Soon 6 Months

Circle 145 on reader service card



 **AS885**



The next generation:

TI's Advanced Schottky magnitude comparator.

One single device—TI's new SN54/74AS885—is now all you need to compare two parallel 8-bit binary words. You would need four standard Schottky parts to equal the functional capability of the AS885. The saving is obvious. The performance outstanding. With TI's Advanced Schottky technology, the next generation of TTL logic is here today.

Speedy and small

The AS885 is more than twice as fast as the standard Schottky arrangement. Typical propagation delay is only 12 ns vs 28 ns (see table).

Contained in a 24-pin, 300-mil package, the AS885 occupies just 0.4 sq. in. of board space instead of 1.0 sq. in. This compact design includes an octal on-chip latch to store one 8-bit input data word.

Savings with the new Advanced Schottky

	SN54AS885	Standard STTL	Your
	SN74AS885	Configuration	Savings
Packages	1	4	3 packages
Package Area	0.4 sq. in.	1.0 sq. in.	0.6 sq. in.
Pins	24	66	42 pins
Performance (t_{pd})	12 ns	28 ns	16 ns
Power	650 mW	1500 mW	850 mW

As for power, consumption is substantially reduced—650 mW compared to 1500 mW.

The AS885 performs a binary 2's complement magnitude comparison of two 8-bit numbers. With a choice of logical or arithmetic routines built right into your system. And, they can be cascaded to any length.

Advanced technology

The new AS885 is the newest member of the growing Advanced Schottky (AS) Series from Texas Instruments.

As the historical leader in Schottky technology, TI has constantly refined the process until, across the line, the AS Series sets new performance standards. Featuring a typical 1.5-ns SSI gate delay and higher-density MSI, the Series is—typically—twice as fast as the original Schottky family.

In addition, there's an Advanced Low-Power Schottky (ALS) Series that's more than two times faster than today's popular 74LS family—at half the power.

And both the AS and ALS devices can be designed-in as simply as you do with TI's popular Low-Power Schottky (54/74LS) and Schottky (74/54S) TTL series.

Figure the savings

Ideal for high-speed processors and microprocessor/microcomputer-based systems, the AS885 produces real bottom-line results. Fewer components, reduced power consumption, greater performance—they add up to savings in design time, board space, production and operating costs.

Initial quantities of the AS885 are available now. Check with your local authorized TI distributor or TI field sales office.

For more information on TI's Advanced Schottky magnitude comparator, simply fill out and return the coupon today.

EL5

Check one:

Please send me more information on your new Advanced Schottky AS885.

You've convinced me. Send me a sample.

Name _____

Title _____

Company _____

Address _____

City _____ State _____ Zip _____

Texas Instruments
P. O. Box 202129
Dallas, Texas 75220



Texas Instruments invented the integrated circuit, microprocessor and microcomputer. Being first is our tradition.

TEXAS INSTRUMENTS

*U.S. price, quantity one
**7.67 μ s if multiplicands do not have to be saved
© 1981 Texas Instruments Incorporated

ARGENTINA 748-1141 • AUSTRALIA (02) 887-1122 • BELGIE/BELGIQUE (02) 720.80.00 • BRASIL 518423 • DEUTSCHLAND 08161/801 • FRANCE (3) 946 97 12 • ITALIA (0746) 69034
JAPAN 03-498-2111 • MEXICO 567-9200 • NEDERLAND 020-473391 • SCHWEIZ/SUISSE 01 740 22 20 • SVERIGE (08) 23.54.80 • UNITED KINGDOM (0234) 223000

841141

Circle 146 on reader service card

Attention,
Multibus™ users...

Only the CD100M
now supports
CP/M and CP/M86
in the perfect
desktop package.



Hear this,
LSI-11 users...

Only the CD100L
emulates a VT103,
an RL02 and an
RX02 in a single
desktop package.

And both now include a 10 megabyte Winchester!

CD100M — THE TOTAL OEM SOLUTION

To give your Multibus microcomputer system increased file storage, the Callan™ CD100M Integrated Work Station now includes a high performance 10 Mbyte 5¼-inch micro Winchester disk drive complete with full DMA and fully automatic and transparent burst error correction. A one Mbyte unformatted floppy provides file entry and back-up. With its integral 6 slot Multibus compatible card cage, intelligent video terminal, and Winchester/Floppy disk system, the CD100M is the *only* single desktop package available to OEM and volume end-users who wish to configure a modular micro-computer system using any Multibus compatible card set. It's the perfect solution, significantly reducing product costs and development time.

CP/M AND CP/M86 CONFIGURATIONS

If you prefer the popular CP/M operating system, Callan can provide the CD100M with either 8-bit or 16-bit micros. A Z80 with 64K RAM and CP/M, or an 8086 with 128K RAM with error correction and CP/M86 are both available as the complete solution for CP/M compatible software. And both systems include 10 Mbyte Winchester performance.

If you're using Multibus cards in your system you must see the Callan™ CD100M Integrated Work Station.

CP/M and CP/M86 are trademarks of Digital Research. Multibus and 8086 are trademarks of Intel Corp. Z80 is trademark of Zilog.

Circle 148 on reader service card

CD100L — COMPLETE DEC COMPATIBILITY

For the OEM or end-user configuring an LSI-11 system, only the Callan™ CD100L Integrated Work Station can emulate a 10 Mbyte RL02 Winchester disk, a 0.5 Mbyte RX02 floppy, and a VT103 Terminal in a *single* desktop unit. Software presently running on RT-11, RSX-11 or other LSI-11 operating systems can now run on the CD100L, reducing hardware costs by as much as 30%. For users who prefer a more complete solution, the CD100L can also be ordered complete with LSI-11/2 or LSI-11/23 and RT-11.

MORE FOR LESS

No other solution compares for performance, features and price. The VT100/VT52 compatible terminal offers 6 video attributes, true split screen with separate scrolling regions standard. The LSI-11 Q-bus compatible card cage provides 7 quad or 14 dual height slots to house even the largest configurations. A Winchester controller is available to directly emulate the 10 Mbyte RL02. RX02 emulation is available either in a 1 Mbyte dual floppy configuration or as 0.5 Mbyte back-up for the Winchester.

If you're tired of multiple package or multiple vendor solutions, you must see the CD100L.

DEC, LSI-11, VT103, RL02, RX02, RT-11, RSX-11, VT100/VT52, LSI-11/2, LSI-11/23 are trademarks of Digital Equipment Corp.

Callan is trademark of Callan Data Systems.



Built-in card cage holds 6 Multibus or 7 quad/14 dual height LSI-11 cards.

Callan™

DATA SYSTEMS

2637 Townsgate Road
Westlake Village, CA 91361
Telephone: (805) 497-6837

World Radio History

Controller board uses PDP-11 chip

DEC unwraps a version of Pascal for the PDP-11 and LSI-11 along with firmware-oriented dual-width processor board

by James B. Brinton, Boston bureau manager

Digital Equipment Corp.'s "Falcon" SBC-11/21 is claimed to be the smallest 16-bit single-board computer yet, and DEC calls the Micropower/Pascal software system announced with it "the first universal programming tool for the LSI-11 microcomputer family." The SBC-11/21 marks the end of the firm's nearly decade-long effort to reduce the PDP-11 architecture to a single chip on a single board, a process that began with the LSI-11 four-chip set. The hardware is thus a technical milestone, but the announcement of Micropower/Pascal will probably affect more users.

Micropower/Pascal extends DEC's operating-system and language capabilities downward toward the smallest board-level computers DEC makes, the LSI-11/2 and the new SBC-11/21. Heretofore, LSI-11 users had to make do with general-purpose software designed for larger systems, such as DEC's RT-11 and RSX-11 operating systems and its Fortran or Macro languages.

Quick work. Now, all but the smallest dedicated applications—those needing no operating system as such—can use Micropower and in almost all LSI-family applications, programs can be written and debugged in Pascal. The offering is said to make much quicker work of applications programming. According to a DEC spokesman, a designer "might require only 20% to 30% of the programming time formerly required. Even the debugger, PASDBG, is written and responds in Pascal. That adds speed too."

Micropower also gives DEC a software growth path for its customers to follow right up into PDP-11-class

computers if they wish. The SBC-11/21 gives a hardware growth path beginning at a lower entry price than DEC has offered before.

The SBC-11/21 is Q-bus-compatible, fits a 5.19-by-8.9-in. dual-width board, and executes the base-level PDP-11 instruction set via its T-11 microprocessor, a one-chip n-channel MOS version of DEC's PDP-11 architecture [*Electronics*, Nov. 3, p. 129] running at 5 MHz.

The SBC-11/21 is targeted at original-equipment manufacturers' applications where space is at a premium, especially firmware-intensive ones. Though the computer comes with 4-K bytes of random-access memory as standard equipment, it can hold as much as 32-K bytes of read-only memory.

Targeted. DEC is frankly pointing the new computer at the 8-bit competition. "It's faster, easier to program, and offers 16-bit precision," says Microcomputer Products group product-planning manager Ted Semple. At a price of \$521 in 100-unit

lots, and only \$790 in single units, the SBC-11/21 is aimed at the share of market now held by 8-bit boards, notably Intel's. DEC has high hopes for the Falcon unit in applications such as laboratory and medical instrumentation, manufacturing monitoring and control, process control, and robotics.

The small unit is equipped with two asynchronous serial ports compatible with RS-232-C and RS-423 standards. According to Semple, the board can communicate in full duplex at 38.4 kilobaud, for a combined rate of 76.8 kilobaud, one that enables customers to use peripherals like DEC's TU-58 cartridge system. The board comes with a real-time clock offering output at 50, 60, or 800 Hz.

A development system for the new board and LSI-11-based systems backs up Micropower Pascal and lets users create software on any PDP-11 running version 4.0 of DEC's RT-11 operating system. A RAM module fits beside the computer, allowing users to load software into RAM and experiment to create the correct set of machine instructions. It is then easy to burn the necessary programmable ROMs.

Deliveries of the SBC-11/21 will begin in December. Micropower/Pascal will be licensed for \$8,500 in quantity, with run-time copies \$30 each; deliveries are set for March 1982.

The Digital Equipment Corp., 146 Main St., Maynard, Mass. 01754 [338]

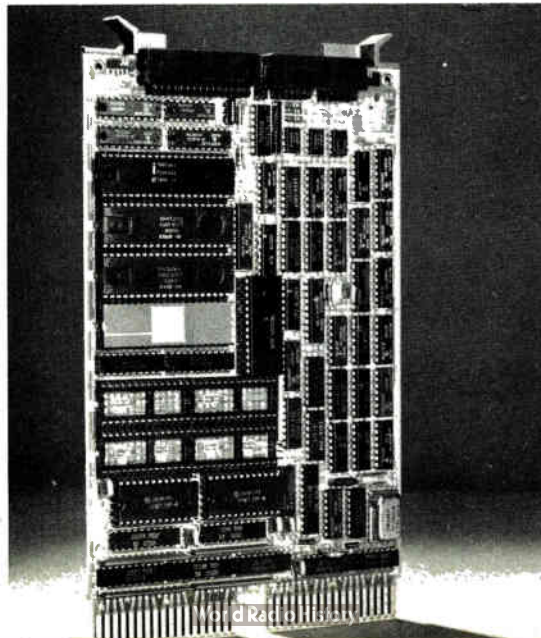

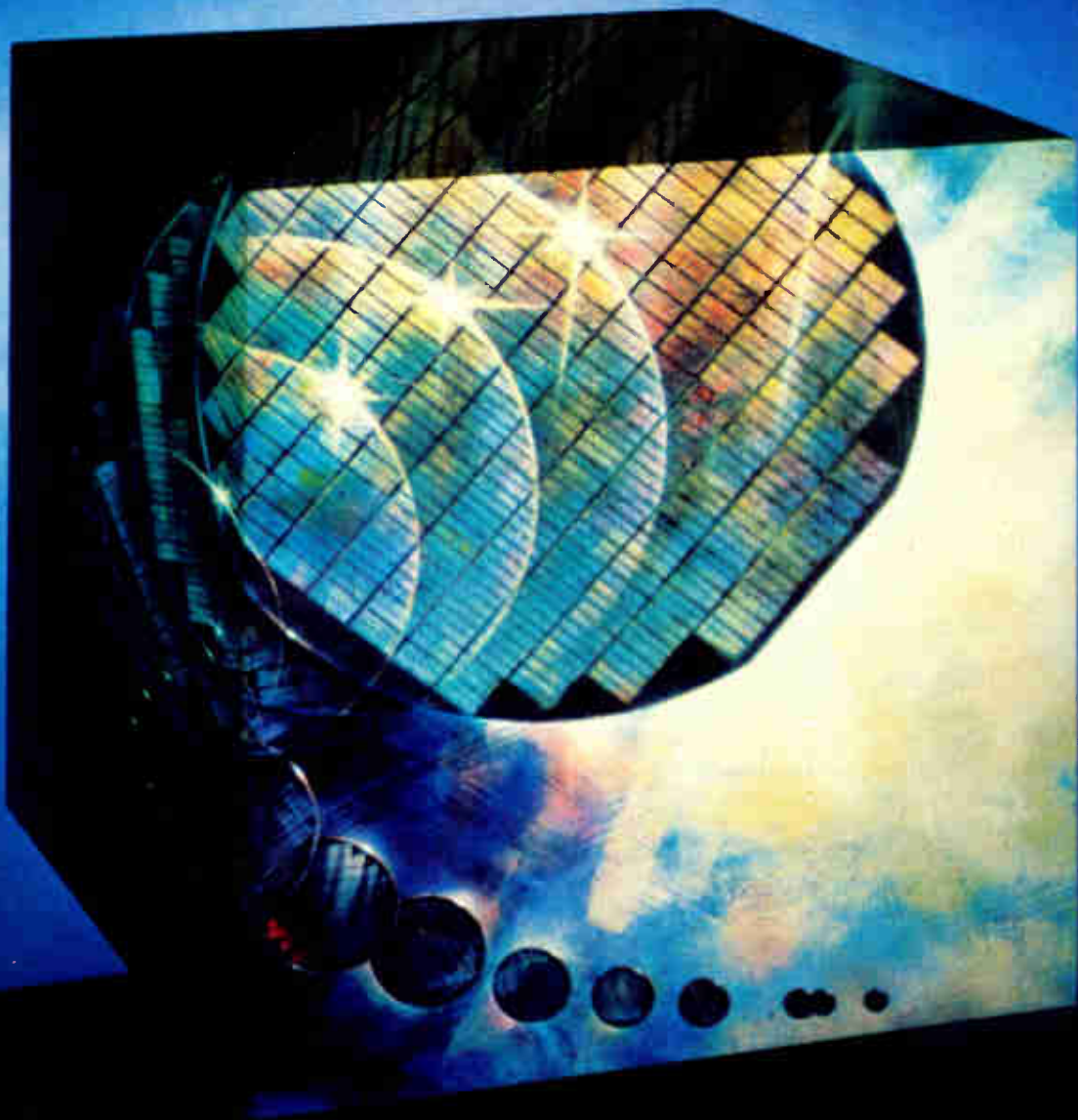

Another new standard from INMOS.

4K^x4/16K Static RAM

The IMS1420: High Speed. Low Power. Available Now.

The VLSI technology leader in 16K static RAMs introduces another industry first. Organized 4K x 4, the IMS1420 offers a chip enable access time as fast as 45ns.

Lowens System Cost

The low entry level price of \$45.00 (100's) for the IMS1420-55 makes this new 4K x 4 a viable alternative to 4K x 1 and 1K x 4 fast static RAMs. It matches their speed, saves board space and reduces power consumption by at least a factor of four. Trade off your 4K designs today and lower your system costs.

Need Higher Speed?

The companion IMS1421 delivers even more performance where higher speed is a must. With a chip select access time as fast as 30ns, the IMS1421 sets a new speed record for 16K memories.

Naturally, both new RAMs operate from a single +5V ($\pm 10\%$) supply and are fully TTL compatible. They're packaged in industry standard 20-pin, 300-mil dips and also industry standard 20-pin chip carriers.

Application Note Tells You How

Check your current 4K static RAM designs today. Chances are good that one of the new INMOS 4K x 4 RAMS offers a better system solution. Call or write for our new application note that tells you how to make the switch - and save.

INMOS 16K STATIC RAMS					
Static RAM Family	Organization	Max. Access Time		Max. Power Dissipation	
		Chip Enable/Select	Address	Active	Standby
IMS1420-45*	4K x 4	45ns	40ns	600mW	165mW
IMS1420-55	4K x 4	55ns	50ns	600mW	165mW
IMS1421-40*	4K x 4	30ns	40ns	600mW	NA
IMS1421-50	4K x 4	40ns	50ns	600mW	NA
IMS1400-45	16K x 1	45ns	40ns	660mW	110mW
IMS1400-55	16K x 1	55ns	50ns	660mW	110mW

* Available 1Q 1982



P.O. Box 16000 • Colorado Springs, Colorado 80935 • (303) 630-4000 • TWX 910/920-4904 • Burlington, Mass. (617) 273-5150 • Dayton, Ohio (513) 439-0988 • San Jose, Calif. (408) 298-1786 • Whitefriars • Lewins Mead • Bristol BS1 2NP • England • Phone Bristol 0272 290 861 • TLX: 444723.

inmos,  and IMS are trademarks of INMOS.

Circle 150 on reader service card

New AMI single-chip Codecs.

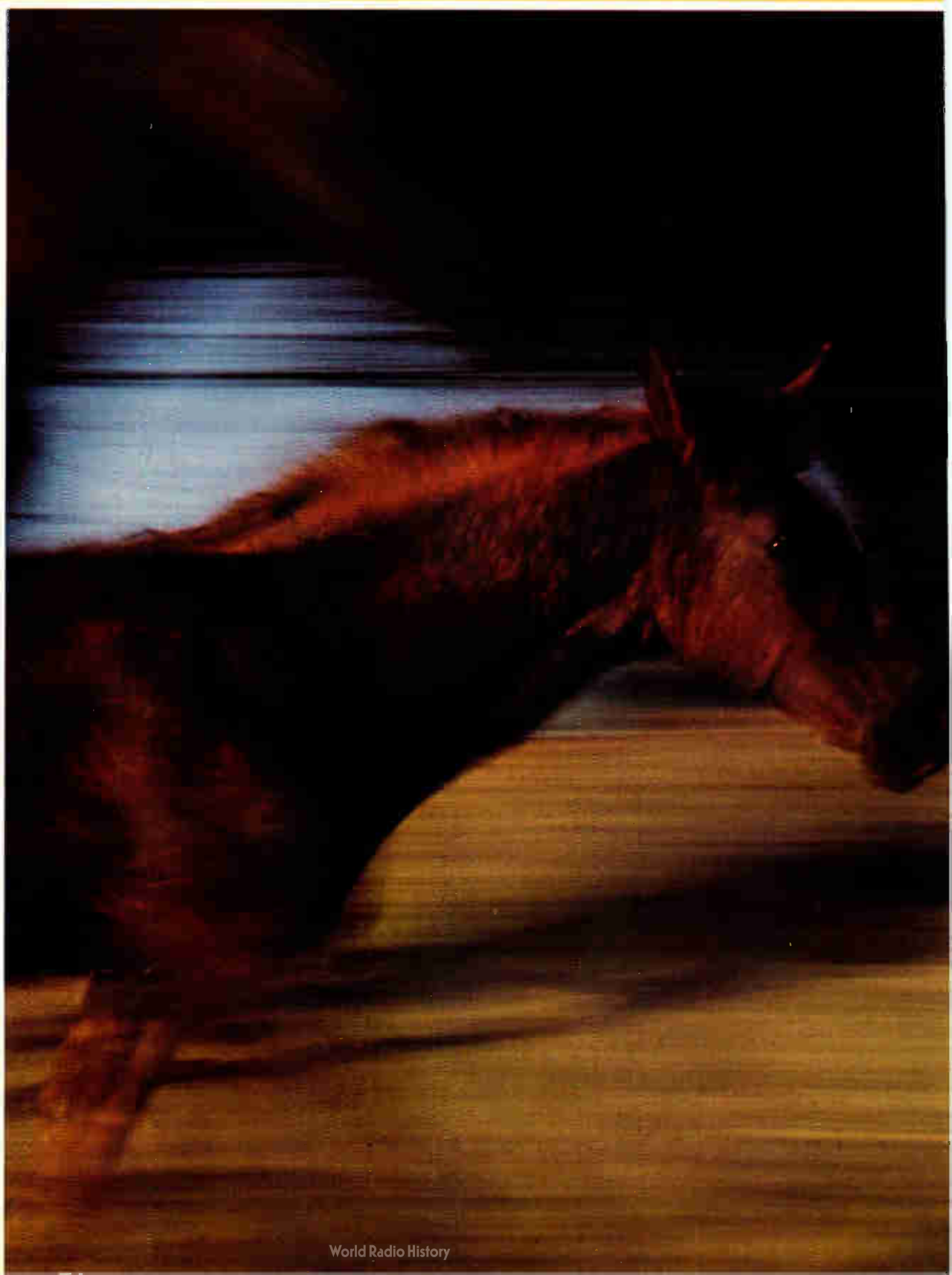

Well-bred and raring to go.

Introducing the thoroughbred of Codexs.

It took years of experience to develop the traits seen in AMI's new single-chip Codexs. Low power consumption. High quality. Cost-effectiveness. All in the single compact package you've been waiting for. And all because of AMI's extensive experience in designing and manufacturing standard and custom Codexs.

We're ready to deliver in quantity now. And that means you can get your μ -Law or A-Law designs off and running ahead of the field.

Breeding makes the difference. Complete with all encoding, decoding and filtering circuits and operating from dual $\pm 5V$ power supplies, the low-noise AMI Codexs use only 60mW (5mW standby). And each meets or exceeds AT&T and CCITT specifications.

Increase your efficiency. In 22-pin packages, the S3506 (A-Law) and S3507 (μ -Law) increase efficiency in any PCM application—PABX, Channel Bank, or digital telephone with fiber optics. Even in non-telephone communications uses. The S3507A provides μ -Law signaling in a 28-pin package as well.

We invite you to compare AMI Codexs against any other alternative—feature for feature, spec for spec. Add them up and you'll agree, the smart money's on AMI single-chip Codexs.

No need to wait any longer. AMI's exciting single-chip Codexs are

ready to go. To find out more about them, or to get our comprehensive 16-page data sheet, visit or call the AMI sales office nearest you. They could make you a winner.

© 1981 American Microsystems, Inc.

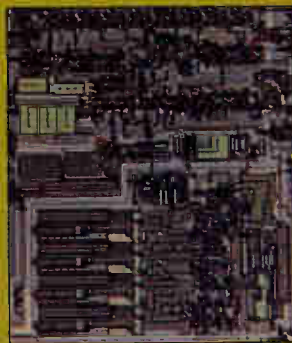

AMI

Microsystems, Ltd.

The most natural solutions in MOS.

Princes House, Princes Street, Swindon, England
SN12HU, Phone (0793) 37852

124 Avenue de Paris, 94300 Vincennes, Paris, France,
Phone (01) 374 00 90

Suite 237, Rosenheimer Strasse 30-32, 8000
Munich 80, West Germany, Phone (089) 483081

Piazza Gobetti 12, Milano 20131, Italy,
Phone (02) 293745

AMI: Unsurpassed in custom and standard communication circuits.

Net gets color graphics, laser printer

Turn-key business-graphics system and high-speed printer hook to Datapoint's ARC net; facsimile interface also introduced

by J. Robert Lineback, Dallas bureau

Datapoint Corp. is bringing three key technologies to its local-area computing network: color graphics, high-speed laser printing, and facsimile communications. The three offerings increase the capabilities of Datapoint's Attached Resource Computer (ARC) network in areas deemed essential for the office of the future.

The firm is taking its first step into the world of color with the introduction of its turn-key business-graphics system. The business-graphics market is expected to grow annually by 80% to 90%, crossing the \$1 billion mark in about four years [*Electronics*, Aug. 25, p. 48].

To meet this growth, Datapoint will be offering a high-resolution (512-by-482-element) raster display, a graphics-input tablet with stylus, and a system-controller package—its 9680 color business system. The

basic configuration will cost \$30,000 with deliveries starting immediately.

Present options for the color system include a dot-matrix printer that combines the four colors from four single-ribbon printheads and two models of film recorders that can expose film for transparencies or prints (35-mm film or Polaroid 8-by-10-in. transparencies and prints). The color printer costs \$15,000, and the color film recorder for 35-mm film only runs \$10,000. A recorder capable of handling both 35-mm and 8-by-10-in. film goes for \$20,000.

Designed for the nontechnical operator, the 9680 system needs no user programming. The system components and peripherals are interfaced with a controller containing a processor and 160-K bytes of random-access memory.

To create shapes, lines, curves, colors, and type fonts, commands are

entered either by keyboard or by "light keys," boxes that appear on the display screen when the stylus is placed on the tablet. The cursor is controlled by moving the pen on the tablet. Once the cursor is sitting on the proper light key, the operator presses the pen onto the tablet. If the user wants to clear the screen of light keys, he merely lifts the pen from the tablet's surface; he can then see the images being created. The cursor can also be controlled by the keyboard.

Responding to a growing demand for laser-based printers—which may represent more than half of the total nonimpact-printer business by the middle of the decade [*Electronics*, Jan. 27, p. 100]—Datapoint is also unveiling its 9660 laser printer. Using an electro-photographic printing process, the 9660 produces images using a matrix of 480 and 240 dots/in. horizontally and vertically, respectively.

It can print on both sides of the paper and up to 20 surfaces each minute (1,300 lines). The 9660, which has a standard buffer memory of 128-K bytes, goes for \$65,000. Deliveries are expected to begin in mid 1982.

Versatile. The printer can hold five different types of paper, and operators can make copies using five different typefaces from any workstation in the ARC network. Documents also may be directed to locked mail-boxes in the printer cabinet. The standard printer has 10 output bins.

The 9660 is so versatile that Datapoint is a bit reluctant to call it a mere printer, says Daniel A. Hosage, executive vice president of interna-



We know how



to make mobile dialling easy

Italtel's radio mobile telephony system RTMS 101: it can provide mobile subscribers with a service of the same quality of that enjoyed by every other subscriber of the telephone network.



20149 Milan (Italy) - 12, Piazzale Zavattari - phone (+ 392) 4388.1

Circle 154 on reader service card

World Radio History



ITALTEL

Telecommunications is our business

Increase Productivity with Automatic PC Board Assembly

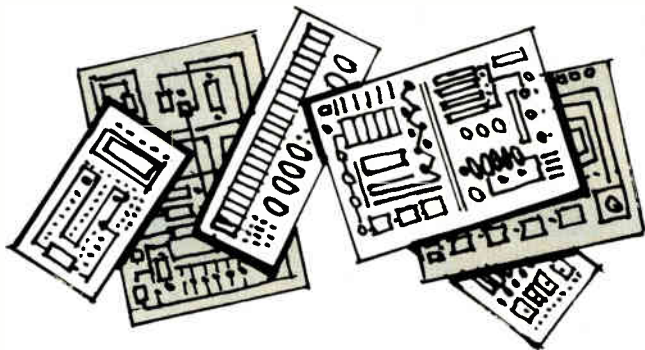

Now 90% of all PC boards can be automatically assembled at high speed, with high reliability. Universal is the only manufacturer to offer the total capability of complete lines of component processing and fully automatic insertion equipment.

Get Universal's Condensed Catalog

- Circuit Board Assembly Equipment
- Hybrid Processing Equipment
- Computer-based Control Systems
- Interconnection Processing and Assembly Equipment
- Component Processing Equipment



Subsidiary of **DOVER CORPORATION**

Universal Instruments Corp. ■ Box 825, Binghamton, NY 13902
607/772/7522 ■ TWX: 510/252/1990

Circle 156 on reader service card

Learn Chemical Safety from Professionals

Thousands of safety concerned people in the Electronics Industry have relied on J.T. Baker Hazardous Chemical Safety Seminars to substantially improve the safety performance of their organizations.

This two-day program offers essential safe training in the handling, storage, and transportation of the hazardous chemicals and gases used in the Electronics Industry.

This highly instructive, up to date, (state of the art) Seminar will be held at the following cities on the dates listed below.

Don't miss this important opportunity to increase your safety awareness in working with the hazardous chemicals and gases unique to the Electronics Industry! For further information, write or call:



The Office of Safety Training
J. T. Baker Chemical Co.
Phillipsburg, NJ 08865
(201) 454-2500

Classes will be conducted in:
December, 1981

3-4 **Boston, MA**
9-10 **Los Angeles, CA**
14-15 **Tucson, AZ**
17-18 **Colorado Springs, CO**



New products

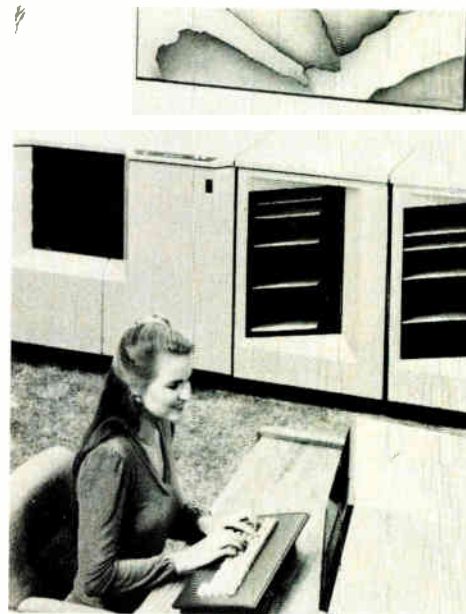

tional operations (he was an executive of Datapoint's Office Systems group during the development of these products). "Considering its variety of type fonts and printing styles, it is almost a new brand of office typesetting machine," he says.

The company's facsimile communications interface permits Datapoint processors to transmit and receive images from most commercially-available facsimile machines adhering to the standards of the International Consultative Committee on Telephony and Telegraphy (CCITT). Stand-alone processors or members of the ARC network may use the interface.

A microprocessor-controlled device, the interface provides facsimile protocols and format conversions necessary for communications with both analog and digital facsimile machines conforming to U. S. and CCITT groups I (analog), and II (analog), and III (digital). The unit communicates with processors over its RS-232-C interface at asynchronous data rates of 9.6 kb/s.

The interface costs \$4,950. A unit with the CCITT group III option costs \$7,450, with deliveries of the interface scheduled to begin in May 1982, the company says.

Datapoint Corp., 9725 Datapoint Dr., MST-41, San Antonio, Texas 78284. Phone (512) 699-7552 [339]

Environment survivor.



Three Series of Amphenol® connectors. Qualified to MIL-C-26482, MIL-C-38999, and MIL-C-83723.

Preferred under MIL-STD-1353B.

This is one tough family of circular environmental connectors. Since they're manufactured to the highest class within the above MIL-Specs, they're ideal for the most demanding ground-support and airborne interconnect jobs. And lots of other applications, too, wherever resistance to damaging fluids, wide temperature ranges, or many other environmental threats is essential.

Each of these Amphenol connectors uses a polymer-contact-retention disc with integrally molded contact-retention clips. It's our own advanced design and drastically reduces the number of connector parts needed.

These connectors are designated: Amphenol 118 Series (MIL-C-26482/ Series 2); Amphenol 418 Series (MIL-C-38999/ Series I and II); and Amphenol 518 Series (MIL-C-83723/ Series III).

For more information, contact the office nearest you.



118 Shown 1/2 actual size.



AMPHENOL INTERNATIONAL LTD.

An  Allied Company

Amphenol International Ltd., 900 Commerce Drive, Oak Brook, IL 60521, USA—Tel: (312) 986-2700—Telex: 206-054

EUROPE: Austria—Amphenol Ges.m.b.H., Tautenhayngasse 22, A-1151 Wien (Vienna), Tel: (0222) 95 15 11 • England—Amphenol Limited, Thanet Way, Whitstable, Kent CT5 3JF, Tel: 02 27-26 44 11 • France—UMD Amphenol, Avenue de Gray, 21 Chemin Du Défois, 39100 Dole, Tel: (84) 72 81 13 • W. Germany—Amphenol-Tuchel Electronics GmbH, August-Häusser-Str. 10 7100 Heilbronn/N., Tel: (07131) 486-1 • Italy—Amphenol Italia S.R.L., Via Plinio 43, 20129 Milano, Tel: (02) 28 70 061 • Sweden—Amphenol Scandinavia AB, Kanalvaeger 1, S194 61 Upplands Vaesby, Tel: 46-8-760-88-035

FAR EAST: Hong Kong—Amphenol International Limited, Room 521-22, New World Centre Office Bldg., Tsimshatsui, Kowloon, Tel: 3-681-283 • India—Amphetronix Ltd., Plot No 105, Bhosari Industrial Area, P.B. No. 1 Poona, 411026, Tel: 83363 • Japan—Dai-Ichi Denshi Kogyo K.K., Shinjuku Bldg. 7-12, 2-Chome, Yoyogi, Shibuya-Ku, Tokyo, Japan 151, Tel: (03) 379-2111

Circle 209 on reader service card

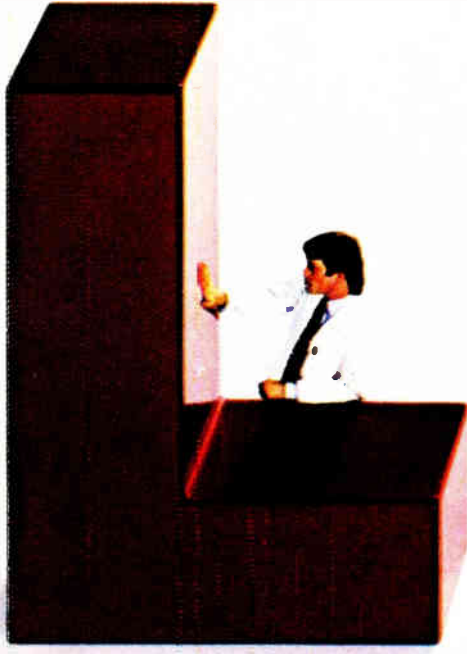

Get colors without losing properties by specifying LEXAN resin in standard or custom-matched opaque and translucent colors; or by using compatible paints. (Available clear too.)

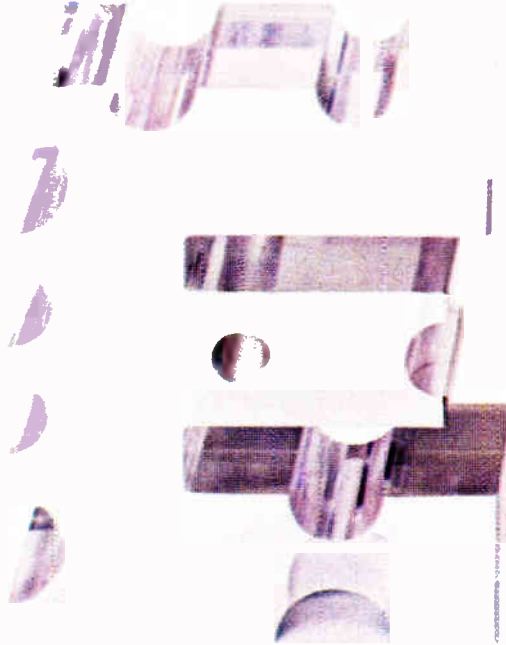

For functional or decorative metallic finishes, molded LEXAN resin lends itself to cathode sputtering, flame spray, arc spray and RFI shielding as well as vacuum-metallizing.



Drill, tap, thread, mill, turn, cut, rout. Standard metal-cutting tools easily machine LEXAN resin prototypes or parts to close tolerances.

LOOK TO LEXAN[®] FOR THE FINISHING EDGE.

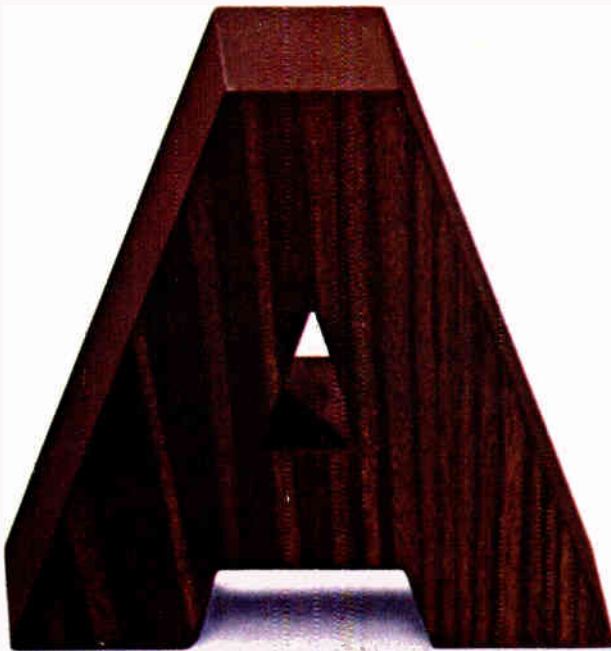

The first time you put pencil to paper is the time to call us in. That way, you can take full advantage of the finishing techniques, functional and decorative, open to you with LEXAN resin. And we'll help all the way. Help make sure finishing enhances design (and vice-versa). Help with processing and performance considerations. Help select supplies and suppliers. In short, we've got the experience and resources to help you see what finishing can be. For a free booklet on finishing and secondary operations, write to LEXAN Products Division, Dept. 491, General Electric Company, One Plastics Ave., Pittsfield, MA 01201. Or call (413) 494-4621.



Self-adhesive decals, hot transfers, silk-screening and other printing methods can produce exact, durable images on molded LEXAN resin.

Designing with LEXAN resin lets you choose from a variety of wood, metallic or colored hot-stamping foils tailored specifically for the resin and your design.

We bring good things to life.
GENERAL  ELECTRIC

New products

Semiconductors

Fast C-MOS RAM idles on 100 μA

4-K-by-1-bit static part accesses in 55 ns maximum, works with C-MOS or TTL

Motorola's MCM65147 4-K-by-1-bit high-speed static random-access memory, made with its high-performance complementary-MOS process, has been developed following a technology exchange with Hitachi, producer of the comparable HM6147 C-MOS static RAM. The exchange was made in connection

with Hitachi's second-source agreement to produce Motorola's 6800 and 68000 microprocessors. Both the Motorola and the Hitachi RAMs are similar to the n-channel Intel 2147.

The 65147 is offered with a 55-, 70-, or 85-ns maximum access time and is directly compatible with TTL levels and Motorola's recently announced high-speed C-MOS logic family [*Electronics*, July 14, p. 46]. With C-MOS inputs, it draws 35 mA maximum from the power supply and only 100 μA maximum when on standby. The latter is an improvement on the Hitachi maximum standby current figure of 800 μA . When TTL inputs are used, the 65147 uses 12 mA maximum on standby and 35 mA maximum when active, figures identical to the corresponding ones for the HM6147.

Motorola's MOS operation made some minor design changes to the RAM, including modification of its input-protection circuitry. In a ceramic dual in-line package, the 55-ns version is priced at \$7.15 each in orders of 100; in like quantities, the 70- and 85-ns parts are \$6.45 and \$5.80 each, respectively. They are also packaged in plastic.

The firm sees two principal uses for the 65147. It will replace n-MOS 2147 RAMs in existing designs to save active power use; the 2147 dissipates 500 mW in a typical active mode, compared to the 65147's 75 mW. Also, Motorola expects its RAM to be used in new fully C-MOS designs that allow the device to run with rail-to-rail logic excursions.

Motorola Inc., 3501 Ed Bluestein Blvd., Austin, Texas 72721 [411]

Chip's diodes are isolated to 1 kV

Four closely matched diodes for hybrid-circuit use come in version wired as bridge

Over 1 kV of silicon dioxide isolation separates the four precisely matched diodes on the Dionics DI 914, a small 25-mil-on-a-side chip for use in hybrid circuits. The two standard versions have metalization patterns for either separate diodes or, in the B version, a connected four-diode full-wave bridge circuit.

Replacing four standard 12-mil Dionics 914 chips with a single diode quad saves more space than an area comparison would indicate, because the four individually mounted chips would require considerable separation to afford comparable isolation. The four diodes, intended for signal-level, not high-power, applications, have close thermal tracking.

Four square. The four matched diodes of Dionics Inc.'s DI 914B chip are separated by over 1 kV of silicon dioxide isolation and wired in a full-wave bridge configuration.

The diodes are isolated not only from each other, but from the bottom of the chip. This allows pure epoxy or adhesive films to be used for bonding to the hybrid substrate, thus reducing die-bonding time at potentially harmful high temperatures. For applications requiring conventional eutectic die bonding, chips can be supplied with gold backing. The manufacturer says that the chip's 4-mil aluminum bonding pads are the industry's largest.

Both versions of the chip are available with breakdown voltage ratings of 75, 60, or 45 v. Parts with a B or QM suffix conduct 20 mA minimum

at a forward voltage of 1.0 v and 10 nA maximum at a reverse voltage 10 v below their breakdown ratings. Each diode presents a total capacitance of 3.0 pF. The forward voltage drops of the DI 914's four diodes are matched over a range of 100 μA to 100 mA. At a forward current of 1 mA, the drop is 1.0 mV (QM suffix) or 30.0 mV maximum (Q suffix).

The four diodes of the DI 914 can be used individually or wired in series or parallel. The DI 914B bridge version is suitable for use in comparative circuits such as timer circuits or differential amplifiers. Both the diode quad and the quad bridge can be supplied to meet most military standards; both are shipped in either K packs or Circle packs.

The diode quad is priced at 32¢ each and the bridge version at 35¢ in lots of 10,000. Delivery is from stock to six weeks.

Dionics Inc., 65 Rushmore St., Westbury, N. Y. 11590. Phone (516) 997-7474 [412]

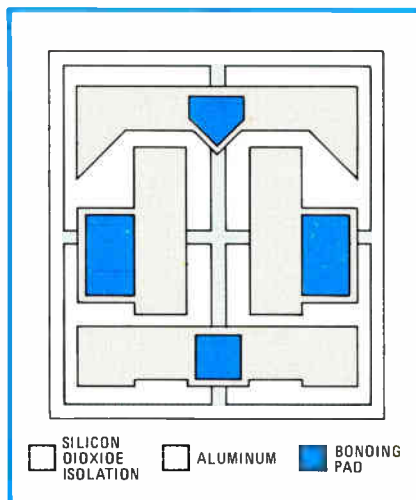

Programmable shift register has a 64-point memory

A solid-state device for short- or long-term storage, the PM-5002 programmable 64-bit shift register re-

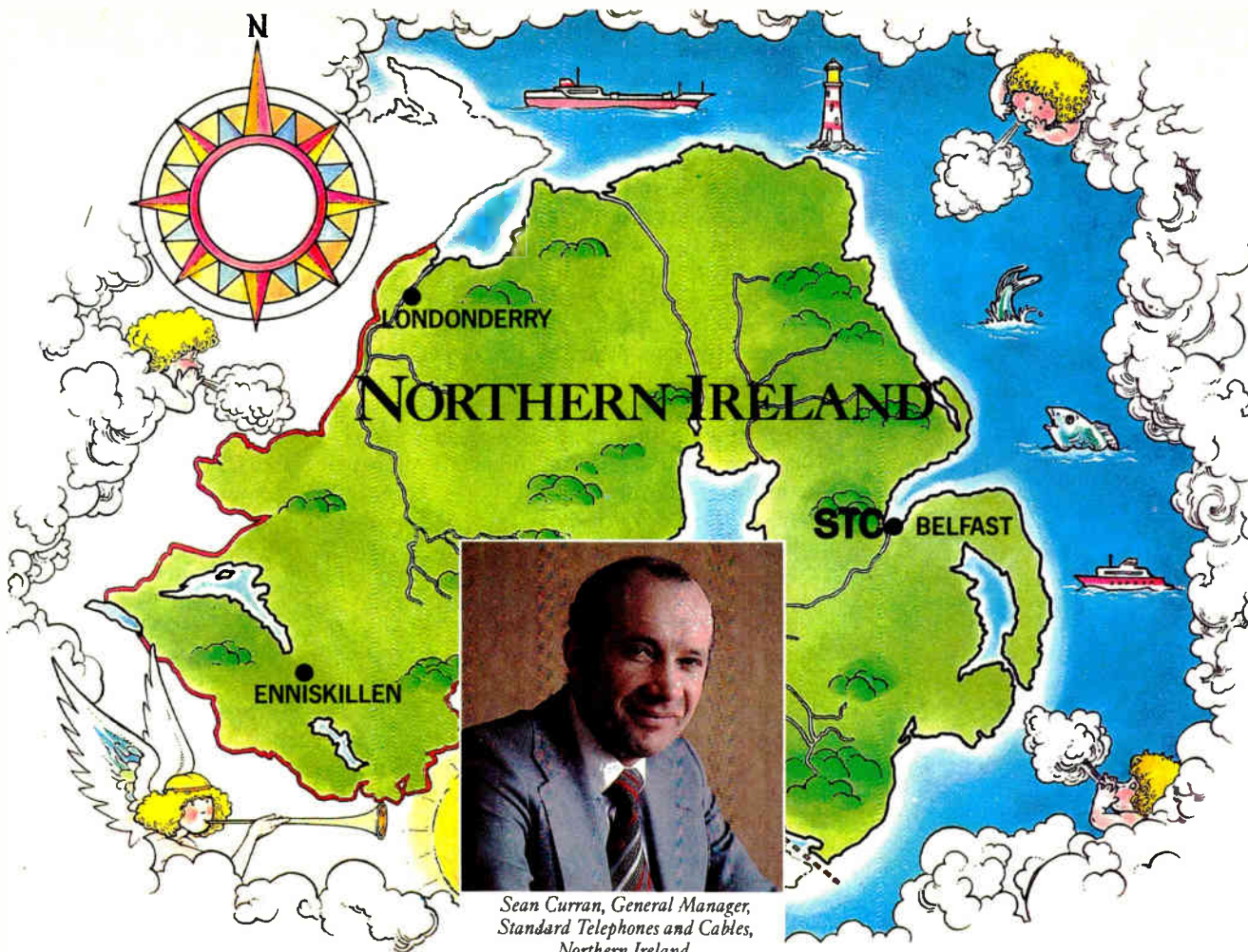

*Sean Curran, General Manager,
Standard Telephones and Cables,
Northern Ireland.*

“New technology? Our Northern Ireland workforce take it in their stride.”

Standard Telephones and Cables (STC) have been in Northern Ireland since 1962.

Its Northern Ireland General Manager, Sean Curran, recently won a worldwide Creative Management Award for the high productivity, profitability and employee motivation of STC's plants in the Province.

Sean Curran himself is loud in praise of his people.

“Flexibility is, without doubt, the single most important attribute of our workforce”, says Mr. Curran.

“Neither new technology nor old habits stand in the way of efficient and effective production – that is my finding as manager of a substantial high-technology telecommunications and electronics manufacturing plant which always meets its targets.”

What's good for STC could also be good for your company. For Northern Ireland offers a sound business environment, a well developed infrastructure and as advanced a telecommunications system as any in Europe.

Plus what Plant Location International of Brussels has described as “overall the best package of Government incentives in the EEC”

It all adds up to high profit opportunity.

Get in touch. We will give you all the facts.

Phone Louis Ritchie at the Ulster Office, 01-493 0601.

**NORTHERN IRELAND:
THE OPPORTUNITIES ARE THERE.
THE PROFITS ARE THERE.**

Louis Ritchie, Industrial Development Organisation for Northern Ireland, Ulster Office, 11 Berkeley Street, London W1X 6BU. Telex: 21839.
Please send me more information on Northern Ireland. (E/17/11/PE)

Name _____
 Position _____
 Company _____
 Address _____
 Telephone _____

NORTHERN IRELAND



New products

ceives information from either open-collector or logic-level inputs. The plug-in device has a 64-point memory capability, but this can be expanded by cascading multiple PM-5002 modules within an individual control unit. The versatility of the device can be enhanced by using



it with an 8-bit shift register that can generate multiple outputs.

The PM-5002 measures 1 3/8 in. square with a height of 2 1/2 in. and is built on an 11-pin base that uses a PMS-11 socket assembly. This assembly has two five-terminal barrier strips and is intended for use in a 3-in.-wide polyvinyl chloride track.

Through an opening in the unit, the operator can program the control's six switches, which operate on a binary number system. The 5002 sells for \$95, with a 28% discount on 100-piece orders. Delivery of small quantities is from stock.

Tri-Tronics Co., 619 Enterprise Dr., Oak Brook, Ill. 60521. Phone (312) 654-3255 [413]

Chip spots, fixes double-bit RAM errors

Able to correct double-bit errors, the basic DP8400 expandable error checker and corrector can examine

16 bits at a time and correct up to two errors. It comes in a 48-pin dual in-line package. Adding units expands it to 32- or 48-bit word sizes; no external components are needed.

Double-bit correction for both hard and soft errors is accomplished with either of two techniques. The complement-correct method, requiring no extra hardware, corrects both types of errors. For systems requiring extreme data integrity—for example, when there are two soft errors—the second approach calls for twice the DP8400s, double the check-bit memory, and a 4-k-byte programmable read-only memory.

Using National's Schottky technology and having low propagation delays, the DP8400 detects an error in a 16-bit word in 21 ns and corrects it in an additional 14 ns. Detection time for 32-bit words is 34 ns. The unit will be available this month for \$60 each in quantities of 100.

National Semiconductor, 2900 Semiconductor Dr., Santa Clara, Calif. 95051. Phone (408) 737-5000 [414]

Kit shown with optional, extra-cost parts.



NEW. THE WHIZ KIT.

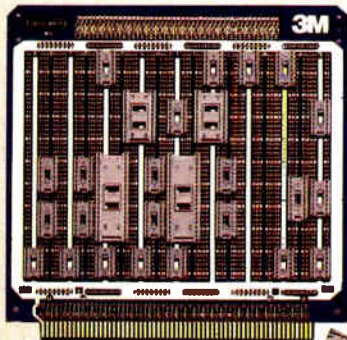

Breadboard 50% faster with the new 3M Whiz Kit. It puts high-quality Scotchflex brand plugstrips, sockets and tools right at your fingertips. So you can assemble a 20 I/C panel in less than half the time needed for hand-wrapping. There's no stripping. No soldering. No crimping.

The kit's proven U-contact components let you use the same insulation-displacement technique for breadboarding that's used in production. Each contact's tin

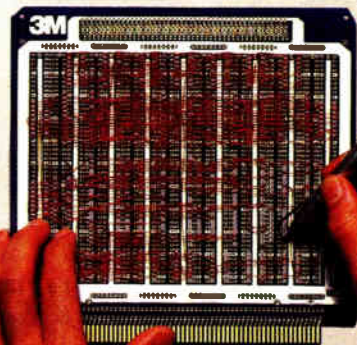

Bipolar multiplier calculates 32-bit products in 80 ns

Using an unlocked logic array, the Am29516 and Am29517 parallel multipliers produce a 32-bit product in no more than 80 ns over the full military temperature range. The 64-pin devices are also available in a commercial grade.

Though the Am29516 is a plug-in replacement for TRW's MPY16HJ, its Imox bipolar fabrication makes it 2.5 times faster. The unit has separate clocks for each of its two input and two output registers.

The Am29517 is suitable for microprogrammed system applications, but differs from the Am29516 in that it has one system clock and three register clocks. The single-clock approach eliminates the problems of clock delay and skew that result from external clock gating.

Both devices feature internal emitter-coupled-logic circuitry for high

speed and both have TTL-compatible input/output ports for maximum interfacing flexibility. They operate from a single 5-v power source. The price for either part is \$157 per piece in 100-lot quantities. Delivery takes 6 weeks.

Advanced Micro Devices Inc., 901 Thompson Pl., Sunnyvale, Calif. 94086. Phone (408) 732-2400 [415]

MOS device provides digital approach to data separation

Converting a serial bit stream from a floppy-disk drive into separate clock and data signals for a floppy-disk controller is eased with the FDC 9216—the unit separates data at less cost and circuitry than with an analog approach and needs no adjustments either.

The most common separation method has been through a complex analog phase-locked-loop circuit that requires several critical control

adjustments. But the large-scale integrated MOS 9216 works totally digitally, compensating for the drive's mechanical speed variations by separate long- and short-term timing correctors. The only peripheral circuitry needed is an external 8-MHz clock.

The new floppy-disk data separator is a monolithic device made with Standard Microsystems' Coplamos n-channel silicon-gate process. It is available in a plastic or ceramic eight-pin dual in-line package. Delivered from stock, each unit sells for \$6.85 in 100-unit lots.

Standard Microsystems Corp., 35 Marcus Blvd., Hauppauge, N. Y. 11788. Phone (516) 273-3100 [418]

LSI controller chip directs traffic on dynamic RAMs

Operating on arrays of 64-K dynamic random-access memories in micro-computer systems and on memory-

IT BEATS THE CLOCK.

plated, so you save on cost.

Bussing is fast—just one step. Wire inserted into the U-contact gives you the equivalent of two wrapping levels. Double up in the contact and save four wrapping levels.

CONVERT RIGHT TO PRODUCTION.

Finished Scotchflex prototypes so closely match production quality that you're saved more time on redesigning and fine-tuning. The U-contact's less than 1/3 the height of an ordinary wrap post. So

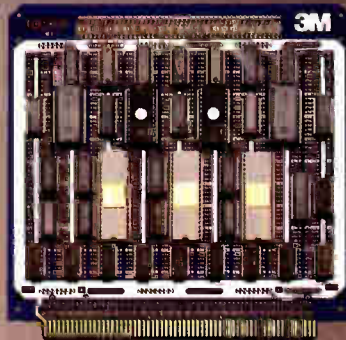

Scotchflex breadboards can be stacked on .600" centers for the most efficient use of space.

You can reuse the Whiz Kit's components up to 25 times. The hand tools are rugged, versatile and maintenance-free. And the kit has its own storage tray. Exposed parts can be easily replaced and stored.

Right now, the 3M Whiz Kit is available at your Scotchflex distributor: Electronic Products Division/3M, 225-4SC, 3M Center, St. Paul, MN 55144.

3M hears you...

How To Comply With The New Copyright Law

Libraries everywhere have found the easy way to fill photocopy requests legally and instantly, without the need to seek permissions, from this and over 3000 other key publications in business, science, humanities, and social science.

Participation in the Copyright Clearance Center (CCC) assures you of legal photocopying at the moment of need. You can:

Fill requests for multiple copies, interlibrary loan (beyond the CONTU guidelines), and reserve desk without fear of copyright infringement.

Supply copies simply and easily from registered publications. The CCC's flexible reporting system accepts photocopying reports and returns an itemized invoice. You need not keep any records, our computer will do it for you.

The Copyright Clearance Center is your one-stop place for on-the-spot clearance to photocopy for internal use. You will never have to decline a photocopy request or wonder about compliance with the law for any publication registered with the CCC.

For more information, just contact:



**Copyright
Clearance
Center**

21 Congress Street
Salem, Massachusetts 01970
(617) 744-3350

a not-for-profit corporation

NAME TITLE

ORGANIZATION

ADDRESS

CITY STATE ZIP

COUNTRY TELEPHONE

New products

expansion boards, the 8203 large-scale integrated peripheral controller multiplexes row and column memory addresses, generates strobes, and controls memory-refresh cycles. It also arbitrates between simultaneous access and refresh requests.

The high-density device has on-chip array drivers and damping resistors in series with the address multiplexer outputs. It controls up to sixty-four 64-K RAMs totalling 256-K bytes of capacity. The 8203 can also be strapped to operate with 16-K dynamic RAMs. By changing only three jumpers, such systems can later be upgraded to accommodate 64-K RAMs. The 8203 works with Intel's 8080A, 8085, iAPX 86, and iAPX 88 families of microprocessors, as well as with other popular 8- and 16-bit central processing units.

Made with Intel's bipolar process technology, the 8203 comes in a 40-pin ceramic dual in-line package and dissipates at most 1.4 W, working from a single 5-V supply. Samples are available now; full production is expected in January. In 100-piece quantities, each unit sells for \$27.15. Intel Corp., 2625 Walsh Ave., Santa Clara, Calif. 95051. Phone (408) 987-7465 [416]

Bipolar chip performs math for 8-bit processors

An intelligent coprocessor for an 8-bit microprocessor, the new SN54/74S508 is claimed to multiply and divide 15 and 25 times faster than popular 8085 and 6800 microprocessors. Able to process digital signals, the 8-bit bus-organized device follows 28 multiplication instructions and 13 division instructions. It executes basic multiplication instructions in less than 0.8 μ s and basic division in under 2.2 μ s.

The bipolar device can also be used in digital modems, personal computers, small-business computers, and intelligent instruments and weapons. Multiplication instructions include positive and negative accumulation and both single- and double-length addition in conjunction with multiplication. Also possible

are continued division of a remainder or quotient and repetitive multiplication followed by division.

In a 24-pin dual in-line package, the SN54/74S508 is available now in both commercial and military specifications. In quantities of 100, the former version is priced at \$64, while the latter is \$96.

Monolithic Memories Inc., 1165 East Arques Ave., Sunnyvale, Calif. 94086. Phone (408) 739-3535 [417]

Low-cost chip houses disk controller-formatter

Designed for 5¼-in. floppy-disk drives, the FD176X family of monolithic controller-formatters have all the features of the industry-standard FD179X family but at a lower cost.

The devices, which can also handle 8-in. drives, operate at 1 MHz and are compatible with existing floppy-disk-drive designs using the 179X version.

Four parts in the family, the FD1761, -63, -65, and -67, cover all combinations of single or double density, true or inverted data bus, and single- or double-sided drives. They may be used with the IBM 3740 single-density or System/34 double-density formats or, alternatively, with nonstandard formats to achieve greater density.

The chips are designed for soft-sectored systems having automatic track-seeking with verification and provide direct-memory access or programmed data-bus transfers. They support single- or multiple-sector read or write operations with automatic sector search in both modes or can read or write the entire track. To further simplify FD176X/9X design-in, data-separator and clock-generator support chips are available. The chip, housed in a 40-pin dual in-line package, sells for \$25.30 in plastic versions and \$36 in ceramic models in lots of 100. The FD176X controllers, which operate over the 0°-to-70°C temperature range, are available immediately.

Western Digital Corp., 2445 McCabe Way, Irvine, Calif. 92714 [419]

FERRANTI Metal Can



- 140 varieties.
- Packaged to BS9300 and CECC 50000 standards.
- Where to sow: telecommunications, military, professional equipment, industrial.

FERRANTI VMOS



- New varieties.
- Fast growing.
- Where to sow for power: telecommunications, military, industrial.

FERRANTI SOT-23



- Hardy perennial for successful hybrids.
- Gives bigger yields.
- Packaged to BS9300 and CECC 50000 standards.

FERRANTI E-Line



- Over 1000 varieties.
- Packaged to BS9300 and CECC 50000 standards.
- Where to sow: telecommunications, military, professional equipment, industrial, consumer.

The seeds of success.



Ferranti Electronics Limited,
Fields New Road, Chadderton,
Oldham, England, OL9 8NP
Tel: 061-624 0515
Telex: 668038

Ferranti GmbH,
Widenmayerstrasse 5, D8000-
Munich-22, West Germany
Tel: 089-293871
Telex: 523980

Ferranti Electric Inc.,
87 Modular Avenue, Commack,
N.Y. 11725, U.S.A.
Tel: 516-543 0200
Telex: 510 226 1490

FERRANTI Semiconductors

Circle 210 on reader service card

FOR THE PRICE OF A NEW CAR, YOU CAN START YOUR OWN COMPUTER COMPANY.

Skim through almost any newspaper and you'll see that for around \$7,000 you can buy a basic new car. Perfect for going back and forth to work.

But for those of you who harbor ambitions of working for yourself, and for those of you who dream of becoming a star where you're now working, there is a far more prudent investment.

The MPT/100 computer you see here.

To start with, the MPT/100 costs a good deal less than a new car.

Besides, the MPT/100 can take you a good deal further.

Inside the MPT/100 you'll find a 16 bit microNOVA[®] computer. 64K bytes of memory. 80 column by 24 line screen. Full keyboard with numeric pad. 716 KB of on-line storage on 358 KB mini-diskettes.

Out back you'll find an I/O bus that accepts the standard microNOVA peripherals, including Data General Winchester-type disks. As well as your own interfaces. Two synchronous/asynchronous communications ports, programmable to 19.2K baud.

And a host of features many desktop computers don't even have as options.

Which is a lot of computer to find in a desktop computer that doesn't take up the whole desk.

As impressive as the hardware may

be, it's the systems software that runs on the MPT/100 computer that makes it the computer to further your ambitions.

A multi-tasking FORTRAN and a multi-tasking PASCAL



that executes at assembly language speeds. An ANSI-compatible BASIC that lets you quickly write large programs that take up a small amount of space. A full range of user-friendly aids like a Command Line Interpreter, a Menu Editor, and a Debugger. And MP/OS, one of the most advanced operating systems in the industry.

With software like that, you can be out making a name for yourself while everybody else is trying to figure out how you did it.

You can take your big ideas anywhere in the world. Because the MPT/100 comes with the same worldwide support we give every Data General computer.

And when you start to carry a lot of weight in your industry, you can migrate all your software, all your peripherals, and everything you've learned. Because we've gone out of our way to make Data General computers get along with each other.

The point we're driving at is that this computer can help you do what a lot of other companies have done with other Data General computers.

Like Finnigan of Sunnyvale, California, one of the world's leading suppliers of Mass Spectrometers. They came to Data General partly because they had to write software elaborate enough to identify the fingerprints of over 30,000 chemicals. Partly because of our worldwide service. And partly because they didn't have to wait a year to get our computers.

Of course buying an MPT/100 may mean driving your present car a while longer. But look at it this way. A few years from now, maybe you'll be driving any car you jolly well please.

For more information about the MPT/100 computer, call your local Data General office, your Data General manufacturers representative, or one of the distributors listed below. Or write us at MS C-228, 4400 Computer Drive, Westboro, MA 01580.

 **Data General**
We take care of our own.

MPT/100 computers are available for delivery from SCHWEBER, HALLMARK, KIERULFF, ALMACSTROUM and R.A.E. in Canada. microNOVA is a registered trademark of Data General Corporation.
© 1981, Data General Corporation.



Lanier introduces the No Problem[®] typewriter for your technical typing.

Want to get your typing back faster than ever before? **NO PROBLEM**

Want to type Greek and math symbols right on the screen? **NO PROBLEM**

Want to type and edit multi-level equations with typewriter simplicity? **NO PROBLEM**

Want to add line drawings and charts to the page? **NO PROBLEM**

Most typewriters — even many of the latest electronic models — are limited to basic typing.

But the Lanier No Problem Electronic Typewriter is multi-use, with extraordinary powers for technical and scientific typing.

No Problem typing — a better way to type.



The No Problem concept

To begin with, the No Problem typewriter speeds up the typing of your proposals, manuals, and reports like no ordinary typewriter can.

It eliminates typing rough drafts on paper. Pages are prepared on a TV-like screen instead.

Changes and corrections are made right on the screen. So no whiteouts. No retyping. No false starts. Whole paragraphs can be moved with the touch of a few keys.

Letter quality printing is done at up to 540 words per minute.



With the No Problem typewriter, one typist can now do work as fast as 3 or 4 people using ordinary electric typewriters.

Plus, the basic intelligence for the No Problem typewriter is contained on No Problem Smart Discs.™ So future functions and improvements can be added with new Smart Discs as they are developed.

One typewriter or a shared system

The No Problem Shared System™ offers you even greater typing capabilities.

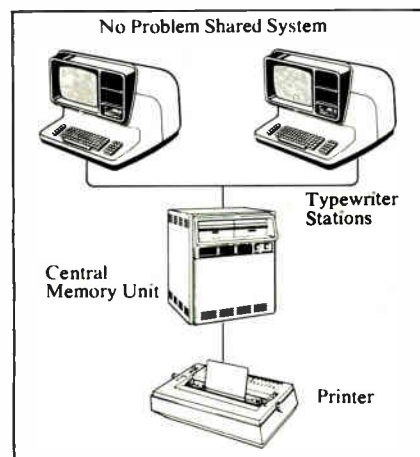

The No Problem Shared System™ adds new capabilities to the already versatile No Problem concept.

The heart of the system is the Central Memory Unit. It can store up to 30,000 pages, giving you lower storage costs per page, and eliminating the need for typists to handle numerous discs.

You can start with one or two typewriter stations connected to the Central Memory Unit, and add typewriter stations or printers as your needs increase.

There is also an attractive economic factor in sharing printers and other equipment.

Advanced features

Consider the old method of incorporating complex mathematical equations into your copy: leave the space blank, then hand letter them in after the page was typed. Or, you could run to the photocopier, then "cut and paste."

With the No Problem Shared System, you can incorporate *and edit* virtually any equation you may encounter—*right on the screen*. It will display *256 different characters*, including Greek and math symbols.

Line drawings can be constructed on the No Problem screen, too.

The No Problem Shared System automatically selects left, right or center page position for numbers, and chapter names on even and odd pages. Repagination automatically updates section numbers to accommodate your additions and deletions.

Advanced editing automatically positions footnotes on the proper page.

And the printing of the No Problem Shared System approaches typeset quality and flexibility. Proportional and bold printing, to fit any format or width, is easily done. Even in two typesyles and two colors on the same page at the same time.

Most of all, the No Problem Shared System can improve your cost/performance ratio dramatically with its increased workpower.

Modular design protects your investment

You can add Shared System typewriter stations, standalone No Problem typewriters, printers and Smart Discs to your office at will.

So your investment will *continue* to be a money-making problem solver as long as you own the equipment.

The No Problem demonstration

Your Lanier representative won't waste your time with a memorized sales pitch.

We would rather show you how No Problem typing can solve *your* problems.

Send us this coupon and we'll call immediately to set up an appointment. Or call toll free **(800) 241-1706**.

Except in Alaska or Hawaii. In Georgia, call collect (404) 321-1244.

© 1979 Lanier Business Products, Inc.

The No Problem Electronic Typewriter

from **LANIER**®
LANIER BUSINESS PRODUCTS, INC.

It does more than just type.

Want to see Lanier No Problem typing in action? **NO PROBLEM.**

Send us the information below and a Lanier representative will call for an appointment.

Name _____ Title _____

Phone _____

Best Time To Call _____

Firm Name _____

Address _____ County _____

City _____ State _____ Zip _____

What kind of typing or word processing system are you using now? _____

Lanier Business Products, Inc.
1700 Chantilly Dr. NE, Atlanta, GA 30324

Nov. 17, '81 Electronics 4 89 E K1

Components

BiFET op amp has multiplexed inputs

Eight-input hybrid contains ladder and switches for digitally programmable gain

Taking a low-cost route, Burr-Brown has combined a programmable-gain operational amplifier made with bipolar and field-effect transistors with an eight-channel multiplexer, giving data-acquisition systems a hybrid front end with maximum-gain nonlinearities of 50 ppm. The single-ended amplifier configuration was chosen to produce a less expensive part than programmable instrumentation amplifiers like the company's 3606.

As analog products marketing manager Dennis Haynes says, "Microcomputer control of data-acquisition components has become so widespread that there is a growing demand for the basic programmable functions at a minimum cost." A 3-bit channel address selects one of eight analog input channels to the PGA100. Another 3 bits determine the tap point on a resistor ladder in the op amp's feedback path to set the channel's gain in binary-weighted steps between 1 and 128 or other

ranges as chosen by the user with an external trim.

One easy way to get more resolution in a data-acquisition system without going to expensive, high-resolution analog-to-digital converters is by increasing the gain of the input channel. "Both process-control and test-equipment applications often require sampling many signals of widely varying levels, as well as signals with wide dynamic ranges," Haynes says.

Although the PGA100's gain inaccuracy is a modest $\pm 0.05\%$ and offset is specified at ± 1 mV, these figures are relatively unimportant for computer-controlled data acquisition, where software is increasingly used for continuous correction of system errors. For example, one

input can be tied to ground, so that the system's output when reading this channel gives a value for the accumulated offset errors in all the components, which can be subtracted from later measurements.

"Instead of tight error specs," says Haynes, "the user can get, for example, a multiplexer that won't be damaged by voltages 20 v beyond the supply voltages and that has very low crosstalk of $\pm 0.003\%$." Other key specifications are a typical settling time to within 0.01% of 5 μ s, and a slew rate of 14 v/ μ s.

The PGA100 is priced at \$43 in 100-unit lots. Delivery is from stock to four weeks.

Burr-Brown Research Corp., International Airport Industrial Park, P. O. Box 11400, Tucson, Ariz. 85734 [341]

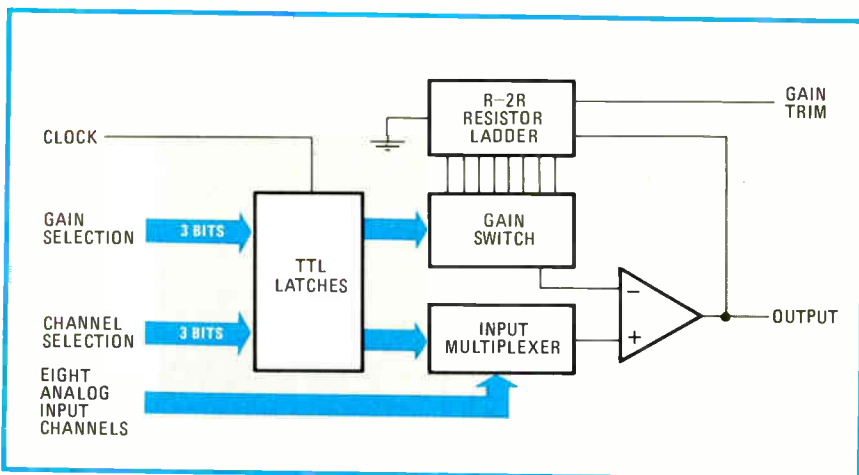

Channel at gain. A microcomputer can select one of eight analog input channels and a binary-weighted gain with Burr-Brown's PGA100 hybrid multiplexing amplifier.

Long capacitors distribute power

Custom-length multiple-tap decoupling capacitors reduce noise, parts count on board

The problem of noise on the power-distribution lines of printed-circuit boards—one that has traditionally been solved with decoupling capacitors at every socket—can be dealt with more effectively and less expen-

sively by a distributed capacitor bus bar. The Cap-Bus, with a capacitance of as much as 0.05 μ F per inch of its length, eliminates the need for power-supply traces on the printed circuit board: the bar serves both as a power-distribution element and as a decoupling capacitance.

The thin distributed capacitor not only saves board space, but is more effective in noise reduction. Tests conducted on 2-MHz shift-register circuits show at least a 500% reduction in the peak noise on power lines compared to the same total capacitance when individual components are mounted at each socket.

The dielectric in the Cap-Bus has a strong temperature coefficient leading to a capacitance increase of 0.006 μ F/ $^{\circ}$ C. The capacitance also decreases slightly with frequency, changing a total of about 18% between 100 Hz and 100 kHz. Maximum operating voltage is 50 v.

Custom configurations. Cost of the Cap-Bus depends on the exact configuration specified; customers can select the total length of the bar, number and location of taps, and total capacitance required. For example, an eight-tap bar ranges from \$1.30 for 0.08 μ F to about \$3.70 for 0.28 μ F total capacitance, divided

AN INNOVATIVE 20 MHz OSCILLOSCOPE THAT EMPHASIZES OPERABILITY

The SS-5702 has flexibility and power which make it ideal for the maintenance and troubleshooting of TVs, VTRs, audio equipment and a wide range of other electronic systems by hobbyist as well as professionals. At the top of its class, the SS-5702 uses a 6-inch rectangular, parallax-free CRT.

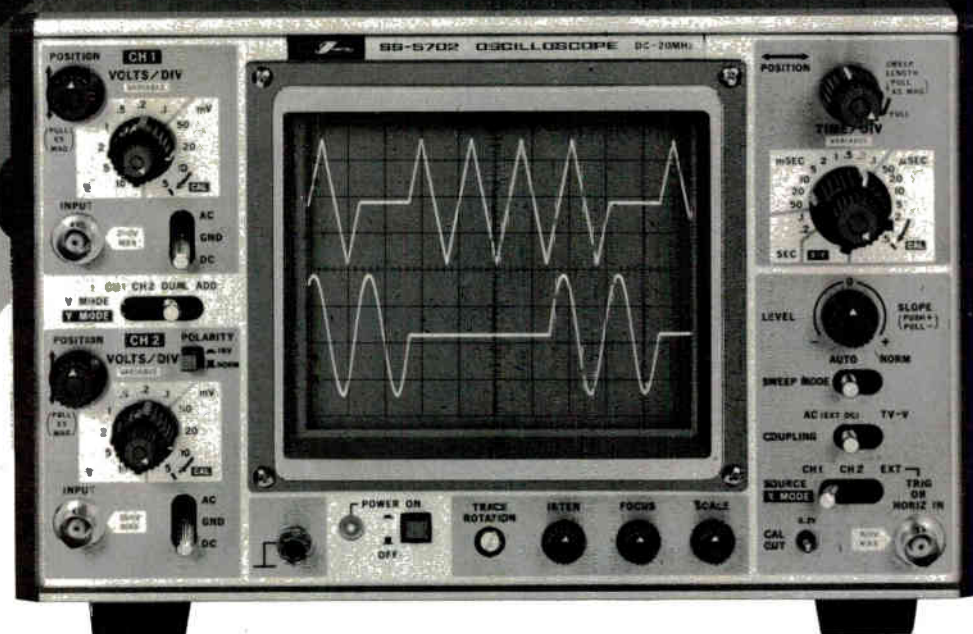

IWATSU SS-5702 DC~20MHz OSCILLOSCOPE

IWATSU makes more than 20 oscilloscopes as well as an impressive lineup of other instruments including logic analyzers and digital memory scopes. The fastest oscilloscope has a maximum frequency of 350 MHz. And the same technological expertise and product quality that make this super high-frequency oscilloscope possible are incorporated in the SS-5702.

- 6-inch rectangular, parallax-free CRT
- TV-V trigger
- Variable sweep length
- Double Lissajous figure
- 1 mV/div to 10 V/div sensitivity
- 100 ns/div to 0.2 s/div sweep
- Differential input with ADD mode
- DC operation (optional)



IWATSU ELECTRIC CO., LTD.

ASAHISEIMEI BLDG., 2-1-3 NIHONBASHI, CHUO-KU, TOKYO, 103 JAPAN TELEX: J24225 TELEIWA

- Austria: Universal Elektronik Import GmbH 54 15 88
- Canada: Associated Test Equipment Ltd. (416) 497-2208
- Chile: Importadora Janssen Y Cia. Ltda. 72 3956
- Denmark: Danstrument aps (03) 28 34 31
- England: ITT Instrument Services 0279-29522
- Finland: Oy Etra AB 780 122
- Italy: Radiel Spl (02) 213.30.56
- Netherlands: Klaasing Electronics BV 01620-51400
- New Zealand: G.T.S. Engineering Ltd. 546-745
- Norway: Solberg & Andersen A/S (02) 19 10 00
- S. Africa: Ultra Instruments (Pty) Ltd. (011) 37-7860/1
- Sweden: Teleinstrument AB 08/38 03 70
- Switzerland: Traco Electronic AG. 01 201 07 11
- West Germany: NBN Elektronik GmbH (0 81 52) 390

examine...

a worldwide perspective.

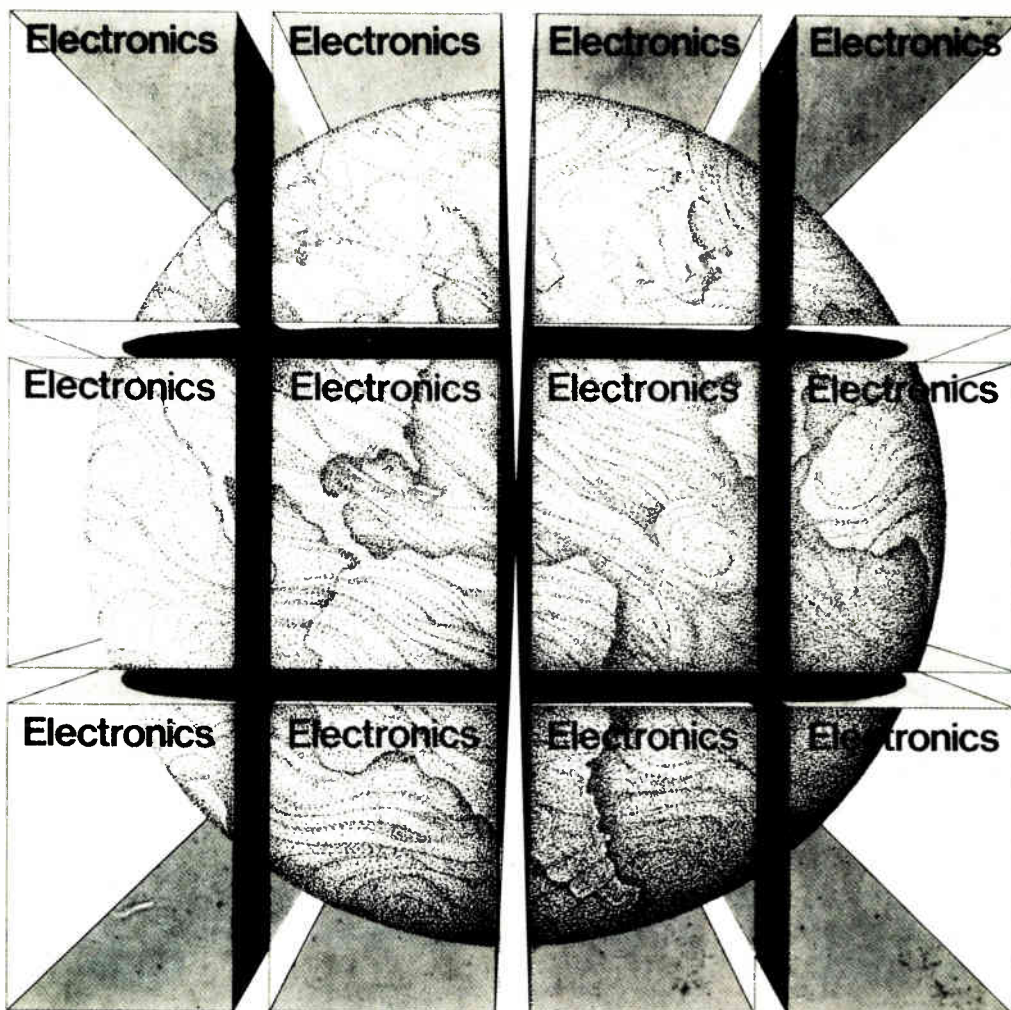

Wherever you are in this world, whatever your specialty...ELECTRONICS magazine's exclusive worldwide, international coverage of electronic technology and business guarantees that our subscribers are the first to know precisely what's happening...when it's happening...regardless of where it's happening.

From San Francisco to Tokyo, Moscow to Tel Aviv, only ELECTRONICS covers the fast-paced changes taking place in today's world of electronic technology. Our overseas editors don't travel to where the news is breaking, they live and work there. They examine and interpret every significant technological and business development on the international electronics

scene to make sure our subscribers not only keep pace...but keep on top.

You owe it to yourself and to your career to find out why nearly 100,000 of your professional colleagues in 127 different countries explore the world of Electronics on a regular basis. Devote one hour of your reading time every two weeks and we'll broaden your dimensions in ways that no one else can. We'll keep you current on what's going on in the technology.

To start your subscription to ELECTRONICS send in the subscription card found in this magazine. Or, write directly to Subscription Department, ELECTRONICS, McGraw-Hill, 1221 Avenue of the Americas, New York, N.Y. 10020.

Electronics Magazine



New products

evenly among the eight tap points. Delivery is in 6 to 8 weeks.

Eldre Components, Inc., 1500 Jefferson Rd., Rochester, N. Y. 14623. Phone (716) 244-2570 [342]

Pair of amplifiers attain high gain, high speed

A 4-bit binary word selects the gain of two instrumentation amplifiers housed in 24-pin ceramic dual in-line packages. The range of gains for the AM-542 extends from 1 to 1,024 in 11 binary steps, and for the AM-543 from 1 to 128 in 8 binary steps.

The AM-542's $\pm 50\text{-}\mu\text{V}$ initial offset voltage and low $1\text{-}\mu\text{V}/^\circ\text{C}$ offset voltage drift are useful in applications requiring low offset drift and high accuracy and gain. Its gain nonlinearity is within 0.005%, its common-mode rejection ratio is 90 dB, and its output-voltage range is $\pm 10.5\text{ v}$ at 5 mA. Different models of this amplifier operate over the commercial, industrial, and military temperature ranges, as do models meeting Mil-Std-883B.

The AM-543, however, is suitable for applications requiring only moderate accuracy but high speed over the commercial temperature range. At unity gain, a 20-v step settles to within 0.01% in only 6 μs , and the unit's slew rate is 13 $\text{V}/\mu\text{s}$. The AM-543 has a 7-MHz small-signal bandwidth at unity gain, a common-mode rejection ratio of 80 dB, and a $\pm 10\text{-ppm}/^\circ\text{C}$ temperature coefficient—its gain nonlinearity is only 0.01%. Prices start at \$129 each for the AM-542 and \$139 for the AM-543, with delivery from stock.

Datel Intersil, 11 Cabot Blvd., Mansfield, Mass. 02048. Phone (617) 339-9341 [343]

GaAs infrared LEDs put out 15 mW of radiant power

A family of high-power gallium arsenide infrared light-emitting diodes having a 950-nm peak-emission wavelength and a spectral half bandwidth of 50 nm is particularly suit-

able for use in infrared remote-control systems, commercial and industrial alarm systems, light barriers, and smoke detectors, as well as short-haul fiber-optic digital transmission systems.

The diodes have a radiant power of 15 mW at 100-mA forward current, and in switching mode, permit radiant intensity levels of 120 mW/steradian for the CQY99, 125 mW/sr for the V290P, and 180 mW/sr for the CQW14, at a forward current of 1.5 A and a pulse duration of 100 μs .

The CQY99, V290P, and CQW14 diodes come in standard T-1 $\frac{3}{4}$ plastic packages and sell for \$0.30, \$0.33, and \$0.36 apiece, respectively, in 1,000-piece quantities. Delivery takes 6 to 8 weeks.

AEG-Telefunken Corp., Route 22, Somerville, N. J. 08876. Phone (201) 722-9800 [344]

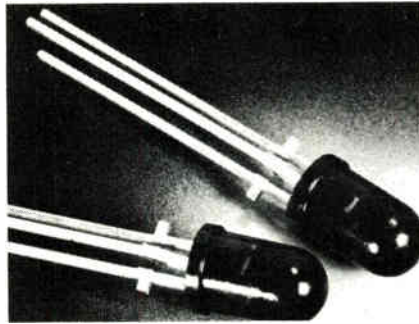

Little op amp packs big drive current

The PA12 power operational amplifier goes beyond the traditional 5-A output of TO-3-housed devices by providing $\pm 15\text{ A}$ at $\pm 50\text{-v}$ supply voltages. This combination represents an output of 440 W for dc circuits like programmable power supplies, heaters, and power light-emitting diodes and 220 W for loads.

Even at 15 A, the PA12 exhibits a low crossover distortion of 0.006%. This level of distortion was accomplished with a class A/B output stage that is biased on by a compensating semiconductor junction (base-emitter voltage multiplier), which is fine-tuned by two thermistors. Inductive kickback protection is pro-

Clamping Ideas from Weckesser

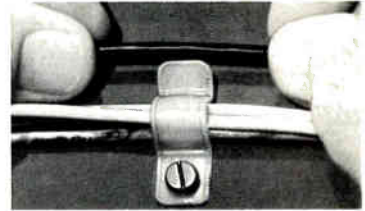

Nylon FLEX-CLIP

Slip wires in or out for changes or removal. Contour of clip plus spring-back flexibility of nylon provides easy assembly, yet holds bundles securely.

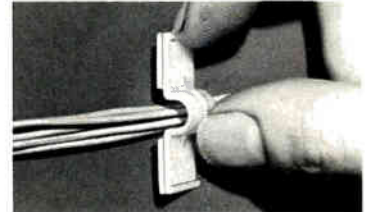

Nylon PRESS CLIP

Peel off... press and it's on to stay. Adhesive-back provides fastest way yet to install clips. Four sizes for bundles from $\frac{1}{8}$ " to $\frac{1}{2}$ " dia.

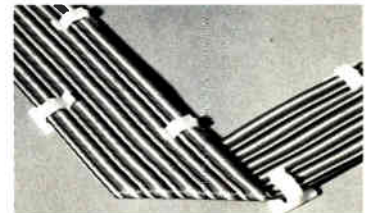

PRESS CLIP for flat cable

One size nylon clip for any width flat or ribbon cable. Used along edges, provides unlimited flexibility in mounting arrangements. Adhesive-back or screw mounting hole.

Write for catalogs.

Weckesser
COMPANY, Inc.

4444 W. Irving Park Road
Chicago, Illinois 60641 (312) 282-8626

TRANSISTOR SOCKETS

Newly-Designed Snap-In Sockets For TO-3 & TO-66

In Stock: The industry's most complete line of transistor sockets, kits and mica insulators. Our sockets are designed for the TO-3 and TO-66 transistors. Also, our latest design in printed circuit sockets plus an extensive line of snap-in sockets.

Sockets are available in the latest U.L. approved materials.

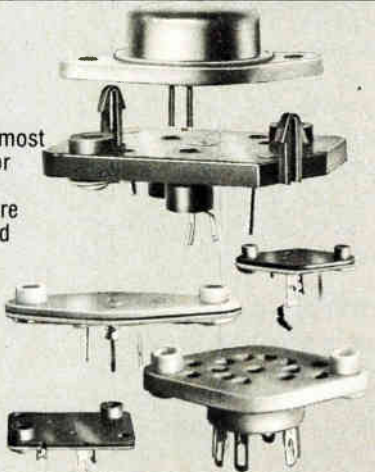

NEW FREE CATALOG ON REQUEST

KEYSTONE

ELECTRONICS CORP.

TWX 710-581-2861 CABLE-KEYELCO

49 BLEECKER STREET, NEW YORK, N.Y. 10012 212-475-4600

Circle 176 on reader service card

Customized

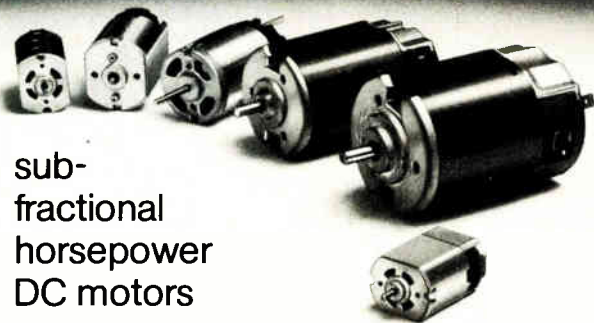

sub-fractional horsepower DC motors

Buehler Products, Inc. offers a complete line of permanent magnet DC motors that are performance rated to your specific application for maximum cost effectiveness. These customized, long life Buehler motors are available with a wide variety of options in voltage, current, torque, speed, electrical connections, and frame size. They're used worldwide in office products, business machines, cameras, computer peripherals, tape recorders, marine and automotive applications. Write for full details on the Buehler FHP motor line.

FHP permanent magnet DC motors
Miniature brushless DC fans
Miniature gear motors

BUEHLER PRODUCTS INC., P. O. Box A, Highway 70 East, Kinston, North Carolina 28501, (919) 522-3101



Circle 212 on reader service card

New products

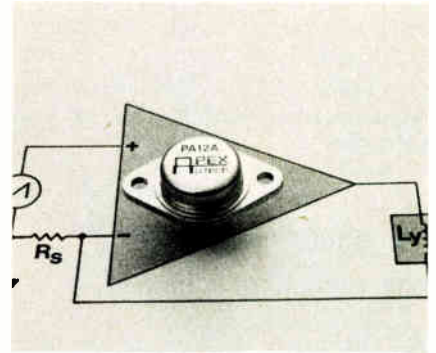

vided by two internal flyback-protection diodes across the output transistors. The positive and negative output current limits are separately programmable from ± 10 mA to ± 15 A.

Other specifications include a $4\text{-V}/\mu\text{s}$ slew rate, a $\pm 2\text{-mV}$ input offset voltage, and a common-mode rejection ratio of 100 dB. Built on a high-thermal-conductance beryllia substrate, the hybrid integrated circuits sell for \$53.85 each in lots of 100. Small quantities may be delivered from stock.

Apex Microtechnology Corp., 1130 E. Pennsylvania St., Tucson, Ariz. 85714. Phone (602) 624-0273 [345]

Potentiometers replace control-panel parts

The Ferenstat potentiometers capitalize on a new variable-speed solid-state sensing technology to perform control functions typically requiring potentiometers, shaft encoders, and thumbwheel switches. With a proprietary array of miniature detectors, the Ferenstat responds to the presence, motion, and direction of a human finger on its surface.

The Ferenstat is microprocessor-bus-compatible and provides parallel, serial, and pulsed outputs. The unit's speed-sensing feature allows the finger's velocity to govern input. For slow finger movements, the input can represent 0 to 10 bits for full distance traveled; fast movement can represent 0 to 256 bits.

As control devices, the Ferenstats have applications in audio equipment, process control, stage lighting, appliances, travelers'-check dispens-

Electronics/November 17, 1981

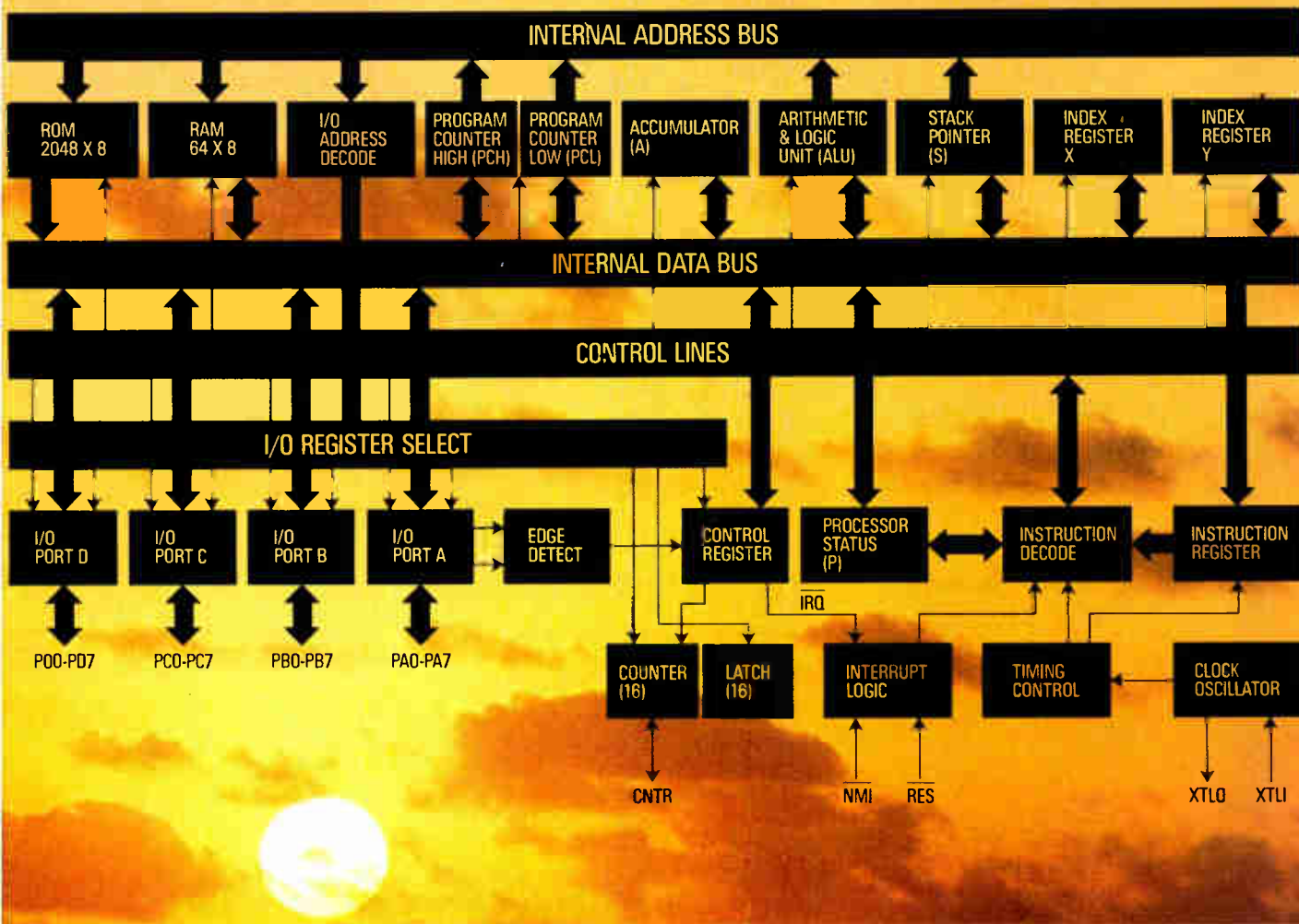

The 6500/1 One-Chip Micro. First, look what it's got. Then, look what it costs.

\$10.50 at 1,000. And there's more good news. No masking charge for the on-board 2K x 8 programmable ROM. And, the MOS 6500/1 is available in either 1MHz or 2MHz versions.

Here's what you get. A microcomputer on a chip. The 8-bit NMOS 6502 CPU, software compatible with your existing 6502 programs. Four I/O ports (32 bi-directional lines). One bi-directional counter line. On-board clock. 2048 x 8 ROM. 64 x 8 static RAM. Your choice of a 1MHz or a 2MHz internal clock. 16-bit programmable counter/latch with four modes. +5V supply. And more. All, on a 40-pin DIP. Plastic or ceramic.

Good old 6502. Simple to program. Familiar. Which means you write software in weeks. Instead of months. And, the 6500/1 is the microcomputer on a chip with software compatibility with its host CPU.

Prototyping? Simple. Build your prototype system with PROMs before committing to mask-programmed production. Our 64-pin prototyping part, the 6500/1E emulator includes all 6500/1 interface lines and brings all internal memory address, data and control lines off-chip. There's even a 40-pin configuration in piggy-back EPROM.

Delivery now. 1MHz or 2MHz. Take your pick. Develop your system, provide us with final ROM masking program and we'll have your 6500/1 μ C's back to you in five weeks. And yes, there are second sources.

More information? Call us. Or, mail us the coupon below. We'll have data sheets on the way to you. Pronto.

commodore
SEMICONDUCTOR GROUP

MOS TECHNOLOGY
950 Ritterhouse Rd.
Norristown, PA 19403
(215) 666-7950

Eastern Regional Office
950 Ritterhouse Rd.
Norristown, PA 19403
(800) 345-6386 Toll Free
TWX 5106604168

Frontier Manufacturing Inc.
2955 N. Airway Ave.
Costa Mesa, CA 92626
(714) 979-6300

Western Regional Office
3330 Scott Blvd.
Santa Clara, CA 95050
(408) 727-1130

Optoelectronics, Inc.
4350 Beltwood Parkway So.
Dallas, TX 75234
(214) 387-0006

Central Regional Office
4350 Beltwood Parkway So.
Dallas, TX 75234
(214) 387-0006
TLX 730-969

Gentlemen, Please send me complete information on the MOS 6500/1 computer on a chip. Include data on your line of 6500 support chips.

Name _____

Address _____

City _____ State _____ Zip _____

FREE CATALOG

OF
Burglar/Fire Alarms

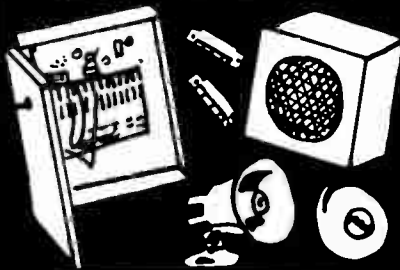

Controls • Power Sources
• Remote Stations • Holdup Alarms • Wireless Components
• Magnetic Contacts • Ultrasonic • Microwave • Infrared
• Sirens • Bells • Glass Protection • Shock Sensors • Phone Dialers • CCTV • Locks • Safes

mountain west

4215 N. 16th St. Dept. E-11
Phoenix, Arizona 86016
1-800-528-6169

Circle 178 on reader service card

ELECTRONIC COMPONENTS



Manufacturers of Quality
Electronic Components

- BATTERY HOLDERS & CLIPS • COILS
- CAPACITORS • CONNECTORS • FUSES
- JACKS • KNOBS • LAMPS • PLUGS
- MICROPHONES • POTENTIOMETERS
- RF COILS • RELAYS • RESISTORS
- SEMICONDUCTORS • SPEAKERS
- SWITCHES • TRANSFORMERS

WE STOCK What We Catalog !

MOUSER ELECTRONICS

11433 WOODSIDE AVE., SANTEE, CA. 92071

PHONE: (714)449-2222 TWX: 910-331-1175

178 Circle 213 on reader service card

New products

ers, automatic tellers, and video games. Depending on the application, Ferenstats may be produced in lengths of 2 to 16 in. without affecting the resolution of controlling functions. As a component, the Ferenstats sell for under \$100 each in original-equipment-manufacturer quantities, but as a replacement part in a control panel they cost considerably less. On small quantities, delivery is from stock.

Tasa Inc., 2346 Walsh Ave., Santa Clara, Calif. 95051. Phone (408) 727-8272 [346]

Ten-stage photomultiplier

withstands harsh temperatures

A high-temperature sodium-potassium-antimony photocathode and a circular-cage copper-beryllium dynode structure form the heart of the C83027E 10-stage photomultiplier, which can operate at temperatures up to 175°C.

The 25-mm-diameter photomultiplier meets the shock, vibration, and acceleration specifications of MIL-



STD-810, ideally suiting it for gross and differential counting in deep-hole drilling where cooling requirements must be minimized. Certified test data for the \$1,500 device is available. Delivery takes 30 days after receipt of order.

RCA Electro-Optics and Devices, New Holland Road, Caller Box 3140, Lancaster, Pa. 17604. Phone (717) 397-7661 [347]

**If you
need
service
on your
subscription
to ...**

Electronics

*Do you want to
change your
address?*

*Have you missed
an issue?*

*Was your copy
damaged?*

**Please call your
representative**

(609) 448-8110*
For immediate help

*9 a.m.—4 p.m. EST



Electronics/November 17, 1981

“Old Reliable” introduces a powerful new microprocessor.

RCA's new 1805 gives you all the 1802 features plus a whole lot more.

The CDP1805 microprocessor uses the register-based architecture of the most popular CMOS microprocessor in history: the 1802.

It's a direct plug-in replacement for the 1802 and 1802A, but its design enhancements give you even better performance. You get a 64-byte RAM for program instructions or data, 22 additional instructions, an 8-bit pre-

settable down-counter with a division by 32 prescaler, event counter mode and pulse width mode.

Our other new microprocessor, the CDP1806, has everything except the RAM. Both are capable of 4 MHz clock, while using less than 25 mW from a 5V supply.

You'll achieve significant chip count reductions, and save execution time and memory space.

For example, the call and return instructions execute four times faster than the routines on the 1802A. And

four new instructions provide direct 16-bit data transfer between internal registers and external memory.

These new microprocessors are supported by a large and growing family of I/O devices, RAMs, ROMs, high-level languages and development systems. Plus full technical support from the people at “Old Reliable.” And remember, we're the people who invented CMOS.

For more information, contact any RCA Solid State sales office or appointed distributor.

RCA Solid State headquarters: Somerville, NJ. Brussels. Sao Paulo. Hong Kong. Circle 179 on reader service card

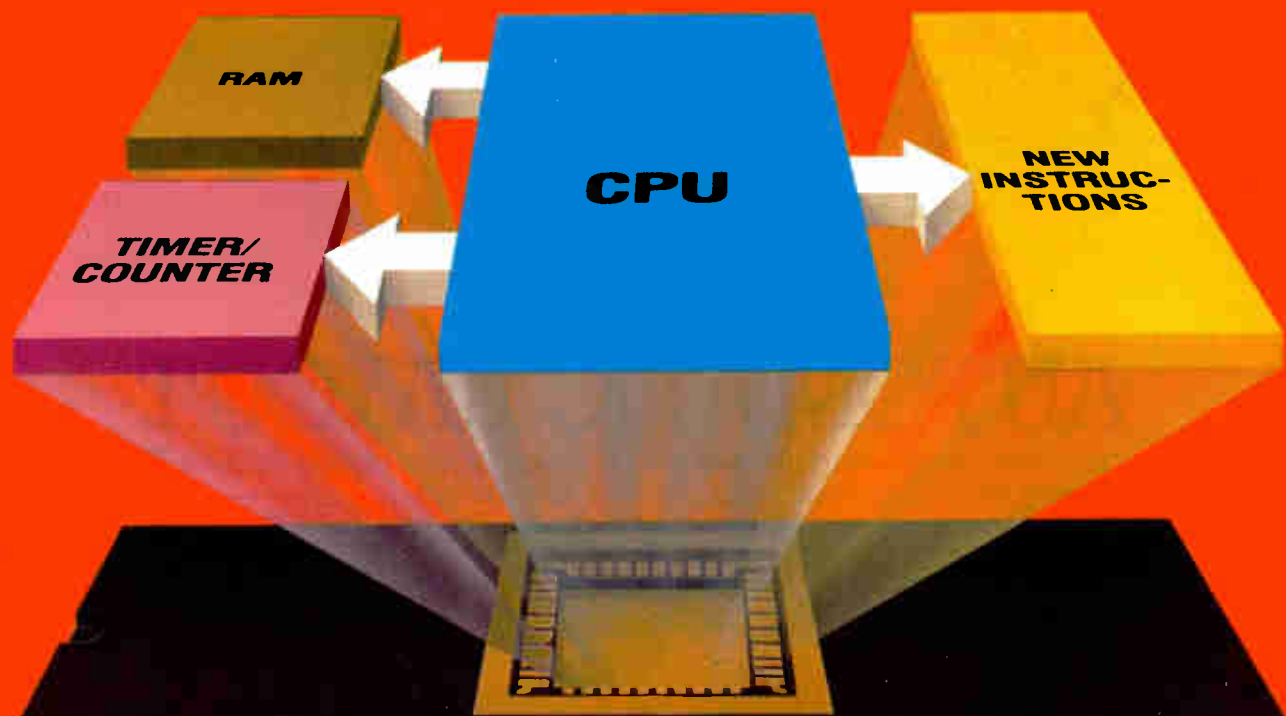

RCA

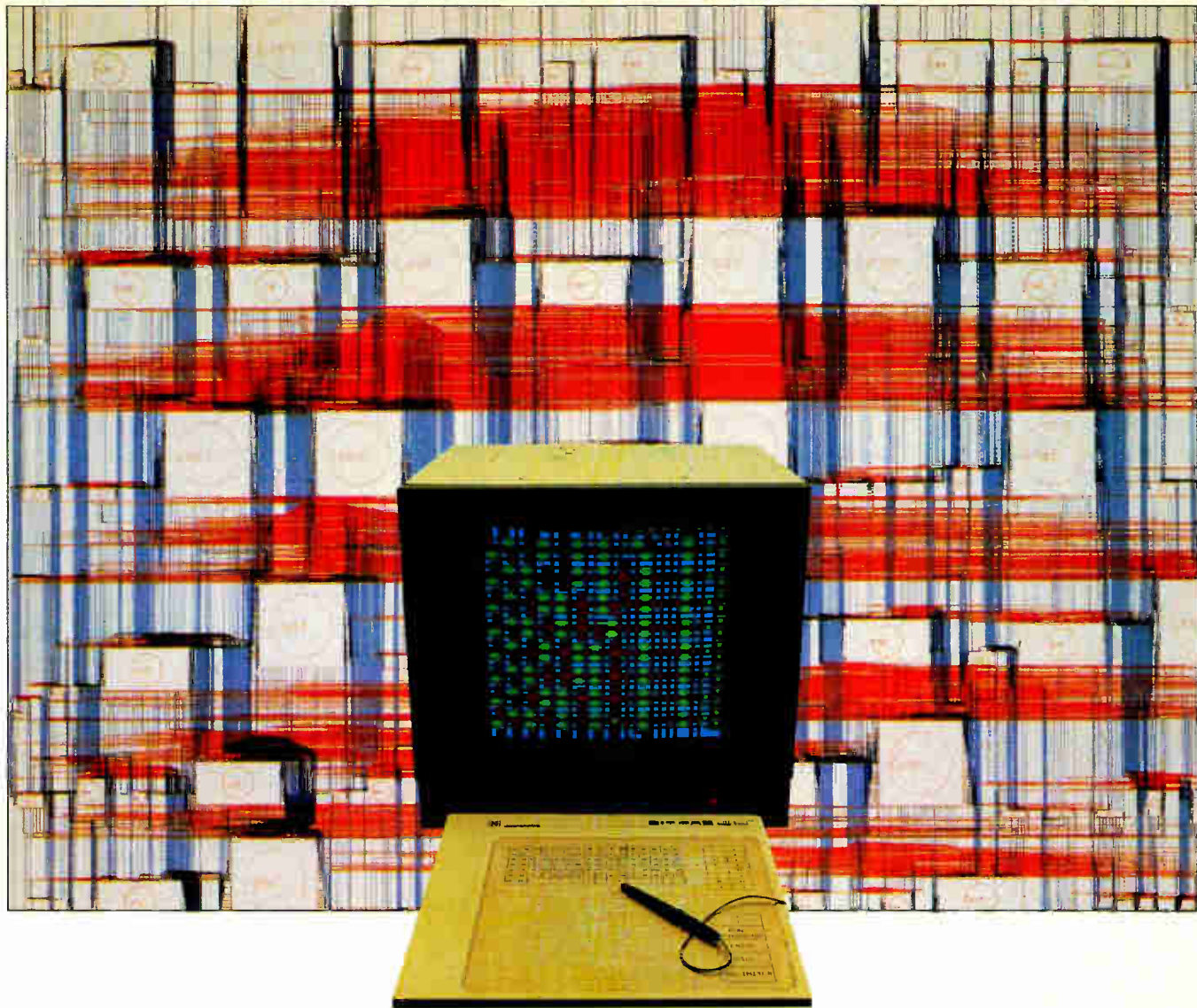

GÆLIC AUTOMATIC LAYOUT

With this software module you can interconnect I.C. cells of mixed sizes to create a VLSI chip layout automatically, without errors and quicker than ever before.

When your product needs a special chip to get you ahead of competition, GÆLIC ensures you get it – Right on time.

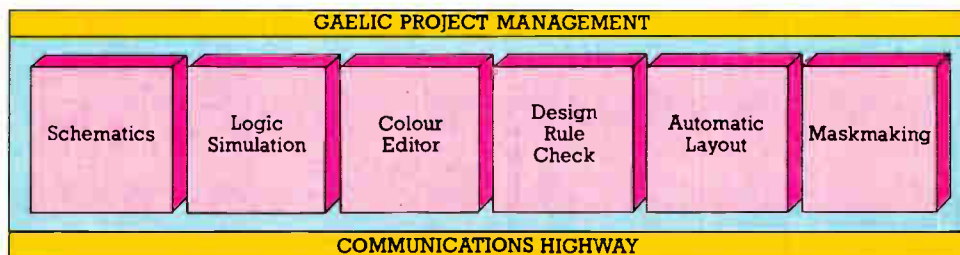

Compeda

Computer Systems for Technology

Compeda Inc, Suite 260, 2180 Sandhill Road, Menlo Park, CA 94025

Telephone: (415) 854 2370

Offices in Paramus, NJ; Chicago; Houston; San Francisco; Tokyo; Munich; The Hague; London.

DOUBLE TROUBLE FOR ALIASES



Twice the channels. Twice the density. Half the cost per channel.

The new Precision System 32 packs 32 programmable channels into the same 7 inches of rack space previously needed for 16.

You get more than 2 digit resolution, with 2047 programmable cut-off frequencies. Time delay filters are superior to Bessel. Elliptics afford 80 dB/octave attenuation. Phase match is within 1° . Interfaces with mini, micro or GPIB.

Savings can run nearly 50% per channel compared with competitive 16 channel units. Fixed frequency and third octave filters available at greater savings. It's a new reason to buy rather than build.

Call Mike Stewart at 607-277-3550 or write for complete specifications.



PRECISION FILTERS, INC.

240 Cherry Street, Ithaca, New York 14850

Circle 181 on reader service card

SCHLUMBERGER ENGINEERS DOWN TO EARTH



We don't fly into the earth, but we do explore it.

Just as the crew aboard a shuttle orbiter combines the latest technology and engineering training to explore space, a Schlumberger engineer uses the latest technology to evaluate subsurface formations. Special devices are lowered into wells drilled miles into the earth's crust. These earth probes operate under extreme environmental conditions to provide answers to the petroleum industry. Shuttle Orbiter? No. We use a half million dollar computerized mobile laboratory.

To investigate the possibility of you taking command of an Earth Explorer, contact a **Schlumberger Engineer** at:

SCHLUMBERGER WELL SERVICES

Carter Robinson

ENGINEER RECRUITING

P.O. Box 2175

Houston, Texas 77001

713/928-4075

Schlumberger

Openings throughout the United States.

An Equal Opportunity Employer M/F

Circle 186 on reader service card

Oak puts E³ up against the world's fastest typists.

In a keyboard market clogged with claims and confusion about "N-key-rollover," look to Oak's FTM[®] keyboard for the practical answer. It provides E³-Entry Error Elimination. And that means precisely what it says. We challenge the fastest typists in the world to make it error. They can't.

Yet E³ makes its real contribution to Oak's Full Travel Membrane (FTM) keyboard—and to you—in the cost column. You get the Entry Error Elimination and 100-million-cycle-plus performance you've got to have in a keyboard at prices far below those of keyboards with comparable performance. That's practical. Entry Error Elimination is a remarkably sensible micro-

processor based N-key-rollover and phantom key lockout system developed by Oak engineers. Without the cost and complexity of Hall Effect and capacitive technologies.

And that's not all. Beneath the FTM keyboard is Oak's proven, industry-leading membrane switch technology. So you get all the good things of membrane switching—reliability, durability, RFI and EMI resistance, design flexibility, and—of course—low cost. All without sacrificing the qualities you demand in a keyboard, right down to human engineered industry standard feel and touch.

Call or write us today for the data and details to prove it. You can't afford not to call Oak.

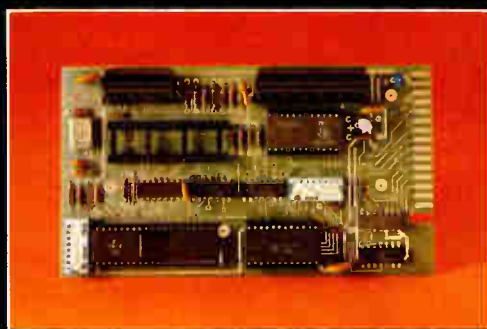

OAK Switch Systems Inc.

An Oak Technology Inc. Company

P.O. Box 517 • Crystal Lake, Illinois 60014

Phone 815/459-5000 • TWX 910-634-3353 • TELEX 72-2447

Circle #215 for further information

Circle #187 to have a salesman call

World Radio History

Computers & peripherals

Streaming drive starts, stops fast

125-in./s tape streamer has capstan and tensioner for 45-in./s start-stop operation

Streaming tape drives generally do not perform well in start-stop operation and start-stop drives have a lower data-transfer rate than do streaming drives. However, Datum Inc.'s DMF-1000 1/2-in. tape drive combines the advantages of both types: streaming at 125 in./s and operating at 45 in./s in a start-stop mode.

The drive, called Gemini for its dual capabilities, controls the tape with a capstan at all times, unlike most streamers, which eliminate the capstan motor to lower drive cost. This motor keeps the tape running at accurately controlled rates and speeds stopping and restarting, even during the streaming mode. Most streaming drives without the capstan will in fact perform start-stop duties, but at only 12.5 in./s and with relatively long ramp times.

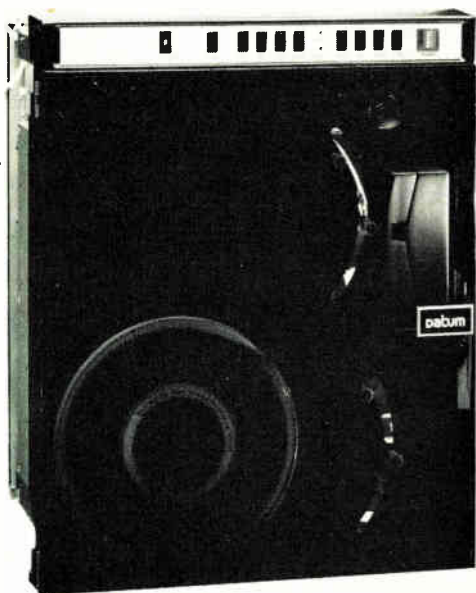

The DMF-1000 also has a tension arm, common in start-stop drives but also omitted on streamers. The tensioner, which maintains 8 lb of pressure on the tape to prevent stretching or breaking, works with the capstan to shorten ramp times.

In standard start-stop operations, the drive accelerates the tape from 0 to 45 in./s in the 8.4 ms specified by ANSI standards. A nominal total of 10 ms is required to get the tape to speed and then begin reading or writing; at 125 in./s, this time increases to 80 ms. It takes 335 ms to stop the tape when it is streaming and back it up to start reading or writing where it left off.

Data can be dumped into Gemini at 200 kilobytes/s at 125 in./s, compared with 160 kilobytes/s for 100 in./s streamers, with no problems due to the higher speed, according to Avner Levy, director of development for the DMF-1000. Datum Inc. selected a speed of 45 in./s for the start-stop mode because most firms want relatively high tape speed even in start-stop processing, says Levy. A minor component change will convert the drive to 25 in./s.

When the drive is streaming, it will drop to 45 in./s if a lack of data being transferred forces it to stop and restart too many times at the higher tape speed. The user then has the option to continue at 45 or go back to 125 in./s.

Users can also select 800 or 1,600 b/in. data storage using inverted nonreturn-to-zero or phase-encoded formats. IBM/ANSI nine-track compatibility is also offered. The drive uses an industry-standard formatted tape interface and it accepts 7- to 10.5-in. reels.

To keep interference low, the firm placed noise-generating output transistors and heat-producing voltage regulators on a single board, isolating them from the devices on a second board

that process the signal. Preamplifiers are located near the read heads to enhance the signal-to-noise ratio during streaming.

In single quantities, the price is \$6,400. Delivery takes 60 days.

Datum Inc., 1363 South State College Blvd., Anaheim, Calif. 92806. [361]

Network link fully automates manufacturing facility

Lower costs, increased capabilities, and an improved network are the benefits of the real-time computer systems, desktop computers, terminals, and data-capture devices comprising the HP 1000 technical computer system for industrial-automation applications.

Under the HP 1000 umbrella, the top-of-the-line Value/65 system consists of a model 65 computer system, 1 or 2 megabytes of main memory, and five software packages. The software bundled into the system is a full American National Standards Institute Fortran 77 compiler, a Pascal compiler, Image/1000 data-base management software, and the Graphics/1000-II 2D and interactive three-dimensional graphics software packages. A Value/65 system with one megabyte costs \$64,685; with two megabytes, \$73,685.

The heart of the Value/65 is the model 65, an F-series computer with a hardware floating-point processor, scientific and vector instruction sets, and fast Fortran processor. It has 256-K bytes of parity memory and a 16-megabyte fixed disk and is priced at \$49,610. Delivery of the Value/65 package is slated for late December.

An upgraded Data Link can accommodate HP 1000 computer systems, HP 9826/35/45 desktop computers, a wide range of terminals, data-capture terminals, and data couplers. It is typically used with a master HP 1000 computer and up to 128 slave devices, communicating at 9,600 b/s. The Multidrop DS/1000-IV option on the Data Link requires one, rather than two, interface boards for each node and lets subordinate computers commu-

"The dependable SM-2 relies on 27 flexible circuits of PYRALUX,"

says M. C. Keel, Vice President and Program Director,
Standard Missile Programs, General Dynamics Pomona Division.



"SM-2 is a proven system with a high reliability record. That record was the result of painstaking effort, and part of the story was the selection of PYRALUX flexible composites to achieve reliable high density packaging," says Mr. Keel. "We can stack printed cable assemblies with PYRALUX 4 layers high in tight missile spaces, bend them 180° and we know they won't fail. We use PYRALUX for all 27 flexible circuits in the Navy's SM-2 missile," he concluded.



The missile's autopilot and battery circuits of PYRALUX consist of two 4-layer flat cable assemblies containing power, signal, and shielded digital circuits.

PYRALUX[®] flexible composites are a family of tough, adhesive-coated, laminated substrates offering high strength for flexible, rigid/flexible multilayer circuitry. The PYRALUX WA/A adhesive provides excellent and uniform adhesion to KAPTON[®] Polyimide Film, minimizing the worry of physical or chemical delamination. Conventional production solvents and chemicals can be used without affecting the bond. PYRALUX also has excellent resistance to the thermal exposure of solder dip, wave and reflow. Circuits can be removed, repaired and resoldered reliably.

Investigate the advantages of specifying PYRALUX flexible composites for your circuitry. For more information, write DuPont Company, Rm. X38894, Wilmington, DE 19898.

PYRALUX[®]
flexible composites



Circle 189 on reader service card

New products



minate at a rate faster than 19,200 b/s. Data Link starts at \$2,776 and Multidrop at \$4,200. Delivery on these units takes eight weeks.

Hewlett-Packard, 8120 Embarcadero Rd., Palo Alto, Calif. 94303. Phone (415) 875-1501 [363]

Minicomputer additions are geared to commercial users

Streamlined compact cabinets house additions to the V77 line of 16-bit minicomputers that boost reliability and performance, lower power requirements, and add 50% to the writable control store's capacity. For example, an enhanced V77-800 system equipped with 0.75 megabyte of memory, a writable control store of 2-K 48-bit words, a cartridge-disk unit, a printer, and a tape drive requires 12 printed-circuit boards and 12 card slots, whereas earlier versions needed 17 boards and 23 slots. Also, a single 150- Λ power supply handles a fully loaded system where two 100- Λ power supplies were previously needed.

The additions include a 128-K-byte and 256-K-byte version of the V77-500 system, priced at \$29,500 and \$33,500 respectively, an enhanced V77-800 priced at \$43,000, and a new compact model, the V77-700, selling for \$36,100.

These processors, configured as commercial systems and designated the V77-550, -750, and -850, consist of a central processing unit, 256-K bytes of memory, a data-communications multiplexer, an operator's console, and either a peripheral disk or a disk-tape system. They are priced as the sum of the components

minus 10%. All systems are available for immediate delivery and can easily be integrated into Sperry's Univac 1100 mainframe settings.

Sperry Univac, P. O. Box 500, Blue Bell, Pa. 19424. Phone (215) 542-4213 [364]

Graphics printer uses uncoated paper

The PrintGraphics print system produces hard copy from video graphics displays on inexpensive paper using most retrofitable graphics cards available with industry-standard alphanumeric displays. All previous graphics copy, other than plotters, required expensive coated electro-sensitive or electrostatic papers. However, pin-addressable matrix printers capable of working in a graphics mode have made it possible to use uncoated paper.

Typical displays with which the PrintGraphics can interface include the Tektronix Plot 10-compatible RG512 and VT640 from Digital Engineering, which are fitted to the Lear Siegler ADM3 series, and the DEC VT100 terminals.

The PrintGraphics system contains a Z80-based controller placed between the graphics display and a pin-addressable printer. Depending on the source image and printer, copies may be made in seconds. The PrintGraphics system is available now and sells for approximately \$962 to \$6,415.

Riva Terminals Ltd., Glendale Park, Fernbank Road, Ascot, Berks., UK [365]

Smart terminal depends on software

Billed as a smart terminal, the Z80-based TS-1 is software-driven for versatile operation and easy enhancement. Besides its native mode, the 26-lb terminal emulates the DEC VT52 and the Lear Siegler ADM31. With an option it can emulate DEC's VT100.

The 60-key keyboard contains as standard a 14-key numeric pad and

12 easily programmed function keys. An additional row of 14 shiftable programmable function keys, yielding 28 functions, is optional and costs \$195. Brightness is software-controlled from either the keyboard or the computer and can be adjusted to 127 levels of intensity. Software switches also select such communication characteristics as parity, bit rate, protocol, refresh rate, transmission mode, and word length.

All software-controlled selections are stored in a continuous complementary-MOS memory that is battery backed. Measuring 12 by 16 by 14 in., the terminal will sell for \$1,295. Delivery takes four weeks.

Falco Data Products Inc., 1286 Lawrence Station Rd., Sunnyvale, Calif. 94086. Phone (408) 745-7123 [367]

Software-driven system eliminates add-ons

A software-based word-processing system that needs no additional components to suit a variety of applications is Toshiba's EW-100. It has a capacity of 295,682 characters using single-sided, single-density 8-in. floppy-disk drives and 1,025,024 characters using double-sided, double-density drives. It prints bidirectionally at a rate of 45 characters/s, using a daisy-wheel printer, and displays 24 lines of 80 characters on its 12-in.-diagonal screen.

The EW-100 features backspace correction, automatic word wrap-around, centering, decimal tabulation, underscore, headers and footers, horizontal and vertical scroll, recorded format, electronic tab set-clear, copy and super copy, move and super move, hyphenation, and simultaneous input/output.

Designed for table-top use, it guides the user through the various steps of operation by displaying messages on its cathode-ray tube. Its keyboard is separate from the CRT for operating comfort. Prices begin at \$7,250 per system.

Toshiba America Inc., Information Processing Systems Division, 2441 Michelle Dr., Tustin, Calif. 92680 [366]



ARINC 600. FIRST TO FLY WITH AVIONIC SPECS.

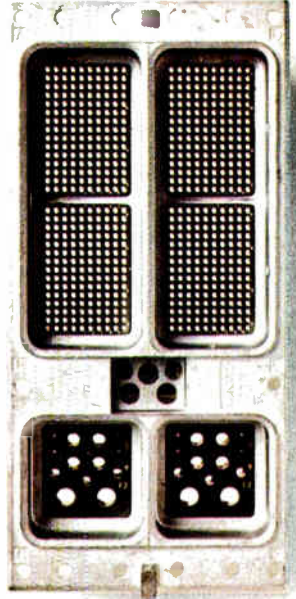
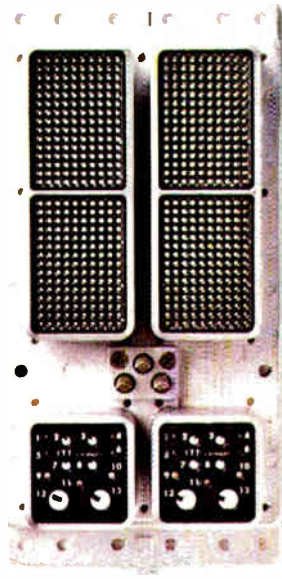

Since rack and panel connectors were first devised, the ITT Cannon Electric name has been synonymous with technological leadership. And when the avionics industry called for a new design to meet the demands of modern technology, ITT Cannon again held center stage with the ARINC 600 connector series. We were the first manufacturer qualified to commercial avionics specifications. That means we've already gone through the learning curve, and can offer you a most dependable line of Arinc connectors.

Cannon's low insertion force BKAD/E series connectors are available in environmental and non-environmental designs. Their contacts are fully interchangeable with our DPX series. And termination tooling is the same for easy retrofitting. You get greater reliability, easier maintenance and lower cost per mated line in a totally installed system.



At ITT Cannon, we have product when you need it. And you can choose from a wide assortment of contact configurations. For immediate information, refer to our pages in EEM. For literature, the name of your local ITT Cannon distributor or other information, contact Rectangular Division Marketing Manager, ITT Cannon Electric, a division of International Telephone and Telegraph Corporation, 10550 Talbert Avenue, Fountain Valley, CA 92708. (714)964-7400. In Europe, contact ITT Cannon Electric, Avenue Louise 250, B-1050 Brussels, Belgium. Phone: 02/640.36.00.

CANNON ITT

You can always connect with Cannon.

World Radio History

Circle 191 on reader service card

RCA Engineering Pioneers of Yesterday — Leaders of Tomorrow...



The same pioneering spirit that introduced television to the American consumer market over three decades ago has become a recognized trademark of RCA's Consumer Electronics Division. In keeping with the emergence of the American home as a major source of family entertainment, the design and engineering of home entertainment products, such as the recently introduced VideoDisc system, which are technically sophisticated yet easy to use has become our major challenge.

Opportunities and Benefits...

We continually seek qualified engineering and technical personnel to assist in the engineering and development of our consumer products. We offer excellent state-of-the-art opportunities for a variety of engineering, operations management and administrative support personnel, including electrical, mechanical, chemical and industrial engineers as well as computer software programmers. Positions may also be available in the areas of Industrial Relations, Sales/Marketing, Finance, Purchasing, Product Planning and Industrial Design. Our employees enjoy one of the most comprehensive benefit packages available in the industry.

Our Locations...

The locations of our facilities offer a healthy, exciting lifestyle for employees and their families. Bloomington and Indianapolis offer the advantages of a major cosmopolitan area only minutes away from beautiful countryside, boating, fishing, parks and other recreational areas. Indiana University at Bloomington and Purdue University at Lafayette as well as the regional campuses of these fine institutions located in Indianapolis offer advanced educational opportunities for both technical and business growth.

Contact Us...

If you're seeking an exciting career in one of industry's fastest growing fields, consider a career with RCA Consumer Electronics — forward your resume in complete confidence to:

RCA
Consumer Electronics Division
600 N. Sherman Drive
Indianapolis, IN 46201

RCA



A Tradition On The Move!

Mallory tantalum capacitors earn top MIL reliability ratings.

In solid tantalums, Mallory is now qualified to provide Level S, the highest reliability rating, for styles CSR 13 and CSR 91. Level S, under MIL-C-39003, means a life failure rate of only 0.001% per 1,000 hours. Here is our current QPL line-up in solids:

MIL Style	Mallory Type	Life Failure Rates
CSR13	TER	M, P, R, S
CSR23	TXE	M, P, R
CSR33	TXR	M, P
CSR91	TNR	M, P, R, S

In wet slug tantalums, we have become the first source qualified at Level R, under MIL-C-39006, for style CLR69 — the extended capacity range wet tantalum, which makes our wet QPL list look like this:

MIL Style	Mallory Type	Life Failure Rates
CLR10	XTM-XTK	L, M, P
CLR14	XTL-XTH	L, M, P
CLR17	XTV	L, M, P
CLR65	TLX	L, M, P, R
CLR69	TXX	L, M, P, R

They're all available from authorized Mallory Distributors. Send for our latest QPL bulletins. Mallory Capacitor Division, Mallory Components Group, P.O. Box 372, Indianapolis, Indiana 46206. (317) 636-5353.

MALLORY

ELECTRICAL/ELECTRONIC GROUP

EMHART

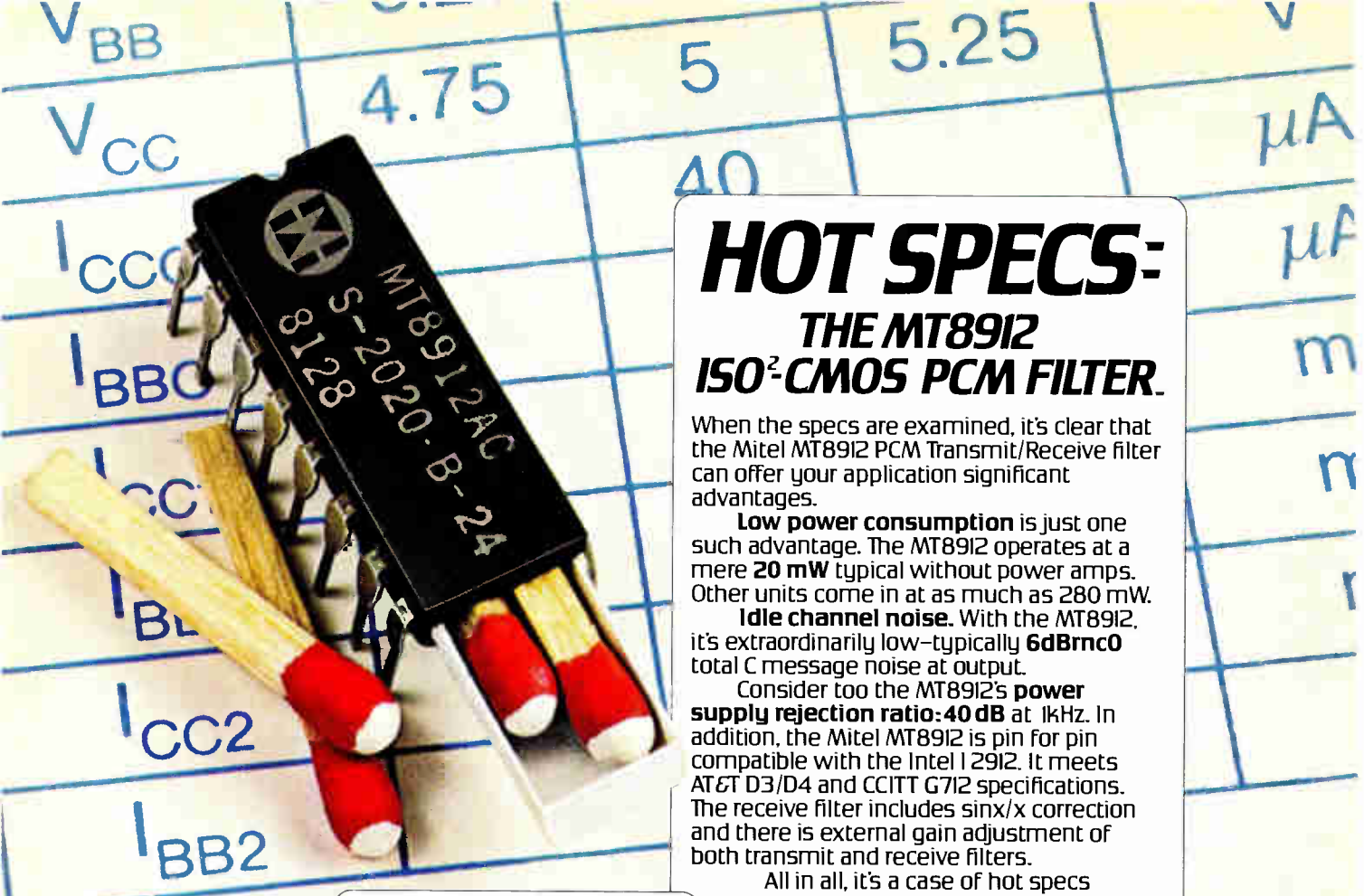

HOT SPECS: THE MT8912 ISO²-CMOS PCM FILTER.

When the specs are examined, it's clear that the Mitel MT8912 PCM Transmit/Receive filter can offer your application significant advantages.

Low power consumption is just one such advantage. The MT8912 operates at a mere **20 mW** typical without power amps. Other units come in at as much as 280 mW.

Idle channel noise. With the MT8912, it's extraordinarily low—typically **6dBmnc0** total C message noise at output.

Consider too the MT8912's **power supply rejection ratio: 40 dB** at 1kHz. In addition, the Mitel MT8912 is pin for pin compatible with the Intel I 2912. It meets AT&T D3/D4 and CCITT G712 specifications. The receive filter includes \sin^2/x correction and there is external gain adjustment of both transmit and receive filters.

All in all, it's a case of hot specs guaranteeing you hot performance.

Find out more about what the Mitel MT8912 can do for your application by contacting your local Mitel sales office.

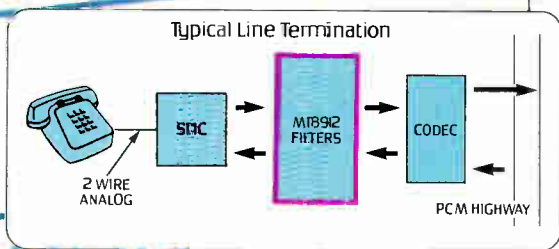
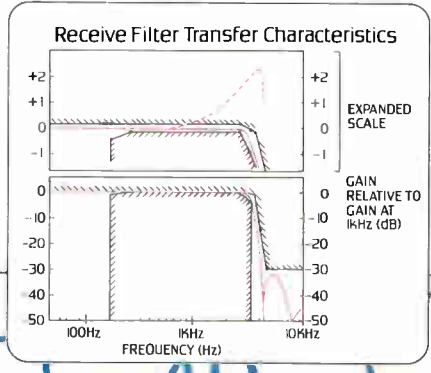
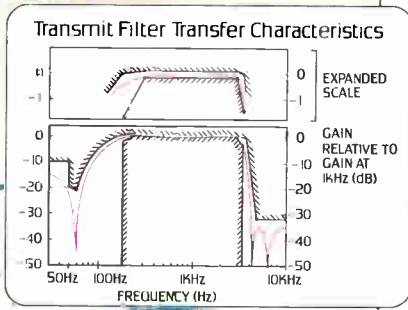

MITEL SEMICONDUCTOR

United States: 2321 Morena Blvd., Suite M, San Diego, California, U.S.A. 92110.
Telephone (714) 276-3421, TWX: 910-335-1242.
P.O. Box 17170, 600 West Service Road,
Dulles International Airport, Washington, D.C., U.S.A. 20041.
Telephone (703) 661-8600, TWX: 710-833-0865.
Canada: P.O. Box 13089, Kanata, Ontario, Canada K2K 1X3.
Telephone (613) 592-5630, Telex: 053-3221, TWX: 610-562-8529.

Europe: 33/37 Queen St., Maidenhead, Berkshire, England SL6 1NB
Telephone 0628-72821, Telex: 849-808.
Bredgade 65A, 2nd Floor, 1260 Copenhagen K, Denmark
Telephone (01) 134712, Telex: 19502.
Asia: TST P.O. Box 98577, Kowloon, Hong Kong.
Telephone 3-318256, Telex: 34235.

Copyright 1981 Mitel Corporation

BUILDING BETTER COMMUNICATIONS

Circle 194 on reader service card

Casual English elicits computer instructions

Forth Inc., of Hermosa Beach, Calif., has contracted with Excalibur Technologies Corp., of Albuquerque, N. M., to develop a data-base management package for the Apple II that responds to such casual commands as "Computer, how many machinists work here?" or "What percentage of project X is complete?" Using Savvy, Excalibur's Z80-based adaptive pattern-recognition processor, the Forth-based system will be able to recognize written words strung together in idiomatic phrases and translate these imprecise patterns into precise computer commands. Savvy is not deterred by extra spaces, misspellings, typing errors, or questions it has not previously answered; and if it fails to act on a command, the user can teach it the meaning of the phrase that caused the failure. Ready in March 1982, the system will sell for under \$1,000. Future versions of Savvy will understand Spanish commands, as well as English, or a mixture of both.

Interface card relays and converts computer commands

The 9702, an initial offering from North Coast Automation Inc., Chesterland, Ohio, is a single-card motor-control interface that has 12- or 16-bit resolution for controlling two axes thanks to two on-board DAC-80- or DAC-71-type digital-to-analog converters. Offered with or without a built-in ± 15 -V power supply, each Multibus-compatible 9702 series board accepts inputs from two position encoders and supplies two analog voltages for driving motors based on microcomputer commands. Prices range from \$865 for the 12-bit version without supply to \$1,195 for the 16-bit model with on-board power supply. Delivery takes three weeks.

Teletype emulator mates CRT terminals with ASR teleprinters

With the TTY communications package, Codex CDX-68 terminals now can support both interactive time-sharing and administrative-message switching. Codex Corp., Mansfield, Mass., claims reduced terminal and network costs through terminal integration of the three most common dialing protocols: teletype, 3275, and 2780/3780; the latter two already were supported by the CDX-68. With the addition of the teletypewriter protocol, which can be licensed for \$100, the terminals can emulate ASCII automatic send-receive teleprinters, and will be compatible with Teletype Corp.'s ASR-33, -35, and -43 systems.

16-bit microcomputer programs in eight languages

Altos Computer Systems' 8086-based ACS8600 single-board 16-bit microcomputer can supply up to eight users with up to 1 megabyte of main random-access memory, plus up to 80 megabytes of on-line floppy- and Winchester hard-disk storage. With error detection and correction and a memory management system, a basic configuration with 512-K bytes of memory, a 10-megabyte hard disk, and floppy-disk backup lists for \$12,990. The four operating systems supported are Xenix, CP/M 86, MP/M 86, and Oasis-16, and programs can be written in Basic, Cobol, Pascal, Fortran, CIS-Cobol, RM-Cobol, Pascal/M-86, and C-Basic-86. The San Jose, Calif., firm will begin deliveries in January of 1982.

TI adds ROMs with special vocabularies

Added to Texas Instruments Inc.'s family of speech 128-K read-only memories are the VM61003 with 147 weather and time words, the 128-item VM61004 for military uses, and the VM61005 with 135 items for avionic markets. In lots of 100, each goes for \$9.75. The devices from the Dallas firm will be available in December.

**An International Opportunity
for
Chief Television Engineer**

The King Faisal Specialist Hospital and Research Centre has a current opening for a Chief TV Engineer in its Audiovisual Department. The AV Department is responsible for the educational and television needs of the Hospital's employees and their dependents. The Hospital is a 250 bed acute care facility located in Riyadh, Saudi Arabia.

Requirements include a BSEE degree, eight years related experience in the design and maintenance of CCTV systems and other AV equipment, and two or more years experience as a supervisor.

Salaries are excellent and benefits include 30 day annual leave, furnished housing, transportation, bonus pay and more.

Interested applicants should forward a resume to: Linda Hogin, Senior International Representative, Hospital Corporation International, P.O. Box 550, Nashville, Tennessee 37202. An Equal Opportunity Employer.

**HOSPITAL
CORPORATION**

**ELECTRONIC
ENGINEERS**
Hardware/Software

Our high-tech client firms in New England & nationwide have openings in hardware & software design, digital circuits, tele-comm, CAD, CAM, microwave, optics, RF warfare systems, etc. MINI-APPLICATIONS. Send resume in confidence to Fred Raisner

Search Incorporated
144 Westminster St
Providence, RI 02903
(401) 272-2250

S.W. & SUNBELT

- Circuits
- Systems
- Product
- CAD
- Micro
- Software
- Hardware
- Optics

\$25,000 to \$50,000

Specialists placing EE's/ME's in data acquisition, peripheral and instrument development companies across the Sunbelt. 100% company Fee Paid. Send resume, geographic preference, salary and salary requirements to:

J. Robert Thompson Companies, Inc.
Management & Employment
Consultants
2200 West Loop South, Suite 800
Houston, Texas 77027
(713) 627-1940

SUNBELT OPPORTUNITIES

Our 14 SE offices cover many Manufacturing Firms which seek experienced degreed Electronic Engineers as well as Entry Levels. Microprocessor/Computer Applications — Hardware/Software, etc. Fee Paid. Confidential Treatment. BEALL ASSOC. Personnel, Box 8915E Greensboro, NC 27419

Career outlook

From teacher to programmer

Massachusetts teachers whose careers have been sunk by budget cuts may be buoyed by a business- and government-funded program to learn computer programming. Project Straight (for short-term retraining and advanced instruction geared to high technology) kicks off this month with a 1,000-hour pilot course funded by the state Department of Education.

The course aims to produce 50 programming graduates over a 26-week period, and could become a model for similar courses across the state, says project manager F. Nelson Burns. Massachusetts computer firms like Digital Equipment Corp., Wang Laboratories, and Nixdorf Computer's U. S. branch are lending executives, programmers, and personnel workers as advisers.

Steering. The advisers form a steering committee that suggests admission standards and curriculum content and counsels students on their career transition. According to Burns, Wang and Nixdorf programmers will even share teaching chores with instructors at the Greater Lowell Regional Vocational Technical School in Tyngsboro, Mass., where the initial course is being held.

"These inputs should help us tailor the coursework to industry's needs and turn out highly employable graduates," says Burns. He adds that as the course progresses the program will encourage contacts between students and industry and also open up recruitment opportunities.

Burns thinks computer users like banking and insurance firms will be the major recruiters of programming graduates, so course instruction is based on the applications-oriented programs such companies offer their own employees. "We're teaching programming skills in a linear sequence, the same a programmer uses to solve applications problems," he notes. "It's a much more hands-on approach than you'll find in most computer-science degree programs, where several subjects are taught simultaneously."

Although one steering-committee

member cautions that firms aiding in Project Straight do not guarantee they will hire program graduates, Ralph A. Crusius, vice president and assistant to the president at Wang Laboratories, observes, "there certainly is a need for entry-level programmers, and any measure to increase the talent pool will get a lot of interest and support."

Project Straight's initial emphasis will be on Cobol-language programming, though later instruction will include Basic, RPG, Assembly, and perhaps some Pascal, Burns notes. Students, who pay a \$300 tuition fee, will work on Wang, Xerox, and Honeywell computers at the Tyngsboro school. For these former teachers, whose jobs evaporated in a series of state-wide budget cuts this year, the program provides an avenue off the unemployment line into an industry with a high demand for their new skills.

Burns says that chances of further funding to extend Project Straight "look very bright; we're already looking at another potential course start-up in January."

The center serves 2,400 students during its normal operating hours, and is large enough to accommodate several Project Straight courses running concurrently. While the first course, which begins Nov. 23, emphasizes Cobol applications, the second will probably focus on word-processing and basic-language training, according to Burns. "We don't want to flood the market with just one kind of skill," he says.

"Technical vocational schools are natural centers for this kind of program," Burns asserts. "They have the equipment already in place, and they normally stand empty every afternoon and weekend." If Project Straight expands to fill those under-used facilities, he believes, there will be plenty of raw talent waiting to move in. Applicants for the first Project Straight course came from 67 different Massachusetts communities. Newly unemployed teachers comprise a large segment of potential students, points out Burns, "and that group alone amounts to about 7,000 people."

-Linda Lowe

IBM has a career opening for an Optical Engineer at its Research Lab in San Jose, California.

This is an exciting opportunity in IBM's research laboratory, offering you technical and career growth.

You would have responsibility for the original design of optical systems. To qualify, you should have experience in optical design with emphasis on computer-aided lens design. Familiarity with lasers would also be desirable. You should have an MS or its equivalent in Optics, Physics, or Electrical Engineering.

Excellent Benefits

IBM's benefits program includes vacation and holidays, tuition refund plan, medical and dental plans, life insurance, retirement.

Write Today

If you are interested and qualify, please send your resume in confidence to IBM Research Personnel Dept. K24X-282, EL, 5600 Cottle Road, San Jose, CA 95193.



LOGISTICS ENGINEERS

INSTEAD OF LOOKING FORWARD TO FRIDAYS, START LOOKING FORWARD TO MONDAYS.

If you find yourself fearing the end of each weekend and absolutely loathing the sound of your alarm clock on Monday mornings, you're not alone.

Most people feel the same way. And generally, it's because they're sick of their jobs.

But, what if you were working on a project which would really challenge your creativity?

And instead of being confined in the confusion of the city, your office was located out in the open, in some of the most beautiful countryside in Southern California.

Do you think Monday mornings would still look the same?

As the newest and fastest growing division of Litton, we're working on one of the most extensive Command, Control and Communications projects of the decade. And we're looking for some very hard to find Logistics Specialists, like you, to fill the following positions:

SUPPLY SUPPORT ENGINEERS - Will analyze engineering drawings and provisioning documentation (PTD) for determination of spares. Must be familiar with supply support techniques including MIL-STD 1552, and have theoretical knowledge of engineering, scientific, and mathematic principles. Minimum of 5 years' directly related experience with a Bachelor's degree in a technical field, or additional related experience.

TECHNICAL INSTRUCTORS - Will be responsible for the development and implementation of technical training programs. Must have a solid background in either electronics, digital circuitry, communication operations, programming, diesel generation, or air conditioning. Openings exist for instructors in basic electronics, radar, computers, peripherals, communications, tropo, programming, diesel generation, and air conditioning.

TECHNICAL WRITERS - Will be involved with all phases of technical publications, including writing equipment manuals and system manuals for digital/analog Command, Control and Communications equipment.

MAINTENANCE ENGINEERS - Will be heavily involved in defining maintenance concepts for Command, Control and Communications systems; Air Defense radar and troposcatter networks. Knowledge of logistics support and maintenance concepts desirable. Experience required based on degree; 4 years' with M.S. or 6 years' with B.S. 10 or more years' experience required for non-degreed individuals. Degree must be in Math, Physics, Computer Science, Electrical Engineering, or other associated discipline.

So, if you know logistics and are ready to change your outlook, simply send us your detailed resume and salary history.

Who knows? You might find there's more to Mondays than looking forward to Fridays.

Contact: Ginny Burdick or Dale DeMarais
Department 407-L1, P.O. Box 5000
Agoura, CA 91301
Equal Opportunity Employer M/F/H



DATA COMMAND SYSTEMS

AEROSPACE PROFESSIONALS

Ford Aerospace and Communications Corporation's Space Information Systems Operation (SISO) is the principle contractor that designed, manufactured, installed, tested, operates and maintains NASA's Houston based Space Shuttle Mission Control Center. With the success of the space shuttle's maiden flight, "STS-1", our involvement continues with technological advancement and support of a number of highly sophisticated command & control and ground data systems that will support "STS" flights through the 1980's. We are also developing the space telescope ground systems for the Goddard Space Flight Center located in the Washington D.C. area.

We have immediate career openings for experienced professionals:

- Digital Design Engineers
- Digital Computer Based Ground Data Systems Engineers
- Aerospace Engineers
- Electronic Production/Industrial Engineers
- Electro-Mech/Packaging Designers
- Scientific Programmers
- Applications Programmers
- Assembly Language Programmers
- Software Engineers

We offer challenging assignments, competitive salaries and comprehensive benefits package. In Houston, we're close to beautiful lakes and the Gulf, enjoy the weather of the sunbelt, plus, in Texas there is no state income tax. Send your resume to: John Brown or Ted Sarno, Ford Aerospace and Communications Corporation, Dept. AJH, P.O. Box 58487, Houston, Texas 77058. We are an equal opportunity employer, m/f/h.



Ford Aerospace & Communications Corporation
Space Information Systems Operation

POSITIONS VACANT

Electronic Engineers: Deal with an EE. I specialize only with electronic positions — EE's and Techs. The top companies rely on me. It makes sense for you and me to discuss your career goals. We speak the same language. Send resume. Call for prompt attention. Noel Cram, EE., 201-297-7111, Consultants, Inc., PO Box 1938, North Brunswick, NJ 08902.

Murkett Associates Qualified Reputable Management placement with national affiliates—fee paid. Box 527 Montgomery, AL 36101.

Computer Development Scientist wanted to develop micro-computer based patient data management system, to adapt such a system to a wide variety of monitors and devices. Must be able to consult with customers in the medical field, coordinate their requests into engineering development, and produce engineering specifications of modifications. Will also be required to formulate marketing strategy for this system. Must have PhD and at least 3 years experience in this patient data field, as well as mechanical engineering background and strong experience in computer systems analysis. \$50,000 per year — 40 hour week — 9 am-5 pm. Resumes to Steve Spencer, Kontron Medical Instruments, 9 Plymouth Street, Everett, MA 02149.

ADVERTISERS

Send all new copy, film or changes to:

ELECTRONICS CLASSIFIED
ADVERTISING CENTER
POST OFFICE BOX 900
NEW YORK, NY 10020

STILL LOOKING FOR YOUR DREAM JOB?



Then be sure to check out the employment opportunities contained in ELECTRONICS' Classified Section.

Or, why not consider placing a Position Wanted ad? The cost is low (only \$1.98 per line) and the results are often rewarding. For more information call or write:

ELECTRONICS

Post Office Box 900
New York, N.Y. 10020 • Phone: 212/997-2556

ATTENTION HARDWARE ENGINEERS:
**YOU'VE EARNED
YOUR SPURS.**

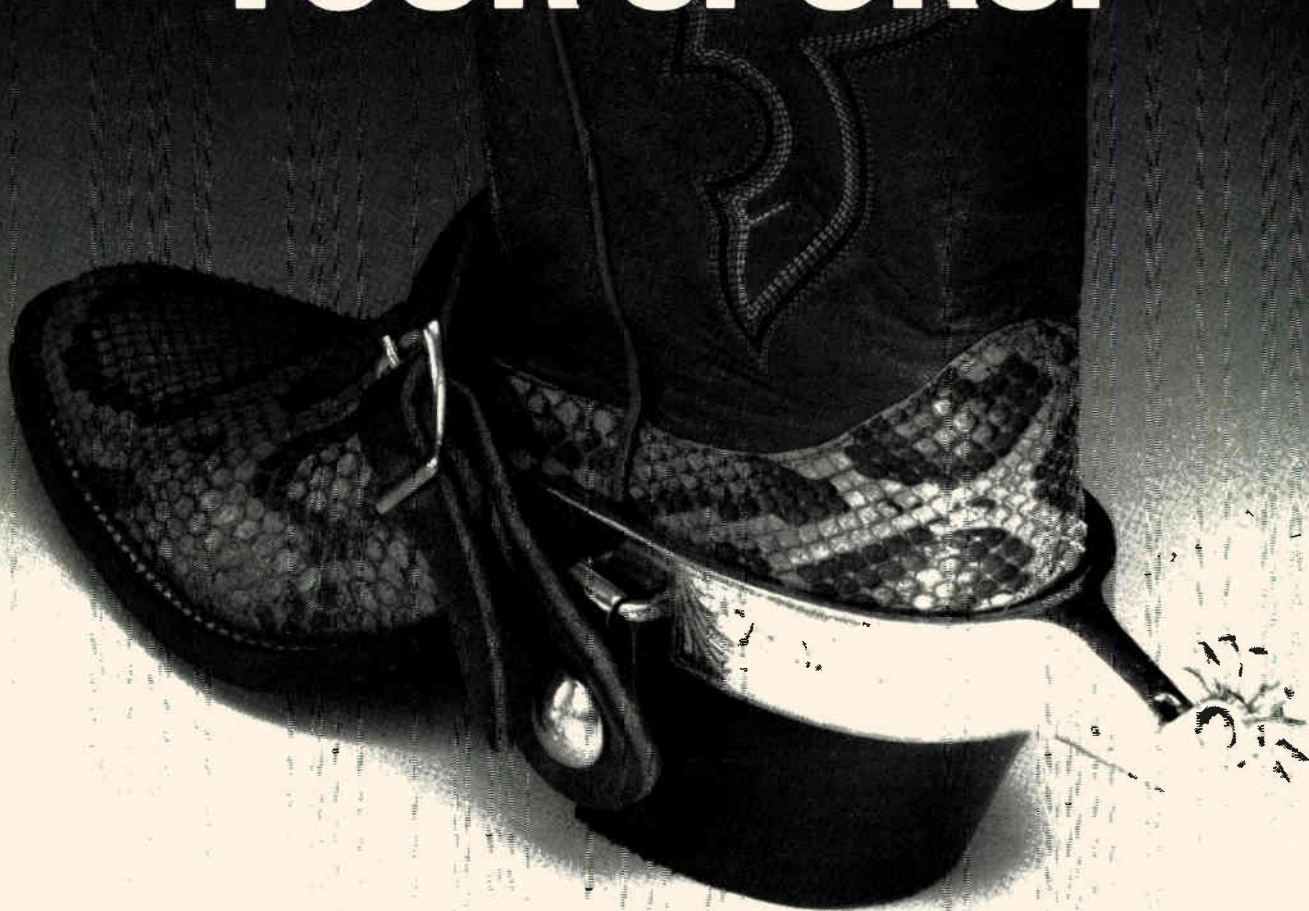

You've put in at least 3 years of practical, on-the-job experience. And now, you've earned your spurs. You've earned the Texas sunshine and you've earned the chance to join the team at E-Systems Garland Division. You'll need your spurs, too, because some of the toughest high-technology electronics problems you can face are solved every day at E-Systems.

**OPPORTUNITIES FOR
HARDWARE ENGINEERS:**

- wide range of jobs:
 - systems analysis, design, development, test and integration in the following areas: computer-based intelligence and reconnaissance systems, command and control systems, electronic warfare, communications systems, digital image processing

- state-of-the-art technology:
 - high-speed digital logic and signal processing
 - communications theory, digital and analog design, and filter design
 - antenna/arrays for precision direction-finding systems
 - RF & IF processors & microwave integrated circuitry
 - microprocessor bit-slice, and high-speed, parallel pipeline processors utilizing MOS, TTL & ECL
 - high probability of intercept receivers

PUT ON YOUR SPURS

Don't miss out on this Texas size opportunity. We are planning to be in the following cities with some of our top technical people to talk with you. Send your resume today for professional review and priority attention:

Atlanta
Bethesda
Boston
Chicago
Dayton
Los Angeles
**Melbourne/
Orlando**
Minneapolis

Newark
Philadelphia
Phoenix
Pittsburgh
San Diego
San Jose
Seattle
St. Louis

If you have a degree and 3 or more years of experience, grab hold of this opportunity — don't delay — send your resume to: Professional Placement, E-Systems, Inc., Garland Division, P.O. Box 226118, Dept. ES29, Dallas, Texas 75266.



E-SYSTEMS

Garland Division

The problem solvers.



GROWTH...

You Hear About It
All The Time...

At Scientific-Atlanta,
YOU FEEL IT!

The excitement of a dynamic, forward-moving company.

We recognize the important role that the performance and abilities of our employees play in the success of the company. We invite you to become part of our growth and join the team of professionals who have helped us establish our position as a leader in the design and manufacture of communications and instrumentation products.

SENIOR R.F. ENGINEERS

Rapid growth in the Subscriber Products Division at Scientific-Atlanta continues to result in new openings for experienced Engineers. We are developing home terminals for the rapidly growing CATV market, which permit expanded entertainment, security, energy management and other services you've been hearing about.

Currently we are looking for Senior Engineers with interest in design and product support of high volume RF products. Qualifications include a BS/EE (MSEE preferred) and 5 or more years experience in small signal RF (to 1GHz) design and/or product support. Applicants should have a strong desire to contribute to high volume, cost-effective products from conception to successful application in the field.

We are located Northeast of Atlanta in an area offering economical housing in a suburban setting, yet only 20 minutes from downtown Atlanta. We're close to the mountains and lakes of North Georgia and a pleasant drive from both Atlantic and Gulf beaches.

If you are interested in exploring these excellent career opportunities, please send your resume with salary requirements to H. HERBERT LOVE at:

Scientific Atlanta

Communications Products Group

HL - 5

Box 105027

Atlanta, Georgia 30348

An Equal Opportunity Employer M/F/V/H

STILL LOOKING FOR YOUR DREAM JOB?

Then be sure to check out the employment opportunities contained in ELECTRONICS Classified Section.

Or, why not consider placing a Position Wanted ad? The cost is low (only \$1.98 per line) and the results are often rewarding. For more information call or write:

ELECTRONICS

Post Office Box 900
New York, N.Y. 10020
Phone 212/997-2556

NOTICE TO EMPLOYERS:

Why we can recommend our readers for the top jobs

The subscribers to this magazine have qualified professionally to receive it. They are also paid subscribers—interested enough in the technological content to have paid a minimum of \$19 for a subscription.

As subscribers to ELECTRONICS, our readers have told you several things about themselves. They are ambitious. They are interested in expanding their knowledge in specific areas of the technology. And they are sophisticated in their need for and use of business and technology information.

Our readers are now in senior engineering or engineering management, or they are on the road toward those levels. In either case, they are prime applicants for the top jobs in almost any area.

If you are interested in recruiting the best people in electronics, these pages are open to you for your recruitment advertising.

Our readers are not "job-hoppers". To interest them you will have to combine present reward with challenge and opportunity for future career advancement.

The cost of recruitment advertising on these pages is \$87 per advertising inch. For information call or write:

Electronics

Post Office Box 900, New York, NY 10020
Phone 212/997-2556

Advanced Micro Devices	22, 23	Hamilton / Avnet Electronics	4C	RCA Solid State	173, 102, 103
• AFGA Gevaert	15E	■ Hewlett Peckard	1, 2C	Rockwell International	142, 143
Alco Electronic Products	48	Hussey / Copper Range	49, 50	• Rohde & Schwarz	1E, 13E
American Microsystems, Inc.	152, 153	INCO	74	Schlumberger Engineers	186
Amphenol N. America Oak Brook	157	Inmos	150, 151	S.D.S.A.	26
Amust Computer Corporation	46	Intel MCO	18, 19	Sharp Corporation	43, 45
Apex Microtechnology Corporation	89	Interdesign Incorporated	100, 101	‡ Siecior / Optical Cable	41
Applied Materials	62, 63	International Electronic Research Corp.	94	‡ Siemens Corporation	155, 166, 167
Asahi Dry Battery Co.	98	Intersil	10, 11	Snap-On Tools Corporation	88
• ASU Components, Ltd.	27E	≡ ITT Cannon Electric	191, 91	• Solartron Ltd. L.D. Division	21E
Avocet Systems	14	• Italtel / SIT	155	Solid State Scientific	59
J.T. Baker Chemical Company	156	• ITT Capacitors	54	‡ South Carolina State Development Board	174
Boschert, Inc.	99	• ITF Communications '82	27E	Spectrum Control	72
• Bryans Southern Instruments, Ltd.	28E	• Iwatsu Electric Co., Ltd.	175	‡ STC Microtechnology	121
Buehler Products, Ltd.	176	Kadak Products Limited	94	• TEAC Corporation	14E
Callan Data Systems	148	■ Keystone Electronics	88, 176	• Techmeshexport	18E
Cambion	98	■ Krohn-Hite Corporation	7	Tektronix Design Automation Division	2
■ Cherry Electrical Products	13	Lanier Business Products	170, 171	Teradyne Incorporated	64-65, 76-79
CM Technologies	80, 81	• Lear Siegler Incorporated	10E, 11E	Texas Instruments Digital Systems	36
Compeda, Ltd.	180	Mallory Capacitor Company	193	Texas Instruments Incorporated (Semiconductor)	85, 146, 147
‡ CTS Corporation / Berne Div	173	Mepco / Electra	17	Thomson CSF / DTE	35
Cyborg Corporation	185	□ Merak	58D	• Thomson CSF Div D.T.E.	41
Datacube, Inc.	16	• Micro Circuits Eng. Ltd.	2E, 3E	TRW LSI Products	97
Data General	168, 169	■ Mini-Circuits Laboratory	5	TRW Optron	27
Dataproducts	104, 105	3M Company Scotchflex	164, 165	• Trio Test Instrument Div.	26E
■ Data Translation	56	Mitel Corporation	86, 141, 194	Universal Instruments	156
DuPont Co Pyralux Flexible Composites	189	Monolithics Memories	53	‡ US Instrument Rentals	92
EG & G Reticon	47	Mos Technology, Inc.	177	Weckesser Company Incorporated	175
‡ Electronic Measurements, Inc.	163	Mostek Corporation	25, 60, 61	Western Digital	75
■ Electronic Navigation Industries	6, 3C	Mountain West	178	• Wild Heerbrugg	19E
EMM SESCO	8	Mouser Electronics	178	Mark Williams Company	9
□ ESCO	58A	‡ Murata Corporation of America	121	□ Yokogawa Electric (Europe)	74A-74D
Fairchild Test Systems	82	• Murata Manufacturing Co., Ltd.	17E	• Zeltron Istituto Zanussi per L'Electronica	16E
■ Farrand Controls	12	Nicolet Instrument Corporation	32		
■ Ferranti Electronics, Ltd.	167	Nippon Electric Company, Ltd.	20, 21		
■ First Computer Corporation	15	• Northern Ireland Dept of Commerce	163		
John Fluke Mfg. Co.	69, 71, 73	Oak Industries	187		
• Fujitsu Limited	4E, 5E	OKI Semiconductor	183, 158, 159		
• GEC M-O Valve	121	Omnibyte Corporation	66		
General Electric	160, 161	□ Panduit	58B, 58C		
General Instrument Microelectronics	95	• Philips CMSD	22E, 23E		
■ GenRad	144, 145	■ Philips T & M	8E		
• Gould Inc. Instruments Division	6E, 7E	• Plessey Semiconductor	91		
Gould Incorporated Instrument Div SC Operations	30, 31	■ Precision Filters	181		
Guardian Electric	28, 29	RCA	192		

Classified and employment advertising

Beall Associates	196
E-Systems Garland	199
Ford Aerospace	198
Hospital Corporation International	196
IBM Corp.	197
Litton Data Command Systems	197
Scientific Atlanta	200
Search Inc.	196
Thompson, J. Robert	196

■ For more information of complete product line see advertisement in the latest Electronics Buyers Guide

* Advertisers in Electronics International

‡ Advertisers in Electronics domestic edition

□ Advertisers in regional issue

The NEW Electronics Buyers' Guide is now available!

Completely new listings of catalogs, new phone numbers, new addresses, new manufacturers, sales reps, and distributors! The total market in a book—four directories in one!

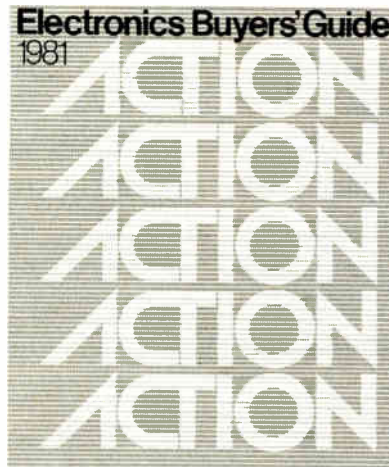

The only book of its kind in the field.

If you haven't got it, you're not in the market.

To insure prompt delivery enclose your check with the coupon now.

Yes, please send me _____ copies of 1981 EBG.

I've enclosed \$30 per copy delivered in USA or Canada. Address: EBG, 1221 Avenue of the Americas, New York, N.Y. 10020.

I've enclosed \$52 for air delivery elsewhere. Address: EBG, Shoppenhangers Road, Maidenhead, Berkshire S16, 2Q1 England.

Name _____

Company _____

Street _____

City _____

State _____ Zip _____ Country _____

Advertising Sales Staff

Advertising sales manager: Norman Rosen
3200 Wilshire Blvd., South Tower
Los Angeles Calif. 90010 [213] 487-1160

Market managers:

Computers & Peripherals: Frank Mitchell, Boston
Test & Measurement: Don Farris, San Francisco
Semiconductors: Norman Rosen, Los Angeles

Atlanta, Ga. 30309: Peter Stien
100 Colony Square, 1175 Peachtree St., N.E.
[404] 892-2868

Boston, Mass. 02118: Frank Mitchell
Paul F. McPherson, Jr.
607 Boylston St., [617] 262-1160

Cleveland, Ohio 44113: William J. Higgins III
[312] 751-3738

Fort Lauderdale, Fla. 33306: Peter Stien
3000 N.E. 30th Place, Suite #400
[305] 563-9111

New York, N.Y. 10020
1221 Avenue of the Americas
Barry Hakala [212] 997-3616
Matthew T. Reseska [212] 997-3617

Philadelphia, Pa. 19102: Joseph Milroy
Three Parkway, [215] 496-3800

Pittsburgh, Pa. 15222: Joseph Milroy
4 Gateway Center, [215] 496-3800

Chicago, Ill. 60611
645 North Michigan Avenue
Jack Anderson [312] 751-3739
William J. Higgins III [312] 751-3738

Southfield, Michigan 48075: Jack Anderson
4000 Town Center, Suite 770, Tower 2
[313] 352-9760

Dallas, Texas 75201: John J. Uphues
2001 Bryan Tower, Suite 1070
[214] 742-1747

Denver, Colo. 80203: Harry B. Doyle, Jr.
655 Broadway, Suite 325
[303] 825-6731

Houston, Texas 77040: John J. Uphues
7600 West Tidwell, Suite 500
[713] 462-0757

Los Angeles, Calif. 90010: Chuck Crowe
3200 Wilshire Blvd., South Tower
[213] 487-1160

Costa Mesa, Calif. 92626: Edward E. Callahan
3001 Red Hill Ave, Bldg. #1 Suite 222
[714] 557-6292

Palo Alto, Calif. 94303: Don Farris,
Larry Goldstein, Lauren Scott
1000 Elwell Court, [415] 968-0280

Paris: Michael Sales
17 Rue-Georges Bizet, 75116 Paris, France
Tel: 720-16-80

United Kingdom: Simon Smith
34 Dover Street, London W1
Tel: 01-493-1451

Scandinavia: Andrew Karnig and Assoc.
and Simon Smith
Kungsholmsgatan 10
112 27 Stockholm, Sweden

Tel: 08-51-68-70 Telex: 179-51

Milan: Ferruccio Silvera and Elio Gonzaga
1 via Baracchini, Italy
Tel: 86-90-656

Brussels:
23 Chaussee de Wavre
Brussels 1040, Belgium
Tel: 513-73-95

Frankfurt/Main: Fritz Krusebecker
Liebigstrasse 27c, Germany
Tel: 72-01-81

Tokyo: Akio Saijo and Hirokazu Nakamura
McGraw-Hill Publications Overseas Corporation,
Kasumigaseki Building 2-5, 3-chome,
Kasumigaseki, Chiyoda-Ku, Tokyo, Japan
[581] 9811

Business Department

Thomas M. Egan
Production Director
[212] 997-3140

Carol Gallagher
Production Manager
[212] 997-2045

Betty Preis
Production Manager Domestic
[212] 997-2908

Thomas Kazich
Production Manager Related Products
[212] 997-2044

Sharon Wheeler
Production Assistant
[212] 997-2843

Frances Vallone
Reader Service Manager
[212] 997-6058

Electronics Buyers' Guide

H.T. Howland, General Manager
[212] 997-6642

Regina Hera, Directory Manager
[212] 997-2544

Classified and Employment Advertising

Gerry F. Moss, Manager
[212] 997-2897

Electronics

Reader Service

For additional information on products advertised, new products or new literature, use these business reply cards.

Complete entire card. Please print or type.

Circle the number on the Reader Service postcard that corresponds to the number at the bottom of the advertisement, new product item, or new literature in which you are interested.

To aid the manufacturer in filling your request, please answer the three questions.

All inquiries from outside the U.S. that cannot reach Electronics before the expiration date noted on the Reader Service postcard must be mailed directly to the manufacturer. The manufacturer assumes all responsibilities for responding to inquiries.

Subscriptions & Renewals

Fill in the subscription card adjoining this card. Electronics will bill you at the address indicated on the card.

Electronics November 17, 1981 This reader service card expires February 17, 1982

NAME _____ TITLE _____

PHONE (_____) _____ COMPANY _____

STREET ADDRESS (Company or home check one) _____

CITY _____ COUNTRY _____

Was This Magazine Personally Addressed to You? Yes No

Industry classification (check one):

- a Computer & Related Equipment
 b Communications Equipment & Systems
 c Navigation, Guidance or Control Systems
 d Aerospace, Underseas Ground Support

- e Test & Measuring Equipment
 f Consumer Products
 g Industrial Controls & Equipment
 h Components & Subassemblies

- 8 Source of Inquiry—All Other INT'L.
 j Independent R&D Organizations
 k Government

Your design function (check each letter that applies):

- x I do electronic design or development engineering work.
 y I supervise electronic design or development engineering work.
 z I set standards for, or evaluate electronic components, systems and materials.

Your principal job responsibility (check one)

- t Management
 v Engineering Management
 r Engineering

Estimate number of employees (at this location): 1. under 20 2. 20-99 3. 100-999 4. over 1000

1	16	31	46	61	76	91	106	121	136	151	166	181	196	211	226	241	256	271	348	363	378	393	408	423	438	453	468	483	498	703	718
2	17	32	47	62	77	92	107	122	137	152	167	182	197	212	227	242	257	272	349	364	379	394	409	424	439	454	469	484	499	704	719
3	18	33	48	63	78	93	108	123	138	153	168	183	198	213	228	243	258	273	350	365	380	395	410	425	440	455	470	485	500	705	720
4	19	34	49	64	79	94	109	124	139	154	169	184	199	214	229	244	259	274	351	366	381	396	411	426	441	456	471	486	501	706	900
5	20	35	50	65	80	95	110	125	140	155	170	185	200	215	230	245	260	275	352	367	382	397	412	427	442	457	472	487	502	707	901
6	21	36	51	66	81	96	111	126	141	156	171	186	201	216	231	246	261	338	353	368	383	398	413	428	443	458	473	488	503	708	902
7	22	37	52	67	82	97	112	127	142	157	172	187	202	217	232	247	262	339	354	369	384	399	414	429	444	459	474	489	504	709	951
8	23	38	53	68	83	98	113	128	143	158	173	188	203	218	233	248	263	340	355	370	385	400	415	430	445	460	475	490	505	710	952
9	24	39	54	69	84	99	114	129	144	159	174	189	204	219	234	249	264	341	356	371	386	401	416	431	446	461	476	491	506	711	953
10	25	40	55	70	85	100	115	130	145	160	175	190	205	220	235	250	265	342	357	372	387	402	417	432	447	462	477	492	507	712	954
11	26	41	56	71	86	101	116	131	146	161	176	191	206	221	236	251	266	343	358	373	388	403	418	433	448	463	478	493	508	713	956
12	27	42	57	72	87	102	117	132	147	162	177	192	207	222	237	252	267	344	359	374	389	404	419	434	449	464	479	494	509	714	957
13	28	43	58	73	88	103	118	133	148	163	178	193	208	223	238	253	268	345	360	375	390	405	420	435	450	465	480	495	510	715	958
14	29	44	59	74	89	104	119	134	149	164	179	194	209	224	239	254	269	346	361	376	391	406	421	436	451	466	481	496	701	716	959
15	30	45	60	75	90	105	120	135	150	165	180	195	210	225	240	255	270	347	362	377	392	407	422	437	452	467	482	497	702	717	960

Electronics November 17, 1981 This reader service card expires February 17, 1982

NAME _____ TITLE _____

PHONE (_____) _____ COMPANY _____

STREET ADDRESS (Company or home check one) _____

CITY _____ COUNTRY _____

Was This Magazine Personally Addressed to You? Yes No

Industry classification (check one):

- a Computer & Related Equipment
 b Communications Equipment & Systems
 c Navigation, Guidance or Control Systems
 d Aerospace, Underseas Ground Support

- e Test & Measuring Equipment
 f Consumer Products
 g Industrial Controls & Equipment
 h Components & Subassemblies

- 8 Source of Inquiry—All Other INT'L.
 j Independent R&D Organizations
 k Government

Your design function (check each letter that applies):

- x I do electronic design or development engineering work.
 y I supervise electronic design or development engineering work.
 z I set standards for, or evaluate electronic components, systems and materials.

Your principal job responsibility (check one)

- t Management
 v Engineering Management
 r Engineering

Estimate number of employees (at this location): 1. under 20 2. 20-99 3. 100-999 4. over 1000

1	16	31	46	61	76	91	106	121	136	151	166	181	196	211	226	241	256	271	348	363	378	393	408	423	438	453	468	483	498	703	718
2	17	32	47	62	77	92	107	122	137	152	167	182	197	212	227	242	257	272	349	364	379	394	409	424	439	454	469	484	499	704	719
3	18	33	48	63	78	93	108	123	138	153	168	183	198	213	228	243	258	273	350	365	380	395	410	425	440	455	470	485	500	705	720
4	19	34	49	64	79	94	109	124	139	154	169	184	199	214	229	244	259	274	351	366	381	396	411	426	441	456	471	486	501	706	900
5	20	35	50	65	80	95	110	125	140	155	170	185	200	215	230	245	260	275	352	367	382	397	412	427	442	457	472	487	502	707	901
6	21	36	51	66	81	96	111	126	141	156	171	186	201	216	231	246	261	338	353	368	383	398	413	428	443	458	473	488	503	708	902
7	22	37	52	67	82	97	112	127	142	157	172	187	202	217	232	247	262	339	354	369	384	399	414	429	444	459	474	489	504	709	951
8	23	38	53	68	83	98	113	128	143	158	173	188	203	218	233	248	263	340	355	370	385	400	415	430	445	460	475	490	505	710	952
9	24	39	54	69	84	99	114	129	144	159	174	189	204	219	234	249	264	341	356	371	386	401	416	431	446	461	476	491	506	711	953
10	25	40	55	70	85	100	115	130	145	160	175	190	205	220	235	250	265	342	357	372	387	402	417	432	447	462	477	492	507	712	954
11	26	41	56	71	86	101	116	131	146	161	176	191	206	221	236	251	266	343	358	373	388	403	418	433	448	463	478	493	508	713	956
12	27	42	57	72	87	102	117	132	147	162	177	192	207	222	237	252	267	344	359	374	389	404	419	434	449	464	479	494	509	714	957
13	28	43	58	73	88	103	118	133	148	163	178	193	208	223	238	253	268	345	360	375	390	405	420	435	450	465	480	495	510	715	958
14	29	44	59	74	89	104	119	134	149	164	179	194	209	224	239	254	269	346	361	376	391	406	421	436	451	466	481	496	701	716	959
15	30	45	60	75	90	105	120	135	150	165	180	195	210	225	240	255	270	347	362	377	392	407	422	437	452	467	482	497	702	717	960

Electronics Reader Service

If the cards below have already been used,
you may obtain the needed information
by writing directly to the manufacturer,
or by sending your name and address,
plus the Reader Service number and issue date,
to Electronics Reader Service Department,
P.O. Box No. 2530, Clinton, Iowa 52734, U.S.A.

Place correct airmail
postage here ... for
faster service.

Electronics

P.O. Box No. 2530
Clinton, Iowa 52735
U.S.A.

Place correct airmail
postage here ... for
faster service.

Electronics

P.O. Box No. 2530
Clinton, Iowa 52735
U.S.A.

The advanced design line of RF power amplifiers... **ENI.**



You can't claim to be "the world's leader in power amplifiers" unless you are. And being the world's leader means giving customers the ultimate in RF power flexibility with a clearly advanced design. That's the reputation we've earned with our product line because there's simply nothing finer in all the world.

And our instrumentation can meet all of your applications, for RF signal generator amplification, RFI/EMI testing, signal distribution, RF or data transmission, NMR/ENDOR ultrasonics and more.

ENI's selection of solid state Class A power amplifiers is unsurpassed,



combining a frequency spectrum of 10 kHz to 1 GHz with power outputs that range from 300 milliwatts to over 4,000 watts. Rugged, compact, and versatile, these units can be driven by virtually any signal source. They're completely broadband and untuned, amplifying inputs of AM,

FM, TV, SSB, and pulse modulations with minimum distortion. Their unconditional stability and failsafe design make them impervious to severe mismatch conditions, and capable of delivering rated power to any load impedance from an open to a short circuit.

Clearly, when it comes to meeting your power amplification needs, you'll get the utmost in flexibility from the advanced design of RF power amplifiers... ENI.

ENI

ENI products available through ENI Power Systems, Ltd., 23 Old Park Road, Hitchin, Hertfordshire, England SG52JS, Tel: Hitchin 51711, TELEX 825153
ENI UK G. And: **AUSTRALIA:** Elmeasco Instruments Pty. Ltd., Concord N.S.W. Australia, Tel: 939-7944 **BELGIUM:** MCR Electronics Marketing, 1420 Braine
L'Alleud, Belgium, Tel: 02/384.80.62 **DENMARK:** Instrutek, 8700 Horsens, Tel: 05-611100 **EGYPT:** Electronic Precision Instrument Co., P.O. Box 1262, Cairo,
Arab Republic of Egypt, Tel: 860819 **FRANCE:** Comsatec, 92300 Levallois-Perret, France, Tel: 758.59.10 **GERMANY, AUSTRIA:** Kontron Elektronik GmbH,
8057 Eching/Munich 1, Germany, Tel: 89-3188-1 **ISRAEL:** RDT Electronics Engineering Ltd., Tel Aviv 61210, Israel, Tel: 483211-5 **ITALY:** Vianello S.p.A.,
I-20121 Milano, Italy, Tel: 34.52.071 **JAPAN:** Astech Corporation, Shinjuku-ku, Tokyo 160, Japan, Tel: Tokyo 343-0601 **NETHERLANDS:** Koning en Hartman
Elektrotechniek B.V., The Hague 2040, Netherlands, Tel: 70-678380 **SOUTH AFRICA:** Associated Electronics (Pty), Ltd., Johannesburg, South Africa,
Tel: 724-5396 **SWEDEN:** Saven AB, S-18500 Vaxholm, Sweden, Tel: 0764/31580 **SWITZERLAND:** Kontron Electronic AG, 8048 Zurich, Switzerland,
Tel: 01 62 82 82 **UNITED KINGDOM:** Dale Electronics, Ltd., Frimley Green, Camberley, Surrey, England, Tel: Deepcut (02516) 5094

World's largest local distributor with 44 locations stocking the finest lines of electronic components and computer products

HAMILTON/AVNET TAKES ON ALL 64K RAM SUPPLIERS WITH MOTOROLA!

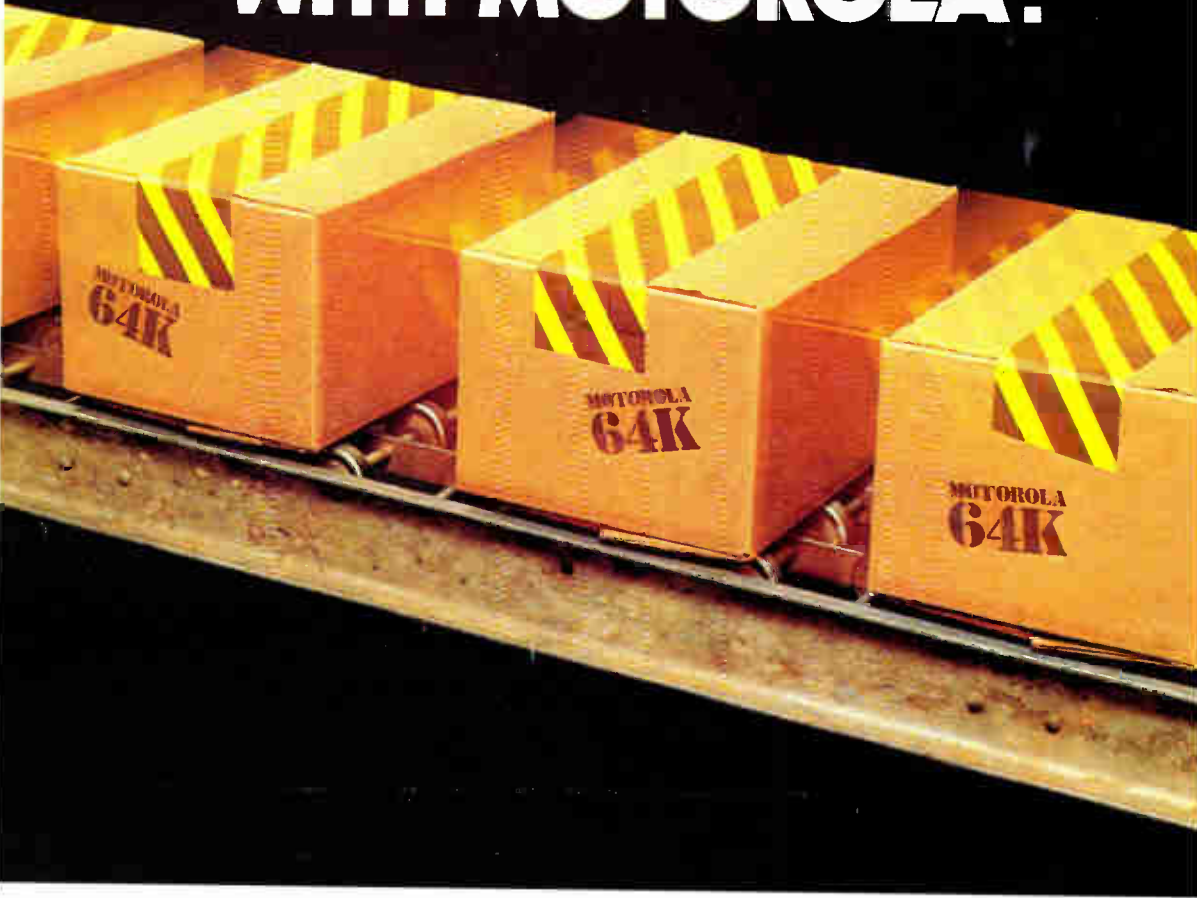

- ALABAMA**
Huntsville (205) 837-7210
- ARIZONA**
Phoenix (602) 231-5100
- CALIFORNIA**
Avnet, L.A. (213) 558-2345
Avnet, O.C. (714) 754-6111
Hamilton, L.A. (213) 558-2121
Hamilton, O.C. (714) 641-4100
San Diego (714) 571-7510
San Francisco (408) 743-3355
- COLORADO**
Denver (303) 779-9998
- CONNECTICUT**
Danbury (203) 797-2800
- FLORIDA**
St. Petersburg (813) 576-3930
Miami (305) 971-2900
- GEORGIA**
Atlanta (404) 447-7507
- ILLINOIS**
Chicago (312) 860-7700
- INDIANA**
Indianapolis (317) 844-9333
- KANSAS**
Kansas City (913) 888-8900
- MARYLAND**
Baltimore (301) 995-3500
- MASSACHUSETTS**
Boston (617) 273-7500
- MICHIGAN**
Detroit (313) 522-4700
Grand Rapids (616) 243-8805
- MINNESOTA**
Minneapolis (612) 932-0600
- MISSOURI**
St. Louis (314) 344-1200
- NEW JERSEY**
Fairfield (201) 575-3390
Cherry Hill (609) 424-0100
- NEW MEXICO**
Albuquerque (505) 765-1500
- NEW YORK**
Long Island (516) 454-6060
Syracuse (315) 437-2641
Rochester (716) 475-9130
- NORTH CAROLINA**
Raleigh (919) 829-8030
- OHIO**
Cleveland (216) 831-3500
Dayton (513) 433-0610
- OREGON**
Portland (503) 635-8831
- TEXAS**
Dallas (214) 659-4111
Houston (713) 780-1771
Austin (512) 837-8911
- UTAH**
Salt Lake City (801) 972-2800
- WASHINGTON**
Seattle (206) 453-5844
- WISCONSIN**
Milwaukee (414) 784-4510
- INTERNATIONAL**
Telex 66-4329
Telephone (213) 558-2441
- CANADA**
Toronto (416) 677-7432
Montreal (514) 331-6443
Ottawa (613) 226-1700
Calgary (403) 230-3586
- JAPAN**
Tokyo (03) 662-9911
Osaka (06) 533-5855

MOTOROLA from HAMILTON/AVNET

Since their entry into the 64K market in 1979, Motorola has shipped more devices than any other U.S. supplier, more than most firms worldwide. And with production at an all-time high, Motorola is committed to meeting your increased demand for their MCM6664 (Pin 1 refresh) and MCM6665 5 Volt dynamic 64K RAMS.

At Hamilton/Avnet, we're proud to say that we've played a major role in getting these high quality memories to customers worldwide. Our in-depth local inventories of the MCM6664 and



MCM6665 allow us to ship your order the day you place it. And by forecasting future product demand, we'll be able to maintain consistent long-range availability and continue our same-day shipment policy.

Considering the new low cost of Motorola's 64K RAMs, plus the savings in PC board real estate and reduced power supply requirements, the time is right to cross over from

16K to 64K. And Motorola is America's leader in 64K RAMs. Call any of our 44 locations today. We've got the 64K answer.

Hamilton Avnet
ELECTRONICS A DIV. OF AVNET INC.

A commitment to stock and serve your local market!

Circle 902 on reader service card
World Radio History

