

FEBRUARY 15, 1979

**CC STILL WOWING THEM IN PHILADELPHIA/122**

New IBM series bows to mixed reviews/ 85

64-K RAM features automatic- and self-refresh modes/ 141

FOUR DOLLARS A MCGRAW-HILL PUBLICATION

# Electronics®

142A 080324 44CAT MAY80  
CS OSBORNE -JR  
PERIPHICON  
BOX 324  
BEAVERTON OR

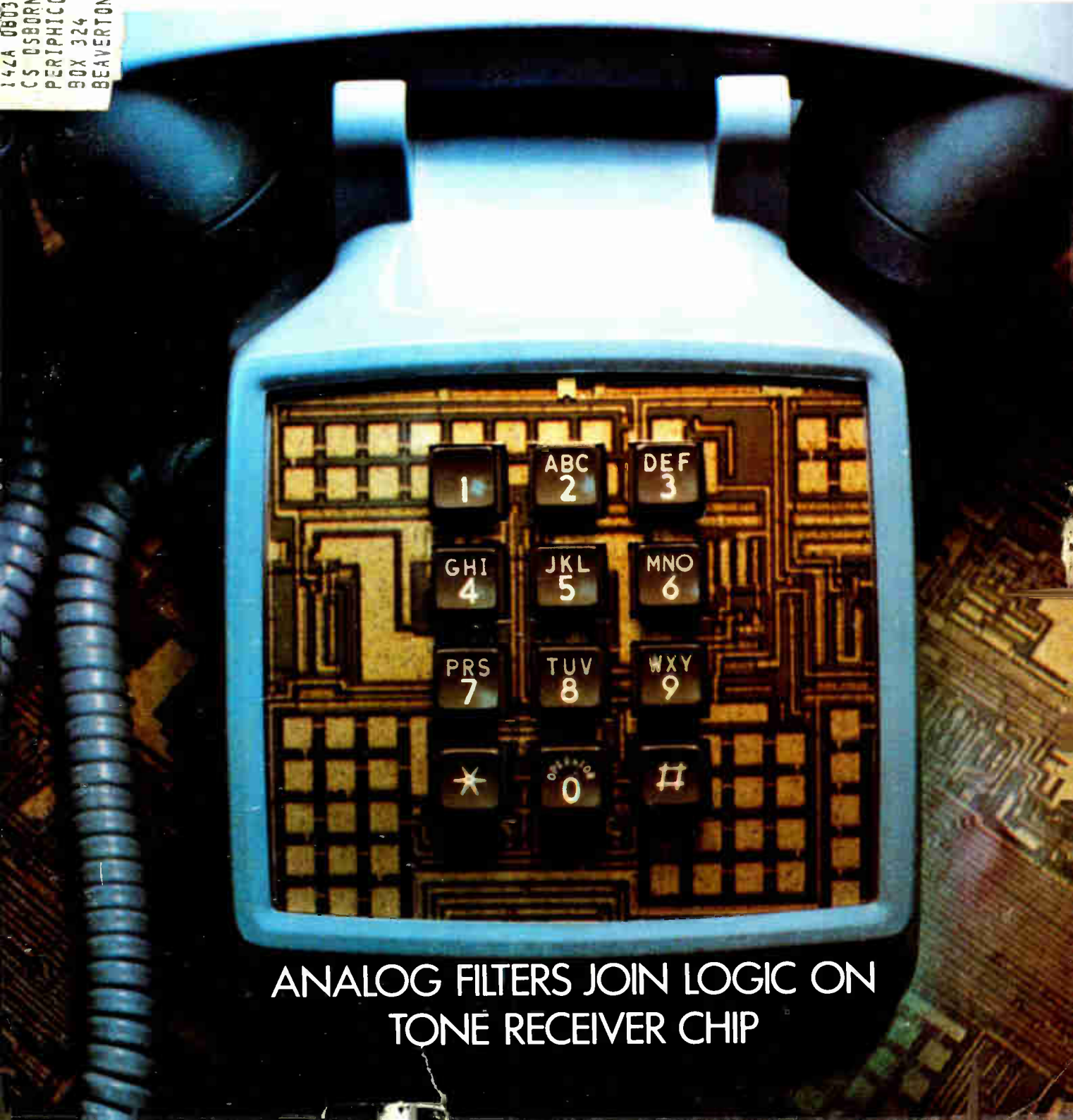

**ANALOG FILTERS JOIN LOGIC ON  
TONE RECEIVER CHIP**

# Find Your Trimmer Application Here...

Model 7102B	Model 7103C	Model 7104D	Model 7105A	Model 7125B	Model 7106B	Model 7126C	Model 7107C	Model 7108

## And incorporate trimmers and resistors in a single MFT™ package!

All trimmer applications require a fixed resistor or resistors to either divide a voltage or limit a current. The revolutionary MFT trimmer/resistor package, pioneered by Bourns, combines cermet trimmers and fixed resistors into a single JEDEC DIP package. More than just a DIP trimmer, the MFT trimmer/resistor contains the total trimmer circuit in one DIP package.

Nine different MFT trimmer/resistor models, available in a broad range of resistance values, provide both multi-trimmer versions and various combinations of fixed resistors and trimmers that will satisfy almost any trimmer application.

**Increased Reliability** — Fewer PC board connections and pre-tested circuitry provide increased reliability. MFT trimmers/resistors are manufactured simultaneously on a common substrate, resulting in better temperature tracking than discrete components. Standard tempco tracking is 50ppm/°C at -55°C to +125°C.

**Saves Time, Space and Money** — Auto- or hand-insertion of one component instead of many; less components to purchase, stock and handle; simplified circuit design; and less PC board space required. A multitude of advantages means increased productivity and lower on-board cost.

**Worldwide Availability** — MFT trimmers/resistors are now available throughout the world from Bourns authorized representatives, distributors and international marketing affiliates.

For new applications, or your next generation of design, join the growing number of engineers who are specifying MFT trimmers/resistors. Call or write today for your MFT catalog. Or, see the EEM directory (Volume 2, pages 3791-3801).

TRIMPOT PRODUCTS DIVISION, BOURNS, INC.,  
1200 Columbia Avenue, Riverside, CA 92507.  
Phone: 714 781-5204. TWX: 910 332-1252.

European Headquarters: Bourns AG, Zugerstrasse 74 6340 Baar, Switzerland. Phone: 042 33 33 33. Telex: 78722.

SALES OFFICES: Ariz 602 257 9015 • Calif 213 582 6391, 408 377 5740 • Colo 303 751-2600 • Fla 305 771 6501 • Ga 404 393 9880 • Ill 312 265 1903 • Ind 317 844 8462 • Md 301 247-0400 • Mass 617 237 6730 • Mich 313 882 1717 • Minn 612 835 2252 • Mo 816 358 8100 • N.J 609 933-2600 • N.M 505 296-0749 • N.Y 516 271-3800, 607 772 2187 • Ohio 216 659-3151 • Tex 214 333 6591 • Wash 206 285 1300 • Canada 514 487-3424, 416 638-5511

# BOURNS

For Immediate Application—Circle 120 For Future Application—Circle 220

# Look at the performance you get with HP's new 20 Hz to 40 MHz Spectrum Analyzer.

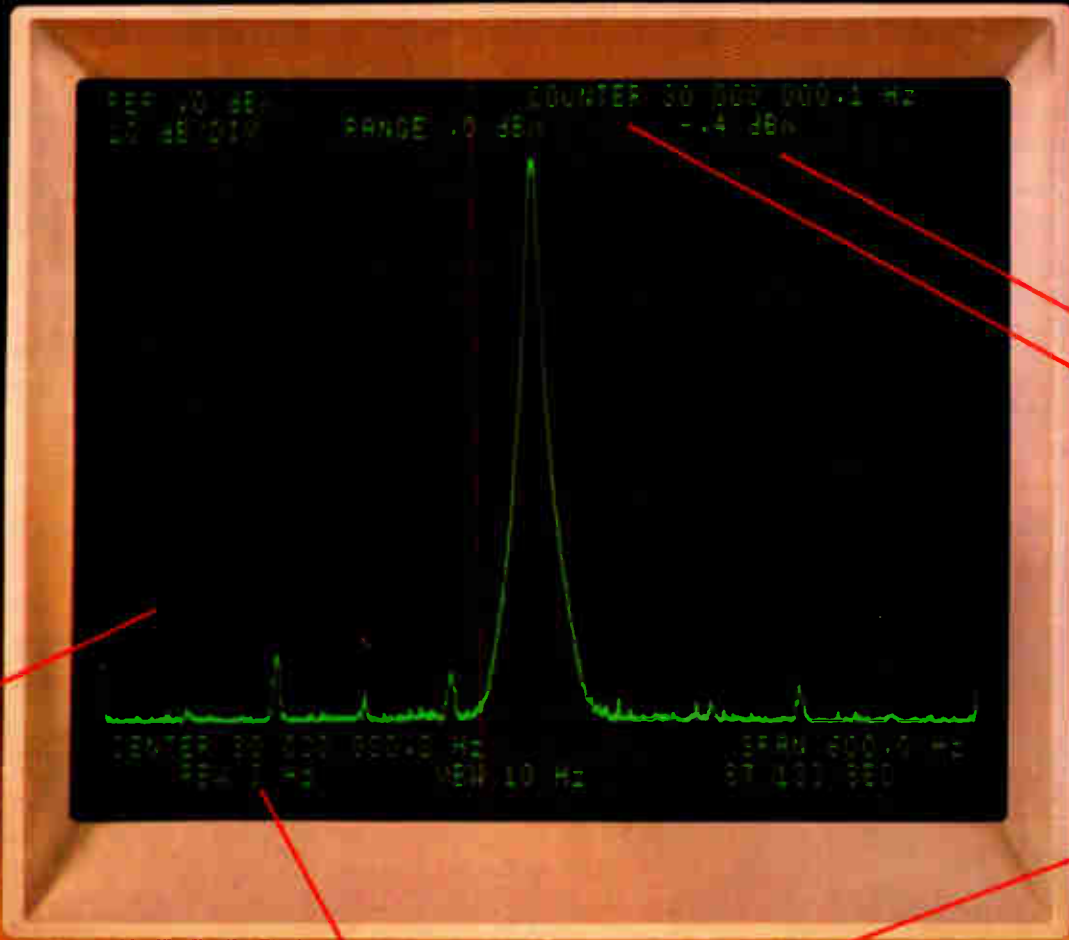

**80 dB dynamic range.** That means 80 dB without noise, spurious signals or distortion products. Total measurement range of -137 dBm to +30 dBm.

**3 Hz resolution bandwidth** lets you resolve 50 Hz and 60 Hz powerline sidebands greater than 80 dB down from a carrier.

**±0.3 Hz frequency accuracy** with 0.1 ppm/mo stability due to a high-performance synthesized local oscillator.

**±0.4 dB absolute amplitude accuracy**—until now only available with a wave analyzer.



HP's new 3585A Spectrum Analyzer delivers all of this capability and more. An internal microprocessor gives you new versatility for spectral measurements, provides accurate answers and saves measurement time.

**Easy-to-use.** With the display marker, you can pick any point on the digitally stored trace and get direct answers without having to count graticule lines, interpolate, or perform calculations. Maximum accuracy is always maintained because of the automatic internal calibration routine. Photo documentation is simple—alphanumeric labeling on the CRT gives you all necessary information to define a spectral sweep.

It's simple to operate too, because control parameters can be easily entered via keyboard and continuously varied with a knob. Autoranging circuitry automatically selects the proper range for you. And bandwidth coupling assures proper resolution and sweep calibration.

Added capability includes internal display marker with direct readout to measure spectral noise density as well as relative frequency and level. Other marker aids simplify display adjustments such as centering a signal and raising it to the reference level.

You can even store two traces and display them either separately or together. Or display the arithmetic difference to simplify comparisons.

**More than programmable.** The 3585A is not only HP-IB\* compatible for easy system integration, but with a desktop computer, it can compute parameters such as total harmonic distortion or log frequency response using measurement data transferred from the analyzer. The computed data can then be sent to the analyzer CRT for convenient display. You can even use the analyzer keyboard to enter data into or call up programs from the desktop computer.

But that's just the beginning. For complete details on the 3585A Spectrum Analyzer, priced at \$17,500\*\*, talk with your local HP field engineer.

\* HP's implementation of IEEE Standard 488-1975.  
\*\* Domestic U.S.A. price only.

098/48A

**HEWLETT  PACKARD**

1507 Page Mill Road, Palo Alto, California 94304

For assistance call: Washington (301) 944-5400, Chicago (312) 255-9600, Atlanta (404) 955-1500, Los Angeles (213) 877-1282

Circle 1 on reader service card

# HP's new concept in DMM's gives you more time to be creative.

Free yourself from time-consuming lab-bench measurements with HP's new 3467A Logging Multimeter.

It is a total measurement station, doing jobs that used to require several instruments. The 3467A combines a 4½-digit DMM, four-channel scanner, digital thermometer, math functions, and printer with timer in a single instrument. It simplifies setups and measurements and gives you a record of data in the units you need (°C, dB, etc.) . . . unattended or manually.

**Identify "hot spots."** The multi-channel 3467A lets you measure temperature changes directly in °C or °F at more than one location. And, with its built-in math functions, printer and timer, you can get a permanent record of temperature changes with respect to time.

**Characterize amplifiers and filters directly in dB.** The 3467A does the work for you. It combines true RMS measurements to 100 kHz, four inputs, and math functions. The 3467A will give you dB response directly; and print auto-

matically at preset time intervals, or manually when you press the "Print" button.

**Analyze temperature dependent parameters.** Use the 3467A's mixed function capability to measure temperature on channels 1 and 2 plus voltage or resistance on the remaining two channels. Then, using the math functions, you can get direct printout of such parameters as amplifier gain vs. temperature.

**Component selection.** Sort resistors to desired tolerance without a precise reference resistor. Simply select the ohms function, enter the reference value as a stored constant and measure your resistors. The 3467A calculates and prints out tolerance values in  $\Delta\%$  directly.

Find out how the new HP 3467A Logging Multimeter, priced at \$2200\*, can make your R&D measurements easier. Your local HP field engineer has all the details. Call today.

\* Domestic U.S.A. price only.

Circle 2 on reader service card

**HEWLETT  PACKARD**

1507 Page Mill Road, Palo Alto, California 94304

For assistance call: Washington (301) 948-6370, Chicago (312) 255-9800, Atlanta (404) 955-1500, Los Angeles (213) 877-1282

09845



## 39 Electronics Review

MEMORIES: New chip replaces standard ultraviolet PROM, 39  
8-K E-PROM also gets a rival, 39  
Zilog previews its pseudostatic RAM, 40  
INDUSTRIAL: GI envisions smart microprocessor-controlled motors, 41  
PROGRAMMING: C language befriends microprocessors, 41  
PACKAGING & PRODUCTION: Mostek piggybacks its E-PROMs, 42  
NEWS BRIEFS: 44  
SOLID STATE: IBM logic adopts new gate arrays, 46  
DISTRIBUTORS: Semiconductor pinch continues to hurt, 48  
IEEE: Suran to balance technical, economic goals, 50  
COMMERCIAL: Five microprocessors raise typewriter's IQ, 50

## 63 Electronics International

GREAT BRITAIN: Multichannel codec uses CCD filters, 67  
FRANCE: Thomson-CSF developing fast optical wafer stepper, 68  
WEST GERMANY: Compander squelches noise better than Dolby, 70  
GREAT BRITAIN: Traffic-information service to start trials, 72

## 81 Probing the News

DATA ENCRYPTION: Cipher-shifters fight it out, 81  
COMPUTERS: IBM 4300 carries a clear message, 85  
COMMENTARY: Testing debate enters new phase, 88  
ABROAD: Scandinavian markets back to normal, 92  
SOFTWARE: Standards issue splits Pascal people, 96

## 105 Technical Articles

SOLID STATE: Decoder mates analog filters with digital logic, 105  
Functional array eases custom ECL design, 113  
DESIGNER'S CASEBOOK: Amplifier phase-adjusts wave generator, 118  
Synchronous counters provide programmable pulse delays, 119  
Counter delivers data in signed or complemented form, 121  
ISSCC: A coming-out party for the important new devices, 122  
Design, process innovations expand memory, logic functions, 123  
Performance barriers fall to unique linear designs, 129  
COMPONENTS: C-MOS-on-sapphire a-d converter beats bipolars, 135  
MEMORY: 64-K dynamic RAM has pin that refreshes, 141  
ENGINEER'S NOTEBOOK: Multiplexer derives six-variable function, 148  
CALCULATOR NOTES: HP-67 finds op amp's gain and CMRR, 149

## 157 New Products

IN THE SPOTLIGHT: LED modules beat space crunch, 157  
PACKAGING & PRODUCTION: System tests while RAM burns (in), 162  
MICROCOMPUTERS & SYSTEMS: Adac offers two Q-bus boards, 170  
SEMICONDUCTORS: Chip implements GPIB interface, 181  
DATA ACQUISITION: I/O boards access memory directly, 190  
COMPONENTS: 52¢ beeper stands only 0.79 in. high, 209

## Departments

Publisher's letter, 4  
Readers' comments, 6  
News update, 8  
People, 14  
Editorial, 24  
Meetings, 26  
Electronics newsletter, 33  
Washington newsletter, 57  
Washington commentary, 58  
International newsletter, 63  
Engineer's newsletter, 152  
Products newsletter, 217  
New literature, 218

## Services

Employment opportunities, 228  
Reprints available, 237  
Reader service card, 239

## Highlights

### Cover: Decoder chip merges analog, digital, 105

Switched-capacitor filters extend metal-oxide-semiconductor technologies into analog signal-processing systems. One result is a decoder that is the first single-chip telecommunications part to combine analog and digital blocks.

Cover photograph is by Art Director Fred Sklenar.

### Chip testing faces greater challenges, 88

As manufacturers of test systems, chip makers, and chip users continue to argue about how to solve the problems of testing large-scale integrated circuits, very large-scale integration is making initial appearances. VLSI calls for the creation of entirely new approaches and increased communication among the three groups involved, says this commentary.

### ISSCC: a hit once again, 122

The International Solid State Circuits Conference continues its role as *the* place to announce major technical advances in semiconductors. Two trends, especially, are growing: putting analog and digital functions on one chip, and using digital techniques for real-time signal processing.

### 64-K RAM refreshes itself, 141

Motorola's 64-kilobit 5-volt-only dynamic random-access memory takes a new route with its use of a single pin to control self-refreshing for both active and idle states.

### And in the next issue . . .

A faster low-power family of Schottky transistor-transistor logic . . . how to design serviceability into microprocessors . . . sewing machines with electronic controls and touch switches.

EDITOR-IN-CHIEF: Kemp Anderson

EXECUTIVE EDITOR: Samuel Weber

MANAGING EDITORS: Arthur Erikson,  
Gerald M. Walker

ASSISTANT MANAGING EDITORS: Howard Wolff,  
Alfred Rosenblatt

SENIOR EDITORS: William F. Arnold,  
Ray Connolly

ART DIRECTOR: Fred Sklenar

#### DEPARTMENT EDITORS

*Aerospace/Military:* Ray Connolly

*Circuit Design:* Vincent Biancomano

*Communications & Microwave:*

Harvey J. Hindin

*Components:* Nicolas Mokhoff

*Computers:* Anthony Durniak

*Consumer and Industrial:* John Javetski

*Instrumentation:* Albert F. Shackil

*Microsystems and Software:* John G. Posa

*New Products:* Michael J. Riezenman,

Richard W. Comerford

*Packaging & Production:* Jerry Lyman

*Solid State:* Raymond P. Capece

CHIEF COPY EDITOR: Margaret Eastman

COPY EDITORS: Mike Robinson,  
Steven Weitzner

ART: Charles D. Ciatto, *Associate Director*  
Paula Piazza, *Assistant Director*

EDITORIAL SECRETARIES: Janet Noto,  
Penny Reitman, Maryann Tusa

EDITORIAL ASSISTANT: Marilyn B. Steinberg

#### REGIONAL EDITORS

*New York:* Ben Mason (212) 997-2245

*Boston:* Pamela Hamilton (617) 262-1160

*Chicago:* Larry Marion (312) 751-3805

*Dallas:* Wesley R. Iversen (214) 742-1747

*Los Angeles:* Larry Waller (213) 487-1160

*Palo Alto:* William F. Arnold

*Robert Brownstein* (415) 968-2712

*Washington:* Ray Connolly (202) 624-7592

*Frankfurt:* John Gosch

*London:* Kevin Smith

*Paris:* Arthur Erikson

*Tokyo:* Charles Cohen

#### McGRAW-HILL WORLD NEWS

*Editor:* Michael Johnson

*Brussels:* James Smith

*Milan:* Andrew Heath

*Moscow:* Peter Hann

*Paris:* Andrew Lloyd

*Stockholm:* Robert Skole

*Tokyo:* Robert E. Lee

PUBLISHER: Dan McMillan

ADVERTISING SALES MANAGER:

Paul W. Reiss

MARKETING ADMINISTRATION MANAGER:

Wallis Clarke

CIRCULATION MANAGER: Karl Peterson

MARKETING SERVICES MANAGER:

Tomlinson Howland

RESEARCH MANAGER: Margery D. Sholes

There was a time when design engineers raised on analog technology had to learn painfully about digital technology. Well, the pendulum has swung, forcing many digital experts to cope with the mysteries of analog design. That is one reason why the team of George Lansberg, Bert White, and Gordon Jacobs of the technical staff for Silicon Systems Inc., Irvine, Calif., is unique.

This group was brought together about a year ago to design the switched-capacitor filter system described in detail on pages 105 through 112. Gordon, 23, did his masters degree research on switched-capacitor filter design at the University of California, Berkeley. There are not too many young engineers today who are knowledgeable on this subject.

Bert, 28, became involved in converter systems while designing with charge-coupled devices at Hughes. He was the systems man on the team. George, 34, brought to the group his experience with metal-oxide-semiconductor and analog integrated circuits, with special emphasis on codecs and converters.

"This is a unique team" George comments. "In fact, this system probably could not have been done by one designer in the time it took."

The group will probably continue to work together on other similar projects. "We still get along with each other after a year," Bert quips.

**Taper-isolated cells . . . H-MOS II . . . analog microprocessor . . . multiprocessed linears.** When words like these begin filling the air, it must be ISSCC time again.

As usual this year's conference is brimming with papers on the latest advances in memories, microprocessors, and linear devices.

The high points of the meeting are reviewed by solid state editor Ray Capece and components editor Nick Mokhoff in the article that starts on page 122. Higher performance is the keynote, according to Ray and Nick. Or, as Ray puts it, "chip manufacturers are not suffering from a shortage of sometimes startlingly innovative designs for boosting memory speed and density."

"Some of the more dedicated LSI circuit designs at ISSCC are quite intriguing, especially those that mix analog circuits with logic in what can only be the start of a trend towards analog-digital LSI," he adds.

As for the linears, Nick points out, "Active filters are this year what the codecs were a year ago, because the design problems that the codecs addressed were only the tip of the iceberg." In essence, interfacing the analog world with today's sophisticated processors has become a major undertaking that has led to the development of a variety of high-performance as well as linear circuits to use with them.

The annual index of *Electronics* articles, a handy compilation that can help you find anything we printed last year, will be available shortly. For a free copy, circle 340 on the reader service card.



February 15, 1979 Volume 52, Number 4 100,066 copies of this issue printed

Published every other Thursday by McGraw-Hill, Inc. Founder: James H. McGraw 1860-1948. Publication office 1221 Avenue of the Americas, N.Y., N.Y. 10020; second class postage paid at New York, N.Y. and additional mailing offices. ID# 172400.

Executive, editorial, circulation and advertising addresses: Electronics, McGraw-Hill Building, 1221 Avenue of the Americas, New York, N.Y. 10020. Telephone (212) 597-1221. Teletype 12-7950 TWX 710-581-4879. Cable address: MCGRAW HILL NEW YORK.

Subscriptions limited to professional persons with active responsibility in electronics technology. No subscriptions accepted without complete identification of subscriber name, title or job function, company or organization, and product manufactured or services performed. Based on information supplied, the publisher reserves the right to reject non-qualified requests. Subscription rates: in the United States and possessions \$17 one year, \$29 two years, \$43 three years; company addressed and company libraries \$23 one year, \$41 two years, \$58 three years; APO/FPO addressed \$35 one year only; Canada and Mexico \$19 one year, \$32 two years, \$47 three years; Europe \$46 one year, \$78 two years, \$110 three years; Japan, Israel and Brazil \$70 one year, \$115 two years, \$185 three years; Australia and New Zealand \$95 one year, \$170 two years, \$240 three years, including air freight; all other countries \$50 one year, \$85 two years, \$125 three years. Limited quota of subscriptions available at higher-than-basic rate for persons allied to field served. Check with publisher for these rates. Single copies: \$4.00. Please allow four to eight weeks for shipment.

Officers of McGraw-Hill Publications Company: Gordon L. Jones, President; Paul F. McPherson, Executive Vice-President; Group Vice-President: Gene W. Simpson; Senior Vice-Presidents: Russell F. Ander-

son; James E. Boddorf, Planning & Development; Ralph R. Schultz, Editorial; Vice-Presidents: James E. Hackett, Controller; Thomas H. King, Manufacturing; Robert L. Leyburn, Circulation; John W. Patten, Sales; Edward E. Schirmer, International.

Officers of the Corporation: Harold W. McGraw, Jr., President, Chief Executive Officer, and Chairman of the Board; Robert N. Landes, Senior Vice President and Secretary; Ralph J. Webb, Treasurer.

Title registered in U.S. Patent Office; Copyright© 1979 by McGraw-Hill, Inc. All rights reserved. The contents of this publication may not be reproduced in whole or in part without the consent of copyright owner.

Where necessary, permission is granted by the copyright owner for libraries and others registered with the Copyright Clearance Center (CCC) to photocopy any article herein for the base fee of \$0.50 per copy of the article plus \$0.25 per page. Payment should be sent directly to the CCC. Copying done for other than personal or internal reference use without the express permission of McGraw-Hill is prohibited. Requests for special permission or bulk orders should be addressed to the publisher. ISSN 0013-5070/79\$0.50+.25

Subscribers: The publisher, upon written request to our New York office from any subscriber, agrees to refund that part of the subscription price applying to copies not yet mailed. Please send change-of-address notices or complaints to Fulfillment Manager; subscription orders to Circulation Manager, Electronics, at address below. Change-of-address notices should provide old as well as new address, including postal zip code number, if possible, attach address label from recent issue. Allow one month for change to become effective.

Postmaster: Please send form 3579 to Fulfillment Manager, Electronics, P. O. Box 430, Hightstown, N.J. 08520.

# DC-DC converters

from **KEPCO/TDK**

convert 12V, 24V, 48V, 130V or 260V input  
to 5V-28V d-c outputs, 30-100 watts

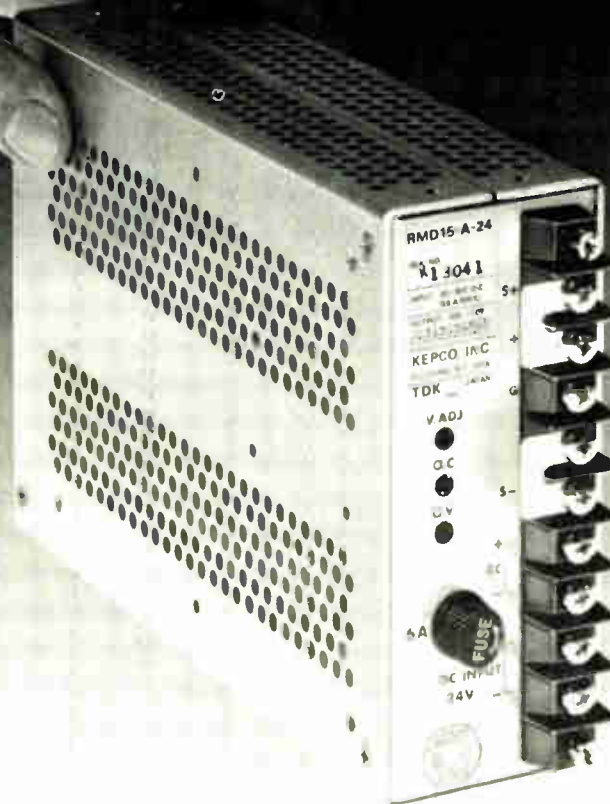

so small and light—  
they'll fit your product

- High frequency conversion for high efficiency
- Fully isolated
- Current limited
- Adjustable output
- Built-in overvoltage protection

**KEPCO**®

For complete specifications write Dept. BUF-14.

KEPCO, INC. • 131-38 SANFORD AVENUE • FLUSHING, N.Y. 11352 • (212) 461-7000 • TWX #710-582-2631 • Cable: KEPCOPOWER NEWYORK

Circle 5 on reader service card

# SIGNAL GENERATOR AMPLIFIER

Our Model 603L is the ultimate in RF signal generator amplifiers. Just plug this low cost unit into any signal or sweep generator in its 0.8 to 1000 MHz range and this completely solid state unit will provide you with the maximum in power flexibility.



With a flat frequency response and 3 watts of linear Class A output (up to 5 watts saturated), the 603L will provide constant forward power, making it ideal for driving reactive or resistive loads.

Priced at \$1895\*, the versatility and usefulness of this outstanding power amplifier can best be demonstrated in your own applications.

For detailed specifications or a demonstration, please contact:

ENI  
3000 Winton Road South  
Rochester, New York 14623  
Call: 716-473-6900 or  
Telex: 97-8283 ENI ROC

\* U.S.A.

## ENI

The World's Leader  
in Power Amplifiers

## Readers' comments

### Missing

**To the Editor:** Your special report, "New networks tie down distributed processing concepts" [Dec. 7, p. 107], states: "In the United States the only public packet-switched network currently running is offered by Telenet Communications Corp."

Not only is there another public packet network, but it is older, larger, and financially more successful than Telenet. I'm referring to Tymnet, which is operated as a common carrier regulated by the Federal Communications Commission.

The Tymnet network has been fully operational since 1971, though it only began operations as a common carrier on April 1, 1977.

Ronald A. Bamberg  
Tymnet Inc.  
Cupertino, Calif.

### Explaining the condition

**To the Editor:** I would like to correct a misstatement and eliminate possible confusion concerning the dc response capability of HP's fiber-optic links ["What designers should know about off-the-shelf fiber-optic links," Dec. 21, p. 89]. Operated normally in the internally coded mode, our link provides true dc response and thus has no restrictions on the data format whatsoever.

We do provide an option at the transmitter to disable our three-level optical internally coded mode (which gives us our dc response) so that our transmitter can be used with other fiber-optic receivers or for testing. With the transmitter in this mode, our receiver requires a 50% duty-cycle signal and a symbol rate above 2 megabauds. This is totally unrelated to the user's desire to encode clock and data together or the use of Manchester coding as claimed.

Lee Rhodes  
Optoelectronics Division  
Hewlett-Packard Co.  
Palo Alto, Calif.

### Correction

In "Hot time for ICs" (Jan. 18, p. 81), the figure shows the results of tests by General Electric Co.'s Electronics Laboratory, Syracuse, N. Y.

# CABLE TESTING

## THE WAY IT SHOULD BE

Tests 1 to 50 conductors or more with continuous readout. Locates shorts, opens, reversals, continuity, ground shorts, shield shorts and intermittent connections instantly.

Adapters available for any connector.

### D-TECTOR™ 1200

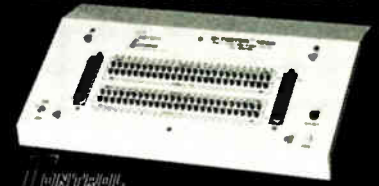

Electronics Company, Inc. ... cost savers in electronics

11035 Harry Hines Blvd, Suite 212  
Dallas, Texas 75229  
(214) 350-6714 or 350-6829

Circle 229 on reader service card

## NEW & DAZZLING!!!

### MS-15 Miniscope



With Rechargeable Batteries & Charger Unit **\$318**

- 15-megahertz bandwidth.
- External & internal trigger.
- Auto or line sync modes.
- Power usage — < 15 W.
- Battery or line operation.
- 2.9" H x 6.4" W x 8.0" D.



**Non-Linear Systems, Inc.**

Originator of the digital voltmeter.  
Box N, Del Mar, California 92014  
Telephone (714) 755-1134 TWX 910-322-1132

Circle 230 on reader service card



# ALL THE PARTS YOU NEED FOR A 4½ DIGIT CASCADABLE COUNTER/DECODER/DRIVER:

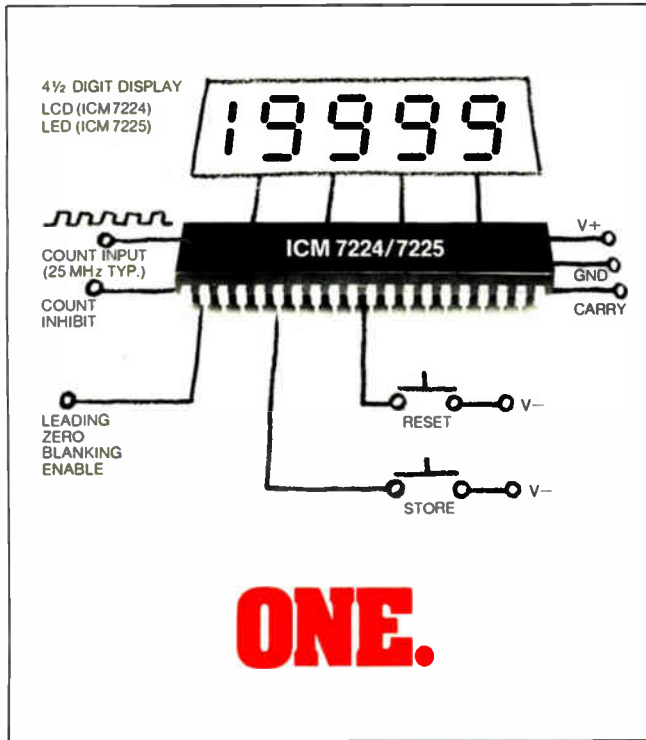

## LCD or LED. One chip.

The ICM7224 (LCD) and ICM7225 (LED) counters offer 19999 maximum count, or 15959 maximum count in version "A" (timer). In both versions, the display is not multiplexed and, RF interference is eliminated. Bright digits are assured (with a guaranteed minimum of 5mA per segment on the ICM7225 LED version).

## High frequency. Low frequency.

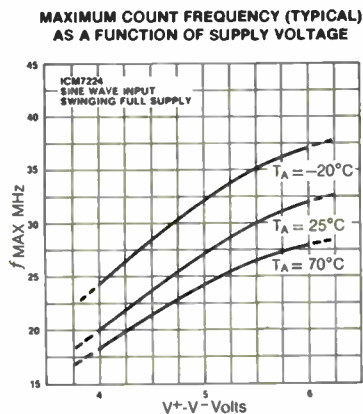

The ICM7224 offers high frequency counting, (15MHz guaranteed; 25MHz typical at 5V). For those applications that require low frequency counting, down to DC, a Schmitt trigger on the count input allows accurate operation in noisy environments or with slowly changing inputs.

## Low power.

Current requirements of the ICM7224 are 10µA up to 1KHz and 1mA at 10MHz with a 5V supply. That means less than 10mW power consumption when counting from DC to 15MHz... terrific for long battery life operation.

## Cascadable.

Cascade in four-digit blocks. The ICM7224/7225 family of counter/decoder/drivers provides a carry output which allows cascading to 8, 12 or 16 digits. Leading zero blanking control pins provide correct blanking on cascaded devices.

## MAXCMOS:® More for less.

Greater reliability. Lower component count. Super performance. Less design and manufacturing cost. At prices like these:

	ORDER PART NUMBER	COUNT OPTION	1-24	25-99	100-999
LCD DISPLAY	ICM7224IPL	19999	\$9.80	\$8.40	\$7.00
LED DISPLAY	ICM7225AIPL	15959	\$8.90	\$6.35	\$5.30

## Available now.

Call your Intersil Sales Office or Franchised Distributor for full information. Or, return the coupon below for complete product information on all the parts you'll need for a 4½-digit cascadable LCD/LED counter/decoder/driver: One.

\*MAXCMOS is a registered trademark of Intersil, Inc.

**INTERISL SALES OFFICES:** CALIFORNIA: Sunnyvale (408) 744-0618, Long Beach (213) 436-9261 • COLORADO: Aurora (303) 750-7004 • FLORIDA: Fort Lauderdale (305) 772-4122 • ILLINOIS: Hinsdale (312) 986-5303 • MASSACHUSETTS: Lexington (617) 861-6220 • MINNESOTA: Minneapolis (612) 925-1844 • NEW JERSEY: Englewood Cliffs (201) 567-5585 • OHIO: Dayton (513) 866-7328 • TEXAS: Dallas (214) 387-0539 • CANADA: Brampton, Ontario (416) 457-1014

**INTERISL FRANCHISED DISTRIBUTORS:** Advent/Indiana • Alliance Electronics • Arrow Electronics • Bell Industries/Century Electronic Division • CESCO • Component Specialties Inc. • Components Plus • Diplomat Electronics Inc., (FLA) • Diplomat Electronics Inc., (NJ) • Elmar Electronics • Harvey Federal Electronics • Intermark Electronics • Kierulff Electronics • LCOMP • Liberty Electronics • R.A.E. Ind. Elect. Ltd. • RESCO/Raleigh • Schweber Electronics • Sheridan Associates • Summit Distributors Inc. • Zentronics Ltd.

# INTERISL

Analog Products—Low Power  
10710 No. Tantau Ave., Cupertino, CA 95014  
Tel: (408) 996-5000 TWX: 910-338-0171  
(800) 538-7930 (Outside California)



One?  
Send me the details on:  ICM7224 (LCD) counter.  
 ICM7224A (LCD) timer.  ICM7225 (LED) counter.  
 ICM7225A (LED) timer.  Send me your Mark Twain Poster.

Name \_\_\_\_\_

Company \_\_\_\_\_

Address \_\_\_\_\_

City \_\_\_\_\_ State \_\_\_\_\_ Zip \_\_\_\_\_

**New possibilities for  
your Printed Circuit  
Board**

## WIMA Miniature Capacitors

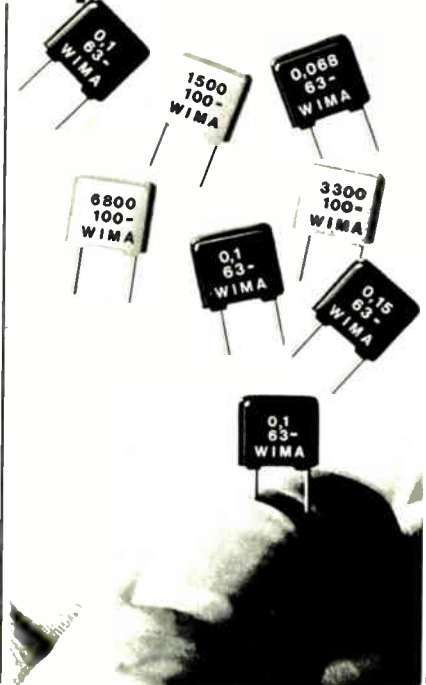

### WIMA MKS 2 with a PCM of 5 mm

The new miniatures from WIMA help you to save space on your Printed Circuit Boards and can be utilised everywhere. They are the smallest plastic cased, metallised polyester Capacitors available.

Capacitance values 0.01 — 0.47  $\mu$ F  
(1  $\mu$ F with 7.5 mm PCM.)

WIMA FKS 2 from 1000 pF.

All capacitors are resistant to moisture.

Please ask for  
our special  
catalogue.



## WILH. WESTERMANN

Spezialvertrieb elektron. Bauelemente  
P. O. Box 2345 · D-6800 Mannheim 1  
Fed. Rep. of Germany

U.S. Sales Offices:  
BOSL & ROUNDY · 3333, Delray Drive  
Ft. Wayne · Indiana 46815  
(219) 483-3378

THE INTER-TECHNICAL GROUP INC.  
North Dearman Street · P. O. Box 23  
Irvington · New York 10533  
(914) 591-8822

TAW ELECTRONICS CO.  
4215 W. Burbank Blvd., Burbank  
California 91505 · (213) 846-3911

8 Circle 8 on reader service card

## News update

■ The makers of minicomputer systems that are plug-compatible with the machines making up IBM's System/370 may be headed for the edge of a cliff now that the giant has brought out its 4300 series [*Electronics*, Sept. 14, 1978, p. 88, and this issue, p. 85], but their attitudes and sales to date indicate otherwise.

For example, Two Pi Co., the Santa Clara, Calif., affiliate of Philips Industries of the Netherlands that started the trend, also leads the pack in deliveries—15 so far. Most have gone to National CSS Corp., Wilton, Conn., says Two Pi president Jared Anderson. During 1979, Two Pi will concentrate on furnishing large volumes of small integrated controllers that will allow users to tie their systems to minicomputer peripherals, he adds.

At National Semiconductor Corp., also in Santa Clara, the System 400 marketing group is "on a high" because of interest in the machine, says Ed McCurtain, manager of System 400 marketing. Despite industry reports of problems, "we've got one delivered so far that is still in [customer's] beta test, and we expect to begin production shipments by mid-February," he says. The focus has been on original-equipment manufacturers.

As for Cambridge Memories Inc. in Waltham, Mass., the first of its CM 1600 series went to National CSS last month. Kent E. Crombie, director of computer systems marketing, says, "The order rate is good and we have a substantial backlog." Peak production is set for April.

Another plug-compatible-system maker, Magnuson Systems Inc., delivered its first M80 series to Boston-based Mitrol, a systems house that offers manufacturing-information-management system software. "It all went well and they paid cash six days later," says L. James Beckman, Magnuson's vice president of marketing. A few more systems are in customers' beta testing, Beckman says; and the Santa Clara company has agreed to supply at least 10 systems to Scientific Time Sharing of Bethesda, Md.

**Robert Brownstein**

# We've got a Gaussmeter



## for your application!

F. W. Bell, the world's leading manufacturer of gaussmeters, has 28 different standard models, and 110 different standard probes. Practically all magnetic measurement requirements are covered by this broad line of precision Hall-effect instruments.

Bell Gaussmeters provide four magnetic field measurement modes . . . direct measurement of the absolute field density, differential measurement of the absolute field density, differential measurement of the difference in field density at two probe locations, incremental field measurements using an expanded scale, and summation measurements. Accuracies range from  $\pm 0.2\%$  FS to  $\pm 4.0\%$  FS. Dynamic ranges are from 0.1 Gauss FS (10<sup>5</sup> tesla) to 100,000 Gauss FS (10 tesla). **If magnetics is your field . . . it will pay you to learn more about F. W. Bell Gaussmeters.**

**Fw BELL INC.**  
A Subsidiary of  
The Arnold Engineering Company  
4949 Freeway Drive East  
Columbus, Ohio 43229  
Phone (614) 886-7501  
Twx. 810-337-2851

Circle 231 on reader service card



# Presents the NEW digital 11/03-L Systems



FLOPPY 11V03-L



VT100



HARD DISK 11T03-L

Standard 11/03-L systems are available as 1 Megabyte Double Density Floppy Disk based or

10 Megabyte Hard Disk Cartridge based RT-11® systems.

These systems are available with choice of LA36, VT52 or VT100 as consoles.

Order Number	11V03-L		11T03-L	
	SRVXSSA	SRVXSSB	SRVXLLA	SRVXLLB
Backplane	KD11-H CPU	KD11-HA CPU	KD11-H CPU	KD11-HA CPU
	MSV11-CD, 16KW Memory	MSV11-DD 32KW Memory	MSV11-CD 16 KW Memory	MSV11-DD 32KW Memory
	Floppy Interface	Floppy Interface	MSV11-CD 16KW Memory	RL01 Controller
	DLV11-F Serial	DLV11-J Serial (4)	RL01 Controller	RL01 Controller
	BDV11 Bootstrap	BDV11 Bootstrap	RL01 Controller	DLV11-J Serial (4)
	Open	Open	DLV11-F Serial	BDV11 Bootstrap
	Open	Open	BDV11 Bootstrap	Open
	Open	Open	Open	Open
Price	\$9,475.00	\$10,325.00	\$16,265.00	\$17,075.00
Delivery	30 Days	60-90 Days	30 Days	60-90 Days
Installation And 90 Day On-site Warranty	Included	Included	Included	Included
Operating System	By Digital Equipment Corporation RT-11* V3B Plus Enhancements			
MOS Memory	16KW	32KW	32KW	32KW
Mass Media Storage	Dual RX02 Double Density Floppy	Dual RX02 Double Density Floppy	Dual RL01 5 Megabyte Cartridge Disk	



TWX NUMBER 910-651-1916

**computer corporation**

corporate square/825 north cass avenue/westmont, illinois 60559/(312) 920-1050

\* Registered trademark of Digital Equipment Corporation, Maynard, Mass

\*\* Registered trademark of First Computer Corporation

# "With microprocessors why take chances on

We keep hearing that microprocessors are all things to all people. Yet, at AMI, orders for custom-designed circuits continue to grow. And, when you take a realistic look at standard microcomputer systems versus made-to-order circuits, it isn't hard to see why.

First, consider capabilities. While it's true that many products using custom circuits could be controlled by microprocessor systems, there are some that clearly couldn't.

For instance, we just produced a custom MPU for a commercial avionics system. It required a series of interrupts that the architecture of a standard microprocessor wouldn't provide. Special display drives, A/D conversion on inputs and specialized high-speed calculations are other areas where off-the-shelf products are clearly out-classed in this application.

Second, look at the real costs of both systems. On the one hand, custom assures the minimum number of circuits. And, although there is some start-up expense, this is easily amortized over the life of the product. On the other hand, standard microcomputer configurations usually require a number of components, taking up more board space, assembly effort and testing time. These costs can run you at least 50% of each part's price. So a multi-circuit microprocessor system often represents as much in indirect costs as in the price of the circuits themselves. These factors alone can make a standard system less cost-effective than a custom job. And that doesn't even include the time and expense involved in programming. You can spend as long getting your software written as we would building the custom hardware.

**Standard and custom should be partners, not competitors.**

In many cases, a 'mixed solution' works

*Is custom expensive? The chart shows that it can actually be more cost-effective than standard devices as the unit volume approaches 30,000 and when assembly, programming and test are taken into consideration.*

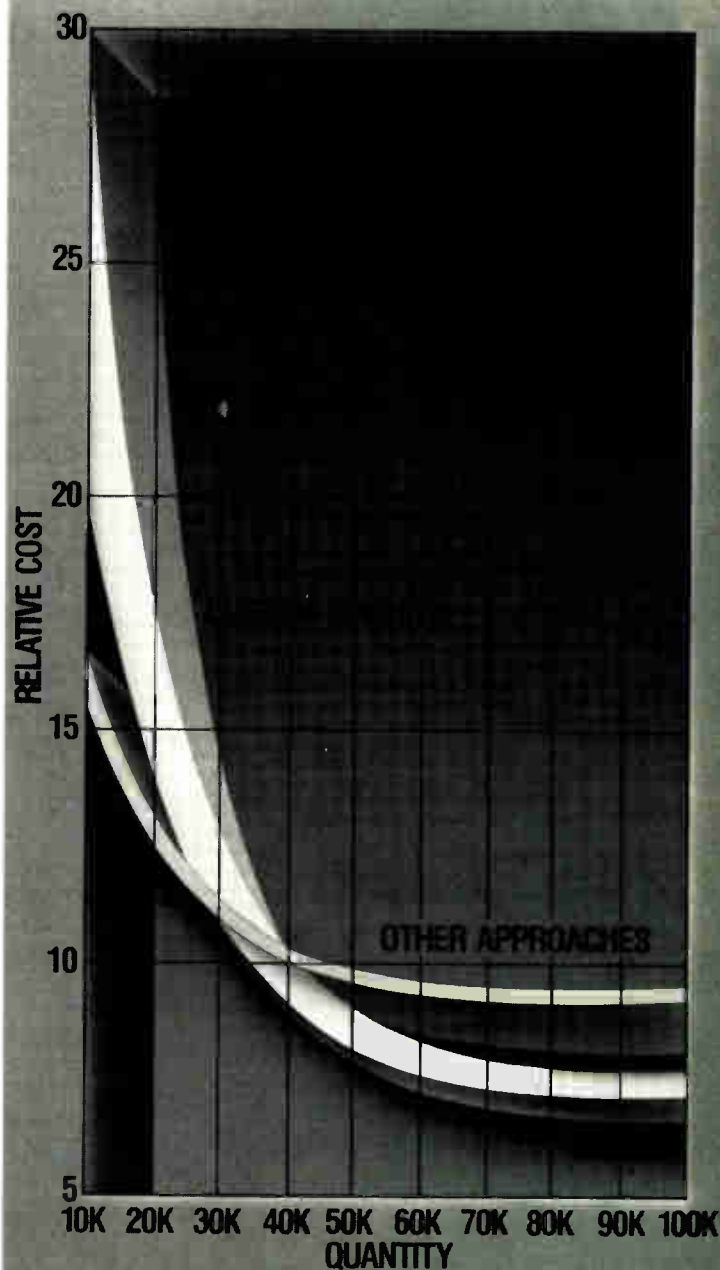

# rs a dime a dozen, custom LSI?"

best—a combination of standard microprocessor and custom peripherals. For instance, we designed a special circuit for a consumer entertainment company to expand the I/O capabilities of a standard 8048 MPU. And for a manufacturer of business equipment, we're working on plans to customize an S2400 (our 4-bit microcomputer) to provide ROM and RAM variations, adding a custom interface chip and clock. To help them get the product to market while we're developing this more cost-effective solution, we're providing them with our standard S6802 8-bit microprocessor.

An advanced home computer provides another example of standard and custom compatibility. A Z-80 microprocessor is supported by three AMI custom circuits—address, I/O and data chips. This trio contains the equivalent of 600 standard SSI and MSI integrated circuits. And, having a fast MPU to work with, our circuits were designed to run at seven MHz. Most important, they perform the intricate graphics functions, lowering the cost to the point where the computer does more for the money than competitive products.

It's apparent that microprocessors, far from shrinking the need for custom, have actually opened up vast new areas of application. In fact, you now have three ways to go—full custom, standard microprocessor or a mixture of both. Since we're the leading custom LSI company and a major supplier of microprocessors (the 4-bit S2000, 8-bit 6800 and 16-bit 9900) and memories, we're in the best position to supply your complete microprocessor system needs.

### Want to know more? It's in the book.

Titled "Six Steps to Success with Custom LSI," our new brochure should answer many of your questions. Such topics as timing, options, processes, test and manufacturing are thoroughly covered, along with a variety of case histories.

It also explains the flexibility that AMI offers. Since we work in 25 variations of four MOS

processes, we don't have to reduce your product's capabilities to fit design or production limitations.

Unlike smaller companies, we're also organized to work with you in any of three different ways. We'll design and produce your circuit from scratch. Or you can handle the design in-house or through a third party, then we'll manufacture it. Or we can arrange a joint venture, where a team from your company and a team from ours work together to create a succession of new products.

Whichever way you decide to go, you'll have the satisfaction of working with the company

that wrote the book on custom MOS. Since 1966, we've created more than 1200 different circuits. We're continually finding new ways to get more onto a chip (up to 67,000 transistors at last count) in less time. As a result, we average seven months from firm specifications to fully tested circuits—the fastest turnaround in the industry.

Why don't you explore all these opportunities with us? To start with, ask for a copy of our book. Write or call AMI Custom

III Marketing, 3800 Homestead Road, Santa Clara CA 95051. Phone (408) 246-0330. Or contact one of these AMI sales offices: California, (213) 595-4768; Florida, (305) 830-8889; Illinois, (312) 437-6496; Indiana, (317) 478-9339; New York, (914) 352-5333; Pennsylvania, (215) 643-0217; Texas, (214) 231-5721; Washington, (206) 687-3101.

And, if you'd like your questions answered in person, we'll make a half-hour presentation right in your office. We think it will help convince you that getting into custom isn't chancey at all.

**AMI**  
AMERICAN MICROSYSTEMS, INC.

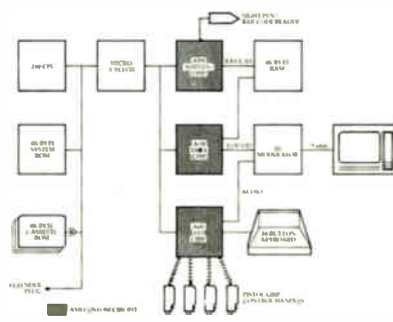

*A triple option: this home computer uses a standard microprocessor, three AMI custom peripherals, plus standard ROMs and RAMs to achieve more performance for the money than any competitive system.*



# HAVE IT

Chances are you're already familiar with Teradyne's L529. This in-circuit test system is well-known as a reliable, economical way to expand board-test capacity.

Now take a good look at the new L527, an equally productive in-circuit tester.

The difference is that the L529 comes with our innovative Pressure Rod Handler, and the L527 is designed to interface with whatever fixturing system you're using now.

## **How our innovative thinking boosts your productivity.**

The L529 and L527 excel at prescreening the faults that occur most frequently: errors in manufacturing and workmanship. Both systems quickly detect a high percentage of such faults as shorts, opens, and missing, backward, or wrong-value components.

Our superior test electronics and diagnostic capabilities

make these systems highly cost-effective ways to test analog, digital, and hybrid boards.

## **Our systems save you time and money.**

Both our systems contain pre-planned test routines and the capacity to self-learn test limits from good boards.

A junior technician can program a board in hours, freeing your engineers for more productive work.

What's more, both the L529 and the new L527 deliver clear, concise error messages in your own product language. Non-technical repair people



**Teradyne's  
L529 Assembly  
Inspection System**

# YOUR WAY.

can pinpoint faults quickly and easily.

## **More ways we save you time and money.**

The L529 with its Pressure Rod Handler solves a lot of problems. It eliminates vacuums and precision tooling while giving you positive, dependable contact. You'll find our Pressure Rod Handler an elegant solution to a difficult problem.

And here's another advantage. With Teradyne's Fixturing Kit you can build your own bed-of-nails fixtures in-house and in just a few days. When ECO's pop up you can handle them immediately, and that means less downtime and more productivity.

## **The New L527 is a significant opportunity.**

We realize that some of you are satisfied with your current fixturing system. To you we offer the new L527. It adapts easily to the handler you're using now, giving you increased board-test capacity without requiring any additional investment or start-up effort.

## **Teradyne means productivity and reliability.**

The L529 and new L527 are obviously productive, but be assured they're reliable, too. All Teradyne systems are built for hard use and backed up by the best support program in the business.

It's time you learned more. For full information write Teradyne, 183 Essex Street, Boston, Mass., 02111. Or call (617) 482-2700.

# TERADYNE

Circle 13 on reader service card



**Teradyne's  
L527 Assembly  
Inspector**



## NEW TEXTOOL ECONO ZIP PRODUCTION SOCKETS

**New TEXTOOL inexpensive ECONO ZIP socket series features easy, safe zero insertion and extraction pressure for "end-user" production requirements.**

TEXTOOL's new low cost ECONO ZIP series of production sockets are especially designed for those applications where initial loading and field replacement of expensive IC's are a necessity and socketry is an absolute requirement.

ECONO ZIP sockets are available in 16, 24 and 40 pin models. They are designed for mounting on standard .100" centers on either axis.

The ECONO ZIP socket is designed for the most simple mechanical action. A device can literally be dropped into the socket. Rotation of the cam to a built-in stop firmly retains the device with exceptionally good electrical contact. Counter rotation of the cam releases the device, thus providing zero pressure during both insertion and extraction.

These economical (U.L. approved plastic) production sockets offer additional device protection features including wide entry holes to accept bent or distorted leads that don't have to be reformed prior to insertion, a screw driver operated plastic cam for easy operation and prevention of accidental unloading, and extremely long life (hundreds of actuations).

**Detailed technical information on new low cost ECONO ZIP production sockets is available from your nearest TEXTOOL sales representative or the factory direct.**



**PRODUCTS, INC.**

1410 W. Pioneer Drive • Irving, Texas 75061  
214/259-2676

## People

### IEEE's Herz to balance demands of members

As Eric Herz talks about his new job—general manager of the Institute of Electrical and Electronics Engineers—his listener envisions a juggler earnestly working to keep a clutch of tenpins aloft. For he talks about the challenge he faces as the IEEE's top administrator in terms of balancing demands, and he chooses his words carefully in discussing those demands.

Roughly half of the institute's 300-odd employees are in editing and publishing activities, with the rest ranging across a spectrum from Washington lobbying to standards setting. Add to this the numerous volunteers and the rest of the 191,000 members, and the sum is many, and sometimes conflicting, voices to which Herz must attend. So he speaks cautiously in outlining his responses to what he hears.

Herz, 51, took over his position on Jan. 1, moving to the IEEE's New York City headquarters from San Diego, where he was a senior project engineer for the Convair division of General Dynamics Corp. Long active in the institute's affairs, he knew what he was plunging into.

A key task, he says, is to make the staff more responsive to members' needs. "I lead myself to believe I have some warm feeling for what people are looking for in the institute," he claims, pointing to his 20 years of volunteer work in section and region operations and in the IEEE's technical activities, where he capped his service by becoming the 1978 vice president for technical activities.

Herz will not directly criticize the mode of operations he inherited, but ideas for its improvement pervade his conversation. "If I can translate the [membership's] needs accurately, I think the staff will do a good job in responding," he summarizes.

**Differing interests.** Herz is circumspect when asked about the IEEE's socioeconomic activities. "We are not a society of common interests, but one of a diversity of inter-



**Turning pro.** Long-time volunteer Eric Herz takes over as IEEE general manager.

ests," he observes. The members are working engineers, managers, entrepreneurs, government employees, teachers, and students, "and we need all for a good organization."

Still, he sees a board of directors' mandate for a broad spectrum of activities, including some socioeconomic activities. "The challenge is how to balance demands for more services with the institute's income," he says.

### Linear designers pursuing higher speeds, says PMI's Erdi

Where speed and power are of paramount importance, scaling down geometries will not be as simple for future analog chips as for digital ones. Designers will be constrained by larger voltages that limit shrinkage, as well as by the need to preserve or even improve accuracy. That is what George Erdi sees in his crystal ball.

Erdi, 40, a veteran analog designer at Precision Monolithics Inc., has just been named staff vice president for design. The prize for being first with quality high-speed devices will be a larger share of the linear business, which Erdi says continues to grow faster than the overall market.

"There's plenty of room for improvement in monolithic a-d [analog-to-digital] converters," he says. "We've barely scratched the surface." Higher speeds, greater accuracy, and wider temperature com-



# Signetics is 1st, 2nd, 3rd and 4th in DAC systems.

**For true  $\mu$ P-compatibility in DACs, nobody gives you more options than we do.**

We brought you the industry's first monolithic DAC system. Our microprocessor-compatible 5018.

Now we've increased your options with three more 8-bit converters in this single-chip series.

Like the 5018, each has key peripheral functions on-chip. That includes input latches, voltage reference and output amplifier.

Super performance from four superior DACs. At prices you'd pay for no-option DACs.

You choose the output: voltage or current. You select the speed. And you pick the accuracy you need, too.

We've also made these complex parts easy to use in a couple of ways:

First, we've got com-



plete applications support data. And whenever you need them, our field applications engineers are ready to help you implement the DAC-to- $\mu$ P interface.

Now you can shift to the premium DAC best for your design: 5018, 5019, 5118, or 5119. Without any premium in cost.

Meet the whole 5018 family at your local Signetics sales office or franchised distributor.

Or send us the coupon to learn how our selectable DACs can save you plenty.

**signetics**

a subsidiary of U.S. Philips Corporation

Signetics Corporation  
P.O. Box 9052  
811 East Arques Avenue  
Sunnyvale, California 94086  
Telephone 408/739-7700

To: Signetics Information Services, 811 East Arques Avenue  
P.O. Box 9052, MS 27, Sunnyvale, CA 94086

Yes! Gear me in on the 5018 DAC family.

My need is urgent. Please have a D/A conversion specialist  
phone me immediately at: (     )     X     \_\_\_\_\_

Name \_\_\_\_\_ Title \_\_\_\_\_

Company \_\_\_\_\_ Division \_\_\_\_\_

Address \_\_\_\_\_ MS \_\_\_\_\_

City \_\_\_\_\_ State \_\_\_\_\_ Zip \_\_\_\_\_

E215

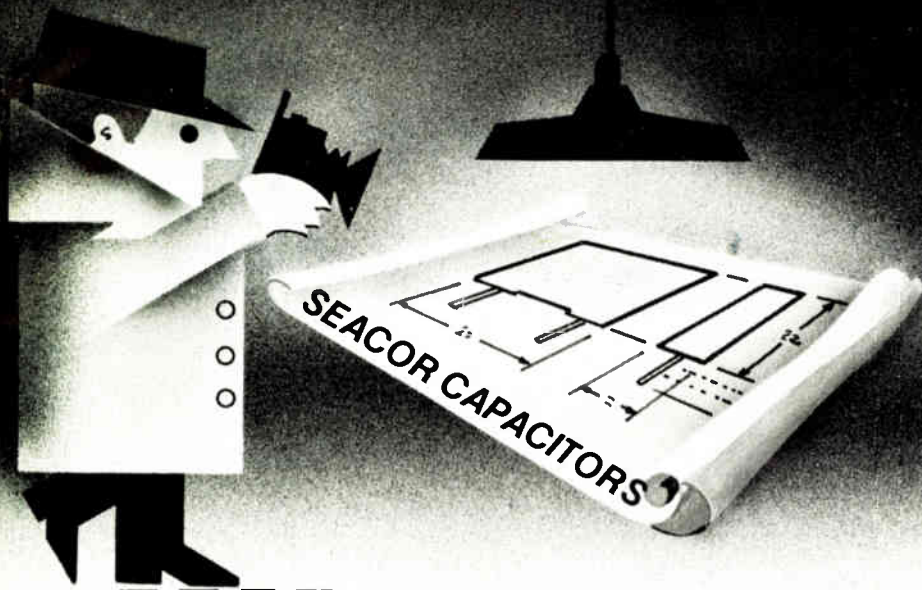

# SECRET INGREDIENT

Actually we have really got a secret ingredient: Seacor. We can't tell you about all of the wonderful things our film capacitors do that their film capacitors can't do. There isn't, you see, much one can do to a film capacitor that has any really important effect on function. One can use the best materials. We do. One can manufacture carefully and be extremely fussy in QC. We do and we are. Care can be taken to be certain that every unit of a type is exactly like every unit of that type. Such care is taken.

And, even if brands X, Y and Z aren't so meticulously made, it is hard for you to be sure of that. The bottom line, therefore, is that our prices and deliveries have to be at least as good and when possible better.

When you come to buy film capacitors, we hope you will consider Seacor. Our catalog is yours, free, on request.

Boom Ba Boom Boom.

**SEACOR INC.,** 123 Woodland Ave., Westwood, N.J. 07675  
Tel. (201) 666-5600 ■ Telex 135354

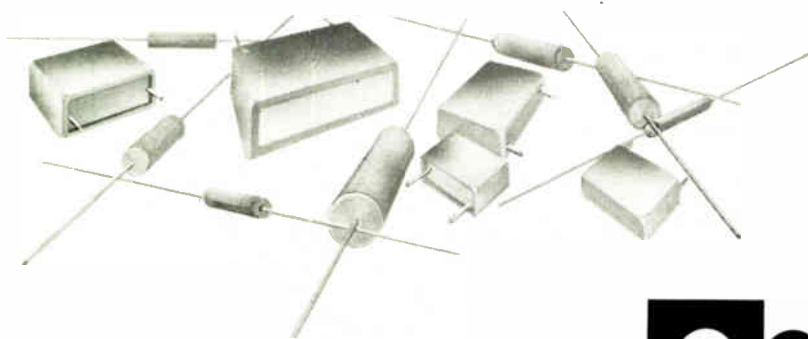

Everything in Film Capacitors



Circle 16 on reader service card



**Limited.** Too many technologies may spread a company too thin, says Erdi.

pensation are just some of the parameters to be improved, he continues. Higher slew rates for operational amplifiers and more precise control of on-resistance in bipolar analog switches will also be designer targets, he predicts.

However, Erdi sees a danger in designing with multiple technologies to achieve particular parameters. It is unlikely that any designer will be expert in several technologies, so several designers may work on the design. The end result of this "design-by-committee" may be "spoiled-broth-on-silicon," Erdi says.

Hungarian-born, Erdi came to Canada after the 1956 revolution and earned his BSEE in 1965 at McGill University in Montreal. He got an MSEE at the University of California at Berkeley the following year and joined Fairchild Camera and Instrument Corp.'s Palo Alto, Calif., research and development laboratory. There he designed the UA 722 digital-to-analog converter and the UA 725 monolithic precision operational amplifier.

Since moving to PMI in May 1969, Erdi has had a hand in designing some 17 products that account for more than half of the Santa Clara, Calif., company's \$15 million in annual revenue. He's glad, he says, that, despite his promotion, he can still keep doing what he loves best—designing linear circuits. □

# Still the world's smallest RF relay ...and the stingiest



When we first told you about the inherently low inter-contact capacitance and low contact circuit losses of our TO-5 relays, you agreed that they were ideal for RF switching. And you began designing them in immediately. They provided high isolation and low I.L. up through UHF (typical performance 45 db isolation and 0.1 db I.L. at 100 MHz).

Then you discovered another benefit — particularly for hand-held transceivers where battery drain is critical. The TO-5 is very stingy on coil power; the sensitive versions draw only 210mV at rated voltage.

So if you're looking for a subminiature RF switch, don't settle for anything less than TO-5 technology. It's available in commercial/industrial as well as MIL qualified types. Write or call us today for full technical information.



**TELEDYNE RELAYS**

12525 Daphne Avenue, Hawthorne, California 90250 • (213) 777-0077



**“Pin hoods...bolts...jackscrews—  
just show me a way to  
reduce connector hardware  
costs without cutting down  
the reliability as well.”**

# O.K. Here it is.

When you switch to the AMP Metrimate Connector line be ready to save as much as \$3.50 per connector. In your product and assembly costs. And in your inventory costs. Because Metrimate gets rid of separate pin hoods, mounting hardware and connecting parts. It molds all of them into a housing designed to true metric dimensions.

Are they reliable? They meet all general requirements of national and international testing and approval groups ranging from UL and CSA to IEC and VDE. And AMP technical service helps make sure things stay that way. They are flexible, too. In fact, you can mix both pins and sockets in the same housing. And choose from a variety of contact types for standard wire, coax cable, or even fiber optics.

Look into the savings. Call the AMP Metrimate Information Desk at (717) 564-0100, Ext. 8400. Or write AMP Incorporated, Harrisburg, PA 17105.

AMP is a trademark of AMP Incorporated

**AMP has a better way.**

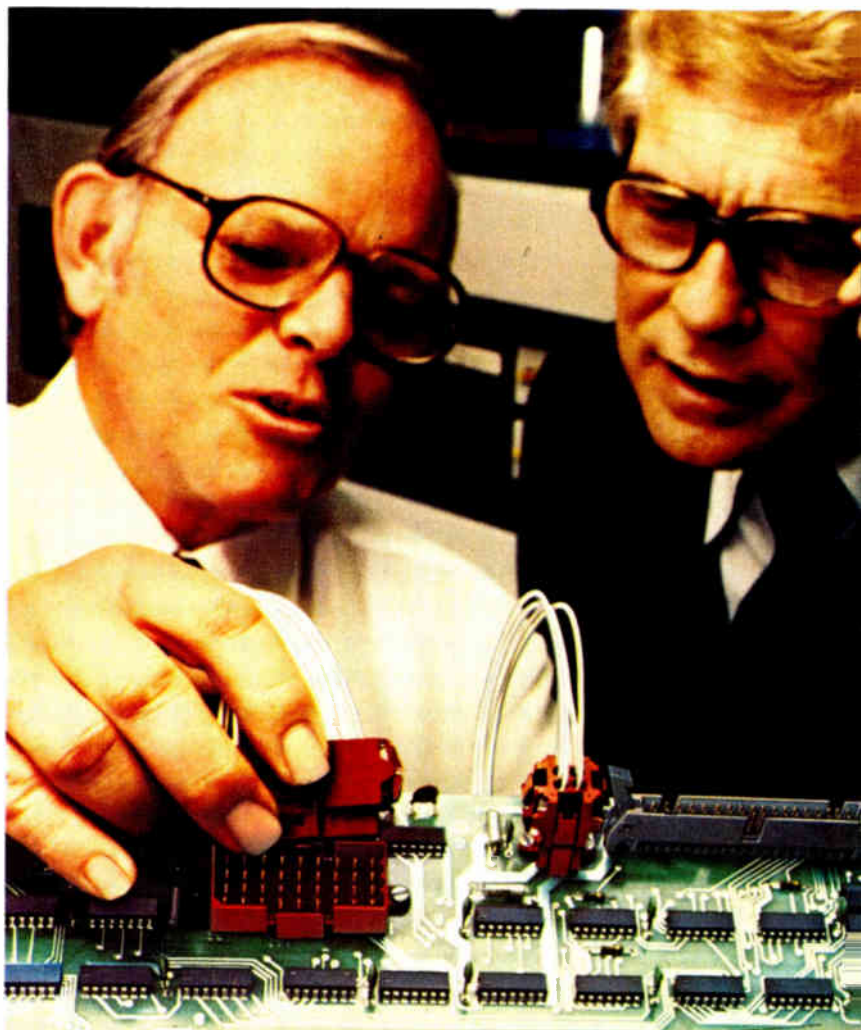

# AMP Metrimate.

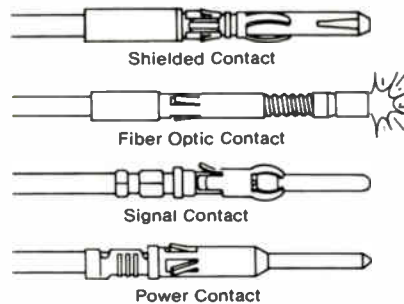
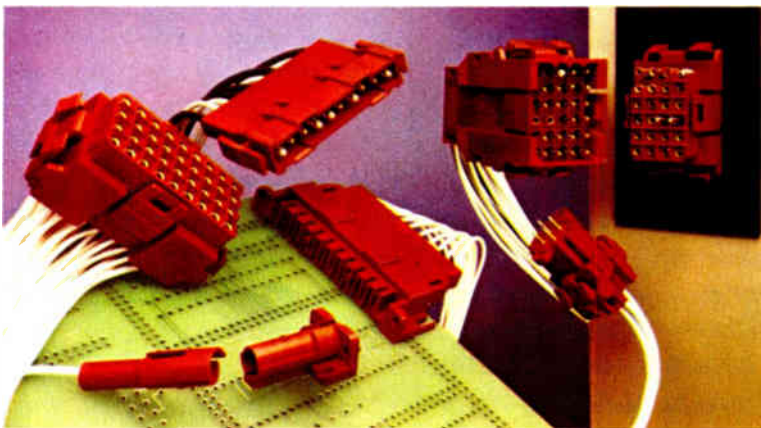

## Some facts worth knowing about AMP Metrimate Connectors

**Description:** Part of AMP's exclusive Multimate Family that accommodates common contacts in a variety of connector housing styles and saves on both tooling and inventory costs.

**Voltage rating:** 380 VAC, 450 VDC (VDE); 600 VAC (UL); 250 VAC (CSA); 440V (IEC)

**Dielectric strength:** 1500 volts rms at sea level

**Temperature:** -55°C to +105°C

**Current rating:** Signal and Power Contacts; 13A max. per contact (limited only by connector block working temperature).

**Insulation resistance:** 5000 megohms, min.

**Contact resistance:** 5.5 milliohms, max.

**Durability:** 250 cycles, tin-plated contacts  
550 cycles, gold-plated contacts

**Where to telephone:** Call the Metrimate Information Desk (717) 564-0100, Ext. 8400.

**Where to write:** AMP Incorporated, Harrisburg, PA 17105

# AMP

# The Mostek 16K

## 5 volt systems, the easy way.

 Now there's a total solution to 5 volt microcomputer systems. Mostek's new 4816 makes it easy. It's 5 volt only. It's 2K x 8. It's a compatible Micro Memory™ from Mostek.

### Easy as static.

The 4816 is as easy to use as static RAMs, but offers all the performance and cost advantages of dynamic RAMs. The 4816 uses a dynamic cell and dynamic periphery to reduce die size to just 31,000 mils<sup>2</sup> as well as power dissipation to only 25 mW standby and 150 mW active. Access time of 150ns and cycle time of 270ns meet the needs of all microprocessor sockets.

### Easy to refresh.

On-chip logic, refresh and interface circuits make the 16K RAM as easy to use as the static RAM it is designed to replace. A single

refresh pin allows flexible control of refresh, or automatic refresh in battery back-up mode. The timing of the refresh pulse is so flexible that it can occur during an active cycle or standby mode. In most 8-bit microprocessor systems as well as the new generation 16-bit microprocessors, the refresh pulse may be conveniently generated from the processor's output controls. In the Mostek system solution, our Z80 provides a refresh output signal that connects directly to the refresh input of the 4816. The 4816 appears totally static to the system.

### Easy to upgrade.

Upgrading your system is as easy as replacing four 2114s or two newer generation 8K static RAMs with a single MK 4816 to improve speed and density while reducing power and costs.

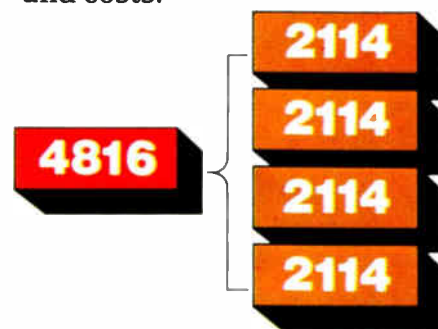

The 4816 is totally compatible with standard ROMs, PROMS, and EPROMs as well as next generation Micro Memories from Mostek.

The 4816 is available now for your system. Just call 214-245-0266 for more information. Mostek Corporation, 1215 West Crosby Road, Carrollton, Texas 75006. In Europe, contact Mostek Brussels; phone (32)02/660.25.68.

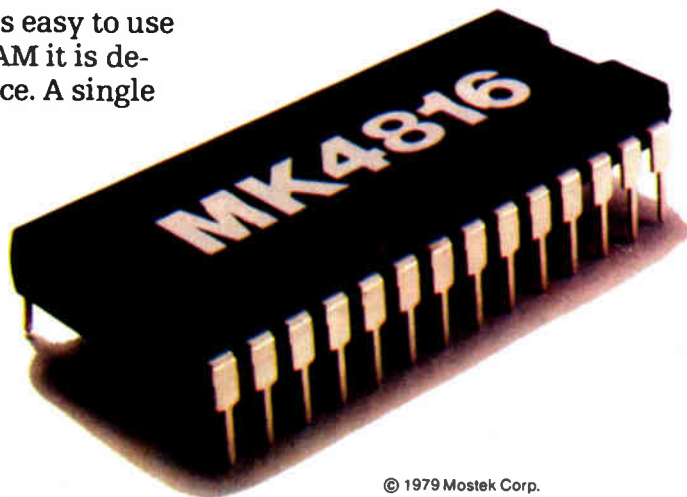

**MOSTEK®**

# Micro Memory

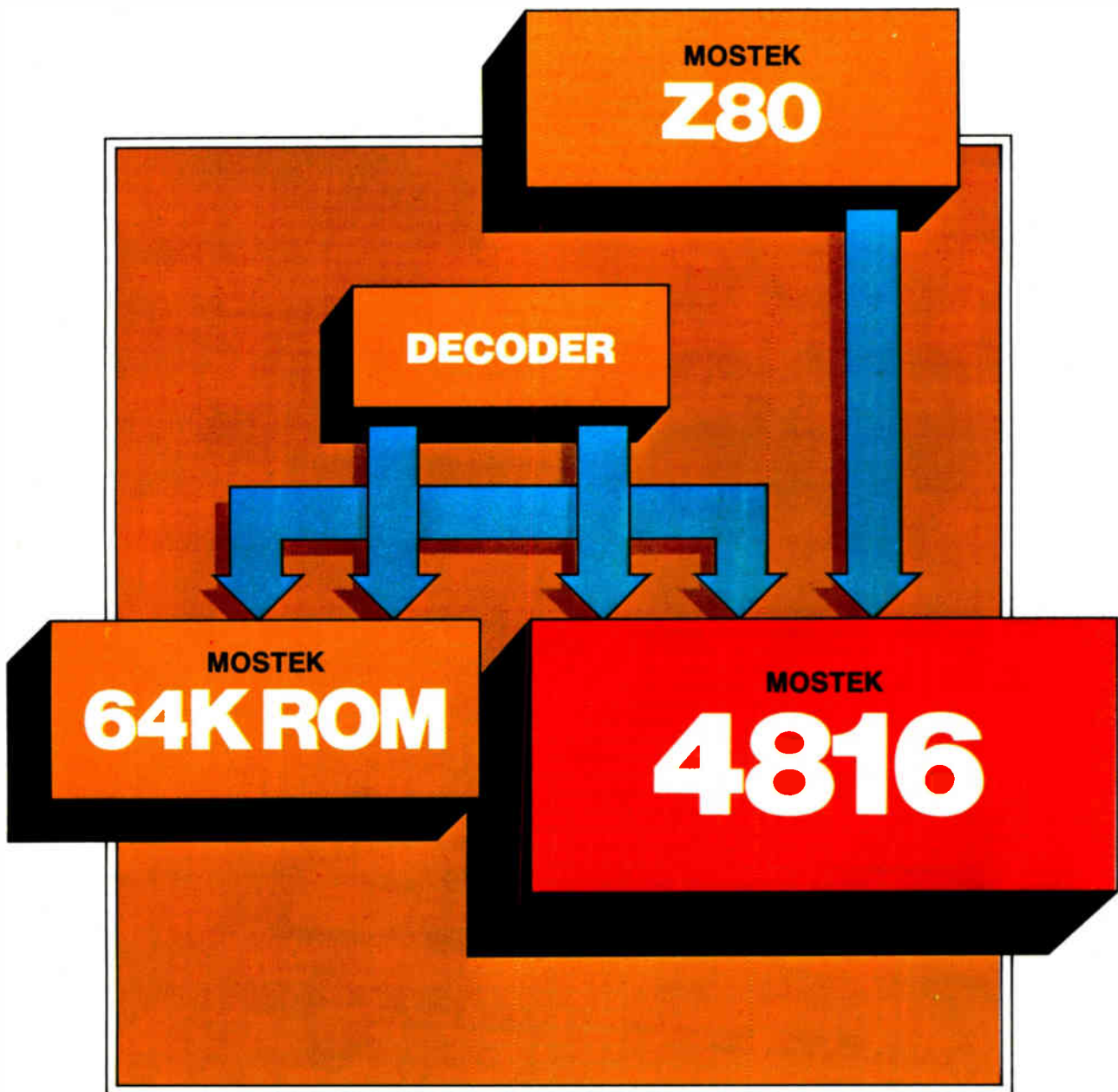

**Mostek's 5 volt System Solution**

# Introducing HP's System 35.





# Under its friendly exterior lurks the power of a minicomputer.



The new System 35 delivers minicomputer performance while retaining those friendly characteristics of a desktop computer. Consider these features:

**Big Memory**—you choose from 64K to 256K bytes of internal read/write memory, of which all but 12K bytes are available for your programs and data. With 256K bytes, System 35 can manage an array of over 30,000 12-digit floating-point numbers. That's big problem-solving capacity.

**Enhanced BASIC Language** possesses some powerful, convenient features you'd normally find only in FORTRAN or APL. It's the same HP enhanced BASIC used with System 45 so you can step up to a bigger system without having to rewrite your programs.

**Assembly Language** is an option for those who are skilled assembly programmers to provide increased power and speed for data acquisition and control applications.

**Real-time I/O performance** makes System 35 an extremely powerful desktop controller. With direct memory access, buffered I/O, 15 levels of priority interrupt, built-in I/O drivers and standard interface options, System 35 handles data acquisition and control tasks with ease.

Yet with all its built-in performance, System 35 remains a friendly, easy-to-use computer. It integrates essential functions such as alphanumeric display—your choice of 24-line CRT or single line LED—typewriter-like keyboard, and a 217K byte magnetic tape drive in one trim, portable package. If needed, you can easily plug in external HP peripherals such as printers, plotters and floppy discs which, for convenience, use the same mass-storage commands as the built-in tape.

For immediate information on System 35, call your local HP desktop computer representative. For literature, send us the coupon, which will expedite its return, or circle our reader service number.

HEWLETT  PACKARD

3404 E. Harmony Road, Fort Collins, Colorado 80525

For assistance call: Washington (301) 948-6370, Chicago (312) 255-9800, Atlanta (404) 955-1500, Los Angeles (213) 877-1282.  
Ask for an HP Desktop Computer representative.

- Please have an HP desktop computer representative call.
- Please send me general literature.
- I am interested in data acquisition and control. Please send the technical supplement.
- I am interested in assembly language programming. Please send the technical supplement.

Name \_\_\_\_\_

Title \_\_\_\_\_ Phone \_\_\_\_\_

Organization \_\_\_\_\_

Address \_\_\_\_\_

City/State/Zip \_\_\_\_\_

3404 E. Harmony Road, Fort Collins, Colorado 80525 E2/15/79

## Speaking the same language . . .

Designers of systems have enough troubles, so those normally gentle souls must be forgiven the dark thoughts they sometimes harbor about software. To the electronics engineer, the arcane art of software writing is a time-consuming and sometimes frustrating experience that seems calculated to cause pain, though it is a vital task that is becoming more so every day.

That's why the experiences of the folks trying to bring us a standard form of that nifty and lately very popular language, Pascal, must bring a bitter and knowing smile to the lips of the average workaday EE. There seem to be enough groups and subgroups, each with its own perfectly good reasons for doing things its own perfectly good way, to mobilize several alphabets. We have ANSI, BSI, and ISO for the standards institutes of America, Britain, and the world; then we have PUG and, for good measure, the IEEE, for the Pascal Users Group and the engineers. The

## . . . even if it's a secret

While on the subject of languages and standards, the brouhaha in Washington over encryption is worth examining. It seems the National Bureau of Standards has come up with a Data Encryption Standard (DES) that has become the center of a storm. The standard was written because of the growing use in the commercial world of codes and ciphers, a practice that just a few short years ago was limited to the world of diplomacy, spies, and similar activities that most of us know only from novels, movies, and television shows. The problem here, however, is the super hush-hush National Security Agency, whose charter is to become involved in and safeguard the nation's communications where they involve national security. But the agency is specifically prohibited from involving itself in commercial or nonsecure Government

basic division is between the academicians, who seem to want the language to stay "pure" insofar as it hews to the word laid down by Pascal's author, Niklaus Wirth, and the industrial users, who appear to be intent on including modifications and extensions to Pascal right in the standard. And there is even a third group, one that feels there is no need to write a standard at all, that every computer maker should be free to incorporate its own form of Pascal programming.

As the article on page 96 describes it, a meeting to talk about standards last December got so involved with intergroup wrangling that the participants did not even get around to electing a chairman; all they managed to accomplish was to schedule another meeting for this month. With Pascal's popularity growing as it is, and with the digital world so dependent on software, now would be a good time for each side to see the merits of the other's view and give a little.

communications, and there's the rub. Some commercial communications people say the NBS, while it says its DES was put together in consultation with the NSA, fell too much under the influence of the super spooks and the result is an inferior standard. On the other hand, the NSA now says it must have first censorship rights on governmental encryption contracts, so that it can safeguard America's security, a form of supervision that seems almost impossible in a democratic system.

The NSA cannot win everything it wants, and its stand is only holding up promulgation of a good standard, whether DES or any other. Despite the fact that its director, Vice Admiral Bobby Inman, took an unheard-of step when he went public at a meeting to plead his case, the NSA would be well advised to negotiate on this matter.

# Heavy duty programmer duplicates PROMs like greased lightning.

## Simple, pass/fail production-line programming.

Use our benchtop M910 production programmer for general production line programming, for blank-checking or verification, or for quality assurance testing. The M910 is so simple and provides such readily understood pass/fail information that you can teach your manufacturing personnel to use it in minutes. In the M910's automatic mode, the operator loads the PROM, pushes one button and the programmer automatically blank checks, duplicates



and verifies. A pass/fail light and an accompanying audio tone give dual indications of PROM status. The M910 also has individual pushbutton selection of blank check, duplicate or verify functions.

## No matter what your PROM, the M910 can program it with maximum yield using one of our vendor-approved plug-in personality modules.

The M910 accepts our full range of PROM personality modules including dedicated modules for single PROMs,

gang modules which let you program up to 8 PROMs simultaneously, and generic modules which program entire PROM families.

The M910 gives you a direct PROM to PROM copy with no intermediary buffering. We use separate sockets for the master PROM and the copy PROM. No programming voltages go to the master socket, so your master can't be accidentally altered or destroyed by operator error.



Like all our control units and PROM personality modules, the M910 comes U.L. listed, designed and built to U.L. electrical safety standards.

It's a fully portable benchtop unit that weighs less than 18 pounds with personality module installed.

## Top yield and throughput per dollar.

An M910 control unit costs only \$1,400. Single PROM personality modules cost from \$350 to \$600. Generic modules start at \$530. Gang modules are \$950 to \$1,050.

## Write for a copy of our PROM User's Information Package.

Pro-Log Corporation,  
2411 Garden Road,  
Monterey, CA 93940,  
phone (408) 372-4593.

 **PRO-LOG**  
CORPORATION  
Microprocessors of your fingertips.

- Resolution 0.025%
- Non-volatile, adjustment free storage.
- Pre-trigger information.
- Digital scale expansion to X64.

# EXPLORER 'SCOPES

- Equivalent write rates to 50 cm/ $\mu$ s.
- Dual beam
- IEEE 488 - RS-232 IB.

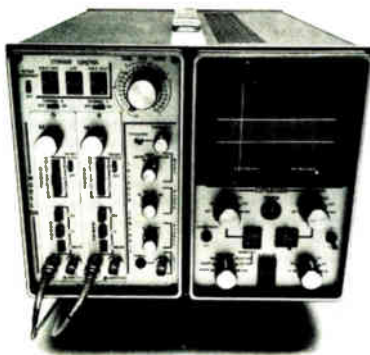

## Quick...Accurate... Convenient.

The EXPLORERS, from Nicolet, are digital oscilloscopes that perform all the functions of traditional 'scopes, storage or non-storage.

They perform these functions brilliantly, with high precision, fantastic storage. Easier operation and greater versatility are bonuses.

In the dc to 10 MHz range, these are the finest oscilloscopes available. They're designed for general scope use, yet, because of the IEEE-488 IB, and other interfaces, they are equally suited for advanced research.

## Seeing is knowing...

For a demonstration and literature call Jim Bartosch at (608) 271-3333 or send reader service card.

**NICOLET  
INSTRUMENT  
CORPORATION**  
**OSCILLOSCOPE DIVISION**  
5225 Verona Road, Madison, Wisconsin 53711  
Telephone: 608/271-3333

## Meetings

**Recent Advances in High-Frequency Communications**, Institute of Electrical Engineers (London), Savoy Place, London, Feb. 26-28.

**Sixth Energy Technology Conference and Exposition**, Electric Power Research Institute (Palo Alto, Calif.), Sheraton Park Hotel, Washington, D. C., Feb. 26-28.

**Comcon Spring '79-18th IEEE Computer Society International Conference**, IEEE, Jack Tar Hotel, San Francisco, Feb. 26-March 1.

**Intelcom '79-International Telecommunication Exposition**, Horizon House International (Dedham, Mass.), Dallas Convention Center, Dallas, Texas, Feb. 26-March 2.

**Digital Microwave Transmission Seminar**, IEEE and Princeton University, at Princeton University, Princeton, N. J., Feb. 27.

**Digital Encoding and Processing of Voice and Video Seminar**, George Washington University, Washington, D. C., Feb. 27-March 1.

**Nepcon West '79**, Industrial and Scientific Conference Management Inc. (Chicago), Anaheim Convention Center, Anaheim, Calif., Feb. 27-March 1.

**ICE '79-International Computer Exposition**, Marcom International Inc. (Tokyo) and Golden Gate Enterprises Inc. (Sunnyvale, Calif.), Tokyo Harumi Fairgrounds, Tokyo, Feb. 28-March 2.

**Optical Fiber Communication Meeting**, the IEEE and the Optical Society of America, Shoreham Americana Hotel, Washington, D. C., March 6-8.

**Conference on the Electronic Printer Industry**, Dataquest Inc. (Menlo Park, Calif.), Orlando Hyatt House, Orlando, Fla., March 7-9.

**Mid-Atlantic Computer Exposition**, The Caravan Group (Newton, Mass.), New York Coliseum, New

York, N. Y., March 13-15.

**12th Annual Simulation Symposium**, IEEE, Causeway Inn, Tampa, Fla., March 14-16.

**Fifth Annual Conference and Exhibit on Industrial and Control Applications of Microprocessors**, Information Gatekeepers Inc. (Brookline, Mass.), Sheraton Hotel, Philadelphia, March 19-21.

**IECI '79-Industrial and Control Applications of Microprocessors**, IEEE, Sheraton Hotel, Philadelphia, March 19-21.

**Automatic Testing Deutschland and Test and Measurement Exhibition '79**, Network/Watts Steadman Ltd. (London), and Gene Selven & Associates (Cupertino, Calif.), Rhein-Main-Halle, Wiesbaden, West Germany, March 20-22.

**Eighth Annual Programmable Controllers Conference and Equipment Display**, Engineering Society of Detroit, to be held at the society's headquarters, March 20-22.

**Corporate-Wide Packet-Switched Data Networks Seminar**, Data Communications Magazine/McGraw-Hill Publishing Co. (New York), Capital Hilton Hotel, Washington, D. C., March 26-27.

**Trends in On-Line Computer Control Systems**, Institute of Electrical Engineers (London), University of Sheffield, Sheffield, UK, March 27-29.

**International Standard X.25 Interface Protocol for Packet Nets and Related Protocols Seminar**, Data Communications Magazine/McGraw-Hill Publishing Co. (New York), Capital Hilton Hotel, Washington, D. C., March 28-29.

**Southeastcon-1979 Southeastern Conference**, IEEE, Hotel Roanoke, Roanoke, Va., April 1-4.

**Spring Conference**, EIA, Shoreham Americana Hotel, Washington, D. C., April 2-5.

# Telecommunications, memories and microcomputers...

## The Mostek System Solution

 Only Mostek offers a complete system for your telecommunication applications. Innovative design techniques give Mostek the edge in telecommunication product features. High density RAMs, ROMs, PROMs and versatile microcomputers complete the picture. Total compatibility from a single source—that's why we call it the system solution.

### Designed by the leader

Mostek made its commitment to telecommunication products in 1974 when we built our first tone dialer. During the past year, we've shipped over three million circuits and earned a reputation as industry's most dependable source for reliable products. Products like tone receivers, tone dialers, pulse dialers, repertory dialers and CODECs are available in volume now. Monolithic filters are coming soon, followed by 2-4 wire converters.

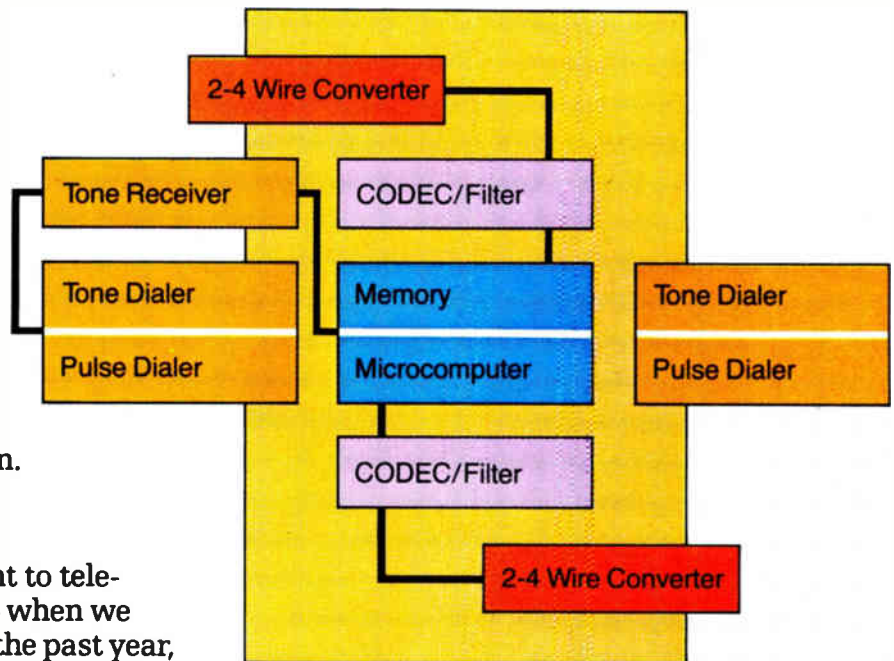

### Designed for tough applications

The Mostek System Solution will meet your toughest specifications. Whether you're designing central office switching systems, key telephone systems, PABX, remote concentrators, channel banks, or automatic call distributors, contact Mostek for the solution, 1215 West Crosby Road, Carrollton, Texas 75006; phone 214/242-0444. In Europe, contact Mostek Brussels; phone (32)02/660.25.68.

**MOSTEK**®

Circle 27 on reader service card



# The HP 2621: sim

Simple doesn't have to mean unsophisticated. The proof is in our new CRT terminal, the HP 2621.

Before building it, we took a long, hard look at the way you use a simple terminal. Then we took the knowledge gained in more than 10 years designing computer products and applied it to engineering an interactive character-mode CRT terminal from the user's point of view.

The outcome was actually two models. The HP 2621A, which sells for \$1450. And the HP 2621P, which has a built-in printer, costs \$2550. You obviously want the sharpest display made. So we used the 9x15 character cell you see on every HP CRT terminal, including the top-of-the-line. And, to help you look back at the data you've entered, we provided two full pages of continuously scrolling memory.

We designed the keyboard like the familiar typewriter, so you don't have to waste time relearning it. We built in eight function keys, too. These control the cursor, rolling and scrolling. And, to make life easier, they're labeled on the screen for self-test, configuration, display and editing.

Editing? On a simple terminal? Certainly. We included character and line insert and delete, clear line and clear display. And, since the 2621 keeps your input separate from your CPU's, you can edit data before sending it to the computer. All without writing a line of system software.

Since flexibility is important in interfacing, we included a user-definable return key that will send your computer whatever code it expects. We also made our terminals compatible with RS232C and Bell 103A, and

able to communicate with your CPU at 110 to 9600 baud.

If you need hard copy at your fingertips, take a look at the HP 2621P. With a keystroke, its built-in 120 cps thermal printer will deliver a printout from the screen in seconds.

So why don't you check out the HP 2621 by calling the nearest HP sales office listed in the White Pages. Or send us the coupon. Then see for yourself how sophisticated a simple CRT terminal can be.



Try this on your favorite CRT! With the 2621P, you just hit a key and in seconds you have hard copy of your CRT display. The built-in thermal printer prints upper and lower case at up to 120 cps.

The 2621's bright, high-resolution CRT, with enhanced 9x15 character cell, displays the full 128-character ASCII character set, including upper and lower case, control codes, and character-by-character underline, in 24 80-character lines.

Eight screen-labeled preprogrammed function keys magnify the power of the 2621's keyboard. Preprogrammed functions include editing, terminal configuration, printer control and self-test.

To make numeric data entry faster and easier, we put the 2621's numeric keypad right in the middle of the keyboard. And the 2621's familiar 68-key keyboard is almost as easy to use as a typewriter.

- I'd like to know more about HP's new 2621A and 2621P with built-in hard copy.
- I'd like to see HP's new 2621A and 2621P with built-in hard copy.
- I'd like to know more about HP's complete family of terminals.

Name \_\_\_\_\_

Title \_\_\_\_\_

Company \_\_\_\_\_

Address \_\_\_\_\_

Phone \_\_\_\_\_

Mail to Hewlett-Packard, Attn: Ed Hayes,  
Marketing Manager, Data Terminals Division, Dept. 647,  
19400 Homestead Road, Cupertino CA 95014.

HEWLETT  PACKARD

*All prices are U.S. list.*

*Available on GSA Contract #GS-00C-01529 from 12/8/78 through 9/30/79*

Circle 29 on reader service card



# IMAGINE

## Zilog rockets out in front again to launch a new generation.

For the first time, the architectural sophistication and data processing capabilities of large, main-frame computers has been captured in the cost-effective, easy to use format of the microprocessor. Now you can have the freedom to create entirely new, innovative systems, unhindered by the primitive architectures of previous microprocessors.



## A revolution in sophistication.

The Z8000 has been designed from the ground up with options to fit your application needs exactly. For the full 8 MB addressing capability, choose the 48 Pin DIP

## Flexibility soars to new heights.



set supports 7 different data types from bits to 32 bit words, has 8 addressing modes and 418 usable opcode combinations.

The general register architecture helps avoid the well-known bottlenecks inherent in dedicated register designs. When this architecture is combined with the powerful instruction set, the Z8000 system throughput is an explosive 50% greater than any other 16 bit microprocessor available today.

The Z8000 allows you to directly address up to 8 MB of memory. All 16 registers are a full 16 bits wide and are completely general purpose. The powerful, problem-solving instruction

version. Its companion device, the Memory Management Unit, opens the way to dynamic relocation, memory protection and multi-tasking applications.

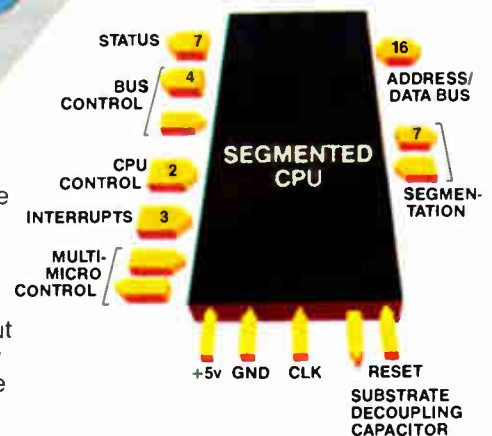

# IMAGINE



# A REVOLUTIONARY NEW WAY TO THINK ABOUT MICROPROCESSOR SYSTEMS. INTRODUCING ZILOG'S Z8000.

For smaller, less memory-intensive applications, select the 40 Pin version of the Z8000. It's software compatible with the 48 Pin Z8000 but addressing is limited to 64KB in each of its six address spaces. It comes in a standard 40 Pin package.

## Wait 'till you meet the family.

We're starting off this new microprocessor era with a bang, but it's just the beginning. Soon to come are the Memory Management Unit, peripheral interfaces, FIFO buffer elements, universal peripheral controller and memories for any application you might have.

And, all the new I/O chips, memories and, of course, the companion Z8, take advantage of the flexible Z-BUS architecture to maximize performance, ease of interconnection and minimize PC board area.

## Zilog delivers on the next generation of microprocessors. Again!

With the introduction of the Z8000, microprocessor technology explodes to new heights. Bursting with a rich and sophisticated architecture, the Z8000 not only opens the way to revolutionizing your next generation

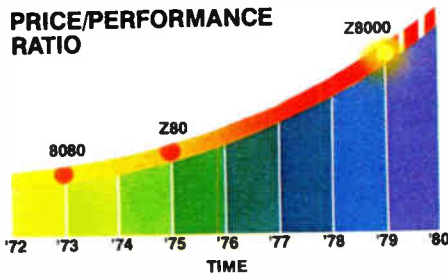

of products, it has the built-in growth potential to carry your product development efforts out to totally new and unexplored horizons.

## Imagine the possibilities, then light your own fuse!



Sound exciting? It is. Get your own fireworks blazing by placing your order today with your nearest Zilog distributor.

In the meanwhile, give your engineering staff a headstart on the fireworks by ordering the Z8000

literature package; in the U.S. order directly from Zilog, elsewhere from your Zilog distributor.



10460 Bubb Road, Cupertino, CA 95014  
(408) 446-4666 TWX 910-338-7621  
EASTERN REGION: (617) 667-2179  
MIDWESTERN REGION: (312) 885-8080  
SO. WESTERN REGION: (714) 549-2891  
NO. WESTERN REGION: (408) 446-4666  
EUROPE (ENGLAND): (0628) 36131/2/3  
WEST GERMANY: (08106) 4035  
JAPAN: 03-476-3010

An affiliate of  
**EXON** ENTERPRISES INC.



Circle 31 on reader service card

The fireworks have just begun!



# MOD POT... Number 1 with more combinations than all others combined.

MOD POT,<sup>®</sup> the original modular potentiometer—available in over a billion combinations. A whole family of resistive elements: hot-molded composition, cermet, conductive plastic. Variety of switch options, vernier drives with solid or concentric shafts. Single, dual, triple or quadruple control sections. Solder lug or PC pins. Save panel space with 5/8" square module. Fast delivery backed by our distributor assembly centers. Ask for Publication 5217.

RESISTANCE ELEMENT	RESISTANCE RANGE	TOLERANCE	TAPERS	POWER RATING (LINEAR TAPER)		
				SERIES 70	SERIES 72	SERIES 73
Hot Molded Composition	50 ohms to 10 megs	±10% or ±20%	Linear (U)	1.0 Watt at 70°C	0.5 Watt at 70°C	0.75 Watt at 70°C
	250 ohms to 10 megs		Modified Log CW (A) or CCW (B)			
Cermet	100 ohms to 5 megs	±10%	Linear (U)	2.0 Watts at 70°C	1.0 Watt at 70°C	2.0 Watts at 70°C
	250 ohms to 1 meg		Modified Log CW (A) or CCW (B)			
Conductive Plastic	100 ohms to 1 meg	±10% or ±20%	Linear (U)	0.5 Watt at 70°C	0.25 Watt at 70°C	0.5 Watt at 70°C
	500 ohms to 1 meg		Modified Log CW (A) or CCW (B)			

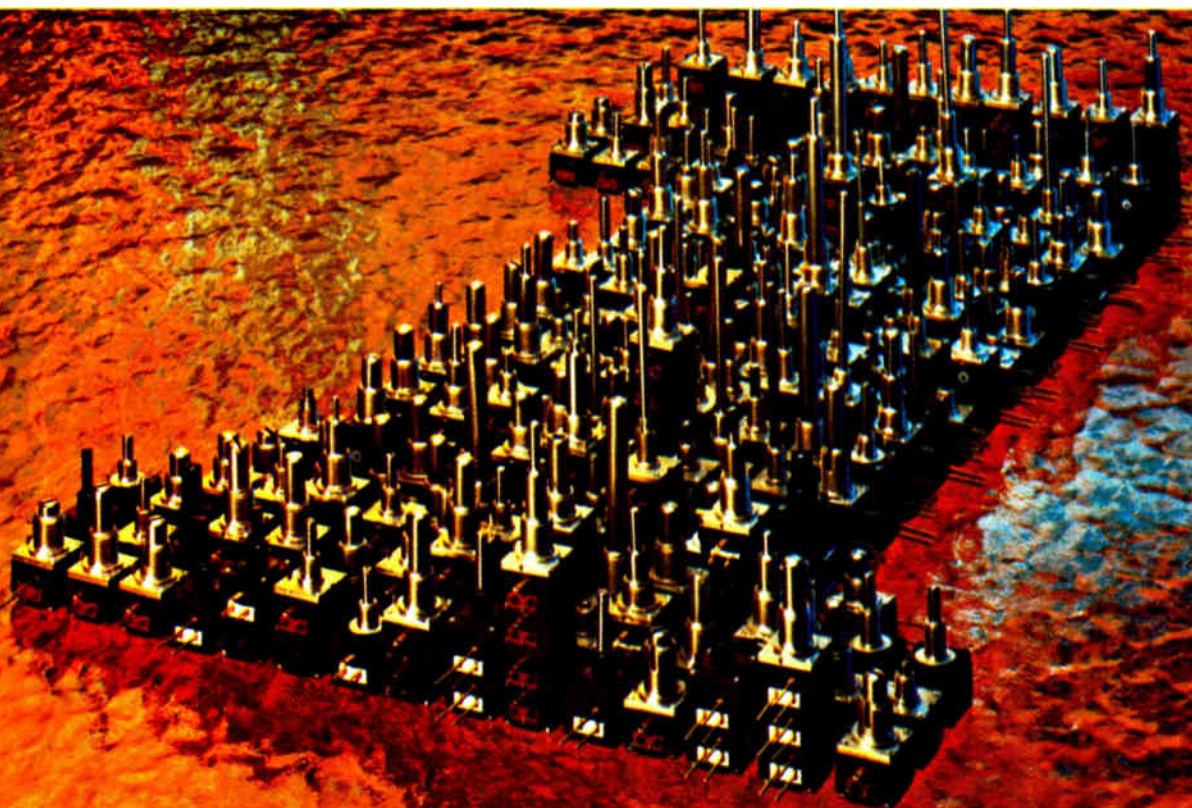

## Quality in the best tradition.



**ALLEN-BRADLEY**  
Milwaukee, Wisconsin 53204

## **Zilog readying 16-K static RAM for partitioning**

Watch for Zilog Inc. to try to get a jump on its memory competitors in the next few months with samples of a 16-K static random-access memory. The byte-wide 6166, pin-compatible with the industry-standard 2716 erasable-programmable read-only memory, is aimed at simplifying the partitioning of microprocessor system memory. The company's clocked single-5-V part features a power-down function that lets the chip operate off supplies as low as 2.5 V, cutting 50-mA active current drain to 10 mA standby. Although the part is much the same as the 4016 announced last year by Texas Instruments [*Electronics*, July 20, 1978, p. 39], its more conservative process, says the Cupertino, Calif., firm, will yield a larger but more easily manufactured die size.

## **Medtronic tests pacemaker run by microprocessor**

Although company officials refuse to discuss it, sources close to Medtronic Inc. say the Minneapolis manufacturer of medical electronics equipment is now testing a heart pacemaker containing a custom microprocessor. In addition to generating a pulse to stimulate the heart muscle to pump blood, the device in Medtronic's unit also transmits external signals about patient and pacemaker condition and can automatically change the unit's pulse width and rate to override a heart malfunction. A few patients already have the pacer installed, but the large-scale and lengthy clinical investigation that is necessary before commercial introduction of the system is not yet under way.

## **Motorola schedules real-time clock for microprocessors**

As a spin-off from its complementary-MOS watch crystal technology, Motorola Semiconductor Group is planning third-quarter introduction of a bus-oriented real-time clock part with battery backup for use in microcomputer systems. It will combine an outboard crystal with on-chip memory. With 52 of its 64 bytes of on-board random-access memory devoted to user data storage, the new peripheral will be useful for, among other things, maintaining exact time-sampling data, even in power-down situations. Officials at Motorola's Austin, Texas, facility plan to offer the device in two versions, the MC146818 in a 22-pin package and the MC14819 in a 28-pin package. The parts are designed to work with various n-MOS machines such as the 8080 and 3870 families, as well as with Motorola C-MOS and n-MOS microcomputer systems.

## **Mostek widens range with \$300 development tool**

Taking aim at a broader spectrum of customers for its MK3870 microcomputer development system, Mostek Corp., Carrollton, Texas, is planning a \$300-range self-contained evaluation and development tool for introduction later this year. With a 3870 debug package in firmware, the new unit will fill out the low-cost end of the market, where Mostek hopes to attract low-volume 3870 users who can't afford the company's \$1,295 SDB-50/70 support board and associated equipment. At the other end of the price scale, Mostek has already taken steps aimed at more support for the 3870. Late last month, the company began shipping an optional plug-in board that enables its \$5,995 Z80 development system—the AID-80F—to support the 3870 as well. The new board, known as the AIM-72, brings the AID-80F in line with an industry trend toward development systems supporting more than one family of parts.

### **ROMs getting bigger, faster at Signetics**

A strong supplier of both bipolar and n-channel MOS read-only memories, Signetics is about to widen its charter with two new byte-wide ROMs that address two ends of the market. Due out first from the Sunnyvale, Calif., company is a high-speed 2,048-by-8-bit MOS device designed to complement—and help alleviate shortages in—16-K bipolar counterparts. First versions of the 24-pin part will feature 150-to-250-ns access times, but a redesign planned with Signetics' short-channel Minimos process is expected to lower that to below 100 ns. For larger microcomputer applications, the Philips subsidiary, which is recognized as the largest shipper of 64-K ROMs, will follow this fall with a 28-pin 131,072-bit ROM—a full 16 kilobytes—having an initial access time of 450 ns.

### **GE joins two others in supplying porcelainized steel**

The importance of porcelainized steel as a substrate has been underlined by the entry of giant General Electric Co. into the business. GE's East Cleveland, Ohio, photo lamp department business group is supplying samples of electronic-grade (low-sodium-frit) porcelainized steel. L. Carl Krotine, OEM specialist at GE, says, "Products are six months to a year away." The only other manufacturers of the material are Erie Ceramic Arts in Erie, Pa., and Alpha Advanced Technology of Newark, N. J.

### **Parts pair works with IEEE-488 bus**

While everyone else working on transceiver chips for the IEEE-488 general-purpose interface bus is handling the 16-line bus with four four-part devices, Motorola in Phoenix has already begun providing samples of an octal bipolar version. **Not only does the MC3447 get the job done with two chips, but it features a fast channel and some of the logic usually needed in external circuits to control the direction of data.** What's more, the chip, in a 24-pin, 600-mil dual in-line package, dissipates less power than anything else on the market—95 mw with all drivers on.

### **Addenda**

GenRad Inc. has gone west to find a manufacturer of universal microcomputer development systems. As of Feb. 28, Futuredata Computer Corp., Los Angeles, will be merged with the Concord, Mass., test equipment manufacturer. **The price: 240,000 shares of GenRad common stock. . . .** A 34-megabyte quarter-inch tape drive being readied by Data Electronics Inc. of Pasadena, Calif., gets its density of 7,200 bits per in. through a seven-track design. **This capacity is double that of the largest reel-to-reel digital tape cartridge drive now available,** the firm says. The recording pattern is serpentine, with adjacent tracks recorded in opposite directions, eliminating rewind time. Called the Microtape, it is priced at \$1,500, with deliveries starting in the third quarter. . . . **Intel Corp. is dropping the prices on its high-performance 8086 16-bit microprocessors 21% and 23%.** The move is viewed as an offensive thrust by Mostek, which will have samples of its second-source version later this year, and as defensive by arch-competitor Zilog, which is about to ship samples of its Z8000 16-bitter. Calling the cut orderly, Dick Konrad, Mostek's national sales manager, says that it should stimulate sales so "we'll have a bigger pie to go after." . . . Motorola and AMP Inc. will introduce a **jointly developed fiber-optic connector system at Nepcon West in Anaheim, Calif., later this month. . . .** The Electronic Industries Association of Japan purchased two-page ads in the New York Times and Washington Post to **outline its side of the TV-dumping controversy.**

# THE DSW WAFER STEPPER.™

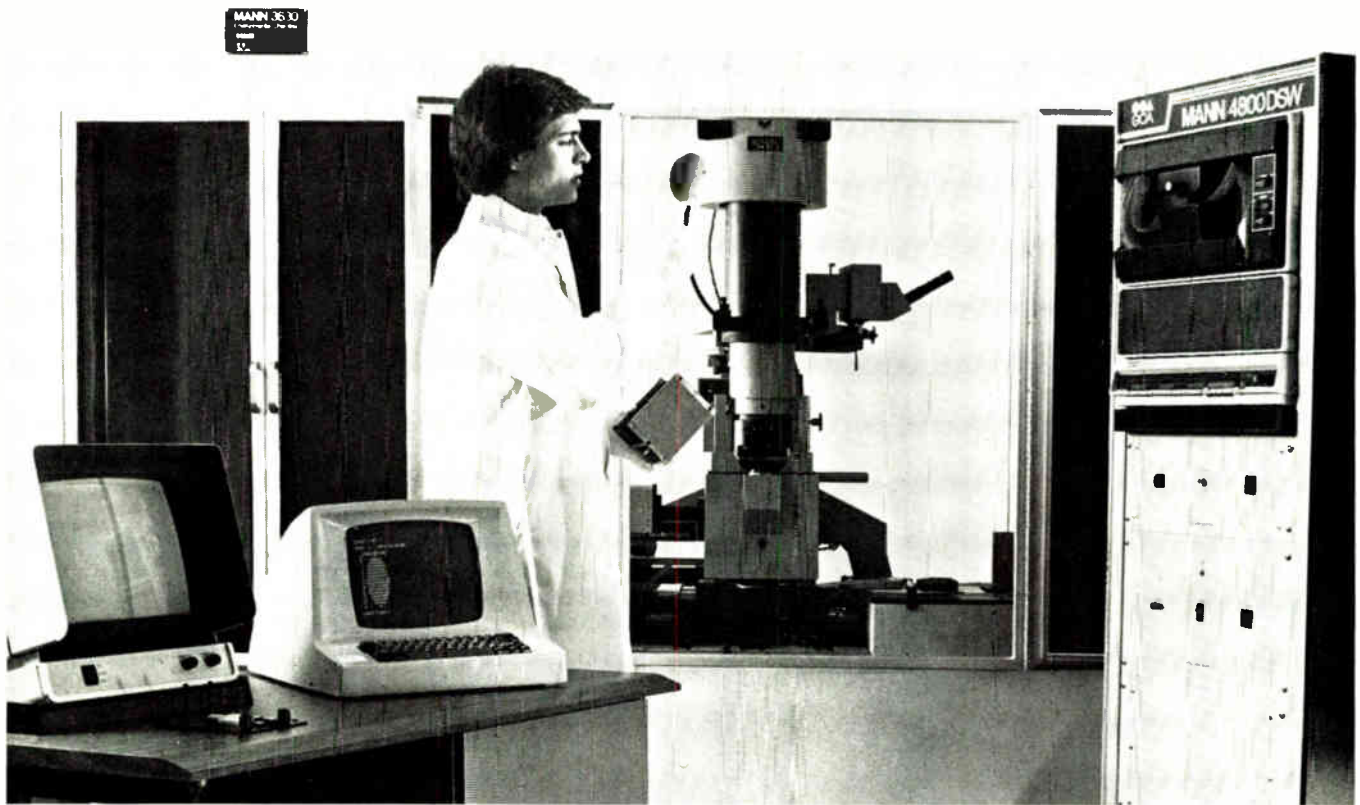

After a hard day's work, a lot of micro-imaging systems have a tendency to quit with the day shift.

Not so with the DSW Wafer Stepper™. The DSW provides high throughput, high yield, day-in and day-out production.

Once the DSW is set to go, you can forget about daily adjustments. And because wafer handling is automatic, you can forget about that too.

But for all its state-of-the-art sophistication, the DSW is simple to operate and easy

to maintain. We can give you immediate, on-the-spot service, no matter where you're located. Or we can train your own people to maintain it.

Over fifty systems have already been ordered by twenty-five IC manufacturers. If you'd like to know why, ask us for literature. If you'd like to see why, ask for a demonstration. Write Bill Tobey at GCA/Burlington, 174 Middlesex Turnpike, Burlington, Massachusetts 01803. Or call him at (617) 272-5600. Telex: 94-9352.



**GCA CORPORATION**  
**Burlington Division**

174 Middlesex Turnpike  
Burlington, Mass. 01803  
(617) 272-5600  
Telex: 94-9352

*Part of the  
GCA/IC Systems Group*

## IT DOESN'T GO DOWN WITH THE SUN.

**\$4 and a coupon  
brand new, bright  
Linear Databook**

# get you our blue, two pound

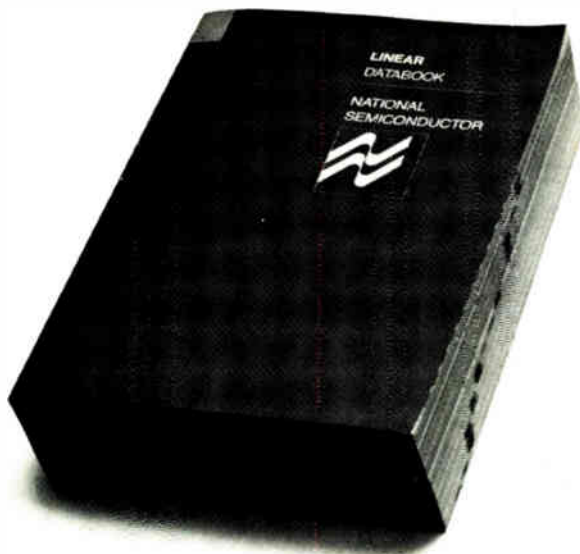

The Linear Leader's new databook has 1,148 pages cataloging 453 products. Including 70 or so new entries.

From analog switches to reference zeners and a lot of imaginative linearizing in between.

Definitions. Cross References. Selection Guides. Electrical Design Curves. Block Diagrams. Guaranteed Electrical Specifications.

Neatly indexed.

All in one bound volume, 36mm thick.

The Linear Story.

You'll have it dog-eared in a month.

National Semiconductor Corporation  
2900 Semiconductor Drive M/S 520  
Santa Clara, CA 95051

O.K. I'd like the most complete compendium of current linear data at my fingertips.

Send \_\_\_\_\_ copies. At \$4 each, here's my check for \$ \_\_\_\_\_.

Name \_\_\_\_\_

Title \_\_\_\_\_

Company \_\_\_\_\_

Address \_\_\_\_\_

City \_\_\_\_\_ State \_\_\_\_\_ Zip \_\_\_\_\_

E 2/15 8-44

 **National Semiconductor**

# You can rent your electronic equipment... and save your company thousands [even tens of thousands].

## REI makes it easy.

Renting is tremendously dollar-efficient.

No matter what type of electronic instrument you need, Rental Electronics, Inc. (REI) probably has it. In stock. And you can rent it for a very short period. 30 days, for example. Also, you pay only

for the time you have the equipment. No

wasted cash.

No bulky, unused equipment sitting around taking up expensive space. No inventory to tax, because it isn't yours. You expense the rental cost and eliminate worries about depreciation. And — more important

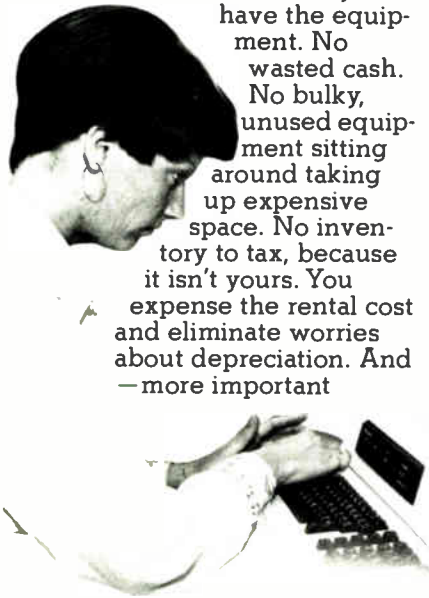

— you don't worry about paying as much as \$50K or more for a piece of equipment and watch race-horse technology make it obsolete before the ink on your check is dry. Frankly, you let your friendly neighborhood rental company take the big money position in state-of-the-art capital equipment. And the biggest, friendliest rental company of them all is us, REI.

You can choose from almost 14,000 pieces of rental equipment . . . and a couple of thousand used instruments for sale.

From a dozen U.S. Rental Centers, three more in Canada, and a separate sales company, REI has

more than \$20-million worth of state-of-the-art equipment on-the-shelf.

Instrumentation recorders,

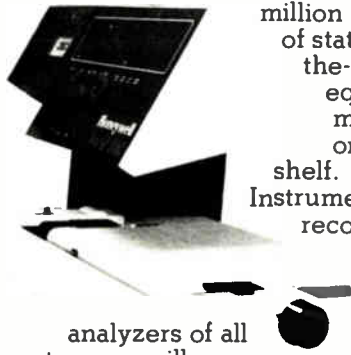

analyzers of all types, oscilloscopes, microcomputer development systems, and much more. And an on-line interactive REI computer system keeps track of all of it, all the time. So we're always ready to bring the equipment you need off-the-shelf quickly to take care of your needs. Plus we're adding better than \$1,000,000.00 in the latest, brand new equipment per month.

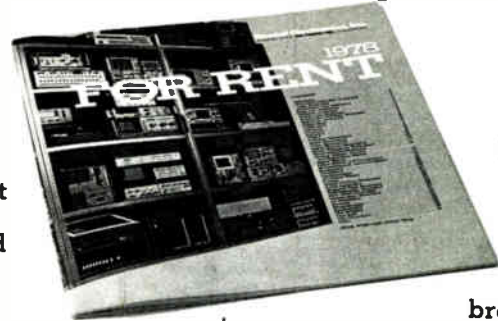

Like REI, our mascot — Mandy — is a different breed of cat.

REI is the biggest, fastest-growing company in the rental business. We've gotten big, and grown fast, because we take care of our customers' needs. Also, buying as much equipment as we do gives us purchasing clout, so manufacturers come to REI first with their new products. This means you can get the newest, just announced equipment from REI fast. To find out for sure what a different breed we are — in terms of people, products, prices and performance — give us a call, or return the coupon now. We'll respond. Immediately.

### Rental Electronics, Inc.

Another of the AMERICAL companies

**CORPORATE HEADQUARTERS:** Palo Alto, CA (415) 324-8080. **U.S. RENTAL FACILITIES:** Northridge, CA (213) 993-RENT (7368); Anaheim, CA (714) 879-0561; Mountain View, CA (415) 968-8645; Ft. Lauderdale, FL (305) 771-3500; Des Plaines, IL (312) 827-6670; Burlington, MA (617) 273-2770; Gaithersburg, MD (301) 948-0620; Oakland, NJ (201) 337-3757; Cleveland, OH (216) 442-8080; Dallas, TX (214) 661-8082; Houston, TX (713) 780-7218; Seattle, WA (206) 641-6444. **CANADIAN RENTAL FACILITIES:** (Rental Electronics Ltd.) Rexdale, Ontario (416) 675-7513; Montreal, Quebec (514) 681-9246; Vancouver, BC (604) 684-6623. **REI SALES COMPANY:** Burlington, MA (617) 273-2777.



**CALL TODAY FOR IMMEDIATE ACTION, OR RETURN THIS COUPON TO REI, 19347 LONDELIUS ST., NORTHRIDGE, CA 91324.**

- Send me your Rental Catalog.
- Send me your Used Equipment Sales Catalog.
- Have someone from your nearest Inventory Center phone me, please, at \_\_\_\_\_

I'm particularly interested in the following equipment: \_\_\_\_\_

GSA #GS-04S-21963 Neg © 1978 Rental Electronics, Inc.

**PLEASE RUSH THE INFORMATION REQUESTED TO:**

Name \_\_\_\_\_  
 Title \_\_\_\_\_  
 Company \_\_\_\_\_  
 Address \_\_\_\_\_  
 City/State/Zip \_\_\_\_\_  
 Phone \_\_\_\_\_

Thousands of state-of-the-art instruments . . . off-the-shelf, throughout North America



## Programming eased by replacement for ultraviolet E-PROM

Hitachi researchers ready plug-in for industry standard 2716 that erases electrically; units due during fourth quarter

The 2716 programmable read-only memory is a hot part. The 16-K device is in such demand that major semiconductor manufacturers, like Intel, Texas Instruments, National, and Japan's Nippon Electric, sell all of the ultraviolet-erasable integrated circuits they can make.

However, workers at Hitachi's Musashi Works and Central Research Labs, both in Tokyo, have come up with a 16-K electrically erasable ROM that is not only plug-compatible with the industry-standard 2716 but, if the Japanese figures are correct, outperforms it in every respect as well. And the Japanese part overcomes the big bugaboo of EE-PROMS: speed. Previous EE-PROMS, too slow for most microprocessors, have trouble keeping up with the top performers.

**Easy erasure.** Although UV devices continue to improve in terms of speed and storage capacity, EE-PROMS offer advantages that cannot be matched. Their big plus, of course, is that they can be erased with an electrical signal instead of the UV light and reprogrammed without being removed from a board. Moreover, E-PROMS require a ceramic package with a quartz window to let the light in. EE-PROMS do not need it, so they lean towards lower production costs.

Hitachi's device, which it says it will deliver in sample quantities

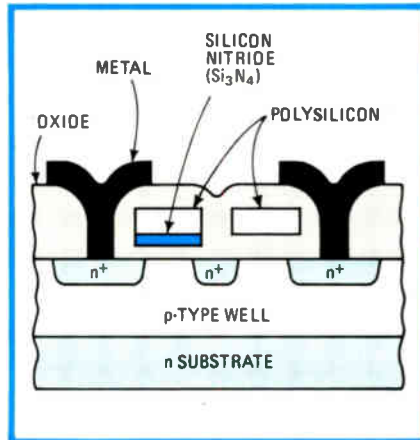

**So long, UV.** Cross section depicts an MNOS storage cell and series addressing transistor in Hitachi's 16-K EE-PROM replacement for the 2716. Data is stored as charge at the nitride-oxide interface.

during the fourth quarter, is described in a paper at this week's International Solid State Circuits Conference in Philadelphia. It is organized like the 2716, as 2-K by 8 bits, and uses n-channel silicon-gate metal-nitride-oxide-semiconductor (MNOS) technologies. Its maximum access time is only 250 ns, little more than half that of the 2716's 450 ns. Its maximum power dissipation is 330 milliwatts, and it can be programmed in 2 seconds and erased in a tenth of a second. In contrast, the 2716 consumes more than 0.5 watt and takes 100 seconds to program, and requires a half hour to erase.

Hitachi's part is also smaller. Even though the 2716 puts two transistors on top of each other to save space, Hitachi uses less area by having an addressing transistor in series with the MNOS storage device, as the cross section shows. Hitachi's

part measures 23,300 mil<sup>2</sup> vs 30,600 for the 2716.

Although there are other nitride-type EE-PROMS in production—General Instrument Corp., Hicksville, N. Y., for example has parts as large as 8-K—the devices are cast as “read mostly.” These are devices using nonstandard voltages whose data may be read constantly but are written over perhaps daily. Such parts find a home in cash registers and programmable television tuners. They do not address the market for microprocessor program storage. All semiconductor manufacturers with E-PROM capability, however, are aware of the obvious advantages of electrical erasability. Intel Corp., according to industry sources, is planning to announce a device before the year's end that will be based on the Famos cell it pioneered in 1970.

EE-PROMS are a bear to build consistently. Not only is oxide growth critical, but erasure is done by carefully controlling the discharge rate from the cells. Ultraviolet light does this very well, but the mechanisms of doing it electrically are not yet as well understood. □

### Memories

## 8-K E-PROM gets a rival, too

While the 2716 faces stiff competition from a PROM that is erasable electrically, another Japanese company, Mitsubishi Electric Corp. in Hyogo, has found a better way to make the 2716's younger brother, the 8-K 2708. It has put complemen-

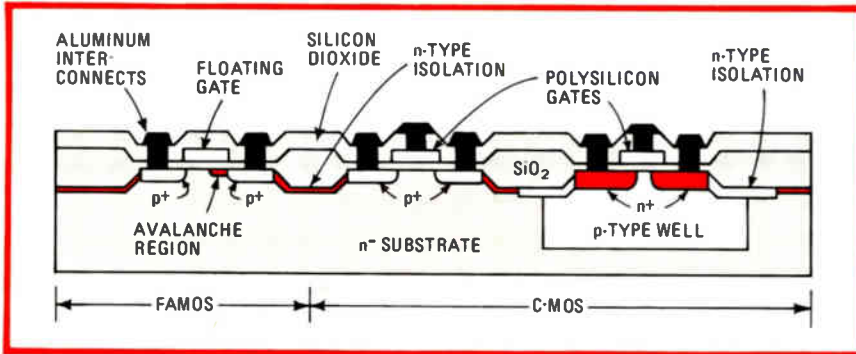

**FA-CMOS.** Mitsubishi combines C-MOS peripheral logic with Famos storage cell to achieve a low-power, programmable memory. It also succeeded in creating a complex structure, but one that requires only 11 mask steps, the same as standard C-MOS.

tary-metal-oxide semiconductors to work in the chip's periphery. This yields a device—another ultraviolet-light-erasable programmable read-only memory—that, the Japanese say, consumes one tenth the power of the 2708 and has negligible standby current. What's more, the part can be read with only +5 volts instead of the +5-v and +12-v power supplies required by the 2708.

Like the 2708 (and 2716), Mitsubishi's M58460S uses floating-gate avalanche MOS (Famos) technology to achieve nonvolatile storage. With Famos, developed by Intel Corp. in 1970, data is stored by charging a floating-gate insulator located above a channel region. The charge alters the memory cell threshold, and the presence or absence of conduction is the basis for readout.

**Common problem.** In fabricating its new memory, Mitsubishi had to overcome a problem common with PROMS: the unintentional application of programming voltages to sensitive peripheral devices. It therefore used arsenic instead of the more common boron to dope the Famos channel region, thus lowering the programming voltage to less than 20 v. Then it raised the threshold of the peripheral C-MOS transistors above this value by fabricating them with a double-diffusion process.

The figure above shows a cross section of the FA-CMOS structure. Mitsubishi says the device has a maximum power drain of 10 milliwatts, in contrast with the 800 mw of the 2708. Standby power is at most a mere 200 microwatts. Maxi-

mum access time for the two devices is the same, 450 ns.

Design rules for the memory cells are 8 micrometers and for the peripheral circuits, 6  $\mu$ m. Mitsubishi engineers say that smaller design rules on future chips will allow them to build 16-K devices of a reasonable size. So far, Mitsubishi is applying the 8-K 2708 in a new telephone receiver it has designed [*Electronics*, Jan. 4, p. 67]. Other products using the device will follow, but the company has not yet decided to sell it as a component. □

## Zilog previews its pseudostatic RAM

Born out of a need by microprocessor systems designers for low-cost, easy-to-use read/write memories, pseudostatic, or self-refreshing, dynamic devices are struggling for acceptance. Now Zilog Inc., in a late paper at the International Solid State Circuits Conference this week, has described its pseudostatic candidate: a 32-K chip, samples of which should be ready by summer, that offers a promising approach to making a dynamic memory as easy to use as a static.

The driving force behind the pseudostatic approach is economic: dynamic memory cells are smaller than static cells, so chip makers can get more cells per wafer, driving costs down. Static RAMs, on the other hand, are easier to hook up: no external refreshing logic is needed. In a

pseudostatic RAM, refreshing circuits are included on the die itself. The result is a part with the small cell of a dynamic RAM and no external refreshing.

Zilog's 6132, organized as 4,096 by 8 bits, surrounds an array of one-transistor dynamic storage cells with an elaborate self-refreshing circuit scheme that makes sure every cell has its contents rewritten at least every 2 milliseconds. A strong point of the design, which uses a single 5-volt supply, is that the memory can refresh itself even while its data is being accessed. Thus the 6132 will not impede a system's throughput by requiring cycles of the central processing unit for refreshing.

**Multiple refreshing.** Zilog designed the chip to decide itself when refreshing is needed. To begin with, Zilog splits the chip into two independent 2-K-by-8-bit arrays, each with its own row-address buffers and decoders. The on-chip refresh circuits refresh one array while the other is being accessed. The split, says Zilog, takes advantage of the sequential nature of most memory-addressing schemes.

Self-refreshing also occurs when the device is idle: both arrays are automatically refreshed simultaneously. In a third mode, an on-chip counter determines if too many memory cycles have occurred since the last refreshing period. If so, the device signals the central processing unit to extend a cycle for a few nanoseconds so that it can refresh itself.

Zilog's approach, which yields a 200-nanosecond access time and 350-ns cycle time, differs subtly from the pseudostatic design used by Mostek Corp. [*Electronics*, Oct. 26, 1978, p. 128]. That, too, provides several levels of self-refreshing.

Both, however, mark a trend toward intelligent memories that support the low cost per bit of dynamic cells with on-chip peripheral circuits to simplify use and minimize power drain. Still, advances in fully static designs, coupled with industry ambivalence towards the various self-refresh schemes, leaves the fate of pseudostatic memories unsettled. □

## GI envisions smart motors

What do power tools, food processors, floppy-disk drives and radio-controlled cars have in common? The answer is motors, and engineers at General Instrument Corp.'s Microelectronics group in Hicksville, N. Y., see those products as perfect candidates for the benefits of microcomputer control. More specifically what the GI people have in mind is the PIC family of 8-bit microcomputers that GI has sold in great quantities for entertainment products like video games.

The number of motors used in this country is staggering. "Fifty million new universal motors are manufactured each year," says Tom Slade, GI's microprocessor applications engineering manager. He adds that universal motors, like those used in household appliances and tools, are not the only kind of motor that can profit from control by microcomputer. "The concept can be applied to any motor, regardless of size or speed. Right now, we're also working with permanent-magnet and ac motors."

**Why do it?** There are many reasons for using digital techniques to control a motor. One is cost: a \$2 single-chip microcomputer can replace the \$10 worth of analog feedback-loop circuitry needed for speed control. The configuration that GI proposes to use is the same—a closed-loop, negative-feedback scheme but with the microcomputer as controller, plus signal-conditioning electronics.

The microcomputer does more than simply adjust speed after comparing the motor's actual and desired values. It also checks motor current against a set of maximum-current values stored in a read-only-memory look-up table on the chip. Using a program nested in the same ROM, the microcomputer limits instantaneous and continuous surge and peak currents and allows a

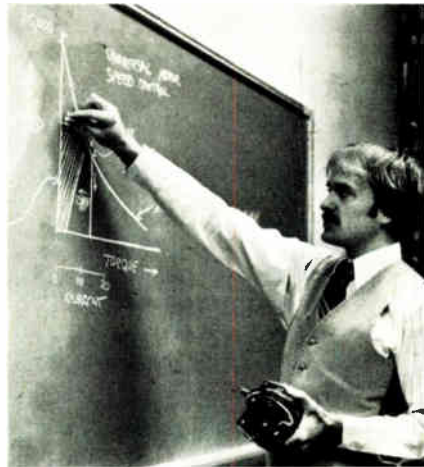

**Motor maven.** General Instrument's Tom Slade converts theory into practice as he discusses programming a microcomputer with a motor's torque-speed characteristics.

manufacturer to cut costs by using a smaller, and cheaper, motor.

But smaller motors may not always be what you want, Slade explains. "Take the vacuum cleaner. Here, what you'd like to use is a larger, more powerful motor, but large motors are subject to surge currents that may be too high for UL approval. The current-limiting program controls the surges nicely."

Higher efficiency is another fringe benefit, either of analog or digital control. Without a speed controller, a universal motor will speed along drawing maximum current regardless of load. Put a microcomputer in charge, however, and the speed will drop to match the load and current can be cut in half.

**Ins and outs.** Getting speed and control data into and out of the microprocessor is relatively easy. One speed-measurement technique compatible with microprocessors uses a Hall-effect switch and a 10-pole magnetic disk to sense the changes in the motor's rotating magnetic field and convert them into digital equivalents of speed. After computing the "error" in speed, the microprocessor converts it into a phase angle at which to drive a triac of the type generally used to speed up or slow down a motor. Speed and torque values are turned into the triac's firing angle through another look-up table in the on-board ROM.

Besides GI, National Semiconductor, Texas Instruments, and Rockwell International are pursuing motor-control programs of their own, using 4-bit parts. Slade defends General Instrument's use of an 8-bit part against charges of overkill in motor-control applications. "I'm not convinced that 4-bit machines have the processing power needed for closed-loop speed control. Our PIC-1655 microcomputer may cost 25 to 50 cents more in quantity, but that's a small price to pay for the current-limiting capabilities many of our customers seem to want."

At present, GI is working with several types of appliance and tool manufacturers, but he declines to reveal who they are. One of the first to introduce a microcomputer control—an open-loop design using a TMS1000 from TI—was Hamilton-Beach, Waterbury, Conn. However, it stressed features for the user rather than advantages to the manufacturer in its introduction [*Electronics*, Aug. 17, 1978, p. 43]. Other products are expected this year. □

---

### Programming

---

## C language befriends microprocessors

C is more than just the third letter of the alphabet—it is also the full name of a programming language that may one day liberate the microprocessor from its current dependence on tedious and error-prone assembly coding. C combines high-level statements with low-level machine control to deliver software that is both easy to use and highly efficient. Even Pascal, now so popular, may one day find itself in C's shadow.

**A beginning.** "I think Pascal is just a stepping-stone to C," says Bill Plauser. He was a member of Bell Labs' technical staff when the language was written in late 1971 by Dennis Ritchie, who is still there and remains a friend. "I've programmed 25 different computers, not for fun, but for a living, and C is the best way I've found to do business," says

## C packs in a lot

The C language contains a number of features that make its code compact yet powerful. For example, C has an operation designated ++ that in effect packs two program steps into one. If placed before a variable, it means increment the variable, then use it (in a computation, perhaps). When placed after, the variable is used first, then incremented.

This kind of powerful shorthand, which pervades the language, certainly helps to limit keystrokes. Peter Honeyman, a Princeton University doctoral candidate who sees a lot of C, also points out that C is succinct because assignment statements can be brought into expressions.

For example, to echo a character from a terminal's keyboard onto its screen might in another language require several statements. But in C, a single expression—while—suffices:

```
while ((c = getchar ()) != control)
    putchar (c);
```

The program fetches a character via the function: getchar. The character is set equal to the variable c, then tested to see if it is a control code (!= means not equal to).

If the character is printable, putchar prints it on the screen and the process is ready to be repeated.

Plauger, "It lets you say what you want to do and there is no getting around that."

C grew out of a research project at Bell Laboratories aimed at developing an efficient system-programming language. System languages are a rare and special breed. Unlike so-called application languages like Fortran and Cobol, system languages must be intimate enough with the hardware to write the most demanding of programs: compilers, operating systems, and text editors.

Plauger left Bell in 1975 and has been busy spreading the word about C. After a three-year-plus stint at a New York City C house called Yourdon Inc., Plauger started his own company six months ago, calling it Whitesmiths Ltd., also in Manhattan. One of his first contracts, a C compiler for Zilog's Z80, came from a large process control company. He is now finished with a PDP-11 cross compiler which means the Digital Equipment Corp. machine accepts C and spits out Z80 assembly language. His next step is to compile the compiler, so he can make it resident in the microprocessor and able to accept C programs with no more help from the mini-computer. Plauger says it will be a few more months.

"The trouble with C is that it is a much bigger language than it looks,"

he says, "Everyone gets stuck on the code generator." The code generator is the back end of a compiler, the part that has to figure out how to make code for a computer.

**Compilers coming.** There are a number of compilers being geared toward microprocessors, and within the next year they will flourish. Like Plauger's, some will be for the Z80. Others will suit the 8080 and 6800, and still others are sure to be built for the coming 16-biters. One company, however, Tiny-C Associates, Holmdel, N. J., has opted to design a C interpreter.

The Tiny-C interpreter, aimed at the part-time rather than the professional programmer, is a subset of Bell's (and Whitesmiths'). It runs on the PDP-11 as well as on the 8080 and Z80 microprocessors and is intended primarily for the education and hobbyist markets. Tiny-C is available on cassette or diskette for \$20 to \$60 to suit various personal computers. Unlike a compiler, which translates programs in big chunks, an interpreter translates on a statement-by-statement basis.

Tom Gibson, a Tiny-C partner, sees a tradeoff between Pascal and C. "Pascal is wordy, and current thinking is that languages should appear to be small and streamlined, and C is that." Gibson does give some credit to Pascal, however. "It

helps the user avoid some programming errors that C does not," he says. "The better-equipped software houses in the future will probably stock both." □

## Packaging & production

### Mostek piggybacks its E-PROMs

As semiconductor manufacturers get better at fabricating erasable programmable read-only memories, an increasing number of single-chip microcomputers are beginning to appear with on-board E-PROM in place of ROM. Texas Instruments, Motorola, and Fairchild are among those either already offering them or about to do so for use in emulation and prototyping. And Intel Corp., which pioneered on-chip microcomputer E-PROM with its 8748 more than a year ago, is planning E-PROM versions of a number of other single-chip machines as well.

But amid this recent rush, Mostek Corp. is taking a much different approach. Instead of putting the E-PROM on the microcomputer die itself, the Carrollton, Texas, company has a new package that "piggybacks" a standard E-PROM part like the 16-K 2716 with a Mostek MK3870 microcomputer. Specifically, Mostek plans to mount a 3870 die in a 40-pin dual in-line "motherboard."

**Plug at the top.** Only slightly larger than a standard 40-pin DIP, this package will have a 24-pin DIP socket on top into which the E-PROM can be plugged. By replacing the ROM on the 3870 die with address and data buffers for the external device, the 3870 can access the external E-PROM as though it were resident on the chip itself.

Mostek plans to sell the entire assembled module, to be called the MK3874 P-PROM, for use in 3870 prototyping and for low-volume applications that don't justify the cost of masked ROM 3870 parts. The part will take no more board space than a 3870 ROM-resident device, thus

# **SCIENCE/SCOPE**

The planet Jupiter will be scrutinized as never before by a spacecraft to be launched from the Space Shuttle in January 1982. NASA's Project Galileo will consist of an orbiter and a Hughes-built probe that will journey together for 42 months to the massive planet. Scientists hope the mission will provide new insight into the origin and evolution of the solar system, as well as reveal why Jupiter mysteriously emits more energy than it receives from the sun.

The probe, after separating from the orbiter, will plunge deeply into the hostile Jovian atmosphere. Its six instruments will take temperature and pressure readings, analyze cloud and atmospheric composition, detect for lightning, and glean other data. The probe will be designed to withstand the force of Jupiter's intense atmospheric pressure for about one hour. The orbiter will relay probe data to earth and will continue its mission and circle Jupiter for 20 months, taking pictures and analyzing the atmospheres of the red-eyed planet and its four largest moons.

Using signals transmitted in sequential bursts lasting 1/30,000th of a second, a Hughes multiplexing system designed for jet aircraft is able to control more than a dozen channels for passenger entertainment and service over a single coaxial cable. Because the signals are too rapid to be discerned separately by the human ear, the channels for high-fidelity stereo music, movie sound tracks, and passenger address announcements all seem to operate simultaneously. Other channels regulated by the system include reading lights and flight attendant call buttons.

By eliminating the need for separate wires to each channel, the system is able to save several hundred pounds of weight. It also offers better reliability, lower operating costs, and improved passenger services. Hughes systems have been installed on every McDonnell Douglas DC-10 in the world today, and now six international carriers have specified the equipment for their Boeing 747s.

Hughes Radar Systems Group has career opportunities for engineers, scientists, and programmers. We design and manufacture many of today's most complex airborne and spaceborne radar electronics systems, including data links, electronic warfare systems, and display systems. These projects incorporate microelectronics, microprocessors, solid state microwave devices, and other advanced technologies. We need Systems Analysts, Microwave Specialists (antenna, receivers, transmitters), Circuit Designers (analog, digital & RF/IF), Scientific Programmers, Mechanical Designers, Product Design Engineers, and others. Rush your resume to Engineering Employment, Hughes Radar Systems Group, 2060 Imperial Hwy., El Segundo, CA 90245.

A contract to develop and build 100 satellite earth terminals has been awarded to Hughes by Satellite Business Systems. SBS, a partnership formed by Aetna Life & Casualty, Comsat General, and IBM, will receive the communications industry's first four-year warranty. The terminals will operate with the system's three satellites, also being built by Hughes to service U.S. businesses, government agencies, and public service organizations.

The unmanned terminals will be the first to use Ku-band frequencies (12 to 14 GHz) on a large scale in a U.S. domestic satellite. This makes possible small terminals located on customer premises, thus eliminating the need for a microwave link. With these highly-reliable redundant terminals, SBS data communications customers will benefit from a very high availability rate. The first engineering model is scheduled for delivery in nine months. All 100 terminals should be delivered by mid-1982.

Creating a new world with electronics



making for easy field prototyping, Mostek says. In contrast to E-PROM-resident microcomputers, the 3874's E-PROM can be removed, reprogrammed, and reinserted many times.

Including a Mostek-built 2716 E-PROM, the 3874 module is expected to sell initially in April in the \$115-to-\$120 range in small quantities, with 100-to-1,000-unit pricing around \$73. The device may also be available without an E-PROM for around \$75 in single units.

As additional 3870 family members become available, the 3874 type of package will be offered with the new dies as well, says Ron Baldrige, Mostek's strategic marketing manager for microcomputer products. The packages will accommodate other standard E-PROM parts besides the 2716, as well as various bipolar ROMs.

Some competitors snickeringly suggest that Mostek chose the 3874 piggyback packaging approach because it did not know how to integrate E-PROM on board a 3870 chip. Baldrige concedes that the difficulty of such a task was a consideration, since E-PROM processing is one of the trickiest technologies in the metal-oxide-semiconductor business today. But he contends that Mostek could have handled the on-chip E-PROM approach, had it chosen to do so. Rather, it prefers the piggyback's advantages.

**Standard gear.** For one thing, users of E-PROM-resident microcomputers have to buy specialized programming equipment, Baldrige says, whereas standard PROM programmers are good enough for E-PROM used with the 3874. And, he continues, users of the 3874 will have more E-PROMs to choose from than they would with a single-chip E-PROM-resident machine. The 3874 in its various configurations will also be able to support the 32-K 2732 and 2532 devices. To integrate that much E-PROM on a microcomputer chip would require circuits so large as to be unproducible today, Mostek says. For smaller program requirements, the 3874 will also handle 8-K 2758 and 82S2708 E-PROM devices.

From Mostek's own viewpoint, it

## News briefs

### TI reports sales of \$2.5 billion

With its eyes on a \$10 billion sales goal by the late 1980s, Texas Instruments Inc. reports a 25% sales gain for 1978, boosting its revenues to \$2.546 billion. Earnings for the year were up 20% to \$140.3 million, compared with 1977 profits of \$116.6 million on sales of \$2.046 billion, the Dallas-based company says. Other key figures just released in TI's 1978 annual report include: a record \$1.4 billion year-end order backlog, some \$486 million more than 1977's; capital and research and development expenditures of \$311 million and \$110 million respectively, up from \$200 million and \$96.2 million in 1977; and employment of 78,571 vs 68,521 a year earlier.

### Makers slash predictions of microwave oven sales

Microwave oven manufacturers are scaling back their industry sales projections, as much because of overoptimistic predictions as because of economic uncertainty. Though Litton Industries' Microwave Cooking Products operation in Minneapolis last year predicted 1979 sales of 3.4 million units, its latest projection for the industry is 2.75 million units. Industry consensus for 1980 sales is only a 9% increase, to 3 million units.

### Hughes, Raytheon named Amraam missile finalists

Development of the Air Force Advanced Medium-Range Air-to-Air Missile, Amraam, is in the hands of Hughes Aircraft Co. and Raytheon Co., under two contracts totaling \$84.5 million. Losers in the competition for the 33-month prototype awards were Ford Aerospace & Communications, General Dynamics, and Northrop. Amraam will improve on its Sparrow predecessor's performance by permitting pilots to fire several missiles at separate targets simultaneously at longer range. Production awards could exceed \$1 billion over 20 years for up to 10,000 missiles.

### Forecast sees Army buys of satcom terminals doubling

Inflation, rather than real growth, will fuel the projected 30% increase over seven years in the military market for communications satellite systems, says Frost and Sullivan Inc. The New York-based market analysts put 1983 spending at \$573 million. In that year the military will more than double its outlays for terminals from just under \$118 million in 1977, the firm predicts. The leading terminal buyer will be the Army, spending a seven-year total of \$883 million, the Navy \$303.5 million, and the Air Force \$245 million.

### Computer Automation cuts mini prices—again

For the second time in three months, Computer Automation Inc., Irvine, Calif., is slashing the price of its low-end minicomputer on a board, the LSI 4/10, and of other models in its board-level Naked Mini line. With a 32-kilobyte memory, the 4/10 sells for \$995, against the \$1,235 price in effect since November, itself a 42% cut. The LSI 4/30 mid-sized mini and the larger LSI 4/90 will be 9% to 48% cheaper, depending on memory.

### Worldwide fiber optics market to push \$2 billion by 1990

Paced by growing telecommunications applications, worldwide demand for fiber-optic cable systems should reach \$1.5 billion to \$2 billion by 1990, says Gnostic Concepts Inc. The Menlo Park, Calif., research company's new survey pegs the North American market at \$27 million for 1978, \$390 million for 1985, and \$974 million by 1990. It estimates the Japanese market at \$2.1 million, \$91 million, and \$333 million, respectively. Outlays in Europe will be somewhere in between.

### Ireland extends tax advantage

With the tax forgiveness feature of its aggressive program for attracting industry due to run out in 1980, the Republic of Ireland has come up with a successor: a tax of only 10% on export profits through 2000. However, allowances for plant expansion could, in effect, still mean a zero tax.

# Standard Microsystems' Family of MOS/LSI circuits.



**Floppy Disc**  
Hard-Sector Floppy Disc  
Data Handler  
FDC3400



**Cassette**  
Cassette/Cartridge  
Data Handler  
CCC3500



**Printer**  
Character Generator  
CG4103  
Static Shift Register  
SR5015  
Shift-Right/Shift-Left  
Shift Register SR5017/18



**Keyboard**  
Keyboard Encoders  
KR2376  
KR3600



**Memory ROM**  
32KROM/ROM 4732



**Custom LSI & Dedicated  
Microprocessors**  
N Channel Silicon Gate  
COPLAMOS®/CLASP®  
P Channel Metal Gate



**Programmable  
Frequency  
Synthesizers**  
Baud Rate Generators  
COM5018/5026/5036/5046  
COM8046/8116 8126/  
8136/8146



**Communications**  
UART COM 2017/2502/  
COM8017/8502  
USRT COM2601  
Multi-Protocol USRT  
COM5025  
ASTRO COM1671



**CRT**  
CRT Controller VTAC CRT5027  
CRT Controller CRT96364  
Character Generator CG7004  
VDAC™ CRT8002

**STANDARD MICROSYSTEMS CORPORATION**  
35 Marcus Boulevard, Hauppauge, New York 11787 (516)273-3100 TWX: 510-227-8898  
**We keep ahead of our competition so you can keep ahead of yours.**

Circle 45 on reader service card

Choose a  
**TELEQUIPMENT**  
Oscilloscope  
for:

**Reliability.**

Like the reliability you'll get when you take the 15-MHz D34 with you on a service call. A dual-trace, battery-powered portable, the D34 is built to take the rigors of on-site service and bounce back for more. It's a top choice for servicing business machines and communications gear.

Reliability is no accident with the D34 or the 8 other instruments built by Telequipment, a division of Tektronix. A family of high value oscilloscopes priced from \$495\* to \$1,995\*, TELEQUIPMENT Oscilloscopes are engineered for reliability from the earliest stages of design. Circuits require minimum calibration and components are chosen for off-the-shelf availability, stability and long life.

And TELEQUIPMENT Instruments are now sold through stocking distributors offering local availability, service, warranty repairs and models previously not sold in the United States.

For facts on Telequipment reliability and the name of the Telequipment Distributor nearest you write: Telequipment U.S. Sales, (43/000), P.O. Box 500, Beaverton, OR 97077 or call: (503) 644-0143.

\*Suggested U.S. list price

**TELEQUIPMENT** 

A division of Tektronix U.S. Ltd. a subsidiary of Tektronix, Inc.

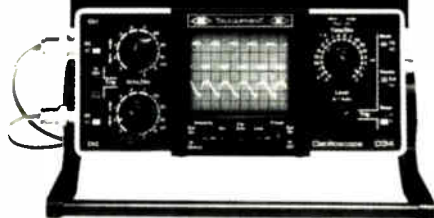

## Electronics review

will easily be able to provide E-PROM for its entire 3870 family with a single 3874 device. It will not have to redesign each chip specially to integrate E-PROM on board, Baldrige notes.

He also points out that the 3874 will be superior as an emulation tool to multichip emulator boards currently used for 3870 prototyping. This is because the 3874 will come much closer to being electrically identical to the part that is being emulated. □

### Solid state

## IBM logic adopts new gate arrays

Besides providing the basic building block for the latest computers from International Business Machines Corp. (see related story, p. 85), the new logic-gate arrays contained in the 4300 processor give an insight into the directions the computer industry giant is taking in implementing large-scale and very large-scale integrated circuits.

The new semiconductors are replacing the firm's so-called monolithic systems technology used in the nine-year-old System/370 line—a current-switched emitter-follower logic design that had gate delays ranging from 6 to 12 nanoseconds and, typically, contained six circuits on a chip.

IBM's future systems will apparently use LSI gate arrays customized by modifying their last layers of metalization. Computer-aided design systems for customizing chips are already installed at some 25 IBM design facilities worldwide.

**Bipolar logic.** The newest gate array uses current-switched bipolar logic. Each contains 1,496 gates, 88 receivers, and 64 high-powered driver circuits on a chip 224 mils square. In the 4300 processor, this bipolar array is used as a microprocessor for the 3880 disk-controller unit and is said to execute more than 5 million instructions per second.

Powered by +5.0- and +1.7-volt

supplies, the chip has typical gate delays of 1.5 ns and nominally dissipates 1.8 watts, according to designers Richard J. Blumberg and Stewart Brenner, who are describing the array at this week's International Solid State Circuits Conference in Philadelphia.

The receiver and driver circuits convert the levels associated with the Schottky transistor-transistor logic used in the rest of the 4300 to those needed by the current-switched logic of the new chip. An IBM spokesman describes this logic as similar to emitter-coupled logic but without the emitter-follower configuration. The higher of the two voltages is used for the receivers and drivers, and the lower is used for the logic gates, thus reducing the chip's overall power dissipation, Blumberg and Brenner say.

**System/38 array.** Also used in the 4300 is the same Schottky TTL gate array employed in the System/38 introduced by IBM's General Systems division [*Electronics*, Nov. 9, 1978, p. 81]. Measuring 179 mils on a side, the chip has 704 logic gates and 121 external connections, uses -1.5- and -4.25-v power supplies, and dissipates 1 w.

IBM's package is unusual. Rather than making all connections on the perimeter of the chip and using a dual in-line package, IBM relies on what it calls a "flip-chip" approach. In the final chip-fabricating step,

**Dots.** A 17-by-17 array of solder bumps marks the spots where connections can be made to the bipolar gate-array chip developed by IBM for a new disk controller.

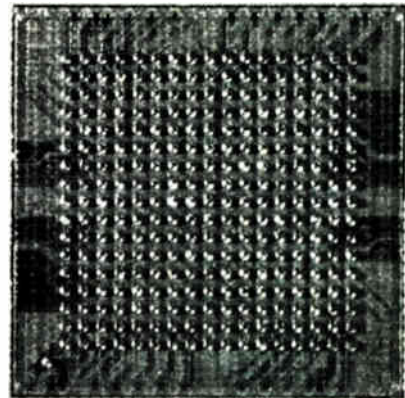



When we surveyed the pulse generator market, we discovered that what many of you wanted was unavailable: a Wavetek pulse generator.

Model 801 takes care of that.

It's a 50 MHz pulse generator with independent width, rate, and delay controls. It's a versatile instrument, with double pulse

capability, a pulse burst mode, and a pulse reconstruction feature. But above all, it's a Wavetek, as you can see, and as you can tell by the low price (just \$1,095).

We could go on about the fixed ECL, TTL, and ECL outputs, and the variable outputs up to plus and minus 20 volts. Or the adjustable rise/fall from less

than 5 nanoseconds. But this is an ad, not a data sheet. So why not circle our reader service number and get all the specs on Wavetek's first pulse generator: WAVETEK, 9045 Balboa Avenue, P.O. Box 651, San Diego, CA 92112. Telephone: (714) 279-2200, TWX 910-335-2007.

**WAVETEK®**

Circle 47 on reader service card

# Nobody ever put one of these on a pulse generator before.

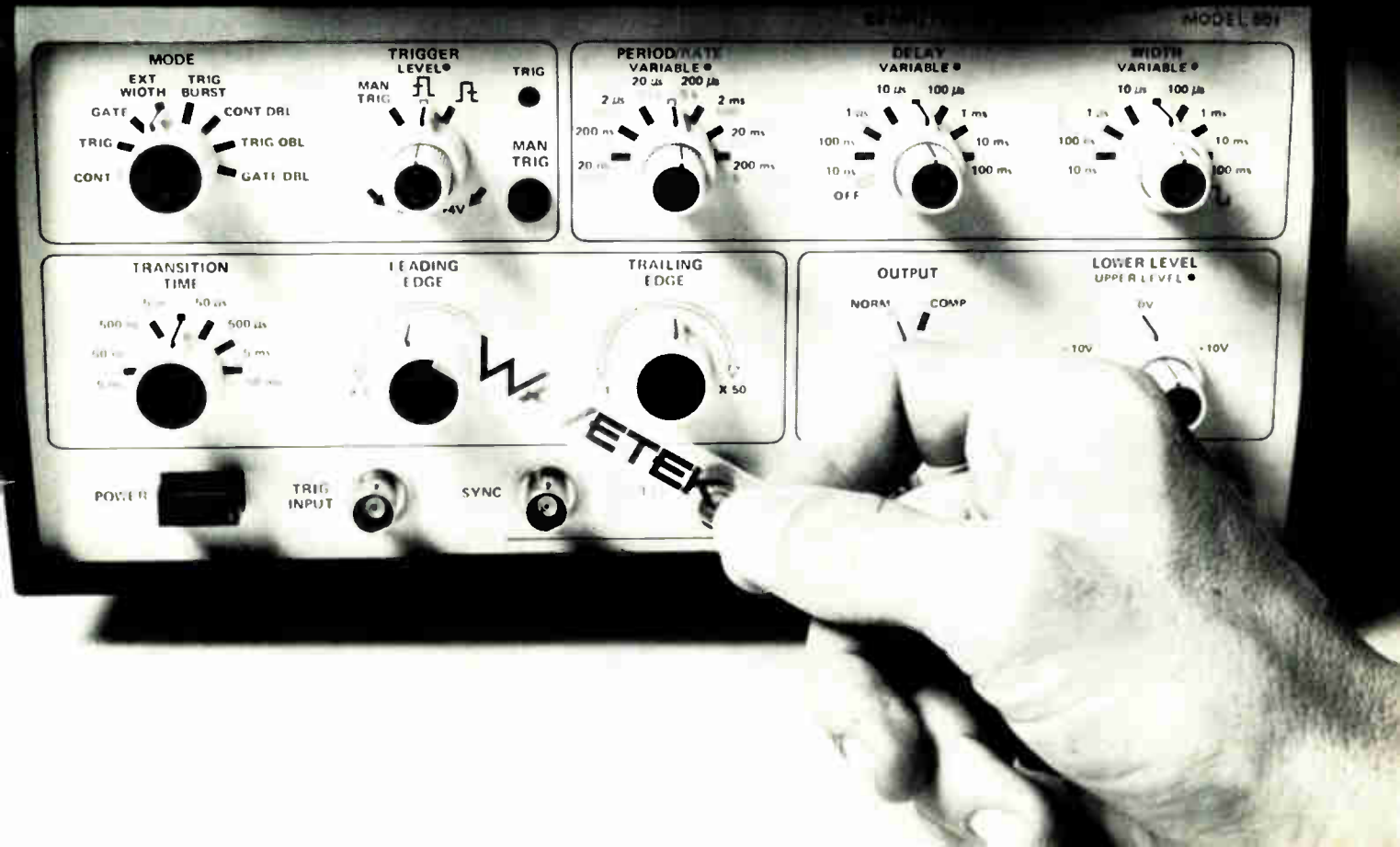

Between \$18,000 to \$45,000

Simply input ideas  
with Joystick or  
Graphic tablet



Computer does work,  
you do the thinking



Instant Recall: Add or delete  
entire blocks of drawings with  
one command

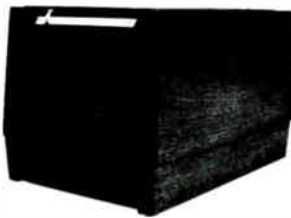

Plotter gives camera ready  
art in minutes

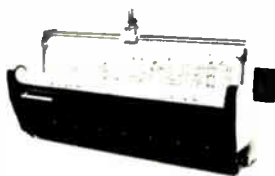

Only at I Corporation  
Order yours today!

- \* PC Layout
- \* Schematic
- \* Mechanical
- \* Hybrid

(415) 848-6600

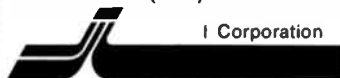

835 Addison Street  
Berkeley, CA 94710

## Electronics review

solder dots, shown in the photograph on page 46, are placed on the chip. The chip is then inverted onto a ceramic carrier and heated so that the solder reflows, bonding the chip to the carrier and making the electrical connection.

This method allows the designer a larger number of external connections and permits connections to be made to the middle of the chip. The microprocessor chip for the 3880 has 249 solder dots arranged in a 17-by-17 grid, although only 94 are used. The Schottky TTL chip has an 11-by-11 grid of 121 solder dots, down from the 132 used on a similar chip in the System/38.

They are made at the Data Systems division, East Fishkill, N. Y. This division was dedicated to making large complex systems and high-performance computers when IBM split its mainframe manufacturing operations last August [*Electronics*, Aug. 17, 1978, p. 44]. This gives rise to speculation that the new chips are the harbingers of faster gate arrays designed for new high-end units. □

## Distributors

### Semiconductor pinch continues to hurt

While all the signs of continued high sales volume have semiconductor companies beaming and large-quantity users coping with stretched-out lead times, distributors are caught in the middle. Orders are indeed coming in from their small-quantity customers, but where's the supply?

Not only are distributors waiting at the end of the supply chain for the newer devices, such as low-power Schottky and 16-K random-access memories, but they report ever longer delays for the established, commodity products. A sampling of key distributors across the country last week indicates that there has been no shortening of lead times so far this year as had been anticipated.

**Why the problem.** The reasons for the supply problem—it's not exactly

a panic situation at this point—are apparent high levels of real demand, double ordering, yield problems last year, and an overcommitment by some semiconductor producers to the as yet low-volume, high-technology products at the expense of the larger-volume established products. As usual, the vendors try to downplay the lead time stretch and make assurances that double ordering is not going to be a problem.

But this bravado does not sway the distributors who remember the boom-to-bust inventory disaster of 1974. For instance, Joseph Semmer, director of semiconductor business development for Hallmark Electronics Inc., a Dallas-based distributor, confirms that supplies of all digital logic parts "seem to have gone haywire in the last 30 days." He reports that in mid-January, Texas Instruments suddenly informed distributors that it would not take any more orders until Feb. 1. Shortly afterward, Motorola Semiconductor informed distributors that it would not take any orders in bipolar logic parts because it was booked up for the year.

"Recently, TI has said it will now take orders for deliveries on an allocation basis for July or August [which TI confirms]," Semmer relates. He expects TI to continue its allocation program on a month-to-month basis but says Motorola is now taking orders only on a "will advise" basis.

**Memories, too.** While distributors are worrying about getting bipolar logic, they are also experiencing problems with memories. In Chicago, Advent Electronics Inc.'s president Abe Halegua reports shortages of 4-K RAMs and read-only memories, including the popular 2716 E-PROM. Another sign of tight supplies to Halegua is the number of out-of-state calls he gets.

"By this measure, supplies of semiconductors are stretched thin in California," he observes.

Distributors in the West confirm this impression. Michael H. Wolf, national product manager of Wyle-Elmar, Mountain View, Calif., reports that low-power Schottky is out

# The Same?

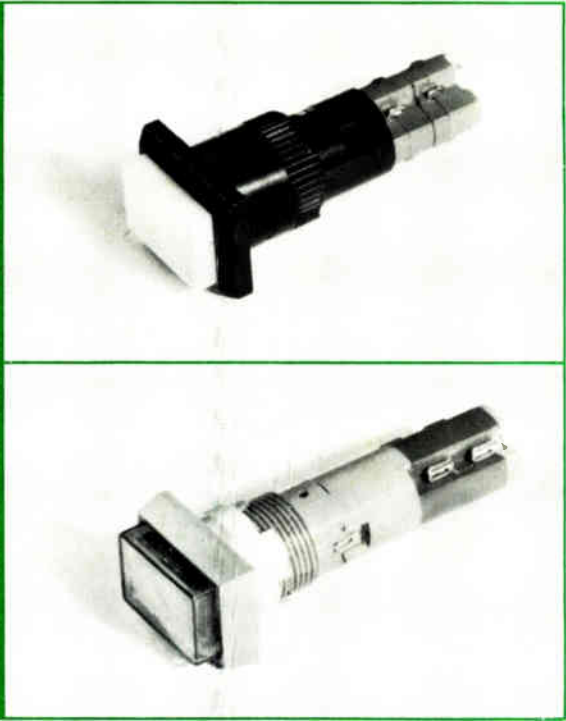

## You may not see the difference... But you'll feel it!

Switches can look very much alike, but those of you who have used the EAO Switch know it can't be duplicated. We have pioneered the switch, both simple and advanced, for over 20 years, and have been filling your performance demands, here in the United States, since 1971.

The advantage now is that we've entered the U.S. market independently. That means you get the same quality switches (such as series 01, 02, 03, 04, 11, 30, 31 and 41) you've been using all these years, directly, from our new Milford, CT headquarters. We will provide you with expanded customer service, engineering assistance, and immediate delivery. You'll be getting the highest in reliability from its original source... at a very competitive price.

As you know, EAO Switch offers the quality minded design engineer the best in instrument grade lighted pushbutton switches. Each one is carefully manufactured at our plant in Switzerland where workmanship and accuracy standards remain unmatched throughout the world.

Proven quality doesn't have to cost more so don't compromise. EAO Switch selects the finest materials, keeps a 20% work force in quality control, and utilizes advanced auto-

mated assembly for strict product uniformity. EAO Switch contacts and terminals are gold plated, light leakage has been virtually eliminated, and when illuminated, you see only true color brilliance... no hot spots, no halo.

The broad line of EAO Switches range from the highly styled to the rugged oil tight. All are backed with engineering know-how and such world wide approvals as UL, CSA, VDE, and SEV. That's why we're recognized as a source of product excellence.

We know that all switches are not created equal, so use your senses, beware of imitations, choose only the finest.

*EAO Switch, you can feel the difference.*



**Series 31 Rectangular Key Lock, from EAO Switch, with low-level switching element.**

# EAO SWITCH CORPORATION

255 Cherry Street/Milford, CT 06460/(203) 877-4577/TWX-EAO SWITCH MFRD 964347

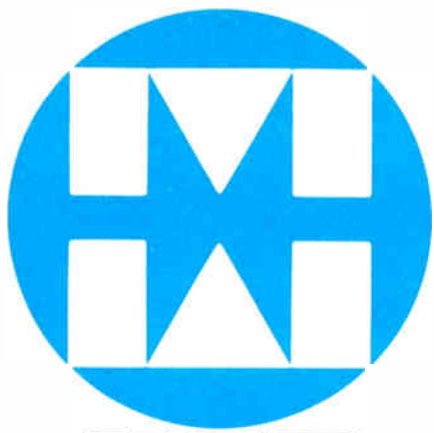

# MITEL

**MD 4104**  
**ISO-CMOS™**  
**QUAD**  
**LOW VOLTAGE TO**  
**HIGH VOLTAGE**  
**TRANSLATOR**  
**WITH 3-STATE**  
**OUTPUTS**

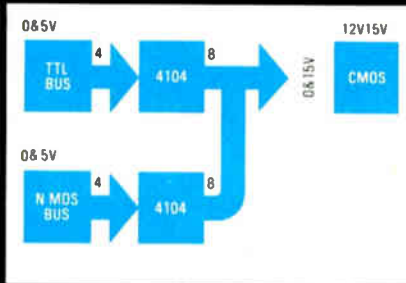

### Featuring:

- 3-State Fully Buffered Outputs
- 5V TTL, NMOS or CMOS to High-Voltage CMOS (12-15V)
- Dual Power Supply Inputs
- Both True and Complimentary Outputs
- Pin-for-pin with the Fairchild F4104/34104
- **LOW PRICE: \$1.00 in Volume Qty.**

Contact the leader in tone receivers and CMOS technology for more information:



1745 JEFFERSON DAVIS HWY  
 SUITE 611  
 ARLINGTON, VA 22202  
 TEL 703-243 1600

**MITEL**  
 Semiconductor

## Electronics review

anywhere from 20 to 50 weeks and standard Schottky is being affected, too. Bipolar PROMs are also stretched, Wolf adds.

Meanwhile on the East Coast, the story is the same with much more concern over double or even triple ordering. Seymour Schweber of Schweber Electronics, Westbury, N. Y., states, "Everybody knows that maybe 40% of their orders are going to disappear, but no one knows when." However, Donald A. Winans, vice president of marketing at Cramer in Boston, hopes that TI's allocation system will help prevent big double-order backlogs. □

## IEEE

### Suran to balance institute's goals

Members of the IEEE can look forward to a year that includes the promise from president Jerome J. Suran to try to strike a balance among the conflicting aims of the factions within the organization. At the same time, they can look to a fight to succeed Suran: executive vice president Leo Young is readying a petition campaign in the belief that the institute's board of directors will pass him over in designating its nominee for the 1980 presidency.

In announcing his program at a mid-January press conference in New York, Suran made it clear that he believes the Institute of Electrical and Electronics Engineers exists primarily to spread technical knowledge among its members. Yet he also voiced support for some of the socioeconomic goals promoted by the U. S. Activities Board.

The USAB is a focus of a basic dispute among members: should the IEEE concentrate on its technical activities to the exclusion of socioeconomic concerns, primarily that of employment. The debate has enlivened the annual campaign for election of officers in recent years. Young wants the IEEE to promote a stronger USAB. He fears USAB will take a back seat if the IEEE board, to

meet this month, chooses as the "official" presidential candidate for 1980 either C. Lester Hogan of Fairchild or Burkhardt H. Schneider of Detroit Edison—both selected by the IEEE nominating committee.

To defuse some of the controversy, Suran has promised to move towards board action on a bylaw change that would move the vice president for professional activities into an elected position [*Electronics*, Nov. 23, 1978, p. 44]. □

## Commercial

### Five microprocessors raise typewriter's IQ

Microprocessors are making their way into office and business machines—but a typewriter with five of them? That's what Olivetti Corp. of America has put into its ET 221, now in production in its Harrisburg, Pa., plant.

"It's a Z80-based system using slave 8041s," says Charles Ericson, manager of product design and development in Harrisburg. The 8041 [*Electronics*, July 7, 1977, p. 109] is an 8-bit single-chip microcomputer called a universal peripheral interface by Intel. "There's one apiece to run the daisy-wheel printer, the carriage, the keyboard, and the display," Ericson says.

**Capabilities.** The under-\$2,000 machine is a typewriter, he emphasizes, but it does boast capabilities associated with word processors. Among these are a 20-character, 5-by-12-dot vacuum fluorescent display for line-at-a-time editing, as well as storage of lines and page formats.

In the editing mode, each line goes into an 8,192-bit n-channel metal-oxide-semiconductor 2114. This static random-access memory stores two lines, as well as serving as a scratchpad for the Z80. The 2114 dumps its line data into an 8-K complementary-MOS dynamic RAM, which can store 829 characters of text—better than a page of an average business letter—as well as the line and page

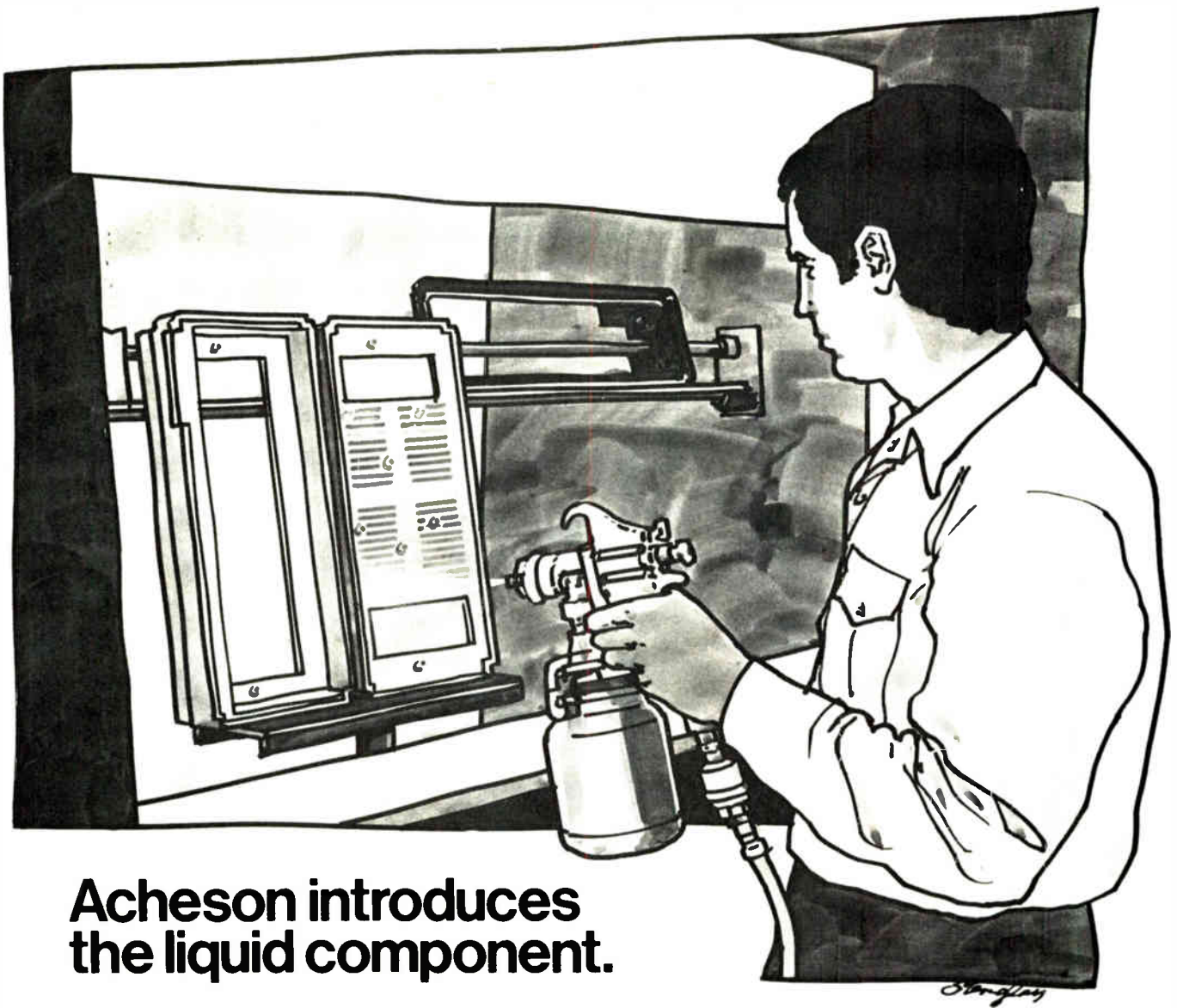

## Acheson introduces the liquid component.

### Electrodag®—for cost-effective control of both EMI and ESD.

To achieve electromagnetic compatibility you must control both EMI and ESD. And that's why Acheson Electrodag coatings should be a precise component *specified* in your initial design. Because Electrodag coatings provide *both* shielding and static bleed.

Highly effective, yet most economical, Acheson Electrodags are easy to apply—by spray, and even easier to cure. They air dry.

Now, compare the broad performance capabilities of Electrodag coatings with the *partial* solution offered by other technologies. Electrodag's ease of application versus the pretreatment, elaborate safety precautions and baking required with other metallic coating systems. All additional costs—for only a partial solution.

Among the wide range of Electrodag coatings you'll find one exactly right for your product. With the right conductivity, the right

solvent, the right degree of shielding and ESD control.

Specify Electrodag—Acheson's liquid component for *complete* EMC at much lower cost.

For additional information send us the coupon below. Or call: (313) 984-5581. In Canada, call: (519) 752-5461.



Electrical Products Dept  
Acheson Colloids Co  
Port Huron, Mi 48060

Please send data on Electrodag coatings

Name \_\_\_\_\_

Title \_\_\_\_\_

Company \_\_\_\_\_

Street Address \_\_\_\_\_

City \_\_\_\_\_

State \_\_\_\_\_

Zip \_\_\_\_\_

# in portable multimeters, compare our features, our quality, our price!

Analog, LED, and LCD—SOAR has the battery-operated multimeters for your application: the engineering and test lab, the field service technician, the small repair shop, and the radio hobbyist. Just take a look at some of the features of our instruments.

## ME-221 ANALOG MULTIMETER

It's drop-proof—the taut band absorbs shocks to 50 G's, and the meter movement is made in the U.S.A. Rugged and versatile, this multimeter has no equal at our price—\$30.00



## ME-521DX DIGITAL MULTIMETER

This truly portable (12.7 oz.) 3½-digit LED precision instrument has a HI-LO switch for all ranges, five function modes, and an accuracy of 0.5% (typical). Price—\$115.00



## ME-523 DIGITAL MULTIMETER

For the price, this is the best multimeter on the market today. It presents the function mode right on the LCD display, has a HI-LO switch for all ranges, an extremely long battery life, and an accuracy of 0.25% (typical). And all this for a price of \$150.00



And let's not forget our workhorse ME-522. It has almost all the features of the 523, but at an even lower price—\$135.00

Contact us TODAY for more details on SOAR's portable multimeters—and why not also inquire about our complete line of bench-type, tilt view DMM's.



**SOAR ELECTRONICS (U.S.A.) CORP.**  
813 2ND STREET  
RONKONKOMA, NEW YORK 11779  
TEL. (516) 981-6444/TELEX 144638

Circle 52 on reader service card

## Electronics review

formats. It can be divided into 10 sectors, recallable independently.

Simultaneously Olivetti is introducing the ET 201, which has just a two-character, seven-segment light-emitting-diode display that indicates print position only. It cannot be used for line-by-line editing.

The new machines are top-of-the-line typewriters, competing with products like the microprocessor-based \$1,485 IBM 50 and 60, which do allow some data and format storage in a RAM. The ET 221/01 capabilities are roughly equivalent to those of the Qyx Level 1 from Exxon Enterprises Inc. [*Electronics*, March 2, 1978, p. 46]. However, the \$1,650 Qyx is a low- or entry-level word processor, and the processing capabilities expand considerably up to the \$7,750 Level 5.

Like the new Olivetti typewriters, the Qyx machines replace almost all electromechanical parts with electronics. But the Qyx word processors stick to Z80s—two in the Level 1 and three in Levels 2 through 5—which also happen to be a product of its fellow Exxon subsidiary, Zilog Inc., Cupertino, Calif.

**Low-cost controllers.** Still, the ET 221/01 is unusual in its lavish use of microprocessor technology. The reason is simple, says Ericson. "Extremely low-cost controllers with a medium-price microcomputer give a tremendous amount of power without appreciably changing the cost." A single processor "can drive the peripherals but will have no time to do anything else." Ericson will not disclose exact cost figures, but he does say the electronics parts are about half the cost of the electromechanical parts they replace.

The program memory is four 32,768-bit 2332 read-only memories. Also used with the 8041s that drive the printer and the carriage are simplified analog-to-digital and d-a converter chips made to Olivetti's design by the Italian semiconductor house, SGS-Ates SpA. Initial production is limited to Harrisburg, but the Italian parent company, Ing C. Olivetti & Co. SpA, also plans to make the machines in one of its European plants. □

## From Electronics Magazine Book Series. Zero-risk trial offer.



### New Product Trends in Electronics, Number One

From "New Products," state-of-the-art materials and equipment, arranged according to function. \$14.95

### Electronics Book Series

P.O. Box 669, Hightstown, N.J. 08520

Send me \_\_\_\_\_ copies of "New Product Trends in Electronics, Number One" at \$14.95 per copy

Discounts of 40% on orders of 10 or more copies. I must be fully satisfied or you will refund full payment if the book is returned after ten-day trial examination.

Payment enclosed  Bill firm  Bill me  
Charge to my credit card:  
 American Express  Diners Club  
 Visa  Master Charge

Acc't No. \_\_\_\_\_ Date exp. \_\_\_\_\_

On Master Charge only, first numbers above name

Name \_\_\_\_\_ Title \_\_\_\_\_

Company \_\_\_\_\_

Street \_\_\_\_\_

City \_\_\_\_\_ State \_\_\_\_\_ Zip \_\_\_\_\_

Signature \_\_\_\_\_

# A/D CONVERTER

## Announcing a cost breakthrough in multi-channel, $\mu$ P compatible converters.

Fairchild just made a 6-channel analog-to-digital converter that's got a lot going for it.

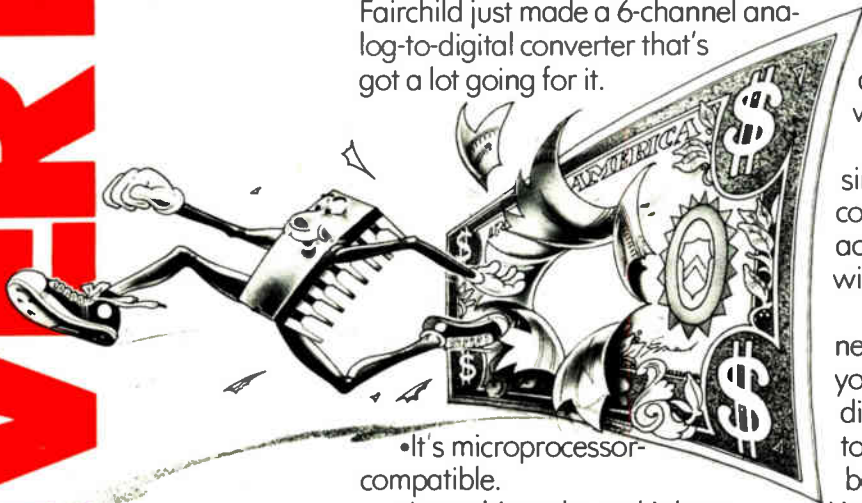

- It's microprocessor-compatible.
- It combines the multiplexer, decoder and sample-and-hold functions with the converter to save board space and eliminate external parts.
- It's low cost.

### Not just low, real low.

For only \$3.50 (100-piece price) you get a complete 8-bit, A/D linear subsystem. And the whole subsystem comes in either a plastic or ceramic 16-pin DIP so you don't have to play expensive design games to make it fit.

### Technical wizardry.

Fairchild technology makes it all possible. The  $\mu$ A9708 is a monolithic 6-channel, 8-bit converter, designed for use with microprocessor systems like the F3870 and the F6800.

It provides 8-bit,  $\pm 1/2$ -LSB conversion in 300 $\mu$ s featuring auto-zero and

full-scale correction capabilities, ratiometric conversion and a wide input dynamic range which includes ground.

The key to the  $\mu$ A9708 is a simple analog-to-pulse width conversion technique used to achieve high-accuracy conversions with no critical external components.

For more details about our new A/D converter, just contact your Fairchild sales office, distributor or representative today. Or use the direct line at the bottom of this ad to reach our Linear Division. Fairchild Camera and Instrument Corporation, 464 Ellis Street, Mountain View, Calif. 94042. Tel: (415) 962-4903. TWX: 910-379-6435.

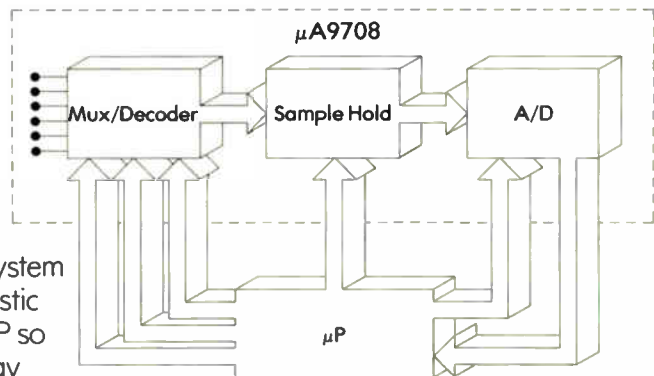

Typical  $\mu$ P Data Acquisition System Utilizing  $\mu$ A9708

**FAIRCHILD**

**Call us on it.  
(415) 962-4903**

# NEC Newscope

## NEC To Supply 100 RF Terminals For U.S. Digital Satellite Services

The Satellite Business Systems, Inc. (SBS) of the United States recently awarded NEC a contract for the provision of 100 RF terminals for its digital domestic satellite communications network.

The RF terminals will have a 5-meter or 7-meter diameter antenna — 14 GHz for transmission and 12 GHz for recep-

tion — and communications equipment including a high-power amplifier, low-noise amplifier and frequency converter.

These earth stations, intended for unmanned operation, will be installed at subscribing private and government organizations, as one of the SBS network

facilities for such domestic satellite services as speech, data, facsimile and television/telephone conference communications.

The 100 RF terminals will be delivered between February 1980 and August 1982.

## NEC America Dallas Plant In Full Swing



NEC America's Dallas plant has begun the full-scale manufacture of electronic private branch exchanges and electronic key telephones to meet increasing demands for these NEC products in the North American market.

The new plant, with floor space of about 5,600 square meters on a 48,000 square meter site, manufactures medium-capacity NEAX-12 electronic private branch exchanges and large-capacity popular Electra-100 electronic key telephones. It will start production of digital telephone switching systems for central office use next year.

## USSR Orders NEC Equipment In Readiness For Olympics

NEC recently announced a total of nineteen NEC System 100 office computers and eighty-four work station terminals will be delivered to the V/O Electronorg-Technica, and put into operation by April 1980.

These computers and terminals will be installed in eight hotels now under construction in Moscow for booking, check-in and check-out operations.

The communications facilities awarded by the V/O Mashpriborintorg consist of an Intelsat standard A earth station, a line-of-sight microwave communications system and studio-to-transmitter links.

The earth station will have access to the Intelsat IV-A communications satellite above the Atlantic Ocean for the transmission of color television, telegram and telephone signals.

It will be capable of transmitting four video programs at the same time via the Intelsat satellite so that receiving coun-

tries can select any of the four Olympic programs. In past Olympic Games, only one video program could be transmitted internationally through a communications satellite.



NEC System 100 office computer





Cassegrain 13-meter diameter antenna at MARISAT shore station in Yamaguchi, Japan.

## Japan's MARISAT Shore Station Is Officially Commissioned

Japan's shore station, the third in the world, was officially commissioned recently for maritime communications via MARISAT satellite above the Indian Ocean.

The shore station, completed by NEC for Kokusai Denshin Denwa Co., Ltd. (KDD), Japan's international communication carrier, is located at Yamaguchi in the westernmost part of the main island where KDD's Intelsat standard A earth station is also located.

The station features a complete duplex configuration except for its 13-meter diameter Cassegrain antenna commonly used both for C- and L-bands. The main facilities include 4 GHz 55K uncooled parametric low-noise amplifiers, 6 GHz

2.7kW air-cooled klystron high power amplifiers, C- and L-band transmitter/receivers, power supply units, and network control processors.

The new shore station is capable of providing 22 high-grade instant telegraph and two telephone lines between land subscribers and ships in the Indian Ocean and the waters off Japan, Southeast Asian countries, etc. via the MARISAT satellite above the Indian Ocean.

With the completion of the Yamaguchi shore station, the MARISAT System can now cover almost all the waters of the world.

In addition to shore station systems, NEC also manufactures a ship terminal which can handle the complete range of MARISAT services.

## NEC Delivers Its Largest Multi-Processor System To Osaka University

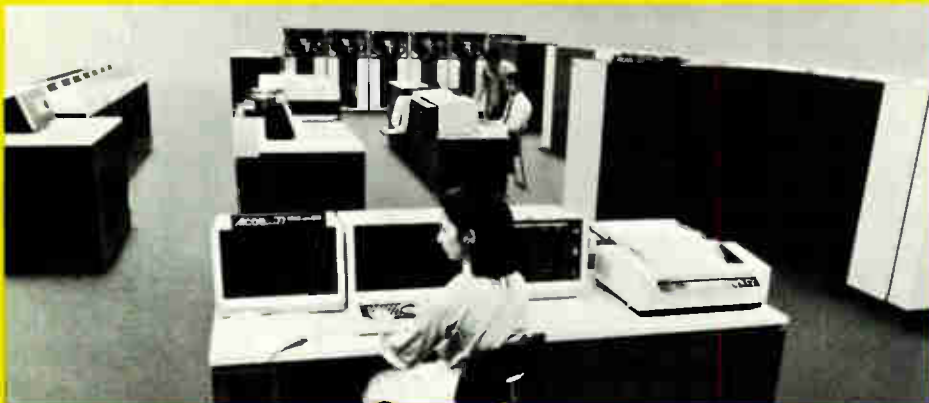

NEC System 900 Model 2 computer.

NEC recently delivered an ultra-large multi-processor system composed of two NEC System 900 Model 2 computers, the first two of the newly-unveiled top end model of the NEC System general-purpose computers, to Osaka University, Japan.

The NEC System 900 Model 2 has the world's largest instructions processing capability of 6.5 MIPS (million instructions per second), and the multi-processor system is capable of processing 11.2 MIPS.

An ultra-large host computer of NEC's

new information processing network architecture "DINA", it was designed on the basis of NEC's "C & C" — communications and computers — technology, and incorporates high-density LSIs with up to 200 gates per chip and LSI packages with up to 110 chips per package.

In addition, the system is intended for distributed multi-processing applications for the first time in the world. It is especially suited for a large-scale communications network and highly-comprehensive on-line data base system.

## First Micro-optic Devices For Optical Fiber Systems

NEC recently announced development of the world's first micro-optic components for optical fiber communications systems.

The new devices are "optical multiplexer", "optical branching filter", "optical directional coupler", "star coupler", "optical isolator" and "optical switch".

Newly developed "optical directional coupler" compared with conventional device.



**NEC**  
Nippon Electric Co., Ltd.  
P.O. Box 1, Takanawa, Tokyo, Japan

# Intel's MCS-86 begins a new era in microcomputers. Cramer delivers the total support to back it up.

Intel has brought forth the mighty MCS-86, the most comprehensive microcomputer system ever. Cramer gets it all together for you with delivery from stock, application assistance and state-of-the-art seminars.

The MCS-86 family is complete with 16-bit 8086 CPU, memory, peripherals, software, development tools and design assistance. You get prolific processing power, direct addressability to a full megabyte of memory with 8-bit and 16-bit signed or unsigned multiply or divide. This whole family is upward-compatible from the 8080 and 8085. The MCS-86 family of circuits comes in kit form, too. It's called the SDK-86 and it contains everything you need to build a useful, functional system.

At the Cramer  $\mu$ University of Microcomputers, you can catch a seminar on the MCS-86 family. Or any other of the tuition-free series of technical seminars conducted by Cramer. And at Cramer's Microcomputer Design Centers, you can get hands-on experience with the Intel MCS-86 and a host of other microcomputers.

Only Intel gives you total support. Only Cramer gives you so much service. Quick deliveries from local stocks. Quick access through a computerized nationwide inventory. Air-pac shipments. Competitive pricing. Technical and design assistance. And, of course, the broadest line of microcomputers, peripherals and systems in the industry. Send the coupon. Or contact your nearest Cramer stocking center today.

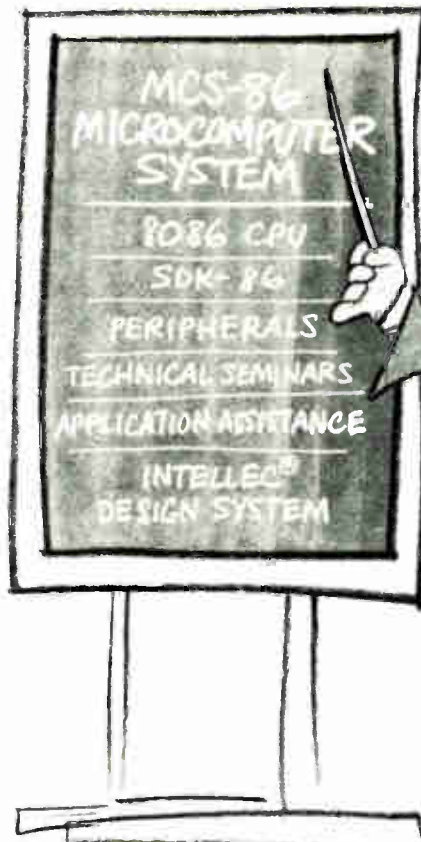

*Professor Chips has all the answers on MCS-86.*



**cramer** | **intel**  
CRAMER ELECTRONICS INC.

## We've got it:

### NORTHEAST

Cramer Electronics, Inc.  
(617) 964-4000  
Connecticut (203) 265-7741  
Rochester (716) 275-0300  
In Canada:  
Toronto Area (416) 661-9222  
Montreal Area (514) 871-8985  
Syracuse (315) 652-1000  
Services (617) 969-8566  
METRO/MID ATLANTIC  
Long Island (516) 231-5600  
New Jersey (201) 785-4300  
Pennsylvania (609) 235-6920  
and (215) 923-5950  
Washington (301) 948-0110

### MID WEST

Chicago (312) 593-8230  
WATS (800) 323-6621  
Cleveland (216) 248-8400  
In Pittsburgh (412) 242-7410  
In Ohio (800) 362-1140  
Outside Ohio (800) 321-1320  
Dallas (214) 661-9300  
Texas WATS (800) 492-6940  
Oklahoma/Arkansas WATS (800) 527-2028  
Houston, Texas WATS (800) 492-6940  
Minnesota (612) 835-7811  
WATS (800) 328-6212

### SOUTHEAST

Atlanta (404) 448-9050  
Outside Georgia (800) 241-4300  
Ft. Lauderdale (305) 973-4250  
Orlando (305) 894-1511  
Winston-Salem (919) 725-8711  
WEST  
Denver (303) 758-2100  
New Mexico (505) 243-4566  
San Diego (714) 565-1881  
In Los Angeles area (714) 540-7612 and (213) 624-8363  
San Francisco (408) 739-3011  
Seattle (206) 575-0907  
In Portland (503) 223-0947

### INTERNATIONAL

International (617) 969-7700  
Telex 92-2486  
Cable-Cramerel  
England 44-09327-85577  
Telex 851-923592

*\*Authorized Intel stocking locations.*

Tell me more about Cramer's and Intel's microcomputer family

- Send me information about attending Cramer  $\mu$ University
- Send me your 784-page Cramer Buyers Guide
- Send me information on the new MCS 86 systems and the prototype design kit
- Ask my Cramer field applications engineer to call me

Name \_\_\_\_\_ Title \_\_\_\_\_  
Company \_\_\_\_\_  
Address \_\_\_\_\_  
City \_\_\_\_\_ State \_\_\_\_\_ Zip \_\_\_\_\_

Mail to: Cramer Technical Literature Center  
85 Wells Avenue, Newton, Ma 02159

E-2/15

## Washington newsletter

---

### **Anti-inflation rules in NASA contract called illegal**

Corporate confusion over President Carter's pay and price guidelines is expanding following a Government attempt to incorporate them into a space shuttle contract congressional investigators say is illegal. At issue is the National Aeronautics and Space Administration's early February award of another \$2 billion to Rockwell International Corp., Downey, Calif., for three more shuttle vehicles. **The contract is the first to make the pay and price guidelines a part of the agreement.** The White House Office of Management and Budget (OMB) has issued regulations requiring compliance with anti-inflation guidelines in all Federal contracts over \$5 million issued after Feb. 15, a ruling that would cover 62% of the Government's \$85 billion annual procurement. Yet Congress's General Accounting Office says the guidelines were issued on a voluntary basis and have no effect in law, and it is urging Congress to act unless OMB cancels its contract requirement.

### **Inquiry set into electronic mail plans of post office**

Competitive private development of electronic message services got a boost late last month when the Federal Communications Commission inaugurated an investigation into the legal and policy issues of the U. S. Postal Service's proposal for electronic computer-originated mail [*Electronics*, Dec. 21, 1978, p. 36]. The new inquiry under Docket No. 79-6 **should forestall Postal Service plans to begin ECOM, as it is known, next month** and thus save the National Telecommunications and Information Administration (NTIA) the embarrassment of not having a policy recommendation ready for the White House on the post office market entry before the service begins. Leaders at the NTIA and the Justice Department oppose the Postal Service plan. But the FCC action came at the urging of another opponent—Graphnet Systems Inc., a small facsimile-message transmission and delivery carrier.

### **FAA names Boeing to study simpler cockpit warning aids**

Now that there are 150 visual and aural warning systems in the cockpit of some modern jetliners, the Federal Aviation Administration wants to simplify and standardize the technology. **Boeing Co. of Seattle is getting a \$917,000 two-year contract to produce and test at least three prototype systems** that the FAA can use in developing guidelines for aircraft and avionics manufacturers. Lockheed and McDonnell Douglas will serve as subcontractors. The agency says multiple alert systems could be replaced, for example, with a single tone that would either draw the pilot's attention to a cathode-ray tube display spelling out the problem or indicate he should push a button to call up a checklist for display.

### **SBS wraps up earth station awards**

Satellite Business Systems Inc., McLean, Va., has completed its initial contracts for components of customer ground stations with an award to Tokyo's Nippon Electric Co. for design, development, and production of 100 port adapter systems. Deliveries will begin next January after SBS tests of three prototype systems, which interconnect the voice and digital ports of the satellite communications controller. **The award, the value of which was withheld, is NEC's third** for major components of the domestic satellite system. Last month NEC won a contract for five terminals to be used in the 12-to-14-gigahertz tracking, telemetry, and command system [*Electronics*, Jan. 18, p. 57]; last year it won a contract for 100 rf terminals for earth stations on customers' premises.

## DOD's opportunities and NATO's threat for 1980

For the second straight year, the Department of Defense's spending plan holds out significant increases in contract dollars for the electronics industries. That money, coupled with the uncertainties developing in other segments of the economy, guarantees greater competitive interest in the Pentagon's programs for the fiscal 1980 year that begins next October.

Money for electronics in the two categories that count—procurement and research, development, test, and engineering—totals more than \$15.5 billion, roughly 40% of the total. The figure represents a 13.3% gain on the current year's spending level and more than offsets inflation, now pegged at just under 7%.

Congress must still act on this good news, of course. Yet conversations with staffers on the House Appropriations and Senate Budget Committees indicate that DOD's bigger budget for electronics procurement and R&D faces few threats and none whatsoever from embittered sponsors of social programs who believe they have been shortchanged by the White House. "Sacred cows like Social Security probably won't be cut the way the White House wants," observes one analyst. "But when that extra money is budgeted, it won't be at the expense of the Pentagon; it will be at the expense of the Federal deficit" that President Carter wants to reduce to \$29 billion.

### New stress on technology

One reason for DOD's budgetary strength this year is Defense Secretary Harold Brown. In his annual report to Congress at the end of January, Brown spelled out policies and programs with remarkable candor, clarity, and precision. It took him nearly 350 pages to do so, and congressional opponents of increased military outlays will find it difficult to find flaws in Brown's spending plans. Rather than attempt to match the Soviet Union and its Warsaw Pact allies on a weapon-for-weapon basis, Brown insists that the U.S. and its NATO allies should strive "for balanced forces: nuclear and nonnuclear; ready as well as modern."

To achieve that modernization, Brown's science and technology segment of the budget is designed to revitalize the interest of the nation's semiconductor companies in military R&D. Dollars for basic technology of all types exceed \$2.3 billion, up from the current \$2 billion level and making it the second straight year in which spending will rise by 14%.

New to the 1980 R&D budget is the program to develop very high-speed integrated circuits

[*Electronics*, Sept. 14, 1978, p. 81]. Brown puts VHSI at the top of his list of nine basic research priorities. With \$32 million to initiate the six-year R&D effort, Brown hopes it will "achieve major advances in IC technology, including an order of magnitude reduction in size, weight, power consumption, and failure rates and a hundredfold increase in processing capacity." Circuits with these capabilities, he says, "will allow important and significant advancements in cruise missiles, satellites, avionics, radar, undersea surveillance, electronic warfare signal intelligence, and systems for command, control, and communications."

Ranked right behind VHSI is Brown's program for increased R&D on precision-guided munitions technology, which he says will "capitalize on increases in microelectronics and signal processing."

### Sharing with NATO

Despite such R&D initiatives and a host of procurement programs heavy with electronics subsystems, U.S. defense contractors still have problems with Harold Brown's programs for the North Atlantic Treaty Organization. Even though strengthening the NATO alliance is a principal reason for the fiscal 1980 increases, U.S. contractors are uneasy about the prospect of sharing technology and contract dollars with their European counterparts within NATO.

In response to Europe's call for "more of a 'two-way street' in defense buying," Brown says the U.S. will increase competition throughout the alliance for new weapons. Moreover, says the defense secretary, "we are making major efforts to buy already developed European equipment for U.S. use where it meets our needs at a competitive price. Finally, we are working on a dual production program in which we will make our latest existing defense developments available for production in Europe."

While Brown believes these programs will produce "a major improvement in the efficiency of defense R&D and procurement for the NATO alliance as a whole," some electronics suppliers see such efforts as threatening more than their military market share. "A lot of companies," says one congressional budget staffer, "suspect they might lose their leverage in related industrial and commercial markets as well if they are obliged to share their technology." The prospect of constituent companies losing dollars and jobs to Europe does not sit well with many members of Congress, and DOD would like to head off industry from raising the issue. **Ray Connolly**

# Now... Power Darlington in 14-lead plastic DIP.

## The perfect package for automatic insertion.

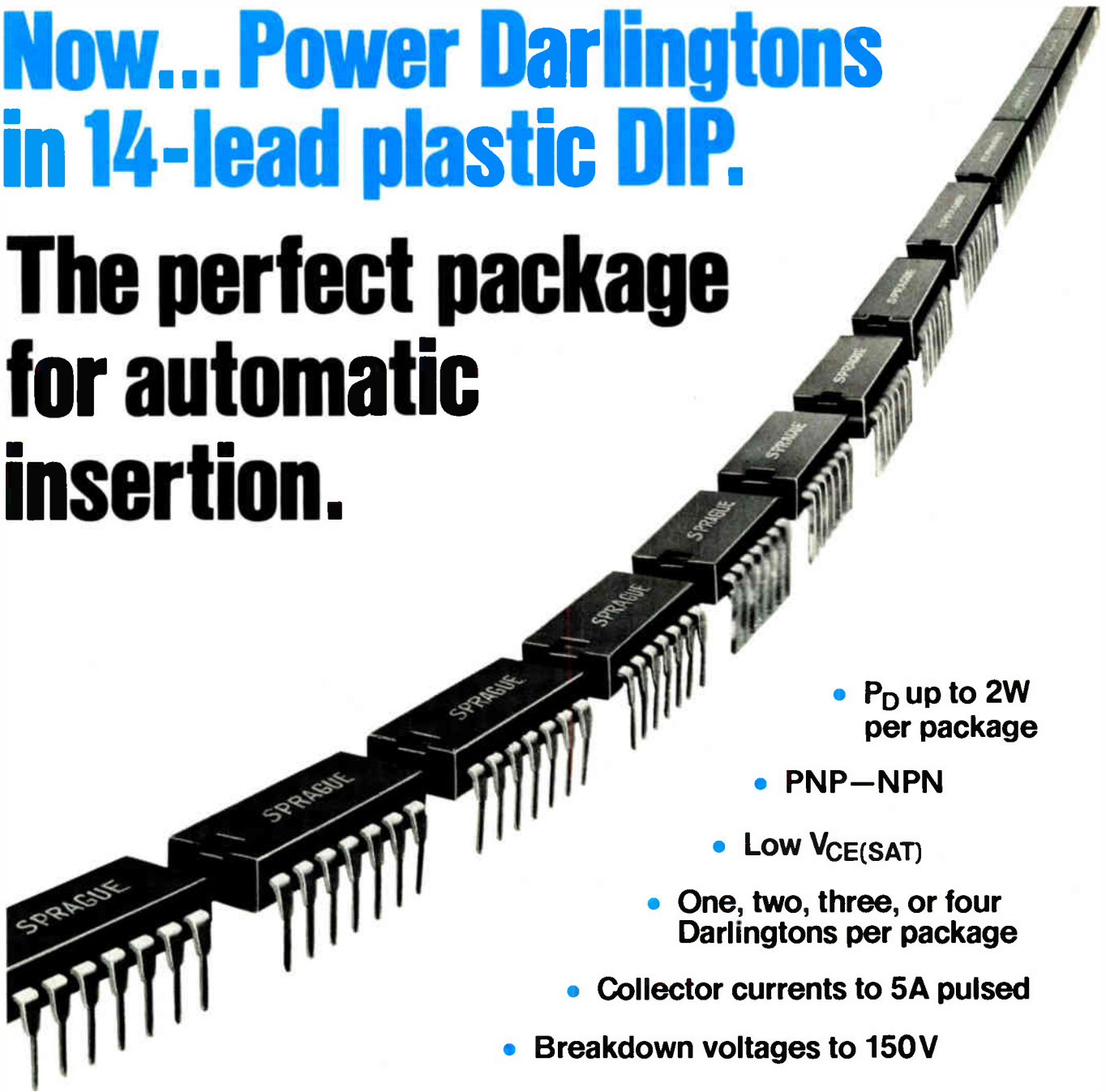

- $P_D$  up to 2W per package
- PNP—NPN
- Low  $V_{CE(SAT)}$
- One, two, three, or four Darlington's per package
- Collector currents to 5A pulsed
- Breakdown voltages to 150V
- Also available as chips; chip sizes range from .020" sq. to .120" sq.
- Don't forget . . . Sprague also makes small signal Darlington's in a TO-92 package and in a chip as well

*For complete information, write or call Allan Kimball,  
Semiconductor Division, Sprague Electric Company,  
70 Pembroke Road, Concord, N.H. 03301.  
Telephone 603/224-1961.*

**THE BROAD-LINE PRODUCER OF ELECTRONIC PARTS**



4SS-8127  
a  
**General  
Cable**  
subsidiary

*. . . and you thought we only make great capacitors.*

# Rent it and Relax!



# When you need electronic equipment without waiting, Leasametric can have it on its way to you in minutes.

There's no reason to call every one in the book when you need electronic test equipment or terminals. One phone call to Leasametric can solve your equipment problems in minutes. You can relax knowing your equipment is on its way to you.

AUTEX, Leasametric's nationwide computerized inventory system, pinpoints the nearest regional inventory center that has the equipment you need. Within minutes, your order is being processed and, in most cases, your equipment will be in your hands in 24 hours.

If it's worth having, you know you can rent it from Leasametric. Our continuously expanding inventory includes a \$35,000,000 rental pool of over 23,000 items from the top 500 electronic manufacturers—including most of the items in the Hewlett-Packard and Tektronix catalogs.

Plus, we're the first to get delivery of the latest equipment. And, with our enormous buying power and resources, chances are good that even if it isn't yet in stock we can locate it for you and let you relax!

No small point, the Leasametric name means the equipment you rent is in working order when we ship it. Our regional maintenance laboratories are traceable to the National Bureau of

A Leasametric exclusive. AUTEX instantly confirms equipment availability and starts your order on its way.

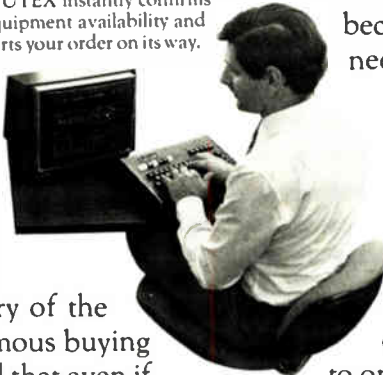

Standards and every piece is thoroughly calibrated before it goes out the door. Test and maintenance facilities are also maintained at most of our dozens of local offices across the country. When you rent it from Leasametric it works!

Renting from Leasametric also makes good economic sense. There's no capital investment. For a modest monthly payment you can be using equipment that could never fit in your budget if you had to purchase it.

Internal approvals are shortened, too, because you can usually rent what you need without major corporate approval cycles. And, of course, renting gives you a chance to use the very latest models. You don't have to watch a major investment in equipment become gradually obsolete. You can take advantage of the latest technologies—check out costly gear without committing to one manufacturer's hardware.

When you need it now, don't wait and don't take on the time-wasteful burden of trying to locate it yourself. To order, or for our latest rental catalog, call one of the relaxing toll free Leasametric numbers shown below. Let us get the equipment you need on its way to you in minutes!

## Leasametric/Rent it and relax.

In the West

**Call 800-227-0280**

In California, call (415) 574-4441

In the Central U.S.

**Call 800-323-2513**

In Illinois, call (312) 595-2700

In the East

**Call 800-638-4009**

In Maryland, call (301) 948-9700

**A Trans Union Company**  
1164 Triton Drive, Foster City, CA 94404

# RCA first in CMOS

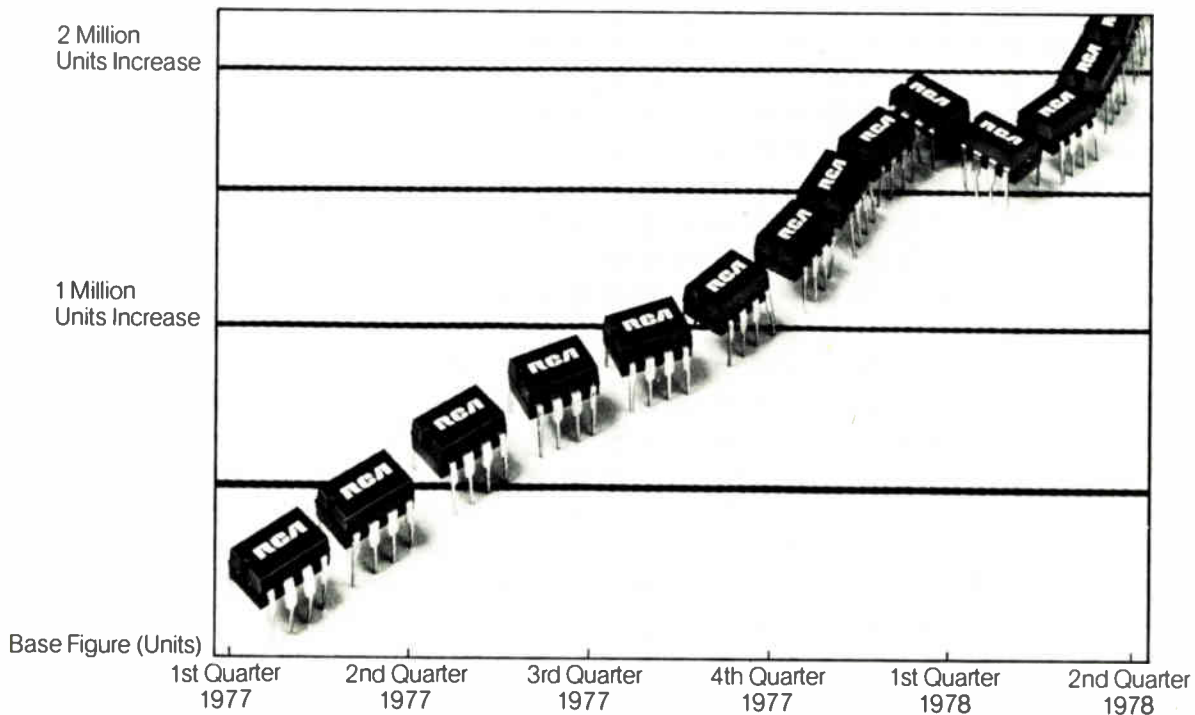

We got the bandwagon started, and we're keeping it rolling. Faster than ever.

### Still adding types

We've just added 15 new types. So now there's a total of 225, the industry's broadest CMOS line. Most of these are available in High Rel versions.

### "B" versions across the board

For just about every "A" there's a "B". Result: More options for a closer match to the application. If you're still using "A"s, be assured that we are as committed to supplying them as ever.

### Volume still climbing

The curve above tells the acceptance story. It shows the increase in actual

sales of COS/MOS ICs off distributors' shelves. With RCA producing COS/MOS at the highest rate in our history, you can be sure of prompt delivery. And we're *continuing* to put more of our energy and resources into the CMOS technology.

For immediate delivery, contact your RCA Solid State distributor. For more information, contact RCA Solid State headquarters in Somerville, NJ; 1130 Brussels, Belgium; Sunbury-on-Thames, Middlesex, England; Quickborn 2085, W. Germany; Ste. Anne-de-Bellevue, Quebec, Canada; Sao Paulo, Brazil; Tokyo, Japan.

RCA COS/MOS experience is working for you

62 Circle 62 on reader service card

# RCA

Electronics/February 15, 1979



## **NEC and NEC Toshiba expand power of low-end mainframes . . .**

Nippon Electric Co. and NEC Toshiba Information Systems Co. have just increased the power of the bottom end of their mainframe line with their ACOS System 250 models 40 and 60, which they say **include features formerly found only on the largest computers**. Both are designed for a combination of multiple-workstation, batch, and on-line processing. Much of the operating system is built as firmware or hardware for faster speed; this design also makes the entire read/write memory available to users. Throughput is said to be 0.1 million instructions per second for the model 40, 0.2 million instructions per second for the model 60. The main memory capacity of the model 40 is from 256 kilobytes to 1 megabyte in 256-kilobyte steps, and the model 60s's capacity extends to 2 megabytes. The two will compete in the same market range as IBM's new System/38 and its just-announced 4300 series (see p. 85).

## **. . . and Siemens extends its low end downward**

Spurred by the market success of its desk-sized computers 7.708 and 7.718, West Germany's Siemens AG will soon come out with its 7.706, another low-cost machine that extends the company's line downward. The new model, which Siemens considers "our answer to IBM's System/38," will rent from upwards of about \$3,700 a month, depending on configuration. Like the 7.708 and 7.718, the 7.706 uses a simplified version of Siemens' virtual, dialog-oriented operating software BS2000. The new model's central processing unit **performs some 90,000 operations per second**. Its main memory has a capacity of 384 kilobytes, extendable to 1,024 kilobytes.

## **Phillips developing 3-Gb/s ECL multiplexer for fiber-optic links**

With an eye to future long-haul fiber-optic telecommunications links, the Philips Research Laboratories in Redhill, Surrey, has come up with a superfast monolithic multiplexer capable of interleaving four 250-mega-bit/second bit streams into a single 1-gigabit/s data stream and of demultiplexing it at the receiver. **Key to the emitter-coupled-logic multiplexer is a current-steering ring circuit that controls a bit serializer and halves the clock rate for a given multiplexed data rate**. The experimental integrated circuit can thus be clocked at up to 1.5 GHz to give a 3-Gb/s maximum data rate. That's at least 10 times faster than production ECL multiplexers. This speed will be needed if the broad bandwidth of fiber-optic links is to be exploited. One-of-eight-line and higher-order multiplexers can be built from combinations of the ICs. Circuit design yields transistors with a 5-GHz cutoff frequency. The part consumes 500 mw.

## **French town gets network that ties bank to POS terminals**

A cashless society of sorts has begun to emerge in Bourg-en-Bresse, an agricultural town some 40 miles northeast of Lyons. Early this month, the Banque Régionale de l'Ain put into service a network of 13 IBM 3614 automatic teller stations and a batch of IBM 3608 point-of-sale-terminals in more than 50 stores and service stations in the town, all tied to the bank's central computer, an IBM 370/138. In addition to the usual card-controlled transactions at the teller stations, card holders can also pay for purchases at the point-of-sale terminals, which both debit the buyer's account and credit the store's account immediately. IBM says this is the first network of its kind in Europe and **the first anywhere that debits and credits accounts in real time through a point-of-sale terminal**.

## International newsletter

---

### **ITT Semiconductors gears up for 64-K RAM production**

For its British-designed 64-K random-access memory, scheduled for the second half of 1979, ITT Semiconductors will back Mostek Corp.'s refresh specification of 128 refresh cycles per 2 ms, rather than Texas Instruments Inc.'s 256 cycles, 4 ms, but has not yet decided on automatic refreshing. With production of 4-K and 16-K RAMs now running at 150,000 parts per month, ITT is the largest memory maker in Europe. It is investing \$20 million, partly supplied by the British government, in 4-inch wafer facilities, project aligners for 3- $\mu$ m line-width electron-beam masks, and an automatic chip-bonding production line at its Footscray, Kent, facility. As the assembly line phases in, ITT plans to bring Far East assembly operations back to the United Kingdom.

### **Fixed-head VCR uses old idea to get reel without end**

A fixed-head video tape recorder being developed by Toshiba Corp. features a cassette with a single reel of endless tape—the planar magnetic video equivalent of Thomas Edison's cylindrical phonograph records. The tape has 220 tracks across its width. Toshiba's scheme allows the 100-meter loop, which runs at 6 m per second, to give one hour of playing time. The relative speed between the head and the tape is similar to that of the currently popular helical-scan VHS and Betamax VCRs (which use a slow-moving tape and rapidly moving heads), permitting the use of the same types of heads and tapes. **The microprocessor included in the prototype permits random access of individual tracks; track access time is 20 ms to traverse one track pitch.** Toshiba says the recorder is suitable for both consumer and professional use.

### **BBC codes composite video color signal to pack in 34 Mb/s**

Hastening the day when European nations will interchange broadcasts over high-quality digital, instead of analog, links, British Broadcasting Corp. engineers have demonstrated a composite PAL signal-coding technique that packs a complete television signal with all its ancillary services into a standard 34-megabit/second data link. In contrast, digitization of the video signal using conventional pulse-code-modulation techniques takes up at least 100 Mb/s. The BBC system cuts the bit rate by **coding the composite video signal, rather than its constituent colors, by removing the line and field blanking intervals,** and by the use of a differential PCM. Britain's Independent Broadcasting Authority is also adopting a similar approach. However, this approach contrasts with West German and French systems using constituent color coding.

### **Hitachi to sell color TVs to China . . .**

Japan's Hitachi Ltd. says it has a contract with the People's Republic of China to supply 20-inch color TVs for reception of PAL telecasts. **The firm will ship 100,000 units,** at the rate of 1,000 a month, starting in March. It will also ship 10,000 air conditioners for nonresidential installations—probably offices.

### **. . . while Sharp will ship LCD capability to East Germany**

The Japanese and East German governments have given the go-ahead for Sharp Corp. to export the plant, technology, and materials to make liquid-crystal displays for calculators and digital watches to the Foreign Trade Enterprise of the GDR Elektronik Export/Import. The plant will be located in East Berlin. Sharp expects to ship equipment in July. **It says that the value of the deal is roughly \$7.5 million.**

# MANY CUSTOM IC COMPANIES CLAIM LEADERSHIP. ONE ACHIEVES IT.

**Quote:** "Silicon Systems is the largest and best independent design company."—Gnostics Concepts. (1)

**Quote:** "Silicon Systems is believed to be the independent design firm with the largest sales revenue."—Anderson/Bogart. (2)

**Quote:** "Both the Development program and production of hundreds of thousands of chips have gone absolutely smoothly."—Linear Corp. (3)

**Quote:** "Silicon Systems chips not only work, but exceed most specifications, including the 140-MHz speed requirement, by a factor of two."—NRAO. (4)

Both independent analysts and customers agree: SSi leads the field in custom IC's. No wonder—we specialize in custom IC's and *only* custom IC's. We offer all the capabilities required to produce custom IC circuits from initial design through small runs or large volume production. What's more, we've maintained the flexibility to work quickly and cost-effectively in any of the processes—TTL, Schottky TTL, ECL, PL, Bipolar Linear, PMOS, CMOS, NMOS—whatever is right for you.

You'll find the full story of our in-depth experience in designing and producing custom IC's in our new

capabilities brochure. Read the case histories. See how our custom circuits have helped Linear Corp. develop a better garage door opener, how two SSi circuits were developed for the National Radio Astronomy Observatory to process antenna information, how a custom SSi IC made feasible a portable battery-operated Edit Code Generator for EECO, how we reduced a complex electronic requirement into a cost-effective production IC for Lear Siegler, etc. Don't take our word for it. Read the case histories and talk to the people who know us best—our customers.

If you haven't taken the custom IC step yet but have been thinking about it, call Jim Meyer for personal answers to your questions, or send for the brochure today.

Silicon Systems incorporated, 16692 Hale Avenue, Irvine, California 92714. Phone: (714) 979-0941.

- (1) Gnostic Concepts, Inc., *VLSI Technological Market Forecast*, 1978, Palo Alto, California.
- (2) Anderson/Bogart, *Vertical Dis-Integration* 1978, Los Altos, California.
- (3) Linear Corp., Bill Schanbacher, President, Inglewood California.
- (4) National Radio Astronomy Observatory (NRAO), Ray Escoffier, Program Manager, Socorro, New Mexico.



## Silicon Systems incorporated

# Three ways digital storage makes Biomation's 8100 number one.

## 1. Capture one-time analog events.

There's no better way to record one-time events than our 8100 Waveform Recorder. It captures analog signals, converts them to digital data, then stores that data in semiconductor memory, provides display, plot or digital outputs of captured signals.

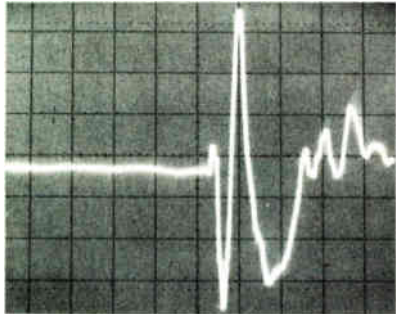

Digital storage techniques enable us to give you "pre-trigger" recording. You can actually begin recording a random signal before you know it's going to occur, and apportion the 8100's memory to record data both before and after the trigger. And set the trigger level to prevent false triggers.

## 2. Complete Systems Integration

Our 8100 often acts as a fast front end for Automated Testing. It provides full flexibility by capturing the analog signal and outputting the digital representation under full program control.

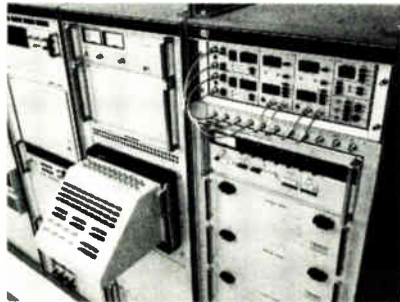

## 3. Perform computer data analysis.

Digital storage gives you maximum analysis flexibility. You can transfer the data, already digitized, to mag tape, disc or other permanent storage. Or you can read the data out directly to a programmable calculator or computer system.

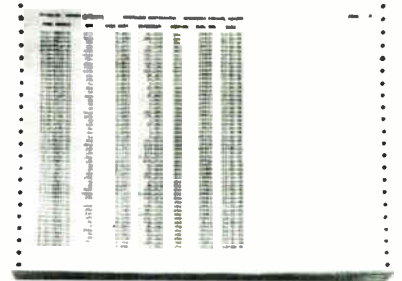

The 8100 features an 8 bit, 100 mHz ADC with 2048 word memory to help you capture and analyze analog signals. Other Biomation products also enable you to convert your scope to a "super scope" by adding digital storage. For more information, or to arrange a demonstration in your lab, call S. Reynolds (408) 988-6800. Or write us: Gould Inc., Biomation Division, 4600 Old Ironsides Drive, Santa Clara, CA 95050.



Circle 66 on reader service card

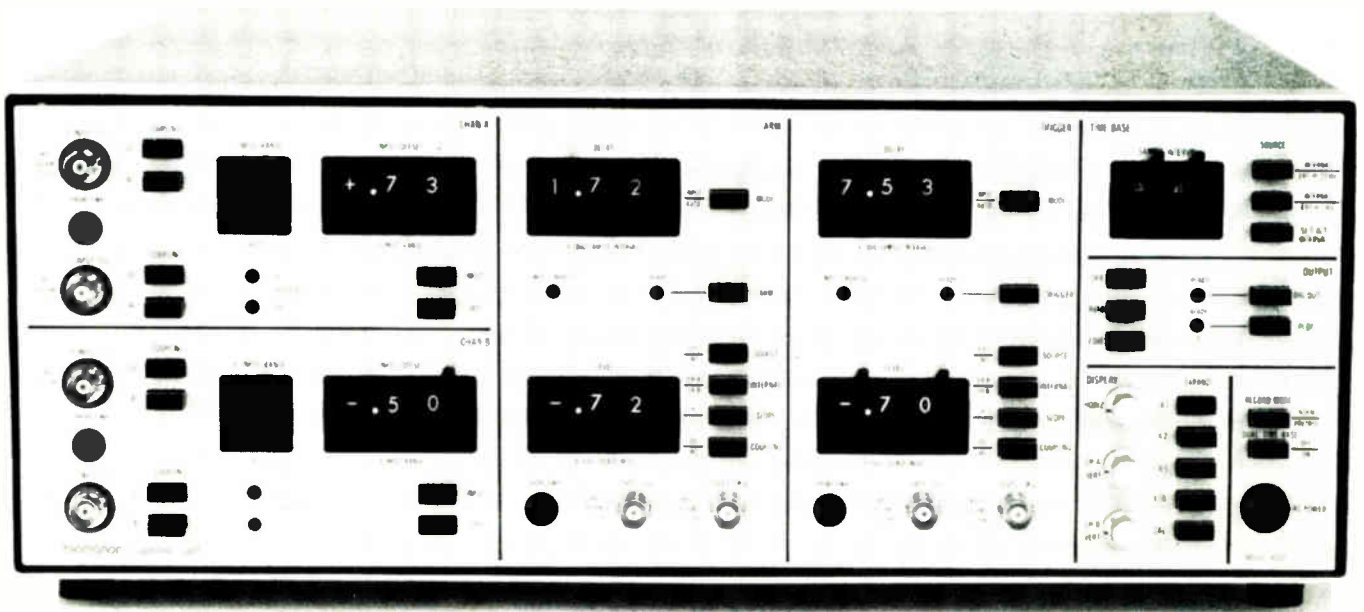

## Multiple-channel codec uses CCD filters for eight subscriber lines

Plessey eschews both usual single-channel approach and switched-capacitor filters in developing a five-chip set

Though most coder-decoders built so far are single-channel devices, some designers argue that multichannel codecs could lower overall system costs by reducing chip count. Opting for the latter approach is Plessey Ltd., with a five-chip set for eight subscriber lines.

Developed by engineers at the firm's Allen Clark Research Centre, Caswell, in collaboration with colleagues at Plessey's Telecommunications Research Centre near Maidenhead, the part uses speedy emitter-coupled logic and high-density integrated injection logic for the single-chip codec. The other four chips use charge-coupled devices to implement the filters needed for the eight transmitting and eight receiving channels.

Furthermore, Peter John Schwartz, a development engineer at the Clark center, who delivered a paper on the set at this week's International Solid State Circuits Conference, is confident that they will soon be able to pack eight filters on a chip instead of four, yielding a three-chip set.

**Feasible.** Samples of the five-chip set are scheduled for the end of 1979, but Plessey has already proved the feasibility of its multichannel concepts with a two-chip successive-approximation codec announced in November [*Electronics*, Nov. 23, 1978, p. 69] that contains no filters. It comprises an ECL chip to perform

the analog function and an n-channel ion-implanted metal-oxide-semiconductor chip for the control logic.

The two are being combined for the new set, and filters are being added.

The two-chip codec operates at 2.048 megahertz, producing a sample every eight clock pulses, or 3.9 seconds. It can decode the full 32 channels of the European CCITT pulse-code-modulation system.

Encoding, though, is slower, because guard bits must be inserted before samples to ensure that the first signed sample bit is accurate and after samples to allow the sampling amplifier to settle. Without these precautions, crosstalk and adjacent channel sampling can occur. Therefore the codec encodes 16

channels. In duplex operation it handles 8 channels—that is to say, 8 subscriber lines.

The 104-by-76-mil bipolar chip contains a fast digital-to-analog converter, band-gap voltage reference, comparator, and two-channel multiplexer. It consumes 350 milliwatts from a 5-volt supply. The 112-by-88-mil control chip contains three registers and the channel-selection logic. It requires 150 mW, also from a 5-v supply.

For the new set, the analog section remains the same, but the control logic will be shoehorned onto the bipolar chip with the aid of a high-density I<sup>2</sup>L layout. This 250-gate logic system will fit into the area now used for the interface buffers and level shifters. Thus the chip size

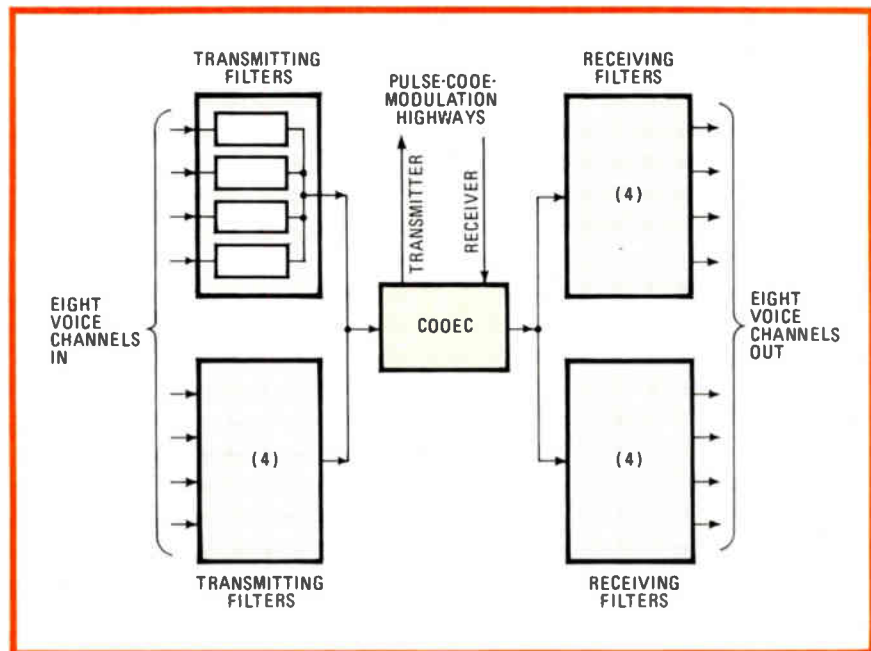

**Five for eight.** Plessey uses five chips to realize a codec (one chip), plus filters (four chips), to service eight subscriber lines. The filters are implemented with CCD technology.

will remain about the same.

To restrict the transmitted signal bandwidth to the 300-Hz-to-3.4-kHz level specified by the CCITT, a channel filter is required. Intel, for one, uses switched capacitors for this function [*Electronics*, Nov. 23, 1978, p. 220], but Plessey has chosen a CCD sampled-data filter. Already realized is a 100-tap transversal filter that consumes 30 mW.

Says Schwartz, "We went for CCD because of the higher circuit densities and lower power consumption achievable. There have been reports that CCD filters are noisy, but we have not found that to be the case." Target consumption for the quad

filter is 25 mW per filter.

There are other advantages to a CCD solution. The CCD input and output sample-and-hold circuits fulfill the normal signal-holding requirement of a sampled-data system, and they can also be clocked sequentially to perform the analog multiplexing function, thus switching each channel in turn onto the codec. In effect, "you get the multiplexer free," Schwartz comments.

Though he will not say what the set has been developed for, a good bet would be System X, the British Post Office's all-solid-state digital exchange system due to be unveiled in Geneva this year. □

### France

## Thomson-CSF getting ready for VLSI with fast optical wafer stepper

One essential for France's plans for very large-scale integration in the early 1980s will be a fast wafer-stepping device. To help realize those goals, Thomson-CSF has come up with a fast photorepetition unit that uses a new alignment method.

Though current forecasts for electron-beam methods suggest a maximum throughput of 10 wafers per hour within the next few years, Thomson-CSF's Corbeville laboratories' unit looks capable of processing 50 3-inch wafers per hour. And with a resolution of 1 micrometer and an

alignment tolerance of 0.1  $\mu\text{m}$ , it promises to outperform other direct-step-and-repeat-on-wafer machines.

Thomson uses a 5- or 10-to-1 projection ratio and thus dispenses with a contact mask. The machine has an automatic search field of 20 by 20  $\mu\text{m}$ , and alignment time is less than 200 milliseconds per mark per axis when initial misalignment is only 1  $\mu\text{m}$ . For a 3-in. wafer having 100-square-millimeter circuits, total alignment time is about 10 seconds, with reindexing at each chip.

To achieve this performance,

Thomson aligns successive exposure zones on the wafer with a reticle in the exposure optics. The positions of the reticle and of the zone are each defined by an L-shaped mark. When the two marks are correctly aligned, they form a cross.

**Analysis.** The images of the zone and reticle marks are projected by separate optical systems onto two areas of a vidicon target. The areas, each have two windows (see figure).

Each window is analyzed successively by a scanning electron beam. Comparison with window-position data yields a video signal from each that is proportional to the extent that the mark image is off from the center of each window.

Actually, Thomson uses the third harmonic of the scanning signals as alignment signals. This, the developers say, is the best compromise for a signal that can handle the search field with adequate accuracy.

The misalignment can be corrected by automatically aligning the reticle and then manually aligning the wafer or vice versa. Thomson used the latter method with its experimental unit because the positioning of the reticle need be only one tenth as accurate as mechanical displacement of the wafer. But it believes the other way around would be faster.

As Michel Lacombat, chief engineer for the project, points out, the firm is not alone in developing high-precision photorepeater techniques. GCA Corp. in the U.S. makes a

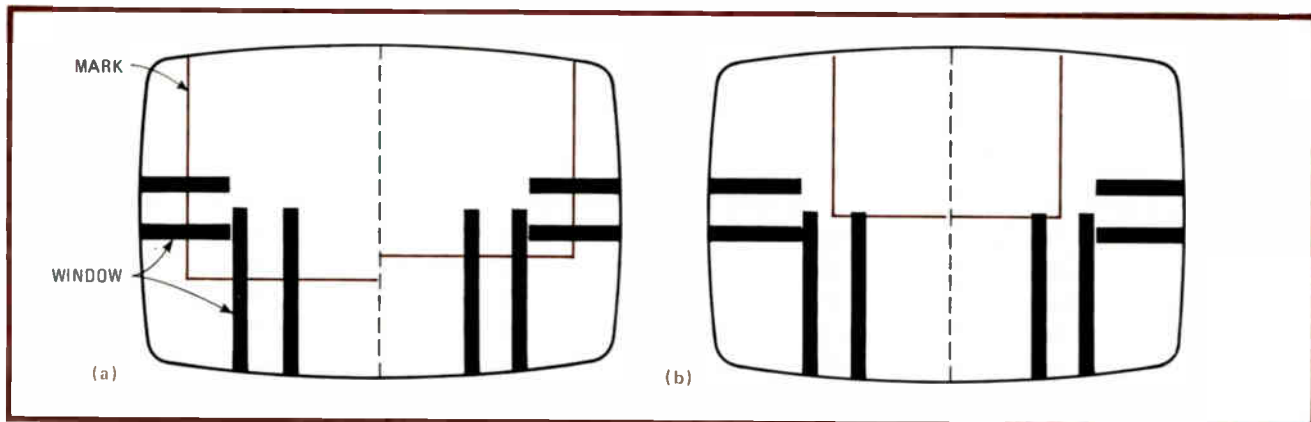

**New lineup.** Thomson-CSF's optical wafer stepper uses an L-shaped mark on the reticle and on the wafer zone for alignment. Images of the marks are projected separately onto two areas of a vidicon target each containing two windows, as shown in artist's rendering (a). The windows are analyzed to adjust both reticle and wafer. When they are aligned, the marks and windows each form a cross (b).

# Can your logic analyzer generate and capture this signal?

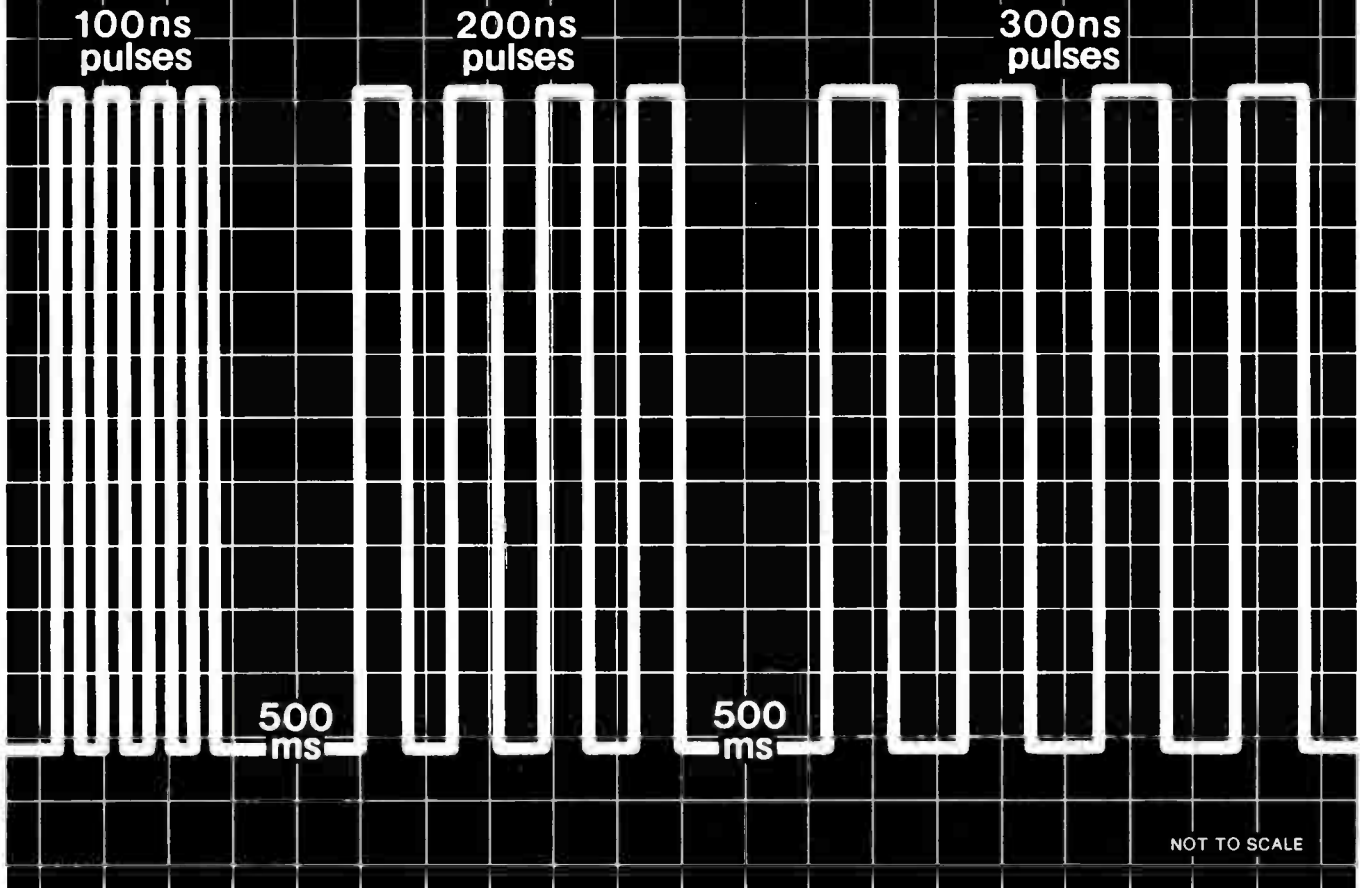

## The Gould DSA 600 can.

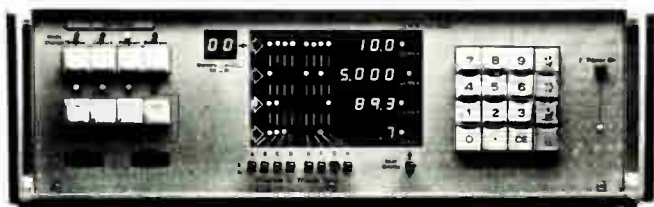

The Gould DSA 600 digital synthesizer analyzer is the first instrument designed to generate and capture pulse trains with unusual values in a state linear display format.

With eight input channels plus qualifiers and 32 memory locations, the processor controlled DSA 600 allows logic waveforms, even unpredictable ones, to be captured, stored and analyzed. It even permits complex sequences of timing, drive or test signals to be readily synthesized or modified without specially constructed hardware.

Electronics / February 15, 1979

The DSA 600 is simple to operate, fast and accurate with no ambiguity or drift because measurements are locked to a precise clock with a timing range of 100 n sec. to 100 sec. for each logic state.

For complete details on the DSA 600, call the toll free number now. Remember the DSA 600 also carries Gould's full two-year warranty covering all parts and labor (exclusive of fuses, calibration and minor maintenance). Or contact: Gould Inc., Instruments Systems Division, 3631 Perkins Avenue, Cleveland, Ohio 44114 for a demonstration.

CALL TOLL-FREE: (800) 325-6400

IN MISSOURI:  
(800) 342-6600

 **GOULD**

Circle 69 on reader service card

69

machine that accepts wafers up to 4 in. in diameter with an alignment tolerance of  $0.1\ \mu\text{m}$  and a throughput of 20 wafers/hour.

Thomson's approach, meanwhile, needs further development. For example, the machine would need new wafer-handling peripheral equipment to feed in wafers and take them away after the photorepetition.

But for the moment, work has stopped as Thomson looks for more government funds. The current level was achieved with the help of the government, and in theory more aid is available for the development of a wafer-stepping machine under the French components plan. So far, though, the government has not decided on a technique or a builder. □

### West Germany

## Audio compander squelches hiss and hum better than Dolby system

Mention "Dolby" and millions of audiophiles think of today's most popular system for suppressing noise in audio-tape equipment and fm stereo receivers. Proof of the excellence of the U. S.-developed system is its use in more than 22 million cassette tape recorders worldwide.

Now preparing to lock horns with Dolby is a noise-suppression system developed for consumer applications by Telefunken GmbH, the entertainment electronics arm of West Germany's AEG-Telefunken.

The new system, called High Com, outperforms Dolby in two important ways, Telefunken says: it removes 10 to 12 decibels more noise; and it does so over virtually the entire audio spectrum, typically 30 hertz to 20 kilohertz. This means that High Com suppresses annoying

power-frequency hum at 50 or 60 Hz. Dolby, on the other hand, is effective only from 300 Hz up.

During compression, low-level signals are amplified so that any noise present in the transmission path or storage medium is swamped by the strengthened signal. The noise is then attenuated during expansion.

High Com—the name derives from high-fidelity compander—is based on Telefunken's three-year-old telcom c 4, a four-channel compander used in broadcast-studio equipment. It provides noise suppression "that is substantial for a system designed for consumer use," says Hans-Joachim Thuy, High Com product manager at the Hanover-based company. When used on an audio cassette tape recorder, noise is reduced by an average of 20 dB to

1% of its original power level.

Telefunken's compander is a bipolar integrated circuit that contains two identical wideband amplifiers and a rectifier (see figure). One amplifier handles the audio signal; the other picks off the output and feeds it to the rectifier. The dc output of the rectifier controls the gain of the main amp and also keeps the output of the feedback amp constant. Use of two amplifiers enhances noise suppression, and the resulting system has a compression-to-expansion ratio of 2:1.

In addition, High Com's feedback configuration makes it relatively insensitive to changes in component specifications because operation is influenced by the ratios of component values, rather than by their absolute values. It is also insensitive to differences in the transmission channel or storage medium—for example, cassette tapes with different recording sensitivities. With a Dolby system, an out-of-spec input to the expander would distort the output, but with High Com, the company says, frequency response is unchanged for signal-level deviations as great as  $\pm 6$  dB.

The IC, in production at AEG-Telefunken's semiconductor facility in Heilbronn, comes in a 24-pin dual in-line plastic package. Designated U401B, it integrates some 450 devices including 200 transistors on a 3.1-by-2-millimeter chip.

**Lots of interest.** Given High Com's good performance, Telefunken officials are confident that it will be widely adopted. Already, some 20 electronics producers in Europe and 4 in Japan have expressed interest, Thuy says, adding that the company will supply the ICs to other firms or grant licenses for their production.

Initially, the system will turn up in cassette recorders, with Telefunken and a number of other companies in Europe to show their first High Com versions at the Radio and Television Exhibition in West Berlin this summer. The recorders will be designed to play back Dolby-encoded cassettes.

The system may also find use in radio receivers, the company says;

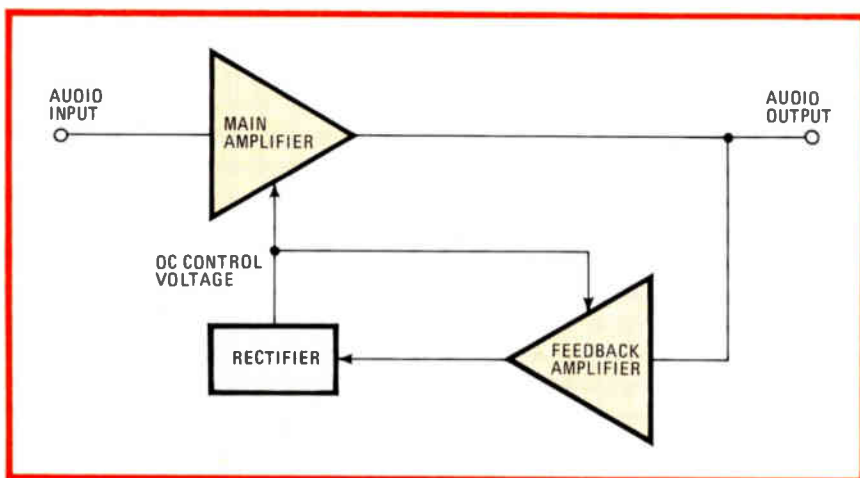

**Doubling up.** Use of two identical wideband amplifiers in Telefunken's High Com compander yields an average noise-suppression figure of 20 dB from 30 Hz to 20 kHz.



# TAKE A CLOSE LOOK AT THESE BURROUGHS PLASMA DISPLAY BREAKTHROUGHS.

Easier to read

Greater brightness

Improved contrast

Larger matrix dot

Broader horizontal  
viewing angle

Lower power  
requirements

Cost effective  
design

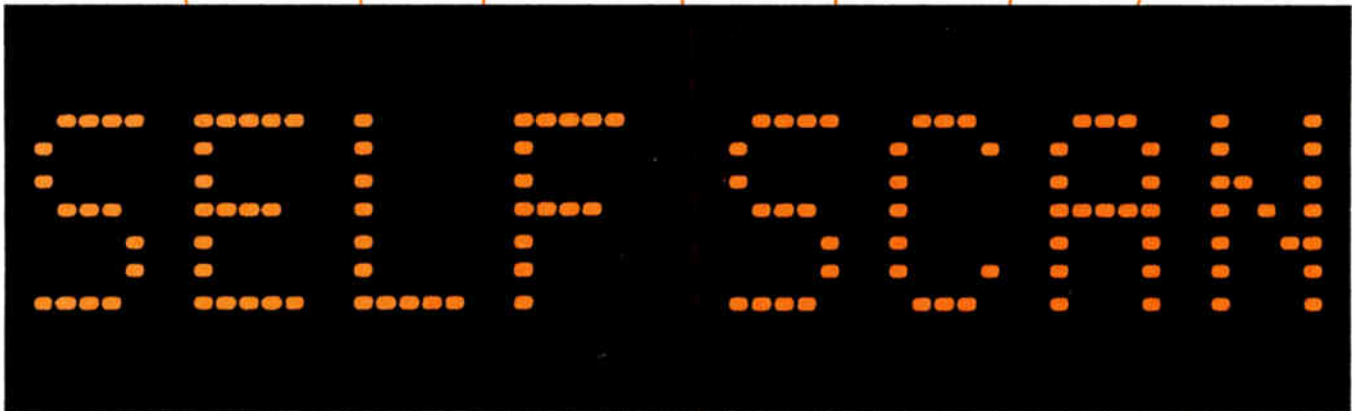

The new Burroughs SELF-SCAN® II single register gas plasma panels are breakthroughs in visibility and readability, making them ideal for all types of applications — from audience information displays to instrumentation applications. They are digitally addressed to interface easily with microprocessors and computers.

Only 15 connections are required. These new units complement Burroughs' standard line of single register 16 and 32 character plasma displays.

The Burroughs SELF-SCAN II 1 x 20 and 1 x 40 displays. Certainly worth looking into.

Burroughs Corporation, Electronic Components Division, P.O. Box 1226, Plainfield, New Jersey 07061. Telephone (201) 757-5000. SELF-SCAN displays are available nationwide through our distributor, Hamilton/Avnet Electronics.

New 1 x 20 panel can be stacked and butted together to give a contiguous large audience information display of any number of characters.



New 1 x 40 panel for instrumentation, data terminals, computers and hundreds of other applications.



You can **see** the difference

## Burroughs



SELF-SCAN is a registered trademark of Burroughs Corporation.

however, that would require that broadcasting authorities and set makers agree to adopt the system on a wide basis, Thuy cautions.

Another application would be in television sets, where interference signals are encountered mainly at the low end of the radio spectrum.

With the new compander built in, a TV receiver would deliver practically noise-free sound.

Currently a bit more expensive than its rival, High Com will come down to Dolby's price level as volume production gets under way, Thuy says. □

---

### Great Britain

---

## Dedicated traffic-information service to start trials in London area

Britain's motorists could look forward to reduced traffic delays and lower fuel bills if a dedicated-broadcast traffic-information service proposed by the British Broadcasting Corp. and shortly to go on trial in the London area is implemented nationally.

Motorists using the system, called Carfax, will be able to pick up detailed news of local traffic delays and road construction or repairs with the aid of a car radio attachment that mutes normal reception when receiving a traffic broadcast from a nearby transmitter.

In all, a chain of 20 low-power transmitters, each programmed to broadcast local news in sequential time slots on a common frequency, would be needed to reach 85% of UK motorists, and 70 transmitters would provide complete coverage. For the London-area trial 5 transmitters will serve a test population of some 500 motorists.

**Backed up.** The official go-ahead for the trial was expected several weeks ago, after a long period of committee evaluation [*Electronics*, March 2, 1978, p. 64], but it has been delayed because of the truck drivers' strike.

Other European countries have already turned to electronics to ease their traffic problems. Since 1974 a number of fm stations in West Germany, Austria, and Switzerland have preceded regular traffic news bulletins with a subcarrier identification tone that activates the car receiver. Called ARI for automobile-drivers' radio identification, the sys-

tem was developed by Blaupunkt-Werke GmbH, a subsidiary of West Germany's Robert Bosch GmbH.

Carfax, conceived by BBC engineer R.S. Sandell six years ago, takes the traffic-information concept a stage further: it is a dedicated system, and it provides much more information tailored to a fairly small area.

Each Carfax transmitter relays messages relating only to its area and so spends most of its time switched off, even during rush hour conditions. The transmitters are time-division-multiplexed in a so-called ring mode, in which only one is broadcasting at any given time.

**Capturing.** To make sure that a motorist's radio responds only to the transmitter in its area, BBC engineers rely on the capture effect of fm broadcasts and enhance it with a high modulation index—that is, a wide deviation at low modulating frequency. Consequently, they chose the medium-frequency band.

In practice, frequency-modulated tones are sent by each transmitter at the start and finish of each message. All other transmitters radiate a low-power continuous-wave inhibiting tone simultaneously with the start tone. The strongest signal—either the start tone or one of the inhibiting tones—captures the car radio.

The message itself is carried by conventional amplitude modulation and has a telephone bandwidth of approximately 300 hertz to 3.5 kilohertz. Finally, the finish tone returns the car radio to normal reception.

This arrangement, says Sandell,

allows all transmitters to operate at the same frequency, resulting in considerable spectrum economy and the possibility of a single international frequency for traffic information. However, ARI already has a head start as a candidate for a European standard system, as several million motorists already use it and it is well established in West Germany.

Three basic receivers have so far been developed for the trials: a completely separate receiver, an add-on unit to existing car radios, and an integrated unit. The motorist can operate his radio in any of three ways: switched to ordinary broadcasts without interruptions, ordinary listening with interruptions for traffic news, and tuned to traffic news only.

According to BBC engineers, a conversion unit for an existing radio might cost something like \$20 in volume production. But others think that figure is optimistic.

Before the London-area trials can get under way, however, a clearinghouse will have to be established to edit police information and schedule it under computer control so that each transmitter reports only messages of local interest.

For their part, Blaupunkt engineers say that their system could be set up immediately in the UK without a dedicated transmitter chain. Nonetheless they have come up with a proposal to harmonize both systems by changing Carfax from the medium- to the very high-frequency band, which ARI uses, and transmitting both ARI and Carfax alert tones.

The trouble with traffic broadcasts by regular stations, such as ARI provides, Sandell responds, "is that they can only give limited coverage. The police gather masses of information on road conditions which they cannot use because there is not enough air time. Another problem is that motorists only want to hear news that might affect them."

More importantly, BBC engineers argue that if Carfax moved to the vhf band, the capture effect it relies on would be less certain, since vhf wave propagation is affected by topological conditions. □

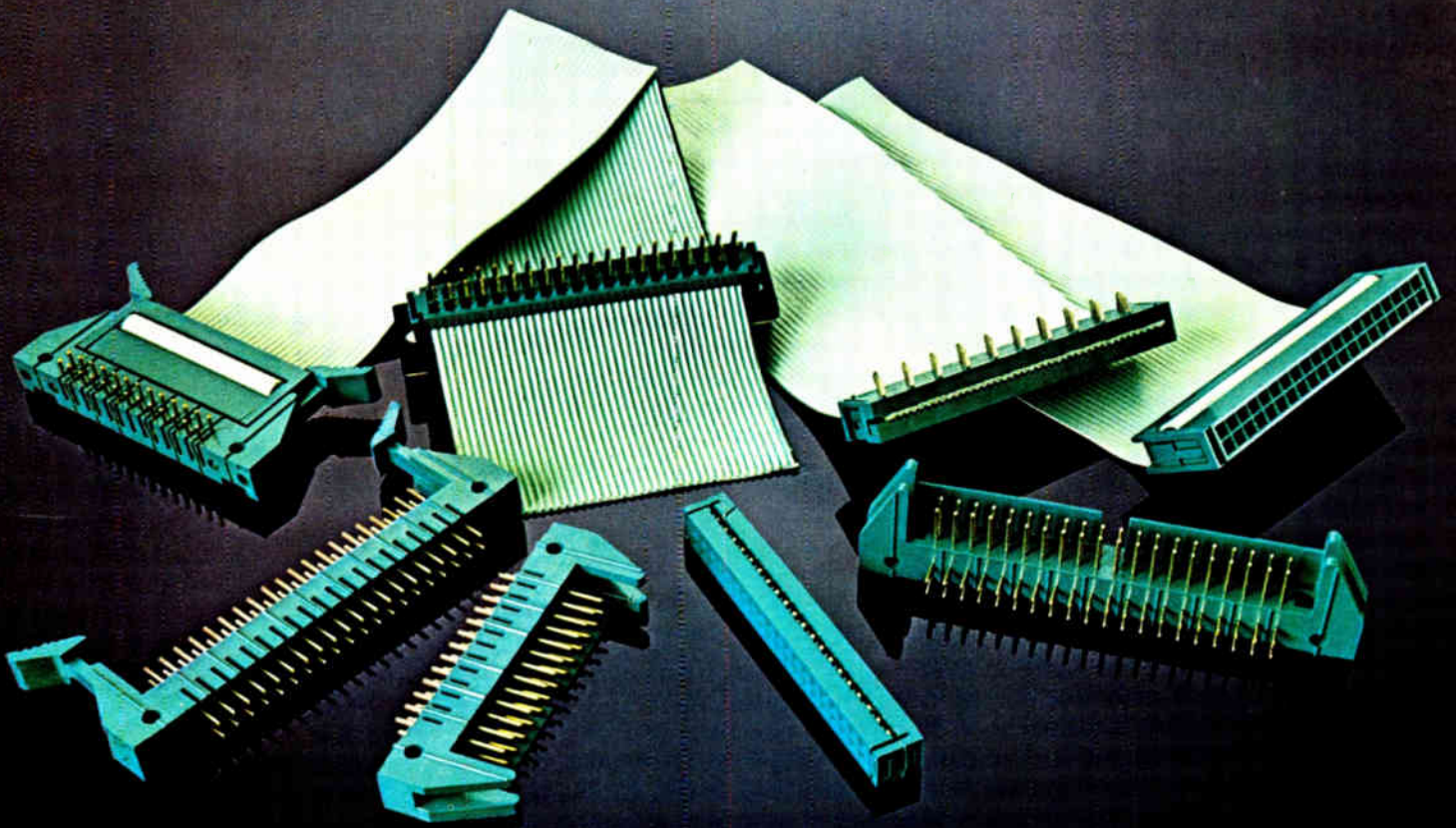

## Our family gives you a flat answer.

Our new flat cable connector family has both standard and stackable sockets, PCB connectors and headers, all designed for lowest total applied cost.

In socket connectors our BA Series gives you a low profile package with the option of either open or closed cover design for both end-cable and through-cable applications.

Our BD Series stackable socket line concept permits stacking two connectors on a wire-wrappable post.

For direct solder applications our BC Series handles PCB connector needs.

Featured with the product family is a simple universal termination system designed for minimum tooling cost.

For your header applications our low profile BB Series line is available for both vertical and right-angle mounting in solder or wire-wrappable designs.

Contact GTE Sylvania, Connector Products Operation, Box 29, Titusville, PA 16354. Phone: 814-589-7071.

Remember, good connections run in our family.



# 1744A STORAGE OSE

HEWLETT

ORE

RASE

ENCE  
OR

VIEW  
TIME

ERASE  
(PUSH)

MAX

ESS

MAX

E

E

Y

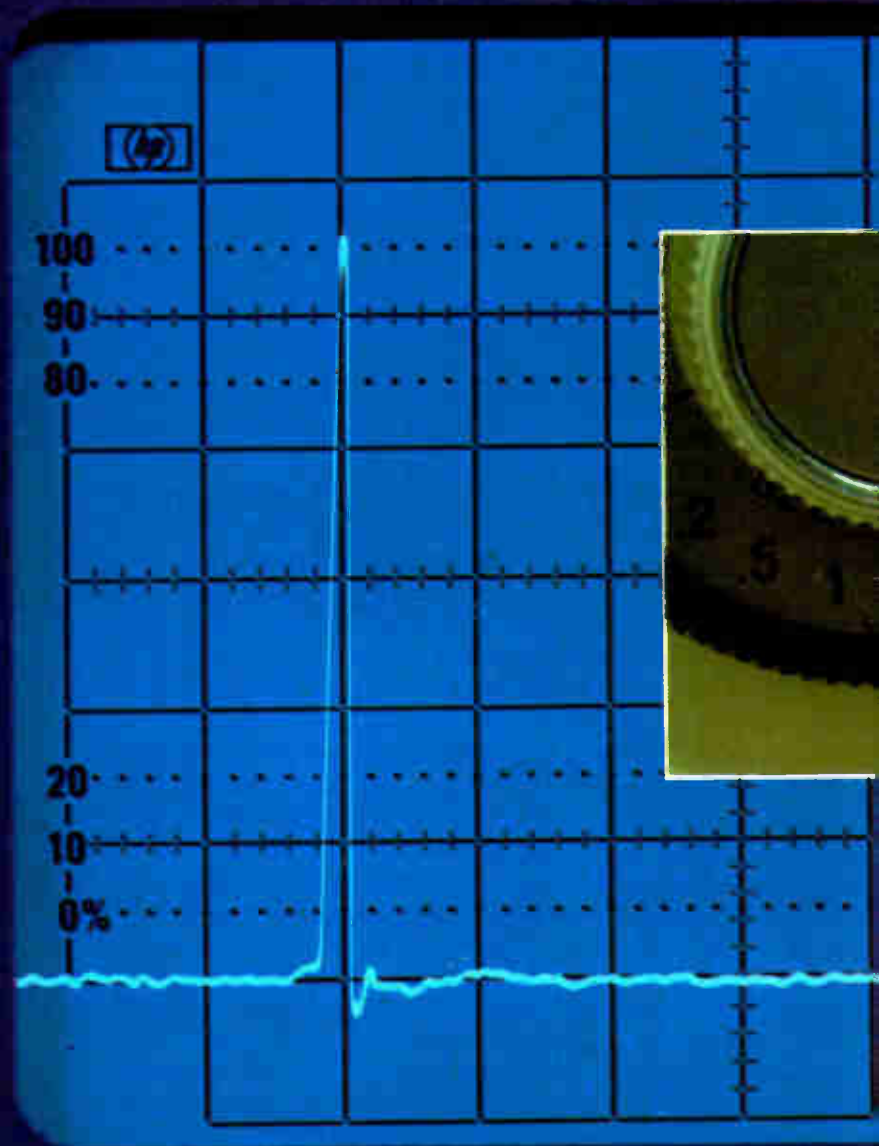

Storage trace as seen using a viewing hood

# OSCILLOSCOPE PACKARD

## For a 100 MHz storage scope that can capture its bandwidth and display glitches this sharply...

### HP's new 1744A is the Answer.

The key to this storage scope's superior performance is HP's advanced CRT design. It's called Expansion Storage. And this faster-writing technique lets you capture single-shot and low-rep-rate events over a larger display area with greater clarity.

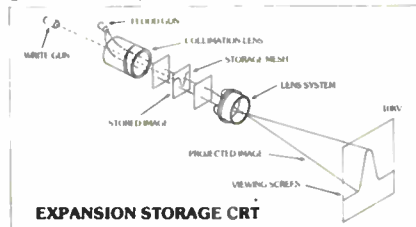

**Take a good, hard look.** Any input signal within bandwidth specification will be displayed cleanly by the 1744A, even at the maximum writing speed of 1800 cm/ $\mu$ sec when using a viewing hood. That provides the sharpness you need for detailed evaluation of hard-to-catch waveforms. Our Auto Erase/Auto Store modes simplify your pursuit of these elusive signals. Auto Erase provides hands-off operation while Auto Store prepares the scope to snare the troublemaker the instant it occurs. Both are powerful tools for capturing the spurious spikes that disrupt your logic circuitry.

**Catch that glitch.** Expansion Storage technology combines a small storage mesh (about the size of a postage stamp)

and an expansion lens system. This exclusive arrangement permits a writing speed of 1800 cm/ $\mu$ s and a fine spot size, which lets the 1744A write faster and further than any other 100 MHz storage scope. That gives you full-scan glitch capture capability over a broad range of sweep speeds and repetition rates.

**A new view.** Three channels are better than two. And with the 1744A you have pushbutton selection of a third-channel trigger view. Now you can view timing relationships between the trigger signal and the two vertical channels simultaneously.

Rounding out the 1744A's capabilities are these convenient measurement features: **Easy-IC Probes** to improve closely spaced probe connections and eliminate shunting hazards; a selectable input impedance (1 megohm/50 ohm) for general purpose probing or 50 ohm matching; and measurement sensitivity as low as 1 mv/div to 30 MHz on both channels without cascading. Priced at \$5250\*, the 1744A furnishes the state-of-the-art technology and performance needed today in digital design and troubleshooting applications.

Call your local HP field engineer for further details. And for a lower cost, high quality storage scope where an

extremely fast writing speed isn't required, ask him about HP's 1741A 100 MHz storage scope.

\* Domestic U.S.A. price only



HEWLETT  PACKARD

1507 Page Mill Road, Palo Alto, California 94304

For assistance call: Washington (301) 948-6370, Chicago (312) 255-9800, Atlanta (404) 955-1500, Los Angeles (213) 877-1282

Circle 75 on reader service card

088-7A

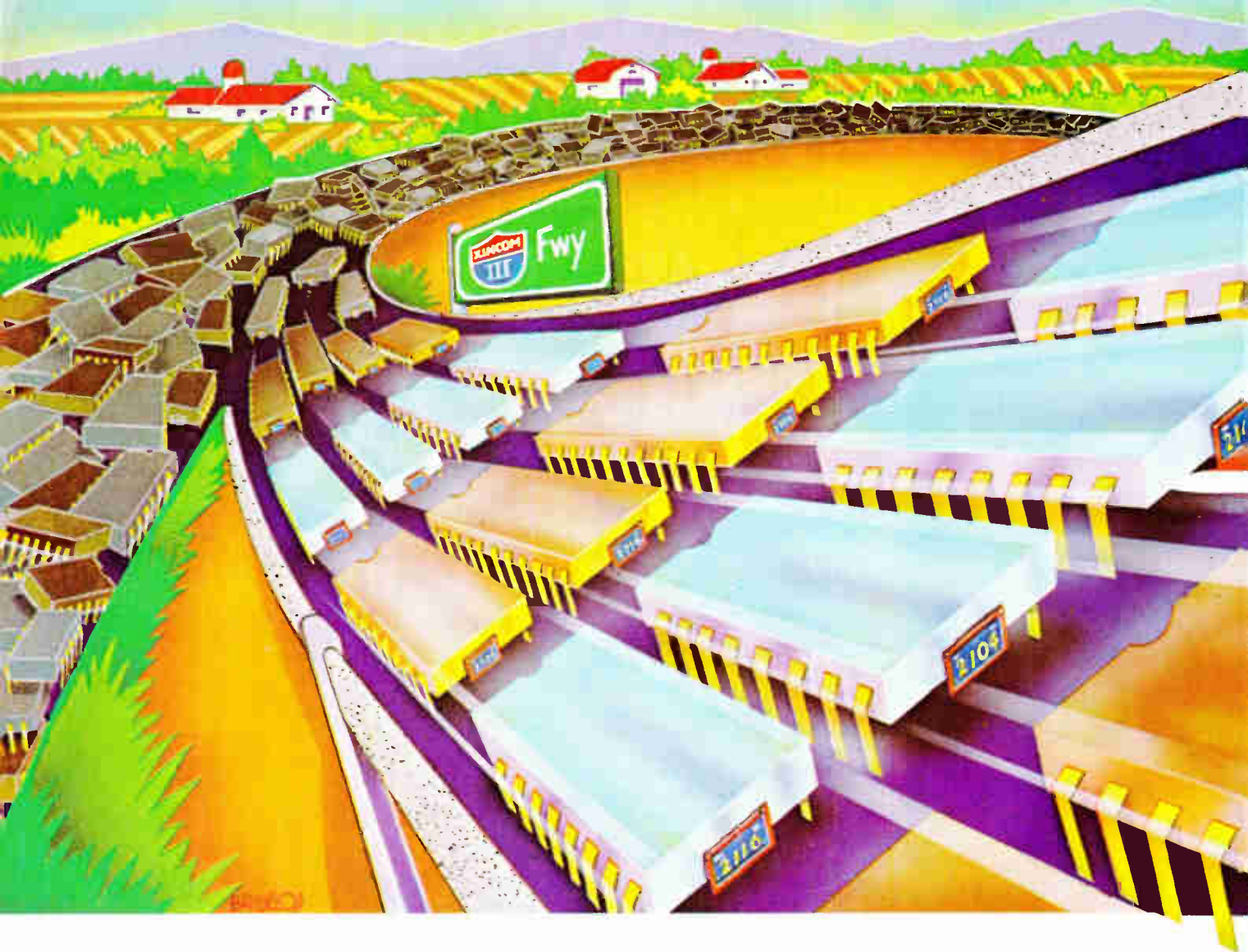

# Parallel testing keeps your memory traffic moving.



Your production line is probably spewing out a virtual river of memory devices: RAMs, ROMs, EPROMs

up to 65K x 8 bits. Your test system can't be a bottleneck. It must pace the flow, not choke it.

Fairchild developed the Xincor 5581 Parallel Operation Memory Tester specifically to speed throughput and help reduce the cost of testing.

The 5581 is a high performance, functional and parametric memory tester. It can parallel test up to four 65K x 4 bit multiplexed address RAMs. And it's done with only two heads, each with two sockets or connectors for wafer probers or

device handlers. Thus, the 5581 combines the throughput of a 4-head tester with the mechanical simplicity of a 2-head system.

In its maximum configuration the 5581 will handle:

- 65K x 4 bit RAMs with multiplexed addresses, four at a time with two at each test head:
- 65K x 8 bit RAMs and 4K x 8 bit ROMs two at a time, one in each test head:
- 65K x 8 bit RAMs or 4K x 8 bit ROMs time sequential with a different device at each head.

On-the-fly timing edge control provides test accuracy and reproducibility for production testing of dynamic MOS and bipolar memories.

The 5581 can be used as a stand-alone tester or as a satellite to the Xincor III distributed test

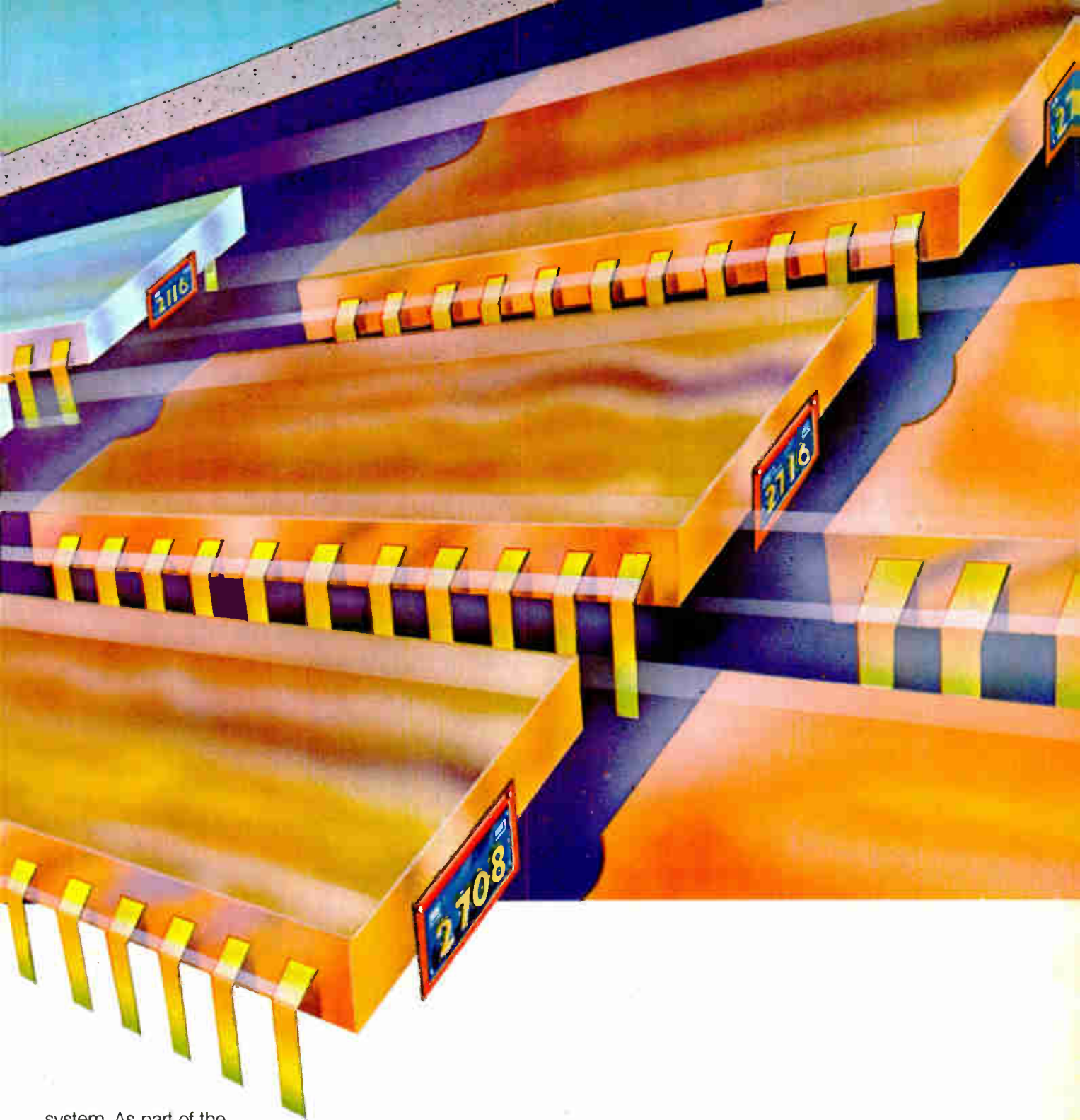

system. As part of the Xicom III test system, it can store, analyze and process vast amounts of test data or prepare schmoo plots, wafer maps, or trend graphs. You also get compiling and test program editing capabilities.

To really appreciate the accuracy and throughput speed of the 5581 you should see one in action. Since there are numerous systems already installed there's probably one close to you. We'll try to set up an appointment for you to see one. Just give us a call. Fairchild Test Systems Group, Xicom Division, Fairchild Camera and Instrument Corp., 1725 Technology Drive,

San Jose, Ca 95110

**FAIRCHILD**

(408) 998-0123

Circle 77 on reader service card

# VAX Program Capacity. Ask any user.

**"VAX offered us almost three times the address space of our 370/168."**

*Bill Miller, Senior Systems Analyst  
Chevron Geophysical Co., Houston, Texas*



Chevron Geophysical is heavily engaged in seismic data processing involving matrix operations on large arrays.

As Senior Analyst Bill Miller states the problem: "Our IBM systems, running on TSS, give 24 bits of true address space — for a maximum program size of 16 megabytes. But only 10 to 12 megabytes of this can be used by the programmer — and our application had grown to the point that TSS was simply cramping us.

"With the VAX-11/780, we know we can have application programs that use a full 32 megabytes as we're configured now — and it could be more if we wanted."

But Chevron didn't buy their VAX without first benchmarking it against the far more expensive 168.

Miller comments: "We developed a number of benchmarks to test specific areas of performance. On the average, the VAX CPU appears

to be about a third as fast as the 168, which is really quite impressive. And it's very possible that for certain applications, we may see a negligible loss of throughput over the 168, thanks to VAX's unique page clustering scheme."

And as far as system performance to date, Miller reports: "The VAX/VMS operating system has been remarkably reliable. The people at Digital have done a phenomenal job."

**"VAX's true 32-bit addressing puts its potential capacity so far out, we don't have to worry about it."**

*Dr. Edwin Catmull, Director,  
Computer Graphics Lab  
New York Institute of Technology,  
Old Westbury, New York*

The Computer Graphics Lab at New York Institute of Technology is a leading research and production facility for computer animated commercial and educational films.

In Dr. Catmull's words, here's what brought NYIT to the VAX-11/780: "While spending years developing our capabilities with mini-computers, we







**“With a 22,000-point data base, we really needed VAX’s huge memory capacity.”**

*Peter Ackermans, Manager of Computer Systems Engineering  
CAE, St. Laurent, Quebec, Canada*

CAE Electronics Ltd., currently has thirteen VAX-11/780 systems under development for both flight simulation and supervisory power control.

Here again, VAX capacity was key. Systems Manager Peter Ackermans told us: “Our SCADA systems for the power market need to handle a 22,000-point data base. VAX’s large memory capacity and the VAX/VMS virtual memory operating system made it a very attractive machine.”

But speed was also important. “In flight simulators,” Ackermans continues, “top FORTRAN performance is essential, and on that score, VAX measures up well. Our FORTRAN programmers have also been impressed with the machine’s debug facility and file handling capabilities.”

Digital’s VAX-11/780, with its true 32-bit address space, has set a new standard for program capacity. This means that you can run large programs easily on VAX, with a potential for growth that’s unmatched in the industry.

But rather than have us tell you about it, send for our new brochure.

And listen to our customers.

continually ran into the problem of small address space. Our work demands the large address space we can get with a 32-bit machine. We were dealing with extremely large, randomly accessed data bases, and memory mapping is not the answer.”

Dr. Catmull continues, “The VAX UNIBUS lets us easily hook up a wide range of special video display equipment that had previously been on the minicomputers, and allows us to easily convert our algorithms.”

According to Dr. Catmull, “VAX has fulfilled our expectations for speed, program size, ease of conversion, and ability to attach special graphics equipment.”



- Please send me the new “VAX—Ask Any User” brochure and detailed Technical Summary.
- Please contact me.

Name \_\_\_\_\_ Title \_\_\_\_\_

Company \_\_\_\_\_

Address \_\_\_\_\_

City \_\_\_\_\_ State \_\_\_\_\_ Zip \_\_\_\_\_

Phone \_\_\_\_\_

My application is:  Education  Medical  Laboratory  
 Engineering  Government  Resale  Other.

Send to: Digital Equipment Corporation,  
Communication Services, 146 Main St., NR-2/2,  
Maynard, MA 01754. Tel. 617-481-9511, ext. 6885. N-2-15-9

**digital**

Teradyne finds the practical solution.  
No. 9 in a series.

# The test system administrator

A sensible way to manage multiple test systems.

These days it isn't uncommon for a semiconductor plant to have on line a dozen or more test systems, each with its own test program library and its own data output terminal. The situation begs for a clustering of systems around a central computer that can store all the programs and collect all the data. Although the basic idea is simple enough, there are significant differences among the various implementations now appearing in the marketplace.

Teradyne's solution, called the Test System Administrator, is based on the proposition that the individual test systems should always be self sufficient in test capability and that the central computer should stick to management and communications functions. A sneeze at the central computer should not, in other words, give the whole test facility pneumonia.

The TSA was therefore designed so that when it is unplugged the test systems connected to it don't skip a beat. The independence is mutual: the TSA (which is in fact the same M365 computer used in Teradyne test systems) can be used for off-line editing and translating jobs as well as its primary management function.

The TSA has enough data-processing capability to develop multiple Shmoo plots, multiple ADART's (distribution analyses), and the like, and the processing is

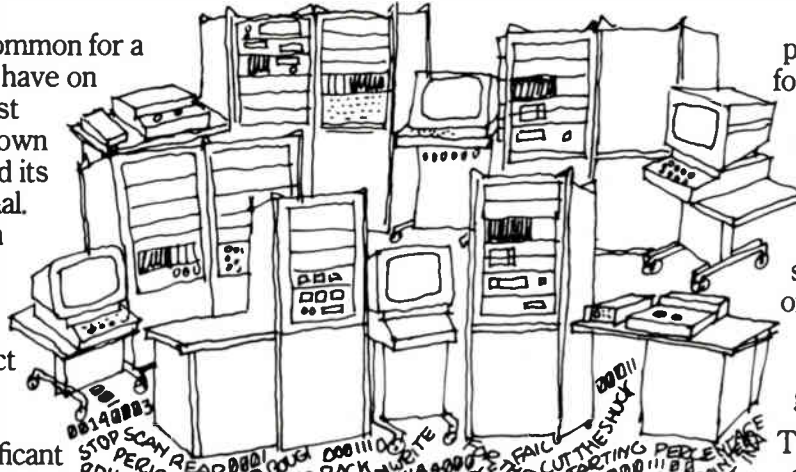

performed in real time for fastest possible utilization. The unit is not only scorekeeper but timekeeper as well. One may direct it to pull summary sheets at a given time of day, for example, or to report the time at which the yield on a given system shifted.

The economic benefits of test system administration fall into two broad categories. First, the data feedback loop is tightened, so that minor processing flaws can't contaminate whole production runs. Second, the test systems themselves are used much more efficiently, even to the point where the need for an additional system may be (gasp) eliminated.

The TSA's reach currently extends to as many as seven systems or as many as 28 test heads. At the moment, these may be any combination of Teradyne J384, J387, or J325 systems, with other systems to be added to the list.

A second-level computer is, of course, only a way station on the road to the automated factory, and the TSA is therefore designed to talk not only down to the test systems but up (via any standard RS232 or Bell 103 link) to a third-level mainframe presiding over an entire operation. The third-level computer, presumably, talks only to God.



**TERADYNE**

Circle 80 on reader service card

## Cipher-shifters fight it out

Data Encryption Standard put together by NBS called too easy to crack; critics also seek to keep NSA out of picture

by Harvey J. Hindin, Communications & Microwave Editor

When the National Bureau of Standards decided to write data-encryption standards in 1971, it had no idea how much controversy the move would generate. Charged by Public Law 89-306—the Brooks Act—with setting Federal standards for effective and efficient uses of computer systems, NBS went ahead and developed an algorithm that guaranteed that  $2^{55}$  (70 quintillion) attempts and the use of the method of exhaustion—keep trying till you get it—would be required to crack any code. But by now it might be wondering if it should not instead have worked out a criticism algorithm.

Since most coding experience had been gained in the kind of hush-hush activities the military and other Government sectors engage in, the NBS went to the experts for assistance: the super-secret National Security Agency (NSA). The two agencies were able to cooperate in the development of the standard, known as the Data Encryption Standard, or DES, since the constituency for the efforts would be Federal agencies and the general buyer, with neither group operating under national security directives and procedures. National security cryptography is the NSA's area under the 1947 National Security Act and no conflicts were anticipated.

But this was not to be. In fact, the DES has come under severe criticism in some quarters. According to Martin E. Hellman of Stanford University in Palo Alto, Calif., the DES, which is the kind of algorithm that uses the same "key" or coding base at both the transmit and receive ends, can be cracked. "A \$20 million machine can search all the keys of

the DES in one day at a cost of \$10,000." Worse yet, he says, under certain circumstances, the cost for each cracking run on a DES-coded information signal is between \$1 and \$100. In fact, of course, any code can be cracked if enough time and money are spent on the job.

Hellman advocates the public-key encryption system, one the NSA had no hand in. In this algorithm, knowledge of the encoding transformation does not automatically imply knowledge of the decoding transformation. Secure data communication in the public system is made possible by

### How DES works

The DES encryption/decryption algorithm is public information and has been published, although individual privacy is insured with a private key. This user-chosen key is 56 bits long and allows  $2^{56}$  possible choices (a). Both the sender and the receiver must have a copy, since the same key is required for both coding and decoding.

Each 64-bit block of data entered into a DES communication system is first transformed through a simple initial permutation that provides two 32-bit channels. Next, all of these bits are reordered according to a defined scheme. Then each 32-bit block is manipulated through 16 iterations with what is called a standard building block (b). Each of these building blocks further permutes the data with the aid of a specific 48-bit key. Each key is different for each of the 16 building blocks and is derived from the 56-bit main key. There is a further simple transposition at the final output, which is similar to the initial transposition. Neither of these transpositions is controlled by an external key.

All of the various scramblings that take place are based on either fixed look-up tables or some permutation procedures. Parts of these were designed by the NSA, and although the transformations themselves have been printed in the Federal Register, the design procedures have been classified, arousing suspicions of "easy-to-decode if you know how."

Decryption is very similar to encryption. The same algorithm is used, but the standard building block keys are used in the reverse order.

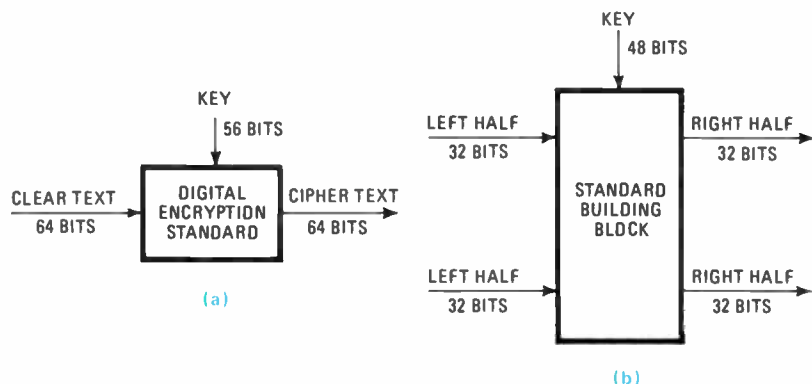

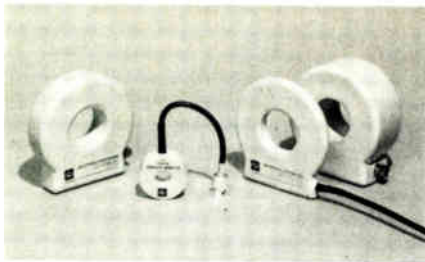

## CURRENT MONITORS

With our monitor and your oscilloscope, read fast pulsed currents (nsec to millisec) of any conductor. Prices range from \$70 for standard, in-stock models. Sensitivities from 1 V/A to .01 V/A; no physical connections required; readings without ground loops; BNC standard; specials upon request.

For further information write or call: Ion Physics Company, P.O. Box 416, Burlington, Mass. 01803. Tel. 617-272-2800.



**ION PHYSICS COMPANY**  
A DIVISION OF HIGH-VOLTAGE ENGINEERING CORPORATION

Circle 82 on reader service card

## What Every "RAM" Needs!



Rechargeable 3.6V, 150 mA Ni-Cad battery model CG-3-150-N provides on-board standby power to prevent volatile memory losses.

The pack's size 2.5" x 2" x .5" and low internal resistance provides both high rate discharge and low drain rate capability.

Units are warranted for one year with prototype quantities in stock - (8.50/unit).

Production 2 to 6 weeks.

from TDI

... the helpful people!

**TELECOMMUNICATION  
DEVICES, INC.**

2320 Wisconsin Ave. • Downers Grove, IL 60515  
(312) 971-3460 • TWX910-695-3222

## Probing the news

simply using a "telephone book" of the codes for encoding wherein the decoding procedures are associated but secret. With the DES system, encoding is the reverse of decoding and the same key is used. Further complicating the issue, patented work on the key system has been done by Ronald L. Rivest and his associates at the Massachusetts Institute of Technology in Cambridge, Mass.

**Hellman not alone.** Other critics have been wondering aloud whether some DES coding design procedures were classified by the NSA so that it could break the code if it had to. Others feel the system is too simple to have more than a 10-year life in practical use. What's more, they ask, why is the code not 128 bits long, the much more secure procedure believed to be in the IBM system that NBS chose as a design model?

However, DES is not so bad, maintains Robert Morris, a computer software researcher at Bell Laboratories. "Doubtless, anyone with sufficient time and money can read messages encrypted with it," he says, "but the time and money required are well beyond the means of the local burglar or even the most skilled embezzler." Multimillion-dollar investments in special-purpose hardware would be needed, he maintains.

He thinks the greatest security problem for DES users will be proper selection, custody, and distribution of the key. He sees "no particular reason to believe there was any subterfuge" involved in the design of some of the scrambling boxes (see "How DES works").

Coding and encryption problems have existed since the earliest days of electrical communication. In fact, telegram security was an issue for Western Union back in 1870. Today, with the use of data banks, there is worry about unauthorized transfer of information, electronic crime, electronic sabotage, and other such security problems in the civilian and commercial sector. While work is starting—Dennis Bransted, NBS project leader for computer security, says, for example, that seven commercial LSI chips have been vali-

dated to perform the DES algorithm—there is still a lot to do.

As procedures are at present, however, the vast store of expertise available in the diplomatic and military organizations can hardly be tapped, if at all. The way the National Security Agency sees it, its mission is to protect the security of United States communications.

This has been variously interpreted as including not only direct defense information, but also economic data and other potentially sensitive material. For example, the encryption community was shaken by Jeremy Stone of the Federation of American Scientists when he said that code cracking can be used to wage economic warfare.

**Denial.** Last month, NSA head Vice Admiral Bobby Inman, addressing the Armed Forces Communications and Electronics Association at the State Department in Washington, declared that his agency has not, as some critics claim, exerted an undue influence on scientific research into encryption theory or the development of commercial products. What's more, he says, it turns out that "the legal resources of the Federal government to control potentially harmful non-Government cryptologic activity are sparse."

The "potentially harmful" issue is the bone of contention. Clearly the NSA approach will be conservative in defining the words, while those interested in better algorithms or encryption equipment will feel just the opposite pressure.

In a clear indication that the NSA does not intend to be liberal in its definition of what is vital to the national security, Inman called for rules that would allow him and his agency to prohibit domestic or foreign dissemination of cryptology research when security is involved. Needless to say, the budding cryptology industry in the U. S. is unhappy about this prospect, for it is still small, despite rapid growth in the last five years. However, most of the suppliers of what encryption equipment is available are foreign concerns. According to Ruth M. Davis, deputy under secretary of defense for research and advanced technology, they accounted for more than 75% of 1977 U. S. sales. □

# The ubiquitous Spectrol dials and the universal Spectrol pot



## Models 15 & 16 Dials/Model 534 Pot

Two of the industry's most popular turns-counting dials are Spectrol's Model 15 digital and Model 16 concentric. And you will often find these "ubiquitous" dials backed-up behind the panel by Spectrol's Model 534 "universal" pot. It's a winning combination worth looking into—easy reading dials that look good on everybody's panel, plus a versatile, wirewound, precision potentiometer available in so many standard and special variations it will fit almost everybody's application. Call or send for data sheets.

**Spectrol**

### SPECTROL ELECTRONICS GROUP

**UNITED STATES** Spectrol Electronics Corporation P.O. Box 1220, City of Industry, Calif. 91745, U.S.A. • (213) 686-1280 • TWX (910) 584-1314

**UNITED KINGDOM** Spectrol Reliance Ltd. Drakes Way, Swindon, Wiltshire, England • Swindon 21351 • TELEX: 44692

**ITALY** SP Elettronica SpA Via Carlo Piscane 7, 20016 Pero (Milan) Italy • 35 30 241 • TELEX: 330091

**GERMANY** Spectrol Electronics GmbH Oberauerstrasse 15, 8000 Munich 70 West Germany • (089) 7145096 • TELEX: 05-213014

Circle 83 on reader service card

# Series 500 Measurement and Control I/O System

A complete subsystem for all your signals.

The newest member of the Neff System 620 family, the Series 500 Measurement and Control I/O System provides a single, computer-controlled interface for various types of I/O signals commonly used in measurement and control applications. It accepts contact closures, TTL or other voltage levels, frequency inputs and low-level analog voltages. Its outputs include contact closures, voltage levels and analog. In addition, the Series 500 provides the interface to the controlling computer and a serial data link to remote systems.

The Series 500 includes a 4K RAM in which the computer can store scan lists, instructions and control words to operate peripheral devices. Data is returned to the computer over a single DMA channel. Completely integrated and cabled standard interfaces are available for most computers and software drivers are available for most popular operating systems.

Configuring the system for any combination of I/O signals is a simple matter. It's done with plug-in function cards selected for the types of signals to be handled - up to 16 function cards per assembly, expandable to 256 function cards per site. Series 500 supports any of the Neff 620 systems for low-level analog data acquisition.

Let us show you how the Series 500 can simplify the instrumentation of your measurement/control application.

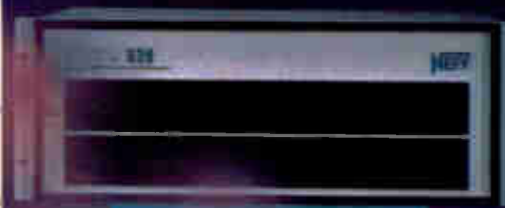

**NEFF**  
INSTRUMENT CORPORATION

Circle 84 on reader service card

1088 E. Hamilton Rd., Duarte, Calif. 91010  
Tel. (213) 357-2281 TWX 910-685-1833

Computers

# IBM has a message: the 4300

---

New series shows determination of the industry leader  
to use new technology to offer more for less money

---

by Anthony Durniak, Computers Editor

IBM is sprucing up its computer line with a fresh coat of high technology. Although the company has consistently dominated the computer market, many competitors have charged IBM with resting on its technological laurels by leaving the nine-year-old System/370 mainframe computers essentially unchanged in the face of rapid developments in almost every area of electronics.

But now the industry leader is polishing its tarnished reputation and using a new generation of chips, peripherals, systems software, and architecture to revamp its line of computers. It is promising improved performance and greater ease of use and maintenance, all at reduced prices, and it has put the rest of the industry, especially the growing legion of IBM-compatible computer makers, on notice that it will use this new technology to lower the quasi-standard price/performance ceiling.

The latest evidence of this, and the third IBM computer to be unveiled in the last four months, is the Data Processing division's long-awaited 4300 series, introduced at the end of January. Discussed in industry circles for the past several months under the code name E-Series, the new computers are seen by industry analysts as only the first wave of new mainframes [*Electronics*, Feb. 1, 1979, p. 36].

Replacing the low end of the System/370 mainframe family, the new 4331 can hold up to 1 megabyte of main memory and has up to four times the instruction execution rate of the 370/115. The 4341, with up to 4 megabytes of memory, is 3.5 times faster than the 370/138. With the price of the 4331 starting at \$65,000

and the basic 4341 tagged at \$245,000, the estimated price/performance ratio is some three to five times better than that of the older units.

Most vendors of IBM-compatible computers say they were expecting the new machines and, even though their analyses are not complete, claim they can continue to compete effectively even with the narrowing of the margin between them and the industry giant. Key to their continued competition, however, will be their emulation of functions IBM has added to the 4300 and its systems software, much of which is in microcode. Because of this, most analysts feel these functions will not be clear until the first 4331 is delivered in the second quarter and the first 4341 is shipped in the fourth quarter.

One segment of the industry less confident about its ability to continue to compete against IBM's more aggressive pricing is the makers of add-on memories. Already, Intel Corp. says it will not pursue the 4300 add-on market.

**H-Series still coming.** Robert Fertig, vice president of Advanced Computer Techniques Corp., New York consultants, adds that these are only the first of the new machines the plug-compatible vendors will have to contend with. "Our technology analysis group expects two more E-Series machines later this year, the biggest of which will offer performance of a 3031 mainframe at about half the price. And of course, we expect IBM to unveil the top-end H-Series early next year."

IBM has been very vague about the inner workings of the 4300s. Though a spokesman says the 4331 has a

memory read cycle time of 900 nanoseconds for 4 bytes and a write time of 1,300 ns, no processor cycle time was available. On the other hand, the spokesman says the 4341 has a processor cycle time of 150 to 300 ns, but he could not give a memory cycle time.

Up to 16 megabytes of virtual memory space is available, the same as the System/370, but the address translation scheme has changed—a

---

**Stacking the deck.** Card containing logic modules is inserted into processor motherboard. Card has four rows containing 67 edge connectors each, for a total of 268.



## Probing the news

spokesman says the 4300 uses a "one-level addressing facility," which sounds like that used in the System/38.

The 4300 processors are heavily microprogrammed and use a novel storage approach that places the microcode in both reloadable control store and in the processor's main memory, thus reducing the processor storage available for user programming. The 4331 has up to 128 kilobytes of control store, yet still needs 16 kilobytes of processor storage for microcode. IBM is keeping the amount of control store on the 4341 a secret, but says that model needs an additional 110 kilobytes of processor storage for microcode.

**Diagnostics.** One feature IBM did reveal was a separate support processor contained in the 4300s. Using its own microcode, this dedicated processor performs diagnostic routines, monitors environmental factors such as power-line conditions and temperature, and is used to provide remote diagnostic capability.

A major contributor to the price/performance improvement is new semiconductor technology such as the 64-K random-access memories introduced earlier [*Electronics*, Nov. 9, 1978, p. 39] and the new bipolar logic gate arrays (see p. 46). Although the semiconductor industry considers the IBM-developed memory and logic chips large, slow, and power-hungry, these chips offer what appear to be interesting, if not unique, solutions to the problems of designing and packaging large-scale integrated circuits and incorporating them into system designs.

For example, when the 64-K RAMs were introduced, they were thought too slow for use in mainframes, and it was pointed out that only 30% of the 1/4-inch-square chip's surface was used for memory. The 4300 reveals the kind of functions contained on the rest of the chip.

**Cache is included.** Two on-chip 8-bit buffers allow data to be read out at 100-ns data rates, three times faster than the typical chip access time of 300 ns. The memory increments using these chips are priced at a startling \$15,000 a megabyte, a

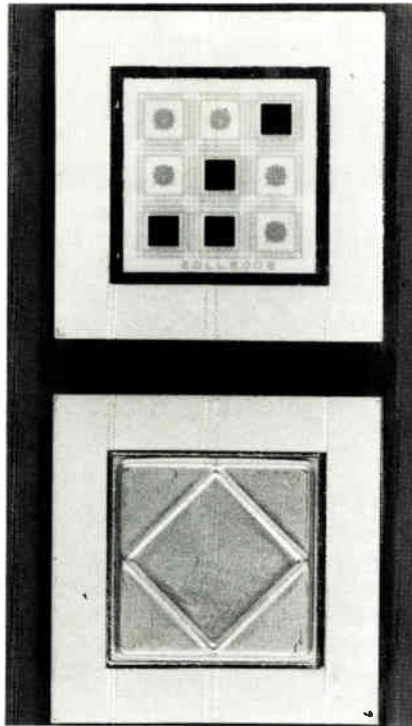

**Layers.** Ceramic modules of 23 layers can interconnect nine chips for the 4331 and 4341. Modules come in two sizes, with the larger (2-in.) holding 19 by 19 pins.

fifth of what IBM charges for memory for the rest of its mainframe line, even after the recent 30% price cut [*Electronics*, Dec. 21, 1978, p. 39].

The 4300 also features a new modular packaging scheme. Central to this is a 23-layer ceramic carrier that holds up to nine of the Schottky transistor-transistor-logic chips and comes in two sizes: 1 1/8 inches square with 196 pinouts or 2 inches square with a staggering 361 pins. Obviously, inserting such a package into a circuit board is tricky, so IBM first solders the logic modules to a 4 7/8-by-7 1/2-inch 8-layer circuit card, which has 268 edge connectors and is later attached to a 16-layer motherboard measuring 11 by 16 in. The resulting assembly is 6 1/2 in. high, but IBM says its modularity provides easier servicing.

**Less power-hungry.** Another advantage of the new components and packaging is the reduction in overall size, so that the new processors are about half as big as the older mainframes and use up to 70% less power and cooling.

In addition to the computer's circuitry, IBM has also improved its peripherals, introducing its largest

disk drive—the 3370. The new drive stores 571 megabytes, twice that of the current top-of-the-line 3350 drive, and has a data transfer rate of 1.859 megabytes per second, a 55% increase over the 3350's rate. Although it is close-mouthed on its details until it ships the first one, the company does admit that the 3370 uses a read/write head "manufactured by a semiconductor process," apparently a reference to thin-film head technology. Priced with controller at \$35,100, the 3370 is about half the price of the dual-spindle 3350 with equal capacity.

**Piccolo calls the tune.** The much discussed "piccolo" disk drive, first delivered in the General System division's System/34 last month [*Electronics*, Feb. 1, p. 36], is also included with the 4300 as the model 3310. The new drive uses an 8-in. disk medium as expected and Winchester technology heads recording at densities of 450 tracks per inch and 8,350 bits per inch. The 3310 stores a total of 64.5 megabytes on six platters and costs \$12,960.

Key to getting the most performance out this hardware, however, is new software. The 4300 has two modes of operation, one to support programs from the existing System/370 computers and a so-called "native" mode that uses the new Disk Operating System/Virtual Storage Extended (DOS/VSE) software. Although IBM has continued its practice of including the basic operating system software in the price of the hardware, many of the advanced features offered under DOS/VSE require additional—and separately priced—program products. The most important of these is the VSE advanced functions package, priced at \$130 a month plus \$44 for maintenance, which supports up to 208 tasks and 12 partitions in a multiprogramming environment and offers what IBM calls improved "performance, usability, installation, and maintenance."

Indicative of the importance software plays in computers today, IBM has established a software support facility and is separately pricing maintenance on all its new software. It will extend the practice next year to the rest of its software, including the bundled systems software. □



# TWO GOOD REASONS THAT MAKE SOLITRON NO.1 IN POWER SCHOTTKY RECTIFIERS:

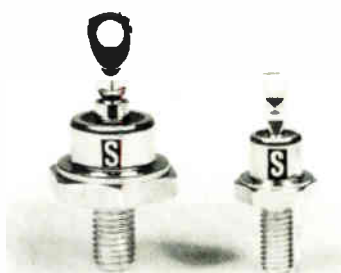

**SD-51 SD-41**

We can even give you three super reasons why these metal-barrier power Schottkys are tops for your high-efficiency, fast switching applications: increased reliability, improved thermal dissipation and lower  $V_F$  drop.

If you're building low voltage, high current power supplies, Solitron's reliable SD-51 in a DO-5 package is just what you need. This 60 amp, 35 volt Schottky features:

- $V_F @ 60A, 125^\circ C \leq 0.60V$
- $I_R @ 35V, 125^\circ C \leq 200mA$
- $C_j @ 5.0V \leq 4000pF$

For lower currents, our proven SD-41 in the DO-4 package is the answer. It's a 30 amp, 35 volt power Schottky featuring:

- $V_F @ 30A, 125^\circ C \leq 0.55V$
- $I_R @ 35V, 125^\circ C \leq 125mA$
- $C_j @ 5.0V \leq 2000pF$

Rugged mechanical construction goes into these power Schottkys to make them tough and long lasting. Both have copper terminals and nickel alloy sleeves, and the SD-51 is designed with a 4 point crimp to minimize contact resistance.

Best of all, our prices are competitive or lower. For complete information on either Schottky, write or call us toll-free at 800-327- 8462.

**Solitron** DEVICES, INC.

1177 BLUE HERON BOULEVARD / RIVIERA BEACH, FLORIDA 33404

(305) 848-4311 / TWX: (510) 952-7610

Telex: 51-3435

Commentary

# Testing debate enters new phase

Problems with VLSI devices require new solutions, with some compromise already beginning to take shape

by Albert F. Shackil, Instrumentation Editor

That the difficulties of testing large-scale integrated circuits has become a three-sided and seemingly unending conflict is well documented: the finger-pointing and blame-shifting of the people who make test systems, those who make circuits, and those who use the circuits has accelerated from conference to symposium to meeting.

But with very large-scale integration just down the road, testing now requires what amounts to the inven-

tion of a new art form and even more communication among three factions that have not been known for their willingness to sit down and swap information.

Fundamental to the obstacles to quick, inexpensive, and efficient tests is the nature of VLSI. Up to now, increases in density—going, say, from 7- to 5-micrometer line widths—have required merely mechanical reductions, very much like manufacturing a size 34 man's suit from a size 40 model. However, getting down to the 1- and 2- $\mu$ m line widths demanded for VLSI means basic changes in design parameters; hence it also means basic changes in thinking.

There are those who think that the industry's attitude toward device testing should change from a component orientation to a system attitude. In other words, LSI and VLSI devices should not be considered components, but rather as systems that must fit in with the construction, testing, debugging, and reliability parameters associated with systems.

Walt Luciw, principal engineer for research and development of advanced circuits at Sperry Univac, Blue Bell, Pa., agrees with this approach. In fact, he goes on to suggest that chip designers implement such system-testing features as

breakpoints in the routine. This, he maintains, "would permit the probing of the microinstruction logic array, arithmetic-and-logic unit, and register banks. It would certainly reduce test times."

The mention of test times brings up a major concern. In fact, it is generally accepted that the testing concept of the industry has been altered by semiconductor management philosophy that anything in a dual in-line package is a component and therefore should take no longer than 12 to 15 seconds to test. This includes the LSI and VLSI devices whose comparable off-chip systems sometimes took as long as 30 days to test, even with the numerous test points accessible to those systems.

**Data wanted.** Complicating the picture is the insistence of the test engineer that he should receive more



**State of the art.** At left is one of the newer testers for microprocessors, microcomputers, and other LSI devices, the Tektronix S-3270 automated test system.

**Remembering.** Shown at the right is an engineer using Teradyne's J387 memory system. It offers a feature called real-time bit mapping that displays the memory layout.



information about device design than he has been getting. But there is no reason to suspect that the device makers will supply any more design information about upcoming VLSI circuits than was sent along with LSI devices.

In general, the communication between chip designer and test engineer has been limited to the designer's giving a functional description of the part along with the critical timing specifications, leaving the test expert, as it were, to his own devices.

This disclosure debate often became the fulcrum of the early disagreements, with the testers insisting that they needed more information and the chip makers equally insistent that they were not going to disclose to the world what they considered proprietary data.

Also a factor is the belief by some device tester firms that going from LSI to VLSI will merely be another step upward, much like the one to LSI from medium-scale integration. As Gary Gillette, an engineering manager at Teradyne Inc.'s Semiconductor Test division, Woodland Hills, Calif., explains it, "Tester manufacturers have seen a continuous rise in chip density over the past 10 years, at a 60% increase in bits per year, and some prefer to think of VLSI as just another name for the latest devices with lithography in the 1-to-2- $\mu$ m region."

That view, naturally, is not shared



# Put image data on the Intel Multibus<sup>T.M.</sup>

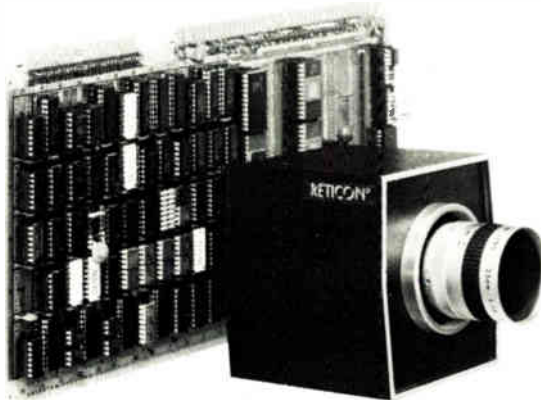

## Our plug-compatible board directly couples Reticon imaging cameras to Intel SBC/Multibus<sup>T.M.</sup> systems

Now you can apply computer power for processing signals from Reticon imaging cameras to achieve greater control and flexibility of non-contact inspection and measurement applications. The RSB-6020 interface boards contain these features.

- Collects data from one or two linear or matrix array cameras.
- Provides on-board preprocessing of signal data for faster and easier computer processing.
- Contains dual RAM memories with relocatable system address space.
- Provides multiple modes of data compression to handle high speed camera scan rates.

Write or call any of the Reticon offices for more information or application assistance.

Boston (617) 246-2718  
Chicago (312) 640-7713  
Los Angeles (213) 995-4663  
Sunnyvale (408) 738-4266

 **EG&G RETICON**

345 Potrero Avenue  
Sunnyvale, California 94086  
(408) 738-4266 TWX: 910-339-9343

## Probing the news

by the chip makers. They point out that a typical LSI gate is  $5\ \mu\text{m}$  wide with  $2\text{-}\mu\text{m}$  design rules. The figures get much smaller for VLSI, with geometries shrinking to the  $2\text{-}\mu\text{m}$  stage and approaching the processing limit. Newer manufacturing processes such as electron-beam lithography are capable of forming chan-

nels in the  $1\text{-}\mu\text{m}$  range with  $0.1\text{-}\mu\text{m}$  design rules. This leads to the dangerous notion that VLSI testing problems will be similar to those associated with past increases in chip density.

Just what are the new problems unique to VLSI? "There are problems of device physics," says Wayne Murakami, manager of computer-aided manufacturing at National Semiconductor Corp., Santa Clara,

Calif., "with the second- and third-order effects that were ignored in the past becoming very important. Device-physics problems like punch-through and trapping of holes become more evident in them."

**Some changes.** Clearly the attitude regarding testability at the design stage, along with feelings about supplying more data, is going to have to change. Also, attendance is increasing at special device-testing seminars such as the Institute of Electrical and Electronics Engineers' workshop on design testability coming up on April 25-26 in Boulder, Colo.

In addition to the matters of communicating chip design data and designing in testability is the economic consideration: someone will have to pay for all this.

**Worth it.** Here, as in the other areas, compromise is called for, one that satisfies the device maker while reducing the overall testing costs of the user. It is probably the job of the chip and system salesman to point out to their customers that, though they may be paying more for devices, they certainly stand to save time and effort on testing.

In addition, says Tom Williams, chairman of the IEEE's subcommittee on designing in testability, "it's to semiconductor houses' advantage to build it in, since an easier-testing component can sell for more."

Such a solution is not impossible—there are already several methods for providing VLSI testability without using up too much silicon, adding more pinouts to the package, or occupying too many of the existing pins. The most popular ones have parallel-in-serial-out shift registers located within feedback loops upon the chip; they enable subsections of the circuit to be accessed through the common bus and test data to be retrieved. IBM calls its version LSSD, for level-sensitive scan design; Sperry's is called scan/set, and Nippon Electric's scan/path.

Thus, progress is being made. Perhaps the best view of all the fuss comes from a computer company official who concludes that device testing is simply an evolution of know-how and that there is nothing to indicate that it will stop evolving when confronted with VLSI. □

# Reed relay smorgasbord

Nobody makes reed relays like Sigma. The reason is we also make our own reed switches—the heart of the relay. Every step of manufacturing is controlled to assure exceptionally reliable relays.

And the choice is almost unlimited.

We can give you a relay exactly right for your particular needs.

Features include hermetically sealed switches for tough environments, magnetic shielding for low noise, ratings to 1,000 volts, speed to 0.5 millisecond, vibration and shock resistant non-position sensitive mercury wetted units. You name it, Sigma has it—or we'll make it.

 **Send for new catalog** describing the complete Sigma line of relays, opto-isolators and photoelectric controls. All at competitive prices from your local distributor.

Sigma Instruments Inc., Braintree, Mass. 02184. (617) 843-5000.

**SIGMA**  
SWITCHING DIVISION



# Reduce Custom Power Supply Time and Cost

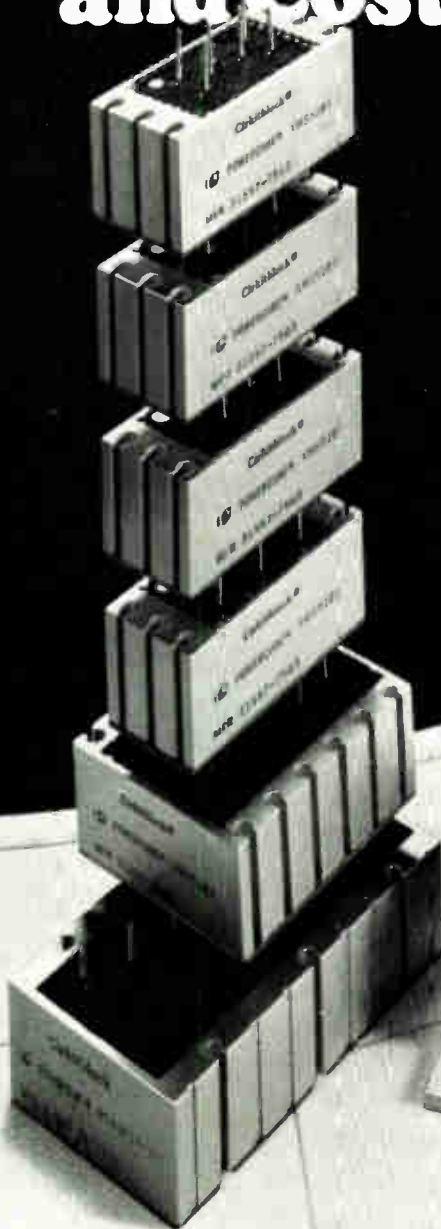

With a handful of Powercube's Cirkitblock<sup>®</sup> modules and a few clip leads, you can quickly synthesize an infinite variety of custom power supplies.

Cirkitblock modules have demonstrated capability to meet most design needs and are packaged within a 1" x 1" x 2" basic building block format so you can assemble supplies of any complexity to any form factor appropriate in building block fashion.

Design time to operating prototype can be reduced by more than 50% because conventional breadboarding is eliminated. Your quickly assembled "breadboard" of modules becomes your operating prototype.

Cirkitblock modules utilize space technology but are specified and priced for industrial as well as military applications. They can substantially reduce the "as installed" power supply costs in airborne and ground based instruments such as receivers, navigational systems, displays, stores management systems, and communication gear.

Cirkitblock functional modules not only save design time and money; they are also a lot of fun to work with.

Circle the reader service number to learn more about Powercube's Cirkitblock functional modules. Send for free catalogues describing the entire Cirkitblock module family and packaging styles for complete power supplies.

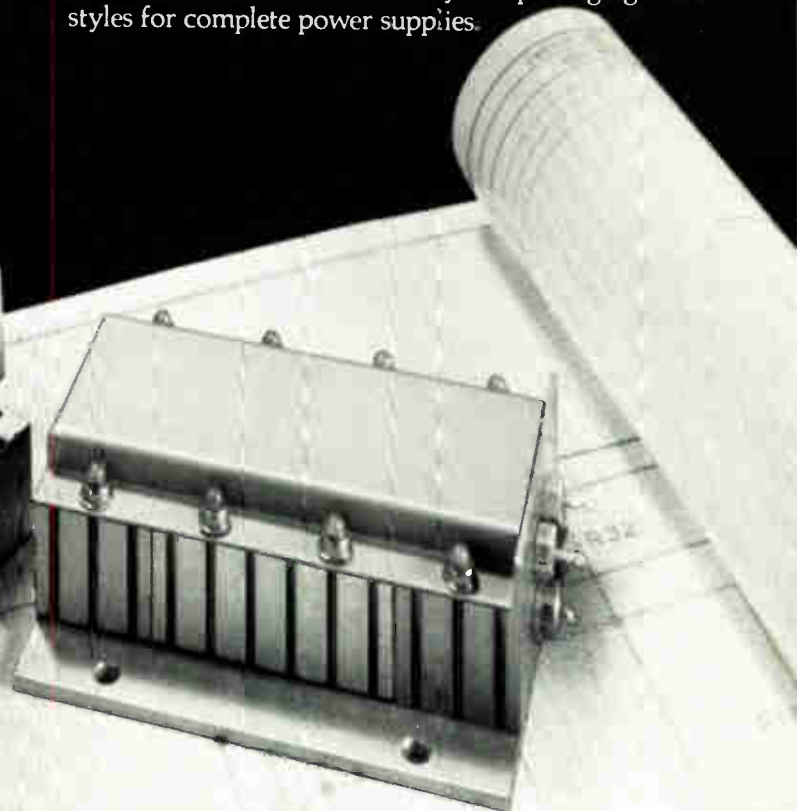

 **POWERCUBE**  
A SUBSIDIARY OF UNITRODE CORPORATION

POWERCUBE CORPORATION  
EIGHT SUBURBAN PARK DRIVE  
BILLERICA, MASSACHUSETTS 01821  
(617) 667-9500

Electronics abroad

# Scandinavian markets back to normal

Sweden making a 1979 comeback to once again set the pace, while Norway, last year's leader, has an austerity program

by Arthur Erikson, Managing Editor International

There are no upstarts in view this year to upset the economic pecking order in Scandinavia.

Sweden, always at the top of the list for sheer size, has edged out of the doldrums and will set the pace for growth among the Nordic countries and perhaps for all of Western Europe as well. Denmark, the No. 2 Nordic economy, also seems set for a spurt in growth after several lackluster years. But Norway, whose North Sea oil boom kept it the pacesetter until the economy overheated last year, will fall back in line this year with a campaign for austerity and thus moderate growth.

With the dominating Swedish economy on a strong uptick, the totals for electronics markets in Scandinavia obviously figure to grow faster this year than they did last. But do not expect anything dramatic. The outlook for consumer electronics is as bleak as the landscape in Lapland and consumer electronics still is a market mainstay. So despite the respectable gains for computers and for communications equipment that turned up in *Electronics'* survey of the three countries last fall, the forecast for equipment markets in 1979 is \$2.352 billion, a 7.9% gain over the 1978 total, estimated at \$2.180 billion. Since the survey figures markets in current money, the nominal rise has to be looked at, because of inflation, through the wrong end of a telescope. Even so, it is a solid improvement over the gain turned in last year, when equipment markets edged up 6% from \$2.056 billion for 1977.

Components markets, in contrast, will rise much the same as they did in 1978. They will hit \$556 million,

up 3.5% over the estimated \$537 million for last year. The only sector anything close to comfortable is integrated circuits, pegged to climb from \$67 million last year to \$73 million this year. That works out to a near-9% increase, not enough to excite anyone in the IC business.

Sweden. After two years in the doldrums, the Swedish economy now has brisk winds blowing behind it. The country's economy watchers, almost to a man, expect 1979 will be one of the best years of the decade as far as growth goes. In the draft budget for the upcoming fiscal year, for example, the government has postulated a growth of 5.4%. If that is right, Sweden will have the highest growth rate in all Western Europe.

The brisker economy will buoy equipment markets—entertainment electronics excepted. The forecast

puts 1979 markets at \$1.205 billion. That means a 9% rise, if the forecast is close to the mark, from the estimated \$1.105 billion for 1978.

Swedish communications-equipment makers presumably can count on a solid home market during the next 12 months. The markets chart posts the sector at \$209 million, a full 15% over the \$181 million estimated for 1978. Spending for defense equipment will stay on its plateau, a fairly high one. But there is a lift in store from Televerket, the state communications agency. Televerket this year will get its first substantial deliveries of AXE stored-program-control exchange equipment from LM Ericsson Telephone Co., for one thing. Other ambitious projects under way that will link subscribers in Stockholm, Copenhagen, Oslo, and Helsinki, and the

SCANDINAVIAN ELECTRONICS MARKETS FORECAST  
(IN MILLIONS OF DOLLARS)

	1977	1978	1979
<b>Total assembled equipment</b>	<b>2,056</b>	<b>2,180</b>	<b>2,352</b>
Consumer electronics	815	802	818
Communications equipment	391	435	484
Computers and related hardware	554	626	703
Industrial electronics	147	156	175
Medical electronics	72	75	78
Test and measurement equipment	51	57	62
Power supplies	26	29	32
<b>Total components</b>	<b>518</b>	<b>537</b>	<b>556</b>
Passive and electromechanical	309	321	331
Discrete semiconductors	61	60	60
Integrated circuits	59	67	73
Tubes	89	89	92

(Exchange rates: Denmark, \$1 = 5.3 kroner; Norway, \$1 = 5.1 kroner; Sweden, \$1 = 4.4 krona)

Note: Estimates in this chart are consensus estimates of consumption of electronic equipment obtained from an *Electronics* survey made in September and October 1978. Domestic hardware is valued at factory sales, prices and imports at landed costs.

# Biomation's K100-D -- no other logic analyzer even comes close.

**No wonder the K100-D is our fastest selling new logic analyzer ever. It gives you 16 channels, 1024 word memory, clock rates up to 100 MHz, signal timing resolution to 10ns—plus a built-in display and keyboard control.**

Biomation's K100-D puts it all right at your fingertips — more performance and features than any logic analyzer ever.

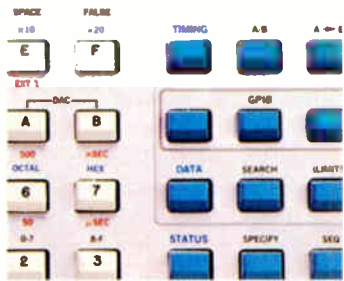

It starts with the micro-processor-controlled keyboard and interactive video display. To give you fast, precise control, the display serves as a comprehensive control status menu, with all selectable parameters in reverse video. There's a single, labelled key for each function, corresponding directly to status display choices. So guesswork is eliminated.

For example, in the data domain, you can direct the display to read in hexadecimal, octal, binary or ASCII, or any combination, by selecting one of four control buttons. There's also a unique "sequence" key that enables you to rearrange the order in which channels are displayed, to aid in data decoding, to simplify side-by-side comparison of timing signals and to enable you to cancel any channels you're not interested in seeing. A separate key controls horizontal expansion.

That gives you an idea of the K100-D's display versatility. Here's a picture of its astounding capture capability.

By providing timing analysis of signals as fast as 100 MHz, you can capture logic signals with resolution to 10ns. And the 100 MHz clock rate protects against obsolescence as the speed of your systems gets faster and faster. The K100-D also has a latch mode that can capture glitches as narrow as 5ns.



With the 32-channel input adapter, the K100-D is ideal for exploring the new world of 16-bit microprocessors. To give you unprecedented analysis capability, there's a built-in Auto Stop capability you can use to detect, record and display any match (or mismatch) between incoming data and previously recorded data held in a reference memory.

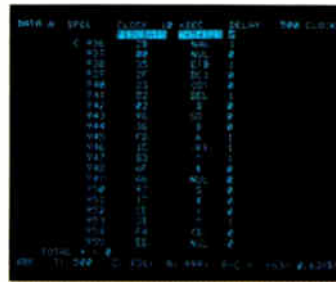

Or using Search Mode you can key in a specific word and the K100-D will find it in memory.

To get the full impact of the K100-D, you really do need to have it at your fingertips. That's why we would like to arrange a demonstration. Call us at (408) 988-6800. Or, for

more information, write: Gould Inc., Biomation Division, 4600 Old Ironsides Drive, Santa Clara, CA 95050.



Circle 93 on reader service card

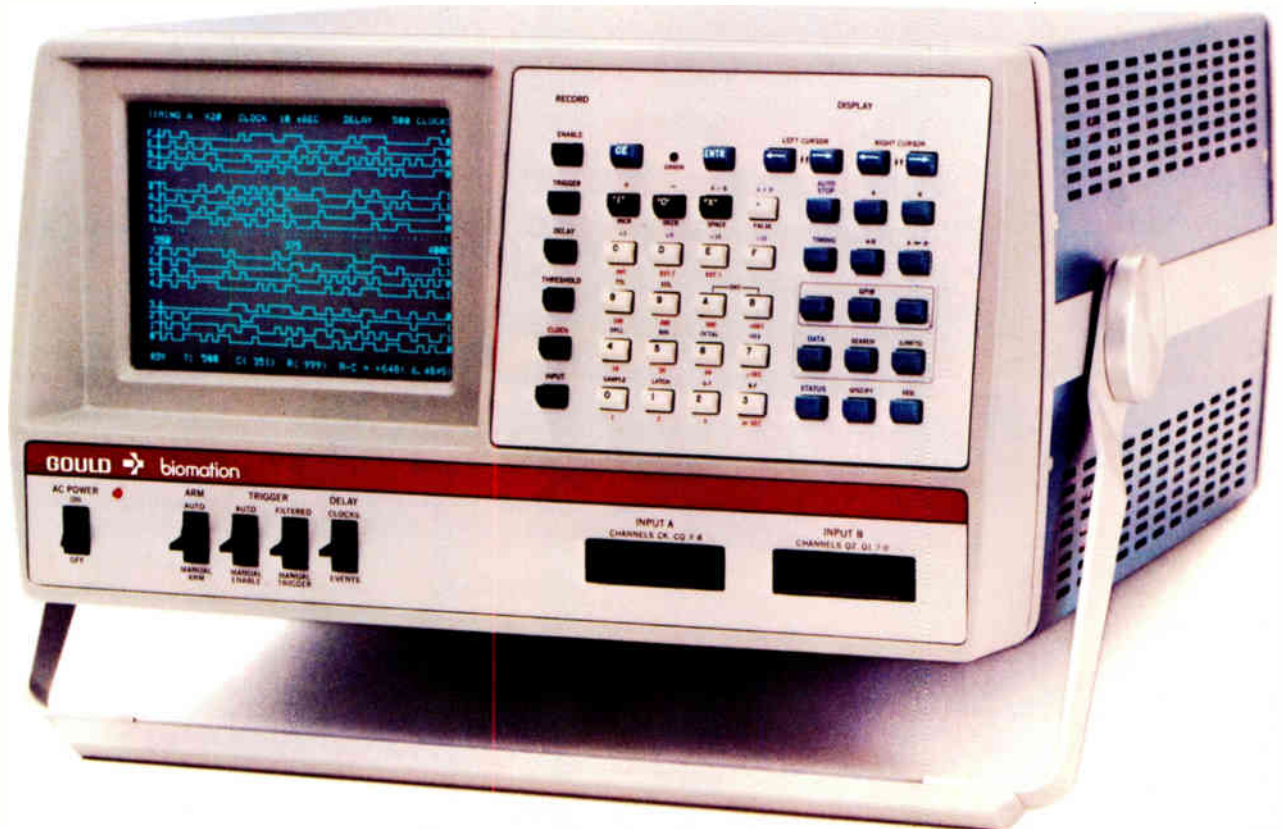

## Probing the news

nationwide paging network that started up late last year [*Electronics*, Jan. 4, p. 67].

Computer makers should do all right, too. The forecast for the sector—data-processing equipment and electronic office equipment—puts the market at just under \$380 million, up 12% from the 1978 figure of \$338 million.

Meanwhile, the country's TV set-makers face immediate and more pressing problems. There is no growth in sight for color-TV sales and nothing yet in sight to spark the market as color-TV once did. So consumer electronics sales will edge up only to \$437 million this year from 1978's \$421 million.

The two major set makers—Svenska Philips AB, a unit of the Dutch-based Philips' Gloeilampenfabrieken group, and family-owned Luxor Industri AB—are both feeling

the pinch. But Luxor has been hit particularly hard. The company, whose sales last year ran about \$110 million, tried to cope with the slope in the home market by emphasizing exports. But sales did not match the high costs involved and Luxor lost last year some \$20 million and recently recast top management.

And as go the set makers, so to a large extent go most component suppliers. The survey suggests only a modest rise in sales this year to \$340 million from last year's \$329 million. The 1979 figure may turn out low; the Swedish industry association, noting "definite optimism" among its 120 member companies, says component sales are up sharply over last year, which was poor. Microprocessor sales certainly will bulge. Products designed around them during the slow years of 1977 and 1978—from hi-fi receivers to forestry machines—will spill into the marketplace this year.

Denmark. Like their neighbors on

the far side of the Kattegat, the Danes foresee better business ahead. After a nearly invisible expansion of 1% last year, the country's Gross Domestic Product (GDP) could grow something like a perceptible 2.5% this year. Anyway, that is the reading by economists at the Organization for Economic Cooperation and Development (OECD), the Paris-based international organization.

Just as important, the Danes hope to whittle down their foreign trade deficit, which has been the traditional bane of their economy. They managed to cut it back by nearly 17% to \$3 billion last year and could do even better in 1979. How much better depends mainly on what kind of wage rise the unions will settle for in upcoming negotiations with employers. Another plus for the year ahead is a rise of 3% in investments.

Unfortunately, these improved prospects for the economy overall will do little to stimulate consumer spending. What is more, the satura-

# Solid State Relays

P&B has the broadest range of standard SSRs in the industry. Available now from authorized distributors.



We have transformer coupled, opto coupled and reed relay coupled SSRs... in seven different case styles. All industrial quality manufactured under a control program based on MIL-Q-9858A procedures.

P&B can also design special SSRs for your unique requirements in any quantity.

In standard or special SSRs, P&B has what it takes to serve your needs. Experience.

Quality. Broadline options. Contact Potter & Brumfield Division AMF Incorporated, 200 Richland Creek Drive, Princeton, Indiana 47671. (812) 386-1000.

# Potter & Brumfield



tion level for color-TV sets is approaching 60% and sales of sets—figured in money or in units—are slipping. The survey forecasts consumer electronics markets this year will run slightly below the \$245 million estimated for 1978. And when there is no lift in consumer electronics, there is no chance for a substantial rise for equipment markets as a whole. Despite a strong gain for computers, the No. 2 sector, the forecast is \$648 million, a hike of 6% over 1978.

As always, Danish electronics hardware producers count more on exports than their home market. The country's 200-odd firms prospered last year and generally see more of the same as they peddle their specialties around the world [*Electronics*, Nov. 9, p. 86].

**Norway.** Although they did not take to wearing 10-gallon hats, the men who govern Norway did let their North Sea oil bonanza go to their heads. To keep their economy

headed up despite the general slowdown around the world, the Norwegians spent oil revenues before they came in and thus acquired a dangerous payments deficit along with an overheated economy. Not only did the forced prosperity suck in imports, it also pushed wages to levels where Norwegian workers were the highest paid anywhere, making many Norwegian products uncompetitive in world markets.

The government slammed on the brakes late last summer with a freeze on prices and wages that is going to last through 1979. So it is not particularly surprising to learn that the growth in GDP will fall sharply—from a rise of 3.75% in 1978 to only 2.5% this year in the view of OECD's forecasters.

It is no surprise, either, that this year Norway's electronic equipment markets won't outpace the others in Scandinavia as they did in 1978. They grew some 9% then to reach \$464 million. This year they will

move up about 7% to just under \$500 million. As in Sweden and Denmark, consumer electronics is no-growth and the gain comes mainly from computers and from communications equipment.

As for components suppliers, their prospects have been lowered several notches by the bankruptcy of Tandbergs Radiofabrikk A/S. Taken over by the government last year, it will stay in the computer terminal business [*Electronics*, Jan. 4, p. 63], but it won't consume components the way it did when it was the sole Norwegian producer of TV sets.

When *Electronics* surveyed the market last fall there was a chance that Tandberg would carry on, and the forecast was \$71 million in components sales. With Tandberg out of the television production picture, the figure this year will fall well below that. □

Last in a series examining European markets. Robert Skole in Sweden, Alfred Petersen in Denmark, and Ottar Odland in Norway reported for this article.

## ...and other solutions to your tough design problems are found in P&B's growing product line.

AMF  
Potter & Brumfield



**NEW S85 Solenoid.** General purpose solenoid has an enclosed coil for extra protection. Pull on operate coils available in AC and DC voltages for intermittent or continuous duty. UL Recognized materials, including Class A (105° C) insulation, are used. Use in machine-tool controls, vending and business machines.

Circle 115

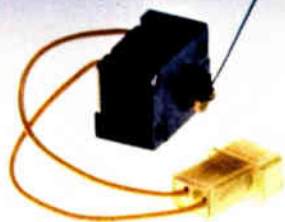

**NEW A5R 1B Sealed Rotary Switch.** Sensitive, miniature switch requires only 4 in.-gms. of torque. Hermetically sealed, magnetically actuated, SPST-NO, contacts are rated low level to 200 mA at 50V DC or 120V AC, resistive. Use as a limit or sensing switch in dust or chemical environments.

Circle 116

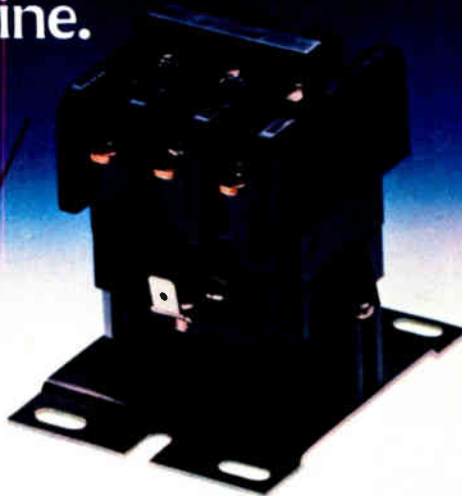

**NEW P25 Definite Purpose Contactor.** UL Recognized. Switches three phase motor loads up to 25 amps, 600V AC, or resistive loads up to 30 amps, 600V AC. Field replaceable contacts, available to 3PST-NO-DM, have a life expectancy of at least 500,000 operations at full load. Auxiliary snap-action switch is available.

Circle 117



**NEW SDAS-01 AC Current Sensor.** Zero insertion loss. Field adjustable for overcurrent and undercurrent levels from 1.5 to 15 amps. Solid State sensing circuit is inductively coupled to a high potential power line. Controls internal SPDT, or DPDT relay. Can switch contactors or annunciators. Built-in time delay allows normal start up and line current variations. Control voltage is 24V AC.

Circle 118

Software

# Pascal people unhappy over standard

---

ANSI, BSI, ISO, and even IEEE are in the act as attempts to settle differences between academicians and industrial users are unavailing

---

by John G. Posa, *Microsystems and Software Editor*

When the American National Standards Institute sponsored an organizational gathering in Washington, D. C., late in December of its X3J9 subcommittee to standardize the programming language Pascal, it probably expected to make some headway. But, as with some other recent Pascal gatherings, progress at the ANSI meeting was minimal. "We agreed only to have another meeting on Feb. 20," says Joe Cointment, Texas Instruments' representative, "We didn't even elect a chairman."

As that meeting nears, a number of issues are turning attempts to arrive at a Pascal standard into a real headache, one that would bring tears to the eyes of Blaise Pascal, for whom the language is named. One problem is that a number of groups claim to be working on a standard already. Worse still, academic factions maintain that the standard should incorporate only the ideas presented by the language's author, Niklaus Wirth, in his revised Pascal Report—without any major alterations. Industrial users contend that modifications and extensions to the language are so essential that they should be embodied in the standard from the outset.

Finally, there is the question of whether language standards make sense at all. While the proponents maintain that it is necessary and would be fruitful for all Pascal machines and users to be able to communicate, particularly since the language has enjoyed a phenomenal growth in the last few years [*Electronics*, Oct. 12, 1978, p. 81], opponents of the idea would just as soon go their own proprietary ways.

In Europe, progress toward stan-



dards has been made for almost two years. A subcommittee of the British Standards Institute called DPS/13/4 first met in Southampton in the spring of 1977. Headed by Tony Addyman of the University of Manchester, this group is still going strong and is backed in the U. S. by the Pascal Users' Group (PUG), based at the University of Minnesota. In the spring of 1978, a working draft for a Pascal standard was given to the International Standards Organization (ISO).

"There was a choice whether to go to ANSI or ISO," says Richard Cichelli, a founder of PUG. "It was decided at Southampton, and every group since has concurred, that ANSI presents significant problems. We wanted only to standardize the language in the report. We don't want to design a new language."

Parallel to the European standards effort, PUG established a working group in June 1976 to consider extensions to Pascal. Now coordi-

nated by Andy Mickel, who also edits PUG's Pascal News quarterly, this group comprises virtually every major implementer around the world, including Wirth himself. PUG was satisfied. There was a group for a standard and a group for extensions. The standard, which the ISO will most likely still adopt, is very close to the language in Wirth's revised report.

But since then, Pascal has become enormously popular, and it seems everybody wants a piece of the action. Kenneth Bowles, a professor at the University of California at San Diego, put together a Pascal system to run on a wide variety of microprocessors. He began quietly to blanket the country with his system, in the hope that it would become a *de facto* standard, and in July 1978 held a workshop to discuss extensions to Pascal. "But it was all about standards," says TI's Cointment.

Some believe that ANSI wants to undermine the British effort—to change Pascal to make sure it is not compatible with ISO's standard. But that's not so, says Justin Walker, a National Bureau of Standards mathematician who convened the ANSI meeting. "There's a good chance we will vote in the British standard," he says. "We first have to get all the groups and interests together and start going in the same direction."

One of those groups is the IEEE. It decided at the ANSI meeting that it should draft a standard of its own, so it met in San Francisco in January to do that. Says ANSI's Walker, "We're trying to set an agreement whereby ANSI and the IEEE can work together, even though we're starting out differently." □

# Let us make something perfectly clear.

When it comes to making assembly instructions easier to understand, one color picture can be worth a lot of words.

Which is why so many manufacturers are turning to the Xerox 6500 Color Copier.

Just place a 35mm color slide of the component you want assembled in the 6500's slide adapter.

Push a button.

In seconds you have inexpensive color copies which would have taken hours to render by hand. Call-out overlays are also easily prepared.

You can even place actual circuit boards directly on the glass platen and create transparent color overlays for use by quality-control inspectors.

And when you're not making color assembly aids with the 6500, you can use it to make color-coded copies of PCB stuffing, rework instructions, parts lists and wiring-harness diagrams.

Once you see the time and money the Xerox 6500 Color Copier can save you, something else will become perfectly clear.

Why you should have one.

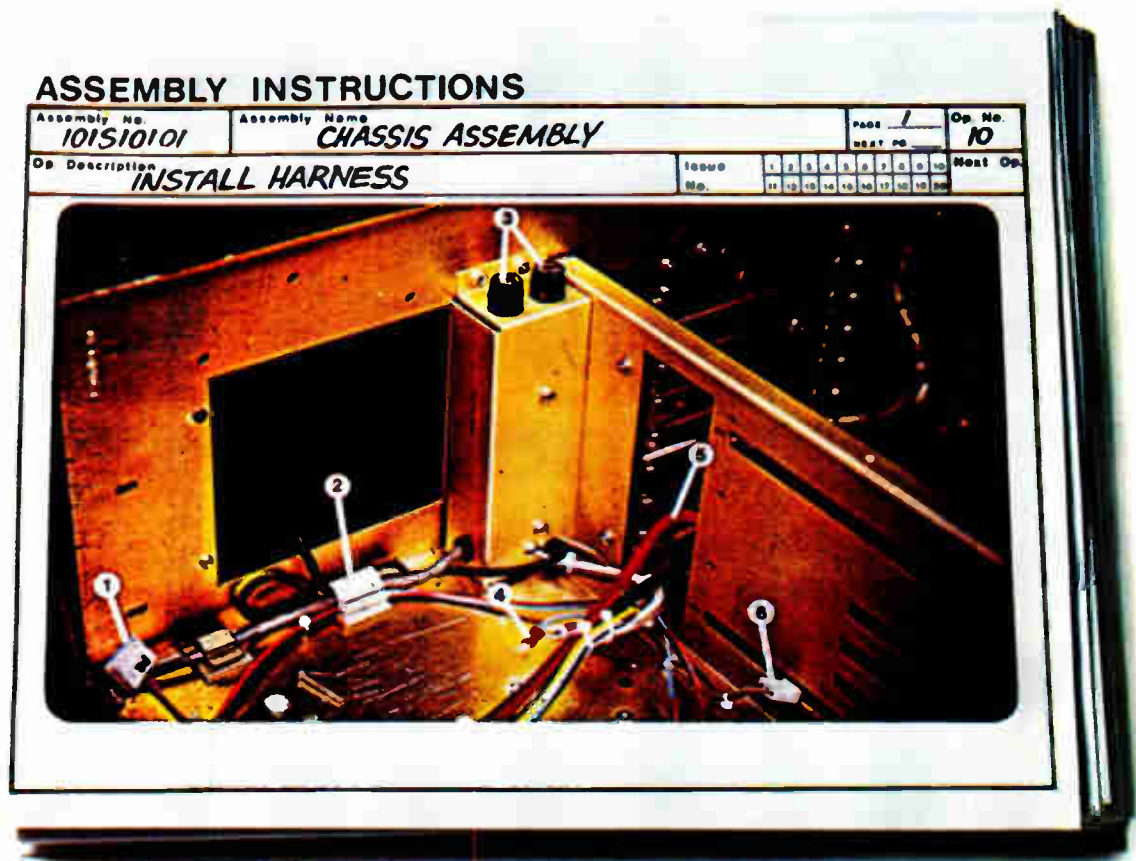

This print made on a 6500.

## XEROX

XEROX® and 6500 are trademarks of XEROX CORPORATION.

Now supports F8, 3870, 3872.

**Our system  
emulates the 8080 and  
the 8085. The Z80.  
The 6800. The TMS 9900.  
And that's just  
for openers.**

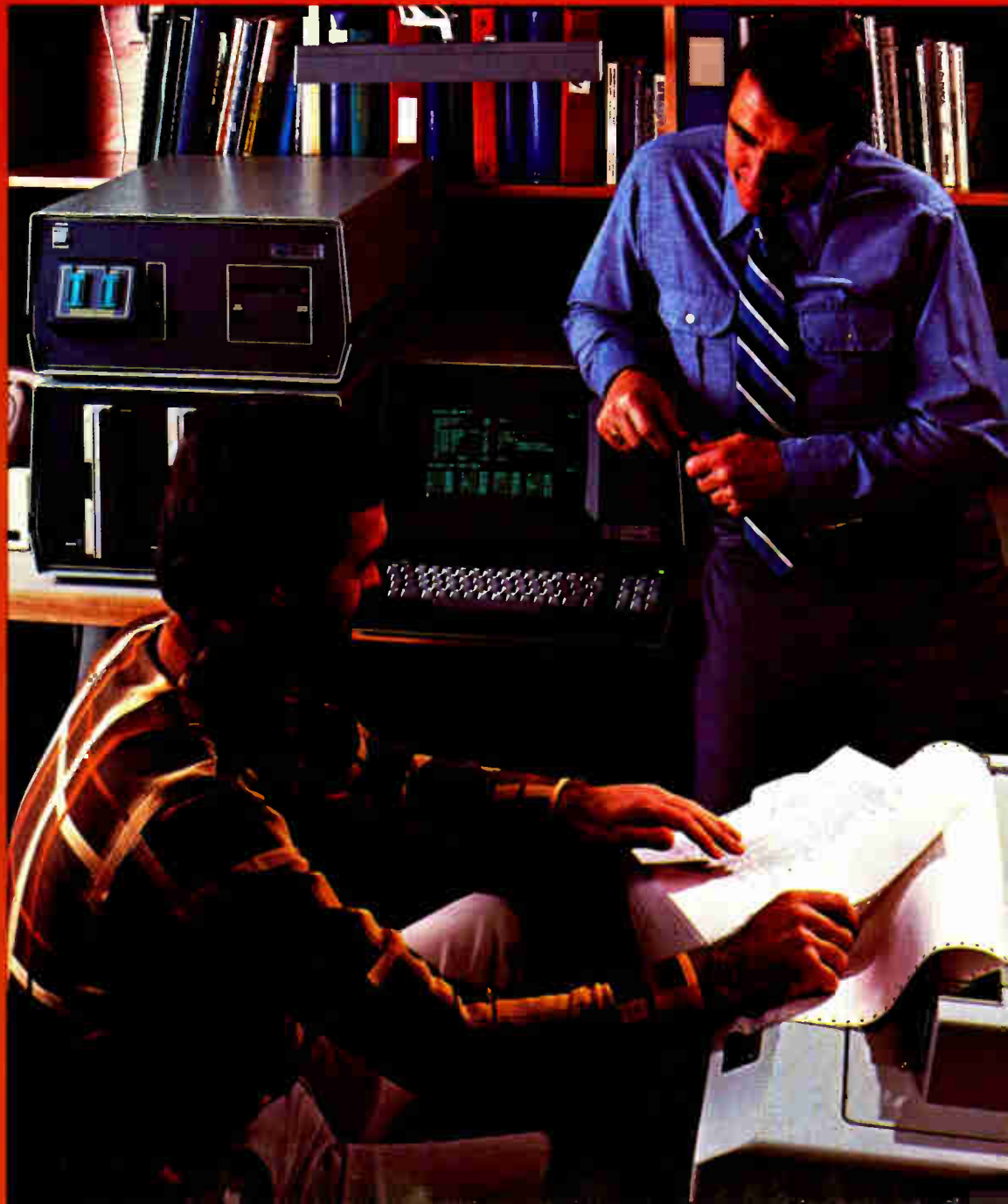

# Because who has time to learn a new system when a better chip comes along?

Both the Tektronix 6001 and 8002 microprocessor development labs now fully emulate the 3870, 3872 and 88. You can select the chip that best fits the job without repurchasing or relearning equipment.

## JOB AFTER JOB, OUR SYSTEM STAYS WITH YOU.

We know time spent learning equipment is best spent on equipment that's going to stay around.

That's why we engineered the first development lab for designers like us who work with major microprocessors.

Now you needn't depend upon one chip vendor. Or buy and learn an entirely new system when you change chips.

## THE BEST IDEAS

Our features are the kind of ideas you'd probably engineer for yourself... the kind of system you get from a chip user, not a chip vendor.

## DISC BASED SYSTEM

Includes text editor, micro relocatable assembler, debugging software and file management utilities, to help simplify software preparation and debugging.

## REAL TIME PROTOTYPE ANALYZER

This invaluable option lets you easily track down timing or program

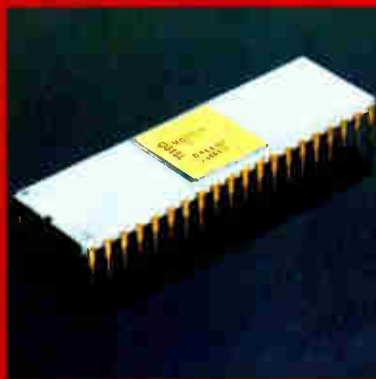

logic problems by dynamically monitoring the microprocessor bus.

## ENHANCED BASIC

This specially enhanced, compiler version of BASIC is compatible with the 8080 and 8085, and includes a subset of Z80 instructions. Extensions include comprehensive interrupt handling and optimization features to produce compact code.

## PARALLEL DEVELOPMENT INTEGRATED TESTING

Hardware and software engineers can test, trace, and debug independently up to the point of integration. Then they can work together, productively.

If you're concerned about how you spend your time, take a close look at a design lab you can use time and again... even when a better chip comes along.

Contact your local Tektronix Sales Office, or write or call Tektronix, Inc., P.O. Box 500, Beaverton, OR, (503) 644-0161. In Europe, Tektronix, Ltd., P.O. Box 36, St. Peter Port, Guernsey, Channel Islands.

**Tektronix**  
COMMITTED TO EXCELLENCE

**Tektronix**  
microprocessor  
development labs.

Designed by  
people on your side  
of the bench.

For 3870 information circle #24, for literature circle #38, for demonstration circle #49. For fast reply call TOLL FREE (800) 547-2312. (In Oregon, call collect 484-9911)

# COMPLETE TEMPERATURE

## OUR NEW TWO-TERMINAL TEMPERATURE TRANSDUCER BEATS EVERYTHING ELSE IN THE $-55^{\circ}\text{C}$ TO $+150^{\circ}\text{C}$ RANGE.

Our new AD590 IC Temperature Transducer is complete and self-contained. It offers you unparalleled absolute accuracy over a  $-55^{\circ}\text{C}$  to  $+150^{\circ}\text{C}$  sensing range. It's only \$1.95/100s in the T0-52 can. Where size is a major factor, a miniature ceramic flat pack is available at \$3.50/100s.

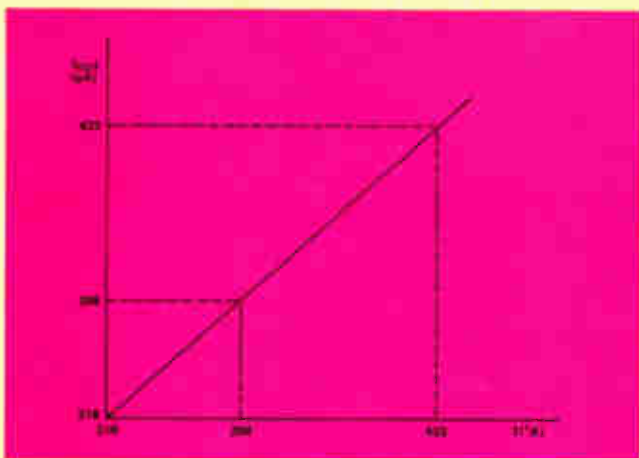

The AD590 is the first two-terminal integrated circuit temperature sensor that's laser trimmed at wafer level to produce an output of  $298.2 \mu\text{A}$  at  $298.2^{\circ}\text{K}$  ( $25^{\circ}\text{C}$ ) and you get  $1 \mu\text{A}/^{\circ}\text{K}$  up and down the entire range. Nothing could be simpler. Or cost less when you're all done.

ACTUAL SIZE:

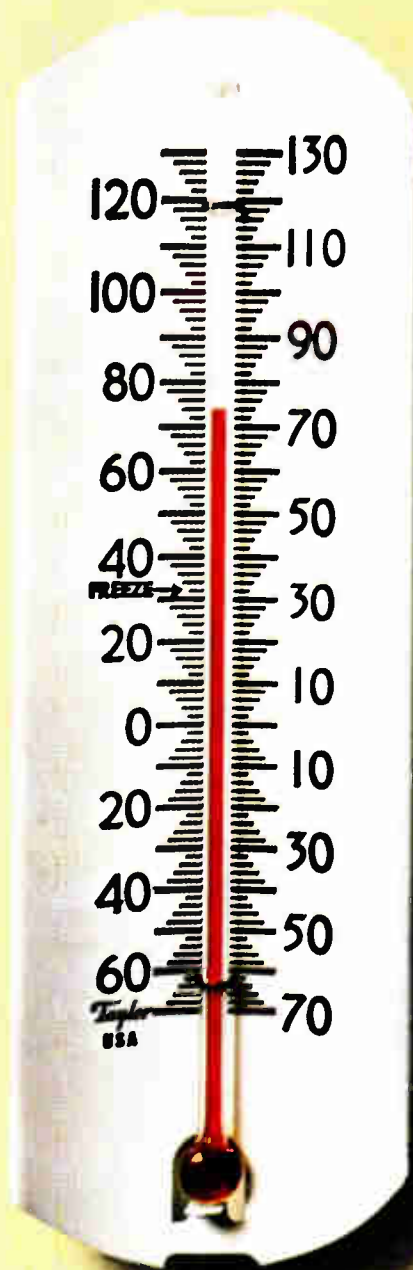

# SENSING. TWO BUCKS.

**FORGET LINEARIZATION  
AND SUPPORT CIRCUITRY,  
THE AD590  
IS ALL YOU NEED.**

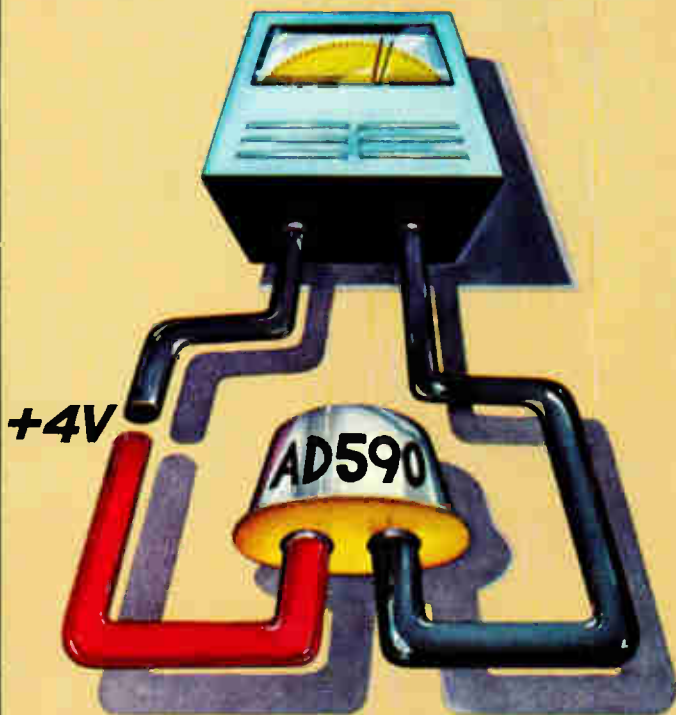

The hot news is that you can forget linearization, trimming and amplification circuitry. You know, the "extras" that always end up adding \$7 or \$8 to the cost of implementation with other devices. Costly transmitters, filters, lead wire compensation and support circuitry are all unnecessary.

Exclusive laser trimming and 100% final testing guarantee complete interchangeability without the need for circuit recalibration. In remote applications, the AD590's current output makes multiplexing easy.

**AT THIS PRICE,  
IT'S IN A CLASS BY ITSELF.**

Thermistors, thermocouples or expensive RTD's just can't compete with the AD590. Price alone is the biggest factor, only \$1.95 in 100s for the TO-52 can, \$3.50 in 100s for the miniature ceramic flat pack. But when you consider the things you get like absolute accuracy,  $\pm 0.5^\circ\text{C}$  maximum non-linearity, easy interchangeability, versatility, and the fact that those costly "extras" are not needed, there's no comparison. The AD590 is in a class by itself. For specs and information, call Doug Grant at (617) 935-5565. Analog Devices, Inc., P.O. Box 280, Norwood, MA 02062.

 **ANALOG  
DEVICES**

## WAY OUT IN FRONT.

# HP's OEM-compatible the start of s

However big the system you're planning, make sure you start with a computer and disc combination from Hewlett-Packard. HP 1000 processors and disc memories were designed to work together. So whatever combination you choose, you're assured of complete compatibility. Then you can add off-the-shelf peripherals and instruments, as well as the equipment you build yourself, to

create extremely reliable, cost-effective OEM systems.

This compatibility extends to our RTE family of real time operating systems, data base management and networking software, too.

By offering computers in a range of speeds and main memory sizes, and discs from 5 to 50MB, we make it easy for you to find the performance you need at the price you can afford. And you have a choice of packaging in standard or low-profile racks, or as separate modules.

## Three ways to mix and match

You can put together all kinds of disc and computer combinations. These three examples cover a range of prices and performance.

**1. Our HP 1000 F-Series computer and 7920 top-loading disc give you a lot of speed and power for \$24,310.** The computer has 128K bytes of 350 ns memory (expandable to 2MB), a Scientific Instruction Set, 14 I/O channels (expandable to 46), hardware floating point, and fast Fortran processor. The 50MB disc has a 25 ms seek time and a transfer rate of 937.5K bytes per second. You can also add storage to 400MB.

**2. At \$17,428, our HP 1000 E-Series computer and 7906 disc is a great combination.** The 64K byte memory (expandable to 2MB) has a 595 ns cycle time (350 ns optional). It has nine I/O channels, expandable to 46. The 7906 disc has half of its 20MB storage on removable cartridges and the other half on fixed platter. Seek time is 25 ms and the transfer rate is 937.5K bytes per second.

**3. For economy, you can pair our HP 1000 M-Series computer with this same 7906 disc.** You get the same ability to expand the 650 ns memory from 64K to 2MB, and similar I/O options. And the price starts at just \$16,187.

*Quantity 50—U.S. domestic OEM prices with cabinetry as shown.*





# e computers and discs: something big.

Another reassuring point: buying from one supplier means good service and support. Especially when that supplier is Hewlett-Packard.

We've been solving problems in the lab and factory for the past forty years, making thousands of instruments, computers and peripherals in that time. So we know exactly what an OEM needs

to make them all work smoothly together.

That's why so many successful OEMs start their systems with one of ours. So check out the full range of HP performance at your nearest HP sales office. You'll find it listed in the White Pages. Or write for complete information to Hewlett-Packard, Attn: Bob Puette, Dept. 649, 11000 Wolfe Road, Cupertino CA 95014.



I'd like to know more about HP 1000 computers and discs for use in systems  for my company  for re-sale to others.

My application is (system function)

For (type of company/industry)

Name

Title

Company

Address

City/State/Zip

Phone

22806HPDS18

Circle 103 on reader service card

# ON THE BENCH, THE MOST ADVANCED DVM. IN SYSTEMS TOO.

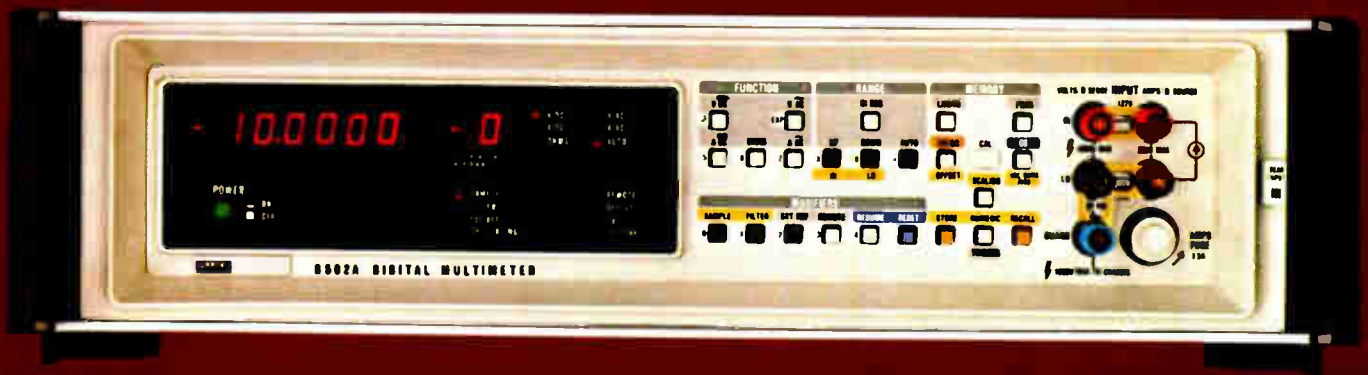

The new 8502A digital voltmeter—the precision DVM just right for both systems *and* bench applications.

It's right because it brings all the power of the 8500A, the world's most advanced system DVM, to the front panel.

Press SCALING and enter any multiplier to scale volts, ohms or amps to temperature, percent, engineering units, or any scale of convenience. Press OFFSET and add or subtract any numerical value to set your prescaled units to the right reference point.

$$"Y=AX+B"$$

If you're looking only for a good/bad indication, use LIMITS and key in both high and low tolerance values on any function. After that you'll get a friendly "Hi, Pass or Lo" reading at full accuracy.

The 8502A remembers its highest and lowest readings. Leave it unattended on a stability test, for example, then touch PEAK, HI and LO later to observe the amount of drift that occurred.

Want 6½-digit resolution? Press HI RES and get it on all functions. This lets you utilize the full instrument accuracy—6 ppm on DC volts.

The 8502A is fast—up to 250 readings/second on the bench, 500/second in a system. This speed is put to work to provide noise rejection through digital averaging. Adding analog filtering gives you up to 100 dB NMR.

Calibration memory is a Fluke exclusive that saves time and money.

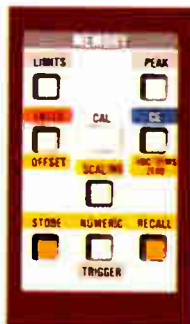

Without removing the voltmeter or taking off covers, simple recalibration is done from the front panel in a few minutes. Lab calibration is recommended only once a year if calibration memory is used.

The five FUNCTION pushbuttons are evidence of another exclusive. Besides volts and ohms, the 8502A can have AC and DC current capability installed, a feature not available in any other precision DVM.

We even provide diagnostic error codes to keep you out of trouble by identifying programming mistakes and hardware errors.

For systems use, we offer more interface options than anyone: IEEE 488, RS-232 or full parallel. And, a switchable front/rear input option is available.

U.S. base price: \$2595.

For more information, contact any one of the more than 100 Fluke offices or representatives, worldwide. In the U.S., CALL (800) 426-0361\*, TOLL FREE. Residents of the U.S.A. and all countries outside Europe, contact: John Fluke Mfg. Co., Inc., P.O. Box 43210, Mountlake Terrace, WA 98043, U.S.A. Telex: 32-0013.

In Europe, contact Fluke (Nederland) B.V., P.O. Box 5053, Tilburg, The Netherlands. Telephone: (013) 673973. Telex: 52237.

\*Alaska, Hawaii, Washington residents — please call (206) 774-2481.

**FLUKE**<sup>®</sup>

6104-8002

Circle 104 for information  
Circle 105 for demonstration

□ Analog-digital large-scale integration is coming to life with the aid of the switched-capacitor filter—a monolithic precision active filter that can be fabricated with any of several standard metal-oxide-semiconductor processes. The addition of this component to the MOS arsenal, which already includes analog-to-digital and d-a converters, stable voltage references, and high-resolution offset-nulled comparators, gives the IC designer virtually all elements of analog signal-processing systems in the same high-density, high-performance technologies that have captured digital large-scale integration.

Demonstrating the power of the switched-capacitor technique in realizing analog-digital LSI is Silicon System's 201 dual-tone multifrequency (DTMF) receiver for decoding Touch-tone telephone numbers (see "The DTMF receiver chip," p. 109). For the first time, one 40,000-square-mil complementary-MOS chip combines a variety of analog and digital functional blocks to efficiently perform a historically cumbersome telecommunications operation. Included are high-Q bandpass filters, sixth-order bandstop filters, comparators, and special-purpose analog circuits, as well as extensive digital logic (Fig. 1). The only outboard components needed are two noncritical capacitors and a 3.58-megahertz crystal—the type found in all color-television receivers.

### Filter approaches

The DTMF receiver, like many other analog systems, requires precision filters—and that usually means precision components. Passive filters could be built with discrete inductors and capacitors, or precision resistors and capacitors combined with operational amplifiers for active designs—but in either case dozens of precision devices are required. More easily manufactured approaches have evolved, one of the first of which was hybrid circuits.

Hybrid active RC filters are built by depositing thin- or thick-film resistors on a ceramic or glass substrate and attaching chip capacitors and integrated-circuit amplifier chips. For a DTMF receiver, dozens of connections must be made between all the R, C, and amplifier elements. Finally, to achieve exact frequency response each filter stage is anodized or laser-trimmed. But little can be done to trim the cost of hybrids; their fate is usually replacement with lower-cost monolithic circuits when technology permits.

Charge-coupled-device (CCD) filters can often meet tight specifications for frequency response, but have certain limitations that have delayed their development in commercial form. Aside from the fact that advanced fabrication processes like double-polysilicon-gate MOS structures are required for building CCDs with good



## Touch-tone decoder chip mates analog filters with digital logic

---

Switched-capacitor filter design builds 40 poles of bandpass, bandstop, and bandsplit filtering with TTL-compatible outputs on complementary-MOS chip

---

by G.M. Jacobs, G.F. Landsburg, and B.J. White,  
*Silicon Systems Inc., Irvine, Calif.*  
and D.A. Hodges,

*University of California, Berkeley, Department of Electrical Engineering*

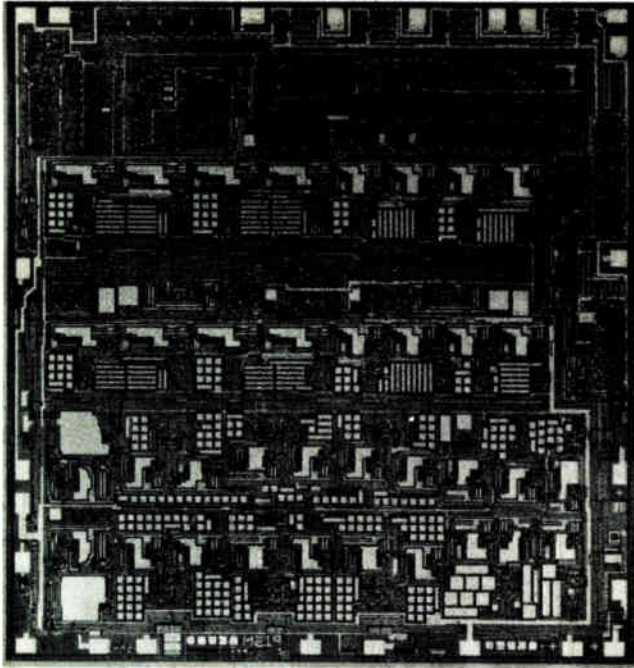

**Analog meets digital.** Integrated on a C-MOS chip is a complete dual-tone multifrequency receiver that performs central-office quality Touch-tone decoding. Twenty percent of the 210-by-220-mil device is digital logic, while the other 80% comprises 40 poles of precision analog filters that need no trimming. Power dissipation is typically 350 milliwatts from a 12-volt supply.

characteristics, thermally generated leakage currents and the excessive areas of silicon required limit CCD filters to a lowest center frequency of about 1 kHz. Moreover, minimizing distortion by raising the sampling rate can drive the number of CCD stages excessively high. Finally, the split-electrode transversal filter configuration usually used with CCDs yields a filter with substantial insertion loss even for frequencies in the pass band, making a good signal-to-noise ratio difficult to achieve with CCD filters. Only in certain applications—time-domain matched filters, for example—are CCD approaches attractive.

Wholly digital filtering techniques that employ only logic and memory elements might be preferable to analog methods in many applications—especially where programmability of the response is desirable. The fact is, however, that both chip area and power consumption for digital filters are still prohibitively large. For functions like the DTMF receiver, which requires fixed precision filters and which is slated for high-volume production, the driving forces are minimal chip size and easy integration that requires no trimming or special processing.

### Enter switched-capacitor filters

Since inductors cannot be integrated practically, active filters built around RC networks seemed the best approach. But the longest RC time constant possible with the usual on-chip resistors and capacitors is 10 microseconds at best—too brief for filters in the audio

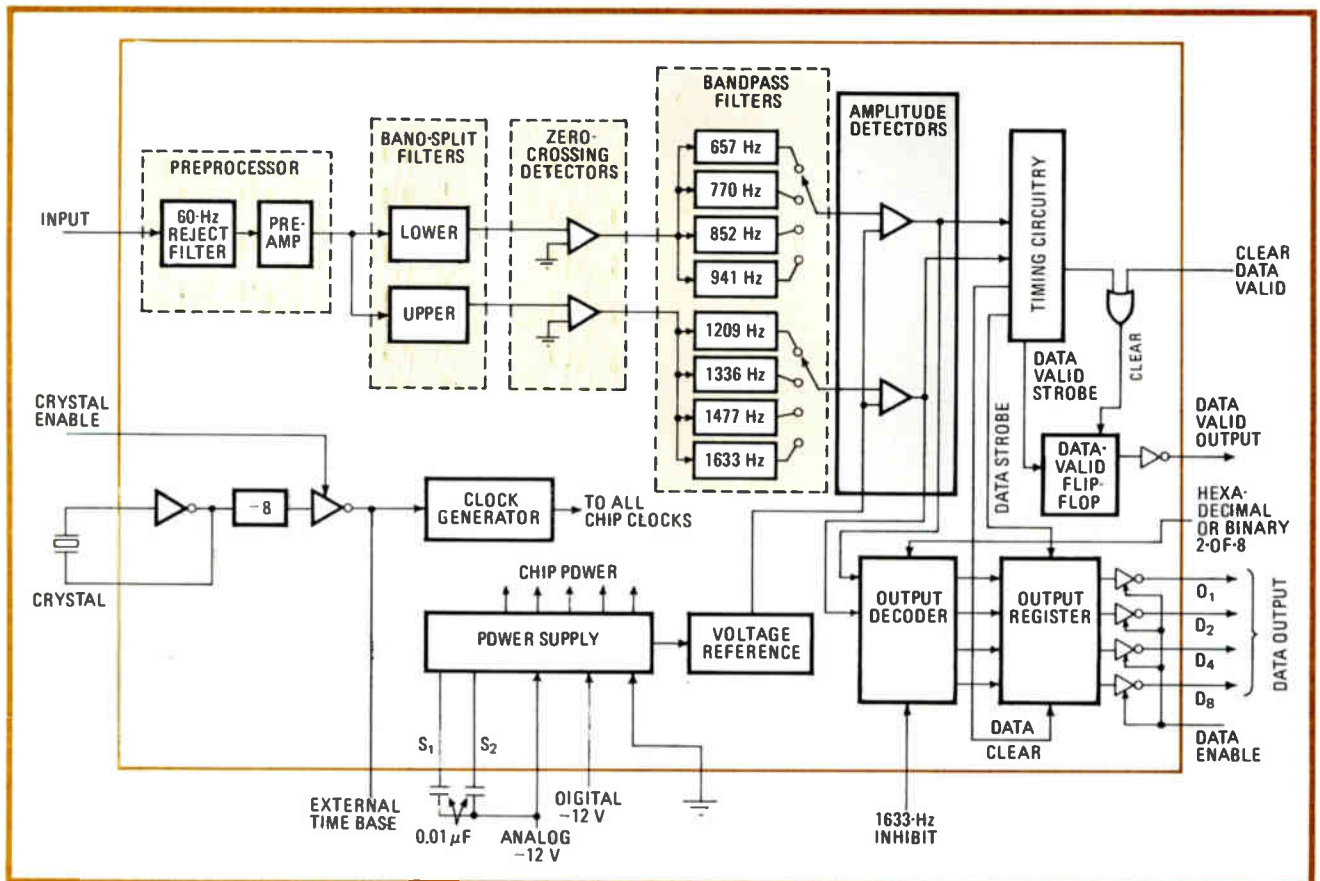

**1. One-chip DTMF receiver.** All the circuits for a dual-tone multifrequency receiver, which requires high-pass, high-Q bandpass, and band-split filters, in addition to extensive digital logic, are integrated with second- and third-order switched-capacitor filters on one chip.

## The DTMF receiver chip

The analog circuits in Silicon Systems Inc.'s 201 dual-tone multifrequency receiver occupy approximately 80% of chip area, the digital circuits 20%. The die, packaged in a 22-pin DIP, measures 210 by 220 mils and uses very conservative design rules: minimum metal width is 7.5 micrometers in the standard metal-gate C-MOS process used. Power dissipation is typically 350 milliwatts from a 12-volt supply. Digital outputs and inputs are transistor-transistor-logic-compatible; outputs are either binary-coded 2-out-of-8 or hexadecimal; and handshake capabilities simplify interfacing with the external system.

In addition to the 40 poles of switched-capacitor filtering, several other circuit functions are required to form the complete DTMF receiver. Digital functions are realized with standard C-MOS circuits. Zero-crossing detector/limiter circuits are ac-coupled comparators that supply square-wave outputs to the bandpass filters. The purity and frequency of an incoming tone is measured by comparing the peak signals at the detector/limiter outputs with the peak signals at the filter outputs. If there is interference or if the incoming signal is not a valid frequency, no bandpass filter will have an output that exceeds the threshold established by the peak detectors and thus no valid tone will be detected.

### SPECIFICATIONS FOR DUAL-TONE MULTIFREQUENCY RECEIVER

Supply voltage	10 to 13 volts
Operating temperature	0 to 70°C
System clock	Internal: 3.58-MHz crystal External: 448-kHz input

#### Receiver performance

Specification	Must accept	Must reject
Low-frequency bandwidth (697, 770, 852, 941 Hz)	$\pm (1.5\% + 2 \text{ Hz})$	$\pm 3\%$
High-frequency bandwidth (1209, 1336, 1477, 1633 Hz)	$\pm (1.5\% + 2 \text{ Hz})$	$\pm 3\%$
Minimum amplitude (each frequency)	-24 dBm at 600 $\Omega$ (53 mV rms)	—
Maximum amplitude (each frequency)	+ 6 dBm at 600 $\Omega$ (1.3 V rms)	—
Twist (high $\div$ low)	+ 4 dB to - 8 dB	—
Tone-valid time	$\geq 40 \text{ ms}$	$\leq 12 \text{ ms}$
Pause time	$\geq 40 \text{ ms}$	$\leq 12 \text{ ms}$
Talk-off performance	$\leq 2$ hits on Mitel test tape (CM7290) (typical)	
60-Hz tolerance	2 V rms	
Outputs	three-state, binary 2 of 8, or hexadecimal	

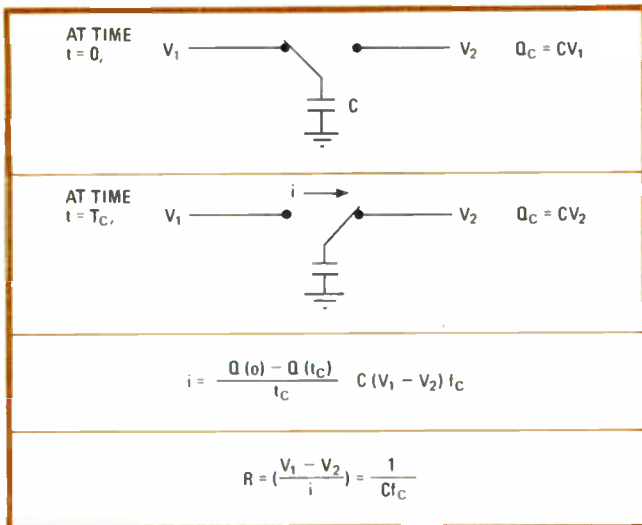

**2. R from C.** Switching a capacitor between two nodes simulates a resistor whose value depends only on the capacitor value and the switching frequency. This switched-capacitor technique allows the integration of precision filters on the DTMF chip.

band, which require time constants as long as 100 milliseconds. In standard IC technologies, the readily attainable capacitance ranges from about 1 picofarad to 100 pF, and the smaller values obviously are preferable since they take up less chip area. To achieve the desired time constant, resistors of from 10 to 10,000 megohms are needed; but none can be diffused, implanted, or deposited with the kind of accuracy and stability required.

In 1976, at about the same time, researchers at the University of California at Berkeley and at Bell-Northern Research in Ottawa recognized that a small capacitor switched rapidly could simulate a high-value resis-

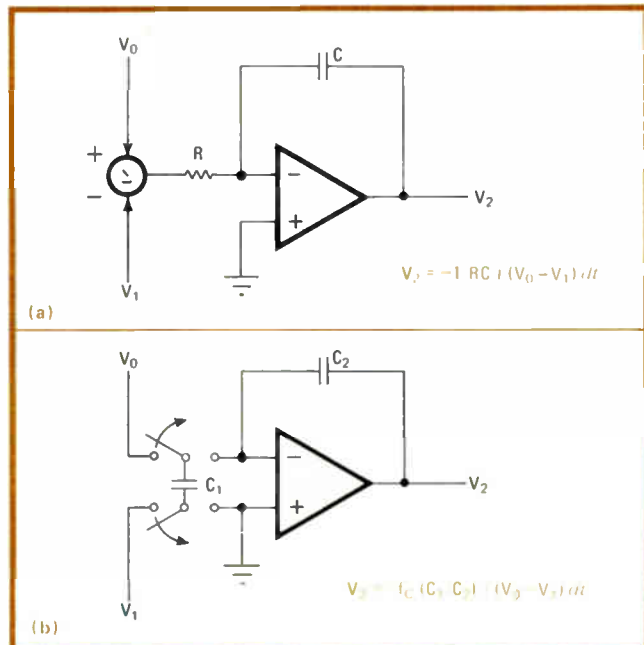

**3. Integrator.** In a modification of standard integrator (a),  $C_1$  of the differential switched-capacitor integrator (b) first charges to the difference between the two input voltages, then transfers the charge to  $C_2$ . The periodic transfer of charge appears as a current flow.

tor.<sup>1,2</sup> The basic scheme and design equations are given in Fig. 2; as shown, the resulting derivation yields a simulated resistor whose value depends only on the capacitance and the switching frequency.

The scheme lends itself well to integrated circuits: switches are easily implemented with small MOS transistors; signal voltages can be sensed with FET-input amplifiers; and operational amplifiers in n-channel MOS and

## Designing a switched-capacitor filter

With a little active filter theory and some classical LC design tables, the task of designing a switched capacitor filter becomes quite simple. The most popular designs implemented with switched-capacitor filters are the classical LC ladders, which are not only well documented,<sup>1,2,3</sup> but are inherently insensitive to variations in component values. Thus, LC ladder filters yield a highly accurate frequency response despite wide tolerances on capacitor values. In this section, the design of a low-pass ladder will be presented in detail.

The active simulation of an LC ladder filter is done with state-variable techniques. The active-ladder (or "leapfrog") configuration was first presented by Girling and Good ("The Leapfrog or Active Ladder Synthesis," Wireless World, July 1970). This configuration models the state variables of the LC ladder exactly, and thus maintains the same sensitivity characteristics as the passive LC prototype.<sup>4</sup> Consider as an example the doubly terminated four-pole LC ladder below:

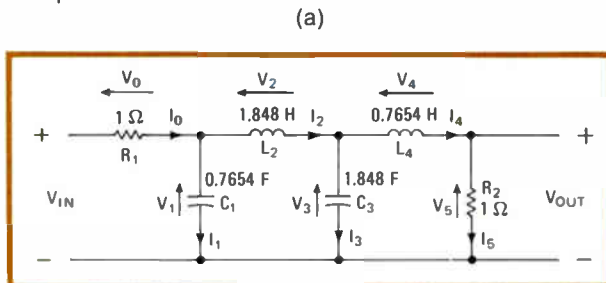

The Butterworth approximation is chosen. The normalized component values given in the table are taken from a catalog of standard filter approximations of which many are in print. The response will be flat in the passband starting at dc and will roll off to 3 dB down at the cutoff frequency  $\omega_0$ . The loss through the filter increases at 24 dB/octave after yielding the low-pass characteristic as shown below. The dc gain is -6 dB due to the  $R_2$ - $R_1$  divider.

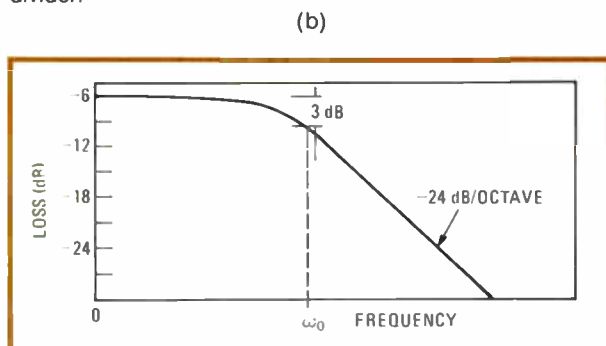

Referring back to (a), a set of equations can be generated using Kirchoff's voltage and current laws:

$V_0 = V_{IN} - V_1$	$V_3 = I_3 (1/j\omega C_3)$
$I_0 = (V_{IN} - V_1)/R_1$	$V_4 = V_3 - V_5$
$I_1 = I_0 - I_2$	$I_4 = V_4 (1/j\omega L_4)$
$V_1 = I_1 (1/j\omega C_1)$	$I_5 = I_4$
$V_2 = V_1 - V_3$	$V_5 = I_5 R_2$
$I_2 = V_2 (1/j\omega L_2)$	$V_{OUT} = V_5$
$I_3 = I_2 - I_4$	

These equations completely describe the operation of the passive LC ladder and are all written describing the relationship between voltage and current of any energy-storing element as an integration. The symbolic representation of the equations shows integrators as triangles and summers as circles.

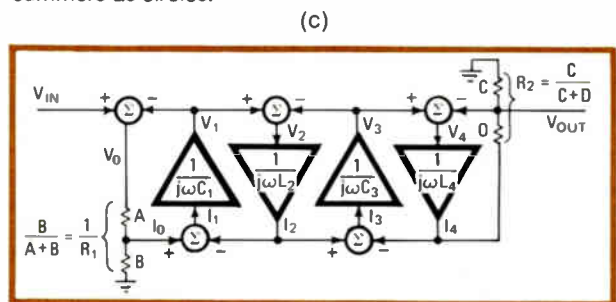

The symbolic representation of the LC prototype is now taking form as a circuit schematic. The integrators can be implemented with switched-capacitors as explained earlier.

Several scaling procedures are still necessary to make the circuit practical for building. Since the operational amplifiers used for integrators respond to voltages, the currents must be converted to voltages by scaling with an arbitrary resistance,  $R$ . For simplicity, the termination resistors  $R_1$  and  $R_2$  are each set to 1. The scaled version is thus:

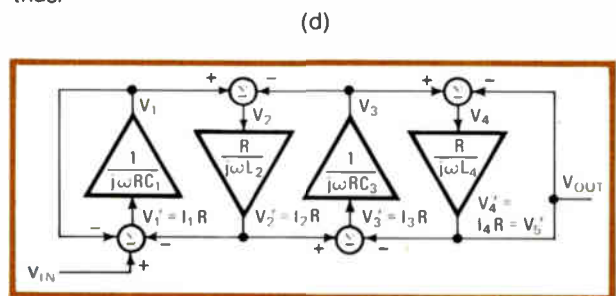

The integrators now have traditional RC or R/L time constants. A differential switched-capacitor integrator has the advantage of easily implementing the integrator and

C-MOS technologies have already been demonstrated. For the first time, RC filters with a wide range of center frequencies can be built on a chip that replaces the resistors with switched capacitors. But perhaps the biggest advantage of the switched-capacitor approach is that the accuracy and stability of equivalent RC prod-

ucts are determined only by capacitance ratios and switching frequency—and overall accuracy of within a few tenths of one percent can be achieved without trimming or adjustments.

The simple equivalence between a switched capacitor and a resistor holds true only for switching frequencies

summing function at each stage shown above. The analogy is shown below:

(e)

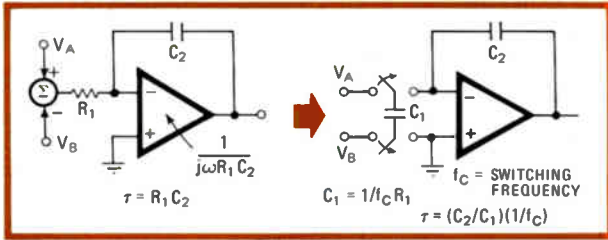

The complete ladder implemented with switched-capacitor integrators looks like:

(f)

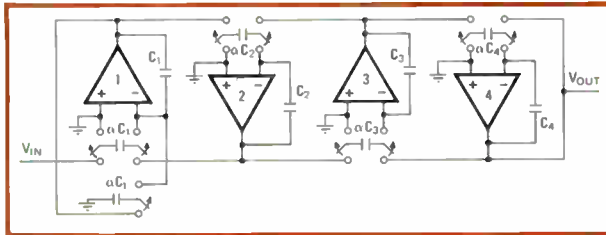

Although the switched capacitors are being clocked at a much higher frequency than the signals passing through the filter, they have a significant time delay. The delay through a switched-capacitor integrator translates into an unwanted phase component or loss in each integrator. Therefore, for proper operation of the ladder, the switches (MOS transistors in integrated form) on adjacent integrators must be clocked as shown by the arrows in the figure.

When the output of integrator 1 changes (switches up), for example, integrator 2 is picking up that change on  $C_2$ , thus minimizing the delay. When clocked that way, the effects of switching are negligible as long as the clock is at a sufficiently high frequency to avoid anti-aliasing or foldover distortion common to any sampled data system.

To complete the example design, actual capacitance values must be calculated for a specific frequency response. For the same Butterworth prototype, a cutoff frequency is assumed of, say, 1 kHz ( $\omega = 6,283.2$  radians/second) and a clock frequency of 40 kHz. (Input signals are thus bandlimited to 20 kHz.) For a 1-kHz  $f_c$ , the prototype in (b) must be scaled down by  $2\pi$  (1 kHz). In addition, the arbitrary scaling resistance is given the value of 1  $\Omega$ . The time constants of the switched-capacitor integrators are then simply the L and C values from the prototype ladder. Each time constant is  $C_2/C_1 f_c$  as shown in the figure. Therefore, the capacitor ratios necessary to implement the Butterworth filter at 1 kHz are calculated to be:

that are higher than the highest frequency being filtered. Since practical clock frequencies for audio-frequency filters are in the range of 50 to 500 kHz, exact design of switched-capacitor filters requires Z-transform analysis, as is true of all sampled-data circuits. Fortunately, digital filter computer programs such as Dinap (developed

Integrator 1 ( $C_1$ )	$\frac{0.7654}{2\pi(1 \text{ kHz})} = \frac{C_1}{\alpha C_1} \frac{1}{40 \text{ kHz}} \Rightarrow \frac{C_1}{\alpha C_1} = 4.87$
Integrator 2 ( $L_2$ )	$\frac{1.848}{2\pi(1 \text{ kHz})} = \frac{C_2}{\alpha C_2} \frac{1}{40 \text{ kHz}} \Rightarrow \frac{C_2}{\alpha C_2} = 11.76$
Integrator 3 ( $C_3$ )	$\frac{1.848}{2\pi(1 \text{ kHz})} = \frac{C_3}{\alpha C_3} \frac{1}{40 \text{ kHz}} \Rightarrow \frac{C_3}{\alpha C_3} = 11.76$
Integrator 4 ( $L_4$ )	$\frac{0.7654}{2\pi(1 \text{ kHz})} = \frac{C_4}{\alpha C_4} \frac{1}{40 \text{ kHz}} \Rightarrow \frac{C_4}{\alpha C_4} = 4.87$

The ratios completely define the frequency response for a given clock frequency. (Also, for given ratios, the response will shift directly with  $f_c$ .) In integrated form, for a ratio of 10, the two capacitors might be chosen at 1 pF and 10 pF to keep the area small. For a discrete version, the same frequency response would be realized using 100 pF and 1,000 pF. Since the only variables are the clock frequencies and capacitance ratios, extremely high accuracy is achievable as well as insensitivity to aging, temperature, and other environmental effects. In most applications requiring a fixed frequency response, a crystal-controlled clock generates the frequency reference.

#### References

1. D. J. Allstot, R. W. Brodersen, and P. R. Gray, "Fully integrable high order NMOS Sampled Data Ladder Filters," ISSCC, San Francisco, Feb. 1978.
2. G. M. Jacobs, D. J. Allstot, R. W. Brodersen, and P. R. Gray, "Design techniques for MOS switched capacitor ladder filters," IEEE Trans. on Circuit and Systems, Dec. 1978.
3. D. J. Allstot, R. W. Brodersen and, P. R. Gray, "MOS switched capacitor ladder filters," IEEE Journal of Solid-State Circuits, Dec. 1978.
4. H. J. Orchard, "Inductorless Filters," Electronic Letters, Vol. 2, June 1976, pp. 224-225.

by Steven Bass and colleagues at Purdue University) can be used for simulating switched-capacitor filters operating at any sampling frequency. One concern worth mentioning here, however, is that input-signal frequency must not exceed half the sampling frequency to avoid fold-over or aliasing distortion, as predicted by the Nyquist theorem.

The equivalent RC active filters can take several forms. But unavoidable parasitic capacitances, many of which are nonlinear, eliminate many of the classical passive and active RC filter circuits from integrated-circuit realization. Filters based upon active integrators eliminate the effects of most parasitics, because inputs are at virtual ground and outputs are voltage-driven. A widely useful building block is the differential integrator, shown in both classical RC form and switched-capacitor form in Fig. 3. For the complete development of an IC filter (see "Designing a switched-capacitor filter," p. 108), a classical LC prototype is first transformed into a state-variable filter, where integrator voltages are the state variables, and then, after scaling, is transformed into the switched-capacitor circuit.

A simplified schematic and the IC implementation of a second-order bandpass filter in switched-capacitor form are shown in Fig. 4a. Eight bandpass filters of this type are used in the DTMF receiver. Bandpass filters of a

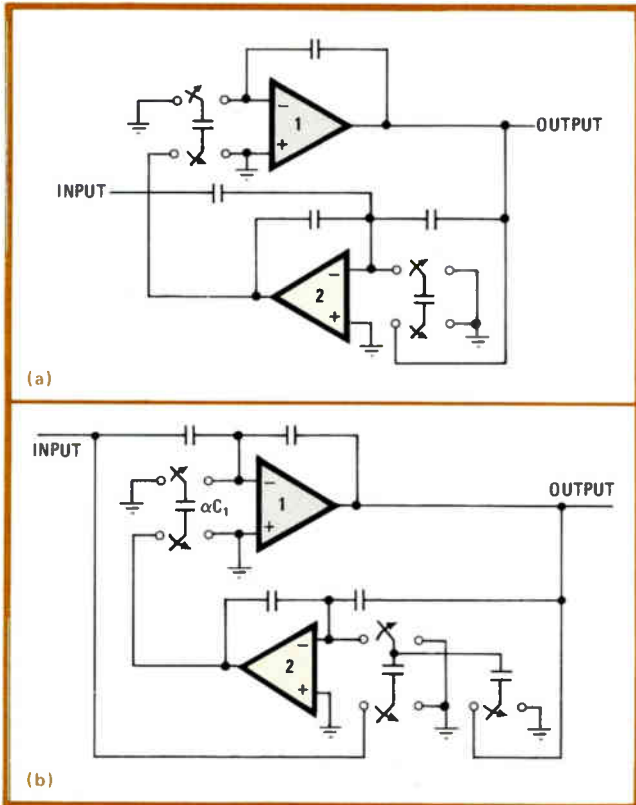

**4. Bandpass, band reject.** Biquadratic switched-capacitor filters are used throughout the DTMF receiver chip. Both bandpass filter (a) and band-reject filter (b) minimize circuit complexity by using operational amplifier 2 as both an integrator and gain block.

higher order can be made by cascading second-order sections or by using a ladder configuration that reduces sensitivity to variations in parameters. The measured frequency response for one such second-order bandpass filter in the DTMF receiver is shown in Fig. 5.

Statistical data on filters from several wafers has shown that the center frequencies have a standard deviation of 0.4% from desired values, and the filters' quality factor,  $Q$ , has a standard deviation of 0.4% from the design value of 15. That level of control, obtained without trimming or adjustments, is ample for the DTMF receiver application.

Both of the bandstop filters in the DTMF receiver are made up of three cascaded second-order sections of the form in Fig. 4b; Fig. 6 gives the measured frequency response of one such section. A 60-Hz-rejection filter is built with a third-order high-pass filter, which provides 60 dB attenuation at 60 Hz, but less than 1 dB at 600 Hz. There is no difficulty in designing and building stopband attenuations up to 60 dB with switched-capacitor circuits.

**Limitations**

Since all factors regarding the accuracy of a switched-capacitor filter—gain,  $Q$ , center frequency, bandwidth, and so on—are set by capacitor ratios, the designs are as good as the best-trimmed active RC and LC filters. Furthermore, the stability with time and temperature of switched-capacitor filters is excellent—drifts are so

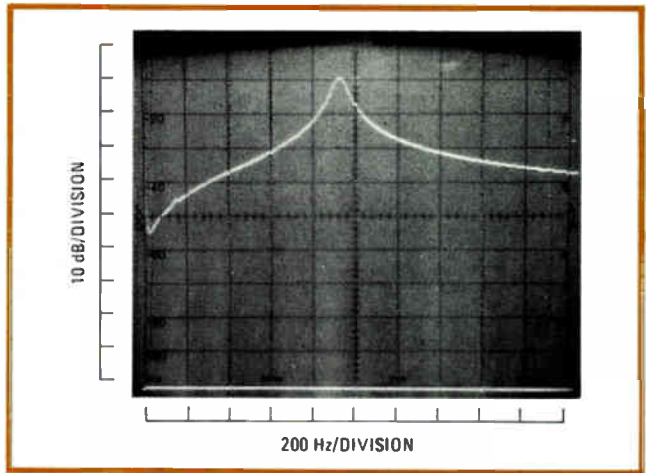

**5. Second-order bandpass.** The frequency response of the 941-Hz bandpass filter in the DTMF receiver chip displays a sharp rolloff. The  $Q$  of the filter is 15. Statistical data on filters from several wafers has shown standard deviations of 0.4% for both center frequency and  $Q$ .

small as to be virtually unmeasurable. The limitations are imposed by the elements of these filters themselves: capacitors, analog switches, and op amps.

Accuracy in capacitor ratios is limited only by the ability to define related capacitor areas through the various masking and processing steps, and several rather obvious techniques can minimize ratio error. Placing ratioed capacitors physically close together heightens the probability that they will experience similar mask and process variations. (The gate oxide that determines capacitance may, for example, undergo some variation in thickness across a chip.) Hence, the proximity of crucial capacitors is important.

Another rule of thumb is to maintain the same periphery-to-area ratio for ratioed capacitors, thereby minimizing any processing shrinkage effects. If these rules are followed, the capacitors become a model of stability: absolute voltage and temperature coefficients are 20 parts per million per volt and 20 ppm/°C, respectively—ratio variations are infinitesimal.

**Analog switches**

The MOS transistor is an excellent analog switch. It has up to a 90-dB on-off ratio, depending on layout, and no inherent offset voltage. Depending on the signal range involved, single-channel switches may suffice; C-MOS switches permit the fullest use of the system supply voltage range.

Gate-overlap capacitance gives rise to voltage offsets due to gate drive feedthrough to sources and drains, but it has no distorting effect. However, it must be considered, since voltage offsets can greatly reduce the linear range available. One caution regarding on-resistance: since minimally sized switches may have on-resistances of tens of kilohms, complete charge transfer may take as long as several hundred nanoseconds, depending on the capacitive load.

Since switched-capacitor filters are sampled-data filters, all nodes must settle between samples. Thus the useful frequency of such filters is limited by the settling time of the operational amplifier integrators. Settling to



## Process considerations for switched-capacitor filters

To minimize costs and risks in the development of the dual-tone multifrequency receiver chip, only proven, standard process technologies were considered for the part. For one, switched-capacitor filters require high-quality analog switches with near-zero control current for precise conservation of charge. That calls for metal-oxide-semiconductor or junction field-effect transistors. Also, the switches must have low parasitic capacitance to minimize charge errors in coupling from clock to signal paths. Parasitic capacitances of MOSFETs are, in general, smaller than those of JFETs in monolithic circuits.

In addition to being precisely ratioed, the capacitors must have a very low voltage coefficient of capacitance to minimize harmonic distortion of the overall filter. Inversion-layer capacitors are ruled out—the capacitors must be formed between two highly conductive layers. Suitable capacitor plates are metal, heavily doped bulk silicon, and heavily doped polycrystalline silicon. The capacitor dielectric must be of high quality with no dielectric relaxation (hysteresis), which could introduce distortion. In this respect, deposited oxides are of questionable quality. Thermally deposited silicon dioxide is strongly preferred as the capacitor dielectric. Finally, the process technology must provide high-density, low-power digital logic.

Of the bipolar transistor processes, candidates for switched-capacitor filters are the bi-FET and the bi-MOS processes. In the former, JFETs are incorporated into a standard analog bipolar IC process by adding two process steps. The drawbacks of the bi-FET process, besides its complexity, are the high parasitic capacitances and relatively large area of the JFETs obtained. Moreover, the integrated-injection-logic circuits achievable are marginal in performance and low in density.

In the bi-MOS process, complementary-MOS devices are added to a standard analog bipolar process by means of two process steps. The availability of the bipolar analog devices is not a significant advantage; in relation to the switched-capacitor filter application a conventional C-MOS process is a substantially less complex alternative. Nonetheless, both bi-FET and bi-MOS can provide the necessary capacitors with the same bulk-silicon MOS structure used for compensation capacitors in standard bipolar operational amplifiers.

Among the MOS processes, metal-gate p-channel MOS,

n-MOS, and C-MOS standard processes provide all of the needed elements. Capacitors are formed between metal and heavily doped source-drain diffusion regions with gate oxide as the dielectric in all of the processes. In addition, the MOS transistor is nearly ideal analog switch, with zero offset and zero control current.

P-MOS is not recommended if only because its use in new designs is on the decline. Similarly, metal-gate n-MOS is not a common process. But metal-gate C-MOS is widely available and provides all the needed features; hence, it was selected for use in the DTMF receiver.

Silicon-gate MOS processes generally provide higher circuit density and smaller parasitic capacitances than the metal-gate processes. The self-alignment of polysilicon gates with source-drain diffusions, however, makes it impossible to obtain a capacitor with low voltage coefficient between polysilicon and bulk silicon. Worse yet, the dielectric between polysilicon and metal is normally a deposited oxide with substantial hysteresis effects. Hence, good capacitors are simply not available in standard silicon-gate n-MOS and p-MOS processes.

Excellent capacitors are available, however, between the two layers of polysilicon in a double-polysilicon n-MOS process. The process used for erasable programmable read-only memories normally employs thermal silicon dioxide between the layers of polysilicon. The only drawback to the process is that it is relatively new and as yet difficult; only the large companies specializing in memories have the expertise. In the future, though, it may fare as an excellent choice for switched-capacitor filters.

A final possibility in the spectrum of large-scale integrated processes is C-MOS built on sapphire substrates, which has often been viewed as attractive for analog ICs. But few versions of this new process appear to offer satisfactory capacitors with low voltage coefficients. Further, leakage currents in SOS transistors are some 100 times greater than in MOS transistors on bulk silicon. Since the signals in switched-capacitor filters are conveyed as charges on capacitors of a few picofarads, larger leakage currents can cause undesirable dc offsets—and that could be troublesome when building low-frequency filters such as the much-used 60-Hz reject filter. In sum, C-MOS on sapphire is not particularly attractive for switched-capacitor filters.

within 0.1% in 1 microsecond is readily achievable and implies a maximum clock frequency of about 1 MHz. In actuality, practical filters have an upper limit of about 200 kHz, limited by the Nyquist criterion. Evolution of fabrication technologies will raise this limit eventually.

### The op amps

MOS transistor amplifiers generate substantially more electrical noise than the best bipolar transistor amplifiers. The total rms noise voltage, integrated over the audio band and referred to the input of a MOS op amp, is in the range of 10 to 50 microvolts. When operating from 10-to-12-volt supplies, the rms maximum signal is about 2.5 v without overloading. Thus the maximum signal-to-noise ratio possible for a one-amplifier system is about 100 dB. Filters employing multiple amplifiers typically show an overall signal-to-noise ratio of 80 to 90

dB. While adequate for data communications, tone signaling, and telephone voice channels, that ratio is not acceptable for highest-quality sound and music systems.

The basic C-MOS operational amplifier, of which 40 are used in the DTMF receiver, is shown in Fig. 7. Because of the large number of amplifiers required, emphasis has been placed on minimizing circuit area and power consumption. Since the amplifier loads are small on-chip capacitors, a low output impedance, which requires large output transistors, is unnecessary. Although in the DTMF receiver any dc offset voltage at amplifier inputs is of little consequence (since response below 697 Hz is not desired), offsets for such amplifiers typically range from 5 mV to 50 mV—and filter output offsets may be greater due to the contribution of switch feedthrough. In other applications, where such offsets are unacceptable, auto-zero techniques have been

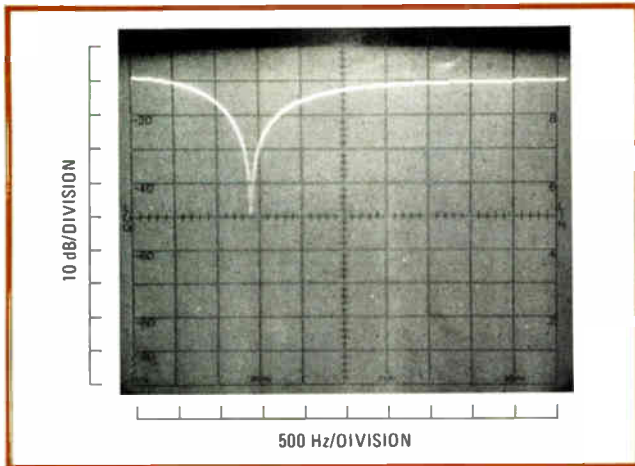

**6. Second-order band reject.** The measured frequency response of a second-order band-reject filter shows a Q of 0.8 and a 40-dB rejection at 1,404 Hz. Three cascaded sections of this type, illustrated in Fig. 4b, make up the two bandstop filters in the DTMF chip.

successfully employed to reduce the effective dc input offset of an MOS amplifier to 1 mV or less.

The amplifiers shown in Fig. 7 have an open-loop gain of 3,000, a unity-gain bandwidth of 2 megahertz, power consumption of 5 milliwatts, and 0.1% integrator settling time of 3 microseconds. Die area per amplifier is a mere 200 square mils—only a quarter that of a typical bipolar-transistor IC operational amplifier.

### Other applications

The melding of analog and digital functions on a single chip with LSI densities brings many additional applications to mind. A fifth-order, sharp-cutoff lowpass elliptic filter, for example, is required prior to sampling voice signals for PCM telephony. Switched-capacitor filters for this application are being introduced by two or more semiconductor firms. Those filters require pass-band ripple of less than  $\pm 0.125$  dB and an overall signal-to-noise ratio on the order of 85 dB, so the application is a challenging test of the achievable characteristics of a filter technology. Although CCD filters for that function have been demonstrated, switched-capacitor filters alone can incorporate the 60-Hz-reject function and appear to have an advantage in signal-to-noise performance. Within two years, codecs and low-pass filters will likely be realized on a single chip.

Modulator-demodulators for data transmission can also be realized in fully integrated form. For instance, frequency-shift-keyed transmission that is normally used for data rates ranging from 100 to 600 bits per second can be realized. A frequency synthesizer develops digital versions of the signals to be transmitted from a precise crystal oscillator frequency, and a d-a converter forms the transmitted analog sine-wave signals keyed between 1,070 and 1,270 Hz for an originating terminal, or between 2,025 and 2,225 Hz for an answering terminal; both circuits serve the modulator function. A sixth-order bandpass filter defines one of two receiving bands, approximately 1,000 to 1,350 Hz, or 1,950 to 2,300 Hz, depending on whether the terminal is in the answering or originating role. A zero-crossing detector and timer

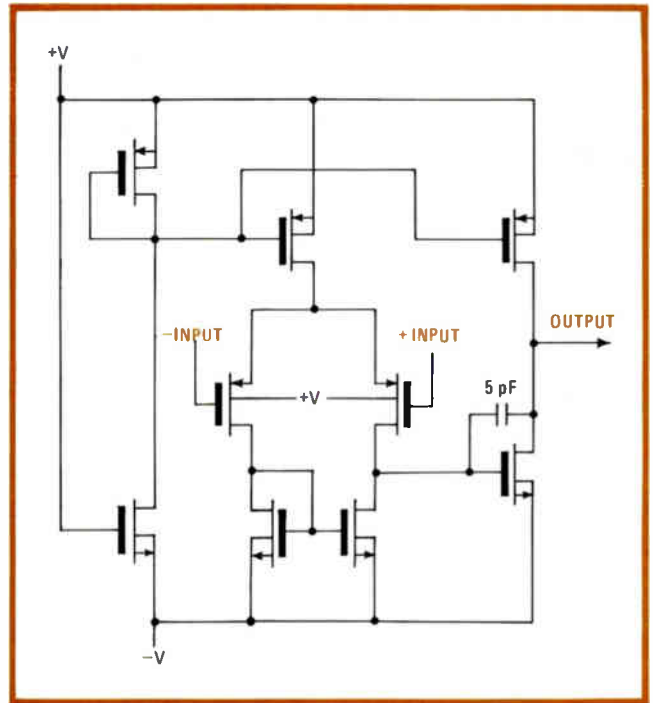

**7. Op amp.** The basic complementary-MOS operational amplifier is duplicated 40 times in the DTMF receiver chip. Its design emphasizes minimal chip area and power consumption. Each op amp dissipates only 5 milliwatts and occupies a mere 200 square mils.

perform the demodulator function. Additional digital circuits provide terminal-control logic, automatic answer and disconnect logic, and clock and timer functions. Single-chip modems incorporating all of those elements and built with switched-capacitor filters will, in fact, be feasible within the year.

Another important new applications area is in voice processing and voice input and output to computers. Speech synthesis using wholly digital techniques has been described recently [*Electronics*, Aug. 31, 1978, p. 109] that produces high-quality speech signals from a serial data stream of 2,400 bits per second or less.

While sophisticated linear predictive coding (LPC) techniques achieve that result, an alternative approach to encoding and synthesizing speech relies on formant analysis, an analog approach that offers certain advantages. First, the technique is well suited to a vocoder (voice encoder-decoder) system. Whereas LPC requires more complex analysis for encoding, formant analysis encodes voice signals using only a spectrum analyzer and pitch extractor. Moreover, formant analysis can produce the same quality speech at a lower bit rate than LPC.

The elements of vocoder systems lend themselves very well to combined analog-digital LSI techniques. The appeal of this approach compared to LPC techniques is that total silicon area may be considerably smaller. □

### References

1. J. T. Caves, M. A. Copeland, C. F. Rahim, and S. D. Rosenbaum, "Sampled analog filtering using switched capacitors as resistor equivalents," *IEEE Journal of Solid-State Circuits*, Vol. SC-12, Dec. 1977, pp. 592-599.
2. B. J. Hosticka, R. W. Brodersen, and P. R. Gray, "MOS sampled-data recursive filters using switched capacitor integrators," *IEEE Journal of Solid-State Circuits*, Vol. SC-12, Dec. 1977, pp. 600-608.

A reprint of this article is available for \$2.00. Write to Electronics Reprint Dept., P. O. Box 669, Hightstown, N. J. 08520. Copyright 1979, Electronics, a McGraw-Hill publication.

# Functional array eases custom ECL design

Macrocell array uses more than 100 logic, interface, and output cells to achieve the equivalent of over 1,000 gates

by Jerry Prioste, Ramu Rao,\* and William R. Blood Jr., *Motorola Inc., Integrated Circuits Division, Mesa, Ariz.*

□ Though emitter-coupled logic is the fastest commercial semiconductor technology, it, too, is being pushed by demanding applications to ever higher speeds, as well as greater densities. And increasingly complex applications mean increasingly complex custom designs.

One approach is to use bit-slice parts like those in the M10800 family [*Electronics*, Feb. 1, 1979, p. 99]. But when a standard family is insufficient, one can opt for Motorola's functional array, the Macrocell, which consolidates dozens of logic elements like flip-flops, adders, and registers into a single integrated circuit. This approach simplifies design, reduces power consumption, and saves board space. What's more, an engineer designing with the Macrocell array need not be an expert in the various ECL logic circuits, since that information is in the computer-aided design library that is an integral part of this approach.

With discrete components, one simply picks the needed functions out of a manual, interconnects them on a circuit board, and writes programs to test the product. With the Macrocell array, however, a single chip replaces a circuit board of approximately 50 IC packages.

The Macrocell concept is an extension of gate arrays currently used in mainframe computers. These arrays consist of 100 to 200 high-speed gates on a chip, interconnected by custom metal patterns to form various complex logic functions. The Macrocell array differs from a gate array in that it is subdivided into functional blocks instead of individual gates. Each Macrocell is itself roughly equivalent to a small- or medium-scale IC.

The array is composed of three cell types (Fig. 1). There are 48 large blocks, called major cells, that hold most of the actual logic circuitry. Arranged in a 6-by-8 array, these cells are identical to each other. Each has about 50 transistors and 50 resistors.

A Macrocell is created when internal metal patterns interconnect a major cell's transistors and resistors to form a logic element. At present, 54 different Macrocell functions have been defined and interconnected in major-cell blocks. These will be described later.

The Macrocell array also employs 32 interface cells at the chip's periphery. These cells do not have the logic power of a major cell. Fourteen functions have been defined thus far, including simple gates, inverters, clock buffers, latches, and so on. Interface cells are used when

\*Now with Sperry Univac, St. Paul, Minn.

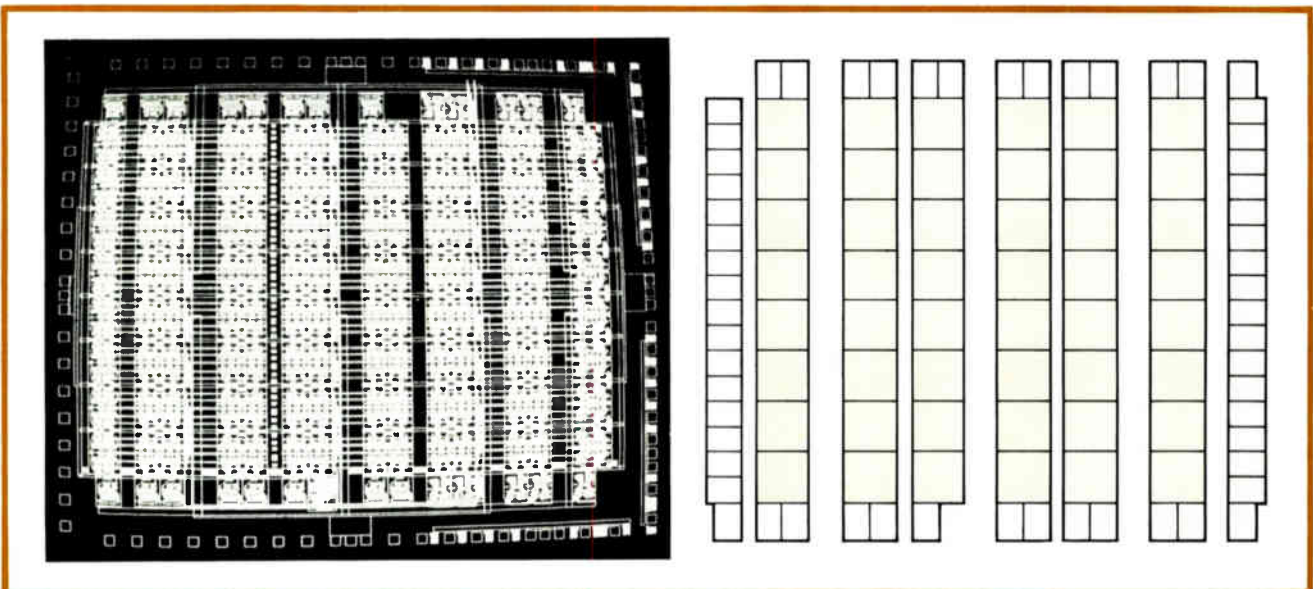

**1. Building blocks.** Macrocell array functions are selected from a CAD library. A designer refers to a CRT display like the one on the left. Diagram on the right shows the relative positions of the 48 major cells (color), 32 interface cells, and 26 output cells (gray).

TABLE 1: PRIMARY FUNCTIONS OF MACROCELL TYPES

Major cells
Dual D flip-flop Single flip-flop with multiplexed inputs Quad latch Dual latch with multiplexed inputs 4-to-1-line multiplexer Quad 2-to-1-line multiplexer 1-of-4-line decoder Priority encoder Priority expander Full adder Dual half-adder Various OR or NOR gates (up to 12 inputs) Various ANO or NANO gates (up to 8 inputs) Various exclusive-OR or -NOR gates (up to 4 inputs) Various OR-ANO, OR-and-exclusive-OR gate combinations
Interface cells
2-to-1-line multiplexer D input latch Dual OR, NOR, ANO, NANO gate Various OR or NOR, ANO or NANO, OR or ANO gates
Output cells
2-to-1-line multiplexer D input latch 25-Ω drive bus transceiver Various OR, NOR, ANO, NANO, exclusive-OR, exclusive-NOR gates

it is inefficient to tie up a major cell.

Although major and interface cells operate with standard 10,000 ECL levels, the relatively low internal current sources (1 milliampere) do not yield full output drive. Thus, though inputs can go directly to any cell of the chip, circuit outputs must first be routed through an output cell. Twenty-six such cells give the array the ability to drive a 50-ohm transmission line, making it compatible with the 10,000 ECL family. A set of 17 functions gives these cells logic power as well.

### Fixed positions

All Macrocell-circuit options are built with a standard process, from diffusion to metal-mask making. This is key to the Macrocell concept. The positions of transistors, resistors, power buses, bias drivers, bonding pads, and so on, are fixed and only have to be engineered once. Development costs are thus reduced for both standard and custom parts.

Currently available bipolar LSI circuits, such as the 2900 transistor-transistor-logic family or the M10800 ECL family, are designed around bit-slice architectures. These function well in many processor applications, but often there are other high-speed logic needs that standard families cannot provide. With the Macrocell array, a custom chip can be defined to meet such needs. Possibilities include high-speed disk controllers, fiber-optic or radio-frequency communications systems, high-speed

test equipment, and mainframe computer systems. Moreover, parts developed for a specific product are difficult to duplicate, so a product can remain proprietary. All three Macrocell types are configured into predefined logic functions (Table 1).

Table 2 lists the major array circuit features. There is actually no fixed number of Macrocell array gates because gate density depends on the functions selected. However, many options can be put together with a set of major, interface, and output cells that exceeds 800 equivalent gates out of the 1,192 possible.

### Fewer watts

When 90% of the cells are used, the chip's power consumption is about 4 watts. Since unused cells are not connected to power buses, actual package power depends on the function performed. Dividing 4 w by 800 gates yields an average gate power dissipation of 5 milliwatts. Output cells capable of driving 25- or 50-ohm transmission lines need more power, and internal gates require somewhat less.

The Macrocell array has 60 logic I/O pins. Of the 60, 34 function only as inputs. The remaining 26 may be used for input, output, or bidirectional I/O bus ports. This flexibility increases the range of part types available to the user.

The bidirectional I/O ports are built with bus-transceiver output-cell functions (see Table 1 again). Through these ports the Macrocell array interfaces directly with system bus lines, thus eliminating the need for external bus-driver circuits. A transceiver's 25-Ω output drive is used to handle bus-line impedances as low as 50 Ω when terminating resistors are at each end of the line.

Macrocells use series-gated structures to perform complex functions with maximum gate speeds. Some of the functions would require at least three delay stages if implemented without series gating. However, it is difficult to determine actual gate speed in the array. Cells connected as simple gates would typically have a 0.9-nanosecond propagation delay (1.3 ns maximum). However, total Macrocell speed is a more meaningful parameter. The slowest major or interface functions listed in Table 1 have a typical propagation time of 1.3 ns (1.8 ns maximum).

Output cells are slightly slower because of the transmission line drive. They have a typical propagation delay time of 1.5 ns and a maximum of 2.2 ns.

The Macrocell array's compatibility with the 10,000 ECL family is a large bonus. Over 100 part types are available that directly interface with the array, including random-access memories, programmable read-only memories, TTL and metal-oxide-semiconductor interfaces, and the M10800 bit-slice processor family. Compatibility means that all parts operate off the same power supplies and match all input, output, and noise-margin specifications.

### Custom development

Custom arrays are designed with a Motorola computer-aided design system (Fig. 2). After deciding on the number of parts, the production volumes for each, and development costs and schedules, the customer receives a

design handbook and a password to the CAD system. The CAD system is accessed over phone lines through a leased or purchased graphics terminal and optional plotter located at the customer's facility.

The CAD system contains the Macrocell library, plus a number of programs to help design and check the circuit. A chip layout shown in Fig. 1 is displayed on the terminal's screen. The designer selects cell functions from the CAD library and places them in the desired cell locations. Using the terminal, he then defines I/O points and specifies point-to-point data-routing information. Additional CAD programs perform logic simulation to verify design accuracy, and others check for violations of interconnection wiring rules.

Cell-to-cell wiring is an important part of option design. The array has 12 channels alongside each Macrocell for cell interconnection. These are in addition to the power buses, as well as the bias-reference voltages and metal interconnections in the cells themselves. With respect to the 6-by-8 array of major cells, there are 100-by-130 metal channels reserved for cell-to-cell and cell-to-I/O-pin routing.

Customers must also generate final test sequences. Here, again, the CAD system is extremely helpful because programs are available to check for paths not

TABLE 2: MAJOR FEATURES OF THE MACROCELL ARRAY

1,192 equivalent gates (approximate)
5-mW average gate power
4-W typical power dissipation (all cells used)
34 input ports, 26 input/output ports
25-Ω drive on up to 8 outputs
Macrocell delay: 0.9–1.3 ns typical, 1.3–1.8 ns max
Compatible with the 10,000 ECL family

covered by the user's test sequence. The CAD programs also yield a test format compatible with Motorola's final-test equipment.

Upon completion of a custom design, information in the CAD system is fed through Motorola's Calma graphics system to a plotter. Drawings of the cell selections and routing patterns are sent back to the designer for final verification. When approved, the Calma data is used for pattern generation and mask making. Custom metal patterns are added to wafers, completing the processing sequence for the ICs. Final test information in

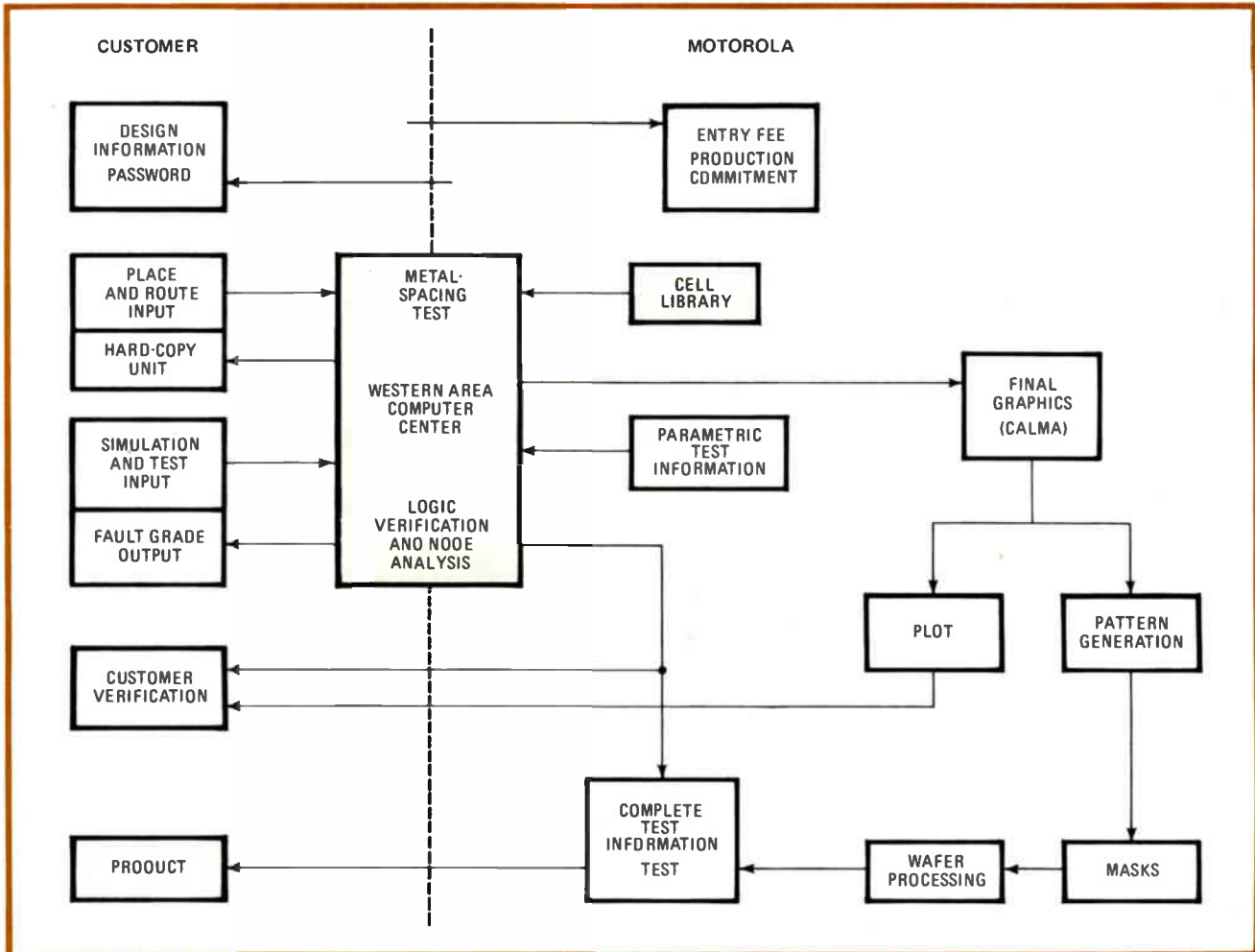

2. Exchange. Motorola's computer-aided design system is essential to developing a Macrocell option. A graphics terminal links the customer to the system via a telephone line. Design inputs are converted into a format that is compatible with final-test equipment.

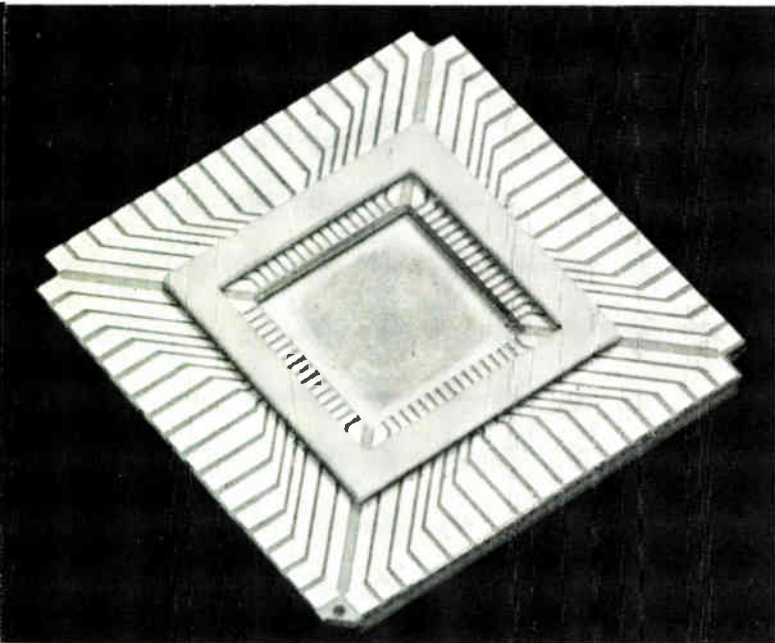

**3. No leads.** The Macrocell's 68-pin leadless package features small physical size, high I/O-pin density, and good thermal characteristics. Support hardware under development will hasten its acceptance as an LSI packaging standard. A 68-pin DIP just wouldn't do.

the CAD system is converted into test programs that are used to test the circuit before shipping the final products.

The popular dual in-line package has serious limitations when pin numbers increase. The 68-pin Macrocell array would require a DIP over 3 inches long. Such a package would take up too much circuit-board area, and impedance of the long leads on the substrate are not suitable for the high speed of ECL signal lines. This package would also be difficult to handle in terms of maintenance or replacement.

Fortunately, system manufacturers, especially main-frame computer companies, realize the need for a standard LSI package and have worked to develop the Joint Electron Device Engineering Council's LSI package standard for devices with 0.05-in. centers. This housing contains 68 pins, is leadless, and has 17 terminals per side (Fig. 3). The IC mounts on a ceramic base slightly smaller than 1 in.<sup>2</sup> Gold-plated metal on the base piece routes signals and power from the package edge to the chip. A ceramic cover over the wire-bonded chip provides a hermetic seal.

The package is mounted upside down in terms of conventional IC practices. The base of the chip is on the top side, away from the pc board. A heat sink is bonded to the package on the same ceramic piece as the chip for efficient heat transfer. The package and heat-sink combination have a thermal resistance of 15°C/w, allowing the relatively high-power circuit (4 w) to operate safely in an air-flow environment.

Two techniques can be employed to mount the package on a pc board. The first uses rows of metal clips that solder to both the IC package and the board. The clips hold the package off the board, yet provide solid mounting and good electrical connection.

The second method uses the package and connector

arrangement illustrated in Fig. 4. The connector (manufactured by AMP Inc.) can be either soldered to the pc board or held in place with a mounting bolt. The leadless IC package fits into the connector and is held in place with a spring clip. Sixty-eight metal tabs near the connector base facilitate testing and troubleshooting by giving access to all 68 package pins.

### Practical?

Consider an 8-bit binary/binary-coded-decimal arithmetic and logic unit made with the Macrocell array (Fig. 5). The circuit features four 8-bit data ports—three for input and one for output. Independently controlled latches can be used to hold data on any input. Five function-select lines determine 32 ALU operations to be performed on the A, B, and C inputs. All commonly used ALU functions are incorporated, including add, subtract, shift left, shift right, increment, decrement, and transfer plus other logic operations.

The propagation delay from input through the ALU to the results output is estimated at 13 ns maximum. Using ripple-carry propagation increases the delay 2.2 ns for each 8-bit increment in the width of the input. Above 32 bits, carry-look-ahead circuits built as part of another Macrocell array option can minimize the delay.

A 16-by-4-bit, triple-port register-file circuit built from the array would have a maximum address access time of 6.5 ns. Four register-file circuits and two ALUs would build a 16-bit system ALU with microinstruction cycle times under 25 ns. This is six to eight times faster than existing speeds for LSI TTL.

The 8-by-8-bit expandable array multiplier in Fig. 6 further illustrates the performance of the Macrocell array. The circuit accepts 8 multiplier and multiplicand

**4. Box.** Metal clips can be used to solder the leadless package of Fig. 3 to a pc board, or the connector shown below can be used. It permits easy replacement without damaging to the circuit board or the package, and the cover provides a hermetic seal.

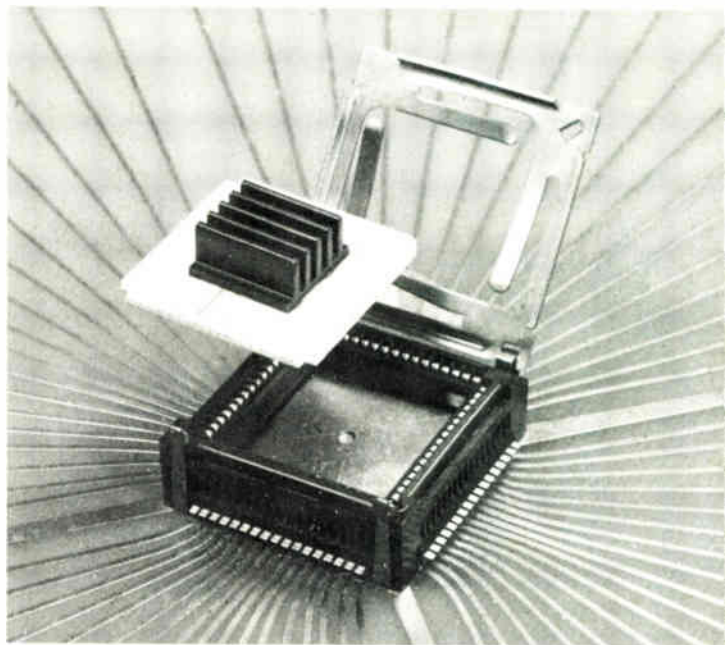

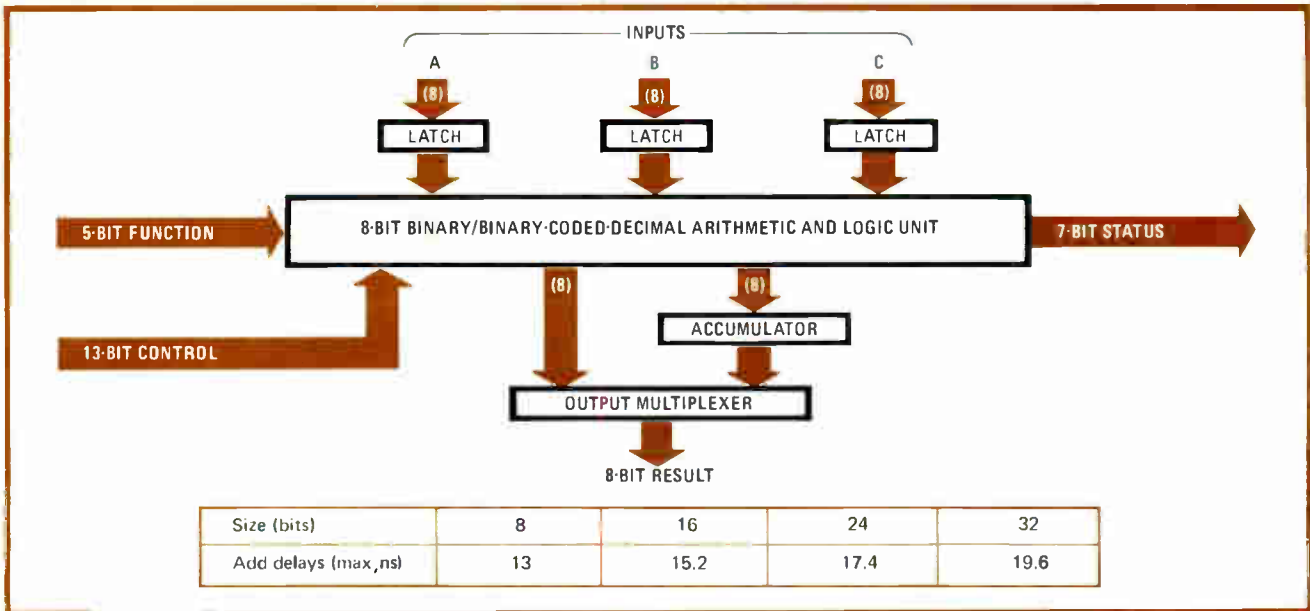

**5. Fast math and logic.** A high-speed 8-bit binary/BCD ALU illustrates the functions and performance of the Macrocell array. This circuit, featuring four 8-bit data ports, requires 57 of the 60 available signal pins and performs all of the common CPU functions.

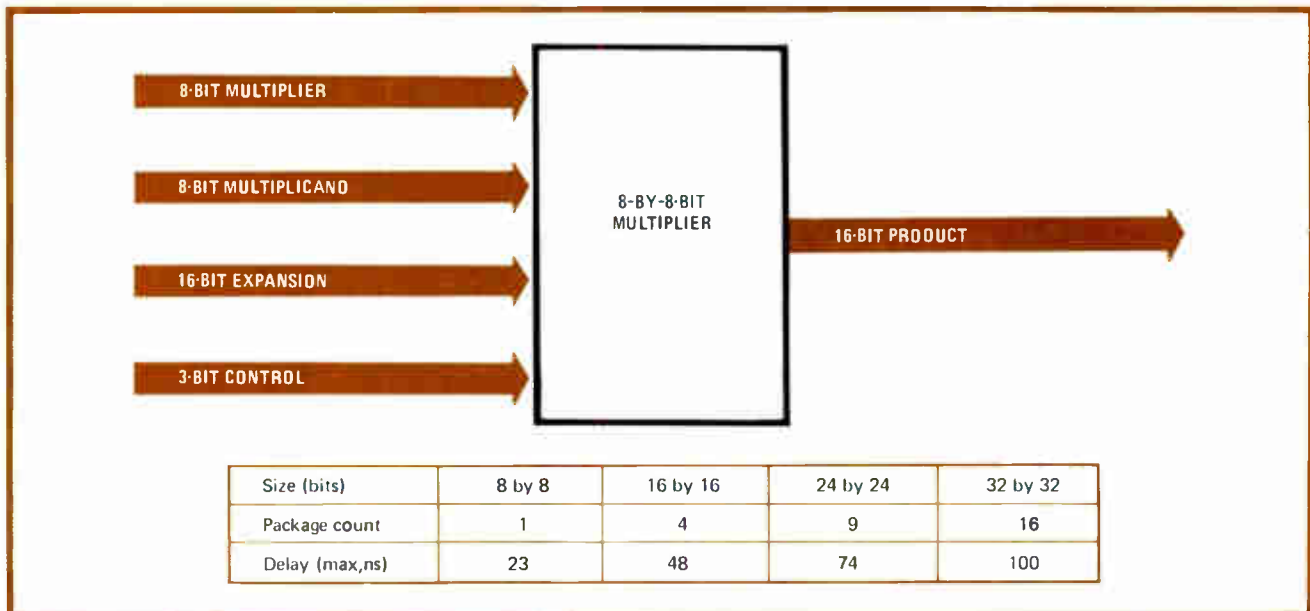

**6. Multiplier.** The 8-by-8-bit multiplier is a good benchmark circuit, since it is widely used. Though the Macrocell design is more complex than most, it is faster and smaller. What's more, it is easily expandable and allows asymmetrical combinations like 16 by 8 bits.

bits and generates a 16-bit product. Control inputs select between 2's complement and sign-magnitude formats, and the expansion inputs allow the array to be expanded without additional part types.

As indicated, four packages are needed for a 16-by-16-bit multiplier, 16 for a 32-by-32, and so on. Asymmetrical combinations such as 16 by 8 or 24 by 8 bits also can be built for specialized applications. Compared with existing LSI products, a multiplier built from the Macrocell array would be many times faster and easier to expand. The 48-ns multiplication time of the 16-by-16-bit configuration should meet the requirements of future high-speed signal-processing systems.

Process developments promise faster logic for other

technologies, like n-channel and complementary MOS, C-MOS-on-sapphire, and integrated injection logic. However, they are many years away from the speeds of today's ECL. Moreover, Macrocell arrays are four to eight times faster than existing bipolar LSI, because of processing improvements and innovative circuit design. Even more important, LSI emitter-coupled logic is an open-ended technology, and processing developments under way could lead to arrays with 1,000 or more subnanosecond equivalent gates in the next few years. □

*This is the second of two articles on high-density ECL. The first, which appeared in the Feb. 1 issue, pages 99-105, discussed the M10800 family of bit-slice parts.*

## Voltage-controlled amplifier phase-adjusts wave generator

by G. B. Clayton  
Liverpool Polytechnic, Liverpool, England

When added to a generator that produces two triangular and two square waves in quadrature, a voltage-controlled, gain-switching amplifier makes it easy to adjust the phase difference of each pair of signals. The entire circuit—that is, the generator and the controller—requires only two chips and one field-effect transistor for providing phase differences from  $0^\circ$  to  $180^\circ$ .

In the arrangement shown, a quad operational amplifier ( $A_1$ – $A_4$ ) serves as the quadrature oscillator, and a dual op amp ( $A_5$ – $A_6$ ) is the control section. Amps  $A_1$  and  $A_2$  form an integrator and comparator, needed for generating the triangular and square waves.  $A_3$  is a zero-crossing detector, used to produce a square wave from the triangular input of  $A_1$ .  $A_4$  produces a second triangular wave from  $A_3$ 's output. Note that the feedback resistor  $R_3$  in the  $A_1$ – $A_4$  loop will prevent  $A_4$  from

drifting into saturation, even if offset voltages from the op amps are high.

In the phase-control section,  $A_5$  acts as the switched-gain element.  $A_2$  and  $Q_1$  control the gain of  $A_5$ . When  $Q_1$  turns on,  $A_5$  has a gain of  $-1$ ; otherwise, its gain is  $+1$ . This element, appropriately biased at its input with a control voltage,  $V_c$ , thus turns on and off sooner or later than usual, depending on the magnitude of the control voltage. This acts to advance or retard  $A_3$ 's on-off transitions on both the rising and the falling edge of  $A_2$ 's square-wave signal. As a result, the signals from  $A_3$  and  $A_4$  lead their respective counterparts at  $A_2$  and  $A_1$  by a value almost linearly proportional to  $V_c$ .

$A_5$ 's output is inverted by  $A_6$ , which is in turn connected to potentiometer  $R_4$  and  $A_2$ .  $R_4$ , included to overcome the effects of component mismatch, is placed strategically, so that it will not interfere with the generation of waves produced by  $A_1$  and  $A_2$ .

If the components and amplifiers are matched, the frequency of oscillation for all waveforms will be  $f = R_2/4R_1CR$ . The relation between control voltage, resistor  $R_4$ 's value, and phase shift is given by:

$$\theta = 90^\circ [(V_c R_2 R_3 / V_{\text{osat}} R_1 R_4) - 1]$$

where  $V_{\text{osat}}$  is 0.7 v below the supply voltage. □

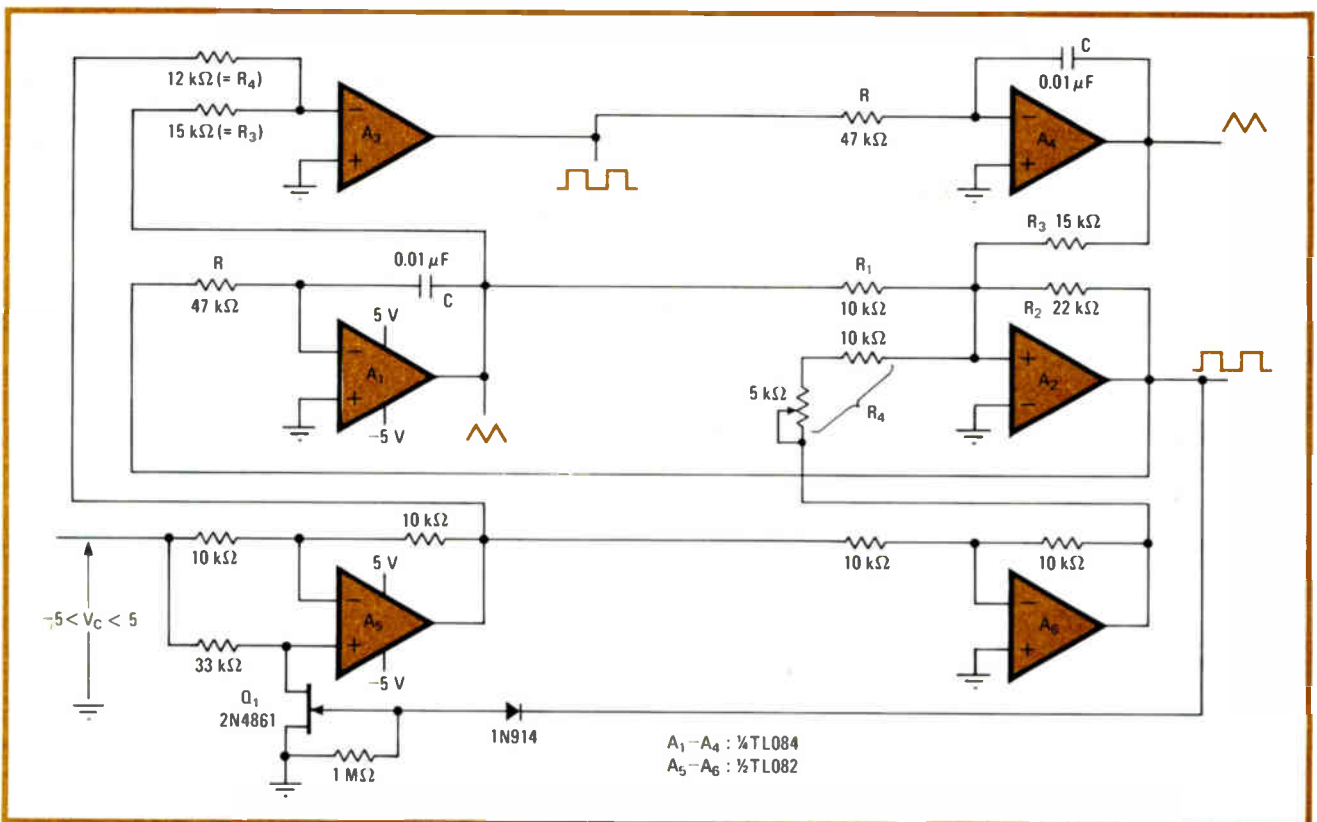

**Quadrature variance.** Waveform generator that normally produces in-quadrature ( $90^\circ$  departure) triangular or square waves is converted into variable phase-delay circuit when gain-switching amps  $A_5$ – $A_6$  are added.  $A_5$ – $A_6$  act to advance  $A_3$ 's turn-on transition, so that signals at  $A_3$  and  $A_4$  lead those at  $A_1$  and  $A_2$ . Phase shift between both sets of waves is controlled by  $V_c$ .



# Synchronous counters provide programmable pulse delays

by R. E. S. Abdel-Aal  
Sunderland Polytechnic, Sunderland, England

In this circuit, cascade counters are digitally programmed to provide pulse delays of 50 nanoseconds to 3.25 milliseconds, accurate to within 50 ns. Selected by a 15-bit binary number,  $N$ , the delays can be ordered in 100-ns steps.

Two chains of synchronous counters, driven by a 20-megahertz clock, delay the input pulse's leading and trailing edge separately. Input pulses, which are asynchronous, are first applied to a dual D flip-flop,  $A_1$ , as shown.  $A_1$  generates a single negative-going clock pulse

when triggered by the 20-MHz clock. The pulse is used to set the bistable latch,  $G_2$ - $G_3$ , thus enabling counters  $A_2$ - $A_5$  to delay its leading edge.

$A_2$ - $A_5$  are wired to perform a fast look-ahead operation for the high-speed multistage counting required. To eliminate glitches that might upset the counter, the carry outputs of both  $A_1$  and  $A_5$  are brought to a NAND gate and then to  $G_2$ - $G_3$ . This ensures the latch will be reset and the desired  $N$  value loaded into the counter only after the previous delay period is ended, despite the differential delays that exist in the signal path.

The input pulse is inverted by  $G_1$  and applied to flip-flop  $A_6$  for the counters that provide delay on the trailing edge of the pulse,  $A_7$ - $A_{10}$ .  $G_6$ - $G_7$  and  $A_7$ - $A_{10}$  perform the function identical to  $G_2$ - $G_3$  and  $A_2$ - $A_5$ .

In actual operation, both counter chains are programmed by the set-delay lines, which are connected to their data-in ports. The delay time is given by  $T = 50(1 + 2N)$  ns. At the end of the delay period,  $N$  is

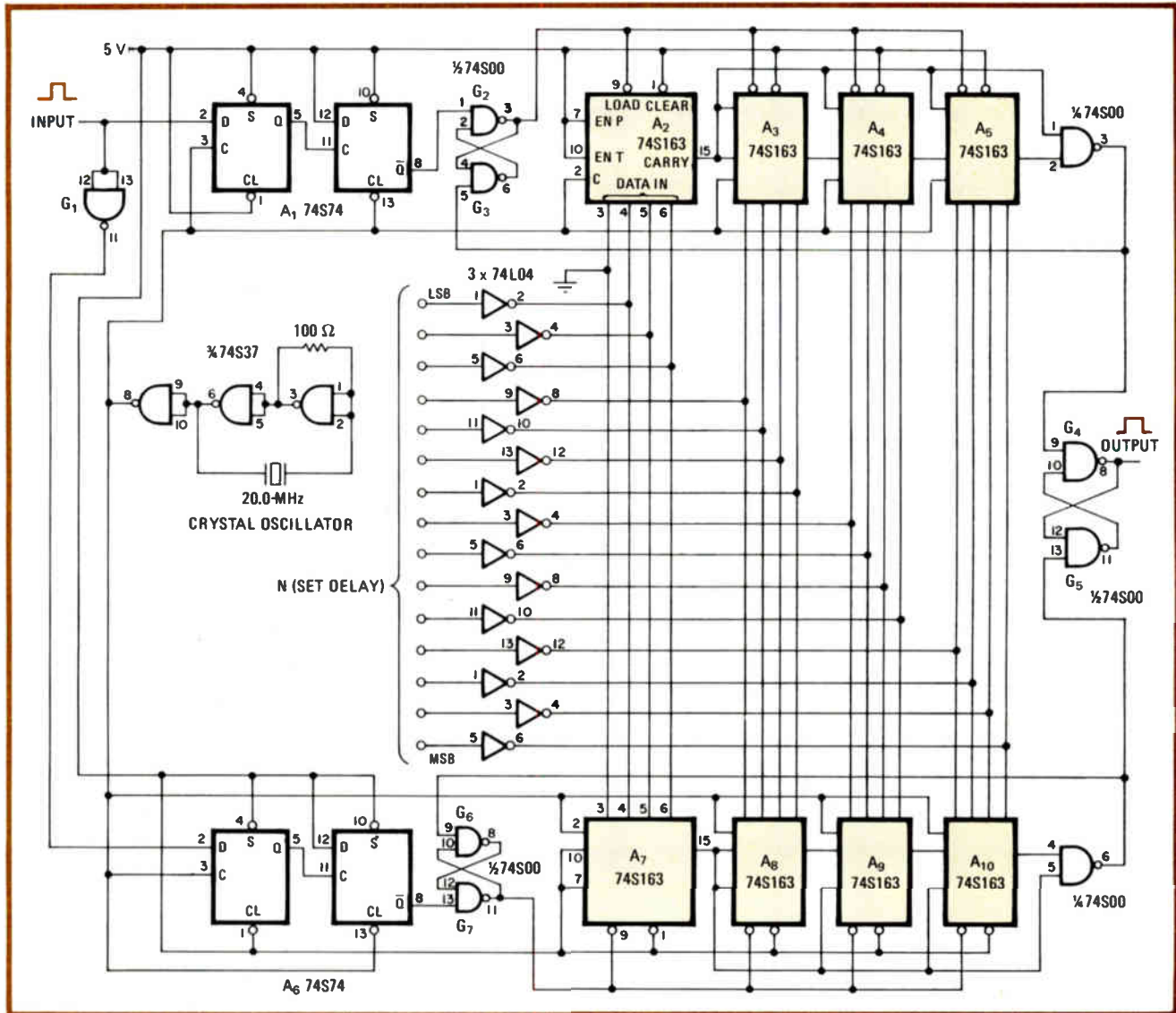

**Two-edge retardation.** Counter chains, of which one starts counting on arrival of the positive edge of an input pulse, the other on its negative edge, use a 20-MHz clock to provide repeatable delays of 50 ns to 3.25 ms on both edges of signal. Delays produced are accurate to within 50 ns. Amount of delay is selected with 15-bit word ( $M$ ). Width of input signal to be processed must be at least 60 ns.

# LEADER OF THE PACK!



**With a Data I/O System 19, you'll  
always be "top dog."**

It's impossible to stay on top of every new development in IC technology—frightening too—especially when it's time to buy a PROM programmer.

Today, there's a lot more in the world to program than PROMs. The programmable logic devices you're specifying today could be dumped next year in favor of a brand new device that can do four times as much and cut the "real estate" in half.

Smart engineers, who want to stay in front of the pack, buy the programmer that won't leave them behind—the Data I/O System 19.

With a System 19 you can program a bipolar PROM, MOS EPROM, FPLA, FPLS, FPGA, PAL, PMUX, programmable port, diode matrix or  $\mu$ P/EPROM. And that's just the beginning of what this remarkable system can do to keep you on top.

Best of all, Data I/O's System 19 is priced within just about everyone's budget.

You haven't shopped around until you've looked at Data I/O. Let us show you the difference. Circle reader service number or contact Data I/O, P.O. Box 308, Issaquah, WA 98027. **For answers fast, call toll free: 800-426-9016.**

Good idea! **DATA I/O**

Programming systems for tomorrow...today

loaded into both counter chains. Note that the circuit is wired such that the N inputs must be active high, ensuring that maximum delay will correspond to a value of N that, when read as a number in standard binary form, is maximum.

Upon the arrival of the leading edge of the input pulse, A<sub>2</sub>–A<sub>5</sub> count up, starting from the number loaded. Simi-

larly, A<sub>7</sub>–A<sub>10</sub> count up on the trailing edge of the pulse. The carry pulse generated by A<sub>5</sub> signifies the end of the delay period. This signal is united with the carry pulse generated by the trailing-edge counter A<sub>10</sub>, at flip-flop G<sub>4</sub>–G<sub>5</sub>. The signal at the output of G<sub>4</sub>–G<sub>5</sub> thus has the same width as the input pulse, but is delayed by a period of time proportional to the number N. □

## Counter delivers data in signed or complemented form

by N. Bhaskara Rao  
U.V.C.E., Department of Electrical Engineering, Bangalore, India

Adding one chip to the basic digital-averaging circuit proposed by Frazier [*Electronics*, Nov. 9, 1978, p. 114] forms a data counter whose outputs express a negative number not only by its magnitude and sign, but by its 2's complement as well. Expressing numbers in the latter form enhances the circuit's usefulness by allowing direct interfacing with computer circuits.

The circuit shown works differently from Frazier's, which generates a sign bit and reverses the direction of the count when the counter is about to move down

through zero. Instead, the 74193 is allowed to go below zero, where its R output becomes 15 and the state of its borrow output changes, thereby clocking the 7470 flip-flop. The 7470's Q output, which is the sign bit, S, then moves high.

The sign bit and the R bits are applied to the 7483 4-bit full adder (not part of the original circuit) through the 7486 exclusive-OR gates. The 7483 and 7486 together form an add-or-subtract unit. As a result, the output of the adder, M, will be equal to R if the 74193 indicates it holds a positive count (S = 0), and will be equal to 16 – R if the 74193 has gone negative (S = 1).

If S = 0, the R bits, as seen at the output of the 74193, will represent the binary equivalent of the number. Any negative number will be represented by its 2's complement value and an enabled borrow bit. □

Designer's casebook is a regular feature in *Electronics*. We invite readers to submit original and unpublished circuit ideas and solutions to design problems. Explain briefly but thoroughly the circuit's operating principle and purpose. We'll pay \$50 for each item published.

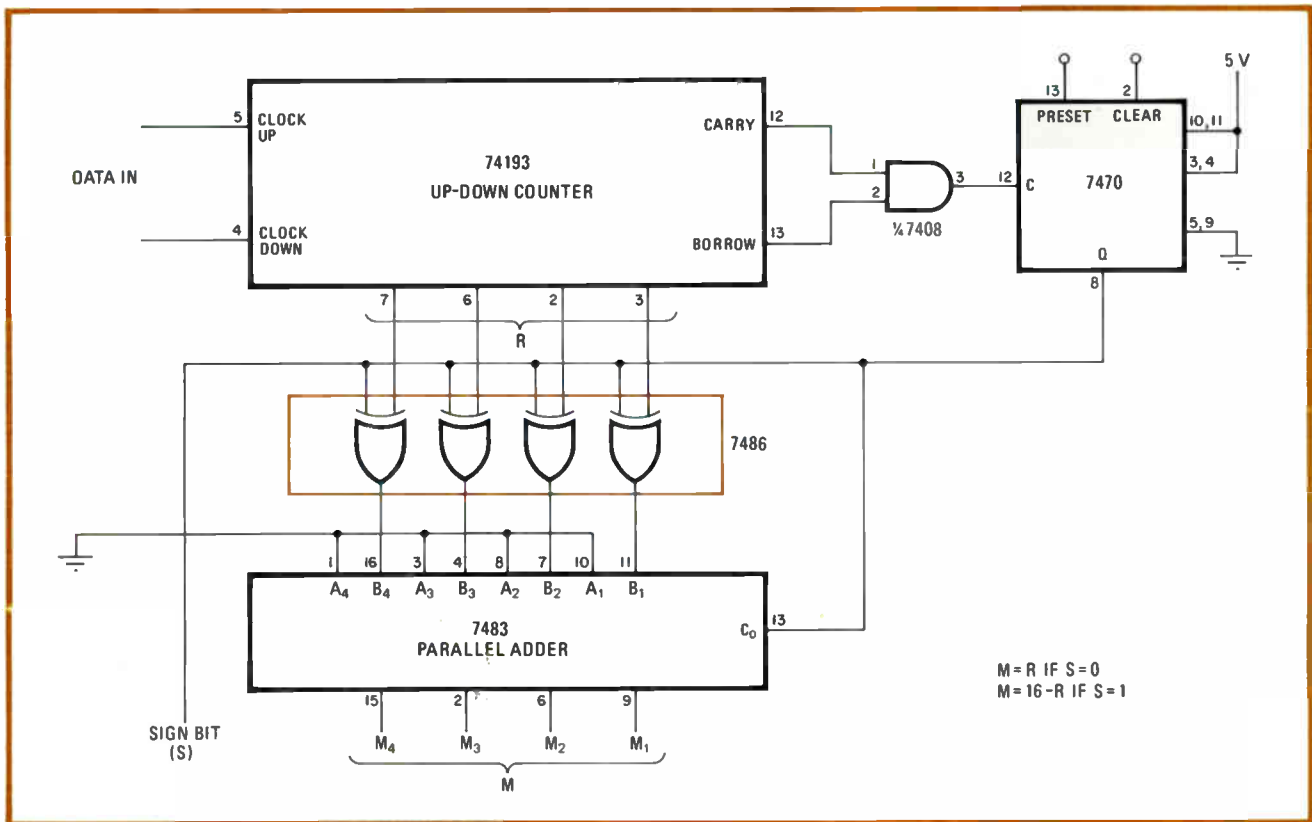

**Number forms.** Availability of any number in both binary equivalent or magnitude-sign forms enhance circuit's interfacing capability. Data generated by 74193, expressed as binary number (R bits), is converted into magnitude-sign form by add-or-subtract unit 7483–7486. R represents the 2's complement of any negative number when counter steps down through zero.

## A coming-out party for the important new devices

*Now in its 26th year, the International Solid State Circuits Conference continues to enhance its reputation as the premier forum for announcements of significant advances in semiconductor technology. One major reason for the stature of ISSCC, which returns to Philadelphia from last year's sojourn in San Francisco, is its unrelentingly high standards for selecting papers from the hundreds of submissions. Another is the conference's traditional role as a precursor of important products.*

*This year is no exception. In the memory area, for example, attendees will be given their first glimpses of superfast static random-access memories from Intel and 64-K RAMs from National, Siemens, and Bell Laboratories. The innovative Japanese are weighing in with some impressively large-capacity devices, presumably fallout from their VLSI program. Even a partial list of the chips would have to include a huge 128-K read-only memory, a 1-megabit wafer-size RAM, and a 5,000-gate logic array. Also in logic, look for the debut of a new high-speed bit-slice family from Fairchild, with slices that are all of 8 bits wide.*

*But linear technology is also an important feature of ISSCC. This year, high-performance conversion devices are spearheading the host of important developments in this area. Speed and accuracy are benefiting from new techniques, as evident in TRW's 35-MHz fully parallel a-d converter, 12-bit a-d or d-a devices from the University of California, Berkeley, Advanced Micro Devices, and Nippon Electric, and a 13-bit unit from Matsushita.*

*Another important trend at this year's meeting is the impact that large-scale integration is beginning to make on linear functions. This can be seen in two major innovative approaches: the combination of analog and digital techniques on the same chip, and the use of digital techniques to do real-time signal processing. The first is exemplified by Silicon Systems Inc.'s tone decoder chip (see p. 105), the second by Intel's new analog microprocessor. These and the growing use of switched-capacitor filter techniques will open a whole new analog world to LSI.*

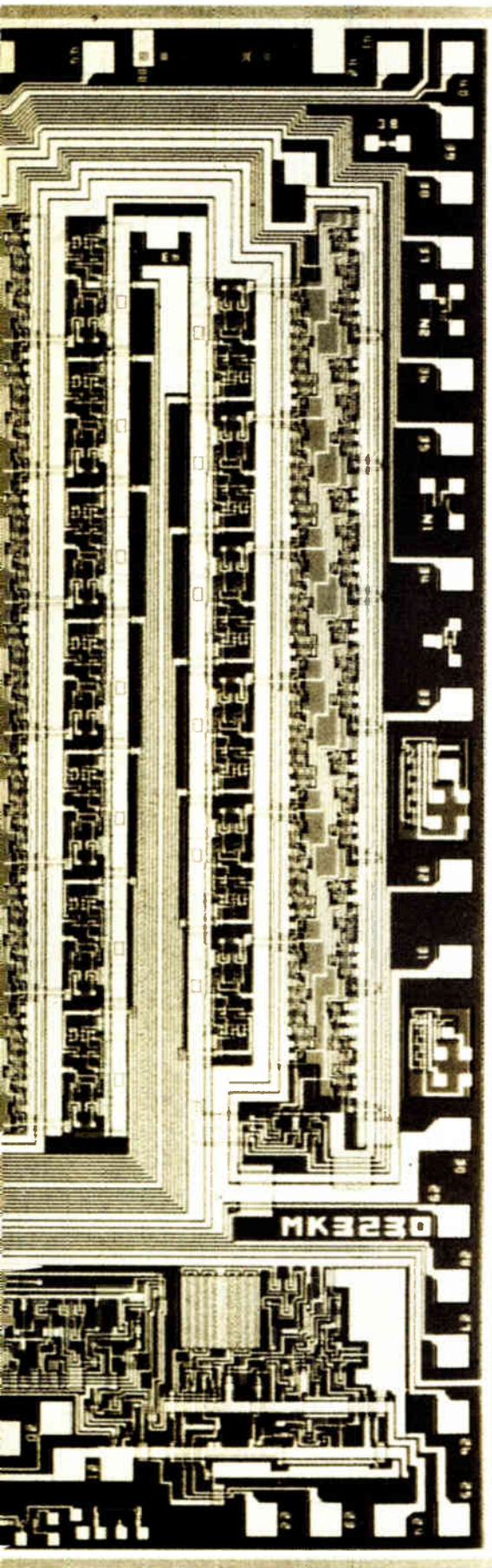

## Design, process innovations expand memory, logic frontiers

by Raymond P. Capece  
Solid State Editor

□ That chip manufacturers are suffering from no shortage of innovative designs is evident from their memory circuits, which adopt new and sometimes startling ways of boosting speed and density. Microprocessors, too, are taking on new challenges, and a trend toward analog-digital large-scale integration is fast developing.

Likely the most unusual entry in the dynamic memory area is Texas Instruments Inc.'s taper-isolated cell for a dynamic-gain random-access memory. First introduced at the International Electron Devices Meeting in December of last year, the taper cell is conservatively posted by the Dallas company as capable of yielding RAMs with read-only-memory densities; in actuality, its theoretical cell size of  $6F^2$ , where  $F$  is the interconnect line width, makes it a viable candidate for a superior 64-K RAM—or even a 256-K device.

Whereas the IEDM presentation covered the physics of the device's operation [*Electronics*, Dec. 21, 1978, p. 31], the ISSCC paper describes its optimization for a large memory array. Shown in Fig. 1, the cell indicates a 1 or a 0 by the presence or absence of a hole packet in the channel region and hence uses a single transistor but no capacitor. The cell area accordingly is only a third that of a conventional dynamic RAM's one-transistor cell.

Other pluses could also accord the taper cell superior performance to conventional RAM designs. First, unlike stratified-charge approaches to eliminating the capacitor, which require a constant-charge signal to be read, the device supplies a constant-current signal. That signal not only provides roughly five times the drive capability of conventional RAMs, according to one TI benchmark, but can actually be designed into the cell to meet a given access-time requirement. Second, diffusion currents, which arise especially at high temperatures, are collected by the taper cell's drain and, as such, contribute minimally to leakage, even at 100°C. Also, the activation energy of that leakage, being much lower than in conventional RAMs, leads TI to believe its cell will be far less susceptible to soft errors caused by alpha particles.

However, generating the negative pulse needed to write a 1 into the cell remains a problem, since the normal n-channel process does not lend itself well to negative swings. TI counters that by adjusting the shallow p-type implant, so that a zero gate-oxide surface potential occurs at a positive gate voltage and the cell can be operated with three-level positive clocks.

A somewhat more conventional approach to the 64-K RAM is taken by National Semiconductor Corp., Santa Clara, Calif. Its triple-polysilicon process (Fig. 2) yields

a 195-square-micrometer cell size and hence a 38,000-mil-square chip (pin 1, incidentally, is left unconnected).

The cell is the usual one-transistor, one-capacitor type. But the capacitor, being formed between two of the three layers of polysilicon, is a high-quality one, says National, unlike the inversion-layer capacitor of 16-K dynamic RAMs. A mere fifth of the total area of improved capacitor's storage node is subject to substrate leakage, and the device has a higher immunity to alpha particles.

National has also improved the sense amplifier, giving it a symmetrical design and two bit lines. Thus the number of memory cells attached to each bit line is halved, increasing the signal level that is sensed, while the symmetry eases the layout and improves the matching of dummy and memory capacitors. The final 5-volt-only chip, arranged into four 16-K arrays, requires 256 refresh cycles at 4-millisecond intervals and provides an access time of 120 nanoseconds.

### Redundancy to the rescue

At Bell Telephone Laboratories Inc., Allentown, Pa., the needs are different and so is the 64-K RAM. To ensure immediate high yields, Bell designs redundancy bits into its n-channel, two-polysilicon-level device. As Fig. 3 shows, each of the chip's two 32-K arrays contains spare rows or columns, which are substituted for defective ones by laser pulsing. An yttrium-aluminum-garnet (YAG) laser with a 1.06- $\mu\text{m}$  wavelength burns open polysilicon lines that are buried under phosphorus-doped glass. No special processing is needed, says Bell, because the laser repairs are done during wafer probing.

Aside from its redundancy and unusual power supplies of +8 and -5 V, Bell's 64-K RAM maintains compatibility with industry-standard 16-K dynamics, since it requires 128 refresh cycles every 4 ms and has an access time of 100 ns. In addition, Bell has made special efforts to reduce power dissipation: there is full selection of only

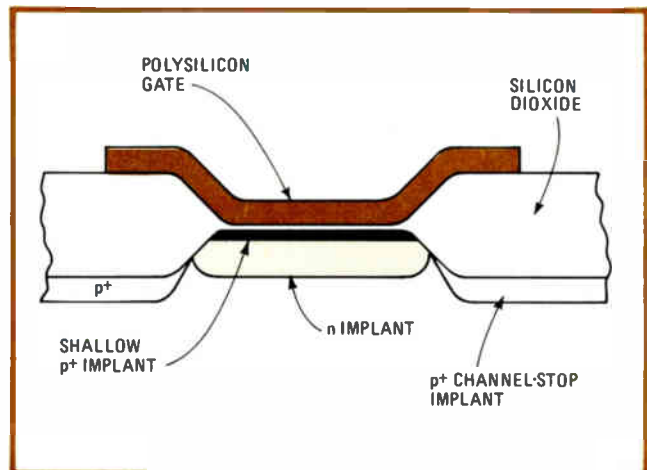

1. New cell. One-transistor RAM cell with no capacitor stores 1s and 0s at different thresholds. TI, which calls the device a taper-oxide dynamic-gain cell, says the device looks good for large memory arrays where it could be driven with three-level positive clocking.

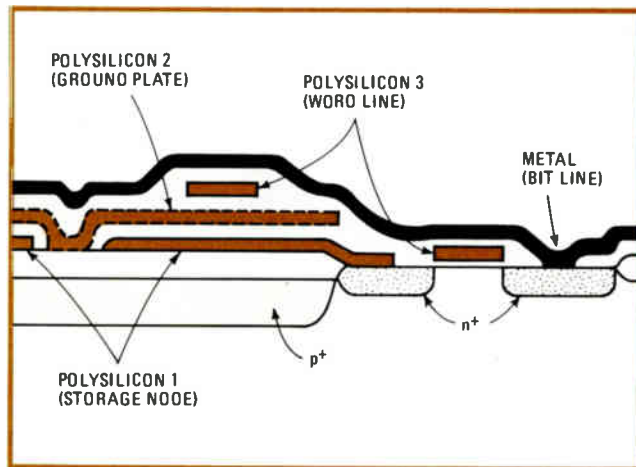

**2. Triple-poly approach.** National Semiconductor is using a three-level polysilicon process to build its 64-K RAM. Advantages of the more complex process, says National, are a better capability and a lessened susceptibility to soft errors caused by alpha particles.

one 32-K array at a time, and the sense-amplifier/column-buffer circuits partially decouple the heavily capacitive column line from the sense amplifier during latching, thus achieving fast access time without the usual high-current spikes.

N-channel MOS static RAMs are forever on the descent in access time, and, as usual, Intel Corp. is leading the parade. In two separate papers, the Santa Clara chip-maker describes its second generation of high-performance MOS, which it calls H-MOS II. By pushing the limits of silicon technology to 2- $\mu\text{m}$  channel lengths and 400-angstrom oxide thicknesses, Intel has driven gate delays way into bipolar territory—400 picoseconds—and produced working 1-K- and 4-K-by-1-bit RAMs with the barely credible access times of 15 and 25 ns, respectively. Of course, even with n-channel MOS, speed isn't free—it comes at a cost of increased power dissipation. But with maximum power ratings of about half a watt, n-MOS still has any bipolar competitor beat, and it easily excels in a memory system where chips can be deselected.

Applying the same scaled-down process to a 16-K-by-1-bit static memory, Intel has produced a 45-ns device—faster than current 4-K chips—yet one that dissipates little more than half a watt. The key to its density is a second level of polysilicon interconnect, which will assuredly be adopted by other semiconductor manufacturers as they gain the necessary expertise.

### A big ROM and the electron beam

Nippon Telegraph and Telephone Public Corp.'s Musashino Electrical Communication Laboratory in Tokyo offers a viable approach to the next generation of read-only memories with its 128-kilobit electron-beam-written ROM. In one go, NTT solves several of the problems of huge ROM arrays: it minimizes die size, holds back power dissipation, and adds flexibility to programming with a scanning electron-beam exposure system.

The 16,384-by-8-bit ROM is arranged in four 32-K arrays, as shown in Fig. 3. Its cell size is a scant  $62 \mu\text{m}^2$ , due to a design in which each pair of bits requires only one contact hole. The resulting die is only 20.6 square millimeters in area.

The power dissipation of the single-5-v device is a low 65 milliwatts, thanks to a dynamic-inverter approach and some clever circuit design. Yet the access and cycle time are more than respectable, at 200 ns and 400 ns, respectively.

Perhaps the most significant feature of the big ROM, however, is its electron-beam programmability. Although at the 1.3-megahertz beam stepping rate used it takes two minutes to program each die, the flexibility of the approach cannot be denied. Each die on a wafer can have different data written into it, since the electron beam operates under software control. The beam modifies the threshold voltage of each MOS device in the array; thus, the data writing is done halfway through the chip fabrication process. The ROM's initial application will be as a character generator for Chinese ideographs, each of which requires 288 bits to define.

At the VLSI Cooperative Laboratories in Kawasaki, Japan, the emphasis is indeed on electron-beam lithography. A paper presented by the laboratory—one of the few entries on process technology—describes some methods of correcting the scattering of the beam's electrons that exposes unwanted areas during direct-wafer writing. The resultant interconnection of adjacent patterns is called the interproximity effect, while the intraproximity effect describes the rounding of a pattern's corners. To combat both, the intensity of the electron beam is modulated by calculations done in real time. At the VLSI lab, new approaches vastly reduce the extent of the calculations necessary.

For interproximity effects, representative points midway between a given pattern and all adjacent patterns are located. Then whenever the beam crosses those points, its intensity is lowered. Such an approach has the advantage of low computation time, since only at those points need high-speed, real-time arithmetic be performed.

Corner-rounding, or intraproximity effects, can be rectified by varying the dose and beam centers in accordance with the pattern size, says the VLSI lab: for pattern geometries of less than  $0.5 \mu\text{m}$  the beam must be moved outside each corner and the beam intensity lowered; for 0.5- to 2.0- $\mu\text{m}$  geometries the exposure can be right on the corner, but dosage must still be reduced; for geometries of more than  $2 \mu\text{m}$  the exposure at the corners can be a constant full dose.

### Logic and memory for the computer

Gaining popularity as replacements for lots of small- and medium-scale integrated logic circuits, master-slice logic arrays are taking many shapes. A paper from Hitachi describes one of the biggest yet: a 5,122-gate device built with integrated injection logic (I<sup>2</sup>L). To

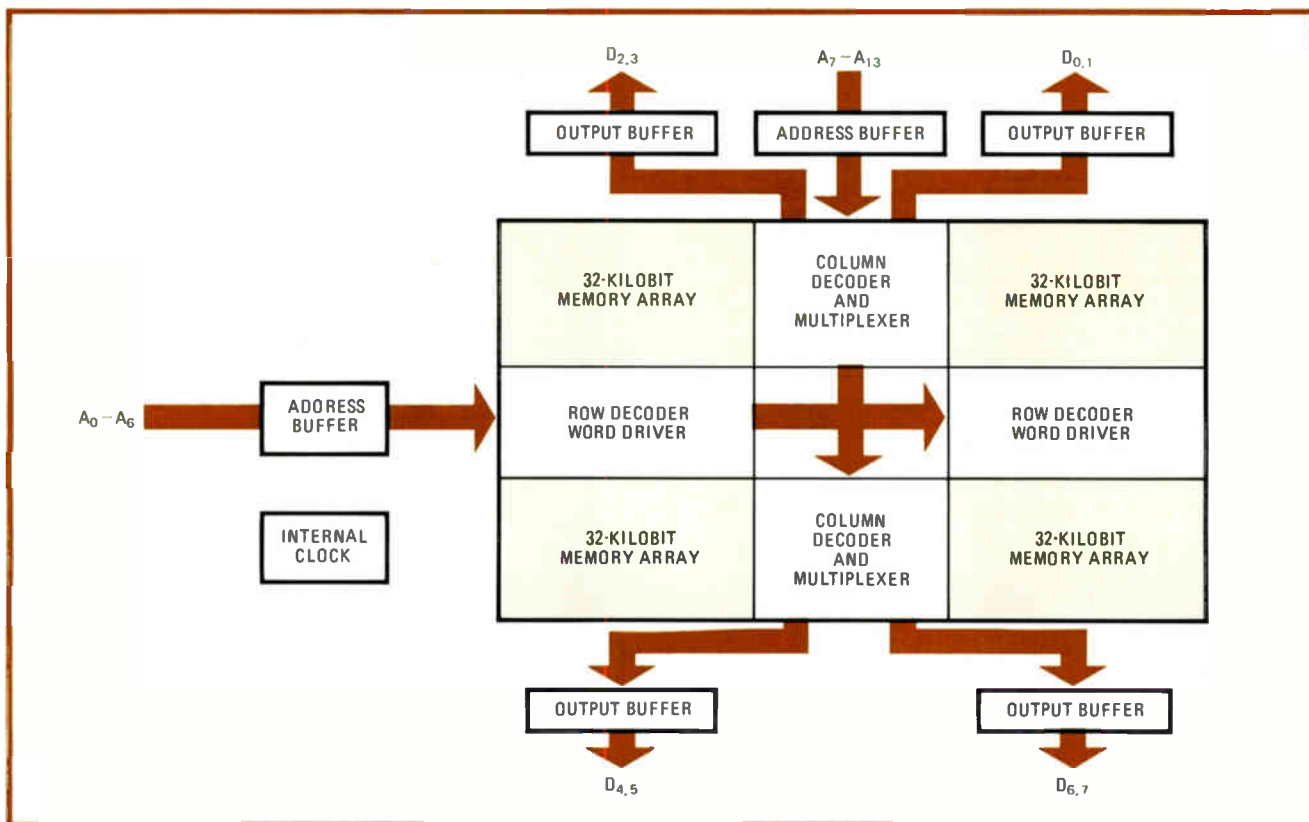

**3. Big ROM.** NTT'S 128-K read-only memory, split into four arrays that provide access to 16,384 bytes, has 65-square-micrometer cells. Writing directly on the wafer, an electron beam programs each device in mid-fabrication by altering its nanosecond thresholds.

reduce voltage drops in injector lines, ground lines are added to keep gate delays on the large (25.4-mm<sup>2</sup>) chip to 10 ns for an injection current of 100 microamperes.

The chip comprises 124 basic block cells placed around two programmable logic arrays (PLAs). Each block cell consists of a D-type flip-flop, 22 I<sup>2</sup>L device-islands for random-logic, and four wiring channels. The PLAs each have 35 inputs and 15 outputs, and product terms can be linked between the two. A line-control unit for computer terminals has been built with the chip, says Hitachi, that replaces 59 transistor-transistor-logic packages with one 42-pin dual in-line package. Using both PLAs and 107 of the 124 basic blocks, the design draws only 300 milliwatts at an 8-MHz operating frequency.

Another paper by Hitachi describes a pair of very high-speed bipolar memory chips used by the Japanese manufacturer in its new M-200H mainframe computer. The two chips are designed to work together to boost the speed of table-lookup and address buffers, and hence the speed of processor execution.

The pair consists of an index-array chip, which mixes 3,072 bits of RAM with 470 logic gates, and a super-fast 1,024-by-1-bit RAM. The mixed chip has an access time of 6.7 ns and typical power dissipation of 3.9 w. The straight RAM has a typical access time of 5.5 ns—the fastest ever recorded, according to Hitachi—yet dissipates only 800 mW.

The index-address chip represents a completely new bipolar memory approach for mainframes. It includes not only the usual peripheral circuits for its memory array, but additional logic for compare functions, which are usually done off chip and thus add propagation delays. The new approach can achieve fast dynamic address translation and cache control.

Basically, the index-array chip is arranged into two sections, each with four 64-by-6-bit RAMs. Although it can function normally as a 256-by-6-bit RAM, it provides in addition parity-checking outputs and a compare output, which indicates whether the word addressed in its memory is the same as one present at its inputs. The combination of logic and RAM boosts the throughput of mainframe buffer memories so much that the idea of such "smart" memories will probably catch on and percolate down even to the microcomputer level. Both the index array chip and the 1-K RAM use the same bipolar process: an oxide-isolated technology with two layers of metalization.

#### Enter the 8-bit slice

Also oriented towards mainframes is a new bit-slice family from Fairchild Camera and Instrument Corp., Mountain View, Calif. Built with Fairchild's Isoplanar emitter-coupled logic and compatible with the 100K subnanosecond logic family, four new 8-bit slice parts

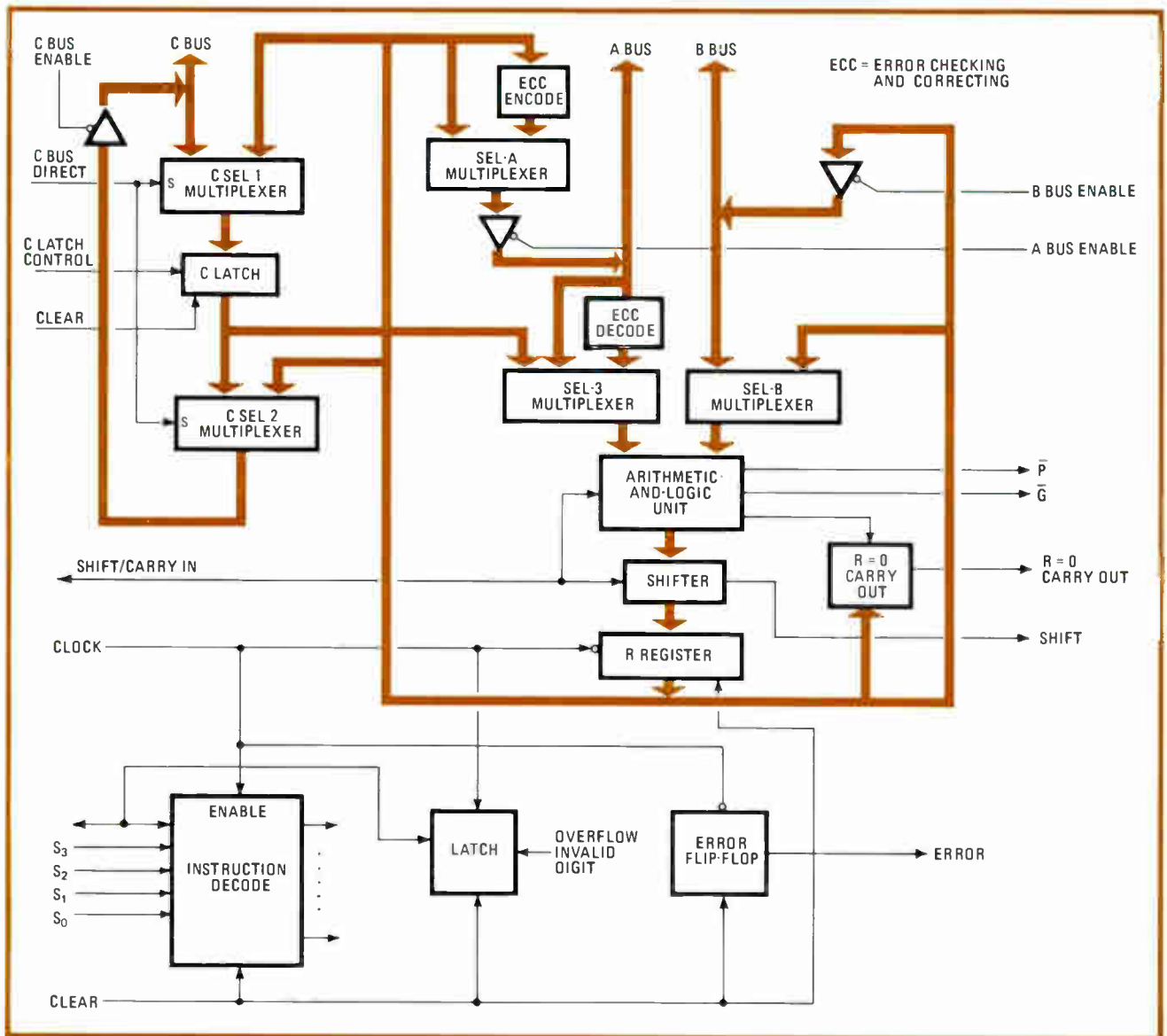

**4. Byte slice.** The start of the 8-bit microprocessor slice family, Fairchild's address- and data-interface unit boasts the densest emitter-coupled-logic design yet. The part has an 18-nanosecond cycle time and is compatible with the 100K logic family.

are succeeding in pushing the limits of ECL density.

The reasoning behind the development is simple, says Fairchild: what good are internal gate delays of 600 ps if interconnect and package delays are the culprits slowing the system? None whatsoever, says Fairchild—only LSI and a bigger slice can improve the performance.

The first part is the address and data-interface unit, shown in Fig. 4, that handles bus-to-bus data and address transfers, data manipulation, and temporary storage. With three bidirectional data buses of 9 bits each (8 bits plus a parity bit) and a healthy 27-instruction set, the chip can add two 64-bit words typically in 25 ns, with the aid of a carry-lookahead chip. The large (47,000-mil<sup>2</sup>) chip dissipates a hefty 4.1 w when operating from an 18-ns clock.

The other 8-bit slices include: a multiple-function network containing six 5-bit latches that assists in error checking and correction and register-stack addressing; a dual-address stack of 32 9-bit words; and a programmable interface unit that makes efficient use of a common, time-shared bus through handshaking, parity generation and checking, and three-state interfacing.

### Rapprochement on chip

Some of the more dedicated LSI circuit designs at ISSCC are quite intriguing, especially those that mix analog circuits with logic in what can only be the start of a trend towards analog-digital LSI. Consider, for example, a one-chip microcomputer from NEC that has a built-in phase-locked loop (PLL). The circuit has been



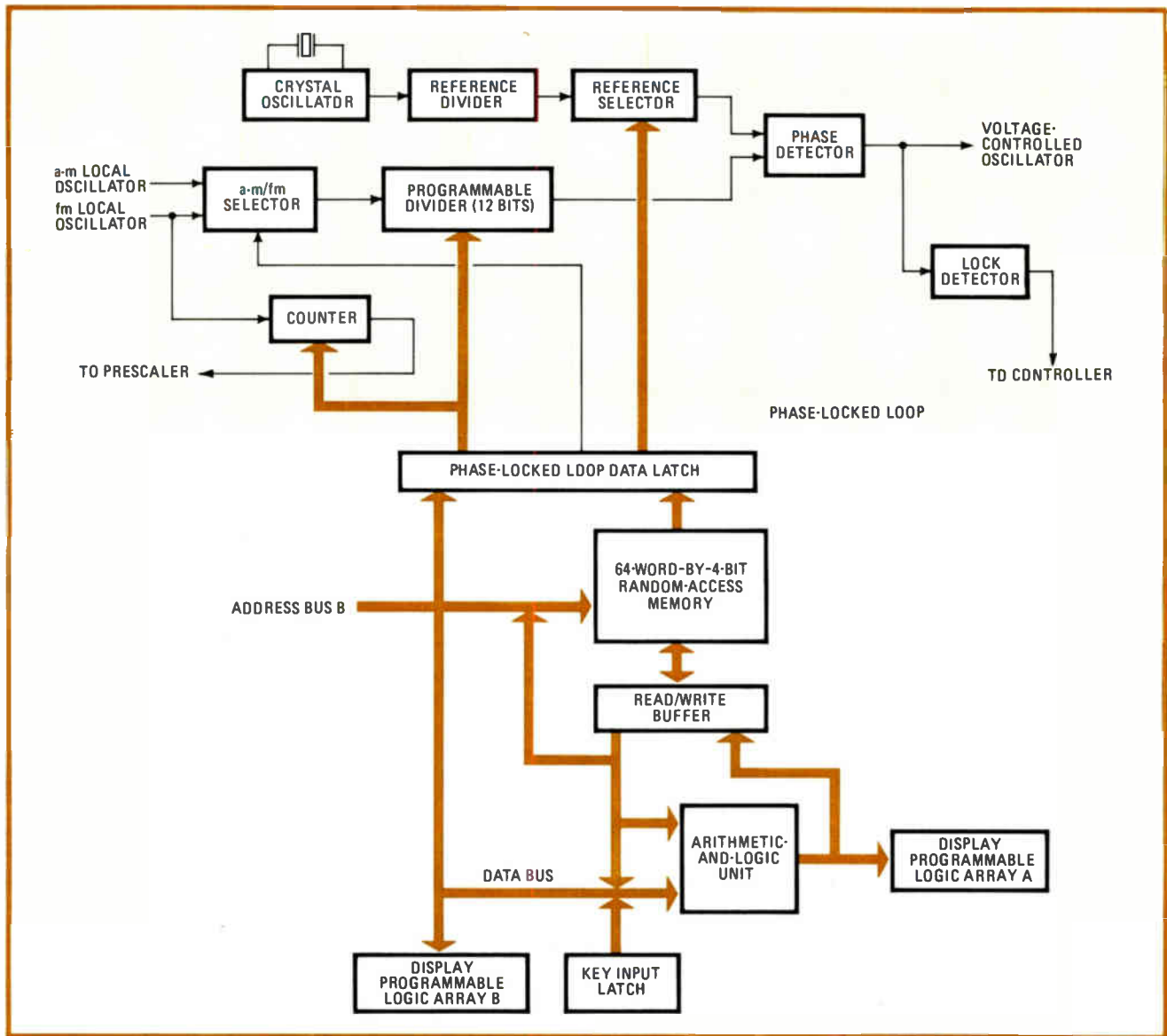

**5. Microprocessor for radios.** NEC digital-tuner chip combines a microcomputer with two phase-locked loops for use in digitally tuned a-m/fm radios. Few other components are needed for a complete radio, as the chip interfaces directly to keyboard and display.

expressly designed for digital a-m/fm radios and packs 15,000 transistors into a 27-mm<sup>2</sup> aluminum-gate complementary-MOS chip.

Figure 5 shows the chip's organization (the PLL section is the tinted area). Not only does the microcomputer portion have programmable logic arrays that eliminate decoding for the digital display of the station frequency, but its 64-by-4-bit RAM can be programmed with up to 14 preset stations. The chip even contains circuits for a time-of-day clock.

The PLL, driven by a crystal, uses the 12-bit programmable divider in its feedback loop to multiply the frequency of the crystal oscillator. To operate in the frequency-modulated band, a prescaler is needed because the PLL locks on a frequency that is a fraction of

the actual rf signal. Few outboard components are needed to complete the digital receiver unit: voltage-controlled oscillators, amplifiers and mixers for the radio-frequency and intermediate-frequency signals, and an audio amplifier and speaker, in addition to the keyboard matrix and display.

#### And now an analog microprocessor

A paper presented by Intel Corp.'s Ted Hoff, one of the digital microprocessor's founding fathers, describes the first analog microprocessor. A breakthrough in signal processing, the chip can serve as the building block for filters, modems, speech synthesizers, and many audio and telecommunications applications. It will be described in detail in the March 1 issue of *Electronics*.

## High resolution

Twelve-bit precision converters have made the grade. Going clockwise from top right, Advanced Micro Devices' fast digital-to-analog converter has resistors diffused into the same substrate as the active components, guaranteeing monotonicity to 13 bits and a settling time of 250 ns. Next, Matsushita Electrical Industrial Co.'s 12-bit analog-to-digital converter mixes three technologies: an integrated-injection-logic network is made with the same diffusion steps as high-frequency bipolar transistors and a p-channel metal-oxide-semiconductor sample-and-hold circuit. Finally, Nippon Electric Co.'s 12-bit complementary-MOS simultaneous-integration converter integrates the input signal over eight intervals, improving the signal-to-noise ratio by an order of magnitude, reducing the internal integrating capacitor value, and attaining the high operating bandwidth of 2 MHz.

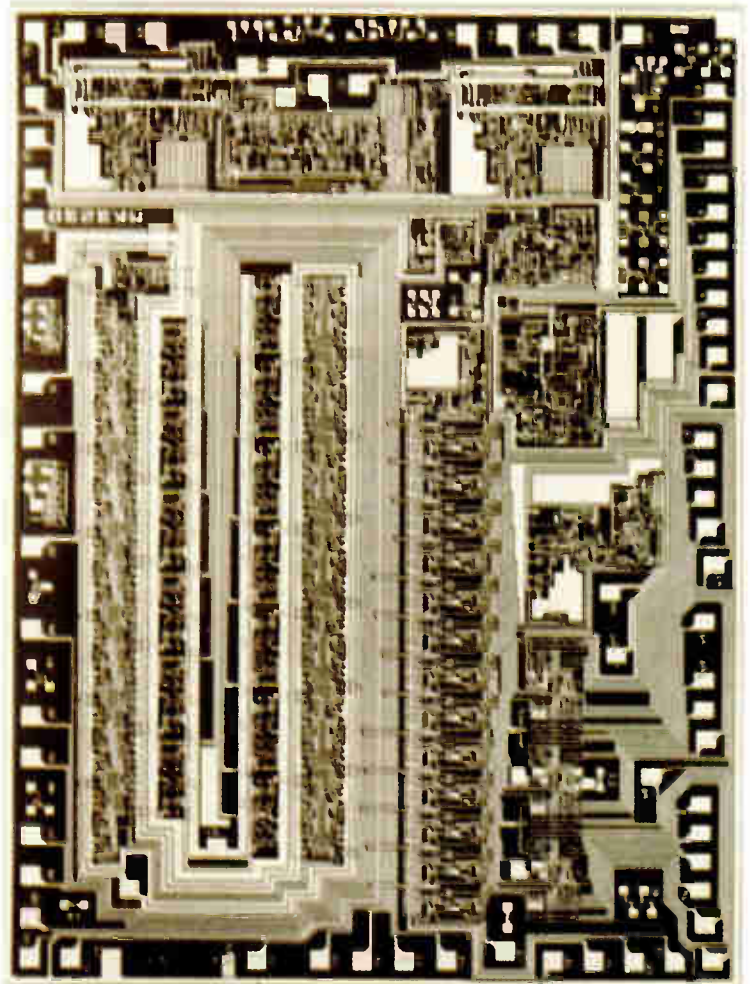
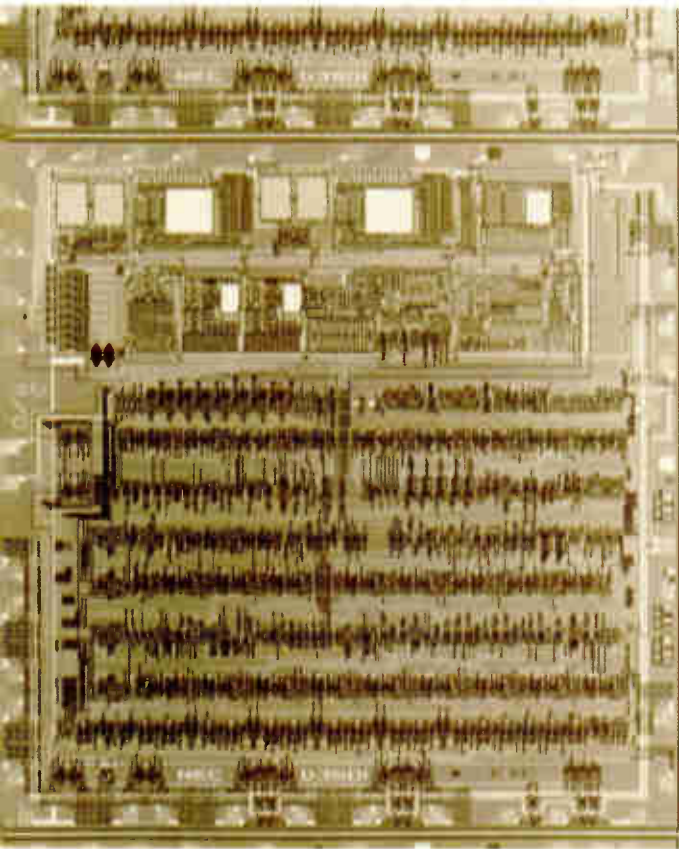
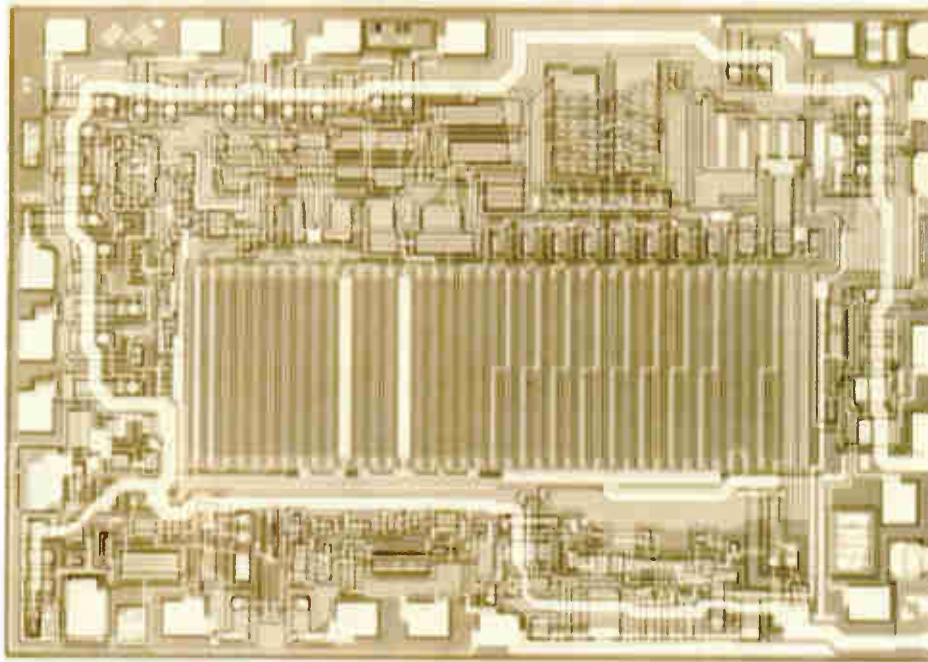

# Performance barriers fall to unique linear designs

by Nicolas Mokhoff  
Components Editor

□ Interfacing the analog world with today's sophisticated processors demands a matching sophistication, and the importance attached to the area is reflected at this year's conference in four complete sessions and numerous scattered papers. At the two data-acquisition sessions, for instance, it is possible to hear about a variety of high-performance analog-to-digital and digital-to-analog converters as well as a couple of interesting linear circuits for use with converters. Other analog chips tackle jobs in electronic organs and communications—filters are especially active.

The TRW Defense and Space Systems Group of Redondo Beach, Calif., is working on a fully parallel 8-bit a-d converter that can sample at rates up to 35 megahertz. The traditional sample-and-hold circuit has been eliminated, and that function is implemented instead by 255 sophisticated strobed comparators and associated logic circuitry. Each comparator accepts a

different dc reference voltage simultaneously with the input voltage. When the device switches from the sample to the hold mode, all comparators display the results of their comparison independently. Peripheral logic gates develop a 1-out-of-256 code and express it as an 8-bit word. Responsible for the high 35-MHz speed is the use throughout of current-mode logic in combination with TRW's unique triple-diffused bipolar technology, which also boosts yields. The 6.5-by-6.7-millimeter chip contains 17,000 active elements.

## Bits by the dozen

In contrast, a 12-bit successive-approximation a-d converter from researchers at the University of California in Berkeley uses only conventional processing to realize its novel circuitry. Implemented in a standard metal-gate n-channel metal-oxide-semiconductor process, the device employs a resistor string to provide a monotonic division of the reference voltage, plus a MOS weighted-capacitor array to subdivide any one of these voltage segments into 256 levels (Fig. 1). The input voltage is sampled and held on the capacitor array by keeping the MOS transistor switch across the comparator closed. Then a search is made among the resistor string taps for the stored sample, and a successive approximation is performed on it once found. By driving the arrays through MOS transistor switches, the researchers claim

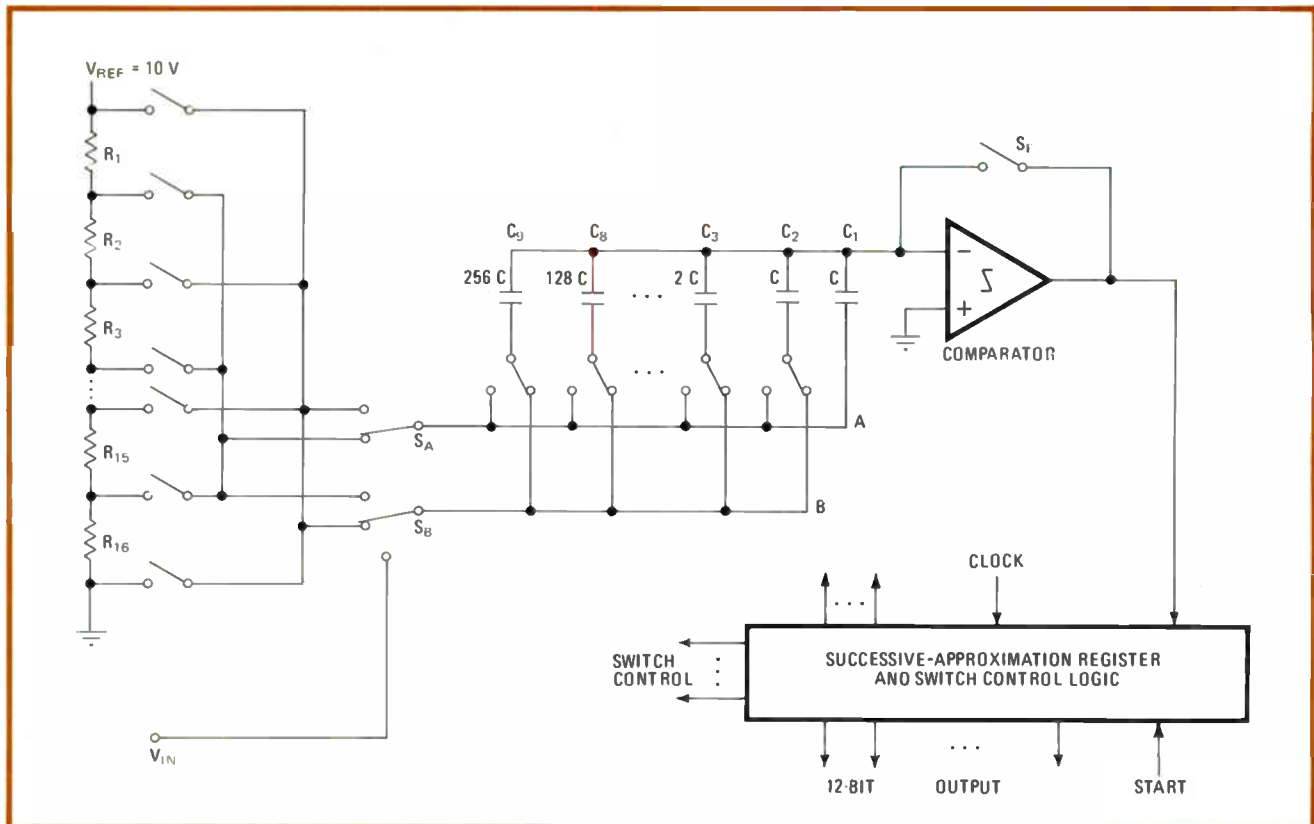

**1. Weighted-capacitor array.** Resistor string divides input voltage into segments, each of which is subdivided by capacitor array into 256 levels. Successive comparison of the stored sample nulls comparator input voltage—array in effect eliminates any comparator offset voltage.

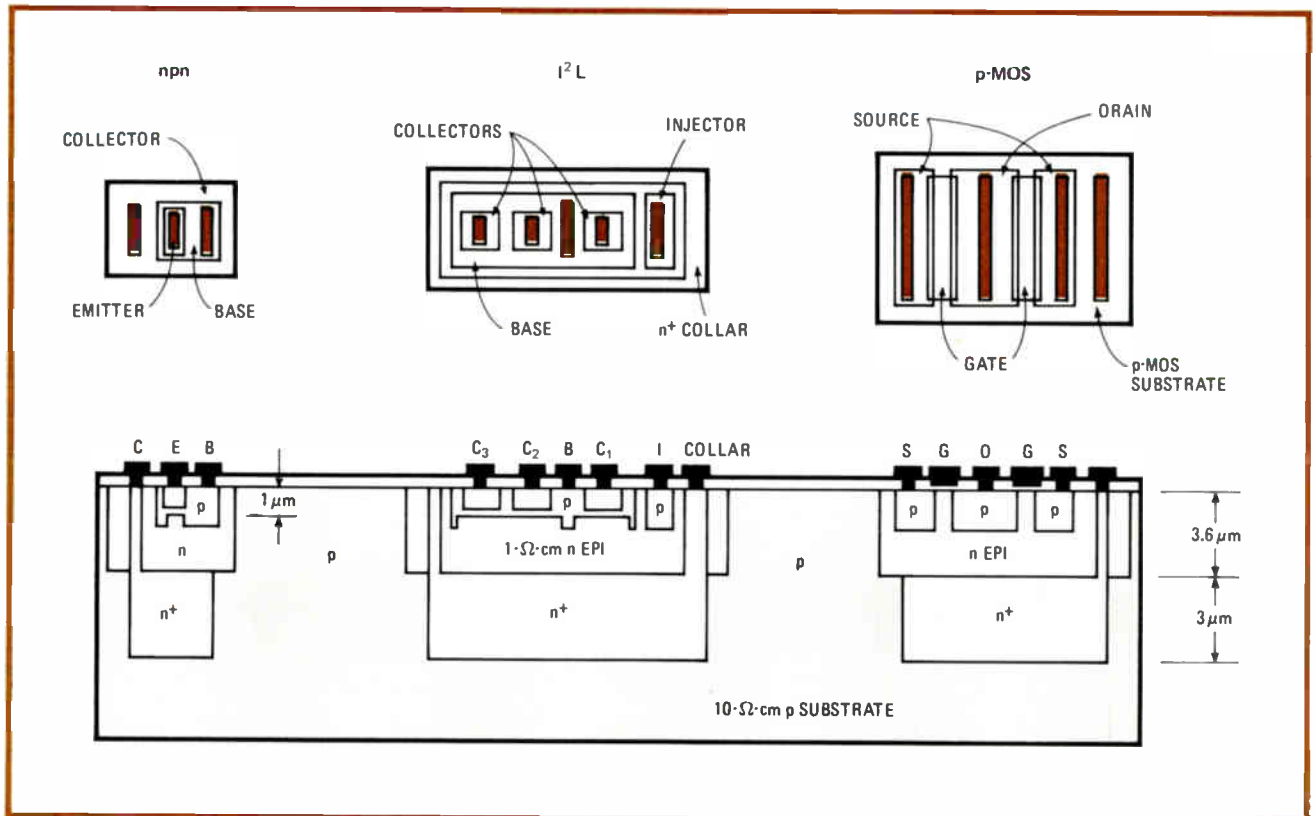

2. **Three in one.** Novel process produces high-speed npn transistors on same p substrate as an I<sup>2</sup>L logic network and a sample-and-hold circuit made up of p-MOS transistors. The 6-by-4.6-mm chip contains 1,200 active devices; another chip contains the resistor network.

they have succeeded in eliminating offset errors.

As for fabrication, the 9,000-ohm resistor string is formed in the normal source-drain diffusion of the n-MOS integrated circuit, while the 50-picofarad capacitor array is formed between metal and source-drain diffusion with the thin oxide mask defining capacitor areas. To give the RC charging transients adequate time to settle, a full 25 microseconds are allowed for the 12-bit conversion.

#### With PCM in mind

A couple of Japanese papers go into detail on a 13-bit converter designed for pulse-code modulation applications and on a 12-bit simultaneous-integration complementary-MOS a-d device. To load a chip with all the elements needed to perform a true 13-bit a-d conversion (Fig. 2), Matsushita Electric Industrial Co. employs a new process that combines three technologies: p-channel MOS for the sample-and-hold circuit, integrated injection logic (I<sup>2</sup>L) for the comparator and control logic network, and an ion-implanted bipolar process for the high-frequency npn transistors used as output logic buffers. In fact, the p-MOS circuit is also ion-implanted for minimum effect on the bipolar transistor characteristics, and the I<sup>2</sup>L network is fabricated by the same diffusion steps as the bipolar transistors.

The device actually consists of two chips intercon-

nected in a 40-pin dual in-line package. One chip has a nickel-chromium resistor network vacuum-deposited on it to ensure the 13 bits of accuracy. The other contains 1,200 active devices making up the a-d converter. The combination yields a conversion time of 16  $\mu$ s, while consuming a mere 1.05 watts.

The 12-bit C-MOS device from Nippon Electric Co. is a monolithic a-d converter employing current-mode analog circuitry. Instead of the conventional dual-slope technique, it uses a simultaneous integration technique, in which the output of the comparator at the end of each preassigned time interval determines either the simultaneous integration of the input current and the reference current or the simple integration of the input current to be performed for each of the subsequent integrating intervals (Fig. 3). Among the significant improvements thus achieved are a much larger equivalent output-voltage range of the integrator, reduction of the external integrating capacitor value, and an order of magnitude increase in the signal-to-noise ratio. The circuit configuration also leads to a relatively fast conversion speed of 500  $\mu$ s, while dissipating a mere 15 mW of power. The NEC part is a +5-V-only device made from a standard silicon-gate C-MOS structure and claims the same linearity as that of its internal amplifiers—a low 0.02%.

Meeting the challenges posed by the conversion of the output of digital systems is Advanced Micro Devices's

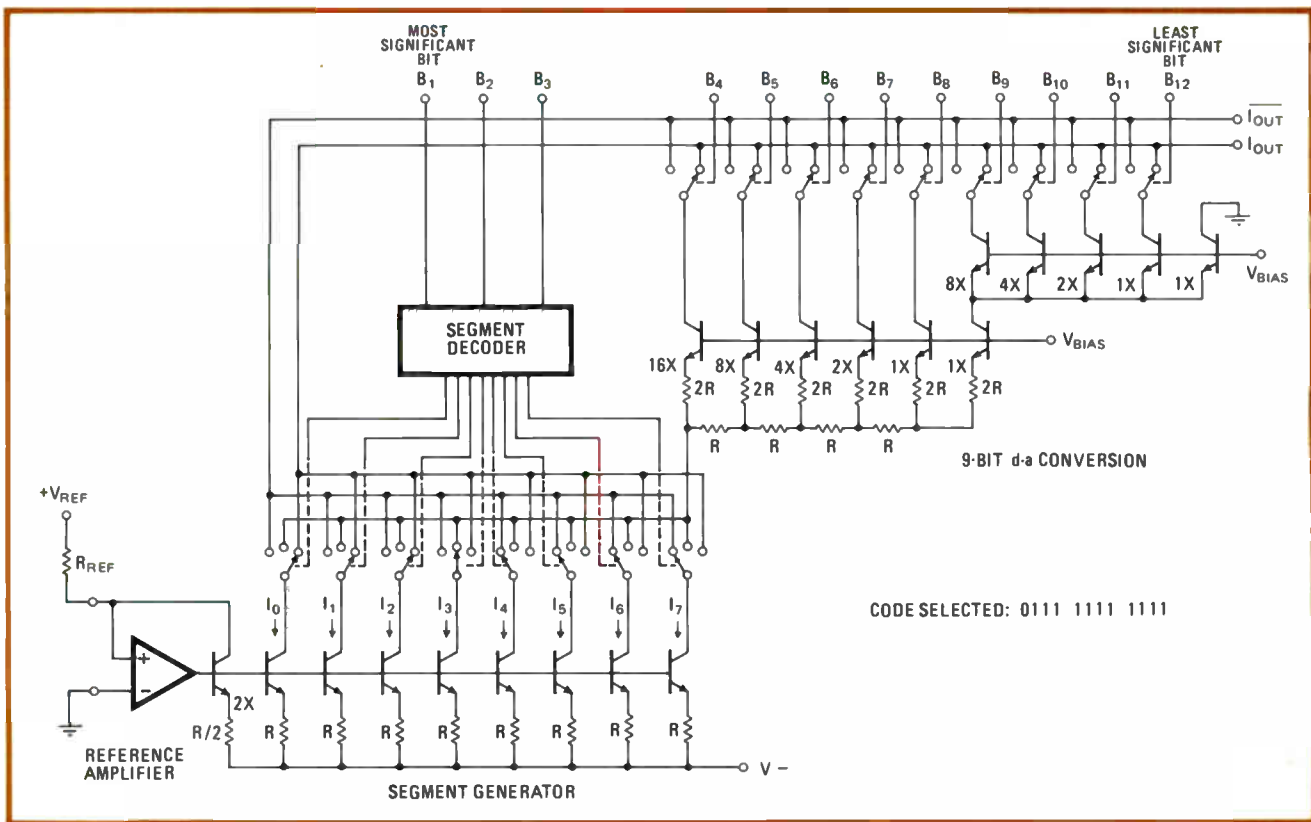

**3. No trimming.** This 12-bit d-a converter is monotonic because diffused resistors on same chip ensure  $\pm 0.01\%$  nonlinearity without trimming. Each of the eight segment resistors carries a current equal to an eighth of full scale and tolerates a  $\pm 0.2\%$  mismatch.

entry into the 12-bit d-a conversion field. Enhancing its reputation for making high-speed converters, the Sunnyvale, Calif., company has fabricated a part that it calls inherently monotonic, on the grounds that its diffused resistors need no trimming yet guarantee differential nonlinearity to  $\pm 0.01\%$  for 13 bits.

Using conventional bipolar processing, the new design technique combines the advantages of both the R-2R and  $2^nR$  approaches to come up with the monotonic characteristic; but instead of the 37 ladder resistors that would be needed by an R-2R network for 12-bit d-a conversion, or the string of 4,096 resistors needed for a  $2^nR$  network, this part requires only 24 resistors. Eight of these resistors are used as current sources for the 3 most significant input bits, thereby generating eight current segments, each of which is divided into 512 current steps and summed to yield the analog output. As can be seen from Fig. 4, no single resistor determines more than one eighth of the full-scale current, since the slope of each segment is determined by one of eight precision matched current sources. Therefore, full monotonicity is preserved within the tolerance of the diffused resistors, here a  $\pm 0.2\%$  mismatch between them. Integrated on a 93-by-134-mil chip, the part is packaged in a 20-pin DIP and consumes 230 to 290 mW, depending on the power supplies.

As for other precision analog devices, one of the most

innovative is a 5-A adjustable regulator from National Semiconductor Corp., Santa Clara, Calif. It exhibits good regulation, even when dissipating 100-w transients, by taking thermal gradients into account. This gradient sensing is accomplished by a couple of transistors that increase the available power output without sacrificing overload protection. Load regulation is to 0.05% at 5 A, and the device can be used for output voltage swings of 1.2 to 33 v.

### Dealing with heat

These characteristics are achieved by having the power transistor made up of individually ballasted emitter stripes in a base section. The base sections of seven emitters are in turn also ballasted with one of the resistors used for current sensing. This and deep n<sup>+</sup> diffused collector contacts assure the transistor of a breakdown voltage of typically 50 v. The output current sensors are diffused n<sup>+</sup> resistors with a positive temperature coefficient of 0.2%/C°, matched to the gradient sense voltage of the current limit transistors, thereby ensuring a fast current limit cutoff.

Another device that uses a clever design to cancel thermal gradients is a voltage-follower IC from Precision Monolithics Inc. of Santa Clara, Calif. A quasi-quad field-effect-transistor layout minimizes mode capacitances to such an extent that a slew rate exceeding

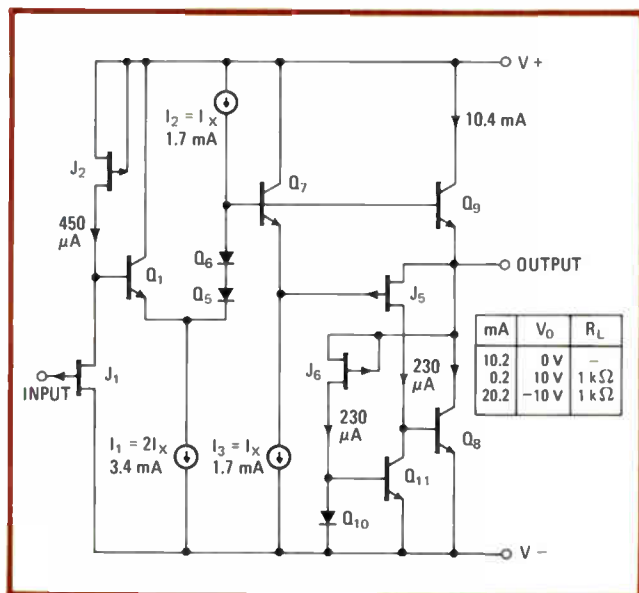

**4. Quasi-quad.** Open-loop design has a quasi-quad configuration in which a pair of eight-channel FETs are separated into two four-channel segments. This retains the advantage of common centroids while limiting capacitance and yielding a 300-V/ $\mu$ s slew rate.

400 V/ $\mu$ s is achievable. In effect, instead of two sets of four separate channel segments for current distribution, the device is split into two sets of four four-channel segments. This configuration retains the benefit of common centroids, yet it holds capacitance well below that of a pure quad layout, since the capacitance generated does not lie in the signal path and therefore is considered negligible. The upshot is a monolithic voltage follower specified for a 90-MHz bandwidth, a slew rate of 300 V/ $\mu$ s, and an offset voltage of 1.5 millivolts.

Also from Precision Monolithics is an example of how a mixed technology can greatly enhance device characteristics. It is a temperature-compensated quad analog switch IC fabricated with a bipolar and field-effect-transistor process. Unlike the on-resistances of its C-MOS and junction-FET counterparts, which fluctuate extensively with variations in applied voltage and/or in temperature, the 85-ohm on-resistance of this IC remains virtually constant when it is operated at low currents: its drift is on the order of 400 ppm/ $^{\circ}$ C at 125 $^{\circ}$ C. A protection circuit guards the device against loss of power and against voltage excursions of 20 V beyond the specified input voltage limits.

### Sound distinctions

Several exotic linear integrated circuits have been designed for special applications. Japan's Matsushita Electric Industrial Co. has developed an analog LSI chip that generates tone signals with even and odd harmonics and exhibits the hyperbolic decay envelope of conventional musical instruments. The MOS analog LSI chip comprises resistive-source MOS devices and sawtooth dividers using modified R-2R networks. The resistive-

source MOS device acts as a variable nonlinear impedance element that enlarges the decay time control from 25 milliseconds to the 2 seconds needed for applications in electronic organs.

Sawtooth wave dividers generate the even and odd harmonics that color the signal source and mellow the musical tone. The IC has five- and six-octave tone-generator circuits of three independent musical notes. Combining four LSI chips would be enough to cover the full 61-key keyboard of an electronic organ.

### Cheaper tuning

Another consumer-oriented IC comes from Toshiba Corp.'s Research and Development Center, which has developed a monolithic device for wideband frequency converter applications in a very high-frequency television tuner. Using a silicon-nitride passivation self-aligned (NSA) bipolar process, the Toshiba engineers were able to put a mixer plus an oscillator plus an intermediate-frequency amplifier on one piece of silicon. The NSA process enables high-frequency bipolar transistors to have a 2-micrometer emitter width, a cut-off frequency of 5 gigahertz, and a collector-to-emitter on-voltage of 20 V. In effect, linking this 34-decibel-gain chip to a MOSFET radio-frequency amplifier chip would satisfy the specification for a solid-state tuner and thereby both miniaturize and cut the cost of a conventional TV tuner.

Also in the consumer area, General Instrument Corp.'s Microelectronics division in Hicksville, N. Y., has come up with an LSI version of a versatile programmable sound generator. The n-channel metal-gate chip measures 144 by 159 mm and comes in a 40-pin DIP. Compatible with most microprocessors, it requires no external timing components to generate sound, this data being stored in program ROM and on occasion in data RAM. The completely software-controlled device consists of an unlikely quantity of registers, data converters, and buffers, as well as peripheral logic circuitry, all under one roof.

Included in this year's linear circuit techniques session is a paper on an IC that has been available for some time as a standard off-the-shelf item but that has some unique features. The 4200 analog multiplier from Raytheon Co.'s Semiconductor division in Mountain View, Calif., marries a well-known analog multiplier/divider concept to a novel on-chip nonlinearity cancellation technique. Since virtually all the nonlinearity caused by the emitter resistance of the transistors is eliminated, the chip's nonlinearity errors are less than 0.03% over a signal bandwidth in excess of 3 MHz.

Current-mode operation is set up by three high-speed differential input amplifiers so configured as to multiply two input currents, divide the result by a third input current, and output the result as a signal current. This design embodies the log-antilog principle that utilizes the logarithmic current-voltage transfer characteristic of the bipolar transistor.

Telecommunications has made its presence felt sharp-

ly in the device world this year, in the form of monolithic active filters, intended mainly for use with last year's ISSCC stars—codecs. In fact, integrated filters for telecommunications are the subject of a panel discussion chaired by P. R. Gray of the University of California at Berkeley. In addition, a number of people are turning a fairly well-known concept—the switched-capacitor filter—into a reality. A small capacitor when switched rapidly resembles a high-value resistor, allowing just capacitance ratios themselves and a check frequency to simulate very stable RC networks. The required switches can now be easily implemented with small MOS transistors, and signal voltages can be sensed with readily available FET input amplifiers fabricated in either n-MOS or C-MOS. All that remains is to put the ingredients on a single chip.

A switched-capacitor filter is at present a part of a two-chip pulse-code-modulated voice coder made by American Microsystems Inc. of Santa Clara, Calif. The circuit consists of a low-pass section of a fifth-order-elliptic ladder-simulation filter type, a novel high-pass state-variable section, and a low-pass elliptic type constructed from two third-order sections connected in tandem. The innovative high-pass section has a design based on the bilinear Z transformation, which unlike designs using analog modeling, does not distort the filter frequency response.

The chip is a combination of n-channel and C-MOS processing with thin-oxide polysilicon-to-metal capacitors fabricated in both. Operating off  $\pm 5$  V, the device can sample at a maximum rate of 128 kilohertz.

Another application for switched-capacitor filters is being tried by a newcomer to the field of telecommunications—Silicon Systems Inc. in Irvine, Calif. This custom house has fabricated a C-MOS LSI version of a dual-tone multifrequency (DTMF) receiver for Touch-tone telephones (see p. 105). As today's DTMF receivers carry too large a price tag to be used anywhere except in shared private branch exchanges and switching centers, this novel monolithic chip now affords the chance for service on a telephone-by-telephone basis.

### A color-TV imager

Some of the more exotic single-chip implementations of complex functions are to be found at the session on solid-state imaging and biomedical applications. Out of Hitachi's Central Research Laboratory comes a 484-by-384-element MOS imager intended for use in a color camera and exhibiting television-like resolution. The 484 rows are on 20- $\mu$ m centers and the 284 columns are on 34- $\mu$ m centers, yielding a horizontal resolution of 260 TV lines and a vertical resolution of 350 TV lines. The peripheral circuits consist of a vertical scanner with the interface circuit and a low-noise horizontal scanner using bootstrap capacitors. The device employs a 7.2-MHz horizontal clock rate.

In an effort to build a close-to-ideal transistor exhibiting both high emitter-to-collector breakdown voltages

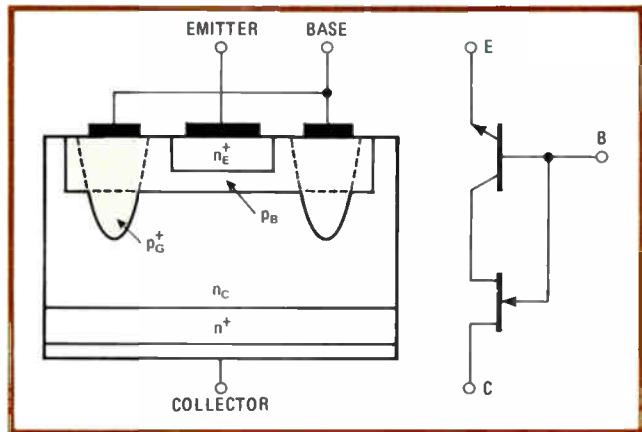

**5. Gate-associated transistor (GAT).** When the gate of a field-effect transistor is grafted onto the base of a standard bipolar device, it is possible to build a high-breakdown-voltage transistor with the narrow base essential for high-frequency performance.

and high cut-off frequencies, researchers at Mitsubishi Electric Corp.'s Semiconductor Laboratory in Japan have come up with a literally hybrid device—a field-effect transistor grafted onto the base of a standard bipolar transistor. The base region of the new device is divided so that part of it operates as an ordinary base and part is doped with a higher impurity concentration and projects into a collector region (Fig. 5). This latter part acts as the gate of a JFET in the off condition, giving the device its name—gate-associated transistor, or GAT.

The gates in the collector region punch through at a lower voltage than the base does. As in a triode vacuum tube, the base region is electrostatically shielded from the collector, but the lower electric field strength near the base-collector junction results in no appreciable charge between breakdown voltage and  $h_{fe}$ . The new structure clearly is useful for fabricating breakdown voltage transistors with a thin base, a necessity for high-frequency devices. GATs therefore succeed in combining cutoff frequencies of 380 MHz with breakdown voltages of 250 V, useful characteristics for high-power applications.

Impatt diodes are solid-state replacements for such bulky microwave power sources as traveling-wave tubes and magnetrons, but till now they have not succeeded in exhibiting pulsed peak powers of more than 20 W. Nippon Electric Co.'s Semiconductor division, however, has fabricated a diode capable of 50-W peak power output at a 10-GHz band. The device operates at an efficiency of 13% under excitation conditions of a 1- $\mu$ s pulse width with a 10% duty factor.

The diode is a ring of silicon with a p<sup>+</sup>-pn-n<sup>+</sup> vapor-epitaxially-grown double-drift region. The 20- $\mu$ m-thick wafer has titanium/platinum/gold film evaporated on both sides, is mounted on a diamond heat sink, and is hermetically sealed in a 3-mm-diameter ceramic package—quite a difference in size from the bulky magnetrons of the past. □

LH Research, the world's largest manufacturer of switching-regulated power supplies, introduces:

# Another MITE!



The *Little-MITE*™ LM-11

5 volt, 50 amp

\$299 SINGLE UNIT PRICE



Now LH Research offers the reserve power of a 5 volt, 50 amp switcher for only a few dollars more than most 5 volt, 30 amp units. And that's only the beginning. There's a whole line of medium power, convection cooled (250-600 watt) Little-MITE switchers, with single or multiple outputs.\*

## DC Input Too!

For dc input applications, LH Research offers the Dyna-MITE™ Series, again in the 250-500 watt range, with single or multiple outputs. Still don't see what you want? Check the chart at the right. Better yet, send for a free switcher selection guide. Nobody markets a broader line of switchers than LH Research.

\*\$299 price refers to LM-11 only.

The LH Research line of switchers

POWER RANGE	SERIES DESIGNATION	OUTPUTS	COOLING	SPECIAL FEATURES
100-175 watts	Tiny-MITE	1 - 4	convection	open frame; UL-recognized
250-600 watts	Little-MITE	1 - 4	convection	new product; UL-recognized
250-500 watts	Dyna-MITE	1 - 4	convection	dc-input
375-750 watts	Mighty-MITE	1 - 7	fan	UL and CSA recognized
750-1000 watts	Super-MITE	1 - 4	fan	UL-pending
250-1500 watts	LH Series	1 - 4	fan and convection	As low as 63¢/watt



LH RESEARCH, INC.  
1821 Langley Avenue  
Irvine, CA 92714  
(714) 546-5279  
TWX 910-595-2540



# C-MOS a-d converter surges to bipolar speed on sapphire substrate

by Daryl T. Butcher, *Electronics Research Center, Rockwell International Corp., Anaheim, Calif.*

□ When monolithic analog-to-digital converters make use of conventional complementary-metal-oxide-semiconductor technology, they can resolve 12 bits—but only at the slow speed characteristic of C-MOS. Silicon on sapphire, though, is one form of MOS technology that equals or exceeds the high performance of bipolar large-scale integration.

The C-MOS-on-sapphire a-d converter shown in Fig. 1 promises to outdo converters processed in integrated injection logic and other advanced bipolar linear and digital circuits. Yet it retains the low power consumption and excellent analog switching capability of C-MOS. For a 12-bit conversion at 5-megahertz speed, it consumes only 15 milliwatts.

Basic to such a fast successive-approximation a-d converter is a fast comparator. To build a comparator that would extract all the speed and power advantages possible from using a sapphire substrate, it was first necessary to characterize and develop MOS transistors on sapphire that performed comparably with bipolar devices. This and the rest of the work on the converter were carried out at Rockwell International Corp.'s Electronics Research Center under a program funded by the military since 1975.

## The pros and cons of sapphire

From the outset, it was clear that the construction of MOS transistors on an insulating sapphire substrate results in mixed blessings.

On the one hand, parasitic capacitances are greatly reduced, so that the devices attain very high switching speeds. Also, the complete device isolation eliminates body effects and simplifies the design and construction of circuits that require transistor sources to operate at potentials other than the power supply voltages. On the other hand, the dielectric isolation not only creates island edge effects and adds a second insulator interface at the back of the transistor, but it also introduces the "kink" phenomenon (Fig. 2).

This phenomenon is a nonlinear transfer characteristic caused by leakage and drain-to-body avalanche currents. When the leakage and/or currents modulate the body voltage in an SOS n-channel device, they cause a rapid increase in output conductance for drain voltages between 4 and 8 volts. The high drain conductance results in a low voltage gain for the device. The voltage

gain factor for typical devices ( $\mu$  in vacuum tube terminology) is limited to less than 50.

Another drawback of SOS devices is that extremely large chip areas are required to achieve even moderate transconductances—hundreds of micromhos. Simple resistive-loaded gain stages are therefore limited to gains of less than 100 (for usable bandwidths). Active-load gain stages also appear useless because of the unfavorable output impedances for both n and p devices.

Finally, when manufactured with MOS technology, the

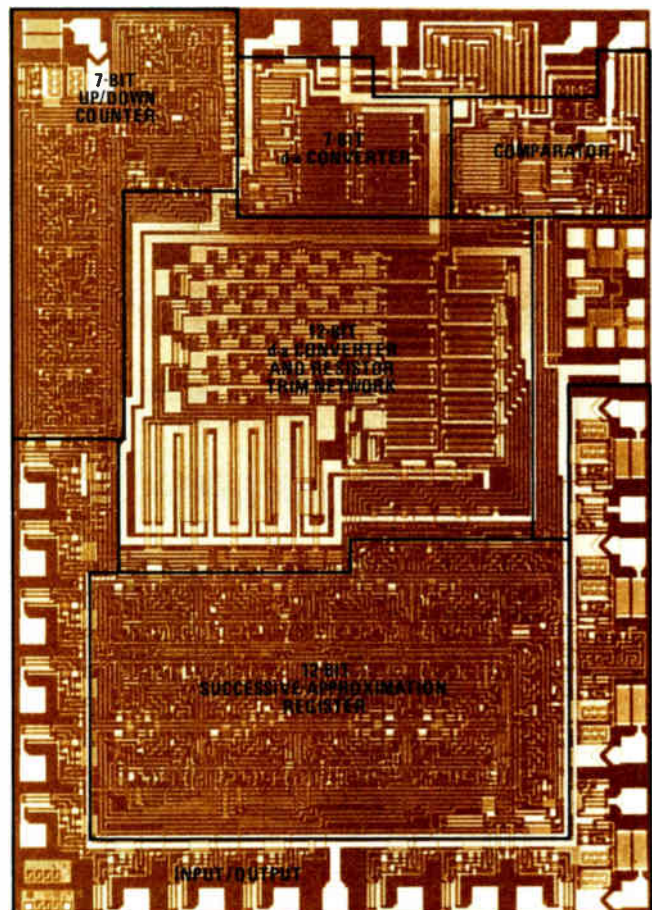

**1. High density.** C-MOS-on-sapphire 12-bit a-d converter occupies 115-by-150 mil chip. The on-chip comparator, the offset voltage correction circuit, and the precision chrome-silicon resistor network between them ensure the device's 12-bit performance.

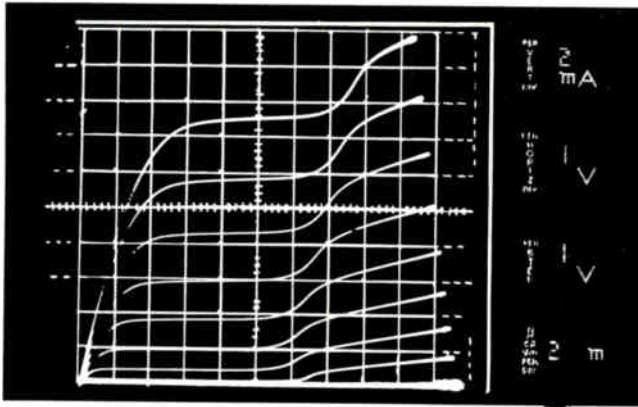

**2. "Kink" phenomenon.** Caused by leakage and drain-to-body avalanche circuits ( $I_{DB}$ ) that modulate the body voltage in SOS n-channel devices, the kink is a highly nonlinear transfer characteristic. Output conductance increases rapidly between 4 and 8 V.

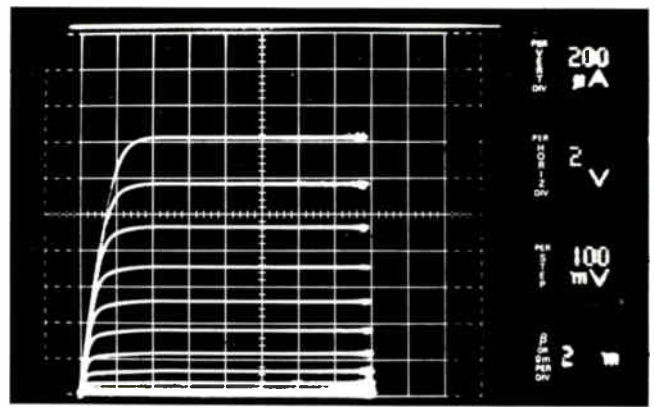

**4. Negligible kinks.** The kink phenomenon is defeated by using a composite amplifier stage whose transconductance is determined by an enhancement-mode device with a relatively short channel length. The stage can achieve a  $\mu$  of  $> 10,000$ .

matched differential amplifier pairs that are fundamental to comparator functioning have in general poor noise characteristics and also high offset voltages, in the region of tens of millivolts. In both respects they are much inferior both to junction field-effect and to bipolar transistors and become still worse when they are fabricated on a sapphire substrate.

### Revival of the tetrode

To develop a useful MOS-on-sapphire amplifier and hence comparator, a circuit concept from vacuum-tube days was revived. This structure (Fig. 3) defeats the kink phenomenon and produces an amplifier with very high output impedance (Fig. 4). When complementary tetrode devices are used as the double-to-single-ended stage of a differential operational amplifier, a node impedance of greater than  $10^8$  ohms and a voltage gain in excess of 80 decibels are obtained. Also, a single-pole amplifier built in this way achieves the exceptional gain-bandwidth performance indicated in Fig. 5.

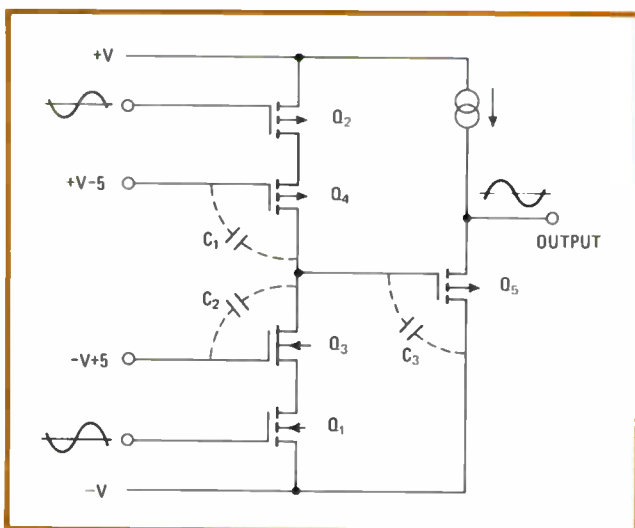

**3. Complementary tetrode amplifier.** The high-gain SOS amplifier converts in-phase voltage signals into push-pull currents in the  $Q_1$ ,  $Q_3$  and  $Q_2$ ,  $Q_4$  stages. A  $10^8$ -ohm impedance at the  $Q_2$  and  $Q_4$  drains yields an 80-dB-plus voltage gain.  $Q_5$  is used as an output buffer.

The amplifier's bandwidth is determined by gate overlap capacitances  $C_1$ ,  $C_2$ , and  $C_3$ . (No separate outside capacitor is needed to stabilize the device.) A metal-gate process yields a high-performance amplifier but, to minimize the overlap capacitance and thus maximize gain-bandwidth performance, a self-aligned silicon-gate construction was preferred. The level of performance thus achieved requires a power dissipation of 5 to 10 mw, which turns out to be the greater part of the converter's power consumption.

### A high slew rate

The amplifier slew rate is also outstanding: 50 volts per microsecond is achieved when source-follower transistors with a relatively large (high-capacitance) output are used. When the amplifier design is modified for implementation with silicon-gate devices and smaller output devices are used, a maximum slew rate of approximately 5,000  $v/\mu s$  is theoretically possible.

In an actual a-d converter, the slow rate has to be very

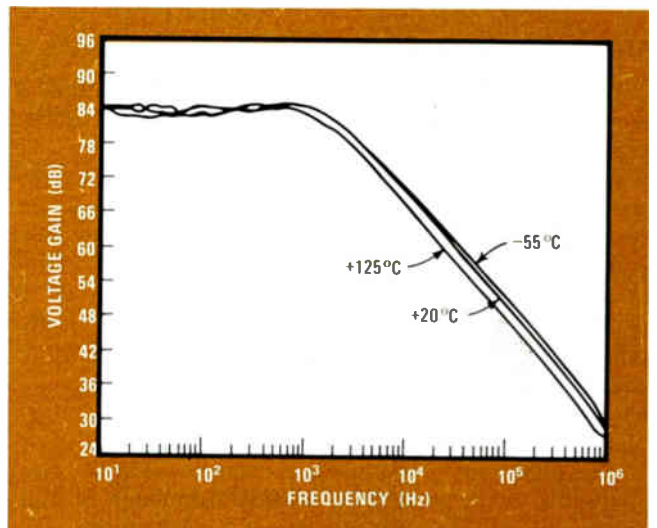

**5. High gain-bandwidth.** The complementary tetrode amplifier structure makes possible a single-pole amplifier, which achieves the unusually good gain-bandwidth product shown here. The bandwidth is determined by the overlap capacitances shown in Fig. 3.

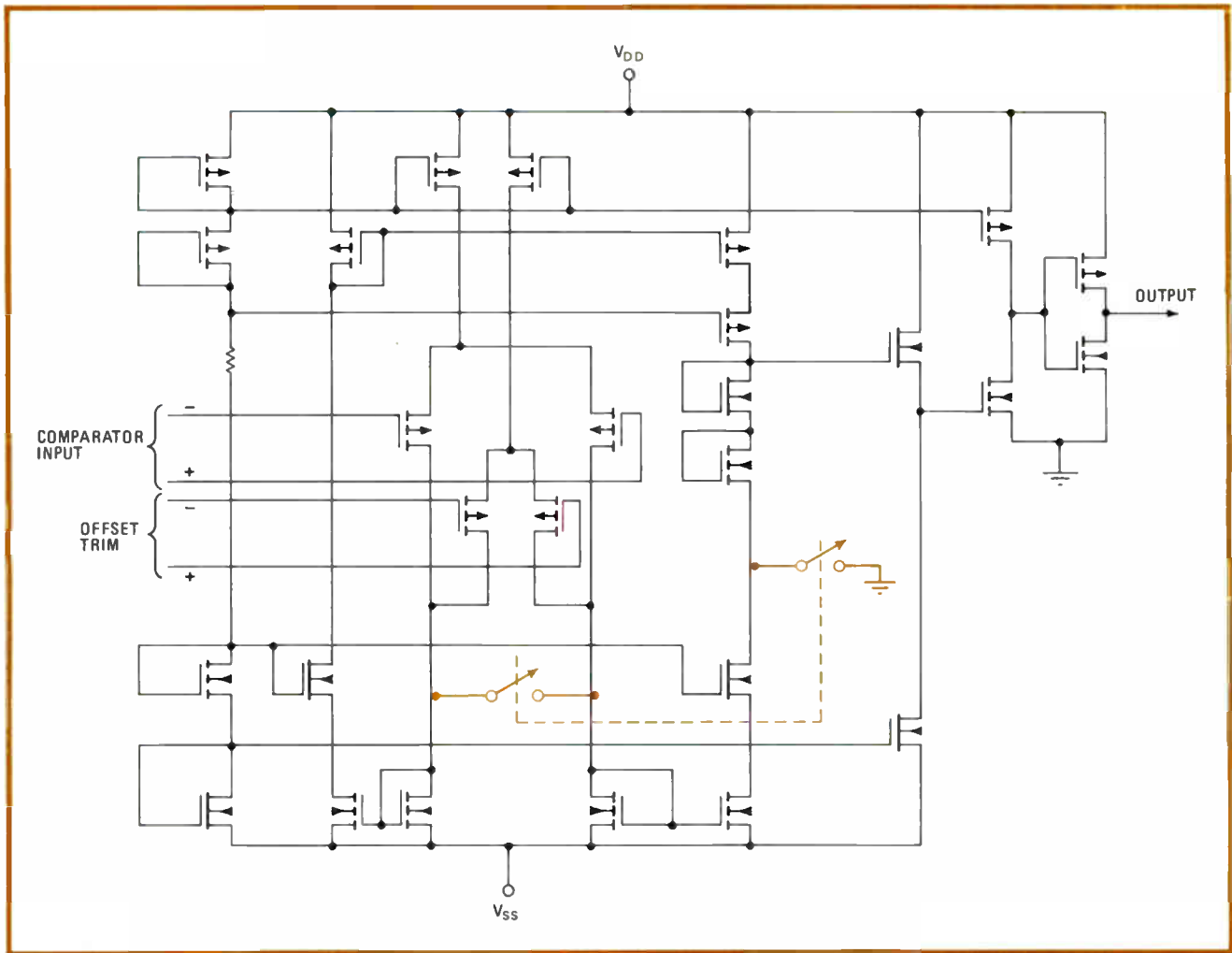

**6. Operating details.** Comparator uses dual-differential input stage and current mirrors to supply input signals to a complementary output stage. Critical nodes shorted to their nominal operating points allow excessive voltage excursions only when a comparator decision occurs.

responsive under small-signal conditions. This design resolves a 1-mV input differential in 50 nanoseconds—amply fast enough for a very high-performance a-d converter. In combination with the low power dissipation of 5 to 10 mW, this speed gives the device speed-power performance much superior to any previously available.

#### Also to be considered

But unusually good bandwidth and slew rate are not sufficient for superior comparator performance. Overload recovery must also be minimized. In the silicon-on-sapphire technology, junction storage is not a problem, since the isolated majority-carrier transistors have negligibly small charge-storage times; however, electrical voltage excursions must be limited to minimize charge/discharge recovery periods. In the comparator used for the 12-bit converter, these effects are eliminated altogether by shorting critical nodes to their nominal operating points during the major portion of each clock cycle, thus allowing excursions from these conditions only during the brief period when a comparator decision is required (Fig. 6).

The a-d design problem, then, becomes tolerable when a high-speed comparator is available. However, several

other obstacles must be overcome. The comparator offset voltage must be reduced to a fraction of the signal weight of the least significant bit. In addition, a method must be established for generating successive-approximation signals.

Several advances have recently been made in weighted-capacitor or charge-equalization conversion. But SOS technology, suffering as it does from relatively high device leakage, is not readily adaptable to this approach. So it seemed preferable to use a conventional Kelvin resistor network to add up the binary-weighted voltages of successive approximation.

#### The resistor network

This decision nevertheless created new design challenges. Resistors are more difficult to produce with high relative accuracy than capacitors. Further, resistor as well as transistor temperature coefficients must be accommodated by the design. Since diffused silicon resistors typically exhibit poor temperature stability for a full 12-bit conversion, a chrome-silicon resistor process was chosen that has a typical temperature coefficient of resistance of 30 parts per million per °C. The resistors are trimmed employing laser burnout of metal links.

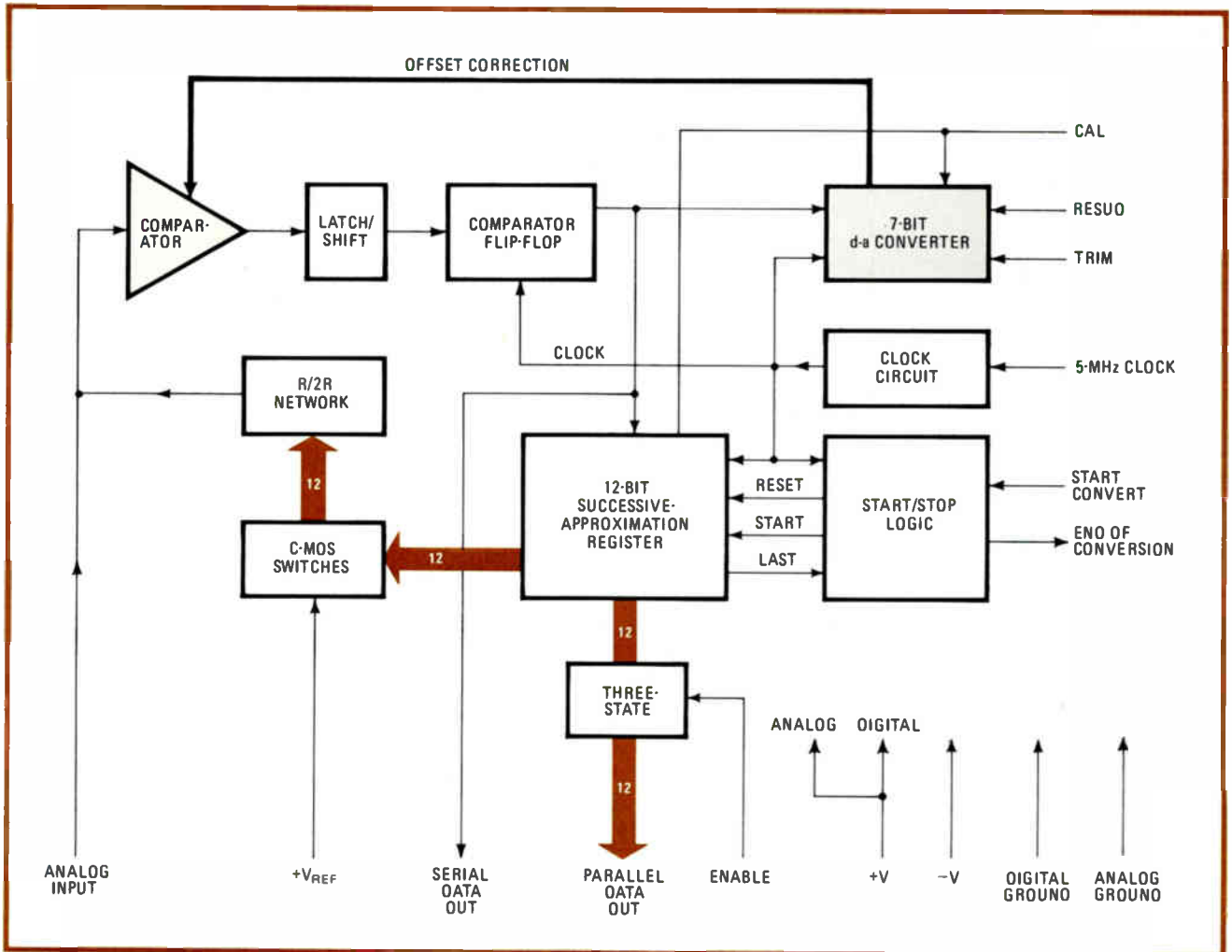

**7. The system.** The complete 12-bit a-d converter is organized conventionally, except for the incorporation of a 7-bit d-a converter for on-line offset voltage correction. The only functions not supplied on chip are clock input, reference voltage, and certain control signals.

Micropads incorporated in the resistor network enable the trimming to be performed during fabrication.

The a-d converter clock diagram is shown in Fig. 7. The organization is conventional, except for the use of a 7-bit d-a converter for offset voltage correction.

### Offsetting offset

Offset voltage adjustment had to be effective over the military temperature range ( $-55^{\circ}$  to  $125^{\circ}\text{C}$ ) and even over radiation environments, so that an initial trim is not sufficient. Since the on-chip 7-bit d-a converter tracks continuous changes in offset voltage, the 12-bit converter's offset voltage can undergo dynamic correction over a range wide enough to cope with such offset-voltage-varying environments as boost-ballistic, reentry or satellite radiation.

Furthermore, an additional system benefit is afforded by the offset-correction circuitry because it rids the comparator of  $1/f$  noise (which may be viewed as an instantaneous offset voltage). The offset-correction d-a converter can be set to midrange, allowed to track the offset voltage continuously, or allowed to update the offset correction following each conversion period (the modes are controlled through the CAL, RESUD and TRIM

inputs of Fig. 7). The last mode of operation requires one additional clock cycle per conversion.

The device requires a clock input, control signals for conversion and data output, and a reference voltage. These functions were not supplied on chip because initial systems applications required synchronous and ratiometric operation using several converters and a common clock and reference. Here, also, the use of a common reference is helpful in keeping system power requirements to a minimum.

### The results

Initial devices have demonstrated performance levels very near the converter design objectives. These included a conversion speed of  $2.5\ \mu\text{s}$  for a 12-bit precision conversion, observed from the very first process wafer. The 15-mw average power dissipation was maintained despite the use of on-board offset voltage correction and other logic circuits. The converter operates off  $\pm 10\ \text{V}$  and accepts input signals of a 0-to-10-V range.

The initial design is slated for use in a high-performance developmental satellite system. Commercial realization of C-MOS-on-sapphire a-d converters is not planned by Rockwell at this time.  $\square$

# The last time you saw a really new bench/portable DMM was 1972.

That's the year our 8000A was introduced. Its custom LSI and solid owner benefits quickly established it as the world's leading DMM.

Now, look at the new 8010A and 8012A: single-chip CMOS designs for problem-solving in the eighties!

**RAZOR-SHARP LCD** for large, no-strain answers at first glance—in any light.

**TOUCH AND HOLD** probe option, so you can thread your way through a component jungle and capture the reading you need.

**FUNCTION POWER:** 22 ranges of AC and DC volts and current, six ranges of resistance, and three ranges of conductance — the missing function on other bench multimeters.

**CONDUCTANCE RANGES** for noise-free leakage measurements to 10,000 M $\Omega$ . A valuable function for bench-testing boards and components, conductance also measures transistor beta (using a bias resistor) and light intensity (by using a photocell).

**OVERLOAD-PROTECTED** — like no other DMM, including rejection of 6000V transients and up to 600V applied to the current terminals.

**HONEST AC ANSWERS** derived from a Fluke hybrid true rms converter. You'll even see the difference on your AC line between the correct value and what your average-responding meter reads. And 50 kHz bandwidth won't let any significant distortion products go unmeasured. Plus, 10 times the basic response you may be limited to now!

**SPECS YOU EXPECT** from Fluke — like  $\pm 0.1\%$  on DC for one year. Both models available with rechargeable batteries, and backed by the same solid warranty and worldwide service that helped make the 8000A the industry standard.

**LEADERSHIP HAS TO BE EARNED.** And we're committed to keeping the price of your confidence as realistic as possible. Like \$239 for the 8010A with a 10A current range, and \$299 for the 8012A with two extra-low ohms ranges that allow measurements from 0.001 $\Omega$  to 10,000 M $\Omega$  — making it the widest range ohmmeter available!

Contact one of the more than 100 Fluke offices and representatives, worldwide, or CALL (800) 426-0361\* TOLL FREE. In the U.S., and all countries outside Europe, write: John Fluke Mfg. Co., Inc., P.O. Box 43210, Mountlake Terrace, WA 98043, U.S.A.

In Europe, contact Fluke (Nederland) B.V., P.O. Box 5053, Tilburg, The Netherlands. Telephone: (013) 673973. Telex: 52237.

Prices U.S. only.

\*Alaska, Hawaii, Washington residents — please call (206) 774-2481.



2502-8010

# For value in frequency counters, count on us.



You won't be disappointed. Because CSC offers more range, more accuracy, more versatility than anyone else . . . at lower prices. Choose from three portable, easy-reading counters and a compact, range-extending prescaler!

Our calculator-sized MAX-550 is the top of the line, with continuous readings from 1000 Hz up to a *guaranteed 550 MHz* and above. Measure AM, FM digital or video signals with this 6-digit, audio-to-UHF know-it-all. No switching or adjusting of polarity, slope, trigger or input level, either. Just turn it on and feed in signal. Only \$149.95\*

Our MAX-100 looks and performs like an expensive instrument. But it's not . . . even though it measures continuously from 20 Hz past a guaranteed 100 MHz, with 8-digit accuracy and 1 Hz resolution. With its high sensitivity, and big .6" LED display, MAX-100 is ideal for a wide range of audio, ultrasonic, RF, video and digital applications. Especially at a modest \$134.95\*

Our MAX-50 may be mini in size, but it offers maximum value. Bringing down measurement costs for CB-ers, hams, computer enthusiasts and audiophiles. Completely automatic, MAX-50 accurately measures signals from 100 Hz to above a *guaranteed 50 MHz*. An outstanding value at only \$89.95\*

Our compact PS-500 Prescaler extends the capabilities of any 50/100 MHz counter from 50 to 500 MHz and beyond. The perfect companion to MAX-50 and MAX-100, it has a 400 mV output, to drive less sensitive counters. Modestly priced at \$59.95\*

When it comes to frequency measurement, we've got you covered. In range. Accuracy. And versatility—with a broad family of accessories from antennas and input connectors to AC and car-battery adaptors.

CSC. Capability you can count on . . . at a price you can afford.

**NEED MORE INFORMATION? CALL TOLL-FREE 800-243-6077** to order, or for the name of your local distributor. Prices slightly higher outside U.S.A.

© 1978, Continental Specialties Corporation. Prices, specifications subject to change without notice.

\*Manufacturer's suggested list.

Corporate Headquarters:  
Continental Specialties Corporation  
70 Fulton Terr., Box 1942, New Haven, CT 06509  
351 California St., San Francisco, CA 94104  
(415) 421-8872, TWX 910-372-7992

CONTINENTAL SPECIALTIES CORPORATION



Europe, Africa, Mid-East: CSC UK LTD.  
Shire Hill Industrial Estate, Units 1 and 2  
Saffron Walden, Essex CB 11 3AQ  
Telephone Number: SAFFRON WALDEN 21682  
TLX 817477

# 64-K dynamic RAM has pin that refreshes

Single signal controls automatic- and self-refresh modes;  
design simplifies peripheral circuitry, needs only +5 V

by David C. Ford, Dick Brunner, and Jerry Moench, *Motorola Semiconductor Products Division, Austin, Texas*

□ A tough competitor is joining what promises to be a crowded field for the 64-K dynamic random-access-memory race: the MCM6664. Besides storing 65,536 bits of information in a standard 16-pin package, this RAM's strengths include a fast access time and low power consumption from a single +5-volt supply (Table 1). What will really make this part stand out in a crowd is the refresh control function available on pin 1. This feature provides automatic- and self-refresh modes in addition to the  $\overline{\text{RAS}}$ -only mode found in other dynamic memories, in which the row-address strobe (RAS) and refresh addresses must be applied to the chip.

Putting the row-address counter and associated logic circuitry on chip means that fewer peripheral chips are required in MCM6664-based systems. A single signal will initiate either of the new refresh modes, depending on the length of time it is applied.

Advances in integrated-circuit design have gotten rid of the need for the -5- and +12-v potential. One of these spare pins is dedicated to the extra address line that the 64-K RAM needs over 16-K parts, and the other is used for the refresh control signal.

This concept makes system design with cost-effective dynamic RAMs almost as easy as with static parts. Now high-density dynamic memories can be designed into

systems without the worry of tracking memory locations to be refreshed, generating the correct addresses, or supplying row-address strobes for refresh operations.

The MCM6664 is fabricated with n-channel silicon-gate technology using Motorola's H-MOS, a high-performance, metal-oxide-semiconductor process under development since late 1975. H-MOS is largely responsible for the move to single-supply operation by virtue of the reduced operating voltages required by its high-gain, short-channel-length transistors. The smaller transistors also are responsible for a reduction in capacitance and a subsequent increase in speed, which further gives rise to an enhanced speed-power product.

## Better bias

The chip also contains a special substrate-bias generator. Traditional substrate-bias generators are free-running; the voltage generated varies in accordance with read/write operations. The MCM6664 has a regulated bias generator using noise-equalization capacitors to produce a more consistent negative potential.

Although substrate bias is not required in a RAM design, it does prevent negative system transients of up to -1.5 V from destroying information stored in the memory. The negative bias also decreases the junction

TABLE 1: THE MCM6664 64-K RAM AT A GLANCE

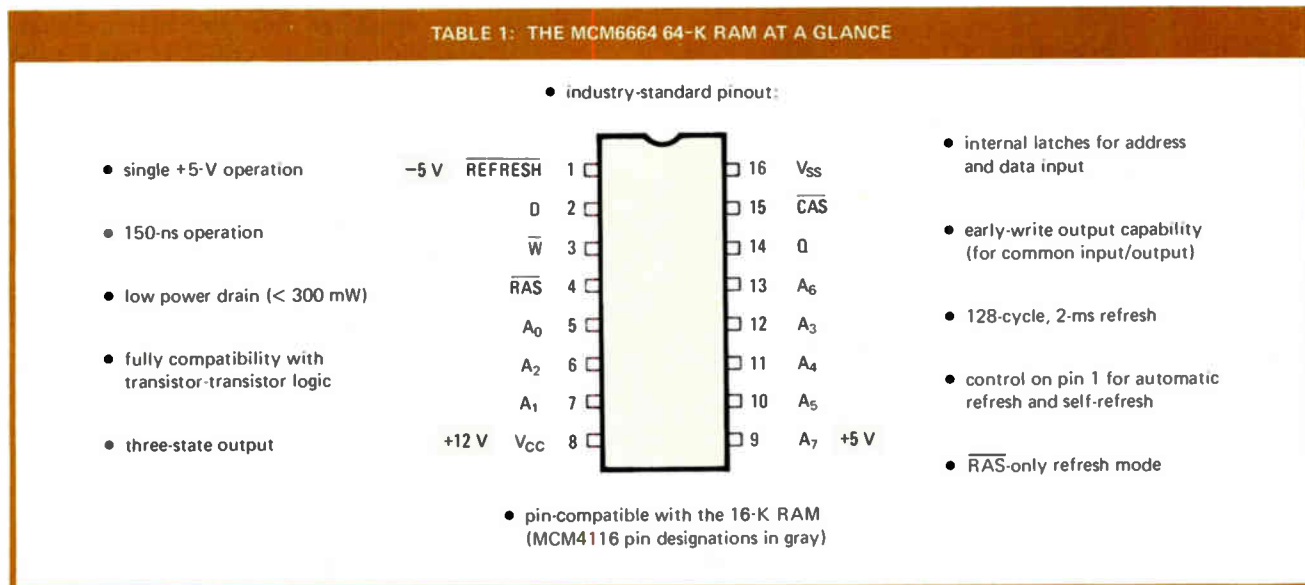

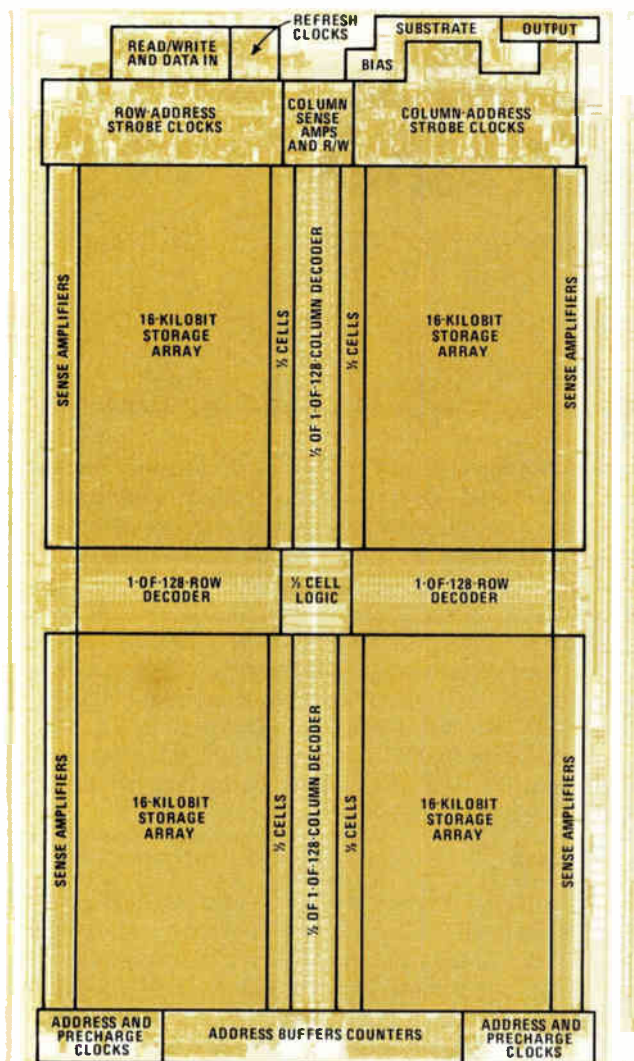

1. Die. The MCM6664, Motorola's 64-K dynamic RAM, has four memory arrays, each 128 bits square, with a resulting 128-cycle, 2-ms refresh period. The chip uses high-performance MOS technology, which is largely responsible for its +5-V-only operation.

capacitance, and since much of the device's power dissipation is the product of capacitance and voltage, the overall active power consumption drops when a substrate-bias generator is used.

### Layout

Figure 1 shows the functional sections of the MCM6664 and represents their approximate position on the die. The RAM was designed with conservative dimensions to enhance producibility. The die, which measures 145 by 260 mils, uses 3-to-4-micrometer geometries and projection printing on all levels to reduce defect densities and improve uniformity.

A total of 512 sense amplifiers are on the chip for a 128-cycle, 2-millisecond refresh period. The sense amps are precisely matched, both topographically and electrically, to allow for variations in alignment and device characteristics.

An easier approach would have been to halve the

number of sense amplifiers, potentially reducing the power dissipation, and perform a 256-cycle, 4-ms refresh. This would yield the same refresh overhead. However, 128 cycles is the same refresh scheme that 16-K RAMs use, which makes substitution easier. Moreover, the MCM6664's approach provides better noise immunity. The signal-to-noise ratio is greater because of the higher-level signals allowed by the shorter refresh time and because each 16-kilobit block of memory has its own bank of sense amplifiers.

Improved noise immunity also stems from the electrical isolation of the sense amplifiers from the bit-sense lines before signals present on the lines are detected. This isolation yields better sensitivity, or noise immunity, because charge is not stolen from the bit lines (see "Folded bit-sense lines reduce alpha errors," p. 143).

Another bonus is that no active dc restoration is needed in the refreshing process. By eliminating the current required to restore the dc levels, the power dissipation by the 512 sense amps is less than required in designs using 256 sense amps with dc-restore schemes. In short, the MCM6664 has all the benefits of 128-cycle refresh without an increase in power consumption.

The net effect of all these techniques is that the maximum active power of the part is roughly half that of 16-K chips. Power dissipation heightens junction temperatures, and this accelerates failure rates. Therefore a reduction in power requirements results in improved reliability for the 64-K RAM.

### A refreshing idea

The increase in silicon area required to implement the two additional refresh modes is just 3 mils on the long side. Thus the 145-by-260-mil chip is only 1.5% larger than it would be without refresh control. What's more, the current consumption of the new refresh circuitry is only 0.8 milliamperes, representing a power increase of less than 5 milliwatts.

Automatic refresh is used during standard operation just like  $\overline{\text{RAS}}$ -only refresh, except that sequential row addresses from an external counter are no longer necessary. In fact, the MCM6664's refresh control circuitry also supplants the need for row- or column-address strobes, address counters, or any critically timed pulse during automatic operation.

The automatic refresh cycle is initiated by bringing refresh low after  $\overline{\text{RAS}}$  has precharged (Fig. 2). The time between the two edges is  $t_{d(\text{RAS})}$ . Shortly after the refresh cycle begins, an internal row-address strobe fires an on-chip row-address counter that presents the next set of 128 row addresses to the memory matrix. For maximum reliability, this counter is refreshed during every memory cycle. The refresh signal can be inactivated (pulled high) after a time period  $t_{w(\text{REF})}$ .

Self-refresh is primarily intended for trouble-free power-down operation. For example, when battery backup is used to maintain data integrity in the memory, pin 1 may be used to place the device in the self-refresh mode with no external timing signals necessary to keep the information alive.

Timing for self-refresh is quite similar to that for automatic refresh (Fig. 2b). The  $\overline{\text{RAS}}$  line is brought



## Folded bit-sense lines reduce alpha errors

The MCM6664 uses a folded bit-sense line to subdue a problem common with open bit-line approaches: noise. With an open bit-line scheme (part a of the figure), noise injected on either of the open nodes is not balanced, which may lead to an error in charge detection. Folded bit lines are only 9 micrometers apart (part b), so that the common-mode noise cancels itself. The configuration also eliminates conductor patterns atop the column decoders, which cuts the capacitance of the bit-sense lines.

The folded bit-sense lines also play a key role in minimizing errors induced by alpha radiation [Electronics, June 8, 1978, p. 42]. Maintaining relatively high levels of stored charge in memory cells and improving the sensitivity of the sense amplifiers is one way that the MCM6664 reduces

the effect of alpha radiation. However, storage-well filling is only one alpha radiation phenomenon. A diffused bit-sense line can sustain an alpha hit with the same result as when a storage well is hit. In fact, an  $n^+$  (highly doped) bit line appears to be even a better collector of alpha-generated charge carriers than are storage cells.

Since the area of the bit-sense line is greater than the area of a storage cell, a good design must consider methods to reduce these effects. The MCM6664 substantially reduces its susceptibility to alpha radiation by using a metal overlay sense line, which dramatically reduces the exposed  $n^+$  area of the bit line. An alpha hit on a metal line will not cause the collection of charge from electron-hole pairs as it will in a diffused bit-sense line.

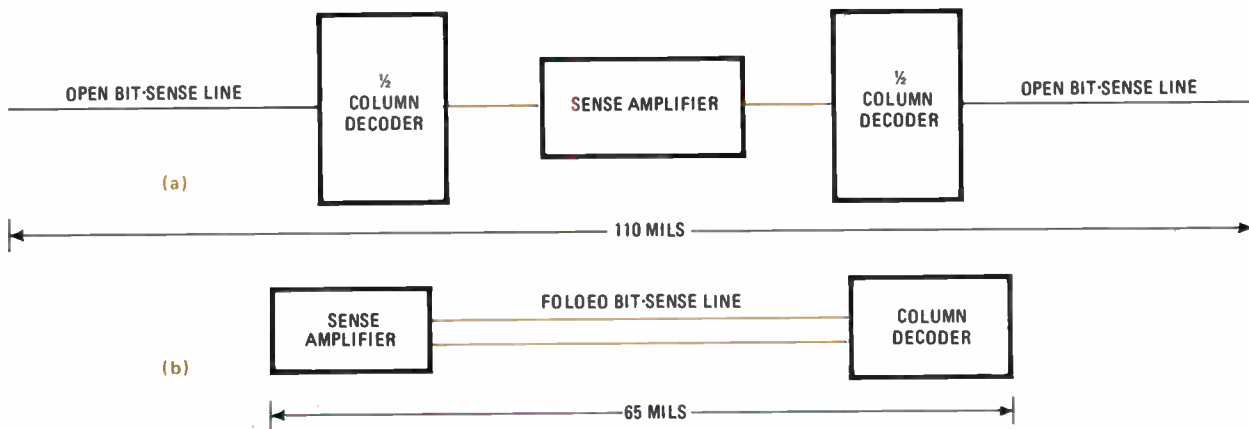

high (or left high), and after the regular precharge time,  $t_d(\text{RAS})$ , the refresh control line can be brought low. Once again, this starts an internal refresh interval, and the MCM6664 provides its own row-address, strobe and refresh-location count.

As long as  $\overline{\text{RAS}}$  remains high and refresh remains low, the RAM will refresh itself. This internal sequence repeats asynchronously every 12 to 16  $\mu\text{s}$ . After 2 ms, the on-chip refresh-location counter has advanced through all the row addresses and refreshed the entire memory. This can continue until a regular memory cycle is desired. Since it is possible that a self-refresh cycle just started, a delay of one cycle time is necessary to guarantee valid data in the next memory cycle.

The MCM6664 offers complete compatibility with systems designed for  $\overline{\text{RAS}}$ -only refresh, which became the industry standard with 4-K and 16-K dynamic RAMs. That is, it allows 128-cycle,  $\overline{\text{RAS}}$ -only refresh exactly as it is performed in the 4116 16-K dynamic RAM. As with the 4116,  $A_0$ - $A_6$  are used during refresh. The new address line,  $A_7$ , is not employed for refresh, so no modification to refresh circuitry is necessary to drop the 64-K chip into existing systems. Figure 2c shows the timing for  $\overline{\text{RAS}}$ -only refresh.

The MCM6664's design allows the  $\overline{\text{CAS}}$ , data-in, write, and address lines to change without affecting the refresh cycle. Thus one portion of the system memory may be refreshed while typical read/write operations are occurring elsewhere. Moreover, internal lock-out circuits

guarantee fail-safe operation. The refresh control and the row- and column-address strobes (CAS) work together to provide the internal refreshing and a three-state output control (Fig. 3).

After a refresh request, the RAM responds immediately, thus avoiding the problem of having to look ahead an additional cycle, common with other schemes. Moreover, output data remains valid for use by the central processing unit because of the three-state output control. The  $\overline{\text{CAS}}$  signal controls the output during refresh or regular memory cycles regardless of other inputs. If  $\overline{\text{CAS}}$  is low, the output remains valid. As soon as a floating output is desired (even during the middle of refresh),  $\overline{\text{CAS}}$  goes high and the output goes to its high-impedance state.

### Output control

The three-state control circuitry can place the output in the high-impedance state during an early write cycle. In such a cycle, the write line ( $\overline{\text{W}}$ ) is pulled low before  $\overline{\text{CAS}}$  to facilitate common input/output operation.

But the key to the MCM6664's output flexibility is in the independent  $\overline{\text{CAS}}$  control. If  $\overline{\text{CAS}}$  is high, the output goes to the high-impedance state regardless of other input conditions or what memory cycle the memory is in at the time. For example, if previous output data needs to be cleared to prepare for a read operation or if a write operation needs to be set up in a system with common I/O,  $\overline{\text{CAS}}$  is simply brought high and the output floats.

The internal CAS line of Fig. 3 always takes the

(a) AUTOMATIC REFRESH<sup>1</sup>

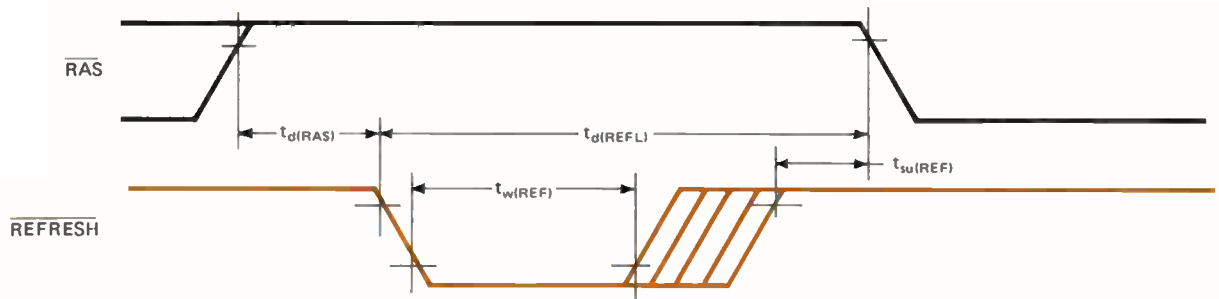

Parameter	Symbol	Minimum	Maximum
Refresh-low delay time before beginning of next cycle	$t_{d(REFL)}$	290 ns	—
Refresh-low duration time	$t_{w(REF)}$	60 ns	8 $\mu$ s
Refresh-high setup time before next memory cycle	$t_{su(REF)}$	20 ns	—
$\overline{RAS}$ -high-to-refresh-low delay ( $\overline{RAS}$ precharge time)	$t_{d(RAS)}$	60 ns	—

(b) SELF-REFRESH<sup>1</sup>

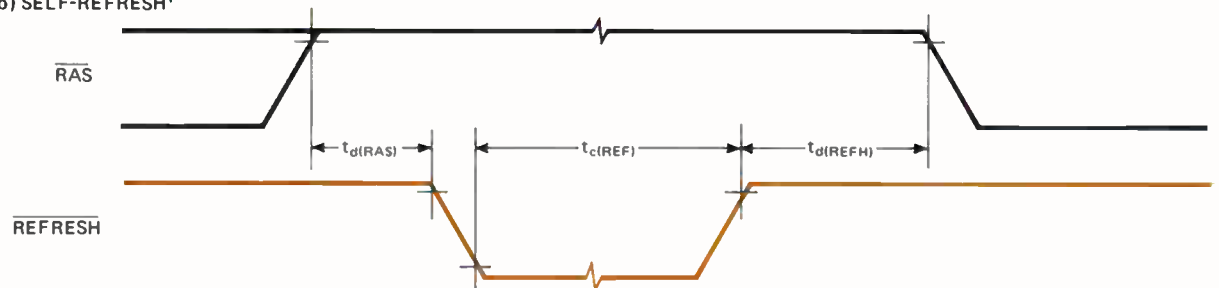

Parameter	Symbol	Minimum	Maximum
Self-refresh cycle time (entire memory refreshed every 2 ms)	$t_{c(REF)}$	16 $\mu$ s	—
Refresh-high delay time before a new memory cycle may begin	$t_{d(REFH)}$	250 ns	—
$\overline{RAS}$ -high-to-refresh-low delay ( $\overline{RAS}$ precharge time)	$t_{d(RAS)}$	60 ns	—

(c)  $\overline{RAS}$ -ONLY REFRESH<sup>2</sup>

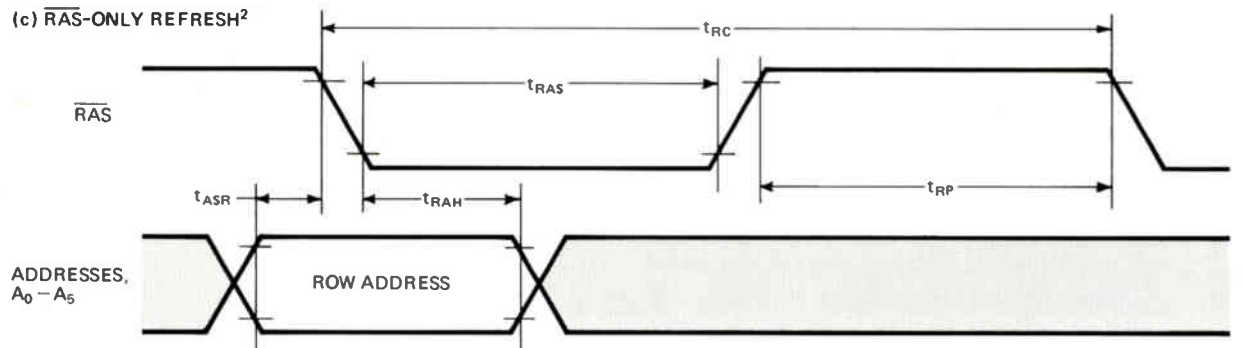

Parameter	Symbol	Minimum	Maximum
Random read or write cycle time	$t_{RC}$	250 ns	—
Row-address-strobe pulse width	$t_{RAS}$	150 ns	—
Row-address-strobe precharge time	$t_{RP}$	60 ns	—
Row-address setup time	$t_{ASR}$	0 ns	—
Row-address hold time	$t_{RAH}$	15 ns	—

1. Addresses, data in, and write ( $\overline{W}$ ) are "don't care".  $\overline{CAS}$  controls the output data. If it remains low, the previous output will remain valid. If it is brought high, the output will assume a high-impedance state.  
 2. Data in and write are "don't care";  $\overline{CAS}$  is high.

**2. Refresh timing.** The MCM6664 has two new refresh modes: automatic (a) and self refresh (b) in addition to  $\overline{RAS}$ -only (c). Automatic refresh removes the need for critically timed signals during typical operation. The self-refresh mode makes power-down a snap.

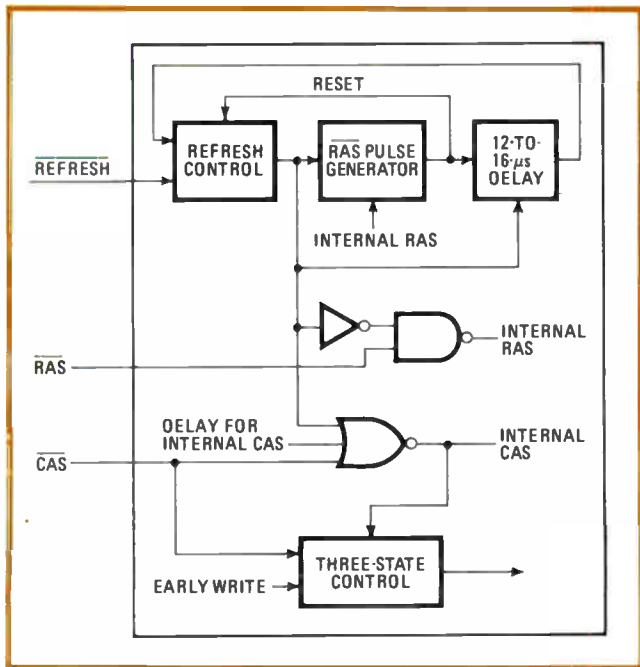

**3. Control.** The refresh control and the row- and column-address strobes work together for refreshing and output control. If  $\overline{\text{CAS}}$  is high, the output goes into the high-impedance state regardless of other input conditions or memory-cycle type.

TABLE 2: OUTPUT BUFFER TRUTH TABLE

Early write	$\overline{\text{CAS}}$	Refresh control (internal CAS)		Output buffer
high	—	—	(—)	high impedance
—	high	—	(—)	high impedance
low	low	low	(high)	maintains previous data
low	low	high	(low)	active

opposite state of the refresh control (Table 2). During a refresh cycle, the output maintains the previous data as long as the external  $\overline{\text{CAS}}$  line is held low. When that line is brought high, the data is cleared and the output is returned to the high-impedance state.

During a regular memory cycle, the data at the addressed location becomes the output level. This is the case when all inputs to the three-input NOR gate in Fig. 3 are low.

### System refresh

When it comes to putting the MCM6664 into systems, the chip's design eliminates the need for much peripheral circuitry, such as a row-address counter. It also radically simplifies the refresh role of the memory controller.

To meet interface requirements, 16-K dynamic RAMs may use a special address-interface circuit, like the 3242, that contains an address multiplexer and refresh address counter (Fig. 4a). At present, there is no similar interface part for 64-K RAMs.

Although these special interface parts simplify memory controller design, they have two fundamental disadvantages. First, they are not universally available (unlike standard transistor-transistor-logic components); second, they are relatively expensive.

Fortunately, the MCM6664 does not require special address interfaces. In fact, for systems with 128 kilobytes or less, all that is required are two standard TTL 8-bit latches (the 74S373s in Fig. 4b).

In systems where the refresh- and CPU-cycle requests are asynchronous, the memory controller requires a settling time. In other words, it needs time to determine which type of cycle to execute when both a refresh and CPU cycle are requested concurrently. If the controller finds that a refresh cycle is to be executed, additional settling time is required with conventionally refreshed

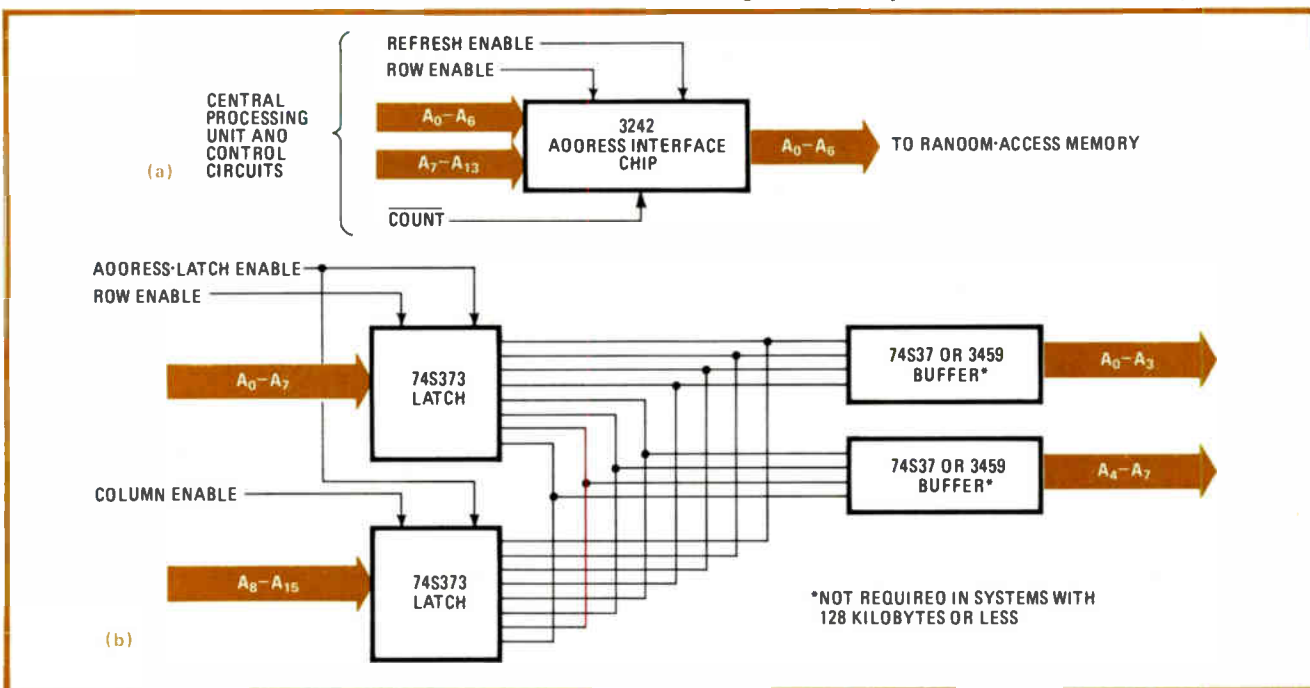

**4. Interface.** A 16-K RAM can use a special chip, like the 3243, which has a multiplexer and counter (a). Such parts do not yet exist for 64-K parts, but their savings are questionable anyway. For systems with 128 kilobytes or less, the MCM6664 needs only two TTL latches (b).

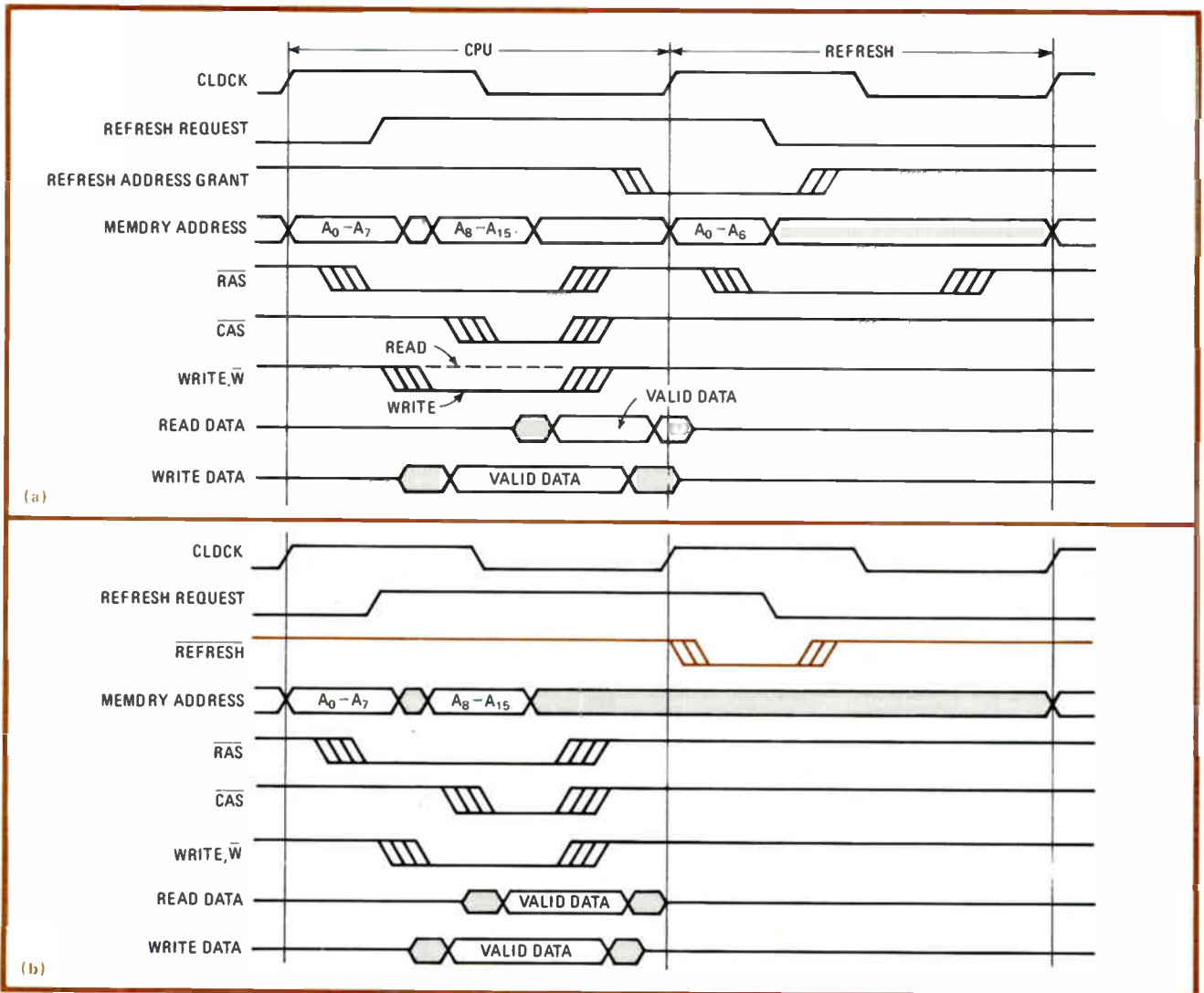

**5. Cycle steal.** With conventional RAMs, dispersed refresh gets complicated. After disabling  $\bar{CAS}$ , an address grant is generated and the refresh address is set up and strobed (a). However, when the MCM6664's  $\bar{REFRESH}$  line is lowered, no strobos or addresses are needed (b).

RAMs because the refresh address first needs to stabilize. With the MCM6664, however, this skew time can be eliminated since the refresh address is generated on chip.

With conventional dispersed refresh, as it is called, the logic flags the memory controller to indicate that the next cycle to be executed will be a refresh. The refresh-request signal is generated by a counter set to a frequency determined by the system's cycle time and the number of refresh cycles required by the memory devices during a specified time period.

When the refresh-request signal is generated, the memory controller switches to the refresh mode and a refresh cycle begins after the current memory cycle is terminated. First, the memory controller must disable the row-address-strobe decoder so that all memory chips receive a  $\bar{RAS}$  signal. Next it must disable the  $\bar{CAS}$  signal and generate a signal that tells the refresh logic to send its refresh address to the address logic block. Then a refresh-control signal disables the CPU address from the memories and enables the refresh address.

With these conditions set up, the controller executes the refresh cycle with an operation time the same as that

for a read or write cycle. At the end of this cycle, the memory controller switches back to a CPU operational mode. Timing for a dispersed-refresh system using RAMs without refresh control is shown in Fig. 5a.

If the refresh address and timing logic are on the memory chip as with the MCM6664, then this sequence becomes much simpler. After the memory controller has determined that a refresh cycle is required, it disables the normal timing sequence, generates a  $\bar{REFRESH}$  signal with noncritical timing and enables the normal timing sequence at the end of the refresh cycle. Figure 5b shows the timing in a MCM6664-based system.

#### Hidden refresh

There are a variety of data-processing systems that cannot steal an occasional cycle to perform the refresh. For these systems, the refresh must appear transparent: the memory system must look as if it is composed of static RAMs.

One way of performing a transparent or hidden refresh is to integrate the refresh cycle into selected CPU cycles. To minimize the cycle time, the refresh cycle

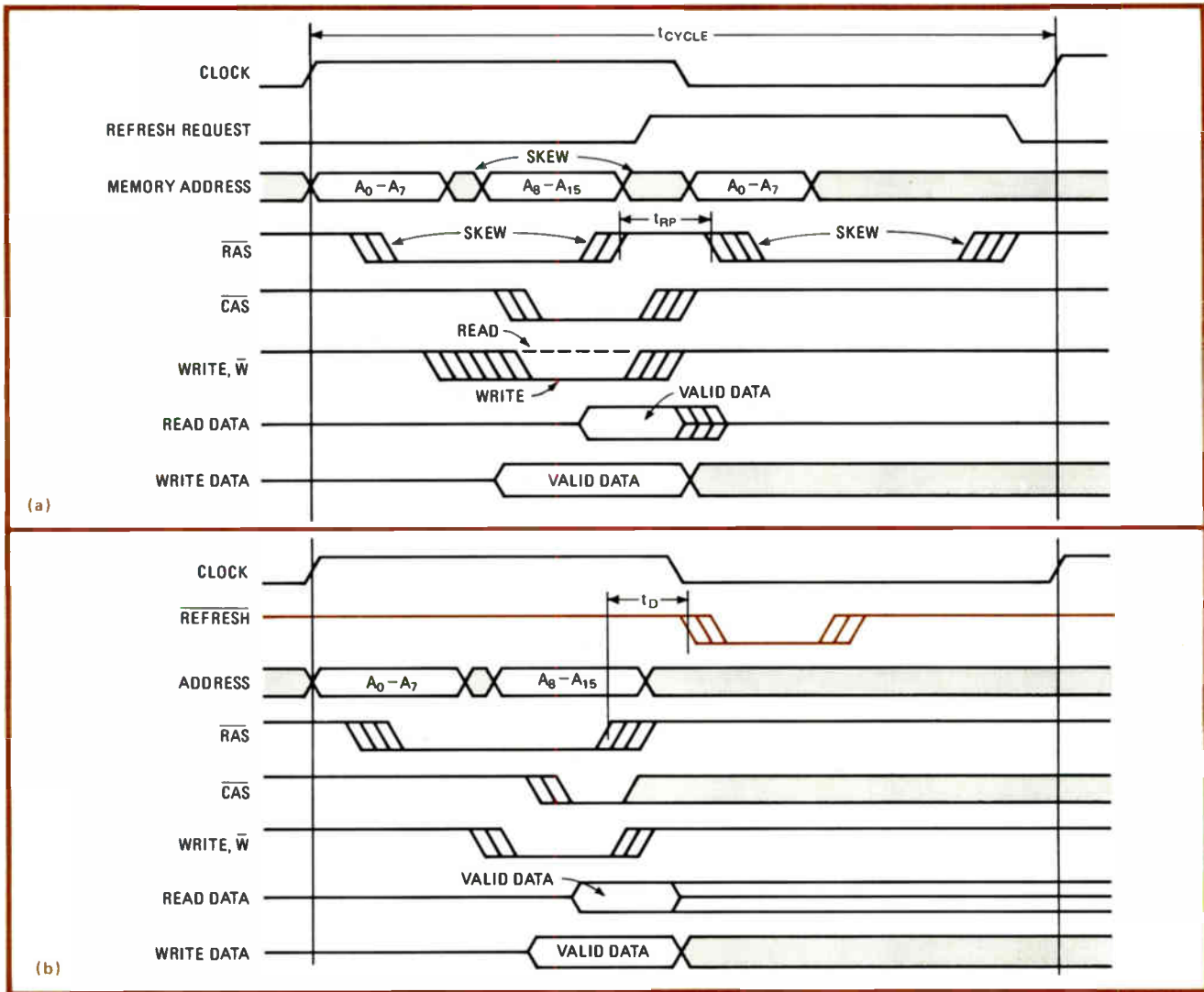

**6. Hidden refresh.** For systems that cannot steal it, an occasional refresh cycle can be integrated into selected CPU cycles. With the MCM6664, the refresh control signal,  $\overline{\text{REFRESH}}$ , can be timed off the trailing edge of  $\overline{\text{RAS}}$ . Timing skew and cycle time are both reduced.

must begin as soon as data transfer to the CPU can be terminated. However, there are limiting factors.

Before a refresh cycle can be initiated, the row-address-strobe signal must return to a high state for the minimum  $\overline{\text{RAS}}$  precharge time,  $t_{RP}$  (Fig. 6a). To minimize the amount of control logic, the CPU timing sequence repeats as a refresh-cycle sequence.

However, the digital control path to initialize the refresh cycle is not necessarily the path used by the central processing unit. Consequently, to ensure minimum  $t_{RP}$ , additional delay between the CPU cycle and the refresh cycle must be added to overcome the timing variations. The timing skew at the trailing edge of the refresh cycle also tends to increase the cycle time, since a new CPU cycle cannot start before  $t_{RP}$ .

With the MCM6664, the timing of the refresh control sequence does not have to be the same as for a CPU cycle. In fact, the control signal,  $\overline{\text{REFRESH}}$ , can be timed off the trailing edge of RAS. Thus, timing skew is minimized and the cycle time is reduced (Fig. 6b).

The MCM6664 also simplifies the design and enhances the performance of those systems requiring

battery backup. With the exception of the logic that detects the power-fail mode, the  $\overline{\text{REFRESH}}$  signal, and the  $\overline{\text{RAS}}$  buffers, all of the hardware can be turned off.

### Battery backup

When a power failure is detected, the power-fail logic forces the  $\overline{\text{REFRESH}}$  output low. After this, the power to the rest of the controller can be removed, except to the  $\overline{\text{RAS}}$ -output gates which must remain high. If the  $\overline{\text{REFRESH}}$  signal stays at a low level for more than 16  $\mu\text{s}$ , internal logic on the memory chip takes over and automatically generates all of the required refresh cycles. The memory chips remain in this mode until the  $\overline{\text{REFRESH}}$  line goes high, ending the self-refresh mode.

With the MCM6664's battery-backup refresh, overall power consumption will be far less than with conventional dynamic RAMs, because less control logic must remain powered up. Since the memory chips do not require any signals during the battery mode, no high-current buffers have to remain active except  $\overline{\text{RAS}}$ . The absence of the external  $\overline{\text{RAS}}$  signal and refresh address eliminates the ac power required to charge and discharge these lines.  $\square$

## Digital multiplexer derives six-variable logic function

by A. Mageswaran  
Tata Institute of Fundamental Research, Ootacamund, India

The chip-optimization method introduced by Siebert ("Digital multiplexers reduce chip count in logic design," *Electronics*, April 28, 1977, p. 120) can be extended, so that logic functions containing six variables can be easily implemented. Using a single 1-of-16-line multiplexer and several gates, most functions can be generated with much less effort than stated by Siebert.

In order to understand how chip count is reduced, consider the implementation of any five-variable function with a 1-of-16-line multiplexer, as was discussed in the aforementioned article. Part (a) of the figure shows a typical truth table and the required setup. Although it is customary to see a logic equation corresponding to the truth table, in reality the advantages of using multiplexers for chip reduction is that explicit writing and minimization of the logic equation are not required.

Here, the multiplexer's data-select inputs are driven by four of the input variables (A–D) and the 16 data lines ( $D_0$ – $D_{15}$ ) are driven by two functions of the remaining variable, E, and logic 1 and logic 0 signals. The function to which a particular data line is to be connect-

ed is easily determined by inspection of the truth table. For example, if variables A–D are all at logic 0, then line  $D_0$  will be selected. Under these conditions, the output F should be 0 when E is 0, and F should be 1 when E is 1. Therefore, line  $D_0$  should be connected to E. Likewise, when inputs A–D address line  $D_1$  (see entries 3 and 4 of the truth table), it is seen that  $D_1$  should be connected to logic 0, and so on.

If this scheme is directly extended to six variables, it will be found that a 1-of-32-line multiplexer or equivalent will be needed. Alternatively, however, a 1-of-16-line device can be used, provided the data lines of the multiplexer are connected to the corresponding functions of both of the remaining variables (E and F) and the logic 0 and logic 1 states. Such a case is shown for the function, again displayed in truth table form, given as an example in (b).

As in the five-variable case, A–D address the data-selected lines. From the first two entries in the truth table, it will be evident after some thought that the exclusive-OR function,  $E \oplus F$ , must be applied to the  $D_0$  line. Similarly, it becomes apparent from the next four entries that data line  $D_1$  must be connected directly to E, and so on. Several gates are required for implementing the E–F functions, but the cost should be below that of the additional multiplexers Siebert's scheme would require to generate the six variables. □

Engineer's notebook is a regular feature in *Electronics*. We invite readers to submit original design shortcuts, calculation aids, measurement and test techniques, and other ideas for saving engineering time or cost. We'll pay \$50 for each item published.

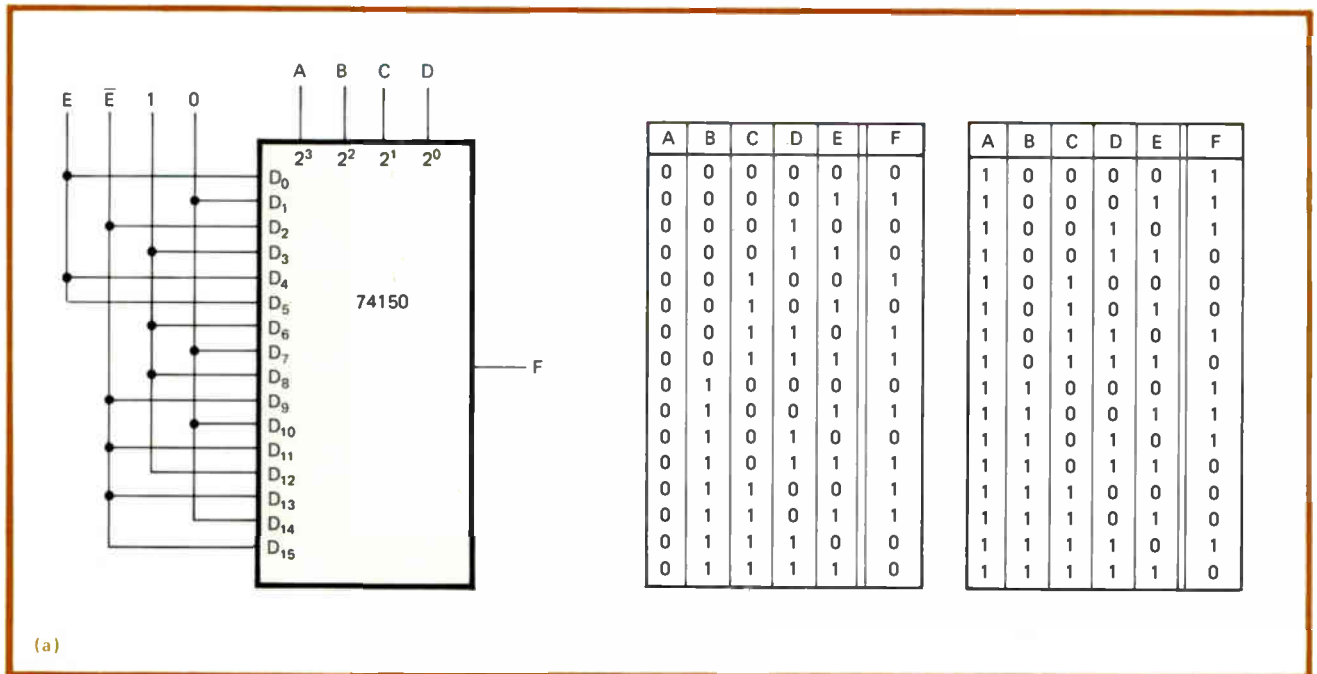

**Variable placement.** General method for implementing any five-variable logic function with multiplexer requires inspection of truth table in order to determine where variable E and logic values 0 and 1 should be placed on data lines (a). Six-variable function can also be implemented with a single multiplexer if variables E and F are united (b). In either case variables A–D drive the multiplexer's data-select inputs.

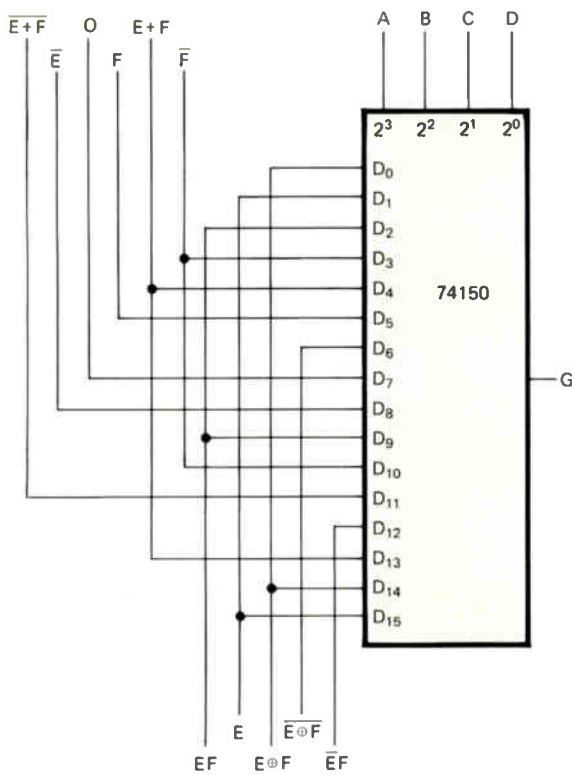

A	B	C	D	E	F	G	A	B	C	D	E	F	G
0	0	0	0	0	0	0	1	0	0	0	0	0	1
0	0	0	0	0	0	1	1	0	0	0	0	1	1
0	0	0	0	0	1	0	1	0	0	0	1	0	0
0	0	0	0	1	1	0	0	1	0	0	1	1	0
0	0	0	1	0	0	0	0	1	0	0	1	0	0
0	0	0	1	0	1	0	1	1	0	0	1	0	0
0	0	0	1	1	1	1	1	1	0	0	1	1	1
0	0	1	0	0	0	0	0	1	0	1	0	0	1
0	0	1	0	0	1	0	1	0	1	0	0	1	0
0	0	1	0	1	0	0	0	1	0	1	0	1	0
0	0	1	1	0	0	1	1	1	0	1	1	1	0
0	0	1	1	0	1	0	1	1	0	1	1	0	1
0	0	1	1	1	1	1	1	1	1	1	1	1	0
0	1	0	0	0	0	1	1	1	1	0	0	0	1
0	1	0	0	1	0	1	1	1	1	0	0	1	0
0	1	0	1	0	1	1	1	1	1	0	1	1	1
0	1	0	1	1	1	1	1	1	1	1	1	1	1
0	1	1	0	0	0	1	0	1	1	1	1	0	1
0	1	1	0	1	1	1	1	1	1	1	1	1	1
0	1	1	1	0	0	1	0	1	1	1	1	0	1
0	1	1	1	1	1	1	1	1	1	1	1	1	1
1	0	0	0	0	0	0	0	0	0	0	0	0	0
1	0	0	0	0	0	1	1	1	1	1	1	1	1
1	0	0	0	1	0	0	0	0	0	0	0	0	0
1	0	0	1	0	0	0	0	0	0	0	0	0	0
1	0	0	1	1	0	0	0	0	0	0	0	0	0
1	0	1	0	0	0	1	1	1	1	1	1	1	1
1	0	1	0	1	0	0	0	0	0	0	0	0	0
1	0	1	1	0	0	0	1	1	1	1	1	1	1
1	0	1	1	1	1	1	1	1	1	1	1	1	1
1	1	0	0	0	0	0	0	0	0	0	0	0	0
1	1	0	0	0	1	0	0	0	0	0	0	0	0
1	1	0	1	0	0	0	0	0	0	0	0	0	0
1	1	0	1	1	0	0	0	0	0	0	0	0	0
1	1	1	0	0	0	0	0	0	0	0	0	0	0
1	1	1	0	1	0	0	0	0	0	0	0	0	0
1	1	1	1	0	0	0	0	0	0	0	0	0	0
1	1	1	1	1	0	0	0	0	0	0	0	0	0
1	1	1	1	1	1	0	0	0	0	0	0	0	0
1	1	1	1	1	1	1	0	0	0	0	0	0	0
1	1	1	1	1	1	1	1	1	1	1	1	1	1

(b)

**Calculator notes**

# HP-67 finds op amp's gain and common-mode rejection

by Michael R. Hyman  
Gamma Scientific Inc., San Diego, Calif.

Analyzing circuits built around operational amplifiers is often complex and almost always time-consuming, even when the configuration is relatively simple. This HP-67/97 program can cut the calculation time from hours to seconds for the general circuit shown in the figure. Both the exact inverting and noninverting closed-loop gain are found, as are the true common-mode rejection ratio (CMRR) and the value of the input matching resistance required to optimize that ratio.

The program finds the inverting closed-loop gain from:

$$\frac{E_o}{E_2} = A^- =$$

$$\frac{R_o[1 + (R_2/R_3) + (R_2/R_{IN})] - [R_F A_o][1 + (R_2/R_3)]}{D}$$

where D is a complex 27-term function of A<sub>o</sub> and all circuit resistances. The noninverting closed-loop gain is found from:

$$A^+ = \frac{(R_o R_s / R_{IN}) + A_o (R_F + R_3)}{D}$$

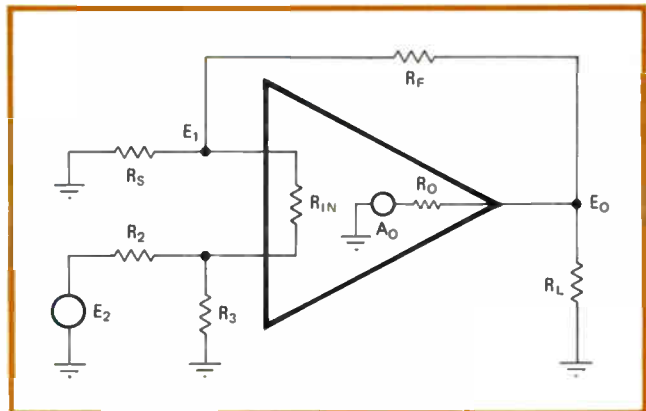

**Time saver.** Complex nodal equations for this standard op-amp circuit are solved in seconds by the HP-67/97. Exact inverting and noninverting closed-loop gain, true common-mode rejection ratio, and the value of R<sub>2</sub> required for infinite CMRR are quickly determined.

# At last, we got the best of Fairchild.

So we had to pay for it.

The important thing is Dynamic Sciences now has Fairchild's DPM line. The best. And we're making it even better.

Our low cost addition to the former Fairchild line offers dramatically increased flexibility—the PC card readily accepts drop-in resistor kits. We can tailor your DPM on the spot, off the shelf, and at a bargain. Since there's no extra engineering time or cost, our Model 72 is yours for only \$29.95\*

Clever, huh? Just what you'd expect from a company smart enough to improve on a product line that's so widely accepted. But then, intelligent responses to the needs of our industry is why we're in the DPM business.

And the best is yet to come.

\*in OEM quantities.

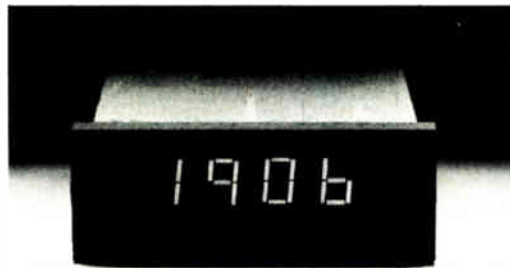

**Dynamic Sciences**  
Instrumentation/Communications/Process Control

16150 Stagg Street, Van Nuys, California 91406, 213-893-6341.



where, in general, the difference between A<sup>+</sup> and A<sup>-</sup> is small but may be significant in some cases.

Having determined both loop gains, and given the circuit's element values and the op amps' specified CMRR (CMRR<sub>s</sub>), the calculator finds the true common-mode rejection ratio in decibels:

$$CMRR_{true} = \frac{A^-}{A^- + A^+ [(CMRR_s + 1)/CMRR_s]}$$

When A<sup>-</sup> and A<sup>+</sup> are expressed in terms of circuit resistances, the optimum value of the input-matching resistor, R<sub>2</sub>, required for maximum CMRR<sub>true</sub> is determined from:

$$R_2 \approx \frac{R_3 [(R_F + R_S)/R_S] [(CMRR_s + 1)/CMRR_s]}{(-R_F/R_S)/CMRR_{true} + R_F/R_S} - R_3$$

To illustrate an example of the program's usefulness, take as an example the following circuit:

$$\begin{aligned} R_{IN} &= 10 \text{ megohms} & R_S &= R_2 = 1 \text{ k}\Omega \\ R_O &= 2 \text{ kilohms} & R_3 &= 325 \text{ k}\Omega \\ R_F &= 325 \text{ k}\Omega & A_o &= 50,000 \\ R_L &= 1.5 \text{ k}\Omega & CMRR_s &= 1778.28 (65\text{dB}) \end{aligned}$$

Keying in the data as instructed reveals that A<sup>+</sup> = 316.08, A<sup>-</sup> = -316.08, CMRR<sub>true</sub> = 1,778.81, CMRR = 65.0 dB, and R<sub>2</sub> = 1 kΩ. R<sub>2</sub> (optimum) is then found to be 1,180 Ω, and the new CMRR is 136.48 dB. □

#### HP-97 PRINTER LISTING: OP-AMP STAGE ANALYSIS

001	LBLC	037	1	073	1	109	1	145	X	181	X
002	SF2	038	+	074	+	110	+	146	CHS	182	STOD
003	RTN	039	RCL0	075	RCL4	111	RCL2	147	RCL5	183	PSE
004	R/S	040	1/X	076	RCL2	112	RCL4	148	RCL0	184	RCL5
005	LBLA	041	X	077	X	113	+	149	+	185	RTN
006	STO0	042	RCL4	078	X	114	X	150	RCL5	186	R/S
007	GSB1	043	X	079	RCL0	115	+	151	RCL6	187	LBLE
008	STO1	044	RCL2	080	÷	116	RCL8	152	÷	188	RCL2
009	GSB1	045	RCL3	081	+	117	+	153	+	189	RCL4
010	STO2	046	÷	082	RCL1	118	STO8	154	1	190	+
011	GSB1	047	+	083	RCL3	119	F2?	155	+	191	RCL4
012	STO3	048	RCL2	084	÷	120	GTO2	156	RCL1	192	÷
013	GSB1	049	RCL0	085	X	121	RCL2	157	X	193	RCL6
014	STO4	050	÷	086	RCL8	122	RCL4	158	+	194	X
015	GSB1	051	+	087	+	123	+	159	RCL8	195	RCLE
016	STO5	052	1	088	STO8	124	RCL7	160	÷	196	1
017	GSB1	053	+	089	RCL5	125	X	161	STOB	197	+
018	STO6	054	RCL1	090	RCL6	126	RCL1	162	RTN	198	RCLE
019	GSB1	055	X	091	÷	127	RCL4	163	LBLD	199	÷
020	STO7	056	STO8	092	1	128	X	164	RCLE	200	X
021	GSB1	057	RCL2	093	+	129	RCL0	165	1	201	RCL2
022	STOE	058	RCL4	094	RCL2	130	÷	166	+	202	RCL4
023	GTOB	059	+	095	RCL0	131	+	167	RCLE	203	÷
024	LBL1	060	RCL5	096	÷	132	RCL8	168	÷	204	÷
025	RCLA	061	RCL6	097	RCL7	133	÷	169	RCLA	205	RCL6
026	STOI	062	÷	098	+	134	STOA	170	X	206	-
027	ISZ1	063	RCL5	099	X	135	RTN	171	RCLB	207	STO5
028	RCLi	064	RCL0	100	RCL4	136	LBL2	172	+	208	PSE
029	X ↺ 1	065	÷	101	X	137	RCL5	173	1/X	209	RCL5
030	STOA	066	+	102	RCL5	138	RCL6	174	RCLB	210	GSBB
031	R/S	067	1	103	RCL6	139	÷	175	X	211	GSBB
032	RTN	068	+	104	÷	140	1	176	ABS	212	GSBB
033	LBLB	069	X	105	RCL5	141	+	177	PSE	213	GSBD
034	RCL5	070	RCL5	106	RCL0	142	RCL7	178	LOG	214	R/S
035	RCL6	071	RCL6	107	÷	143	X	179	2		
036	÷	072	÷	108	+	144	RCL2	180	0		

#### Instructions

- Key in program
- Enter circuit parameters  
(R<sub>IN</sub>), A, (R<sub>O</sub>), R/S, (R<sub>F</sub>), R/S, (R<sub>L</sub>), R/S, (R<sub>S</sub>), R/S, (R<sub>2</sub>), R/S, (R<sub>3</sub>), R/S, (A<sub>O</sub>), R/S, (CMRR<sub>s</sub>), R/S  
Specify R<sub>IN</sub> in megohms, all other resistances in kilohms.  
The noninverting closed-loop gain is displayed.
- Press C to set an internal flag, preparing the calculator for finding the inverting closed-loop gain  
When B is pressed, the gain will be computed and displayed.
- Press D to find the common-mode rejection ratio (CMRR)  
The CMRR value in dB will also be displayed, followed by the value of R<sub>2</sub>.
- Press E to find the optimum value of R<sub>2</sub> required to effect a corresponding change in the CMRR  
The new value of R<sub>2</sub> will be momentarily displayed, followed by the new value of CMRR both as a ratio and in decibels. R<sub>2</sub> will then be displayed again.
- To find the change in the noninverting closed-loop gain caused by the change in R<sub>2</sub>, press RCL A. Follow this step by pressing RCL B to find the inverting closed-loop gain.

## Engineer's newsletter

---

### Resistor trimming optimizes generator's sine wave

Intersil's 8038 function generator produces a sine wave by shaping a triangle wave with a ladder network, two rungs of which are accessible. The potentials imposed on these pins (1 and 12) by external sources determine both waveform symmetry and distortion. But independent adjustment of those potentials to optimize the waveform, as proposed in the application notes, may be **very difficult in practice because both parameters are functions of both potentials**, says Pete Pomeroy of United Electronics Corp., South Africa. Instead of using potentials, Pomeroy proposes placing one potentiometer that varies from 60 to 100 k $\Omega$  between pin 12 and ground of the device to control symmetry and another that varies from 10 to 20 k $\Omega$  between pins 1 and 12 and ground to control distortion. Because of the low resistance values used in the ladder, the pots have little effect on the voltage distribution within, so that adjustments can be made more easily. Once the sine wave's symmetry is optimized with the first pot, it is a simple matter to reduce distortion by a factor of two or three with the second pot. No retrimming is necessary.

### EIA announces standards for resistors, other passive components

The Electronics Industries Association has issued RS-452 and RS-186-E, two documents that recommend the standardization of the physical and electrical properties of high-voltage, high-resistance fixed film resistors and set methods for testing passive components. RS-452 describes axial and radial resistors having values of up to 499 megohms, working voltages to 20 kV, and power ratings to 5 W. RS-186-E is a revised version of an earlier report that discusses the testing of components under varying degrees of severity. The base document includes an index of 13 test methods, which are available individually, **for checking the effects of humidity, corrosion from salt spray, vibration, thermal shock, and heat on component life**. RS-452 costs \$7.80. RS-186-E is \$3.00, as are each of the 13 test method descriptions. All may be ordered from EIA, 2001 Eye St., N. W., Washington, D. C. 20006.

### Voltage-controlled video amp makes wide-ranging AGC

Video amplifiers having differential inputs lend themselves to applications where their peak output can be easily set by a control voltage—a property that makes them excellent as automatic gain controls, observes Yishay Netzer of Haifa, Israel. In contrast with amplifiers whose output is controlled by varying their transconductance (current control), the differential devices **have wider bandwidth and are much simpler to implement in AGC stages**.

Netzer uses the Fairchild  $\mu$ A733, plus a field-effect transistor as a voltage-controlled resistor. Either an n- or a p-channel FET may be chosen, depending on whether the control voltage,  $V_c$ , is negative or positive. The FET's source and its drain (operating without supply voltage) are connected between the emitters of the differential-input transistors of the  $\mu$ A733, pins 9 and 4 respectively. The control voltage is applied to the gate of the FET through a 20-k $\Omega$  resistor. To linearize the response further for large signal swings, a 20-k $\Omega$  resistor in series with a 0.1- $\mu$ F capacitor can be placed between the gate of the FET and pin 4 of the  $\mu$ A733. The gain of the amplifier is inversely proportional to the FET's resistance and is given by  $A = A_o(1 - V_c/V_p) + A_p$ , where  $A_o$  is the FET's nominal gain,  $V_p$  is its pinch-off voltage, and  $A_p$  is the gain at pinch-off and beyond.

Vincent Biancomano

# Why is the Digitec Datalogger 3000 already the most popular logger in the world?



## most powerful & easiest to use

The Datalogger 3000 puts more power in your hands than any other datalogger.

**MORE DATA ACQUISITION.** The 3000 handles the widest variety of inputs: ac and dc voltages, ac and dc currents, resistances, all thermocouples, RTD's, thermistors, digital and contact closures — all standard.

### MORE COMPUTATION.

The 3000 opens up the power of mathematical computation. It can determine an Average, Difference, Deviation from a Mean, extract Square-Roots and more. You can easily convert to engineering units with 30 programmable offset and scale factors. That's 900 different  $a + b$  equations. Two unique tables feature the exclusive "U-PLOT" function (User Programmable Linearization Tables). This powerful feature provides linearization for any transducer or transmitter.

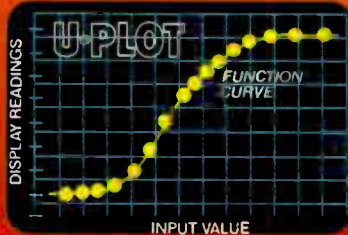

**MORE DECISIONS.** The 3000 offers 100 programmable set-points for alarm detection. You can assign up to 4 different hysteresis, with priority levels, to each channel for "High," "Low," or "Equal to" decisions. You can Alarm on rate of change or alarm transitions. Ten standard Alarm Hysteresis provide outputs for sensor failure and control. And, only Digitec Dataloggers visually spell out alarm messages on a built-in CRT.

Behind all these standard features is 32K of memory. That's enough power to support a system of up to 3000 points.

The Datalogger 3000... more powerful than any other datalogger.

The Datalogger 3000 is as easy to use as it is powerful. All communication is in everyday English. We spent many years developing programming innovations so you can program your system in minutes.

**PROGRAM PROMPTING.** A built-in CRT display provides prompting to guide you through each step of your program. The Datalogger asks you simple questions in plain English and supplies multiple-choice answers. This interactive prompting assures quick and accurate program entry. Programming is further simplified by utilization of conventional data acquisition terms, no need for complex, computer languages.



**CASSETTE LIBRARY.** Once your program requirements have been defined, they can be saved on the built-in cassette. This lets you create a library of application tapes. Simply drop in a cassette and the Datalogger will completely program itself. Changing programs, therefore, is as easy as changing cassettes. The same cassette deck can be used to record measured data for future reference.

**COMPLETE COMMUNICATION.** The built-in CRT provides more information than possible with conventional datalogger displays. You can see 10 channels of system information at a single glance. For hard copy, a standard built-in alphanumeric printer quietly records data. In communication with peripheral devices, the 3000 offers the widest variety of interfaces: ASCII outputs, both serial and parallel, relay outputs, external condition input, and composite video output use all standard.

The Datalogger 3000... easiest to use than any other datalogger.

For a free brochure or "hands-on" demonstration, just call Daryl Barnaby collect. (513) 254-6251

**Digitec.**

**UNITED SYSTEMS CORPORATION**

1100 Shuman, Piquette Avenue, P.O. Box 10000, Cincinnati, Ohio 45210 (513) 254-6251

Information Only circle #113

Demonstration Only circle #112

*Digital signal processing is here.*



# TRW takes another step in digital signal processing

## PRESENTING OUR 33-NSEC, ONE-CHIP ANALOG/DIGITAL CONVERTERS

We've developed a family of single chip, 30MHz A/D converters with VLSI technology. They're TTL devices that bring all the advantages of digital signal processing to high-speed, wide-bandwidth signals like those used in radar, broadcast video and closed-circuit TV systems. We've designated the 8-bit converter TDC-1007J and the 6-bit device, TDC-1014J.

With digital processing of video signals, you can use simple algorithms to control video images of all kinds. You can freeze, store, and replay the action; compress and expand time; fade in, fade out, wipe, and superimpose—all under non-critical digital control.

Our inexpensive A/D converters make the connection to all this flexibility.

Because we invented TTL and refined it to the level of VLSI, our converters enjoy the luxury of operating as *flash converters*, rather than depending on tedious, successive-approximation techniques.

Our TDC-1007J features full

eight-bit resolution. It is a single chip with 255 comparators and a resistive voltage divider. Activating a single device pin strobes the comparators, encodes all their binary outputs into an eight-bit word, and stores the word in an output latch. All this can happen 30 million times a second—now *that's* video-speed data conversion!

The TDC-1007J provides four output data formats and does not require a sample-and-hold circuit at the front end; it is unsurpassed for both NTSC and PAL color video systems.

Our six-bit converter chip, the TDC-1014J, is no falloff from the larger device—it is made with its own 63-comparator mask set and features all the speed, linearity, and utility of its big brother. Use it for applications that call for reduced resolution and cost—like ultrasound, X-ray, radar, and CCTV.

Both the eight-bit A/D and the six-bit A/D are packaged in industry standard DIPs. The larger -1007J has 64 pins; the smaller -1014J has 24. They are both powered by +5V and -6V supplies; the -1007J uses 2W and the

-1014J needs only 750mW. Both are radiation hard.

The TDC-1007J (in 100s) is priced at \$485. The TDC-1014J (in 100s) is priced at \$186. (And these are only our introductory prices—they will go lower like all monolithic devices.)

Like all TRW LSI products, the TDC-1007J and -1014J are available from stock at Hamilton/Avnet. For more information, send in the coupon or talk to one of our digital signal processing experts at 213/535-1831.

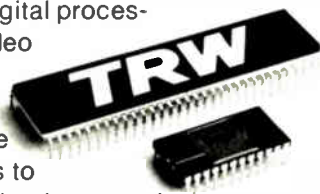

### TRW LSI Products

An Electronic Components Division of TRW Inc.  
P. O. Box 1125  
Redondo Beach, CA 90278

Please send data sheets on the new TDC-1007J, 8-bit and TDC-1014J, 6-bit A/D converters.

Name \_\_\_\_\_  
Company \_\_\_\_\_  
Div/Dept \_\_\_\_\_ Mail Code \_\_\_\_\_  
Address \_\_\_\_\_  
City \_\_\_\_\_  
State \_\_\_\_\_ Zip \_\_\_\_\_

E-2

**TRW** LSI PRODUCTS  
...for Digital Signal Processing

# Rent A Complete Measurement System?

# Sure, From General Electric!

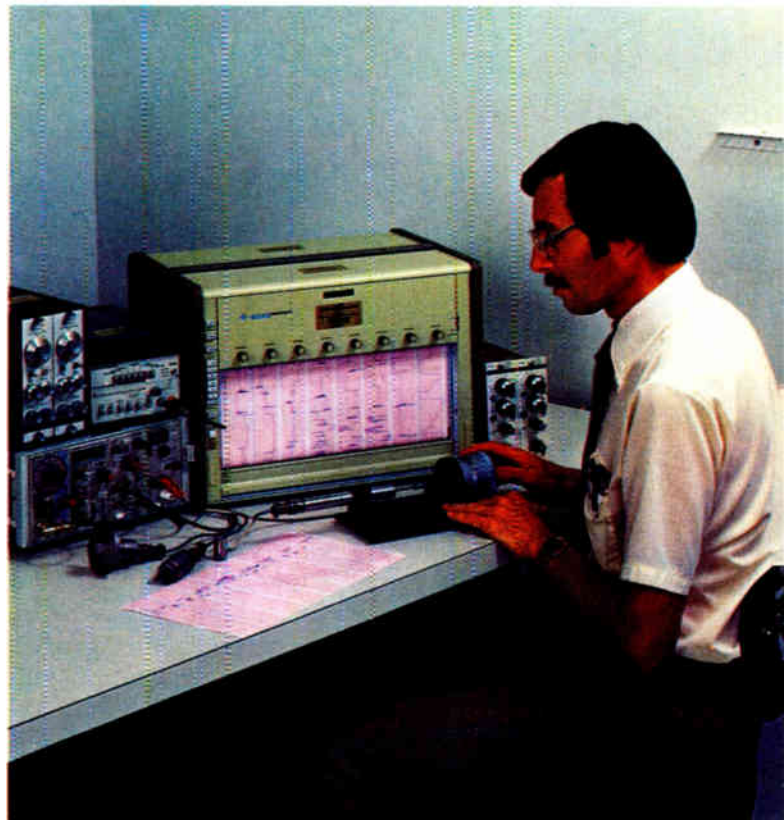

**Quick-rental<sup>®</sup>  
instruments**

When you need instrumentation to measure pressure, vibration, temperature, stress-strain, etc., call General Electric. Our inventory of over 15,000 rental instruments including recorders, signal conditioners and transducers, enables us to configure a system to meet your measurement requirements.

Our Rental Specialists are application experts and can help you select the right equipment for the job.

General Electric has six stocking inventory centers and more than 40 sales offices. You are never more than a phone call away from the instruments or measurement systems you need.

For your Free Rental Catalog, CALL COLLECT (518) 372-9900 or your nearest sales office listed below or write General Electric Company, Apparatus Service Division, Bldg. 4, Room 210, Schenectady, N.Y. 12345.

ALA. BIRMINGHAM (205) 925-9449 • ARIZ. PHOENIX (602) 278-8515 or 8516, TUCSON (602) 294-3139 • CAL. LOS ANGELES (213) 642-5350, SACRAMENTO (916) 383-4986, SAN FRANCISCO (415) 436-9260 • COL. DENVER (303) 320-3255 • CONN. SOUTHWINGTON (203) 621-4059 • FLA. JACKSONVILLE (904) 751-0615, MIAMI (305) 696-0811 • GA. ATLANTA (404) 457-5563 • ILL. CHICAGO (219) 933-4500 or (312) 854-2994 • IND. INDIANAPOLIS (317) 639-1565 • KY. LOUISVILLE (502) 452-3311 • LA. NEW ORLEANS (504) 367-6528 • MD. BALTIMORE (301) 332-4713 • MASS. BOSTON (617) 396-9600 • MICH. DETROIT (313) 285-6700 • MINN. MINNEAPOLIS (612) 522-4396 • MO. KANSAS CITY (816) 231-4377 or (816) 231-4620, ST. LOUIS (314) 965-7115 • NEW JERSEY CLIFTON (201) 471-6556 • N.Y. BUFFALO (716) 876-1200, SCHENECTADY (518) 385-2195 • N.Y.C. CLIFTON, N.J. (201) 471-6556 • N.C. CHARLOTTE (704) 525-0311 • OH. CINCINNATI (513) 874-8512, CLEVELAND (216) 441-6111, TOLEDO (419) 691-3501 • ORE. PORTLAND (503) 221-5101 • PA. PHILADELPHIA (609) 424-4450, PITTSBURGH (412) 462-7400 • S.C. GREENVILLE (803) 277-4093 • TENN. MEMPHIS (901) 527-3709 • TEX. BEAUMONT (713) 842-4514, DALLAS (214) 357-7341, HOUSTON (713) 672-3570 • UT SALT LAKE CITY (801) 292-4411 • VA. RICHMOND (804) 232-4576 • WASH. SEATTLE (206) 575-2987 • W.V. CHARLESTON (304) 345-0920 • WISC. MILWAUKEE (414) 744-0110 • PUERTO RICO PONCE (809) 843-4225 or 4625.

**GENERAL  ELECTRIC**

# LED modules beat space crunch

By rearranging the C-MOS chip that drives light-emitting diodes  
Litronix realizes space savings of 33% and 46% in intelligent display

by Robert Brownstein, San Francisco regional bureau

**Small microprocessor-based systems** such as hand-held controllers and instruments, as well as data terminals, generally have been unable to keep up with the rush to market of their larger cousins, in part because of the lack of effective small displays. The bigger systems can use cathode-ray tubes, but the smaller versions have had to get by with less capable light-emitting-diodes and liquid crystals.

Essentially, the problem has been a space crunch—trying to fit 20 alphanumeric characters, plus their decoders, drivers, buffer memory, and random-logic control circuits, in a 3.5-inch-wide package. With the introduction this month of its DL1414 intelligent display modules, Litronix has come up with an answer. In fact, the first full-production units, like earlier samples, are slated to go into the new Lexicon hand-held language translator [*Electronics*, Dec. 7, 1978, p. 50]. Moreover, David M. Barton, Litronix product marketing manager, claims that the translator could not have met its size and cost targets without the display module.

**Direct hookup.** These modules hook up directly to a microprocessor's address bus and data bus, making hardware design relatively easy. Behind the module's four-digit LED display is a complementary-metal-oxide-semiconductor large-scale integrated circuit that contains all the functional logic needed to translate 7-bit ASCII data into any of 64 alphanumeric characters.

The microprocessor simply treats the module as if it were a random-access memory, writes in an ASCII "word," and moves on to other tasks

as the module decodes and displays the characters it has stored, Barton explains.

The DL1414 and a larger module, the DL2416, due out in March, make both electrical and physical design easy, as well, Barton says. Litronix' first intelligent module, the DL1416, has the C-MOS chip side by side with the displays (left in photo), but the new packages move it behind the displays, so their sizes shrink by 33% for the DL2416 (lower right) and 46% for the DL1414 (upper right). What's more, the modules' shape makes it possible to align them horizontally or vertically, thus facilitating the design of displays needing more than a single line of characters.

**Wide view.** A plastic immersion lens, an integral part of the package, magnifies the LED digits, making

them appear 160 mils high (the DL2416) or 112 mils high (the DL1414). The maximum viewing angle, a function of actual LED size and lens optics, has been increased from 25° for the older 1416 to 40° for the new 1414 and 50° for the 2416.

The two new intelligent display modules operate from a single 5-V supply, with the larger unit drawing approximately 100 mA and the smaller 50 mA. Price for each in 1,000-piece quantities is \$26 and \$13 respectively. The higher cost of the DL2416 compared with that of the DL1416 (\$18.75 apiece for 1,000) is due to using larger diodes (which have lower production yields) to obtain the greater viewing angle.

Litronix Inc., 19000 Homestead Rd, Cupertino, Calif. 95014. Phone (408) 257-7910 [338]

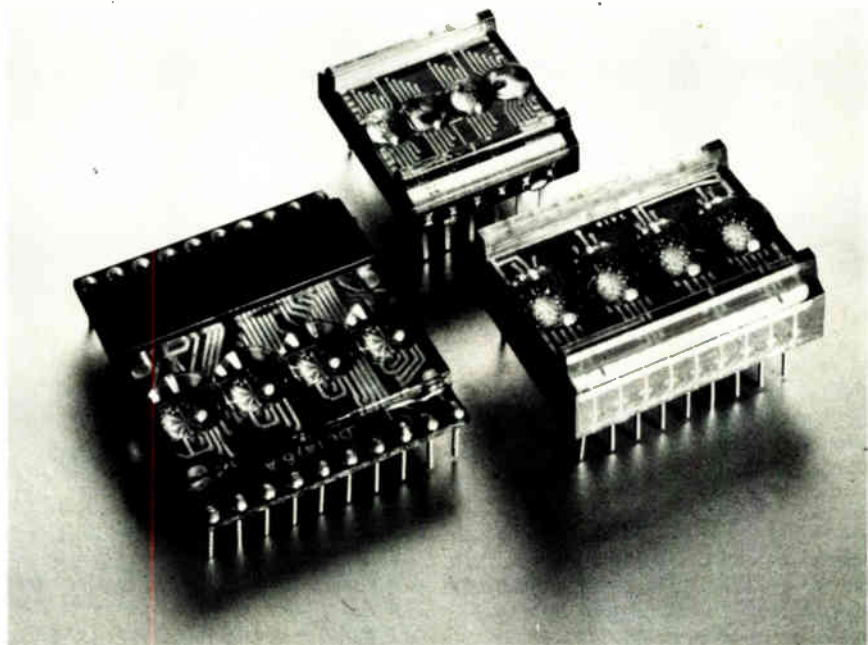

# Why IERC's new heat dissipation system for .300" DIPs is more efficient, simpler and costs less than alternate technologies.

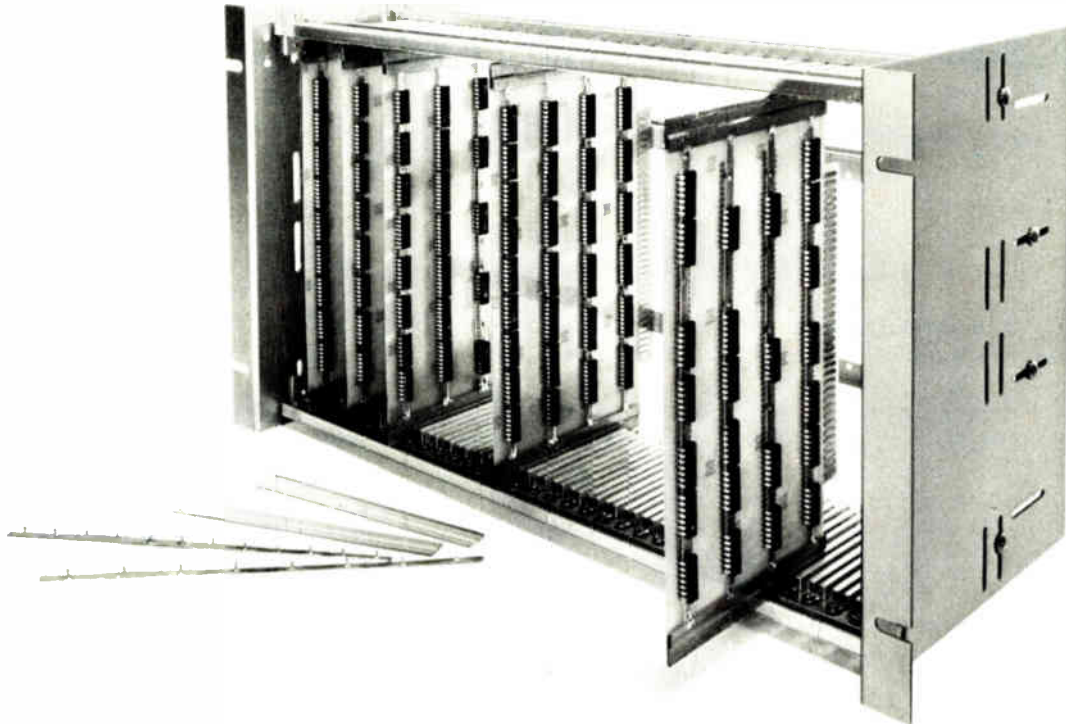

The IERC system provides significant thermal transfer for better thermal balance as well as an efficient thermal interface from DIPs to card holder.

## The Problem

The thermal management of large numbers of dual-inline packages on a single PC board can be a problem, particularly in telecommunications and logic networks. Single DIPs rarely dissipate as much as one watt, but a board full of them can add up to 15-25 watts. IERC's system of conduction bars and side rails provides a simple, inexpensive, off-the-shelf solution to the problem.

## Some Expensive Solutions

Ladder networks will do the job. Of course there is the cost of fabrication, and the difficulty of epoxying the networks to the boards, which makes assembly and repairs a nightmare.

Another approach is to plate heat-dissipation strips directly onto the board. A good idea for some applications, except the cross-sectional dimensions of plated strips (and hence their dissipating efficiency) is limited by the plating process. Also, plated strips require valuable board space and often introduce capacitance and induction problems into your design.

Boards with heat-dissipating metal cores require extremely careful engineering, and are costly and very difficult to make.

## IERC's Better Solution

IERC's heat dissipation system consists of conduction bars and side rails, both of which are made from high-thermal-conductivity copper (solder plated) and are available in practically any length. The conduction bars can be wave-soldered into

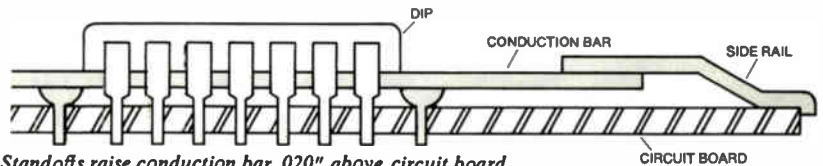

Standoffs raise conduction bar .020" above circuit board to accommodate metal traces between the standoffs, and to permit removal of solder residue.

**IERC's conduction bar system lowers substrate temperatures 30% — 40%.**

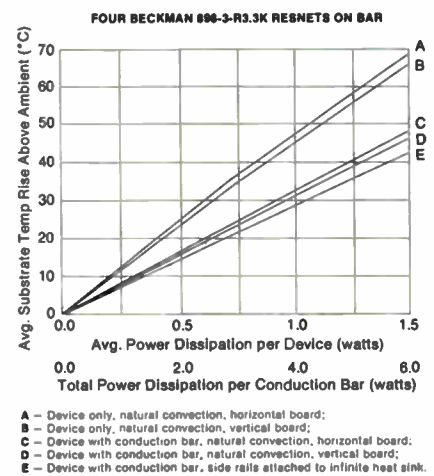
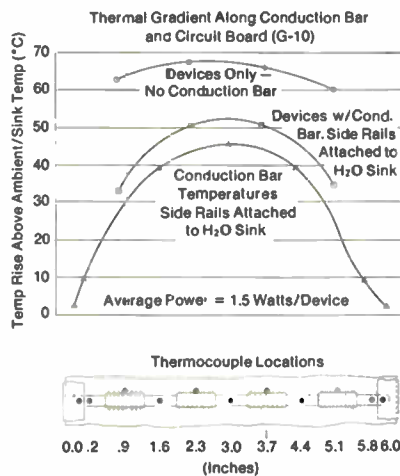

place along with other board components. The IERC system permits quick fabrication of a custom heat-dissipating network for .300" DIP systems, with no restrictions on the distance between DIPs or rows of DIPs. Call or write today for more information.





# A lot of people are talking CODEC.

**We're delivering now.** At Siliconix, CODEC is more than just talk. Our DF331/DF332 per channel system is now in volume production to support volume requirements. Prices are low and going even lower as more and more systems commit to Siliconix' format. Since ours is the only CODEC with a licensed second source, we've got everything it takes to be the first industry standard. And you're assured of designing PCM or PABX systems with parts that are here today and a supply that will be going strong when you move into production.

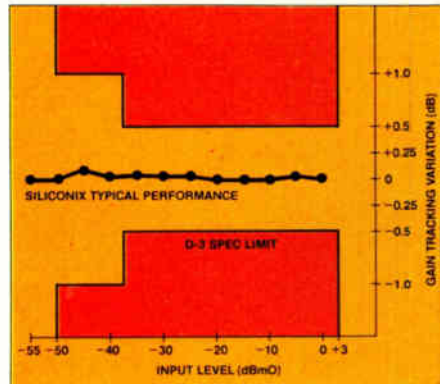

Gain Tracking DF331/DF332 Pair

Volume availability, alternate sourcing and good economics — they're all excellent reasons to call Siliconix first. Perhaps the best reasons, though, are the unique features and performance of our CODEC.

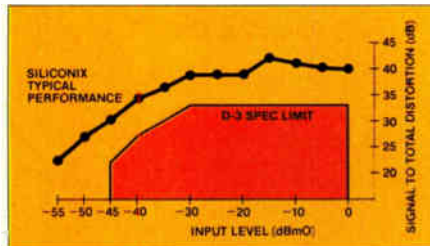

Signal to Total Distortion DF331/DF332 Pair

**Low Power.** Siliconix' two-chip CODEC gives designers low active power and even lower standby dissipation. Typical active requirement for the chip pair is only 80 mW. In standby, power is reduced to 11 mW.

**Superb specs.** Backed by Siliconix' 17 year experience in high performance analog circuitry and CMOS technology, our CODEC coder/decoder pair is designed to perform to ATT D-3 channel bank system specs and CCITT specs shown.

**Asynchronous operation.** Since encoder and decoder are separate parts in Siliconix CODEC, you don't have to depend on local clocks for timing. Independent timing means simpler circuit requirements and more efficient signal processing.

## Flexible designing.

Siliconix' CODEC gives designers three additional advantages that can make the switch to digital even easier. In D-3 channel banks, our *A/B signaling* capability eliminates external circuitry and further simplifies timing requirements. An *internal auto zero* feature holds input offset voltage to a minimum. And designers working on conference calling PABX applications will like our decoder's *fast conversion rate*. Since it operates four times faster than the encoder, you can design with multiple time slots to a single decoder.

## Get us on the line:

**(408) 988-8000.** Talk to our CODEC marketing manager, Barry Boulton. He's ready to help you get Siliconix CODEC into your design — and into your hands. He'll give you details, data sheets and delivery schedules. Or write Barry at Siliconix, Inc., 2201 Laurelwood Road, Santa Clara, CA 95054.

**Siliconix**

# Siliconix puts it on the line.

Circle 159 on reader service card

# PMI'S PCM Shared CODEC

## *It'll leave you grinning like a Cheshire Cat*



"Would you tell me please, which way I ought to go from here?" Alice asked the Cheshire Cat.

"That depends a good deal on where you want to get to," said the Cat.

"I don't care where, so long as I get *somewhere*," said Alice.

"Then it doesn't matter which way you go," said the Cat.

With that passage from *Alice in Wonderland*, written more than 100 years ago, Lewis Carroll brilliantly summed up the attitude of many people today.

Telephone switching equipment designers right now all want to convert their products to PCM, and they don't care which way they have to go as long as they know they'll get there, and at the lowest cost per line. They know that to get there requires coder/decoder (CODEC) but the device manufacturers have hit them with so many claims and false promises that, like Alice, they aren't sure which way to turn.

PMI's PCM Carrier, CO and PABX customers don't have to ask which way to go because they're already there. They got there with multichannel shared CODECs designed with PMI COMDAC® companding digital-to-analog converters, which PMI has been delivering to them *off the shelf* since 1975. In fact, our COMDAC®  $\mu$ -Law and A-Law converters (the DAC-86, and DAC-87), are actually in service carrying telephone traffic today. Some have been in operation for over two years in carrier systems, PABX's and remote terminals, with performance that meets or exceeds telephone system specifications.

Of course, some people argue in favor of a single-channel CODEC approach, especially those *Digital Dreamland* houses which can't offer you the *linear* components you need for shared CODEC. Certainly you can get where you want to go with single channel CODECs. Eventually! And if you can afford the price, board space, and believe in price *projections* and *eventual* second sources.

To understand why you'll get there faster and cheaper by going our way, just think in terms of *IC packages* per line rather than CODECs per line.

You see, to provide one *single-line* CODEC per line for 24-line channel bank, takes a minimum of 24 CODECs. In fact, some of the announced single line CODECs are two-package sets. So a 24-line system takes 48 of these "Tweedle Dee-Tweedle Dum" sets.

"But all single-line, single chip CODECs are in huge 24 pin packages!" exclaimed Alice. "That's 576 total pins!"

"Right," said the Cheshire Cat, "and these take up a lot of board space. Even the 2-package CODECs are in 16 or 18 pin packages which aren't small either."

"A PMI 24-line shared CODEC takes about 32 packages—about the same! However most of them are in 8 lead or 14 lead packages. Total pin count is only 424! That's a 26% 'hole saving'!"

The Cheshire Cat told Alice, "You can't take less than nothing!" However, when you make PC boards, holes are nothing but they cost something. With the PMI shared CODEC approach, *you* can save lots of board space and hole drilling. That's something!

These are today's PUBLISHED 100 piece prices for off the shelf parts, many with second sources. Of course, you can buy them for much less in larger quantities, TODAY as well as in the future. (50% off for 100K.)

	TOTAL COST AT PUBLISHED 100 PIECE PRICES	TOTAL NUMBER OF PINS
<b>ENCODER FOR 24 LINES</b>		
3 COMDACs® Converter (DAC-86μ-Law or DAC-87 A-Law)	\$ 27.00	54
3 Comparators (CMP-01)	9.00	24
3 SAR's (2502-PC)	9.90	48
3 S/H AMPS (SMP-81)	28.50	42
3 8-Channel Multiplexers (MUX-88)	22.50	48
1 Voltage Reference (REF01 = 10V or REF02 = 5V)	2.95	8
9 Gates (TTL)	3.00	126
<b>DECODER FOR 24 LINES</b>		
1 COMDAC® CONVERTER	9.00	18
1 OP AMP (OP-16)	2.50	8
3 8-Channel Multiplexers (MUX-88)	22.50	48
<b>21 TOTAL LSI/MSI IC PACKAGES PER LINE</b>	<b>\$136.85</b>	<b>424</b>
	<b>\$5.70</b>	<b>18</b>

"Why go to all this trouble just to save a few bucks?" one might ask. The Cheshire Cat knows! Why do you think he's grinning? He knows that CODECs are a major cost item in PCM systems, and less expensive CODECs mean more competitive systems. Is there any telephone equipment manufacturer who doesn't have to worry about competition? (Well, maybe ONE!)

Furthermore, the Cheshire Cat is grinning because he knows that if you don't try to put so many different functions on one chip, the process can be optimized for each function. This not only means lower cost per line due to higher yields, but also lower noise, better performance and better reliability. System signaling and supervision are flexible with the shared CODEC approach, too.



### A COMDAC® Converter is not a CODEC

"If you're not a CODEC, what are you, then," said the circuit designer.

"I'm a D/A converter," said the COMDAC® CONVERTER ("CC").

"A likely story indeed. You have no reference, no op amp. You're 'incomplete'."

"Ah, but I'm optimized," said "CC," grinning like the Cheshire Cat. "I conform precisely to the μ-Law or A-Law, whichever you prefer. I do both the conversion and companding and need no special ion implant or thin film processes. So I work inexpensively and reliably."

"I have thin film resistors," interrupted the Voltage Reference.

"Sure, but you're a small chip," chortled the "CC." "Furthermore, we only need one of you for lots of channels, so your cost is negligible."

"What about my ion implant?" asked OP-16.

"You're a small chip, too," replied "CC." "You need the fancy processes to get your speed and input accuracy. But I'm not about to let you on the same chip with me! Otherwise, I'd have to get the ion implant, too, and my friend Circuit Designer doesn't want to pay for it where it's not needed. Besides, I only need you to decode. For encoding, I can do nicely without you, thank you!"

"But you need me for encoding and I get ion implant, too," said SMP-81.

"Yes, but for a different reason," said "CC." "You don't have FETs like OP-16. You use ion implant for Super Beta, so you can work in the heat or in the cold, and still do the job. I do need you for encoding, but not for decoding. Sorry, no economic advantage to having you on my chip. Oh, and before you ask, Comparator, I don't need you to decode either. So you stay off my chip, too."

"What about me?" asked MUX-88. "I'm new. I have low cross-talk, low on-resistance, super off-isolation, meet all system specs and cost less than any analog MUX on the market!"

"RIGHT!" said "CC." "What's your question?" "I guess I just answered it," said MUX.

PMI's CODEC parts are *all* available right now. And they're all backed by PMI's reputation for high quality and reliability with our world famous Triple Passivation Process.

You already know how easy it is to get lost in Linear Wonderland, so let PMI be your guide. If you can tell us where you want to be, we can tell you how to get there. Then we'll *both* be grinning like the Cheshire Cat while everyone else is still trying to find the road.

Send in the coupon below for your free "WHY IS PMI SMILING?" samples to start you on your way — or get them from the guys on the following page.

If someone beat you to the coupon, write to us for your sample. Or circle #200 for literature.



#### Precision Monolithics, Incorporated

1500 Space Park Drive  
Santa Clara, California 95050

Phone: (408) 246-9222 TWX: 910-338-0528 Cable: MONO



#### Precision Monolithics, Incorporated c/o BOURNS AG

ZUGERSTRASSE 74, 6340 Baar, Switzerland

Phone: 042/33 33 33

Telex: 78722



I'd like for PMI to make me grin like a Cheshire Cat. Please send me the following samples:

- |   |   |
|---|---|
| <input type="checkbox"/> COMDAC® DAC-86 (μ-LAW) CONVERTER | <input type="checkbox"/> MUX-88 — 8-CHANNEL BIFET MULTIPLEXER |
| <input type="checkbox"/> COMDAC® DAC-87 (A-LAW) CONVERTER | <input type="checkbox"/> OP-16 — BIFET OP AMP                 |
| <input type="checkbox"/> SMP-81 — S/H AMPLIFIER           | <input type="checkbox"/> REF01 — 10 VOLT REFERENCE            |
| <input type="checkbox"/> CMP-01 — COMPARATOR              | <input type="checkbox"/> REF02 — 5 VOLT REFERENCE             |
- I don't need samples, but data sheets will make me grin too.

Mail to either of the above addresses.

My name \_\_\_\_\_

Title \_\_\_\_\_

Company \_\_\_\_\_

Dept. \_\_\_\_\_

Address \_\_\_\_\_

Packaging & production

## System tests while RAM burns

---

Unit simultaneously handles  
64-K dynamic and 4-K static  
read/write memories

---

As 65,536-bit read/write random-access memories begin to appear on the market, users as well as chip makers will want to put the new devices through environmental tests. Unfortunately, such testing usually takes many steps and much time. To help out, Aehr Test Systems is introducing a burn-in system with a

difference it makes functional tests on memories while it burns them in.

Called the MBT-100, the system can perform functional tests on 64-K dynamic and 4-K static memories with no need for the user to make any hardware changes, according to Aehr president Rhea Posedel. He believes his system can save time in reliability testing, where the procedure now is to "cook them, take them out, and test them, and then put them back in and cook them." Furthermore, he points out, "then you only pick up the gross errors; you don't pick up the soft errors."

Test parameters, including clock rates and power-supply voltage levels, are stored in an electrically erasable programmable read-only memory. Thus, during a 12-hour burn-in, the memory parts could be sub-

jected, for example, to a data-retention test, a voltage stress test, and a logic pattern to which they are particularly susceptible. Failures are logged on a printer that lists the precise test conditions under which the part failed as well as the nature of the test and the time.

The MBT-100 can test up to 832 chips at a time and has two zones—one for 64-K dynamic memories; the other for 4-K statics. Typical testing speed is 2 MHz (500-ns cycle time), although static memories can be tested with cycle times as low as 300 ns.

An 8080 microprocessor controls system timing and interfacing, but proprietary circuitry of the 7400 series, mostly low-power Schottky, energizes the driver boards, handling clock drives and error monitoring, Posedel says. There is one driver board for each burn-in position. The tester, whose main chamber measures approximately 3 by 4 by 5 feet, sells for about \$60,000.

Aehr Test Systems, 440 Hurlingame Ave., Redwood City, Calif. 94063. Phone (415) 366-3831 [391]

---

## Meter tests components between 10 kHz and 10 MHz

Most LCR meters test components at a single frequency—not necessarily the one at which the component will be operating. But the 4275A LCR meter, a microprocessor-controlled instrument, can test a component at any of 10 frequencies between 10 kHz and 10 MHz. Also, the amplitude of the test signal can be varied from 1 mV to 1 V rms.

The meter can completely characterize a device's impedance or admittance. It can measure the inductance and Q of magnetic components such as ferrite cores and filter coils, as well as the capacitance, equivalent series resistance, and dissipation factor of various types of capacitors. It also provides direct readout of resistance, inductance, conductance, reactance, susceptance, and the magnitude and angle of admittance and conductance. Full-scale measure-

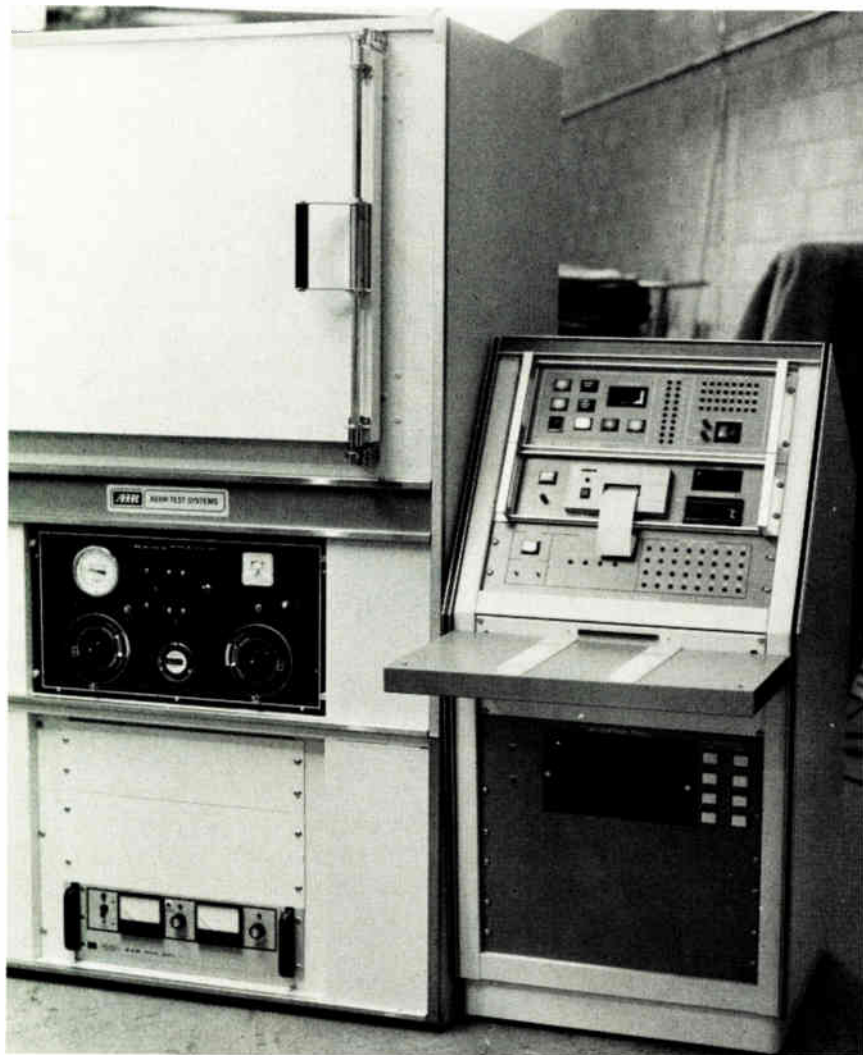

ments range from 100 nH to 1 H, 1 pF to 100  $\mu$ F, and 1  $\Omega$  to 10 M $\Omega$ —all accurate to within 0.1% of reading. The instrument can measure and display two parameters simultaneously with 4½- or 5½-digit resolution.

The 4275A can be integrated into a system with either an isolated or a nonisolated interface-bus option, both of which offer total automation of complex measurements. Two dc bias options, covering the range from 0 to  $\pm 100$  v dc, eliminate the need for external dc supplies.

The instrument operates from an input of 100, 120, or 220 v ac  $\pm 10\%$  or 240 v ac  $+5\%/-10\%$ , at 48 to 66 Hz. Selling for \$8,720, the unit measures 177 by 425.5 by 574 mm and weighs 18 kg. Delivery time is 60 days.

Hewlett-Packard Co., 1507 Page Mill Rd., Palo Alto, Calif. 94304 [394]

## Wrapped-wire posts do double duty

T46-5-9 posts can function individually as terminals for wrapped-wire interconnections or side by side to mate to a ribbon-wire connector. Each 0.025-in.-square post extends 0.24 in. above the board and 0.64 in. below. These lengths allow the post to be wrapped with two and three wires, respectively. The posts are also offered with top lengths of 0.32 or 0.42 in. and bottom lengths of 0.36 or 0.42 in. A stop bar ensures consistent insertion depth.

The tin-plated T46-5-9 sells for \$3.58 for a package of 100, and \$28.93 for 1,000. The gold-plated

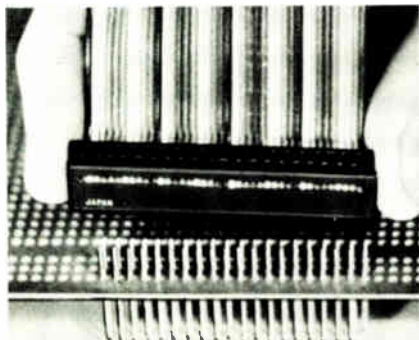

T46-5A-9 sells for \$5.97 for 100 and \$51.93 for 1,000.

Vector Electronic Co., 12460 Gladstone Ave., Sylmar, Calif. 91342. Phone (213) 365-9661 [395]

## Rotary table speeds substrate exposure

The 8422 rotary table has dual alignment fixtures that let it expose one substrate while the operator is still unloading a previously exposed one. The system can be used for contact or proximity printing and will accept masks and substrates of various sizes. Masks may range from 2 by 2 in. to 5.5 by 5.5 in., substrates from 1 by 1 in. to 6 by 6 in. in size. The table can be positioned precisely in the X, Y, and Z directions.

Depending on the table style, the price ranges from \$2,000 to \$10,000. Delivery time is 10 to 12 weeks.

Oriel Corp., 15 Market St., Stamford, Conn. 06902. Phone (203) 357-1600 [396]

## Etcher combines dry-plasma and reactive-ion techniques

The DEA-503 reactive-ion etching or dry etching system is designed to meet the fine-resolution requirements of extremely high-density integrated circuits. The unit produces patterns to within 0.2  $\mu$ m and etches aluminum at 2,000  $\text{\AA}$  per minute with selectivity to silicon dioxide of 30:1. The use of planar electrodes keeps etching uniform, with a deviation of only  $\pm 5\%$  from lot to lot. Having an idle time of less than 15 seconds, the system processes 30 2-in., 14 3-in., or 7 4-in. wafers per cycle. According to the manufacturer, etching can be done with extremely low power, resulting in minimal semiconductor damage. An end-point detection monitor, which measures luminous spectra in the plasma, is optional. The system sells for from \$70,000 to \$100,000. Delivery time is four months.

Roberts' Associates, 536 Weddle Dr., Sunnyvale, Calif. 94086 [397]

## PMI SALES OFFICES

### CALIFORNIA

1500 Space Park Drive  
Santa Clara, CA 95050 (408) 985-6616

9800 S. Sepulveda Blvd., Suite 818  
Los Angeles, CA 90045 (213) 670-3791

### ILLINOIS

605 East Algonquin Road, Suite 470  
Arlington Heights, IL 60005 (312) 437-6697

### MASSACHUSETTS

200 W. Cummings Park, Suite M-32  
Woburn, MA 01801 (617) 933-1517

### PENNSYLVANIA

P.O. Box 346  
Ridley Park, PA 19078 (215) 521-1441

### TEXAS

2550 Walnut Hill Lane, Suite 166  
Dallas, TX 75229 (214) 357-1581

## PMI DISTRIBUTORS

### BELL INDUSTRIES

Gardena - (213) 515-1800  
(714) 521-4914

Sunnyvale - (408) 734-8570

### CENTURY ELECTRONICS

Albuquerque - (505) 292-2700

Salt Lake City - (801) 972-6959

Wheatridge - (303) 424-1985

### CESCO ELECTRONICS

Montreal/Quebec - (514) 735-5511

### ELMAR/WYLE

Bellevue (Seattle) - (206) 453-8300

Commerce City (Denver) - (303) 287-9611

Mt. View - (415) 961-3611

### FUTURE ELECTRONICS

Montreal, Quebec - (514) 735-5775

Ottawa, Ontario - (613) 820-9471

Toronto, Ontario - (416) 663-5583

### GERBER ELECTRONICS

Dedham - (617) 329-2400

### HALL-MARK ELECTRONICS

Austin - (512) 837-2814

Baltimore - (301) 796-9300

Bloomington - (612) 884-9056

Dallas - (214) 234-7400

Earth City - (314) 291-5350

Elk Grove - (312) 437-8800

Ft. Lauderdale - (305) 971-9280

Houston - (713) 781-6100

Huntington Valley - (215) 355-7300

Huntsville - (205) 837-8700

Orlando - (305) 855-4020

Raleigh - (919) 832-4465

Shawnee Mission - (913) 888-4747

Tulsa - (918) 835-8453

West Allis - (414) 476-1270

Worthington - (614) 846-1882

### HARVEY ELECTRONICS

Binghamton - (607) 748-8211

Lexington - (617) 861-9200

Norwalk - (203) 853-1515

Pine Brook - (201) 575-3510

W. Henrietta - (716) 334-5920

Woodbury - (516) 921-8700

### INTEK ELECTRONICS

Vancouver - (604) 324-6831

### INTERMARK ELECTRONICS

San Diego - (714) 279-5200

(714) 453-9005

Santa Ana - (714) 540-1322

Sunnyvale - (408) 738-1111

### LIBERTY/WYLE

El Segundo - (213) 322-8100

Phoenix - (602) 249-2232

San Diego - (714) 565-9171

### PIONEER ELECTRONICS

Cleveland - (216) 587-3600

Dayton - (513) 236-9900

Elk Grove - (312) 437-9680

Indianapolis - (317) 849-7300

Livonia - (313) 525-1800

Pittsburgh - (412) 782-2300

### SEMI-OICE

Long Beach - (213) 597-0358

### WESTATES ELECTRONICS

Chatsworth - (213) 341-4411

Costa Mesa - (714) 549-8401

Sunnyvale - (408) 744-1555

### YANKEE ELECTRONIC SUPPLY, INC.

Londonderry - (603) 625-9746



**We think an OEM computer should be able to take your marketing around the world.**





At Digital, we think the last thing an OEM computer should do is limit your options.

Not just your performance options.

But your marketing options too.

That's why we make computers that you can add value to, and then sell virtually anywhere.

They're available with features like a universal power supply that will work from any electrical current in the world at the flick of a switch.

We even engineer our products to fit into standard sized shipping containers. To be handled easily by the fewest number of people. To be assembled quickly by almost anyone, without special tools.

At Digital, our approach has always been to give OEMs more than just great product. Just as important are the extra quality features, the extra testing that can make your design and marketing job easier. The software compatibility that can take you from micros to 32-bit large-scale computers, from one generation to the next. The worldwide service capability that can be tailored exactly to the way you run your business. It's an approach designed to help you meet a wide range of computer strategies.

You probably already know a lot about Digital performance. To find out the rest, send for our new brochure, "The Thinking Behind the Industry's Largest Selling Line of OEM Computers."

Digital Equipment Corporation, (PK3/M-86), Maynard, MA 01754. (617) 493-6253. In Europe: 12 av. des Morgines, 1213 Petit-Lancy/Geneva. Tel. 93 33 11. In Canada: Digital Equipment of Canada, Ltd.

**We build a lot more than performance into an OEM computer.**

**digital**

Circle 165 on reader service card

# Engineers . . . Isn't it about time you had one more moving experience?

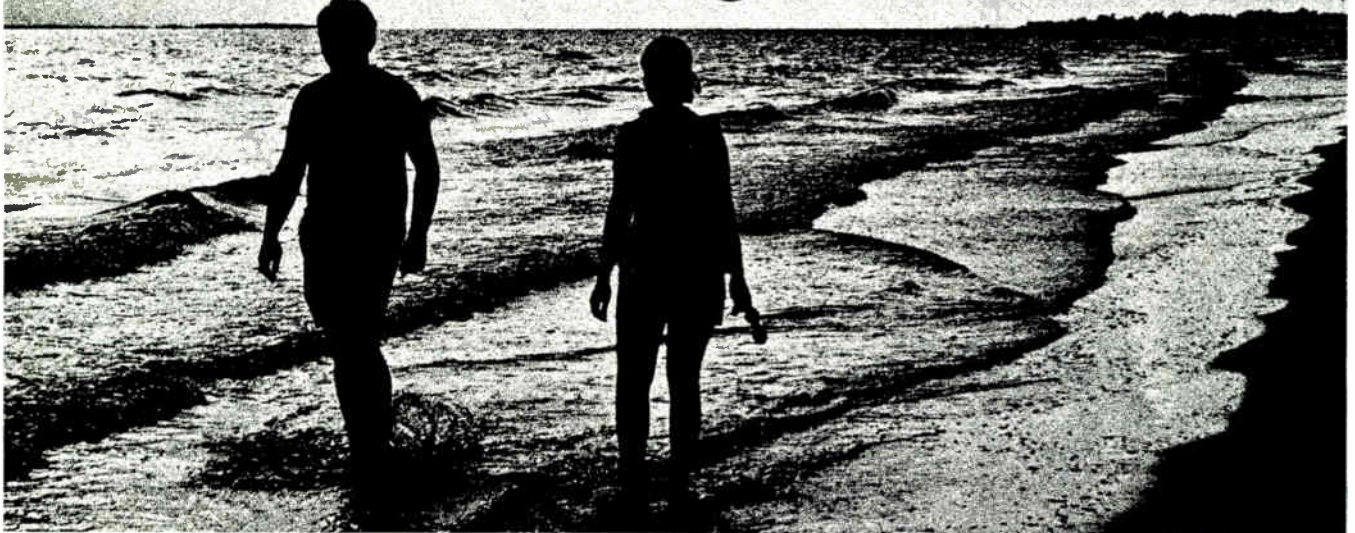

Instead of sitting around just wondering what it would be like to join the nation's number one avionics team you owe it to yourself to find out. Over 80 longterm sub-contracts and millions more in diversified R&D business have created exciting and secure career opportunities for top engineers with Honeywell-in-Florida. A higher after-tax take-home pay, a lower cost of living, a more exciting career challenge, and a new life in one of America's "most liveable" cities where vacation begins every day after work. It all adds up to Honeywell-in-Florida.

You'll appreciate Honeywell-in-Florida's commitment to engineering excellence. And the freedom you'll have to realize your full career potential in a company which recognizes and rewards achievement.

## Welcome To The Good Life!

Living on Florida's famous Suncoast is more than just sun and sand and fun.

Sure, there's a 98.9041 per cent chance of sunshine every day and you can swim in the middle of winter. But equally as important, you can watch a Broadway show or Las Vegas headliner talent, catch major league NFL football or NASL Soccer, enjoy first class opera and symphony concerts, or tour one of the many art museums in the area. Or you can take the whole family to nearby Disney World, Circus World, or Busch Gardens. Whatever you want to do is here for you. On Florida's famous Suncoast. The family place.

If being involved with something really significant is important to you, then we're your

kind of company. And if you and your family like the idea of moving to Florida's Suncoast, where your new salary with Honeywell-in-Florida will be worth thousands more a year, rush us the "Instant Application" in complete confidence, of course.

### Honeywell-in-Florida has immediate and long term needs for Engineers in the following disciplines:

- Mechanical Design
- Software Engineering
- Systems Engineering
- Computer Systems
- Digital Design
- Analog Circuit Design
- Reliability Engineering
- Analog Design
- Production Test
- Production Build
- Electronics Design

Avionics Division  
**Honeywell**  
in Florida A place in the sun for you!

Honeywell is an equal opportunity employer actively seeking applicants under its Affirmative Action Program.

\*Christian Science Monitor.

## "INSTANT APPLICATION"

Name \_\_\_\_\_  
Address \_\_\_\_\_  
City \_\_\_\_\_ State \_\_\_\_\_  
Zip \_\_\_\_\_  
Home Phone \_\_\_\_\_  
Business Phone \_\_\_\_\_  
Job Applying for \_\_\_\_\_  
Present Employer \_\_\_\_\_  
Salary requirements \_\_\_\_\_  
Present salary \_\_\_\_\_  
Dates Employed \_\_\_\_\_  
Job title \_\_\_\_\_

Duties \_\_\_\_\_  
Previous Employer \_\_\_\_\_  
Dates Employed \_\_\_\_\_  
Job title \_\_\_\_\_

Duties \_\_\_\_\_  
Previous Employer \_\_\_\_\_  
Dates Employed \_\_\_\_\_  
Job title \_\_\_\_\_  
Duties \_\_\_\_\_  
Education \_\_\_\_\_  
Other Experience \_\_\_\_\_

Mail to: G Manthos  
Avionics Division,  
Honeywell-in-Florida  
13350 U.S. Hwy 19  
Pinellas County, Florida 33733

Avionics Division  
**Honeywell**  
in Florida A place in the sun for you!



# The Panasonic Dream Machine.

Selecting the right microcomputer for your product is tricky business. There are so many variables. Like the technology. What's available to fit your design requirements? With how many on-chip functions? How many instructions? How fast? How much memory?

Now there's one family of microcomputers with all the right answers. The Panasonic 4-bit MN1400 series.

### Three technologies

Panasonic MN1400's are available as C-MOS, P-MOS and N-MOS to fit your specific design requirements. You can fit the right chip to your design.

Model	Package	On Chip Memory		
		Instruction ROM	Data RAM	
N-MOS	MN1400	40 Pin DIP /Plastic	1024 x 8 bits	64 x 4 bits
	MN1402	28 Pin DIP /Plastic	768 x 8 bits	32 x 4 bits
	MN1403	18 Pin DIP /Plastic	512 x 8 bits	16 x 4 bits
	MN1404	16 Pin DIP /Plastic	512 x 8 bits	16 x 4 bits
	MN1405	40 Pin DIP /Plastic	2048 x 8 bits	128 x 4 bits
	MN1498	40 Pin DIP /Plastic	External	64 x 4 bits
P-MOS	MN1430	40 Pin DIP /Plastic	1024 x 8 bits	64 x 4 bits
	MN1432	28 Pin DIP /Plastic	768 x 8 bits	2048 x 8 bits
	MN1435	40 Pin DIP /Plastic	32 x 4 bits	16 x 4 bits
C-MOS	MN1450	40 Pin DIP /Plastic	1024 x 8 bits	64 x 4 bits
	MN1453	18 Pin DIP /Plastic	512 x 8 bits	16 x 4 bits
	MN1454	16 Pin DIP /Plastic	512 x 8 bits	16 x 4 bits
	MN1455	40 Pin DIP /Plastic	2048 x 8 bits	128 x 4 bits

### Varying computing power

The 12-strong MN1400 microcomputer family offers devices with varying amounts of computing power, so you can choose the chip that meets your specific requirements. And even if your memory needs change, you can substitute another model within the family and save your basic design. You pay only for the computing power you need.

### They're all on the chip

We put all these microcomputer functions on a single chip:

- ALU
- Up to 16,384 (2048 x 8) bit ROM
- Up to 512 bits (128 x 4) RAM
- Two 4-bit parallel input ports
- 4-bit parallel output port
- 8-bit output port with PLA
- With 12 discrete output lines
- 8-bit counter/timer
- Clock generator

Add to that the fast 10 $\mu$ s instruction speed and a powerful instruction set with up to 75 versatile instructions that let you computerize a variety of end products with ease.

And you needn't stop with design. Panasonic takes you from concept through production with software and hardware development tools: cross-assemblers, edit software and debugging and prototyping hardware, and, of course, fast turnaround in mask preparation.

So if on-chip capability has been giving you sleepless nights, take the Panasonic cure. For complete information and prices write to Panasonic Electronic Components, One Panasonic Way, Secaucus, NJ 07094; or call (201) 348-7269.

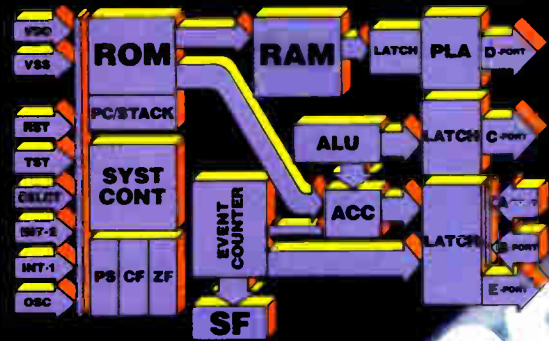

P-MOS

N-MOS

**The 4-bit  
microcomputer with  
three technologies  
and varying  
computing power**



**Panasonic**<sup>®</sup>  
just slightly ahead of our time

Circle 167 on reader service card

## YOU'LL FEEL RIGHT AT HOME AT BOEING.

Since most of us spend the better part of our lives at work, it should feel good to be there.

But if your job has turned hum-drum and ho-hum, it probably doesn't.

Maybe Boeing can help you put the zing back in your workday.

We're growing by leaps and bounds. With all kinds of aerospace projects going on. On land. In the air. At sea. In outer space. We're creating job opportunities and excitement all over the place.

To put it simply, your days at Boeing would be full.

Then when the workday's over or the weekend rolls around, you can feel even more at home. Because you'll be living in one of America's most beautiful cities — Seattle.

If a job at Boeing sounds so far like it might be worth leaving home for, we'd like to tell you more.

Just send your résumé to The Boeing Company, P.O. Box 3707-LRT, Seattle, WA 98124.

An equal opportunity employer.

### WE HAVE IMMEDIATE OPENINGS IN:

#### COMMUNICATIONS ENGINEERING

- Analysis, Design and Test

#### E/E DESIGN ENGINEERING

- Computers and Displays Design
- Digital Circuit Design
- Electronic Packaging Design
- Wiring and Connector Design

#### E/E MANUFACTURING ENGINEERING

- Microelectronics
- Electronic Equipment
- Printed Wiring Boards

#### E/E PARTS ENGINEERING

#### SOFTWARE ENGINEERING

- Operational Software Development
- Software/Computing System Design and Analysis
- Software/Computing System Test and Evaluation

#### SYSTEMS ENGINEERING

- Systems Design and Analysis
- Systems Requirements Definition

#### TEST ENGINEERING

- Automated Test Instrumentation Development
- Electrical/Electronic Test
- Test Systems Software Development
- Test Program Planning
- Flight/Mission/Systems Test

**BOEING**  
GETTING PEOPLE TOGETHER

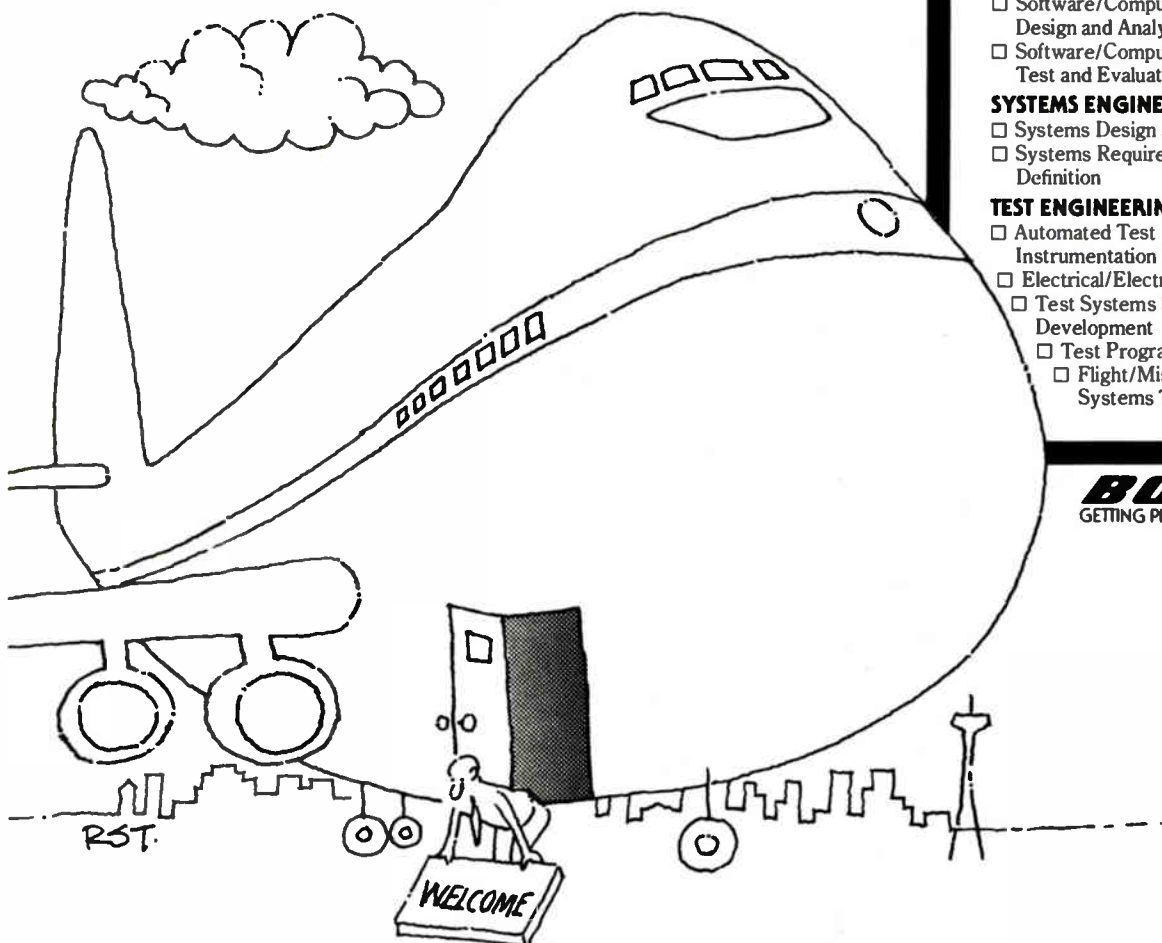

MOTOR SHOWN ACTUAL SIZE

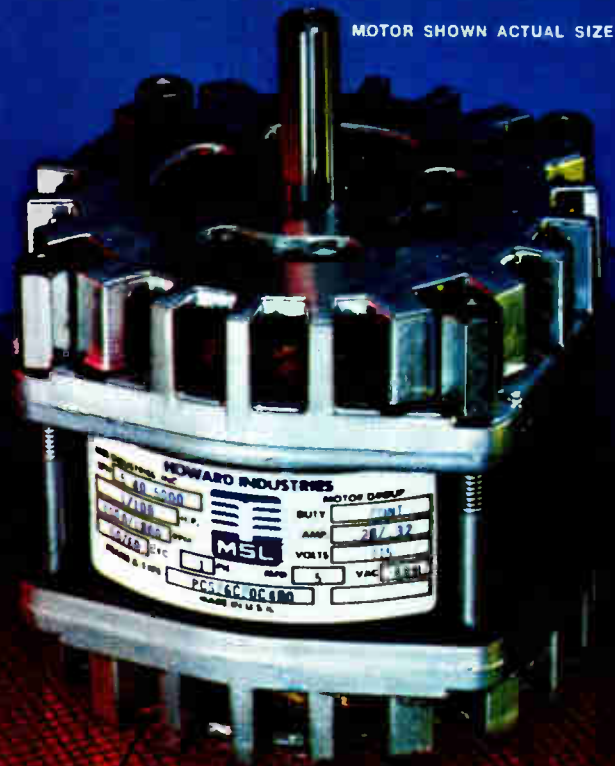

# NEW line of "high performance" induction drive motors

Same power in a  
smaller package!

Completely  
interchangeable!

Howard's new "high performance" line of FHP motors is perfectly suited for all types of business equipment drives. 16.7% shorter than motors of equal power — only 2¾" high.

#### WIDE RANGE OF DESIGN CONFIGURATIONS

Square wave 24VAC—48VAC, Frequency 50-60 cycles, Voltage 100 V thru 256 V, Speeds synchronous to 3600 RPM, non-synchronous to 3400 RPM, Power 1/100 HP to 1/10 HP.

UL and CSA approvable, available in PC, capacitor start or split phase models.

SEND FOR NEW 26-33 Frame Induction Motor Catalog with full specifications.



# HOWARD

HOWARD INDUSTRIES One North Dixie Highway, Milford, Ill. 60953. Phone: (815) 889-4105

Circle 169 on reader service card

# Volkmeters for Sunny Days!

Now with LCD's  
AND longer battery operation



LM-300 3 digits \$114  
LM-350 3½ digits \$144

**Features Include:**

- Measures VDC, VAC, DCmA, ACmA (four ranges each) and ohms (five ranges). • Auto zero, auto polarity and overload indication.
- DC accuracy - LM-300: 1%; LM-350: 0.5%.
- Input protection. • Small size: 1.9" H x 2.7" W x 4.0" D. • Optional NiCad batteries and charger unit available at extra cost.



**Non-Linear Systems, Inc.**

Originator of the digital voltmeter.  
Box N, Del Mar, California 92014  
Telephone (714) 755-1134 TWX 910-322-1132

Circle 170 on reader service card

## MOVING?

Please give us 4 weeks advance notice. Attach the label for your old address, write in your new address below, and send to Fulfillment Manager, Electronics, P.O. Box 430, Hightstown, N.J. 08520.

OLD  
ADDRESS  
LABEL

**NEW ADDRESS**

Name \_\_\_\_\_

Address \_\_\_\_\_

City \_\_\_\_\_

State/Province \_\_\_\_\_

Zip/Postcode \_\_\_\_\_

Country \_\_\_\_\_

## New products

Microcomputers & systems

### Adac offers two Q-bus boards

Data-acquisition card has 14-bit resolution; dual-port board saves computer space

With input/output boards for the LSI-11 and LSI-11/2 popping up like mushrooms after a spring shower, a board has to offer something special to create interest in potential users. For Adac's model 1014 data-acquisition system, that something special is 14-bit resolution and accuracy. For the model 1750 dual-port asynchronous serial line I/O card, the key feature is its small-quantity price of \$395. Both new boards are dual-width units—8.5 by 5 inches—and are compatible with the Digital Equipment Corp. Q bus.

The model 1014 data-acquisition

system has a relatively high throughput rate of 10 kHz. It requires 15  $\mu$ s to settle and 85  $\mu$ s to perform a 14-bit analog-to-digital conversion. The system provides 16 single-ended or 8 fully differential channels, which can be expanded up to 64 single-ended or 32 differential using an expander board. Full-scale ranges are selected by means of jumpers, whereas register and vector addressing is done by means of on-board DIP switches.

The temperature coefficient of nonlinearity of the 1014 is less than 1 part per million of full-scale range per °C. The unit's operating temperature range of 0° to 55°C suits it well for conditions in a computer environment. Extensive shielding over the analog circuitry ensures that the computer circuitry will not interfere with the reliable acquisition of input signals.

The 1014 can gain access to the computer in one of three ways: by program control, by program interrupt, or by direct memory access. With either program control or

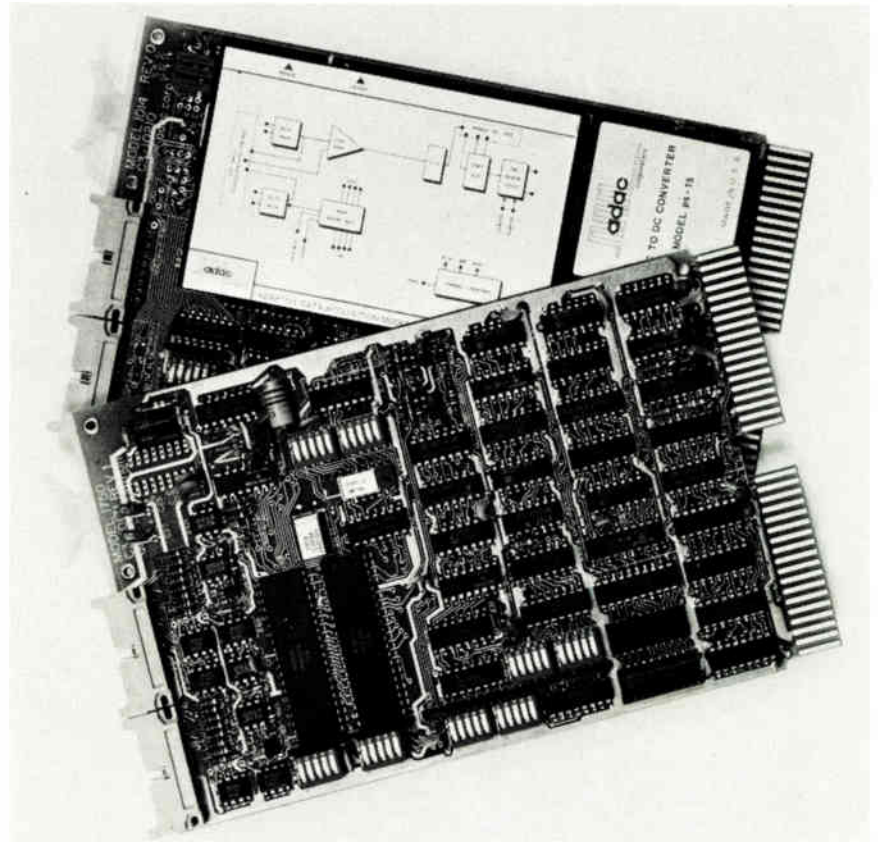

# How do you see fiber optics?

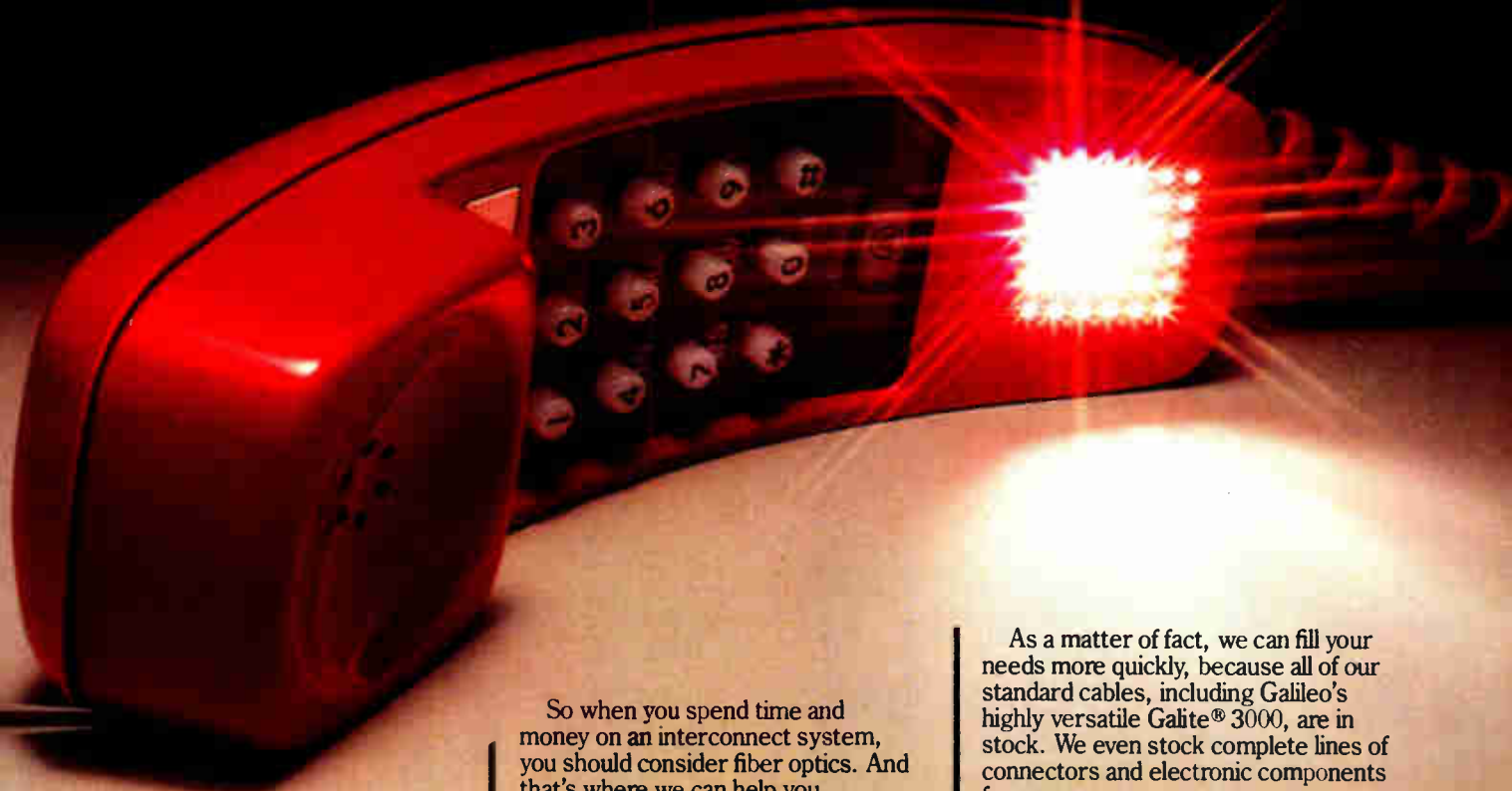

Fiber optics is getting so much publicity from its use in telephone communications that you may see that as its only important application. It's not.



Optical communication cables are being used in computers, process instruments and control applications. They weigh less and take less space. They eliminate electrical and electronic interference as well as ground loops. They can be more economical. And every day, they're making the old standard interconnect systems obsolete, one by one.

So when you spend time and money on an interconnect system, you should consider fiber optics. And that's where we can help you.

We can help you make the right choices for your system. Choices in line attenuation, mechanical strength, environmental isolation, light coupling efficiency. Choices in every element you need.

Ours is the broadest line of optical communication cables in the industry. We've been working with fiber optics for 20 years. And engineers have already put more than 2,000,000,000 feet of our fiber optic products in use. Since we make our cables from raw materials to finished product, we can fill your needs exactly. And at the least expense.



**Galileo Electro-Optics Corp.**  
Galileo Park, Sturbridge, Massachusetts 01518

**Progress made practical.**

As a matter of fact, we can fill your needs more quickly, because all of our standard cables, including Galileo's highly versatile Galite® 3000, are in stock. We even stock complete lines of connectors and electronic components for you.

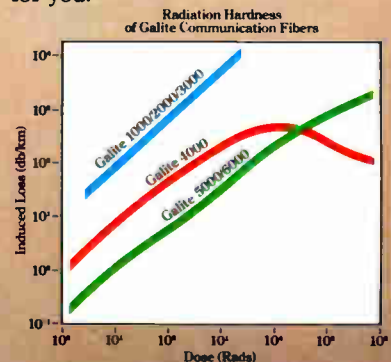

You can write to Galileo for a detailed information package that will give you a good idea of what fiber optics can do for you today. Or you can call Galileo's application engineers at (617) 347-9191 for specific personal help on how... and where fiber optics could fit into what you're doing today.

You will find we offer more than fiber optics. We also offer know-how.

Circle 171 on reader service card

# It's no coincidence that Murata-Georgia is the fastest growing ceramic capacitor manufac- turer in the U.S.A.

In 1973, we made a decision: Murata-Georgia would create an unsurpassed ceramic capacitor capability and we'd do it fast. We're well on our way. Since 1974, our Rockmart, Georgia plant, already one of the most automated ceramic disc facilities in the world, has been expanded four times. We're presently building a completely automated plant to meet the unprecedented demand for monolithic glass, epoxy and chip capacitors in Douglasville, Georgia. Our corporate headquarters in Marietta, Georgia ties it all together with one of the most sophisticated data processing systems in the industry for inventory control and customer service.

Combine Murata-Georgia's rapidly expanding production capability with a line of ceramic

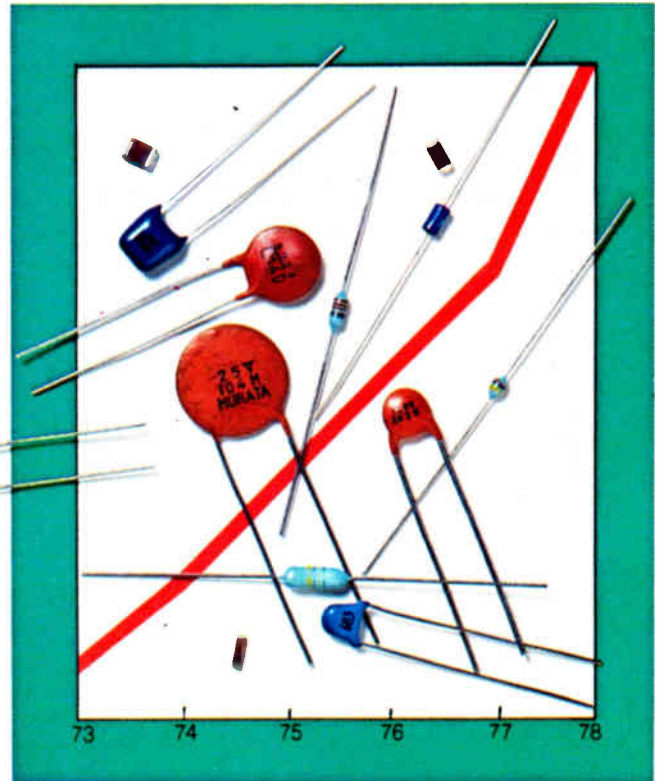

discs, monolithics and high voltage units based on over 30 years of ceramic capacitor experience, and it's easy to understand why Murata-Georgia is the fastest growing manufacturer in the field.

Coincidence? Not on your life. We've planned it that way.

**muRata-Georgia**

MURATA CORPORATION OF AMERICA

1148 Franklin Road, S.E.

Marietta, Georgia 30067

Phone: 404-952-9777

## New products

program interrupt, the 1014 operates as an independent unit. With DMA it can transfer data into the computer memory at its top speed of 10 kHz, according to A. L. Grant, vice president for marketing and sales. Grant expects the 1014 to be used mainly in scientific research and development, although he maintains that some applications also exist in process control and other industrial areas. "The biggest area will be R&D," he says, "but it will sell in all three marketplaces." In quantities of one to four, the system is priced at \$1,195.

**Compact.** Adac's second new Q-bus product, the model 1750 has more going for it than just its \$395 price, also in quantities of up to four. The board saves a lot of space by providing two independent serial I/O ports on a single card. Each I/O channel will perform serial-to-parallel and parallel-to-serial data conversions using universal asynchronous receiver/transmitters (UARTs). Transmission may be carried out at switch-selectable rates from 50 to 19,200 bauds. The transmitter will also perform parallel-to-serial conversion of data provided by the LSI-11 bus with a 5-, 6-, 7-, or 8-bit data format; the length of the code is switch-selectable. The receiver does serial-to-parallel conversion with the same format.

Each channel can operate with the following interfaces: RS-232-C, RS-423, RS-422, an optically isolated active 20-mA channel loop, or an optically isolated passive current loop. Jumpers allow each channel to be set up independently for a particular line discipline.

The 1750 contains sockets for a 512-word-by-16-bit programmable read-only memory, which may be used for program storage of bootstraps, down-line loading, or other functions. Alternatively, two 512-byte-by-8-bit fusible-link PROMs can be used to store two 256-by-16-bit arrays. Addressing of one or both arrays is automatically available using wire-wrapped jumper-selectable DEC REV11-compatible addresses.

There will be two major areas in

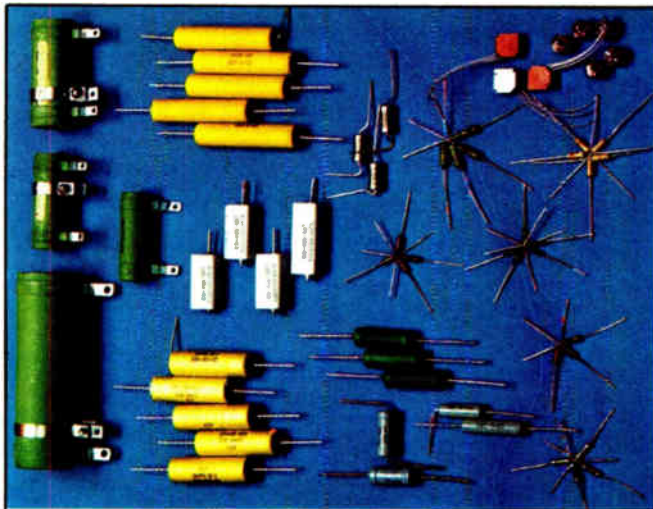

# NEED RELIABLE CIRCUITRY? ELORG RESISTORS WILL DO THEIR BIT!

With their specifications that meet IEC standards for dimensions, ratings and tolerances.

Some 50 types of fixed, variable, wirewound and non-wire resistors include

- S2-33i miniature metal film resistors for 0.25W and 0.5W power dissipation ratings; maximum temperature coefficient  $500 \times 10^{-6}/^{\circ}\text{C}$ ; packed in adhesive tape or placed on tape reels; color code markings;
- S1-4M carbon resistors for 0.25W power dissipation ratings, average temperature coefficient  $800 \times 10^{-6}/^{\circ}\text{C}$ ; packed in adhesive tape or placed on tape reels; color code markings;
- precision non-wire fixed resistors S2-29 for 0.125, 0.25, 0.5, 1.0 and 2.0W power dissipation ratings, temperature coefficient  $\pm 25 - \pm 300 \times 10^{-6}/^{\circ}\text{C}$ ; resistance tolerance  $\pm 0.1$ ;  $\pm 0.25$ ,  $\pm 0.5$  and  $\pm 1.0$  percent;
- thermal resistors;
- photoresistors;
- varistors.

## Sole exporter -



32/34 Smolenskaya-Sennaya  
121200 Moscow  
USSR

Telephone 251-39-46, Telex 7586

# You get a much better performance when the maestro is a SHARP SM-4.

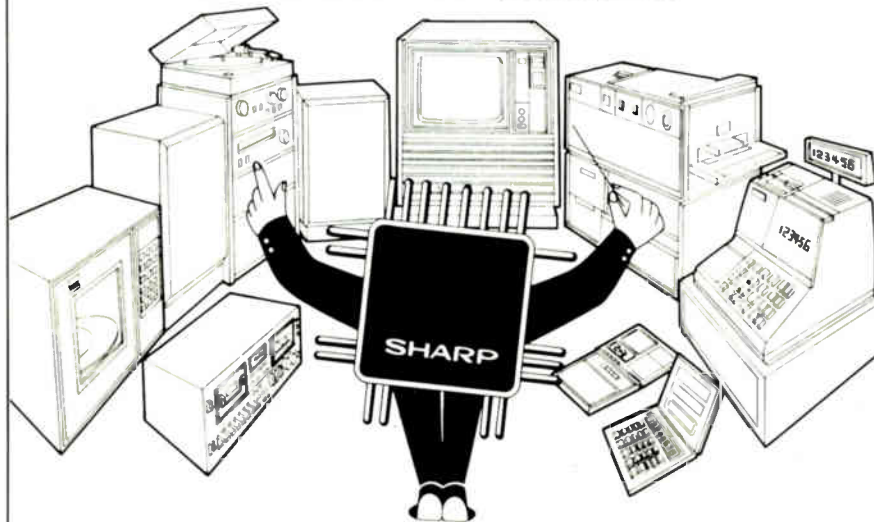

## Low power consuming 4-bit one chip C-MOS microcomputer for direct interface with Liquid Crystal Displays (accurate time control with crystal oscillator)

Our little SM-4 delivers a perfectly-orchestrated performance from all kinds of instruments—from calculators to vending machines. And it's not only versatile, it consumes very little energy. Since it contains high RAM/ROM capacities, static shift register, 15-stage divider and other peripheral circuits on one chip, it can be mass produced at a substantial reduction in cost. So at Sharp, we've already put our little semiconductor to work directing the operation of such products as our electronic tape processor and clock-calculators. So look over the numbers behind the SM-4 performance. We think you'll like this little maestro so much you'll end up asking for encores.



ROM capacity	2268 bytes x 8 bits
RAM capacity	96 words x 4 bits
Instructions	54
Subroutine level	1 level
Input port	6 bits
Output port	41 bits
Input/output port	4 bits
Divider	15-stage divider with reset
Drive circuit	LCD internal drive circuit (external RAM drive)
Others	Internal crystal oscillation circuit, internal low voltage detection circuit, single power supply (-3V Typ.), 60-pin quad package

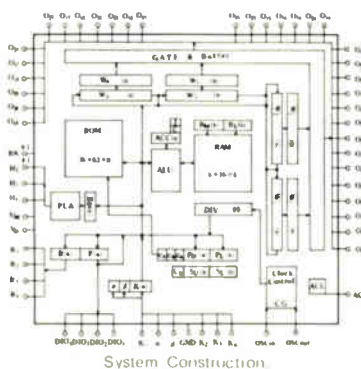

### Applications

- Clock-calculators
- Programmable remote controls
- Programmable digital timers
- Programmable timing systems
- Multi-function telephone sets
- Cameras etc

For further information, write to:  
Mr. Nobukazu Yagi, Sales Representative

**SHARP ELECTRONICS CORPORATION**  
10 Keystone Place  
Paramus, New Jersey 07652



## New products

which this card will be used extensively, according to chief engineer Richard B. Plummer. The first is a laboratory situation in which the user has his own computer terminal and there are also floppy disks and line printers—a host-satellite situation. The second is an application in which a large number of peripherals at remote data-gathering locations must be controlled. Current applications for similar serial I/O cards call for up to three full-size cards—two DEC DLV11s and one REV11.

Delivery time for both the 1014 and the 1750 is 30 days after receipt of order.

Adac Corp., 70 Tower Office Park, Woburn, Mass. 01810. Phone Al Grant at (617) 935-6668 [371]

## Chip combines extras needed for small system operation

With 256 bytes of static random-access memory (RAM), two timers, a serial input/output (I/O) port and three external interrupts all on a single chip, the MK 3886 "Combo" can form a small control system with a minimal number of additional chips. All that is needed is a central processing unit (such as a Z80), an oscillator circuit, a programmable read-only memory, and a single 5-V power source.

To preserve volatile data, the unit has a low-power standby mode for its lower 64 bytes of RAM, which are also write-protected. The two on-chip timers are software-programmable. In addition to the zero-count output on both timers, timer A has an external-interrupt input linked directly to its control circuitry that

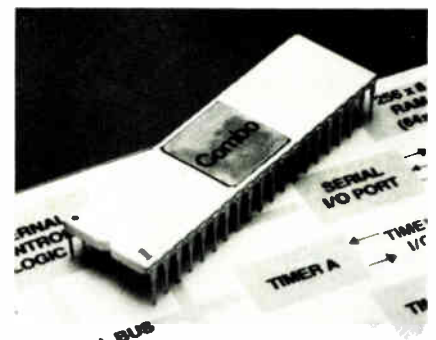



# How do GE Econopower™ Triacs cut production costs?

## Packaging.

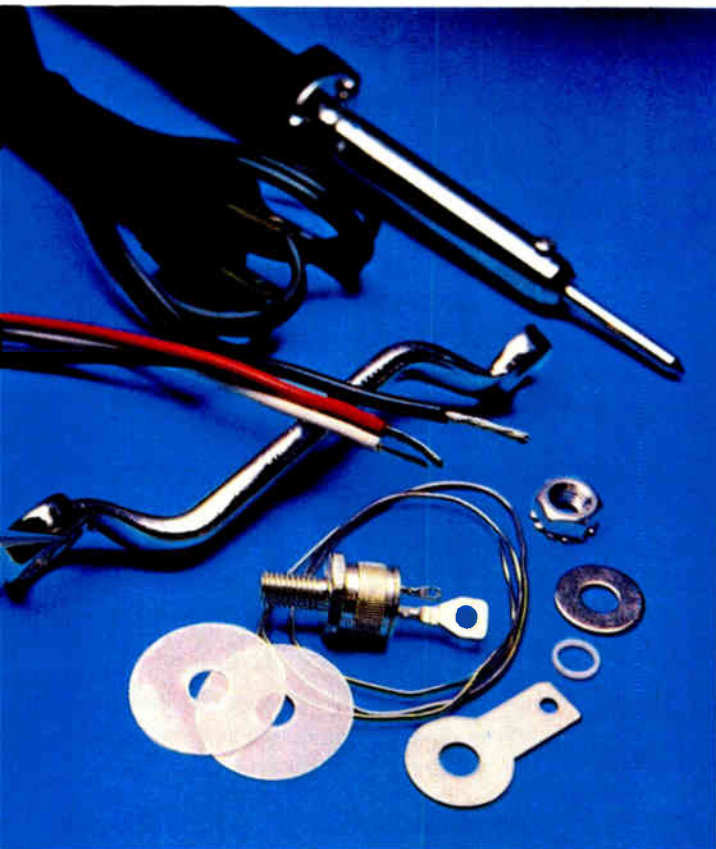

General Electric introduces the SC160 Econopower™ Triac as a direct response to your industrial and appliance needs. You asked us for a low cost, isolated Triac package with FASTON terminals to speed up production and cut assembly costs. So, we've developed the Econopower package that combines these features to meet your needs.

Along with the electrically isolated TO-3 configured flange, you'll find 1) a glass passivated pellet for low leakage and stable blocking life, 2) a pellet sub-assembly mounted to copper metallization which is directly bonded to ceramic by a GE patented process, 3) FASTON terminals for strong, permanent connections without soldering and 4) epoxy encapsulation for ruggedness.

The new SC160 Econopower Triac has a rating of 25 amperes (RMS), up to 600V. This new user-oriented Triac, attractively priced starting at \$2.78 in 10 K lot quantities, is another indication of our Triac leadership. We invented the Triac. We wrote the book

**Electronics** / February 15, 1979

on them. And we'll continue to offer new Triac types to meet your needs.

For a free SC160 sample kit, write to General Electric Company, West Genesee St., Auburn, N.Y. 13021; call George Sawchuck (315) 253-7321, Ext. 368, or contact your authorized distributor.

In Europe, contact International General Electric of New York, Dundalk, Ireland, (042) 32371, TELEX: 6500.

™Trademark of General Electric Company

222-07C

There's more  
to GE semiconductors  
than meets the eye

GENERAL  ELECTRIC

Circle 175 on reader service card 175



**BUILD!**

**A P Terminal and Distribution Strips are ideal building blocks for your breadboarding.**

Now you can put together as simple or as elaborate a breadboard as you want—and be sure of top quality all the way. A P Terminal and Distribution Strips give you the world's easiest (and most economical) way to assemble full-performance solderless breadboards of any size or shape.

Our versatile modules come in 10 sizes—terminal strips with from 34 to

128 terminals in 4 and 5 tie-point groups, distribution strips with from 12 to 36 terminals in 4 tie-point groups. Hardware and mounting templates are included.

Electronic components and wire jumpers plug right into spring-clip terminals of noncorrosive copper alloy 770. You get superb contact, time after time.

Order these wonderfully useful building blocks from your local A P distributor. Who is it? Phone (toll-free) 800-321-9668. And ask for the complete A P catalog, The Faster and Easier Book.

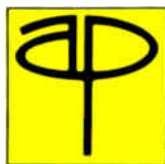

**A P PRODUCTS INCORPORATED**

Box 110L • 72 Corwin Drive  
Painesville, Ohio 44077  
Tel. 216/354-2101  
TWX: 810-425-2250

**Faster and Easier is what we're all about.**

**New products**

provides two additional timer modes, for pulse width measurement and event counting. Timer B is designed to toggle its output on each cycle, thus generating a square wave that can be tied to the chip's serial I/O port for transmission timing.

The serial I/O port is basically a 16-bit shift register that operates synchronously or asynchronously in a half-duplex mode at an external clock rate, with end-of-word interrupts. The 3886's three interrupt lines allow independently vectored, maskable, priority interrupts from external sources.

Housed in a 40-pin dual in-line package, the 3886 will sell initially for \$35.30 in single quantities and will be priced at \$17.65 at the 1,000-piece level.

Mostek Corp., Microprocessor Marketing Department, 1215 West Crosby Road, Carrollton, Texas 75006. Phone (214) 242-0444 [373]

**Control board gives glitch-free displays**

Compatible with Motorola's EXORciser system, the NES002A is a cathode-ray-tube control board that provides glitch-free operation at full processor speed. Display formats of 24 lines of 80 or 84 characters or 25 lines of 80 characters can be chosen. Characters are generated in a seven-by-nine-dot matrix.

The board, which provides either composite or separate sync outputs, is priced at \$495 in single quantities. Delivery time is about two to three weeks.

Nixon Engineering Co., 578 Menker Ave., San Jose, Calif. 95128. Phone Robert Nixon at (408) 287-2816 [376]

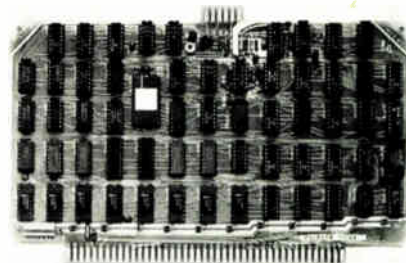

# NOW...

# obsolete decoupling capacitors



# with Q/PAC™

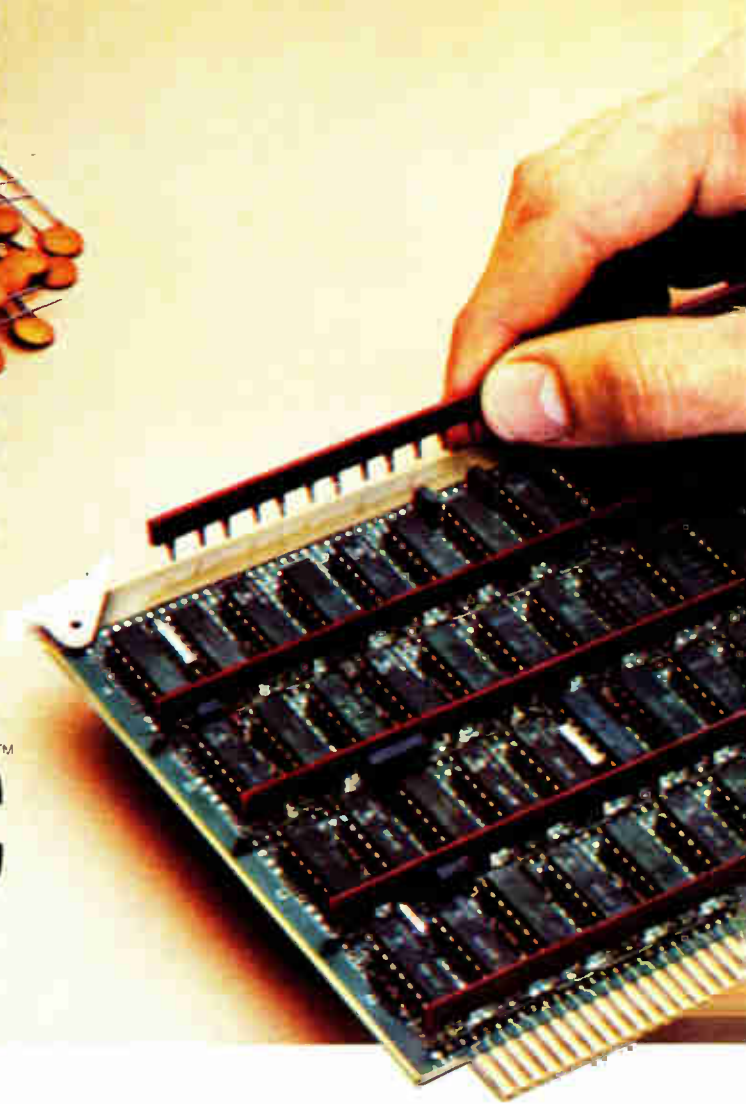

New, high capacitance Q/PAC<sup>\*</sup> power distribution elements are the exciting, revolutionary way to eliminate decoupling capacitors from printed circuit boards. Rugged Q/PAC elements are easy to install and increase system reliability through reduced part count.

Q/PAC elements are available in capacitance values up to 0.05 $\mu$ f per inch in lengths up to 16 inches. Configurations allow for either vertical mounting or horizontal installation under DIP packages.

\*Patent Applied For

See us at  
NEPCON 79 WEST  
Booth 1331

For immediate need circle #177

Q/PAC elements eliminate the need for on board power traces and extra board layers. They maximize packaging density and minimize signal interconnection problems.

Q/PAC elements feature a low dissipation factor, low inductance and low impedance.

Pack more on static and dynamic MOS memory boards, more on critical random logic boards.

Contact the Q/PAC Product Specialist at (602) 963-4584.

**ROGERS**

Rogers Corporation  
Chandler, Arizona 85224

EUROPE Mektron NV Gent Belgium JAPAN Nippon Mektron Tokyo

For information only circle #246

# Ball introduces the industry standard in CRT monitors. Again.

Accepts wider range of horizontal input pulse

Electronic horizontal video centering

IC regulated power supply on AC models

Electronic H and V linearity control

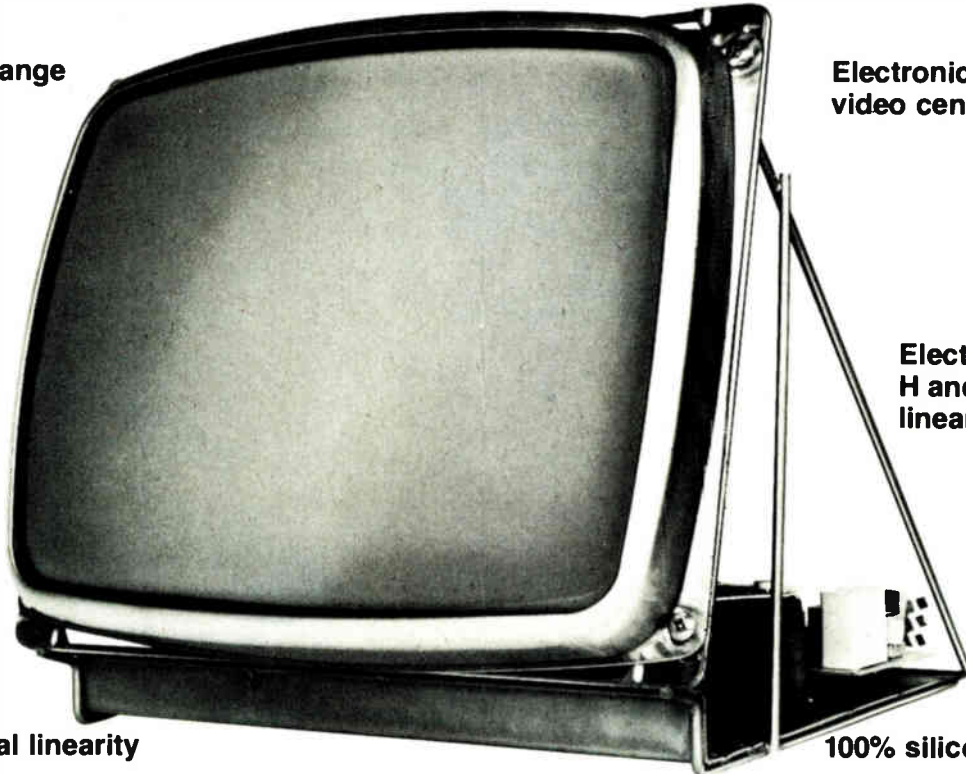

Improved vertical linearity

100% silicon circuitry

## Now with advanced features you'd never expect in a general purpose data display!

Check out Ball's TV-Series direct drive monitors. The improved performance. The advanced circuitry. The new benefits engineered into our field proven line that's already world famous for high reliability and maintainability.

As before, our specially selected CRT gun and deflection components deliver bright, well defined characters with low geometric distortion. And of course Ball's rugged wire frame and simple subassembly construction offer maximum component cooling and accessibility.

Best of all, our improved TV-Series monitors are completely interchangeable in form, fit and function with first generation designs. You can upgrade right now without interface problems.

**Compare life cycle costs.  
You'll have a Ball.**

Call your nearest Ball representative. He'll be glad to introduce you to an old friend. The 2nd generation TV-Series monitors.

Ball Corporation                      Electronic Display Division  
P.O. Box 43376, St. Paul, Mn. 55164 (612) 786-8900. TWX: 910-563-3552

**General Sales Offices:**

Addison, Illinois (312) 279-7400      Santa Clara, California (408) 244-1474  
Ocean, New Jersey (201) 922-2800      Upland, California (714) 985-7110



# SE 7000: Multiband performance – Multi-channel check-out

SE 7000 Series Instrumentation Recorders give you 8 speed recording up to 2MHz Direct, 500 kHz FM and up to 30 k bpi HDDR. The SE 7000 has in addition a unique range of features essential to lab quality recording, with a convenience, simplicity and reliability that no other recorder can offer.

Consider, for instance, the versatile built-in calibrator module with DVM for “set and forget” control, and the unique simultaneous all-channel FM electronics to electronics facility, without tape movement – the higher reliability of hard-wired, all speed active filters, equalisers and other tape speed

sensitive components – the proven dependability of co-planer format resulting in more gentle tape handling and lower tape wear.

Don't accept second best. We would like to show you how the SE 7000 can match your requirements in instrumentation recording. Call us on 203-744-3500 or send reader card for details.



**EMI** EMI Technology

EMI Technology Inc.,  
55 Kenosia Avenue, Danbury CT 06810.  
Tel 203-744-3500 T W X 710-456-3068

*SE 7000M – the only wideband portable with built-in 14 channel electronics to electronics FM calibration and pre-record checkout.*

A member of the EMI group. International leaders in music, electronics and leisure.

Circle 179 on reader service card

# We want you to have our new catalog of standard ICs

*...but that isn't all...*



Up till now you've never met a semiconductor company so willing to work with you.

Yes, you personally. As an important part of the team using our advanced computer aided design techniques to solve even your most perplexing, sophisticated, challenging IC problems.

With your unique knowledge of your problem... combined with our unique knowledge of IC technology, we'll get the job done. At the right price. With the right delivery date.

What makes Cherry Semiconductor so sure we can help solve your problems? Experience and past success that have made Cherry a trusted name in industry for

more than 25 years. But, we're far from just a "custom" house. We've already helped solve a lot of "standard" problems that you'll find in our just-published catalog of non-custom digital and linear bipolar ICs.

**Here's a quick rundown on the contents of our new, free-for-the-asking 36 page catalog of digital and linear ICs:**

Low level amplifiers — differential amplifiers — level detectors — DC to DC converters — timing circuits — motor speed controls — optical detector systems — camera controls — flip chips.



# CHERRY SEMICONDUCTOR

CHERRY SEMICONDUCTOR CORPORATION 99 Bald Hill Road, Cranston, Rhode Island 02920/(401) 463-6000/TWX 710 381 1757

Circle 180 on reader service card

## New products

Semiconductors

# Chip implements GPIB interface

Fabricated in Locmos, device provides complete source and acceptor handshake capability

A monolithic circuit that provides all the functions required to connect a programmable instrument to the IEC/IEEE-488 general-purpose interface bus (GPIB) features both talk and listen modes and fits in a standard 40-pin dual in-line package. Designated the HEF-4738, the chip is fabricated with Locmos (local-oxidation complementary-metal-oxide-semiconductor) technology—a high-density process, which makes it possible to put the circuit on just one chip. Locmos has all of the advantages of C-MOS plus faster operation (comparable to that of transistor-transistor logic) and improved noise immunity. Also, the HEF-4738's

inputs may be driven by C-MOS, TTL, and low-power TTL levels, while its outputs are capable of driving TTL buffers.

The chip affords complete source and acceptor handshake capability. It can also be used with instruments that are talkers, listeners, or talker/listeners. It provides complete service-request capability, remote/local operation selection, parallel-poll capability, and device-clear and device-trigger capabilities.

The HEF-4738 can operate from supply voltages between  $-0.5$  and  $+18$  V, but the recommended range is 4.5 to 12.5 V. The maximum current into any input or output is 10 mA, and the power-dissipation rating for the entire package is 400 mW. The device may be operated in ambients between  $-40^\circ$  and  $+85^\circ\text{C}$  and is offered in a choice of plastic or metal-ceramic packages.

The HEF-4738 has been available in Europe from NV Philips Gloeilampenfabrieken, Eindhoven, the Netherlands, developer of both the circuit and the Locmos process. Philips is also the parent company of Signetics, which is marketing the chip in

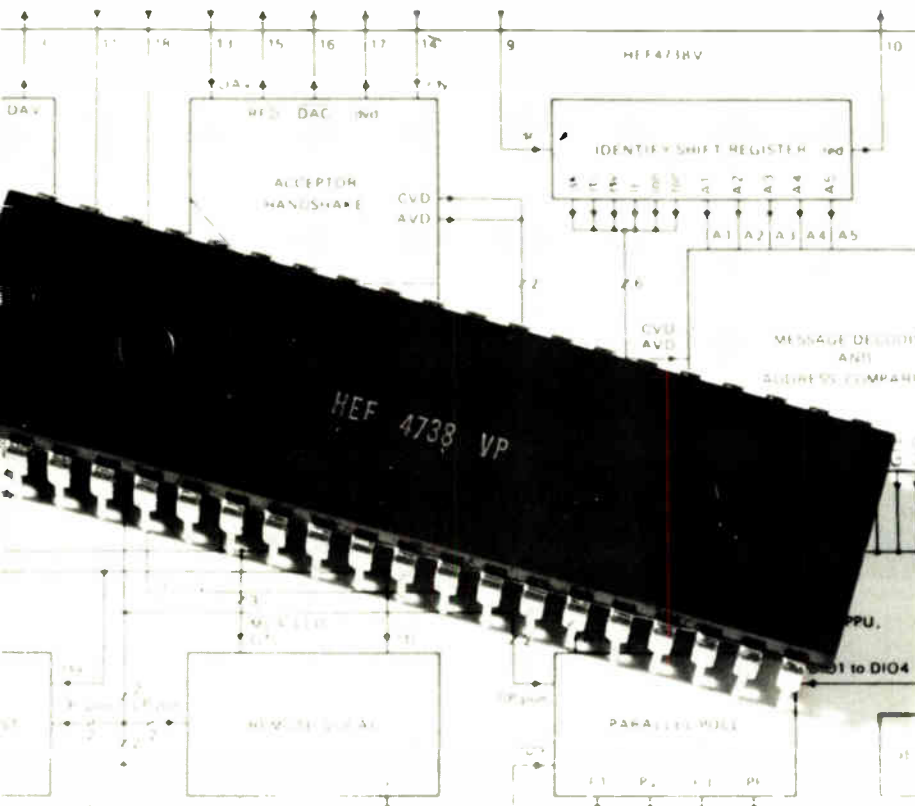

## RTV SILICONE RUBBER WITH SUPERIOR THERMAL CONDUCTIVITY

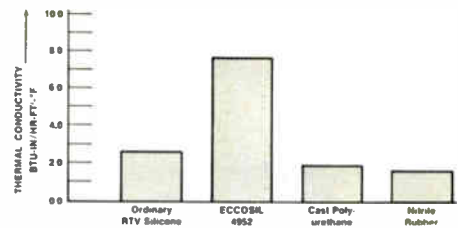

Comparative thermal conductivity graph shows the superior heat dissipation properties of ECCOSIL<sup>®</sup> 4952 over other various elastomers. ECCOSIL 4952 cures at room or elevated temperature to a flexible silicone rubber capable of withstanding 500°F (260°C). Recommended for potting and encapsulating components from which heat is to be dissipated.

Circle 247 on reader service card

## PLASTIC AND CERAMIC FOAMS



New ECCOFOAM<sup>®</sup> folder of plastic and ceramic foams for electronics now available. Foam-in-place, sheet stock, syntactic and artificial dielectrics are offered along with tabulated chart of properties for more than 15 products.

Circle 248 on reader service card

## CRYSTAL CLEAR CASTING RESINS



ECCOCLEAR casting resins with high optical clarity are used in encapsulations and coatings wherever visual display and inspection of electrical/electronic components is required. Eleven crystal clear epoxies, silicones, urethanes, polyesters and hydrocarbons are described in new ECCOCLEAR folder.

Circle 181 on reader service card

## EMERSON & CUMING



Dewey and Almy Chemical Division  
W. R. Grace & Co.  
Canton, Massachusetts 02021 U.S.A.  
Telephone (617) 828-3300

# ALWAYS A STEP AHEAD

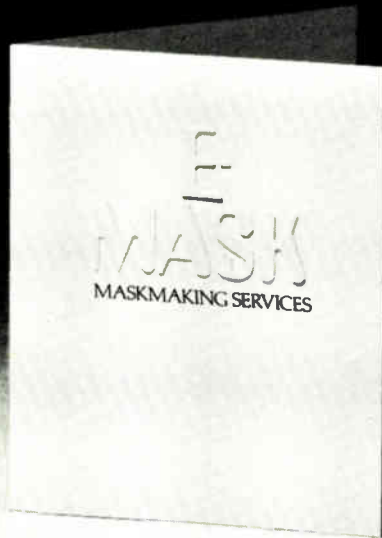

We have served the semiconductor industry for almost 20 years and have handled every kind of maskmaking requirement from simple diode patterns to complex bubble memories. Our reputation for technological leadership is widely acknowledged by the major semiconductor and system manufacturers in the industry. This brochure tells all about E-MASK and how we stay a step ahead. Send for it, or call us today.



## **ELECTROMASK**

**The Technology leader in the Masking Industry**  
A subsidiary of TRE Corporation  
6109 De Soto Ave., Woodland Hills, CA 91367  
Phone: (213) 884-5050, Telex 67-7143

Circle 182 on reader service card

# The magazine you're reading now, could be your own.

Drop off the routing list. Get your own fresh, unclipped copy mailed to your home or office. Turn to the subscription card in the back of the magazine. If somebody has beat you to it, write: Electronics, P.O. Box 430, Hightstown, N.J. 08520.

## **New products**

the U.S. The U.S. price for the plastic-packaged version, in quantities of 25 to 99, is \$26.25. Delivery is from stock.

Signetics, P. O. Box 9052, 811 East Arques Ave., Sunnyvale, Calif. 94086. Phone (408) 739-7700 [411]

## **Decoder-driver family does standard and custom jobs**

The MN1205 series is not just another family of decoder-drivers: one member drives four-by-eight matrixes of light-emitting diodes (the MN1205A), others turn on seven-segment LED displays of two digits (the MN1205D and E), and still another handles custom applications. The heart of these units is a programmable logic array (PLA) that, in the last case, can be masked according to a customer's wishes.

Inputs to the complementary-metal-oxide-semiconductor part are in 4-bit nibbles, with two nibbles required to format the 14-line output. Each nibble is latched into either the upper or lower data latch, depending on whether the input signal on the data-select pin has a positive- or negative-going edge. Both nibbles are then fed to the PLA for conversion.

An MN1205 device comes in a plastic, 22-pin, dual in-line package and operates from a single 5-v supply. Standard units are priced at \$4.75 each in 1,000s and are deliverable from stock or in up to eight weeks. Custom devices will be supplied in minimum quantities of 5,000.

Electronic Components Division, Panasonic Co., One Panasonic Way, Secaucus, N. J. 07094. Phone Bill Bottari at (201) 348-7276 [413]

## **High-speed PROMs serve convenient portions**

Frustrated by taking nibbles when you really want a whole byte? The newest members of the SN74S family of high-speed Schottky program-



# Longer Life, Greater Reliability

The key to our unique Golden Touch capacitive keyboard is our patented, hinged moving plate design.

We create our capacitive effect with a hinged moving plate and one fixed plate, both attached to the printed circuit board. This gives our keyswitch much greater capacitance, at any given displacement, than the sponge-on-a-stick design used in other capacitive keyboards.

As a result, our keyswitch is virtually impervious to dust, debris, moisture and electrical noise. That's why we rate our Golden Touch at 250,000,000 MCBF—double anybody else's rating.

It also is why we guarantee a 1% AQL and give a 2-year warranty.

All our Golden Touch keyboards are designed precisely to your specifications—because we sell only to volume OEMs—so you can get whatever options, circuitry and configuration you want.

All this at competitive prices.

## **DIGITRAN**

The Digitran Company is a division of Precision Electronics and Components  
855 South Arroyo Parkway • Pasadena, California 91102  
Phone (213) 449-3110 • TWX 910-588-3794, TELEX 67-5485

Circle 183 on reader service card



## New dimensions in measurement flexibility.

We call it the Series 6000 Amplitude Measurement System. You might call it a cost-effective solution to hundreds of measurement requirements.

The heart of this new product is a precision digital multimeter, but its capabilities only begin where the most advanced DMM leaves off. Yet your investment will probably be no more than you're now paying for a lot less.

### Increased flexibility

In addition to its basic capabilities, it automatically computes ratio; measures directly in dB, gain or attenuation, and gain vs. frequency; has full math capability; automatically performs single limit, hi/lo limit, or "7-bin" sort testing; and computes averages for up to 10,000 readings.

The Series 6000 also features an Exchangeable Calibration Module, directly traceable to NBS standards, which allows instant recalibration right at the bench.

This is an instrument that cannot be fully described in a single ad. It features a new concept in calibration, in maintenance and in instrumentation technology—all designed to improve your operation while cutting your costs. Call or write today.

For demonstration, circle No. 184  
For literature, circle No. 251

# RACAL-DANA

## RACAL

The Series 6000 combines all the functions of these instruments: DC Voltmeter • DC/DC Ratiometer • AC Voltmeter • AC/AC Ratiometer • dB Meter • Ohmmeter • DC Millivoltmeter • 2 Channel Scanner + DMM • DC Amplifier • Comparator Box - up to seven sorting "bins" • Fault Alarm - Single or multiple limit • High Speed Digitizer • A/D Converter • Voltage Deviation Meter • Gain/Attenuator Meter • Computing Multimeter with: Averaging, Min/Max Peaks, Scaling/Factoring, Self Test, Self Calibration, Digital Offsets, Hi/Lo Limits.

RACAL-DANA INSTRUMENTS, 18912 Von Karman Avenue, Irvine, CA 92715; Ph: 714/833-1234; Duke Street, Windsor, Berkshire SL4 1SB, England, Ph: (07535) 69811; 91 Route de Gardes, 92 Meudon-Bellevue, France, Ph: 027-7575.

## New products

mable read-only memories introduced last spring [*Electronics*, May 25, 1979, p. 224] provide 1,024 by 8



bits of storage. Plug-compatible with earlier 1-K-by-4-bit PROMs, the units are particularly attractive for micro-computer applications.

Like the earlier members, the byte-wide SN74S memories are available in two versions: three-state (478) and open-collector (479) output. They feature maximum access times of 70 ns and maximum enable times of 40 ns and consume 630 mW typically—about the same amount as a 4-K unit.

In 100-piece lots, the PROMs are priced at \$21.60 in ceramic packages and \$19.35 in plastic. Deliveries will begin this quarter.

Texas Instruments Inc., Inquiry Answering Service, P. O. Box 225012, M/S 308 (Attn: 74S478-479), Dallas, Texas 75265 [414]

## Darlington devices drive fluorescent digits or segments

Designed to interface low-level digital logic and vacuum fluorescent displays, the UDN-6116A and 26A consist of six npn Darlington output stages and associated common-emitter input stages. The units may be used either as segment or digit drivers and all outputs can be activated simultaneously.

Pull-down resistors are incorporated in each output stage so that, in most instances, additional components are not needed for a complete interface. The UDN-6116A is compatible with transistor-transistor-logic and 5-V complementary-metal-

# MULTIBUS compatible data acquisition and control systems.

The ADAC 700 Series of data acquisition systems plug directly into the MULTIBUS of single board computers from Intel and National. The 710 Series is the first low level analog to digital system available that includes such unique features as the capability to withstand common mode voltages of up to 250V while digitizing low level outputs from bridges, thermocouples and other low level transducers. A software programmable gain amplifier with optional cold junction compensation circuit can be programmed on a channel to channel basis. The low level analog to digital card and low level multiplexer expander card can be supplied with either 8 or 16 differential inputs per card. Resolution is 12 bits.

The 735 A/D high level analog to digital series is supplied with 16 to 64 single ended or pseudo differential inputs. It also is jumper selectable for 8, 16, or 32 differential analog inputs. The inputs can be either voltage or current loop. The 735 A/D features a 12 bit high speed analog to digital converter with throughput rates of 35 KHz basic and 100 KHz optional. The series include bus interfacing with a software selection of program control/program interrupt and a jumper selection of memory mapped I/O or isolated I/O. Up to 2 channels of 12 bit digital to analog converters can be supplied.

The extensive series of MULTIBUS compatible analog I/O boards is further complemented by the 735 DAC Series. They are supplied with up to 4 channels of 12 bit digital to analog converters, MULTIBUS interfacing, 2 scope/recorder pen control circuits, 8 discrete digital outputs with 8 high current sinks, 8 discrete digital inputs, and memory mapped or isolated I/O interfacing. Optionally available are third wire sense for ground noise rejection and 4 to 20 ma current loop outputs.

Send for full technical data:

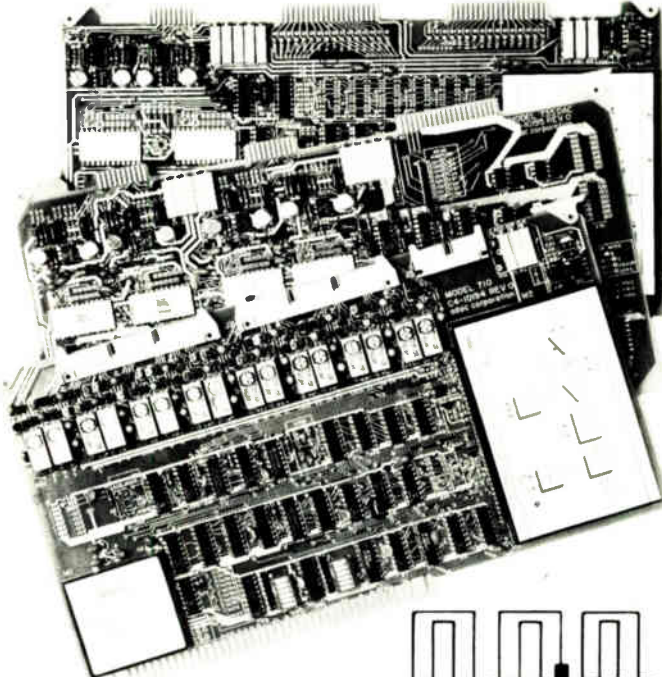

**adac**

CORPORATION

70 TOWER OFFICE PARK • WOBURN, MA 01801 • 617-935-6668



# pencil programmable timer

- Programming ease and simplicity — a soft pencil (#2) and eraser is all the "software" you'll ever need.
- Program up to 10 independent channels.
- Continuous range of timing cycles — from 10 msec all the way to 99.9 hours.
- Crystal-controlled time base — virtually 100% repeatability.
- Resolution that's better than 0.4% of the total cycle.
- Remote control capability — Start, Pause, Reset, Disable.
- Wide range of interface options to meet most output requirements.
- Zero reset time.



For complete details, prices and a demonstration, write or call

**XANADU CONTROLS**

Division of Valcor Engineering Corp.

45 Fadem Road • Springfield, N.J. 07081 (201) 467-8100 Telex: 139241

## New products

oxide-semiconductor devices; the UDN-6126A works with 6-to-15-V MOS logic.

With either device, the output is activated when the input is pulled toward the positive supply. The drivers work with 5-to-85-V supplies, so they can provide a maximum output voltage of 85 v. Operating from 0° to 70°C, they are priced at \$1.17 in lots of 1,000. Delivery is from stock.

Sprague Electric Co., 35 Marshall St., North Adams, Mass. 01247 [415]

## Low-voltage amplifiers consume little power

In audio applications where the power budget is tight, series 500 low-voltage linear amplifiers may fit the bill. Available in packages as small as 3.56 millimeters square, the units can operate from battery voltages in the 1-to-2-v range. They consume about 1 mW in the active state and

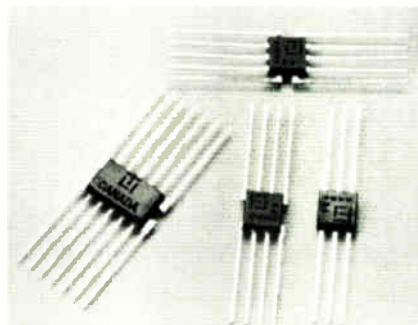

as little as 100  $\mu$ W when quiescent.

Models can provide gains of up to 70 dB and put out as much as 10 mW, keeping distortion to less than 1%. Some models, intended primarily for portable communications applications, permit automatic gain control. The parts might also be used in cassette recorders.

In 1,000-piece lots, the amplifiers range in price from \$3 to \$6 each. Sample quantities are in stock and delivery of production quantities takes six to eight weeks.

Linear Technology Inc., 3435 Landmark Rd., Burlington, Ontario L7M 1T4, Canada. Phone Bob Simpson at (416) 335-2996 [416]

# CRT COPIER for 2640's

The new Model 8640  
CRT copier provides hard  
copies from HP 2640  
Series terminals

*in less than 10 seconds*

The Houston Instrument 8640 CRT copier, at \$4495, provides you with permanent high quality hard copies from any HP 2640 Series terminal equipped with HP's video interface. Utilizing HI's electrostatic technologies, the Model 8640 produces permanent non-fading copies at about one third of the cost of comparable dry silver copies. The Model 8640 is the choice hard copy adjunct to your terminal.

- No warm up time
- Proven electrostatic printing technique for high contrast output and no fading
- Low operating noise
- Inherent high copying speed capability
- Provides copies from up to four terminals (with Model 8640A)
- Price for Model 8640 \$4495\* (Model 8640A \$4995\*)



\*U.S. Domestic Price only

**houston  
instrument**

DIVISION OF BAUSCH & LOMB

ONE HOUSTON SQUARE  
(512) 837-2820

AUSTIN, TEXAS 78753  
TWX 910-874-2022

EUROPEAN HEADQUARTERS

Rochesterlaan 6 8240 Gistel Belgium  
Phone 059/277445 Telex Bausch 81399

*"the graphics - recorder company"*

**"Also send for information on our  
Tektronix 4010 Series terminals"**

Visit us at the  
Pittsburgh Conference booths 217 & 219

For rush literature requests or local sales office information only, persons outside Texas call toll free 1-800-531-5205

# Compare construction and see why our high current $V_{CE(sat)}$ is lowest.

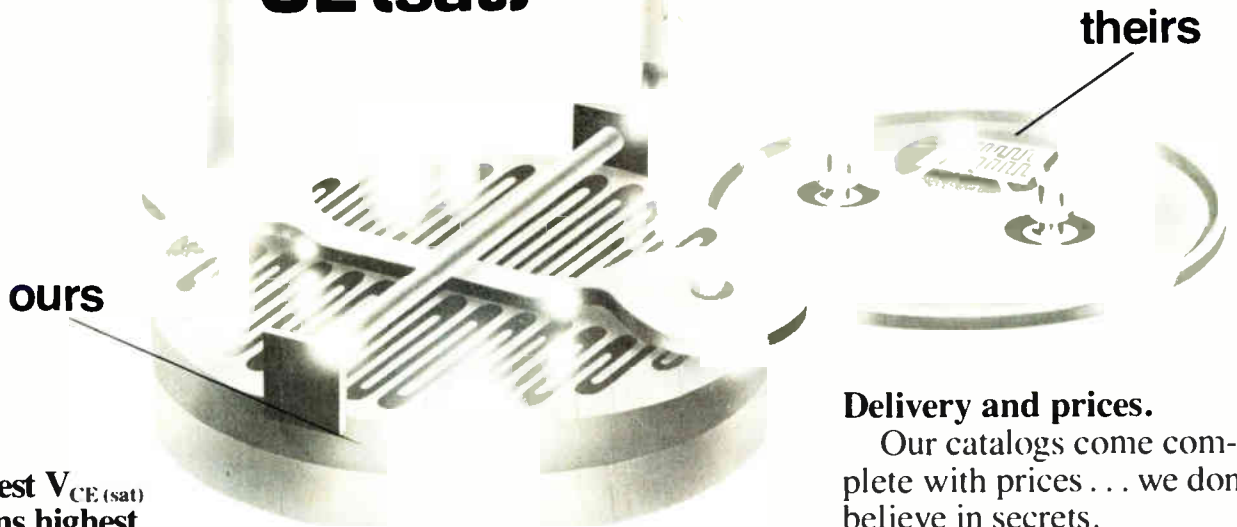

**Lowest  $V_{CE(sat)}$  means highest efficiency**—this is especially important with transistor operation above 30 Amps. As you know, at high currents most transistors also have  $V_{CE(sat)}$  in excess of 1.5 Volts. Such high  $V_{CE(sat)}$  causes loss of efficiency, excess heating and heat-induced reliability problems. PowerTech transistors have a *maximum*  $V_{CE(sat)}$  rating of *less than* 0.75 Volts at anywhere from 50 to 300 Amps. Compare these ratings to others and judge for yourself.

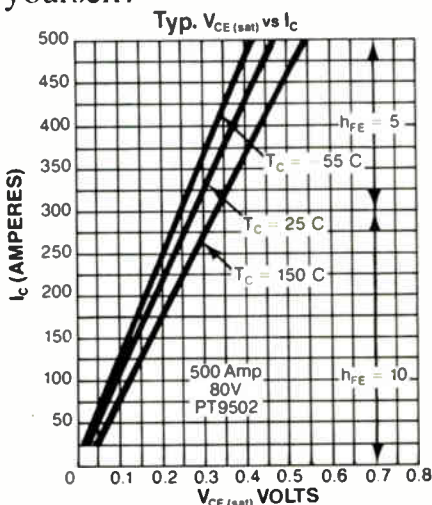

## Copper makes the difference.

We use extra-heavy copper metalizing on our bigger, beefier chip:—thereby assuring maximum thermal and electrical conductivity and yielding the lowest  $V_{CE(sat)}$ . Their smaller chips use thin aluminum-metalizing with fragile, current-limiting wires (*ours* have solid copper posts).

Which would you rather have your circuit depend on? And we don't stop there. To guarantee rapid delivery, we pre-mount our chip on an integral moly-copper heat sink so we can categorize and pre-test the module at high currents to insure maximum reliability prior to mounting in the package of your choice (again 100% tested to the most stringent MIL/AERO specs). They, on the other hand, must first mount their chip on the package, then test to determine if it's shippable.

## Delivery and prices.

Our catalogs come complete with prices . . . we don't believe in secrets.

While our initial device cost may be slightly higher, in the long run we believe you'll find that it's less expensive to use transistors that keep on working.

We rely on direct factory-to-customer contact to ensure 100% responsiveness, backed up by the flexibility of chips already built, pre-tested and ready for whatever electrical/packaging requirements you may have.

But see for yourself: call for further information and assistance: Sales Engineering, PowerTech, Inc., 0-02 Fair Lawn Ave., Fair Lawn, N.J. 07410: (201) 791-5050.

TYPICAL PRODUCTS			
$V_{CE(sat)}$ Max.	$V_{CE}$	PART NO.	
0.5V @ 300A	80V	PT-9502	
0.35V @ 200A	120V	PT-9503	
0.75V @ 100A	200V	PT-4500	
0.75V @ 70A	120V	PT-5927	
0.75V @ 60A	400V	PT-4503	
JAN-TX Types Also Available			
Guaranteed SOA			

## PowerTech, Inc.

"BIG IDEAS IN BIG POWER"

By **SESCO**...  
it works!



# The Cook-able Computer

## Introducing a ruggedized version of Intel's iSBC\* 80/10A Single Board Computer

### From Cryogenics to Hades

Our ruggedized SECS 80/10A likes it hot — or cold. It shrugs off shock, vibration, moisture. And thrives on dust, dirt and grime.

Meets MIL-E-5400, 16400, 4158 — and more. This makes our SECS 80/10A perfect for military systems and tough industrial applications — petroleum, steel, oceanography, communications.

In fact, anywhere a rugged microcomputer is needed.

### Functional counterpart of Intel iSBC 80/10A

Exclusively licensed by Intel, our SECS (Severe Environment Computer System) is a functional counterpart of the standard iSBC 80/10A board. Even uses the same development system software.

\*Trademark of Intel Corporation

### The difference is in the packaging

Our SECS 80/10A, which uses rugged Intel 883B chips, is mounted on a 9" by 6" shock and vibration resistant, full ATR compatible board. Conduction cooled, it operates from -55°C to +85°C. Add our numerous support modules and you end up with a versatile severe environment microcomputer system at a fraction of the development cost.

### Other SESCO products

We also have a complete line of MIL SPEC core and semiconductor memories. New products include D-DAS, a digital data acquisition system for the 1553 bus, and SETS, a compact digital tape recorder with 23 megabit capacity.

When you're faced with a tough environment, "buy SESCO... it works!"

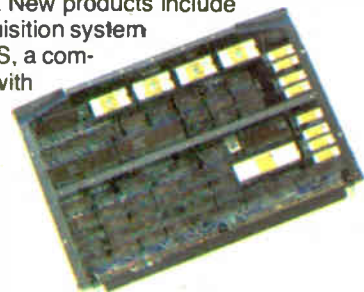

SECS 80/10A

**EMM SESCO**

Severe Environment Systems Company

A Subsidiary of Electronic Memories & Magnetics Corporation

20630 Plummer Street • P.O. Box 668 • Chatsworth California 91311  
Telephone: (213) 998-9090 • Telex: 69-1404

Circle 189 on reader service card

Over 20,000  
in Use  
Field Proven  
Lab Accuracy DPM



PM-4 \$170  
0.02% Accuracy

- $\pm 1, \pm 10, \pm 100$  or  $\pm 1000V$  range.
- Auto zero & polarity.
- Programmable decimal.
- Range change capability.
- Protected input.
- 1"H x 2.5"W x 3.25"D.
- Large 0.3" LED display.



**Non-Linear Systems, Inc.**

Originator of the digital voltmeter.  
Box N, Del Mar, California 92014  
Telephone (714) 755-1134 TWX 910-322-1132

Circle 190 on reader service card

**Bonds  
are for  
beginnings.**



**Take stock in America.**  
With higher paying U.S. Savings Bonds.

## New products

Data acquisition

### I/O boards access memory directly

Units for Unibus computers  
also offer programmable gain  
and Z-axis point plotting

Users of Digital Equipment Corp.'s PDP-11 Unibus minicomputers, particularly the PDP-11/34, now have another family of analog input/output subsystems that allow the computer to easily handle analog data in laboratory and industrial applications. It's the DT1711 series from Data Translation Inc., which probably packs more capability on the individual hex-size boards than previously available boards.

There are six boards in the series offering various features, but Paul Severino, vice president for engineering, believes the on-board direct-memory-access option of the DT1711 analog I/O board and DT1712 input-only board will be the series' most popular feature, "espe-

cially in labs with PDP-11/34s." He adds that he knows of no similar board that offers on-board DMA on both input and output. Fred Molinari, Data Translation's president, points out that when a computer user buys a fast system, such as a PDP-11/34, he wants to get data into and out of memory fast. "When you buy a wizard for a lot of money, you don't want to hobble it, so direct memory access will be attractive," Molinari observes.

The basic 1711 offers 16 single-ended or 8 differential 12-bit input channels, a throughput rate of 35 kHz, and two channels of 12-bit digital-to-analog output with a power amplifier, and Z-axis point-plotting capability for \$1,800. The basic 1712 input board provides the 16 single-ended or 8 differential 12-bit channels and the 35-kHz throughput rate for \$1,240. The DMA option for both of these adds \$500 to the price, and there are two other options for both: a programmable-gain amplifier (\$175) and a 100-kHz throughput (\$300). The DT1712 is expandable to 64 single-ended channels at additional cost.

The DT1714 is a low-level analog-input board for full-scale signal

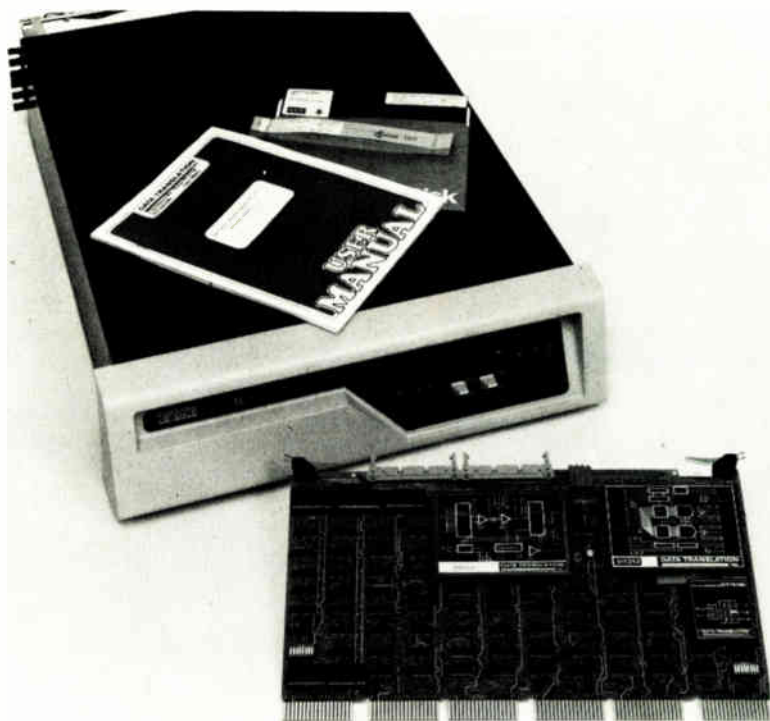



**TEKTRONIX**  
thinks your logic analyzer  
should be as versatile  
as you are

So ours let you sample *synchronously* and *asynchronously*.



Use the 7D01F  
for hardware  
and software  
applications.

As a digital designer you must be versatile enough to do the entire design job. Logic and timing. Software and hardware analysis. Activity on and off the bus.

And so you need a logic analyzer that lets you synchronously verify logic and trace program flow on the bus, then asynchronously verify timing sequences and examine chip to chip transactions off the bus. A logic analyzer, in short, as versatile as you are.

Tektronix Logic Analyzers are versatile. In the synchronous mode, examine software flow using the clock of the system under test—up to 20 ns sampling rate. Switch to asynchronous and sample with the Logic Analyzer's own clock—up to 10 ns sampling rate. Pulse anomalies and timing problems are out in the open, where you can see them. With one logic analyzer.

**Synchronous and asynchronous sampling: It helps**

make our Logic Analyzers versatile. So you can do today's job and tomorrow's. So you can change applications without changing your logic analyzer.

Contact Tektronix Inc., P.O. Box 500, Beaverton, OR 97077, in Europe, Tektronix, Ltd., P.O. Box 35, St. Peter Port, Guernsey, Channel Islands.

**Tektronix**  
CORPORATION

# PDP-11\* interface . . . from MDB

Peripheral Device Controllers ■ Systems Modules  
General Purpose Interface Modules  
Communications/Terminal Modules  
I/O Cables ■ Accessory Hardware

When it comes to PDP-11 interface, MDB has it:

- Peripheral Device Controllers for most major manufacturer's
  - Printers
  - Card equipment
  - Paper tape equipment
  - Plotters
- Systems Modules
  - IEEE instrumentation bus
  - DR11B Direct Memory Access single quad module
  - DR11C General Purpose Interface module, a direct DEC equivalent
  - Digital I/O Module
  - Unibus Terminator
- General Purpose Interfaces
  - 11B Direct Memory Access with 12 IC positions for user logic
  - 11C Module with 16 bit input and 16 bit output registers; 20 user wire wrap positions
  - 1710 Bus Foundation Module with pins for 40 user IC positions
  - Wire Wrappable Module with pins for 70 user IC positions
- Communications/Terminal Modules
  - MDL-11 Asynchronous

Serial Line Adapter  
MDL-11W Asynchronous Serial Line Adapter with line frequency clock  
MDU-11 Synchronous Serial Line Adapter

- Cable Subassemblies
  - I/O cable for 20mA current loop
  - I/O cables for EIA Asynchronous and Synchronous
  - Double-ended jumper cable
  - GP I/O 50, 40, 34, 26 and 20 conductor ribbon cables

MDB interface products always equal or exceed the host manufacturer's specifications and performance for a similar interface. MDB interfaces are completely software transparent to the host computer. MDB products are competitively priced, delivery is 14 days ARO or sooner.

MDB places an unconditional one year warranty on its controllers and tested products. Replacement boards are shipped by air within twenty-four hours of notification. Our service policy is exchange and return.

MDB also supplies interface modules for LSI-11\*, IBM Series/1, Data General and Interdata computers. Product literature kits are complete with pricing.

**MDB** 1995 N. Batavia Street  
Orange, California 92665  
714-998-6900  
SYSTEMS INC. TWX: 910-593-1339

## New products

ranges from 10 mv to 10 v. It sells for \$1,340 with 16 single-ended (8 differential) channels, and otherwise offers the same capability as the 1712. There is also a low-level version of the 1711, the DT1715 I/O board for input ranges from 10 mv to 10 v, which is priced at \$1,800.

Completing the family are the DT1718 and 1719. The former is an isolated low-level 12-channel analog-input board, priced at \$1,990. It has a 12-bit integrating a-d converter, and programmable or fixed full-scale input ranges from 10 mv to 10 v and provides 250 v of isolation. It and the 1719 are both well suited to industrial applications, where isolation is required.

The latter has four channels of analog input, with isolation to 250 v, two channels of nonisolated analog outputs, the same programmable or fixed full-scale input ranges as the 1718, power amplifier output, and Z-axis point-plotting capability.

The 1719 also sells for \$1,990. Delivery of all the boards is 30 days after receipt of order.

Data Translation Inc., 4 Strathmore Rd., Natick, Mass. 01760. Phone (617) 655-5300 [381]

## C-MOS a-d converters give 12-bit accuracy in 2 bytes

Compatibility with microprocessors, a much touted capability in today's market, is of little value if unaccompanied by the accuracy needed for optimum system performance. Two series of hybrid analog-to-digital converters, however, are now claiming both attributes. Moreover, the complementary-metal-oxide-semiconductor units complement series 7545 and 7546 d-a converters [*Elec-*

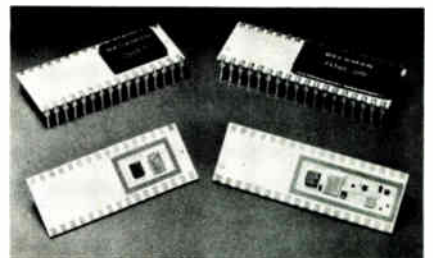

\*TM Digital Equipment Corp.

# Let's talk business.



Good business. Profitable business. Your business. We can help. With decades of research and development behind us, Hi-G remains dedicated to providing premium quality electrical and electro-mechanical products at affordable prices. Combining advanced design with highly automated production gives you more for your business dollar. All the way down the Hi-G product line.

With fastfit™ RF connectors from the Cambridge Products Division. Solenoids

from the Magnetec Division. Flagship™ and Q.P.L. relays from the Relay Division. Time delay relays and LIQUA-SENSE™ liquid level sensors from the Electronics Division. Multi-layer PC boards from the Defiance Division. And professional-grade transformers from the Merrimack Division. If it's made by a division of Hi-G, it's made right. And that makes good business sense. For us. For you.

Let's talk about your special requirements. How we

can meet them with economical, highly reliable Hi-G products. If you mean business, let's talk. Call Alvin Lukash, President. (203) 623-2481.

**Hi-G Incorporated**  
580 Spring Street,  
Windsor Locks, CT 06096.



**Let's talk business.**



## Our New Spectrum Analyzer MS62C/D does only what it's told.

Some spectrum analyzers give you a pretty picture of their own noise and internally generated spurious signals. Not ours. With a dynamic range of 70 dB and noise of less than  $-122$  dBm, our new MS62C and MS62D come pretty close to showing you only what you put into it. Even with a  $-30$  dBm input signal, spurious components are kept to  $-100$  dBm or less. A wide frequency range from 50 Hz all the way to 1.7 GHz means this is one spectrum analyzer you can use for a wide range of applications: base band, video, radio, or mobile. Controls have been simplified for quick pushbutton operation, and overall size and weight have been reduced for ease in carrying. Operates on a.c., d.c., or battery power. MS62C comes with a normal persistence-type CRT (P7 phosphor), while MS62D comes with a storage-type (P31 phosphor) display screen.

For comprehensive literature on Anritsu's  
Spectrum Analyzer, contact—

**Anritsu**

**ANRITSU ELECTRIC CO., LTD**  
MEASURING INSTRUMENTS DIVISION  
SALES DEPARTMENT:

12-20, Minamiazabu 4-chome, Minato-ku, Tokyo 106 Japan  
Phone: (03) 446 1111/Telex: 0 242 2353  
Cable: ANRITDENKI TOKYO

• U.S.A. Anritsu America, Inc. Tel: (201) 569 4474 • West Germany Knott Elektronik GmbH Tel: (08178) 4085 • U.K. Dymar Electronics Limited Tel: Watford 37321 • France Triplex Airtonic Tel: (1) 946-96-48  
• Italy Vianello S.p.A. Tel: (02) 54 40 41 • Spain Unitronics, S.A. Tel: 242 52 04 • Holland C.N. Rood B.V. Tel: 070 99 63 60 • Belgium C.N. Rood S.A. Tel: 02 35 21 35 • Sweden Teleinstrument AB Tel: 08 38 03 70 • Singapore O'Connor's (Pte.) Ltd. Tel: 637944 • Australia NEC Australia Pty. Ltd. Tel: Melbourne 560 5233 • Malaysia O'Connor's (Malaysia) SDN. BHD. Tel: 51563/5 • Brazil Anritsu Eletrônica Comercio Ltda. Tel: Rio 221 6086

## New products

*tronics*, Nov. 24, 1977, p. 141] and are offered at relatively low prices.

The 7555 and 7556 series use successive-approximation techniques to derive outputs with guaranteed 12-bit accuracy. For compatibility with typical 8-bit busing schemes, the converters have three output states (high impedance and logic high and low).

Outputs are available either from the serial output register or in parallel form after the end-of-conversion pin goes high. The parallel output is separated into 2 bytes: one containing the 4 most significant bits (MSB) and the other containing the 8 least significant bits (LSB). A separate inhibit line for each byte controls when it drives the data bus.

Members of both series are linear to within  $\frac{1}{2}$  LSB and are available in commercial and military temperature versions. The 7555 converters are made up of a successive-approximation register, a switch-and-clock chip, a thin-film ladder network, and an input scaling resistor; users can add an external comparator and a reference of  $-10$  to  $+10$  V to form a complete conversion system. The commercial version of these units is priced at \$26.60 in 100s.

The 7556 units include the 7555 circuitry plus a high-speed comparator and precision  $-10$ -V reference. They can perform a 12-bit conversion in  $50 \mu$ s, typically consume only 200 mW, and sell for \$54.80 in hundreds. Both series are available from stock.

Beckman Instruments Inc., Technical Information Section, Advanced Electro-Products Division, 2500 Harbor Blvd., P. O. Box 3100, Fullerton, Calif. 92634 [383]

## System acquires data with easy-to-program computer

Where data gathering and system control are subject to variation and refinement, the 7252C data-acquisition system allows operators unfamiliar with sophisticated programming techniques to reprogram quickly with simple keystrokes. The system's computer can be addressed

# When you need rockers & toggles or more than rockers & toggles...



Come to the people who've always been specialists in having more good ways to solve problems: Dialight. What we've done in indicator lights, illuminated switches, readouts and LEDs, we're doing now in miniature rockers and toggles.

This new Dialight family of switches, which comes in a full range of sizes is, we're proud to point out, all-American made.

When you consider all the configurations of styles, sizes, life and safety ratings, colors and mountings, you'll find there are literally hundreds of thousands of design combinations. Such a number of possibilities

can in itself be a problem, except that the new Dialight catalog is specifically designed to prevent confusion and help you quickly and easily find the most advantageous combination of features for your applications.

If you'd like to see what Dialight quality rockers and toggles can do for the looks, durability and economics of your products, contact us today for the Dialight "Meets Your Need" Book. Your free copy will include a list of stocking distributors in the U.S. and Canada.

**DIALIGHT**  
A North American Philips Company

Made in the U.S.A. by DIALIGHT

## Dialight meets your needs.

Eastern Canada: Munro Electronics Corp. Ltd., Mississauga, phone: (416) 676-1042  
Western Canada: Arwin Technical Sales, N. Vancouver B.C., (604) 980-4346

Circle 195 on reader service card

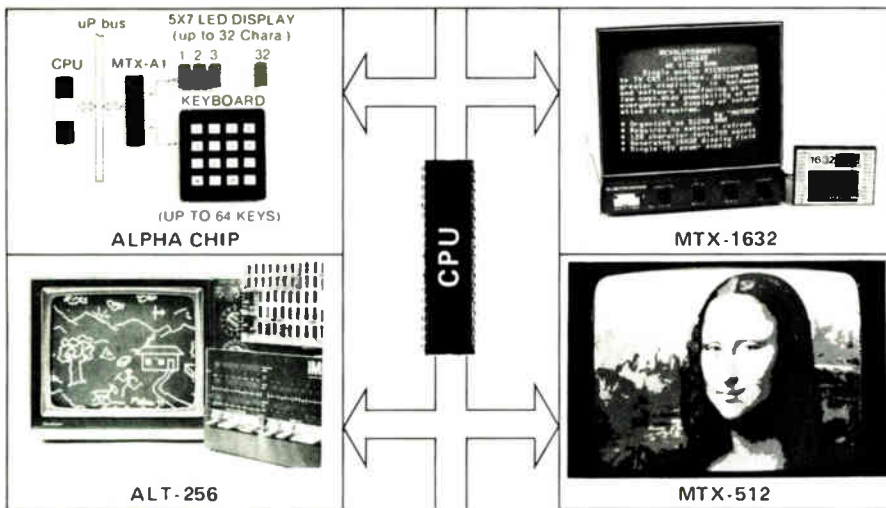

## matrix microprocessor displays

- VIDEO RAMS
- GRAPHICS
- ALPHA CHIP

A family of alphanumeric CRT controllers. Wide range of display formats  
 A family of versatile CRT controllers. Resolutions from 256 x 256 to 512 x 512  
 A family of single chip LED alphanumeric keyboard display controllers

Matrix offers you a highly diversified line of innovative display controllers. Our products have proven themselves in almost every imaginable application: from ground control displays for the Viking mission to Mars to hobby displays. You can choose from one of the most complete lines of micro-mini-computer CRT and display controllers in the industry.

These state of art OEM devices come as complete off the shelf, ready to use sub-systems. (Single chips, modules, PCB's). They connect directly to any uP and can drive standard TV monitors. We offer many products which are plug-in compatible with industry standard buses including DEC LSI-11, Intel SBC-80, S100 bus and Prolog. Matrix also offers a unique custom design capability which ranges from complex single chip controllers to complete systems

If you need a display for your uP, let us know. We are ready to help you.



## matrix electronic systems

TLX 05-825651

P.O. BOX 56 AHUNTSIC STN. MONTREAL QUE H3L 3N5 TEL (514) 481-6838 or (514) 735-1182  
 U.S. ONLY TRIMEX BUILDING MOORE'S N.Y. 12958

Circle 196 on reader service card

# Sprague-Goodman. The first and last name for trimmer capacitors.

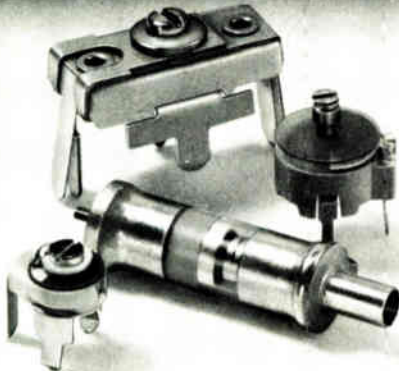

## PISTONCAP™/CERAMIC/FILMTRIM™/MICA

At Sprague-Goodman we specialize in trimmer capacitors. They're our only business. So we offer prompt service and off-the-shelf delivery of our full line of catalog parts. From multi-turn tubular Pistoncap® in glass or quartz, thru ceramic single turn and Filmtrim™ plastic single turn, to our new Mica compression line.

Our comprehensive line of trimmer capacitors deliver reliability at competitive prices, and our staff is always available for custom designing to your needs.

So the next time trimmer capacitors are called for, call us or your distributor and ask for them by name... Sprague-Goodman.



## Sprague-Goodman Electronics, Inc.

(An Affiliate of the Sprague Electric Company)

134 FULTON AVE GARDEN CITY PARK N.Y. 11040 • 516-746-1385 • TLX 14-4533

Circle 257 on reader service card

## New products

using a standard ASCII keyboard plus 43 special function keys that provide most Basic instructions.

In addition to performing standard arithmetic operations and mathematical functions, the computer makes transcendental and matrix manipulations of input data. The basic 7252C accepts 10 low-level inputs from such sensors as thermocouples and strain gages, displays readings on a 5½-digit multimeter at a rate of 12 samples per second or in graphic form on its 9-in. cathode-ray tube, and creates reports with its 80-column, 320-character/s printer.

Priced at \$15,200, the system comes with 8 kilobytes of read/write semiconductor memory, 89 kilobytes of minifloppy storage (both of which are expandable), and a 42-kilobyte Basic interpreter. Optional input/output expanders are available. Delivery time is 45 days.

FI Electronics, 968 Piner Rd., Santa Rosa, Calif. 95401. Phone Edward Bollet at (707) 527-0410 [384]

## D-a converters multiply 20-MHz reference inputs

Engineers who want to provide digital gain control for systems operating at up to 20 MHz can now get a hybrid 10-bit multiplying digital-to-analog converter to do the job. Called the DAC-HA10B, the d-a converter accepts a reference that varies from as much as -12 to +12 V in that frequency band.

For a full-scale change in digital input, the unit's output current settles to within ½ least significant bit within 1.3 μs. The differential linearity error and the gain temperature coefficient are, respectively, ±½ LSB and 20 ppm/°C at most.

The converters come in +5-V- and +15-V-supply versions and in commercial, industrial, and military temperature grades. For those respective grades, the units are priced at \$31, \$41, and \$73 in single quantities. Delivery time is four weeks.

Datel Systems Inc., 11 Cabot Blvd., Mansfield, Mass. 02048. Phone Eugene Murphy at (617) 828-8000 [385]

# What makes Northern Ireland work for the electronics industry?

More than 40 firms in the industry are at work in Northern Ireland today. Companies headquartered in the U.S., Europe, and Great Britain are engineering everything from appliances to sophisticated components.

The industry is long established. Support services are in place for research and development as well as for manufacturing. And there are special grants available to help you turn R&D into profitable products.

There is no shortage of skills in the work force of Northern Ireland. American companies who have come here find that people bring to work not only experience, but also a deep sense of company loyalty, a good labor relations record, and positive attitudes toward attendance and productivity.

New arrivals also find transportation links and first-class telecommunications that make it easy to do business in the Common Market or anywhere

else. And nowhere in the EEC is there a better overall package of incentives to help a new venture succeed.

Find out how the people and the province can work for you. Get the facts from Reg Browne or George McLaren at the Northern Ireland Industrial Development Office in New York. They can quickly tailor an offer of assistance to suit your plans. Call (212) 593-2258. Or write: NIIDO, British Consulate-General,

150 E. 58th Street,  
New York, NY 10022.

Kieran Fitzpatrick works. An apprentice for the past year, he's building a career in electronics with Grundig.

## Northern Ireland works.

Circle 197  
on reader service card



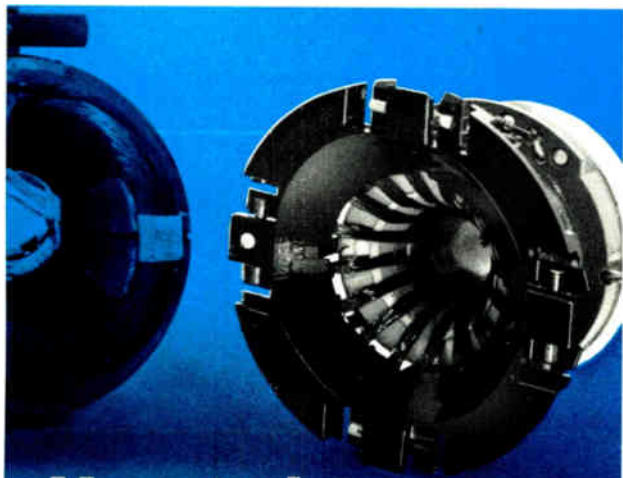

## How to impress Accounting

That's the department most likely to be impressed by "bottom line" results. And, why we've developed a lower cost commercial stator-wound yoke. It does (we admit) cost more than the ordinary TV type saddle yoke, but results in the most favorable "bottom line" figure.

You can prove that to yourself. Finish filling in the column below:

	Ordinary TV type yoke	Syntronic Yoke
Cost of yoke	\$ _____	Ask Syntronic's price
Cost of correction magnets	\$ _____	(not necessary)
Cost of hardware to hold magnets	\$ _____	(not necessary)
Cost of labor to attach magnets	\$ _____	(not necessary)
Cost of labor to adjust magnets	\$ _____	(not necessary)
Cost of replacing rejected yokes that fall short of meeting customer standards	\$ _____	(not necessary)
Cost of recycling product that does not meet Q.A. standards due to yoke deficiencies	\$ _____	(not necessary)
Cost of field service to make adjustments to satisfy customer	\$ _____	(not necessary)
Extra sales expense and "persuasion" necessary to sell non-competitive displays	\$ _____	(not necessary)

"Bottom line" total \$ \_\_\_\_\_ \$ \_\_\_\_\_



**syntronic instruments. inc.**

100 Industrial Road, Addison, IL 60101  
Phone: (312) 543-6444

## Electronics Magazine Books Offers You:



- 1. Microprocessors** What you must know about available micro-processor technology, devices, information, 4th printing. \$8.95
- 2. Applying Microprocessors** 2nd and 3rd generation technology. 26 detailed applications from data networks to video games. \$9.95
- 3. Large Scale Integration** Covers the basic technology, new LSI devices, LSI testing procedures, plus system design and applications. \$9.95
- 4. Basics of Data Communications** Includes 47 articles from Data Communications magazine covering more than 11 key areas. \$12.95



- 5. Circuits for Electronics Engineers** Contains 306 circuits arranged by 51 functions from Amplifiers to Voltage Regulating Circuits. Saves design drudgery. \$15.95
- 6. Design Techniques for Electronics Engineers** Nearly 300 articles drawn from "Engineer's Notebook." A storehouse of design problem solutions. \$15.95
- 7. Memory Design: Microcomputers to Mainframes** The technology, devices, and applications that link memory components and system design. \$12.95
- 8. Personal Computing: Hardware and Software Basics** More than 50 articles from leading publications in the field. \$11.95

Electronics Magazine Books P.O. Box 669, Hightstown, NJ 08520

I must be fully satisfied or you will refund full payment if the book is returned after ten-day trial examination. Send me:

- \_\_\_\_\_ copies of 1. *Microprocessors* @ \$8.95  
 \_\_\_\_\_ copies of 2. *Applying Microprocessors* @ \$9.95  
 \_\_\_\_\_ copies of 3. *Large Scale Integration* @ \$9.95  
 \_\_\_\_\_ copies of 4. *Basics of Data Communications* @ \$12.95  
 \_\_\_\_\_ copies of 5. *Circuits for Electronics Engineers* @ \$15.95  
 \_\_\_\_\_ copies of 6. *Design Techniques for Electronics Engineers* @ \$15.95  
 \_\_\_\_\_ copies of 7. *Memory Design: Microcomputers to Mainframes* @ \$12.95  
 \_\_\_\_\_ copies of 8. *Personal Computing: Hardware and Software Basics* @ \$11.95

Discounts of 40% on orders of 10 or more of each book.

Payment enclosed  Bill firm  Bill me

Charge to my credit card:

American Express  Diners Club  
 Visa  Master Charge

Acct. No. \_\_\_\_\_ Date Exp. \_\_\_\_\_

On Master Charge only, first numbers above name \_\_\_\_\_

Name \_\_\_\_\_ Title \_\_\_\_\_

Company \_\_\_\_\_

Street \_\_\_\_\_

City \_\_\_\_\_ State \_\_\_\_\_ Zip \_\_\_\_\_

Signature \_\_\_\_\_





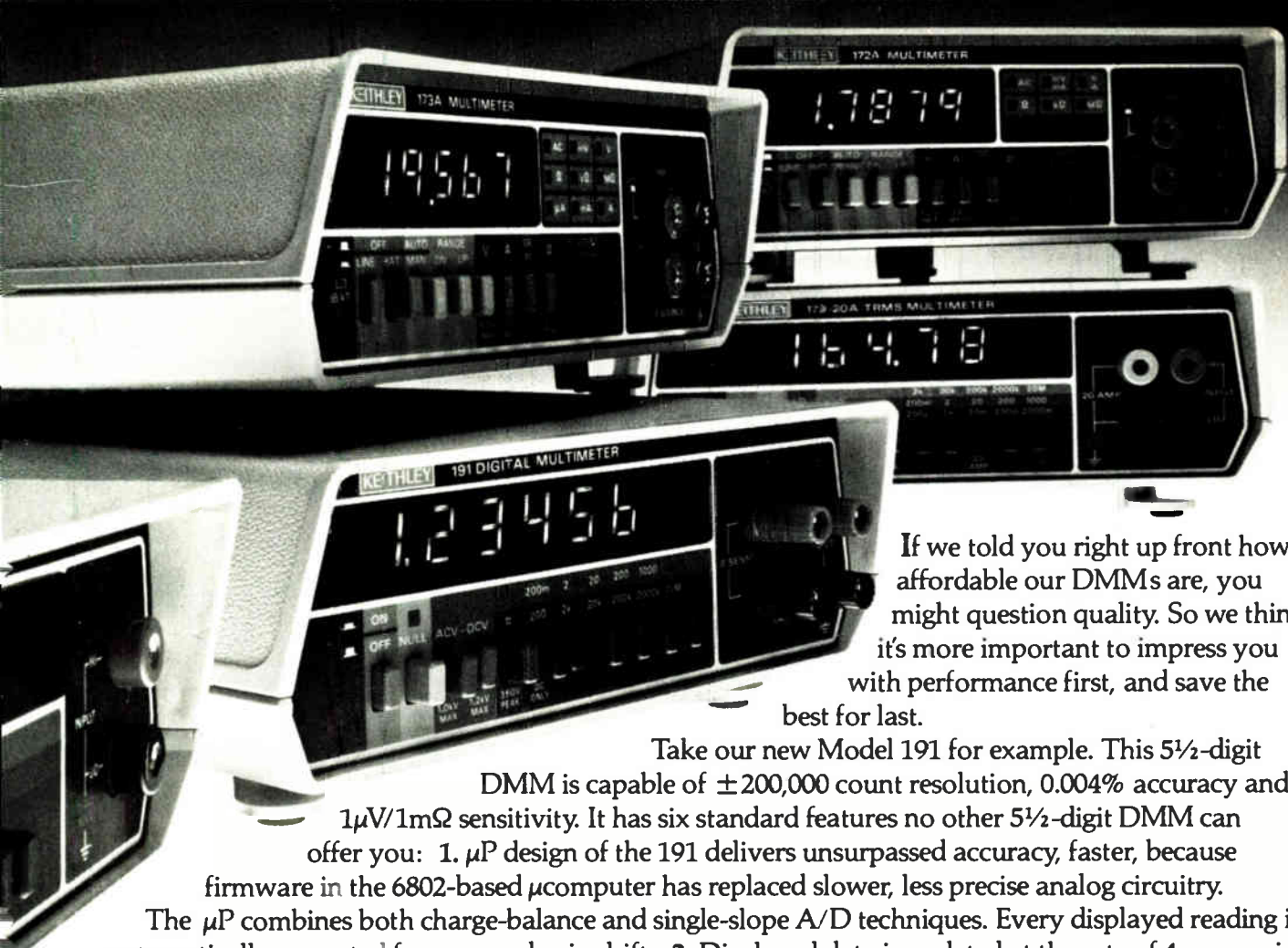

If we told you right up front how affordable our DMMs are, you might question quality. So we think it's more important to impress you with performance first, and save the best for last.

Take our new Model 191 for example. This 5½-digit DMM is capable of ±200,000 count resolution, 0.004% accuracy and 1μV/1mΩ sensitivity. It has six standard features no other 5½-digit DMM can offer you:

1. μP design of the 191 delivers unsurpassed accuracy, faster, because firmware in the 6802-based μcomputer has replaced slower, less precise analog circuitry.
2. The μP combines both charge-balance and single-slope A/D techniques. Every displayed reading is automatically corrected for zero and gain drift.
3. Displayed data is updated at the rate of 4 conversions per second—the fastest rate of digit change readable by the human eye. Settling time is 0.5 seconds.
4. The 191 automatically suppresses low-level noise by means of a non-linear digital filter free of dielectric absorption and leakage problems associated with analog techniques.
5. Pushbutton arithmetical correction of residual error is faster and easier than potentiometer zeroing. The nearest competitive units offering pushbutton null standard cost thousands of dollars more than the 191.
6. The 191 is capable of 2 and 4-terminal measurements from 1mΩ to 20MΩ across 6 ranges. Simply adding two more sense leads automatically enables Kelvin measurements. No changing input terminals or pushbutton settings.
7. The price of the 191 is \$499.

We don't talk price until you're hooked.

In a nutshell, Keithley Instruments has made the 191 and every one of our DMMs the finest performance/value in its class. Tell us what you need.

Once you see how well we meet that need, we think you'll be sold on a Keithley DMM.

For information on any Keithley DMM, call (800) 321-0560/Telex: 98-5469.

In Ohio, call (216) 248-0400.

**KEITHLEY**

Keithley Instruments, Inc.  
28775 Aurora Road  
Cleveland, Ohio 44139  
(216) 248-0400  
Telex: 98-5469

Keithley Instruments GmbH  
Heighhofstrasse 5  
D-8000 München 70  
(089) 714-40-65  
Telex: 521 21 60

Keithley Instruments, Ltd.  
1, Boulton Road  
GB-Reading, Berkshire RG2 0NL  
(0734) 86 12 87

Keithley Instruments SARL  
44, Rue Anatole France  
F-91121 Palaiseau Cedex  
01-014-22-06  
Telex: (842) 204188

Circle 258 for demonstration  
Circle 199 for literature





# AO STEREOSTAR<sup>®</sup> Microscope. It has everything from A to Zoom.

**ALL ESSENTIAL FEATURES FOR AN  
OUTSTANDING INDUSTRIAL MICROSCOPE**

**Auxiliary Lenses: .5x, 2x**

**Body Rotation: 360°**

**Eyepieces: 10x, 15x, 25x**

**Field Size Range (inches): .13-2.25**

**Magnification: Standard 7-30x; Range 3.5-150x**

**UL listed Illuminator**

**Working Distance: Standard, 4.0 inches; Range, 1.4-5.7 inches**

**Zoom Range: .7-3x; Zoom Control: Dual Side Mounted; Zoom  
Ratio: 4.3-1**

These are all features you want and need for efficient assembly or inspection of microcomponents. The AO STEREOSTAR ZOOM Microscope was specifically designed for production-line applications. It's easy to use, with plenty of working distance plus coupled zoom control conveniently located on both sides. And traditional AO quality optics give very high resolution for crisp, sharp images. Send for a detailed brochure. American Optical, Scientific Instrument Division, Buffalo, NY 14215.

**AO**  
American  
Optical

200 Circle 259 on reader service card

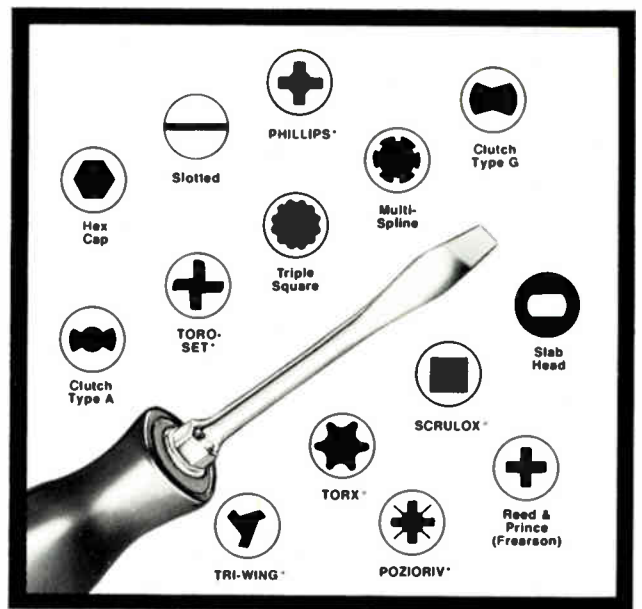

## If you have the fastener *Snap-on* has the tool

Snap-on offers screw drivers with bits in various sizes to fit all of the screw heads shown above. For complete details see your Snap-on representative or write us. Snap-on Tools Corporation, 8051-B 28th Avenue, Kenosha, Wisconsin 53140. 432

PHILLIPS, POZIORIV, TRI-WING, and TORO-SET are registered trademarks of the PHILLIPS SCREW COMPANY. SCRULOX is a registered trademark of PAN AMERICAN SCREW. TORX is a registered trademark of CAMCAR/TEXTRON.

**Snap-on Tools**

Circle 260 on reader service card

### From Electronics Magazine Book Series. Zero-risk trial offer.



#### Memory Design: Microcomputers to Mainframes

The technology, devices, and applications that link memory components and system design. As published in *Electronics*. \$12.95

#### Electronics Book Series

P.O. Box 669, Hightstown, N.J. 08520

Send me \_\_\_\_\_ copies of "Memory Design: Microcomputers to Mainframes" at \$12.95 per copy

Discounts of 40% on orders of 10 or more copies.

I must be fully satisfied or you will refund full payment if the book is returned after ten-day trial examination.

Payment enclosed  Bill firm  Bill me

Charge to my credit card:

American Express  Diners Club  
 Visa  Master Charge

Acc't No. \_\_\_\_\_ Date exp. \_\_\_\_\_

On Master Charge only,  
first numbers above name \_\_\_\_\_

Name \_\_\_\_\_ Title \_\_\_\_\_

Company \_\_\_\_\_

Street \_\_\_\_\_

City \_\_\_\_\_ State \_\_\_\_\_ Zip \_\_\_\_\_

Signature \_\_\_\_\_

Circle 201 on reader service card →

# LAS 5000 SERIES

## Connection Diagrams

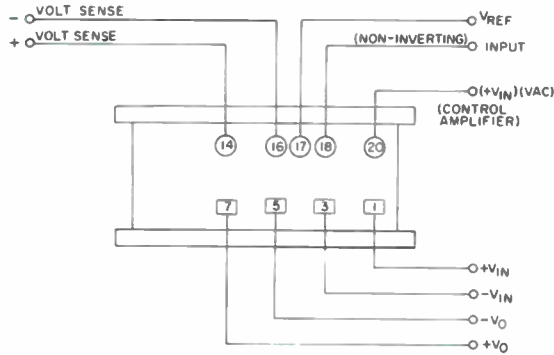

**9-PIN POWER HYBRID VOLTAGE REGULATOR**

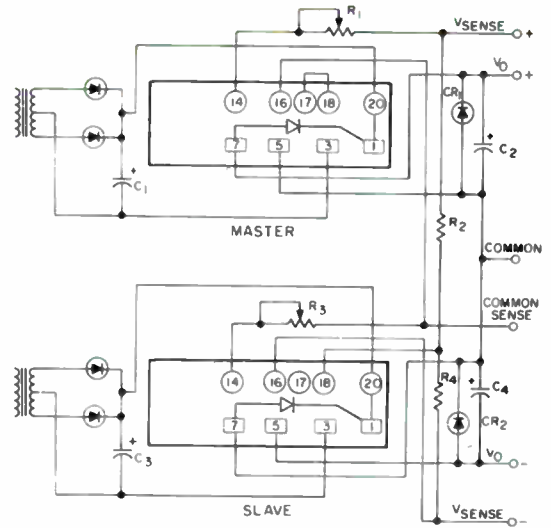

**DUAL TRACKING POWER HYBRID VOLTAGE REGULATOR CIRCUIT**

### NOTES

1. Minimum value of input filter capacitors C<sub>1</sub> and C<sub>3</sub> is determined by:  $C_1, C_3 = I_o \times (1000 \text{ mfd/amp recommended})$
2. Minimum value of output capacitors C<sub>2</sub> and C<sub>4</sub> is determined by:  $C_2, C_4 = I_o \times (100 \text{ mfd/amp})$
3. Minimum value of output voltage adjust resistors R<sub>1</sub> and R<sub>3</sub> is determined by:  $R_1, R_3 = (0.25V_o \times 1000\Omega/V)$  ohms wirewound. Use next highest standard value.
4. Values of tracking reference voltage divider resistors R<sub>2</sub> and R<sub>4</sub> for all models are determined by:
  - a)  $R_2 = (2000V_o - 2490)$  ohms,  $\pm 1\%$ ,  $\frac{1}{2}W$  film
  - b)  $R_4 = 2.49K$  ohms,  $\pm 1\%$ ,  $\frac{1}{2}W$  film
5. Rectifiers CR<sub>1</sub> and CR<sub>2</sub> should be rated at peak inverse voltage of 50V and forward current equal at least to maximum rated  $I_o$ .

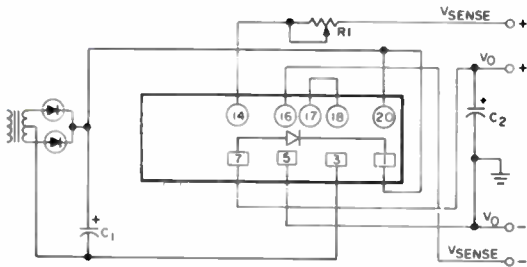

**POSITIVE POWER HYBRID VOLTAGE REGULATOR CIRCUIT**

## CONTACT YOUR NEAREST LAMBDA SALES OFFICE

**ATLANTIC REGION**  
 Melville, New York 11746  
 515 Broad Hollow Road  
 Tel. 516-694-4200  
 TWX: 510-224-6484

**MID-WESTERN REGION**  
 Arlington Heights, Ill. 60005  
 2420 East Oakton St., Unit Q  
 Tel. 312-593-2550  
 TWX: 910-222-2856

**NORTH-EASTERN REGION**  
 Lexington, Massachusetts 02173  
 2 Militia Drive  
 Tel. 617-861-8585  
 TWX: 710-326-7558

**FAR-WESTERN REGION**  
 Carson, Calif. 90746  
 20601 S. Annalee Ave.  
 Tel. 213-537-8341  
 TWX: 910-346-7649

**SOUTH-WESTERN REGION**  
 Corpus Christi, Texas 78410  
 121 International Drive  
 Tel. 512-883-6251

**NORTH-WESTERN REGION**  
 Sunnyvale, California 94086  
 599 N. Mathilda Ave.,  
 Tel. 408-738-2541  
 TWX: 910-339-9243

FOR TECHNICAL INFORMATION CALL  
 JIM ARNOLD AT (512) 883-6251  
 121 INTERNATIONAL DRIVE  
 CORPUS CHRISTI, TEXAS 78410



**LAMBDA**  
 ELECTRONICS

## Operational Data

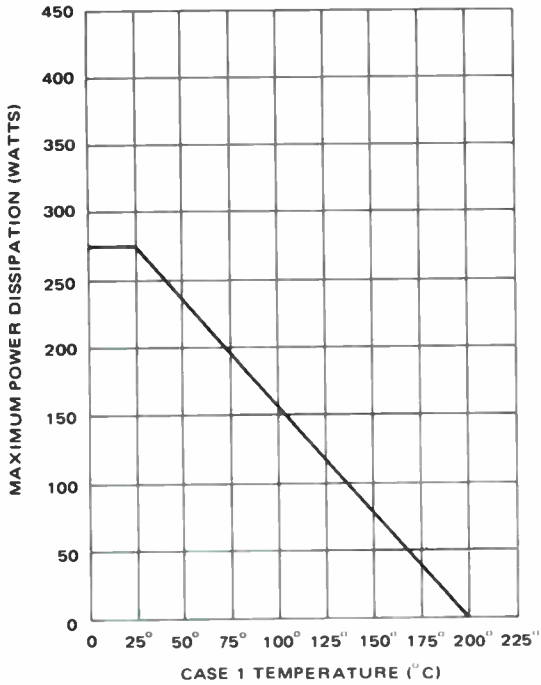

**POWER DERATING CURVE AS A FUNCTION OF CASE 1 TEMPERATURE**

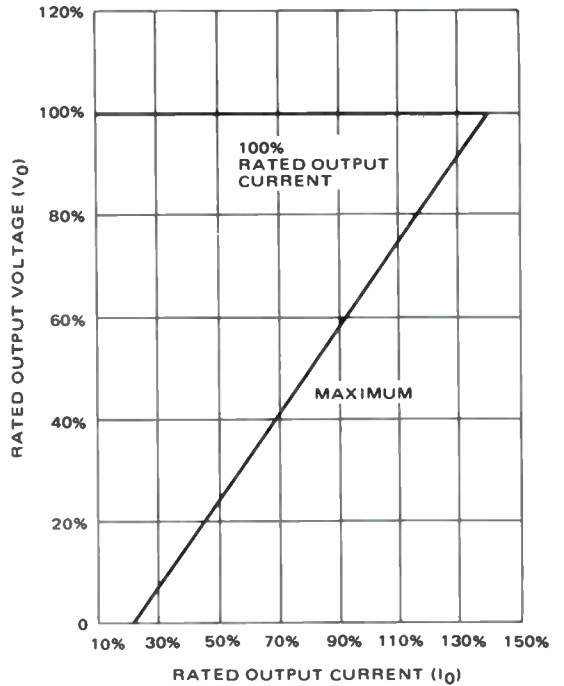

**SHORT CIRCUIT PROTECTION CHARACTERISTIC, LAS 5000 SERIES**

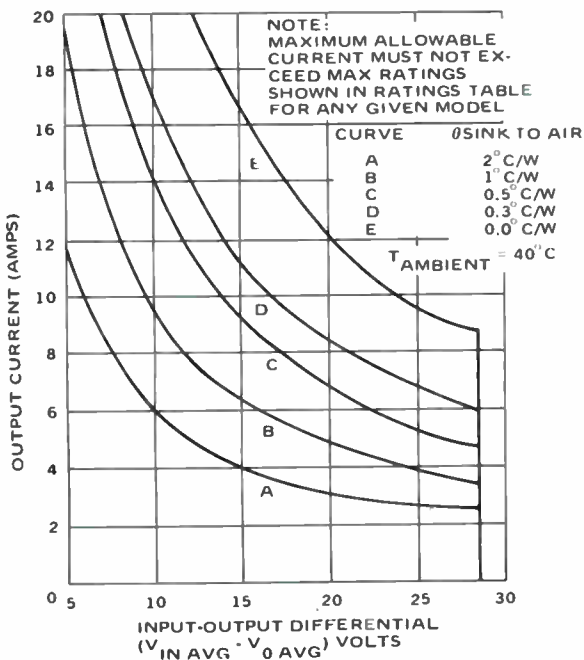

**DC SAFE OPERATING AREA AS A FUNCTION OF HEATSINK THERMAL RESISTANCE TO AIR AT 40° AMBIENT TEMPERATURE FOR LAS 5000 SERIES**

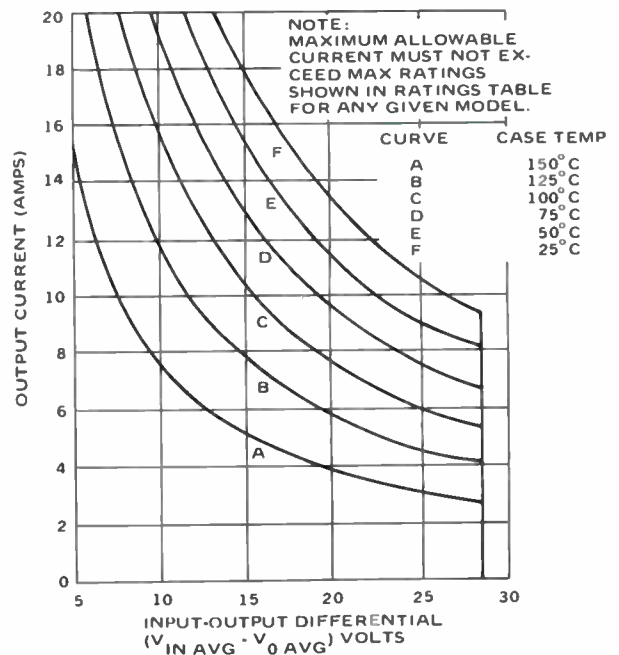

**DC SAFE OPERATING AREA AS A FUNCTION OF MODULE CASE TEMPERATURE FOR LAS 5000 SERIES**

# LAS 5000 SERIES

## Regulator Performance Specifications

### 20 amp, 270 watt positive regulator

#### General Description

The LAS 5200 Series of Power Hybrid Voltage Regulators is designed for applications requiring a well regulated output voltage for load current variations up to 20 amperes. A key feature of the LAS series of Power Hybrid Voltage Regulators is its construction. A high degree of thermal isolation between the heat generating power elements and the heat sensitive control and reference elements is achieved by the placing of the power section on the heat-dissipating base of the unit, and the control stage on the heat-dissipating upper surface. This thermal isolation results in extremely low thermal drift characteristics for changes in power levels.

PARAMETER	SYMBOL	CONDITIONS	MIN.	MAX.	UNITS
Input voltage to pin (1) <sup>(A)(H)</sup>	$V_{IN(1)}$		7.25	40.0	volts
Input voltage to pin (20) <sup>(A)(G)</sup>	$V_{IN(20)}$		11.9	40.0	volts
Output voltage	$V_o$		4.75	29.4	volts
Input-output differential <sup>(A)(F)</sup>	$V_{IN(1)} - V_o$		2.5	28.6	volts
Input-output differential <sup>(B)(F)</sup>	$V_{IN(20)} - V_o$		7.20	28.6	volts
Output current	$I_o$			20.0	amps
Standby current	$I_Q(1)$			30.0	mA
Standby Current	$I_Q(20)$			7.0	mA
Power dissipation	$P_D$	Plate #1 @25°C		270.	watts
Power dissipation	$P_D$	Free Air @25°C Amb		11.	watts
Thermal resistance junction—Case #1	$\theta_j - C1$			0.65	°C/watt
Thermal resistance junction—free air	$\theta_j - FA$			12.0	°C/watt
Storage temperature	$T_s$		-55	+125.	°C
Power transistor junction temperature	$T_j$			+200.	°C
Regulation line <sup>(C)</sup>				0.014	%/ $\Delta V_{IN}$
Regulation load <sup>(D)</sup>				0.2	%
Programming resistance				1000 nominal	ohm/volt
Programming voltage				one/one	volt/volt
Temperature coefficient				0.015	%/°C
Ripple attenuation <sup>(E)</sup>		$V_{IN(1)}$ minimum 60. $I_o$ maximum			dB

#### NOTES:

- Separate DC input voltages for power circuit (pin 1) and control pin (20).
- Common input voltages for power circuit (pin 1) and control pin (20).
- $I_o$  constant for entire input voltage range from [ $V_{IN(1)}$  &  $V_{IN(20)}$  min.] to [ $V_{IN(1)}$  (20) max.]
- $V_{IN}$  constant for entire range from 0 to full load.
- Ripple attenuation is 54 dB min. for 24V and 28V models.
- Minimum input-output differential based on  $T_j > 25^\circ\text{C}$ .
- For AC source to Pin 20 with source resistance less than 10 ohms, minimum VAC = 12V rms. For other conditions consult factory.
- Maximum input voltage is 30V for LAS 5205 and 5206.

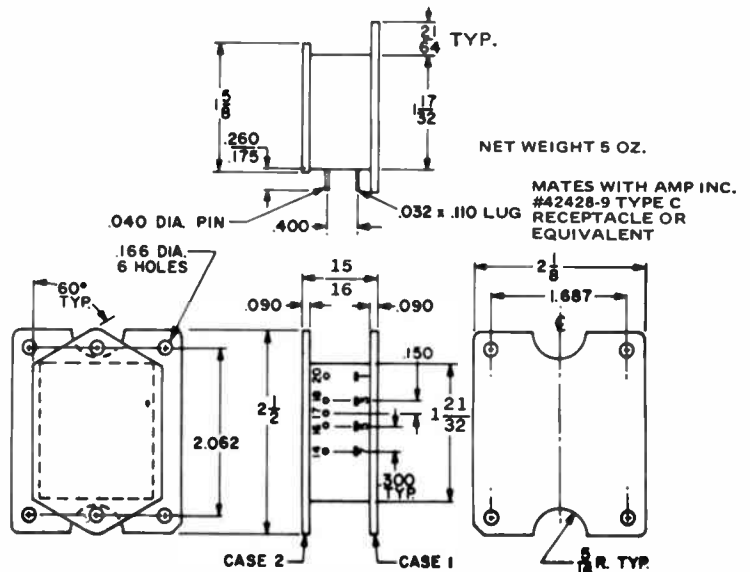
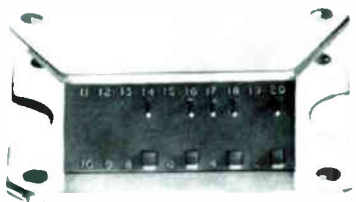

OUTLINE DRAWING, POWER HYBRID VOLTAGE REGULATOR, LAS 5000 SERIES

$V_o$ VOLTS	MODEL	$I_o$ AMPS	1-24	25-49	50-99	100-249	250-499	500-999	1000
5±5%	LAS 5205	20	\$80	\$65	\$55	\$46	\$46	\$42	\$38
6±5%	LAS 5206	20	80	65	55	46	46	42	38
12±5%	LAS 5212	15	80	65	55	46	46	42	38
15±5%	LAS 5215	15	80	65	55	46	46	42	38
24±5%	LAS 5224	14	80	65	55	46	46	42	38
28±5%	LAS 5228	13	80	65	55	46	46	42	38

## Connection Diagrams

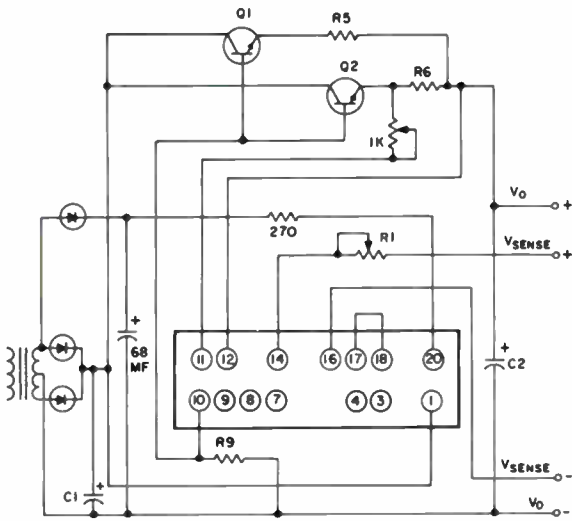

**POWER HYBRID VOLTAGE REGULATOR  
USED AS A DRIVER FOR HIGHER  
CURRENT OUTPUTS USING PEAK DE-  
TECTOR FOR CONTROL AMPLIFIER  
INPUT VOLTAGE**

### NOTES

1. Minimum value of input filter capacitors C1 and C3 is determined by:  $C1, C3 = I_o \times (1000 \text{ mfd/amp})$  recommended.
2. Minimum value of output capacitors C2 and C4 is determined by:  $C2, C4 = I_o \times (100 \text{ mfd/amp})$ .
3. Minimum value of output voltage adjust resistors R1 and R3 for LAS 3205 is 3K ohms. See note 4 to determine value for all other models.
4. Minimum value of output voltage adjust resistors R1 and R3 is determined by:  $R1, R3 = (0.25V_o \times 1000\Omega/V)$  ohms
5. Values of tracking reference voltage divider resistors R2 and R4 for all models are determined by:
  - a)  $R2 = (2000V_o - 2490 \text{ ohms} \pm 1\%, \frac{1}{2}W \text{ film})$
  - b)  $R4 = 2.49K \text{ ohms}, \pm 1\%, \frac{1}{2}W \text{ film}$
6. Values of current sharing resistors R5 and R6 are determined by:  $R5, R6 = (N \times 0.5V)/MAX I_o$  ohms  $\pm 3\%$  wirewound where N = number of emitter current sharing resistors required.
7. Nominal value of the current sharing resistor R10 determined from table below:

R10	Model
.05 $\Omega$	LAS 3205, 3206
.064 $\Omega$	LAS 3212, 3215, 3224
.075 $\Omega$	LAS 3228

8. Value of current sensing resistor R7 is determined by  $R7 = 2.5V/I_o$  ohms, nominal, wirewound.
9. Rectifiers CR1 and CR2 should be rated at peak inverse voltage of 50V and forward current equal at least to maximum rated  $I_o$ .
10. Value of  $I_{cbo}$  drain resistor R9, is determined by  $R9 = (V_o)/(N \times MAX I_{cbo})$  ohms,  $\pm 5\%$  composition where N = number of external series pass transistors.
11. All fixed resistors shown on diagrams with given values in ohms are  $\frac{1}{2}W$  composition.
12. Temperature rise of Case 2,  $\Delta TC_2$ , is given by the following:
  - a) For no external heat sink on case 2.  
 $\Delta TC_2 = 0.25 P_D \theta_{J1-A}$
  - b) For an external heat sink on case 2 with thermal resistance  $\theta$

$$\Delta TC_2 = \frac{\theta \cdot HS_2}{50^\circ \text{ C/W} + \theta HS_2} \times P_D \theta_{J1-A}$$

## LAS 3000 SERIES

### Outline Drawing

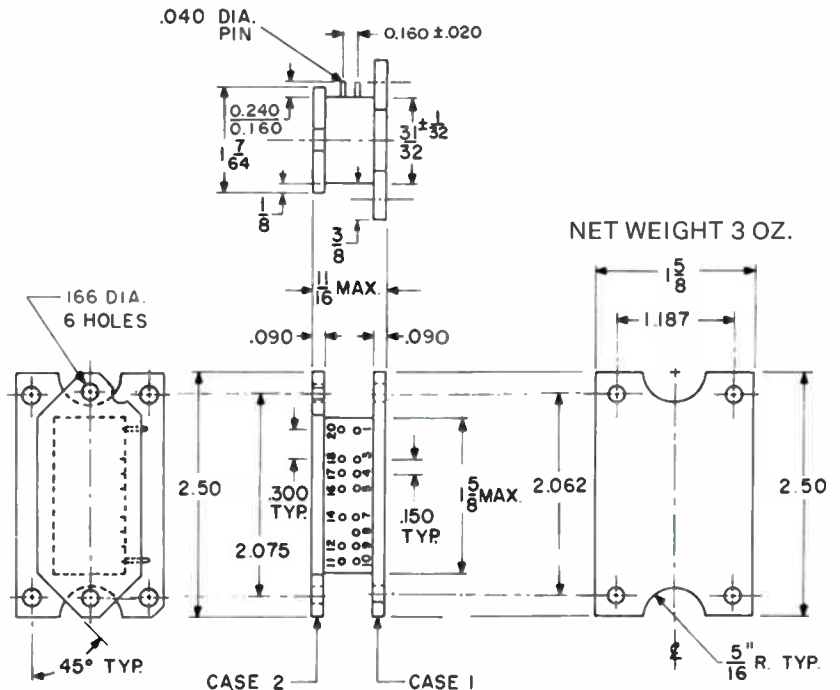
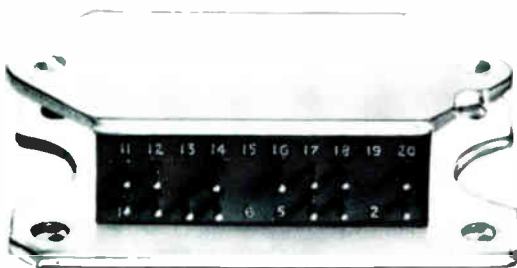

**OUTLINE DRAWING, POWER HYBRID  
REGULATOR, LAS 3000 SERIES**

# LAS 3000 SERIES

## Connection Diagrams

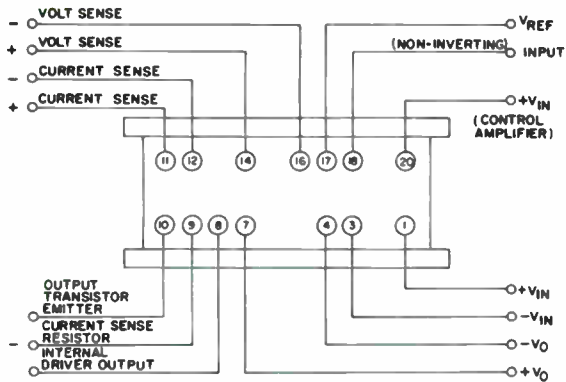

**14 PIN POWER HYBRID VOLTAGE REGULATOR**

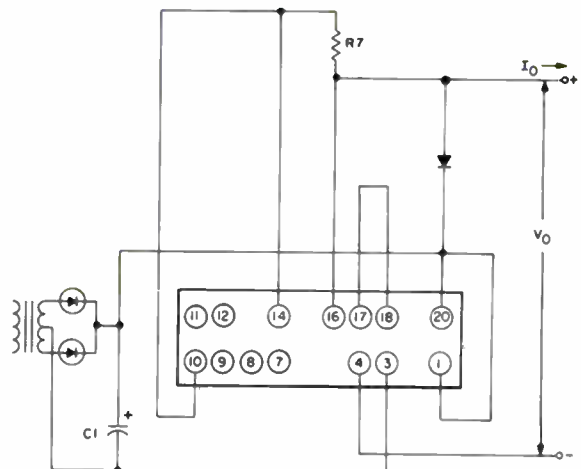

NOTE:  $V_{IN\ MIN} = 7.9 + V_0$

**POWER HYBRID CURRENT REGULATOR  
CIRCUIT FOR LAS 3205 ONLY**

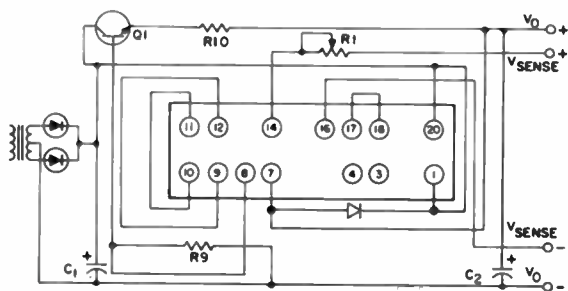

**POWER HYBRID VOLTAGE REGULATOR  
USED WITH PARALLEL PASS TRAN-  
SISTOR FOR HIGHER OUTPUT CURRENT**

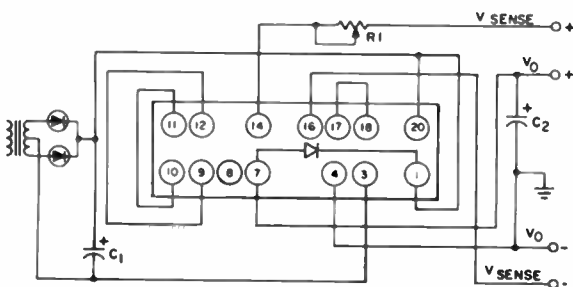

**POSITIVE POWER HYBRID VOLTAGE  
REGULATOR CIRCUIT**

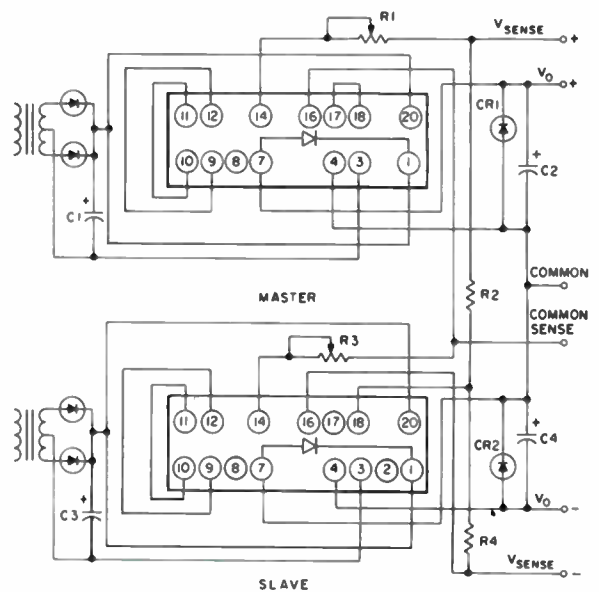

**DUAL TRACKING POWER HYBRID VOLT-  
AGE REGULATOR CIRCUIT**

## Operational Data

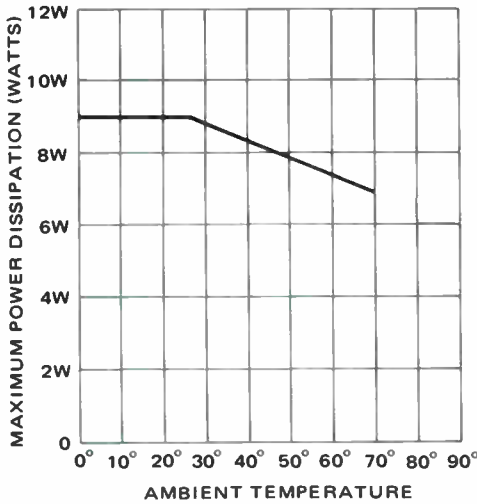

**FREE AIR DERATING CURVE**

NOTE: MAXIMUM ALLOWABLE CURRENT MUST NOT EXCEED MAX. RATINGS SHOWN IN RATINGS TABLE FOR ANY GIVEN MODEL.

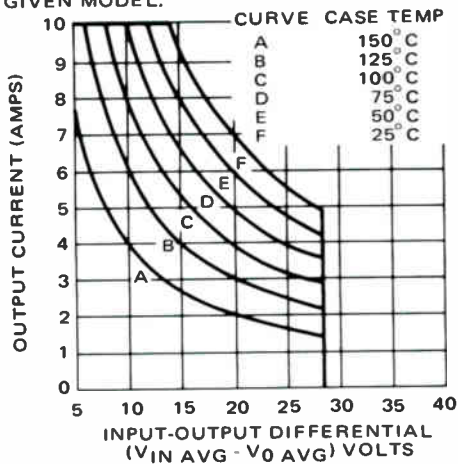

**DC SAFE OPERATING AREA AS A FUNCTION OF MODULE CASE TEMPERATURE, FOR LAS 3000 SERIES**

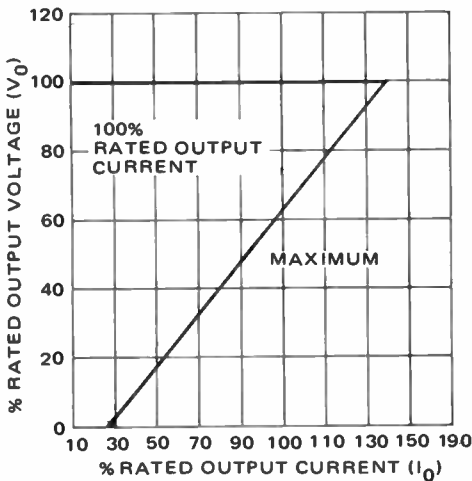

**SHORT CIRCUIT PROTECTION CHARACTERISTIC**

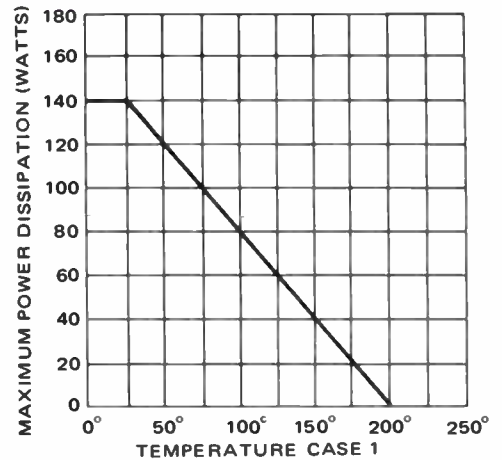

**POWER DERATING CURVE AS A FUNCTION OF CASE 1 TEMPERATURE**

NOTE: MAXIMUM ALLOWABLE CURRENT MUST NOT EXCEED MAX. RATINGS SHOWN IN RATINGS TABLE FOR ANY GIVEN MODEL.

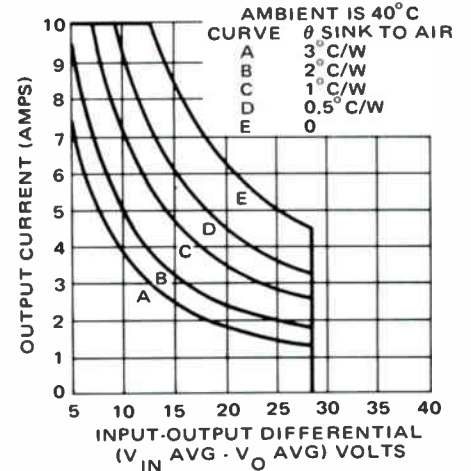

**DC SAFE OPERATING AREA AS A FUNCTION OF HEATSINK THERMAL RESISTANCE TO AIR AT 40°C AMBIENT TEMPERATURE FOR LAS 3000 SERIES**

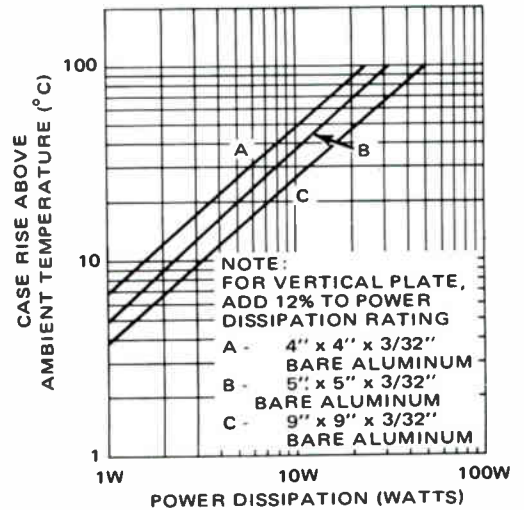

**TYPICAL HEAT SINKING DATA FOR HORIZONTAL PLATE**



# LAS 3000 SERIES

## Regulator Performance Specifications

### 10 amp, 140 watt positive regulator

#### General Description

The LAS 3200 Series of Power Hybrid Voltage Regulators is designed for applications requiring a well regulated output voltage for load current variations up to 10 amperes. A key feature of the LAS series of Power Hybrid Voltage Regulators is its construction. A high degree of thermal isolation between the heat generating power elements and the heat sensitive control and reference elements is achieved by the placing of the power section on the heat-dissipating base of the unit, and the control stage on the heat-dissipating upper surface. This thermal isolation results in extremely low thermal drift characteristics for changes in power levels.

PARAMETER	SYMBOL	CONDITIONS	MIN.	MAX.	UNITS
Input voltage to pin(1) <sup>(A)(G)</sup>	$V_{IN(1)}$		5.2	40.0	volts
Input voltage to pin(20) <sup>(A)</sup>	$V_{IN(20)}$		7.9	40.0	volts
Output voltage	$V_O$		2.7	29.4	volts
Input-output differential <sup>(A)(F)</sup>	$(V_{IN(1)} - V_O)$		2.5	28.6	volts
Input-output differential <sup>(B)(F)</sup>	$(V_{IN(20)} - V_O)$		5.2	28.6	volts
Output current	$I_O$			10.0	amps
Standby current	$I_{Q(1)}$			20.0	mA
Standby current	$I_{Q(20)}$			7.0	mA
Power dissipation	$P_D$	Plate #1 @25°C		140	watts
Power dissipation	$P_D$	Free Air @25°C Amb	9		watts
Thermal resistance junction-Case 1	$\theta_j - C1$			1.25	°C/watt
Thermal resistance junction-Free Air	$\theta_j - FA$			15	°C/watt
Storage temperature	$T_s$		-55	+150	°C
Power transistor junction temperature	$T_j$			+200	°C
Regulation line <sup>(C)</sup>				0.01	%/ $\Delta V_{IN}$
Regulation load <sup>(D)</sup>				0.2	%
Programming resistance				1000 nominal	ohms/volt
Programming voltage				one/one	volt/volt
Temperature coefficient				0.015	%/°C
Ripple attenuation <sup>(E)</sup>		$V_{IN(1)}$ Minimum 60 $I_O$ Maximum			dB

#### NOTES:

- A. Separate DC input voltages for power circuit (pin 1) and control circuit pin (20).  
 B. Common input voltages for power circuit (pin 1) and control pin (20).

- C.  $I_O$  constant for entire input voltage range from [ $V_{IN(1)}$  &  $V_{IN(20)}$  min.] to [ $V_{IN(1)}$ , (20) max.]  
 D.  $V_{IN}$  constant for entire range from 0 to full load.  
 E. Ripple attenuation is 54 dB min for 24V and 28V models.  
 F. Minimum input-output differential based on  $T_j$ , > 25°C.  
 G. Maximum input voltage is 30V for LAS 3205 and LAS 3206

$V_O$ VOLTS	MODEL	$I_O$ AMPS	PRICE QTY.						
			1-24	25-49	50-99	100-249	250-499	500-999	1000
5V ± 5%	LAS 3205	10	\$38	\$34	\$29	\$25	\$25	\$21	\$20
6V ± 5%	LAS 3206	10	38	34	29	25	25	21	20
12V ± 5%	LAS 3212	8.5	38	34	29	25	25	21	20
15V ± 5%	LAS 3215	8	38	34	29	25	25	21	20
24V ± 5%	LAS 3224	7.5	38	34	29	25	25	21	20
28V ± 5%	LAS 3228	7	38	34	29	25	25	21	20

BUILD YOUR OWN POWER SUPPLIES  
WITH LAMBDA'S

# High current semiconductor voltage regulators

270 WATTS 20 AMPS-140 WATTS 10 AMPS

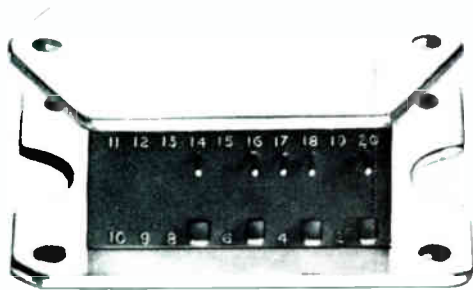

ACTUAL SIZE



**THIS HYBRID REPLACES...**

**ALL THESE PARTS**

Up to 28V, up to 20A—0.01% line reg. 0.2% load reg.  
built-in short circuit and overload protection

**THE WORLD'S BROADEST LINE OF  
SEMICONDUCTOR VOLTAGE REGULATORS 150 MA TO 30 AMPS**

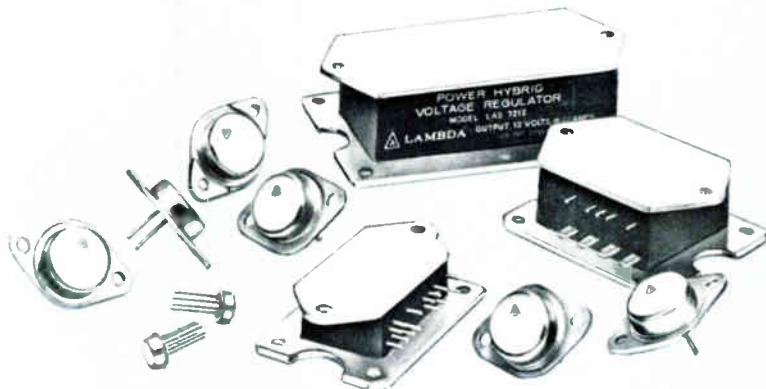

**LAMBDA SEMICONDUCTORS**

### Components

# 52¢ beeper stands only 0.79 in. high, is clearly audible

Beepers, small transducers that emit tones of approximately 2.1 kHz, are turning up in everything from micro-processor-based toys and pocket pagers to remote-control units for telephone answering systems. The QMB series promises to make these chirpers even more nearly ubiquitous, for the small devices—they measure only 0.63 in. in diameter by 0.79 in. high, including pins—are priced at just 52¢ in quantities of 1,000 or more.

The series consists of three models that differ by dc voltage rating: 1.5, 6, and 12 v. Each consists of a coil and a metal cone with a rare-earth magnet. The resistance of the coil varies directly with the voltage ratings, and for the three models the coils are 165, 260, and 430  $\Omega$ .

With an input signal of 2.1 kHz, the low-voltage model requires only a 15-mA driving current and the higher-voltage models need 30 mA. At 8 in. from the unit, the clearly audible signal has a minimum sound-pressure level of 70 dB.

Unlike other beepers, the QMB operates at frequencies as low as 1 kHz and voltage levels as low as 1 v, but, like audio speakers, the unit functions best in matched-impedance circuits. It is housed in a polyacetal resin package and has pins



spaced on 0.3-in. centers. Delivery is from stock to five weeks.

Star Micronics Inc., 200 Park Ave., Suite 2308, New York, N. Y. 10017. Phone Arnie Peters at (212) 986-6770 [341]

### Solid-state relay refracts light

There's a new kind of solid-state relay in town—one that couples the output from light-emitting diodes to the gates of silicon controlled recti-

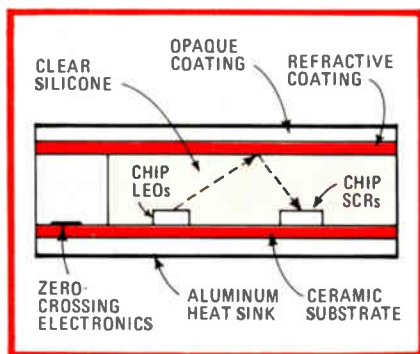

fiers through a light path of clear silicone epoxy. The result is a device, called the OptoFilm solid-state relay, that can switch up to 2A with a 50-mA input.

Moreover, its price is attractive: \$3.90 each in 10,000-piece quantities, with the promise of dropping significantly under \$3 in the near future. Also, a 5-A device is just a couple of months away.

"We tried to ignore everything that had been done before and to attempt completely different things," says Ed Rodriguez, president of the manufacturer, Theta-J Corp., and its main idea man.

OptoFilm is indeed unusual. Truly a semiconductor device, it can be fabricated using hybrid technology. It uses the refractive properties of materials to reflect light from a pair of LED chips onto a pair of SCR chips, as shown in the figure. One LED-SCR pair switches the ac load voltage on; the other switches it off.

The relay can isolate up to 3,750 v ac from input to output and also maintains a maximum peak repetitive off-state voltage of  $\pm 400$  v dc.

It has switching times of 8 ms and a leakage current of 100  $\mu$ A.

Theta-J Corp., 208 Cummings Park, Woburn, Mass. 01801 [342]

### Optocoupler outputs linearly while isolating to 7,500 V

To isolate a measurement system from an analog signal sensed by, say, a thermistor or medical electrode, designers have resorted to building their own circuits. Usually, such circuits contain an optocoupler, sometimes called an optoisolator, as well as an op amp and discrete transistor to linearize the coupler's output. Now, however, designers can purchase an optocoupler whose output is linear up to 250 kHz, typically, and whose isolation capability is 7,500 v, peak.

Designated MOC5010, the component consists of a gallium-arsenide infrared-emitting diode (IRED) optically coupled to a bipolar monolithic amplifier. Input currents are amplified at a gain of 200 mV/mA to provide outputs of up to 4 v, peak to peak. The emitter-follower output impedance is typically less than 200  $\Omega$ .

The UL-recognized device comes in a six-pin, plastic, dual in-line package and works from a 12-v supply. It is available from stock and is priced at \$3.25 in lots of 100 or more.

Motorola Semiconductor Products Inc., P. O. Box 20912, Phoenix, Ariz. 85036. Phone (602) 244-4556 [343]

### Power inductors come in pigmy packages

Though quite small, type LL series inductors are very much at home with relatively large currents. The 0.49-in.-long, 0.365-in.-diameter elements are available in six inductance and current values ranging from 120  $\mu$ H and 1.6 A to 5,000  $\mu$ H and 0.25 A.

Hermetically sealed to meet the requirements of MIL-T-27, the units

# THERMOTRON'S SYSTEM 211

The most programmable  
Environmental  
Controller

FEATURING...



## MICRO-COMMAND

THERMOTRON'S MICRO-COMPUTER PROGRAMMER with keyboard control of 50 program intervals. .1 to 999.9 minutes per interval. Visual display of program entry instructions and progress. Can be looped and has optional Prom capabilities. Available as retrofit to update existing controls. Ask for Micro-Command model #013024.

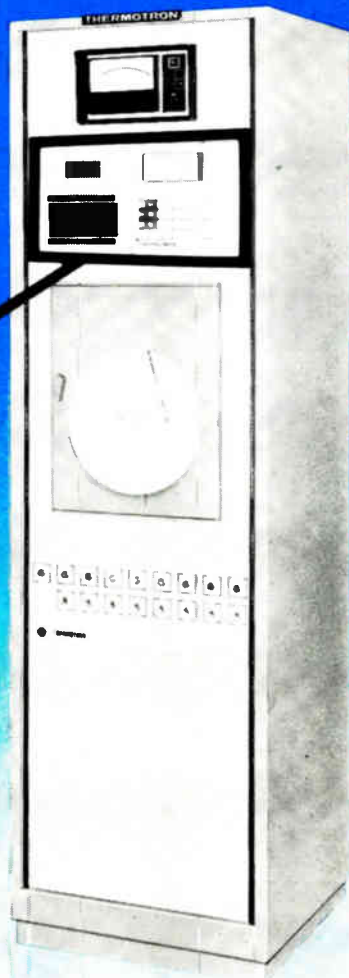

- THERMOTRON'S TEMPERATURE CONTROLLER Bi-directional heating and cooling. Range:  $-87^{\circ}\text{C}$  to  $+190^{\circ}\text{C}$ .
- CIRCULAR CHART RECORDER Progress and completion accurately recorded.
- THERMOTRON PRODUCT SAVER Precise under/over temperature control of product is automatic; has audible and visual alarm. Factory Mutual approved. Accuracy  $\pm 1/4\%$ .
- OPERATOR CONTROL From profile entry to test completion.



Small Business Subcontractor of the Year • 1977 Region 5

**THERMOTRON CORPORATION**

KOLLEN PARK DRIVE, HOLLAND, MI 49423; PHONE 616-392-1492; TWX 810-292-6164

Circle 210 on reader service card

# If this magazine is worth your time, it's worth 58¢.

Drop off the routing list. Avoid the Perils of Passalong. Get your own fresh, unclipped copy mailed to your home or office \$17 (65¢ per issue) for a one-year U.S. subscription. (\$19 in Canada.) Turn to the subscription card in the back of the magazine. If somebody beat you to it, write: Electronics, P.O. Box 430, Hightstown, N.J. 08520.

## New products

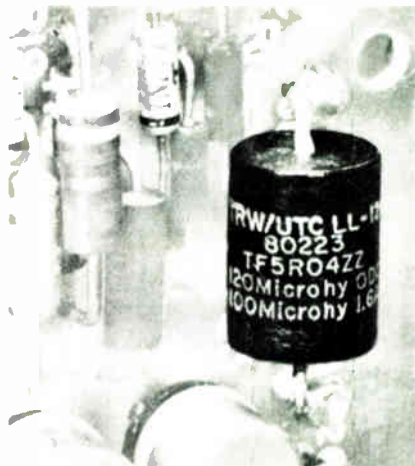

are specified at 1 v and 20 kHz. At rated dc current values, the inductors experience a rise in temperature of approximately  $40^{\circ}\text{C}$  and a drop in inductance not in excess of 20%. In production quantities, type LL inductors sell for less than \$5.50 each and delivery of the units is from stock to eight weeks.

TRW/UTC Transformers, 150 Varick St., New York, N. Y. 10013. Phone Austin Profeta at (212) 255-3500 [345]

## Low-noise isolation amplifier drives guards and shields

Intended for biomedical applications, the IA294 not only offers low input noise (typically  $5 \mu\text{V}$  from 10 Hz to 1 kHz) but also provides drivers for active guards and shields, thus further ensuring low-noise performance in circuit.

For a balanced source impedance, common-mode rejection, input to



# In 1979, you are going to ask the 64k question.

## International Microsystems will have the answer.

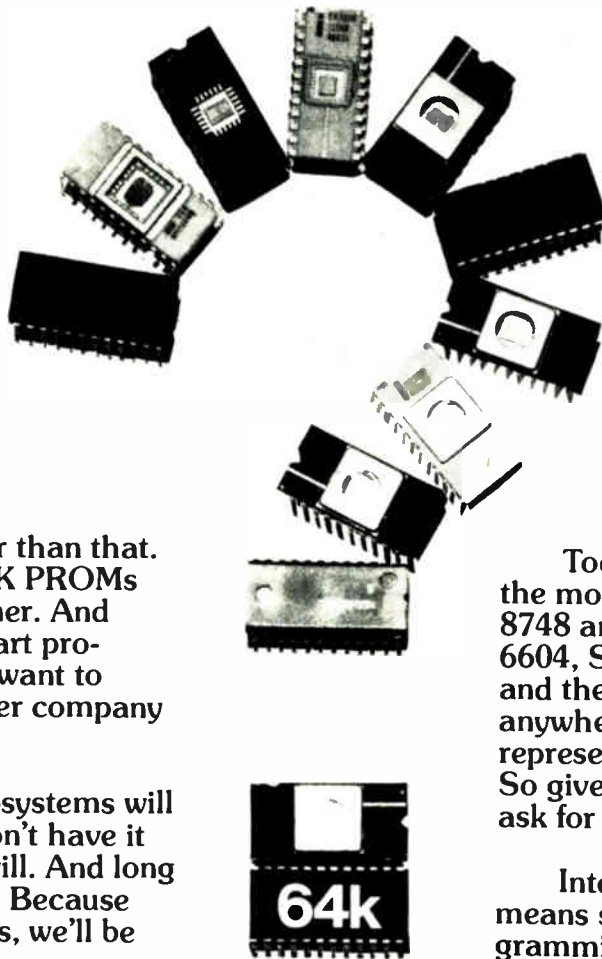

It may come sooner than that. But the point is, that 64K PROMs are just around the corner. And when you're ready to start programming them, you'll want to know which programmer company can do the job.

International Microsystems will have the answer. We don't have it yet, of course. But we will. And long before your need arises. Because when you're ready for us, we'll be ready for you.

Today, we have modules for the most advanced PROMs—Intel 8748 and 8755, Intersil 6603 and 6604, Signetics 82S191, TI 2532 and the Harris 76161. And if you're anywhere in the U.S., we have a representative ready to serve you. So give them a call, and be sure to ask for your trial demonstration.

International Microsystems means state-of-the-art PROM programming. We don't have all the answers, yet. But that's because no one has all the questions.

**Labtronics**  
166 Pickard Building  
Syracuse, N.Y. 13211  
315-454-9314

**KD Associates**  
201 Benton Ave. Suite 201  
Linthicum Heights Md 21090  
301-636-1151

**NS Associates**  
195 Greer Road  
Woodside Calif 94062  
415-854-4870

**Scientific Sales Corp.**  
2555 E. 55th Place  
Indianapolis Ind 46220  
317-253-4606

**Southwest E/M Engineering, Inc.**  
21602 N. 21st Ave  
Phoenix Az 85068  
602-993-0250

**JMR**  
3145 Bordenstown Ave  
Parlin N.J. 08859  
201-727-5335

**Robert Meyers Associates**  
613 W. Cheltenham Ave  
Nietzse Park, Pa 19126  
215-224-1663

**EQS**  
12692 Opalocka Drive  
Chesterland, Ohio 44026  
216-729-2222

**Scientific Sales Corp**  
9001 Bloomington Frwy  
Bloomington Minn 55420  
612-681-3300

**Synergetic Representatives**  
13101 Commodore Drive  
Largo Fla 33542  
813-596-5331

**Newmar Associates, Inc.**  
55 Salem Street  
Lynnfield, Mass 01940  
617-245-7960

**Magaro & Associates**  
P.O. Box 76652  
Atlanta Ga 30328  
404-252-6609

**Scientific Sales Corp.**  
7257 West Touhy Ave  
Chicago Ill 60648  
312-775-7594

**X-O Sales Corp**  
110 South Monaco Pkwy  
Denver Col 80224  
303-333-4539

**Microcomputer System Sales**  
1971 Dublin  
El Toro, Calif 92630  
714-766-4511

# M

**I**nternational **M**icrosystems, Inc.  
**Dewitt Center**  
11554 C Avenue  
Auburn, California 95603  
(916) 885-7263, 7262

Even ten feet away, the new Series X-70 Solid State Piezo Audio Indicator demands attention with its strong, strident tone. Only 1.2" (31 mm) deep and 2.1" (53 mm) wide, the X-70 can be specified with PC pins or wire leads. Get all the details on the X-70, and our entire line of Audio Indicators. Write or call Projects Unlimited, Inc., 3680 Wyse Road, Dayton, Ohio 45414, Tel. (513) 890-1918, TWX 810-450-2523.



**85dbA@10ft.**

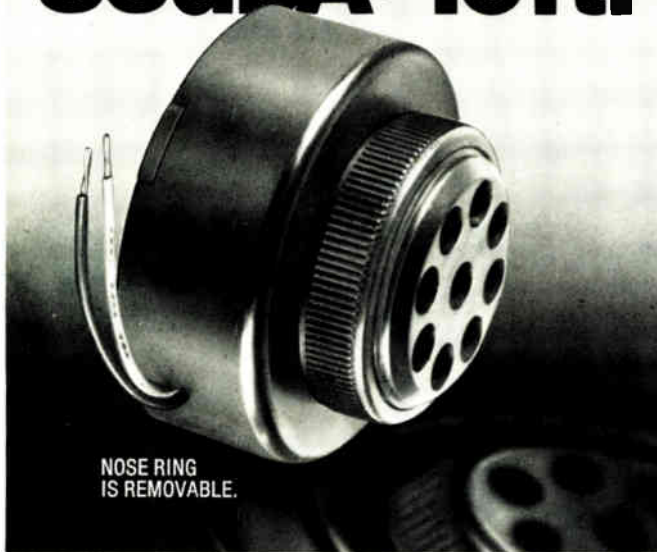

NOSE RING IS REMOVABLE.

Circle 212 on reader service card

**Exclusive Sheldahl FLEXSWITCH® kit**

**Only \$10<sup>00</sup>**

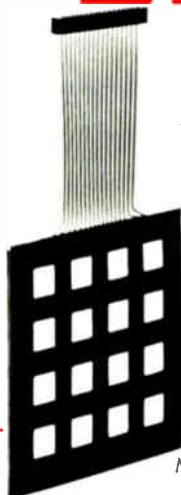

With scissors, modify this .030 thick, non-tactile panel into a 2-16 key, water and dust-resistant switching module. Prototype kit includes: design guidelines, complete instructions, a Sheldahl FLEXSWITCH®, flexcircuit connector, press-on nomenclature and RFQ check-sheet. Available in production quantities at reduced prices. Pressure sensitive back.

Mail to: Sheldahl Electrical Products Division  
P.O. Box 170, Northfield, MN 55057

Please send me \_\_\_\_\_ FLEXSWITCH kit(s). For each ordered I enclosed check or money order for \$10.00.

Name \_\_\_\_\_ Title \_\_\_\_\_  
Company \_\_\_\_\_  
Address \_\_\_\_\_  
City \_\_\_\_\_ State \_\_\_\_\_ Zip \_\_\_\_\_



**Sheldahl**

Specify Switch type:  
Short to ground   
Crosspoint

**New products**

output, is typically 126 dB; with a 5-k $\Omega$  source imbalance it is 120 dB, as is the CMR input to input. Isolation is 6,500 v peak for a 10-ms pulse and 5,000 v dc continuous.

The IA294 is priced at just \$99 each and delivery is from stock to four weeks.

Intronics Inc., 57 Chapel St., Newton, Mass. 02158. Phone (617) 322-7350 [346]

**Side-stackable LED matrix measures 1.16 in. high**

Members of the LRT1057 series of 5-by-7-dot matrixes measure 1.16 in. from first dot to last. When these large, light-emitting-diode units are placed side by side, the horizontal spacing between dots is uniform, so characters can be made to "walk" across the face of the display.

The gray-faced units are available with red, yellow, green, or orange LEDs. Depending on color, the units range in price from \$4.08 to \$6.80 each in lots of 100 or more. Delivery is from stock.

Industrial Electronic Engineers (IEE) Inc., 7740 Lemona Ave., Van Nuys, Calif. 91405 [347]

**Programmable wideband unit drives high-speed ECL**

The PM-501M can drive a 50- $\Omega$  terminated cable at rates in excess 500 MHz with a minimum pulse width of 1 ns. Thus, the ultra-wideband programmable driver can be used in the testing of emitter-coupled-logic devices and other high-speed parts.

Rise and fall times are typically 500 ps with a 1-v output and propagation delay is 900 ps. Output offset is programmable continuously from +0.5 to -2.0 v, as is output amplitude from 0.5 to 1.5 v, peak to peak.

Specified for operation from 0° to 50°C, the PM-501M is priced at \$250. Delivery is from stock to four weeks.

Tau-tron Inc., 11 Esquire Rd., North Billerica, Mass. 01862. Phone (617) 667-3874 [348]

# Why our monitors are good for your image.

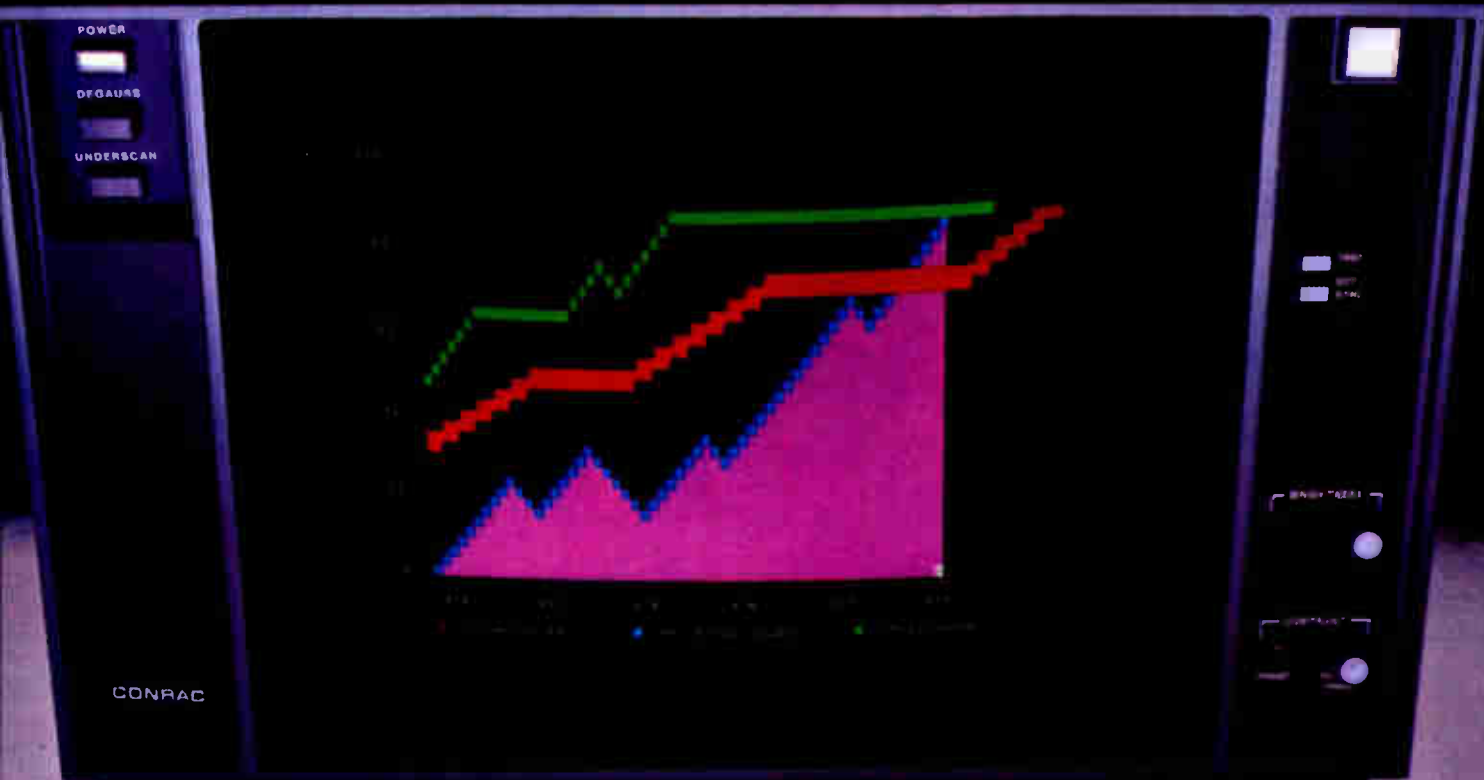

With a Conrac OEM monitor in your system, you can relax. Because image is what we're all about.

Just how good is Conrac's visual quality?

Good enough to be preferred by demanding network broadcast professionals six-to-one over all other brands combined.

For your demanding customers, we make a broad line of color and monochrome monitors, including RGB display, computer-generated imagery, graphic display, and alpha-numeric display types.

A wide range of models assures you a monitor that fits your system's needs. Standard or custom, Conrac quality is more than screen deep.

All our monitors feature advanced modular circuitry design for maximum reliability and serviceability. In the field, Conrac models include convenient pull-out drawers for full front-access to critical controls.

And since Conrac monitors are manufactured in the U.S., there's always fast access to parts.

Call or write today for the complete story on Conrac price-performance advantages. Conrac Division, Conrac Corporation, 600 North Riverside Avenue, Covina, CA 91724. Phone: 213-966-3511. Telex: 6751437.



**CONRAC**

We're more than meets the eye.

# Just published!

Your guide into the fascinating world of...

## PERSONAL COMPUTING Hardware and Software Basics

A reliable, easy-to-use resource that tells you...  
What's available in hardware and software, including costs.  
Who's using it, and what they've experienced.  
How it all works.  
Why it's caught on so fast, including practical applications to use now.

Some of the most exciting advances in computing are taking place, not in research labs and commercial facilities, but in homes across the country. All sorts of people with a basic background in mathematics and electronics are taking the computer revolution into their own hands—experimenting with new equipment and technology, and devising their own *personal* applications.

If you've considered joining them, if you've thought about building or buying your own computer—this is a fast, up-to-date guide that answers all your questions precisely and reliably.

At your fingertips, all the most needed information on...

- what's available in personal computers
- the most popular microprocessor chips
- programming at microprocessor level and in high-level languages
- design hitches and how to prevent them
- where to buy
- plus a glossary of the most current terms in home computing

Drawn from major publications throughout the industry...

To get all the up-to-the-minute information and guidelines presented here, you'd have to read through numerous issues of...

- Electronics • Datamation • Mini-Micro Systems • BYTE
- Interface Age • IEEE Spectrum • Kilobaud • People's Computers

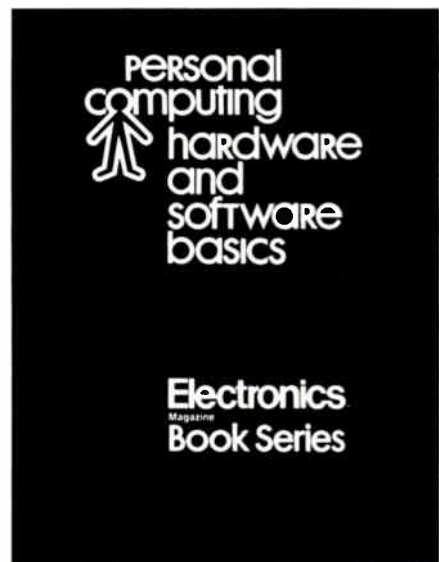

edited by  
Raymond P. Capece, Solid State Editor,  
Electronics Magazine  
266 pages, \$11.95

### Table of Contents

- Part 1: Introduction to Personal Computing.**  
The term defined, equipment and components, costs, applications.
- Part 2: Basic Computer Theory.**  
Microcomputer architecture with the emphasis on memory.
- Part 3: Advanced Microcomputer Theory.**  
Board-level computers using the most popular microprocessor chips.
- Part 4: Reviews of Personal Computers.**  
Features and capabilities of the most widely used microcomputers.
- Part 5: Software for Microcomputers and Microprocessors.**  
Description and uses of both machine-level and high-level programming languages.
- Part 6: Specifications and Other Useful Information.**  
Glossaries, microprocessor specs, electronics symbols, buying used equipment.

**Electronics Magazine Books**  
P.O. Box 669, Hightstown, NJ 08520  
(609) 448-1700, ext. 5494



No. of Copies	Title	Price
_____	Microprocessors	\$ 8.95
_____	Applying Microprocessors	\$ 9.95
_____	Large Scale Integration	\$ 9.95
_____	Basics of Data Communications	\$12.95
_____	Circuits for Electronics Engineers	\$15.95
_____	Design Techniques for Electronics Engineers	\$15.95
_____	Memory Design: Microcomputers to Mainframes	\$12.95
_____	Personal Computing: Hardware and Software Basics	\$11.95
_____	New Product Trends in Electronics	\$14.95

If after my 10-day free-trial examination I am not fully satisfied I understand that my payment will be refunded.

Payment enclosed  Bill firm  Bill me

Charge to my credit card:

American Express  Diners Club  
 Visa  Master Charge\*

Acct. No. \_\_\_\_\_ Date Exp. \_\_\_\_\_

\*On Master Charge only, first numbers above name \_\_\_\_\_

Name \_\_\_\_\_ Title \_\_\_\_\_

Company \_\_\_\_\_

Street \_\_\_\_\_

City \_\_\_\_\_ State \_\_\_\_\_ Zip \_\_\_\_\_

Signature \_\_\_\_\_

Discounts of 40% on orders of 10 or more copies of each book.



# Single or dual track, MFE is the driving force in cassette transports.

We revolutionized the digital cassette industry by making the first simple, reliable tape drive.

Now we offer that reliability in a full line of transports, both single and dual track.

**The Single-Track 250B.** With just two moving parts (no mechanical adjustment, ever) the 250B offers a record of performance no competitor can match: an MTBF of 15,000 hours. The 250B also has the widest ANSI/ECMA-compatible read/write speed range on the market: 5-40 tps and data transfer rates up to 32K bps.

**The Dual-Track 450B.** This new model gives you up to 720,000 formatted character storage, and features the exclusive TACHLOK™ servo speed control — for constant tape speed. Like the 250B, the 450B has data transfer rates up to 32K bps and needs no mechanical adjustment. Both models are available with a variety of interface options.

**The Single-Track 250BH — for hostile environments.** This incredibly rugged version of the 250B can handle just about any condition. Operating temperatures from -40°C to +70°C, for example. And all kinds of shock and vibration. The 250BH has been field proven in some of the toughest applications you can name. Indoors and out. In a wide range of industries.

All three models are available in volume, ready to ship. And we can customize to meet your exact design requirements.

For details, contact MFE Corporation, Keewaydin Drive, Salem, NH 03079. Tel: 603-893-1931. TWX 710-366-1557/TELEX 94-7477. In Europe, MFE Products Sa, Vevey, Switzerland. Tel. 021 52. 80. 40/

TELEX 26238. (MFE has complete worldwide representation. Contact us for the rep nearest you.)

\*MFE Corporation

## MFE

Dual-track 450B

Single-track 250BH  
Hostile  
Environment

Single-track 250B

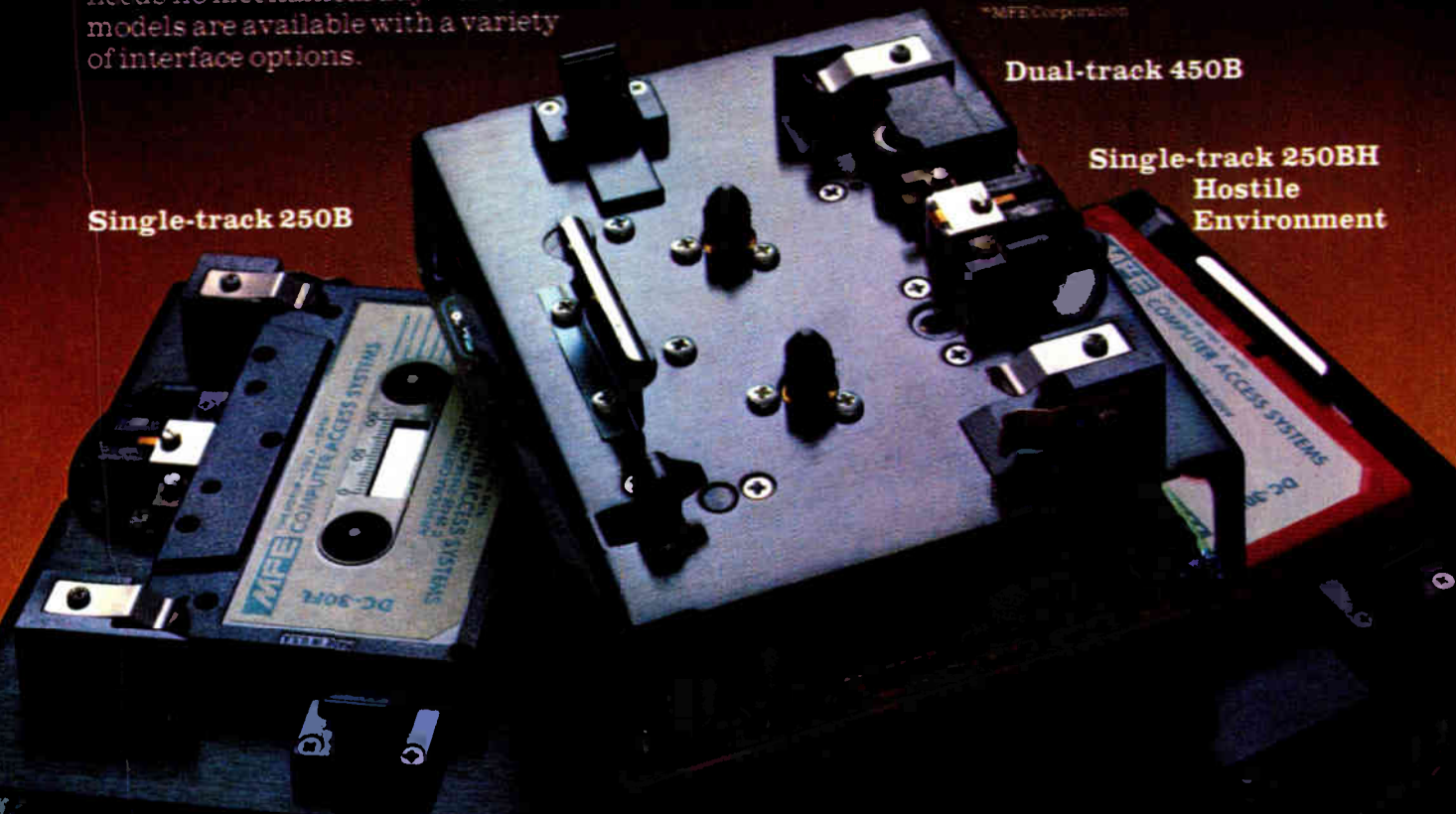

# MICRO POWER

## The fastest 32K ROM available. That's Rockwell Micropower.

Rockwell is now producing industry standard, fully-static NMOS 32K, 24-pin ROMs. We've got capacity for more orders in 1979 if you're ready to order right away.

The fast R2332-3 features maximum access and cycle time of 300ns. Both the R2332-3 and the standard 450 ns R2332 use 400 mW power and one 5V power supply.

R2332 and R2332-3 inputs are TTL compatible with a 400 mV minimum noise immunity on both the HIGH and LOW inputs. All eight outputs are tri-state drivers capable of driving 100 pf and a TTL gate.

The R2332 operates totally asynchronously and requires no clock input, so it's compatible with both static and clocked-static versions. Two mask-programmable chip select inputs allow four 32K ROMs to be OR-tied without external decoding.

A fast ROM plus fast turnaround from us to you. That's Rockwell Micropower.

Contact a local Hamilton/Avnet distributor or write: D-727-F5 Microelectronic Devices, Rockwell International;  
P.O. Box 3669, Anaheim, CA 92803,  
or phone (714)  
632-3729.

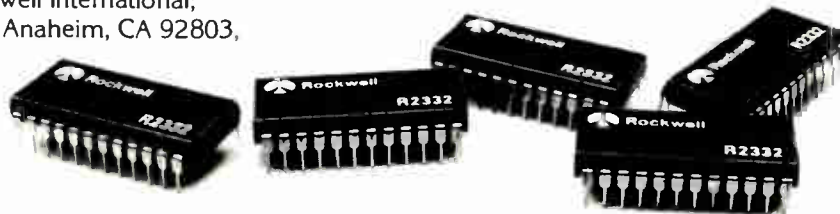

**Rockwell International**

...where science gets down to business

### **D-a unit converts 12 blts in 50 ns**

Datel Systems Inc., Mansfield, Mass., has unveiled the fastest 12-bit digital-to-analog converter on the market today. **The current-output device will settle to within 1 least significant bit in 50 ns.** Part of Datel's DAC-HF series, the converter is packaged in a 24-pin dual in-line package. It consumes 780 mW and will sell for between \$139 and \$219, depending on temperature range.

### **Chip includes 4½-digit counter, decoder, and driver**

Intersil Inc., Cupertino, Calif., has the distinction of being the first company to integrate a 4½-digit counter, a decoder, and a display driver on a single silicon chip. Two versions of the device are being offered: **the 7224 for liquid-crystal displays and the 7225 for light-emitting-diode displays.** Both complementary-metal-oxide-semiconductor devices can handle input rates of 15 MHz and require only a single 5-v dc supply. In hundreds, the LCD version, which contains an oscillator for generating the backplane signal, sells for \$7, whereas the LED version is priced at \$5.30. The units are available now.

### **3-μs a-d converter expected from Analog Devices**

Look for Analog Devices Inc.'s Semiconductor division, Wilmington, Mass., to come up with a 12-bit analog-to-digital converter with a conversion time of 3 μs. The part, which should be out within the next three months, will be housed in the company's unique slam pack package and **will sell for a low \$100 each in large quantities.**

### **Interface chip gets more flexible**

Signetics Corp., Sunnyvale, Calif., is upgrading its popular 2651 programmable communications interface chip with an "extended" version that fits the same sockets but offers more flexibility in the selection of transmission rates. **The new chip will be offered in three versions, each of which has a choice of 16 selectable rates up to a maximum of 38.4 kilobits per second.** Available now in sample quantities, the new chips will sell for \$13.05 in plastic and \$15.05 each in ceramic for quantities of 100 or more.

### **Two companies cut prices for DEC-compatible gear**

To strengthen its position in the market for computer peripherals compatible with Digital Equipment Corp. computers, Xebec Systems Inc., Santa Clara, Calif., **is dropping prices for its cartridge disk controller from \$2,800 to \$1,975.** At this price the Xebec quad will be more competitive with the bottom of the growing DEC-compatible market, according to Bob Sigal, marketing manager.

Another company lowering prices on equipment made to work with computers from DEC is Data Translation Inc., Natick, Mass. **The company is making price cuts on its line of dual-height boards for the LSI-11/2.** Affected are the DT2762 high-level data-acquisition system, which is being reduced from \$695 to \$545; the optional programmable-gain amplifier for the system, which has been cut from \$175 to \$100; the DT2764 low-level data-acquisition system, whose price is being slashed from \$795 to \$545; the DT2766 four-channel, 12-bit analog-input board, which has been cut from \$695 to \$545; and the DT2767 four-channel, 8-bit analog-input board, whose price has dropped from \$495 to \$445.

# ONE-CHIP CMOS LSI

## FM/AM DIGITAL TUNING SYNTHESIZER SM5220A

- Digital Car Radio will Clear the Cost Barrier
- The First CMOS Single Chip
- FM/AM USA Band Application
- Digital Readout of Frequency and Clock
- 6 Channel Memory for FM & AM Respectively
- Last Channel Memory Function for FM & AM Respectively
- Manual and Auto-Scan Tuning
- High Precision Digital Clock
- Channel Indication Possibility
- 28 Pin DIP
- Supply Voltage: 5V
- Operation Possibility down to 3V

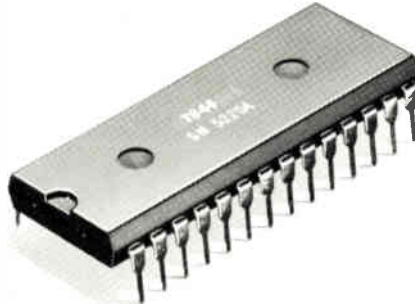
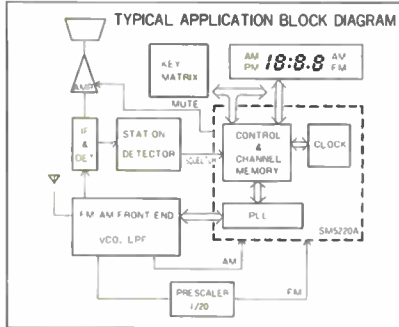

DISTRIBUTOR

**KANEMATSU-GOSHO(U.S.A.)INC.**

CHICAGO : PHONE (312)437-7010/TELEX(W/U)028-2438, 025-4306

MANUFACTURER

**NIPPON PRECISION CIRCUITS L.T.D.**

HATTORI BLDG. 1-10-3 KYOBASHI CHUO-KU TOKYO, JAPAN. TELEX 3543632 NPC J.

Circle 218 on reader service card

## New literature

**Circuit-board hardware.** Described in a 24-page booklet is a line of electronic hardware, including component and cable clips, circuit-board support-spacers, hold-down strips,

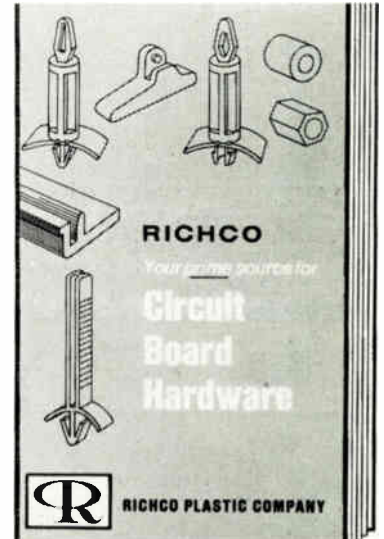

and board ejectors. Dimensional drawings and ordering information are provided on all products. Richco Plastics Co., 5825 North Tripp Ave., Chicago, Ill. 60646. Circle reader service number 421.

**Power supplies.** Detailed information on power supplies capable of providing 60 amperes at 1 to 200 volts is contained in a 52-page catalog. Comprehensive lines of miniaturized (in both printed-circuit-board and chassis-mounting versions), plug-in, premium-performance, general-purpose, narrow-profile, laboratory benchtop, and unregulated power supplies are included. Many models have dual and triple outputs. Acopian Corp., Easton, Pa. 18042 [422]

**Rf and i-f signal-processing hybrids.** High-reliability hybrid circuits for radio- and intermediate-frequency signal-processing applications are illustrated and described in an eight-page brochure. It gives application information and specifications for a wide variety of hybrids, among them two- and three-way power dividers, double-balanced mixers, rf switches, phase modulators, 180° and quadrature hybrids, bidirectional couplers, and amplifiers. Composite hybrids



**PLASTIC  
CABLE  
CLAMPS**

**SCREWS & NUTS**

More plastic cable clamps in more types, more sizes and in more materials than anyone else. Over 240 types and sizes of molded nylon screws and nuts. Also broad line of flame-retardant Seolon 6/6 Nylon screws, nuts and clamps. All stocked for immediate shipment.

**FREE SAMPLES**

Write for sample packet, literature and prices.

**Wackesser COMPANY, Inc.**

4444 West Irving Park Road • Chicago, Illinois 60641 • 312/282-8626

Circle 261 on reader service card

**Once a year,  
you have  
the opportunity  
to see the latest  
product  
developments  
across the  
entire electrical  
engineering  
industry  
-all in one place-  
at the  
Hanover Fair.**

**Electric Power Transmission**

---

**Electrical Energy Supply**

---

**Telecommunications**

---

**Measuring, Testing, Control and  
Automation Equipment**

---

**Electronic Components and Sub-  
Assemblies**

---

**Electrical Installation**

---

**Electric Lighting**

---

**Specialized Areas and Processes  
in Electrical Engineering**

---

**Information for Your Visit  
to the Fair**

The Fair Planner and technical brochures will be available from February onwards. You can order the documents you need with this coupon.

Please send me the technical brochure

- Electric Power Transmission
- Electrical Energy Supply
- Telecommunications
- Measuring, Testing, Control and Automation Equipment
- Electronic Components and Sub-Assemblies
- Electrical Installation
- Electric Lighting
- Specialized Areas and Processes in Electrical Engineering
- Fair Planner with the complete programme of all the specialist markets at the 1979 Hanover Fair

Deutsche Messe- und Ausstellungs-AG  
Messegeleände, D-3000 Hannover 82  
Tel.: (0511) 891, Telex: 0922728

Name: \_\_\_\_\_

Company: \_\_\_\_\_

Street: \_\_\_\_\_

Town/Postal Code: \_\_\_\_\_

All the decisive innovations - in one place  
at one time.

587 ELS

**Wednesday, 18th - Thursday, 26th April**



**Hanover  
Fair '79**

# HOW A VACUUM RELAY CAN HELP SAVE YOUR DAY

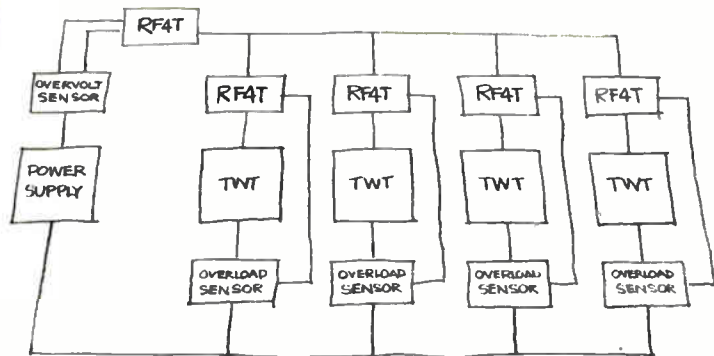

RF4T  
(Shown 1/2 size)

This RF4T vacuum relay from ITT Jennings is used in high voltage microwave power supplies to protect traveling wave transmitting tubes (TWT's).

The TWT's modulate radar signals to 7 KV at up to 20 amps RMS. The power supply has an over-voltage sensing circuit on the output. In the event of excessive voltage, the RF4T pulls the TWT's out of the circuit to protect them. Other RF4T relays are in each TWT circuit along with overload sensors. Should any tube short or overload, that tube can be taken out of the circuit without overloading the power supply or damaging the system.

The RF4T has ground isolation built in, along with special tungsten contacts, making it uniquely suited for this hot switching job. It has test voltages to 10 KV peak, speeds as low as 5 ms, shock ratings to 50 g, and it weighs about 1 oz.

If you're designing power supplies or other circuits where high voltage hot load switching is critical, then the RF4T vacuum relay can help save your day.

For more information about the RF4T or other vacuum relays in our large product line, contact us at 970 McLaughlin Avenue, San Jose, CA 95122. Or call us at (408) 292-4025.

## JENNINGS ITT

Circle 262 on reader service card

## 1978 EBG!

Completely new listings of catalogs, new phone numbers, new addresses, new manufacturers, sales reps, and distributors! The total market in a book—four directories in one!

**To insure prompt delivery  
enclose your check with the  
coupon now.**

Electronics Buyers' Guide  
1221 Ave. of the Americas  
New York, N.Y. 10020

Yes, please send me \_\_\_\_\_ copy(ies) of 1978 EBG.  
 I've enclosed \$25 per copy delivered in the USA or Canada.

I've enclosed \$35 per copy for delivery elsewhere (\$47 if shipped by Air). Full money-back guarantee if returned in 10 days.

Name \_\_\_\_\_  
Company \_\_\_\_\_  
Street \_\_\_\_\_  
City \_\_\_\_\_ State \_\_\_\_\_ Zip \_\_\_\_\_



## New literature

that incorporate two or more functions on a single substrate are described in a separate section. Raytheon Co., Industrial Components Operation, 465 Centre St., Quincy, Mass. 02169 [423]

**Accelerometers.** Written for the user and designer of systems that measure shock, vibration, and acceleration, Technical Information Bulletin No. 781 gives a detailed description of the construction, performance, and advantages of eight types of accelerometers. The eight-page bulletin includes information on strain-gage and servo-type accelerometers,



along with schematics and block diagrams that will clarify how they operate and where they can be most effectively applied. Self-induced cable noise due to shock and vibration is explained and methods of determining various types of measurement-system deficiencies are discussed. Gulton S-C Division, 1644 Whittier Ave., Costa Mesa, Calif. 92627 [424]

**Data-conversion design.** The 80-page "Data Conversion Design Manual" covers the 8700 series analog-to-digital and the 9400 voltage-to-frequency and frequency-to-voltage converters, made using complementary-metal-oxide-semiconductor technology. It is available from Teledyne Semiconductor, 1300 Terra Bella Ave., Mountain View, Calif. 94043 [425]



# 16 bits and then some... and Datawest packs it all together



DATAWEST will cut your data acquisition system and digital signal processing system cost by applying time proven techniques to your application. Putting together a successful analog-to-digital data acquisition system requires more than just a good **A/D converter**. Expertise is needed in signal conditioning, front end multiplexing and digital techniques. DATAWEST has been designing and manufacturing systems for sophisticated applications for over a decade. DATAWEST-designed systems, installed all over the world, are being used in a wide variety of applications including geophysical studies, vibration analysis, nuclear system monitoring and bio-medical research. DATAWEST supplies complete analog-to-digital data acquisition systems from **input amplifier to computer interface**, including the DATAWEST line of **array processors**. Field proven standard modules (plus custom interface circuits if needed) can be assembled to provide reliable, cost-effective systems to meet specific needs.

The 390 system offers high resolution and high speed utilizing the DATAWEST 16-bit, 150 kHz **A/D converter**.

#### Other DATAWEST products:

- **Array Processors**
- **Channel Simulators for IBM 360/370**
- **Digital Audio Delay Systems**
- **12, 15 and 16 bit A/D Converters**
- **12, 15 and 16 bit D/A Converters**
- **Complete Scientific Signal Processing Systems**



For information regarding DATAWEST products, contact David Long, Director of Technical Marketing  
7333 East Helm Drive • Scottsdale, Arizona • (602) 948-3280  
TWX 910-950-1289 DATAWEST SCOT

# Printing Data and Graphics on the same card

doesn't have to throw you a curve...

Our DMTP-9 programmable card printer/plotter does both — prints the full alphanumeric ASCII character set, and prints graphics for plotting too.

All it took was combining our long-life 5 x 7 dot matrix needle head with a stepping motor that controls ticket positioning until the message (alphanumeric or graphics) is complete. Result: both analog and digital data, on the same card.

Use it with blood — gas and other medical analysis instruments. Extend the capabilities of a weighing system. Add a new dimension to time card and production control. And, print on either multi-part forms or single cards ... on impact-sensitive paper or with ribbon. Even program character pitch for standard or enhanced printing for up to 32 characters per line, and approximately 39 lines.

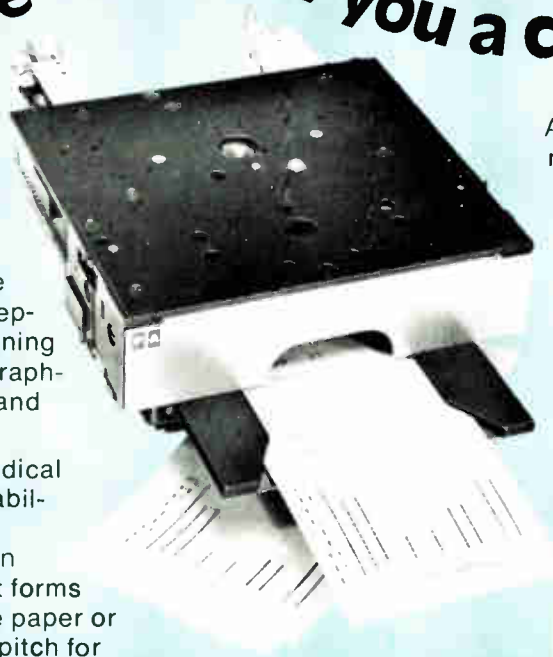

Adjustable for table-top or wall mounting, the DMTP-9 is available with controllers, power supplies and interconnect cable systems for complete microprocessor/microcomputer compatibility. For more details, call or write: Practical Automation, Inc., Trap Falls Road, Shelton, CT 06484; (203) 929-5381



**PRACTICAL  
AUTOMATION  
INC.**

Circle 222 on reader service card

It's a one-source book for the best of every-IC-thing. A 68-page new catalog covering CAMBION's broad line of integrated circuit packaging and handling devices. It's packed with a wide range of IC sockets, panels, build-it-yourself socket cards, IC card files, drawers and trays.

This new, FREE catalog makes it easy for you to locate what you need from the largest and broadest lines of IC packaging products anywhere—CAMBION. Plenty of drawings and photos—and an inventory to back them up. Write for it today: Cambridge Thermionic Corporation, 445 Concord Avenue, Cambridge, Massachusetts 02138. Or telephone: 617-491-5400.

## **FREE!** New and expanded CAMBION® IC accessories catalog



222 Circle 263 on reader service card

## **OVENAIRE...**

...now, more than ever, your best bet for crystal oscillators.

Ovenaire's oscillator capabilities have been enhanced by the acquisition of W.H. Ferwalt, Inc.

- **STATE-OF-THE-ART HIGH STABILITY CRYSTAL OSCILLATORS** with stabilities to  $5 \times 10^{-10}/\text{day}$  and  $7 \times 10^{-11}/^\circ\text{C}$ .
- **OVENIZED CRYSTAL OSCILLATORS**  $3 \times 10^{-9}/^\circ\text{C}$  at low cost.
- **TCXO's** with temperature stabilities to  $\pm 1 \times 10^{-7}$  0 to  $50^\circ\text{C}$ .
- **DIP HYBRID CIRCUIT CRYSTAL OSCILLATORS** with temperature stabilities to  $\pm 20$  ppm.

...and, as always, your best bet for crystal and component ovens.

- **ELECTRONIC CONTROL MINIATURE OVENS FOR:** HC-18U, HC-25U, HC-42U, HC-43U crystals TO5 & TO8 crystal, transistor or IC 14 Pin & 16 Pin DIP IC.

Plus a complete range of ovens for commercial and military applications.

### **OVENAIRE-AUDIO-CARPENTER**

Division of Walter Kidde & Company, Inc.

706 Forrest St., Charlottesville, Va. 22901  
804/977-8050 TWX 510-587-5461

**KIDDE**

Circle 264 on reader service card



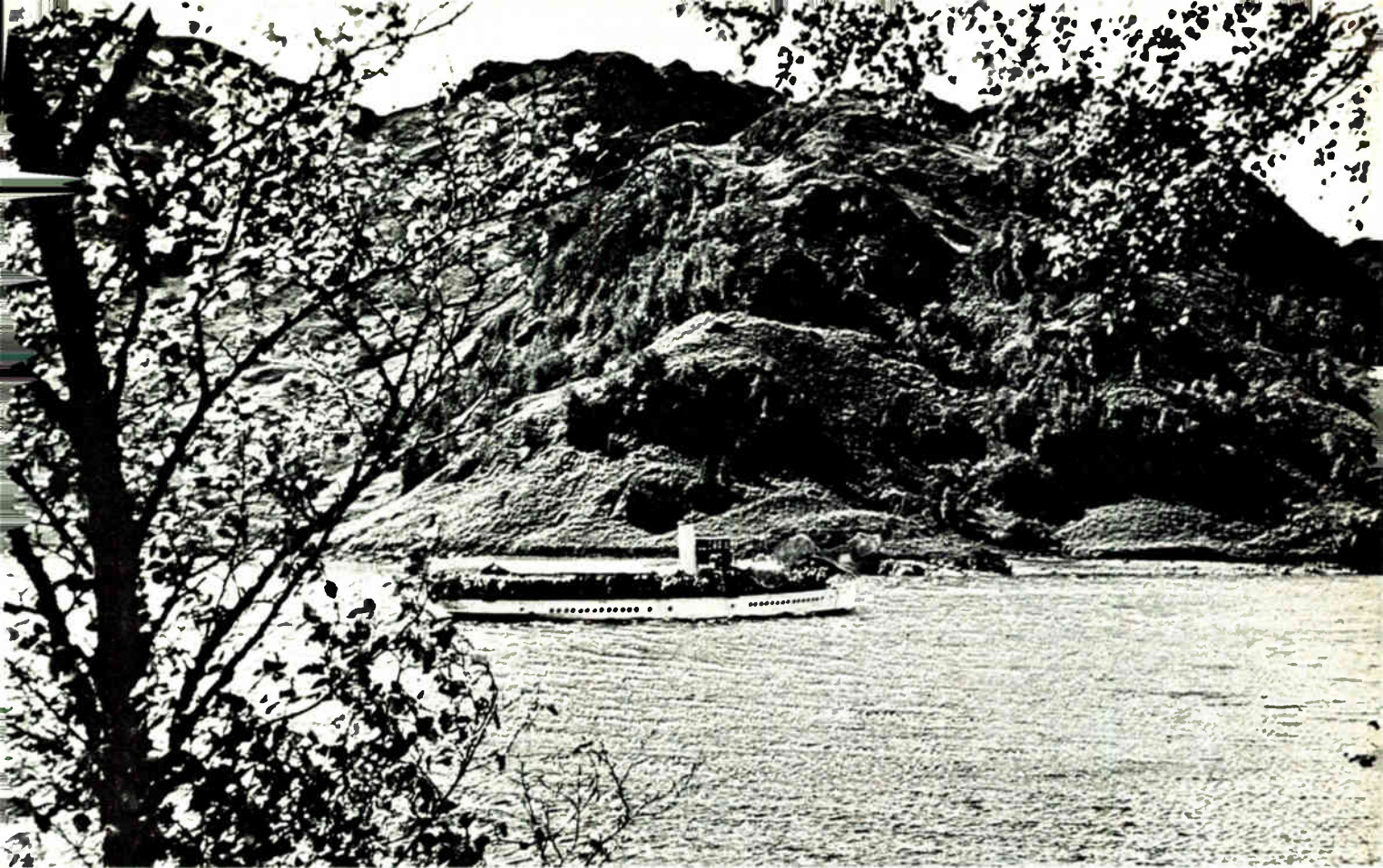

*Loch Katrine in the Trossachs — where Glasgow draws much of its exceptionally pure water*

# Glasgow's unique industrial resource -unfailing supplies of the purest water in Europe

The lochs which ring the city do much more than make Glasgow an attractive centre for the tourist. They make it an attractive base for industries that need pure and abundant water.

From these lochs comes the purest piped water in Europe — and some of the purest in the world. Certainly the purest in any major conurbation.

And the supply never fails. Even in the U.K. droughts of 1976, industry in Glasgow could still use water without restriction.

## **Inexpensive water**

There is another reason why Glasgow is so attractive to industries heavily dependent on fresh water. Because Glasgow's water is so available, so close at hand, it is inexpensive water.

There is yet a third reason, too. In Glasgow, there is no charge for disposal of industrial effluents. That, in itself, can make a big difference to costs in many industries.

So if your processes need pure water, get in touch. We'll help fill in the facts and figures for you. And we'll show you the other resources Glasgow offers industry.

## **Room for you**

First and foremost, Glasgow has room for new industry. Nearly five million square feet of factory space, in units to suit any size of company, are immediately available. And there are over 300 acres of industrial building land, offering sites of five acres up.

So you won't be cramped for space. Nor will you be isolated in some remote industrial estate. All these sites are well inside the city — making it easy to recruit and keep staff.

## **Glasgow's other resources**

Glasgow has other resources, too. A well-educated workforce, traditionally orientated towards sophisticated industrial processes. The service and sub-contracting

resources of a major industrial centre — tool-making, packaging, printing, maintenance. Excellent links to the rest of the U.K., and to foreign markets, by road, rail, sea and air. And the leisure facilities of a great city, surrounded by some of the finest countryside in the world.

But, for the full story, contact D. S. Logan, Industrial Development Officer, City of Glasgow District Council, Sun Life House, 116 West Regent Street, Glasgow G2 2RW. Telephone 041-332 9700.



# **GLASGOW**

city to build on

# A new introductory Electronics



## MICROELECTRONICS

**Digital and Analog Circuits and Systems** By J. Millman. 881 pp., 700 illus. This giant book takes you step by step from a qualitative knowledge of a semi-conductor, to an understanding of the operation of devices, and finally, to an appreciation of how these are combined to form micro-electronic chips.  
423/27X Pub. Pr., \$24.50 Club Pr., \$19.50

**HANDBOOK OF OPERATIONAL AMPLIFIER CIRCUIT DESIGN.** By D. F. Stout. Edited by M. Kaufman. 434 pp., 223 illus. Compact, concise, highly concentrated, and containing a storehouse of information, this one-stop volume will help you solve any op amp circuit problem!  
617/97X Pub. Pr., \$29.65 Club Pr., \$17.50

**CRYSTAL OSCILLATOR DESIGN AND TEMPERATURE COMPENSATION.** By M. E. Frerking. 240 pp., illus. With this guide you can design virtually any crystal oscillator encountered in commercial or military electronics, including logic gate and integrated circuit oscillators. An important part of this book is its authoritative and thorough treatment of temperature compensation.  
784/973 Pub. Pr., \$16.95 Club Pr., \$13.50

**STANDARD HANDBOOK OF ENGINEERING CALCULATIONS.** By T.G. Hicks. Editor-in Chief. 1,200 pp., 428 illus. Tells you *what* to do, *when* to do it, and *how* to do it—giving step-by-step solutions to the design and application problems that engineers encounter daily. Containing some 1,000 calculation procedures accompanied by worked-out numerical examples, it also features 4,000 related calculation procedures.  
287/341 Pub. Pr., \$27.50 Club Pr., \$19.95

**ELECTRONICS DESIGNERS' HANDBOOK.** Edited by L. J. Giacoletto. 2nd Ed. 2,344 pp., 1,686 illus. Now doubled in size and with 90% of its material new, this famous classic (first edition by Landee, Davis, Albrecht) has been thoroughly revised and updated to give you not only the *how* and the *why* of all your design work but also the *how much* of every design step you take!  
231/494 Pub. Pr., \$52.50 Club Pr., \$39.50

**DIGITAL INTEGRATED CIRCUITS AND OPERATIONAL AMPLIFIER AND OPTOELECTRONIC CIRCUIT DESIGN.** Edited by B. Norris. 206 pp., 400 illus. Having this vast amount of case-tested data, proven shortcuts, worked-out circuit designs, and circuit diagrams handy saves you valuable time for your other, more vital, areas of creative design—and cuts down costs in *all* areas!  
637/539 Pub. Pr., \$19.50 Club Pr., \$14.50

**OPTOELECTRONICS Theory and Practice.** By Texas Instruments Incorporated. Edited by A. Chappell. 442 pp., 475 illus. Right here is where you'll find all the knowledge and know-how you need to take any of today's optoelectric components and develop your own circuits and uses. You get both the background and the technical specifics (with all the proven circuits you want!)  
637/555 Pub. Pr., \$21.50 Club Pr., \$17.00

**MICROCOMPUTER-BASED DESIGN.** By J. P. Peatman. 604 pp., 400 illus. Do all your best day-to-day and supercreative designs around today's microcomputers with the specific "how-to" help here! Big new printing has more pages, lots more new material, including data on such "hot" third generation micros as Intel 8048/8748, Zilog Z80, and a first and valuable overview of the Motorola 6809!  
491/380 Pub. Pr., \$24.50 Club Pr., \$17.50

## BE SURE TO CONSIDER THESE IMPORTANT TITLES AS WELL:

**DIFFERENTIAL EQUATIONS FOR ENGINEERS.** By T. M. Creese & R. M. Haralick.  
135/10X Pub. Pr., \$17.50 Club Pr., \$13.50

**APPROXIMATION METHODS FOR ELECTRONIC FILTER DESIGN.** By R. W. Daniels.  
153/086 Pub. Pr., \$31.50 Club Pr., \$19.50

**MANAGEMENT OF ENGINEERING PROJECTS, 2/e.** By V. G. Hajek.  
255/342 Pub. Pr., \$16.95 Club Pr., \$12.50

**CIRCUITS FOR ELECTRONIC ENGINEERS** By Electronics Magazine  
191/573 Pub. Pr., \$24.50 Club Pr., \$17.00

**APPLIED ELECTROMAGNETICS** By M. A. Plonus  
503/451 Pub. Pr., \$21.00 Club Pr., \$16.50

**PRACTICAL ELECTRICAL PROJECT ENGINEERING** By L. B. Roe  
533/92X Pub. Pr., \$19.50 Club Pr., \$15.50

**DIGITAL INTEGRATED ELECTRONICS** By H. Taub & D. Schilling  
629/218 Pub. Pr., \$23.50 Club Pr., \$16.95

**POWER TRANSISTOR AND TTL INTEGRATED CIRCUIT APPLICATIONS** By Texas Instruments  
637/547 Pub. Pr., \$19.50 Club Pr., \$12.95

**MICROPROCESSOR AND MICROCOMPUTER SYSTEMS** By G. V. Rao  
783/659 Pub. Pr., \$24.50 Club Pr., \$19.50

**MODERN DIGITAL COMMUNICATIONS** By E. J. Ross  
783/853 Pub. Pr., \$10.95 Club Pr., \$9.30

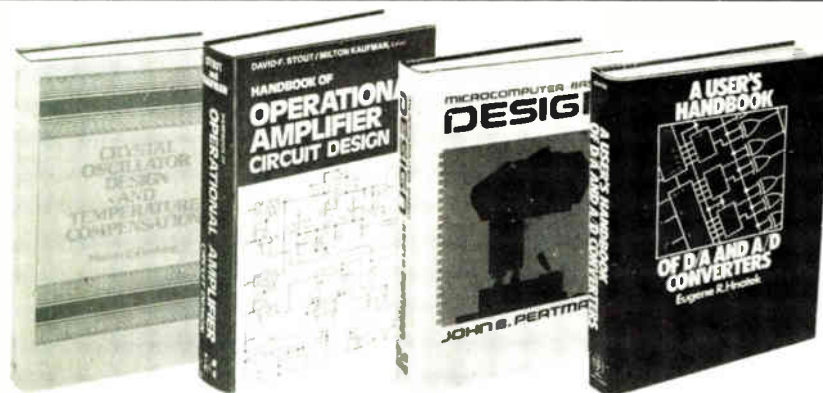

# Offer to new members of the and Control Engineers' Book Club

**ELECTRONICS ENGINEER'S HANDBOOK.** Editor-in-Chief, D. G. Fink. 2,104 pp., 2,026 illus. Huge in every sense, this instant-reference volume gives you every latest essential in the field, 2,100 formulas and equations, a 2,500-item bibliography, and every illustration you need to clarify all of modern electronics!  
209/804 Pub. Pr., \$49.50 Club Pr., \$35.00

**GUIDEBOOK OF ELECTRONIC CIRCUITS.** By J. Markus. 1,018 pp., illus. Are you constantly on the lookout for circuits that will meet your needs? Here's a giant collection of them to use "as is" or to adapt to your own ideas. Complete with values.  
404/453 Pub. Pr., \$37.50 Club Pr., \$27.50

**DESIGN TECHNIQUES FOR ELECTRONICS ENGINEERS.** Electronics Book Series. By ELECTRONICS Magazine. 370 pp., illus. The whole gamut of complex techniques required when you're designing a circuit or system is explained and shown in the superb collection of the "best of the best" from *Electronics* magazine.  
191/581 Pub. Pr., \$24.50 Club Pr., \$17.50

**DIGITAL COMPUTER ELECTRONICS.** By A. P. Malvino. 404 pp., illus. The only prerequisite for your daily use of this book is dc-ac theory and an elementary knowledge of diodes and transistors. With just these you can take full advantage of every sentence, diagram, circuit, and table in this introduction to computers in general and to microprocessors in particular.  
398/615 Pub. Pr., \$14.95 Club Pr., \$10.95

**PROFESSIONAL ENGINEERS' EXAMINATION QUESTIONS AND ANSWERS.** By W. S. LaLonde, Jr., and W. J. Stack-Staikidis. 3rd Ed. 601 pp., 276 illus. Over 500 questions and complete answers—suitable for all states—prepare you for passing your exams for the E.I.T. certificate and your P.E. license.  
360/936 Pub. Pr., \$19.50 Club Pr., \$14.50

**MICROPROCESSORS & SMALL DIGITAL COMPUTER SYSTEMS FOR ENGINEERS & SCIENTISTS.** By G.A. Korn 390 pp. This exceptional book is your quick reference for expert advice on product selection, interfacing, and programming. Containing a huge variety of computer possibilities, system features, and costs, it's also a terrific tool for career updating.  
353/670 Pub. Pr., \$27.50 Club Pr., \$18.95

**ELECTRONICS DICTIONARY.** Edited by John Markus. 4th Ed., 768 pp., 1,173 illus., 17,090 terms. With the new edition of this world-renowned dictionary you'll be able to quickly find the meaning and correct usage of any electronics term, no matter how obscure!  
404/313 Pub. Pr., \$24.50 Club Pr., \$19.50

**A USER'S HANDBOOK OF D/A AND A/D CONVERTERS.** By E. R. Hnatek. 472 pp., illus. Keep this guide handy for help in designing, using, and applying D-to-A and A-to-D converters. The stress is on the simplified designs made possible by today's high-quality precision ICs.  
767/149 Pub. Pr., \$24.95 Club Pr., \$18.50

**HANDBOOK FOR ELECTRONICS ENGINEERING TECHNICIANS.** By M. Kaufman and A. H. Seidman. 520 pp., 695 illus. Rely on this technician's godsend for all your work with analog and digital integrated and discrete circuits. Here are the stiff brush-up you want and the solutions to every possible problem.  
334/013 Pub. Pr., \$23.50 Club Pr., \$16.50

**MASTER OP-AMP APPLICATIONS HANDBOOK.** By H.W. Fox. 467 pp., 320 illus. There's enough practical build-it information in this book to keep you breadboarding and experimenting and creating for years! It shows you how to put op amps to work in literally hundreds of different circuits, in hundreds of hardworking applications.  
784/477 Pub. Pr., \$16.95 Club Pr., \$13.50

any one  
of these great  
professional books

for only **\$1.89**

values up  
to \$52.50

Special \$1.89 bonus  
book comes to you  
with your first  
club selection

## ELECTRONICS AND CONTROL ENGINEERS' BOOK CLUB saves you both time and money!

Here is a professional book club designed to meet your on-the-job engineering needs by providing practical books in your field on a regular basis at *below publisher prices*. If you're missing out on important technical literature—if today's high cost of reading curbs the growth of your library—here's the solution to your problem.

The *Electronics and Control Engineers' Book Club* was organized for you, to provide an economical reading program that cannot fail to be of value. Administered by the McGraw-Hill Book Company, all books are chosen by qualified editors and consultants. Their understanding of the standards and values of the literature in your field guarantees the appropriateness of the selections.

*How the club operates:* Thirteen times a year you receive free of charge *The Electronics and Control Engineers' Book Club Bulletin*. This announces and describes the Club's featured book for that period as well as alternate selections available at special members' prices. If you want to examine the Club's featured selection, you do nothing. If you prefer one of the alternate selections—or if you want no book at all—you notify the Club by returning the card enclosed with each Bulletin.

As a Club member, you agree only to the purchase of four books (including your first selection) over a two-year period. Considering the many books published annually, there will surely be at least four you would want to own anyway. By joining the Club, you save both money and the trouble of searching for the best books.

### MAIL COUPON TODAY

**ELECTRONICS AND CONTROL ENGINEERS' BOOK CLUB**  
P.O. Box 582, Hightstown, New Jersey 08520

Please enroll me as a member and send me the two books indicated. I am to receive the bonus book at the introductory price of \$1.89 plus my first selection, plus tax, postage and handling. If not completely satisfied, I may return the books within 10 days and request that my membership be cancelled. If I keep the books, I agree to take a minimum of three additional books during the next two years at special Club prices (guaranteed 15% discount, often more). I will receive the Club Bulletin 13 times a year. If I want to examine the featured selection, I need take no action. It will be shipped automatically. If, however, I want an alternate selection—or no book at all—I simply notify the Club by returning the convenient card always enclosed. I will always have a minimum of ten days in which to return the card and you will credit my account fully, including postage, if this is not the case. Membership in the Club is continuous but cancellable by me at any time after the four-book purchase requirement has been filled. *This order subject to acceptance by McGraw-Hill. Orders from outside the continental U.S. must be prepaid. All prices subject to change without notice. Offer good for new members only. Postage and handling charges are added to all subsequent shipments.*

#### WRITE BELOW:

Code No. of \$1.89 book

Code # of 1st selection



NAME \_\_\_\_\_

ADDRESS \_\_\_\_\_

CITY \_\_\_\_\_

STATE \_\_\_\_\_

ZIP \_\_\_\_\_

**EXTRA SAVINGS:** Remit in full with your order, plus any local and state tax, and McGraw-Hill will pay all regular postage and handling charges.

**E33378**

# Classified section FOR ENGINEERING/TECHNICAL EMPLOYMENT OPPORTUNITIES

## CLASSIFIED SALES REPRESENTATIVES

Atlanta	404/892-2868	Cleveland	Mac Huestis	216/781-7000	Houston	Mike Taylor	713/659-8381	Philadelphia	Dan Ferro	215/568-6161
Boston	Jim McClure 617/262-1160	Dallas	Mike Taylor	214/742-1747	Los Angeles	Ana Galaz	213/487-1160	Pittsburgh	Dan Ferro	412/391-1314
Chicago	Bill Higgins 312/751-3733	Denver	Shirley Klotz	303/837-1010	New York	Larry Kelly	212/997-3594	San Francisco	Peter McGraw	415/362-4600
		Detroit	Mac Huestis	313/873-7410				Stamford	William Eydtt	203/359-2860

Sales Manager—Mary Ellen Kearns—212/997-3306

## Wanted: Innovators

Innovative solutions to complex problems in electronic warfare and advanced telecommunications have earned AMECOM a worldwide reputation. If you're a creative professional with ideas, if you thrive on fresh thinking instead of what's been done before, take time now to investigate positions with us of uncommon potential.

Be part of our next technical breakthrough.

Immediate openings exist now for:

**ANALOG OR DIGITAL PROCESSING ENGINEERS  
TELECOMMUNICATIONS SYSTEMS ENGINEERS  
ELECTRONIC WARFARE PROCESSING ENGINEERS  
RF ENGINEERS**

We're part of a Fortune top 50 corporation, we're growing fast, and we're in a pleasant Maryland suburb close to the Nation's capital with your choice of city, country, water or mountain living and recreation.

Call COLLECT or write: Bill McAmis, (301) 864-5600  
Amecom Division, LITTON SYSTEMS, INC.,  
5115 Calvert Road, College Park, MD 20740

An equal opportunity employer, M/F/H.

Amecom Division  
**LITTON  
SYSTEMS, INC.**

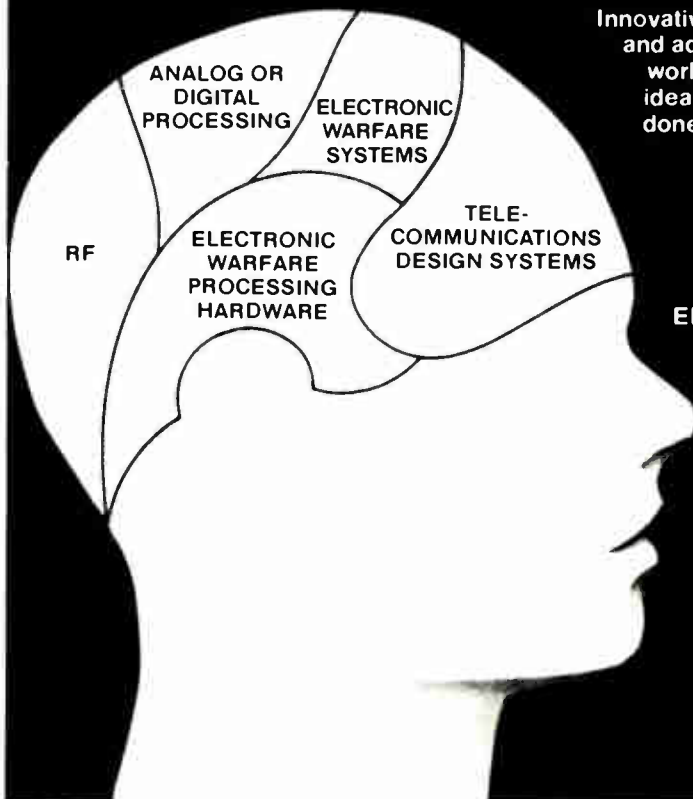

## ELECTRONIC ENGINEERS

**ENGINEERS to \$50,000.** New England/Metro NY is our market. Openings at all levels within the nation's highest demand area for electronic pros in design, application, systems. ACCESS GROUP, 111 High Ridge Road, Stamford, CT 06905 (203/356-1166).

**ELECTRONICS ENGINEERS, \$15,000-\$45,000.** Choice entry-level to management positions immediately available in Pennsylvania & national locations. Reply in strict confidence to J. G. Weir, President, WEIR PERSONNEL SERVICES, 535 Court St., Reading, PA 19603 (215/376-8486).

**BSEE / ELECTRONIC DESIGN ENGINEERS, \$15,000-\$35,000.** Immediate, desirable upstate New York & nationwide. Junior to senior project management. In confidence send resume or call James F. Corby, President, NORMILE PERSONNEL ASSOC., INC., 5 Leroy St., Box 110 Westview Station, Binghamton, NY 13905 (607/723-5377).

**DESIGN ENGINEERS to \$30K.** Central Penna. Design connectors/terminals, E/M components. Outstanding relocation package. Prompt confidential reply. MECK ASSOC. PERSONNEL, 1517 Cedar Cliff, Camp Hill, PA 17011 (717/761-4777).

**ENGINEERS.** We specialize nationally in the electronics industry at the 0-5 yrs experience level. If you are worth more than you are making or your career is stagnated, send your resume. CAREER ASSOC., 583 State Rd., N. Dartmouth, MA 02747 (617/997-3311).



**NATIONAL  
PERSONNEL  
CONSULTANTS**

## SUPERVISING ENGINEER

BONNEVILLE PRODUCTIONS has an immediate opening for an electronic engineer to supervise technical operations of our tape duplication operation. Qualifications necessary include a BSEE (or equivalent training plus experience), thorough experience in magnetic tape theory and recording techniques (professional systems), an excellent troubleshooting background and the ability to supervise a staff of four engineers and technicians. Experience with Cetec/Gauss tape duplication equipment is preferred. Tape production and engineering areas are designated no-smoking. Please reply with resume, references and salary requirements to:

Lorna van Komen  
Bonneville Productions  
130 Social Hall Ave.  
Salt Lake City, Utah 84111

## Telecommunications Engineers

Reaching Out To Face The Challenge Of Our Environment...

*on the San Francisco Peninsula*

The need to communicate is universal. In Palo Alto, California we are pioneering the development of computer controlled business and residential voice and data communications systems, utilizing real-time stored program control and minicomputer/microprocessor implementation. The challenge we face is to give human dimensions to state-of-the-art technology. Join us. At BNR, one of the leading R&D laboratories in North America, you can experience the innovative freedom, technical challenge and rapid professional growth inherent in contributing to the concept and design of the most advanced telecommunications systems. Our continuing growth has created a variety of openings for engineers and managers who enjoy working in an environment of exploration, and individual recognition:

### Technical Management

We require a MS/PhD in EE or CS and up to 8 years of related telecommunications experience to manage teams of hardware, and systems engineers in the design, documentation, specification of future telecommunications systems.

### Hardware Engineering

Designs include data networks, digital and analog microprocessor-based peripheral equipment for PABX switching systems. We require a BS/MSEE and experience in the areas of digital and analog design, microprocessors, transmission, codecs, phase-locked loops and TTL.

### Power Engineering

Design, test and evaluate small solid state switching power supplies. Requires a BSEE and 3+ years of experience, including design of analog and magnetic circuits and magnetic components.

### Systems Engineering

Define new EPABX features, software, specification requirements and evaluate transmission performance for digital telecommunications systems. Analyze complex data communications networks. We require a BS/MSEE or CS and 3+ years of telecommunications experience.

We offer excellent compensation, one of the best benefits programs on the San Francisco Peninsula, generous relocation assistance, a progressive and stimulating environment, and outstanding opportunities for personal recognition and professional growth.

For prompt consideration and reply, please send your resume to Ellen Ohmer, Employment Manager, BNR INC., Mail Stop 454, 3174 Porter Drive, Palo Alto, CA 94304. An equal opportunity employer.

 **BNR**  
Subsidiary of  
Bell-Northern Research  
The R & D Laboratory for  
Northern Telecom and Bell Canada



## ENGINEERS

- Connecticut Living
- Advanced Technology
- International Travel
- Personal Development

Combine at General Electric's Circuit Protective Devices Dept. near Hartford. Leading the industry in personal Ground Fault Protection and Industrial Power Circuit Devices requires a continuing effort in solid state technology. These careers are at the leading edge of the business.



### MATERIALS AND PROCESSES ENGINEER

Select and specify processes, materials and standards used for manufacture of printed wiring board assemblies, thick film substrates, photo-resist processing, solid state materials and structural plastics.

Requires BS Che. Eng. or CHEM or equivalent with materials processing experience in circuit board manufacturing technology.



### ELECTRONIC COMPONENTS RELIABILITY ENGINEERING

Selection, evaluation and specifying discrete electronic components, Direct and monitor reliability and environmental testing procedures. Requires BSEE or Physics and two years' reliability or components design engineering. Knowledge of circuit design and failure analysis useful. Excellent communications skills required.



### PRODUCTION ENGINEER

Directs new product introductions. Designs improvements in product costs and quality. International travel necessary to coordinate activities with satellite plants.

Requires BSME or EE with working knowledge of high-speed mechanisms and electro-mechanical devices. Strong communications skills required for interface with vendors, manufacturing staff, and regulatory agencies.

We offer an outstanding package of salary, benefits and stable, long-range growth.

Apply by mail with resume to—

R. Butler  
CPD—41 Woodford Avenue  
Plainville, Connecticut 06062

**GENERAL ELECTRIC**

*An equal opportunity employer M/F*

## FLIGHT TEST ENGINEERS

McDonnell Aircraft Company has immediate openings for engineers experienced in Flight Test data systems applications. Career opportunities include development, operation and support of Flight Test data systems on F-15, F-18, AV-8 and advanced aircraft projects in one or more of the following applications.

- Mini-Computer Technology
- Computer Programming
- Flight Test Data Assessment
- System Design
- Airborne Instrumentation
- Installation Design — Electrical & Mechanical
- Electronic Circuit Design
- Micro-Processor Technology

Please send your resume in confidence to:

W. B. Kellenberger, Section Manager  
Professional Employment  
Department E-02 • P. O. Box 516  
St. Louis, Missouri 63166

**MCDONNELL DOUGLAS**

An Equal Opportunity Employer

**CORPORATION**

## COMPUTER ENGINEERS

### Explore Your Opportunities

The ENGINEERING RESOURCES GROUP specializes in providing growth opportunities for engineers in the Southwest & Western states.

- Digital Design
- Systems Programmers
- Test Engineers
- Manufacturing Engineers
- Quality Engineers
- Industrial Engineers
- Field Engineers

Please call us collect or send your resume to: **Engineering Resources Group, 20380 Town Center Lane, Suite #260, Cupertino, CA 95014. (408) 446-5111. Cele Horn, Sr. Consultant.**

# Engineering Resources Group

A division of the  
**Computer Resources Group**  
Employers Pay All Fees

## The Engineers Index

### Systems Engrs. Data Processing Electronics

Salaries to \$46,000

Manufacturing Engrs.

ECM Engrs.

Tool Design Engrs.

Air Traffic Contr'l. Syst. Engrs.

Rotating Devices Engrs.

Thermometric Engrs.

Digital CKT Design Engrs.

Power Systems Engrs.

Sr. Military Systems Engrs.

Field Engrs. (Electronic Equip.)

Digital Systems Engrs.

Production Control

Programmers/Mgrs.

QA and/or QC Engrs.

Technicians

Companies Assume Our Fees.

Submit Resume, Call or Visit:

**THE ENGINEER'S INDEX**

133 Federal Street, Suite 701

Boston, Massachusetts 02110

Telephone (617)482-2800

### POSITIONS VACANT

**Electrical Engineers and Systems Analysts**—Expanding programs offer stimulating growth opportunities with an established research organization for full-time applied R&D engineers having above-average capabilities and BS/MSEE degrees. Multiple openings in Atlanta and Macon locations. Work areas include: electronic warfare systems analysis, computer modeling and simulation, operations analysis, systems integration, etc. Recent Graduates with good academic records \$15—24K. 3-10 Years Appropriate Experience to \$35K. Excellent fringes include: Vacation 21-days first year, plus Christmas week and other paid holidays. Educational opportunities with tuition reimbursement. Opportunities for individual publication. U.S. Citizenship required. R. P. Zimmer, Code E, Engineering Experiment Station, Georgia Institute of Technology, Atlanta, Georgia 30332. An Equal Employment/Education Opportunity Employer.

### EMPLOYMENT SERVICES

Electronic engineering growth positions with clients located nationally. Our service is enhanced by the fact that I am an EE with 20 years in industry and over 10 years in placing professionals on an employer fee paid basis. Send your resume to Joe Torcassi, Director, J. Anthony & Associates, PO Drawer AD, Lynchburg, OH 45142. 513 364-2305.

### BUSINESS OPPORTUNITIES

**Minority Interest For Sale**—Marketing oriented entrepreneur wanted for key position in Medical electronics company located in Denver area. Stock available. Contact Vern D. Kornelsen, 1018 First National Bank Bldg., Denver CO 80293. Tele: (303) 893-0011.

### DESIGN ENGINEER

High Voltage Capacitors & Pulse-Forming Networks

Immediate opening for an experienced capacitor/PFN design engineer with a leading manufacturer of specialty pulse modulator components for airborne, ground base, and shipboard radar systems. Forward resume to Tobe Deutschmann, Jr.

**TOBE DEUTSCHMANN LABS INC.**

550 Turnpike Street  
Canton, MA 02021

*An equal opportunity employer.*

### SOUTHEAST OPPORTUNITIES

We have immediate openings with the most progressive clients in the Southeast and nationally for E.E.'s with Data Processing background involved in the computer field. Send resume to: **Continental Personnel, Inc., P.O. Box 11321, Charlotte, NC 28220. (704) 525-2160.**

### POSITIONS VACANT

**Semiconductor Device Modeler** National Bureau of Standards—The Electron Devices Division, NBS, is a leader in research on advanced measurement technology associated with the characterization of materials, processes, and fabrication systems used in the manufacture of VLSI components. In conjunction with this effort we need creative, innovative thinkers to formulate mathematical models associated with the operation of state-of-the-art devices and advanced test structures with emphasis on relationships between material defects and electrical characteristics. This position allows for in-depth study of the problem, freedom to publish results, and opportunity to interact freely with the semiconductor community. The salary is competitive and negotiable depending on individual experience. To be considered, send your resume or Personal Qualifications Statement (SF-171) to: Deborah Raisher, National Bureau of Standards, Administration Bldg., Room A-123, Wash., D.C. 20234. An Equal Opportunity Employer.

**Murkett Associates Qualified** Reputable Management placement with national affiliates—fee paid Box 527 Montgomery, AL 36101

### RESUMES

**Creative Job Hunting.** Creativity in job hunting and resume writing is so rarely shown that it can really entice a prospective employer. Inject a little creativity into your resume and job seeking efforts to get that really prized possession. For your copy of "Creative Job Seeking" send \$3.00 payable to: CHJ-1 Route 3, Box 45 Hayden Lake, Idaho 83835.

### BUSINESS OPPORTUNITY

**How To Earn Money As A Consultant** (including specimen contracts) \$25 Business Psychology Int'l 890/44 National Press Bldg. Washington, D.C. 20045.

# ELECTRONIC ENGINEERS

## Qyx

Qyx, a Division of Exxon Enterprises Inc., is the creator of the world's first Intelligent Electronic Typewriter. It performs all of the standard typewriter functions, plus communications, editing, display and mini-diskette file storage capabilities through modularly up-gradable, microprocessor based components—and all in a single typewriter sized package.

If you are an ambitious engineer with experience in one or more of the following areas, this is an opportunity to join a rapidly expanding company:

- EMI/Electro-Static Discharge.
- Microprocessor/digital design.
- Dynamic RAM/EPROM design.
- Electronic keyboard design/specification.
- Custom IC design/specification (bipolar/MOS).
- Low cost advanced chip/device packaging.
- Floppy controller design.
- Stepper/Servo Motor Control.
- Analysis and design of electromagnetic structures.
- Electro-mechanical, design-oriented engineers with experience in terminal analysis, machine design, etc.

A bachelor's degree is required; advanced degrees are desirable.

Qyx offers an attractive salary and major company benefits program, plus the career growth possibilities inherent in this dramatic new communications product. We are located in a highly attractive suburban Philadelphia area.

Please send your resume, with salary requirements, to:

Mr. R. H. Thurman, Dept. 151  
Qyx, Division of Exxon Enterprises Inc.  
P.O. Box 429  
Exton, PA 19341

An equal opportunity employer M/F  
Minorities and females are encouraged to apply

# Qyx

Intelligent Typewriter Systems  
A Division of **EXXON** Enterprises Inc.

We are an equal opportunity employer. m/f



3 times as wide as Earth, the Red Spot of Jupiter (upper left) is being investigated by Bendix engineers

## A true story to tell your grandchildren

You'll certainly have something to tell them if you join us at the JPL Deep Space Lab in Pasadena, and the Goldstone Tracking Complex.

Bendix Field Engineering is responsible for command and control of the Pioneer and Voyager spacecraft.

For the next several years Bendix professionals will be exploring the clouds of Venus, Jupiter's moons, the rings of Saturn, and farther reaches of space, where no man has ever gone before.

This is exciting work, and these are the only places doing it. We offer you a chance to join them.

You won't get a chance like this anywhere else in the world.

Or out of it.

We're looking for:

- Software Engineers
- Evaluation Engineers
- Programming Engineers
- Network Controllers
- Computer Technicians

Call collect (213) 577-2304 to arrange an interview, or send your resume, in strict confidence to:

John Mansfield, Dept. E  
Bendix Field Engineering Corporation  
171 N. Altadena Drive  
Suite 220  
Pasadena, CA 91107

# Bendix

## Field Engineering Corporation

Equal Opportunity Employer M/F

# Digital Voice and Signal Processing

A small but growing group needs a ground-floor specialist in computerized application of digital voice. The person we are looking for would have in-depth knowledge of all current A/D conversion methods, all current compression and compaction methods, and a strong background in digital signal processing. A good background in audio and digital electronics is desirable. Although well versed in all the current research areas relating to digital voice, this individual must be motivated toward the application of that knowledge to a product.

Our attractive Connecticut location offers a quiet New England environment with abundant recreational opportunities and large metropolitan areas within easy reach.

Unparalleled opportunities for career advancement with our rapidly expanding group can be investigated by sending your resume to:

Manager, Professional Employment  
Department E31  
Burroughs Corporation  
105 Newtown Road  
Danbury, Connecticut 06810

An Equal Opportunity Employer M/F

## Burroughs

## ELECTRICAL DESIGN ENGINEERING OPPORTUNITIES

*Join The Search For The  
Technology of Tomorrow*

Gould Ocean Systems is a precision manufacturer of high reliability electronic and electromechanical devices for use above and below the ocean. To continue our leadership in this exciting field, we are interested in finding professionals who are capable of original thought and constructive imagination in the following fields:

### SENIOR ELECTRICAL ENGINEER

To perform circuit analysis and design for hardware/software projects and provide production support. Requires a BSEE, supervision skills, and at least 6 years experience in hardware development and test programs. Government contract experience preferred.

### SENIOR ENGINEER

To perform systems analysis of state-of-the-art high specific power systems to be used for various under-sea propulsion systems. Candidate will generate system requirements and oversee design integration and evaluation processes. Candidate should possess a BSEE or MS or PhD in Electrical Engineering and have prior experience in Fortran IV and other computer aided analysis. 7-10 years previous power control engineering experience; 2 of which would have encompassed leadership abilities.

### ELECTRICAL ENGINEER

To perform initial analysis of circuitry leading to design fabrication and integration for high specific power electric propulsion drive systems. Candidate should possess a BS or MS in Electrical Engineering. Some previous training in Fortran IV and 2-5 years experience in circuit design with solid state high power control networks is preferred.

We provide an excellent starting salary with regular performance reviews and an outstanding fringe benefit package. Most important, we provide an atmosphere where you can earn professional recognition working on a variety of high priority assignments. For additional information and confidential consideration, send your resume to:

**GOULD OCEAN SYSTEMS DIVISION**  
18901 Euclid Avenue  
Cleveland, Ohio 44117

An Equal Opportunity Employer, M/F/H.

**GOULD**  
Ocean Systems Division

#### PRODUCT ENG.

E/M Timers \$21 K.

Pathfinder

P.O. Box 447

Commack, NY 11725

Engineering Recruitment  
Nationwide

#### ELECTRONIC ENGINEERS

Nationwide opportunities are available to talented & degreed Electronic Engineers looking for a career. Reply in confidence to Stu Hopard for prompt & confidential service.

Taft Personnel Agency  
521 5th/43St, NYC 10017  
212-697-0100



## NUCLEAR OPPORTUNITIES

### ENGINEER NUCLEAR/ MICROPROCESSORS

Theory and application of micro-processors in solid state technology applied to reliability and to maintenance reduction in control systems and supporting services for a nuclear reactor. BSEE or equivalent and relevant experience in lead position.

### ENGINEER NUCLEAR INSTRUMENTATION

Design engineering to update reactor control systems while meeting stringent process requirements. Simplify existing reactor control systems with improved instrumentation. BSEE or equivalent and relevant experience. Send resume and salary history in confidence to: Mr. Bob Jorge, Ref. E.L., United Nuclear Industries, Inc., P.O. Box 490, Richland, WA 99352.



US Citizenship required.  
Equal Employment Opportunity is Our Pledge and Our Practice.

NUCLEAR OPERATIONS DIVISION  
**UNITED NUCLEAR INDUSTRIES, INC.**

### DESIGN ENGINEERS

Client R&D center requires Micro-processor, Analog & Digital Engineers, 19-35K **EMPLOYER FEE PAID**, send resume w/salary data to **CORPORATE RECRUITERS**, 525 Omaha Tower, 2120 So. 72nd, Omaha, NE 68124, 402/393-5515

### NATIONWIDE ELECTRONICS PLACEMENT

Digital Ckt Dsgn \* Hardware Sys Dsgn  
Analog Ckt Dsgn \* Software Sys Dsgn  
Quality Reliability \* Test Equipment Mince  
Entry Level through Management  
All Fees are Exclusively Employer Paid  
Resume Format Guide  
Available Upon Request  
**E. J. STEPHEN ASSOCIATES**  
Tri-State Mall, Claymont, DE 19703  
(302) 798-6861

### SCHOOLS

**World Open University—A Non-Resident Graduate School—Division of Electrical, Electronics & Computer Engineering offers full graduate courses in areas: Applied Mathematics & Physics; Electronics Engineering; Electrical Circuits; Computers & Advanced Programming; Communications Systems; Control Systems; Energy-Power Systems; Nondestructive Testing—leading to M.S., Ph.D., Sc.D., Eng.D., Tech. D.—guided by full professors having a series of original contributions to inter-national learned societies. Request complete information to WOU, PO Box 5505, Orange, CA 92667, USA, enclosing \$5 in US, or US \$7 outside of US, for airmailing. Self-authored original paper reprints from national learned societies may get proper credits. WOU is racially nondiscriminatory. To mention Electronics in request.**

# ENGINEERS

## Give Your Career a Leap Forward with AMECOM in '79!

**TELECOMMUNICATIONS SYSTEMS  
RF SYSTEMS  
SHIPBOARD COMMUNICATION SYSTEMS**

At AMECOM, the systems division of Litton, we're working on the forefront of technology, and we have positions of uncommon growth potential for innovative systems engineers who want their careers to take a leap forward in 1979. If you are an analog or digital processing engineer with systems or hardware design experience in the RF Communications or Telecommunications field, you owe it to yourself to investigate super career growth positions at levels to \$32,600 PLUS. Managerial positions are also available.

Our professional staff addresses state-of-the-art technological problems in ELECTRONIC WARFARE, VOICE AND DATA SWITCHING and long range point to point communications in a thoroughly professional working environment.

AMECOM's modern facilities are located in a pleasant college town in Maryland, close to the Chesapeake Bay, still only a half hour's drive from the Nation's Capital, providing you with a convenient choice of city, suburban, country or waterfront living without onerous taxation.

AMECOM offers excellent compensation and benefits, and your opportunity to maximize your professional potential. For more information, send your resume including salary history in confidence, or better yet, call now COLLECT during business hours to:

**PHILIP T. FOSTER  
(301) 864-5600**



Amecom Division  
**LITTON SYSTEMS, INC.**

5115 Calvert Rd., College Park, Md. 20740  
An Equal Opportunity Employer M/F

# PROJECT MANAGERS

**Visualize,  
Conceptualize, Realize**

Utilize all your abilities at Zenith. Interfacing directly with our Design and Production staffs, you will develop equipment to produce innovative products for the 80's. Scope of responsibilities ranges from design to pilot runs, and everything in-between. These are unique opportunities for you to gain satisfaction and recognition while utilizing both your creative design orientation and your mechanical abilities. Positions are available for the following results-oriented engineering managers:

## PROJECT MANAGER - YOKE PRODUCTION

You will be involved in the development and implementation of micro-processor equipped automated machinery used for Television Yoke production as well as training individuals to wind, assemble and test yokes. Experience in the development and modification of tool/machine combinations used in Yoke production equivalent to 5 years is required along with a working knowledge of microprocessors and a BSEE or BSME (or equivalent).

## PROJECT MANAGER - MACHINE DEVELOPMENT

You will be responsible for the design of new or alteration of existing production equipment required for specific projects. Duties will include resolving equipment problems, assisting in the preparation of training programs on equipment, and traveling to facilities to ensure proper machine set-up and operation. To qualify you should have experience in the design or alteration of production equipment for use in a manufacturing process equivalent to 5 years and a BSME or equivalent knowledge.

If you're looking for new challenges, greater responsibilities and excellent career opportunities in specialized fields of engineering, join the nation's leader in Color Television. In addition we offer an excellent salary and outstanding benefit package including profit sharing. Qualified applicants should send a resume or letter outlining work history and salary requirements or

**CALL COLLECT**

**Mr. Michael Maciekowich  
312/745-2666**



**RADIO CORPORATION**

1900 N. Austin  
Chicago, IL 60639

*An Equal Opportunity Employer M/F*

# ELECTRONIC ENGINEER

## RF Equipment Design

Grumman Aerospace Corporation has an immediate opening for an Electronic Engineer with a B.S.M.S. in Electrical Engineering, Physics or Electro-physics. Two to five years experience in the design, development, test and integration of various types of antenna and related microwave components into aircraft and space vehicles is also required.

In addition to an excellent facility with mathematics and computer programming, ability and experience should include the theoretical analysis of diffraction and scattering of electromagnetic waves from metal or non-metallic objects.

Qualified applicants should send their resumes in strictest confidence to: **Mr. Dan R.F. Nettuno**, Manager, Professional Employment.

**GRUMMAN AEROSPACE CORPORATION**  
BETHPAGE, NEW YORK 11714

AN EQUAL OPPORTUNITY EMPLOYER M/F U.S. CITIZENSHIP REQUIRED

## NOW IS THE TIME ... TO HIRE A STUDENT THIS SUMMER.

First, it's later than you think, with schools closing on different semester schedules, and students torn between lining-up "sure" jobs now or gambling that something in their chosen field will come along later.

Second, and most important, it's in our industry's best interest to encourage and hold its life-blood by providing practical experience in their future profession.

And, since there'll always be more applicants than openings, you'll be able to select the cream of the crop, then evaluate them

with an eye towards hiring, when as coveted graduates, the job market might be in their favor.

Because we believe this program is of mutual benefit to both employer and employee alike, we again offer our services as a clearing-house.

Just fill out and return the coupon below, and we'll include your organization in a free listing to be sent to Placement Directors and Department Heads at leading colleges and universities across the nation. They'll post it, and the students will contact you directly.

### Free summer help listing

MAIL TO: ELECTRONICS/POST OFFICE BOX 900/NEW YORK/NY 10020

NAME/TITLE (of individual to be contacted)

ADDRESS: (Mailing address of your personnel office)

ORGANIZATION: (Firm, Company, Government Agency or Institution)

TYPE AND NUMBER OF STUDENTS SOUGHT: Electronics Avionics

Technician Computer Science Other: (Draftsman, etc.)



2/15/79

Note: Last date coupons can be accepted for this year's student mailings is 4/6/79

# Inmos.

## The challenge. The rewards. And Colorado too.

We're looking for people of singular talent. We're looking for people who realize the chance comes rarely to help shape the character and destiny of a high technology company.

We expect Inmos to be a great company. The products we develop will push forward the frontier of VLSI technology. We will create an atmosphere in which independent thinkers can flourish; an atmosphere which can sustain entrepreneurial instincts. The chance to share in Inmos' success will be a strong incentive in attracting the special breed we seek.

We're depending on innovators to help us compress the time it takes a new company to be a major factor in the high technology, semiconductor industry. We're looking for people from every discipline.

We'll be running hard. It won't be easy. That's why we chose the location for headquarters of our U. S. operations so deliberately: Colorado Springs, at the foot of Pike's Peak, in the Rocky Mountains. It's a place the people of Inmos can refresh their spirits and imaginations. It's a place our families will find stimulating.

To lead, to operate on the cutting edge in our industry, takes sufficient capital to avoid the hazard of being always short term oriented. Inmos will be properly financed from the outset.

We want to hear from you. About your achievements, your backgrounds. We're going to build a great company. Together.

*Inmos. Some of you have been preparing all your lives for a chance like this.*

*Richard L. Petritz, Paul R. Schroeder, Iann M. Barron*  
Inmos Corporation  
2860 South Circle Dr.  
Colorado Springs, Colorado 80906  
303-576-7130

Inmos Ltd.  
Whitefriars  
Lewis Mead  
Bristol BS-1  
272-290-861

Acheson Colloids	51	Elorg Electronorgtechica	173	Matsushita Electric Trading Company	12E
ADAC	185	EMM SESCO	189	MDS Systems	192
Allen-Bradley	32	EMM Technology	179	MFE Corporation	215
Allen-Bradley Electronics Ltd.	16E	EMM/Semi	2E	Mitel Semiconductor Inc.	50
Amp Inc	18,19	Emerson & Cuming Inc	181	Mostek Corporation	20,21 27
American Microsystems Inc.	10,11	Enertec Schlumberger	3E	‡ Murata Corporation of America	172
American Optical Scientific Instrum. Div.	200	Fairchild Test Systems	76,77	Murata Mfg. Co. Ltd.	174
AMF Potter and Brumfield	94,95	Fairchild (Semiconductor Operations Division)	53	■ National Semiconductor Corp.	36,37
Analog Devices	100,101	First Computer Corporation	9	Neff Instrument Corporation	84
Anritsu Electric Co. Ltd.	194	■ John Fluke Mfg. Co.	139,104	• NEOHM SPA	7E
AP Products	176	GCA Burlington	35	■ Nicolet Instrument Corp. Oscilloscope Div.	26
Ball Display Division	178	‡ Galileo Electro Optics Corporation	171	■ Nippon Precision Circuits Ltd	54,55 218
F. W. Bell, Inc. Div. of Arnold Eng. & Allegheny Ludlum	8	■ General Electric Company Semiconductor Dept.	175	■ Non-linear Systems, Inc.	170, 6 190
The Boeing Company	168	‡ General Electric Instrument Rental Division	156	Northern Ireland Inc Devel. Organization	197
Bourns Inc	2nd cover	Glasgow District Council, City of	223	‡ Panasonic Industrial Div.	166,167
Burr Brown Research Corporation	183	Gould Blomation	93,66	• Peterborough Development Corporation	38
Burroughs	71	Gould Inc./Instruments Oscilloscopes	69	• Philips Elcoma	13E
Cambridge Thermionic Corp.	222	GTE Sylvania/Connector Products Operation	73	• Philips TMI	5E
Cherry Electrical Products	180	■ Hewlett-Packard	1,2,22,23,28,29,74,75,102,103	Powercube Corporation (Div. of Unitrode)	91
Clairex Electronics	4th cover	HI-Q Incorporated	193	Power Tech	188
Conrac Div / Conrac Corporation	213	‡ Honeywell Florida	166	Practical Automation	222
Continental Specialties	140	Houston Instrument	187	Precision Monolithics	180,161 183
Control Electronics	6	‡ Howard Industries	169	■ Projects Unlimited	212
Cramer Electronics	56	■ Hughes Aircraft	43	‡ Racal-Dane Instruments Inc.	184
Data I/O Corporation	120	I Corporation	48	‡ Racal Thermionic Ltd.	166,167
Datawest Corporation	221	Interface Technology	238	RCA Solid State	62
Deutsche Messer AG	219	International Electronic Research Corp.	158	Reticon Corporation	89
Diallight	195	International Microsystems Inc	211	‡ Rental Electronics	38
Digital Equipment Corporation OEM 11 Group	144,145	Intersil	9	Rockwell Microelectronic Device Division	216
Digital Equipment Corporation PDP	78,79	Ion Physics Co.	82	Rogers Corporation	177
‡ Digitran Company	183	• Italtel/SIT	11E 15E	• Rohde & Schwarz	7E, 65
• Dionex Gas Plasma Systems	171	ITT Jennings	220	Scanbe Division of Zero Corporation	238
Dynamic Sciences	150	■ Keithley Instruments	199	• SDSA	9E
‡ EAO Switch Corporation	49	■ Kepco Inc.	5	■ SEACOR INC.	16
Electromaek Inc	182	■ Lambda Electronics Corporation	201-208	• SEPA	14E
Electromatic Components Ltd	3rd cover	‡ Leasametric	60,61	‡ Sharp Corporation	174
Electronic Navigation Industries	6	LH Research Inc	134	Sigma Instruments Inc.	90
Electronics & Control Engineers Book Club	224-227	Matrox Electronic Systems	196	Signetics Corporation	15

# ELECTRONICS REPRINTS

No. of  
copies  
wanted

## Articles

- \_\_\_ R-901 1979 world market survey and forecast 24 pp \$4.00
- \_\_\_ R-829 Special report: New networks tie down distributed processing concepts 16 pp \$3.00
- \_\_\_ R-827 Tackling the very large-scale problems of VLSI: a special report 15 pp \$3.00
- \_\_\_ R-825 1978 technology update special issue \$4.00
- \_\_\_ R-821 Codex answer the call 18 pp \$4.00
- \_\_\_ R-817 How bit-slice families compare 18 pp \$3.00
- \_\_\_ R-816 Packaging technology responds to the demand for higher densities 9 pp \$3.00
- \_\_\_ R-815 Higher power ratings extend V-MOS FETs' dominion 8 pp \$2.00
- \_\_\_ R-813 Data-link control chips: bringing order to data protocols 10 pp \$3.00
- \_\_\_ R-811 Multiplexing liquid-crystal displays 10 pp \$3.00
- \_\_\_ R-809 New methods and materials stir up printed wiring 10 pp \$3.00
- \_\_\_ R-807 Here come the big, new 64-K ROMs 14 pp \$3.00
- \_\_\_ R-805 Why and how users test microprocessors 8 pp \$3.00
- \_\_\_ R-801 World market report 1978 24 pp \$4.00
- \_\_\_ R-734 Microcomputer families expand 20 pp \$4.00
- \_\_\_ R-730 Special report—Automotive electronics gets the green light 10 pp \$3.00
- \_\_\_ R-728 Flexible circuits bend to designers' will 10 pp \$3.00
- \_\_\_ R-724 Special report—Technologies squeeze more performance from LSI 22 pp \$3.00

## Charts

- \_\_\_ R-823 Communications satellites \$3.00
- \_\_\_ R-516 Electronic symbols \$2.00
- \_\_\_ R-213 Electromagnetic spectrum (updated 1976) \$3.00
- \_\_\_ R-326 Optical spectrum (6-page report and chart) \$3.00

## Payment must accompany your order

Make check or money order payable to Electronics Reprints. All orders are shipped prepaid by parcel post. Allow two to three weeks for delivery. For additional information call (609) 448-1700 ext. 5494.

Mail your order to:

Janice Austin  
ELECTRONICS REPRINTS  
P.O. Box 669  
Hightstown, N.J. 08520

## Advertising Sales Staff

**Advertising sales manager: Paul W. Reiss**  
1221 Avenue of the Americas, New York, N.Y. 10020  
[212] 997-4371

**Atlanta, Ga. 30309: Michael Charlton**  
100 Colony Square, 1175 Peachtree St., N.E.  
[404] 892-2868

**Boston, Mass. 02110: Frank Mitchell**  
607 Boylston St.  
[617] 262-1160

**Chicago, Ill. 60611**

645 North Michigan Avenue

Jack Anderson [312] 751-3739

Robert M. Denmead [312] 751-3738

**Cleveland, Ohio 44113: William J. Boyle**

[714] 586-5040

**Costa Mesa, Calif. 92626: Robert E. Boedicker**

3001 Red Hill Ave. Bldg. #4 Suite 242

[714] 557-6292

**Dallas, Texas 75201: John J. Uphues**

2001 Bryant Tower, Suite 1070

[214] 742-1747

**Denver, Colo. 80203: Harry B. Doyle, Jr.**

123 Speer Blvd. #400

[303] 837-1010

**Detroit, Michigan 48202: Jack Anderson**

1400 Fisher Bldg.

[313] 873-7410

**Fort Lauderdale, Fla. 33306: Michael Charlton**

3000 N.E. 30th Place

[305] 563-9111

**Houston, Texas 77002: John J. Uphues**

601 Jefferson Street, Dresser Tower

[713] 659-8381

**Los Angeles, Calif. 90010: Robert J. Rieley**

Robert E. Boedicker, 3200 Wilshire Blvd., South Tower

[213] 487-1160

**Minneapolis, Minn. 55435: Robert M. Denmead**

4015 W. 65th St.

[312] 751-3738

**New York, N.Y. 10020**

1221 Avenue of the Americas

John Gallie [212] 997-3616

Matthew T. Reseska [212] 997-3617

**Philadelphia, Pa. 19102: Matthew T. Reseska**

Three Parkway

[212] 997-3617

**Pittsburgh, Pa. 15222: Matthew T. Reseska**

4 Gateway Center

[212] 997-3617

**Rochester, N.Y. 14534: William J. Boyle**

Power Mill Office Park, 1163 Pittsford-Victor Rd.,

Pittsford, N.Y. 14534

[716] 248-5620

**San Francisco, Calif. 94111: Don Farris**

Dean Genge, 425 Battery Street,

[415] 362-4600

**Paris: Patrick Mouillard**

17 Rue-Georges Bizet, 75116 Paris, France

Tel: 720-73-01

**United Kingdom & Scandinavia: Robert Ghey**

34 Dover Street, London W1

Tel: 01-493-1451

**Scandinavia: Andrew Karnig and Assoc.**

Kungsholmsgatan 10

112 27 Stockholm, Sweden

Tel: 08 51 68 70 Telex: 179 51

**Milan: Ferruccio Silvera**

1 via Baracchini, Italy

Phone 86-90-656

**Brussels:**

23 Chaussee de Wavre

Brussels 1040, Belgium

Tel: 13-73-95

**Frankfurt/Main: Fritz Krusebecker**

Liebigstrasse 27c, Germany

Phone 72 01 81

**Tokyo: Akio Saijo, McGraw-Hill**

Publications Overseas Corporation,

Kasumigaseki Building 2-5, 3-chome,

Kasumigaseki, Chiyoda-Ku, Tokyo, Japan

[581] 9811

**Business Department**

**Thomas M. Egan**

Production Director

[212] 997-3140

**Carol Gallagher**

Production Manager International

[212] 997-2045

**Betty Preis**

Production Manager Domestic

[212] 997-2908

**Thomas Kazich**

Production Manager Related Products

[212] 997-2044

**Marieanne Meissner, Production Assistant**

(212) 997-2843

**Frances Vallone**

Reader Service Manager

[212] 997-6057

**Electronics Buyers' Guide**

**H.T. Howland, General Manager**

[212] 997-6642

**Regina Hera, Directory Manager**

[212] 997-2544

**Thomas Kazich, Production Manager**

[212] 997-2044

**Marieanne Meissner, Production Assistant**

[212] 997-2843

**Frances Vallone, Reader Service Manager**

[212] 997-6057

**Classified and Employment Advertising**

**Frank Eberle, Manager**

[212] 997-2557

‡ Silicon Systems	65
Siliconix	159
Snap-On Tools Corporation	200
SOAR Corporation	52
Solitron Devices Inc	87
■ Spectrol Electronics	83
■ Sprague Electric	59
Standard Microsystems	45
• Sullivan Ltd.	60
■ Syntronic Instruments Inc.	198
■ Tektronix	191
• Tektronix Datatek NV	10E
Tektronix MDA	98,99
‡ Telequipment	48
Telecommunication Devices Inc	82
■ Teledyne Relays	17
Teradyne Inc.	12,13 80
Textool Products Inc.	14
Thermotron Corporation	210
• Thomson CSF Division D.T.E.	49
TRW LSI Products	154,155
■ United Systems Corporation Sub. of Monsanto	153
• Unitrode Corporation	169
Wavetek San Diego	47
Weckesser Company Inc	218
Wildberg Brothers	238
Wilhelm Westermann	8
Xanadu Controls	186
Xerox Corporation	97
• Zeltron	156
Zilog	30,31

## Classified and employment advertising

F. J. Eberle, Manager 212-997-2557

Bendix Field Engineers	231
Bonneville Productions	228
BMR, Inc.,	229
Burroughs Corp.,	232
Continental Personnel	230
Corporate Recruiters	233
Engineers Index	230
Engineering Resources Group	230
General Electric Co.,	229
Goold Ocean Systems Div.,	232
Grumman Aerospace Corp.,	234
Inmos Corp.,	235
Litton Systems, Amcon Div.,	228,233
McDonnell Douglas Corp.,	230
National Personnel Consultants	228
Nuclear Industries	233
Pathfinder Associates	232
Qyn Co.	231
Stephen, E. J.	233
Taft Personnel	232
Tobe Deutschmann Labs., Inc.,	230
Zenith Radio Corp.,	234

■ For more information of complete product line see advertisement in the latest Electronics Buyers Guide

\* Advertisers in Electronics International

‡ Advertisers in Electronics domestic edition

## IC's easily installed with Scanbe's New 40-pin ZIF Connector

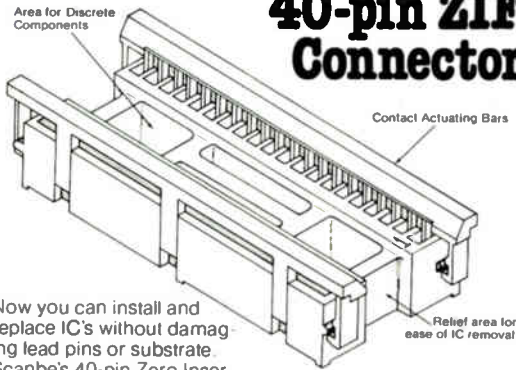

Now you can install and replace IC's without damaging lead pins or substrate. Scanbe's 40-pin Zero Insertion Force IC connector features actuating bars to open and close contacts. Designed to guard against accidental opening of contacts during operation. Edge wipe design for highest contact pressure. Contact resistance after condition-

ing, 14 milliohms; withdrawal force per contact, 23 grams. Contacts are made of CA770 and are available with gold plating, P/N 11857-01, without gold plating, P/N 11857-02.

**Immediate delivery from local Scanbe distributors.**



3445 Fletcher Ave. P.O. Box 4159 El Monte, CA 91731  
Telephone: (213) 579-2300 TWX: (910) 587-3437

Circle 238 on reader service card

if you use  
precious metals  
(gold, silver, platinum and palladium)  
You need this  
free booklet



Prepared by the  
most experienced  
(and helpful) people in  
precious metals  
reclamation  
since 1907

**Wildberg Bros.**

349 Oyster Point Blvd.  
South San Francisco, CA 94080  
(415) 588-1120

Write or call

Circle 265 on reader service card

## The biggest problem with your IEEE bus...

So your new equipment conforms to IEEE standards. Great. But your system doesn't work. Not so great. Either your interface or your software isn't compatible. But which one?

Look no further. This is Model 488. The IEEE Bus Monitor/Analyzer from Interface Technology.

It records, analyzes, and controls. It stimulates, calibrates, tests, and verifies. In short, it does the thinking — and the searching — for you.

Call today for a demonstration of this remarkable time saver. Now that you're on the bus, you don't want to miss the boat.

...is finding why  
your bus has a problem.

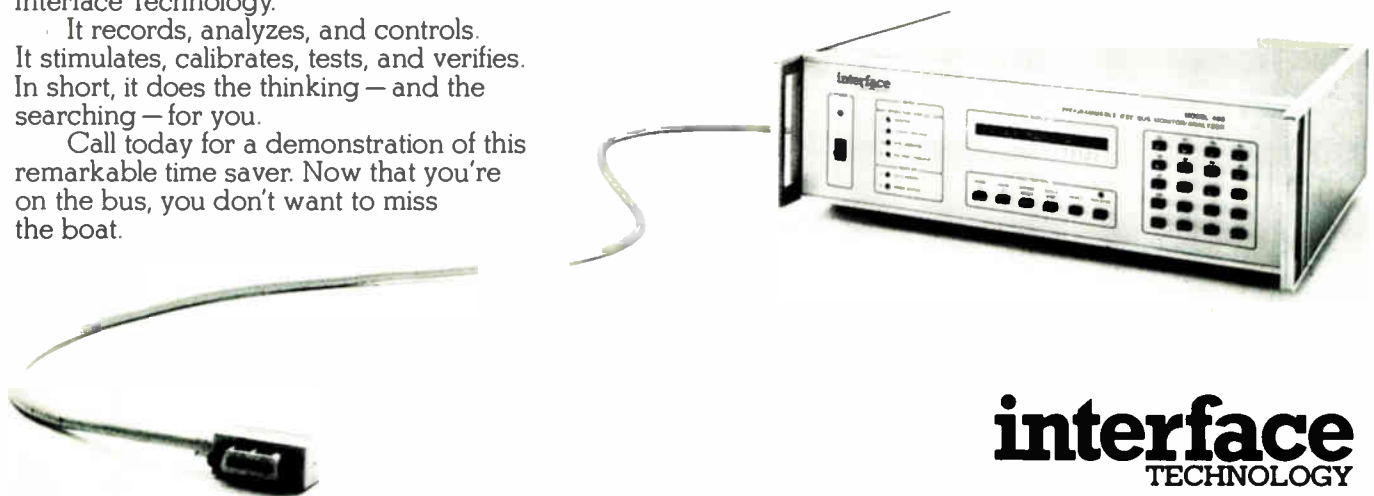

**interface**  
TECHNOLOGY

852 North Cummings Road • Covina, California • (213) 966-1718

238 Circle 266 on reader service card

Electronics / February 15, 1979

# Electronics

## Reader Service

For additional information on products advertised, new products or new literature, use these business reply cards.

Complete entire card.

Please print or type.

Circle the number on the Reader Service postcard that corresponds to the number at the bottom of the advertisement, new product item, or new literature in which you are interested.

To aid the manufacturer in filling your request, please answer the three questions.

All inquiries from outside the U.S. that cannot reach Electronics before the expiration date noted on the Reader Service postcard must be mailed directly to the manufacturer. The manufacturer assumes all responsibilities for responding to inquiries.

### Subscriptions & Renewals

Fill in the subscription card adjoining this card. Electronics will bill you at the address indicated on the card.

## Electronics February 15, 1979 This reader service card expires May 15, 1979

NAME \_\_\_\_\_ TITLE \_\_\_\_\_

PHONE ( \_\_\_\_\_ ) \_\_\_\_\_ COMPANY \_\_\_\_\_

STREET ADDRESS (Company  or home  check one) \_\_\_\_\_

CITY \_\_\_\_\_ STATE \_\_\_\_\_ ZIP \_\_\_\_\_

Was This Magazine Personally Addressed to You?  Yes  No

### Industry classification (check one):

- |  |  |  |
|--|--|--|
| <input type="checkbox"/> Computer & Related Equipment            | <input type="checkbox"/> Test & Measuring Equipment      | <input type="checkbox"/> Independent R&D Organizations |
| <input type="checkbox"/> Communications Equipment & Systems      | <input type="checkbox"/> Consumer Products               | <input type="checkbox"/> Government                    |
| <input type="checkbox"/> Navigation, Guidance or Control Systems | <input type="checkbox"/> Industrial Controls & Equipment |  |
| <input type="checkbox"/> Aerospace, Underseas Ground Support     | <input type="checkbox"/> Components & Subassemblies      |  |

### Your design function (check each letter that applies):

- I do electronic design or development engineering work.  
 I supervise electronic design or development engineering work.  
 I set standards for, or evaluate electronic components, systems and materials.

### Your principal job responsibility (check one)

- Management  
 Engineering

Estimate number of employees (at this location): 1.  under 20 2.  20-99 3.  100-999 4.  over 1000

1 16 31 46	61 76 91 106	121 136 151 166	181 196 211 226	241 256 271 348	363 378 393 408	423 438 453 468	483 498 703 718
2 17 32 47	62 77 92 107	122 137 152 167	182 197 212 227	242 257 272 349	364 379 394 409	424 439 454 469	484 499 704 719
3 18 33 48	63 78 93 108	123 138 153 168	183 198 213 228	243 258 273 350	365 380 395 410	425 440 455 470	485 500 705 720
4 19 34 49	64 79 94 109	124 139 154 169	184 199 214 229	244 259 274 351	366 381 396 411	426 441 456 471	486 501 706 900
5 20 35 50	65 80 95 110	125 140 155 170	185 200 215 230	245 260 275 352	367 382 397 412	427 442 457 472	487 502 707 901
6 21 36 51	66 81 96 111	126 141 156 171	186 201 216 231	246 261 338 353	368 383 398 413	428 443 458 473	488 503 708 902
7 22 37 52	67 82 97 112	127 142 157 172	187 202 217 232	247 262 339 354	369 384 399 414	429 444 459 474	489 504 709 951
8 23 38 53	68 83 98 113	128 143 158 173	188 203 218 233	248 263 340 355	370 385 400 415	430 445 460 475	490 505 710 952
9 24 39 54	69 84 99 114	129 144 159 174	189 204 219 234	249 264 341 356	371 386 401 416	431 446 461 476	491 506 711 953
10 25 40 55	70 85 100 115	130 145 160 175	190 205 220 235	250 265 342 357	372 387 402 417	432 447 462 477	492 507 712 954
11 26 41 56	71 86 101 116	131 146 161 176	191 206 221 236	251 266 343 358	373 388 403 418	433 448 463 478	493 508 713 956
12 27 42 57	72 87 102 117	132 147 162 177	192 207 222 237	252 267 344 359	374 389 404 419	434 449 464 479	494 509 714 957
13 28 43 58	73 88 103 118	133 148 163 178	193 208 223 238	253 268 345 360	375 390 405 420	435 450 465 480	495 510 715 958
14 29 44 59	74 89 104 119	134 149 164 179	194 209 224 239	254 269 346 361	376 391 406 421	436 451 466 481	496 701 716 959
15 30 45 60	75 90 105 120	135 150 165 180	195 210 225 240	255 270 347 362	377 392 407 422	437 452 467 482	497 702 717 960

## Electronics February 15, 1979 This reader service card expires May 15, 1979

NAME \_\_\_\_\_ TITLE \_\_\_\_\_

PHONE ( \_\_\_\_\_ ) \_\_\_\_\_ COMPANY \_\_\_\_\_

STREET ADDRESS (Company  or home  check one) \_\_\_\_\_

CITY \_\_\_\_\_ STATE \_\_\_\_\_ ZIP \_\_\_\_\_

Was This Magazine Personally Addressed to You?  Yes  No

### Industry classification (check one):

- |  |  |  |
|--|--|--|
| <input type="checkbox"/> Computer & Related Equipment            | <input type="checkbox"/> Test & Measuring Equipment      | <input type="checkbox"/> Independent R&D Organizations |
| <input type="checkbox"/> Communications Equipment & Systems      | <input type="checkbox"/> Consumer Products               | <input type="checkbox"/> Government                    |
| <input type="checkbox"/> Navigation, Guidance or Control Systems | <input type="checkbox"/> Industrial Controls & Equipment |  |
| <input type="checkbox"/> Aerospace, Underseas Ground Support     | <input type="checkbox"/> Components & Subassemblies      |  |

### Your design function (check each letter that applies):

- I do electronic design or development engineering work.  
 I supervise electronic design or development engineering work.  
 I set standards for, or evaluate electronic components, systems and materials.

### Your principal job responsibility (check one)

- Management  
 Engineering

Estimate number of employees (at this location): 1.  under 20 2.  20-99 3.  100-999 4.  over 1000

1 16 31 46	61 76 91 106	121 136 151 166	181 196 211 226	241 256 271 348	363 378 393 408	423 438 453 468	483 498 703 718
2 17 32 47	62 77 92 107	122 137 152 167	182 197 212 227	242 257 272 349	364 379 394 409	424 439 454 469	484 499 704 719
3 18 33 48	63 78 93 108	123 138 153 168	183 198 213 228	243 258 273 350	365 380 395 410	425 440 455 470	485 500 705 720
4 19 34 49	64 79 94 109	124 139 154 169	184 199 214 229	244 259 274 351	366 381 396 411	426 441 456 471	486 501 706 900
5 20 35 50	65 80 95 110	125 140 155 170	185 200 215 230	245 260 275 352	367 382 397 412	427 442 457 472	487 502 707 901
6 21 36 51	66 81 96 111	126 141 156 171	186 201 216 231	246 261 338 353	368 383 398 413	428 443 458 473	488 503 708 902
7 22 37 52	67 82 97 112	127 142 157 172	187 202 217 232	247 262 339 354	369 384 399 414	429 444 459 474	489 504 709 951
8 23 38 53	68 83 98 113	128 143 158 173	188 203 218 233	248 263 340 355	370 385 400 415	430 445 460 475	490 505 710 952
9 24 39 54	69 84 99 114	129 144 159 174	189 204 219 234	249 264 341 356	371 386 401 416	431 446 461 476	491 506 711 953
10 25 40 55	70 85 100 115	130 145 160 175	190 205 220 235	250 265 342 357	372 387 402 417	432 447 462 477	492 507 712 954
11 26 41 56	71 86 101 116	131 146 161 176	191 206 221 236	251 266 343 358	373 388 403 418	433 448 463 478	493 508 713 956
12 27 42 57	72 87 102 117	132 147 162 177	192 207 222 237	252 267 344 359	374 389 404 419	434 449 464 479	494 509 714 957
13 28 43 58	73 88 103 118	133 148 163 178	193 208 223 238	253 268 345 360	375 390 405 420	435 450 465 480	495 510 715 958
14 29 44 59	74 89 104 119	134 149 164 179	194 209 224 239	254 269 346 361	376 391 406 421	436 451 466 481	496 701 716 959
15 30 45 60	75 90 105 120	135 150 165 180	195 210 225 240	255 270 347 362	377 392 407 422	437 452 467 482	497 702 717 960

# Electronics Reader Service

If the cards below have already been used,  
you may obtain the needed information  
by writing directly to the manufacturer,  
or by sending your name and address,  
plus the Reader Service number and issue date,  
to Electronics Reader Service Department,  
P.O. Box No. 2530, Clinton, Iowa 52734.

Affix  
Postage  
Here

## Electronics

P.O. Box No. 2530  
Clinton, Iowa 52735

Affix  
Postage  
Here

## Electronics

P.O. Box No. 2530  
Clinton, Iowa 52735



# The leader by any logic!

**S-SYSTEM BY ELECTROMATIC OF DENMARK!** Also includes Logic Relays. Europe's leading maker of electronic plug-in relays are now available in the United States. They out perform all others. *We'll be happy to prove it!*

Distributor Inquiries Invited.



## ELECTROMATIC COMPONENTS LTD.

742 West Algonquin Road  
Arlington Heights, Illinois 60005  
(312) 364-0100 TWX 910-222-3452

Outside the United States, contact your  
Local ELECTROMATIC Sales Office located  
in 43 countries World Wide

Circle 901 on reader service card

**electromatic**  
**S - SYSTEM**  
SL 160 220  
SUPPLY 220 VAC  
LOGIC RELAY  
BISTABLE w. MEMO.  
SINGLE INPUT

RELAY ON

**electromatic**  
**S - SYSTEM**  
SM 155 220  
SUPPLY 220 VAC  
TACHOMETER  
RELAY  
200 - 2000 RPM

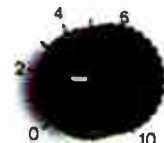

RELAY ON

**electromatic**  
**S - SYSTEM**  
SL 160 220  
SUPPLY 220 VAC  
LOGIC RELAY  
BISTABLE w. MEMO.  
SINGLE INPUT

RELAY ON

**electromatic**  
**STEM**  
220  
VAC  
TIDS  
RELAY

RELAY ON

**electromatic**  
**S - SYSTEM**  
SC 189 220  
SUPPLY 220 VAC  
RECYCLER  
1 - 99 sec.



OFF sec.



ON sec.

RELAY ON

**electromatic**  
**STEM**  
220  
VAC  
PHOTO  
RAY  
ED LIGHT

RELAY ON

**electromatic**  
**STEM**  
95 220  
VAC  
TEMPERATURE  
LEVEL RELAY



RELAY ON

**electromatic**  
**S - SYSTEM**  
SE 110 220  
SUPPLY 220 VAC  
INFRARED PHOTO  
RELAY  
MODULATED LIGHT

RELAY ON

**electromatic**  
**STEM**  
220  
VAC  
RELAY



RELAY ON

**electromatic**  
**- SYSTEM**  
130 220  
VAC  
RELAY  
AND  
S-INPUT

RELAY ON

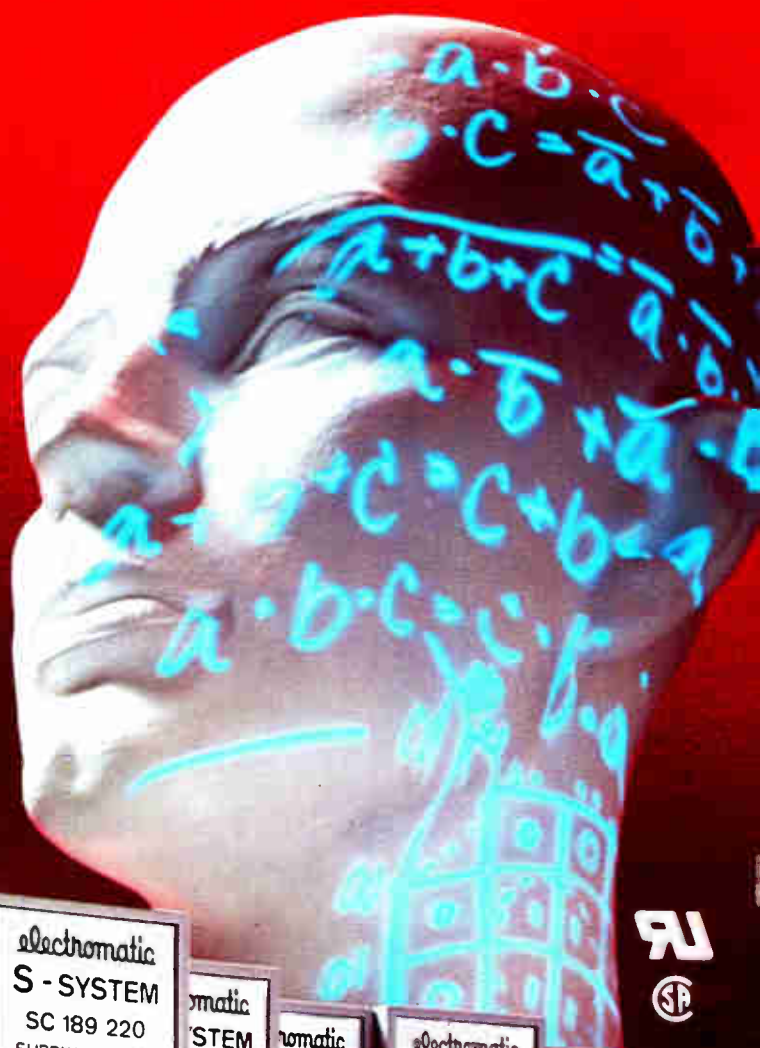

# First in the Industry!

## LEDs with PHOTOCONDUCTORS

### in DIP OPTO-ISOLATORS

Clairex has developed these four LED/photoconductive cell isolators in the conventional dual-in-line package. They are truly an industry first! The inherent slower speed response of a photoconductive cell, as compared to a silicon detector, provides an ideal unit for

noise and transient immunity.

All four units have a photoconductive cell output capability of 250 volts PAC along with an isolation voltage of 1500 PAC. They also feature a minimum  $R_{OFF}$  of one megohm and guaranteed  $R_{ON}$  maximums

at  $I_f$  biases of 16 ma and 1 ma respectively.

The CLM 50 and CLM 51 incorporate a GaP LED with a photoconductive cell for both linear and logic functions. The CLM 60 and CLM 61 feature two GaP LEDs connected in inverse parallel in their input cir-

cuits to facilitate an a-c input signal to the isolator.

For complete details or any other assistance with your opto-electronic problems, call 914-664-6602 or write Clairex®, 560 South Third Avenue, Mount Vernon, New York 10550.

March 1977



### LED- PHOTOCONDUCTOR DIP ISOLATORS

The CLM50 and CLM51 incorporate a GaP LED connected with a photoconductive cell to provide a 1500V photo isolation for both linear and logic functions. The units provide true voltage output capability of 250V PAC, isolation voltage of 1500V PAC and a maximum QFT resistance of 1 Meg. Controlled resistances are featured at 16ma and 1ma respectively. The units are always tested and certified to meet the highest reliability standards possible and meet or exceed all industry specifications.

LED	CHARACTERISTIC	TEST CONDITIONS	Min.	CLM Type	Max.	UNITS
$I_f$ max.	Maximum forward current	$I_f = 16 \text{ mA}$		CLM 50	2.0	mA
$V_f$	Forward voltage	$V_A = 3 \text{ V}$		CLM 51	2.5	Volts
$I_A$	Reverse current			CLM 50	250	microamps
PHOTOCELL $V_{max}$	Cell voltage	25° C		CLM 50	250	Volts DC or PAC
P	Power dissipation	25° C	5W	CLM 51	1.5W	Watts
PHOTOMOD $R_{ON}$	On resistance	$I_f = 16 \text{ mA}$ $I_f = 16 \text{ mA}$	1 Meg	CLM 50	1.5 Meg	ohms
$R_{OFF}$	Off resistance	5 sec. after $I_f = 0$ at 4 VDC on cell	1 Meg	CLM 51	500	ohms
$t_r$	Rise time	Time to 63% of final condition at $I_f = 16 \text{ mA}$	60	CLM 50	100	microseconds
$t_d$	Decay time	Time to 100%	1500	CLM 51	1500	microseconds
$V_{iso}$	Isolation			CLM 50	1500	Volts DC or PAC
$\alpha_{LED}$	LED temperature coefficient	$I_f = 16 \text{ mA}$		CLM 51	1	%/C

**CLAIREX ELECTRONICS**  
A DIVISION OF CLAIREX CORPORATION  
560 South Third Avenue, Mount Vernon, N.Y. 10550 (914) 664-6602

March 1977



### DUAL LED PHOTOCONDUCTOR DIP ISOLATORS

The CLM60 and CLM61 incorporate two GaP LEDs connected in inverse parallel and coupled to a photoconductive cell. They feature 250V PAC input and output. The photoconductive cell output feature 250V PAC, isolation voltage of 1500V PAC, maximum QFT resistance of 1 Meg and minimum  $R_{OFF}$  resistance. Controlled resistances are featured at 16ma and 1ma respectively.

LED	CHARACTERISTIC	TEST CONDITIONS	Min.	CLM Type	Max.	UNITS
$I_f$ max.	Maximum forward current	$I_f = 16 \text{ mA}$		CLM 60	2.0	mA
$V_f$	Forward voltage			CLM 61	2.5	Volts
$I_A$	Reverse current			CLM 60	250	microamps
PHOTOCELL $V_{max}$	Cell voltage	25° C		CLM 61	250	Volts DC or PAC
P	Power dissipation	25° C	7.5W	CLM 60	2W	Watts
PHOTOMOD $R_{ON}$	On resistance	$I_f = 16 \text{ mA}$ $I_f = 16 \text{ mA}$	1 Meg	CLM 61	1.5 Meg	ohms
$R_{OFF}$	Off resistance	5 sec. after $I_f = 0$ at 4 VDC on cell	1 Meg	CLM 60	500	ohms
$t_r$	Rise time	Time to 63% of final condition at $I_f = 16 \text{ mA}$	60	CLM 61	100	microseconds
$t_d$	Decay time	Time to 100%	1500	CLM 60	1500	microseconds
$V_{iso}$	Isolation			CLM 61	1500	Volts DC or PAC
$\alpha_{LED}$	LED temperature coefficient	$I_f = 16 \text{ mA}$		CLM 60	1	%/C

**CLAIREX ELECTRONICS**  
A DIVISION OF CLAIREX CORPORATION  
560 South Third Avenue, Mount Vernon, N.Y. 10550 (914) 664-6602

# CLAIREX ELECTRONICS

A Division of Clairex Corporation  
Circle 902 on reader service card