

Monolithic multipliers for a-c 100

\$1.00 A McGraw-Hill Publication

Low-power design for mini-tv 106

June 8, 1970

Illiack 4 processor turns on this summer 123

# Electronics®



**Silicon on sapphire  
for subnanosecond MOS**

14Z K55956 44R86 02-71  
R KISSLER  
BASIC COMM ELEC  
BOX 956  
MA 02148 98837

# GR knocks down the price of Frequency Synthesizers!

Across-the-board price changes now offer you the chance to pick up just the synthesizer you need at the lowest prices ever!

GR's fully equipped synthesizers (including 7 programmable digits and a continuously adjustable decade) have been reduced by as much as 26%. For instance:

- The 1161 and 1162 Synthesizers, with respective frequency ranges of 0 to 100 kHz and 0 to 1 MHz, are now only \$4990.
- The 1163, with 30-Hz to 12-MHz range, is reduced to \$5290.
- The 1164 (10-kHz to 70-MHz range) is now \$7195.

If you don't need fully equipped models, you can compound the savings by omitting some of the features. You can save \$300 if you have no need for the continuously adjustable decade. Or you can order your synthesizer with as few as three digits – subtract \$230 for each digit you leave out.

These are the same synthesizers you wanted before because of their specifications – now they're even better because economy has been added to quality! Even with the new lower prices you still get a room-temperature quartz-crystal oscillator with a temperature coefficient better than  $2 \times 10^{-7}/^{\circ}\text{C}$ , 200- $\mu\text{s}$  switching time, rms phase-noise modulation as low as -70 dB, spurious signals down 60 dB and beyond, and compact size (only 5½ inches high)! It's a buyer's market!

If you're looking for performance up to 160 MHz without an oversized price tag, GR also has the 1165 Synthesizer for only \$5900.

Complete pricing information and specifications are available from the General Radio District Office nearest you or from our home office at 300 Baker Ave., West Concord, Mass. 01781. In Europe write Postfach 124, CH 8034, Zurich, Switzerland.

Prices apply only in the U.S.A.

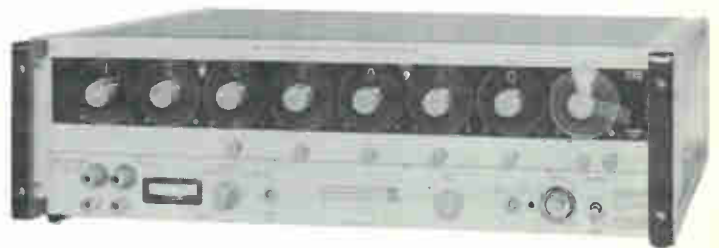

GENERAL RADIO

ATLANTA 404 633 6183 / BOSTON 617 646-0550 / CHICAGO 312 992-0800 / CLEVELAND 216 886-0150  
DALLAS 214 637-2240 / LOS ANGELES 714 540 9830 / NEW YORK (N.Y.) 212 964-2722 (IN NJ) 201 943-3140  
PHILADELPHIA 215 646-8030 / SAN FRANCISCO 415 948-8233 / SEATTLE 206 747-9410 / SYRACUSE 315 454-9323  
WASHINGTON, D.C. 301 881 5333 / TORONTO 416 292-3395 / ZURICH (0511) 47 70 20

Circle 900 on reader service card

# Draw your own conclusions with this new time-share terminal.

Now you can have a time-share terminal that lets you see your data graphically— instantly — as it prints out on your Teletypewriter. Now you can plot for comprehension, for meaningful report illustrations, for permanent records. And do it while the time-share data's coming in.

The HP 7200A Graphic Plotter is the first major advance in time-share flexibility since the Teletypewriter itself. The Graphic Terminal feeds from standard EIA ASCII inputs and automatically plots computer data in points, lines, curves, bar graphs, pie

charts, or any other useful engineering, mathematical or business graphics you need. Plot directly from the Teletype keyboard, too, or silence the Teletypewriter and use the plotter alone. It's the end of the graphic time lag.

The HP 7200A is easy to use and requires no special operating or programming/language knowledge. It plots smooth lines, not the staircase drawn by the incremental recorder. And it lets you position the graph where you want it on any type or size of graph paper up to 11" x 17".

Talk to your time-share service about

Hewlett-Packard's new 7200A Graphic Plotter. If your service doesn't offer it yet, have them give us a call. The Graphic Terminal. For people who can benefit from a dash of art with their cold hard data.

HEWLETT  PACKARD

GRAPHIC RECORDERS

11921

Circle 1 on reader service card

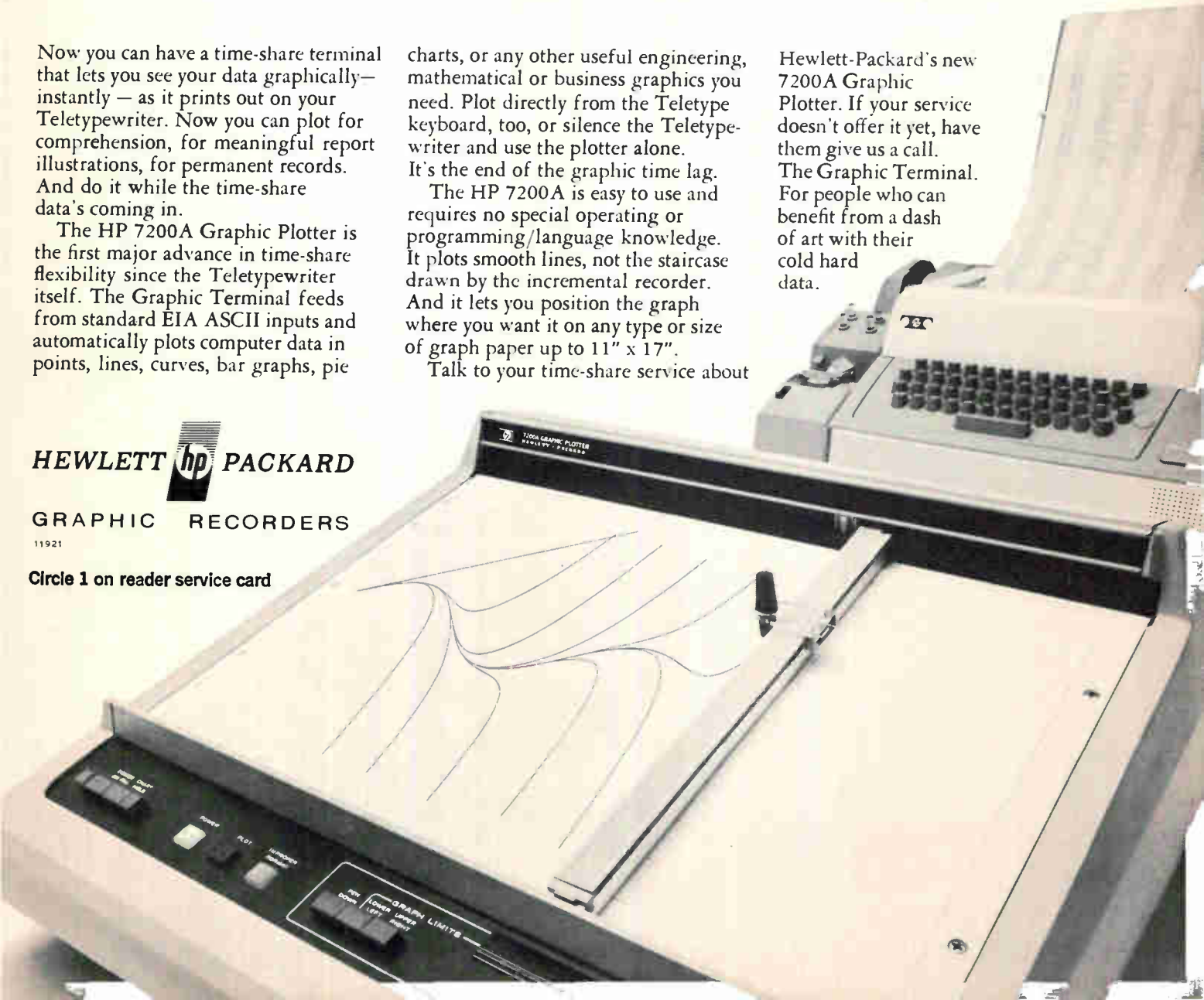





## Don't be a go-between. Let your instruments and computer communicate directly.

You shouldn't have to hand-type data to get your research or production test results processed on a computer. Nor control test conditions manually when the computer could be doing it for you.

Instead, use our new HP 2570A Coupler/Controller. It automatically transfers data from a group of instruments to a central computer or time-sharing terminal — or records on punched tape for off-line processing. *And* it allows the computer to control your test conditions.

Up to seven devices at a time can be interfaced through the 2570A to a central computer or time-sharing

terminal. Plug-in cards for the 2570A mate with measuring instruments like digital voltmeters and counters; with stimuli like voltage sources and frequency synthesizers; and with logging devices like teletypewriters, high-speed tape punches and graphic plotters.

Because the 2570A communicates in ASCII, it can be used with most computers and commercial time-sharing services. Plug-in program cards take care of instrument housekeeping, simplifying your computer program.

Mainframe price for the 2570A Coupler/Controller is only \$1625; interface cards average around \$600 per

device. With this low-cost Coupler/Controller, you can bring all the computing power, memory capacity and sophisticated program library of a large computer to bear, inexpensively, on your research or production test problem. Your local HP field engineer has all the details. Give him a call or write Hewlett-Packard, Palo Alto, California 94304; Europe: 1217 Meyrin-Geneva, Switzerland.

**HEWLETT**  **PACKARD**

DATA ACQUISITION SYSTEMS

06003R



## Features

### Probing the News

- 123 **Computers:** Illiac 4 enters the home stretch  
129 **Data handling:** Digital cassettes overcome their past

### U.S. Reports

- 37 **Displays:** Rand-IBM project yields low-price terminals  
38 **Displays:** Motorola seeks buyers for Totalscope; light-emitting diode has built-in memory  
39 **Advanced technology:** The magnetic-oxide road for bubbles  
40 **Government:** FBI to spend bundle on fingerprints  
42 **Radar:** Predicting volume of rainfall  
42 **Computers:** Voice-response system  
44 **Contracts:** Sanders sues Navy; Draper Lab splits  
47 **Integrated electronics:** GE's threshold detector  
48 **Companies:** The GE-Honeywell merger  
50 **For the record**

### Electronics International

- 61 **Japan:** Crt eliminates need for a-d circuitry in digital applications  
61 **West Germany:** Compressing channels for multilingual tv; laser keeps track of satellites  
63 **International:** Safety standards proposed for appliances  
64 **Great Britain:** Lightweight military speech digitizer

### New Products

- 137 **In the spotlight**  
137 Photo-quality displays widen markets for crt's  
143 **Microwave review**  
143 Design triples magnetron's life  
147 **Components review**  
147 Tiny chips offer high capacitance  
151 **Instruments review**  
151 Detector warns of leakage current  
155 **Data handling review**  
155 Testing for data-cassette errors  
156 Plotter interacts with computer  
158 Digital filter can be multiplexed  
163 **Semiconductor review**  
163 High-voltage MOS drives display  
165 **New materials**

## Articles

- Integrated electronics 82** **Low voltage offers new jobs for MOS commutators**  
Fabrication processes for bipolar compatibility yield 20-Mhz multiplexer switching rates  
Dale Mrazek,  
National Semiconductor Corp.
- Advanced technology 88** **Silicon on sapphire gets together for a comeback**  
Some firms say fabrication wrinkles have been ironed out and see a big market; others disagree  
Electronics' staff
- Circuit design 96** **Designer's casebook**  
▪ Build ring counters with standard MSI  
▪ Telemetry signal conditioner centers its slicing level  
▪ Comparator and a-c coupling provide d-c transformer action
- Solid state 100** **Try the monolithic multiplier for versatile a-c designing**  
Since their circuitry is external, monolithic devices can be tailored to a-c applications that are impractical for potted units  
Edward Renschler and Donald Weiss,  
Motorola Semiconductor Products Inc.
- Consumer electronics 106** **Low-power design is heart of penlight-powered mini-tv**  
IC's, varactor tuning, and a single uhf/vhf antenna yield quality audio and video on just a 5-volt battery power supply  
Reiichi Sasaki and Kyoichi Uno,  
Matsushita Electric Industrial Co.

## Departments

- |    |                          |     |                          |
|----|--------------------------|-----|--------------------------|
| 4  | Readers Comment          | 40  | Index of Activity        |
| 9  | Who's Who in this issue  | 59  | International Newsletter |
| 14 | Who's Who in electronics | 69  | Washington Newsletter    |
| 22 | Meetings                 | 166 | New Books                |
| 33 | Electronics Newsletter   | 167 | Technical Abstracts      |
|    |                          | 169 | New Literature           |

# Electronics

EDITOR-IN-CHIEF: Kemp Anderson

EXECUTIVE EDITOR: Samuel Weber

MANAGING EDITORS: Robert Henkel, News;  
Arthur Erikson, International

SENIOR EDITORS: H. Thomas Maguire,  
Stephen E. Scrupski

ASSOCIATE EDITORS: William Bucci, Richard  
Gundlach, John Johnsrud, Howard Wolff

## DEPARTMENT EDITORS

*Advanced Technology:* Laurence Altman;  
*Communications & Microwave:* Leon M. Magill;  
*Components:* Joseph Mittleman; *Computers:*  
Wallace B. Riley; *Consumer:* Roger Kenneth  
Field; *Industrial Electronics:* Alfred Rosenblatt;  
*Instrumentation:* Owen Doyle; *Military/*  
*Aerospace:* Herman Lowenhar; *New Products:*  
H. Thomas Maguire (Mgr.), William P. O'Brien,  
George Weiss; *Packaging & Production:*  
Stephen E. Scrupski; *Solid State:* George F.  
Watson

COPY EDITORS: William S. Weiss, Chief;  
Edward Flinn

ART: Charles D. Ciatto, Assistant Director

PRODUCTION EDITORS: Susan Huriburt,  
Arthur C. Miller

EDITORIAL RESEARCH: Virginia Mundt

EDITORIAL SECRETARIES: Barbara  
DiBenedetto, Claire Goodlin, Vickie Green,  
Terri O'Neill, Bernice Pawlak, Patricia Ritter

## BUREAUS

*Boston:* James Brinton (Mgr.), Gail Farrell;  
*Los Angeles:* Lawrence Curran (Mgr.), Ralph  
Selph; *New York:* Peter Schuyten; *San*  
*Francisco:* Stephen Wm. Fields (Mgr.), Marilyn  
Howey; *Washington:* Ray Connolly (Mgr.),  
James Hardcastle, Lois Vermillion; *Frankfurt:*  
John Gosch; *London:* Michael Payne; *Paris:*  
Arthur Erikson; *Tokyo:* Charles Cohen

## McGRAW-HILL WORLD NEWS

*Director:* Walter A. Stanbury; *Atlanta:* Fran  
Ridgway; *Chicago:* Robert E. Lee; *Cleveland:*  
Arthur Zimmerman; *Dallas:* Marvin Reid;  
*Detroit:* James Wargo; *Los Angeles:* Michael  
Murphy; *San Francisco:* Margaret Drossel,  
Tyler Marshall; *Seattle:* Ray Bloomberg;  
*Washington:* Charles Gardner, James Canan,  
Herbert W. Cheshire, Seth Payne, Warren  
Burkett, William D. Hickman; *Bonn:* Robert F.  
Ingersoll; *Brussels:* James Smith; *London:*  
Marvin Petal; *Mexico City:* Gerald Parkinson;  
*Milan:* Jack Star; *Moscow:* Axel Krause; *Paris:*  
Robert E. Farrell, Stewart Toy; *Tokyo:* Mike  
Mealey

PUBLISHER: Dan McMillan

ASSISTANT TO THE PUBLISHER: Wallace  
Carmichael

PLANNING & DEVELOPMENT MANAGER:  
Donald Christiansen

ADVERTISING SALES MANAGER: Pierre Braudé

CIRCULATION MANAGER: John D. Drummond

RESEARCH MANAGER: David Strassler

PROMOTION MANAGER: Tomlinson Howland

ADVERTISING SALES SERVICE MANAGER:  
Wallis Clarke

## Readers Comment

### Panic button

To the Editor:

Regarding pollution, the average citizen is starting to say: "Oh if there's a problem, 'they' will do something about it." We of the scientific community are "they," and we are doing next to nothing.

It's time to stand up and take notice that the earth is a dying planet. The cold, hard fact is that in 30 to 50 years all life on earth will cease. This is not hysteria, or the ranting of a soothsayer or religious fanatic. This is the scientific, technological truth. It took man 100 million years to reach a population

of 4 billion. In only 30 years, this figure will double. Things are happening, and the environment is degrading at a rate that leaves little time for deliberation.

Those who fly across the U.S. must have noticed that during the past few years, the pollution in this country has spread from the Atlantic to the Pacific. No longer do you see a yellow cloud over Los Angeles, one over New York, and blue sky in between. The yellow cloud now stretches from Los Angeles to New York and from Chicago to Houston. Even Mexico City, 7,000 feet high in rural Mexico, is densely covered with smog.

What is man going to do to his

(Continued on p. 6)

## Welcome back

Readers will note an important change in the masthead for this issue. Electronics has a new editor-in-chief, Kemp Anderson. Director of editorial training at McGraw-Hill Publications Co. for the last three years, Kemp succeeds Don Christiansen, who assumes new responsibilities in planning and development for the publisher.

Samuel Weber has been named executive editor. Formerly manager of Electronics/Management Center, Sam will be responsible for technical departments. Named managing editors and continuing their present responsibilities are Robert Henkel, for news, and Arthur Erikson, for the international section.

Both Kemp Anderson and Sam Weber return to Electronics with many years of experience behind them. Kemp joined McGraw-Hill in 1957 and served as chief of the Dallas and Los Angeles news bureaus. He was in charge of Electronics' news department from 1964 to 1967. Sam joined Electronics in 1958 and was associate managing editor from 1964 to 1967. After a year as chief editor of Electro-Technology, Sam came back to McGraw-Hill to start the Electronics/Management Center.

It's with great pleasure that we welcome Sam and Kemp back to Electronics.



Publisher

June 8, 1970 Volume No. 43, Number 12  
89,117 copies of this issue printed

Published every other Monday by McGraw-Hill, Inc. Founder: James H. McGraw 1860-1948. Publication office 99 North Broadway, Albany, N.Y. 12202; second class postage paid at Albany, N.Y. and additional mailing offices.

Executive, editorial, circulation and advertising addresses: Electronics, McGraw-Hill Building, 330 W. 42nd Street, New York, N.Y. 10036. Telephone (212) 971-3333. Teletype TWX N.Y. 710-581-4235. Cable address: MCGRAWHILL N.Y.

Subscriptions solicited only from those professionally engaged in electronics technology. Subscription rates: qualified subscribers in the United States and possessions and Canada, \$8.00 one year, \$12.00 two years, \$16.00 three years; all other countries \$25.00 one year. Non-qualified subscribers in the U.S. and possessions and Canada, \$25.00 one year; all other countries \$50.00. Air freight service to Japan \$50.00 one year. Single copies: United States and possessions and Canada, \$1.00; all other countries, \$1.75. Officers of McGraw-Hill Publications Company: Joseph

H. Allen, President; John R. Emery, J. Elton Tuohig, Senior Vice Presidents; Donald B. Gridley, Group Vice President; Vice Presidents: John R. Callahan, Editorial; John M. Holden, Marketing; David G. Jensen, Manufacturing; Jerome D. Luntz, Planning & Development; Robert F. Marshall, Administration; Robert M. Wilhelm, Finance; Director of Circulation: Ralph Blackburn. Officers of the Corporation: Shelton Fisher, President and Chief Executive Officer; John J. Cooke, Senior Vice President and Secretary; Gordon W. McKinley, Vice President and Treasurer.

Title © registered in U.S. Patent Office; © Copyright 1970 by McGraw-Hill, Inc. All rights reserved. The contents of this publication may not be reproduced either in whole or in part without the consent of copyright owner.

Subscribers: The publisher, upon written request to our New York office from any subscriber, agrees to refund that part of the subscription price applying to copies not yet mailed. Please send change of address notices or complaints to Fulfillment Manager; subscription orders to Circulation Manager; Electronics at address below. Change of address notices should provide old as well as new address, including postal zip code number. If possible, attach address label from recent issue. Allow one month for change to become effective.

Postmaster: Please send form 3579 to Fulfillment Manager, Electronics, P.O. Box 430, Hightstown, N.J. 08520.

# New, Rugged 5kW Magnetron for Microwave Heating

This F 1123 Magnetron tube is a microwave source specially designed for industrial heating. It delivers a typical CW power of 5 kW at a fixed frequency between 2430 and 2470 MHz. The output connector doesn't require cooling and allows easy coupling to the wave guide RG 112/U or coaxial 1½". The tube, which features an impregnated-type cathode, utilizes only a small amount of filament power. It is usually built with an integral magnet, but may be fitted with an electromagnet for particular requirements.

Magnetron tubes used in microwave heating offer the advantages of speed, even heating, con-

trollability and efficiency. Today they are being increasingly used for moisture removal, chemical changes, and biological changes in a growing number of industrial processes. For complete information write or call your nearest Cain & Company representative, or contact us directly.

## TYPICAL OPERATION

Heater voltage (V) .....	0
Cathode voltage (kV) .....	5.2
Cathode current	
— Average current (A) .....	1.5
— Peak current (A) .....	3.2
Power output (kW) .....	5.0
Efficiency (%) .....	65
VSWR .....	1.1

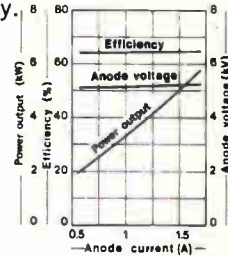

**THOMSON-CSF**

Thomson-CSF Electron Tubes, Inc./50 Rockefeller Plaza/New York, N.Y./10020 (212) 245-3900

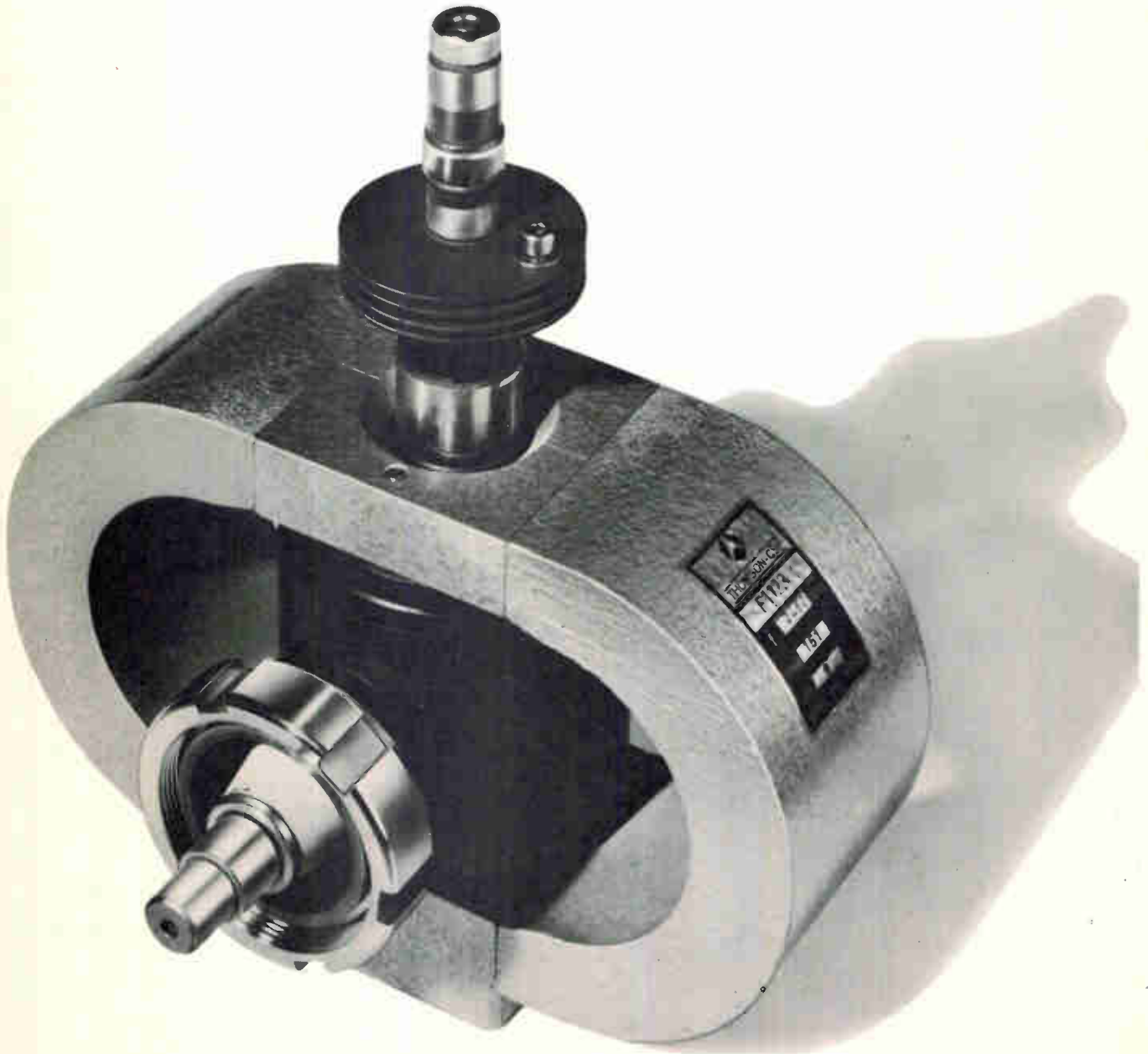



# JOSLYN'S SURE CURE FOR SWELLING CURRENT



It comes as a single unit (a spark gap) or packaged with other exclusive properties. Either way, Joslyn's cure for swelling current (surge) is nanosecond quick, long lasting, and is sure to work. Again and again and again! True, your more devastating surges might possibly perhaps destroy a Joslyn protector. But your electronics will still go on working\*. Over ten years of field use says so.

Don't experiment with other means when you can't afford a failure! For positive protection, Joslyn has the answer. Write or call today for facts on how to solve your protection problem for swelling current.

\*when protector is properly selected and connected

*When you can't afford a failure . . .*



## JOSLYN

### ELECTRONIC SYSTEMS

Joslyn Electronic Systems  Santa Barbara Research Park   
P.O. Box 817  Goleta, Calif. 93017  Tel. (805) 968-3551

1906

## Readers Comment

environment during this time of rapid technological growth? It seems that as man approaches the apex of his knowledge and is about to reach out and contact other planets, he finds his environment rapidly disintegrating into a quagmire of pollution, slime, and waste. This negative aspect completely cancels his technological thrust.

What we should do, drastic as it may sound, is limit the population of the United States to 200 million, and that of the world to 4 billion; tax people in proportion to the number of children they have; and initiate laws that will keep life sacred.

We must immediately assign space, automotive, military, industrial, and educational teams to the problem of limiting population and controlling the waste produced by dense population.

Evidently, man's time on earth is limited, regardless of what we do. The question is, are we going to allow life to perish in 35 years, or are we going to use all our technological knowhow to prolong this time by 500 or 1,000 years.

Eugene Frank

President,  
B&F Instruments Inc.  
Cornwells Heights, Pa.

## Laser talk

To the Editor:

Suggestions are again being made to use laser beams for free space communications despite the menace to eye tissues. Users would obviously be tempted to raise power levels during poor visibility despite the hazards. Even scattered laser beams can be dangerous.

The generally more sensible application of millimetric microwaves is conspicuously ignored in most articles printed about laser communications. Apparently, the public needs protection from the glamorization of the laser in more ways than one, and nothing short of a counter-propaganda campaign will nullify the misleading publicity.

M.J. Lazarus

Department of Physics  
University of Lancaster  
England

**For proven performance...small size...moderate cost...**

## order METFILM<sup>®</sup> 'E' ORANGE DROP<sup>®</sup> CAPACITORS

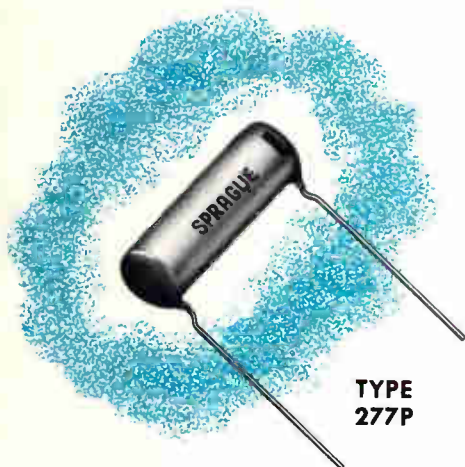

TYPE  
277P

INFORMATION RETRIEVAL NO. 515

- Space-saving metallized PETP polyester-film capacitors with excellent capacitance stability, high insulation resistance
- Capacitor sections assembled under controlled atmospheric conditions and protected against moisture by a wax-free conformal coating of epoxy
- Radial leads, straight or crimped, for mounting on printed wiring boards
- Voltage ratings, 100 thru 600 volts d-c
- Operating temperature range, -55 C to +85 C
- Request Engineering Bulletin 2040

4SC-9159R1

**Buy resistors with built-in dependability...**

## Vitreous-enamel BLUE JACKET<sup>®</sup> POWER WIREWOUND RESISTORS

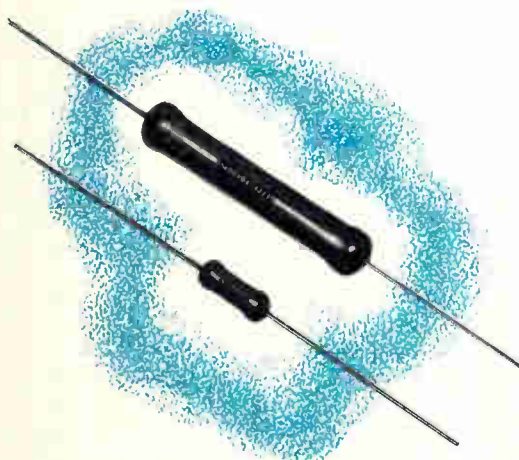

INFORMATION RETRIEVAL NO. 516

For Engineering Bulletins as noted above, write to:  
Technical Literature Service, Sprague Electric Co., 35  
Marshall Street, North Adams, Massachusetts 01247.

- All-welded end-cap construction eliminates moisture along leads, also anchors leads securely to resistor body
- Expansion coefficients of vitreous coating, ceramic core, and end caps are closely matched
- Standard wattage ratings include 1, 2, 2.5, 3, 5, 7, 10, and 11 watts
- Also available with radial tab terminals in ratings from 8 to 230 watts
- Request Engineering Bulletin 7410D

4SR-9145R2

**THE BROAD-LINE PRODUCER OF ELECTRONIC PARTS**



\*Sprague' and '®' are registered trademarks of the Sprague Electric Co.



# NEW!

Is 0 x 0 really zero in your multiplier?

## Accurate Analog Computing with Magnetic Multipliers

Product Accuracy

1%  
Absolute

Flat Pak magnetic modulators, analog multipliers, demodulators mount directly on IC cards.

- Flat Pak design only 0.1" thick
- Zero Hysteresis
- No external pots

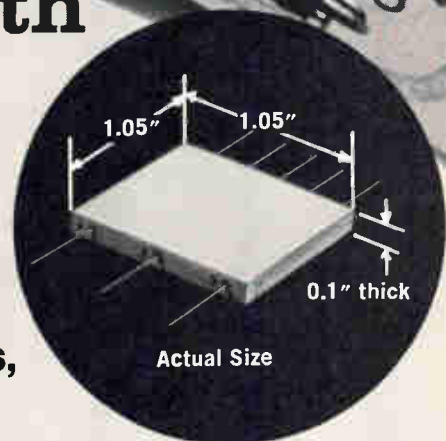

Product accuracy 1% absolute or 2 MV whichever is greater over the temperature range of -55°C to +125°C

- Hybrid assemblies mount directly on IC cards.
- Space saver design, typical dim. 0.1" thick x 1.0" x 0.75".
- Rugged design, extreme reliability. MTBF design goal 0.25 per million hours.
- Extremely low drift over -55° to +125°C range.
- Not affected by high intensity nuclear radiation.
- No external nulling or offset adjustments.
- No additional components or temperature compensation required.
- No external operational amplifiers required.
- ± 15 V DC power supply unless otherwise specified.
- Linearity: Better than 1% absolute or 2MV whichever is greater.
- Analog Multiplying Functions:

$$\begin{aligned} \pm DC \times \pm AC &= AC \\ \pm DC \times \pm DC &= \pm DC \\ AC \times AC &= AC \\ \pm DC \times AC &= \pm DC \\ AC \times AC &= \pm DC \end{aligned}$$

### MAGNETIC MULTIPLIERS

Dynamic Product Range

80 db

### Magnetic Modulators

Dynamic Range:

60 db

As an Analog Multiplier of a Bipolar DC signal times an AC signal, the output **product accuracy** is 1% of point, or 2 MV, whichever is greater over a dynamic range of 10,000:1 in each quadrant.

Parameters over the temperature range of -55°C to +125°C :

- 1) Product accuracy 1% of point or 2 MV whichever is greater
- 2) Zero Point Drift: ... Less than 2 MV of in phase component
- 3) Gain Slope Stability: ..... Less than 2% change
- 4) Dynamic range and output wave quality independent of temperature variations
- 5) Distortion: ..... Less than 1%

Typical input/output parameters:

X Signal: ..... 0 to ±5V  
Y Signal: ..... 0 to ±5V  
Output: ..... 0 to 5V RMS across 5KΩ or greater

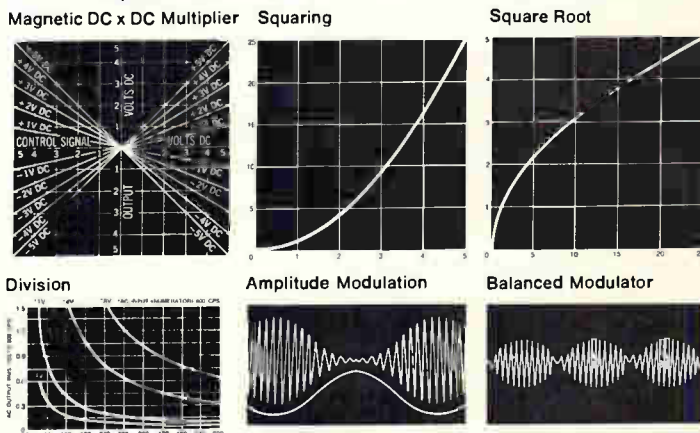

There is No Substitute for Reliability  
**GENERAL MAGNETICS, INC.**

135 Bloomfield Avenue, Bloomfield, New Jersey 07003



# Who's Who in this issue

**Innovative designs** often result from a meeting of engineering minds. In the case of the article on the mini tv that starts on page 106, the minds belong to authors Reiichi Sasaki and Kyoichi Uno. Sasaki received a degree from Tohoku University in 1953. Since 1955 he's been with the Matsushita Co.'s Wireless Research Lab, where he's now assistant manager of the television development department. Uno obtained his degree from Kyushu University. He's worked on development of tv receivers at Matsushita, and is assistant manager of the television division's technical department.



Sasaki

Uno



Renschler

**Motorola men** Ed Renschler and Don Weiss are the authors of the article on monolithic multipliers that begins on page 100. Renschler holds BSE and MSE degrees from Arizona State University, and is working toward a Ph.D. He's a technical staffer at Motorola's IC Applications Research Lab, and formerly headed the linear IC applications group. Weiss is a BSEE graduate of the University of Illinois. He joined Motorola last year, and works in linear IC applications.



Weiss

**An international network** of *Electronics* and McGraw-Hill editors was responsible for reporting the article on silicon-on-sapphire technology that starts on page 88. The overseas inputs came from Charles Cohen in Tokyo, James Smith in Brussels, Stewart Toy in Paris, Michael Payne in London, and John Gosch in Frankfurt. *Electronics'* staffers Stephen Wm. Fields, Ralph Selph, Peter Schuyten, Richard Gundlach, and Robert Henkel contributed information gathered from sources across the United States. The package was tied together by George Watson.

**Design and application** has been Dale Mrazek's specialty for a number of years. A BSEE graduate from the University of Denver, Mrazek, author of the article on MOS commutators that begins on page 82, spent six years as a design and applications engineer at various semiconductor and systems manufacturers. He's now a digital applications engineer at the National Semiconductor Corp. in Santa Clara, Calif. His present work includes MOS memory products, read-only memories, analog switches, and organization of advanced products.



Mrazek

# National does it

## and

## and

## and

Every time someone improves on one of our monolithic linear circuits, it turns out to be us. Specs on commercial versions are unbelievable. Write for data. National Semiconductor Corporation, 2900 Semiconductor Drive, Santa Clara, California 95051. Phone (408) 732-5000, TWX 910-339-9240, Telex 346-353.

# again

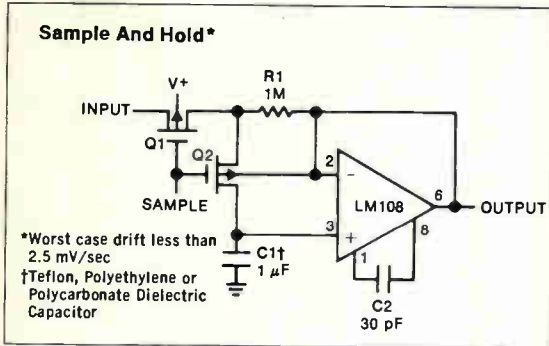

## LM108 Op Amp

From the inventor of the super-gain transistor—the ultimate Op Amp. Maximum bias current 3nA; max. offset current 400pA over  $-55^{\circ}\text{C}$  to  $+125^{\circ}\text{C}$  temperature range. Max. offset voltage of 0.5mV and  $5\mu\text{V}/^{\circ}\text{C}$  drift also available. Operates from  $\pm 2\text{V}$  to  $\pm 20\text{V}$  supplies, drawing only 300nA. Useful in high impedance circuits or in analog memories.

**\$60.00 in hundred up quantities.**  
**\$10.00 for the commercial LM308.**

# again

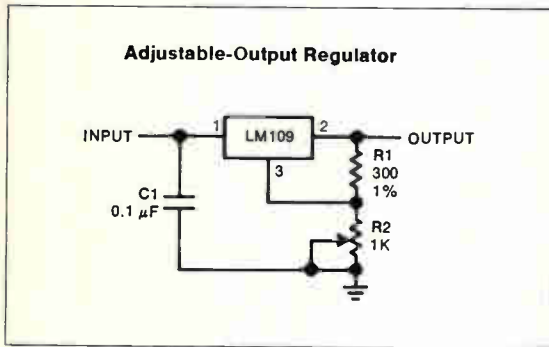

## LM109 Regulator

Simple as one, two, three. Just hook the input to the unregulated supply, the output to the load and the ground to ground. This 3 lead device gives output currents over 1A. And thermal overload protection makes it virtually blow-out proof. Prime function is a 5V on-card regulator for digital logic, but it can be adjusted for higher voltages.

**\$20.00 for TO-5, 200mA, \$25.00 for TO-3, 1A. Prices for commercial parts \$5.50 and \$6.50. Hundred up prices.**

# again

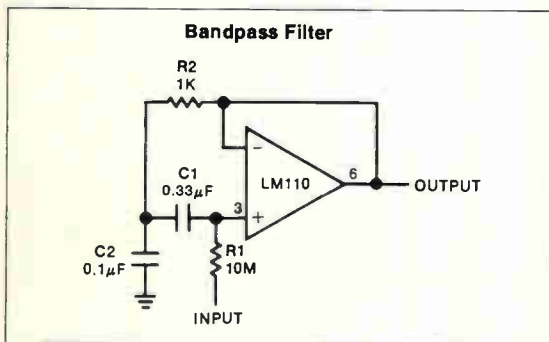

## LM110 Follower

Uses super-gain transistors to get 20MHz bandwidth and  $30\text{V}/\mu\text{s}$  slew in a follower with 10nA maximum bias current. Plug in replacement for most popular Op Amps in follower applications. Ideal as fast, high impedance buffer or inactive filters.

**\$10.00 in hundred up quantities.**  
**Commercial LM310 \$3.25.**

# again

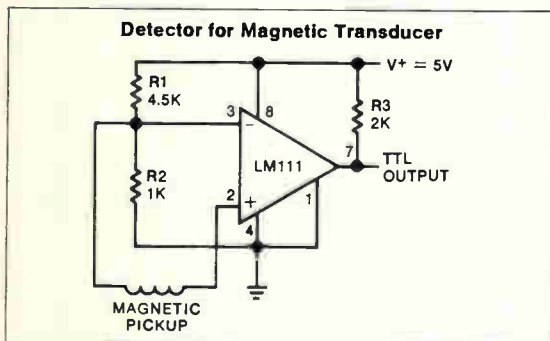

## LM111 Voltage Comparator

First truly universal IC comparator. Works with  $\pm 15\text{V}$  Op Amp supplies or even a single 5V logic supply. Output will drive RTL, DTL, TTL or MOS logic. It will handle lamps or relays up to 50V at 50mA. Max. bias current of 100nA and off-set current of 20nA are decades lower than previous IC's. Plugs into 710 socket.

**At \$12.00 in hundred quantities, it's beyond comparison. LM310 commercial part \$3.25.**

**National/Linear**



# RADIATION ANNOUNCES

a "do-it-yourself"

# BIPOLAR ROM

**512 bits (64 x 8)**

**65 ns access time**

**0° to +75°C, \$47.00\***

**-55° to +125°C, \$61.50\***

**\* 100 — 999 unit price**

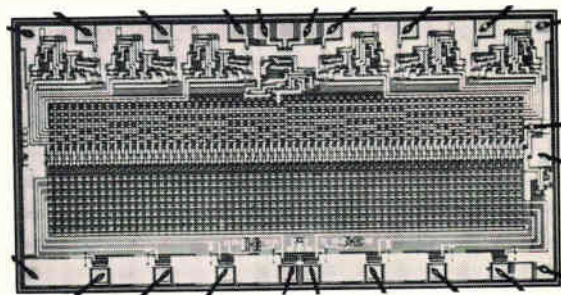

# ONE PROM\* FOR ALL ROMS

\*(Programmable Read-Only Memory)

**It's made for a complete range of applications:**

- Microprogramming
- Combinational Logic
- Sequential Logic
- Code Conversion

**...or any application requiring many ROMS of differing patterns.**

## ***HERE'S HOW YOU GET IT!***

1. Order the ROM-0512 off the shelf.
2. Generate the truth table.
3. Electronically program each PROM, yourself.
4. Plug it in!

## ***HERE'S WHAT YOU GET!***

- Custom programmed ROMS
- 65 ns access time
- DTL/TTL compatibility
- Wired "or" output
- 24-lead dual in-line or 24 lead flat pack

***...And we haven't even scratched the surface!***

Lexington, Massachusetts (617) 862-1055  
Norwalk, Connecticut (203) 853-3848  
Frederick, Maryland (301) 862-5400  
Oaklawn, Illinois (312) 423-8010  
Dallas, Texas (214) 231-9031  
Albuquerque, New Mexico (505) 268-3549  
Palo Alto, California (415) 321-2280  
Long Beach, California (213) 426-7687  
P. D. Box 37, Melbourne, Florida 32901 (305) 727-5430

EXPORT SALES, DAGE CORPORATION, STAMFORD, CONNECTICUT

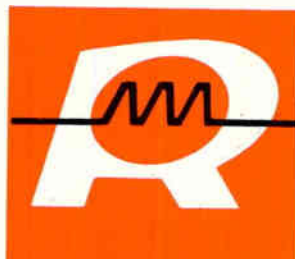

**RADIATION**  
INCORPORATED  
SUBSIDIARY OF HARRIS-INTERTYPE CORPORATION  
MICROELECTRONICS DIVISION

Copyright © 1970 By Radiation, Incorporated

# FREE Engineering Handbook on Electromagnetic Delay Lines

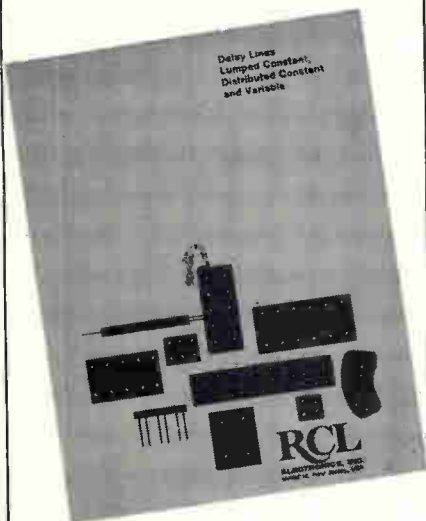

**We've reserved  
a copy  
for your desk . . .**

Terms . . . engineering definitions . . . how to specify delay lines . . . characteristics of various types . . . specifications . . . they're all included in this concise, easy-to-read handbook . . . yours for the asking.

**LUMPED CONSTANT ...  
DISTRIBUTED CONSTANT  
... VARIABLE**  
all three types are covered  
in this reference  
handbook.

# RCL

**RCL ELECTRONICS, Inc.,**

General Sales Office:

Seven Hundred  
South Twenty First Street  
Irvington, New Jersey 07111

## Who's Who in electronics

"We believe that we have a novel approach and we're going to apply it to an untapped market." So says George Larse, president of the Larse Corp. in Palo Alto, Calif. The market is the industrial automation field; the approach is MOS large-scale integration. "Most MOS/LSI products in the world today are for the computer industry; we intend to ignore this market and concentrate in areas that are essentially devoid of this technology."

The industrial automation field includes process control, traffic control, and system monitoring. And the market is untapped, says Larse, because "the big semiconductor houses don't have the application engineering knowledge for the industrial control market; they lack the detailed knowledge of end user requirements. The industrial people themselves have hesitated in going to the semiconductor houses because they are aware that their volume requirements are small compared to the computer industry and, thus, the cost would be very high. And they have difficulty acquiring skilled MOS designers because the designers are scarce. We got them because of our product plan and our incentive plan."

**Braintrust.** What Larse has done is assemble a group of people who know the market and who know how to design MOS/LSI circuits. Larse himself has about 19 years' experience in the aerospace industry. Most recently he was manager of an advanced military space program where he was responsible for the design, production, and operation of "highly complex spacecraft, ground checkout, and launch facilities, and large-scale computer data processing system."

The other founders include Richard Kunkle, vice president, who was a consultant on projects including large-scale automated security monitoring systems (Larse's second product area), data acquisition, and process control; Daniel Lubarsky, product development manager, who has designed systems for data acquisition, telemetry, and security, and was responsible for the development of an

automatic voice-channel selection system for the Federal Bureau of Investigation; and Robert Scott Jr.

So far the team has designed and built the first two system building blocks—a 16-bit scanner-encoder-transmitter dubbed SENT, and a 16-bit receiver-decoder called REDE. Each of these is an MOS chip—Larse's philosophy is that you must put as much on a chip as possible.

**Blocks.** But he is quick to point out that the Larse Corp. is not going to be a semiconductor—or a systems maker; "We are going to supply building blocks that will offer cost and performance advantages over present equipment." As an example, Larse points to the SENT. "Our MOS/LSI unit draws under 100 milliwatts, but the breadboard, which was made up of digital IC's, drew over 30 watts—we have an optimum design."

Larse says that because the chips were designed to be building blocks, they incorporate many features and offer many options not always used in each system, such as the choice of output modes: frequency shift keying, frequency keying (a-m), or d-c. "We did this," Larse says, "because we want to use the same chip in as many applications as possible."

**Can a man** who's made it as a major general in the U.S. Air Force cut it in a competitive industrial society? For John L. Martin the answer so far is yes. It will be definitely yes if the Federal Aviation Administration and the world's airlines can be sold on his bird—the Communications Satellite Corp.'s Aeronautical Services Satellite. After four years of effort, Comsat believes its recent proposal of a synchronous satellite for transoceanic air traffic communications, control, and navigation will meet the carriers' requirements. And the satellite is known informally as John Martin's bird—a pseudonym honoring the special assistant to Comsat president Joseph Charyk.

Comsat's first Aerosat proposal



# Even in power supplies, somebody makes progress once in a while. This is the new NIMS high voltage power supply.



## It's a Fluke.

Fluke's new NIMS (nuclear instrument module system) high voltage power supply is priced about the same as the three major competitors, \$460. That's where the similarity ends.

In every other pertinent spec, the new Fluke 423A exceeds or at the very least meets the competition. And, in addition, it offers some exclusive features all its own. Let's go down the list. Only Fluke offers a full 0 to 3000 volts, line and load regulation of 0.001 and 0.002 percent across the board. Only Fluke offers portable bench case or NIMS bin module. Only Fluke offers remote analog slewing of the output or manual operation. Only Fluke offers a current limit of 15 ma. Other specifications are output current, 0 to 10 ma, Resolution, 100 mv. Accuracy, 0.25%. Ripple and noise, 5 mv peak-to-peak (10 Hz to 1 Mhz). Polarity is reversible at the rear panel. Size is 2.7" x 8.7" x 9.7". Price with case is \$495.

For full details, see your Fluke sales engineers or contact us directly.



Fluke, Box 7428, Seattle, Washington 98133. Phone: (206) 774-2211.  
TWX: 910-449-2850. In Europe, address Fluke Nederland (N.V.), P.O. Box 5053,  
Tilburg, Holland. Phone: (04250) 70130. Telex: 884-50237. In the U.K., address  
Fluke International Corp., Garnett Close, Watford, WD2 4TT.  
Phone: Watford, 27769. Telex: 934583.

# THE VS-80 Sweep generator ALL SOLID- STATE

## TECHNICAL LEADERSHIP IS STATE-OF-THE-ART SOPHIS- TICATION & PERFORMANCE

Test capabilities usually available only through the use of two or more instruments are yours in the Texscan VS-80. It covers all normal IF bands, and FM, VHF TV, UHF TV, and most communication bands . . . can be used for radar and communications RF, IF, and video testing, also as a chirp radar simulator and for wide band amplifier testing. VS-80 is available in a ruggedized model that meets MIL-T-21200F, as

well as in the popular laboratory/field model. Write for free descriptive literature with complete technical details.



RUGGEDIZED UNIT

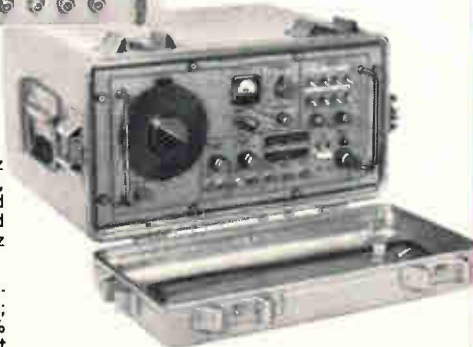

### key specifications

#### LABORATORY UNIT

**Frequency Range:** 1 MHz to 1200 MHz in two overlapping, switchable bands, 1-300 and 290-1200. Can be centered on any frequency between 1 MHz and 1000 MHz and sweep up to 1200 MHz at maximum sweep.

**Sweep Width:** On the low band, continuously variable from 50 kHz to 300 MHz; on the high band, can be varied to 40% at 1000 MHz. Unit also has CW output mode for signal generator applications.

**RF Output:** Rated at least 0.5 vrms into a 50-ohm load.

**Operating Temperature:** Continuous  $-20$  to  $+55^{\circ}\text{C}$ ; intermittent to  $+71^{\circ}\text{C}$ .

**Shock:** 20 G's, 3 shocks along each of 3 mutually perpendicular axes.

**EMI:** IAW Mil-Std-826A, notice 1, class Gp.

**Reliability:** 500 hours MTBF IAW Mil-Std-781A, Test level E except lower temperature  $-20^{\circ}\text{C}$ .

**Maintainability:** IAW Mil-Std-470 & 471.

#### PRICE AND DELIVERY

Model VS-80 \$1550.00

Model VS-80 DH \$3050.00 (Combination Case)

Delivery is within four weeks maximum; in some cases models and accessories are available from stock.



*Texscan* CORPORATION

2446 NORTH SHADELAND AVENUE

INDIANAPOLIS, INDIANA 46219

Phone 317-357-8781—TWX: 810-341-3184

## Who's Who in electronics

in 1966 was not made public. It called for a pilot program with one vhf satellite over the Atlantic Ocean. Martin says the reason the proposal and a similar one last year were shelved was that they got bogged down in the question of future aircraft conversion to uhf communications. The Atlantic-Pacific satellite system now under consideration at the Department of Transportation will operate on vhf, with uhf capability for FAA experiments. If the proposal is accepted, development time will be 28 months. Comsat plans to run the satellite for five years, charging users a flat monthly fee for use, with no development cost to the Government or the airlines, says Martin.

**Hit and run.** Recalling a case a year or more ago, Martin says an air traffic controller found, in plotting the courses of two overseas airliners, that they would be at the same spot over the ocean at the same time—and couldn't raise either pilot from land. That time it didn't spell disaster, but it does spell out some "very important needs," says Martin. "We don't think we should wait while we have the technical capability." While he can't guarantee this latest proposal won't end up in a file drawer at the Transportation Department, he is "sure the program is going to go—it's a question of when."

Martin, who looks much younger than his 50 years, has been working with satellites for the last 11 years, the last five as director of special projects for the Air Force Space and Missile Systems Organization (Samsco), and previously as director of the Pentagon's Office of Space Systems. How does he feel about being able to talk about his satellites? "It's quite a change," understates Martin.

After service in the Army Air Corps during World War II, Martin received a BSAE from the Brooklyn Polytechnic Institute, and an MSEE from MIT. He was in the Air Force for almost 30 years—"29 years, six months and four days, as I recall"—and is looking forward to a "full second career" in domestic satellites.

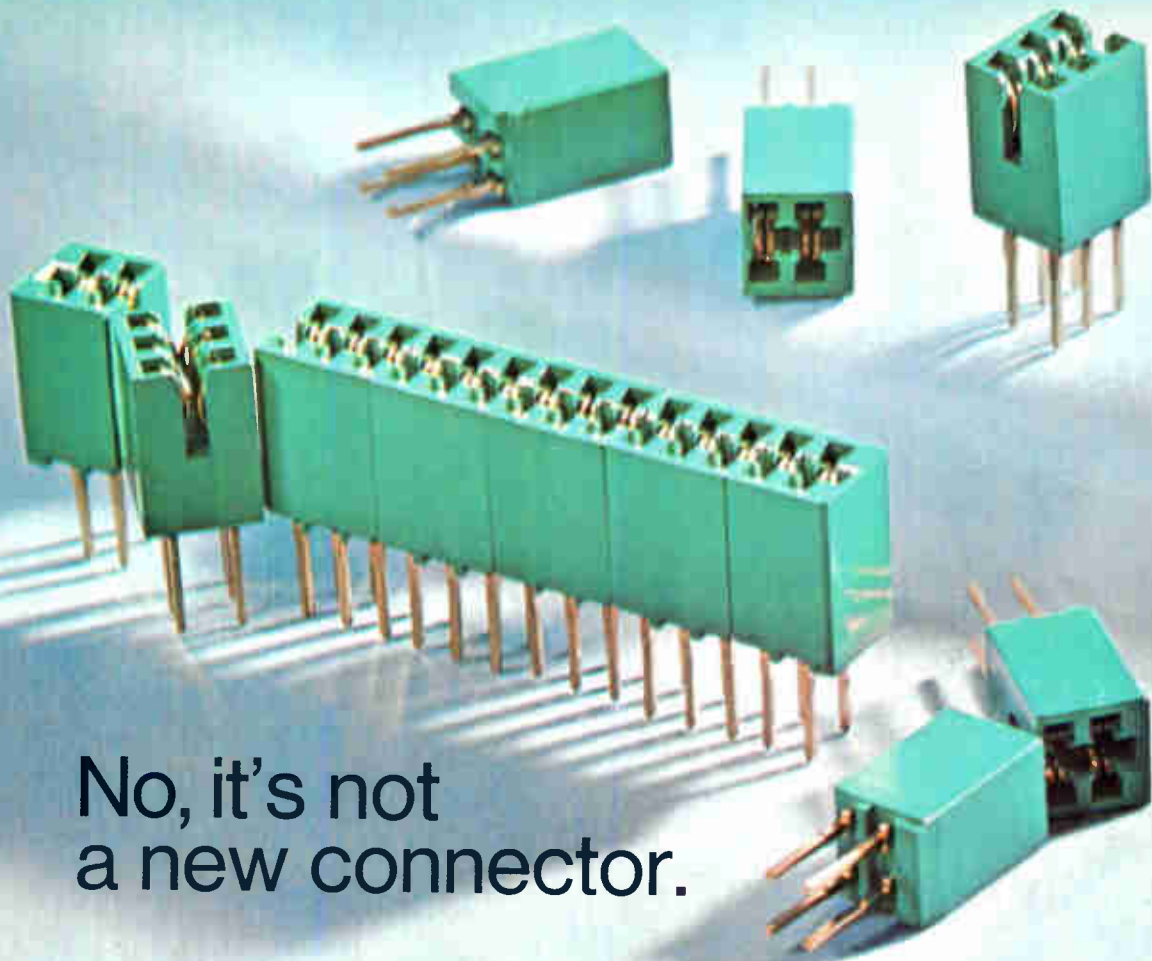

No, it's not  
a new connector.

It's a new kind of connecting.

The little connectors above are really one connector. You take as many pieces as you need, mix them together, and use them to connect any size of p.c. board to a mother board.

That's not spectacularly new. Connector modules for use in bread-boarding have been around for a while.

But these new Mojo™ Series 6308 p.c. connector modules\* are not just for bread-boards and prototypes.

Not hardly.

When used with plated-through holes on the mother board, they are one of the slickest production tricks to come along in quite a while. Contact tails combine a square wire-wrapping post with a specially designed locking feature which, when press-fitted into a plated-through hole, provides a gas-tight and reliable electrical connection.

No, you don't have to solder.

Yes, you can wire-wrap if you want.

And, yes, you'll save time and money in moving from prototype into production. Because connectors

of virtually any size can be built up economically from just two sizes of modules, you don't need a large inventory. Or custom connectors. And you only have to insert modules where connectors are required, saving a few more pennies.

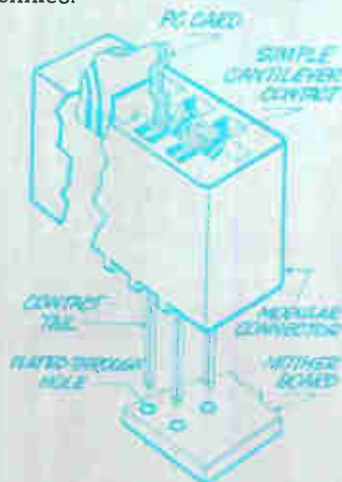

And, no, you don't give up a bit of connector reliability. The exclusive swaged single-beam design of the dual-readout contact provides optimum spring rate and deflection characteristics. A preload applied

to the contact nose in the insulator makes sure that the contact really holds on to the card, while keeping the contacts well apart when the card is removed from the connector.

Mojo™ p.c. connector modules:  
Specs in brief

**Material**

Glass-filled DAP

**Contacts**

Cantilevered-beam, dual read-out, bifurcated nose. .150" centers. Center modules have 6 contacts. End modules have 4 contacts, molded-in card guide.

**Tails**

.031" square wire-wrapping type

**Mounting**

Press fit, in .048" dia. plated-through holes, 3/32" to 1/8" thick board.

For more information, write, wire, call, or TWX us for our Mojo™ p.c. connector module data sheet. Elco Corporation, Willow Grove, Pa. 19090. 215-659-7000; TWX 510-665-5573.

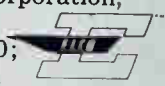



# To make a Register that does a lot more than shift,



Fairchild's 9300 is the world's most versatile shift register. And we can prove it. The 9300 Four-bit Universal Register can perform as a high-speed shift register, modulo N counter, up/down counter, storage element, four clocked D-type latches, a programmable divider, a binary to BCD shift converter,

serial to parallel converter (and vice versa), and a dozen other functions. It's a prime example of the kind of versatility inherent in Fairchild's entire MSI family.

Other features which help make the 9300 the fastest-selling register on the market include a 20MHz shift frequency, J and  $\bar{K}$  inputs (which, tied together, provide D-type input), gated synchronous parallel inputs, Q and  $\bar{Q}$  outputs.

The 9300 is completely compatible with all Fairchild MSI elements. It comes in a 16-lead hermetic DIP and Flatpak in both military and industrial temperature ranges.

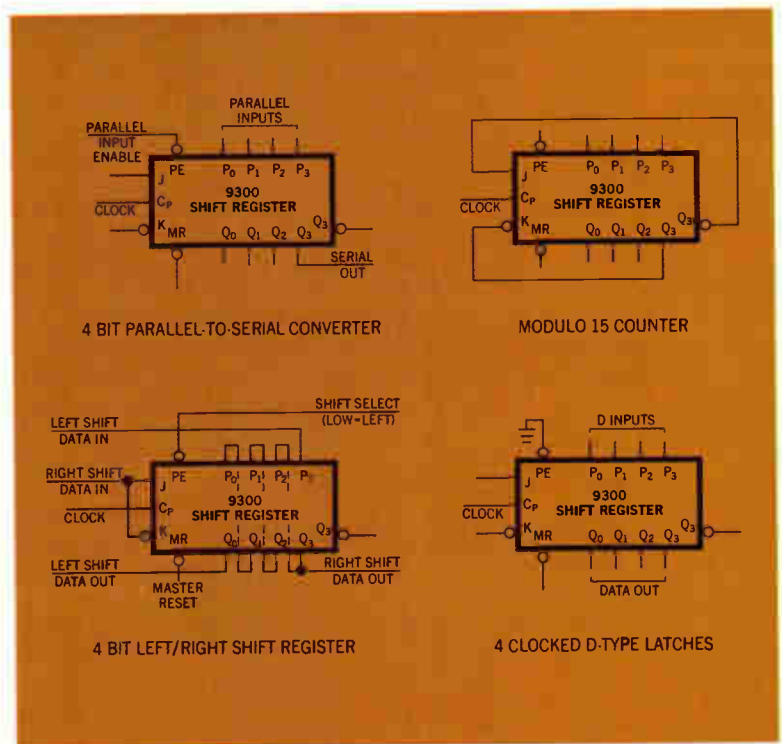

To order the 9300, call your Fairchild Distributor and ask for:

PART NUMBER	PACKAGE	TEMPERATURE RANGE	PRICE		
			(1-24)	(25-99)	(100-999)
U4L930051X	Flatpak	-55°C to +125°C	\$21.45	\$17.15	\$14.30
U4L930059X	Flatpak	0°C to +75°C	10.70	8.60	7.15
U6B930051X	DIP	-55°C to +125°C	19.50	15.60	13.00
U6B930059X	DIP	0°C to +75°C	9.75	7.80	6.50

# you have to get serious about MSI family planning.

We put together a family plan by taking systems apart. All kinds of digital systems. Thousands of them.

First we looked for functional categories. We found them. Time after time, in a clear and recurrent pattern, seven basic categories popped up: Registers. Decoders and demultiplexers. Counters. Multiplexers. Encoders. Operators. Latches.

Inside each of the seven categories, we sifted by application. We wanted to design the minimum number of devices that could do the maximum number of things. That's why, for example, Fairchild MSI registers can be used in storage, in shifting, in counting and in conversion applications. And you'll find this sort of versatility throughout our entire MSI line.

Finally, we studied ancillary logic requirements and packed, wherever possible, our MSI devices with input and output decoding, buffering and complementing functions. That's why Fairchild MSI reduces—in many cases eliminates—the need for additional logic packages.

The Fairchild MSI family plan. A new approach to MSI that's as old as the industrial revolution.

It started with functional simplicity, extended through multi-use component parts, and concluded with a sharp reduction in add-ons. Simplicity. Versatility. Compatibility.

Available now. In military or industrial temperature ranges. In hermetic DIPs and Flatpaks. From any Fairchild Distributor.

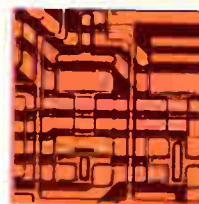

**OPERATORS**  
9304 - Dual Full Adder/Parity Generator



**LATCHES**  
9308 - Dual 4-Bit Latch  
9314 - Quad Latch



**REGISTERS**  
9300 - 4-Bit Shift Register  
9328 - Dual 8-Bit Shift Register

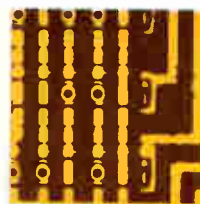

**MULTIPLEXERS**  
9309 - Dual 4-Input Digital Multiplexer  
9312 - 8-Input Digital Multiplexer

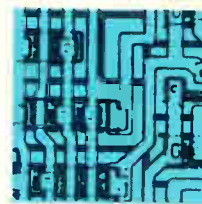

**DECODERS AND DEMULTIPLEXERS**  
9301 - One-Of-Ten Decoder  
9315 - One-Of-Ten Decoder/Driver  
9307 - Seven-Segment Decoder  
9311 - One-Of-16 Decoder  
9317 - Seven-Segment Decoder/Driver  
9327 - Seven-Segment Decoder/Driver



**COUNTERS**  
9306 - Decade Up/Down Counter  
9310 - Decade Counter  
9316 - Hexadecimal Counter



**ENCODERS**  
9318 - Priority 8-Input Encoder

**FAIRCHILD**  
SEMICONDUCTOR



**Bell & Howell  
& Jacob & Haag & Hull & Lewis  
& Czuha & Shitara & Reid & Stefansson  
& Bane & MacDonald**





Of course you know Bell & Howell. Chances are, you went to school together. But you probably don't know Jacob, Haag and the rest. They're carving out a whole new group for Bell & Howell. The Electronics & Instruments Group. A group that makes equipment you'd hardly find in your old classroom. Like systems for identifying air and water pollutants. Control systems for chemical companies. Aircraft entertainment and mini-theaters. Materials for computer read-out and communications systems for hospitals.

But in one respect, the new group is just a chip off the old block. The same care goes into making oscillographs and digital transducers that goes into making projectors. There's a lot more to Bell & Howell than meets the eye. For a look at how far we've gone since your old school days, just write to . . .

Bell & Howell, Electronics & Instruments Group, 360 Sierra Madre Villa, Pasadena, Calif. 91109



**BELL & HOWELL**

© Copyright 1970 Bell & Howell

# TRYGON systems power supplies are...

**FOR  
IMMEDIATE  
DELIVERY**

**Slot &  
Wide Range  
Sub-Rack &  
Modular  
Single and  
Multiple Output**

- For Systems, OEM and Lab applications
- Proven high quality and reliability
- Modules to 210 VDC; 18A
- Sub-Racks to 161 VDC; 25A
- Full Racks to 320 VDC; 70A
- A full choice of standard rack adapters and accessories

Write today for your copy of Trygon's  
1970 Power Supply Handbook

**TRYGON POWER SUPPLIES**

111 Pleasant Avenue, Roosevelt, New York 11575  
Tel: 516-378-2800 TWX: 510-225-3664  
Trygon GmbH 8 Munchen 60, Haidelweg 20, Germany

## Meetings

### Mariners converge on the capital

When members of the Marine Technology Society gather June 29 in Washington for their three-day annual conference and exposition, there could well be one poetic mimic to declaim "God save thee, ancient Mariner! From the friends that plague thee thus!" And the verse by Coleridge would not be inappropriate to the sixth annual gathering of marine technologists, for they are fully aware that expansion of their industry is plagued by limited Federal funds and limited job opportunities. As the society's vice president for research and education, Adrian Richards, put it: "The present market for ocean science and ocean engineering jobs is repressed because of the severe cut-back in governmental spending. The outlook for 1971 and possibly 1972 looks bleak."

**Tight program.** Nevertheless, registrants at the Sheraton-Park Hotel face a tight three days with 27 concurrent technical sessions to update them on marine technol-

ogy's direction and future. "No time is lost this year with overviews and generalities," says program chairman Lincoln D. Cathers. There's a Monday morning general session treating the tanker Manhattan's trans-Arctic voyage to Alaska and the Deep Sea Drilling Project. Subsequent sessions treat such specifics as buoy technology and development (on Monday and Tuesday afternoon, respectively); underseas vehicle development (Monday afternoon and Wednesday morning); and oceanographic instrumentation sessions (Wednesday morning and afternoon).

Systems specialists will watch for a Monday night session on interconnection system technology for the 1970's, plus two others on Wednesday treating habitat and instrumentation power systems and vehicle and habitat power systems.

For further information contact MTS Headquarters, 1730 M St., N.W., Washington, D.C. 20036.

### Man in the loop

The Institute of Navigation hopes to give a new perspective to man's role in getting from here to there when it gathers for its 26th annual meeting at the U.S. Air Force Academy in Colorado Springs for three days beginning July 1. Day-long sessions on air, space, and marine navigation will highlight the meeting.

Following a Wednesday morning military panel on the role of man in aerospace defense, strategic, tactical and airlift navigation, a joint paper by Autonetics authors C.S. Hoffman and J.J. Csaja will examine man's future as an aircraft navigator. An afternoon session that day will deal in detail with various aspects of advanced avionics, including distance-measuring equipment, and inertial and area navigation.

**Stars.** The July 2 space session will feature speakers from the military, industrial, and academic community, including a paper by IBM Federal Systems division authors Schlee and Neilson detailing an advanced stellar attitude-reference system for spacecraft.

The concluding session on marine navigation on July 3 will feature morning papers to identify requirements and levels of professional education or training to assure that marine, surface, and sub-surface navigation continues to have the essential manpower and expertise for orderly progress. The post-luncheon session will then put forth papers analyzing programs to prepare men for their roles as identified by earlier sessions, and to

(Continued on p. 24)

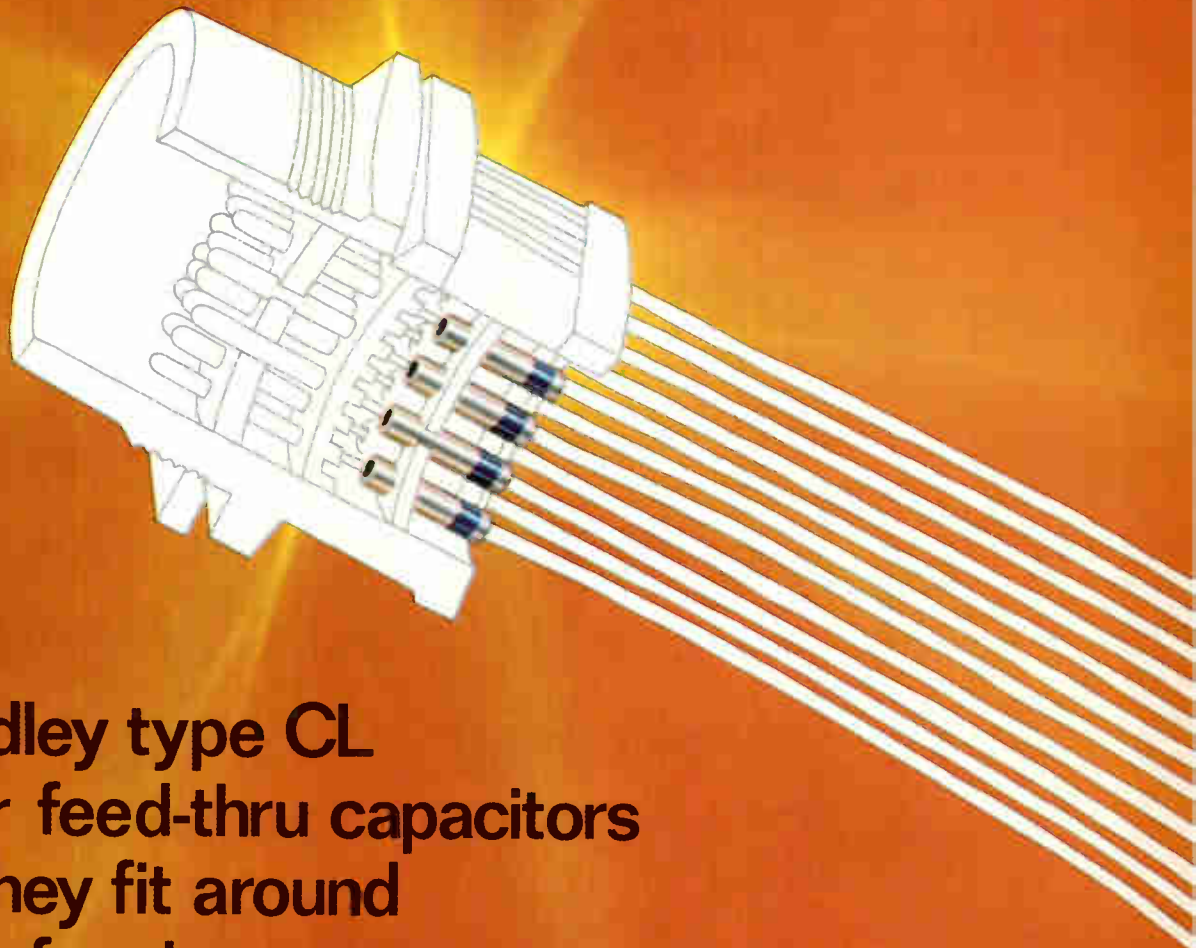

## Allen-Bradley type CL multi-layer feed-thru capacitors so small they fit around the head of a pin.

**VOLUMETRIC EFFICIENCY.** Big words that explain why Allen-Bradley type CL feed-thru capacitors are so small. Our unique multi-layer concept shaves size to a minimum, without affecting performance. It took Allen-Bradley to get filter capacitors down to their fighting weight. Now rolled capacitors are no longer a design alternative.

Concentric layers of proprietary Allen-Bradley ceramic and noble metal electrodes are fired together for unmatched protection against moisture and contamination. Rugged. Non-polar. With lower inductance and far less noise.

Voltages to 200 WVDC. Temperatures to 125°C. Capacities to 1.0  $\mu$ F. High dielectric strength and reliability.

Several styles and sizes are available through your appointed A-B industrial electronic distributors. For further information write: Marketing Department, Electronics Division, Allen-Bradley Co., 1201 South Second Street, Milwaukee,

Wisconsin 53204. Export office: 1293 Broad Street, Bloomfield, N.J. 07003 U.S.A. In Canada: Allen-Bradley Canada Ltd., 135 Dundas St., Galt, Ontario.

### **ALLEN-BRADLEY**





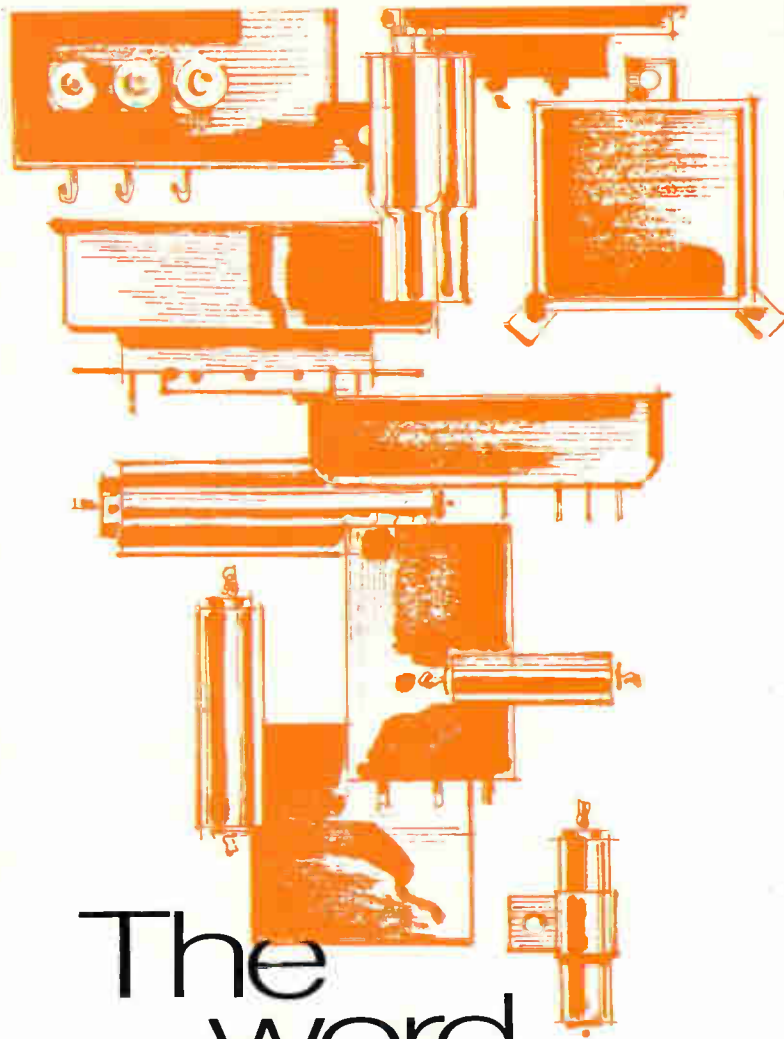

The  
word  
is filtering  
down...

## Captor is capable

Captor is the bright new face in electronic components, particularly filters. Deeply experienced. Imaginative. Capable of producing miniature EMC filters, communications and security filters, custom design filters/assemblies, and other electronic components. Capable too of fast delivery, competitive prices, testing, research. Capable of handling any size RFI/EMC filter order. Has the good word about Captor reached you yet? Write for our capabilities brochure today!

 **CAPTOR**  
CORPORATION

*Electronics Division*

5040 Dixie Highway, Tipp City, Ohio 45371, Phone: (513) 667-8484

## Meetings

(Continued from p. 22)

identify equipment essential to education and training of these men.

The Hotel Broadmoor and the Ramada Inn at Colorado Springs have been named residential sites for residents.

For further information call Maj. Harold L. Beckman, USAFA (ONA), USAF Academy, Colo. 80840.

## Calendar

**Conference on Solid State in Industry, IEEE;** Statler-Hilton Hotel, Cleveland, June 15-16.

**Applied Superconductivity Conference,** Bureau of Standards, University of Colorado, Office of Naval Research, and American Institute of Physics, Boulder, Colo. June 15-17.

**International Symposium on Information Theory, IEEE;** Hotel Huis ter Duin, Noordwijk, Netherlands, June 15-19.

**International Computer Conference, IEEE;** Washington Hilton Hotel, June 16-18.

**Solid State Sensors Symposium,** Instrument Society of America, IEEE; Hotel Radisson, Minneapolis, June 18-19.

**Design Automation Workshop, IEEE;** Sheraton Palace Hotel, San Francisco, June 21-25.

**Joint Automatic Control Conference, IEEE;** Georgia Institute of Technology, Atlanta, June 24-26.

**Summer Power Meeting and EHV Conference, IEEE;** Biltmore Hotel, Los Angeles, July 12-17.

**Conference on Dielectric Materials, Measurements and Applications, IEEE;** University of Lancaster, London, July 20-24.

**Conference on Nuclear and Space Radiation Effects, IEEE;** University of California at San Diego, July 21-23.

**International Conference and Exhibition on Water Pollution Research, IEEE;** San Francisco, July 19-31; Honolulu, Aug. 2-5.

**Photovoltaic Specialists Conference, IEEE;** Seattle Center, Washington, Aug. 11-13.

(Continued on p. 26)



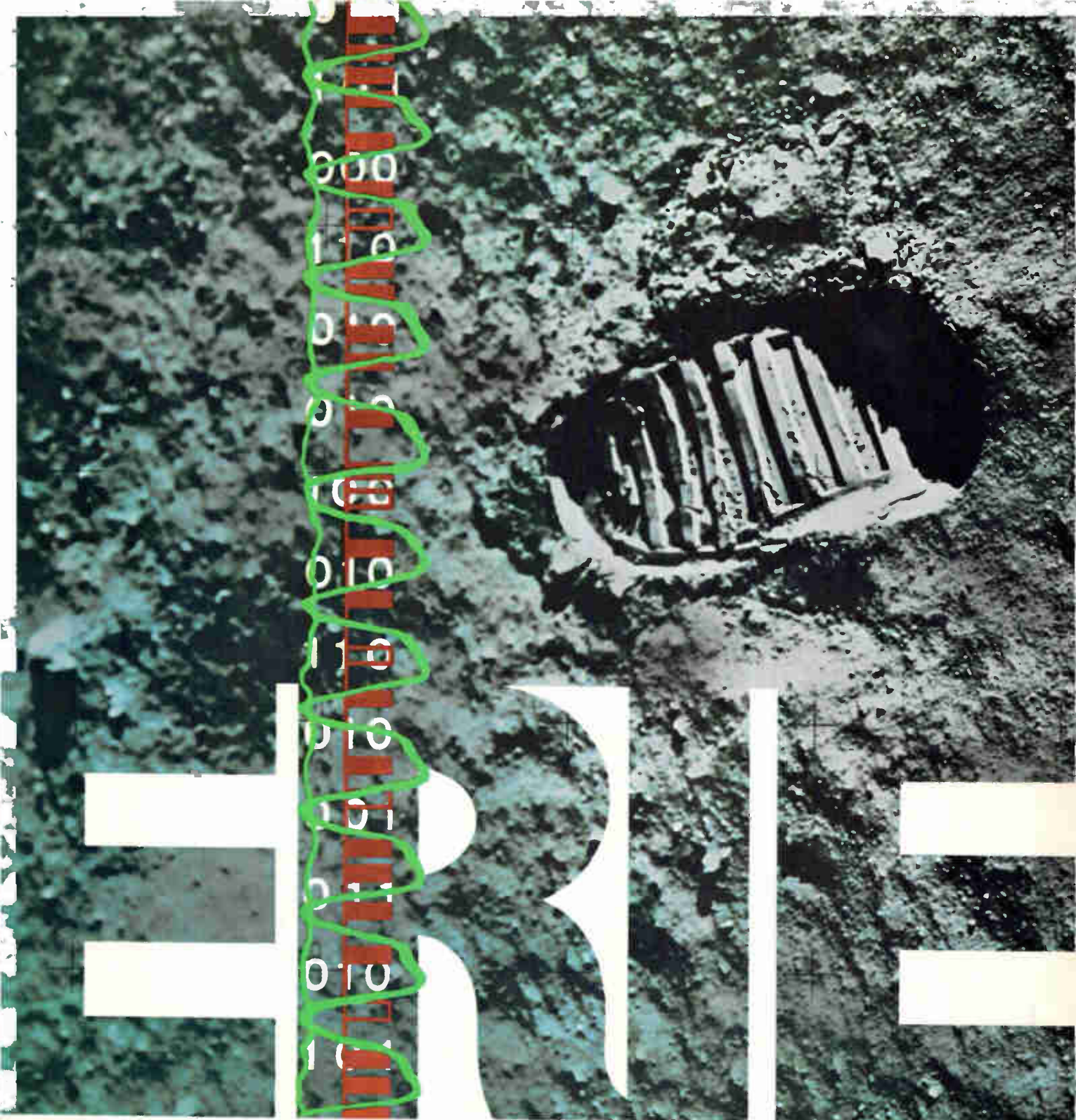

When you can't afford a "wrong number"...

Symbolic representation of the TV, voice, ranging data and biomedical telemetry signals from the moon. Photograph courtesy of NASA.

## bring ERIE in early.

Where are they? How are they? What do they see... and say? NASA and the world want to know. And, the only way to find out is over the special Motorola S-band equipment on both the Command and Lunar Modules. Once the Apollo Astronauts are over 30,000 miles out, it's their only communications link with Earth. It simply can't fail. That's why Motorola called on ERIE TECHNOLOGICAL to develop the EMI filters and Monobloc capacitors that would help this equipment perform flawlessly on every Apollo mission since Motorola has been involved. Proof, once again, that it pays to bring ERIE in early.

**ERIE TECHNOLOGICAL PRODUCTS, INC.**

644 West 12th Street, Erie, Pennsylvania 16512  
(814) 453-5611



# NOW HIGH-PERFORMANCE SCRs TO MEET THE CRITICAL NEEDS OF...

- Power Inverters
- A.C. Motor Variable Speed Drives
- Induction Heaters
- Pulse Width Modulators



NATIONAL®  
DISC PACKAGED  
REGENERATIVE GATE\* SCRs  
provide these plus factors...

- + Voltages to 1000 V
- +  $dv/dt$  to 500 V/ $\mu$  sec.
- + Turn-off time to 15  $\mu$  sec.
- +  $di/dt$  to 800 A/ $\mu$  sec.
- + Low power gate drive
- + Operation to 20 KHz, with low switching losses
- + 175 and 380 amperes RMS
- + Also available in stud packages to 470 amperes RMS

\* A NATIONAL® exclusive.  
Patent No. 3,486,088

We welcome requests for detailed data and application assistance. Contact...

## NATIONAL ELECTRONICS, INC.

a varian subsidiary

Geneva, Ill. 60134, phone 312-232-4300

## Meetings

(Continued from p. 24)

International Conference on Microelectronics, Circuits, and Systems Theory, IEEE; University of New South Wales, Kensington, Sydney, Australia, Aug. 18-21.

AFMA National Conference, Armed Forces Management Association; International Hotel, Los Angeles, Aug. 20-21.

Western Electronic Show and Convention (WESCON), IEEE; Biltmore Hotel, Sports Arena, Los Angeles, Aug. 25-28.

Preparation and Properties of Electronic and Magnetic Materials for Computers, The Metallurgical Society, Statler-Hilton Hotel, New York, Aug. 30-Sept. 2.

### Short courses

Measurement Engineering, State University of New York at Stony Brook; June 22-26; \$195 fee.

Modern Optics: Basic Processes and Components, University of California at Los Angeles; Boelter Hall, Room 4428, June 22-26; \$310 fee.

Magnetic Thin Films, University of California at Los Angeles; Boelter Hall, Room 4403, June 22-27; \$370 fee.

Management Seminar in Systems Reliability and Engineering Operations, University of California at Los Angeles; Rieber Residence Hall, Fireside Room, June 22-27; \$485 fee.

### Call for papers

Northeast Electronics Research and Engineering Meeting (NEREM), IEEE; Sheraton Boston Hotel and the War Memorial Auditorium, Boston, Nov. 4-6. July 1 is deadline for submission of papers to Program Chairman, IEEE NEREM-70, 31 Channing St., Newton, Mass. 02158

Symposium on Feature Extraction and Selection in Pattern Recognition, IEEE; Argonne, Ill., Oct. 5-7. July 1 is deadline for submission of short papers to Professor K.S. Fu, School of Electrical Engineering, Purdue University, Lafayette, Indiana, 47907.

International Electron Devices Meeting, IEEE; Washington, Oct. 28-30. Aug. 1 is deadline for submission of abstracts to Edward O. Johnson, Program Chairman, 1970 International Electron Devices Meeting, RCA Corp., Electronic Components, 415 South Fifth Street, Harrison, N.J. 07029.



## ELECTRONIC COMPONENT DESIGNERS:

### PUT YOUR MINIATURIZATION REQUIREMENTS IN THE RIGHT HANDS!

When you're designing small . . . materials selection becomes a bigger consideration. Uniformity of magnetic behavior, for example, becomes an extremely critical factor in miniaturized applications. In such instances, the smallest change in a material's response to a given current can be enough to upset the operation of an entire electronic system.

Many other considerations, equally as critical, must be made in selection of materials for miniaturized, high-precision and ultrasensitive equipment.

Carpenter specialization brings you a full range of electronic alloys, all made to meet exacting quality standards. Among them: Magnetic Core Irons, High-Permeability Alloys, Temperature-Compensator Alloys, Glass-Sealing Alloys, Controlled-Expansion Alloys, Electrical-Resistance Alloys, Magnetostrictive and High-Saturation Alloys, plus others. Each of these materials is made to consistent standards of uniformity for dependable, long-lasting performance. Your Carpenter representative can give you full details. Steel Division, Carpenter Technology Corporation, Reading, Pa. 19603.

European Office: Emmastraat 39, Amsterdam-Z, The Netherlands

**CARTECH**

CARPENTER  
TECHNOLOGY



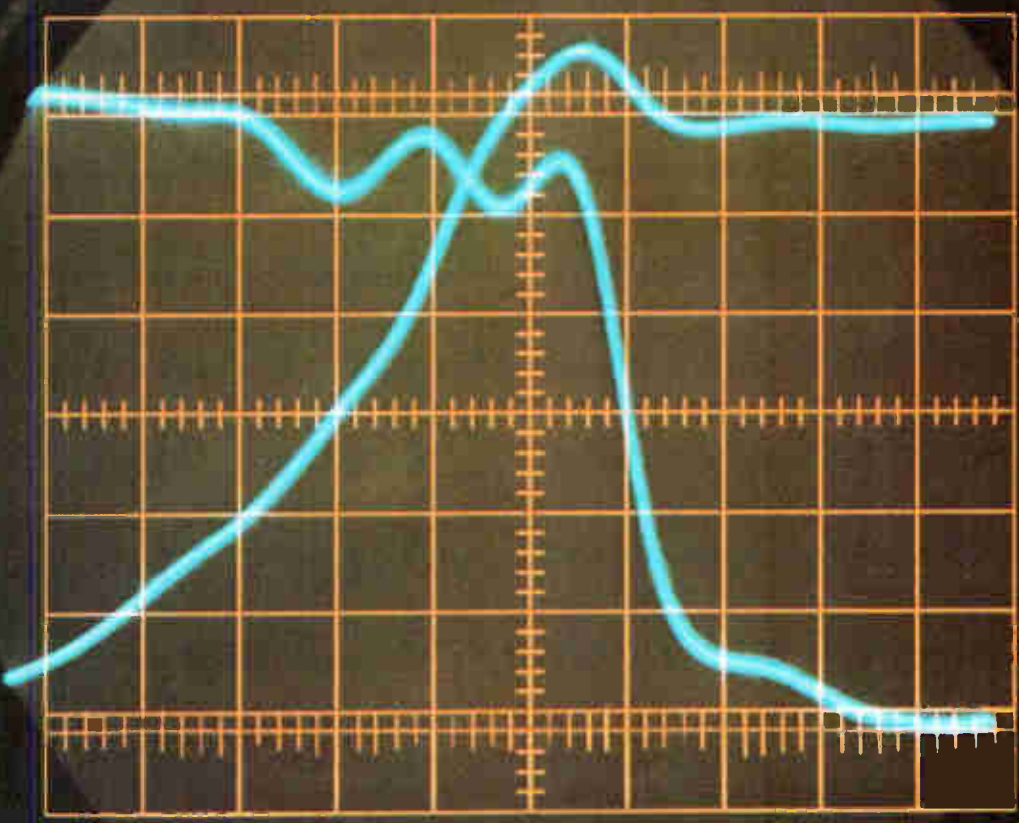

It's quiet  
in TTL

# 3 ns at 20 mW.

## A new technology is born with TI's Schottky-clamped 54/74 TTL.

Until now, speeds below 5 ns could only be achieved with current mode (unsaturated ECL-type) technology.

Now, TI has built integrated Schottky-barrier diode clamped transistors\* into its popular Series 54/74 integrated circuits. Our new 54S/74S family combines the high speed of unsaturated logic and the low power of saturated TTL logic. The best speed/power combination yet—and priced below competitive ECL logic families.

You gain these advantages, compared to conventional TTL integrated circuit technology:

- Typical gate propagation delay: 3 ns.
- Power dissipation: 20 mW per NAND gate at 50% duty cycle.
- 100 MHz typical flip-flop clock input frequencies.
- Smaller device geometries reduce internal capacitance—and increase speed.
- Schottky-barrier diode input clamps provide fast clamping protection.
- Active pulldown network squares transfer curves and raises logical '1' output level.

\*Texas Instruments has patented this technique in U. S. Patent number 3,463,975 titled "Unitary Semiconductor High Speed Switching Device Utilizing a Barrier Diode" issued August 26, 1969 (originally filed in 1964).

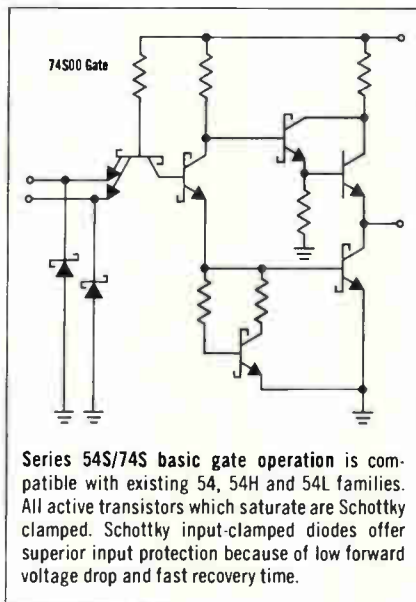

Series 54S/74S basic gate operation is compatible with existing 54, 54H and 54L families. All active transistors which saturate are Schottky clamped. Schottky input-clamped diodes offer superior input protection because of low forward voltage drop and fast recovery time.

And you also gain these advantages, compared to current mode logic technology:

- Lower power dissipation.
- Better noise immunity. Typical d-c noise margins—more than 1V.
- Conventional PC boards may be used due to smaller line reflections with unterminated lines.
- Direct interface with all popular TTL and DTL families—same 5V power supplies (critical regulation not required), same logic functions, same packaging.

Broad applications. Series 54S/74S Schottky TTL circuits are ideal

for applications in all high-speed digital systems:

- Computer central processor units.
- Peripheral controls.
- Digital test and measurement equipment.
- Digital communications systems.

Now available in plastic dual-in-line packages are the SN74S00N—Quadruple 2-input positive NAND gates. The SN74S20N—Dual 4-input positive NAND gates. And the SN74S112N—Dual J-K negative edge triggered flip-flop (separate preset, clear and clock).

More are coming in 1970. TI is developing 13 circuits in the revolutionary 54S/74S series, including other standard TTL gates (NANDs, AND, HEX inverter, AND-OR-INVERT), dual J-K and D flip-flops, as well as MSI counters and shift registers. Ceramic DIPs and flat packs will be available soon.



For more information on the most significant TTL advance in four years, get our new Bulletin CB-118. Circle 275 on the Reader Service Card or write Texas Instruments Incorporated, P. O. Box 5012, MS 308, Dallas, Texas 75222. Or call your nearest authorized TI Distributor.



# TEXAS INSTRUMENTS INCORPORATED



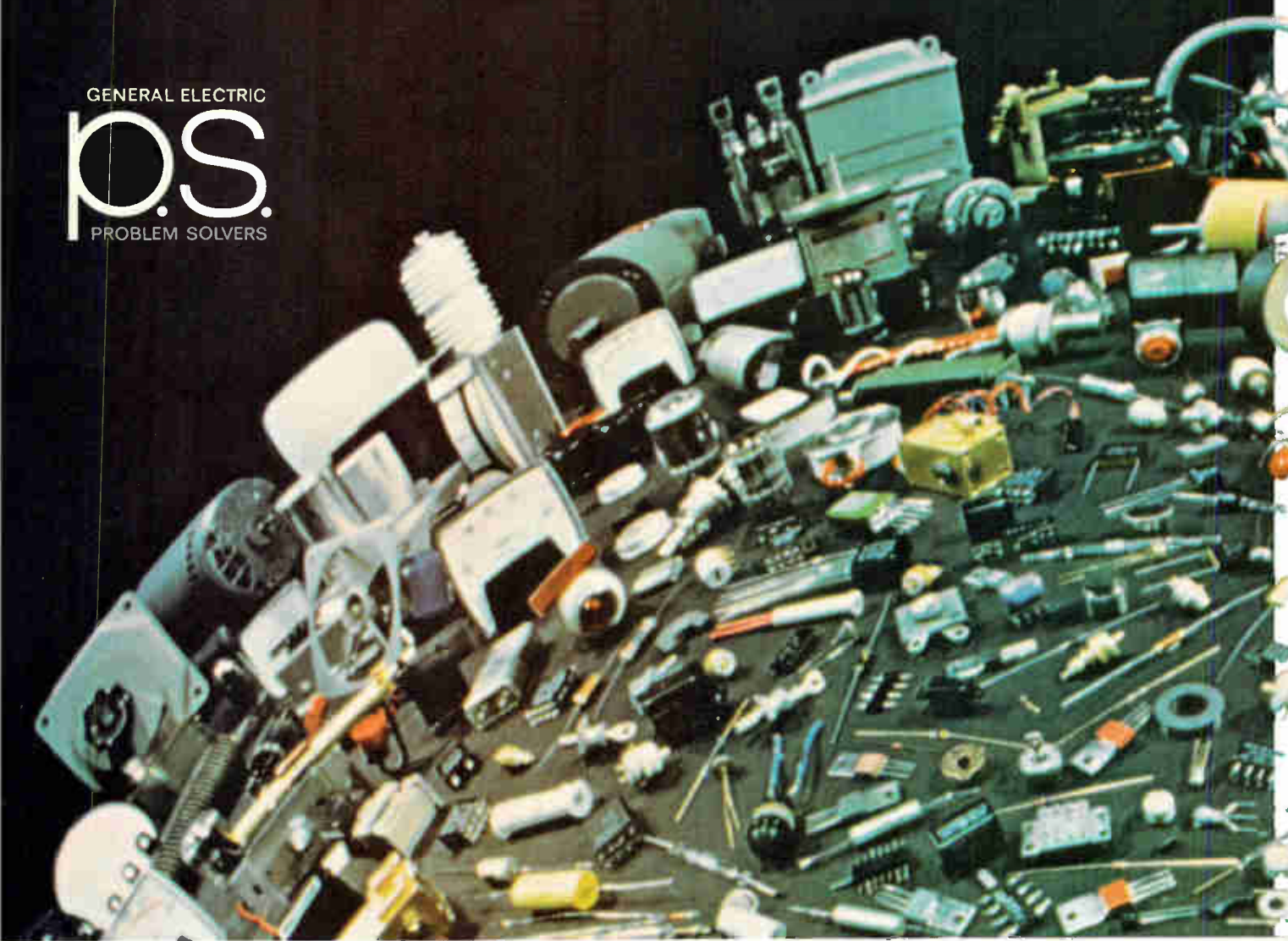

## General Electric helps you solve the tough ones

GE has the broadest line of electronic components in the industry. From the tiniest integrated circuits to powerful high performance motors, GE components help you solve your tough problems . . . in design, in performance, in economy. Take a look at these GE problem solvers.

**p.s.1** General Electric delivers 19 new epoxy TO-18 transistors for demanding applications. GE's encapsulated devices are performance-proved, reliable. And they cost less than metal-case devices.

The new epoxy transistors include PNP types, PNP/NPN complementary pairs, and low level amplifiers. They offer breakdown voltages as high as 60V with excellent beta linearity and dissipate up to 500 mW. They handle collector currents up to 1 amp. Get spec sheets on GE's new epoxy transistor lineup. Circle number 316

**p.s.2** GE meter relays put accurate dependability into critical new medical systems. A new heartbeat monitor, for instance, uses GE meter relays to indicate the heart beat visually. And they have the added capability to sound an alarm when preset limits are reached.

Either the easy-reading BIG LOOK® or the low profile HORIZON LINE® styles feature solid state control for precise accuracy. Put GE dependability into your critical circuits. Circle 317 for details.

**p.s.3** Forget capacitor leakage problems with GE military-type tantalum wet slugs. The special GE design incorporates a double elastomer seal that maintains performance even through the 35 temperature cycles required by MIL-C-3965E. And life tests show a capacitance change of less than 5% in 2000 hours operation.

GE wet slugs come in 4 case sizes for applications up to 125 volts dc; 1.7 to 1200  $\mu$ f. GE's 20 years experience is your assurance of dependability. For complete information, circle 318

**p.s.4** GE Microwave Circuit Modules save up to 60% in size and weight for critical communications and radar systems. GE MCM's may be used as oscillators, amplifiers, multipliers, detectors, mixers, integrated isolators and circulators. And they are extremely stable even in adverse environments.

The GE C-2003E, for example, is used in pulsed transponder applications. It operates dependably from -54 to +125C and withstands vibrations at 15G from 20 to 500 Hz. Frequency stability is  $\pm 3$ MHz with minimum life of 500 hours operation. Get GE's MCM catalog. Circle 319

**p.s.5** New magnetic material gives 6% increase in residual flux density . . . resists demagnetization. GE's new Alnico 8C was developed for applications requiring high resistance to demagnetization plus a higher flux output than other Alnico 8 alloys.

Alnico 8C is the latest development in GE's complete line of Alnico permanent magnets. It's another example of the technical expertise you get when you specify General Electric to solve your magnet problems. For details on the entire GE Alnico family circle 320

**p.s.6** Get more capacitance in less space with GE computer-grade capacitors. These aluminum electrolytic units deliver up to 540,000  $\mu$ f at 5 VDC (34,000  $\mu$ f at 100 volts) . . . highest capacitance per case size available. They are rated for continuous duty at 65C or at 85C





## with the broadest line of electronic components

with proper voltage derating.

GE computer grades feature high ripple current capability with low equivalent series resistance. Nine case sizes are available. Circle 321

**p.s.7** Rechargeable GE nickel-cadmium batteries give you longer operating life. Proved GE reliability puts longer battery power into your application at an economical price.

Nominal ratings range from 0.1 amp-hours to 4.0 amp-hours in sealed cells and up to 160 amp-hours in vented types at the one-hour rate. Put dependable GE power in your circuit. Circle reader card number 322

**p.s.8** Programmable UJT lets you control the key parameters with just two resistors. That's right. You control  $\eta$ ,  $R_{B8}$ ,  $I_p$  and  $I_v$  so that you design your own unijunction as you design the circuit.

Low leakage and peak point currents make GE's D13T programmable UJT a natural for long interval timers. High breakdown voltages, fast trigger pulsing and low voltage operation add versatility. And the plastic TO-98 case helps solve economy problems. Get full details. Circle number 323

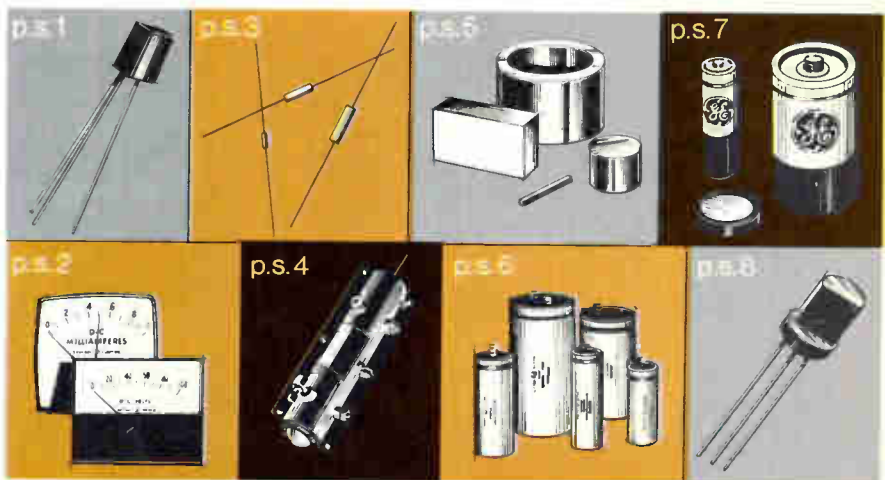

Let General Electric help solve your component problems. Call your nearest Electronic Components Sales Operation Office. Or check with one of the many authorized GE distributors. P.S. Problems? General Electric has solutions.

285-64

GENERAL  ELECTRIC

Top  
of any  
line



## Most accurate, most versatile 5-digit multimeter — period.

Here's the finest, most advanced measuring instrument available. It's Cimron's Model 6853 Digital Multimeter, the truly new five digit DMM that offers versatility and reliability unobtainable until now.

Years of building standard multimeters, and years of engineering costly modifications to fit special applications, have resulted in the most complete measurement capability ever put into a single, compact instrument.

With DC accuracy up to 0.001%, the 6853 gives you six DC ranges (100 Nanovolts to 1100V); nine

ohms ranges (10 Microhms to 100 Megohms); four AC ranges (1V to 1100V); DC and AC ratios plus much, much more. Auto ranging, remote programmability, five print options, out-of-range indication and automatic desensitization to name just a few.

Because all options are standard plug-ins for the basic instrument, Cimron has eliminated the need for special modifications or external units in virtually any measurement or systems application.

We invite you to compare our "Customer Concern" construction,

advanced design, unsurpassed expandability and long list of other exclusive features. They make the new 6853 Digital Multimeter the "top of the line" at Cimron. That means the top of any line — period.

And if you buy millivolts you get ohms free. Call (714 276-3200) or write Cimron, Department D-145, 1152 Morena, San Diego, California.

*the hot line of DMM's*

**CIMRON**



CIMRON DIVISION

Circle 32 on reader service card

LEAR SIEGLER, INC.



---

# Electronics Newsletter

---

June 8, 1970

## AWADS to undergo Air Force tests

The Air Force should begin testing Texas Instruments' Adverse Weather Aerial Delivery System later this month. Developed for C-130 transports to allow them to bring paratroopers over a drop zone at night and in foul weather, AWADS incorporates the first operational Ka-band radar, built by TI, and the first purchase in production quantities of an aircraft station-keeping system, built by Sierra Research.

Radar-screen pictures from the precise, ground-mapping radar—part of a dual X- and Ka-band system—have been excellent in contractor tests, according to an Air Force source.

The Air Force is also deciding whether to buy 45 additional AWADS-equipped craft that would act as pathfinders for a formation of transports. These would be in addition to the 39 C-130's (plus two prototypes) that are to be equipped with the full AWADS and the 169 planes marked for station-keeping gear only. Also being considered: a provision for terrain-following capability, as well as the addition of AWADS to the C-141 fleet.

## Motorola last of big 3 into silicon gate

Motorola has made it unanimous among the big three semiconductor makers in the swing to silicon-gate MOS. Roger Helmick, Motorola's manager of digital IC product planning, says the process will be "firmly established by the end of the fourth quarter, and we'll have products by the end of this year or the first quarter of 1971." Helmick says the first product probably will be a memory component. He thinks silicon-gate MOS will be more easily manufactured than conventional p-channel MOS with its metal gate, and is betting on silicon-gate technology to eventually "be the ruler of the MOS world."

Little Intel Corp. blazed the trail with silicon-gate products, followed by Fairchild, which has also introduced products. Then Texas Instruments said that it had given silicon-gate the green light [*Electronics*, March 16, p. 33] and would have its first products before year's end. Thus, it appears that TI and Motorola will be neck and neck with silicon-gate product introduction.

Signetics, another convert, is still to be heard from about its product timing, although a source there says the firm has a process dedicated to the technology, "and we're 100% go. We have product plans, and they're for real."

## \$75,000 price tag for Sperry inertial strapdown system

The first stock laser inertial measurement unit—Sperry Gyroscope division's strapdown unit using helium-neon ring laser gyros—will sell initially for \$75,000 for a three-axis system with driving electronics. Accelerometers are optional. A simple-axis system costs \$50,000. Units will be assembled from parts on hand in three to four months.

Lifetime of the system, which uses a glass lasing tube in aluminum supports, is specified at better than 10,000 hours. Accuracy is 0.4%, dynamic range  $\pm 400^\circ$  per second, with an angular resolution of 3.4 arc seconds. And Sperry says its gyro is already being used as the attitude reference on classified aircraft and missile programs. Once in production, the price could fall as low as \$5,000. Electronically adjustable piezoelectric reflectors at the corners of the lasing cavity's equilateral triangle help maintain cavity stability by keeping the length of the reflecting

---

# Electronics Newsletter

---

path at the peak gain value. The unit comes in two parts—a 13-pound sensor package 9½ inches in diameter and 7 inches high, and driver electronics.

## Instrument house to talk trade-in

Some car-dealer pizzazz is coming to the instrument business. Within 60 days a major instrument company will announce a trade-in policy: it will take Tektronix oscilloscopes as part payment for counters, digital voltmeters, and other wares. Then, Rental Electronics Inc. will buy the old scopes and turn them over to its resale arm, the Equipment Marketing Co. Edward Herman, Rental's president, won't identify the instrument house but says it's not Tektronix or Hewlett-Packard.

## Bower, man behind Hughes I/MOS, quits to start firm

Robert Bower, whose five years of work in ion implantation finally pushed Hughes Aircraft Co.'s MOS division into commercial I/MOS production [*Electronics*, May 25, p. 125], has left Hughes, and plans to go into business for himself. Bower, 33, had been doing ion-implantation research work in both microwave and MOS devices until he was named assistant manager of the new MOS division last fall and was charged with making I/MOS a production reality.

Bower says the division is "committed up to its ears" to I/MOS, but he feels that the overall operation should have concentrated on fewer market areas. And Bower isn't sold on complementary MOS, which Hughes is getting into after being licensed by RCA. He says he wants any new company he forms to be in MOS "and future technologies along that line," and he suggests ion implantation will be a part of it. Bower says he's "fairly far downstream with some sources of capital."

## Hertz to replace computer system

The Hertz Corp. has requested proposals by June 10 on the first phase of a computerized reservation system to replace its present equipment. The giant rental company has adopted a conservative, building-block approach to the purchase.

The plan is to establish a central office in Oklahoma City with a toll-free 800 phone number. Phase 1 would have 100 cathode-ray-tube terminals plus a minicomputer acting as a store-and-forward switcher. Information would be punched into the crt display in page form for disk storage. Under phase 2, slated for 1971, this equipment would become the front end for a big mainframe—in the IBM 360 or RCA Spectra family. Still further down the line is a full-blown airline-type system with retrieval by name.

## Addenda

In case any doubts remain about the general bearishness of the economy and the electronics industry in particular, here's another sign: booth space commitments for Wescon are down 10% from last year. Show officials expect the trend to hold, reflecting the biggest drop since 1965, another bad business year. The big exhibition will be held in Los Angeles from August 25 to 28 . . . And Xerox Data Systems has joined the list of companies forced to cut back personnel. XDS has made an across-the-board reduction—350 jobs, or 6% of the 5,500-man work force. . . . Now that Motorola is marketing eight 5400 TTL functions in chip form, there are at least two beam-load IC sources. The other is Raytheon.

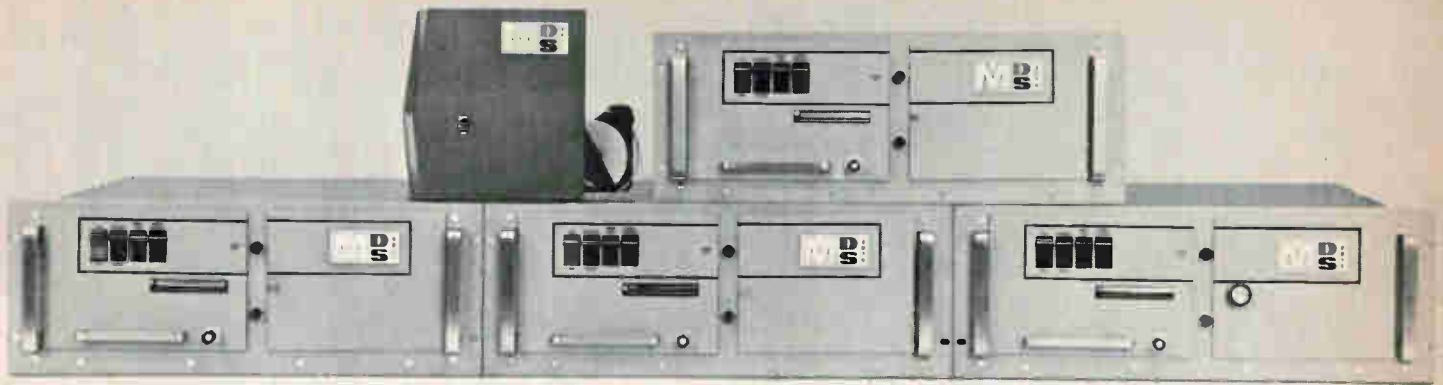

## Five new printers from Mohawk.

These 5 new printers plus the 6 original Franklin printers give MDS a product line of strip and lister printers that can fill any requirement.

Our five new printers are the 2015 through the 2019. They're all fully buffered, asynchronous, have ultra-reliable TTL integrated circuits, and can operate on either 50 or 60 cycles. The lister printers range from 8 columns to 20 columns with printing rates from 10 to 20 lines per second. While the 2016 and the 2018 are numeric, the 2017 and 2019 are alpha-numeric. All four have programmable zero suppress and format control. And two of them, the 2018 and 2019, are character-serial. The 2015 strip printer features first character readability and a full 96 character ASCII font.

Our six original Franklin printers, the 800, 1200, 1600, 2200,

and 3200, add more capabilities to our line. Such as speeds up to 40 lines per second, a range of positive and negative interfaces, synchronous operation, and capacities up to 32 columns.

And, of course, all these printers are in production and are available for immediate delivery.

For more information about these MDS/Franklin digital printers, or about special printers like airline ticket printers, boarding pass printers, and card serial printers, call your nearest MDS salesman.

Mohawk Data Sciences Corp.  
King of Prussia, Pa.





YT19 system cabinet, holds all the equipment shown (except teletypewriter) with room to spare.

CD51 controller-digitizer with programmable gain, controls 1024 channels, 10ns aperture time.

TE33 teletypewriter with paper tape reader and punch. (Includes controller.)

CF16 minicomputer with a 4K x 16-bit memory (expandable to 24K) and four different I/O modes. (Includes software.)

Optionally available: MR50 high-level multiplexer and associated channels (approximately \$2400 extra), if you want to mix high and low level signals. Also 10, 12 or 15-bit D to A converters for closed loop systems, and a variety of other off-the-shelf instruments and options to solve virtually any data acquisition problem.

PE20 peripheral controller for CD51/DM40 combination.

OP50 multiplexer switch card contains 8 switches with screw terminals. Each DM40 accommodates up to 16 such cards. Switch cards with other terminal types also available.

OP59 power supply for up to eight DM40s.

DM40 low-level differential multiplexer accepts up to 128 input signals (optionally expandable to 1024) in the range  $\pm 2.5\text{mV}$  to  $\pm 10\text{V}$  full scale, at a rate up to 20kHz, and with a CMR of 120db at DC.

All instruments and interfaces will be cabinet mounted and functionally tested together prior to delivery. If you're in a hurry, call (213) 679-4511, ext. 3668 or 3391.

**XDS**  
Xerox Data Systems  
El Segundo, California

**The last reason you should buy our data acquisition system is the price: \$21,600.**

# Co-op graphic terminals display thrift

Rand's straightforward design lets casual user get picture power as needed; heart of centralized setup is image-distribution system developed at IBM

**Providing fully dedicated,** interactive graphic terminals for a large community of users at the same facility can become an expensive proposition. With that in mind, and operating under a broad charter from the Advanced Research Projects Agency (ARPA), the Rand Corp. has developed a graphics display system that costs only one-sixth as much per terminal, or about \$500 a month, as conventional systems.

Tom Ellis, assistant director of Rand's computer systems group, headed by Keith Hungerford, says that the system uses scan conversion and video recording techniques under development at IBM since 1964. A cooperative Rand-IBM effort has been under way since early 1966.

**Simple.** Ellis explains that the design concept "called for the stations to be very straightforward; we tried to keep the keyboard as much like a typewriter as possible for the casual user in an office atmosphere." Another aim, says Ellis, was to centralize expensive equipment so that a large number of users "can get bursts of graphic power out of the system when they want it.

"We wanted to provide the fully interactive capability of a terminal like the IBM 2250 without the cost. Our studies show that most people only use the full graphics capability a small percentage of the time, so we depend on the averaging power of the number using the system at any particular time," he explains. Trial of the system at Rand has confirmed that the major portion of terminal use involves program debugging and operator evaluation of information displayed.

The heart of the system is an image-distribution system built by

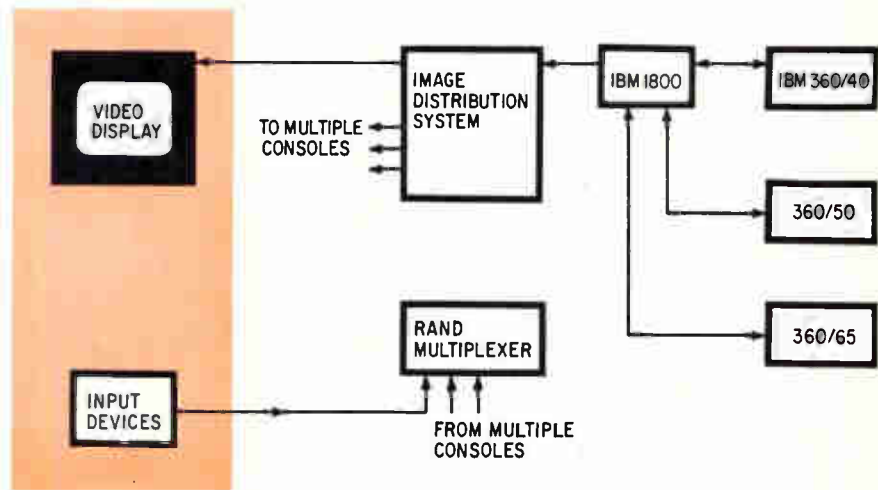

**Coming and going.** Rand system permits use of many interactive graphic terminals for only \$500 a month per terminal.

IBM and housed in four desk-sized packages containing a microprogram controller, analog gear, a 32-channel analog disk recorder, and modulator-demodulator equipment.

**Link.** An IBM 1800 is used as a communications controller between the distribution system and IBM 360/40, 360/50, and 360/65 computers. The 1800 has 32,768 words of memory, of which about one-third is for program and the remainder for buffer space. To relieve the 360's of high interrupt rates associated with individual key strokes, the 1800 does any editing that stays within one line. Full duplex interchange between the 360's and the 1800 is provided.

The microprogrammer in the image-distribution system drives conventional stroke character and analog line generators that feed to an analog bus for distribution to three scan converters.

A quick-erase scan converter, developed by IBM, is a key factor in the system, according to Ellis. A standard vidicon with electrical read-write is optically coupled to a flash tube that discharges and erases the target within a few

microseconds, whereas most vidicons require from 30 milliseconds to 1 second for an erase. Thus, as soon as the scan from one picture is complete, the image can be erased and the scan repeated, permitting multiplexing at a high rate. A single gun in the converter discharges a pattern, and the converter uses beam-steering techniques and switches raster scan, to read in video format. Each scan converter can address any of 32 disk buffer channels through a 32-position electric channel select switch. When writing in a particular channel, the picture is continuously refreshed. Access time with 25 users on each scan converter is typically about 30 milliseconds. The system provides up to 32 independently refreshed pictures.

**Sounding off.** To get the required bandwidth, the system utilizes a 32-inch diameter analog recording disk, another IBM development, as a video buffer. The disk has 32 simultaneous tracks with 10 megahertz video bandwidth, and uses a vestigial sideband recording technique. Each head has its own read-write amplifiers. From the video

## U.S. Reports

buffer, the signals go to an allocation patchboard containing mixers and video logic for relay to the terminal television monitors. A 10-Mhz, 873-line video format is sent on the coaxial cable, and sync pulses are modulated on the cable to give a 26 kilobytes-per-second data rate. The bits are amplitude modulated to give an audio carrier. A simple modem at the terminal strips the signal and provides a video signal for the tv set.

Only two input devices are now used. One, a 45-character keyboard, has four modes: upper case, lower case, 45 special symbols, and a function-key mode, with each key representing a single function. The other is a Rand pen, which can be used for freehand description, object movement, and erasure on a 1,024-by-1,024-point grid. The system can address up to eight input devices per terminal.

### Displays

#### Show your stuff

Motorola's Government Electronics division has developed a bantam-weight 16-inch cathode-ray tube display with the ruggedness of an I-beam and versatility that approaches the science-fiction level. The display, developed under a \$419,000 Rome Air Development Center contract, is designated the tactical modular display, AN/USA-26(V)2, and has been nicknamed Totalscope by Motorola. Although there is no present operational requirement for the display, Motorola hopes to produce it in quantity and will be making presentations to the Army, Navy, and FAA—in fact, to any agency willing to listen.

The story is well worth hearing. The display is the result of a nearly decade-old RADC program to develop a lighter and more flexible radar display than the AN/UPA-35, the triservice workhorse since the mid-1950's. RADC's Microelectronics Display Program resulted in the development of a series of successively smaller and more versatile displays.

The UPA-35 weighs in at a big

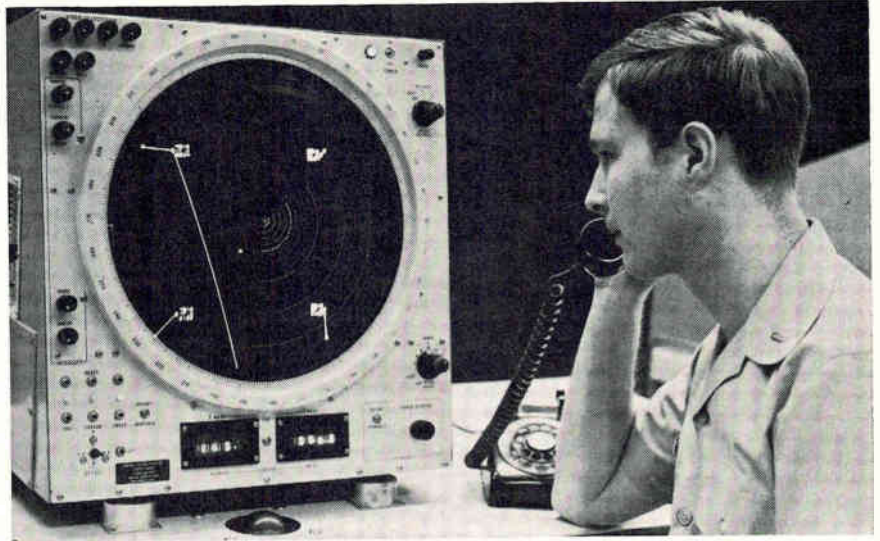

Screen test. Computer-interfaced display reads out range, bearing to a radar target. Other modes: map drawing, data display.

650 pounds, consumes 1,800 watts, and has a mean time between failures of only 120 hours. The Totalscope, by comparison, weighs a mere 94 pounds, consumes 280 to 400 watts, has an MTBF of 1,500 to 2,000 hours, and has extensive self-test features, which augment its modular construction to yield a 15-minute mean-time-to-repair figure. The new display also is battlefield rated, and has passed severe shock, vibration, temperature, humidity, and altitude tests, as well as a stringent r-f interference test.

**Choice.** It operates in either of two configurations, radar or management. Changeover, which involves switching certain functional modules as well as the modular, plug-in front panel, takes less than an hour.

In the radar mode the display may be used as a simple plan-position-indicator repeater that has been augmented by the addition of alphanumeric, vectors, and processed track information. It may be interfaced with any computer from a PDP-8 to a 7090 to derive readout of point-to-point range and bearing or x-y offset. Also, it produces light-gun editable alphanumeric tags for targets or waypoints selected from the 4,096-by-4,096 matrix which corresponds to the crt face and organizes the display of synthetic data.

When set up in its management

configuration, the display uses a 30-key data control unit for instruction inputting. A key sequence, or an individual key, can create up to 64 instructions, defining the display operation that's to be superimposed on the computer's software instructions. The display can mix and match graphics with alphanumeric and special symbology. Up to 2,560 alphanumeric, with a character size variable between 50 mils and  $\frac{3}{8}$  inch, or 360 hand-drawn line segments, can be displayed with flicker-free, 30-hertz refreshment.

Both configurations have a cursor displacement and rotation capability, and can accurately offset the display center up to 512 nautical miles. Each also includes instantaneous return to center or return selected point for the cursor, the ability to slew selected points, data blocks or line segments with the light gun, and to flash any such selected elements at a variable rate. The display is as versatile as the software of its associated computer, and even so inexpensive a computer as the PDP-8—can put it through a wide variety of paces.

### Red eye

It is generally agreed that, unlike crt displays, the potential of solid state light-emitting diode arrays for compact, portable, battery-operated displays is enormous. A step



toward that potential has been taken by Hewlett-Packard Laboratories in Palo Alto, Calif. with the announcement of an all-semiconductor matrix display.

It is a rectangular matrix of 32 by 50 gallium-arsenide-phosphide diodes offering full graphic and symbolic capability (anything that can be realized with a dot pattern—alphanumerics, mathematical symbols, pictures) where the memory is built into the display. Thus, both memory (latch semiconductor output driver) and diode share the same current, a condition that offers better utilization of input power. The circuit also provides a diode output level adjustable between 10 and 25 foot-lamberts, so that minimum power can be used depending on ambient light conditions. Moreover, since all memory circuits are integrated into the diode module and are compatible with standard transistor-transistor-logic switching circuits, H-P's unit can be interfaced directly with computers, keyboards, and tape recorders.

**Reducer.** This built-in storage leads to reduced requirements for the external buffer refresher memory and scan converter. Costly buffer circuits can be eliminated entirely or greatly simplified. Each image element also has storage capability, including selective write and erase, so that a great variety of operation modes are available: line-by-line scan in any direction, selective write and erase, diagonal write patterns and so on. In addition, since the display is built up with individual diode bars—each one a 32-diode line—arrays as large as needed can be attained.

Because the memory drive circuit is integrated with the diode, power can be conserved. Since the on current flows through the light-emitting diode, the access logic can be turned off after the storage is in the latch. By contrast, in a conventional flip-flop, part of the power flows through the other half of the flip-flop, so that full power must be supplied throughout the addressing cycle.

**Throw-in.** Furthermore, the use of an npn and pnp transistor pair



Snooping. Output drive latch means better use of input power in this light-emitting-diode matrix.

in the diode drive circuit requires only a 30% increase in chip area and, therefore, gives a storage element almost for free. Besides, the memory and npn-pnp latch allow high-speed random access to the diode. Write times are 180 nanoseconds within a diode module and 125 nsec between modules. Erase time is always 100 nsec. Thus, a complete frame of 1,600 elements can be written in 5.76 microseconds, while a tv-size panel binary display can be generated in less than 50  $\mu$ sec. Also, 10,000 to 20,000 picture frames per second could be generated, and completely random address—jumping from element to element—can be accomplished in less than 200  $\mu$ sec.

In fact, with this new generation of displays, the operation time of the display, long a bottleneck in write/erase systems, instead may require faster computer interface circuits to fully realize display capabilities.

## Advanced technology

### Breaking the bubble

Surprising though it may seem, Bell Laboratories isn't the only research organization active in magnetic bubbles. True, Bell is hoping to use the bubble technique to provide low-cost, high-density switching and memory circuits.

And it's busy getting great mileage out of its research—which indeed is extensive—by trotting out at conferences its well-known color movie showing the bubble domains running around their magnetic circuits. Other companies have been processing magnetic domain materials for decades (IBM, Sperry, MIT's Lincoln Lab). And magnetic domains in motion—what Bell's system is all about—is no recent invention. In fact, Autonetics has been in the magnetic oxide business since 1961.

Now from its Materials Research Laboratory in Anaheim, Calif., Autonetics is first to disclose that it has successfully grown magnetic bubble epitaxial films. What's more, Autonetics is using the magnetic oxides—in particular the garnets, of which yttrium indium garnet is one—which are better suited to bubble domain devices than flux-grown orthoferrites, the process and material Bell has been banking on. Autonetics deposits YIG on the nonmagnetic substrate gadolinium gallium garnet (GGG). This combination was originally used for microwave magnetostrictive delay lines, but now is paying off in high-quality magnetic bubble material that could mean a new approach to magnetic domain circuitry.

**Down garnet path.** Autonetics is confident that the garnets, not the orthoferrites, are the way to go for good bubble material. For one thing, the garnets (especially YIG) are much less sensitive to changes in temperature—a particularly severe problem with the orthoferrites. Their bubble diameter and mobility are highly dependent on temperature, which limits device stability. The orthoferrites probably will require temperature-stability control in actual system operation, a process that devices built with the garnets may well avoid. Also, since the garnets have a low anisotropy constant, and mobility is inversely related to anisotropy, the garnets should offer greater mobility than the orthoferrites. This leads to faster circuits and decreased power requirements.

Besides choosing the garnets, Autonetics favors epitaxial films of

June 8, 1970

## Electronics Index of Activity

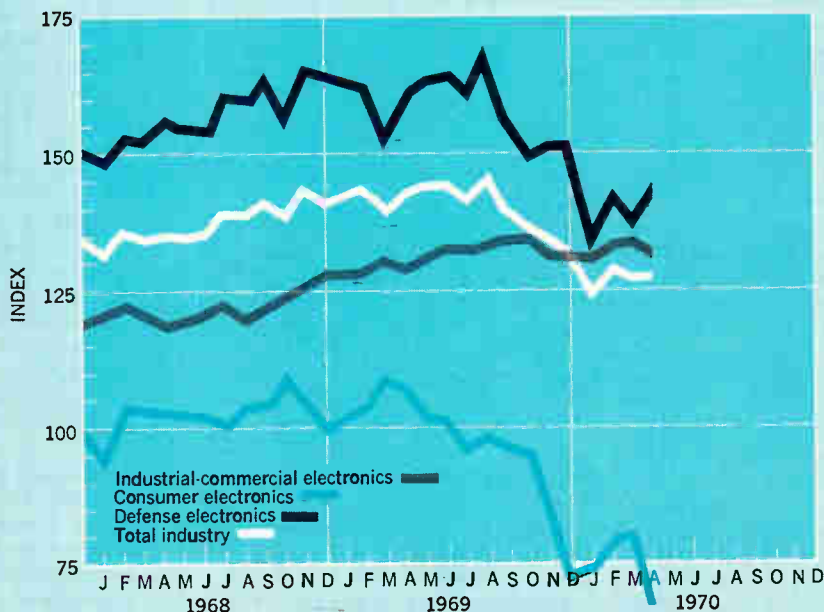

Segment of Industry	Apr. 1970	Mar. 1970*	Apr. 1969
Consumer electronics	67.5	80.4	107.1
Defense electronics	144.7	139.0	165.3
Industrial-commercial electronics	132.7	134.6	130.9
Total industry	127.8	127.5	131.4

Electronics production resumed its climb in April after the slight dip of March. All it took was 0.3 index point to do the job—to 127.8 from March's downward revised 127.5. To add to the rosy look, the total was off just 3.6 from the year-ago figure, the smallest year-to-year gap since last November.

While two of the three components in the index dropped last month, the increase in the third more than made up the difference. Consumer electronics was down for the first time in four months, and it was down with a vengeance—12.9 points. This was the sharpest decline in consumer activity since the 18.7-point slide of June 1967. Industrial-commercial production was down 1.9, its first decline in five months, while the defense sector rose sharply 5.7 points

Indexes chart pace of production volume for total industry and each segment. The base period, equal to 100, is the average of 1965 monthly output for each of the three parts of the industry. Index numbers are expressed as a percentage of the base period. Data is seasonally adjusted.  
\* Revised.

those materials on a suitable substrate over the bulk single crystal material grown by the flux method that Bell is using. With flux growths it is difficult, expensive, and time-consuming to realize high-quality material. To date, using flux methods, crystals up to only 1 square centimeter have been routinely grown. And even with these, flux inclusions are always present—they are difficult and expensive to remove.

Another problem with flux-grown bubble materials is that homogeneity is extremely difficult to achieve. For a magnetic bubble material to be useful it must contain mixtures of the rare earths. This means that ions of different sizes must be incorporated into the material. To solve this problem with flux methods requires very large melts—50 pounds; the good samples must be chipped out.

This isn't the case with thin-film epitaxial growths, which offer great control over dopants. Using chemi-

cal vapor deposition (CVD), Autonetics has been able to modify its very thin YIG films to produce extremely homogeneous bubble material in film thicknesses from 1 to 50 microns; the GGG substrate then provides the mechanical strength. These films, because they are so thin, provide a high bubble density—up to several million bubbles per square inch. Since the average diameter of a bubble is approximately 1.2 times the thickness of the film, the thinner the magnetic film the smaller the bubble, and the greater the bubble density. Although it has built no shift registers yet, Autonetics says that with its new material it can easily get 2.5 million bits per square inch.

But density is not the whole story. Autonetics film growths not only save time—a few hours compared to a few weeks for flux-grown film—but the films can be used as grown. Bulk growths, by contrast, require a great deal of post-growth processing. Further-

more, epitaxial growths can use lower quality starting materials than bulks and still achieve the required final material purity. This should go a long way toward reducing the costs of bubble material fabrication and hence eventually lower the cost per bit. Ultimately, this will be the only parameter that will convince systems memory designers of the value of using the magnetic bubble technique instead of MOS approaches.

### Government

#### Informer

The Federal Bureau of Investigation wants to spend \$795,000 in fiscal 1971 on fingerprint automation research—nearly four times the \$200,000 annual outlay since 1967. The FBI request points up the increased importance of an accurate scanning system to law enforce-



NEW from UNITRODE  
**INDUSTRIAL ZENERS**

**Armored in glass...  
 5 times the surge  
 protection of plastic**

**20¢**

**High-volume production economies mean  
 typical Unitrode fused-in-glass reliability  
 in 1 Watt and 5 Watt families  
 at the price of plastic.**

**Order your free samples today.**

- 1 Watt family starts at 20¢ each in 100 K lots. Comparably low prices on 5 Watt and smaller quantities.
- Fills the need for quality zeners in the 750 mW to 5 Watt range.
- Voltage range from 6.8 to 200 Volts.
- Smallest size and weight in the industry.
- Low impedances to insure sharp knees.

IN STOCK READY TO DELIVER NOW • WRITE ON YOUR LETTERHEAD FOR FREE SAMPLES AND DATA SHEETS

**TOUGH AS ALL GET OUT FROM THE INSIDE OUT**  
 With the silicon die metallurgically bonded between terminal pins of the same thermal coefficient, the hard glass sleeve is fused to the entire outer silicon surface. Result — a voidless monolithic structure.



*For Fast Action call Bud Anderson collect . . . today!*

A product of the wide ranging semiconductor technology of

**UNITRODE**



580 Pleasant St., Watertown, Massachusetts 02172 (617) 926-0404

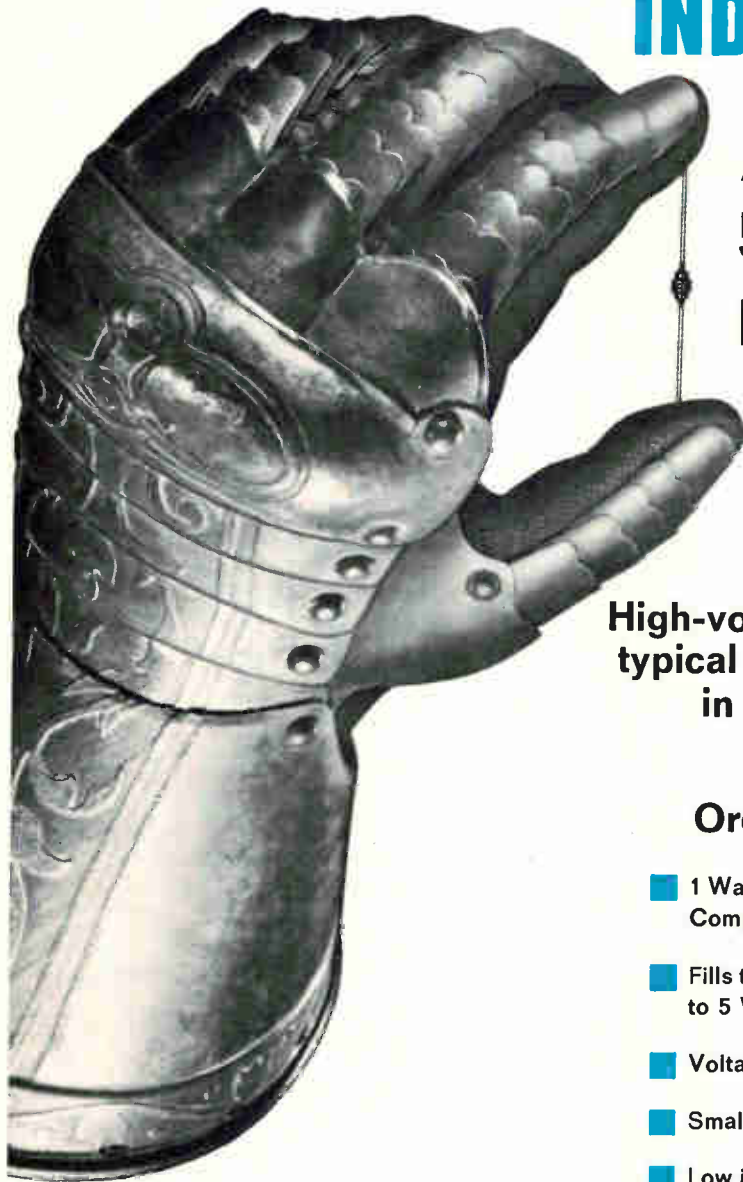

1N4736 Series — 1 Watt  
 UZ8706 Series — 1 Watt

Actual Size



UZ4706 Series — 5 Watt  
 UZ4806 Series — 5 Watt

Actual Size





## U.S. Reports

ment agencies around the U.S.

FBI Director J. Edgar Hoover told the House Appropriations Committee that the agency plans a \$350,000 contract for development of a prototype electronic fingerprint reader. Prime contenders for the system are said to be the Autonetics division of North American Rockwell and Cornell Aeronautical Laboratories. Both have performed engineering feasibility studies for the FBI [*Electronics*, March 30, p. 52].

Hoover says the prototype reader will scan a fingerprint and generate a numerical code from the print, to be matched with computer-stored prints for identification. Joseph Wegstein, manager of a National Bureau of Standards fingerprint research program in conjunction with the FBI, says a high-speed, parallel-processing device must be developed for comparing prints so that the computer does not have to run through the FBI's entire fingerprint file—containing some 195 million prints—each time it makes a search. Print matching now is a programming function. The FBI also plans \$165,000 in contracts for overall systems development of the scanner, including a matching and classifying system.

**Reading quality.** Problems in developing an electronic reader—which the FBI thinks can be overcome—include low contrast quality due to variations in ink application, and distortion caused by skin elasticity. Current technology allows a computer to read the number and relative location of ridges, which average about 75 to a finger, but it cannot compensate for significant distortions.

When fingerprint scanners are developed to the point where results of a scan can be transmitted from computer to computer, says Charles Rogovin, administrator of the Justice Department's Law Enforcement Assistance Administration, fingerprints will replace the 18 to 20 personal descriptors now required to identify an offender in LEAA's criminal history data bank [*Electronics*, April 27, p. 115].

Other applications will be in police investigation divisions, which

are responsible for taking prints at the scene of a crime. The commercial market, however, would be small—sources say a police department would need only one, or at most two, fingerprint scanners for identification operations.

### Radar

#### Weather eye

A weather radar system that employs a central computer to predict rainfall across several large areas is being tested by the Environmental Science Services Administration. It's the first step in a plan to conserve rainfall in the parched Southwest.

This system employs the WSR-57 radar. It also was used in the system that successfully proved last year at the National Severe Storms Laboratory at Norman, Okla., that radar could be used to record location and volume of rainfall. This year, however, a digitizer and a data recorder have been added, so that the system can be interrogated by a central time-sharing computer every 15 minutes via telephone lines. Working with the NSSL is another agency, the Weather Bureau's Office of Hydrology, which will use the data to develop flood-prediction techniques.

The time-sharing computer, in turn, will be used to predict the course and rainfall rate of storms within a 100-mile radius of the radar installation. With the system, says Kenneth Wilk, an NSSL radar scientist, researchers will be able to study areas as small as a single watershed or a single storm.

After finding out where the rain falls, the hydrology office eventually hopes to develop techniques to control the valuable precipitation and thus save it for use in Oklahoma. According to NSSL, the radar will play a major role in collecting the data because it monitors rainfall in a 30,000-square-mile area. When calibrated with rain gages during operation, the agency adds, the measurement is more accurate than is possible under either technique.

### Computers

#### Phoneme phenom

What with its ability to read, write, and do arithmetic, you might expect a computer to talk more than it does. Unfortunately, a computer—or actually its peripheral voice-response unit—has a very poor memory for spoken words; vocabularies are small and difficult to change.

But a voice-response system being developed by the Multiplex Systems division of the Instrument Systems Corp., Huntington, N.Y., could alter this picture by providing vocabularies that can be varied by changing software, rather than hardware. In addition, the system stores the basic word units digitally in a read-only MOS memory, instead of typical analog fashion—magnetic tape or film.

**Audience.** The result is an all-solid-state unit whose voice can be multiplexed over telephone lines to hundreds, if not thousands, of users, according to Martin Slavin, Multiplex Systems' president. He says that the company began thinking about the technique while it was working on the passenger entertainment system for the Boeing 747.

The machine can be programmed to respond to questions posed via an ordinary pushbutton telephone regarding whatever information is stored in the user's computer. And the telephone might also be used as a remote terminal for entering data.

Slavin's machine is flexible, he says, because it stores phonemes, rather than the specific words or phrases stored by the usual voice-response machine. Phonemes are the basic component sounds, or frequency patterns, or words—the smallest unit of speech that distinguishes one utterance from another. There are something like 44 phonemes in English to form all the words in the language. (Actually, a few more basic sounds are needed to handle certain sounds that affect each other in undesirable ways when uttered in sequence.) Using something like 60 phonemes, the machine could

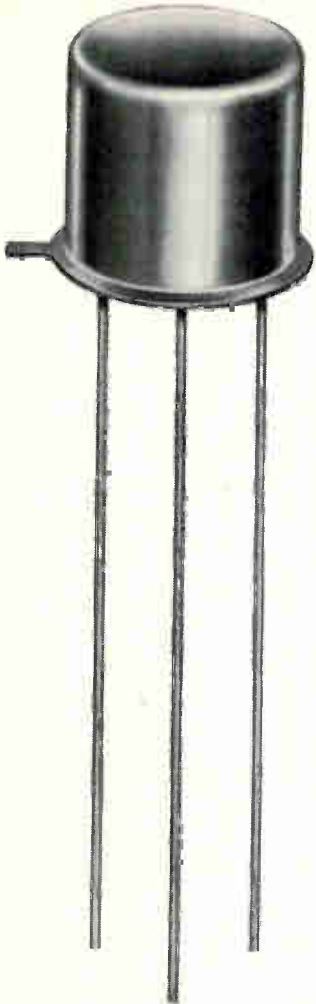

# 24¢

## INDUSTRIAL SCR's



**Only last month  
you couldn't touch  
an SCR in a  
metal package  
for anywhere near  
the price of plastic**

### ID 100 Series

Anode current rating 500mA @ 100°C Case.  
Voltage ratings to 200V.  
200µa max gate trigger current.  
Peak On-Voltage 1.7V max @ 1 Amp.  
TO-18 can with 0.5" leads.

(SSPI Product Group)

**Now you can . . . .**

### ID 200 Series

Anode current rating 1.6A @ 70°C Case.  
Voltage ratings to 200V.  
200µa max gate trigger current.  
Peak On-Voltage 2.2V max @ 4 Amps.  
TO-5 can with 0.5" leads.

(SSPI Product Group)

■ Sensing types start at 24¢ each in 100K lots. Comparably low prices on control types and smaller quantities.

■ Typical Unitrode quality . . . from the people who introduced the first lead-mounted SCR's 12 years and millions of SCR's ago.

■ Electrically equivalent to most widely used plastic devices.

■ Used for lamp or relay driving, sensors, pulse-generators, timing circuits, motor controls, and process controllers.

IN STOCK READY TO DELIVER NOW • SEND FOR YOUR FREE SAMPLES AND COMPLETE SPECS

*For Fast Action call Pete Jenner collect . . . today!*

A PRODUCT OF THE WIDE RANGING SEMICONDUCTOR TECHNOLOGY OF

# UNITRODE



580 Pleasant St., Watertown, Massachusetts 02172 • (617) 926-0404

## U.S. Reports

be made to speak in English, French, Italian—any major Indo-European language—says Slavin. It all hinges on the programing which compiles the phonemes in the proper order.

**No synthesis.** The unit is not a speech synthesizer, constructing speech purely from computer data, says Slavin [*Electronics*, Sept. 29, 1969, p. 54]. Rather, to load the memory in Slavin's machine a human voice recites a word group containing all the phonemes. The frequency pattern in these words is immediately converted to eight-bit digital equivalents.

Each basic sound is processed digitally using a special technique, for which patents are pending, that strips out the redundant or repetitive frequencies and leaves the minimum information that's needed, according to Slavin.

The company is now readying a production prototype and hopes to be in production by the end of the year. A basic machine, selling for under \$15,000, will come with enough compiling memory for 50 words; programing for additional words is available in 100-word increments. And any of the words can, of course, be altered by reading in a new program. Extra two-way phone interface channels can also be added. The program or compiler read-write memory will also be made of MOS devices. Multiplex Systems is evaluating 4,096-bit devices supplied by several manufacturers.

### Contracts

#### Sanders vs. Navy

Once upon a time there was a military electronics corporation that lived in a small New Hampshire town. One day in 1966, it was asked by the Navy, "Can you design and build us some secret airborne electronic countermeasure equipment?" And the corporation, Sanders Associates, said it could. "Good," said the Navy, "here's a letter contract."

Thus did Sanders start the grim and unprofitable story known as the AN/ALQ-100 program. It de-

signed, built, and delivered on time equipment whose performance made the Navy very happy when it frustrated ground-based radars in Southeast Asia.

However, Sanders became frustrated, too. It now has the Navy in the U.S. Court of Claims in Washington trying to collect some \$5 million, an amount it alleges was an agreed profit.

**The issue.** Though the elements of the tale reverse the better publicized pattern of contractor cost overruns, late delivery, and performance below specification, the issue in the trial scheduled to begin July 7 is far more intriguing. In the words of one source close to the case, the issue is: "What should the earnings be for a contractor that does a good job?" Is it entitled to more than 6% net when it responds with superior hardware?

The equipment in question has been delivered to the Naval Air Systems Command and been installed in A-4, A-6, and A-7 Navy attack planes. And the court already has ruled that the Navy may not challenge the ALQ-100's performance. The package receives enemy radar signals, warns the pilot his aircraft is being painted by radar, and then time-delays recorded signals and returns them to the enemy site to confuse the system as to the aircraft's location.

Two years following Sanders' receipt of its letter contract for the system in 1966, according to court records, Rear Adm. Robert L. Townsend of the Naval Air Systems Command offered to change the contract to a \$140 million fixed-fee award that would guarantee the company a 10% return on its sales. Sanders agreed to the terms, provided that Adm. Townsend would vouch for the Navy's acceptance of the contract.

This agreement, the record shows, was put into the form of a "memorandum of agreement," but a few months later there was a new catch. The chief of Navy material, who according to Navy regulations has the right to reject contracts over \$5 million, refused to approve because the rate of return was too high.

**In the red.** The breakdown of negotiations hurt Sanders badly that year. Because the Navy funds weren't coming in, the company alleges, it had to dip into corporate funds to keep the program in operation. Even after the Navy started paying the cost component of the contract, Sanders posted one of its first deficits in its first quarter 1969 report because the Navy refused to pay the kind of profits the firm had expected.

So Sanders filed suit in early 1969 for the \$5 million difference between what Adm. Townsend had agreed to pay and what the Navy had in fact paid plus \$10 million for additional units the firm says the Navy ordered. The Justice Department, which represents the Navy, countered by stating that the Navy had paid Sanders \$127-million for the cost of the equipment and a \$7.68 million fee. That fee represents a 6% return—all that a defense contractor deserves, the Justice lawyers contend.

In the preliminary legal jousting that always precedes this type of trial, Sanders appears to have done well. The Court of Claims, denying a government motion, indicated that it would reject the government claim that the Sanders contract was terminated, which under armed services procurement regulations would entitle the firm to a 6% return. Later, a court commissioner issued an order that prohibited the Navy from challenging the quality or effectiveness of the equipment because it tarried in carrying out earlier court orders.

What the court must now decide is the worth of performance in government contracting. Sources close to the case say a decision is expected between Labor Day and Thanksgiving.

### Splitting

It was just eight months ago that an MIT panel recommended that the Charles Stark Draper Laboratory, formerly the Instrumentation Laboratory, would accept no more weapons contracts and would turn its attention to social problems. At the same time, MIT announced



# tektronix® expands the 7000 series

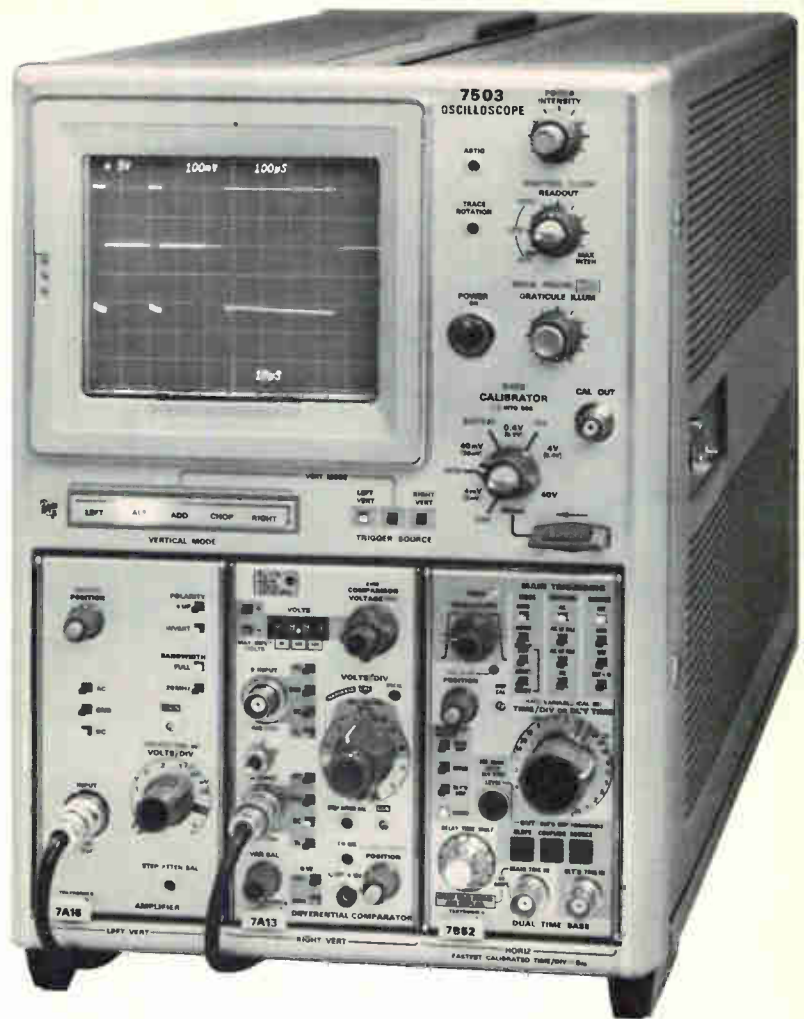

## New Three-Plug-In Mainframe New Dual Time Base Plug-In

A third mainframe and a fifth time base are added to the growing 7000-Series. The **NEW 7503 THREE-PLUG-IN OSCILLOSCOPE** offers bandwidths up to 90 MHz, depending on the plug-in selected. The **NEW 7B52 Dual Time Base** features four sweep modes: Main, Intensified, Delayed, and Mixed. The Mixed Sweep is **CALIBRATED**, allowing you to **MEASURE . . . not just MONITOR.**

Simultaneous measurements can be made by multiple plug-ins with widely different features. Some of the features of the fourteen plug-ins currently available are: dual-trace, 75 MHz at 5 mV/div (four-trace, 75 MHz with two units) • differential, 100,000:1 (100 dB) CMRR at 10  $\mu$ V/div • differential comparator, 75 MHz at 1 mV/div and comparison voltage accurate to 0.1% • random or sequential sampling, 25-ps risetime (depending upon the sampling head) • two single-trace amplifiers, 90 MHz at 5 mV/div • current amplifier, 75 MHz at 1 mA/div.

For faster and easier measurements, Auto Scale-Factor Readout, which is exclusive to Tektronix, labels the CRT with time/div, volts or amps/div, invert and uncal symbols, and automatically corrects for 10X probes and magnifiers. All the data is on the CRT, where you need it, for faster measurements with fewer errors. And, looking into the future, the readout system is designed to meet needs other than of today's plug-ins.

The CRT display above is just one example of the flexibility and measurement ease that is **YOURS** when you use an oscilloscope that features Auto Scale-Factor Readout and dual vertical amplifier plug-ins. Pulse width, period, amplitude, and aberrations are all quickly measured in **ONE** display by applying the same signal to both amplifiers. With the 7B52 Time Base in the **MIXED** mode, two different

sweep speeds are displayed simultaneously—the first 4 div at 100  $\mu$ s/div, the last 6 div at 10  $\mu$ s/div (the delay time multiplier control can be rotated to start the faster sweep at any point on the main sweep). The DC offset feature of the 7A13 Differential Comparator Amplifier is used to obtain the bottom trace. With a deflection factor of 100 mV/div, the pulses are effectively 100 divisions high, giving the resolution needed to detect aberrations and precisely measure pulse amplitude of  $-9.91$  V (accurate to 0.1%).

For *even greater versatility*, 2 four-plug-in mainframes are available, the 7704 (150-MHz) and 7504 (90-MHz) Oscilloscopes. The 7000-Series does not require a full complement of plug-ins, you can start with only one horizontal and one vertical plug-in and add more as your measurement requirements change. When your plans call for the purchase of a new oscilloscope, evaluate the Tektronix 7000-Series . . . it's **EXPANDABLE.**

Your Tektronix field engineer will gladly demonstrate the complete **VERSATILITY** of the New Tektronix 7000-Series Oscilloscope System, in **YOUR** lab with **YOUR** signals. Contact him locally or write: Tektronix, Inc., P. O. Box 500, Beaverton, Oregon 97005. See your 1970 Tektronix catalog for complete specifications.

Prices of instruments shown:

7503 — 90-MHz, Three-Plug-In Oscilloscope . . . . .	\$1775
7A16 — 90-MHz, Single-Trace Amplifier . . . . .	600
7A13 — 75-MHz, Differential Comparator Amplifier . . . . .	1100
7B52 — Dual Time Base . . . . .	900

U.S. Sales Prices FOB Beaverton, Oregon  
Available through our new leasing plan.



**Tektronix, Inc.**  
committed to technical excellence

# SCIENCE/SCOPE

A high-speed digital MODEM transceiver -- one of the smallest, lightest, most versatile in the defense communications field -- was delivered to the U.S. Air Force recently by Hughes. The 70-lb. MODEM (modulator-demodulator) replaces a current 250-lb device. It transmits or receives 1200 or 2400 digital bits per second in a narrow frequency range over normal telephone circuits, and will be used in conjunction with military computers, teletypes, radars, and other sensors.

Switzerland's computerized air defense system -- built in California by Hughes but code-named "Florida" by the Swiss -- has been accepted and put in operation. It consists of several radar stations that provide simultaneous range, bearing, and height data to the high-speed Hughes computer, nerve center of the system. Should a target be identified as an immediate threat, the commander can request all-weather aircraft or surface-to-air missiles to intercept and destroy.

New uses for lasers developed by Hughes include cutting clothing patterns for Genesco, Inc., Nashville garment manufacturer; prototype of the computer-controlled system can cut different patterns singly from a variety of materials much faster than a blade...and trimming thick or thin film resistors with a laser resistor trimmer that can cut nichrome, gold, chromium, and tantalum films as well as standard inks; its single Q-switched laser is split and distributed to as many as four individually controlled trimming stations.

Three custom-designed calibration vans, first of their kind, have been delivered to the U.S. Navy by Hughes. The mobile vans conform to interstate highway requirements and will be driven to the dock to calibrate the Pacific fleet's electronic and ordnance equipment -- eliminating the present expense of removing ships' equipment to land-based laboratories and substantially reducing down-time.

Current programs at Hughes Research Laboratories include: 1) Study of the physics and applications of low-voltage gas discharges. 2) Study of "double stream" plasma instabilities, noise generation in plasmas, and behavior of plasmas in crossed electric and magnetic fields. Physicists or electrical engineers with experience in solid-state microwave are needed. Accredited degree and U.S. citizenship required. Please write: Mr. Al J. Simone, Hughes Research Laboratories, Malibu, California 90265. Hughes is an equal opportunity employer.

New MOS products from Hughes include: a low-threshold-voltage discrete device for bilateral switching of signals in low-impedance lines...a triple 66 dynamic shift register combining more than 1200 MOS devices into a monolithic array... an ion-implanted, dual 64-bit two-phase dynamic shift register for data handling at a rate of 10 MHz...a dual 16-bit static shift register than allows direct interface at data input/output terminals with TTL/DTL bipolar circuits.

A new, all-electronic mass memory device developed by Hughes promises to make computer information processing faster, simpler, and more efficient. Trademarked DYNABIT, it stores vast quantities of information on magnetic wire thinner than a human hair. It has no moving parts, can withstand severe environmental conditions, and can be adapted to new or existing computer applications.

Creating a new world with electronics

**HUGHES**

HUGHES AIRCRAFT COMPANY



## U.S. Reports

Draper's retirement as lab director and replacement by Charles L. Miller, head of the Urban Systems Lab. Now MIT president Howard W. Johnson has ordered a two-step program to make the lab a separate corporate entity with its own board—and with Draper himself as board president pro tempore.

The reason is that little money has been found for social programs, and Johnson concluded that the lab could not operate under the panel's restrictions without layoffs and "loss of capability."

**Moving out.** The first step, effective June 1, establishes the lab as a separate division within the school. The board has complete responsibility for the division and has the authority to undertake new contracts. In the second step the lab will be made independent of MIT, but whether the lab will be a private nonprofit corporation, a division of another, or otherwise, is not yet known.

Since the lab is now a separate division of MIT, the prohibition on weapons work doesn't hold any more, says Draper. Although it wasn't able to bid on weapons contracts for several months, the restriction didn't hurt because the lab now holds many long-term contracts. "An element of uncertainty was introduced," says Draper. "but that's settled now."

However, MIT stands to lose the \$5 million a year it received from the Government for indirect expenses connected with the lab such as bookkeeping, legal fees, and such. For example, the expenses of the MIT library are a function of the number of people who use it, and the 600 professionals at the Draper Lab are included in that number. Similar expenses will continue but the school will no longer receive money to help defray the cost of services provided for Draper Lab personnel.

**Confident.** Once independent, the Draper Lab will have to build up its own legal department, among others, and this may be an added expense. Draper doesn't think the lab has to worry about pricing itself out of business, however. "We've never been competitive," he says, "we've always been so far

ahead there's never been any competition. With our background, we ought to be ashamed if we can't keep up."

As for the lab's prospects once it becomes independent, Draper says, "The lab is healthy; people here are happy about our status now. We have ideas and contracts. We may not only survive but expand. I feel the lab has plenty of creativity and vitality; even in the troubled waters of today we can swim pretty well."

### Integrated electronics

#### Find

An integrated circuit that could be as ubiquitous as the operational amplifier is being manufactured at the General Electric Integrated Circuits Project. The circuit is a threshold detector that can be used for such diverse applications as low-voltage relay driving, thyristor triggering, lighting, temperature or humidity control, square-wave generation, or level detection.

Up to now, such functions have had to be performed by a cardful of discrete components, usually incorporating a unijunction transistor.

GE is packaging the chip—the company calls it Accu-switch—in a hermetically sealed TO-5 can with four leads. They're currently available in sample quantities at \$5 apiece, and GE has at least one major customer, a manufacturer of industrial control equipment. If the market turns out to be as large as GE expects, the IC will be made in a plastic-encapsulated version.

**Trigger.** Essentially, the Accu-switch performs as a Schmitt trigger; it turns on at a voltage equal to 0.6 of the supply voltage. However, unlike the usual Schmitt trigger, the Accu-switch has a high input impedance and therefore doesn't load the driving circuit. The threshold voltage is immune to power supply and temperature variations—the threshold voltage varies less than 0.1% regardless of changes in conditions. The circuit operates from supply voltages rang-

# A lot of people are saying Hughes is into a lot of things

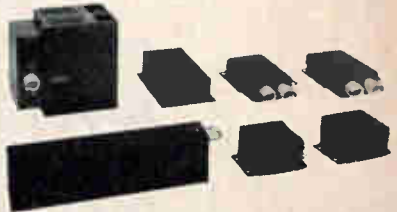
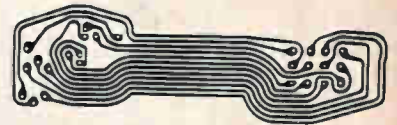
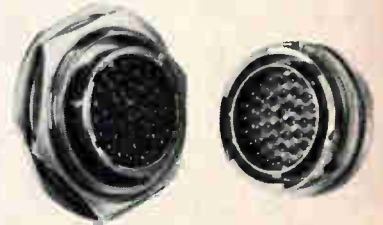

## A lot of people are right.

And with good reason. Hughes makes better electrical connectors (RS 287), flat flexible cable and circuit assemblies (RS 288), direct view storage and scan converter tubes (RS 290), display systems (RS 291), and multiplex systems for remote communications/control (RS 292).

### HUGHES

HUGHES AIRCRAFT COMPANY  
INDUSTRIAL ELECTRONICS GROUP



## U.S. Reports

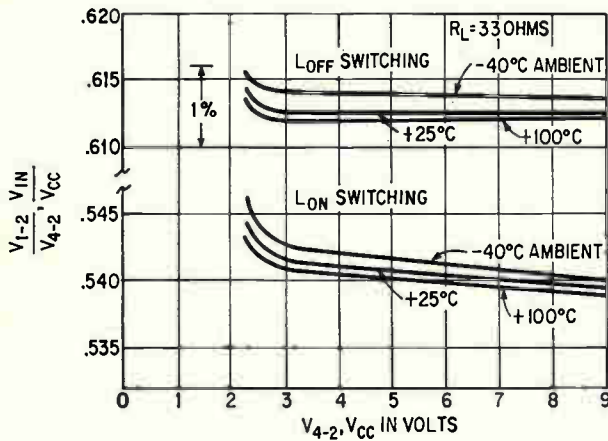

Steady. Switching voltages are extremely stable with respect to variations in power supply voltage and temperature. The threshold drift is considerably less than 1% for the Accu-switch.

ing from 2.3 to 9 volts, and is therefore directly compatible with standard battery voltages and bipolar logic power supplies.

Functionally, the circuit consists of a differential amplifier, a reference voltage source, a hysteresis stage, and an output stage. The hysteresis stage assures that the circuit won't be turned off unintentionally; typically, the voltage must drop at least 10% below the threshold before the circuit will turn off. The output stage provides currents up to 250 milliamperes, and thus can drive such loads as lamps and relays directly.

## Companies

### Another other

Everyone knows why General Electric in effect sold its computer business to Honeywell—the business simply wasn't making money. But in sorting the dozens of unanswered questions generated by the deal, one comment from a GE manager perhaps sums it up best:

"I expect that in five years there will be only three big, across-the-board computer makers: IBM, Univac, and the new GE-Honeywell company. The rest will be making special systems or will be zeroed in on particular market segments."

**Unloading.** While top executives of both companies have been muzzled while the deal is squeezed through the wringer of corporate and Justice Department approval, one Honeywell insider says that

there will be a separate subsidiary with its own board of directors. Another says Honeywell liked the purchase—it got 81.5% for its \$110 million plus 1.5 million shares of common stock—partly for image reasons. "Although in the pre-1960 era, Honeywell sold large mainframes, it didn't scale them up as the 1960's proceeded. It concentrated on a lucrative market for what now are considered to be medium-sized computers, and only recently installed the first of its 4200's and 8200's."

Old GE hands feel that GE sought out Honeywell. They explain that the GE board has been dissatisfied with performance—both sales and electronic—of the company's large machines and brought constant pressure on Chairman Fred J. Borch to either turn the operation around or sell it. There also have been rumors of unhappiness inside GE with the 600 line, though a spokesman says that early software problems have been licked.

In any event, it's pretty much agreed that Honeywell is basically buying two items—GE's 600 line and its European operations. The question remains, though, whether Honeywell's response is going to be a GE or Honeywell mainframe; some feel that Honeywell has simply bought lots of purchase orders for its own computers and will discontinue the 600 line.

**Side by side.** Here's how the 600's stack up with the high end of the Honeywell 200 series—the 3200, 4200, and 8200:

▶ The 615, which rents for \$30,000 a month, has a cycle time of 2 mi-

croseconds, an add time of 4  $\mu\text{sec}$ , and a memory capacity of 32,768 to 262,144 words of 36 bits.

▶ The 635, which rents for \$35,000 to \$167,000 a month, has a cycle time of 1  $\mu\text{sec}$ , add time of 1.9  $\mu\text{sec}$ , and a capacity of 65,536 to 262,144 words of 36 bits.

▶ The 655, which rents for \$80,000 a month, has a cycle time of 0.5  $\mu\text{sec}$ , add time of 0.6  $\mu\text{sec}$ , and the same capacity as the 635.

▶ The 3200, which rents for \$19,000 to \$32,000 a month, has a cycle time of 1  $\mu\text{sec}$ , add time of 14  $\mu\text{sec}$ , and a capacity of 131,000 to 534,000 words of six bits.

▶ The 4200, which rents for \$24,000 to \$50,000 a month, has a cycle time of 0.75  $\mu\text{sec}$ , add time of 13  $\mu\text{sec}$ , and the same capacity as the 3200.

▶ The 8200, which rents for \$35,000 to \$80,000 a month, has a cycle time of 0.75  $\mu\text{sec}$ , add time of 1.75  $\mu\text{sec}$ , and a capacity of 262,000 to 1 million words of six bits.

On one point, nobody disagrees: the European marketing moxie that the GE organization will bring to Honeywell. This alone may have been enough to swing the deal, with Honeywell taking over the 600's just to get Europe. With GE's overseas subsidiaries, Honeywell will have engineering, production, and marketing in the Common Market, the sterling area, and the Outer Seven countries. And foreign marketing has been a weakness of Honeywell computer operations. For GE, on the other hand, foreign operations have been its only computer profit area.

As for physical facilities, GE now makes its mainframes in Phoenix, peripherals in Oklahoma City, and does its heavy thinking in New York and Bridgeport, Conn. Overseas, there are plants near Paris and Milan and one in Amsterdam.

## Avionics

### Will B-1 be one?

Will the Air Force ever get beyond the prototype stage with its B-1, the strategic bomber that will replace its aging fleet of B-52's? Of

# TRW X440 Metallized Polycarbonate Capacitors

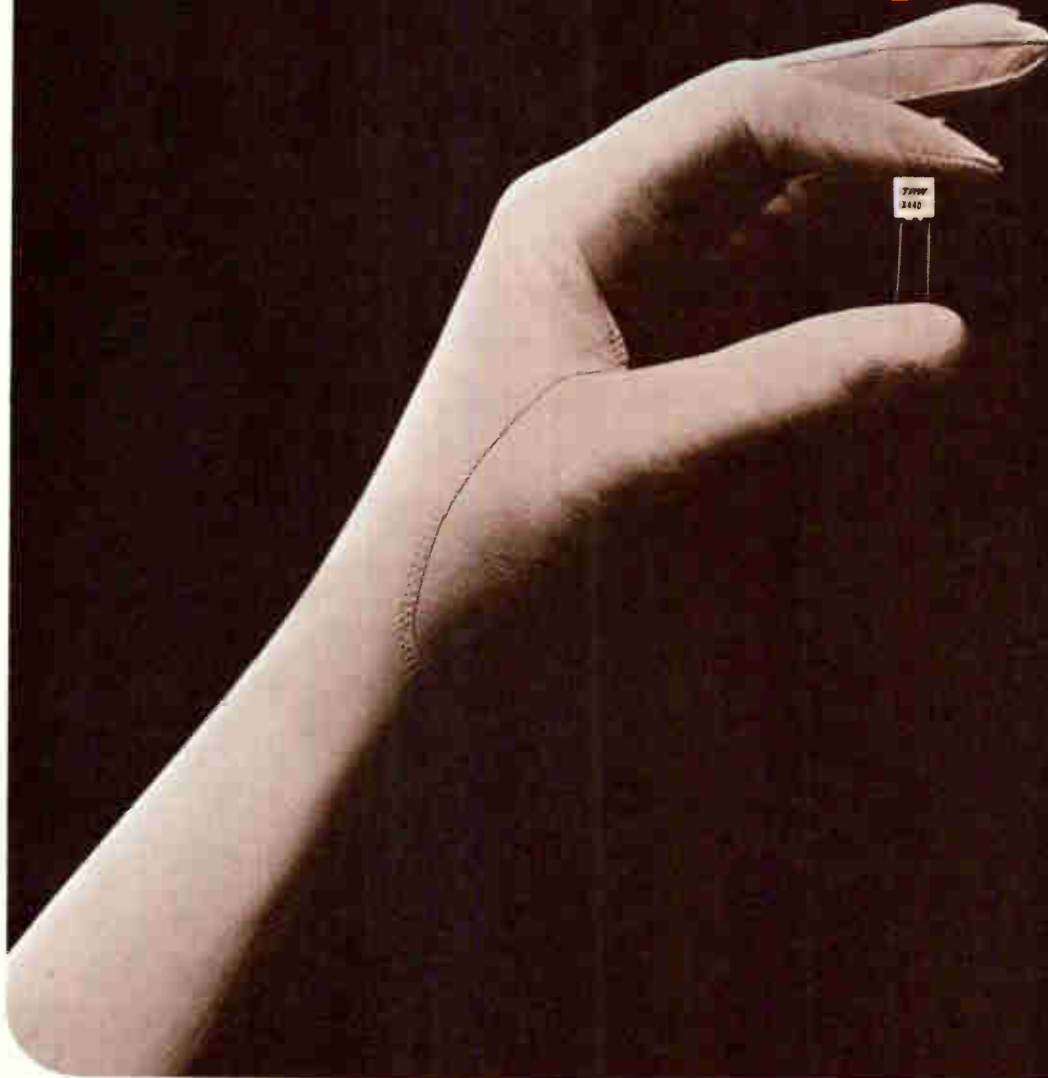

...fit like a glove!

14-75

Stand-out, premium quality in new capacitors that package so efficiently, so "tightly" that they always fit on your crowded printed circuit board!

Precision-dimensioned epoxy cases and precisely located leads take care of the "fit" problem. TRW know-how in metallized polycarbonate materials takes care of your rigid stability

and reliability requirements.

Environmental and electrical performance of the new TRW X440 metallized polycarbonate capacitors is even *better* than before. They're the smallest film capacitor on the market...and they fit like a glove!

Voltage...50VDC; Capacitance ...001 to .10 mfd; Tolerance to  $\pm 1\%$ .

For samples, detailed data and applications assistance, contact TRW Capacitor Division, Box 1000, Ogallala, Nebraska. Phone:(308) 284-3611. TWX:910-620-0321.

## TRW®

# Aces for the Bridge Game

## 1.5 Ampere Single-Phase Silicon Bridges 50 Thru 600 PRV

Immediately available from authorized  
General Instrument Distributors

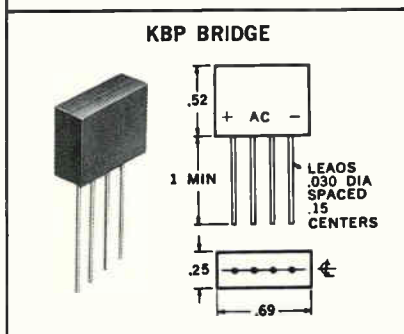
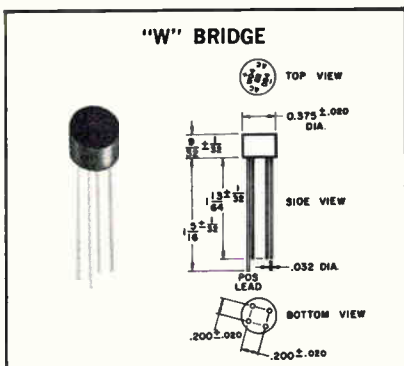

PRV	TYPE	1-99	100-999	1000
50	W005 KBP005	\$ .88	\$ .60	\$ .51
200	W02 KBP02	.93	.62	.53
400	W04 KBP04	.98	.65	.56
600	W06 KBP06	1.03	.69	.58

ALSO AVAILABLE: 3, 5 and 10 Ampere Single-Phase Bridges and 5 and 10 Ampere Three-Phase Bridges.

Write for General Instrument's "Full House" Condensed Catalog and detail bulletins to: General Instrument Corporation, Semiconductor Assembly Division, 65 Gouverneur Street, Newark, N.J. 07104



## U.S. Reports

the political and technological arguments opposing the program, the Air Force finds most difficult to challenge the assertion within Congress that strategic bombers, if not obsolete already, will definitely be of little value in the 1980's when they are finally ready for deployment. Intercontinental missiles, along with a fleet of 76 FB-111 aircraft and the remaining upgraded B-52's in inventory, will provide a sufficient missile backup capability, critics of the B-1 expenditure contend.

Though individual B-1 costs are estimated between \$25 million and \$30 million at a projected purchase of 240 or more aircraft, estimates of the total cost over the system's lifetime could run to \$25 billion or more if the Air Force buys new tankers for in-flight refueling of the B-1. USAF sources acknowledge that present KC-135 tankers would not fulfill the B-1 program's requirements and the service is saying little about the ACT program—an Advanced Capability Tanker system still only on paper.

**Mark 2.** While Boeing topped the competitive list with a price proposal that topped McDonnell-Douglas's technological edge, an in-house Air Force plan to put an austere version of the controversial Mark 2 avionics into the new airframe is likely to generate greater interest. This would appear to lock in North American Rockwell's Autonetics division as principal avionics supplier—some compensation for its low score in the airframe competition. However, Pentagon sources hint that Autonetics may not have that avionics competition locked since the Air Force is entitled to have the prime seek competitive bids on avionics packages redesigned around the original Mark 2.

To quench criticism of the new strategic bomber's cost, a number of Pentagon and Air Force sources believe specifying Mark 2—or variations thereof—can be shown as a money-saving move. First, it would save substantial avionics development money. Second, it would permit the Air Force to show it is able to recoup some of its investment in the costly avionics developed and

then canceled for the General Dynamics F-111.

The Air Force desire to find a new application for the Mark 2 system, one ranking official says, is what led to some published speculation that the service plans to buy off-the-shelf avionics for the B-1—speculation he says is not altogether accurate. "To me, 'off-the-shelf' means available today, and I can't see the point in buying equipment available today for a plane that won't even fly as a prototype for another four years at least." The suggestion is the Air Force will proceed with improvements on Mark 2 while funding at a relatively lower level other avionics now in advanced development in the hope that a high-performance package will be available off-the-shelf when its new bird is ready.

## For the record

**Numbers.** An automatic mechanical telephone dialer has been developed by Robotguard of Philadelphia to replace the interface device required by the Bell System whenever non-Bell telephone equipment is installed. According to David Lipshutz, president of the company, the FU-44 can save the user as much as \$4.60 per month per trunk. This is possible since there is no electrical connection between the non-Bell telephone system and Bell-owned lines.

**Sale.** Boeing is looking for time-sharing customers for its large inventory of computer equipment, valued at more than \$100 million. It has created the Boeing Computer Services division, comprising its computer capabilities at Philadelphia; Huntsville, Ala.; Wichita, Kan.; and Seattle. This is Boeing's first major attempt to diversify as aircraft business sags.

**Credit.** The May Co. will install TRW Data Systems' Credifier 3300 customer credit-verification system in its 17 Southern California department stores [*Electronics*, March 30, p. 50].



# THREE NEW OP AMPS YOU HELPED DESIGN



## AVAILABLE FROM STOCK

These new amplifiers represent three of the best design alternatives emerging from today's technology. They have been created as a result of literally thousands of contacts between you, the op amp user, and Analog Devices' applications engineers. Each is designed to maximize *user value*... that is, the best possible performance at the lowest possible cost.

### LOW COST FET

\$12 Unit Quantities

At just \$12. in unit quantities, the **Model 40** becomes the FET input op amp recommended in nearly all general purpose applications where high input impedance and low bias current are required. Two versions are offered which differ only in initial offset voltage, input bias and difference current, and price. The encapsulated module measures 1" x 1" x 0.5".

### CHOPPERLESS DIFFERENTIAL

0.25 $\mu$ V/ $^{\circ}$ C

Newest in a series of low drift chopperless differential op amps, the **Model 184** gives chopper-stabilized-like performance with the application flexibility of differential inputs, coupled with low cost. The 184 is recommended for an extremely wide variety of high performance applications and promises to become the industry standard for low drift requirements. Three versions are available, differing principally in drift characteristics and cost. Package size is 1.5" x 1.5" x 0.4".

### FAST SETTLING FET

0.6 $\mu$ s to 0.01%

Settling time of just 0.6 $\mu$ sec to 0.01% accuracy makes the new **Model 45** applicable to many high speed/fast settling requirements such as A/D and D/A converters, pulse height amplifiers, etc. Input parameters are characteristic of FET differential input amplifiers. Two versions are available with differing offset and drift specifications. Package size is 1.12" x 1.12" x 0.4".

SPECIFICATIONS	MODEL 40	MODEL 184	MODEL 45
	J   I   K	J   I   K   L	J   I   K
OPEN LOOP GAIN	5 x 10 <sup>4</sup>	3 x 10 <sup>5</sup>	10 <sup>5</sup>
RATED OUTPUT, min	±10V @ 5mA	±10V @ 5mA	±10V @ 20mA
FREQUENCY RESPONSE			
Unity gain, small signal	4MHz	500kHz	10MHz
Full power response, min	100kHz	5kHz	1MHz
Slew rate, min	6V/ $\mu$ sec	0.3V/ $\mu$ sec	75V/ $\mu$ sec
INPUT OFFSET VOLTAGE @ 25 $^{\circ}$ C, max, $\mu$ V	Adj to 0	±250   ±100   ±100	Adj to 0
Average vs. temp 10 to 60 $^{\circ}$ C, max, $\mu$ V/ $^{\circ}$ C	±50   ±20	±1.5   ±0.5   ±0.25	±50   ±15
INPUT BIAS CURRENT @ 25 $^{\circ}$ C, max	-50pA   -20pA	(0,+) 25nA	-50pA   -25pA
Average vs. temp 10 to 60 $^{\circ}$ C, max, nA/ $^{\circ}$ C	doubles every 10 $^{\circ}$ C	-0.25	doubles every 10 $^{\circ}$ C
INPUT DIFFERENCE CURRENT @ 25 $^{\circ}$ C	±25pA   ±10pA	±2nA	±25pA   ±10pA
Average vs. temp 10 to 60 $^{\circ}$ C, nA/ $^{\circ}$ C	doubles every 10 $^{\circ}$ C	±.02	doubles every 10 $^{\circ}$ C
INPUT IMPEDANCE			
Differential	10 <sup>11</sup> $\Omega$    3.5pF	4M $\Omega$	10 <sup>11</sup> $\Omega$    3.5pF
Common mode	10 <sup>11</sup> $\Omega$    3.5pF	1000M $\Omega$	10 <sup>11</sup> $\Omega$    3.5pF
PRICE			
1 - 9	\$12.   \$19.50	\$45.   \$60.   \$75.	\$38.   \$48.
10 - 24	\$11.80   \$18.70	\$43.   \$57.   \$71.	\$36   \$46.



ANALOG DEVICES, INC.  
221 Fifth Street  
Cambridge, Massachusetts 02142  
Tel: 617/492-6000

Data on these three amplifiers is contained in a new brochure featuring pre-selected Analog Devices' op amps. The amplifiers outlined in this short form catalog are those recommended for about 85% of the requirements evaluated by Analog Devices' applications engineering department. Available without charge on request.

# If you're designing frequency-sensitive circuits, aren't these the measurements you should be making?

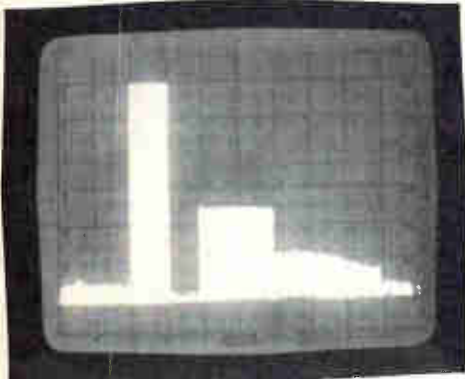

## Oscillator Output Spectrum

Frequency scan: 0-100 MHz. Log display (LOG REF = 0 dBm).

Oscillator output is flat at -10 dBm, 20 to 30 MHz. Second harmonic is 35 dB down and flat; third harmonic goes from 50 to 55 dB down.

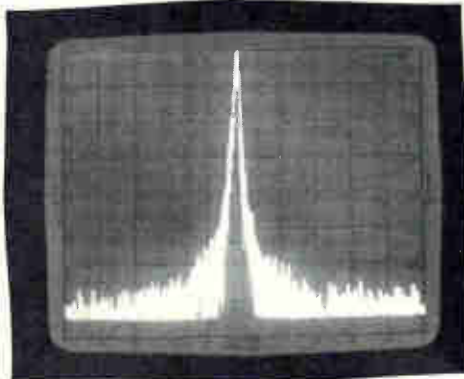

**Spectral Purity** Center frequency: 100 MHz. Scan width: 5 kHz/div. IF bandwidth: 300 Hz. Log display (LOG REF = 0 dBm).

Major noise sidebands are approximately 55 dB below carrier.

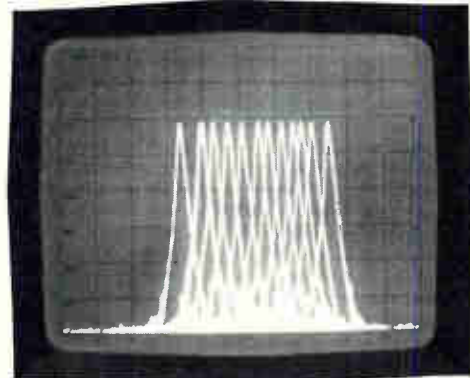

**Frequency Drift** Center frequency: 800 MHz. Scan width: 10 kHz/div.

Scans are triggered at 10 second intervals and stored on CRT. Drift = 42 kHz in 2 minutes.

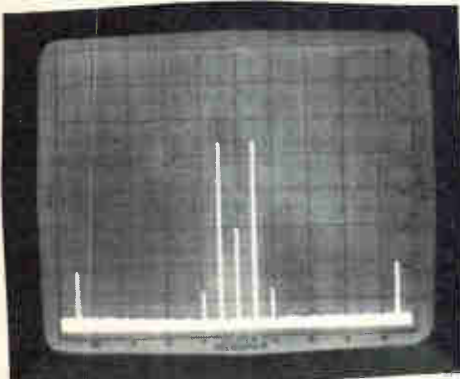

**Conversion Efficiency** Center frequency: 50 MHz. Scan width: 5 MHz/div. Log display (LOG REF = -10 dBm).

Double-balanced mixer with 0 dBm drive at 50 MHz and -30 dBm at 5 MHz. Display shows 45 and 55 MHz sidebands at -36 dBm; i.e., 6 dB conversion loss. (Display also shows signal feed-through at 50 MHz and harmonic distortion products at 40 and 60 MHz.)

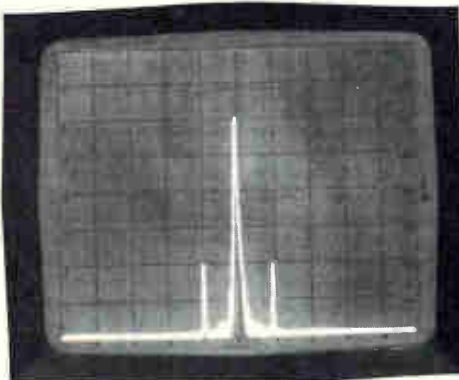

**AM Modulation Index** Center frequency: 60 MHz. Scan width: 10 kHz/div. Log display (LOG REF = +10 dBm).

Low level 10 kHz modulation of 60 MHz carrier shows sidebands 40 dB down, i.e., 2% AM. Sidebands as low as -70 dB or 0.06% modulation can be measured.

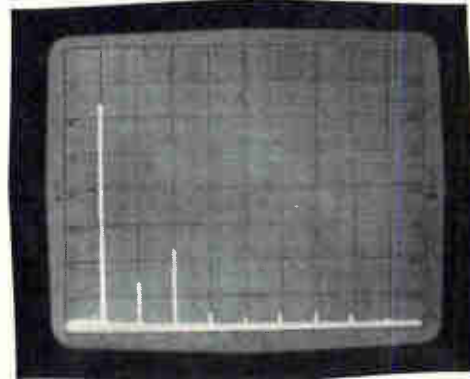

**Harmonic Distortion** Frequency scan: 0-50 MHz. Log display (LOG REF = 0 dBm).

Harmonic content of -16 dBm 5 MHz signal is displayed: 2nd harmonic -50 dB, 3rd harmonic -40 dB, others < -60 dB. Harmonic content as a function of absolute fundamental level can be observed.

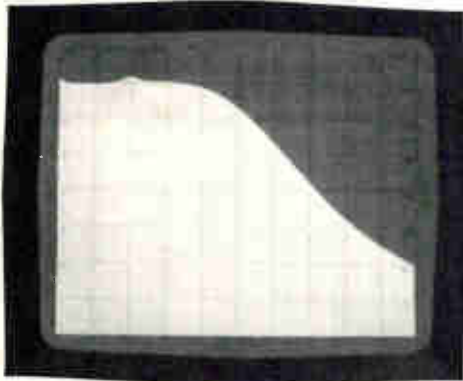

**Amplifier Response** Frequency scan: 0-500 MHz. Log display (LOG REF = +10 dBm).

With flat input at -20 dBm, gain and frequency response are read directly from CRT (20 dB gain,  $\pm 2$  dB to 200 MHz, 0 dB gain at 320 MHz).

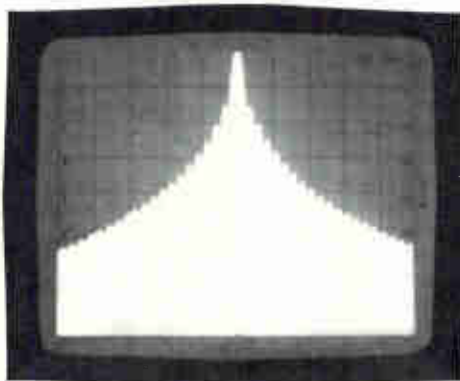

**Transmission Bandwidth**

Center frequency: 800 MHz. Scan width: 0.5 MHz/div. Log display.

Spectrum of pulsed 800 MHz carrier shows 2.2 MHz frequency range between -40 dB lobes, which is bandwidth required to pass 99% of energy.

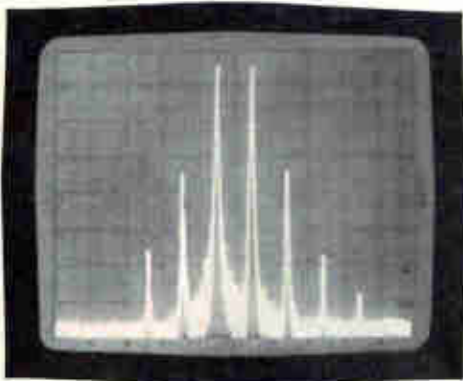

**IM Distortion** Center frequency: 60 MHz. Scan width: 100 kHz/div. Log display (LOG REF = +10 dBm).

Two-tone test using 59.95 and 60.05 MHz signals at +5 dBm each shows third-order sidebands 30 dB down. Higher order IM products can also be measured.

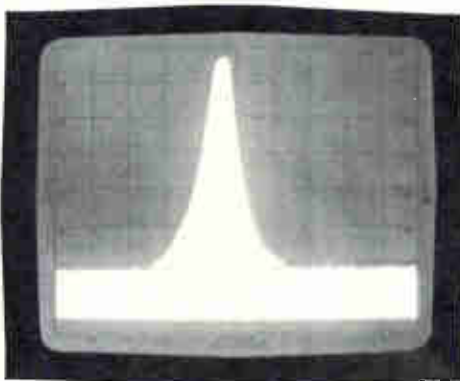

**Filter Response** Frequency scan: 0-100 MHz. Log display (LOG REF = 0 dBm).

With 0 dBm test signal, passband insertion and stopband rejection of 50 MHz bandpass filter are displayed. Insertion loss is 3 dB, 3 dB bandwidth approximately 4 MHz and 60 dB bandwidth is 36 MHz (Shape factor = 9).

There's only one lab tool that gives you the complete, accurate picture of measurements in the frequency domain: HP's series of fully calibrated spectrum analyzers. One covers 1 kHz to 110 MHz; the other goes from 500 kHz to 1250 MHz. Either is a convenient, easy-to-operate basic instrument for general circuit design that enables you to make all the measurements you see on these pages, plus many more. Use it as a tuned voltmeter, a wave analyzer, distortion meter, frequency meter and power meter. Its absolute amplitude calibration, low distortion, high sensitivity, wide sweep capabilities and wide dynamic range make it a true multi-purpose frequency domain measuring instrument.

The analyzer displays absolute signal levels both in dBm and volts from +10 dBm to  $< -120$  dBm (0.8V to 0.1  $\mu$ V). And  $> 70$  dB distortion-free dynamic range permits exceptional accuracy in measuring complex signals.

Sweep the entire frequency range, then reduce the scan width for a closeup view of any portion down to .0002% of the initial sweep. Selectable bandwidths let you get down to 50 Hz resolution with the lower frequency RF unit and to 300 Hz with the 1250 MHz unit. A variable persistence display shows the full trace even at the slow sweeps necessary to achieve high resolution.

You can perform all these measurements as easily as you operate your bench scope. Using HP's lab spectrum analyzers is simple and results are easy to interpret. The cost of the 8553B 110 MHz RF section is \$2100; the 8554L 1250 MHz RF section is \$3300. Either can be used with the basic 8552A IF section (\$2050) and 141T Variable Persistence Display section (\$1700). There's a normal persistence display unit available, too. Your Hewlett-Packard field engineer has the complete details; or write to Hewlett-Packard, Palo Alto, California 94304; Europe: 1217 Meyrin-Geneva, Switzerland.



HEWLETT  PACKARD

SIGNAL ANALYZERS



**Up Op Amp Power.** No separate, discrete driver transistor needed now — it's all there on one monolithic, EpiBase\* power chip: driver transistor, output device and base-emitter resistors.

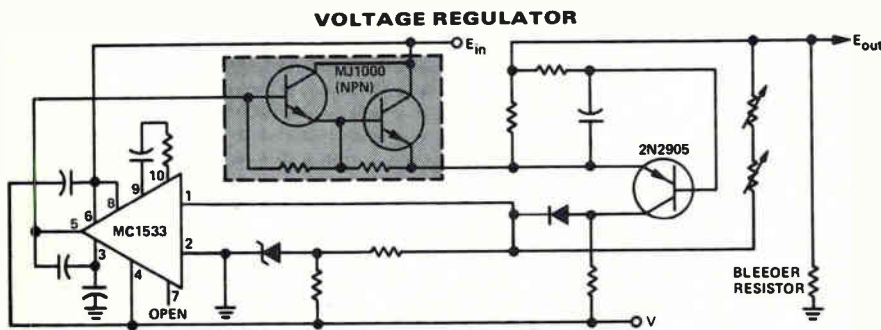

**Compress Your Costs.** Cut space and heat sinking needs, assembly time and components because the driver device is now on the same heat sink as the output unit. Reliability rises, too.

**DARLINGTONS SIMPLIFY!**

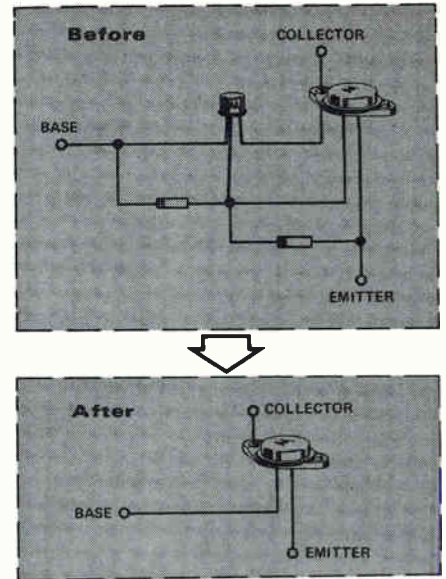

# Power Darlington

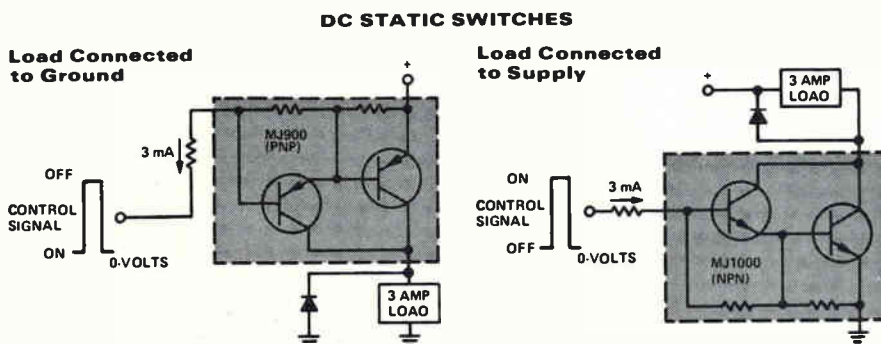

**Put In Either Polarity.** Positive or negative-based systems are possible with your choice of either PNP or NPN devices that can also be used as complements in audio amplifiers.

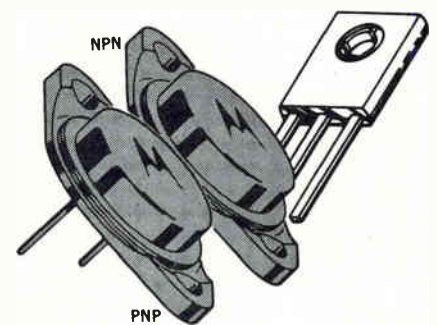

**Perform With Package Variety.** Besides the 5 A, TO-3 darlington, you'll soon have your choice of Thermopad plastic packages 77 and 90 — two sizes of case economy that will further reduce design costs.

*- where the priceless ingredient is care!*



**LAMP FLASHER**

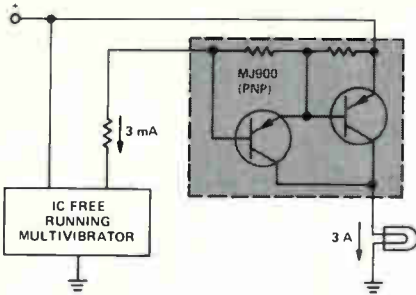

**Innovate With I/C's.** Drive the 3 A darlington with power levels derived from integrated circuit logic gates. Go from milliamperes to amperes directly, compatibly, easily.

**DC MOTOR SPEED CONTROL**

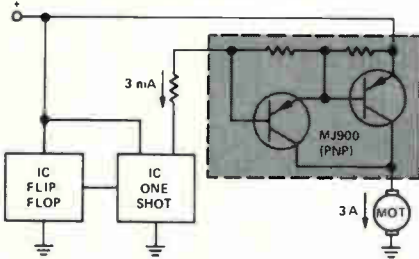

Obtain 1,000 dc gain. Yesterday, 25 minimum beta was great — today, Motorola power darlington's give you a minimum of 1,000 . . . an unheard-of, commercial/industrial state-of-the-art first!

**30-W AMPLIFIER USING COMPLEMENTARY SYMMETRY**

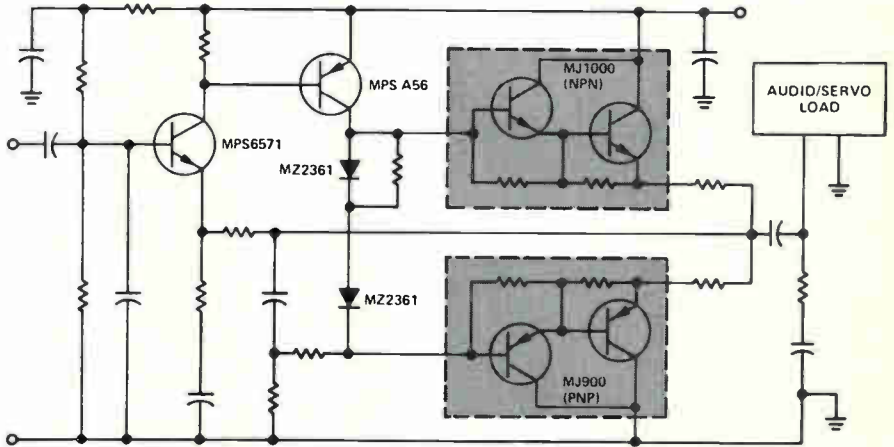

# Revolutionize Today

**Revolutionize Right Now.** Introduce your relay or solenoid drivers, audio amplifiers, power supply regulators, servo amplifiers and series pass regulators to today's world of silicon power darlington systems — contact your franchised Motorola distributor for evaluation units or, for complete data, Box 20912, Phoenix, 85251 . . . the place it all begins.

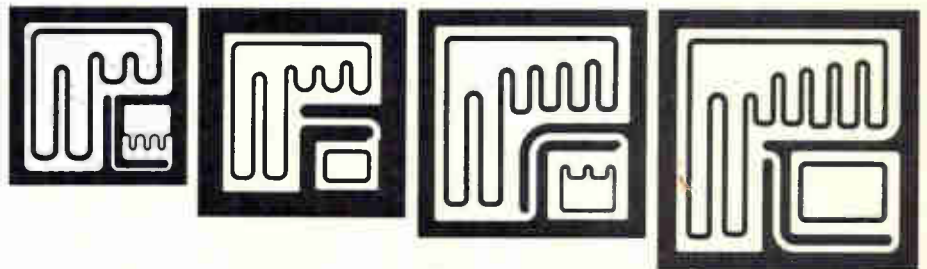

Power Darlington		I <sub>C</sub> A (Cont)	V <sub>CEO (h<sub>FE</sub>)</sub> V	h <sub>FE</sub> @ I <sub>C</sub> (min)	P <sub>D</sub> W	I <sub>CSO</sub> @ V <sub>CS</sub> mA	SOA	Price 100 Up	
PNP	NPN							PNP	NPN
MJ900	MJ1000	5	60	1,000	90	0.2 @ 60V	3A @ 30V	\$2.90	\$2.50
MJ901	MJ1001		80	@ 3A				\$3.30	\$2.90

\*Trademark Motorola Inc.

The circuitry shown external to Motorola products is for illustrative purposes only, and Motorola does not assume any responsibility for its use or warrant its performance or that it is free from patent infringement.

# MOTOROLA Silicon Power Transistors

# First look at the largest, fastest LSI shift registers ever built. 2½¢/bit.



In 100-piece quantities.

## In stock right now.

Intel's silicon-gate MOS technique has done it again: produced monolithic LSI shift registers with twice the capacity (1024 bits) and five times the speed (5 MHz) of any other. Total clock capacitance is only 140 pF, half the capacitance per bit of any other TTL compatible register.

You can get a single TO-5 can that holds one long 1024-bit register (Model 1404) or two 512-bit registers (Model 1403). And we have a 16-lead DIP with no less than four 256-bit registers (Model 1402).

All are available right now at the lowest bit prices in history: about 2½¢ per bit in 100-piece quantities.

Power dissipation is only 500 mW at 5 MHz clock rates, and drops to 200 mW at 1 MHz rates. Input and output logic levels are TTL DTL compatible.

For immediate delivery phone your local Intel distributor: Cramer Electronics or Hamilton Electro Sales. Or call us collect at (415) 961-8080.

Intel Corporation is in high-volume production at 365 Middlefield Rd., Mountain View, Calif. 94040.

intel<sup>TM</sup>  
delivers.



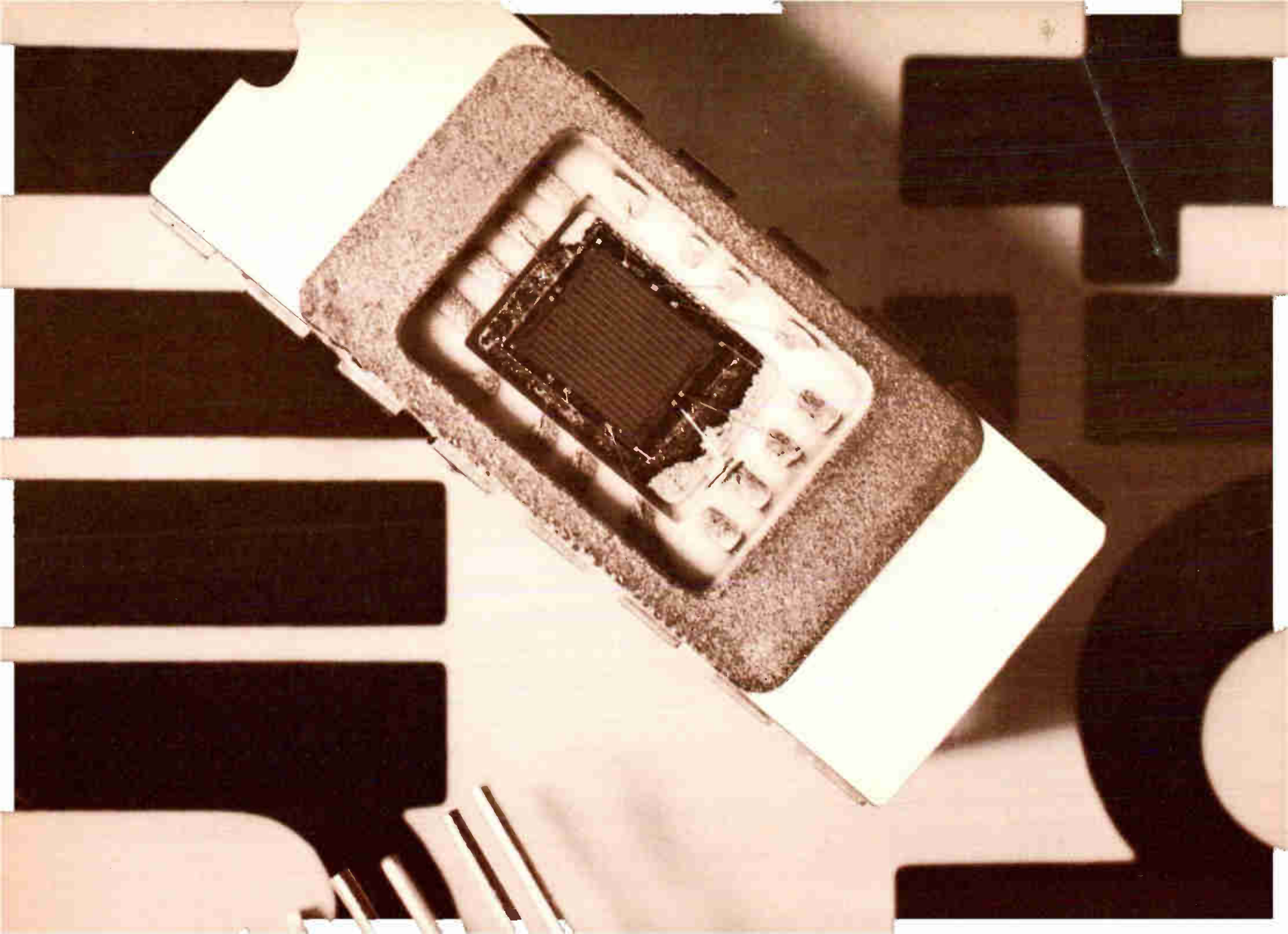

# MICROWAVE

...dimensions that make Andrew's  
antenna systems capability unique

We sell more microwave antennas than anyone. Two or three times as many. It's this, plus a unique "degree of completeness" that makes Andrew the better buy. It's antennas. *And* waveguide or coaxial cable. Made to work together. *All* the hardware you need. Plus *all* of the software necessary to guarantee performance as specified. It's technical assistance *on an international basis*. Help all the way through the installation if you need or want it. Anywhere in the free world. Like to know more? Communicate with Andrew.

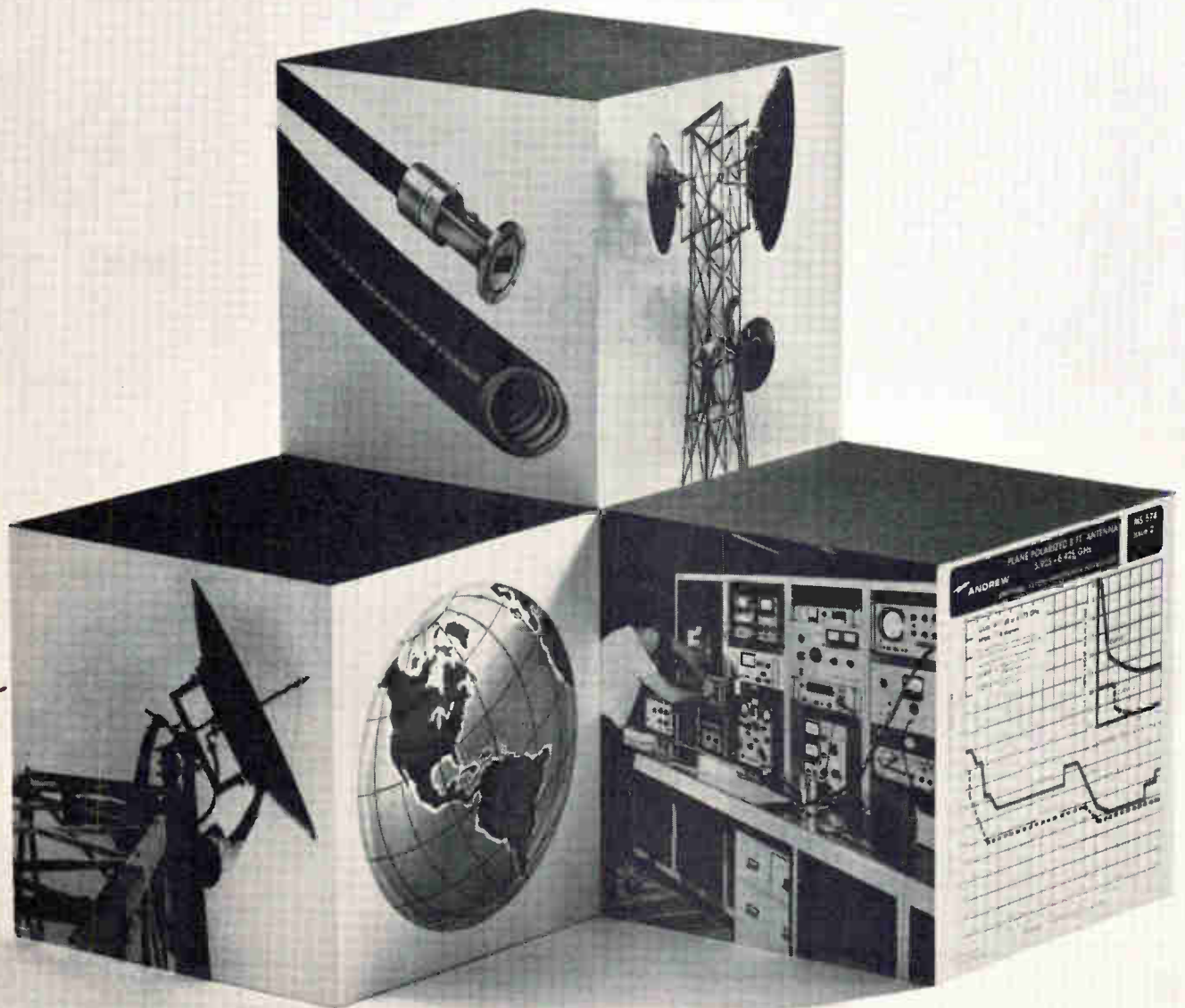

**ANDREW**

2-69

CONTACT THE NEAREST ANDREW OFFICE OR ANDREW CORPORATION, 10500 W. 153rd STREET, ORLAND PARK, ILLINOIS 60462

Circle 58 on reader service card



---

# International Newsletter

---

June 8, 1970

## AEG-Telefunken to show low-cost color tv recorder

Enter another firm in the electronic video-recording sweepstakes. This time it's West Germany's AEG-Telefunken, which will announce a color system later this month. Telefunken will confirm only that it uses disks for video and audio playback on a tv set.

Industry insiders say, however, that the Telefunken version should cause something of a stir. The reason: price. According to one source, the video playback portion will cost around \$140 and simply plug into the antenna jacks of the tv set. Furthermore, once the disks are in mass production five minutes of color programming will cost less than six cents to record. The disks are made by Teldec, a joint venture of Telefunken and Decca.

## Philips to produce varactor-tuned tv in Great Britain

While most British tv makers are still only in the planning and evaluation stage of varactor-diode tuning. Philips Electrical, a subsidiary of the international Philips organization, is getting ready to introduce the first British-made varactor-tuned tv set. The first two models—22-inch and 26-inch all solid state color units—are to go on the market sometime in August. The larger of the two also is likely to be the first in Britain to use the Philips group's new 26-inch overall (25-inch viewable diagonal) square-cornered tube.

Along with the four-diode Philips-built uhf electronic tuner, the sets will contain four integrated circuits—two more than in any other British-made color set—including an IC sound intercarrier and color demodulator.

## NTT field tests two-way tv set up for CATV systems

Nippon Telegraph and Telephone Public Corp. (NTT) is field testing hardware intended for eventual use by CATV systems that will include two-way transmission of video signals. The year-long feasibility trial is being conducted along a two-and-a-half-mile coaxial transmission line between a head end, or terminal station, and the campus of an NTT-operated training school.

Repeaters stationed at 1,640-foot intervals amplify signals for both normal tv programming from the head end to the subscriber in the 70- to 250-megahertz tv band and for so-called reverse transmission from the subscriber to the head end in the 20- to 60-Mhz band.

In the present tests, the terminal station feeds to its subscribers both broadcast-quality commercial tv signals and locally derived signals, for which an industrial tv camera is used. At subscriber locations similar industrial-type cameras send signals back to the head end. In both cases, the industrial cameras have modulators whose output is a 6-Mhz-wide tv signal.

## British firm offers standard radar vtr

Banking on its belief that recorders of ground air traffic control data will become as standard as airborne data recorders, Britain's EMI Electronics has put together a radar display video tape recorder based on an off-the-shelf Sony tv recorder. Radar vtr's are presently one-of-a-kind, and EMI says that by making a black box it can sell them for \$20,000 apiece—a fraction of what a comparable custom ground recorder would cost.



---

# International Newsletter

---

The company says it selected the Sony one-inch vtr because it doesn't need modification to record radar data. It has two heads, permitting continuous recording of radial scan data. Normally, tv vtr's have a single head that doesn't record during the frame flyback period.

## Matsushita making low-priced multilayer p-c boards

Matsushita Electric has just gone into production with a low-cost multilayer circuit board that does away with conventional laminations and etching.

The added layers are put atop a two-sided p-c board that's fabricated using the company's Duston technique, in which the connection pattern is printed on the substrate as an adhesive, with copper blown onto it, followed by curing and plating. After a two-sided board receives its copper, Matsushita coats it on both sides with an epoxy insulating layer and then repeats the connection-pattern process, this time doing the plating after the board has been drilled.

Matsushita has made test boards with six layers, but will produce only four-layer versions initially. Along with the lower lamination costs, the company says it's getting added savings because the technique works with inexpensive paper phenol substrates that cannot ordinarily be used for multilayer boards.

## Digital guidance set for new British fighter aircraft

Elliott Flight Automation won a \$12 million contract to equip most of the 200 Jaguar fighter-trainer aircraft ordered by the Royal Air Force with digital inertial navigation and weapons guidance systems. Although the exact number of planes to be equipped remains classified, the contract marks the first Royal Air Force use of digital navigation-attack systems.

The Elliott equipment will consist of a microminiature 8,000-word, 2-microsecond adaption of the company's established 920 series computer, an inertial platform based on the one being produced for the Nimrod maritime patrol craft, and a moving map display for the pilot. Elliott is scheduled to deliver the first systems to the British Aircraft Corp. in the fall.

## Japanese predict continued growth in electronics

The Japanese electronics industry confidently predicts that the brisk pace of expansion achieved in recent years will continue well into the 1970's. According to a detailed production forecast just released by the industry's trade association, total industry output will climb to \$15.55 billion by 1973 from the \$7.61 billion figure that was registered last year.

The Electronic Industries Association of Japan made its forecast after surveying member firms' medium-term business plans. One important factor in the outlook: fully \$2.42 billion of 1973's production will be accounted for by items such as cassette-based video tape recorders that are not being mass produced now.

The fastest-growing sector of the industry will be industrial electronics, where growth will average 20.9% each year for a total of \$4.61 billion in 1973. Second on the list is componentry, which will expand at an average rate of 14.1%, which means \$3.47 billion by 1973. Coming in third will be consumer products, which will rise at a 10.5% clip to \$5.22 billion.

# Analog-to-digital circuitry is out with new display tube

Electron gun in Japanese cathode-ray tube uses a matrix of isolated electrodes; positive bias at intersections allows electron beams to pass through holes to the faceplate

Though cathode-ray tubes are often used for character display in digital calculators and terminals, complicated and expensive digital-to-analog circuitry is required to make the system perform. This is a fact of life designers have just had to live with—until now. Japan's ISE Electronics Corp. has come up with a multiple-beam crt display tube that eliminates the need for the a-d circuitry.

Initially, the tubes will be made in four- and seven-inch sizes. The four-inch version will display 10 lines of 14 to 16 characters each; the seven-incher, 16 lines of 20 characters. ISE officials say that although the tube's initial cost will be somewhat higher than standard black-and-white crt's when deliveries start sometime this fall, the price is expected to drop given time and increased production.

Perhaps the most significant structural difference between the ISE tube and conventional crt's is that sandwiched between the first and second electron-gun grids is a matrix of electrodes consisting of seven horizontal and five vertical metal ribbons with holes cut in them at their intersection points. The ribbons are isolated from each other by a sheet of mica which has holes that correspond to those in the matrix. The vertical and horizontal matrix electrodes are sufficiently negatively biased to cut off the supply of electrons to the first grid, except where intersection occurs. There, a sufficiently positive bias allows 35 separate electron beams to pass through to the number one grid, which also has cut in

it holes corresponding to the matrix and is operated at a positive potential of 13 volts. Thus the 35 beams first pass through the matrix electrodes, and then the first grid.

**Enlarged.** The aperture at the intersection defines initial beam size. Both the individual beams and the image of the holes in the matrix are focused by the electron lens, which consists of the gun's other electrodes. The size of both the beams and the entire matrix image pattern are enlarged at the tube faceplate, so the matrix electrodes in effect act as the tube's true control element. Another substantial difference between ISE's design and standard tubes is that there is no electron crossover in the region between the cathode and grid number one.

To write letters or symbols on the faceplate, positive selection pulses are applied to the matrix electrodes. For unambiguous selection, the tube uses a single-direction scan—selection pulses applied to the vertical ribbons are displaced in time; selection pulses are applied to the horizontal ribbons simultaneously.

Though it sounds complex, ISE engineers say that the actual decoding circuits are fairly simple—a read-only memory, such as a diode matrix, is adequate. Characters are moved around the tube's face by horizontal and vertical deflection coils. For displays with a standard format in which several numbers are constantly scanned in succession—a desktop calculator, for example—staircase deflecting waveforms are used. In this case the

vertical waveform would remain at the same level for all characters on one line while the horizontal waveform would move one step for each character line. At the end of the line the vertical waveform would advance one more step and the process would be repeated.

## West Germany

### Compressed sound

A big step toward multilanguage television broadcasting is currently being taken by engineers at Standard Elektrik Lorenz AG, a West German subsidiary of ITT. At the company's central applications laboratories, a team of engineers headed by Gerhard-Guenther Gassman worked out a system that transmits 12 sound channels—each one in a different language—synchronously with one video channel.

Contrary to conventional tv systems that transmit video and sound channels separately, SEL's new system, dubbed Compressed Multi-sound (COM), compresses all sound signals together and then integrates both sound and video signals into a single "video-sound" signal. This combined signal is recorded on tape and radiated by just one transmitter.

SEL engineers liken their sound compression technique to a simple sound recording phenomenon. If, for example, speech is recorded on tape at 9.5 centimeters per second,

and if that tape is then played back at 19 cm/sec, the playback time is reduced by one half and the frequency, or bandwidth, is doubled.

The SEL transmission system relies on very much the same principle. But here, the time compression ratio, instead of being 1:2 as in the recording example, is 1:385, thus, reducing the time by a factor of 385 while all frequencies are increased by the very same amount.

Video signals are, in reality, frames that are transmitted and received one after the other. Short no-transmission periods between each frame contain several lines for test and synchronizing signals plus 12 completely vacant lines. SEL uses those 12 lines in this no-transmission period in its COM system to carry the time-compressed sound signals—one signal per line. Thus, during tv broadcasts the transmitter sends out video and sound signals sequentially, with each sound channel time-compressed by the 385 factor.

**Figures.** SEL derives its time-compression factor of 385 from the time it takes to transmit one frame plus the time for the no-transmission period—20 milliseconds. The time for either a video or a vacant line is 52 microseconds. Thus, it follows that in the 625, 5 megahertz bandwidth-transmission norm used throughout most of Europe, the time compression equals 52 usec

over 20 msec which, in turn, equals one over 385. The corresponding bandwidth expansion would be the reciprocal value, namely 385 over one, which equals 5 Mhz over 13 kilohertz.

In operation, each sound signal is sent through a dynamic compression stage, which suppresses that signal's dynamic characteristics to increase the signal's noise immunity. The signal is then fed to a clock pulse-controlled memory. During the transmission of a video signal the tv camera is connected directly to the transmitter. Between individual frames, however, a switch disconnects the camera and connects the memory to the transmitter output. A clock pulse reads out memory, while another clock pulse reads sound signals into the memory.

Unlike the transmitter, which must have as many memory units as there are sound channels to be transmitted, the receiver needs only one memory. From a common video-sound demodulator, the demodulated signals are applied across the video amplifier to the picture tube. Prior to the start of the particular vacant line that corresponds to the desired sound channel, the line counter sends a control signal via the line selector, and the memory switches to the memory circuit. The line counter, in turn, is controlled by vertical and horizontal synchronizing pulses.

During the vacant-line period, the time-compressed sound signal from the demodulator goes to the memory unit which is controlled by the clock frequency. Within the following 20 msec the memory furnishes the sound signal, clocked at about 15.6 khz via a simple dynamic expander to a conventional low-frequency amplifier. Thus, the receiver requires neither a sound i-f amplifier nor a sound demodulator.

**Breadboarded.** SEL says its COM system is still only a proposal. However, preproduction work is well under way at the company's Esslingen-based applications labs, and a breadboard version of the system already is operational. Now the company plans to replace the discrete components in the various subsystems with integrated circuits. "The big problem now is not so much a technical one," Gassman says. "It's getting international tv authorities to agree on appropriate standards for multi-sound transmissions." He adds that only multisound capability would allow a truly worldwide exchange of tv programs. As it is, the United Nations has called on the International Radio Consultative Committee to come up with a workable solution to multisound transmissions.

SEL engineers will discuss the COM system at the Chicago conference on broadcast and television receivers this week.

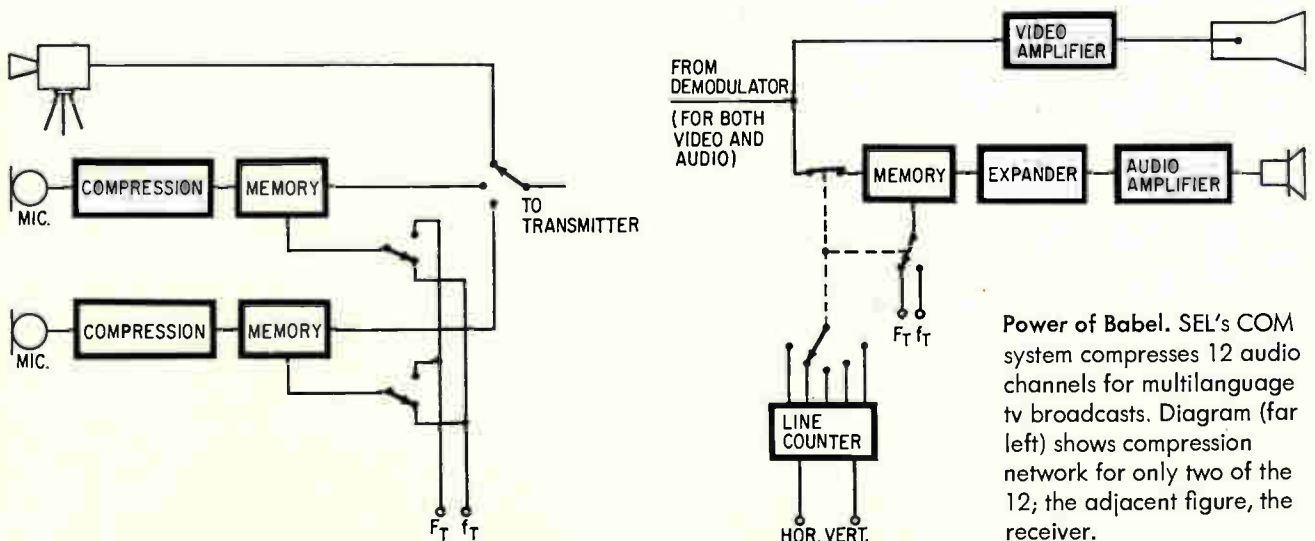

**Power of Babel.** SEL's COM system compresses 12 audio channels for multilanguage tv broadcasts. Diagram (far left) shows compression network for only two of the 12; the adjacent figure, the receiver.



## Track record

Technically speaking, there's nothing wrong with displays currently being used at ground stations to keep track of earth-orbiting satellites. Among the common types is a 500-by-500 array of lamps installed behind a translucent world map that lights up on command from a computer. Another is a computer-controlled stylus that traces the satellite's orbit on a silver-coated plate located in a map projection system.

But convinced there's a lot of room for improvement, engineers at Siemens have come up with yet another version of a display system. They feel it represents a far more elegant, but—and this is more important—a less expensive way of getting the job done.

What they've built is a computer-controlled laser-based system to keep track of satellites. The first one, installed and working at the German Satellite Control Center in Oberpfaffenhofen, near Munich, is keeping track of "Azur," a research satellite built by Messerschmitt-Boelkow-Blohm GmbH.

**Road map.** The new Siemens display, like other versions, derives its basic input data from the large digital computer (in this case a Siemens 305) normally used at ground stations for making orbit calculations. This data is then fed to another, but much smaller computer, a Siemens 101. The 101 feeds x and y coordinate values to a pair of digital-to-analog converters. Small currents coming from amplifiers associated with the a-d converters are applied to the laser's microgalvanometer deflection system; the laser itself is rigidly mounted some 15 meters in front of a world map; different current amplitudes correspond to different x-y position coordinates. Two deflection mirrors, electromagnetically coupled to the deflection system, are thus moved in small incremental steps about their axes. In this way the laser beam traces the satellite's orbit on the map.

The beam stops for 80 microseconds at each of the 500 x-y coordinates on the map, except for that spot that indicates the satel-

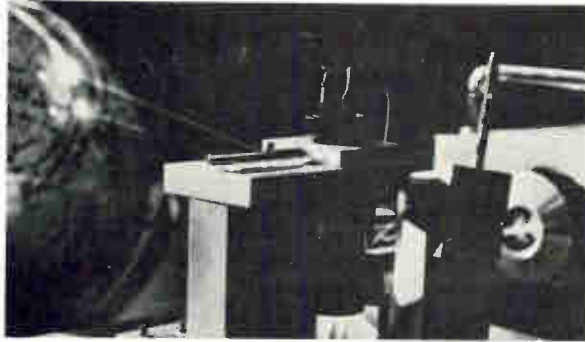

**Light trace.** Computer-controlled laser system developed by Siemens keeps track of satellites elegantly and inexpensively.

lite's actual position. There, it stops for a full two milliseconds, thus illuminating more brightly the satellite's true position, as opposed to its general orbit. This tracing process is repeated 25 times per second so that in actual appearance the orbit appears as a continuous curve with one bright spot in it.

Cost for the system, which includes the laser—a Siemens LG 641 helium neon type with an output power of 5 milliwatts—the deflection equipment, and the 101 computer is about \$28,000.

## International

### Radiation rule

The first international standards for safety of household and similar electrical appliances have been drafted and proposed for adoption by the International Electrotechnical Commission (IEC) following a two-week meeting in Washington.

The standards, though not as rigid in some respects as U.S. internal requirements, represent a significant accomplishment for the 54-nation assembly, according to William A. McAdams, president of the U.S. National Committee and General Electric standards executive.

But McAdams sees the possibility of "a major breakthrough" if the IEC adopts a plan being considered by its Technical Committee 56. Under the plan the commission would take over responsibility and operation of what is now called the Tripartite Accord for Electronic Components [*Electronics*, March

30, p. 69]. Under the accord, initially proposed by Britain, France, and West Germany, electronic components imported into Europe would have to meet certain quality assurance and certification standards mutually acceptable to the participating nations. Since the U.S. has been barred from either participating in or observing negotiation of the tripartite pact, American manufacturers have viewed it as a serious threat to their export market. They have dubbed the agreement a potential nontariff trade barrier. It follows naturally that the U.S. strongly supports the IEC proposal to take over the certification scheme since the U.S. could then actively participate.

**The vote.** Should Technical Committee 56 endorse the new role for IEC, the plan—like the appliance safety rules—would be subject to what McAdams calls IEC's "six months rule." Under this procedure, proposals for adoption by the member nations are voted on at the end of six months. "It takes an 80% vote for approval," McAdams explains, "but member countries that do not reply are counted as having voted in favor."

Though it took three years of effort to reach appliance safety standards, McAdams says one of the significant standards to be proposed is that for microwave cooking ovens. The IEC will vote to adopt a maximum microwave-oven radiation standard of 10 milliwatts per square centimeter at a distance 5 cm from the oven's surface. Though this is less than the standard of 1 mw in the factory and 5 mw for ovens in use just proposed by the U.S. Bureau of Radiological Health, the IEC proposal

does correspond to the U.S. industry standard before the bureau acted [*Electronics*, May 25, p. 75].

The U.S. chairman believes the 10 mw microwave radiation standard is nonetheless an achievement for IEC. Considering that the proposal is the result of the first meeting of IEC's new microwave committee, McAdams says, "even agreeing on the 10 mw level is progress. It sets the stage for reconsideration at almost any time."

In addition to the overall appliance safety rules, McAdams says he expects the IEC to have "another eight or 10 more documents for consideration on safety standards for specific appliances following conclusion of activities of other committees."

### Great Britain

#### Scale for speech

Military men would like to see all of their communications signals go the all-digital route—even down to the foot soldier's radio-telephone equipment. This ideal unit would digitize his speech, and it would remain digital through transmission and switching until it reaches the ultimate receiver. But the digital coders and decoders to be included in tactical gear would have to be light and simple.

Now this goal is closer to being a reality. In equipment under development for the British Armed Forces, the government's Signals Research and Development Establishment and GEC-AEI Electronics Ltd. together have produced what they call a delta-sigma modulated speech digitizer incorporating digital control of companding.

**Feedback.** In conventional delta modulation, the analog waveform is digitized by transmitting a continuous stream of pulses which are positive or negative according to whether the input signal amplitude at a clock pulse is higher or lower than a stored approximation of its amplitude at the previous pulse. The modulation is accomplished by feeding back the last pulse into an integrator, which sends the re-

sulting quantized amplitude level into a comparator for matching against the incoming signal level. Error voltage determines whether the next pulse will be positive or negative. If clock rate is reasonably fast and the quantizing steps are reasonably small compared to the input signal wave's rate of change, feeding the pulse stream into an analogous network at the receiver creates a recognizable—though, in this application, inadequate—copy of the input wave.

Telephone microphones have a pre-emphasizing characteristic which increases the signal level of the higher frequencies in the voice spectrum, and unmodified delta modulators quickly become overloaded at high frequencies because the rate of change of signal amplitude increases with frequency and becomes too great. With delta-sigma modulation, on the other hand, the integrator is between the comparator and pulse modulator, thus achieving less sensitivity to overload than in plain delta modulation. Delta-sigma modulation effectively makes the overload level independent of frequency in the 250-hertz to 2.4-kilohertz range.

For companding, the team chose the syllabic format over instantaneous companding because the latter requires a larger bandwidth. In syllabic companding the signal is compressed by a circuit whose gain is varied, not according to instantaneous amplitude, but to a mean amplitude smoothed over a time interval of the same order as the syllabic intervals occurring in natural speech waveforms. Hence, peak values are depressed.

The companding control signal, like the basic digitization control signal, is derived from the transmitted output signal. It is used to vary the amplitude of the feedback signal sent into the comparator; expanding the feedback signal is equivalent to compressing the input. This is accomplished by incorporating a pulse-height modulator in the feedback path, but instead of being controlled by demodulation of the transmitted output signal, it is regulated by logical operations performed on the transmitted digit pattern. The same data

is available at the receiver and is used in rebuilding the analog wave.

This digital control system depends on recognition of like-polarity digits in the output line. The team has found that at 20 kilobits per second a 3-to-1 compression law is optimal. This value is effectively provided by a system which recognizes streams of three or more adjacent like digits in the output line, and increases the feedback voltage accordingly. Circuitry consists of a three-stage shift register in the transmission output line and parallel logic which provides an output when all three stages are in the same state. Logic output feeds via the syllabic integrator to the pulse-height modulator, which in turn controls the height of the pulse fed back to the comparator.

**Idling along.** When there is no input signal there is no output from the logic; the pulse height control voltage is at its minimum. This corresponds to the basic binary pulse amplitude. In this state the shift register is idling, with an alternating pattern of digits passing through it. When an input appears, the pulse stream pattern is irregular but there is no output from the logic until three consecutive like-polarity digits arrive. Then the logic output increases the pulse-height modulator's output, which in turn boosts the feedback pulse amplitude. This amplitude must vary according to the density of batches of three like digits. It's achieved by the syllabic integrator, which smooths the logic output into the pulse-height modulator. The decoding equipment is analogous to the coding equipment. A low-pass filter in the signal line eliminates unwanted h-f signals.

The team calls the system Scale for syllabically companded and logically encoded delta-sigma speech conversion system. GEC-AEI has built Scale in two hybrid thick-film packages, for coder and decoder. Each measures 2 by 1.5 by .5 inches and dissipates about 1 watt. The team claims an improvement in dynamic range to 40 decibels, nearly three times the range of an un-companded system, without sacrifice of signal-to-noise ratio, which is about 15 db maximum.



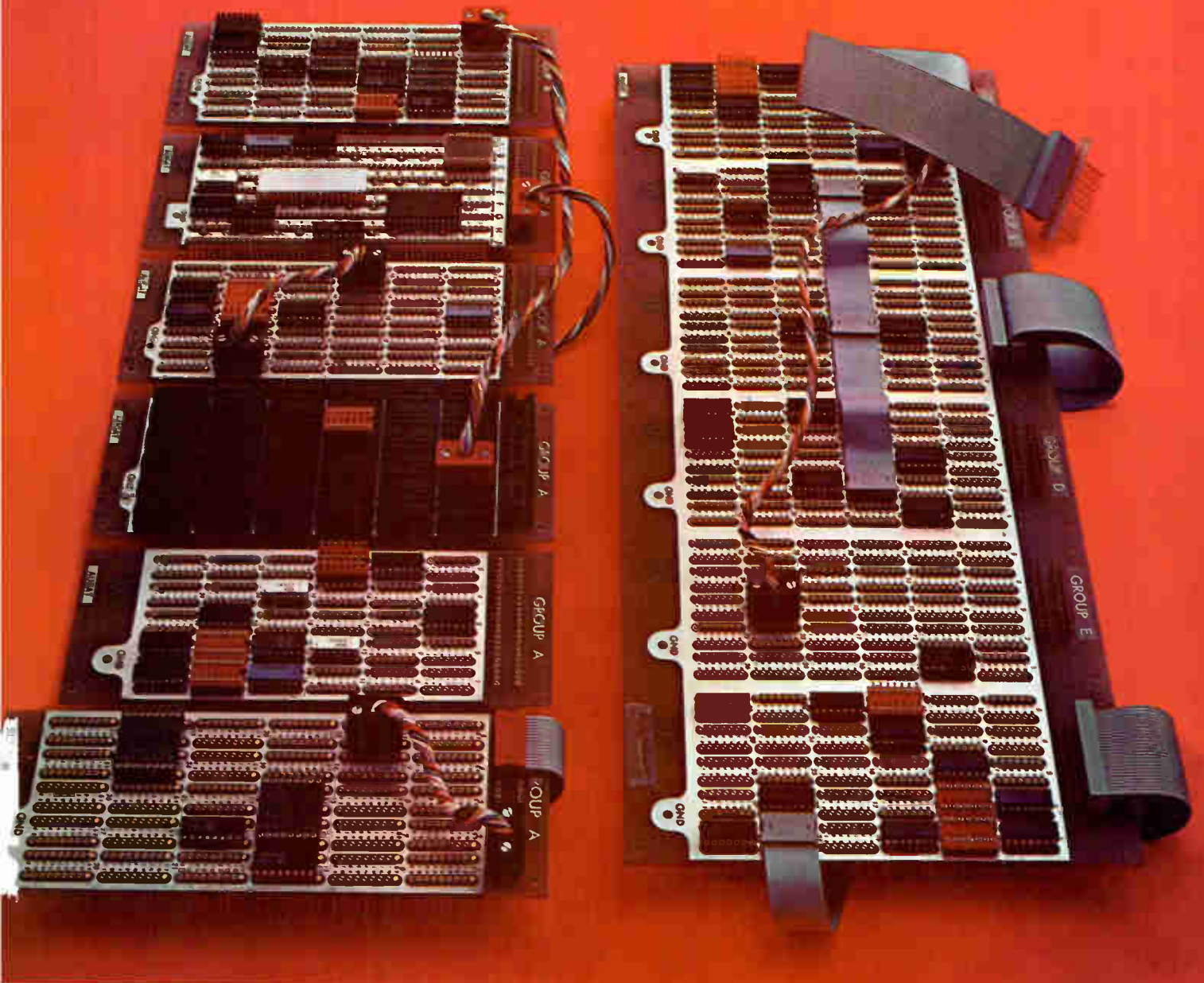

## 6x30=180

Now – specify 30 pattern panels, or any multiple up to 180 patterns – all standard catalog items.

Unique new I.C. packaging concept results in far greater flexibility, plus sizeable savings in space, time and money.

Modular panels are available in continuous rows of contacts for universal use, as well as 14 and 16-pin configuration.

Accessories include plugs with cable for interfacing and I.O. connections, and adaptors for mounting discrete components.

Close tolerances permit simplified mounting of single or multiple panels automatically wire wrapped on one plane – a service provided by Augat.

Let us show you the new approach to breadboarding, prototyping and production. Call us, (617) 222-2202, or write for new Catalog No. 266, Augat, Inc., 33 Perry Avenue, Attleboro, Massachusetts 02703.

**AUGAT** INC.

BOOTHS 3949-50  
NEPCON EAST





**“No one made a  
small, quiet, medium-speed  
chain printer for \$9500.  
So Mohawk did.”**

*George C. Hohl, OEM Marketing Director, discusses a new product.*

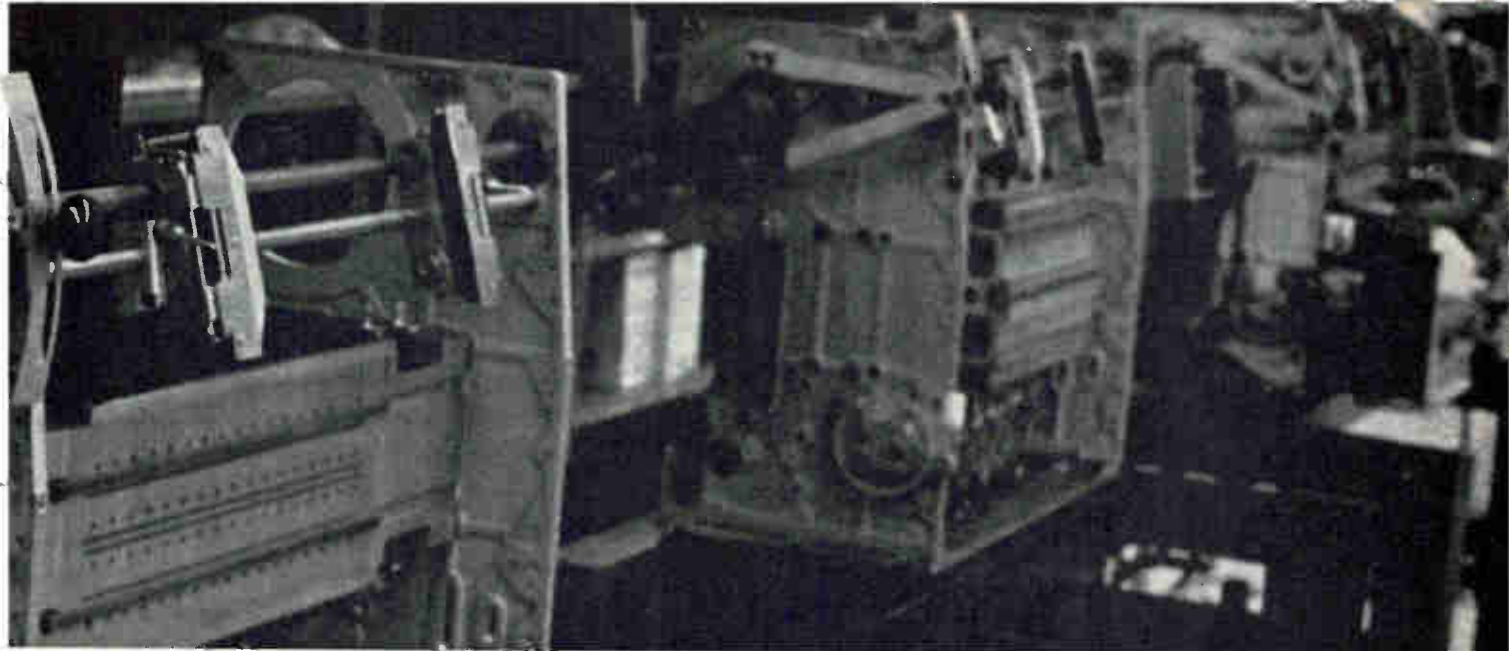

“We saw a gap in the printer field. Either you paid a lot of money to get a lot of speed and sophistication, or you could pay a little and get very little in return. We decided to aim our printer somewhere in between.

“Chain printers are mechanically simpler, easier to maintain, less expensive. Their flat face characters give good print characteristics, too.

“Our design requirements were rough. We wanted 300 lines-per-minute with such niceties as easily changeable fonts, and yet we wanted to sell it for less than \$10K. It had to be small, and yet we couldn't lose accessibility. The design engineers grumbled, but they made it.

“The changeable font cartridge is great—an operator can quickly switch the font chain—and we're offering fonts from 16 to 128 characters.

“We designed a disposable ribbon cartridge to make ribbon

changes quick and clean. Paper handling is enclosed to stay clean, too. And everything that could be modularized, was modularized.

“We considered noise reduction vital—anyone who has worked in a printer room knows why. Well, compared to other printers, you'd hardly know this one was working.

“We're selling the printer for \$9500 in OEM quantities, and some variations cost even less. So you get a lot of performance in a very little printer—for very little money.”

Mohawk Data Sciences Corp.  
Herkimer, New York





## Leave my power supply system alone! You can get your own in only 9 days from Acopian.

"I tried struggling through that old power supply system catalog. It was like a jigsaw puzzle, hunting for the pieces I needed for my new power system. There had to be a better way.

"Then I remembered the Acopian hotline. I called it. I told them the DC voltages and currents I wanted. Discussed panel size. Meters. Switches. And other accessories.

"They gave me a firm price. Right on the phone. It was a lot less than I expected. I had our buyer phone in the P.O. And Acopian designed,

built, tested and shipped it in nine days. Completely wired.

"So go order your own Acopian power system . . . It's easy!"

### HOW TO ORDER ACOPIAN POWER SYSTEMS

- Call Acopian collect
- Tell us the outputs and accessories you need
- Get a firm price
- **Shipment** of completely wired system will be made in 9 days.

For immediate service, call the Acopian hotline: (215) 258-5441. For literature, write Acopian Corp., Easton, Pa. 18042. And remember, Acopian also offers 82,000 different DC power modules, every one shipped with this tag . . .





---

# Washington Newsletter

---

June 8, 1970

## Mallard looks like a dead duck

Despite the personal efforts of Deputy Defense Secretary David Packard "and a team of four or five others" from the Pentagon's top ranks, Project Mallard is a dead duck in the eyes of House Appropriations Committee officials. The appeal to turn the Army program into a tri-service effort failed to persuade Texas Democrat George Mahon's defense appropriations subcommittee, which stood by last year's recommendation to terminate the communications project and then turned down a DOD attempt to reclaim the \$20 million sought in fiscal 1971 for the multi-nation tactical system.

Committee sources say DOD has not given up the battle. Despite evidence that Mallard's technology works well, Congress believes DOD needs to do more homework to determine "what kinds of communications it really needs" before pushing ahead with this type of program. Money for the program technically remains in the appropriations bill because the DOD budget was just about locked up. However, committee sources say the funds will be knocked out when the bill is marked up in closed session.

## EIA president's budget cut 22%

The EIA's board of governors has ordered president George D. Butler to trim his operating budget by \$200,000, or about 22%. This budget is separate from those of EIA's divisions, which draw their revenues directly from member dues.

One of the first activities to be cut will be the international department. This function will be taken over by a new division with dues-paying members [*Electronics*, April 13, p. 70]. A limit on EIA activities on Capitol Hill and at the White House, both under Butler's purview, could increase these efforts within the divisions, some of which have opposing legislative and regulatory interests, and could intensify some already serious internal splits within the association. The EIA economy drive is not unlike others in the Western Electronic Manufacturers Association, the American National Standards Institute, and the Business Equipment Manufacturers Association—all of which reportedly are experiencing dues collection problems.

## Road guidance R&D killed . . .

Dissatisfied with the Department of Transportation's justification for an electronic route guidance system for highways [*Electronics*, Aug. 18, 1969, p. 138], the House Appropriations Committee has wiped out the program's \$1.4 million in R&D funds.

Noting that R&D would run to more than \$4 million in future budgets, and that equipping the nation's highways and vehicles eventually could run to hundreds of millions of dollars, the House group challenged the necessity and value of the program. "We've got a lot more pressing national priorities," says one committeeman, "so drivers are just going to have to continue eyeballing their way around for a while longer."

## . . . but Capitol Hill smiles on ecology

With ecology rising close near the top of national priorities, Congress is about to give industry a focal point for its interests—a joint committee on environment technology. The House has approved formation of the

---

# Washington Newsletter

---

group and the Senate is expected to bestow its blessing on a similar proposal by Sen. Edmund Muskie, (D., Me.) before this session ends. The joint committee would pull together authority scattered throughout the Congress, where nearly every committee has some responsibility for at least one aspect of the environment.

The new unit will be responsible for pollution monitoring and control, oceanography and water resources, communications, transportation, power supplies, and any facet of technology which affects the environment.

## Off-shelf navigation for space shuttle?

NASA is considering use of off-the-shelf aircraft navigational systems aboard the space shuttle, to keep costs down. The agency is looking at systems that industry plans for the mid-1970's to see if they can be modified. One NASA source says, "There are many advantages in staying out of the trap of developing equipment for our own needs." He adds that unless laser communications systems can be shown to be far less costly than microwave, they will not be included. Work on the final design of the shuttle is expected to begin in late 1971 or early 1972 if Congress gives the go-ahead.

## Microwave carriers look at optical links

Data Transmission Co., the University Computing Co. subsidiary that plans to build a national microwave network for digital communications, is experimenting with optical data links for urban areas to escape the high cost and legal difficulties involved in downtown cable installations. A similar optical infrared system for "building-hopping" within a city is being investigated by Microwave Communications Inc. for the Chicago terminus of its Chicago-St. Louis route.

Datran is testing a light-emitting diode as transmitter and a photo-sensitive transistor as receiver to achieve a 100-foot hop between rooftops in a downtown area. Although Datran could interconnect with the Bell System for its local loops, the company is seeking an alternative to hold errors down to the one bit in  $10^6$  rate called for in its network design. Further, an optical link would circumvent the legal question of private service carriers' rights to tear up public streets to lay cable, and the cost—as high as \$40,000 a mile in downtown areas.

## Addenda

A top-level plan is in the making to dump some of the avionics packages from Lockheed's costly and controversial C-5 Galaxy supertransport. Deputy Defense Secretary David Packard suggested this when he told the Congress: "If we agree to pay for additional airframe development, as I conclude we must, I am sure we will find some of the avionics requirements, in hindsight, were not needed." Packard noted that only limited use can be made of the multimode radar, the automatic flight control system, and the inertial doppler navigation package [*Electronics*, May 25, p. 55] . . . Pollution-monitoring authorities of the Health, Education, and Welfare and the Interior Departments should be transferred to the Commerce Department's Environmental Science Services Administration, says Rep. Bertram Podell (D., N.Y.), as a "logical extension" of his bill making ESSA a clearing house for pollution-monitoring data. The Podell bill will probably go the way of many another proposal for coordination of environmental efforts—death in the Congressional hopper.

# Sylvania introduces a new 40-lead, glass-ceramic, sandwich-type, unitized, hermetically sealable large scale integrated circuit package.

(whew.)

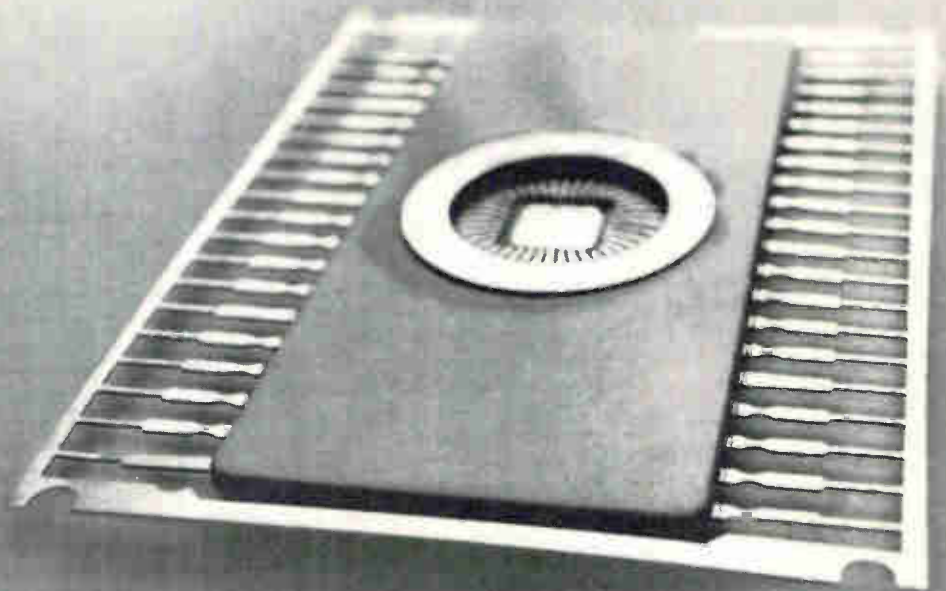

Here is the first glass-ceramic package in the IC major leagues. And that, friends, marks the beginning of the end of the LSI package shortage. Write to: Sylvania Precision Materials, Parts Division, Warren, Pa. 16365. Or telephone: 814-723-2000. Ask for Bill Williamson.

**SYLVANIA**  
GENERAL TELEPHONE & ELECTRONICS



# Ultrasonic Cleaning... Basic Systems... Standard Consoles... Degreasers (with or without Ultrasonics) ... Automated cleaning systems...

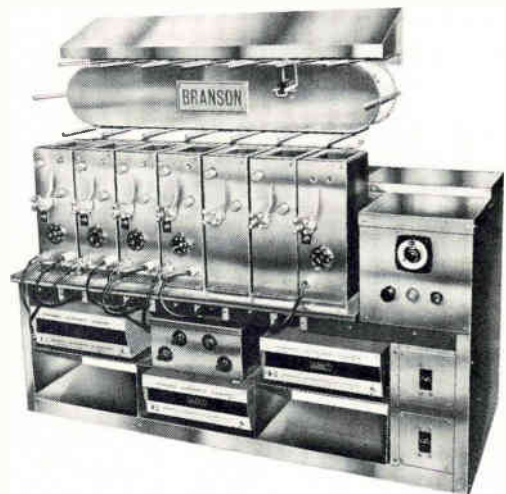
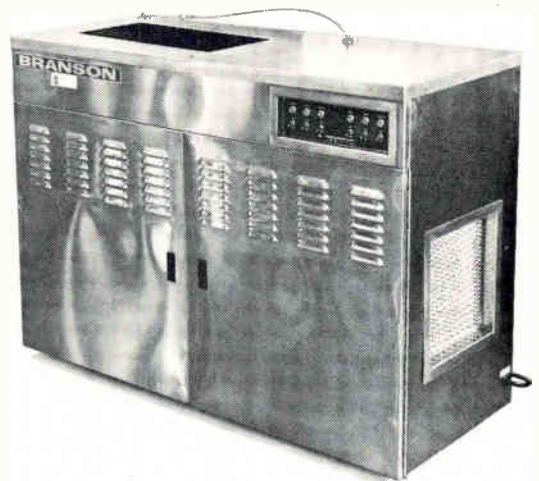

**BRANSON**  
instruments company

*For sound ideas in cleaning, testing and measuring.*

ZM1000  
TUBE  
NOW



295  
IN THOUSAND LOTS

The Amperex ZM1000 is the first digital numerical indicator tube, designed from the ground up for high-volume applications. It provides big economies, not only in initial cost but also in application. Its low price of \$2.95 in thousand lots is only part of the story... in volume, the ZM1000 sells for less than \$2.00.

We scrapped every notion about how to make numerical indicator tubes and developed a completely new design that offers unsurpassed performance and reliability at mass-production prices.

Every ZM1000 has a built-in decimal-point indicator. Use it if you wish — or ignore it... in either case, there's no additional cost for the decimal-point. The ZM1000's large numerals are clearly legible at 35 feet, yet an 8-digit readout can be installed in only 6 inches of panel.

Superior design makes the ZM1000 more economical to use, too; its high-temperature base is designed to plug directly into a printed circuit board or an inexpensive, readily available socket.

- IMPORTANT FEATURES
- Dynamic life expectancy..... 200,000 hrs.
  - Height of numeral..... 0.6"
  - Tube diameter..... 0.75"
  - Height of tube..... 1.67"

For complete data and comprehensive application bulletin on indicator-driver circuits for the ZM1000, write: Amperex Electronic Corporation, Semiconductor and Microcircuits Division, Slatersville, Rhode Island 02876.

**Amperex®**  
TOMORROW'S THINKING IN TODAY'S PRODUCTS

A NORTH AMERICAN PHILIPS COMPANY

# circuit problems?



## ultra-high leakage resistance

Devices with leakage resistance in excess of  $10^{12}$  ohms are available for circuits requiring this property. Such applications would include sample and hold for A to D conversion, and capacitor memory systems. See Signalite Application News for typical applications.



## voltage regulators better than 1% accuracy

These subminiature voltage regulators are used in regulated power supplies, as reference sources, photomultiplier regulators, oscilloscopes, calibrators, etc. They are available in voltages from 82 to 143 V. They are used in multiples as regulators in KV ranges. See Signalite Application News for typical applications.



## photo-cell applications

The A074 and A083 have been designed for use with Cadmium Sulfide or Cadmium Selenide photo-cells. Applications include photo choppers, modulators, demodulators, low noise switching devices, isolated overload protector circuits, etc. Speed of operation is limited only by the photo-cells. See Signalite Application News for typical applications.



## neon timers

The bi-stable characteristics and high leakage resistance of Signalite's special glow lamps make them ideal as a component for timing circuits. The basic circuit resembles a relaxation oscillator network. See Signalite Application News for typical applications.

# Signalite

## glow lamps have solved problems in these areas:

- Voltage Regulation & References
- Photo-Cell Drivers
- SCR Triggering
- Timing
- Photo Choppers
- Oscillators
- Indicator Lights
- Counters
- Voltage Dividers
- Surge Protectors
- Logic Circuits
- Flip-Flops
- Memory
- Switching
- Digital Readouts

Signalite glow lamps combine long life, close tolerance and economy, and are manufactured with a broad range of characteristics to meet individual application requirements. For a creative approach to your design problem . . . contact Signalite's Application Engineering Department.

### SIGNALITE APPLICATION NEWS —



is used to communicate new and proven techniques and applications of Signalite's neon lamps and gas discharge tubes. Signalite Application News provides a forum for an exchange of ideas to keep the design engineer aware of the versatility of neon lamps and their many applications. Copies are available from your Signalite representative or contact Signalite.

Circle 314 on reader service card

# Signalite



A DIVISION OF  
GENERAL INSTRUMENT

1933 HECK AVE., NEPTUNE, N.J. 07753  
(201) 775-2490

319



# the essential reference books from SAMS

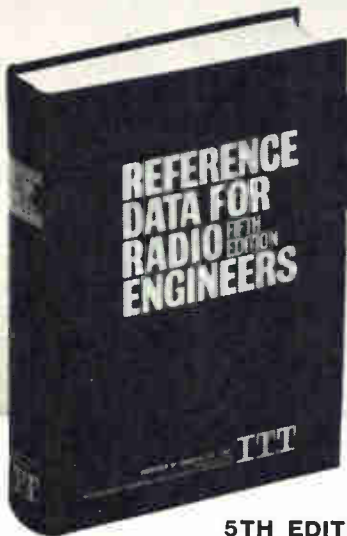

**5TH EDITION**  
of the world-famous electronics data source  
**REFERENCE DATA FOR  
RADIO ENGINEERS**

OVER 350,000 COPIES SOLD IN PRIOR EDITIONS  
Now contains 50% MORE DATA to include major information developed over the past 12 years (includes all-new data on micro-miniature electronics, space communications, navigation aids, reliability and life testing, international telecommunication recommendations, switching networks and traffic concepts, and quantum electronics). Provides, in addition, comprehensive data on all basic phases of electronics, including tables, formulas, standards, and circuit information. Prepared by an outstanding group of practicing engineers, professors, and industry and government experts, under the direction of the International Telephone and Telegraph Corporation staff. 45 data-packed chapters; 1196 pages; over 1350 illustrations; plus 41 page index. Order 20678, only ..... \$20.00

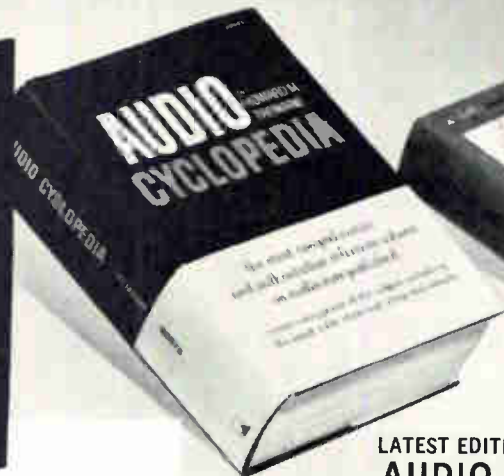

LATEST EDITION OF THE RENOWNED  
**AUDIO CYCLOPEDIA**

by DR. HOWARD M. TREMAINE. This completely revised edition is the most comprehensive work on every phase of audio—virtually a complete reference library in a single volume. Includes the latest developments, right down to the newest solid-state and integrated circuits. Contains authoritative, concise explanations of thousands of topics in the fields of acoustics, recording, and reproduction. Covers basic principles, components and devices, film recording, studio techniques, motion picture equipment, audio installation techniques, audio measurements, etc. Over 1700 pages; 1600 illustrations. Truly the definitive reference work covering the entire audio art. Order 20675, only ..... \$29.95

**MODERN DICTIONARY OF ELECTRONICS (3rd Edition)**

by RUDOLPH F. GRAF. This bestselling book now defines more than 16,500 terms directly associated with electronics. Includes special pronunciation guide. Also includes terminology often expressed in Greek alphabet symbols, abbreviated expressions for transistor parameters, and the most widely used electronic symbols and abbreviations. Covers terms used in the fields of microelectronics, space electronics, semiconductors, computers, data processing, etc. This famous work is the most complete and useful electronics dictionary available today. Over 400 illustrations. 608 pages. Order 20600, only ..... \$9.95

**HANDBOOK OF ELECTRONIC  
TABLES & FORMULAS (3rd Edition)**

A convenient one-volume source for all charts, tables, formulas, laws, symbols, and standards used in electronics. Includes valuable data for technicians, as well as useful circuit design data for engineers. With 8-page full-color chart showing latest FCC frequency spectrum assignments. Order 20648, only ..... \$5.50

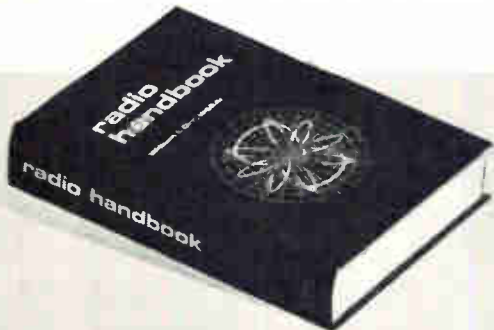
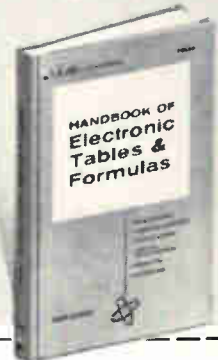

NEW 18TH EDITION OF THE FAMOUS E & E  
**RADIO HANDBOOK**

by WILLIAM I. ORR, W6SAI. Completely updated edition of the famous communications handbook which is the electronics industry standard for engineers, technicians and advanced amateurs. Explains in authoritative detail how to design and build all types of radiocommunications equipment. Includes SSB design and equipment, RTTY circuits, latest semiconductor circuits and IC's, as well as special-purpose and computer circuitry. Provides the broadest coverage in the field on how to build and operate a comprehensive variety of high-performance equipment. Order 24020, only ..... \$13.50

**HOWARD W. SAMS & CO., INC.,** Dept. EL-6  
4300 W. 62nd St., Indianapolis, Ind. 46268

Ship me the following books:

20678     20675     20600     20648     24020

\$ \_\_\_\_\_ enclosed.

Name \_\_\_\_\_

Address \_\_\_\_\_

City \_\_\_\_\_ State \_\_\_\_\_ Zip \_\_\_\_\_

# There are important reasons why users of rectifier stacks buy from Tung-Sol®

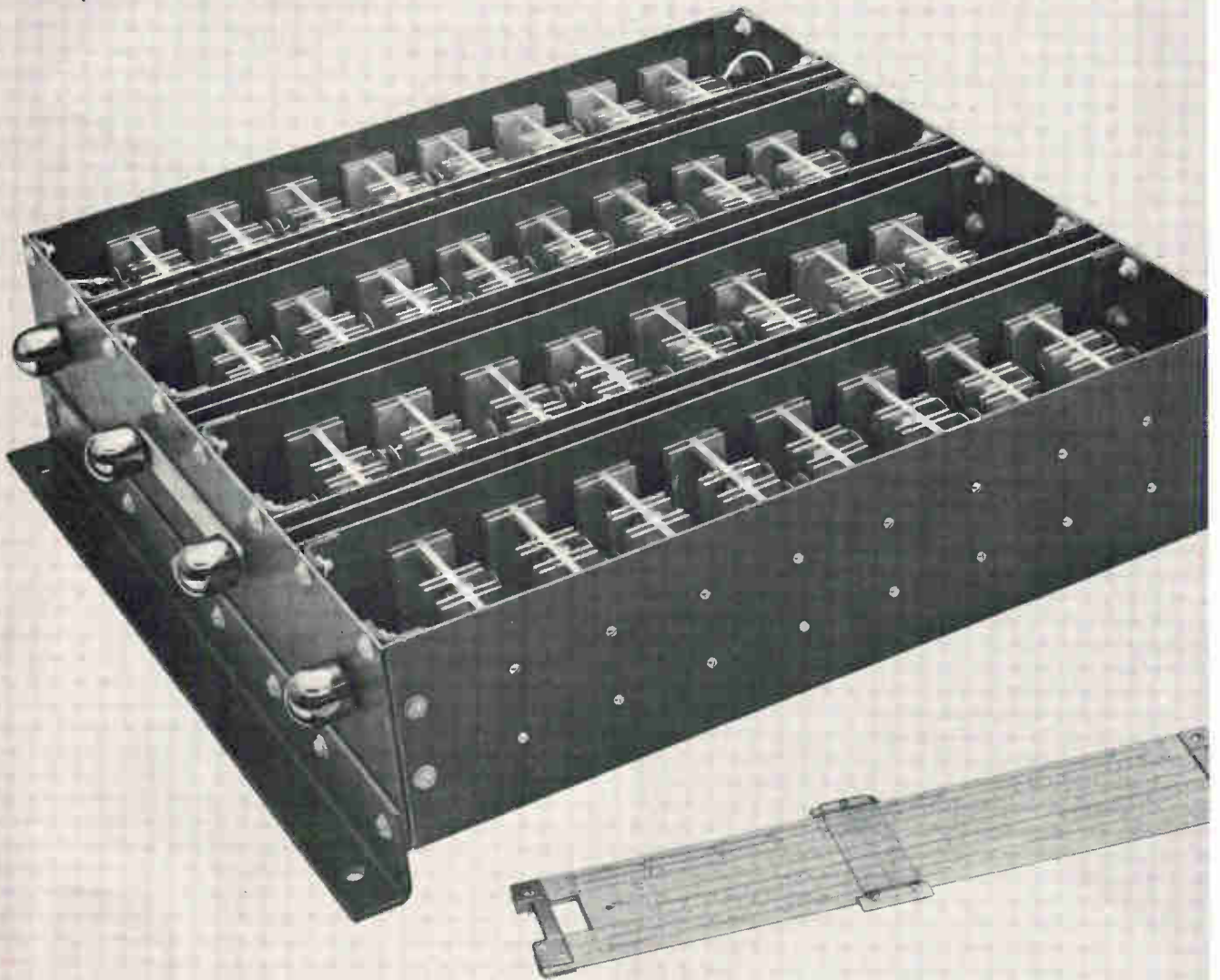

Have you had to make space and mounting concessions... more than you'd like to? Are you re-evaluating your rectifier stack requirements? Then you may want to hear more about what Tung-Sol has to say.

Tung-Sol modular stack construction combines precise ratings in packages that conserve space, minimize weight... and does it at low cost.

Even if you build your own stacks, we are certain that we can demonstrate worth-while savings in labor, materials and testing. Our guarantee eliminates your reject expense and deliveries can be scheduled to reduce your inventory and storage costs.

One of our most important services is free. Describe your rectifier stack requirements and we'll give you a completely detailed proposal — no charge.

Most of our customers started by taking us up on this offer.

## **TUNG-SOL DIVISION / Wagner Electric Corporation**

630 W. Mt. Pleasant Avenue, Livingston, N.J. 07039  
TWX: 710-994-4865 / Phone: (201) 992-1100; (212) 732-5426

Trademark TUNG-SOL Reg. U. S. Pat. Off. and Marcas Registradas





# Perfect chips at the push of a button

60x — Silicon (.038"x.038"x.014")

Chips are cut by the new Taft-Peirce slurry process. They are clean cut and perfectly square for easy handling by automatic processing devices. Identical die size is reproduced every time.

Abrasive slurry bombardment from precisely positioned revolving discs does the cutting and gives perfect chips. No scribing or breaking that can cause irregular die shapes.

Wafers up to 3" in diameter, regardless of thickness, number of layers, or composition of material can be easily processed by the Mark III Dicing Machine. (Produced under license from I.B.M.)

If you produce semi-conductor components including RAM, ROM, or LED devices, we can demonstrate a higher yield with a lab test under your specified conditions.

Drop us a line or phone today for further technical information or a lab test: The Taft-Peirce Manufacturing Co., 18 Mechanic Avenue, Woonsocket, Rhode Island 02895; Phone 401-762-1000.



**TAFT•PEIRCE**

## Mark III Dicing Machine



# TEC Can Save You 477\* Steps on Your next Display Panel



\*Based on a 60 indicator panel.

## To build a conventional panel you'll:

Buy, stock and inspect . . . . .	60 indicators	Mount . . . . .	60 indicators
Punch . . . . .	60 panel holes	Wire . . . . .	120 terminals
Engrave . . . . .	60 legends	Inspect . . . . .	120 connections
		TOTAL STEPS . . . . .	480

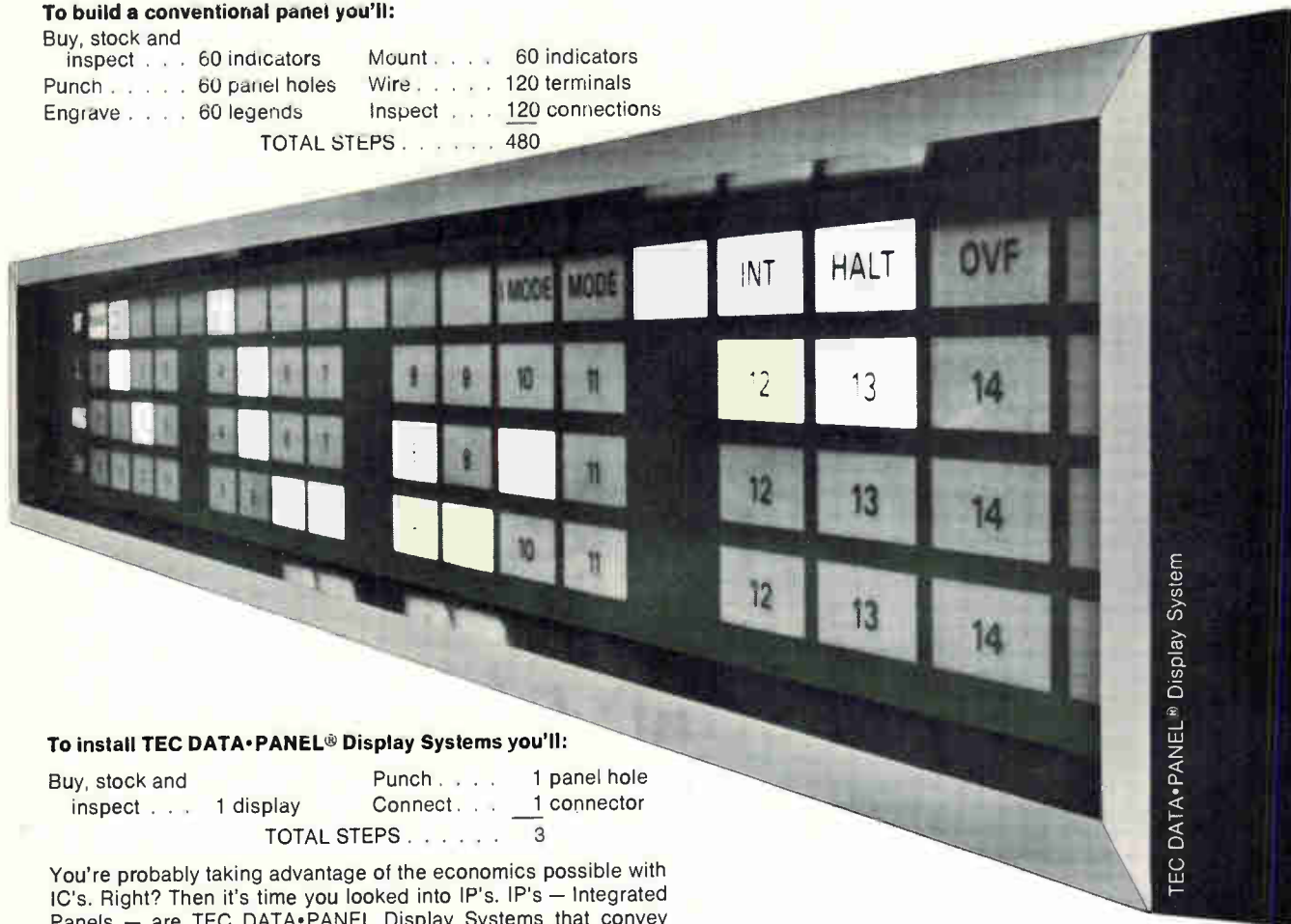

## To install TEC DATA•PANEL® Display Systems you'll:

Buy, stock and inspect . . . . .	1 display	Punch . . . . .	1 panel hole
		Connect . . . . .	1 connector
		TOTAL STEPS . . . . .	3

You're probably taking advantage of the economics possible with IC's. Right? Then it's time you looked into IP's. IP's — Integrated Panels — are TEC DATA•PANEL Display Systems that convey messages and symbols brilliantly and colorfully in a single viewing plane. Better display, yet costing less per point than individual indicators. And they cut installation work by 50% or more.

DATA•PANEL Display Systems handle any message, any symbol, in any size, in any color. Adaptable to any installation. Flexible. Reliable. Complete. Function as a total input-output system.

TEC is the leading independent supplier of a complete line of display/control products and systems. For information, call: (612) 941-1100. Or write: TEC, Incorporated, 6700 So. Washington Avenue, Eden Prairie, Minnesota 55343.



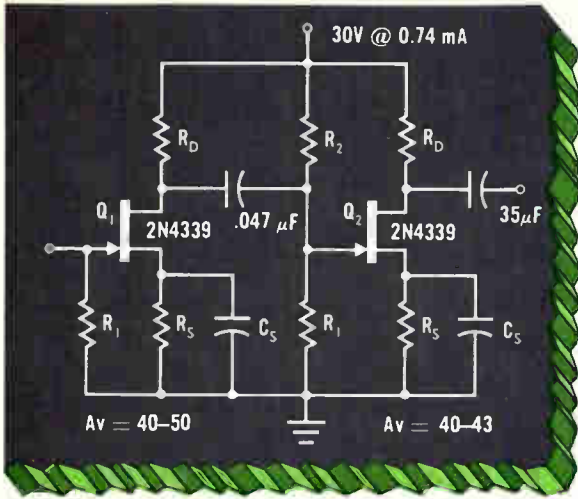

# FET AMPLIFIERS SIMPLIFIED

Using the new "full data" sheets from Siliconix you can develop a circuit design like the one above without calculations! An amplifier design chart, for example, gives component values, required supply current, maximum output level and gain limits for a range of supply voltages.

Here's a portion of the chart from the 2N4338-41 series general purpose FET:

	$V_{DD}$	$R_S$	$R_1$	$R_2$	$C_S$	$I_{DD}$	$R_D$	$e_o$ Max	$A_v$
Q <sub>1</sub>	30	1800	1M	$\infty$	40 $\mu$ F	0.42 mA	51K	4.5V	40-50
Q <sub>2</sub>	30	9100	1M	13M	35 $\mu$ F	0.32 mA	43K	5.0V	40-43

Siliconix assumes no responsibility for circuits shown, nor does it represent or warrant that they do not infringe any patents.

In addition you get a full set of performance curves with data on noise, gate current, output conductance and, most important, limiting transfer and transconductance curves showing temperature effects. Now biasing, gain calculation and circuit design are as easy as reading!

Be sure you're on our list for these "full design" data sheets. Write or call the nearest office.

- New York: Sy Levine (516) 796-4680
- New England: Al La Croix (617) 762-8114
- Ft. Worth/Dallas: Charlie Williams (214) 231-8151
- St. Louis: Jim Spicer (314) 291-3616
- Minneapolis: Ed Koelfgen (612) 920-4483
- Southern California: Dave Ferran (213) 420-1307
- Northern California: Chuck Brush (408) 246-8000



**Siliconix incorporated**

2201 Laurelwood Road • Santa Clara • California 95054  
 Telephone (408) 246-8000 Extension 201 • TWX: 910-338-0227  
 In Europe: Siliconix Limited, Saunders Way, Sketty, Swansea, Great Britain

# There isn't another like it. A 1/4-inch, single-pole, six position, 28-vdc. Helipot switch for PC boards.

**Beckman** INSTRUMENTS, INC.

**HELIPOT DIVISION**

Fullerton, California 92634

INTERNATIONAL SUBSIDIARIES: AMSTERDAM; CAPE TOWN;  
GENEVA; GLENROTHES, SCOTLAND; LONDON; MEXICO CITY;  
MUNICH; PARIS; STOCKHOLM; TOKYO; VIENNA

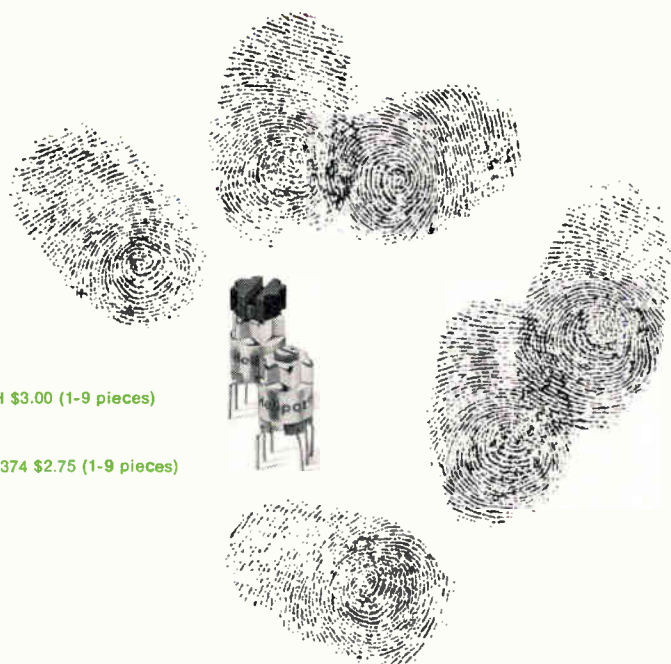

Model 374H \$3.00 (1-9 pieces)

Model 374 \$2.75 (1-9 pieces)



# Article Highlights

---

**Low voltage offers  
new jobs for  
MOS commutators  
page 82**

Thanks to fabrication processes that reduce MOS FET switching thresholds to make them compatible with bipolar IC's, a new world of applications is opening up for MOS commutators. TTL-MOS units now can sample at 20-megahertz rates, and even all-MOS multiplexers can achieve 1-Mhz rates with 99% accuracy. And the devices, made of (100) silicon, are free of parasitics and have very low leakage currents.

**Silicon on sapphire  
getting together  
for a comeback  
page 88**

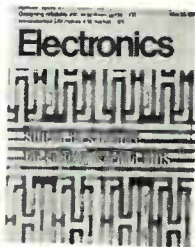

Despite a promising introduction, silicon-on-sapphire technology never got off the ground because of fabrication problems. Now, however, many IC makers are giving SOS a second look. At least three claim to have overcome the manufacturing woes, and are building SOS devices that operate at frequencies 10 times higher than their bulk-silicon counterparts. But other companies are not yet convinced of the salability of SOS IC's, though they are studying various approaches to the technology. And still other firms see no future at all for SOS. (Cover photo by RCA Corp.)

panies are not yet convinced of the salability of SOS IC's, though they are studying various approaches to the technology. And still other firms see no future at all for SOS. (Cover photo by RCA Corp.)

**Monolithic multiplier  
as a versatile  
a-c design tool  
page 100**

Multiplier modules generally have been expensive and restricted for use in simple d-c multiplication. Now, monolithic multipliers are available at prices as much as two-thirds lower than potted units. And since all circuitry is external, the monolithic units can be custom-tailored to perform a wide variety of a-c designing chores.

**Low-power design  
is the heart of  
penlight-powered tv  
page 106**

One important goal of miniaturization is low power drain. It's achieved in a tiny Japanese tv receiver whose screen measures just 1½ inches diagonally. With varactor-diode tuning, a single antenna for both uhf and vhf, 11 IC's for signal processing and deflection, and a new transistorized voltage regulator, total drain on the set's four-penlight-battery power supply is just 1.35 watts.

---

## Coming

**Ion-implanted MOS**

Ion implantation is more than just a method of improving the frequency performance of MOS integrated circuits. It's also a versatile technology that permits, among other things, tailoring the threshold voltage, high or low, to the application and integrating entirely new devices in the IC chip.

# Low voltage offers new jobs for MOS commutators

National Semiconductor's *Dale Mrazek* explains how fabrication processes for bipolar compatibility yield 20-megahertz switching rates for MOS multiplexers

● Until recently, the range of applications for MOS monolithic commutators was considerably restricted. High-precision analog switching was confined to relatively low rates—about 10 kilohertz—because of the large noise transients produced by metal oxide semiconductor switching transistors. Now, thanks to development work aimed at reducing threshold voltages to make MOS digital IC's compatible with bipolar devices, a new and broader range of applications is opening up.

The fabrication processes that lower switching-voltage thresholds of MOS transistor have cut transient noise levels by at least 50%, while reduction in impedance and leakage current also have enhanced performance. The benefits of lowering threshold voltage are additive, particularly in multichannel commutators where the signal may go through several switches in series.

Although they switch analog voltages, the MOS field-effect transistors in these commutators can interface with logic IC's almost as readily as low-voltage MOS IC's—either MOS or bipolar logic can control the MOS FET gate voltages. Thus, transistor-transistor logic can drive an MOS commutator at rates up to 20 megahertz, with analog sampling accuracy (ratio of output to input voltages) better than 99%.

As a result, low-threshold MOS commutators have caught on in aerospace applications, and they are becoming increasingly attractive for high-speed sampling

in such areas as in-flight checkout, aircraft sampled-data systems and multiplexers for communications. Perhaps the most important potential application is high-speed audio sampling for pulse-code-modulated telephone transmission systems.

The fabrication techniques now in use (see Panel, p. 85) produce MOS FET's whose threshold voltage  $V_{TH}$  is 1.8 to 2.0 volts, against about 4 volts for a conventional MOS FET. Practical MOS circuits do have some  $V_{BS}$ , bulk—(substrate) to—source bias and usually a signal voltage at the source, which raises the working value of  $V_{TH}$ . However, the gate-voltage change needed to switch a low- $V_{TH}$  transistor becomes proportionally smaller than that of the higher-voltage device as bias and signal voltage decrease. The switching level typically can be kept within the range of bipolar logic outputs.

A general equation describing these relationships is  $V_{TH} = -K \pm [(2\phi_F + V_{BG})]^{1/2} + V_{GS}$  where  $K$  is a device constant (usually 0.8 to 1.2) and  $2\phi_F$  is the threshold voltage at zero bias. To insure that the MOS FET switches on under all signal conditions,  $V$  must swing from at least  $V_X$  to  $(-V_{TH} - \Delta V - V_X)$ , where  $\pm V_X$  are the limits of the signal to be sampled.  $\Delta V$  is the overdrive needed to lower the switch's series resistance to the desired level (mainly reduction in  $R_{ON}$  obtained by driving  $V_{GS}$  to a more negative state), and is proportional to  $V_B$ , which must, in turn, be larger than

At the threshold. The importance of the threshold voltage is illustrated in this schematic of the operation of a p-channel enhancement-type MOS FET (the basic element of most MOS integrated circuits). It conducts when the gate voltage is more negative, by at least  $V_{TH}$ , than the potential of the bulk semiconductor substrate,  $V_{BS}$ . The oxide under the gate electrode acts as the dielectric of a capacitor. Electrons gathering on the gate electrode cause holes (absence of electrons) to appear in the channel region. There, n-type silicon is converted to p-type, eliminating the p-n diode junctions that blocked current flow between source (the most positive terminal) and drain  $V_{TH}$  is the bias at which the layer of intrinsic semiconductor, with no surplus of electrons or holes, and the p-channel reach the drain diffusion. Conduction begins at this point and increases as  $V_G$  goes more negative than  $V_{TH}$ .

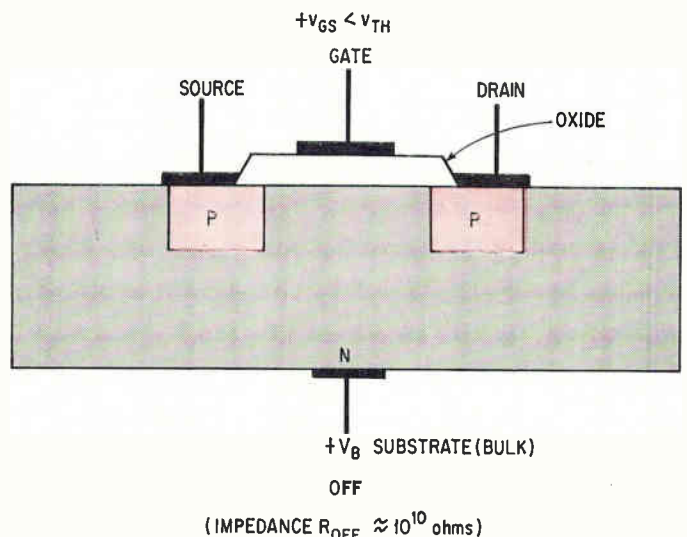

the maximum positive excursion of  $V_X$ .

If the signal range is fairly wide, say  $\pm 10$  V, the advantage of a low- $V_{TH}$  MOS FET is minimized: the gate voltage of a MOS FET with a 2-volt threshold would have to swing from +10 volts to about -20 volts for accurate commutation, compared with a required swing of +10 volts to about -26 volts for a 4-volt threshold device. However, the difference becomes quite significant at lower signal voltages. At  $V_X = \pm 1$ v, for example, the conventional device requires a swing from at least +1 volt to -10 volts while the low- $V_{TH}$  device does the job with +1 volt to -6 volts, about a third less. High-speed, low-impedance TTL gates can control a commutator in the latter voltage range because small transitions can be made very rapidly. And they are close enough to bipolar logic transitions to use simple, high-speed TTL-to-MOS interfaces.

Furthermore, a low- $V_{TH}$  switch generally can handle a larger signal range than a high- $V_{TH}$  device of comparable size because the zener-breakdown voltage of the p-n diodes formed between source and drain and the substrate is not reached as quickly. Multichannel switches made with (100) silicon typically operate with a maximum control-voltage change of from +14 volts to -30 volts, permitting  $V_X = \pm 14$  volts. Relatively few practical applications require a swing of such magnitude. If a larger signal voltage must be handled,

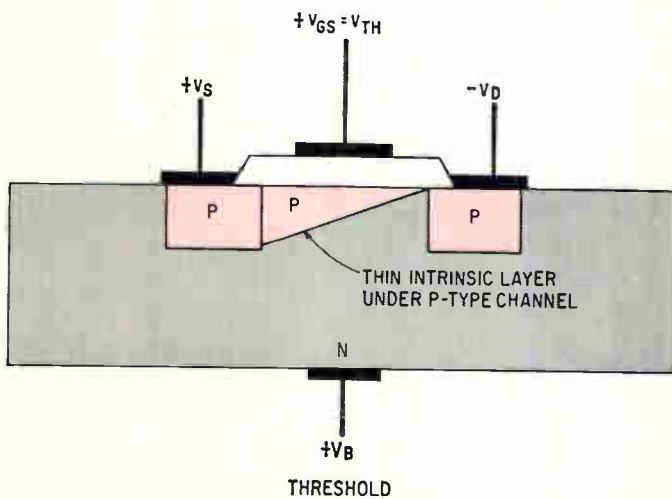

it would be cheaper to use a scaler than to pay for a high-voltage multiplexer with heftier control circuitry.

For optimal signal accuracy and maximum switching rate, all impedances should be fairly constant as well as low. Since  $R_{ON}$ , the resistance of a MOS FET while on, varies with signal voltage, it cannot be compensated as readily as the more stable impedances in the remainder of the commutator's switching circuitry.

MOS commutators usually are structured as series switches—two or more ranks of commutators (page 87). The added ranks of commutators generally are used to minimize the control circuitry. But when additional MOS FET's are put in each signal channel the value and range of variation of the conducting channel's  $R_{ON}$  are increased. If  $V_X$  varies, the error ratio,  $V_{out}/V_{in}$ , tends to vary because  $R_{ON}$  is a function of the effective switching threshold which rises and falls with  $V_X$ .

There is no way to keep  $R_{ON}$  absolutely constant. The effect of variation usually is reduced by increasing the circuit's other impedances, but this lowers the maximum switching rate. A low- $V_{TH}$  eases this problem greatly. Low- $V_{TH}$  analog IC switches made with (100) silicon achieve  $R_{ON}$  values comparable to those of higher- $V_{TH}$ , discrete MOS FET's—from 250 to 300 ohms at  $V_X = -10$  volts, and about 100 ohms when  $V_X = +10$  volts. The  $R_{ON}$  of a high- $V_{TH}$  IC commutator, in contrast, typically is a few hundred ohms higher; some exceed several kilohms.

To swamp out the voltage-divider effect on  $R_{ON}$  in series with the source and load impedances, it has been customary to use a load value,  $R_L$ , that is much larger than the combination of  $R_{ON}$  and  $R_S$ . Output impedances in the megohm range often are needed with high  $V_{TH}$  devices, whereas very low values of  $R_S$  and  $R_L$  can be used with low- $V_{TH}$  commutators. These low impedances and the very low impedance of the TTL circuit controlling the gate are two of the principal sources of this commutator's exceptionally high speed.

Source impedance usually is made to equal  $R_{ON}$  so that leakage currents of the turned-off MOS FET's can return to a low-impedance signal generator. While leakage per switch is small in an IC commutator, several switching devices with a common output in the same semiconductor substrate could have leakage currents that add up to seriously degrade signal accuracy. However, leakage is so small in commutators made with (100)

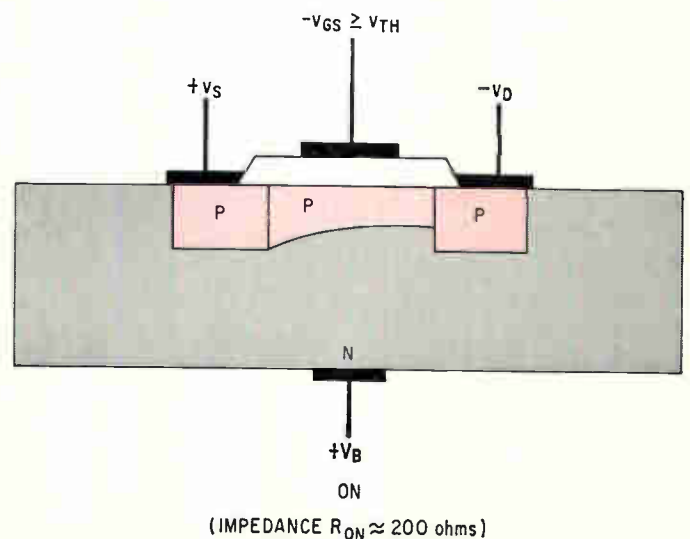



silicon that they will work well up to a temperature of 125°C, (commutators made with (111) silicon are specified for a maximum operating temperature of 85°C; increased leakage at high-temperature operation makes them inaccurate above this limit).

Regardless of the MOS FET type, the off resistance,  $R_{OFF}$ , of a well-made device generally is at least  $10^{10}$  ohms, high enough to prevent the signals in the off channels from appearing at the output and degrading the accuracy of the sampled signal. If the off channels include high-frequency sources there may be significant a-c feedthrough, but this can be prevented.

A commutator is absolute switching-speed-limited by the time required to charge and discharge the device's capacitances. Circuit impedances affect speed by contributing to the RC time constants. However, the practical switching rate of a precision commutator primarily depends on the time the output amplifier requires to recover from noise transients produced during the charge-discharge cycles. Low- $V_{TH}$  processing cuts transient recovery time at least in half because the peak transient amplitude is halved.

In all MOS FET's, transmission of a turn-on or turn-off signal is followed by a delay whose duration depends on the magnitude and rate of change of the gate-control voltage. At turn-on, the delay is lengthened by the RC time constant of the gate-bulk capacitance and the source. Capacitances and impedances in the signal path cause a similar delay at turn-off. As  $V_{GS}$  goes negative, turning the switch on, energy is pulled through the source and load impedances, and the gate-source and gate drain capacitances. At turn-off  $V_{GS}$  goes positive, and energy is pushed out through the same paths.

Thus, negative turn-on and positive turn-off transients appear at the summing node. These transients are generally much larger than signal voltages, so that even the relatively small transients encountered in a low- $V_{TH}$  MOS FET can saturate the output amplifier. One method designers of discrete commutators use to minimize transients at the summing node is to drive adjacent channels with coincident turn-on and turn-off signals. With this approach, negative-going transients from channels that are turning on partially cancel out positive-going transients from channels that are turning off. When the output amplifier is an integrator, the amounts of energy pulled through the summing node will be minimized in effect, by being averaged out. Unfortunately, coincident-drive, discrete-component circuits are fairly complex and expensive, and require complementary transistor pairs. Essentially the same effect can be obtained in a high-speed commutator, at a much lower cost.

A TTL decoder such as a DM 7842 can select channels so fast that one channel is turning on while another is turning off. Control-voltage transitions occur in less time than the turn-on and turn-off delays of the MOS FET's, so the transients are suppressed in just nanoseconds. In fact, when the signal voltage is going either negative or positive simultaneous with a transient that's going in the same direction, the transient is practically invisible in the output—it actually helps change the output signal to the correct level more rapidly. It's almost as if the high commutation rate makes the high commutation rate possible. However, such rates are not practical with high- $V_{TH}$  commutators, because TTL decoders could not directly control such devices. Low-impedance drivers are

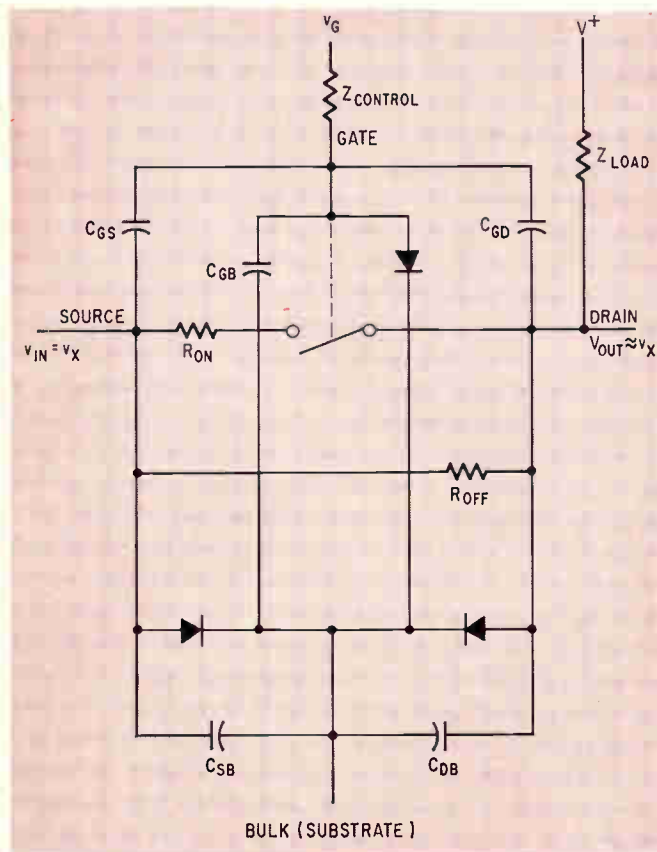

**Tiny transients.** This equivalent of a MOS FET circuit offers further insight into the importance of lowering the switching threshold. The smaller change in  $V_G$  will result in smaller and briefer transients appearing at source and drain. The value of  $R_{ON}$ , the MOS FET's conducting impedance also will be less at any given value of  $V_G$  more negative than  $V_{TH}$ . Increasing sampling accuracy, defined by the ratio  $V_{out}/V_{in}$ .

## It's all in the processing

The most direct and reliable method of reducing a MOS FET's switching voltage threshold is to use silicon that is grown and cut with a (100) crystal orientation rather than the conventional (111) orientation.

The (100) process greatly reduces the number of uncommitted atomic bonds on the silicon surface, thus reducing the amount of charge that must be placed on the gate capacitance to convert the n-type silicon substrate to a p-type channel. But, at present,  $V_{TH}$  cannot be made reliably low without backup processes that minimize drift of the inherent  $V_{TH}$  value (about 1.6 volts).

The gate oxide must be thick to prevent pinholing. It also must be free of contaminants, especially mobile alkali ions such as sodium. This requires a high degree of decontamination in processing equipment—for instance, electron beams now are used to deposit thin-film metal for intraconnections and electrodes. Wafer lots are pulled off the production line and the process is decontaminated anytime  $V_{TH}$  drifts 0.25 volt or more.

Other threshold-lowering techniques are not as reliable; among them, the use of ordinary (111) silicon with the gate dielectric formed with thinner layers of silicon oxide and silicon nitride. Nitride is denser and has a higher dielectric constant than oxide. But, the additional processes required to form the nitride layer and the thinness of the underlying oxide layer degrades the reliability of this method.

Pinholes are very prevalent in thin oxide layers, and the use of nitride won't prevent process contamination. Furthermore, polarization and traps generated at oxide-nitride interfaces may shift the threshold up to 1 volt in either the positive or negative direction, depending on applied bias and temperature. This can't happen when silicon oxide is the only dielectric.

Another potential problem with other processing techniques is that in large-scale devices small n-type areas around the MOS FET's are used for element isolation. Although low-voltage operation improves isolation, allowing closer spacing of devices, unless the insulating layer under adjacent thin-film interconnections and electrodes is very stable, changes in the voltage characteristics can invert parts of the isolating substrate to p-type regions causing faulty operation. The possible formation of parasitic channels due to field inversions, a phenomenon which is typically enhanced by lower switching thresholds, is prevented by a field-doping process which yields even greater field-inversion thresholds than those of conventional (111) silicon.

Finally, silicon cut along the (100) plane is much cleaner electrically than (111) silicon. Leakage is very low in (100) devices—1 nanoampere at 25°C in the MM 454 commutators, for example, and 50 na at 85°C. The MM 454 is a complex device, however: a simple switch like the MM 450 shows only 8 na at 85°C. While any silicon device's leakage rises rapidly with temperature, only MOS FET's made with (100) silicon are specified at operating temperatures to 125°C.

essential for high commutation rates because they quickly source and sink transients. In this respect, TTL integrated circuits make almost ideal drivers, but they make a good match only with low- $V_{TH}$  commutators.

In cases where the analog input signal is a-c rather than d-c, there will be a charge transfer through the gate-source and gate-drain capacitances of the turned-off MOS FET's. This results in output-voltage fluctuations due to the appearance at the summing node of signal voltages from a channel that is supposed to be off. This problem is called a-c feedthrough or channel-feedthrough or channel-feedthrough noise.

Fortunately, most a-c transducer voltage outputs are below 10 khz and the problem can be averted simply by using a low-impedance gate driver. Then the transients sink into the driver instead of going to the output. A high signal-source impedance would make this technique more effective, but also would cause larger transients in the turned-on channel, imposing longer recovery times and slower commutation rates.

There is a simple detour around this impasse: driving the gate from a low-impedance voltage source shunts any feedthrough signal to ground rather than letting it appear at the load resistor. In practice, this approach will provide isolation greater than 40 db at signal frequencies up to about 1.5 Mhz. The driver impedance itself also must be low at high frequencies, of course.

All of these factors have been optimized in the system shown on page 86. At 20 Mhz, its accuracy with  $V_x = \pm 1$  volt is almost 99%. Source and load impedance can be kept very low because  $R_{ON}$  is only about 200 ohms per channel. The gate change is only 7 volts (from +1 volt to -6 volts), and the high-speed TTL control makes the transients coincide.

The eight-channel configuration shown can be the building block for very large solid state commutators. Each four-channel MOS FET switch is a monolithic chip (National Semiconductor MM 451). The TTL channel selector is a decoder (DM 7842) designed to convert four-bit binary-coded-decimal inputs into decimal-number outputs. Only eight outputs are needed here, so the decoder's fourth input is grounded.

The TTL outputs are converted to MOS control signals through an interface network consisting of identical passive circuits on each control line. An interface similar to the one shown is needed for each channel.

Higher and higher. This eight-channel commutator uses TTL drivers to switch MOS FETs at rates up to 20 Mhz. Sampling accuracy is almost 99% for input voltages up to  $\pm 1$  volt.

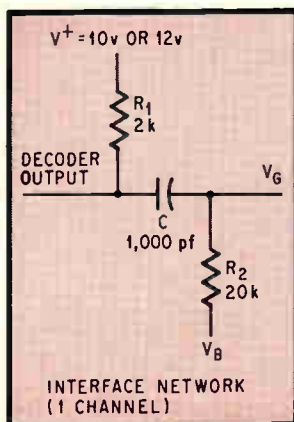
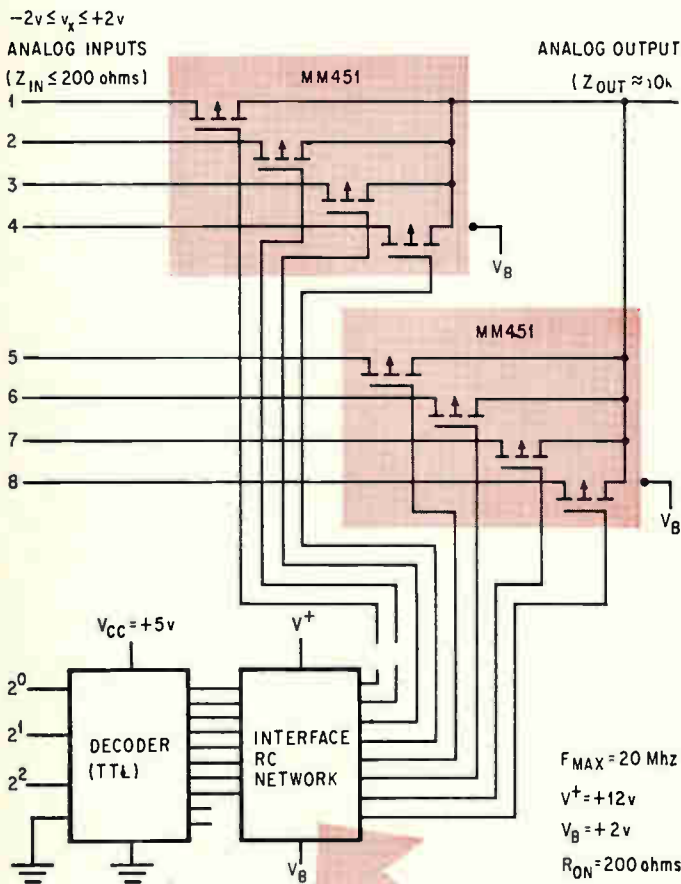

While the TTL logic outputs are positive, MOS FET's require negative and positive gate biases to turn on and off, respectively. The necessary voltage changes are made with capacitors.

Assuming first that the TTL output is at the normal TTL logic 1 level of about 2.5 volts, there will be +6 volts across the capacitor due to  $R_1$ . Since  $R_2$  is connected to +6 volts ( $V_{SS} = +6$  volts in this system), the MOS FET gate bias will be no more negative than 0 volts, and that channel will be kept off.

When the TTL output switches from a logic 1 to a logic 0 level, the voltage seen by the capacitor drops from +6 volts to about 0.4 volt. Bias on the gate therefore will drop from 0 volt to about -6 volt, turning on the channel. The commutator is controlled, then, by selecting the location of an "0" bit in the decoder output and making all other outputs 1.

$R_1$  is connected to a voltage higher than +6 volts to assure that the TTL output rises rapidly during a transition from logic 0 to logic 1. This is a requirement for quick, clean channel turnoff. The opposite transition, to the more negative level, normally is quite fast and gets a boost from the excellent current-sinking capability of TTL. By comparison, nothing approaching a 20-Mhz rate could be achieved with diode-transistor logic drivers because of their higher impedance.

It's important to choose TTL drivers that do not break down when their outputs are pulled up to about +10 volts. The DM 7842 has a diode in the output stage that protects the output transistor at high voltages; other devices in the National TTL family have similar output stages. These are equivalent to Series 5400 TTL, which also can be used to assemble suitable control logic. The DM 7842 is especially convenient because only one driver chip is needed for every eight channels in the commutator system.

There is a delay of 10 to 15 nsec, mainly due to the RC constant of the interface, between a transition in the TTL output and on-or-off channel switching. However, the delay is evidenced as an overall time shift; it neither affects the commutation rate nor significantly reduces the 50-nsec sampling time permitted by a 20-Mhz rate. Commutator output can be synchronized to any data processing subsystem by applying a comparable delay in the line from the system clock to the processor.

The MM 451 chip also is available with DTL monolithic driver in a flatpack. This hybrid IC, the MH 453, does not require an external interface network, but is not as fast as the other combination. It will operate at frequencies to 500 khz and switch analog signals of  $\pm 10$  volts under direct TTL or DTL logic control. The four MOS FET's of the MM 451 are connected in a dual differential configuration, useful for combining and comparing signal voltages.

Despite their larger voltage swings and transients, all-MOS commutators need not be limited to low-frequency operation. The system on page 87 has better than 99% accuracy at 1 Mhz with  $v_x = \pm 10$  volts. Similar systems, optimized for smaller signal-voltage ranges, would be even more accurate and could be improved further by operating at less-than-maximum sampling frequency.

In this example of an all-MOS commutator, each of the MM 454 four-channel commutators contains four MOS FET's like those in the MM 451 and, in the same chip, a



four-bit MOS counter and decoder for channel selection and all-channel blanking. The circuit design includes a zero-impedance return for the analog switch gates. The system samples the 16 channels sequentially, much like a rotary driven mechanical commutator.

The MM 454 is designed as a building block for large sequential sampling systems. However, any particular channel could be selected with external output-gating logic. If random channel selection were the normal operating mode, the MM 451 and external selection logic could be used. Two ranks of commutators, similar to the arrangement illustrated, would simplify the control logic. For example, one gate driver would turn on channels A<sub>1</sub>, B<sub>1</sub>, C<sub>1</sub> and D<sub>1</sub>, and a second driver would select channel A<sub>1</sub> by turning on channel E<sub>1</sub>—which requires a lot less control circuitry than would be the case in selecting 1 out of 16 channels directly. And only one more monolithic commutator is needed.

Either way, a very critical system design requirement is a guarantee that only the selected channel conducts during the sampling interval. This is achieved by the single three-input NOR gate. Commutator C is used as the master element. It divides down the 1-Mhz clock signal through a 4:1 countdown circuit, which is provided in the MM 454 to facilitate submultiplexing. Commutator E's four channels therefore sequence at a 250-khz rate. Meanwhile, each of the four channels in commutators A, B, C, and D are sequencing at 1 Mhz. The analog output sequences through A<sub>1</sub>, A<sub>2</sub>, A<sub>3</sub>, and A<sub>4</sub> in order when E<sub>1</sub> is open, B<sub>1</sub> through B<sub>4</sub> when E<sub>2</sub> is open, and so forth.

The 4:1 countdown output of commutator E (1/16 Mhz) is fed back through the NOR gate to the reset inputs of commutators A, B, and D. The reset every cycle keeps them in step with commutator C—and therefore commutator E. The NOR gate's output also can be used to maintain synchronization of the commutator with other signal processing systems.

Looking to the future, ease of interface with bipolar logic ICs and low dissipation should guarantee a wider market for low-threshold MOS devices. Techniques are being developed to directly couple digital as well as analog MOS circuits to bipolar logic, and successes to date include a data-storage system with a 16 Mhz transfer rate, using parallel MOS storage circuits. ●

Right on. All-MOS commutators can provide high sampling accuracy for signal inputs of up to  $\pm 10$  volts but are not as fast as TTL-MOS combinations. The circuit shown here has an accuracy of 99% at a 1-Mhz sampling rate.

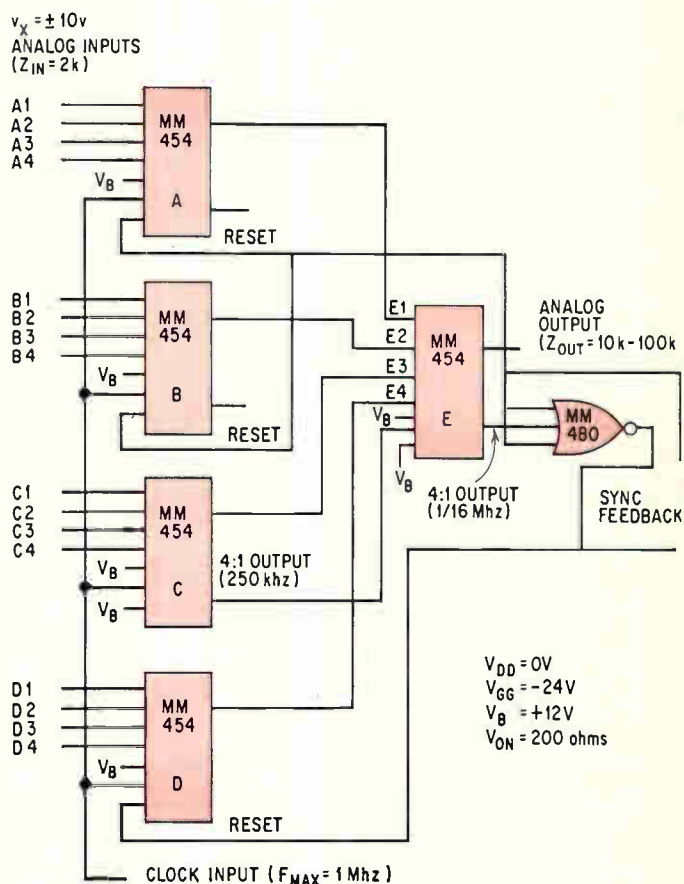

# Silicon and sapphire getting together for a comeback

Some firms say fabrication wrinkles have been ironed out and predict a big market, but others disagree; *Electronics'* staff looks into the pros and cons both at home and abroad

● After a well publicized introduction by Autonetics five years ago, silicon-on-sapphire technology quietly faded into the background. Despite the significant advantages SOS promised in reducing parasitic capacitance in integrated circuits, thereby improving high-frequency performance, severe fabrication problems involved in putting single-crystal silicon on sapphire discouraged the semiconductor manufacturers.

Now some semiconductor houses have found that they can handle the manufacturing problems. And companies like RCA, Plessey, Autonetics, and Signetics see a strong possibility that SOS IC's—or variations such as silicon on spinel and other insulating substrates—will become commercially available, perhaps in as little as a year.

To be sure, not every company agrees with this view. Fairchild, Bell Telephone Laboratories, and IBM, for example, have little interest in the technique. And still others adopting a wait-and-see attitude. Texas Instruments, for instance, predicts at least a three to five year wait before a market develops.

The fundamental advantage of the silicon on sapphire technique is the extremely high insulation resistance that the sapphire substrate provides. As a result, there is no interaction among IC components on the sapphire—leakage current is essentially zero, as is capacitance. SOS IC's therefore can switch at much faster rates than their conventional counterparts built of bulk silicon. The decrease in parasitic capacitance is so dramatic that metal oxide semiconductor IC's—normally regarded as rather slow devices—can, when built on sapphire, match the speed of bipolar circuits.

At RCA's David Sarnoff Research Laboratories, complementary metal oxide semiconductor SOS IC's are being built that are as fast as the fastest conventional bipolar circuits. So far, RCA has built a 16-bit associative memory with nanosecond stage delay, and a 50-bit shift register that operates at a clock rate of 90 megahertz, about two orders of magnitude better than bulk-silicon MOS IC's. RCA's current project is a random-access memory that is expected to have an access time of 30 to 40 nsec with full decoding (versus a few hundred nsec, typically, for bulk-silicon MOS). Engineers at RCA hope to get 250-Mhz clock rates in the near future.

RCA is sufficiently encouraged to commit itself to building a pilot production line for C-MOS-SOS IC's this summer. The company hopes, if it goes into mass

production, to tap what it sees as a vast market for high-speed semiconductor memories. And in addition to speed, MOS-SOS IC's would offer lower power consumption and higher noise immunity than would bulk-silicon IC's because of the lower leakage and capacitance. And once sapphire becomes available in large quantities, that availability plus the smaller number of process steps would dramatically reduce prices.

The Air Force and NASA share RCA's enthusiasm for the technique. The AF Avionics Laboratory at Wright-Patterson Air Force Base plans to continue its support of SOS device development for at least another two years. Next on the list is adaptation of ion-implantation and silicon-gate technology to SOS.

Autonetics, the company that started all the fuss, has had to retrench its SOS development work to a great extent because of the company's current heavy commitment of resources to production of bulk-MOS large-scale integrated circuits. Nevertheless, Autonetics has confidence in the future of SOS. James Luisi, process engineer for the Autonetics Products division predicts a \$10 million annual market for SOS diode arrays within the next three years. He says that Autonetics has in mind a high-speed, low-cost SOS read-only memory that would sell for well under 1 cent per bit. A decision still has to be made on production and marketing for the ROM, as well as the amount of resources to be invested in the effort. But the matter is under discussion. The ROM is a 5,120-diode array measuring 25 by 25 mils in a 42-lead, hermetically sealed dual-in-line package. Selling price would probably be about \$50 each.

This diode array is being considered, says Luisi, "because it's the simplest device you can make, and it could form a solid base as a commercial product." However, "the real test is in whether you can bring off complementary circuits," he concedes. He believes that production of the SOS diode array would provide enough profits and leverage to move the company into complementary circuits.

In England, Plessey Co. also has plans to establish a pilot production line for SOS IC's later this year. By the summer of 1971, Plessey expects to be supplying sample quantities of SOS IC's to customers. The first production circuits are likely to be memory IC's, as at RCA.

Using SOS MOS techniques, Plessey researchers have made experimental eight-bit static shift registers which

will operate from d-c to about 5 Mhz. A seven-stage ring oscillator made up of seven inverters in series has also been built and used to check the technology. A device now being constructed with an eye to possible production is an eight-stage ripple-through counter which could be used for divide-by-256 functions in a frequency synthesizer. In this application, the SOS MOS circuit would replace bipolar-transistor circuits to give lower power consumption—an important factor in battery operated receivers.

Another company with a strong interest in SOS is the Signetics Corp. At that company, the insulating substrate is neither sapphire nor spinel. Instead, it's "a proprietary material with a proprietary process," according to David Kleitman, director of R&D, and it reportedly has significant advantages over other materials. Signetics hasn't yet decided whether to go ahead with mass production of its silicon-on-insulating-substrate circuits, but the decision could be made in the next few weeks. Meanwhile, the process is essentially ready.

At many other companies, on the other hand, there's a remarkable indifference to SOIS in any form:

- A Fairchild semiconductor spokesman reports that his company has no R&D work going on in SOIS.
- A source at Bell Telephone Laboratories in Murray Hill, N.Y., says, "We aren't doing anything in SOS

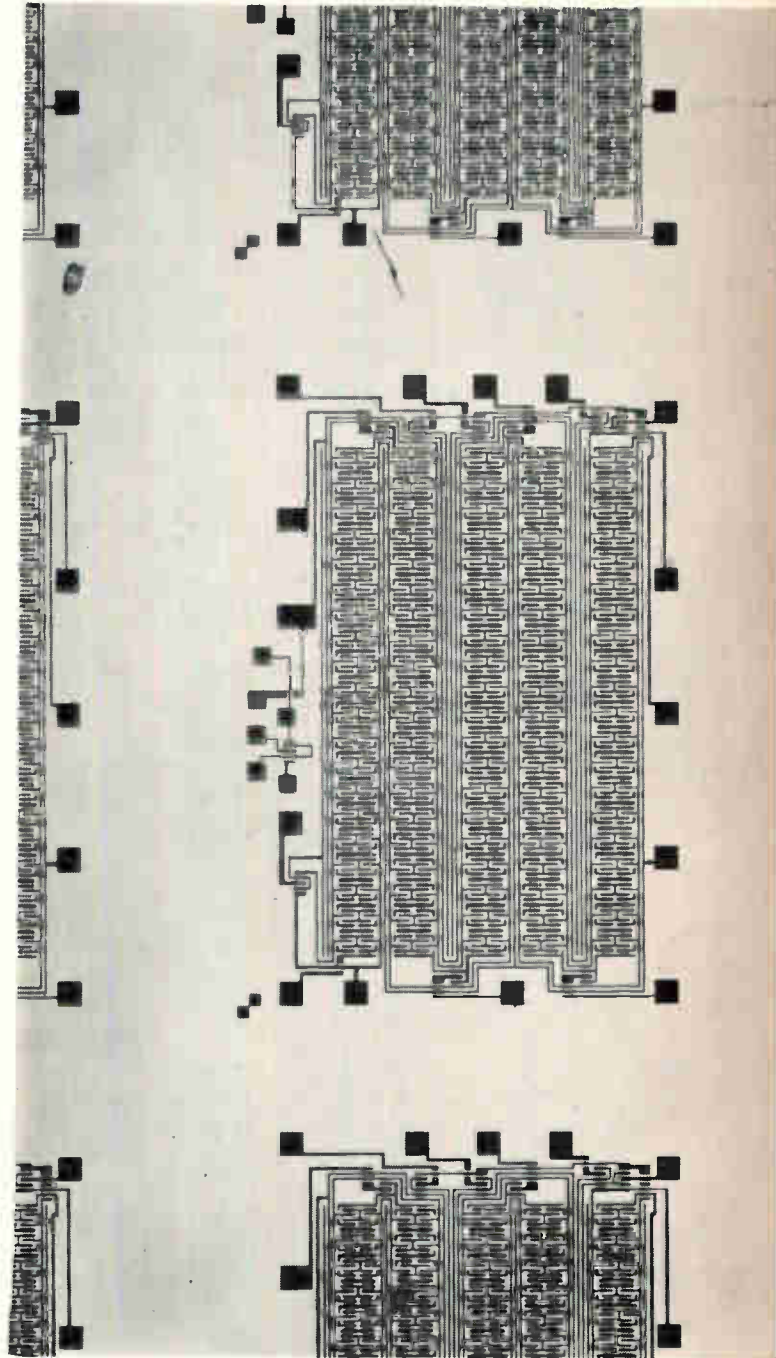

Packed-in. RCA's complementary MOS circuits are believed to be the most complex built by SOS technology to date. This 50-bit dynamic shift register, also shown on cover, operates at a frequency as high as 90 Mhz and as low as 200 khz. It contains 420 MOS transistors, half of them n channel and half p channel, on a 70 by 100 mil chip.



## **“... the cost disadvantage of sapphire is one of those things that's definitely going to disappear when you get into high volume ...”**

because we don't feel it has applications for our needs.” ■ “There is no major activity going on in SOS at IBM's Components division,” says a spokesman for that company.

One engineer sums up the prevailing attitude at these and similar companies this way: “SOS is a solution looking for a problem. Besides, for the money we'd have to put into it, we don't find its performance advantages striking enough. Sapphire is expensive and spinel has a tendency to crack. Further, SOS packing density is quite low.”

In fact, the company that may have been the first to use the SOS technique, the Mitsubishi Electric Corp., gave up its R&D work on SOS two years ago. The company's Semiconductor Research Laboratory claims to have grown epitaxial silicon on sapphire even before all the brouhaha engendered by the Autonetics announcement. Mitsubishi decided that the quality of the epitaxial layers was too low to be suitable for mass production.

However, the objections to SOIS don't dismay engineers and scientists at RCA Labs. They're aware, for instance, that sapphire presently costs about five times more per unit area than silicon does. But Joseph Burns, who heads RCA's SOS activity, points out, “We are at nowhere near the volume production that TI and others are in silicon. The cost disadvantage of sapphire is one of those things that's definitely going to disappear when you get into high volume.”

Far from regarding sapphire as a cost disadvantage, RCA engineers feel that it may actually help to reduce costs by increasing the manufacturing yield. They have been achieving yields of as much as 50% on their complex IC's. Joseph H. Scott, who has concentrated on the processes for SOS at RCA, explains: “There are good reasons to expect that silicon on an insulating substrate should give you a higher yield than you could get with bulk silicon, simply because you don't have nearly as much silicon surface.” In the associative memory that RCA is developing, for example, silicon accounts for less than 5% of the total surface area. The surface crystal defects in the silicon, which can be ruinous in bulk-silicon device production, therefore become much less significant in SOS.

In addition, there's no need to worry about metalization shorting out to the substrate—a common cause of rejection in bulk-silicon IC's, caused by pinholes in the

insulating oxide. In SOS, the metalization is deposited directly on the substrate; the oxide layer isn't necessary.

Pinholes are much less of a problem in general, except, of course, for pinholes directly over the channel region. An unwanted diffusion through a pinhole to the sapphire substrate will have no effect. As a result of all these yield-improving factors, “you should be able to build a bigger chip and put more functions on it,” Scott says.

Essentially, the SOS fabrication process consists of polishing the sapphire wafer so that it's flat and smooth, growing a thin layer of single-crystal silicon on the wafer, and then etching the silicon layer to form a separate silicon island for each component in the circuit. The islands are then masked and dopants diffused into them to create the required transistors, diodes, resistors, and capacitors, in much the same way that these components are created in conventional bulk-silicon IC's.

The single most critical step in this sequence is the growth of the silicon film on the sapphire substrate. Because of the significant difference between the crystal structure of sapphire and that of silicon it's difficult to assure that the silicon layer is monocrystalline. The silicon crystal has cubic symmetry, whereas sapphire has rhombohedral symmetry. This mismatch means that the deposited silicon has a distorted crystal structure at the interface with the sapphire, although the silicon structure tends to become more nearly ideal as the distance from the sapphire increases. However, the silicon film thickness can't be increased indefinitely because height of the silicon islands then would become too high for reliable deposition of the metalization. At RCA, for example, the silicon-film thickness is held to about 1 micron, and although this is no larger than the oxide steps in some bulk-silicon IC's, depositing continuous metal stripes over such a height can be tricky, as bulk-silicon IC manufacturers well know.

Because of the inherent mismatch between silicon and sapphire crystals, carrier mobility of the silicon film is somewhat lower than that of bulk silicon. A minority-carrier mobility of around 300 centimeters<sup>2</sup> per volt-second is considered extremely good for SOS, but this figure is nowhere near the 1,500 cm<sup>2</sup>/volt-sec that is attainable in bulk silicon.

The low mobility of carriers in SOS results in very poor performance in bipolar SOS transistors. If current

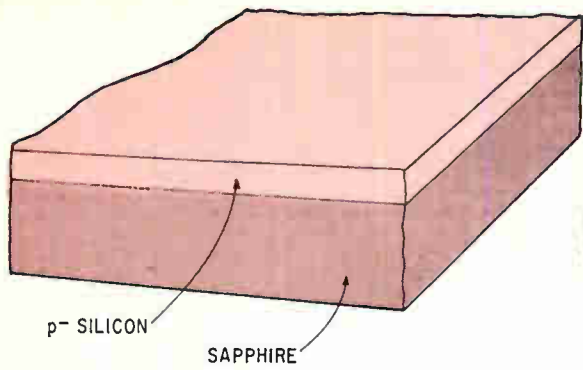

p- SILICON  
SAPPHIRE

SINGLE-CRYSTAL SILICON  
DEPOSITED ON SAPPHIRE

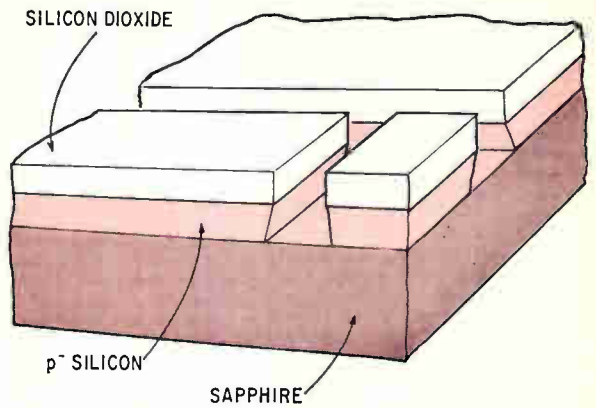
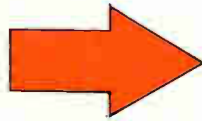

SILICON DIOXIDE  
p- SILICON  
SAPPHIRE

FORMATION OF OXIDE, PHOTO-MASKING,  
ETCHING TO FORM ISLANDS

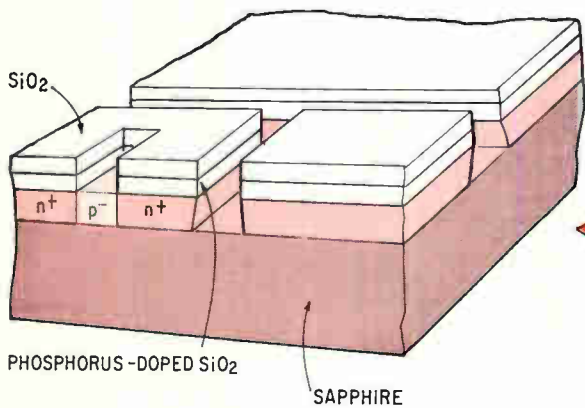
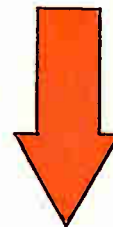

PHOSPHORUS-DOPED SiO<sub>2</sub>  
SAPPHIRE

DIFFUSION OF PHOSPHORUS FROM OXIDE  
TO FORM SOURCE AND DRAIN

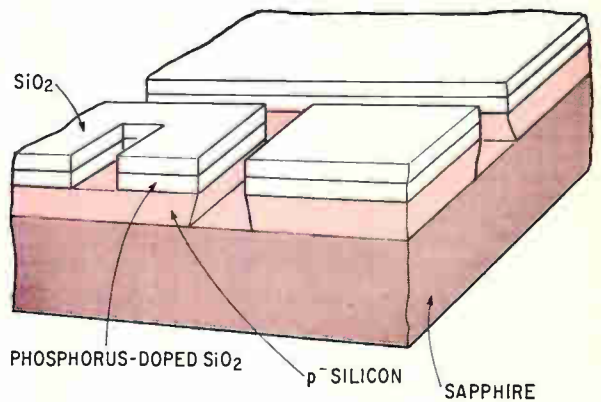
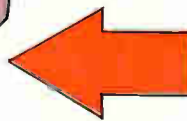

PHOSPHORUS-DOPED SiO<sub>2</sub>  
p- SILICON  
SAPPHIRE

OXIDE REMOVAL, FORMATION OF PHOSPHORUS-DOPED  
OXIDE AND UNDOPED OXIDE LAYERS, ETCHING OF GATE REGION

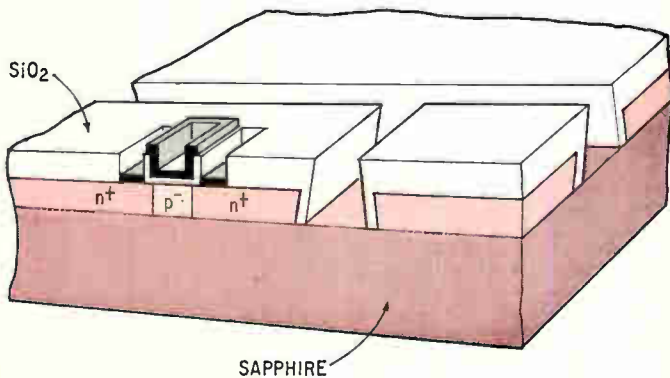
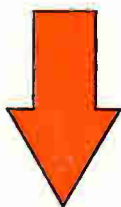

SAPPHIRE

OXIDE REMOVAL AND RE-FORMATION,  
DEPOSITION OF ALUMINUM CONTACTS

**Step by step.** Fabrication of silicon-on-sapphire integrated circuits consists of formation of silicon islands on the sapphire substrate, followed by diffusion of devices into the islands. Sequence shown here is based on that used at RCA, but is representative of other companies' methods. To make complementary p<sup>+</sup>-p<sup>-</sup>-p<sup>+</sup> MOS transistors, boron-doped silicon dioxide would be used.

gain approaches 10, it's remarkable. Most companies have, therefore, written off bipolar SOS IC's, and are concentrating on MOS, which is much less sensitive to carrier mobility.

Besides its effect on mobility, crystal disorder in the silicon film creates something of a processing problem because the rate of diffusion varies with the crystal structure. Thus, dopants diffuse faster near the sapphire interface than they do at the surface of the silicon film. In practice, this differing rate means that a drain and source of an MOS transistor—both of which are diffused into the film—could connect to each other under the channel region, which would make the transistor defective.

Another major fabrication problem is autodoping, or contamination of the silicon film by the sapphire substrate. Aluminum and oxygen from the sapphire can enter the silicon film and act as charges that upset the operation of the devices.

External contamination is more of a problem than with bulk silicon. The sapphire acts as an almost impenetrable barrier, concentrating contamination from the outside within the silicon.

Approaches to these fabrication problems are nearly as numerous as the companies active in SOS. Siemens AG, for example, eschews the use of sapphire, substituting spinel which matches the cubic symmetry structure of silicon. Thus, regardless of the crystal orientation of the spinel substrate, an epitaxial, single-crystal silicon film can be deposited. Another advantage of spinel is that it causes less unwanted doping of the silicon; under similar conditions, the concentration of autodopants in the silicon film is 10 times less with spinel than with sapphire. Siemens, however, still considers its work in SOIS largely investigative. Nevertheless, using the silicon on spinel technique, the company has made MOS transistors with switching times of less than 1 nsec and is now experimenting with MOS IC's, including complementary MOS.

Spinel has been rejected, temporarily at least, at several other companies because it's hard to get and because it has less desirable mechanical properties than sapphire.

Signetics has abandoned both sapphire and spinel for its unidentified proprietary material, which, the company says, degrades the silicon film less than either of those materials. Also, minority-carrier mobility is high—220 to 230  $\text{cm}^2/\text{volt-sec}$  for p-channel devices and 350 to 375  $\text{cm}^2/\text{volt-sec}$  for n-channel devices. The company has built discrete devices with its technique that have a maximum frequency of oscillation well above 1 gigahertz.

A French company, Sescosem, was discouraged by the difficulty of putting single-crystal silicon on sapphire and decided to try reversing the operation: the company's researchers start with a silicon substrate and deposit a thin film of sapphire on it. Turning out a high-quality sapphire thin film is vastly easier than making sapphire crystals and polishing them precisely, according to Jean Grosvalet, research director of Sescosem's laboratory at Corbeville, outside Paris. The sapphire film should also prove to be much cheaper to produce than bulk-sapphire crystals, Grosvalet believes. However, he adds, "We're not 100% sure of reliability—that a sapphire thin film won't microcrystallize with time." To find out, his group is now conducting high-temperature tests of sap-

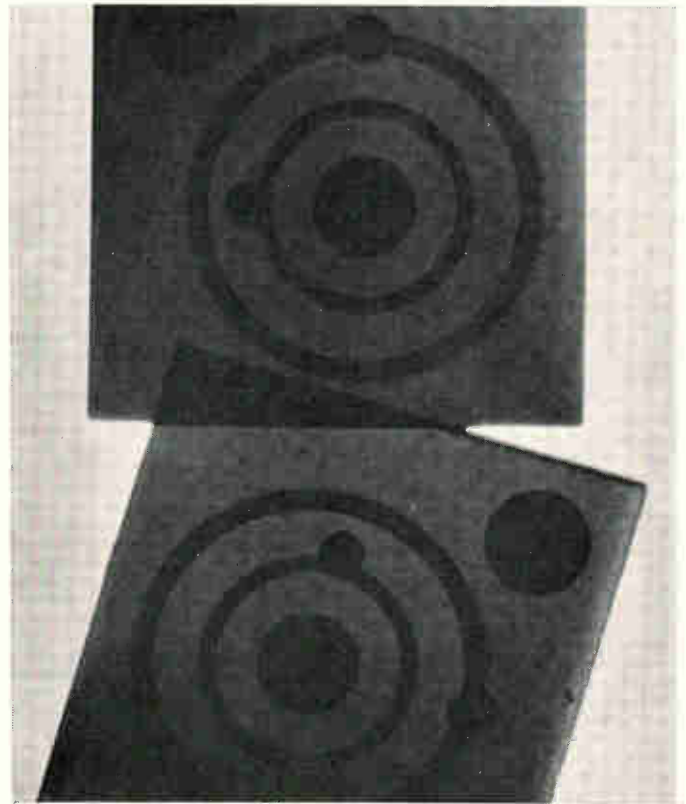

**See-through.** In experimental thin-film MOS transistor made by Philips' silicon-on-silicon technique, the silicon is so thin it transmits visible light. Chip is about 1 millimeter square.



**Fast.** Siemens' silicon-on-spinel transistor switches in less than 1 nanosecond. The light background is the transparent spinel; grey area is silicon, and black area is the metalization.

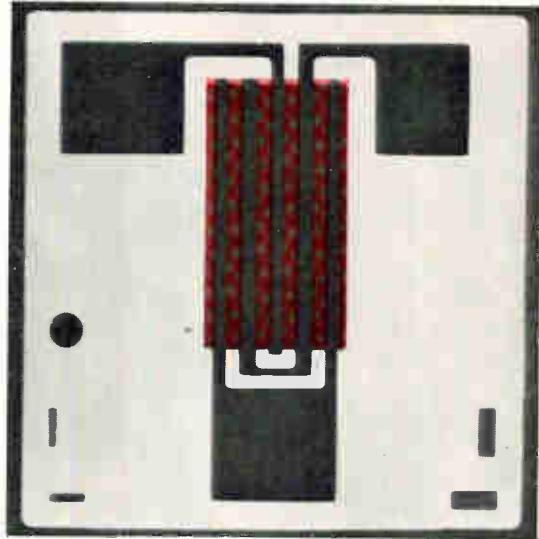

phire on silicon. He expects to know in a few months if the film holds up, and the firm will then decide whether to turn out its first SOS devices, which would be complementary MOS IC's. Grosvalet is highly optimistic.

Another exotic SOIS technique is being investigated by Tadatsugu Ito, of the School of Science and Engineering at Waseda University in Tokyo. Ito's method makes use of polycrystalline silicon between component islands on the insulating substrate, resulting in a more nearly planar surface and thus avoiding the problem of depositing interconnection metal over high, steep slopes. The polycrystalline silicon has a resistance level of several tens of megohms and, thus provides a high degree of isolation, although not as much, of course, as the noncontiguous form of SOIS where there is no material between islands. Because the polycrystalline silicon is a different color, it also facilitates mask alignment.

Ito uses spinel for the insulating substrate. The process starts with the sputtering of a 5,000- to 6,000-angstrom layer of silicon dioxide on the entire surface of the spinel. Photoetching removes the  $\text{SiO}_2$  from regions where devices are to be fabricated; the  $\text{SiO}_2$  is left on the substrate only where lateral isolation is required. Silicon is then vacuum-deposited on the substrate. But in the regions where the  $\text{SiO}_2$  prevents the deposited silicon from contacting the substrate, the deposited silicon takes on a polycrystalline structure.

One advantage of Ito's process over the usual chemical epitaxial process is that substrate temperatures can be lower—about 700°C instead of 1,100 or 1,200°C. The carrier mobility of this low-temperature silicon is quite high, about 90% of that of bulk silicon.

Scientists at Philips Gloeilampenfabrieken's Research Laboratory in Eindhoven, the Netherlands, have become dissatisfied with silicon films on sapphire and have turned to silicon on polycrystalline silicon. Their approach seems to be a cross between true SOIS and the dielectric isolation techniques used by such firms as Radiation Inc. Philips starts with a 200-micron-thick wafer of  $n^+$  silicon and grows a 10-micron layer of epitaxial  $n$  or  $p$  silicon on it. The epitaxial layer is then coated with 1 micron of silicon dioxide followed by 200 microns of polycrystalline silicon. The next step is to remove the original  $n^+$  material, leaving just the single-crystal  $n$  or  $p$  layer, the oxide, and the polycrystalline material. The single-crystal silicon can be separated into islands

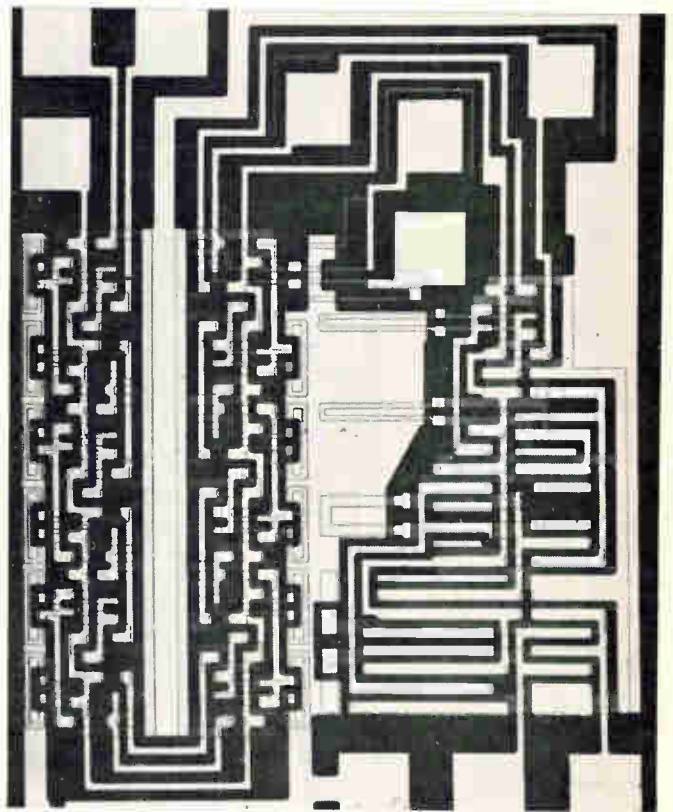

**Clocked.** Eight-bit MOS shift register built by Plessey can operate at clock rates of 5 Mhz. This micrograph was made by reflected light. The silicon appears gray, the sapphire black, and the aluminum interconnections white. The circuit contains 32 gated load resistors, 96  $p$ -channel MOS transistors, and two source-drain resistors.

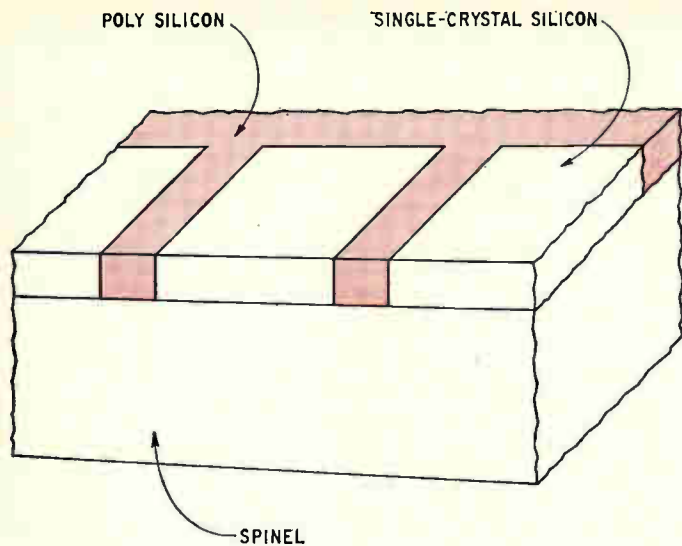

**Variation.** Approach to SOIS developed at Waseda University has moats between silicon islands filled with polycrystalline silicon, producing a planar surface. Thus, there are no high steps for the metalization to climb.

and devices diffused into them.

The next result is similar to silicon on sapphire, but with a significant difference: the single-crystal layer, because it was grown on silicon instead of sapphire, has a less distorted crystal structure. In fact, bipolar as well as MOS devices can be fabricated with the process. Philips, however, doesn't want to go commercial at the present time, presumably because there is not yet an obvious market.

However, the companies that are probably the most advanced in SOIS technology—RCA, Plessey, and Autonetics—are sticking with sapphire as the substrate material and using classical device structures. RCA's approach is to compensate for the crystal disorder and contamination in the silicon film during the fabrication of the devices. For example, RCA eliminates oxidation whenever possible and minimizes the wafer's exposure to high temperatures. RCA's Scott maintains that thin-film silicon, because of its crystal distortion and its thinness, is essentially different from bulk silicon. He says that the failure of other manufacturers to appreciate this difference accounts for their lack of success with SOIS. "The assumption that since you've got silicon, you can process it just like bulk silicon is what leads you far astray," Scott says. "You can't just measure Hall mobilities and lifetime and say, 'OK, it's a silicon film, substitute it in the factory line and produce devices'."

Autonetics seems to have its SOS diode-array process well in hand. However, Autonetics' Luisi says that much remains to be done in the processing of complementary MOS IC's. He says: "I don't think it will be commercially feasible until process-control equipment is improved for better control of resistivity levels in epitaxial deposition."

Plessey's approach to fabrication differs sharply from that of RCA. Instead of treating thin-film silicon as a special case, Plessey's aim is to make the SOS MOS production process entirely compatible with the company's standard bulk MOS production process. This way, production can be switched from standard MOS to SOS MOS simply by changing from bulk silicon to silicon on sapphire without changing the diffusion and oxidation schedules. Peter Newman, in charge of silicon work at Plessey, says: "We look on SOS as a variant of our standard p-channel MOS process, for making circuits generally about an order of magnitude faster for a

given power consumption than ordinary MOS circuits."

Hart uses the silane ( $\text{SiH}_4$ ) decomposition process for silicon deposition because  $\text{SiH}_4$  leaves no corrosive decomposition products. Furthermore, a single-crystal layer can be deposited at 1,000 to 1,100°C, which is about 100° lower than temperatures required in the halide ( $\text{SiCl}_4$ ) reduction process. Hart reports that the absence of decomposition products and lower temperatures, together, cut down the penetration of aluminum from the sapphire into the silicon. The concentration of aluminum that does get in is further reduced to a level of not more than  $10^{15}$  atoms per cubic centimeter by heat treatment for about an hour at 1,100°C in an inert atmosphere. "Reducing contamination below the level where it affects resistivity control is not a problem any more," Hart claims. ●

## Bibliography

R.W. Downing and P.J. Hagon, "Silicon-on-Sapphire Device and Integrated-Circuit Processing Technology," IEEE Wescon, Technical Papers 16 A-3, A-4, August 1965.

Arnold Miller, "Silicon-on-sapphire for freedom and flexibility," *Electronics*, Feb. 20, 1967.

J.R. Burns and J.H. Scott, "Silicon-on-sapphire complementary MOS circuits for high speed associative memory," *AFIPS Conf. Proc.*, Vol. 35, 1969 Fall Joint Computer Conf.

Heinrich Schlotterer, "Growing silicon on spinel adds up to high isolation, fast switching in IC's," *Electronics*, Oct. 27, 1969.

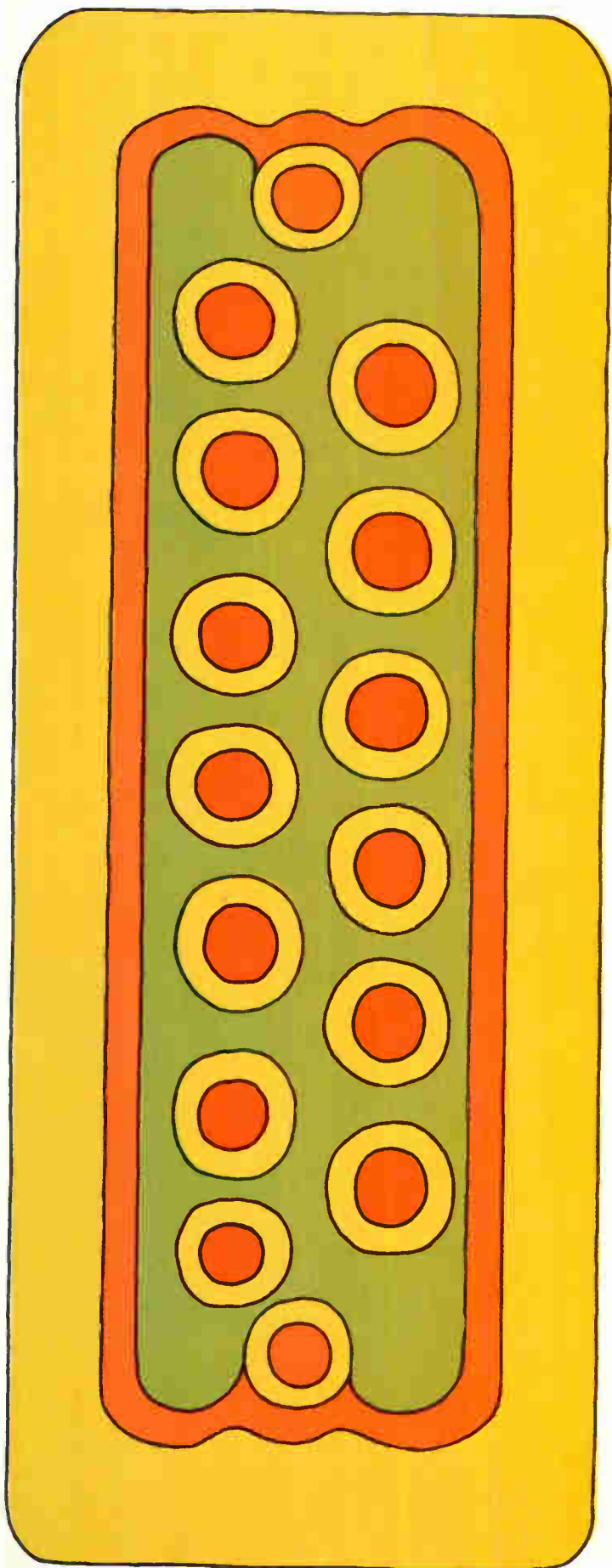

# Winchester Electronics

the  
innovative thinking  
needed to solve  
today's  
problems.

Looking for a quick solution to a particularly knotty connector problem? Look to Winchester Electronics first.

We've got a reputation for producing answers to problems before they exist. So there's always a chance yours might not be a problem after all. For example, we produced our MRE series of miniature rectangular connectors before any specs existed. They've since become the standard for mil spec MIL-C008384. Our MRAC crimp-contact connectors set the standard for MIL-C-22857.

So you see, it's a good idea to contact Winchester Electronics first before you call a problem a problem. With our pioneering spirit, we may have solved your problem years ago. To find out, write or call Winchester Electronics, Main Street and Hillside Avenue, Oakville, Conn. 06779.



**WINCHESTER  
ELECTRONICS**

DIVISION OF LITTON INDUSTRIES





# Designer's casebook

*Designer's casebook is a regular feature in Electronics. Readers are invited to submit novel circuit ideas and unusual solutions to design problems. Descriptions should be clear. We'll pay \$50 for each item published.*

## Build ring counters with standard MSI

By Wolfgang Nadler

University of Pennsylvania, Philadelphia

Only a few connections between standard medium-scale integrated circuits are needed to assemble a ring counter, based on a simple circuit that decodes the output of a binary counter. Since the decoding does not allow more than one output, only one pulse will go around in the ring, even if false triggering should occur.

The straight-binary, ripple-carry counter is driven by the clock pulses and in turn drives two decoding networks through appropriate gating circuits.

One decoder generates outputs 0 to 7 while the other generates 8 to 15 by inverting the fourth-level binary output, input D. Reset can be taken from any output to determine the number of active stages in the ring.

A strobe input is required to prevent transient spikes which may be caused by the propagation delay between stages in the counter. The output pulses are 180° out of phase with the input train of pulses.

Only one decoder would be needed for a ring counter with 10 or less outputs, while a divide-by-12 counter would give a space of two clock pulses before the ring pulse repeats. The direct feedback for reset can be used with any configuration and will always take up one ring output interval of time.

In the circuit shown, outputs 8 and 9 of the decoders are not used because they are the same as the 0 and 1 outputs of the other counter and thus would be redundant.

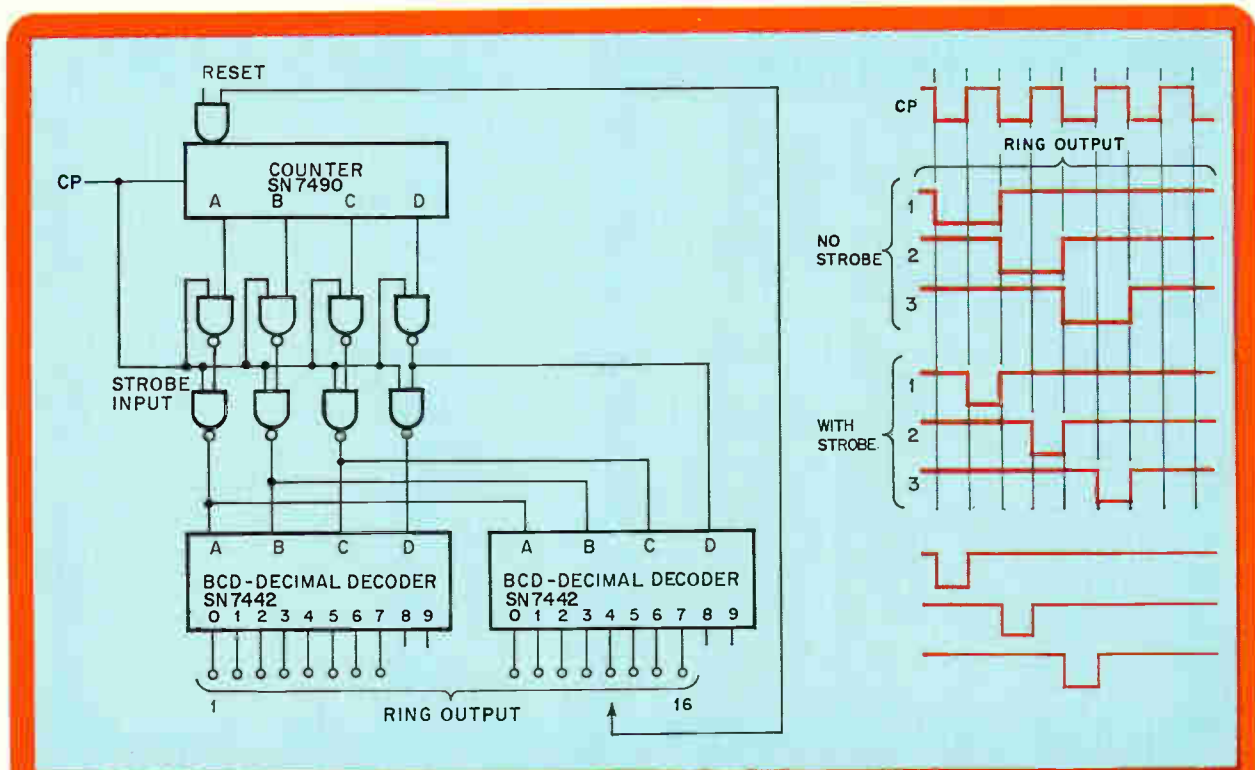

Around the ring. The ring counter uses a basic straight-binary counter to drive two decoders, which provide a pulse that steps in sequence through each of the output lines. The number of stages in the ring is variable and can be set by taking the reset off any of the output lines.

# Telemetry signal conditioner centers its slicing level

By Jeff Schlageter

Fairchild Semiconductor, Mountain View, Calif.

A noisy telemetry signal can be conditioned for optimum signal-to-noise performance by slicing away the noise. This technique can result in an 8-decibel signal-to-noise ratio, a 10-db improvement over circuits previously used. In telemetry a common method of coherent bit detection is to filter the incoming signal before sampling. However, filtering is not very effective in cases where the signal frequency falls within the noise bandwidth. In that case, the signal conditioner described here may be preferred over the filter. The circuit features a slicing level that automatically adjusts itself to the center of the input signal amplitude, is mini-sized, has a 200 microwatt standby power, and can handle signals from 2 to 5 volts peak-to-peak.

The signal is fed through an impedance matching resistor,  $R_1$ , to one input of a differential amplifier  $Q_1-Q_2$ . The other differential amplifier input is biased at a potential that is exactly one half the

peak-to-peak input signal amplitude by the network consisting of  $D_1$ ,  $R_5$ ,  $D_2$ ,  $R_7$ ,  $C_3$ ,  $R_9$ ,  $R_{10}$ . Diode  $D_1$  is biased by resistor  $R_5$  to provide a negative reference for point A, thus, effectively clamping the input to that level. Diode  $D_2$  rectifies the input signal and charges up  $C_3$  to almost the peak signal voltage level. Then, when properly chosen,  $R_9$  and  $R_{10}$  divide this level to one half the input peak-to-peak signal amplitude with respect to point A and apply it to the base of  $Q_2$ . Consequently, an input signal variation a few millivolts above or below this level at the base of  $Q_1$  will drive  $Q_4$  to full output swing and appear at the output as an inverted but noise-free replica of the input. The circuit exhibits good stability with temperature variation.

The choice of circuit element values depends on the frequency of the input signal. This circuit was designed for an input signal of 4 kilohertz, and although it will work over a wide range of input frequencies, certain precautions should be observed when deviating from the design. For example, the charging time of capacitor  $C_3$  through  $D_2$  and  $R_7$  must be much shorter than the discharge time through  $R_9$  and  $R_{10}$ . Also, the discharge time of  $C_3$  should be long compared to the period of the input signal. To avoid excessive droop at point A, the discharge time of  $C_1$  through  $R_1$  must be long compared to the positive input pulse width.

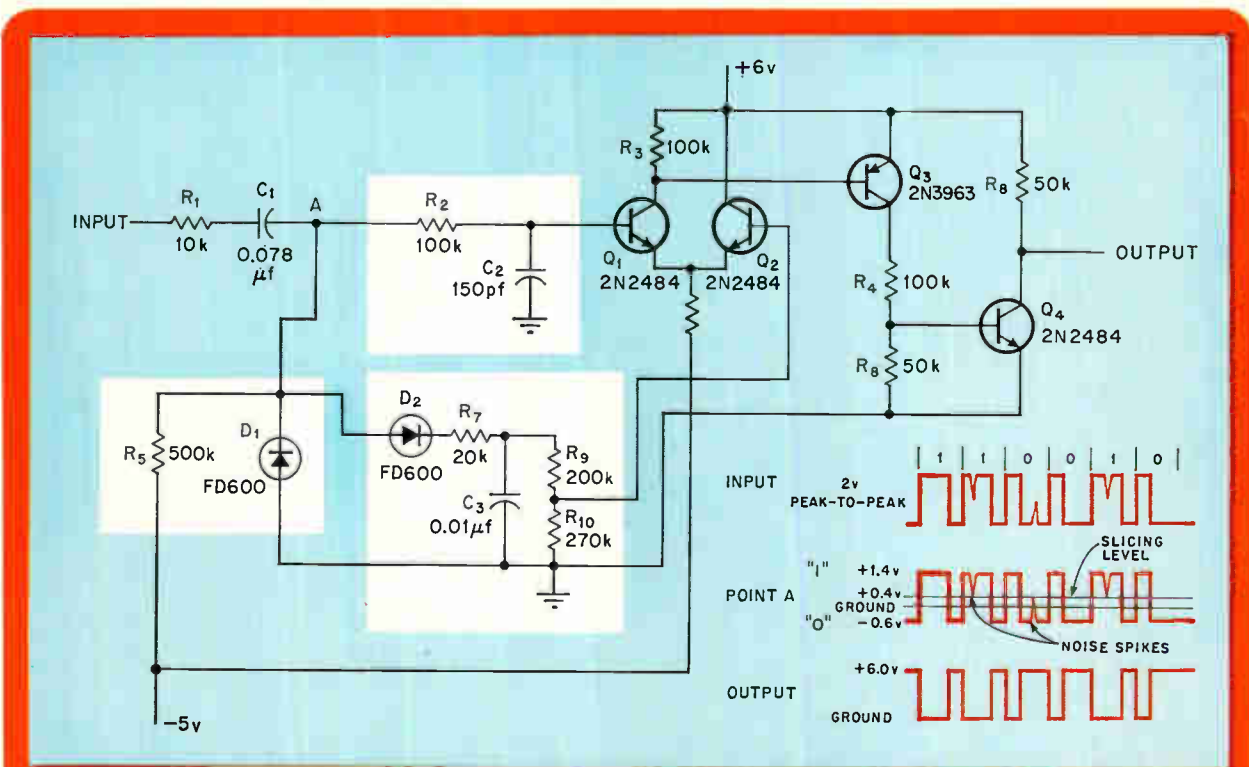

**Sliced thin.** The noise in a telemetry signal is sliced away by driving the output to its full value when the input varies from its nominal level by only a few millivolts. Transistors  $Q_1$  and  $Q_2$  form a differential amplifier with inputs of the signal itself and one half the peak-to-peak value of the input.

# Comparator and a-c coupling provide d-c transformer action

By Thomas J. Carmody

PRD Electronics Inc., Westbury, N.Y.

One way to avoid problems arising because of different grounds in a-c systems is to use a transformer for isolation. For d-c circuits, however, it's not so easy to go to the shelf and take down a d-c transformer. Consider the case where a control signal is to energize logic circuits when a power supply's voltage drops below a certain value. The power supply is operating at 120 volts above ground, and the control logic is referenced to ground. To transform the high voltages to the 5-volt d-c logic level and to provide isolation, a comparator circuit with a-c coupling to the logic circuit is used as the d-c transformer.

The 240-volt supply output is divided down by  $R_1$  and  $R_2$  so that 2.4 volts is applied to the

inverting terminal of the integrated comparator. The comparator gets its reference and supply voltages by tapping off the supply with a zener diode and current-limiting resistor. The 12-volt comparator reference is set by the zener, and stepped down by  $R_3$  and  $R_4$  to a constant 2.3 volts, which is applied to the positive input of the comparator. When the high-voltage input drops below 230 volts, the inverting input drops below 2.3 volts and the comparator output rises since the comparator's non-inverting input—2.3 volts—is now higher than the voltage applied to the inverting input.

This rapidly changing leading edge is a-c coupled through  $C_1$ , which also provides d-c isolation, and differentiated to produce a positive pulse to turn on  $Q_1$ . The output of  $Q_1$  drives the compatible logic, which, in turn, provides the required control action.  $C_2$  isolates the d-c grounding systems and is also made large compared with  $C_1$  to provide a low-impedance return for differentiated signals.

The current limiting resistor,  $R_5$ , supplies a current of 12 milliamperes to the comparator. The -5-volt supply for the comparator is, in this case, tapped off a negative supply that shares a common return with the 240-volt supply.

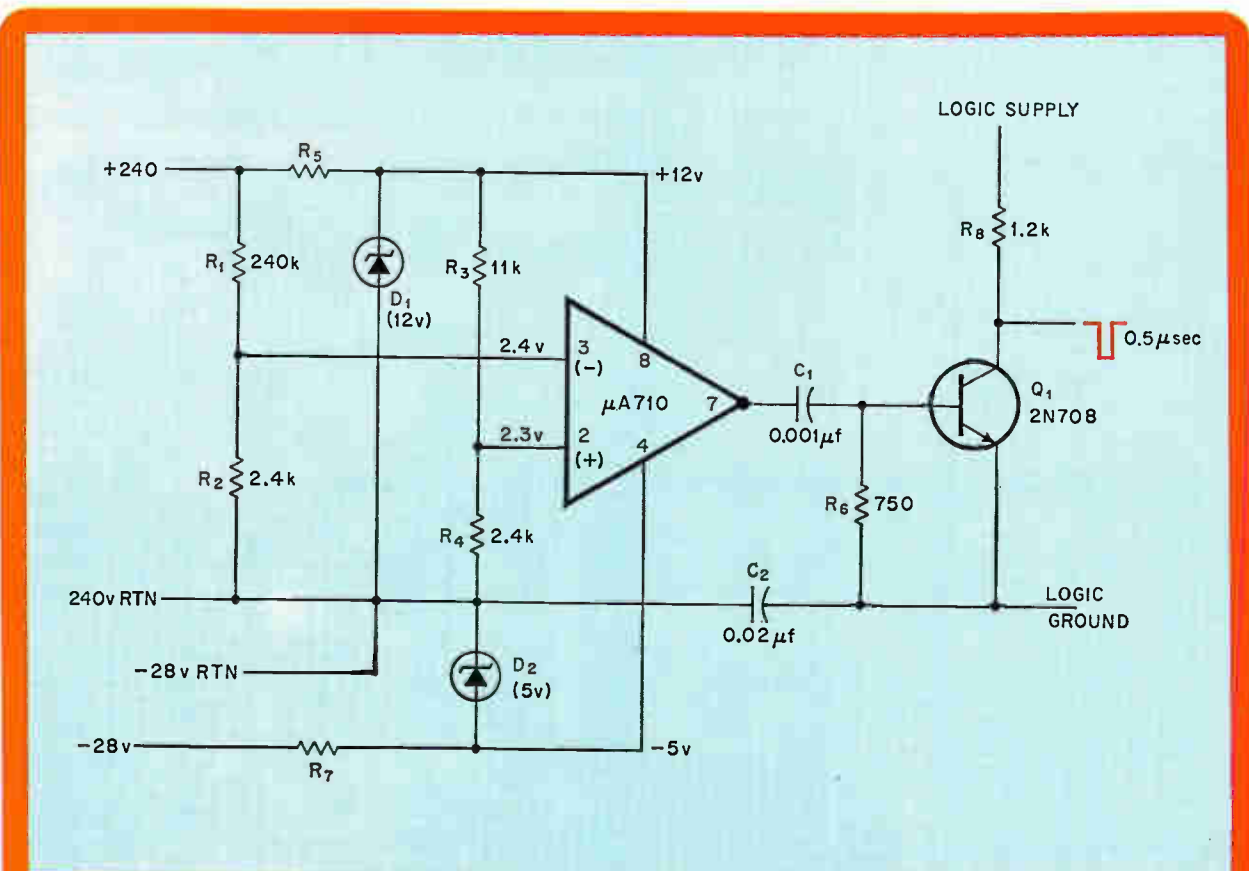

No common ground. When the 240-volt supply voltage drops below 230 volts, less than 2.3 volts is applied to the inverting input of the comparator. The comparator then switches because its reference level is set at 2.3 volts. The a-c coupling isolates the high-voltage from the low-voltage output logic.



# Samples - at continuously adjustable rate.

# Triggers - one knob control 3Mv to 2000MHz.

# Displays - no ambiguity DC to 2000MHz @ 1Mv sensitivity.

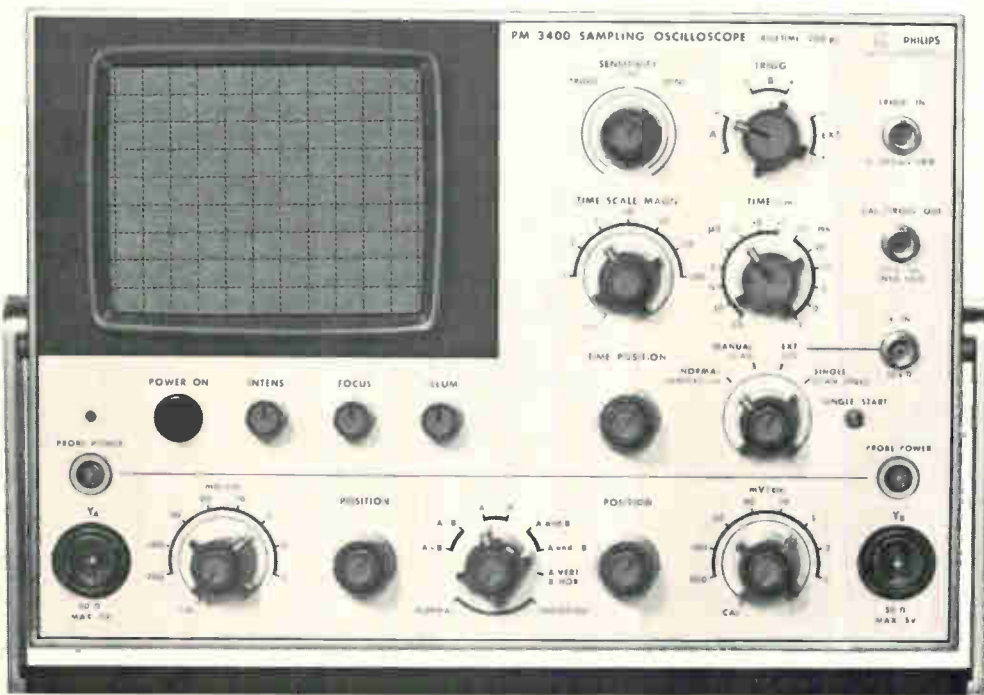

PM 3400  
Sampling Oscilloscope  
\$2,725

More of the Unbeatable  
Philips Scopes

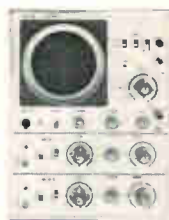

PM 3231  
15MHz 10mV  
Dual Beam  
Delay Lines  
\$1,050



PM 3200  
10MHz  
2mV/div  
\$495

**Compact (9" x 13" x 19") excellent cost/performance ratio** (\$2,725 is all it takes), **unique circuitry** and design (we list the innovations below) make the new Philips PM 3400 sampling oscilloscope an unusually capable and versatile instrument . . . in fact it's the only one of its class.

The innovations: Continuously adjustable sampling rate. Electronic signal smoothing plus long persistence phosphors give unambiguous display, undistinguishable from real time

scopes. Internal triggering, to catch leading edges, to 2.0 GHz and higher. DC to 2.0 GHz bandwidth, sensitivity variable between 1 mv and 200 mv/cm. Rise time, 200 ps, trigger sensitivity 3 mv. Electronically compensating amplifiers maintain a linear scope presentation over the 8 x 10 area of the CRT.

Write us today for technical data . . . see for yourself in full detail why we say that the PM 3400 rates a cost performance ratio of excellent.

**PHILIPS  
ELECTRONIC  
INSTRUMENTS**

750 S FULTON AVE., MT VERNON, N.Y. 10550  
A DIVISION OF PEPI, INC.

# Try the monolithic multiplier as a versatile a-c design tool

Since their circuitry is external, monolithic devices can be tailored to a-c tasks impractical for potted units, say *Edward Renschler and Donald Weiss of Motorola*

● Until recently, packaged multiplier modules were used primarily for d-c multiplication. This limitation applied because the circuitry required to optimize d-c multiplication interferes with potential a-c applications such as a-c multiplication, frequency doubling and modulation and demodulation. Now, however, monolithic multipliers make such a-c applications practical.

In potted multipliers, all the circuitry—for the translation of the output voltage to a reference level, trimming, and an output amplifier—is internal. But the monolithic multiplier achieves its versatility because these extra circuits are external to the unit. So a designer, instead of working around the inherent limitations of the potted device, can tailor his circuit to fit his requirements.

The introduction of monolithic multipliers early in 1969 brought with it the potential for price decreases made possible by monolithic fabrication. Now, with units priced considerably below \$20.00, multipliers can be used where cost is a critical factor.

Basically, the multiplier provides an output signal proportional to the product of two inputs, with the proper algebraic sign (four-quadrant multiplication). But it can also divide, square, take square roots and provide ratios. It helps solve many control and instrumentation problems—monitoring of power and fluid flow, for example. It can also solve complex nonlinear equations and root-mean-square problems; generate trigonometric functions, and perform operations such as frequency doubling, modulation, and dynamic-gain control.

The basic multiplier can be viewed as a grounded-emitter amplifier, with input-output relationship

$$V_o = CV_{in}I_E$$

However, the two input variables, emitter current  $I_E$  and input voltage  $V_{in}$ , are not independent of each other. The term  $C$  is a gain constant with proper dimensions to make the equation dimensionally valid. This concept is the basis of Motorola's MC 1595 monolithic multiplier, on page 101. The main amplifier is a cross-coupled quad differential unit,  $Q_5$ ,  $Q_6$ ,  $Q_7$ , and  $Q_8$ . It's similar to the grounded-emitter amplifier, but with independent emitter currents and input voltages. The cross coupling performs inversions necessary to achieve four-quadrant operation.

The  $I_E$  factors—the emitter currents to the quad amplifier—are the same as the collector currents of input

transistors  $Q_1$ ,  $Q_2$ ,  $Q_3$ , and  $Q_4$ . These currents are made linear functions of the input voltage,  $V_x$ , with the constant-current sources and emitter degeneration with  $R_x$ . Therefore, the quad amplifier's output voltage is linearly related to its own emitter current, and thus also is linearly related to input voltage  $V_x$ .

However, for the  $V_{in}$  component, the output current of the amplifier could be exponentially related to its input (base-emitter) voltage. If the voltage  $\Delta\phi$  applied to the base terminals of the quad amplifier were a linear function of the signal voltage  $V_y$ , the output current would be an exponential function.

To eliminate this nonlinearity, the  $V_y$  signal is preconditioned before it is applied to the main amplifier. This is done by passing the current resulting from the  $V_y$  signal through diodes  $D_1$  and  $D_2$ . As the current from the input amplifiers  $Q_1$  and  $Q_2$  passes through the diodes, the voltage developed across the diodes behaves logarithmically—in a nonlinear fashion that's the exact complement of the type produced in the quad amplifier transistors. Therefore, the output current of the quad amplifier, in response to its base voltage, also is linear. Thus  $V_o = K V_x V_y$ .

For this model, the circuit's scale factor  $K$ , is

$$K = \frac{2 R_L}{R_x R_y I_3}$$

In the working circuit, resistors  $R_x$  and  $R_y$  are external, so the gain can be adjusted for a specific requirement.

Since  $V_o$  is the product of the input voltages, a scaling factor of unity or greater could result in a large output, unless the inputs are quite small. Therefore, the scale factor must be set by the user to fit each application.

Unlike potted-module types, the monolithic MC 1595 does not have internal circuits for such functions as offset trimming or output level shift. The user designs the external circuitry to set up the multiplier for his input and output signal requirements and stay within the multiplier's operating range.

Assume, for example, that the multiplier is to handle a range of input signals of  $\pm 10$  volts. The output voltage then would be a maximum of  $\pm 100$  volts if  $K$  were made unity. But this output swing probably would be too large; a  $K$  of 0.1 would be more suitable, reducing output level to a maximum of  $\pm 10$  volts.

**Balanced modulator.** One application for the monolithic multiplier is as a balanced modulator. Here, the audio input signal is 1.6 kHz and the carrier is 40 kHz.

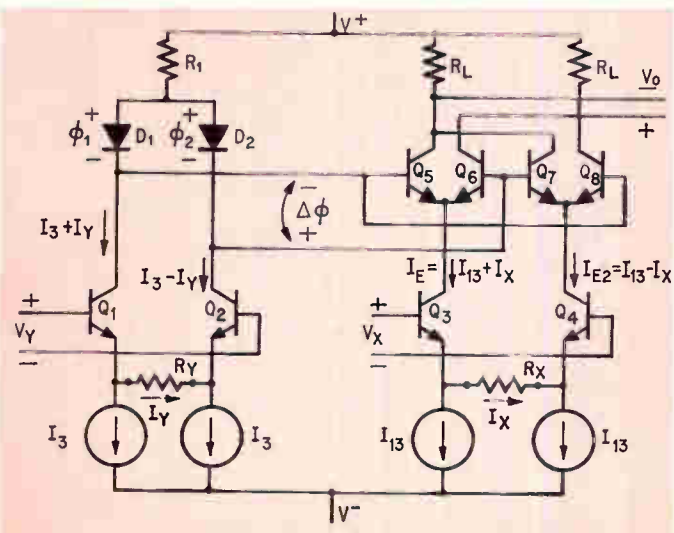
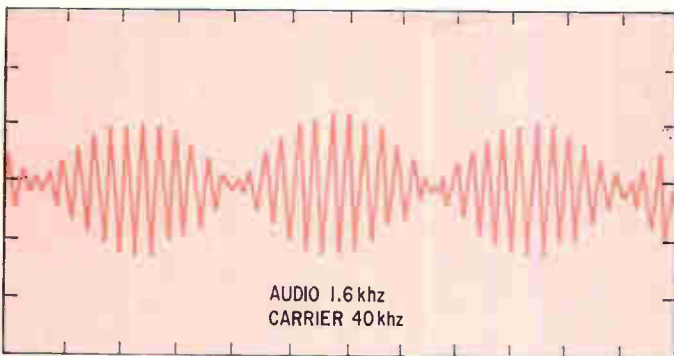
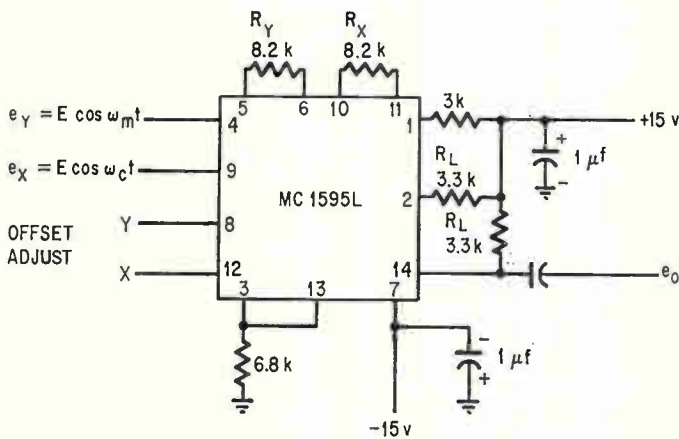

The required external resistors  $R_x$  and  $R_y$ , shown below, must be chosen to handle the maximum input voltage swing without introducing nonlinearity. Hence, to avoid cut-off of the input amplifiers  $Q_1$ - $Q_2$  and  $Q_3$ - $Q_4$ ,

$$V_{x(max)} < I_{13}R_x$$

$$V_{y(max)} < I_{13}R_y$$

For  $V_{x(max)} = V_{y(max)} = 10$  volts and  $I_{13} = I_3$

$$R_x = R_y > \frac{10v}{I_3}$$

$I_3$  and  $I_{13}$  should be made as small as possible to minimize power dissipation in the multiplier. However, if  $I_3$  becomes very small, the desired scale factor,  $K = 2R_L/R_xR_yI_3$ , may be difficult to obtain. In practice, reasonable values for  $I_3$  range from 0.1 milliamperes to 2 ma. If 1.0 ma is chosen for  $I_3$ , then

$$R_x = R_y > \frac{10v}{1ma} = 10k$$

However, this value of resistance only insures that a 10-volt input signal will not operate the amplifier beyond cutoff. During input-signal peaks, emitter current will reach zero, traversing a highly nonlinear region. To avoid this,  $R_x$  and  $R_y$  should be made about  $\frac{1}{3}$  or more larger than the minimum, or, say, 15 k.

With  $K$  chosen to be 0.1,  $R_L$  may be calculated.

$$R_L = \frac{KI_3R_xR_y}{2} \approx 11k$$

Now the supply voltages can be selected. Three are required—the positive supply  $V_1$  for the Y channel, the  $V^+$  voltage, and the  $V^-$  voltage. In practice the Y-channel supply voltage may be obtained from  $V^+$  via resistor  $R_1$ . From a data-sheet curve for maximum allowable input voltage, the designer determines that for an input swing of  $\pm 10$  volts, voltage  $V_1$  may have a minimum value of +12 volts. With a 1.5-volt safety margin,  $V_1$  becomes about 13.5 volts.

The positive supply is determined from:

$$V^+ = V_1 + \frac{KV_{xmax}V_{ymax}}{2} + I_{13}R_L + 2v \text{ (safety margin)}$$

$$= 13.5 + 5 + 11 + 2v$$

$$= 31.5 \text{ (select nominal } +32 - v \text{ supply)}$$

**Multiplier.** Basic equivalent multiplier relies on differential amplifiers and current sources for its operation. Multiplication is possible in all four quadrants. Credit for the design and development of the MC1595 goes to Rich Davis and Jim Solomon of the Motorola Linear IC Research and Development department.



**Frequency doubler.** When two equal cosine waves are applied to X and Y, the result is a wave shape of twice the input frequency. For this example the input was a 10-khz signal, output was 20 khz.

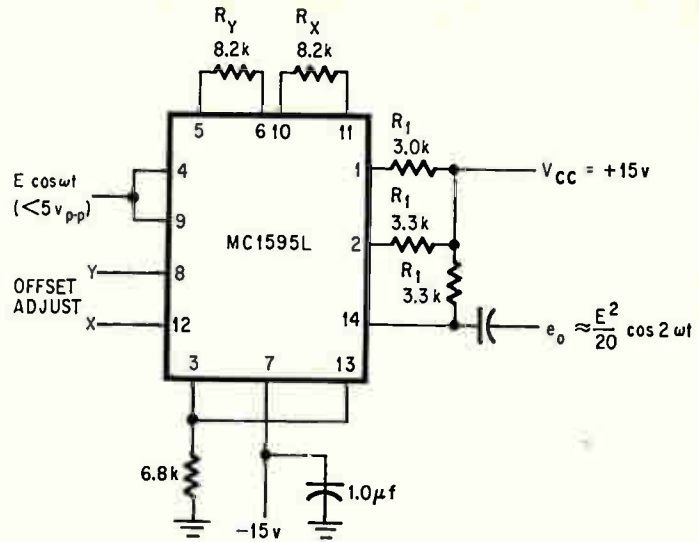

Now  $R_1$  can be found

$$R_1 = \frac{V^+ - V_1}{2 I_3} = \frac{32 - 13.5}{(2)(1.0)} = 9.25k$$

Select  $R_1 = 9.1 k$ .

The negative supply is selected so that the maximum voltage between the input and the negative supply does not exceed the 30-volt breakdown limit with maximum positive input voltage applied.

Furthermore, the negative supply should be at least 2 volts more negative than the most negative input voltage. For  $V_{in(max) negative}$  of  $-10 v$ , select  $V^-$  of  $-15 v$ .

The currents  $I_{13}$  and  $I_3$  are set by dropping resistors from ground to pins 13 and 3, respectively.

$$R_{13} = \frac{V^- - \phi}{I_{13}} - 500$$

where  $\phi = V_{BE} = 0.75$  at  $25^\circ C$ .

$$\text{Similarly: } R_3 = \frac{V^- - \phi}{I_3} - 500$$

For  $I_{13} = I_3 = 1 ma$ ,  $R_3 = R_{13} = 13.75k$

The seven applications that follow demonstrate the versatility of the monolithic multiplier. If a potted multiplier is used for these cases, the results generally would not be as good because the potted units have circuits that, although they optimize d-c multiplication operation, can hinder these a-c applications.

**Frequency doubling** often is done with a diode where the fundamental plus a series of harmonics are generated. However, extensive filtering is required to obtain the desired harmonic, and the second harmonic obtained under this technique usually is small in magnitude and requires amplification.

When a multiplier is used to double frequency the second harmonic is obtained directly, except for a d-c term, which can be removed with a-c coupling.

$$e_o = KE^2 \cos^2 \omega t$$

$$e_o = \frac{KE^2}{2} (1 + \cos 2\omega t)$$

A potted multiplier can be used to obtain the double frequency component, but frequency would be limited

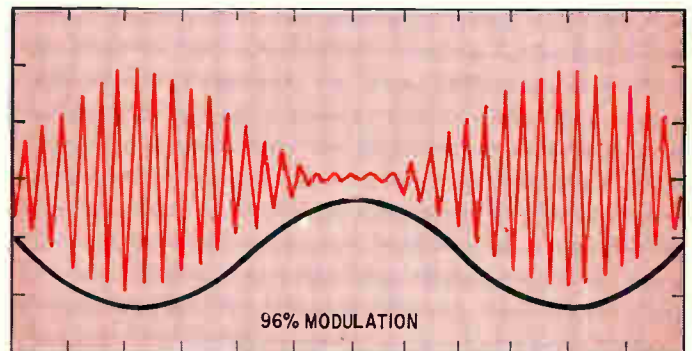
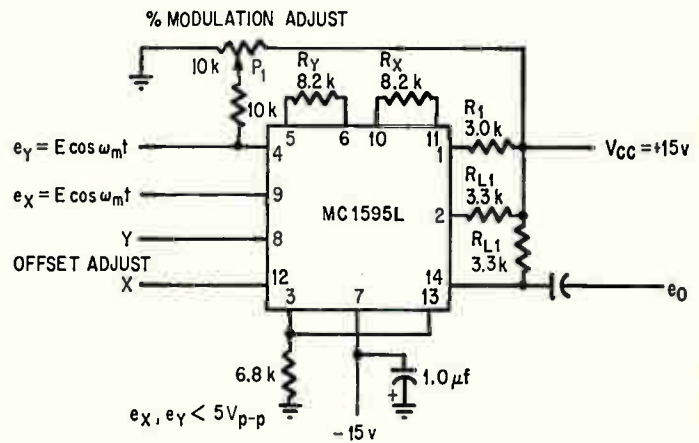

**Modulator.** The multiplier performs amplitude modulation, similar to balanced modulation, when a d-c term is added to the modulating signal with potentiometer  $P_1$ .

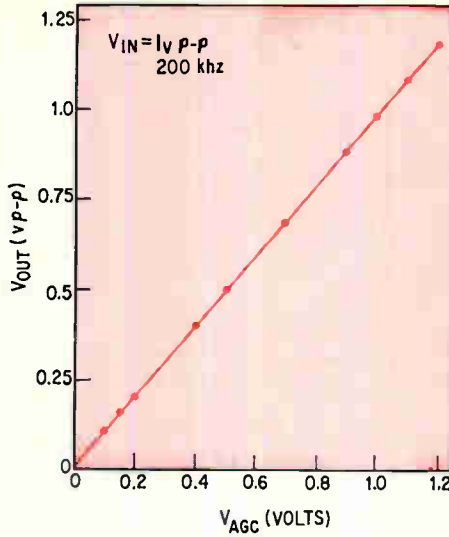
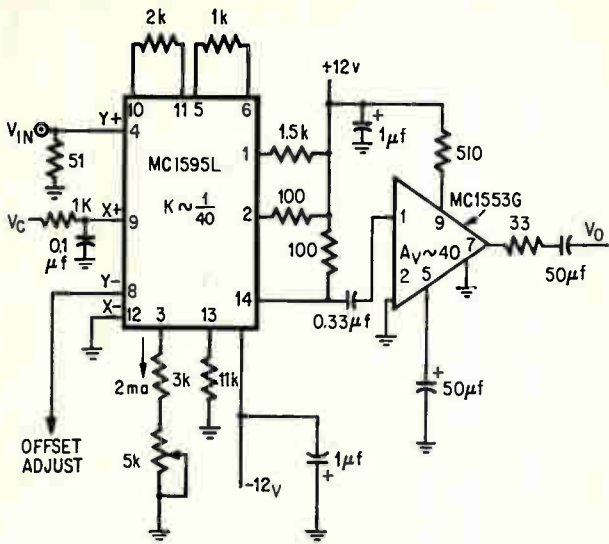

**Automatic gain control.** Linear gain control of a 1-volt peak-to-peak signal is performed with a 0-to-1-volt control voltage. If  $V_c$  is 0.5 volt the output will be 0.5 volt p-p.

by its internal level-shift amplifier. In the monolithic units, the amplifier is omitted.

In a typical doubler circuit, conventional  $\pm 15$ -volt supplies are used. An input dynamic range of 5 volts peak-to-peak is allowed. The circuit generates waveforms that are double frequency; less than 1% distortion is encountered without filtering. This configuration has been successfully used in excess of 200 khz; reducing the scale factor by decreasing the load resistors can further expand the bandwidth.

A slightly modified version of the MC1595—the MC1596—has been successfully used as a doubler to obtain 400 Mhz.

Another application for the MC1595 is that of a balanced modulator. The defining equation for balanced modulation is

$$K(E_m \cos \omega_m t)(E_c \cos \omega_c t) =$$

$$\frac{KE_c E_m}{2} [\cos(\omega_c + \omega_m)t + \cos(\omega_c - \omega_m)t]$$

where  $\omega_c$  is the carrier frequency,  $\omega_m$  is the modulator frequency and  $K$  is the multiplier gain constant.

A-c coupling at the output eliminates the need for level translation or an op amp; a higher operating frequency results.

Adding some d-c to the  $\omega_m$  signal in the balanced

modulator yields amplitude modulation. Here, the identity is

$$E_m(1 + m \cos \omega_m t)E_c \cos \omega_c t =$$

$$KE_m E_c \cos \omega_c t + \frac{KE_m E_c m}{2}$$

$$[\cos(\omega_c + \omega_m)t + \cos(\omega_c - \omega_m)t]$$

where  $m$  indicates the degree of modulation. Since  $m$  is adjustable, via potentiometer  $P_1$ , 100% modulation is possible. Without extensive tweaking, the 96% modulation, as shown on page 102, was obtained where  $\omega_c$  and  $\omega_m$  were the same as in the balanced-modulator example.

**A problem common to communications** is to extract the intelligence from single-sideband received signal. The ssb signal is of the form

$$e_{ssb} = A \cos(\omega_c + \omega_m)t$$

and if multiplied by the appropriate carrier waveform,  $\cos \omega_c t$ ,

$$e_{ssb} e_{carrier} =$$

$$\frac{AK}{2} [\cos(2\omega_c + \omega_m)t + \cos(\omega_c)t]$$

If the frequency of the band-limited carrier signal,  $\omega_c$ , is ascertained in advance the designer can insert a

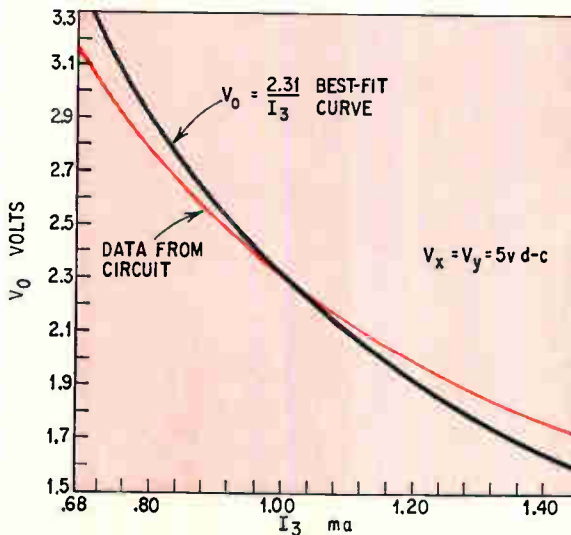
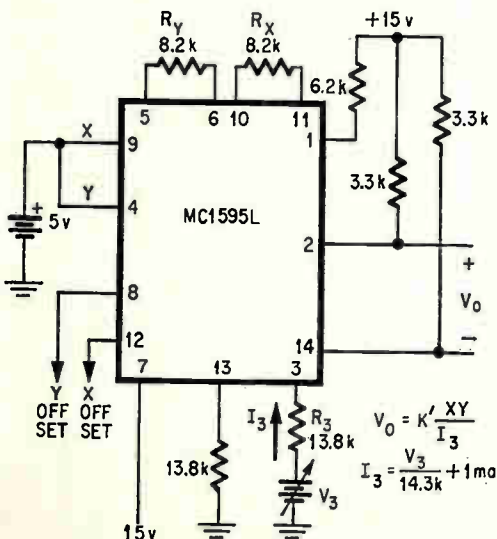

**Multiply and divide.** Simultaneous multiplication and division are performed with this circuit for the multiplier. The plot indicates the results.

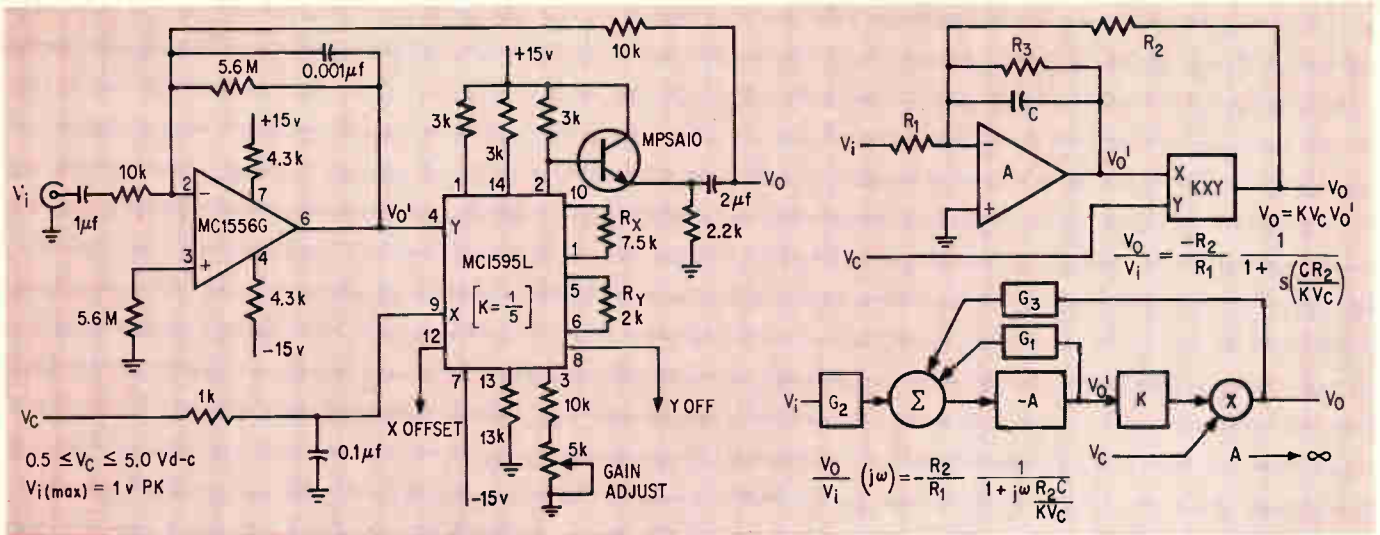

low-pass filter and obtain the  $(AK/2)(\cos \omega_c t)$  term with ease. He also can use an op amp for a combination level shift-active filter, as an external component. But in potted multipliers, even if the frequency range can be covered, the op amp is inside and not accessible, so the user must accept the level shifting provided, and still must add a low-pass filter.

To obtain a linear gain control, the designer could feed to one of the two MC1595 inputs a signal that would vary the unit's gain. The following example demonstrates the feasibility of this application. Suppose a 200 khz sine wave, 1 volt peak-to-peak, is the signal to which a gain control will be added. The dynamic range of the control voltage  $V_c$  is 0 to +1 v. These must be ascertained and the proper values of  $R_x$  and  $R_y$  can be selected for optimum performance. For the 200-khz operating frequency, load resistors of 100 ohms were chosen to broaden the operating bandwidth of the multiplier, but gain was sacrificed. It will be made up with an amplifier operating at the appropriate frequency.

The signal is applied to the unit's Y input. Since the total input range is limited to 1-volt p-p, a 2-volt swing, a current source of 2 ma and an  $R_y$  value of 1-kilohm is chosen. This takes best advantage of the dynamic range and insures linear operation in the Y-channel.

Since the X input varies between 0 and +1 volt, the current source selected was 1 ma and the  $R_x$  value chosen was 2 kilohms. This also insures linear operation over the X input dynamic range.

Choosing  $R_L = 100$  assures wide-bandwidth operation. Hence, the scale factor for this configuration is

$$K = \frac{R_L}{R_x R_y I_3^-}$$

$$= \frac{100}{(2k)(1k)(2 \times 10^{-3})} v^{-1}$$

$$= \frac{1}{40} v^{-1}$$

The 2 in the numerator of the equation is missing in this scale-factor expression because the output is single-ended and a-c coupled.

To recover the gain, an MC1552 video amplifier with a gain of 40 is used. An op amp also could have been

used with frequency compensation to allow a gain of 40 at 200 khz. The MC1539 op amp can be tailored for this use; and the MC1520 op amp does it directly.

The configuration shown above yields a transfer function of a single-pole low-pass filter whose pole location can be controlled linearly by the external voltage,  $V_c$ . Such a circuit might be used as an adaptive audio filter or as a voltage-tunable low-pass network.

For the basic analysis of the low-pass filter, assume that both  $A_{in}$  and  $Z_{out}$  are ideal for multiplier and op amp. (The ideal  $Z_{out}$  for the multiplier will be justified through impedance buffering); the op amp exhibits ideal open-loop low-frequency gain ( $A \approx \infty$ ); and  $R_3 \gg R_1$  or  $R_2$ , and may be ignored in calculations.

For the circuit shown above,

$$V_o = KV_c V_o'$$

where  $K$  is the multiplier gain constant,  $V_o'$  is the output from the op amp, and  $V_c$  is the external control voltage.

$$\frac{V_o}{V_i}(j\omega) = \frac{-R_2}{R_1} \frac{1}{1 + j\omega \frac{R_2 C}{KV_c}}$$

The result is a first order, low-pass filter with a 3-db corner frequency of

$$f_c = \frac{KV_c}{2\pi R_2 C} \text{ hz}$$

The overall closed-loop gain for frequencies below  $f_c$  is  $-R_2/R_1$ .

An important limitation applies to input amplitudes and design parameters: for constant output level, the signal requirement at the multiplier's input becomes large for decreasing values of control voltage  $V_c$ . This could lead to nonlinear operation. The problem is most severe at low frequencies where the op amp is operating with very little, if any, roll off.

The equation for the upper amplitude limit of  $V_1$  is

$$V_{i_{max}} = \frac{KV_c R_1 (V_{1_{max}})}{R_2} \left[ 1 + \frac{R_2 C}{2\pi f} \right]$$

where  $V_1$  is as before—the input to the low-pass filter, and  $V_{1_{max}}$  is the maximum a-c input signal that the multiplier can accommodate to maintain linear operation.



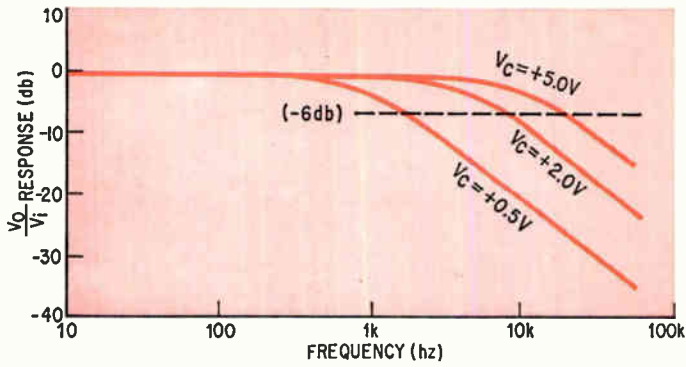

Low-pass filter. Voltage-variable low-pass filter, left, is represented by an op amp model or a feedback model, for evaluation. Curves above show results.

To demonstrate the feasibility of this application, a circuit was designed and built to operate over the audio frequency range. This filter achieves one full decade control with  $V_c$  varying between 0.5 v and 5.0 v. Hence, one decade frequency control is expected. For  $V_x = 5$  v max,  $R_x = 7.5$  k was selected. For 0-db overall attenuation, well below the corner frequency, and with  $V_{c\max} = 5.0$  v, the multiplier gain constant is chosen to be  $K = \frac{1}{5}$ .

For  $\pm 15$ -volt supply operation, 1-volt peak can be handled easily at the output, and for  $V_c = +5.0$ ,  $K = \frac{1}{5}$ , the Y-input must accommodate 1-volt peak. Thus  $R_Y = 2$  k is reasonable, and  $R_L$  is fixed at 3 k. The emitter follower (MPS-A10) is used to make  $Z_{out} = 0$ .

Since low voltage operation is required for the op amp, supply dropping resistors of 4.3 k can be used.

Earlier attempts at division required a multiplier and two op amps, and the following limitations applied: division in only one quadrant was allowed; a latchup condition often occurred, and multiplication could not be done simultaneously with division.

A method that enables simultaneous multiplication and division is shown on page 103. The X and Y inputs are in a normal multiplication mode, independent of  $I_3$ .

The transfer function for the multiplier is

$$V_o = \frac{2R_L V_x V_y}{R_x R_y I_3}$$

If  $I_3$  can be controlled externally over some reasonable operating range, the function

$$V_o = K' \frac{XY}{Z}$$

is feasible, with X, Y, Z independent variables.

The value of  $I_3$  is found from

$$I_3 = \frac{V_3 - V^- - \phi}{R_3 + 500}$$

where  $V_3$  is the variable voltage for the control of  $I_3$ ,  $V^-$  is the  $-15$ -volt supply, and  $\phi$  is a diode potential (0.75 volt). In typical use,  $V_3 = 0$  and  $R_3 = 13.8$  k for  $I_3 = 1$  ma. Choose  $R_3 = 13.8$  k so that  $I_3 = 1$  ma at  $V_3 = 0$ , for an initial study. Applying a constant  $+5.0$ -volt d-c to both X and Y inputs,  $I_3$  is found as

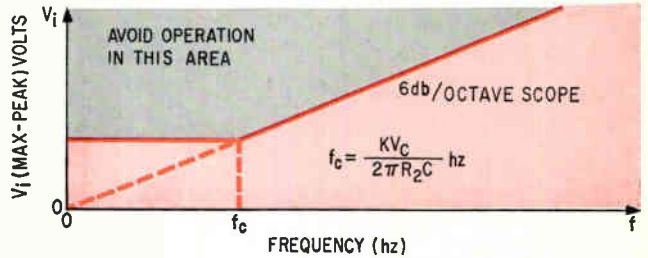
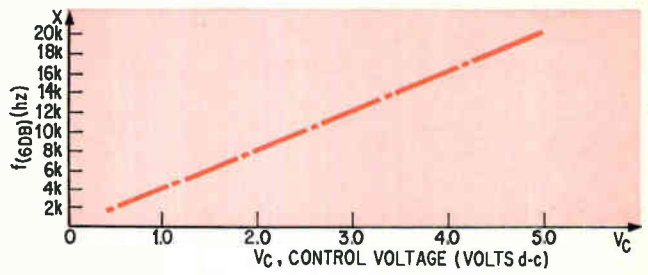

$$I_3 = \frac{V_3}{14.3k} + 1.0 \text{ ma}$$

The experimental data is shown on page 103 in color. The black curve represents a best-fit result—normalized at 1 ma—and is represented by

$$V_o = \frac{2.31}{I_3}$$

For  $K = 0.1$ ,  $V_o$  at  $I_3 = 1$  ma should be 2.5 volts with both X and Y set at  $+5.0$  volts. However, the output offset capability, the level translation network, and op amp have been omitted for simplicity.

A brief computer analysis on the experimental data with a curve-fitting library routine shows that the data curve fits the hyperbolic function

$$V_o = 0.427 + \frac{1.89}{I_3}$$

which is of the correct form for  $I_3$  in milliamperes. ●

### Bibliography

- Gilbert, B., "A Precise Four-Quadrant Multiplier with Subnanosecond Response," IEEE Journal of Solid-State Circuits, December 1968.
- Renschler, E., "Theory and Application of a Linear Four-Quadrant Monolithic Multiplier," EEE, Vol. 17, No. 5, May 1969.

# Low-power design is heart of penlight-powered mini-tv

Matsushita's *Reiichi Sasaki* and *Kyoichi Uno* tell how IC's, varactor tuning, and single vhf/uhf antenna yield quality audio and video on just a 5-volt battery supply

● The development of integrated circuits and other miniaturized components has given a tremendous boost to efforts aimed at drastically reducing size and power consumption in electronic equipment. But the mere availability of components does not guarantee that just connecting them will yield a satisfactory circuit—the design must capitalize on the new capabilities. One such successful approach is a miniature tv set, built by Matsushita of Osaka, Japan, that measures just 2¼ by 4¼ by 6¾ inches. Here new designs were applied to 11 thick-film hybrid integrated circuits that perform most of the functions—and the set draws only 1.35 watts from a set of penlight batteries.

Some of the basic characteristics of miniaturization—low power drain, confined quarters, and tiny component size—had to be considered vis-a-vis the television's requirements in picture size, brightness, resolution, sensitivity, synchronization, and audio fidelity. But the result was a highly innovative design—a tv set with a 1½-inch diagonal viewing screen, all-electronic tuning, and a single antenna for both vhf and uhf reception. Matsushita developed a new approach to video processing—gain distribution suited to IC design and a transistor detector—and also came up with a voltage regulator that can maintain 0.1-volt regulation during battery voltage drops from 5.5 volts to 4 volts.

One basic way to miniaturize the set was to reduce

power drain to allow use of small batteries so a 4-volt supply was used instead of the 12-volt supplies common to transistorized tv's. And the use of a single unswitched antenna for both vhf and uhf reception—most sets use separate antennas—also helped reduce overall size. Another innovative approach is electronic tuning through variable capacitance diodes, fixed inductors, and switching diodes, rather than the usual fixed inductors and mechanical switching. And the required gain is maintained even though the circuit component count is reduced because the mixer stage of the vhf tuner doubles as an intermediate-frequency amplifier in the uhf mode.

**Electronic tuning** serves yet another purpose—since mechanically switched inductors are eliminated, so are contact wear, microphonic noise, and restricted tuner location resulting from mechanical coupling requirements. Vhf band coverage is effected through p-n junction switching diodes that reduce circuit inductance since the vhf frequency range—the 54- to 88-megahertz low band and the 174- to 216-Mhz high band—is too broad to cover directly with variable capacitance diodes. The p-n junction switching diodes are located between two inductors in four tuned circuits; for low-band operation, the diodes are reverse-biased, acting as open circuits, and both coils are in the circuit. For high-band operation, the switching diodes are forward-biased, shorting out one coil. In all cases, individual channels are tuned

*Tight squeeze.* Matsushita's tiny tv occupies less than 76 cubic inches; the diagonal measurement of the picture tube is 1½ inches.

by varying the d-c voltage applied to the variable capacitance diodes.

Band switching in the vhf tuner is accomplished as follows: the switching diodes' anodes are connected to the junctions of the low- and high-band coils as well as to the +4-volt d-c supply. For the low-band vhf channels, the cathodes of the switching diodes are directly connected to +25-volts d-c, the value from which the tuning voltage for the variable-capacitance diodes is derived. This voltage then back-biases the switching diodes, which appear as open circuits. Thus, the switching diodes do not affect the coils, and maximum inductance appears in conjunction with the variable-capacitance tuning diodes. When the high-band channels are selected, the cathodes of the switching diodes are connected to ground, causing the diodes to conduct and appear as short-circuits. The low-band coils are shorted out and the variable-capacitance diodes act in conjunction with the high-band coils alone.

Coil-switching is not required in the uhf tuner because the entire uhf band—470 to 890 Mhz—represents less than a two-to-one frequency ratio, against the four-to-one vhf frequency ratio. The tuning is accomplished using three variable-capacitance diodes instead of the gauged-variable-capacitor found in mechanically coupled uhf tuners.

Power drain has been kept to a minimum. The power

drain of the vhf tuner's low-band circuitry is only 32 milliwatts and is 72 mw for the high band. For the uhf tuner, including the vhf mixer/uhf amplifier stage, drain is only 60 mw.

Matsushita's uhf tuner includes a common-base transistor r-f amplifier stage. Most transistorized uhf tuners don't use an r-f amplifier stage, but feed directly into a mixer. The additional amplification permits the vhf mixer stage to be used as an i-f preamplifier for uhf reception. And the extra gain introduced by the r-f amplifier input in the uhf tuner circumvents the use of the entire vhf tuner as the uhf i-f preamplifier, a common configuration in other tv sets. The r-f amplifier compensates for the degradation of the selectivity characteristics and increased losses resulting from the series resistance of the variable-capacitance diodes. During uhf reception, the r-f amplification and oscillator stages of the vhf tuner are disabled by removing the +4-volt d-c supply voltage. The i-f signal from the uhf tuner is amplified by the vhf mixer; +4-volts is applied to the vhf mixer.

The uhf tuner gain is about 18 decibels; the vhf mixer's gain when used as an i-f preamplifier is about 12 db. Thus the 30-db overall gain for the uhf tuner is higher than that of the vhf tuner—25 db for low band and 20 db for high band.

**The single vhf-uhf antenna** is another interesting feature. To prevent the vhf tuner from loading the antenna while receiving uhf, a low-pass filter was placed at the vhf tuner's input, presenting a high impedance in the uhf frequency range. Likewise, a high-pass filter at the input of the uhf tuner prevented it from loading the vhf tuner. It also was necessary to select a cable length between the vhf and uhf tuners that would minimize any interaction between the two tuners. The cable length had to be much less than one-quarter wavelength,  $\lambda/4$ , at the highest vhf frequency. If not, and if the cable length approached  $\lambda/4$  at some frequency within the vhf band, the high impedance of the uhf tuner would appear as a very low impedance at the vhf tuner, reducing vhf sensitivity.

The output of the vhf tuner feeds into the video processing circuitry where the gain requirement is 100 db. This high-gain requirement poses special problems for a miniaturized design, especially one using integrated circuits. The large amounts of parasitic capaci-

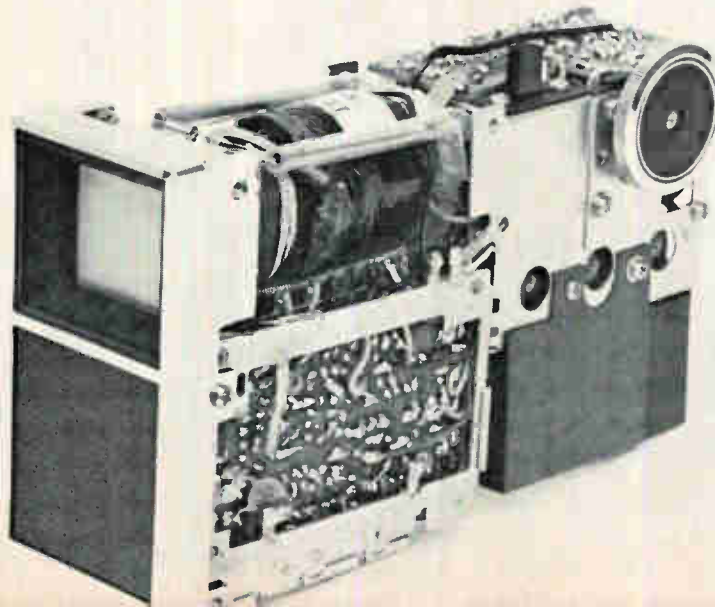



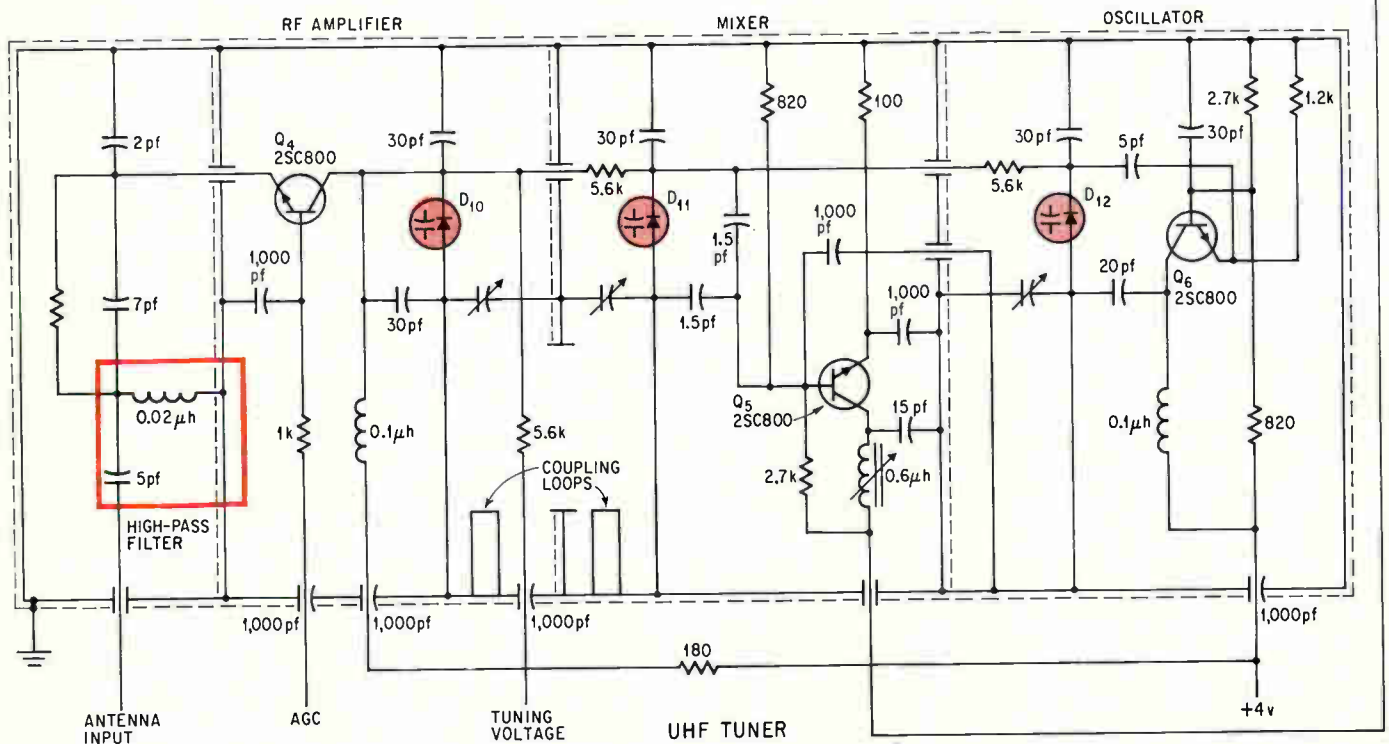
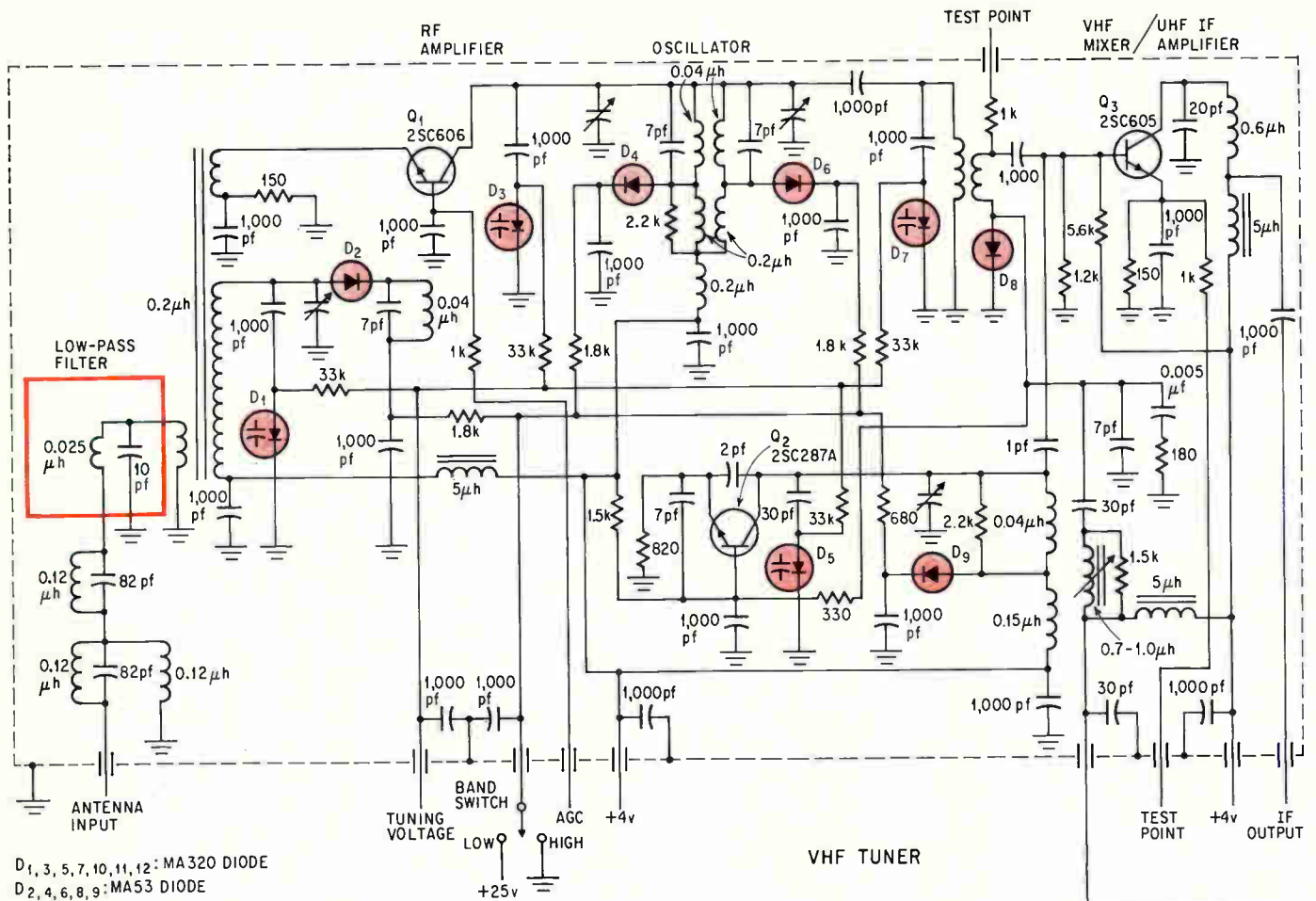

A switch. The variable capacitance diodes and the p-n junction switching diodes (shown in color) replace the mechanical vhf channel selector switch and separate inductances in most other tv tuners. Because the tuning range is much less in the uhf band, no switching diodes are required. The mixer stage of the vhf tuner also serves as an i-f preamplifier for the uhf signal. In the vhf tuner, optimum matching is used to prevent loss of gain at the low +4-volt supply voltage. A matching transformer is used in addition to the double-tuned circuit at the tuner's input; this matching arrangement stabilizes the r-f and mixer circuits against changes in power supply voltage thereby providing the best possible operation.

tance between circuit elements and the small distance available between input and output terminals cause feedback, making it difficult to achieve stable, high gain in these small areas. Rather than use the brute-force approach of several IC's in cascade with coupling circuits between them to obtain the 100-db gain—at the expense of high power drain—the overall gain distribution of the video processing circuitry was changed to achieve stability and lower power drain.

The gain assigned to the video i-f amplifier is only 50 db rather than the usual 60 to 70 db. This allows use of just one hybrid IC for i-f amplification. The remaining gain is made up by using a transistor detector instead of the more common diode unit, yielding a detection gain of 12 db rather than a loss of 8 db—a 20-db saving. The detector is followed by a video amplifier with a gain of 34 db, for a total video processing gain of 96 db.

**The transistor detector** is part of a second hybrid IC, which also includes the video amplifier stage. A bandpass filter at the video i-f amplifier's input shapes the input signal bandwidth; the detector has square-law detection characteristics. The transistor detector also increases the tv's sensitivity—it can handle much lower level signals than diode detectors, which usually require signals of several-volts amplitude. Because the transistor detector requires much less signal strength, it can be placed near the tuner or i-f amplifier terminals without feedback and unstable operation.

Although selectivity is improved by this type of detection, the output signal actually suffers from differential amplitude distortion—the white levels are compressed while the black levels are expanded. Black is represented by a modulated carrier amplitude that is 75% of the maximum envelope amplitude, while white corresponds to an amplitude normally about 12.5% of the maximum.

However, although this type of distortion is undesirable in large-screen tv sets, it offers a significant advantage for small screen tv sets—it improves average picture brightness. And transistor detection increases the noise-rejection characteristics of the tv set for the synchronization signal—peak levels of the synchronizing pulses extending above the black level are expanded more than the noise added to the blanking signals at the black level.

Another step toward miniaturization is the reduction of adjustable inductors required in the input bandpass filter to achieve the desired bandpass characteristics. The bandpass filter at the input to the video processing circuitry was designed to use only one adjustable inductance, while the adjacent channel trap and the IC's output filter use fixed inductances. This design uses only one variable inductor, against the six or eight in conventional transistorized tv sets, without a sacrifice in selectivity.

**The video i-f amplifier IC** consists of three direct-coupled amplifier stages and a capacitively-coupled output amplifier stage. The +4-volt d-c power supply is directly connected to the collector of the output transistor stage, allowing delivery of the largest possible output signal swing. Direct coupling for the first three stages reduces power consumption because there is no need for special bias power for each stage. Direct coupling also makes it possible to obtain a broad range of automatic gain control.

Forward age is applied to the first stage of the video i-f amplifier; reverse age applied to the second stage increases the mismatching loss at the output of that stage. The second stage is used as an impedance converter between the first and third stages. The third stage is unaffected by the age applied to stages one and two, and when the video processing stages are operated at maximum gain, the gain of the first and third stages is

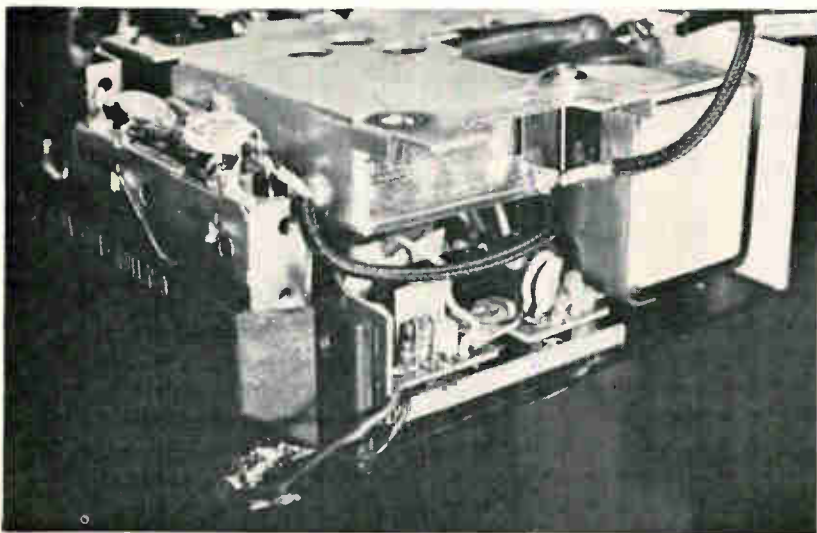

**Up front.** The mini tv is seen laying on its side. The uhf tuner, shown on the left, is mounted below the larger vhf tuner. The coaxial cable, shown on the right, connects the rod antenna to the vhf tuner; the other coaxial cable connects the uhf tuner to the mixer stage of the vhf tuner where final i-f preamplification is carried out when the set is in the uhf mode.

## Deflect we must

One of Matsushita's principal design goals was reduction of all mismatches to the smallest possible value. This was achieved through sophisticated circuit design and elimination of all inductors and transformers not absolutely needed in the deflection and high-voltage circuits. The problems were to generate 5 kilovolts for the cathode-ray tube in extremely cramped quarters—insulation, and prevention of induction of high-voltage pulses to other circuits. They were solved by replacing the open-winding U-core flyback transformer found in most tv sets with a pot-type core unit whose windings are inside the core. The 5-kv voltage was generated with an 11-time voltage multiplier using diodes and a low-voltage transformer instead of straight rectification of the output of a high-voltage transformer.

The high-voltage circuit's step-up rectifier reduces the effects of high voltage transformer insulation. And since the high-voltage transformer step-up ratio isn't too large, the effects of high-voltage winding stray capacitance on the flyback pulse is reduced—pulse width is kept under 12 microseconds. The voltage multiplication consists of progressive sharing and transfer of charge from the larger-sized input capacitors to the smaller output capacitors.

The horizontal and vertical deflection circuits each use two hybrid-ic's—an oscillator and buffer in one and a

driver and output stage in the other. Only the horizontal deflection stage uses automatic frequency control.

Both horizontal and vertical oscillator circuits use emitter-coupled multivibrators. These require fewer components and no inductors. However, when the circuit is operated at a low supply voltage, 5 volts, the effects of base-to-emitter voltage and temperature are large. Added to this effect are the high frequency of the horizontal oscillator and the separation of the horizontal triggering sync pulses in a differentiating circuit, which accentuates noise. Thus an afc circuit is needed to control the horizontal oscillator voltage. But the 60-hertz frequency of the vertical oscillator and the use of direct triggering to synchronize it eliminates the need for afc in this circuit. A buffer stage isolates each oscillator from its driver and output stage.

Although the oscillator and buffer stages of the two deflection stages are quite similar, the driver and output circuits are different. The horizontal driver and output transistors are connected in a modified Darlington connection to eliminate the driver transformer requirement. In this arrangement the driver transistor is operated as an emitter-follower, making possible a driver current amplification factor of 4,500. This allows the output to supply a peak current of 300 milliamperes with very little drive from the oscillator stage.

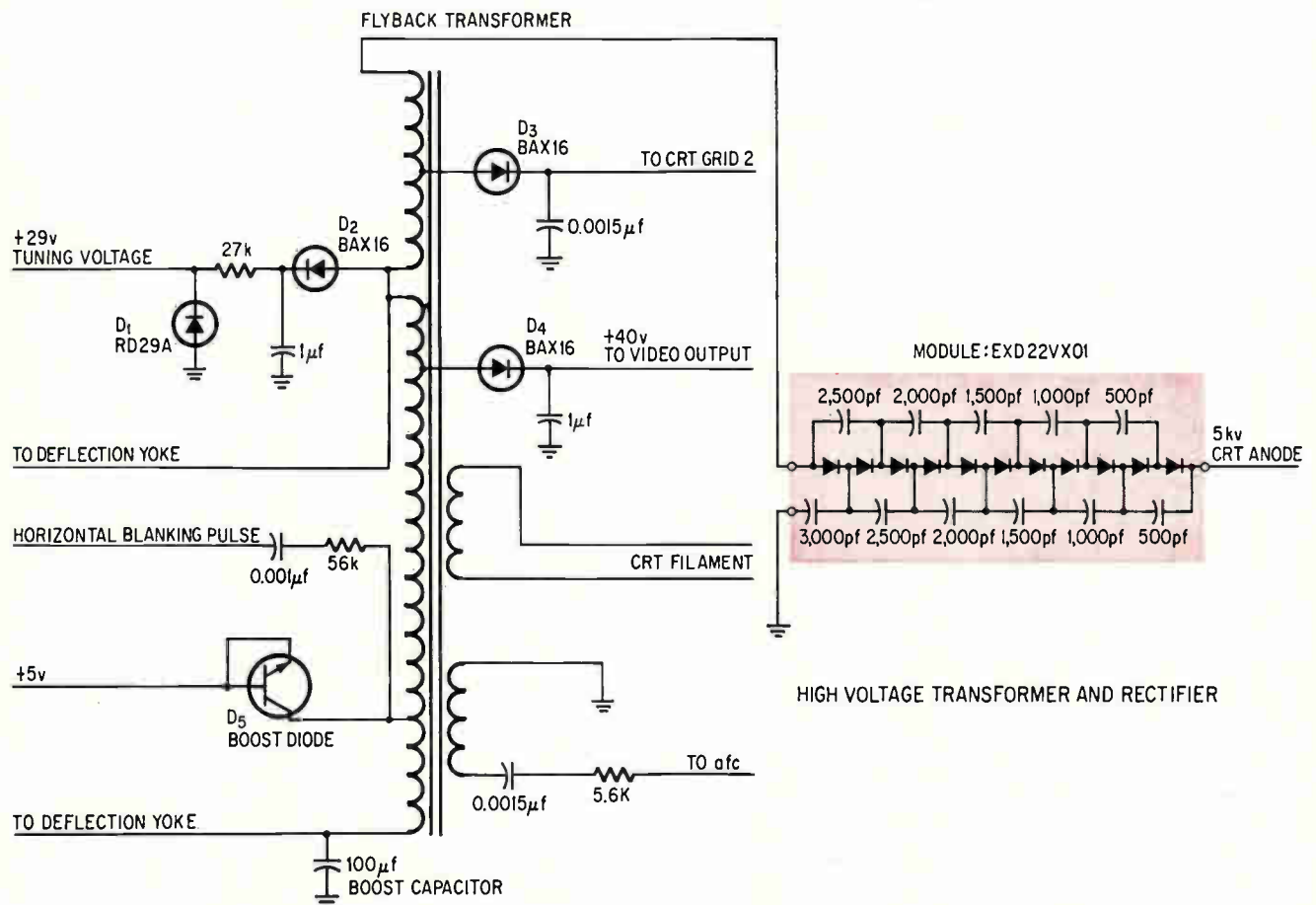

**High-voltage and deflection.** The 11 diodes in the high-voltage circuitry, seen above, are used to generate the 5-kilovolt crt anode voltage. The signal from the sync separator enters the horizontal deflection circuit, shown top right. The first IC is the oscillator-buffer while the second IC is the driver-output stage. Much of the circuitry is located outside the IC's including the afc which comes from the sync separator stage. The vertical deflection stage, shown bottom right, is similar to the horizontal stage because it also contains two IC's with the same functions. Afc is not required in this circuit due to the low vertical oscillator frequency, 60 hertz, and the use of direct triggering.



In the horizontal deflection stage, the oscillator circuit IC and the output circuit IC are capacitively coupled. However, during oscillator drive this capacitor is charged by rectification of drive current, causing the operating point of the circuit to shift. This effect is eliminated by connecting a diode from the base of the driver transistor to ground. The diode connection has its polarity opposite to that of the equivalent diode looking into the driver transistor base; its forward resistance is equal to that of the equivalent driver-transistor diode to minimize charging of the coupling capacitor. Since operating-point shift is eliminated, the output stage can be driven while maintaining minimum power dissipation.

There is no horizontal size control—it would draw excess current and decrease efficiency. As battery voltage falls from +5 volts, the balanced design of the horizontal output circuit causes the deflection amplitude and the high voltage to fall proportionally. Since the required deflection amplitude is inversely proportional to the high voltage, the raster width still fills the picture tube, but there is a decrease in brightness.

The vertical deflection output stage uses a class B single-ended push-pull circuit. This circuit eliminates the output transformer in the usual class A amplifiers found in most other tv's and is capable of higher efficiency. It also makes

for a smaller and lighter vertical output package.

The vertical deflection output stage operates as a current transformer. Current flows during both halves of the input cycle—into the coupling capacitor for one half and from the coupling capacitor during the other. When operated as a class B amplifier biased at cutoff, current flows from the power supply only half of the time. Thus the peak-to-peak current out of the vertical circuit can approach twice the peak current drawn from the power supply or eight times the average current. Peak-to-peak current in this tv is 110 ma while the average current is 30 ma, or about four times the average current drawn from the power supply. The current transformation ratio is smaller than expected—half the current flows when there is no input signal—and is consequently called idle current. The high idle current is useful—it eliminates crossover distortion in the push-pull circuit and stabilizes the operating point to reduce the effect of temperature variations.

The vertical output IC contains circuitry that blanks the picture tube during vertical and horizontal retrace. Positive-going signals from both deflection stages are inverted by a blanking amplifier, Q15, cutting off the picture during retrace. The sync separator IC was designed empirically to separate sync pulses from the video despite signal strength variations.

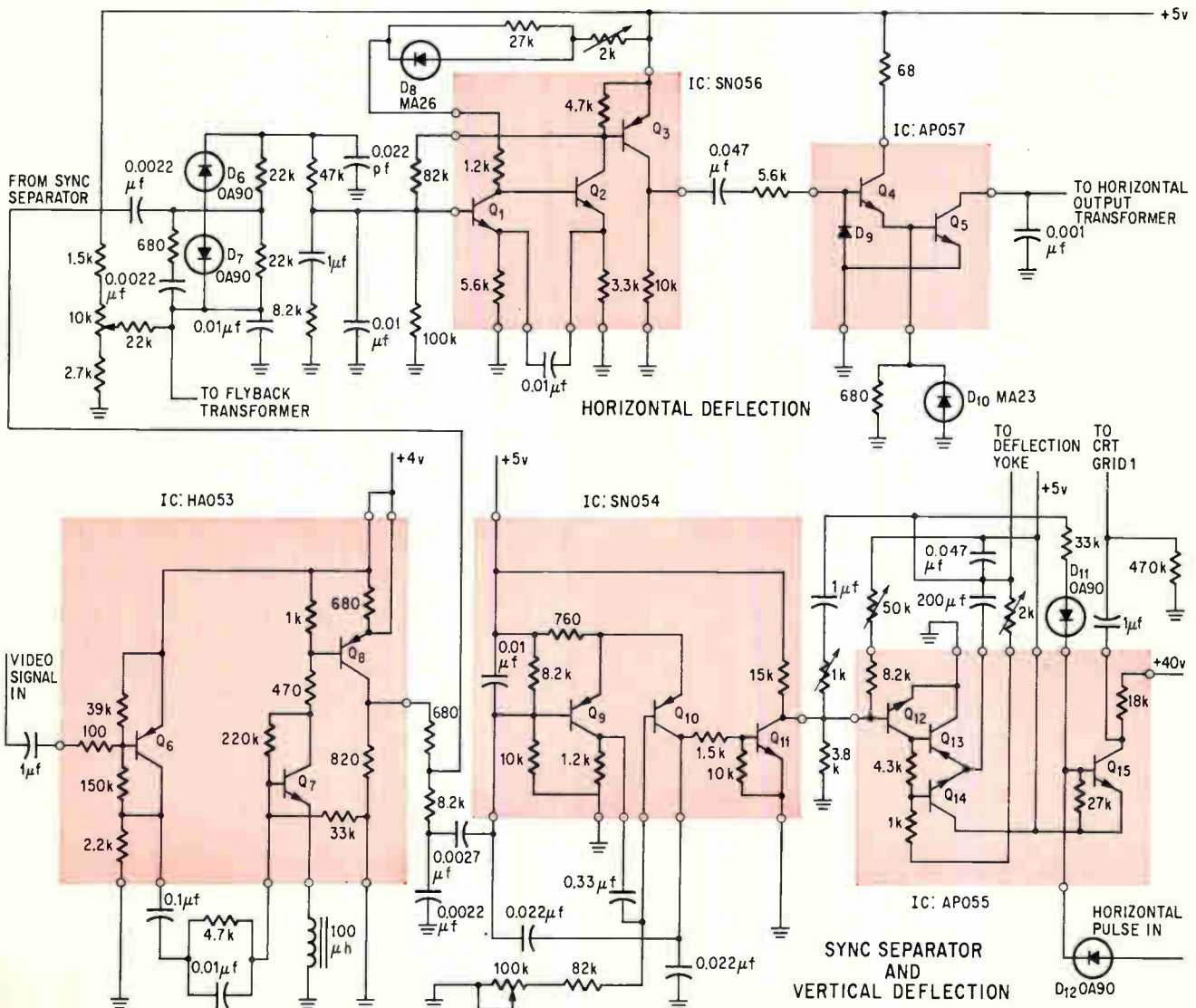

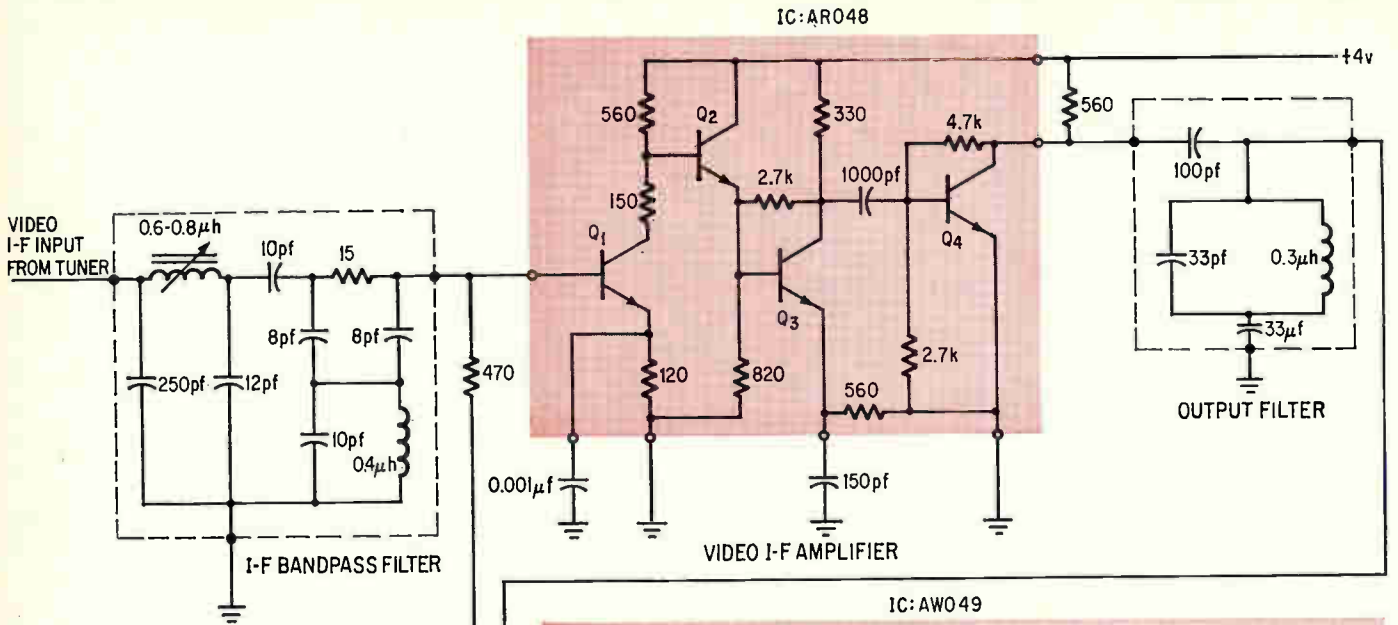

Up the video. Three standard IC's handle the video i-f processing chores. The transistor detector, Q5, is used to achieve 12 db of gain rather than the 8 db loss common with diode detectors. The noise canceller, Q8, greatly improves sync circuit stability by removing noise appearing with the video signal.

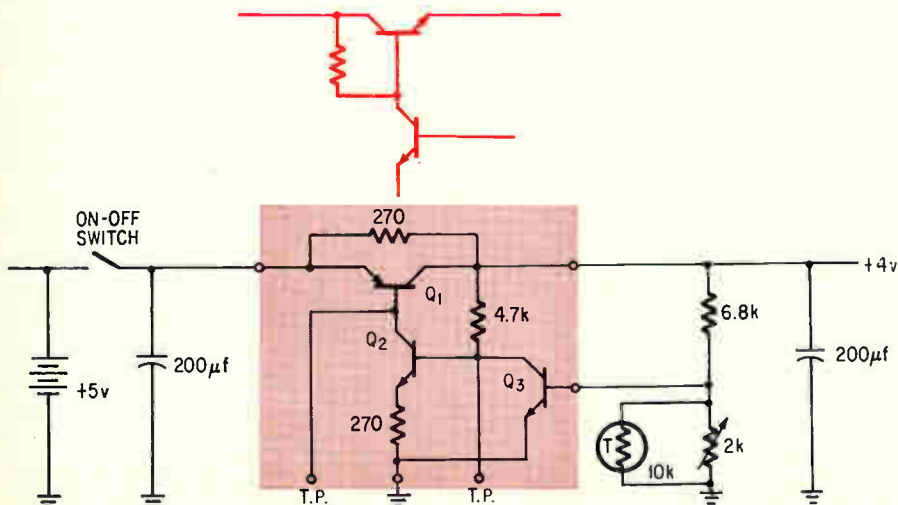
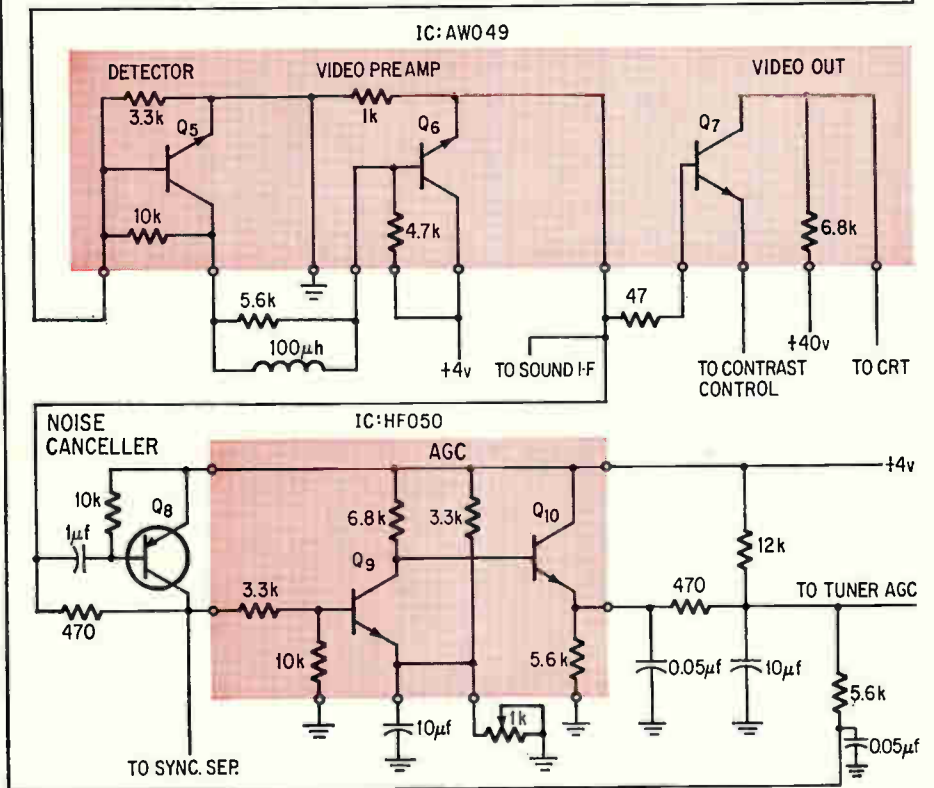

**Close regulation.** The pnp series control transistor regulator, Q1, located in the IC, is a major departure from the more commonly used npn configuration, shown above in color. Direct connection of the emitter of Q1 to the unregulated supply makes possible operation in a heavily saturated mode with a collector-to-base voltage of only 0.1 volt—base current is determined the effective resistance between the base and ground. The 270-ohm resistor in shunt with the series transistor permits regulator operation when the power supply is turned on.

inputs of  
ow the desired  
appropriate  
filter in the uhf  
filter in the vhf tuner  
the uhf signals. This design and  
length of coaxial-line between  
two tuners—much less than one-  
quarter wavelength at the highest vhf  
frequency—allow a single rod antenna  
to be used for both vhf and  
uhf reception.

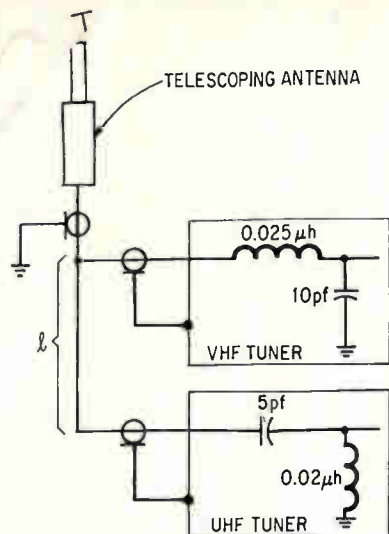

16 db each while that of the fourth stage is 20 db. Since stage two has a power gain but no voltage gain, it does not contribute to the overall voltage gain of the video i-f amplifier.

The three-stage age circuitry was designed to insure stable operation over a wide range of signal amplitudes. A portion of the video input, including noise, to the age circuitry comes from the sound i-f pick-off point. It's capacitively coupled to the base of the input transistor of the third IC in the video processing circuitry—the age and noise canceller.

This capacitor passes the constant noise but does not respond to the fast-moving video, so the noise appears in inverted form at the transistor's collector. Hence, the inverted noise signals cancel the noise appearing with the video; it's directly coupled to the collector via a 470-ohm resistor. Since the collector feeds the sync separator as well as the age circuit, the noise canceller greatly improves sync-circuit stability.

The video from the noise canceller going to the age circuitry is amplified by the second transistor in the IC. The third transistor peak-detects the signal and provides a low output impedance. This transistor is reverse biased from the +4-volt d-c supply. This reverse bias sets the value of the age output voltage when the tv is operating at maximum sensitivity.

The video i-f amplifier draws only 11 ma from the +4-volt d-c supply while the transistor detector and the video preamplifier stage draw another 2 ma. To develop sufficient voltage, the video output stage draws 2.5 ma from the 40-volt power supply, attained by rectifying part of the high-voltage pulse from the fly-back transformer. The video output stage power drain is only 100 mw, far below the 500 mw common in most other transistorized tv's. This low power drain is a direct result of using a picture tube with a high transconductance and a low cutoff voltage—only 25 volts. The power drain of the age circuitry is only 4 mw.

Miniaturization also affected the design approach to the set's power supply. The power source is four nickel-cadmium AA-size batteries whose internal impedance is small and whose absolute value of internal impedance is under 100 milliohms each. This is of paramount importance—if the internal impedance is high, output voltage will change with the audio output signal. A portion of this signal will be superimposed on the output of the video output stage, causing black bars to

appear on the screen. And this voltage variation also will appear on the sync and sweep oscillator voltages, causing the picture to rock. A transistor voltage regulator was designed to hold the voltage at the signal circuits to  $\pm 4 \pm .1$  volts.

The silicon pnp series control transistor regulator is a major departure from conventional designs, where with the output taken from the emitter, base current flows from the higher potential unregulated supply through a resistor into the base. And to get base current to flow through the resistor, the potential of the unregulated supply must exceed that of the base by several tenths of a volt, while for load current to flow, the base must exceed the emitter by 0.7 volt. Thus the output voltage is at least 1 volt lower than the unregulated supply voltage. Since the unregulated battery voltage is only 5 volts, minimum voltage loss in the series resistor to the base would be excessive for this configuration.

The pnp configuration makes it possible to design a power supply with a minimum voltage loss of 0.1 volt. The emitter of the pnp transistor is connected to the unregulated supply. This makes the base current independent of the base-to-collector voltage—base current is determined by the effective resistance between the base and ground. Thus it is possible for the transistor to operate in a highly saturated mode with a collector-to-base voltage of only 0.1 volt. Hence, the regulator can operate satisfactorily during battery discharge from the initial value of 5.5 volts to 4 volts.

The sound i-f amplifier and the audio amplifier were designed using two IC's, but not the usual RCA CA-3013. This IC was not used because it contains a very large number of active circuits and would drain too much power. The sound i-f circuit used draws only 28 mw while the audio amplifier draws 80 mw when there is no audio input signal present.

The sound i-f circuit uses a ceramic filter discriminator circuit. The unit has a series resonance—more than 100 kilohertz below the 4.5-Mhz i-f frequency—and a parallel resonance—more than 100 khz above 4.5 Mhz. At the series resonant frequency, voltage across the filter is minimum, while at the parallel resonant frequency, almost all the voltage appears across the filter. The output voltage from this stage has the familiar S shaped curve which is linear for about 70 khz on either side of the 4.5-Mhz center frequency. The bandwidth of the 4.5-Mhz sound intermediate frequency is  $\pm 200$  khz. ●





**The CSP-30  
digital computer  
has a 200  
nanosecond add  
(steady now) and a  
1 microsecond multiply.  
That's real time.**

Two-hundred-billionths-of-a-second add. *YES!* And one-millionth-of-a-second multiply. *ECSTASY!* The new CSP-30 digital all-time- great computer. Operating at 10 MHz to perform *there's no business like* continuous real-time high-resolution Fast Fourier Transforms *show business* at sampling rates up to about 45 kHz. (Indescribably propitious!) The CSP-30. Built for speed freaks whose tempus doth not fugit fast enough.

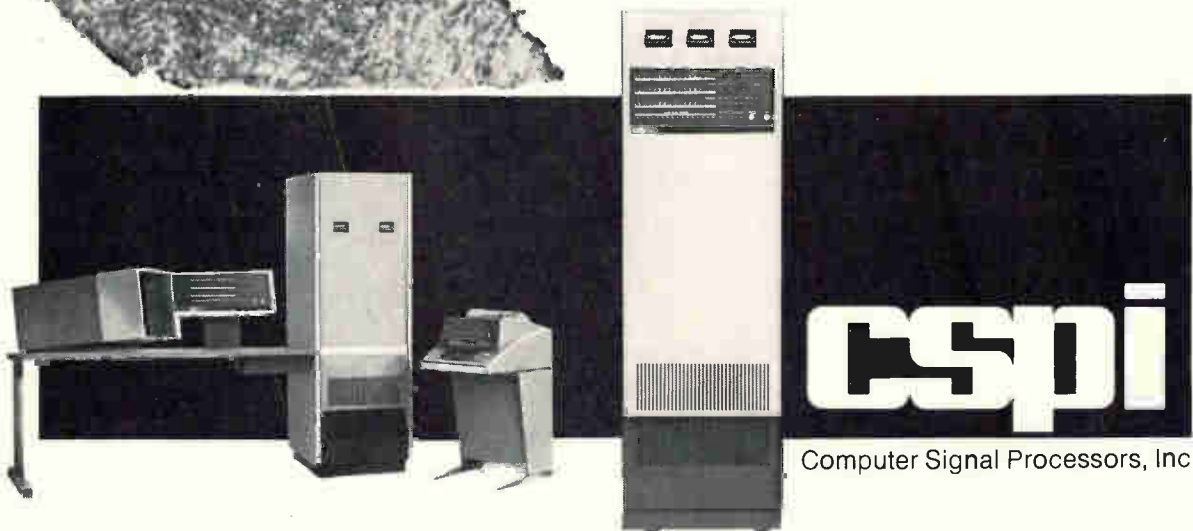

Computer Signal Processors, Inc.

209 Middlesex Turnpike, Burlington, Massachusetts 01803

# The most for your money: in 8 channel recorders, it's the new Brush® 480.

Minimum cost per channel and maximum data presentation.

That's the cost/performance package called the Brush 480... most versatile, least expensive 8-channel recorder of its kind.

It's the economical solution to your problem of analyzing eight variables on a common time base.

The Brush 480 has eight 40 mm channels, two event markers, and twelve pushbutton-controlled chart speeds that run from 0.05 to 200 mm/second. It's available as a compact portable or can be rack mounted.

Although small in size, the 480 has all those familiar Brush exclusives. Like a patented pressurized ink system that puts crisp rectilinear traces

right into the paper. So there's no smudging, no puddling. And messless throw-away ink cartridges can be replaced in minutes.

The 480 comes factory-calibrated and, thanks to our special pen-position servo system, we guarantee 99½% accuracy. Frequency response at 50 divisions is flat within  $\pm 2\%$  of full scale from d-c to 40 Hz.

And the Brush 480 is compatible with our multi- and single channel signal conditioners so you can select the conditioning best suited for your measurements, whether it's temperature, pressure, strain, voltage, current, position, velocity or what have you.

The Brush 480. It's one of the few bargains left. For more information,



write for bulletin 934-18. Brush Instruments Division, Gould Inc., 3631 Perkins Avenue, Cleveland, Ohio 44114, or Rue Van Boeckel #38, Brussels 14, Belgium.

**GOULD BRUSH**

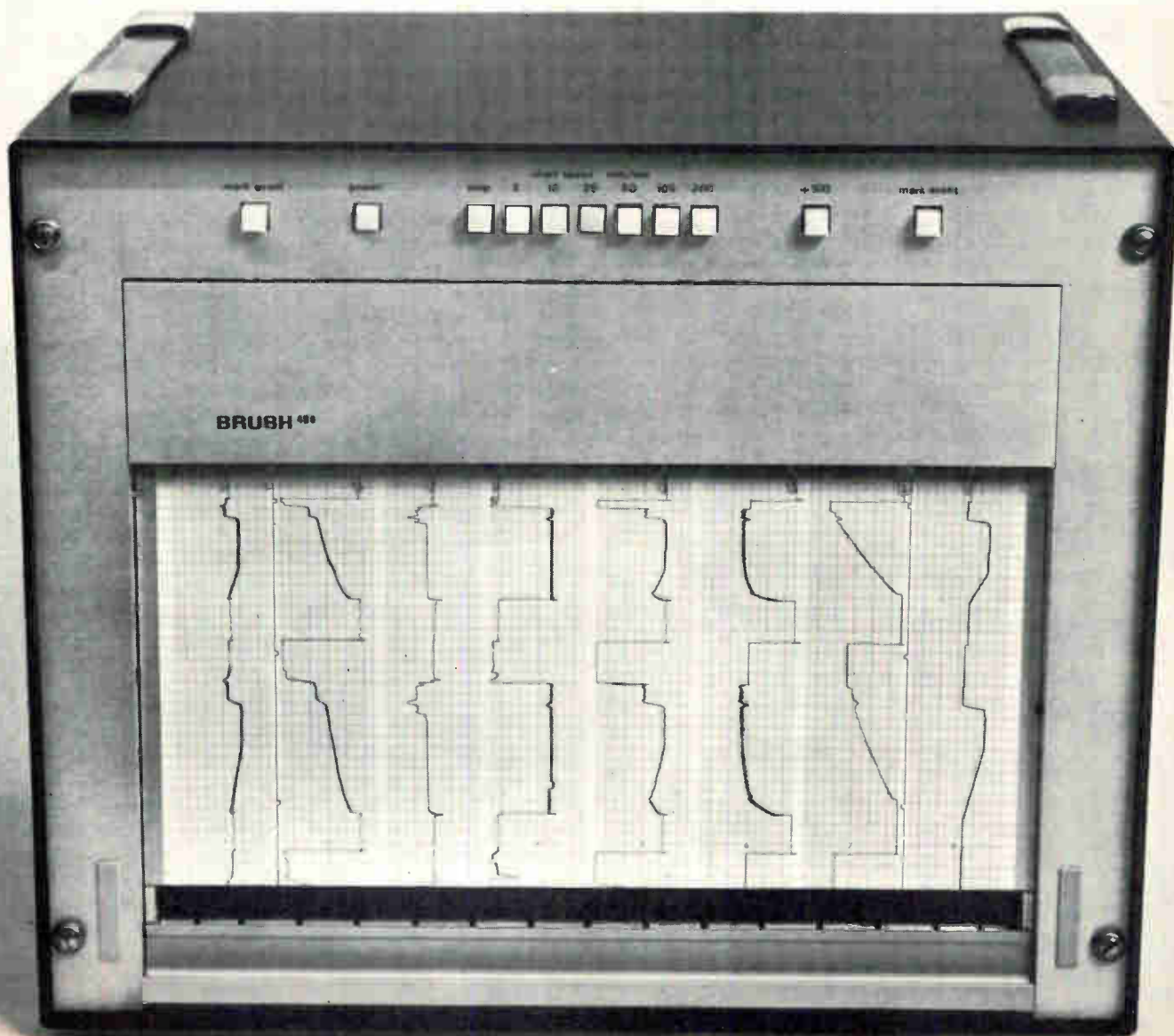





*Who ever heard  
of a computer  
with an*

# EPU?

Unlike any other computer you've ever seen, the GRI 909 Computer, a Direct Function Processor, has an expandable instruction set. Starting with the basic configuration of nearly one hundred instructions, it can be expanded with firmware modules to literally thousands of instructions.

Typical units in our standard library of plug-in firmware operators are "Multiply/Divide", "Byte Swap/Pack", "Byte Comparator", and "General Purpose Registers". And, if you prefer, you can make up and plug in your own proprietary operators.

This is a true hardware expansion of the processor unit . . . not merely a read-only memory execution of subroutines. (Although the GRI 909 can handle that too, of course.)

Don't box yourself in. Get the GRI 909. It's a family of computers within a single processor unit.

For more information on the Direct Function Processing technique write:

**GRI Computer Corp.**

 76 Rowe Street,  
Newton, Mass. 02166  
(617) 969-7346

\* EXPANDABLE PROCESSOR UNIT

 THE NEW BREED





# The industrial emergence of Iowa:

122 of America's top 500 companies now operate 457 plants in Iowa.

As World War II ended, the farm states of the Midwest found themselves in a difficult position. Technological and biological advances had made it possible for one farmer to farm more land than ever before. The result — fewer and fewer farm jobs. With the prospect of mass unemployment in the future, Iowa set out to industrialize herself.

Slowly at first, then more rapidly, Iowa's industrial capacity grew as her recruitment methods reached a high level of sophistication. In recent years Iowa trade missions have jetted abroad, seeking new markets for Iowa products. High level brainstorming sessions have produced some startling ideas. A new promotion theme — "Iowa . . . a place to grow" — has been developed. A contemporary new symbol depicting growth in all directions has been designed. Iowa's dynamic young governor has led groups of Iowa businessmen throughout the nation acquainting industrial prospects with Iowa's advantages. Today Iowa's soaring industrial output exceeds even her enormous agricultural contribution. Among the new industries selecting Iowa sites last year: General Mills, Inc. and Kitchens of Sara Lee are building plants in the state and Transamerica Investors Group is erecting a 20-story office building.

Iowa's biggest asset is her people. Iowa colleges and universities graduate more Ph.D.'s per capita than any other state. Her work force is intelligent, educated and endowed with typical Midwestern pride in work. Personnel Directors privately admit Iowa plants are generally more productive than sister plants in other states.

Iowa has made one of the most successful agricultural-to-industrial transitions in history . . . adding one while keeping another. In the 1970's, Iowa is truly a place to grow.

# If you think Iowa is just a cornfield . . . think again.

For a number of important reasons, Iowa's factories produce even more than her fields . . . reasons you should know. For information about the industrial emergence of Iowa, send this coupon.

(Confidential Reply Coupon)

Iowa Development Commission  
Dept. E-4, 250 Jewett Building  
Des Moines, Iowa 50309

NAME \_\_\_\_\_

FIRM \_\_\_\_\_

ADDRESS \_\_\_\_\_

CITY \_\_\_\_\_ STATE \_\_\_\_\_ ZIP \_\_\_\_\_

 **Iowa**  
a place to grow

Iowa Development Commission

# NOW... A NEW AND EXPANDED MANUFACTURING SYSTEM FOR HIGH TECHNOLOGY INDUSTRIES

## ...by Hamilton Precision Metals

• COMPUTER • INSTRUMENT • TELECOMMUNICATION • BUSINESS MACHINE

The Precision Metals Division of Hamilton Watch Company is now geared to meet the requirements of computer, instruments, telecommunication and business machine manufacturers—as well as other high technology industries—with high-quality precision strip, foil and wire processing, precision Photoforming® and parts assembly.

Hamilton's metals technology includes precision rolling of ultrathin strip and foil and wire drawing in pure metals, commercial alloys and proprietary metals with highly specialized properties. This facility also includes heat-treating and annealing to provide the physical or magnetic properties required.

Photoformed parts are produced from the precision-rolled strip and foil in high volume, meeting the most rigid shape and dimensional specifications. Parts are manufactured by modern, high-production equipment in the most advanced chemical etching facility featuring "ultraclean" production conditions.

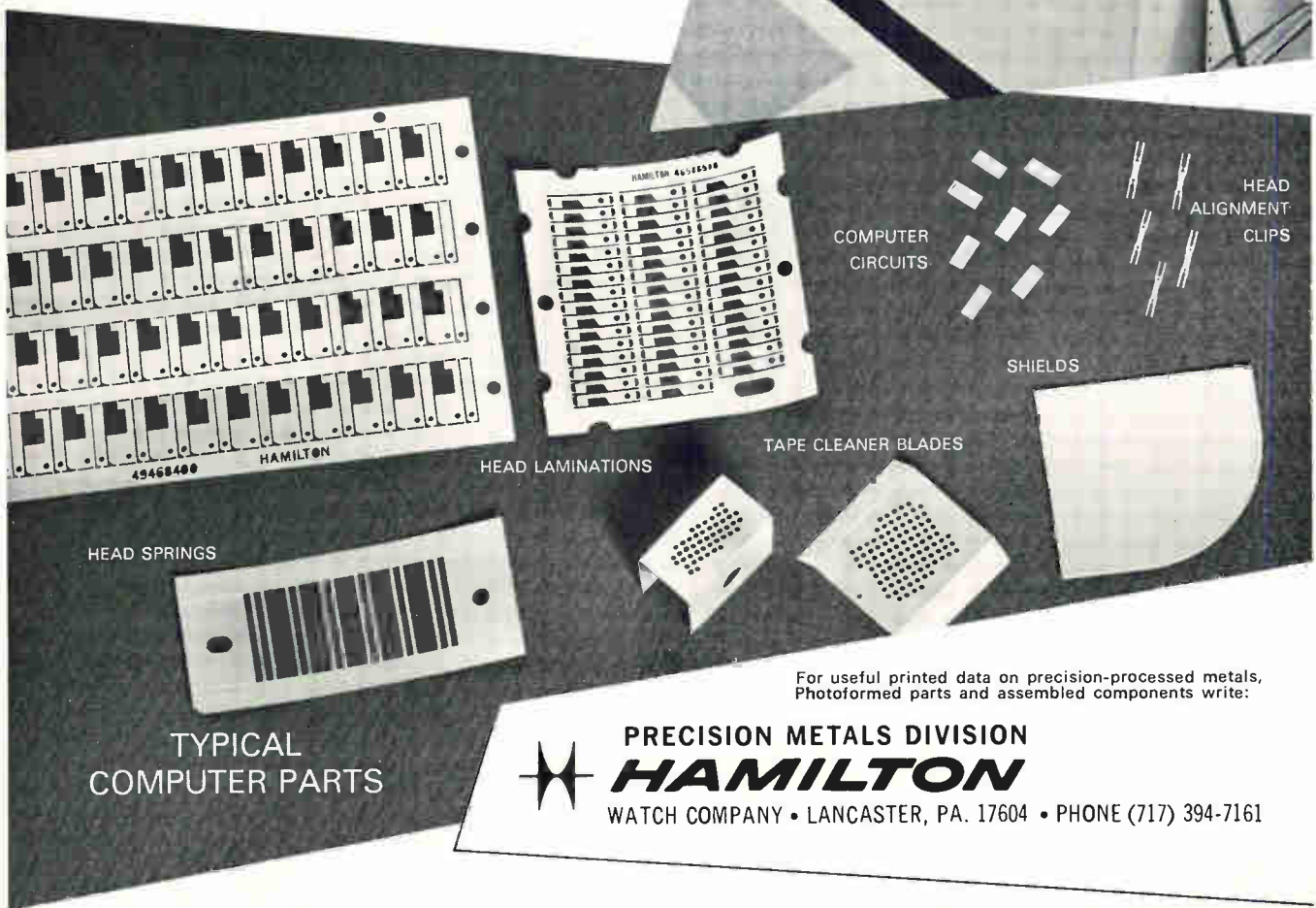

TYPICAL  
COMPUTER PARTS

For useful printed data on precision-processed metals, Photoformed parts and assembled components write:

**PRECISION METALS DIVISION**  
**HAMILTON**  
 WATCH COMPANY • LANCASTER, PA. 17604 • PHONE (717) 394-7161

# Unigraph 22™ The first total Photoplotter System

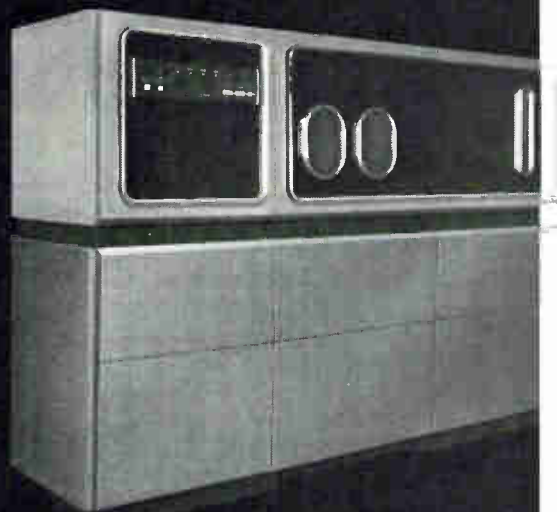

**it plots...it develops...it duplicates**

Select from up to 300 images to produce any linear or circular artwork desired as large as 22 inches square. Plot lines as fine as .001" without "ballooning" or "necking" or as wide as one inch with exceptional accuracy at a speed of 3.2 inches a second.

Do all this without the need for a separate darkroom or special environmental room controls which are included within the new Unigraph 22 system. Move the system through a 30" doorway, install in minutes and

produce your artwork masters and production prints wherever and whenever you need them . . . in the drafting room . . . in the engineering department . . . in the design area . . . or in all of them — It's that easy to install and surprisingly inexpensive to lease or buy.

For information, phone (714) 644-0281, or write, Universal Graphics, Inc., Marketing Dept./Suite 905, 550 Newport Center Drive/ Newport Beach, California 92660.

**UNIVERSAL  
GRAPHICS**





# the fate of the “open” Reed Relay IS SEALED!

shown actual size



For almost the price and size of open types, this new Struthers-Dunn MRRK Series has all the advantages of conventional enclosed, magnetically-shielded reed relays.

A new fast method of plastic sealing gives complete protection that your production department will really appreciate during mounting, soldering, and cleaning. Insulation resistance remains above  $10^{12}$  ohms.

Only 0.66" wide by 1.29" long by 0.48" high (including 4 standoff pads), the case accommodates single or double coils and up to 3 single-throw or up to 2 double-throw, miniature reed switches. Internal leads are welded to 0.1" grid-space P/C terminals.



In stock now at Struthers-Dunn distributors in most popular configurations. For detailed information, request Data Bulletin B/3330 on the new MRRK Series. Check the Reader Service number shown below.

## There's always more to draw on where you find the most to start with



**World's Largest Relay Line**  
More than 5,348 different types! Sold through more than 100 franchised distributors! Get our Stock Relay Catalog 1010 for details on the most frequently-needed aerospace, reed, industrial, and special-purpose relays, contractors, and motor controls. Check the appropriate Reader Service number at right.

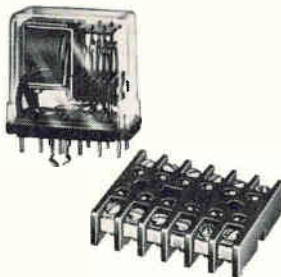

**Largest Line Of Plug-Ins**  
This integrated line of general-purpose, latch, sequencing, and timing relays will save your wiring time, make control panels neater, cut costs. S-D socket terminals are all instantly accessible and on one plane. No complex multiple-level wiring! Send for full story. Check the proper Reader Service number at right.



**More Ways To Reverse A Motor**  
No one else offers as wide a choice of motor reversing contactor designs for general and definite purpose applications up to 100 HP . . . including hoists, motor-operated doors, windows and elevators as well as machine tool auxiliaries. Details on request. Check the proper Reader Service number at right.

### SEND FOR THIS DATA

Check numbers on the Reader Service Card for any or all the items of interest to you.

- #324 MRRK Relay Bulletin
- #325 Stock Relay Catalog
- #326 Plug-in Relay Bulletins
- #327 Motor Control Catalog



## STRUTHERS-DUNN, INC.

PITMAN, NEW JERSEY 08071

# Stable Mates.

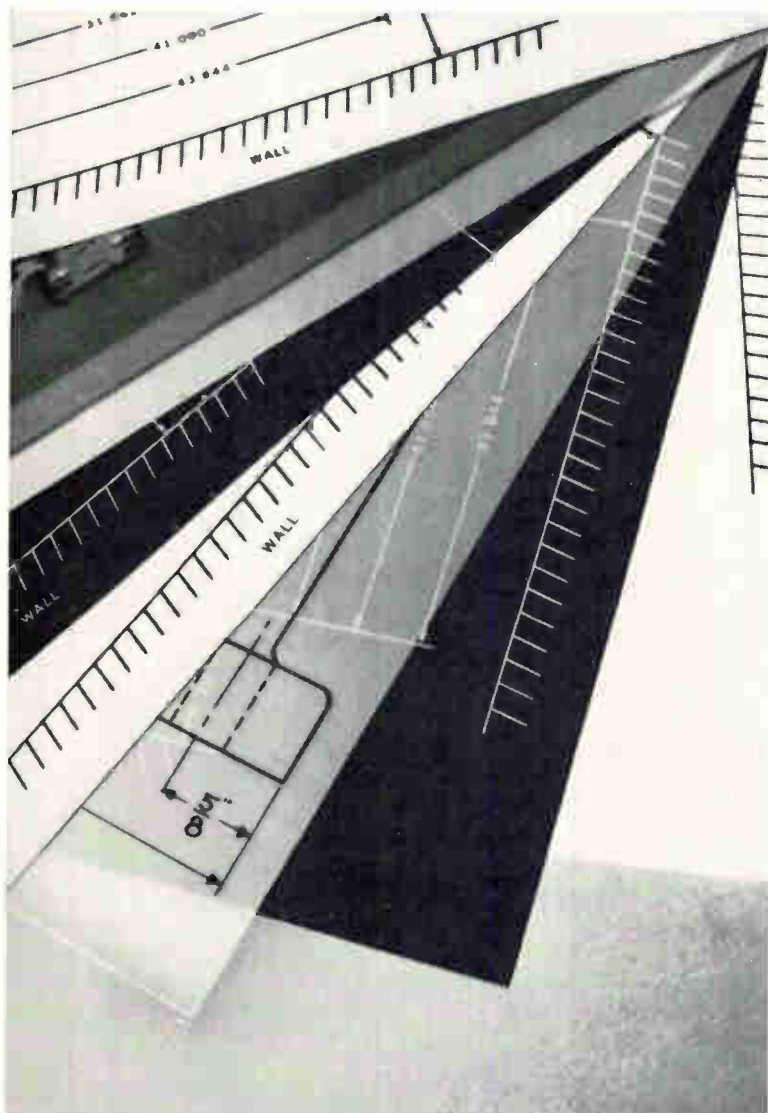

## New Kodagraph Super-K papers give you unusual dimensional stability.

Chances are you know how well Kodagraph Estar base films hold their size. Now Kodak introduces Super-K papers that give you better dimensional stability than conventional papers. And they lie flat and resist soiling, too.

Takes only two minutes to process them in the Kodak Supermatic processor, which also handles Estar base films. Or you can use conventional processing methods. You'll like the results either way.

For all the facts, contact your local Kodak Technical Sales Representative. Or write Eastman Kodak Company, Business Systems Markets Division, Dept. DP739, Rochester, N.Y. 14650.

**DRAWING REPRODUCTION  
SYSTEMS BY KODAK**

Kodak

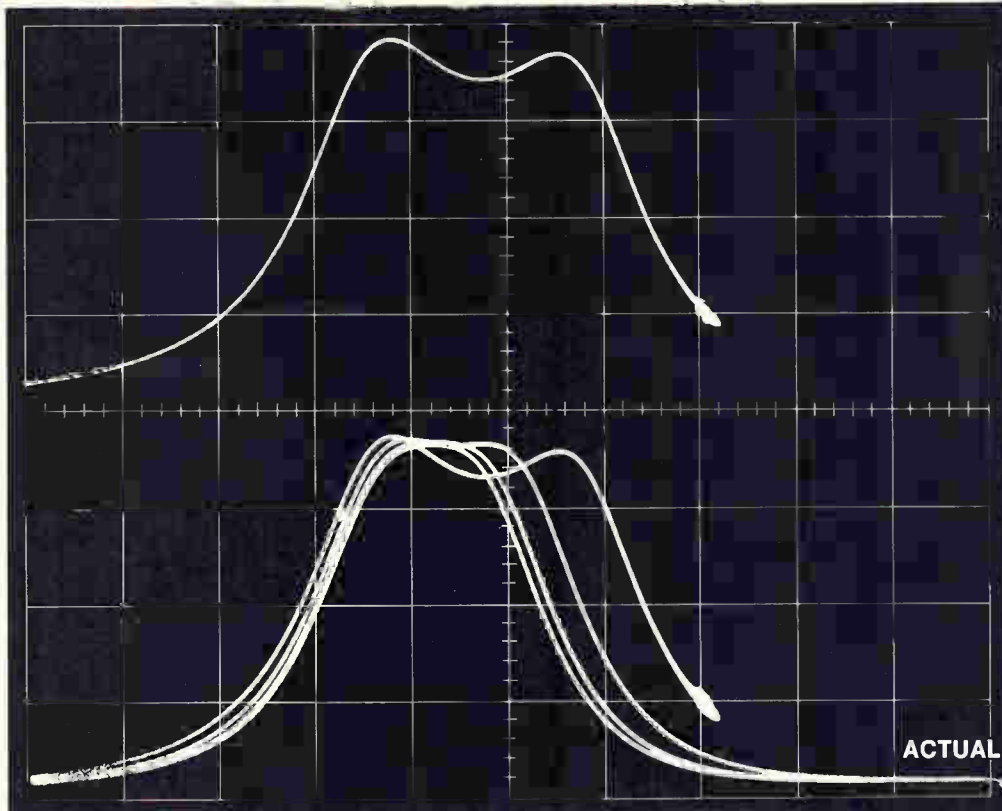

CH1  
> 100  
mV

CH2  
> 100  
mV

HORIZ  
200  
mS

ACTUAL SCREEN SIZE

# A DUAL-BEAM FAMILY

Performance in a Configuration to fit YOUR individual application

Big performance . . . in a compact size! Performance characteristics of this dual-beam oscilloscope family include high-gain, wide-bandwidth amplifiers with 19 calibrated deflection factors from  $10 \mu\text{V}/\text{div}$  to  $10 \text{V}/\text{div}$ . The voltage inputs (differential or single ended) have a bandwidth of DC to 1 MHz at all deflection factors. Current probe inputs are also provided for each beam with 10 Hz to 1 MHz bandwidth and eight calibrated deflection factors ranging from 1 mA to 200 mA/div. A wide sweep range is provided in 21 steps from  $1 \mu\text{s}/\text{div}$  to 5 s/div. The convenient direct reading magnifier provides sweep magnification ratios of up to 50 times. Bright fiber-optics automatically read out scale-factors adjacent to the extra large 8 x 10 div (1.27 cm/div) CRT.

This big display area is available in a  $6\frac{1}{2}$ " conventional or rugged bistable storage CRT; both have internal graticules. Three instrument configurations are available, each at the same price. They are: a  $5\frac{1}{4}$ " high rackmount, a 6" high x  $17\frac{3}{4}$ " wide low-profile cabinet and a 10" wide upright cabinet. Save space without compromising your measurements!

Ask your Tektronix Field Engineer for a demonstration. For complete specifications consult your 1970 Tektronix Catalog or write: P.O. Box 500, Beaverton, Oregon 97005.

5031 (Storage) . . . . . \$2500    5030 (Conventional) . . . . . \$1850

These oscilloscopes are available through our new Leasing Plan.  
U.S. Sales Prices FOB Beaverton, Oregon



**Tektronix, Inc.**



committed to progress  
in waveform measurement



# Illiac 4 enters the home stretch

Supercomputer should be installed and running by early 1971—two years late

By Wallace B. Riley

*Electronics' staff*

● It's standing on one leg instead of four, its clock rate is more than 20% slower than originally planned, and it's two years late, but the world's fastest computer, Illiac 4, has finally overcome the last in its long series of technical hurdles. Conceived many years ago and under development at the University of Illinois since 1966, the supercomputer should be installed and running by late this year or early in 1971. That's the prediction of Daniel L. Slotnick, project chief at the university and Lawrence G. Roberts, director for information processing techniques in the Pentagon's Advanced Research Projects Agency, which is funding it.

Slotnick, who is the "father" of Illiac 4, has had to overcome much resistance to the machine's design and gambled on using several state-of-the-art approaches to hardware. He was dealt a poor hand on two of them: Texas Instruments pulled out of its contract to design and build medium-scale integrated circuits for the project [*Electronics*, April 14, 1969, p. 47], and Burroughs Corp., builder of the machine for the university, discontinued work on the thin-film main-frame memories it had originally proposed for the machine. Slotnick apparently has pulled off a brilliant coup here, though. Burroughs has accepted the first semiconductor memory for Illiac 4 from Fairchild Semiconductor; it's one of the first computers, if not the first, to use a semiconductor main-frame memory.

Essentially 64 computers (or one quadrant) operating in parallel, and handling more than 200 million instructions a second, Illiac 4 originally was planned as a four-

**Big Board.** Technician checks one of the multilayer boards used in the Illiac 4 control unit. Circuits on the board are standard dual-in-line packages. Texas Instruments supplies the custom emitter-coupled logic circuits, which are being used instead of the MSI devices originally intended for the computer. The board measures 20 by 24 inches.



quadrant system consisting of 256 separate processors with a speed of 1 billion instructions per second. Spiraling costs torpedoed the four quadrants and the switch from MSI to conventional IC's, as well as fewer processor elements, was largely responsible for the drop in system speed. Even so, the Illiac 4 will be 20 times faster than the fastest machines now being sold.

Illiac 4 was designed primarily to tackle problems, particularly matrix-oriented types, that can't be solved reasonably rapidly by conventional computers. Illiac 4's applications will include problems in weather prediction, economics, and linear programming—a technique for optional solving of certain types of problems involving many variables.

Only the simplest of such tasks are feasible today.

An input-output subsection, comprising two fast disk storage units and their controllers, feeds data to the 64 computers, and a conventional Burroughs B6500 computer serves as Illiac 4's "front end," coordinating the system's operation.

The single-quadrant version now being built will be completely assembled at Burroughs Corp., tested as a working system, then disassembled and shipped to the university to be put back together again. The massive system will be eight feet high and just over 53 feet long.

Each of its 64 computers, called processing units, contains a proc-

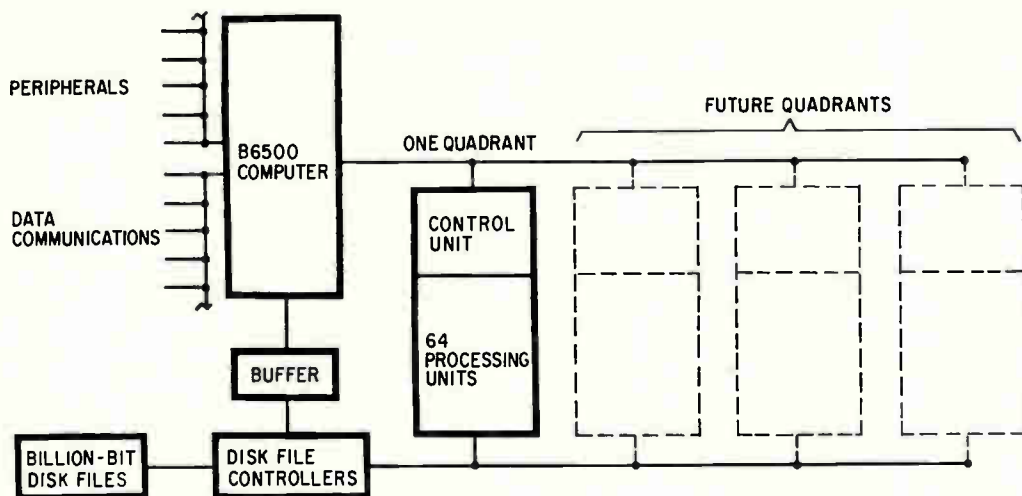

**Illiac 4.** The 64 processing units in one quadrant operate in parallel to execute 200 million instructions per second. Instrumentations and data from outside world are passed by the B6500 computer to the disk files, from which they are retrieved by individual memories in the 64 processors.

essing element—corresponding to a conventional computer's main arithmetic and logic unit—a memory, a memory interface section, and a power supply. At its Paoli, Pa., laboratories Burroughs is debugging the first three production prototype processing elements. Several more elements are essentially complete and production has started on the remaining ones.

The speed with which the first processing element was put into operation after it had been assembled is remarkable. Debugging took only a few hours, instead of

the usual two or three months. Only a handful of logic and wiring errors were found, and these were easily corrected, say Slotnick and his long-time associate, Arthur B. Carroll, now head of a design-automation firm, Automation Technology Inc. Slotnick and Carroll both attribute this success to extensive simulation and checking before the design was committed to hardware.

**Milestone.** The semiconductor memories themselves represent an important milestone. "Without the impetus of the Illiac 4 project, they

might not have been available commercially for another year at least," asserts Rex Rice of Fairchild Semiconductor's research and development lab, which was responsible for designing and packaging them. "We fully expect to achieve an order of magnitude improvement in yield and reliability with Illiac's eight-million bit memory," says Rice. Though yields still are considerably below the figure Fairchild hopes to attain (reportedly as high as 8% at the package level relative to the raw wafer), Fairchild's production is only in the start-up phase.

One key to the high reliability was to make the bits on each of the memory's chips individually addressable; the 64-bit words that the memory sends the processor come from 64 chips accessed simultaneously. It's then possible to put chips in 16-lead, dual-in-line packages in which only one lead carries data in and out. Says Rice, "We could have improved performance slightly by using simpler decoding; for example, having a single chip produce 16 bits in parallel. But this would have required many more data leads, which in turn, would have required larger packages." Furthermore, these extra leads would require more external connections that would detract from reliability.

**Turning back the clock.** While there's complete agreement that the semiconductor memories are one of the better things that's happened to Illiac 4, the main memory was originally proposed as thin-film. Burroughs had pursued planar magnetic thin films as a

## ARPA's network

Hand in glove with Illiac 4's progress is the continuing development of ARPA's national network of computers [*Electronics*, Sept. 30, 1968, p. 131]. This network will eventually interconnect computers in about 20 research institutions from coast to coast. Phase 1 of the network, involving 14 sites, is well under way and should be in full operation by the fall of 1970. Phase 2, which includes connections to the Illiac 4, will be undertaken next year or whenever funds are available.

"The network offers a way to share the resources of many machines among many people," says ARPA's Lawrence G. Roberts. "Every computer site can't have everything that people might want to use; the network makes all sites' facilities available to everyone."

Without the network, programs and files from one installation that are needed at another must be transmitted over telephone lines in a tape-to-tape or similar operation, or even mailed. Furthermore, data often must be translated into a form that can be used by the receiving installation, making interactive operation impossible. On the network, the whole file need not be transmitted—only the part that is needed at any particular moment. Access can be obtained in roughly a tenth of a second; and even large chunks of files can be transmitted in seconds, making true interactive use feasible.

Illiac 4, as originally conceived, didn't take the network into account; it was envisioned only as a big machine for certain kinds of big problems. But as the network concept developed, it quickly became evident that a small change would be required in the direction of Illiac's concept. The Illiac project's overall goals were unaffected; the change affects only who can use the machine and how.

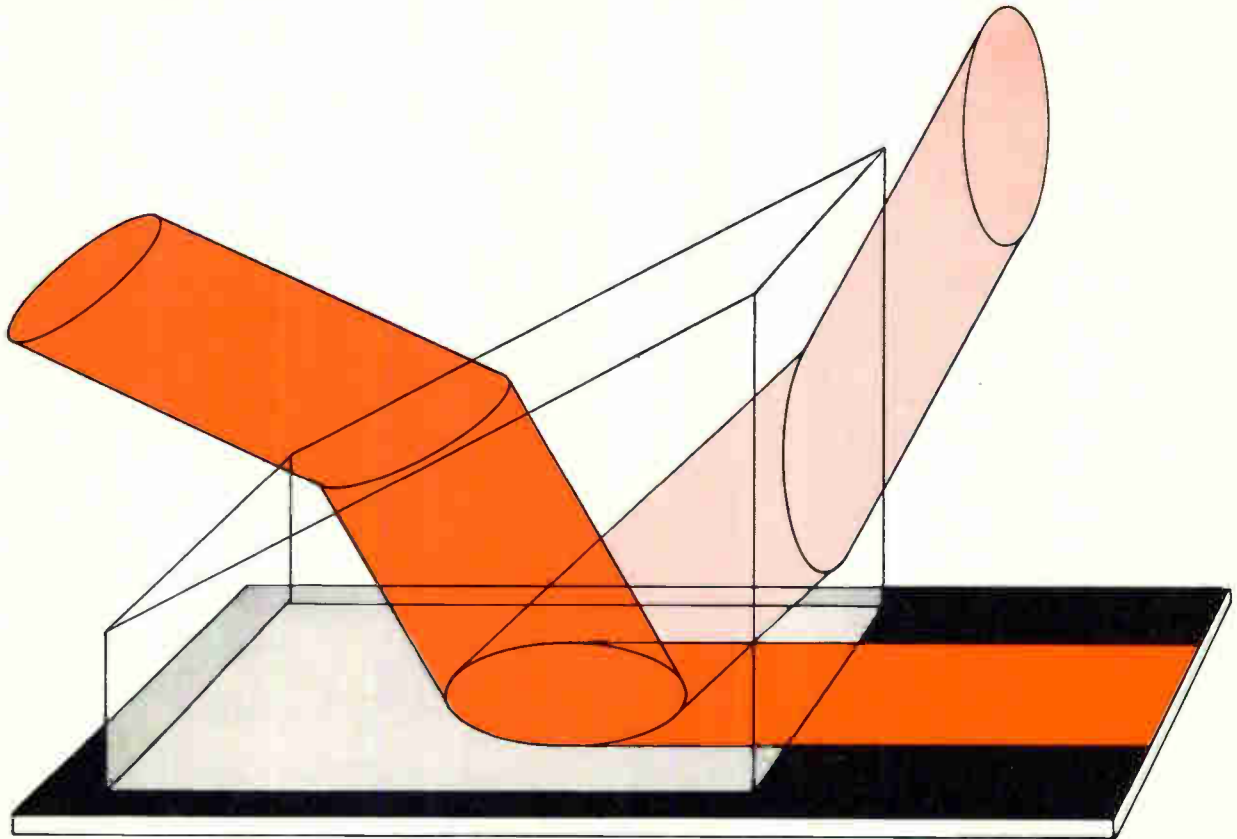

### Breaking through an interface

When we need the great bandwidth of optical communications, we'll also need devices and circuits in which light can flow much like electricity in wires of conventional circuits. Laser beams may be guided into circuits made of thin films of semiconductor. In these, the transmitted signals will be modulated, switched, converted in frequency, etc.

But one difficulty is getting light into—and out of—films which may be less than a micron thick. It isn't practical to direct a light beam through the edge of such a thin film. Also it's difficult to make the edge optically perfect.

Now, scientist P. K. Tien of Bell Laboratories has found a way to feed light into the film through its surface.

The method is illustrated above. A prism is held close (within a wavelength) to the semiconductor. A laser beam through the prism refracts downward and strikes the base of the prism at some angle. The phase velocity of the light now has two components: one perpendicular to the film, one parallel to it. At the proper angle, the parallel component equals the phase velocity of light in the semiconductor and light energy is coupled into the film. (If a similar prism, facing the opposite way, is placed against the film in the path of the light beam, the light will be coupled back out of the film.)

In an experiment with red helium-neon laser light (6328-A wavelength), Tien has coupled 50% of the light's

energy, in a single mode, into sputtered zinc-oxide or zinc-sulfide films on a glass substrate. From theoretical calculations, 80% should be possible.

By choice of angle at which the light beam strikes the "coupling face" of the prism, Tien can excite any of eight discrete propagation modes in the semiconductor film. Each can act as a separate communications channel. The number of possible propagation modes increases with film thickness.

This discovery may someday be a key to highly miniaturized electro-optic devices for processing information.

From the Research and Development Unit of the Bell System:



**Bell Labs**



# low cost systems

\*Prices shown are 1000-lot.

## ELFIN Neon Display!

Latest 7-segment Elfin neon display and mating hi-volt BCD to 7 segment decoder-driver.

Combination Price **12.71\***  
Circle 509



MG-17

## Plug-in Display & Matrix

Segmented display operates on 5VDC and plugs into mating module with decimal input, easy mounting.

Package Price **11.58\***  
Circle 510



MTX-4000

## Plug-in Display w/BCD Input

Similar to above, except module has BCD input decoder-driver. Simply gang for multiple use.

Package Price **17.67\***  
Circle 511



DDM-702

## ELFIN with Memory or Counter

Popular single plane neon display and BCD decoder-driver with memory or decade counter. Your choice.

Combination Price **16.19\***  
Circle 512



MG-17

## Miniature Display!

Small incandescent single plane display operates from 5V source. Decimal input. Compact size: 1/2" x 1".

Combination Price **13.71\***  
Circle 513



MS-250A

## Display Has Wire Leads

Bright image, single plane display with 10" leads and BCD input decoder-driver.

Combination Price **13.94\***  
Circle 514



MSDD-702

Immediate Deliveries on Above Items

# ALCO

ELECTRONIC PRODUCTS, INC.  
Lawrence, Massachusetts 01843

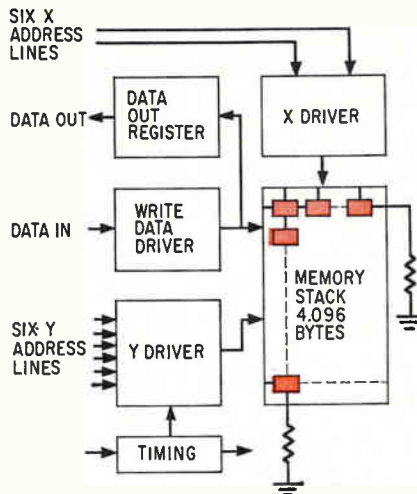

Memory system. Chip in one of 64 memories contains 256 bits plus decoding, driving, and sensing circuits. Memory contains 128 chips.

memory medium for some years, believing they could be produced for large units at exceptionally low costs. However, one observer says, the company couldn't meet its production cost objective without investing considerable time and development money, a risk Burroughs wasn't willing to take at the time. Still another change from the

original plan was a cutback of the 25-megahertz clock rate to about 20 Mhz; this rate may shrink even further. Nearly all the instructions in the processors' repertoire can be executed at the 20-Mhz rate, but three or four of the more complex ones tend to bog down if pushed much beyond 16 or 17 Mhz. Burroughs engineers hope to make some small design changes that will permit all instructions to run at, or very close to 20 Mhz; these instructions dictate the speed of the entire processor.

Slotnick also would like to see the clock rate pushed up as far as possible, but doesn't intend to let it hold up the project. "It would involve trading nanoseconds for weeks," he says, "and we've lost enough weeks already"—about 100 from the original schedule, which called for completion of the computer in late 1968 [*Electronics*, April 4, 1966, p. 36].

The cutback in speed is in addition to the reduction last year from a 256-processor system, made necessary by spiraling costs. The speed cut was required partly because of TI's discontinuance of MSI work and partly, according

## Rapping with Illiac

In addition to hardware problems the Illiac 4 project has been experiencing some difficulty with software. For example, says ARPA's Roberts, significant language changes have been made. The original compiler design was too inefficient; another, somewhat less sophisticated compiler works reasonably well, but requires the programmer to have a more detailed knowledge of the system's characteristics than did the original compiler.

Many users want Fortran, mainly because they're accustomed to it. Fortran, of course, is not well suited to a machine like the Illiac 4 because it would be impossible to obtain the full benefit of the Illiac 4's parallel processing capability. But some investigators are working on an extension of the language that utilizes more of Illiac 4's computing power.

Time-sharing with Illiac 4 over ARPA's national network will be rather unusual. Many users who have problems suited to the Illiac and who have access to the network will want to take advantage of both, because they will get results much faster. The Illiac's operating system is being designed to handle this kind of operation; but like other time-shared computers it will swap portions of the programs and data between the memories of the 64 processors and the Illiac 4's magnetic-disk bulk storage.

The Illiac 4 will swap at a faster rate than a conventional computer, but not as much faster as its computational rate. Therefore the Illiac will run more efficiently if it works on one program for a longer time interval between swaps than would a conventional machine. This "slot" of machine time is likely to be measured in seconds rather than in milliseconds; the algorithm that defines it hasn't yet been firmly established, although its general characteristics are known.

to a Burroughs spokesman, because of "complications in the control unit for the quadrant." TI's dropout forced Burroughs to resort to conventional "discrete" IC's—which it is still buying from TI. The circuits are custom-designed emitter-coupled logic units in dual-in-line packages. These smaller packages and longer interconnections present different impedances from those of the MSI circuits that result in driving problems at higher frequencies.

**Setback.** TI's dropout—easily the project's most damaging technical setback—was twofold. According to the original contract, Burroughs was to design the logic for the processing element and send the design to TI, which would incorporate it into integrated circuits and build the processing elements. These would then be shipped back to Burroughs, which would assemble the elements into the processing units and the units into quadrants, together with Burroughs-designed and -built control units.

But when TI discontinued its work on MSI, Burroughs took over the actual building of the elements.

The speed cutback means that the completed system won't be capable of the billion instructions per second originally planned. This is what a typical instruction mix in a four-quadrant system would have achieved at the originally specified clock frequency. But with a slower clock rate in a single quadrant, the pace will be more like 200 million instructions per second—still adequate to demonstrate Slotnick's objectives, and still substantially faster than the 1-to-10 million-per-second rate in machines like Control Data's 7600 or IBM's System 360, model 195.

This 200-million rate may yet edge higher. Although cost considerations dictated last year's cutback from four quadrants to one, enough interest has been generated in the capabilities of a system like Illiac 4's that a second quadrant may yet materialize at some time in the future. Any such a move would be financed by new classes of users—biologists, psychologists, lawyers, and others.

One bright spot appears in revised cost estimates that recently have been made available. While original cost figures rose so sharply

that the project was cut back from four quadrants to one, these figures included one-time-only design and development costs. Furthermore, Burroughs says costs now have been reasonably stabilized, so an additional quadrant would probably cost \$5 million or so, not the \$20 million being spent for one.

**Housekeeping.** For the additional users and because space in the university's digital computer laboratory is limited, Illiac 4 is presently scheduled to be installed in a new building now under construction on the campus. The building will house the Center for Advanced Computation, a new administrative subdivision of the university's graduate college.

But in spite of the new building, it's remotely possible that the Illiac 4 may instead be assembled somewhere off campus—to protect it from possible damage during student uprisings. It's felt that the students assume that, because the Department of Defense is paying for the new computer, its principal applications will be military. In fact, the main connection between the Illiac 4 and military applications is the fact that military agencies are just as interested as anybody else in long-range weather forecasts and in complex linear programming problems. If the computer is relocated, however, the new CAC building will be devoted to facilities for a variety of other computer-oriented projects.

Nobody's been named yet to be director of the new center. But it's hard to imagine anybody but Dan Slotnick in that position. Slotnick, according to those who know him, is the very picture of perseverance. Years ago he tried to get IBM to build a large parallel processor; later, he persuaded Westinghouse Electric Co. to start the project. Westinghouse is said to have landed a firm order for the machine from the Lawrence Radiation Laboratories, but corporate management was reluctant to make a commitment beyond a few experimental versions far smaller than the full-size system. Then, once Slotnick got going at Illinois, he was injured in an airplane accident and was out of action for nearly a year. But he bounced back to pull the project even out of the MSI tailspin.



LABORATOIRES de  
MARCOUSSIS

## NANOSECOND TIME INTERVAL METER MODEL CC20

RANGE : 1 nsec. to 999 msec.  
1 nanosecond RESOLUTION  
Crystal aging rate : 1 part in 10<sup>9</sup>/day  
Internal NIRAAP logic

centre de recherches de la compagnie générale d'électricité  
91 - MARCOUSSIS (FRANCE) — Tél. 920.82.50 — Telex : 26 877 LABMARCO



2B Paris 131





There's not a single solitary reason  
why he should have to wait  
for a computer.

He needs UCC's Computer Utility.

Our large-scale computers can provide you with another *first shift* to end your engineers' wait time. Through the UCC Computer Utility Network we can focus massive computing power on your computing problems anywhere in the United States. Problems in, solutions back in seconds. You plug into the Utility Network through your own terminal, a UCC COPE, or other compatible system.

There is another segment of the Computer Utility Network you may want to investigate. That is the marrying of your in-house computing capability with the Utility Network through our facility management service. This includes network-compatible hardware and software systems,

software maintenance and enhancement, computer engineering, operators and supervision. With this system, you will have the UCC Utility Network available for peak loads and back-up. Don't wait for a computer — call or write your nearest UCC Center today.

the total service **Computer Utility** company



**UNIVERSITY COMPUTING COMPANY**

1949 North Stemmons Freeway, Dallas, Texas 75207

Computer Utility Centers in: Boston, Chicago, Dallas, Denver, East Brunswick, N.J., Houston, Kansas City, Los Angeles, New Orleans, New York, Palo Alto and Tulsa.

Circle 128 on reader service card



# Digital cassettes overcome their past

No longer just converted audio units, new high-performance digital cassette and cartridge recorders promise to snare large chunk of small-systems market

By Marilyn Howey

Electronics' staff

**Digital cassette** tape recorders only a few years ago were no more than converted audio machines that suffered from tape skew and jitter, poor frequency response, low mechanical tolerances, and—worst of all—data dropout. But the picture has changed dramatically. A new generation of precision digital cassettes and cartridges designed to meet rigid specifications is making an increasingly deeper dent in the minicomputer and other small systems markets. Estimates for sales volume of digital cassettes and cartridges by 1975 start at \$150 million and reach \$500 million. Ampex estimates the 1970 market at between \$6 million and \$8 million.

As the market grows, some of the giants in the magnetic tape field can be expected to join small companies already making cassette and cartridge recorders. Ampex, National Cash Register, Honeywell, and Bunker-Ramo are among those already in.

Meanwhile, industry marketing managers predict a wide variety of applications, the foremost being a replacement for paper tape. Len Gilmore, marketing director of Mobark Instruments, reports his company has a cassette unit that plugs into the back of a teletypewriter, providing three to five times the output speed of paper tape at about the same cost. Other uses frequently mentioned are as interfaces with IBM electric typewriters, reel-to-reel tape, and IC testers. Prices for cartridge and cassette units range from \$600 to \$2,900, and their variety offers the user an almost bewildering array of choices.

But the market's newness holds

back equipment standardization; manufacturers still debate the relative merits of cassettes—the original Philips-Norelco packages—and cartridges, which come in various sizes. However, there's a decided trend toward the Philips-Norelco cassette package and toward inter-machine compatibility, according to Robert H. Lander of the Data Packaging Corp., which makes both cassettes and cartridges.

**Double.** Lander would get an argument from Tri-Data, which now has over 50 customers for its CartriFile systems, a double cartridge unit. The model 4096 is a modularly constructed total tape system—with one cartridge atop the others. The system sells for \$5,700. Tri-Data which manufactures all parts in-house, attributes unit reliability to the cartridge's design. Sales engineer Don Bailey says: "We worked to design as many moving and wearing parts into the cartridge as possible, because the cartridge is easier to repair than the machine itself." The Tri-Data cartridge contains two endless-loop tapes, ¼-inch wide and 150 feet long, and carries a warranty of 200 tape-hours in motion.

The 4096 employs a continuous drive with a tape speed of 10 inches per second. Bit-serial, phase-encoded recording is done simultaneously on two tracks; this redundancy allows for error detection, and up to three bits in a row can be corrected.

Cybercom is another company that shares Tri-Data's faith in a non-Philips compatible system. Cybercom's system, the Mark 1 key encoder, uses a cassette almost

twice as large as the Philips unit. Designed to replace punched cards, the system includes a key-to-tape unit for \$8,300, and a converter for \$11,500. The converter accepts the cassettes as input and produces IBM-compatible, ½-inch computer tape as the output. Howard Peter, Cybercom's marketing manager, says that some users have reported increases of about 50% in data throughput with the Mark 1.

Nevertheless, most companies pin their hope on Philips-compatible units, and have come up with several ingenious ways to improve performance and reliability. The six-month-old Mobark Instruments Corp. in Sunnyvale, Calif., has introduced a series of standard-equipment cassette transports, ranging in price from \$950 to \$1,800. The Mobark equipment has a patented optical tachometer disk developed by company president Mogazi Barkoukie. Strobed light pulses passing through 10 slots in each 90° arc of the disk produce a precise incremental tape motion. The same control method is used in Mobark's model 200 for continuous recording and reproducing.

**Modular.** Mobark's equipment features modular construction. Tape transport, logic cards, power supply, or case may be purchased individually. All systems use the Philips cassette. Maximum tape speed on any unit is 15 ips; average fast forward/rewind time is 35 seconds. Options available include choice of phase-encoded or NRZ data format; parallel or serial recording (all in eight-bit blocks up to 32 bits); beginning-of-tape and end-of-tape optical sensors; and

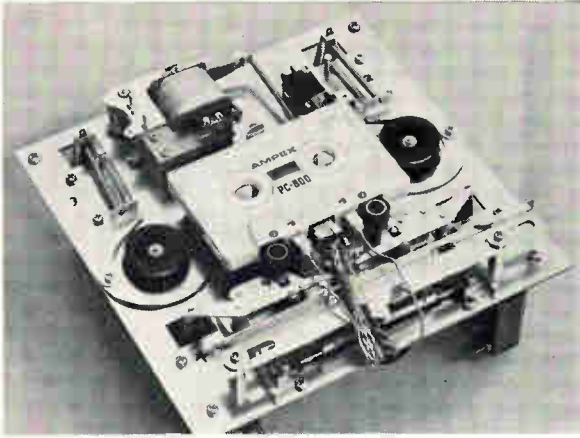

#### Computer class.

Ampex's model TMC is precision-engineered to meet computer standards for high reliability and low error rate. The cassette recorder has a cast-metal base plate, tape guides on each side of its read/write heads, and ball bearings throughout. To ease maintenance, electronics are modular.

read-after-write error detection, whereby the machine automatically stops if data isn't recorded. An optional back-space capability lets the operator manually or remotely go back one character at a time through the entire length of the cassette. Back spacing automatically erases recorded data.

Gilmore of Mobark thinks that the biggest market for the company's systems will be in the replacement of paper tape. But the company has many other applications in mind for the future, including interface with IBM typewriters,

and use in crt and keyboard terminals. All models are built with transistor-transistor and diode-transistor logic, and Gilmore says, "We can hit all applications with our present standard equipment, so this year we're perfecting synchronous and incremental transports."

Another approach to reliability is used by Barkoukie's former employer, the Ampex Corp. Ampex recently announced a heavy-duty model TMC cassette transport [*Electronics*, April 27, p. 132] which was developed after an extensive

market survey. Ampex's first digital cassette tape drive, it has a cast-metal baseplate and a total of 22 ball bearings on moving surfaces for increased stability and durability. Precise head-to-tape contact is achieved through double tape guides on both sides of the head.

The TMC writes in the NRZI format. It has two-track complementary recording, which is fast becoming an industry standard. When a bit is recorded on one track, the bit's complement is simultaneously recorded on the second track. Because of the coding format, information combined from the two tracks causes a polarity change for each bit recorded. The system thus has an inherent clock based on the square-wave output of the polarity changes. In the TMC, any gap in this output generates a signal to indicate an error. Most other companies employ similar two-track redundancy for error detection in their models. Ampex claims a maximum error rate of 1 in  $10^6$  bits and estimates an average error rate of 1 in  $10^8$  bits.

**Stress stability.** Another company, Compucord of Waltham, Mass., stresses mechanical stability

### Which cassette?

Presently, about five companies make Philips-type cassettes specifically for digital applications, and an enormous number make audio cassettes. Ampex recently introduced its PC-800 digital cassette, which employs the same basic design rules that the company uses in its tape transports. The side pieces are molded from a plastic that is temperature stable and can be held to a fairly close tolerance, thus providing a precise reference plane from which to build the rest of the cassette. Other major changes are ball-bearing hubs that keep the tape in the center of the cassette, and a four-point tape guide that isolates changes in the pack from the head area.

The company uses computer-grade tape that is certified for dropouts as it is being loaded into the cassette. Completed units are then "statistically checked". In one unusual modification Ampex molded two slots (one on each side) into the case. These slots expose the tape or leader to photo-transistors in Ampex's TMC transport. Ampex says that most transports have end-of-tape detection on the front of the cassette, where such detection really can't help much, and the tape runs out in the middle of a data field.

One company that believes in a rigid cassette is the Auricord division of the Scovill Mfg. Co. The difference is that Auricord's cassette is metal. Leonard Rosenblatt, General manager of Auricord, says that the tolerances in plastic cassettes vary a great deal because of the heat shrinking during molding.

Robert Lander, director of finance at Data Packaging, Inc., says that two major problems are vibration and tape tension. The first problem was solved in its digital cassette through tight tolerance design which minimized movement of internal parts. The second was handled through attention to internal roller design, tape-wrap angles, and pressure-pad design.

Information Terminal Inc., is also betting on close tolerance plastic units with a plus—the tape is checked for dropouts as it is loaded into the cassette, and every cassette is checked again for dropouts after assembly.

K/Tronic Inc., formed about a year ago to manufacture digital cassettes, uses the standard Philips package inside and out. However, K/Tronic buys parts made to its specs and does the assembling and certifying itself. Jack Buchanan, president, says "The Philips specs are very general and not 100% checked. Philips talks a good game on enforcement, but if you look at the audio market, you'll know that they don't. K/Tronic's tape and plastic parts are 100% tested." He adds that because of this testing, mechanical tolerances are much higher than with audio units.

In regard to its competitors' claims that the cassettes should be special plastic or even metal, Buchanan says "We have to consider the cost of the consumable item. One reason that this media was selected was because it's inexpensive". But although price is very important, Buchanan admits that part of the problem is psychological. "We fall into thinking that plastics don't have precision. But they can have very high tolerances."



**SPUTTERING  
TARGETS**

**GLAZED  
PARTS**

# Get higher yields across the board

**THICK  
FILM  
PASTES**

**O-I microelectronic materials make the difference.**

Higher yields. That's where the little things mean a lot.

Like with package sealants. If you could get 5 more good seals on every 100 packages you make, think of the money you'd save.

Like with thick film conductor pastes. Good paste can make a circuit. Bad paste can break it. Forever.

Like with substrate glazes, insulating films, glazed package parts, preform materials and sputtering targets.

We make them all. And more. They're all compatible, highly sophisticated products from the O-I family of work-together electronic materials.

To you, they mean higher yields. Across the board. We'd like to prove it to you. Write us a letter about your materials needs. We'll get back to you fast with literature. Samples, too, if you'd like.

You'll see. Our materials *do* make the difference.

**OWENS-ILLINOIS**  
ELECTRONIC MATERIALS  
Toledo, Ohio 43601

**PACKAGE  
SEALANTS**

**INSULATING  
FILMS**

**PREFORM  
MATERIALS**

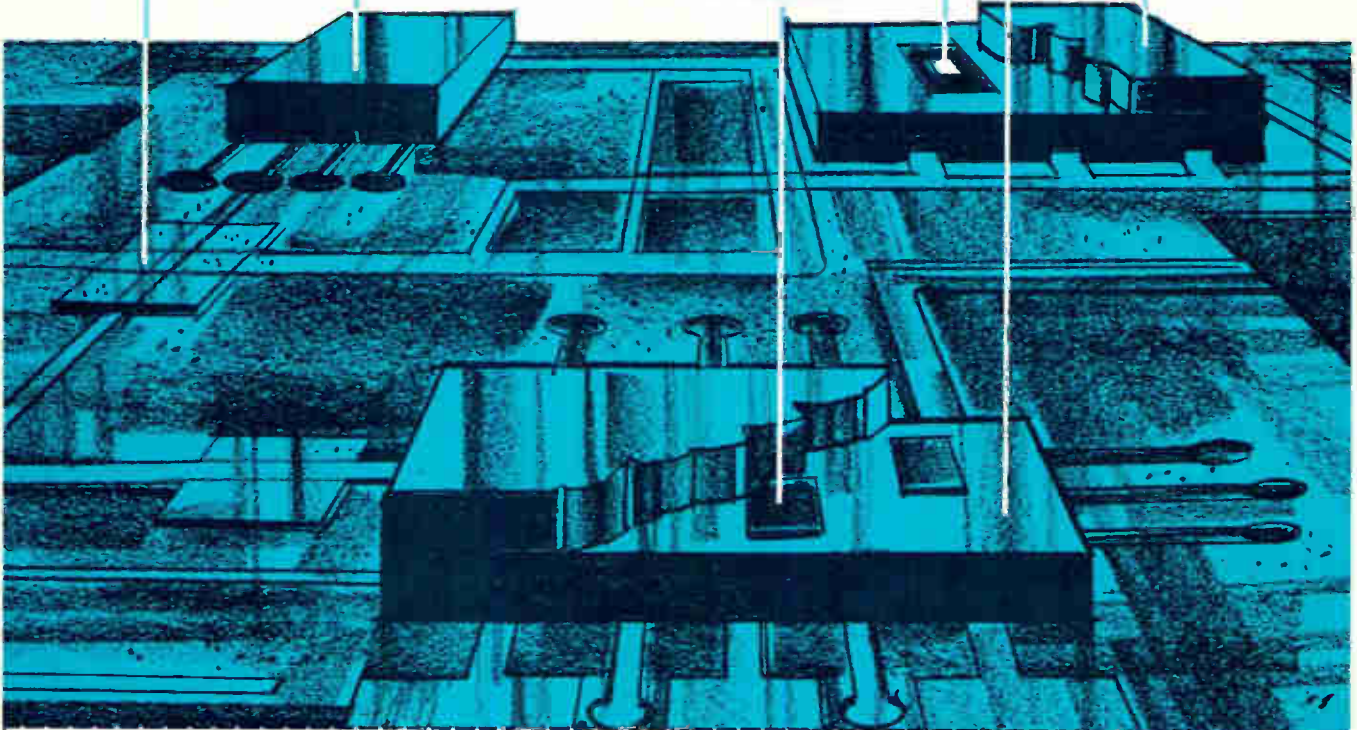

OWENS-ILLINOIS, INC.  
Customer Service Mgr.  
Electronic Materials  
Dept. T-6  
Box 1035  
Toledo, Ohio 43601

Please send me literature on:

- Package Sealants
- Substrate Glazes
- Sputtering Targets
- Have a technical representative call.
- Glazed Package Parts
- Thick Film Pastes
- Preform Materials

Name \_\_\_\_\_  
 Title \_\_\_\_\_  
 Company \_\_\_\_\_  
 Address \_\_\_\_\_  
 City \_\_\_\_\_ State \_\_\_\_\_ Zip \_\_\_\_\_



# If you can't stand the heat ...

stay out of the kitchen!



Here are components that stand the heat ... and the cold ( $-55^{\circ}\text{C}$  to  $+125^{\circ}\text{C}$ ) without voltage de-rating. The dissipation curve is as flat as a pancake ... and the other specs are out of this world. Maybe your recipe calls for

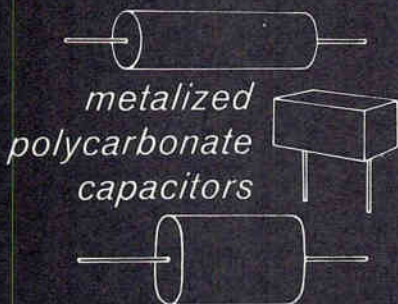

Try Standard's PC2-E (Rectangular Epoxy) and PC2-W (Wrap and Fill).

Send for Catalog and complete details.



**CONDENSER CORPORATION**

Dept. E-6

1065 West Addison Street  
Chicago, Illinois 60613 • (312) 327-5440

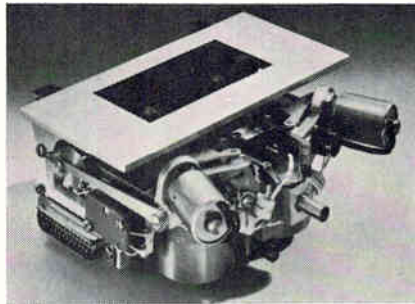

Initial entry. Raymond Engineering's first cassette-type recorder has hysteresis synchronous motors and two capstans. Solenoids control pinch rollers.

in its units, the 1100 cassette deck and the 1200 and 1400 cassette recorders. Robert Crawford, president, says, "Apparently many have just been waiting for a deck with good mechanical specs. We're finding the market much broader than we had figured."

Since introducing its 1100 deck, which uses a hysteresis synchronous capstan motor, Compucord has tightened up on its specs even further. Crawford reports, "We found that a tight hold of the cassette itself was more important than indicated earlier. And we also found the accuracy of pinch-roller pressure had a large effect on instantaneous speed accuracy. We now get accuracy of  $\pm 0.25\%$ ."

The units are NRZI coded with two-track redundancy recording, and detect errors using a parity check that's run before the final output. Error rate is estimated at between 1 bit in  $10^8$  to 1 bit in  $10^9$ . Price for the complete system, the Computette 1500, including electronics, is \$1,500 to \$1,800. The deck alone cost \$300.

As the market develops, more companies are moving in. The Raymond Engineering Co. in Middletown, Conn., which has been making digital tape recorders for the aerospace industry for 10 years, is branching out into the commercial field and expects to have its model 6406-01 ready for market in a month. Raymond also emphasizes precision tape control. Its bidirectional transport has two capstans and is driven by hysteresis synchronous motors, similar to Compucord's 1100. Solenoids control the pinch rollers, and dynamic braking provides fast, smooth start-and-stop action. Tape tension is

further enhanced by two d-c torque motors around a Philips cassette.

The unit has phase-encoded, two-track redundant recording and is TTL/DTL compatible. A read amplifier combines data from the two tracks, and a signal detector indicates error and allows for recovery of data. Like many present systems, the Raymond recorder is modularly constructed; it carries a price tag of \$650 in quantities of 1,000.

Another of the West Coast companies, Data Instruments in Sepulveda, Calif., has two special cassette-based products. One is an offline electric typewriter-cassette recorder terminal. The other is a changer-reader that moves from one tape to the next in 10 seconds, and aids the transfer of data from cassette-using terminals to large computers. Designed primarily for data storage, the recorder terminal offers tape speeds ranging from 2 to 20 ips, and a dropout rate of 1 in  $10^6$  bits. The recorder uses standard audio cassettes that have a hard oxide coating on the tape.

There are two channels of recorded data, and error detection is handled with a read-after-write parity check, as opposed to two-track redundancy. Recording is done in the NRZ format and powered by a stepping drive. Company spokesman James K. Meador states that the combined typewriter-cassette system has an average 10-year life span.

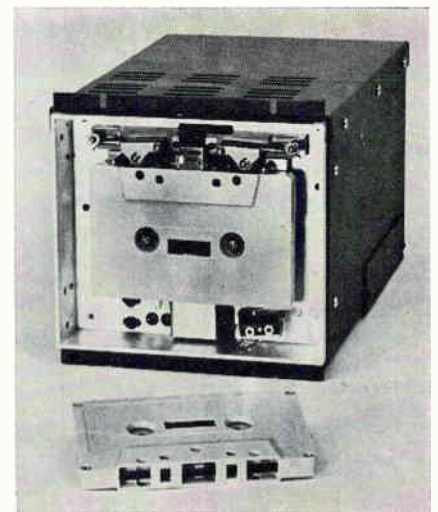

Precision. Strobed light pulses passing through 10 slots in Mobark Instruments Corp. unit are responsible for precise incremental tape motion.

# We can't afford to be complacent.

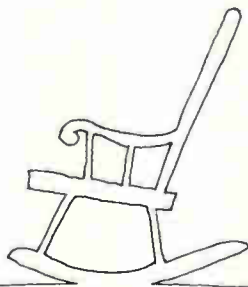

Seven years ago we shook the relay world with the birth of the TO-5 (SPDT) relay. It was quite a breakthrough in the state of the art. Your demands for other configurations in the TO-5 transistor can led to the introduction of magnetic latching and sensitive relays. In 1966, we performed another relay miracle by combining a transistor and a relay in the same TO-5 can. Would wonders never cease? We did it again in 1969 with what we fondly call our "Solid Citizen;" a series of solid state relays for industrial and military applications.

Our competition has increased, we know this, and further

we welcome it; after all, isn't imitation the sincerest form of flattery? We know that as long as there are unsolved switching problems we can't afford to sit on our little cans and watch the world go by. We have other wonders up our sleeves and will let the world know when we're ready.

No, sir, no easy chairs for us. We like it this way. We invite you to write or call and ask for any technical assistance regarding our growing family of little switching devices.

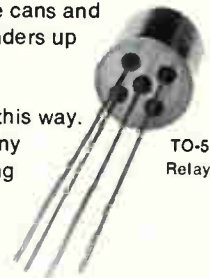

TO-5 Relay



**TELEDYNE RELAYS**

3155 West El Segundo Boulevard, Hawthorne, California 90250 / Telephone (213) 679-2205



# DATA TRANSMISSION



TOTAL ELECTRONIC  
SYSTEMS CAPABILITY.  
SPECIALISTS IN  
TIME/FREQUENCY,  
RADAR AND  
DATA SYSTEMS  
OFFERING RAPID  
GROWTH.



RESEARCH CORPORATION  
an equal opportunity employer

P.O. BOX 222, BUFFALO, N.Y. 14225



Monitor. Battery-operated Dytro Corp. unit accepts multichannel analog inputs; output is in a computer-compatible digital cassette.

**Built for oil.** Although catering largely to the original equipment maker custom market, the Dytro Corp of Hicksville, N.Y. has two standard products: the Portalog series 600 data logger, and a new cassette tape checker, the TC-1000 (see page 155). The data logger originally was built for a company that wanted to take readings on oil being sucked out of the ground; the logger principally monitors control measurements, sensors, and the like. The battery operable unit is timed with a tuning fork, and Dytro claims 0.1% accuracy. The logger accepts multichannel analog inputs, and output is in a computer-compatible cassette; Telex compatibility is optional. A three-digit a-d converter and pre-settable six-digit header allow for precision-timed sampling. Two analog input channels are sampled 40 times a second per channel for periods of 5, 10, or 20 seconds.

Dytro's most recent product is a \$1,200 cassette tape checker, the TC-1000. Designed initially for in-house use, the company has now marketed this stand-alone unit in two versions. One features an immediate read-after-write check; the second writes, is rewound, and then reads the tape. With its ability to count data errors on each track of cassette tape, the TC-1000 should prove a valuable tool for potential buyers of cassette transport systems.

Those users interested in a fast rewind might consider the Compu/Corder from the Sykes Corp. The system has a read/write speed of 5 ips and employs a biphase-encoded recording format. Packing density is 1,000 bits per inch, and the data transfer rate is 500 char-

acters per second. The recorder stores up to 3.6 million bits in the direct access mode, and 7.2 million bits in the two track mode. And the Compu/Corder rewinds at 120 inches per second.

In the standard line, the system interfaces with the PDP 8, 8L, 8S, and 12, the Varian 6201, and Data General's Nova. Single unit price for the entire system is \$2950. Interface with other systems is available at extra cost. Sykes supplies its own cassettes and offers three separate software packages with the unit:

- ▶ Basic, which is a set of read/write subroutines that allow the user to process data in traditional sequential form.
- ▶ Debar, direct access read/write subroutines;
- ▶ Ucheck, which lets the user check the system.

Another machine intended for storage use is a manually operated cassette recorder marketed by Computer Displays in Waltham, Mass. The DCR-1 is sold in tandem with CD's ARDS-100A crt console; the recorder is not yet offered as a separate unit. The company claims that it is using "the only really good deck" coming out of Japan, but won't name the supplier; the deck's electronics are modified for the system.

The company emphasize the machine's dropout performance of less than 1 in  $10^6$  bits. There is no redundancy during recording; measurement of error rate is done with a cross-correlation technique and endless loops of tape with specific numbers of errors planted in the bit stream. Sales of the DCR-1 at \$850 have been limited to fewer than 50 units, largely due to the company's insistence that it be sold in conjunction with the console.

Other companies also are producing custom-made and specialized equipment, and spokesmen in the industry envision applications extending beyond present capabilities. Crawford of Compucord reports that the Teletype Corp. wants deck makers to come up with an alternative or adjunct to paper tape for its ASR-33. He foresees other unexpected applications, including a hand-held deck to take user data from a special water meter and a deck inserted in the back of a tv set to record viewer preferences. ●



# NEW AUTO-POLARITY FET V-O-M SPEEDS TESTING

You've probably imagined the convenience and time-saving you'd enjoy if you could just clip one of the V-O-M leads to ground or to the chassis, and have your meter always read upscale regardless of the polarity of any other terminal you touched.

No need to imagine it any more . . . you can see it and try it right now at your Triplet distributor. Called the Triplet Model 602, it's probably the most convenient V-O-M ever built. Its convenience goes well beyond the auto-polarity feature, though . . . to AC and DC measurements from 10 mV to 1000 V in 8 ranges at 11 megohms DC and 10 megohms AC input resistance . . . AC and DC from 0.02 to 1000 mA in 4 ranges . . . resistances from 0.2 ohms to 1000 megohms in 6 ranges. And with an accuracy of 3% on voltage measurements, and a rugged suspension-type meter movement, the Model 602 has what it takes to make your job easier.

This great new V-O-M is only **\$100** suggested USA user net. For more information, or for a free, no-obligation demonstration, call your local Triplet distributor or your Triplet sales representative. Triplet Corporation, Bluffton, Ohio 45817.



*The World's most complete line of V-O-M's . . . choose the one that's just right for you.*

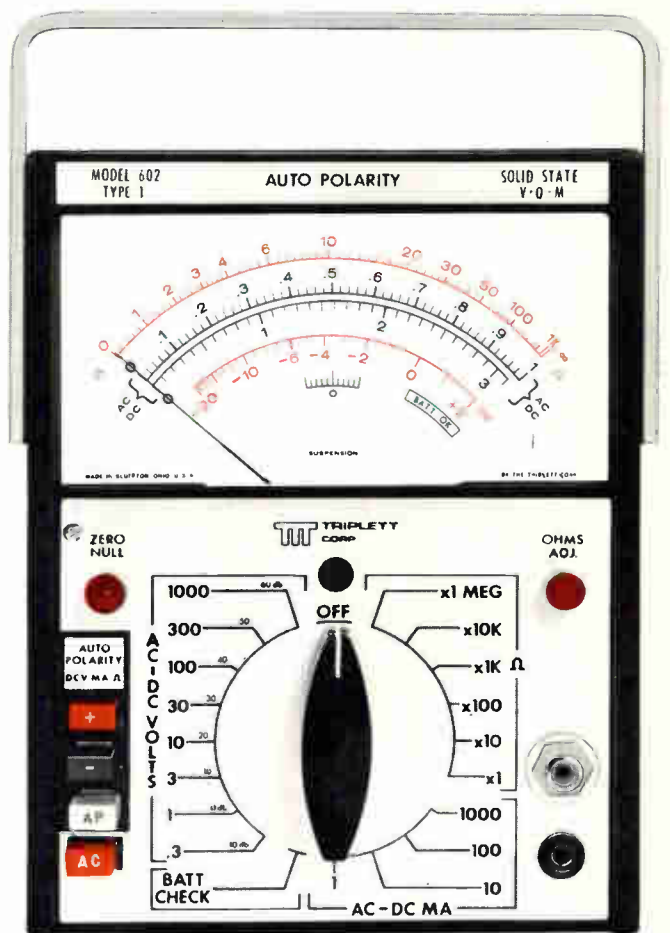

1. Auto Polarity . . . convenient and time-saving; creates memory and suppressed scale.
2. High sensitivity (.3V AC and DC) at constant 11 megohms input resistance.
3. Simplified scale with only 2 arcs for 24 AC/DC ranges.

# cure your logic testing headaches

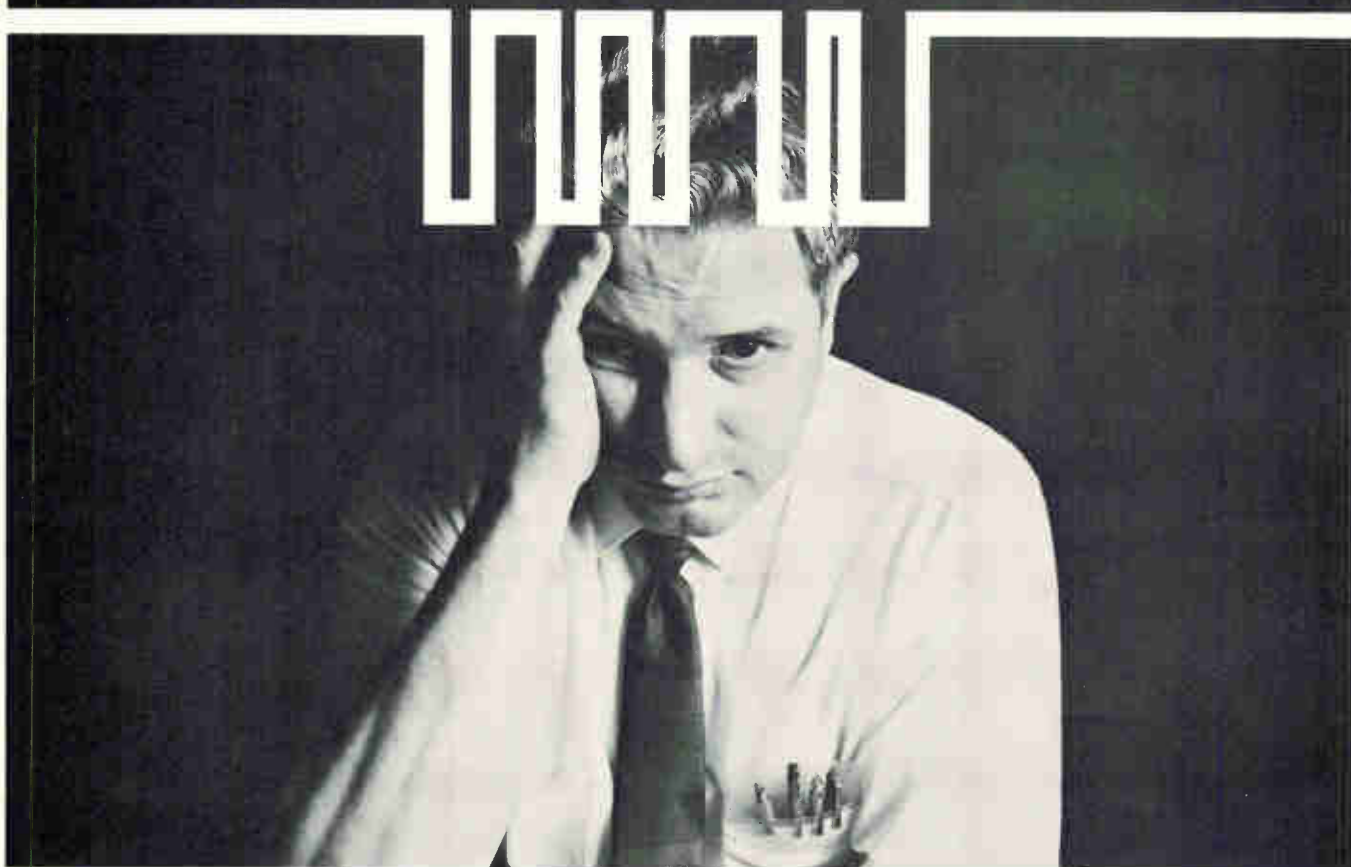

Mellonics offers new automated diagnostic tools for detecting functional logic faults in sequential digital circuits. These computer programs have already cured test headaches in dozens of circuits, some with more than 400 logic elements.

Specifically, we have programs for: **Logic Simulation** which certifies design correctness; **Test Sequence Validation** which verifies that all potential func-

tional faults in a logic design will be detected by your test procedure; **Automatic Test Sequence Generation** which produces a test procedure assuring that all testable functional faults in a logic design will be detected.

These services are economical and easy to use with guaranteed full data security. For more information contact Test Systems Marketing.

MELLONICS SYSTEMS DEVELOPMENT DIVISION  
LITTON INDUSTRIES  
1001 WEST MAUDE AVE., SUNNYVALE, CALIFORNIA 94086 (408) 245-0795



# Photo-quality crt displays find new jobs

Better grayscale capability, sharper resolution, faster read-write cycles and lower prices widen applications in medicine, computers, aerospace

By George Weiss

*Electronics' staff*

**High-grayscale** crt displays are producing sharp-resolution images of almost photographic quality. This and other advances are opening up new applications in X-ray transmission, computer output in microfilm, image enhancement, flight simulation and checkout, satellite picture transmission, viewing of microscope slides, and quality-control inspection.

In addition to the improved display quality and speed, crt terminals are also offering new capabilities which increase display versatility. At the same time prices are dropping—on some displays prices already have fallen within the budgets of schools, hospitals, and laboratories.

Princeton Electronic Products Inc. is offering a unit which it calls the lowest-price storage tube display system on the market. The PEP 400 terminal plus an 800- or 1,200-line Lithocon storage tube sells for \$3,750 and \$4,250 respectively. The tube can display 10 shades of gray which can be retained for 15 minutes during readout. It has an electronic zoom similar to movie cameras, making it useful for close-up viewing.

Dicomed Corp. is emphasizing high-density photographic quality. Its displays—the Dicomed 30, 31, and 36—generate 64 shades of gray. Prices vary from \$15,000 to \$24,500—off the shelf. Also offered is the Dicomed 55 image digitizer at \$29,500. Uses for the terminal are in X-ray analysis and viewing pictures sent back by satellite.

Sanders Associates and Data Disc Corp. are producing grayscale by a refresh technique instead of a storage-tube approach.

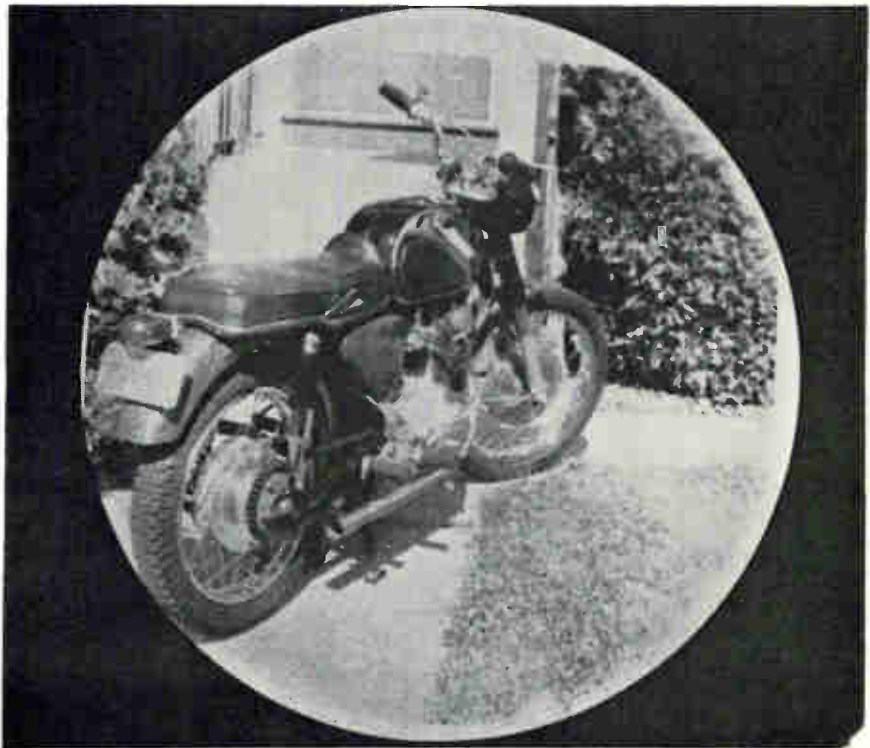

**Off the tube.** The picture was taken directly from a cathode-ray tube that is capable of displaying 64 different shades of gray.

For those who want hard copy in grayscale, Dresser Systems is marketing a device using a different technique—a lasergraphic plotter which displays 16 shades of gray from a developed roll of film 40 inches wide.

Until now, the storage tube has been used in a limited number of applications because of its inherently slow speed and poor resolution. Most storage tubes use a wire mesh as the target structure, upon which a dielectric salt is evaporated. But the finer the mesh, the more difficult it is to deposit the dielectric without closing up the holes. This severely limits resolu-

tion and the mesh structure demands very high beam currents, another degrading factor.

Princeton Electronic Products' new storage tube uses silicon as the target structure. The choice was logical—the semiconductor industry already has proven that silicon can be used for the highest-resolution photoetching. The result is the Lithocon storage tube which, PEP says, packs in more lines per square inch than any previous tube. In fact, resolution is so fine that a 1-inch-diameter tube (7¼ in. long) can resolve 1,200 television lines within the target structure.

Added to higher resolution are



# The big difference between chip capacitors and our 505 series

## they're trimmable

Our new 505 series is compatible with chip bonding techniques for microcircuit and strip line applications . . . and they're trimmable in ranges from .1 to 100 pF!

But trimmability is only one of the plus advantages of this new series, they feature high Q (self-resonant into X band),  $\Delta C$ 's of 1 to 15 pF, and low temperature coefficients ( $0 \pm 20 \text{PPM}/^\circ\text{C}$ ).

When your application calls for high Q chips, be sure to check the 505 series, they do everything a chip does — plus. Send today for full details.



*Johanson*

MANUFACTURING CORPORATION

400 Rockaway Valley Road, Boonton, N.J. 07005  
(201) 334-2676 TELEX: 13-6432

Electronic Accuracy Through Mechanical Precision

faster read and write times. "Whereas most tubes operate in the range of one to three kilovolts," says Wilbur Herbener, PEP's vice president, "ours operates nominally at 250 volts, giving us much faster writing cycles."

The Lithocon reads and writes 30 frames per second, about 4 microseconds per line. Erasure times are about 8 to 10  $\mu\text{sec}$  per line.

The Lithocon is one of the first storage tubes to display a gray-scale. The analog input signal can be broken down into 10 shades of gray, which can be stored for 15 minutes before initial fade sets in. With the reading beam off, images can be stored for weeks.

Writing and erasing selected areas or points on the crt's screen was the exclusive domain of raster-scan refresh systems, which made these devices most attractive to users of time-shared interactive graphic terminals. However, both PEP and Dicomed now include these features in their storage scopes. This makes a significant contribution to the flexibility of their terminals.

Herbener points out that it's fairly difficult to switch a couple of kilovolts around the target quickly, but in the Lithocon a maximum of only 200 volts is switched over a 1-inch-diameter area. "We can write an alphanumeric character or vector anywhere on the screen and then erase it, giving us the same capability as other crt terminals," adds Herbener. "Combine this with the crt's built-in video capability and you get a storage scope that can overlay characters and vectors on top of video images."

**Light to dark.** Dicomed uses a totally different storage-tube concept. About a year and a half ago, Dicomed bought from Thomas Electronics a dark-trace storage tube in which potassium chloride is the target material. The molecules darken to a selected shade of gray when struck by an electron beam. The extremely fine grain structure of the KCl molecules allows very high resolution. The Dicomed 30 resolves 1,024 by 1,024 addressable points over an 8-inch viewing area. And, says Wayne Huelskoetter, the firm's vice president, it's easy to double the resolution—the new

Dicomed 36 will offer a resolution of 2,048 points over a slightly larger viewing area.

The key feature of this crt terminal is its 64 shades of gray. According to Thomas, the storage tube originally was designed to display bilevel (black and white) information. However, engineers at Dicomed applied special signal-processing techniques to modulate the beam through 64 intensity levels, believed to be the most in the industry.

Because of the slow chemical activity of the KCl molecules, the image can be retained for hours following display. Images displayed on storage tubes using phosphorous material tend to degrade faster because of the continuous energy flow in the phosphor molecules.

Dicomed has built into its term-



Tight. The tube's 1-inch silicon target resolves 1,200 tv lines.

inal some special electronics that permit the beam to be moved around for selective writing and erasing. However, its write and erase times are much slower than PEP's display. One image requires 80 to 100 seconds for generation and 10 seconds for erasure.

**Refresher.** Data Disc uses a disk memory to refresh the tv monitor. A 1,000-line tv monitor displaying over 1 million bits of information (bilevel) requires 10 tracks. To produce a grayscale, the number of tracks is multiplied by the number of bits in the gray code. Thus, 16 shades of gray would take up 40 tracks on the disk for one picture.

According to Data Disc, a picture can be displayed in a couple of revolutions of the disk—either 30 or 60 milliseconds. The image then

can be erased in one revolution. And the system refreshes 30 frames per second for the standard tv.

**Satellite computer.** A costlier system than Data Disc's is the Sanders' display system—the ADDS/900.

The Sanders display can resolve 1,024 lines containing 1,024 elements that can assume any of 16 brightness levels. The problem of supplying the large amount of memory used to refresh such a system was partially solved by using a small satellite computer.

Arne Schumacher, a project engineer on the system explains, "We have two ports coming into the central processing unit, splitting the core into two sections. One section handles the refresh of the display and doesn't tie up the computer's main memory. The computer continues to do calculations during refresh, increasing the user's available computer time."

Another feature is the variable positioning time of the indicator's electron beam. Positioning time is a function of distance moved on the screen. Most other displays allow a fixed time for the beam to reach its destination. This time must necessarily be the longest it takes for the beam to move anywhere on the screen.

Thus, the deflection time for full screen on a 20-inch monitor is 10 microseconds; for half screen, 5  $\mu$ sec;  $\frac{1}{4}$  screen, 2.5  $\mu$ sec. "This amounts to a tremendous throughput saving when you consider that the average deflection on a display system is  $\frac{1}{4}$  screen," says Schumacher.

**Versatile tools.** What do all these features mean in terms of the marketplace for display terminals? As one customer put it, "Display terminals no longer are just expensive toys to play with, but have become practical tools."

In hospitals, more than 200 million X rays are taken each year, a figure that is increasing at a rate exceeding 5% each year. Often the diagnostic procedure time is limited because the radiologist must travel to and from hospitals and offices or he must wait for an X ray to be retrieved from storage.

At Dicomed, engineers have built a digitizer which converts the image on an X ray to digital information for input to a com-

## Overshadows All-

### The Pan Man

# SURVEILLANCE RECEIVING SYSTEM



Without the shadow of a doubt, the WJ-RS-160 is unique in the surveillance receiver field. Especially now with the extension of its frequency range to 1000 MHz—covering 30–1000 MHz with six plug-in tuners.

The system consists of the Type 205 Sweeping and Manual Receiver, the DRO-308 six-digit Frequency Readout with DAFC (Digital Automatic Frequency Control) and the SM-7301 five-inch Signal Display with beam intensification.

Examine these attributes for a low-cost sweeping receiver that is compact and versatile, then write, call or hurry on over:

- Receives AM, FM, pulse signals 30–1000 MHz
- High dynamic range
- Low noise
- High spurious signal rejection
- Digital readout of tuned frequency with DAFC
- Versatile for airborne, ship, mobile and fixed site applications
- Compact: only 8 $\frac{3}{4}$  inches high by 19 inches wide
- Costs a fraction of what you'd expect

World's Largest Selection of Receiving Equipment for  
Surveillance, Direction-Finding and Countermeasures

CEI DIVISION



WATKINS-JOHNSON

6006 EXECUTIVE BOULEVARD, ROCKVILLE, MARYLAND 20852 • (301) 881-3300



## Quick-connect Fuseholders and Fuseblocks

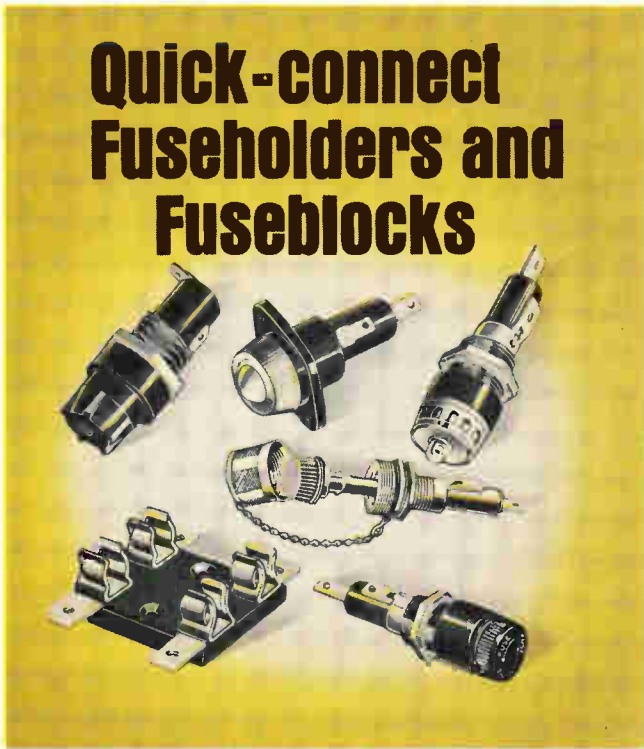

The complete line of BUSS fuseholders and fuseblocks is available with quick-connect terminals to save assembly time and cut costs.



Write for BUSS Form SFB

Bussmann Mfg. Division, McGraw-Edison Co., St. Louis, Mo. 63107

Circle 140 on reader service card

## Tron Rectifier Fuses



Available in sizes from 1/2 to 1000 amps for voltages up to 1500, TRON Rectifier Fuses are ideal for protecting variable speed drives, inverters, battery chargers, plating power supplies, power controls, and any other application where fast opening and great current limitation are required.

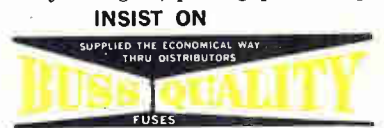

Write for BUSS Form TRFS

Bussmann Mfg. Division, McGraw-Edison Co., St. Louis, Mo. 63107

Circle 140 on reader service card

## BUSS: The Complete Line of Fuses and . . .



Every year, ELECTRONICS attracts requests for over 125,000 editorial reprints.

They're like interest payments on our million-dollars-a-year editorial principle.

That's how much we spend annually to produce timely, authentic, and useful articles like those listed on the reader service card as reprints currently available.

Investment and interest make both ELECTRONICS and its readers more meaningful to its advertisers.



puter. The X ray can then be reconstructed on the remote display terminal. Using a Dicomed display, biomedical engineers at the University of Missouri's medical center are working on ways to enhance the image of X rays so that a much greater contrast can be achieved between light and dark areas.

Dicomed's newest display terminal will have an added flexibility feature: it will be possible to display several pictures on the screen simultaneously, without first waiting for one picture to be displayed, then erasing it, and displaying the next picture.

Another area arousing interest is in microfilm storage and retrieval systems, using a digitizer and transmitting over low-cost telephone lines. Closed-circuit television is not only an expensive system, but many microfilm experts believe tv can't transmit images that are sufficiently clear.

**Zoom.** Princeton Electronic Products sees its Lithocon tube as useful in many applications because of its versatility in generating x-y images, video storage, and video scan conversion. One special fea-

ture of this storage tube is an electronic zoom. A control knob on the PEP 400 video/graphic storage terminal sets the beam's scan for any portion of the target area. This part of the target is subsequently blown up to the full size of the crt's viewing area. If the beam scans 1/4 of the target horizontally and vertically, the effect is a full-screen view of that area blown up 16 times.

A biochemist could focus a vidicon camera on a microscope slide, snap the image, and store it in the tube. Then he could view the slide on the crt and scan any part of the slide that he wishes to observe at closer range. Previously, software programs were used.

At one time, grayscale display seemed to be the exclusive province of crt terminals, because the shading was accomplished by modulating the intensity of the crt's beam, but Dresser Systems in Houston has applied a different technique: a laser digital plotter generates hard copy with 16 different intensity levels. The system LGP-2000, produces spot sizes of 10 mils or 5 mils on photographic film and plots at a rate of 38 inches per minute at

the 10-mil resolution and 9.5 inches/minute at the 5-mil resolution, across a 40-inch scanning width.

The digital information from a computer is converted to analog voltages which are subsequently used to key a laser modulator. The beam passes through an optical system including an aperture that is previously set to the desired resolution. The light is reflected onto the film by a rotating mirror and scanning system. As the mirror rotates, the angle of incidence of the laser beam changes, and the reflected beam scans across the plotting plane. As the beam traverses, the modulator keys the laser beam on and off in either black and white, or 16 shades of gray producing the photographic image.

One of the important features of the system is the accuracy of reproduced plots. If the same plot is produced on the same machine at two different times, the resultant plots, when overlaid, will register with each other to within 0.0001 inch—an essential feature in the production of integrated-circuit and printed-circuit-board masks.

## Fuseholders of Unquestioned High Quality

### FUSES

for protection of Electronic Devices



There is a complete line of BUSS Quality fuses in 1/4 x 1 inch, 1/4 x 1 1/4 inch, and miniature sizes, with standard and pigtail types available in quick-acting or dual-element slow blowing varieties.



Write for BUSS Form SFB

Bussmann Mfg. Division, McGraw-Edison Co., St. Louis, Mo. 63107

### Subminiature Fuses and Fuseholders



BUSS has the fuses and fuseholders for space-tight applications, in a wide range of ampere ratings from 1/100 to 15. Allow visual inspection of element. Tiny but tough, they're built to withstand severe environments.



Write for BUSS Form SFB

Bussmann Mfg. Division, McGraw-Edison Co., St. Louis, Mo. 63107

# The Fastest A-D Converter Company Grows Other Things



A-D Encoder Module



D-A Converter

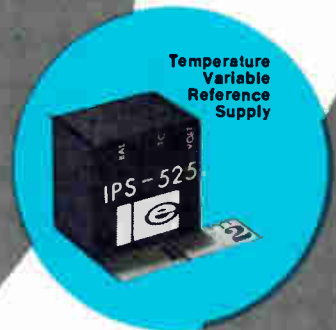

Temperature Variable Reference Supply



Sample-and-Hold Amplifier



MODEL	MAXIMUM WORD CONVERSION SPEED	RESOLUTION	APERTURE TIME	% of Full Scale Accuracy ( $\pm 1/2$ LSB) @ 25 C
<b>SERIES A</b>				
IAD-1104	80 MHz	4 bits	0.2 nsec	$\pm 3\%$
IAD-2104	60 MHz	4 bits	0.2 nsec	$\pm 3\%$
IAD-3105	30 MHz	5 bits	0.6 nsec	$\pm 1.6\%$
IAD-5105	20 MHz	5 bits	0.7 nsec	$\pm 1.6\%$
IAD-1206	12 MHz	6 bits	1.0 nsec	$\pm 1\%$
<b>SERIES B</b>				
IAD-1207	10 MHz	7 bits	0.2 nsec	$\pm 0.4\%$
IAD-2208	6 MHz	8 bits	0.5 nsec	$\pm 0.2\%$
IAD-3210	3 MHz	10 bits	0.3 nsec	$\pm 0.05\%$
IAD-1850	1 MHz	8 bits	1.0 nsec	$\pm 0.2\%$
IAD-1309	1 MHz	9 bits	0.8 nsec	$\pm 0.1\%$

All equally impressive. Like our fast aperture sample-and-hold amplifier, with aperture time on the order of tenths of nanoseconds. Then there's the fast throughput A-D encoder modules, offering throughput rates less than a microsecond. And fast-settling D-A converter modules, with capabilities of settling to 10 bit accuracy within 50 nanoseconds, with output buffer included.

There's even a precision voltage regulator that provides independent adjustment of output voltage and temperature coefficient.

Incidentally, about our A-D converters. They're not just ultra-fast. They'll handle word sizes ranging from 4-10 bits. Data conversion rates up to 320 megabits, aperture time on the order of tenths of nanoseconds.

Inter-Computer Electronics—we manufacture a complete line of A-D converters, D-A converters, compatible multi-channel multiplexers and computer interface equipment. If you'd like to hear from us about what we can do for you,



INTER-COMPUTER ELECTRONICS INC.

1213 Walnut Street, Lansdale, Pennsylvania 19446

# Cathode design lengthens magnetron's life

Positive-anode  $K_u$ -band oscillator operates in excess of 1,000 hours, providing 40 watts of peak power at a 25% duty cycle

**Reliability** has never been one of the magnetron's strong points. However, a newly developed series of positive-pulse magnetrons exhibit a tube life of more than 1,000 hours, a three- to five-times increase over that of previous designs. This significant advance will mean fewer oscillator changes for doppler navigational radars in commercial aircraft and for military

fusing systems. Also, transmitter designers, with longevity in mind, have an alternative to the less stable klystron. And the magnetron signal has a high duty cycle and high repetition rate.

The new series covers C through  $K_u$  bands and has a peak output range of from 0.1 watt to 3.5 kilowatts and an average of from 0.1 to 50 watts. The first tube of the series

—a  $K_u$ -band unit—puts out 40 watts of peak power while operating at a 25% duty cycle. Labeled the BLM-304 by Varian Associates, the tube's 1,000-hour life relies on several design innovations.

The new cathode has been designed to offer more than 15,000 hours life—a span achieved by reducing the current density by more than 50% over previous designs,



X-band solid state oscillator has a 700-Mhz tuning range. Operating in the 9 to 9.7 Ghz range, the device has a control voltage sensitivity of 100 Mhz per volt. Frequency response is d-c to 10 Mhz with a stability of  $\pm 50$  ppm/ $^{\circ}$ C. Output power is 59 mw minimum. Input voltage requirements are  $\pm 28$  v, 500 ma max. Trak Microwave Corp., Eisenhower Blvd., Tampa, Fla. [401]

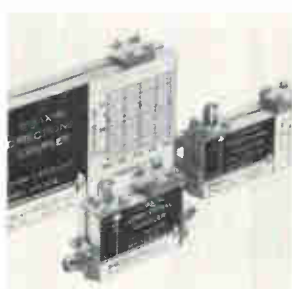

Miniature coaxial couplers series 4510 come in 6, 10, 20, or 30 db models in any of 7 octave bandwidths, collectively covering the 0.25 to 18 Ghz range. Coupling values are held within 0.5 db of nominal, and five calibration frequencies are clearly plotted on the nameplate. The smallest couplers measure  $1\frac{1}{2} \times 1 \times 9/16$  in. PRD Electronics Inc., 1200 Prospect Ave., Westbury, N.Y. [402]



High-power linear amplifier model A52D2-M covers 500 to 1,000 Mhz without compromising noise figure. It can produce  $\pm 22$  dbm with a 5.5 db noise figure. Unit has  $35 \pm 0.5$  db gain and input/output vswr of 1:7.1 maximum. It will enable systems designers to take advantage of class A amplification without sacrificing critical operating parameters. Optimax Inc., Ambler, Pa. [403]



Tunable bandpass filters series VF cover the frequency range of 50 Mhz to 4,000 Mhz with any single model covering more than an octave. The series is available with either a 3- or 5-section response and has a 3 db bandwidth of 5%, insertion loss from 0.2 db to 1.5 db, and vswr less than 1.5:1. Texscan Microwave Products Corp., 7707 N. Records St., Indianapolis 46226 [404]



Miniature medium-power coaxial attenuators models 5 and 6 are d-c to 18 Ghz units. Largest of the devices is less than 3.9 in. long and 1.7 in. in diameter. Power handling capability is a maximum of 25 w to 10 w average input power, depending upon nominal attenuation value. Maximum peak power rating is 5 kw. Weinschel Engineering, Gaithersburg, Md. 20760 [405]



Sweep oscillator 230A utilizes plug-in r-f units with solid state oscillator sources providing coverage from 10 Mhz to 18 Ghz with a minimum power output of at least 20 mw up to 4 Ghz and 5-10 mw to 18 Ghz. All ranges have external leveling capability. Internal leveling is available with all but the 12.4-18 Ghz range. Tyco Laboratories Inc., 25-14 Broadway, L.I.C., N.Y. [406]

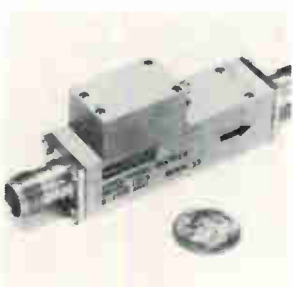

Directional coupler 1025 covers 8 to 1,030 Mhz with flatness of  $\pm 0.2$  db. It has a built-in crystal detector, and is calibrated to provide constant detection sensitivity. The sampler is for measurements of power delivered to a remote load, and for automatic power level control at any point in an r-f system. Kruse-Storke Electronics, 790 Hemmeter Lane, Mountain View, Calif. [407]



Coaxial termination model 9800J is designed for high power dummy load applications over broad frequency ranges. Power handling capability is 200 w average, 1 kw peak, and frequency range is 2-10 Ghz at full power. Maximum vswr is 1.35, and characteristic impedance is 50 ohms. Unit price is \$300; delivery, 30-45 days. Sage Laboratories Inc., 3 Huron Dr., Natick, Mass. 01760 [408]



# more than a power supply

You get more than a power supply when you specify this or any Hewlett Packard power supply. An international network of 220 sales/service offices are at your disposal . . . the most comprehensive service manuals detailing every aspect of the supply from theory and operation to troubleshooting . . . protection circuitry including an internal overvoltage "crowbar" to safeguard delicate loads, standard on this Low Voltage Rack (LVR) Series. OUTPUTS: 10V @ 20, 50, or 100A; 20V @ 10, 20, or 50A; 40V @ 3, 5, 10, 30, or 50A; 60V @ 3 or 15A. RIPPLE AND NOISE: typically 200 $\mu$ V rms, 10mV p-p. Remote Programming and lots more. Prices start at \$350.

## and you can customize it with these options . . .

- 10-Turn Output Voltage and Current Controls
- Chassis Slides
- 3-Digit Graduated Decadial for Voltage or Current
- 115V, 208V, or 230Vac Inputs
- 50Hz Input.



HEWLETT  PACKARD

POWER SUPPLIES

Over 100 power supplies are described in the 1970 HP Electronics Catalog. Write for your copy.

# hp DC POWER

From 10 $\mu$ V to 4000V

From 1 $\mu$ A to 2000A

From \$90 to \$3,500

From manual to computer controlled.



## LOW COST SUPPLIES

Compact laboratory power supplies can be stacked or rack mounted. Choose from 6 well-regulated models: 10V @ 1A; 25V @ .4A; 50V @ .2A. Three Constant Voltage/Current limiting models — \$90. Three Constant Voltage/Constant Current models — \$115.

**Constant Voltage/Constant Current with Automatic Crossover, Remote Programming, Remote Sensing, Auto-Series or Parallel, Optional Internal Over-voltage "Crowbar"**

## MEDIUM POWER / TRANSISTOR REGULATED



Precisely regulated. Programming speeds as fast as 500 $\mu$ s. 20 models: 7.5V @ 3 or 5A; 10V @ 10A; 20V @ 1.5, 3, 5, or 10A; 30V @ 1A; 40V @ .75, 1.5, 3, or 5A; 60V @ 1 or 3A; 100V @ .75A; 160V @ .2A; 320V @ .1A. \$144 to \$395.

## MEDIUM POWER / SCR REGULATED

8 models: 20V @ 15 or 45A, 40V @ 10 or 25A; 60V @ 5 or 15A, 120V @ 2.5A; 600V @ 1.5A. \$360 to \$550.

## HIGH POWER/SCR REGULATED

12 Models: 4V @ 2000A; 8V @ 1000A; 18V @ 500A; 36V @ 300A; 64V @ 150A; 110V @ 100A; 220V @ 50A; 300V @ 35A; 600V @ 15A. \$1275 to \$3500.



... positive-anode device

provides short pulse widths ...

thereby improving the cathode's primary emission characteristics.

The interaction space of the magnetron has been redesigned to distribute the r-f energy in a more efficient manner. The area of the resonator structure has been increased to improve power dissipation.

"The high reliability of this tube will stave off the intrusion of solid-state devices upon hollow-state devices," says George Glenfield, product sales manager of Varian's Eastern Tube division.

**Positive side.** The positive-pulse magnetron has several decided advantages over its negative-pulse counterpart. For one thing, the positive-pulse device provides shorter pulse widths by maintaining a high d-c voltage on its anode. For example, the BLM-304 has 700 volts applied to its anode; when oscillation is desired, only 200 additional volts need be added to reach the oscillation voltage of 900 volts. Since 200 volts can be applied and removed in less time than 900 volts can be, a shorter pulse with a faster rise-time is possible. The cathode and the pole pieces of the positive-anode magnetron are kept at the same potential, thereby removing the need for cathode-end shields and making for a more efficient magnetic circuit. This configuration eliminates unwanted pre-pi-mode oscillation currents, which flow internally without contributing to the r-f output of the magnetron.

The BLM-304 can operate at a fixed-frequency of from 13.28 to 13.37 gigahertz with a peak-power output of 40 watts at a 25% duty cycle. The tube has a pulling factor of 20 megahertz for a 1.31:1 vswr and a maximum pushing factor of only 2 Mhz. The maximum pulse-to-pulse jitter is 600 kilohertz. The pulse-repetition rate of the BLM-304 can vary from 60 to 120 khz. Forced-air or conduction cooling is required. The tube measures 3.28 by 2.88 by 2.40 inches and weighs 25 ounces.

The BLM-304 is available now, at about \$750 in small quantities. Varian plans to concentrate on the X- and K<sub>u</sub>-band models for now and leave the C-band version for a later date. The K<sub>u</sub>-band model will be available only on demand. Following an initial tool-up, production rate will be 100 to 150 magnetrons a month.

Varian Associates, Eastern Tube Division, Beverly, Mass. [409]

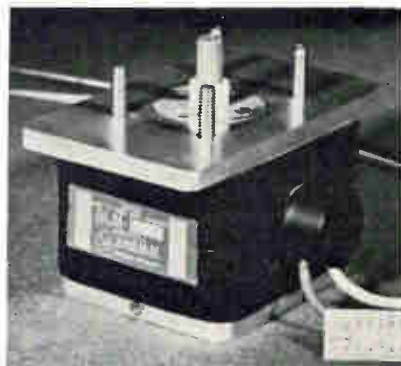

Long-lived.

Design features of new magnetron are said to triple its life expectancy compared to types currently in use.

**Do we have  
a versatile, thin-film deposition  
system for you!**

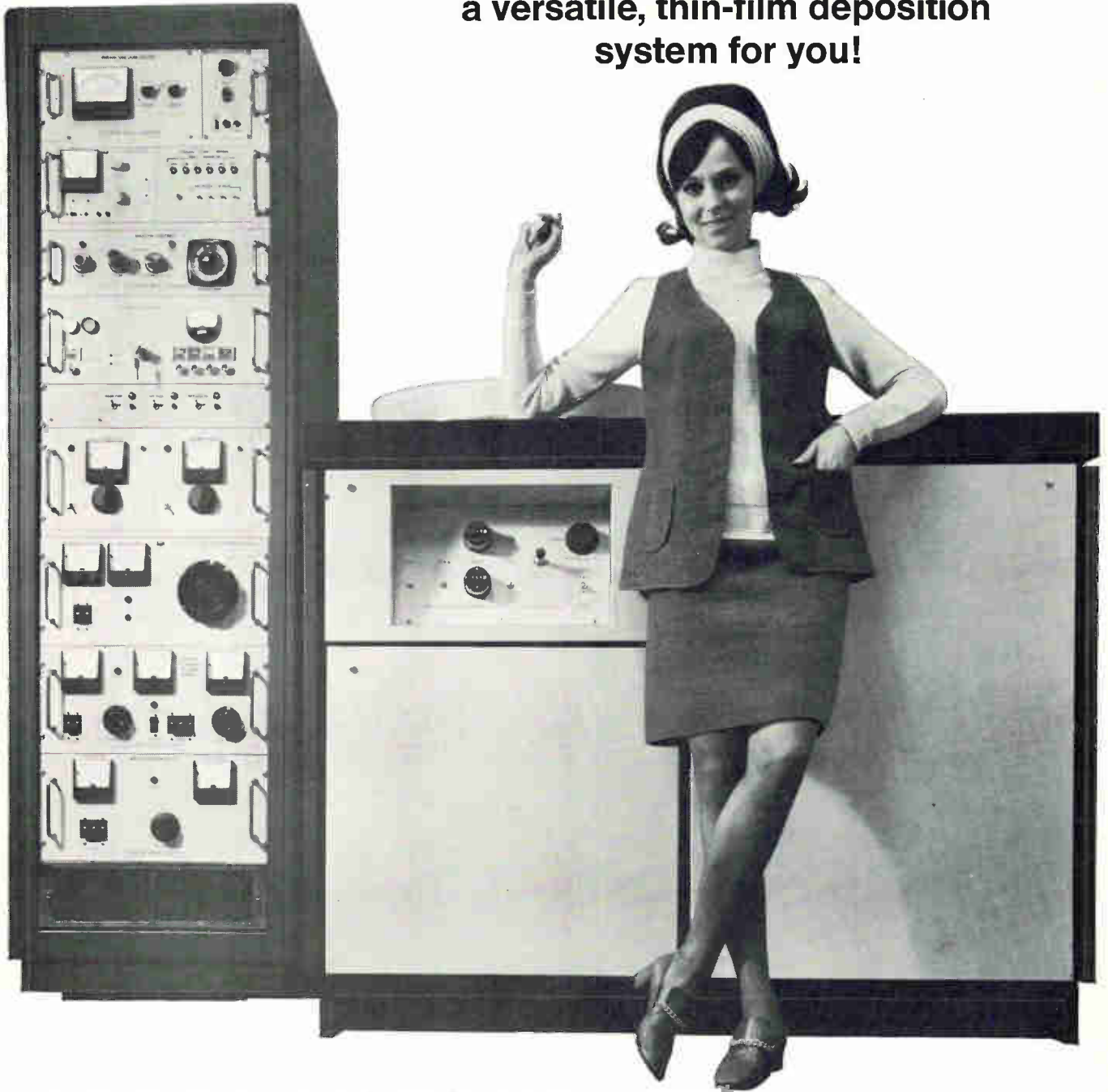

It's the new AST-601, an ideal unit for thin-film production operations like yours. Ideal because it teams high product throughput with reasonable cost.

What about sequence versatility? Four modular work stations let you handle a variety of operations including sputtering (DC/RF, diode or triode), sintering and evaporation. Substrate handling versatility, too? You bet, thanks to a rotational fixture which accommodates various size substrates, shuttering, substrate heating and shielding between work stations. And the AST-601 even offers automatic control of the vacuum cycle to prevent operator error.

Easy loading. Versatile. Economical. That's the new AST-601 for you. For more information, write: The Bendix Corporation, Scientific Instruments and Equipment Division, 1775 Mt. Read Blvd., Rochester, N.Y. 14603.

Scientific Instruments and Equipment Division is part of Bendix Aerospace-Electronics Company.





# Tiny chips offer high capacitance

Available in 33 ratings, ceramic components are aimed at filter applications in thick-film circuits

**Designed** for such thick-film applications as bypass filters in automobile radios, Sprague's new ceramic-chip capacitor, type 242C, offers a quality component in a miniature package. The device has no leads, is unencapsulated, and has metalized terminations. It is less than one-quarter the size of a penny and is aimed at high-capacitance-per-area jobs.

The chip capacitors in the series are easily attached to microcircuit substrates by any of three commonly used techniques—solder reflow, conductive epoxies, or electron-beam welding. Capacitance values from 22 picofarads to 0.1 microfarad are available in most standard ratings. Availability of 33 different ratings makes it possible for the designer to choose a value

closest to his requirement.

The capacitors, designated Monolithic by Sprague, are manufactured by alternately depositing very thin layers of ceramic dielectric material and metal electrodes to achieve the desired value. The formed chip then is fired as a single piece into a rugged block. Problems such as cracking, flaking, and crazing—common with some

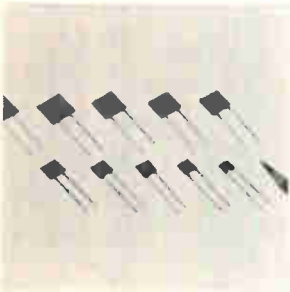

Single-film silvered mica capacitors type 91M have lead spacings interchangeable with those of conventional ceramic disk capacitors. They are available in 45 ratings ranging from 10 pf to 680 pf at 500 v in the EIA 5% preferred number series. The graduated case sizes are offered to insure minimum size and cost in each rating. Sprague Electric Co., North Adams, Mass. 01247



Mercury-wetted signal switching relays series CR300 offer analog signal switching at precision levels normally associated with digital computers. They feature less than 0.1  $\mu$ v thermal emf, and long life (10 billion operations). Single quantity prices start as low as \$14.90; delivery, 5 to 15 days. Computer Products Inc., 1400 Gateway Drive, Ft. Lauderdale, Fla. 33307 [342]



Corona-free chip capacitors are manufactured from a new high voltage dielectric formulation that provides more than three times the working voltage previously possible. Development of this new line makes possible the use of chip capacitors in h-v power supplies and makes possible subminiaturization of these instruments. Tech-Trans Inc., 7596 Eads Ave., LaJolla, Calif.

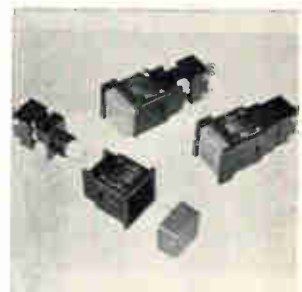

Lighted pushbutton switches series 01-600 offer a reliable, low-cost approach for a wide variety of applications. The easy-to-install snap-in housing is available in bezel, single barrier or double barrier design. Indicator, momentary and alternate action units are available, also 1- or 2-pole switch packages. Illinois Tool Works Inc., 6615 W. Irving Park Rd., Chicago [344]

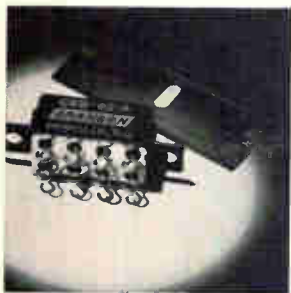

Solid state, time delay relay type QR half-size crystal can size unit, is said to be the smallest available to meet Mil Spec environments. Timing accuracy over a wide range of temperature and voltage is assured by a built-in regulator and filter which also eliminates triggering and timing errors often caused by transients. Branson Corp., Vanderhoof Ave., Denville, N.J. 07834 [345]

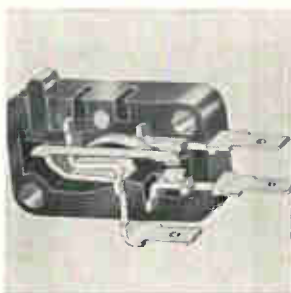

Miniature switches G2 and G3 feature low operate force, high electrical ratings, and maximum mechanical and electrical reliability. Both come with a wide variety of standard integral actuators and are especially suited for timing applications, and areas where low cost and dependability are essential. Precision Switch Corp., 161 Westchester Ave., Port Chester, N.Y. 10573 [346]

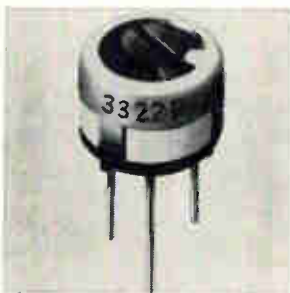

Single-turn, Palirium cermet-element, adjustment potentiometer model 3322 measures 0.25 in. diameter by 0.24 in. high and is sealed to withstand any wave soldering and immersion cleaning process. Operating temperature range is  $-65^{\circ}$  to  $+175^{\circ}$ C. Resistance range is 10 ohms to 1 megohm. Power rating is 0.5 watt at  $85^{\circ}$ C. Bourns Inc., 1200 Columbia Ave., Riverside, Calif.



Monolithic ceramic chip capacitors feature an end metalization process that eliminates open circuits resulting from silver leaching or scavenging common in conventional end termination systems. Capacitance range is 10 to 330,000 pf and 10 to 5,600 pf in the BX and NPO dielectrics, respectively. Union Carbide Corp., Components Dept., P.O. Box 5928, Greenville, S.C. 29606 [348]

... devices designed for automated handling ...

similar units—are avoided, the company says.

Operating temperature range for the chips is  $-55^{\circ}\text{C}$  to  $+85^{\circ}\text{C}$ , measured at 1 megahertz  $\pm 1$  kilohertz at  $25^{\circ}\text{C}$  for values up to 1,000 pf, and at 1 khz  $\pm 100$  hertz for values above 1,000 pf. Measurement voltage is  $1.0 \pm 0.2$  volts rms. Component tolerances of 10% and 20% are available. The devices in the line are designed to operate at 30 and 50 volts d-c.

Four body codes are available in the ceramic-chip capacitor. The first body code, 082, is available in 22-pf to 390-pf capacitors, the second, 075, can be obtained for 120-pf to 1,200-pf units. Body code 067 is available for 1,000-pf to 0.022- $\mu\text{f}$  values, and the last body code, 023, can be obtained in 6,800-pf to 0.10- $\mu\text{f}$  values.

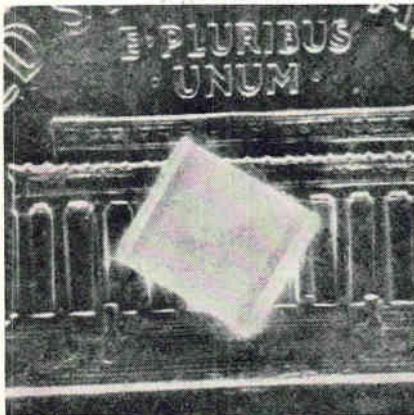

Miniature. Chip-style ceramic capacitor, shown on top of a section of a penny, is available in 33 different ratings.

Maximum change in capacitor value over the operating temperature range breaks down as follows: for the 082 body type the change is  $\pm 60$  ppm/ $^{\circ}\text{C}$ ; for the 075  $-750 \pm 120$  ppm/ $^{\circ}\text{C}$ ; for the 067,  $\pm 15\%$ ; and for the 023,  $+22, -56\%$ .

The units, available from stock, are 0.125 inch long, 0.175 inch wide, and 0.065 inch high. They are designed to accommodate automated handling systems.

Sprague Electric Co., North Adams, Mass. [349]

## Get your free C103 SCR from your authorized GE semiconductor distributor

- |   |   |  |
|---|---|--|
| <p><b>ALABAMA</b><br/>Birmingham<br/>Forbes Distributing Co. (205) 251-4104<br/>Huntsville<br/>Electronic Wholesalers, Inc. (205) 534-2461</p> <p><b>ARIZONA</b><br/>Phoenix<br/>Hamilton Electro of Arizona (602) 272-2601<br/>Kierulff Electronics, Inc. (602) 273-7331</p> <p><b>ARKANSAS</b><br/>Little Rock<br/>Carlton-Bates Co. (501) FR 5-5375</p> <p><b>CALIFORNIA</b><br/>Culver City<br/>Hamilton Electro Sales (213) 870-3301<br/>El Monte<br/>G. S. Marshall Company (203) 686-0141<br/>Los Angeles<br/>Kierulff Electronics, Inc. (213) OV 5-5511<br/>Mountain View<br/>Elmar Electronics (415) 961-3611<br/>Hamilton Electro Sales (415) 961-7000<br/>Oakland<br/>Britt Electronics (415) TE 4-5888<br/>Palo Alto<br/>Kierulff Electronics, Inc. (415) 968-6292<br/>Riverside<br/>Electronic Supply (213) 683-8110<br/>San Diego<br/>Hamilton Electro Sales (714) 279-2421<br/>Kierulff Electronics, Inc. (714) 278-2112<br/>G. S. Marshall Company (714) 278-6350<br/>Western Radio &amp; TV Supply (714) BE 9-0361</p> <p><b>COLORADO</b><br/>Denver<br/>Electronic Parts Co. (303) 266-3755<br/>Hamilton Electro Sales (303) 443-8551<br/>L. B. Walker Radio Co. (303) WE 5-2401</p> <p><b>CONNECTICUT</b><br/>North Haven<br/>Cramer Electronics, Inc. (203) 239-5641<br/>Norwalk<br/>Arrow Electronics (203) 838-4851<br/>Waterbury<br/>Bond Radio Electronics, Inc. (203) 753-1184</p> <p><b>DELAWARE</b><br/>Wilmington<br/>Almo Industrial Electronics (302) DL 6-9467</p> <p><b>FLORIDA</b><br/>Ft. Lauderdale<br/>Cramer Florida Electronics (305) 566-7511<br/>Hollywood<br/>Schweber Electronics (305) 927-0511<br/>Miami<br/>Electronic Wholesalers, Inc. (305) 696-1620<br/>Orlando<br/>Electronic Wholesalers, Inc. (305) 841-1550<br/>Hammond Electronics (305) 241-6601</p> <p><b>GEORGIA</b><br/>Atlanta<br/>Jackson Electronics Co. (404) 355-2223</p> <p><b>ILLINOIS</b><br/>Addison<br/>Hamilton Electro Sales (312) 543-8500<br/>Chicago<br/>Electronic Distributors, Inc. (312) AV 3-4800<br/>Newark Electronics Corp. (312) 638-4411<br/>Semiconductor Specialists, Inc. (312) 279-1000</p> <p><b>INDIANA</b><br/>Evansville<br/>Ohio Valley Sound (812) HA 5-6173<br/>Indianapolis<br/>Graham Electronics, Inc. (317) ME 4-8486<br/>Semiconductor Specialists Inc. (317) 243-8271</p> <p><b>IOWA</b><br/>Cedar Rapids<br/>Deeco, Inc. (319) EM 5-7551</p> <p><b>KANSAS</b><br/>Wichita<br/>Interstate Electronics Supply Corp. (316) AH 4-6318</p> <p><b>KENTUCKY</b><br/>Louisville<br/>P. I. Burks Co. (502) 583-2871</p> <p><b>LOUISIANA</b><br/>Lafayette<br/>Ralph's of Lafayette (318) 234-4507<br/>New Orleans<br/>EPCOR (504) 486-7441<br/>Sterling Electronics, Inc. (504) JA 2-8726</p> | <p><b>MAINE</b><br/>Portland<br/>Holmes Distributors, Inc. (207) 774-5901</p> <p><b>MARYLAND</b><br/>Baltimore<br/>Kann-Eliert Electronics, Inc. (301) TU 9-4242<br/>Hanover<br/>Hamilton Electro Sales (301) 796-5000<br/>Rockville<br/>Cramer/Washington, Inc. (301) 424-2700<br/>Schweber Electronics (301) 427-4977<br/>Salisbury<br/>Almo Industrial Electronics (301) PI 2-1393</p> <p><b>MASSACHUSETTS</b><br/>Dedham<br/>Gerber Electronics (617) 329-2400<br/>Newton Centre<br/>Cramer Electronics, Inc. (617) WO 9-7700<br/>Springfield<br/>T. F. Cushing, Inc. (413) 788-7341<br/>Waltham<br/>Schweber Electronics (617) 891-8484</p> <p><b>MICHIGAN</b><br/>Detroit<br/>Radio Specialties Co. (313) 491-1012<br/>Grand Rapids<br/>Newark-Industrial Electronics (616) 452-1411<br/>Redford<br/>Semiconductor Specialists, Inc. (313) 255-0300</p> <p><b>MINNESOTA</b><br/>Edina<br/>Lew Bonn Company (612) 941-2770<br/>Minneapolis<br/>Semiconductor Specialists, Inc. (612) 866-3434<br/>St. Paul<br/>Gopher Electronics Co. (612) 645-0241</p> <p><b>MISSISSIPPI</b><br/>Jackson<br/>Ellington Radio, Inc. (601) FL 3-7877</p> <p><b>MISSOURI</b><br/>Kansas City<br/>Radio Lab, Inc. (816) HA 1-0171<br/>North Kansas City<br/>ECI Semiconductors Inc. (816) HA 1-8400<br/>University City<br/>Olive Industrial Electronics (314) VO 3-4051</p> <p><b>NEBRASKA</b><br/>Lincoln<br/>Scott Electronic Supply Corp. (402) 434-8308<br/>Omaha<br/>Radio Equipment Co. (402) 341-7700</p> <p><b>NEW JERSEY</b><br/>Camden<br/>General Radio Supply Co., Inc. (609) 954-8560<br/>Cedar Grove<br/>Hamilton Electro Sales (201) 239-0800<br/>Cherry Hill<br/>Hamilton Electro Sales (609) 662-9337<br/>Mt. Ephraim<br/>Almo Industrial Electronics (609) 933-3800<br/>Pennsauken<br/>Cramer/Penn, Inc. (609) 662-5061<br/>Totowa<br/>Arrow Electronics, Inc. (201) 256-7331</p> <p><b>NEW MEXICO</b><br/>Albuquerque<br/>Kierulff Electronics, Inc. (505) 268-3901<br/>Sterling Electronics, Inc. (505) 247-2486</p> <p><b>NEW YORK</b><br/>Cheektowaga<br/>Standard Electronics, Inc. (716) 685-4330<br/>East Syracuse<br/>Cramer Electronics, Inc. (315) 437-6671<br/>Endicott<br/>Standard Electronics, Inc. (607) 754-3102<br/>Farmingdale, L. I.<br/>Arrow Electronics, Inc. (516) MY 4-6800<br/>Hauppauge<br/>Cramer Electronics (516) 231-5600<br/>Rochester<br/>Cramer/Rochester, Inc. (716) 275-0300<br/>Rochester Radio Supply Co. (716) 454-7800<br/>Rome<br/>Rome Electronics, Inc. (315) FF 7-5400<br/>Syracuse<br/>Hamilton Electro Sales (315) 437-2641<br/>Westbury, L. I.<br/>Schweber Electronics (516) ED 4-7474<br/>Yorkville<br/>Valley Industrial Electronics, Inc. (315) RE 6-3393</p> | <p><b>NORTH CAROLINA</b><br/>Charlotte<br/>Dixie Radio Supply Co. (704) 377-5413<br/>Raleigh<br/>Southeastern Radio Supply Co., Inc. (919) 829-2311<br/>Winston-Salem<br/>Electronic Wholesalers, Inc. (919) 725-8711</p> <p><b>OHIO</b><br/>Akron<br/>Sun Radio Co., Inc. (216) 434-2171<br/>Cincinnati<br/>Hughes-Peters, Inc. (513) 351-2000<br/>Cleveland<br/>Pioneer-Standard Electronics, Inc. (216) 432-0010<br/>Columbus<br/>Electronics Marketing Corp. (614) 299-4161<br/>Hughes-Peters, Inc. (614) AX 4-5351<br/>Dayton<br/>Srepeo Electronics, Inc. (513) BA 4-3871<br/>Toledo<br/>Warren Radio Co. (419) CH 8-3364</p> <p><b>OKLAHOMA</b><br/>Oklahoma City<br/>Trice Wholesale Electronics (405) JA 4-4415<br/>Tulsa<br/>Oil Capitol Electronics Corp. (918) TE 6-2541</p> <p><b>OREGON</b><br/>Portland<br/>Hamilton Electro Sales (503) 255-8550</p> <p><b>PENNSYLVANIA</b><br/>Philadelphia<br/>Almo Electronics Corp. (215) OR 6-6000<br/>Pittsburgh<br/>R.P.C. Electronics (412) 782-3770<br/>Semiconductor Specialists, Inc. (412) 781-8120<br/>York<br/>Rosen Electronics Co. (717) 843-3875</p> <p><b>RHODE ISLAND</b><br/>Providence<br/>W. H. Edwards Co. (401) 781-8000</p> <p><b>SOUTH CAROLINA</b><br/>Columbia<br/>Dixie Radio Supply Co., Inc. (803) 253-5333</p> <p><b>TENNESSEE</b><br/>Chattanooga<br/>Harpe Electronic Distributors, Inc. (615) 267-2381<br/>Kingsport<br/>Radio Electric Supply Co. (615) 247-8111<br/>Memphis<br/>Stuff City Distributing Co. (901) 276-4501<br/>Nashville<br/>Electra Distributing Co. (615) AL 5-8444</p> <p><b>TEXAS</b><br/>Arlington<br/>Arco Electronics (817) CR 7-2231<br/>Dallas<br/>Hamilton Electro Sales (214) ME 8-0900<br/>Sterling Electronics (214) 357-9131<br/>Wholesale Electronic Supply (214) TA 4-3001<br/>El Paso<br/>McNicol, Inc. (915) LO 6-2936<br/>Midland Specialty Co. (915) 533-9555<br/>Houston<br/>Hamilton Electro of Houston (713) 526-4661<br/>Sterling Electronics (713) 623-6600</p> <p><b>UTAH</b><br/>Salt Lake City<br/>Kimball Electronics (801) 328-2075</p> <p><b>VIRGINIA</b><br/>Charlottesville<br/>Virginia Radio Supply Co. (703) 296-4184<br/>Richmond<br/>Meridian Electronics, Inc. (703) 353-6648<br/>Roanoke<br/>Peoples Radio &amp; TV Supply Co. (703) 342-8933</p> <p><b>WASHINGTON</b><br/>Seattle<br/>Almac/Strum Electronics (206) 763-2300<br/>Hamilton Electro Sales (206) MA 4-5930<br/>Kierulff Electronics, Inc. (206) RO 3-1550<br/>Washington Electronics, Inc. (206) MU 2-9981<br/>Tacoma<br/>C&amp;G Electronics Co. (206) BR 2-3185</p> <p><b>WEST VIRGINIA</b><br/>Charleston<br/>Chemcity Electronics (304) 342-8151</p> <p><b>WISCONSIN</b><br/>Milwaukee<br/>Electronic Exportors, Inc. (414) 374-6666<br/>West Allis<br/>Marsh Radio Supply Co. (414) 545-6500</p> |
|---|---|--|

GENERAL  ELECTRIC

221-25



# GENERAL ELECTRIC wants to GIVE you an SCR

BECAUSE WE KNOW YOU'LL BE BACK FOR MORE

We're so confident that our C103 will meet your low current SCR needs that we'd like to give you one so you can try it in your circuit. Just fill out the coupon below and we'll send you, free, a new 800 ma SCR.

This new C103 features the same pellet structure as the performance-proven C106 (4-amp SCR).

Epoxy-encapsulated in the TO-18 plastic package, GE's C103 is available in peak reverse voltage ratings from 30 to 200 volts.

The C103 combines high surge capability (8 amps) with a low forward blocking current ( $1\mu\text{A}$ ) and offers a very sensitive gate ( $200\mu\text{A}$ ).

The C103 low-cost low current SCR is so versatile that it can

replace more than 200 existing SCR's and is easily interchangeable in both package and electrical characteristics.

And because it's rugged, it's ideal for use in industrial and military as well as consumer applications such as motor controls, indicator drivers, off-the-line regulators for appliance and electronic equipment, light, heat and proximity detection, temperature and pressure control, counting or switching and as gate amplifiers for larger devices.

GE's C103 is now available from distributors' stock or in volume from the factory.

To get your sample C103 SCR, fill out the coupon below and present it (or mail it) to your authorized General Electric distributor.

For more information, write General Electric Company, Section 220-89, 1 River Road, Schenectady, N. Y. 12305. In Canada: Canadian General Electric, 189 Dufferin Street, Toronto, Ont. Export: Electronic Sales, IGE Export Division, 159 Madison Avenue, New York, N. Y. 10016.

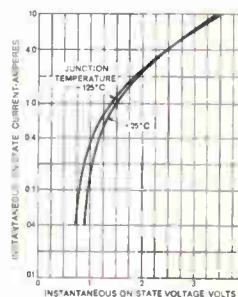

C103 RATINGS

Peak reverse voltage	200 volts max.
RMS On-state current	0.80 amp. max.
Gate trigger current	200 $\mu$ amp. max.
Peak surge current	8.0 amps. max.
Peak reverse and off-state current	1.0 $\mu$ amp. max.

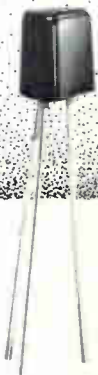

GENERAL  ELECTRIC

Circle 149 on reader service card

## FREE SCR SAMPLE

Present (or mail) this coupon to your authorized GE distributor (see listing on opposite page).

Attn: Industrial Sales Mgr. Please furnish 1 C103 SCR.

Rating:  30V  60V  100V  200V

Name \_\_\_\_\_

Firm: \_\_\_\_\_ Position: \_\_\_\_\_

Street \_\_\_\_\_

City \_\_\_\_\_ State \_\_\_\_\_ Zip \_\_\_\_\_

Distributor Name \_\_\_\_\_

Offer expires July 31, 1970

A





**You'll get  
the direct print paper  
on the right faster.**

There's no need for "hurry" stamps on Astroprint oscillographic papers. Easy ordering and direct delivery are part of the package.

You also get a direct print, orthochromatic paper unsurpassed for

trace density, instant pop-up (less than 1 second), excellent image stability and sharp contrast. On mercury vapor, Xenon, and cathode ray light sources.

Astroprint DP 90 (for open magazine applications) and DP 80 (for closed magazines).

As a starter, test us for delivery and cost. Just call your local Xerox Product Specialist or write to Xerox Corporation, Dept. HL, Rochester, New York 14603.

The paper will prove itself.

**XEROX**

Xerox and Astroprint are registered trademarks of Xerox Corporation.

# Detector sounds off to warn of leakage currents

Designed for safety checks, this low-priced instrument triggers at 5  $\mu$ amps and can also sense electric fields

**Hospitals** may be hazardous to your health: that word comes from engineers and doctors who have investigated the problem of patients being electrically shocked.

It's a complex problem, and so are many of the proposed remedies. But not all. A simple approach that could ease the problem is the making of routine hospital-wide checks for leakage currents. To do this,

though, hospitals need detectors that are inexpensive, easy to use, and portable. The Daniel Woodhead Co. claims these features for its Bio-Medical Field Probe, a detector which sounds an alarm when more than 5 microamps flow through it. A little larger than a pack of king-size cigarettes, the detector runs off a 9-volt battery and costs \$65 in small quantities.

Woodhead has aimed the detector, with its white package and 5- $\mu$ amp threshold, straight at the medical market, but the instrument can be used in any application where leakage is a problem. For example, an engineer could use the detector to check his grounds in any network or test setup.

Besides measuring current, the detector can also sense electric



Laser interferometer model 5950 Lasergage provides measurement of position changes to a resolution of  $\frac{3}{4}$  microinch. It is a portable, direct-reading instrument designed to be a secondary length standard. Applications include the control and measurement of critical dimensions in IC fabrication, and for standards laboratories. Perkin-Elmer Corp., 131 Danbury Rd., Wilton, Conn. [361]



Universal IC card tester model ICT-100 series is designed for maintenance of all digital card families. Operating controls, visual no-go indicator and test jacks are conveniently located on the front panel. The compact, portable unit employs standard IBM punched cards for flexibility. General Dynamics, Dynatronics Operation, P.O. Box 2566, Orlando, Fla. 32802 [362]



Laser power meter model 50 is a high accuracy, rugged instrument designed for industrial, laboratory and experimental applications. Circuitry employed eliminates switching error and potential switch failure. Unit comes complete with stand and the sensor head is adjustable from 2 to 7 in. in height. Price is \$125. Electrotest Instruments, Colorado Ave., Santa Monica, Calif. [363]



Digital laser power meter 20A features 6 ranges for full scale readouts from 1  $\mu$ w to 100 mw. Least significant digit represents 1  $\mu$ w on the most sensitive scale. With accessory beam splitter attachment full scale readouts up to 100 w are possible. Unit includes analog and BCD outputs. Price is under \$1,000. United Detector Technology, 1732 21st St., Santa Monica, Calif. [364]



X-Y display oscilloscope model 101 is for all types of swept frequency and other measurements. It has a bright 11-in. screen marked with 2-cm squares for easy clear viewing. High sensitivity, variable from 5 mv/cm to 50 v/cm is another feature. Unit measures 11 x 9 x 11 $\frac{1}{4}$  in., weighs 16 lbs. Price is \$395. Telonic Industries Inc., P.O. Box 277, Laguna Beach, Calif. [365]

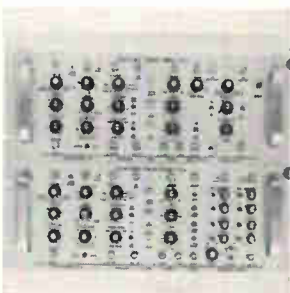

Signal simulator model 5G901 is a versatile signal generator designed primarily for use as a training device for electronic warfare operators. It can also be used to synthesize signals for the evaluation and check-out of radar and EW systems. It consists of six waveform generator modules and four transform function modules. ESL Inc., 495 Java Drive, Sunnyvale, Calif. 94086 [366]



Solid state r-f millivoltmeter model 92A offers a basic accuracy of 1% of reading plus 1% of full scale. It measures 100  $\mu$ v to 3 v from 10 khz to 1.2 Ghz in 8 ranges by convenient pushbutton selection. It has true rms response up to 30 mv (up to 3 v with proper accessory). A linear d-c output is provided. Price is \$750. Boonton Electronics Corp., Parsippany, N.J. 07054 [367]



Solid state FET volt-ohm-meter model 176 features an exclusive complementary symmetry circuit that protects FET's from over-voltage transients and provides balanced temperature compensation. Other features include true peak-to-peak a-c measuring and high a-c frequency response (to 3 Mhz). Price is \$99.95. Dynascan Corp., 1801 W. Belle Plaine Ave., Chicago 60613 [368]

# some of the 9.999 REASONS

## DP 400 Series Digital Panel Meters



- 2K, 4K, or 10K Count Resolution
- Up to  $\pm 0.02\% \pm 1$  Count Accuracy
- BCD Output
- Optional 1 G ohm Input Impedance and Negative Polarity Indicator
- Unit Qty. Price...
  - 2,000 Count—under \$200
  - 4,000 Count—under \$215
  - 10,000 Count—under \$275

CALL: 305-933-5561  
WRITE: P.O. Box 23849  
Ft. Lauderdale, Fla. 33307



**COMPUTER  
PRODUCTS®**  
FORT LAUDERDALE

... a switching network disconnects the battery  
if more than 5  $\mu$ amps flow into the detector ...

fields. This is valuable, for example, where flammable gases are used or where interference is being monitored.

Vice president Russell Stoll also sees the detector finding work—in a different package—on the end of a steam shovel's boom. There it would stop the boom when it swings too close to a power line.

But for the time being, hospitals are the marketing target. Their safety problems come from a number of conditions. Grounding systems in many hospitals are old and inadequate; medical electronic instruments and simple appliances, such as lamps and tv's, often are poorly designed in terms of patient safety; and hospital personnel, from doctors down, usually know little about such things as properly grounding an instrument.

**Exposed.** The result often is that a patient is exposed to a number of low-voltage sources. His bed's frame, the metal cover on his lamp, the chassis of the electrocardiograph next to him—each may be several hundred millivolts away from ground and from each other. If the patient is across one of these sources—say he leans on the bed and touches the lamp—leakage currents will flow through him. There's no agreement as to how low a current can be lethal, but the consensus is that the maximum acceptable leakage current is 5  $\mu$ amps.

To detect this 5  $\mu$ amps, the detector user extends its telescoping probe, throws the instrument's toggle switch to L, and connects

the ground terminal to some reference point, such as an instrument's ground terminal. He then touches the probe to a surface; if its potential drives more than 5  $\mu$ amps to ground, the detector sounds its alarm, out loud through its own speaker or into earphones.

To detect fields, he switches to S and puts the probe into the area to be monitored.

The detector is an audio amplifier that's turned on by a field or leakage current. The voltage picked up by the probe goes through a high-impedance amplifier to a sawtooth-wave generator whose output frequency modulates a relaxation oscillator over a range of 500 to 1,500 hertz. An amplifier sends the oscillator's output to the speaker or the earphones. This all happens when the probe's voltage is above some threshold. Back at the input amplifier, though, the input voltage also goes to a switching network which connects the detector's battery to the generator, oscillator, and output amplifier. If the voltage isn't high enough, no power gets to these circuits, and there's no alarm.

The probe was the idea of Denes Roveti, a Maryland-based inventor who licensed Woodhead to make them. It's not an exclusive license; Roveti's own Instrutek Inc. also makes the detectors and sells them for \$92.50.

Daniel Woodhead Co., 220 Huehl Rd., Northbrook, Ill. 60062 [369]

Instrutek Inc., 15 Lincoln Park Center, Annapolis, Md. 21401 [370]

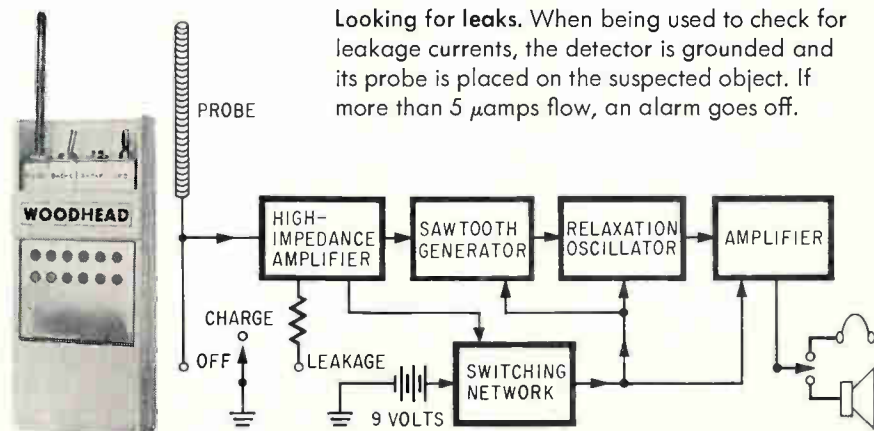



# When you're looking for a plant site, Georgia won't hand you a fancy line. We'll hand you Fantus Facts.

We Georgians think our state is the best place to locate your new plant or facility.

But you don't have to take our word for it. Take the Fantus Company's. As you know, Fantus is an internationally known, internationally respected site location consulting firm. Georgia has retained them to make 24 individual SIC industry cost analyses. Studies that will tell you in detail how much profit you could make by locating in Georgia.

So if you're considering a new site for your company, send in the coupon below. You'll get the facts. The whole facts. And nothing but the facts.



Georgia Department of Industry & Trade, P.O. Box 38007, Atlanta, Georgia 30332

Please send me information about the following Fantus Studies:

- Electronic Switching and Relay Equipment
- Fluorescent Lamp Ballast and Specialty Transformers
- Character Recognition Equipment

Name \_\_\_\_\_

Address \_\_\_\_\_

City \_\_\_\_\_ State \_\_\_\_\_ Zip \_\_\_\_\_

**Georgia's got it.**

# It took us years to develop the best stereo microscope.

## Now give us a few minutes to prove it.

Let us compare our StereoStar/ZOOM to any stereoscopic microscope in your lab.

Our microscope offers high resolution, larger fields of view, greater working distance. We have as wide a magnification range as you're likely to need: a full 6 to 1 zoom range with magnifications from 3.5 X through 210 X. The zoom control knob is coupled—so that it's conveniently located on both sides, for either left or right-hand operation. And the entire head is easily rotatable through 360°.

135 years of optical excellence went into the AO StereoStar/ZOOM. Let us compare it to any stereo microscope in your lab. After all, if it's worth your money, it's worth your time.

Call your AO Representative. Or write for our convincing 24-page brochure.

 **AMERICAN OPTICAL  
CORPORATION**  
SCIENTIFIC INSTRUMENT DIVISION • BUFFALO, N.Y. 14215

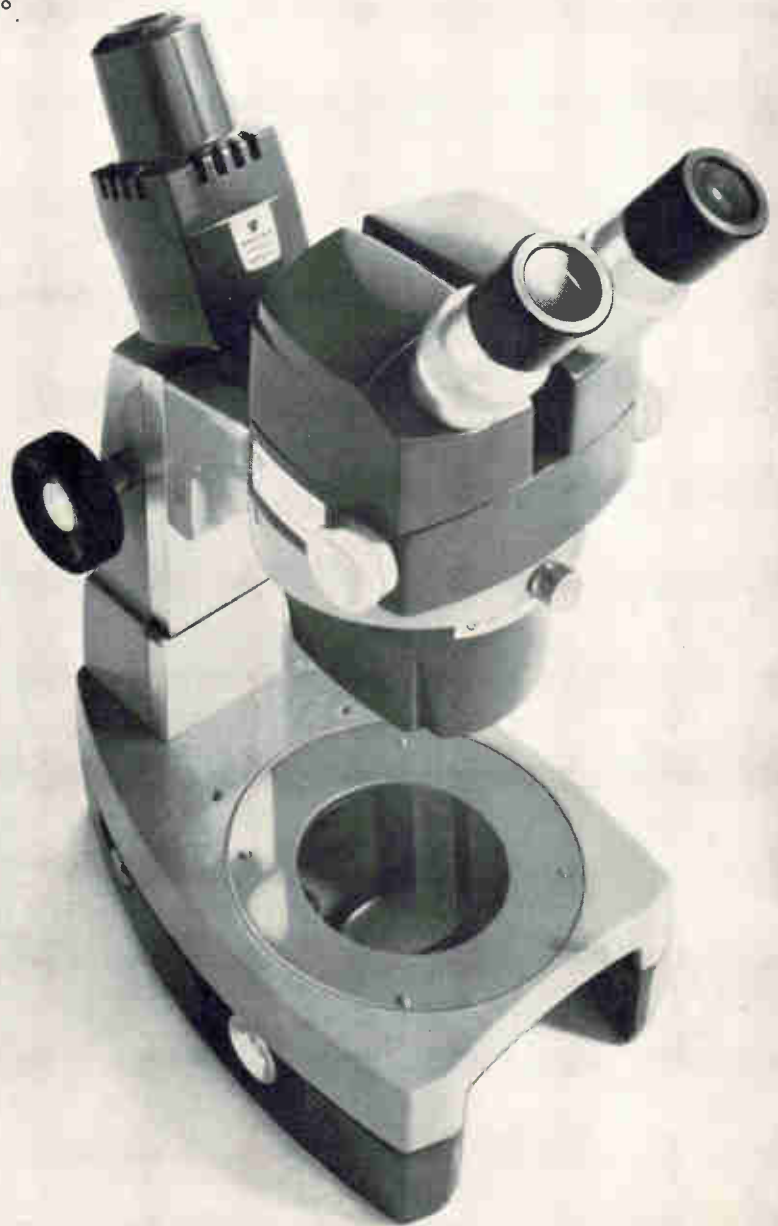

# Tester tracks down digital-cassette errors

Stand-alone unit aids users by examining performance characteristics and providing information on bit density and operating speed limits

**Checking out** the performance characteristics of a digital cassette can be a time-consuming task for a user. He must key data bits onto the tape, using something like a solenoid-operated keying machine. After processing the data through a computer, he visually inspects a printout to see if the cassette is everything the manufacturer says it is.

At the Dytro Corp., a maker of cassette-based systems, the company's engineers decided to find a better way. They designed a stand-alone cassette tape checker that continuously writes 1's onto the cassette's tape and then reads the tape for dropped bits and errors—all in a matter of minutes. Originally developed for in-house use, the TC-1000 is being put on the

market for \$1,200.

The company offers two versions. One reads immediately after writing; the other one writes, is re-wound, and then reads the tape. The advantage of the first is the speed of a single-pass inspection, while the second permits the user to determine if there is any tape manipulation during rewind that in any way alters the data. It offers

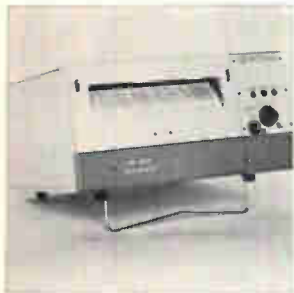

Digital teleprinter MC3000 is designed to improve and eventually replace all military teletypewriters. It is a non-impact page printer, weighing less than 50 lbs, rugged in its environmental specifications, and all at print speeds of 3,000 lines per minute. The unit's input interface works with many data systems. Litton Industries, 1 Executive Park, Englewood, Colo. [3811]



Output printer model 7721 is an optional unit designed for use with computer performance analyzers. Printing of analysis data is performed in either of two print modes—tabular digital, or graphical output—and eliminates the need for attended operation of the analyzer. Computer and Programming Analysis Inc., 1103 Kings Highway North, Cherry Hill, N.J. 08034 [3821]



Compact, high-speed line printer model 2910 is designed to operate under extremely rugged environmental conditions, to meet MIL-E-16400 specifications. It interfaces directly with a computer in character serial, bit parallel mode. It also has a serial communication line interface capability. Data Products Corp., 6219 DeSoto Ave., Woodland Hills, Calif. [3831]



Desk-top crt display terminal model 2000 is fully interactive with a computer and completely compatible with existing programs and programing practices. It features a flicker-free 1,998 character display, and offers both split screen and highly flexible editing capabilities, including character and line insertion and deletion. Hazeltine Corp., Little Neck, N.Y. 11362 [3841]



Electronic digital scanner called dijitscan 1000 accepts low level BCD inputs in parallel and provides them sequentially at the output. Applications include interfacing devices such as digital voltmeters, counters, A/D converters and keyboards with recording devices such as paper tape punches, printers, etc. Pivan Data Systems Inc., 6955 N. Hamlin Ave., Lincolnwood, Ill. [3851]

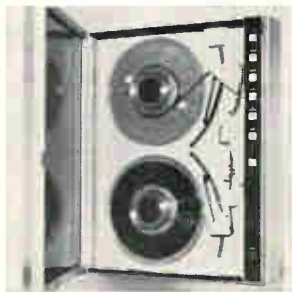

Low-speed magnetic tape units designated series 2870/2890 offer 7 track recording at 556 or 800 bpi and 9 track capability at a data density of 800 bpi, 1600 bpi phase encoding, or 800/1600 dual density. Units operate at 25 ips without program restrictions. A read-after-write check allows parity verification while writing. Data Action, 4575 W. 77th St., Minneapolis 55435 [3861]



General purpose printing counter 22408 offers a counting speed of 10 pulses per second. Print-out periods of 1 every minute or 1 every 6 minutes can be selected by a panel switch. The counter can be made to print out totals accumulatively, or, reset to zero after each print-out. It features modular construction. Price is \$500. Stoelting Co., 424 N. Hoeman Ave., Chicago 60624 [3871]



Low-cost computer, called the Devonshire, is designed to accept and deliver data to and from as many as 253 various types of communications devices simultaneously. Virtually any type of remote terminal—displays, keyboards, printers, plotters, other computers, etc.—may be used with the unit. Devonshire Computer Corp., 377 Elliot St., Newton, Mass. 02164 [3881]



# WE'VE GOT A BETTER WAY TO MAKE PRINTED CIRCUITS!



## New techniques developed to make circuit boards more reliable.

The Printed Circuits Operation of CDC used a unique etch-back technique for producing reliable multi-layer circuitry for the Mercury project. Its success is indicated by the fact that the same techniques were used in the Gemini and Apollo projects without design change . . . millions of inter-facial connections with no known failures.

Designs ranged from double-sided circuitry to complex 15-layer circuit boards . . . using sequential laminating, extra fine line width and spacing, and plated slots and edges . . . and were used for systems control telemetry, hi and low level multiplexer, command module telemetry, LEM flight control system, and the seismograph experiment.

The Mercury-Gemini-Apollo program demonstrates our capability for the design and production of high quality circuit boards. Hundreds of other projects use our circuit boards in many phases of civilian and military equipment. We've got a better way to make printed circuitry.



F-104

Developed new technique to produce circuit boards with more reliable plated-thru holes.



C5

We introduced circuit boards that had the highest density circuitry ever used before on a production basis.



F-111

New industry technique was used to produce multilayer circuit boards with an internal heat sink.



PHOENIX

Required new techniques for manufacturing heat sinks and insulation by chemical milling.



707

Reliable circuit boards in high volume at low cost were produced for this project.



POSEIDON

Developed new technology for sequential laminating multilayer circuit boards with aluminum backbone.



**This design and production experience can work for you . . . CALL US NOW.**

**CONTROL DATA**  
CORPORATION

CONTROL DATA CORPORATION  
PRINTED CIRCUITS OPERATION  
7800 COMPUTER AVENUE  
MINNEAPOLIS, MINN. 55435  
PHONE: (612) 927-5681

a closer simulation of actual operating conditions.

The TC-1000 is useful not only for vendor qualification and incoming inspection of cassettes, but also for periodic inspections of already-used cassettes to determine how much life is left in them. In other words the tester eliminates one major uncertainty in a cassette-based system: is the trouble in the cassette or in the system?

In operation, the TC-1000 counts data errors for each track of a cassette tape, and the result is a statistical examination of this count versus the length of the track itself. Furthermore, dropped bits are scored by an amplitude detector that has an adjustable threshold. Thus, the machine tells the operator where to write and where not to write on the cassette, and it tells him the operating speed limits of the cassette, bit density versus skewing characteristics, rewind characteristics, dynamic range criteria, tape thickness versus error rate, signal to noise ratio, and—in selected applications—which tapes have the highest output, the most stable output or the lowest error rate.

Dytro Corp., 63 Tec Street, Hicksville, N.Y. 11801 [389]

Data handling

## Plotter interacts with computer

Automated design system aimed at work on LSI, p-c boards, components

As large-scale integration becomes more complex, there is a need for more interaction among elements of the man-machine design team. When—for example—the plotting board remains off-line, additional time-consuming steps are required in drawing, checking, and correcting.

A system developed by the Computervision Corp. eliminates many of these steps because in its system

the plotting board interacts with the computer and the crt display.

The effect is to simplify design of LSI wafers, printed-circuit boards, and components. The 34-by-44-inch plotting surface lets the designer work on a large area scaled to LSI dimensions. Using pen or pencil, the designer sketches on paper, whereas previously he would have had to manipulate images on a crt with a light pen. As the plotter arm traces the sketch, the digitizer enters the coordinate information directly into a computer without the need for the operator to punch cards. The terminal's cathode-ray storage tube permits quick previewing of the design. Since the plotter and the crt are both interactive and share



Team. Man, computer and plotter interact in design job.

common electronics, the designer need only call up a cell from the computer for display on the crt, move the plotting arm to the location on the drawing where he wishes to have the cell placed, and hit the plot key on the keyboard. Whatever is on the crt or in the computer can be drawn at any location on the plotting surface.

If the symbol needed in a plot is not in the computer's data base, the designer can draw the symbol on the crt and the plotter-digitizer will send the symbol to the data base. To erase errors, the operator runs the arm over the incorrect lines while the DELETE button is depressed on the keyboard.

**Under pressure.** The plotter-digitizer can resolve vectors as small as 2 mils. The maximum plotting speed is 9 inches per second, and the plotting head uses two program-selectable pens. The plotting arm does not use the common rack-and-pinion digitizing

Solitron now offers a complete line of Hi-Rel PNP/NPN power transistors from 2 amps to 100 amps. Typical applications for these complementary devices are power inverters, switching regulators and hi-current amplifiers. Features include:

- Excellent Beta Linearity
- Outstanding Switching Capabilities,  
 $f_t = 25 \text{ MHz}$  (typical)
- Hi-Rel Construction
- Up to 300 W Power Capability

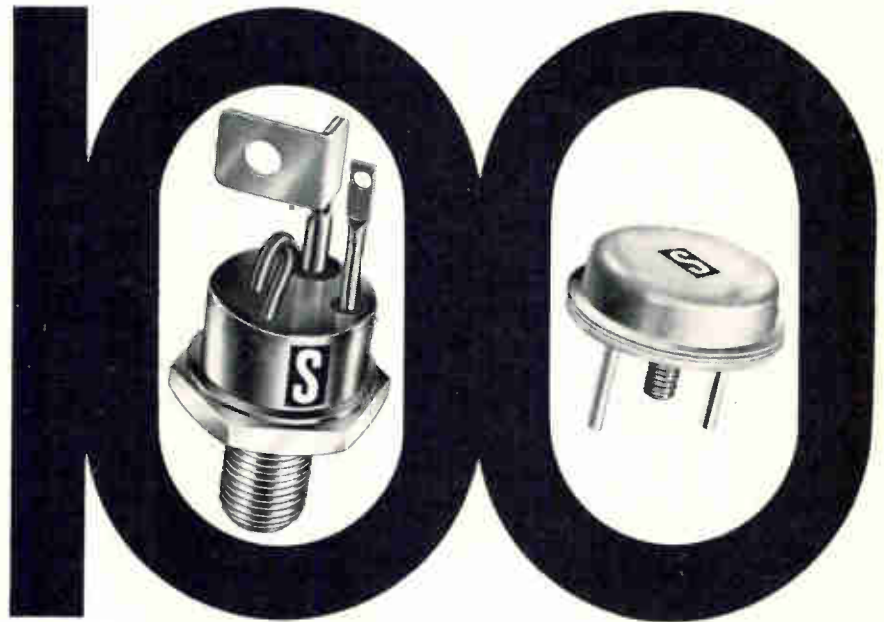

## AMP Hi-Rel Complementary PNP/NPN SILICON POWER TRANSISTORS

Type Number TO 114		Type Number TO 68		Rated Breakdown Voltages		Performance Specifications			
						$V_{CE}$ (SAT) Volts		$h_{FE}$	
						$I_C = 40 \text{ A}$		$I_C = 40 \text{ A}$	
						$I_B = 8 \text{ A}$		$V_{CE} = 10 \text{ V}$	
PNP	NPN	PNP	NPN	$V_{CE}$	$V_{EB}$	PNP	NPN	Min	TYP
SDT 3902	SDT 8920	SDT 3602	SDT 8601	60	8	2 V	1 V	10	30
SDT 3903	SDT 8921	SDT 3603	SDT 8602	80	8	2 V	1 V	10	30
SDT 3904	SDT 8922	SDT 3604	SDT 8603	100	8	2 V	1 V	10	30

Dial 1-800-327-3243 for a "No Charge" telephone call and further information.

**Solitron** DEVICES, INC.

1177 BLUE HERON BLVD. / RIVIERA BEACH, FLORIOA / (305) 848-4311 / TWX: (510) 952-6676

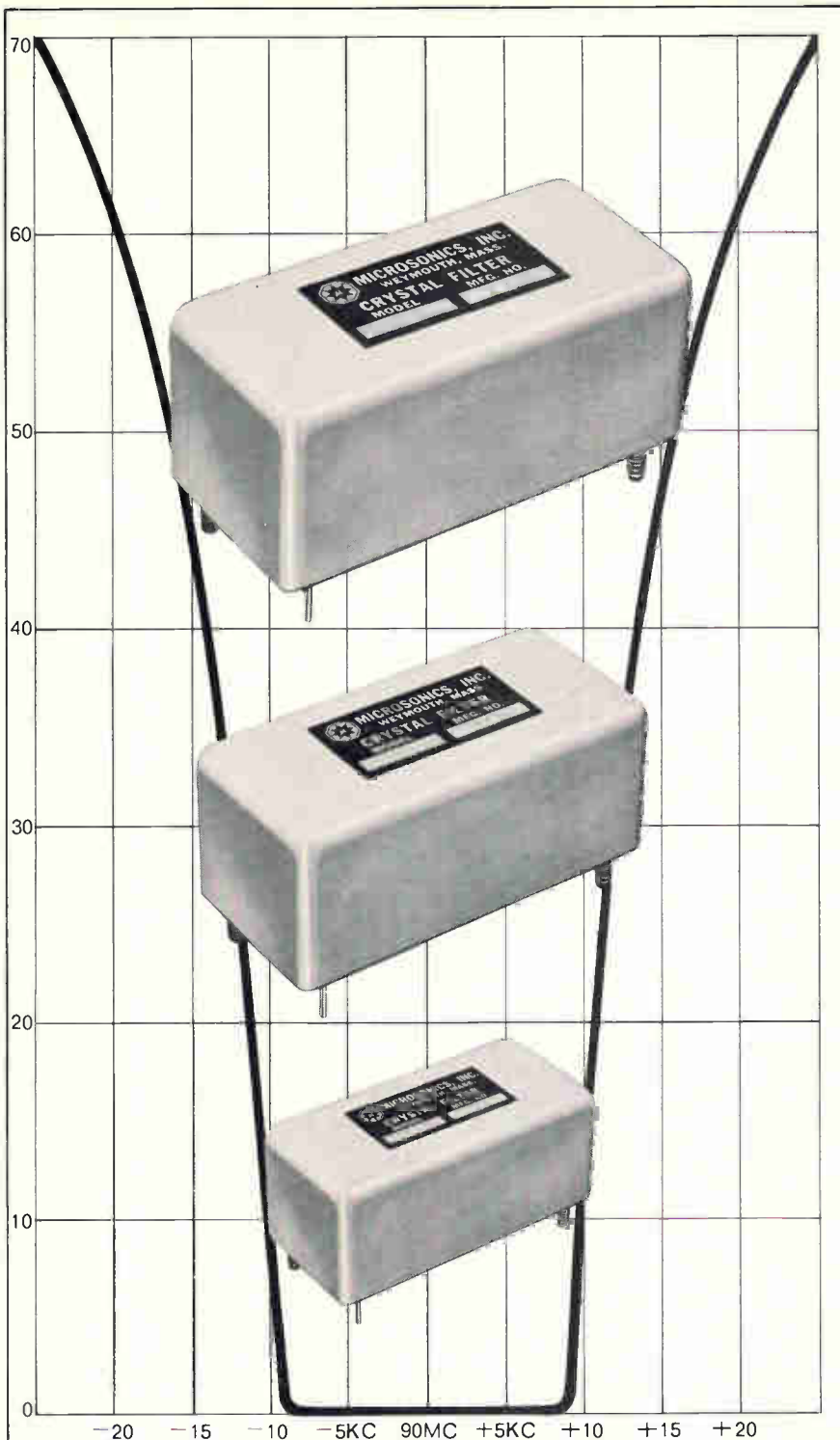

**MICROSONICS**  
*for proven design, reliability &  
 performance in*  
**CRYSTAL FILTERS**



Write for Bulletins today  
**MICROSONICS**  
 60 Winter Street, Weymouth, Mass. 02188  
 Tel: 617 337-4200  
 A division of the Sangamo Electric Company

scheme. Instead, a pressure transducer senses the force from the operator's hand and converts this force into a drive signal that is sent to the stepping motors. Since the digitizer is driven by motors, the arm automatically locks and tracks in the direction of an applied force. The drive mechanism can be locked in any one of eight vector directions.

The basic terminal, Interact-graphic I, consists of a 6 $\frac{3}{8}$ -by-8 $\frac{1}{4}$ -inch storage-tube display with a 58-key alphanumeric keyboard and joystick controlled cursor, a 34-by-44-inch plotter/digitizer, and a basic Fortran software package. The terminal costs \$47,500.

Computervision Corp., Northwest Industrial Park, South Ave., Burlington, Mass. 01803 [390]

Data handling

**Digital filter  
 can be multiplexed**

Modular, programmable unit  
 offers sampling rates  
 up to 500 khz at 16 bits

**High accuracy** is the big attraction in digital filters. And when a programmable memory is added, the filter can perform a wide variety of signal processing tasks. By using a sampled-data approach to perform arithmetic operations, the digital filter can be used in communications, acoustic, biomedical, and geophysical systems to perform many functions, including automatic testing, speech processing and simulation, adaptive equalization, system simulation, and modulation-demodulation.

A programmable digital filter developed by Rockland Systems has four basic components—adders, multipliers, shift-register delays, and a memory. It uses a cascaded-modular approach; the basic building block is second order—two poles and two zeros. These blocks then are combined or multiplexed to realize any number of filters in any desired order. A serial, rather than



**At 100,000 G's acceleration  
this ceramic chip weighs  
only 3/4 of a pound!**



**Would your ICs maintain mechanical integrity under this force?**

At 100,000 Gs acceleration this 101mm by 101mm by 15mm chip exerts a pulling force of 3/4 of a pound. The chart below illustrates the weight of the chip at other G levels. More and more companies are centrifuging integrated circuits to verify their mechanical integrity. The cost in production quantities is low and the quality control benefits are significant. Call or write for a copy of our new 44 page CENTRISAFE® Engineering Data File. It tells the whole story.

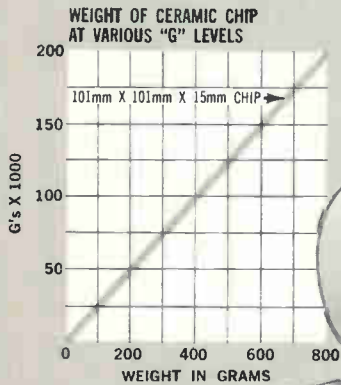

**TRIO-TECH, INC.**  
OF CALIFORNIA  
2435 N. Naomi Street, Burbank, California 91504  
(213) 846-9200, TWX: 910 498-2709,  
FAX: RHN Burbank, Cable: TRIOCAL

**ANNOUNCING**

**PLUG-IN DIGITAL MEASURING SYSTEM  
MODEL 3202**



3 1/2 digit. Nine wide range plug-ins for measurement of AC-DC Voltage, DC Current, Resistance, Capacitance, Frequency and Time. Digital Printer and Set Point Controller accessories.  
Main Frames from \$385.00  
Plug-Ins from \$100.00

**DIGITAL MULTIMETER  
MODEL 3300**

3 1/2 digit, with internal rechargeable battery pack. 26 ranges for measurement of AC-DC Voltage, AC-DC Current, and Resistance.

\$395.00 including rechargeable battery pack



**25 MHz OSCILLOSCOPES  
MODEL 5000 & 5002**

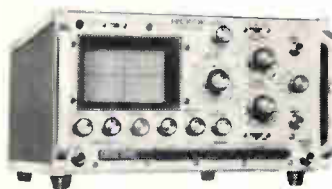

Solid State, high performance single and dual trace models. Simplified, stable triggering to 50 MHz.

Single Trace \$725.00  
Dual Trace \$995.00

**NEW INSTRUMENTATION CATALOG**

A new Catalog describing these instruments and listing your local Hickok Representative is now available. Send for your copy today.



**HICKOK** INSTRUMENTATION GROUP  
10514 Dupont Ave., Cleve., Ohio 44108  
Phone (216) 541-8060

# DIGIMETRIX

- 5 Functions - 25 fully PROTECTED ranges.
- 300 mV FS (1000  $\mu$ V resolution) AC and DC.
- 10 M $\Omega$  CONSTANT input impedance.
- Analogous indicator.



## Digital-IC test system TX 935 A

We are so confident of the performance and operating features our tester offers that we are prepared to install it in your plant, instruct your personnel in its use and leave it for up to three months under our "extended evaluation — with option to purchase — plan."

Your only obligation during this period is a nominal monthly rental of \$250 which is applied in full toward the purchase price.

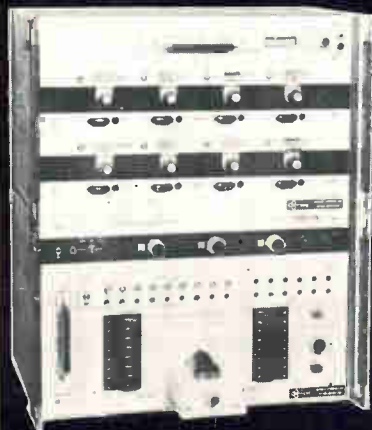

TX935A will functionally check and analyze all types and configurations of ICs for significant input and output parameters plus complete logic function. Programming is by plug-in PC board or optional manual pinboard.

Three modes for production testing and evaluation; Automatic GO/NOGO; Automatic Pinpointing of Defects; and Semi-Automatic Analysis & Display of each Logic Function. Gating (at no extra cost) for use with automatic sorters.

**COST?** As illustrated above, the Analyzer and Power Supply, ready to operate — \$4100. Additional units are available for expanded capabilities up to a System Cost in the \$6000 range.

Sound interesting? Contact **ADVANCED TECHNOLOGY AND SYSTEMS CORPORATION**

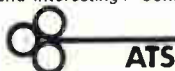

1143 Post Road, Riverside, Conn. 06878  
Phone (203) 637-4337 — Telex 96-5979 —

ITT - METRIX local agents  
all over the world.



parallel, approach is used to yield digital circuitry. Its modular format is well suited to large-scale integration, the flexibility of different filter configurations by a change in memory, and multiplexing for efficient hardware utilization.

Rockland Systems' 4000 series offers an internal bit rate of 16 bits and a 500-kilohertz sampling rate; word lengths can be modified in four-bit increments. The filters can be time-shared with up to 50 second-order filters at a 10-khz sampling rate, available from each unit. They also are available either as recursive structures—both poles and zeros for sharp frequency-domain cutoffs—or as nonrecursive structures—zeros only for finite impulse responses. The filters use bipolar transistor-transistor logic, while the shift-register delays are constructed using metal oxide semiconductors to achieve high packaging densities. The filters are programmable by read-write memories for the multichannel mode and by read-only memories for the fixed-filter mode.

The 4100 series filter is a general-purpose signal processing unit for data analysis, simulation and testing. It includes a read-write memory with optional keyboard entry, or an ROM with preset filter coefficients. The 4300 series unit can be used as a wave analyzer to provide extremely narrow band-pass or band-reject filters with either constant or programmable bandwidth throughout its frequency range. The 4400 series unit is offered, as a programmable comb filter, while for speech synthesis applications, the 4500 series unit has been developed. The 4600 series unit can be programmed to be a variable low-pass, high-pass, band pass or band-reject filter. Finally, the 4900 series filter is designed for phase equalization, variable delay, and Hilbert transformation.

Prices for the filters range from \$5,000 for an all-digital device with no analog-digital and d-a conversion and only one ROM to \$20,000 for a fully programmable unit that features 64 second-order sections with an input for either a keyboard or a minicomputer. All filters are approximately 5¼ by 17 by 14 inches. Delivery time is 120 days.

Rockland Systems Corp., 131 Erie Street, East Blauvedt, N.Y. 10913 [391]



# PASS ME THE AVO!

SIL VOUS PLAIT • POR FAVOR

Worldwide, "Pass the AVO" means someone wants the most accurate, most reliable multimeter... anywhere. Twenty four ranges for AC and DC current, voltage and resistance. Full meter protection includes fuse, velocity actuated mechanical cutout and diode protection for meter movement.



This internationally famous AVO Model 8 has for over 50 years set the highest standard in multimeters. Over a million in use today!

Calibration, parts and service by factory trained personnel are available at our Plainview, N.Y. facility and in most countries throughout the world.

## GENCOM DIVISION

varian/EMI

90 EXPRESS STREET PLAINVIEW N Y 11803  
TELEPHONE (516) 433 5900

Write for your copy of Catalog 958 describing the AVO Model 8 and many other AVO instruments.

Circle 178 on reader service card

## FOR EXCELLENCE IN PUSH BUTTON SWITCHES SPECIFY GRAYHILL

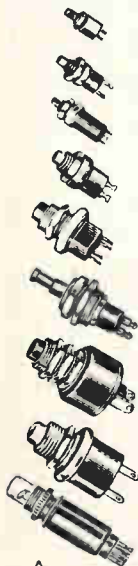

### A WIDE SELECTION TO CHOOSE FROM...

- Ratings To 10 Amp.
- SPST, SPDT, DPST, DPDT
- Diameters From 1/4" To 7/8"
- Behind Panel Dimension As Small As .32"
- Momentary - Push-Pull - Lighted - Alternate Action (Push-On, Push-Off)
- Wiping, Snap Action And Butt Contacts
- Solder Lug, "Faston" Or Printed Circuit Terminals
- Life Expectancy Up To 1,000,000 Operations

For your Grayhill Engineering Catalog offering complete technical data—contact



523 Hillgrove Avenue  
LaGrange, Illinois 60525  
Area Code 312, Phone 354-1040



... the Difference Between Excellent and Adequate

Circle 179 on reader service card

we're  
**BIG...**

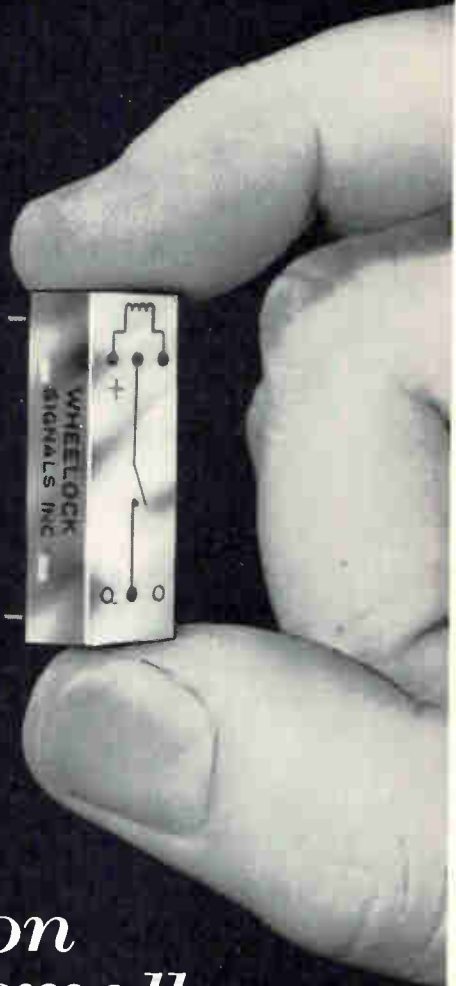

## on small REED RELAYS

Wheelock probably has the reed relay you're looking for. Write for catalog describing the Wheelock Big Family of Small Relays

*Wheelock*

SIGNALS, INC.  
273 Branchport Ave.  
Long Branch, N. J. — 201-222-6880

Circle 161 on reader service card

161



# In Florida Business Adds Up!

**We've Got the Competitive  
Edge For New Industry –  
And We Can Prove It!**

When you add up the competitive advantages that are part of Florida industrial site selection, it's a stopper.

We can show you a variety in site selection few other states can boast. Where else can you have your choice of **13** deepwater ports — more than many foreign countries?

We have a new set of laws concerning revenue bond financing that will make your comptroller's eyes light up.

Our recruitment and training program solves the staffing problem before you open your doors. (And at no cost to you!)

For the young and technically skilled we have educational, recreational, and living advantages that make Florida a prime attraction.

Florida has a great deal for you. Before you make a move, take a good look at that competitive edge. Phone (904) 224-1215, or send the coupon.

## Florida

DEPARTMENT OF COMMERCE  
107 WEST GAINES STREET  
TALLAHASSEE, FLORIDA 32304

**HANDY COUPON FOR YOUR CONVENIENCE!**

Florida Department of Commerce / 107 West Gaines St.  
Tallahassee, Florida 32304 / Att.: Dept. "D-1"

*I'm interested in a business or industrial future in Florida.  
Please send me more information.*

Name .....

Title or Position .....

Company .....

Street .....

City ..... State ..... Zip.....

# High-voltage MOS drives display

10-bit shift register withstands 100-volt transients, is designed to work with gas-discharge tubes or EL panels

**When you build** an MOS transistor that can handle 100 volts and put it on the same IC chip with a low-threshold shift register, you get a shift register that can be driven by transistor-transistor-logic circuits and can drive a Nixie or Digivac tube directly.

This is just the course taken by National Semiconductor in its MM 5081. It's a high-voltage MOS static

shift register that has TTL-compatible serial input, 10 parallel outputs that can stand off -55 volts, 10 latching-type storage stages, and a serial output. This combination of functions allows the MM 5081 to directly drive lamps, electroluminescent panels, and the new gas-cell arrays [*Electronics*, March 16, p. 98].

Usually, a Nixie driver is a de-

coding circuit driving a transistor that drives the Nixie. The only high-voltage driving circuits available previously were hybrid units, without a memory capability.

Two operational modes are possible with the MM 5081. The register stages can either shift the bits to the serial output for recirculation, or store the data indefinitely. Thus the displayed characters can

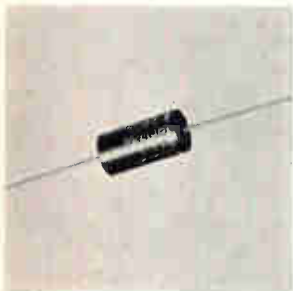

Silicon rectifier cartridges series RC1731-4 feature a rectified output current of 500 ma at 25°C ambient, voltages from 1,500 to 5,000 v, and forward half sine wave, single cycle surge currents of 50 amps peak. All units are constructed of voidless/non-cavity, glass passivated, diffused rectifier diode cells. Rectifier Components Corp., 124 Albany Ave., Freeport, N.Y. [436]

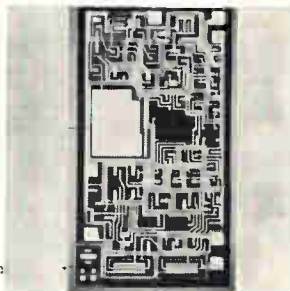

Monolithic J-FET input operational amplifier  $\mu$ A740 provides betas of more than 15,000 and operates with 200 pa max. current into either input, which is less than one-tenth the input current offered by punch-through devices. Input impedance is  $10^{12}$  ohms. Unity gain slew rate is 6 v/ $\mu$ sec. Fairchild Semiconductor, 313 Fairchild Dr., Mtn. View, Calif. [437]

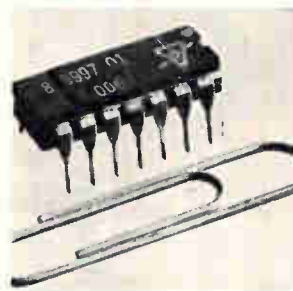

Monolithic TTL IC's series 7400N consist of 14 circuits, including NAND and AND-OR-INVERT gating functions as well as dual D and J-K flip flops. They are enclosed in an all-ceramic, dual-inline 14-lead package known as Cerdip. All operate from a single 5-v supply and are performance rated over the range of 0° to +75°C. Sylvania Electric Products Inc., Buffalo, N.Y. [438]

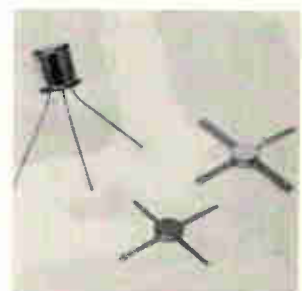

Hermetically sealed silicon, gold metalized open transistors are designated AT-25, 25A and 25B, in TO-72 packages, and AT-50, 50A, 51, 52 and 55 in stripline packages. They offer a choice of graded low-noise, high unneutralized gain and medium output power options. The AT-25 is for use to 1,000 Mhz; the AT-50, to 2,000 Mhz. AvanteK Inc., Copper Rd., Santa Clara, Calif. [439]



Single diffused mesa silicon npn power transistors now include the TO-66 package. Features include:  $V_{CBO}$  rating to 140 v, and  $I_C$  of 4 amps (typically) at 25°C, with a power capability of 30 w. Peak collector currents range from 3 to 7 amps. A unit price of 84 cents each in 100-999 lots is offered for the 2N3054 transistor. Power Physics Corp., Box 626, Eatontown, N.J. [440]

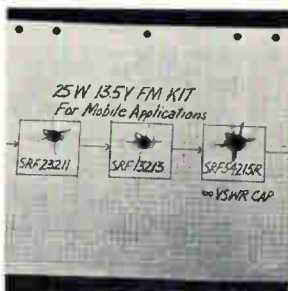

R-f power transistor kit is for commercial mobile radio applications. It consists of a pre-driver (SRF23211), driver (SRF13213) and output stage (SRF54215R) in stripline stud cases. The kit is for use in f-m applications where output power levels up to 25 w at 175 Mhz are needed with a 13.5 v supply. Solitron Devices Inc., 1177 Blue Heron Blvd., Riviera Beach, Fla. [441]

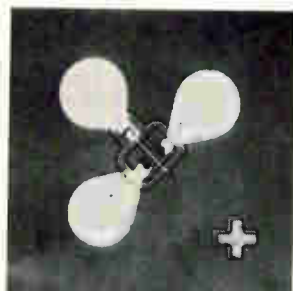

Eight matched dual n-channel FET's feature ultralow gate current and low differential drift. The 2N5902 through 2N5905 have a maximum  $I_G$  of 3 pa, while the 2N5906-9 have only 1 pa  $I_G$ . The most closely matched devices in the series, 2N5902 and 2N5906, offer 5 mv maximum offset with 5  $\mu$ v/°C differential drift. Siliconix Inc., Laurelwood Rd., Santa Clara, Calif. [442]

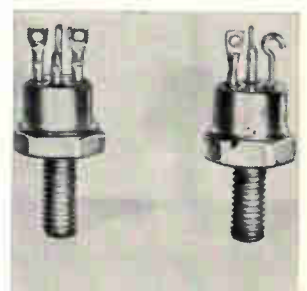

Power switching transistors, 2N5658 and 2N5659, are 20 amp, 30 w devices. A failure rate of less than 0.01%/1,000 hours can be attained in normal service. Surface leakage has been reduced to the nanoamp level. Units are suited for military/aerospace and control systems applications. Price (1,000 pieces) is \$29 each. Unitrode Corp., 580 Pleasant St., Watertown, Mass. 02172 [443]

# THE MOST ACCURATE RF MILLIVOLTMETER PROGRAMMABLE AVAILABLE ONLY FROM BOONTON

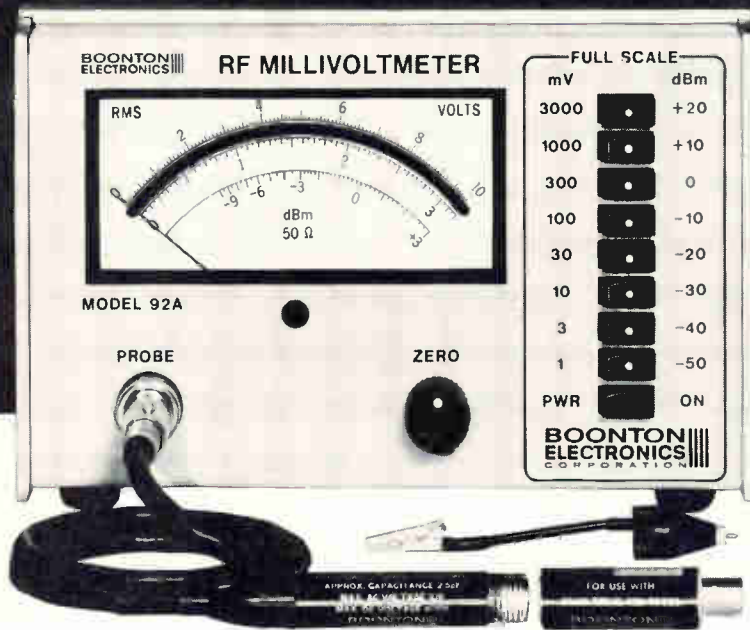

The Model 92A has been designed as the definitive rf millivoltmeter. Accuracy at all frequencies and voltage levels is the best ever offered by Boonton Electronics, long a leader in the rf millivoltmeter field.

Fast warm-up, high reliability, long intervals between calibrations, plug-in PC boards for ease of servicing, light weight, and no heat, are characteristics of the Model 92A's solid state design.

## STANDARD FEATURES

- Programmable
- Measures 100  $\mu$ V to 3 V\* from 10 kHz to 1.2 GHz
- True RMS response to 30 mV\*\*
- Convenient push-button ranging and half-rack packaging
- Fast, high level dc output
- High input resistance, low input capacitance
- Overload protection to 400 V dc, 10 V ac
- VSWR less than 1.15 up to 1.2 GHz

Price: \$750 Standard Unit

\*To 300 V, up to 700 MHz with accessory 100:1 divider  
\*\*To 3 V, up to 700 MHz with accessory 100:1 divider

Call or Write for Details or Demonstration

**BOONTON**  
**ELECTRONICS**  
CORPORATION

ROUTE 287  
PARSIPPANY, N.J. 07054  
Telephone: 201-887-5110  
TWX: 710-986-8241

... billboard control  
is one of the first jobs ...

be swept along a line of indicators, frozen on a stationary display, or made to reappear periodically at any desired repetition rate. Under another arrangement, a code-converting/character-generating read-only memory can be placed at the register input to display numbers and symbols, or alphanumeric. Thus a circuit designer can obtain almost as much flexibility from a lamp or a panel display as he could from a cathode-ray tube. "In fact," says Gene Carter, marketing manager for MOS products at National, "one of the first applications for the 5081 is controlling a matrix of neon lamps in a billboard."

Carter says that the key development in making the MM 5081 "is more than the actual device structure, it's also the manufacturing process." He compares the process to the forming of an electrolytic capacitor. "At time zero," he says, "an electrolytic capacitor is a dead short and it has to be formed by applying a voltage across it. We do a similar thing to the output transistors in the 5081. In a shift register, the output is usually a resistor and a transistor used in an inverter configuration, but because of the high-voltage characteristics of the output transistors used in the 5081, we have an uncommitted drain output, and the lamp that is being driven is the load resistance.

"The ignition voltage—the voltage at which the lamp will fire—may be around 55 volts, but at time zero, the breakdown voltage of the output transistor is about 40 volts. So we have to form it," Carter notes. "We do this under a stress setup in which we apply 100 volts across the output transistors through 40-kilohm current-limiting resistors for one second. This stress setup takes advantage of the breakdown voltage phenomenon in the output transistors and pushes up the breakdown voltage from 40 to about 70 volts."

The shift register is available off the shelf for \$25 each in quantities of 100.

National Semiconductor Inc., 2900 Semiconductor Drive, Santa Clara, Calif. [444]



New materials

## Mix of resins sets viscosity



Eccoseal 63 and Eccoseal 63HV are a pair of compatible, very low electrical loss resins, the former with low viscosity and the latter with high viscosity. Thus, by mixing the two in the proper proportions, any viscosity between 10 and 20,000 centipoise is available to the user. Other features include low vapor pressure prior to polymerization, low evaporation during cure, and flat dielectric properties from  $-65^{\circ}$  to  $+375^{\circ}$  F. The system is recommended for impregnating capacitors, coils, filters, and other electronic components where maintenance of high Q is important. Emerson & Cuming Inc., Canton, Mass. 02021 [421]

Low-loss dielectric material called Hi-Q Potting is for encapsulating high-frequency and microwave devices and circuits. The low dielectric constant and small dissipation factor limit circuit losses at high frequencies. Material is available from inventory priced at \$12 per lb with liberal quantity discounts. Transene Co., Route 1, Rowley, Mass. 01969 [422]

Custom-clad metal strip known as Econ-O-Clad, in combinations of two or more ferrous, non-ferrous, or precious metals, is now being produced. It is used to facilitate production of items such as lead frames for integrated circuits, frames and lids, capacitor and battery cans, base tabs and solder preforms. Engelhard Minerals & Chemicals Corp., Pine & Dunham Sts., Attleboro, Mass. 02703 [423]

High-conductive elastomer silicone compound called Xecon CS-1 is for use in critical emi, waveguide and pressure sealing applications, and is available in sheets, cut gaskets or molded gaskets. Xecon has durometer ratings from 40 to 85; will withstand a continuous temperature of  $200^{\circ}\text{C}$ ; will not crack, even when bent on itself; and will withstand temperatures to  $-60^{\circ}\text{C}$ . It has resistivities from 0.001 to 0.010 ohm-cm, a tensile strength from 100 to 500 psi, elongations from 100 to 350 psi. Metex Corp., Edison, N.J. [424]



o.e.m.

# LogAbax

new product  
serial printer 50 ch./sec.  
model Lx 50

an inexpensive solution, for an output peripheral, suitable for all e.d.p. systems.

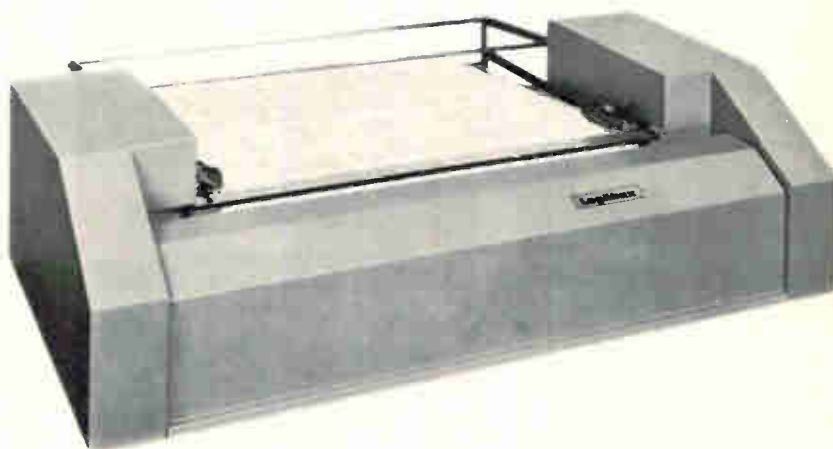

## specification summary

The printer is of the mosaic type and functions character by utilizing standard paper forms.

PRINTING VELOCITY	50 ch./sec.
Nº OF CHARACTERS PER LINE	233
DENSITY	2,5 mm (0.097")
CHARACTER SET	64
HEIGHT OF CHARACTERS	2,5 mm (0.097")
HEAD VELOCITY	150 ch./sec. 14.65"/sec. Rapid skipping to one of 32 positions.
FORM HANDLING	1 or 2 sets of form tractors. A set consists of four tractors one pair to feed, the other pair as take up.
FORMS	SPEED. 30 lines/sec. Standard perforated, continuous, fanfold. Up to 60 cm (23.5") max. N.C.R. or Minnesota. Up to 6 copies.

 **LogAbax**

79, avenue Aristide-Briand

94-ARCUEIL

Tel. 253.20.85

FRANCE

## manufacturer of office computer

See us at international computer conference and exposition.

WASHINGTON, Hilton Hotel, Wash. D.C.

June 16 - 18 - 1970 - Booth Nº 118

## TAKE THE SKILL OUT OF PHASE MEASUREMENTS

SAVE TIME WITH AN EASY  
TO READ DIGITAL READOUT



- Ideal for phase linearity and critical measurements where best commercial accuracy is required. Phase reading accuracy:  $\pm 0.1^\circ \pm \phi/180 \times 0.25^\circ$  where  $\phi$  is phase angle being measured.
- Switchable phase detector response time from 30 ms to 4 secs. optimizes phase information display time.
- With one instrument and without the need for accessories you have the flexibility of measuring phase at signal levels from 1 mV to 400 V on either channel over the range 10 Hz to 2 MHz. (Another WILTRON phase meter goes down to 0.5 Hz).
- For plotting or for external circuit control, phase information is available from three separate outputs: (1) 4 digit NIXIE tubes, (2) Analog of phase, (3) BCD 1248 for computer tie-in.
- For direct phase measurements on balanced transmission lines, lattice networks, etc., the input circuits can be switched to differential or single ended.
- Phase reference switchable from  $0^\circ$  to  $180^\circ$  for maximum accuracy at small and large phase angles.

**NEW LOW PRICE: \$1,865.**

WILTRON also offers a Model 350 phase meter with a meter readout for \$885.



930 EAST MEADOW DRIVE  
PALO ALTO, CALIFORNIA 94303  
(415) 321-7428

W102

## New Books

### Plug-in data processing

Information utilities  
Richard E. Sprague  
Prentice-Hall Inc.  
200 pp., \$8.95

Dick Sprague is one of perhaps a dozen individuals whose names are almost synonymous with time-sharing, the cashless society, and other manifestations of information utilities. Therefore, one would expect his book on the subject to be quite good. In general, it lives up to this expectation.

Its only fault is that it is inclined to be long on rhapsody and short on hard facts. Therefore, from the engineer's point of view, it is pretty light.

Sprague compares the information utility to the telephone system, and shows the interrelationships of various kinds of utilities. He describes several existing or proposed information utilities, in banks, brokers' offices, the travel industry, professional billing services, information retrieval, and others.

The book also describes six different kinds of information utilities in some detail; the general-purpose type, the checkless society, theater-ticket services, a lottery service, tax service, and personal data service. This last provides information for a manager to assist him in managing, be he the corner grocer or the president of General Motors. Incidentally, it also happens to be a plug for Sprague's own business.

In the section of the book on design considerations, the engineer, looking for something to sink his teeth into, won't find it. The discussion is at a rather low level, technically. The section also takes up the regulatory implications of an information utility.

The concluding part, entitled "Today and Tomorrow," is intended as a collection of blue-sky projections—what our grandchildren will do as a result of the ideas discussed in the earlier part of the book. But the collection lacks the impact that the author perhaps intended it to have, because to a certain extent the whole book is written as a blue-sky projection.

But there is a long, strongly

worded, and excellent section on the invasion of privacy. Sprague's position here is that a national data bank would eliminate the uncontrolled invasion of privacy now practiced by credit bureaus and other organizations that extend credit.

### Recently Published

**Fault Diagnosis of Digital Systems**, H.Y. Chang, E.G. Manning, and G. Metzger, John Wiley & Sons, 159 pp., \$9.50

Describes techniques for generation, selection, and evaluation of automated diagnosis procedures. Included are basic definitions, methods of deriving and selecting tests for combinational and sequential circuits, a discussion of a system of programs for generating and simulating tests, and ways to interpret diagnostic test results.

**Electromagnetic Energy Conversion Devices and Systems**, S.A. Nasar, Prentice-Hall, 391 pp., \$15.50

Deals with incremental motion transducers, energy conversion in continuous media, induction, synchronous, and d-c machines. Emphasis is on using analog and digital computers, and applications of electromagnetic field theory.

**Medical Electronic Equipment**, G. Dummer and J. Robertson, Pergamon Press, 2 volumes, vol. 1 837 pp., vol. 2 877 pp., \$27.00

Lists biomedical equipment from all over the world. First volume covers clinical, diagnostic, and therapeutic equipment; second lists monitors, computers, and recorders. Both volumes classify according to type and describe equipment by specification sheets.

**Electronics Components and Measurements**, Bruce Wedlock and James Roberge, Prentice-Hall, 338 pp., \$12

Provides specific information on a broad range of electronic test equipment and procedures for their application. Format is designed to give the reader a practical knowledge of modern electronic components and instruments, how they work, and the purposes for which they are used.

**Choosing and Using Ship's Radar**, Captain F.J. Wylie, American Elsevier, 150 pp., \$8

Examines factors that affect quality of shipboard radar performance. Includes a brief description of design, choice, installation, maintenance, and outlines procedure for extraction and computation of radar data.



# Technical Abstracts

## Keeping ECL fast

Interconnection of ECL Circuits for Maximum Gate Density  
Emory C. Garth  
Texas Instruments  
Austin, Texas

Before the full potential of high-speed emitter-coupled logic can be realized, some major advances in techniques for interconnecting integrated circuit chips are necessary. The problem with present commonly-used interconnections is that they cause propagation delays that are a very significant percentage—often greater than 25%—of the delay of the ECL circuit itself.

Fortunately, partial solutions are available so that it's not necessary to wait until new and exotic interconnection designs emerge from the lab before enjoying the advantages of ECL. As a sample of what can be done by adapting present interconnection methods to ECL, Texas Instruments has designed and built a multilayer circuit-board and IC assembly that significantly reduces propagation delay due to wiring. The circuit board contains 17 interconnection layers and can hold 308 dual-in-line-pin IC packages. The card contains 352 connector pins—272 for signals and 80 for power-supply connections.

This approach veers away from conventional designs in at least one major respect: the characteristic impedance of the transmission-line interconnections is 40 ohms instead of 50 ohms. This lower impedance permits a 15% reduction in the thickness of the metal, and thus reduces the overall thickness of the circuit board. More important, the impedance allows a 25% reduction in transmission-line length for the same distributed line load.

Another difference is the use of short stub lines, which appear as lumped capacitances to the signal source, as well as the usual distributed-capacitance transmission lines. Although these stub interconnections add to both switching time and propagation delay, the net increase is less than if distributed transmission lines were used in their place because of the shorter distance the signal must travel. The maximum permissible

length for a stub involves a trade-off between switching speed and ease of interconnection, and experimental measurements under various load conditions should be taken to determine the maximum length.

The TI concept uses multilayer motherboards to interconnect the circuit boards to allow continuation of transmission lines on and off the circuit boards.

Presented at IEEE, New York, March 23-26.

## Help from holograms

Holographic Optical Memories For Data Storage  
L.K. Anderson  
Bell Telephone Laboratories  
Murray Hill, New Jersey

Photographic film long has been recognized as a potential high-density storage medium. But mechanical problems, such as possible degradation by dust particles and the difficulty of precisely aligning an optical retrieval system, have delayed genuine progress in optical memory design.

Holograms are changing this picture. The nature of holography is such that a speck of dust may lower readout intensity but it cannot completely obscure a bit. Holograms also are relatively insensitive to misalignment of the retrieval beam; a bit only can be misread when the beam-positioning system is severely degraded.

Thus far, experimental memories fabricated with holography have been read-only types. High-speed acousto-optic deflection systems now provide memories with over 16 million bits in the form of 4000 "pages", each of 4,096-bit capacity with 2-microsecond random access time to each page. The reconstructed holograms are imaged onto a 4,096-phototransistor array; interim storage can be effected by replacing the phototransistors with charge-storage flip-flops.

Interest in read-write memories has been spurred by recent work with photochromic materials. One changeable holographic memory has been proposed that could use either a photochromic film or even a thermoplastic as the recording medium. An extension of this design includes photochromic solids

# think one plane



## MINIATURE NEON ELFIN®

ELFIN® — the new single plane, segmented neon readout indicator provides brighter displays, uniform clarity, wider viewing and easy readability. 0.41" diameter allows four digits in a 2" space. Numerals are .413" high.

The MG-19 ELFIN® forms numerals 0-9, + and —, some alpha symbols and a decimal point.

The MG-17 ELFIN® displays numerals 0 to 9, and has two decimal points.

\$2.99 each in 1000 lots.

MS-250A



MS-4000B

## MINIATURE INCANDESCENT

ALCO's low cost metal encased readouts have reliable T-1, 5-volt MIL GRADE lamps. Large, easy-to-read figures on a single plane provide a bright display that is clearly read under ambient light conditions. Numeric and symbol readouts are available. Character height .46" (MS-250A), and .6" (MS-4000B).

These low-voltage readouts are designed to be used with ALCO 7-Segment Decoder-Drivers and can be mounted with stock mounts and bezel kit assemblies.

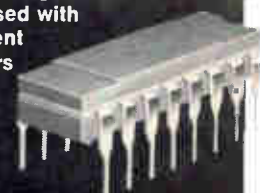

Send for detailed catalog.

# ALCO

ELECTRONIC PRODUCTS, INC.

Lawrence, Massachusetts 01843



## AUTOTRACK MOUNT



360 degree azimuth, 21° degree elevation sweep with better than 1 mil. accuracy. Missile velocity acceleration and slowing rates. Amplidyne and servo control. Will handle up to 20 ft. dish. Supplied complete with control chassis. In stock—immediate delivery. Used world over by NASA, USAF, MP-61-B. Type SCR-584. Ideal satellite tracking. Large spare parts inventory for back-up.

### ANTI-AIRCRAFT GUN MOUNT

Will handle 6,000 lbs. rapid slew through 360° azimuth, 180° elevation. Mobile.

### COUNTERMEASURES TRAINER

Covers L-band, S-band, X-band, all radars. Tacan, UHF drone control, VHF drone control, Communications band. All housed in shelter.

**FIBERGLASS RADOME** Will handle 20 foot antenna. Easily erected & shipped. \$4800.

## PULSE MODULATORS

### 250 KW HARD TUBE PULSER

Output 16 kv 16 amp. Duty cycle .002. Pulses can be coded. Uses 5D21, 715C or 4PR60A. Input 115 v 60 cy. AC \$1200 ea.

### MIT MODEL 9 PULSER 1 MW—HARD TUBE

Output 25kv 40 amp., 30kv 40 amp. max. Duty cy. .002. 25 to 2 microsec. Also 5 to 5 microsec. and 1 to 5 microsec. Uses 6C21. Input 115v 60 cycle AC. Mfg. GE. Complete with driver and high voltage power supply. Ref: MIT Rad. Lab. Series, Vol. 5, p. 152.

### 2 MEGAWATT PULSER

Output 30 kv at 70 amp. Duty cycle .001. Rep. rates. 1 microsec. 600 pps. 1 or 2 msec. 300 pps. Uses 5948 hydrogen thyratron. Input 120/208 VAC 60 cycle. Mfr. GE. Complete with high voltage power supply.

### SCR 584 AUTOTRACK RADARS

Our 584s in like new condition ready to go, and in stock for immediate delivery. Ideal for telemetry research and development, missile tracking, satellite tracking. Fully Deso. MIT Rad. Lab. Series, Vol. 1, pps. 207-210, 228, 284-286. Comp. Inst. Bk available \$25.00 each.

HUNDREDS MORE IN STOCK  
LARGEST RADAR  
INVENTORY  
IN WORLD.  
WRITE  
FOR  
CATALOG  
ON YOUR  
LETTERHEAD

## AUTOMATIC TRACKING SYSTEM

Sci. Atl. Mod. 3101-370 Antenna Pedestal. AZ-EL 15 deg. per second rated speed. 23 inch dia. bearing. Complete w/control console & mag. amplifiers. Also in stock complete Glo-track receiving system for 200-400 MHz telemetry band including 12' square quad. Ilexix. All part of Atlas missile instrumentation system.

### AN/GSS-1 PASSIVE TRACKER

10 cm passive automatic tracking system with 6 foot parabola. Complete, mounted on van. Supplied by GE for Atlas instrumentation system.

## MICROWAVE SYSTEMS

### SPARE PARTS IN STOCK

Nike Ajax, Nike Hercules, M-33, MPS-19, TPS-ID, TPS-10D, FPS-6 SPS8, SCR-584, MPQ-18. From Largest Inventory in World

### 200-2400 mc. RF PKG

Continuous coverage, 30 Watts Cw nominal output. Uses 2C39A. Price \$575.

### L BAND RF PKG

20 KW peak 990 to 1040 Mc. Pulse width .7 to 1.2 micro sec. Rep. rate 180 to 420 pps. Input 115 vac Incl. Receiver \$1200.

### 200-225 mc RADAR SYSTEM

1 Megawatt output, 200 nautical mile range for long range detection of medium and high altitude jet aircraft as well as general search. AN/TPS-28.

### AN/GMD-1B RAWIN RADAR

L-Band Radiosonde Tracking System. Complete, now cond. in stock for immed. del. AN/GMD-2 computer mfg. Gen'l Mills also in stock.

### 500 KW L BAND RADAR

500 kw 1220-1359 msc. 160 nautical mile search range P.R.I. and A scopes. MTI. thyratron mod 5326 magnetron. Complete system.

### C BAND AUTOTRACK

1 Megawatt 10 ft. Parabola. Sperry.

### AN/GPG-1 SKYSWEEP TRACKER

3 cm. auto. tracking radar system. Comp. pkg. w/indicator sys. Full target acquisition & auto. tracking. Input 115v 60 cy. new. In stock for immed. del. Entire sys. 6' x 3' x 10'. Ideal for infrared tracker, drone tracker, missile tracker, R & D

### INDICATOR CONSOLES

AN/SPA-4A, PPI 10", range to 300 mi.  
VJ-1 PPI 12", range to 200 mi.  
VL-1 RHI 12" to 200 mi. 60K ft.

# Radio-Research Instrument Co.

45 W. 45th St., New York, N.Y. 10036 ■ 212-586-4691

## Technical Abstracts

or such ferroelectric materials as single-crystal lithium niobate, offering a potential for vastly increased capacity by exploiting a third dimension. It would be possible to superimpose as many as 1,000 holograms in the same small area by slightly altering the beam-illumination angle to read each hologram.

Presented at IEEE, New York, March 23-26.

## Shift from the lab

Microstrip diode phase shifters at C and X bands  
Charles S. Ward and Raymond G. Forest  
Microwave Associates, Inc.  
Burlington, Mass.

Miniature four-bit phase shifters for C and X bands are beginning to emerge from the laboratory. Recent work sponsored by the Rome Air Development Center has resulted in the development of wide-band transmission-type shifters which are both small enough for airborne applications and able to handle high average power. Four phase shifters have been made, two at C band, including one with integral drivers, and two at X band. One of the X-band units also includes drivers and this one, like its C-band equivalent, is limited to 100 watts peak power and 10 watts average. The bandwidths of these phase shifters lie between 5% and 7%, insertion loss ranges from 1.7 to 2 decibels, and switching speed is less than a microsecond.

All of the units use a transmission line periodically loaded with diode-terminated hybrids and stubs, or both. The single high-power shifter is packaged in an alumina wafer in a section of WR-90 waveguide and uses 24 glass-sealed pin-diode chips for stub termination. Single-step ridge transformers provide input and output transitions from strip to waveguide. This device has an average vswr of 1.28 through its band—425 megahertz centered at 8.5 gigahertz—and an average insertion loss of 2 db. Phase error is about three degrees rms and power-handling capability is 3 kilowatts peak, 30 watts average.

Presented at IEEE, New York, March 23-26.

ADDRESS BOX NO. REPLIES TO: Box No. Classified Ad. Dept. of this publication. Send to office nearest you.  
NEW YORK, N. Y. 10036; P. O. Box 12  
CHICAGO, Ill. 60611; 645 N. Michigan Ave.  
SAN FRANCISCO, Cal. 94111; 255 California St.

## POSITION VACANT

Senior Technician or electronics engineer with 3-5 years experience in consumer electronics needed to teach in the area of electronics repair. Salary commensurate with qualifications. Send resume to Dr. A. A. Paloumpis, Dean of Instruction, Illinois Central College, P.O. Box 2400, East Peoria, Illinois 61611.

## EMPLOYMENT SERVICES

Fee Paid Employment Service for all technical fields since 1959. Over 1,000 U.S. client cos. Send resume. Atomic Personnel, Inc., 1518 Walnut St., Box L, Phila. Pa., 19102.

A Small & Truly Professional Fee-Paid employment service for engineers & scientists. Nationwide. Write or call Joseph P. Corcoran Personnel Consultants, 505 Germantown Pike, Lafayette Hill Pa. (215) 825-0848.

## POSITION WANTED

Electrical Engineer Seeking Overseas Assignment, no children, BSEE with 8 years of broad experience in analog and digital circuits, system hardware, computers and project supervision. PW-1679, Electronics.

## BUSINESS OPPORTUNITY

Capital Contacts—Before you try Public or Private Placements to Underwriters, Investment Banking Houses, write for free helpful information to Confidential Consultant, 817 51st St., Brooklyn, N.Y.

# "SEARCHLIGHT"

IS

## Opportunity Advertising

—to help you get what you want.  
—to help you sell what you no longer need.

Take Advantage Of It

For Every Business Want

"Think Searchlight First"

# New Literature

**Oscillators.** Fork Standards Inc., 211 Main St., West Chicago, Ill. 60185. Eight-page catalog 70C covers a line of tuning fork and crystal oscillators. Circle 446 on reader service card.

**Delay lines.** Daven division, McGraw-Edison Co., Grenier Field, Manchester, N.H. 03103. Four-page bulletin DL-270 discusses in detail seven prime parameters that must be considered in specifying a delay line. [447]

**Industrial interconnections.** Amphenol Industrial division, Bunker-Ramo Corp., 1830 S. 54th Ave., Chicago 60650. A comprehensive line of electrical/electronic connectors, plugs and sockets is described in a 32-page catalog. [448]

**P-c connector guide.** Elco Corp., Willow Grove, Pa. 19090. Revised and expanded to 56 pages, the 1970 edition of this guide describes 26 separate series of Varicon metal-to-metal p-c connectors, as well as IC and test-probe sockets. [449]

**A-d converters.** Phoenix Data Inc., 3017 W. Fairmount Ave., Phoenix, Ariz. 85017. A four-page bulletin describes analog-to-digital converters available in seven standard configurations, from the eight-binary-bit ADC 870 through the 14-binary-bit ADC 1470. [450]

**Line-driven chopper.** Solid State Electronics Corp., 15321 Rayen St., Sepulveda, Calif. 91343, offers a bulletin describing the model 66 transistorized, line-driven chopper. [451]

**Stepless temperature controller.** Gulton Industries Inc., 3860 North River Rd., Schiller Park, Ill. 60176, has published a bulletin on the model JAD solid state, stepless temperature controller. [452]

**Single-crystal gallium arsenide.** Laser Diode Laboratories Inc., 205 Forrest St., Metuchen, N.J. 08840, has issued a data folder describing single-crystal gallium arsenide available in bulk (in-got) or wafer form. [453]

**D-a converter.** Beckman Instruments Inc., 2500 Harbor Blvd., Fullerton, Calif. 92634. A two-page catalog sheet describes a complete digital-to-analog converter in hybrid IC form. [454]

**Computer manual.** Raytheon Computer, 2700 S. Fairview St., Santa Ana, Calif. 92704. A 660-page manual for the 706 computer is written for the requirements of automation engineers and system designers. [455]

**Optoelectronic devices.** Monsanto Co., 11636 Administration Dr., St. Louis, Mo. 63141. An illustrated application book for the firm's optoelectronic devices may be obtained by writing on company letterhead.

**Operational amplifiers.** Analog Devices Inc., 221 Fifth St., Cambridge, Mass. 02142. A six-page folder selects the 12 most widely used operational amplifiers from the company's 100-odd catalog items, giving full specifications and brief application suggestions. [456]

**Digital data acquisition.** Vidar Corp., 77 Ortega Ave., Mountain View, Calif. 94040. Bulletin 120B explains how digital data acquisition systems can automatically measure temperature, pressure, force, strain, and other physical parameters. [457]

**Panel meters.** Triplett Corp., Bluffton, Ohio 45817. Comprehensive 20-page catalog D-70 features a line of standard and special panel meters. [458]

**Input terminal.** Transcom Inc., 12 Tobey Rd., Bloomfield, Conn. 06002, has available a brochure that briefly outlines the capabilities of its newest input terminal, the IT-216. [459]

**Scr's for inverter use.** International Rectifier, 233 Kansas St., El Segundo, Calif. 90245. Silicon-controlled rectifiers for inverter applications are presented in illustrated engineering brochure A-130. [460]

**Interface IC.** Texas Instruments Inc., P.O. Box 5012, M/S308, Dallas 75222. Application report CA-150 discusses the multiple uses of the recently announced SN75450 peripheral interface integrated circuit. [461]

**Ceramic substrates.** Accumet Engineering Corp., 25 Broad St., Hudson, Mass. 01749, has available technical bulletin A-21 on the surface characteristics of ceramic substrates. [462]

**Infrared detectors.** Mullard Inc., 100 Finn Court, Farmingdale, N.Y. 11735. A quick reference to the company's infrared detectors is shown in a short form catalog available on company letterhead request.

**Thyristor circuits.** Westinghouse Electric Corp., P.O. Box 868, Pittsburgh, Pa. 15230. Illustrated brochure AD54-582 lists the advantages, disadvantages, and differences in performance of two basic thyristor circuits for three-phase controlled rectification applications. [463]

**Power modules.** Abbott Transistor Laboratories Inc., 5200 W. Jefferson Blvd., Los Angeles 90016. Over 3,600 power supplies are presented in a 76-page catalog, covering a-c to d-c, d-c to a-c, and d-c to d-c conversions. [464]

**Electromagnetic delay lines.** ESC Electronics, 534 Bergen Blvd., Palisades Park, N.J. 07650, has available a brochure describing electromagnetic delay

# SRC word generators go to great lengths to test your logic circuits.

## Up to 960 bits to be exact.

Now you can simulate digital inputs and outputs of computers and peripheral equipment. Simulate paper and mag tape devices, TLM and TTY. Or test IC's, LSI's, MOS-FETS, and data modems. With SRC word generators you have the highest unique serial bit capacity in the industry — 960 bits in our Model 912 and 900 bits in our Model 900.

Or if you don't need that capacity, try our new Model 905 with up to 100 bits serial. Or our 916, with up to 16 parallel channels of 30 bits each or 480 bits serial. Now with IBM card and SRC's patented linear octal switch programming. And we can pour it on at clock rates to 10MHz.

For all the information you'll need, write today. SRC Division, Moxon, Inc., 2222 Michelson Drive, Newport Beach, California 92664 (714) 833-2000.

**SRC**  
**SRC DIVISION**  
Moxon, Inc.

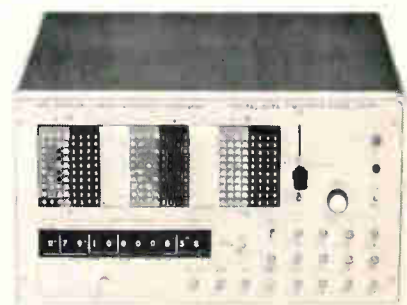



# DIGITAL TV



CVI video sampling instruments allow your computer to "look" at practically anything. High accuracy bandwidth compression of conventional television signals opens new doors to data processing in research and industrial applications. Let us tell you about some of our unique video devices.

COLORADO VIDEO, INCORPORATED

P.O. Box 928 • Boulder, Colo. 80302 • Phone (303) 444-3972

# cv

Video Data Acquisition • Processing • Display • Transmission

Circle 175 on reader service card

# circuit-stik<sup>INC.</sup>

## INSTANT CIRCUIT BOARDS!

**A NEW ELECTRONIC  
PACKAGING  
CONCEPT\***

From  
schematic  
drawings to  
card cage systems—  
**IN ONE STEP!**

- NO ETCHING
- NO DRILLING
- NO ART WORK

**SEND FOR YOUR  
FREE CATALOG  
AND SAMPLES.**

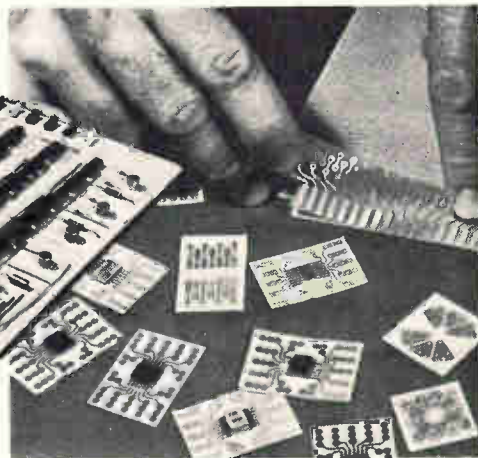

All types of circuit-element configurations may be mixed and combined on the same board.

# circuit-stik<sup>INC.</sup>

1518 W. 132nd STREET, GARDENA, CALIFORNIA 90249

\*Patent Pending

## New Literature

lines for critical air-traffic-control applications. [465]

**IC packaging.** Microelectronic Subsystems Inc., 20 Burr St., Framingham, Mass. 01701, has published a booklet presenting a discussion on the advantages of integrated-circuit packaging utilizing the hybrid-circuit approach. [466]

**Graphic data converter system.** Computer Equipment Corp., 14616 Southlawn Lane, Rockville, Md. 20850. The Minmac graphic data converter system for computer-independent reduction of analog/graphic data into digital form is described in a two-page data sheet. [467]

**Multiplexers.** Tel-Tech Corp., 11810 Parklawn Dr., Rockville, Md. 20852. The TTC-2000/3000 Concentrators, a new generation of multiplexers for data communications economy, are illustrated and described in a 12-page brochure. [468]

**Relays.** Computer Products Inc., 1400 N.W. 70th St., Fort Lauderdale, Fla. 33307. A six-page bulletin covers the CR300 series CompuReed low-level signal switching relays. [469]

**Instrumentation amplifiers.** Neff Instrument Corp., 1088 E. Hamilton Rd., Duarte, Calif. 91010. A 12-page application note describes correct input connection practices for differential amplifiers. [470]

**Reset timers.** Cramer Division, Conrac Corp., Mill Rock Rd., Old Saybrook, Conn. 06475, has issued a six-page illustrated brochure on the 472-473 series of reset timers. [471]

**Vibration transducers.** Bell & Howell Co., 360 Sierra Madre Villa, Pasadena, Calif. 91109, has released four-page catalog 1322-2 on vibration transducers and vibration-monitoring equipment. [472]

**Modular process computer.** General Electric Co., 2255 W. Desert Cove Rd., Phoenix 85029. Brochure GED-6328 describes the GE-PAC 4010 modular process computer. [473]

**Ladder networks.** Vishay Resistor Products, 63 Lincoln Highway, Malvern, Pa. 19355. A 14-page application engineering bulletin surveys the d-a and a-d requirements for networks and describes design principles for R/2R and bcd ladders. [474]

**Operational amplifier.** CTS Microelectronics Inc., West Lafayette, Ind. 47906. Data sheet 6862A is available with complete information on the series 862 cermet thick-film, hybrid operational amplifier for medium-voltage applications. [475]







# Cryogenic testing?

**Emerson would have liked that.**

Old Ralph Waldo said it: "Men love to wonder, and that is the seed of our science."

Well, if you're "sowing the seed of science" as far down as  $-320^{\circ}\text{F}$ ., NCG is the logical source for the industrial gases you'll need. Liquid nitrogen is only one of our cryogenic gases. We also reliably deliver argon and oxygen in liquid form. The distinct properties of each gas provides environmental control as well as precise low temperatures.

NCG supplies any quantity of these industrial gases—from cylinders to complete air separation plants. And we arrange a delivery schedule that assures a ready supply at all times. Write to us for detailed information.

## NCG<sup>®</sup>

**CHEMETRON CORPORATION**  
NATIONAL CYLINDER GAS DIVISION  
840 North Michigan Avenue • Chicago, Illinois 60611

**CHEMETRON**  
TRADEMARK

©1970, Chemetron Corporation

- Texscan Corporation 16  
MacGill/Ross Inc.
- Thomson CSF Electron Tubes Inc. 5
- Mohr & Co. Inc. 159
- Trio Tech Inc. of California 135
- Robert A. White Advertising
- Triplett Electrical Instrument Company 49
- Byer And Bowman Advertising
- TRW Electronics, Capacitors Division 74
- Fuller, Smith & Ross Inc.
- TRW Semiconductor Inc. 22
- Fuller, Smith & Ross Inc.
- Trygon Electronics Inc. 76
- Technical, Industrial & Scientific Marketing Inc.
- Tung Sol Division of Wagner Electric Corp. 41-43
- Winius Brandon Company 128

- Unitrode Corporation 119
- Silton Brothers Inc.
- University Computing Company
- Management Communication Consultants Inc.
- Universal Graphics Inc.
- Marketing Directions Inc.

- Watkins Johnson Company 139
- Williams C. Estler Advertising 21E
- Westinghouse CDS 161
- Wheelock Signals Inc. 166
- McCarthy, Scelba, DiBiasi Adv. Agency Inc.
- Wiltron Company 95
- Vanderwyck Associates Inc.
- Winchester Electronics Division of Litton Industries
- Wilson, Haight & Welch Inc.

- Xerox Corporation 150
- Hutchins Advertising Company Inc. 36
- Xerox Data Systems
- Doyle Dane Bernbach Inc.

### Classified & Employment Advertising

F.J. Eberle, Manager  
212-971-2557

EMPLOYMENT OPPORTUNITIES ..... 168

EQUIPMENT  
(Used or Surplus New)  
For Sale

Radio Research Instrument Co. .... 168

- For more information on complete product line see advertisement in the latest Electronics Buyer's Guide
- Advertisers in Electronics International

### Electronics Buyers' Guide

George F. Werner, Associate Publisher  
[212] 971-2310

Regina Hera, Directory Manager  
[212] 971-2544

Mary Tully, Production Manager  
[212] 971-2046

Sales Offices:  
Boston, Ben Briggs [617] CO2-1160  
Detroit, Mac Heustis [313] 962-1793  
New York, Cliff Montgomery [212] 971-3793  
Jim Vick [212] 971-2661  
Chicago, Bob Denmead [312] MO4-5800  
Los Angeles, Kenneth Watts [213] HU2-5450  
Philadelphia, Tim Bemis [215] LO8-6161

## FREE SAMPLES



Printed Wiring Shapes and Patterns for Artwork Accuracy in Seconds

Yours — free for the asking — a trial sample packet of By-Buk time saving pressure sensitive printed wiring drafting aids. Discover the efficiency of this partner to faster, more accurate artwork production. By-Buk offers thousands of ideas in printed wiring shapes, patterns and tapes. Individually die cut on quick release backing paper. Easy to apply. Available in opaque black, transparent red and transparent blue.

See these cost savers for yourself. Send for your free samples, plus 20 page product line catalog.

**BY-BUK COMPANY**

4326 W. Pico Blvd.  
Los Angeles, Calif. 90019  
(213) 937-3511

Circle 176 on reader service card

# Your Heart Fund Fights

HEART ATTACK  
STROKE  
HIGH BLOOD PRESSURE  
INBORN HEART DEFECTS

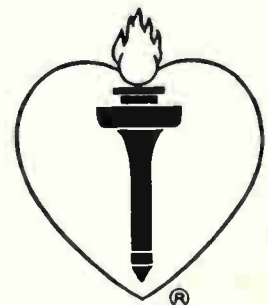

## Advertising Sales Staff

James T. Hauptli [415] DO 2-4600  
Western Advertising Sales Manager

Warren H. Gardner [212] 971-3139  
Eastern Advertising Sales Manager

Atlanta, Ga. 30309: Charlton H. Calhoun, III  
1375 Peachtree St., N.E.  
[404] 892-2868

Boston, Mass. 02116: William S. Hodgkinson  
McGraw-Hill Building, Copley Square  
[617] CO 2-1160

Cleveland, Ohio 44113: William J. Boyle,  
55 Public Square, [216] SU 1-7000

New York, N.Y. 10036  
500 Fifth Avenue  
James R. Pierce [212] 971-3615  
John A. Garland [212] 971-3617  
Michael J. Stoller [212] 971-3616

Philadelphia, Pa. 19103:  
Jeffrey M. Preston  
6 Penn Center Plaza,  
[215] LO 8-6161

Pittsburgh, Pa. 15222: Jeffrey M. Preston,  
4 Gateway Center, [412] 391-1314

Rochester, N.Y. 14534: William J. Boyle,  
9 Greylock Ridge, Pittsford, N.Y.  
[716] 586-5040

Chicago, Ill. 60611: Ralph Hanning,  
Kenneth E. Nicklas, 645 North Michigan  
Avenue, [312] MO 4-5800

Dallas, Texas 75201: Richard P. Poole,  
1800 Republic National Bank Tower,  
[214] RI 7-9721

Houston, Texas 77002: Richard P. Poole,  
2270 Humble Bldg. [713] CA 4-8381

Detroit, Michigan 48226: Ralph Hanning,  
2600 Penobscot Building  
[313] 962-1793

Minneapolis, Minn. 55402: Kenneth E. Nicklas,  
1104 Northstar Center [612] 332-7425

St. Louis, Mo. 63105: Kenneth E. Nicklas,  
The Clayton Tower, 7751 Carondelet Ave.  
[314] PA 5-7285

Denver, Colo. 80202: David M. Watson,  
Richard W. Carpenter  
Tower Bldg., 1700 Broadway  
[303] 266-3863

Los Angeles, Calif. 90017: Ian C. Hill,  
Bradley K. Jones, 1125 W. 6th St.,  
[213] HU 2-5450

Portland, Ore. 97204: Don Farris,  
James T. Hauptli, 218 Mohawk Building,  
222 S.W. Morrison Street,  
Phone [503] 223-5118

San Francisco, Calif. 94111: Don Farris,  
James T. Hauptli, 255 California Street,  
[415] DO 2-4600

Paris: Denis Jacob  
17 Rue Georges Bizet, 75 Paris 16, France  
Tel 727 33 42, 727 33 60

United Kingdom and Scandinavia  
London: Oliver Ball, Tel: Hyde Park 1451  
34 Dover Street, London W1

Milan: Robert Saidel, Roberto Laureri Jr.  
1 via Baracchini Phone 86-90-656

Brussels: Denis Jacob  
27 Rue Ducale Tel: 136503

Frankfurt/Main: Hans Haller  
Elsa-Brandstroem Str. 2  
Phone 72 01 81

Geneva: Pierre Braude  
1 rue du Temple Phone: 31 95 60

Tokyo: Noboru Matsumoto, McGraw-Hill  
Publications Overseas Corporation,  
Kasumiqaseki Building 2-5, 3-chome,  
Kasumiqaseki, Chiyoda-Ku, Tokyo, Japan  
[581] 9811

Osaka: Akihiko Kamesaka, McGraw-Hill  
Publications Overseas Corporation, Kondo  
Bldg., 163, Umegae-cho Kita-ku [362] 8771

Australasia: Warren E. Ball, IPO Box 5106,  
Tokyo, Japan

### Business Department

Stephen R. Welss, Manager  
[212] 971-2044

Thomas M. Egan,  
Production Manager [212] 971-3140

Maury D'Gongora,  
Assistant Production Manager [212] 971-2045

Dorothy CarmesIn, Contracts and Billings  
[212] 971-2908

Frances Vallone, Reader Service Manager  
[212] 971-2865

# Now you can specify:

- Clean-cut, modern design
- Time-Tested, tough phenolic case
- Environment-Free Viewing Area

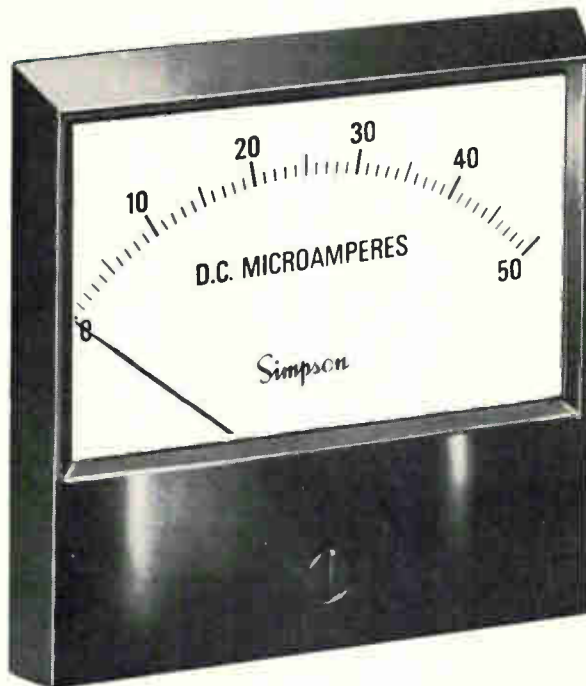

all in the new Simpson

## CENTURY SERIES

### PANEL INSTRUMENTS

- 1½", 2½", 3½" and 4½" sizes. Ranges, scales and other characteristics to meet your exact requirements.
- Variety of movements. Matching Relays, Wattmeters and Elapsed Time Meters also available.

Standards now in stock at electronic distributors everywhere. For custom specials, see your Simpson Representative... he's listed in the Yellow Pages. For more details, write for Bulletin 2081.



### SIMPSON ELECTRIC COMPANY

5200 W. Kinzie St., Chicago, Ill. 60644, Phone: (312) 379-1121

Export Dept: 400 W. Madison St., Chicago, Ill. 60606, Cable SIMELCO

IN CANADA: Bach-Simpson, Ltd., London, Ontario

IN INDIA: Ruttonsha-Simpson Private, Ltd., International House,  
Bombay-Agra Road, Vikhroli, Bombay



# TRW announces new ruggedized 1 GHz transistors

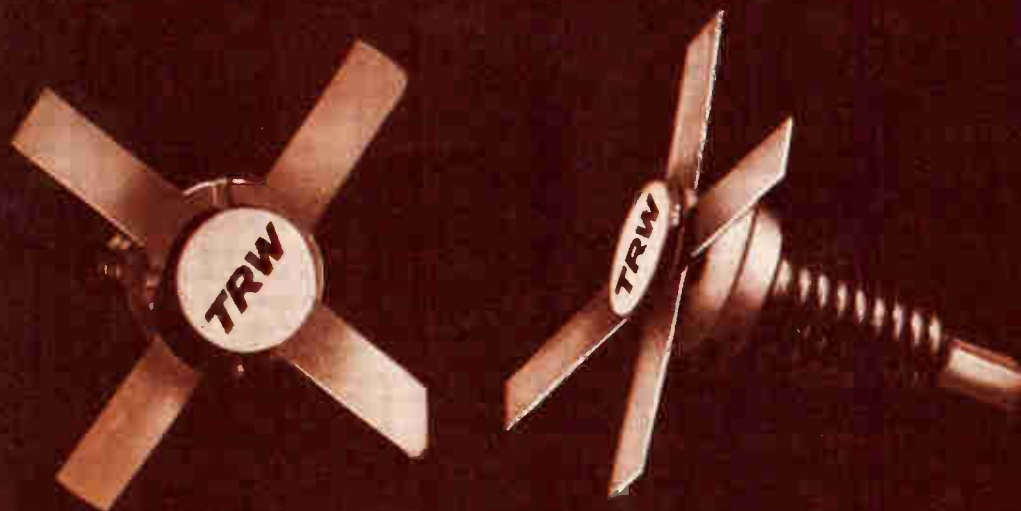

## Infinite VSWR...improved gain...Ultraceramic package

TRW was first to break the Gigahertz barrier in RF Power Transistors. Now our technology has produced new state of the art ruggedized power at 1 GHz. The new 3 watt 2N5764 and 5 watt 2N5765 offer significant performance advantages over the older 2N4430 and 2N4431.

They will withstand severe mismatch — any load, any phase. Gain is increased to 6 dB and efficiency to 40%. Both operate from a 28 volt source. Both are in advanced ultraceramic strip-line packages.

Contact any TRW distributor or TRW Semiconductors Inc.,

14520 Aviation Blvd., Lawndale, California 90260. Phone: (213) 679-4561. TWX: 910-325-6206.

TRW Semiconductors Inc., is a subsidiary of TRW Inc.

# TRW®

# Electronics reader service

Warning: The Post Office now requires your ZIP CODE on all mail. Please include your ZIP CODE number when filling out your reply card.

Use these handy post cards for more detailed information on: products advertised, new products, new literature.

Circle the number on the Reader Service post card that corresponds to the number at the bottom of the advertisement, new product item, or new literature in which you are interested.

Please print clearly. All written information must be legible to be efficiently processed.

If someone has beaten you to the post cards, you may obtain the needed information by writing directly to the manufacturer, or by sending your name and address, plus the Reader Service number, to Electronics Reader Service department.

All inquiries from outside the U.S. that cannot reach Electronics before the expiration dates noted on the Reader Service post card, must be mailed directly to the manufacturer. The manufacturer assumes all responsibilities for responding to inquiries. Electronics merely provides and clears requests for information from inquirer to manufacturer.

Correct amount of postage must be affixed for all mailings from outside the U.S.

### To subscribe to or to renew Electronics

Fill in the "For Subscriptions" area on the card if you desire to subscribe to or renew your present subscription to Electronics. Send no money. Electronics will bill you at the address indicated on the Reader Service post card.

### Multi-product advertisements

For information on specific items in multi-product advertisements which do not have a specific Reader Service number indicated write directly to manufacturer for information on precise product in which you are interested.

12 For employment inquiries fill in home address. June 8, 1970 Card Expires August 8, 1970 14

Name \_\_\_\_\_ title \_\_\_\_\_ For Subscriptions  
 new  renewal  
 3 years \$16.00  
 1 year \$8.00

Company\* \_\_\_\_\_

Address \_\_\_\_\_

City \_\_\_\_\_ State \_\_\_\_\_ Zip Code \_\_\_\_\_

1	20	39	58	77	96	115	134	153	172	191	210	229	248	267	286	305	324	343	362	381	400	419	438	457	476	495	514	962
2	21	40	59	78	97	116	135	154	173	192	211	230	249	268	287	306	325	344	363	382	401	420	439	458	477	496	515	963
3	22	41	60	79	98	117	136	155	174	193	212	231	250	269	288	307	326	345	364	383	402	421	440	459	478	497	516	964
4	23	42	61	80	99	118	137	156	175	194	213	232	251	270	289	308	327	346	365	384	403	422	441	460	479	498	517	965
5	24	43	62	81	100	119	138	157	176	195	214	233	252	271	290	309	328	347	366	385	404	423	442	461	480	499	518	966
6	25	44	63	82	101	120	139	158	177	196	215	234	253	272	291	310	329	348	367	386	405	424	443	462	481	500	900	967
7	26	45	64	83	102	121	140	159	178	197	216	235	254	273	292	311	330	349	368	387	406	425	444	463	482	501	901	968
8	27	46	65	84	103	122	141	160	179	198	217	236	255	274	293	312	331	350	369	388	407	426	445	464	483	502	902	969
9	28	47	66	85	104	123	142	161	180	199	218	237	256	275	294	313	332	351	370	389	408	427	446	465	484	503	951	970
10	29	48	67	86	105	124	143	162	181	200	219	238	257	276	295	314	333	352	371	390	409	428	447	466	485	504	952	971
11	30	49	68	87	106	125	144	163	182	201	220	239	258	277	296	315	334	353	372	391	410	429	448	467	486	505	953	972
12	31	50	69	88	107	126	145	164	183	202	221	240	259	278	297	316	335	354	373	392	411	430	449	468	487	506	954	973
13	32	51	70	89	108	127	146	165	184	203	222	241	260	279	298	317	336	355	374	393	412	431	450	469	488	507	955	974
14	33	52	71	90	109	128	147	166	185	204	223	242	261	280	299	318	337	356	375	394	413	432	451	470	489	508	956	975
15	34	53	72	91	110	129	148	167	186	205	224	243	262	281	300	319	338	357	376	395	414	433	452	471	490	509	957	976
16	35	54	73	92	111	130	149	168	187	206	225	244	263	282	301	320	339	358	377	396	415	434	453	472	491	510	958	977
17	36	55	74	93	112	131	150	169	188	207	226	245	264	283	302	321	340	359	378	397	416	435	454	473	492	511	959	978
18	37	56	75	94	113	132	151	170	189	208	227	246	265	284	303	322	341	360	379	398	417	436	455	474	493	512	960	979
19	38	57	76	95	114	133	152	171	190	209	228	247	266	285	304	323	342	361	380	399	418	437	456	475	494	513	961	980

First class  
Permit no. 42  
Hightstown, N. J.

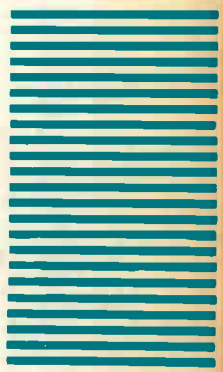

**Business reply mail**  
No postage stamp necessary if mailed in the United States

Postage will be paid by

**Electronics  
Reader service department  
Box 444  
Hightstown, N.J. 08520**

12 \*For employment inquiries fill in home address. June 8, 1970 Card Expires August 8, 1970 14

Name \_\_\_\_\_ title \_\_\_\_\_ For Subscriptions  
 new  renewal  
 3 years \$16.00  
 1 year \$8.00

Company\* \_\_\_\_\_

Address \_\_\_\_\_

City \_\_\_\_\_ State \_\_\_\_\_ Zip Code \_\_\_\_\_

1	20	39	58	77	96	115	134	153	172	191	210	229	248	267	286	305	324	343	362	381	400	419	438	457	476	495	514	962
2	21	40	59	78	97	116	135	154	173	192	211	230	249	268	287	306	325	344	363	382	401	420	439	458	477	496	515	963
3	22	41	60	79	98	117	136	155	174	193	212	231	250	269	288	307	326	345	364	383	402	421	440	459	478	497	516	964
4	23	42	61	80	99	118	137	156	175	194	213	232	251	270	289	308	327	346	365	384	403	422	441	460	479	498	517	965
5	24	43	62	81	100	119	138	157	176	195	214	233	252	271	290	309	328	347	366	385	404	423	442	461	480	499	518	966
6	25	44	63	82	101	120	139	158	177	196	215	234	253	272	291	310	329	348	367	386	405	424	443	462	481	500	900	967
7	26	45	64	83	102	121	140	159	178	197	216	235	254	273	292	311	330	349	368	387	406	425	444	463	482	501	901	968
8	27	46	65	84	103	122	141	160	179	198	217	236	255	274	293	312	331	350	369	388	407	426	445	464	483	502	902	969
9	28	47	66	85	104	123	142	161	180	199	218	237	256	275	294	313	332	351	370	389	408	427	446	465	484	503	951	970
10	29	48	67	86	105	124	143	162	181	200	219	238	257	276	295	314	333	352	371	390	409	428	447	466	485	504	952	971
11	30	49	68	87	106	125	144	163	182	201	220	239	258	277	296	315	334	353	372	391	410	429	448	467	486	505	953	972
12	31	50	69	88	107	126	145	164	183	202	221	240	259	278	297	316	335	354	373	392	411	430	449	468	487	506	954	973
13	32	51	70	89	108	127	146	165	184	203	222	241	260	279	298	317	336	355	374	393	412	431	450	469	488	507	955	974
14	33	52	71	90	109	128	147	166	185	204	223	242	261	280	299	318	337	356	375	394	413	432	451	470	489	508	956	975
15	34	53	72	91	110	129	148	167	186	205	224	243	262	281	300	319	338	357	376	395	414	433	452	471	490	509	957	976
16	35	54	73	92	111	130	149	168	187	206	225	244	263	282	301	320	339	358	377	396	415	434	453	472	491	510	958	977
17	36	55	74	93	112	131	150	169	188	207	226	245	264	283	302	321	340	359	378	397	416	435	454	473	492	511	959	978
18	37	56	75	94	113	132	151	170	189	208	227	246	265	284	303	322	341	360	379	398	417	436	455	474	493	512	960	979
19	38	57	76	95	114	133	152	171	190	209	228	247	266	285	304	323	342	361	380	399	418	437	456	475	494	513	961	980

# Reprint service

All Electronics editorial matter available in reprint form:

For reprints of special reports and feature articles see list on right side of this page. Send your order to Electronics Reprint Department at the address indicated. To expedite mailing of your order for single reprints please send cash, check or money order with your order. Allow 3-4 weeks for delivery.

Bulk reprints of editorial matter can be ordered from current or past issues. The minimum quantity is 100 copies. Prices quoted on request: call 212-971-6643, or write to address below.

Warning: The Post Office now requires your ZIP CODE on all mail. Please include your ZIP CODE number when filling out your reply card.

3

## Business reply mail

No postage stamp necessary if mailed in the United States

Postage will be paid by

First class  
Permit no. 42  
Hightstown, N. J.



Electronics  
Reader service department  
Box 444  
Hightstown, N. J. 08520

To order reprints or for further information, please write to: Electronics Reprint Department, 330 West 42nd Street, New York, N.Y. 10036.

To expedite mailing of your order for single reprints please enclose payment with your order.

You may order any of the below listed reprints by key number. Discounts on quantities over 10.

- Key no. R-01 Computer-aided Design: Part I, The Man-machine Merger. 16 pages. \$1.25.
- Key no. R-04 Multilayer Circuit Boards: Sharpening An Imperfect Art. 7 pages. 50¢.
- Key no. R-06 Report on Japanese Technology: Sony. 20 pages. 50¢.
- Key no. R-010 Special Report on Large Scale Integration. 54 pages. \$1.50.
- Key no. R-011 Medical Electronics (1967). 8 part series, 44 pages. \$1.25.
- Key no. R-012 Special Report on Gallium Arsenide 17 parts. 32 pages. \$2.00
- Key no. R-016 Special Report on The Transistor: Two Decades of Progress. 48 pages. \$1.50.
- Key no. R-017 Special Report on Ferrites. 16 pages. \$1.00.
- Key no. R-021 Infrared Detector Characteristics. 23 x 11 inch fold-out chart. 50¢
- Key no. R-022 Active Filters: Part II, Varying the Approach. 8 pages \$1.00
- Key no. R-023 Special Report: Tomorrow's Communications. 32 pages \$1.75
- Key no. R-024 1969 Electronics Index to Technical Articles and Authors. Free
- Key no. R-025 Combined reprint of 1970 European and U.S. Markets Reports with two foldout charts. 62 pages \$1.75

SPECIAL REPRINT OFFER—75c  
Key no. R-026 The Seventies: super but seething. A 56-page business outlook prepared by McGraw-Hill's Business Week.

- Key no. R-79 MOS Integrated Circuits. 12 pages. 50¢.
- Key no. R-78 The Overlay Transistor. 15 pages. 50¢.
- Key no. R-64 Field Effect Transistors. Parts I, II, and III. 64 pages. \$1.00.

12 Please Print Clearly

June 8, 1970 Card Expires August 8, 1970 14

Name \_\_\_\_\_ title \_\_\_\_\_  
Company \_\_\_\_\_  
Address \_\_\_\_\_

For Subscriptions

- new  renewal  
 3 years \$16.00  
 1 year \$8.00

1	20	39	58	77	96	115	134	153	172	191	210	229	248	267	286	305	324	343	362	381	400	419	438	457	476	495	514	962
2	21	40	59	78	97	116	135	154	173	192	211	230	249	268	287	306	325	344	363	382	401	420	439	458	477	496	515	963
3	22	41	60	79	98	117	136	155	174	193	212	231	250	269	288	307	326	345	364	383	402	421	440	459	478	497	516	964
4	23	42	61	80	99	118	137	156	175	194	213	232	251	270	289	308	327	346	365	384	403	422	441	460	479	498	517	965
5	24	43	62	81	100	119	138	157	176	195	214	233	252	271	290	309	328	347	366	385	404	423	442	461	480	499	518	966
6	25	44	63	82	101	120	139	158	177	196	215	234	253	272	291	310	329	348	367	386	405	424	443	462	481	500	900	967
7	26	45	64	83	102	121	140	159	178	197	216	235	254	273	292	311	330	349	368	387	406	425	444	463	482	501	901	968
8	27	46	65	84	103	122	141	160	179	198	217	236	255	274	293	312	331	350	369	388	407	426	445	464	483	502	902	969
9	28	47	66	85	104	123	142	161	180	199	218	237	256	275	294	313	332	351	370	389	408	427	446	465	484	503	951	970
10	29	48	67	86	105	124	143	162	181	200	219	238	257	276	295	314	333	352	371	390	409	428	447	466	485	504	952	971
11	30	49	68	87	106	125	144	163	182	201	220	239	258	277	296	315	334	353	372	391	410	429	448	467	486	505	953	972
12	31	50	69	88	107	126	145	164	183	202	221	240	259	278	297	316	335	354	373	392	411	430	449	468	487	506	954	973
13	32	51	70	89	108	127	146	165	184	203	222	241	260	279	298	317	336	355	374	393	412	431	450	469	488	507	955	974
14	33	52	71	90	109	128	147	166	185	204	223	242	261	280	299	318	337	356	375	394	413	432	451	470	489	508	956	975
15	34	53	72	91	110	129	148	167	186	205	224	243	262	281	300	319	338	357	376	395	414	433	452	471	490	509	957	976
16	35	54	73	92	111	130	149	168	187	206	225	244	263	282	301	320	339	358	377	396	415	434	453	472	491	510	958	977
17	36	55	74	93	112	131	150	169	188	207	226	245	264	283	302	321	340	359	378	397	416	435	454	473	492	511	959	978
18	37	56	75	94	113	132	151	170	189	208	227	246	265	284	303	322	341	360	379	398	417	436	455	474	493	512	960	979
19	38	57	76	95	114	133	152	171	190	209	228	247	266	285	304	323	342	361	380	399	418	437	456	475	494	513	961	980

1

## Business reply mail

No postage stamp necessary if mailed in the United States

Postage will be paid by

First class  
Permit no. 42  
Hightstown, N. J.



Electronics  
Reader service department  
Box 444  
Hightstown, N.J. 08520



# Here's the first I-C regulated bench power supply to give you 0-10 volts at 1 amp for \$75.00

With built-in tracking OV \$90.00  
Also available 0-20, 0-40, 0-120 vdc

### Regulation

line 0.01% + 1mv  
load 4 mv

### Ripple and noise

250  $\mu$ v rms; 1 mv p-to-p

### All silicon dc power supply using integrated circuits to provide regulation system

except for input and output capacitors, rectifiers and series regulation transistors

### Multi-position operation

lies flat or stands erect

### AC input

105-132 vac 47-440 Hz (Current ratings based on 57-63 Hz.)

### Weight

less than 6 lbs.

### Output

5-way binding posts

### Ambient operating temperature

0°C to +50°C

### Temperature coefficient

0.015% + 300  $\mu$ v/°C

### Adjustable current limiting

0% to 110% of rating

### Storage temperature

-40°C to +85°C

### Convection cooled

### Die-cast aluminum construction

### No overshoot

on turn-on, turn-off or power failure

### Controls

coarse voltage adjust, fine voltage adjust, current adjust, ON/OFF switch, meter function switch.

### Indicators

power ON light and dual-function meter

### AC input option

add suffix "-V" to model number for operation at 205-265 vac, 47-440 Hz. Derate current 10% for 47-53 Hz.

In U.S. and Canada add \$10.00 to price.

### Guaranteed for 5 years material and labor

### LL series bench-type supply 5½" x 5½" x 3¾"

Model	ADJ. VOLT RANGE VDC	CURRENT RANGE(1)	Price(2)
LL-901	0-10	0-1.0 amp	\$75
LL-902	0-20	0-0.65 amp	85
LL-903	0-40	0-0.35 amp	85
LL-905	0-120	0-65 ma	99

### WITH BUILT-IN TRACKING OVERVOLTAGE PROTECTION

LL-901-OV	0-10	0-1.0 amp	\$90
LL-902-OV	0-20	0-0.65 amp	99
LL-903-OV	0-40	0-0.35 amp	99

### NOTES:

(1) Consult factory for operation at 50 Hz or temperatures above 50°C. Ratings apply 0-50°C.

(2) Independently adjustable OV protection available as accessory on LL-901, 902 (LC-OV-10, range 3-24 vdc) and LL-903 (LC-OV-11, range 3-47 vdc) price \$20.

(3) Prices are USA list prices only, FOB Melville, N. Y.; North Hollywood, Calif.; Montreal, Canada. All prices and specifications are subject to change without notice.

(4) The following charges are applicable for shipment from other than Melville, N. Y.:

Value of Order
up to \$50.00
\$51.00 to \$180.00
\$181.00 to \$300.00
\$301.00 to \$500.00
\$501.00 and over

### Handling Charge

\$1.00
\$2.00
\$4.00
\$6.00
FOB Melville, N. Y. only

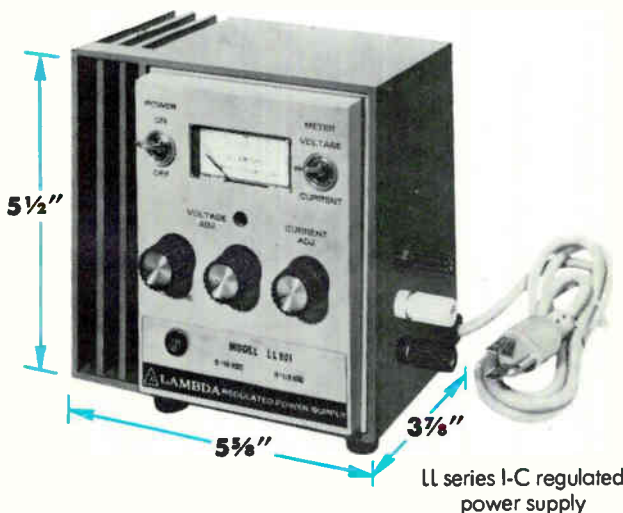

Lambda maintains a total inventory of over 10,000 power supply units located in Los Angeles, Montreal and New York for 1-day delivery—5 year guarantee.

▲ Lambda Electronics Corp., 515 Broad Hollow Road, Melville, Long Island, New York 11746 • Tel. 516-694-4200.

# IT'S A WINNER!

# VERSAWATT



VERSAWATT is RCA's plastic unit on a solid-copper base which displays brute power dissipation capability—up to 50 watts in the transistor line; power handling capability up to 10 kW in thyristors. It is rugged. It has "volumetric" efficiency. It has compactness—a space-saving advantage over larger, equivalent types—that makes VERSAWATT an ideal package for PC board applications where hermetic types previously were employed.



#### RCA VERSAWATT Transistor Family

TYPE	V <sub>CER</sub> (sus)**	h <sub>FE</sub>
2N5293+	75 V	30-120 @ I <sub>C</sub> = 0.5 A, V <sub>CE</sub> = 4 V
2N5294+		
2N5295+	50 V	30-120 @ I <sub>C</sub> = 1 A, V <sub>CE</sub> = 4 V
2N5296+		
2N5297+	70 V	20-80 @ I <sub>C</sub> = 1.5 A, V <sub>CE</sub> = 4 V
2N5298+		
2N5490*	50 V	20-100 @ I <sub>C</sub> = 2.0 A, V <sub>CE</sub> = 4 V
2N5491*		
2N5492*	65 V	20-100 @ I <sub>C</sub> = 2.5 A, V <sub>CE</sub> = 4 V
2N5493*		
2N5494*	50 V	20-100 @ I <sub>C</sub> = 3 A, V <sub>CE</sub> = 4 V
2N5495*		
2N5496*	80 V	20-100 @ I <sub>C</sub> = 3.5 A, V <sub>CE</sub> = 4 V
2N5497*		

+ $\theta_{j-c}$  = 3.5°C/W max. \* $\theta_{j-c}$  = 2.5°C/W max. \*\*R<sub>BE</sub> = 100 ohms

#### RCA VERSAWATT Triac Family

	V <sub>DROM</sub>	I <sub>GT</sub>	
		I <sub>+</sub> + III - modes	I <sub>-</sub> - III + modes
40668	200 V	25 mA max.	60 mA max.
40669	400 V	25 mA max.	60 mA max.

$\theta_{j-c}$  = 2.2°C/W max.

VERSAWATT means versatility in mounting possibilities. RCA offers three basic configurations (you can devise your own option to fit your needs). These configurations are for PC boards and direct plug-in for TO-66 sockets.

VERSAWATT is a plastic package offering different chips for outstanding electrical performance—in transistors, from milliamperes to several amperes. In thyristors, 120- and 240-volt line operation VERSAWATT 8-ampere triacs have low thermal resistance—better than many hermetic types. They offer a high 100 A peak surge current capability.

VERSAWATT has proven reliability, backed by data from more than three years of field testing in commercial and industrial applications. An added plus: VERSAWATT transistor units employ Hometaxial-base construction, the industry's best answer yet for freedom from second breakdown.

Check the charts for units packaged as VERSAWATT transistors and thyristors. There are more to come. Right now, see your local RCA Representative or your RCA Distributor for more information. For technical data on specific types, write: RCA, Commercial Engineering, Section 76F8/UT5156R, Harrison, N.J. 07029.