

Wrapped wire gains on multilayers 56

\$1.00 A McGraw-Hill Publication

Complementing MOS and bipolar on one chip 72

August 31, 1970

Op amp model for convenient analysis 78

Electronics®

**Guiding light
for optical
integrated
circuits**

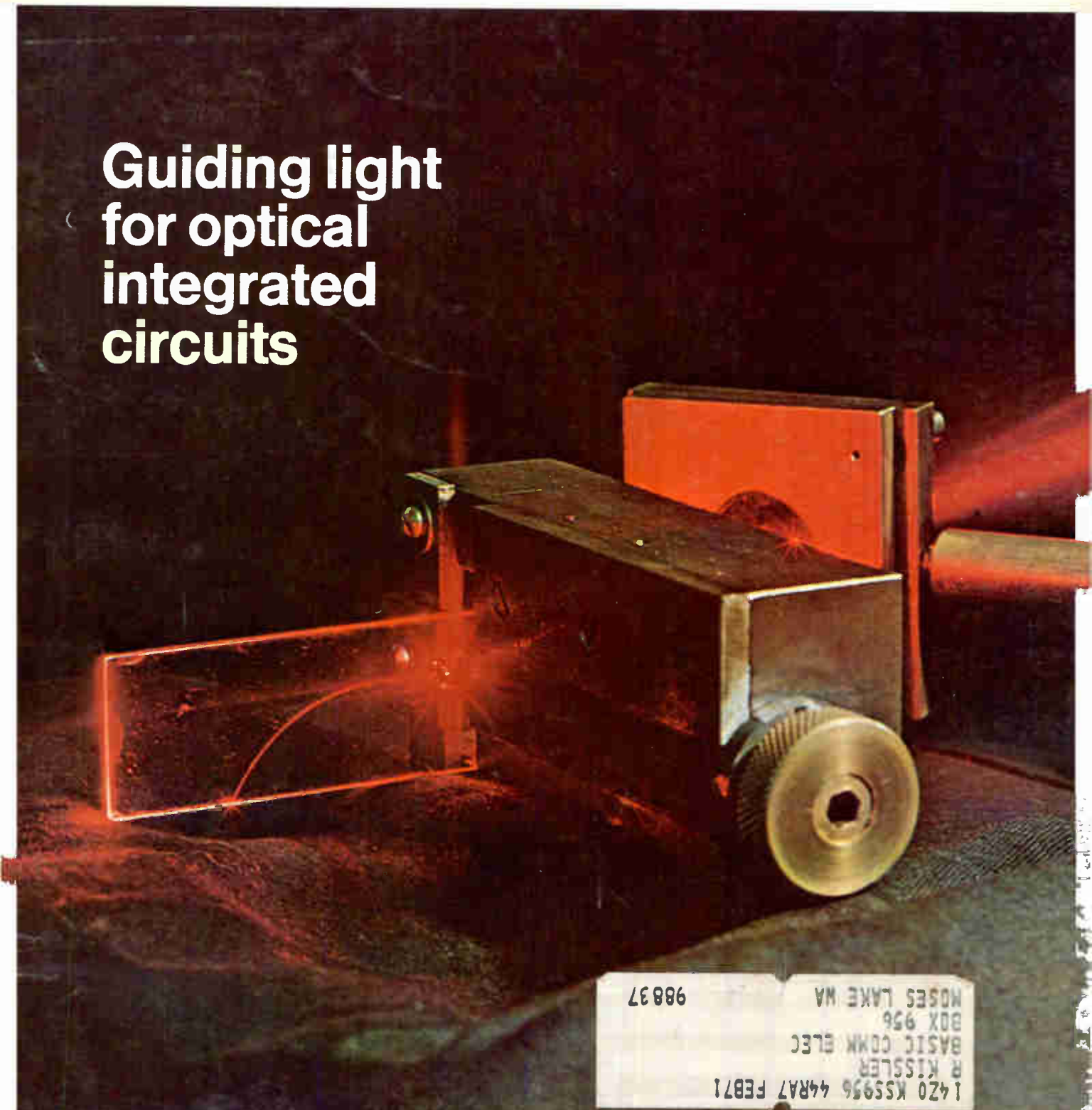

1420 KSS956 44RA7 FEB71
R. KISSLER
BASIC COMM ELEC
BOX 956
MOSES LAKE WA 98837

Suppose you wanted an Automatic RLC Bridge

that could measure up to 2 M Ω resistance, 2000 H inductance, and 0.2 F capacitance, plus equivalent series resistance and leakage current. A bridge with 5-digit resolution for reactance and resistive readouts, automatic decimal point and units of measurement; a 20-measurements-per-second capa-

bility; 120-Hz and 1-kHz test frequencies; 5-terminal connections to preserve a basic 0.1% accuracy; a built-in 0 to 3-V bias or external bias to 600 V; optional remote programmability and data output.

And prices that start at \$4,450. (in U.S.A.)

Where could you possibly find such a bridge?

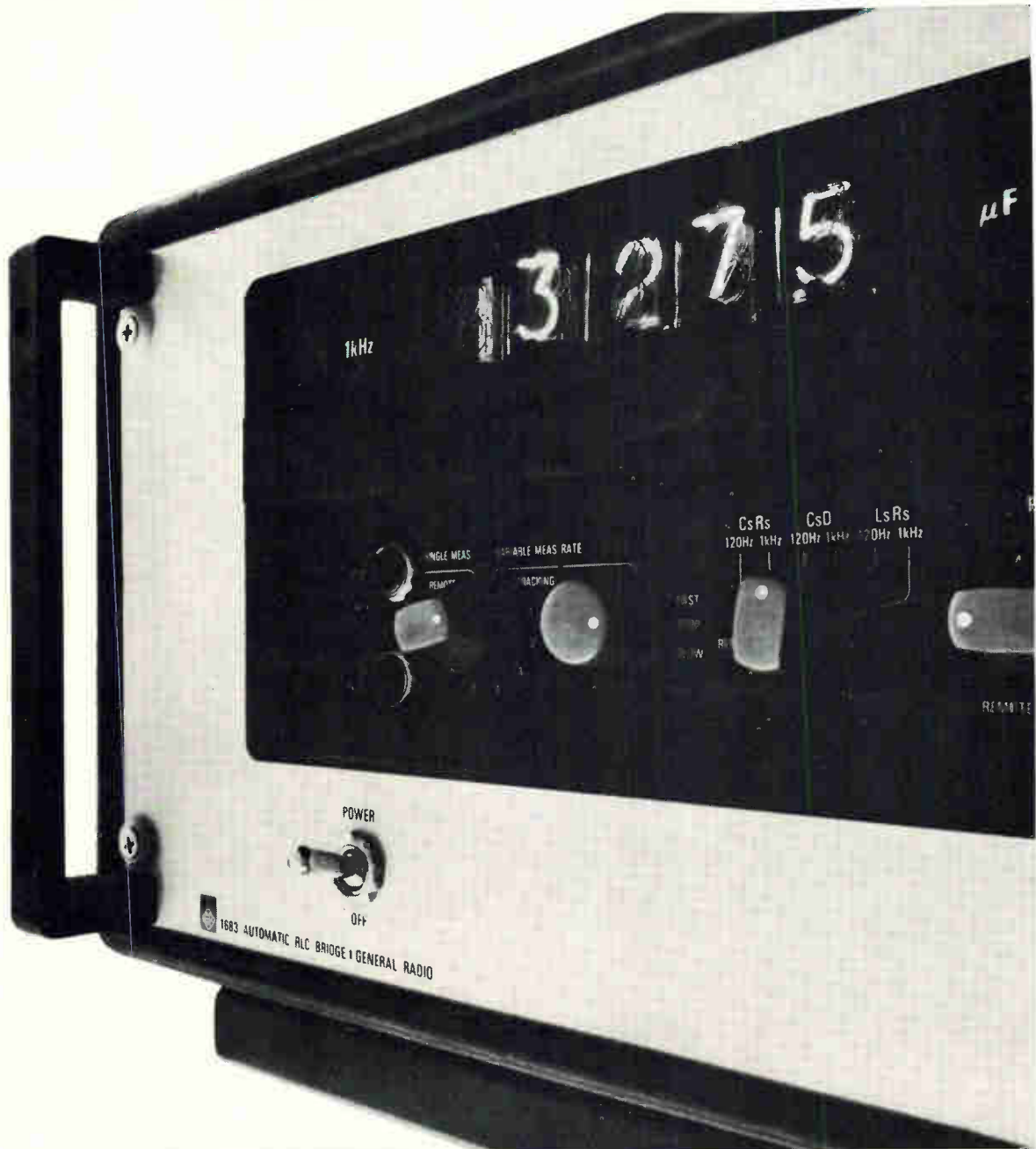

1683 Automatic RLC Bridge by



General Radio

Concord, Mass. 01742 Europe: Postfach 124, CH 8034 Zurich, Switzerland

ATLANTA 404 633-6183 / BOSTON 617 646-0550 / CHICAGO 312 992-0800 / CLEVELAND 216 886-0150
DALLAS 214 637-2240 / LOS ANGELES 714 540-9830 / NEW YORK (N.Y.) 212 964-2722 (N.J.) 201 943-3140
PHILADELPHIA 215 646-8030 / SAN FRANCISCO 415 948-8233 / SEATTLE 206 747-9190 / SYRACUSE 315 454-9323
WASHINGTON, D.C. 301 881-5333 / TORONTO 416 252-3395 / ZURICH (051) 47 70 20

Circle 900 on reader service card

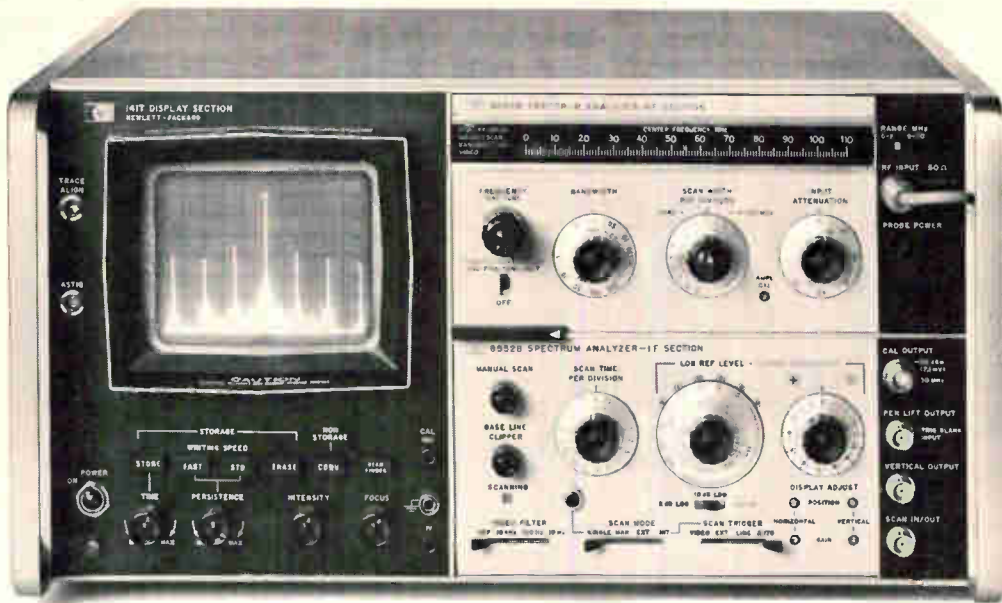

How do you improve the world's best spectrum analyzer?



Add counter accuracy and a tracking signal source.

Combine HP's new 8443A Tracking Generator/Counter with the HP 110 MHz Spectrum Analyzer and you can make the most precise, complete frequency-domain measurements ever. The 8443A produces a visible marker that you can place anywhere on the spectrum analyzer display and immediately get 10 Hz resolution digital measurement of that point. The 8443A is more, too: a precision signal source that will make swept measurements over a 120 dB range and still produce the marker to determine any specific frequency with counter accuracy.

The 8553B/8552B Analyzer itself covers 1 kHz to 110 MHz with scans as wide as 100 MHz and as narrow as 200 Hz. It provides absolute amplitude calibration, better than -130 dBm sensitivity, over 70 dB dynamic range, 10 Hz resolution, plus exceptional stability (<1 Hz FM) and flatness. The 8443A capitalizes on all the qualities of the analyzer to function both as an accurate frequency counter and as a precision source for complete swept frequency measurements.

With the system you can make much more precise design and production

line measurements of filters, mixers, modulators, oscillators, amplifiers and RF systems. For example, you can now:

- measure to 10 Hz the frequency of nanovolt signals in the presence of much larger ones. Use the tuneable marker to find the signal and measure its frequency on the 8443A counter readout. You can easily identify IM distortion products, hum sidebands, spurious signals, and the like, because the 8443A is a frequency-selective counter with the analyzer's incredible sensitivity.
- completely characterize devices such as narrowband, high Q devices with simple, quick measurements. Use the tracking generator to sweep the spectrum and measure the frequency of any point on the response curve to 10 Hz. You can precisely measure passband flatness and shape factor on filters as narrow as 20 Hz, and make swept-reflection or return loss measurements. In other words, the tracking generator combines with the analyzer to provide a complete swept test system.

- test and align RF communications systems with unprecedented ease, thoroughness and precision. The high resolution and stability of the analyzer lets you see each and every signal, and the 8443A measures their frequency to 10 Hz. The system is also a natural for surveillance applications since you can scan broad and narrow ranges, resolve all signals of interest and count their frequency.

Call us for a demonstration. The system is easy to set up and you'll find it simple to use as an oscilloscope. If you've already got an HP 110 MHz spectrum analyzer, you can add the tracking generator/counter for \$3500. The high-resolution 8553B/8552B with variable persistence display costs \$6750. Ask your HP field engineer for details. Or write Hewlett-Packard, Palo Alto, California 94304; Europe: 1217 Meyrin-Geneva, Switzerland.

04015

HEWLETT  PACKARD

SIGNAL ANALYZERS

What makes this the best low-priced digital printer you can buy?

Printing wheels, not drums. Each wheel is interchangeable so you can alter any individual column and include special characters at minimal cost. Tailor your printer to your individual needs.

Prints with or without ink. Rotating ink roller means reliable ink printing. No intricate ribbon advance mechanism. If you'd rather use pressure-sensitive paper and no ink, just take out the roller.

10 lines/second printing. Prints ten columns three times faster than any other low-priced printer. Free your system from long print cycles.

Field-proven heavy-duty mechanism. It's the one used for years in our 20 lines/second printer so at 10 lines it's just coasting. Moving parts are held to a minimum. In a word, what you get is reliability.

Price: \$1150 complete. Beat that value!

For the full story on this great new economical, flexible HP 5055A Digital Recorder, call your nearby Hewlett-Packard field engineer. Or write to Hewlett-Packard, Palo Alto, California 94304; Europe: 1217 Meyrin-Geneva, Switzerland.

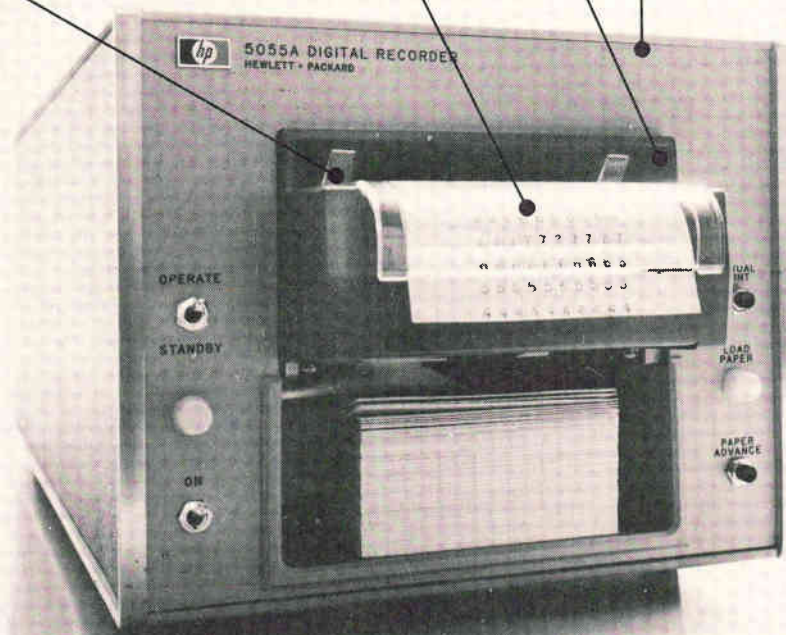

HEWLETT  PACKARD

Features

Probing the News

- 87 **Solid state:** Bell bipolar process ready
- 90 **Manufacturing:** IC printing
- 93 **Packaging:** Plastic MOS set to go
- 94 **Space electronics:** Shuttle faces woes
- 97 **Computers:** Old reliables find new takers

U.S. Reports

- 37 **Lasers:** C-w diode laser at room temperatures
- 37 **Integrated electronics:** Better beam leads and laser scribing
- 38 **Avionics:** Shrink a computer for aviation market
- 39 **Air traffic control:** Satellites vs. superbeacons
- 39 **Solid state:** Hybrid frequency synthesizer saves p-c cards
- 40 **Lasers:** Dye laser puts out over wide band
- 40 **Space electronics:** Lunar Rover guidance system
- 41 **Computers:** System for Congress
- 42 **Communications:** Reactions to low-cost Bell modem; ESS called problem-free
- 44 **Companies:** Ampex eyes semiconductor memories
- 44 **Memories:** NRMEC set for market
- 46 **Microwave:** Radiation detection with diode system
- 46 **Government:** Hazards of radar exposure

Electronics International

- 135 **Great Britain:** Color tv camera checks itself
- 136 **West Germany/Canada:** Fancy flight recorder
- 136 **Japan:** Vertical pnp
- 137 **Great Britain:** Microwave effect
- 138 **The Netherlands:** Betting on two cores per bit

New Products

- 103 **In the spotlight**
- 103 Minicomputers penetrate N/C field
- 107 Dot-display unit challenges scopes in digital-circuit checkout field
- 111 **Instruments review**
- 111 Wideband recorder fits in attache case
- 112 No-frills counter has low price
- 114 **Data handling review**
- 114 Code your own keyboard
- 117 Versatile terminal is simple to use
- 119 **Packaging and production review**
- 119 Checking out ICs in their real world
- 120 Die bonder gives accuracy of 1 mil
- 122 Precision scribe reduces waste
- 127 **New materials**

Articles

Packaging and production

- 56 **Point-to-point wiring gains new popularity among DIP users**
It's easier and cheaper to update circuitry if point-to-point wiring replaces multilayers for short runs of DIP arrays
Stephen E. Scrupski
Packaging and production editor

Advanced technology

- 60 **Optical waveguides bring laser communications closer**
Thin film guides of transparent glass point the way to optical circuits for signal processing
J.E. Goell, R.D. Standley, Tingye Li
Bell Telephone Laboratories Inc.

Circuit design

- 68 **Designer's casebook**
 - Fail-safe flame sensor provides control functions
 - Single hex inverter picks data signals from noise
 - Field effect transistor converts triangles to sines

Solid state

- 72 **Complementary MOS and bipolar make it together on a single chip**
Complementary circuit takes eight masking steps, but saves real estate; device drives heavy capacitances at high speeds with little power loss
Fred J. Link
NASA Goddard Space Flight Center and Robert Cook and Robert J. Lesniewski
Solid State Scientific Corp.

Computer-aided design

- 78 **Linear IC model takes to computer analysis**
Mathematical representation of monolithic op amp lets designer run worst-case and statistical analyses quickly
Raymond Reid
Honeywell Inc.

Departments

- 4 Readers Comments
- 9 Who's Who in this issue
- 12 Who's Who in electronics
- 22 Meetings
- 33 Electronics Newsletter
- 51 Washington Newsletter
- 127 New Literature
- 130 Technical Abstracts
- 133 International Newsletter

Title R registered U.S. Patent Office; © copyright 1970 by McGraw-Hill Inc. All rights reserved, including the right to reproduce the contents of this publication in whole or in part.

EDITOR-IN-CHIEF: Kemp Anderson

EXECUTIVE EDITOR: Samuel Weber

MANAGING EDITORS: Robert Henkel, News;
Arthur Erikson, International

SENIOR EDITORS: H. Thomas Maguire,
Stephen E. Scrupski

ASSOCIATE EDITORS: William Bucci, Richard
Gundlach, John Johnsrud, Howard Wolff

DEPARTMENT EDITORS

Advanced Technology: Laurence Altman;
Communications & Microwave: Leon M. Magill;
Components: Joseph Mittleman; Computers:
Wallace B. Riley; Industrial Electronics:
Alfred Rosenblatt; Instrumentation: Owen
Doyle; Military/Aerospace: Herman Lowenhar;
New Products: H. Thomas Maguire (Mgr.),
William P. O'Brien, George Weiss; Packaging
& Production: Stephen E. Scrupski;
Solid State: George F. Watson

COPY EDITORS: William S. Weiss, Chief;
Margaret Eastman, Edward Flinn

ART: Fred Sklenar, Director
Charles D. Ciatto, Assistant Director

PRODUCTION EDITORS: Susan Hurlburt,
Arthur C. Miller

EDITORIAL SECRETARIES: Barbara
DiBenedetto, Claire Goodlin, Vickie Green,
Terri O'Neill, Bernice Pawlak, Patricia Ritter

FIELD EDITORS

Boston: James Brinton (Mgr.), Gail Farrell;
Los Angeles: Lawrence Curran (Mgr.);
New York: Peter Schuyten; San Francisco:
Stephen Wm. Fields (Mgr.), Marilyn
Howey; Washington: Ray Connolly (Mgr.),
Jim Hardcastle, Lois Vermillion; Frankfurt:
John Gosch; London: Michael Payne; Paris:
Arthur Erikson; Tokyo: Charles Cohen

McGRAW-HILL WORLD NEWS

Director: Walter A. Stanbury; Atlanta: Fran
Ridgway; Chicago: Robert E. Lee; Cleveland:
Arthur Zimmerman; Dallas: Marvin Reid;
Detroit: James Wargo; Los Angeles: Michael
Murphy; San Francisco: Margaret Drossel,
Tyler Marshall; Seattle: Ray Bloomberg;
Washington: Charles Gardner, James Canan,
Herbert W. Cheshire, Seth Payne, Warren
Burkett, William D. Hickman; Bonn: Robert F.
Ingersoll; Brussels: James Smith; London:
Marvin Petal; Milan: Jack Star; Moscow:
Axel Krause; Paris: Robert E. Farrell, Stewart
Toy; Tokyo: Mike Mealey

PUBLISHER: Dan McMillan

ASSISTANT TO THE PUBLISHER: Wallace
Carmichael

PLANNING & DEVELOPMENT MANAGER:
Donald Christiansen

ADVERTISING SALES MANAGER: Pierre Braudé

CIRCULATION MANAGER: John D. Drummond

RESEARCH MANAGER: David Strassler

PROMOTION MANAGER: Tomlinson Howland

ADVERTISING SALES SERVICE MANAGER:
Wallis Clarke

Readers Comment

Hospital safety

To the Editor:

I read your article on safety in medical instruments [Feb. 17, 1969, p. 92] with great interest as I was about to become involved in that exact topic. In June 1969, the Health, Education and Welfare Department, through the Michigan Association for Regional Medical Programs, approved a project, which has been renewed until August 1971, to conduct a survey of electronic devices used in special care areas. As a result of that grant, Dr. Henry Green, the project director, and I have encountered many facets of the medical electronic safety questions raised in your article.

So far, we have surveyed 12 hospitals in the Detroit area to document the type and occurrence of malfunctioning and misused equipment in special care areas such as the cardiac care unit. The equipment we investigated was not necessarily newly purchased, nor did it always represent the most up-to-date model. However, it was assumed to be reliable and was, in fact, used daily as a diagnostic or therapeutic device in patient care. During our survey, we were not interested strictly in equipment, but also in the special care facility itself, which we examined from the standpoint of patient safety.

We tackled the investigation of hospitals on a quality versus quantity basis. Depending on the size of a particular hospital we may have spent up to two weeks collecting data on equipment and its proper utilization by the medical staff. We found pacemakers that

would not pace, monitors whose specifications fell below those recommended by the American Heart Association, defibrillators incapable of defibrillation and various other assorted facts. Since our discoveries, we have attempted to report them in a discrete fashion. There does not seem to be one specific area where blame can be laid. The manufacturer certainly has an obligation for his equipment, but the hospital administrator must share responsibility for maintenance.

In an effort to begin a solution, we presented our information to the Inter-Society Commission for Heart Disease Resources. Our report generated so much enthusiasm within that organization that a study group was formed on the topics of instrument design, safety, and maintenance.

The purpose of the group is to make recommendations which will lead to improvements in the design, maintenance, and utilization of these devices. We hope the media for such changes will include the certification of manufacturers and inspectors of this equipment, education of medical personnel concerning safe and effective use, suggestions for legislation, and, in some cases, direct and specific recommendations that a given device or technique be modified.

One of my prime concerns, however, is not only to generate enthusiasm in the medical profession, but also to encourage cooperation among engineers involved in medical electronic equipment. Physicians alone will not solve the immediate problems.

G.E. Hieb

Project engineer,
Cardiac Care Unit Surveillance
Project
Southfield, Mich.

August 31, 1970 Volume No. 43, Number 18
89,616 copies of this issue printed

Published every other Monday by McGraw-Hill, Inc. Founder: James H. McGraw 1860-1948. Publication office 99 North Broadway, Albany, N.Y. 12202; second class postage paid at Albany, N.Y. and additional mailing offices.

Executive, editorial, circulation and advertising addresses: Electronics, McGraw-Hill Building, 330 W. 42nd Street, New York, N.Y. 10036. Telephone (212) 971-3333. Teletype TWX N.Y. 710-581-4235. Cable address: MCGRAWHILL N.Y.

Subscriptions solicited only from those professionally engaged in electronics technology. Subscription rates: qualified subscribers in the United States and possessions and Canada, \$8.00 one year, \$12.00 two years, \$16.00 three years; all other countries \$25.00 one year. Non-qualified subscribers in the U.S. and possessions and Canada, \$25.00 one year; all other countries \$50.00. Air freight service to Japan \$50.00 one year. Single copies: United States and possessions and Canada, \$1.00; all other countries, \$1.75.

Officers of McGraw-Hill Publications Company: Joseph

H. Allen, President; John R. Emery, J. Elton Tuohis, Senior Vice Presidents; Donald B. Gridley, Group Vice President; Vice Presidents: Ralph Blackburn, Circulation; John R. Callahan, Editorial; William P. Giallo, Administration; David G. Jensen, Manufacturing; Jerome D. Luntz, Planning & Development; Joseph C. Page, Marketing; Robert M. Wilhelm, Finance.

Officers of the Corporation: Shelton Fisher, President and Chief Executive Officer; John J. Cooke, Senior Vice President and Secretary; Gordon W. McKinley, Vice President and Treasurer.

Title © registered in U.S. Patent Office; © Copyright 1970 by McGraw-Hill, Inc. All rights reserved. The contents of this publication may not be reproduced either in whole or in part without the consent of copyright owner.

Subscribers: The publisher, upon written request to our New York office from any subscriber, agrees to refund that part of the subscription price applying to copies not yet mailed. Please send change of address notices or complaints to Fulfillment Manager; subscription orders to Circulation Manager, Electronics at address below. Change of address notices should provide old as well as new address, including postal zip code number. If possible, attach address label from recent issue. Allow one month for change to become effective.

Postmaster: Please send form 3579 to Fulfillment Manager, Electronics, P.O. Box 430, Hightstown, N.J. 08520.

Best for Hybrid Circuits...

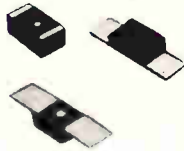

PIPS OF CHIPS

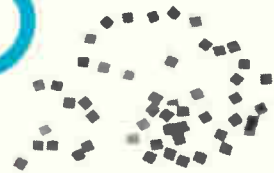

DOMINO[®] Molded Solid-electrolyte Tantalum Capacitors

Designed for hybrid circuit and low-profile flatpak printed circuit board applications. Fully-molded construction for superior mechanical and humidity protection. Excellent stability. Compatible with automatic insertion equipment. Available with and without extended tab terminals.

Write for Engineering Bulletin 3532.

MONOLYTHIC[®] Chip Ceramic Capacitors

Offer a unique combination of high volumetric efficiency, wide selection of capacitance ranges and body formulations, and moderate cost. Excellent adherence of metallized terminations eliminates problems often encountered with other chip ceramic capacitors. Available in four EIA-preferred chip sizes.

Write for Engineering Bulletin 6200.

Technical Literature Service
Sprague Electric Company
35 Marshall Street
North Adams, Mass. 01247

45-0148



THE BROAD-LINE PRODUCER OF ELECTRONIC PARTS

**National sells
MOS than Fairch
TI and Signetics**

**Guess which one
is selling shift
registers at
a penny a bit.**

more old, Motorola, combined.

Who else?

National just came out with the MM5016, a bipolar compatible 512-bit dynamic shift register with a five dollar price tag (in quantities of 100). The MM5016 should interest designers of CRT refresh memories, radar delay lines or fast access drum memories. And engineers looking for a small and stable replacement for glass and magnetostrictive delay lines.

Now guess who's selling 600ns ROM's.

National again. We just introduced the MM5240, a bipolar compatible, 2560 bit character generator that offers you off-the-shelf standard fonts in addition to its blazing speed. We've priced the MM5240 at \$30.00 (in quantities of 100) and now await orders from people involved in character generation, random logic synthesis, micro-programming and table look-up.

What else?

Well, National recently introduced still another MOS, the MM5001. The MM5001 is

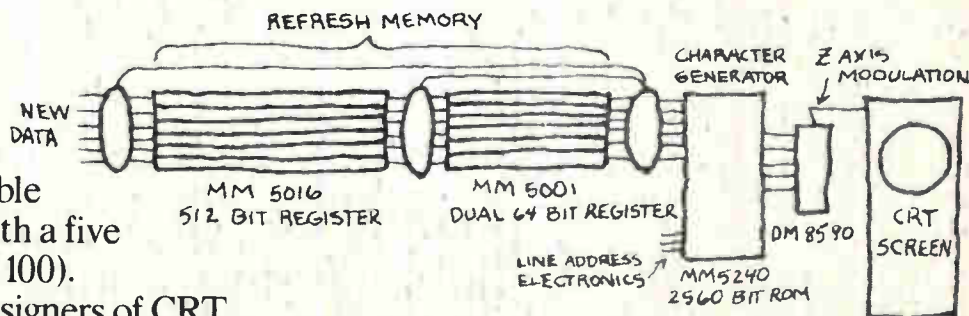

a dual, 64-bit dynamic shift register. Like the MM5016 and the MM5240, it's bipolar compatible. It costs just \$10.80 (in quantities of 100), and you'll find the MM5001 handy in a variety of data handling and computer type applications.

All three of National's new MOS products have application in CRT refresh memories. We've written an application brief to give you all the details. The brief awaits you now at your National distributor. So do the products. National Semiconductor Corporation, 2900 Semiconductor Drive, Santa Clara, California 95051/Phone (408) 732-5000, TWX (910) 339-9240.

National

Design breakthrough in FM-IF systems: two new RCA IC's for more performance, with fewer components

Two new RCA Linear IC's now offer you a brand new approach to FM-IF system economy and performance. The CA3076 (high-gain IF amplifier/limiter) and the CA3075 (IF amplifier, limiter, FM detector, and audio preamplifier) have been designed to bring you an IF system with dramatic reductions in external components. And—to make the total economics of your system attractive—RCA has priced the CA3076 at \$1.60 (1,000-unit level) and the CA3075 at \$1.40 (1,000-unit level).

For your applications in communications receivers and high-fidelity equip-

ment, with FM IF's requiring bandwidths to 20 MHz, here are some highlights on these two new RCA types:

The CA3076 has an input limiting voltage (knee) of 50 μ V (typ.) and 80 dB (typ.) gain with 2-kilohm load at 10.7 MHz. It contains an integral voltage regulator, for operation at power supply voltages from 6 V to 15 V.

The CA3075 limits with an input voltage of 250 μ V (typ.) at 10.7 MHz. It has low harmonic distortion and excellent AM rejection—55 dB (typ.) at 10.7 MHz. Differential peak detection permits single-

coil tuning. The CA3075 incorporates an audio preamplifier with 21 dB (typ.) voltage gain, and an integral voltage regulator, for operation at power supply voltages from 8.5 V to 12.5 V.

For further information, see your local RCA Representative or your RCA Distributor, or write: RCA, Commercial Engineering, Section 70H-31/CA42, Harrison, N.J. 07029. International: RCA, 2-4 rue du Lièvre, 1227 Geneva, Switzerland, or P.O. Box 112, Hong Kong.

All components required for a typical IF strip are shown in this illustration.

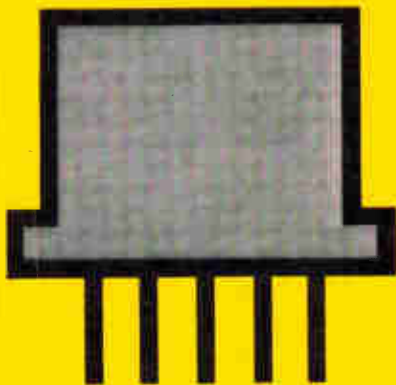
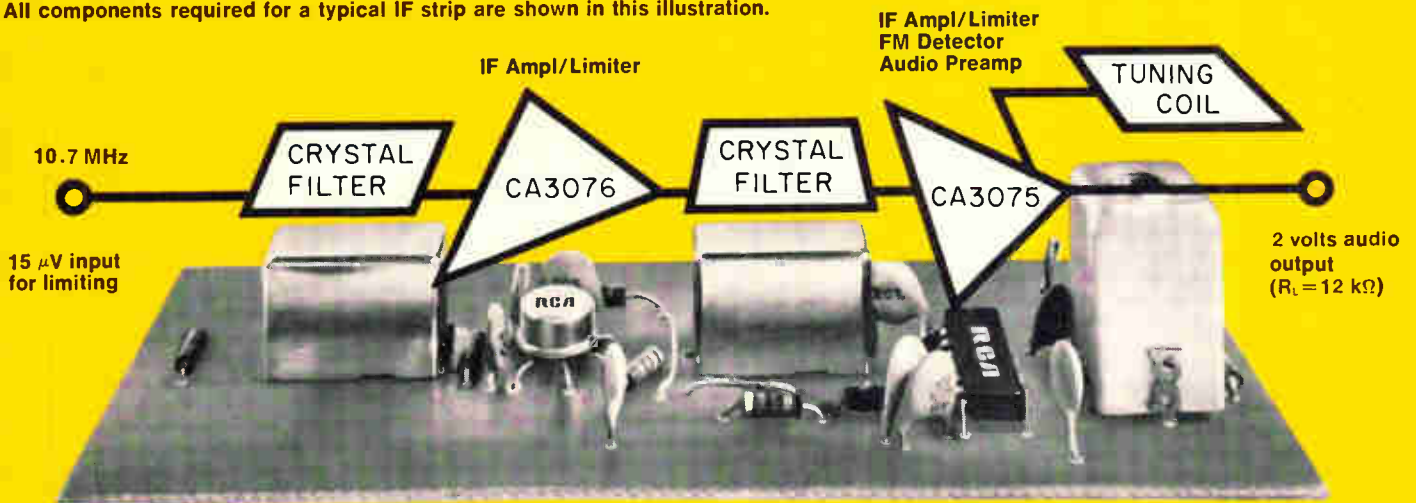

CA3076 IF ampl/limiter

Voltage gain: 80 dB (typ.) with 2k Ω load
 Input limiting voltage: . . . 50 μ V (typ.)
 Freq. capability: Up to 20 MHz
 Package: 8-lead TO-5
 Price: \$1.60 (1000-unit level)

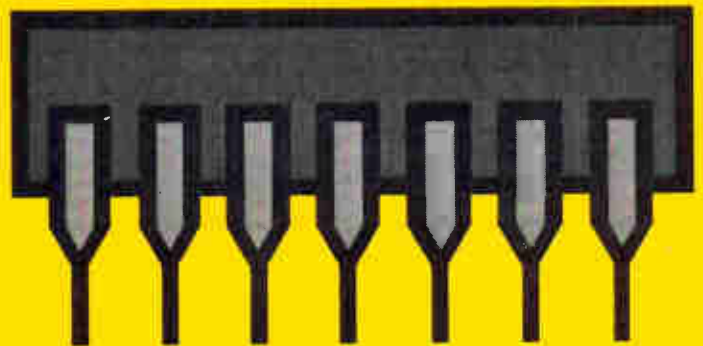

CA3075 IF ampl/limiter, peak detector, and audio preamp

Voltage gain (audio preamp): 21 dB (typ.)
 Input limiting voltage: 250 μ V (typ.)
 Freq. capability: Up to 20 MHz
 Package: 14-lead DIP (formed leads)
 Price: \$1.40 (1000-unit level)

Circle 8 on reader service card

RCA

Integrated Circuits

Who's Who in this issue



Li

Goell

Standley

With three Ph.D. degrees and 22 years of experience at Bell Labs among them, Tingye Li, J.E. Goelle, and R.D. Standley are eminently qualified to write about the optical waveguide technique described in the article on page 60. Li, who holds a Ph.D. from Northwestern, joined Bell Labs in 1957. He heads the

repeater techniques research department. Goell's doctorate was awarded by Cornell. A five-year Bell veteran, he's worked on millimeter wave communications and optical ICs. Standley received his Ph.D. from the Illinois Institute of Technology. Since 1966 he's done research on thin film optical techniques.



Reid

A worst-case design-problem for a government agency led to the development of the accurate computer model of the linear operational amplifier described in the article on page 78. The author, Raymond Reid, has been promoting the use of computers for this type of analysis ever since. Reid is a graduate of Texas A&M. In 1959, he joined Honeywell Inc. in St. Petersburg, Fla. His work there includes worst-case and radiation analysis of discrete and integrated circuits for Minuteman 3 computers.

Circuit design is the tie that binds the authors of the article on C-squared MOS starting on page 72. Fred J. Ling is with NASA Goddard Space Flight Center, where he tests and designs telemetry systems and C/MOS circuits. Both Robert Cook and Robert J. Les-

niewski are with Solid State Scientific Corp., where Cook is manager of the MOS department and Lesniewski heads the technical program, which is responsible for development of new MOS products in LSI memories and their related circuits.

FRAME SIZES

CONSTRUCTION TYPES

MOUNTING STYLES

M49-FRAME
3 IN. DIA.

BOLTED STEEL
END SHIELD

END SHIELD
MOUNTING

M59-FRAME
3.4 IN. DIA.

Unitized
MOTOR-STEEL
END SHIELD

SOLID BASE
MOUNTING

19 FRAME
3⁷/₈ IN. DIA.

BOLTED
ALUMINUM
END SHIELD

THROUGH
BOLT
MOUNTING

29 FRAME
4⁷/₈ IN. DIA.

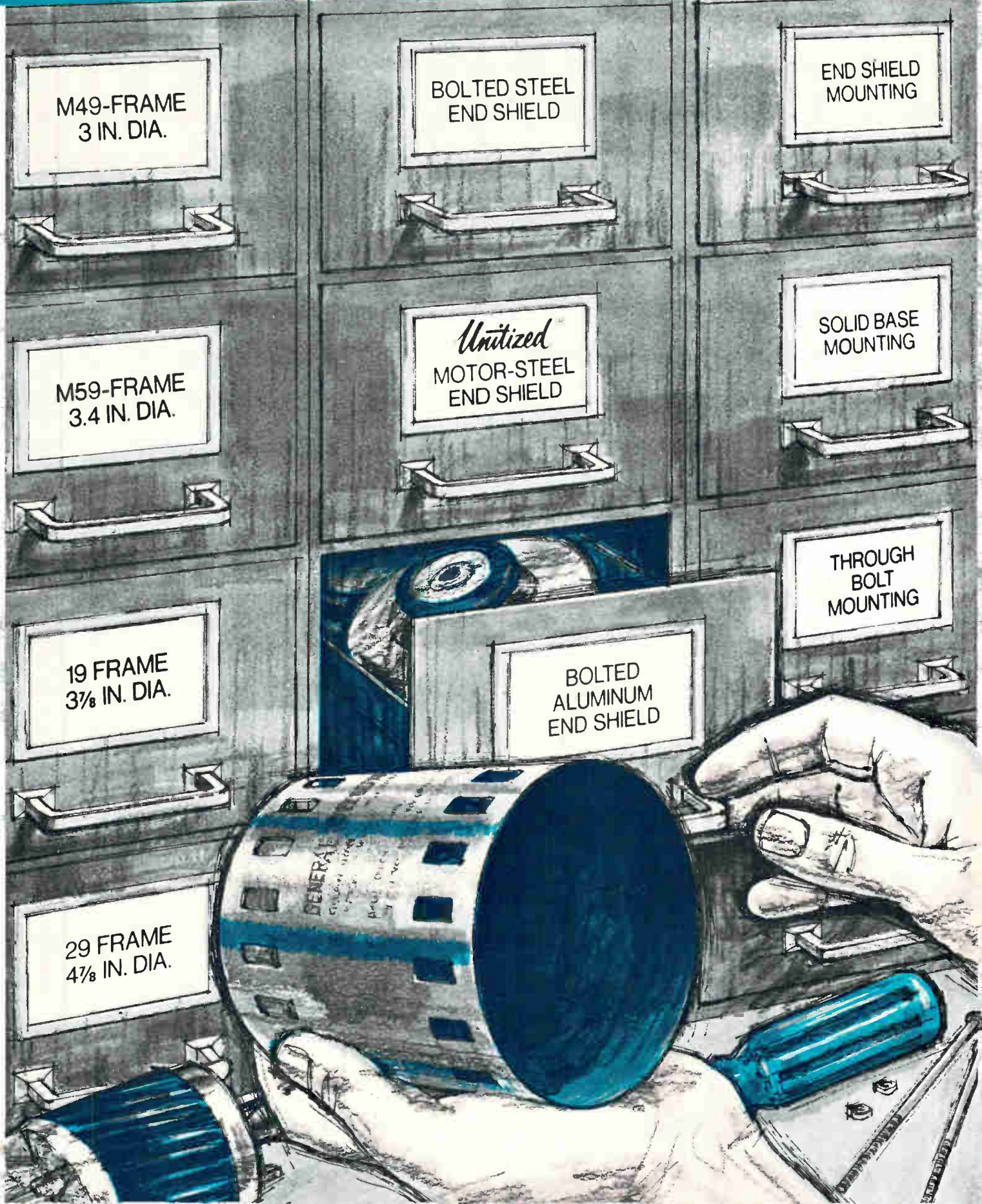
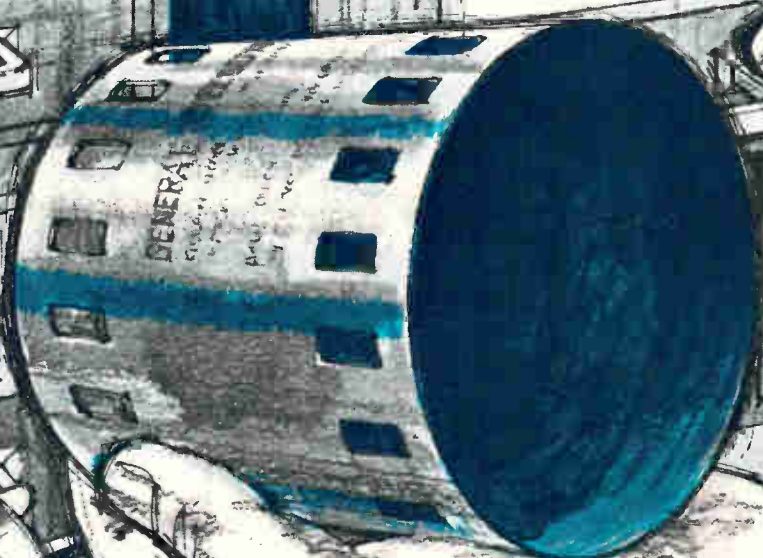

Solve your motor application problems with General Electric's versatile, "custom engineered" induction motors

Now you can combine all the application benefits of a motor specially designed to your requirements with the advantages that come with a "catalog" item.

How? By choosing the GE induction motor design features that satisfy your special electronic application needs from the many options available, such as . . .

- four different construction and mounting styles . . .
- three bearing systems . . .
- nine different electrical types . . .
- and four insulation systems.

The result is the versatility of design to meet your needs in a standardized motor. This custom engineering design approach means you can be sure that the GE motor you choose will be compatible with your product's design—both electrically and

mechanically. Here are just some of the choices that make this possible:

Construction types—Rigid steel shell either open or totally enclosed. Cast aluminum or steel endshields. Assembled with through-bolts or GE's patented process for manufacturing Unitized® motors. Endshield, through-bolt, solid-base or resilient-base mountings.

Bearing systems—Various sleeve or ball bearing design combinations.

Electrical types—Split-phase, capacitor start, permanent-split capacitor, shaded pole, polyphase and a complete line of reluctance-synchronous

motors. Available in single or dual rotation and instantly reversible designs.

Insulation systems—Class A, B, F and H insulating materials cover the range of temperature requirements.

Get the full story on how these reliable, versatile induction motors can help in your specific application. Call your nearby GE Electronic Components Sales Office today, or write to Section 727-27, General Electric Company, Specialty Motor Department, Fort Wayne, Indiana 46804.

P.S. Motor problems? General Electric has solutions!



GENERAL  ELECTRIC

Who's Who in electronics

Plenty of publicity but few commercial applications—that's been the story of liquid crystals. Thus, as one of his first official acts upon assuming command of RCA's Solid State division, William C. Hittinger set up the Solid State Optoelectronics division and placed Edward O. Johnson, 50, in charge.

But commercial liquid crystal exploitation is only one phase of that operation. Other technologies under the optoelectronics banner include infrared-emitting diodes, solid state injection lasers, photocells, and tunnel diodes. In fact, according to Johnson, the new group encompassing all these areas will now be like a little company within a big one. Previously all these activities were scattered throughout the Solid State division.

One potential market for this "little company," comments Johnson, who previously was manager of engineering technical programs for RCA's Electronic Components division, is "law-and-order" electronics. The whole field of intrusion alarm systems—silicon detectors in particular—is just really starting to open. But as Johnson points out, the larger companies—RCA included—have been rather slow getting into the business on a system basis. One reason, says Johnson, is the difficulty in assembling the talent necessary for such a new venture. Instead, Johnson's operation will be supplying hardware to the small houses that have been formed solely to take advantage of this market.

Other markets targeted by the optoelectronics group include photocells for street lights, oil burners, and the like; tunnel diodes with switching speeds in the picosecond range, and, of course, liquid crystal displays.

As Johnson sees it, one of the weakest areas in electronics right now—hence, one worth exploiting—is displays. The advantages of liquid crystals are well known: they don't wash out in sunlight; they can be made into large or small displays, and they require little power.

Johnson says that his group should have its first commercial



Johnson

products within a year, possibly within six months. Currently, says Johnson, his team is working with specific customers on an assortment of products, although he won't say what. As for the much-talked-about dot matrix display using the crystals, Johnson sees that development as quite far down the line—as much as 10 years away.

Looking back on his career, Alan J. Grant, new executive vice president at the Aerojet-General Corp., sees it as having been shaped by people, rather than specific incidents. "What makes me happy is working for someone from whom I can learn something," he asserts. The 44-year-old Grant, one of two executive VPs at the El Monte, Calif., firm, is responsible for the Electronics and Environmental Systems divisions, along with the Advanced Products group.

Of Grant's hiring, an Aerojet spokesman says, "We needed someone with management and technical experience to head up what we think are some of the most exciting parts of the company and make them grow. They have much more potential than they've demonstrated."

Aerojet management is counting on him to exercise what he describes as his forte: developing new equipment based on electronic and mechanical disciplines. Grant came to Aerojet from Fairchild Camera and Instrument Corp., where he was a group vice president. There he was exposed to two "tutors:" Fairchild President C. Lester Hogan, "one of the most inspirational leaders I've known and who has the backing of one of the great men in new technology," Sherman Fairchild, chairman.

Before joining Fairchild, Grant was president of Lockheed Electronics Co., where he worked with Lockheed chairman Daniel Haughton, "one of the best business managers I've ever met." Grant started out at what was to be the Autonetics division of North American Rockwell Corp., and moved up to become vice president and general manager of the then Computer and Data Systems division. "People engineering became my thing in 1959" at Autonetics, Grant says, "and that's when I decided to be a professional manager." The education of Alan Grant continued when he became president of Litton Industries' Guidance and Control Systems division. "The Litton experience provided the best financial education I've ever had," Grant notes.

Now he's hoping to put it all together for Aerojet president Jack H. Vollbrecht, "who has the highest business principles I've found and who has a team of the highest professionals." Vollbrecht took over at Aerojet last November and changed very few key people, so Grant observes "Now I have to match the technical depth to the growth opportunities."

Those opportunities are opening up in forward-looking infrared systems and satellite sensors at the

HIGH PRODUCTION, LOW COST CUSTOM MOS/LSI.

Besides turning the corner on high volume production, North American Rockwell Microelectronics Company has developed innovations to make custom MOS devices at the lowest prices in the industry. For one thing, all MOS chips are home grown. Economies result from in-house control at every stage.

And cost effectiveness is only one of many customer appeals.

The only house where everything's in-house.

Today, NR-Microelectronics is the only company with total capability to transfer a multiplicity of circuit functions into a single MOS/LSI device and then mass-produce them.

With our versatile computer equipment, we've designed more logic capability

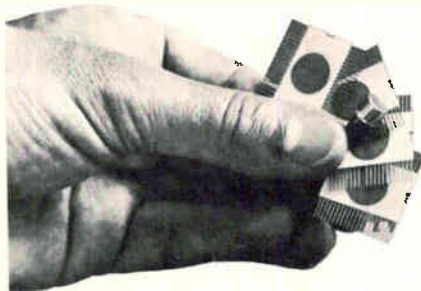

into a given circuit on a larger chip than other semiconductor manufacturers.

Prices guaranteed, product guaranteed.

We're ready to protect our customers with guaranteed prices for the number of years required.

And if we design the custom circuits you use, we're prepared to guarantee that they'll be yours exclusively.

Does anyone need 200,000 MOS/LSI devices a month?

In our Anaheim plant are two custom processing lines: medium volume and high volume—the latter is

now producing at a monthly rate of 200,000 plus.

Firm commitments will more than double this production in 1971.

But we have substantially greater capacity. . . which is being increased daily by processing innovations.

So we're ready for more orders —both medium & high volume custom MOS/LSIs.

Our telephone number is

(714) 632-2231. Our zip code in Anaheim, California, is 92803.

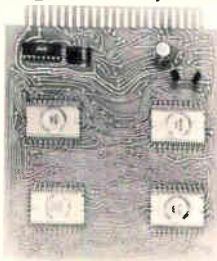
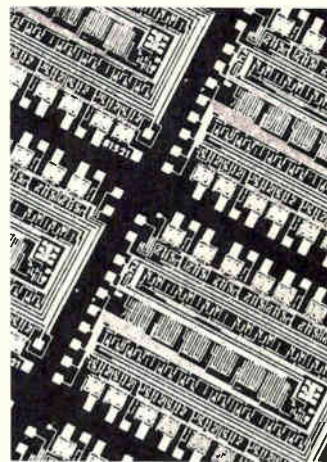

**North American Rockwell
Microelectronics Company**

JUST OFF THE PRESS!

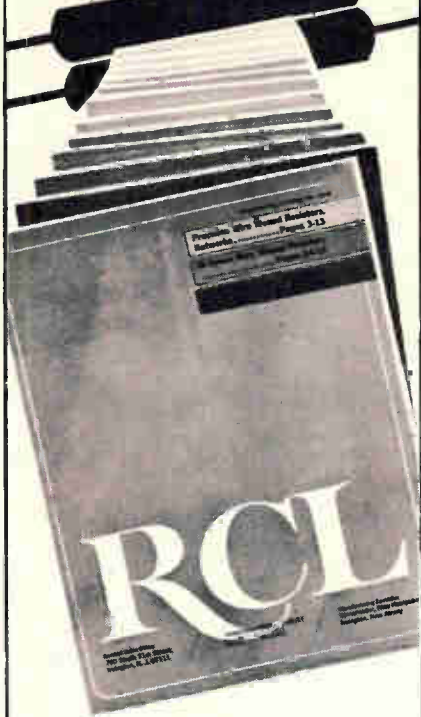

RCL's NEW RESISTOR CATALOG

the industry's most extensive and most accurate compilation of engineering information on wire-wound resistors

PRECISION/HI-SPEED POWER/WIRE-WOUND RESISTORS

including: beryllium oxide core power resistors . . . 22 special temperature coefficients from -50 PPM to +6000 PPM . . . sub-miniature precision resistors . . . ladder and summing networks.

Write for your free copy today!

RCL

ELECTRONICS, INC.
700 South 21st Street
Irvington, New Jersey 07111

Who's Who in electronics



Grant

Electronics division; in medical and biological systems plus microwave systems and surface-effect ships in the Advanced Products group, and in such things as water purification and waste management systems in the Environmental Systems division. Aerojet officials admit that they're often regarded as a propulsion company. By acquiring Grant, widely known in the electronics business, they hope to further change the image.

Hardly unusual is Fred Chernow's belief that electrical engineering students should be confronted with real-world problems to solve in a real-world environment if they're preparing themselves to work in industry. However, the 38-year-old educator has an unusual opportunity to offer his students practical preparation.

In fact, Chernow, professor of electrical engineering at the University of Colorado in Boulder, Colo., is director of the technical staff at Boulder's University Instruments Corp. University Instruments, an equipment manufacturer, was formed earlier this year as an affiliate of the KDI Corp. of Cincinnati, which sponsors research work at the university to the tune of \$250,000 a year. University Instruments has granted rights to manufacture and market some of the hardware that's grown out of that relationship.

"KDI has helped by giving us

freedom in using research funds so that we can select bright young undergraduates for lab jobs," Chernow says. Some of them have been working on wide bandgap semiconductors for light emission and detection in the photoconductive semiconductors and devices laboratories, of which Chernow is co-director. In the process, they've made no small contribution to the cadmium sulfide device work on which University Instruments draws for an optical communications link that's being readied for a test in a CATV application.

Chernow teaches a course in statistical thermodynamics for junior and senior EE students. "The classical engineering curriculum may use books that are a couple of years old and give the student no contact with the real world," he says. "Examinations often become a question of who can memorize best and who got the best sleep the night before." In his course, Chernow gives the students a sheet with all the formulas they'll need for an examination a week in advance, but he doesn't want them memorized.

"There may not be only one right answer," Chernow says. He likes to throw in a hooker occasionally. "We might ask them something like this: 'If you drop an olive into a martini containing so many cc, how much will it change the entropy of the universe?'" Turning more serious, Chernow points out that he spends the last three weeks of the course on semiconductors: "I try to get them to understand the properties of materials and they wind up understanding p-n junctions through statistical thermodynamics."

An ion implantation machine developed by students and faculty members and which University Instruments plans to market, is another outgrowth of KDI-sponsored research. Chernow says it will be much smaller than commercially available implanters because it uses a unique mass separation technique. University Instruments also is readying two other product lines for the market: real-time optical spectrometers and liquid electrostatic high-voltage generators.

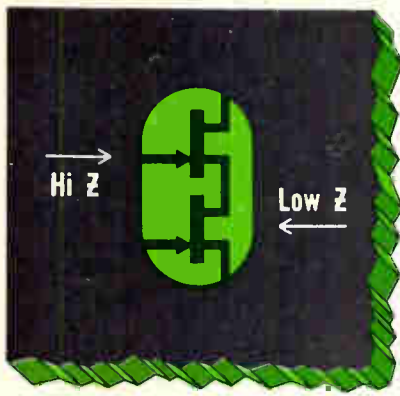

LOW OFFSET Source Followers with DUAL FETS

Get near unity voltage gain impedance transformation, low offset voltage and low temperature drift with these Siliconix duals.

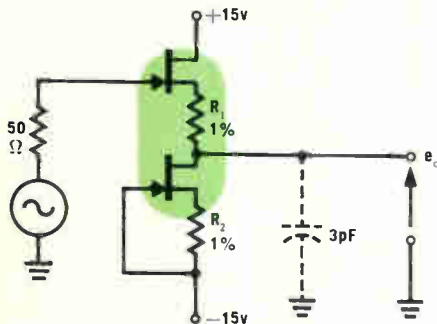

Here's a high-Z-to-low-Z example: The lower FET is the constant-current generator, the upper is the source follower. Offset voltage is given by $V_{GS1} = I_{D1}R_1 = I_{D2}R_2 = V_{GS2}$.

The devices typically perform this way:

DEVICE	Typical Offset (mV)	Typical Drift ($\mu\text{V}/^\circ\text{C}$)	e_n max. (V p-p)	Voltage Gain (A_v)	BW (MHz)	Output Resistance (R_o, Ω)	$R_1 = R_2$ (Ω)
2N5519	15	80	27	.98	5.6	3,000	2,000
U235	25	100	28	.98	7.0	3,300	2,000
U257	100		27	.98	18.0	1,200	1,000

And these are typical gain-frequency plots:

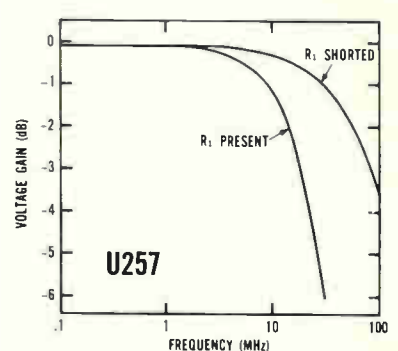
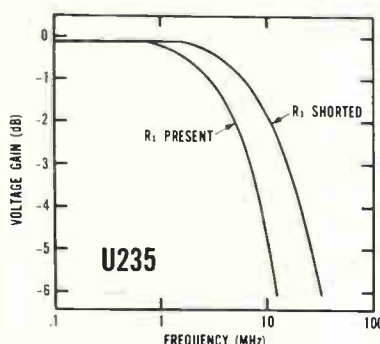
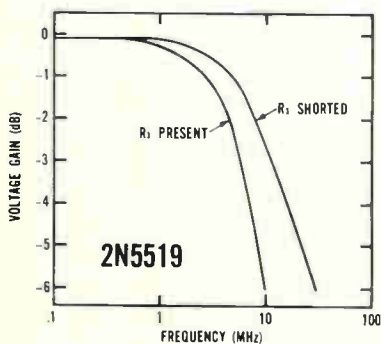

For complete data and supplementary information on Siliconix duals, write or call any of the numbers below.

- New York: Sy Levine (516) 796-4680
- New England: Al La Croix (617) 769-3780
- Ft. Worth/Dallas: Charlie Williams (214) 231-8151
- St. Louis: Jim Spicer (314) 291-3616
- Minneapolis: Ed Koelfgen (612) 920-4483
- Southern California: Dave Ferran (213) 420-1307
- Northern California: Chuck Brush (408) 246-8000



Siliconix incorporated

2201 Laurelwood Road • Santa Clara • California 95054
Telephone (408) 246-8000 Extension 201 • TWX: 910-338-0227
In Europe: Siliconix Limited, Saunders Way, Sketty, Swansea, Great Britain

Our engineers have to do a good job, because our salesmen don't.

Now don't get us wrong. Our salesmen are great guys and they've made us the world's largest power supply company. But when it comes to our modular power supplies, they do very little selling. And we don't blame them because they would rather sell \$1,000 instruments than \$89 modular power supplies.

Yet, people have bought over 25,000 of them (ranging from 0 to 330 Vdc—to 300 watts). And 65% of these are repeat orders. Why? Before you turn the page, may we quickly give you six hard-nosed reasons:

1. We're the most experienced in the industry — 26 years in this business.
2. When it comes to the acid test of any power supply — response time — we out-perform all others: 20 — 35 μ s.
3. In all critical specifications, ours surpass all others. (For instance, our regulation is $\pm 0.005\%$ for line and load changes, ripple is 300 μ V rms — 3 mV p-p.)
4. Our supplies require no heat sink in ambients to 71°C.
5. Our modular power supplies and accessories are UL listed.
6. We inventory more power supplies than most manufacturers sell in a year. (And we burn in every one for 48 hours before we ship it.)

Those are the same reasons why the industry has bought over \$150 million worth of Sorensen power supplies.

And those are the same reasons why you may want to consider Sorensen the next time you consider power supplies. For complete information on any of our power supplies (or for our 124-page Power Supply Handbook and Catalog) call our Applications Engineer, Steve Charleston (collect) at (203) 838-6571, or write to him at Sorensen, Richards Ave., Norwalk, Connecticut 06856. Circle 200 on the inquiry card.

Sorensen
POWER SUPPLIES

AN OPERATION OF RAYTHEON CO.



We've got a whole bunch of transistor stands!

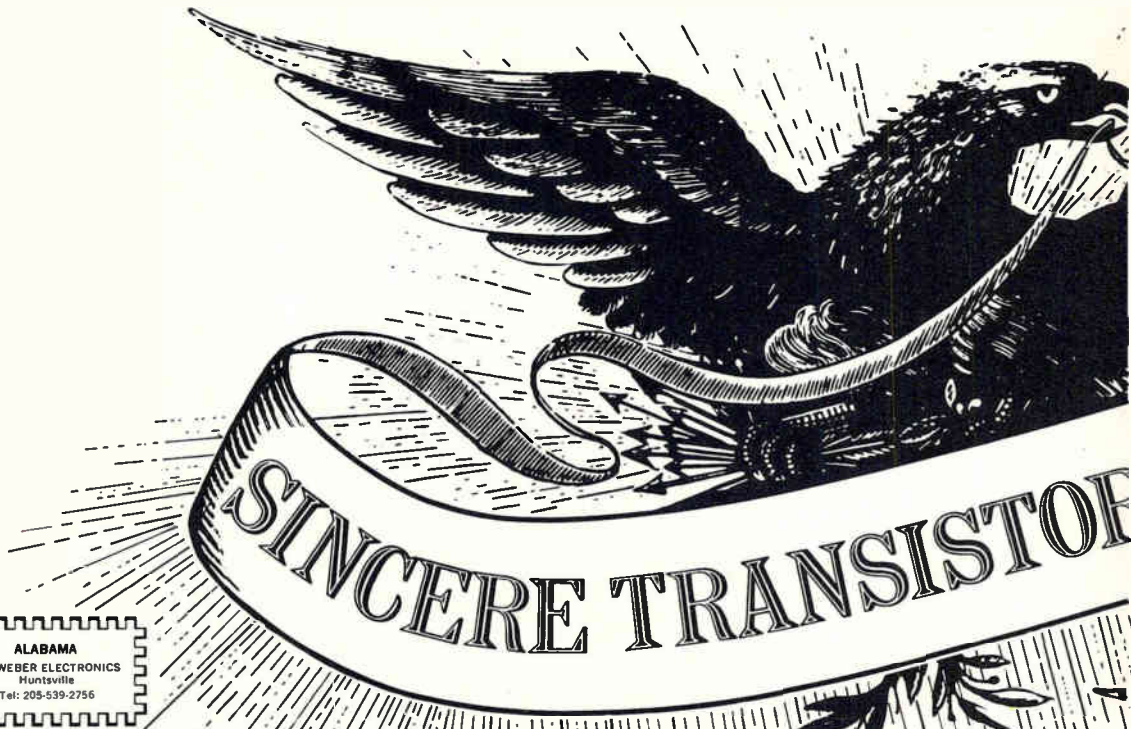

ALABAMA
 SCHWEBER ELECTRONICS
 Huntsville
 Tel: 205-539-2756

CALIFORNIA

AVNET ELECTRONICS Culver City Tel: 213-836-7200	HAMILTON/AVNET ELECTRONICS Mountain View Tel: 415-961-7000	G. S. MARSHALL COMPANY El Monte Tel: 213-686-1500
ELECTRO SALES Culver City Tel: 213-870-7171	HAMILTON/AVNET ELECTRONICS San Diego Tel: 714-279-2421	G. S. MARSHALL COMPANY San Diego Tel: 714-278-6350
		G. S. MARSHALL COMPANY Sunnyvale Tel: 408-732-1100

COLORADO
 HAMILTON/AVNET ELECTRONICS
 Denver
 Tel: 303-433-8551
 CRAMER/DENVER
 Denver
 Tel: 303-758-2100

INDIANA
 SEMICONDUCTOR SPECIALISTS, INC.
 Indianapolis
 Tel: 317-243-8271

MICHIGAN
 SEMICONDUCTOR SPECIALISTS, INC.
 Detroit
 Tel: 313-255-0300
 SHERIDAN SALES CO.
 Southfield
 Tel: 313-358-3333

CANADA

AVNET ELECTRONICS OF CANADA, LTD. Toronto Tel: 416-789-1838	R. A. E. INDUSTRIAL ELECTRONICS, LTD. Vancouver Tel: 604-253-8494
AVNET ELECTRONICS OF CANADA, LTD. Montreal Tel: 514-381-9126	SCHWEBER ELECTRONICS Toronto Tel: 416-925-2471

CONNECTICUT
 CRAMER ELECTRONICS, INC.
 North Haven
 Tel: 203-239-5641

ILLINOIS
 F-J-R ELECTRONICS
 Rosemont
 Tel: 312-678-8560
 HAMILTON/AVNET ELECTRONICS
 Schiller Park
 Tel: 312-678-6310
 SEMICONDUCTOR SPECIALISTS, INC.
 Chicago
 Tel: 312-279-1000

MARYLAND
 HAMILTON/AVNET ELECTRONICS
 Baltimore
 Tel: 301-796-5000
 SCHWEBER ELECTRONICS
 Rockville
 Tel: 301-427-4977
 CRAMER/WASHINGTON
 Rockville
 Tel: 301-424-2700

GEORGIA
 CRAMER ELECTRONICS, INC.
 Atlanta
 Tel: 404-451-5421

FLORIDA

POWELL-FLORIDA Orlando Tel: 305-423-8586	HALL MARK ELECTRONICS Orlando Tel: 305-855-4020
CRAMER FLORIDA, INC. Fort Lauderdale Tel: 305-566-7511	SCHWEBER ELECTRONICS Hollywood Tel: 305-927-0511

KANSAS
 HAMILTON/AVNET ELECTRONICS
 Prairie Village
 Tel: 913-362-3250

MASSACHUSETTS
 CRAMER ELECTRONICS, INC.
 Newton
 Tel: 617-969-7700
 SCHLEY ELECTRONICS CORP.
 Watertown
 Tel: 617-924-1500
 SHWEBER ELECTRONICS,
 Waltham
 Tel: 617-891-8484



At The Sincere Transistor & Diode Company, business is booming. So much so that we can't supply the whole country from our place on Fairchild Drive in Mountain View.

So, we've made a deal with some nice people all over the country to distribute our stuff.

Now, instead of calling the factory direct, you only have to phone your local Sincere distributor, whose name and

number appear on this page.

And I've made the same promise to all my transistor stand operators. "Boys," I told them, "I'll guarantee to fill your orders in 24 hours or less; you take it from there. And, boys... be nice to the customers, like I taught you."

The Sincere Distributors. They're such nice boys.

Molly Sincere

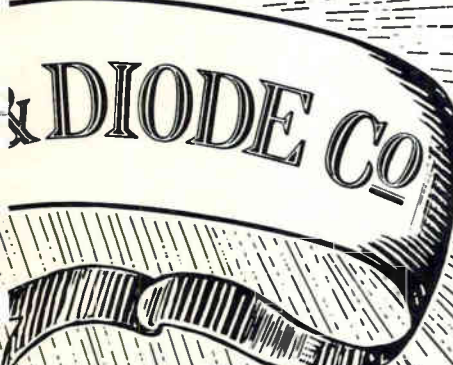
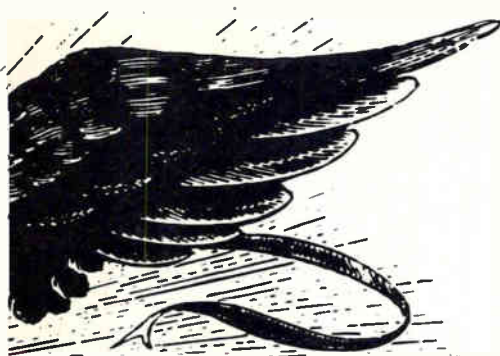

NEW JERSEY
HAMILTON /AVNET ELECTRONICS
Cherry Hill
Tel: 609-662-9337
SCHLEY ELECTRONICS CORP.
Rutherford
Tel: 201-935-2120

ARIZONA
CRAMER/ARIZONA
Phoenix
Tel: 602-263-1112
HAMILTON /AVNET ELECTRONICS
Phoenix
Tel: 602-272-2601

TEXAS
ARCO ELECTRONICS INC.
Dallas
Tel: 214-239-9123
HAMILTON /AVNET ELECTRONICS
Houston
Tel: 713-526 4661
NORVELL ELECTRONICS, INC.
Dallas
Tel: 214-357-6451
NORVELL ELECTRONICS, INC.
Houston
Tel: 713-774-2568

WASHINGTON
HAMILTON /AVNET ELECTRONICS
Seattle
Tel: 206-624-5930
KIERULFF ELECTRONICS
Seattle
Tel: 206-763-1550

LOUISIANA
STERLING ELECTRONICS CORPORATION
New Orleans
Tel: 504-522-8726

TENNESSEE
POWELL ELECTRONICS, INC.
Fayetteville
Tel: 615-433-5737

MINNESOTA
HAMILTON /AVNET ELECTRONICS
Minneapolis
Tel: 612-920-5866
SEMICONDUCTOR SPECIALISTS, INC.
Minneapolis
Tel: 612-866-3433

NEW MEXICO
CRAMER ELECTRONICS
Albuquerque
Tel: 505-265-5767

OHIO
F.J.R. ELECTRONICS
Dayton
Tel: 513-278-9411
SCHWEBER ELECTRONICS
Cleveland
Tel: 216-333-7020
SHERIDAN SALES CO.
Cincinnati
Tel: 513-761-5432
SHERIDAN SALES CO.
Cleveland
Tel: 216 524 8120

PENNSYLVANIA
POWELL ELECTRONICS, INC.
Philadelphia
Tel: 215-724-1900
SEMICONDUCTOR SPECIALISTS, INC.
Pittsburgh
Tel: 412-718-8120
SHERIDAN SALES CO.
Pittsburgh
Tel: 412-243-6655

MISSOURI
HAMILTON /AVNET ELECTRONICS
Hazelwood
Tel: 314-731-1144
SEMICONDUCTOR SPECIALISTS, INC.
St. Louis
Tel: 314-423-6500

NEW YORK
CRAMER ELECTRONICS
Westchester
Tel: 6-275-0300
CRAMER ELECTRONICS, INC.
Syracuse
Tel: 315-455-6641
SUMMIT DISTRIBUTORS, INC.
Buffalo
Tel: 716-884-3450
HAMILTON /AVNET ELECTRONICS
Syracuse
Tel: 315-437-2641
SCHWEBER ELECTRONICS
Westbury, Long Island
Tel: 516-334-7474
HAMILTON /AVNET ELECTRONICS
Baldwin, Long Island
Tel: 516-223-8000

UTAH
CRAMER ELECTRONICS
Salt Lake City
Tel: 801-487-3681



SINCERE TRANSISTOR & DIODE COMPANY
313 Fairchild Drive, Mountain View, California 94040

**Everyone talks
correed reliability,**



here's the way it looks.



Switches under glass.

The heart of every AE correed is a reed switch consisting of two overlapping blades. For protection, we seal them inside a glass capsule. But only after we pull out all the dirty air and pump in a special, pure atmosphere. That way there's no chance of contact contamination or oxidation. Ever.

Notice our terminals are one piece. A special machine delicately forms them to precision tolerances. It's a lot of work, but one-piece terminals have distinct advantages over the two- and three-piece kind.

For one thing, there's no extra joint so you're always assured of a positive contact. Also, one piece terminals are more reliable when the correed is used to switch low-level analog signals. That's because thermal EMF is reduced to practically zero.

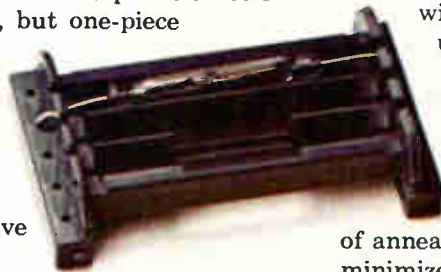

A different kind of bobbin.

Since we go through so much trouble with our correed capsules, we designed a special bobbin to protect them.

It's molded of glass-filled nylon. (You know how plastic chips and cracks.) Moisture and humidity have no effect on this stubborn material. No effect means no malfunctions for you to worry about. No current leakage, either.

Running the full length of the bobbin are a series of slots. They pamper the capsules and keep them from getting damaged or jarred.

And to help you remember which terminal is which, we mold the terminal numbers into the end of the bobbin. You can read them at a glance.

Little things mean a lot.

Reliability means that we pay attention to the little things. Like the tiny pressure rods we use in every miniature correed. They're placed at

each end of the bobbin, across the one-piece terminals. What they do is prevent stresses from being transmitted from the terminals to the reed blades. This keeps the contact gap right on the button. All the time.

The contacts are normally open. To provide them normally closed, we employ another little device—a tiny magnet. It's permanently tucked into a slot next to the reedcapsule. The magnetic action keeps the contacts normally closed.

Coiled by computer.

Once all the parts are secure in the bobbin, we cover them with protective insulation. Around this, we wind the coil. You can be sure the coil winding is correct. It was all figured out for us by computer.

Our next step is to protect the coil. We do that with more protective insulation.

A coat of iron.

On top of the insulation goes a layer of annealed iron. It acts as a magnetic shield and minimizes interaction between coils. Also, it improves the sensitivity of the entire unit. A coat of iron is standard on all AE correeds.

Finally comes super wrap.

To wrap it all up, we use some very special stuff. A layer of mylar laminated material.

It's so tough we guarantee it to withstand all cleaning solvents known to man.



It's attention to detail that helps us keep our miniature relays miniature. Now we're just waiting to show you how perfectly it measures up to your specifications. Automatic Electric Company, Northlake, Illinois 60164.

AUTOMATIC ELECTRIC

SUBSIDIARY OF GENERAL TELEPHONE & ELECTRONICS

Circle 21 on reader service card

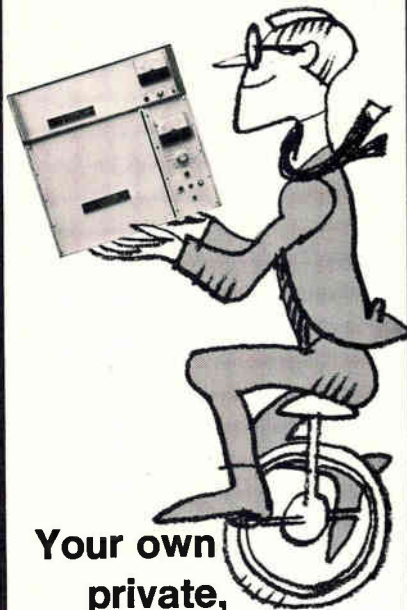

**Your own
private,
movable
Microwave.**

Moving around? New Farinon TR-2500 microwave speeds and simplifies the extension of voice and data circuits to temporary locations. And you can take advantage of mobile licensing in the 2450-2500 MHz band. Equipment can be moved when and where you like without re-licensing.

Meeting normal industry standards for telephone or data transmission, you can operate up to 12 high-quality voice channels. A complete terminal (including multiplex) can be mounted on a portable rack or in an outdoor cabinet.

Because TR2500 is a true microwave system, you get the privacy and high quality of microwave transmission. And since TR2500 operates in a mobile band, you have the convenience of mobile licensing. Move with TR2500.

Talk to Farinon.

Farinon

Farinon Electric, 935 Washington St., San Carlos, Cal. 94070

Meetings

Making waves

Undeterred by NASA's shrunken budget, this year's symposium of the IEEE's Group on Antennas and Propagation will give undiminished emphasis to space topics. That's where much of the theoretical action remains—as well as a great deal of practical activity. The first session of the meeting, which will be held Sept. 13-17 in Columbus, Ohio, will have seven of its nine papers on space-related topics and an entire session of the Institute of Scientific Radio Union is devoted to millimeter-wave propagation experiments using the ATS-5 satellite.

Propagation through plasmas also will receive its share of attention. Here the emphasis is on the environments encountered by re-entry vehicles, but several papers will discuss auroral and solar-burst phenomena. A session on wind and rain effects will cover frequencies through 34.8 gigahertz and another on ionospheric disturbances will concentrate on the lower regions of the spectrum. Antiballistic-missile topics are represented by several

papers, among them one on UHF auroral backscatter (Bell Labs), one on electromagnetic pulse tests of phased-array elements (GE), and three papers relating to backscatter from re-entry vehicles.

Phased-array technology is represented by, among others, a paper on very-wideband arrays, another on an X-band reflective array, and one on a sidelobe-reduction technique. Large-aperture antennas will be discussed by several speakers, with emphasis on sidelobe control and the design of feeds and subreflectors. Several sessions will be devoted to the theory and practice of propagation over and through various media. One paper will discuss point-to-point communication on the moon, another will cover wave propagation in dense forests, and two others will discuss the equally difficult urban environment, with emphasis on multipath problems.

For further information contact D.L. Moffatt, Ohio State University, Box 3115, Columbus, Ohio 43210.

Calendar

Conference on Microwave and Optical Generation & Amplification, IEEE; Amsterdam, the Netherlands, Sept. 7-11.

International Broadcasting Convention, IEEE; Grosvenor House, Park Lane, London, Sept. 7-11.

Petroleum & Chemical Industry Technical Conference, IEEE; Camelot Inn, Tulsa, Okla., Sept. 14-16.

Annual Technical Symposium, Society of Photo-optical Instrumentation Engineers; Anaheim Convention Center, Calif., Sept. 14-17.

International IEEE/G-AP Symposium and Fall USNC/URSI Meeting, Ohio State University, Columbus, Sept. 14-17.

Annual Solid State Devices Conference, IEE; University of Exeter, England, Sept. 15-18.

Conference on Gas Discharges, IEE; London, Sept. 15-18.

Intersociety Energy Conversion

Engineering Conference, IEEE; Frontier Hotel, Las Vegas, Sept. 20-25.

Conference on Engineering in the Ocean Environment, IEEE; City Marina Auditorium, Panama City, Fla., Sept. 21-24.

Conference on Electron Device Techniques, IEEE; United Engineering Center Auditorium, New York, Sept. 23-24.

Fall Broadcast Technical Symposium, IEEE, Washington Hilton, Sept. 23-26.

Industry & General Application Group Annual Meeting, IEEE; La Salle Hotel, Chicago, Oct. 5-8.

Government Microcircuit Applications Conference: GOMAC, Department of Defense, Army, Navy, Air Force, NASA, Department of Commerce, National Bureau of Standards, Post Office Department; U.S. Electronics Command, Fort Monmouth, N.J., Oct. 6-8.

Symposium on Microwave Energy,

(Continued on p. 24)

Where's the trend to denser p.c. packing going?

Here's one answer. Actual size.

Use Elco Series 6309 card-edge connectors and you can condense the connectors for ten pc boards into 17.1 square inches. Without paying a premium for the privilege.

That's one thousand contacts. On .100" centers. Ready for wrapping. Easy.

But that's only one answer. We have eighteen others. With contact spacings of .100", .125", .150", or .200", accommodating from 14 to 100 contacts in eight different basic configurations.

And that's not counting our Mojo™ (.150") modular connectors, which obligingly, inexpensively, change their size to suit the job at hand.

Ready to accept your boards. Ready to be mounted on metal plates, frames, and boards and with their tails wrapped for whatever little thing you're making. (We can even do that job for you.)

You'll find all our little helpers in the Elco Card-Edge Connector Guide. Call, write, wire or TWX us for a copy. Elco Corporation, Willow Grove, Pa. 19090. 215-659-7000; TWX 510-665-5573. Or Elco Pacific, 2200 Park Place, El Segundo, California 90245. 213-675-3311; TWX 910-325-6602.



ELCO Card Edge
Connectors

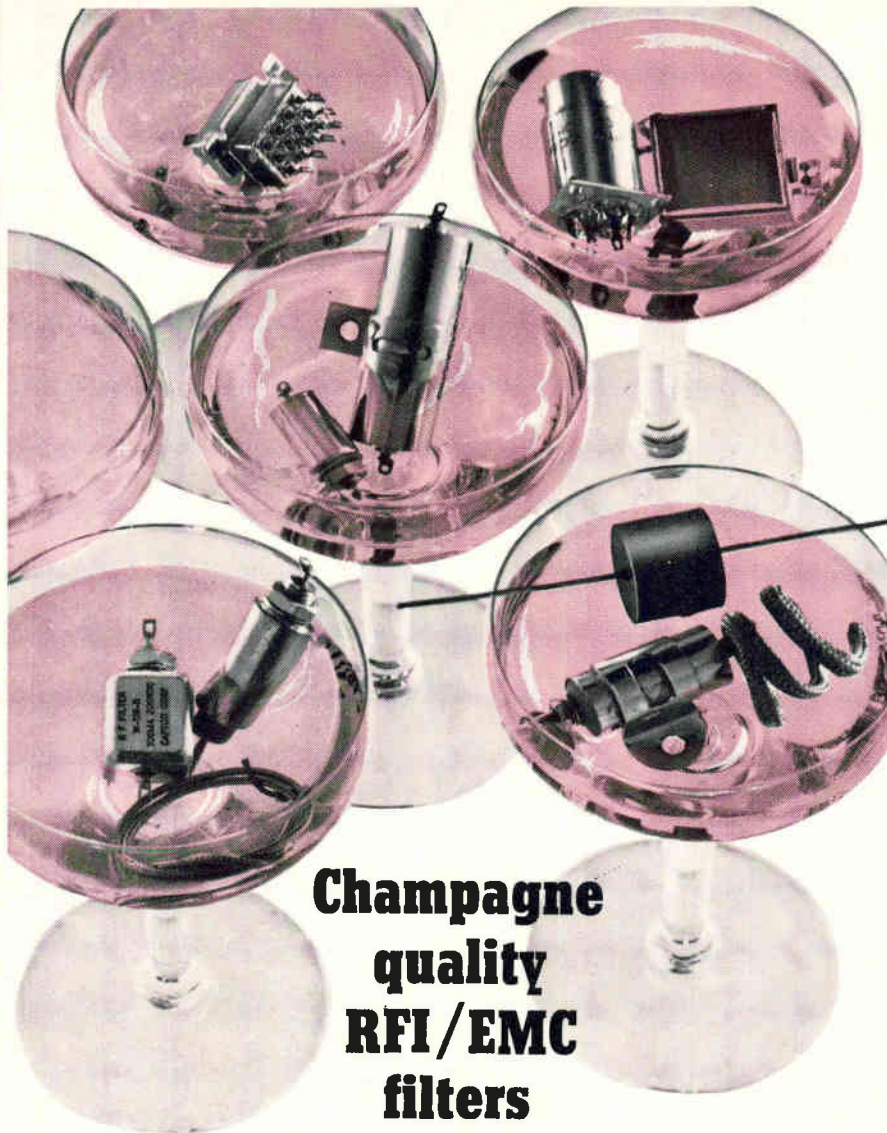

**Champagne
quality
RFI/EMC
filters
at beer prices**

A toast! May you and your products benefit from finer, lower-cost filters from Captor Corporation. Captor combines knowledgeable application engineering with a quality assurance program that extends through every manufacturing step from order entry to final packaging. Costs are closely controlled because production is geared to a specific electronic components family: miniature RFI/EMC filters, communications and security filters, and custom designed filters and assemblies. Captor's new environmentally conditioned plant is designed expressly for fast, efficient manufacture of this integrated product line. Write for our capabilities brochure today and drink in the whole story.

CAPTOR
CORPORATION
Electronics Division

5040 Dixie Highway, Tipp City, Ohio 45371, Phone: (513) 667-8484

Meetings

(Continued from p. 22)

International Microwave Power Institute, Scheveningen, Holland, Oct. 7-10.

American Society for Information Science Meeting, Sheraton Hotel, Philadelphia, Oct. 11-15.

International Telemetry Conference, Electronic Industries Association, Instrument Society of America; International Hotel, Los Angeles, Oct. 13-15.

Systems Science and Cybernetics Conference, IEEE; Pittsburgh, Oct. 14-16.

Digital Computer Applications in Engineering Sciences in Turkey, IEEE; Istanbul Technical University, Oct. 14-17.

Short courses

Antennas, George Washington University; Washington, D.C., Sept. 21-25; \$300 fee.

Basic R&D Management, Pennsylvania State University; University Park, Pa., Oct. 4-9; \$200 fee.

Computer Aided Design Synthesis of Aerospace Design, University of California at Los Angeles; Boelter Hall, Oct. 19-23; \$310 fee.

Call for papers

National Conference and Exposition on Electronics in Medicine, Medical World News, Modern Hospital, Postgraduate Medicine, Electronics, McGraw-Hill Publications; Sheraton-Boston Hotel and John B. Hynes Civic Auditorium, Boston, April 13-15, 1971. **Sept. 15** is deadline for submission of abstracts to Dr. John Truxal, Institute Professor at Polytechnic Institute of Brooklyn, New York.

Operator, Engineer and Management Interface with the Process Control Computer, Systems Engineering and Applications Committees of the International Federation of Automatic Control, American Automatic Control Council, the Instrument Society of America, and Purdue's Schools of Engineering; Purdue University, Lafayette, Ind., August 1971. **Oct. 1** is deadline for submission of abstracts to Symposium Committee, Purdue Laboratory for Applied Industrial Control, Purdue University.

NEW



*New Allen-Bradley
hot-molded Type GD
dual variable resistor
shown actual size*

TWO
IN
ONE

Allen-Bradley hot-molded dual variable resistor

Here's the most compact two section variable resistor currently available—the new Allen-Bradley dual Type GD. It's one-half inch in diameter and only a fraction of an inch longer than the popular single section type G control. The case is dust-tight as well as watertight. ■ Both resistance tracks in the dual Type GD are solid, hot-molded elements, which provide long operating life. As with the single Type G, the noise level is low initially and actually decreases with normal use. Adjustment is smooth at all times with virtually infinite resolution. And low inductance permits operation at frequencies far beyond the usable range of wirewound controls. ■ In addition to standard application, these new dual Type GD controls are ideally suited for use in compact attenuators. ■ Dual Type GD controls are available with nominal resistance values from 100 ohms to 5.0 megohms. You can get immediate delivery at factory prices from your authorized A-B industrial electronics distributor. Or write: Marketing Dept., Electronics Div., Allen-Bradley Co., 1201 S. Second St., Milwaukee, Wis. 53204. Export Office: 1293 Broad St., Bloomfield, N.J., U.S.A. 07003. In Canada: Allen-Bradley Canada Limited.



ALLEN-BRADLEY
QUALITY ELECTRONIC COMPONENTS

Custom(er) Cable Constructions by Chester

Proof of Chester's ability to produce plastic coated multi-conductor cable construction to customer requirements is reflected in part by the production samples shown on these pages. Though only representative of the thousands of "specials" made for our many customers they graphically prove Chester's ability to translate a wide range of special multi-conductor needs into dependable and practical cable constructions.

When standard cable constructions will not suffice, Chester's vast resources, technical skills and manufacturing facilities are placed at your disposal to manufacture conductors, insulations and jackets to meet your most exacting requirements.

Whatever your multi-conductor cable needs, check first with Chester. We know you'll be more than pleased with the expeditious and thorough handling of your request.

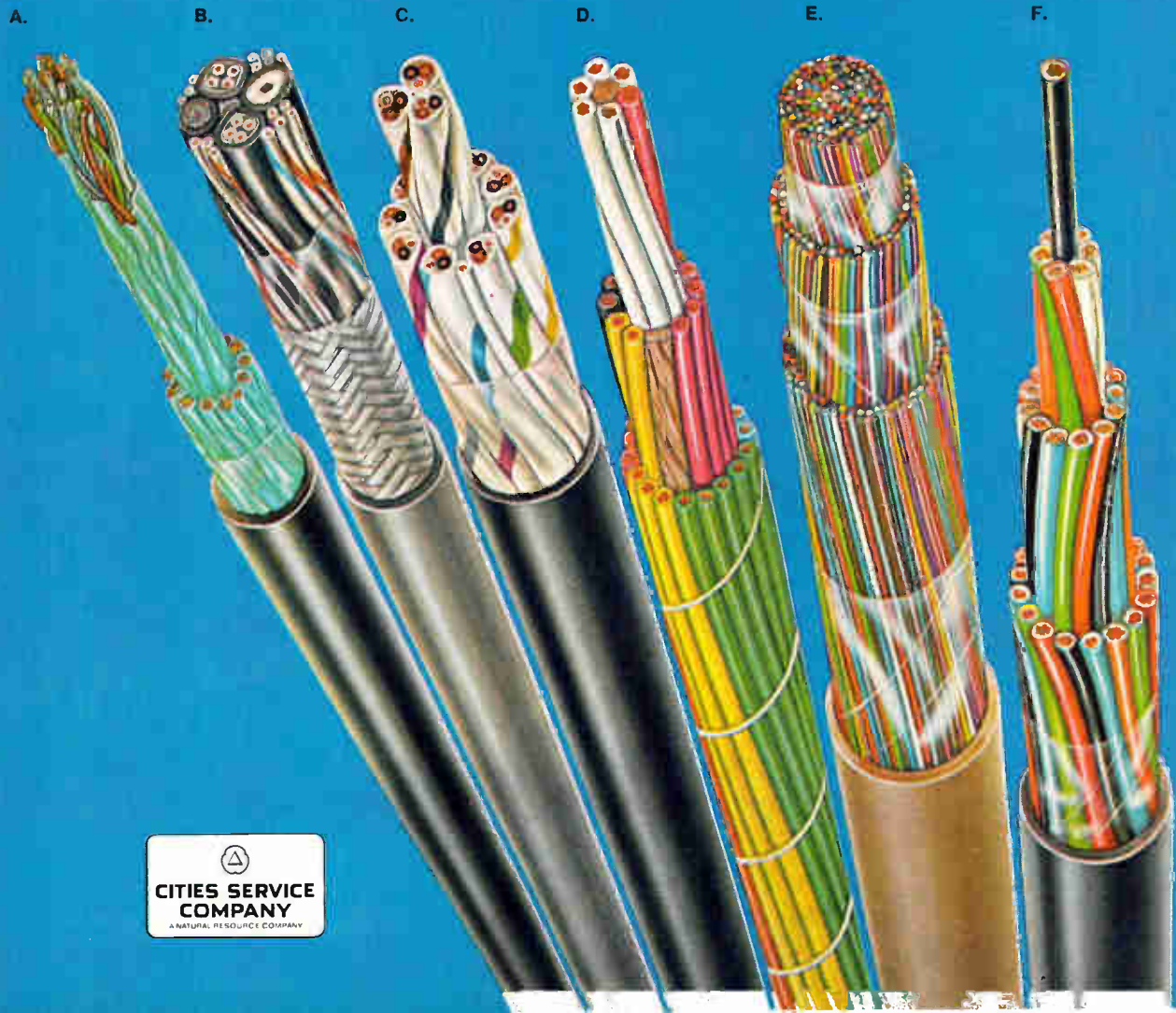

- A. RECORDING STUDIO:** Audio sound cable: 25 shielded pairs, stranded copper conductors, low loss insulation, twisted with uninsulated drain wire, isolated aluminum tape shields, cabled, PVC jacket.
- B. TV CAMERA MFR.:** Camera control cable for Audio and Video signals: a composite of PVC and polyethylene insulated conductors, cabled, overall braid shield, PVC jacket.
- C. AIRCRAFT SIMULATOR MFR.:** Control cable: 12 triples shielded jacketed, stranded copper conductors, PVC insulated, individual shield jacket color coded, cabled overall PVC jacket.
- D. ELEVATOR MFR.:** Control cable: 35 conductors, stranded copper, PVC insulated, conductors coded by colors and printed numbers, cabled with open binder; individual conductors U/L listed.
- E. INTERCOM EQUIPMENT MFR.:** 250 conductor inter-office communication and signaling cable: solid bare copper, PVC insulation, paired, cabled, PVC jacket; U/L listed.
- F. ELECTRIC UTILITY CO.:** Station control cable for general use: 37 conductors, stranded, polyethylene and PVC insulated, color coded, cabled, overall tough PVC jacket; per NEMA/IPCEA Specifications.
- G. LARGE CITY:** Communication cable: 50 pairs, polyethylene insulated, cabled, continuous layer of copper shielding tape, PVC jacket; per spec. IMSA-19-2, 600 volts.
- H. LEADING SHIPBUILDER:** shipboard cable: stranded conductors, nylon-jacketed PVC insulation, pairs shielded and jacketed, cabled, PVC jacket, and aluminum braid armor overall; per spec. MIL-C-915.
- I. U. S. GOVERNMENT:** Coaxial cable: type RG-218/U, solid copper conductor, polyethylene insulated, copper braid shield, PVC jacket; per spec. MIL-C-17/79.
- J. BROADCASTING COMPANY:** Remote control broadcasting cable: stranded conductors, polyethylene insulation, pairs & triples shielded and jacketed, cabled, PVC jacket overall.
- K. COMPUTER MFR.:** Computer control cable: 55 conductors, stranded copper conductors, PVC insulated, formed into 7 groups of 7 conductors, cabled, PVC jacket; U/L listed.
- L. MACHINERY MFR.:** Bus drop cable: 3 PVC insulated stranded conductors, with split uninsulated grounding conductor, cabled, overall PVC jacket; U/L listed; per NEC.



CHESTER CABLE

OPERATIONS

CITIES SERVICE COMPANY

CHESTER, NEW YORK • 10918

PHONE: (914) 469-2141 TWX (914) 469-9801

Circle 27 on reader service card



General Electric helps you solve the tough ones

GE has the broadest line of electronic components in the industry. From the tiniest integrated circuits to powerful high performance motors, GE components help you solve your tough problems . . . in design, in performance, in economy. Take a look at these GE problem solvers.

p.s.1 New GE computer-grade capacitor offers 50% greater ripple current capability. GE's new 92F provides 30 to 50% lower ESR for better frequency capability. High efficiency permits reduction in size and weight over conventional units.

This newly-developed GE capacitor has a life expectancy of up to 3000 hours at 85C. Temperature capability up to 120C gives increased reliability or eliminates derating or additional cooling. Get complete specifications on this new GE capacitor. Circle 316

p.s.2 Replace 200 different SCR's with GE's versatile C103. This rugged epoxy encapsulated low-current SCR comes in the TO-18 plastic package and is ideal for tough military and industrial uses as well as many consumer applications.

The C103 is available in peak reverse voltage ratings from 30 to 200 volts. It combines an extremely sensitive gate (200 μ A) with a high surge capability (8 amp) and a low forward blocking current (1 μ A). Get full details. Circle 317

p.s.3 GE Sintered Alnico magnets give you high energy products with superior temperature stability and physical characteristics. And only GE can provide a complete line of Sintered Alnico materials.

Sintered Alnico has its greatest advantage in applications where mechanical work is required in small complex shapes. GE materials offer up to 12000 gauss induction and 1550 oersted coercive forces. For complete data or application help, circle 318

p.s.4 New Hi-TECH ceramic metal components . . . custom-designed problem solvers. GE's Hi-TECH line offers a variety of alumina, forsterite and other special ceramic materials . . . sealed to virtually any metal . . . and custom-engineered to meet your toughest operational requirements.

Use in severe environments, for example, to withstand ultra-high tempera-

tures and hyperactive chemicals. Ideal for vacuum or gas-filled devices, electrical equipment or machine parts. Find out how GE can custom design the ceramic component you need. Circle 319

p.s.5 Get long-life portable power with rechargeable GE nickel-cadmium batteries. Nominal ratings range from 0.1 amp-hours to 4.0 amp-hours in sealed cells and up to 160 amp-hours in vented types at the one-hour rate. And GE batteries are rechargeable for longer operating life.

Get details on how to put longer battery life into your application. Circle 320 for complete information.

p.s.6 Get more magnetic performance per size and weight with GE cast Alnico 5-7 and 9 permanent magnets. GE's columnar grain cast Alnico 5-7 provides high inductions at 7.5 million energy products. Cast Alnico 9 couples high coercive forces with 9 million energy capabilities.

Complete directionality of grain growth permits design freedoms which were impractical before. Check with GE's application experts. Or for complete details, circle 321



with the broadest line of electronic components

p.s.7 Select your indicating instruments from industry's most complete line. For measurement and control of electrical quantities, get GE Panel Meters and Meter Relays in the popular BIG LOOK® and HORIZON LINE® styles. 1½" edgewise instruments are ideal for compact display problems.

And the new BIG LOOK Frequency Meters in three ranges . . . 45-55Hz, 55-65Hz and 380-420Hz . . . are now available for engine generator sets, panel boards and inverters. For complete catalog, circle 322

p.s.8 New complementary power transistors are color coded for easy identification. GE's 4-amp NPN/PNP power transistors (D44C/D45C) are molded in plastic packages to provide tough pellet protection in the most demanding applications. Three round leads fit the standard JEDEC TO-66 configuration.

These color-molded transistors feature low collector saturation voltage, excellent gain linearity and fast switching. Apply them in countless industrial and consumer circuits. For details, circle number 323

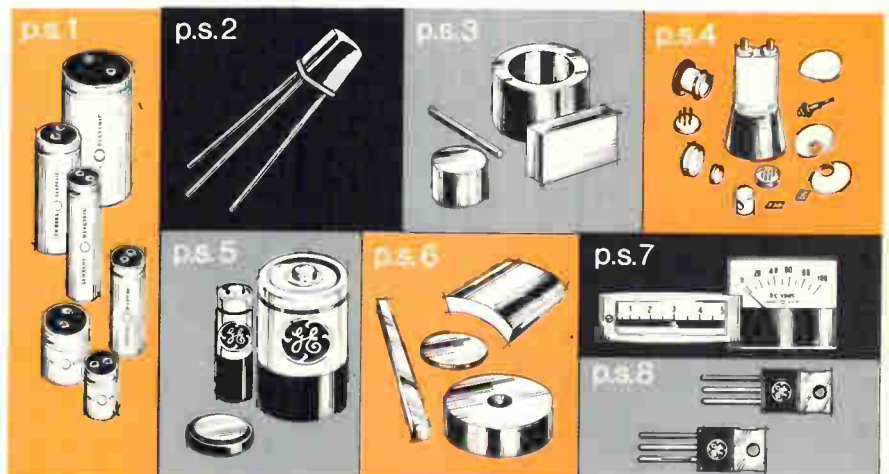

Let General Electric help solve your component problems. Call your nearest Electronic Components Sales Operation Office. Or check with one of the many authorized GE distributors. P.S. Problems? General Electric has solutions.

285-65

GENERAL  **ELECTRIC**



By 1979, newspapers will be printed in your living room.

You won't have to roll up the carpet. Or even cover up the furniture.

Because all it will take is a compact print-out unit attached to an ordinary tv set.

When you're ready for the stock market closings, ball game scores or movies listings, you'll simply push a button.

Instant newspaper. And you'll be able to get any part of it, or all of it, any hour of the day or night.

The fact is, the products of electronics technology will be doing more for our lives tomorrow than electricity does for us today.

Automated highways will drive our cars. Home computers will cook the food and wash the clothes. Electronic health maintenance programs will even help us avoid illness.

Who are the master minds masterminding these changes?

Our readers. Engineers and technical managers who must keep abreast of all fast-changing developments. Industry-wide and world-wide. Which is why they come to us.

Every two weeks, Electronics magazine presents them with a complete, up-to-the-minute picture of the state of the technology.

Last year alone, Electronics presented six times as much information on consumer electronics as any other publication in the field. And twice as much on communications.

If you expect to be part of the future, speak to the men who are working on it today.

Electronics, a McGraw-Hill market-directed publication.

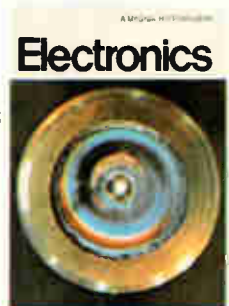

Our readers are changing the world.

We've got the dope on 26 companies at Spring Joint.



Twenty-six companies were in on it. They didn't breathe a word.

You wouldn't either, if you had something special going for you to give you lower development costs, quicker start-up, and more competitive pricing.

We won't tell you who these companies were.

But we will tell you their secret.

Every one of them utilized advanced, off-the-shelf MOS circuits from the same source—Electronic Arrays.

Fifteen of these 26 companies were less than three years old, which points out that EA's broad line of off-the-shelf MOS registers, ROMs, Read/Write RAMs and logic arrays are especially suited to companies needing low-cost product development and sure-fire delivery.

Now that we have your ear, we'd like to keep you clued in. Whisper the password—MOS—to your EA distributor or representative. Or write directly to the source: Electronic Arrays, Inc., 501 Ellis Street, Mountain View, Calif. 94040. (415) 964-4321.



**electronic
arrays, inc.**

Electronics Newsletter

August 31, 1970

National to expand tri-state TTL line

National Semiconductor plans shortly to introduce two more bus-organized TTL circuits. Conventional TTL can't be used in a bus-organized system without modifications that seriously impede their operation.

The three-logic-state devices—off, on, and disconnected—have an equivalent NAND gate at their outputs, with a switching device on the chip that effectively disconnects the entire chip from its load. This permits them to be connected into a bus-organized system, in which a common output line is directly connected to the outputs of several circuits in parallel, and results in improved system modularity and reduced design, assembly, wiring, and testing costs.

The two MSI circuits join a quad-D flip-flop introduced earlier this year by National. One is a party-line driver, which can send output signals along a line up to 900 feet long. Standard TTL, in comparison, can go just 10 inches. The other new circuit, a demultiplexer, is similar to the quad-D flip-flop except that it has no storage.

Sylvania halts work on Soniscan memory

Sylvania Electronic Systems has abruptly halted work on its Soniscan magnetoacoustic bulk memory system and observers are wondering if the firm hasn't scratched a possible winner in the commercial mass memory sweepstakes.

Not only are those working on Soniscan upset and confused, but the Navy also is puzzled. After a glowing report from the Naval Air Development Center, the Naval Air Systems Command became interested in Soniscan for its Advanced Airborne Digital Computer.

Not only is Soniscan's packing density high at 5,000 bits per cubic inch, but also its cost could be as low as 0.1 to 0.2 cent per bit.

Officially, Sylvania is re-evaluating its approach to marketing Soniscan. The possibilities are: to continue to develop the scheme internally, to split the effort off as a partially owned new venture, or to stop development entirely. A decision probably won't be made for about two weeks. If Soniscan is cancelled or spunoff, it will be done primarily because the company is tightening its spending in the R&D area, observers say.

Capital bind squeezes minicomputer firms

The capital crunch is beginning to take its toll of fledgling minicomputer companies. Two Santa Ana, Calif. firms appear to be on the ropes, and one of them, Computer Development Corp., may already have been counted out just three months after announcing its cd 200 machine. The unit was to sell for \$3,500 with 1,000 bytes of core memory [*Electronics*, May 11, p. 168]. Now, a recorded message greets telephone callers, informing them that the firm's number is no longer in service and that there is no new number. It's known that Varian Data Machines has considered buying the rights to the cd 200, "but nothing has been consummated," says Varian Data Machines president George Vosatka.

Omnicom Computer Corp., which announced plans for a more sophisticated machine, the Omnus 1, to sell for between \$5,000 and \$6,000, "should have closed down six weeks ago," says one company principal, but has been hanging on without major financing as long as possible, hoping to find backers. "We'll either have to sell the product rights, sell the company, or close down very soon," says this source.

Electronics Newsletter

Four-Phase Systems set to introduce super minicomputer

A tabletop computer with "throughput" approaching that of an IBM 360/30 is about to be introduced by Four-Phase Systems. The System IV/70 gets its power from a large instruction set—120 major instructions plus a host of minor ones—and the use of LSI on a scale much greater than in commercially available hardware [*Electronics*, Feb. 16, p. 109].

The processor consists of just 12 LSI devices on a single board: six read-only memories, three random logic, and three byte slice circuits. Unlike most minicomputers, the instructions include several for character manipulation with most oriented toward business applications.

Its most significant application is expected to be in controlling crt displays. Most present display systems show only what the computer sends them. But replacing such "dumb terminals" with a stripped-down IV/70 can halve the cost, the company says. Such terminals, in addition, would be a full-fledged general-purpose computer, capable of running several background programs and a full complement of input/output equipment as well. This approach makes possible performance that can't be approached by anything on the market except perhaps at 40 times the cost, the firm claims.

National taking new look at silicon gate MOS?

When Intel and Fairchild Semiconductor introduced silicon gate MOS products [*Electronics*, Sept. 29, 1969, p. 88], National Semiconductor brushed aside their claims for the process, saying that it could do the same things with its 1-0-0 process. But now, a year later, National may be changing its tune. The company has hired Thomas Klein, an engineer who was heavily involved in silicon gate processing technology at Fairchild Semiconductor.

National's official stand still is that they will not change over to silicon gate devices in the near future, but the speculation is that the firm's new random access memory products will employ the technique.

Navy chooses Army antenna array for sub-to-satellite link

The Naval Underwater Sound Laboratory, looking for a submarine-mounted antenna array for tactical satellite communications, has chosen a type of planar array originally developed for the Army by ITT's Defense Communications division.

The new award for delivery of a preproduction model of the AS-(XU-1)/BRA array is worth \$100,000. The antenna will operate in the 7.2- to 8.4-gigahertz band. The version built by ITT for the Army's Satellite Communications Agency was a two-board sandwich of strip-line corporate feeds and printed dipolar radiators. The Navy array, like the Army's, will use dual, circular polarization, but will aim at 19- to 20-decibel sidelobes and aperture efficiencies in excess of 60%.

Data General slates new minicomputers

Data General Corp. will introduce two lower-priced models of its 16-bit minicomputer line at the Fall Joint Computer Conference Nov. 17. They'll be an extension of the present machines, compatible both in hardware and software with the Nova [*Electronics*, Dec. 9, 1969, p. 76] and the Supernova [*Electronics*, Nov. 10, 1969, p. 116]. Pricing will be in the range of current eight- and 12-bit machines, but performance will be in line with today's more powerful 16-bit computers—a combination the company expects to achieve by using LSI including some circuits not now used in minicomputers.



All toroids look alike.

Our PULSE-RATEDTM toroids really are alike.

We developed the concept of *pulse rated* toroids to eliminate tedious selection problems. Now we've developed new materials. Fully proven. Component tested. So you get guaranteed performance over a temperature range of 0° to 60° C.

Pulse-rated toroids not only simplify your selection process, they practically eliminate scrap. So you get 100% yield in your pulse transformer production.

Specifications provided for every *pulse-rated* toroid include pulse in-

ductance, volt-microsecond product, and temperature behavior under pulse conditions.

Parylene-coated *pulse-rated* toroids in sizes and specifications to suit your design requirements are now available for off-the-shelf delivery. Want some? We welcome the opportunity to send you samples. And hot-off-the-press spec sheets. And to consult with you about your design problems. Write Indiana General, Electronic Products, Keasbey, N. J. 08832.

indiana general 

a division of Electronic Memories & Magnetics Corporation

were
Photocells ~~are~~ too expensive
for my application

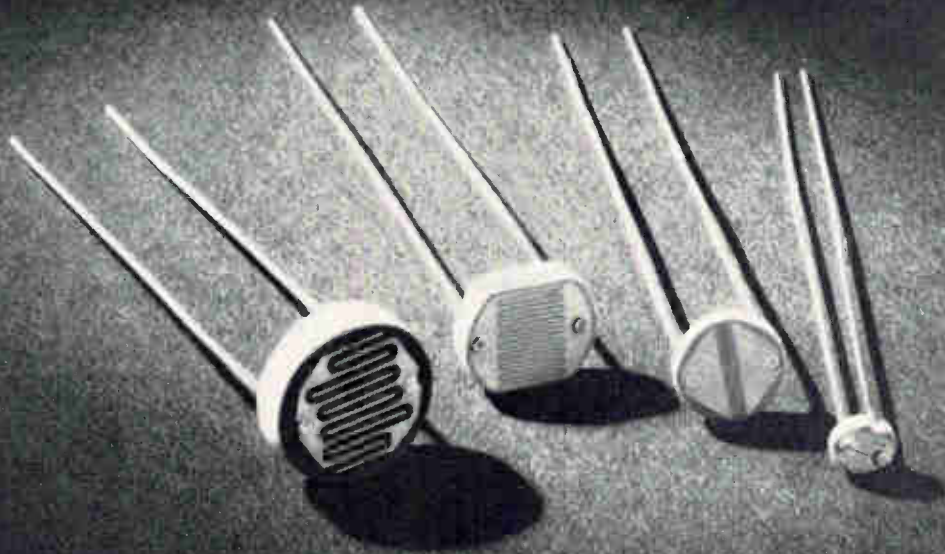

New low-cost design offers many new application possibilities

Plastic encapsulated cells are now readily available in 4 sizes from .170 inches to .435 inches in diameter... and they're as rugged and nearly as reliable as hermetically sealed cells for many applications.

Look again at the applications where you thought photocells were too expensive. We'll send you free samples if you'll tell us why you need them: Call (914) 664-6602 or write Clairex®, 560 South Third Avenue, Mount Vernon, New York 10550.

CLAIREX ELECTRONICS

A DIVISION OF CLAIREX CORPORATION

Circle 36 on reader service card

C-w diode lases at room temperature

Bell's gallium arsenide narrow-junction device opens way for use in wideband optical communications

What may go down as the most significant achievement in semiconductor lasers this year has happened quietly. At Bell Laboratories, researchers have obtained continuous operation at room temperature from a double heterojunction, gallium-arsenide alloy, injection laser—and at current densities low enough to make this laser feasible for applications previously denied it. Up to now, the intense heat generated during the lasing period allowed only pulse operation.

Operating continuously at room temperature, the injection (diode) laser makes an ideal source of optical energy for small signal applications. It is small, can be fabricated by standard diode fabricating methods, and, unlike solid state and gas lasers, can be modulated directly, without the use of inefficient electro-optic crystals. This ease of modulation is particularly valuable for optical communication and signal processing systems, where complex wideband data must be transmitted on optical carriers and processed at optical frequencies.

With this new development, Bell is rapidly getting together all the pieces of an optical communication system. Work is well ahead on thin-film optical ICs that could form the basis of an optical repeater channel. An extensive effort is in progress to obtain efficient long-haul optical transmission from optical transmission lines, similar in concept to Bell's trial guided-millimeter-wave system. The room-temperature diode laser could supply the needed link.

Continuous operation at room temperature was made possible by improved methods of liquid phase epitaxial growths, with which narrower active regions can be achieved. And because the optical energy is confined more efficiently

to the lasing cavity, lower current densities are required for useful output. In fact, Bell's laboratory samples have GaAs p-layers, less than 1 micron thick, that during continuous room-temperature heat-sinking operation allow current densities as low as 1,000 amperes per square centimeter for special square diodes and as low as 1,600 A/cm² for Fabry-Perot structures.

In the past, current densities as high as 6,000 A/cm² were common. Moreover, measured output of 20 mw at these low current densities was at a figure that is quite respectable when you consider that 100 mw would be a sufficient power level for most communication applications. Outputs approaching this requirement should result from optimization of these experimental techniques—better heat sinking, narrower junctions.

Bell's diode is a new four-layer structure, with an alloy layer (Al_xGa_{1-x}As) on either side of the GaAs active p region, to achieve the better confinement. Doping concentrations of the various layers were instrumental in obtaining the low current density in the narrow region. The layers were grown on polished and etched (111) and (100) faces of an n-type GaAs substrate.

Integrated electronics

New style beam leads

After trying for 18 months to use the beam-lead process pioneered by Bell Laboratories for MOS/LSI arrays and finding it wanting, engineers at North American Rockwell Microelectronics have come up with a different approach.

What NRMEC engineers had to do was get around such problems as sputtering the platinum, tita-

nium, and gold on MOS devices. And to get rid of the extra masking step required in back-etching chips apart, they went to laser scribing.

They had run into trouble when they tried to sputter platinum-titanium-gold onto the contact pads, and in sputtering the same metalization system over the silicon dioxide layer of the devices, explains Ronald E. Harris, NRMEC's manager of beam-lead development.

"We were getting increases in threshold voltages that couldn't be annealed out of the MOS devices,"

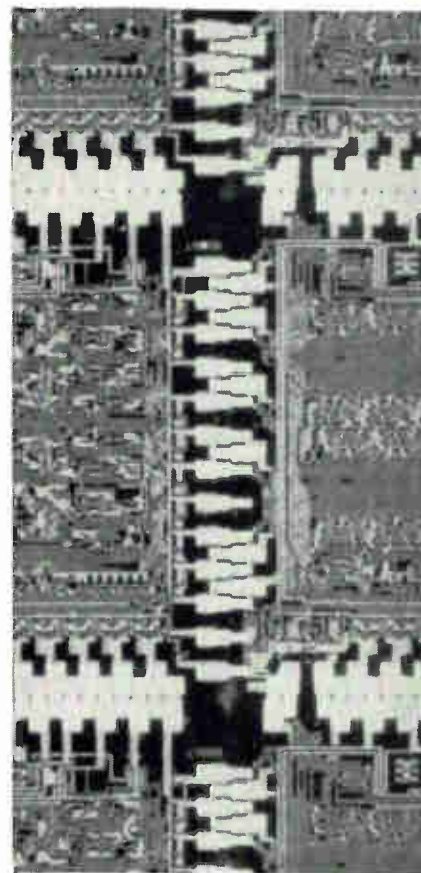

Tight fit. Interleaving of beam leads shows how closely the chips can be placed in NRMEC's process. Shown are shift register chips measuring 180 by 216 mils.

U.S. Reports

Harris states. "So we switched from sputtering to filament evaporation of chromium and gold with palladium between them. In making these changes and going to an MOS process, we've essentially come up with a new process compared to the Bell Labs' method," he adds.

But what he believes is really unique at NRMEC is laser scribing from the back of the 10-mil-thick wafers instead of back etching, which he says is a burden because it dictates an extra masking step, wastes silicon, and can lower yields if the etchant spreads laterally.

The yag laser, x-y positioning table, and controls were bought as individual components and put together in a system that runs at 10 inches a minute. A two-inch-diameter wafer can be scribed in several minutes, Harris says, if the dice are large. The system is controlled so that the laser beam penetrates about nine mils through the back of the 10-mil wafer, reported incorrectly earlier as 10-micron wafers [*Electronics*, Aug. 17, p. 34].

In depositing gold beam leads on gold metalization, NRMEC has retained the silicon-nitride passivation of the Bell Labs technique because it works well with MOS devices, too. Thus, with gold metalization, NRMEC performs the nitride passivation step, and etches contacts through the nitride and silicon dioxide below it. The chromium-palladium-gold deposition follows, and then the metal runs are defined by masking and etching. Next comes reactive deposition of another silicon dioxide layer, and an etch through that down to the beam area, which allows gold plating of the beams till they are a half mil thick.

Gold beam leads are also being put on wafers metalized with aluminum. But in this add-on process, a second vacuum deposition is required after the initial aluminum deposition, to lay down the beams. The aluminum interconnects are put down atop the nitride layer, and silicon dioxide is deposited over them. The oxide is etched through to the aluminum contact areas, then the wafers go back into vacuum deposition. They get a

chromium-copper-gold system that forms the layer onto which the half-mil-thick beams are later plated after masking and etching have defined the precise metal runs.

The medium-volume production line on which the beam-lead laser-scribed wafers are running could process 8,000 wafers a month, not necessarily all beam-lead and laser-scribed devices. The parts it is presently producing are used in military systems made by Autonetics.

Avionics

Little giant

What does Honeywell hope to accomplish by miniaturizing and ruggedizing its old reliable DDP-516 computer and calling it the HDC-601? Plenty. With the military general-purpose avionics market expected to reach at least \$100 mil-

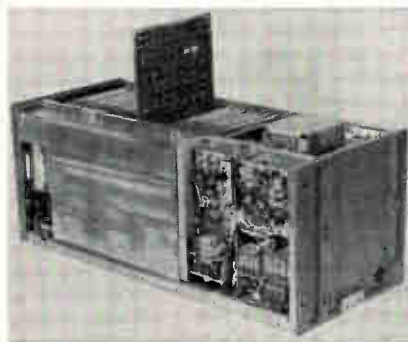

Rugged. The HDC-601, with TTL logic card shown. Plated-wire memory is in covered package to left of logic.

lion through 1975, Honeywell hopes to bite off a big chunk for itself by bracketing, in one unit, a wide range of that market's computer requirements plus a lot of extras [*Electronics*, Aug. 17, p. 34].

One of Honeywell's strongest selling points is the wide acceptance enjoyed by the 516 in both its standard and previously ruggedized versions. More than 800 are in use around the world, many by government agencies. Now that Pentagon purchasing rules have been rewritten to read "fly-before-

buy," the 516's three-year history of successful multipurpose use is a big asset. Another is its extensive software library that can be used without modification for the 601.

The company's first success has been with the Air Force's AN/ASN-101, Gimballed Electrostatic Aircraft Navigation System (Geans), an inertial navigator with accuracy believed to be around 0.1% of distance flown. Geans is being considered for the B-1 bomber and on Awacs, and the 601-P (plated-wire memory) has been approved as the Geans guidance computer.

The Air Force also is planning to use it on a reconnaissance and target-location program. The first 601-P has been delivered to Honeywell's Minneapolis facility for use in the latter program and, under a \$5.3 million contract from Air Force Systems Command at Wright-Patterson AFB, Honeywell's Aerospace division will manufacture three of the Geans guidance units, each comprising an inertial platform, a 601-P, a platform/computer interface unit, and a control/display input device.

Honeywell engineers have slashed the 601's weight to 30 pounds from the 516's 250 pounds. Size reduction has been even more dramatic: the miniaturized unit occupies only 0.7 cubic foot, shrunk more than 40:1 from the 30 cubic feet of the 516. Power consumption also has been slashed—to 122 watts, compared to 1 kilowatt for the standard 516 and 1,400 watts for the even larger ruggedized 516.

Available software, which would cost just under \$1 million to duplicate from scratch, includes Fortran IV compiler; symbolic-to-binary coding translation; input/output data formatting; real-time on-line executive; a scientific routines package; a subroutine library; and utility, test, and diagnostic programs.

The 601 also is compatible with the full line of 516 peripherals—magnetic tape, disk and drum stores, paper-tape punch and reader units, punched-card readers, line printers, teletypewriters, and an alphanumeric display terminal with a 16-line, 1,024-character capacity.

Anyone with a 516 and some of these peripherals can check the 601's performance before investing in one, or having ordered one, can write and debug new software well in advance of hardware delivery.

The 601 features parallel organization, 16-bit word length, memory size from 8,000 words to 32,000 words in 8,000-word increments, 0.5-microsecond memory access time and 1 μ sec and 19 μ sec, respectively. The unit is designed around MSI circuits mounted on plug-in boards and using transistor-transistor logic. Signetics' series 8000 TTL ICs are used widely, as are comparable lines from Fairchild, Motorola, and Texas Instruments.

Air traffic control

Satellites vs. beacons

Satellites will be pitted against superbeacons in a high-level debate between a White House panel and the Federal Aviation Administration. The President's Scientific Advisory Committee (PSAC), whose air traffic control panel is headed by satellite proponent Richard Garwin, will shortly release a challenge to the FAA's proposed use of an air traffic control radar with a data link capability. The agency is supporting superbeacon development recommendations of its Air Traffic Control Advisory Committee (ATCAC) [*Electronics*, Aug. 17, p. 111].

The PSAC role stems from its review of the ATCAC two-year analysis of U. S. air traffic control needs which was completed last year [*Electronics*, Oct. 27, 1969, p. 127]. Although PSAC will not recommend that satellites be substituted for beacons, its expected criticism of radars with data link capability is already being interpreted as a backdoor plea for accelerated development of air traffic control satellites.

A source on the panel says that it "does not see eye to eye" with the FAA on its proposal to develop the superbeacon radars during the next six years, but is expected to recommend that the FAA continue to use

its present beacon system. As soon as a data-link capability is needed, he adds, the panel will recommend that a dedicated data-link system be installed. And one strong candidate for the communications function is satellites, he says.

"We're not saying use satellites," the source states. "We're asking: what is the state of technology in a number of advanced areas? What does it do best?" Costs are very important, he points out, yet the system laid out by the ATCAC committee for the 1980's is highly labor intensive. The cost of a satellite system, on the other hand, is unknown.

Ben Alexander, the chairman of ATCAC, views satellites differently. "Adding satellites would do nothing for the crunchier areas of air traffic control," he says. The "crunchier" areas are air traffic saturation at major areas, the serious risk of midair collision, and the general lack of automation.

"I believe that with our recommendations we can very, very comfortably cope with air traffic growth for the next 20 years," Alexander says, and adds that this improvement can be made at a very low risk—something that can't be said for satellites.

Nor could satellites cope with synchronous garbling of transponder signals, caused by the overlapping of replies in high traffic areas, which remains one of the largest single problems in air traffic control. According to the ATCAC chairman, it could be solved if decoder-equipped planes were interrogated for altitude and identity link during the superbeacon's dead cycle. These planes, most of which would be commercial craft, could then decline to respond during the beacon's area search cycle, eliminating what is a major source of garble.

Once the data link was operative, the channel could also be used to warn aircraft away from collision courses, he adds. With satellites, however, neither problem would be addressed. "Satellites are unrealistic and too expensive," Alexander says. If money is available for satellites, "it should be put into automation."

Solid state

Hybrids pack it in

Though MOS in general and memory elements in particular have been attracting most of the attention lately, Fairchild Semiconductor's hybrid group is making a bid for some of the limelight. The group has been working on a frequency synthesizer for telecommunications equipment, a complete system that will be packaged in four 30-lead flatpacs with an upper frequency limit of 200 Mhz.

Says one Fairchild engineer, "The best available method of selecting frequencies until now has been to use a prescaler, combined with discrete devices, on about three p-c boards. But with our ap-

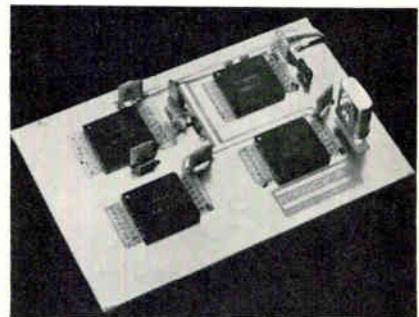

Card. Frequency synthesizer uses one p-c board instead of the three usually needed.

proach, the four hybrids and the crystal, coils, and other components will all fit on one board."

In operation, the synthesizer controls the frequency of a local oscillator by means of a phase-locked loop, which links a voltage-controlled tuner and oscillator, a logic prescaler, a programable divider, and a reference divider and oscillator.

The tuner-oscillator is a two-stage, grounded base r-f amplifier with mixer, local oscillator and integrator sections. It is voltage tunable in two bands over a range of 80 Mhz to 150 Mhz, and has a sensitivity of better than 1 microvolt. Tuning is provided by two sets of matched varactor diodes, each of which may be switched in

U.S. Reports

parallel for band selection. Automatic gain control range is 100 db.

The prescaler is a multilayer emitter-coupled logic circuit capable of prescaling down from 150 Mhz. It has programable prescale division ratios of 5, 10, and 20. A pulse-swallowing technique permits the ratios to be programed to a 5/6, 10/11, or 20/21 combination, which allows the system reference frequency to remain unaltered.

The divider operates at 10 Mhz and provides synchronous counting and parallel entry. It supplies three decades of program counting, two decades of pulse swallowing, and a frequency phase comparator latch, all in the same package. Incorporated in this circuit are five MSI binary-coded decimal counters.

The reference divider-oscillator contains a programable reference divider and interface circuitry. It provides synchronous counting and parallel entry.

All four circuits were combined with other Fairchild ICs to form a complete 3 to 150 Mhz receiver. The whole design took much less time than would have been possible with discretes. And Fairchild engineers feel that the building block technique will allow the synthesizer to be used in other applications, such as instrumentation and special test gear.

Lasers

Tuning with tint

When researchers started experimenting with dyes in liquid lasers some five years ago, the goal was to broaden the range of emission. Glass and gas lasers were notorious for emitting only at narrow lines and, though this was good for research, more practical endeavors—like communications and optical signal processing—needed wide-band emission.

So when liquid lasers, laced with inorganic dyes and sometimes called chemical lasers, were made to lase over a band as wide as 400 angstroms, the work appeared to be on the right track. Now researchers at Bell Labs, using a

chemical reaction that occurs within an organic single-dye liquid mixture, have managed to achieve pulse emission continuously tunable over roughly half the visible spectrum—about 1,700 Å, in fact—which is better than four times that previously reported.

The colors range from yellow to ultraviolet, the peak power of about 45 kilowatts occurs at the blue line of 4,900 Å, and the pulse widths, following the pump, are 10 nanoseconds. Over the entire emission band, pulse power averages 5 to 10 kilowatts. Higher powers are available if bandwidth is sacrificed—say down to 1,000 Å.

An organic dye such as 4-methylumbelliferone is put in an acid solution. When suitably pumped with, for instance, a nitrogen laser at 3,371 Å, a chemical reaction occurs between the dye molecules and the hydrogen molecules in the acid, and produces some dye molecules in a form different from those normally excited. Each of these two states of the dye molecules emits in its own characteristic spectrum. By adjusting the concentration of hydrogen ions in the liquid, the rate of reaction can be manipulated and thus the relative concentration of new and normally excited dye molecules can be controlled.

This means that controlled quantities of both molecular forms exist simultaneously during each lasing period, permitting emission over both bands of the two forms. A conventional diffraction grating setup is used to tune the laser to any frequency in the band.

There are still problems. One is the heat absorbed from the pump energy, which by causing local changes of refractive index in the liquid tends to blow it apart. This restricts the energy that can be pumped into the liquid (about 120 kw) and thus limits the pulse rate or duty cycle to about 10 pulses per second. By increasing thermal conduction out of the liquid (flowing it transversely to the pump beam), the system can, however, be driven at 100 pps.

Around the corner for dye lasers: electrical wideband tuning, which will make any frequency in the band available instantaneously.

Space electronics

Guiding Rover

Man's ability to go to the moon and return with a high degree of accuracy is no guarantee that he can navigate with similar precision on the moon's surface. So to make sure the astronauts get back to their lunar module after surveying the moon's surface in the Lunar Rover—an activity scheduled for Apollo 17—the Boeing Co.'s Seattle electronics group has built a sophisticated navigation system for the Rover. In fact, one Boeing engineer says that it might be the most complex navigation system ever put on what amounts to a "dune buggy."

The Rover's navigation system, which can best be described as a dead reckoning system, employs a directional gyro and wheel counters which produce signals that are con-

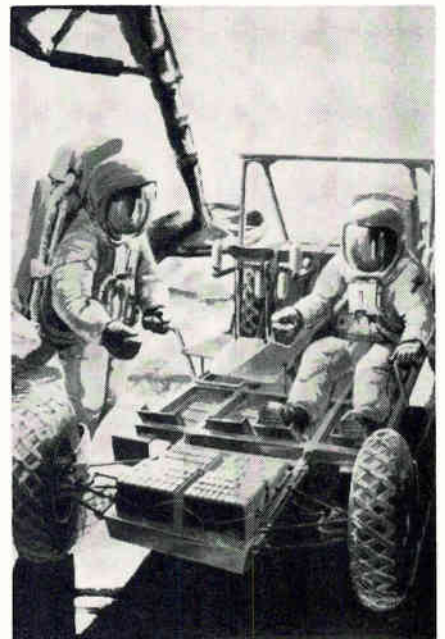

Move over. Sketch of Boeing's lunar rover design. Vehicle would do 10 mph on battery-powered electric motors, weigh 400 pounds, and negotiate one-foot obstacles.

verted into bearing, range, velocity, distance, and heading. These readings are displayed for the driver, and although the system is conventionally designed, it presented some challenging problems to its

designers—the biggest one being heat dissipation.

Because the Lunar Rover is designed to carry people and experiments, little weight was allotted for the navigation system. As a result, the system had to be very compact. And since the atmosphere is very thin on the moon, the heat that is produced by the gyro and the processor is not dissipated fast enough.

Boeing's answer was simply to thermally isolate the gyro and the processor and bolt them to a thermal strap—a device that conducts the heat from the p-c boards to one edge of the guidance system package. Here, the heat is dumped into the Rover's batteries, which can store a certain amount of heat without being severely affected. After the sortie, or whenever the Rover is at rest, a thermal antenna (a shiny metallic umbrella) is connected to the batteries to radiate stored heat into space.

Operational lifetime of the Lunar Rover on the moon, according to current plans, will be 54 hours during the lunar day. It will be able to make any number of sorties up to a cumulative distance of 75 miles. Because of the limitations of the life support systems, however, the vehicle's range will be restricted to a radius of about three miles from the lunar module.

However, the maximum error for the system is 6° of bearing and 600 meters range. This would bring the astronauts close enough to the lunar module so that they could see it.

Computers

Digitizing Congress

When the new Congress convenes in January, it will face an issue as controversial and costly as the ABM system—whether to establish the building blocks for a Congressional computer system [*Electronics*, Dec. 8, 1969, p. 41]. With a system billed as the largest ever to be developed, with billions of dollars to be spent over 10 to 15 years, Stanford Research Institute and eight other

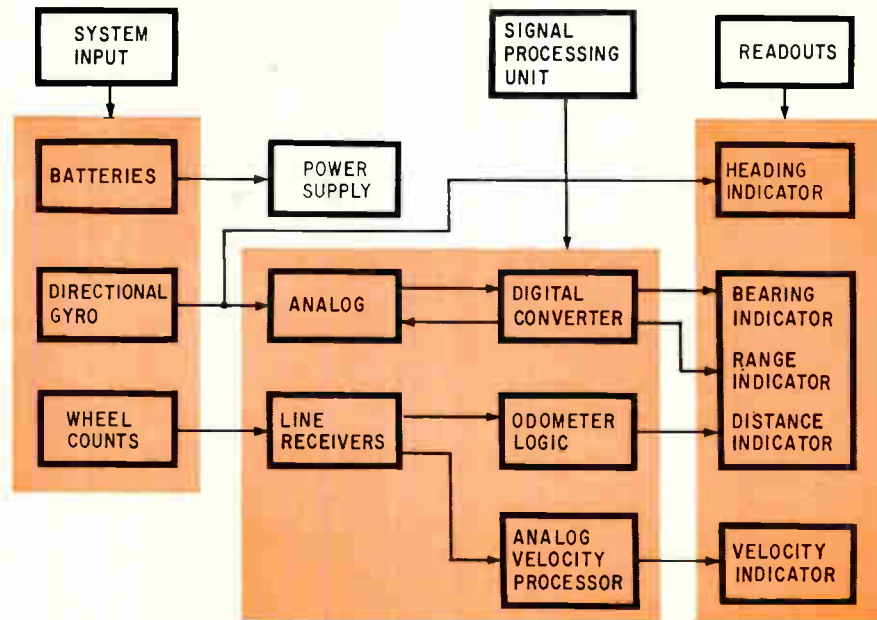

Road mapper. Navigation system for Boeing's lunar rover uses directional gyro and wheel counters. The system, described as a dead reckoning approach, uses batteries to store heat not easily dissipated in the moon's thin atmosphere.

software houses will submit a master plan for the system to the House Committee on Administration by the end of this year. The committee's job is to provide operational services to the 435 Representatives.

Committee sources say that eventually Congress will have a system with terminals in all offices, and interfaces with Executive Branch departments. But preceding this will be a series of interim systems, the first of which most likely will be a data bank for legislative information, calendars, committee schedules and witnesses, and some files, to be expanded as the system evolves. The System Development Corp. is defining the information-handling requirements, with Stanford Research Institute acting as primary planning contractor.

The other contractors and their roles: the Mitre Corp., progress monitoring; the Computer Science Corp., information flow between Capitol Hill, the Executive Branch, and the private sector; EDP Technology, Federal grant programs information system; the General Computing Corp. and the Scientific Resources Corp., potential application of microform technology;

the Intech Corp., training programs, and System Consultants Inc., designing of an automatic mail management system. The nine study contracts for the system total \$450,000.

Requests for proposals for the first portion of the system may go out as early as 1972. After Congress approves the first phase, many other segments will not require legislation. Only major segments which require changing the House's rules must pass the Congress.

Though many contractors will be involved, there is understandable—and valid—industry apprehension over building a system for use by more than 400 politicians, who have varying ideas of how a computer system should serve them in their work.

Some House members want econometric models built into the system to predict the effect of a change in one part of the economy on their own districts or on other economic sectors. This, along with the budgetary data to be programmed into the system would require "the biggest computer we can get our hands on," according to committee sources.

Other aspects of the system in-

U.S. Reports

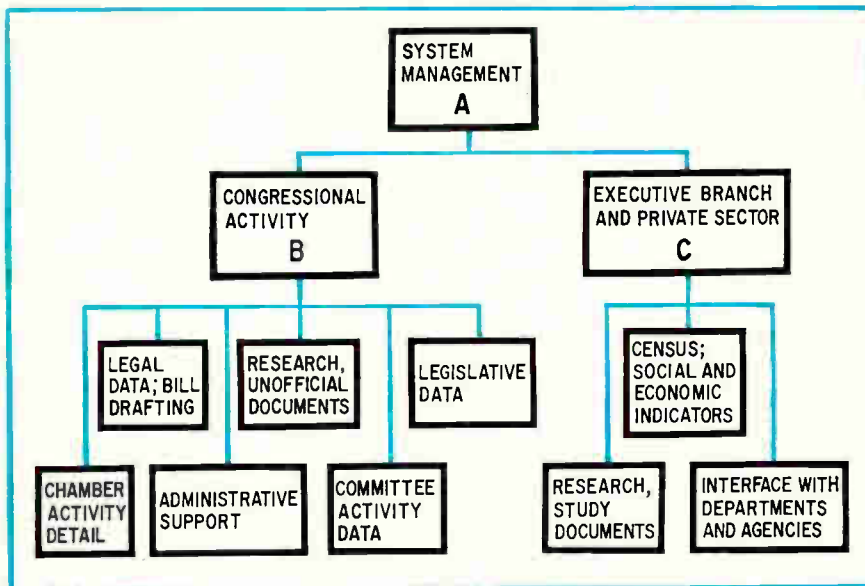

Data flow: These are the elements of the planned computer system for Congress. The Mitre Corp. is reviewing and evaluating progress. The Stanford Research Institute is formulating system concept (A), with the System Development Corp. coordinating Congressional elements (B) and the Computer Science Corp. handling the Executive Branch and private sector (C).

clude automatic addressing and mailing, electronic voting [*Electronics*, Aug. 17, p. 49], and the merging of microform with computer technology. Minicomputers would be used for committee and subcommittee housekeeping.

The Senate is almost a year and a half behind the House in planning for 20th century operations. A new Senate subcommittee on computer services, headed by Sen. B. Everett Jordan (D., N.C.), is studying how to apply computer technology to the Senate.

Communications

Modem race

When the Bell System introduced its 113A low-speed data set that's to lease for less than half the price of an earlier Bell model, competitors' reactions ranged from knowing winks to controlled despair.

Typical of the former is the view of one large modem maker that evaluated a 113A on the basis of parts and labor costs. The conclusion: the new entry is priced very close to cost, which the manufacturer interprets as Bell's last stab at a market that's slipping away.

The maker predicts Bell's share of the modem market will drop considerably by 1974 because of the market's growth and Bell's inability to service all of it.

Not so, says Jack Gerber, marketing director at the International Communications Corp., a division of Milgo Electronics. "Many independent manufacturers of low-speed modems will be hard pressed to stay in the market," he asserts. "Since the low-speed technology is easy to implement, there are many companies in it without much of a backup. They will be the ones to feel the effects of the 113A."

A major maker of high-speed modems, Gerber's firm is having second thoughts about breaking into the low-speed modem market.

What's more, the 113A isn't going to be Bell's final word on the subject. Scheduled to cost \$9 to \$12 a month after an initial fee of \$20 to \$40, it is the first in a series of single-mode sets. While the 113A is an originate-only model that operates manually in full duplex at speeds up to 300 bauds, an answer-only version, the 113B, will come out at the first of the year. It will cost \$12 to \$15 monthly with the same initial fee.

The 113B, in printed circuit card

form, will mount in a 113 Multiple Data Station that sits at the computer end of a time-share system. The 113B can accommodate 120 cards in the large version and 20 in the small unit. It is designed to replace the 103E station for the user who doesn't require features such as call-out and automatic answering.

As for the contention by some independents that the new data set is a loss leader whose cost eventually will be socked to voice network users, Bell says that just isn't so. One spokesman states: "We plan to make good money on the 113A and it's slated to be the largest running set in the Bell System."

Switching problems

Trying to find out if any bugs infect the Bell System's highly touted Electronic Switching Systems (ESS) is something like finding an empty taxi on a rainy day. You feel one must be out there somewhere, but that knowledge brings small comfort. The official Bell line is that ESS problems are mostly software; hardware glitches are few and far between. Tales of twisted communications abound (see 'Wrong number,' p. 44). And while there are just eight ESS exchanges in New York City now, the whole U.S. is scheduled to be all ESS by the year 2000.

In any event, to deal with those software woes, Bell is trying a new approach called the Technical Assistance Center. It will be introduced in October in New York and will eventually service all ESS offices, freeing maintenance people for other duties. The city of Chicago was the site of the initial TAC installation.

"In this system, maintenance personnel will perform all the software analysis of latent problems at the central TAC location," says Gil Woglam, ESS engineer at New York Telephone. During the program's first phase, the center will communicate with the individual ESS offices by Teletype. As more ESS locations open, local control centers will interface them with the TAC office.

The second phase of the TAC

NEW

3 - PLUG - IN OSCILLOSCOPE

- 60-MHz Bandwidth
- Dual-Trace, 5 mV/div
- 5 ns/div Sweep Rate
- 2% Accuracy
- 8 x 10 cm Display
- Solid State

\$2325 COMPLETE WITH PLUG-INS

The TEKTRONIX 7503 THREE-PLUG-IN OSCILLOSCOPE offers *more* measurement capability per dollar than any other quality oscilloscope.

Easier to use. An exclusive peak-to-peak auto-triggering mode provides a triggered sweep throughout the 360° range of the level/slope control. The front panel is uncluttered, lighted push-button switches are extensively used to conserve space. Controls are conveniently related to function through the use of a color-keyed front panel.

Faster measurements. Auto Scale-Factor Readout is exclusive to Tektronix! It labels the CRT with time or frequency/div; volts, ohms, C (temperature), or amps/div; invert and uncal symbols; and automatically corrects for 10X probes and magnifiers. Readout is required when using the NEW 7D13 Digital Multimeter and the NEW 7D14 Digital Counter plug-ins. It can be ordered initially or as a conversion kit, which is easily installed. Either case, the cost is only an additional \$400.

THE 7000-SERIES

An Integrated Test System! With the introduction of the 7D13 and 7D14 digital plug-ins, the 7000-Series becomes an Integrated Test System. **ITS** much more than an ordinary oscilloscope. SEVENTEEN plug-ins covering a wide performance spectrum are available to solve virtually all of your measurement problems. Some of the features offered are: dual-trace, differential comparator, 10- μ V differential, sampling, current amplifier, digital multimeter and digital counter. For instance, plug-ins can be chosen to give the 7503 delaying sweep and 90-MHz bandwidth.

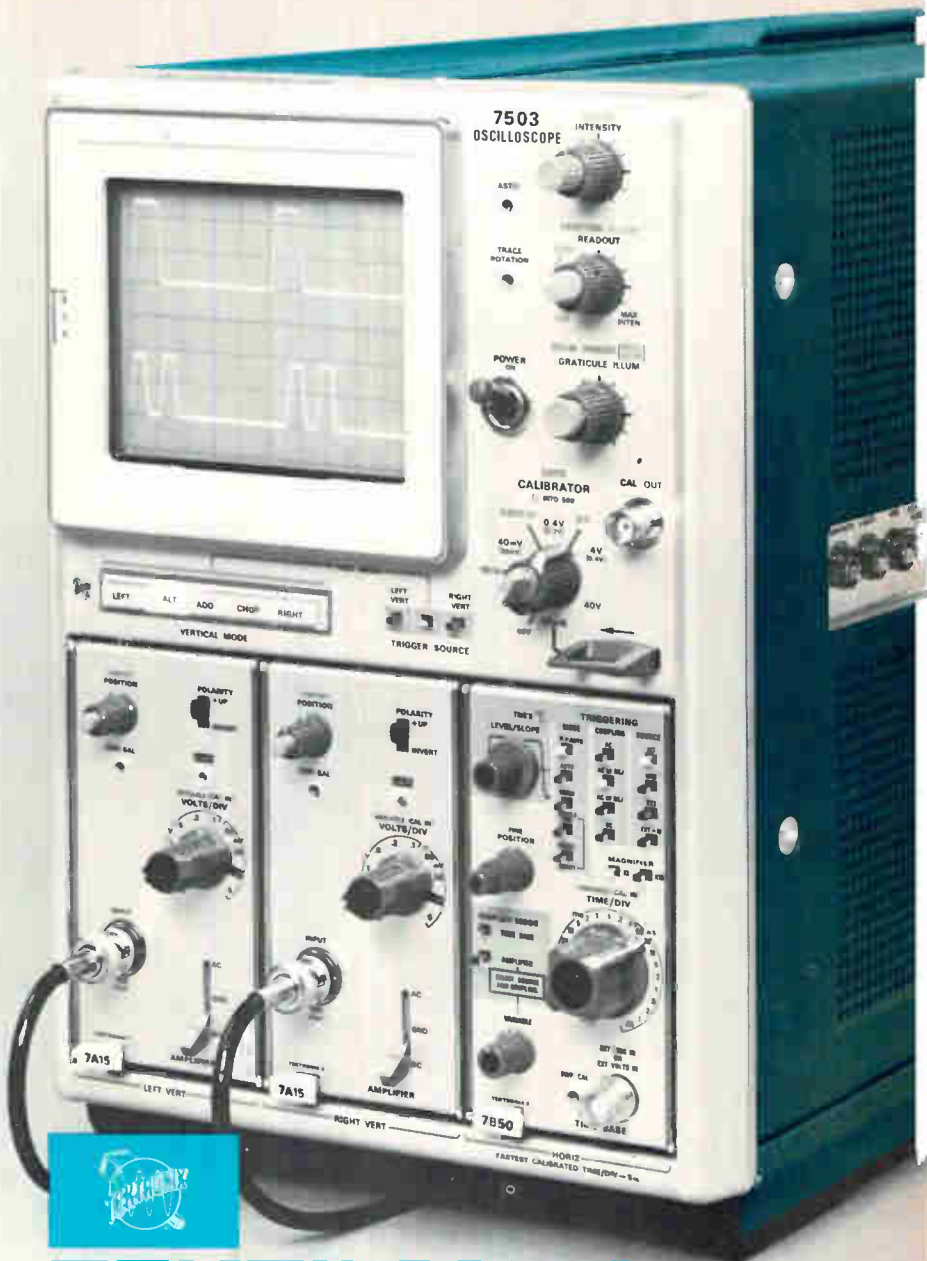

TEKTRONIX®

committed to progress
in waveform measurement

Greater versatility. The following 7000-Series mainframes offer unique four-plug-in versatility. The 7704 (150 MHz), R7704 (150-MHz rackmount), 7504 (90 MHz), and 7514 Storage (90 MHz). The 7000-Series does not require a full complement of plug-ins, you can start with only one horizontal and one vertical plug-in and add more as your measurement requirements change.

Your Tektronix field engineer will gladly demonstrate the complete versatility of the New Tektronix 7000-Series Oscilloscope System, in YOUR lab with YOUR signals. Contact him locally or write: Tektronix, Inc., P. O. Box 500, Beaverton, Oregon 97005. See your 1970 Tektronix Catalog and WESCON Supplement for complete specifications.

7503 Oscilloscope without readout, Option 1	\$1375
7A15 Single-Trace Amplifier	\$ 250
7B50 Time Base	\$ 450
7503 Oscilloscope with readout	\$1775

U.S. Sales Prices FOB Beaverton, Oregon
Available in U.S. through the Tektronix lease plan

program will be the relocation of the ESS office's master control center to the TAC center to allow control of the switching system from the maintenance location. The final TAC phase will be the use of a single master control center for all the ESS offices in the city. Control of a particular office will be done by electronic switching and telemetry. Replacement of faulty units will still be left to repairmen at the ESS office.

Wrong number

New York's Plaza 8 exchange became infamous last year when an advertising agency bought a full page in the New York Times to tell clients that it was still in the city even though phone calls weren't getting through. Plaza 8 is an ESS exchange. New York Bell blamed the mess on an underestimate of the area's load.

Small problems still exist. Recently, the same agency complained to the phone company that incoming calls were tying up two lines apiece. The reply was a form postcard. When an *Electronics* editor asked the phone company about it, he was informed that no problem existed. Shortly after, however, a repair foreman called the agency to say that he was putting maintenance men on overtime to solve the problem.

Companies

Chip-minded

The Ampex Corp.'s annual report for fiscal 1970 notes that the Computer Products division was one of only two divisions that didn't fall short of profit objectives. And Eugene E. Prince, vice president and general manager of the division, which manufactures cores, core stacks, arrays, memory systems, tape drives, and now disk drives in Culver City, Calif., intends to keep it that way. That's why he doesn't want to add the cost of semiconductor wafer fabrication to his operation now, even though he does intend to get into semiconductor memories.

His solution is to give contracts to Intersil and the Intel Corp. for MOS random-access memory chips to be built to Ampex designs. Each contract is for one year, and each covers just one chip now, "although we're looking at additional programs with them," Prince says. The designs are the product of an engineering group in the division that's responsible for keeping abreast of semiconductor technology.

Intersil is to begin delivering devices in October, Intel in December. "We probably won't use both companies' technologies in the same system, but we could use both in different systems," Prince explains. Though he won't state the size of the system his division will build with MOS memory components, he does say that it will be less than a million bits, and should be on the market by mid-1971.

However, his reaction to IBM's introduction of its system 370/155 suggests the trend Ampex may follow. "I think the 370/155 offers the best kind of cost tradeoff," Prince asserts. "It has a 150-nanosecond buffer in the mainframe that combines with a 2.1-microsecond core memory, and I think the high-speed buffer and cost-competitive core is the right way to go."

Prince's plan is to let the semiconductor manufacturer concentrate on processing while Ampex tries to cut costs in assembly and packaging. "We're in the research stage now," he says, adding briefly that Ampex is comparing plastic packages and ceramics, is studying multichip designs, and will do its high-volume assembly of semiconductor memories overseas to cut costs (the firm has facilities in Hong Kong and Taiwan).

But like most other memory houses, Ampex is far from throwing in the towel on cores. Prince estimated six months ago that the 1975 memory market would be 55% cores and 45% semiconductors, but he thinks the low-cost estimates for semiconductor memories were overly optimistic. That's why he thinks assembly and packaging will be the best cost-cutting

areas. Prince predicts solid growth for cores over the next five years, and says some semiconductor memory houses are probably underestimating the cost competitiveness of cores over the next three years.

Memories

Core of the matter

The marketing strategy of the North American Rockwell Microelectronics Co. in Anaheim, Calif., continues to unfold. The firm unveiled its first MOS memory system [*Electronics*, Aug. 3, p. 26] at the Western Electronics Show and Convention Aug. 27, and from the noises being made by officials, the company sounds more and more as if it intends to slug it out in commercial competition. Irwin Lucks, product manager for memories, says NRMEC is taking dead aim at the core memory system business with its line, the first results of which are designated the Memos I family.

The initial demonstration unit has 2,048 words by eight bits on a 6.5-by-12-inch card that includes all drive and clock circuitry. The board contains 32 packaged 512-bit-by-one-word MOS random-access, read-write memory chips, plus four more packages holding the address decoders and clock circuitry. Lucks says NRMEC is shooting for prices between 2 and 3 cents a bit in quantities of 100 cards or more.

He's quick to add, however, that this is only a demonstration unit—organizational flexibility will be the key to the memory product line. For example, Lucks says the company offers greater word-bit flexibility than the traditional semiconductor memory component house that doubles the word capacity when considering systems applications, going from 1,024 words to 2,048, 4,196, and so on.

NRMEC will offer capacities as small as 1,024 words, and can go on up to the mainframe region—65,536 words—in increments as small as 64 words. Bit lengths up to 40 are available. This way, Lucks

New low prices for RCA's COS/MOS IC'S

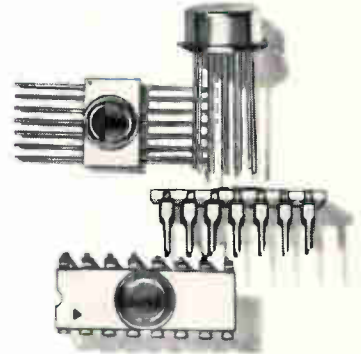

Once again, as production volume follows market demand, RCA has substantially reduced COS/MOS IC prices. Result: more engineers can take advantage of the unique performance features of the COS/MOS technology in their new and existing logic-circuit designs. Before you begin a new design, evaluate the exceptionally high performance and outstanding reliability of COS/MOS IC's: check cost, check power requirements, check cooling requirements, check noise sensitivity. You'll find many reasons for incorporating RCA's COS/MOS IC's in today logic-circuit designs for tomorrow's production savings.

COS/MOS FEATURES— Typical Values at $V_{DD}=10V$

- Extremely low quiescent-power dissipation
Gates — $P_T = 10 \text{ nW/pkg}$
MSI circuits — $P_T = 5 \mu\text{W}$
- Speed
Gates — propagation delay (t_{pd}) = 50 ns @ $C_L = 15 \text{ pF}$
MSI circuits — clock pulse frequency (f_{CL}) = 2.5 MHz
- Excellent dc and dynamic noise immunity, 4.5 V over full operating - temperature range
- High dc fanout > 50
- Simple circuit and subsystem design
- Compatible gate-level and MSI functions
- Operation from one unregulated power supply 6 to 15 V
- Full military operating-temperature range —55°C to +125°C
- Stable performance over wide ranges of supply voltage and temperature

For further information on COS/MOS integrated circuits, see your local RCA Representative or RCA Distributor. Ask for the following COS/MOS application information: "Noise Immunity", ICAN 6176; "Astable and Monostable Oscillator Designs", ICAN 6267; "COS/MOS IC Reliability Data", RIC 101. Or write: RCA, Commercial Engineering, Section 70H-31/CD46, Harrison, N. J. 07029. International: RCA, 2-4 rue du Lièvre, 1227 Geneva, Switzerland, or P.O. Box 112, Hong Kong.

Flat Pack Type No.	DIC Type No.	Description	Flat Pack Price-Each (1000 or more quantities)	DIC Price-Each
Gates				
CD4000	CD4000D	Dual 3-input NOR plus inverter	\$ 3.90	\$ 3.25
CD4001	CD4001D	Quad 2-input NOR	4.10	3.45
CD4002	CD4002D	Dual 4-input NOR	4.25	3.60
CD4007	CD4007D	Dual complementary pair plus inverter	3.40	2.75
CD4011	CD4011D	Quad 2-input NAND	4.10	3.45
CD4012	CD4012D	Dual 4-input NAND	4.25	3.60
—	CD4019D	AND-OR select gate	—	5.25
Flip-Flops				
CD4013	CD4013D	Dual-D with set/reset capability	5.60	4.95
Hex Buffers/Logic-Level converters				
—	CD4009D	Inverting	—	5.50
—	CD4010D	Non-inverting	—	5.50
Multiplexers				
CD4016	CD4016D	Quad bilateral switch	6.00	5.40
Memories—MSI				
CD4005	CD4005D	16-bit NDRO	10.00	9.45
Static-Shift Registers—MSI				
CD4006	CD4006D	18-stage register	10.00	9.50
—	CD4014D	8-stage synchronous parallel or serial input/serial output	—	10.55
—	CD4015D	Dual 4-stage serial-input/parallel-output	—	10.55
Counters—MSI				
CD4004	—	7-stage ripple counter/freq. divider	8.20	—
—	*CD4004T	—	—	7.50
—	CD4017D	Decade counter/divider with 10 decoded outputs	—	11.00
—	CD4018D	Presetable divide by "N" counter	—	9.65
—	CD4020D	14-stage ripple-carry binary counter/divider	—	12.50
Adders—MSI				
—	CD4008D	4-bit full adder with parallel carry out	—	10.60

*TO-5 package
(COS/MOS IC's listed in bold-face type are recent additions to the line.)

RCA Integrated Circuits

U.S. Reports

figures, the customer has a better chance of buying only as much memory as he needs.

"We're tailoring to the customer," Lucks stresses. "If he needs 5,120 words by 17 bits, we can provide it, and we can also provide the board size and the kind of connector he needs to interface to DTL, TTL, or ECL." He believes the product line and service NRMEC will offer will be particularly appealing to computer or peripheral manufacturers that don't have large memory system design groups. He's also convinced the NRMEC approach will be competitive in at least 50% of today's core memory subsystem market.

Typical specifications for systems in the Memos I line will be: cycle times down to 750 nanoseconds, with a 500 nsec access time; operating temperature from 0°C to 70°C; power consumption of 0.25 milliwatt per bit, typically.

Barry Waggoner, applications engineer for MOS memories, adds that NRMEC will be able to mix random-access and read-only functions with both using the same address decoder circuits. Besides the 512-word-by-one-bit RAM, the firm has developed a receiver driver, an address decoder, a 512-by-8 ROM, and a 64-by-8 RAM.

Cards ready for sale now are the 2,048-by-8 unit and one holding 1,024 words of 16 bits. About 45 days would be required for a custom board design, a little longer if the customer wants NRMEC to put the custom logic interface on the board. This is a typical turnaround time for a read-write system; a read-only memory would take perhaps a month longer because the customer's bit pattern will have to be encoded with masking.

Microwave

Radiation probe

The Department of Health, Education and Welfare's push for standards to control microwave radiation from a variety of sources—ovens, industrial drying systems, and military hardware [*Electronics*, Oct. 13,

1969, p. 123]—is accelerating efforts by several subordinate agencies to devise an instrument that can effectively measure such radiation. That effort has yielded a prototype near-field probe using diode detectors to minimize interactions with the field being measured. Developed by the Illinois Institute of Technology Research Institute for the Public Health Service, the unit has advantages and disadvantages compared to commercially available probes—such as Narda Microwave's 8100 model—which use thermocouple detectors, say PHS sources.

The IITRI project was developed last year by A.W. Rudge and R.M. Knox. It was undertaken "because of the difficulty that was being encountered in measuring electromagnetic radiation leakage from microwave ovens and the need for improved measurement instruments," asserts Robert L. Elder of the PHS Electronic Products division.

Potential advantages of a diode detector probe, say Rudge and Knox, include a wide dynamic range up to 47 decibels, significant insensitivity to ambient temperature variations; coverage of both frequency bands without part changes; use of a small probe antenna—overall dipole length is 0.8 centimeter—negligible backscatter, and operation with a high-impedance voltmeter or oscilloscope. Coupled with other technical performance specifications, the basic probe is "very flexible and can be readily adapted" for a variety of uses, say its developers.

Though PHS officials concede all these points and add that the diode detector is far more rugged for field use than those using thermocouples, the IITRI concept faces a severe production limitation—diode matching. "Thermocouples have the advantage of uniformity," says one PHS source, which makes it far simpler to match two components for use in a detector. Diodes, on the other hand, must be "tested by the hundreds" before a satisfactory match can be made.

To resolve this problem, PHS says it is getting preliminary data on some Schottky barrier diode types.

Government

Radar hazards

Suspecting a connection between exposure to microwave radiation from radar systems and mongolism in radar workers' children, the Health, Education and Welfare and Defense Departments have launched a study to determine the biological effects, if any, of exposure.

Johns Hopkins University, in a general interview study of mongoloid children and their parents published in 1965, reported a "truly puzzling association" between exposure to radar and mongoloid offspring. The finding was incidental to the study, which reported a definite relationship between material exposure to radiation from fluoroscopic and therapeutic treatments and mongoloid children.

The university is conducting the current study effort with \$75,000 from HEW's bureau of Radiological Health and the Army. The HEW bureau emphasizes that it is not yet looking for a cause-effect relationship, but for statistical associations.

Radiation exposure can cause chromosomal aberrations, according to Johns Hopkins, and exposure to radar could be one explanation for the reisoic chromosome 21 found in the majority of mongoloids. Those who work with radar could also be subject to cataracts and damage to reproductive organs.

HEW says there also could be a difference in effects between sitting in front of a radar screen and exposure to radiation in the area of a radar dish. Johns Hopkins is interviewing fathers of over 200 mongoloid children in the Baltimore area, to determine the exact mode of exposure.

For the record

All-seeing eye. An image-intensification system built around a direct-viewing tube [*Electronics*, Sept. 29, 1969, p. 47] has been given the name Owl Eye by manufacturer Aerojet Delft Corp. of Azusa, Calif. Some 25 units have

New TRW Broadband RF Amplifier

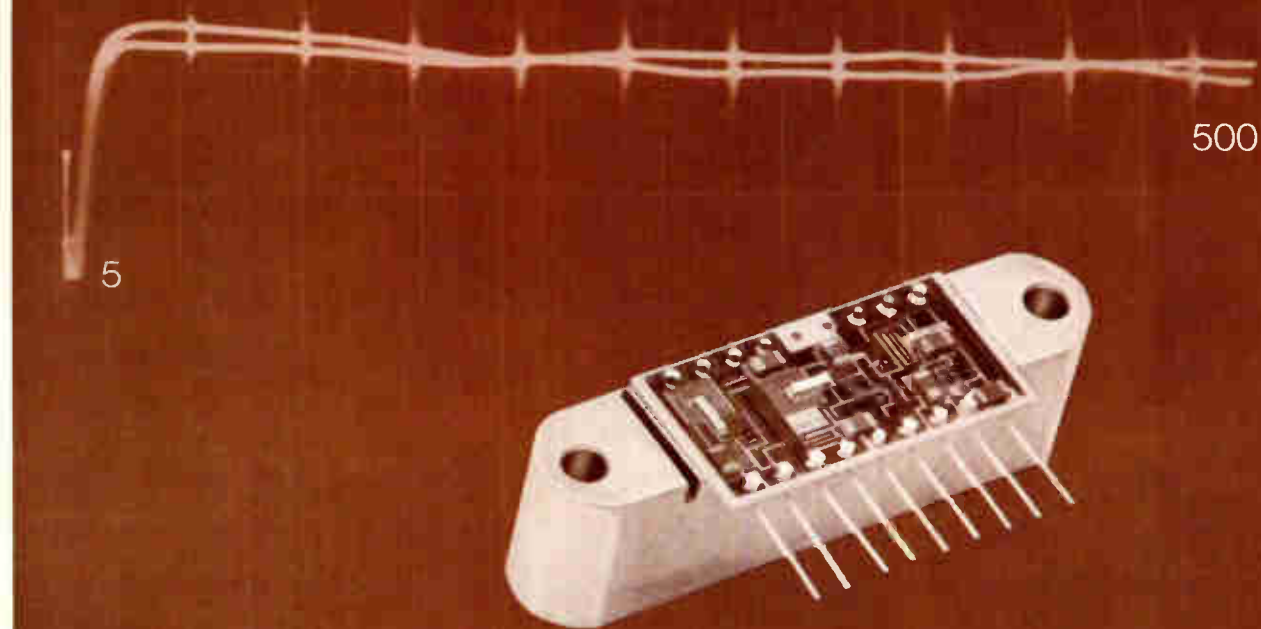

#8-69

From 5 to 500 MHz.....400 mW output

This hybrid microelectronic amplifier module for broadband RF service provides extreme stability and the most reliable performance obtainable. The versatile CA 800 provides power and bandwidth previously unattainable with this hybrid circuitry.

With a 28 volt supply...over a 5 to 500 MHz bandwidth...the CA 800 provides a gain of 25 dB at a maximum output of 400mW. Distortions, such as noise, cross

modulation, and second order beat are at new lows for this type of circuitry.

The class "A" bias network has $\pm .003\%$ per $^{\circ}\text{C}$. stability, while the transistor chips have a proven 1,000,000 hours MTBF. Advanced packaging features eliminate all bond-wire lead connections, provide a large combination heat sink-mounting spacer, and compatibility with pc board assembly.

Order from the factory or any TRW distributor. For application assistance, contact TRW Semiconductor Division, 14520 Aviation Boulevard, Lawndale, California 90260. Phone: (213) 679-4561. TWX: 910-325-6206.

TRW[®]

From atmosphere to 5×10^{-7} Torr in under 4 minutes.

Or whatever pressure you need. Automatically. All day long.

The HVS-200 cycles faster than any other system made: Up to 450 L/S ion pumping, electron-beam titanium sublimation pumping and over 3800 square-inches of cryogenic surface.

Interchangeable feedthrough spools and exclusive modular design give you shortest production downtime too.

The fully enclosed roughing system reprocesses automatically. Just push the button. The motor driven hoist can handle all types of bell jars. All controls are on the front panel.

It's ideal for work in microelectronics, optics, metallurgy, surface research, electron-microscopy, environmental testing, electron tube processing, plastics, and ion implantation.

Ideal because it works. Faster than any other system.

But then it should. After all, we've been making vacuum equipment for over ten years. Write: Hughes Vacuum Equipment, 2020 Oceanside Blvd., Oceanside, Calif. 92054.



HUGHES

HUGHES AIRCRAFT COMPANY
INDUSTRIAL PRODUCTS DIV.
OCEANSIDE, CALIFORNIA

WE CAN EMPTY IT FASTER THAN ANYONE.

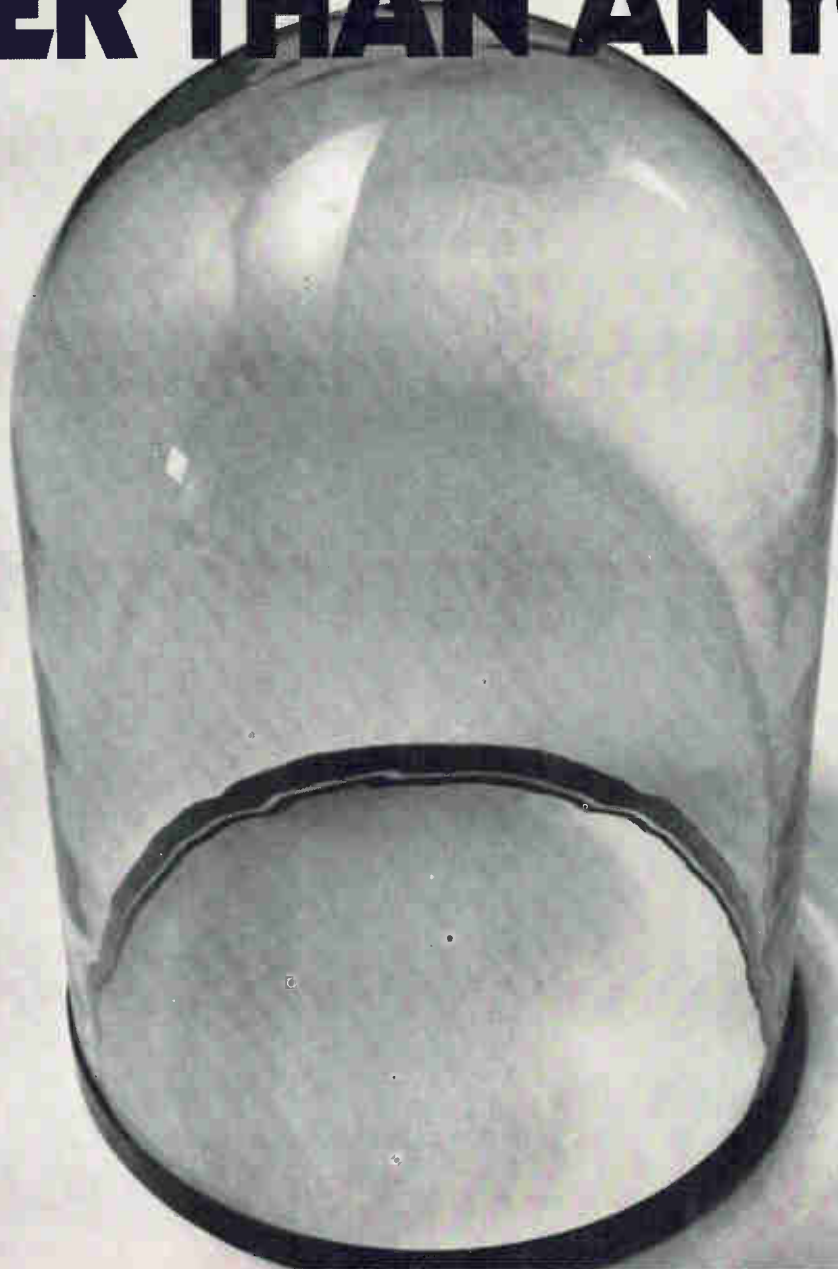

U.S. Reports

been sold, mostly to law enforcement agencies at a price of \$7,500 each. The three-stage night-viewing device, which has a minimum gain of 12,000 and a typical gain of 18,000, allows direct viewing by more than one person, and permits photos or motion pictures of the image to be taken and used as evidence. With its aid, New York City police found jewel thieves hiding in a darkened building. Recently, too, Aerojet Delft lent an Owl Eye to the Altadena, Calif., Sheriff's Mountain Rescue Team, to help locate a 17-year-old hiker who had become separated from his group after dark in rugged terrain. The boy was quickly found.

Big bang. A Navy Phoenix missile has performed flawlessly in its first test flight, according to Hughes Aircraft, its developer. A converted F-9F Cougar fighter was blasted out of the sky when the Phoenix passed close to it and was detonated by a proximity fuze. The missile was launched at a range described only as "many miles;" however, Hughes did say that it was greater than the range of any existing air-to-air missile. The Phoenix and the AWG-9 missile control system was destined for the Navy's new F-14A fleet defense fighter.

Signs of the times. Slippage in the U.S. economy is reflected in new government and industrial data on electronic component and product sales. In the last quarter of 1969, according to the Commerce Department, factory shipments of components rose 5.2% to \$1.22 billion over the comparable 1968 period. But the final-quarter figures were up only 1.4% from the seasonally low third quarter. Shipments on defense contracts, in particular, fell down in the quarter, dropping to less than 20% of the components total.

Fast gage. An instrument that uses an ultraviolet photometric detector to measure mercury contamination in air or water has been developed by the Olin Corp. It can analyze samples continuously, says Olin, and almost instantaneously

measure and record mercury concentrations ranging to 10 parts per billion. Previously, a well-equipped lab was needed using sophisticated equipment in a multistep analytical process that sometimes required several hours. The new instrument is small enough to be portable.

Fax or copy. A facsimile machine that doubles as an office copier has been developed by Matsushita Graphic Communications System of Japan and will be marketed in the U.S. by Visual Sciences Inc. of Huntington Station, N.Y. Called the Remotecopier, it electrostatically reproduces copies on ordinary paper at a cost of about 2½ cents a copy. The use of a 300-foot roll of paper makes it possible to receive facsimile copies with no attendant present. Normal transmission time is six minutes, but a simple gear adjustment will reduce copying time to three minutes, making the Remotecopier compatible with other fax machines. The unit contains its own acoustic coupler, and the transmitter/receiver electronics are mounted on 3 printed circuit cards. When a major distributor is found, the machine will sell for \$2,500; leasing arrangements will be available at \$75 a month.

EVR programs. Motorola Systems of Chicago expects by late fall or early winter to deliver more than 100 of its EVR teleplayer systems to universities quick to jump at the American Program bureau's lecture series. The cartridge programs will feature such speakers as Al Capp, the cartoonist; Ralph Nadar, the consumer products hawk; and Dick Gregory, comedian and civil rights militant. Motorola is a CBS licensee for EVR.

Purchase. The Deutsch Relay division is completing the acquisition of the relay division of Bourns Inc. The Bourns group, now in Riverside, Calif., will be moved to the East Coast and located at one of Deutsch's two facilities. This marks the third relay acquisition for Deutsch this year. All three have complemented the company's product line—none competes.

A lot of people are saying Hughes is into a lot of things

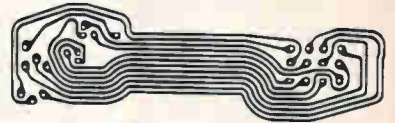
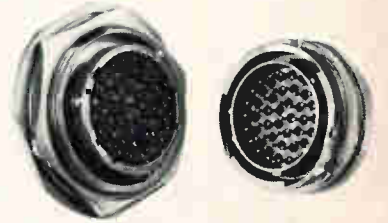

A lot of people are right.

And with good reason. Hughes makes better electrical connectors (RS 287), flat flexible cable and circuit assemblies (RS 288), direct view storage and scan converter tubes (RS 290), display systems (RS 291), and multiplex systems for remote communications/control (RS 292).

HUGHES

HUGHES AIRCRAFT COMPANY
INDUSTRIAL ELECTRONICS GROUP

SATELLITE STATION ANTENNAS

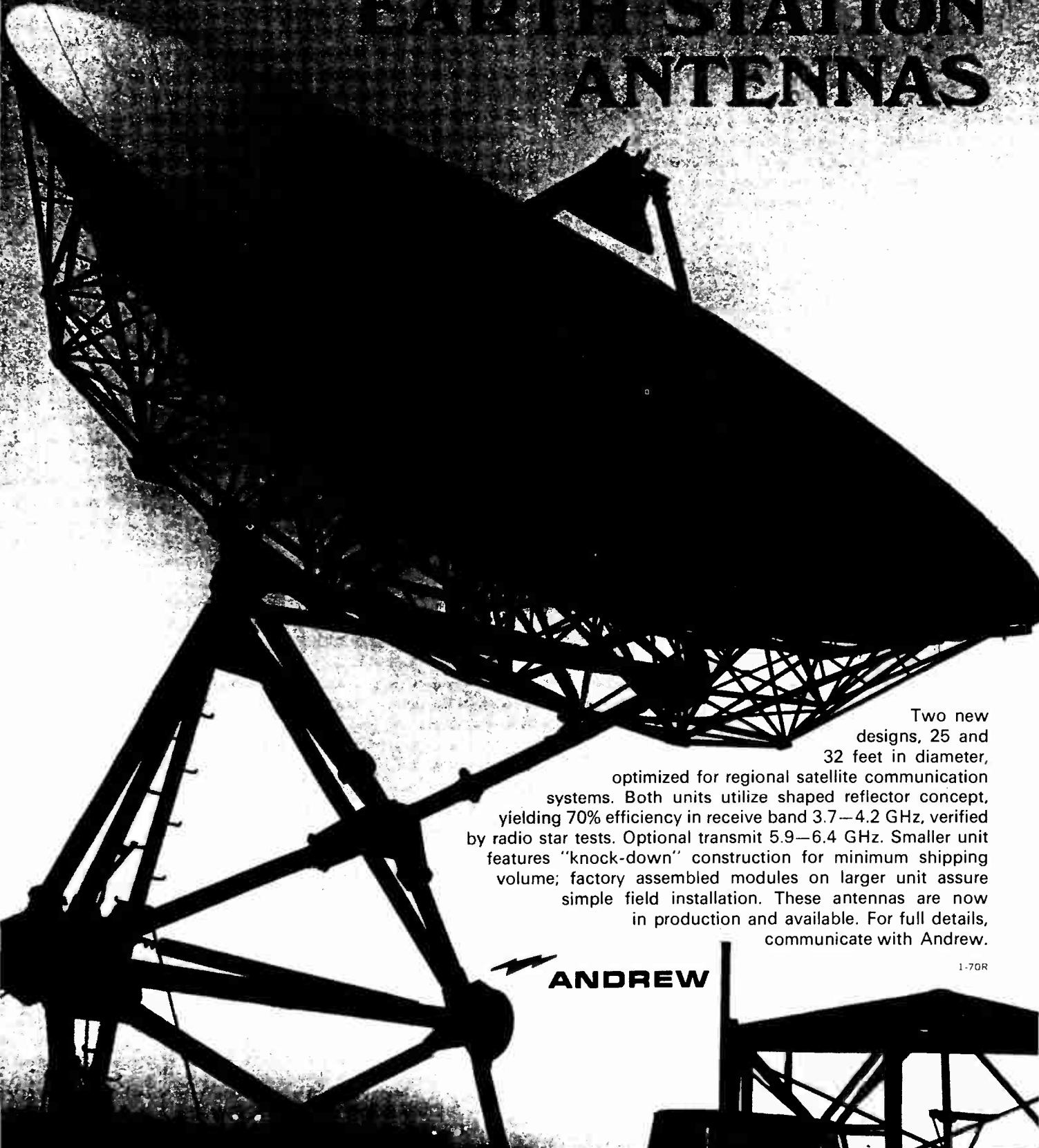

Two new designs, 25 and 32 feet in diameter, optimized for regional satellite communication systems. Both units utilize shaped reflector concept, yielding 70% efficiency in receive band 3.7—4.2 GHz, verified by radio star tests. Optional transmit 5.9—6.4 GHz. Smaller unit features "knock-down" construction for minimum shipping volume; factory assembled modules on larger unit assure simple field installation. These antennas are now in production and available. For full details, communicate with Andrew.

1-70R



ANDREW



ANDREW CORPORATION, 10500 W. 153RD STREET, ORLAND PARK, ILLINOIS 60462, PHONE (312) 349-3300

Washington Newsletter

August 31, 1970

First engineer named to White House post as science adviser

Stronger emphasis on applying technology to domestic problems—that's how the appointment of electronics engineer Edward E. David Jr. as Science Adviser to the President is being read. The move follows the predicted resignation of Lee A. DuBridge [*Electronics*, July 20, p. 68]. The selection of the 45-year-old chief of Bell Laboratories' communications systems research breaks the tradition of putting a university scientist without industry affiliations in the post, and has divided the ecstatic engineering and dismayed academic science communities.

Where DuBridge was regarded as ineffective in maintaining, much less increasing, research funds for scientists—\$160 million was cut from fiscal 1971 grants—university sources suspect David will not only live with these economies, but also direct more of the available funds to industry's development side of the R&D cycle at the expense of research.

A second concern of scientists is David's orientation to defense R&D—he's worked on underwater sound and antisubmarine warfare programs—which university researchers believe already has more than its share of total R&D funds. Nevertheless, David believes health, health services, transportation, and housing are among the country's "technological problems" along with defense.

Low tops list for NASA post

The campaign to promote George M. Low to NASA administrator from the No. 2 spot he now holds scored solid political gains with the outspoken support of Rep. James G. Fulton (R., Pa.), ranking minority member of the House committee that oversees the space agency's budget, and the concurrence of committee chairman Rep. George Miller (D., Calif.). Also favoring Low, who very much wants the post that will be vacated Sept. 15 by Thomas O. Paine, is his long experience with NASA.

NASA employees, however, tend to favor the deputy associate administrator, Wernher von Braun, a strong personality who is popular on Capitol Hill. But his role as leader of Germany's World War II missile program clouds his political acceptability. Other names recurring in the competition include Air Force secretary and former NASA deputy, Robert Seamans, and MIT engineering dean Raymond L. Bisplinghoff, another former NASA aide, who was recently nominated to become deputy director of the National Science Foundation.

Changes to come in DOD procurement, Packard warns . . .

Deputy Defense Secretary David Packard is now strongly on record for changes in Pentagon procurement practices. In a West Coast speech, he said the "real mess" in procurement is one best solved internally, and that DOD can do the job without Congressional interference or putting General Accounting Office auditors in the position of making management decisions. But Packard warns that legislative criticism and controls will grow unless DOD and its contractors can simplify and speed up the procurement process to give better systems performance.

Packard favors most of the 113 recommendations in the Blue Ribbon Defense Panel's report [*Electronics*, Aug. 17, p. 109]. But, he rejects the panel's principal recommendation—the creation of three deputy defense secretaries—on the ground that it supports greater centralization, rather than decentralization, of authority. Instead, Packard believes more authority can be given the three service secretaries.

Washington Newsletter

**... modification
of Joint Chiefs
role also forecast**

The Joint Chiefs of Staff, whose broad powers would be virtually eliminated under the panel recommendations, receive superficial support from Packard. "The report greatly underrates the Joint Chiefs," he says in an obvious effort to soothe ruffled JCS feathers. Yet he is quick to point out that "we do need to streamline the chain of command for operations."

**Four systems
foreseen in
domestic satellites**

Of the dozen or so firms on record as intending to file applications for a domestic communications satellite system, four are likely to emerge as actual fliers, suggest Federal Communications Commission sources. Western Union has already filed a proposal, and Communications Satellite Corp. and Hughes Aircraft are expected to file in October, University Computing Co. in December. The rest of the field will end up as users. AT&T sources say the most acceptable approach would have users work through Comsat to set up a multi-purpose network.

The commercial broadcast networks are expected merely to study the proposals of Comsat and Western Union, in a search for an alternate to AT&T. Program transmission payments to AT&T will run to \$70 million this year, and the networks hope to cut it to \$40 or \$50 million with satellites. RCA and General Telephone and Electronics are considering joining forces with WU or Comsat, sources believe. TelePrompter Corp., sponsor of the Hughes system, wants to serve cable tv.

**Air traffic control
planning base
may be broadened**

Industry may get a chance to help the Federal Aviation Administration plan and design the nation's air traffic control system. If the FAA's newly formed Systems Engineering Management Staff [*Electronics*, Aug. 17, p. 59] can't do the mammoth job, Mitre Corp. or "a major corporation with a broad base like General Electric" would be the only sources available to take on the work, one White House source says. Many, however, fear that Mitre's long-lasting relationship with the FAA and the Air Force's Sage system has narrowed its perspective, the source notes. What's more, chances of industry playing a bigger systems role would increase dramatically if satellite proponents [see page 39] succeed in landing a bigger role in the next generation of air traffic control equipment.

**Little chance seen
for government
EDP standard**

Pressure to standardize the peripheral interface of computers acquired by the Government is growing, but there's only a slim chance that a standard will be developed soon. Congressional pressure stems from the General Accounting Office, where officials say that the lack of such an interface has been costing the Government \$120 million a year [*Electronics*, July 20, p. 48]. GAO says the Government would save if it could use non-plug-to-plug compatible peripherals available through independent manufacturers in place of the mainframe manufacturers' units.

Little will happen, however, because neither the Office of Management and Budget nor the big user agencies are expected to push hard for a standard interface. Industry, too, opposes its development. Federal officials fear that the National Bureau of Standards plan to develop a standard based on third generation equipment would retard manufacturers intent on introducing fourth generation equipment.

DCS "Analog-to-Analog" Converters are Beautiful...

because they are the lowest distortion
data gathering devices made!

Between the two analogs a lot of beautiful
things happen. For example, magnetic tape
recording of 18 channels of data per tape
track, time correlation of data, and nulling
of tape speed variations on playback.

Analog-to-Analog Converters?

It's simply our way of describing the finest
precision data acquisition/reduction system
available. You might call it frequency
modulation and demodulation.

We take your precision test data and FM
multiplex it, allowing you to record and
faithfully detect it, and provide
distortion-free output data identical
to the original transducer's output.

As you see, it is simple... the DCS
analog-to-analog converter converts your
original signal back to your original
signal—faithfully and repeatably.

These are the principal components for
your next data acquisition system.

OM-5 Series Differential Millivolt Controlled Oscillators

Highest input sensitivity currently available...
5 millivolts peak.

Unique Auto-Calibration "Talk Back" feature...
reduces operator error to insignificant levels.

Driven Common Mode Guard Shield...
significantly improves the AC CMR of the amplifier.

FD-15 Discriminator

Special Sampling Output Signal can be activated by
external control strobe for application to A/D
converters. Output data of many discriminators may
be bussed together for a PAM Serial Data Train.

Quench Circuit effectively grounds the output,
protects galvanometers and avoids processing
valid data when the input signal is removed.

Subcarrier deviation... $\pm 1\%$ to $\pm 40\%$

Data response... DC to 400 kHz.

Harmonic distortion... 0.5% for a
modulation index = 2

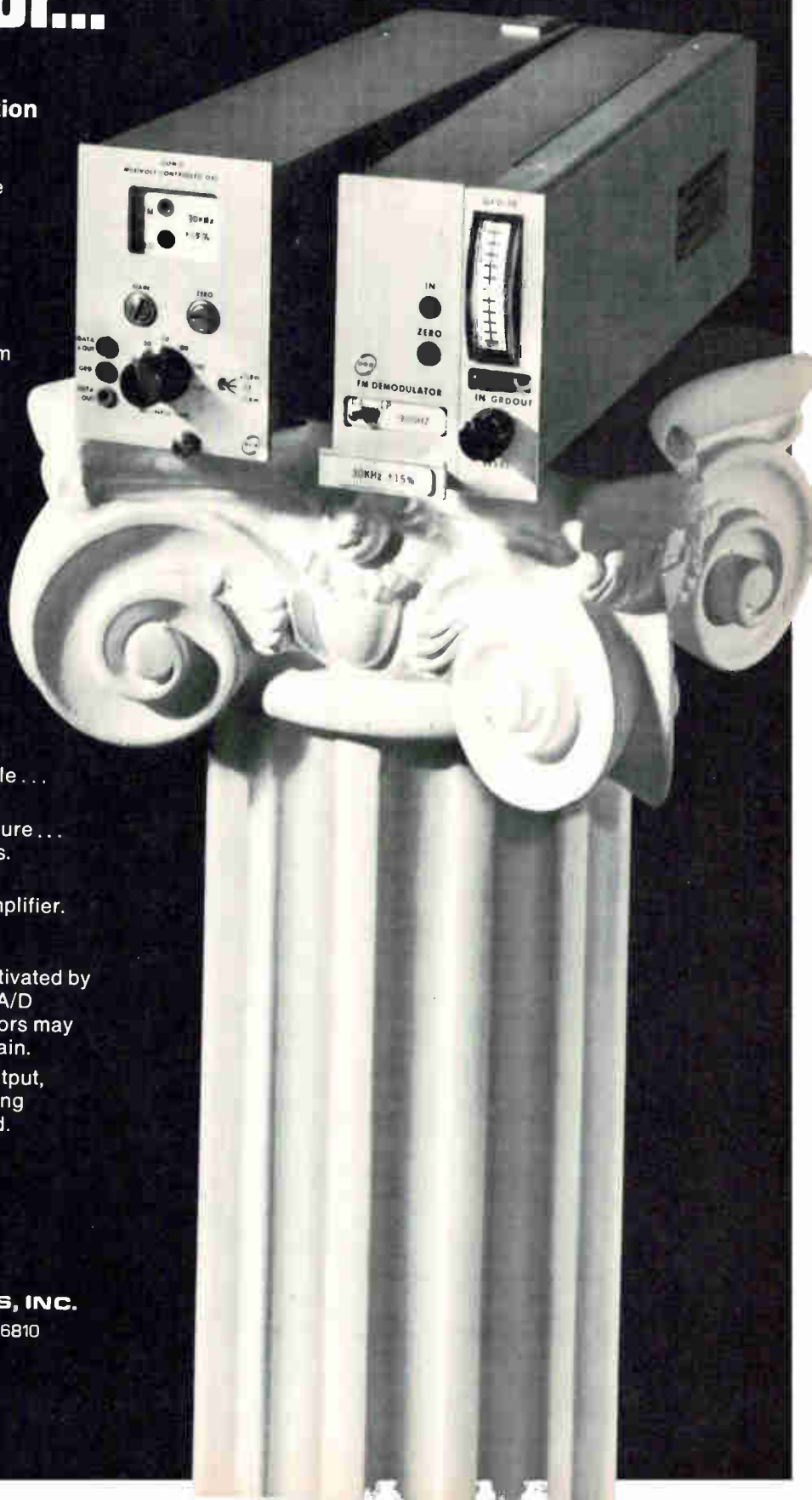

DATA-CONTROL SYSTEMS, INC.

Commerce Drive, Danbury, Connecticut 06810
203 743-9241

Circle 53 on reader service card

Guess the price of HP's new counter



Clues:

it averages time intervals to 10 picoseconds
it has a built-in 0.05% integrating DVM
it's dc to 50 MHz, CW or burst
its counter and DVM are easily programmable

Surprise: \$1550. That modest amount buys a Hewlett-Packard timer/counter that does things universal counters never did before. For example, it averages time intervals as short as 0.15 nanoseconds. So you can resolve to 10 picoseconds on repetitive signals.

That modest sum also buys a counter with a built-in integrating digital voltmeter. So it's the only counter that can measure internal trigger level settings or other inputs with DVM precision. Now you can measure 10 to 90% rise times, half power points and other voltage-dependent time intervals. That means unprecedented simplicity, for example, in propagation

delay measurements. The counter also features four integration times. As a DVM, it provides three voltage ranges, 60 dB noise rejection and 0.05% accuracy.

Even without these exclusive features, the 5326's are real bargains. They count to 50 MHz direct with seven-digit resolution (eight digits optional), measure period and multiple period average and scale input frequencies by any power of 10 up to 10^8 . They measure ratio and they totalize.

With programming and BCD output options, the 5326's fit easily into systems applications. Counter and DVM are DTL programmable through a common connector.

You can get all of these benefits in a 5326B for \$1550, or buy the same counter less the DVM, in the 5326A for \$1195. Either way you look at the 5326 A or B—either a great counter value. Your local field engineer has all the facts about HP's new IC counter line. Give him a call or write Hewlett-Packard, Palo Alto, California 94304; Europe: 1217 Meyrin-Geneva, Switzerland.

HEWLETT  PACKARD
ELECTRONIC COUNTERS

Article Highlights

Point-to-point wiring gains new popularity among DIP users
page 56

Discrete wiring methods such as wire wrapping and Termination Point, usually reserved for back panels, now show up in the logic portions of computer peripherals and industrial control systems. The reason: designers attain fast turnaround in production, yet can leave designs open for last-minute customer requirements or newly introduced ICs.

Optical waveguides bring laser communication closer
page 60

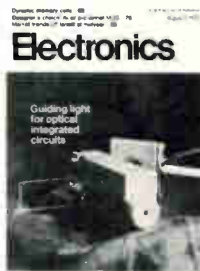

Increasing demands on communications facilities force systems planners to continually seek transmission systems with ever-higher bandwidths. Optical transmission with its micron-sized wavelengths offers a striking increase in capacity over microwave and millimeter wave systems. But it took the development of thin film optical waveguides—the heart of an optical integrated circuit—to smooth the way for such a move. And integrating the circuit promises still more sophistication in terms of ruggedness, reliability, compactness, and the potential for batch processing.

Complementary MOS and bipolar make it on a single chip
page 72

Providing the best of two worlds, a new IC fabrication technology, "C squared," grows two kinds of transistors, thought of as mutually exclusive, on the same chip. Combining complementary (nnp and pnp) bipolars with complementary (n channel and p channel) MOS delivers compactness and low power dissipation along with high speed and good output-drive capability.

Linear IC model takes to analysis by computer
page 78

Operational amplifiers are complex devices, and those containing linear ICs are even more so. Now a mathematical model provides an accurate representation of the monolithic op amp and lets a designer determine open- and closed-loop frequency response as well as frequency stability for circuits employing the devices. In addition, he can evaluate the effects of parameter drifts.

Coming

Japan report

Japan's supercharged economy, the world's third largest, is growing at better than 11% this year, and its electronics industry is providing a strong push. After surveying the Japanese industry in depth, *Electronics* presents a detailed report on technology, production, and estimated market sizes.

Point-to-point wiring gains new popularity among DIP users

It's easier and cheaper to update circuitry if point-to-point wiring replaces multilayers for short runs of dual in-line package arrays

By Stephen E. Scrupski, *Packaging and production editor*

□ Over the past year, wire wrapping has been gaining ground, at the expense of multilayers, as a means of interconnecting dual in-line integrated circuit packages. And so have other forms of point-to-point discrete wiring. The process usually involves inserting a dual in-line package (DIP) into a socket with special terminals that are thrust through a perforated board and linked by wire.

Users report their growing preference for the freedom to change circuit layouts that wire wrapping allows, since this flexibility lets them keep in step with rapidly evolving ICs. Manufacturers corroborate their reports: DIP sockets with wire-wrap terminals, they say, as well as panel assemblies of such sockets, have been selling in twice the numbers they did last year.

This particular use of wire wrapping, though on the increase, is still only a small part of the total wire wrapping market. It's closely related to the rapid growth of DIP usage in computer peripheral systems and industrial control systems. Even here, it is primarily being used in sections that have high integrated logic content and not those that mix ICs with discrete components, which are difficult and expensive to handle in wire-wrapping sockets. Moreover, it is confined to the production of breadboards, prototypes and short runs, because wire-wrapping costs, unlike multilayer costs, don't fall off as production quantities rise.

Still, within these limits, wire wrapping and other, essentially similar methods of interconnection are winning adherents. In the strictest sense, "Wire-Wrap" is a trademark applied by Gardner-Denver Co., Quincy, Ill., to its equipment for the wire-wrapping procedure originated by Bell Laboratories in the early 1950s. A Gardner-Denver machine automatically wraps the stripped end of a solid wire five or seven times around a square sharp-edged post, deforming both post and wire in the process to ensure an intimate bond.

Termi-Point, developed by Amp Inc., Harrisburg, Pa., resembles Wire-Wrap, except that it employs a small clip that strips the insulation from the wire at the same time as it is being forced down over wire-end and terminal. It produces the same intimate

bond as wire wrapping, with solid or stranded wire.

Some engineers, however, question the economics of using special wrap-terminal sockets for dual in-line packages (DIPs). With some dual in-lines selling for only 30 cents, a socket can cost as much or more than the integrated circuit itself. George Messner, of Photocircuits Corp., Glen Cove, N.Y., is one who sees the use of socketed DIPs leveling off for this reason. It's also difficult to insert ICs into sockets and will be even more difficult when large-scale integrated circuits appear.

Therefore, Photocircuits has its own approach, which it calls Multiwire [*Electronics*, June 22, p. 39], a numerically controlled head lays an insulated wire on a p-c board, making crossovers possible while retaining plated-through holes and solder connections for IC leads. The single-sided board thus acts as a multilayer board but without the need for artwork.

A similar process, called Infobond, was developed by Inforex Inc., Burlington, Mass. In this system,

Big board. Over 750 dual in-line integrated circuits are mounted and interconnected by wire-wrapping on this socket board, made by Augat, which acts as a central processing unit in the Raytheon 706 computer.

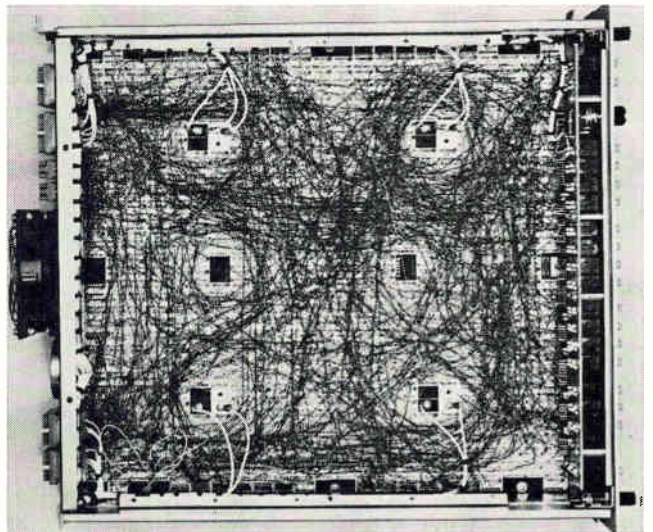

Between hare and tortoise

Not all engineers look at quick turnaround as a wire-wrapping versus custom multilayer-board question. Middle ground has been discovered by Allen Chertoff and James Foti at Loral Electronics Systems, Bronx, N.Y.

Chertoff, assistant chief engineer for microminiaturization, explains that a multilayer board can be partly standardized, with conductors on the inside layers kept unchanged and with the customized pattern reserved for the two outside layers. For example, power and ground connections could go from anywhere on the outer layers to fixed pads on the inner layers. In this way Chertoff claims he can produce a new assembly in less than two weeks after approval of logic diagrams.

Loral actually applies this approach to three levels of packaging—the IC chip and a multilayer ceramic substrate as well as the multilayer p-c board.

The chip is a Fairchild Micromatrix unit that lacks only the top level of metalization to give it a unique gating arrangement. Up to 16 chips fit onto the ceramic substrate, a five-layer unit with one layer reserved for customization. Up to 9 of these substrates fit onto the multilayer board, which has six layers, the two outer being variable.

Since each level can be customized independently of the other levels, processing can be done in parallel, usually in less than two weeks.

insulated wire is automatically routed on a p-c board and soldered to pads. Infobond is being used in Inforex's Intelligent Key Entry System, which replaces keypunch and verification equipment as well as key-tape equipment. According to Inforex, the method not only offers more flexibility than multilayers, it also provides greater interconnection density than wire-wrapping.

The costs of these interconnection methods are repetitive, since each connection is paid for, regardless of how many boards are being made. Automation is most economical, of course. Wire-wrapping costs, for example, run about 45 cents a wire (two terminations) in a completely manual mode, where the operator works from a wiring list; 10 to 12 cents a wire in the semi-automatic mode, where a computer positions a guide over the terminal to be wrapped by an operator with a hand gun; and only 5 to 6 cents in the automatic mode. Manual wrappings may produce 30 to 50 wires an hour, semi-automatic machines about 150 to 180 wires an hour, and automatic machines about 500 to 600 wires an hour.

But automation can be carried still further. Microsystems Technology Corp., of Burlington, Mass., has a system of semi-automatic wrapping stations tied into a time-shared PDP-8 computer in which each station operates independently of the others. A basic system, performing up to 400 terminations, sells for less than \$25,000, according to the company, and stations can be added for \$11,000 each. The memory stores up to 5,000 wire routings and can be expanded to store over 17,000. Raytheon, Waltham, Mass., also offers a time-shared computer wire-wrapping system that uses a Raytheon 704 computer which drives up to 16 stations.

One of the main reasons why engineers turn to wire-wrapping is fear of obsolescence. Semiconductor companies are turning out new dual in-line packages so fast that one wire-wrapping advocate says, "The circuitry that's being put on a multilayer board today will be put on a single chip tomorrow." Although he overstates the rate of change, there may be as much as a 20% improvement in IC complexity every six months, which means that, once a product design is frozen, it may be only six months before a com-

petitor comes out with another design that uses 20% fewer components for as many functions or the same number of components to perform 20% more.

This was one reason why Information Instruments, Ann Arbor, Mich., recently acquired an automatic Gardner-Denver Wire-Wrap machine to interconnect about 200 ICs on an 8- by 13-inch board. Information Instruments, which manufactures programmable process controllers, buys the boards with just an array of 14-, 16- and 24-pin DIP sockets and then programs the machine for the interconnections that determine the boards' functions.

Since the wiring can be changed at any time, from the breadboard stage to final production, by simply changing the software, wire wrapping gives the company a flexibility in design that, says manufacturing manager George Rolfe, it didn't get from multilayers. He adds that he has many multilayer boards in the back of the shop that will never be used, either because they have faults that aren't repairable or because design changes have made them obsolete.

Such design flexibility makes customization easy. At Recognition Equipment, Dallas, standards engineer Ed Marshall has been using sockets for the past year. In the optical character recognition equipment made by his company, Marshall says many modifications are necessary in each customer's system. The company's latest OCR unit, the Input 80, introduced in June, uses wrapped wires.

Another consequence of this flexibility is that the packaging engineer doesn't have to wait around for a final circuit design but can accept a preliminary design, allowing the logic designer to make small changes almost until the time the equipment is shipped out the door.

The circuit designer also benefits, since he can put a ground plane right on top of the board for the ICs to rest on, instead of burying it farther away from the ICs.

In addition, DIPs mechanically inserted in sockets make boards easier to repair. If a field engineer, for example, suspects a particular IC on a p-c board of being defective, it takes him a highly paid half-hour or 45 minutes to unsolder it. For though there

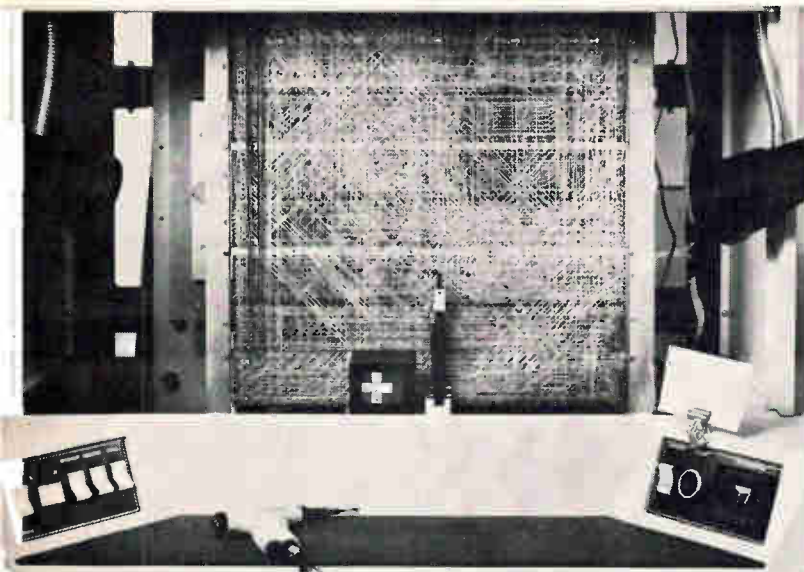

Business end. Microsystems Technology Corp. wire-wrapping machine, shown here in a back-panel wiring setup, allows operator to wrap up to 400 wires an hour. Panel moves vertically and guide moves horizontally under time-shared control of computer. Display unit, center, warns operator of a wire change and indicates with 1-2-4 coding the direction of the next move. Touching the gun tip to a contact on the guide closes a ground circuit, and causes the machine to move to the next terminal.

How to wet your feet

No big investment is necessary to give wire wrapping a try, for a number of companies offer wire-wrapping services.

In the West, for example, Data Technology of Mountain View, Calif., takes the customer's logic diagram and delivers wrapped boards, fully checked out, with the devices inserted in the sockets. A wrapped board containing, say, 20 14-pin dual in-line packages and four 16-pin packages is priced at about \$72.50 in quantities of 100, according to Ron Maddox, applications engineer at Data Technology.

Also Iotron International, Sunnyvale, Calif., a recently formed manufacturing consultant organization, has semiautomatic wire-wrapping machines from Microsystems Technology Corp., Burlington, Mass. (see photo, above) in its manufacturing laboratory so that customers may experiment with various production methods before settling on one.

In the East, Cambion in Cambridge, Mass., besides making sockets and socket arrays for dual in-line ICs, offers wire-wrapping services.

Also in Massachusetts, at Waltham, Raytheon offers wrapping services and, being in on the computer end of things (see page 56), has an arrangement with Augat, Inc., Attleboro, Mass., to offer computer programs for all Augat IC socket panels. Augat makes wire-wrapping sockets and complete panels for DIP's, and is developing a method for soldering DIP terminals directly to the ends of wrap posts mounted in a board.

are many tools for extracting ICs from boards during soldering, they all leave something to be desired, says Tom Malek, project engineer at Burroughs Corp.'s Defense, Space and Special Systems group in Paoli, Pa. "There's just too much heat for the p-c board when you're trying to unsolder a 24- or 40-pin package. The field engineer ends up clipping the IC leads and then unsoldering the stubs one at a time," he explains. Thus, for most kinds of point-to-point wired boards, field engineers need only carry spare ICs, rather than a complete set of components mounted on a p-c board—and in a typical system three quarters of the boards may be unique although there may be only eight distinct types of IC.

Malek became a "big fan" of wire wrapping because it permits fast turn-around time. His group at Burroughs 18 months ago was faced with a short lead time for producing some shipboard equipment. It would have taken too long to design and debug printed circuits boards but, by wire-wrapping boards with IC sockets, the group met the schedule and the military specifications as well.

Others, however, argue that turn-around time on printed circuits boards is bound to improve as computer-aided design methods become more refined. Many companies already use digitizers to convert a rough layout into digital information for use by a photoplotter to prepare the artwork for the board, shortening artwork preparation time from a few weeks to a few days. Others are automating the entire process. Algorex Inc., Hicksville, N.Y., for example, has programs that check logic, place components, route the conductors, design the multilayer board and produce numerical control tapes for wrapping machines that do back-panel wiring.

But a third alternative exists. Clark Coffee, general manager of Autologic, Inc., San Francisco, a company that specializes in computer-aided design of p-c boards, predicts that many users will go the wrapping route for a prototype and then use the same wire-routing data base for the p-c board in production.

A similar approach is envisaged at the Systems division of Electronic Arrays, Inc., Northridge, Calif., which uses wrapped wires in its model 9900 magnetic tape controller. Here the ICs are soldered into the board, their leads connected to wrap pins by etched conductor paths, and the pins linked with wrapped wiring. Both wiring and components are on the same side of the board, permitting the boards to be installed half an inch apart, whereas having wiring and components on opposite sides of the board, the more usual procedure, would compel 1¼-inch spacing. According to the company, it would be easy to install p-c boards on the same half-inch racks, and easy, too, to use the wire-routing data to design them, if volume justified it. But it could cost up to \$1,000 to produce the first p-c version of each board, or up to \$30,000 for a typical 30-board system—too large an investment when the board designs may soon need revision.

For high-speed logic, multilayer makers claim an edge over wrapped terminations. They point out that close control of transmission line impedance is

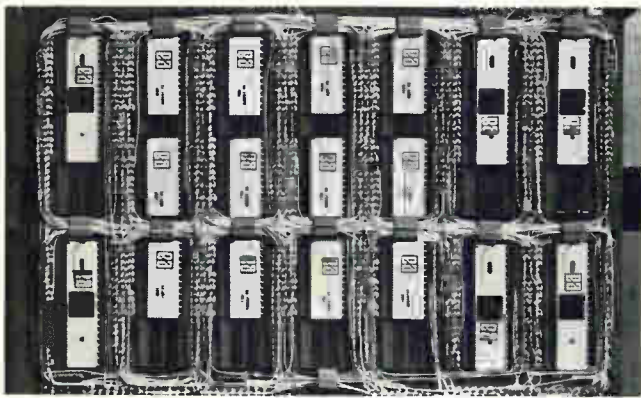

Close-up. DIPs used in a magnetic tape controller made by Electronic Arrays are linked by wrapped wiring on the same side of the board. Half-inch spaces make it economical to replace the wire-wrapped boards with p-c boards should production volume increase.

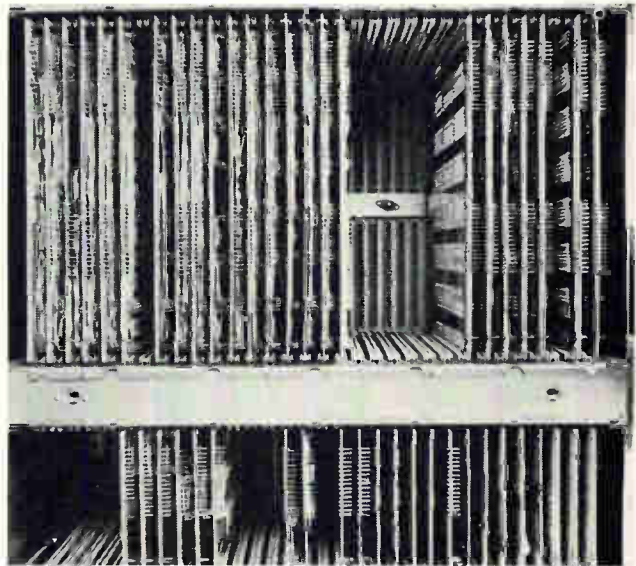

needed, and multilayer boards, with their constant dielectric thickness and flat conductors running over ground planes, provide the natural means for this.

But Tore Anderson, manager for rf connector products at Winchester Electronics Division of Litton Industries, Oakville, Conn., and long active in the microwave field, argues that the regularity with which the automatic machine lays down wire maintains reasonably constant capacitance along the line, and that the extension of the wrap post has negligible capacitance compared with the line capacitance. He says that tests performed at Winchester indicated that a fairly constant impedance level is obtained with the wire through the 5-nanosecond region.

Ron Maddox, applications engineer at Data Technology, Mountain View, Calif., which sells wire-wrapping services, also maintains the problems of high-speed systems are soluble with wrapped wire. He says proper logic partitioning is the key. For example, he says, his company has made some small production runs of systems using MECL 2 and SUHL 3 by "carefully bunching the critical logic."

The use of wrapped wire interconnects also lessens the crosstalk because there are not so many directly parallel lines as in a p-c board. And as Rolfe of Information Instruments points out, if a crosstalk does occur between two conductor paths in a system under test, it's an easy matter to change the wire-routing program.

Another doubt often raised about wire-wrapped termination concerns their reliability. The wraps can be dislodged even though the wrapping procedures produce a gas-tight seal between wire and terminal. Wires may also break since they are mechanically tied down only at their ends and the longer wires can "flap in the breeze."

But wire-wrapping manufacturers point to the use of wire-wrapped terminals in one of the Apollo computers as proof of their reliability, although in that application an encapsulant was poured over the terminals to give added mechanical strength. They also cite a January, 1969 Navy report TR 1242, (DCC

689117) from the Naval Avionics Facility in Indianapolis, which states that tests "demonstrated the solderless wrap to be a stable reliable connection capable of withstanding environmental extremes well in excess of those required for most present military applications."

Ironically enough, while wrapping is extending its influence down to the component interconnection level, multilayer boards are moving into the back-panel wiring area. One multilayer board manufacturer says that wire-wrapping on the back panel is actually helping his multilayer sales, since the elimination of soldered connections from wire harnesses on the back panel and the use of wire-wrapping produce regular contacts easily interconnected with multilayer boards. He cites one recent case in which 2,000 terminations had to be made, at a wire-wrapping cost of about 10 cents each. Up to 75% of these terminations, such as the power lines, grounds, and many of the signal paths, were fairly immune to engineering change, and for them it would be possible to supply a motherboard multilayer, to fit over the wire-wrapping terminals and to cost less than \$150. Then the remainder of the terminals—the connections susceptible to change—could be linked with wire wrapping.

Hewlett-Packard, Palo Alto, Calif., also combines p-c boards and discrete wiring for back panels, though engineers there use Termi-Point. Clyde Coombs, now manufacturing manager of Hewlett-Packard's Singapore plant, but previously corporate process engineering manager at H-P, says the H-P computer is using Termi-Point for wiring for the back plane and two-sided boards for interconnecting the dual in-line packages.

With a two-sided board, he says, he can handle 74 dual in-line circuits on a single 8- by 9-inch board. While in this case the tolerances are kept to about 10-mil line widths and 15-mil spacing, to avoid the use of more layers, Coombs predicts greater use of multilayer boards on the back plane in combination with Termi-Point, with the board carrying the ground plane and the power busing. □

Optical waveguides bring laser communication closer

Thin film guides of transparent glass point the way to optical circuits for signal processing

By James E. Goell, Robert D. Standley and Tingye Li, *Bell Laboratories Inc., Holmdel, N. J.*

□ The enormous bandwidth of laser light and its information-carrying potential are characteristics that excite the designer of communications systems. But between him and exploitation of those prospects loom many technical obstacles.

Among them are the difficulties involved in the critical placement of bulky lenses, prisms, and mirrors, and in ensuring mechanical stability. And still missing are reliable, compact components to perform the workaday circuit functions required in any communications system—modulation, filtering, coupling, delay, switching, multiplexing, and detection.

To overcome these problems of scale and reliability, researchers are turning to the concept of integrated optics. This is in many ways a direct extension of the technology developed for semiconductor integrated circuits, and should therefore, if the same batch-processing techniques are employed, bring the economics to optical systems as semiconductor ICs have brought to digital systems.

Completely encapsulated in glass, optical integrated circuits would be rugged and compact. They would occupy an area several orders of magnitude smaller than do free-standing optical circuits. Moreover, with prisms or gratings as mode transducers, coupling into thin-film guidelines can achieve efficiencies approaching 100%.

The fundamental elements out of which optical ICs will have to be built are planar thin-film optical waveguides. Formed by embedding transparent dielectric film in a substrate, they have already been produced in the laboratory. The next step is to optimize the material and route the waveguides to create the various circuit components. These will resemble, in principle and sometimes appearance, their larger microwave counterparts. Much of this work, however, has yet to reach the experimental stage. At every stage, too, new materials and techniques of fabrication are and will be required.

For example, many optical systems, such as those incorporating directional couplers and frequency selecting filters, require low-loss single-mode propagation. But since single modes are obtainable only with a waveguide that has cross-sectional areas of below a few square microns and that exhibits a loss of below 1 decibel per centimeter, the metallic guid-

ing structures used in semiconductor ICs for microwave frequencies won't do. For, though the right size, they are an extremely lossy medium for optical waves, on the order of a few hundred db/cm.

This is why designers of optical circuits are turning to dielectric waveguides. Nonplanar dielectric waveguides, in the form of bundles of glass fibers, have been used for many years for image transmission and incoherent light sensing. A planar version for optical ICs could take the form of one dielectric material deposited or thermally evaporated on a substrate of another dielectric. Or it could be fabricated as a buried layer within a substrate by one of the new ion-exchange or ion-implant methods.

The sketch below, which indicates a thin film of transparent material embedded in a polished transparent substrate, illustrates the principle behind all such dielectric waveguides. To trap a light wave

Microcircuit. Instead of the metal waveguides of lower frequency integrated circuits, optical integrated circuitry uses guides of thin, transparent glass film, deposited on a polished glass substrate. For guiding, the film's index of refraction has to be greater than the substrate's index. Since the individual guides are only a few microns wide by a fraction of a micron thick, an entire circuit could cover an area no larger than a few square centimeters.

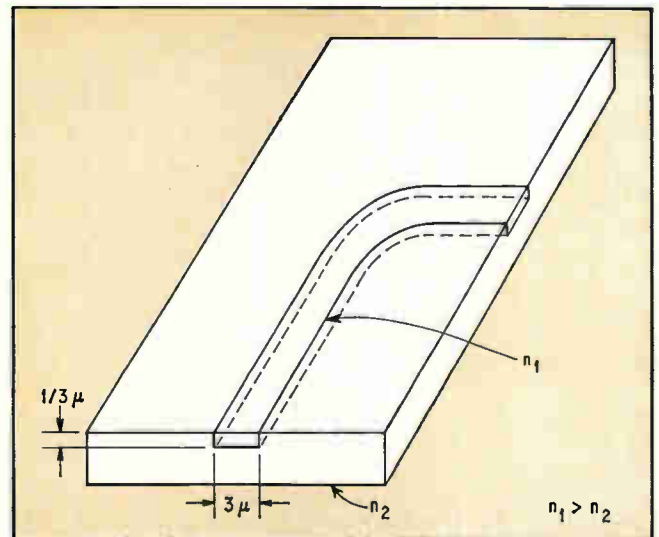

within its boundaries, a film's index of refraction must be greater than that of the substrate, since this difference establishes conditions of total internal reflection at the boundary of the film. The required circuit pattern is etched in the film by techniques similar to the photolithographic process of semiconductor technology but yielding higher resolution, since the individual guides have to be only a few microns wide by a fraction of a micron thick. (Most of the devices, in fact, are less than a few millimeters long and an entire circuit—say a single-channel repeater for voice, data, and video communication—could occupy only a few square centimeters.) After etching, the entire circuit is encapsulated by an overlay of a film of substrate material, protecting the resulting miniature circuit from the environment.

In practice, fabricating optical circuits out of thin films imposes stringent control requirements to assure

low-loss, single-mode transmission and to retain mechanical and temporal stability. Losses in thin film are caused by optical absorption in the film material and also by scattering due both to imperfections within film and to surface roughness. Many commonly used laboratory glasses, like Corning 7059 in bulk form, have losses of only a few db per meter. This would be low enough, given perfect fabrication methods, to yield films with attenuation factors of a fraction of a db per centimeter, a tolerable figure for most optical integrated circuits.

However, film fabrication methods can and often do give rise to compositional variations between the bulk starting material and the film, which cause losses over and above that attributable to bulk loss effects. Crystallization of the material during film processing can create optical scattering centers in the film which are not present in the bulk material and which cause

Good guide. Coupled by prism to a rectangular waveguide, light has been launched successfully in both straight and curved sections. The curved sections were constructed by a back-sputtering technique, using quartz fibers as shadow masks. Also shown is a microphotograph of a typical section of a curved guide. The waveguides have a thickness of 0.3 microns, a width of 20 microns, and a radius of curvature of about 1.2 cm.

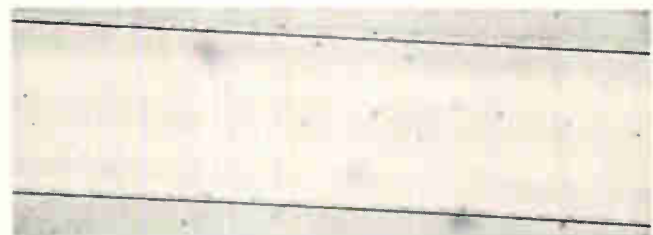
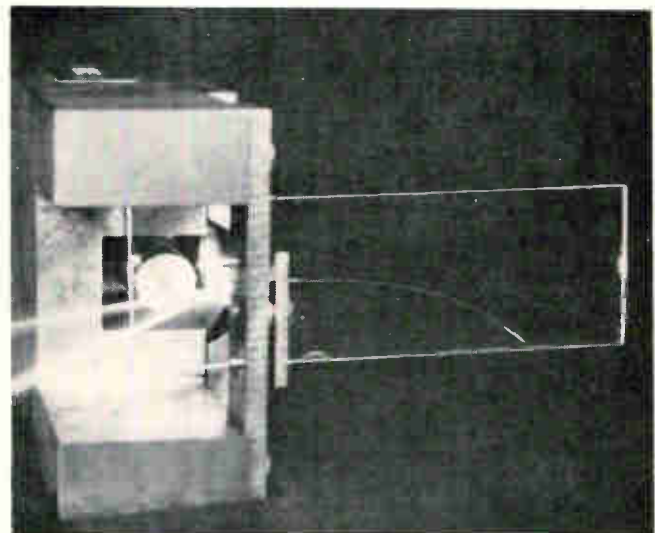
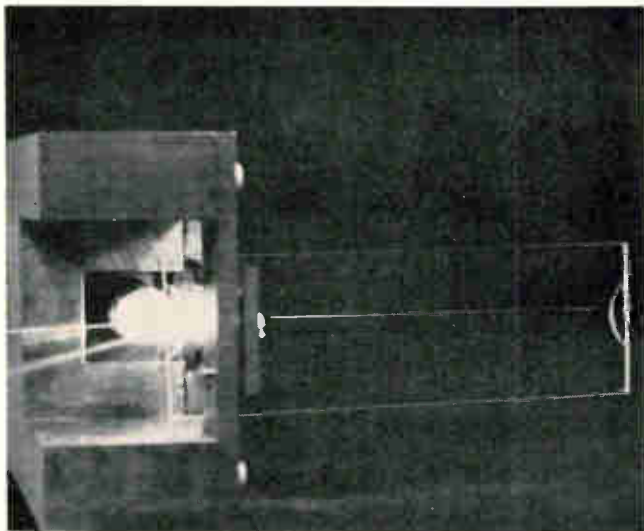

additional losses. Irregularities in the guide walls also cause optical energy to radiate out of the guide.

Calculations made by Dietrich Marcuse of Bell Laboratories indicate how closely a tolerance has to be held on guide wall finish. In a single-mode guide, having a 1% difference in refractive index between it and the substrate, wall roughness less than a few hundredths of a wavelength, i.e. a few hundred angstroms, would be necessary to keep guide losses below approximately 0.5 db/cm.

To achieve such smoothness on film only 0.5 microns thick, special production techniques are being investigated. At Bell Labs particular interest is focused on ion irradiation, ion exchange and r-f sputtering. Thermal evaporation, pyrolytic deposition and epitaxy also are being studied.

By irradiating fused silica with high-energy ions, regions of higher refractive index can be created within it. The formation of this higher density material is attributable to several interrelated events: ion entrapment, structural displacement of the host medium, and chemical combination.

The process involves embedding successive layers in the substrate until a film of the desired thickness is formed. A stream of ions with a given energy will come to rest at a well defined distance below the surface of the silica, forming a thin Gaussian-distributed layer with the desired index at that level. Since the distance of penetration depends on the energy, by continuously changing the energy of irradiation after a layer is formed, and thereby changing the distance of penetration, it has proven possible to build up a buried guide. A proton-irradiated layer of 1% higher index buried in fused quartz transmitted light successfully by Schineller and his co-workers at Wheeler Laboratories. Irradiation with ions other than protons has been tried, but to date the properties of films produced with this method have not been determined.

Eventually, by programing the ion stream in a manner similar to the deflection techniques used with electron-beam technology, it should also be possible to create a buried circuit with the necessary configuration.

The process of ion exchange also can produce a surface layer of higher refractive index than the substrate. By immersing a glass substrate in a solution of molten salt, it is possible to exchange one type of ion in the glass surface with another ion in the salt and so produce a high-index layer. Although like the buried layer of ion irradiation, the surface layer produced by ion exchange has a more gradually graded index of refraction, that is, it varies more gradually throughout the cross-section of the film.

Some success with ion exchange in producing glass fibers with graded index has been achieved by a team in Japan headed by T. Uchida, and work is in progress to produce graded-index films suitable for light guidance on planar substrates.

Whereas ion implantation and ion exchange both alter the substrate surface layer to achieve the desired refractive index change, the sputtered glass process produces a film of higher refractive index

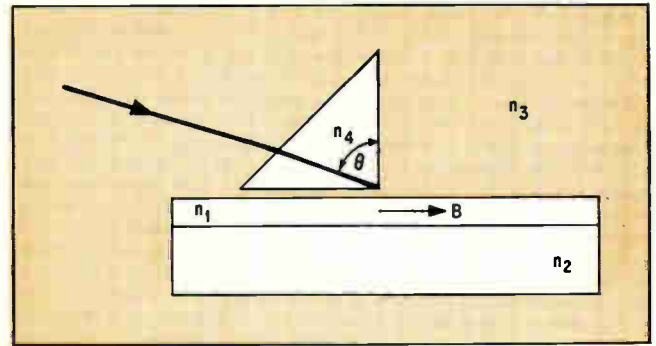

Prism coupling: Coupling to the guide will occur when the refractive index of the prism is greater than the index of the guide. By adjusting the angle of the incident beam it's possible to couple more than 50% of the incident power to the film; in theory, almost 100% is possible. The free space propagation constant k is related to the film propagation constant β by the equation: $\beta = n_4 k \sin \theta$, where $k = 2\pi/\lambda$.

directly on the substrate. At present it appears to be the most promising method of the three, producing light guides with losses well below the crucial 1-db/cm level. The best films prepared to date by r-f sputtering had polished laboratory glass slides (refractive index: 1.515) as their substrate and used Corning 7059 glass (refractive index: 1.53) as their source material. The sputtering is done in the normal way, by bombarding the source material in a vacuum with ions. The material thus removed from the source is deposited on the substrate. This process allows both the desired film thickness and the required surface quality to be routinely achieved.

Another material that shows promise as source material in the sputtering process is alumina-doped silicon dioxide, from which films have been produced with optical qualities approaching that of the 7059 films. A SiO_2 target covered with strips of alumina is sputtered to obtain the mixture of film materials.

What makes this material system attractive is that, by adjusting the doping levels, it's possible continuously to vary the refractive index of the film from 1.458 to about 1.6 and so tailor the refractive index of the film to any specification. Thus film layers of different refractive indexes can be laid down with the same sputtering process.

However, early tests indicate that the higher index films have higher scattering loss and lower sputtering rate than the lower index films, so it is the lower end of the index range which will probably be of most interest. Other dopants are also being evaluated for a wide range of indexes and lower losses.

With good thin-film waveguides available, it's essential to be able to couple optical energy efficiently into the film. One method being developed is a prism-coupler system similar to that used in internal reflection spectroscopy.

A schematic of the prism coupler is shown above. Here the refractive index of the prism is greater

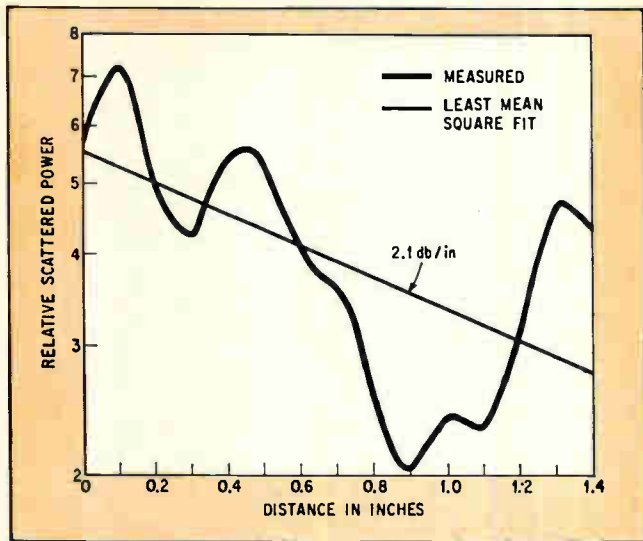

Scatter power. Measurements of relative scattered power of a 7059 glass film taken with a fiber-optic probe show that the average loss is approximately 2.1 db/inch (less than 1 db/cm). The loss was determined from the average slope by the method of least squares. The high peaks in the curve, caused by relatively large scattering centers formed at the film-substrate interface, can be eliminated by using a higher quality substrate material.

than the index of the film. A narrow gap of lower index than the film separates prism and film. By adjusting the angle of the incident beam, it is possible to couple light into the guide via the evanescent field in the gap. Efficient excitation of the guided mode in the film occurs when the phase velocity of the evanescent field matches that of the mode.

With a prism of this type, more than 50% of the incident power has already been coupled to films—and theory promises close to 100%. Both straight and curved thin-film waveguides have been coupled to in this way.

To evaluate the quality of a film, an optical fiber probe has been developed to measure transmission loss. The probe, with a photocell attached to its end, moves along the length of the film and takes samples of the intensity of light scattered at right angles to the film. If the scattering centers are uniformly distributed along the film, then a plot of the scattered power versus length of the film gives the film loss. Measurements taken in this manner show that, for a 0.6328-micron laser beam launched in a straight 7059 glass film, the average scattered power loss is less than 1 db/cm, well within circuit requirements.

A plot of the data is shown above, where the average slope is fitted by the method of least squares. The high peaks in the measured curve are caused by large scattering centers occurring where film and substrate meet; however, use of a higher quality substrate would eliminate this source of scattered light almost entirely.

Waveguides with bends are essential for practical integrated circuits, despite the fact that such bends produce both radiation losses and unwanted modes.

Calculations of the index difference required for a 1% loss in a curved guide, whose length and radius of curvature are equal, are shown in the table. The table indicates that, in order to keep the radiation loss of a bend to a tolerable level, the index difference Δ between film and substrate must increase as the bending radius R decreases. However, this leads to higher radiation losses, which are due to guide imperfections. Thus there is a tradeoff between index differences, bending radius and optical loss. An index difference range of between a few tenths of one percent and a few percent appears most practical.

Experimental models of curved sections of rectangular waveguides have been constructed by back-sputtering a 3,000-Å film made of 7059 glass using quartz-fiber shadow mask. A quartz fiber with the desired radius of curvature is placed on a film and the entire assembly put in an evacuated sputtering chamber. The film not masked by the fiber is then removed by the stream of ions, leaving a curved guide.

By this method waveguides have been made that are 0.3 micron thick, 20 microns wide, and with radii of curvature of about 1.2 cm. These dimensions are compatible with the construction of such devices as couplers and resonators. Unfortunately, techniques to measure optical transmission losses in such small structures have not yet been developed.

When it comes to fabricating an entire dielectric waveguide circuit however, things get rather more hypothetical. Several methods have been suggested. A scanning ion beam could be programed to write a circuit which would be buried under the surface of a fused silica substrate or other material. Similarly, a beam of ultraviolet radiation could write a circuit of higher index in a substrate of organic material such as polymethylmethacrylate (Lucite). In principle the latter scheme has already been demonstrated by Tomlinson and his co-workers at Bell in an experiment in which the density (specific gravity) of the Lucite was increased under the influence of ultraviolet light, yielding buried layers of higher index.

Every fabrication method adopted from semiconductor technology would, however, need to be modified to produce waveguides with smooth enough walls to ensure the low loss required. For example, if the irradiating beams were writing a circuit, it would have to be more tightly controlled and better stabilized than for fabrication of conventional circuits to yield the required edge definition of less than $\lambda/30$. Other

CALCULATED WAVEGUIDE DIMENSIONS		
Δ	$\frac{\alpha}{\lambda}$	$\frac{R}{\lambda}$
0.1	0.745	30
0.01	2.36	1,060
0.001	7.45	37,000

Guidelines to line guides

For many years, rigorous theoretical solutions have existed to the problems of dielectric waveguides—provided they are an infinite slab or else circular or elliptical in cross section. But the complex boundary problems of rectangular dielectric rods have eluded theoreticians. However, approximate solutions have now yielded some insights into their general properties, and computer-aided numerical analysis is assisting in the design of practical components for optical integrated circuits.

To understand how rectangular dielectric rods guide light in optical integrated circuits, it's best to consider the simpler slab waveguides first.

In the figure on the right is shown a schematic of a lossless dielectric slab of thickness b and index of refraction n_1 , bounded by semi-infinite regions of indexes n_2 and n_3 , with $n_1 > n_2 \geq n_3$. The slab is assumed to be of infinite length in the x and z directions.

The solutions to Maxwell's equations for this geometry represent the field functions of two discrete sets of propagating modes, the transverse electric (TE) and the transverse magnetic (TM), plus a continuum of radiating modes. The transverse variations of the electric and magnetic fields of the propagating modes are described by sine and cosine functions within the slab, and by decaying exponential functions external to the slab. Some of the low-order modes also are illustrated.

The propagation constants for the various modes are determined from equations which are not subject to closed-form solution, so that graphical or numerical solutions must be used. When n_2 is greater than n_3 , there exists a minimum thickness below which no propagating modes can exist in the n_1 medium. However, when $n_2 = n_3$, the lowest order TE and TM modes propagate at all frequencies; these modes are known as the principal modes of the guide and are the desired modes of propagation.

A plot of k (the free-space propagation constant) versus β (guide propagation constant) for either TE or TM modes and for the case $n_2 = n_3$ is shown on page 65. Also shown are the boundary lines $\beta = n_1 k$ and $\beta = n_2 k$. All propagating waveguide solutions lie in the region between two boundary lines.

The continuum of radiating modes exists in the region to the left of the upper boundary. The slope of the upper boundary is the velocity of light in the outer medium and the slope of the lower boundary is the velocity of light in the slab. For propagation near the lower boundary, the fields are confined mainly to the slab, but, as the upper boundary is approached, the fields extend to infinity.

The k -versus- β plots for $n_2 \neq n_3$ are similar, except that principal modes do not exist.

For the case $n_2 = n_3$, the cutoff wavelength λ_c for the various modes is given by the relationship

$$\lambda_c = (2b/q)(n_1^2 - n_2^2)^{1/2}$$

where q is the mode order. This equation can be used to calculate the largest slab thickness for which only principal modes can propagate. For example, for a glass substrate ($n_2 = 1.5$) with a film of 1% higher

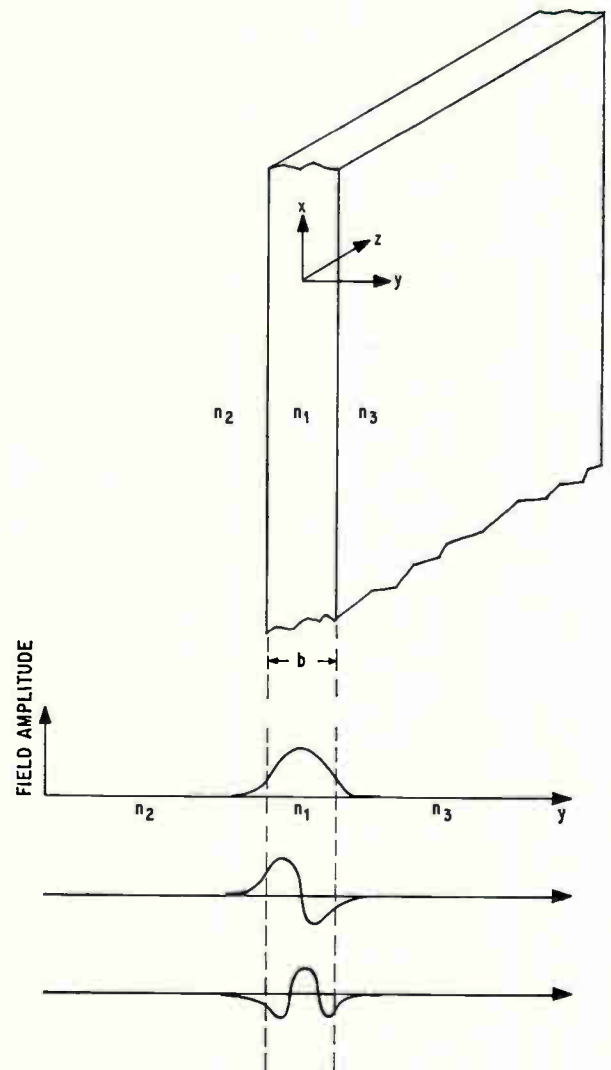

Slab waveguide theory. Solutions to Maxwell's equations for an infinite slab in the x and z directions represent the field functions of two discrete sets of propagating modes, the transverse electric (TE) and the transverse magnetic (TM), plus a continuum of radiating modes. Transverse variations of fields within the slab are sine and cosine functions; externally they are decaying exponential functions.

index, the largest slab thickness for principal mode propagation is about two and a half wavelengths; this limits the guide thickness to less than a few microns for most applications.

Because of the difficulty of matching fields at the rectangular boundary, analysis of the rectangular dielectric waveguide is considerably more complex than that of the slab waveguide. E.A.J. Marcatili at Bell's Crawford Hill's Lab has obtained approximate analytical solutions to cases of close confinement, that is, for cases where the energy is traveling principally in

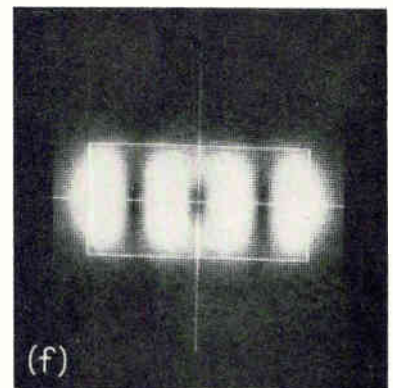
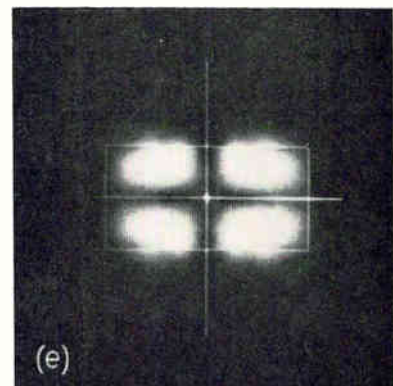
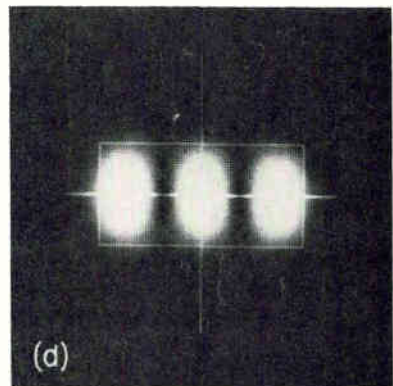
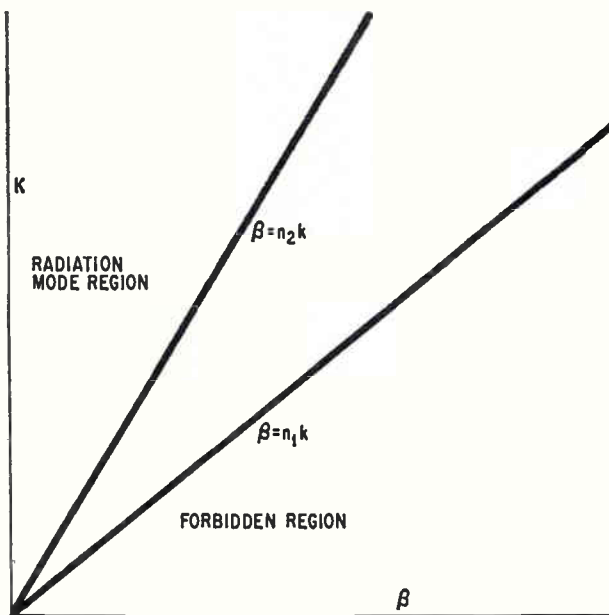
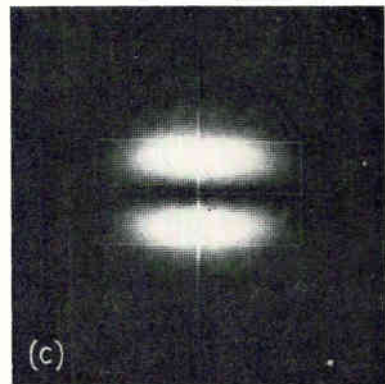
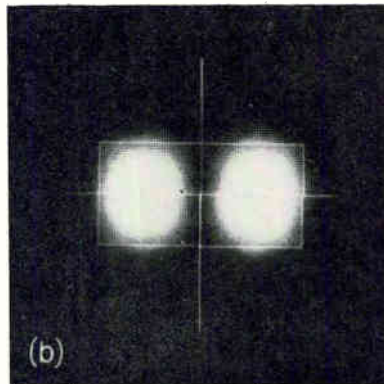
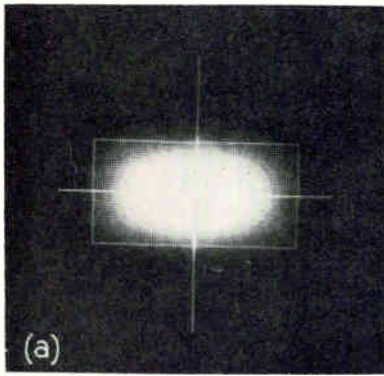

Well bounded. When one material surrounds all sides of a buried waveguide ($n_2 = n_3$), the lowest order TE and TM modes, propagating at all frequencies, are known as the principal modes of the guide. As shown in the plot of k ($2\pi/\text{free space wavelength}$) versus β (propagation constant), all propagating wave solutions for the case lie between two boundaries: the radiation mode region and the forbidden region.

the core of higher index. One of the authors (Goell) has also performed a numerical analysis which verifies these approximate results.

Qualitatively, the behavior of rectangular waveguide modes is very similar to that of slab waveguide modes. The series of photographs shows computer-generated mode patterns of the first six dielectric waveguide modes for rectangular guides. These patterns are made up of dots whose area is proportional to the computed local power density of the mode. The outlined rectangle represents the boundary of the higher-index core.

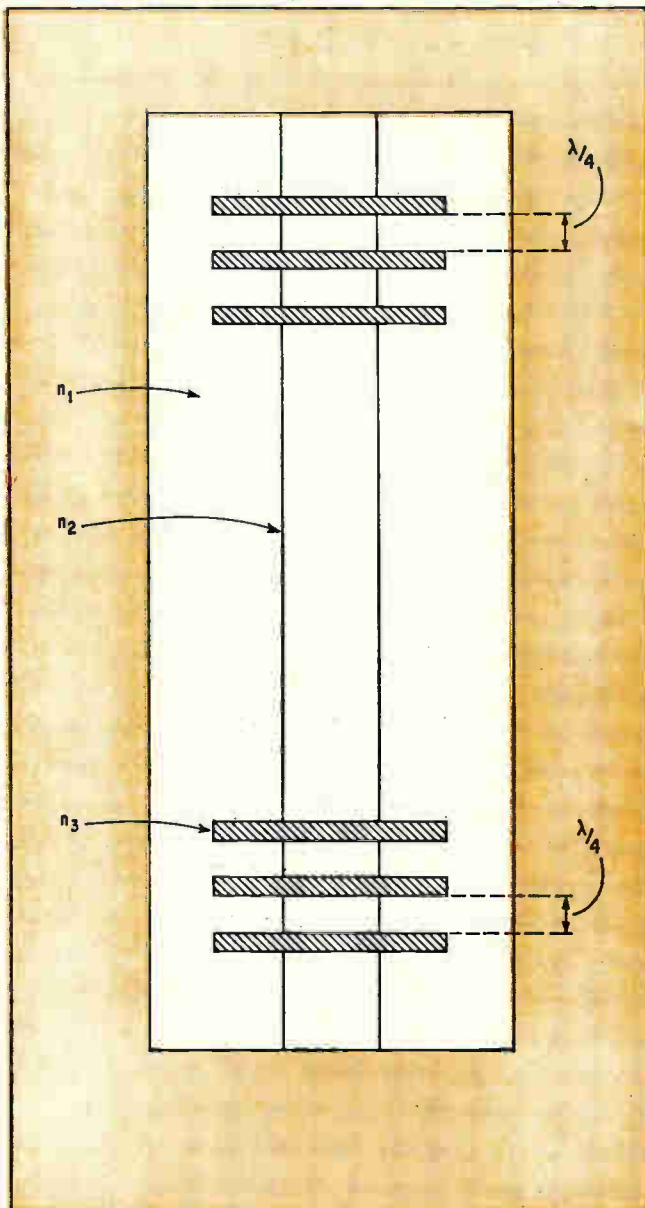

methods have difficulties, too. For example, chemical etching of glass film usually leaches its constituents and clouds the surface, so etching by this method may not be feasible.

Again, conventional photolithographic techniques, using optically exposed photoresist for masks, do not approach this order of edge resolution. A promising approach to the problem is first to expose photoresist with a scanning electron beam and then to reverse-sputter the unwanted film. Using electron-beam techniques, gold grids consisting of 700-Å lines separated by 1,400 Å have been produced by Alex Broers at IBM, showing that the required resolution is achievable.

However, there are problems: incompatibility between film and photoresist, and the requirement that the resist withstand the temperature rise occurring in back-sputtering. An additional problem is that conventional scanning electron beam microscopes are relatively slow at writing circuits of a practical size.

Resonator. Transmission line guide becomes a resonator when a series of partially reflecting lines are placed at an odd quarter-wave multiple apart to reinforce reflections at the desired peak frequency.

Integrated devices. As shown on p. 67 (top), complete range of optical devices, both passive and active, could be built for signal processing by using thin-film waveguides. Layout of directional coupler (left) resembles those designed for millimeter-wave and microwave frequency ranges. In operation, the exponentially decaying fields of the two parallel guides would overlap and provide continuous coupling. In simple phase modulator (middle), either the film or the substrate would be electro-optic material. In channel-dropping filter (right), loop resonator coupling the two straight sections is resonant at one frequency.

However, by a process involving mechanical movement of the substrate as well as the beam, it may be possible to generate masks at rates suitable for complex circuit fabrication.

Using one or more of these techniques, it is possible to hypothesize the planar construction of all the devices required in the signal processing circuits of optical communication systems, since these devices can be directly developed from curved and straight sections of dielectric thin film waveguides.

For example, a straight section of guide becomes a passive resonator when mirrors are placed at its ends, or when a series of partially reflecting lines, across and perpendicular to the guide, are placed an odd multiple of a quarter wavelength apart to reinforce reflections at the resonator's peak frequency. Such a configuration is shown on the left. The partial reflectors may be thought of as layered dielectric mirrors which are large enough in the transverse plane to intercept most of the guide-wave energy. They could be regions of higher refractive index placed in the substrate, or they could be grooves.

By adding a small concentration of neodymium ions and by providing a pump, this passive resonator would become an active resonant cavity, that is, a laser. This component could be used as a local oscillator for modulation and demodulation, or as an amplifier.

A simple directional coupler could be formed by placing a U-shaped waveguide section in the coupling field of a straight waveguide section. This type of coupler is very similar in appearance and principle to those in use at millimeter-wave and microwave frequencies. The configuration is shown on page 67, top right. The exponentially decaying fields of the two parallel sections of both guides overlap in the substrate, providing continuous coupling. It has been calculated that the coupling between the guides is strong enough to allow practical couplers to be only fractions of a mm to a few mm long.

A simple phase modulator could be constructed by using electro-optic material (potassium dihydrogen phosphate—KDP—for example) for either the waveguide or the substrate beneath the waveguide. As shown in

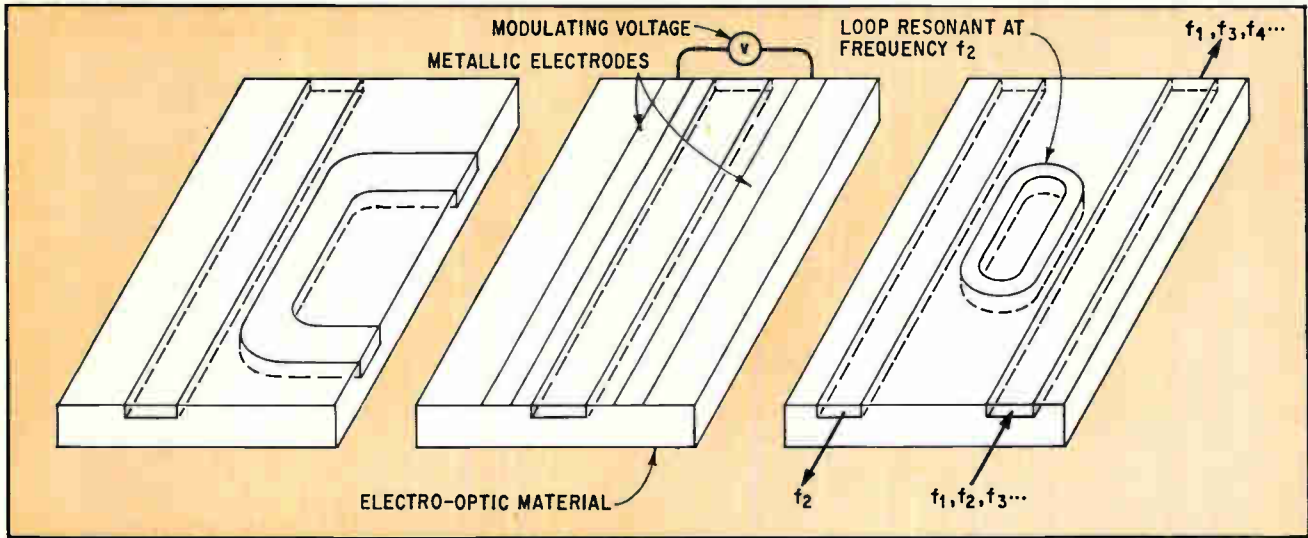

center figure above, parallel metal electrodes would supply the modulating voltage. These electrodes, applied by standard photolithography could have a very small interelectrode spacing since the guide would be only a few microns wide; thus a modest driving voltage would yield a large modulating field.

Using a loop resonator and two parallel guides, as shown above, right, a frequency-selective filter could be built, say for a channel-dropping or combining network. The loop's diameter determines its resonant frequency; it would be built to resonate at the center frequency of the channel to be dropped (removed from the band of frequencies making up the transmitted signal). Calculations show that the area of such a device need be only a few square mm.

It is possible to envision a number of communications systems using these and similar components. One such system—a pcm repeater for a frequency multiplex system—is shown schematically on the right. An incoming laser beam is demultiplexed by an input series of channel-dropping filters. Each of the optical signals is then converted to a baseband signal by an avalanche photodiode detector. The baseband output of the diode is then amplified, and the pulses reshaped, by the regenerator. These pulses are applied to the modulating circuit of a gallium arsenide diode laser. The output pulses produced at different frequencies by the diodes are then recombined by the channel combining filters and transmitted.

Similar systems using heterodyne detection can also be envisioned. They would require the addition of local oscillators and directional couplers. □

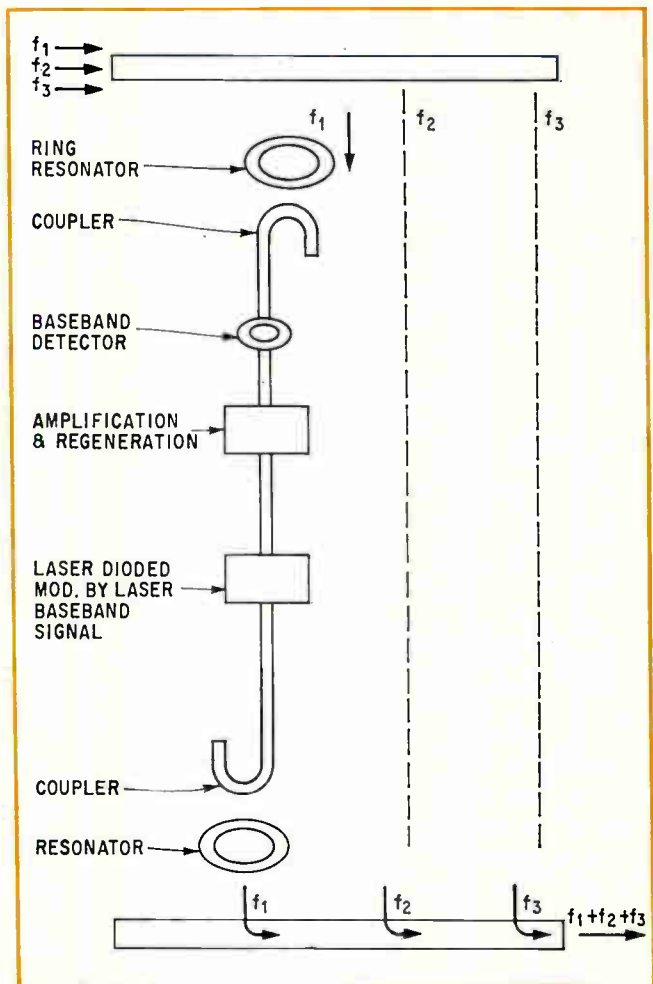

Optical repeater. With thin film technology, optical analogs to the conventional repeater can be envisioned. Ring resonator selects one channel from the incoming band, and couples it to a detector, where it is received and sent to a regenerator to be reshaped. These pulses then modulate a diode laser and are returned to the mainstream through a coupler and resonator. Identical channels for all frequencies in the band would be provided in future practical installation.

Bibliography

- R.E. Collin, "Field Theory of Guided Waves," McGraw-Hill, New York, 1960.
 S.E. Miller, "Integrated Optics: An Introduction," Bell Syst. Tech. Journ., Vol. 48, September 1969, p. 2059.
 E.A.J. Marcatili, "Dielectric Waveguide and Directional Coupler for Integrated Optics," Bell Syst. Tech. Journ., Vol. 48, p. 2071, September, 1969.
 J.E. Goell, "A Circular-Harmonic Computer Analysis of Rectangular Dielectric Waveguides," Bell Syst. Tech. Journ., Vol. 48, p. 2133, September 1969.
 J.E. Goell and R.D. Standley, "Integrated Optical Circuits," Proc. IEEE, Vol. 58, October 1970.

Single hex inverter picks data signals from noise

By Charles A. Herbst

Dumont, N.J.

Noise spikes can be eliminated from a digital tape-recording or signal-processing channel with just a single package of diode-transistor logic and a few timing components. The DTL hex inverter, which functions as a pulse width discriminator and pulse generator, decides if the incoming pulses are too narrow to be data bits. Those that qualify as data bits finally produce fixed-width pulses.

Capacitor C_1 is normally in a discharged condition at the output of inverter A. The negative-going edge of an input pulse causes C_1 to begin charging toward 5 volts. If the pulse is long enough for C_1 to charge up to about 1.5 volts, through R_1 , inverter B will switch and cause the output of inverter C to go positive. Positive feedback through R_2 insures a rapid change of state.

Now, the positive input to inverter D makes the monostable multivibrator—inverters E and F—generate an output pulse whose width is fixed by the time constant of the RC network. But if the original input pulse is too short, there is no output pulse. Capacitor C_1 is again discharged.

The component values allow the input stage to sense pulses longer than 1 ms and the output stage to generate pulses about 15 μ s wide.

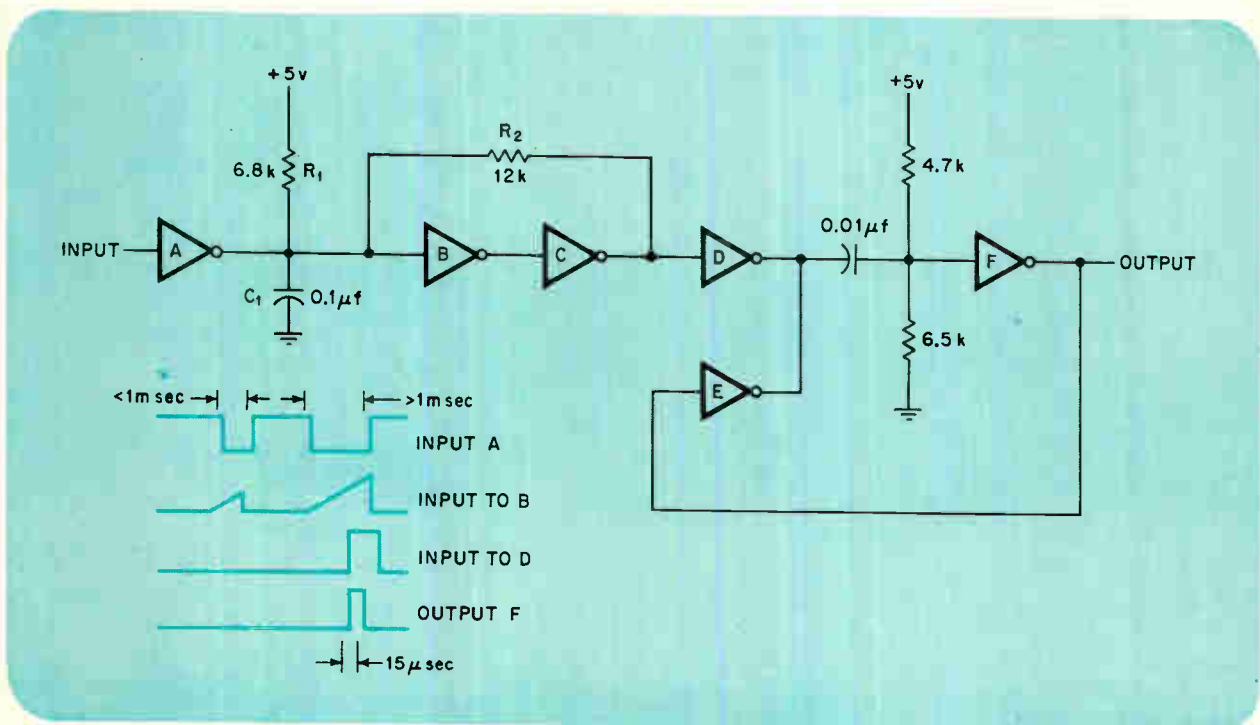

Discrimination. The monostable multivibrator can't be triggered unless the input inverter sees a pulse long enough to charge C_1 to 1.5 volts. This voltage level triggers inverters B, C, and D, making the one-shot generate a pulse. Short noise spikes never get past inverter A.

Field effect transistor converts triangles to sines

By William E. Peterson

ITL Research Corp., Northridge, California

Conversion of triangular waveshapes to sinusoids is usually accomplished by diode-resistor shaping networks, which reconstruct the sine wave segment by segment. A much simpler method exploits an unusual property of junction field effect transistors.¹

The principle is illustrated in the figure. A triangular-shaped voltage is applied across the drain and source of a junction FET with its gate

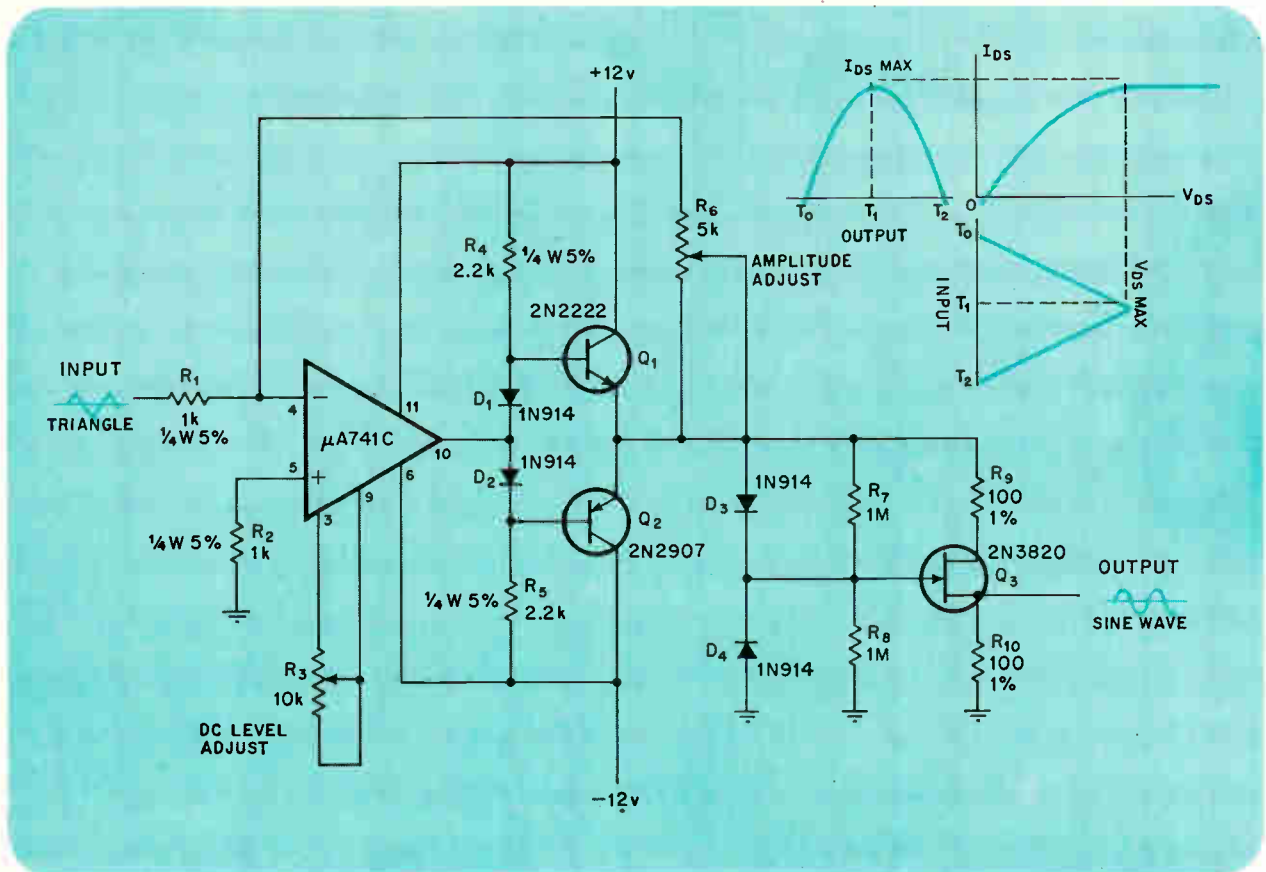

Easy conversion. Transfer characteristic of junction field effect transistor resembles a sinusoid, providing mechanism for triangle-to-sine conversion. In circuit, monolithic op amp provides gain for driving junction FET Q_3 . Two simple control adjustments yield sinusoid with less than 2% distortion.

lead grounded. The drain-source channel has a low impedance, and the triangular wave source must be capable of delivering adequate current.

The FET transfer curve in the region below V_{DS} closely approximates a quarter sinusoid. If the triangle amplitude is carefully adjusted so that its peak corresponds to V_{DSmax} , the current I_{DS} flowing through the channel takes the form of a segment of a sinusoid. This scheme produces the first half of the sine wave. The other half is generated by the reciprocal characteristics of the drain and source leads. That is, as long as gate polarity is preserved, the drain and source may be interchanged to produce a mirror image of the FET transfer curve across the I_{DS} axis. Thus, a negative triangular input varying about ground will yield a sinusoidal drain-source current of opposite polarity.

A practical implementation of the converter is shown in the schematic. An operational amplifier ($\mu A741C$) provides the necessary gain with the addition of low-impedance drive network Q_1 - Q_2 . Fairchild epoxy FET Q_3 furnishes the desired transfer characteristic. Potentiometer R_6 sets the triangle amplitude. Resistors R_9 and R_{10} provide de-

generative feedback to reduce harmonic distortion of the sinewave output. Diodes D_3 and D_4 provide the necessary switching of the gate lead during the crossover of the signal polarity.

Harmonic distortion of less than 2% is easily achieved with the two controls and a CRT. For proper operation, the input triangle waveform must have constant peak-to-peak amplitude, swinging about ground. To adjust the converter with a given triangle amplitude, control R_6 is varied while the output is viewed on a CRT until the peaks of the output waveform are just beginning to round off. Next, the d-c level control R_3 is varied to adjust the positive and negative portions of the sinusoid for symmetry, while the final triangle amplitude is achieved with R_6 .

Since the circuit operates as a nonreactive filter the input frequency is restricted only by the operational amplifier's rolloff frequency of 10 kHz. Higher frequency operation may be achieved with a different operational amplifier.

Reference

1. R.D. Middlebrook and I. Richer, "Nonreactive filter converts triangular waves to sines," *Electronics*, March 8, 1965, p. 96.

Look at the screen, not the knobs.

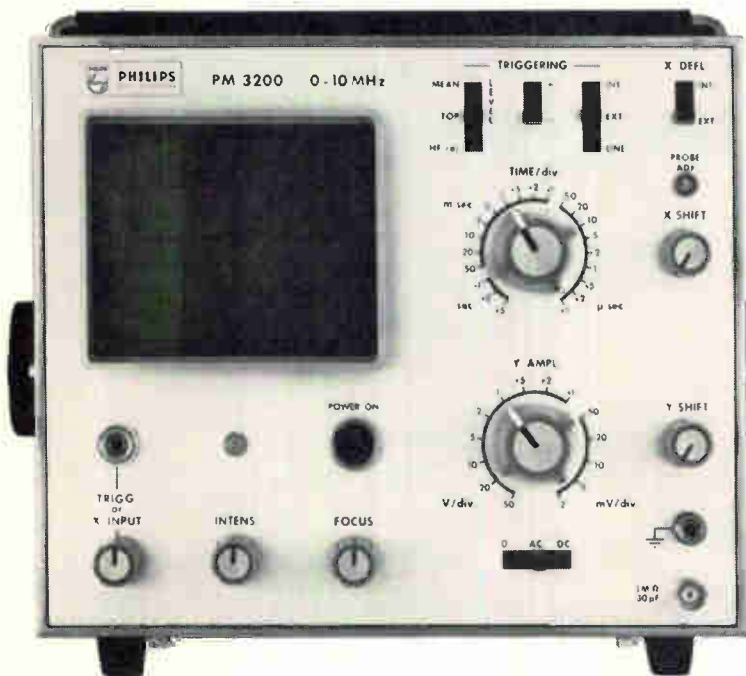

PM 3200
10MHz
2mV/div
\$495



More of the Unbeatable
Philips Scopes

PM 3231
15 MHz: 10mV
Dual Beam Delay Lines
\$1,050

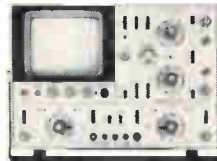

PM 3250
50 MHz: 2mV
Dual Trace
\$1995

Three fewer controls mean you spend more time measuring, less twiddling. Dc balance, trigger stability and manual level are out. So triggering is fully automatic.



Explanation. When waveforms start looking like this: all other automatic trigger circuits stop triggering. So you have to switch to manual and start knob twiddling. With the PM 3200 you switch from "mean" to "top" and stay with signal-derived, fully automatic triggering.

In either position automatic means automatic over the whole of the 10MHz range. And then on to at least twice this nominal bandwidth figure.

This unique Philips circuit has yet another feature. Whatever the signal, even no signal and whatever the sweep speed, the trace is always clearly visible.

There's no dc balance control because none is needed. Drift is feedback and virtually eliminated. (At max. sensitivity 1/4div/24hours).

The PM 3200 is highly portable (11.7 lbs.). Battery pack optional.

For information, contact:
Philips Electronic Instruments, 750
S. Fulton Ave., Mt. Vernon, N.Y. 10550

**PHILIPS
ELECTRONIC
INSTRUMENTS**
750 S. FULTON AVE., MT. VERNON, N.Y. 10550
A DIVISION OF PEPI, INC.

Complementary MOS and bipolar make it together on a single chip

Complementary circuit takes eight masking steps, but saves real estate; device drives heavy capacitances at high speeds with little power loss

By Fred J. Link, NASA Goddard Space Flight Center, Greenbelt, Md.

Robert Cook and Robert J. Lesniewski, Solid State Scientific Corp., Montgomeryville, Pa.

□ Although it's easier said than done, the fabrication of complementary metal oxide semiconductor transistors and complementary bipolar transistors on the same integrated circuit chip would seem to be the perfect marriage of convenience. The complementary p-channel and n-channel MOS transistors, which serve as the internal logic or memory cells, offer high packing density and extremely low leakage and power dissipation. Acting as the other partner, the complementary npn and pnp bipolar transistors, employed as emitter followers, supply the current that drives the external line capacitances and provides a large fan-out capability.

Flying in the face of convention, this complementary MOS, complementary bipolar approach—called C squared—has demonstrated that experimental ICs can directly interface with transistor-transistor logic circuits and operate at TTL speeds. The high speed—10 to 25 times faster than C/MOS alone could provide—stems from the bipolar transistors' ability to drive highly capacitive loads; whereas a quiescent power dissipation of less than 100 nanowatts is due to the C/MOS transistors.

Also, C-squared technology appears fully compatible with ion implantation and silicon gate technology. Incorporating these techniques into the C-squared approach would double the improvement in switching speed of the MOS or C/MOS circuits now afforded by the integrated complementary bipolar transistors.

These C-squared ICs were developed by the Solid State Scientific Corp. for the National Aeronautics and Space Administration's Goddard Space Flight Center to show the feasibility of the approach. The program clearly indicated that C-squared technology should be fully competitive with other IC processes in cost as well as performance.

Enroute to reality, C-squared technology had to overcome a certain amount of bias against such a match. One argument maintains that putting bipolar and MOS transistors on the same chip overly complicates the fabrication; it would be better to go either all-bipolar for speed or all-MOS for economy. However this position is specious for C-squared circuits. The combination of high speed and extremely low power is unique and highly desirable in large memories and battery-powered equipment. It's true that C-squared fabrication requires more major process

steps: there are eight photomasking steps instead of the six required for C/MOS, an increase of one third. But chip area is one third less for C squared than for C/MOS, and yet the output drive capability is the same. And since fabrication cost is proportional to the number of photomasking steps and inversely proportional to the chip area, there is no net increase in cost for C-squared circuits over C/MOS ICs with the same fan-out.

Once the dragons had been put to rest a major problem in the development program still remained up in the air: how to form both npn and pnp transistors in the same chip. Many companies resort to compromises such as the lateral and substrate pnp transistors, shown opposite. These structures are relatively easy to fabricate, but their current gain (beta) leaves much to be desired. Without high gain the basic purpose of the C-squared technique—to provide a substantial output current with little input current—would be subverted.

For the lateral pnp transistor, the emitter and base are diffused into the n-type substrate, which then serves as the base of the transistor. The base width—and hence beta—is, therefore, determined by the separation between the holes etched in the photoresist for the emitter and collector. The base width is extremely difficult to control in this structure; a difference in spacing between the emitter and collector so slight that it couldn't be discerned through a lab microscope can mean an order of magnitude difference in beta. Thus, the dimensional tolerance acceptable in conventional IC fabrication won't insure consistently high gain in lateral pnp transistors.

An additional problem with lateral pnp transistors is their low base-collector breakdown voltage. This occurs because the base-collector junction isn't located deep in the silicon as it is in other structures, and surface effects, therefore, reduce the breakdown voltage.

As it is with lateral pnp transistors, control of base width tolerance accounts for most of the difficulty in making the substrate pnp transistor. This structure requires a p-type substrate, on which an n epitaxial layer is deposited. A p region is diffused into the epitaxial layer to form the emitter. The p substrate then becomes the collector, and the n epitaxial material between it and collector becomes the base.

For the constant emitter diffusion depth that would prevail in the substrate pnp transistors on a single silicon wafer, the beta of the individual transistors would depend on the epitaxial layer thickness at that point. Even in the best epi material, the variation in thickness causes a wide variation in beta.

Because of these problems, neither the lateral nor the substrate pnp transistor were adequate for C-squared circuits. Fortunately, there's another pnp structure that proves compatible with npn's on the same chip: the vertical transistor, also shown at right. Although fabrication of a vertical transistor requires much more precise control of the collector dopant concentration, the results are worth the trouble: both beta and base-collector breakdown voltage are consistently high in the vertical pnp transistor. Moreover, the vertical structure requires no more process steps than the lateral or substrate versions. The vertical structure is formed by diffusing p^- , n , and p^+ regions into the n -type substrate to act as the collector, base, and emitter, respectively.

After the decision to use a vertical pnp transistor had been made, a series of experiments were run to determine the best diffusion schedule for the vertical device—the best combination of diffusion concentration, time, and temperature that would result in the required beta and still be compatible with the fabrication of the npn, p-channel, and n-channel transistors. With this experimental data in hand, fabrication of the complete C-squared integrated circuit became straight-forward. The table on page 76 shows typical parameters for the pnp and other transistors.

The overall sequence of steps requiring photo-masks, illustrated on the following page, is as follows:

- ▶ A p^- diffusion that becomes the body of the n-channel transistor, the collector of the pnp, and the base of the npn.

- ▶ A deep p^+ diffusion to surround the collector of the pnp transistor and thus reduce the collector resistance.

- ▶ An n diffusion for the base of the npn.

- ▶ A p^+ diffusion for the drain and source of the p-channel transistor and the emitter of the npn. This same diffusion can be used, if desired, to make devices with slightly different characteristics by using it to form the base of the npn and reduce the contact resistance of the n-channel transistor's p^- region.

- ▶ An n^+ diffusion for the source and drain of the n-channel transistor and for the emitter and collector of the npn.

- ▶ Formation of the thin gate oxide for the MOS transistors.

- ▶ Opening of holes in the thick oxide for emitter, base, collector, drain, and source contacts.

- ▶ Deposition of aluminum metal in the contact holes.

Using this basic procedure, the bidirectional C-squared read/write memory-driver circuit was built. The transition time of the C-squared circuit turned out to be far faster than that of an equivalent C/MOS circuit, as shown on page 76. With both circuits driving a 200 picofarad load at a V_{DD} of 10 volts, the C-squared circuit's rise time of about 110 nanoseconds was almost 40 times faster than the C/MOS

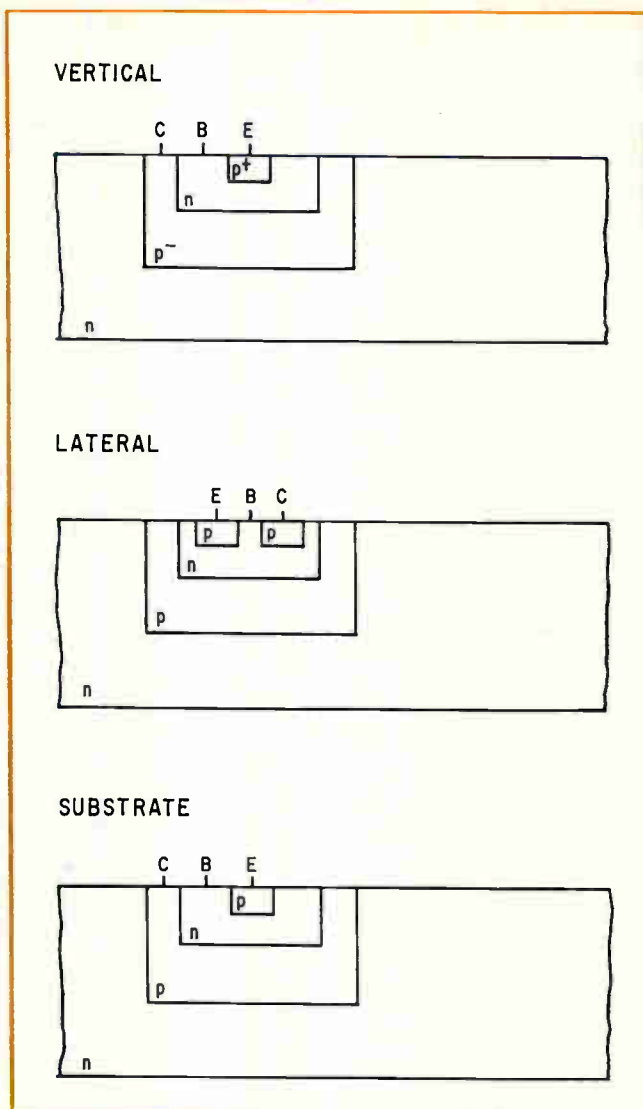

Three of a kind. Combining both pnp and npn transistors in a single integrated circuit can be accomplished using vertical, lateral, and substrate structures. The vertical type was selected for C-squared ICs because it provides the highest beta and emitter-base breakdown-voltage rating.

circuit; the fall time about 4 times as fast.

At a more usual load, 50 pf, C squared has a rise time of 49 nsec and a fall time of 90 nsec; for C/MOS, the values are 420 nsec and 900 nsec.

The edge in speed found in C-squared results from the capacitance-transformer properties of the complementary-bipolar emitter follower at the output of the chip. The capacitance seen by the internal MOS transistors is equal to the external load capacitance divided by the beta of the emitter follower. (This is why a high beta is essential in the bipolar transistors.) For example, if the emitter-follower beta is 100 and the load is 100 pf, the MOS circuitry will have an effective load of only 1 pf, plus whatever capacitance is associated with the bipolar transistors.

Essentially, the complementary bipolar output transistors allow the inherently high speed C/MOS circuitry to retain that speed when driving highly ca-

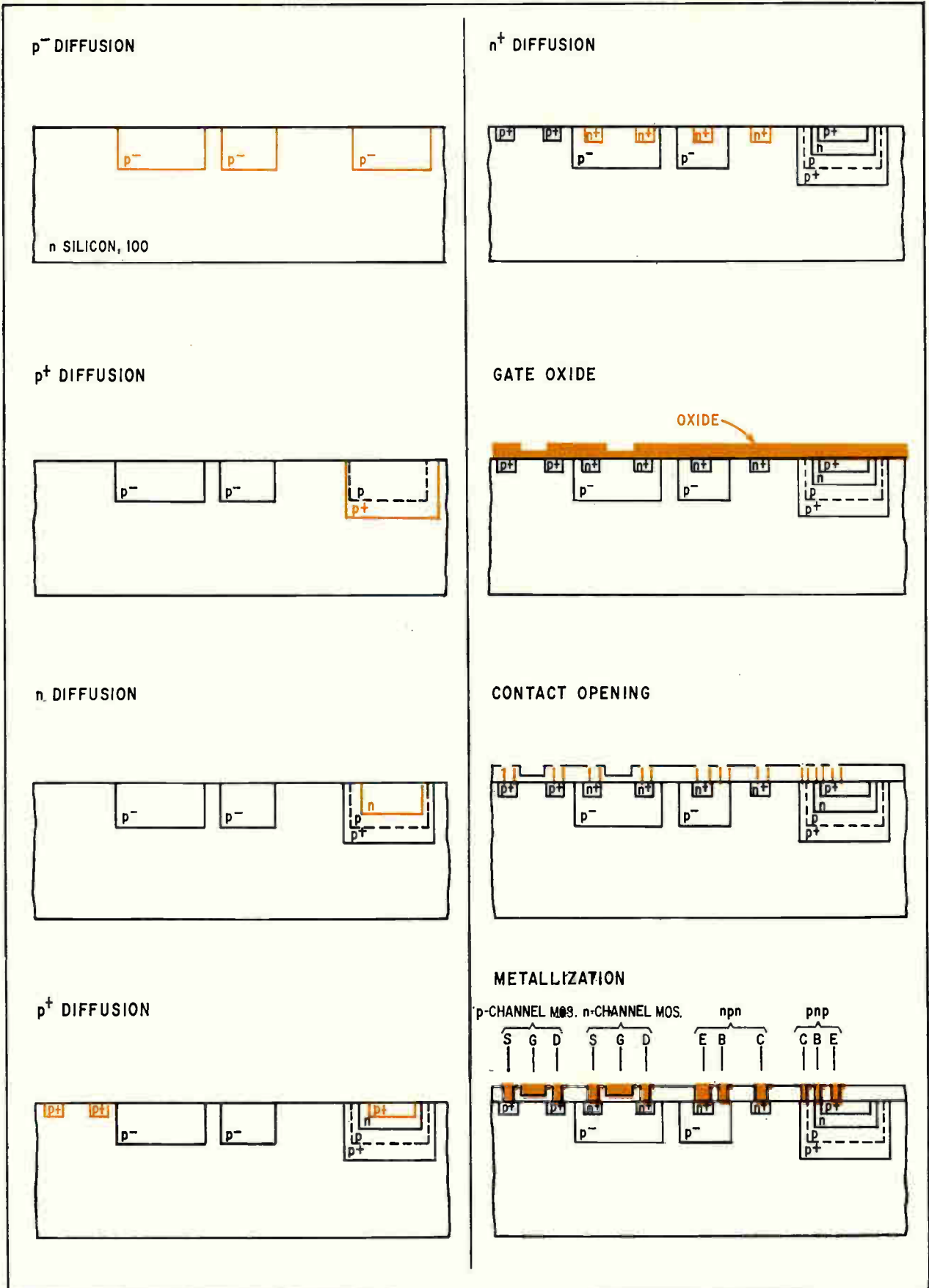

Fabrication. Eight photomasking steps are required to make C-squared ICs, two more than for C/MOS ICs. Whenever possible, the same photomasking and diffusion steps are used to form parts of more than one device; the n⁺ photomasking and diffusion are used to make parts of the n-channel MOS and npn bipolar transistors.

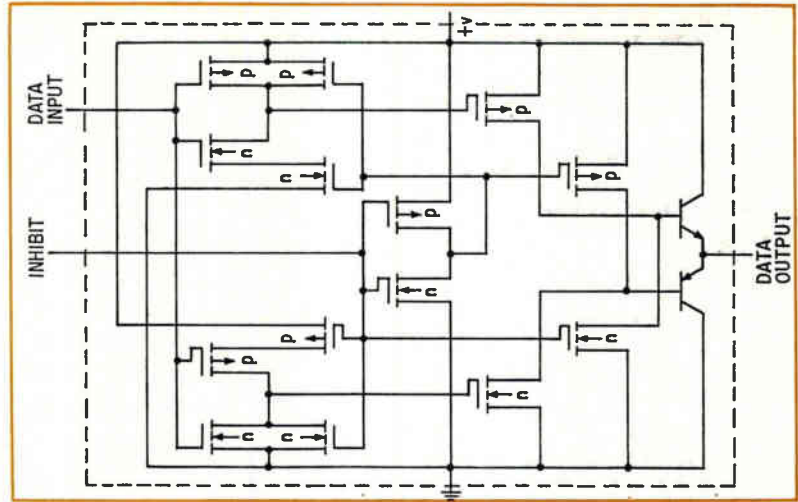
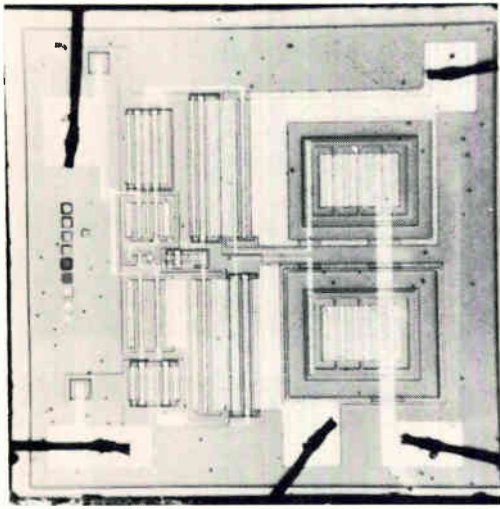

Intermix. Circuit built to demonstrate C-squared technology is a bidirectional driver that can read out and write into a memory. An npn and pnp transistor are at bottom of chip; p- and n-channel MOS transistors are at top.

capacitive external loads.

A little caution, however, is necessary. Under certain conditions, the emitter-follower capacitance transformer can work in reverse. If the bases of the bipolar transistors are floating, the capacitance could multiply instead of divide when the MOS transistors drive the emitter. This turnabout can be avoided by designing the bias circuitry so that the bases never float.

Although it may be troublesome, the problem of floating pales into insignificance when pitted against the chip area saved by using bipolar output devices. A good idea of the savings can be ascertained by examining a representative C/MOS IC consisting of a counter and shift register. The C/MOS output transistors, to supply the required output current, each have a channel length of 20 mils, and altogether, they occupy one-third of the total chip area. Moreover, a device with a 20-mil channel presents a sizable capacitance to the internal MOS transistors. These internal devices, therefore, must be made larger to provide the required drive current—which again uses up real estate. With the bipolar output, on the other hand, the output-transistor area can be reduced 25 times, so that it hardly contributes at all to the total chip area.

From the viewpoint of design, C-squared circuits fall into two basic categories: bidirectional, which uses a single terminal for input and output, and unidirectional, which employs separate input and output terminals. The data input-output buffer, shown above, represents the bidirectional type. Here it's necessary to drive a large capacitance—well over 100 pf—and high beta is, therefore, needed to minimize the capacitive loading of the previous stage.

The bidirectional driver is actually a strobed output driver. When the inhibit line is in the logic zero state, whatever logic level appears on the data input terminal will appear at the data output terminal, and the complementary bipolar transistors can therefore drive the load connected to the data output termi-

nal. But if the inhibit line is at logic one, the bases of the pnp and npn transistors are reverse biased by a p- and an n-channel transistor, respectively. Effectively, then, both bipolars are off. This permits data from other sources to use the same line shared by the data output terminal. However, this scheme is feasible only if the emitter-base breakdown voltages are greater than the logic levels.

Getting the required BV_{EBO} of 25 volts or more from the bipolars mandates some compromise with speed. For high voltage, particularly, the device design requirements are diametrically opposite to those for high speed. Thus, in the bidirectional C-squared IC, the bipolar transistors have a somewhat wider base region and lighter base-dopant concentration than speed considerations would require. Nevertheless, the speed is far greater than that of C/MOS alone.

The other basic type of C-squared circuit is the unidirectional type, which might be used to drive a clock line or an address line. Here, the input signal is never driven into the emitters of the bipolar output transistors, and emitter-base breakdown ratings of 6 or 7 volts are adequate. Since the high-breakdown voltage capability is no longer needed, the bipolar transistors can be designed with a shallow, concentrated base diffusion and their full speed and high-beta potential will be realized. Typically, the unidirectional circuit consists of C/MOS inverters and complementary bipolar output transistors.

For the future, computer designs of several C-squared circuits have been made. In these designs, complementary MOS pair propagation delays of 20 nsec were predicted even though the assumptions made were conservative.

One potential IC design that resulted in a memory-address decoder in which the bipolar complementary pairs are not located just at the outputs, but are interspersed with the internal MOS pairs. Most decoders have large internal fan-outs that can load down the internal MOS transistors capacitively, and hence slow them. Internal bipolar transistors can supply the fan-

Complementary performance

Bipolar devices

DEVICE	BV _{CSO} @ 10 μ A	BV _{ESD} @ 10 μ A	BV _{CES} @ 10 μ A	V _{CE} @ I _C =1 mA, I _B =0.1 mA	BETA @ I _C =10 mA
pnp	60V	30V	60V	0.5V	150
nnp	80V	50V	80V	0.15V	50

MOS devices

DEVICE	V _T @ 10 μ A	BV _{DSS} @ 10 μ A	I _{DSS} @ 10 V
p Channel	2.3V	50V	1 nA
n Channel	1.9V	30V	1 nA

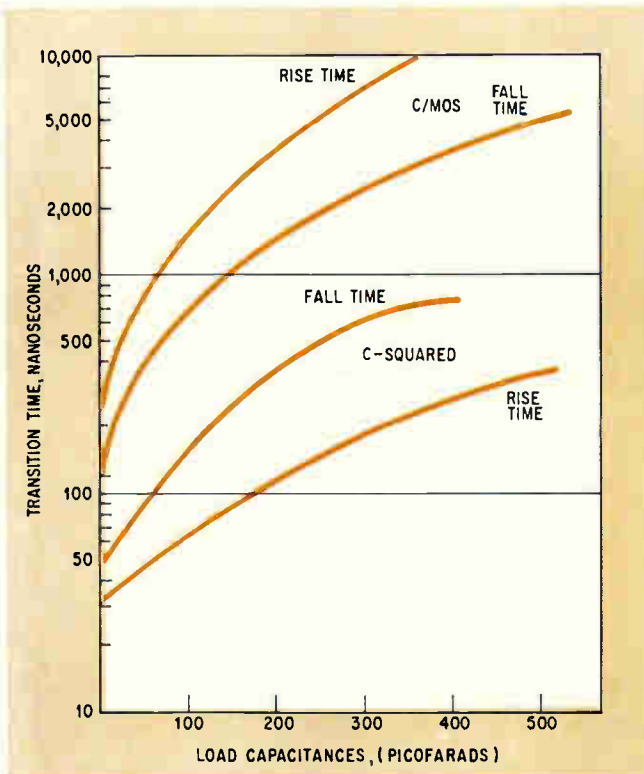

Faster. Comparing the transition times of a C-squared bidirectional driver with the equivalent C/MOS version points up C-squared's greater speed advantage. The C-squared circuit was optimized for bidirectionality and, therefore, does not represent the ultimate speed capability.

out capability that's needed and, thus, boost the speed.

Another design application for C-squared techniques is a dynamic shift register IC. Right now, the clock buffers on the chip set the speed limits for MOS or C/MOS dynamic registers. A really fast dynamic register needs huge buffers to drive the large capacitive load—20- or 30-mil-channel devices, which require considerable area. However, if bipolar clock buffers were used, there would be no increase in chip area. Furthermore, the entire circuit could run at the register's high internal speed—about 20 megahertz, which is twice as fast as a C/MOS circuit.

Contrary to what one might expect, the speed ad-

vantage of C-squared technology when driving highly capacitive loads is achieved without an increase in dynamic power dissipation—a situation quite different from that prevailing in other IC technologies. Once the load capacitance has been charged by the emitter follower, the dissipation of the IC drops to the nanowatt level that is characteristic of C/MOS circuits.

Another factor, aside from capacitive loads, that strongly influences the speed of C/MOS ICs is supply voltage. The slow switching speeds of C/MOS at low supply voltage has inhibited its usefulness as an interface with standard TTL. But C-squared ICs show little degradation in switching performance under low voltage, high load conditions. At higher supply voltages—above 10 volts—the output rise time of C-squared circuits changes only slightly, but the fall time does increase substantially, indicating that current saturation causes the effective series collector resistance to increase. However, a supply voltage of +5 volts is convenient for most applications and, here, the speed advantage of C-squared is 25 times that of C/MOS.

As part of the C-squared development program, three different MOS inverter geometries and two different bipolar geometries were investigated to determine how switching speed varies with geometry. For the MOS geometries the ratio of channel width to channel length is the criterion, and W/L ratios of 100, 50, and 25 were evaluated. As expected, the larger ratios with their greater drive capability exhibited faster switching. In switching to a logic one, for instance, the device with a W/L ratio of 100 required a switching time (propagation delay plus rise time) of 160 nsec; decreasing the ratio to 25 increased the switching time to about 350 nsec. In both cases, load capacitance was 120 pf and supply voltage V_{DD} was +10 volts. This type of data, and the beta of the output emitter follower, allows the IC designer to select the minimum MOS geometry.

The two bipolar-device geometries were evaluated using the same MOS inverter W/L ratio of 100. Total area of these geometries, including both the npn and pnp transistors, was 212 mil² and 408 mil². In either case, the switching time was about 100 nsec at 100 pf load. This suggests that even smaller bipolar geometries can be used in future designs without any loss in switching speed. □

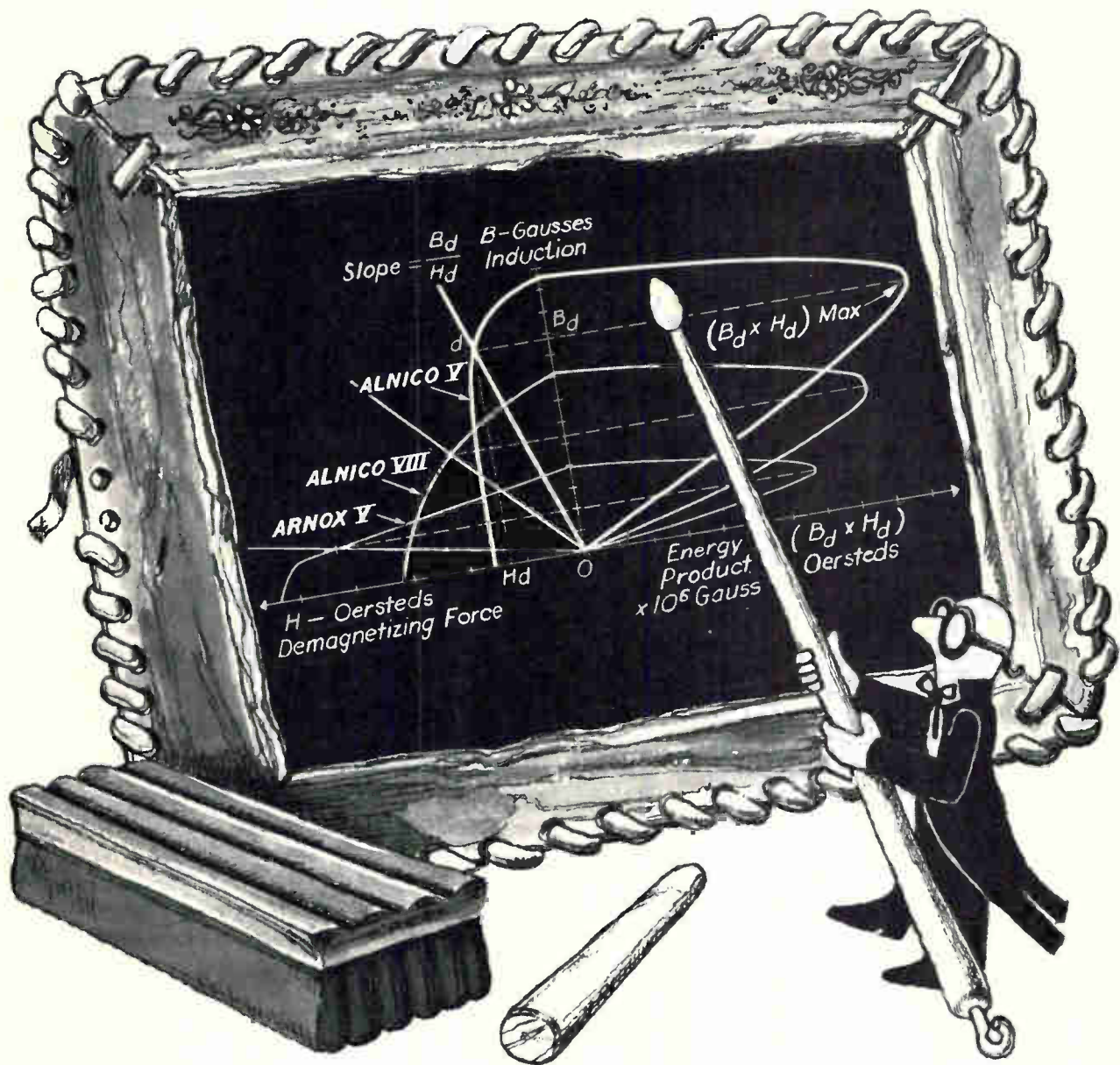

Energy product.

Choose: Maximum in cast or sintered Alnico. Or as much as you need in Arnox ceramic. Both from Arnold.

Seeking a top-quality source of supply and service for permanent magnets for anything from mikes to meters to motors to magnetos? Arnold's the answer. Examples: Our cast Alnico magnets with maximum energy product per unit volume. Our sintered Alnico—same maximum energy product in homogeneous, close-tolerance magnets available in intricate shapes.

And our Arnox[®] hard ferrite magnets, made from non-strategic materials, with a variety of energy products, in non-oriented or highly oriented configurations.

Trust the Arnold reputation for the newest and the best in permanent magnets. At measurable cost savings, too. Call or write for the convincing details.



The Arnold Engineering Co., Dept. E2, Marengo, Illinois 60152 • Member Company of Allegheny Ludlum Industries • Branch Offices and Representatives in Principal Cities

Linear IC model takes to analysis by computer

Mathematical representation of the monolithic op amp lets designer run worst-case and statistical analyses quickly to pin down the complex behavior of linear circuits

By Raymond Reid, Honeywell Inc., St. Petersburg, Fla.

□ Thanks to its versatility, the monolithic linear integrated circuit has found its way into a number of diverse linear applications. But as components go, the linear IC is a complex device, and analysis of its behavior under different conditions to predict performance proves fairly tedious without a computer.

A newly developed mathematical model of a linear IC now brings the convenience and speed of computer-aided design to closed-loop, open-loop, and feedback-stability analysis of various circuits using linear ICs. Although developed for the popular Fairchild $\mu A709$ linear IC, the model can be modified easily for applications to other types, like the National LM101 and the RCA CA-3015. The model should prove useful to all designers with access to ECAP, CODED-CAP or any of the other general-purpose linear circuit analysis programs.

To be useful, a linear IC model must describe for the computer such parameters as input resistance and capacitance, output resistance, d-c voltage gain, forward frequency roll-off characteristics, internal frequency characteristics, and circuit parasitic parameters. With such a model available not only can the designer predict the effects of changes in external circuit parameters but he can also perform a worst-case analysis by varying the value of a component within the linear IC to tolerance extremes to determine its effect on the overall circuit response. In this way, the engineer can establish whether a particular op amp will fail in a circuit when certain types of parameters drift. These include drifts in component tolerances, power-supply voltages, temperatures, and circuit-driving and load impedances.

In addition to worst-case analysis, a statistical analysis may be performed using a computer program. The statistical analysis essentially yields a three-sigma solution and reflects more realistically the performance that can be expected from a circuit.

To determine a set of "input-output" characteristics without very much available information with which to define internal operating conditions, a black box representation of the LIC was assumed. Two external resistor-capacitor branches, added to the model, accommodate component values actually used for frequency compensation. The resulting slight in-

crease in model complexity was easily justified by the additional convenience for the designer. In the simplified schematic of the $\mu A709$, shown directly below, pin number designations correspond to the actual device terminals.

One of the compensating RC networks is connected between pins 1 and 8; the other between pins 5 and 6. Pins 1 and 8 are input-compensation points, where the roll-off lag-lead network is formed by R_5 , C_6 , and R_7 . Resistor R_5 represents the internal transfer resistance of the circuit; C_6 is an external capacitor, and R_7 is an external resistor. Usually, the input compensation lag should be left in effect for no more than three decades of frequency, otherwise, the circuit's operation will be retarded. To achieve the right amount of lag, R_7 is usually 0.001 times the value of R_5 . Pins 5 and 6 are the output-compensation points. Here, internal resistor R_{10} and external capacitor C_{11} form an open-loop lag network.

Elements R_{in} and C_{in} represent the device input resistance and capacitance, and R_o is the output

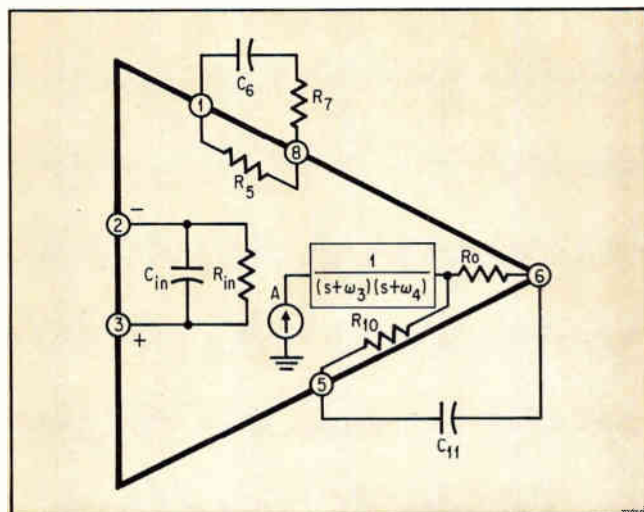

Compensation. Simplified schematic of $\mu A709$, shows external networks usually added to provide frequency compensation. New model provides means for specifying network components to computer for analysis tasks.

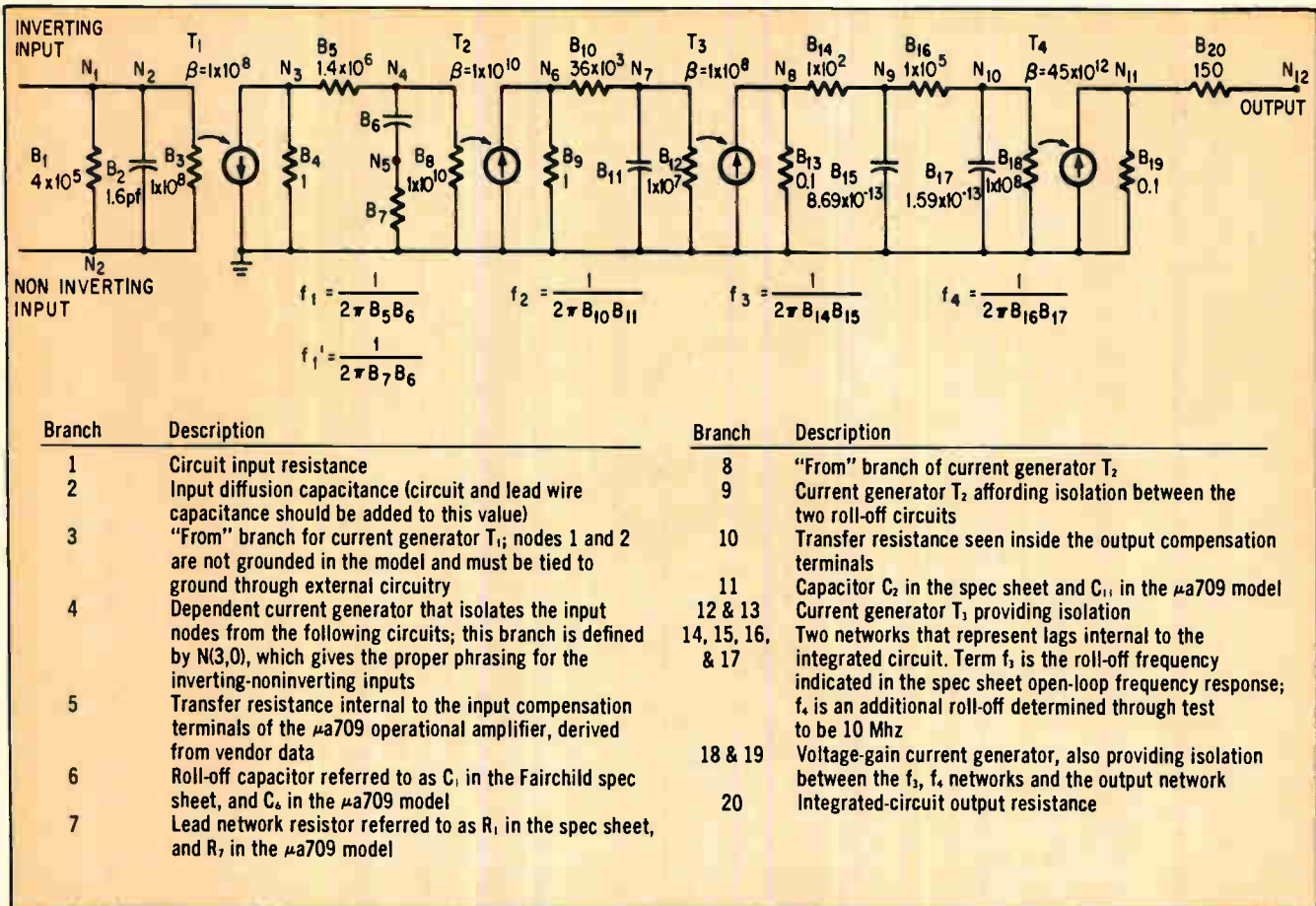

Working model. Circuit represents the $\mu A709$ linear IC as it is described to the computer. Branch definitions are listed in the table.

resistance. The end-to-end d-c voltage gain notation is A . Internal roll-off characteristics at the higher frequencies, about 1 megahertz for the 709, are described mathematically by two lag corners, $(s + \omega_3)$ and $(s + \omega_4)$, in the internal transfer function of the model.

The complete model for the $\mu A709$ is shown directly above. In the diagram N 's refer to nodes and B 's refer to branches of the model. Circuit components used in conjunction with the 709 are connected to the model input and output terminals as they occur in the actual circuit. Each branch of the model is described on this page.

An example of how the model can be used in analyzing a circuit design appears on the next page. The designer can also apply the model to a parameter derating procedure. For example, consider the variation of voltage gain with temperature in an application where the operating temperature range was 0°C to 85°C and the specified power supplies were ± 15 v d-c $\pm 5\%$.

Two items of published data are available from the manufacturers. The $\mu A709$ specifications list the minimum and maximum gain at ± 15 d-c over a temperature range from -55°C to $+125^\circ\text{C}$. Application data provides a plot of open-loop voltage gain versus temperature for the 709 at several supply voltages.

The specified minimum and maximum gains are plotted as points on the curve at 70 kv/v and -55°C (max) and at 25 kv/v and 125°C (min). The gain curve, when supply voltage $V_s = \pm 15$ v, is redrawn once to pass through the maximum gain point and redrawn again to intersect the minimum gain point. These transposed curves represent the minimum and maximum open-loop gain at ± 15 d-c as a function of temperature. The maximum gain, 63 kv/v, within the temperature range of 0°C to $+85^\circ\text{C}$, is picked off the upper curve at 0°C , and the minimum gain thus determined is 28 kv/v at $+85^\circ\text{C}$.

A typical open-loop voltage-gain-sensitivity-to-power-supply variation is reproduced¹ at the bottom left of page 82. The gain variation for ± 0.75 v at 15 is 4 kv/v. The end-of-life parameter variation for integrated circuits is somewhat vague since extensive life test data is not yet available. To derive realistic variation figures, assumptions were pessimistic to assure as large a design margin as possible, while basing the variations on the best available information. The derated gains for the 709 predicted here were calculated using $+10\%$ and -30% for end-of-life gain variation.

As indicated earlier, the response curve breaks or changes direction at two internal frequencies, which

Modeling a follower

Nowadays, voltage followers enjoy a certain vogue as one type of circuit application for the operational amplifier. Exhibiting very high input impedance, low output impedance, a voltage gain of unity, this popular circuit may, depending on the op amp used, have a bandwidth from d-c to several megahertz. In the simple schematic for this circuit, shown at the right, the letter A stands for the IC op amp.

Circled numbers represent the pin connections of the 709, and N_1 , N_2 etc. refer to the computer model node numbers. The 200-picofarad roll-off capacitor, connected between pins 5 and 6 on the actual amplifier, is hooked up between node 7 (N_7) and ground (N_6) in the model; ϕ is zero. Although the usual feedback resistance between pins 6 and 2 is zero, in this example, it is 1 ohm. Power-supply connections, pins 4 and 7, have no significance in the computer model since only the a-c characteristics are of interest. Recommended values for a closed loop gain of 1v/v are 5,000 pf and 200 pf for the roll-off network capacitors and 1.5 kilohms for the resistor. A plot of voltage gain, in decibels and phase shift versus frequency for this circuit is shown at the right.

The open-loop frequency response, both phase and gain, helps to determine feedback stability. To calculate this frequency response, a designer connects a voltage generator to the noninverting input, node 2, and the ground; the 1-ohm resistance goes between nodes 1 and ground. The frequency response for this circuit appears on page 5. The frequency plot indicates that the unit gain crossover occurs at 1 megahertz, where the phase margin is 56° ($180^\circ - 124^\circ$). The gain margin—the gain at 180° phase lag—exceeds 18 db (0 - 18 db).

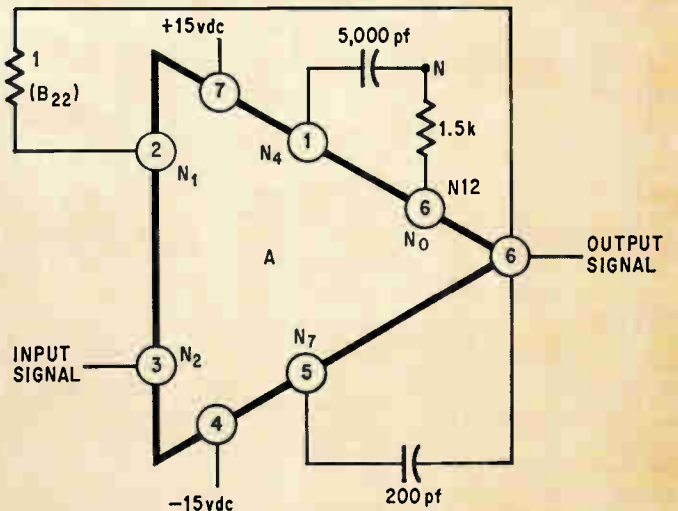

Linear integrated circuit voltage follower.

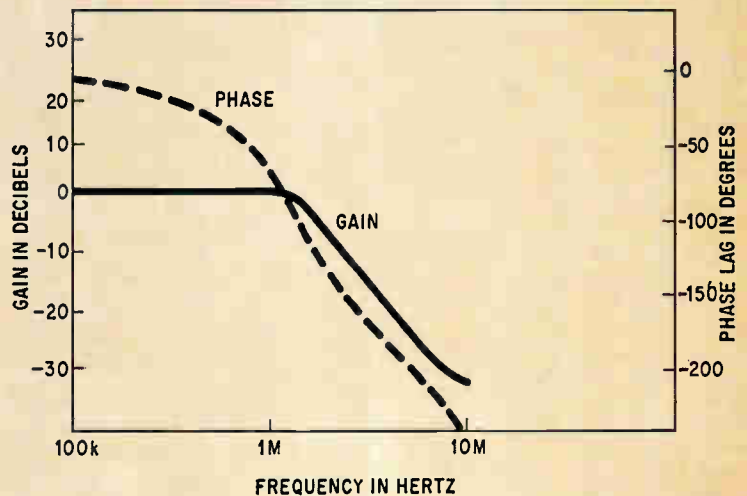

Closed-loop frequency response for the 709 op amp.

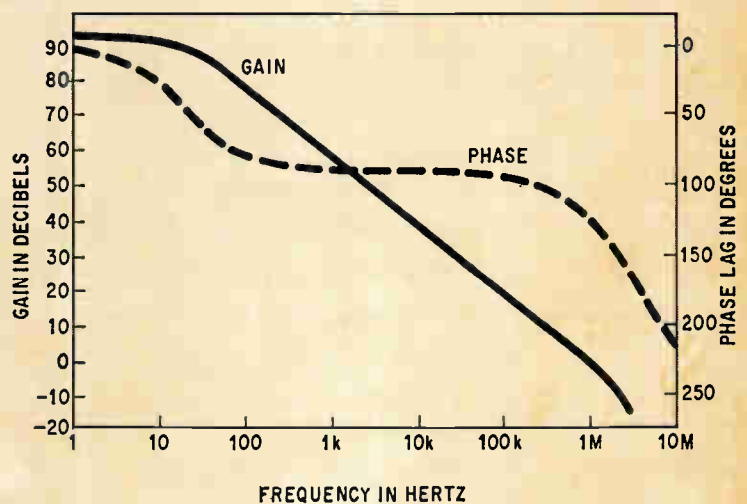

Open-loop frequency response for the 709 op amp.

Model parameters and their worst-case values

Parameter	Designation	Units	Nominal value	Maximum value	Minimum value
Input resistance	B ₁	kilohms	400	900	87
Input capacitance	B ₂	picofarads	1.51	2.2	1.61
Input compensation transfer resistance	B ₅	megohms	1.4	3.07	0.88
Output compensation transfer resistance	B ₁₀	kilohms	36	147	8.6
Internal rolloff 1		megahertz	1.83	3.07	0.856
	B ₁₅	10 ⁻¹³ f	8.69	5.18	18.6
Internal rolloff 2		megahertz	10	10	10
	B ₁₇	10 ⁻¹⁰ f	1.59	1.59	1.59
Voltage gain	T ₄	kv/v	45	73.7	21.6
Output resistance	B ₂₀	ohms	150	650	150
Input compensation capacitor (1% glass)	B ₆		depends on application	+2.5%	-1.5%
Output compensation capacitor (1% glass)	B ₁₁		depends on application	+2.5%	-1.5%
Input compensation resistor (1% film)	B ₇		depends on application	+2.25%	-2.25%

are defined as f_1 and f_2 , respectively. In terms of the model's components, f_1 is given by

$$f_1 = \frac{1}{2\pi R_5 C_6}$$

$$f_2 = \frac{1}{2\pi R_{10} C_{11}}$$

Usually, the first break is stopped after three decades. Thus, f_2 should occur at a frequency of $f_1 \times 10^3$, which is assured by selecting C_{11} to respond to this frequency value.

$$R_7 = \frac{1}{2\pi C_6 (f_1 \times 10^3)}$$

$$C_{11} = \frac{1}{2\pi R_{10} (f_1 \times 10^3)}$$

Using this procedure, the open-loop gain breaks at f_1 and rolls off at 20 decibels per decade until the effects of internal time constants are dominant. The open-loop phase angle remains -90° .

The first internal lag corner frequency, f_3 is defined within the amplifier schematic as predicted on the data sheet for typical open-loop frequency response plots. Four plots shown at the bottom of the next page represent four different compensation networks whose internal corners occur at about 1 Mhz. Curve-fitting each of these plots with the aid of the ECAP program, establishes a single lag value for f_3 that could be considered typical: the root mean square of these four corner frequencies is 1.83 Mhz $\pm 10\%$.

Beyond this lag value—1.83 Mhz—the model rolls off at the rate of 40 db/decade, and the open-loop phase angle approaches -180° . Oscillation can occur in the 709 if the feedback added around the amplifier is more than a given compensation allows for. This occurrence would indicate that more than 180°

phase lag exists in the open-loop amplifier.

Establishing the f_4 corner frequency—the next step—is done by varying C_6 and C_{11} in a nonsaturating switching circuit until a lightly damped condition remains after each switching. These capacitance values were inserted in the model along with measured input resistance, open-loop gain, input-compensation transfer resistance and typical output-compensation resistance, first internal corner frequency (f_3), and output resistance. Frequency response curves were run while varying f_4 until the closed-loop frequency

Temperature variation. Curve for 15 volts is transposed upward and downward to establish the maximum and minimum open-loop gain plots.

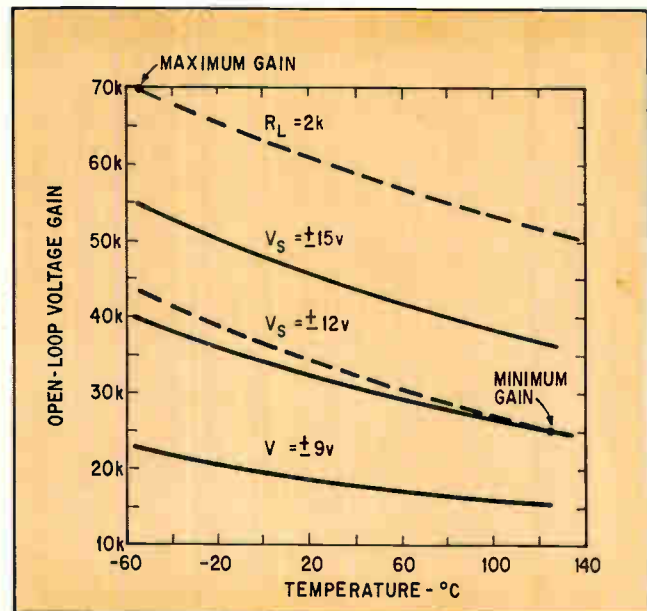

response peak corresponded to the measured ringing frequency of the circuit. In this manner, f_4 was found to be 10 Mhz.

The model parameter tolerances, tabulated on the preceding page, are conservative. So much so, in fact, that using the extreme values in a worst-case analysis of phase lag at feedback-gain crossover, will deliver some dismal results, especially if bandwidths greater than 8 to 10 kilohertz are required. Nevertheless, these tolerances will point out problem areas before they appear in a production cycle.

A designer will come closer to reality by converting the worst-case tolerances to ones that take tolerance-value distribution into consideration. Since it would be a rarity if all tolerances simultaneously went to their worst-case extremes, the root-sum-squared approach, denoted R_{ss} , more realistically predicts actual circuit design performance. One method of conversion is to calculate a new R_{ss} tolerance, $R_{ss}T$, for each worst-case tolerance, W_{ct} . This is done by forming the ratio of each W_{ct} to the total R_{ss} tolerance divided by the summation of the W_{ct} terms squared. Expressed mathematically

$$R_{ss}T = W_{ct}^2 \times \frac{\sqrt{\sum W_{ct}^2}}{\sum W_{ct}^2}$$

A summation of the values thus calculated gives the total R_{ss} tolerance. For example, take four parameter tolerances, say 5%, 10%, 15%, and 25%. The R_{ss} of these tolerances is

5% ²	=	0.0025
10% ²	=	0.01
15% ²	=	0.0225
25% ²	=	0.0625
$\sum W_{ct}^2$	=	<u>0.0975</u>

Voltage sensitivity. Open-loop voltage varies linearly with changes in power supply voltage. At 11.5 the gain is 30 k Ω .

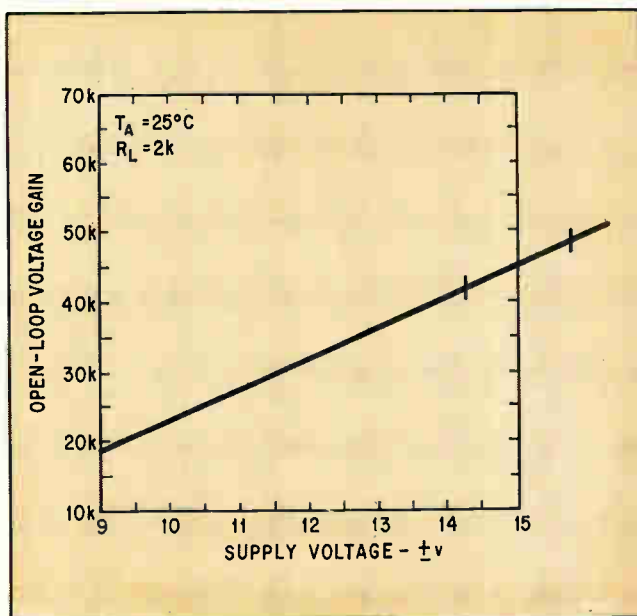

and $\sqrt{0.0975} = 0.31224$ or 31.2%

Forming the ratio of each W_{ct}^2 to $\sqrt{\sum W_{ct}^2} / \sum W_{ct}^2$ yields

0.0025×0.31255	=	0.8%
$\frac{0.01}{0.0975}$		
0.01×3.2026	=	3.2
0.0225×3.2026	=	7.2
0.625×3.2026	=	20.0
		<hr/>
		31.2%

The sum of the R_{ss} tolerances equals the R_{ss} of the W_{ct} 's. Taking another approach the designer could draw on one of the several statistical analysis computer programs available. With them, the gain and phase shift for single frequencies can be calculated. However, when analysis over a range of frequencies is needed, the programs have to be set up to retain the parameter values that were used in the solution.

All the approaches cited must go beyond worst-case analysis to get practical results. Although, worst-case analysis insures the greatest design margin, not every circuit will survive such stringent analysis. Yet, this design margin, at the expense of additional circuitry, tight initial tolerances, and reduced temperature range may be necessary to meet extremely high reliability programs. Moreover, production costs have proven to be lower for circuits that have been worst-case analyzed because marginal design problems have been detected and removed.

The same topological model is adaptable to any linear IC operational amplifiers; only the parameter values and tolerances need be changed. \square

Reference

1. "Fairchild Semiconductor Integrated Circuit Data Catalog," 1970 edition, Fairchild Semiconductor, Mountain View, Calif.

Frequency response. Four compensating networks applied to the linear IC model all display an internal corner frequency at about 1 Mhz.

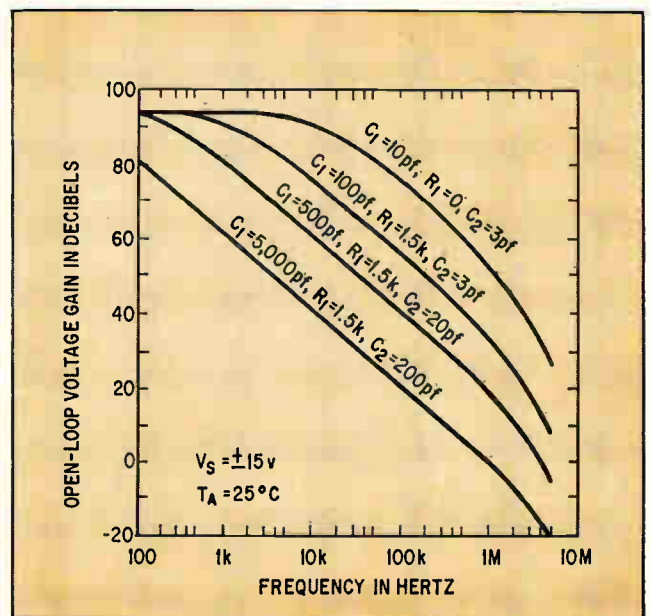

Some MOS static from Signetics.

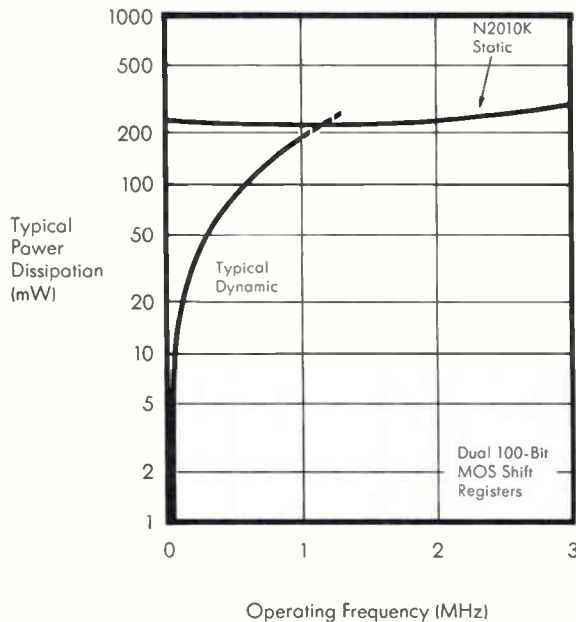

Our new 3 MHz static shift register.

That's some static!

Now you don't have to be stuck with dynamic shift registers simply because of their price, speed and power advantages. You can head in new directions. With Signetics new MOS dual 100-bit static shift register.

We call it the N2010K for short.

In short, it is easier to use than a dynamic device. Works in the same applications. Doesn't need any more power. Operates at higher speeds than most dynamic shift registers. And it's competitively priced: \$4.00 each for 100 to 999 units.

Our N2010K comes in a 10-pin TO-5 package and you can buy it off the shelf from Signetics or Signetics Distributors. Now.

Some other Signetics MOS dual static shift registers also available off the shelf: S2002K/3000 25-bit, S2003K/3001 32-bit, S2004K/3002 50-bit, S2005K/3003 100-bit. Buy them by the numbers: ours first/theirs second.

Plus the S2001K, a dual 16-bit device compatible with the aforementioned devices.

Our MOS data sheets are yours for the writing. Or better yet, buy sample devices for evaluation.

Give yourself some static. You deserve it.

Signetics

Signetics Corporation / 811 E. Arques Ave., Sunnyvale, California 94086 / A subsidiary of Corning Glass Works

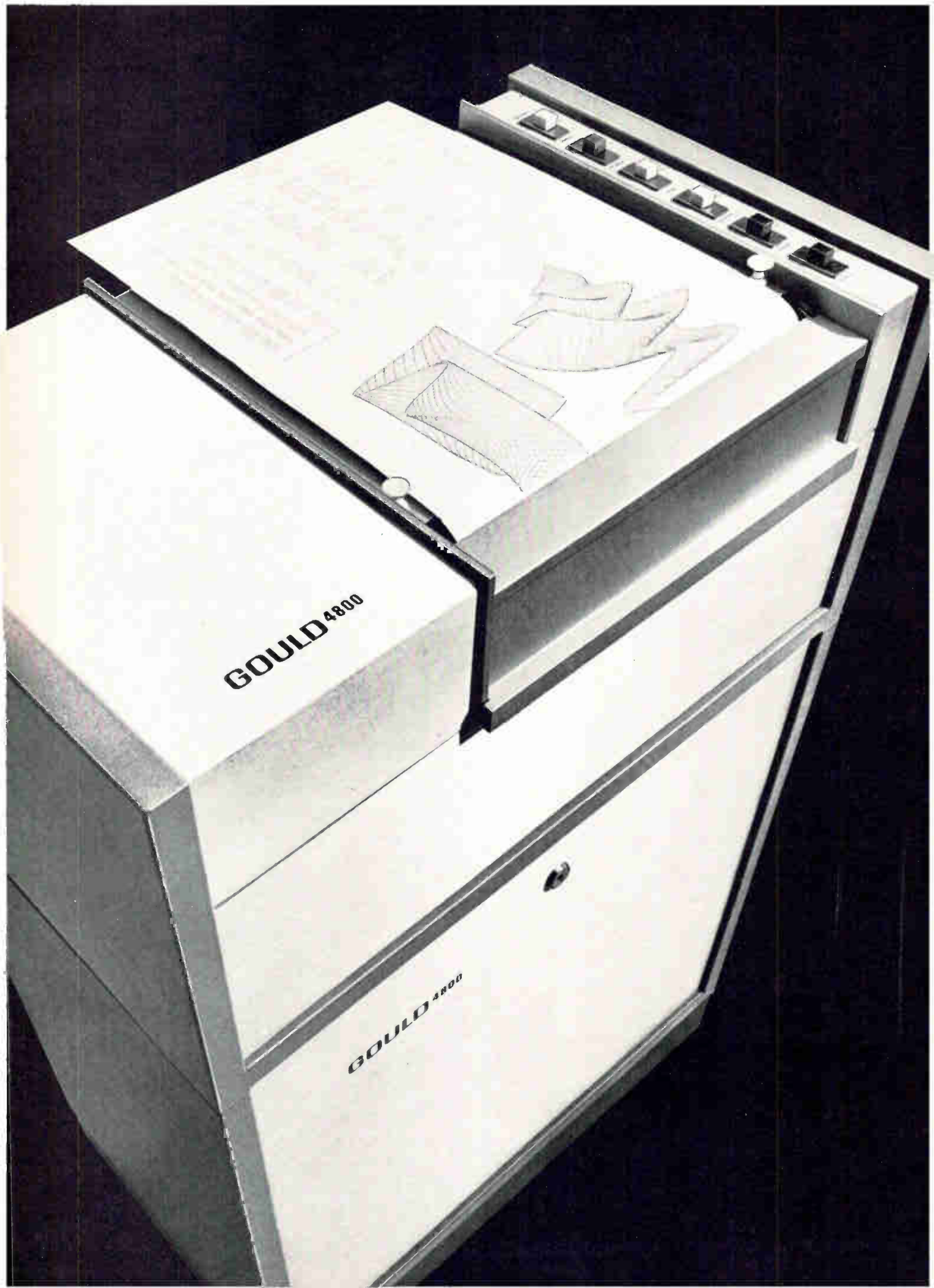

GOULD 4800

GOULD 4800

This is the fastest printer around. It also produces both alphanumerics and graphics.

And printout is 132 columns wide on an 11 x 8-1/2 format!

The practical continuous speed of the standard line printer is 600 lines per minute. But the new Gould 4800-II will deliver 4800 lines per minute. And it'll produce both alphanumerics and graphics — simultaneously — directly from any source of digital input as data transmission by telemetry, radio microwave, and/or land line.

There's a new character generator, too. With an ultimate capability of three 128 character fonts with dot matrices up to 15 x 15.* And because it has a 132 character buffer, you don't have to burden your computer's memory banks. The input control lines are built-in, too. Which makes it comparatively simple to interface the 4800 with almost any computer you have in mind.

The 4800 provides programmed control for a

variety of output forms . . . line and letter spacing, paragraphing, columns and so forth. Plus a convenient capability to translate bit mode input into generalized graphics. But speed and versatility are just part of our story. Because it's electrostatic, the 4800 is infinitely quieter than line printers. Because it has fewer moving parts, it's more reliable. And because it's a lot simpler, it's priced well below printers that can't come close to the performance. So there you have it: the Gould 4800 electrostatic hardcopy printer. Isn't it time we talked? Graphics Division, Gould Inc., 3631 Perkins Avenue, Cleveland, Ohio 44114.

*Supplied standard with unit:
One 64 character font with
5 x 7 dot matrix.

GOULD CLEVITE

The Gould 4800. The next generation of high-speed printers.





portable
from any viewpoint

Tektronix 422 Oscilloscope

The 422 isn't portable as an afterthought—it was designed that way for your convenience. It's designed to travel in your car, aboard airplanes and boats, in mobile electronic facilities—anywhere you have room for a small 22-pound package. When you reach your destination, simply remove the panel cover and the ruggedized 422 is ready to display waveforms with laboratory precision. Dual channel, 10 mV/div (ch 2 is 1 mV/div AC), 50 ns/div sweep rate with X10 mag, 15-MHz performance in a "portable designed" package. Take along a 422 when you need a truly portable, high-performance oscilloscope.

The 422 is available in AC and AC/DC models. The AC model operates from 115 or 230 VAC, 45 to 440 Hz; the AC/DC model operates from AC, an internal rechargeable battery pack or from external 11.5 to 35 VDC.

For a demonstration of the 422 in your application call your Tektronix Field Engineer or write, Tektronix, Inc., P. O. Box 500, Beaverton, Oregon 97005.

422 AC Model \$1500—422 AC/DC Model with batteries \$1990, FOB Beaverton, Oregon.

Available in U.S. through the Tektronix lease plan



Tektronix, Inc.
committed to technical excellence

AC/DC Model

Bell bipolar process ready to go

Western Electric set to produce simplified collector-diffusion isolation ICs but other firms doubt cost savings are worth performance tradeoffs

By George F. Watson

Solid state editor

News of a simplified bipolar fabrication process inexpensive enough to compete with MOS attracted plenty of attention in the semiconductor industry two years ago. But now that Bell Laboratories is about to turn its collector-diffusion isolation (CDI) process over to Western Electric for pilot production, the other companies are notably more restrained.

For although CDI has the advantages of fewer fabrication steps, permitting lower costs, higher yields, and higher packing densities, many feel that the resulting compromises in performance nullify its value. Bell disagrees. It feels that the price advantage will be significant when the devices are turned out by the hundreds of thousands. And bipolars offer low, sharply defined, and precisely controlled switching thresholds, permitting significantly lower signal and power supply voltages and hence lower power consumption for a given switching speed than in MOS circuits.

The CDI process differs from conventional bipolar fabrication in two ways. It uses the epitaxial layer as the base region, eliminating the base diffusion step, and it combines the deep collector and isolation diffusion steps. With CDI the deep-collector diffusion contacts the buried collector deep in the substrate and minimizes interaction between transistors.

Performance. The simplicity of CDI fabrication is achieved at the cost of lower collector-base breakdown voltage, higher inverse current gain, and higher collector junction capacitance per unit area. Nevertheless, in the CDI circuits built by Bell, switching speed is

equal to that of the best conventional TTL circuits—four nanoseconds per gate—and power dissipation is extremely low—six milliwatts per gate.

CDI is just the first step, says Bell. Two other bipolar fabrication techniques in the wings promise

even greater economy (albeit with lower performance): base-diffusion isolation (BDI), which requires ever fewer steps than CDI, and the tri-mask technique (TRIM), which requires less steps than MOS.

Bell engineers are reluctant to predict the future of any of the

Simplicity. Bell Labs' processes cut number of masks needed, eliminating some diffusion and oxidation steps. Standard process requires six masks, but CDI needs five, BDI (not shown) four, and TRIM three, one less than is needed to make simplest MOS IC. Tradeoffs are in performance.

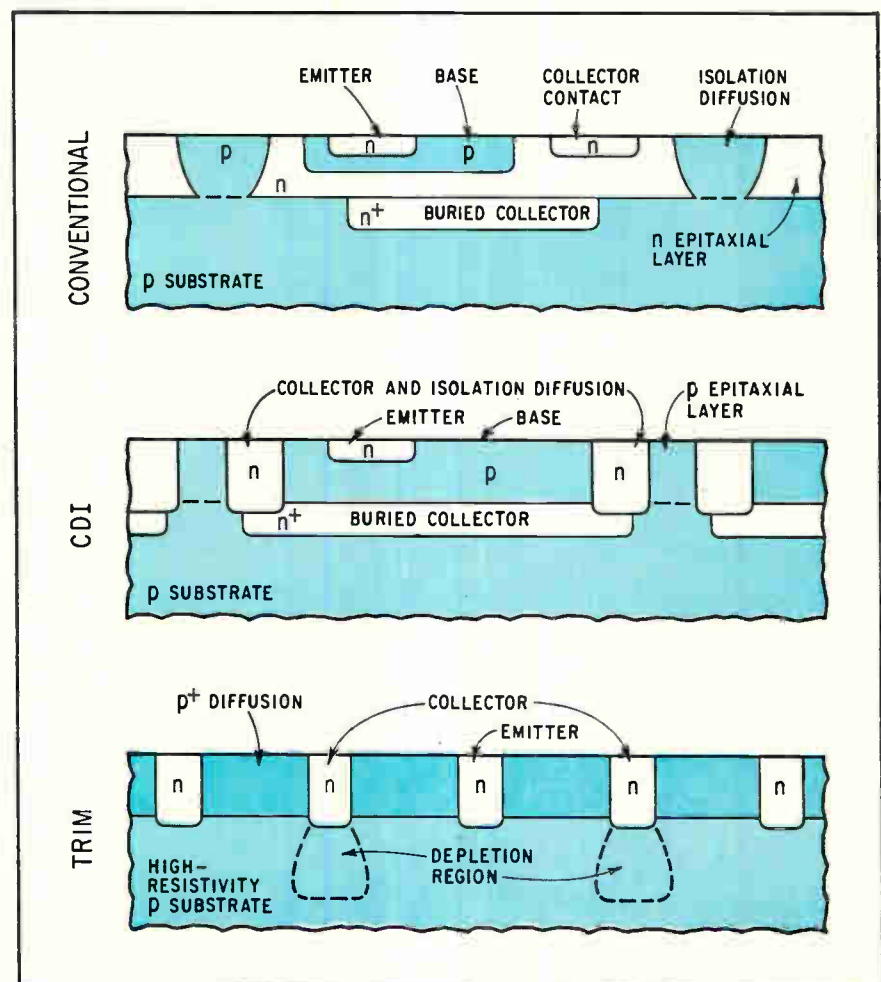

... it's evident Bell has made a firm commitment to the CDI approach ...

rapidly changing simplified bipolar techniques. The relatively low speed of MOS, for example, can be substantially prodded by the silicon gate process. If this can be achieved inexpensively, the position of MOS vis-a-vis CDI and BDI could change radically. In addition, magnetic bubble memories and charge-coupled devices may prove to be important contenders for the role of mass data storage. Nevertheless, it's evident that the Bell System has made a firm commitment to the CDI approach, and regards the other low cost bipolar techniques, particularly TRIM, with optimism.

To each his own. Bell is far from abandoning MOS technology, however. "It's impossible to make sweeping statements about the advantages of the collector-diffusion isolation process over MOS," cautions Bernard Murphy, who heads Bell's exploratory device department. "We have to look at specific functions," he adds, noting that MOS still has a clear advantage, for example, in shift registers. MOS, with its fewer contacts and reduced metalization, performs the same functions as CDI but in a third less chip area, boosting yield and lowering cost.

On the other hand, CDI has a distinct edge in random access memories, where, unlike shift registers, devices come in various sizes. With RAMs, chip area, including peripheral elements, such as addressing circuitry, is about the same for both processes.

CDI also offers a clear advantage for general-purpose logic applications. Here, MOS's low output current gives it only a limited capability for driving circuits.

However, other companies aren't as optimistic. An engineer at Fairchild Semiconductor says that though CDI and TRIM may look cheaper on paper, production economics are open to question. "Even if the cost for CDI is lower, the performance tradeoffs are too great. And since CDI doesn't eliminate the production problems of other bipolar processes—getting thin epitaxial layers and controlling small

geometries, for example—why use it," he says.

At Signetics, an R&D engineer reports that devices have been built using each of the low-cost bipolar techniques, "but we see no advantage; we can get the same results—higher packaging density and lower cost—with thin, 3-micron, epitaxial layers." Manufacturing costs are concentrated in testing and packaging, he claims. "If all you need is 'adequate performance,' use plastic packaged devices. The cost savings with BDI or CDI may be only a fraction of a cent."

Bell doesn't answer this directly but claims that the admittedly small cost savings add up in mass production. Moreover, Bell's packaging costs are quite low—beam leads are used, and the circuits are arrayed as bare chips on a ceramic substrate—so process costs are a larger portion of the total.

Not all the semiconductor houses are as quick to write off the new bipolar techniques, however. Texas Instruments says it has evaluated both CDI and TRIM in "preliminary and exploratory" studies. Its conclusions: both techniques could be used in high-complexity logic circuitry and memories. Though TI wouldn't spell out its plans here, the work apparently is continuing.

Bell's CDI circuits are in the TTL configuration, with 12 gates per chip. While not a high level of integration, Bell engineers felt that this array is optimal because more gates would require a larger chip and thus adversely affect yield; the gate propagation delay is not low enough to make propagation delay between chips a factor, and it allows beam-lead mounting, permitting many chips to be mounted as cheaply as one.

The BDI technique is in an anomalous position right now. Although it's simpler than CDI, the more recently developed TRIM technique may eclipse BDI. There are two versions of the BDI structure: with and without a buried collector layer. The former is similar to the conventional bipolar structure, except that the base diffusion is used to isolate the tran-

sistors from each other, eliminating the need for a separate isolation diffusion. Although the base diffusion isn't deep enough to penetrate through the n-type epitaxial layer to the p-type substrate, isolation is achieved by applying a reverse bias to the base-isolation contacts that's sufficient to extend the surrounding depletion layer to the substrate. Fabricating BDI with buried collector is only slightly less complex than making the conventional bipolar IC, and although BDI has lower isolation capacitance and hence higher maximum operating speed, some companies aren't sure this advantage makes further exploitation warranted.

Simplicity. BDI without the buried collector layer is considerably simpler—it requires only four photomasking steps, in fact, no more processing than for a planar transistor. But the TRIM technique is even simpler, and is suited to the same applications as no-buried-collector BDI—bulk memories.

TRIM requires only three masking steps and no epitaxial layer. Starting with a p-type substrate of high resistivity, Bell diffuses a p-type layer over the entire wafer (this will eventually form the base region), then diffuses n-type collectors and emitters simultaneously. The high-yield potential of the process has been confirmed in the laboratory, Murphy reports.

In the TRIM IC structure, the high resistivity p-type material represents "a sea that surrounds all the transistors," Murphy explains. This material, in combination with the always-reverse-biased collector junctions, provides a barrier against carriers that flow from one transistor to another, thus isolating them. Bell achieves 99% isolation, Murphy reports—of the 10 milliamperes flowing through one collector, only 10 microamperes find their way to the collector of the adjacent transistor, not enough to significantly affect operation.

Transistors in the TRIM IC have a gain-bandwidth product, f_T , of 30 to 100 gigahertz and current gain (beta) of 10 to 30. "By the standards of normal bipolar ICs these values are low," Murphy says, "but for memory circuits they are perfectly adequate, and at any rate, you can't use the high f_T at the lower power levels."

Who provides 99.98% microcircuit reliability? Centralab!

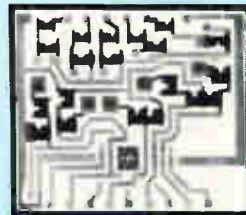

Thick film microcircuit reliability depends on quality control at every stage . . . from design and manufacturing through application and use. At Centralab we have established a single Quality Assurance System that includes some 89 quality and reliability control procedures. This System, which meets MIL-STD-883 requirements, is applied to everything we produce, whether for military, consumer or industrial use. A total of 45 procedures control quality at the design and development stage; 24 during fabrication and assembly; and 20 are applied to verification during application and use. The procedures include use of our DESC-approved environmental test laboratory, one of the few such facilities in the Midwest.

By strictly adhering to these standards and procedures, we've been able to greatly minimize failures. Predicted failure rates for a typical Centralab module average 0.2 failures per million hours.

If quality and reliability aren't enough, we are the leading manufacturer of microcircuits. We've been in the thick of it for 25 years. We've produced more than 500,000,000 thick film circuits in some 5,000 designs. With this kind of manufacturing experience, we can provide product samples in three weeks; production quantities 8 weeks from prototype approval.

At Centralab, we're geared for quality and service. To find out how you can put both to work for you, write for a copy of our new Thick Film Microcircuit brochure.



CENTRALAB

Electronics Division
GLOBE-UNION INC.

5757 NORTH GREEN BAY AVENUE
MILWAUKEE, WISCONSIN 53201

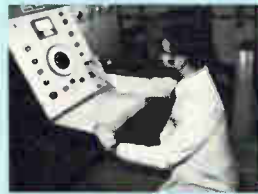

**CENTRALAB PRODUCTS
ARE MARKETED INTERNATIONALLY THROUGH
GLOBE-UNION INC. - INTERNATIONAL DIVISION**

M-7016

Projections in IC printing

Though more expensive and tougher to use than contact printers, projection printing systems could soon appear on IC production lines

By George Weiss

New products editor

Hailed a few years ago as the successor to contact printing of integrated circuits, projection printing did not after all make it. But improved projection printing systems and a better understanding of how to use them are reviving interest among semiconductor houses. Some expect to start producing with projection printing within a year or two, and one projection print system maker claims that his equipment is already installed in a production line.

Projection printing uses optical imaging to transfer IC patterns to wafers and so dodges the chief drawback of contact printing—the fact that when the wafers come in contact with the IC mask they scratch it and rapidly wear it out. In the projection process, mask and wafer never touch each other, so mask life could be indefinite and unscored masks would mean higher device yield.

But IC makers have some reservations. Projection printers, they point out, are tougher to use than contact printers, cost ten times as much, are not as versatile, and as yet aren't geared for automatic processing and handling of wafers. But to complaints that the systems don't perform as well as their makers claim, the system manufacturers retort that too often semiconductor houses aren't using their machines correctly.

Pros and cons. One of the houses currently evaluating the technique is Motorola Semiconductor. Arnold Lesk, director of the central research laboratories in Phoenix, reports that "Projection printing ranks among the more important

techniques to pursue to improve yields and lower costs. It's getting close to usability for reasonable geometries and, if it's not slower than contact printing, we may get the initial costs back in mask savings. But the problem is still the optics. Because of the complex lens structure, you have to pick a particular wavelength for the lens, and it will handle only that wavelength. So a photoresist that works well at that wavelength has to be used."

At Fairchild Semiconductor, a projection print camera is being used to make IC memories on two-inch wafers, according to an engi-

neer close to the scene. He claims that Fairchild has improved yields over previous projection printers, finds the system works at least as well as the contact method, but has encountered difficulty in tooling for production. Colin Knight, who just took over responsibility for Fairchild Semiconductor's mask-making facility, says, "It may be 18 months to two years before we see projection printing equipment in a production environment."

But even when the bugs are ironed out, projection printing won't completely eliminate contact printing, according to Texas Instru-

Making an imprint. Projection printers, like this one from Telefunken, house complex optics of more than a dozen lenses, to accurately transfer mask patterns onto silicon wafers, vidicon targets, or plates.

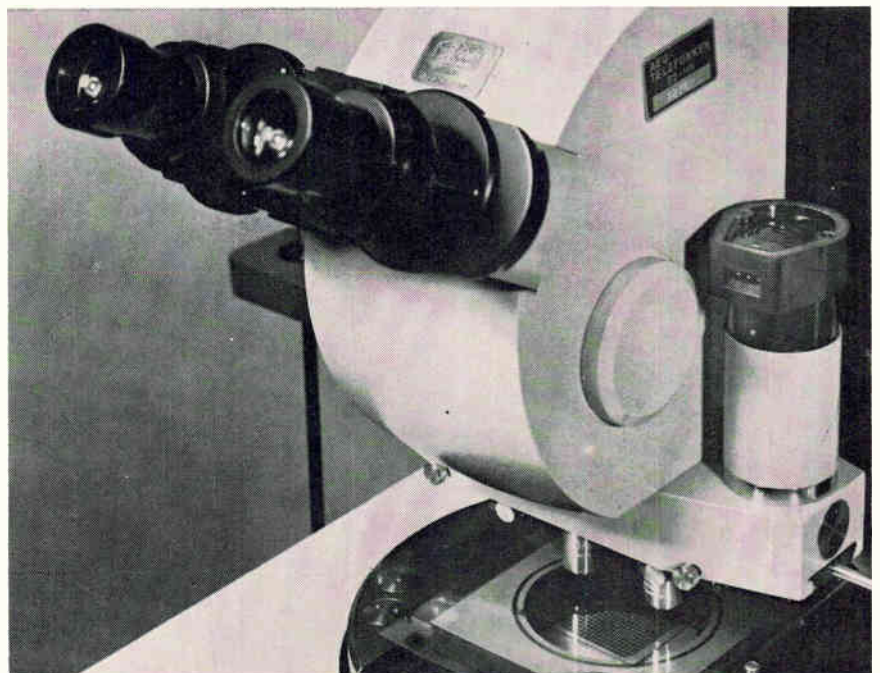

ments' James Dey, manager of the photoresist program. "There'll always be areas where contact printing will be important, in particular geometry sizes and short production runs where mask costs aren't significant," he notes.

Criticism. Dey says that TI is investigating several types of projection printers, but complains that contrast decreases significantly when images are projected through a lens. This makes projection printers trickier to use than contact printers where "you have very high contrast ratio between the light and dark areas of the image." And he points out that few makers of this equipment "have much experience in the use of projection printing systems." Projection print makers define specs in terms of the resolution you're capable of seeing, whereas users depend on what they actually can get out of the system, he reports.

But Stuart Held, manager of special optics at Ehrenreich Photo-Optical Industries, a subsidiary of Nikon, is critical of IC makers who say they can't derive promised results and bemoan lens distortion. "In projection printing there's no distortion through a 1:1 symmetric lens. Very few understand this and will play with their system for months before they come to this realization."

In production. Held claims that one of his customers has "at least three 1:1 projection systems on line, is using lenses interchangeably and achieving good results." The system has a total cycle time—wafer-in, aligned, exposed, wafer-out—of less than 30 seconds and handles wafers of 64 mm in diameter with resolution of 2 microns—a resolution that changes from center to edge by no more than 4%.

Formidable difficulties with projection printers include the aligning of masks and wafers. Most systems use manual methods. However, the Ehrenreich systems now on line apparently use an automatic mask aligning technique developed by Computervision of Burlington, Mass., [*Electronics*, Feb. 16, p. 170] which is said to do the job in a few seconds.

Projection printers also require precise control of photoresist, which must be spread in just the right thickness and uniformity and

be free of pin holes. Cleaning and preparation steps, type illumination, exposure time, and type filter are all more critical than in contact printing.

Yet another problem—high cost—stems in part from the larger lenses designed to work with larger wafers. Larger lenses require better resolving powers, and a refractive index that is completely uniform over the entire area of the glass—a difficult manufacturing task. Another problem is mounting the heavy lenses.

Other companies that make projection printing systems include Canon, AEG-Telefunken, and Ushio Electric Inc. Several optics firms also deliver lenses made to the specifications of the IC manufacturer, who then puts together his own system.

Projection systems will probably find their widest use initially in mask replication—a smaller market than wafer fabrication but potentially more profitable. HLC Manufacturing Co., Willow Grove, Pa., for example, is about to market its first system for duplicating masks with accurate reproduction of lines 2 microns wide over a 64-mm diameter. HLC says the system handles emulsion or chrome masks up to 3 x 3 inches on plates 4 x 5 inches. According to vice president, Richard W. DeMott, the system should save companies a great deal of money "because working copies can be made directly from the master without making a series of copy masters." Sometimes as many as 20 copy masters are now made in contact printing production facilities.

Another company, David W. Mann, Burlington, Mass., which makes mask duplicating equipment, is more cautious. Aubry Tobey, marketing manager, points out that while contact printers cost between \$3,000 and \$4,000, projection printers run from \$30,000 to \$60,000. "Suppose the semiconductor industry leans more toward the manufacture of custom circuits, then there will be a lower volume output and the projection printer costing \$60,000 may not be paying for itself as quickly as it should," he warns, but adds, "but if you're going to talk just about large volumes of standard ICs, then the projection printer will pay off."



What's the difference?

Some typical squirrel cage photomultipliers. All similar in shape. But the one in the foreground, the new EMI Type 9781B, is different. Take a look at these typical performance figures:

- Photocathode sensitivity... 55 μ A/L
- Overall gain at 1000V... 2×10^7
- Overall voltage at gain of 10^6 ... 650V
- Dark current at gain of 10^6 ... 1.2nA

The 9781B, a 9 stage tube with UV transmitting glass envelope, is designed for use with low level UV and visible radiation in spectrometer and similar applications. The B11A (B11-88) base means the 9781B will replace other tubes of this design to improve system performance.

For details of the complete EMI P.M. tube range contact:

GENCOM DIVISION
varian/EMI

80 EXPRESS STREET, PLAINVIEW, N.Y. 11803
TELEPHONE: (516) 433-5900

Low energy switching problem? Leave it to our "GOLDIE"...



"Goldie"—the new Cherry gold crosspoint contact switches solve practically every low energy switching problem. They do it with a contact design innovation that helps prevent the two main causes of contact failure:

1. Formation of insulating chemical films on contacts
2. Mechanical interference of foreign particles on contacts.

Our new "Goldie" switches combine a solid layer of gold alloy (69% gold, 25% silver, 6% platinum) contact material

with a crossed knife-edge configuration. These provide interfaces inert to chemical action and virtually eliminate contact closure interference from foreign particles. Low contact resistance is maintained throughout the switch lifetime, which is measured in millions of operations. Initial insertion resistance is below 50 milliohms.

Take a closer look at our problem-solving "Goldie" switches. Send for the sample of your choice today.



Hewlett-Packard Desk Top Calculator uses 63 Cherry "Goldies"

FREE SAMPLE SWITCH



E69 Push Button
Circle Reader
Service No. 000

E53 Low Torque
Circle Reader
Service No. 000

E63 Subminiature
Circle Reader
Service No. 000

S31 Open Miniature
Circle Reader
Service No. 000

E21 Miniature
Circle Reader
Service No. 000

CHERRY Makers of patented Leverwheel/Thumbwheel, Matrix Selector and Snap-Action Switches.

CHERRY

CHERRY ELECTRICAL PRODUCTS CORP. • 3608 Sunset Avenue, Waukegan, Illinois 60085

Plastic MOS is off and running

With reliability problems apparently solved, RCA, National Semiconductor, and General Instrument are set to go with plastic-packaged MOS devices

By Peter Schuyten

New York bureau

Semiconductor makers for the past two years have been racing to lick the problem of reliability in plastic-encapsulated MOS integrated circuits. Price is the main selling point of MOS, and the cheaper plastic package will drop the cost of MOS ICs even further. Now, several companies seem to have conquered the problem and the flood of new products is about to begin.

The big three semiconductor houses—Fairchild, Motorola and Texas Instruments—from the beginning have trailed in the MOS market and they appear to be left standing at the gate again. The company that got the jump on the plastic-packaged MOS market, surprisingly enough, is RCA's Solid State division, not considered a major force in the MOS market. RCA introduced a line of 19 plastic encapsulated complementary MOS ICs at Wescon, Aug. 25.

Close company. But RCA won't be by itself for long. General Instrument, for example, plans to introduce its first commercial product in September—a 512-bit shift register. National Semiconductor expects to put out its initial plastic products before the end of the year, and Intel Corp. says it's just three months away from introducing its first commercial plastic MOS device.

Plastic encapsulation already is effecting dramatic price cuts. RCA's plastic C/MOS units, in an epoxy dual-in-line package, range from simple gates like a dual three-input NOR plus inverter circuit to an MSI four-bit full-adder with parallel carry out; they're 25% to 35% cheaper than identical RCA hermetic devices shown at Wescon.

The reliability problems in packaging MOS in plastic stem from the fact that MOS devices, unlike their bipolar counterparts, are surface effect circuits, and as such are much more susceptible to both electrical and physical contamination. Thus the package becomes an extremely critical component.

RCA's solution was to coat the chip, after bonding to the lead frame, with a polymer material to prevent intimate contact between the plastic package and the chip. With this one exception, virtually all other manufacturing steps are the same as those for the division's hermetic C/MOS line.

Tough choice. Finding the right polymer, however, is not as simple as it might sound, notes Harry Weisberg, manager for MOS IC product design and technology. Various factors affecting the development of such a coating include acidity and alkalinity (it must be chemically neutral), viscosity and vapor transmission properties, and electrical polarity (again, it must be neutral). Perhaps most important, the coating must have the same coefficient of thermal expansion as the chip, the bonding wires, the gold lead frame, and the epoxy package. Not surprisingly, RCA declines at this point to divulge the composition of its coating, but Weisberg, who has been investigating modified versions of standard polymers for more than two years, says it's a resilient material, not unlike rubber but harder.

RCA's plastic-packaged C/MOS line is temperature rated from -40°C and $+85^{\circ}\text{C}$; hermetic counterparts range from -55°C to

-125°C . Quiescent power dissipation is from five to 10 times higher than in similar military rated devices, depending on the particular unit. Simple NOR gates in a hermetic package, for example, dissipate about 1 microwatt; their plastic counterparts about $10\mu\text{W}$.

Reliability, of course, is the most important factor in plastic-packaged MOS. Operating life tests performed by RCA on a sampling of 80 devices at 10 volts at 55°C case temperature resulted in no total failures over nearly 380,000 hours. This works out at a .27% failure rate per 1,000 hours.

While RCA uses the polymer/overcoat approach to protect its MOS chips, General Instrument's packaging engineers have taken a different tack. They found that no conformal coating is needed because the nitride used in their conventional MOS line was adequate to protect the chip. The circuit is put directly in the silicone package.

Beam leads. GI plans to follow its 512-bit shift register with other 14- and 16-lead ICs later next month. Early next year, the company expects to start producing 24- and 40-pin packages. Beam lead techniques, which replace manual wire bonding, will be the key to making larger units at low cost.

North American Rockwell's Microelectronics Co. is trying still another approach. Although the company is reluctant to reveal any specifics, it is known to be examining silicon nitride to protect the gate and oxide regions, while glass would be used for the metal contact areas. However, according to one company official, sodium con-

tamination is still showing up in some of the silicone packages.

National Semiconductor is going much the same route as RCA. Its package will be silicone, and the chip will be covered with some type of conformal coating, says Ed Thompson, the firm's director of quality assurance and reliability.

Intel Corp., according to marketing vice president Robert Graham, has found that plastic is a natural for silicon gate MOS because the gate area is easily protected. "All you do it shoot a little water into the furnace and you get silicon dioxide over the gate. Thus one of the main problems with plastic—gate deterioration—is eliminated," Graham explains. And it's the same for n-channel, p-channel, or complementary MOS, he adds. With the SiO₂ over the gate and gate oxide, aluminum is run from the source and drain up over the edge of the gate to protect it from ionic effects. Intel's life tests have shown no drift leakage in 60,000 hours.

Texas Instruments isn't specific about its plans, apparently holding off until it's sure all the problems are solved. "We are doing substantial testing to make sure that when we do move, it won't be a false start," says David Roop, MOS marketing manager. He says only that TI will "phase plastic packaging into production in the near future."

Motorola expects to offer MOS in plastic packages by next spring. It will take that long because of the time needed to complete life tests. Signetics also is waiting for more reliability data and expects to have products on the market by the second quarter of 1971.

Doubters. One of the few MOS houses professing little interest in plastic is American Microsystems Inc. The firm has been looking at plastic since 1966, says senior vice president Warren Wheeler "and we've seen nothing to prove that we should be in plastic." Ceramic is more reliable, he says, and claims it is close in price. "We just don't feel safe in plastic," Wheeler adds.

Another is Fairchild Semiconductor, which, says Harry Neil, MOS marketing manager, has no plans to announce any plastic packaged MOS products. In fact, he says "the company doesn't have an extensive effort going; we don't feel the pressure yet to go into it."

Space electronics

Shuttle faces tough going

Electronics are cut back as tight money and lagging interest gang up on NASA's budget

By Jim Hardcastle

Washington bureau

Just a year after man first landed on the moon, the team responsible for Apollo 11 is facing a hard fact. Their next step in space—a reusable shuttle that would ferry men and material into orbit on an airline-like basis—is in financial trouble. As a result, development of electronics for the craft may be nearly halved if NASA goes to a low cost shuttle using only one stage to

orbit or a two-stage craft using existing boosters.

Lean times and lagging interest in the space program will hold NASA's budget at around \$3 billion a year for the foreseeable future—\$2 billion shy of the amount the space agency was granted during Apollo's golden years, industry marketing men and NASA officials predict. And holding on to even this

Flying ferry. Artist's conception of space shuttle operation at the Kennedy Space Center shows service on the orbital section of the craft.

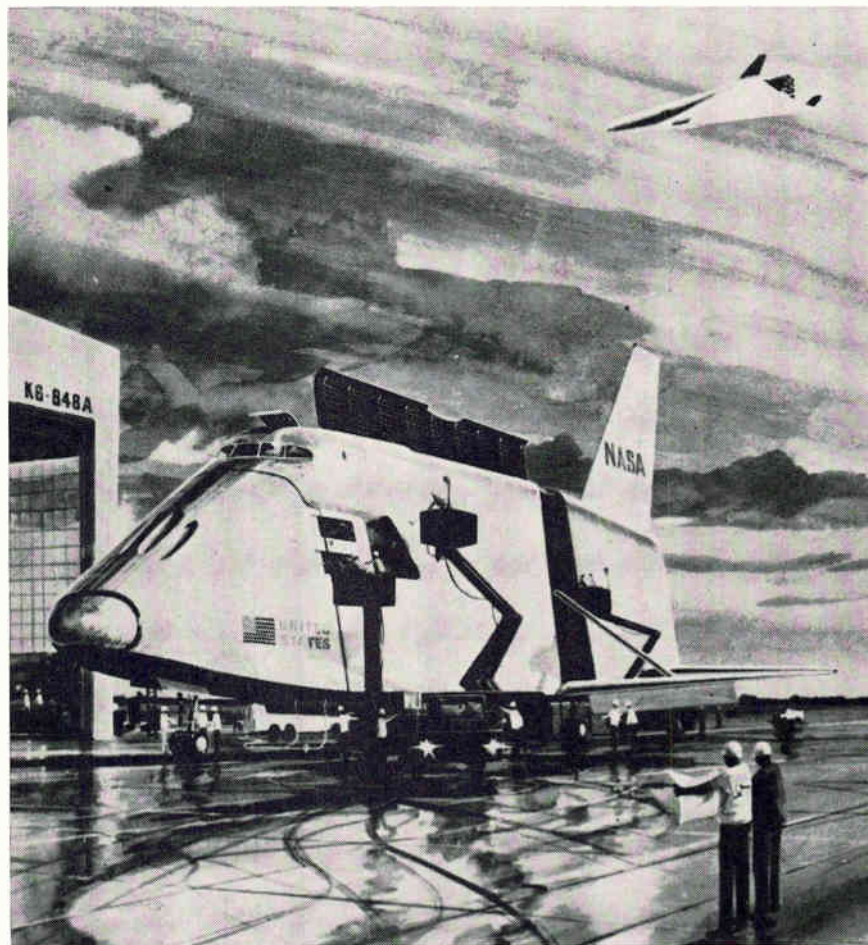

amount will require adroit salesmanship before a tightfisted Congress that shows signs of boredom with technical feats.

As a result, NASA is falling back into what one contractor calls a "study mode," seeking ways to trim the \$1.5 to \$2.5 billion annual peak the space agency would spend if it started work on a shuttle based on current designs. In the process, however, NASA must be careful to maintain most of the features of the shuttle called for in present plans, such as reusability, size and weight of payload, and lower operating costs, that NASA officials say justify building the craft in the first place.

Low cost shuttles being studied include a bell-shaped one-shot to orbit the booster by Chrysler's Space Division; a one-shot booster with drop tanks by Grumman and Lockheed; and a reusable orbiter with an expendable Saturn-like booster by Grumman. Marshall Space Flight Center, NASA's main rocket development center, is also looking at the use of a reusable booster with an expendable orbiter.

No matter what configuration is finally selected next year for engineering design, one bit is safe: NASA's wish book of electronic items to be carried aboard the shuttle will be much thinner. Already, one major item, a docking radar that can track non-cooperative targets, has been demoted from NASA's level 1 or "must-have" list to its roster of mere "desired characteristics." In the end, says one industry source, "they may wind up using Class A eyeballs."

Many other electronic items that were slated for development will be simplified or cut out all together. Still more will be scavenged from Apollo or adapted from another fertile source, the new generation of avionics put together for the SST and the jumbo jets, industry sources say.

"A year ago, we laid down a set of requirements based on what would be nice to have" says Cline would be nice to have," says Cline eight that is redefining the shuttle's electronics at the Manned Spacecraft Center in Houston. But due to cost restraints, he continues, "we're now stopping, regrouping, and studying our electronics requirements again." Most of the

items in NASA's wish book cost a great deal of money, he says. "What we're trying to find out is what can we do without spending that kind of money and still have a reasonable capability."

Originally, electronics hardware was expected to account for 25% to 40% of total shuttle cost, but it now looks like it will be about 25% of a much smaller dollar total.

The days when performance was all that counted at NASA are gone, says Clarence Gay, who's in charge of shuttle systems engineering. "We not only want a piece of equipment that will do the job, we want one that will do the job at a certain cost," he says.

Bogey. Stripped-down electronics hardly provide all the answers for a craft designed to be used for 100 missions. Operational costs and maintenance soar when systems are taken out of the craft and placed on the ground or when hardware designed for a one-shot mission is put into a reusable craft. That's why NASA is introducing a management tool it calls the "cost bogey" to reduce both development and operational costs.

As an example of the cost bogey, Gay says, "We might tell a systems builder that we will pay \$500,000 for a specific black box." The contractor is supposed to work against this cost target and use his ingenuity to come up with a system that will do the job. He must, however, keep operations cost in mind. "If he saves money in the

development area and his system requires a lot of money to operate, he hasn't done a thing," Gay says, hinting that the contract would end at that point.

Common redundancy—a technique widely used in the jumbo jets—is another means of shaving development and operations costs, one key shuttle engineer says. Weight, he says, isn't really a significant issue. The shuttle's electronics will only constitute 1/27th of the craft's weight.

By using triple or quadruple system redundancy, he notes, with a simple voting circuit to weed out malfunctioning systems, NASA can avoid the expense of developing backup systems. What's more, he adds, redundant systems commonly do not require checkout gear for both primary and backup systems; this equipment often is elaborate as the unit it monitors.

Checkout systems, he points out, can cost a great deal of money to develop, but they're a must when a primary system and a backup are used without redundancy.

Finally, he says, high-level common redundancy provides a shortcut to meeting NASA's requirement for electronic systems that can sustain two critical point failures before degradation in performance occurs. "If we had three inertial guidance platforms and one blew, we would always have two more to bring us back," he notes. "That's what they're doing in the 747 today and the airlines have sharper pencils than we do."

Marked down

Breaking the "performance-at-any-price" habits that marked the Apollo program will not be easy, says Clarence Gay, chief of the shuttle's systems engineering team. Tradeoffs and compromises will be musts to keep the price down "and we haven't really worked in this kind of mode before," he says. "Neither has industry."

The pressure to reduce the shuttle's \$6 to \$9 billion development cost has been applied on every front. McDonnell-Douglas and North American Rockwell, the two contractors at work under \$8 million preliminary design contracts, have been told to design two types of shuttles: one with 1,500 miles cross-range the Air Force says it would like to have, the other with the 200- to 300-mile cross-range NASA says it needs. Unless more money is forthcoming, chances are good NASA will turn to a lower cross-range version when it awards final design contracts sometime next summer.

But even the low cross-range versions McDonnell-Douglas and North American are working on are two-stage shuttles, a type of craft industry sources say would cost from \$1.5 to \$2.5 billion a year during the program's peak because there are two vehicles involved.

Tips on cooling off hot semiconductors

See how other circuit designers use IERC heat sinks/dissipators to hold junction temperatures below rated maximums, improve circuit performance and reliability

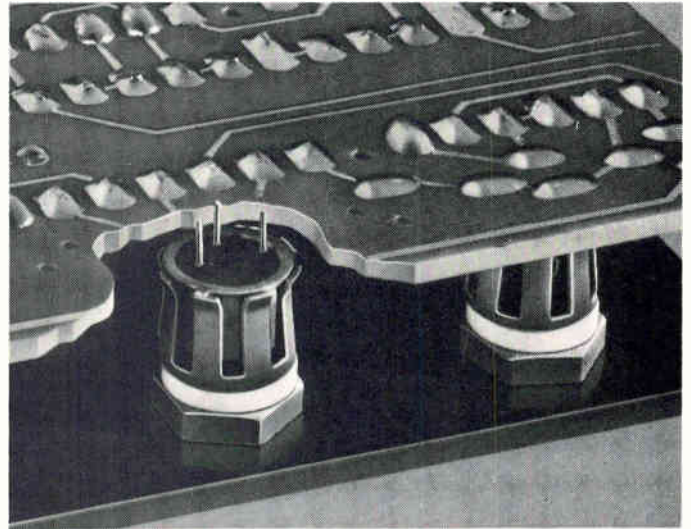
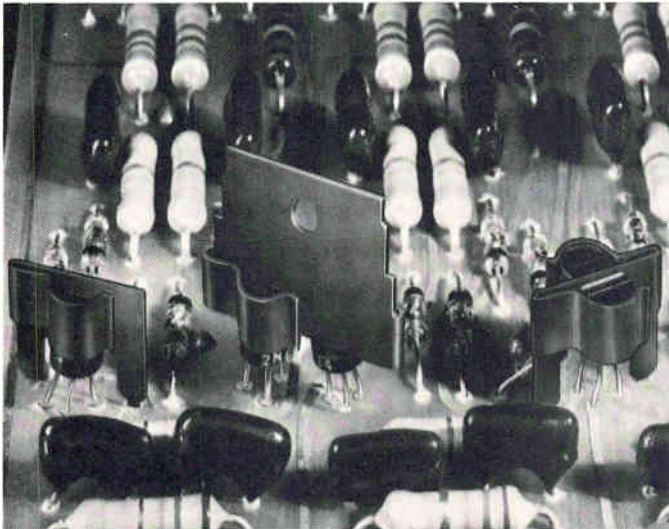

RO97's, RO97A's, X20's (D-Style) and other lead mounted, low power "plastic" transistors can be operated at up to 65% more power with IERC dissipators. They cost only pennies, provide excellent retention in severe environments, reduce failures from solder heat during assembly. 5 different styles; both single and dual models.

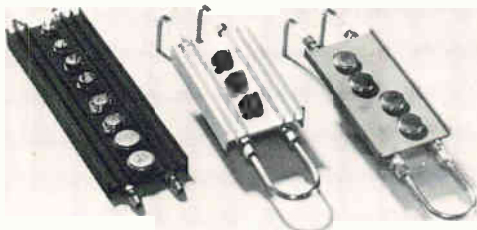

Replace elaborate forced air cooling systems for power devices. IERC fluid cooled systems provide up to 1,000 watts of dissipation in less than 45 cu. in. Parallel or series flow; open or closed loop systems. All standard mounting hole patterns; specials, too. Lengths from 6" to 3' standard.



TO3's, TO66's, TO15's and other case-mounted devices can be operated with many times more power when mounted in UP's. In still air, the staggered fingers dissipate by radiation and convection. In forced air, turbulence moves the air around each finger. Efficient in any direction. Outperforms extrusions dramatically.

For low capacitance between transistor and chassis, use IERC Thermal Links with BeO washers. BeO has the thermal conductivity of aluminum, yet cuts capacitance up to 2/3rds. Excellent dissipators and retainers. Each size fits a complete JEDEC case diameter range for TO5's and TO18's. Dual and quad models also.

Is yours a special heat problem? Talk to the thermal specialists at IERC. They have the problem solving experience to come up with a practical, low cost solution.



Free 4-page Short Form Catalog. Complete ordering and pricing information on the world's broadest line of heat sinks/dissipators and retainers for lead and case mounted semiconductors.

Heat Sinks/Dissipators

IERC



INTERNATIONAL ELECTRONIC RESEARCH CORPORATION / A CORPORATE DIVISION OF DYNAMICS CORPORATION OF AMERICA / 135 WEST MAGNOLIA AVENUE, BURBANK, CALIFORNIA 91502

Old reliables find new takers

Used computer sales may go from \$50 million this year to \$500 million in 1975, though they have not yet hurt sales or leasing of new models

Companies looking for a computer these days don't have to lease or buy a new machine. Markdowns of 30% to 75% are luring more and more bargain hunters into buying second-hand computers from some 30 firms that either stock used machines or act as middlemen.

Depending on whom you talk to, estimates for 1970 sales of used computers range from a low of \$20 million to a high of \$250 million, the later figure including party-to-party as well as broker sales. But predictions for sales in five years start at \$500 million and go up to a billion.

However, used-computer sales haven't quickened as sharply as predicted earlier in the year, largely because of cash shortages and the wait-and-see attitude adopted by many prior to IBM's 370 announcement. Thus, most sources feel the used-computer market hasn't yet made a dent in leasing, though some expect this to happen when the economy picks up.

Meanwhile, airports, insurance companies, data processing firms, and others who have bought used computers from brokers, report that units are delivered on time, in working order, and are doing a nice job at considerable savings. One reason for their satisfaction is the policy throughout the used market of only handling computers that have been maintained properly and that qualify for service contracts.

Bouquets. "We considered the IBM 360, the Honeywell, and Univac systems but felt we could buy the 5-year-old IBM 1401 at a lower price," relates Arthur Shipe, data processing manager with Cntee Sand and Gravel Co., Laurel, Md. "Computers become

dilapidated but don't wear out; with maintenance they should last five to 10 years." Shipe admits he compromised on computer speed but notes, "It's pretty hard to beat a used 1401. I know it's a work-horse because we already have one." Generally, brokers can get customers the used computer of their choice in 30 days, Shipe reports. "They can either find what we want or cannibalize one computer to make up another."

Similarly, W.B. Brown, executive vice president of Management Services, Inc., the largest southern-based data processing firm, has nothing but praise for his 1401 bought last December for \$52,000. Hardware was ordered, installed, and operating in three weeks' time, he reports, thereby freeing the firm's IBM 360 from work better suited to the 1401.

One company, Southwestern Drug Corp. in Dallas, switched to used computers. But instead of buying, it leased an IBM 360 from Business Computers, Inc. "We got

a 360 that was newer than the one we'd been leasing from IBM at 20% off IBM's current price," relates Ray Easley, purchasing manager. He says the whole deal took less than three months.

Savings vary with the age and popularity of the machine and with the broker. One house, for example, sold a five-year-old IBM 360/30 with a 64 kilobit memory for \$121,000, at least \$50,000 less than a new unit. An IBM 1401 with a memory capacity of from 4 kilobits to 16 kilobits, which sold for from \$250,000 to \$1 million new, can now be had for a 20% to 25% markdown from one broker. Generally, brokers find IBM machines have the quickest turnover, and at least one firm won't handle any other company's machines.

Detective work. Brokers have several ways of hunting down used computers. TLW Computer Industries in Atlanta, for example, gets its machines through advertising, direct mail, recommendations, and telephone calls, from all corners

What the makers are doing

Since the impact of the used computer market on new machine sales is still slight, computer makers aren't making a big thing of it. Some, though, will sell trade-ins either at a discount or, after refurbishing, as new machines.

At IBM, trade-ins and rentals are offered as-is to used computer houses for a period of 60 days. If there are no takers, IBM either reconditions the machine and uses it to fill open orders or scraps it.

Sperry Rand's Univac division recently set up a resale department to liquidate out-of-production, idle inventory. Machines that require a major rebuilding job sell for 24 months of the list net rental cost, and others that can be reconditioned in the field sell for 18 months of that cost.

Honeywell EDP doesn't sell used computers, but refurbishes trade-ins and sells them as new with a 12-month warranty. Xerox Data Systems offers discounts on some refurbished trade-ins and returned, leased units.

of American business—banking, insurance, manufacturing, to name a few. Like several other brokerage houses, TLW holds equipment in inventory until there's an order for it, then conditions it for sale.

Brokers initiate sales in the same way, though one took a more colorful approach. Adolf F. Monosson, president of the American Used Computer Corp., a subsidiary of the Boston Used Computer Group, spent three days at the Spring Joint Computer Conference wearing breadboards that proclaimed his prices in large letters.

Used computers are almost always in good condition, says Monosson. "Manufacturers almost have a guarantee from creation to death. And the older the computer, the better; there may be a little wear, but the bugs are ironed out."

Nevertheless, most firms are extremely cautious about what machines they handle. "We used to just make phone calls and put two people together, or buy the equipment and never inspect it," relates Charles Barry, vice president of Computer Discount Corp., Des Plaines, Ill. "But we have a new policy that we adopted after a computer being considered for purchase by a client was found to have been used around the clock, preventing the necessary maintenance and engineering updating work from being done."

Working against the used computer market is the fact that many larger companies will only lease computers, and then for no more than three years, according to Robert Rischitelli, manager of Machine Brokers International Corp.'s Cleveland office. They won't buy computers, because "they're afraid of getting tied down with obsolete equipment." But "obsolescence is in the eye of the beholder," counters Ralph Kort, district manager of Dataware Marketing, Inc. in San Francisco. "A ten-year-old computer can serve some people well."

This article was put together by William Bucci with reporting by Gail Farrell in Boston, Marilyn Howey in San Francisco, and Peter Schuyten in New York. Additional inputs came from McGraw-Hill World News correspondents Lisa Lazorko in Philadelphia, Herbert Maguire in Detroit, Stan Fisher in Atlanta, Marvin Reed in Dallas, Ray Lewis in Cleveland, Robert Lee in Chicago, and Michael Murphy in Los Angeles.

Get your FREE rectifiers from your authorized GE semiconductor distributor

ALABAMA	MARYLAND	DHID
Birmingham Forbes Distributing Co. (205) 251-4104 Huntsville Cramer/Huntsville, Inc. (205) 536-4493 Electronic Wholesalers, Inc. (205) 534-2461	Baltimore Kann-Elliott Electronics, Inc. (301) 889-4242 Hanover Hamilton/Avnet Electronics (301) 796-5000 Rockville Cramer/Washington, Inc. (301) 424-2700 Schweber Electronics (301) 427-4977 Salisbury Almo Industrial Electronics (301) 742-1393	Akron Sun Radio Co., Inc. (216) 434-2171 Cincinnati Hughes-Peters, Inc. (513) 351-2000 Cleveland Pioneer-Standard Electronics, Inc. (216) 432-0010 Columbus Electronics Marketing Corp. (614) 299-4161 Dayton Pioneer-Dayton (513) 236-9900 Toledo Warren Radio Co. (419) 248-3364
ARIZONA	MASSACHUSETTS	OKLAHOMA
Phoenix Hamilton/Avnet Electronics (602) 272-2601 Kierulff Electronics, Inc. (602) 273-7331	Dedham Gerber Electronics (617) 329-2400 Newton Cramer Electronics, Inc. (617) 969-7700 Springfield T. F. Cushing, Inc. (413) 788-7341 Waltham Schweber Electronics (617) 891-8484	Oklahoma City Trice Wholesale Electronics (405) 524-4415 Tulsa Oil Capitol Electronics Corp. (918) 836-2541
ARKANSAS	MICHIGAN	PENNSYLVANIA
Little Rock Carlton-Bales Co. (501) 375-5375	Detroit Radio Specialties Co. (313) 491-1012 Grand Rapids Newark-Industrial Electronics (616) 452-1411 Redford Semiconductor Specialists, Inc. (313) 255-0300	Philadelphia Almo Electronics Corp. (215) 676-6000 Pittsburgh R.P.C. Electronics (412) 782-3770 Semiconductor Specialists, Inc. (412) 781-8120 York Rosen Electronics Co. (717) 843-3875
CALIFORNIA	MINNESOTA	RHODE ISLAND
Culver City Hamilton Electro Sales (213) 870-3301 El Monte C. S. Marshall Company (213) 686-1500 Los Angeles Kierulff Electronics, Inc. (213) 685-5511 Mountain View Elmsr Electronics (415) 961-3611 Hamilton/Avnet Electronics (415) 961-7000 Oakland Brill Electronics (415) 834-5888 Palo Alto Kierulff Electronics, Inc. (415) 966-6292 Riverside Electronic Supply (714) 683-8110 San Diego Hamilton/Avnet Electronics (714) 279-2421 Kierulff Electronics, Inc. (714) 275-2112 C. S. Marshall Company (213) 686-1500 Western Radio & TV Supply (714) 239-0361	Edina Lew Bonn Company (612) 941-2770 Minneapolis Semiconductor Specialists, Inc. (612) 866-3434 St. Paul Gopher Electronics Co. (612) 645-0241	Providence W. H. Edwards Co. (401) 781-8000
COLORADO	MISSISSIPPI	SOUTH CAROLINA
Denver Electronic Parts Co. (303) 266-3755 Hamilton/Avnet Electronics (303) 443-8551 L. B. Walker Radio Co. (303) 935-2401	Jackson Ellington Electronic Supply, Inc. (601) 355-0561	Columbia Dixie Radio Supply Co., Inc. (803) 253-5333 Greenville Dixie Radio Supply Co., Inc. (803) 239-1328
CONNECTICUT	MISSOURI	TENNESSEE
North Haven Cramer Connecticut (203) 239-5641 Norwalk Arrow Electronics (203) 838-4851 Waterbury Bond Radio Electronics, Inc. (203) 753-1184	Kansas City Radio Lab, Inc. (816) 421-0171 North Kansas City ECI Semiconductors Inc. (816) 421-8400 St. Louis Olive Industrial Electronics (314) 863-7800	Chattanooga Harpis Electronic Distributors, Inc. (615) 567-2381 Kingsport Radio Electric Supply Co. (615) 247-8111 Memphis Bluff City Distributing Co. (901) 276-4501 Nashville Electra Distributing Co. (615) 255-8444
DELAWARE	NEBRASKA	TEXAS
Wilmington Almo Industrial Electronics (302) 656-9467	Lincoln Scott Electronic Supply Corp. (402) 434-8308 Omaha Radio Equipment Co. (402) 341-7700	Dallas Arcu Electronics (214) 239-9122 Hamilton/Avnet Electronics (214) 638-0900 Sterling Electronics (214) 357-9131 El Paso McNicol, Inc. (915) 566-2936 Midland Specialty Co. (915) 533-9555 Houston Hamilton/Avnet Electronics (713) 526-4661 Sterling Electronics (713) 623-6600
FLORIDA	NEW JERSEY	UTAH
Ft. Lauderdale Cramer/Florida, Inc. (305) 566-7511 Hollywood Schweber Electronics (305) 927-0511 Miami Electronic Wholesalers, Inc. (305) 696-1620 Orlando Electronic Wholesalers, Inc. (305) 841-1550 Hammond Electronics (305) 241-6601	Camden General Radio Supply Co., Inc. (609) 964-8560 Cedar Grove Hamilton/Avnet Electronics (201) 239-0800 Cherry Hill Hamilton/Avnet Electronics (609) 662-9337 Mr. Ephraim Almo Industrial Electronics (609) 933-3800 Pennsauken Cramer/Pennsylvania, Inc. (215) 923-5950 Totowa Arrow Electronics, Inc. (201) 256-7331	Salt Lake City Kimball Electronics (801) 328-2075
GEORGIA	NEW MEXICO	VIRGINIA
Atlanta Jackson Electronics Co. (404) 355-2223	Albuquerque Kierulff Electronics, Inc. (505) 268-3901 Sterling Electronics, Inc. (505) 247-2486	Charlottesville Virginia Radio Supply Co. (703) 296-4184 Richmond Meridian Electronics, Inc. (703) 353-8648 Roanoke Peoples Radio & TV Supply Co. (703) 342-8933
ILLINOIS	NEW YORK	WASHINGTON
Addison Hamilton/Avnet Electronics (312) 543-8500 Chicago Electronic Distributors, Inc. (312) 283-4800 Newark Electronics Corp. (312) 638-4411 Semiconductor Specialists, Inc. (312) 279-1000	Buffalo Standard Electronics, Inc. (716) 685-4320 Endicott Standard Electronics, Inc. (607) 754-3102 Farmingdale, L. I. Arrow Electronics, Inc. (516) 694-6800 Hauppauge Cramer/Long Island (516) 231-5600 Rochester Cramer/Rochester (716) 275-0300 Rochester Radio Supply Co. (716) 454-7800 Rome Rome Electronics, Inc. (315) 337-5400 Syracuse Cramer/Syracuse (315) 437-6671 Westbury, L. I. Schweber Electronics (516) 334-7474 Yorkville Valley Industrial Electronics, Inc. (315) 736-3393	Seattle Almco/Stroum Electronics (206) 763-2300 Hamilton/Avnet Electronics (206) 624-5930 Kierulff Electronics, Inc. (206) 763-1550 Tacoma C&G Electronics Co. (206) 272-3185
INDIANA	NEW YORK	WEST VIRGINIA
Evansville Ohio Valley Sound (812) 425-6173 Indianapolis Graham Electronics, Inc. (317) 634-8486 Semiconductor Specialists Inc. (317) 243-8271	Albany Cramer/Albany (518) 337-5400	Charleston Mountain Electronics (304) 342-8151
IOWA	NORTH CAROLINA	WISCONSIN
Cedar Rapids Deeco, Inc. (319) 365-7551	Charlotte Dixie Radio Supply Co. (704) 377-5413 Raleigh Southeastern Radio Supply Co., Inc. (919) 828-2311 Winston-Salem Electronic Wholesalers, Inc. (919) 725-8711	Milwaukee Electronic Expeditors, Inc. (414) 374-6666 West Allis Marsh Radio Supply Co. (414) 545-6500
KANSAS	OKLAHOMA	CANADA
Wichita Interstate Electronics Supply Corp. (316) 264-6318	Portland Holmes Distributors, Inc. (207) 774-5901	Toronto Canadian General Electric Co., Ltd. 537-4481
KENTUCKY	EXPORT	EXPORT
Louisville P. I. Burks Co. (502) 583-2871	IGE Export Division 159 Madison Ave. New York, N. Y. 10016	
LOUISIANA		
Lafayette Ralph's of Lafayette (318) 234-4507 New Orleans EPCOR (504) 486-7441 Sterling Electronics, Inc. (504) 522-8726		
MAINE		

GENERAL ELECTRIC

221-29

FREE RECTIFIER SAMPLES

Present (or mail) this coupon to your authorized GE semiconductor distributor.
ATTN: INDUSTRIAL SALES MGR. Please furnish up to four free rectifiers shown below.

Circle cat. no. and insert qty. (max. 4)	50V	100V	200V	400V	600V	800V
A14 1-amp	A14F	A14A	1N5059	1N5060	1N5061	1N5062
A15 3-amp	A15F	A15A	1N5624	1N5625	1N5626	
A114 1-amp fast recovery	A114F	A114A	A114B	A114D	A114M	

NAME _____ FIRM _____
 POSITION _____ STREET _____ CITY _____
 STATE _____ ZIP _____ Distributor Name _____

Offer expires October 31, 1970

A

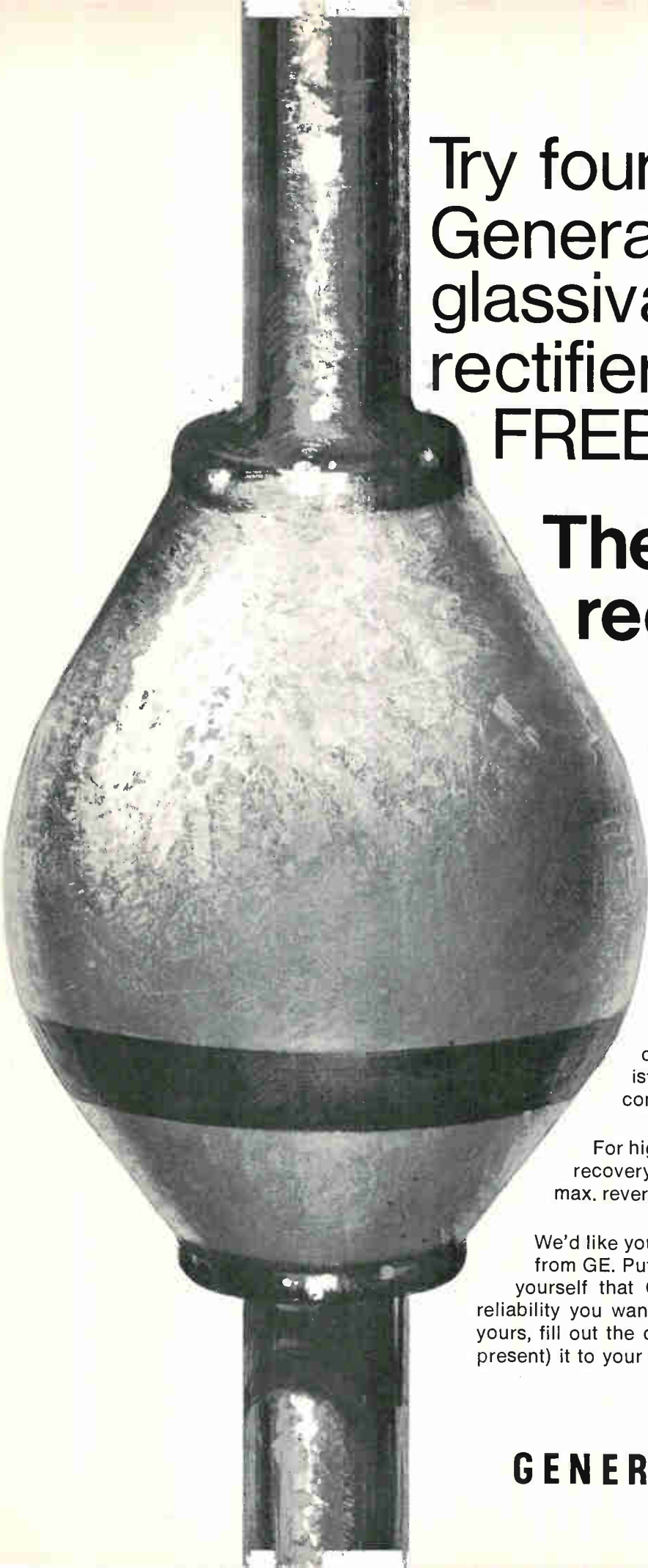

Try four
General Electric
glassivated
rectifiers
FREE

**The reliable
rectifier**

The best way to assure reliability in a low-current rectifier pellet is to put it in a package that really protects it. Protects it from shock, humidity, vibration and temperature.

And that's just what we do with General Electric's glassivated 1-amp (A14) and 3-amp (A15) rectifiers. Solid glass provides passivation and protection of the silicon pellet's P-N junction—no organic material is present within the hermetically sealed package. In addition, rigid mechanical support and excellent thermal characteristics are provided by the dual heat sink construction.

For high-frequency applications, GE offers a fast-recovery rectifier, the 1-amp A114, with a 200 nsec. max. reverse recovery.

We'd like you to try up to four free glassivated rectifiers from GE. Put them to any test you can think of. See for yourself that GE's A14/A15/A114 rectifiers deliver the reliability you want for your low current application. To get yours, fill out the coupon on the opposite page and mail (or present) it to your authorized GE semiconductor distributor.

220-85

GENERAL  **ELECTRIC**

Circle 99 on reader service card



It's not rain or snow that's holding up your mail.

It's eighty-two billion pieces of mail every year.

Knowing the volume is going nowhere but up, the U. S. Post Office has asked our Electronics division to explore the possibility of electronic transmission of some of the mail to help lighten the load.

In addition to an analysis of satellite, microwave and laser sending methods, the in-depth study is investigating delivery by in-home printing devices.

We think it will be possible one day to send a million letters coast to coast every minute without anyone but the correspondents knowing what's been written.

The day of the electronic post office hasn't arrived. But for now, electronics can help move the mails in another way. In a San Diego test, we're posting electronic letters.

These letters are printed circuit cards. They're enclosed in envelopes and packages that you can't tell apart from ordinary mail.

The printed circuit has no power, but when it passes a monitor, it immediately identifies itself, so we know when and where it's been mailed and where it's going.

With this kind of information, we'll know more about what happens to a letter that becomes part of the mail.

Sorting out eighty-two billion pieces of mail is a problem. But we put technology to work solving problems from the bottom of the sea to outer space...and a good bit in between.

GENERAL DYNAMICS

1 Rockefeller Plaza, New York, N.Y. 10020

Emancipate your time...



New HP Stat-Pac Makes System 9100 Your Personal Statistician

You have some tough decisions to make. The data is ready but the time-share terminal is booked up for the rest of the day. An educated guess is too risky. What to do? Put the decision-making power of statistical analysis on your desk or bench. The HP System 9100 Computing Calculator puts answers to important questions just a touch away — no need to wait for the services of a programmer or wait in line for a time-share terminal. The new Stat-Pac, latest addition to the 9100 software, contains 100 *applied* statistical programs that you use for decision-making in every field, from business to scientific

research. Areas covered are general statistics, distribution functions, test statistics, curve fitting, harmonic analysis, sampling theory, analysis of variance, operations research, and reliability and quality control. These programs are formatted and ready for entry into your 9100. For instantaneous entry, store often-used programs on the exclusive magnetic card. Since many of these programs include the HP 9125A X-Y Plotter, you will be free from tedious (and inefficient) hand plotting of graphs and charts.

How's this for a vital statistic? Users tell us that the System

9100 is solving 58% of their problems for \$1.11 per computing hour. Lease, rent, and purchase options available. For further information, or to arrange a "hands-on" demonstration at your desk, write: Hewlett-Packard, P.O. Box 301, Loveland, Colorado 80537 In Europe: Hewlett-Packard, 1217 Meyrin-Geneva, Switzerland.

090/32

HEWLETT  PACKARD

HP CALCULATOR SYSTEM 9100

Minicomputers penetrate N/C field

Market for numerical control may reach \$100 million in 1970; machine tool exhibits in Chicago next month provide showcase for systems

By Alfred Rosenblatt

Industrial electronics editor

"If you don't have a computer, don't bother going to the show," says an executive of a major machine tool company. The show he's talking about is the National Machine Tool Show, opening Sept. 21 in Chicago. The tool exhibit, and the Production Engineering Show opening a day later, will highlight new computer-controlled manufacturing systems. And with these systems will come a new era in the machine tool industry: computers, rather than punched tapes, will direct numerically controlled tools.

Minicomputers will be at the core of many of these new systems. To the electronics industry, this means an important new market. Computerized numerical control and its larger, sophisticated version, direct numerical control, will soon take over in the numerical control field. Estimated sales in 1970 of numerical control equipment range between \$80 and \$100 million, and that's attracting many electronics companies.

Some, like Bryant Computer Products, will be teaming with established machine tool builders—in Bryant's case, its corporate parent, the Ex-Cell-O Corp., perhaps the largest machine tool manufacturer in the nation. Others, like the Digital Equipment Corp., are readying their own systems. So is the Xenex Corp., of Waltham, Mass., until now a data processing systems consultant. And still other companies, like Midwestern Computer Controls, are being formed specifically to enter the new field.

Join up. These companies join the array of numerical control and machine tool manufacturers who

have announced the development of computerized and direct numerical control systems that have varying degrees of sophistication. These include Sundstrand Machine Tool's Omnicontrol, General Electric's CommanDir, Westinghouse Electric's New World, Allen Bradley's System 7300, and Cincinatti Milatron's system. With the exception of Midwestern Computer, all of these companies will be demonstrating equipment at the shows in Chicago.

The Ex-Cell-O multi-machine control system represents one of three approaches being applied to computer-directed numerical control. It is designed to work with, rather than replace, numerical control systems currently being used. "We leave on the machine tool the numerical control a customer may

already have," explains group vice president James L. Koontz. "And we come in behind it with our system."

This approach replaces only the numerical controller's punched tape, relying on the hard-wired logic in the N/C director to supply the signals for driving the machine tool motors. A design similar to this one is being followed, for example, by GE in its CommanDir system.

Total. In its most sophisticated version, Sundstrand's Omnicontrol replaces the entire numerical controller at each machine tool with its own control logic package. Program signals for manufacturing a machine part come directly from a computer. In another configuration, the Omnicontrol can also interface with a customer's equip-

Control. Bryant Computer Products' system drives up to 16 machine tools through adapters that interface with each tool's N/C controller. Paper tape reader takes over if computer fails.

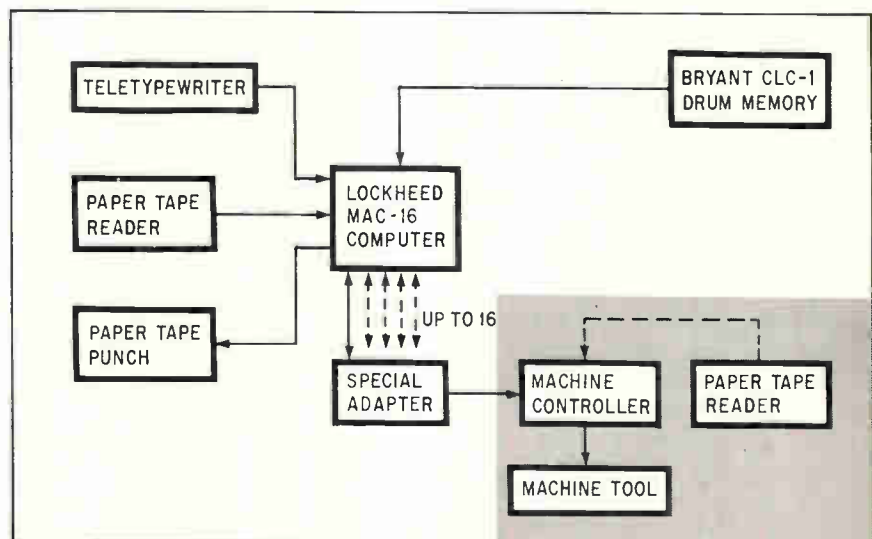

ment much like Ex-Cell-O's system. The Omnicontrol also offers a cathode ray tube display unit from which a program can be manipulated or supervisory information displayed. And it's possible to build up the system to truly gigantic proportions: a basic master control unit accommodating as many as 15 machines can be expanded, with extra memory storage, to control as many as 256 machines, according to Sundstrand.

An example of the third approach, aimed at the small machine shop, is that taken by the Digital Equipment Corp. DEC replaces the complete numerical controller with a control unit incorporating a PDP-8L minicomputer. However, the system can control only two machines at most from programs stored in its core memory. Cutting things still finer and using one computer per machine tool are companies such as Allen-Bradley and Westinghouse.

The Ex-Cell-O system, on the other hand, controls as many as 16 different types of tri-axis machine tools through adapter units that interface with whatever type of numerical controller a customer may have.

Off the floor. Information to the adapter, sitting beside the machine tool out on the factory floor, comes from the computer which can be as far away as 2,500 feet in an environmentally controlled room. The computing system includes a Lockheed Electronics MAC 16 minicomputer as the central processor, a Bryant Computer Products CLC 1 drum memory for storing programs, and a teletypewriter input/output device.

The computer system, instead of a punched tape, drives the hard-wired logic circuitry in the numerical controller at the tool. By not replacing the controller with its own unit Ex-Cell-O hopes to make as few changes as possible in a machine shop's normal operation, according to Koontz. In addition to keeping costs down, this should also make it easier for a customer to accept the DNC concept, he says. Cost of the basic Ex-Cell-O system is \$150,000, including software, plus \$10,000 to \$12,000 for each interface adapter.

Several reasons exist for computerizing numerical control. Elim-

inating the punched tape on the machine tool automatically does away with a major source of machining errors and spoiled parts caused by torn and dirty tapes, and incorrectly read information. In addition, the new systems place the control of machine tools firmly in the hands of management for the first time, according to Melvin Bergman, the engineer leading the Bryant development. The systems will provide real-time information about what's happening on the factory floor, detailing such things as how many of a given part have been completed, how long the operation has taken, and when a machine has malfunctioned.

Flexible. In the Bryant system, these programs are prepared on punched tape, much like an ordinary numerical control tape is prepared, and read into the system via a high speed tape reader. If the computer should fail, it's then possible to put these tapes on the numerical controllers and have the machine tools carry on without the computer.

Digital Equipment is preparing its computerized numerical control system for application to point-to-point and contouring machines at the "bottom end of the machine tool spectrum," according to Russell Doane, manager of the project. This means relatively simple machines such as two-axis drilling and milling machines, lathes, and punch presses.

The PDP-8L computer at the center of the DEC system relies on a 4,000-word, 12-bit core memory to store two part programs at a time. The processor also performs the logic needed to direct the movement of two, generally identical, machine tools. A single cabinet, 5 feet by 4 feet by 16 inches, houses the system which, with two separate operator's consoles perched atop it, is placed next to the machine tools on the factory floor. The cabinet contains interfaces that connect the computer system to the two operator's consoles, three Teletypes, and the stepping motors on the two machine tools.

Trio. One of the teletypewriters, which are all placed in an office environment, is used to prepare the part programs and read them into the computer. The other two report supervisory information.

The operator's console also provides the part programmer with an unusual amount of program-editing capability for a machine without a crt display. This is done with a series of legends printed on the operator's console which define the things the programmer may want to edit. There is also a row of Nixie tubes to present part dimensions.

A similar system interfacing with the servos of several machine tools is being developed by the Xenex Corp., using a Honeywell H-112. Another Honeywell minicomputer is being used in a control system, dedicated to cutting cams, which is being brought to market by mid-western Computer Controls.

The new H-1662 system solves the exact equations defining the cam surfaces using a computer program, instead of relying, as do present N/C cam cutters, on a series of short, straight lines.

The result is relatively simple programming, entered on a teletypewriter, and an extremely smooth cam surface, says Honeywell.

Each cam-cutting control system, with one Honeywell H-316 computer, interfaces to the machine tool stepping motors, and an ASR-33 Teletype, will cost \$45,000.



First step. Tektronix Inc. is entering N/C field with a two-axis (\$9,750) and three-axis (\$11,000) model for both point-to-point and contouring machines. Position and command registers operate in binary code, so they can be used in computer-directed systems being planned. Prices do not include type 611 storage display (\$2,695) that provides quick check for any gross errors in programming.

**"Bigger and better...this
engineer's bible..."**

-Electronics Magazine

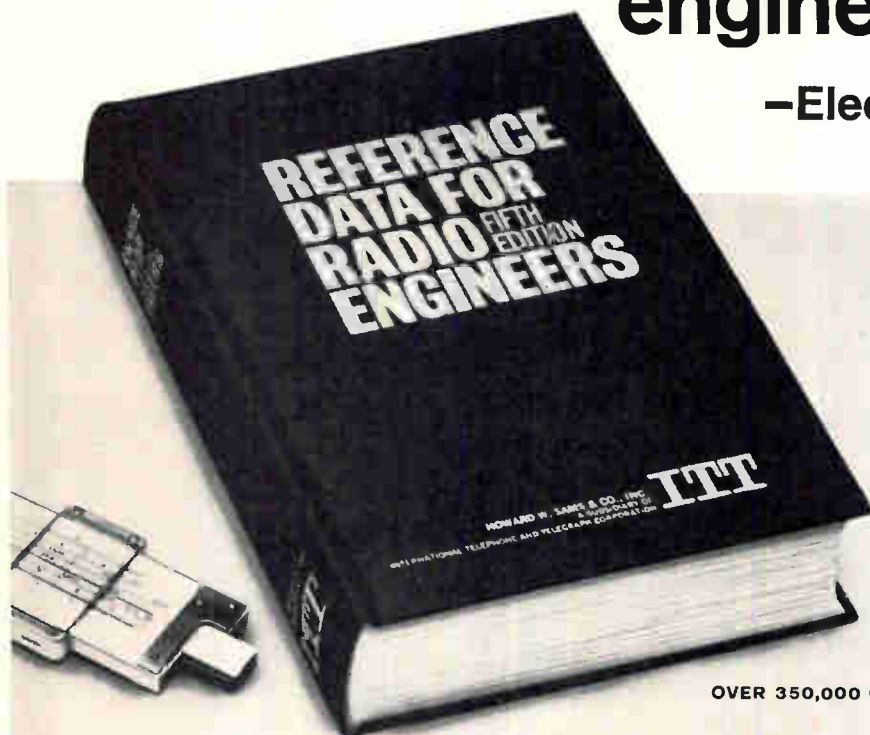

**5th EDITION of a
world-famous reference**

Now contains 50% MORE DATA to include major information developed over the past 12 years. Prepared by an outstanding group of practicing engineers, professors, and industry and government experts, under the direction of the International Telephone and Telegraph Corporation staff.

OVER 350,000 COPIES SOLD IN PRIOR EDITIONS

Reference Data for Radio Engineers

CHAPTER CONTENTS

- | | |
|--|--|
| Frequency Data | Transmission Lines |
| *International Telecommunication Recommendations | Waveguides and Resonators |
| Units, Constants, and Conversion Factors | Scattering Matrices |
| Properties of Materials | Antennas |
| Components or Parts | Electromagnetic-Wave Propagation |
| Fundamentals of Networks | Radio Noise and Interference |
| Filters, Image-Parameter Design | Broadcasting and Recording |
| Filters, Modern-Network-Theory Design | Radar Fundamentals |
| Filters, Simple Bandpass Design | Wire Transmission |
| Attenuators | *Switching Networks and Traffic Concepts |
| Bridges and Impedance Measurements | Digital Computers |
| Magnetic-Core Transformers and Reactors | *Navigation Aids |
| Rectifiers and Filters | *Space Communications |
| Magnetic Amplifiers | Electroacoustics |
| Feedback Control Systems | Nuclear Physics |
| Electron Tubes | *Quantum Electronics |
| Electron-Tube Circuits | Information Theory |
| Semiconductors and Transistors | Probability and Statistics |
| Transistor Circuits | *Reliability and Life Testing |
| *Microminiature Electronics | Miscellaneous Data |
| Modulation | Fourier Waveform Analysis |
| | Maxwell's Equations |
| | Mathematical Equations |
| | Mathematical Tables |

*New chapters on subjects not covered in 4th Edition

1196 PAGES • 1350 ILLUSTRATIONS
plus 41 page index

The FIFTH EDITION of this widely used reference work has been completely revised and updated. It provides in a single volume comprehensive data on all basic phases of electronics, including tables, formulas, standards, and circuit information—PLUS—all-new data on microminiature electronics, space communications, navigation aids, reliability and life testing, international telecommunication recommendations, switching networks and traffic concepts, and quantum electronics. Includes over 1300 charts, nomographs, diagrams, tables, and illustrations. 45 data-packed chapters. 1196 pages of invaluable information for practicing radio and electronics engineers.

10-Day Free Examination

HOWARD W. SAMS & CO., INC., Dept. EL-80
A Subsidiary of International Telephone & Telegraph Corporation
4300 West 62nd Street, Indianapolis, Ind. 46268

- Send me REFERENCE DATA FOR RADIO ENGINEERS for 10-day examination, without cost or obligation. If I decide to keep the volume, I will send \$20.00 (plus postage) in 10 days; otherwise, I will return the book within 10 days.
- \$20 payment enclosed. Send my copy postpaid with full 10-day refund privilege. (Include sales tax where applicable.)

Name _____

Company _____

Address _____

City _____ State _____ Zip _____

When you're known for Rolls-Royces,

it's hard to get Volkswagen buyers to think of you.

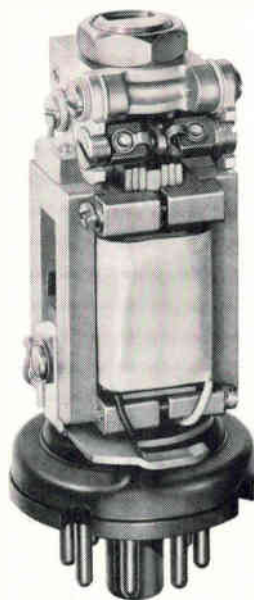

Series 72 Pulse and
Telegraph Polar Relay
... pulse repetition to
400/sec., life in hun-
dreds of millions of
operations

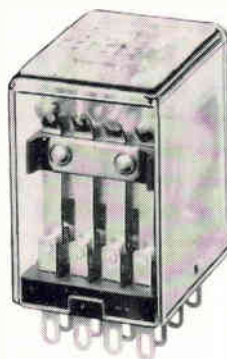

Series 67
General purpose
AC & DC, 4PDT, 5A

SIGMA has 2000 good, different general-purpose relays— many for 50¢/pole.

If you think of Sigma as a sensitive, close-differential relay house, you're partly correct. We're also a low-priced, general purpose relay house — as a substantial number of vending machine, alarm system, industrial control, copier and communications equipment manufacturers will attest.

For demanding applications such as computer peripherals, you can have one-cubic-inch 4PDT switching, on AC or DC coil signals, of low-level to 5-amp. loads at least 100,000 times with the Series 67. Fast wiring, mounting and interchangeability results from PC or solder terminals, or in sockets with PC or solder terminals.



Single-, two- or three-pole switching of loads up to 10 amps, for one million operations at 28 VDC or one-half million at 115VAC, is provided by the versatile and quickly-installed Series 68.

For up to 6PDT switching of low-level to 5 amp. loads by voltage adjustment, or 1-amp. loads on sensitive current adjustment, the Series 62 combines long life (up to 50 million operations with bifurcated contacts) with moderate cost.



For positive response to coil signals as low as 50 mw, at a cost of under 75¢/relay in quantity, the Series 65 is well-suited to TV channel selectors, slide projectors, vending machines and similar uses involving SPDT switching of 1-amp. loads.

Up to 3PDT switching of 5- or 10-amp. loads, on AC or DC voltages, is available in the compact and low-cost Series 50; wide application in automated equipment, switching small motors, solenoids and other relays.



We'll be glad to supply detailed technical data on any of the general-purpose relays mentioned, with complete price and delivery information on standards. Better yet, tell us your requirements (load, life, cost, driving signal, operating speed and environment) and let us recommend the relay best suited to the job. We can save you time, disappointment and perhaps some money as well. Sigma Instruments, Inc., 170 Pearl St., Braintree, Massachusetts 02185.

SIGMA
INSTRUMENTS INC

Dot-display unit challenges scopes in digital-circuit checkout field

By George Weiss

New products editor

Ruggedness and small size stand as primary requirements for field service test gear, particularly at remote user locations. The all-purpose oscilloscope does not have these features and, for testing digital equipment, the high resolution and analog-waveform capability of the standard scope are unnecessary. On the other hand, logic probes and voltmeters won't divulge anything about the time sequence of the data, ruling them out for many field tests.

That's why Compta Inc. decided to develop a specialized instrument to test data processing and communications equipment at customer locations. A serviceman can hold the 14-ounce digital test instrument, called the Compta-Scope, in his hand or attach it to his belt. Despite its smallness, the instrument is built to withstand work-area shock and vibration. A row of 40 light-emitting diodes can display positive and negative pulses, as well as d-c levels. The instrument stores pulse widths of 25 nanoseconds.

The Compta-Scope's usefulness extends to computer mainframes, peripherals, and communication terminals. John Genet, vice president of engineering, points out that test equipment often costs much more than it should. He says, "I am thinking of alphanumeric cathode ray tube terminals, which may run as low as \$2,500, being serviced by \$2,000 oscilloscopes." The Compta-Scope sells for \$435 plus the price of required plug-ins. He adds that use of the six controls on the front panel can be easily mastered.

"The light-emitting diodes fit well into the purpose and scheme of the instrument because they're

compatible with ICs, have a long life, and are much more rugged than filament indicators. In addition, the LEDs have a much faster response time than an incandescent bulb and therefore give us some latitude in sweep speeds," comments Genet.

The Compta-Scope tests any type of logic including transistor-transistor logic, emitter-coupled logic, and even relay systems. The operator need only select the appropriate p-c plug-in card. The unit also accommodates either bipolar or metal oxide semiconductor voltage levels.

One of the most significant features of the Compta-Scope is its ability to display and store non-repetitious signals without the bother of refreshing or the use of a storage scope.

In operation the Compta-Scope uses a sampled-time-domain principle. The unit samples data at a selected sweep rate and displays each sample by an individual light-

emitting diode. During each sample period, the instrument tests the voltage level of the input data. If the voltage exceeds a threshold value, adjustable by a front panel thumbwheel switch, the corresponding indicator will light, signifying a logic 1 level. If the input voltage remains below the threshold, the corresponding indicator remains off for the logic zero state. The combined samples result in a two-level quantized display of signal versus time. After a sweep, the display holds until a new sweep is triggered.

The threshold for TTL logic can be set at 250-millivolt increments from 0.25 to 1 volt, and thereafter at 500-millivolt steps up to 4 volts. Thus, to observe a binary signal whose logic 1 level is between 1 and 1.5 volts, the threshold is set at 1 volt. During the sweep, the diodes that light indicate that the waveform has exceeded the threshold, i.e. a logic 1 level exists. When the amplitude falls below 1



Tight check. Tester monitors digital performance. Unit's light-emitting diodes display 1s and 0s of pulses, and stores them.

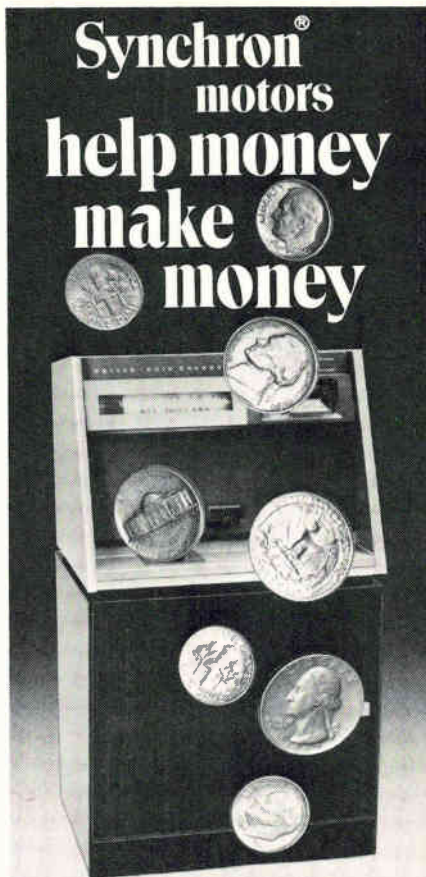

In the vending business, a would-be customer with dollar bills and no coins might just as well be flat broke. Unless there's a bill changer around. Like this one made by Rowe International.

Feed it a dollar bill and, presto! Instant alchemy. That useless paper is turned into spendable change.

The acceptance of the bill provides a signal which is transformed into multiple pulses in a Hansen-actuated electromechanical pulse chopper. Impulses are then sent to a memory unit and the payoff is actuated. The major reason why Hansen motors are specified: "Dependability."

Contact your Hansen man and find out how Hansen dependability can help you.



HANSEN

Manufacturing Company, Inc.
Princeton, Indiana 47570



HANSEN REPRESENTATIVES: CAREY & ASSOCIATES, Houston and Dallas, Texas; R. S. HOPKINS CO., Sherman Oaks, Calif.; MELCHIOR

ASSOCIATES, INC., San Carlos, Calif.; THE FROMM CO., River Forest, Ill.; JOHN ORR ASSOCIATES, Grand Rapids, Mich.; H. C. JOHNSON AGENCY, INC., Rochester, N.Y.; WINSLOW ELECTRIC CO., Essex, Conn.; Villanova, Pa., and Teaneck, N.J.
EXPORT DEPARTMENT: 2200 Shames Drive, Westbury, N.Y. 11590

... in manual operation, data is displayed and stored until sweep is retrigged ...

volt, the diodes remain unlit. Rise and fall times, and complex waveforms such as sawtooths can be measured by incrementing through each threshold from ground to the peak amplitude and observing which lights change state as the edge of the waveform is followed.

The time scale is divided into 40 equal parts, one for each of the diodes. The sampling periods are derived by dividing down the system's 10-megahertz master clock. By turning a thumbwheel switch on the panel, each diode indicator assumes a time period from 100 nanoseconds up to 100 milliseconds. The increments are on a 1-2-5 time base sequence.

Two p-c boards—one for the mainframe and the other for the plug-in—hold all the electronics including medium scale integrated circuits. The unit uses either a rechargeable nickel-cadmium battery pack or an a-c power supply of ± 5 volts. All plug-ins will cost \$105 each and be immediately available for TTL, DTL, and RTL. The optional battery pack sells for \$95.

"Basically, we use a 40-bit shift register to store the digitized input data, and this register in turn drives the light-emitting diode display," says Genet. "The plug-ins perform a simple analog to digital conversion with one bit of output for each conversion period. If the signal at a particular time interval is above the threshold set by the operator, a binary 1 is stored in the flip-flop corresponding to that time segment. The flip-flop drives an indicator which turns on when the signal is a 1."

Besides those for time and threshold, the controls include an AUTO and TRIGGER pushbutton and a SYNC MODE thumbwheel switch with four positions. Depressing the TRIGGER button initiates four types of sweeps: internal or external positive, or internal or external negative.

The triggering modes are analogous to conventional scopes, in which either data (internal) or sync input can trigger the sweep on

either a leading or trailing edge of a pulse.

For automatic operation, the AUTO button is depressed and on completion of the sweep and display, the scope automatically re-triggers on the next synchronizing event. In the manual mode, when the button is released the data is stored and displayed until the operator re-triggers the scope.

The light-emitting diodes, made by Monsanto, are spaced on $\frac{1}{8}$ -

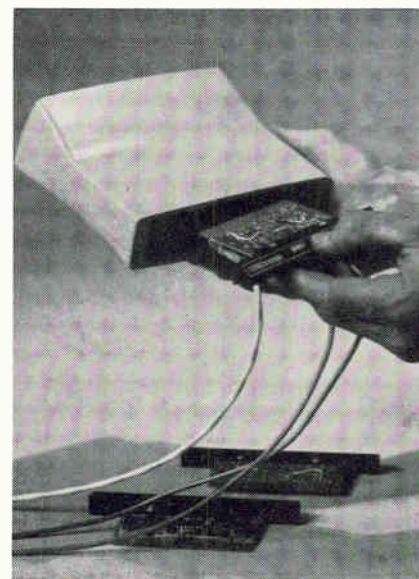

What goes in. Plug-ins needed to test various logic families are inserted in connector at rear.

inch centers on a 5-inch indicator panel. The whole unit measures 6.5 by 5.3 by 2.4 inches and weighs 14 ounces without the supply.

The accuracy of the time base is $\pm 3\%$, and the threshold $3\% \pm 20$ millivolts with a sensitivity of 15 millivolts over threshold. Minimum trigger pulse width is 25 nanoseconds, and minimum trigger amplitude is 50 millivolts over threshold. Threshold of the sync input is 1.5 volts ± 150 millivolts.

Compta will design plug-ins to accommodate other types of logic or handle special-purpose applications.

First deliveries are scheduled for September.

Compta Inc., 4402 Cleveland Rd., Syracuse, N.Y. 13215 [339]

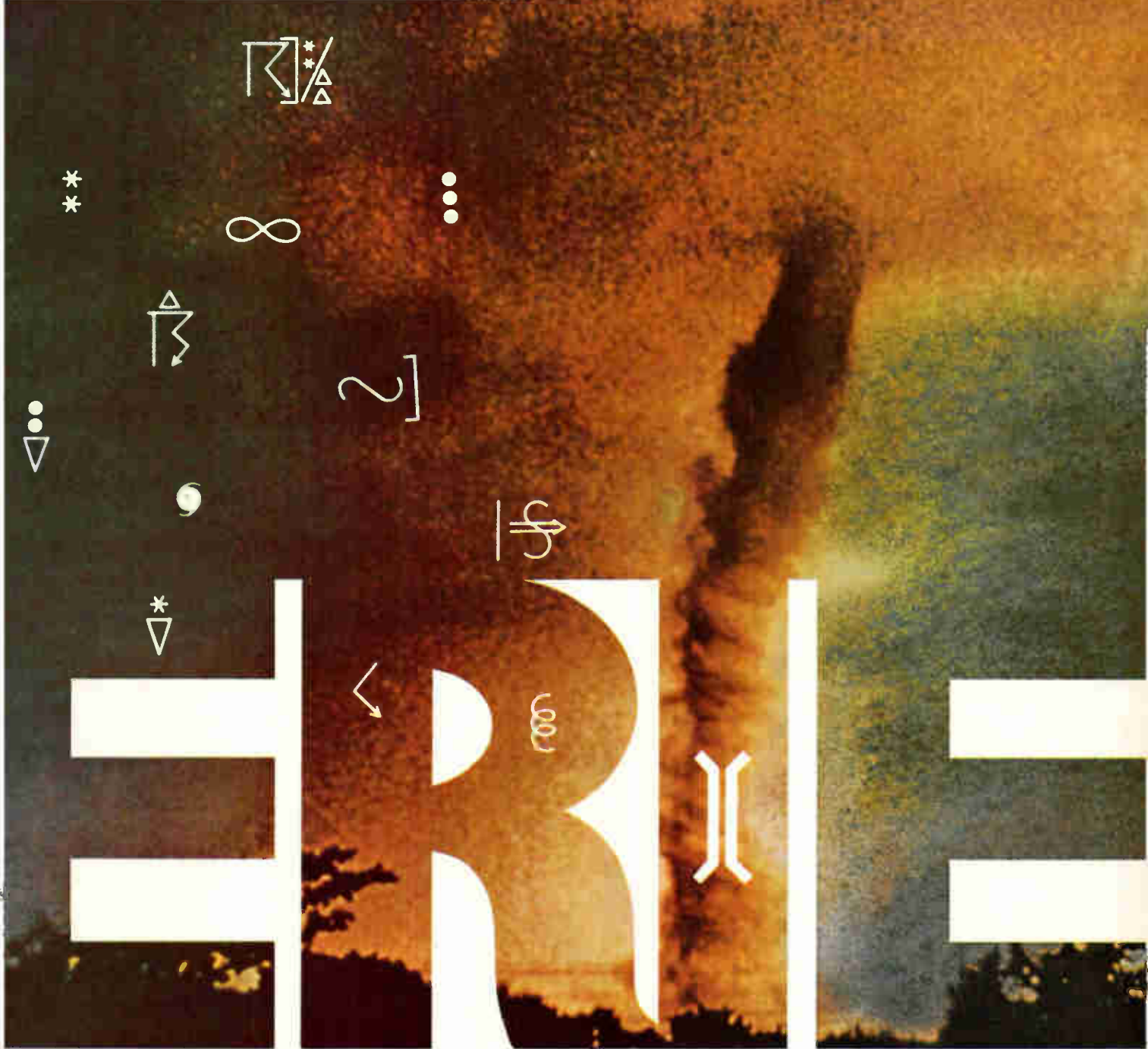

When you're adding a new "twist" to tornado tracking...

Symbolic representation of global weather as plotted by Burroughs ILLIAC IV computer.

bring ERIE in early.

Cyclone off Ceylon. 17-inch snow at Salem. Tropical storm in Trinidad. World-wide weather reports? No, forecasts! Made four days in advance... with the same accuracy as present one-day predictions. That's just one of the superscale jobs possible with the incredible new ILLIAC IV computer designed by the University of Illinois and built by Burroughs Corporation. Unlike conventional computers that process serially, ILLIAC IV utilizes parallel processing... crunching numbers on many matrix problems or differential equations simultaneously, and at super speeds. From the start, ERIE engineers have worked closely with Burroughs to develop the highly-sophisticated resistor/capacitor and resistor modules at the heart of ILLIAC IV. Proof, once again, that it pays to bring ERIE in early.

ERIE TECHNOLOGICAL PRODUCTS, INC.
644 West 12th Street, Erie, Pennsylvania 16512
(814) 453-5611

Circle 109 on reader service card



Look at Acopian's new mini-module dc power supplies

Look at their size. Single output models (there are duals, too) are as small as 2.32" x 1.82" x 1.00". And they can all be soldered directly into printed circuit boards.

Look at their performance. Load and line regulation is 0.02 to 0.1% depending on the model selected. Ripple is only 0.5 mv RMS. And Acopian's long experience in power supply technology assures high reliability.

Look at the choice of outputs. There are 58 different single output modules ranging from 1 to 28 volts, 40 ma to 500 ma. Duals are available in 406 different combinations

of voltages. And these are **true** dual power supplies, with like or different outputs in each section that are electrically independent of each other. Perfect for powering operational amplifiers. Or for unbalanced loads.

Acopian mini-module power supplies		
	Singles	Duals
Output Voltages (vdc):	1 to 28	1 to 28
Output Currents (ma):	40 to 500	40 to 250
Line and Load Regulation:	.02 to 0.1% depending on model	
Ripple:	0.5 mv RMS	
Ambient Temperature (without derating)	0 to 55°C	
Polarity:	outputs floating and isolated	

Look at their price. Single output models start at \$39, duals at \$58.

For a look at all the facts, write or call Acopian Corp., Easton, Pa. 18042. And just like Acopian's other 82,000 power supplies, every mini-module is shipped with a tag that looks like this . . .



Wideband recorder fits in attache case

Lightweight unit goes to 375 khz in direct mode and 100 khz in f-m; NiCd battery supplies the required 25 watts

The name's the same—almost—and just by looking at it, there's no way to tell the new magnetic recorder from the older model. But the Lockheed Electronics Co.'s 417 wideband is quite a bit different from the older 417.

The changes show up in the bandwidth spec and in the internal circuitry. The new unit responds to frequencies up to 375 kilohertz in

the direct-record mode, and to 100 khz in the f-m mode. That's an almost fourfold improvement for direct recording and a tenfold jump for f-m operation. To boost these ranges Lockheed engineers redesigned much of the recorder's circuitry, and, in the process, turned to ICs. "The only thing that looks the same is the envelope—the box that it's in," says program engi-

neer Richard Yessian.

Nevertheless, the 417 wideband maintains many features of the 417, such as seven-channel recording. The unit weighs less than 30 pounds, and can be packaged in an attache-type case. An internal nickel cadmium battery powers the recorder, which draws 25 watts. With these features, the 417 wideband can be taken to remote loca-



Automatic noise figure meter model 792A1 features a 75 ohm, 10 to 250 Mhz tuned amplifier input and a 75 ohm, 10 to 1000 Mhz full range noise head. A direct-reading panel meter provides noise figure readings over a range of 0 to 20 db for the 6-db automatic reference; 3 to 30 db for gas tube and solid state sources. Kay Elemetrics Corp., Pine Brook, N.J. 07056 [361]



Taut-band multimeter model N-2 has 41 ranges. D-c voltages range from 0.012 to 600 v full scale. A-c voltages range from 1.5 to 600 v. These are flat to 100 khz. D-c current ranges are from 30 μ a to 6 amps f-s. A-c current ranges cover 150 μ a to 6 amps. Resistance, db level and temperature are also measured. Medistor Instrument Co., N. Northlake Way, Seattle, Wash. [365]



Digital multimeter model 262A has available 25 ranges for measuring d-c voltage and current, a-c voltage and current, and ohms. It has a basic d-c accuracy of 0.1% of reading. All the d-c ranges feature automatic polarity indication; and automatic zero correction circuitry assures maximum stability. Price is \$375. United Systems Corp., 918 Woodley Rd., Dayton, Ohio 45403 [362]



Sampling logarithmic voltmeter model 220 has a frequency of 100 hz to 1 Mhz and 84-db dynamic range. It has direct digital readout of single or multiple bursts of a-c signals. Typical applications include high-speed component testing, and analysis of direct or reflected acoustical signals. Dranetz Engineering Laboratories Inc., 1233 Worth Ave., Plainfield, N.J. [366]



Portable tester model H-720 identifies silicon and germanium semiconductor materials as N or P types, with fast swing needle readout. Readouts are achieved with minimal probe pressure especially suitable for use on very thin substrate. The long-life probe pins are easily replaced when required. Unit measures 8½ x 6 x 8 in. Semimetals Inc., 172 Spruce St., Westbury, N.Y. 11590 [363]



Heat flow meter model 860 offers 10% accurate measurements from -300° to +400° F. Measurements are repeatable to within \pm 2% at any temperature on all ranges except the two most sensitive where repeatability is limited by meter noise. Rise time is less than 1 sec on all ranges except the most sensitive where it is 3 sec. Keithley Instruments Inc., Aurora Rd., Cleveland [367]

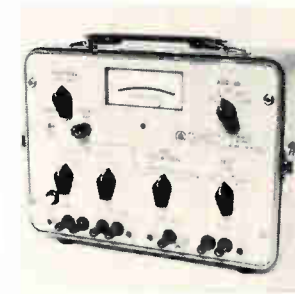

Test sets models 481A and 481B permit measurement of echo return loss and singing point return loss on wire line transmission systems. The 481A, a portable version, measures 2- and 4-wire parameters. The 481B is a rack-mounted type for central office use and measures 4-wire characteristics. Bowmar/ALI Inc., subsidiary of Bowmar Instrument Corp., Acton, Mass. [364]

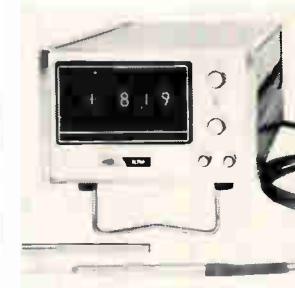

Direct-reading gaussmeters are available in six models, from inexpensive Hall effect instruments to a digital readout nuclear magnetic resonance unit complete with a 5-in. crt display. They meet every application from production line testing or magnetic field mapping to research lab magnetic field measurements. Alpha Scientific, 460 Roland Way, Oakland, Calif. [368]

CLASSIFIED ADVERTISING

SEARCHLIGHT SECTION

BUSINESS OPPORTUNITIES
USED OR SURPLUS EQUIPMENT

RADAR SYSTEMS GROUND AND AIRBORNE. AUTOMATIC TRACKING ANTENNA SYSTEMS. NIKE AJAX. NIKE HERCULES. M-33. MSO-1A. MPS-19. MPS-9. SCR 584. TPS-1D. TPS-28. FAA-ASR-2. AIRBORNE SYSTEMS. APN-84. APN-102. APS-20. APS-27. APS-45. DPN-19. DIGITAL COMPUTERS. IBM 650. IBM 704.

LARGEST INVENTORY OF RADAR AND MICROWAVE EQUIPMENT IN THE WORLD.

RADIO RESEARCH INSTRUMENT CO.

45 WEST 45TH ST. N. Y. 10036 212-JU 6-4691

free catalog

POTTING APPLICATORS

MANUAL AND DISPOSABLE

6cc 12cc 30cc

FOR POTTING, ENCAPSULATING, AND SEALING OF MINIATURE COMPONENTS

PHILIP FISHMAN COMPANY
7 CAMERON ST., WELLESLEY 81, MASSACHUSETTS

ADDRESS BOX NO. REPLIES TO: Box No.
Classified Adv. Dept. of this publication.
Send to office nearest you.
NEW YORK, N. Y. 10036: P. O. Box 12
CHICAGO, Ill. 60611: 645 N. Michigan Ave.
SAN FRANCISCO, Cal. 94111: 255 California St.

EMPLOYMENT SERVICES

The Resume Game: An Insider's Guide How to write & use yours successfully. Cover letter/resume samples. \$2. Plymouth Pubs, Box 318A Plymouth Mtg Pa. 19462.

BUSINESS OPPORTUNITY

Capital Contacts—Before you try Public or Private Placements to Underwriters, Investment Banking Houses, write for free helpful information to Confidential Consultant, 817 51st St., Brooklyn, N.Y.

Mr. Used Equipment Dealer:

When you advertise in the Searchlight Section . . . You have hired your most persuasive salesman:

He's efficient . . . He thrives on long hours . . . His territory is the entire nation . . . and overseas . . . He doesn't see buyers of used and new surplus equipment: They see him—regularly. They depend on him.

He is Searchlight—The section of this publication where wise dealers advertise and list their stocks for sale.

SEARCHLIGHT SECTION

Classified Advertising Div.

Post Office Box 12

New York, N. Y. 10036

tions, or used in cramped instrumentation labs.

One company already has found a job for the 417 wideband. Mounted in a single-engine Cessna, the recorder stores data coming from an infrared scanner. "The (old) 417 was very attractive in that area," says Yessian. "However, because of its limited bandwidth, the resolution of the mapping with the infrared didn't have as much detail as the customer desired. He says that the wideband has improved the performance of the over-all system."

Operating range for the recorder is 0°C to 40°C, and tape speed holds to within 1% over this span. Flutter is less than 0.2% rms, and the signal to noise ratio is—depending on recording mode and tape speed—between 27 and 35 decibels.

Although the 417 wideband comes put together, customers order it in parts. The transport is \$8,100. Signal processing boards for each channel cost between \$165 and \$280, and plug-ins for each tape speed and each channel cost between \$40 and \$95. Speeds range between 3¼ and 30 inches per second. The least expensive unit would just record directly over seven channels (no playback capability) at only one speed, and would sell for \$9,255 (no plug-ins needed for direct recording).

Plug-ins are available also for running the recorder from a car or plane battery, or from a-c.

Lockheed Electronics Co., U.S. Route 22, Plainfield, N.J. 07061 [369]



New instruments

No-frills counter has low price

There's only one control on this \$1,250 device; range is 0.1 hz to 20 Mhz

The man whose needs are few and whose wallet is thin is the target for Monsanto Electronic Instruments' new counter, the 107A. Its only control is a sensitivity dial, but that's because the 107A has nothing else to control. It's just for giving frequency. It can't measure a signal's period or other time intervals, nor can it count input pulses or do other jobs that counters often handle.

According to a Monsanto spokesman, the 107A will appeal to engineers who don't want to pay \$1,500 or more for a counter with capabilities they'll never use. To get the 107A, they will have to put out only \$1,250.

The 107A isn't by any means the lowest-priced counter on the market. In fact, the 107A has a high-priced feature—speed. Over a range of 0.1 hertz to 20 megahertz, the counter has a measuring time equal to the period of the input. Thus the maximum measuring time is 10 seconds, and for inputs in the kilohertz range and above, the time per reading is a matter of microseconds. What's more, accuracy comes with this speed. Over the entire frequency range the instrument's accuracy is ± 1 count plus a factor determined by the aging rate and temperature stability of a crystal-controlled clock.

It's not quite fair to say that the 107A has only one talent. Inside is a circuit that calculates revolutions per minute from the frequency of the input. To get into this rpm mode, the user flips a switch on the counter's back panel.

The 107A is small, to complement its small price tag: it measures 4¼ inches high, 7½ wide, and 11 inches deep.

Monsanto Electronic Instruments, 620 Passaic Ave., West Caldwell, N.J. [370]

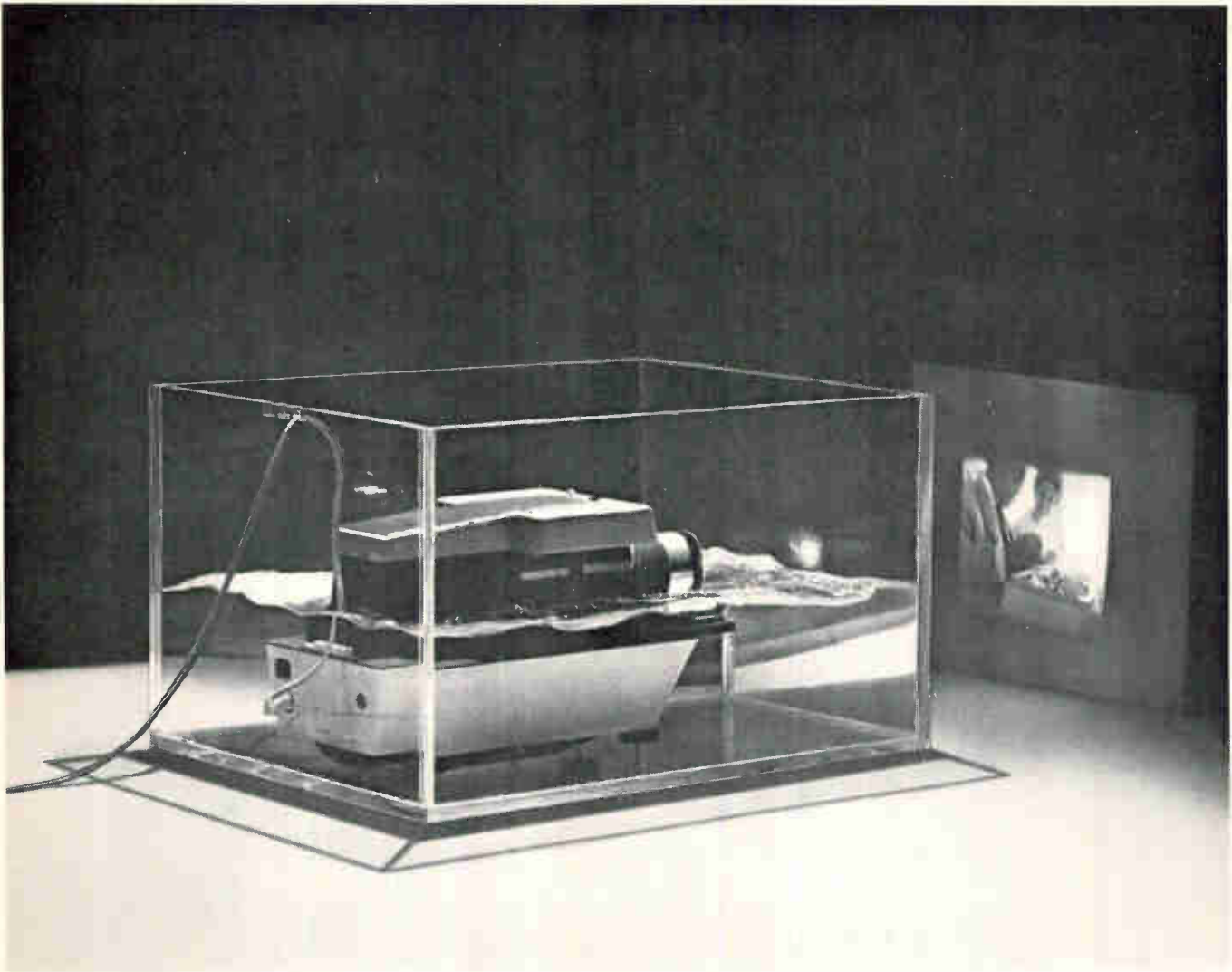

Our dry test bath results are completely projectionable.

If ever there was a dry liquid . . . this is it. Stick your hand in, it comes out dry. Not moist but totally dry.

Stick a microelectronic circuit in it and you find out immediately whether it leaks or has other flaws . . . and it comes out dry. Ready to use or ship.

Fluorinert[®] Brand Electronic Liquids are a whole new generation of testing agents for temperature and gross leak evaluations for all manner of electronic miniature devices.

Wide temperature variations don't affect their performance. They have unique dielectric properties. They don't react with even

the most sensitive of component materials. They are inert . . . in the most inclusive sense of the word.

Send the coupon for the whole story. 3M Company, Chemical Division, 3M Center, St. Paul, Minnesota 55101.

What we send you may be dry, but it'll be illuminating.

Fluorinert[®] Electronic Liquids 3M_{CORPORATION}

3M Company, Chemical Division, 3M Center
St. Paul, Minn. 55101

KAX 8-70

Send me all the details about Fluorinert Brand Electronic Liquids.

Name _____

Company _____ Title _____

Address _____

City _____ State _____ Zip _____

Code your own keyboard

'Kit' gives user choice among 128 schemes, saving prototype costs; pressure buildup and release in each key lets operator feel when data enters

"Wire it yourself, or give us your specs and we'll wire it for you." It's user's choice with the keyboard kit marketed by Cherry Electrical Products Corp.

The kit includes a printed circuit board with the electronics already laid out, plus up to 64 keys and a space bar. The customer develops his own encoding scheme and wires the keys with Wire-Wrap or Termi-

Point contacts. This approach avoids the large initial costs of producing a breadboard model to check out prototype equipment.

Guy MacArthur, project engineer at Cherry, points out the advantages to the once-only user: "It generally costs the keyboard manufacturer about six weeks and \$2,000 in p-c board layout and engineering time to make an evaluation

prototype. With our Wire-Wrap version it takes only about half a day of our time to lay out the board and about two hours of a technician's time to wire it up." The price, depending on the options, will run between \$250 and \$375.

The following features can be incorporated with the keyboard: single, dual, or tri-mode (unshifted, shifted, and control) outputs, shift

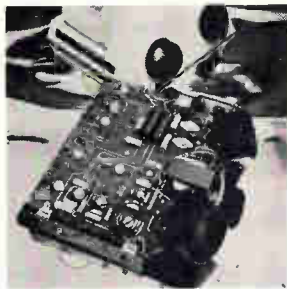

Compact acoustic coupler, called Coupler II, will accommodate data transmission rates up to 300 baud. It incorporates an acoustic cup fitting which mounts the telephone hand set on an angle, thus retarding the carbon build-up which occurs in vertically mounted hand sets and destroys their operation after a time. Communications Logic, 6400 Westpark, Houston [381]



Data set type 7103 provides full-duplex asynchronous digital transmission at rates to 300 baud on standard voice-grade telephone lines. It is interchangeable with the Bell System 103 data set. It is available in three modes: originate-only, answer-only, and automatic selection for originate or answer operation. Tele-Dynamics Div. of AMBAC Industries Inc., Ft. Washington, Pa. [382]

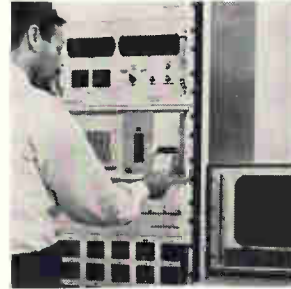

Video display unit presents up to 50 inputs in the form of individual vertical bar charts on one cathode-ray tube. It is available as optional equipment for the company's digital data acquisition systems. The crt displays information in a much more readable form than a 24-point strip chart recorder. Electronic Modules Corp., P.O. Box 141, Timonium, Md. 21093 [383]



The Datapoint 2200, referred to as an "intelligent terminal", offers keyboard entry, video display, dual magnetic tape cassette unit for both program and data storage, automatic Bell System compatible communication capability, and general purpose computing. The desk-top unit features a crt display. Computer Terminal Corp., 9725 Data Point Dr., San Antonio, Texas [384]

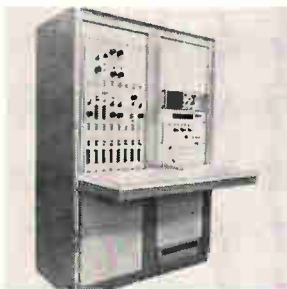

Automatic computer memory plane and stack tester model 101 is a universal system that will test any 2D, 2½D, or 3D memory core array, or larger stacks by sections. Model 101 has five strobe discriminators for precise definition of the output wave shape. Price is \$35,000. Delivery can be made in 90 days. Dataram Corp., Route 206, Princeton, N.J. 08540 [385]



Single-capstan, vacuum column digital tape transport is designed for low cost computer and data acquisition applications. Designated SC1035, the unit provides bidirectional tape speeds to 45 inches per second and data reliability features. Pinch rollers and mechanical adjustments have been eliminated. Potter Instrument Co., East Bethpage Rd., Plainview, L.I., N.Y. [386]

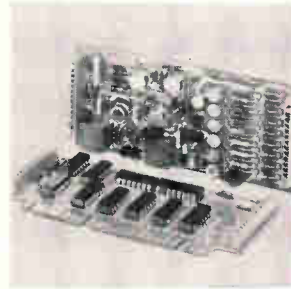

Nine-bit A/D converter model 6409 features high speed (greater than 250,000 conversions/sec), small size (4.5 x 2.16 x 0.75 in.), and low cost (\$335). It uses a capacitance decoupler circuit that greatly reduces accumulated diode capacitance and simplifies the coupling to the TTL logic section of the converter. Data Technology Corp., 1050 E. Meadow Cr., Palo Alto, Calif. [387]



Disk drive 441 Twin-Pac offers benefits of two separate disk drives, at near single-drive cost, to users of small- to medium-size computers. Each disk pack stores 23.2 million bits on four surfaces for a total of 46.4 million bits. Transfer rate from one pack to the other is 15,000 eight-bit bytes per sec. Century Data Systems Inc., S. State College Blvd., Anaheim, Calif. [388]

Allen-Bradley cuts space requirements with new sealed type Z cermet trimmers



Type Z
½-watt trimmer
shown 5 times actual size

this latest addition to the Allen-Bradley line of cermet trimmers...the type Z...affords high performance in an especially compact package

The cermet material — an exclusive formulation developed by Allen-Bradley — provides superior load life, operating life, and electrical performance. For example, the full load operation (½ watt) for 1000 hours at 70°C produces less than 3% total resistance change. And the temperature coefficient is less than ± 250 PPM/°C for all resistance values and throughout the complete temperature range (-55°C to $+125^{\circ}\text{C}$).

The Type Z is ruggedly constructed to withstand shock and vibration. The unique rotor design ensures smooth adjustment and complete stability under severe environments. The leads are permanently anchored and bonded. The connection exceeds the lead strength — opens cannot occur. Leads are weldable.

The enclosure is *SEALED*. It is both dust-tight as well as watertight and can be potted. Mounting pads prevent moisture migration and also post-solder washout. You can get immediate delivery at factory prices from your authorized A-B industrial electronics distributor. Or write: Marketing Dept., Electronics Div., Allen-Bradley Co., 1201 S. Second St., Milwaukee, Wis. 53204. Export Office: 1293 Broad St., Bloomfield, N. J., U. S. A. 07003. In Canada: Allen-Bradley Canada Limited.

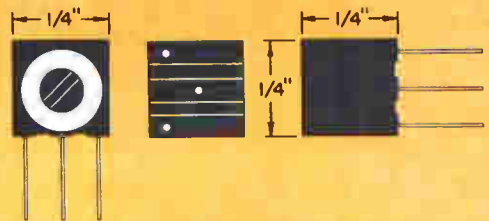

SPECIFICATIONS SUMMARY

- Adjustment: Horizontal or vertical.
- Temperature Range: -55°C to $+125^{\circ}\text{C}$.
- Resistances: 50 ohms through 1 megohm. Lower resistances available.
- Tolerances: $\pm 20\%$ standard, $\pm 10\%$ available.
- Resolution: Essentially infinite.
- Rotational Life: Less than 2% total resistance change after 200 cycles.
- Rotation: 300° single turn.
- End Resistance: Less than 3 ohms.



ALLEN-BRADLEY
QUALITY ELECTRONIC COMPONENTS

BRAND-REX PRESENTS

BUCK ROGERS

IN THE 25th CENTURY

TRAPPED IN ORBIT AROUND MARS, DR. HUER HASTENED TO COMPLETE HIS NEW DEFENSE SYSTEM TO WARD OFF THE BAND OF ATTACKING TIGER MEN...



IF I CAN GET THIS CENTRAL CONTROL SYSTEM RIGGED IN TIME IT WILL SET UP AN INVISIBLE BARRIER AROUND OUR SPACE SHIP THAT EVEN THE TIGER MEN CAN'T PENETRATE...BUT I'M STUMPED. WHERE WILL WE GET ALL THE SPECIALIZED WIRE WE NEED TO WRAP THIS COMPUTER'S BACK PANEL?

THIS LOOKS LIKE A JOB FOR **BRAND-REX** WIRE. IT'S TOUGH STUFF. LUCKILY SPACE SCOUT SHIPS ALWAYS CARRY AN AMPLE SUPPLY.

INCREDIBLE, BUCK. THERE ARE 11 DIFFERENT KINDS OF **BRAND-REX** BACK PANEL WIRES HERE! AND LOOK AT ALL THE COLORS!

SOMETHING FOR EVERY OCCASION, DOC. HERE'S THE **KYNAR** WIRE WE NEED.



SHORTLY...

THE INVISIBLE SHIELD IS WORKING!

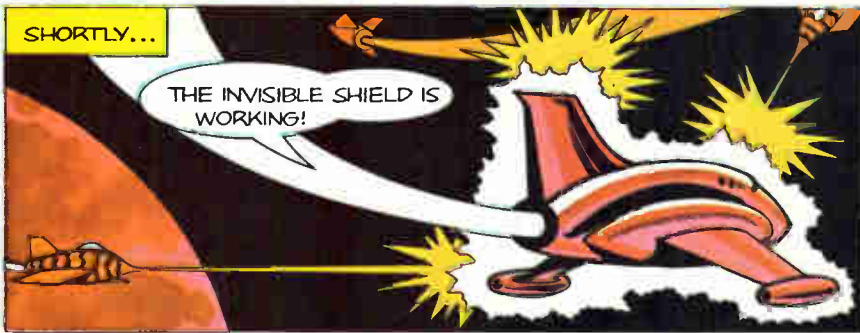

LOOKS LIKE **BRAND-REX'S** BACK PANEL WIRE IS THE REAL HERO OF THIS TALE. AND NO WONDER. **BRAND-REX** OFFERS MORE DIFFERENT WAYS TO WRAP UP A BACK PANEL THAN ANYONE ELSE IN THE UNIVERSE.

SO REMEMBER, EARTHFOLKS: THE NAME **BRAND-REX** MEANS WIRE AND CABLE THAT'S WAY AHEAD OF ITS TIME. TODAY PRACTICALLY EVERY MAJOR PROCESSING UNIT AND ITS PERIPHERAL EQUIPMENT USE AT LEAST ONE KIND OF **BRAND-REX** BACK PANEL WIRE. WHY NOT SEND FOR THE NEW **BRAND-REX** SPECIFICATION BR-212D AND GET A FULL COLOR BUCK ROGERS WIRE WRAP® WALL CHART FREE! JUST WRITE TO:

BRAND-REX DIVISION
AMERICAN ENKA CORP., WILLIMANTIC, CONN. 06226
THE PLANET EARTH

BRAND-REX, WAY AHEAD IN WIRE AND CABLE



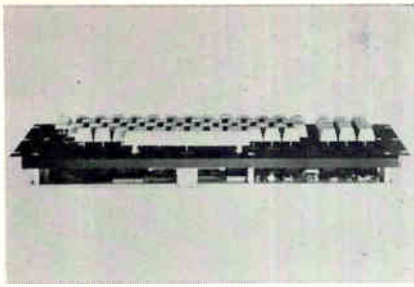

On key. Typing data is easier with built-in "feel" mechanism.

lock, positive or negative logic, seven-bit output or eight-bit with parity, and steady state or pulsing strobe. In addition, N-key rollover can be added on a small second-level board. A typist can then press several keys and produce the proper outputs from each key regardless of the sequence with which the keys are released.

The kit includes all the features of Cherry's new keyboards shown last week at Wescon.

The hardwired electronics consists of a 1-megahertz free-running multivibrator, an eight-stage binary counter, a 1-of-16 decoder, a one-shot multivibrator, and three multiplexers.

The free-running multivibrator generates a 1-Mhz clock frequency, which is used to operate the counter. The four least significant bits of the counter are continuously scanned by the 1-of-16 decoder, the three most significant bits by the three multiplexers. The fact that only one of the multiplexers can be active for any one mode provides flexibility in changing codes for shift, unshift, and control modes. The operator can go from lower case to upper case (shift) to control case and sometimes to a numeric case from one key. This four-way freedom results from depressing the basic key, which will normally produce the lower case code, and simultaneously depressing the shift or control, or numeric mode key.

Matrix. Encoding is accomplished by a matrix, which represents 128 possible codes. To wire a key for a desired code, the proper connection is made between the decoder output and multiplexer input with the Wire-Wrap or Termi-Point contacts. When the key is depressed, an electrical path is provided between the decoder and the multiplexer, which in turn

gates a pulse to the one-shot multivibrator, generating a timing pulse that stops the counter at the selected code.

One unusual feature of the unit that aids the operator in typing in data is "keys that feel." Each key comprises a spring and magnet assembly which exerts an upward force against the operator's fingers. When the key is being depressed and travels a certain distance, the magnet's threshold is overcome prying it loose. The force against the finger is released and a click sounds indicating the transfer of data.

Cherry Electrical Products Corp., 3600 Sunset Ave., Waukegan, Ill. 60085 [389]

Data handling

Versatile terminal is simple to use

Interactive machine uses MOS buffer as recirculating register

Too many data terminals on the market are "built by pro's for pro's," according to Arthur J. Murphy senior vice president of Western Data Products Inc. "We're aiming at applications in which untrained people need to enter data into a computer."

Charles McGehee, director of program management for the Los Angeles firm, says the WDP-1070 will fill the gap between simple units that read bar-coded cards and use a 10-key set to communicate with a computer, and the highly sophisticated systems that include cathode-ray tube displays with 1,024 characters of information. An interactive terminal, the WDP-1070 uses a 256-character MOS buffer as a recirculating shift register. Consisting of 6 chips, the register provides 16 lines, each containing 16 characters. Any line may be addressed at any time, and its contents displayed on a 5- by 7-dot matrix display—a convenient capability when correcting errors.

The WDP-1070 transmits in ASCII code using frequency-shift key-

ing at 10 characters per second. As an alternative, it can be provided with a Touch-Tone voice answerback communications system. The 16-character dot-matrix display is standard; a 32-character and a two-line 64-character display panel will be offered as options.

In a typical operation, a medical secretary enters information from an insurance form and avoids processing a claim through the mail. The 16 lines of 16 characters provide enough space for the information needed in this type application. She enters the patient's name, birthdate and other pertinent data with a standard teletypewriter keyboard. After being displayed for verification, the data is stored in the buffer. By pressing a memory transmit button, the secretary dispatches the data to the insurance company's central computer.

The terminal could be used in real-time keyboard-to-computer communications, such as inventory control and cost collection. In the latter case, an operator enters an employee's card number and his time on a given job into a computer, obviating the need for keypunching or key-to-tape operations.

The terminal with ASCII and 16 characters of alphanumeric display sells for about \$1,000 in quantities of 100. Delivery takes 90 days after receipt of order. Other options include a magnetic card reader for entering repetitive data, a cassette recorder with 10,000 characters for applications in which batch processing rather than real-time interaction with the computer is desired, and either a strip printer or page printer. Addition of these options boosts the price to about \$3,000 in quantities of 100.

Western Data Products Inc., 2531 Pontius Ave., Los Angeles 90064 [390]



On line. Keyboard, card reader, or cassette recorder are used to transmit data to computer.

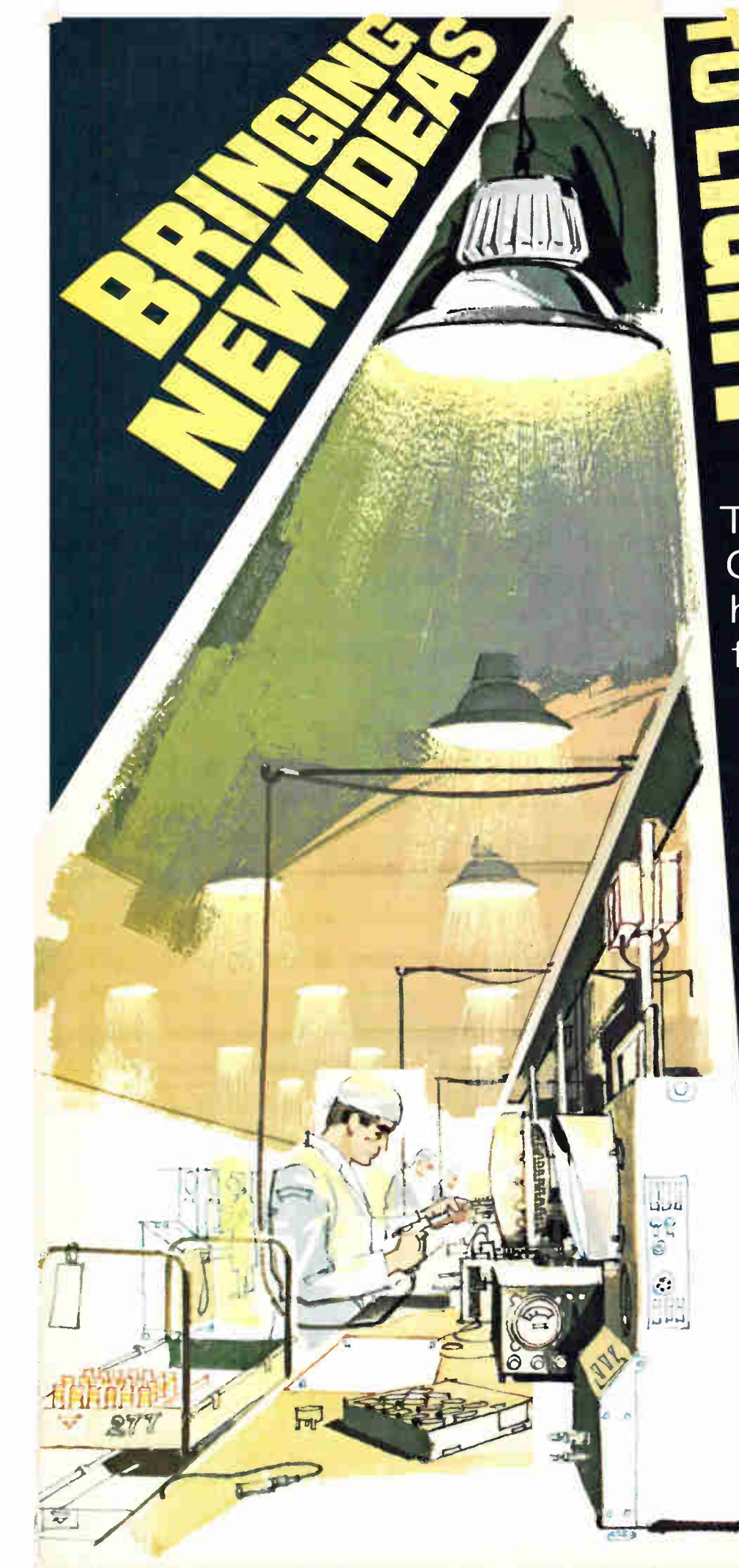

**BRINGING
NEW IDEAS**

TO LIGHT

The new
GE Lowmount*:
high-intensity lighting
for 10 to 20 foot
mountings.

Now put the economies and conveniences of high-intensity-discharge light sources to work at 10- to 20-foot mounting heights.

The Lowmount delivers comfortable, cool and even illumination. How? With a new refractor design that spreads out lamp beam and heat and lowers brightness. Arc tube is completely hidden from any viewing angle. Sealed charcoal-filled optical assembly keeps airborne dirt and gas away from reflector and lamp. Unit accommodates 400-watt ballasts for mercury metal halide, and Lucalox® lamps and is rated for 40 Centigrade ambients.

It's ideal for textile, electronic, food processing and other industrial applications.

See your GE representative for the facts on the new Lowmount luminaire. Or write Lighting Systems Department, Hendersonville, North Carolina 28739.

*Trademark of General Electric Company 460-56

GENERAL  ELECTRIC

Checking out ICs in their real world

Dynamic test station introduced at Wescon exercises devices with rise times of less than 1 nanosecond

A Boston company that reached out to the West Coast in efforts to extend its IC testers' capabilities to dynamic testing, went to market last week with what it says is the first instrument to check out integrated circuits having rise times of less than one nanosecond.

Teradyne Dynamic Systems, a subsidiary of Boston-based Teradyne, introduced at Wescon a dy-

amic test station for its bipolar-IC testers. The critical high-frequency portions—in search of which Teradyne went West—include a real-time measurement system, a single-socket fixturing system, and dual pulse generators in a single module. Manufacturers of similar hardware, says president Jack Salvador, give specifications for each module in such a system without giving

specs for the whole system. The S-257 specs on the other hand, relate to the entire system, measured at the test socket.

Thus, Salvador points to what he calls "a legitimate 1-nsec bandwidth at the test socket compared with something less than 2 nsec for the best of previous field-installed hardware." This means that the S-257 actually has a 350-mega-



All-digital, thin-film deposition system automatically controls deposition rates and film thickness to 0.1% or better with resistance heated, E-beam and sputtering sources. Basic system consists of a film thickness monitor, controller and programmer. Dimensions are 10.5 x 17.2 x 15.8 in. Price is \$4,810. Granville-Phillips Co., 5675 E. Arapahoe Ave., Boulder, Colo. 80308 [421]



Automatic terminal machine model TFM installs vinyl-insulated, nylon-insulated or uninsulated terminals mounted on low-cost Mylar tape. It is foot-pedal actuated and crimps between 1,500 and 2,000 terminals per hour. No die changing is required as the die assemblies are rotated on turntables to accept varied terminal sizes and types. Burndy Corp., Norwalk, Conn. 06852. [422]



A 12-inch-wide belt furnace has been developed with new V-bottom quartz muffle for firing thick-film circuits and glassing. The unit processes approximately 8,000 1 x 1 in. substrates per hour. Each heated zone is fully instrumented with solid state digital controls. Price is \$22,000; delivery 14-16 weeks. BTU Engineering Corp., Bear Hill, Waltham, Mass. 02154 [423]



Semiautomatic circuit-board assembly machine requires no special equipment other than a drill and soldering iron. The Circuitmaster can be operated by an unskilled person after only five minutes' introduction. The machine handles boards up to 20 x 20 in., covering up to 10 x 10 in. Vision Optical Instruments Inc., 34 Dumont Ave., Staten Island, N.Y. 10305 [424]



Fast-loading, rotating basket etcher PJ-669 is for chemical cleaning, etching, plating, and polishing of wafered and diced semiconductors, ceramic, and metal substrates. Fabricated of corrosion resistant PVC and fluorocarbon polymers, the etcher features infinitely variable speed control and instant reversibility. Geoscience Instruments Corp., E. 3rd St., Mt. Vernon, N.Y. [425]

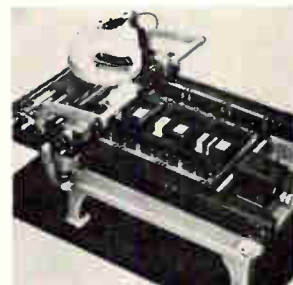

Dry offset printing machine is for marking/printing components of irregular or flat surfaces. It is designed to facilitate rapid changes in copy. Type, cuts or printing wheels may be used individually or together. The machine collects the copy and permits lines to be as close to each other as necessary. Eastern Marking Machine Corp., 30 Alabama Ave., Island Park, N.Y. [426]

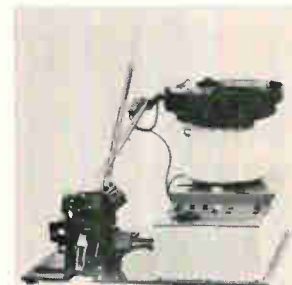

Single-sleeve DIP carrier loader model 8834 is a high-production system developed to insert, in proper alignment, the DIP devices into carriers. It features a pushbutton operation capable of automatically loading 5,000 devices per hour, by dial setting. It will accommodate 14- and 16-lead ceramic and plastic devices. Delta Design Inc., P.O. Box 1118, La Mesa, Calif. [427]



P-c board tester 8000 tests cards up to 160 pins with failure status and operating instructions recorded on printouts and, if desired, punched on paper tape. It offers keyboard or punched paper tape entry in easy-to-program low level language. Test instructions can be executed at a 500-nsec rate. Price is \$19,800. Tab Products Co., 550 Montgomery St., San Francisco [428]

... tests are on a real-time basis; one pulse is applied to the gate and a measurement taken . . .

hertz bandwidth, which is necessary to measure 1-nsec rise times.

The S-257 will be sold with two Teradyne testers already on the market: the J-259 and the J-283. The former is about four years old and does d-c testing; addition of the S-257 test station provides dynamic testing capability. One system has already been installed at Motorola's Semiconductor Products division.

"Our philosophy is to test a device as close to the environment of its real world as we can," Salvador says. "That's why Teradyne Dynamic is using a real-time measurement system instead of a sampling method." He says that if the propagation time through a gate is 7 nsec, "we apply one pulse to the gate and make one measurement instead of making the same measurement 500 or 1,000 times at a slower rate and then time-averaging it."

Don't touch. Adjustments in the field are unnecessary and, in fact, can't be done. Instead, if the system isn't properly calibrated when it's delivered, the circuit card at fault is traced with the help of the display on the front panel, and is replaced. This approach, plus automatic calibration of the pulse generators, helps get rid of human error, Salvador believes. Automatic calibration is achieved digitally rather than having an operator or technician periodically "tweak" an imprecise pulse to the desired pulse. With the S-257, a programmer specifies the pulse configuration he wants to see at the test socket. Then when a test tape is loaded, the system calls up the pulse generators and the real-time measurement unit, and modifies the program values "so that what the system sees at the socket is the measurement asked for," Salvador explains. "This eliminates the greatest single source of error there is in pulsed parametric measurements over a long period," he asserts.

Salvador says the shoebox-size fixturing package is about one-fourth the size of comparable fixtures. It uses a two-tier board incorporating a "family board" and a

"swap block." For each family of ICs—series 7400H TTL, for example, there's a family board. Then the swap block plugs into the family board, defining the pins as inputs or outputs. There's one swap block for each different device within a family to be tested; the swap block incorporates the 24-pin socket.

The S-257 includes an optional automatic handler for up to 4,000 devices per hour. Basic price of the S-257 is approximately \$100,000. When it's used with the Teradyne J-259 or J-283 testers, the total package costs around \$200,000.

Teradyne Dynamic Systems, 9551 Irondale Ave., Chatsworth, Calif. 91311 [429]

Packaging and production

Die bonder gives accuracy of 1 mil

High-speed unit offers production rates up to 6,000 per hour

High-volume production is much talked about in the semiconductor business—some companies are in it and others strive for it. And so it's no surprise that when a company develops a die bonder that is five times faster than what is generally

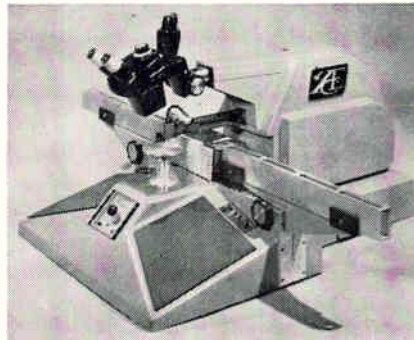

Lineup. As one chip is bonded, the operator lines up the next one under the microscope.

available, the preproduction units go quickly on-line.

This is what happened with the DB 1000 thermo-compression die bonder by Kasper Instruments. The first machines went to SGS and National Semiconductor, and now that Kasper is in production, it is quoting four to six weeks delivery time.

Designed primarily to strip-bond discrete devices, the machine can handle wafers up to 3.5 inches in diameter. Strip width is 1.5 inches maximum. But Kent Worthen, vice president of marketing, points out the machine's adaptability for integrated circuit strips or carrier belts. An infinite strip-indexing mechanism on the machine provides an indexing range from 0.050 to 1.5 inches.

When bonding is taking place, the operator lines up the next chip under the microscope and places a projected image target over the chip. Transistor chips are picked up from the top, but ICs, because they are larger and require a scrubbing motion when placed on the header, are picked up from their edges. (If they were picked up from the top, the metalization pattern on the top layer would be scratched.) Bonding force is adjustable from 30 to 200 grams. Placement accuracy is ± 1 mil on the header—an accuracy that is good enough for most automatic wire bonding equipment, says Worthen.

Kasper's next product will be an automatic wire bonder, according to Worthen.

Other features include a zero-voltage switching motor controller that eliminates electrical noise, and a solid state proportional heat controller with a $\pm 2^\circ\text{C}$ accuracy up to 500°C at the bonding point. The strips, whether they be TO-92 transistor strips or dual in-line lead frames, are loaded into a magazine and fed to the bonding head. Handling is automatic through the heater station, and the strips are fed into another magazine after bonding. The strips are located within ± 0.001 -inch nonaccumulative tolerance per unit.

The basic price for the DB 1000 thermo-compression die bonder machine is \$8,000.

Kasper Instruments Inc., 983 Shulman Ave., Santa Clara, Calif. 95050 [430]

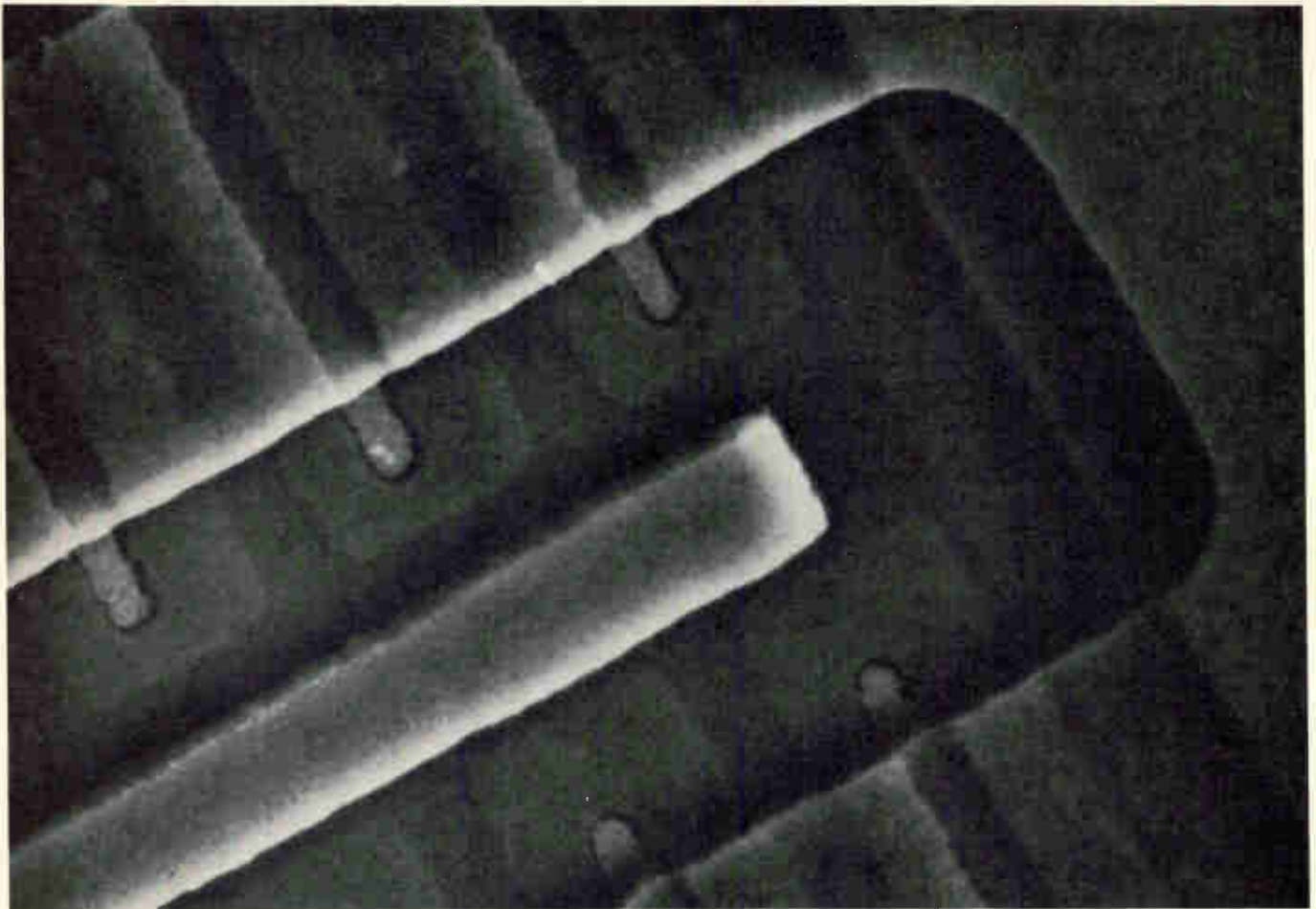

1600x scanning electron photomicrograph of an interdigitated RF power transistor, enlarged about 2x.

These emitter fingers are 2 to 2.5 microns wide. To clean them you need a FREON® cleaning agent.

FREON fluorocarbon cleaning agents wet and penetrate to clean thoroughly at the sub-micron level. Their high density combined with low surface tension lifts soils and floats away trapped contaminants other solvents miss.

In fact, using FREON solvents has increased production acceptance dramatically for many microcircuit manufacturers.

And there are five more reasons why you should be using FREON solvents:

1. Chemically Pure and Stable. No need for acid acceptance and scratch tests. No inhibitors needed. Parts dry residue-free.

2. Compatibility. No damage to widely used materials of construction.

3. Low Boiling Point (under 120°F). Ideal for low temperature vapor degreasing. Cooling time eliminated. No damage to heat-sensitive parts. Low heat passage to work environment.

4. Lower Overall Cleaning Costs. FREON is recoverable for reuse indefinitely: Power requirements are low in vapor degreasing. Fewer production rejects. Save labor by cleaning complete assembly instead of separate parts.

5. Safe. Nonflammable, nonexplosive, low in toxicity.

If you have a cleaning problem or are looking for an improved cleaning system, write today to Du Pont Company, Room 8902, Wilmington, Delaware 19898.



The smallest

QT-8B is a handy handful that your budget can hold.



The portable

Use it anywhere because QT-8B operates on AC or battery power.

Even in your car with an optional Car Adaptor QTA-3.



The Power Structure

First use of ELSI cell other than space and military.

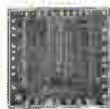

ELSI (Extra Large Scale Integration) shown approximately 16 times actual size. Measures just 1/8" square.

Executive Calculator

MicroCOMPET by **SHARP**

SHARP CORPORATION, Japan

Packaging and production

Precision scriber reduces waste

Split-field optics also speed alignment, processing of IC wafers

One of the most critical steps in integrated circuit assembly is wafer scribing. One misplaced scribe can wipe out many good devices. Tempress, a leading manufacturer of these machines, has developed a new model that can help minimize this waste.

A new split-field optical system allows faster alignment, by as much as 90%, and permits greater scribing precision by unskilled operators. "And an increase in scribing precision permits narrower streets, and therefore processing of as many as 10% more devices on each wafer," according to Frank Christensen, president.

"Before, you had to scribe a line and then check it, and then scribe a line in the other direction and check it, too. This took up to 100 seconds, but now you can align the wafer with just the optics and this takes only 10 seconds," says Christensen. As to why more accurate scribing is needed, Christensen says, "As the wafer size has increased, the path or street size has decreased so we needed a way to look at the outer areas of a chip at the same time. The answer was split-field optics."

"Existing split-field units were expensive—\$4,000—and very bulky," he says, "so we redesigned the optics." In effect, Tempress took the optical path and folded it so that it is half the size. And instead of needing two outboard lamps, the Tempress unit requires only one, and this is built into the housing. Lamp life is 10,000 hours and it is controlled by a proximity switch—when the operator's head approaches the instrument, the lamp turns on.

The new split-field optical system has more than 30 components, including 12 lenses, three prisms, 16 mirror surfaces, four beam divi-

U.S. Subsidiary: SHARP ELECTRONICS CORP., 178 Commerce Road Carlstadt, New Jersey

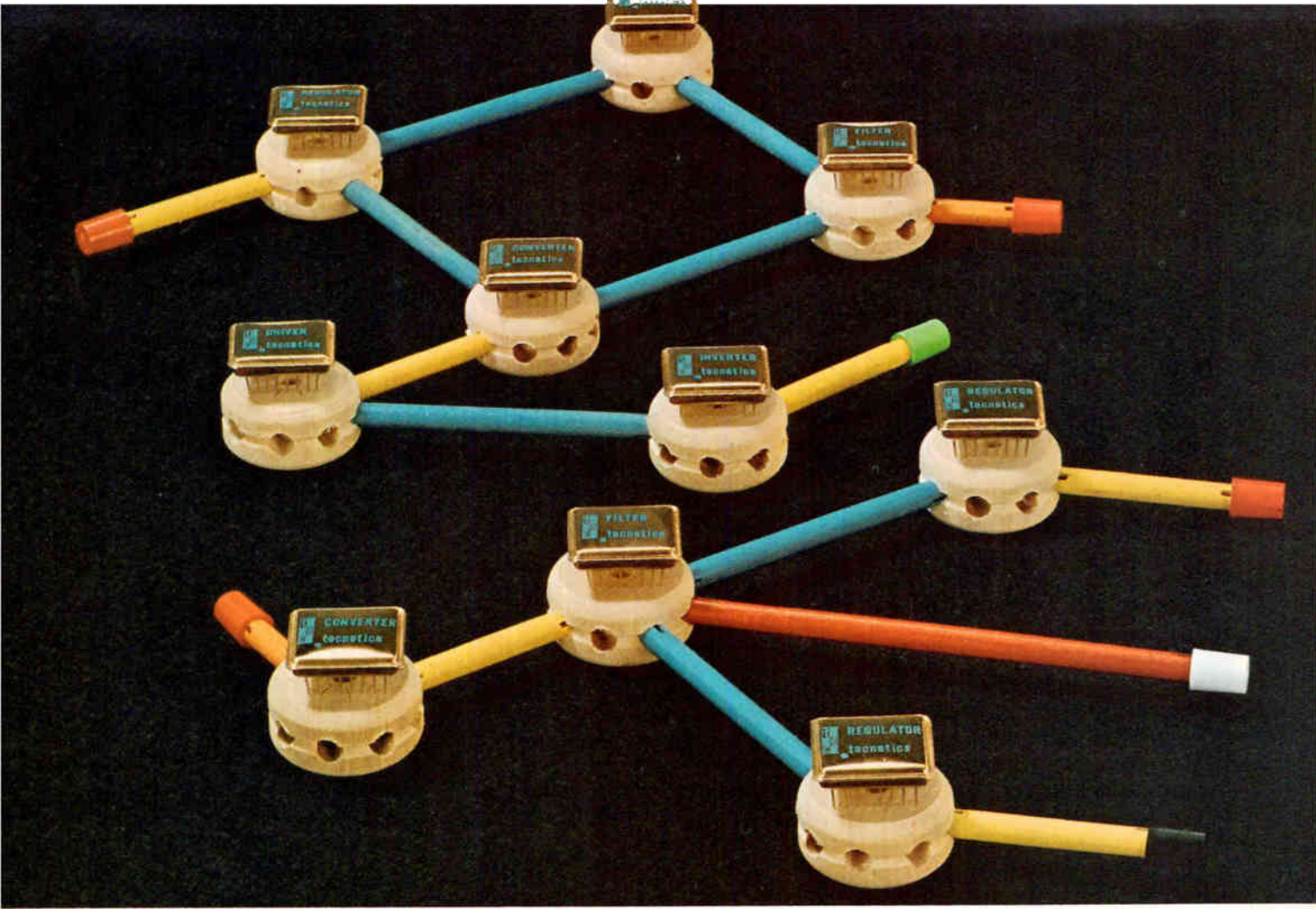

Tecnetics Report No. 5

Here's the industry's first practical hybrid microelectronic converters -- in 5, 12 and 20V inputs.

Meet our new series of 3 watt hybrid microelectronic DC-DC converters for on-card mounting in military and industrial point-of-load applications.

These unique converters are available now—in hermetically-sealed cold-welded metal packages designed to meet requirements of MIL-STD-883 for hermeticity, shock, vibration, and other environmental conditions.

Specifications

- Input voltage: 5, 12 or 20 VDC nominal operating
- Input power: Less than 4W typ. @ full load, 2W typ. @ half load
- Output power: 3 watts maximum
- Isolation: 300 VDC
- Single outputs: All popular outputs available from 5 to 300 volts for all inputs, or can be supplied to your exact output voltage requirements.
- Dual outputs: ±12, ±15, ±18, ±25 Volts

APPLICATIONS

Post-Regulated Converter



Typical specs:
Line Regulation (24 to 32): 0.02% • Load Regulation (½ to full): 0.01% • Ripple (p-p): 0.1%

Post-Regulated Dual Converter

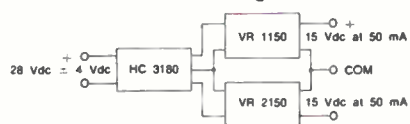

Typical specs:
Line Regulation (24 to 32): 0.05% • Load Regulation (½ to full): 0.01% • Ripple (p-p): 0.6%

These converters are the latest in Tecnetics' series of cold weld hybrid power conditioning components. Regulators and inverters are also available off-the-shelf—and other modules on the way include reference amplifiers, drivers, filters, and more.

For more information on TEC power conditioning products, call collect 303-442-3837, or see EEM, EBG, or write: Tecnetics, Inc. (formerly Transformer-Electronics Co.), P.O. Box 910, Boulder, Colorado 80302. In Europe, contact Technique et Produit, Paris (626-02-35); or Industrial Electronics, Frankfurt/Main (0611) 725130.



The innovators in power conditioning.

Circle 123 on reader service card

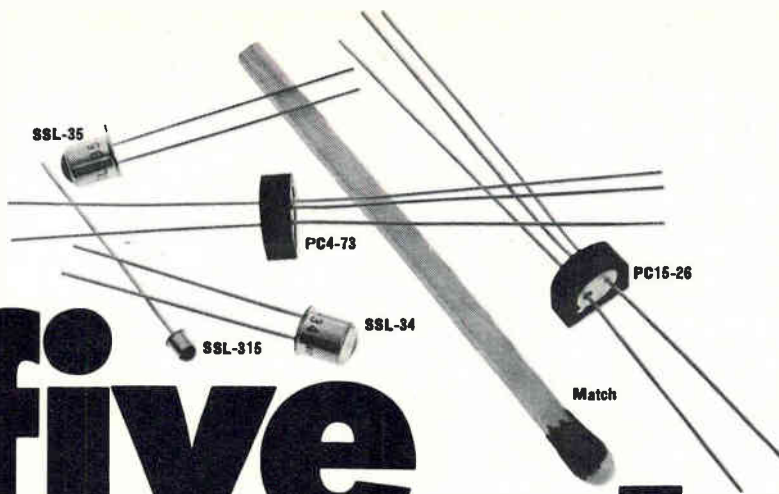

five more!

from General Electric, five new bursts in the SSL explosion.

At GE, solid state lamp technology is booming. And no wonder. For reliability, long life and fast switching speeds, no other SSL's outperform General Electric SSL's (previously known as light emitting diodes). Or withstands shock and vibration better. They practically eliminate maintenance costs. And these five new GE SSL's offer you other outstanding benefits:

- SSL-35** A gallium arsenide infrared SSL with more milliwatt output per dollar (5.5mW at 100mA) than any other SSL on the market. So you can locate it farther from the detector, or use less expensive detectors. Typical applications: intrusion alarms, safety devices and computer-related uses like BOT and EOT sensing. Price \$3.90 each in 1,000 quantity.
- SSL-315** A gallium arsenide infrared SSL, hermetically sealed, with twice the power (1mW at 20mA) of our SSL-15. High (4%) external efficiency. Less than 1/10th inch diameter. For printed circuit board applications, tape readers and other photoelectric systems. Price \$3.27 each in 1,000 quantity.
- SSL-34** Another high output gallium arsenide infrared SSL, giving up to 1/2 Watt peak power output. Permits increasing distance between lamp and detector. Applications similar to SSL-35. Price \$2.50 each in 1,000 quantity.
- PC15-26** A photon coupler consisting of a gallium arsenide SSL and an NPN planar silicon phototransistor. Has the inherent reliability of a transistor, and can withstand severe shock and vibration. Recommended for electrical isolation and high speed switching. Isolates up to 2,500 volts. Price \$7.20 each in 1,000 quantity.
- PC4-73** First of its kind. Combines a gallium arsenide SSL and an NPN planar silicon photodarlington amplifier. Has the highest transfer ratio (125%) of any coupler on the market today. Isolates up to 2,500 volts. Price \$6.50 each in 1,000 quantity.

Ask us for complete mechanical and electrical data on all five of these new GE SSL products. Or send for free detailed information on the entire General Electric SSL line — or order either of these new SSL Manuals: Theory, Characteristics and Applications, \$2.00. Applications only, \$1.00. Write: General Electric Company, Miniature Lamp Department, M-E, Nela Park, Cleveland, Ohio 44112.

GENERAL  ELECTRIC

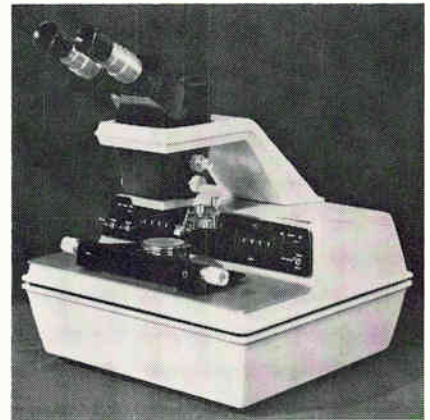

Two views. Split-field reticule shows street size and chip's outer area at same time.

ders, and two windows. All lenses are achromatic. Field diameter is 0.180 inch, and an operator can resolve a 2.0-micron line. The reticule, which was especially designed for machine alignment, has both lateral and angular adjustment.

The Tempress model D and the Tempress wafer-breaking kit form a complete system for semiconductor dicing. Initial setup is the same as the firm's model C scribing machine. The key to the operation is the accurate alignment of the scribing tool with the centerline of the wafer street pattern.

After the wafer is placed on the automatic scribing machine, initial observation will most likely show a misalignment. Since the top- and the bottom-half fields are up to 1.5 inches apart, the appearance of alignment deviation is emphasized. The machine operator can then adjust the wafer angle to bring the street pattern approximately parallel to the alignment reticule. The operator adjusts the linear position of the wafer and the wafer angle so that the alignment reticule patterns are centered on a single street. Then the operator can make an inspection with a conventional measuring microscope after making a test scribe line to show it is exactly on the street's centerline. The use of the split-field reticules eliminates the slight variance previously obtained with a single optical system.

The model D sells for \$5,570 and delivery will be off-the-shelf by mid-October.

Tempress Industries Inc., 980 University Ave., Los Gatos, Calif. 95030 [431]

Remember when the Peace Corps happened?

There was an electricity, a shared smile. Most of us said, "What a great idea!" And thousands of Americans said, "I want in."

Just like that. The Peace Corps was in business, exporting a product that the cynics had made jokes about for two hundred years:

The American Innocence, the notion that people can change things.

The supply of volunteers was unlimited. Before the Sixties ended more than 40,000 Americans – most of them young and white and college educated – had joined the Peace Corps.

Whatever happened to the Peace Corps?

What happened was that America, the world's leading exporter of innocence, ran out of the product at home. Let's not go through the list again. Growing up anytime, anywhere is hard work. Growing up in America has become almost unbearable.

The Peace Corps had some growing up to do, too.

It had to stop telling young people that love alone conquers all, because it doesn't.

It had to stop saying that volunteers could be "agents of change" – political change – because it wasn't true.

It had to stop pretending it wasn't a United States government agency, because it is.

It had to learn that – believe it or not – people in faraway lands know more about what

they need than we do. (And when they ask for help, they're very specific: an electrician, two city planners, five math teachers, an experienced farmer.)

Today the Peace Corps is in 60 countries. That's 59 more than it started in. It's changed a lot, but so has the world and so has America, and so – after all – have you.

The Peace Corps is still a remarkable idea for people who need to help, nose to nose. But it's not like it used to be.

It's better.



Real Time saver.

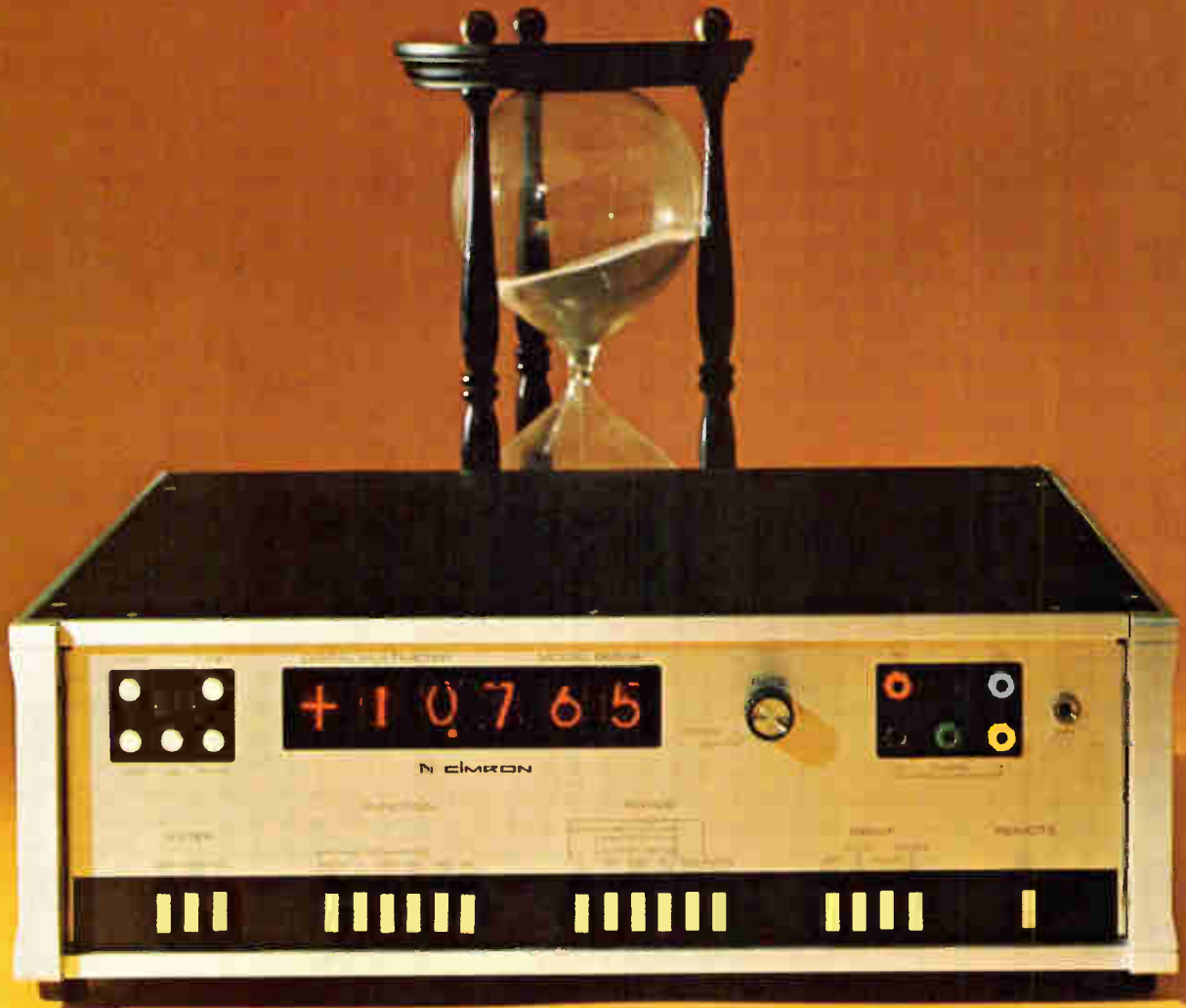

Now you can record 1,000 high accuracy readings per second without breaking guard.

Cimron found an answer to the speed vs. isolation problem that's been putting a damper on digital data gathering. Now our 6653A Multimeter can digitize up to 1,000 readings per second and record the data on continuous magnetic tape or store the information in a computer for real-time processing.

Our unique high-speed capability is achieved by a plug-in option which increases the thrupt rate threefold. This option is compatible with any new or existing 6653A.

Ultimate common mode rejection is maintained which prevents loss of accuracy due to noise in low level signals. The 6653A can't be matched for its overall measurement capability, accuracy and stability in its price range. You get the greatest number of options including sample and hold, AC, millivolt and ohms. With the autorange and combined ohms-millivolt converter plugged in, it can autorange through all six DC ranges.

For systems applications, Cimron

offers five buffered or unbuffered printout plug-ins.

Engineered with all IC logic and modular construction, the basic 6653A with accuracy of ± 1 digit is just \$1,740.00. And it all adds up to Cimron customer concern.

Write to Cimron, Department E-100, 1152 Morena Blvd., San Diego, Calif.

CIMRON



Circle 126 on reader service card

LEAR SIEGLER, INC.

CIMRON DIVISION

Powders match high-purity jobs



The HPM-539 series powders are available in purities as high as 99.999% in sizes from -50 mesh to +1 micron. These powders include metals, oxides, salts, special alloys, cermets, rare earths and special powder blends. They are now used for various production and research applications including flame and plasma spraying, semiconductor dopants and alloys, hot pressed materials, metallurgical research, and special fillers. Aremco Products Inc., P.O. Box 145, Briarcliff Manor, N.Y. 10510 [341]

Rosin core solder known as AE16 was formulated to meet high-speed production in the electronics industry. It is non-corrosive, non-hygroscopic, non-conductive, and fungus-resistant in accordance with military specifications. The flux core is a combination of pure water-white gum rosin and an activating agent that permits unusually fast conditioning of metal surfaces. AE16 is available in wire diameters 0.125 in. to 0.006 in. It comes in 1-lb, 5-lb, 25-lb, and 50-lb spools and in 350-lb drums. Bow Solder Products Co., 25 Amsterdam St., Newark, N.J. 07105 [342]

Hi-Tech alumina and fosterite ceramics have widespread application in electronic and electrical products requiring close tolerance ceramic-to-metal seals and other design innovations. Typical application areas include: substrates for thin- and thick-film circuits; vacuum and gas-filled devices; hermetically sealed electronic components; vacuum products; electrical deposition equipment, and systems subject to severe environmental conditions. General Electric Co., 316 E. Ninth St., Owensboro, Ky. 42301 [343]

Five basic dielectric ceramics are available for use in low-loss, high stability, and closely matched microwave structures usually involving ferrites. The dielectrics, offering dielectric constants of 6, 13, 16, 25 and 50 are of the magnesium titanate class. The mate-

rials are available in rings and toroids, bars, disks and custom shapes . . . limited to approximately 4-in. diameter and 1-in. thick for disks; 1 x 3/4 x 6 in. for bars. In application, the dielectric materials are used in conjunction with a ferrite core. The ferrite is the nonreciprocal element of a circulator, isolator or phase shifter. Use of ceramic dielectrics permits operation at higher power levels or over a wider temperature range than plastic materials. MCL/Chemicals Division, Solitron Microwave, 37-11 47th Ave., L.I.C., N.Y. [344]

Non-burning, epoxy formulation designated 92128 is for high-temperature electronic applications. It has the advantage of passing ASTM standards without the inclusion of halogenated compounds which can decompose at high temperatures. The system cures in two hours at 150°C and is suitable for use as a casting or encapsulating coating. Nitine Inc., Clifton, N.J. 07015 [345]

Two new laminates—65M27 Special and 65M28 Special—have been developed in response to the need for measles resistant, warp-free, high impact strength, high insulation resistance, glass epoxy copper clads that can be drilled or punched as easily as ordinary G-10 and FR-4 laminates. Samples exposed to 90% relative humidity at 95°F for more than a month are being floated on 500°F molten solder without measling. Westinghouse Electric Corp., Hampton, S.C. 29924 [346]

Cermet gold containing 92% Au (as fired) in screen-printable form is the latest conductive coating for thick-film fabricators. Sheet resistivity value of the new paste is 0.004 ohm/square. Suggested applications for the S-4300 include resistor terminations, die attachment and wire-bonding by means of ultrasonics or thermocompression. Cermalloy, Division of Bala Electronics Corp., 14 Fayette St., Conshohocken, Pa. 19428 [347]

Silcote Z is a new ceramic aggregate that is silver coated with smoothness and complete stability to heat and aging. Not only does it approximate the conductivity of silver loaded resins but cost figures are down so that conductive resins with less than 2 ohms resistance can sell at \$7 per pound. Silcote Z is a suitable conductive filler for epoxies, urethanes, paints, inks, coatings and other resins. Isochem Resins Co., Lincoln, R.I. [348]

High-temperature, ceramic flat slabs withstand a continuous operating temperature of up to 1200°C, and at intermittent heating cycles, 1450°C. Uses are in thick-film circuits, sintering, and other refractory applications. The slab is immune to all furnace atmospheres, and is free of metal-contaminating impurities and reducible oxides. In the size of 4 by 8 by 1/4 inch thick, the slabs cost \$12.50. Starnetics Co., North Hollywood, Calif. [349]

New Literature

Operational amplifier. Teledyne Semiconductor/Amelco, 1300 Terra Bella Ave., Mountain View, Calif. 94040. A four-page data sheet details complete electrical and physical parameters for the 809 linear operational amplifier. Circle 446 on reader service card.

Instrument rental: Beckman Instruments Inc., Electronic Instruments Division, 2200 Wright Ave., Richmond, Calif. 94804, has published a 22-page bulletin describing its recently announced rental program [448]

Data terminals. Teletype Corp., 5555 Touhy Ave., Skokie, Ill., 60076. Uses and technical specifications of a new line of magnetic tape data terminals are detailed in a one-page flyer. [449]

Elapsed time indicators. A. W. Haydon Co., 232 N. Elm St., Waterbury, Conn. 06720. Two-page bulletin M1600-R1 introduces a new line of five-digit elapsed time indicators designed for industrial and commercial use where miniature size, light weight and low cost are design considerations. [450]

Coaxial cable. Precision Tube Co., Church Rd., & Wissahickon Ave., North Wales, Pa. 19454, has published a 28-page catalog on Coaxitube, its semi-rigid coaxial cable. [451]

Tape recorder/reproducer. Tape-Athon Corp., 502 S. Isis, Inglewood, Calif. 90301, has released a four-page brochure describing the model 1000 professional tape recorder/reproducer. [452]

Lasers. Apollo Lasers Inc., 6365 Arizona Circle, Los Angeles 90045, has available two data sheets and a detailed price list on a complete line of sealed-off CO₂ lasers. [453]

D-c supplies. Computer Products, 1400 N.W. 70th St., Ft. Lauderdale, Fla. 33307, offers a bulletin describing in detail the PM800 series unregulated d-c power supplies. [454]

X-band tunable magnetron. Microwave Associates, Burlington, Mass. Bulletin 1549 covers two positively-pulsed 10- and 20-watt beacon magnetrons that provide mechanical tuning over the 8.5 to 9.6 Ghz range. [455]

Transistor tester. Lorlin Industries Inc., Precision Rd., Danbury, Conn. 06810. A brochure outlines complete information on automatic transistor tester models A and B. [456]

Amplifiers. C-Cor Electronics Inc., 60 Decibel Rd., State College, Pa. 16801, has available a short form catalog of pulse, wideband, video, and power amplifiers. [457]

Data logger. Dytro Corp., 63 Tec St., Hicksville, N. Y. 11801. A two-page



it's helped A lot of people glue THINGS THEY THOUGHT COULDN'T BE GLUED.

For example, how do you bond neoprene to fluoroelastomer? (Eastman 910® Adhesive does a great job if you etch the fluoroelastomer with sodium before you apply the adhesive.) Or rubber to polyacetal? (Pretreating the polyacetal with chromic acid increases bond strength 500%.)

Questions like these come from a lot of big companies. And from a lot of smaller ones. The answers come from our technical service laboratory. And from our more than ten years of experience with cyanoacrylate adhesives. (We invented them.)

And we have more answers. Like how to make Eastman 910 set faster, or slower. How to make

your bonds stronger, or more heat-resistant, or more impact-resistant, or whatever.

So if you're trying to glue something, and you're having a problem, we may be able to help. Contact your Eastman 910 distributor, or call Dick Blair at (615) 246-2111 at Eastman Chemical Products, Inc. in Kingsport, Tennessee.

He and our lab people are pretty good at finding what's wrong and setting it right.

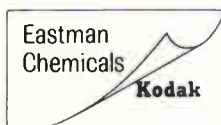

Circle 143 on reader service card

DYNAMIC FUNCTIONAL TESTING MEANS:

- Faster, more effective development of your digital products.
- Reduced hours for production test.
- Fewer field service calls.

CANOGA DIGITAL SYSTEMS delivers programmable Dynamic Digital Analyzers at surprisingly low prices.

- Test rates to 8 MHz.
- Up to 256 inputs and 256 outputs.
- No complex programming language.

Model 7010 shown



Call (213) 341-6744

or write:

CANOGA DIGITAL SYSTEMS
8851 Mason Avenue
Canoga Park, California 91306



E=2(C+EDP)X

Last year, Electronics magazine contained twice as much information on computers and electronic data processing as the next leading electronic publication.

If the cover of this magazine has your name and address on it, there is no better formula for keeping yourself abreast of the industry's technology.

New Literature

product sheet describes a portable data logger with cassette storage. [458]

Tape transport. Potter Instrument Co., East Bethpage Rd., Plainview, N. Y. 11803, has released a data sheet describing the SC 1035, a low cost, medium-speed tape transport. [459]

Ceramic capacitors. San Fernando Electric Mfg. Co., 1501 First St., San Fernando, Calif. 91341. General characteristics and complete ordering data by series for the West-Cap line of Monoceram ceramic capacitors are highlighted in a 24-page catalog. [460]

Stop clocks. The A. W. Haydon Co., 232 N. Elm St., Waterbury, Conn. 06720. Bulletin M1703-R1 updates a line of a-c and d-c resettable digital stop clocks designed for applications requiring accurate measurement of time intervals. [461]

Tunnel diodes. KMC Semiconductor Corp., Parker Rd., Long Valley, N. J. 07853, offers a four-page brochure featuring performance curves, typical circuit configurations and general engineering data on a line of tunnel diodes. [462]

A-d converter. Datascan Inc., 111 Paulison Ave., Clifton, N. J. 07013, has issued a data sheet covering the model DM-721, a four-bit analog-to-digital converter. [463]

Silicone products. Dow Corning Corp., Midland, Mich. 48640. A 20-page bulletin details a variety of silicone products for improving the performance, reliability, safety, and service life of all types of electronic products. [464]

Power supplies. Trygon Electronics Inc., 111 Pleasant Ave., Roosevelt, L.I., N.Y. 11575, has issued a condensed catalog on precision lab/modular/OEM power supplies. [478]

Thermistors. Yellow Springs Instrument Co., Yellow Springs, Ohio 45387. An eight-page catalog covers the company's line of interchangeable thermistors and linear-output thermistor components. [479]

D-c power supplies. Wanlass Instruments, 1540 E. Edinger Ave., Santa Ana, Calif. 92707, has published an eight-page bulletin entitled "Innovation in Instrumentation" discussing a line of d-c power supplies. [480]

Information-retrieval program. Remote Computing Corp., One Wilshire Bldg., Los Angeles 90017. A three-page application abstract describes a computer program that enables time-sharing users stationed at desk-side remote terminal devices to perform data-management and information-retrieval functions. [481]

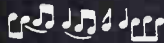

YOU'RE
WHISTLING
IN THE
DARK . . .

. . . if you think that heart disease and stroke hit only the other fellow's family. No one is immune. Protect the hearts you love. For authoritative information, ask your Heart Association. For medical advice see your doctor. To safeguard your family . . .

GIVE...
so more will live
**HEART
FUND**



Contributed by the Publisher

We don't know of anyone who wants
a 300 ips dual nine right now.



But we made one anyway...
just so you can have it
when you need it.

DUAL NINES to these
specs

- IBM Compatible
- 3200 FRPI
- Typical Write-to-Read
Feed-Through,
No External Shield
Required:
 - 18 ips < 3%
 - 60 ips < 2%
 - 120 ips < 1%
 - 200 ips < 1%
 - 300 ips < 1%



HAMILTON DIGITAL CONTROLS inc.
423 Broad St., Utica, N.Y. 13501 • Tel. 315/797-2370

Inquire about our complete line
of Computer Tape Heads

KEYBOARD **MINIATURES**

Unusual momentary
magnetic repulsion
Alco push button
switches have ce-
ramic magnets that
eliminate springs.
Glass reeds, 1/2" dia.
metal case. 100 mA
@ 50 VDC. SPST,
N.O. or N.C. .110"
flat or .058" round
terminals.



ALCOSWITCH® MAGNETIC ACTION
DIV. OF ALCO ELECTRONIC PRODUCTS, INC., LAWRENCE, MASS.

Circle 164 on reader service card

REMOTE CONTROL **MINIATURES**

For safe, shock-free
remote control cir-
cuit applications.
Compact, plastic
case houses step-
down transformer &
relay. 115 VAC in-
put, 5A capability.
Available with U/L
approval. FR-105.

ISOLATION RELAY



ALCOSWITCH® U/L
AVAILABLE
DIV. OF ALCO ELECTRONIC PRODUCTS, INC., LAWRENCE, MASS.

Circle 129 on reader service card

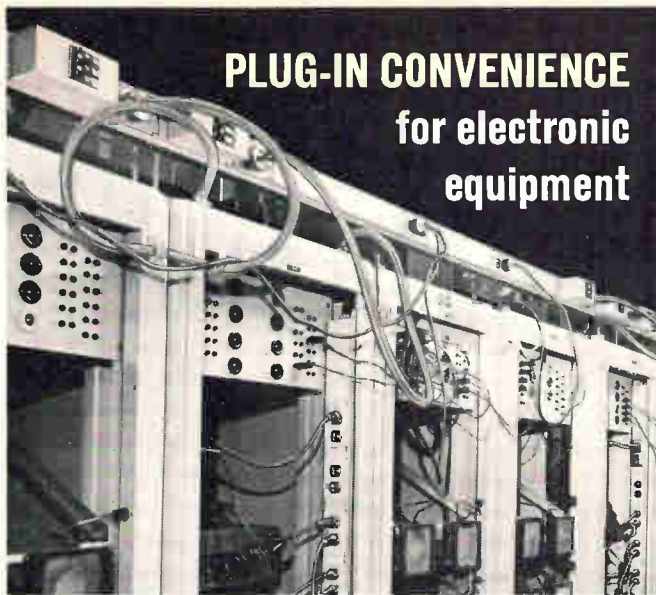

This test rack has power outlets right where they're needed — the last word in plug-in convenience! Easy-to-mount Plugmold® Multioutlet Systems are highly useful behind or inside cabinets, panels, consoles . . . in all types of complex electronic gear. If you make, test or use electronic equipment, write today for wiring systems literature.



THE WIREMOLD COMPANY / HARTFORD, CONNECTICUT 06110

Circle 144 on reader service card



CVI video sampling instruments allow your computer to "look" at practically anything. High accuracy bandwidth compression of conventional television signals opens new doors to data processing in research and industrial applications. Let us tell you about some of our unique video devices.

COLORADO VIDEO, INCORPORATED
P.O. Box 928 • Boulder, Colo. 80302 • Phone (303) 444-3972

cvi

Video Data Acquisition • Processing • Display • Transmission

130 Circle 130 on reader service card

Technical Abstracts

Pay and choose

The complexity of general-purpose remote terminals
Joseph F. Ossanna
Bell Telephone Laboratories Inc.

Although remote computer terminals are available that range in complexity and cost from very low to very high, the additional capability for a given increment in cost isn't always justified.

The Bell System's Touch-Tone telephone, and similar devices manufactured by other telephone companies, is inexpensive, widely available, and very useful for many applications. However, these applications are somewhat limited because there are only 10 or 12 characters available at the input. Moreover, the instrument has only audio output, precluding complex input and output sequences.

Despite costing perhaps 10 times as much as a Touch-Tone telephone, the model 33 Teletype yields a proportionately greater increase in utility: a 64-character input set and a hard-copy output. However, the unit is capable of only rudimentary graphic output.

More complex teleprinters, including the model 37 Teletype, as well as others manufacturers' products, represent a small step up in cost and complexity but a larger input character set, permitting a great improvement in capability.

The next step, to alphanumeric crt terminals, trades mechanical for electronic complexity. They are considerably faster than teleprinters and permit local editing, but they don't provide hard copy, so that the user can't work off-line. This is a high price to pay; the speed advantage and the editing capability probably aren't worth it.

On the other hand, when graphic capability is also available, the increased utility balances the loss of hard copy. These terminals cost at least twice as much as the better teleprinter, and the fancier dynamic graphic crt terminals are almost astronomical in cost.

What we really need is a terminal that has a graphic output on a storage tube, plus hard copy, for the price of a model 37 Teletype.

Presented at the IEEE Computer Group Conference, Washington, June 16-18.

Circle 131 on reader service card →

Get sine, square and triangle functions—and positive and negative going pulses, positive and negative going ramps—in the new HP 3310A. And there's more! You'll have these seven functions over a decade of decades—0.0005 Hz to 5 MHz.

All this capability is packed into a package only 7¾" wide, 4½" high, 8" deep! With the 3310A Function Generator performing many of the functions of the pulse generator, ramp

generator, bias box and amplifier on your bench—think about the clutter you eliminate...the instant access you'll have to all these signals.

With the dc offset capability of the 3310A, you can put any of the functions where you want them—easily and without biasing. And, with the choice of high or low level output, you can get clean low level signals without an external attenuator. You get a maximum of 15 V peak-to-peak into 50 Ω—and that's plenty of power to eliminate most needs for external amplification.

Add to this the external frequency control capability which allows you to sweep over a 50 to 1 range or tie the 3310A into a system—the price

of only \$575—solid-state reliability—and you know the HP 3310A is more than a function generator!

Order your HP 3310A today from your nearest HP Sales Office. For full specifications, write to Hewlett-Packard, Palo Alto, California 94304. Europe: 1217 Meyrin-Geneva, Switzerland.

HEWLETT  PACKARD
S I G N A L S O U R C E S

099/9

This One Is More Than A Function Generator!





CARPENTER ELECTRONIC ALLOYS...MATCHED TO EVERY SPECIAL REQUIREMENT OF THE ELECTRONIC DESIGN ENGINEER.

Today's electronics industry is being challenged to set the stage for the new decade. A decade that will see more advancement in technological growth than has been recorded in the past century.

Much of this growth will require highly selective materials with critically balanced properties and characteristics.

Because Carpenter has always anticipated the needs of the electronic design engineer, many of these advanced materials are already in existence . . . available through the Carpenter Service Center network. Others are being developed right now

in Carpenter's Research and Development laboratories.

The complete range of Carpenter electronic alloys includes Magnetic Core Irons, Glass-Sealing Alloys, High-Permeability Alloys, Electrical-Resistance Alloys, Magnetostrictive and High-Saturation Alloys, Controlled-Expansion Alloys and others. The flawless quality of these materials can provide new standards of quality for your products of the seventies. See your Carpenter representative for full details. Steel Division, Carpenter Technology Corporation, Reading, Pa. 19603.

European Office: Emmastraat 39, Amsterdam-Z, The Netherlands

CARTECH CARPENTER
TECHNOLOGY

International Newsletter

August 31, 1970

**French tv makers
hope tax cut will
end sales slump . . .**

French tv set makers are banking on a recent sales tax cut, which lowers retail set prices by about 5%, to pull the industry out of its recent doldrums. French firms sold only 530,000 black-and-white sets in the first half of this year, down 8% from 1969 first-half sales. Color tv sales have been disappointing, too. Industry executives predicted in January that 1970 sales would at least double the 107,500 color sets sold last year. But only 57,000 receivers were sold in the first half, against 36,000 in the like 1969 period. At that rate, this year's total would reach only about 170,000 sets. West German firms, in contrast expect to sell up to 900,000 color sets this year.

Though tv sets have been exempt from general government restraints on consumer credit, set makers tend to blame the psychological impact of the credit squeeze and official measures to encourage savings. Tight credit, too, has kept tv firms from expanding distribution systems, say tv trade association officials. Retailers now are plastering show windows with signs proclaiming lower tv prices following the sales tax cut, in the hope that the traditionally better fall selling season will come on stronger than usual and make up part of the first-half decline.

**. . . while British
market flourishes**

The expanding British market for color tv—last year's total sales of about 150,000 sets was equalled in the first six months of 1970—is encouraging foreign manufacturers of portable and low-price monochrome sets to step up competition in anticipation of a lucrative second-set market. Japan's Toshiba and Hitachi will soon offer their small portables in Britain, joining such labels as Sony, Sanyo, and Teletron which last year landed about 17,500 sets in Britain. No British manufacturer makes small portables, and Japanese dominance is likely to keep it that way.

The Russians, too, plan to sell in Britain, offering a 23-inch monochrome set, called Rigonda for \$170, about \$20 less than for a comparable British set. Loss-leader pricing to open up a market has been tried before by the Russians in consumer electronics. Two years ago, British stereo phonograph makers successfully prevented the Russians from unloading considerable numbers of good quality Rigonda stereo phonographs on the British market at dumped prices.

**International bids
seen for computer
on Viggen fighter**

The Swedish Air Force expects to see tough bidding for major European and North American electronics firms for the central computer to fly on the fighter version of Saab-Scania's Viggen supersonic aircraft. Bids are due on Nov. 1, and some have already been submitted. Officials, as customary, will give few details about the bidding and who is bidding, but it's expected that Saab-Scania, which supplies the computer for the attack version of the Viggen, now in production, will be among the bidders. It's understood, however, that IBM and Canadian Marconi may be in the running, too.

Although funds to produce the fighter version in quantity still await formal approval by Parliament, the fighter should be in production by the middle 1970s. The Air Force is now winding up tests on the attack version, and the first series-produced versions will be delivered next July. A trainer version, which has just been built, underwent initial test flights in July.

International Newsletter

Japanese to remove import restrictions on some ICs ...

The Japanese government's intention to remove import restrictions from both digital and linear integrated circuits with up to 100 elements starting Sept. 1 comes at a strange time—just at the moment when there are many complaints that American manufacturers are selling ICs at below-cost prices in Japan. However the Ministry of International Trade and Industry, according to sources there, views the move as part of the government's long-term plan for liberalization rather than being a reaction to present conditions. What's more, further relaxation of restrictions on circuits with more elements probably will not come about for some time.

It is important to note that conditions in Japan differ in some respects from those in most other countries. All the six general-purpose computer manufacturers also produce ICs and largely supply their own requirements, so that it is not easy for foreign suppliers to muscle into the business. And the major concern of these manufacturers now is with the LSI circuits needed for upcoming faster machines. The other big market for ICs in Japan is desk calculators, and that market will likely be converted mainly to MOS LSI—with more than 100 elements per chip—in the near future. In a related move, the government will also remove import restrictions on electronic calculators that have memory capacities of less than 2,000 bits and do not include a printer.

... but move to subsidize LSI development

In one countermeasure to the IC liberalization, MITI is asking the Ministry of Finance to grant low-interest loans allowing Japanese manufacturers to invest in large-scale integration equipment. MITI considers promotion of LSI production important because demand for arrays, chiefly for desk calculators, is being met mainly by imports from the U.S. According to MITI, demand for LSI, on an import license approval basis, climbed from 173,000 arrays worth about \$2.5 million in 1969 to 1.026 million arrays worth \$15.3 million in the first six months of 1970.

MITI figures the investment needed for LSI is a major drag on Japanese companies for several reasons. For one, the required investment is large and there is a 1.5- to two-year lag between investment and start of shipments. Then, too, they have no missile contracts to carry part of the load. What's more, profit margin is small because prices will be kept low by competition from U.S. manufacturers. Since MITI estimates investment required for LSI will be about \$28.8 million, it proposes that the government bank make available 40% of the total or \$11.5 million in fiscal 1971. A MITI source says it would like to keep the system and, after LSI funding ends, use it for whatever is needed then.

Improved coax cable developed in Britain

A coaxial cable shielding three orders of magnitude more effective than conventional double-braid coaxial screening, no bulkier, and only slightly more expensive has been developed by researchers at Britain's Atomic Energy Establishment at Winfrith. The new cable is effective from 10 kilohertz to over 100 megahertz and is the answer, the inventors believe, to the problem of how to screen instrument leads carrying small signals—10 millivolts or less—in industrial environments.

The shielding is made from three copper braids separated by layers of high-permeability mu-metal tape. Interestingly, it performs better at high frequencies than at low. The surface transfer impedance is claimed to be only 10 microhms per meter length at 10 KHz dropping to 1 microhm, instead of rising to 100 microhms, at 100 Mhz.

Tv camera checks itself out

Servo-driven potentiometers, controlled by comparator circuits, automatically adjust balance, alignment, and registration in seconds

Every few days, or sooner if it's used roughly, a color tv camera has to be checked over. Tube gains have to be equalized, the focus and alignment of each tube have to be tested individually and the registration of the images from each tube has to be checked. This procedure takes from five to 15 minutes depending on the camera and how long it's been out of use.

Now Marconi Co. has brought out a camera which accomplishes all this checking automatically at the press of two buttons, cutting the time to between a few seconds and three minutes, the company claims. Though it's only a three-tube camera—there's no luminence tube—it's said to offer performance equal to four-tube cameras.

The automatic adjustments are made by servo-driven potentiometers, under control from analog and digital comparator circuits. When the start buttons are pressed, an indicator light stays on as long as the camera is checking itself. When the resetting is complete all checking and resetting circuits are deactivated, so that accidental effects during operation, such as current surges, can't ruin the settings. The potentiometers have thumb-wheel adjustment as well as servo drive so that manual adjustment can be employed in an emergency.

The checkout proceeds in two stages. Pressing the first button initiates a preliminary color balance check followed by tube alignment and registration. The second button isn't pressed until just before the camera goes on the air. Then it initiates a second color balance check to adjust the camera to the background illumination.

While the camera is operating the images from the tubes are examined continuously for any regis-

tration deviations. This is done by continuously comparing transitional waveforms in the tube outputs. If one tube seems to be out of line with the others—and a second check in another part of the picture shows it's not a false alarm—a correction is automatically applied to the tube deflection circuits.

When the first button is pressed, the image of an internal test slide is reflected into the camera's light-splitting optical system and thus



On the button. Marconi's new color camera features at-a-touch testing.

into the camera tubes. The first operation is a preliminary color balance carried out by adjusting the gains of the red and blue channels to match green channel gain. A rocking focus voltage then is applied to each tube in sequence, and the tube alignment currents are adjusted until they produce the minimum displacement at the center of the picture. Registration checking proceeds by examining the three rasters simultaneously at several points to detect any displacement of the red and blue signals with respect to the

green. The parameters tested are width, height, rotation, skew, horizontal and vertical centering, and horizontal linearity.

The second color balance check, done after the lens hood has been removed, is achieved by pointing the camera so that some convenient small white object occupies at least 10% of the picture area. When the button is pressed the iris is set automatically to give a peak green signal of 0.6 volt, and the red and blue channels are adjusted to meet this level.

The new camera is called the Mark VIII. Norman Parker-Smith, technical manager of Marconi's Broadcasting division, says the luminence tube was dropped since its main point has always been to minimize registration errors, and the new camera employs three new techniques that raise registration of the three color tubes to the point where the luminence tube is redundant.

Besides the continuous self-check in operation, registration is improved by eliminating the differences in the lag times of the three colors. Differential lag creates a tendency for the red and blue to hang behind the green sufficiently to become noticeable when three-tube cameras are following fast white objects. Lag is inversely proportional to image brightness, and by making the red and blue images smaller and therefore brighter than the green image, red and blue lag have been cut to equal green lag.

Further improvements in registration were achieved with very precise deflection yokes. The yokes are made by deep etching of 0.005-inch copper cladding on the outside of ground borosilicate glass tubes. Two deflection tubes are used in each camera tube, mounted

concentrically. The outer carries the line scan coil and the inner holds the field scan coil. Both are surrounded by a conventional focus coil. The glass is tough and has a very low coefficient of expansion. Each coil is only a single layer of copper, with a minimum conductor width of 0.01 inch.

Tony Heightman, who is in charge of the department that developed the camera, says the great advantage of the copper-on-glass technique is that it allows coils to be formed precisely and exactly alike, making it much easier to obtain identical performance from the camera tubes. He says the improvement spreads over into resolution, which is more uniform over the tube target than when conventional deflection coils are used. The new camera and the new yoke technique will be described at the International Broadcasting Convention in London next week.

West Germany/Canada

Fancy flight recorder

Standard flight data recorders perform one function: storage of aircraft data on tape for evaluation on the ground. However, a new flight data recording system developed by West Germany's Dornier System GmbH and Canada's Leigh Instruments Ltd. goes much further. It not only records aircraft information on magnetic tape, but it also initiates voice warning messages during flight and reads out the state of the aircraft after landing on a quick-look display. And it's closely keyed to computer-controlled maintenance analysis on the ground. What's more, its crash recorder unit amounts to a totally new data recovery system.

The Dornier, Leigh equipment dubbed Leads 200, has undergone several months of testing on F104G Starfighters, the Luftwaffe's workhorse fighter plane. Dornier has high hopes that the equipment soon will become standard on these aircraft. It costs about DM100,000 or about \$27,500.

The Leads 200 system is de-

signed around a central electronic unit installed behind the pilot's seat. The 24-pound, cigarbox-sized unit—which uses integrated circuits extensively—processes and digitizes up to 64 different streams of aircraft data, such as speed, altitude, yaw, pitch and roll, and prepares that data for pulse code modulation recording on magnetic tape.

In addition to the recording electronics, the central unit contains circuits which compare the incoming data with fixed or dynamic boundary values. These circuits initiate voice warnings for the pilot when critical conditions are reached or indicate faulty functions on the quick-look panel for ground maintenance crews. The warnings, prerecorded on tape, can be played back to the pilot during flight in the sequence of their urgency. The pilot can receive up to 16 different messages on critical aircraft behavior.

Connected to the central unit is the system's maintenance recorder, a cassette tape machine with 3 hours of recording time for voice and digital data. This 3-lb. unit, also installed behind the pilot's seat, stores all flight data fed to the central unit and all voice communications between the pilot and the ground control station. The cassette is removed and evaluated after every flight for maintenance and ground testing.

Crash recorder, also working in conjunction with the central unit, is located in the plane's tail and contains an endless-loop magnetic tape which stores all flight data for the last 1.5 hours and all voice communications for the last 30 minutes of flight.

This device, unlike others, does not need to be armored or fire-proofed against crashes. It is protected either by being dropped just as a fire or mechanical deformation of the plane's structure starts or is jettisoned when the pilot seat ejection system is activated.

The housing resembles a plastic cushion about 15 inches square. This cushion, which has an aerodynamic configuration enabling it to glide away from the aircraft in a steep curve with rapidly diminishing kinetic energy, has been found

to be fit for reuse after test drops onto a concrete runway from nearly 2,000 feet. It also can float and is equipped with an omnidirectional transmitter to facilitate location. The container, including emergency transmitter and tape recorder, weighs less than 10 lbs.

The data from the recorders are evaluated in computer-controlled ground equipment. Depending on the efficiency of the computer a large number of aircraft can be served by one evaluation installation. The data from the maintenance recorder—from the crash recorder dropped in the event of an accident—is transcribed onto an incremental recorder. During the transcription the time and nature of any data exceeding the boundary values are printed out together with a quality analysis of that data. It is then made available for computer evaluation or correlation with earlier flights. It can, for example, be recorded in analog form on the ground equipment's multichannel recorder.

Japan

Vertical pnp for ICs

Complementary symmetry output stages provide an easy method of using a single-ended circuit to drive a single-ended push-pull output stage, while minimizing circuit complexity and components. But since pnp output transistors can't be grown readily in integrated circuits, quasicomplementary circuits are used in their place.

Engineers at Nippon Electric Co. have developed a new method of fabricating vertical pnp transistors to replace the horizontal vertical pnp devices often used in quasicomplementary output stages and similar applications.

NEC's circuit replaces the pnp output transistor with a pnp-npn Darlington-connected pair that operates in the same manner as a pnp transistor. Output capability is that of the npn transistor, while effective current gain is the product of that of the two transistors. Thus the pnp device is used mainly for

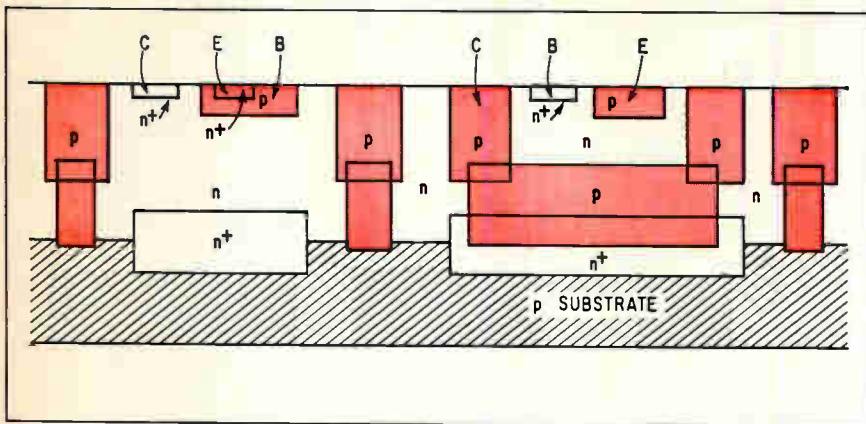

Ups and downs. Nippon Electric researchers have fabricated vertical pnp transistors (right) to go with npn transistors for quasicomplementary output.

phase inversion and need not have a high current gain.

The vertical pnp transistor developed at Nippon Electric has electrical characteristics similar to conventional vertical transistors. It is completely isolated from the substrate and can be produced by conventional IC fabrication techniques. Fabrication starts with the p-type substrate used for conventional transistors. Buried n^+ layers are diffused into the collector regions of both the npn and pnp transistors. While this diffusion is standard for npn devices, it is not usual for lateral or vertical pnp transistors. This step is followed by a p diffusion into the buried layer of the pnp transistors, and around the periphery of the npn units.

The p diffusion is relatively non-critical. The only important requirement is that surface concentration of dopant must be limited so that even after the diffusion the surface of the n^+ buried layers in the pnp transistor regions remains n-type. This p diffusion is an extra step, although it has been used in some integrated circuits to reduce the area occupied by the isolation diffusion.

Next n-type epitaxial layer is grown in the substrate. During the growth and during subsequent processing steps, the dopants diffuse upward into the epitaxial layer. Since boron's diffusion constant is about an order of magnitude higher than that of antimony, boron diffuses further upward and forms the p-type collector region of the pnp transistor. The remainder of

the transistor fabrication is done in the usual manner.

Interestingly, the p isolation diffusion need extend downward only far enough to reach the ascending buried p diffusions, rather than all the way down to the substrate. Since diffusion processes spread both vertically and horizontally, smaller isolation diffusion depth means smaller width and a saving in semiconductor real estate.

Breakdown voltage from substrate to emitter and base of the vertical pnp transistors runs about 62 volts. Collector-to-emitter breakdown voltage, with base open, varies inversely with current gain. Measured values include breakdown voltage of 60 volts for transistors with current gain of 50, 25 volts for current gain of 100, and 10 volts for gain of 300. Cutoff frequency typically is 20 megahertz, and noise figure is typically 6 or 7 decibels.

Nippon Electric is starting to include these vertical pnp transistors in production ICs that will reach the market soon. First applications will be audio output circuits with power outputs up to several watts.

Great Britain

Microwave effect

At the Royal Radar Establishment, where much of the original work on practical Gunn oscillators was carried out, researchers have discov-

ered that an undoped gallium arsenide chip can function as a simple room-temperature microwave amplifier if its physical dimensions and free-charge carrier density have the right values and relationship.

So far the researchers, Chris Baynham and David Colliver, have obtained only very low power outputs and are claiming only that they've discovered an effect that may yield practical applications. Baynham will talk about it in detail at the Solid State Devices Conference at Exeter University in mid-September.

The output gain stems from round-trip compounding of the basic negative conductivity gain of the GaAs. Hence, in principle, it has something in common with the laser amplification process. Baynham applies a d-c field through the chip to induce the transferred electron effect, just as in a Gunn oscillator. In this state the chip exhibits negative conductivity so that a microwave signal fed in grows spatially as it progresses through the chip. So far, to keep the temperature down, the field has been pulsed with the mean above the threshold necessary for the transferred electron effect, but steady field trials will follow.

Unlike a Gunn oscillator, however, the new effect works when Baynham chooses a free charge carrier density and a chip dimension in the direction of the applied field that, taken together, are below the critical level necessary for domain formation. That means no domains travel through the thickness of the chip and there is no Gunn-type generation of microwave radiation. In one of the experiments Baynham will describe, the free charge carrier density was 1.7×10^{13} electron per cubic centimeter, coupled with a chip thickness of 80 microns.

Baynham discovered that when the 80-micron thick chip was 0.48 inch long and a microwave signal was inserted along its length, initial negative conductivity amplification was boosted by round-trip gain within the chip, which acted as its own cavity. The emission was in line with the long axis of the chip

and at right angles to the applied field, in contrast to Gunn-type emission which is in line with the applied field. No emission occurred when the chip length was reduced by 0.12 inch. A second chip cut from the same slice and 0.46 inch long worked all right with an emission spectrum slightly higher than the first chip, but when its length was cut by 0.1 inch it wouldn't work.

The field was applied in 1-microsecond pulses at 50 hertz, through silver-tin contacts on the largest chip faces. The chip was observed using a spectrum analyzer, latch-and-hold signal processing circuits, integrators and a pen recorder. When the chip worked, Baynham obtained a broad output spectrum, with half-power points more than a gigahertz apart, centered around 3.5 Ghz. Output power was low, with a peak value of about 1 microwatt per megahertz of the bandwidth.

Because the microwave radiation generated within the chip is only partly reflected by the surfaces during the round-trip process, there must be a minimum gain during travel before round-trip oscillations will generate. This value depends on the negative conductivity of the specimen and its length in the direction of wave propagation. Baynham has worked out a product of these two factors which defines the threshold of round-trip gain: it's of the order of 10^{13} centimeters⁻².

The Netherlands

Two cores per bit

For memory makers, it's a sticky time to decide on the technology that will fill the gap between ferrite-core and semiconductor systems not far down the pike.

"The semiconductor houses are shouting that cheap chips will be available in a matter of time and that cores will die out," says Anthony M. Aben, general manager of the passive components group at the Philips Elcoma division. "The success of plated wire depends on how much the manufac-

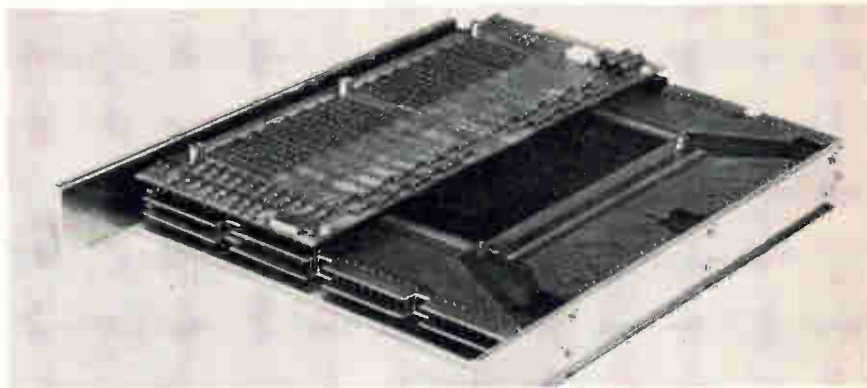

Stacked up. Philips latest version of its two-core-per-bit memory is more compact than the prototype first shown in 1968, thanks to smaller core geometry.

turer has to invest," he asserts. "If the industry really wants to push it can make plated wire technology as cheap as it wants. But we feel that in 1970 it's not necessary to go to new technology. This may not be so in 1972 or 1973."

Philips will test this philosophy when its U.S. distributor, Ferroxcube Corp., displays its new fast memory system at the Fall Joint Computer Conference in Houston. The new memory will be a two-core-per-bit unit with a capacity of 4,096 words of 36 bits each. Its cycle time, 250 nanoseconds, is achieved with partial switching—only the material immediately surrounding the hole is switched between the 1 and 0 states, not the whole volume of the core. Partial switching is noisier than the complete process, but the two-core-per-bit design helps overcome this problem.

The prototype of the new memory was shown in 1968. Since then, however, Philips has introduced several refinements. Among other things, the latest model is physically smaller and better organized, core-pitch in the bit direction is 12.5 mils instead of 25 mils in the earlier model, and there is a new 18-mil core with better temperature, output, and coercive-force characteristics. While the Houston model still will feature an improved version of the 19-mil core, Philips has the 18-mil version in production and will furnish such memories early next year. Philips also will add a 16-kiloword, 36-bit system.

Advantages claimed for the two-

core-per-bit system are twofold. First, like plated wire, it is bipolar, making it necessary to detect only whether the output is positive or negative. Thus, Philips can use a special low-cost sense amplifier. Since output of the pulses in the two-core-per-bit systems is 30 millivolts compared to about 4 or 5 mv for plated wire, the sense detector can get along on simpler, less expensive ICs. To obtain the same cycle speeds with plated wire, on the other hand, requires roughly the same number of more costly amplifiers.

The sense polarity detector is a monolithic chip containing two sense amplifiers. The sense amplifier's input stage is a differential amplifier. Its two inputs are linked to a loop which senses the current from the cores.

In addition, there are inputs determining which of the two sense amplifiers is being read. Depending on which line of the digit/sense line pair is addressed, a polarity correction is required. This function is performed by a signal on either of two additional inputs. This polarity correction is necessary since the sense current flows in opposite directions in the two input lines. The sense amplifier's output is available at current mode logic levels. Philips claims samples of the detectors have shown sensitivity better than the 30 mv required.

A second advantage of two-core-per-bit technology is easier core threading. As a two-dimensional system, it is necessary to thread only two wires—the digit/sense line and the word line.

Everything's clearer with the flat one!

Letters! Digits! Symbols! Equations! All varieties of data are displayed as undistorted images on Zenith Flat-Face Metal CRTs. Ideal for light pen operations, alphanumerics and analog presentations — they're even available with a rear port for optical chart projection. When you need CRTs, face up to the flat one. Write for details.

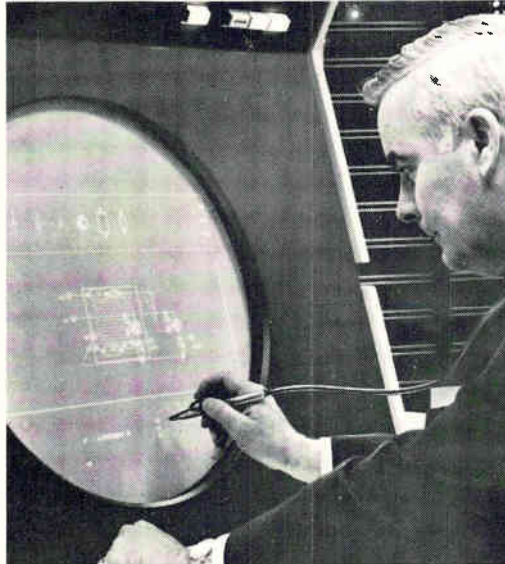

ZENITH RADIO CORPORATION
THE RAULAND DIVISION

5614 W. JARVIS AVE. • CHICAGO, ILL. 60648 • 312-647-8000

Circle 145 on reader service card

TIGHT-WAD BREADBOARD DESIGNER

*The ELite 2 is stingy with your money - with your time
When it comes to advanced circuit design*

This dynamic lab in a box will enable you to design, layout, test and construct (and re-use) all IC and discrete components circuitry (LIS, MSI, MOS) **WITHOUT SOLDERING, SPECIAL TOOLS, PLUGS OR PATCH CORDS.**

PLUS THESE BUILT-IN FEATURES:

- Wide range function generator — sine, square, triangle
- Wide range pulse generator—bi-polar outputs
- 3 monitored power supplies — floating, stable, short circuit proof
- 12 data display lamps — high input impedance ± turn-on thresholds
- All breadboard interconnections with solid #22 gauge hook up wire
- Desk top convenience: 6 inches high, 17½ inches wide, 12 inches deep.
- **ORDER ONE TODAY**

Write or call for complete specifications catalog

PRICE
\$1,300
COMPLETE

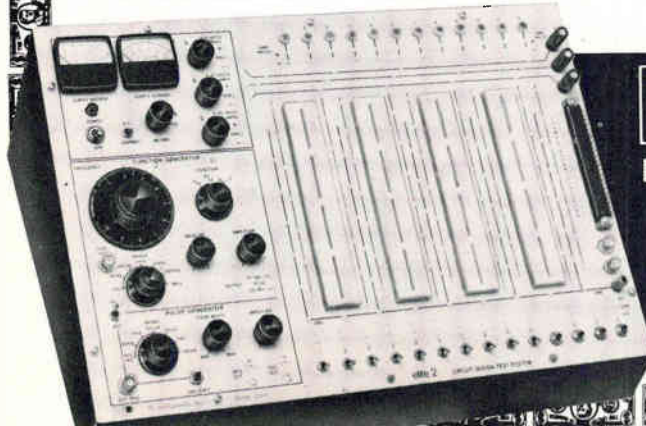

EL Instruments Incorporated

61 First Street
Derby, Conn. 06418

Phone:
203/735-8774

Advertising Sales Staff

Pierre Braudé [212] 971-3845
Advertising Sales Manager

Atlanta, Ga. 30309: Charlton H. Calhoun, III
1375 Peachtree St., N.E.
[404] 892-2868

Boston, Mass. 02116: William S. Hodgkinson
McGraw-Hill Building, Copley Square
[617] CO 2-1160

Chicago, Ill. 60611: Ralph Hanning,
Kenneth E. Nicklas, 645 North Michigan
Avenue, [312] MO 4-5800

Cleveland, Ohio 44113: William J. Boyle,
55 Public Square, [216] SU 1-7000

Dallas, Texas 75201: Richard P. Poole,
1800 Republic National Bank Tower,
[214] RI 7-9721

Detroit, Michigan 48226: Ralph Hanning,
2600 Penobscot Building
[313] 962-1793

Houston, Texas 77002: Richard P. Poole,
2270 Humble Bldg. [713] CA 4-8381

Minneapolis, Minn. 55402: Kenneth E. Nicklas,
1104 Northstar Center [612] 332-7425

New York, N.Y. 10036
500 Fifth Avenue
James R. Pierce [212] 971-3615
Warren H. Gardner [212] 971-3617
Michael J. Stoller [212] 971-3616

Philadelphia, Pa. 19103:
Jeffrey M. Preston
6 Penn Center Plaza,
[215] LO 8-6161

Pittsburgh, Pa. 15222: Jeffrey M. Preston,
4 Gateway Center, [412] 391-1314

Rochester, N.Y. 14534: William J. Boyle,
9 Greylock Ridge, Pittsford, N.Y.
[716] 586-5040

St. Louis, Mo. 63105: Kenneth E. Nicklas,
The Clayton Tower, 7751 Carondelet Ave.
[314] PA 5-7285

James T. Hauptli [415] DO 2-4600
Western Advertising Sales Manager

Denver, Colo. 80202: David M. Watson,
Richard W. Carpenter
Tower Bldg., 1700 Broadway
[303] 266-3863

Los Angeles, Calif. 90017: Ian C. Hill,
Bradley K. Jones, 1125 W. 6th St.,
[213] HU 2-5450

San Francisco, Calif. 94111: Don Farris,
James T. Hauptli, 255 California Street,
[415] DO 2-4600

Paris: Denis Jacob
17 Rue-Georges Bizet, 75 Paris 16, France
Tel 727 33 42, 727 33 60

United Kingdom and Scandinavia
London: Oliver Ball, Tel: Hyde Park 1451
34 Dover Street, London W1

Milan: Robert Saidel, Roberto Laureri Jr.
1 Via Baracchini Phone 86-90-656

Brussels: Denis Jacob
27 Rue Ducale Tel: 136503

Frankfurt/Main: Hans Haller
Elsa-Brandstroem Str. 2
Phone 72 01 81

Tokyo: Noboru Matsumoto, McGraw-Hill
Publications Overseas Corporation,
Kasumigaseki Building 2-5, 3-chome,
Kasumigaseki, Chiyoda-Ku, Tokyo, Japan
[581] 9811

Osaka: Akihiko Kamesaka, McGraw-Hill
Publications Overseas Corporation, Kondo
Bldg., 163, Umegae-cho Kita-ku [362] 8771
Australasia: Warren E. Ball, IPO Box 5106,
Tokyo, Japan

Business Department

Stephen R. Weiss, Manager
[212] 971-2044

Thomas M. Egan,
Production Manager [212] 971-3140

Dorothy Carmesin, Contracts and Billings
[212] 971-2908

Frances Vallone, Reader Service Manager
[212] 971-2865



all the logic that fits, in print

Yet we call it a "Condensed" catalog, because we've packed into relatively few pages the complete and new CAMBION line of TTL integrated circuit logic assemblies.

General purpose cards, Counters, Timing Circuits, Registers, Decoders, Analog Circuits, Interface cards and more... you'll find them all incorporating the popular 74/54 IC families. In addition to detailed data on each card, the catalog contains operating specs and general descriptive text for the design engineer developing his own subsystem.

No matter how many catalogs you already have, this one will extend your capabilities, without overextending your bookshelf. Send us your name, we'll send you a copy. Cambridge Thermionic Corporation, 463 Concord Avenue, Cambridge, Massachusetts 02138.

Standardize on

CAMBION[®]
The Guaranteed Logic Assemblies

Circle 146 on reader service card

$E=2(C+EDP)X$

Last year, Electronics magazine contained twice as much information on computers and electronic data processing as the next leading electronic publication.

If the cover of this magazine has your name and address on it, there is no better formula for keeping yourself abreast of the industry's technology.

You say you want a

low-profile snap-in-mounting push button switch or matching indicator that is interchangeable with most 4-lamp displays... available in a full range of cap colors... with a choice of bezels with or without barriers in black, gray, dark gray or white.



and a

legend presentation that's positive (like this one) or negative (like the one below) or just plain (like the one above)... one that's white when "off" and red, green, yellow (amber), blue or light yellow when "on"... or colored both "on" and "off."



and a

highly reliable switch proven in thousands of installations... available in momentary or alternate action... N.O., N.C. or two circuit (one N.O., one N.C.)... that accommodates a T-1 3/4 bulb with midget flanged base, incandescent, in a range of voltages from 6-28V.



etc.
etc.
etc.

Now, for the first time Dialight gives you custom panel designing with a standard line of push-button switches and matching indicators

Dialight offers a broader range of switch and indicator possibilities than you'll find anywhere in a standard single-lamp line.

Sizes: 3/4" x 1", 5/8" square and round.

Send today for our new full-color catalog L-209.

DIALIGHT

Dialight Corporation, 60 Stewart Ave., Brooklyn, N.Y. 11237

DT-125

Now read this...



Actual Size

14 digits in 14 centimetres with the new Philips PANDICON*!

Putting numbers into electronic calculators, computers and data terminals isn't so difficult these days. But getting numbers out — legibly and economically — can be another matter.

Unless, of course, you've heard about Philips' new PANDICON fourteen-decade integrated readout tube, type ZM 1200.

Its legibility you can see for yourself. No more unnatural spaces between digits. Decimal points and punctuation marks where you expect them to be. Coherent numbers instead of 14 separate digits — all in a

space less than the width of this page. But there are other advantages too. Economy, for example. All 14 digits in one and the same tube. To provide this display with ordinary single tubes, somebody would have to make 168 external connections. The PANDICON needs only 27. Interconnections are inside — protected from damage. You save on drive components because only one decoder-driver is needed for the full 14-digit display. You save on power too — it consumes only 1.5 to 2 W.

Best of all is the reliability. We're not ready to quote Mean-Time-Between-Failure figures yet, because after hundreds of thousands of life-test hours, we haven't had enough failures to make statistically significant conclusions. It may take some time yet, as we anticipate an MTBF of 500,000 hours. Meanwhile, we've given you a full one-year guarantee on this tube — with the strong suspicion it will live 10 times as long! After all we have over 60 years experience in gasdischarge physics.

If 14 digits are too much, we can offer you 8, 10 and 12 digit tubes soon.

Our engineers have also developed a Dynamic Drive Module type DDM 14 to go along with the PANDICON. Everything is described in our new PANDICON data file, which is yours for the asking.

Philips Electronic Components and Materials Division, Eindhoven, the Netherlands.

Distributed and sold in the U. S. by: Ampere Electronic Corporation, Providence Pike, Slatersville, R. I. 02876.

* Registered trade-mark of N. V. Philips' Gloeilampenfabrieken, Eindhoven, the Netherlands.

PHILIPS

Circle 147 on reader service card

DIGITAL APPLICATIONS CORPORATION dac

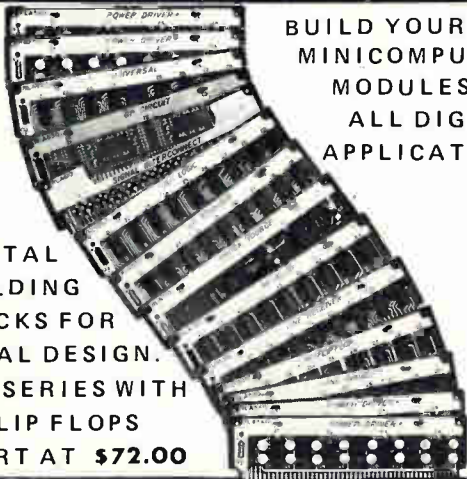

BUILD YOUR OWN MINICOMPUTER! MODULES FOR ALL DIGITAL APPLICATIONS

DIGITAL BUILDING BLOCKS FOR TOTAL DESIGN. RLA SERIES WITH 14 FLIP FLOPS START AT \$72.00

ASK FOR OUR FREE CATALOG TODAY
CALL US COLLECT (213) 882-0076

dac
9168 DESOTO AVENUE
CHATSWORTH CALIFORNIA

A DIVISION OF
POWERTEC
THE POWERHOUSE

Circle 142 on reader service card

THINK DIGITAL



NEON READOUT DRIVER MODULE

Factory assembled Elfin readout modules with built-in decoder-drivers are ready to plug into your systems. Choice of decoder-drivers or with memory, counter, Model DM-17G.

USES ELFIN* 7-SEGMENT DISPLAY TUBE

15.89
IN 500 LOTS

ALCO
LAWRENCE, MASS.

* Manufactured Under a License By Burroughs Corp.

THINK DIGITAL



7-SEGMENT INCANDESCENT

7-Segment display uses T-1 lamps having the long life of neons. Figure size is .340" x .614". One-piece metal case has built-in filter. Bezel and mount assemblies available. Model MS-4000BR.

PLUG-IN MODULE

BCD-TO-7 SEG. OR DECIMAL INPUT DECODER-DRIVER

ALCO ELECTRONIC PRODUCTS, LAWRENCE, MASS.

Circle 165 on reader service card

New LC Series power package IC regulated Modular Power Supply

The LCS-A is another package in the LC series of 7 package sizes providing single and dual outputs; wide range of d-c voltages, up to 150 volts; wide range of currents, up to 3.0 amps; priced from \$99.00.

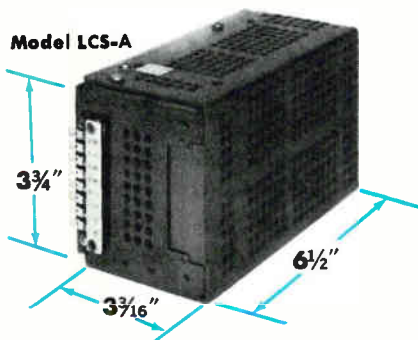

LCS-A SINGLE OUTPUT MODELS (Fixed Voltage)



3 3/16" x 3 3/4" x 6 1/2"

MODEL	FIXED VOLT. RANGE VDC	MAX. AMPS. AT AMBIENT OF:				PRICE (2)
		40°C	50°C	60°C	71°C	
LCS-A-3	3±5%	3.0	2.5	2.0	1.4	\$99
LCS-A-3P6	3.6±5%	2.9	2.4	1.9	1.3	99
LCS-A-4	4±5%	2.9	2.4	1.9	1.3	99
LCS-A-4P5	4.5±5%	2.8	2.3	1.8	1.2	99
LCS-A-5	5±5%	2.7	2.3	1.8	1.2	99
LCS-A-6	6±5%	2.6	2.2	1.8	1.2	99
LCS-A-8	8±5%	2.4	2.0	1.7	1.1	99
LCS-A-10	10±5%	2.1	1.8	1.5	1.0	99
LCS-A-12	12±5%	1.9	1.7	1.3	0.9	99
LCS-A-15	15±5%	1.8	1.5	1.2	0.9	99
LCS-A-18	18±5%	1.6	1.3	1.1	0.8	99
LCS-A-20	20±5%	1.4	1.2	1.0	0.8	99
LCS-A-24	24±5%	1.1	1.0	0.85	0.70	99
LCS-A-28	28±5%	1.0	0.9	0.75	0.60	99
LCS-A-36	36±5%	0.90	0.80	0.70	0.50	99
LCS-A-48	48±5%	0.60	0.55	0.50	0.45	99
LCS-A-100	100±5%	0.18	0.18	0.18	0.18	109
LCS-A-120	120±5%	0.15	0.15	0.15	0.15	109
LCS-A-150	150±5%	0.10	0.10	0.10	0.10	109

All-silicon DC power supply using integrated circuits to provide regulation system

Convection cooled

no external heat sinking required

Regulation

line or load .01% + 1 mv

Ripple and noise

250 μv rms; 1 mv p-to-p

Wide input voltage and frequency range

105-132 vac, 47-440Hz

205-265 vac, add suffix "V" to model number

Wide temperature range

-20°C to +71°C

Temperature coefficient

.01% + 300 μv/°C external programming resistor

.015% + 300 μv/°C internal programming resistor

Remote programming

1000 ohm/v nominal or volt/volt

Remote sensing

Automatic current limiting

Series/parallel operation

with similar single or dual units

Multi-current-rated

Overvoltage protection

available as accessory up to 70 vdc

Other LC models are available with these voltage and current ranges:

LCS-1	to	120 vdc,	to	275 ma.,	from	\$ 70
LCS-2	to	120 vdc,	to	550 ma.,	from	\$ 80
LCS-3	to	60 vdc,	to	1.2 a.,	from	\$ 90
LCS-B	to	150 vdc,	to	3.7 a.,	from	\$125
LCS-4	to	150 vdc,	to	4.5 a.,	from	\$130
LCS-C	to	150 vdc,	to	4.5 a.,	from	\$150
LCD-2	to	120 vdc,	to	300 ma.,	from	\$125
LCD-3	to	60 vdc,	to	700 ma.,	from	\$150
LCD-A	to	120 vdc,	to	1.0 a.,	from	\$155
LCD-4	to	120 vdc,	to	1.8 a.,	from	\$190

"S" denotes single, "D" denotes dual output.

LCS-A SINGLE OUTPUT MODELS (Wide Range)



3 3/16" x 3 3/4" x 6 1/2"

MODEL	ADJ. VOLT. RANGE VDC	MAX. AMPS. AT AMBIENT OF 1				PRICE (2)
		40°C	50°C	60°C	71°C	
LCS-A-01	0-7	2.0	1.9	1.6	1.1	\$99
LCS-A-02	0-18	1.1	1.0	0.9	0.7	99
LCS-A-03	0-32	0.69	0.64	0.60	0.45	99
LCS-A-04	0-60	0.37	0.34	0.31	0.25	99
LCS-A-05	0-120	0.10	0.10	0.10	0.10	109

NOTES: (1) For operation at 360-440Hz, consult factory for ratings and specifications. For operation at 47-53 Hz derate current by 10%.

(2) Prices are USA list prices only, FOB Melville, N.Y.; North Hollywood, Calif.; Montreal, Canada. All prices and specifications are subject to change without notice. The following charges are applicable for shipment from other than Melville, N.Y., except for Canadian customers.

Value of Order

up to \$50.00
\$51.00 to \$180.00
\$181.00 to \$300.00
\$301.00 to \$500.00
\$501.00 and over

Handling Charge

\$1.00
\$2.00
\$4.00
\$6.00

FOB Melville, N.Y. only

Lambda's Distributor Division maintains a total inventory of over 10,000 power supply units located in Los Angeles, Montreal and New York for 1-day delivery - 5 year guarantee.



Write for complete Lambda Catalog!

Lambda Electronics Corp., 515 Broad Hollow Road, Melville, Long Island, New York 11746 • Tel. 516-694-4200

Lambda International—Canada, Montreal, Quebec Tel: 514-697-6520; **England**, Portsmouth, Hants. Tel: Cosham 73221;

France, Versailles, Paris Tel: 951-03-34 or 951-11-36; **Israel**, Haifa Tel: 722925 or 724314; **Germany**, Berlin Tel: 0311-7923371,

Munich Tel: 0811-432025.

Take advantage of RCA's ability to supply superior SCR's and Triacs... when you need them.

Ask our solid-state specialists why RCA's broad line of industrial SCR's and triacs excel in quality, reliability, and performance. They'll tell you that RCA thyristors are subjected to some of the toughest quality assurance tests in the industry. Thus, they save design dollars by virtue of superior performance in critical applications.

Ask users of industrial thyristors why RCA is a key supplier and they'll tell you RCA services the industry! Whatever the application—area lighting to avionics, regulators to inverters, or power supplies to modulators—RCA has SCR's and triacs to meet your application requirements.

Use these SCR's and triacs in your control applications:

SCR Family	Rating		Triac Family	Rating	
	$I_T(RMS)$	V_{DROM}		$I_T(RMS)$	V_{DROM}
40740	10 A	600 V	40795	10 A	600 V
40752	20 A	600 V	40797	15 A	600 V
2N690	25 A	600 V	40671	30 A	600 V
2N3899	35 A	600 V	2N5443	4Q A	600 V

NOTE: SCR ratings of 100, 200, & 400 volts and triac ratings of 200 & 400 volts are available in each family. Stud packages & isolated-stud packages are also available in each rating.

For further details and your copy of the latest thyristor catalog, THC-500, see your local RCA Representative or your RCA Distributor. Or write RCA Electronic Components, Commercial Engineering Section 70H-31/UR6, Harrison, N.J. 07029. International: RCA, 2-4 rue du Lièvre, 1227 Geneva, Switzerland, or Post Office Box 112, Hong Kong.

RCA
Thyristors

