

Electronics[®]

Faster r-f device testing: page 94

Special report on gallium arsenide: page 105

A suitcase-sized computer memory: page 138

November 13, 1967

\$1.00

A McGraw-Hill Publication

Below: Crystal of gallium arsenide
opens new horizons in electronics, page 105

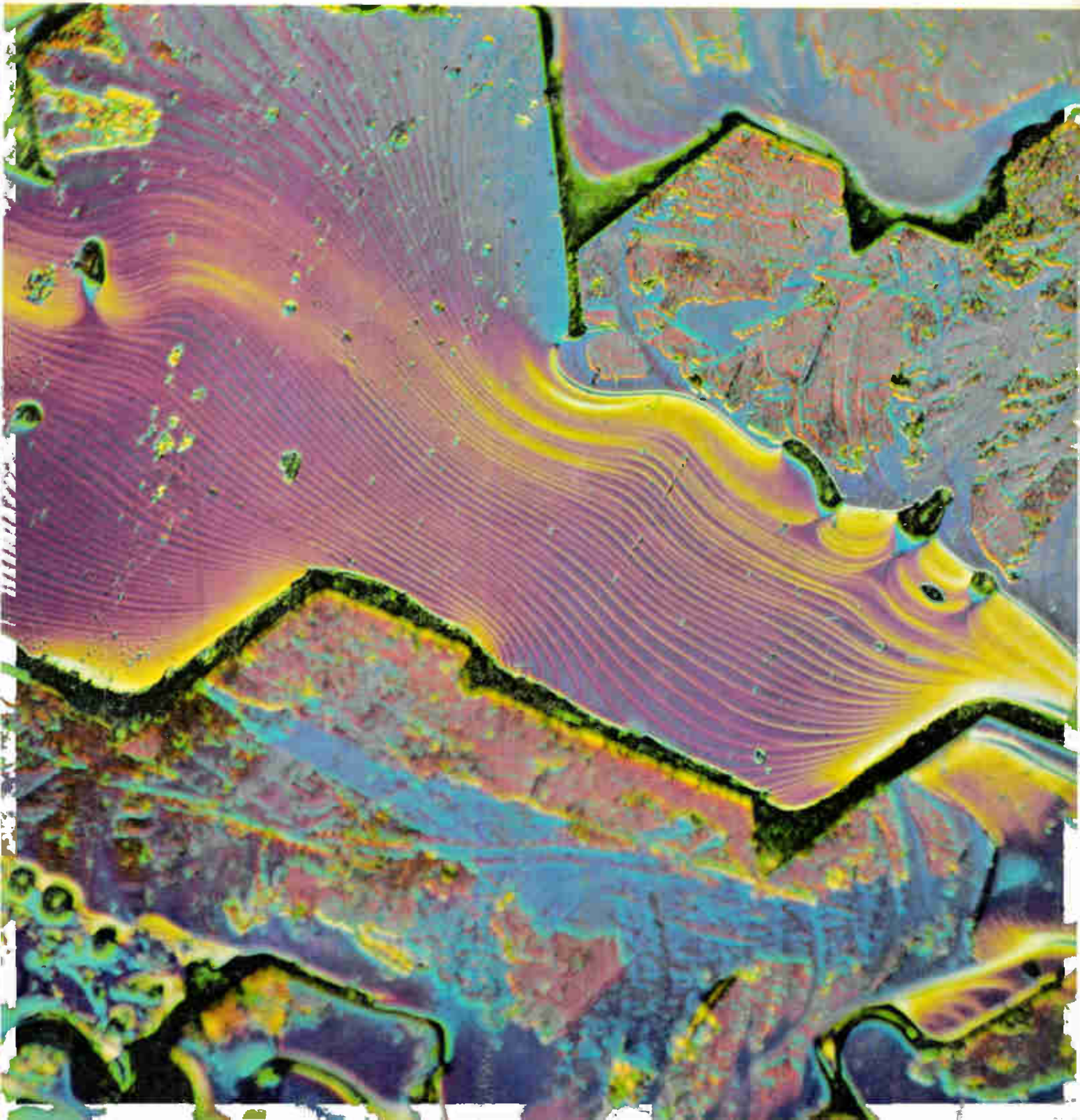



NEW

DO-T200™ SERIES

**ULTRAMINIATURE TRANSISTOR TYPE
AUDIO TRANSFORMERS**

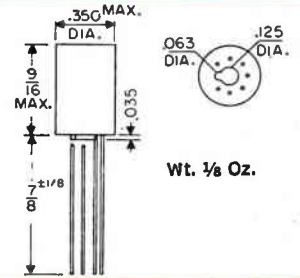

Wt. 1/8 Oz.

U. S. PAT. NO. 2,949,591; others pending.

This DO-T200 series of transistor transformers and inductors has been newly added to the UTC lines of stock items available for immediate delivery. These transformers provide the unprecedented power handling capabilities and the inherent reliability found only in the basic structural design of the UTC DO-T Family of miniature transformers. This reliability has been dramatically proven in the field.

Leads are 7/8" long, .016 Dumet wire, gold plated, and may be either welded or soldered. They are uninsulated and are spaced on a .1" radius circle, conforming to the termination pattern of the "TO-5" cased semiconductors and micrologic elements.

DO-T200 series of transformers are designed for Class R application. On special order they may be designed to Class S Specifications. No additional life expectancy is gained by using Class S insulation systems at Class R temperatures.

In pulse coupling impedance matching applications, (when measured with a 30 microsecond input pulse voltage wave), typical values for these transformers are: 5% or less droop, zero overshoot, and less than 10% backswing.

Special unit modifications, such as additions and deletions of leads, changed lead lengths, different impedance ratios and incorporation of electrostatic shields, etc., are available in these constructions.

• Manufactured and successfully tested to complete environmental requirements of MIL-T-27B

- Most Ruggedized MIL Structure, Grade 4, Metal Encased
- Hermetically Sealed
- Immediate Delivery From Stock
- Straight Pin Terminals
- Full Conformance to MIL Mounting Requirements
- Excellent Response
- Solderable and Weldable Leads
- High Efficiency
- Low Distortion

Type No.	MIL Type	Pri. Imp.	D. C. ma± in Pri.	Sec. Imp.	Pri. Res.	Mw Level	Application
DO-T255	TF4RX13YY	1K/1.2K CT	3	50/60	115	100	Output or matching
DO-T275	TF4RX13YY	10K/12K CT	1	1.5K/1.8K CT	780	100	Interstage
DO-T277	TF4RX13YY	10K/12K CT	1	2K/2.4K split	560	100	Interstage
DO-T278	TF4RX13YY	10K/12.5K	1	2K/2.5K CT	780	100	Driver
DO-T283	TF4RX13YY	10K/12K CT	1	10K/12K CT	975	100	Isol. or Interstage or Pulse
DO-T288	TF4RX13YY	20K/30K CT	.5	.8K/1.2K CT	830	50	Interstage
DO-T297	TF4RX16YY	200,000 CT	0	1000 CT	8500	25	Input and Chopper
DO-T200SH	Drawn Hipermalloy shield provides 15 to 20 db shielding through side of case						

±DCma shown is for single ended useage. For push pull, DCma can be any balanced value taken by .5W transistors. Where windings are listed as split, 1/4 of the listed impedance is available by paralleling the winding.

THE DO-T FAMILY OF COMPONENTS



All these hermetically sealed, ultraminiature transistor transformers & inductors are to MIL-T-27B, Grade 4, Class R, Life X. Except PIP: to MIL-T-21038B, Grade 6, Class R, Life X.

DO-T Flexible leads. Freq range 300 CPS—10KC & up. Power up to 1/2 W. Size 1/16 dia x 1 1/2" h. Wt approx 1/10 oz.

DI-T Flexible leads. Freq range 400 CPS—10KC & up. Power up to 1/2 W. Size 1/16 dia x 1/4" h. Wt approx 1/15 oz.

DO-T200 Series. See above

DI-T200 Series Straight pin gold plated. Dumet leads. Freq range 400 CPS—100KC. Power up to 500 mw. Size 1/16 d x 3/8" h. Wt approx 1/15 oz.

PIL Inductors range from .025 hy to .8 hy, DC 0 to 10 ma. Transformers from 500 ohms to 10,000 ohms impedance. Freq range 800 cps—250 KC; power up to 100 MW. Size 1/16 dia x 1/16" h. Wt 1/20 oz.

PIP (Pulse). Flexible leads. Wide application pulse transformers, to MIL-T-21038B specifications. Size 1/16 dia x 1/16". Wt 1/20 oz.

DO-T400 (Power) Flexible leads, power transformer. Power output 400 mw @ 400 cycles. Size 1/16 dia x 1 1/2". Wt 1/10 oz.

AND SPECIAL, CUSTOM BUILT COMPONENTS TO YOUR SPECIFICATIONS

Write for catalog of over
1,300 UTC TOP QUALITY
STOCK ITEMS
IMMEDIATELY AVAILABLE
from your local distributor.



UNITED TRANSFORMER CO.

DIVISION OF TRW INC. • 150 VARICK STREET, NEW YORK, N. Y. 10013

IN CANADA: A. C. SIMMONDS & SONS LIMITED, AGINCOURT, ONTARIO

1 to 110 MHz in one sweep... with 0.5% linearity

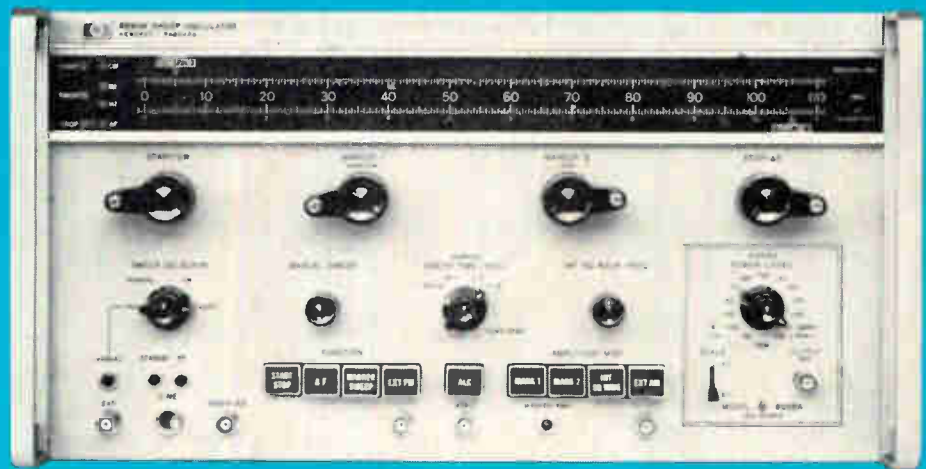

Swept frequency testing of broadband RF devices and systems is fast and accurate with the new HP 8698A RF Plug-in for the HP 8690A Sweep Oscillator. High linearity, calibrated power levels and flat output simplify your test set-ups. And this same unit is ideal for narrow-band and CW tests because of its low residual FM and high-resolution frequency dial. Then too, the 8690A main unit accepts 17 other sweeper units covering 1 to 40 GHz in octave and waveguide bands.

Major performance specifications

8698A installed in 8690A Sweep Oscillator.

Operating modes: START/STOP and MARKER sweeps (end points continuously and independently adjustable over entire frequency range); ΔF sweep (calibrated width adjustable from 0 to 10% of frequency range); CW operation.

Sweep modes: Automatically recurring, manual, triggered, external FM (DC to 2 kHz rate); sweep times from 0.01 to 100 seconds.

Frequency range: 0.1 to 11 MHz and 1 to 110 MHz, selected by front-panel switch.

Frequency accuracy: $\pm 1\%$ of full scale.

Frequency linearity: $\pm 0.5\%$ of sweep width.

Residual FM: 0.1-11 MHz < 150 Hz peak, 1-110 MHz < 500 Hz peak.

Power output: At least +20 dBm max. (2.24 VRMS) into 50 ohms; Calibrated output adjustable in 10 dB steps from +10 dBm to -110 dBm, full vernier adjustment between steps. Source impedance 50 Ω .

Output accuracy (vernier in CAL position): ± 2 dB (+10 to -60 dBm), ± 3 dB (-70 to -110 dBm). Output flatness, ± 0.25 dB (typically ± 0.1 dB over any 10 MHz range).

Price: Model 8698A, \$950. (Model 8690A, \$1550.)

Get full information about this new RF Sweeper-Generator from your local HP field engineer, or write Hewlett-Packard, Palo Alto, Calif. 94304; Europe: 54 Route des Acacias, Geneva.

HEWLETT  PACKARD

SWEEP OSCILLATORS

04/721

RECORD DATA IN INK ON Z-FOLD PAPER AND READ IT LIKE A BOOK

The new Hewlett-Packard 7850 Series Rectilinear Fluid-Process Recorder produces ultra-clear traces on Z-fold paper or rolls. The numbered Z-fold pages offer more convenient access to recorded data. Contactless pen tip sensing and a low-pressure ink system produce traces of constant width throughout the recorder's

variable speed ranges of .025 to 200 mm. per second. Designed with modular, solid-state electronics, the 7850 Series Recorder provides high-resolution, permanent, rectilinear recording of up to eight variables from dc to 160 Hz.

A wide selection of 8800 Series Preamplifiers provides signal conditioning to the driver-amplifiers which drive the recording pens of the recorder.

The 7850 Series system includes a preamplifier power supply, a driver amplifier power supply and a cabinet to house the complete unit. The frequency response of the recorder is 160 Hz for 10 div p-p deflection and 60 Hertz maximum for full scale deflection. Maximum ac or dc non-linearity is 0.5% full scale. Additional features include: 14 electrically-con-

trolled chart speeds; built-in paper take-up; low ink supply warning light; plug-in ink supply cartridge that may be replaced while the recorder is in operation and complete modular construction of all components for easy maintenance:



For complete information on the 7850 system, optional and related equipment, contact your local HP Field Office or write Hewlett-Packard Company, 175 Wyman St., Waltham, Mass. 02154.

HEWLETT  PACKARD

17701

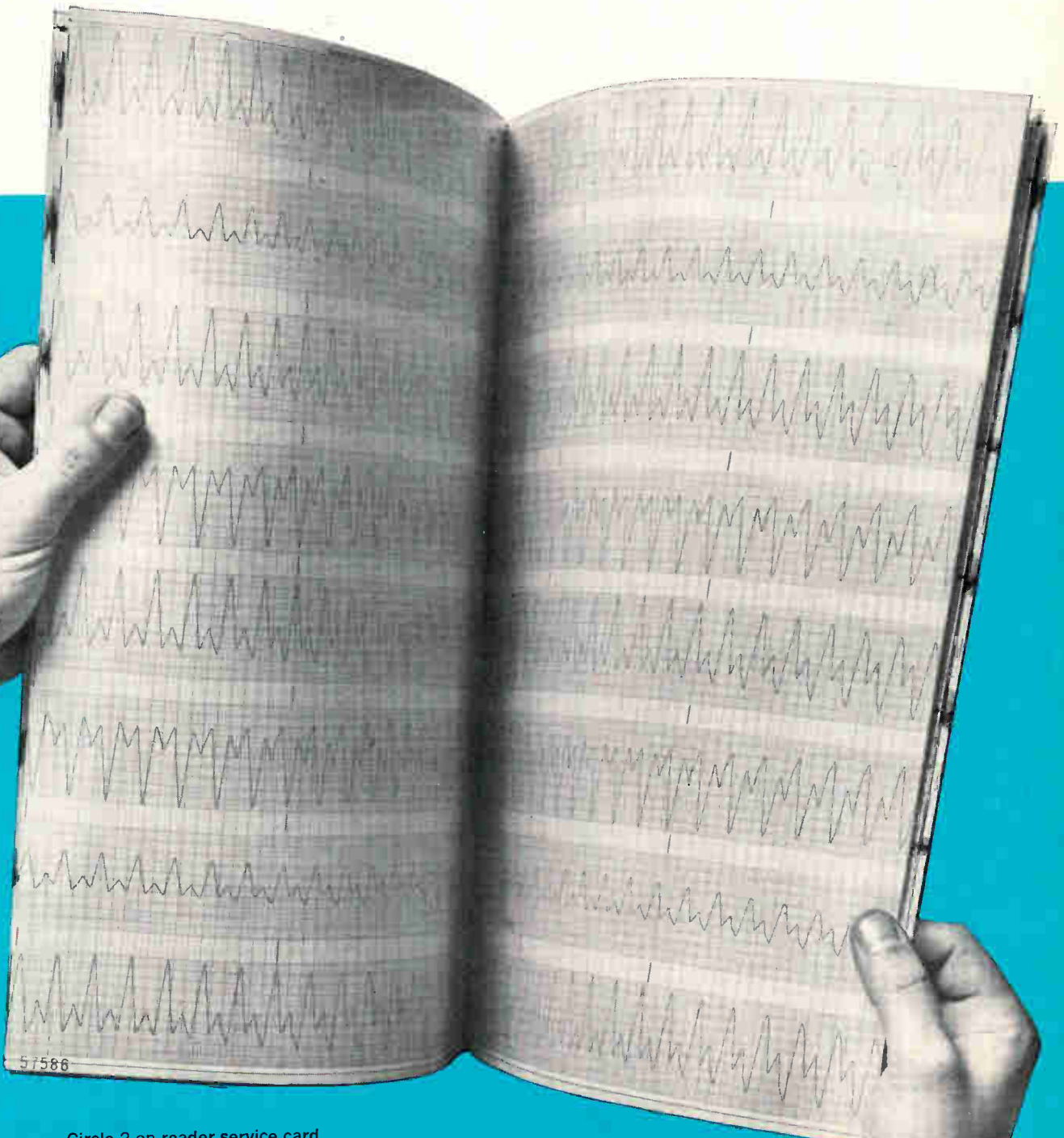

Circle 2 on reader service card

Electronics

Volume 40, Number 23
November 13, 1967

News Features

Probing the News

- 165 Space-ground link hardware on schedule despite setbacks
- 173 Uhf-tv picture fading
- 179 Countdown begins on Intelsat's future

Electronics Review

- 45 Computers: Unwarped memories
- 46 Solid state: Hot dice
- 46 Space electronics: New twist; Looking sharp
- 48 Medical electronics: The good old ways
- 50 Advanced technology: Hot spot storage
- 50 Integrated electronics: Neat trim
- 52 Manufacturing: IC overseer
- 54 Consumer electronics: Music in IC major; Short circuited
- 56 Avionics: All ahead slow
- 58 Communications: Out of one, many
- 58 Industrial electronics: Stock taker
- 59 Government: Voyage to nowhere
- 60 For the record

Electronics Abroad

- 305 Soviet Union: Red glow in space
- 305 The Netherlands: Filling the blanks
- 306 Great Britain: New beat
- 307 France: Foresight
- 308 West Germany: New geometry; Where away?
- 310 Japan: Tuned IC; Inside job

New Products

- 201 Massive core memory runs at lightning speed
- 204 New components review
New components: Avalanche brightens photodiode outlook; Walls of bulb are color-full; Double feature pickup tube
- 215 New semiconductor review
- 215 New semiconductors: Linear IC's take baby step toward LSI; Still another IC for television
- 224 New instruments review
- 224 New instruments: Hands-off frequency sweeping; Materials sensor measures heat flow
- 234 New subassemblies review
- 234 New subassemblies: Making sure of dotted i's and crossed t's; Color tv camera sells for \$9,850; 2-minute detector of water pollution; The price is right—even with cores
- 251 New microwave review
- 251 New microwave: Ultrafast switching—it's a snap; Coaxial connector for fast crimping
- 259 New production equipment review
- 259 New production equipment: Controlled overloading tunes up resistors; Welding fasteners quick as a flash

Title R registered U.S. Patent Office; © copyright 1967 by McGraw-Hill Inc. All rights reserved, including the right to reproduce the contents of this publication, in whole or in part.

Technical articles

- Instrumentation 94 Delay line speeds r-f testing
Electrically lengthening one path of a heterodyning test set reduces testing time sharply
Frederick F. Rogers, Western Electric Co.
- Circuit design 99 Designer's casebook
 - Integrated circuit drives neons directly
 - Ring radiator succeeds in mobile vhf radio
 - Relay actuator produces one-hour pulses
 - Push-pull capacitors multiply input voltage
 - Transistor replaces supply in amplifier
 - Oscillator waits for switch to quiet down

- Solid state 105 **Special report: The many facets of gallium arsenide (cover)**
- 106 Gallium arsenide begins to keep its promises
Stephen E. Scrupski, senior associate editor
- 108 Special features make the difference
David Richman, RCA
- 110 Crystals hold key to the future
J.M. Woodall, IBM
- 113 An all-in-one process for building junctions
J.J. Tietjen and L.R. Weisberg, RCA
- 114 Film making: a delicate job
K.L. Lawley, Bell Telephone Laboratories
- 116 Getting dopants on the beam
K.E. Manchester, Sprague Electric Co.
- 117 An almost ideal substrate
C.P. Sandbank, Standard Telecommunication Laboratories
- 118 Off to a good start
Arthur Uhlir Jr., Microwave Associates
- 119 Narrow field for bipolars
Hans Strack, Texas Instruments
- 122 Fast moving field effect transistors
Hans Becke, RCA
- 123 Microwave mixing and detecting
C.M. Howell, Microwave Associates
- 125 Beating the heat in injection lasers
Hans Rupprecht, IBM
- 127 GaAs light era on the way
J.R. Biard and Hans Strack, Texas Instruments
- 129 Two Gunn holdups slow microwave oscillators
D.G. Dow, Varian Associates
- 131 LSA can come to mean large-size advantages
J.A. Copeland, Bell Telephone Laboratories
- 132 Bulk-effect boosting
H.W. Thim, Bell Telephone Laboratories
- 133 Pulsating passages
Masakazu Shoji, Bell Telephone Laboratories
- 134 Over the horizon, IC's
E.W. Mehal, Texas Instruments

- Computers 138 Suitcase-size memory for longer space trips
Pulse techniques and MOS transistors shrink memory size
D.E. Brewer, Wright-Patterson Air Force Base and S. Nissim and G.V. Podraza, Bunker-Ramo

Departments

- 4 Readers Comment
- 8 People
- 14 Meetings
- 16 Meeting Preview
- 23 Editorial
- 25 Electronics Newsletter
- 46 Index of activity
- 69 Washington Newsletter
- 264 New Books
- 274 Technical Abstracts
- 286 New Literature
- 299 Newsletter from Abroad

Electronics

Editor-in-Chief: Lewis H. Young

Associate managing editors

Technical: Donald Christiansen
News: Robert Henkel
Copy: Sally Powell

Senior associate editors

John F. Mason, Joseph Mittleman, Stephen E. Scrupski, Harry R. Karp

Department editors

Advanced technology: Stephen E. Scrupski
Avionics & Space: Alfred Rosenblatt
Computers: Wallace B. Riley
Consumer electronics: John Drummond
Design theory: Joseph Mittleman
Industrial electronics: Harry R. Karp
Instrumentation: Carl Moskowitz
Military electronics: John F. Mason
New Products: William P. O'Brien, Stephen Fields
Solid state: Mark B. Leeds
Staff writer: Howard Wolff

Section editors

Electronics abroad: Arthur Erikson
Electronics review: Stanley Zarowin
New Products: H. Thomas Maguire
Probing the news: Eric Aiken

Regional bureaus

Domestic

Boston: James Brinton, manager; Robin Carlson
Los Angeles: Lawrence Curran, manager; June Ranill
San Francisco: Walter Barney, manager; Mary Jo Jadin
Washington: Robert Skole, manager; William D. Hickman, Paul Dickson, Patricia C. Hoehling

Foreign

Bonn: John Gosch
London: Michael Payne
Tokyo: Charles Cohen

Copy editors

James Chang, Frederick Corey

Graphic design

Art director: Saul Sussman
Assistant art directors: Ann Mella, Valerie Betz
Production editor: Arthur C. Miller

Editorial secretaries: Claire Benell, Lynn Emery, Kay Fontana, Patricia Gardner, Lorraine Longo

McGraw-Hill News Service

Director: John Wilhelm; Atlanta: Fran Ridgway; Chicago: James Rubenstein;
Cleveland: Arthur Zimmerman; Dallas: Marvin Reid;
Detroit: J. Wirgo; Houston: Robert E. Lee; Los Angeles: Michael Murphy, Gerald Parkinson
Pittsburgh: Louis Gomolak
San Francisco: William F. Arnold
Seattle: Ray Bloomberg; Washington: Arthur L. Moore, Charles Gardner,
Herbert W. Cheshire, Seth Payne, Warren Burkett, James Canan, William Small

McGraw-Hill World News Service

Bonn: John Johnsrud; Hong Kong: Don Kirk; London: John Shinn;
Mexico City: Bruce Cross; Milan: Ronald Taggiasco;
Moscow: Howard Rausch; Paris: Peter Kilborn;
Rio de Janeiro: Wes Perry; Tokyo: Marvin Petal

Reprints: Susan Nugent

Circulation: Milton Drake

Publisher: Gordon Jones

Electronics: November 13, 1967, Vol. 40, No. 23

Published every other Monday by McGraw-Hill, Inc. Founder: James H. McGraw 1860-1948.
Printed at 99 North Broadway, Albany, N.Y. 12207; second class postage paid at Albany, N.Y.

Executive, editorial, circulation and advertising addresses: McGraw-Hill Building, 330 W. 42nd Street
New York, N.Y. 10036. Telephone (212) 971-3333. Teletype TWX N.Y. 710-581-4235. Cable address:
MCGRAWHILL N.Y.

Subscriptions solicited only from those professionally engaged in electronics technology. Subscription rates:
qualified subscribers in the United States and possessions and Canada, \$8.00 one year, \$12.00 two years,
\$16.00 three years; all other countries \$25.00 one year. Non-qualified subscribers in the U.S. and
possessions and Canada, \$25.00 one year; all other countries \$50.00. Air freight service to Japan \$50.00
one year. Single copies: United States and possessions and Canada, \$1.00; all other countries, \$1.75.

Officers of McGraw-Hill Publications: Joseph H. Allen, President; Bayard E. Sawyer, Executive Vice-President;
J. Elton Tuohy, Senior Vice-President-Operations; Vice Presidents: John R. Callahan, Editorial;
John M. Holden, Marketing; Paul F. Cowie, Circulation; Angelo R. Venezi, Production; Jerome D. Luntz,
Planning & Development; Robert M. Wilhelm, Controller.

Officers of the Corporation: Donald C. McGraw, Chairman of the Board; Shelton Fisher, President;
L. Keith Goodrich, Robert E. Slaughter, Executive Vice Presidents; Donald C. McGraw, Jr.,
Senior Vice-President; John J. Cooke, Vice-President & Secretary; John L. McGraw,
Vice-President & Treasurer.

Title © registered in U.S. Patent Office; © Copyright 1967 by McGraw-Hill, Inc. All rights reserved. The contents
of this publication may not be reproduced either in whole or in part without the consent of copyright owner.

Subscribers: The publisher, upon written request to our New York office from any subscriber,
agrees to refund that part of the subscription price applying to copies not yet mailed.
Please send change of address notices or complaints to Fulfillment Manager; subscription
orders to Circulation Manager, Electronics at address below. Change of address notices
should provide old as well as new address, including postal zip code number. If possible,
attach address label from recent issue. Allow one month for change to become effective.

Postmaster: Please send form 3579 to Fulfillment Manager, Electronics,
P.O. Box 430, Hightstown, New Jersey 08520

Readers Comment

No exceptions

To the Editor:

I would like to correct one statement made in the article "Strengthening a link . . . or replacing it" [Aug. 21, p. 39] to the effect that everyone except Amphenol would be forced to requalify as suppliers of MIL-C-26500C. This is not the case. Amphenol, as well as all other potential suppliers of a connector qualified to MIL-C-26500C, will have to qualify by running the required tests in the manner specified. As a matter of fact, we have already asked permission to start such qualification testing at Amphenol.

J.E. Atkinson

Vice president
Amphenol Connector Division
Chicago, Ill.

New light

To the Editor:

"Is Einstein wrong?" was the heading you gave to a letter from Pascal M. Rapier [July 10, p. 4] discussing the article "Settling on the moon" [May 15, p. 110].

Rapier had suggested that either Einstein's theory "that the phase of a light signal is independent of velocity . . ." is wrong or that "the lunar soft landings whose velocity and range data were obtained from radar doppler techniques . . . impossible under Einstein's theory" were fakes.

C. J. Badewitz, the author of the article, replied that Einsteinian doppler shifts encountered in the Surveyor approach velocities differ from such shifts calculated by means of classical theory by a completely negligible amount.

Neither of these gentlemen appears to have read "Light Velocity and Relativity," by Arthur S. Otis. This 130-page booklet presents some half-dozen disproofs of the postulate questioned by Rapier. One of them concerns the doppler shift.

The postulate is: the velocity of light is constant in all inertial systems.

Dr. Otis argues thusly: since light velocity $v = \lambda f$, and since λ

60 MHz flip-flops, 5 nsec gates

Sprague SSL* is the fastest TTL

(Super-Speed Logic)



and they're pin compatible with series 8000



for maximum systems speed, check out
Sprague SSL Super-Speed Logic

PROPAGATION DELAY	5 nsec
POWER DISSIPATION	25 mW
NOISE IMMUNITY	1.0 V
FANOUT	11
FLIP-FLOP TOGGLE FREQUENCY	60 MHz

For additional information
write to:
Semiconductor Division
Sprague Electric Company
115 Northeast Cutoff
Worcester, Mass. 01606

★Trademark

SPRAGUE WORCESTER... the world's finest microcircuit facility

455-7100



*Sprague' and '®' are registered trademarks of the Sprague Electric Co.

300 Hz to 31 MHz

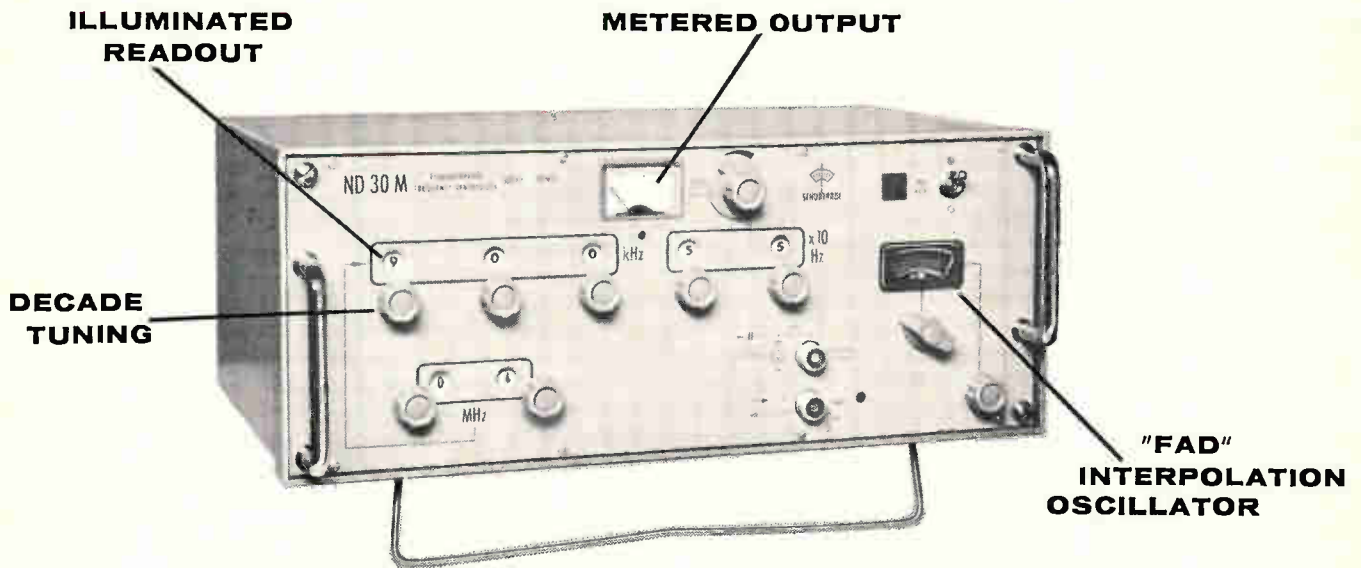

TYPE ND 30M

FREQUENCY SYNTHESIZER

FEATURES

- Built-in 1 MHz crystal has proportional oven and $5 \times 10^{-9}/^{\circ}\text{C}$ stability
- Spurious and noise suppression better than 80 dB
- All solid state design
- Modular construction
- High resolution search oscillator . . . 130 divisions
- AC or battery operated

FNA-SPEKTROGRAMM

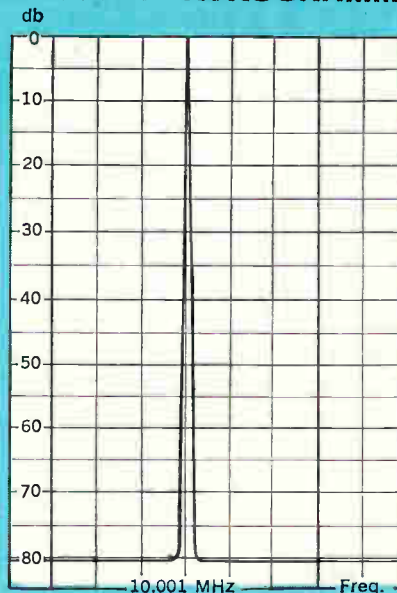

SPECTRAL PURITY OF ND 30M
FREQUENCY SYNTHESIZER
200 Hz per division Measured at BW of 10 Hz

Type ND 30M is the latest in a line of Frequency Synthesizers providing unusually high accuracy and ease of operation. Continuously variable over its range, each model provides a direct digital readout, with no tuning required. Perfect for bridge measurement; work with filters, networks, nuclear magnetic resonance, and as a source of reference frequencies for standards labs. These units can also be supplied in 19" rack mountings.

Type ND 1M (300Hz to 1.1MHz)
Type ND99K (0 to 110kHz)

Get The Extra Capability,
Greater Reliability, and
Longer Useful Life Of . . .



ROHDE & SCHWARZ

111 LEXINGTON AVENUE, PASSAIC, N. J. 07055 • (201) 773-8010

Inquiries outside the U.S.A. should be directed to: Rohde & Schwarz, Muehlhofstrasse 15, Munchen 8, West Germany.

does not change but the spectro- scope shows various amounts of red shift for distant receding stars, meaning that f decreases accordingly, then v must decrease accordingly. A similar spectroscopic shift toward violet occurs for approaching stars, indicating an increase in the observed "invariant" velocity of light.

One can conclude from this that Einstein's postulate is invalid, and that any error in the techniques of the Badewitz article is negligible even if it is valid.

Howard S. Balsam, P.E.
Support engineer
Sanders Associates Inc.
Nashua, N.H.

Protection channels

To the Editor:

The statement in Electronics Newsletter [Sept. 18, p. 25] that, "Essentially all of the Bell System's fault-location and switching, to sidestep an out-of-commission line or microwave transmitter, is currently done manually," is inaccurate. All of our broadband cable and radio systems are under constant check by automatic systems that switch to protection facilities on the same route rapidly and automatically.

It is the availability of these protection channels that permit the restoration system that the news item describes. Total failures, such as those caused by destruction of a microwave tower, occur only rarely but are, of course, very serious when they do occur. The protection channels on other routes are now used to restore service manually from a route (microwave or cable) experiencing a total failure. We are now in the process of

automating this procedure to restore service.

C.H. Elmendorf
Asst. vice president
American Telephone & Telegraph Co.
New York

▪ But telephone systems engineers told Electronics reporters that the equipment in use is inadequate to meet the needs of today's heavy traffic and that a modern system is needed to replace the present automatic checkout gear and the repairmen who must still manually search through a maze of wires to find a fault.

Premature

To the Editor:

Under the heading, "Around the World" [Sept. 4, p. 209] you reported that Jules Leger, currently ambassador to France, will succeed the retiring Alphonse Ouimet as head of the Canadian Broadcasting Corp.

Although Ouimet announced his intention of retiring about a year ago, a successor has not been named as of this date. However, the Prime Minister has indicated that new legislation pertaining to broadcasting in Canada is about to be introduced in the House of Commons, and that the appointment of a successor to Ouimet would be made this fall.

David H. Orr
Corporate Supervisor
Information Services—CBC
Ottawa, Ontario

▪ Reader Orr is right. So would Electronics have been had we said that Leger will most likely be named to succeed Ouimet.



Aged

Our precision resistors are aged to improve reliability, and we guard the process like a vintage champagne maker. Ageing is just one of many extra steps that make our precision components the most reliable you can specify. A few of our components are described briefly below.

1. Precision Wire-Wound Card Resistors

Consider ESI resistors whenever small changes in the resistive element can affect the performance of the final assembly. Initial accuracy to $\pm 0.0015\%$. Yearly stability to ± 10 ppm.



2. Dekastat® Decade Resistors

Designed for use with dc and at audio frequencies, these multi-decade resistors feature an accuracy of $\pm 0.02\%$. All units carry a two-year guarantee.



3. Dekapot® Resistive Voltage Dividers

These rapid-setting potentiometers have a terminal linearity up to 0.002%. Kelvin-Varley circuitry provides constant input impedance.



4. Dekatran Transformer Voltage Divider

The patented coaxial dial is easy to read and adjust. Accuracy of 0.001% and long-term stability are achieved through gapless toroidal cores of very high permeability.



esi

Electro Scientific Industries, Inc.
13900 NW Science Park Drive
Portland, Oregon 97229

SUBSCRIPTION SERVICE

Please include an Electronics Magazine address label to insure prompt service whenever you write us about your subscription.

Mail to: Fulfillment Manager
Electronics
P.O. Box 430
Hightstown, N.J. 08520

To subscribe mail this form with your payment and check new subscription renew my present subscription

Subscription rates: qualified subscribers in the U.S.: 1 year \$8; two years \$12; three years \$16. Non-qualified: 1 year \$25. Subscription rates for foreign countries available on request.

CHANGE OF ADDRESS

ATTACH LABEL HERE

If you are moving, please let us know five weeks before changing your address. Place magazine address label here, print your new address below.

name

address

city

state

zip code

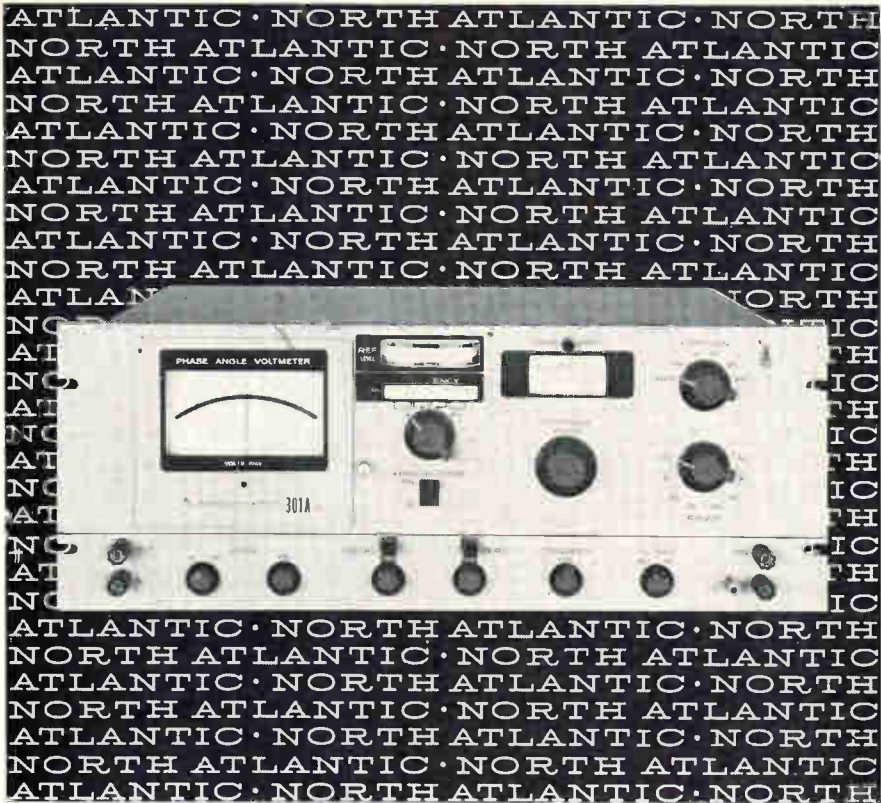

how to measure phase angle down to .25° from 10Hz to 100KHz (plus in-phase and quadrature!)

North Atlantic's Model 301A Broadband Phase Angle Voltmeter* adds a new dimension to AC by enabling you to measure phase angle, in-phase and quadrature while frequency is varying over half-decades...without recalibration. It provides complete coverage from 10Hz to 100KHz and incorporates plug-in filters to reduce the effects of harmonics in the range from 27Hz to 28KHz with only 11 sets of filters. Vibration analysis and servo analysis are only two of the many applications for this unit. Selected specifications are listed below:

Voltage Range.....	1 mv to 300 volts full scale
Voltage Accuracy.....	2% full scale
Phase Dial Range.....	0° to 90° with 0.1° resolution (plus 4 quadrants)
Phase Accuracy.....	0.25°, 31.6Hz to 31.6KHz (derating to .6° at 10Hz, 1° at 100KHz)
Input Impedance.....	10 megohms, 30μf for all ranges (signal and reference inputs)
Reference Level Range.....	0.15 to 130 volts
Harmonic Rejection.....	50 db
Nulling Sensitivity.....	less than 2 microvolts
Size.....	19" x 7" x 13½" deep
Price.....	\$2790.00 plus \$160.00 per set of filters

North Atlantic's sales representative in your area can tell you all about this unit as well as other Phase Angle Voltmeters* for both production test and ground support applications. Send for our data sheet today.

**Trademark*



NORTH ATLANTIC industries, inc.
 TERMINAL DRIVE, PLAINVIEW, NEW YORK 11803 • 516-681-8600

People

Intersil Inc.'s appointment of **Ward Gebhardt** as marketing director without a product reflects the optimism that prevails at the fledgling semiconductor firm started by Jean Hoerni, developer of the planar process, founder of Amelco Semiconductor, and guiding spirit behind the entry of the Union Carbide Corp. into semiconductors. Though Intersil has only 15,000 square feet of plant facilities and some \$2 million in backing, Gebhardt left a comfortable spot as marketing manager for discrete components at the semiconductor division of the Fairchild Camera and Instrument Corp.



Ward Gebhardt

"We already have some proposals out, trying to find out who wants what," Gebhardt explains. "Our present plant is strictly for research and development and prototype fabrication. But we are geared for fast expansion. The R&D is not so far beyond the market that we can dispense with a marketing man. You need one for long-term planning, to help in the language and pricing for bidding on specific circuits."

Gebhardt has known Hoerni since 1963, when both did some consulting work for Union Carbide. The chance to work with Hoerni at Intersil—where the financial rewards for success could be enormous—may have dictated the decision to leave Fairchild.

To **Theodor F. Hueter**, the field of ocean engineering appears to be "at the Sputnik 1 hour," poised for exciting thrusts, but saddled with the omnipresent brake on funding imposed by the war in Vietnam. The 50-year-old Hueter, an acoustics ex-



Theodor F. Hueter



Cinch-NuLine delivers Omega[®] MIL-C-26500 connectors in 6 to 8 weeks

We're completely tooled to supply whatever you need in the MIL-C-26500 line.

Name your shell style, contact size, and insert configurations, or even ask for G-Type conductive shells of chrome-plated aluminum. You can have exactly what you need, and get it delivered in 6-8 weeks.

Cinch-NuLine Omega connectors exceed the stringent requirements of MIL-C-26500 for performance and reliability. They operate continuously at 200°C, take short exposures to 800°C, and withstand violent thermal shock and vibration and resist corrosion, ozone, sand and dust.

When you need MIL-C-26500 connectors, get them fast . . . from Cinch-NuLine.

Contact any Cinch Electronics Group sales office, or write to Cinch-NuLine, 10115 S. Sixth Street, Minneapolis, Minnesota, 55416, for a quotation on your requirements.

LOCAL AVAILABILITY

Cinch-NuLine Omega connectors are available in small quantities, from your local Cinch-NuLine distributor.

COMING SOON

MIL-C-81511

Astro/348[®]

CONNECTORS

New high density cylindrical connectors with 0.085" pin spacing meeting all requirements of MIL-C-81511 (Navy).

*Manufactured under license agreement with Amplicon Corporation. © 1975

CINCH-NULINE

DIVISION OF UNITED CARBIDE

MEMBER



Only from Sprague!

DIGITAL-TO-ANALOG

HYBRID D to A CIRCUITS

with precision components not found in monolithic integrated microcircuits

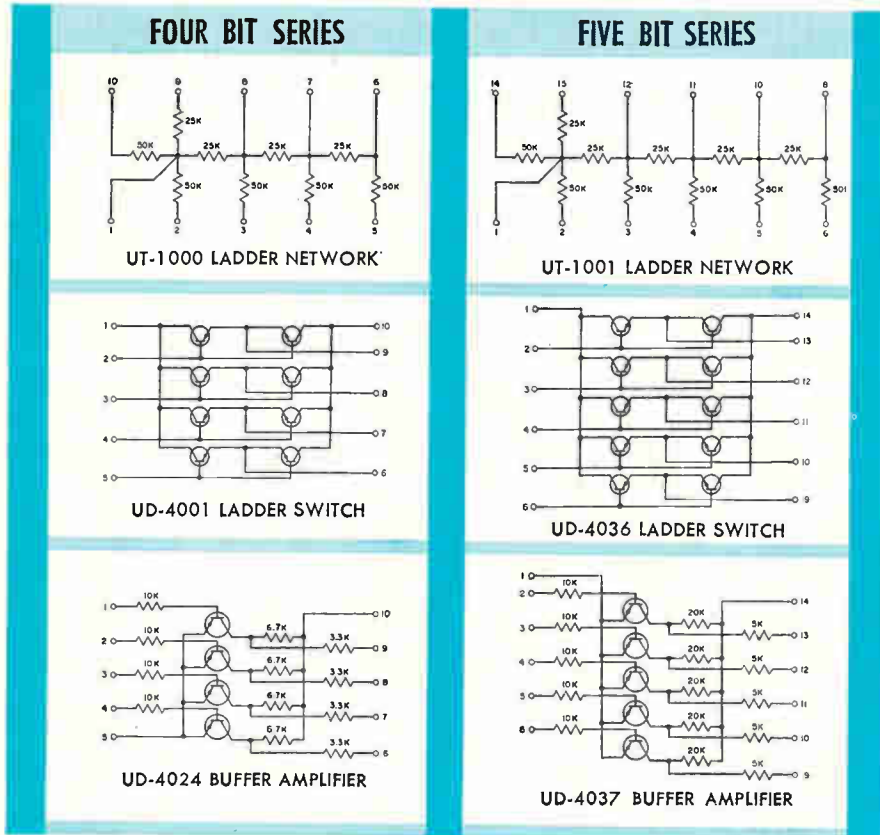

Up to 12 bits with less than 1/2 bit error!

- Improved tracking over temperature range of -55°C to $+125^{\circ}\text{C}$.
- 3 to 1 size reduction over conventional converters using discrete components.
- Reduced handling of components . . . fewer external connections . . . lower assembly costs.
- Silicon-base hybrid microcircuits in hermetically-sealed flat packs.
- 4-bit series expandable to 8 or 12 bits . . . 5-bit series expandable to 10 bits.
- Combination of precision thin-film tantalum nitride resistors, nickel-chromium resistors, and active devices of planar construction.
- Packaged for compatibility with monolithic circuits.

For complete technical data on D-to-A microcircuits, write to Technical Literature Service, Sprague Electric Company, 35 Marshall St., North Adams, Mass. 01247.

SPRAGUE COMPONENTS

THIN-FILM MICROCIRCUITS
INTEGRATED CIRCUITS
TRANSISTORS
CAPACITORS
RESISTORS
PULSE TRANSFORMERS
455-7141

INTERFERENCE FILTERS
PACKAGED COMPONENT ASSEMBLIES
FUNCTIONAL DIGITAL CIRCUITS
MAGNETIC COMPONENTS
CERAMIC-BASE PRINTED NETWORKS
PULSE-FORMING NETWORKS



Sprague and *®* are registered trademarks of the Sprague Electric Co.

People

pert, was recently chosen to head Honeywell Inc.'s Marine Systems Center.

The Center consists of two facilities—the West Covina, Calif., headquarters and a site in Seattle. Total employment for the two installations has grown from about 750 two years ago to some 1,300, and Hueter looks for it to reach 2,000 once the Vietnam conflict subsides. He expects to get a good share of military business. For example, there are the Navy's DX destroyer program in which Honeywell would probably compete for antisubmarine warfare hardware development, and an improved version of the Navy's Asroc antisubmarine rocket, which was developed by the Marine Systems Center.

One of Lee Rice's first moves as senior vice president of the Ogden Corp. of New York will be to get the company into the electronics business. "We plan to acquire several electronics companies by mid-1968 and exceed \$250 million in electronics sales by the early '70's," says the Washington-based executive.



Lee Rice

Rice says he plans to "create a broad technology base as a viable business and to serve Ogden's other activities," which include shipbuilding, metals and food processing, biomedicine, water treatment, chemicals, and demolition. Ogden now has technical laboratories in Los Angeles and Sunnyvale, Calif., and Long Island, N.Y., which provide environmental and functional testing for aerospace and oceanographic equipment.

The electronics companies Rice has in mind will include a mixture of "those concerned with advanced development and those dealing in a product line, mainly in the areas of pollution control and for the chemical industry."



AT WABC-TV MACHLETT ML-7007 HIGH-POWER TRANSMITTING TUBES HAVE JUST LOGGED 125,000 HOURS.

Where prime time requires prime performance specify Machlett transmitting tubes. Available now:

The new Machlett short form catalog, from The Machlett Laboratories, Inc., 1063 Hope Street, Stamford, Connecticut 06907.



THE MACHLETT LABORATORIES, INC.

A SUBSIDIARY OF RAYTHEON COMPANY

Do something nice

National Semiconductor Corporation

2975 San Ysidro Way
Santa Clara, California 95051

Please send nice, new short form catalog to my friend.

FRIEND'S NAME _____

FRIEND'S COMPANY _____

FRIEND'S TITLE _____

FRIEND'S ADDRESS _____ FRIEND'S ZIP _____

National Semiconductor Corporation

2975 San Ysidro Way
Santa Clara, California 95051

Please send nice, new short form catalog to my friend.

FRIEND'S NAME _____

FRIEND'S COMPANY _____

FRIEND'S TITLE _____

FRIEND'S ADDRESS _____ FRIEND'S ZIP _____

National Semiconductor Corporation

2975 San Ysidro Way
Santa Clara, California 95051

Please send nice, new short form catalog to my friend.

FRIEND'S NAME _____

FRIEND'S COMPANY _____

FRIEND'S TITLE _____

FRIEND'S ADDRESS _____ FRIEND'S ZIP _____

National Semiconductor Corporation

2975 San Ysidro Way
Santa Clara, California 95051

Please send nice, new short form catalog to my friend.

FRIEND'S NAME _____

FRIEND'S COMPANY _____

FRIEND'S TITLE _____

FRIEND'S ADDRESS _____ FRIEND'S ZIP _____

for someone, today.

National Semiconductor Corporation

2975 San Ysidro Way
Santa Clara, California 95051

Please send nice, new short form catalog to my friend.

FRIEND'S NAME _____

FRIEND'S COMPANY _____

FRIEND'S TITLE _____

FRIEND'S ADDRESS _____ FRIEND'S ZIP _____

National Semiconductor Corporation

2975 San Ysidro Way
Santa Clara, California 95051

Please send nice, new short form catalog to my friend.

FRIEND'S NAME _____

FRIEND'S COMPANY _____

FRIEND'S TITLE _____

FRIEND'S ADDRESS _____ FRIEND'S ZIP _____

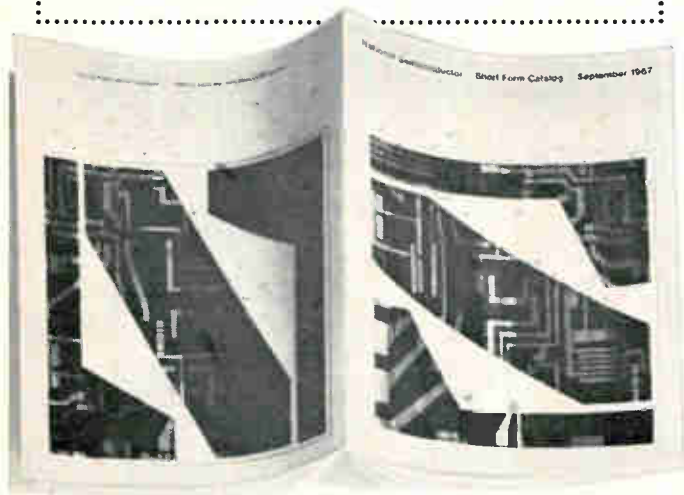

Nice, new short form catalog

National Semiconductor Corporation

2975 San Ysidro Way
Santa Clara, California 95051

Please send nice, new short form catalog to my friend.

FRIEND'S NAME _____

FRIEND'S COMPANY _____

FRIEND'S TITLE _____

FRIEND'S ADDRESS _____ FRIEND'S ZIP _____

National Semiconductor Corporation

2975 San Ysidro Way
Santa Clara, California 95051

Please send nice, new short form catalog to me.

MY NAME _____

MY COMPANY _____

MY TITLE _____

MY ADDRESS _____ MY ZIP _____

RCL miniature 1/2" rotary switches



(Actual Size)

INDUSTRY'S MOST COMPLETE SELECTION

- Shorting AND non-shortening poles may be grouped on one deck in any combination.
- Up to 12 positions per deck shorting or non-shortening.
- As many as 6 poles per deck.
- All individual deck parts are self-contained, and are permanently molded into place.
- Life expectancy 200,000 mechanical operations.

"Off-the-Shelf" Shipments

Write for complete engineering information

RCL

General Sales Office

RCL ELECTRONICS, INC.

700 South 21st Street
Irvington, New Jersey 07111

Meetings

Computer Conference, American Federation of Information Processing Societies; Convention Center, Anaheim, Calif. **Nov. 14-16.**

Meeting of the Anti-Missile Research Advisory Council, Advanced Research Projects Agency; U.S. Naval Postgraduate School, Monterey, Calif., **Nov. 14-16.**

International Exhibition of Industrial Electronics, Swiss Industries Fair, Basle, Switzerland, **Nov. 14-18.**

Missile System Meeting, American Institute of Aeronautics and Astronautics; Monterey, Calif., **Dec. 4-6.**

Symposium on Theory and Measurement of Atmospheric Turbulence and Diffusion in the Planetary Boundary Layer, Atmospheric Sciences Laboratory of the Army Electronics Command; Sandia Base, Albuquerque, N.M., **Dec. 5-7.**

Vehicular Conference, IEEE; New York Hilton, New York, **Dec. 5-7.***

Symposium on Reliability, IEEE; Sheraton-Boston Hotel, Boston, **Jan. 16-18.**

Power Meeting, IEEE; Statler-Hilton Hotel, New York, **Jan. 28-Feb. 2.**

Aerospace and Electronic Systems Convention, IEEE; International Hotel, Los Angeles, **Feb. 13-15.**

International Solid-State Circuits Conference, IEEE; Sheraton Hotel, Philadelphia, **Feb. 14-16.**

Scintillation and Semiconductor Counter Symposium, IEEE; Shoreham Hotel, Washington, **Feb. 28-March 1.**

International Convention and Exhibition, IEEE; New York Coliseum and New York Hilton Hotel, New York, **March 18-21.**

Symposium on Microwave Power, International Microwave Power Institute, Statler Hilton Hotel, New York, **March 21-23.**

Joint Railroad Conference, IEEE; Conrad Hilton Hotel, Chicago, **March 27-28.**

International Magnetics Conference, IEEE; Sheraton Park Hotel, Washington, **April 3-5.**

Business Aircraft Meeting and Engineering Display, Society of Automotive Engineers, Broadview Hotel, Wichita, Kan., **April 3-5.**

Short Courses

Low Frequency Standards, U.S. Dept. of Commerce, National Bureau of Standards, Washington, **Dec. 11-13;** \$90 fee.

Process Control, University of Wisconsin's Department of Engineering, Madison, Wis., **Dec. 13-15;** \$70 fee.

Automation and Publishing, The American University's Center for Technology and Administration, Washington, **Jan. 15-18;** \$175 fee.

Call for papers

Colloquium on Information Retrieval, University of Pennsylvania's School of Electrical Engineering; University of Pennsylvania, Philadelphia, **May 3-4, 1968.** **Dec. 1** is deadline for papers to David Lefkowitz, Moore School of Electrical Engineering, University of Pennsylvania, Philadelphia, Pa., 19104.

Power Meeting, IEEE; Sherman House, Chicago, **June 23-28, 1968.** **Feb. 9** is deadline for submission of papers. Authors should advise the technical conference services office of IEEE if they expect to submit a paper.

Conference on Precision Electromagnetic Measurements, IEEE; National Bureau of Standards Laboratories, Boulder, Colo., **June 25-28, 1968.** **Feb. 12** is deadline for submission of summaries and abstracts to Donald King, Aerospace Corp., Box 95085, Los Angeles, Calif. 90045.

* Meeting preview on page 16.

THE connector THING

A periodical periodical designed to further the sales of Microdot Inc. connectors and cables. Published entirely in the interest of profit.

Everybody wins! Play Microdot

In the words of Virginia Woolf, it's time for fun and games.

For this new national pastime, you simply need a smattering of history, mythology and current events. And some information about Microdot's cable products. We'll supply you with the latter. For the rest, go listen to Walter Cronkite.

We got started on this activity while we were sitting around one evening with a bottle of Slivovitz (we ran out of Scotch), trying to think of memorable ways to remind you of the various unique features of Microdot cables. Like—

Like our Mini-Noise cable—reduces noise voltage from shock and vibration by a factor of more than 100 to 1 compared to untreated cable. This makes possible the transmission of extremely faint signals through coax cable without audio frequency noise. Off-the-shelf.

Like our microminiature coax cable—uses a fine silver-plated copper steel-covered wire. You get 50 ohm impedance, and even with the addition of dielectric, outer shield and protective jacket, the nominal O.D. does not exceed .080". And we can get that O.D. down to .025" in a range of hundreds of different cables.

Like our new complete in-house capability to produce precision quality multi-conductor cables, which includes twisting, extruding, shielding and jacketing—the whole deal. All under one roof. And we can cable hundreds of conductors into one unit.

Like we're the only one to produce a high temperature, low weight, low capacitance coax cable through the use of a cellular Teflon dielectric. Especially suited to the requirements of video tape recorders.

Historical

Like Microdot's Twinaxial cable—to be used when you need to send two signals from a single source which must both terminate at the same point. No need to use two coax cables; therefore lower cost and greater flexibility.

Now when you think of cables, you think of cablegrams. And when you drink a lot of Slivovitz, it sort of takes you back through time and you come up with stuff like this:

Spaghetti Grams

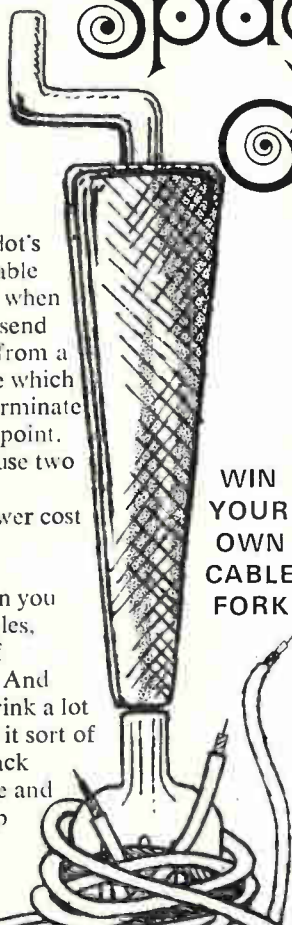

WIN
YOUR
OWN
CABLE
FORK

Low noise Spaghetti-Gram:

"You lose. Signed, Calvin Coolidge?"

High temperature Spaghetti-Gram:

"Julius, honey, ain't nobody home tonight but me. Signed, Cleopatra!"

Miniature size Spaghetti-Gram:

"Cancel that order for bras. Signed, Twiggy?"

Dual shield Spaghetti-Gram:

"I can lick any guy in the joint. Signed, Brunhilde?"

Large size multiconductor Spaghetti-Gram:

"Send more elephants. Signed, Hannibal?"

Get the idea. You can use any of the features of any of our cable products, such as low noise (Mini-Noise), special requirements (Multiconductors), high temperature, low weight, and, of course, small size. You don't really need the Slivovitz. It works well even with Sanka.

About the fork

No, Melvin, we won't explain the relationship between cable and spaghetti. We call

it a cable fork, and if you don't want to use it for eating cables that's your problem. The manufacturer describes this

handy gadget as a "revolutionary breakthrough that leaps forward from antiquated hand labor to the modern machine age!" We won't try to top that. We'll just explain that you stick it into the pasta and then turn the little handle to save getting spaghetti all over your celluloid collar.

Want one for your very own? Okay. Just send us a Microdot Spaghetti-Gram scribbled on company stationery and taking off from any of the product features we've discussed. We'll send you a beautiful cable fork along with more literature on our cable products than we care to mention.

But hurry. We've already run out of Slivovitz. It won't be long before we run out of cable forks. (That means offer is limited.)

But hurry. We've already run out of Slivovitz. It won't be long before we run out of cable forks. (That means offer is limited.)



**MICRODOT
INC.** 220 Pasadena Avenue
South Pasadena, Calif. 91030.

Mini-Noise is a registered trade-mark of Microdot Inc. Cable Fork is open to question.

PLOTAMATIC

x-y recorders offer more performance, features, value

just compare the specs

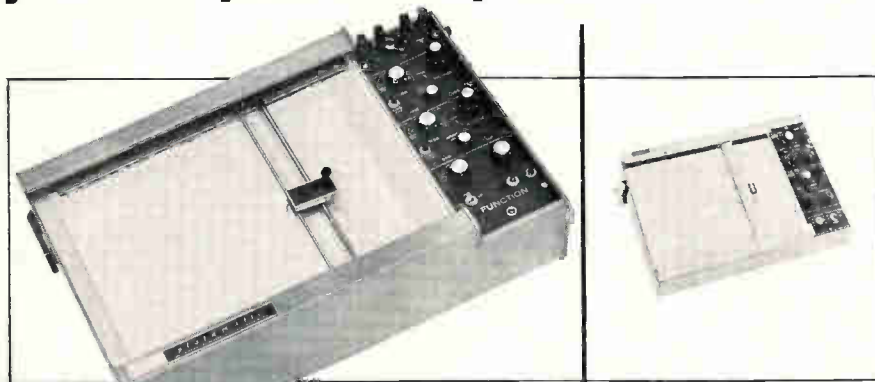

	BBN/DE 600	HP
Input Impedance	1 megohm, constant all ranges	100K on four most sensitive ranges
Paper Holddown System	Vacuum: better holddown, easier line-up, quiet	Electrostatic: attracts dust particles
Servo System	Sealed follow-up pots (no slide wire cleaning kits)	Open slide wires (require frequent cleaning)
Calibration Check	Push-button zero check on control panel	Must remove X-Y input signals
X-Y Zero Adjustment	No shift from zero calibrate position regardless of full scale input range selected	Shifts from zero calibrate position when attenuator input range is adjusted for proper full scale setting
Price	\$25 less	

Plotamatic is a clear winner on these and other basic important features. You'll want to test all features right in your own lab. We have 30 models of X-Y recorders to choose from. Call us, and we'll bring the particular Plotamatic best suited for you to compare and evaluate. Or write for our complete Plotamatic brochure.



BOLT BERANEK AND NEWMAN INC
DATA EQUIPMENT DIVISION

2126 South Lyon Street, Santa Ana, California 92705 ■ Phone: (714) 546-5300

Meeting preview

Crowded spectrum

As is becoming usual when land mobile radio users gather, frequency congestion will be a major topic of discussion at this year's annual IEEE Vehicular Conference, Dec. 6 to 8. At the New York meeting, W.L. North of the Federal Communications Commission will report on a study of the problem in a 34-mile-square area including metropolitan New York.

North recommends the use of computers to plan frequency assignments, two-frequency systems to ease intermodulation problems, and cooperative base stations. With all this, however, he warns that additional frequencies will be needed in the New York area by around 1975-77.

Equipment scored. At the same session, R.C. Eldridge of the British Columbia Telephone Co. will blame the height and power of many base-station transmitters and the sensitivity of receivers for much of the traffic interference and, in the long run, for reducing the number of available channels.

To extend the range of highway and railroad communication systems with fixed transmitters, a solid state repeater with a stable gain of 140 decibels at 450 megahertz can amplify attenuated signals. J.G. Churcher will describe the device, which was developed in England at Pye Telecommunications Ltd.

Also on the agenda are reports on two mass-transportation radio communications systems that will operate in the 150-Mhz band. C.E. Paul of Bell Telephone Laboratories will outline the projected radio telephone service on a high-speed train planned for runs between Washington, D.C., and New York. And Seymour Dornfield of the New York City Transit Authority and G.H. Kamerer of the Radio Corp. of America will describe a radio system to be installed in New York's 4,000 buses.

Plaudits. At a session on reliability, Otmar Schreiber of the General Instrument Corp. will praise the contributions of thermoelectric generators to very-high-frequency communications.



Converts BCD to printed form.



Produces strip-chart record of digital data



Compares measured values with preset limits



Selects C and D (or G) range, balances, presents visual and BCD outputs



Sequentially connects capacitors to bridge.



Makes parallel-to-serial conversion for data processing and analysis

Push for Automatic Measurements

These are the basic building blocks for a variety of automatic capacitance-measuring systems that can test capacitors at rates as high as 120 per minute. Such systems are used for production testing and sorting, incoming inspection, zero-defects quality-assurance programs, and environmental-test runs for design evaluation. Cost analyses by owners of 1680 systems indicate savings of up to 80% or more on the per-unit cost of component inspection over manual methods.

The heart of each system is GR's 1680 Automatic Capacitance Bridge, which automatically selects C and D (or G) range, balances, and displays measurements in digital form. Measurement range is 0.01 pF to 1000 μ F and basic accuracy is 0.1% of reading for C and G, 1% of reading \pm 0.001 for D. Price is \$4975 in U.S.A.

Other system components designed around the 1680 bridge are shown below:

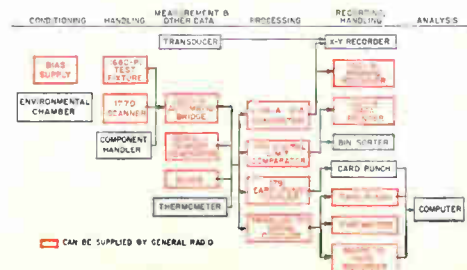

Three of these instruments are new:

Type 1770 Scanner System, for sequential connection of many capacitors to the bridge; modular construction permits up to 100 input channels; guarded connection; six operating modes; visual display and BCD output of channel number. Price dependent upon requirements; about \$3500 for a guarded, 50-channel model.

Type 1781 Digital Limit Comparator, makes possible fully automatic capacitor sorting; compares BCD output of the 1680 bridge with limits of C and D (or G), preset on the 1781 front panel; GO/NO-GO visual indication and relay-contact output. Price, \$1625 in U.S.A.

Type 1791 Card-Punch Coupler, a parallel-to-serial converter for driving an IBM 526 Card Punch from the BCD output of the 1680 bridge and other digital instruments; 22-digit capacity. Price on request.

For additional information, write General Radio Company, W. Concord, Massachusetts 01781; telephone (617) 369-4400; TWX (710) 347-1051.

GENERAL RADIO

Circle 17 on reader service card



An automatic capacitor test system produced by General Radio.

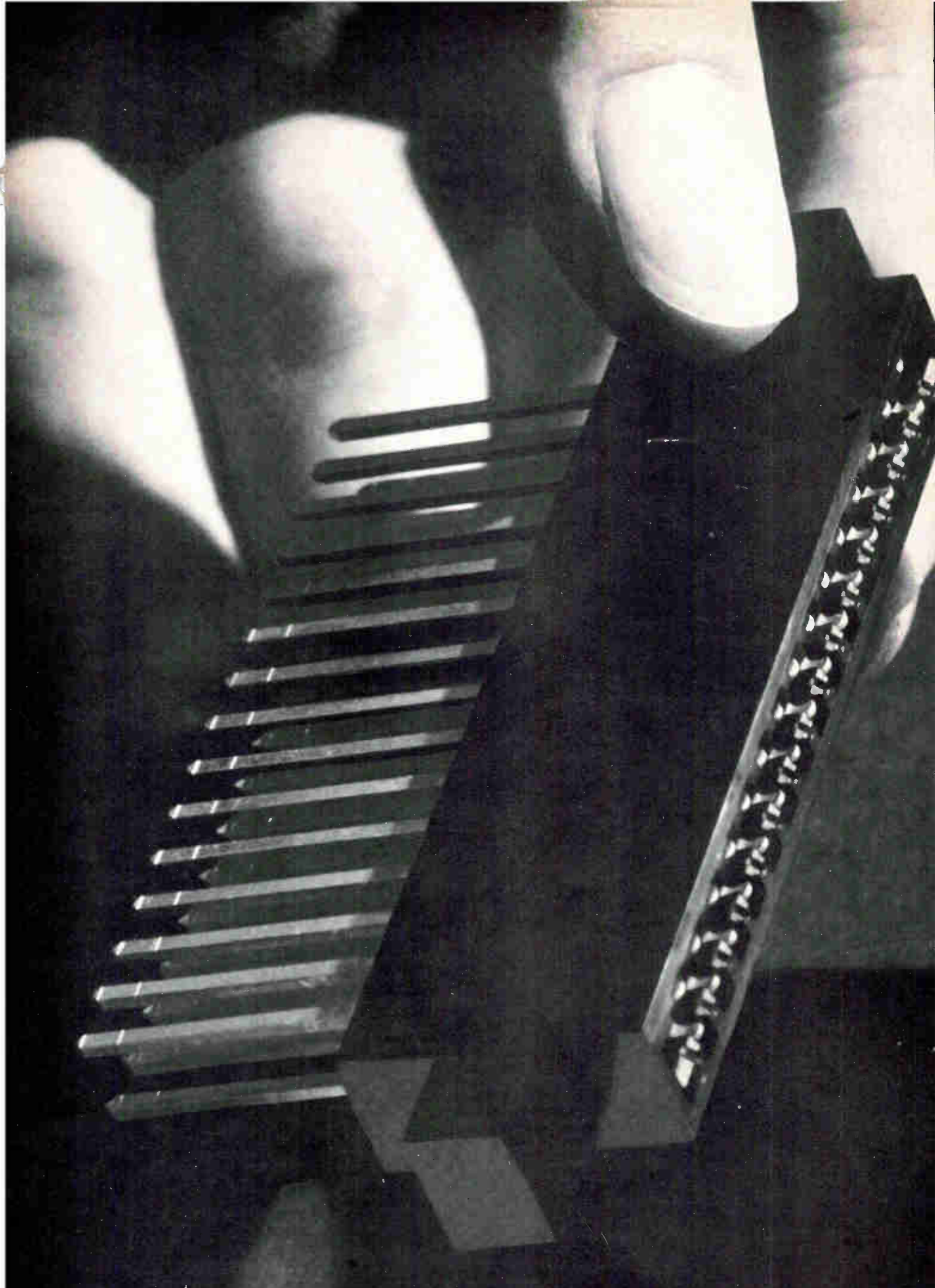

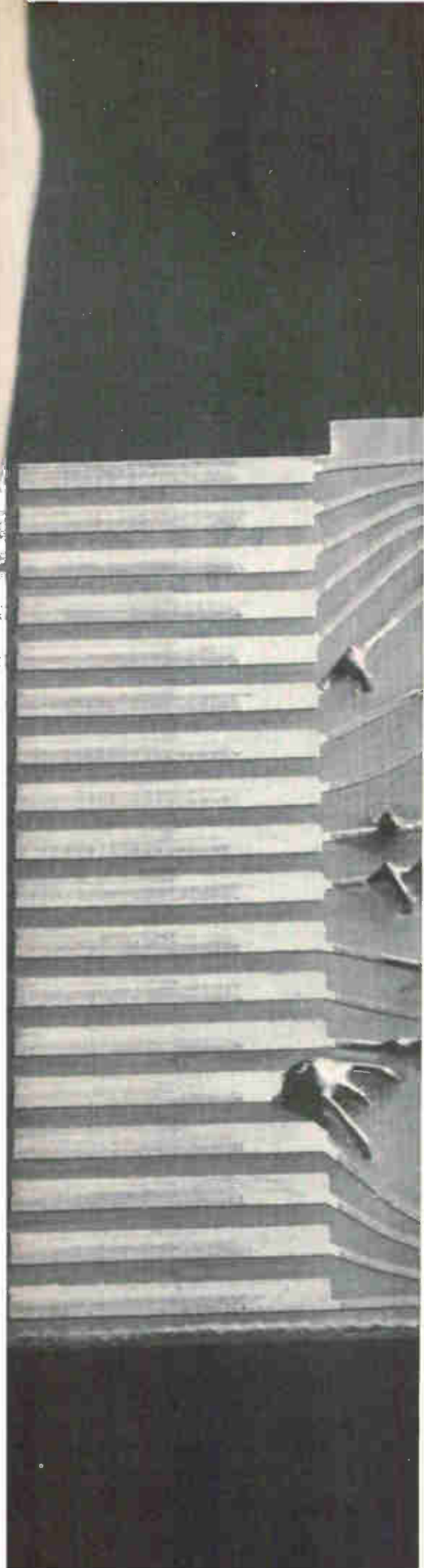

Off-the-shelf PMT from Amphenol

PMT means Precious Metal Tip, a wrought gold dot welded to printed circuit connector contacts. PMT is 100 times thicker than ordinary contact plating. We have 22 different PMT connectors that will work for 20 years, and they're all standard production items. Pre-tensioned contacts spring back to position insertion after insertion —without damaging P.C. boards. You'll pack about twice as many contacts in the same space, too: 56 in a No. 28 connector, 36 in a No. 18. PMT could be your best printed circuit connector buy. Call your nearest Amphenol Sales Engineer or write to **Amphenol Connector Division**, 1830 S. 54th Avenue, Chicago, Illinois 60650

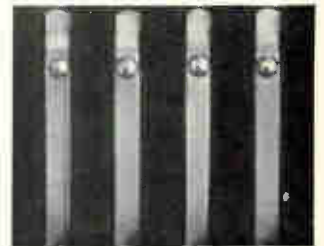

Cut-away Amphenol PMT connector shows welded gold dots on contacts



TM

AMPHENOL

Circle 19 on reader service card

Build with 3 more linear IC innovations from RCA...

New Versatility for Commercial, Industrial, and Military Use

High-frequency wide-band amplifier/phase detector

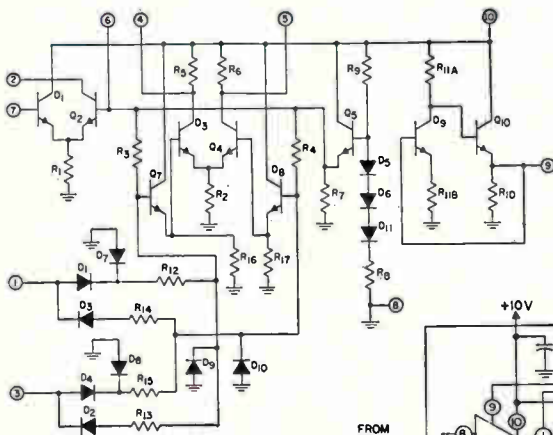

Block diagram of typical AFC application in color TV receiver. Also suitable for B&W and FM receivers.

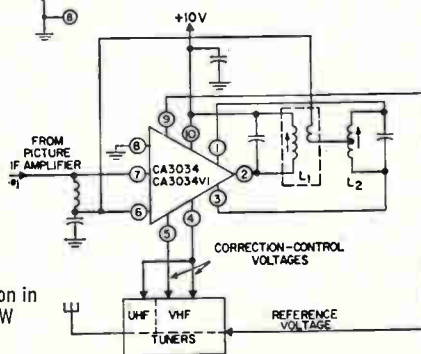

- For Automatic Fine Tuning in VHF and UHF receivers
- Dual phase detector with differential output amplifier
- Compensated reference voltage supply
- Operating temperature range -55°C to $+125^{\circ}\text{C}$
- Total current drain 9 mA (type) @ $V_{\text{CC}} = 10\text{V}$
- Output offset voltages between terminals #4 and #5 1.5V max. @ $V_{\text{CC}} = 10\text{V}$
- Input impedance 2K Ω typ



RCA CA3034 in 10-lead TO-5 package. Price \$1.75 (1000+)



RCA CA3034V1 with preformed leads. Price \$1.75 (1000+)

3-in-1 wide-band amplifier array— 132 dB (typ) Gain!

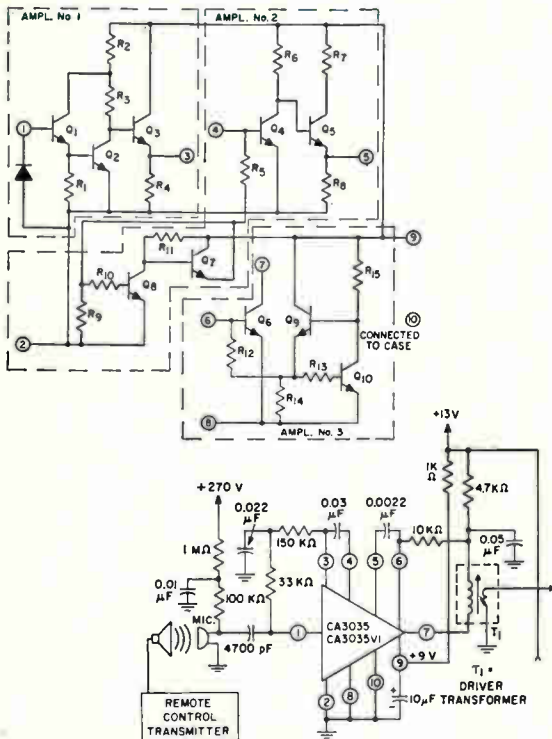

Low noise performance and outstanding wide-band response make this three-in-one unit general purpose amplifier array ideal for TV remote control.

- Three separate amplifiers; gain and bandwidth for each adjustable by external circuitry
- Can operate as individual units—or in cascade for 132 dB gain (typ) @ 40 KHz
- Voltage gain—Ampl. #1 44dB typ
Ampl. #2 46dB typ
Ampl. #3 42dB typ
- Bandwidth @ -3 dB point—Ampl. #1 500 KHz
Ampl. #2 2.5 MHz
Ampl. #3 2.5 MHz
- Operating temperature range -55°C to +125°C
- All three amplifiers single-ended, only one power supply needed
- Typical applications: TV remote control; IF systems; instrumentation amplifiers; chopper amplifiers



RCA CA3035 wide-band high-gain ampl. in TO-5 package. Price \$1.50 (1,000+)



RCA CA3035V1 with preformed leads. Price \$1.50 (1,000+)

Dual Darlington amplifier array

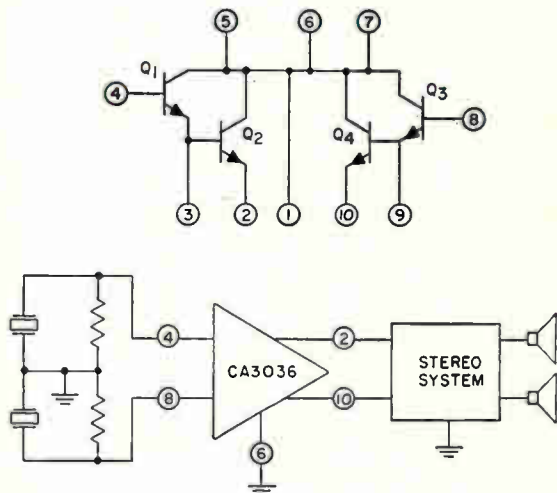

Block diagram of application as stereo phono pre-amp. Cartridges designed around the CA3036 can provide enhanced fidelity, low hum pick-up without shielding. Response flat to 1MHz @ $R_L = 1K\Omega$

- Voltage gain for either pair 26 dB (typ)
- Power gain for either pair 47 dB (typ) @ $f = 1$ KHz
- Gain-bandwidth product for either pair 200 MHz
- h_{FE} for either pair 4540 typ. @ $I_{C1} + I_{C2} = 1$ mA
- Operating temperature range -55°C to +125°C
- $V_{CE0} = 15$ V max.
- $V_{CB0} = 30$ V max.
- $V_{EB0} = 5$ V max.
- I_C (each transistor) = 50 mA max.
- Emitter-follower output
- Typical applications: stereo phono amplifiers; differential amps; op amp driver; mixer



RCA CA3036 Dual Darlington Array in 10-lead TO-5 package. Price 98¢ (1,000+)

Ask your RCA Distributor for his price and delivery. For Technical Data write to RCA Commercial Engineering Section ICN11-1, Harrison, N.J. 07029.



RCA ELECTRONIC COMPONENTS & DEVICES

**The Most Trusted Name
in Electronics**

**The new AO
StereoStar/ZOOM
Microscope
gives you high
resolution,
new convenience,
superior optics
and wide
magnification
range.**

Here are a few of the outstanding advantages that make the new AO[®] StereoStar/ZOOM Microscope the finest instrument of this type available today:

- Widest total magnification range: 3.5–210X
- High resolution to meet the most exacting needs
- The most convenient zoom control available
- Choice of five interchangeable, rotatable zoom power bodies
- Crisp, sharp images at all magnifications
- Extra large field of view and high eyepoint eyepieces
- Wide choice of stands for every purpose
- Long working distance
- Even illumination over the entire field
- Coolest operating illuminator.

See for yourself. Contact your AO Sales Representative for a demonstration, or write for our 24-page, full-color brochure on the newest in stereo microscopes—the AO StereoStar/ZOOM.

*TM Reg., American Optical Co.



**AMERICAN
OPTICAL
COMPANY**

**INSTRUMENT DIVISION
BUFFALO, NEW YORK 14215**

Circle 22 on reader service card

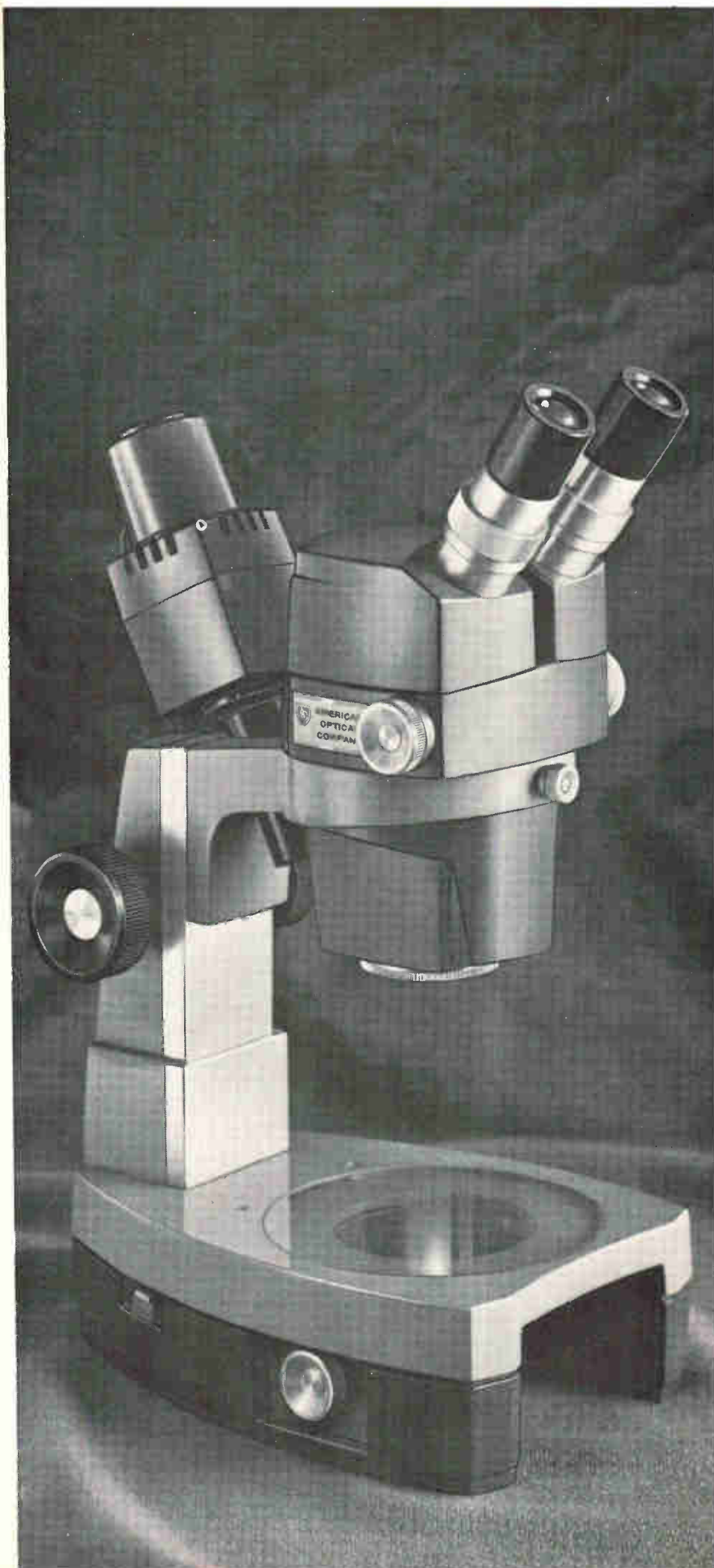

Editorial

Special-interest education

Despite the turmoil on college campuses these days, more students are staying on after graduation to earn graduate degrees instead of plunging into the worlds of industry or business. One reason has been the exemption from the draft and the Vietnam war. But almost as important has been a growing recognition among students that a bachelor's degree is just not enough in today's complex industrial environment. In no area has the interest in graduate study been heavier than in electronics and electrical engineering. Unfortunately, the increase in quantity of advanced degrees has meant a sharp drop in the quality of the education administered.

Business has encouraged the move to more education by its prospective employees. Many engineering managers get a feeling of confidence if an applicant owns a graduate degree. At the very least, it shows an inclination for scholarship. At the most, it could mean broad knowledge, an exposure to research techniques, and a mastery of new complex technology.

This feeling shows up dramatically in the salary differentials that are now being paid for advanced degrees. Twenty years ago, an engineer with a master's degree would find it was worth \$300 to \$500 more a year in starting salary. Today that same master's degree can be worth as much as \$2,000 to \$4,000 a year. On the West Coast, graduates with a Ph.D. degree, and a specialization in semiconductor technology for example, start at over \$16,000 a year, without a day's industrial experience.

Despite all this, there is a nagging suspicion among some engineering managers that the advanced degree candidates in engineering are not worth all this extra pay. They believe that technical graduate education has deteriorated over the past 10 years so that the bearer of a master's degree in engineering is more a technician versed in some narrow specialty than a full-fledged engineer trained in advanced techniques, the connotation formerly associated with advanced degrees. And this applies equally to those who take advanced degrees in part-time study while they work at engineering jobs.

At fault for this decline in stature of the advanced degree are both business and colleges. Traditionally, colleges must serve the economy by producing the kind of graduates industry wants or needs. Over the past 10 years the electronics industry, particularly, has wanted specialists who would work in a specified narrow area, rather than the broad expert trained in

fundamentals. Such apparent expertise has looked good on proposals made to the Government for defense and space projects.

As part of the academic proclivity to service the economy, universities have rushed to tailor graduate curricula to the product and interest mixes of nearby companies. On the West Coast you find electrical engineering curriculum heavily endowed with semiconductor, computer, and radar technology—reflecting the aerospace-oriented activities of western firms. Courses and curriculum at eastern and midwestern colleges reflect the local interests of their industries and companies.

Even if a company or government facility sets up shop far in the wilderness, if it's big enough a local college is likely to follow with an extension service geared to the facility's special interests. Its graduates come out with masters' degrees and specialized training limited to such narrow disciplines as wind tunnel instrumentation, or missile range data gathering.

Looking closely you can turn up some extreme—almost absurd—examples of this loosening of academic standards in advanced degrees. For example, one new graduate with a master's degree in the new specialization of bioinstrumentation engineering has never had a single course in transistor circuit design or semiconductor technology. His undergraduate curriculum clung to tube technology (in the mistaken belief that the receiving tube may someday make a comeback); at graduate school, he took life science courses instead of the searching kind of engineering course that would teach him how and why phenomena happen.

Industry used to complain, sometimes bitterly, that colleges were not responsive to their needs for graduates. But that was 30 years ago when liberal arts training predominated. Today, the opposite criticism has to be leveled. The colleges are so responsive to what industry says it wants that a university does the job of a company's training department instead of being an academic institution of higher learning.

Some colleges brag that their engineering professors are in close contact with industry because the academicians consult for local companies. Consulting has become so lucrative that professors vie feverishly with each other for these plums and are anxious to please the industrial paymasters who augment their university salaries so lavishly. Under such circumstances, it is easy to see why courses tend to follow some companies' specific interests so closely.

If advanced degrees are to regain their former stature and meaning of training well above the bachelor level, the academicians have to regain control of the curriculum. More emphasis has to be placed on intellectual effort and less on workbench practice. U.S. colleges are turning out too many engineers who are technicians and not enough who are trained to advance technology by thinking through problems and putting new phenomena to work.

Engineers who have learned to live with the flutter problem in hysteresis synchronous motors will find that living comes easier now. Especially in voice/data recording applications.

Indiana General's unique inverted stator design provides up to six times the rotor inertia of conventional designs. Flutter characteristics are so low as to be practically negligible.

And the price is not so high that it

restricts the use of our inverted stator motor solely to recording devices. It is so economical to manufacture that it's priced competitively with induction type motors, making the Indiana General hysteresis motor economically practical for units like fans and blowers. And, the inverted stator design significantly reduces start-up input power-surge and combines very high operating efficiency with low slip characteristics.

Indiana General inverted stator motors are smaller and lighter than conventional synchronous motors and are available in a wide range of sizes, mountings, power ratings and torques. You can get full details by writing Mr. R. D. Wright, Manager of Sales, Indiana General Corporation, Electro-Mechanical Division, Oglesby, Illinois.

INDIANA GENERAL 

New inverted hysteresis motor design drives the flutter out of recording equipment.



Electronics Newsletter

November 13, 1967

Raytheon will push bipolar FET op amp

The Raytheon Co.'s semiconductor operation, which cut sharply into Fairchild Semiconductor's 709 sales when that company ran into production difficulties last spring, isn't going to wait for Fairchild to falter again. Like Fairchild [Electronics, Oct. 2, p. 25], Raytheon is in the early development stage of a fully compensated operational amplifier that uses field-effect transistors in the input stage. The interior of the chip will contain bipolar elements.

Raytheon has confidently promised one customer sample circuits by December. The company is working with both junction and metal-oxide-semiconductor FET's for the input stage. The high impedance of FET's is said to give the op amp more potential applications. The MOS impedance is inherently higher, but that of a junction FET may be high enough, and junction devices are easier to make than MOS.

Siegel may buy laser center

It appears that Lear Siegler Inc. has found a buyer for its unprofitable laser-systems center in Ann Arbor, Mich. Likely purchaser: either a group of the center's engineers or Kieve M. Siegel's fast-growing KMS Industries Inc. of Ann Arbor.

Spy satellite runs into delay

Although Air Force officials will say nothing publicly about the super-secret program 949—the integrated reconnaissance satellite—they're privately admitting that the project is five months behind schedule. TRW Systems group is building the satellite and Aerojet-General Corp. its sensors under a contract awarded last year [Electronics, Dec. 26, 1966, p. 49]. Indications are that the delay has been caused by technical difficulties not, as rumored, by a stretchout of funding.

GE will market a set-it-yourself unijunction device

A "programable" unijunction transistor (UJT) that permits the user to set firing voltage and sensitivity levels has been developed at General Electric's Semiconductor division. GE, which invented the UJT, hopes the new device will help restore the sales lead it formerly enjoyed.

Conventional devices have nonadjustable intrinsic standoff ratios that establish the firing point; the new unit's triggering level can be varied by adding two external resistors. The programable unit, a p-n-p-n structure similar to a silicon-controlled switch, is compatible with monolithic integrated-circuit fabrication. It can be used for firing thyristors or as an oscillator. Other likely applications: in timing, sensing, and control networks. The new units will be marketed before year's end.

Lockheed improving rotor antenna radar

An improved model of its radar using a rotor-blade antenna is being readied for tests by Lockheed Electronics. The higher power integrated circuit version, to be tested aboard a five-place Fairchild-Hiller FH-1100 copter delivered early this month, will weigh 130 pounds and deliver 30 kilowatts. The earlier model, tested on a two-passenger Enstrom F-28, put out only 2 kw.

Lockheed is developing a phased-array antenna to be placed into the nose of the helicopter, replacing the mechanical scanning unit and

Electronics Newsletter

its dome. The company plans a sales push for its multifunction radar, good for mapping and navigation, terminal landing, weapons delivery, and limited station keeping.

Motorola readying 3rd generation ECL

A third-generation emitter-coupled-logic line will be introduced next year by Motorola Semiconductor. The company is aiming the MECL-3 integrated circuits at the ultrahigh-speed computers expected to be introduced in 1970 or 1971.

Motorola seeks a 1-nanosecond typical propagation time; switching speed of the MECL family now on the market is 5 nanoseconds. Jim Burns, manager of IC marketing, says the current-mode line will include flip-flops that operate at frequencies between 200 and 400 megahertz.

By the skin or the teeth

A hearing aid that uses the teeth and the skin to conduct sound is being developed by a small New York City electronics company, Intelectron Corp. The development is significant because it could result in a hearing aid considerably smaller than those currently in use.

In the Intelectron model sound is not produced by the motion of air as it is in conventional hearing aids which use loudspeakers—but through bone conduction. Consequently, the hearing aid has smaller parts.

In one model, a radio-frequency receiver is placed in a patient's tooth; the "sound" is then conducted through the tooth to the ears' nerves. And in an earlier model, which was used for rehabilitating the hard of hearing, an electrode is attached to the patient's skin.

Due for mailing

President Johnson's spending freeze so far has held back the Post Office from issuing contracts from its \$18 million R&D budget this year, but department officials are hopeful that they can start letting the first of some 100 to 150 awards by the end of the year. The Post Office also promised the 300 industry representatives attending a briefing earlier this month a list of R&D contracts it will put out for bids.

Addenda

A sweeper plug-in, developed at Hewlett-Packard Co.'s Loveland, Colo., division, contains the first integrated circuit turned out by the new IC facility there. Construction of the facility began only last spring. The IC is a diode chain used to give a logarithmic shape to the dynamic response of the instrument. . . . Interior Secretary Stewart L. Udall is trying to interest Westinghouse and General Electric in establishing electronics plants in "new towns" that might be built on Indian lands in New Mexico and Arizona. He's citing as precedent the dozen electronics firms attracted to another new town, two-year-old Reston, Va. . . . Happy days are here again at Autonetics where officials, winding up development tests on four programs, are anticipating orders for more than 2,000 airborne computers. The computers, all members of the D26J family, will go on the Condor and short-range attack missile (Sram), both air-to-surface weapons, and the FB-111 and the RF-111 aircraft. . . . Litton Industries has won a hot contest to build the Army's Tacfire (tactical fire direction system). Under an award that could reach an estimated \$50 million, the firm will build a system to provide automatic data processing for all elements of information needed by an artillery officer. Burroughs and IBM were the losers.

TTL Trends

from Texas Instruments

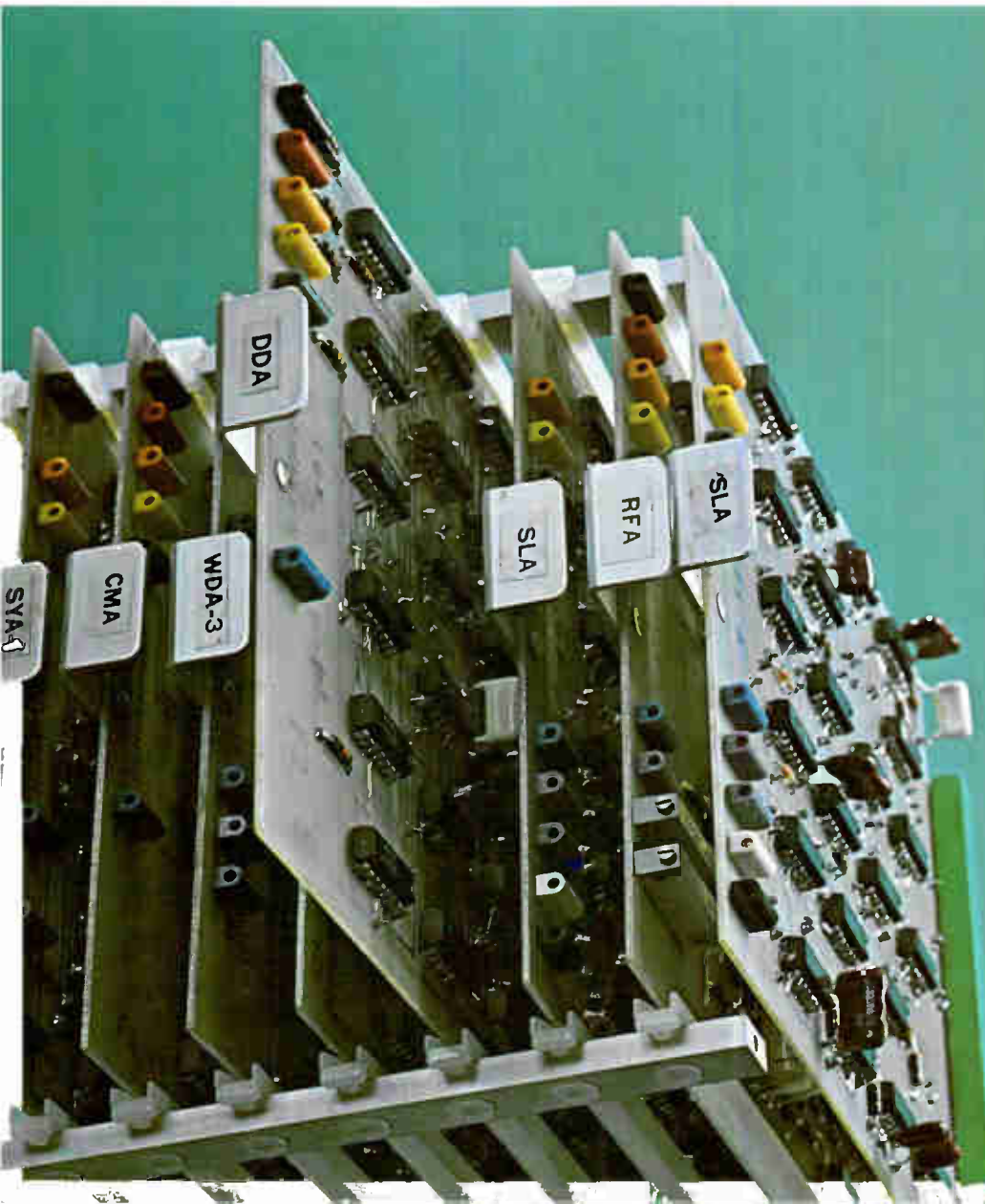

This rack contains electronics for the new Bunker-Ramo 2100 machine tool numerical control system. By using Series 74 TTL complex-function ICs from Texas Instruments, B-R keeps costs far below that of other systems of similar capability. At the same time, the already high reliability is further increased by an order of magnitude, while noise immunity and computing speed capability are also greatly improved (see page B). Many OEMs are building greater business opportunities for tomorrow by going with the complex-function TTL trend in their product designs today.

Why Bunker-Ramo chose TTL complex functions for new NC systems



These low-cost numerical control systems offer as standard most of the functions normally found in far more expensive equipment. They are the first such systems to employ ICs for all non-power functions. Shown with Dean W. Freed, General

Manager of the NC Division, the Bunker-Ramo 2100 (right) is a two-axis positioning and straight-cut control, while the 2200 (left) is a three-axis positioning and straight-cut control, with optional two-axis incremental slope and arc capability.

Series 74 complex-function TTL integrated circuits from Texas Instruments have enabled Bunker-Ramo to further improve reliability and performance, while reducing size and cost of the numerical control systems shown above.

Series 74 TTL offered many performance as well as cost advantages. These included higher noise immunity and faster speed, plus

the economies made possible by complex-function circuits.

High noise immunity

Since numerical control systems usually operate in an electrically noisy environment, the high noise tolerance (typically one volt) and the low input impedance (70 to 150 ohms) of Series 74 circuits are big

advantages. Bunker-Ramo engineers found that this reduced shielding and line-filtering requirements, while simplifying many associated design problems.

High speed

TTL's high speed gives important design advantages, even though today's NC systems often do not

Do ICs really cut costs?



The answer is an emphatic yes! That's no promise. It's a fact... with proof to back it up.

We've gathered some of the proof in the folder pictured at the left. This 6-page brochure describes how other industrial manufacturers have achieved revolutionary product advances with ICs. Like these OEMs, you too can significantly reduce equipment size and weight . . . make major performance improvements... achieve new systems capability... *dramatically reduce costs!* For your copy, check No. 200 on the TI information service card.

But that's not all! Check number 202 for the 48-page brochure that contains performance, application, and catalog information on all 180 Series 54/74 TTL ICs.

An 84-page report provides results of TI's "Tougher-than-military" testing program. It's yours for the asking. Check number 203.

A new 24-page color brochure that gives information on all plastic-encapsulated semiconductors—including Series 54/74 ICs—is also available. Check No. 204.

Please send the following:

- | | |
|--|--|
| 200 <input type="checkbox"/> 6-page case history brochure | 203 <input type="checkbox"/> 84-page IC plastic package reliability report |
| 201 <input type="checkbox"/> 48-page complex-function IC data book | 204 <input type="checkbox"/> 24-page plastic S-C brochure |
| 202 <input type="checkbox"/> 48-page TTL brochure | 205 <input type="checkbox"/> 16-page "Total Reliability at TI" |

NAME _____
 TITLE _____
 COMPANY _____
 ADDRESS _____
 CITY _____ STATE _____ ZIP _____

E



To get the literature you want, check the appropriate numbers, fill out the card, and drop it in the mail. If you prefer, circle the same numbers on the magazine Reader Service card.

E

SN7482 is a two-bit binary adder that has a typical carry time of only 8 nsec per bit. The logic diagram shows the complexity of an SN7482.

SN7483 is a four-bit binary adder that is equivalent to 34 gates in a single package.

BCD-to-decimal decoder/driver

Here is a real cost saver! The SN7441 replaces conventional decoding consisting of one dual four-input gate, two triple three-input gates and a dual two-input gate, plus four inverters and ten transistors. Output is sufficient to directly drive gas-filled readout

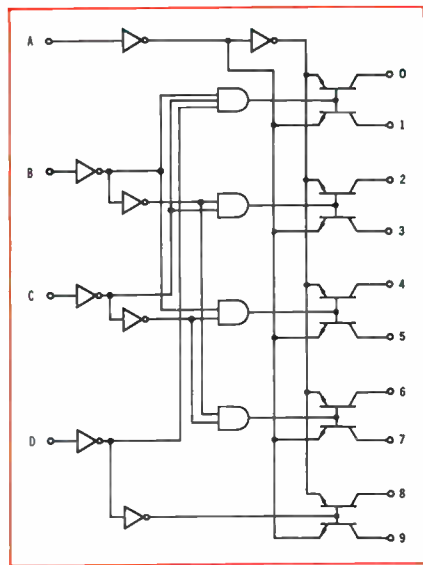

tubes, miniature lamps, and many small relays. The logic diagram (above) shows the complexity of an SN7441.

Quadruple latch

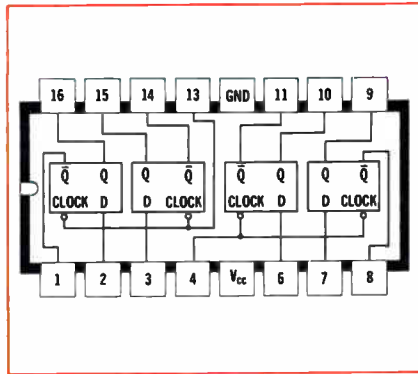

A single SN7475 quadruple latch replaces eight AND-OR-INVERT gates...greatly reducing package count and costs.

This monolithic quadruple bistable latch offers complementary Q and Q-bar outputs. The device is ideally suited for such applications as temporary storage of binary information between processing units and input/output or indicator units.

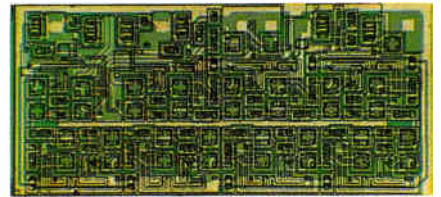

Shift register

SN7491A is a monolithic serial-in, serial-out eight-bit shift register that is composed of eight R-S master/slave flip-flops. It includes both input gating and clock driver, and is capable of storing and transferring information at clock rates up to 18 MHz.

Want to know more about how you can upgrade your new designs with Series 54/74 TTL from Texas Instruments? Start by sending for the comprehensive literature offered on the Information Service Card . . . or call your nearest TI sales engineer or authorized TI distributor.

AIR MAIL

First Class
Permit No. 7284
Dallas, Texas

BUSINESS REPLY MAIL

NO POSTAGE STAMP NECESSARY IF MAILED IN THE UNITED STATES

Postage Will Be Paid By

TEXAS INSTRUMENTS INCORPORATED

P. O. Box 5474
Dallas, Texas 75222

Attention: Inquiry Answering
Mail Station 407

require all the speed available. While clock rates of 4 MHz are common today, 20 MHz and up are possible with TTL. To the user, this reserve speed gives an extra measure of performance insurance ... and longer productivity before obsolescence.

In addition, B-R found that the extra speed of TTL also made possible simpler circuitry. For example, a function that would have had to be performed in parallel fashion with lower speed logic can now be performed in serial fashion with Series 74 TTL. This results in fewer circuits and a simpler, less expensive, more reliable system.

20 percent fewer ICs

The complex-function circuits available in the Series 74 line also made possible a 20 percent reduction in package (and circuit board) count. Since the cost of any system is largely proportional to the number of elements used, Bunker-Ramo designers were able to realize important economies.

For example, a decade counter is often made up from four J-K flip flops and a gate...perhaps three packages. Bunker-Ramo used a single SN7490N instead. Since about 40 decade counters are used in a typical NC system, the savings in integrated circuit and circuit board costs are substantial.

Improved reliability

By using Series 54/74 ICs in the new 2100 and 2200 NC systems, Bunker-Ramo engineers found that they were able to surpass reliability standards established

by existing discrete-component designs, since the number of soldered connections were substantially reduced. Also, B-R engineers could place more functions on each circuit board...reducing the number of circuit boards by about 20 percent and further improving reliability.

You get a broader choice of complex-function circuits in Series 54/74 from TI

Complex-function circuits to add, count, store, decode, and perform many other jobs are available in TI's Series 54/74 TTL line...industry's most complete logic family. These complex-function ICs can help you achieve the same kinds of performance and economic advantages realized by Bunker-Ramo.

For a comprehensive data book describing all Series 54/74 complex-function ICs, just check 201 on the TI information service card.

Counters

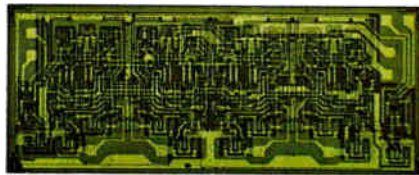

TI offers counters capable of dividing by 2, 3, 4, 5, 6, 8, 10, 12, and 16 at typical rates of 18 MHz. When used singly or in combination, they can perform most division or counting functions that might be required. Furthermore, they afford tremendous reductions in package count, soldered connections, and

costs. In addition to the SN7490Ns used by B-R, SN7492 divide-by-twelve counters and SN7493 four-bit binary counters are available. As may be required by the application, each of these devices offers the flexibility of several alternative interconnection arrangements in the system circuitry.

Adders

If you need adders, TI offers a broad selection. SN7480 is a high-speed, single-bit binary full adder with complementary inputs, complementary sum outputs, and inverted carry output.

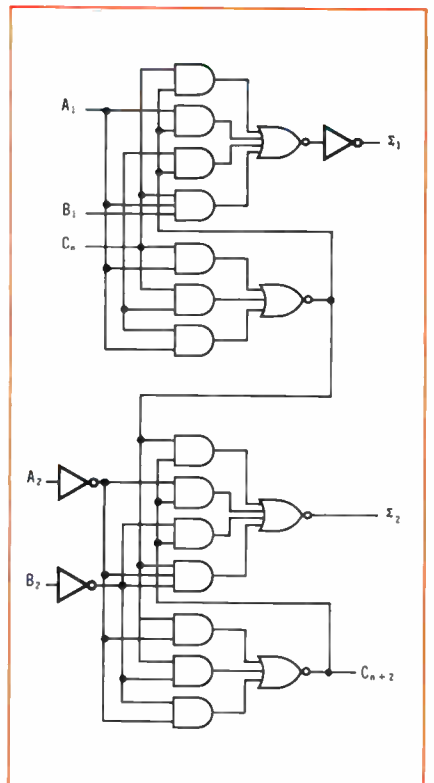

TEXAS INSTRUMENTS
INCORPORATED

Quality analysis... TI reliability starts here!

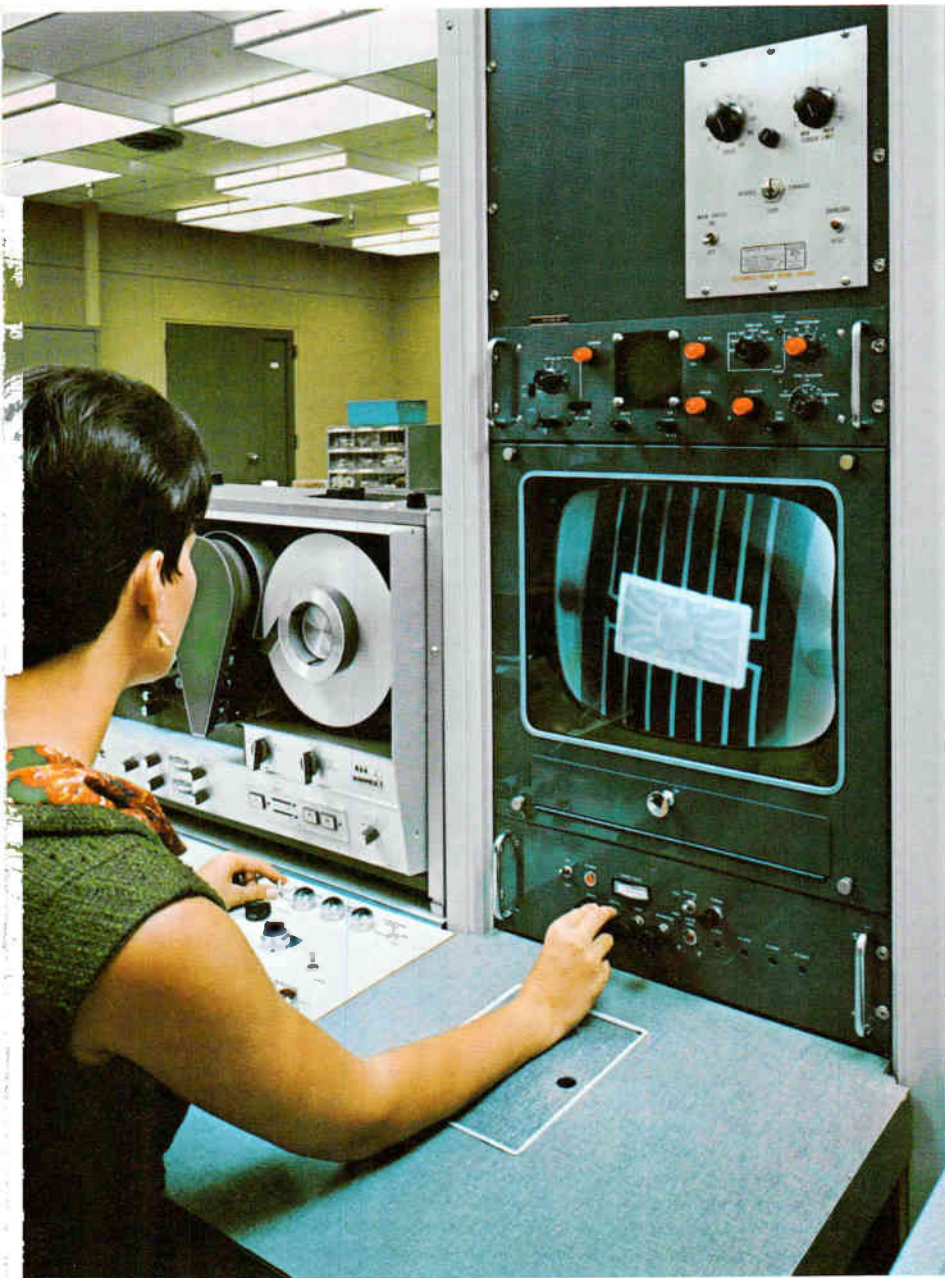

Any really successful reliability program must start with correcting the causes of failure *before they occur in the field*, and TI's Reliability Analysis Laboratory... established in 1962... has been examining the "where, what, when, how and why" aspects of IC failures for more than five years.

This lab has facilities to analyze each individual element within even the most complex integrated circuit and can duplicate failure mechanisms under precisely controlled conditions.

Typical of these quality-analysis studies is the X-ray video monitoring facility shown at the left. This important analytical tool permits full 360° observations in both vertical and horizontal planes. It reveals failure mechanisms that might otherwise escape detection.

Following identification of failures, the analysis is forwarded to a corrective-action group. Here, TI's in-depth technical resources — including physicists, chemists, and metallurgists, as well as research, design, and manufacturing engineers — are focused on the problem. After evaluation of all data and reports, necessary corrective actions are undertaken.

Quality analysis is only one of many steps taken by TI to ensure reliability of integrated circuits. Other important steps are described in a new 16-page brochure in full color... *Total Reliability at TI*. Check number 205 on the TI information service card for your copy.



TEXAS INSTRUMENTS
INCORPORATED

For a clear picture of Centralab...

...keep an eye on our ripples

In our years of manufacturing miniature and subminiature components, we've made many ripples, and a few splashes, in the electronics industry:

Centralab designed and produced the world's first carbon composition potentiometer and for more than 40 years has been an industry leader. In 1936 we introduced the first temperature-compensating ceramic capacitor in America. We were first to offer dual controls and to add integral line switches to variable resistors. Our exclusive  integrated circuits have been key elements in the miniaturization of electronic equipment. During World War II days Centralab developed the ceramic disc capacitor design for military requirements. And our Ultra-Kap[®] ceramic disc capacitor has replaced millions of larger, more costly devices.

Centralab sales have increased substantially every year and our services have grown proportionately. Our products are sold, by separate sales groups and from separate warehouses, to original equipment and distributor markets.

Centralab's tested and proven products include capacitors, packaged circuits, rotary switches, potentiometers and technical ceramics. In October, 1966, we erected a push button switch manufacturing plant and in May, 1967, we acquired solar devices and semiconductor facilities.

Innovation, growth and stirring the waters are nothing new at Centralab; and we don't intend to stop. As technology advances and components become smaller, more complex and more sophisticated, we'll keep our feet wet.

To help keep abreast of Centralab developments, we'll be happy to send you complete product literature.



CENTRALAB

Electronic Division

GLOBE LINDEN, WIS.

5757 NORTH GREEN BAY AVENUE

MILWAUKEE, WISCONSIN 53201



talk about systems...

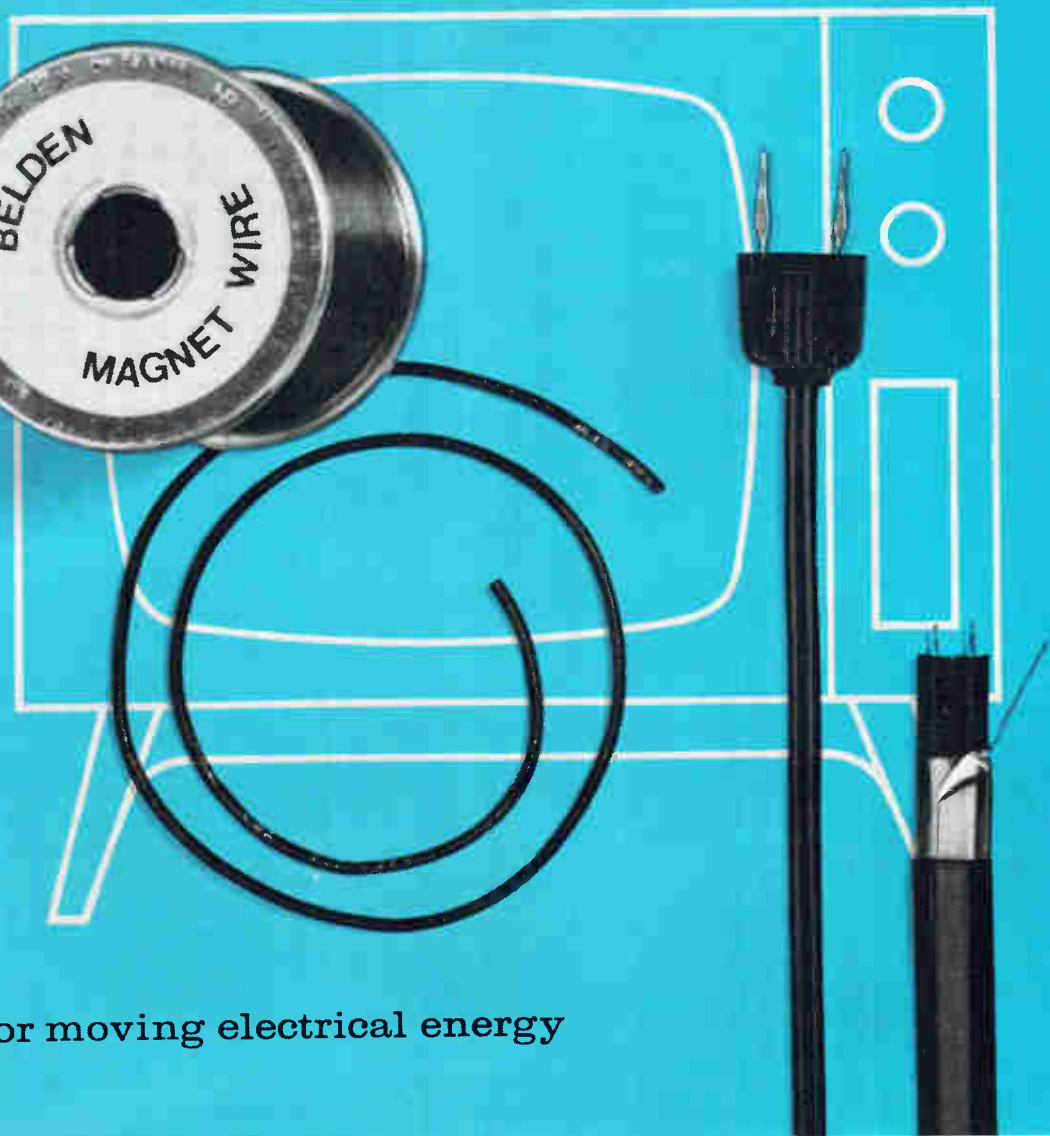

new ideas for moving electrical energy

G-2-7A

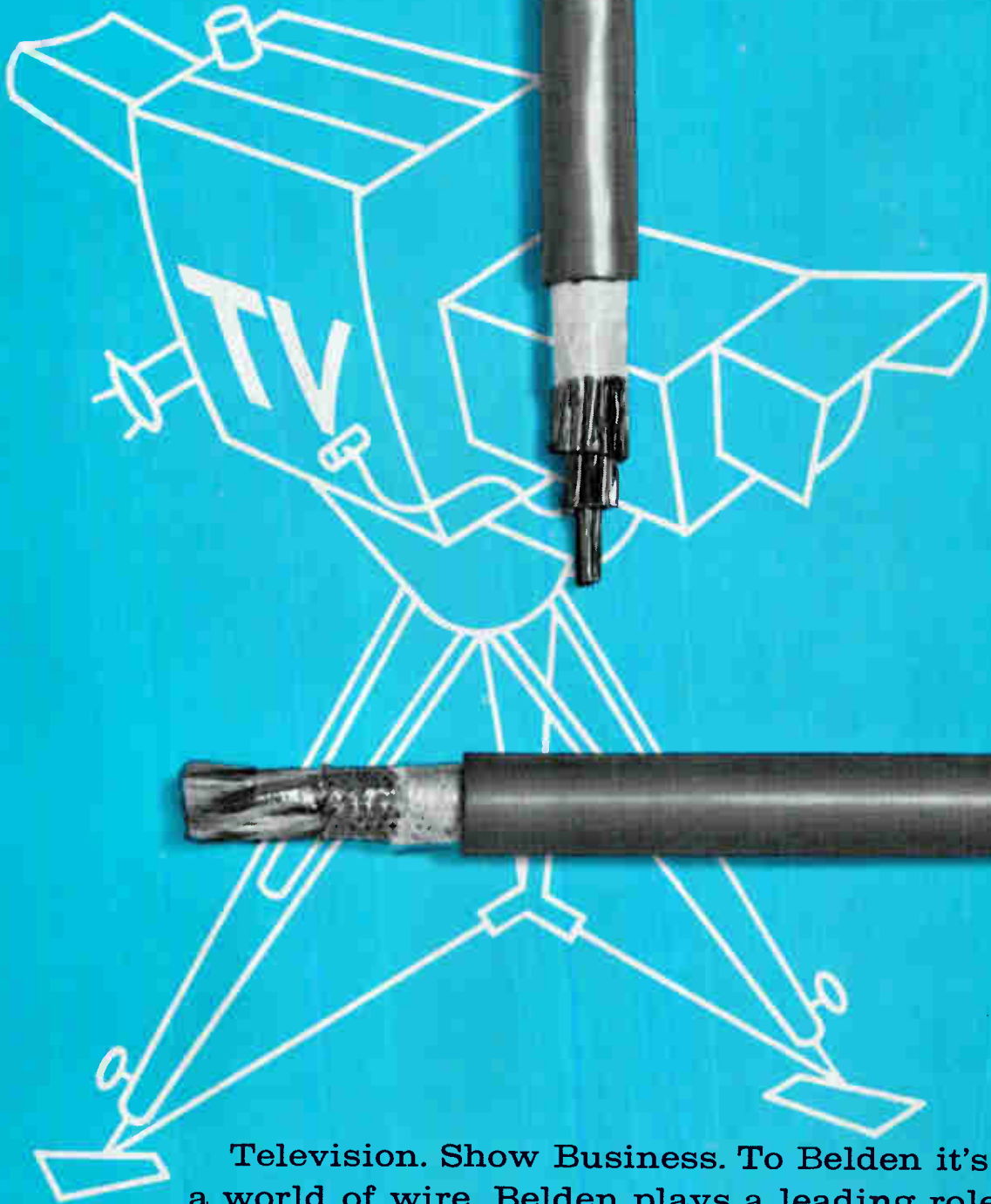

Television. Show Business. To Belden it's all a world of wire. Belden plays a leading role in many complex systems of sight and sound communication. By delving into design, processing, packaging and a host of factors, Belden's team of wire specialists have helped many people wring out hidden costs. Success takes a supplier that is really perceptive – one who makes all kinds of wire for all kinds of systems. Want to join us in wringing out values and costs? Just call us in...Belden Corporation
P.O. Box 5070-A, Chicago, Illinois 60680.







Pioneering?

You don't have to have someone re-invent the wheel

The answer to your latest switching problem may already have been developed. And, if there's any place in the world where you can get it right off-the-shelf, it's MICRO SWITCH.

Many of our switches would be considered specials by some people. But at MICRO SWITCH they are available without special engineering costs. They are available now. And they are application-proved reliables.

Main reason for this extra service is that we've specialized in nothing but switches for over 30 years. And in the process have come up with the world's largest selection of switches.

Engineering and application help is also available from MICRO SWITCH. Our field engineers are thoroughly experienced in solving switching problems. You will find them a cost-saving addition to your design team.

Call a local MICRO SWITCH Branch Office (See Yellow Pages, "Switches, Electric"). Or write . . .

MICRO SWITCH

FREEPORT, ILLINOIS 61032

A DIVISION OF HONEYWELL

HONEYWELL INTERNATIONAL • Sales and service offices in all principal cities of the world.
Manufacturing in United States, United Kingdom, Canada, Netherlands, Germany, France, Japan.

Circle 37 on reader service card

Take the EAI plotter test.

Give us your signal, and we'll show you better results on EAI X-Y plotters than any comparable machine on the market . . . often at lower cost.

We state emphatically: EAI has the finest machines available. And a superior service reputation that backs them to the hilt.

We developed the first commercially produced X-Y plotters to tie in with our analog computers, and we've been building them at the computer-quality level ever since.

There is a whole family available: different features, different prices . . . one for *your* needs. Here are a few of the extras you can count on in every EAI plotter. Single Loop Direct Drive — eliminates complex string

and pulley systems. Plug-in Inking System — writes in any position at top plotter speed. Simple cartridge replacement. High Dynamic Performance — the real test of an outstanding plotter.

The sure way to confirm these facts is to ask for a demonstration.

Tell us what you're looking for in a X-Y plotter.

We'll set up a test date.

Don't pass it up.

EAI[®] **ELECTRONIC ASSOCIATES, INC.**
West Long Branch, New Jersey

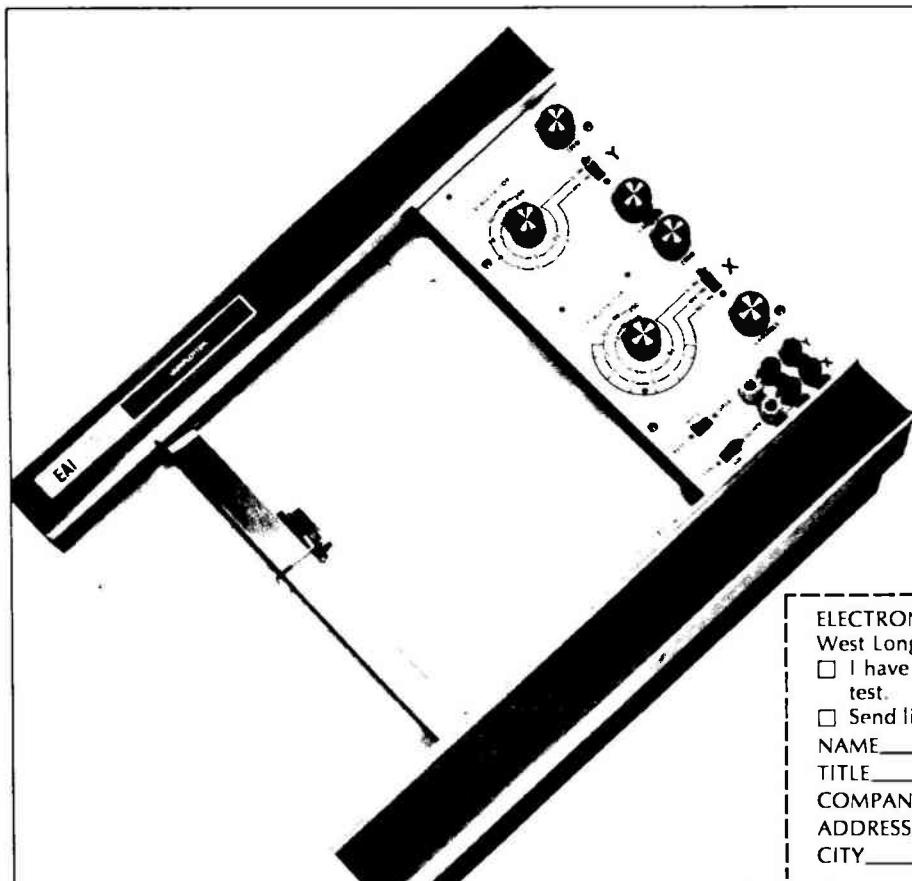

Here's just one member of the family we'd like to show you. It has the features you want plus a full 10" x 10" plotting area. Check the brief specs:

Series 1125—\$1590

- Accuracy 0.1%
- 18 calibrated D.C. ranges with variable control
- 1/2 mv/inch sensitivity
- Built-in multi-range time base
- Rack or bench mount without adapters
- Inch or centimeter scaling
- Plug-in disposable ink cartridge
- Ten-turn zero and scale factor pots

ELECTRONIC ASSOCIATES, INC. E-117
West Long Branch, New Jersey 07764

I have the signal. Let's put it to the EAI plotter test.

Send literature on X-Y plotters.

NAME _____
TITLE _____
COMPANY _____
ADDRESS _____
CITY _____ STATE _____ ZIP _____

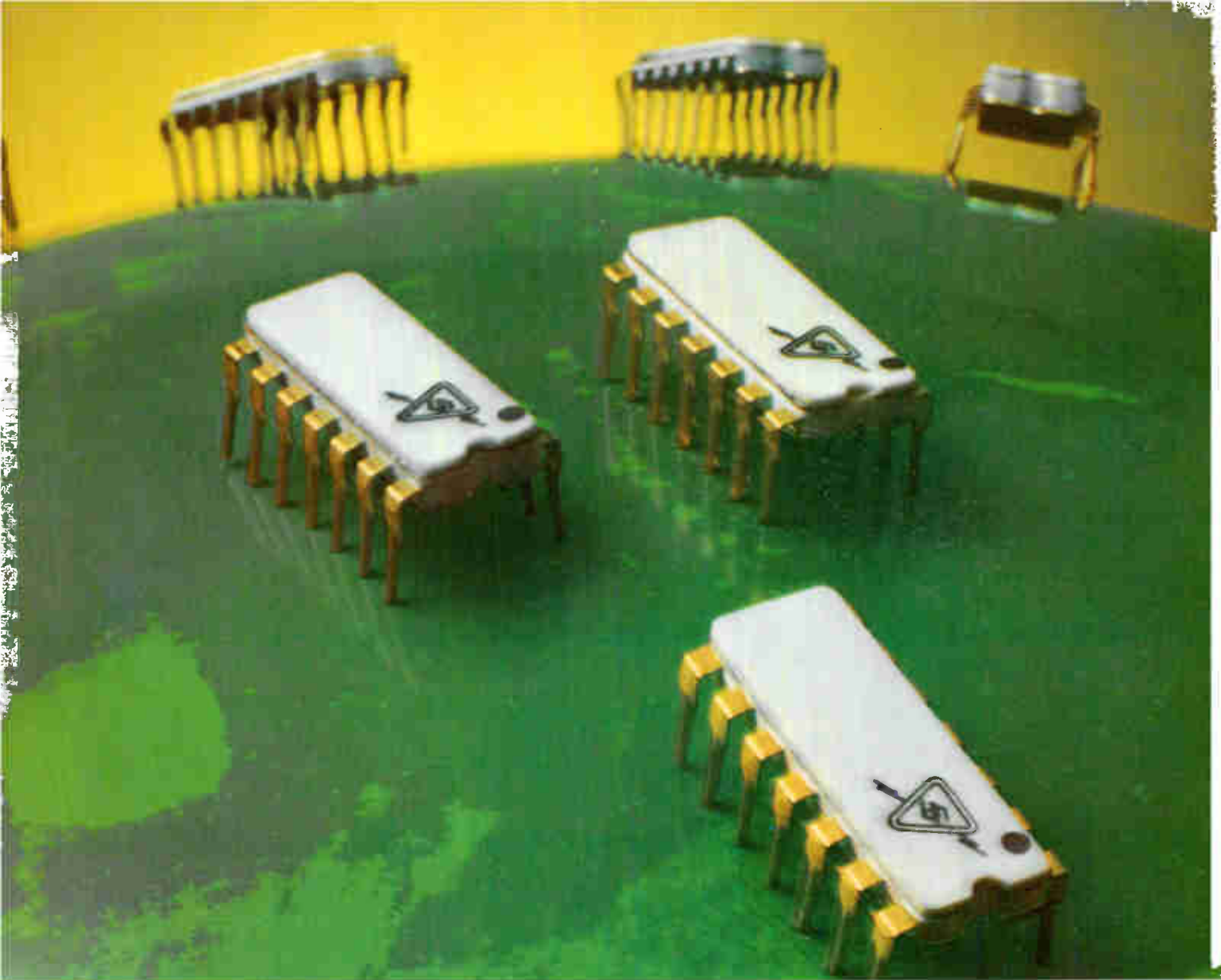

It pays to pick the fastest... in the computer race, it's SUHL/TTL.

We became deeply involved in TTL before anyone. That's why in TTL we're way ahead with SUHL™ ICs, the fastest IC line in the industry.

Our SUHL line keeps breaking speed records—now down to 5 nsec—without compromising noise immunity and power dissipation. That's why we're the prime source for TTL and why Sylvania Universal High-level Logic ICs are being second-sourced. In fact, several of the largest electronic manufacturers standardized on SUHL ICs,

even though Sylvania was their only source.

We have the most modern manufacturing facilities in the industry. All our ICs are made with one optimum process to maximize performance characteristics of every unit. Automated test equipment insures the ultimate in production monitoring, final testing, and quality control. So get SUHL's speed and reliability.

Sylvania Semiconductor Division, Electronic Components Group, Woburn, Massachusetts 01801.

SYLVANIA
SUBSIDIARY OF
GENERAL TELEPHONE & ELECTRONICS **GTE**

Circle 39 on reader service card

Circle 40 on reader service card →

NASA turned to Airco for helium and...

reliability. To pre-cool Centaur rocket engines, Airco delivered 5,500 gallons of liquid helium. The largest single commercial delivery of helium ever made. & it took only 42 hours, in one of Airco's 10,000 gallon trailers, from Kansas to Cape Kennedy.

That's the way Airco works. & from 25 points spotted across the country. We're the number one helium supplier & we perform for all our customers — large & small. For more information write us at 150 East 42nd Street, New York, N. Y. 10017.

AIRCO
Industrial Gases

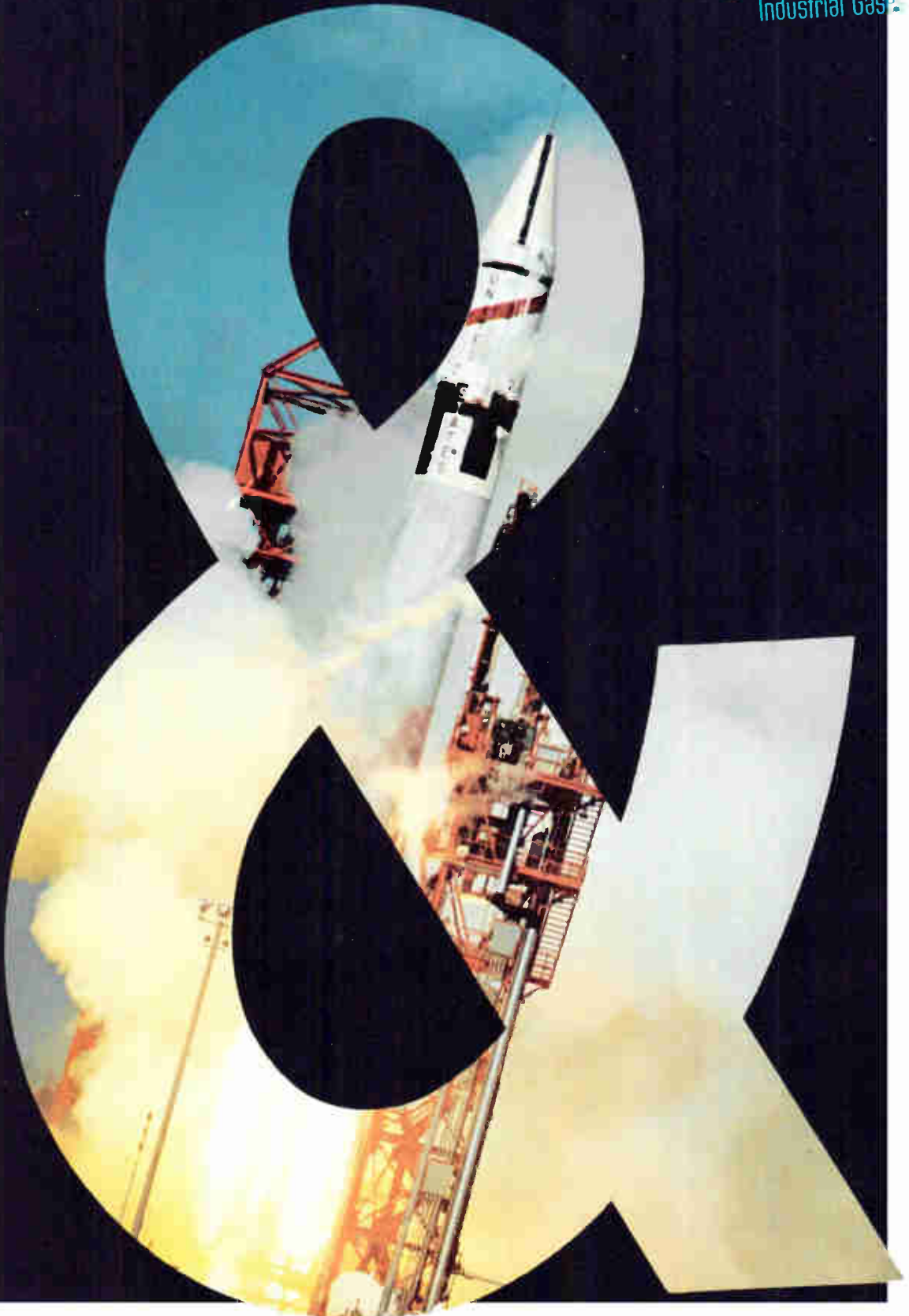



COMPONENT CAPSULES

Here's industry's most complete offering of reed switch relays

GE reed switch relays give you both the small size and high response you need for multi-relay applications. Each GE reed switch relay you buy provides extremely long electrical and mechanical life. Units are available in a wide variety of forms including standard, small, and miniature for open printed circuits, enclosed printed circuits, tube plug-ins, and bracket-, channel- or stud-mounting. **Circle Number 90.**

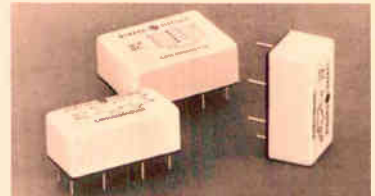

GE reed switch relays are particularly applicable for latching, timing, and voltage- or current-sensing

8 microwave tube exhibits in one



Coming your way — the General Electric Microwave Tube Van

This traveling exhibit shows you just some of the reasons General Electric is one of the world's leading microwave tube producers! The van features "live" demonstrations of:

- Distance Measuring Equipment (DME).
- Radar Altimeter.
- Spectrum Analyzer.
- Unit Oscillator.
- Voltage Tunable Magnetron.

And many other tube and solid state attractions. Write about a possible GE microwave van visit to your plant. **Circle Number 91.**

High-performance computer-grade capacitors

General Electric 86F aluminum electrolytic capacitors, with improved volumetric efficiency, provide extra high volt-microfarad capacity for power supplies, industrial control equipment, and energy storage applications. Units are available to 370,000 μf (at 5WVDC) and at voltages to 450WVDC. Ripple current ratings are as much as 100% higher for a given case size than are earlier models designed for similar uses. **Circle Number 92.**



Fuel Cells—
What's available from GE today?



While off-the-shelf hardware cannot yet be offered, prototypes of packaged fuel cell power sources—for communication or sensing equipment or for battery charging—are now being tested. These units weigh as little as one quarter pound per watt and deliver upward of 80 watt-hours per ounce of special fuel. Completely self-contained fuel cell power packages have been developed for long unattended operation in remote or underwater environment. (Example: 44-kilowatt-hours at 175 watt-hours per pound, 5 watt continuous with hourly 500-watt peak.)

Inquiries for experimental application are invited.

Circle Number 93.

MORE



Lower cost—yet higher sensitivity with the new L14B photo transistor

Priced at 97¢ in lots of 100-999, General Electric L14B photo transistors feature high sensitivity. Light current (typically) = 7mA at 10v when irradiance is 5mW/cm². Typical applications include card and tape readers, door openers, counters, and contactless potentiometers. **Circle Number 94.**

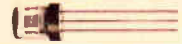

Shown actual size

Bias your reed relay with Lodex® permanent magnets

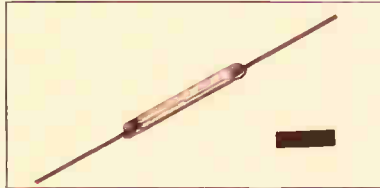

Reed switch with Lodex magnet

This revolutionary new permanent magnet material—the result of years of extensive General Electric research—offers reed switch and reed relay users high piece-to-piece magnetic uniformity. Lodex permanent magnets provide extremely close physical tolerances . . . can either be pressed to the precise intricate shape you require (reducing your overall package size) or extruded for greater physical strength.

Circle Number 95.

GE panel meter relays available in 2 styles



Type 195 BIG LOOK

GE meter relays are ideal for precise temperature control, over-temperature protection, hazardous atmosphere control, hydraulic pressure consistency—wherever control of auxiliary equipment is needed. Contactless action and “piggyback” plug-in design provide exceptional reliability and easy installation. Choose BIG LOOK® or new HORIZON LINE® meter relays in a variety of sizes.

Circle Number 96.



Type 196 HORIZON LINE

New full line of high-performance, regulated d-c power supplies

GE d-c power supplies are available in a wide selection of 50 Hz and 60 Hz models with output voltages ranging from 10 to 200 VDC. Each unit features static-magnetic circuitry for long-life reliability and holds d-c output voltage to within ±1% despite incoming line-voltage fluctuations over the rated range of 97 to 130 volts. Other advantages include:

- operation from -10 to 40C ambient.
- total ripple content: 1% rms or less.
- plus or minus grounded installation.
- overload protection to 200% of rated load.

Circle Number 97.

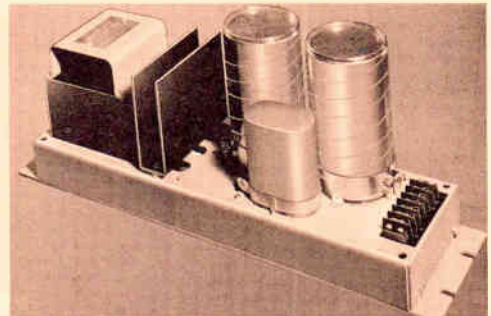

Typical power supply, model 9T66Y989

New cooling fan assemblies for electronic equipment cabinets

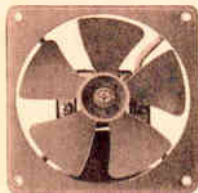

100 CFM assembly

New 100 CFM (and similar 90 CFM) fan assemblies are powered by reliable GE shaded-pole motors and measure slightly under 4¾-inches square. 500 CFM assemblies are powered by GE unit-bearing, 4-pole, shaded pole motors and measure less than 6¼ inches deep with a 10-inch diameter fan venturi. Both units require only simple ON-OFF switches for operation and are designed for years of quiet, dependable continuous-duty operation without maintenance.

Circle Number 98.



500 CFM assembly

WE MAY NOT OFFER EVERYTHING YOU WANT FROM ONE COMPONENTS SUPPLIER. BUT WE DO COME A LITTLE CLOSER THAN ANYONE ELSE.

285-30

Only **Solitron**

offers

250v

400v

500v

600v

700v

High Voltage

NPN Silicon Power

Transistors

in 3 Packages!

CHARACTERIZATION CURRENT LEVEL			
	$I_C = 1.0A$	$I_C = 2.0A$	$I_C = 3.0A$
V_{CEX}	$h_{FE} = 15 \text{ Min}$ $V_{CE(sat)} = 0.5V$ $V_{BE(sat)} = 1.0V$	$h_{FE} = 10-50$ $V_{CE(sat)} = 0.5V$ $V_{BE(sat)} = 1.5V$	$h_{FE} = 10 \text{ Min}$ $V_{CE(sat)} = 0.5V$ $V_{BE(sat)} = 1.5V$
250V	SDT1050 SDT1150 SDT1250	SDT1055 SDT1155 SDT1255	SDT1060 SDT1160 SDT1260
400V	SDT1051 SDT1151 SDT1251	SDT1056 SDT1156 SDT1256	SDT1061 SDT1161 SDT1261
500V	SDT1052 SDT1152 SDT1252	SDT1057 SDT1157 SDT1257	SDT1062 SDT1162 SDT1262
600V	SDT1053 SDT1153 SDT1253	SDT1058 SDT1158 SDT1258	SDT1063 SDT1163 SDT1263
700V	SDT1054 SDT1154 SDT1254	SDT1059 SDT1159 SDT1259	SDT1064 SDT1164 SDT1264

SDT1050 - SDT1064



TO-3
100W @ 75°C

SDT1150 - SDT1164



TO-66
50W @ 75°C

SDT1250 - SDT1264



TO-61
100W @ 75°C

Solitron now offers silicon power transistors, with V_{CEX} up to 700 Volts, in three different packages: TO-3, TO-61 and TO-66. These high reliability devices, priced low, have many applications including vertical and horizontal TV circuits, audio amplifiers, inverters, converters and relay drivers. They replace similar higher priced units now on the market.

To obtain additional information on these devices, Dial 1-800-327-3243 for a no charge telephone call.

When you think of semiconductors... think Solitron!

Solitron DEVICES, INC.

1177 BLUE HERON BLVD. / RIVIERA BEACH, FLA / (305) 848-4311 / TWX: (510) 952-6676

New PAR Lock-In Amplifier Measures Signals in the Presence of Noise by Crosscorrelation

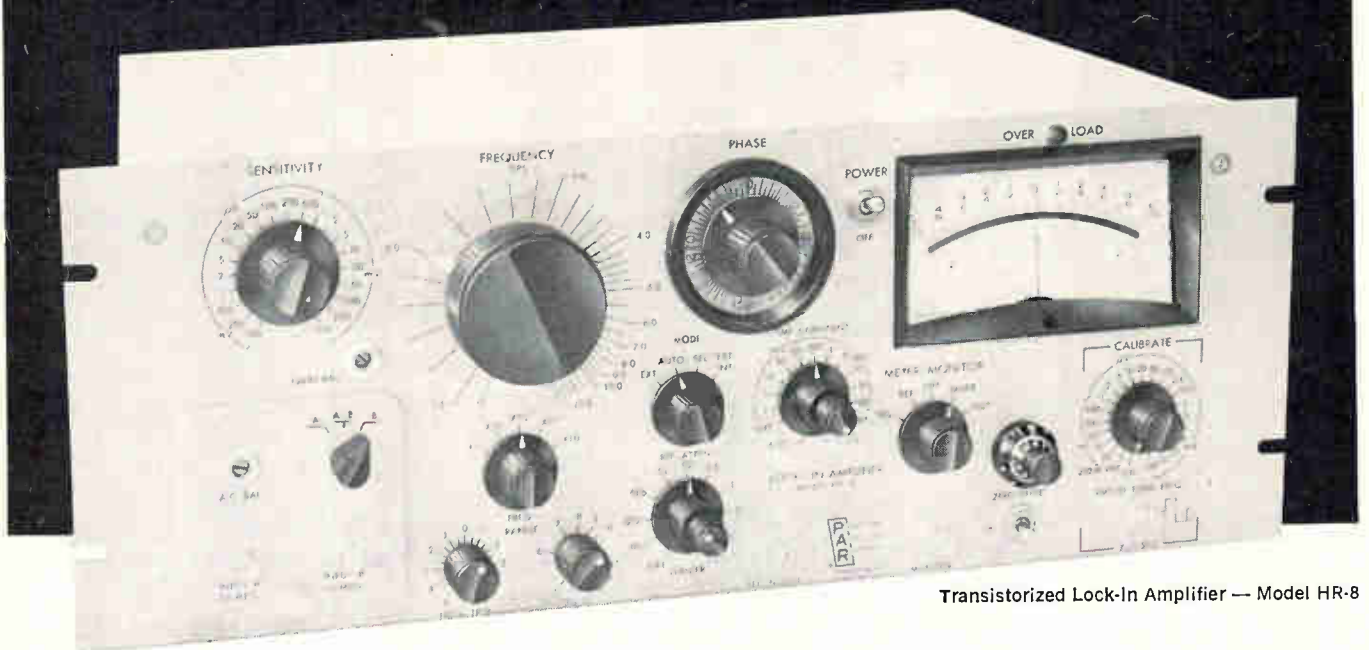

Transistorized Lock-In Amplifier — Model HR-8

The PAR Model HR-8 Lock-In Amplifier represents a significant advance in signal processing equipment for experimentalists who must measure low-level signal intensities in the presence of noise. It employs the theoretically optimum technique for signal recovery, and can be incorporated into a large class of experiments in which the signal of interest is, or can be made periodic, and in which a reference voltage related in frequency and phase to the signal can be obtained. The Model HR-8 first amplifies and bandlimits the input signal and then crosscorrelates it with the reference signal, suitably phase shifted and shaped. The crosscorrelation of input and reference signals yields a DC output voltage proportional to the signal of interest, while the crosscorrelation of the reference and noise results in no net DC voltage. The system can also be described as a continuously integrating, highly sensitive, phase conscious voltmeter, the response of which is "locked" to that particular frequency and phase at which the signal information has been made to appear.

Technical Features:

Frequency Range: 1.5 cps to 150 KC continuously tunable in 5 ranges.

Time Constants: 11 values in 1-3 sequence extending from 0.001 to 100 seconds. Single or double section RC filtering.

Pre-Amplifiers: Interchangeable low-noise pre-amplifiers, operable either within the HR-8 or remotely, are used.
Type A: Differential 10 megohm input.
Type B: Low impedance transformer input for low source impedances.

Sensitivity: 21 calibrated full scale ranges in 1-2-5 sequence.

With Type A Pre-Amplifier: 100 nanovolts to 500 millivolts rms.

With Type B Pre-Amplifier: 1 nanovolt to 5 millivolts rms.

Output: ± 10 volts full scale, single-ended with respect to ground. Will drive galvanometric and servo recorders.

Frequency Selective Amplifiers: Notch network in negative feedback loop used in both signal and reference channel tuned amplifiers. Reference channel Q of 10. Signal channel Q adjustable from 5 to 25 with calibrated dial (no gain change with Q adjustment).

Phase Adjustment: Calibrated 360° phase shifter, providing continuous rotation as well as a four position quadrant switch which shifts phase in 90° increments.

Price: \$2,250 with either Type A or Type B Pre-Amplifier.

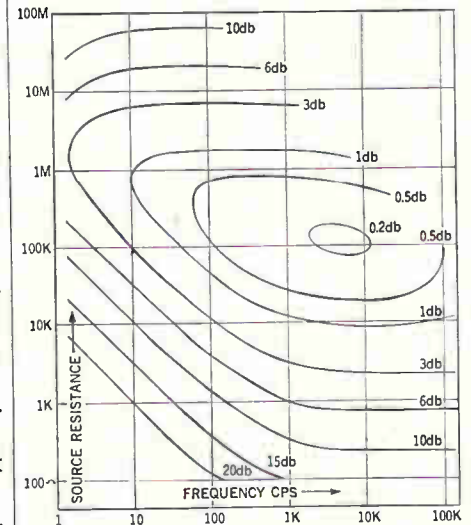

Contours of constant noise figure for a typical PAR Type A preamplifier plotted to show dependence on frequency and source resistance at 300° K. Amplifier operated single-ended.

Write for bulletin No. 120 on the HR-8 or ask for information on PAR's complete line of Lock-In Amplifiers and accessories.

PAR PRINCETON APPLIED RESEARCH CORP.
Dept. D
Box 565, Princeton, N. J., Tel. (609) 924-6835

Electronics Review

Volume 40

Number 23

Computers

Unwarped memories

Woven plated wire memories have a half dozen advantages over other types of memories. They provide both nondestructive and destructive readout; high speed (100 nanoseconds undestructive or 250 nanoseconds destructive, full cycle); high bit density; low power consumption; a temperature range of -54° to $+125^{\circ}\text{C}$; and light weight. Take those advantages, lower the price 20% while improving reliability, and you have a good part of the reason for \$1 million in new contracts received by the Librascope group of General Precision Inc. for various airborne applications.

Librascope has made the improvements by dramatically reducing the number of soldered wire joints from 704 on one side of a 64x64 (4,096-word) memory to only 256.

To and fro. Plated wire memories are made by weaving magnetically plated wires (digit wires) at right angles to insulated copper wires (word wires) the way cloth is woven. With the old system used by Librascope, the word wires came off a warp and the digit wires came from a spool mounted on one side of the loom. Alternate

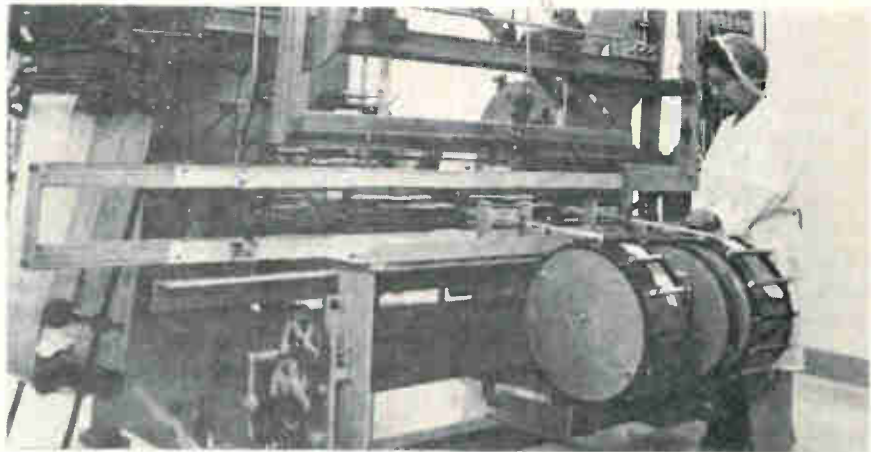

More for less. New Librascope loom produces memories, rolling onto drum, that cost 20% less while offering improved reliability.

strands of word wire were raised and the digit wires were pulled between them. The digit wires were then cut off, the position of the strands was reversed, and the process was repeated. Each word wire in a matrix was discrete and many solder connections were needed to complete the circuit in a word winding.

Now the positions of the wires have been reversed. The word wires come in from the side and are threaded between the digit wires. The warps are replaced by spools, each carrying a digit wire. The digit wires come through two stations, meaning that the loom can weave two arrays at the same time, from 2 to 5.8 in. wide. Four shuttles at each station carry the

word wires back and forth between the digit wires. Of the four, one carries the word coil wires, another is for dummy lines (spacers), a third is for magnetic keeper wires that help shape the magnetic field and cut down noise ratios, and the fourth is a spare.

Plus. What this boils down to is that the word wires, woven as continuous filaments throughout the matrix, are cut off only at the end of a word. Only two joints have to be soldered for each word. With the old system 13 joints had to be soldered on a five-turn word coil and nine on a four-turn because the loom used a broadcloth pattern—no continuous thread in either direction. Also, the new technique is much more flexible because word lengths can be changed within two or three minutes merely by adding or eliminating digit wires from the spools behind the loom.

Gordon Osborne, Librascope's product marketing manager for woven plated wire memory systems, estimates the total 1968 market for aerospace computer memories at about \$40 million. He says the company's contracts, many of them classified, include:

- A buffer for telemetry data on a space probe. The original con-

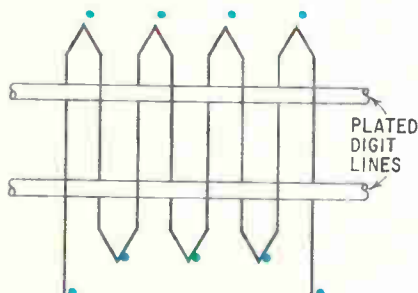

Solder . . . With the old system, a woven plated wire memory had nine solder points to link a four-turn word coil to the outside world.

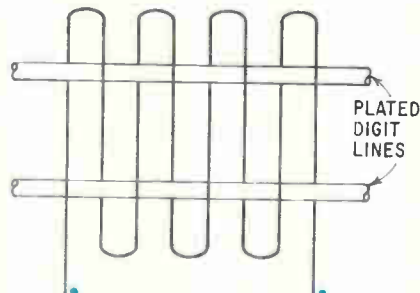

. . . saver. The new continuous filament method developed by Librascope accomplishes the hookup with only two solder points.

tract called for power consumption of less than 10 watts. Libroscope has demonstrated operation at ½-watt including peripheral electronics. Flight hardware is scheduled for delivery by August or September of 1968.

▪ A 4,096-word, 36-bit nondestructive readout memory module as the main internal memory for a variety of space computers. Dimensions will be 6x6x4 inches, including all electronics and an auxiliary power converter. The contract calls for six flight hardware units to be delivered by April 1968.

▪ A contract for 200-memory element arrays of 4,320 nine-bit words for a missile program. The memory will be loaded before launching and continuously read during flight as the program memory for a space-borne telemetry system. Power consumption requirement is

less than 3 watts.

▪ A contract for a memory for an airborne computer. Basically it will be a permanently woven, read-only memory, although parts of it will have both read only and nondestructive readout on the same plane. Requirements include operation at one-microsecond rate, average total power dissipation of less than ½-watt, density of 2,500 bits per sq. in., and absolutely fixed and nonvolatile data storage. A prototype will have an 8,192-bit capacity.

▪ A contract for several hundred 60,000-bit memory stacks for an orbiting satellite that will have to operate on less than two watts for up to three years. Flight hardware is scheduled for qualification later this year. The system will be used as a sequencer or programmer for telemetry transmission.

Solid state

Hot dice

There are now two ways to slice a silicon wafer—the conventional way and the new Air Force way. The new way promises to boost yields to 100% from the present 60% to 90%.

Traditionally, integrated circuit manufacturers dice the wafer by scribing it with a diamond-tipped needle and then applying bending stresses. Although engineers have long been trying to perfect a thermal slicing technique, they've been unsuccessful. Spokesmen at Radio Corp. of America, Bell Laboratories, Texas Instruments, and International Business Machines Corp. agree that they're no closer to thermal slicing than they were a year and a half ago.

Now it turns out that an engineer at Tinker Air Force Base, Okla., has overcome thermal-slicing hazards—such as alteration of wafer geometry and silicon contamination—by conducting the process in an inert nitrogen atmosphere, using an 0.0005-inch-wide tungsten ribbon. The flat, homogeneous ribbon is stretched across the wafer in a lattice conforming to the desired slicing configuration and a-c current is applied to the wire. The wafer, hot on one side and cold on the other, then breaks along the wire lines. The Air Force engineer, Edwin B. Lyons, says that the thermal method is just as rapid as the diamond scribe.

Space electronics

New twist

Having gained a lead in the communications-satellite field with a simple design that stabilizes a craft by spinning it, the Hughes Aircraft Co. has come up with an approach that can result in the first spin-stabilized satellites with solar paddles, and in more accurately aimed antennas with sharply increased effective radiated power. So

Electronics Index of Activity

November 13, 1967

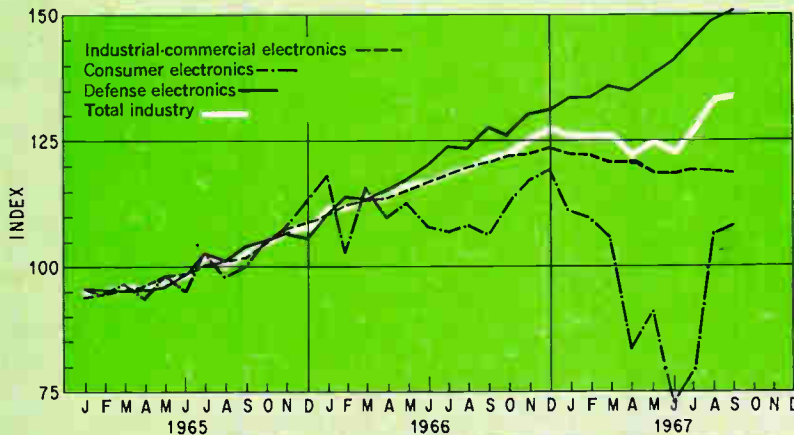

Segment of Industry	Sept. 1967	Aug. 1967*	Sept. 1966
Consumer electronics	107.8	106.7	105.9
Defense electronics	150.7	149.0	127.3
Industrial-commercial electronics	118.6	118.9	120.6
Total industry	134.1	133.0	121.6

Electronics production in September rose for the fifth consecutive month, climbing 1.1 points from August and 12.5 points from the September 1966 level. Consumer production, which had spurted 27.2 points in August, advanced only 1.1 points in September. However, that was enough to put this index at its highest level since February's 109.8. Defense electronics output also went up in September, but the 1.7 point gain was the smallest month-to-month increase since May. Industrial-commercial volume slipped 0.3 point from August and 2 points from the year-earlier pace to a level 4.8 points off its record high of 123.4 in December 1966.

Indexes chart pace of production volume for total industry and each segment. The base period, equal to 100, is the average of 1965 monthly output for each of the three parts of the industry. Index numbers are expressed as a percentage of the base period. Data is seasonally adjusted.
* Revised.

promising is the technique, called Gyrostat, that Hughes plans to apply it to proposed designs for the Intelsat 4 communications satellite, NASA's Applications Technology Satellite models F and G, and the domestic communications craft.

The Gyrostat method spins the satellite about its minor axes of inertia to produce a spin-stabilized spacecraft with a despun platform. This stationary platform would carry the solar paddles and parabolic antennas, which could be fixed on the sun and the earth, respectively, according to Anthony J. Iorillo, assistant manager of advanced design at the Hughes Satellite Systems Laboratories and the developer of the Gyrostat technique.

Scatter guns. Early Hughes spin-stabilized communications craft such as Syncom 1 carried omnidirectional antennas that wasted radiated power in signals that didn't hit the earth. Later models such as the ATS-1 had electronically despun, phased-array antennas, but these were limited in size, and the power generated by the satellite was restricted by the diameter of the launch vehicle. Also, the fact that all these satellites spun about their axis of maximum inertia limited their height, which, in turn, limited the number of solar cells that could be attached to them.

"We like the spin-stabilized satellites because they have lasted longer in orbit than other kinds," says the 29-year-old Iorillo. "They have simplicity and reliability. So we've built on the spin-stabilization technology and extended it to handle a broad class of new missions.

"We're providing a space platform that can be very accurately and reliably oriented in space. Application of the Gyrostat principle yields a stable base that allows us to talk about antenna-pointing accuracies to within a half-mile of where we want the beam on the ground, and this is achieved with simple sensors." Iorillo adds that this is the equivalent of accuracies of 5 to 10 arc seconds. The National Aeronautics and Space Administration is interested in such accuracies, he explains, because it plans to relay communications on laser beams from planetary distances to earth

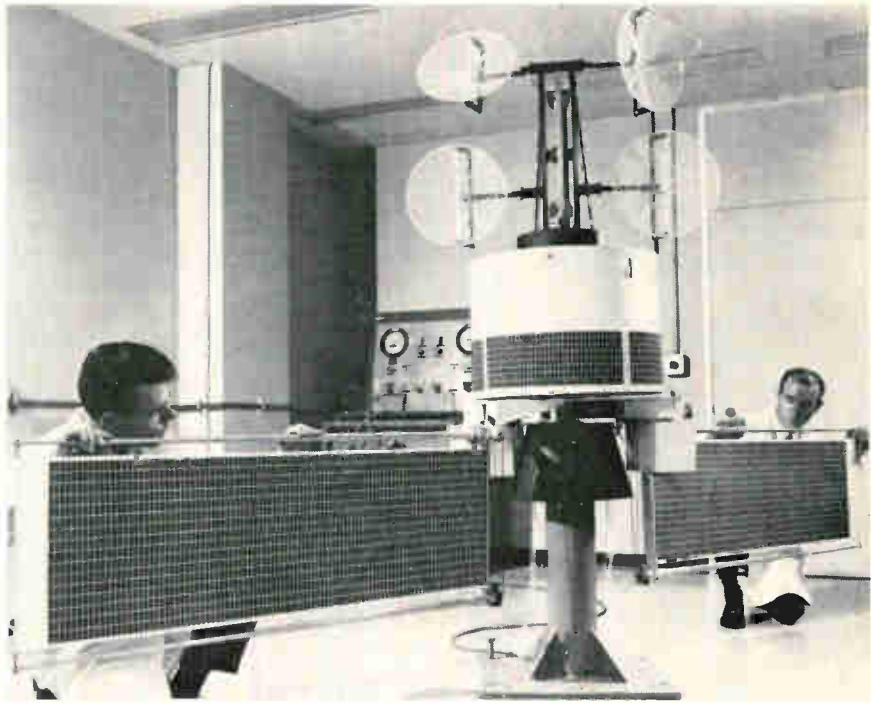

More and better. Gyrostat principle enables communications satellite to have solar paddles, more accurately aimed antennas, and permit greatly increased effective radiated power.

via an earth-orbiting repeater.

NASA is also interested in using the Gyrostat concept in the second generation of ATS satellites, Iorillo says. ATS program officials at Goddard Space Flight Center have already proposed a Gyrostat satellite to NASA headquarters, he adds, but the fate of the follow-on ATS series is now uncertain because of the pinch on space agency funds.

Comsat too. The Communications Satellite Corp. has shown interest in Gyrostat satellites to the tune of \$500,000. The money represents the Hughes share of a study of multipurpose synchronous communications satellites for Comsat.

Iorillo says the Gyrostat concept could produce a domestic communications satellite radiating power 45 to 50 decibels above a watt; the satellite's capacity would be 12 television channels. This compares with a figure of 25 dbw for communications satellites now under development, such as TRW Inc.'s Intelsat 3.

The addition of solar paddles oriented toward the sun can boost effective radiated power to levels of 70 to 80 dbw, Iorillo goes on. Levels that high would be compatible with the small-diameter earth an-

tennas envisioned for use with satellites broadcasting directly to the home.

Looking sharp

Pity the earthbound astronomer. He can observe only about five of the 21 decades in the electromagnetic spectrum because of atmospheric distortion. (The atmosphere severely attenuates emanations from extraterrestrial sources.) To get beyond the distortion area and observe the entire spectrum, he hopes to put telescopes in orbit around the earth—and the National Aeronautics and Space Administration agrees that this should be done.

The first such telescope will be mounted in an Apollo to concentrate on solar observations, as part of the Apollo Applications Program, despite a fiscal cutback because NASA Administrator James Webb thinks it's a high-priority project.

After Congress cut \$300 million from NASA's fiscal 1968 Apollo Applications Program request late last month, Webb said the agency would still build four updated Sat-

urn I launch vehicles, beyond those needed for the Apollo manned lunar landing effort. This, he said, would allow at least one attempt to conduct the two highest priority items in the applications program—the orbital workshop and the Apollo Telescope Mount.

Farsighted. But researchers at Douglas Aircraft Co. are looking beyond the Apollo Telescope Mount toward the period 1970-1980, and trying to come up with an evolutionary orbiting observatory plan to fit the spacecraft that will be available then. The space agency's Marshall Space Flight Center has provided \$475,000 for Douglas, a component of McDonnell Douglas Corp., to analyze the needs of a manned orbital support facility for future astronomical research from space. The three-phase study began last December and is to be completed next February.

Although none of the three phases is complete, the effort is far enough along for its director at Douglas to comment on results to date. Harry L. Wolbers, program manager for space station subsystem analysis at the Douglas Space Systems Division, Huntington Beach, Calif., says the study has three phases. Task A is to define the astronomers' research objectives; Task B is to recommend instrumentation to implement those objectives; Task C is to develop a flexible plan that accommodates the outputs of Tasks A and B in the space vehicles that will be available from 1970 to 1980.

Task A is no mean one. Wolbers says his team has conferred with as many astronomers as possible to determine the objectives of greatest scientific significance to be pursued from outside the atmosphere. So far, 92 observation requirements have been suggested.

The output from Task B will be the establishment and evaluation of instrument groups needed to carry out Task A's observation requirements. "We'll conduct a commonality analysis and come up with possibly 10 equipment groups that cover this range of requirements," says Wolbers. Kollman Instrument Corp. is principle subcontractor to Douglas for this portion of the study.

Cross your H. Of the four antennas being considered for radio-frequency observations—terminated loop types, orthogonal terminated loops, a combination tethered orthogonal loop and terminated loop, and crossed H types—the crossed H is one that looks feasible, says Wolbers. A tethered pair of crossed H antennas, with directivity of 5.9 to 8 decibels and a frequency range from 0.5 megahertz to 10 Mhz, may be as far apart as six miles. An exotic version of the terminated loop shows promise for low-frequency studies down to 0.05 Mhz. The two loops could be as far apart as 25 miles at each end of the supporting structure, and electronically linked to give interferometric data.

Medical electronics

The good old ways

When a hospital administrator installs a computer to help him control soaring operation costs he often finds he's taken on two new financial headaches: the price of purchasing or leasing the equipment with its complex input terminals and the expense of teaching nurses to operate them. But by using old-fashioned punch-card readers instead of those terminals, Medelco Inc., a subsidiary of Scam Instrument Corp., thinks it has a way to avoid those headaches.

The system consists of punch card units for data transmission, a magnetic drum memory for data storage, and an electronic arithmetic unit for data manipulation. It functions as a message center that substitutes written for oral messages and, at the same time, maintains an inventory of material within the hospital, records patient charges, keeps a bed census, and can be used for employee time-card data.

Price is light. Capable of handling all the data requirements for a 432-bed hospital (up to 5,000 transactions a day), the Medelco system will lease for about \$5,000, roughly one-third the monthly rental fee of a computer with compa-

table capacity. It will sell outright for about \$200,000. Even hospitals with as few as 50 beds can find Medelco's system an attractively priced answer to many problems. And, although the first system has only recently been placed in operation, Medelco's approach already has advocates. According to Lou Philipps, Medelco's president, the company has a \$1 million order backlog for the system.

Dubbed THIS, for total hospital information system, it combines the punch card system and magnetic drum memory to transmit instantaneously information to and from hospital departments. Each order, whether for drugs, hospital services, or special equipment, is acknowledged and stored in the memory to be reported to the accounting department.

Operation is simple. A punched card, made up for the patient when he is admitted, carries information such as name, date, address, doctor, and method of payment—specifying his insurance plan—in typewritten form and in punch-card code. In addition, each nurses' station has a rack of prepunched order information cards covering every service and medication. Similar cards are kept in such areas as X ray and the pharmacy, for all services performed there.

Push, print. When the nurse receives the patient information card and the physician's instructions, she selects the proper order cards from the rack and inserts them along with the patient card into the card reader. Instructions are printed out immediately in all concerned departments, including accounting, and the nurses' station for confirmation and for the patient's chart. If medication is ordered from the pharmacy, the teletypewriter there even prepares labels for the prescription items.

One of the attractive features of THIS, according to Gene Stanos, Medelco's chief engineer, is the fact that the system can be used by personnel who have no prior training. Another plus for the small hospital is that all components are interchangeable, minimizing service requirements.

Not only does the system offer

TRW SPACE SAVING SOLID TANTALUM CAPACITORS

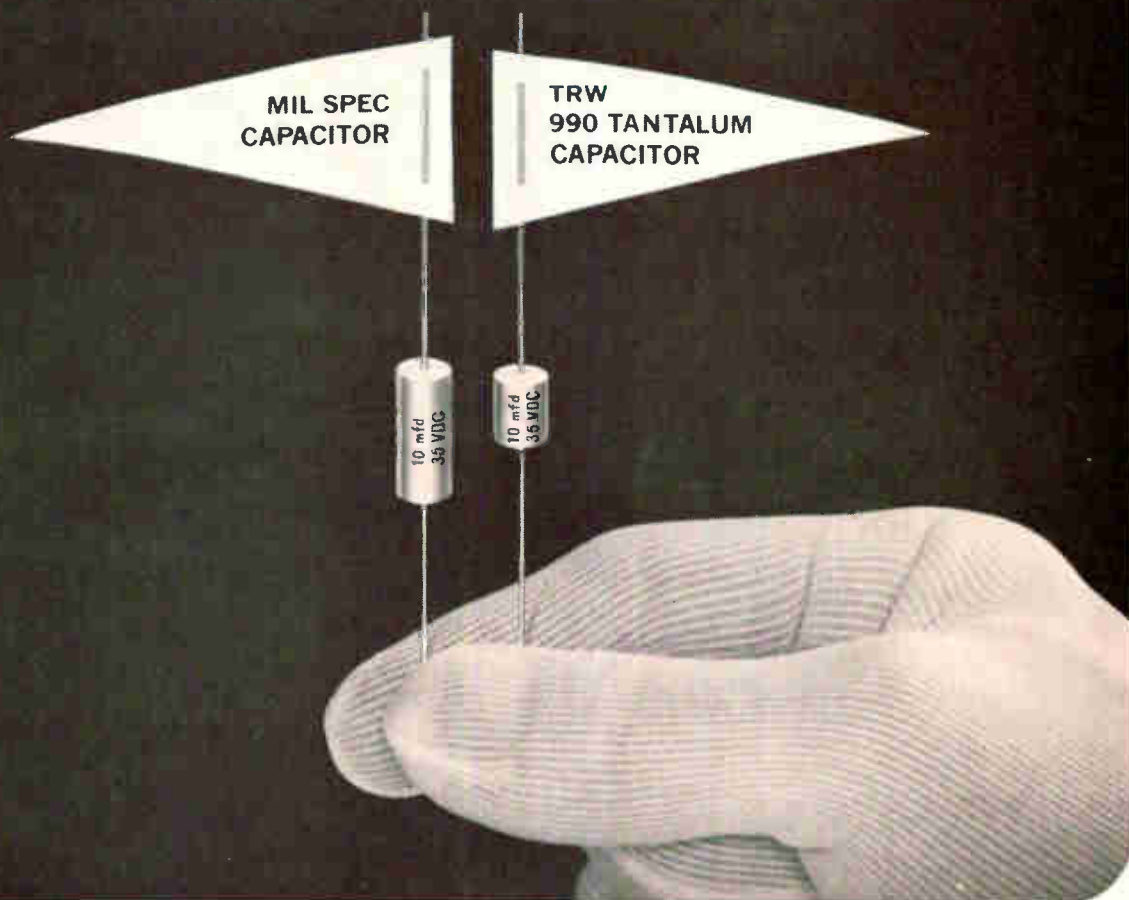

MIL spec performance...in half the space!

Type 990 miniature solid tantalums typify TRW's creative engineering. They're *designed* to fit in half the space. *Designed* to give better shock and vibration resistance. *Designed* to MIL

specs. They're *designed* to be the best hermetically sealed tantalums you can buy. Values from 8.2 to 330 mfd, 6 to 35 V.

Get the TRW tantalum story on space-savers like the 990,

on standard MIL types and tantalum hi rel capability. Contact TRW Capacitor Division, TRW INC., Box 1000, Ogallala, Nebraska. Phone (308) 284-3611. TWX: 910-620-0321.

TRW[®]

hospital administrators a means of acquiring budgetary control information, but it reduces clerical work and insures quick, accurate transmission of orders. And with the additional paper work demanded by government medical programs such as Medicare and Medicaid, that's vital.

Advanced technology

Hot spot storage

Optical memories for computers promise to deliver enormous capacity, high density, and dazzling speed. Their potential has attracted the attention of several companies, some of whose attempts to develop such memories have been in vain. One that has succeeded is Honeywell Inc.

Scientists at the company's research center in Hopkins, Minn., have worked out a way to store binary information in a manganese-bismuth film, using a laser capable of operating at two power levels—one for writing in and a lower one for reading out data. The technique works at room temperature and can repeatedly read and rewrite information in the same place indefinitely.

Room-temperature operation is an inherent advantage for the technique over the cryogenic requirements of a europium oxide memory under study at International Busi-

ness Machines Corp. [Electronics, Sept. 18, p. 45], even though at those low temperatures EuO does work better. And Honeywell has thus far escaped the fate of Itek Corp., which tried to develop a read-only photographic memory but failed [Electronics, March 20, p. 47].

Film property. Both Honeywell and IBM have exploited the magneto-optic properties of their film. The film has a natural ferromagnetic axis that can be oriented perpendicularly, pointing either up or down. If the film is heated beyond its Curie temperature— $+360^{\circ}\text{C}$ for MnBi, and -176°C for EuO—its magnetization plunges. If it then cools in a magnetic field, its intrinsic magnetic vector aligns itself with this external field. And if a beam of linearly polarized light is directed on the film, its plane of polarization is rotated to the right or left depending on whether the magnetization of the film is up or down.

Both MnBi and EuO are capable of rotating the plane several degrees as it passes through a film only 1,000 angstroms (10^{-4} millimeter) thick.

A laser pulse focused on a small area of the film for a microsecond is enough to heat that spot above the Curie point. But a microsecond later, the film has cooled off almost to its initial temperature and is remagnetized. Binary data can thus be written by a laser beam having a few milliwatts continuous power focused down to many kilo-

watts per square inch. The same beam, throttled back by a modulator, does not heat the film appreciably, but its angle of polarization is rotated so that the recorded data is read out, theoretically at a speed of up to 100 million bits per second.

Stick to a spot. A film of EuO is much more transparent than one of MnBi of similar thickness, and is therefore more easily read—but at cryogenic temperatures. But MnBi's opacity—95% for a reddish light—improves its absorption of the energy in the laser beam. Thus, a small spot heats up quickly without spreading outside the beam area. "In this respect, manganese bismuth is unique," says M. Donald Blue, who heads the project. "We know of no other material that rotates polarized light so well and still has such a high absorption coefficient—and all at room temperature."

A practical limit now appears to be a spot 3 microns in diameter; theoretically, this could be reduced to 1 micron if problems caused by heat diffusion and lens aberrations can be overcome. Three-micron spots 10 microns apart lead to a packing density of 6.25 million bits per square inch.

These figures point to the eventual development of mass memory units with 30 times as much data per unit volume as conventional magnetic disk units, and also to relatively small—but extremely fast—memories in a small volume subsystem.

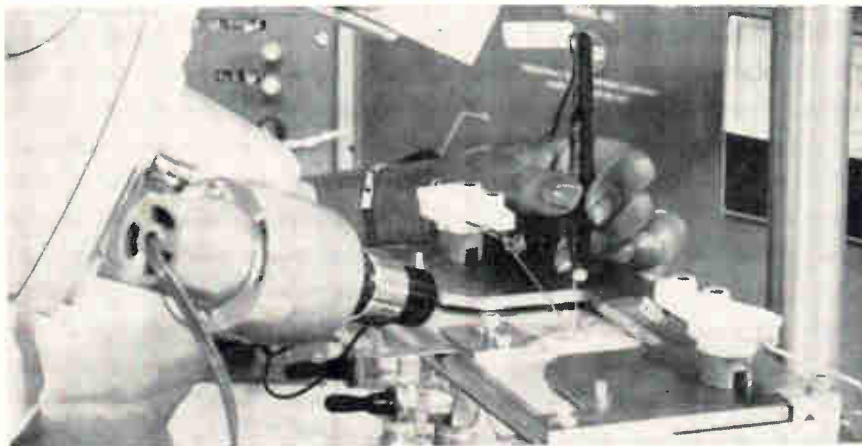

Tool. End-point sensor can be used for resistor trimming in General Instrument's hybrid IC's after they're packaged.

Integrated electronics

Neat trim

When users of hybrid integrated circuits want premium characteristics they have two alternatives. They can ask the manufacturer to trim component values (for a price) or cut into available space by adding external trimmer potentiometers and precision resistors (also for a price).

Now General Instrument Corp.'s Hybrid Microcircuit department is marketing hybrid IC's—such as reg-

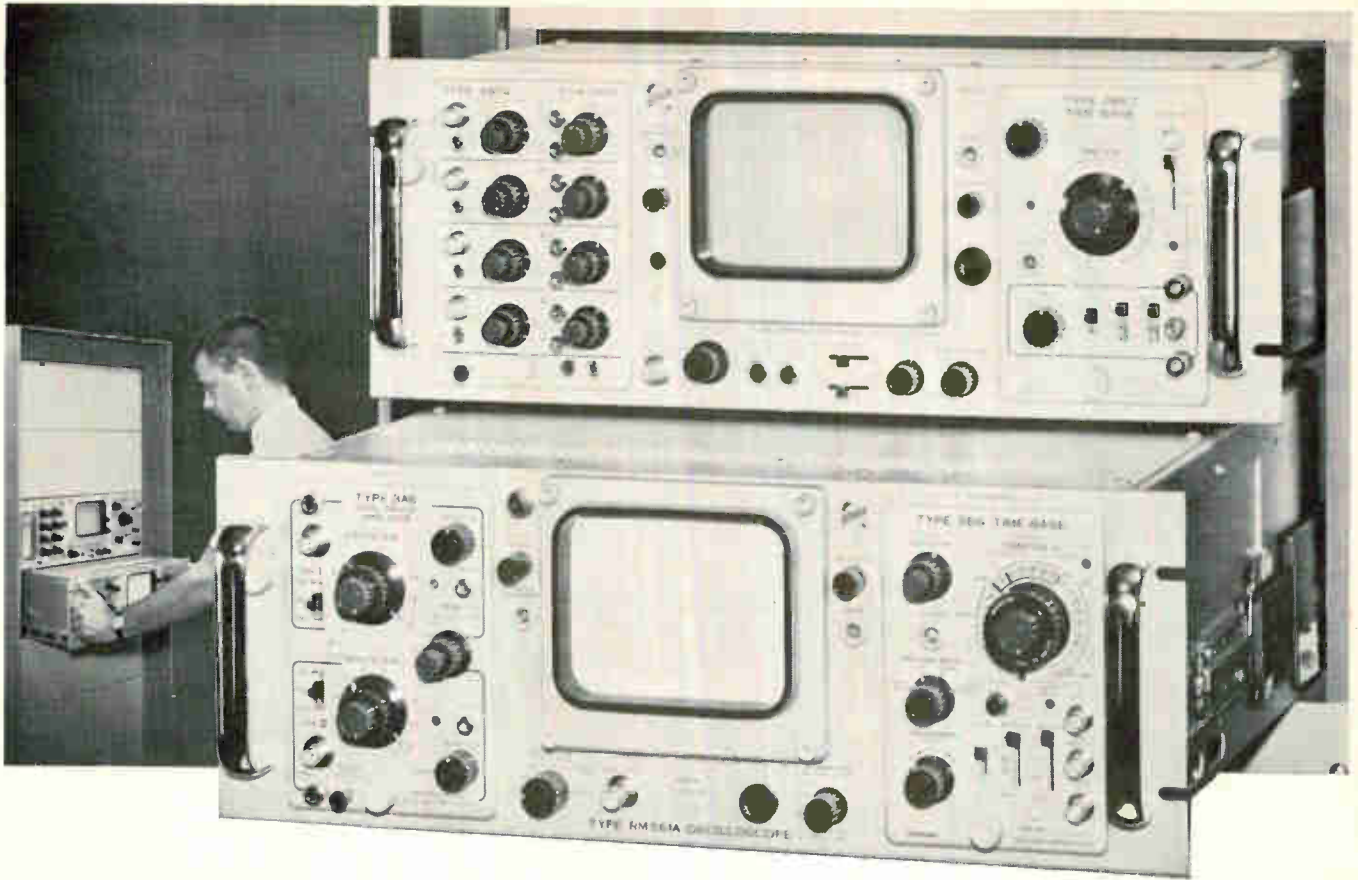

plug in a Tektronix rack-mount oscilloscope

- Conventional or storage
- Multi-trace, differential, sampling and spectrum analyzer plug-ins
- 7 inches of rack height

The Type RM561A 7-inch high rack-mount oscilloscope provides conventional oscilloscope performance with measurement capabilities extending from DC through 1 GHz with appropriate plug-in units. It has an 8 by 10-cm CRT with a bright P31 phosphor and an illuminated, internal graticule.

The measurement system illustrated consists of the Type RM561A with the Type 3B4 Time-Base Plug-in and the Type 3A6 Dual-Trace Amplifier. The Type 3B4 provides versatile triggering and calibrated sweep speeds from 5 s/div to 50 ns/div. A direct-reading magnifier provides up to X50 magnification about the center of the CRT. The Type 3A6 Dual-Trace Amplifier has DC-to-10 MHz bandwidth and 35-ns risetime over its 10 mV/div to 10 V/div deflection range.

Type RM561A Oscilloscope	\$ 580
Type RM561A MOD 171A (Includes slide-out tracks)	\$ 630
Type 3B4 Time Base	\$ 425
Type 3A6 Dual Trace Amplifier	\$ 525

The Type RM564 split-screen storage oscilloscope is virtually two instruments in one. It offers all the advantages of a storage oscilloscope plus those of a conventional plug-in oscilloscope. The contrast ratio and brightness of stored displays are constant and independent of viewing time, writing and sweep speeds, and signal repetition rates. The entire screen or either half can be used for storage and/or conventional displays. In the stored mode, either half of the screen can be erased independently of the other half. A rear panel connector permits remote erasure of either or both halves of the display.

The plug-ins shown in the Type RM564 are the Type 2B67 Time-Base Unit that has calibrated sweep speeds from 5 s/div to 1 μ s/div extending to 200 ns/div with the X5 magnifier, and the Type 3A74 Four-Channel Amplifier that provides DC-to-2 MHz bandwidth over its 20 mV/div to 10 V/div calibrated deflection range.

Type RM564 Storage Oscilloscope	\$1025
Type RM564 MOD 171A (Includes slide-out tracks)	\$1075
Type 2B67 Time-Base	\$ 225
Type 3A74 Four-Channel Amplifier	\$ 625

U. S. Sales Prices FOB Beaverton, Oregon

For a demonstration, contact your nearby Tektronix Field Engineer or write: Tektronix, Inc., P. O. Box 500, Beaverton, Oregon 97005.



*Conventional or storage
oscilloscopes*

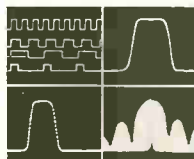

*...with multi-trace, differential,
sampling and spectrum analyzer plug-ins*

OFF THE SHELF

modular silicon

POWER SUPPLY

Compact

4 1/2 x 4 1/8 x 1 5/8 overall.

All silicon semi-conductors ($\pm 5\%$) adjustment, response time of 50 microseconds. The input is 105-125V, 60-400 Hz with load and line regulation of 0.05%. Operating temperature range is -20°C to $+70^\circ\text{C}$ with stability of 0.5%/8 hrs., TC of 0.02%/°C. Ripple and noise less than 1 MV RMS.



Model	MA Current	Nom. Voltage
RS-5-6-9	0-600	9
RS-5-5-12	0-500	12
RS-5-4-15	0-400	15
RS-5-3-18	0-300	18
RS-5-2.5-24	0-250	24
RS-5-2-30	0-200	30

ABOVE MODELS \$59.00 (1-9) UNITS

Models above are shipped promptly from stock. Other solid state power supplies also available. Write or call telling us of your requirements.

SCINTILLONICS

SUBSIDIARY OF HCI
Phone 303/482-4752

P. O. Box 701,
Ft. Collins, Colo. 80521

Electronics Review

ulators and amplifiers—that can be trimmed by the user after the package is sealed.

The company makes the free ends of appropriate cermet resistors available to the user by putting extra leads on the package. Application of high-voltage pulses across the resistors trims the component to desired levels. To prevent harm to other devices in the package that have lower breakdown points, key resistors on the substrate are formed with one end free. Thus the trimming signals aren't coupled to associated circuitry. After application of the pulses, the free end is connected to the remainder of the circuit simply by adding an external wire.

Manufacturing

IC overseer

Has integrated circuit manufacturing grown enough to justify the use of digital computers for controlling test, inspection, and process operations? It's a question some IC makers are starting to ask, and at least one is trying to answer.

In Florida, the ITT Semiconductor division of the International Telephone & Telegraph Corp. started a two-month study last week which could result in the largest commitment so far for computer-controlled IC manufacturing and testing. "If our concept proves feasible, ITR will spend about \$10 million for extensive centralized computer IC test equipment in the next five years," says Irwin A. Horowitz, ITR Semiconductors' director of information systems.

Putting control computers into a plant is not a lightly-made decision, such manufacturing plants as refineries and steel mills have discovered. A control computer project takes about two to three years of study, engineering, programming, installation, and—not the least important—a large investment before it becomes fully operative.

Specialists. Now, like most IC makers, ITR uses dedicated test stations, each one doing fixed tasks

and directed by a special-purpose computer. In the future, it hopes to direct all of its test stations from two large central computers.

When Horowitz took over his new assignment last June, he made a quick assessment of information needs of the West Palm Beach plant and noted three factors worthy of deeper study:

- The steep growth pattern of IC sales—and more complex IC's in the future—warrants large expenditures for test equipment.

- One-third of the cost of present IC testers goes for special purpose computer-directors, two-thirds for programmed power supplies.

- Less than 50% of labor cost is for IC production, the rest for testing and inspection.

Until recently, ITR has been playing catch-up in the IC business, serving as second source for Fairchild-designed devices. This year ITR expects to sell more than 3 million IC's, including diode-transistor logic, transistor-transistor logic, complementary-transistor logic, and linear packages. Next year, volume should rise to 15 million units—including devices of ITR's own design—which will amount to about 7% of total estimated IC sales of \$360 million.

Peas in a pod. What Horowitz hopes to do first is consolidate IC testing strategy into two central computers and interface them with numerous satellite test stations, all essentially alike. Flexibility for testing a variety of IC's will thus be accomplished by programming rather than by individual adjustment of electrical and environmental parameters for each type of IC at each station.

Horowitz' study team includes two ITR engineers with hands-on experience in IC testing, two corporate staffers knowledgeable in programming and communication, and two fulltime men and other specialists as needed from the Burroughs Corp. who will aid in specifying computer size and configuration.

Horowitz selected Burroughs after interviewing five computer makers—all of whom offered their men to the team free of charge. He emphasized Burroughs has no assurance it will get the computer order. If and when equipment is



The World's Most Complete Line of...

PRECISION TRIMMER CAPACITORS

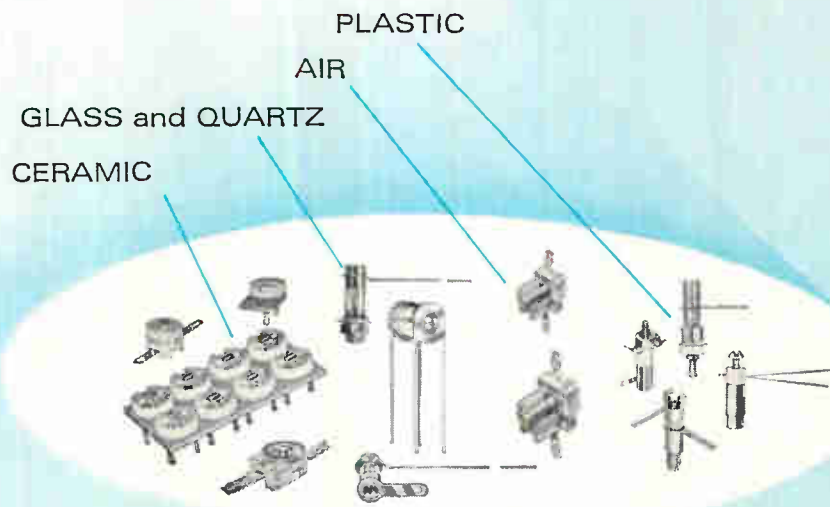

MINIATURIZED ERIE TRIMMER CAPACITORS FOR PRINTED CIRCUIT BOARD... OR PANEL MOUNT APPLICATIONS—MILITARY OR COMMERCIAL TYPES

When knowledgeable engineers discuss quality Precision Trimmer Capacitors... ERIE is the name most often mentioned as the best single-source in the industry.

Today, miniaturized ERIE Trimmer Capacitors are available in a wide selection of dielectrics for virtually any circuit application... Ceramic, Glass, Quartz, Air and Plastic.

For more than 20 years ERIE has earned an enviable reputation for quality components. Quality, however, is a by-product of experience and advanced engineering capability. At ERIE, Precision Trimmer Capacitors are smaller than ever with better than ever quality.

If you have a specific Trimmer Capacitor problem... we suggest ERIE as your one-stop source. One of our standard units will probably fulfill your requirements. If not, our Trimmer Engineering Department will welcome the opportunity to discuss your circuit needs.

Write TODAY for new Precision Trimmer Capacitor catalog.

Another Series of Components in Erie's Project "ACTIVE"
Advanced Components Through Increased Volumetric Efficiency

ERIE

TECHNOLOGICAL

PRODUCTS, INC.



Formerly
Erie Resistor
Corporation

Erie, Pennsylvania

Compact electronics package?

COOL IT...

...with a small size, long life, high output AiResearch fan.

Garrett-AiResearch special purpose fans are individually designed and custom built to deliver more flow and greater pressure rise with a minimum envelope size.

Take a typical AiResearch small size fan: computer-optimized for required performance under all operating environments; our own motor, engineered and manufactured for a perfect match to its fan; and up to 40 percent more airflow than any other ventilating fan of similar input, size, and weight.

Next time you need a ventilating fan for a very special airborne or ground electronics enclosure specify AiResearch. Available for high temperature and cryogenic applications, with flow rates and power requirements as specified. AiResearch Manufacturing Division, Torrance Facility, 2525 190th Street, Torrance, California 90509.

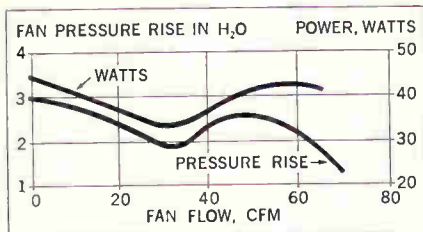

AIRESEARCH SPECIAL PURPOSE FANS



Electronics Review

bought, vendors will bid to specs developed by the team.

During its study the team will specify computer, interface, and test station sizes and configurations; will consider such related factors as lease or purchase, programing, communications, service, and expandability; and will set up project schedules and manpower needs.

Voila. IRR hopes the system will produce data at each test point which can be fed back for on-line process control, diagnostics to test the test equipment, go/no-go signals, production and labor efficiency data which can also be used to simulate and forecast product throughput, and timely inventory information for its marketing department.

Although it's up to the study team to establish specifics, Horowitz estimates now the job will use, for reliability reasons, two somewhat redundant large computers—"like IBM 360 Model 40's or 50's"—and multi-interface gear under control of supervisory programs.

If the study says yes to computers, IRR will take a fresh look at test stations.

Consumer electronics

Music in IC major

Motorola's Semiconductor division has a major foothold in the lucrative electronic organ market as a result of having produced the first integrated circuits designed expressly for organs—a frequency divider and a dual-gate keyer [Electronics, July 24, p. 96]. But other major IC producers, with the incentive of \$200 million worth of electronic organs to be sold this year, have entered the lists.

The first challenge to Motorola came from Philco-Ford [Electronics, Oct. 30, p. 26] in the form of a seven flip-flop, dual in-line frequency divider package priced at 30 cents a flip-flop, compared to Motorola's 50 cents.

Here comes GE. Now the General Electric Co. is sampling a

metal-oxide semiconductor IC designed for organs, designated the PA448. It's a six-stage frequency divider available in two configurations: one with each stage cascaded in series, the other with inputs in a 1-2-3 cascaded combination.

Frequency division is accomplished by synchronous sequential logic in which all conditions that could lead to a false output have been eliminated. Divided outputs are fed to a push-pull amplifier that also acts as a buffer. The PA448 will be offered in a dual in-line plastic package. GE says it will be priced competitively with Motorola's MC 1124A per flip-flop but is noncommittal about being able to compete with the Philco-Ford price.

Since most of the 125,000 electronic organs made each year use more than 100 flip-flops per organ, IC makers hope to find an outlet for 10 million divider circuits a year.

Short circuited

Earlier this year integrated circuit makers began a big push for the potentially huge TV set and entertainment equipment market [Electronics, June 12, p. 38]. There was plenty of talk about big orders around the corner. Today, six months later, not only are they still around the corner, but Texas Instruments is scrapping its hybrid monolithic series and Fairchild Semiconductor, with inventories of its μ 717 sound i-f amplifier built up, has stopped producing it, at least temporarily.

TI developed and manufactured a line of multifunction hybrid IC's for i-f and audio stages in TV sets, radios, and phonographs. The products were sound, and the hybrid approach appeared better than the monolithic construction chosen by its rivals. TI chose hybrids for its pilot IIC1000 IC line for good reasons:

- The circuits were offshoots of units being made for IBM's 360 computer.
- Development costs were lower than for monolithics.
- Manufacturing costs for the

new...

smaller...

4 amp

50-100 nanosec.

ultra-fast recovery

controlled avalanche

high voltage epitaxial

rectifiers

THE UNIQUE UNITRODE CONSTRUCTION

With the silicon die metallurgically bonded between terminal pins of the same thermal coefficient, the hard glass sleeve is fused to the entire outer silicon surface. Result — a voidless, monolithic structure.



ACTUAL SIZE

**the only
lead mounted 4 amp with
100 nanosec. max recovery
PIV's to 250 V
80 amp surge capacity
Full power operation
at frequencies up to
100 kHz square wave
and 350 kHz sine wave
1/10 the size . . .
1/14 the weight of
a comparable stud-mount.**

Check 323 Readers Service Card

ACTUAL SIZE

**2 amp
typically 50 nanosec. recovery
PIV's to 250 V
25 amp surge capacity
Full power operation
at frequencies up to
100 kHz square wave
and 350 kHz sine wave
1/7 the size . . .
1/3 the weight of
comparably rated devices.**

Check 323 Readers Service Card

UNITRODE®

580 PLEASANT ST., WATERTOWN, MASS. 02172
TELEPHONE (617) 926-0404 TWX (710) 327-1296

Specify New Oscillators and Power Modules from Austron!



CRYSTAL OSCILLATORS

Output frequencies from 50 Hz to 10 MHz. Stabilities from 1×10^{-6} to 1×10^{-10} per day. High frequency stability over operating ranges as great as -55°C to $+85^{\circ}\text{C}$.



TUNING-FORK OSCILLATORS

Packaged units include basic resonators or complete oscillator units. Range of frequencies, stabilities and mechanical configurations available.



POWER MODULES

5 VA to 1 KVA, AC output with AC or DC input, square or sine-wave output, 50 Hz to 5 kHz, frequency tolerances to $\pm 0.00005\%$, output regulation to $\pm 2\%$.

Write today for data sheets on these, and other Austron components.



AUSTRON INC.

10214 NORTH INTERREGIONAL HIGHWAY,
AUSTIN, TEXAS 78753
TELEPHONE (512) 454-2581

low-volume evaluation period were less than for monolithics.

▪ Diverse semiconductor elements, required to minimize customer redesign efforts but not amenable to monolithic fabrication, could be combined in hybrids.

Failure. The thick-film IC's were priced in the same range as competitive monolithics also aimed at displacing tubes and transistors in tv sockets. Despite this, the products didn't catch on. A TI marketing official admits "the IC's have not satisfactorily met the economic requirements of the consumer electronics industry." The company has dropped the entire hybrid line and is revising its approach to the consumer market.

Realizing it has fallen behind its competitors, TI hopes to get back in contention by developing integrated electronic components providing even more functions in the IC package, such as an entire i-f strip. The integrated electronic components being worked on make greater use of monolithic content and also contain thin- and thick-film circuitry.

Meanwhile, none of the six or more major set makers who sampled Fairchild's $\mu 717$ sound i-f amplifier, supplied on a bread-board mockup last spring, has given Fairchild any indication that it will design the 717 into a tv set.

The 717 has also been sampled by the high-fidelity components industry but so far there are no takers. As one leading audio engineer points out, the 717 "does not provide adequate limiting for use as an i-f amplifier in our f-m receivers." Fairchild will only say that it will announce an equivalent IC that is "more flexible" sometime this month.

Avionics

All ahead slow

Competing fiercely for an R&D award that would give the winning firm a running start on another large receiver market to come out of the Navy's Omega program, de-

sign teams are rushing to wrap up their bid packages before the Nov. 16 deadline.

The award calls for two computer-equipped engineering models of airborne receivers to be used in the very-low-frequency navigation system. Delivery date will be one year after the contract is signed. The second phase of the contract calls for two prototype receivers for flight tests. The timing depends on when the Navy can get the money to pay for them.

Budget squeeze. Getting enough money for the entire Omega program has been a problem. But Navy officials believe the \$2 million presently budgeted for research and development of the airborne receiver will be released despite the spending squeeze caused by the Vietnam war. They concede, however, that both building the airborne prototypes and expanding Omega's ground-transmitter network into a worldwide system will probably have to wait until spending for the war eases [Electronics, Oct. 16, p. 69].

Although no one knows how many sets the Navy and other military services will buy, one company believes total sales will top 5,000 over the next five years.

Estimates of the airborne-receiver price range from \$25,000 to \$40,000 once production lines are operating, a far cry from the ship-board receiver's hoped-for price of \$2,500. The primary difference between the two sets is that the airborne version will be tied to a computer for automatic operation. The Navy hopes Omega will be used in small planes, so is specifying a top weight of 75 lbs., including 30 to 40 lbs. for the computer.

The computer will convert the Omega coordinates it gets from the receiver to latitude and longitude data—something that can be done manually on ships but not by busy pilots. The Navy also wants a receiver that can be plugged into an aircraft's central computer or work alone with minor changes.

Cost secondary. The proposals due this week will be evaluated by the Navy on the basis of technology, not cost. Although the winner will have to compete for produc-

**When it comes
to color-TV
receiving tubes**



**RCA
Engineers
never let
well-enough
alone!**

TAKE DAMPER TUBES FOR EXAMPLE:

First...

THEY DESIGNED THE 6AU4GT. THEN THEY DEVELOPED THE 6DW4 WITH IMPROVED CHARACTERISTICS. THIS TUBE IS NOW PERFORMING IN MILLIONS OF COLOR-TV SETS.

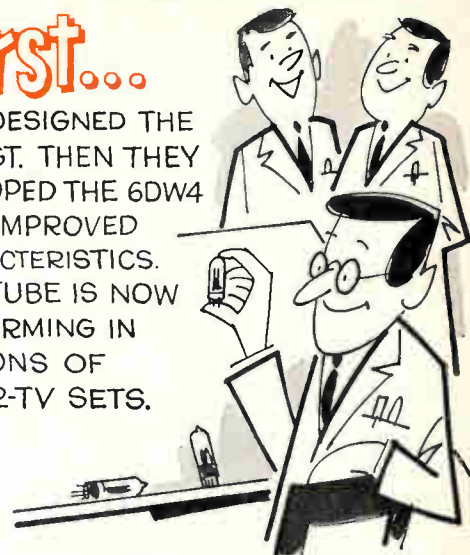

But...

THERE ARE STIMULATING CHALLENGES FOR THE ENGINEER TO STILL FURTHER IMPROVE DAMPER TUBES. FOREMOST IS TO REDUCE TUBE-VOLTAGE DROP.



Now...

THEY HAVE A NEW CATHODE WITH A PRESSURE-WELDED COATING - THE BEST EVER FOR DAMPER TUBES. IT PERMITS TIGHTER SPACING WITH NO DANGER OF DAMAGE TO THE COATING RESULTING FROM ARC-OVER, SPUTTERING OR HOT SPOTS.

RESULT:
RCA'S NEW 6CL3 WITH LOWER TUBE-VOLTAGE DROP LESSENS THE LOAD ON THE HORIZONTAL-DEFLECTION OUTPUT TUBE.



✓CHECK THESE RCA-6CL3 FEATURES:

HEATER ... 6.3V @ 1.2 A
MAX. PEAK INVERSE PLATE VOLTAGE ... 5500 V
MAX. PEAK PLATE CURRENT... 1300mA
MAX. AVERAGE PLATE CURRENT... 250mA
MAX. PEAK NEGATIVE HEATER-CATHODE VOLTAGE... 5500 V
TUBE VOLTAGE DROP ... 16V @ 350 mA (INSTANTANEOUS)
MAX. PLATE DISSIPATION 8.5 W

THE SAME PERFORMANCE PROFILE IS AVAILABLE IN BOTH 12CL3 (12.6V, 0.6A HEATER) AND 17CL3 (16.8V, 0.45A HEATER) TYPES.

RCA Engineers are quite excited about the pressure-welded coating of the new cathode. They see it as giving them new opportunities for still further improvements in damper tubes and other types as well. But RCA Engineers are always pursuing new ideas, working on new designs to bring color-TV circuit designers tubes that will provide even better performance at the lowest possible cost.

For news of the latest color-TV receiving tube developments, call your nearest RCA District Office. For specific data on the 6CL3, write to RCA Electronic Components and Devices, Commercial Engineering F19DE-2, Harrison, N. J. 07029.

RCA DISTRICT OFFICES—OEM SALES: EAST, 2075 Millburn Ave., Maplewood, N.J. 07040, (201) 485-3900 • MID-ATLANTIC, 605 Marston Pike, Haddonfield, N.J. 08034, (609) 428-4802 • MID-CENTRAL, 2511 East 19th St., Bldg. G2, Atkinson Square, Indianapolis, Ind. 46205, (317) 546-4001 • CENTRAL, 446 East Howard Ave., Des Plaines, Ill. 60018, (312) 827-0033 • WEST, 6363 Sunset Blvd., Hollywood, Cal. 90028, (213) 461-9171 • INTERNATIONAL OPERATIONS, RCA International Division, Central and Terminal Aves., Clark, N.J. 07066, (201) 485-3900 • 118 Rue de Rhene, Geneva, Switzerland, 35 75 00.



The Most Trusted Name in Electronics

Circle 57 on reader service card

CONVERT RADAR, SONAR, AND IR DATA TO TV DISPLAY WITH THE ELECTROSTORE®

This TV display is a composite of a compass reference superimposed on a stored

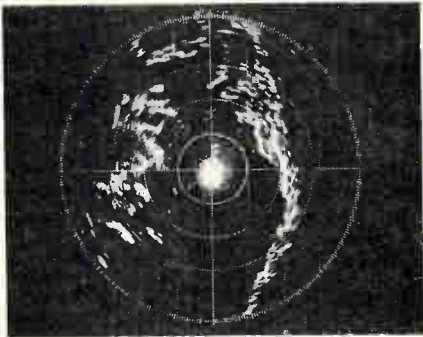

ppi display. It is an example of how the Electrostore Model 221 can convert radar data to a high resolution TV picture.

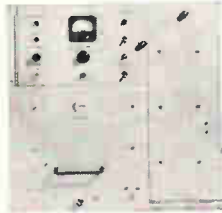

Model 221 Electrostore
single-gun storage tube
Input/Output Response
10 MHz or 20 MHz
Input Amplitude
Required 0.7 volts to
2.0 volts p-p
Deflection Amplitude
5 volts p-p
Deflection Response
DC to 800 KHz
Programmer Optional

The Model 221 scan-converter utilizes a cathode-ray recording storage tube. Input video signals and deflection information are applied to the tube through various amplifiers and control circuitry. Data is stored within the tube in the form of a raster, circular, or spiral scan. This information can be read off periodically through appropriate amplifiers without destroying the stored data. The input can be up-dated periodically and the stored information erased partially or in its entirety. By introducing the proper signals, the Electrostore can convert a variety of formats to TV display, i.e. computer-to-TV, radar-to-TV, IR-to-TV, or sonar-to-TV.

Write for technical memos and application notes covering the Electrostore.

i image
instruments

15 Stevens Street
Andover, Mass. 01810
Tel. (617) 475-4940

A DIVISION OF
DASA CORPORATION

Electronics Review

tion-model awards, it most likely will be selected if past procurement practices prevail.

The Northrop Corp.'s Nortronics division, which is developing the shipboard receiver, the AN/SRN-12, under a contract awarded last summer [Electronics, July 10, p. 48], is believed to have an edge on the airborne unit award. Another company making a strong bid for the work is Pickard & Burns Electronics, a division of the Gorham Corp., teamed with the Kearfott division of General Precision Inc. Other top contenders are IRT, Ryan, and Litton.

Industrial electronics

Stock taker

Getting quotes on stock prices to brokers quickly with electronic devices has been a significant factor in the booming sales of stocks around the country. Now the next logical step, which might help spur sales still more, is being taken.

With a desk-top display developed by Bunker-Ramo Corp., Stamford, Conn., a broker not only can ask for the latest stock prices but he can key in a buy or sell order as well. The order will then be automatically switched through the broker's teletype communications system to the floor of the exchange where it is to be executed.

Windows. The display, part of Bunker-Ramo's new Telequote 70 market information system, consists of two six-inch cathode ray tubes placed side by side. On the screens a broker will be able to look at several market services such as the stock tickers from the New York and American Stock Exchanges, Bunker-Ramo's own stock market quote and trend services, and wire service reports of financial news.

In addition, the display can select information from the brokerage house's own computer-based information system, including research reports and records of a customer's portfolio. Graphs of the behavior of the entire market or a



Market. Bunker-Ramo stock data system.

single stock can be displayed as well as alphanumeric characters.

Communications

Out of one, many

The search continues for effective ways of getting many frequencies from a single coherent light source. Researchers at Bell Telephone Laboratories think they're on the right road. Their reason: an electro-optic crystal has been used to shift the frequencies of a continuous helium-neon laser over a range of ± 45 gigahertz. Previously, electro-optic techniques have only been able to shift laser frequencies 2 kilohertz.

Unlike parametric techniques, which can shift frequencies over a wider range, electro-optic techniques don't require elaborate instrumentation for precise tuning. And parametric techniques can't tune continuous-wave lasers.

Versatile. M. A. Dugay, who refined the electro-optic tuning technique with J. W. Hansen, points out that it can be used in laser communication systems and in multiple resonance studies of the atomic and molecular structure of materials.

In the Bell technique, a mode-locked helium-neon laser emits a wide band of frequencies continuously, locking the phases of these frequencies 10 million times a second. During this time, the frequencies add constructively and destructively, forming narrow light pulses.

The rest of the time, the pulses are emitted haphazardly and output is low. The light pulses travel through a lithium-niobate crystal, a material whose index of refraction changes in an electric field. At the instant a pulse forms, a 10-megahertz radio frequency signal is applied to the crystal, changing its index of refraction and therefore shifting the phases of the light frequencies. This phase change shifts the frequencies of the laser pulses. Amount of shift depends upon the amplitude and frequency of the r-f signal, the crystal's length, and the number of times pulses travel through the crystal.

Loaded. C-w lasers that produce pulses in this manner may carry large amounts of information in future optical pulse-code-modulation communications systems.

In pcm systems, many high-speed pulse streams could be frequency multiplexed to increase the transmitted bandwidth. The electro-optic technique makes it possible to tune these narrow pulse streams.

Government

Voyage to nowhere

A year ago, the Voyager program to land an unmanned craft on Mars loomed as one of the more interesting and expensive new projects on the U.S. space agenda. Last week, an official at NASA's Office of Space Sciences and Applications in Washington said: "There's no such thing as a Voyager office anymore. Within a few weeks you won't even be able to find anyone tied in with the program. As far as we're concerned, the project can't go in 1973 as originally planned—and if you ask us if it can go in 1975, we'd just have to say we don't know."

Surgery. The closing of the Voyager office and the halting of the program for the time being was predictable in the light of Congressional cuts in NASA's fiscal 1968 budget. Hope for Voyager still existed late last month as the Senate tried to get \$36 million to keep the program alive. But it was

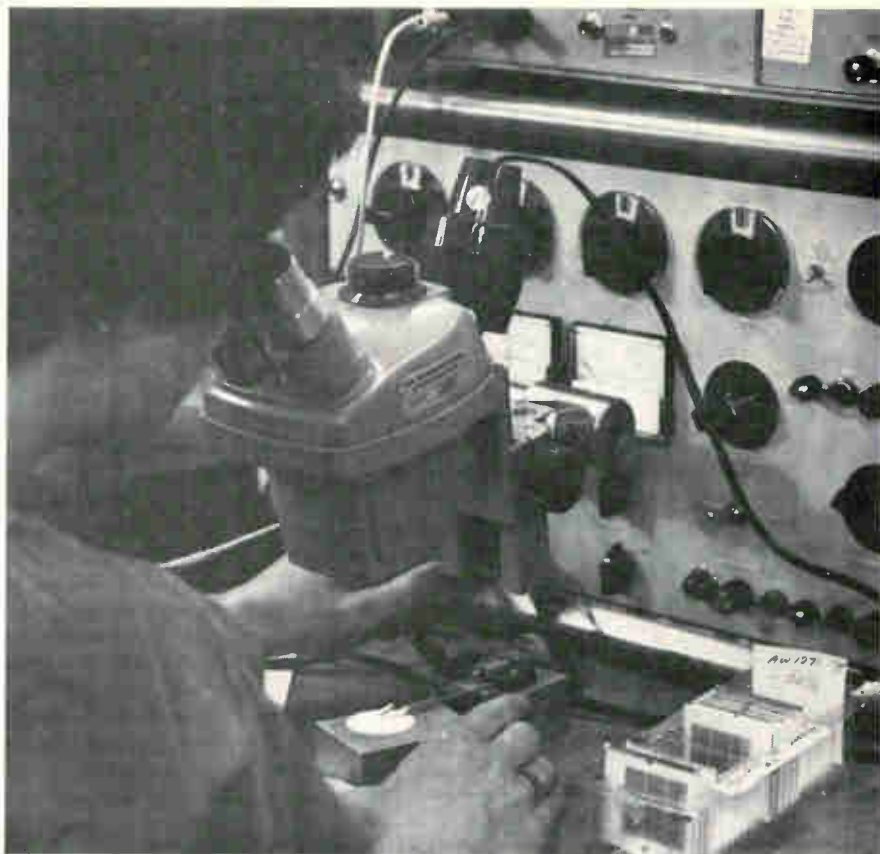

LOW-COST SOLUTION TO RESISTOR ADJUSTMENT

Bunker-Ramo's Unique Lease Arrangement Puts Precision Equipment in Your Plant

Now you can lease Bunker-Ramo's unique precision adjuster at a low monthly rate plus 1 cent per pulse... our substrates are also available, providing a complete microelectronics package with no investment in capital equipment.

Bunker-Ramo's proprietary equipment and processes have been thoroughly tested in daily production of custom microcircuits over a five-year period. We trim thin-film resistors to .01% and match the temperature coefficient of resistance to track to within $\pm 5\text{ppm}/\text{C}^\circ$.

A demonstration will convince you that we have the unique technical know-how that allows you to get exactly the precision you want in the package that meets your needs... and it's available for installation on your premises now!

Contact Joe Crist, Sales Manager, Microelectronics Operation, (213) 346-6000, Extension 546, or write to:



THE BUNKER-RAMO CORPORATION
DEFENSE SYSTEMS DIVISION
8433 FALLBROOK AVENUE • CANOGA PARK, CALIFORNIA 91304

The original lacing tape
is still the best . . .

. . . and saves money too!

That's

GUDELACE® 18

You ought to try
a sample . . .



GUDELACE
ties tight, makes
firm harnessing—*fast!*

It is important, of course, for you to use tape that complies with military specs, or commercial stipulations, but the usual allowances for wax content in such specs give no consideration to the best lacing conditions. Gudebrod GUDELACE is made within the specs—BUT, it's made too, for easy handling, tight knotting, firm harnessing. THAT'S WHERE IT SAVES MONEY, in the harnessing operation. GUDELACE, the original harness lacing tape, is manufactured under strict control. Every yard is impregnated exactly the same, exactly right. You can count on that—and on getting better harnessing—*fast*—with minimum rejects. Why not send for a sample, test it any way you want. Let your harness crew try it. You'll be glad you did! (Remember, the Gudebrod Lacing Tape line includes tape for nearly every special situation—ask for The Product Data Book.)

NOW—GUDEBROD HAS
TWO AIDS TO FASTER—
BETTER HARNESSING



**CABLE-LACER®
& GUDE-SNIPS®**

The production tested Cable-Lacer is now reduced in price—only \$9.95. Holds bobbin of tapes—makes tight knots. The palm held GUDE-SNIPS provide convenient tape cutting—using either right- or left-hand, \$3.75.



GUDEBROD

GUDEBROD BROS. SILK CO., INC.

Founded 1870

12 SOUTH TWELFTH STREET
PHILADELPHIA, PA. 19107

Electronics Division

dropped when both Houses agreed on a space agency appropriation of \$4.6 billion—\$502 million less than the requested \$5.1 billion. Besides postponing Voyager and some other embryo programs, the reduction in the space appropriation to a level \$370 million below last year's funding has already had the following effects:

- Plans are being completed for a layoff of 1,454 NASA employees. Hardest hit of the agency's facilities will be the Marshall Space Flight Center in Huntsville, Ala., where 700 will be scratched from the payroll. And reports from recent industrial aerospace meetings indicate the absence of those once ubiquitous recruiting teams.

- NASA officials are now engaged in a series of meetings to review the direction of the space effort and revise spending plans. A spokesman at NASA headquarters says the administrators will be considering new operating plans for every program except Apollo.

- This is traditionally the time of year when work starts on the next budget. Says an official: "We're in a difficult spot; we should be working on the fiscal 1969 budget right now but won't be able to get to it until we can settle on the effect the 1968 appropriation will have."

For the record

Crystal ball. While American manufacturers as a whole anticipate an 8% increase in 1968 sales over this year, electronics manufacturers look to a 6% rise, a McGraw-Hill survey finds. The fall survey of preliminary plans for capital spending reveals that electronics firms plan to hike their capital spending for new plants and equipment 4% in 1968, against a 5% increase by all of American business. The electronics industry anticipates a 4% increase in the prices it will have to pay for new plants and equipment next year—one point less than industry as a whole. But spending for new plants and equipment would be cut back the same 0.4% in the event of a tax

increase or surcharge as for other industries. Some reasons for electronics' relatively less optimistic expectations than other industries: the belief that the Government will reduce spending in general and NASA programs in particular, and the feeling of some executives that they had better be prepared to pay for overexpansion in 1966 and 1967. That overexpansion was due to the anticipation of booming color television sales which failed to materialize.

Hot gem. Sapphire crystals grown in a molten solution now can be pulled out looking as if they have been extruded, says Tyco Laboratories Inc. The Waltham, Mass., company, using a proprietary process, apparently can control temperature at specific points in the molten solution. The new technique, developed by A. I. Mlavsky, Tyco vice president, and Harold E. LaBelle, staff scientist, apparently controls the temperature in the melt so closely that crystals emerge in almost any simple shape. Sapphires coming out of Tyco's furnace in early production are nearly flat enough for use as an integrated circuit substrate—and, unlike standard substrates, wouldn't require lapping and polishing. Funding Tyco's research is the Air Force Materials Laboratory at Wright-Patterson Air Force Base, Dayton, Ohio.

Laser group. The Electronic Industries Association's board of governors has approved the establishment of a group serving laser manufacturers [Electronics, Oct. 16, p. 26]. The EIA earlier had been uncertain about whether to form a full subdivision on lasers or a committee on laser engineering—and while it deliberated, 31 laser manufacturers formed their own Laser Industry Association. Now that the EIA also has a laser group, it's planning to appoint a committee made up of laser manufacturer representatives who will work out the scope and structure of the group. James Secrest, executive vice president of EIA, says he foresees no competition between the two groups and expects "a certain amount of cooperation and exchange of information."



FOR BETTER, FASTER WIRE HARNESSING—

GUDEBROD
CABLE-LACER[®]
NOW REDUCED TO **\$9.95**
[10% OFF, LOTS OF 50] ea.

Production economics enable Gudebrod to offer the production tested Cable-Lacer at a new low price. Holds bobbin of tape. Facilitates lacing and knotting.

GUDEBROD
GUDE-SNIPS[®]
NEW HANDY TOOL— **\$3.75**
[\$37.50 IN DOZEN LOTS] ea.

Unique, palm held tape snips. Allow free use of fingers while holding in hand. Right- or left-hand use. Sharp, drop-forged cutlery steel blades. Spring action.

Special Offer!

So that you may try them and see the money-saving way they facilitate the harnessing operation—we'll send you postpaid, one Cable-Lacer, one Gude-Snips and a bobbin of lacing tape for just \$14.00. Test for yourself how these tools can help you make better harnesses, faster and for less money.

GUDEBROD BROS. SILK CO., INC.

Founded in 1870
12 South Twelfth Street
Philadelphia, Pa. 19107

BOTH:
ACTUAL SIZE

USE THE COUPON
FOR SPECIAL OFFER

Check enclosed, send me, postpaid:

- The special offer of Cable-Lacer, Gude-Snips and bobbin— **\$14.00***
- I just want the Cable-Lacer— **\$9.95***
- Send only the Gude-Snips— **\$3.75***

Name _____

Company _____

Address _____

G **UDEBROD**

*In Pennsylvania please add sales tax.

Electronics Division

this 5 ampere, 4PDT
miniature telephone type
direct plug-in Relay
gives you everything—

Reliability
Space saving
Versatility
and ECONOMY

IN STOCK
for immediate delivery

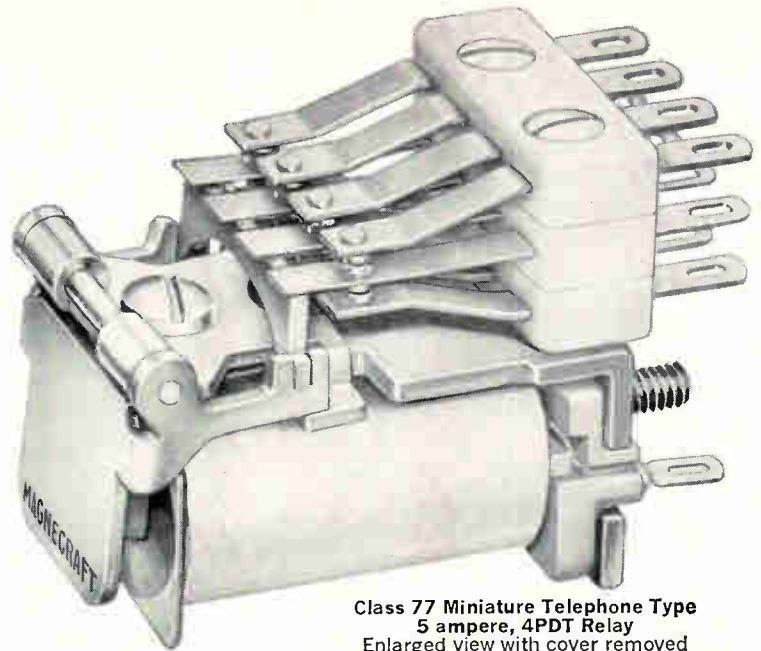

**Class 77 Miniature Telephone Type
5 ampere, 4PDT Relay**
Enlarged view with cover removed

Designed and Manufactured in USA

Direct, Plug-in Terminals give you plug-in relay assembly for the mere extra cost of the socket.

Plug-in Terminals are Pierced and Tinned for solder connections where required.

Telephone Type Relay Design assures unsurpassed adjustment stability through long life.

One-piece Combination Contact Arms and Plug-in Terminals avoid internal wiring.

Oversize Insulating Blocks of Molded Resin rigidly secure the combination contact arm/terminals for mechanical and electrical stability through long life.

The Basic Design provides greatly increased contact pressure without added coil power.

Precision-built, Hinge-pin Armature Bearings assure lowest friction for maximum contact pressure and stabilized adjustment through long life.

The Crackproof See-through Plastic Snap-on Cover protects the relay from dust and stray electrical contacts.

The Application Versatility of Class 77 Relays is illustrated in Figures 1 through 6.



Fig. 1

**Standard Class 77
Relay and Socket**
(approx. actual size.)

Socket is Optional
The socket can be wired as quickly as the relay; plug-in assembly adds only cost of the socket.

IN STOCK
for immediate delivery
Standard Class 77,
5 amp. 4PDT with coils
for commonly used
AC and DC voltages.

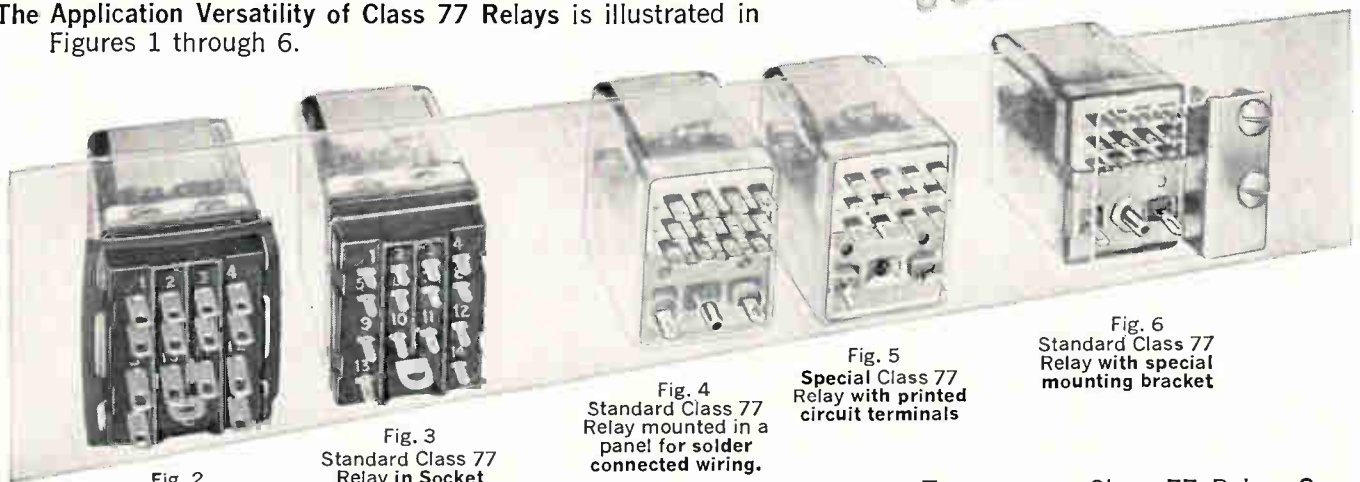

Fig. 2
Standard Class 77
Relay in Socket with
solder terminals
(same combination as
shown in Fig. 1)

Fig. 3
Standard Class 77
Relay in Socket
with printed circuit
terminals.

Fig. 4
Standard Class 77
Relay mounted in a
panel for solder
connected wiring.

Fig. 5
Special Class 77
Relay with printed
circuit terminals

Fig. 6
Standard Class 77
Relay with special
mounting bracket

Try our new Class 77 Relay. See how it can help complete tough circuits in close space as well as meet tight budgets. Phone the MAGNECRAFT REPRESENTATIVE or contact us direct for literature and samples.

MAGNECRAFT ELECTRIC CO.

5575 N. Lynch Avenue, Chicago, Ill. 60630 Phone 312-282-5500

Most complete line of reference zeners — with stability to 0.5 mv/year . . .

Semcor TCRE's!

Semcor pioneered the first silicon diffused junction TCRE in 1957. And kept right on going and growing. Today, many call its line of precision zener reference elements "the finest, most reliable and complete in the industry." Look it over and you'll agree. Voltage from 6.2 V to 200 V. Temperature coefficient from .01 % / °C to .0002 % / °C. Temperature range as wide as -55°C to +185°C. And long-term stability as low as .5 mv/year. Whether your need is for a standard or custom unit, don't speculate. Get everything you seek in a reference element — plus prompt delivery — by specifying Semcor. A division of Components, Inc. — industry's leader in fair pricing, prompt delivery and superior reliability of electronic components. For full information, see your nearest dealer or write: 3540 W. Osborn Road, Phoenix, Arizona 85019. Phone 602-272-1341.

LONG TERM STABILITY TEST

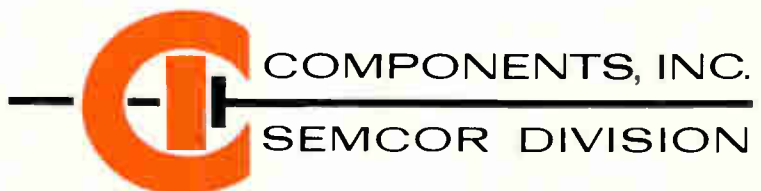
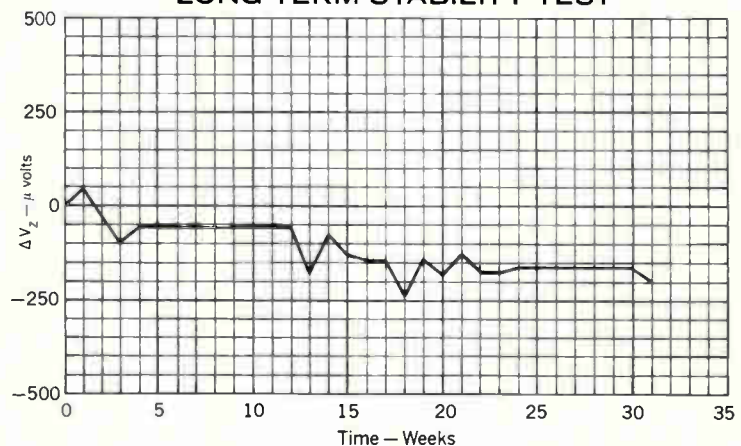

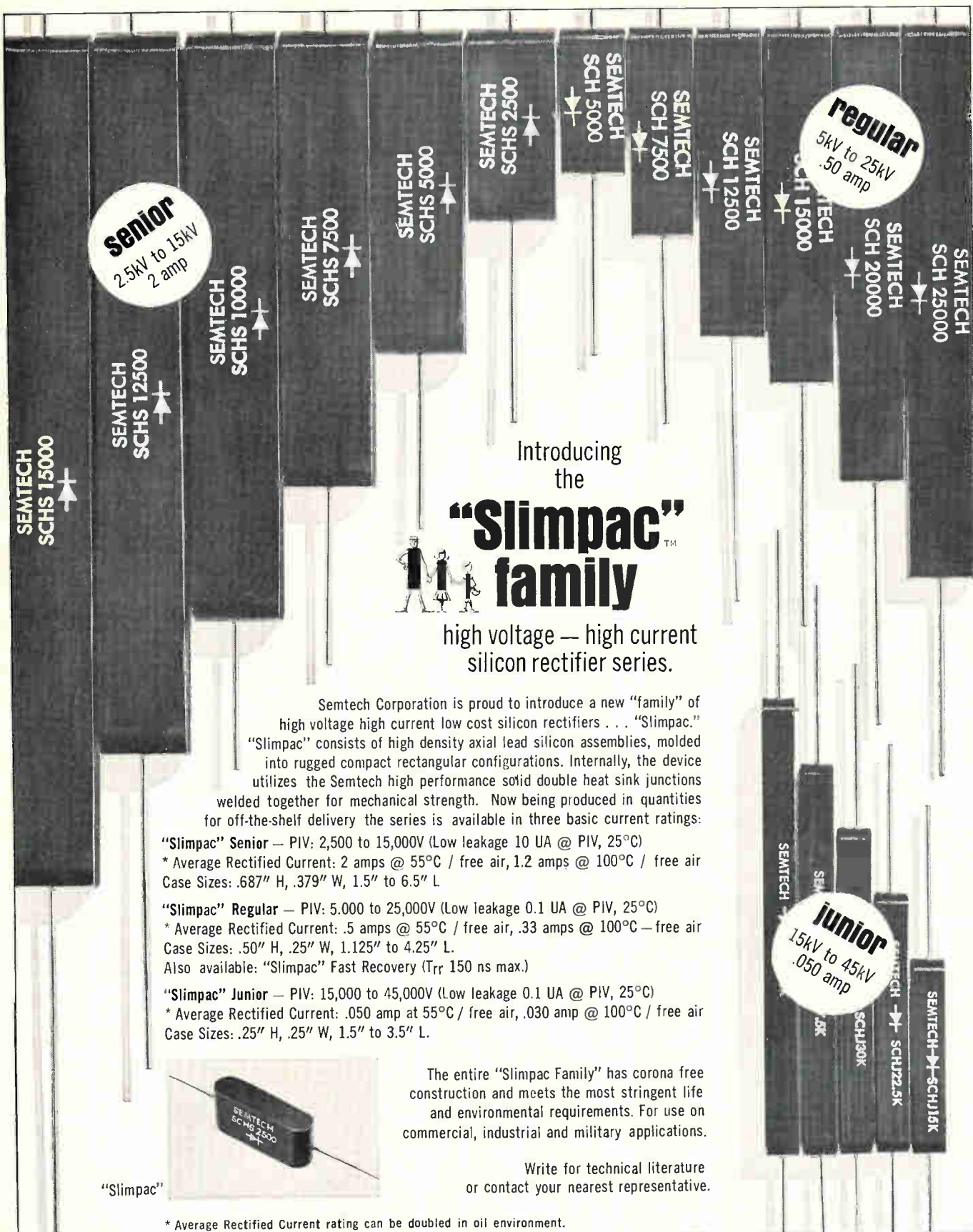

Senior
2.5kV to 15kV
2 amp

regular
5kV to 25kV
.50 amp

junior
15kV to 45kV
.050 amp

Introducing
the
"Slimpac"TM
family



high voltage — high current
silicon rectifier series.

Semtech Corporation is proud to introduce a new "family" of high voltage high current low cost silicon rectifiers . . . "Slimpac." "Slimpac" consists of high density axial lead silicon assemblies, molded into rugged compact rectangular configurations. Internally, the device utilizes the Semtech high performance solid double heat sink junctions welded together for mechanical strength. Now being produced in quantities for off-the-shelf delivery the series is available in three basic current ratings:

- "Slimpac" Senior — PIV: 2,500 to 15,000V (Low leakage 10 UA @ PIV, 25°C)
* Average Rectified Current: 2 amps @ 55°C / free air, 1.2 amps @ 100°C / free air
Case Sizes: .687" H, .379" W, 1.5" to 6.5" L
- "Slimpac" Regular — PIV: 5,000 to 25,000V (Low leakage 0.1 UA @ PIV, 25°C)
* Average Rectified Current: .5 amps @ 55°C / free air, .33 amps @ 100°C — free air
Case Sizes: .50" H, .25" W, 1.125" to 4.25" L
Also available: "Slimpac" Fast Recovery (Tr_r 150 ns max.)
- "Slimpac" Junior — PIV: 15,000 to 45,000V (Low leakage 0.1 UA @ PIV, 25°C)
* Average Rectified Current: .050 amp at 55°C / free air, .030 amp @ 100°C / free air
Case Sizes: .25" H, .25" W, 1.5" to 3.5" L



"Slimpac"

The entire "Slimpac Family" has corona free construction and meets the most stringent life and environmental requirements. For use on commercial, industrial and military applications.

Write for technical literature
or contact your nearest representative.

* Average Rectified Current rating can be doubled in oil environment.

SEMTECH CORPORATION

Western Offices: 652 Mitchell Rd., Newbury Park, California, 91320 (805) 498-2111 / from L.A. (213) 628-5392 TWX: 910-336-1264
Central: 140 No. La Grange Rd., La Grange, Illinois, 60525 (312) 352-3227 TWX: 910-683-1896
Eastern: 116-55 Queens Blvd., Forest Hills, N.Y., N.Y. 11375 (212) 263-3115 TWX: 710-582-2959
European Sales: Bournes AG, Alpenstrasse 1, Zug, Switzerland (042) 482 72/73

SM709 RAYTHEON SM709 RAYTHEON SM709 RAYTHEON SM709 RAYTHEON
RAYTHEON SM709 RAYTHEON SM709 RAYTHEON SM709 RAYTHEON SM709 RAYTHEON
SM709 RAYTHEON SM709 RAYTHEON SM709 RAYTHEON SM709 RAYTHEON
RAYTHEON SM709 RAYTHEON SM709 RAYTHEON SM709 RAYTHEON SM709 RAYTHEON
SM709 RAYTHEON SM709 RAYTHEON SM709 RAYTHEON SM709 RAYTHEON
RAYTHEON SM709 RAYTHEON SM709 meets NASA Spec. 85M02717

for a steady date with Apollo

Our selected SM709's will provide a steady influence on NASA's Apollo-borne earth-orbiting telescope. If you can use a high yield, low-cost linear amplifier that conforms to the toughest set of electrical and mechanical reliability specifications in the business, write or call Raytheon Company, Semiconductor Operation, 350 Ellis Street, Mountain View, California 94040 (415) 968-9211

RAYTHEON

We've killed the DIRTY ENEMY!

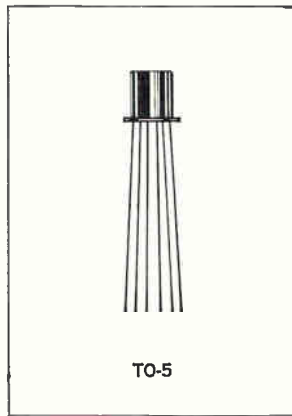

When we say CLEAN, we mean it. The DESIGN of our TO-5 Relay permits repeated cleaning and baking with no degradation in relay performance. As a result of this pre-stressed design... WE CAN CLEAN THE RELAY.

The cleaning of all TO-5 Relays is controlled by systematic micron-particle count and non-volatile residue (NVR) measurements on the cleaning fluid. Dirty gases could be sealed into the relay so we use a residual gas analyzer. We measure the gas contaminants during vacuum baking until they are reduced to an acceptable level. After out-gassing, the relay

remains in an inert atmosphere, i.e., pure, dry nitrogen, until final sealing.

We have left nothing to chance... constant improvement is our hallmark. The relays we produce today are not the same relays we produced one year ago. Our job is not to stand still but to continue to deliver to our customer the most reliable TO-5 relay that today's technology (paced by Teledyne Relays) will permit.

Why don't you find out more about our very clean, all-welded, state-of-the-art TO-5 Relays? Send for our TO-5 Relay Catalog.



TELEDYNE RELAYS

A TELEDYNE COMPANY

3155 West El Segundo Boulevard • Hawthorne, California 90250
Telephone (213) 679-2205 • 772-4357

Circle 67 on reader service card



From Westinghouse...
the only 0.5 mil
resolution CRT in a
"plug-in" package...
no design or
assembly headaches.

It's simply not economical for you to design and assemble yokes, shields, and CRT's as well as Westinghouse does in its unique "plug-in" packages. For example, the assembly above. It's a fiber-optic CRT package with 0.5 mil resolution that meets mil-specs on shock and vibration. And it's ready to operate. You save many, many hours of engineering and technician time.

This is only one of many Westinghouse CRT packages. For details, write. We have over 400 vacuum electronics engineers who want to help you. Westinghouse Electronic Tube Division, Elmira, New York 14902.

ET-4008

You can be sure if it's Westinghouse



By solving an "unsolvable" cleaning problem, Freon® helped perfect Hamilton's electric watch.

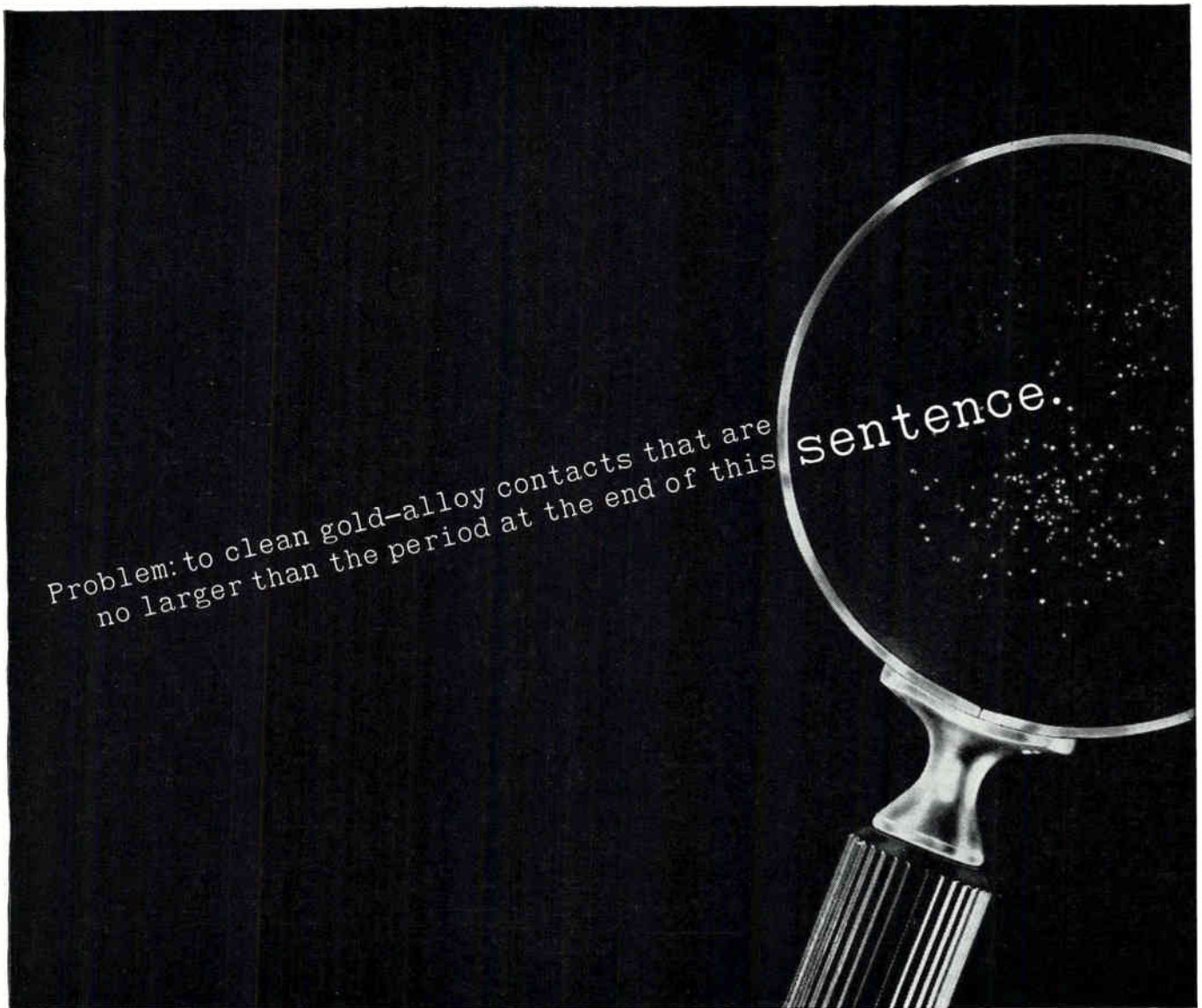

Problem: to clean gold-alloy contacts that are no larger than the period at the end of this

sentence.

Those specks under the magnifying glass are gold alloys. Each one acts as a contact that transmits power from a tiny battery to the timekeeping mechanism of the Hamilton electric watch ... which now ranks with the best of critical timepieces.

Unless these contacts, located in extremely tight assemblies, are *completely free* of soils and stains, however, the watch will malfunction. Or not function at all. And this was precisely the problem that confronted Hamilton engineers during the watch's development in Lancaster, Pa. They simply could not get the contacts clean *enough*. Even the cleaning agents they used left trouble-making stains.

The problem wasn't solved until FREON*, with its unique properties, was introduced into the cleaning operation. FREON has *low* surface tension, which allows it to penetrate the tightest assembly. At the same time, FREON has *high* density. This permits the quick release of all stains left by trapped cleaners. And because it vaporizes at a little above room temperature, FREON dries rapidly, leaving no stains of its own.

Hamilton uses FREON to clean parts ranging from $\frac{1}{16}$ of an inch (the contacts) up to $\frac{1}{4}$ of an inch ... including $\frac{1}{8}$ -inch, intricately designed toothed wheels. As many as 3,000 parts are cleaned in an ultrasonic tank simultaneously. So successful was Hamilton's experience with FREON that the company now uses it in its military area.

For instance, FREON is used in a degreaser to remove soils from a gravity-triggered release installed in parachute flares.

Do you have a tough cleaning problem that FREON can solve? Write Du Pont, Room 5623, Wilmington, Del. 19898. (In Europe, write Du Pont de Nemours International S.A., FREON Products Div., 81 route de l'Aire, CH 1211 Geneva 24, Switzerland.)

*Du Pont registered trademark for its fluorocarbon cleaning agent.



BETTER THINGS FOR BETTER LIVING... THROUGH CHEMISTRY

Washington Newsletter

November 13, 1967

College dropout: classified research

Dismayed by the mounting opposition of faculty and students to on-campus secret research for the military, the Pentagon plans to henceforth assign only unclassified projects to universities. Of the approximately \$300 million of defense research being conducted at universities, only about 8% is classified. **It's expected that this work will either be declassified or transferred to private industry or Government labs.** However, John Foster, director of defense research and engineering, wants to retain some top university scientists as individual consultants on secret projects.

Cox takes new line on CATV's role

The wall of FCC opposition to CATV continues to crumble. Federal Communications Commissioner Kenneth Cox appears to be switching sides, making majority opinions favoring CATV petitions more of a likelihood. Softening his position in recent speeches before CATV regional meetings, Cox acknowledged that technological advances are outmoding the five-channel ceiling he once strongly backed. He asked the cablemen to consider offering programs without commercials—his solution to the copyright problem. Cox suggested that CATV operators charge additional fees for nonbroadcast services such as telemetering and opinion polling.

Bioengineering plan is dropped by NIH

National Institutes of Health director James A. Shannon is being realistic. **Because the White House is cutting back nonmilitary spending he won't request extra funds for biomedical engineering next year, despite earlier plans for a new bioengineering division [Electronics, July 24, p. 50].** Shannon hopes that industry—particularly electronics and aerospace—will take the initiative and develop new medical equipment.

High-speed modem goal of five firms

Five firms have contracts to develop prototype 9,600-bits-per-second modems (modulator-demodulators) for competitive testing by the Defense Communications Agency as early as next spring. Standard military modems now operate at 2,400 bits per second, though several 4,800-bits-per-second systems have been developed. **The military services want capacity boosted to cut the error rate, speed communications, and reduce costs: some leased lines cost the Pentagon \$30,000 a month.** The high-speed modems would be used primarily for digitized voice communications.

At work on prototypes are Lincoln Laboratory and IBM for the Air Force; Bell Labs and Honeywell for DCA; and the Codex Corp. for the National Security Agency. Several other companies are working on the high-speed modems on an in-house basis.

McNamara approach to outlast him

No matter when Defense Secretary Robert S. McNamara leaves his post—and there's a growing conviction that he wants to get out some time next year—**there'll be no significant change in the McNamara approach to budgeting and contracting.** In the seven years he's held office, longer than any other Secretary of Defense, McNamara made systems analysis

Washington Newsletter

and cost-effectiveness keystones of his policy in budgetary and contracting matters.

It's understood that McNamara would like to resign soon after the new defense budget is completed and submitted to Congress next January. But President Johnson is expected to persuade him to stay on until the critically important November, 1968 election. A Washington newspaper quoted McNamara directly as saying he does plan to quit "some time" next year.

Cabinet status for communications?

The White House is putting out feelers on the idea of a Department of Communications. It would include the Department of Transportation, the Federal Communications Commission, and key communications groups within the Department of Defense, the Office of Emergency Planning and the General Services Administration.

Insiders say Transportation Secretary Alan S. Boyd, raised to cabinet level status only this year, wants to expand his domain and cover broader areas, making his department similar to communications ministries in other nations.

ARM guidance unit set for production

Mounting aircraft losses due to North Vietnamese anti-aircraft fire—both conventional and missile—have moved the Pentagon to put the air-to-ground Standard ARM, a radar-homing missile, on the top-priority list. A go-ahead has been given IBM for a production run of the target identification and acquisition system (Tias), the ARM's guidance unit.

The order comes less than a year after General Dynamics received the ARM prime contract and only a month after the completion of flight tests [Electronics, Sept. 4, p. 54]. The ARM will replace the Shrike as the prime Air Force and Navy air-to-ground missile. The Tias, to be carried aboard the aircraft, is built around the IBM 4 pi computer.

Martin unit to build Rada test hardware

Martin-Orlando will get an okay from the Army within the next month to start producing the first test hardware for the Random Access Discrete Address (Rada) system, an automatic dial radio network for tactical communications. Under a new contract covering third-phase development of the secure gear, Martin will build three user-to-user Rada sets for local area calls, plus a retransmission unit for calls within the system but beyond the range of the basic unit.

December date set for total package bids on destroyer

Request for proposals will go out to industry early in December for the first combat ship to be designed by industry rather than the Navy. The new class of highly automated destroyers, known as DX for destroyer experimental, will be procured as a total package, an approach that combines design, development, production and maintenance of a ship in one contract. Primary function of the DX will be as an antisubmarine craft, but anti-aircraft missiles may be added later. A large number of ships will be built, enough to warrant setting up an automated shipyard for series production.

The Navy doesn't plan to develop any new weapons or electronics systems for the DX, but will incorporate systems under development that will be ready for the fleet by 1974. The contractor will select and integrate all systems and will be named by May, 1969.

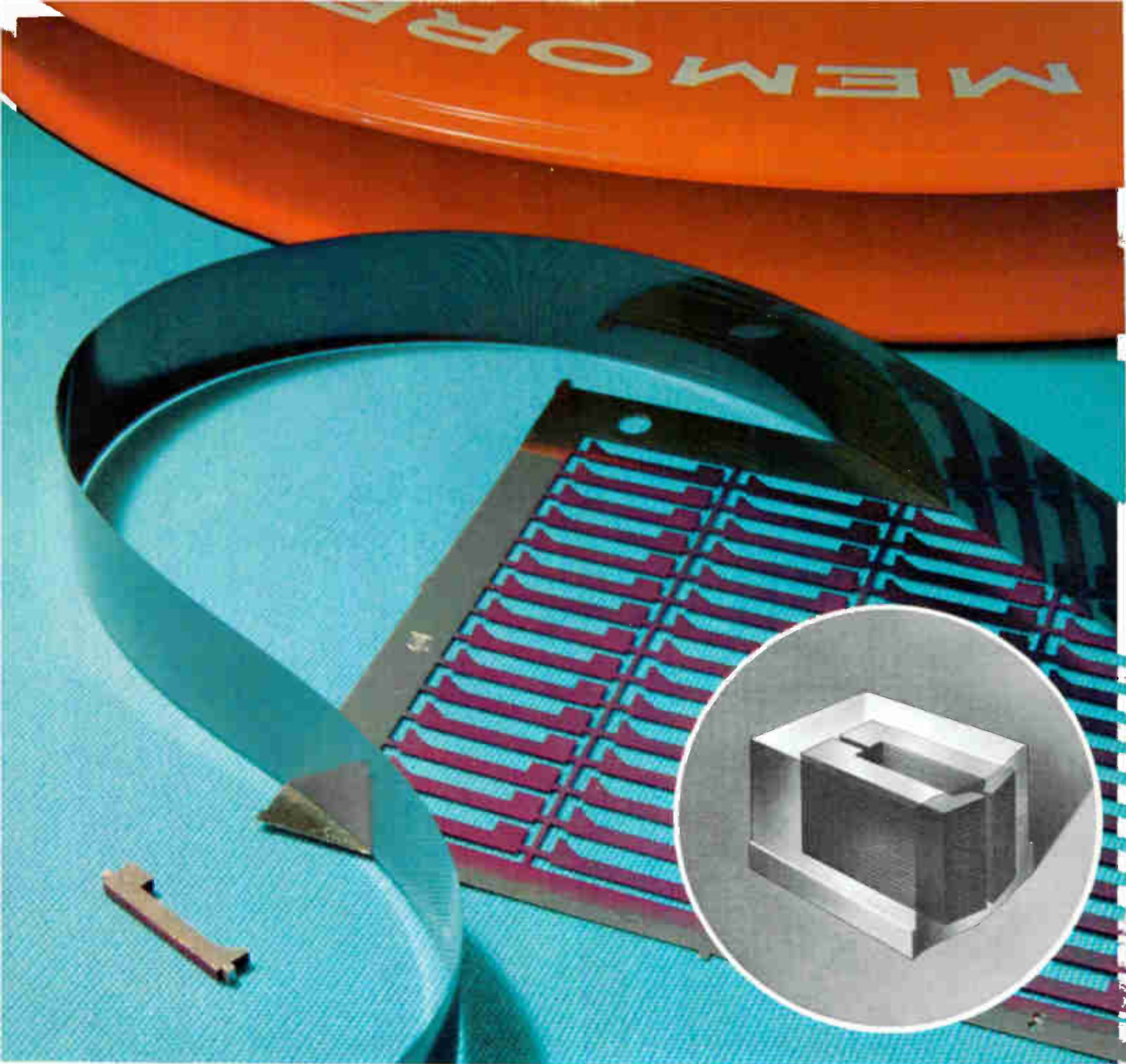

This teacher is stacked!

It will "teach" your magnetic heads to read and write. And it is stacked for your convenience right at Micro Science Associates, where the finest magnetic head laminations have been precision photo etched for half a decade. Not only will we provide cores fabricated to your own specifications, but, if you desire, we will furnish your laminations in fret form, coated

with a thermo-setting adhesive to allow you the flexibility of in-house experimentation with advantages of our automated, accurate coating service.

Another ADDED VALUE product of Micro Science Associates, one of the Alloys Unlimited family serving industry through better materials and processes.



M I C R O S C I E N C E A S S O C I A T E S

2274 Mora Way, Mountain View, California 94041/Phone (415) 968-7215/TWX 910-379-6938

A Subsidiary of Alloys Unlimited, Incorporated

Circle 317 on reader service card

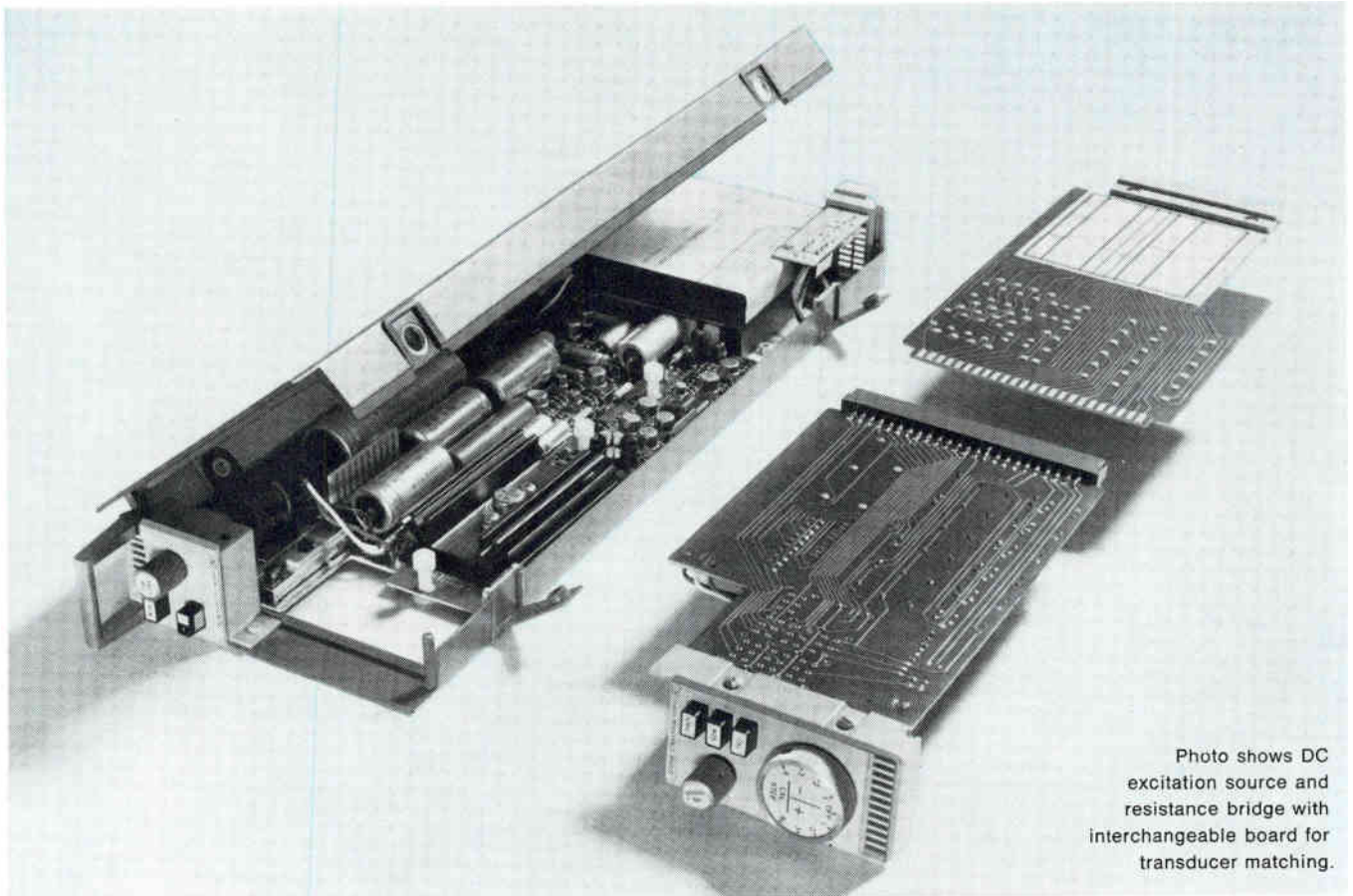
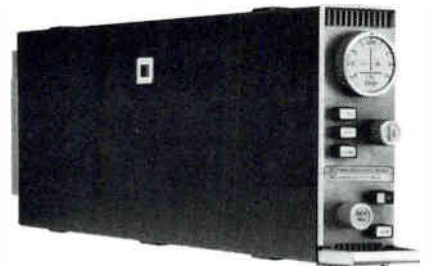

Photo shows DC excitation source and resistance bridge with interchangeable board for transducer matching.

Plug-together Signal Conditioners



with high performance, low-cost adaptability

A floated, guarded DC excitation source provides switch-selectable constant-voltage and constant-current operating modes, plus a unique mode for linear output from single active arm bridges. Exceptional environmental stability saves man-hours maintaining large systems in calibration.

Resistance bridge module provides bridge completion, balancing, calibration and normalizing functions. Minimum cost adaptation to transducers is afforded through a detachable board for mounting components for a specific transducer.

The excitation source may be used on a per-channel basis for maximum isolation, or with up to five transducers using inex-

pensive excitation couplers for each channel... or many transducers can be excited from an external power supply, and you can have local regulated level control. Plug-together design allows change from shared to individual channel excitation.

Price for excitation and conditioning: from \$160 to \$360 per channel (for rack-mounted, cabled system) depending on configuration.

For information on the 2480 Series or compatible data acquisition instrumentation call your local HP field engineer or write Hewlett-Packard, Palo Alto, California 94306; Europe: 54 Route des Acacias, Geneva.

HEWLETT *hp* PACKARD

SIGNAL CONDITIONERS

06706



Our 'instant color' circuit breakers.

(The second surprise is that they don't cost a lot of gold.)

Nobody has ever accused Heinemann of being down in the bargain basement of the circuit breaker world. (But almost everyone will admit that our performance well justifies our price.)

The Series JA is a breaker of a somewhat different stripe. The usual Heinemann features are all there—temperature-stable trip-points, precise current ratings, choice of time delays, optional special-function internal circuits. But they cost less in the JA wrapper.

And you can have color, too. Not all over the breaker, of course—just in the part that shows. The mounting boss.

A very simple arrangement of color caps lets you change the boss from basic black to any of eight other colors. You can thereby instantly color-code the breakers to pilot lights, operational sequences, or anything else you might have in mind. Or, you can use them just because they dress up a panel handsomely.

The JA can be had in any integral or fractional current rating from 0.100 to 30 amperes. Standard maximum voltage ratings are 250vac, 60 or 400 Hz; 65vdc. Our Bulletin 3350 will give you complete specs and catalog data. A copy is yours for the asking, of course. Heinemann Electric Company, 2700 Brunswick Pike, Trenton, New Jersey 08602.



HEINEMANN

Two more 24 Kt. gold processes from Sel-Rex. One may be 99.99+⁰% better for you.

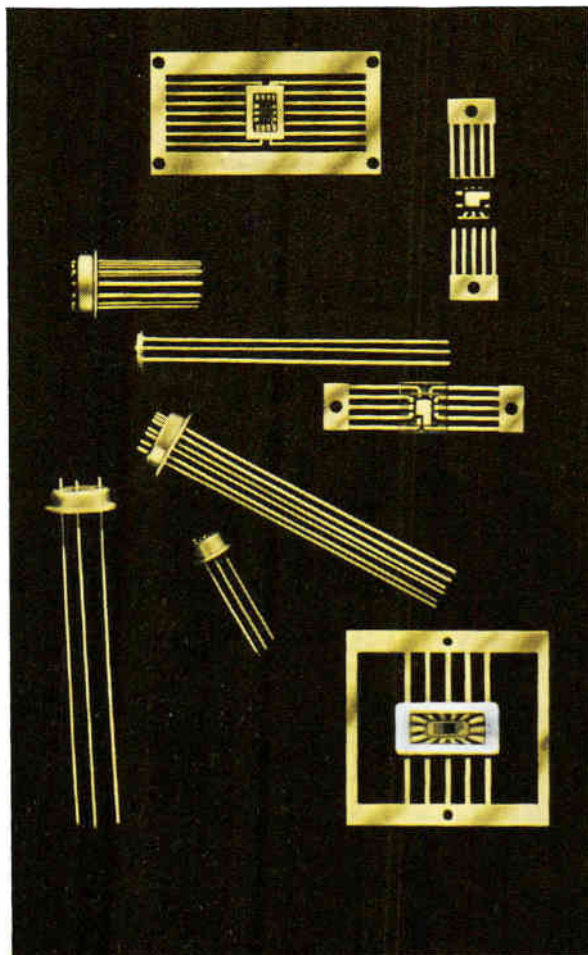

Deposits from Pur-A-Gold 125* and Pur-A-Gold 401* neutral gold plating processes are 99.99+% pure, free of organic contaminants and are uniform in distribution. Both processes are used in semi-conductor manufacture because they're extremely stable and consistently produce high performance results.

One maker of integrated circuits gets excellent die attachment with only .000050" of a 401 deposit in place of the .000100" he needed with a previous process. A transistor manufacturer reports excellent high temperature resistance for a 125 deposit . . . 350°C in air for over one hour without discoloration.

Which process is better for you depends on *your* product, *your* processing cycle and *your* performance specifications. But with either, you get more than a reliable plating process. You get the back-up service that has made Sel-Rex the leader in precious metal plating technology. Write for a comprehensive guide to precious metal processes.

Sel-Rex Corporation
Dept. X-11, Nutley,
New Jersey 07110



*Processes patented, trade marks registered

Subsidiaries and associated companies in Canada, Switzerland, Great Britain, France, Holland, Japan, West Germany.



Problems in aerospace/ground support? Clare puts you in control

Everywhere contact switching is indicated, Clare capability can put you in control. In aerospace and ground support systems, where reliability is the key to success. In cost-conscious industrial process control, or high-speed data processing systems. In demanding communications networks, or instruments of utmost accuracy.

Wherever contact switching can optimize control systems—whenever long life, high reliability, advanced capability, and maximum economy are needed—let Clare put you in control.



C. P. Clare & Co.—worldwide.
a GENERAL INSTRUMENT company

Clare contact switching... for optimty in
Industrial Process Control Electronic Data Processing Aerospace and Ground Support Communications Instrumentation



you've got it made

... when you
let **FANSTEEL** do it!

Let FANSTEEL make your electronic parts for you. What type of parts? For instance:

(1) FANTORK™. Chassis-Mounted Heat Sinks that give you up to 3-times greater shank torque and provide comparable heat dissipation of wrought copper alloys. With a complete FANTORK part . . . all you do is die-bond, attach leads and assemble. Or, we'll do any . . . or all . . . of these steps for you . . . braze the steel threaded shank into the sintered copper base . . . add pre-form backing discs (with or without coatings) . . . put on a steel weld ring . . . coin a projection into sintered copper base for direct ultrasonic welding of can . . . insert pins . . . or plate entire assembly. **(2) Lead Assemblies**—from refractory to conventional lead materials in close tolerance diameters from .025" to .125" . . . plated to your specifications. **(3) Semiconductor Backing Discs**—either pressed and sintered . . . punched . . . or cut . . . from tungsten or molybdenum. Fansteel coating technology assures positive wetting action. All sizes throughout the power ratings. Whatever your component parts need . . . LET FANSTEEL DO IT! Our diverse packaging technologies will help you reduce component assembly time and costs. For complete information on value engineered Fansteel parts, call your Fansteel representative . . . or write us.

1.

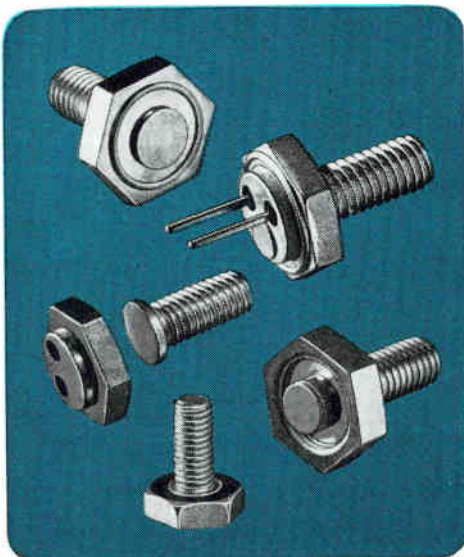

2.



3.



FANSTEEL

METALLURGICAL CORPORATION

ELECTRONIC PARTS DIVISION
NUMBER ONE TANTALUM PLACE
NORTH CHICAGO, ILLINOIS 60064



NOW...

a miniature 4PDT 3 amp plug-in relay that's

QUALITY

all the way

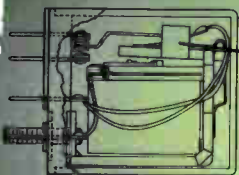
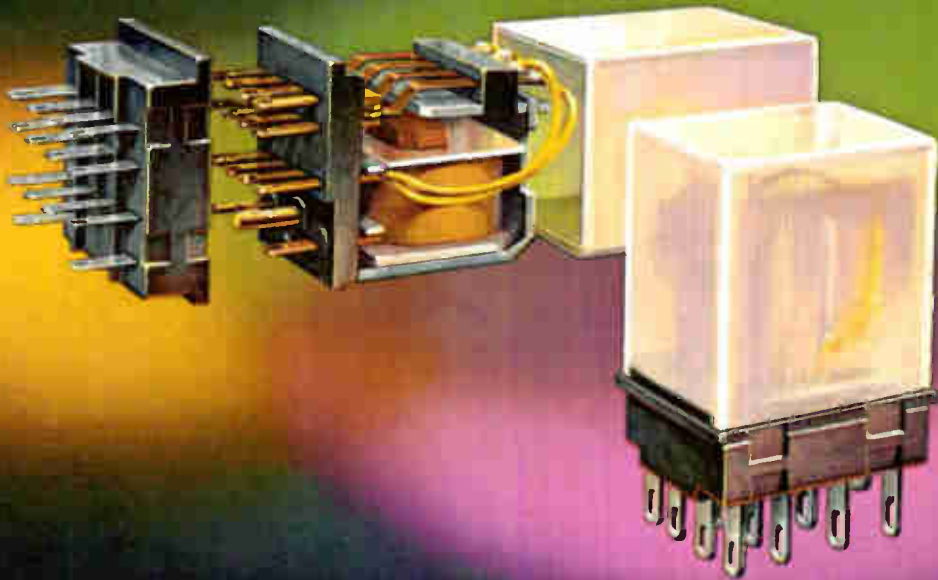

QUALITY— Heat-resistant LEXAN cover is standard on 1300 series.

QUALITY— Molded parts are glass-filled polyester for higher arc resistance.

QUALITY— Expected life in excess of 100,000,000 operations.

QUALITY— Rated at 250,000 operations at rated load AC.

This is Guardian's new 4PDT 3 amp plug-in relay. Designed and built for maximum endurance and reliability, it is especially suitable for computers, data processing, logic systems, business machines, or any other application that requires uncompromising quality. The new 1300 Series is available AC or DC, plug-in or quick-disconnect, 6 to 115 VAC and 6 to 110 VDC. Contact rating 3 amps at 30 VDC or 115 VAC resistive. WRITE TODAY for descriptive brochure.

GUARDIAN  **ELECTRIC**

Guardian Electric Manufacturing Company 1550 W. Carroll Ave. Chicago, Ill. 60607



**King Radio needed:
capacitors that stay reliable even
with extreme cold, humidity
and vibration.**

**So King Radio chose: capacitors
of MYLAR.**

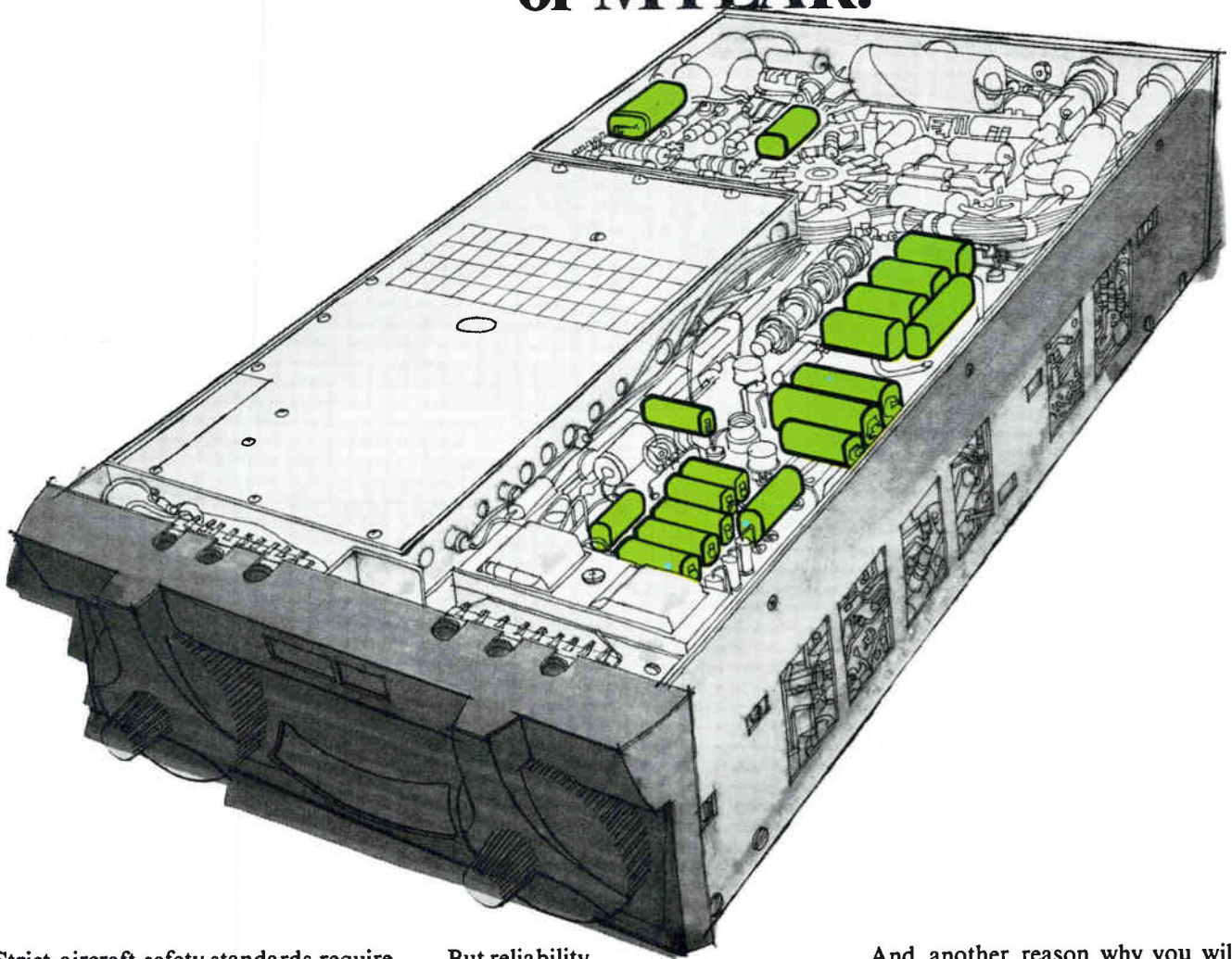

Strict aircraft safety standards require the most reliable navigation equipment available. That's why King Radio Corporation uses capacitors of MYLAR* for their Distance Measuring Equipment. MYLAR can take temperature extremes from -60° to $+150^{\circ}\text{C}$; MYLAR remains constantly stable under humid conditions.

But reliability isn't the only reason King Radio chose MYLAR. The extremely high dielectric strength of MYLAR permits its use in thinner film, thus helping King Radio to build the lightest and most compact distance measuring unit on the market. MYLAR is available in films as thin as 15 gauge.

And another reason why you will want to investigate using capacitors of MYLAR: they usually cost no more than others. Write for complete technical data to DuPont Company, Room 4960A, Wilmington, Delaware 19898. (In Canada, for information write Du Pont of Canada Ltd., Post Office Box 660, Montreal, Quebec.)

DU PONT MYLAR®
EST. 1802

*DU PONT'S REGISTERED TRADEMARK FOR ITS POLYESTER FILM.

Foxboro engineers select A-B hot molded potentiometers
"Best repeatability—component-to-component
and setting-to-setting"

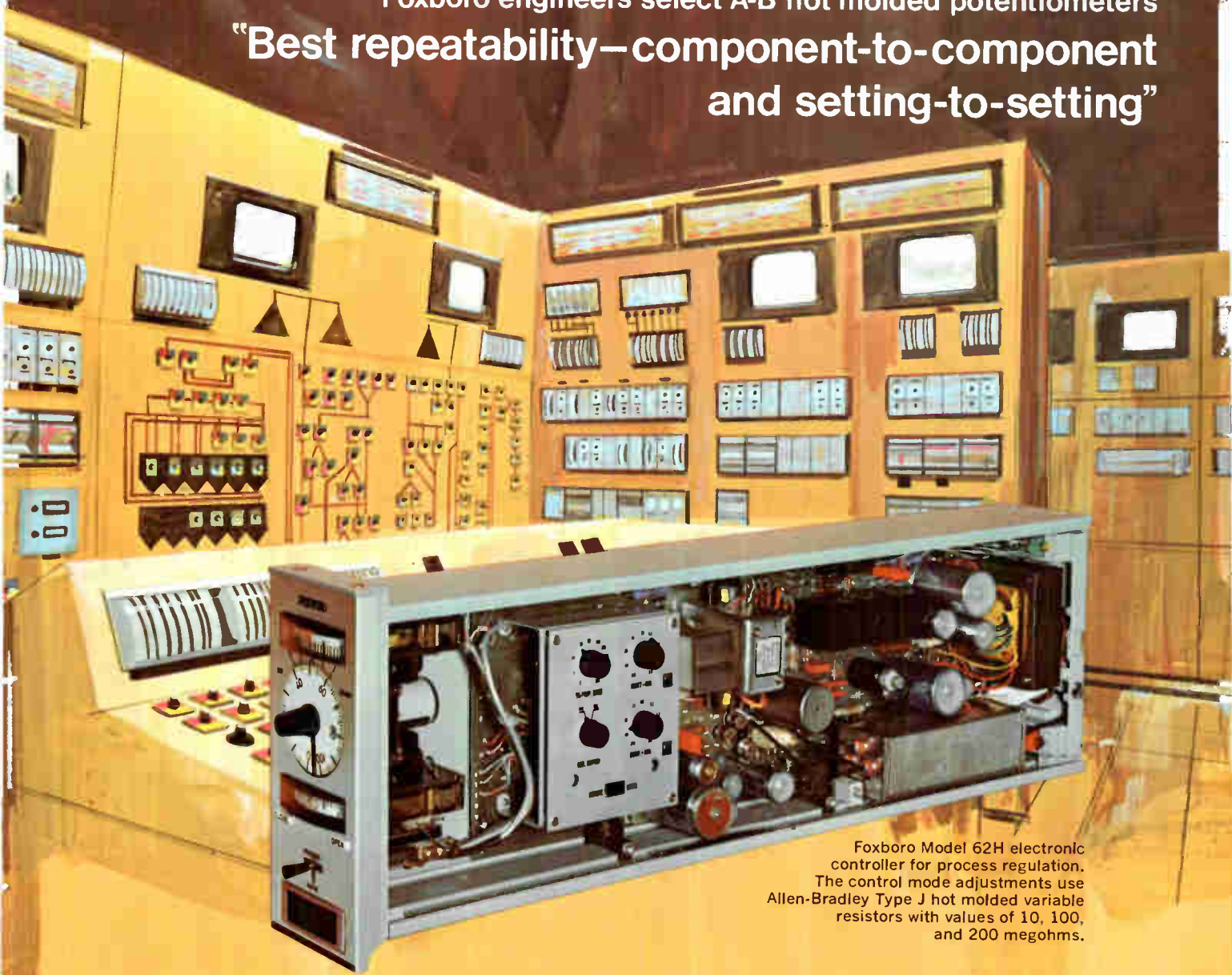

Foxboro Model 62H electronic controller for process regulation. The control mode adjustments use Allen-Bradley Type J hot molded variable resistors with values of 10, 100, and 200 megohms.

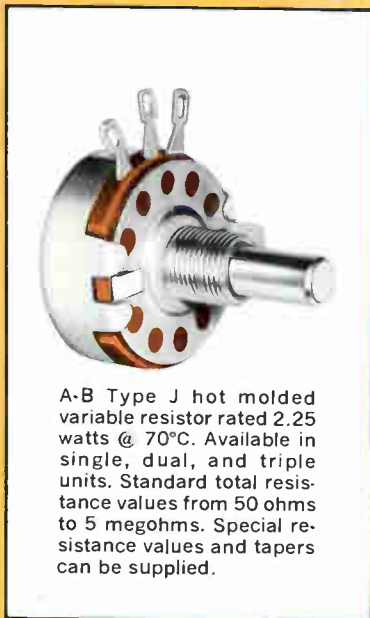

A-B Type J hot molded variable resistor rated 2.25 watts @ 70°C. Available in single, dual, and triple units. Standard total resistance values from 50 ohms to 5 megohms. Special resistance values and tapers can be supplied.

Widely used throughout the process industries, the Foxboro Model 62H Universal Controller is a highly dependable precision instrument. During the years of painstaking development, Allen-Bradley engineers worked closely with Foxboro to provide a potentiometer having unusually high resistance values, which would provide the precise performance required.

Allen-Bradley Type J potentiometers were the answer. They have a solid hot molded resistance track which is produced by an exclusive A-B molding technique that assures extremely long operating life. Accelerated tests—exceeding 100,000 revolutions—show very slight resistance change. Control is smooth at all times with adjustment approaching infinite resolution. There are none of the abrupt turn-to-turn resistance vari-

ations inherent in wirewound controls. Furthermore, Allen-Bradley Type J potentiometers are—for all practical purposes—noninductive, permitting their use throughout the frequency spectrum.

Whether your particular circuit design can be best satisfied with one of the millions of standard Type J variations or whether it calls for unusual resistance characteristics, it will pay you to look first to A-B Type J potentiometers. Their more than 25-year history of providing superior performance is your guarantee of complete satisfaction. For full details, please write for Technical Bulletin 5200: Allen-Bradley Co., 222 West Greenfield Avenue, Milwaukee, Wisconsin 53204. In Canada: Allen-Bradley Canada Limited. Export Office: 630 Third Ave., New York, N. Y., U.S.A. 10017.



ALLEN - BRADLEY
QUALITY ELECTRONIC COMPONENTS

7 STANDARD single and double pole units with concentric shaft and vernier operation.

16 STANDARD resistance values from 50 ohms to 5 meg.

2 STANDARD tolerances 10% and 20%.

5 STANDARD resistance tapers.

18 STANDARD electrical tap options.

46 STANDARD shaft lengths from 3/8" to 6.0".

3 STANDARD shaft endings.

9 STANDARD variations of bushings.

4 STANDARD locating lug options.

4 STANDARD switch options with single and double pole.

Allen-Bradley offers a 1,000,001 standard variations of Type J Potentiometers

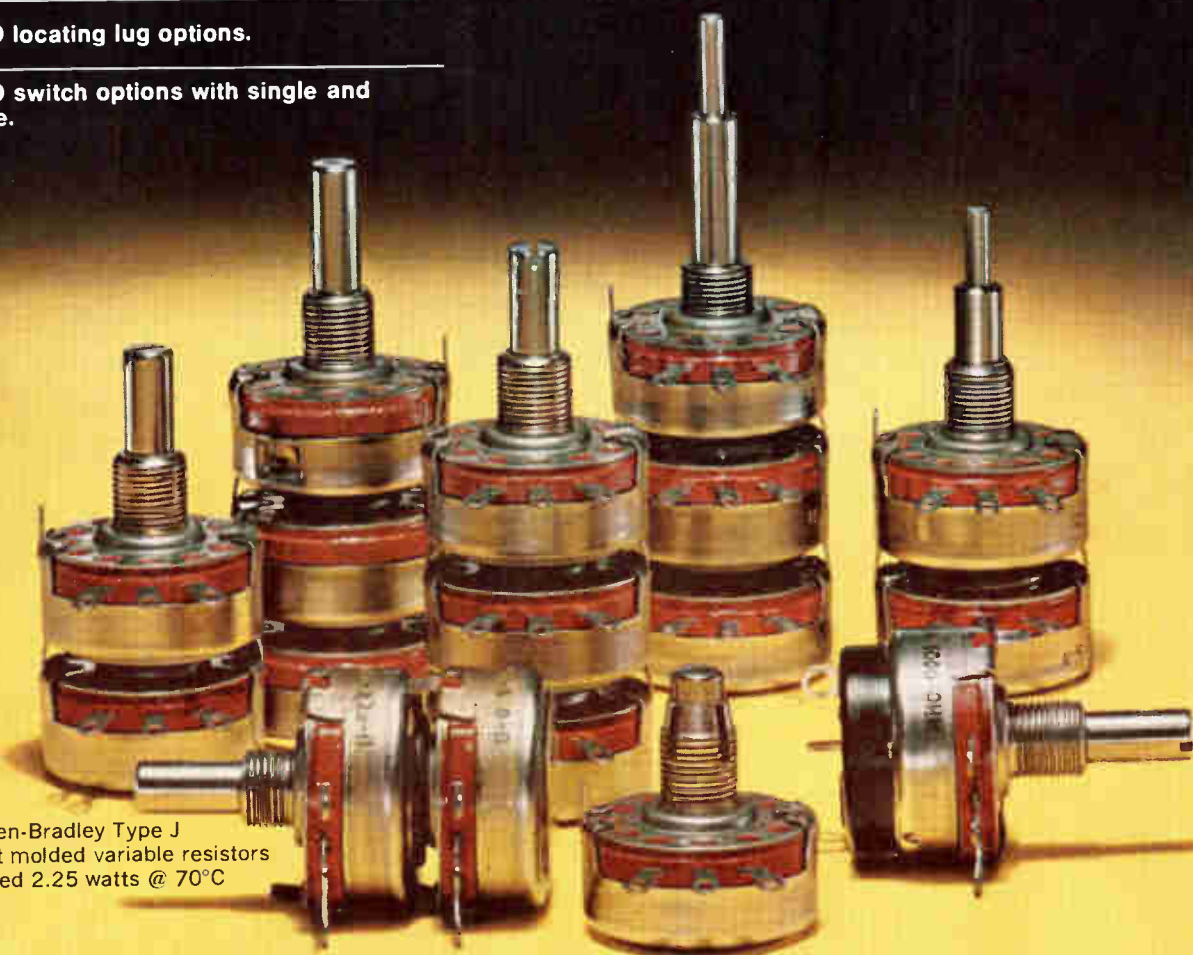

Allen-Bradley Type J
hot molded variable resistors
rated 2.25 watts @ 70°C

These *standard* variations in the Allen-Bradley Type J hot molded potentiometer line eliminate the need for a "special" control. When you include the numerous special resistance values and tapers in which the Type J can be supplied, the variations become virtually infinite.

Yet, all of these Type J variable resistors have one thing in common—each and every one is made by the same A-B hot molding process—your guarantee of "tops" in quality. The solid hot molded resistance track assures extremely long life—exceeding well beyond 100,000 complete operations on accelerated tests with less than 10% resistance change. Control is always smooth and free from the sudden turn-to-turn resistance changes of wire-

wound units. And being essentially noninductive, Type J controls can be used at the higher frequencies—where wire-wound units are totally impractical.

Let Allen-Bradley Type J variable resistors be the answer to your special requirements—it's almost certain there's a "standard" unit in the Type J line. And you *know* you're obtaining the ultimate in reliability and performance. For more complete information on Allen-Bradley Type J potentiometers, please write for Technical Bulletin 5200: Allen-Bradley Co., 222 W. Greenfield Ave., Milwaukee, Wis. 53204. In Canada: Allen-Bradley Canada Limited. Export Office: 630 Third Ave., New York, N.Y., U.S.A. 10017.



THREE PNP TRANSISTORS NOW GIVE YOU HIGHER CURRENT, HIGHER VOLTAGE, AND LOWER NOISE AT LOW COST



...ALL 3 ARE GERMANIUM.

When you are looking for state-of-the-art performance in many key areas of semiconductor design, there's still a lot to be said for Germanium devices: 60 amperes in a TO-3 or TO-36 case; 320-volt operation at less than 0.5 μ / volt; 1.6 dB maximum noise figure at 200 MHz for less than \$3.00! For a complete report on Motorola's three new breakthrough Germanium types, write Box 955, Phoenix, Arizona 85001. We'll include a new Germanium Transistor Selection Guide.

There's no end to Motorola Germanium Semiconductors!

2N4048-53 2N4276-83	20-60 V V_{CE0}	0.30 V $V_{CE(sat)}$ @ 50A	As Low As \$2.35, 100-up*
MP3730/MP3731	200-320 V_{CE}	0.5 V $V_{CE(sat)}$ @ 6.0 A	5 · 10 A_{dc} I_c max
MM5000-02	1.6 · 2.2 dB NF @ 200 MHz	20-24 dB Min G_{re} @ 200 MHz	\$1.50-2.95

*And substantially lower in larger quantities.

-where the priceless ingredient is care!



MOTOROLA
Semiconductors

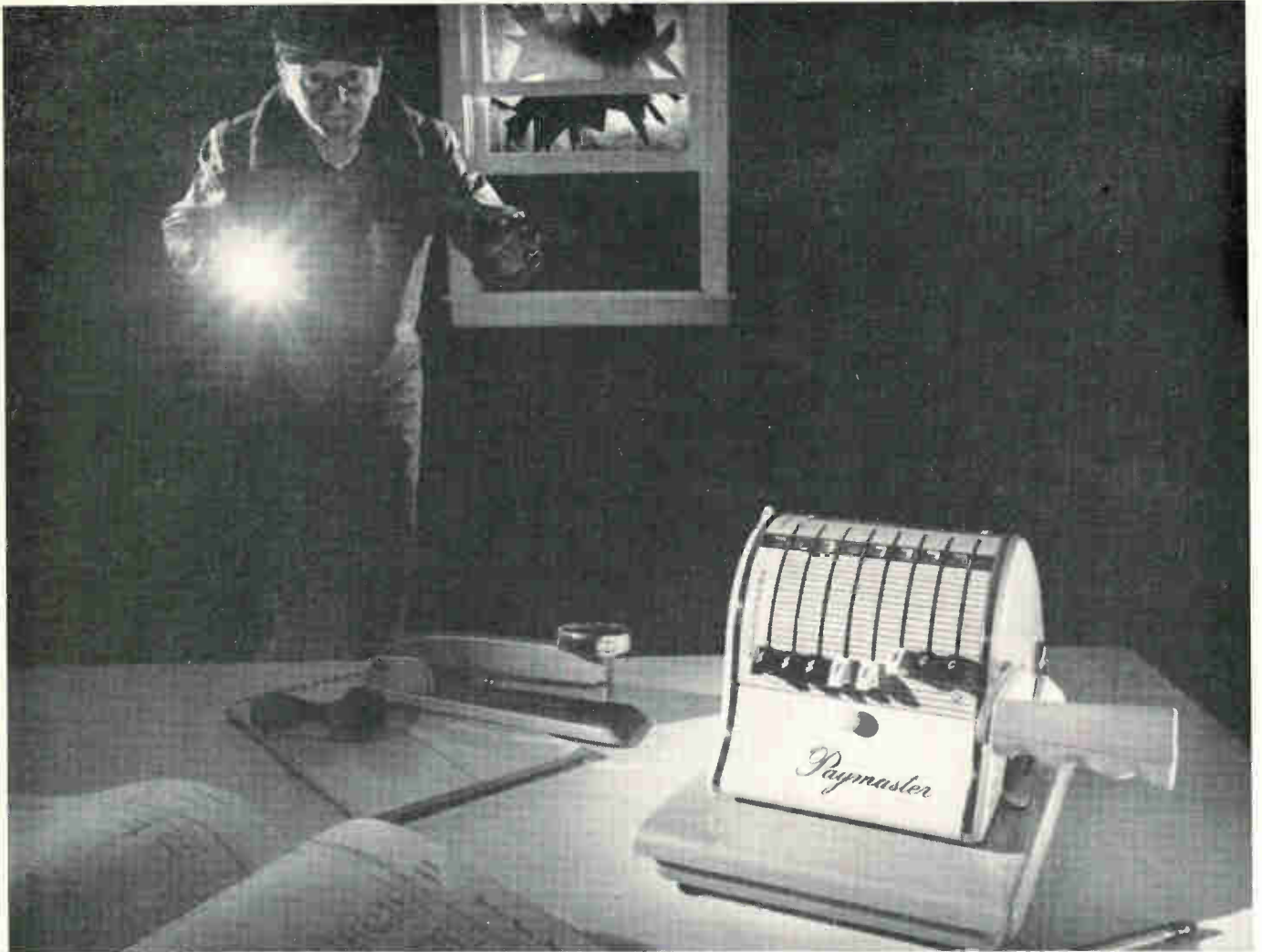

Paymaster needed a battery to turn its Checkwriters into burglar traps.

Mallory made it.

What can we do for you?

Paymaster needed a battery. A battery to power the electronic alarm systems of its Checkwriters. A battery that would be inexpensive and easy for customers to replace. A battery that would hold its power for years while it protected the machine. Yet a battery that could keep the alarm screaming for hours if a burglar tried to steal the invaluable device.

Mallory made it. The battery—a Duracell® alkaline battery. Two of these penlight-sized energy cells can keep the Checkwriter's alarm shrieking long after a burglar has been scared away. They hold that power too—retain 85% of their original capacity even after 2 years storage. And they are available in retail stores almost anywhere in the world.

UNUSUAL USES AND UNUSUAL BATTERIES

"The type of battery suitable for a given application is no longer a matter of cell geometry, as it has been in the past, but one of an electrochemical system that will operate most effectively for a particular use." (Samuel Ruben, discoverer of the electrochemical principles that made possible the sealed mercuric oxide, manganese oxide and silver oxide alkaline batteries.)

And hundreds of designers have already taken these words to heart. They've dreamed up devices such as battery-operated pacemakers used inside the body to stimulate the heartbeat, radio transmitters carried by birds to trace their migration patterns, standard-size binoculars that can be used to see in the dark. Wrist radios (a la Dick Tracy) have already been designed around the power of mercury cells. So have hearing aids so small they fit entirely inside the ear canal. It's getting to the point where if it uses electricity, chances are it can be battery-powered.

OVER 1000 DIFFERENT TYPES

Mallory currently makes over 1000 batteries of all sizes and capacities. If we're not actually producing the battery you need, we'll be glad to work with you in designing a new one. Please write the Technical Sales Department, Mallory Battery Company, a division of P. R. Mallory & Co. Inc., South Broadway, Tarrytown, New York 10591. Or call us at 914-591-7000. (In Canada: Mallory Battery Company of Canada Limited, Sheridan Park, Ontario.)

±0.05% regulation is only one of twelve outstanding specs in Helipot's exclusive new microcircuit dc voltage regulator series.



MODEL 803 DC Voltage Regulator, one of a complete family of six miniature, hybrid cermet thick film units with outputs from 3 to 32 volts.

The other eleven:

- short circuit proof models
- small size—0.5 sq. in.
- low profile—0.170"
- up to 5 amps load current
- output range—3 to 32 volts
- fixed and adjustable outputs
- fully sealed
- hybrid cermet construction
- operating temperature range: -55°C to +125°C
- 60 db ripple rejection
- mil spec tested

The applications:

Helipot Series 800 DC Voltage Regulators are physically compatible with dual in-line and flat pack integrated circuits. This permits system use of unregulated power with precise regulation at the point of use. In addition to the 1,000:1 ripple rejection capability, these units provide excellent circuit decoupling and protection from transients and sudden power surges.

	Application		
	Digital Circuits 3 to 9 Volts	Analog Circuits 9 to 21 Volts	Airborne and General Purpose Circuits 20 to 32 Volts
Fixed Output	Model 805 Reader Service No. 491	Model 801 Reader Service No. 492	Model 803 Reader Service No. 493
Adjustable Output	Model 806 Reader Service No. 494	Model 802 Reader Service No. 495	Model 804 Reader Service No. 496

The price:

- \$30.00—fixed output models
 - \$35.00—adjustable output models
- (prices are 1-9 quantity, delivery from factory stock)

Ask your local Helipot sales representative for information or circle the appropriate number on the reader service card.

Beckman®

INSTRUMENTS, INC.
HELIPOT DIVISION

FULLERTON, CALIFORNIA • 92634

INTERNATIONAL SUBSIDIARIES: GENEVA; MUNICH; GLENROTHES, SCOTLAND; TOKYO; PARIS, CAPETOWN; LONDON; MEXICO CITY

WANT A



SENSITIVE ANSWER?

80 mW

CALL THE MAN FROM Hi-G...

Switch 150 W with 80 mW. This is the amplification of switching power you get from the new BCN series of 5 amp sensitive relays. Dependable performance comes in an all welded, crystal can configuration measuring 1.275" x .800" x .400". Typical weight is 1 oz.

The BCN series is manufactured in accordance with MIL-R-5757 and is available for fast delivery in single and double pole units in all standard configurations and header styles.

Write or call Hi-G for bulletin #135A. It provides full details on this high quality line of 5 amp sensitive crystal can relays in stock at your Hi-G distributor. Test data and performance capabilities are available on request. Tel: 203-623-2481.

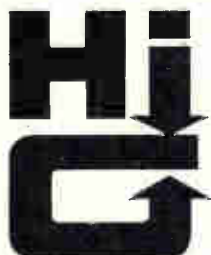

INCORPORATED

SPRING STREET & ROUTE 75 / WINDSOR LOCKS, CONNECTICUT 06096

ANOTHER OUTSTANDING DEVELOPMENT BY THE MAKERS OF BUSS FUSES

TRON RECTIFIER FUSES

*for the
Protection
of
Solid State
Devices*

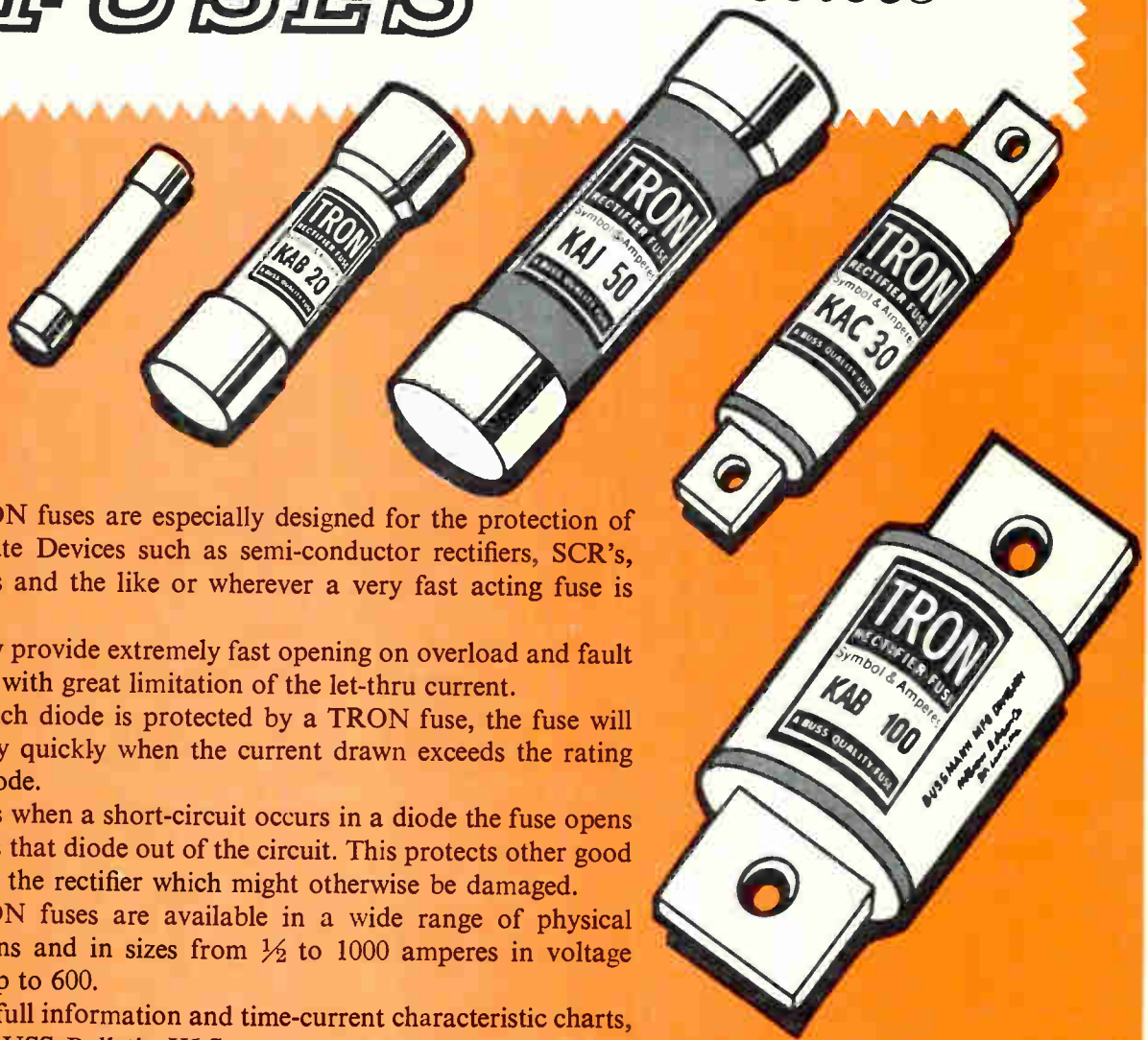

TRON fuses are especially designed for the protection of Solid State Devices such as semi-conductor rectifiers, SCR's, thyristors and the like or wherever a very fast acting fuse is needed.

They provide extremely fast opening on overload and fault currents, with great limitation of the let-thru current.

If each diode is protected by a TRON fuse, the fuse will open very quickly when the current drawn exceeds the rating of the diode.

Thus when a short-circuit occurs in a diode the fuse opens and takes that diode out of the circuit. This protects other good diodes in the rectifier which might otherwise be damaged.

TRON fuses are available in a wide range of physical dimensions and in sizes from $\frac{1}{2}$ to 1000 amperes in voltage ratings up to 600.

For full information and time-current characteristic charts, ask for BUSS Bulletin HLS.

BUSSMANN MFG. DIVISION, McGraw-Edison Co., St. Louis, Mo. 63107

FOR MODERN ELECTRICAL
PROTECTION *Insist on...*

SUPPLIED THE ECONOMICAL WAY... THRU
ELECTRONIC DISTRIBUTORS

BUSS QUALITY

Parylene proves itself

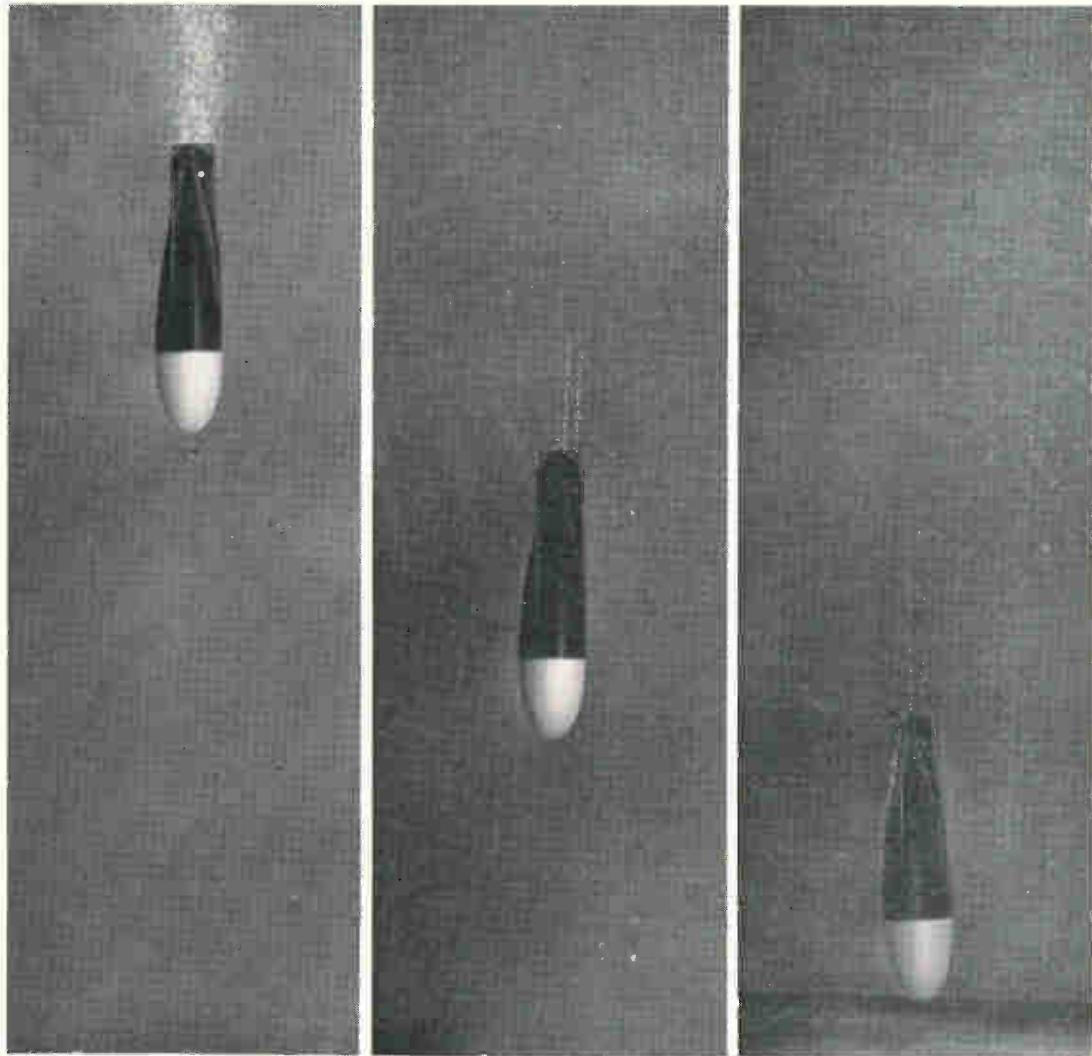

at 250 fathoms.



The Sippican Expendable Bathythermograph System accurately and rapidly measures and records the temperature of ocean waters down to depths of 1,500 feet. Heart of the system is an 8-inch probe, that carries, as its temperature-sensing element, a miniature-sized thermistor, shown on the left.

The protective coating for the thermistor had to be extremely thin (0.5 mil), yet had to be formed as a uniform, continuous, adherent layer, even around sharp corners.

Only BAKELITE parylene was able to meet these critical requirements and also provide the necessary dielectric and corrosion-preventing properties. The Sippican Corporation coated the thermistors under a parylene license from Union Carbide Corporation.

The ability of parylene to be vacuum-deposited in uniform micro-thin coatings is unmatched. True conformal coatings can be as thin as 0.002 mil or as thick as 3 mils or more...and they

won't bridge, run, sag, bloom, blister, wrinkle or blush! As a conformal coating, parylene is a primary dielectric, an excellent moisture barrier, resists softening at high temperatures and its chemical resistance is outstanding.

With all of these special properties, parylene is recommended as conformal coatings on discrete components or high density circuitry, for fast responding sensing probes, photo-cells or memory units.

This plastic is already used as ultra-thin pellicles for such applications as beam splitters in optical instruments and windows for nuclear radiation measuring devices.

Thin coatings of BAKELITE parylene can even be used to increase the over-all heat transfer coefficient of desalination condenser tubes by promoting dropwise condensation.

Possibly your product could benefit from this new plastic. For more information, write to Dept. E-11, Union Carbide Corporation, Plastics Division, 270 Park Avenue, New York, N. Y. 10017. BAKELITE is a registered trade mark of Union Carbide Corporation.



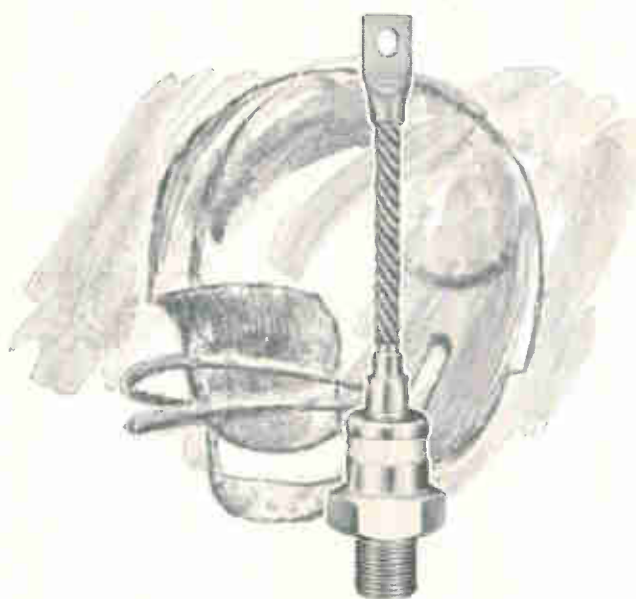

Put in the first team

Syntron's Full Line of Avalanche Silicon Rectifiers Score High

When you need reliable conversion of electric power, call on the performance-proven line with built-in protection against voltage transients. Diodes with complete Jedec listings from 1 to 250 amperes. Efficient Avalanche Silicon Controlled Rectifiers in 3 sizes—16, 70 and 150 amperes. Mail coupon.

Please send details about Syntron's Complete Line of Rectifiers

Name & Title _____

Company _____

Street _____

City & State _____ Zip _____



SYNTRON COMPANY

241 LEXINGTON AVE. • HOMER CITY, PA. 15748

TELEPHONE 412-479-8011

Sales Representatives Coast-to-Coast

67R5



**familiar faces
from the
world's broadest
line of
indicating
relays**

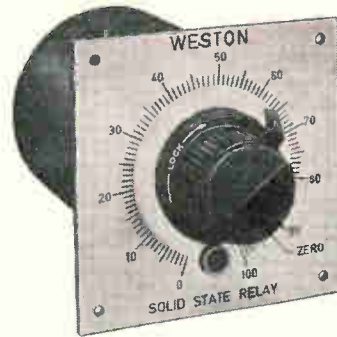

Model 1062 Control Relay—no moving parts, not even relay contacts; voltage ranges from 0-1 volt, current ranges from 0-100 μ a; 200-millisecond response time with 0.5% repeatability typical; zero adjust and trip indicator on 320° scale.

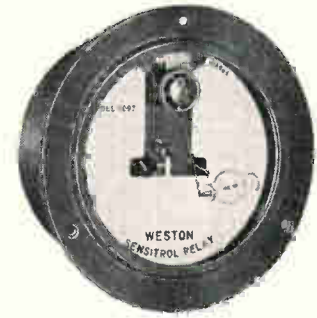

Model 1092 Sensitrol® Relay—low cost; all purpose; magnetically shielded; wide range adjustability; ideal for use in engineering breadboard circuits.



Model 705 Sensitrol® Relay—highly sensitive; surface or flush mounted; single or double, fixed or adjustable contact; ranges as low as 0.5-0.5 μ a.

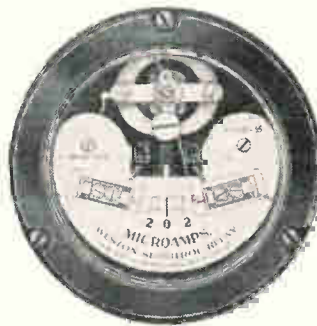

Model 723 Sensitrol® Relay—sealed; shielded; internal reset; solder terminals; single or double magnetic contact; ranges as low as 1-0.1 μ a.

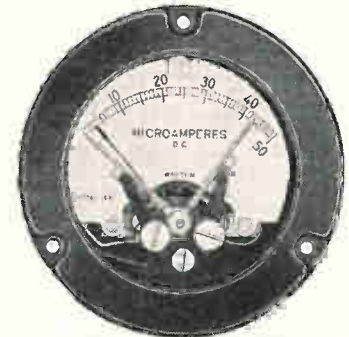

Model 1097 Ruggedized 3½" Relay—Load Current Contact Aiding type fully meets applicable portions of military ruggedized spec; sealed; long scale; shielded; solder terminals; single or double adjustable contacts.

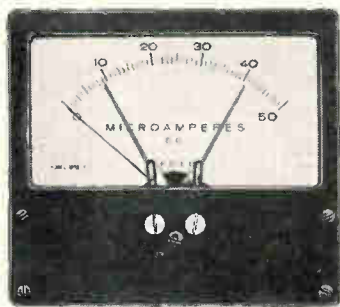

Model 1075 Photronic Relay—operates without physical contact; single or double adjustable set points; continuous reading beyond set point; taut band frictionless mechanism; solid state switching circuit; ranges from 10 μ a.*

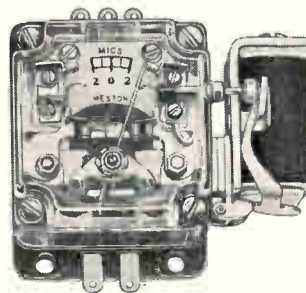

Model 813 Miniature Relay—compact and lightweight; sensitive and Sensitrol (magnetic) contacts; single or double contact; ranges as low as 2-0.2 μ a.

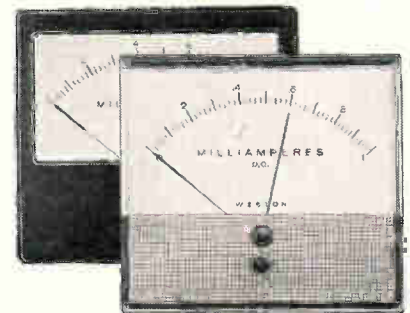

Model 1930/1940 Photronic Relay—3½" and 4½" in either bakelite or plastic front; low cost; add-on power supply and solid state switching circuit; shielded; non-physical, adjustable contact.*

**Photronic is a Trademark of Weston Instruments, Inc.*

Weston Instruments, Inc. • Newark Division • Newark, N.J. 07114

WESTON® *prime source for precision... since 1888*

Your 1967 Catalog Enclosed



DC Power Supply Modules

**GUARANTEED
FOREVER**

acdc electronics inc.

Name _____
Company _____
Address _____
City _____ State _____ Zip _____

acdc electronics inc.

2475 S. 10th Street • Milwaukee, Wis. 53219

If you'll circle Reader Service #25,
we'll send you one by return mail.



Some people can make anything with Signetics' linear integrated circuits.

Like this FM receiver our friend put together. Its IF strip is made up of Signetics' new 510 Dual RF/IF Amplifiers. It will never win a prize for either industrial or electronic design—but then, it wasn't intended to. Does it work? We had it running continuously during the recent WESCON show. Our booth traffic indicator says that some 20,000 engineers saw it, heard it, and thought it sounded pretty good. We know that lots of them can design a better receiver with the same parts. That's their business. Ours is making integrated circuits.

Want to know more about the Signetics' 510 Dual RF/IF Amplifier? Send for a data sheet and a reprint of Ralph

Seymour's WESCON paper on its design and applications.

Want to know more about Signetics' other new linear IC's—the 515 Differential Amplifier and 516 Operational Amplifier—or about the field-proven 501 Video Amplifier and 518 Voltage Comparator? Just ask. We'll get data sheets and application notes to you...fast.

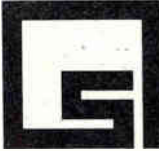
**SIGNETICS
INTEGRATED
CIRCUITS** 
A SUBSIDIARY OF CORNING GLASS WORKS

SIGNETICS SALES OFFICES: Metropolitan New York (201) 992-3980; Upper New York State (315) 469-1072; Southwestern (214) 231-6344; Western Regional (213) 272-9421; Eastern Regional (617) 245-8200; Mid-Atlantic (609) 858-2864; Southeastern (813) 726-3734; Midwestern Regional (312) 259-8300; Northwestern (408) 738-2710.

DISTRIBUTORS: Compar at all locations listed below. Semiconductor Specialists, Inc. (312) 279-1000; Terminal Hudson Electronics (212) 243-5200; Wesco Electronics (213) 684-0880; Wesco Electronics (405) 968-3475; Hammond Electronics (305) 241-6601; Avnet Electronics Corp. of Massachusetts (617) 272-3060.

DOMESTIC REPRESENTATIVES: Jack Pyle Company (415) 349-1266. Compar Corporation at the following locations: Alabama (205) 539-8476; Arizona (602) 947-4336; California (213) 245-1172; California (415) 697-6244; Colorado (303) 781-0912; Connecticut (203) 288-9276; Florida (305) 855-3964; Illinois (312) 775-5300; Maryland (301) 484-5400; Massachusetts (617) 969-7140; Michigan (313) 476-5758; Minnesota (612) 922-7011; Missouri (314) 428-5313; New Jersey (609) 429-1526; New Mexico (505) 265-1020; New York (518) 436-8536; New York (607) 723-8743; New York (716) 684-5731; New York (201) 471-6090; North Carolina (919) 724-0750; Ohio (216) 333-4120; Ohio (513) 878-2631; Texas (214) EM 3-1526; Texas (713) 649-5756; Washington (206) 725-7800.

INTERNATIONAL SALES: France, Germany, Italy, Belgium, Holland, Luxemburg, Spain—Sovcor Electronique, 11, Chemin de Ronde, Le Vesinet, (S.-&O.) France. United Kingdom, Ireland, Sweden, Denmark, Norway, Switzerland, Austria, Portugal—Electrosil Ltd., Lakeside Estate, Colnbrook-By-Pass Slough, Buckinghamshire, Great Britain. Australia—Corning, 1202 Plaza Building, Australia Square, Sydney, N.S.W. 27-4318. Canada—Corning Glass Works of Canada, Ltd., Leaside Plant, Ontario, Canada (416) 421-150. Israel—Optronix, P.O. Box 195, Ramat-Gan, Israel 724-437. Japan—ASAHI Glass Co., Ltd., Corning Products Sales Dept. No. 2, 3-Chome Marunouchi, Chiyoda-ku, Tokyo, Japan.

You can tell Celanese Nylon from other nylons by the label.

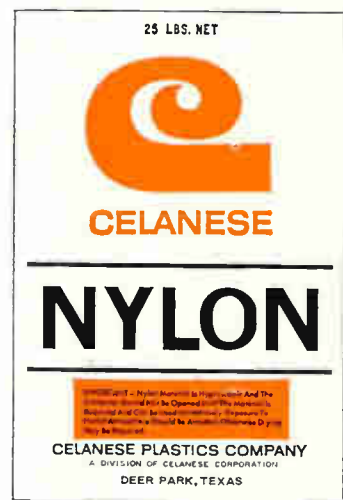
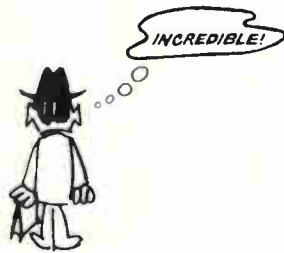

Not at all. Celanese Nylon is fully competitive. In quality. In physical properties. In molding characteristics. In meeting established specifications. Customers who have been using Celanese Nylon resin since the first of the year agree.

And isn't it nice to have another completely dependable source of type 6/6 nylon!

Celanese Plastics Company—and the entire Celanese Corporation—is committed to volume production of the best possible nylon resins. We offer them in quantity right now. Including glass-reinforced Celanese Nylon grades. And a general-purpose black resin. There will be even more in the

near future. More resins. More advanced nylon technology. More molding and marketing assistance.

But you'd expect that from Celanese, a leader in the development of engineering resins. Remember Celcon. And, of course, we do have some twenty-five years of nylon technology behind us.

Let us give you all the facts about Celanese Nylon. Write to: Celanese Plastics Company, Dept. 133-K, P.O. Box 629, Linden, New Jersey 07036.



Celanese Plastics Company is a division of Celanese Corporation. Canadian Affiliate: Canadian Chemical Company, a division of Chemcell (1963), Limited. Export Sales: Amcel Co., Inc., and Pan Amcel Co., Inc., 522 Fifth Ave., New York 10036.

new

NIXIE® TUBE DRIVERS WITH INTEGRATED CIRCUITS MAKE "BUY" DECISIONS

- PRICED AS LOW AS \$26.00 INCLUDING THE NIXIE TUBE (100 QUANTITY) ■ SMALLEST, MOST CONVENIENT PACKAGES ■ COMPATIBLE WITH TTL, DTL, & RTL ■ DECODER/DRIVERS WITH OR WITHOUT MEMORY ■ COMPLETE ASSEMBLIES AVAILABLE OFF-THE-SHELF FROM BURROUGHS AND DISTRIBUTORS ■ 0.6" CHARACTER HEIGHT OR 0.3" CHARACTER HEIGHT NIXIE TUBES ■ MINIMAL NOISE PROBLEMS — DRIVERS ARE MOUNTED AS CLOSE TO TUBES AS POSSIBLE.



ACTUAL SIZE (even with memory).



ACTUAL SIZE miniature drivers.*

SPECIFICATIONS OF IC NIXIE TUBE DRIVERS

Part Number	Tube Type	Character Height	Max. Overall Length (with tube)	Max. Height	Max. Width	Has Memory	Input Code	Price 100 quantity (includes NIXIE tube)
BIP-8806	Standard B-5991	0.6"	2.506"	1.583"	0.750"	Yes	4 line 8-4-2-1 BCD	30.00
BIP-8804	Standard B-5991	0.6"	2.506"	1.583"	0.750"	No	4 line 8-4-2-1 BCD	26.00
BIP-9801	Miniature B-4998	0.3"	2.648"*	0.960"	0.480"	No	4 line 8-4-2-1 BCD	42.00

*Note new shorter overall length.

For additional information contact, Burroughs Corporation
P.O. Box 1226, Department D2, Plainfield, N.J.



Burroughs Corporation

Technical Articles

**Delay line speeds
r-f testing**
page 94

A simple system electrically lengthens one path of a heterodyning test set to produce a different frequency. The unit reduces the time required for device tests while maintaining the same accuracy, range and sensitivity of the single-frequency heterodyne setup normally used for such tests.

**Special report:
The technology of
gallium arsenide**
page 105

Electronics

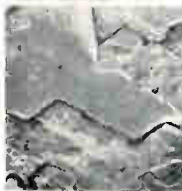

Because of its better characteristics at high frequency and high temperature, gallium arsenide is the most promising compound semiconductor material around. Even more important than its use in such conventional devices as transistors and integrated circuits is its application in light-emitting diodes or in bulk-effect devices such as the Gunn-effect oscillator or the limited space

charge accumulation device. In this 32-page special report, 18 experts have prepared 17 articles that describe the state of the technology of gallium arsenide. The subject is divided into three major areas: materials, devices, and advanced technology. For the cover, photomicrographers at Texas Instruments Incorporated have magnified a slice of gallium arsenide, symbolic because some of the major work that still remains to be done is in the purification of crystalline material.

**Suitcase-size memory
for longer space trips**
page 138

A portable memory that dissipates only 3.5 watts has been developed for the Air Force. It is the first of what could be a whole family of digital equipment, each member of which dissipates so little power it can be battery-powered easily. To reduce power consumption, the new memory uses pulse techniques and metal oxide semiconductor transistors. Potential applications range from space travel to education.

**Coming
November 27**

- Designing a transmission line by computer
- Using integrated operational amplifiers
- Avionics goes digital with a new VOR system
- Chirp improves communications

Delay line speeds r-f testing

It electrically lengthens one path of a heterodyning test set to produce a difference frequency; the system is basically simple and reduces the time needed to measure transmission characteristics

By Frederick F. Rogers

Western Electric Co., North Andover, Mass.

Measuring transmission characteristics of radio-frequency devices, traditionally a time-consuming task, can be speeded with a broadband, high-loss measurement test set developed by the Western Electric Co.

The unit has the range, accuracy, and sensitivity of a single-frequency heterodyne system, but without that system's complexity. And, unlike conventional swept systems, it doesn't need two signal sources. A delay line creates the difference frequency necessary for heterodyning, and thereby eliminates the need for the complex synchronizing circuits and mechanisms normally employed to keep the difference frequency constant.

Called the Incremental Heterodyne Frequency (IHF) test system, the set is capable of measuring insertion losses, return losses, and voltage standing wave ratio.

Against the tide

As a general rule, increases in the range and accuracy of r-f devices have demanded increases in the complexity of the systems used to test them. The application here of delay-line techniques, long used for making phase measurements, bucks this trend. The resulting instrument is simple and cuts the time needed to test an r-f device with wide dynamic and broad frequency ranges. In one trial,

The author



Frederick Rogers is an engineering associate at the Merrimac Valley Works of the Western Electric Co. He joined the company, the manufacturing arm of the Bell System, in 1957, and has since worked on microwave communications systems.

a developmental model of the IHF system operated over bandwidths of 0.5 and 1 gigahertz at test frequencies of 6 and 11 Ghz; the system's dynamic range was 35 decibels.

The set's test signal is derived from a single, swept-frequency source. The signal is split into two paths, one (A) connected to a mixer by a delay line, the other (B) coupled directly to the mixer. The path with the delay line is therefore electrically longer, as in diagram at top of page 95.

An attenuator is used to drop the signal in test path B at least 20 db below the level in the other path. In a heterodyning system, it should be noted, the amplitude of the mixer output is directly proportional to the magnitude of the weaker signal. In this case, test results are carried via path B.

A second attenuator in the same path establishes a reference level on a readout device—usually an oscilloscope. Once the reference level is set, the r-f device to be tested is substituted for the attenuators. The mixer's output, a pulse-modulated signal, contains the test results.

At any instant in time, the swept signal can be regarded as a single frequency. Since the source is a linearly swept frequency generator, it produces, in effect, a series of instantaneous frequencies.

Delays make a difference

If a single set of instantaneous frequencies in the two paths is represented by f_1 and f_2 , respectively, and the mixer output frequency by f_3 , the values of f_1 and f_2 arriving at the mixer at any time are a function of the sweep rate, r (the rate of change of frequency in hertz/second). If d_1 and d_2 represent the delays in paths A and B, respectively, and $d_1 > d_2$ and $f_1 < f_2$ when r is positive, then $f_2 = r(d_1 - d_2) + f_1$

The desired mixer output (f_3) is the difference frequency $f_2 - f_1$. If the delay and sweep rate are

constants, then f_3 is also a constant and can be expressed as $r(d_1 - d_2)$.

This equation is easier to use if it's stated in terms that represent the variables controlling the mixer output frequency. Letting D equal the difference in delay ($d_1 - d_2$), W/T the sweep rate r (where W equals the sweep bandwidth and T the sweep time), and F the mixer output frequency f_3 , yields the equation $F = DW/T$.

The graph at the right shows some F versus T curves for various values of D with W constant; both computed and measured values are given. Difference errors—about 10% in this case—can be attributed to: imprecision in the tuned-frequency voltmeter used to measure the mixer output frequency; the linearity of the ramp generator operating the swept-signal source; the flyback time required for static discharge of the glass envelope on the swept-signal source tube (backward wave oscillator); dispersions caused by the components of path A; frequency modulation caused by any or all of these factors; and the operator's inability to accurately measure the sweep times. Any improvement in these areas would, of course, improve the quality of the test data, though a 10% error isn't objectionable in production-line testing—the system's intended application.

Proof positive

The incremental heterodyne approach is essentially a time-domain, frequency-domain concept. In the simplified test circuit shown in the diagram above, detectors x and y represent the mixer input. The peaks at the centers of the photograph on page 98 are wavemeter pips that are caused by frequency modulation of the swept source and that originate before the signal reaches the beginning of paths A and B. But the scope presentation indicates that the pips traveling through the paths arrive at the

Continued on Page 98

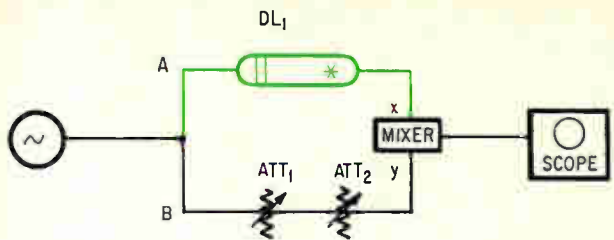

Signal delay. Intermediate frequency is established by electrically lengthening one signal path with a delay line.

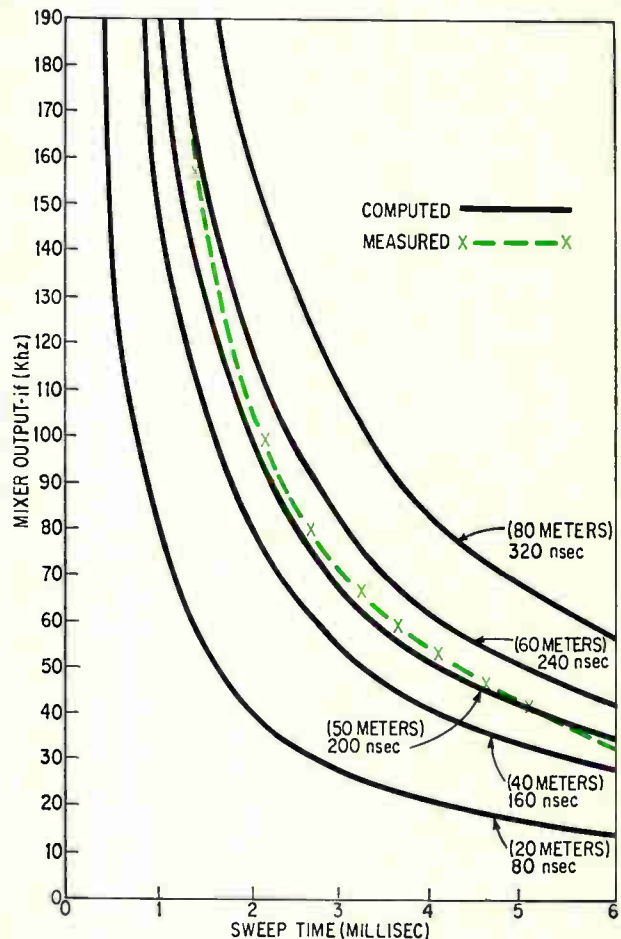

Predictable i-f. Two parameters can be controlled to establish the intermediate-frequency output from the mixer. In this graph, the i-f was calculated over a range of sweep times at various fixed values for the delay. Actual measurements differed from computed values by only 10%.

ATT ₂ setting (r-f) (db)	ATT ₃ setting (i-f) (db)	Scope sensitivity (mv)	Readout (mv)
8	50	20	66
10	48	20	66
12	46	20	68
15	43	20	68
20	38	20	68
25	33	20	68
30	28	20	68
35	23	20	68
40	18	20	68
45	13	20	68
46	12	20	68
47	11	20	68
48	10	20	70
50	8	20	70

Dynamic range 12-47 or 35 db

r-f power at ports A and B

A: @ 11.27 Ghz, power = -5.4 dbm

B: @ 11.27 Ghz, power = -21.4 dbm (ATT₂ set at 31 db)

B: @ 11.27 Ghz, power = -10.6 dbm (ATT₂ set at 10 db)

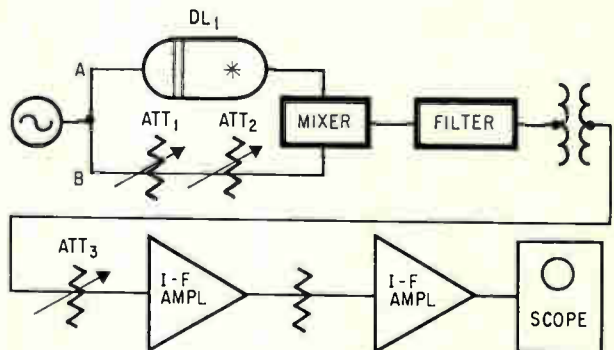

Test setup. In an arrangement to determine the system's dynamic range, attenuators ATT₂ and ATT₃ are changed by identical amounts and the output is read on an oscilloscope. As indicated in the table, the scope's output remains constant with input signals ranging from 12 to 47 db.

The competition

There are a variety of conventional circuits that can be used to measure the insertion loss, return loss, and vswr of r-f devices. The simplest, the single-frequency, single-detection measuring circuit, A at right, uses a point-by-point technique in which the frequency of the signal source is manually switched each time a measurement at a new frequency is required. Insertion and return losses are measured with a square-law detector. The configuration A measures insertion losses; the second circuit, B, measures voltage standing wave ratios and return losses.

The simpler circuit has a signal source, a variable r-f attenuator, an r-f detector, and readout device. In the other circuit, a slotted line, a precision termination, and a shorting plate are added.

Combo. Another popular configuration, the modulated single-frequency, single-detection measuring circuit, C at right, also employs point-by-point, square-law-detection

techniques. As it combines both of the previous circuits—plus a modulator and a demodulator—it can measure all three characteristics.

The single-frequency heterodyne measuring circuit, diagram D, is useful for extended range measurements. But two signal sources are needed, and they have to be adjusted for every frequency change. The circuit has three sections, of which one—the beat frequency oscillator section—resembles the first circuit discussed here minus the detector and presentation device. The second section—the test signal oscillator—resembles a combination of the first and second circuits, and the third consists of a mixer, an intermediate-frequency preamplifier, an i-f attenuator, an i-f amplifier, a detector, and a presentation device.

The signal strength levels at the mixer of this system must be maintained throughout all measurements, and the difference fre-

quency between the rso and bfo sections must be kept constant.

The difference frequency between the rso and bfo is called the i-f and is usually much lower than either of the oscillator frequencies. Amplification of the i-f increases sensitivity and extends the measurement range.

Modifications. In all of these approaches, the need to switch frequencies wastes time. The signal source can be replaced in any of these circuits with a sweeper—an oscillator whose output frequency is systematically varied many times per second from a start to a stop frequency through a band of frequencies. But severe frequency modulation of the i-f and misalignment of the i-f with respect to the narrow pass band of the i-f amplifiers can occur if the sweepers aren't synchronized.

The circuits can be further modified with hybrid junctions to eliminate the slotted line for return loss and vswr measurements. Adding these junctions boosts the circuits measurement capabilities, but makes for greater complexity.

Technique	Measures			Measurement		Data accumulation		Comments
	IL	RL	vswr	Range (db)	Tolerance (db)	Point-by-point	Continuous (swept source)	
Incremental heterodyne frequency	x	x	x	70	±0.2		x	Needs only one source for heterodyning; simple presentation device such as scope can be used.
Single-frequency, single detection	x	x (a)	x (a)	30	±0.2	x	(b)	Limited range but simplest circuit. Require manual frequency adjustment.
Modulated single-frequency, single-detection	x	x	x	50	±0.2	x	(b)	Amplification of modulating frequency increases system's sensitivity and extends useful range
Single-frequency heterodyning	x	x	x	70	±0.2	x	(c)	Most complex but most versatile of these systems. Two sources and synchronizing are essential.

(a) Slotted line must be added to measure vswr and RL.

(b) Signal source can be swept to reduce test time and eliminate point-by-point measurements. There are no serious implementation problems.

(c) Sweeping of signal sources provides time-saving benefits, but complex synchronizing circuits and mechanisms are needed to keep frequency difference constant.

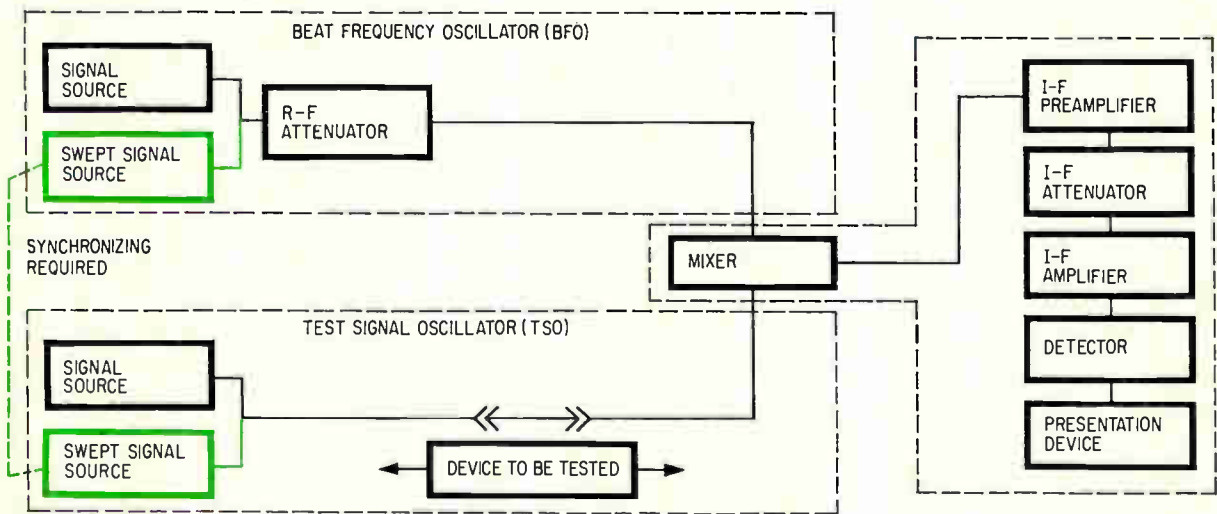
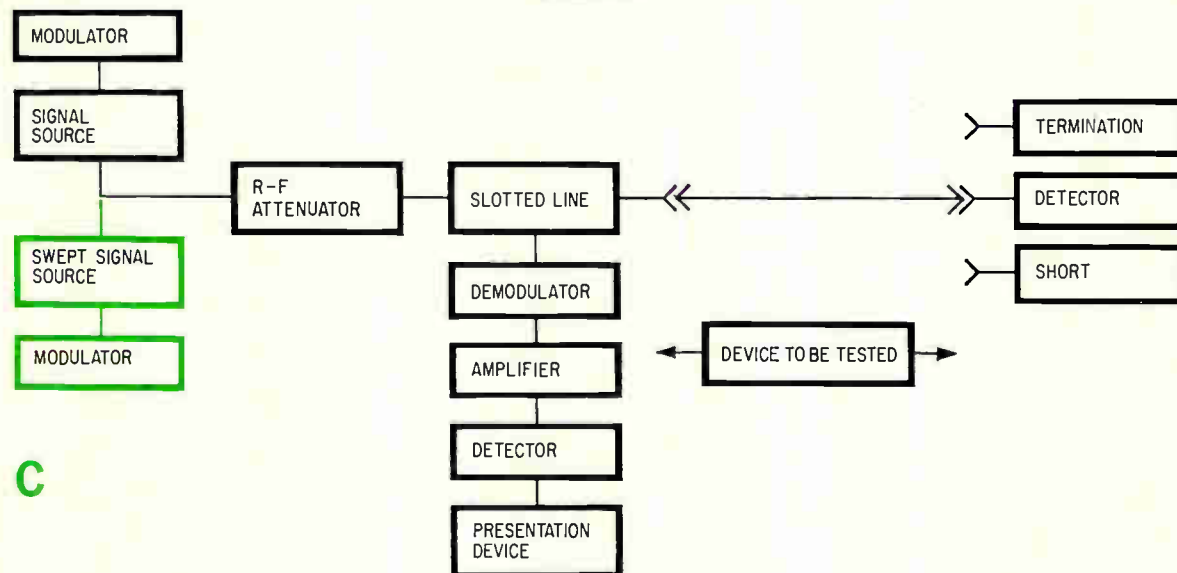
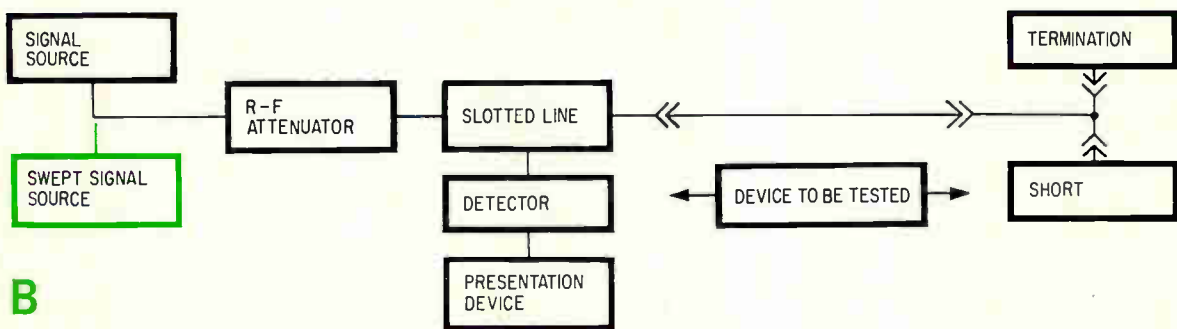
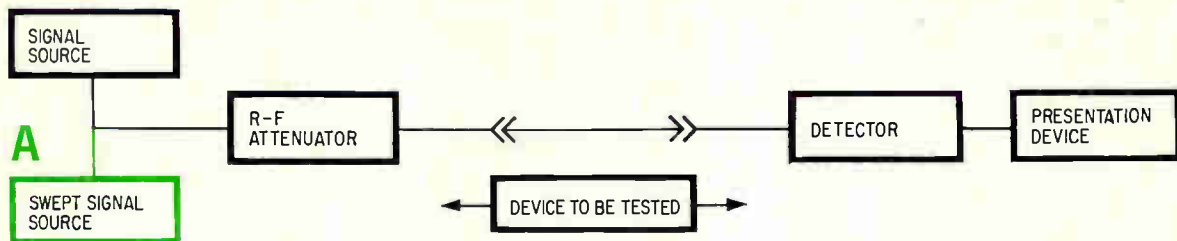

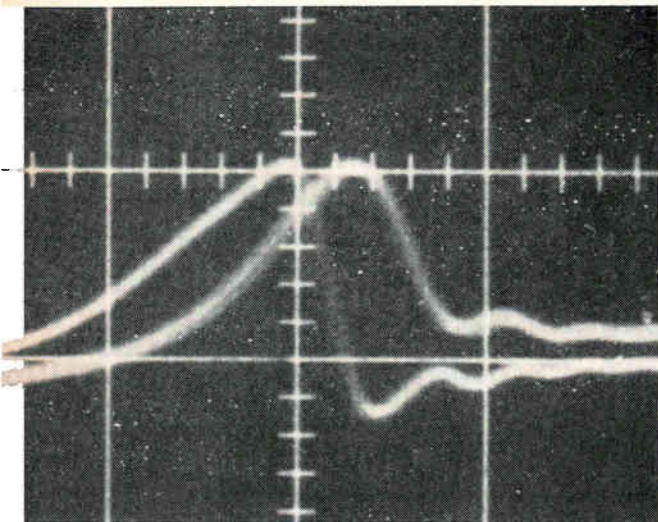

Time lag. Pips created by frequency-modulating signal sources and introduced into test system at the start of the two signal paths arrive at the mixer at different times.

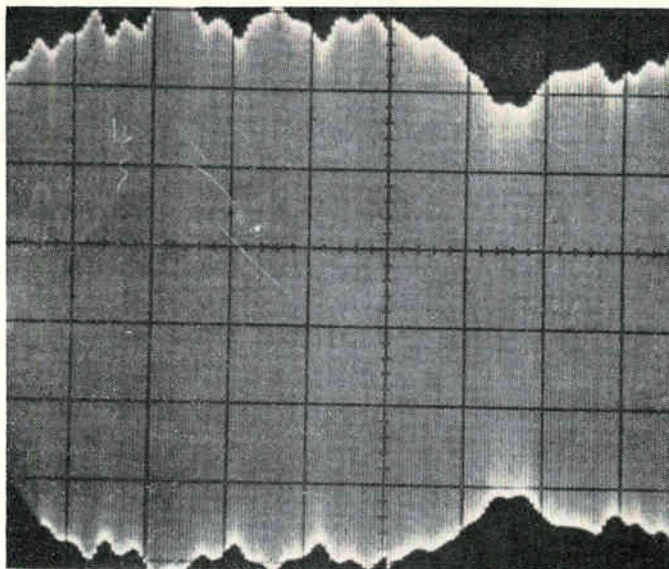

Typical output. Test results are confined to the envelope of the oscilloscope display. Shown here is the mixer output signal after the i-f has been filtered and amplified.

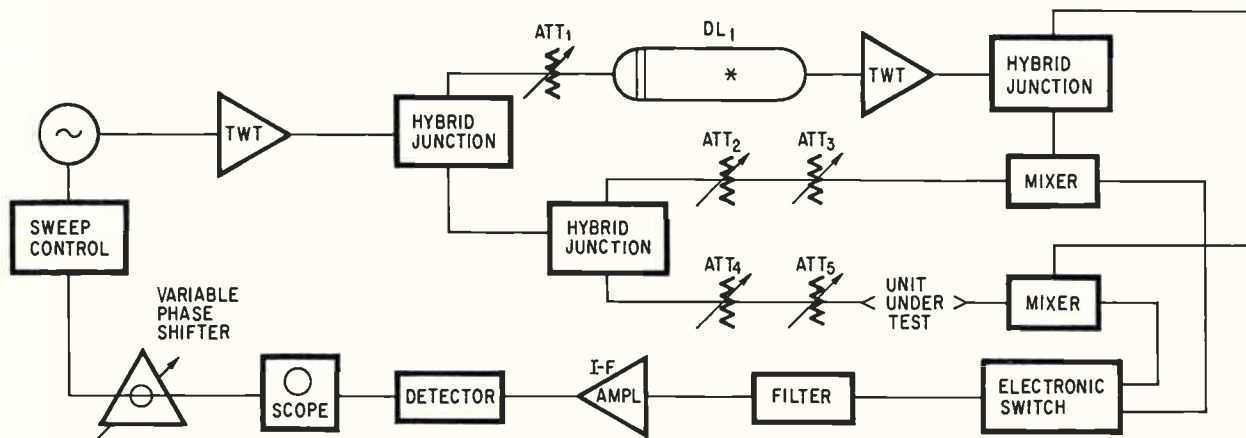

Final form. Test set modified for laboratory use contains both an automatic calibrating path and a phase shift control. The signal through the path with attenuators ATT₂ and ATT₃ is alternately compared with the signal in the test path and the one in the electrically lengthened path. The scope's reference point is thus always available for comparison.

continued from page 95

detectors at different times, the actual time difference being equivalent to the delay difference between paths A and B, less about a 10-nanosecond delay caused by the scope's dual trace preamplifiers.

The displacement between two identical frequencies proves that two different frequencies originating at the swept-signal source are present at the detectors at the same time.

The number of points sampled by the test set depends on the mixer output frequency, and the only useful information in the output is contained at the peaks and valleys of the modulated signal's envelope. While this is satisfactory for a production-line instrument, a laboratory system should be able to measure abrupt losses occurring between the sample points.

The μ R system gains this capability when a 360-

degree phase shifter, shown above, is added to the measuring circuit. The phase shifter enables the operator to move any point on the envelope through as much as a one-cycle change and to investigate the test results at that discrete sample point.

Measurements made with the new circuit have been correlated to within a tenth of a decibel with a conventional sweeper test set. Losses of more than 50 db have been observed with sensitivities of 1 to 2 db per centimeter on an oscilloscope.

Bibliography

- "Swept Frequency Techniques," Hewlett-Packard Co., Application Note #65.
- Frederick Terman, "Electronic & Radio Engineering," fourth edition, McGraw-Hill Book Co., p. 568, "Heterodyne Action," and p. 558 "Square Law Detection."
- Radiation Laboratories Series, Vol. 11, "Technique of Microwave Measurements," chap. 13.

Designer's casebook

Designer's casebook is a regular feature in Electronics. Readers are invited to submit novel circuit ideas, packaging schemes, or other unusual solutions to design problems. Descriptions should be short. We'll pay \$50 for each item published.

Integrated circuit drives neons directly

By G.V. Wintriss

Tyco Labs, Waltham, Mass.

Neon glow-lamp indicators can be turned on and off by low-voltage integrated circuits, even though the circuits cannot handle the relatively high voltages needed to drive the lamps. The voltage incompatibility, an old problem, is simply and inexpensively sidestepped by not applying neon voltages directly to the ic's.

Assume the neon lamps, N_1 and N_2 , have a breakdown voltage of 71 volts and require a maintaining voltage of 60 volts at V_1 . The indicator supply voltage at V_2 is a pulsating direct current that can turn the lamps on and off with each cycle of line power.

Now consider the instantaneous voltages applied to N_1 and N_2 with the 1 output of the ic flip-flop high—say 4 volts. When V_2 rises to 70 volts, N_1 has 70 volts applied to it while N_2 sees only 66 volts, the difference between V_2 and the voltage at the 1 output.

As V_2 continues rising to 71 volts, N_1 fires. N_2 remains off, at 67 volts. As soon as N_1 fires, it begins drawing current and V_1 drops to the maintaining voltage of 60 volts. Now, N_1 is on, but N_2 cannot turn on since 60 volts is below that needed for breakdown.

When the supply voltage cycle causes V_2 to drop below 60 volts, N_1 extinguishes; it turns on and off with each cycle of V_2 as long as the ic's 1 output is

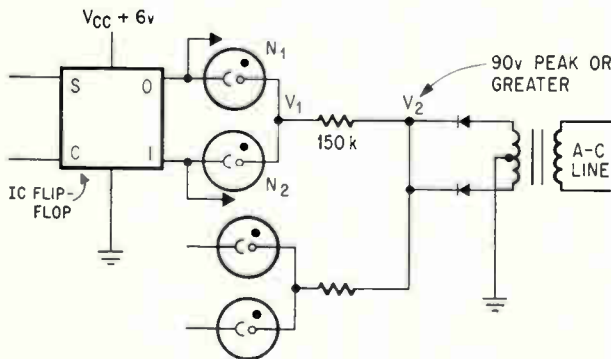

Driver circuit. Since N_1 and N_2 are connected in parallel, only one lamp can fire at a time.

high. Likewise, if the 0 output is made high, N_2 fires each cycle and N_1 remains off.

The breakdown voltages of N_1 and N_2 do not have to be precisely matched. The circuit operates properly when the difference between the firing voltages of N_1 and N_2 is less than the difference between the ic's high and low output voltages. This requirement is met with conventional lamps, such as the NE-23. The operating life over which they continue to meet the requirement is predictable.

Ring radiator succeeds in mobile vhf radios

By G.W. Horn

Industria Radio-Elettrica Telecomunicazioni, Trieste, Italy

A hula-hoop antenna performs well at very high frequencies if the loop is made resonant and if the open waveguide, formed between the loop and its ground plane, is adequately dimensioned. In contrast, the conventional configuration of this type of antenna—a directional discontinuity ring radiator (DDRR)—has very poor radiation efficiency at vhf but is usually good at medium and high frequencies.

The open waveguide of the standard design [Electronics, Jan. 11, 1963, p. 44] becomes so small at frequencies above 50 megahertz that the electromagnetic field cannot be launched into space efficiently. Also, the high-impedance and grounded ends of the loop are close together, inducing out-of-phase r-f voltages in the feed point. Bandwidth is reduced and the voltage standing-wave ratio deteriorates seriously at vhf.

It was found that the DDRR becomes efficient at vhf when the loop is 56 electrical degrees in diameter. The open waveguide becomes perfectly symmetrical and the cross-section of the radiating slot is made twice as large as in the conventional design.

For best results, a half-wave loop is made to resonate at the operating frequency by connecting a small, well-insulated trimmer capacitor between ground and the point of highest impedance in the loop. To compensate for the reactive loading effect

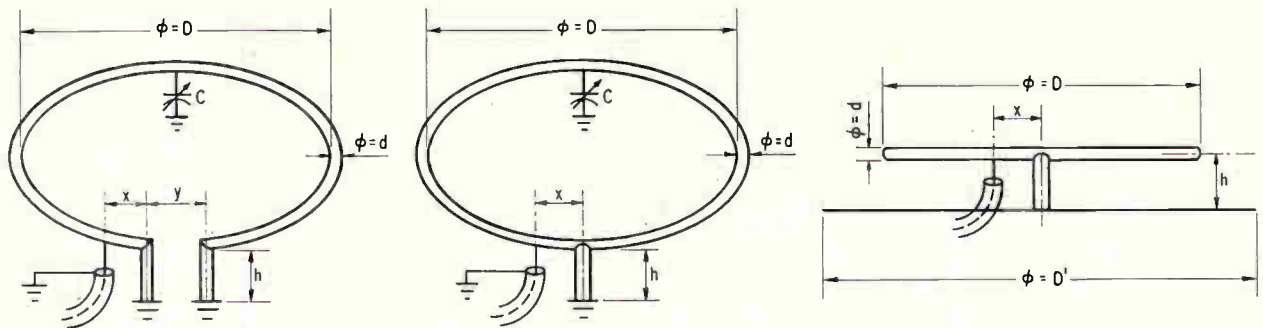

New ring. Efficiency of radiator antenna (left), is improved at very high frequencies by adding capacitor, eliminating the discontinuity gaps (center), and making ground-plane diameter, D' , twice loop diameter D (right).

of the capacitor, the loop's diameter is reduced to about 52 electrical degrees. The correct termination is found by moving the feed point through a distance shown as X in the first sketch.

The bandwidth is determined by the diameter, d , and the height above the ground plane of the rod used to form the loop.

Field intensity measurements of such half-wave D^2RR 's show that they are not only superior to the conventional D^2RR , but have 1-decibel better gain than the standard quarter-wave verticle dipole. Radiation directivity was as good as the theoretical omnidirectional pattern given in the 1963 report. A 3-db jump in the directivity pattern is caused by the discontinuity at Y . The length of Y is not critical, and the jump in field intensity can be eliminated by reducing Y to zero, as in the second sketch, closing the loop.

Several half-wave D^2RR 's have been made for

mobile radio applications. The dimensions for the 156 to 17-Mhz band are:

- $D = 10$ inches
- $d = \frac{1}{8}$ inch
- $h = 1\frac{3}{8}$ inch
- $X = \frac{1}{2}$ inch, for 50 ohms impedance

This antenna's ground-plane diameter is approximately $2D$.

The antenna is well-suited to vhf/f-m use, acting as a sharp bandpass filter centering on the operating frequency. It rejects adjacent-channel interference much better than conventional dipoles. Receiver signal-to-noise ratio is also better when the loop is grounded through the vehicle frame, to drain off static charges.

The low profile of the antenna, when mounted on an automobile roof, makes for low wind resistance and therefore less signal flutter, and inconspicuous appearance.

Relay actuator produces one-hour pulses

By David L. Pippen

National Aeronautics and Space Administration, White Sands Test Facility, N.M.

Long pulses at slow repetition rates for timing applications are generated by a free-running pulser consisting of solid state components and a relay. Pulse widths and rates from 20 milliseconds to several minutes can be obtained by changing the values of the resistors and capacitors that govern time constants.

The component values allow pulse width to be adjusted from approximately 50 to 150 msec, at a nominal repetition rate of one pulse per second. Stability of the repetition rate is within 2% over normal operating temperatures.

When a direct current is applied to the circuit, capacitor C_1 charges through resistors R_3 and R_4 until the firing point of the unijunction transistor, Q_1 , is reached. This time delay, adjustable with R_3 , establishes the repetition rate.

After Q_1 is triggered, the silicon controlled rectifier, SCR_1 , fires and energizes relay K_1 , closing the normally open contact K_{1B} . Now, power is applied through R_2 and R_5 , charging C_2 ; this time delays the pulse width and is adjusted with R_2 . The charging of C_2 fires the second unijunction transistor, Q_2 , and SCR_2 .

The low impedance of SCR_2 in its on state shunts SCR_1 so it returns to its off state. At the same time, K_1 returns to its de-energized position. The pulse-width-determining circuit is now fully recovered and waits for the next triggering signal from Q_1 . Several low-priced, high-sensitivity SCR 's tried in this circuit did not function adequately, since they sustained conduction with less than 5 microamperes anode current. The on-state resistance in the SCR_2 must be low enough to assure SCR_1 's turning

Slow-running pulser. Charging of the capacitors delays transistor and silicon controlled rectifier switching, to stretch output pulses.

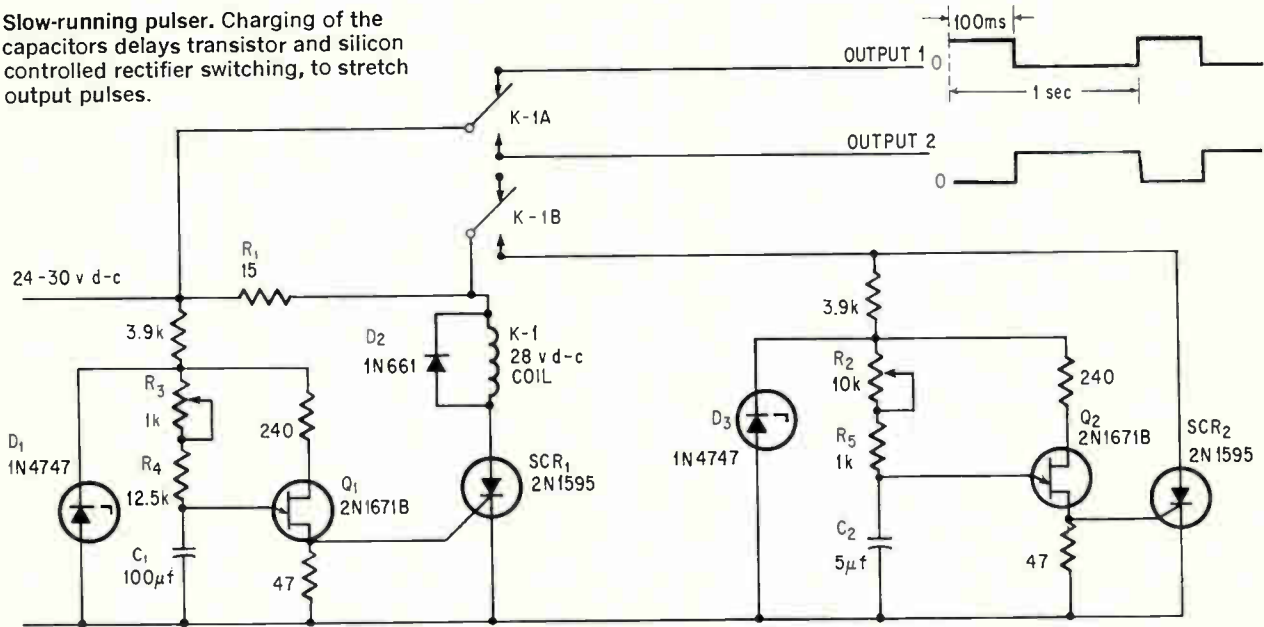

off when it is shunted.

The two 20-volt zener diodes, D_1 and D_3 , keep the voltage in the timing circuitry constant. Diode D_2 suppresses the relay coil's inductive kick, preventing erratic double-pulsing. Resistor R_1 limits the anode current of SCR_2 to a safe value.

As noted in the diagram, a double-pole, double-throw relay results in two complementary outputs. If output rise and fall times of less than approximately 20 msec are required, reed relays can be used. A reed relay's response time is less than 2 msec and has a longer life than a relay.

Push-pull capacitors multiply input voltage

By Charles D. Brock and Leslie E. Johnston

Service Engineering Division, Oklahoma City Air Material Area, U.S. Air Force, Oklahoma City, Okla.

Supply-voltage drops can be kept to a minimum, as required in some solid-state systems, when the back-biasing voltage for switching transistors is supplied by a circuit that functions as a d-c to d-c noninductive autotransformer.

The circuit's design principle can also be extended to full-wave transformation, from the half-wave configuration shown. Stages can be cascaded to provide voltage multiplication with higher efficiency than other noninductive d-c to d-c converters. And if voltage regulation is needed in an otherwise unregulated system, the direct-current autotransformer can do the job.

The principle is best explained by visualizing the circuit as based on a double-pole, double-throw switch. When the switch is in position 1, capacitor

C_1 is charged to the input voltage. Moving the switch to position 2 discharges C_1 into capacitor C_2 . Since the negative terminal of C_2 is at the positive input potential, C_2 's positive terminal is raised to a higher potential. Therefore, the output voltage is higher than the input voltage. The rise in potential at C_2 depends upon its capacitance with respect to C_1 . Returning the switch to position 1 initiates another cycle.

In the actual circuit, the cycles are initiated continuously by the relaxation oscillator formed by unijunction transistor, Q_1 . Its output triggers flip-flop Q_2 and Q_3 , whose outputs in turn are amplified

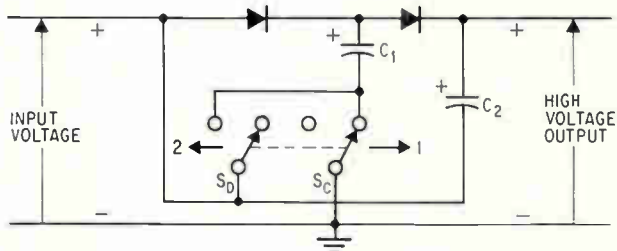

Charge-discharge. Two capacitors are switched so that the first discharges into the second, raising the potential of the second at its positive terminal.

Solid state

The many facets of gallium arsenide

Already the stuff of varactors, light emitters, injection lasers, and microwave diodes, GaAs is reaching a point of development where it can win a place in almost all electronic applications

Introduction by Stephen E. Scrupski, senior associate editor

Materials

- I. **Basic properties** by David Richman
- II. **Single crystals** by J.M. Woodall
- III. **Vapor-phase growth** by James J. Tietjen and Leonard R. Weisberg
- IV. **Epitaxy** by Kenneth L. Lawley
- V. **Ion implantation** by Kenneth E. Manchester
- VI. **Semi-insulating substrates** by C.P. Sandbank

Devices

- I. **Varactors—the first GaAs devices** by Arthur Uhlir Jr.
- II. **Bipolar transistors** by Hans Strack
- III. **Field effect transistors** by Hans Becke
- IV. **Schottky-barrier diodes** by Charles M. Howell
- V. **Injection lasers** by Hans Rupprecht
- VI. **Light-emitting diodes** by J.R. Biard and Hans Strack

Advanced technology

- I. **Gunn effect** by Daniel G. Dow
- II. **LSA diodes** by John A. Copeland
- III. **Transferred electron amplifiers** by Hartwig W. Thim
- IV. **Domain effects** by Masakazu Shoji
- V. **Integrated circuits** by Edward M. Mehal

Gallium arsenide begins to keep some promises

Always just around the corner, this versatile compound semiconductor is finally challenging silicon and germanium in a host of uses, and is tackling some special applications all its own

By Stephen E. Scrupski

Senior associate editor

As multifaceted in application as it is in its crystal structure, gallium arsenide is on the verge of challenging germanium and silicon for the over-all championship of the semiconductor field. But the challenger has been brought along slowly, and rather than immediately risking a direct confrontation with its rivals in the transistor field, it may begin by outflanking them in light-emitting and bulk-effect applications.

New developments in the use of germanium and silicon as semiconducting materials are trailing off; it would not be an oversimplification to say that most of the work with these materials is now directed toward finding new ways to arrange devices, deposit insulation, and form photomasks. But materials research in the field of gallium arsenide is on the upswing. The conferences covering basic materials—electrochemical and metallurgical society meetings, for instance—are being inundated with papers on compound semiconductors.

Of these compound semiconductors, gallium arsenide is receiving the lion's share of attention. In terms of processing refinements, it's far ahead of the others. In the same terms, it's still far behind silicon, but silicon can't do all that GaAs does.

GaAs is today the most versatile of all semiconducting materials; the articles following will emphasize this. Varactors, transistors, microwave diodes, light-emitting diodes, injection lasers, bulk microwave power sources, negative resistance, amplifiers, and bulk-effect integrated circuits—all are possible with gallium arsenide.

Of these, only varactors, Schottky-barrier microwave diodes, light-emitting diodes, and injection lasers are being made in quantities that even approach conventional "production" levels. But ad-

vanced gallium-arsenide devices are waiting in the wings—in fact, they're being demonstrated in laboratory models.

Lifting the lid

And when the bulk-effect devices finally hit the market, a new world will open up, one in which functional integrated circuits are designed by shaping the material and by chemical processing. With such circuits, now being built at Bell Telephone Laboratories by Masazuku Shoji and at Standard Telecommunication Laboratories, Harlow, England, by C. P. Sandbank, we can forget about such individual components as transistors.

The key factor in gallium arsenide's success up to now is a single property—a higher electron mobility than either silicon or germanium. Gallium arsenide also has a wider band gap, a feature suggesting high-temperature uses. But Arthur Uhlir of Microwave Associates, author of the section on varactors in this report, sums up the present situation: "High-temperature characteristics, though they were once given as the main reason for research in gallium arsenide, have not been a very significant factor in the application of any gallium-arsenide device."

In fact, as Uhlir notes in his article, the one GaAs application that has anything to do with temperature involves cryogenic freezing just a few degrees above absolute zero. This is the cooled parametric amplifier, which uses a gallium-arsenide varactor in a low-noise receiver.

The main obstacle to fuller exploitation of GaAs is its relative impurity compared with germanium and silicon. These elemental semiconductor mate-

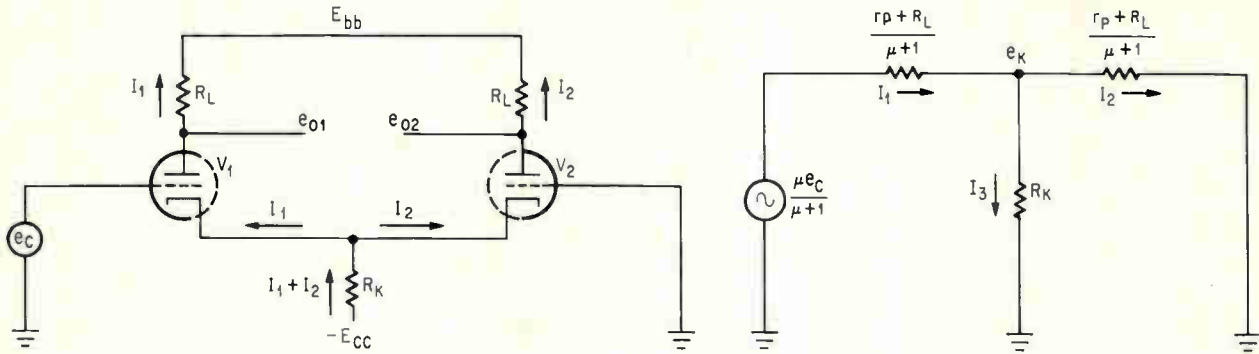

Conventional amplifier. Output balance of a conventional paraphase amplifier requires a large cathode resistor, R_K , and a negative power supply. At the right is the equivalent circuit.

signal outputs e_{o1} and e_{o2} , μ is the amplification factor of each tube, r_p is the tube's plate resistance, and R_L is the load.

A silicon npn transistor is more efficient as a current source in the cathode circuit than a resistor. It requires relatively low voltage, and the current supplied does not vary when the voltage across the

transistor varies. Therefore, current balance is better and $-E_{cc}$ is not needed. The difference in output signals is less than 1% when load resistors, R_L , are well matched. Resistors R_1 and R_3 form a bias-resistance network that can easily be redesigned, using conventional transistor circuit design methods, to suit similar applications.

Oscillator waits for switch to quiet down

By Peter T. Rux

Corvallis, Ore.

Slight delays in turn-on and turn-off times, built into a low-speed oscillator in the form of an extra transistor, enables digital circuits to be checked at a rate of only 2 hertz. The operator can watch the logic operate a visual indicator, confident that outputs will not be false because of contact bounce in the control switch or because he switched off the oscillator in the middle of a cycle.

The circuit is at rest with the switch, S_1 , in the stop position. Transistors Q_1 and Q_3 are on and

the output is at $V_{CE(SAT)}$. The base of the extra transistor, Q_2 , is also at $V_{CE(SAT)}$, so it is off. When S_1 is moved to the run position, Q_2 remains off until capacitor C_2 is sufficiently charged through resistors R_1 and R_2 to turn on Q_2 's base. The delay, indicated in the waveform diagram, blocks any spikes caused by contact bounce.

When Q_2 turns on, it acts with Q_3 as an astable multivibrator. Diode D_1 and R_3 let the output rise sharply. The oscillator rate is controlled by the time constants of $(R_1 + R_2)C_2$ and R_4C_1 .

Returning S_1 to the stop position stops the oscillator immediately if Q_2 is in the off position. Transistor Q_2 cannot turn back on, since Q_1 is on and the oscillator remains in the rest condition. Alternatively, if Q_2 is on when S_1 is switched to stop, Q_1 is off and the oscillator completes the cycle without being affected by switch contact bounce. At the end of the cycle, Q_2 turns off and Q_1 keeps it off.

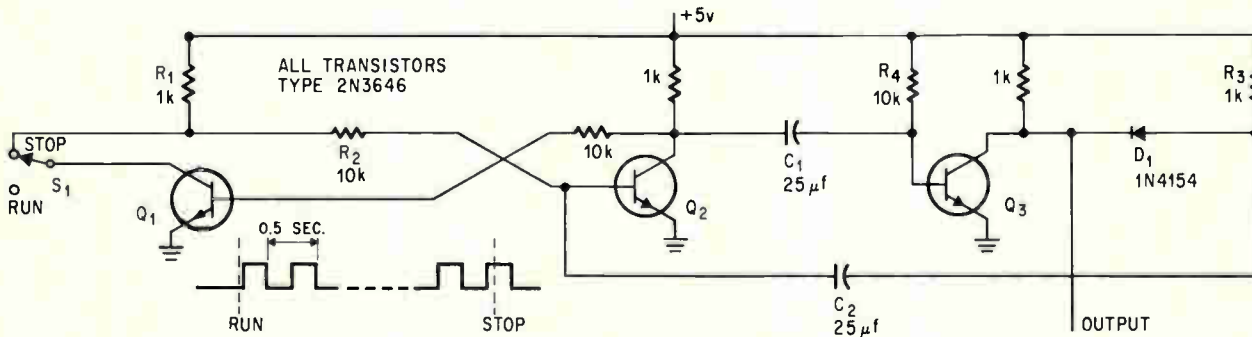

Safe wait. Capacitor C_2 delays turn-on of transistor Q_2 until the contact of switch S_1 has stopped bouncing. Transistor Q_1 won't let the oscillator turn off until the cycle in progress is ended.

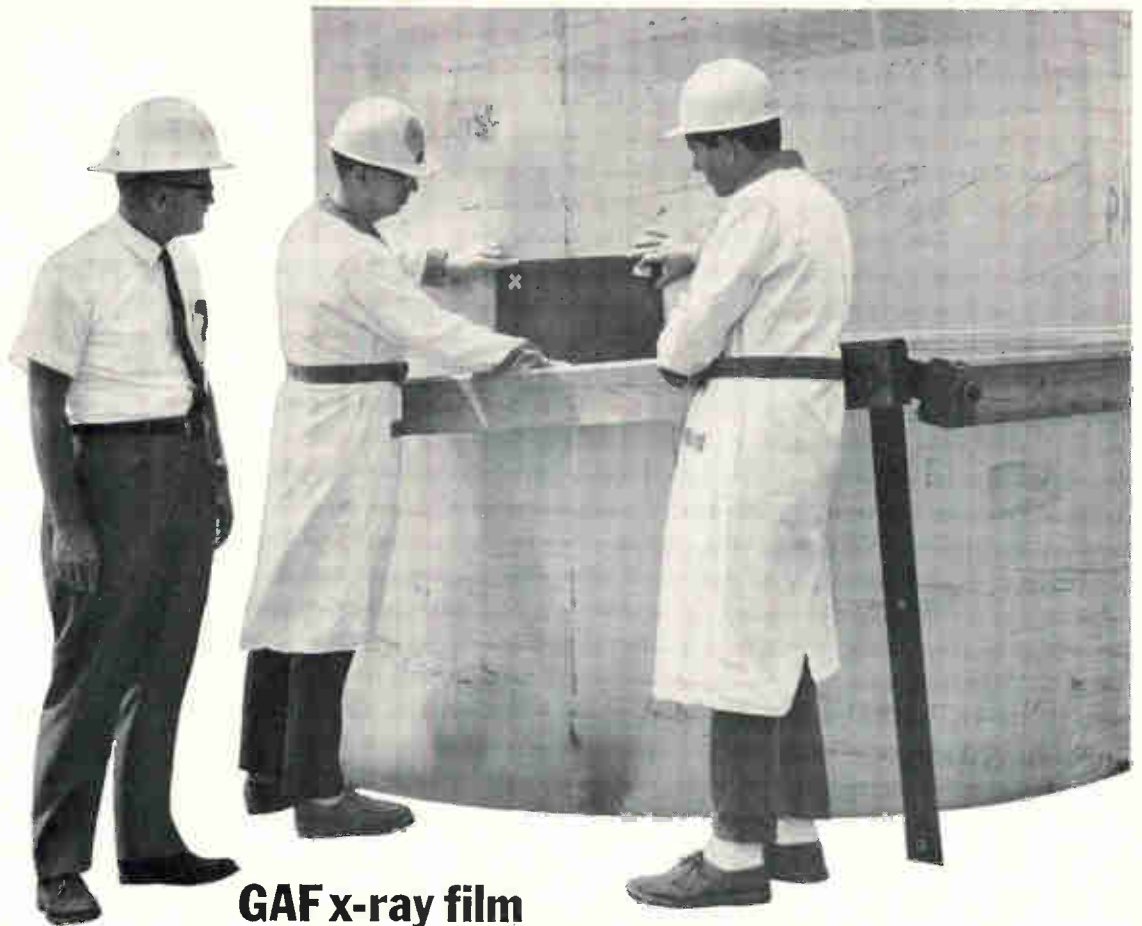

**GAF x-ray film
assures quality welds
in Sun Shipbuilding's
revolutionary high-performance
gas-turbine freighter**

The new Adm. Wm. M. Callaghan is a ship of many "firsts."

The first large cargo vessel with modified aircraft jet engine—a twin gas-turbine installation. The largest and fastest privately owned freighter under the U.S. flag. And one of the first ships procured under performance standards.

But it's *not* the first time the Sun Shipbuilding and Drydock Company depended on GAF Industrial "A" x-ray film. Sun has relied on GAF for quality control of its welds for more than 20 years.

Says chief radiographer William Collins (pictured here supervising x-ray procedures), "We find the combination of GAF Industrial "A" x-ray

film and GAF chemicals to be very compatible for good sensitivity and reliability in all our radiography."

The speed and accuracy of GAF radiography has actually helped improve welding techniques, making for



greater construction efficiency. This has enabled Sun to launch its precedent-making ship in record time. Designed for long-term charter to MSTs, the vessel's combination of high speed (in excess of 25 knots) and large deck area, could well set a trend for use of gas-turbine power.

The need for quality welds, in thicknesses ranging up to several inches, virtually necessitates GAF radiography for unusual construction problems. For this job, Industrial "A" film was selected.

There's a prime-quality GAF job-matched x-ray film for *your* construction needs. Contact your GAF x-ray distributor or your local GAF representative for further information.

01867

gaf GENERAL ANILINE & FILM CORPORATION

140 WEST 51 STREET, NEW YORK, NEW YORK 10020

rials can be zone-refined in a vacuum after growth, but there's no second step in GaAs purification.

This problem of impurities means, for example, that GaAs transistors can't be built with a spread between the doping in the emitter and the doping in the collector, though a wide spread would mean a better device. Silicon starts out with a lower impurity level and it achieves the spread, but designers of gallium arsenide devices cannot begin with a high impurity level and get the spread by heavily doping the emitter because there is a solubility limit on dopants. P-type impurities have higher solubilities, but the engineers want an n-type emitter for an npn transistor because the electron's mobility is about 20 times that of the mobility of the hole.

Invasion routes

Light-emitting diodes are just now beginning to find their way into optical encoders, where their solid state reliability offsets their high initial cost.

One of the next big areas to be invaded by GaAs devices will be that of displays—numerical readouts. Gallium arsenide diodes emit light in a direction perpendicular to the junction, so the longer the device, the wider the light beam. This contrasts with the injection laser, which emits light in the plane of the junction in a narrow, flat beam. To produce visible outputs, gallium arsenide-gallium phosphide diodes must be used, since gallium arsenide diodes emit light in the infrared at about 9,000 angstroms, just outside the visible spectrum.

Once the visible wavelength is obtained, it's a simple matter to arrange the diodes in the form of a segmented readout and to form various numerals by pulsing different diodes. No such readouts are on the market yet, but it's only a matter of time before they find use in small instrument-panel displays.

Injection lasers, too, seem to be on the verge of fulfilling their early promise. Gallium-arsenide coherent emitters are slated for use in sensing obstructions on railroad tracks [Electronics, Oct. 30, 1967, p. 25], and in an Air Force short-range communications link and an intrusion alarm system that may be used in Vietnam [Electronics, Oct. 30, pp. 44].

Sandwich

Still another use for gallium arsenide is being studied by researchers at Carnegie-Mellon University. A heterojunction transistor with a germanium base and collector and a gallium arsenide emitter is being developed there for microwave operation.

The two materials are compatible in basic crystal lattice dimensions and in thermal coefficients of expansion, and the researchers are using the wide band gap of GaAs as a high potential barrier at the emitter-base junction to reduce the injection of carriers from the base back into the emitter. This reduction allows much heavier doping in the base; with resistance lowered, the frequency response is boosted.

GaAs works

Like silicon and germanium, gallium arsenide owes its semiconducting properties to the structure of its energy bands—the conduction band, where electrons flow, the valence band, where holes flow, and the gap between the two bands.

At room temperature, not many electrons have enough energy to jump the gap and thus contribute to current flow. But if the material is doped with certain impurity atoms, electrons can be added at energy levels just below the conduction band, where it takes little energy to boost them up.

These impurities are called donors because each atom donates an electron, making the material n-type. Similarly, the material can be made p-type by introducing acceptor impurities that insert empty energy levels just above the top of the valence band, where electrons can be boosted out of the valence band into them, leaving holes behind.

Once free in their bands, electrons and holes can move under the influence of an electric field. Current depends on the mobility of each type charge carrier, and this mobility, the ratio of carrier velocity to electric field, has the dimensions of centimeters per second divided by volts per centimeter, or $\text{cm}^2/\text{volt-sec}$.

The electrons are normally more mobile than the holes. The material's conductivity, the reciprocal of its resistivity, is the product of three factors: the carrier concentration, usually stated in carriers/ cm^3 ; the mobility; and the elementary electron charge.

In the valleys. As will be described in the first of these articles, the gallium-arsenide conduction band has two valleys separated by a small energy gap. Electrons in the lower-energy valley have a higher mobility than those in the upper-energy valley, and when the voltage across a sample of gallium arsenide is raised, an increasing number of electrons are excited into the upper, lower-mobility, valley. Resistivity, therefore, increases as voltage increases.

When the electrons in the upper valley outnumber those in the lower, the material takes on a differential negative resistance. This effect, however, is unstable, and an accumulation of charges, or domains, starts to form.

Layers. Any deviation in charge concentration in the material will cause the formation of a charge accumulation layer and a depletion layer. At a point where the electron density suddenly decreases because of, say, nonuniform doping, the field will increase and the electrons will move more slowly. (On the negative resistance portion of the characteristic, increased field produces decreased current.)

At the edge of the depletion layer nearest the negative electrode, electrons traveling toward the positive electrode will tend to accumulate and the accumulation layer will grow; at the edge nearest the positive electrode, electrons will tend to move away from the depletion layer faster than they move into it and the depletion layer will grow.

The layers move across the sample at the average electron drift velocity, about 10^7 cm/sec, until they reach the positive electrode, where they disappear. New accumulation and depletion layers then appear, and the process repeats itself.

Some special features make the difference

By David Richman

RCA Laboratories, Princeton, N.J.

The similarities between gallium arsenide and the elemental semiconductors, germanium and silicon, are important but hardly surprising—all three have the same basic crystal structure, zinc-blende and diamond, that accounts for their semiconducting properties. But gallium arsenide's place as potentially one of the most important semiconductor materials rests on the differences.

A gallium-arsenide p-n junction, for example, is an efficient light emitter; germanium and silicon diodes are not.

For germanium and silicon, the conduction-band minimum occurs at a momentum different from that of the maximum of the valence band. But in GaAs, the minimum and the maximum occur at the same momentum—a feature that's the basis for the injection laser and the light-emitting diode.

Gallium arsenide thus is a direct-gap material; an electron can make the transition directly from the conduction band to the valence band without changing momentum and can give up its energy in the form of a quantum of light.

In germanium and silicon, indirect-gap materials; electrons cannot move from one band to the other with the same momentum and they must give up most of their energy to the lattice in the form of lattice vibrations, or phonons.

Mobility

Two other significant differences—gallium arsenide's greater energy-band gap and the greater mobility of electrons in its conduction band minima—give the material its higher temperature and higher

frequency capabilities.

Electron concentration and mobility are often used to judge the purity of a sample of GaAs. Pure material has about 1×10^{15} electrons/cm³ and a mobility greater than 8,000 cm²/volt-sec. Less pure material has higher electron concentration and mobilities in the 5,000 cm²/volt-sec. range. In pure material, the mobility increases as temperature decreases; mobilities of over 100,000 cm²/volt-sec have been measured at temperatures of about 77°K.

GaAs is the basic material of Gunn-effect devices because there are two valleys in its conduction band, one of which is at a slightly higher energy level—about 0.36 electron-volt—than the other. Electrons in the lower-energy valley have much greater mobility than those in the other valley, though the energy difference between the two levels is so small that strong electric fields give the electrons enough energy to move from one minimum to the other. When the upper—higher energy—valley is more densely populated than the lower, the material exhibits a differential negative resistance; as the voltage is increased, more electrons move up to the lower-mobility band and the current decreases, causing bulk instabilities such as the Gunn effect.

Impurity

The maximum purity attainable with present GaAs crystal-growing methods is about 10^{15} impurity atoms per cubic centimeter. Since GaAs has about 4.4×10^{22} atoms/cm³, this limit corre-

Energy-band properties

Property	Ge	Si	GaAs
Band gap (ev)	.67	1.106	1.40
Type of band gap	Indirect	Indirect	Direct
Calculated maximum electron mobility at 15° C (cm ² /v-sec)	3,950	1,900	11,000
Calculated maximum hole Mobility at 25° C (cm ² /v-sec)	1,900	425	450
Electron effective mass	.55	1.1	.043-.071
Intrinsic electrons at 25° C (cm ⁻³)	2.4×10^{13}	1.5×10^{10}	1.4×10^6
Intrinsic resistivity at 25° C (ohm-cm)	46	2.3×10^5	3.7×10^8

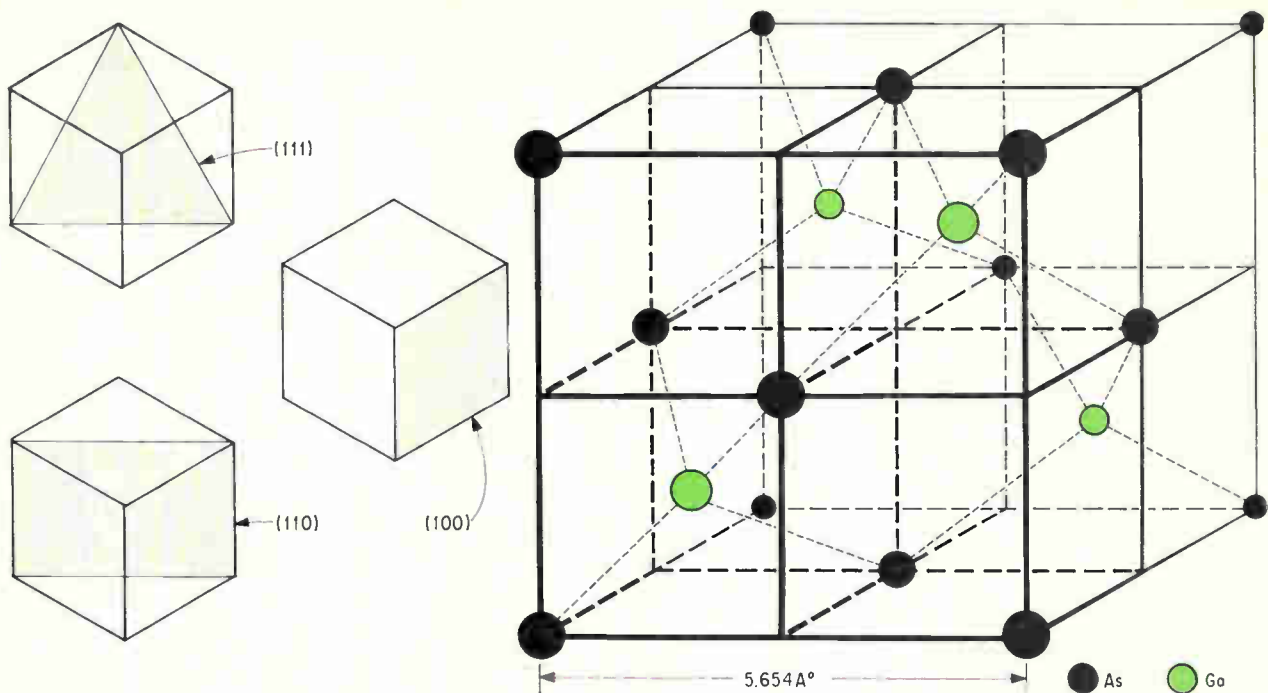

Crystal structure. Gallium arsenide crystallizes in a zinc-blende structure, where each atom bonds with its four neighbors. Major crystal plane designations are at left.

sponds to about 2 parts in 10^8 , or 0.02 parts per million. Stated in another way, the best GaAs is about 99.999998% pure when it leaves the crystal-growth apparatus, or, as often designated, it has seven 9's purity.

Germanium and silicon, the purest elements made today, have one or two 9's higher purity than GaAs because they can be zone refined. The purest GaAs is made by vapor deposition.

Gallium arsenide can be made either n or p by adding impurity atoms during crystal growth or by diffusion. An element from group II—zinc, for instance—will substitute for gallium in the lattice and, since it has one less electron than gallium, will create holes in the valence band and make the crystal p type. An element from group VI such as selenium will substitute for arsenic and contribute one additional electron to the conduction band, thus making the crystal n-type.

The group IV atoms are amphoteric dopants—

that is, they may act either as donors or acceptors. At low concentrations, they occupy only one—gallium or arsenic—of the lattice sites, but as their concentration increases, they begin to occupy the other type of lattice site. Silicon in GaAs, for example, is a donor at low concentrations, displacing arsenic, but becomes an acceptor, displacing gallium, in heavily doped n-type material.

The ease with which the impurities release their extra electrons or holes to the conduction or valence bands depends on the position of the impurity energy level in the band gap. So-called shallow dopants lie close to the conduction or valence bands, and it takes little energy to ionize them. Deep donors or acceptors lie near the middle of the gap and aren't fully ionized at room temperature.

Latticework

Gallium arsenide owes its basic semiconducting properties to its crystal structure—a zinc-blende-

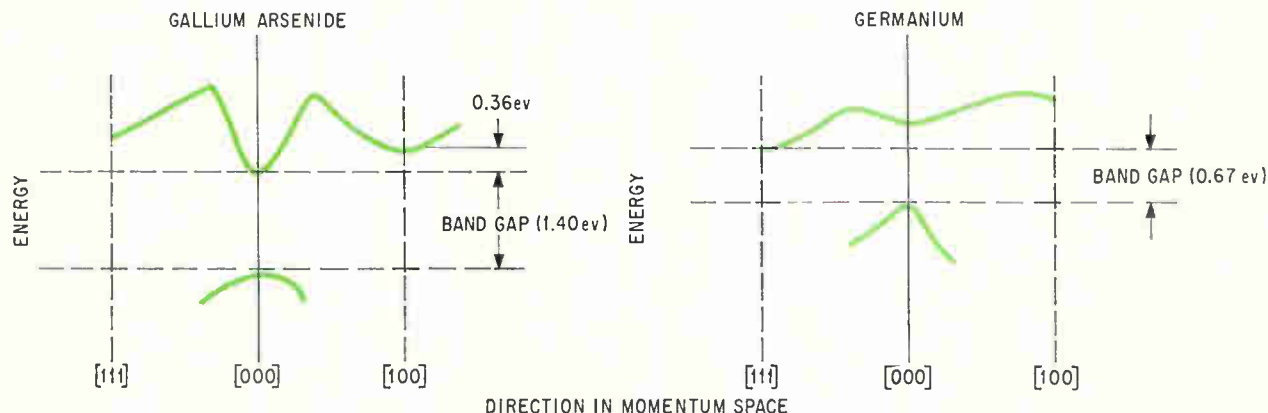

Energy bands. Comparison of gallium-arsenide and germanium structures shows differences that account for GaAs light-emission and bulk effect properties.

Matchups

Property	Germanium	Silicon	Gallium arsenide
Melting point (°C)	936	1,420	1,238
Solid density (gr/cm ³)	5.328	2.329	5.316
Lattice constant (Å)	5.658	5.430	5.654
Distance between nearest neighbors (Å)	2.45	2.35	2.45
Atoms per cm ³	4.42 x 10 ²²	5.0 x 10 ²²	4.43 x 10 ²²
Vapor pressure at melting point (atm)	10 ⁻⁹	10 ⁻⁷	1
Specific heat (cal/gm)	.074	0.167	.086
Dielectric constant	15.7	12	11.1
Thermal coefficient of expansion (°C ⁻¹)	6.1 x 10 ⁻⁶	2.33 x 10 ⁻⁶	5.93 x 10 ⁻⁶

type lattice. Each gallium atom is surrounded by four arsenic atoms at the corners of a tetrahedron, and each arsenic atom is surrounded in the same way by four gallium atoms. Germanium and silicon crystallize in a diamond lattice with all sites occupied by the same type—germanium or silicon—atoms.

With germanium or silicon, all 111 faces of the crystal have the same chemical reactivity, since the atoms are the same when viewed from any direction. But in the zinc-blende structure, all 111 faces

present alternating layers of gallium and arsenic atoms, and opposite planes have different surface atoms—gallium in one direction and arsenic in the other. As might be expected, the two surfaces react differently to chemical treatment.

The near equality of the lattice constants—the spacing of the unit cells in the crystal—and the thermal coefficients of expansion are the features that permit the epitaxial growth of germanium on gallium arsenide, a useful method in forming heterojunction transistors.

Materials II

Crystal holds key to the future

By J.M. Woodall

International Business Machines Corp., Yorktown Heights, N.Y.

"To achieve better, more uniform results, it is clear that better materials are needed." This comment, found all too often at the conclusion of an article about gallium-arsenide devices, emphasizes the increasing importance of crystal growth techniques.

Epitaxy—the atom-by-atom growth of a layer of GaAs on bulk crystal—has proved a success, but the attainment of more reliable, more uniform, and longer-lived devices requires improved methods of bulk crystal growing. The future of epitaxial devices depends on the quality of the bulk-grown substrates.

Device-quality GaAs is grown by freezing the molten material at 1,242°C into a single crystal structure free of chemical contamination and structural defects. Besides producing high temperatures and promoting single-crystal growth, the apparatus used must prevent the melt from dissociating. The

arsenic in the melt has a dissociation pressure of one atmosphere, and without this external vapor pressure it would leave the melt, thereby chemically unbalancing the crystal structure. Either this pressure must be provided, or as in a newer method, the melt can be encapsulated, and an inert gas used to block the escape of the arsenic.

Two paths to growth

Two methods of crystal growth are now popular, the Czochralski and the horizontal Bridgman (the vertical Bridgman method is not as convenient for use with semiconductor materials). In the first method, a seed crystal is inserted in the melt and then slowly withdrawn so that the melt forms a meniscus and solidifies as it's raised above the molten surface, repeating the same single-crystal structure as the seed. Typical high-purity results of

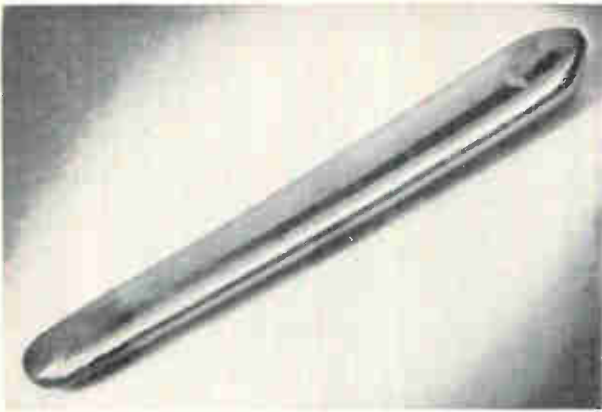

Bridgman crystal. The shape taken is that of the fabrication boat.



Czochralski crystal. Cylindrical shape results from twisting as crystal is lifted from the melt.

the Czochralski method are about 4×10^{15} electrons per cubic centimeter and an electron mobility of about $7,000 \text{ cm}^2/\text{volt-sec}$.

In the horizontal Bridgman technique, the melt is slowly passed through a temperature gradient spanning the melting point, causing the melt to progressively solidify into a single-crystal structure. Although the melt need not be seeded to produce a single crystal, growth in a preferred crystal-plane direction requires seeding. The Bridgman method yields GaAs with about 5×10^{14} electrons/cm³ and a mobility of $8,000 \text{ cm}^2/\text{volt-sec}$.

Seals and capsules

There are two versions of the Czochralski method. The first employs a sealed system to contain the arsenic vapor, while the other, more recently developed, form encapsulates the melt in a viscous material.

In the first version, the system must be held above 614°C to maintain the proper arsenic pressure, and all parts except the melt must be made of materials that don't react with arsenic vapor.

Nonreactive high-temperature seals and feedthroughs are sometimes used to raise the seed crystal from the melt. In a more popular method, the seed is held and lifted by iron parts that are encapsulated in quartz and magnetically coupled to an external lifting mechanism. The melt is usually heated with a radio-frequency coil, while the rest of the sealed quartz system is heated by a resistance furnace to maintain the arsenic pressure.

With the Czochralski method, one can observe the crystal during growth and immediately verify whether single-crystal growth has begun. But this advantage the technique has over the Bridgman is offset by the problem of uniformly lifting the seed out of the melt with magnetic coupling or

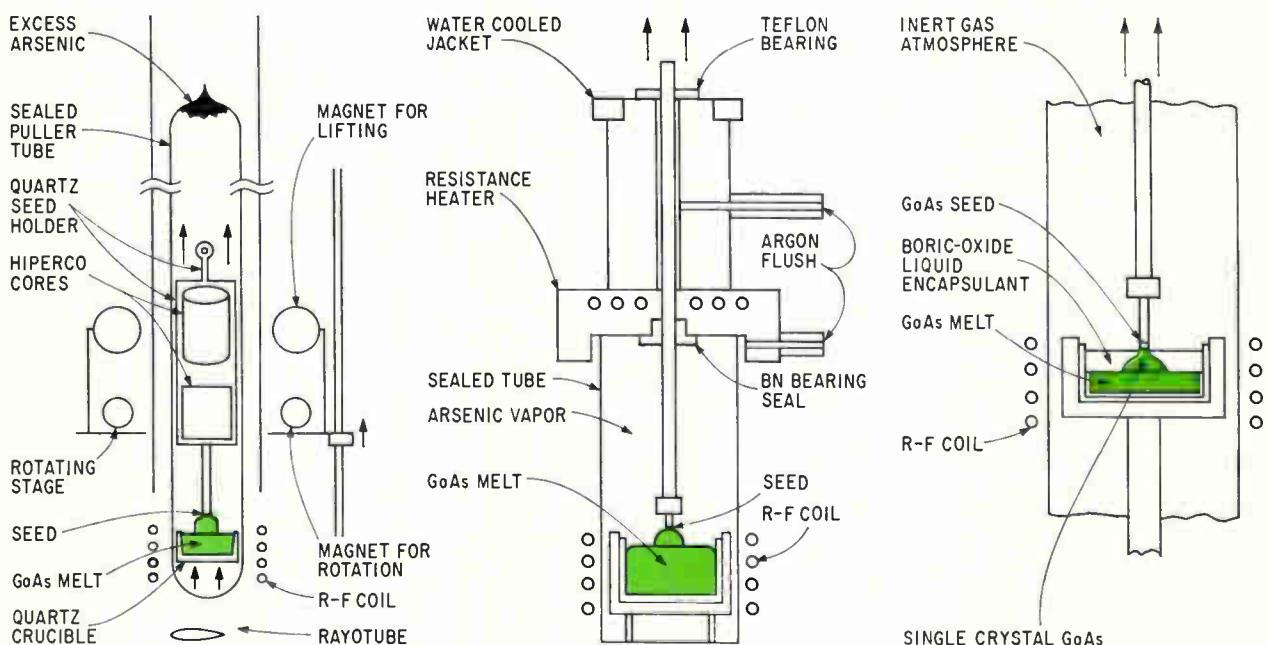

Seed lifting. Three basic methods of Czochralski single-crystal growth mechanisms: sealed system with magnetic lifting (left); nonreactive feedthrough seals and mechanical lifting (center); boric-oxide encapsulant (right).

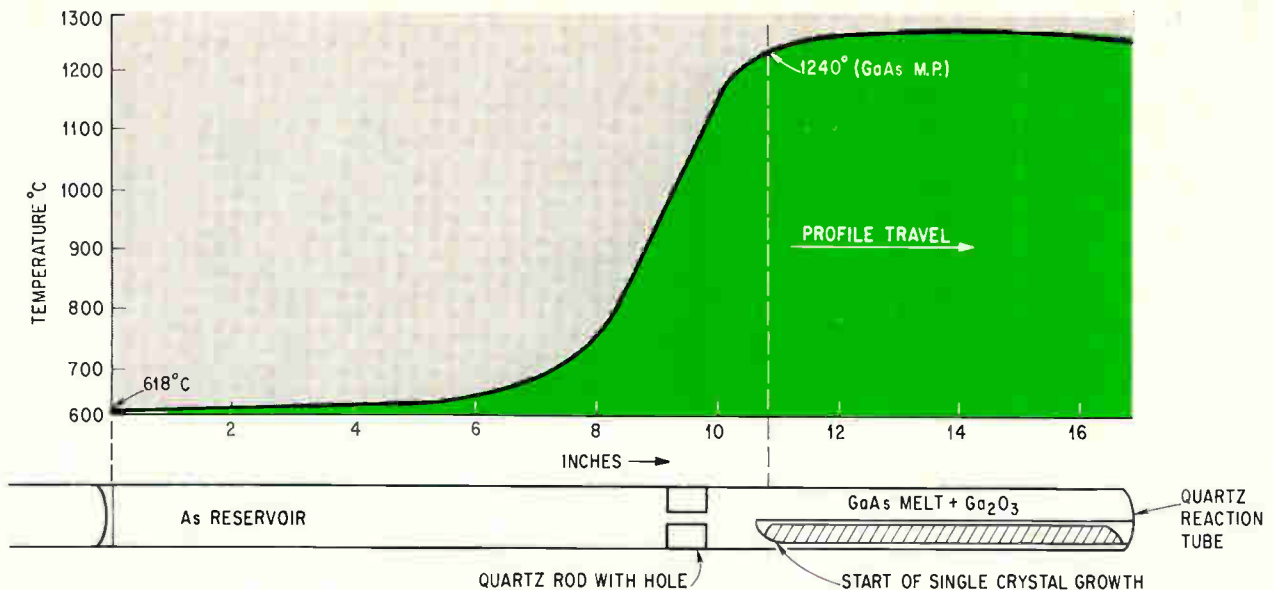

Passing through. In the horizontal Bridgman method, the GaAs melt is passed through a temperature gradient and single-crystal material forms on the cooler end.

special seals and feedthroughs. Because the motor-driven apparatus working through magnetic coupling or special seals may have small speed variations, the crystal cannot be grown at a microscopically uniform rate and the dopants tend to collect, often in periodic striations. In the Bridgman method, the motor-driven apparatus runs at a more uniform speed because it's simpler and operates at room temperature.

In the other version of the Czochralski method, the need for arsenic vapor is eliminated altogether by encapsulating the melt in a viscous nonreactive material such as boric oxide, B_2O_3 . Little arsenic escapes from the melt when an inert gas such as argon is applied outside with a pressure of one atmosphere.

The crystal is grown by dipping the seed through the B_2O_3 and then withdrawing it at a uniform rate. As the grown crystal passes through the seal into the inert atmosphere, it picks up a thin layer of B_2O_3 . This method thus allows the use of more stable seed-lifting mechanisms and should result in the growth of more perfect crystals.

Boatloads

The horizontal Bridgman method generally produces higher-purity material and a more uniform crystal. As with the Czochralski, the system is sealed and contains one atmosphere of arsenic vapor. A boatload of molten GaAs traveling through a temperature gradient forms a single crystal in the shape of the boat.

Neither the melt nor the solid crystal should adhere to or be constrained by the boat. This puts some restrictions on the choice of boat material—a factor of no importance in the Czochralski method.

One advantage of the Czochralski method is that it affords a wide choice of crucible materials; the major concern is the chemical reactivity, not, as

in the Bridgman method, whether the melt wets the crucible. Aluminum-nitride, boron-nitride, and aluminum-oxide crucibles have all been successfully employed in growing high-purity GaAs.

Also, a special graphite crucible for Czochralski growth offering a desirable temperature gradient and good r-f coupling for heating has recently been used to grow dislocation-free GaAs—the substrate required for epitaxial growth of dislocation-free material.

With a recent development, the horizontal Bridgman method is also capable of producing dislocation-free material. This material, seeded crystals grown near the 310 direction in sand-blasted quartz boats and doped with 2×10^{18} tin atoms/cm³, has yielded the best room-temperature laser devices made so far, even though GaAs crystals grown in quartz are generally contaminated with silicon from the quartz at a concentration of 1 part per million or 10^{17} atoms per cm³—a high impurity level by semiconductor standards.

Although 1 part in 10^6 silicon content doesn't affect laser devices, most other applications couldn't tolerate that level of impurity. But with modifications in the growth apparatus and additions of Ga_2O_2 to the melt—to suppress the reaction of silicon with the melt—this contamination can be reduced to about 1 part in 10^8 .

Crystals grown this way are generally semi-insulating—having resistivities near 10^8 ohm-cm—but heat treatment produces high-mobility GaAs with resistivities between 1 and 1,000 ohm-cm depending on the temperature and length of heat treatment.

For more on . . .

Crystal growth: L.G. Bailey, Transactions of Metallurgical Society of AIME, March 1967, p. 310.

An all-in-one process for building junctions

By James J. Tietjen and Leonard R. Weisberg

RCA Laboratories, Princeton, N.J.

A hard fact of life is that the production of a good crystal of bulk gallium arsenide takes us only one step towards achieving a practical GaAs device. The p-n junctions must also be formed, and this is often the most difficult part of the task.

Alloying and diffusion methods used successfully with germanium and silicon often aren't good enough for GaAs devices. The high temperatures required can bring contamination, movement of defects in the crystal, or a decrease in carrier lifetimes.

With vapor-phase epitaxy, the device can be prepared in one continuous process. In this method, dopants are introduced as a single-crystal material is being epitaxially grown so that the p-n junctions are formed as the device takes shape, eliminating high-temperature processing after growth. Since the dopants are in a gaseous state, they can be introduced or removed at nearly any desired rate.

Gases for GaAs

The vapor-phase growth technique (for details, see the following article) is novel in that it uses gaseous reagents, such as arsine (AsH_3) and, if a gallium-arsenide phosphide diode is being made, phosphine (PH_3) for the supply of gaseous phosphorus. The independent introduction of these elements involves only a simple cracking of the gases. This eliminates the time delays of such epitaxial systems as the AsCl_3 , in which the reagents must slowly reach equilibrium before full control is possible.

Precise control of doping is shown in the photo of the varactor diode. Here a GaAs $n^+n^-p^+$ structure is epitaxially grown in one continuous process on a GaAs substrate. Each layer is only 10 microns thick, yet junction planarity and uniformity is evident—no smearing of the junction boundaries can be seen. In the finished structure, the n-region has an electron concentration in the low $10^{15}/\text{cm}^3$ range and a mobility of about $6,000 \text{ cm}^2/\text{volt-sec}$ despite the presence of heavily doped layers on either side. Thus there was little problem with autodoping—the undesired diffusion of dopants

from one portion of the device to another.

This technology has already produced several GaAs and $\text{GaAs}_{1-x}\text{P}_x$ devices with properties never achieved before—varactors, injection lasers, light-emitting diodes, and Gunn diodes.

More than a thousand GaAs varactors have been prepared with vapor-phase techniques, and they exhibit the best combination of breakdown voltage (greater than 50 volts) and cutoff frequency (greater than 150 GHz at -6 v bias) yet reported. Furthermore, the diodes are extremely uniform, with little variation in electrical characteristics in different regions of the wafer. The junctions are quite abrupt, with an n-factor equal to 0.49 (the theoretical value of n for an abrupt junction is 0.5).

By vapor-phase growing $\text{GaAs}_{1-x}\text{P}_x$ alloys with

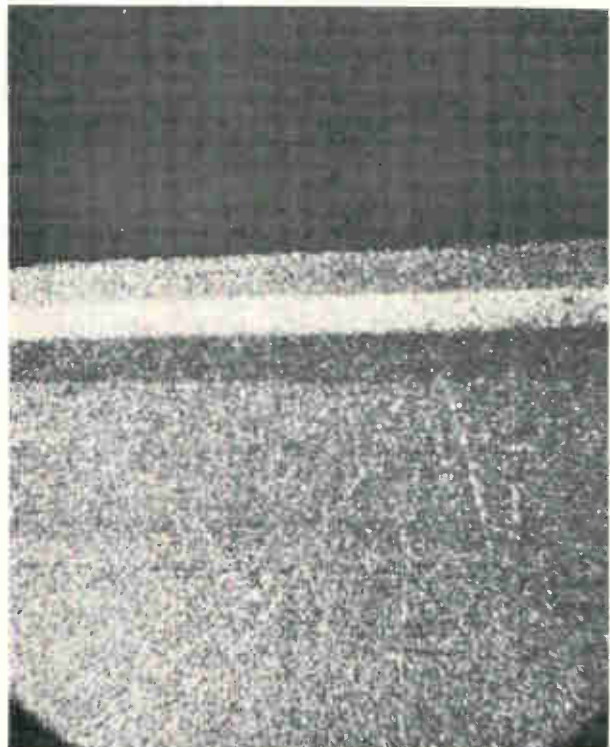

Planar junction. Varactor fabricated by vapor-phase method has narrow uniform junction.

p^+n^+ junctions, several hundred injection lasers emitting visible light at room temperature have been fabricated, the only such devices yet reported. One laser operating at 4.2°K is the brightest electro-luminescent source ever prepared. Others emitting visible light in a continuous-wave mode at 77°K have also been built.

Multilayer

A major problem with GaAs and $GaAs_{1-x}P_x$ light-emitting diodes is that much of the light given off is reabsorbed by the diode itself. To minimize this, a phosphorous-rich layer is placed above the p-n junction to act as a window for the light to pass through. This multilayer structure would be difficult to build with ordinary fabrication procedures, but is easily prepared with vapor-phase technology. Such a diode has provided a brightness of 135 foot-lamberts at a current density of 10 amps/cm².

For a Gunn diode, $n^+n^-n^+$ layers are vapor-grown in one continuous process with the n^- region as thin as 1 micron. This again demonstrates the absence of autodoping effects. Using such a structure with a 2.5-micron-thick n^- region, a Gunn oscillator has operated in the transit-time mode at 40 Ghz, the highest frequency reported for this kind of operation.

The same type structure with an n^- -layer 100 microns thick has provided 143 watts of pulsed power at 2.2 Ghz.

For more on . . .

Vapor phase growth: J.J. Tietjen, J.A. Amick, *Journal of the Electrochemical Society*, July 1966, p. 724.

Epitaxial varactor diodes: J.J. Tietjen, G. Kupsky, H. Gossenberger, *Solid State Electronics*, 1966, p. 1049.

Epitaxial Gunn devices: R.E. Enstrom, C.C. Peterson, *Transactions of the Metallurgical Society of AIME*, March 1967, p. 413.

Materials IV

Film-making: a delicate job performed under pressure

By Kenneth L. Lawley

Bell Telephone Laboratories, Murray Hill, N.J.

The growth of a single-crystal material on a substrate of a similar material is the key step in fabricating many semiconductor devices. The epitaxial process produces material not attainable with bulk crystal or diffusion processes. Because of the low temperature of these processes, pure crystals can be grown, allowing the full realization of the high electron mobility possible with gallium arsenide.

Gallium-arsenide films are harder to grow than elemental semiconductors because there are no suit-

able gallium compounds that are gaseous at room temperature and atmospheric pressure. Both the arsenic and gallium gaseous compounds must therefore be supplied to the reactant system under closely controlled conditions.

The three deposition methods generally applied use:

- bulk GaAs as a source and water vapor or a chloride as a transport medium;
- pure gallium as a source for the gaseous gallium compound and arsine or arsenic trichloride for the arsenic;
- condensed GaAs in liquid gallium.

Pure and simple

The simplest of these methods is the first. The bulk material is exposed to an oxidizing gas, and the products of this reaction serve as the gaseous source from which gallium arsenide is deposited. Water vapor, hydrogen chloride, or chlorine diluted in hydrogen are usually used as the oxidizing gas, though other halides have been tried.

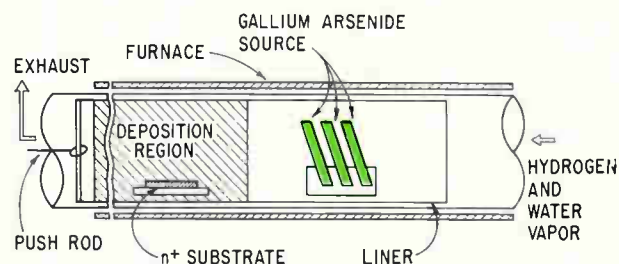

Water carrier. In the water-vapor epitaxial method, bulk gallium arsenide is used as the source.

Water vapor reacts with the GaAs crystal at about 1,050°C to form hydrogen, arsenic vapor and the volatile suboxide—or vapor form—of gallium. This reaction is reversed at a lower temperature—about 1,000°C—in another part of the reactor, where a GaAs film is deposited on the GaAs substrate.

Mainly because of impurities transferred from the source crystal and contamination caused by the high temperatures necessary for deposition, the minimum donor impurity attainable so far is $2 \times 10^{15}/\text{cm}^3$ with mobilities exceeding 7,000 $\text{cm}^2/\text{volt-sec}$.

Doped films can be grown from source crystals doped with selenium and tellurium. However, silicon and the p-type dopants, zinc and cadmium, aren't transferred. Films can be grown at rates of 10 to 60 microns per hours on the preferred 111 plane.

When chlorides are used, the reactions at the GaAs source take place at 800° to 850°C—the temperature at which the chlorine or chloride reacts to form gallium trichloride and arsenic vapor. At the substrate temperature—about 750°—monochloride, formed from trichloride, combines with the arsenic vapors to form a GaAs film.

Chloride-produced films are less pure than water-vapor-grown material, probably because most impurities in the feed gas and source crystal are too easily transferred to the film as chlorides. Common donors and acceptors are readily transported from source to film in this system. Growth rates are comparable to those attainable with water vapor, but the preferred growth plane is 100.

Purer

In the second major epitaxial method, the vapor-phase, a gaseous gallium compound is formed and mixed with an arsenic compound. Gaseous gallium trichloride is generated by passing hydrogen chloride or chlorine over gallium in the reactor system. The chlorine can come from a tank or from the decomposition of arsenic trichloride.

The arsenic and gaseous gallium compounds are mixed in the reaction chamber and passed over the GaAs substrate at from 750° to 800°. Deposition occurs when the gaseous mixture is thermodynamically unstable with respect to the substrate—a condition believed attributable to the gallium monochloride-arsenic gas reaction.

This technique can yield high-purity films (donor impurities about $10^{15}/\text{cm}^3$, mobility about 6,000 to 7,000 $\text{cm}^2/\text{volt-sec}$) on semi-insulating or highly doped substrates. Hydrogen sulfide and selenide have been used to prepare n-type layers, and dimethyl zinc or zinc metal to prepare p-type on a variety of planes.

Purest

The purest films produced by chemical vapor deposition have been grown with the technique that uses a condensed source of GaAs in liquid gallium. The source mixture is presynthesized

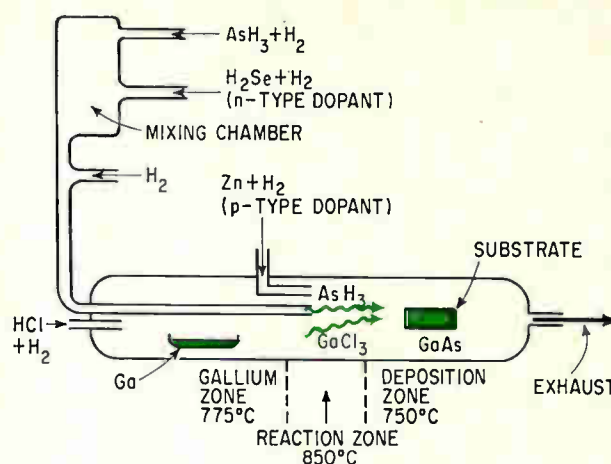

Gaseous gallium. Vapor-phase gallium is obtained by passing hydrogen chloride over it; arsine is used for the arsenic.

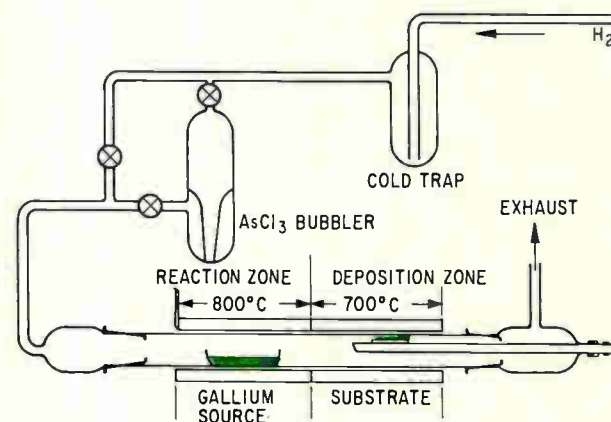

Skin effect. A GaAs skin is formed on the pure gallium source to serve, in turn, as the source of gallium arsenide.

before deposition by exposing liquid gallium to arsenic trichloride. If the arsenic vapor pressure exceeds the decomposition pressure of the GaAs-in-gallium solution at the operating temperature (about 850°C), a GaAs skin forms on the gallium and serves as the source of GaAs. After this skin is formed, a substrate is exposed to the source reaction products at about 750°C.

This method has been used by British researchers to grow films with donor impurity concentrations of less than $10^{15}/\text{cm}^3$ and room-temperature mobilities of about 9,000 $\text{cm}^2/\text{volt-sec}$. The maximum electron mobility at the low temperature of about 56°K is about 140,000 $\text{cm}^2/\text{volt-sec}$, and growth rates are about 10 to 20 microns per hour.

Other methods haven't received the attention given chemical vapor techniques, but the coevaporation of arsenic and gallium and liquid regrowth are currently being reinvestigated.

For more on . . .

Water vapor method: K.L. Lawley, *Journal of Electrochemical Society*, March 1966, p. 240.

Arsine vapor phase method: J.J. Tietjen, J.A. Amick, *ibid.*, July 1966, p. 724.

GaAs in gallium: D. Effer, *ibid.*, October 1965, p. 1020.

Getting dopants on the beam is a long-term project

By Kenneth E. Manchester

Sprague Electric Corp., North Adams, Mass.

The technique of implanting dopants in crystals of gallium arsenide with a high-energy beam of ions is still at an early stage of development. Holding out the promise of alternative methods for building devices requiring limited processing temperatures and a precisely shaped doping profile, ion implantation can eventually complement existing diffusion method for doping semiconductors.

In the field of light-emitting gallium-arsenide devices, the technique would make it relatively easy to build the junctions close to the surface; this would enhance light-emitting properties by reducing absorption before the light leaves the surface. Diodes made with implanted dopants in the laboratory have emitted about the same levels of light as diffused diodes.

There are two major obstacles to practical ion-implanted GaAs devices: our ignorance of the details of the implantation process and impurities in

the GaAs substrates. However, the considerable efforts being made to understand ion implantation in silicon should carry over into the area of gallium arsenide.

Experimental diodes

At the Sprague Electric Corp., zinc has been implanted in n-type GaAs, and tellurium in p-type GaAs; ions have been accelerated to 40 and 80 kiloelectron-volts, a relatively low energy level, to produce shallow junctions.

Two types of diodes were formed by this process, each doped with 80-keV zinc ions. One was annealed in an argon atmosphere for 20 to 30 minutes at 650°C, the temperature above which arsenic tends to leave the GaAs surface—a thermal etching effect. The other was annealed for 10 to 15 hours at the same temperature in argon. The diode surfaces were protected with a layer of silicon dioxide to further prevent thermal etching.

The first diode had an essentially abrupt junction and a sharp reverse breakdown. A good thermally diffused diode with a similar background carrier concentration would have a similar junction but a more gradual reverse breakdown.

The second diode had a graded junction, a higher reverse breakdown voltage, and a relatively high forward resistance. The rate at which the impurity concentration decreased away from the junction was about $10^{20}/\text{cm}^3$ per centimeter—about 1/100th the grading coefficient of a typical diffused graded-junction device.

The low grading coefficient indicates a long tail on the implanted distribution due to deeply penetrating ions. This tail may be the result of either a channeling phenomenon occurring during implantation—where ions travel down open channels in the GaAs lattice—or a diffusion process during the long annealing period.

Comparisons

Both diodes emitted light at 9.2 microns when forward biased, but the abrupt-junction diode

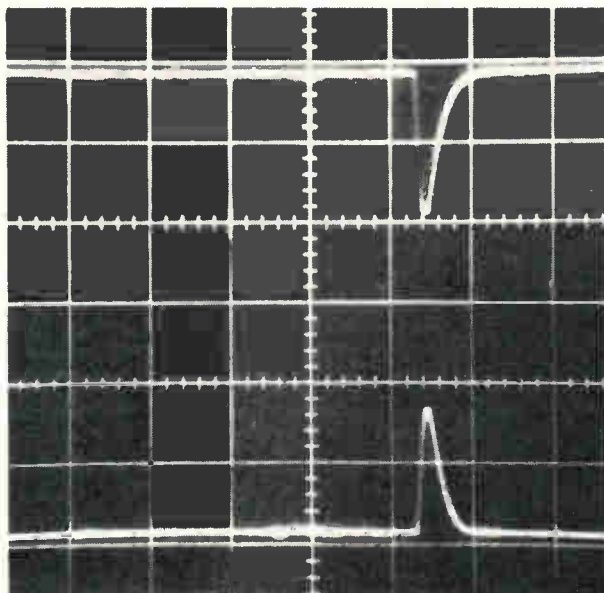

Implanted outputs. Ion-implanted diode with 80 keV zinc ions delivers sharp pulse (lower trace) in response to input (upper trace).

showed the higher power output and efficiency. The best implanted diodes have exhibited power outputs of about 2 milliwatts per ampere forward current. Good diffused-junction GaAs diodes also produce about 6 mw/amp output.

Researchers at the Ion Physics Corp., Burlington, Mass., report that sulfur implantations in p-type GaAs with ion energies of 400 to 800 keV through a sputtered quartz film produce junctions 0.25 and 0.50 microns deep. Diodes made this way have characteristics similar to those of diffused structures.

GaAs implanted at low substrate temperatures—100°C or less—must be annealed to heal the damage caused by the impact of the high-energy ions and also to enable the injected atoms to move into the positions of active acceptors or donors. Not only isn't this annealing process fully understood, but the results of GaAs annealing don't appear to be as consistent as those achieved with silicon.

For more on . . .

Implants in GaAs: P.E. Roughan, K.E. Manchester, *Bulletin of American Physical Society*, 1967, p. 140.

Materials VI

An almost ideal substrate

By C.P. Sandbank

Standard Telecommunication Laboratories, Harlow, England

With all its potential for generating microwave power, emitting light, or multiplying frequencies, one of gallium arsenide's most important jobs may be one in which it does nothing. In its semi-insulating form, it merely isolates GaAs devices from one another in a monolithic integrated circuit, or isolates a single GaAs device from a heat sink to raise power.

The material has already played this passive role in experimental IC's, high-power devices, and domain-originated functional IC's—dofic's, but there is still room for improvement in the properties of the semi-insulating substrates.

Semi-insulating gallium arsenide has dielectric properties that provide excellent isolation from d-c to microwave frequencies while retaining a crystal structure that is an ideal substrate for the epitaxial growth of semiconducting GaAs. In fact, some of the best semiconducting GaAs has been deposited on GaAs substrates.

Semi-insulating gallium arsenide was first characterized at the Services Research Laboratory in Baldock, England, by C.H. Gooch, C. Hilsum, and B.R. Holeman. The first ingots actually appeared accidentally during a procedure that normally produces the semiconducting form.

Resistivity of intrinsic GaAs at room temperature is about 10^8 ohm-centimeters, corresponding to an intrinsic carrier density of about 10^7 carriers/cm³. The best epitaxial growth methods produce donor impurity levels of about 10^{14} atoms/cm³—representing a resistivity of about 10 ohm-cm. To make higher-resistivity material, the donors must in some

way be balanced by compensating acceptor atoms, a difficult task.

Several impurities—notably oxygen and copper—can produce semi-insulating properties, but the best way to grow semi-insulating material was introduced by two Texas Instruments researchers, A.R. Cronin and R.W. Haisty. They found that when chromium was used to dope GaAs, the material behaved in a manner consistent with the mechanism that J.W. Allen of the Baldock facility originally suggested to explain the semi-insulating phenomena.

Allen realized that it was highly unlikely that the donor and acceptor impurities present in the ingot balanced exactly. He therefore postulated that shallow donor levels are compensated for by an access impurity that gives rise to a deep acceptor level near the center of the band gap. The acceptors contribute relatively few ionized carriers—holes with low mobility—at room temperature, Allen suggested.

Recently, D.R. Heath, P.R. Selway, and C.C. Took at Standard Telecommunication Laboratory, Harlow, England, identified this level in some chromium-doped ingots grown by the horizontal Bridgman process. They used measurements of photoconductivity to show that the acceptor level associated with chromium at room temperature is 0.79 electron volts from the conduction band and 0.64 eV from the valence band. It thus stands almost in the middle of the band gap.

Semi-insulating crystals with resistivities greater than the 10^8 ohm-cm level can now be consist-

ently produced. This resistivity stems from the high density of traps, and from the fact that mobilities are normally much lower than those in the semiconducting n-type crystals. Typical electron-mobility values for the semi-insulating material lie between 200 and 2,000 cm²/volt-sec. Because the electrons are more mobile than the holes, they account for most of the small current flow.

Lab results

Semi-insulating GaAs has been deposited epitaxially by Haisty and P.L. Hoyt of π , who obtained resistivities of up to 10⁵ ohm-cm by doping with iron. And J. Franks and P.R. Selway of Standard Telecommunication Laboratory have made p-i-n diodes in which the intrinsic region was formed by the diffusion of chromium into n-type slices having an initial carrier concentration of more than 10¹⁶ per cm³. Resistivities at the surface of the intrinsic layer were measured at 10⁸ ohm-cm.

These results demonstrate the feasibility of integrated circuits in which the semi-insulating properties of the substrate are brought to the surface by a local diffusion of chromium to produce isolating channels in the semiconducting layer.

Peak mobilities of 100,000 cm²/volt-sec have been achieved at the Standard Telecommunication Laboratory with semiconducting n-type GaAs vapor-deposited on semi-insulating GaAs by the arsenic trichloride-gallium process. Researchers at srrl also report mobilities of 8,000 at room temperature (56,000 at 78°K) with n-type layers deposited from the liquid phase on semi-insulating substrates. The fact that n-type layers of GaAs can be grown on semi-insulating substrates simplifies the evaluation of the epitaxial process.

For more on . . .

First characterization: C.H. Gooch, C. Hilsun, B.R. Holeman, *Journal of Applied Physics Supplement*, 1961, p. 2069.

First fabrication: F.A. Cunnell, J.T. Edmond, W.R. Harding, *Solid State Electronics*, 1960, p. 97.

Chromium doping: G.R. Cronin, R.W. Haisty, *Journal of Electrochemical Society*, 1964, p. 874.

Compensation effects: J.W. Allen, *Nature*, 1960, p. 403.

Epitaxial semi-insulating PaAs: P. Hoyt, R.W. Haisty, *Journal of Electrochemical Society*, 1966, p. 296.

Epitaxial semiconducting layers: J. Whittaker, D.E. Bolger, *Solid State Communications*, 1966, p. 181.

Domain-originated functional IC's: C.P. Sandbank, *Solid State Electronics*, 1967, p. 369.

Devices I

Off to a good start

By Arthur Uhlir Jr.

Microwave Associates Inc., Burlington, Mass.

For its first use in a practical device—the varactor diode—gallium arsenide was in the right place at the right time. In the late 1950's, makers of microwave systems needed low-noise parametric amplifiers and frequency multipliers that couldn't be built with other semiconductor materials.

The use of gallium arsenide for varactors in microwave systems is a reflection principally of quantitative features such as high electron mobility and retention of conductivity at 4.2°K liquid helium temperatures—a must for cooled, low-noise parametric amplifiers. In this respect, the varactor differs from more recent GaAs devices such as light-emitting diodes, lasers, and piezoelectric transducers, where the emphasis is on properties that are qualitatively different from those of silicon and germanium.

GaAs varactors have scored their biggest success in low-noise parametric amplifiers. Here they compete with silicon devices in uncooled appli-

cations and have the cooled field to themselves.

At room temperature, the higher electron mobility of GaAs yields a series resistance lower than that of silicon, and cutoff frequencies three or four times higher. This, however, doesn't result in a comparable drop in amplifier noise. For one thing, losses stemming from the relatively low mobility of holes in the p-type regions of the GaAs diode and from the finite conductivity of the cartridge metal reduce the cutoff-frequency advantage to a factor of about two—600 gigahertz against silicon's 300 Ghz. For another, high pumping frequencies are needed at room temperature to take full advantage of varactors with high cutoff frequencies.

When cost is no object, however, refrigeration will make parametric-amplifier noise negligible in comparison with noise from antenna feeds. It's far easier to design such an amplifier with a GaAs varactor than with silicon or germanium because

only a few silicon or germanium devices will function at liquid helium temperatures, and those that will work have low-temperature electrical characteristics different from those at room temperature.

Gallium arsenide's low-temperature behavior has just one flaw: thermal conductivity—no bargain at any temperature—becomes even worse. This doesn't mean that the diodes are in any danger of burnout by pump power, but merely that they will heat up to some temperature, say 20°K, where the thermal conductivity is better but the noise worse.

For all this, the attainable noise temperatures are still remarkably low; in fact, the noise temperature of a parametric amplifier is often lower than that of a varactor.

Frequency multipliers

GaAs varactors haven't substantially penetrated the multiplier field. They are used to some advantage for output powers of 1 to 100 milliwatts at output frequencies above 20 gigahertz, where the high cutoff frequency dominates other considerations, but silicon is the universal choice at lower frequencies and higher powers. Among the reasons for this preference for silicon are higher yield for relatively large junction areas, better thermal conductivity, longer life, and lower cost.

An even more fundamental reason may be silicon's substantially longer minority carrier lifetime, a feature that, in a forward-biased p-i-n diode structure, permits the storage of a large amount of charge in the form of hole-electron plasma. This charge can be released rapidly across the depleted regions that form on either side of the plasma as bias is reversed. The degree to which this action can take place in GaAs varactors has never been

thoroughly evaluated, but it is certainly much less than in silicon. Any hole-electron plasma in GaAs tends to decay through light emission, and perhaps even faster because of material imperfections.

In one circuit study, multiplier efficiency was directly related to carrier lifetimes in GaAs varactors having otherwise similar characteristics. (Short carrier lifetimes can be estimated from the ratio of capacitance to conductance for varied forward bias.)

Carrier lifetime is also a significant factor in parametric amplifiers, where the longer lifetimes of silicon diodes give wider bandwidth.

Tuning in

In tuning applications, however, lifetime appears to be a negligible factor. Yet GaAs varactors aren't widely used for electronic tuning of receivers, primarily because of the insufficient yields of high-capacitance diodes with junction areas substantially larger than those of parametric-amplifier varactors. However, material studies will almost certainly provide answers to the problems of low yield and high initial costs.

A factor of two in cutoff frequency, though important in a given circuit, can only add an octave of frequency to varactor-tuned receivers. This hypothetical octave band (which might today be 1-2 Ghz) would be at frequencies too high for silicon varactors but not for GaAs. Still higher frequencies will require digital tuning by p-i-n diodes.

An octave band in the ultrahigh-frequency or microwave regions points toward important future tuning applications for gallium-arsenide varactors. And GaAs varactors are the only devices for tuning circuits operating at any frequency at liquid helium temperatures.

Devices II

Narrow field for bipolars

By Hans Strack

Texas Instruments Incorporated, Dallas

Any material that tries to invade silicon's home grounds—the transistor field—is in for a battle. Gallium arsenide stands alone in the Gunn-effect and light-emitting-diode areas, but present bipolar GaAs transistors don't measure up—either in price or performance—to comparable germanium and

silicon devices. However, they do have a chance to win a few encounters in the high-temperature field, where germanium and silicon won't work.

The major hurdle, as in other applications, is the starting material. A low solubility of impurities bars a wide range of doping concentrations from

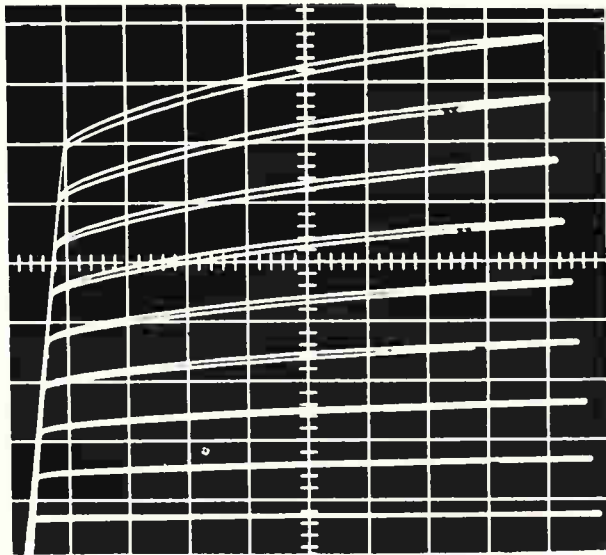

-196°C

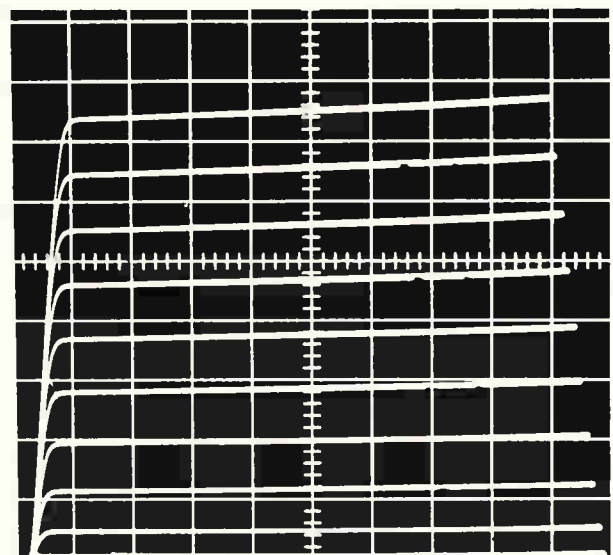

25°C

Temperature effects. Common-emitter characteristics of GaAs bipolar transistor at -196°C , left, and at room temperature, right. Vertical calibration is 1 milliamperes/division, horizontal is 1 volt/division; base current increases 0.1 milliamperes with each step.

emitter to collector, and thus limits emitter efficiency and base spreading resistance.

In addition, it's difficult to measure the other material properties bearing on transistor operation, and difficult, with present processing methods, to do anything about changing them.

Although they have only partly fulfilled expectations, GaAs transistors have been a major factor in the development of other GaAs devices. Because of their dependency on material quality and fabrication processes, GaAs bipolar transistors are sensitive tools for the study of GaAs material and device technology.

Performance forecast

About 10 years ago, it was commonly predicted that GaAs transistors would bypass silicon and germanium devices in temperature and frequency performance because of gallium arsenide's wider band gap and higher electron mobility. Based on a maximum operating temperature of 100°C for germanium, engineers projected silicon transistors operating at up to 250°C and GaAs transistors at up to 450°C .

The highest operating frequency is related to the product of electron and hole mobility in the case of bipolar transistors, and to the majority carrier mobility with unipolar (field effect) transistors. Bipolar GaAs and germanium transistors lead silicon devices in this mobility factor; the two are equals at higher frequencies because the higher electron mobility of GaAs is offset by germanium's higher hole mobility and somewhat higher dielectric constant.

GaAs unipolar transistors should operate at frequencies roughly twice as high as the top levels for germanium unipolar transistors, which, in turn, should surpass those of silicon devices by about the same factor.

The first GaAs transistors were fabricated from Czochochalski-grown material. Reproducibility was very poor and current gains were low. Boat-growing led to better devices, but high current gain could only be achieved consistently after the introduction of vapor-phase epitaxial methods.

But the problems of relating material properties to device performance still remain; it isn't yet possible to define "good" transistor material, or even to influence critical parameters by changing growth conditions. The conveniently measurable properties of the material, such as dislocation density, mobility, and doping level, don't relate to transistor performance, although they are useful for basic material.

However, the recently applied cathodoluminescence technique may provide a means of selecting suitable GaAs material for device fabrication. In this technique, GaAs is bombarded with electrons that penetrate deep. From deep inside, the GaAs emits light related to such parameters as diffusion length and lifetime.

The influence of particular dopant elements on device performance is small compared with the effect of the starting material. Almost all transistors have been of the npn type because of the wide ratio of electron to hole mobilities—about 20:1 in GaAs.

The general difficulty in making GaAs transistors is that only two to three orders of magnitude concentration difference can be achieved between emitter and collector; with silicon transistors, the concentration difference runs to four or five orders of magnitude. In GaAs, the collector concentration is typically about $10^{16}/\text{cm}^3$. At lower concentrations, thermal conversion of n-type to p-type material occurs, sometimes caused by fast diffusing acceptors such as copper. The solubility of electrically active donors in GaAs (the maximum

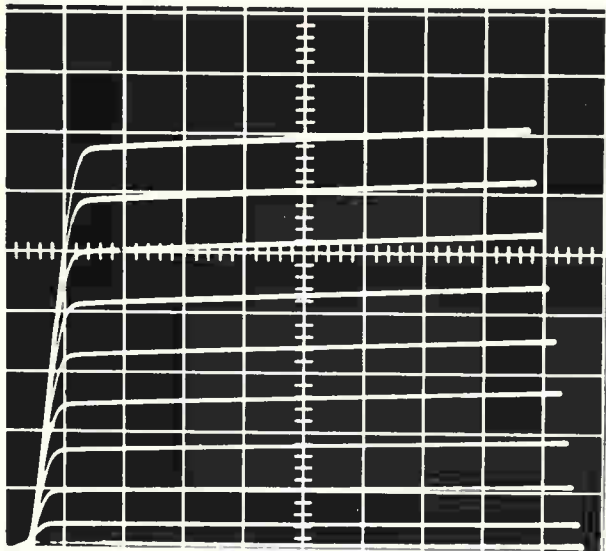

300°C

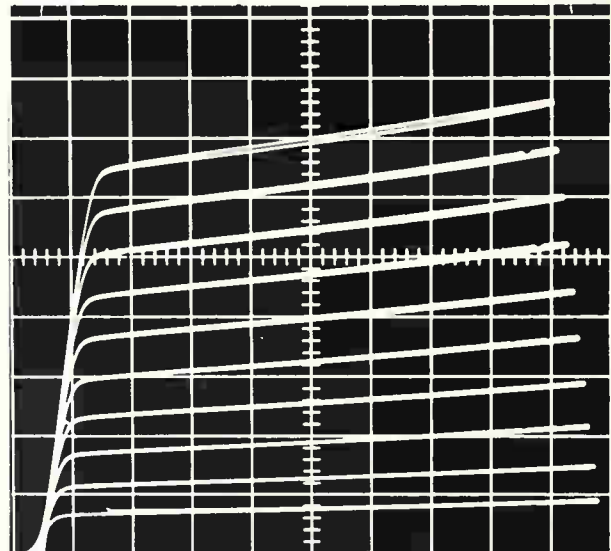

400°C

High temperature. Common-emitter characteristics at 300°C, left, and 400°C, right. Calibration is the same as for curves at left.

doping concentration possible for the emitter) is about 2 to $3 \times 10^{18}/\text{cm}^3$. The base concentration consequently has to be kept between, say, 2 to $3 \times 10^{17}/\text{cm}^3$ at the surface of the p-type base region. In contrast to donor solubility, the acceptor solubility is high, about $10^{21}/\text{cm}^3$; this could allow high emitter doping, but pnp transistors are undesirable because of the low mobility of holes.

Base making

The techniques developed to fabricate base regions with the desired doping profile fall in three categories:

- Deep diffusion with subsequent etch-back of the p-layer to the required thickness of about 1 to 1.5 microns.
- Diffusion through a mask such as silicon oxide, to reduce surface concentration and diffusion depth.
- Epitaxial deposition of a uniformly doped p-type layer.

Because of the relatively high vapor pressure of arsenic over GaAs at the diffusion temperature, special techniques have been developed for diffusions performed above 700°C. The GaAs slice is sealed in an evacuated quartz ampul together with the proper amount of dopant, and arsenic is added to reduce arsenic loss from the surface. Another way of preventing arsenic evaporation is to seal off the surface with a layer of either reactively sputtered silicon dioxide or silicon dioxide deposited by thermal oxidation of tetraethylorthosilicate (TEOS). Unlike silicon, which has its silicon dioxide, gallium arsenide doesn't have a natural oxide to protect it.

The TEOS method produces a better film in terms of density and leakage than sputtering does. When the TEOS, heated in the presence of an oxygen-rich atmosphere, breaks down, the silicon links with the oxygen and deposits on the GaAs wafer. Since the

operational temperature is 450°C, there is no problem of arsenic leaving the GaAs surface.

Performance

The most striking characteristic of GaAs bipolar transistors is that actual cutoff frequencies are always below the values calculated from mobility and device geometry. Transistors with high d-c current gains generally have low cutoff frequencies, and vice versa. Also high d-c gains appear strongly dependent on temperature, while low d-c gains do not.

For example, transistors with common-emitter current gains of about 200 don't operate above 50 megahertz, devices with intermediate current gains of 20 have cutoff frequencies at about 500 Mhz, and devices with cutoff frequencies near 1 Ghz don't exhibit d-c gains higher than 10. Thus, the product of common-emitter d-c current gain and current-gain cutoff frequency seems to be about 10^4 Mhz.

However, transistors with intermediate current gain and intermediate cutoff frequency can be used over a wide temperature range. Devices with a d-c current gain of about 10 have been operated in a liquid helium environment (4.2°K) and at temperatures up to 500°C without the gain varying by more than $\pm 20\%$.

The explanation for this discrepancy between theoretical and observed frequency performance is the presence in GaAs of traps that limit electron mobility. The nature of these traps is only partially understood. While deep donors such as oxygen are known to hurt transistor performance, deep acceptors such as iron have been known to improve it.

Applications for high-temperature transistors are limited to those environments in which cooling systems for silicon devices are impractical or unfeasible. Possible jobs would be in test equipment

for deep oil wells and in gear for space probes near the sun.

Stability

Before GaAs can be considered for high-temperature circuits though, serious stability problems must be solved. All GaAs transistors suffer from instability when operated over long periods of time, even at room temperature. At temperatures of 400°C to 500°C, the possibility of a rediffusion of emitter and base regions must be considered. Although individual transistors have been operated over periods of several thousand hours in a 300°C ambient environment with little degradation, these results are not reproducible with all transistors.

Studies of the stability of GaAs have produced a better understanding of the degradation of transistors, light-emitting diodes, and microwave devices. But failure-mechanism studies of GaAs devices have just scratched the surface of the problem.

For more on . . .

Comparisons with Ge, Si: D.A. Jenny, Proceedings of the IRE, June, 1958, p. 959.

Cathodoluminescence studies: D.B. Wittry, D.F. Kyser, Journal of Applied Physics, 1967, p. 375.

Iron doped transistors: H. Strack, Gallium arsenide—Institute of Physics and Physical Society Conference Series No. 3, p. 206.

Devices III

Fast-moving FETs can outpace rivals

By Hans Becke

RCA Electronic Components and Devices Division, Somerville, N.J.

Gallium-arsenide bipolar transistors may have a hard time trying to replace their silicon counterparts, but the story may be different in the case of field effect transistors. Gallium arsenide enters the race with at least one big plus—a far higher electron mobility than silicon's. This feature can mean more gain at higher frequencies to go along with gallium arsenide's higher temperature performance.

The frequency response of a field effect transistor is primarily determined by the mobility of the majority carriers—electrons in an n-channel device—and GaAs has a 5:1 edge over silicon on this score. Two recent developments, a very-high-frequency device using silicon nitride as a gate insulator, and a microwave device using a Schottky barrier as the gate, demonstrate the potential of GaAs FETs. Since both depend on channel carrier mobility for high-frequency performance, they have the same frequency response limits.

Both are made in planar form and can be easily incorporated into integrated circuits. Such transistors, working with other new gallium-arsenide devices, could herald a new era in IC's.

The silicon-nitride, insulated-gate FET, developed at the Radio Corp. of America, has provided 22 decibels gain at 200 megahertz though it wasn't

designed with a high-frequency geometry. Silicon devices with the same geometry give only 16 db gain at the same frequency [Electronics, June 12, 1967, p. 82].

The device channel was made with the hydride vapor technique of J. J. Tietjen and J. A. Amick of RCA Laboratories [details on p. 115]. A thin layer of lightly doped n-type GaAs was epitaxially grown over a p-type substrate and covered with a layer of silicon nitride. After the Si_3N_4 was masked and the source and drain sites were etched, tin was diffused into the source and drain sites to provide heavily doped n-type material for use with the contacts, which were then applied over the gate channel region and also over the source and drain sites.

Fewer surface states

Silicon nitride has a big advantage over silicon dioxide here in that it allows the electric field produced by the gate to penetrate deeper into the GaAs because it produces fewer surface states to terminate the gate field near the surface. This affords greater control of the channel current and a higher transconductance—typically, about 10 to 25 millimhos against silicon's 8 to 10 millimhos. The trans-

conductance rises with increases in frequency because the surface states have less effect at higher frequencies—they can't follow the high-frequency signals.

The Schottky-barrier transistor, developed at the Fairchild Semiconductor division by a group including W. W. Hooper, P. L. Hower, and W. T. Lehrer, gave a maximum oscillation frequency of about 3 Ghz, and a gain of 10 db at 1 gigahertz. Its designers say the device, described in detail at the International Electron Devices Meeting in Washington last month, promises a useful gain at frequencies above 10 Ghz.

Though easier to make than the insulated-gate FET, the Schottky-barrier unit can only be operated in the depletion mode because it uses a reverse-biased junction for the gate. Enhancement mode operation—no standby power—is not possible since the gate junction would become forward biased, short-circuiting the input.

For more on . . .

Silicon-nitride insulator FETs: H. Becke, J. White, *Electronics*, June 12, 1967, p. 82.

Schottky-barrier gate FETs: W.W. Hooper, W.I. Lehrer, *Proceedings of the IEEE*, July 1967, p. 1237.

Devices IV

Microwave mixing and detecting

By Charles M. Howell

Microwave Associates Inc., Burlington, Mass.

Point-contact microwave diodes, after 25 years of faithful service, may soon go into forced retirement. In the frequency range below 5 gigahertz, Schottky-barrier microwave diodes with better noise figures, better resistance to burnout, and higher reliability are now commercially available. And, except for burnout resistance, these advantages persist all the way up to 100 Ghz.

Gallium-arsenide Schottky-barrier mixer diodes can be made with noise figures so closely approaching a mixer diode's ideal 4.5 decibels that any difference between the devices lies in the calibration of the instruments used to measure them. GaAs Schottky-barrier detector diodes, which have requirements different from mixer diodes, have sensitivities that also approach an ideal level.

A Schottky diode made of silicon gives about the same noise figure through X band as a GaAs device, and both approach the limit of an ideal rectifier. Above X band, however, GaAs appears to have a small but significant edge in noise figure, although silicon diodes still cost less, are more uniform, and require less local oscillator power. However, improvements in the quality of epitaxial GaAs are narrowing this gap.

Working wall

A rectifying junction can be made between an n-type semiconductor and a metal contact by choosing a metal whose work function is higher than the semiconductor's. With lower capacitance

and less carrier storage, this rectifying junction can operate at far higher frequencies than can conventional junctions.

A video receiver that uses a diode to detect microwave energy is simple and broadband, but has a top sensitivity of -50 dbm over a signal range of d-c to about 12 Ghz; a heterodyne receiver would be 50 to 60 db more sensitive.

The sensitivity of an ideal video detector is determined by the video impedance of the diode and the noise contributed by the video amplifier. High sensitivity can thus be achieved only with high impedances. But getting a good broadband match to

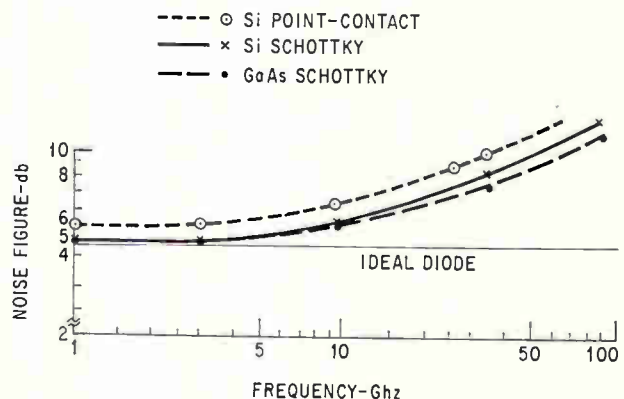

Noise figure. Operational characteristics of Schottky-barrier mixer diodes made with silicon and GaAs.

these high impedances over large bandwidths is a formidable task, and most designers resort to biasing the diode to reduce its impedance, or to padding the unit; both measures decrease sensitivity.

For high video impedances, the capacitance of the diode junction must be very small—less than 0.2 picofarad for S-band detectors and less than 0.05 pf for X-band.

The Schottky diode detector then must have as small a junction capacitance as possible; a large video impedance; low series resistance; and a Q between 10 and 20 at the operating frequency.

Therefore, the material chosen should have high electron mobility and small dielectric constant, and the diode should be made with a thin, high-resistivity epitaxial layer designed so the space charge of the junction can punch through into the substrate at or near the operating bias.

Epitaxial GaAs is thus an excellent choice. It offers a higher mobility of n-type material than does silicon, and is grown at lower temperatures, an incidental factor that can enhance control of doping in the epitaxial layer and reduce grading of the substrate-epitaxial interface. Too much grading gives a narrower-than-optimum diode space charge and boosts junction capacitance.

Generally, the larger the junction, the better the burnout resistance, but GaAs has less than a quarter of the thermal conductivity of silicon, and these factors tend to offset each other.

Gallium-arsenide Schottky detector diodes are made by depositing one of many possible metals on a clean epitaxial wafer. Nickel and gold are easily deposited, but nickel has a higher eutectic temperature with GaAs (500°C) and therefore a greater resistance to burnout.

The knee of the forward conductance curve depends on the work function of the metal used and on the crystal orientation of the gallium arsenide. The table gives a list of various metals and their barrier heights on planes 111 and 100 in GaAs and silicon; the height doesn't appear to affect sensitivity. All GaAs Schottky detector diodes require bias because the variable conductance doesn't occur near zero bias.

For a typical X-band diode, an n-type epitaxial GaAs layer 0.5 to 1 micron thick with doping of less

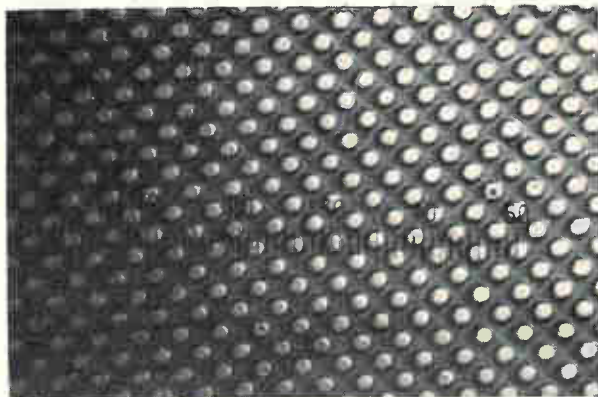

Pinheads. Array of Schottky-barrier metal contacts on batch-fabricated GaAs slice.

Barrier heights of metals

Elemental metal	n-type, GaAs Orientation		n-type Silicon Orientation
	(111)	(100)	(111)
Nickel	0.83	0.70	0.58
Gold	0.99	0.90	0.79
Silver	0.94	0.85	0.62
Tungsten	—	0.73	0.67
Aluminum	0.80	0.71	0.63
Tin	0.70	0.68	0.60
Copper	0.80	0.73	0.58

Note: All heights measured to ± 0.02 v

than 10^{16} electrons/cm³ is first coated with a layer of aluminum borosilicate glass 2 to 5 microns thick. This glass has a dielectric constant of 3.8 and also matches the thermal expansion of the GaAs well.

After the dielectric layer has been deposited, ohmic contacts are applied to the substrate; sintered gold-tin contacts give low ohmic resistance.

The Schottky diodes are formed by photoetching holes through the dielectric layer to expose the GaAs. The metal is deposited either by vacuum evaporation through a mask or by electrodeposition from a proper solution; there appears to be no difference between diodes made with either process. After the metal-semiconductor junction has been formed, the hole is filled with metal.

Because it's difficult to make the necessary low parasitic capacitance contacts—which should be less than 0.02 pf—a small plated whisker is bonded to the junction. But a junction only 1 micron thick is difficult to contact, so many small junctions are formed and contact is made to one randomly.

Microwave mixers

The ideal microwave mixer is a multiport device with large-signal and small-signal parameters determined by the variable conductance set up by the local oscillator and the terminations of each port.

The mixer diode's important electrical characteristics are conversion loss, the noise ratio at the intermediate frequency, and the impedances at each of the four ports. The conversion loss depends not only on the impedances presented at each port but on the termination presented to the harmonics of both the signal and local oscillator. However, if the mixer circuit is taken to be ideal, the image is resistively terminated, no signal power is lost in the higher-order harmonics, and the diode's conversion loss depends on signal match and resistive losses.

An ideal mixer diode presents to the signal a time-varying conductance whose average value can fall within a wide range without hurting performance (in contrast to the detector situation). In a typical Schottky diode, the corresponding impedances will be 100 to 300 ohms, depending on the local oscillator drive. The capacitance of the junction tends to shunt this variable conductance. Because its barrier impedance is far lower than a detector's, the mixer

diode can use larger capacitance junctions, but more attention must be paid to the series resistance.

Another mixer-diode design consideration is the minimizing of the local oscillator power requirement. Silicon diodes need less of this power than GaAs devices do. Local oscillator power is often limited, especially at high frequencies or where a solid state source is used. The power requirement for minimum noise figure in an unbiased mixer diode depends directly on the barrier voltage of the junction, so the junction should have as low a barrier height as possible.

Yet another consideration is dynamic range. In a typical mixer, signal compression occurs when the signal power is less than 20 db below the local oscillator. One can boost the local oscillator power to increase dynamic range, but as the field across the junction increases it starts field-induced minority carrier injection. This injection rapidly increases the shot noise and conversion loss of the diode. The onset of injection limits the maximum usable local oscillator power.

In general, the injection begins at current densities inversely proportional to barrier height. Thus, larger local oscillator powers can be used with low barrier junctions if the r-f bias doesn't exceed the breakdown of the diode; normally, however, this isn't the case.

A GaAs Schottky mixer diode's junction capacity must therefore be less than 0.4 pf for S band and 0.20 pf for X band, its series resistances should be no more than 3 to 5 ohms, and its barrier should be low. The metals with the lowest barrier potentials are tin and nickel, but tin is susceptible to burnout because it forms a low melting eutectic with GaAs.

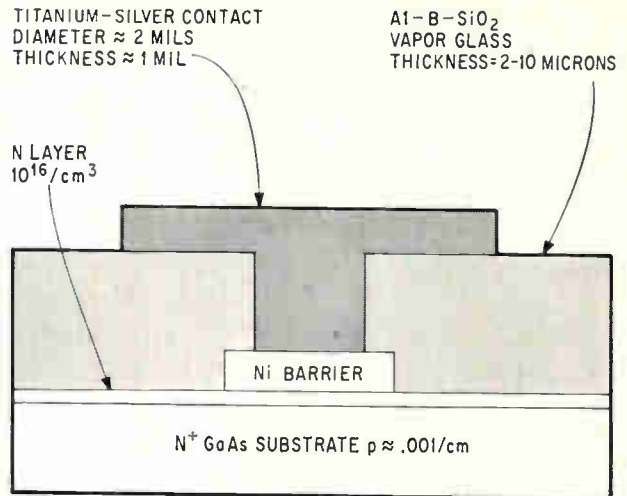

Metal barrier. Schottky-barrier diode formed with nickel contact on semiconducting GaAs layer.

The 100 crystal face has a low barrier for all metals and seems good for thin epitaxial layers.

The starting material for fabrication is 100-oriented epitaxial GaAs with the same doping level used for the detector diode. However, because the bias set up by the local oscillator extends the space charge, the mixer diode's epitaxial layer can be as thick as 1.5 microns.

Junction diameters are much larger than those for detectors—5 to 10 microns in X band and as large as 12 to 20 microns in S band. These larger junctions permit the forming of a bilithic diode. The glass can be deposited over the edge of the junction and thermocompression contacts made.

Devices V

Beating the heat in injection lasers

Hans Rupprecht

International Business Machines Corp., Yorktown Heights, N.Y.

Since that day in 1962 when IBM and GE almost simultaneously announced the development of injection lasers, gallium arsenide has been the material most often chosen for these devices.

The GaAs injection laser is only a few thousandths of an inch long and produces a beam of

coherent light that can be directly modulated with nanosecond pulsing of input current. Because of these features, applications are envisioned in portable communications and ranging systems and in optical coupling of high-speed circuits.

However, if the advantage of small size is to be

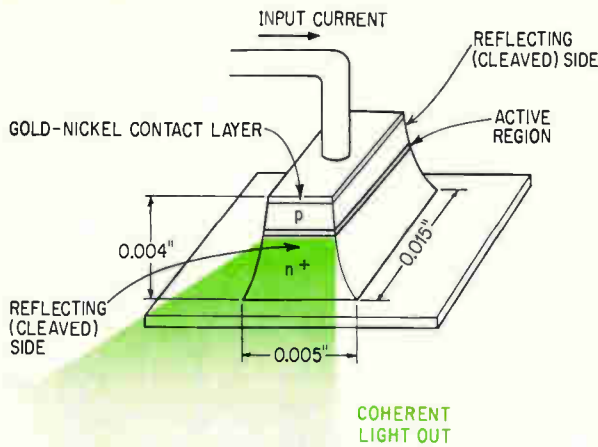

Flat beam. Gallium-arsenide injection laser produces coherent light in plane of junction.

fully realized the laser must be operated at the environment's temperature. Today's goal is high pulsed power and continuous operation at 300°K, or at least at temperatures above 100°K, where simple cooling equipment can be used. Limitations on the duty cycle and ambient temperature primarily stem from heating effects within the laser.

Researchers reported, back in 1962, that when a GaAs diode is forward biased, electrons are injected from the n side into the p side, and that—in a region about 1 micron wide—the conduction-band electrons recombine with holes in the valence band and give up their energy as radiated light. The emitted photons have an energy close to the energy separation of the conduction and valence bands—the so-called band gap, which is about 1.4 electron-volts for GaAs at 77°K.

The recombination can occur spontaneously, where individual events are completely uncorrelated, or by a mechanism first proposed by Einstein in 1918—an emission induced by another photon. It's this process of induced emission that leads to the phenomenon of lasing.

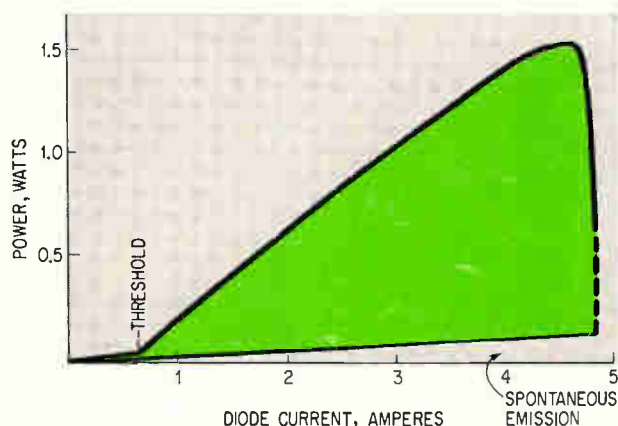

Laser power. Stimulated emission region (in color) shows high-power output above threshold.

Getting in the mode

In a Fabry-Perot structure, a resonant cavity with two parallel reflecting surfaces, the photons that propagate perpendicular to the reflecting sides multiply fastest. When a certain threshold current is reached, they outnumber the photons propagating in other directions. The gain then becomes equal to the losses from absorption inside the cavity and at the partially reflecting end faces, and the diode enters a lasing mode of operation.

During operation, the junction temperature rises because of ohmic power losses within the diode and because much of the stimulated radiation is internally absorbed. The rise in junction temperature increases the threshold current density needed for laser action and thus cuts power output. When this temperature hits a level that boosts the threshold current above the applied diode current, lasing stops.

Much effort is being made to reduce threshold current density—normally about 100,000 amperes per square centimeter—and to make it as independent of temperature as possible. Geometric configurations that reduce ohmic losses and allow effective heat transfer from the junction to the heat sink are being sought.

Progress is reported toward both major goals. By forming the p-n junction with either a double-diffusion process or liquid-phase epitaxial process, the threshold can be lowered by a factor of 4 or 5 at 300°K. Values as low as 26,000 amp/cm² have been observed in diodes with a cavity length of 0.38 millimeter.

Despite the progress in high-power technology, continuous operation hasn't been extended much beyond liquid-nitrogen temperatures; typical values are about 3 watts continuous power at 77°K. When pulse operated at room temperature, improved diodes have delivered about 10 watts.

Declining powers

Laser diodes tend to degrade during operation. There appears to be an irreversible decrease in power output if a certain current density is exceeded, a situation frequently accompanied by a physical chipping of the reflecting surface along the junction line. The cause isn't fully understood.

It was determined early in the laser's history that near-perfect substrates are needed as a starting material. Periodic fluctuations in the doping level due to unstable growth conditions increase threshold current and decrease power output because the losses tend to become larger. Local inhomogeneities due to clusters of defects have a similar effect and are probably responsible for the oft-observed filamentary lasing mode, where only narrow "stripes" in the junction are lasing.

For more on . . .

Injection lasers: G. Burns, M.I. Nathan, Proceedings of the IEEE, July 1964, p. 770.

GaAs light era on the way

By J. R. Biard and Hans Strack

Texas Instruments Incorporated, Dallas

Conventional miniature incandescent lamps may soon be in for some competition from gallium-arsenide light emitters. Prices for the GaAs devices have dropped from the \$100 level of the recent past to \$10 today, and will soon be down around \$1. With that kind of price tag and with solid state efficiency and reliability, GaAs emitters may be just the devices to put light to work in electronic circuits.

These light emitters have been made with nearly 100% internal quantum efficiencies—where each injected carrier emits one photon. The problem is to find a way for the light generated in the crystal to exit through the surface.

Light in most electroluminescent diodes is produced on the p-side of the junction when electrons recombine with holes that are bound to an acceptor or with free holes in the valence band. The band-gap energy in GaAs is about 1.4 electron-volts at 25°C, meaning that light is emitted in the near infrared at about 8,900 angstroms. To get visible light, a compound of GaAs and gallium phosphide must be used. With a mixture about 33% GaP and 67% GaAs, red light is emitted at a wavelength of 6,700 angstroms.

Knifing through

Light generated near the junction is emitted in all directions, but only light striking the exit surface at an angle smaller than the angle of total reflection (16° in GaAs) can leave the crystal.

Because the radiative transitions are random, the devices are called spontaneous emitters; in contrast, the recombination processes in injection lasers are stimulated by photons.

The p-n junction in spontaneous GaAs light emitters can be formed either by diffusion or epitaxy, but quantum efficiency will be affected by the properties of the starting material and the fabrication process. Starting material for diffused-junction light emitters is usually bulk n-type GaAs doped with tellurium, tin, or silicon; typical electron concentrations run between $5 \times 10^{17}/\text{cm}^3$ and $3 \times 10^{18}/\text{cm}^3$.

The best of the present light-emitting diodes use crystals doped with such group IV elements as tin or silicon. The p-region is formed by diffusing zinc

into the n-type substrate.

Studies of the electro-optical properties of the p-region, in which nearly all the light is generated, show that emission efficiency is highest where there is a graded, rather than abrupt, impurity distribution at the junction. Another factor is the doping level in the active p-region extending several electron-diffusion lengths away from the junction. High zinc concentration can cause non-radiative recombination centers to form, and these reduce the quantum efficiency. A heavily doped p-region at the surface of the zinc-diffused region will reduce the contact spreading resistance.

Three-step diffusion

One way to form the graded junction is a three-step diffusion; a zinc diffusion is followed by re-diffusion without a zinc source in order to grade the junction and reduce the zinc concentration, and the process is capped by a shallow p⁺ diffusion.

Zinc diffusions are performed in sealed ampuls with either elemental zinc, binary compounds such as ZnAs₂, or ternary compounds such as GaZn_xAs_{1-x} as the source.

Typical diffusion temperatures are in the 800°C-to-900°C range and junction depths are on the order of 8 microns. Contacts to both the p- and n-type regions are made by evaporating a gold-



Well-rounded. Light-emitting diode made with hemispherical dome to improve light emission properties.

antimony alloy.

Recently, light emitters with improved efficiency and stability have been made by vapor-phase or solution epitaxy on bulk-grown substrates. The vapor-phase epitaxial technique [see p. 113] has been used to achieve a controlled degree of compensation and to approximate a graded diffused junction.

Light emitters built of bulk or vapor-phase epitaxial GaAs are processed in an arsenic-rich environment. Different properties are created when the material is grown in a gallium-rich environment by solution epitaxy; more stable and efficient light emitters have been produced in the laboratory with this technique.

A reactor used to fabricate high-purity and heavily doped solution-grown GaAs is on page 129 above. A substrate slice is inserted into a gallium melt saturated at around 900°C with doped or undoped GaAs, depending on the electrical properties desired. Upon cooling, a deposit is formed on the substrate. When group II elements are used for doping the melt, p-type deposits result; n-type deposits are obtained with group VI impurities. Group IV impurities are amphoteric; they lead to either n- or p-type deposits depending on the growth temperature.

The loss mechanisms of spontaneous emitters are different from those of lasers. Laser light exits in the junction plane through surfaces perpendicular to the junction, and light loss occurs because of free carrier absorption, cavity leakage, and transmission through the exit surface. Spontaneous light emission is isotropic and most of the light exits through planes parallel to the junction; losses are caused by bulk absorption, total reflection, and transmission.

Since the optical absorption losses in the bulk are about 10 times greater than the effective losses in the cavity, and since most of the emitted light is reflected back into the material, spontaneous emitter structures are generally less effective than lasers.

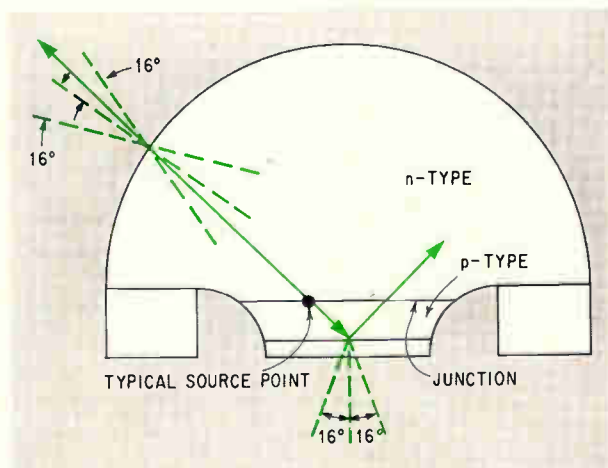

Light dome. Hemispherical shape of emitter assures that light falls within angle of transmission.

To offset total reflection losses, spontaneous light emitters have been built with a light-emitting junction embedded into a GaAs hemisphere. If the ratio of the sphere diameter to the junction diameter is equal to the dielectric constant of GaAs—about 12—no total reflection losses occur. Although absorption losses increase because of the longer light path in the crystal, the dome structure improves efficiency by about an order of magnitude.

Another way to improve external efficiency is to reduce the absorption losses. Because n-type GaAs doesn't absorb light originating at the p-side of the junction as much as p-type GaAs does, the n-type material is used for the dome structure. Solution-grown junctions doped amphotERICALLY with silicon emit light at 1.33 eV, about 0.1 eV below the band-gap energy. In this energy range, the absorption is considerably reduced.

The average efficiency of a planar light emitter in bulk-grown GaAs is about 0.2% at room temperature. The efficiency of a dome-structure device of the same material would be about 2% and that of the best solution-grown diode with a hemispherical exit surface is 20%.

The light emitter's efficiency can also be increased by an antireflection coating with a dielectric such as silicon monoxide to increase the transmissivity of the GaAs-air interface. If the losses due to total reflection bulk absorption are cut, the external efficiencies of lasers and spontaneous emitters should be about comparable. Laser differential quantum efficiencies of up to 40% have been reported for pulse operation.

The fact that efficiency generally increases at lower temperatures has never been completely explained, but contributing factors are reduced absorption, increased injection efficiency, and decreased radiative lifetime. Efficiencies of 45% at 77°C have been reported for dome structures in bulk-grown GaAs.

Laser efficiency isn't linked to temperature to any pronounced degree. Differential laser efficiencies of 50% at 77°K have been measured. The threshold current for lasing, however, depends to a large extent on temperature. Typical values are 10,000 amp/cm² at 25°C, 1,000 amp/cm² at 77°K, and 100 amp/cm² at 4°K.

Applications

Spontaneous emitters will probably be the first volume-produced GaAs devices. The two areas where these light sources are most likely to have an impact are data processing and, with GaAs-GaP alloys, indicator lamps. In both fields, solid state light emitters are superior to conventional units in both efficiency and reliability.

Miniature card-reader light sources have delivered 30 milliwatts per ampere total output in a 20° solid angle, and about 15 microwatts of radiant power into a 2.5° solid angle for a diode current of 50 milliamperes. To focus the light, the dome-shaped GaAs emitter is placed in a reflector package. The dimensions of the package, 120 mils diam-

eter and 175 mils length, allows a high package density.

Considerable progress has been made toward developing light emitters that are stable over long periods of time. Test data on planar units with expanded gold-titanium contacts indicate a 20,000-hour useful life. The expanded contacts are believed to prevent surface deterioration, the main cause of device degradation. Light emitters fabricated in solution-grown GaAs exhibit more stability than those built in bulk GaAs, a fact that may be due to the higher surface stability inherent in solution-grown material.

High-power light sources might be used for communication systems and large-area illumination. Solution-grown diodes doped amphotERICALLY with silicon have produced 200 mw/amp light. Semiconductor light sources have been used in voice-modulated communications systems operated in daylight over several miles, and video signals have been transmitted successfully over a distance of several hundred feet.

A wide variety of applications can be forecast for linear arrays of light emitters in areas such as film annotation and information storage. And monolithic arrays of up to 60 elements have been fabricated with minimum outputs of 1 to 2 mw/amp.

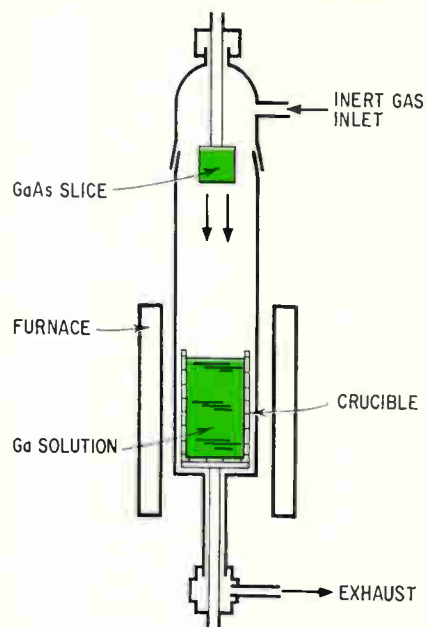

The solution. Solution-growth apparatus for fabricating highly efficient gallium-arsenide emitters.

For more on . . .

Solution epitaxy: H. Nelson, RCA Review, December 1963, p. 603.

Device degradation: J.R. Biard, G.E. Pittman, J.F. Leezer, Gallium arsenide—Institute of Physics and Physical Society Conference Series No. 3, 1967, p. 113.

Advanced technology I

Two Gunn holdups slow microwave oscillators

By Daniel G. Dow

Varian Associates, Palo Alto, Calif.

Two barriers, neither of them insurmountable, are delaying the development of practical microwave Gunn-effect oscillators. One is the difficulty of getting the right quality, reproducible gallium-arsenide material and the second—almost a corollary of the first—is to get a good yield.

Once over these hurdles, the material costs per device will be negligible and, because the device fabrication itself is straightforward, the ultimate device cost will be low. As they near this tempting goal, researchers are stepping up their efforts.

To make a practical microwave Gunn oscillator, the still-to-be-perfected Gunn diode must be embedded in a resonant circuit. By matching the circuit to the diode it will be possible to achieve:

- Tunability of 1.5 to 1 at high efficiency, and 3 or 4 to 1 at reduced efficiency
- Efficiency as high as 25%
- Peak power-frequency-squared product of approximately 1,000 watts-GHz²
- Highly stable oscillations, with noise properties comparable to good klystrons.

View from the labs

Although results are still short of these predictions, progress is being made in the research laboratories. The highest reported continuous-wave power is 340 milliwatts at Nippon Electric in Japan; researchers at Bell Laboratories have reported 140 mw, and a number of other U. S. com-

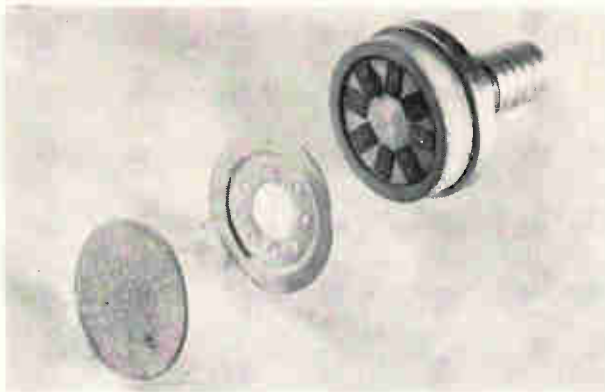

High power. Parallel assembly of Gunn-effect diodes boosts power output.

panies are claiming powers up to 200 mw.

In pulsed research, experiments at Varian have produced 615 watts at 1,100 Mhz. However, the oscillator was restricted to a very low duty cycle because it used crystals grown from the melt by the horizontal Bridgman, or boat-grown, process. Although this technique produces good crystals, they have too much carrier compensation for practical applications.

The highest pulsed powers using epitaxial material are those reported by Radio Corp. of America—143 watts peak at 2,200 Mhz. Also reported by RCA was a device showing 24% efficiency at 112 watts, 1,900 Mhz. This high efficiency was attributed to a controlled doping profile. The RCA investigators also reported stability of both power and frequency against wide temperature excursions.

Commercial devices, however, are still rare. Although several companies are actively developing experimental Gunn diodes, the only ones being offered for sale are by Mullard (5 mw at X band) and Texas Instruments (10 mw at X band).

No compensation

The desired doping level for Gunn effect is about 10^{15} atoms/cm³. This is less than one part in 10^7 , and cannot be achieved in boat-grown material. Thus, the needed high-resistivity n-type GaAs (anything lower than about 5×10^{15} /cm³ in doping density) must be made by compensating the shallow donors, close to the conduction band with acceptors, and allowing the deep donor levels to provide the active electrons. But—because the deep donors are not fully ionized at room temperature—the semiconductor carrier density is sensitive to temperature and can be effectively used only in research applications.

A practical device must be able to operate over a wide ambient temperature range; this alone would rule out compensated material. Even more critical is the fact that compensated material, whose conductivity increases as temperatures increase, will cause thermal runaway and device destruction under modest thermal stress. For example, the impressive data on pulsed LSA devices

of boat-grown material applies only to pulse lengths of 100 nanoseconds. Microsecond pulses would probably tell a different story—thermal runaway and a short-circuiting conductive channel.

Keeping pure

More success has been achieved with epitaxial GaAs where the crystal grows in a pure environment at temperatures from 650° to 850°C and the required purity can be held. Purity cannot be held at the melting temperature of GaAs (1,242°C) needed in the boat-growing procedure.

Vapor epitaxy, in which the gallium and arsenic are transported independently to a GaAs substrate, has been used with success for thin layers for several years, but the process is being worked at its limits to achieve the needed purity for Gunn diodes. More recently, there has been renewed interest in growth from a liquid (usually gallium) solution which may offer better control of purity.

A typical Gunn-effect oscillator designed to deliver 20 mw at X band requires a layer of GaAs, grown epitaxially on a highly doped substrate, which is about 10 microns thick, homogeneous in doping level to perhaps 20%, and with an average doping level between 0.5 and 2 times 10^{15} carriers/cm³.

Many wafers of material with these specifications have been fabricated in a large number of laboratories, yet the yield and controlling process variables are but slightly understood. The saving factor is that the active device is only 0.1 mm across, and it is conceivable that one square centimeter of good material could make 10,000 useful 20-mw oscillators.

The homogeneity problem is even worse with pulsed devices. Pulsed devices require larger areas of gallium arsenide than c-w devices to withstand the higher voltages. For example, an oscillator to deliver 1,000 watts peak at 1,000 Mhz would ideally use about 0.2 cm² of material homogeneously doped to 2×10^{14} donors/cm³. It may take another two years to refine the processes enough to do this.

Making contact

Most good ohmic contacts to GaAs fall into two general classes—alloy and epitaxy. Much of the early work with Gunn effect was done with alloyed tin contacts. These seem to give good performance, but are not suitable for operation at elevated temperature, and under some conditions they show fairly rapid degradation. More recently, alloy combinations such as gold-tin, gold-germanium, silver-indium-germanium, tin-nickel, and many others have been reported.

The liquid epitaxy process for growing contacts consists of saturating a pool of liquid tin with GaAs, allowing the mixture to envelop the GaAs wafer and cool a few degrees before removing it. The result is that a thin layer of GaAs, heavily doped with tin, grows on the surface of the wafer. This heavily n-type surface layer may then be easily contacted by almost any metal.

LSA can come to mean large-size advantages

By John A. Copeland

Bell Telephone Laboratories, Murray Hill, N.J.

Power and frequency limits of solid state devices are extended when a wafer of gallium arsenide is operated as a microwave oscillator in the limited space charge accumulation mode. The diode is thicker and longer than a Gunn device, and the greater size provides higher power, higher impedance, and easier heat dissipation.

The LSA mode exploits the negative resistance of GaAs while preventing the material from breaking into Gunn-type oscillations. The material is biased at a point where the oscillating microwave-frequency electric field can swing down into the positive resistance region for a brief interval during each cycle to quench the Gunn domain.

In operation, the frequency of oscillation depends on the tuning of the resonant cavity rather than on the basic property of the LSA diode; however, the frequency must fall within certain limits to accomplish the Gunn-squelching action. Domains form faster in GaAs that has a high carrier concentration—a sample doped at $10^{-15}/\text{cm}^3$ will form a domain in about 0.1 nanosecond, the period of a 10-gigahertz wave. If the sample is more heavily doped, it



Resonant stub. Limited space charge accumulation diode has half-wave stub in its package for operation at 150 Gz.

has to be operated at a higher frequency to switch the electric field back into the positive resistance region quickly to prevent domain formation.

The limit is set by the ratio of doping to frequency, n/f , which must be between 2×10^4 and 2×10^9 . Maximum efficiency, about 17%, occurs at a ratio of 6×10^4 . Thus, for operation at a millimeter-wave frequency of 50 Ghz, the optimum doping level is about $3 \times 10^{15}/\text{cm}^3$.

The most recent reported results are 20 milliwatts continuous power between 44 and 88 Ghz, achieved at the Bell Telephone Laboratories, and 630 watts peak pulse power in X band, at Cornell University. Other diodes have been operated with detectable power up to 150 Ghz.

Doping hangup

A big problem is that doping must be uniform throughout the sample. If it varies by $\pm 30\%$, the maximum efficiency drops from the theoretical 17% to about 10%. The best efficiency yet observed, in fact, has been 9%.

The scene of most activity in this field, therefore, is the materials lab rather than the microwave-circuits facility. Researchers are satisfied that once uniform doping is achieved, LSA devices will be a practical source of microwave or millimeter-wave power.

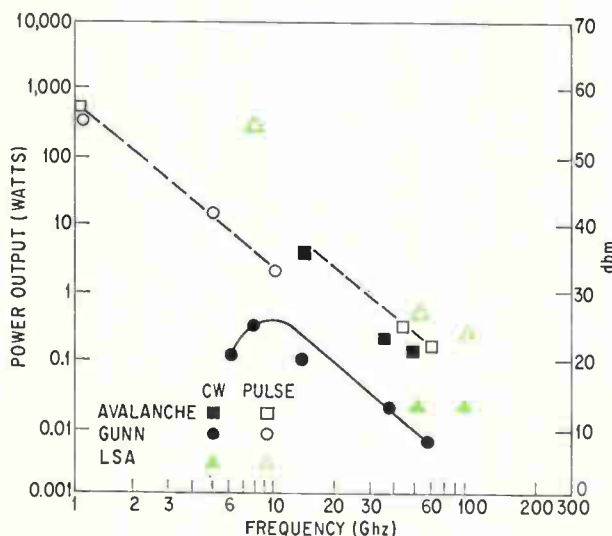

Outputs. Comparison of power-frequency characteristics of various microwave solid state sources.

Bulk-effect boosting

By Hartwig W. Thim

Bell Telephone Laboratories, Murray Hill, N.J.

Solid-state amplifiers have been catapulted into the millimeter-wave range by gallium arsenide's negative resistance properties. Studies on these new bulk-effect amplifiers are too recent to say with certainty how practical and widely used they may become. But the signs are good; bulk-effect amplifiers, like bulk-effect oscillators, offer the promise of simple, low-cost devices, competitive with transistor amplifiers which have had tough going at microwave frequencies. Tunnel diodes, the only other solid-state microwave amplifier, could be easily outclassed since they can produce only about a hundredth of a percent of the power available from bulk-effect amplifiers.

Bulk-effect amplifiers can be considered as three basic types:

- The stable amplifier, which has been operated up to 50 gigahertz.
- The traveling-domain amplifier, which has delivered 100 milliwatts at 6 Ghz.
- The unilateral traveling-wave amplifier, which has been operated at 0.1 mw at 1 Ghz.

Stable amplifier

Developed in 1965 at Bell Telephone Laboratories, the stable amplifier—also called a subcritically doped amplifier—uses a GaAs wafer whose product of doping and length, n_0L , is less than 10^{12}cm^{-2} . This restriction is necessary to prevent Gunn-type oscillations, since the crystal is too short and too lightly doped for the domains to form.

A bias field of several thousand volts per centimeter is applied across the short wafer with only about 20 volts needed to set up this high field. The result is that electrons injected from the cathode are decelerated on their way toward the anode because of the differential negative mobility. A nonuniform field—low at the cathode and increasing across the device toward the anode—builds up and becomes stable after one transit time. The differential d-c resistance is positive, but an applied a-c signal will see a negative resistance at frequencies corresponding to the integral multiples of the transit time. For the 50-micron wafer, the transit time is 0.5 nsec, and the frequencies for negative resistance are 2 gigahertz, 4 Ghz and so

forth, up to the millimeter-wave region.

For a three-terminal amplifier circuit, the wafer is mounted in a conventional reflection-type circuit that has a broadband circulator. The incident signal enters port 1 of the circulator, exits at port 2 to the GaAs wafer, is amplified and then reflected back to the circulator and into the load resistance connected at port 3.

For a typical wafer, about 50 microns thick, the gain peaks at 10 decibels at 4 Ghz, the second harmonic of the fundamental transit-time frequency. Gain can be increased by adjusting the characteristic impedance of the transmission line to a value close to the negative resistance of the diode. However, the maximum output power per unit cross section is restricted by the limitation on the n_0L product. These subcritically doped amplifiers have achieved saturation levels in the order of 1 milliwatt and efficiencies of about 0.1%.

Traveling domain

The traveling-domain amplifier uses the negative resistance property of traveling high-field domains in Gunn oscillators. Such domains exist only in wafers with n_0L products greater than 10^{12}cm^{-2} . Because of the cyclic formation and disappearance of the domains at the contacts, this amplifier, in contrast to the stable amplifier, oscillates at the transit-time frequency while amplifying at some other frequency.

The only difference between the circuits of the stable amplifier and the traveling-domain amplifier is that in the latter a resonant cavity is connected to the coaxial line close to the GaAs wafer to act as a short circuit for the Gunn oscillations. The length of the cavity is thus an integral number of wave-lengths at the transit-time frequency of the Gunn oscillations, and the signal circuit is decoupled from the oscillator circuit, reducing parametric effects.

The traveling-domain amplifier is linear until the output power approaches the power available from the same device when operated as a Gunn oscillator. The maximum output power obtained from a traveling-domain amplifier was 0.1 watt, the efficiency 1%. The upper frequency limit was 11 Ghz, slightly higher than the transit-time fre-

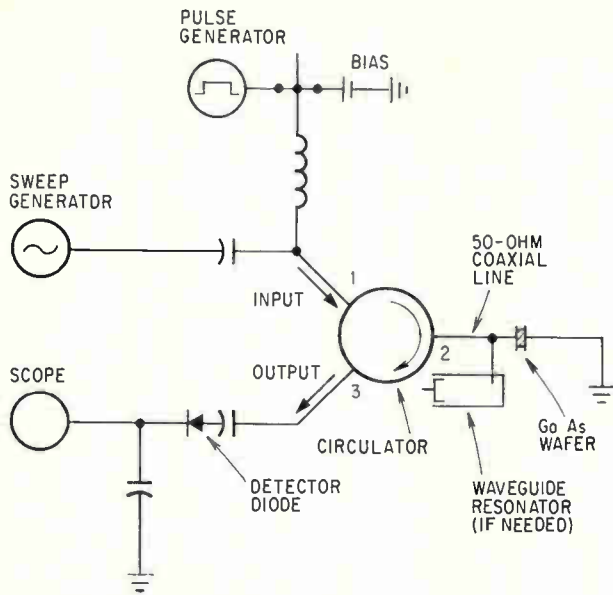

Amplifier. A gallium-arsenide wafer displays a negative resistance in this reflection-type amplifier.

quency. The noise figure measured on the stable and traveling-domain amplifiers was about 20 decibels, suggesting that both will be used as high power amplifiers rather than low-noise devices.

Advanced Technology IV

Pulsating passages

By Masakazu Shoji

Bell Telephone Laboratories, Murray Hill, N.J.

The discovery of the Gunn effect, besides opening new possibilities for solid state microwave power sources, could be a significant step towards realizing a concept that has intrigued designers for years—the bulk-effect functional integrated circuit. Here there would be no p-n junctions or individual components; the device would perform a function simply because of its shape and material properties.

With a specially shaped chip of gallium arsenide, for example, moving Gunn domains might be used to generate current pulses of almost any waveform. Since the domain has a constant current density as it sweeps through the material, all that's needed to increase the current to the outside circuit at any point in the cycle is a larger cross-sectional area at the corresponding part of wafer. When the domain

Unilateral traveling-wave

Researchers at Stanford University recently proposed a two-port unilateral traveling wave type, several space-charge wavelengths long, in which a signal is injected at a contact placed near the cathode contact in order to excite space charge waves. Such a wave grows along the length of the diode and excites a larger signal at a contact placed near the anode. It is thus similar to a two-cavity klystron amplifier, where the signal is injected in one cavity, coupled to the electron beam, and extracted at a second cavity.

As in the subcritically doped amplifier, the n_0L product must be smaller than 10^{12}cm^{-2} to avoid formation of high-field domains (spurious oscillations). Little gain has been obtained around 1 GHz, and gain compression occurred when the output power reached 0.1 mw. If coupling can be improved, amplification should occur over broad frequency bands.

For more on . . .

Stable amplifier: H.W. Thim, M.R. Barber, B.W. Hakki, S. Knight, M. Uenohara, *Applied Physics Letters*, September 1967, p. 167.

Traveling domain amplifier: H.W. Thim, *Proceedings of the IEEE*, March 1967, p. 445.

Traveling-domain amplifiers: H.W. Thim, *IEEE Transactions on Electron Devices*, September, 1967.

Traveling wave amplifier: P.N. Robson, G.S. Kino, B. Fay, *IEEE Transactions on Electron Devices*, September 1967.

reaches this point, the total current changes.

Tailored shapes

The current waveform takes the shape of the device. If a triangular waveform were desired, the device would be shaped like a rooftop; if a dip in the waveform were desired, a notch would be cut in the device. The usual Gunn-effect current spikes also appear in the waveform when the domain reaches the anode, but they can be used as synchronizing pulses, or, if they might upset circuit operation, can be subtracted out by a uniformly shaped device connected in parallel.

Samples have been made with electron concentrations of 4 to $7 \times 10^{14}/\text{cm}^3$. The material was cut into pieces 40 by 40 mils square and 10 to 20 mils

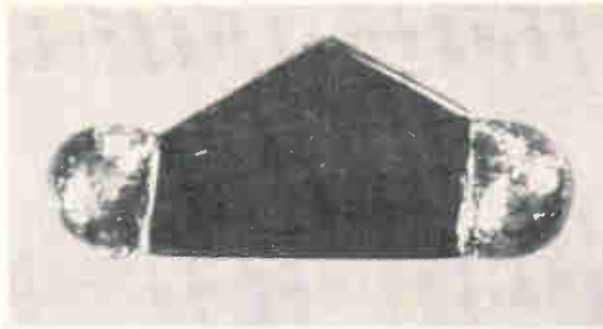

Current generator. Peaked shape of gallium-arsenide sample is reproduced in the output current waveform.

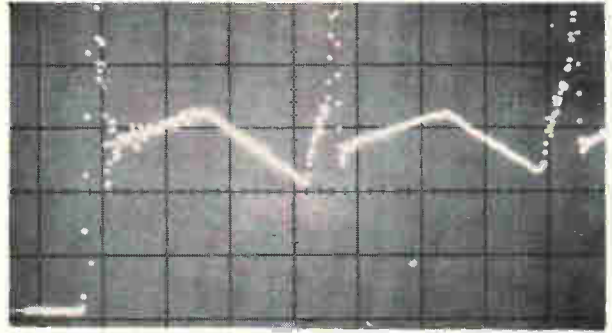

Current wave. Pulses, shown on sampling scope, were produced by a GaAs bulk generator of the type at left.

thick, and ground carefully to desired shapes. The pieces then were cleaned, etched, and alloyed with pure indium contacts.

Another basic type of bulk-effect pulse generator employs contacts placed along the path of the domain to produce extra pulses at any point in the cycle. The contact is separated from the bulk material by a layer of high-resistivity material, an oxide formed by exposing the surface to air for several days. The oxide allows extra current to flow around the domain as the domain passes under it, and this shunt current appears in the output at a point corresponding to the position of the contact. When the domain reaches the anode, it delivers its normal current pulse to the output circuit.

Controlled pulses

The extra current pulse in the high-resistivity region can be switched in and out of the cycle with a switch connecting the contact to ground. The cur-

rent can then be shunted to ground and won't appear in the output.

Samples operating in this way were made of n-type GaAs with concentrations of 4 to $7 \times 10^{14}/\text{cm}^3$. A typical size was 40 mils long, 20 mils wide, and 20 mils thick. Pure indium contacts were alloyed to the ends, and the samples were exposed to air for from two to 60 days to oxidize the surface. Silver paint contacts then were applied to the surface to form the control electrodes.

Many applications are possible. For one, a multi-contact device could perform logic, and, if the switches on the external current paths were replaced with photoconductive material, could be used as an image scanner.

For more on . . .

Waveform generators: M. Shoji, Proceedings of the IEEE, May 1967, p. 720.

Current pulse generators: M. Shoji, Proceedings of the IEEE, May 1967, p. 710.

Advanced technology V

Over the horizon: gallium arsenide IC's

By Edward M. Mehal

Texas Instruments Incorporated, Dallas

Indicative of today's fast-paced technology is the fact that gallium-arsenide integrated circuits are being developed right along with the discrete devices. Although the additional fact that these IC's cost more than their silicon counterparts and are harder to fabricate will generally limit them to a

few special jobs, they do have a clear field in two areas—the microwave and the optoelectronic. The microwave GaAs IC may be with us soon; the optoelectronic IC is farther off.

The key to monolithic gallium-arsenide circuits is the semi-insulating form of GaAs. This material

The authors

Four of the authors are from the Radio Corp. of America. Hans W. Becke is an engineering group leader active in R&D on silicon and gallium arsenide devices at the Electronic Components and Devices division. He holds a master's degree from Newark College of Engineering, and an engineering degree from the Ohm-Polytechnical Institute, Nuremberg, Germany. David Richman of RCA Laboratories received his Ph.D. from Cornell University and is working on the preparation of group III-V semiconductors from the melt and vapor phase. James J. Tietjen, also of RCA Laboratories, received his Ph.D. from Pennsylvania State University and is a research leader in the semiconductor materials research techniques and injection group. Leonard R. Weisberg is head of the semiconductor and luminescence research group at RCA Laboratories, where he has specialized in materials research on III-V compounds.

Kenneth Manchester, who has a Ph.D. in chemistry from Stanford University, is a department head at the Sprague Electric Corp.'s research and development laboratory in North Adams, Mass. He is doing basic work in the interaction of ion beams and solids.

Texas Instruments is represented by three authors: J.R. Biard, manager of the optoelectronics branch; E. W. Mehal, head of the compound semiconductor materials section, and Hans Strack, head of the device

physics section. Biard, who got his Ph.D. from Texas A & M University in 1957, directs research in gallium-arsenide and gallium-phosphide devices, and headed the efforts that led to the first commercial gallium-arsenide light

source. Mehal, who holds a master's degree in chemistry from the University of Michigan, specializes in the

Microwave Associates



Uhlir

Howell

RCA



Richman

Tietjen



Weisberg

Becke

Texas Instruments



Strack

Mehal

preparation of high-purity semiconducting compounds and in vapor deposition on semiconductor substrates. Strack holds a Ph.D. from the University of Bonn, Germany, and is engaged in studies of gallium-arsenide transistors

and microwave devices. **IBM**

The two contributors from Microwave Associates Inc., Arthur Uhlir Jr. and Charles M. Howell, have been with the company since 1958 and worked on the first commercial varactor diodes. Uhlir now is vice president and manager of the semiconductor division and Howell is head of engineering for solid state and integrated microwave components and devices. Uhlir received his Ph.D. in physics from the University of Chicago in 1952, and Howell, a chemical engineering major, got his master's in business administration, from Northeastern University in 1961.

The two International Business Machines Corp. authors, Jerry M. Woodall and Hans S. Rupprecht, are at IBM's Thomas J. Watson Research Center in Yorktown Heights, N.Y. Woodall, a graduate of Massachusetts Institute of Technology, is now specializing in crystal-growing techniques and injection lasers. Rupprecht received his Ph.D. from Friedrich Alexander University, Erlangen, Germany, and is now studying injection lasers and related light-emitting devices.

C.P. Sandbank, head of research on microelectronic

Bell Telephone Laboratories



Thim

Shoji

Copeland

Lawley

techniques and solid state bulk effects at Standard Telecommunication Laboratories Ltd., Harlow, England, did much early work on bulk-effect devices and coined the term "dofic"—domain originated functional integrated circuits—to describe them.

The Bell Telephone Laboratories contributors, John Copeland, Masakazu Shoji, Kenneth Lawley, and Hartwig Thim, all work at the Murray Hill, N.J., facility. Copeland, a Ph.D. from Georgia Institute of Technology was the first to predict the possibility of LSA oscillations. Shoji, with a Ph.D. in electrical engineering from the University of Minnesota, is in the solid state device electronics department. Kenneth L. Lawley, a Ph.D. in metallurgy from Ohio State University, is with the semiconductor and thin-film materials department. Thim received his doctorate from Technische Hochschule, Vienna, and is working on bulk devices.

Daniel G. Dow of Varian Associates received his Ph.D. from Stanford University and is now manager of microwave semiconductor work at Varian's central research laboratory.



Woodall



Rupprecht

STL



Sandbank

Varian



Dow

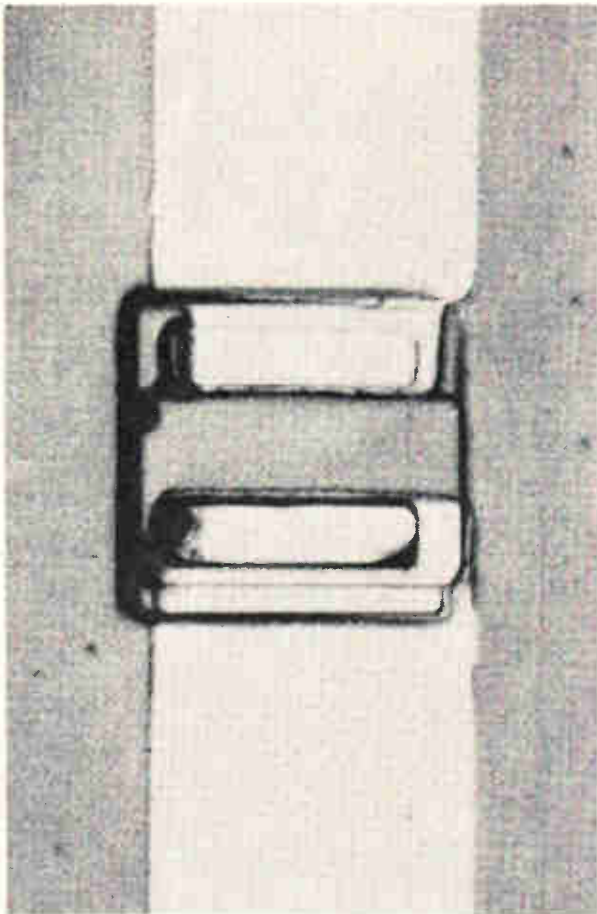

Gunn oscillator. Planar device designed for use in 94 Ghz microwave-receiver integrated circuit.

provides a single-crystal matrix for the epitaxial growth of GaAs devices and affords excellent electrical isolation between components.

The basic building process sounds simple: pockets are etched in a wafer of semi-insulating GaAs to accommodate active devices, semiconducting GaAs is epitaxially grown in these pockets, and a layer of metalization is added to interconnect the devices with microstrip transmission lines. Of course, there are practical problems—how to get the semi-insulating GaAs, etch clean-cut holes, and grow pure epitaxial layers.

Fabrication

The first step in the process is to orient the GaAs semi-insulating substrate to a 111 surface and then to chemically polish the surface to remove any defects. As a mask, a silicon dioxide film about 0.3 microns thick is applied externally by sputtering or chemical deposition methods; the best method found at Texas Instruments is the thermal oxidation of tetraethylorthosilicate (TEOS).

Next, the pockets delineated by the SiO₂ mask are etched out. Most of the common etching techniques produce holes with irregularly shaped bottoms, due to greater etching around the periphery of the hole. But this effect has been eliminated with a hydrogen peroxide-sodium hydroxide solution

that's reaction-rate limited rather than diffusion-rate limited and yields an etched hole with a planar bottom.

Care must be taken when semiconducting GaAs is deposited in the pockets; if these depositions project above the surface, masking will be upset. Pockets of different dimensions must therefore be filled separately to minimize overgrowth in the smaller ones. Regions with overgrowth of less than 1 micron have been achieved on 111-oriented substrates. The semiconducting GaAs used has a fairly low impurity content—around $1 \times 10^{15}/\text{cm}^3$ —and can be controllably doped with sulfur or tin to produce the required n-type carrier concentration for the devices.

Possible components

Planar bipolar transistors that could possibly be used in integrated circuits have been fabricated by Wilhelm von Muench of the International Business Machines Corp. lab in Boeblingen, Germany. He used one selective deposition of n-type GaAs into semi-insulating GaAs, and formed base and emitter regions by planar diffusions. Field effect transistors also have been fabricated on semi-insulating GaAs substrates, and these too might find employment in integrated circuits.

Microwave circuitry has been the principal area of application. Gunn oscillators and Schottky-barrier diodes made in planar form with selective deposition techniques are now being combined into microwave IC's.

The planar Gunn oscillators, which have operated at up to 28 Ghz, require three selective depositions of GaAs—two n⁺ regions for contacts, and an n⁻ area as the active region.

An IC for the front end of a 94-gigahertz microwave receiver is being built at TI under a contract from the Air Force Avionics Laboratory, Wright-Patterson Air Force Base, Dayton, Ohio. It consists of a Gunn oscillator in a resonant circuit operating at about 31 Ghz; a tripler circuit that converts the 31-Ghz Gunn oscillator signal to 94 Ghz to serve as the local oscillator source; and a balanced mixer using two Schottky-barrier mixer diodes.

For more on . . .

Selective epitaxial growth: E.W. Mehal, R.W. Haisty, D.W. Shaw, *Transactions of the Metallurgical Society of the AIME*, March 1966, p. 263.

Etching planar-bottom holes: D.W. Shaw, *Journal of Electrochemical Society*, 1966, p. 958.

Planar bipolar transistors: W. von Muench, H. Statz, A.E. Blakeslee, *Solid State Electronics*, 1966, p. 826.

Planar field-effect transistors: W.W. Hooper, W.I. Lehrer, *Proceedings of the IEEE*, July 1967, p. 1237.

Schottky-barrier diodes: T.H. Oxley, J.G. Summers, *Gallium arsenide—Institute of Physics and Physical Society Conference Series No. 3*, 1967, p. 138.

Reprints of this report are available at \$2.00 each.
© Copyright 1967, Electronics® A McGraw-Hill Publication

WE ALWAYS KNEW OUR UNIBLOC* PLASTIC TRANSISTORS WOULD PASS MIL-STANDARD RELIABILITY TESTS

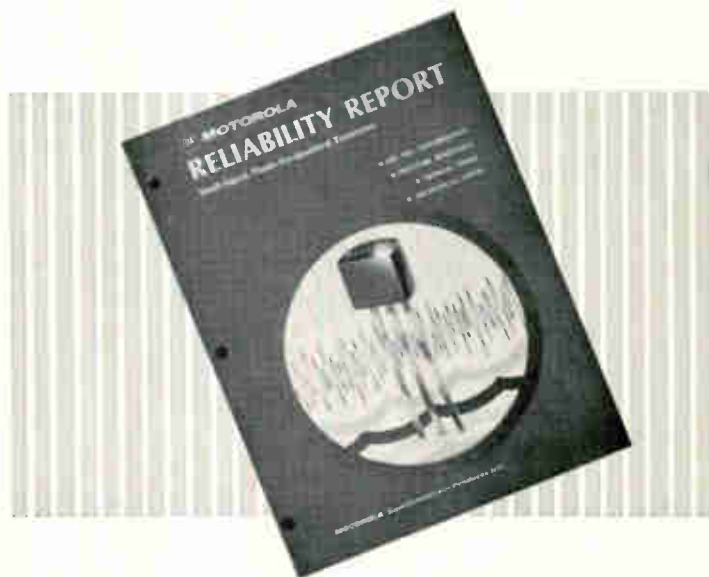

...HERE'S PROOF!

Find out for yourself how Motorola's single piece Unibloc transistor package has achieved a new high order of reliability. Send for a copy of the "Reliability Report on Plastic Transistors," Box 955, Phoenix, Arizona 85001. *Trademark of Motorola Inc.

-where the priceless ingredient is care!



MOTOROLA
Semiconductors

Suitcase-size memory for longer space trips

Employment of pulse techniques and MOS transistors results in a portable computer storage that dissipates only 3.5 watts, reducing power requirements and stretching mission times

By Dewey E. Brewer

Wright-Patterson Air Force Base, Dayton, Ohio

and Samuel Nissim and George V. Podraza

Bunker-Ramo Corp., Canoga Park, Calif.

Just as a businessman steps off a plane with attaché case in hand, so may an astronaut someday step out of a spaceship, onto the moon or Mars, carrying a computer. The idea isn't far-fetched. A portable memory dissipating only 3.5 watts and designed to fit into a 21-inch suitcase is now being evaluated by the Air Force for various classified applications.

The memory is the first of what is expected to be a whole family of complex digital equipment, each unit of which will dissipate only a small amount of power—provided perhaps by a self-contained battery—and will be portable.

Development of integrated-circuit technology from gate to function to system levels has reduced the cost of such assemblies, and the amount of power they require. A production run of memory systems based on the prototype design would perhaps cost as little as 10 cents per bit in 1972, and might dissipate even less power if individual transistor tolerances were tightened. The 10-cents-a-bit level is about the price of present conventional magnetic memories.

At such costs, semiconductor memories would be competitive with conventional types made of ferrite cores or thin films, particularly in such sophisticated applications as associative memories, scratchpads, input-output buffers, and index registers. And low power dissipation would give semiconductor circuits the edge in aerospace applications, where the weight of power sources is always a problem. Ferrite cores need high driving power, and the thin films' small output signals demand

complex sense amplifiers that also require high power.

Cutting power

Power reduction was at least as important a consideration as size in the development of the memory. Designers concentrated on the memory rather than on an entire computer, because the memory subsystem dissipates 40% to 60% of the total power in present aerospace computers. Paring memory power requirements could, therefore, significantly reduce over-all power requirements and the weight of power supplies, thereby extending mission times. Low power dissipation was emphasized at the expense, where necessary, of other parameters such as size and weight; a little extra weight devoted to power conservation, it was reasoned, can save many times more weight in power supplies.

The prototype model in the suitcase is a random-access memory suitable for production at reasonable cost. It has 1,024 words of 30 bits each, built with metal oxide semiconductor transistor arrays for storage, and bipolar transistors for the peripheral accessing circuits. It provides nondestructive readout with an access time of 0.7 microsecond, and a full read or write cycle of 1 microsecond.

The designers chose these integrated circuits because pulsing permits MOS flip-flops to be operated at a very low power level, and because MOS is well suited to low-cost large-scale integration. The bipolar devices used in address decoders,

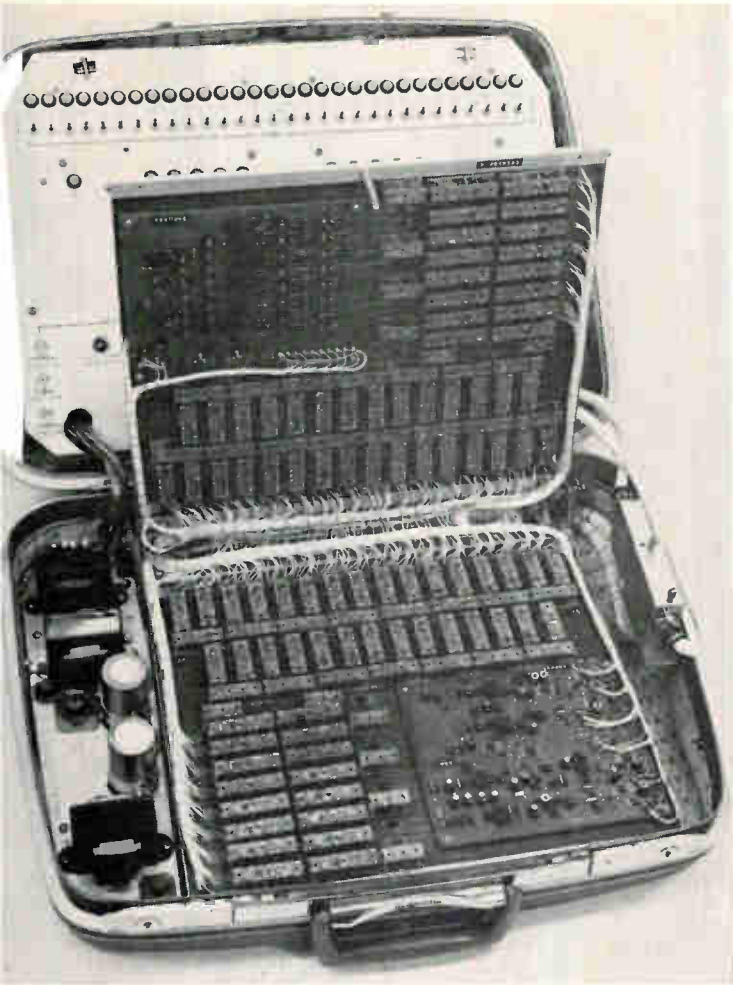

Prototype. This experimental system, which operates on only 3.5 watts exclusive of the exerciser (top), is the forerunner of a family of low-power, portable, complex digital devices.

write drivers, sense amplifiers, and control circuits are commercially available integrated circuits. Interface circuits between MOS array and bipolar peripherals were built with discrete components, because at the time the design was frozen, level-shifting circuits weren't commercially available.

The peripheral circuits are also operated with pulse techniques to reduce power consumption. Special nonlinear switching circuits with inductive source impedances afford further savings in power, when driving large capacitive loads in the MOS array and distribution lines.

Cell block

The basic memory cell has a nominal threshold voltage of 5 volts. In the diagram at the right transistors Q_1 and Q_2 form the bistable storage elements of the cell; their loads are Q_3 and Q_4 respectively. Transistors Q_5 and Q_6 are biased off except when data is being written into the cell or read out.

If Q_1 is conducting, the voltage at its gate is negative, driving electrons out of the adjacent n-type material and establishing a p-channel between

the p-type source and drain. The conduction establishes a voltage of +12 at the drain of Q_1 and the gate of Q_2 , holding Q_2 in its normal, nonconducting state. Conversely, the drain of Q_2 is near ground, and this level at the gate of Q_1 keeps that transistor conducting.

However, capacitance exists between the Q_2 drain and the substrate, and leakage current from the drains of Q_2 and Q_6 , plus the source of Q_4 , charges the capacitance slowly toward 12 volts. If this voltage buildup were permitted to continue, Q_2 would eventually turn on and the data stored in the flip-flop would be lost.

To eliminate the accumulated charge, the "restore" pulse periodically turns on Q_3 and Q_4 , opening a path to ground. With Q_2 cut off, its transconductance is nearly zero, and the path transmits only the small amount of charge on the parasitic capacitance. But Q_1 is conducting; the sum of the two transconductances of Q_1 and Q_3 is only slightly greater than that of Q_1 alone, so the turn-on of Q_3 has no appreciable effect on the current through Q_1 .

Repulsing charges

The restore pulse must be frequent enough to assure that the drain of the cutoff transistor never accumulates enough charge to cause trouble even under worst-case conditions. In the low-power memory, the restore pulse has an amplitude of 18 volts, a duration of 1.5 microseconds, and a repetition rate of about 10 kilohertz (duty cycle of 1.5%). The memory cell would work if the restore input were kept "on" all the time; in fact, its switching time would be considerably faster. But the power dissipation would also be much higher.

The gating transistors, Q_5 and Q_6 , and the current source transistor, Q_7 , are used when data is transferred into or out of the cell. A particular

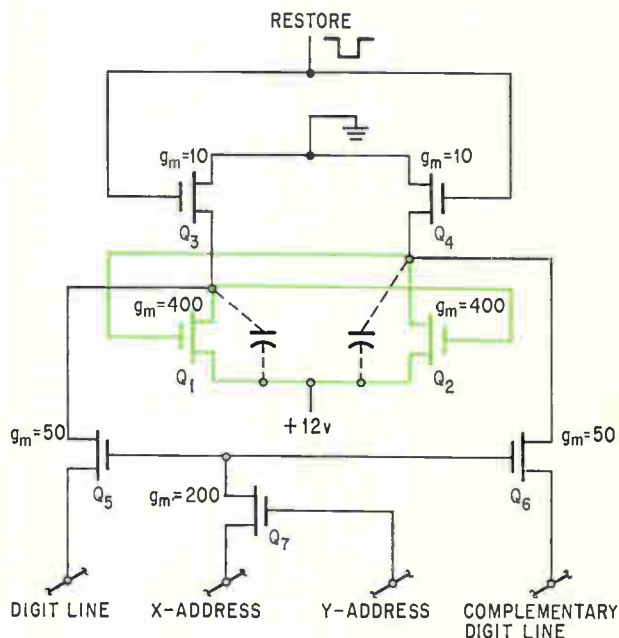

Basic cell. Sixty-four of these cells are deposited on a single 80-by-100-mil chip. The key to low power dissipation is the restore pulse.

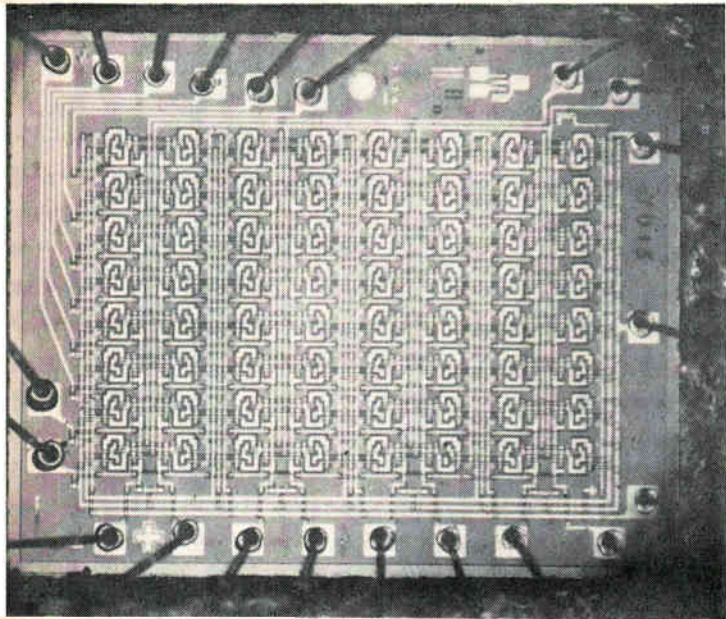

Memory chip. The 64 individual cells are easily discernible in this microphotograph.

x-address line is common to all the cells in a single row of a chip, and one y-address line is common to all the cells in a column. Therefore, one x-address and one y-address pulse select a single cell on the chip. The y-address opens the gate of Q_7 , applying the negative level of the x-address to the gates of Q_5 and Q_6 and turning both transistors on.

To read data from the cell, both digit lines are kept at or near ground. Assume that Q_1 is conducting and Q_2 is off. When Q_5 and Q_6 turn on, current from Q_1 flows into the corresponding digit line through Q_5 ; no current flows through Q_6 because the drain of Q_2 is already at ground. A differential amplifier of them is receiving the current, and thereby connected to the digit lines senses which senses the state of the addressed cell.

To write data in the cell, a positive-going pulse is applied to one of the two digit lines while the other remains at ground and while Q_5 and Q_6 are on. If, for example, this positive pulse appears at the source of Q_6 , it is transmitted to the drain of Q_2 and thence to the gate of Q_1 , which, if previously conducting, turns off. The drain of Q_1 discharges to ground through Q_5 and the other digit

line, and this ground level then turns on Q_2 , reversing the states of the bistable elements.

The monolithic chip shown in the microphotograph at left measures 80 by 100 mils and contains 64 memory cells. These cells contain one bit in each of 64 different words. Thus 30 of the chips can store 64 full 30-bit words, and 16 sets of 30—480 chips altogether—give the 1,024-word capacity of the memory. Each chip is mounted in an individual 22-lead flatpack.

Pro and con

The addressing method employed is similar to the coincident-current technique common in magnetic memories except that the MOS array uses coincident voltages. The MOS memory has a number of advantages over magnetic memories; for one, it requires simpler peripheral circuitry because its inherently non-destructive readout makes it unnecessary to regenerate stored data after reading it out. The relatively high-amplitude read-out signals from the array and high signal-to-noise ratio of the output also simplify the peripheral circuits. Nevertheless, the memory's power dissipation is mostly in the peripheral circuits, not in the storage elements, as in magnetic memories.

Volatility is the principal disadvantage of the MOS memory, as compared with magnetic memories. Even momentary loss of power invariably causes loss of data. This difficulty is somewhat offset by the low power consumption, which makes an auxiliary battery source practicable to prevent data loss.

Also, the MOS memory cannot be used at temperatures over 60°C., nor unshielded in the presence of nuclear radiation.

Mad but methodical

The 1,024 words in the memory are addressed by 32 x-address lines and 32 y-address lines; one of each can locate any single word. However, each bit of the word is on a separate chip, so that each address line must be connected to 30 different chips. This leads to a rather complicated routing of the address lines.

The easiest way to visualize the routing is by analogy with a conventional three-dimensional memory. Such an organization contains 30 planes, stacked vertically, with 1,024 bits—one bit of each

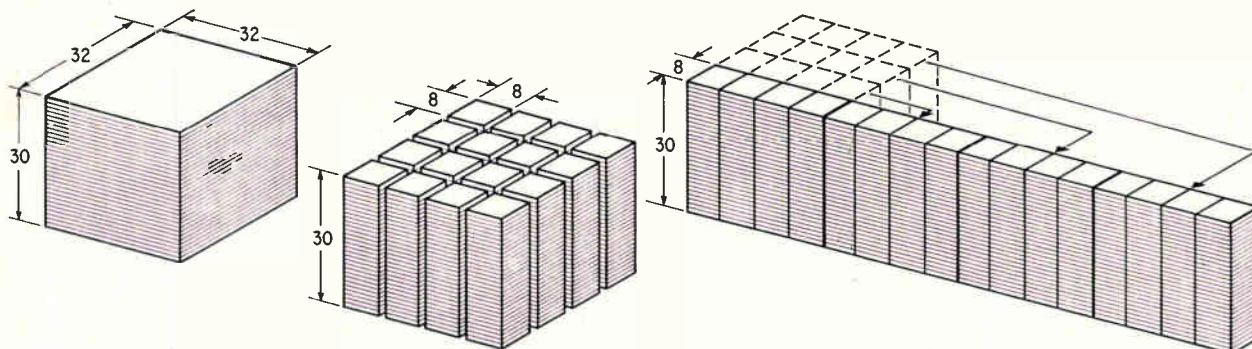

Rearrangement for routing. The array of low-power monolithic chips can be handled conceptually by dividing the conventional 3-D array into 16 parts, lining them up and spreading them out on one plane.

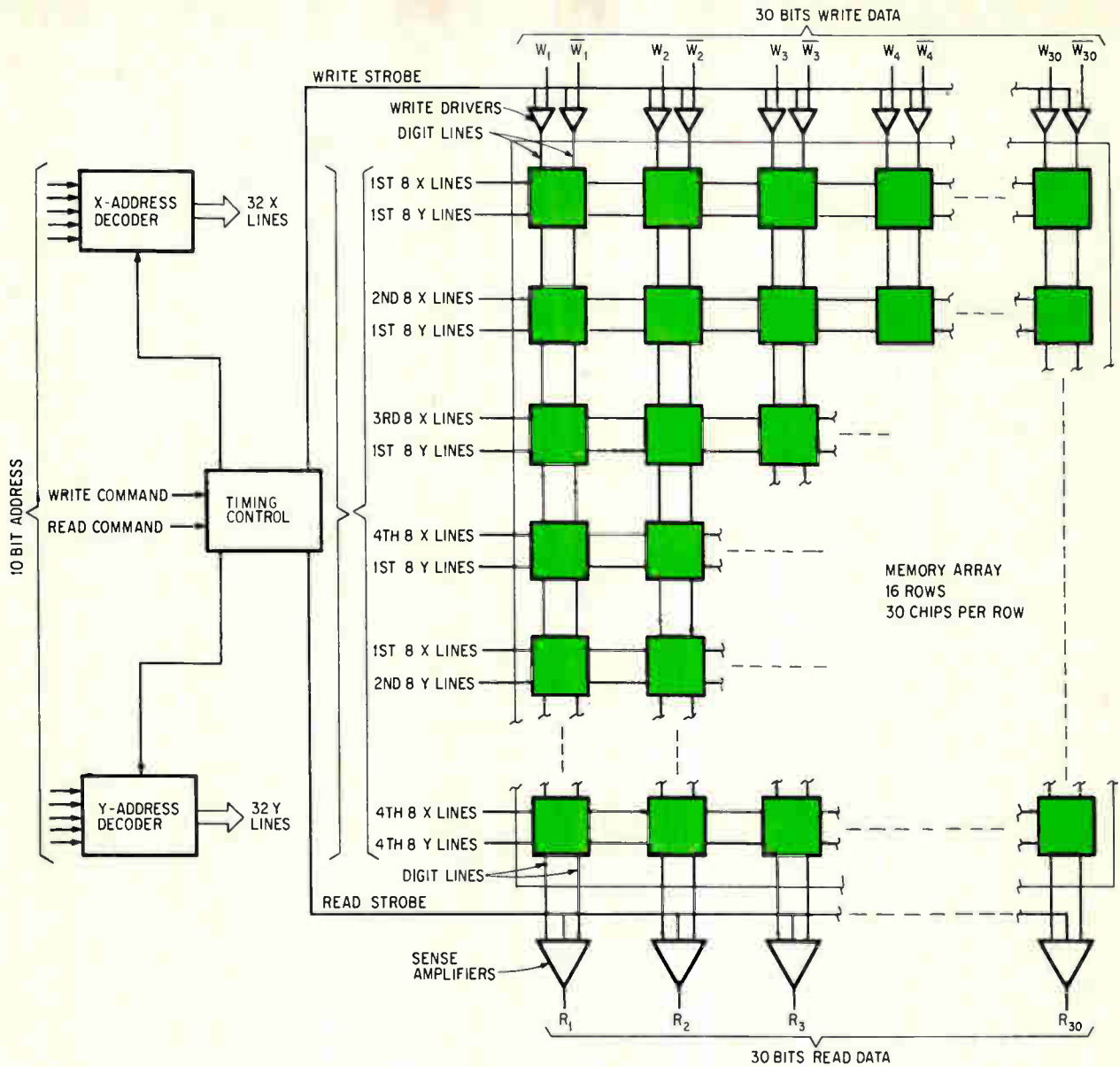

Array. The 480 MOS chips, each in its own flatpack, are indicated in color. The address decoders and other peripheral circuits are also integrated, but use bipolar transistors.

word—in each plane. Each plane is an array of 32 by 32 bits, and is accessed by 32 address lines in each direction. One x-address line and one y-address line intersect at one bit position on each plane; corresponding lines on all planes are interconnected so that one x-address line and one y-address line intersect at 30 bit positions on the 30 planes.

The array of 32 by 32 bits on each plane can be realized by a square group of 4 by 4 chips stacked 30 deep with 8 by 8 bits on each chip. Eight address lines provide access to each side of every chip, and are connected across the gap between chips to provide continuity through each square group of 16 chips in the same way as in the basic 32-by-32 array.

But packaging chips in a 3-D stack isn't feasible. Somehow the 30 groups of 16 chips have to be rearranged into a two-dimensional layout, retain-

ing the access in each direction by 32 address lines. This is where the complication in address line routing comes in.

If the 16 chips in each planar group are rearranged in a 1-by-16 row instead of a 4-by-4 square, and if the 30 rows, each 1-by-16, are laid side by side instead of being stacked on top of one another, the two-dimensional layout is achieved.

The first eight y-address lines are connected to all the chips in the first four rows of the final 16-by-30 layout, the second eight y-address lines to the second four rows, and so on. The first eight x-address lines are connected to the chips in rows 1, 5, 9, and 13, the second eight to rows 2, 6, 10, and 14, and so on. As Shakespeare's Polonius said, "though this be madness, yet there is method in't."

The memory chips are shown in color in the block diagram above; the peripheral circuits, not colored, include the address decoders, write

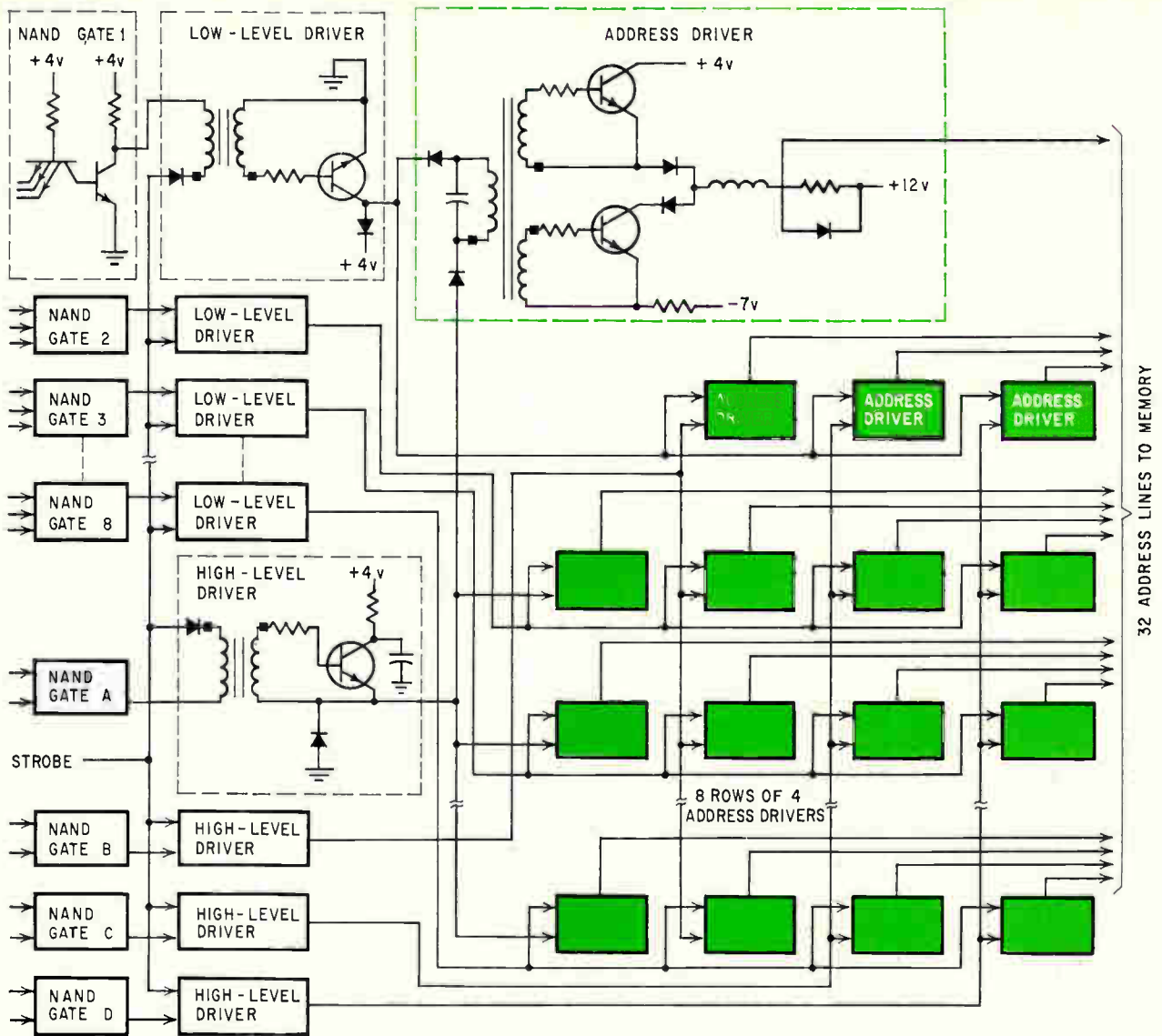

Address decoder. A matrix arrangement translates five bits from the memory exerciser into 32 address lines that locate a specific word in the memory. A new inductive line driver circuit reduces the power dissipation [see detailed schematic diagram on page 145].

drivers, sense amplifiers, and timing circuits. The feasibility model also contains a memory exerciser (in the same suitcase!), which supplies write data and checks read data for errors.

The 1,024-word capacity requires a 10-bit address, which is divided into two five-bit parts, one for x and one for y . A common pair of digit lines connects all 1,024 memory cells corresponding to a specific bit in each word. One or the other digit line is pulsed by the write driver when data is being written, and current on one or the other digit line is picked up by the sense amplifier during a read operation. Write and read strobe signals activate the corresponding circuits during the respective operations, so that data being written does not pass through into the sense amplifiers.

On the periphery

Two identical address decoders generate the x and y signals for addressing the memory. The

memory exerciser transmits 10 bits and their complements to the decoders—five bits to each decoder. In the decoder, eight NAND gates—standard commercially available integrated circuits—decode three of the five bits, and four other NAND gates decode the other two. A given address actuates one high-level and one low-level matrix driver, which together select a single address driver out of a 4-by-8 matrix of address drivers; the low-level driver is actually only a ground return for the high-level driver. The address driver generates a signal on one of the 32 address lines.

The memory exerciser transmits the data to be written into the memory, each bit with its complement, on 60 lines to the write drivers, and the write command signal activates those drivers that have binary 1 inputs, placing the signal on the corresponding digit lines.

In the driver's quiescent state, transistor Q_4 is conducting, as in the schematic opposite, ground-

ing the digit line. The write command signal and a binary 1 on the data line turn off Q_4 and turn on Q_2 , so that the 12-volt signal appears on the digit line. The disappearance of the write command pulse turns off Q_2 and turns on Q_3 , opening a fast discharge path for the digit line; Q_4 turns on again, to hold the digit line at ground.

Each digit line is also connected to a sense amplifier. When a read command signal is received, the memory cells of the address word supply current to the digit lines. The sense amplifiers pick up the difference between the currents in the two complementary digit lines and generate an output accordingly.

In the sense amplifier, shown on the next page, transistors Q_5 and Q_6 form a differential amplifier that biases the flip-flop Q_1 and Q_2 . The strobe read signal sets the flip-flop to the state toward which the differential amplifier previously biased it. Buffer transistors Q_3 and Q_4 isolate the circuit from the output loading, which might be unbalanced and therefore more sensitive. In the absence of a signal from the differential amplifier, both transistors in the flip-flop turn off at the trailing edge of the strobe signal.

To avoid the large surge of current that would

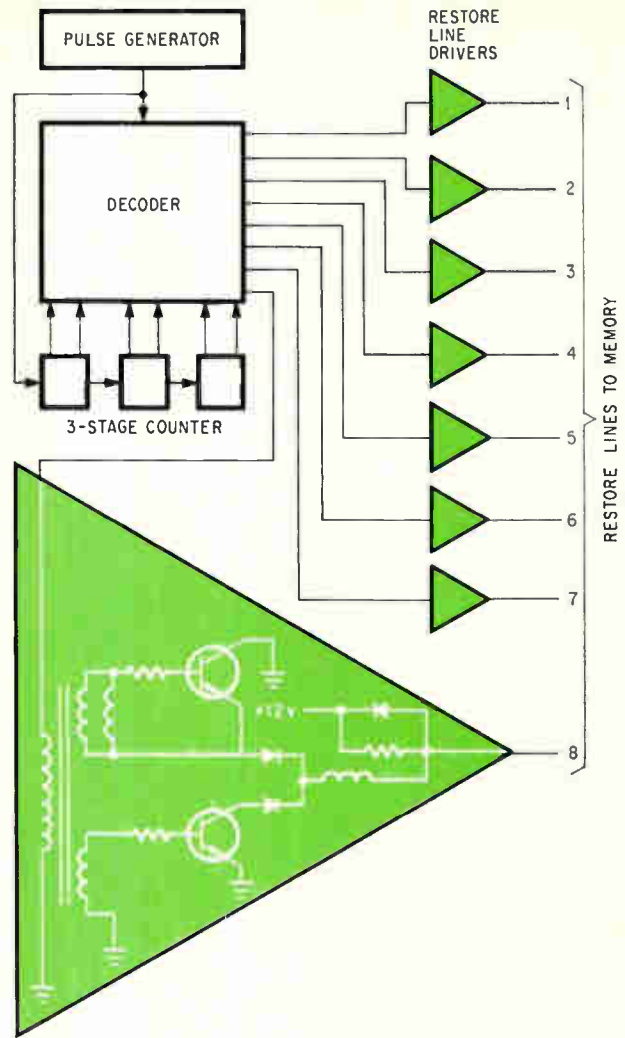

Restore generator. To avoid the need for large current pulses when the restore pulse goes out, only $\frac{1}{8}$ of the memory is restored at a time. The pulse generator operates at eight times the nominal restore rate, sending restore pulses to each section of the memory in rotation.

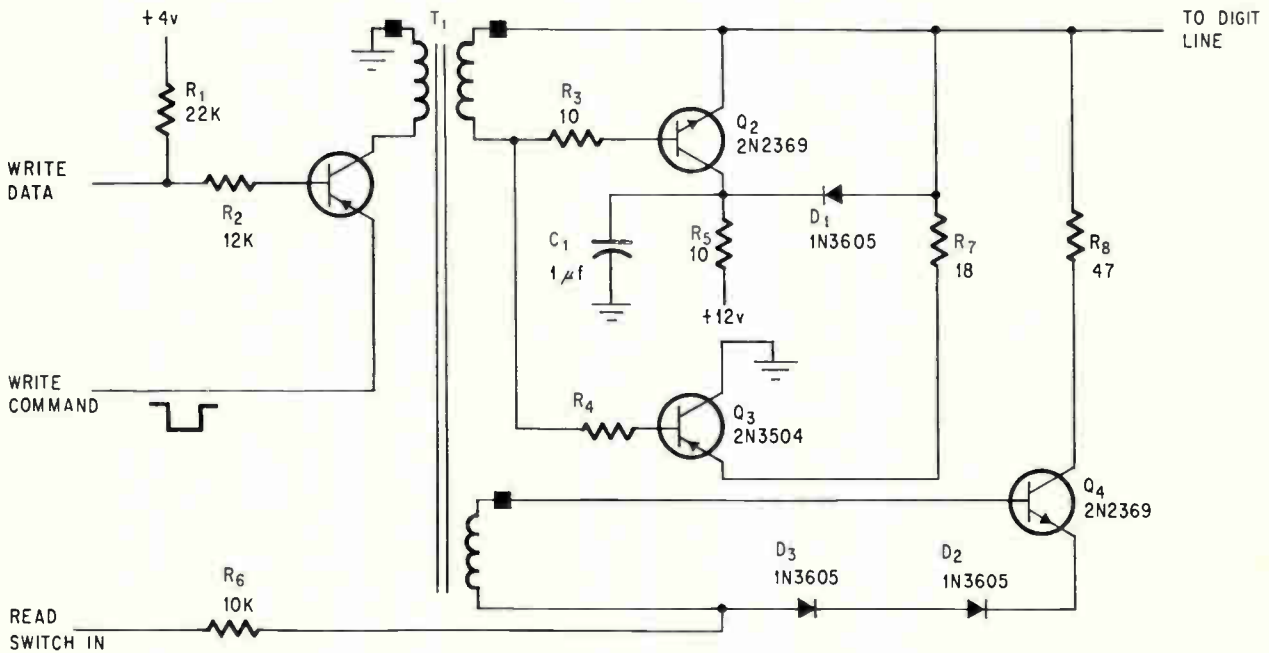

Write driver. A 12-volt positive signal appears on the digit line through Q_2 and discharges quickly through Q_3 . The heavy line capacitance makes the inductor-and-switch combination of the address driver impractical here, but the circuit's low duty cycle keeps power dissipation down.

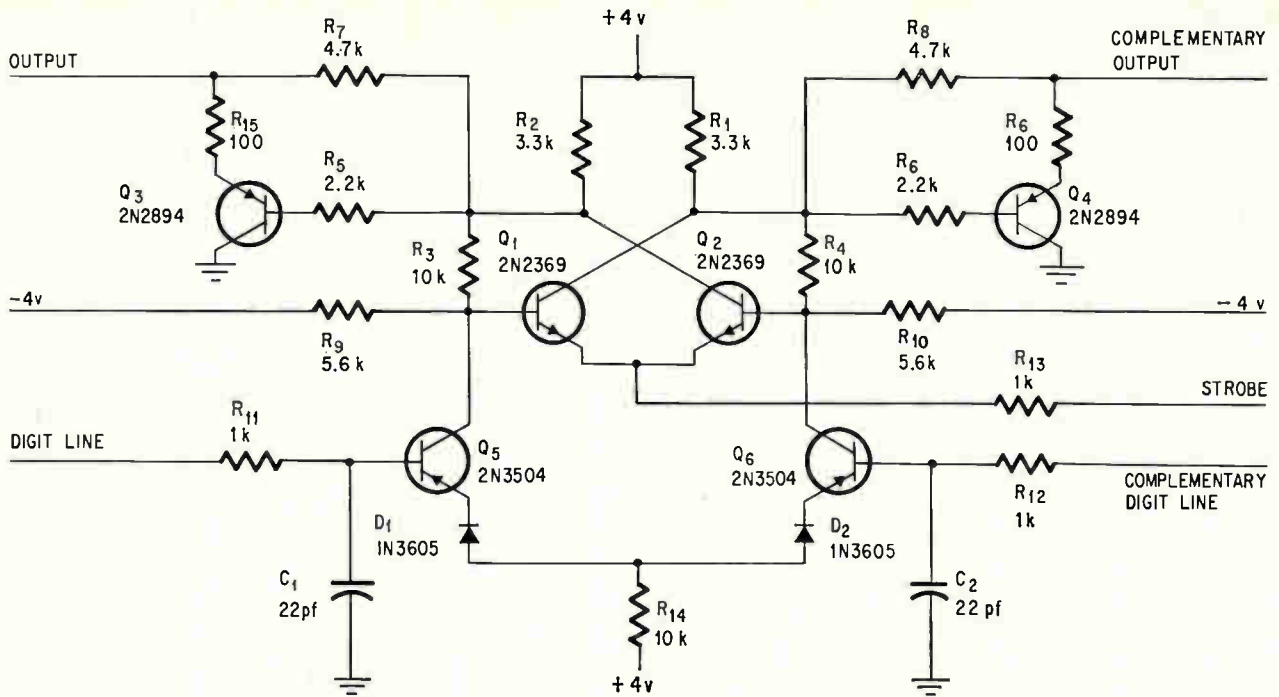

Sense amplifier. In the absence of a strobe pulse, this circuit is completely "off." A current differential on the two digit lines in the center, and the strobe sets the flip-flop in one of its two stable states, establishing the two complementary outputs.

occur if a restore pulse were applied simultaneously to the entire memory, the memory is divided into eight sections that receive a pulse one at a time in rotation. A self-contained restore clock, asynchronous to the rest of the system, steps a three-stage counter and, following each count, delivers a pulse to one of the eight drivers in an order determined by a decoder. The restore pulse driver circuits are quite similar to the address drivers.

Timing control is done entirely by integrated monostable multivibrators.

Pack it in

The MOS storage elements are packaged on both sides of two multilayer printed-circuit boards, each 12 by 14½ inches; a third board carries the x-address decoder and the restore generator, and a fourth carries the y-address decoder and control circuits. All these boards are mounted in one end of the bottom of a Samsonite suitcase; the power supply is in the other end of the bottom. The memory exerciser is mounted at the top and connected to the memory by two connectors. An external computer could also operate the memory through these connectors.

The total measured power of the assembly is 3.4 watts, when the ratio of write to read operations is 3:10, the clock rate is 1 megahertz, and temperature is between 0° and 60° C. Continuous writing of data that repeatedly changes the state of every storage element in a word requires considerably more power than continuous reading, of course. Such continuous writing involves the active driving of many circuits rather than merely the detection

of their various states.

The memory array itself dissipates slightly less than 1 watt, thanks to the restore-pulse technique. The exact figure is 930 milliwatts, or 30.3 microwatts per cell. Another 0.7 watt is dissipated in the 64 address driver circuits, of which only two are in operation at any one time; the smallness of this amount reflects, to a large extent, the special switching circuits.

The technique for cutting the dissipation can best be understood by comparing it with the straightforward driving technique. The address, digit, and restore lines in the memory array present relatively large capacitive loadings to their respective driving circuits. The energy, W , stored in this distributed capacitance is

$$W = \frac{1}{2}CV^2$$

where C is the total capacitance in farads and V is the voltage across the capacitance.

The energy stored in charging the capacitance is, of course, returned when the capacitance discharges, because the capacitance itself ideally dissipates no energy. However, energy equal to that stored is dissipated in the resistance through which the capacitance is charged (to demonstrate, square the exponential expression for the current in an RC circuit, multiply by R , and integrate), and this amount of energy is dissipated in both the charging and discharging processes. Therefore, the total amount of energy dissipated in a single charge-discharge cycle is

$$W = CV^2$$

Power is the average rate of energy dissipation

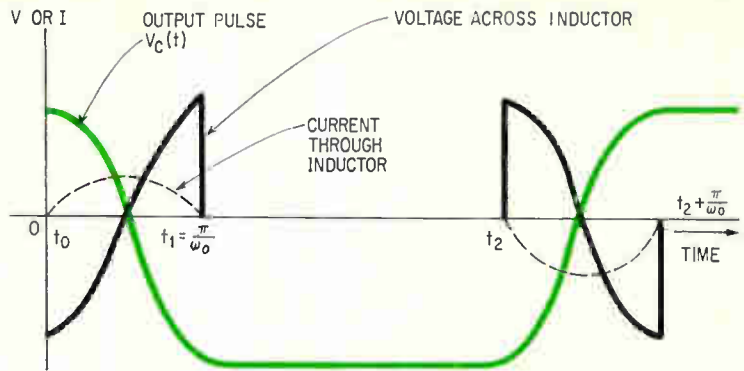
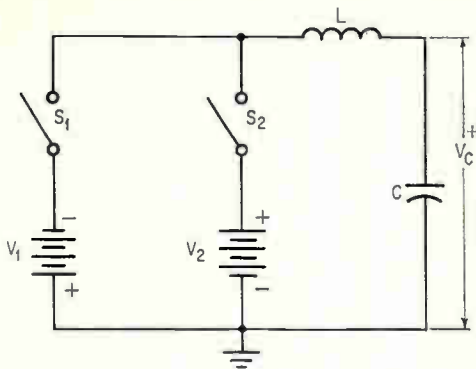

Driving principle. A resonant capacitance-inductance combination changes the voltage across the capacitance quickly without dissipating any power. The switches prevent ringing. Resultant pulse is in color.

per unit time, or

$$P = W/t = CV^2/t$$

But time measured in seconds is the inverse of frequency in hertz. Therefore

$$P = CV^2f$$

The typical capacitance of an address line is 1,200 picofarads. If, in addition, $V = 26$ volts and $f = 1$ Mhz, the dissipation is 0.8 watt. And since the memory contains two sets of address drivers, the total dissipation is 1.6 watts—as compared with the 0.7 watt actually attained.

Stop the clock

The designers managed to attain this power dissipation by using a line driver with an inductive output impedance to form a resonant circuit with the distributed capacitance of the line. The driver also has nonlinear characteristics that prevent this resonance from ringing, as shown in the simplified schematic and waveform sketch above.

The initial voltage on the capacitor is $V_c(0)$. After switch S_1 is closed at time $t_0 = 0$, the voltage across the capacitor is

$$V_c = V_1 + V_c(0) - V_1 \cos \omega_0 t$$

where

$$\omega_0 = \frac{1}{\sqrt{LC}}$$

At time $t_1 = \pi/\omega_0$, that is, after one-half cycle of the resonant ringing voltage, the capacitor voltage has reached its negative maximum, $2V_1 - V_c(0)$. For example, if $V_1 = -7$ and $V_c(0) = +12$, this negative maximum would be -26 volts. If switch S_1 is opened at this instant, the capacitor remains charged to this value; no power has been dissipated, because all the components are lossless in this idealized example. Effectively, the clock has been stopped at this instant.

If switch S_2 is closed at some later time, t_2 , the clock starts again and the capacitor is

$$V_c = V_2 + V_c(t_2) - V_2 \cos \omega_0 t$$

where $V_c(t_2)$ is the voltage just prior to the closing of switch S_2 . Both switches open at $t_2 + \pi/\omega_0$. In the diagram, the two voltage sources have equal magnitudes and signs, and because the circuit is lossless, the final voltage equals the initial, meaning no power has been dissipated. In the actual circuit there are power losses in components and voltage drops across semiconductor switches,

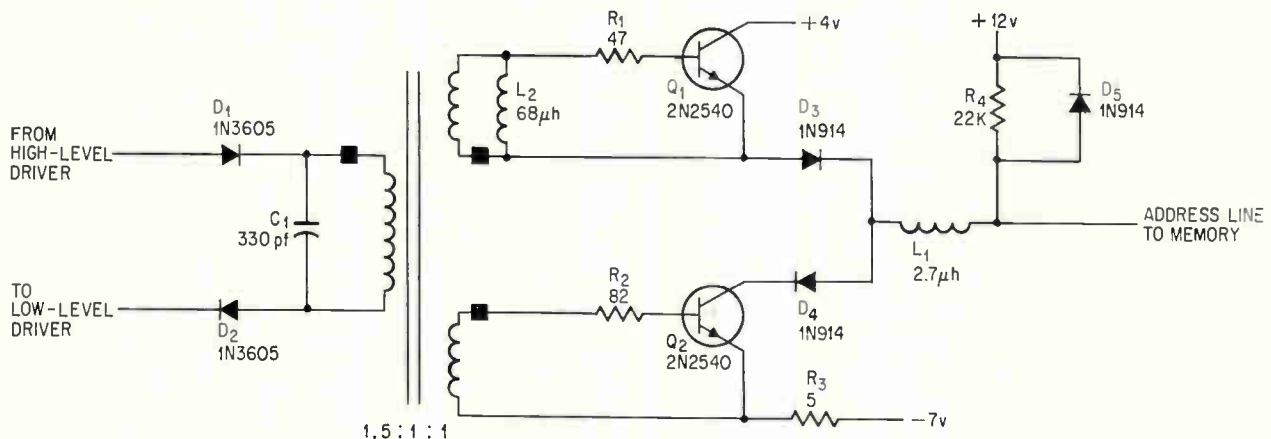

Line driver circuit. Transistor Q_2 is analogous to the switch, S_1 at the top of the page; transistor Q_1 corresponds to S_2 . Capacitance is distributed along the address line. The diodes prevent the recharging of the capacitance after the first half-cycle of the ringing that would otherwise occur.

and V_1 must therefore be of greater magnitude than V_2 to compensate.

The address driver, shown at the bottom of page 145, embodies the design principles illustrated in the idealized example. The line capacitance is initially charged to +12 through resistor R_4 . The primary of the transformer is shunted by a capacitor that balances the stray capacitance of the network when the high-level driver is actuated and the low-level driver is not. When the high-level driver turns on, therefore, the voltage appears across the transformer, turning on transistor Q_2 .

The saturated transistor connects the line capacitance through inductance L_1 to the -7-volt supply, and the resonant circuit begins to oscillate. But after only half a cycle, diode D_4 becomes reverse biased, thus effectively disconnecting Q_2 from the output.

When the high-level driver turns off, the transformer input voltage drops quickly, turning on transistor Q_1 . (Observe the polarity marks on the transformer windings.) The line capacitance charges up to its initial level through Q_1 .

When circuit losses and semiconductor voltage drops are considered, the parameter values shown provide a 26-volt negative pulse on the address lines. The angular frequency given by a 2.7-microhenry inductance and 1,500-picofarad capacitance is 15.8×10^6 radians per second, corresponding to address-pulse rise and fall times of about 0.2 microsecond each.

The same technique is also used in the restore drivers, but not in the write drivers. The high digit line capacitance would have made additional power supply voltages necessary for an inductor-and-switch circuit. But the write drivers normally contribute very little to total system power because of their low duty cycle.

The sense amplifiers dissipate very little power because they are essentially shut off in the absence of any input signal or strobe.

Up the road

Advanced as this memory system is, further improvements are in sight. The list includes:

- **Complexity.** About four times the number of bits could be built on a single chip with today's technology if a tenth the speed of the present low-power memory, or less, is permissible. With such a design, the same flatpack could also contain peripheral and restore-pulse circuits.

- **Speed.** When metal-over-metal crossovers are developed to the point where they can replace the present junction crossovers, they will afford either double the speed or double the density of the present chip, and could permit a substantially reduced restore-pulse duty cycle. Complementary MOS devices could boost the present model's speed by a factor of 10 or more.

- **Power.** A lower-frequency restore pulse would reduce power dissipation even further, and by a significant amount.

- **Cost.** Volume production is bound to bring it

down. Duplicating the present model would cost something over \$2 per bit. A production run of 1,000 systems would cost perhaps 50 cents per bit.

- **Size.** Larger memories following the present design could be easily made by adding flatpacks. The limiting factors would be reduced readout signal-to-noise ratio because of crosstalk, and the additional capacitance on the digit lines, with the resultant loading on the driver circuits. The size of the present memory could probably be double or quadrupled with only minor modifications—new shielding, new inter-connection boards, an 11-bit decoder, and perhaps a bigger suitcase. Memories larger than 4,096 words are practical, but would require multiplexed driving and sensing circuits, and would therefore dissipate somewhat more power per bit.

Bibliography

R. Lee, "Electronic Transformers and Circuits," John Wiley & Sons, New York, 1955, pp. 298-302.

Harley A. Perkins and Jack D. Schmidt, "Integrated semiconductor memory system," AFIPS Conference Proceedings, Vol. 27, Part 1 (Fall Joint Computer Conference), 1965, p. 1,053.

J.R. Burns, J.J. Gibson, A. Harel, K.C. Hu, and R.A. Powlus, "Integrated memory using complementary field-effect transistors," Digest, International Solid State Circuits Conference, 1966, p. 118.

I. Catt, E. Garth, and D.E. Murray, "A high-speed, integrated-circuit scratch-pad memory," AFIPS Conference Proceedings, Vol. 29 (Fall Joint Computer Conference), 1966, p. 315.

Ryo Igarashi and Toru Yaita, "An integrated MOS transistor associative memory with 100-nsec cycle time," AFIPS Conference Proceedings, Vol. 30 (Spring Joint Computer Conference), 1967, p. 499.

G.V. Podraza, S. Nissim, and D. Brewer, "A low-power MOS monolithic memory array," Digest, First Annual IEEE Computer Conference, 1967, p. 87.

Dewey E. Brewer, Sam Nissim, and George V. Podraza, "Low-power computer memory system," to be presented at the Fall Joint Computer Conference, 1967.

The authors



Dewey Brewer joined the Air Force Avionics Laboratory in 1962 and has since worked mostly on memory devices and systems. Previously he worked for the Martin Co. in Orlando, Fla., designing ground-support equipment for the Pershing missile system.



Sam Nissim is the manager of advanced computer development in Bunker-Ramo's information technology laboratory. Before 1964, he worked in the computer division of Thompson Ramo Wooldridge Inc., Bunker-Ramo's corporate predecessor.



George Podraza is a staff consultant specializing in circuit and hardware design. He has been with Bunker-Ramo since 1963, coming from the Martin Co. in Baltimore.

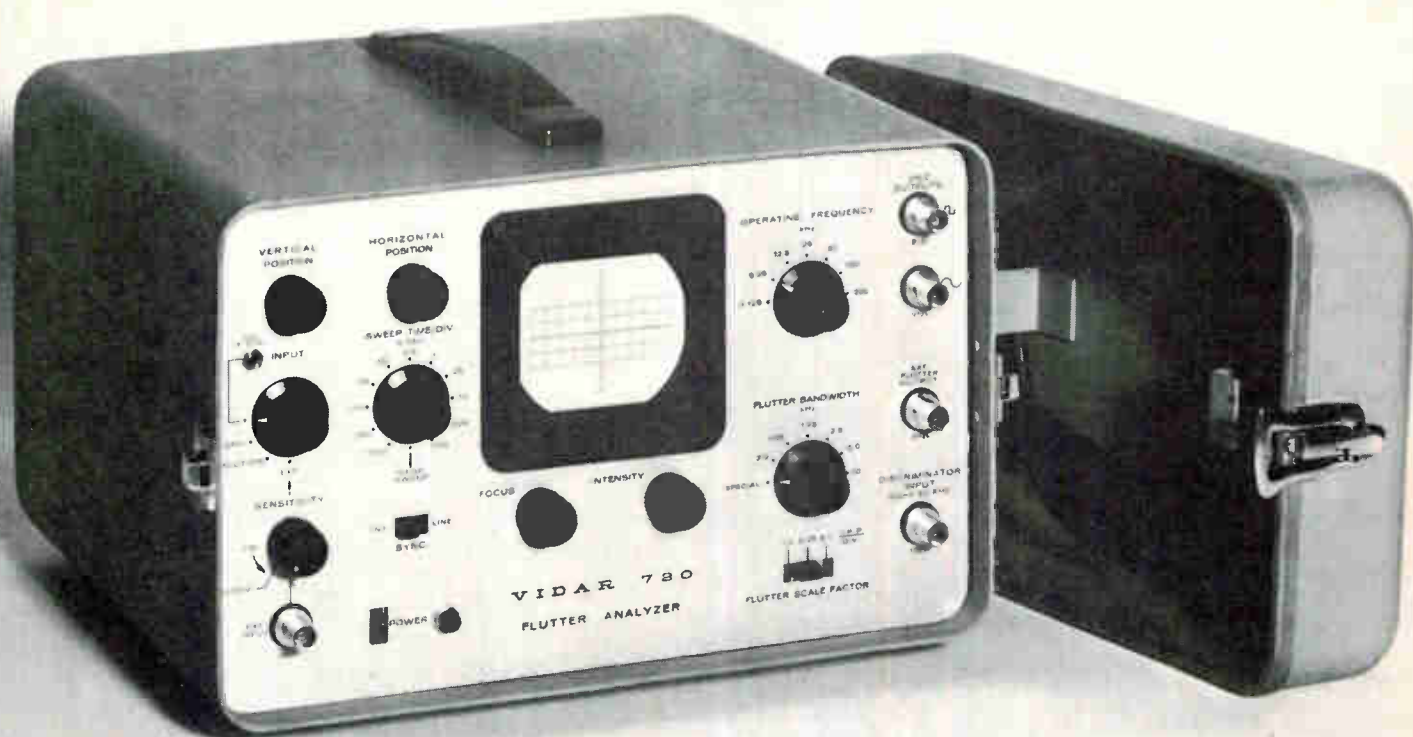

If you use recorders...

shouldn't you check flutter *before* you gather valuable data? VIDAR'S 720 analyzes and measures flutter accurately, quickly, and conveniently in accordance with IRIG 106-66 and recorder manufacturers' recommendations. The oscilloscope display helps you analyze and track down flutter components as low as 0.02% peak-to-peak over flutter bandwidths ranging from 0.2 Hz to 20 KHz. For complete details on this VIDAR laboratory-quality instrument contact Carl Smith, (415) 961-1000, VIDAR Corporation, 77 Ortega Avenue, Mountain View, California 94040.

VIDAR

TUNG-SOL 28 GP SERIES POWER SUPPLIES

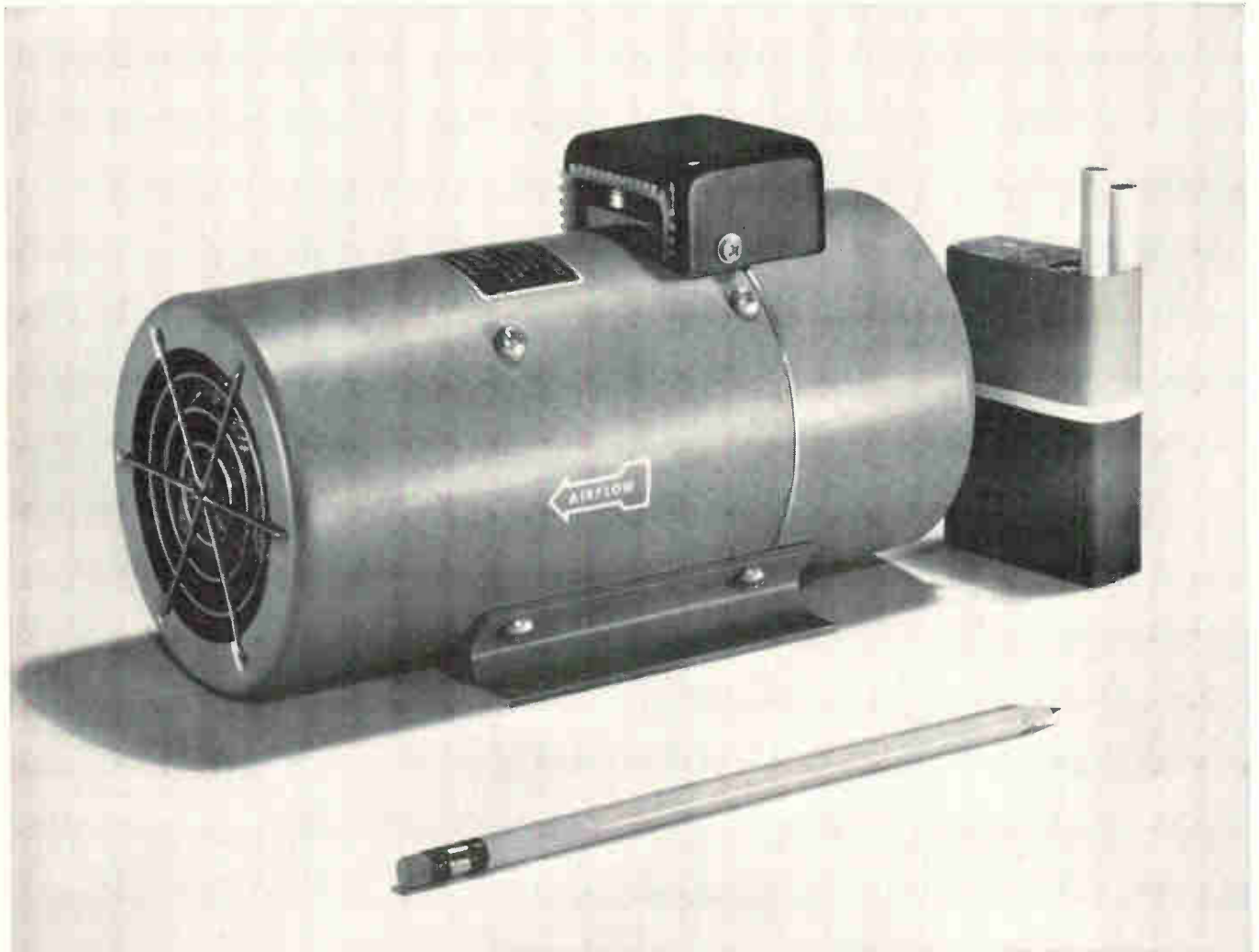

up to 400 AMPS. D.C. in new weight-saving package

A tremendous break-through was achieved in space and weight reduction of air-borne power supplies when the Tung-Sol Y-series configuration was first developed. Now, this unique design has been adapted to the requirements of ground-based equipment, to provide the same advantages for applications in the 100 amp. to 400 amp. range.

The Tung-Sol 28 GP series consists of four standard units that supply 100, 200, 300 or 400 amps. at 28 volts D.C. from an input of 115 volts, three phase, 400 c.p.s. They are production items available on an off-the-shelf basis. All units embody high-performance characteristics. They have high environmental adaptability and are especially suited to seaborne installations. Important, also, is the fact that they can be mounted in any attitude. For air transportable equipment, the weight factor is an exceptional advantage.

<p>28 GP 100</p> <p>Output: 100 Amps. Size: 8½" L x 4" W x 5⅞" H Weight: 7.5 lbs.</p>	<p>28 GP 300</p> <p>Output: 300 Amps. Size: 10½" L x 6" W x 7½" H Weight: 19 lbs.</p>
<p>28 GP 200</p> <p>Output: 200 Amps. Size: 10½" L x 5" W x 6⅞" H Weight: 13 lbs.</p>	<p>28 GP 400</p> <p>Output: 400 Amps. Size: 13" L x 6" W x 7½" H Weight: 26 lbs.</p>

For full technical information write for Bulletin.

TUNG-SOL DIVISION
Wagner Electric Corporation

630 West Mt. Pleasant Ave. • Livingston, N.J. 07039

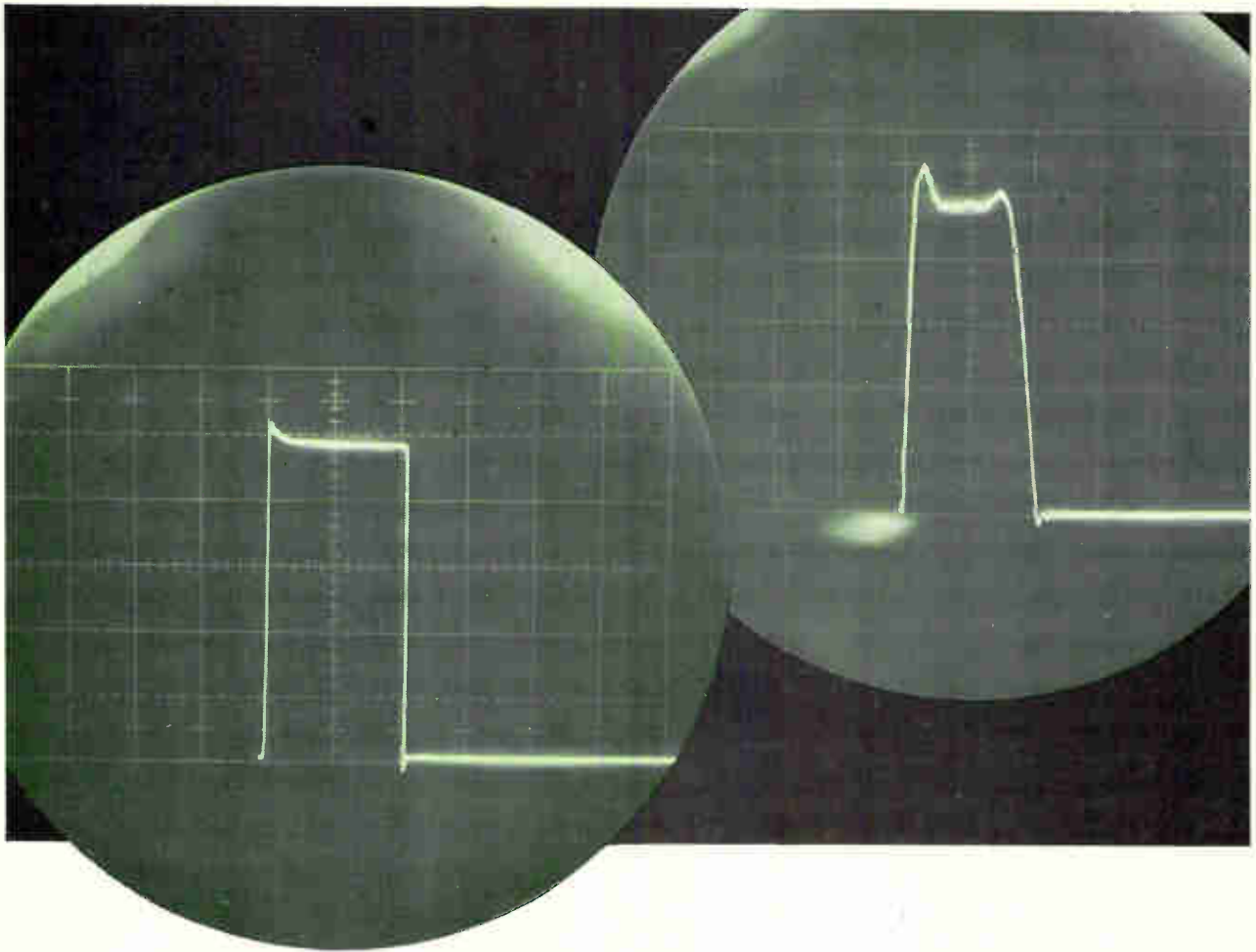

Two 100-megawatt modulator waveforms can't indicate your best choice in a switch tube. But our unbiased advice can.

That's because we're experts in both high-vacuum power tubes and hydrogen thyratrons for pulse modulation. So we play no favorites when it comes to helping you with tube selection. In fact, we work directly from your particular application requirements in specifying or designing the right tube for the job.

We're used to solving problems in existing systems, too. For example, negative grid current in high-vacuum power tubes. It was a characteristic that had been caus-

ing excessive equipment downtime in LORAN navigation transmitters ...until we developed the Type F-1086 vacuum tube in which there is no negative grid current throughout the operating range of the equipment.

We've been just as busy in ceramic hydrogen thyratron R&D. For Type 8479/KU-275A, we perfected a new keep-alive electrode. It allows the tube to switch up to 100 megawatts and maintain less than 0.15 microseconds variation in anode delay time over a wide range of operating conditions. The result: a "repeatable" tube for the largest linear accelerators.

By applying a new gradient technique from our F-1087 100-KV thyratron development, we are developing a tube that will have almost four times the current-carrying capability as the KU-275A... and with even greater voltage hold-off.

And we're doing a lot more in the gas-and-power-tube field to benefit your design needs. Ask us for general information or specific answers. Write: Dept. EL, Electron Tube Division, International Telephone and Telegraph Corporation, P.O. Box 100, Easton, Pa. 18043.

ELECTRON TUBE **ITT**

Why the big swing to silicone molded devices?

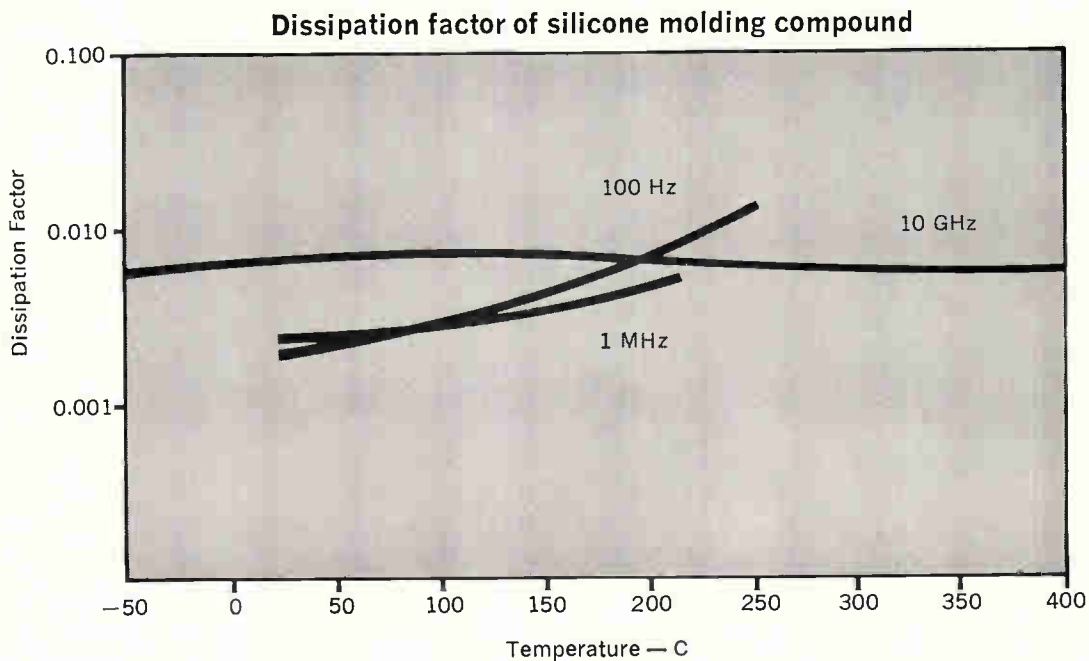

Why the big swing to silicone molded devices? . . . Electrically stable materials over a wide range of temperatures from low to high frequencies—as shown graphically above. Silicone molded packages do not limit the design or performance of high frequency semiconductor devices. Design characteristics will not drift due to changing electrical properties of the molded package.

That's why the rapid growth in the number of devices—from simple diodes to integrated circuits—packaged in silicone molding compound. Of course, there are other important reasons.

No derating necessary. Devices packaged in silicone molding compounds can be operated at their full power potential. This enables designs with a higher device density per given volume. For example, one manufacturer reduced the size of a power diode to 1/30th of its glass packaged counterpart. Compared to other plastic materials, the package size is from 1/5th to 1/3rd smaller, since derating due to package stability is not required.

No cracking—Dow Corning silicone molding compounds—unlike other organic thermal setting plastics—are virtually unaffected by heat and thermal shock. For example, a power resistor molded in Dow Corning® 307 molding compound was subjected to repeated cycling from -65 C to 350 C without damage to the packaging material or the device. Dow Corning® brand molding

compounds subjected to 1000 hours at 300 C (572 F) show no significant change in physical and electrical properties.

Will not burn. Silicone molding compound is inherently non-burning. Thus components packaged in silicone molding compound will not constitute a fire hazard. No flame snuffers are needed . . . a source of ionic contamination for devices packaged in organic plastic materials. With silicone molding compound there are no ionic or polar constituents when properly used, to affect junction performance.

Low water absorption—Dow Corning silicone molding compounds have low water absorption even after long aging at maximum operating temperatures.

Competitive Price. Silicone molding compound costs only a fraction of a cent per device. Thus, it enjoys a substantial price advantage over metal cans and glass packages.

Manufacturing Economies. Transfer molding enables devices to be packaged with minimum of manual labor and supervision. Good mold release and minimum flash assure high production rates and reduced de-flashing costs.

For technical data on why the swing to Dow Corning silicone molding compounds in device packaging, write Dept. 3723, Electronic Materials Division, Dow Corning Corporation, Midland, Michigan 48640.

Giant Killers

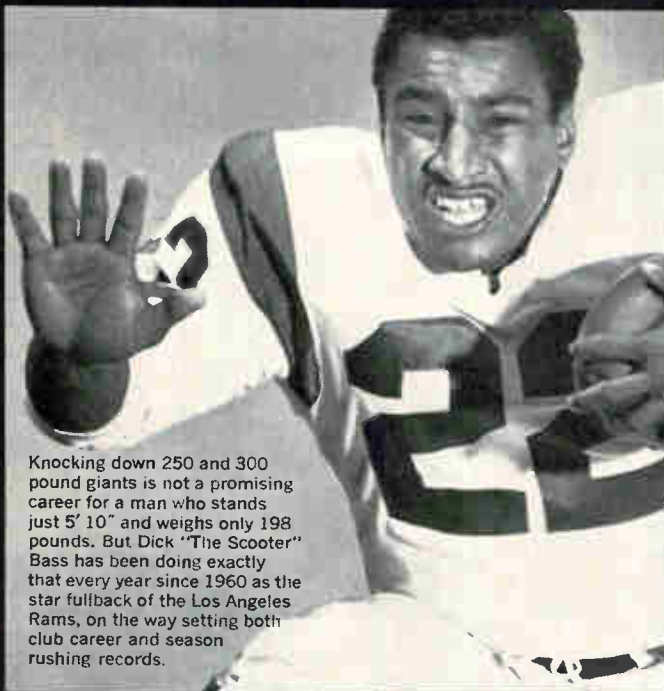

Knocking down 250 and 300 pound giants is not a promising career for a man who stands just 5' 10" and weighs only 198 pounds. But Dick "The Scooter" Bass has been doing exactly that every year since 1960 as the star fullback of the Los Angeles Rams, on the way setting both club career and season rushing records.

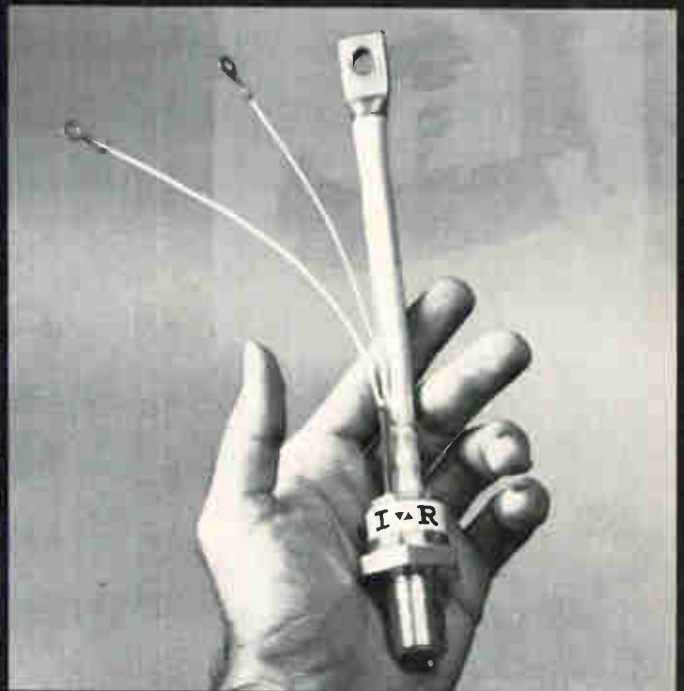

When we broke the news of our logic-triac to the world last September, we suspect that we upset some of the giant names in industry who also dabble in rectifiers. □ Our triac is the world's most powerful (200 Amps, 400-1000 Volts), made possible by our exclusive epitaxial process. Where ordinary triacs are limited to say household appliances, our logic-triac can handle enough power to run a freight elevator. □ The "logic" capability means you can control both AC and DC, since the device has selective gate characteristics. Therefore the same freight elevator with a three phase induction motor will be controlled by IR logic-triacs to go up or down, slow or fast, and accomplish dynamic braking more easily by imposing a DC current through the triacs to the motor. □ Our complete technical and application data on logic-triac can make you master of this giant killer. Ask for it.

INTERNATIONAL RECTIFIER



Semiconductor Division, 233 Kansas Street, El Segundo, California 90245, Phone (213) 678-6281

This is AE's Class B relay.

Use it where a less expensive relay would cost too much.

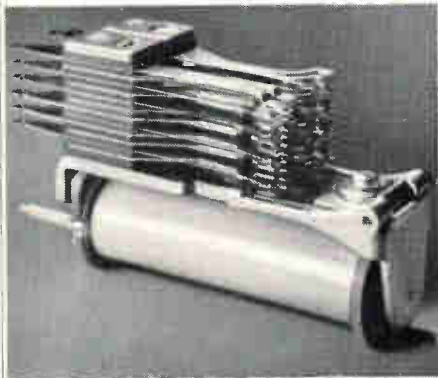

The Class B is a premium-quality telephone-type relay. It can give you at least 400 million operations with unfailing contact reliability. And it seldom needs maintenance.

That's why it's probably the most inexpensive relay you can use—where long-term reliability is a must.

In commercial and industrial control applications, the AE Class B delivers just what you'd expect of a telephone relay. It combines good sensitivity with excellent stability. Withstands extreme temperatures. Provides a wide range of practical operate and release timing...a range much wider than possible with smaller types of relays.

The Class B has two armature ratios (long, for fast acting

or pulsing—short, for slow-release and chatter-free AC operation). It also features twin contacts to insure against contact failure, a permanent wear-free backstop, pin-type armature bearings—plus a sturdy, stable heel-piece.

Newest Class B relay is the Series BRM latching version. When pulsed, remanent magnetism keeps the BRM latched without power consumption until it is restored by a second pulse.

Find out more about the Class B relay—the industry standard for long-term economy. Ask for Circular 1993. Just write to the Director, Relay Control Equipment Sales, Automatic Electric Company, Northlake, Illinois 60164.

AUTOMATIC ELECTRIC
SUBSIDIARY OF
GENERAL TELEPHONE & ELECTRONICS **GTE**

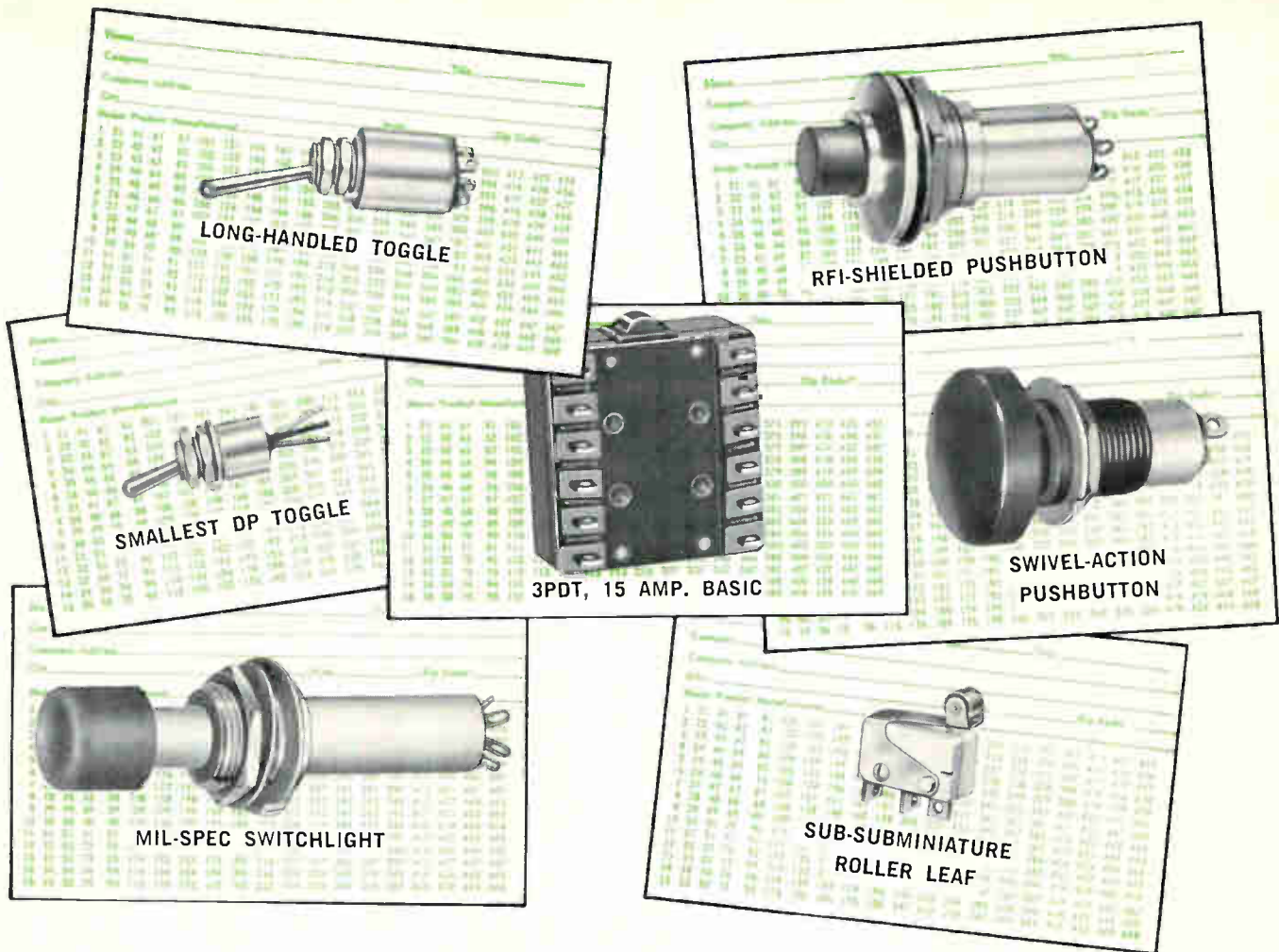

Why send 7 cards to 7 suppliers to find 7 switches?

Send one card to Control Switch now, connect with 167,921 switches!

Control Switch makes more types of switches than any one else in the fields we serve. Including RFI-shielded switches, sub-subminiature toggles, basic precision switches and RFI-shielded indicator lights.

If you send for all the Control Switch material listed below, you'll have the most complete reference file you can get from any source. You'll save time chasing all over every time you need a different switch or indicator light.

You'll also connect with reliable performance.

For Control Switch concentrates on quality components for systems, instruments and equipment where you cannot gamble on performance!

We also concentrate on highly-qualified distributors. Each specializes in electro-mechanical and electronic components. Each talks your language. Each has well-rounded Control Switch stock. Check your distributor on any need. Or contact us direct.

SEND FOR THESE TODAY

Check numbers on the Reader Service Card corresponding to those at left below for any or all of these Control Switch references. While you're at it, get 'em all!

- #330 Condensed Switch Catalog 100
- #331 Basic Snap-Action Switch Catalog 110
- #332 Toggle Catalog 180
- #333 Indicator Light Catalog 120
- #334 Hermetic Switch Catalog 130
- #335 Switchlite Catalog 220
- #336 Pushbutton Catalog 190
- #337 RFI-Shielded Component Bulletin 62A

C
C
CONTROLS
COMPANY
OF AMERICA

CONTROL SWITCH DIVISION
1420 Delmar Drive, Folcroft, Pennsylvania 19032
A Subsidiary of
General Precision Equipment Corp.

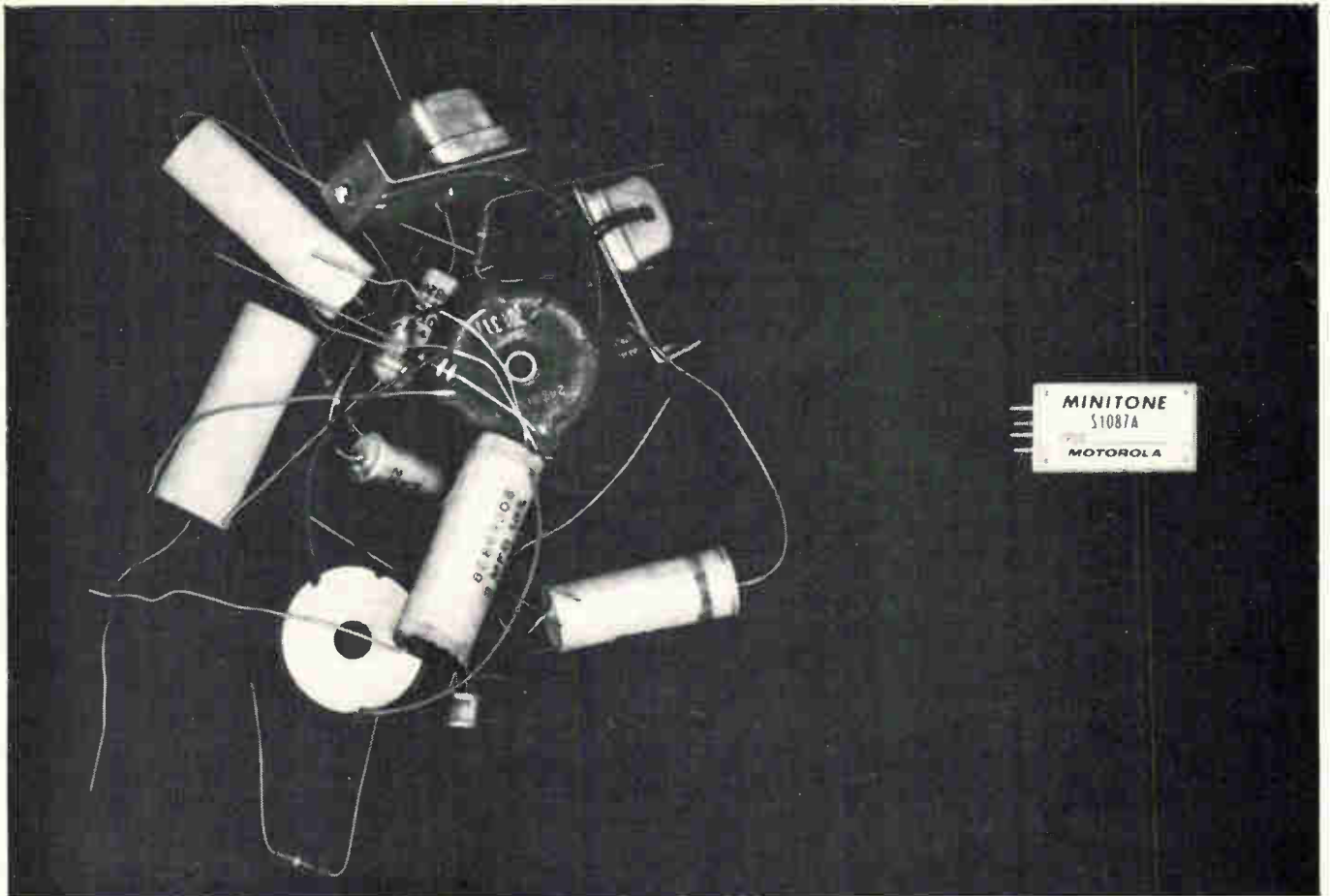

Two ways to achieve selective signaling

The MINITONE reed on the right does it better

Motorola's new miniaturized resonant reed either generates a highly stable audio tone, or provides very selective decoding. It does the job better because it's small, has excellent stability, and contains no contacts to wear out. And the MINITONE resonant reed is more economical; it eliminates the expense of extra components and design time needed to build highly selective tone oscillators and associated compensating circuits. Take a look at these facts:

SMALL SIZE: About $\frac{1}{4}$ of a cubic inch in volume. Measures only 1.11" x 0.619" x 0.393".

LONG LIFE: No contacts to wear out or cause malfunctions; life comparable to solid-state devices. Plus 3-year warranty.

HIGH STABILITY: Frequency tolerance $\pm 0.1\%$. Temperature stability better than $\pm 0.001\%$ per $^{\circ}\text{C}$ between -30°C and $+100^{\circ}\text{C}$ (25°C reference).

WIDE FREQUENCY RANGE: From 67 Hz up to 3150 Hz.

QUICK DELIVERY: Over 200 standard frequencies available from stock.

RUGGED CONSTRUCTION: Exceeds E.I.A. standards for shock and vibration.

PROVEN PERFORMANCE: Reeds have been proven in thousands of demanding situations, such as in aviation, control systems and radio communications applications.

FOR MORE INFORMATION contact your Motorola representative. Or write for bulletin TIC-3214.

MOTOROLA COMMUNICATIONS AND ELECTRONICS INC.
Dept. EO, 4900 West Flourney Street
Chicago, Illinois 60644. A subsidiary of Motorola Inc.



MOTOROLA
PRECISION
INSTRUMENT
PRODUCTS



Why buy price at any cost

To pay too little is to obviously speculate. To spend too much is to be foolishly extravagant. The real value of any purchase is determined in performance, not price. Resistors are like this also.

For years, Stackpole fixed composition resistors have been the standard of value for many leading manufacturers of electrical and electronic equipment. Engineers have become familiar with the testing and evaluation that go into each Stackpole resistor order. Purchasing people know they can expect prompt delivery. And management is assured of complete, in-depth service backed by sixty years of experience.

It's for reasons like these that Stackpole resistors are selected to maintain top performance on so many established products and on a growing number of brand new ones. Such confidence and loyalty cannot be based on price alone, but instead come from the kind of dependability that builds a reputation for your product.

Uniformity is a known characteristic of Stackpole resistors. Unique production methods coupled with thorough testing assure you absolute performance. You can rest assured that the Stackpole resistors you order today will be identical in every way, order after order.

Are you getting what you pay for in a resistor? Why not investigate the value Stackpole resistors can give you. Quality, economically priced and backed by the recognized name . . . Stackpole. There are four sizes to choose from: 2, 1, 1/2 and 1/4 watts.

For samples or a copy of our new booklet, "How to spot a quality resistor", write: Stackpole Carbon Company, Electronic Components Division, Kane, Pa. 16735. Phone: 814-837-7000. TWX: 510-695-8404.



STACKPOLE
ELECTRONIC COMPONENTS DIVISION

Which of these lasers best meets your requirements?

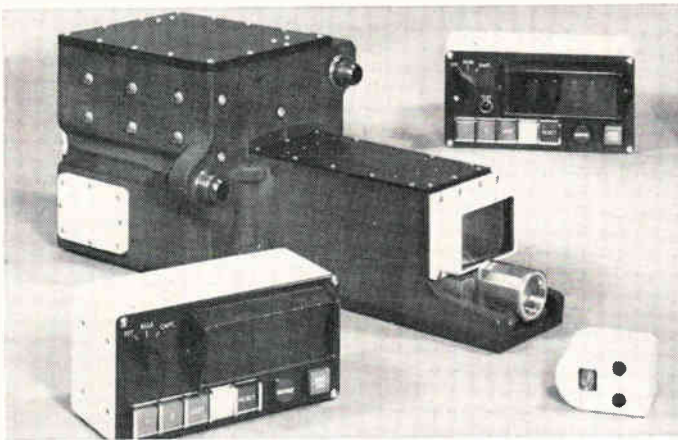

Laser Rangefinders. American Optical Company is engaged in developing laser rangefinder systems for ground support and airborne applications. In these projects, the company's Space-Defense Group combines its extensive experience in fire control optics with basic glass laser technology and high precision manufacturing capabilities.

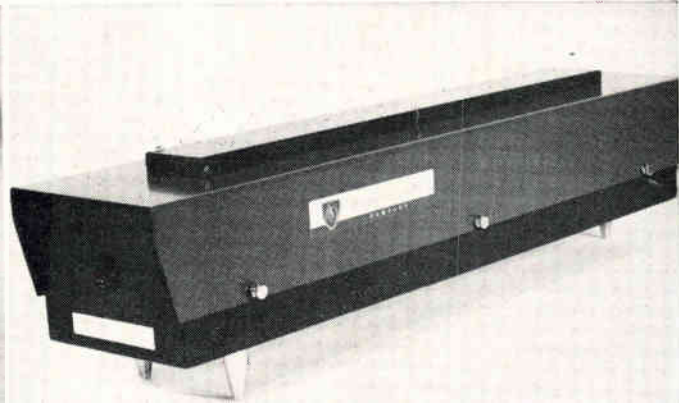

Models 10, 20, 30 lasers. American Optical offers extremely versatile, highly efficient laser systems featuring long pulse outputs of 15, 75 and 150 joules respectively. Fired in excess of 100,000 shots without breakdown, these systems are ideal for laboratory or production use. They utilize AOLux® neodymium glass laser rods and are available with or without rotating mirror or Pockels cell Q-switching, and power supplies.

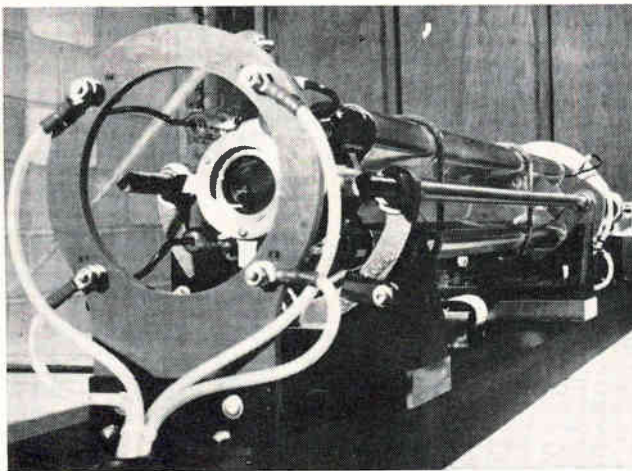

Model 5000 Laser system—the highest energy single-element laser system ever built. Delivered to Ballistics Research Laboratories, Aberdeen, Md., it uses a clad AOLux® laser rod 3.8 cm O.D. x 94 cm long to produce 5000 joules at a slope efficiency of 3%. The high optical quality laser glass and low neodymium doping level minimize thermally induced distortions. Using a remote mirror and special glass cladding limits beamspread to 10 milliradians full angle at the half energy points at an output level of 2700 joules.

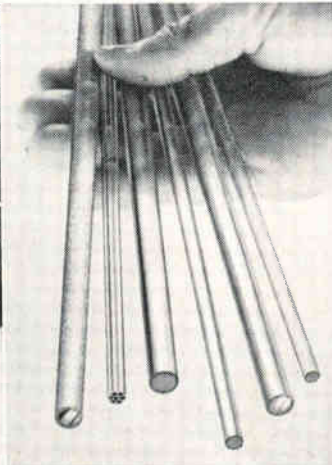

AOLux® clad and unclad laser rods are available in diameters up to 1½", lengths to 2 meters, and in 10 different neodymium dopings. They feature low threshold operation, high energy conversion efficiencies, high damage thresholds, long fluorescent lifetime, high optical quality and low loss coefficients—characteristics which make neodymium-doped glass ideal for an increasing number of laser applications.

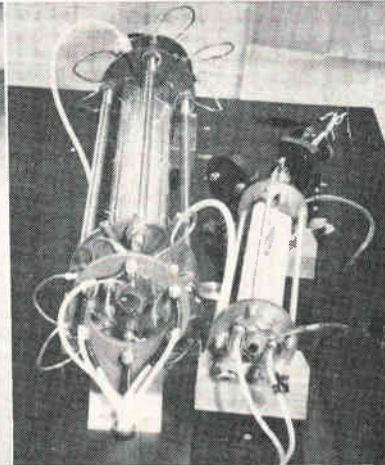

One gigawatt Q-switched system. This versatile Model 60 Laser consists of a 1.2 cm x 53.4 cm AOLux® neodymium-doped glass rod oscillator and 2.54 cm x 94.6 cm glass laser rod amplifier. Triggering, synchronization, and Q-switching with a rotating mirror provide 1 gigawatt at 60 joules output with pulse width of 60 ns. The oscillator amplifier system can be operated with a long pulse energy output of several hundred joules. Repetition rate: 1 shot every 3 minutes. Beam divergence: 5 milliradians.

American Optical Company welcomes inquiries about its laser systems and components—whether for laboratory experimentation or ballistics research, rangefinders or altimeters, or for laser welding, balancing or drilling. For more information on the systems and components

shown here, write: *American Optical Company, Space-Defense Group, 4709 Baum Boulevard, Pittsburgh, Pennsylvania 15213. Resumes from engineers and scientists—in a wide range of disciplines—are welcome. Write to American Optical Company at the address above.*



AMERICAN OPTICAL COMPANY

Space-Defense Group • Pittsburgh, Pa. 15213



*Charles-Francois de Cisternay Dufay
Dangled from the ceiling in a very quaint way;
Charged electrically in this odd pose,
He shot off sparks from the end of his nose!*

One of a series of...
Vignettes in Electronic History

A limited number of full-color reproductions
of the Dufay painting, along with the story of his
experiment, are available upon request.

In his own peculiar manner, Dufay discovered positive and negative electric charges and helped pioneer the way to our wonderful world of electronics. Today, with better scientific procedure, Spectrol tackles the most challenging assignments in electro-mechanical components. Typical of Spectrol's capability in "specials" and "high reliability" components are its precision potentiometers on the Command Module for the Apollo man-on-the-moon program. That kind of capability explains why Spectrol precision potentiometers are found on more systems throughout the world than any other pots.

And, although the "spec" in "Spectrol" stands for "special," we still offer our customers over two-hundred-million options to choose from in our line of *standard* precision potentiometers and trimmers. That's why more and more engineers are calling Spectrol "the component man's component company." If you're a component man shouldn't you be using our products, or helping us make them?

Spectrol Electronics Corporation
A subsidiary of the Carrier Corporation
17070 E. Gale Ave., City of Industry, Calif. 91745
Copyright © 1967



Better Components for Better Systems: precision potentiometers • trimming potentiometers • turns-counting dials • miniature switches

new digital readout

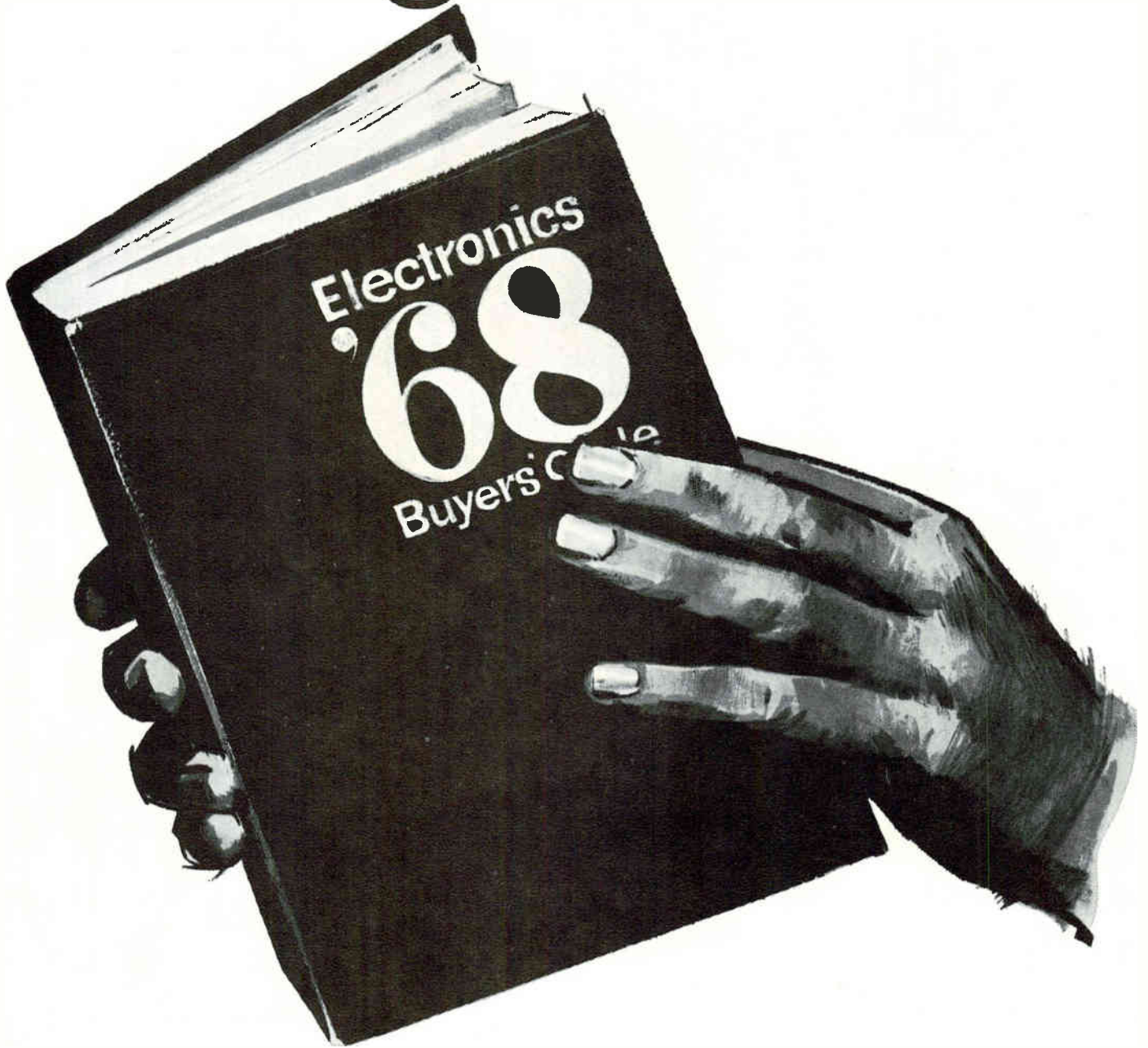

-lets your fingers flip through the entire electronics industry.

The '68 EBG gives you almost instantaneous desk top retrieval of 4 million bits of information that constitute the electronics industry.

If the answer to a problem involves finding a product or the people to supply it, this year the Electronics Buyers' Guide can help you find it faster than ever.

The '68 EBG yellow pages integrate editorial product

listings and advertiser's specifications in one continuous alphabetical section that is 4,000 categories long.

The green section tells you who's nearest, with the product you want, by listing local telephone numbers and addresses for more than 6,000 manufacturers.

Use the '68 EBG. And whenever you find an answer to your problem, tell them who sent you.

Electronics Buyers' Guide

A McGraw-Hill *Market Directed* Publication, 330 West 42nd Street, New York, N.Y. 10036

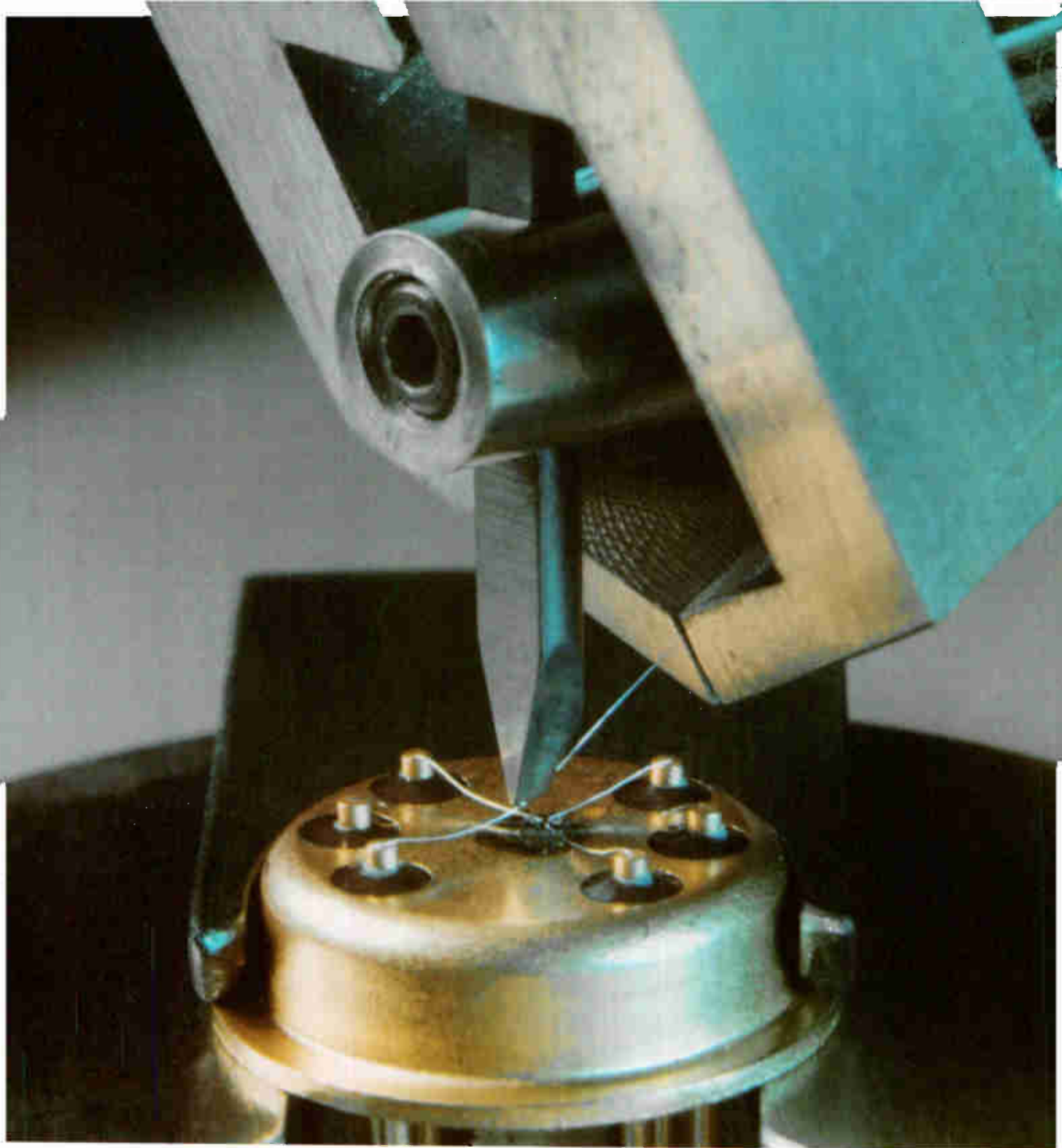

Craftsmanship in hard materials...an industry standard

HIGH PRECISION TUNGSTEN CARBIDE BONDING TOOLS, SUCH AS THE ONE SHOWN IN THIS 13X MAGNIFICATION OF AN ULTRASONIC LEAD BONDING OPERATION, WERE PIONEERED AND INTRODUCED AS PRODUCTION DEVICES BY TEMPRESS . . . IN 1963, THE TEMPRESS CAPILLARY TUBE, AN INDUSTRY STANDARD . . . IN 1967, THE ULTRASONIC BONDING TOOL, AN INDUSTRY STANDARD.

The techniques and the specialized machinery developed to produce such precision products from ultra-hard materials have not been duplicated; quite probably will not be, for they are a result of the unique combination of Tempress people and the

Tempress philosophy. To meet its responsibilities, Tempress maintains a continuing expansion program, limited only by strict adherence to the Tempress Standard of Excellence. (It requires as long as 11 months to train an operator for certain operations.) The same uncompromising standard is applied to Tempress Automatic Scribing Machines and to the entire growing family of Tempress miniature assembly tools and production equipment.

LEAD BONDING, DUAL FET, COURTESY OF UNION CARBIDE ELECTRONICS



TEMPRESS

Tempress Research Co., 566 San Xavier Ave., Sunnyvale, Calif. 94086

Circle 159 on reader service card

POTSa New England Tradition

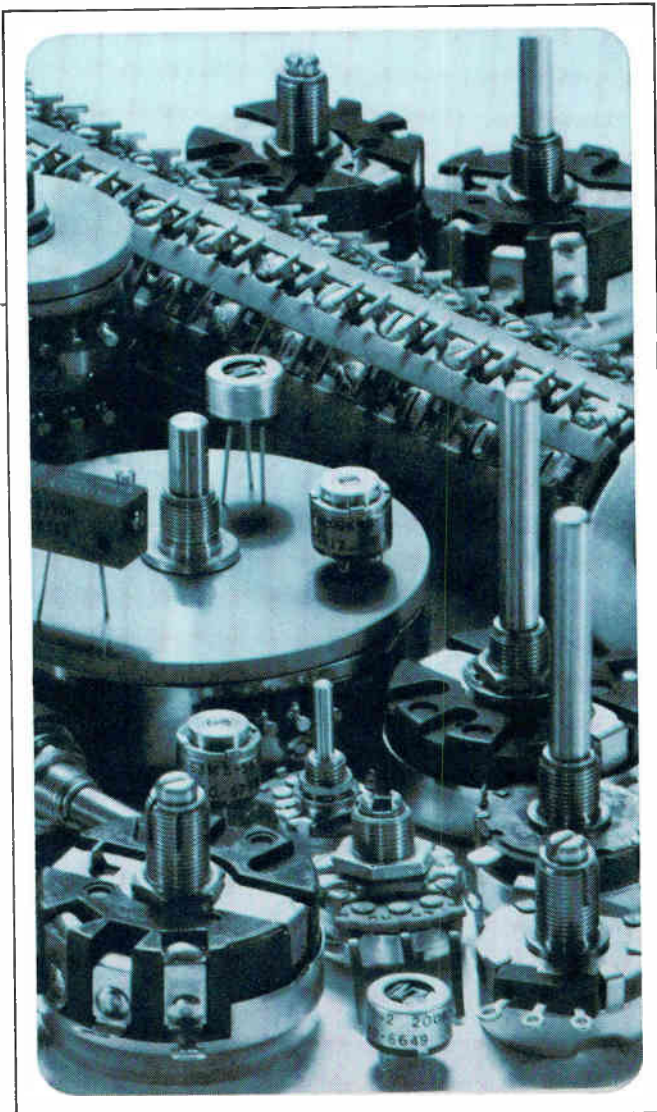

A TRADITION AT CLAROSTAT TOO is the manufacture of precision pots to meet every need. For more than 40 years, Clarostat craftsmanship has made it a leader—the recognized source of guaranteed performance potentiometers for industrial, military and service-replacement applications. Whether you need ½" single turn potentiometers; 10-turn, tight-tolerance potentiometers; high versatility, single-turn potentiometers; vari-phase, single-turn potentiometers; single turn, sine/cosine potentiometers, or other types, you can depend on Clarostat for minimum wear, low noise, long life and zero backlash. Once you try Clarostat, it is likely they will become your own traditional choice of pots on the basis of honest value, off-the-shelf delivery and quick service.

CLAROSTAT

CLAROSTAT MFG. CO., INC., DOVER, NEW HAMPSHIRE 03820

We keep some powerful experiments quiet.



Fuel cells don't have to be noisy. We developed one for the Army that you can't hear only 100 feet away. This 300-watt cell should produce 28 VDC for more than 1000 hours without special attention.

Yet, complete with cell stack, blower, pump, starter and voltage regulator, it weighs only 30 lbs.

Fuel cells are the lightest, most effective, non-mechanical devices yet discovered for generating electric power.

We make them in all sizes.

But fuel cells are only one of the activities that keep Union Carbide up front, on the frontiers of electronics. For instance, among other things, we're leaders in research, development and production of single crystals and crystal products; solid tantalum and foil-film capacitors; laser systems and accessories; solid state devices.

These are among the reasons to think of Union Carbide for help before your projects get beyond the talking stage.



ELECTRONICS

Union Carbide Corporation, Electronics Division, 270 Park Avenue, New York 10017.

An Equal Opportunity Employer

AIR MAIL PAR AVION CORREO AERO AIR MAIL

AERO
CORREO
AVION
PAR
MAIL
AIR
AERO
PAR
CORREO
AVION
PAR

PAR
AVION
CORREO
AERO
AIR
MAIL
PAR
AVION
CORREO
AERO

Dear ITT: I'm tired of

- slipped deliveries
- incoming QC rejections
- out-of-line prices...

...from my present small signal transistor suppliers. To qualify your PNP/NPN high speed switches, NPN core drivers and general purpose amplifiers per the enclosed prints, rush test data and samples by return **AIR MAIL**

Please qualify your devices per the attached prints.

NAME _____

COMPANY _____

ADDRESS _____

CITY _____ STATE _____ ZIP _____

AIR MAIL PAR AVION CORREO AERO AIR MAIL

semiconductors **ITT**

ITT SEMICONDUCTORS IS A DIVISION OF INTERNATIONAL TELEPHONE AND TELEGRAPH CORPORATION, 3301 ELECTRONICS WAY, WEST PALM BEACH, FLORIDA 33407
 FACTORIES IN FLORIDA • CALIFORNIA • MASSACHUSETTS • ENGLAND • FRANCE • GERMANY • PORTUGAL • AUSTRALIA



If your target is precision, why not start with it?

Durez® phenolic, diallyl phthalate, and alkyd molding compounds

Start by specifying the precision compounds from Durez for the molding of your electrical components.

The precision compounds deliver, in the mold and on the job. They'll give you the precision results your specs call for, every time. They solve the tough problems, like wall thicknesses of .050" or superior corrosion resistance.

The wide line of Durez phenolic, diallyl phthalate, and alkyd molding compounds offers the balance you want from these key design requirements: good electrical and thermal properties, impact strength,

durability; relatively low cost; heat, corrosion, and chemical resistance; flame retardance; dimensional stability; and retention of electrical properties after long periods at high humidity.

Durez sales engineers and technical service men are standing by to help you get the precision compound that can best handle your specific application.

For complete information, write Durez Division, Hooker Chemical Corporation, 9011 Walck Road, North Tonawanda, N. Y. 14120



EFFECTIVE OCTOBER 1, 1967

CTS ^{2-watt} ^{3/4" dia.} Cermet Pots

in Wirewound or Carbon Price Range

**less
than**

98¢ each
(in production quantities)

Only CTS, high volume automated producers of cermet controls, offers a line of 3/4" dia., 2-watt cermet potentiometers at prices you would expect to pay for industrial wirewound or carbon pots.

Series 550 combines long life, low noise, high overload capability, high stability and wide resistance range in compact construction that exceeds MIL-R-23285 (a tighter cermet version of MIL-R-94). Single, dual and concentric constructions.



Series 550

2-watt 3/4" dia.

Cermet Variable Resistor

Compare these specifications (linear taper)		
	Standard Characteristics	Optional Characteristics (no more than 10c extra per item)
Temperature Coefficient		
Resistance ohms	TC PPM	TC PPM
40Ω to 1.35KΩ	-50 to +200	-0 to +100
1.36KΩ to 2.9KΩ	-100 to +300	-0 to +250
3KΩ to 1.35 meg.	-100 to +250	± 100
1.36 meg. to 5 meg.	± 250	± 150
ENR	± 2%	± 1%
Rotational Life	50,000 cycles ± 5% Δ R	100,000 cycles ± 10% Δ R
Resistance Range	50 ohms through 1 megohm	25 to 49 ohms or 1 megohm to 5 megohms
Independent Linearity	± 5%	± 3%

For help in your application, call on CTS, the world's largest producer of variable resistors.

Most models available through CTS distributors.



Founded 1896

CTS OF BERNE, INC.
BERNE, INDIANA

Subsidiary of CTS Corporation, Elkhart, Indiana

Probing the News

Space electronics

Space-ground link hardware on schedule despite setbacks

Philco-Ford and Motorola will have S-band ground system ready next spring for Air Force satellites from six stations

By Lawrence Curran

Los Angeles regional editor

Despite the miseries the Air Force has endured in developing the space-ground link subsystem and its follow on, the advanced version, hardware deliveries will begin late next spring—right on schedule.

The first space-ground link subsystem (SGLS) was designed to standardize and consolidate all of the tracking, telemetry, and command functions of all Air Force satellites. Using ultrawide bandwidth and high-speed pulse-code-modulation techniques, at least three separate communications links are integrated into a single multiplexed S-band channel: ultrahigh frequency for command, S band for tracking, and very high frequency for telemetry. The advanced version was designed to boost the capacity of the subsystem's data rate from 1 million to 20 million bits per second.

Season's greetings. Late last year, it was reported that someone connected with the program had accepted gratuities from representatives of a firm interested in securing a development contract [Electronics, Dec. 26, 1966, p. 49]. An Air Force investigation confirmed the allegation, but concluded that the gratuities did not represent an attempt to influence the service's decision [Electronics, Feb. 20, p. 54].

Then, TRW Inc.'s systems group, which built an SGLS prototype that passed orbital tests with flying

colors, ran into cost problems. As a result the company lost the ground station hardware development contract to a team composed of the Philco-Ford Corp.'s Western Development Laboratories, Palo Alto, Calif., and Motorola Inc.'s Government Electronics division, Scottsdale, Ariz.

Second thoughts. The latest problem concerns the advanced subsystems. Last month the Air Force cancelled a request for proposals for ground-station tape recorders to store the 20-megabit-per-second data stream that was to have been transmitted by certain satellites. Observers close to both programs single out two spacecraft that would need the high data rate provided by ASGLS—the Manned Orbiting Laboratory (MOL) and the supersecret reconnaissance satellite known only as Program 949 [Electronics, Oct. 2, p. 26]. However, an Air Force spokesman says the MOL probably won't need the 20-megabit data link, and that cancellation of the tape recorder project suggests that the satellite program requiring the high data rate has either been cancelled or reoriented.

Whether or not there is a spacecraft that requires the ASGLS, an industry source says the Air Force still anticipates a need for the high bit rate it provides, and development work continues.

Hardware for the orbital portion

of the advanced link is shrouded by security requirements but almost all of the ground terminal equipment for both the SGLS and ASGLS is unclassified. Motorola engineers, working on the ground equipment for the advanced version, have been ordered to stop work on a pulse-code modulation demodulator and check-out equipment for the orbiting vehicle. However, they have also been told to get on with the development of the rest of the hardware and to "quit conjecturing about what the final version of the system is going to look like."

Motorola, Philco-Ford's subcontractor, will supply most of the ground terminal equipment for both the SGLS and the advanced subsystem. Fred Kemmeries, Motorola's engineering project manager for both programs, says the SGLS receiver's big jobs are to autotrack Air Force satellites with 14-foot and 60-foot antennas from six sites, provide up-link command data, and handle down-link telemetry. "In this sense, the link is very similar to NASA's unified S-band system," he says.

There will be ground stations at Vandenberg Air Force Base, Calif., on Guam, Hawaii, at New Boston, N. H., Kodiak, Alaska, and one in the Indian Ocean. Kemmeries says the Hawaii, Guam, New Boston, and Vandenberg installations will be equipped with advanced space-



Please send me the latest Acopian catalog that lists

**62,000
DIFFERENT
POWER
SUPPLIES**

available
for shipment
in 3 days.

Name _____

Title _____

Company _____

Address _____

City _____

State _____

ZIP _____

ACOPIAN CORP.
EASTON, PENNSYLVANIA
TEL: (215) 258-5441



... Motorola emitter-coupled logic is used in the digital ranging gear ...

ground link sub-system gear.

Motorola's SGLS contract specifies that the firm will provide Philco-Ford with a ground receiver and analog ranging equipment, essentially a monopulse tracking system, according to Kemmeries; digital ranging equipment; a digital range rate extractor; a demodulator; a doppler frequency converter; a baseband separation unit; and a 1.7 megahertz biphasic sub-carrier demodulator. Motorola expects to finish its share of the SGLS work before the first site—Hawaii—goes operational.

I. Versatile receiver

The SGLS antennas are slaved to the receiver. Motorola built a receiver for TRW for the developmental ground stations but the current model has been redesigned. A wideband autotracking mode, incorporating a frequency synthesizer for continuous tunability over the SGLS spacecraft transmitter range of 2,200 to 2,300 Mhz, has been added as has fault-isolation circuitry and indicators that permit tracing of malfunctions to any of the 50 individual subassemblies. The fault isolation feature gives a 15-minute mean time to repair, says Kemmeries. The wideband autotracking mode is required because the receiver is a monopulse unit, and has recently been given the job of pointing the 60-ft. antenna for the ASGLS carrier. The unit already had the antenna pointing job for the SGLS carriers.

The SGLS has two down-link carrier waves. The first—carrier 1—provides return ranging and various low-data-rate subcarriers up to 1.7 megahertz. The second—carrier 2—provides telemetry data at rates up to 1 million bits per second.

Pickup. When SGLS carrier 1, the basic S-band carrier, is operating, the receiver provides two error outputs—one each for azimuth and elevation. The 60-ft. antennas have four feedhorns picking up signals from the spacecraft. The receiver processes the outputs from the horns, summing and differencing them to provide an error signal.

These are S-band signals, which the receiver converts to two analog d-c voltages—one each for azimuth and elevation.

The error is zero when the spacecraft "is dead center on the antenna," says Kemmeries. A plus error or minus error is generated if the spacecraft is off center, and the error is fed to the antenna servo system to position the antenna properly in azimuth and elevation. Kemmeries says this antenna signal error detection function is performed in either a phase-locked or wideband mode; the 60-ft. antenna is monopulsed while the 14-ft. unit is conically scanned.

In addition to detecting antenna signal errors, the Motorola receiver also does data-demodulating for the principal carrier for range, range rate, and telemetry signals. The digital ranging equipment is connected to the receiver and the ground station transmitter. This apparatus provides a digital code word, which the transmitter sends to the spacecraft's transponder. The word is a pseudo-random noise signal with a length of more than 5 million bits and a duration of 5 seconds, giving the ranging equipment the ability to track spacecraft at lunar distances—even though the Air Force requires only a synchronous orbit ranging capability.

II. Odd jobs

The retransmitted signal sent back by the spacecraft transponder is demodulated by the receiver and fed to the digital ranging equipment; the system's accuracy is approximately 100 yards. All active circuitry in the digital ranging equipment uses Motorola emitter-coupled logic supplied by the company's Semiconductor Products division. Kemmeries says there are 31 cards in the ranging equipment, with about 500 MECL packages per system.

Range rate—the spacecraft's speed—is determined this way: analog doppler outputs from the receiver are fed to the doppler frequency converter, which processes them together with a sub-

multiple of the transmitted frequency, and provides a signal that contains exact two-way doppler information. This output is fed to the range-rate extractor, which converts the data to digital form and sends it along to a ground station computer that produces a digital value for range rate. The extractor also uses MECL circuitry and has a clock rate of 30 Mhz.

The SGLS receiver also demodulates telemetry and voice subcarriers that are transmitted to the baseband separation unit. There is a 1.024-Mhz biphase modulated subcarrier for low-speed digital telemetry at rates up to 128,000 bits per second; a 1.25-Mhz wideband — 20 kilohertz — subcarrier that is frequency-modulated for voice and wideband analog signals; and a 1.7-Mhz subcarrier that is either frequency modulated or biphase modulated, depending on the spacecraft mission, providing a data rate up to 256,000 bits per second.

Megabit monitor. The SGLS receiver also processes signals on a second S-band carrier transmitted from the spacecraft simultaneously with carrier 1 and feeds them to the carrier 2 demodulator. Carrier 2 accommodates biphase pcm digital telemetry data at rates from 128,000 bits per second to 1 million bits per second. It is 5 Mhz lower than the carrier 1 frequency to provide the 1 megabit capability plus a guard band.

A third carrier wave processed by the SGLS receiver is the advanced subsystem data carrier. Kemmeries says the receiver will be able to pinpoint the ground-terminal antenna even if this carrier is the only one transmitted by the spacecraft. Carrier 3 relays the spacecraft's pcm signal at a data rate between 2.5 million and 20 million bits per second. It could also be used for wideband f-m transmissions up to 10 mhz. One observer points out that the latter capacity would permit the link to relay television signals from an orbiting vehicle.

Off the air. Most of the time, carrier 3 will probably not be operating at the same time as carriers 1 and 2. If it is, Kemmeries says, a second SGLS receiver will be assigned to it, eliminating the need for a guard band like that between

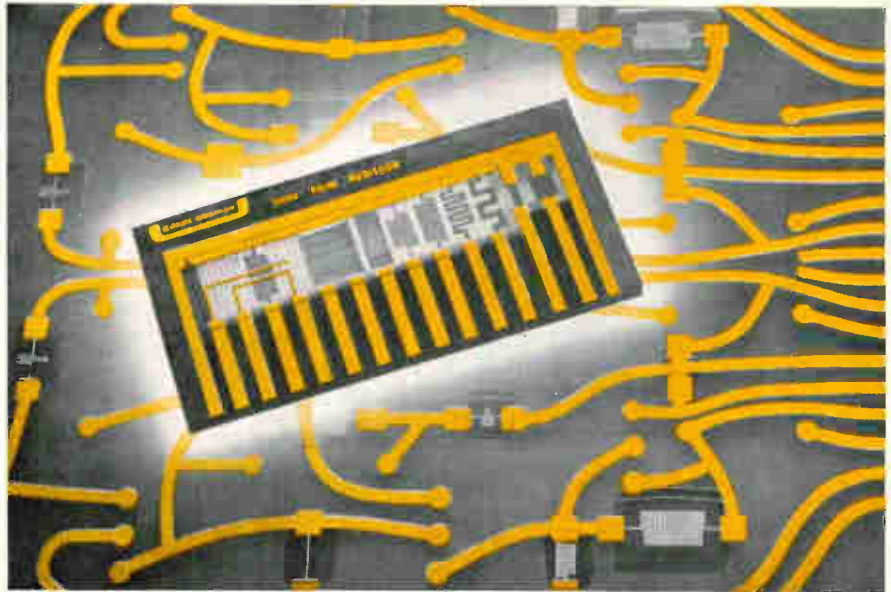

Now... Thin Film Resistors from Cinch-Graphik

Now you can order thin film resistors as an integral part of the world's finest printed circuits. This Cinch-Graphik innovation offers packaging design flexibility and economy never before possible. These electronically deposited resistance patterns are only 2 millionths of an inch thick. They occupy virtually no space, weigh practically nothing, and are competitive in price and performance with discrete resistors. In addition, Cinch-Graphik's thin film resistors are stable, reliable and have electrical characteristics as good as ordinary resistors. Available in resistance values from 10Ω to 150KΩ, these resistors can be utilized in single or multilayer circuits on standard printed circuit laminates. Other components or conductor paths can be placed directly on top of the thin film resistors.

Specifications:

Value Range on Single Resistivity	10 ohms - 150,000 ohms	(5000 hours @ 75°C @ 2 watts/in ²)	Drift	always positive
Sheet Resistivity	10 ohms - 50 ohms/sq.			Less than 2%
Resistor Tolerances	5%, 10%, 20%	Resistor line width and spacing	5 mils min.	
Temperature coefficient of Resistance	+80 ppm	Resistor thickness	600 angstroms @ 50 ohms sheet resistivity.	
		Power dissipation	2-4 watts/in ²	

For additional details or specifications, call, write or wire:

CINCH-GRAFIK

D I V I S I O N O F U N I T E D - C A R R



200 South Turnbull Canyon Road, City of Industry (Los Angeles), Calif. 91744 • Phone (213) ED 3-1201. Sales offices in 33 principal cities throughout the United States, Great Britain, Canada, Australia and West Germany.

CONSISTING OF CINCH MANUFACTURING COMPANY, CINCH-GRAFIK, CINCH-MOHADNOCK, CINCH-NULINE, UCINITE (ELECTRONICS) AND PLAXIAL CABLE DEPT.

Glass-Epoxy Copper-clad

through TAYLOR'S TOTAL RELIABILITY PLAN:

Raw materials, panels or punched blanks to your reliability requirements. You get what you order from a fully integrated source.

FAST DELIVERY from two fully equipped plants — one at Valley Forge, Pa., the other at La Verne, Calif. Or from warehouses in Chicago, Ill. and other key locations.

... **FULL SIZE SHEETS, CUT-TO-SIZE PANELS or PUNCHED BLANKS** to satisfy fabricating and processing requirements. Ease of fabrication is a plus value in printed circuit production.

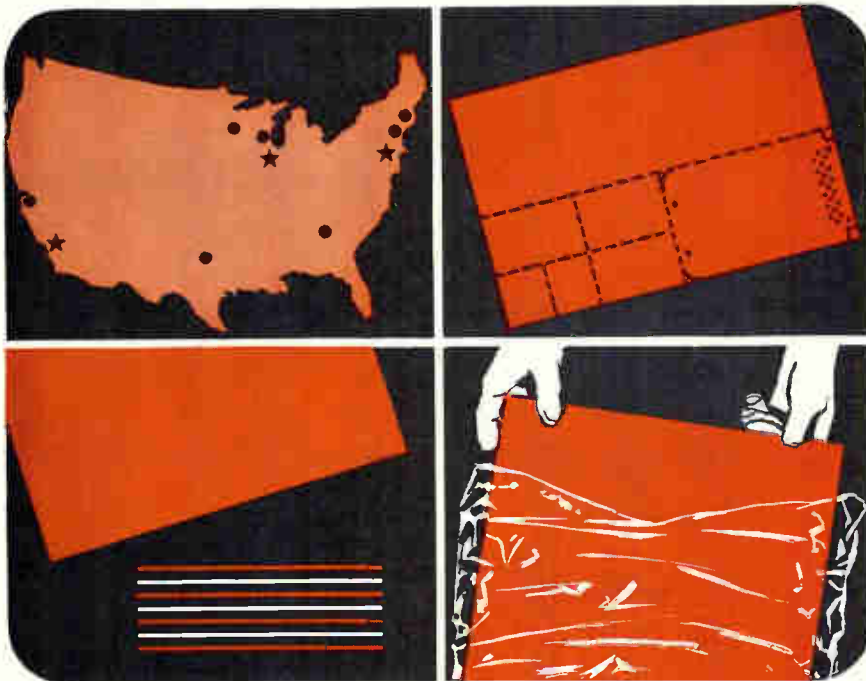

... **STANDARD AND ULTRA-THIN FORMS.** Standard sheets in all grades. Ultra-thin sheets and multilayer prepreps in GEC 500 (G-10) and Fireban 600 (G-10, FR-4).

... **WHITE GLOVE HANDLING** in atmosphere-controlled white rooms, careful processing, extremely tight quality control and special packaging assure top performance.

Taylor's copper-clad has proven total reliability demonstrated by an ever increasing number of major OEM's and commercial etchers. This acceptance substantiates our claim for unsurpassed quality, ease of fabrication and delivery to your scheduled requirements. Let us demonstrate this reliability to you. Ask for a sample (give grade designation and copper combination) and a copy of Bulletin GB-2.



Taylor copper-clad

TAYLOR CORPORATION • Valley Forge, Pa. 19481

Phone: 215-666-0300 TWX: 215-666-0659

West Coast Plant: La Verne, Calif.

Also manufacturer of Taylor laminated plastics, Taylorite® vulcanized fibre and Tayloron® prepreps

carrier 1 and carrier 2.

Receiver refinements. A threshold improvement demodulator in the receiver demodulates carrier 3's f-m data, using a wideband modulation tracking phase-locked loop that yields a 4-decibel threshold improvement. "This means that you can have 4 db less signal before you reach the deterioration point where the f-m signal is lost in noise," Kemmeries explains. He says that this is equivalent to extending antenna diameter from 60 ft. to about 95 ft.

The most significant features in the SGLS receiver, say Motorola officials, are the 4-db threshold improvement, the wideband autocorrelation capability with spectrums up to 35-Mhz of bandwidth, and tunability across the band using a frequency synthesizer in the phase-locked mode. These are all state-of-the-art developments, Kemmeries says. For wideband autocorrelation, the receiver compares the signal on a sum channel with signals on two angle channels, and puts out a d-c signal proportional to the antenna-pointing error.

Motorola has a line of standard radio-frequency components in the receiver called E, for extruded, and P, for potted, modules. The E module is a standard plug-in aluminum housing for all r-f packaging; the P modules fit inside. Motorola has 19 standard modules, including phase detectors, mixers, wideband amplifiers (100 to 200 Mhz with relatively flat response), variable gain amplifiers, power amplifiers, video amplifiers, and phase shifters. These units are epoxy potted and plated with tin for r-f shielding.

Two for one. A typical SGLS ground station will have one of each of the ground station subsystems plus a backup. "This redundancy, in effect, gives you two stations at each site," Kemmeries says.

III. Advanced link

A typical advanced space-ground link subsystem terminal will have three wideband receivers, each with an f-m demodulator. There will be three pcm demodulators and two pcm bit synchronizers. All of these units are connected in-line. In addition, there will be two pieces of automatic checkout

equipment—a pem simulator and a test transmitter—to make loop tests when there is no airborne transmitter in the loop. All this equipment will be in six racks.

Motorola's Government Electronics division makes everything but the pem demodulators and the test transmitter, which are being developed by Philco-Ford.

Government-furnished tape recorders and a classified piece of hardware to maintain communications security will be integrated into the terminal complexes.

The advanced link equipment picks up the S-band signals on carrier 3 only, and goes to work after the SGLS receiver has pinpointed the antenna. It has a minimum data rate capacity of 2.5 million bits per second. "The ASGLS hardware adds a high data rate pem ability to the tracking sites," says Kemmeries. "There is a receiver in the ASGLS that is a functional repeat of the SGLS receiver, but it has only about one-fourth the hardware of the SGLS version."

Separate ASGLS receivers are needed so that carriers 1 and 2—the SGLS carriers—and carrier 3 can operate simultaneously. In this situation, carrier three would be relaying signals from a different spacecraft at a different frequency from carriers one and two.

Busy signals. The receiver output goes to the pem demodulator, essentially a quadrature demodulator, and two wideband phase detectors. It has a loop that locks coherently to the carrier. The pem demodulator can operate either quadrature or biphase.

Kemmeries explains that the S band has four possible phases representing one of four possible vectors. In the quadrature mode, the pem demodulator has half the rf spectrum width it does in biphase mode for the same bit rate. "This is so the Air Force can put more spacecraft into the S-band frequency," says Kemmeries. "The system could handle two or three if they were all ASGLS vehicles."

From the pem demodulator, the signal goes to the pem bit synchronizer, which has a phase-lock loop that locks coherently to the data and yields matched filter detection of the data. The pem bit synchronizer operates either biphase or quadrature and incorpo-

CONRAC
CORPORATION

CHOOSES VISHAY RESISTORS (over 100 of them) FOR NEW SOLID-STATE AIR-DATA COMPUTER

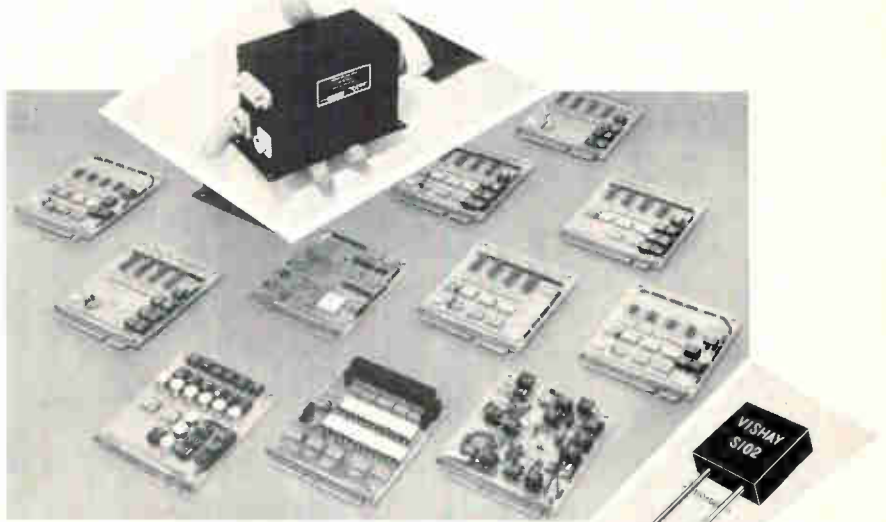

"Vishay accuracy, plus resistance and temperature stability, best meet D-A ladder network's need for resolution of 1 part in 2¹⁵. Also chosen for use in voltage divider of function generator . . . for same spec combination."

Conrac Corporation's 3 lb., 58.5 cu. in. ADC shrinks size 10 times, weight 3-5 times, and simplifies maintenance . . . with unique solid state design.

Conrac engineers met critical space and accuracy requirements by relying on the "no-trade-off" performance of more than 100 Vishay resistors. Vishay's **standard** performance specs (even better on special order) include:

- 0.01% absolute tolerance
- $0 \pm 1 \text{ ppm}/^\circ\text{C}$. TC (0° to $+60^\circ\text{C}$. range)
- Stability—Shelf: Guaranteed 25ppm/yr. (50/3yrs.)
Load: 0.030% (2000 hrs., 125°C .)
- Fast Speed (<1 ns. to 100 MHz. and above)
- No noise ■ Very small size

These and other Vishay features (including reliability) are expanding the design and performance possibilities in the most demanding applications. Your Vishay man can tell you for whom and where.

The "why" is in these two free brochures. Send for your copies today.

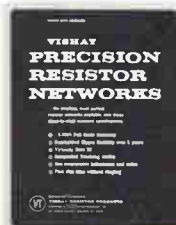
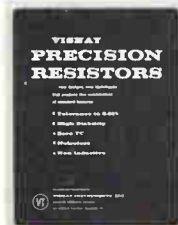

VISHAY
RESISTOR
PRODUCTS



a division of Vishay
Intertechnology, Inc.
633 Lincoln Highway
Malvern, Pa. 19355



introducing the "PIXIEPOT"TM at an IMPossibly low price!

Duncan Electronics now offers for the first time in the history of the potentiometer industry a PRECISION, TEN-TURN WIREWOUND pot for less than \$6.00. In fact, the new Model 3253 "PIXIEPOT" potentiometer is yours for as low as \$3.97 each in production quantities and only \$5.95 each for 1-24 units.

Outstanding "PIXIEPOT" potentiometer features:

- Length: ONLY 3/4"
- Diameter: 7/8"
- Linearity: ±0.25%
- Resistance Range: 100 ohms to 100K ohms
- Power Rating: 2 watts @ 20°C
- Temperature Range: -25°C to +85°C
- Resolution: Better than any precision pot twice its size.

The Model 3253 "PIXIEPOT" potentiometer incorporates all of the fine engineering workmanship you've come to expect from other Duncan products. Only our new, unique production techniques enable us to bring this potentiometer to you at these unheard of prices.

And if you need your "PIXIEPOT" potentiometers in a hurry, we guarantee they'll be on an airplane out of Los Angeles within 24 hours after receipt of your order!

How can a "PIXIEPOT" potentiometer help you?

Call or write your Duncan representative (listed on the facing page). He will personally deliver to you, FREE, a 1K "PIXIEPOT" potentiometer for your evaluation in exchange for the filled out certificate.

This certificate redeemable for one 1K "PIXIEPOT"



(TYPE OR PRINT)

MY APPLICATION IS _____

NAME _____

COMPANY _____ TITLE _____

ADDRESS _____ DIVISION _____

CITY _____ STATE _____ ZIP _____

This offer expires December 1, 1967



DUNCAN ELECTRONICS, INC. • 2865 FAIRVIEW ROAD, COSTA MESA, CALIFORNIA 92626

ENGINEERING SALES REPRESENTATIVES

ALABAMA, Huntsville
Orbe, Inc.
Tel: (205) 881-8230

ARIZONA, Phoenix
Southwest Engineering Company
Tel: (602) 944-1521

CALIFORNIA, Costa Mesa
Duncan Electronics, Inc.
(Factory Sales Office)
Tel: (714) 545-8261

CALIFORNIA, San Francisco
Jack Pyle Company
Tel: (415) 349-1266

CONNECTICUT, New Haven
Gerber Sales Co., Inc.
Tel: (203) 777-6279

FLORIDA, Orlando
Orbe, Inc.
Tel: (305) 424-0978

FLORIDA, St. Petersburg
Orbe, Inc.
Tel: (813) 894-0687

ILLINOIS, Chicago
Carlson Electronic Sales Co.
Tel: (312) 774-0277

MARYLAND, Baltimore
Biechler Associates, Inc.
Tel: (301) 825-8222

MARYLAND, Rockville
Biechler Associates, Inc.
Tel: (301) 762-6210

MASSACHUSETTS, East Longmeadow
Gerber Sales Co., Inc.
Tel: (413) LAurel 5-3059

MASSACHUSETTS, Waltham
Gerber Sales Co., Inc.
Tel: (617) 891-8040

MINNESOTA, Minneapolis
Carlson Electronic Sales Co.
Tel: (612) 788-4111

MISSOURI, Kansas City
Harris-Hanson Company
Tel: (816) 444-9494

MISSOURI, St. Louis
Harris-Hanson Company
Tel: (314) 647-4350

NEW JERSEY, Harrington Park
B. B. Taylor Corporation
Tel: (201) 768-0969

NEW YORK, Baldwin, L.I.
B. B. Taylor Corporation
Tel: (516) 223-8000

NEW YORK, Rochester
Reed Electronics, Inc.
Tel: (716) 473-2767

NEW YORK, Syracuse
Reed Electronics, Inc.
Tel: (315) 468-5488

NEW YORK, Vestal
Reed Electronics, Inc.
Tel: (607) 748-7391

OHIO, Cleveland
Rockford Controls Ohio, Inc.
Tel: (216) 531-4841

OHIO, Dayton
Rockford Controls Ohio, Inc.
Tel: (513) 274-1911

PENNSYLVANIA, Millersville
Biechler Associates, Inc.
Tel: (717) 872-2793

PENNSYLVANIA, Pittsburgh
Rockford Controls Ohio, Inc.
Tel: (412) 731-4600

TEXAS, Dallas
Robert R. Thomas Company
Tel: (214) 363-8591

TEXAS, Houston
Robert R. Thomas Company
Tel: (713) 644-2369

WASHINGTON, Seattle
Hamilton-Electro Corporation
of the Pacific Northwest
Tel: (206) 624-5930



DUNCAN electronics, inc.

... the bit stream will be sent to custom equipment ...

rates a signal combiner to delete ambiguity from the data.

Kemmeries says that a matched filter in the pcm bit synchronizer "makes the best decision possible as to what digital symbol was sent to the space vehicle in the presence of noise that is corrupting the whole channel. The bit synchronizer puts out a string of zeros and ones that is neither in word nor frame format."

Before the recent program change, Motorola was to have furnished a general-purpose pcm decommutator that would recognize individual words and frames in the data, and set it up for data processing equipment. It now appears that the bit stream will be passed to data-processing equipment peculiar to the airborne user program.

IV. Hybrid approach

George Rupprecht, project leader in Motorola's advanced development section, says all the pcm equipment in the advanced link ground hardware the company is building will use hybrid integrated circuits from a semistandard line developed by the Government Electronics division with its own funds. These devices have been proven in other Motorola equipment, and Rupprecht believes this demonstrated capability was a big factor in winning the advanced link contract.

"We have six kinds of wideband amplifiers that have different functions," Rupprecht says. "The hybrids are used mainly in the baseband equipment, mostly for multiplier functions. There are high-gain and low-gain amplifiers, and some d-c restoration amplifiers, plus three straight differential amplifiers with varying gains and power levels. All have bandwidths greater than 100 Mhz. We use hybrid amplifiers because they give us the speeds and bit rates we need." The pcm equipment specifications call for a maximum bit rate of 24 million per second, and Motorola engineers are attempting to hold differential delays to typical speeds of around 0.2 nanoseconds.

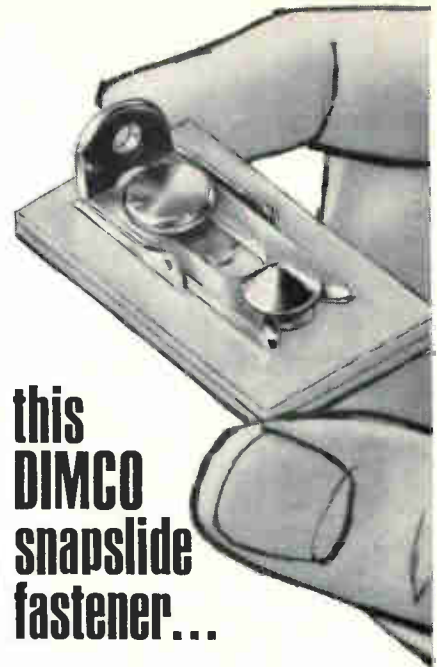

this
DIMCO
snapslide
fastener...

holds assemblies
securely...

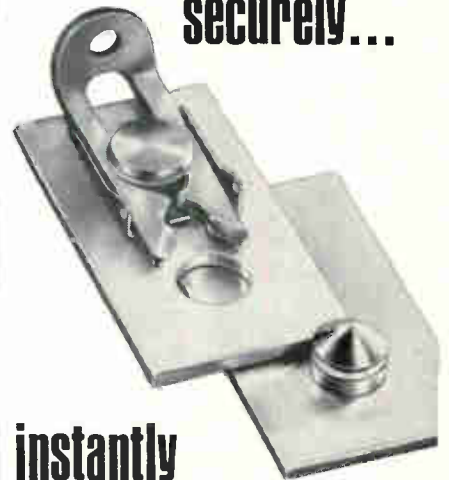

instantly
engages/releases...



write for
new
handbook

Dimco-Gray Snapslide Fasteners hold assemblies firmly despite shock or vibration... never need adjustment, even with repeated use. Instant snap action engages or releases fastener... no tools required. Approved under Military Standards. Handbook illustrates typical applications, stimulates design ideas, describes attachment methods. Write for free copy today.

DIMCO-GRAY CO., 204 E. SIXTH ST., DAYTON, OHIO 45402

If we raised the prices of our "off-the-shelf" regulated DC power supplies 25%, you'd expect these features:

- Regulation: Line: $\pm 1\%$ for $\pm 13\%$ line voltage change. Load: $\pm 2\%$ for any load voltage change between $\frac{1}{2}$ load and full load.
- Ripple: 1% RMS maximum.
- All-solid-state components for stability and reliability. No complex circuits.
- Convection cooling. No fans or moving parts.
- All components conservatively rated for continuous duty.
- Ferroresonant, isolated winding, constant voltage transformer providing isolation from line voltage fluctuations, and protection from short circuits.
- Wide selection of control voltages and currents.
- Fast response to line load changes.

But we give you all these features without a premium price. Because our thirty-five years experience in perfecting DC power supplies for critical applications, such as computers, has shown how to refine and simplify designs, to provide most value and performance per dollar.

Acme Electric Corporation, Dept. 31, Cuba, New York 14727

Acme Electric

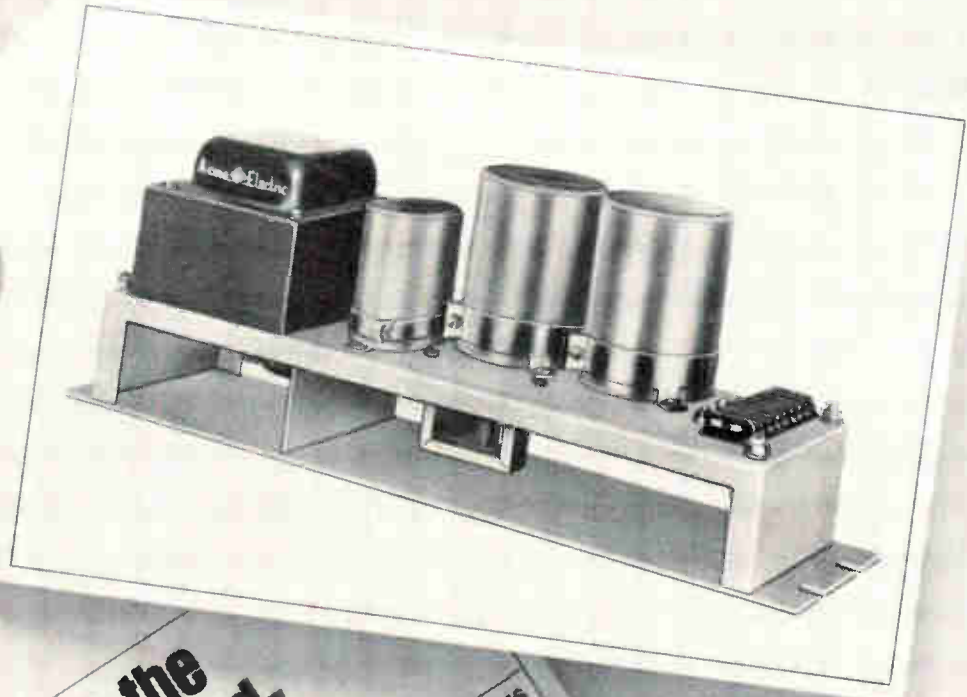

Here's the Dollars-and-cents proof:

SINGLE PHASE, 100-130 VOLTS INPUT, 60 CYCLES			
Number Catalog	Volts	Amps	Quantity of Watts
PS-41422	24	2	48 \$109.20
PS-41423	24	6	144 148.70
PS-57353	24	10	240 153.90
PS-47125	24	15	360 161.20
PS-47173	24	25	600 202.80
PS-47638	28	8	224 145.80
PS-41424	48	4	192 138.30
PS-57357	48	6	288 214.25

SINGLE PHASE, 100-130 VOLTS INPUT, 60 CYCLES			
Number Catalog	Volts	Amps	Quantity of Watts
PS-47519	48	10	480 \$182.00
PS-57358	48	15	720 197.50
PS-47718	100	4	400 148.80
PS-41425	125	2	250 283.90
PS-47457	125	6	750 168.70
PS-41426	150	2	300 140.40
PS-41427	200	1	200 140.40

The items listed here are a sampling from Acme Electric's broad line of stock power supplies. Write for "off-the-shelf" DC power supplies. And when you need special DC power supplies, call on Acme Electric for detailed engineering assistance.

Uhf television on borrowed time

Medium faces economic eclipse at hands of cable system operators despite best efforts of the FCC to promote and protect its interests

By Peter J. Schuyten

Assistant editor

Two months ago the Federal Communications Commission handed down a decision in a community antenna television case that spotlighted the tenuous commercial position of ultrahigh-frequency broadcasting. Cable tv is potentially the most lethal threat to uhf telecasting, the medium the FCC chose to nurture as the best means of easing overcrowded conditions in the very-high-frequency spectrum. Despite superficial statistics to the contrary, uhf has never really taken hold, and now CATV has it under the gun.

Because cable operators alleviate the vhf spectrum's traffic jam by distributing tv and other signals over coaxial cable networks, what may well happen is that the entire television industry will have to plan its future around it.

In the Sept. 12 decision, the FCC denied a petition from the Suburban Cable TV Co. Inc. to bring signals from three independent New York City stations into Philadelphia. Officially, Suburban's request was turned down because copyright legislation that might have a profound impact on the CATV business is pending in Congress. However, cable operators and conventional broadcasters appear well on the way to settling this matter on their own. With the copyright issue resolved, CATV interests will inevitably press new petitions in Philadelphia as well as other major markets.

The FCC's stated intention in pro-

moting uhf is to open the airways to more stations and stimulate a greater variety of programs than can be accommodated in the vhf range. In the U.S. there are 2,000 to 2,200 extra channels available in the uhf belt. But the advent of large-scale CATV systems makes the problem of the crowded vhf spectrum less critical.

New ballgame. In addition, cable tv threatens to break down the traditional market structure of broadcasting. Since the lucrative economics of this business have been largely based on an artificial scarcity of stations, the FCC has been forced to referee a very rough struggle among special-interest groups while trying to protect its

suggests that this situation is not necessarily a bad one. Nicholas Johnson, an FCC commissioner, for example, is at odds with his agency's policy. He believes Philadelphia, where three commercial uhf stations are operating, would be as good a place as any to check the impact of imported signals.

I. Late, late show

The question of just how uhf would fare without FCC protection is being raised at the theoretical midpoint of its development cycle. In 1964, when the law specifying that all tv receivers must be equipped to receive uhf went into effect, observers predicted it would take at least eight years before conversion was completed. This so-called all-channel law had roots in a hasty decision made by the FCC during the 1940's.

After World War II, the commission decided that tv would operate in the vhf band at first, despite urgent recommendations to the contrary by its

own staff engineers. They reasoned—correctly as it turned out—that vhf lacked the capacity to accommodate a nationwide tv system.

Vested interests. But vast amounts of money had been invested in television before and after the war. With a payoff in sight, many parties impatiently pressured the FCC to authorize vhf broadcasting immediately. At the time, the development work on uhf transmission and reception



avored fledgling.

The commission assumed regulatory jurisdiction over cable operators early in 1966 and effectively froze them out of the top 100 metropolitan markets in the U.S. [Electronics, June 26, p. 143]. But waivers have been, and are being, granted in many key outlets, including New York City and Los Angeles. As a result, uhf broadcasting is still very much in jeopardy.

An increasingly vocal minority

Need...
FAST REVERSING ACTION?
Need...
TIMED MEASUREMENT?
Need... to meet
CHANGING PRESSURES?

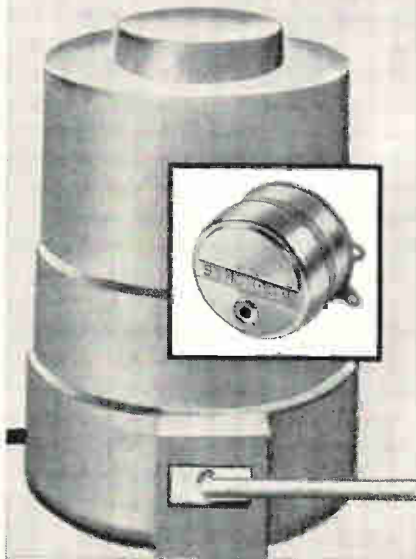

turn the job over to SYNCHRON® MOTORS!

Any time you have *any* motor application that requires extreme flexibility, extreme versatility and extreme accuracy, think first of Synchron motors. Here at Hansen Manufacturing, we specialize in working with you to help you in design, engineering and production problems. Come to us for the motors, and the application experience you want. Call us—or if you're not in a hurry, write today for complete specifications on the type of motor and application you have in mind. No obligation, of course.



HANSEN REPRESENTATIVES: CAREY & ASSOCIATES, Houston and Dallas, Texas, R. S. HOPKINS CO., Sherman Oaks, Calif., MELCHIOR & MACPHERSON, INC., San Carlos, Calif., THE FROMM COMPANY, Elmwood Park, Ill., H. C. JOHNSON AGENCY, INC., Rochester, N.Y., JOHN ORR ASSOCIATES, Grand Rapids, Mich., WINSLOW ELECTRIC CO., Essex, Conn., Narberth, Pa., and New York, N.Y. EXPORT DEPARTMENT, 64-14 Woodside Ave., Woodside, N.Y.

...uhf broadcasting is ill-served by those who minimize its problems...

equipment was a couple of years behind vhf progress. Rather than risk criticism for further delays, the commission gave vhf a go-ahead in 1948.

By 1949 so many stations operating in the same channels were interfering with each other that a three-year freeze on allocations was necessary. While the commission was studying the situation, uhf boosters watched in dismay as millions of tv sets equipped to receive only vhf signals rolled off production lines.

In 1952 the fcc rescinded its ban and opened up the uhf band. But there was little incentive for broadcasters to build stations because the chances of set owners spending extra money for uhf equipment were nil.

Eventually, the vhf band became so crowded that Congress—at the behest of the fcc—passed the all-channel law in 1962 in an effort to stimulate investment in uhf stations. Statistically, the legislation has proved a big success: an estimated 50% of the sets now in use around the country are equipped to receive uhf. And as of October the number of on-the-air uhf stations totaled 204, as against 573 vhf installations.

Mournful numbers. For all their optimistic projections, uhf operators and fcc officials are well aware that sets with uhf receivers are one thing and sets with uhf antennas quite another. Good reception of uhf tv signals depends as much upon the quality of the antenna used as it does upon the effective radiated power level of the transmitter. Although no definitive data have been compiled, there is a significant discrepancy between the total of all-channel receivers in use and the number that can get a good uhf signal without being tied into a community antenna television operator's system.

A source in the fcc's broadcast bureau is philosophical about the disparity. He says: "It's up to the set owner. If he wants good uhf reception, he should invest in a quality yagi antenna." However, the commission is apparently con-

tent to permit this position to popularize itself among consumers.

II. Bad press

Controversy over the quality of uhf television signals has also proved something of a drag on the field's growth. Network spokesmen in particular insist that uhf transmission is inherently inferior to vhf. However, the evidence suggests that any disparity is the result of economic, rather than technical, factors.

Test case. In 1961 the fcc got \$2 million from Congress to check the quality of uhf signals in New York City. A 50-kilowatt transmitter and an antenna mounted atop the Empire State Building were used. The experiment, conducted in a metropolitan area with every conceivable type of interference, proved that uhf signals are virtually indistinguishable from vhf. And, concluded the final report, under ideal conditions, the picture, in both black and white and color, is clearer. In addition, engineers say that because there is less man-made noise in this band, a light signal—assuming power is adequate—is inherently better than vhf.

The fcc has established 5 megawatts as the maximum permissible effective radiated power level for uhf stations. While one broadcaster is known to have boosted his signal into the 4-megawatt range with 110-kilowatt transmitter and a 1,000-foot-high tower antenna, the majority of new uhf stations simply cannot afford the kind of investment involved in such facilities.

III. Prose and Cons

Nor is uhf's cause particularly helped by efforts to minimize its difficulties. For example, William Walker, director of broadcast management for the National Association of Broadcasters, frequently speaks of the industry's rosy prospects at the trade group's regional get-togethers. The only factors that could retard the growth of uhf, says Walker, are direct broadcast satellites and CATV.

Actually, satellites are well

within the realm of technical possibility and cable television is increasingly a fact of life. So much so, in fact, that the Columbia Broadcasting System, the Westinghouse Electric Corp., the Tele-Prompter Corp., and the National Broadcasting Co., among others, are scrambling to expand their stake in the fast-growing field.

Schools of thought. The truth is that CATV is an emotional issue with uhf operators. David M. Baltimore, president of uhf station WBRE-TV in Wilkes-Barre, Pa., says: "Cablemen are a bunch of pirates, stealing property that belongs to the broadcasters." He believes CATV should be a supplement to tv rather than its master. "The prospects for uhf are good, if CATV can be restrained," he says.

But Seymour Siegel, director of New York City's Municipal Broadcasting System and head of uhf station WNYC-TV, says: "Cable tv has built the better mousetrap, and the broadcasting industry should plan its future around the new technology." As far as WNYC is concerned, Siegel believes CATV can only help the station fulfill its role as a minority interest programer by bringing signals into homes with reception problems.

Tripartite. Baltimore and Siegel represent two segments of the uhf picture. Baltimore's station has network affiliation while Siegel's programs largely for cultural and ethnic minorities. A third kind of operation, like WPIL in Philadelphia, is oriented toward an independent programing format. Such facilities are most seriously threatened by the emergence of CATV.

In the Philadelphia case, which involved WPIL, attention focused on the importation of distant signals as perhaps the most immediate hazard for uhf operators. Leonard Stevens, president of WPIL, says: "It is unfair competition when I have to pay for programing while CATV can bring in the same format over its cables without a fee and compete for an audience."

In the eye of this storm is the problem of copyright payments. "This issue should be resolved through negotiation within the next 12 months," says Frederick Ford, president of the National Community Television Association. "Once CATV is paying its own way,

Why pay more for a fan that...

delivers less air? creates more noise? breaks easily?



Get the Pamotor Model 4500 4½" axial fan that delivers 115 cfm, runs at a noise level of 37.5 dB SIL, is of all-metal construction, and has UL Yellow Card Recognition. It has a lubrication-free life in excess of 20,000 operational hours, continuous duty at 55°C. Yet it costs only \$8.55 in lots of 100.

Now is the time to switch to PAMOTOR!

Get complete information. Fill out the coupon below.
Better yet, call (415) 863-5440 now.

Yes, give me the facts on the 4½" all-metal Model 4500 fan that delivers more air with less noise . . . reliably.

Have sales representative call Send me complete data

Name.....Title.....

Company.....Phone.....Ext.....

Address.....City.....State.....Zip.....

PAMOTOR, INC.

312 Seventh Street, San Francisco, Cal. 94103

... IT's the MOST ...
EXCEPT FOR PRICE

NEW **KH** ALL-SILICON
R-C OSCILLATOR
holds PERFORMANCE but
LOWERS PRICE

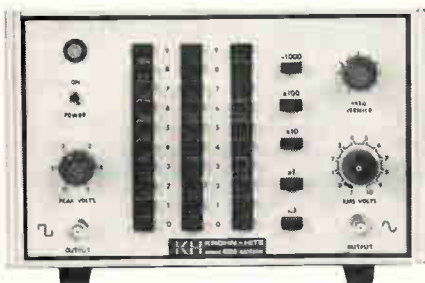

MODEL 4100, brand new R-C Oscillator with push-button frequency control. Sine- and Square-Wave simultaneously from 0.01 Hz to 1 MHz. Price \$550. Provides performance of higher priced units. 5 3/4" H x 8 3/4" W x 14 1/2" D.

Using advanced circuit techniques, Krohn-Hite has produced a new R-C Oscillator, at a medium price, with traditional K-H Quality.

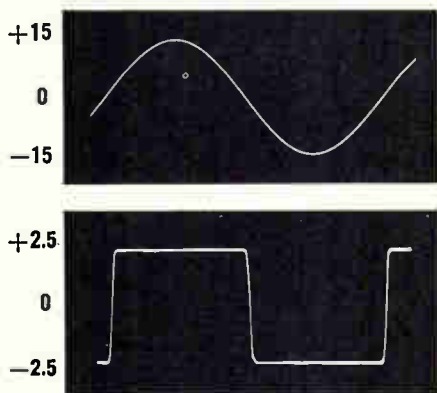

SIMULTANEOUS SINE AND SQUARE-WAVE outputs pack real power (up to 1/2 watt into 50 ohms). Photos show open circuit output voltages at 1 MHz.

These outputs typify the performance of the Model 4100. Add to this half-watt output, 0.5% frequency accuracy, 0.03% distortion, 0.02% hum and noise, 0.02 db frequency response and 0.02%/hr. amplitude stability and you get a clearer picture of what we're talking about.

There's much more in KH Data Sheet 4100
Write for a copy

KH KROHN-HITE
CORPORATION
580 Massachusetts Avenue, Cambridge, Mass. 02139
Telephone: 617/491-3211

Playing the field

Cable tv operators are moving nimbly to exploit the opportunities available to their medium. Among the newest: a service that will use CATV facilities to pretest the impact of television commercials in consumers' homes. A joint venture of the H&B American Corp., a large cable system operator, and Audits & Surveys Inc., a marketing research firm, the new company, Television Testing, will go after advertising agency trade.

The demographic and brand preference characteristics of four medium-sized markets—Ventnor, N. J.; Lompoc, Calif.; Dubuque, Ia., and Walla Walla, Wash.—are being profiled for storage in computers. These data banks can be sampled to get the reactions of specific audience groups.

Viewers selected by the computer will be advised to watch a certain program when tests are scheduled. A monitoring device will determine how many sets were tuned in for how long. Phone calls will be made to test consumers' recall and the results verified later by market surveys of the test area. The service will start in January.

it will be up to the FCC to reevaluate its position concerning the industry's right to import signals."

Another difficulty for uhf operators centers about network affiliation. A spokesman at one of the big three puts it this way: "The networks prefer not to spill programming into uhf; they do so only when there are no other outlets in an area." This source cites two reasons for this policy: "There is at best a 50% penetration of uhf receivers in the television market, and even with a maximum effective radiated power the quality of a uhf picture is not as good as vhf."

Niche. Since uhf's future will be determined to a large extent by the fate of the vibrant CATV industry, many observers believe the whole broadcast field must reorient its goals to accommodate the upstart. Siegel, as well as several FCC commissioners, suggests that uhf operators should seek to provide viewers with programming unobtainable elsewhere. Shows keyed to self-improvement including cultural, educational, and community-interest formats are among the possibilities.

NEW **KH** ALL-SILICON
DIGITALLY TUNED
VARIABLE FILTER
FEATURES

ULTRA LOW FREQUENCY
96 DB/OCTAVE SLOPE



MODEL 3342 DUAL-CHANNEL, MULTI-FUNCTION FILTER provides low-pass and high-pass operation with 96 db attenuation slope or 48 db slopes as band pass or band reject filter. The digital frequency control provides cut-off frequencies from 0.001 Hz to 100 kHz with 2% calibration accuracy and excellent resettability. Size: 5 1/4" H x 19" W x 16 1/2" D.

The new Krohn-Hite Series 3300 operates on either line or batteries, with 0.1% distortion and provides gain of 20 db.

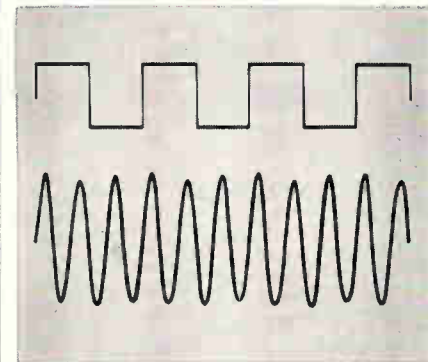

RECORDING ILLUSTRATES gain and selective response of Model 3342, in minimum band-pass operation, to a 0.01 Hz square wave. Output consists primarily of third harmonic component of input.

This kind of low-frequency performance is backed by other important specifications. Examples are:

Filter Characteristics: Either 4 or 8-pole Butterworth (maximally flat) and R-C for transient-free operation.

Digital Tuning: Six bands, 3 digits; rotary switches.

Maximum Attenuation: 80 db.

Dynamic Range: 80 db.

Input Impedance: 10 megohms.

Output Impedance: 50 ohms.

Write for Data

KH KROHN-HITE
CORPORATION
580 Massachusetts Avenue, Cambridge, Mass. 02139
Telephone: 617/491-3211

Report from

**BELL
LABORATORIES**

Photos of a rainstorm

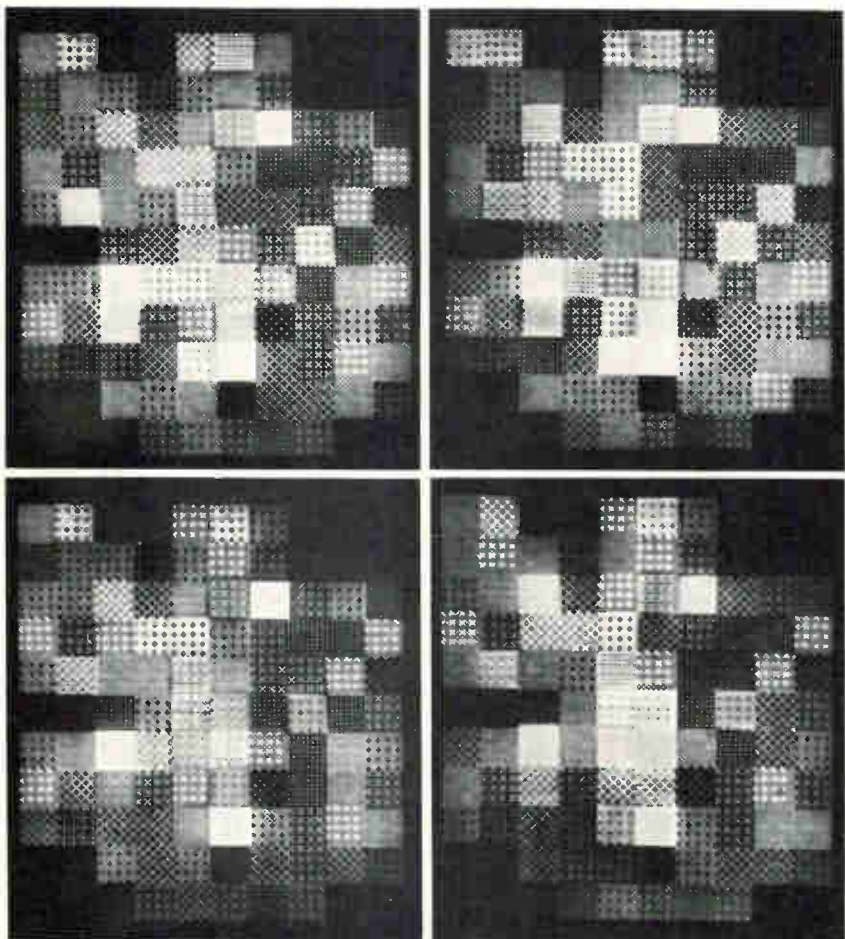

Sequence of computer-generated rainfall-rate patterns at 10-second intervals. (Order is upper left and right, then lower left and right.) Small "patches" correspond to geographic positions of 93 rain gauges. Each patch can have one of 48 computer representations of rain rate: dark for no rain, gradually brightening for increasing rainfall. Thus, each of the four frames "maps" a rainstorm in the area, and the sequence is like a motion picture. (Detailed data are recorded on magnetic tape for analysis and correlation with radio transmission characteristics, but the display gives a quick overall view.)

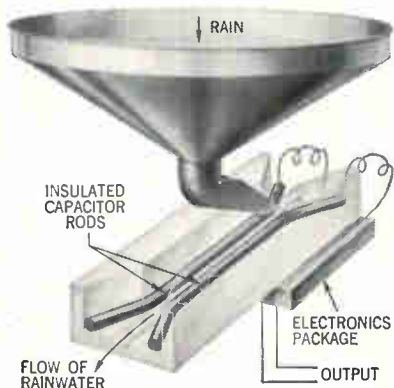

The new rain-rate gauge. Rain collected in funnel, top, flows along 45° incline between two insulated rods... the electrodes of a capacitor in an oscillator. Heavier rainfall lowers the oscillator frequency. The gauge can detect one raindrop, yet is accurate within five percent at rates of more than 10 inches per hour.

The pictures at the left represent rain on a 60-square-mile area in east-central New Jersey on November 28, 1966. Actually, they are four photos of a computer-generated display. The brightness of each little "patch" indicates the rainfall rate at each of 93 gauges spaced throughout the area.

We study rainfall because it impairs higher-frequency microwave radio transmission. But no one has had detailed data on its effects. All we had were relatively infrequent rainfall readings from a few gauges near radio paths. We needed—and now have—almost instantaneous readings of rainfall rate from closely spaced gauges over an area.

The result? We have learned a lot about rainfall—for example that heavy, small-area concentrations of rain occur and shift around within a wide-area storm. More important, we can now begin to relate rainfall patterns to specific transmission difficulties. With this information we are improving our strategies for establishing, despite the weather, more reliable radio relay paths at higher microwave frequencies.

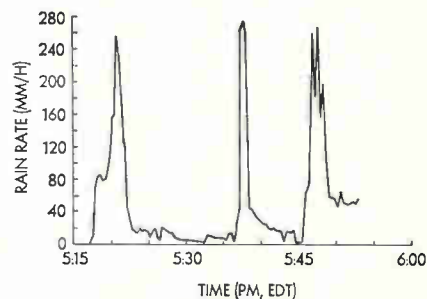

Rainfall rate on one gauge during a storm on May 27, 1965. Note rapid response of gauge to changing intensity of rain.



Bell Telephone Laboratories
Research and Development Unit of the Bell System

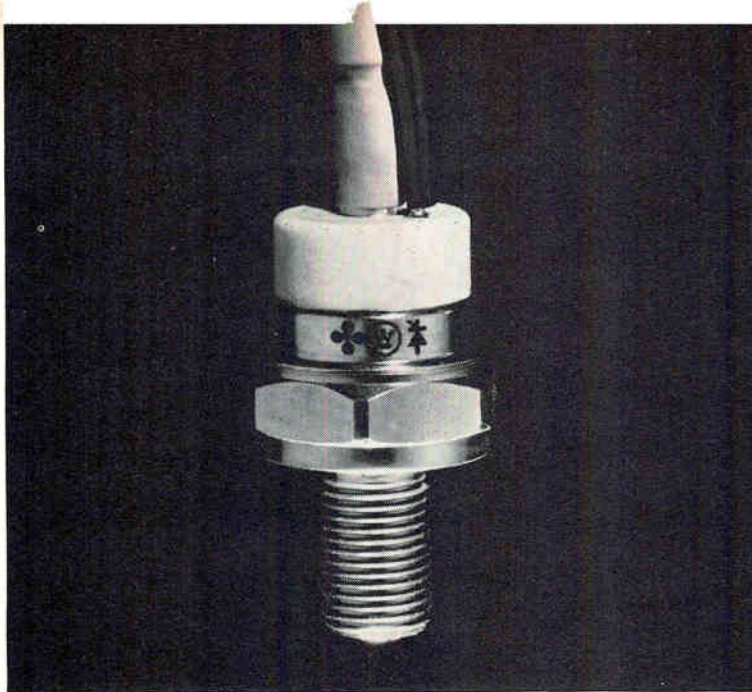

**14% more power
per dollar.**

New full capacity thyristors from Westinghouse

It's a breakthrough. We've added 14% more power capacity to thyristors without adding to the price. The extra amps are free.

These new thyristors (Types 250 and 251) are rated at 80 and 40 amps AVE. With them you can uprate existing SCR circuits without cost increase. In new circuits, these devices help you even more. They allow you to achieve simpler, lower-cost designs.

Our breakthrough was in bringing out the full inherent capacity of thyristors. New diffusion techniques have been used. And critical thermal stresses have been eliminated with exclusive Westinghouse CBE construction.

Design Opportunities—Look at the characteristics comparison charts here. You can see the opportunities. For example, if you make a 1½ hp. motor control, you could uprate it to 2 hp. with a simple thyristor switch from "Brand X" to Westinghouse.

Here's another cost-cutter: simplify circuits by reducing dv/dt protection networks. Until now, dv/dt on standard thyristors has been limited to 200 μ sec.

COMPARATIVE FIGURE-OF-MERIT CURVES
—THREE COMPETITIVE THYRISTORS

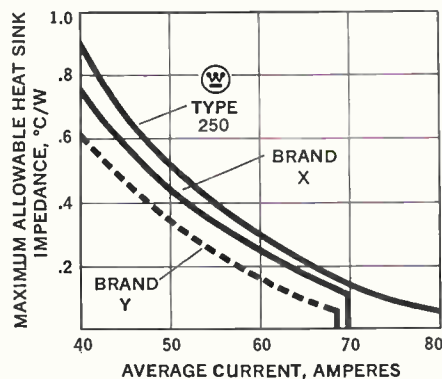

Westinghouse offers a minimum of 300/ μ sec. (typically 600/ μ sec.) to full V_{FB} .

Maybe you're working with a 550 volt power supply. Then here's the industry's first positive control... thyristors that block 1800 volt transients and 1500 volts steady-state.

When you design drive circuitry, our maximum I_{gt} of 100 ma. is an optimum figure. It's low enough so you can achieve low-cost circuitry, high enough to minimize false triggering.

Data For Thought—Let your ingenuity rove with full data to go on. You'll find many more circuits to capitalize on the Westinghouse "full capacity" thyristor. We'll be glad to help. Just call your local Westinghouse salesman. Or phone us at (412) 925-7272. Or write Westinghouse Semiconductor Division, Youngwood, Pennsylvania 15697.

COMPARISON OF PERFORMANCE CHARACTERISTICS
— 70-80 AMP DEVICES

	Ⓜ 250	BRAND X	BRAND Y
Current (I_{RMS}/I_{AVE})	125/80	110/70	110/70
Applied Current ($\theta_{SA}=.125^{\circ}C/W, T_A=40^{\circ}C$)	71.5	64.4	70.0
Voltage (V_{FB}/V_{FT})	1500/ 1800	1300/ 1550	1300/ 1560
dv/dt (Exponential to full V_{FB})	300	200	200
I_{gt} ($T_J = 25^{\circ}C$)	100	150	150

COMPARISON OF PERFORMANCE CHARACTERISTICS
— 35-40 AMP DEVICES

	Ⓜ 251	BRAND X	BRAND Y
Current (I_{RMS}/I_{AVE})	63/40	55/35	55/35
Applied Current ($\theta_{SA}=.44^{\circ}C/W, T_A=40^{\circ}C$)	40	35	35
Voltage (V_{FB}/V_{FT})	1500/ 1800	1300/ 1550	1300/ 1560
dv/dt (Exponential to full V_{FB})	300	200	200
I_{gt} ($T_J = 25^{\circ}C$)	100	100	150

You can be sure if it's Westinghouse



Countdown begins on Intelsat's future

Hallway talk at ITU conference centers on Comsat plan to revise ownership of consortium at 1969 parley and on big question of contract allocations

More prelude than climax, the two-week planning conference of the 137-nation International Telecommunications Union ending Nov. 15 in Mexico City sets the stage for the 1969 renegotiation of the agreements covering worldwide satellite communications systems. Formal sessions at this month's get-together concentrated on projections of 1970-75 global telecommunications needs. But satellites proved the unbilled stars of the show—especially among delegates from the 60 member nations of the International Telecommunications Satellite (Intelsat) consortium.

Unofficially at issue in Mexico City were touchy questions raised by the Communications Satellite Corp.'s white paper outlining the U.S. position on the future of Intelsat [Electronics, Oct. 30, p. 52]. Resolution of these problems will not only shape the future of international telecommunications systems but give foreign nations a greater voice in the management of the consortium. At stake, of course, is national pride as well as a bigger share of the procurement pie, which thus far has been largely the preserve of U.S. firms.

I. Counterrevolution

The initial Intelsat agreement signed by 13 nations in 1964 specified that the structure of the organization be subject to renegotiation in 1969. The Interim Communications Satellite Committee, established to hammer out recommendations for a permanent organization and global system, will hold its 29th meeting Nov. 29 in Washington, D. C.; six additional conferences are scheduled before the 1969 renegotiation sessions.

Last month, Comsat, Intelsat's manager and majority stockholder, began pushing for an expansion of the organization's communications role. In a proposal urging that the

consortium continue in essentially its current form, the company seeks authorization for Intelsat to operate navigation, weather, aeronautic, and earth-resources satellites as well as spacecraft providing communications services.

Gun shy. In an effort to blunt charges that it dominates Intelsat, Comsat suggests that the maximum voting strength of a single nation be limited to 50%; each member's share would be determined by its use of consortium-supported facilities—excluding domestic satellites. This formula would reduce Comsat's share from the current level of 53.5% to perhaps 35% by the early 1970's.

The U.S. position paper takes no notice of independent regional satellite systems, but Comsat is known to be dead set against such projects. The paper outlines four plans for domestic satellite service—all within the Intelsat network.

Finally, Comsat recommends that it serve as Intelsat's manager under a formal contract with the interim group, meaning that it would continue to negotiate and administer all contracts. The com-

pany contends that this "would provide continuity and make use of the experience accumulated."

II. Yanqui no!

The question of who gets hardware contracts is potentially the biggest stumbling block to an Intelsat accord in 1969. The consortium's four present operational satellites—two over the Pacific and two over the Atlantic—were all built by the Hughes Aircraft Co. On order from the systems group of TRW Inc. are six 1,200-channel Intelsat 3's, the latest generation spacecraft; the first will be delivered next spring, about three months behind schedule.

Overseas contractors and foreign governments aren't particularly pleased with the made-in-America stamp on operational hardware. But a source at a West Coast concern with a large stake in communications satellite development claims the situation is changing. If the recent study contracts for Intelsat 4—a 10,000-channel multi-purpose bird [Electronics, Aug. 21, p. 59]—are any criteria, he says, at least a third of the systems work

Share the wealth

While national feelings and simple economics are spurring foreign members of the International Telecommunications Satellite consortium to press for a better break on hardware awards, a successful U. S. contractor may, on its own, have broken the American grip on these orders. An estimated 35% to 40% of the work on two Intelsat 3 satellites being built by the systems group of TRW Inc. will be handled by firms from outside the U. S.

Officials at TRW say Comsat's request for proposals didn't mention foreign participation. But after TRW suggested using overseas contractors, Comsat took to the idea and wrote it into the contract, which covers six spacecraft and provides an option on 12 more.

As a result, the following outfits will furnish the designated support on the fifth and sixth satellites in the series: Britain's Hawker Siddeley Dynamics Ltd. (spacecraft structure); France's Société Anonyme de Télécommunications (solar array) and Engins Matra SA (attitude-determination subsystem); Japan's Mitsubishi Electric Corp. (power subsystem, excluding battery and solar array); Switzerland's Contraves AG (electrical integration assembly); and West Germany's Entwicklungsring Nord (positioning and orientation propulsion system).

PERMACOR[®]
powdered iron cores
...unequaled for
design and prompt
delivery!

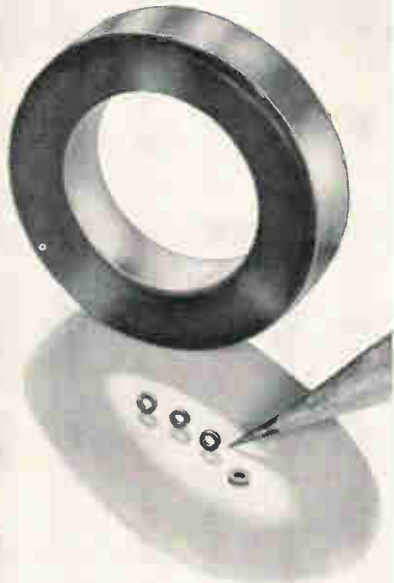

Illustrated: TOROIDAL IRON CORES
 available from 1/8" to 2" O.D.

As the largest maker of iron cores in the world, we offer unequalled production and design facilities for any core design problem. AND, we stock a full line of standard cores at all times.

Need the best in cores . . . Plain, Hollow, Threaded, Insert, Tuning, Cup, and Toroidal Iron Cores, Iron Coil Forms, Sleeves, Flexible Magnetic Shielding, Bobbins and special shapes . . . write and find out why we are unequalled.

PERMACOR[®]
 A Division of Radio Cores, Inc.
 9540 Tulley Ave., Oak Lawn, Ill. 60454
 Phone: 312-422-3353

... Comsat's sweeping proposals for Intelsat were artfully timed . . .

will be done outside the U.S.

Some of the more important members of the consortium would like an even bigger share of the contracts, however. Japan, a number of European nations, and Australia would like the 1969 agreement to stipulate that every third satellite be built outside the U.S. Such a provision is probably unrealistic, this official says, because most nations trail the U.S. in such key fields as reaction controls and apogee motors.

Play for time. But there may still be some international foot-dragging on Intelsat 4 in the hope of a better deal after the 1969 renegotiation. Intelsat has to get the interim committee's approval for the launch, scheduled for 1970. If a go-ahead could be put off, some reason, many countries could catch up technologically.

The U.S. executive believes the less developed nations won't put obstacles in the way of Intelsat 4 since they badly need the communications services it could provide. He also holds that Comsat should continue to oversee international operations, but that management of regional and domestic systems be delegated to area associations and individual countries.

III. Skillful ploy

Comsat's sweeping proposals for Intelsat's future were artfully timed. Most interested parties have had insufficient time to develop hard positions, and the company expects no substantive reaction before a mid-January meeting of the interim group. In the meantime, Comsat will have had the benefit of being able to gauge the potential response to its bombshell.

One thing is already clear: the formula linking votes to usage should bring some offbeat supporters into the American camp, where Japanese and British authorities profess to be already. Italy, for example, takes greater advantage of Intelsat-financed facilities than do either France or West Germany. The same may soon be true of Spain, which activates a ground station this month and ex-

pects an increase in its traffic with South America.

Such a prospect cannot help but vex France and Germany, which are planning to put a regional communications satellite system, called *Symphonie*, into service by 1971. Comsat opposes such efforts on the grounds that they will "drain the global organization."

However, neither France nor Germany appears particularly discomfited by Comsat's stance; the French for their part have urged that communications satellite activities be autonomous in each of four geographical sectors of the globe, and that Intelsat's authority be reduced to coordinating overlapping efforts.

Home front. Domestic satellite systems also threaten international communications amity. Canada, for one, is determined to get an operational network—with or without U.S. cooperation—by the early 1970's [Electronics, Sept. 4, p. 131]. In proposing that domestic satellite programs without Intelsat blessing be proscribed, Comsat can fall back on the technological muscle of the U.S. Renegade nations would presumably get short shrift from the National Aeronautics and Space Administration should they seek launching facilities, boosters, and the like. However, the European Space Vehicle Launcher Development Organization may eventually offer an alternative to U.S. aid—albeit an expensive one—and Russia appears willing to support selective efforts. The Soviets have agreed to put up a French research satellite, and the two countries already exchange tv broadcasts over Russia's *Molnya*.

Ironically, Comsat's stringent proposals in this area are at odds with a recommendation it made last April for a pilot project. At this moment, the company is in the incongruous position of resisting domestic programs outside the Intelsat orbit while trying to get an independent project off the ground for the U.S.

Comsat officials point out that domestic satellites will be a necessity for certain countries. In Chile,

**Spurious-free
3 GHz Dispersion!**

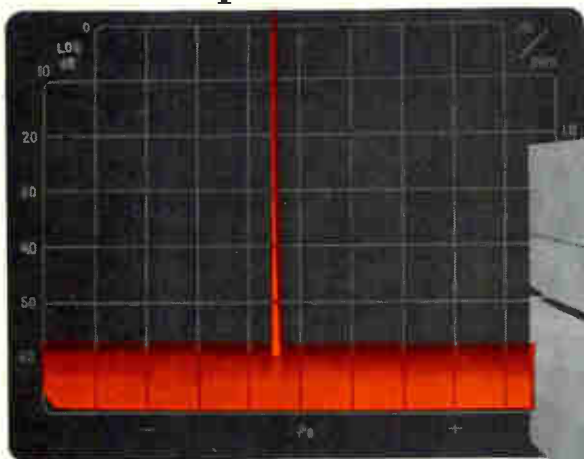

**Calibrated
10 kHz Dispersion!**

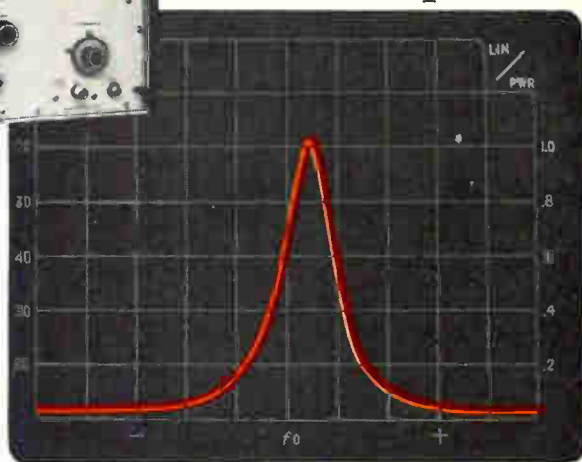

**only one...
the Panoramc SPA-3000
Microwave
Spectrum Analyzer
delivers both!**

You can have full 3 GHz dispersion in the 0.01 to 9.0 GHz range and greater than 2 GHz dispersion up to 40 GHz at sensitivities from -105 dbm with the new Panoramc Model SPA-3000. And, you don't have to buy an expensive preselector to eliminate inband images and multiple responses — even at maximum dispersions. In addition, the SPA-3000 provides calibrated dispersion ranges as low as 10 kHz.

Ideal for wideband surveillance and narrow pulse measurements, the Model SPA-3000 is a stable solid-state swept-front-end analyzer, with an easy-to-use internal phase-lock for the BWO, resulting in less than 100 Hz peak-to-peak incidental FM for a true 1 kHz resolution capability. A calibrated 60 db on-screen log display permits accurate comparison of CW and pulse signals of greatly differing levels, even those requiring the wide 1-MHz Bandwidth for optimum frequency analysis. Time domain measurements can also be made using the synchroscope capability offered by the unique combination of wide bandwidth and fast sweep rates.

This new analyzer features built-in stepped RF, as well as stepped and continuously variable IF attenuators to preclude IM products; RF and IF frequency markers for auto-calibration; stepped and continuously-variable dispersion and bandwidth settings; smallest size, lowest weight and power consumption.

The Model RF-3000 Tuning Unit is also available separately as an add-on module to convert Panoramc's moderately-priced Models SPA-100 and SPA-100A into the Model SPA-3000; offering maximum flexibility to meet any combination of application and budgetary requirements.

Call or write for a demonstration or complete technical data.

**SINGER
INSTRUMENTATION**

PANORAMIC • EMC • EMPIRE • GERTSCH • SENSITIVE RESEARCH

THE SINGER COMPANY, METRICS DIVISION • 915 Pembroke St., Bridgeport, Conn. 06608, U.S.A. • Phone (203) 366-3201 • TWX 710-453-3483

Circle 305 on reader service card

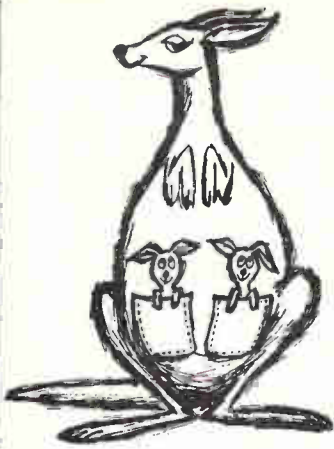

When Space makes the difference...

PEC SPECIFY
TYPE LK
CAPACITORS

Now, you can enjoy space savings of up to 80% without comprising electrical characteristics. Type LK capacitors are the little ones with tremendous power... 4 times the life of MIL-C-25A. Add to this superior resistance, better power factor, improved resistance, wider temperature range, and voltage ratings from 600 to 50,000 volts.



For the BIG FACTS on small capacitors, write for Bulletin LK today.

Write for new complete catalog today!



Plastic Capacitors, INC.

2620 N. Clybourn • Chicago 14, Ill.
DI 8-7335

for example, the Andes mountains constitute a communications barrier between north and south. And Brazil could use a satellite system for communications between its populous east coast and primitive interior regions.

IV. The big picture

James McCormack, Comsat's chairman, lists navigational aids for air traffic control, shipping assistance, rescue work, disaster warning, and earth-resources management as potential jobs for Intelsat. Although the company anticipated little opposition to such grandiose schemes, a division of opinion is already shaping up. German officials feel that the density of air traffic in Europe is not great enough to demand Intelsat control, so they plan no push for such services. France is also unenthusiastic about expanding applications within Intelsat's framework, but might go its own way, possibly with Russian help, to establish an independent system for areas it considers important—West Africa, Europe, and Canada. On the other hand, Italian sources back Comsat. "It's not the service but the means," says one.

Room at the top. Another problem, one of a technical nature, is sure to affect the outcome of the Intelsat renegotiations. The equatorial belt, the only space location that can accommodate communications satellites in synchronous orbit, has a finite capacity; just how finite has been the subject of feverish investigation. Last month, Comsat reported that two spacecraft can operate within less than 2° of each other in a 23,000-mile-high orbit without interference (at this altitude, 2° equals about 1,000 miles). Before the latest experiment, estimates of the necessary separation ranged from 2° to 6°.

However, though there is more parking space up there than most observers had dared hope for, some locations are more attractive than others. For example, the optimum spot for a communications satellite linking London and Tokyo is 26.5° east longitude. Spacecraft more than 1° off either way would lose one of the cities. As a result, the number of satellites linking London and Tokyo will have to be held to two or three at the most.

ECCOSORB®

COMPLETELY REVISED

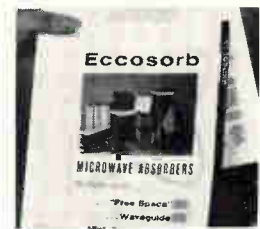

Six page folder in color describes and gives performance data on the complete line of Eccosorb® Microwave Absorbers for Free Space and Waveguide.

Circle 327 on reader service card

DIELECTRIC MATERIALS CHARTS



Charts in full color contain data on all important materials used by electrical and electronic engineers.

Circle 328 on reader service card

ECCOSHIELD®

RF SHIELDING MATERIALS



Brand new six page folder in color describes a complete line of Eccoshield products to combat RFI conductive plastic sheet and gaskets, adhesives, coatings, caulking compounds, metallic foil—the works.

Circle 329 on reader service card

Emerson & Cuming, Inc.



CANTON, MASS.
GARDENA, CALIF.
NORTHBROOK, ILL.
Sales Offices
in Principal Cities

EMERSON & CUMING EUROPE N.V., Oevel, Belgium

SCIENCE/SCOPE

The odds against Surveyor 5's success jumped to 1000 to 1 when a loss of helium pressure was detected shortly after midcourse correction. Without sufficient pressure to move propellant to its three small vernier engines, the spacecraft could not be slowed and steadied to a soft landing on the moon.

Racing against time, a task force of NASA, Jet Propulsion Laboratory, and Hughes scientists worked around the clock to program a new landing sequence, telescoping 11 weeks of work into 40 hours. They verified their calculations on computers, tested duplicate vernier engines, then radioed the instructions that brought Surveyor 5 to a perfect soft landing.

When Surveyor 5 was turned off for the lunar night on September 24, it had returned 18,006 pictures of a new potential landing site for astronauts and had lowered a device to analyze the chemical composition of the moon's surface by radiation.

The new shipboard satellite communications sets Hughes is now delivering to the U.S. Navy promise to end the interruptions and blackouts caused by atmospheric and solar disturbances that have long plagued long-distance radio transmission. Shipboard or base commanders will be able to communicate with each other by voice or Teletype over vast distances. Messages will be relayed by DOD's random-orbiting satellites.

The birth of Hurricane Sarah was discovered in a cloud-pattern photo of the eastern Pacific taken September 6 by NASA's ATS-1 satellite. Succeeding photos showed Sarah's growth to a full-fledged hurricane on September 11 (its title was changed to "typhoon" when it crossed the international date line September 14). The 2,000 residents of Wake Island, warned days in advance, were safe in typhoon-proof buildings when Sarah's 140-mph winds left the outpost a shambles on September 16.

Full-color photos of the Atlantic cloud pattern will be taken by the ATS-C satellite scheduled to be launched this fall. The spin-scan cloud cameras for both ATS satellites were developed by Santa Barbara Research Center, a subsidiary of Hughes Aircraft Company, which is building the Applications Technology Satellites for NASA's Goddard Space Flight Test Center.

Hughes has immediate openings for engineers in the following fields: weapon systems, design and analysis, data processing, communications system design, radar system design and development, structural analysis, design and packaging, and display systems. Minimum requirements: two years of applicable experience, accredited engineering or scientific degree, U.S. citizenship. Please send your resumé to Mr. J. C. Cox, Hughes Aircraft Company, Culver City, California. Hughes is an equal opportunity employer.

Five different types of spacecraft carry traveling-wave tubes by Hughes. These little TWTs — the invisible links that make radio communications and picture sending possible — have already operated more than 133,000 hours in space. They are in use on Comsat's Early Bird and Intelsat satellites and on NASA's ATS and Syncom satellites and Surveyor spacecraft, all built by Hughes.

The Apollo manned lunar landing vehicle and the Saturn booster will also be equipped with Hughes TWTs. Other spacecraft include Lunar Orbiter V, Venus-bound Mariner V, and Pioneer.

Creating a new world with electronics



This Keystone Thermistor assembly



in this
CLIFTON
integrating
tachometer

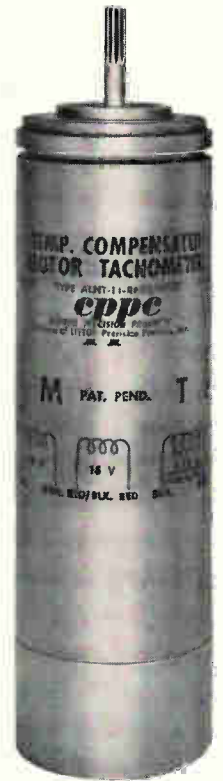

Makes all this difference in temperature performance

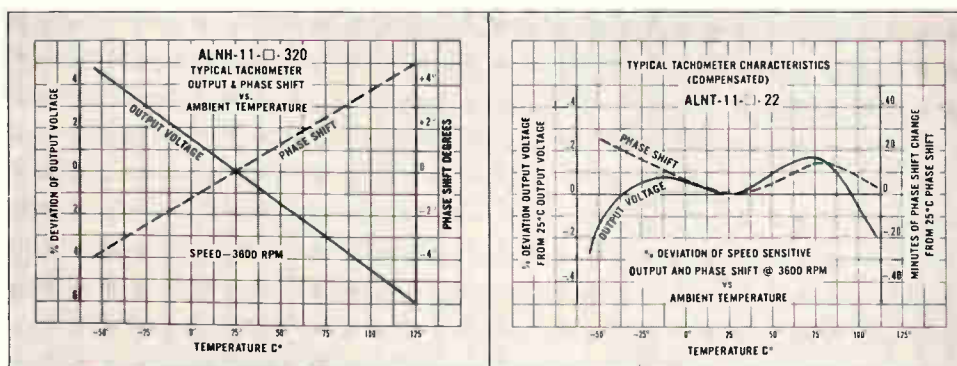

In precision computing applications using integrating tachometers, variations in output characteristics with temperature must be held to a minimum. To obtain the required performance, Clifton, Division of Litton Industries employs temperature compensation. □ The improvement in performance resulting from temperature compensation is shown graphically above. □ Responsible for the contrast is a Keystone Thermistor assembly. This is one of hundreds of different configurations made to specific customer requirements to the highest standards of quality and performance. May we have your inquiry? KEYSTONE CARBON COMPANY, St. Marys, Pennsylvania 15857

Keystone
leads

in creative thermistor technology

SCIENCE/SCOPE

The odds against Surveyor 5's success jumped to 1000 to 1 when a loss of helium pressure was detected shortly after midcourse correction. Without sufficient pressure to move propellant to its three small vernier engines, the spacecraft could not be slowed and steadied to a soft landing on the moon.

Racing against time, a task force of NASA, Jet Propulsion Laboratory, and Hughes scientists worked around the clock to program a new landing sequence, telescoping 11 weeks of work into 40 hours. They verified their calculations on computers, tested duplicate vernier engines, then radioed the instructions that brought Surveyor 5 to a perfect soft landing.

When Surveyor 5 was turned off for the lunar night on September 24, it had returned 18,006 pictures of a new potential landing site for astronauts and had lowered a device to analyze the chemical composition of the moon's surface by radiation.

The new shipboard satellite communications sets Hughes is now delivering to the U.S. Navy promise to end the interruptions and blackouts caused by atmospheric and solar disturbances that have long plagued long-distance radio transmission. Shipboard or base commanders will be able to communicate with each other by voice or Teletype over vast distances. Messages will be relayed by DOD's random-orbiting satellites.

The birth of Hurricane Sarah was discovered in a cloud-pattern photo of the eastern Pacific taken September 6 by NASA's ATS-1 satellite. Succeeding photos showed Sarah's growth to a full-fledged hurricane on September 11 (its title was changed to "typhoon" when it crossed the international date line September 14). The 2,000 residents of Wake Island, warned days in advance, were safe in typhoon-proof buildings when Sarah's 140-mph winds left the outpost a shambles on September 16.

Full-color photos of the Atlantic cloud pattern will be taken by the ATS-C satellite scheduled to be launched this fall. The spin-scan cloud cameras for both ATS satellites were developed by Santa Barbara Research Center, a subsidiary of Hughes Aircraft Company, which is building the Applications Technology Satellites for NASA's Goddard Space Flight Test Center.

Hughes has immediate openings for engineers in the following fields: weapon systems, design and analysis, data processing, communications system design, radar system design and development, structural analysis, design and packaging, and display systems. Minimum requirements: two years of applicable experience, accredited engineering or scientific degree, U.S. citizenship. Please send your resumé to Mr. J. C. Cox, Hughes Aircraft Company, Culver City, California. Hughes is an equal opportunity employer.

Five different types of spacecraft carry traveling-wave tubes by Hughes. These little TWTs — the invisible links that make radio communications and picture sending possible — have already operated more than 133,000 hours in space. They are in use on Comsat's Early Bird and Intelsat satellites and on NASA's ATS and Syncom satellites and Surveyor spacecraft, all built by Hughes.

The Apollo manned lunar landing vehicle and the Saturn booster will also be equipped with Hughes TWTs. Other spacecraft include Lunar Orbiter V, Venus-bound Mariner V, and Pioneer.

Creating a new world with electronics



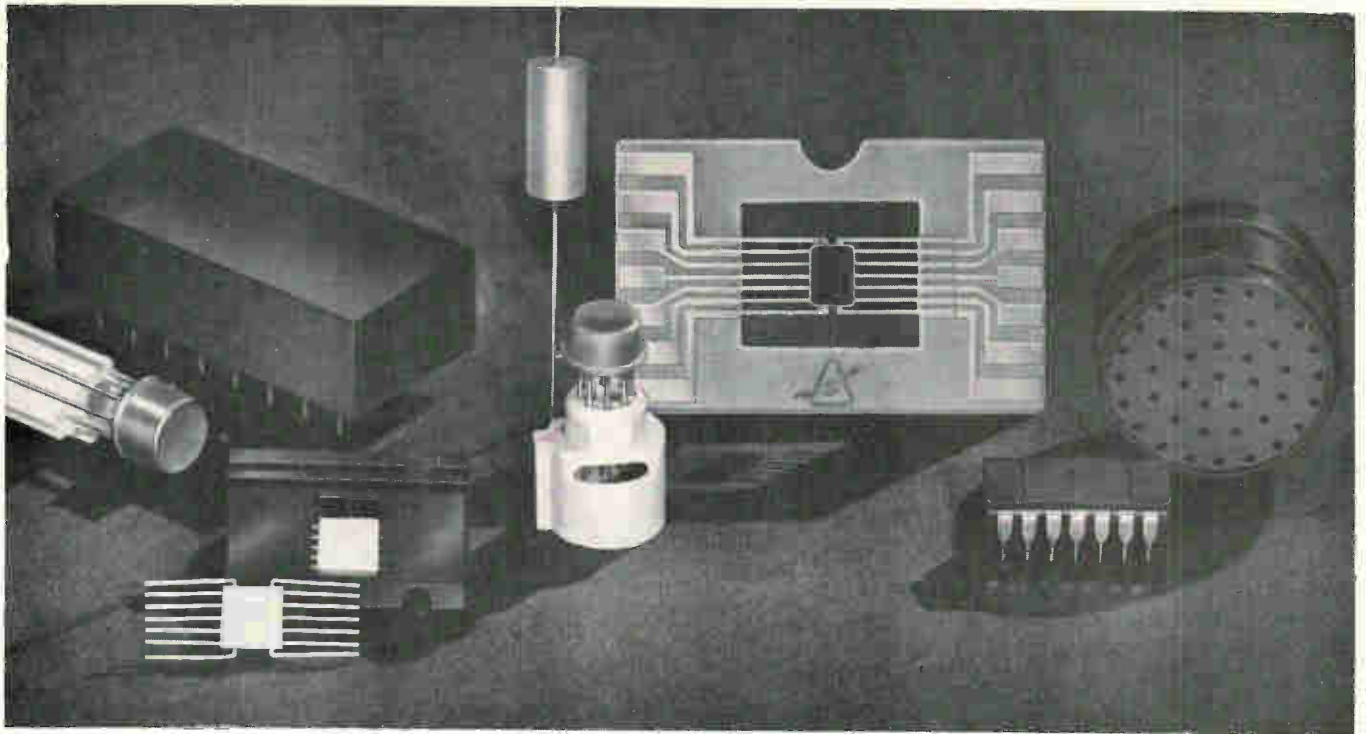

Good marking . . . makes the difference

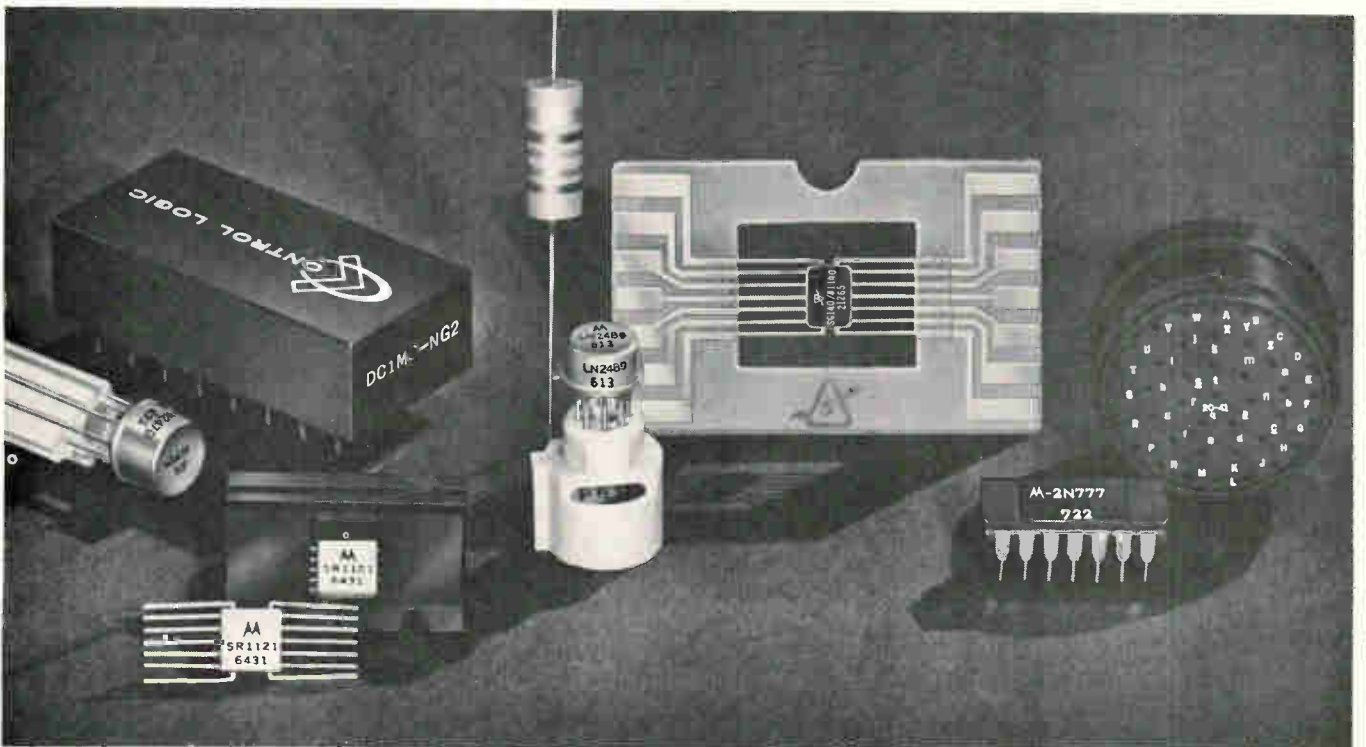

Don't waste time improvising and experimenting. Call in a Markem man and get acquainted with today's broadest line of marking equipment. Machines capable of putting several bands on a miniature diode; combining sequential numbering with identification; printing 14 characters plus trademark in an area 0.125" in diameter; printing integrated circuits in or out of carrier, registered to tab; and employing new techniques to meet severest durability specs. Whether your problem is size, speed or cost, we can help. Write Markem Machine Company, 305 Congress Street, Keene, New Hampshire.

EQUIPMENT AND TECHNOLOGY TO HELP YOUR PRODUCT SPEAK FOR ITSELF

MARKEM®

Lockheed's 417.



Lockheed makes the portable portable. At 28 pounds, including its self-contained batteries, the 417 recorder comes in at 50 pounds less than any comparable recorder. And the 417 measures up in more ways than weight. □ It starts off with a price tag as low as \$7000. It operates on 110/220 volts AC/DC, with a power consumption that goes down to 10 watts. It has an exclusive, rugged low-mass differential capstan drive for precision operation under

vibration in any position. It has ph lock servomotor control; a simplified maintenance-free transport mechanism; a frequency response of 100 kc direct kc FM; and, scaling in at only 14" x 1 x 6", it can even fit under an airplane seat. □ We believe the 417 is the best portable recorder on the market. But check it out yourself. □ Just ask for the Lightweight, one of a family of recorders for undersea, land, air and space applications.

The lightweight.

LOCKHEED ELECTRONICS COMPANY
A Division of Lockheed Aircraft Corporation, Edison, New Jersey

Here's why you should now be using Datavue* Indicator Tubes



CK1904—Interchangeable with B59956 and NL809.



8422—Interchangeable with B5991 and NL8422.



CK1903—Interchangeable with B5992 and NL5992.

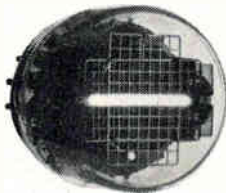

CK1901—Interchangeable with B5016 and NL5016; CK1902—Interchangeable with B5032, NL5032, B50911 and NL50911.

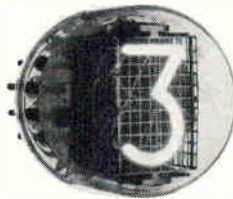

8421—Interchangeable with B5092 and NL8421; 8037—Interchangeable with B5031 and NL8037. Also available: 6844A.

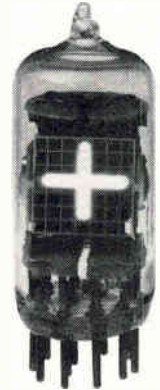

CK1900 (used with CK8650, CK1905, CK1906); CK1907 (used with 8754)—Interchangeable with NL843.



8754—Also available with right- and/or left-hand decimal points; Interchangeable with NL840/8754. Decimal-point types interchangeable with NL841, 842, 848.



CK1905; CK1906 (right-hand decimal point).



CK8650

These indicator tubes—just a few of Raytheon's wide selection—offer you advantages in design, economy and performance. For example:

You don't need to revise designs. Raytheon's Datavue round and rectangular end-view tubes conform to EIA ratings—interchange with other brands. And Raytheon also offers you a selection of side-view types—and "specials" with up to 12 characters, \pm signs, symbols, etc., to your specifications.

You can buy them at low cost. All Datavue Indicator Tubes are priced

competitively—or lower. Most side-view types, for example, cost less than \$5 each in lots of 500 or more.

Reliably trouble-free readouts. All Datavue characters are fully formed—not segmented. The fully formed characters are brightly displayed and easy to read—at distances up to 30 feet.

They last for years. They're made better because of Raytheon's experience—40 years of producing more than 100,000,000 cold cathode gas-filled tubes with carefully controlled electrical performance. Ultra-long-

life types, for example, have dynamic life expectancies of 200,000 hours or more.

They're readily available—in sample and production quantities. For samples, prices, or technical information, call your Raytheon regional sales office or distributor. Or write: *Raytheon Company, Industrial Components Operation, Quincy, Mass. 02169.*

*Trademark of Raytheon Company

Industrial Components Operation—A single source for Circuit Modules/Control Knobs/Display Devices/Filters/Hybrid Thick-Film Circuits/Industrial Tubes/Optoelectronic Devices/Panel Hardware.



Just 40¢ to ship a cubic foot of PELASPAN-PAC® loose-fill packing via 1st class (anywhere within the U.S.). \$3.20 for other kinds of packing materials. Gives you an idea of the savings in truck and rail costs when you use PELASPAN-PAC. A cubic foot of it weighs only 8 oz., 8 times lighter than other packing materials.

PELASPAN-PAC does a better job of cushioning delicate

electronic instruments on trips from here to there. The curled pieces of expanded polystyrene interlock. They actually hold the packed item in suspension. Never wad into a lump or collapse like makeshift packing materials do.

PELASPAN-PAC has other ad-

vantages. It's clean and dust free. So easy to work with, you'll realize major savings in labor time and cost.

Now that you've weighed the facts, isn't PELASPAN-PAC the best?

Your nearby distributor has it. Write us for his name.

The Dow Chemical Company, Plastics Sales, Department 71230, Midland, Michigan 48640.



Packing for shipment? Weigh the cost.

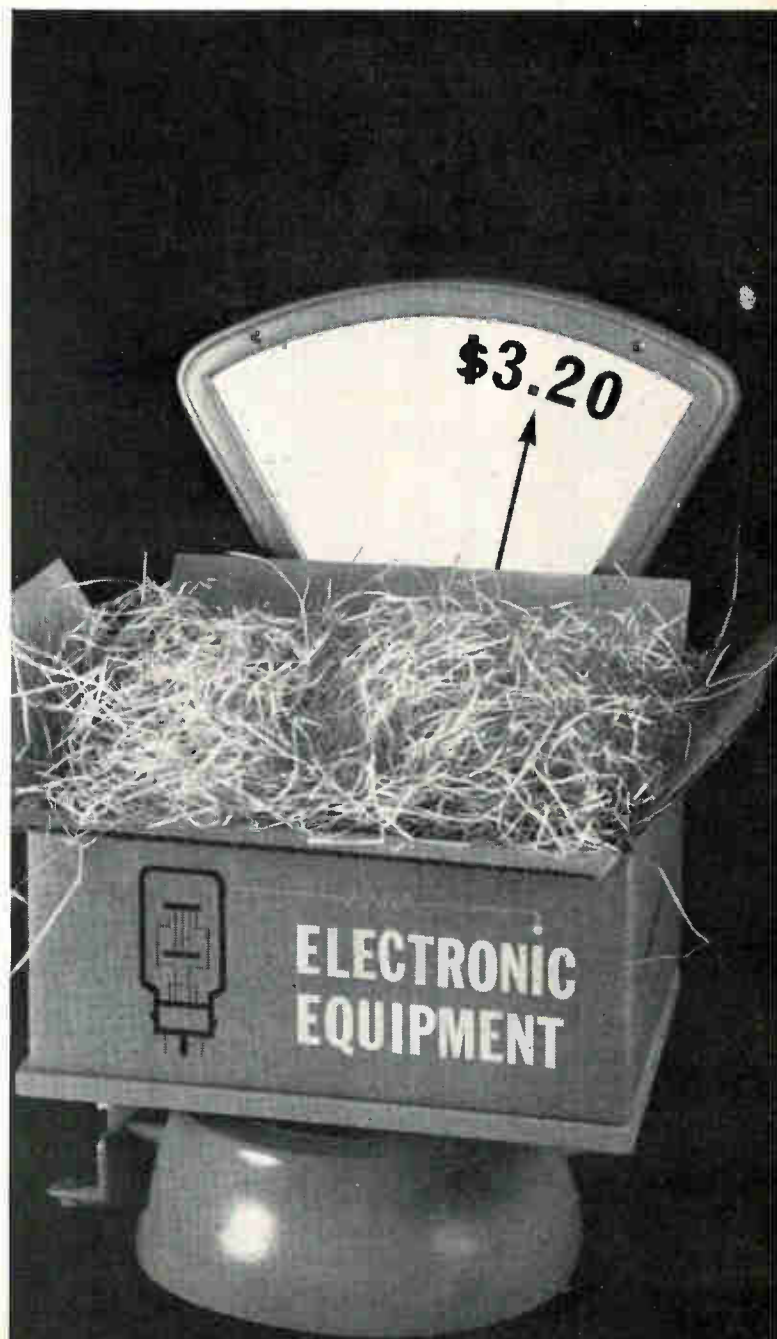
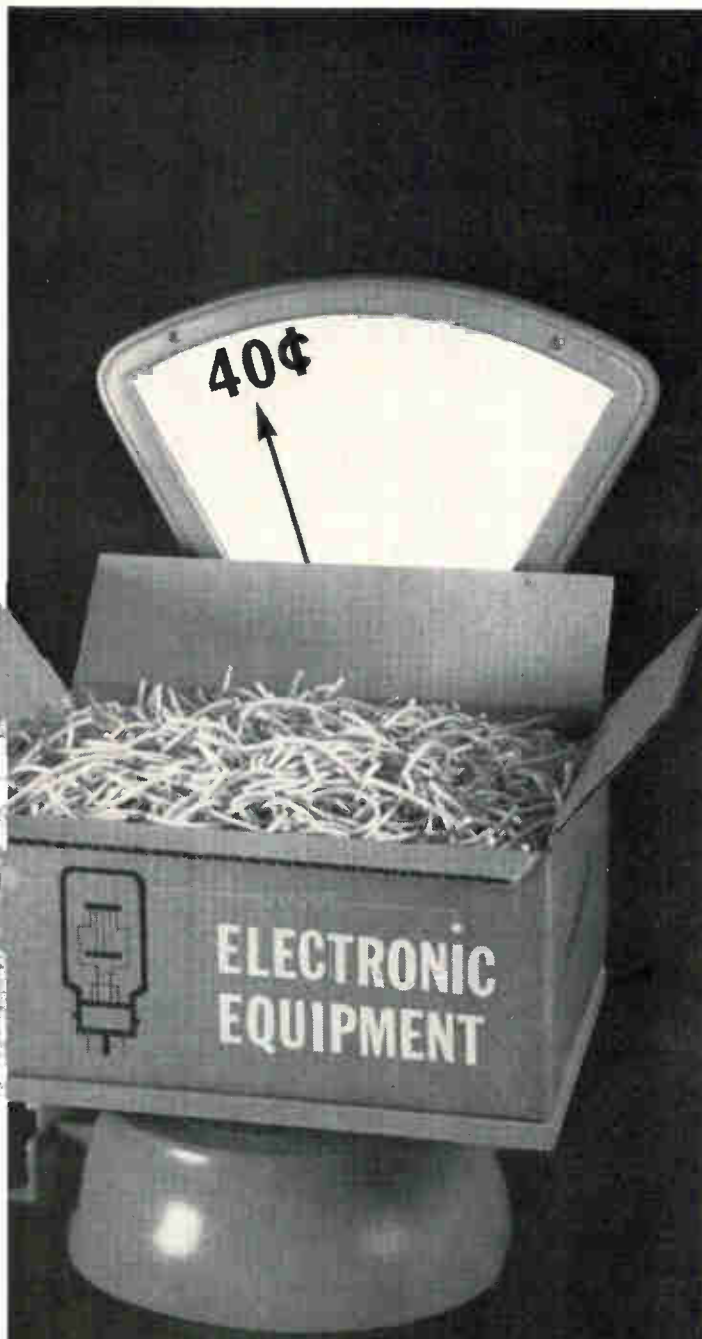

If it's so great, how come it's so cheap?

It's only \$5,000 because you said that's what it ought to cost. Our market research boys told us there was a tremendous need for an IC tester specifically designed for QC, QA, reliability testing, and everyday engineering evaluation. They also told us we could sell four times as many at \$5,000 as we could at \$7,500.

So we gave our design department a list of functions, a \$5,000 pricetag, and locked the door. Here's what came out: A \$5,000 IC tester that:

- Performs both pulse and dc parameter tests as well as functional tests without external equipment.
- Has a measurement accuracy of 1% (0.1% with an optional digital readout DMM.)
- Can be operated by a bright girl with half-a-day's training.
- Programs with thumbwheels in less than 60 seconds for most IC's.
- Has power supply accuracy of 0.1% \pm 1mv. (All supplies have adjustable current or voltage limiting and will both source or sink current.)

- Has Kelvin connections to the device under test.
- Has self powered, line-isolated modules.
- Has a complete line of device adaptors available.

How were we able to deliver so much machine per dollar? It was a snap. All we did was make every damn penny do a dime's work. We did it by committing to an annual agreement wherever there was a price advantage.

We did it by cutting out the fat. If a function was non-essential, it went. (This is one un-gilded lily.)

We did it with painstaking project engineering. For example, the loads module: We could have made 1% capacitive loads. But it would have cost three times as much, and no one knows what to do with capacitive accuracy of better than 5% anyhow. Another example: the thumb-wheel switches. We found a great one, but discovered the price included \$2 each for a pair of stainless-steel screws. We bought them knocked-down,

assembled them ourselves and used 6¢ screws instead.

Or the pulse generator. Ours is equivalent to two single-channel output units like the ones that Datapulse sells for \$775. They're great, but by sacrificing separate control and adjustment (which isn't necessary in our tester anyway) and the fancy case cut the price in half.

We found a terrific \$15 digital switch. But we didn't use it. We built one without superfluous extras for a buck and a half apiece.

We're handling the AC-switching with 32 controlled planar devices. This saves 192 reed relays, that is to say, greenbacks.

One thing we did was hardest of all. We cut the profit margin. We're honest-to-gosh taking only $\frac{3}{4}$ the typical profit.

One more thing. The 990 turns out to cost \$4,950 instead of \$5,000. Use the extra \$50 to take the little woman out to a show and dinner.

Write for complete technical data, or if you're in a hurry, call us collect.

Redcor's 990 IC tester

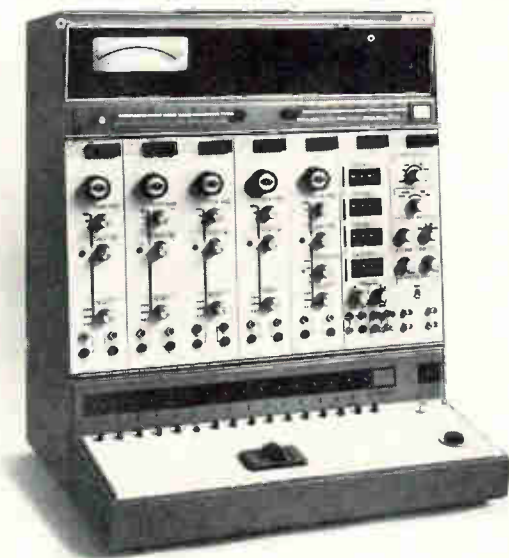

Redcor Corporation/7800 Deering Avenue/Canoga Park, California/(213) 348-5892/TWX 910-494-1228

Design engineer Bob Alden searched for nearly an hour to find he didn't have the information he needed.

Chances are 10 to 1 he'd have found it in less than 5 minutes in the new Sweet's Industrial Information System*



Sweet's Industrial Information System is a vendor catalog file on microfilm. Because we make no charge to vendors, and microfilm everything they have in print, Sweet's has more than 600,000 pages of vendor data including application notes, reliability tests, price lists and names of distributors and reps. What's more, the Sweet's vendor catalog file on microfilm is updated every 60 days!



Small wonder.

In addition, the Sweet's system is tailored to your needs by adding the vendors you want - at no extra cost. We start with a basic file of the most wanted information. Update it regularly, and then—to top it off—"personalize" the file by adding the complete vendor information you request. It also reduces storage area by 98%, cuts redundancies in design efforts and increases sources and use of standard items.

You can install a Sweet's vendor catalog file on an annual subscription for less than the cost of a file clerk. Sweet's vendor catalog files are in use in plants with as few as fifty employees. The "user-orientated" idea not only provides current knowledge of the component state-of-the-art, but also expedites the purchasing function. Because of its complete coverage, more than 60% of our recent installations have replaced other microfilmed vendor catalog systems.



A new McGraw-Hill Information Service

* formerly IRI Information Retrieval Incorporated

It takes about 2 hours to demonstrate to your key people. But in much less time than that your design, standards, quality control, drafting, receiving, inspection and purchasing people will realize that a Sweet's Industrial Information System is the next best thing to a raise in pay! We have demonstration teams in most principal cities. To arrange a demonstration, send the coupon today, or call collect: George Stevens, (212) 971-3941.



Find it fast. Make a print-out in 6 seconds.

SWEET'S INDUSTRIAL INFORMATION SYSTEM
330 W. 42nd St., New York, N. Y. 10036
Dept. #B-57

- I'd like to see a demonstration of the Sweet's Industrial Information System. Have your representative call me for an appointment.
- I'm not ready for a demonstration at this time, but please send further information.

Name _____ Title _____
 Company _____
 Address _____
 City _____ State _____ Zip _____
 Telephone _____ Ext. _____
 Number of employees at this location _____

We have have not had experience with a vendor catalog file on microfilm.

In addition to the Vendor Catalog File on microfilm we're interested in Mil Specs Mil Standards.

Keep ahead of your competition.

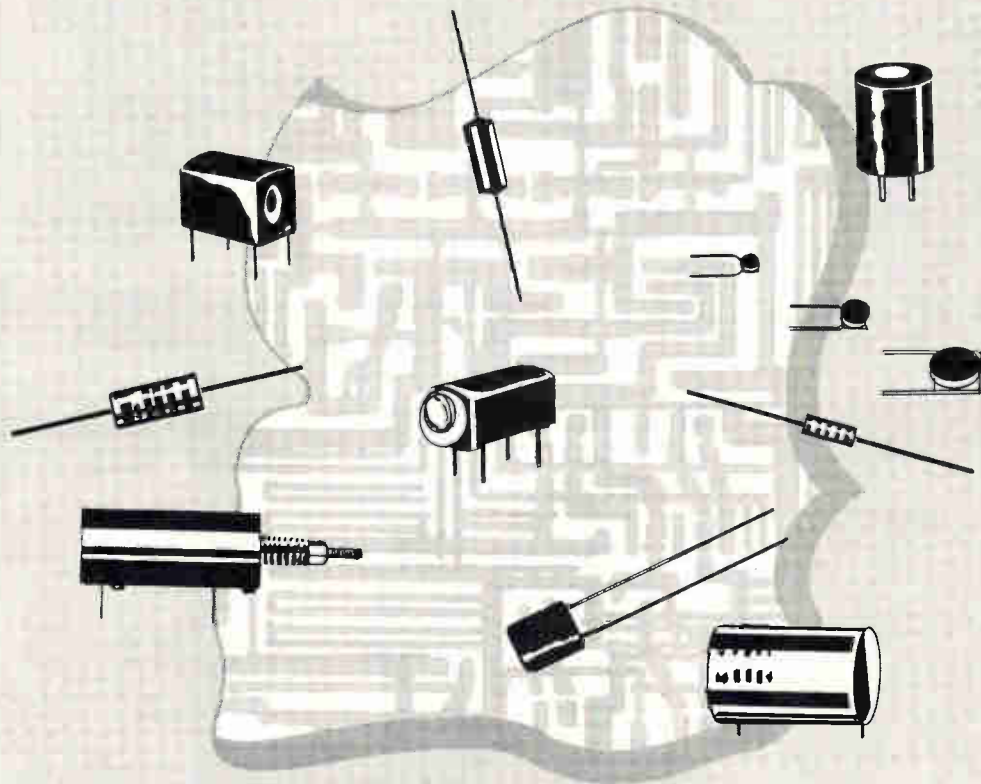

We do.

Delevan is the most experienced coil and transformer manufacturer in the world. We got that way . . . by innovating . . . by packing high values into the smallest configurations known today.

Combine engineering talent with large volume production experience and you have a company you can depend on. Try us!

**Delevan Electronics
Corporation / Division**



AMERICAN
PRECISION
INDUSTRIES INC.

270 QUAKER ROAD / EAST AURORA, NEW YORK 14052 / 716 652-3600

OTHER DIVISIONS OF AMERICAN PRECISION INDUSTRIES INC.: BASCO, INC. • ELECTRO-MECHANICAL PRODUCTS DIVISION

one crimp

Slip our COAXICON*
Connector on your
stripped cable.
Crimp center conductor,
braid and insulation
with our matched tool.
Takes 15 seconds.
Same impedance
as the cable.
Uniformity, inspectability,
reliability at lowest cost.

*Trademark of AMP Incorporated



AMP



PUT YOUR IDEAS INTO ACTION WITH THE HELP OF AMP ENGINEERING... WORLDWIDE.

AMP INCORPORATED
Harrisburg, Pa. 17105

Please send me more information on COAXICON Connectors.

NAME _____
COMPANY _____
ADDRESS _____
CITY _____ STATE _____ ZIP _____

This Keystone Thermistor assembly



in this
CLIFTON
integrating
tachometer

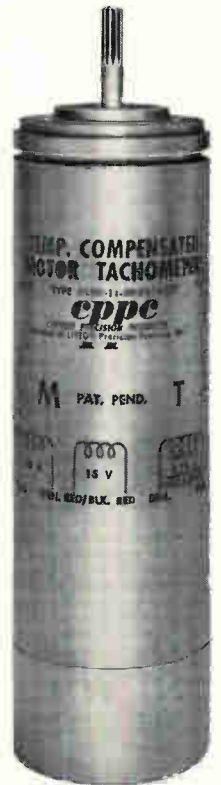

Makes all this difference in temperature performance

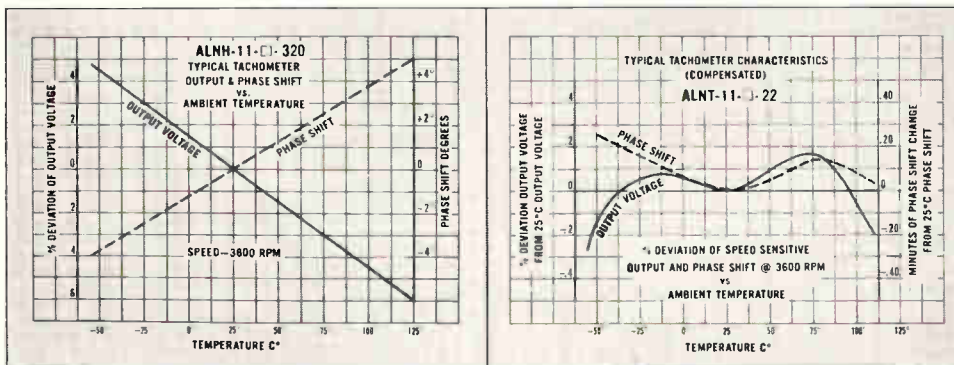

In precision computing applications using integrating tachometers, variations in output characteristics with temperature must be held to a minimum. To obtain the required performance, Clifton, Division of Litton Industries employs temperature compensation. □ The improvement in performance resulting from temperature compensation is shown graphically above. □ Responsible for the contrast is a Keystone Thermistor assembly. This is one of hundreds of different configurations made to specific customer requirements to the highest standards of quality and performance. May we have your inquiry? KEYSTONE CARBON COMPANY, St. Marys, Pennsylvania 15857

Keystone
leads

in creative thermistor technology

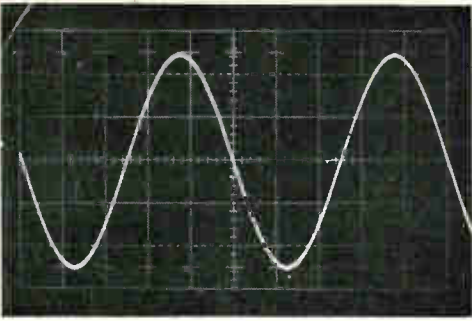

Sine wave

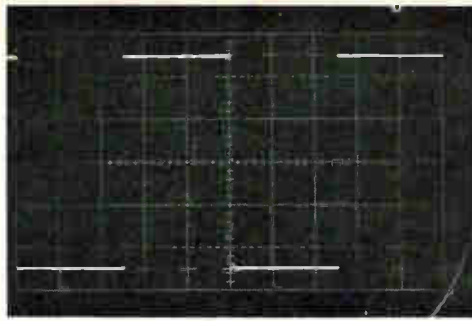

Square wave

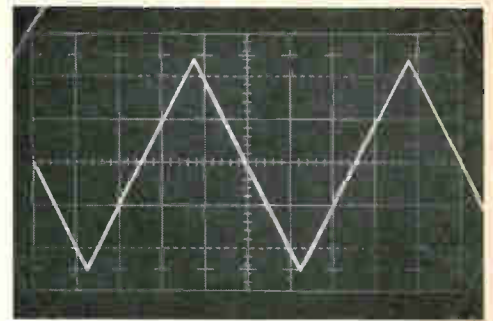

Triangle wave

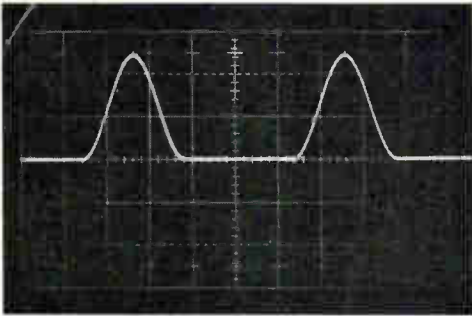

Sine² pulse

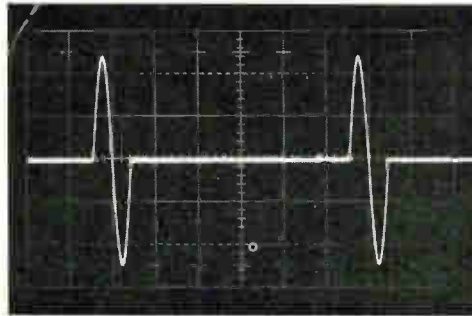

Triggered

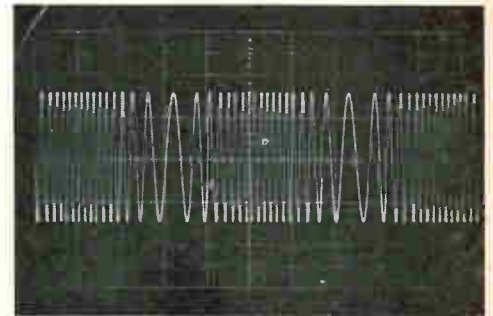

Frequency modulation

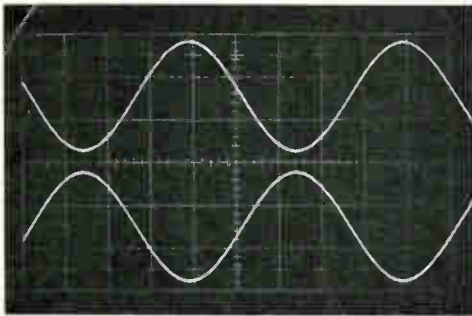

180° phase shift

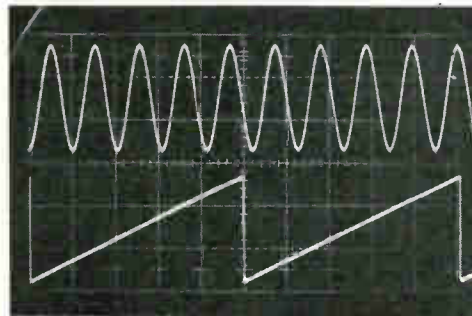

Two independent generators

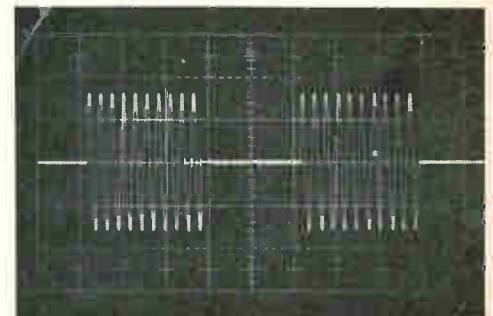

Tone burst

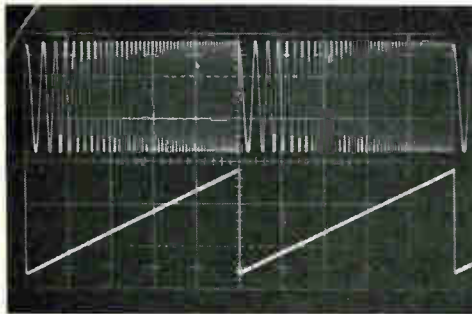

Continuous sweep

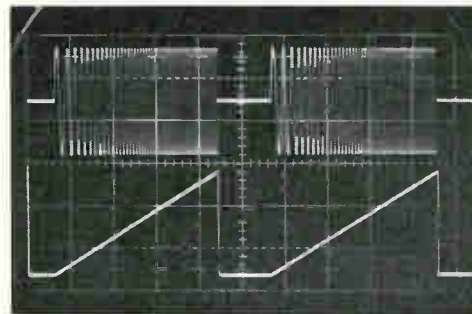

Triggered sweep

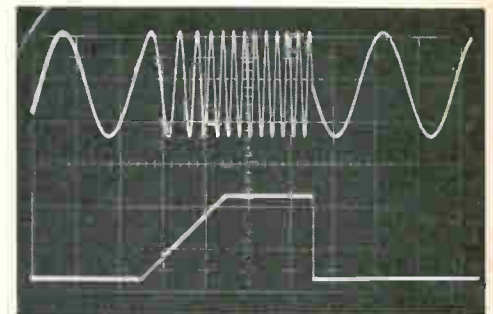

Sweep and hold

The Model 114 covers a frequency range of 0.0015 Hz to 1 MHz. Get one for \$795.



WAVETEK®

8159 Engineer Rd., San Diego, Calif., Tel. 279-2200
P.O. Box 651, San Diego, Calif. TWX 910-335-2007

What does the CD-65 have that all other 2½D memory systems don't?

MORE STRINGENT DESIGN CRITERIA + HIGHER RELIABILITY + GREATER USER VERSATILITY.

The CD-65 is designed with the demanding user in mind. Operating margins in this unit are significantly greater than accepted industry standards. Mechanical packaging of key circuits and magnetics in the CD-65 provides a system organization easily adapted to custom application. All circuits are worst case designed and are verified by customer examination. □ Featuring a newer 2½ D packaging concept, the CD-65, with a 650 nanosecond cycle time, permits faster speeds and definite economies for larger word systems. The CD-65 is available in sizes from 8K to 65K words—each containing from 16 to 144 bits. □ Speaking of words, may we have some with you? We'd like to tell you more about the CD-65. For more information, write: Lockheed Electronics Company, Memory Products, 6201 East Randolph Street, Los Angeles, Calif. 90022. Or phone (213) 722-6810.

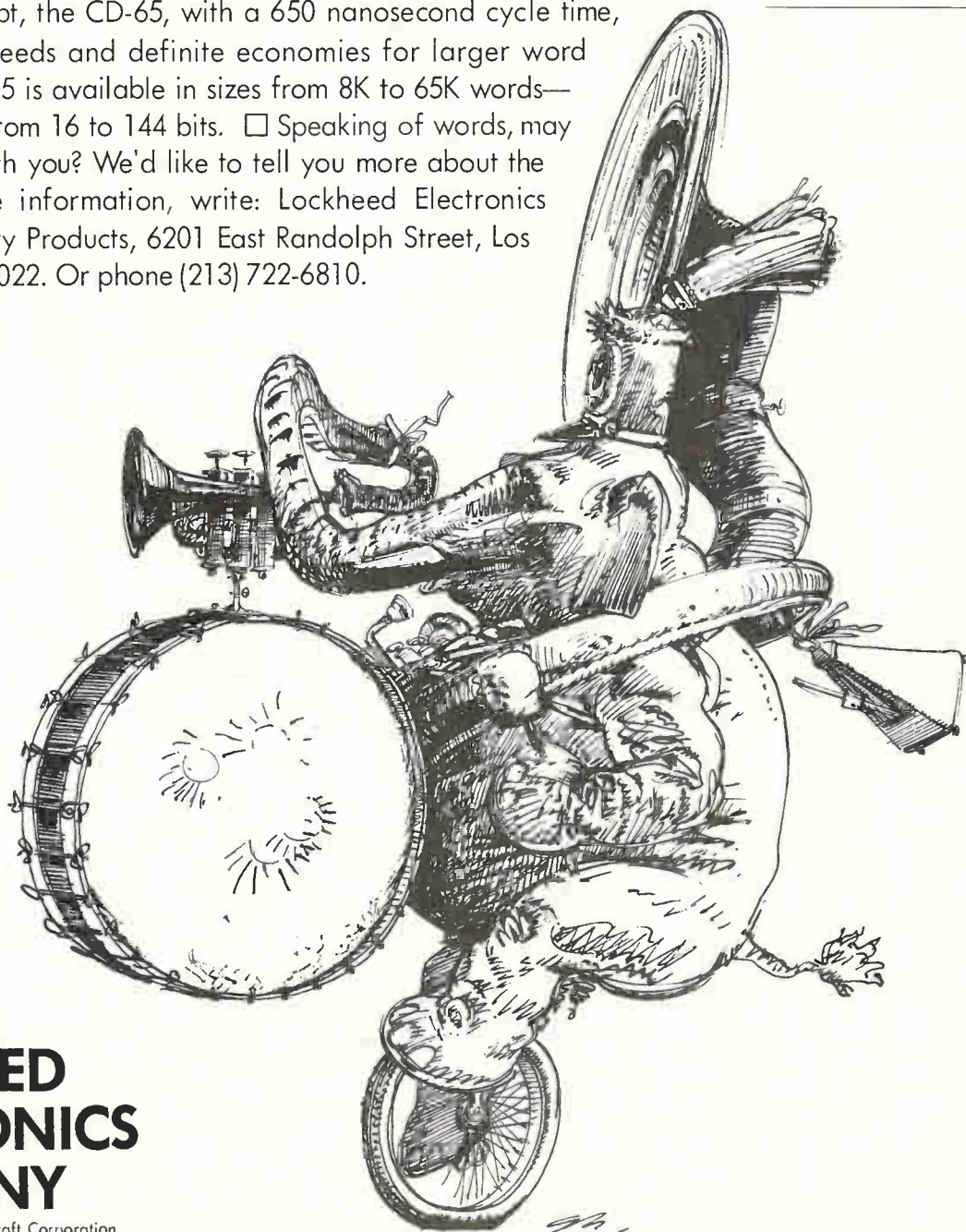

**LOCKHEED
ELECTRONICS
COMPANY**

A Division of Lockheed Aircraft Corporation

Our
roof
is
proof...

CHESTER
N.Y.

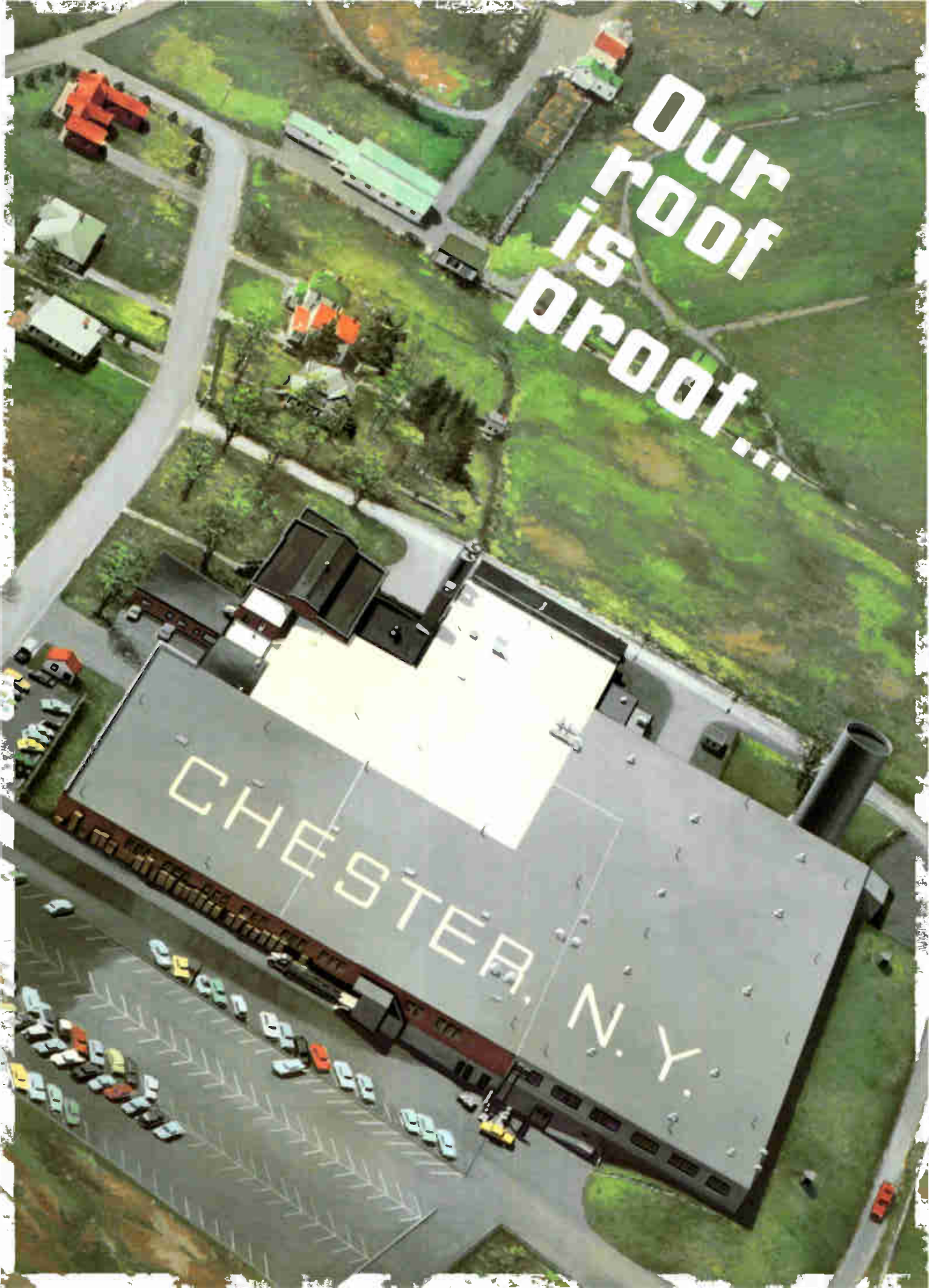

Chester's growth through service

We can't think of a more graphic way to portray "Growth Through Service", than the illustration on the preceding page. The dark roof area represents Chester's plant expansion during the past ten years . . . expansion made necessary by the increasing requirements of our many valued customers in the electrical and electronic industries.

Actually, though, it's what's under the roof that counts: — The newest and most advanced production machinery . . . expanded research and test facilities . . . exacting quality control techniques . . . modern materials handling systems . . . and most important — experienced people, skilled in the manufacture of Plasticote® Wire and Cable.

Today . . . while we plan for the future . . . we still continue to meet industry's present requirements with unequalled service. The ultimate ingredient of this service is the most important facet of Chester's story of growth . . . the close, personal attention to each customer's requirement.

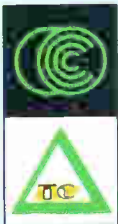

CHESTER CABLE CO.

DIVISION TENNESSEE CORPORATION, CHESTER, NEW YORK 10918

A SUBSIDIARY OF CITIES SERVICE COMPANY

PHONE: (914) 469-2141

TWX (914) 469-9801

Printed in U.S.A.

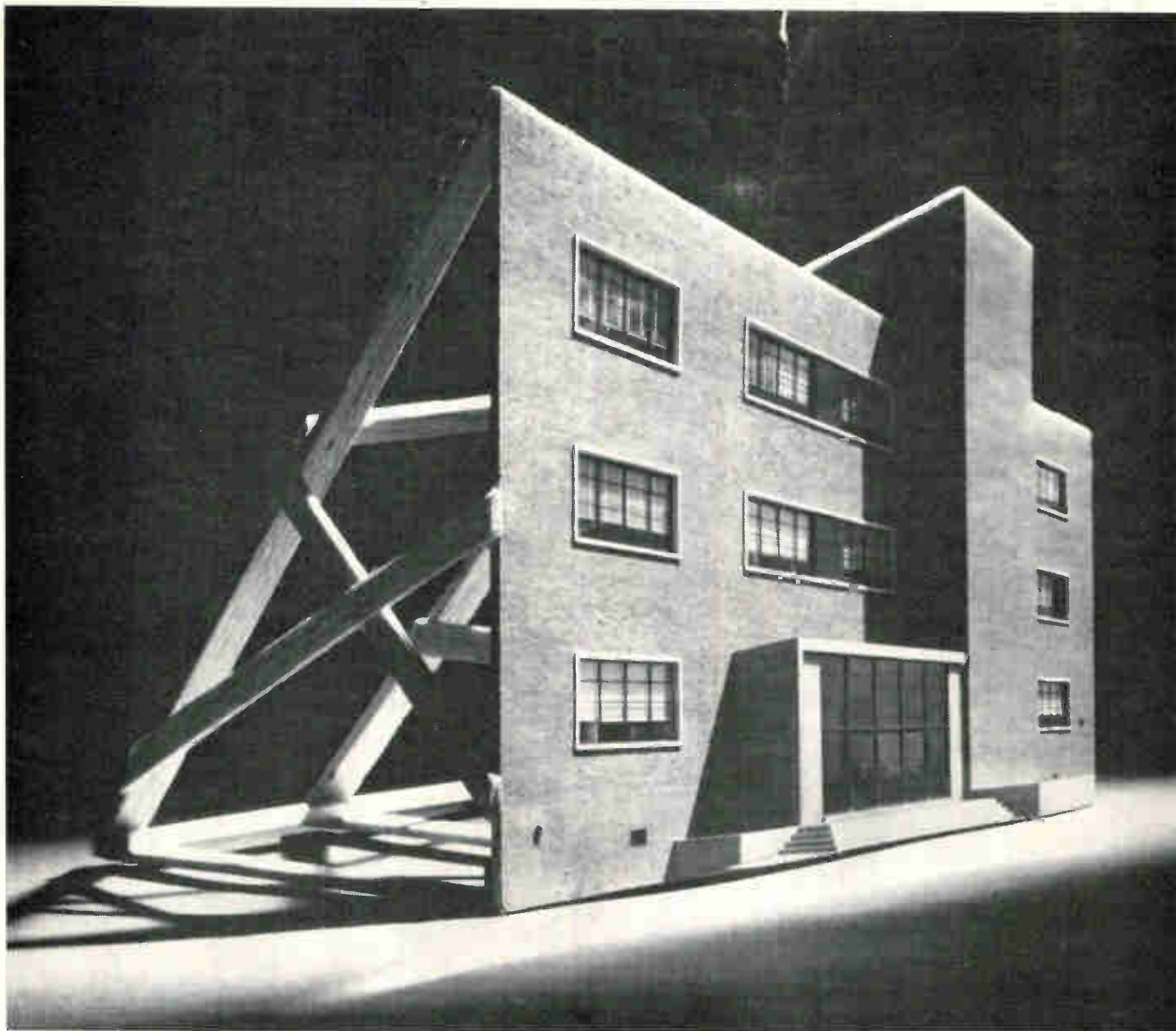

The Milgray Branch Plan

**There's more to it than
some chips off the old block.**

There's a little bit of show biz in some of us. Even in electronics distribution. An impressive display in front *can* be good for business. And a letterhead loaded with branch office listings *can* set a beautiful scene for selling.

As long as the customer doesn't go back-stage after the first act.

Which is why we've always built every

Milgray branch to be a real branch. Not a twig. Not a prop. And behind each front, you'll find a back...not just a jangle of frantic telephone lines to a home office in a distant city.

We still feel that the only show to put on for a Purchasing Agent is an "Appearing Act." Preferably on his receiving platform.



MILGRAY And that's no act.

Milgray/New England 617-272-6800
 Milgray/New York 212-YU 9-1600
 Milgray/Delaware Valley 215-BA 8-2000
 Milgray/Washington 301-864-6330
 Milgray/Cleveland 216-881-8800
 Milgray/International 212-YU 9-1600

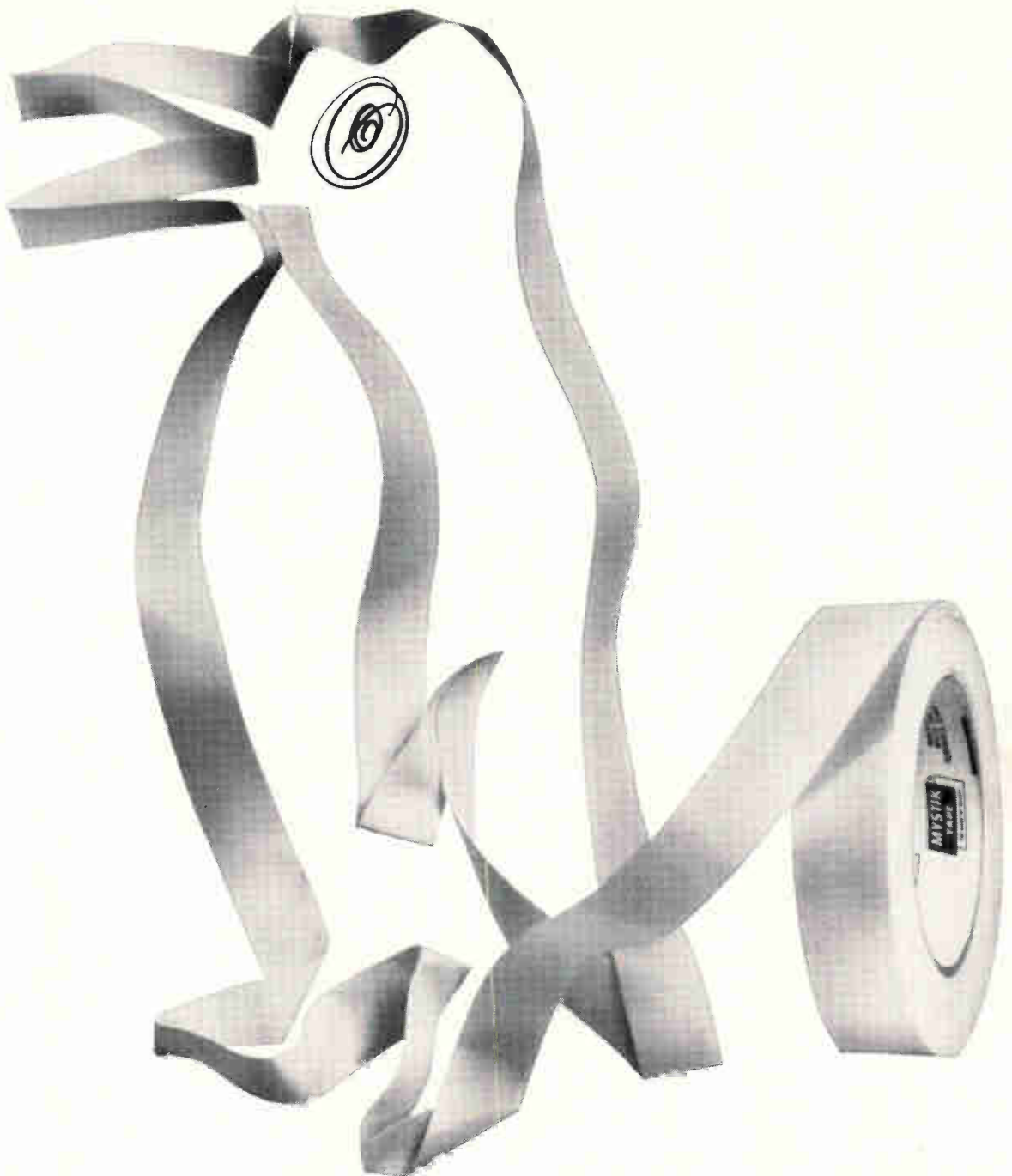

For hot and cold insulation...Mystik 7000!

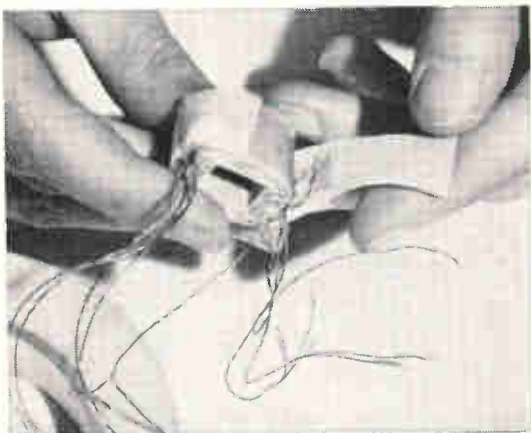

Superior thermal and electrical properties make Mystik 7000 suitable for an unusual range of cryogenic and elevated temperature applications. Uniquely inorganic, it has a tightly woven high tensile glass cloth backing with a pressure-sensitive silicone adhesive. Mystik 7000 has exceptionally high dielectric strength and offers high conformability and excellent shear resistance.

Here is a remarkable tape, perfect for insulating motors, generators or other components which must perform in critical operating environments.

This is only one of the Mystik family of tapes for the electrical industry. If you have an insulating problem or extreme temperature requirement, call your Mystik distributor. He's in the Yellow Pages under "Tape". Or write: The Borden Chemical Company, Mystik Tape Div., 1700 Winnetka Ave., Northfield, Illinois.



**BORDEN
CHEMICAL**

POLY-SIL PLASTIC MIL RECTIFIER AT HALF THE COST OF GLASS



Popular
1N3611 series
now available
from IRC...
off-the-shelf.

Up to now these units were available only from one source and at nearly twice the cost. Now, IRC (the resistor people) offers a Poly-Sil rectifier that's a real money saver for all your low-power MIL applications. Check these prices.

TYPE	1-99	100-999
JAN 1N3611	\$1.49	\$.99
JAN 1N3612	1.95	1.30
JAN 1N3613	2.70	1.85

Commercial versions at lower cost

These units have a single-cycle surge rating of 20 amps.

Tough and durable, Poly-Sil completely surrounds all internal parts. This solid construction is stronger than comparable glass packages.

A great combination of low cost and superior performance, the 1N3611 series is available off-the-shelf in production quantities. See your IRC representative or write for data. IRC, Inc., Semiconductor Division, 727 Lynnway, Lynn, Mass. 01905.

SPECIFICATIONS



ACTUAL SIZE

MIL.....	Meets MIL-S-19500/228D
RATINGS.....	2A @ 25° C
	1A @ 100° C
	0.3A @ 150° C
VOLTAGE.....	200, 400, 600
TEMP. RANGE	
operating.....	-65° C to 150° C
storage.....	-65° C to 175° C



SEMICONDUCTOR DIVISION

GLASS-TO-METAL SEALS

by
AIRPAX

Exacting customer specifications are met by the quality, glass insulated terminals manufactured by Airpax.

A wide variety of terminal designs are producible and glass can be color coded for identification. (We like blue, one reason is that blue is supposed to be difficult.)

Leads can be kovar, or sleeved solid copper, or tubular. A large choice of standardized pins and lugs permits quick delivery to your specific needs. A 90 page catalog giving technical details is yours for the asking.

AIRPAX ELECTRONICS

CAMBRIDGE DIVISION, CAMBRIDGE, MARYLAND 21613

Phone 301-228-4600

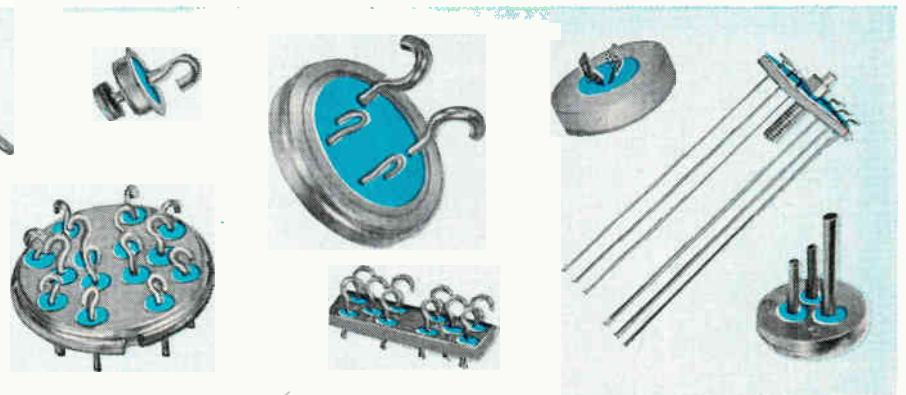
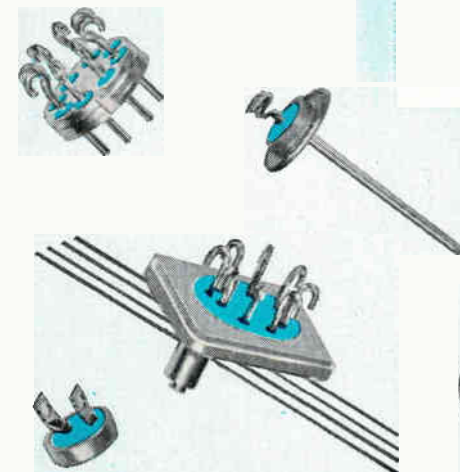
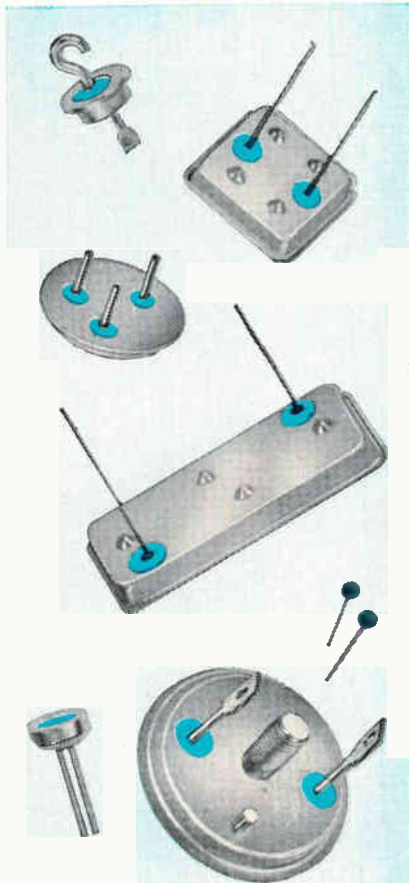

New Products

New computer equipment

Massive core memory runs at lightning speed

Capacity of almost 20 million bits and cycle time of 2.7 microseconds can double computer productivity

This week at the Fall Joint Computer Conference in Anaheim, Calif., the Ampex Corp. introduces a memory with a speed-capacity combination that can double the productivity of computer systems using bulk core memories.

The model RM has a cycle time of 2.7 microseconds and a capacity of nearly 20 million bits, a double feature unique among memories of comparable cost. It will sell for less than three cents per bit, or about \$500,000. Smaller versions with one or two 5-million-bit sections will also be available.

"We expect high-speed mass memories to play a big role in new generations of large-scale computers," says Eugene E. Prince, Ampex vice president. "They will provide substantial programing and run-time economies."

In capacity and speed, a bulk core memory usually stands midway between a computer's main memory and its auxiliary storage units, such as magnetic disk files and magnetic drums.

A main memory has a cycle time that may range from 0.5 to 2.0 μsec , but a capacity of no more than 2 million bits. Faster memories are considerably smaller. Disks and drums, on the other hand, can store 1,000 times more data. And, in some cases, they can deliver the data at dazzling speeds. Because they are electromechanical, however, they require milliseconds to locate stored data before they can pro-

duce it. Bulk core units store between 10 and 100 million bits, and most have cycle times between 5 and 10 μsec .

The yardstick. Two main memories presently available on commercial computers exceed the performance of the new Ampex bulk core unit. One is on the General Electric Co.'s 635 computer, and the other on the Burroughs Corp.'s B-8500. The 635 memory, which is made by Ampex, has a 37-million-bit capacity and operates with a 1- μsec cycle; it consists of 32 one-million-bit-plus modules operating in parallel, and is considerably more expensive to produce than the new memory. The B-8500 has a 12-million-bit capacity, and a 0.5- μsec cycle. But unlike GE's, Burroughs' memory is a thin-film type.

In comparing memories in size and speed, the yardstick is the quotient of number of bits in millions divided by the cycle time in microseconds. For most bulk core memories this comes out between 5 and 10; for the Ampex machine, it is 13.3; GE, 37; and Burroughs, 24.

Only one other commercially available memory approaches the speed of the Ampex RM, but it is only half the size. Fabri-Tek Inc. has a 10-million-bit memory with a 2.75- μsec cycle time.

I. Interleaved sections

Ampex's RM is made up of four sections, each having almost 5 million bits. Each section has its own

decoding, driving, and sensing circuits, enabling it to be operated independently of the others. The memory is capable of accepting four different read or write commands from the computer 200 nanoseconds apart. After four commands have been received, a 1,900-nsec pause is necessary before the first section can accept another command.

Called interleaving, this technique is commonly used in large memories. The 200-nsec limit is determined by the time required to load an address into a section's address register. Most computers cannot generate new memory requests that fast. The Ampex unit can operate continuously in the interleaved mode at an average cycle time of 675 nsec—one-fourth the complete cycle time for each section—which is a little more realistic for present-day systems.

Share technique. The four sections share two sets of input and output data and control paths, enabling the entire memory to operate as a common-data bank for two independent computers. Each section has its own auxiliary keyword memory, with which either computer can protect its own data from access or destruction by the other—a standard procedure without which no multiprocessing system would be feasible. With the auxiliary memory, access to the bulk memory must be accompanied by a keyword; keys stored in the auxiliary memory correspond to different blocks of storage in the bulk memory. Unless the keyword matches the corresponding key, the memory rejects the attempted access.

II. Two dimensions plus

The memory has a 2 $\frac{1}{2}$ -dimensional organization—that is, a single bit-wire threads 1,024 cores in one direction and 1,024 in the opposite direction. Selection of either set of cores is determined by the direction of current in the 1,024

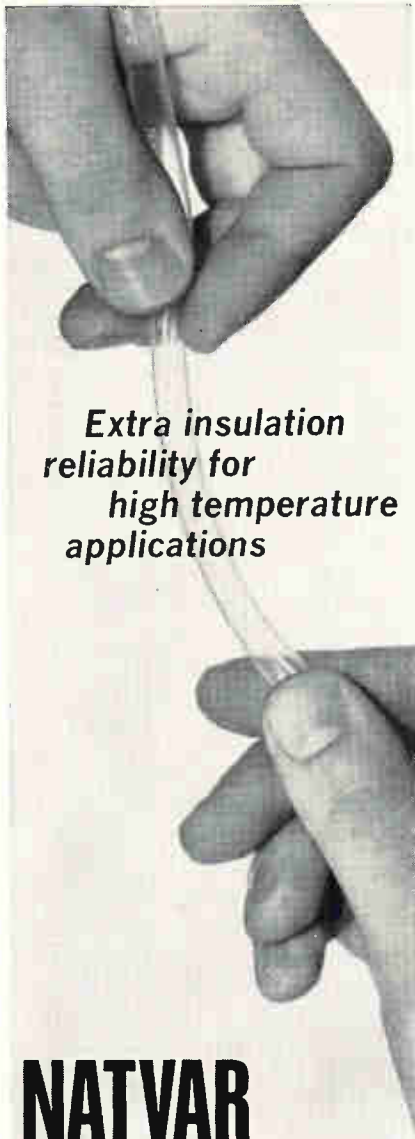

**Extra insulation
reliability for
high temperature
applications**

NATVAR 400 Vinyl Tubing

Here's an insulation you can rely on when the heat's on. Because Natvar 400 vinyl tubing has excellent thermal life. In fact, it's U.L. recognized for 105°C continuous operation. Besides that, it has exceptional resistance to oils.

Use Natvar 400 high temperature vinyl tubing to insulate leads... terminations... wiring... electronic equipment... oil filled transformers... harnesses.

Available in a wide range of sizes and colors—in continuous lengths or cut pieces. Send for FREE samples and complete technical data.

NATVAR CORPORATION
P. O. Box 67, Rahway, New Jersey 07065

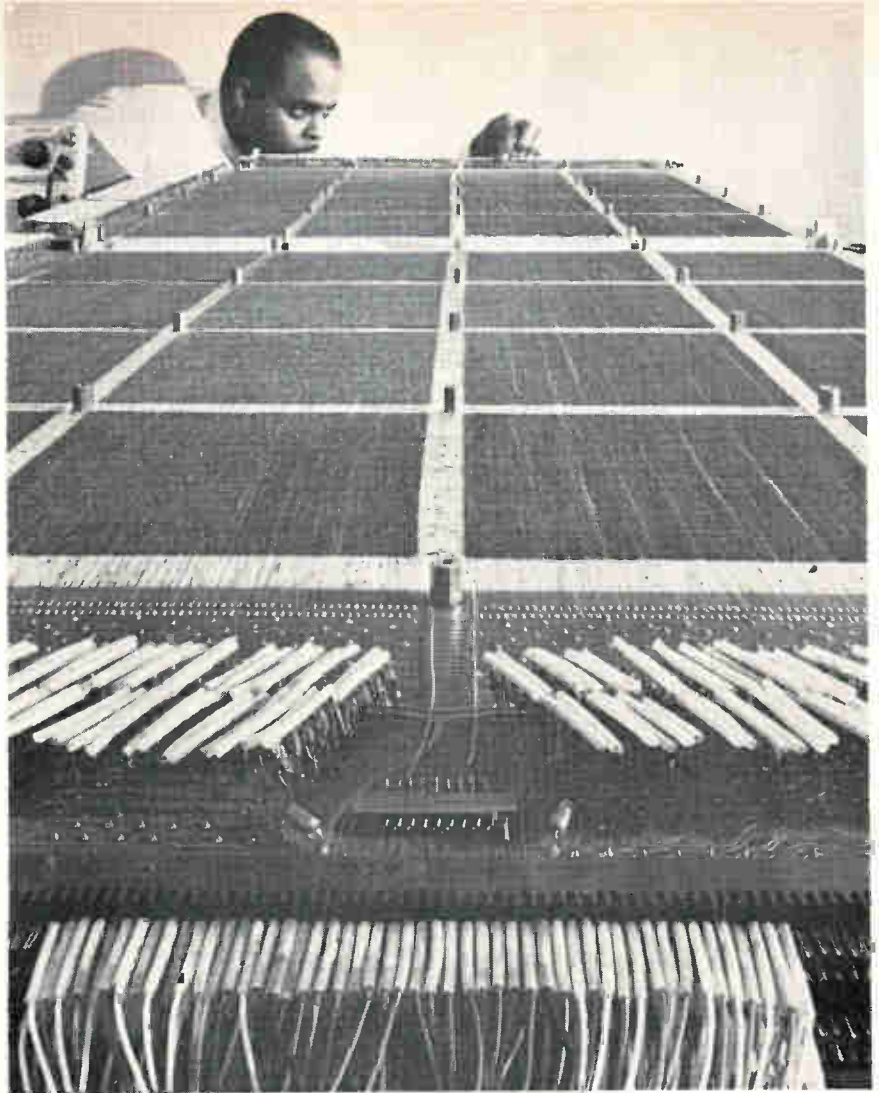

Flat plane. A single five-million-bit section opens, like pages in a book, for maintenance and repair.

word windings that are common to each. One word-winding wire threads two corresponding cores, one in each set. For increased reliability, each wire passes through the fold in the array, thus reducing the number of solder connections that must be made during fabrication of the memory.

Data is stored in the form of 262,144 words of 72 bits each. These 72 bits are written into or read out of the memory in parallel, and can represent eight standard computer bytes of nine bits each, or two 36-bit words, or any other submultiple of 72. Each section of 65,536 words is mounted on its own folding ground plane, resembling a four-page booklet having 16 square mats of cores on each page.

The memory's high speed was attained by minimizing the length of lines, and running the bit and word lines close to the ground plane, thus limiting inductance. The bit lines also go out and back,

through adjacent rows of cores—another way of minimizing inductance.

Double duty. Even higher speed would have been possible if the designers had not sacrificed some features to minimize costs. Only two wires thread each core; so the same wire is used for bit current when writing, and for sensing when reading. Every memory cycle consists of a read half-cycle followed by a write half-cycle. When reading, the write half-cycle restores the readout information. Because of the wiring's double duty, transients on the lines must be allowed to die out before bit current can be sent. This takes time.

There is also only one sense amplifier per bit, which cuts costs but increases the number of cores serviced by a single amplifier. This increases the amount of noise that a single amplifier must screen out.

Ampex Corp., Computer Products Div., Culver City, Calif. [338]

ulano[®] is the leading manufacturer of screen process stencil film

...any kind!

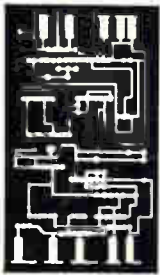

*In screen processing
of complex printed circuitry ...
there's no margin for error!
That's why Ulano offers
a complete line of
Screen Process Stencil Films
especially designed for
the Electronics Industry.*

ulanoTM

610 DEAN STREET, BROOKLYN, N. Y. 11238

NEW YORK • CALIFORNIA • CHICAGO • ZURICH

In Europe: ULANO A. G., Untere Heslibachstrasse 22, Kusnacht 8700, Switzerland

*For free working samples, write today
on your letterhead for Kit No. 5848*

Circle 503 on reader service card

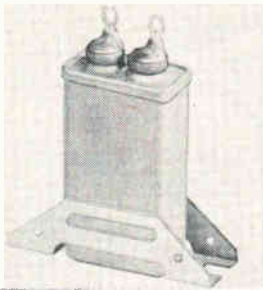

The Modiflex capacitors, using a combination of synthetic film and a liquid plastic dielectric, are rated up to 250 μ f. Standard tolerance for nominal values of 0.1 μ f and higher is $\pm 10\%$; under 0.1 μ f, $\pm 20\%$. Power factor is 0.004 at 60 hz and 25°C. Operating temperature without derating is -40° to $+125^\circ$ C. Industrial Condenser Corp., 3243 No. California Ave., Chicago 60618. [341]



A fixed time delay relay encapsulated in epoxy is for p-c and aerospace uses. It is a spst, normally open unit with an input-output isolation resistance of 1,000 megohms at 100 v d-c. It operates from -40° to 60° C. Life expectancy is 15 million cycles. The unit is $1\frac{1}{16} \times 1\frac{3}{16} \times \frac{9}{16}$ in. Price starts at \$25.65. Universal Technology Corp., 107 New St., Pitts- ton, Pa. 18640. [342]

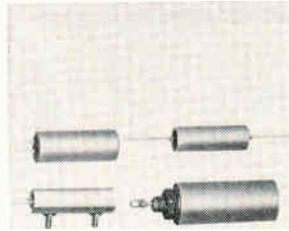

Metalized polycarbonate capacitors series 22E, in hermetically sealed tubular cases, come in 200, 400, and 600 v ratings in sizes from 0.174 x 0.500 in. to 0.750 x 1.875 in. Capacitance values are 0.001 to 5.0 μ f with tolerances from 20% to 1%. Temperature coefficient is 1.5% max. change from -55° to 25° C. SEI Mfg., 18800 Parthenia St., Northridge, Calif. 90324. [343]

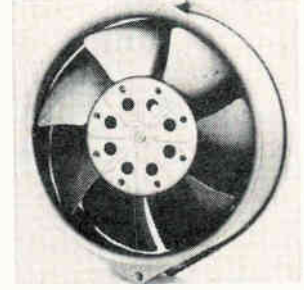

Miniature axial fans series 7500 combine high air delivery and low noise level. They feature aerodynamic design of the pressure type blades. With a free air delivery of 275 cfm, the unit will sustain delivery as high as 225 cfm at 0.2 in. of water back pressure. The venturi design limits noise factor to a low of 40.5 db at 3,350 rpm. Pamotor Inc., 312 Seventh St., San Francisco 94103. [344]

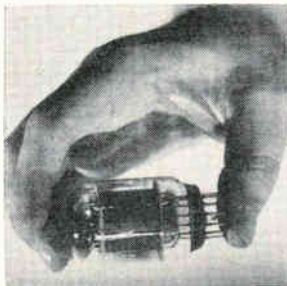

Double-triode-pentode compactrons are for color tv receivers. The 6AK9 has a heater voltage of 6.3 ± 0.6 v, a heater current of 1.6 amps. The 16AK9 has a heater voltage of 16.4 v, a heater current of 0.6 ± 0.04 amp. The pentode section is suited for vertical deflection amplifier use; triode sections, for general purpose uses. General Electric Co., Owensboro, Ky. 42301. [345]



Tuning-fork resonator TF600 is a $\frac{1}{2}$ -oz., 0.2-cu-in. unit that can be provided with any fixed frequency from 400 hz to 2,400 hz. Accuracy is 0.01% at 25°C. Operating temperature range is -55° to 85° C. An input of 6 ma at 28 v d-c is typical. Output is up to 5 v rms into 20 kilohms when used with proper drive. Bulova Watch Co., 61-20 Woodside Ave., Wood- side, N.Y. 11377. [346]

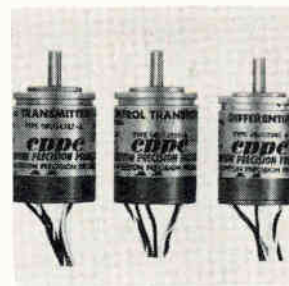

Size 8 synchros are available with over-all length of 1.015 in., which is 0.226 in. less than standard size 8's. Weight is also reduced to 1.15 oz. Standard accuracy of 7 minutes max. error is maintained. The line includes transmitters, control transformers, and differentials. Units have stainless steel housing. Clifton Div., Litton Industries, Marple at B'way, Clifton Heights, Pa. 19018. [347]

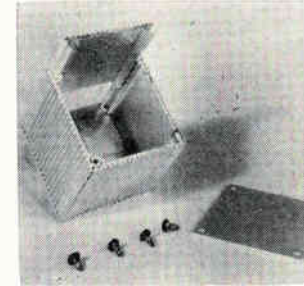

Enclosures known as Mini-Cool are constructed to contain a variety of precision devices. The line is available with integral heat sink walls. Made of lightweight aircraft alloy aluminum, they feature a lock joint at each corner which tightens when the screw fasteners are installed. Sizes range from 2 x 2 x $1\frac{1}{2}$ to 2.6 x 2.6 x 10 in. Sarex Corp., 1001 Roosevelt Ave., Car- teret, N.J. 07008. [348]

New components

Avalanche brightens photodiode outlook

Detector combines high gain of photomultiplier tube with small size and power requirements of photodiode

Combining the best of two worlds is a silicon photodiode that operates in an avalanche mode. Developed by EG&G Inc. and designated the AV-102, the unit offers the low-voltage and small-size advantages of solid state light detectors while providing the high gain and low-

noise characteristics of photomultiplier tubes.

In photomultiplier tubes, which usually have 10 sections (dynodes), the emission from one section triggers the next so that a cumulative effect produces high gain. The disadvantages of these tubes are that

they are large and require both a high-voltage power supply and a high-impedance load. But at high frequencies, high impedance causes a noise problem.

Photodiodes, on the other hand, are small, low-voltage devices requiring low-impedance loads, thus avoiding the high-frequency noise problem. But they lack high gain. What EG&G engineers wanted was a device that incorporated the advantages of both a photodiode and a photomultiplier. The company considered such a product highly marketable, particularly for laser communications systems in which high gain and low noise at high

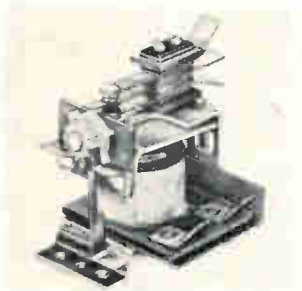

Unlike conventional relays that require a continual energizing of the coil to hold contacts open or closed, the RBM137 bistable relay transfers contacts on a momentary coil pulse, and contacts remain in a position of transferred state until coil is again pulsed. Unit is available in pole forms up to spdt, 12 amps at 115 v a-c. Essex Wire Corp., 131 Godfrey St., Logansport, Ind. 46947. [349]



Plug-in chopper model 75 features a transformer-coupled isolating drive network so that it can be driven from a 400 hz power line or from a drive source that is common to the d-c voltage being chopped. Sinusoidal or square wave drive may be utilized from 270 hz to 100 khz. Units withstand shock of 500 g for 11 msec. Solid State Electronics Co., 15321 Rayen St., Sepulveda, Calif. 91343. [350]



Industrial/commercial p-c transformers in the Deci-Miniature series are designed for control, instrumentation, audio, molded and other solid state applications. All have molded-in terminals that provide fixed mounting centers. Units measure $\frac{3}{4} \times \frac{3}{4} \times 1\frac{1}{2}$ in., weigh $\frac{1}{2}$ oz. Prices range from \$2.10 to \$3.50 in 100 lots. Microtran Co., 145 E. Mincola Ave., Valley Stream, N.Y. 11582. [351]



Molded epoxy, solid tantalum capacitors, the Econotan E series, are for high volume commercial use where cost, space, and radial leads are important. Tolerances are ± 20 and $\pm 10\%$; ratings, 35 and 50 wvdc. Capacitances range from 0.0047 μ f at 50 wvdc to 22 μ f at 6 wvdc. Leakage is 0.02 μ a/ μ f-v; impedance, less than 1 ohm at 1 Mhz. Components Inc., Smith St., Biddeford, Me. 04005. [352]

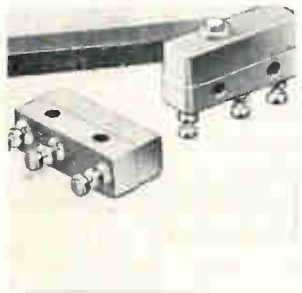

Subminiature, snap-action switch series 15 features a self-cleaning, full-floating blade that dampens actuation shocks reducing contact bounce. It has a 360° enclosed high temperature housing of diallyl phthalate. The switches are guaranteed for 1,000,000 operations minimum. Fine silver contacts are rated at 5 amps. Hi-Tek Corp., 2220 S. Anne St., Santa Ana, Calif. 92704. [353]

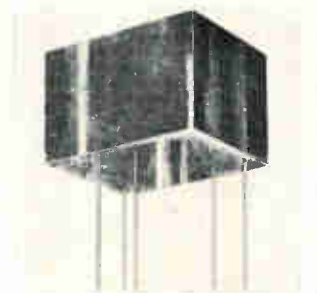

Designed for high-speed switching of single-ended analog signals, a solid state relay is adaptable for commutator input gates, choppers, dry circuit, a-to-d voltage comparators, and sample and hold amplifiers. Offset voltage is ± 50 μ v; signal sensitivity, 1 μ v; signal level, ± 10 v. Units measure 0.6 x 0.6 x 0.8 in. WEMS Inc., 4650 W. Rosecrans Ave., Hawthorne, Calif. 90250. [354]

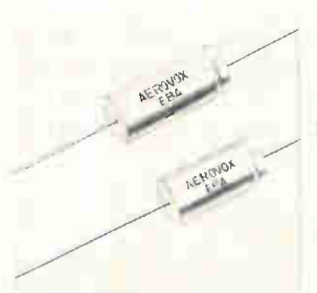

Use of welded joints at all critical terminations eliminates variable or high resistance connections in the EBA series aluminum-cased electrolytic capacitors. Capacitance ratings are from 1 to 1,000 μ f, with d-c nominal voltage ratings of 3, 6, 10, 15, 25, 35, 70, and 100 v. Units measure from $\frac{1}{4}$ to $1\frac{1}{2}$ in. in diameter and $1\frac{3}{4}$ to $1\frac{1}{2}$ in. long. Aerovox Corp., New Bedford, Mass. 02741. [355]



Dry reed relays series MRRK have a two-piece, molded thermoplastic case. Terminals and cover are welded ultrasonically to form a sealed, moisture-proof enclosure. The relay base holds up to 10 terminals with 0.1-in. grid spacing. Operating temperature range is -25° to $+85^{\circ}$ C. Insulation resistance exceeds 10^{12} ohms. Struthers-Dunn Inc., Pitman, N.J. 08071. [356]

frequencies are necessary.

New tactic. The AV-102 ushers in another phase of EG&G's new marketing approach. Previously, the company would work on a new device only if it was needed for a system that EG&G was developing. The change in thinking stems from the company's diversification program which includes development of custom-made radiation-detection systems and components based on semiconductor technology. The Massachusetts company has been prime contractor to the Atomic Energy Commission for instrumentation of nuclear explosions since its founding 20 years ago. In addition

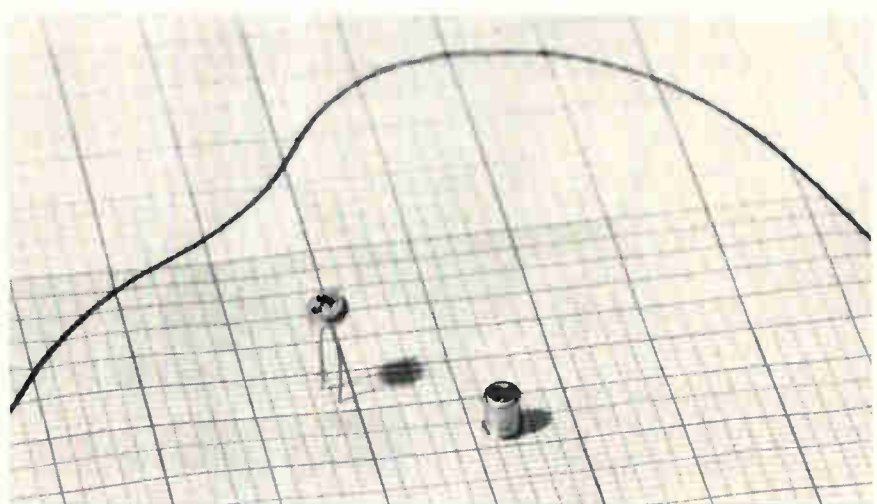

Peaked. Spectral response of the avalanche diode peaks at 0.9 microns.

KEEPING COOLANT FROM KILLING POWER TUBES...

One way Barnstead pure-water equipment works for electronics engineers.

Barnstead Coolant Repurifying Loops add thousands of hours to the life expectancy of transmitting tubes and other electronic power gear such as radar components, lasers, and magnets.

They keep water or ethylene glycol coolant free from impurities, oxygen and submicron particles that cause hot-point deposits, corrosion, premature burnouts; and maintain the coolant's electrical resistance.

Shown below: commercial Model PL- $\frac{1}{2}$, for systems up to 150 gallons. Others available for systems up to 12,000 gals. and larger.

Other Barnstead equipment designed for you.

Barnstead Transistor Washers and Microelectronic Cleaning Stations make a few gallons of hot, pure water — do the work of thousands.

Barnstead Demineralizers, Stills, Storage Tanks and Piping put pure water on tap wherever, whenever your process or equipment needs it.

Ask us for a no-obligation recommendation concerning your pure-water needs!



Helping you get more out of water!

Barnstead
STILL AND STERILIZER COMPANY
505 Rivermor Street
Boston, Mass. 02132

... avalanche mode
boosts gain ...

to diversifying through acquisition of smaller companies, it is designing lines of high-speed devices to detect and measure nuclear events. The new diode is a further extension of this program into special semiconductor devices.

The avalanche diode's spectral range is from 0.35 to 1.13 microns, with its response peaked at 0.9—the wavelength of light emitted from gallium-arsenide lasers. The major problem with laser systems is that because the beam has to travel long distances, the amplitude of the signal portion of the beam gets lost in noise. To reduce the effects of noise, the detector's impedance must be low and its signal-to-noise ratio, high. The AV-102 satisfies both conditions.

Avalanche threshold. If the AV-102 is operated below 11 volts—the point at which it goes into avalanche—its gain would be that of a conventional photodiode. But when operated in the avalanche mode, with a cumulative multiplication of carriers taking place, the diode's gain is increased 300 times. This increase is caused by the entire junction area being active. In conventional photodiodes, only part of the junction is active.

Memory systems is another application in which the AV-102 could be teamed with a laser. Reading out information after it has been recorded on photographic film, for example, requires a highly sensitive detector because much of the light is lost to the film. Also, the detector requires the capability of rapid response to a wide range of frequencies. This type of memory has applications where a large quantity of read-only data is to be stored for future recall.

Specifications

Signal-to-noise improvement	300 to 1 for 50-ohm load
Sensitivity at 0.9 microns	0.5 $\mu\text{a}/\mu\text{W}$
Spectral range	0.35 to 1.13 microns
Frequency response	d-c to 1 Ghz
Operating avalanche voltage	8 to 15 v
Junction capacitance	1.5 pf
Dark current at 1 v	0.001 μa
Active area	$2 \times 10^{-5} \text{ cm}^2$
Package	TO-18
Price	\$275

EG&G Inc., 160 Brookline Ave., Boston, Mass. 02215 [357]

For Airborne Military and Space Memory Systems

RCA's high-density memory stacks are tested and proved to military specifications

These military-type high-density stacks are available in various capacities up to 4k x 32...operating temperature range from -55°C to +125°C. And we can provide fast delivery of most configurations...just let us know your requirements!

Other sizes available where requirements warrant it.

RCA "building-block" construction provides wide flexibility of electrical capacities, ruggedized construction, improved reliability and faster delivery.

Greater reliability is assured because core mats are continuously wound—solder joints are kept to a bare minimum. Fewer frames result in smaller size, lighter weight, tighter, more compact package. The RCA 30/18 lithium ferrite cores provide wide-temperature operation. The complete package withstands vibrations up to 15G's.

Backed by more than two years of manufacturing experience and strict quality control, these RCA High-Density stacks are proved to MIL specs before you

order them. In many cases we can make initial deliveries in eight to ten weeks.

May we have one of our salesmen arrange for a demonstration for your specific military applications? Contact your RCA Field Representatives for details and availability for your requirements. Or call Marketing Dept. (617-441-7200), RCA Memory Products Division, Needham Heights, Mass. 02194. For Technical Bulletin MP317, write RCA Commercial Engineering, Section FN11-2, Harrison, N. J. 07029.

Designed to meet requirements of MIL Specifications MIL-E-5400, MIL-T-5422

30/18 High-Density Stack	
Capacity: 4096 words 25 bits	Shock: 50g
Temp. Range: -55°C to +125°C	Altitude: 0 to 70,000 ft.
Vibration: 10-500 cps 15g	Humidity: 10 days

4k x 16
4k x 15
4k x 14

4k x 17
4k x 18
4k x 19

4k x 10
4k x 9
4k x 8
4k x 6

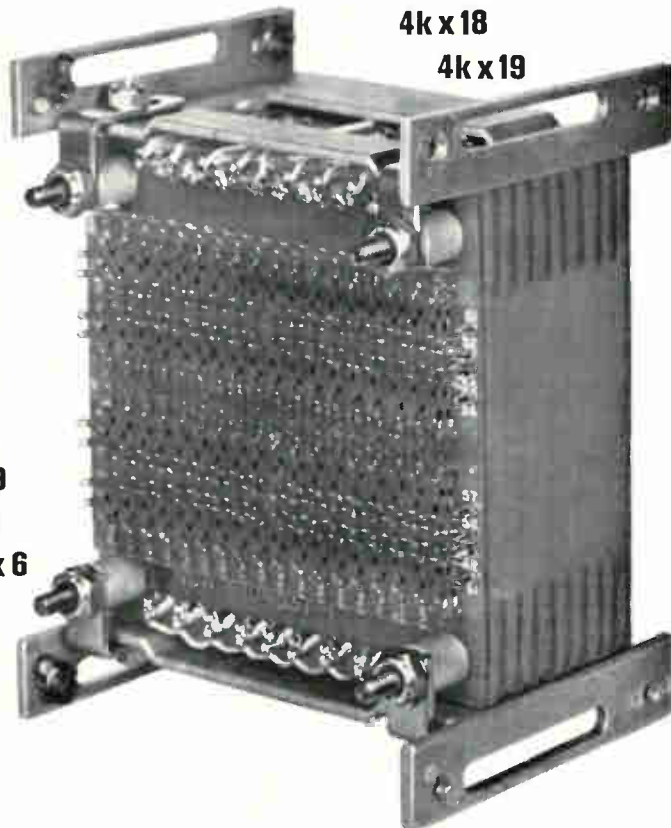

4k x 20
4k x 23
4k x 24
4k x 25

4k x 26
4k x 32

See a display of these and other military stacks and systems, Booth 118, FJCC, Anaheim — Nov. 14-16, 1967.



RCA Electronics Components and Devices

THE MOST TRUSTED NAME IN ELECTRONICS

CHOPPERS • RELAYS • TRANSFORMERS • SWITCHES

JAMES

ISOLATES NOISE WITH SHIELDED TRANSFORMERS

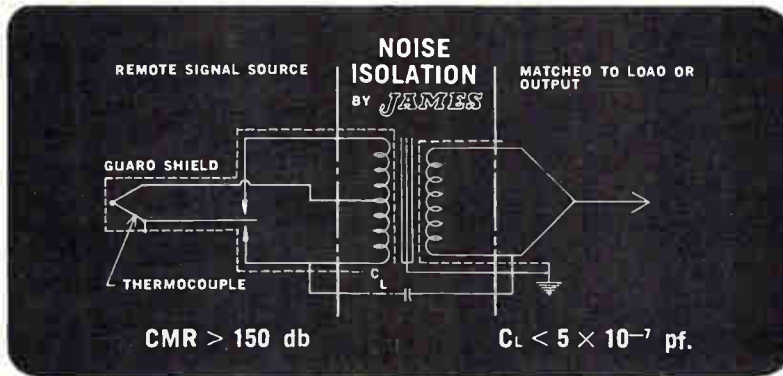

150 db COMMON MODE REJECTION

SIGNAL-GUARD TRANSFORMERS

Low and Medium Frequency (DC to 100KHz) response

Designed for use in analog acquisition and computation equipment. James Signal-Guard provides isolation, voltage comparison, impedance matching, and common mode rejection.

DATA-GUARD TRANSFORMERS

High Frequency Signal (1KHz — 40MHz)

Designed and shielded to isolate and terminate high frequency signal data in the form of pulses. AM and FM modulated carriers, multiplexed signals, and other low to high frequency data.

ELECTRO-GUARD TRANSFORMERS

Power (1 watt to 100VA)

Electrostatically shielded for use in signal conditioners, bridge supplies, and Zener reference supplies to isolate circuits from noise transients and undesirable common mode voltage commonly carried on power lines.

WRITE FOR FULL TECHNICAL DETAILS

JAMES[®] ELECTRONICS INC.

4044 North Rockwell
Phone 312-463-6500

• Chicago, Illinois 60618
• FAX — JML

New components

Walls of bulb are color-full

Pilot lights can be used to color-code information on electronic equipment

Electronic equipment may soon blossom out with tiny fluorescent pilot bulbs in different shades of the rainbow. Manufacture of the cold-cathode gas-filled bulbs has been started by Toyo Musen Co.

Conventional neons work on the principle of an electric potential exciting gas molecules. When the molecules are excited, electrons jump from one energy level to another. This change in state of internal electrons causes energy to be released in the form of light. The colored bulbs operate on a completely different principle, similar to a cathode ray tube. The potential across the electrodes causes the gas in the envelope to emit electrons, not photons. These electrons strike the fluorescent coating on the inner wall of the bulb, causing the coating to emit photons. Changing the color of the bulbs necessitates changing only the fluorescent material, not the gas.

The bulbs are similar in electrical

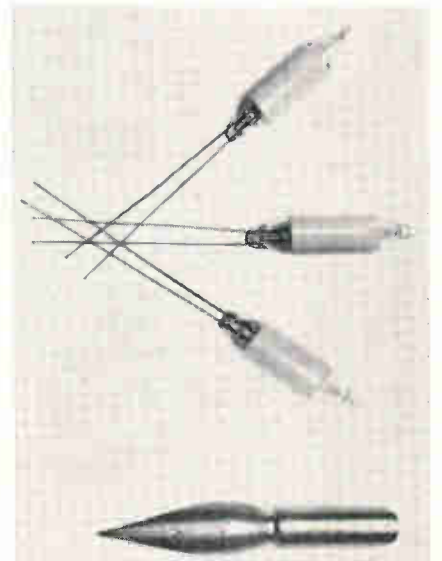

Lighting the way. Colored fluorescent bulbs make for easier reading on instrument panels.

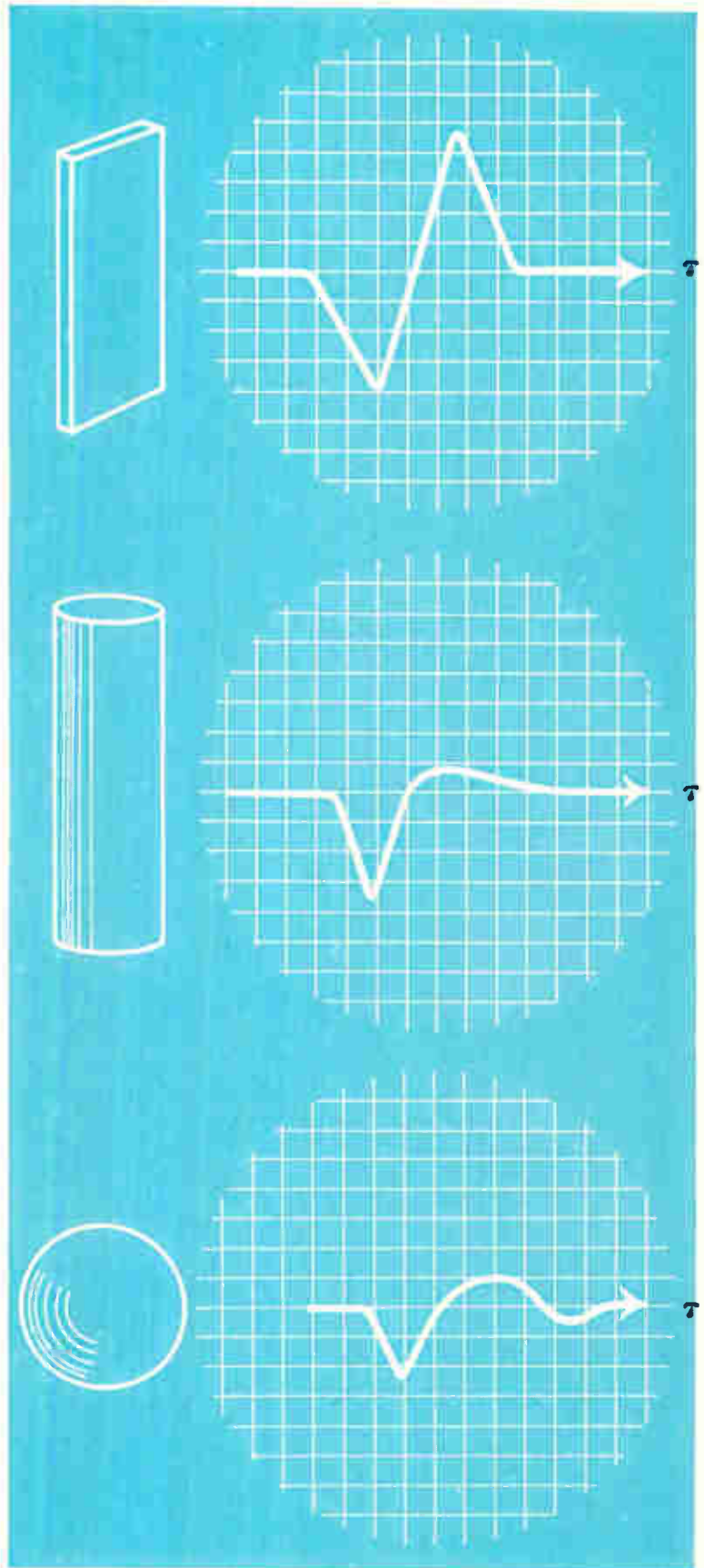

A new technology developed by Sperry scientists is making significant improvement in the identification of radar targets.

Its name? Picosecond technology, the generation and analysis of impulse-like illuminations. The backscatter signatures for these illuminations are more easily analyzed and permit the identification of target shapes, such as flat plates, cylinders, spheres, etc.

Some typical target scattering data are shown in the accompanying traces at a time scale of 100 picoseconds per division.

In addition, Sperry's work in picosecond technology is providing the basis for improved wide-band microwave components.

This is just one of the many scientific achievements of Sperry Rand Research Center. Sperry can help you meet technological objectives through research in materials, components and systems.

SPEERY RAND
RESEARCH CENTER
SUDBURY, MASSACHUSETTS 01776

**Sperry research is breaking the time barrier
...to make radar target identification easier**

AC Regulation:

**LINE
LOAD
FREQUENCY**

0.1%



THE NEW
G/M

Magnetic AC Line Regulator

Especially Suited to Flight Instrument and
Analog/Digital Computer Applications

Eliminates the need for:

Tuned Resonant Circuits, Bulky Inductors and
Capacitors, Ferro Resonant Techniques, Saturable
Reactor Circuits, Buck-boost Transformers, etc.

G/M Solid State Magnetic AC Line Regulators are particularly applicable where an accurate and stable AC reference source is required. Output is a clean sinusoidal wave form containing low harmonic distortion.



There is No Substitute
for Reliability

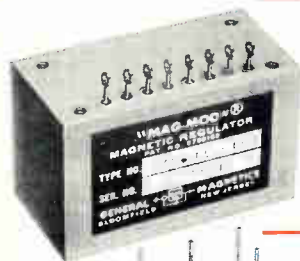

Specifications—Type MLR 1091-3

LINE VOLTAGE:	103-126V AC 400Hz $\pm 20\%$
OUTPUT:	15V AC $\pm 1\%$ 400 Hz (includes initial setting accuracy)
LOAD:	(800 Ω —1 meg Ω)
DISTORTION:	Less than 2%
REGULATION:	$\pm 0.1\%$
DC POWER:	$\pm 12V \pm 5\%$



Specifications—Type MLR 1106-1

LINE VOLTAGE:	15V AC $\pm 20\%$; 3860Hz $\pm 20\%$
OUTPUT:	10V AC $\pm 1\%$ 400Hz (includes initial setting accuracy)
LOAD:	20K
DISTORTION:	5%
REGULATION:	$\pm 0.1\%$
DC POWER:	$\pm 12V \pm 5\%$

Request Illustrated Bulletin MM 111

General Magnetics • Inc
135 Bloomfield Ave., Bloomfield, N.J. 07003

... color bulbs help
computer debugging ...

and mechanical specifications to high-brightness NE-2 neon bulbs. The big difference is that the Japanese units have fluorescent material on the side walls of the bulb, and use an unidentified gas that is not neon. Colored light is emitted from the entire wall surface, not just from a small region around the electrodes. The brightness of the new bulbs is of the same magnitude as high-brightness neon units.

In computers, where neon bulbs are used on front panels to indicate the logic state of different sections of the memory, the colored units will make debugging an easier chore. Neons are now used because there is no filament to burn out, they require very little current, and there is no initial current surge that could damage the logic circuitry that drives them.

If a program doesn't work, or if the computer stops at some point, the only clue to the trouble comes from the neons, telling the operator about each section of the memory. To look at a maze of orange lamps is almost as confusing as looking at the memory cores themselves. Using the three colors for different sections simplifies the process of finding out what went wrong.

The first bulbs being produced are red, yellow, or green. Other colors have been manufactured experimentally. The units (in Japan) are priced at about 15 cents each in small quantities. This compares with about 10 cents for high-brightness NE-2's and 6 cents for standard NE-2's.

A major American manufacturer of indicator lamps says that it could have built colored neon bulbs years ago, but the demand for such devices is not as great as the demand for multicolored alphanumeric readouts. The color approach to alphanumeric readouts is not going the gas tube route, but rather to solid state electroluminescent panels, according to the U.S. company. The ideal result of the electroluminescent panel research would be an alphanumeric readout that can change its color by changing the frequency of the applied voltage.

Toyo Musen Co., Tokyo [358]

Quiet pleases.



Muzzle
RF noise.
Crimp a
COAXICON★
Connector
on your
stripped cable
in 15 seconds.
One stroke.
One tool.
Match the
impedance
of the cable.
Only three parts.
No Heat. No Solder.
Uniformity, inspectability,
reliability.
All at lowest cost.

★Trademark of AMP Incorporated

AMP

Circle 211 on reader service card

PUT YOUR IDEAS INTO ACTION WITH THE HELP OF AMP ENGINEERING... WORLDWIDE.

AMP INCORPORATED
Harrisburg, Pa. 17105

Please send me more information on COAXICON Connectors.

NAME _____

COMPANY _____

ADDRESS _____

CITY _____

STATE _____

ZIP _____



Actual Size

MODEL RF20
contactless resonant
reed encoder/decoder
.395 x .620 x 1.100

REMOTE CONTROL SWITCHING WITH AUDIO SIGNALS

An audio tone can be generated by an electronic oscillator or resonant reed encoder circuit, then transmitted by wire or radio. The tone activates a resonant reed relay to perform a control function.

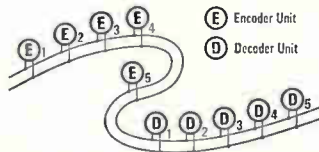

A single pair of wires, or a leased telephone line, can carry the audio signals for a complete control system.



For inaccessible areas or mobile installations, a radio transmitter and receiver system can carry the signals.

Bramco reeds permit over 50 selective control frequencies within the 67 to 1600 cps spectrum. This is assured by: (1) the narrow response bandwidth of about 1% for decoders and (2) the high accuracy of Bramco reed encoders (1/10 of 1% of design frequency).

A big advantage of reeds in control switching is that they are ideally suited for simultaneous and sequential coded tone systems. The actual number of control functions possible in such a system is virtually unlimited. For example, over 3300 individual control functions are possible with only 16 frequencies coded sequentially in groups of three.

Compared to other types of tone filters, resonant reeds are small and inexpensive. They give more control functions per spectrum, per size, per dollar.

If you work with controls that select, command, regulate, or indicate, you should know about how it can be done with audio signals. We custom design and stock a broad line of encoder/decoder components and modules.

For literature write Bramco Controls Division, Ledex Inc., College and South Streets, Piqua, Ohio, or call 513-773-8271.



BRAMCO CONTROLS DIVISION, LEDEX INC.
College and South Streets, Piqua, Ohio 45356

New components

Double feature pickup tube

Can view laser patterns;
short decay time permits
detection of motion

A pickup tube that operates like a vidicon but has an unusual double feature has been developed by Tokyo Shibaura Electric Co. It is highly sensitive to long infrared wavelengths yet has a short decay time. Other infrared detectors offer one feature or the other but seldom both. The range of sensitivity widens the applications of the tube. The short decay time makes it useful for viewing moving objects.

Toshiba's tube has a lead oxide target similar to those in its Sensicon tube and in the Plumbicon developed by Holland's NV Philips Gloeilampenfabrieken. The addition of antimony sulphide to the lead oxide provides the sensitivity to infrared. Toshiba hints that it mixes the two while the lead oxide material is being evaporated.

Plumbicon, like vidicon, is based on the principle of photoconduction. However, Philips engineers claim that performance of the Plumbicon is better because it uses a large-area p-i-n photodiode as the light-sensing target mechanism. This, they say, gives it the advantages of an extended linear transfer characteristic, no discernible dark current, and a very small photoconductive lag.

The sensitivity range runs from visible light to wavelengths up to two microns. The tube can detect objects heated at 200°C or more.

Toshiba expects the tube to be used to view infrared laser mode patterns and to observe dislocations in germanium and silicon crystals; also for supervision of dark rooms in photographic film plants, and for remote measurement of temperature distributions in hot objects. The tube also has security and military applications.

Tokyo Shibaura Electric Co., Tokyo
[359]

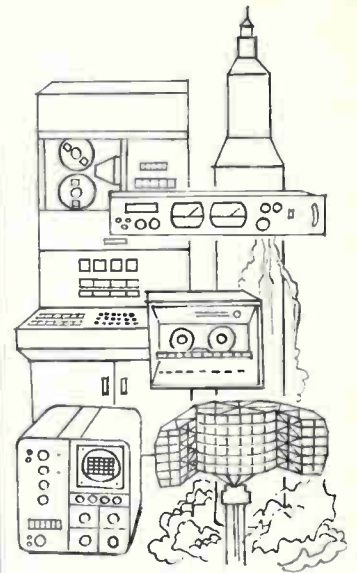
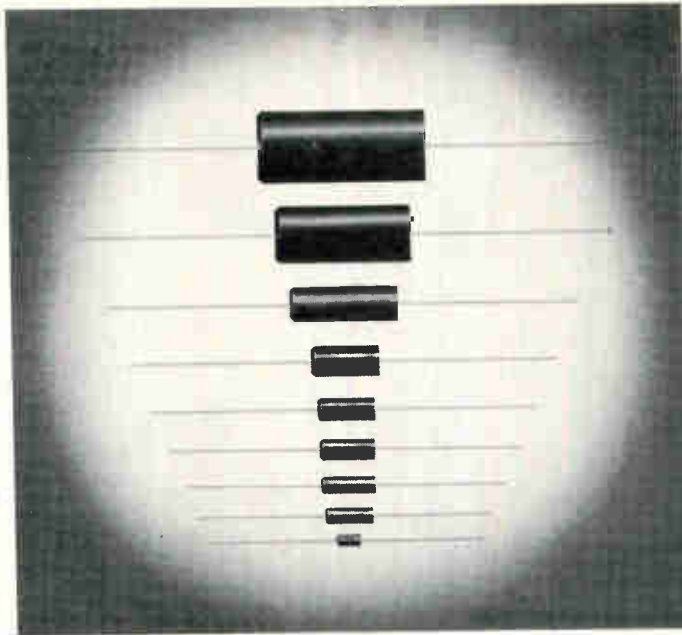
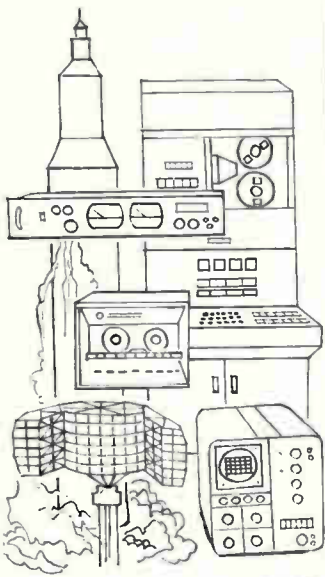

Now NCI "T"-SERIES offers a COMPLETE Line of RELIABLE, Low-Cost, Molded Solid Tantalum Capacitors for Computer, Military and Industrial Applications!

9 case sizes! Lower costs! . . . Now you can design or specify NCI trustworthy tantalums into circuits where in the past it was not economically possible. These "T" Series Tantalum Caps remain extremely stable over a wide temperature range, and meet all industry test standards for shock, vibration and moisture resistance . . . also Military Spec. MIL-C-26655B. Our "T" Series Bulletin has complete facts.

NCI "T"-SERIES FEATURES

- -55°C to $+85^{\circ}\text{C}$; and up to 125°C with $\frac{2}{3}$ derating
- 6 to 50 VDC
- .0047 – 330 microfarads
- Low leakage current
- Low dissipation factor
- Minimal capacitance change at temperature extremes



Our new 36,000 sq. ft. plant was specifically designed for volume production of high-reliability tantalum capacitors. The very latest equipment in a controlled temperature and humidity environment, and highly skilled personnel, assure service and dependability to the industry. Also, an elaborate testing laboratory certifies each product lot for quality and reliability prior to shipment. Call us collect at 305/842-3201 and let's discuss your particular needs. Our recommendations usually will save you money and can broaden your circuit applications.

Keep your eye on



Manufacturer of Wet, Solid & Molded Tantalum Capacitors

NATIONAL CAPACITORS, INC.

5900 Voss Road, West Palm Beach, Florida 33407

If you buy HP counters, we have news for you.

Systron-Donner makes advanced counter instrumentation that has no equivalent in the HP catalog. That's why it pays to check with Systron-Donner before you buy. You'll find equipment with unique capability like:

1. A plug-in that will extend your counter's frequency range to 15 GHz – measuring FM and pulsed RF as well as CW and AM. The only way to get the full dc to 15 GHz range in one cabinet. No calculations. Displays final answer.



1.

2.

2. Plug-ins that produce automatic readings of microwave frequencies. By far the most compact and economical equipment for producing automatic readings in the 0.3 to 3 GHz band or the 3 to 12.4 GHz band.

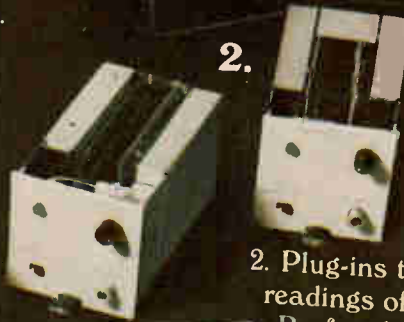

3.

3. "Thin Line" counters that take only 1 1/4" of rack space. Built with ultra-reliable integrated circuits to give you automatic frequency measurements – dc to 100 MHz or 0.3 to 12.4 GHz.

These are the highlights of expandable systems that will make just about any measurement possible with counters.

The accuracy of our basic 50 MHz and 100 MHz counters is unsurpassed. (Time base aging rate is only 5 parts in 10¹⁰ per 24 hrs.) All devices to extend the range or add functions are convenient plug-ins – not rack mounts. The newest are a prescaler to extend counter range to 350 MHz and a heterodyne converter to measure noisy signals in the 0.2 to 3 GHz range.

Are you surprised that Systron-Donner is a step ahead of HP in counter technology? How else could we stay in business?

Systron-Donner Corporation, 888 Galindo Street, Concord, California 94520

Send for catalog.



SYSTRON  DONNER

Circle 131 on reader service card

New Semiconductor Review



Germanium power transistor series SDT2700 is a 15-amp device in a TO-36 case. Collector-to-base voltage is 40 to 60 v; collector-to-emitter voltage, 25 to 50 v. The general purpose unit is for use in industrial and commercial power amplifier and switching applications. The series is available from stock. Solitron Devices Inc., 1177 Blue Heron Blvd., Riviera Beach, Fla. 33404. [436]



Molded block silicon rectifiers in the RHP series offer a forward current of 2.25 to 2.5 amps at 50°C ambient and a piv rating of 3,000 to 50,000 v with a recovery time of 300 nsec when measured from 1 amp forward current to 30 v blocking. Surge rating is 150 amps. Price is \$82.75 each in 100 lots. Electronic Devices Inc., 21 Gray Oaks Ave., Yonkers, N.Y. 10710. [437]

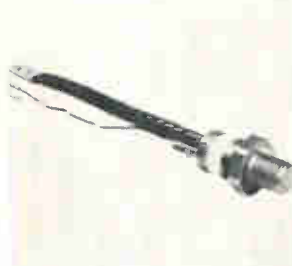

High power SCR's, with voltage ratings to 1,200 piv, come in two styles. Both feature high surge current capability for optimum coordination of load characteristics with fuse or other protection systems. One series, rated 275 amps rms, conforms to Jedec outline TO-93; the other, rated 110 amps rms, Jedec TO-94. IRC Inc., 401 N. Broad St., Philadelphia, Pa. 19108. [438]



Monolithic dual TTL, JK master-slave flip-flop DM7501 is for high-speed control and counting uses where multiple data inputs are not required. The unit has a toggle rate of 25 Mhz, 1-v noise immunity, a guaranteed clock skew of 15 nsec; and meets all requirements of the SN5473 dual flip-flop. National Semiconductor Corp., 2950 San Ysidro Way, Santa Clara, Calif. 95051. [439]

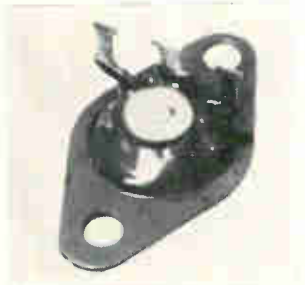

Safe operating area specified, plastic power transistor B-5001 provides TO-66 mounting compatibility and isolated collector without using extra hardware or washers. Maximum ratings: collector-to-emitter breakdown voltage, 35 v; collector current, 3 amps; junction temperature, -65° to +150°C. It features betas from 20 to 250. Semiconductor Div., Bendix Corp., Holmdel, N.J. 07733. [440]

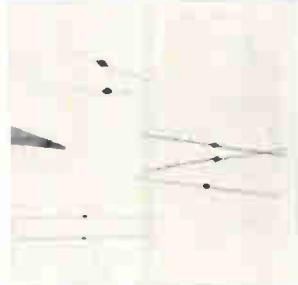

Microminiature zener diodes in the MLV line are electrically interchangeable with Jedec types 1N-437A-1N4372A and 1N746-1N-757. They are available for regulation at voltages as low as 0.3 v. Units come in a package 0.100 x 0.060 in. They have power dissipation ratings of 750 or 250 mw depending on the leads. Computer Diode Corp., Pollitt Dr. South, Fair Lawn, N.J. 07410. [441]

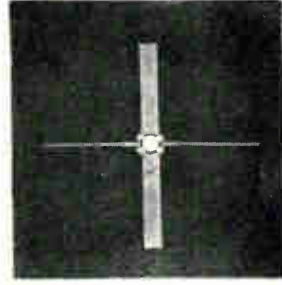

Transistors in the K disk package are for amplifier and oscillator circuits operating above 1 Ghz. For amplifier circuits, the K disk, made from beryllium oxide, provides increased power gain and lower system noise figure. Oscillator circuits get greater power output at higher frequencies and temperatures. KMC Semiconductor Corp., Parker Rd., Long Valley, N.J. 07853. [442]



Silicon rectifier stacks come in 3 families: OSB-, OSM- and OSS-9210. OSB can be used in 1-phase full circuits or 2-phase half-wave circuits; OSM, in 1- or 3-phase bridges or in voltage doublers. Both have prv's from 2 to 15 kv in 1 kv steps. OSS can be used in 1-phase half-way circuits and has prv's from 3 to 30 kv. Ampere Electronic Corp., Slatersville, R.I. 02876. [443]

New semiconductors

Linear IC's take baby step toward LSI

Monolithic circuits range from amplifiers to complete f-m front ends with a minimum of external connections

Borrowing a technique used in LSI interconnection, Amelco Semiconductor has developed a linear integrated circuit that, depending on how many are used, can operate as either a simple amplifier or a multifunction radio-frequency receiver.

The monolithic circuit, designated the 911, is made up of three diodes, three transistors, and two resistors. Other IC's in the series are merely two or more 911's interconnected on the wafer.

Instead of using a universal chip having 35 or more elements,

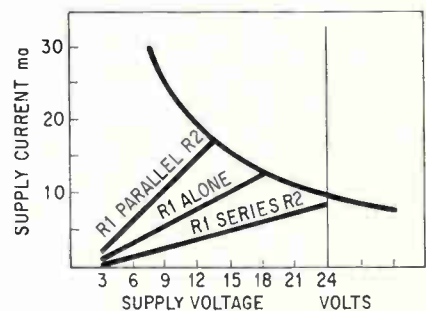

Bias. Arrangement of resistors allows proper selection of bias voltage.

Amelco, a division of Teledyne Inc., follows the same course taken for digital circuits in large-scale integration: different master inter-

1
PUNCH

20
HOLES

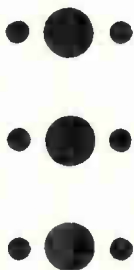

Or 37 holes! Or 2 — or 86! With press brake or punch press, Di-Acro Adjustable Punches and Dies are quickly arranged to fit your layout exactly. Easy to repeat a setup. Use over and over. Ask for 12-page folder . . . Tells about starter-set too. See your distributor or write us.

20
HOLES

COUNT
'EM

di-acro **DI-ACRO**
division of **HOUDAILLE INDUSTRIES INC.**
4311 EIGHTH AVENUE
LAKE CITY, MINNESOTA 55041

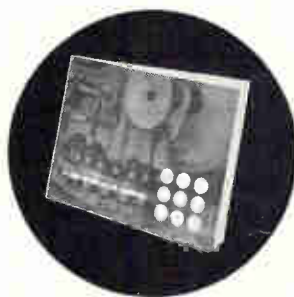
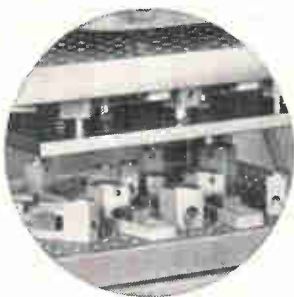

NOTCHES
COUNT.
TOO

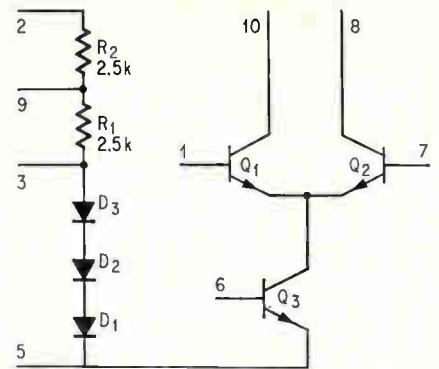

Access. Component placement enables simple external connection.

connection patterns are used on the wafers containing the basic structures.

Versatility. Aimed at the consumer entertainment equipment market, the 911 was designed to be versatile yet sell for \$2.55. It is an npn differential amplifier with an npn current source. D-c biasing is achieved by a self-contained bias chain that is made up of the resistors R_1 and R_2 , and diodes D_1 , D_2 , and D_3 . To establish a desired operating current, R_1 , or a combination of R_1 and R_2 , forces a current from the positive supply, through the diodes, to ground. Because the diode characteristics are known, the current causes a predictable voltage drop across each diode. When the voltage is applied to the base-emitter junction of a transistor, and if the transistor is matched to the characteristics of the diode, a current will flow in the transistor's emitter equal to the current forced in the diode. This matching is accomplished because D_1 is actually a transistor, identical to Q_3 in geometry, with its collector-base junction shorted.

Circuit designers accustomed to choosing r-f transistors for high-frequency applications, and audio transistors for d-c and low-frequency applications, will find that there is no difference between the two types in the monolithic construction of the 911. For example, collector-emitter breakdown voltages better than 30 volts, typical d-c current gain of 100 at 1 milliamp, and current gain-bandwidth products from 500 to 800 megahertz are common to monolithic ic's.

Combinations. Four interconnected combinations of the 911

Large helpings? *precisely!*



Smaller and smaller and smaller parts... tighter and tighter tolerances... in larger and larger quantities... this is the story of microceramics. Regular production includes substrates so tiny that a teaspoon holds more than 8,000 parts! Coors offers a complete facility for creating small, consistent, ceramic substrates - in several Coors Alumina and Beryllia ceramics, metallized or unmetallized. To assure economy, "as-fired" parts are produced in quantity, to extremely close tolerances (as shown at right). Let Coors provide the special help you need. Write for Data Sheet No. 7002. Get on-the-spot answers. Dial Coors-303/279-6565, Ext. 361. For complete design criteria, write for Coors Alumina and Beryllia Properties Handbook No. 952.

Coors

CERAMICS

ALUMINAS • BERYLLIAS • MAGNESIAS • SPECIAL OXIDES
Coors Porcelain Co., Golden, Colo.

Circle 217 on reader service card

EXAMPLES OF AS-FIRED TOLERANCES HELD BY COORS IN REGULAR PRODUCTION

HOLE PATTERN DIA. .200 ± .0005		.205 x .257 x .030' LOCATION OF .016 DIA. HOLES HELD WITHIN .001
.060 DIA. .030 I.D. .001 CON- CENTRICITY		.097 x .222 .007 THICK- NESS ± .0005 .001 CAMBER
.143 DIA. .013 THICK- NESS ± .0005 .001 CAMBER		.186 DIA. .013 THICK- NESS ± .0005 .001 CAMBER
.268 DIA. .002 FLAT- NESS		.008 SLOT WIDTH
.010 THICK- NESS ± .001 .001 MAX. CAMBER		.015 THICK- NESS ± .001 .001 MAX. CAMBER .230 I.D.

Something new under the sun
The Bissett-Berman E-CELL

Time integrator
consumes μ watts;
fires 100-w load

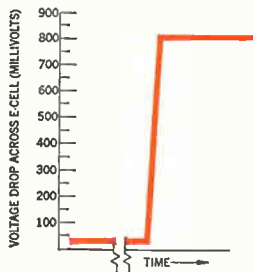
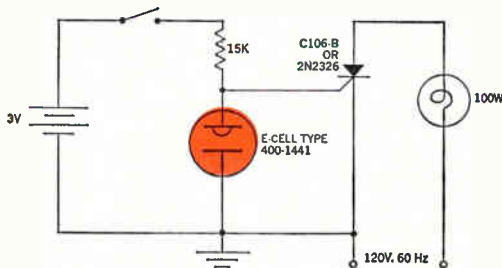

* The Bissett-Berman E-CELL[®] is a unique "liquid state" electrochemical timing and integrating component now being manufactured in high volume on fully automatic production lines. E-CELLs are designed for single use or re-cycling, can be set or re-set in the field, and are furnished in wire-lead or plug-in versions. A multiple-electrode E-CELL enables complex functions such as two-phase timing — or subtotaling and totaling — with



Actual size

signal outputs at each step. E-CELLs can generate accurate time delays ranging from a fraction of one second to months; can integrate events from one to infinity; and can operate in the **nanowatt** range. Operating/storage temperature is -55°C to 75°C . E-CELLs have been tested and approved by users for severe shock and vibration tolerance in accordance with military specifications. Patents applied for.

For technical information and application notes, contact: Components Division, The Bissett-Berman Corporation, 3860 Centinela Avenue, Los Angeles, California 90066; Telephone: Area Code 213, 394-3270.

**BISSETT
BERMAN**

... complete r-f sections
on one monolithic chip ...

and the 911 itself are being offered initially. These range from the 912, a dual emitter-coupled amplifier, to the 915, a complete amplitude-modulation intermediate-frequency strip, with built-in automatic gain control (agc).

In designing the 912 as a single-function device, the packaging cost is minimized by requiring only eight pins for the two independent stages. Since each stage has its own bias chain, the need for external biasing components is reduced. When two 912's are connected, for example, in a 10.7-Mhz frequency-modulated i-f strip with conventional transformers, there is an over-all gain of about 100 decibels. This combination, offered as the 914, is a complete f-m i-f strip, with only external transformers and bypass capacitors required.

While the 912 trades flexibility for package pin reduction, the 913 —two connected 911's—requires a 16-pin package, but performs a variety of functions. Each half of a 913 can be used independently as a cascode, emitter-coupled, or self-contained d-c amplifier.

The most complex configuration is the 915, a 16-pin package that is made up of four basic modules. Three cascode amplifiers, capable of 30 to 40 db power gain per stage, and a self-contained agc loop are connected. Components from the fourth module form a diode detector, an emitter-follower agc buffer, and an emitter-follower output buffer. The accessibility of various internal points, in the 16-pin package, allows external control of the agc threshold, determination by external capacitor values of detector response, agc time constants (fast attack, slow decay characteristics are possible), and shaping of the i-f bandpass characteristics.

According to a company spokesman, no insurmountable system problems have been encountered with the four-module chips, indicating that further increases in complexity to six or eight modules per chip are currently possible in r-f systems.

Amelco Semiconductor Inc., Box 1030, Mountain View, Calif. 94042 [444]

1.34 × 10⁵ COMBINATIONS

(ONE OF THEM HAS GOT TO WORK FOR YOU.)

When we say our Trim Trio has enormous application potential, we're not kidding. The combination of numbers surprised us too. For any of our three types of contacts—sub-min coax, machined or continuous formed strip—will work in any of nine connector blocks (14 to 152 positions). In any combination.

And if you wanted to count wire sizes, or figure the twisted pairs our sub-min coax can

accommodate, or leave some contact holes open, the possibilities would truly be endless. Probably most of them haven't been used yet. Surely some of them will

solve your problems.

And Burndy can make your installation problems easier, too. Whether you crimp one at a time on a hand tool or 3,000 per hour with a Hyfematic™ you can count on built-in quality control, save time and money. For the full story and details on the combination that will work for you—from breadboard to production—write for our Bulletin MS67.

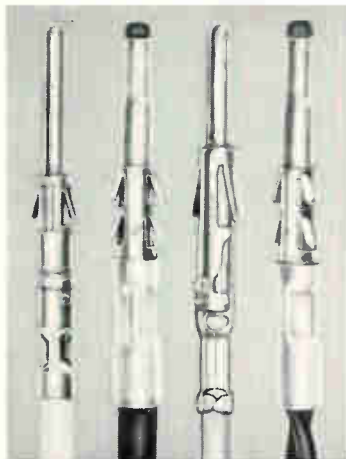

Machined Sub-min Coax Strip Hylen Twisted Pair

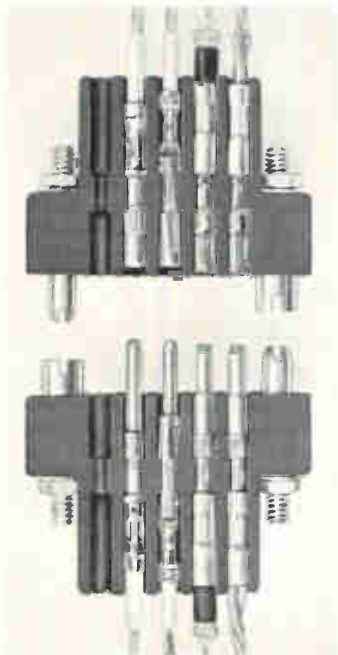

 **BURNDY**
NORWALK, CONNECTICUT

INTERNATIONAL SALES HEADQUARTERS AND MANUFACTURING FACILITIES:

CANADA: Scarboro, Ontario / ENGLAND: St. Helens, Lancs. / BELGIUM: Mechelen / MEXICO: Naucalpan de Juarez
BRAZIL: Sao Paulo / JAPAN: Tokyo / Sales Offices in Other Major Cities

Circle 219 on reader service card

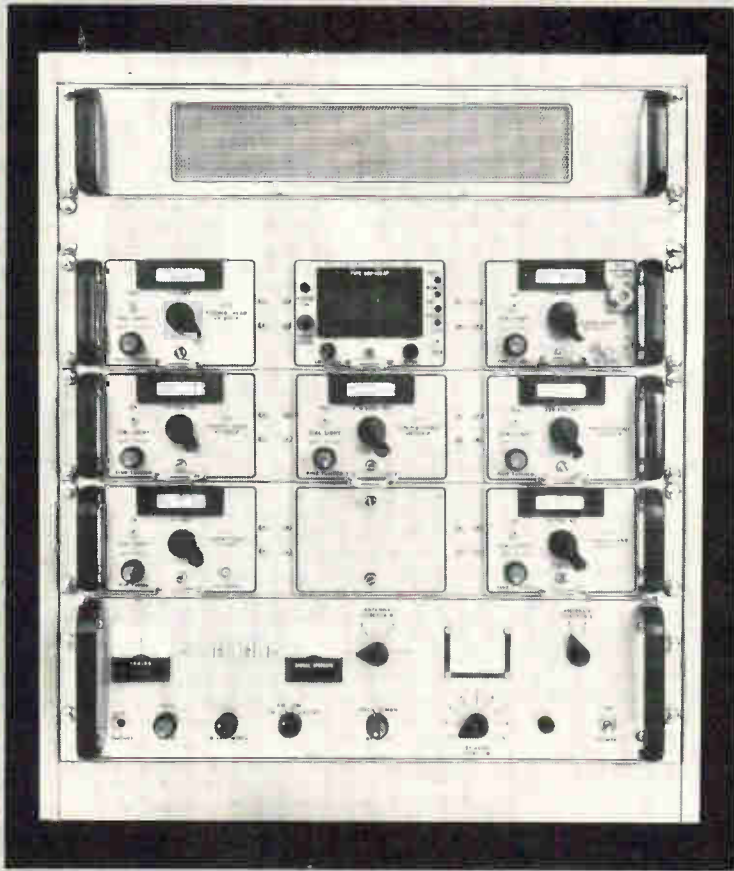

ACL

SR 209-4 RECEIVING SYSTEM

Plug-in RF Tuners

Frequency Range 2 MHz to 4 GHz

IF Bandwidths 1 KHz to 8 MHz

Signal Display Units

AM - FM - CW - PULSE

Write or phone for detailed specifications



ASTRO COMMUNICATION LABORATORY, INC.
9125 GAITHER ROAD, GAITHERSBURG, MD. 20760
TELEPHONE (301) 948-5210 TWX 710-828-9706

New semiconductors

Still another IC for television

Single-coil winding
minimizes tuning
of detector-limiter

Trying to get integrated circuits designed into television sets is a kind of mating game.

The IC maker will tailor the characteristics of his device to make it highly compatible with existing circuitry—to minimize redesign problems for the set manufacturer; and he will pack as much function into the chip as economics will permit—to lessen the number of external interfacing components and the number of adjustments.

Above all this, however, the paramount consideration is cost. If the IC price is not right, the mating game is off. So the IC maker will usually hedge his product investment by including features attractive to the easier-to-sell industrial and military market. Such seems to be the approach followed by Sprague Electric Co., latest member of the IC club to enter the lucrative consumer market [Electronics, Aug. 7, p. 88].

Sprague has developed a linear IC frequency-modulation detector and limiter, aimed at TV channels and FM receivers. The device is also suited for automatic-frequency-control system telemetry and for

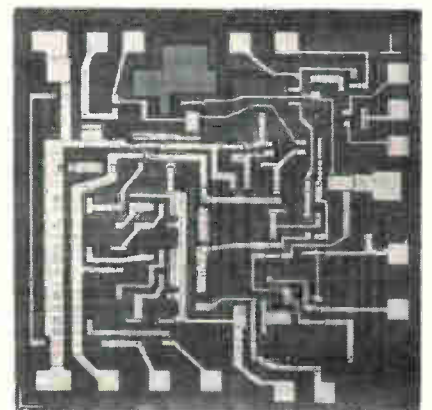

Chipfull. Circuit includes 25 active elements and 18 diffused resistors.

Whatever
the
switching
assignment...



HATHAWAY
FORM "C"
MINIATURE
DRIREED RELAYS
can do it!



Problems with your small form C reed relays?

Hathaway's true form C Drireed relay is your answer!

- High reliability
- Consistent contact resistance
- Operating speeds up to 500 Hz.
- True break before make
- Short bounce characteristics on normally closed contact
- Uniform long life



SPDT GENERAL PURPOSE RELAY



DPDT MILITARY TYPE RELAY



SPDT LOW SILHOUETTE RELAY

HATHAWAY INSTRUMENTS, INC.
5250 E. EVANS AVE. • DENVER, COLORADO 80222
(303) 756-8301 • TWX 292-2935

Buy RELIABILITY! Buy HATHAWAY!

RUSH

HATHAWAY INSTRUMENTS, INC.
5250 E. EVANS AVE. • DENVER, COLORADO 80222

Please send me Hathaway's

NEW DRIREED SWITCHES and RELAYS Condensed Catalog

Name _____

Title _____

Company _____

Address _____

City _____ State _____ Zip Code _____



**who produces foil
that cuts
magnetic core
production time
by more than 93%?**

By changing production from a mechanical process to frets (frame style laminations) photoetched from Hamilton precision-rolled moly permalloy, stainless steel and beryllium copper, a manufacturer of magnetic head cores cut production time from five days using 12 operators to two days using two operators.

This strip and foil furnished by Hamilton Precision Metals is precision rolled to give it the excellent surface and ultraclose tolerances required for photoetching. Hamilton's unique capability produces foil as thin as 70 millionths and precision strip up to 0.100" thick with tolerances as fine as $\pm 5\%$ or better.

Hamilton Precision Metals is your prime source for ultra-precision-rolled metals in mass production quantities. 7 proprietary metals, 12 pure metals and 112 commercial alloys are available from Precision Metals. Write today for new 48-page data book.

HAMILTON PRECISION METALS

division of Hamilton Watch Company, Lancaster, Pa. 17604

**... balance network
lowers distortion ...**

radar applications.

Designated the ULX-2111A, the complex chip contains 19 transistor elements, 6 diodes, and 18 resistors. It requires only one single-winding coil for tuning, so a screwdriver is all that is needed to tune the detector. Most counterparts in discrete semiconductor networks and in IC's require complex phase-shift networks.

Some competing devices also offer simplified tuning, but they do not provide the limiting action associated with the balanced phase detector.

On the Sprague chip is a three-stage amplifier, a limiter, and a balanced detector, all of which work in tandem to provide linear gating. Filtering out of unwanted signals is high—the a-m rejection of signals riding on the f-m carrier is 45 decibels. The circuit's capture ratio is 1.4 db, and its distortion products are 1.5% maximum.

The IC's bandwidth extends from 5 kilohertz to 50 Mhz. Its output is sufficient to drive either vacuum tube or transistor power amplifiers in tv sets directly. An output-connection option is provided, so the IC may be used as a 60-db broadband amplifier. In nearly all applications for the device, only a 12-volt power supply is required.

Sprague says the price of the device cannot be determined until the process is moved from its research laboratory to production facilities in Worcester, Mass. The unit is the first of a series of consumer-oriented IC's to be introduced on a one-a-month basis during 1968.

During the past six months, at least six major competitors have been introducing IC's aimed at the same tv and f-m receiver sockets [Electronics, June 12, p. 38; June 26, p. 163].

Specifications (tv application)

f_o	4.5 Mhz
Deviation	± 25 khz
V_c	+12 v
P_{dis}	200 mw
V_{out}	0.60 V rms
Limiting threshold	400 μ v rms
A-m suppression	46 db
Distortion, maximum	1.5%

Sprague Electric Co., North Adams, Mass. [445]

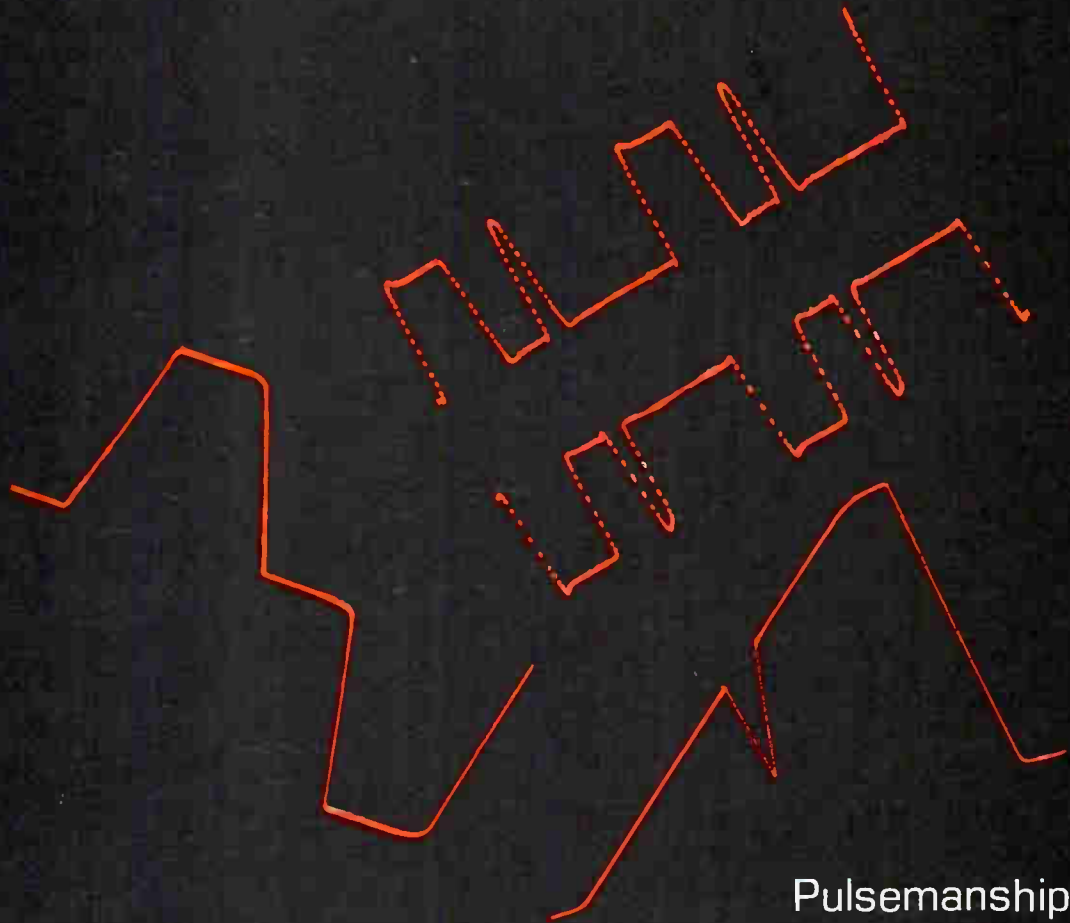

Pulsemanship

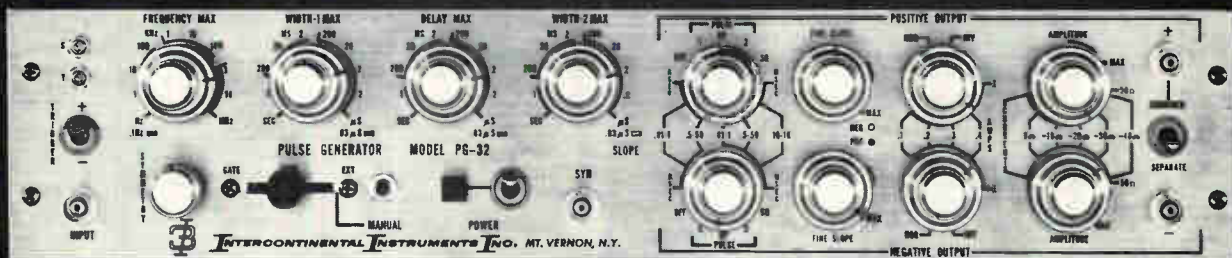

The name of the game is versatility. Formal designation Model PG-32 — probably the most versatile pulse generator ever designed. A single PG-32 can do just about everything two conventional pulsers can do and do it better, much more economically, reliably and simply.

The PG-32 is really two independent pulse generators in a single package, operating at the same repetition rate. Two channels, not just two BNC's. From either channel one can get single or double pulses, positive and negative, the complement of either, all at rep rates from 0.1 Hz to 20 MHz (double pulse) in 8 ranges plus vernier.

Current pulses, ± 25 mA to 400 mA, or voltage pulses, ± 20 mV to ± 20 V, or square waves. A 3V sync.

Please note: you can control independently for each channel, rise and fall time (10 ns to 1 sec), width (independently for each pulse — 30 ns to 1 sec) and delay (50 ns to 1 sec), all over the widest dynamic ranges available. The two outputs are simultaneous and can be used separately or in combination: the combined mode makes possible DC-offsets or bipolar pulses of up to 10V. All of this comes in a 3½" high solid-state package.

With the output parameter control provided, the PG-32 is capable of pro-

ducing a variety of waveforms otherwise requiring a plethora of pulse and waveform generators. *Does this tell your capital budget anything?*

We'd like to tell you more: about frequency, width, delay, stability, distortion, source impedance, gating and triggering, etc., etc.; but it can't all be done here. So . . . Invite us to your next pulsemanship match. We'll bring one of our Grand Masters, the PG-32.

Intercontinental Instruments, Inc., an Affiliate of CHRONETICS, 500 Nuber Avenue, Mt. Vernon, New York (914) 699-4400. Europe: 39 Rue Rothschild, Geneva, Switzerland (022) 31 81 80.

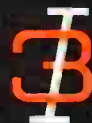

PRODUCT OF
CHRONETICS

New Instruments Review

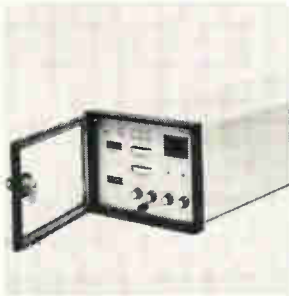

Two-component blender model 99C is available in 2 configurations: to ratio one flow to the other or to ratio one flow to the total flow. It will accept high-frequency turbine meter inputs or low-frequency meter inputs. Equipped with memory capability, the 99C produces a 10-15 ma signal to control the ratioed flow. Foxboro Co., Mechanic St., Foxboro, Mass. 02035. [361]

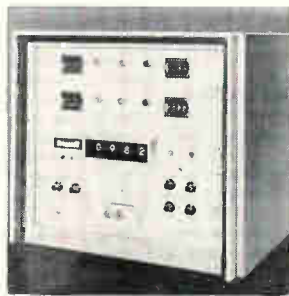

Capacitance test system 1201-DS-2 sorts or grades up to 1,200 components per hour into several categories (5%, 10%, 20% or 4 to 8 pf, 8 to 11 pf, etc.) with 0.1% absolute accuracy. Components are inserted into a guarded test fixture or test jig, with capacitance indicated on a 4-digit readout. Micro Instruments Co., 12901 Crenshaw Blvd., Hawthorne, Calif. 90250. [362]

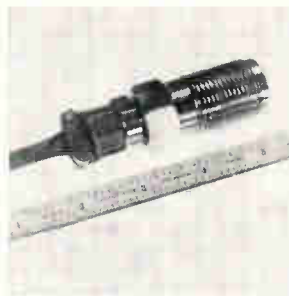

High-pressure transducer model GT-24 is designed for dynamic measurements. Pressure range is 0-20,000 through 0-100,000 psig; sensitivity, 3.0 mv/v minimum; natural frequency, 50 khz; non-linearity, $\pm 0.5\%$ full scale max; repeatability, 0.1% full scale max.; operating temperature, cryogenic to 300°F. General Transducer Co., Corvin Dr., Santa Clara, Calif. 95051. [363]



F-m communications monitor CE-3 makes off-the-air measurements of base stations up to 50 miles away. It offers a choice of 3 r-f preselector plug-ins—20-80, 120-180, and 450-512 Mhz—or a broadband r-f mixer plug-in for close-in monitoring and in-shop measurements. The instrument weighs 38 lbs. Cushman Electronics Inc., 166 San Lazaro Ave., Sunnyvale, Calif. 94086. [364]

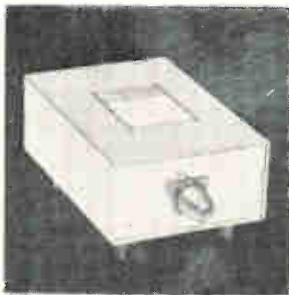

Pressure-to-frequency transducer PF-1001 is for missile, spacecraft, aircraft, and industrial f-m telemetering. Pressure ranges are from 0 to 200 psig up to 0 to 5,000 psig. Any center frequency from 400 hz to 12 khz with a deviation of $\pm 7.5\%$ is available. IRIG channels from 1 to 12 can be specified. Solid State Electronics Corp., 15321 Rayen St., Sepulveda, Calif. 91343. [365]



Short stroke, d-c/d-c linear motion transducer model 15 delivers 5 v d-c output for 0.010-in. travel with better than $\frac{1}{2}\%$ linearity. It incorporates a linear variable differential transformer with a completely integrated oscillator-demodulator-amplifier built into the potted enclosure. Prices start at \$145. C-E Electronics Inc., 363 W. Glenside Ave., Glenside, Pa. 19038. [366]

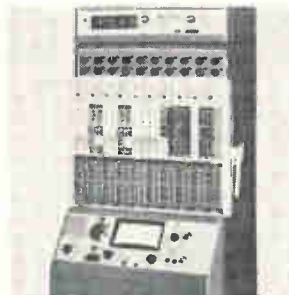

Digital voltmeter series 6250 mounts magnetically to the top of computers. It provides 4-digit readout of analog voltage signals. Voltage ranges (1 and 10 v) are push-button selected. Input impedance of the dvm is 10 megohms; conversion time, 100 msec. Accuracy is $\pm 0.1\%$ of full scale ± 1 digit. Price is \$495. Electronic Associates Inc., West Long Branch, N.J. 07764. [367]

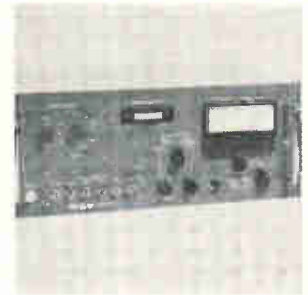

Automatic noise figure meter model 792A offers variable impedance and balanced outputs. It provides complete measurements up to 26.5 Ghz and metered noise figure ranges of 5 to 30 db for waveguide and diode sources and 0 to 20 db for hot wire and diode sources. Input sensitivity is 0 to 75 dbm; input impedance, 50 ohms nominal. Kay Electric Co., Pine Brook, N.J. 07058. [368]

New instruments

Hands-off frequency sweeping

Plug-in checks range from 0.1 hz through 100 khz; can be teamed with new log converter to make Bode plots

For different categories of electronic devices, frequency-response tests are key stages in the design and manufacturing processes. A hearing aid, for example, must amplify only those frequencies which the wearer cannot hear well. A hi-fi speaker must be carefully tested

with variable-frequency input signals. The servocontrol system on an aircraft can go into oscillation if wrong-frequency signals are let loose.

To meet these differing needs, a new sweep plug-in built by Hewlett-Packard Co. permits frequency-

response checks to be made over a range from 0.1 hertz to 100 khz quickly and accurately. It sweeps over these measurement ranges without the need for any knob-twiddling between ranges or for switching from one instrument to another.

Designed to work with the company's 3300A function generator and to provide it with both wide- and narrow-band capabilities, the model 3305A plug-in sweeps from 0.1 hz to 100 khz in three overlapping four-decade ranges.

Any part or all of one range can be swept by setting calibrated start-frequency and stop-frequency



Surface temperature transducer R-104 has a base resistance of 10,000 ohms. Measuring from -100° to $+350^{\circ}\text{F}$, the unit, when used with a suitable bridge network, yields a high level output of more than $10\text{ mv}/^{\circ}\text{F}$ as a linear function of temperature. The unit is $\frac{3}{8}$ in. in diameter \times 0.050 in. thick. Eon Instrumentation Inc., 15547 Cabrito Road, Van Nuys, Calif. 91406. [369]

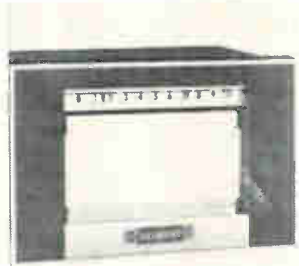

Incremental strip chart recorder series IR-100 provide up to 6 analog plotting pens, each accurate to within $\pm 0.25\%$ of full scale, and have an incremental paper drive. They are suited for applications where the data is event-dependent rather than time-dependent. The drive motor can operate at up to 200 steps/sec. Compac Corp., 52 Bethpage Rd., Hicksville, N.Y. 11801. [370]



A-c/d-c differential voltmeters reduce the dependence on a highly accurate d-c voltmeter to achieve good a-c performance. Model A-45 has $\pm 0.25\%$ a-c accuracy; model A-45A, $\pm 0.15\%$ a-c accuracy. Prices are \$595 and \$695, respectively. D-c accuracy is $\pm 0.1\%$ for either model. Both units use FET's. Medistor Instrument Co., 4503-8th Ave., NW, Seattle, Wash. 98107. [371]



Temperature controller model 52-B is designed for rugged duty on packaging, plastics, sealing, and other machines. Temperatures to 600°F and higher are sensed by a stainless steel sheathed thermistor probe. Output power to the heater load of up to 3,000 watts is smoothly modulated by a solid state triac. Athena Controls Inc., 314 West Ridge Pike, Conshohocken, Pa. 19428. [372]



Portable 1,024-channel pulse analyzer model 1010 has a 12.5-Mhz digitizing rate and 15- μ sec memory cycle. Count capacity of the memory is 10^6-1 count per address. Operating modes are provided for pulse height analysis, multiscaling (at count rates up to 1 Mhz) and analog sampling. Technical Measurement Corp., 441 Washington Ave., North Haven, Conn. 06473. [373]



Multiple-wave function generator 9010 provides sinusoidal, square, and triangular signal waveforms. All outputs are available at the front panel, with continuously variable frequencies from 0.005 hz to 1 Mhz in 8 ranges. A selectable, 30-v output is provided, with continuously variable level and d-c offset. Beckman Instruments Inc., 2200 Wright Ave., Richmond, Calif. 94804. [374]

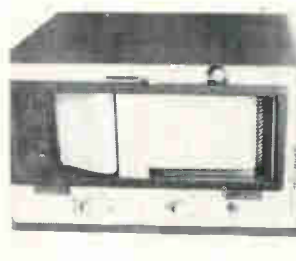

TR-220 series event recorders simultaneously record 20 or 40 separate on-off events. They feature deflection-type presentation with 3-msec response time. The stylus is designed to operate through more than 5 million events without failure. The recorders take a 200-ft-long chart roll. Up to 18 speeds are available. Techni-Rite Electronics Inc., Industrial Park, Warwick, R.I. 02887. [375]

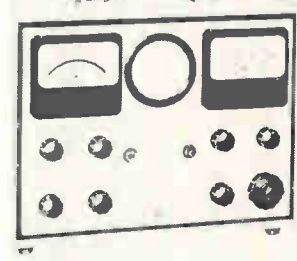

Frequency selective voltmeter model 2006 directly measures voltages in a-m/f-m, single side-band, and tv frequency ranges. The battery-powered unit features 7 overlapping ranges from 100 khz to 230 Mhz. It performs a number of selective r-f voltage measurements within a 2-mv to 50-v range. B&K Instruments Inc., 5111 W. 164th St., Cleveland, Ohio 44142. [376]

dials on the front panel. The time taken to sweep from the start frequency to the stop frequency is selected from the front panel and is adjustable from 100 seconds to 10 milliseconds. Sweep time is independent of the frequencies or range being swept. This feature provides better resolution and accuracy for narrow-band sweeps than previously obtainable, according to H-P.

Teamwork. The 3305A is ideal for use with either x-y recorders or oscilloscopes. An automatic pen-lift feature is provided for x-y recorder operation. When teamed with H-P's Moseley division's new

model 7562A log converter, a Bode plot of a system can be made directly over a four-decade frequency range with a dynamic range of 80 decibels.

Because the sweep limits are easily set to any frequency within a range and are independent of each other, the 3305A is also suited for narrow-band up or down sweeping. For example, the steep skirts of an active filter can be displayed on a scope or x-y recorder.

A manual sweep control adds flexibility by permitting the user to sweep manually with one turn of the control from the start-frequency setting to the stop-frequency set-

ting. It may be used to set up the display limits, locate frequencies of interest in the sweep, or add reference frequency marks on an x-y plot.

A constant sweep-output voltage, independent of frequency range, sweep width, or the start and stop frequency settings, eliminates the need to readjust the x-axis display even if the sweep width, frequency range, or start or stop settings are changed. This also permits magnifying a small portion of a wide-band sweep to cover the entire width of the display without any sweep output adjustments.

Other features include a local or

Always connect subminiatures with Winchester Electronics.

Take cable and panel mounted rectangulars. We've got them with solder or crimp removable contacts. From 4 to 50 contacts with current ratings of 3 to 7.5 amps. Standardized high-density rectangulars also, that allow you three current ratings — 3, 5, or 7.5 amps — with one size connector and one size panel cutout.

Need pc connectors? We've got edge-board, right-angle or flat-mounted pc's on .050, .078 or .100 contact centers. With solder, eyelet or dip solder terminations for 1/32 to 1/4-inch boards. And we've got micro-miniature pc connectors for use

with integrated thin film and semi-conductor circuitry.

If you're looking for circular cable or panel mounted connectors, you'll find them with 1 to 12 contacts. Contact centers from .025 to .040 with current ratings of 3 to 7.5 amps.

They're all on the shelf of

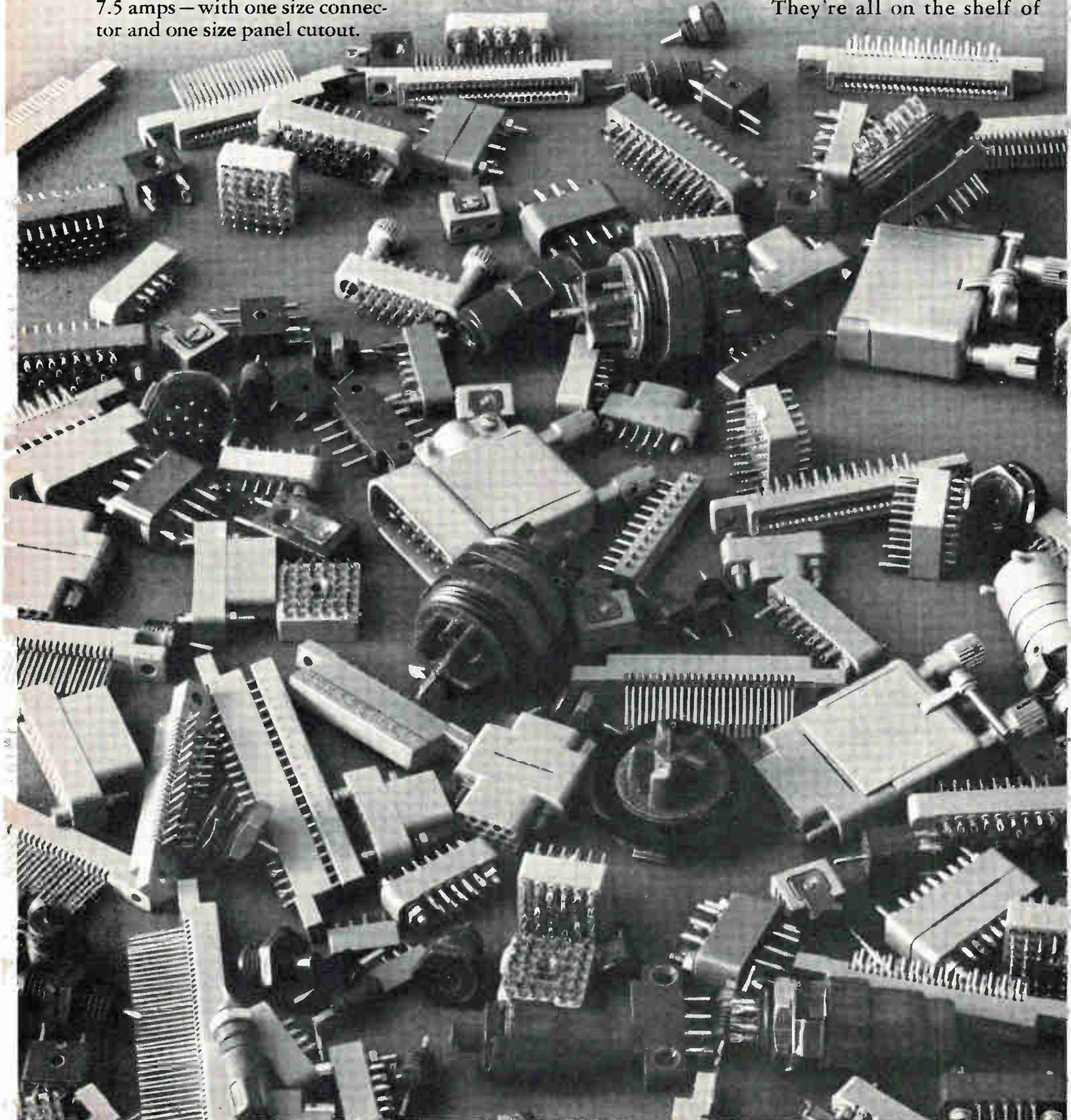

your Winchester Electronics distributor. You'll find him close as your phone — make the connection now. Winchester Electronics, Main St. & Hillside Avenue, Oakville, Conn. 06779.

WINCHESTER ELECTRONICS
LITTON INDUSTRIES

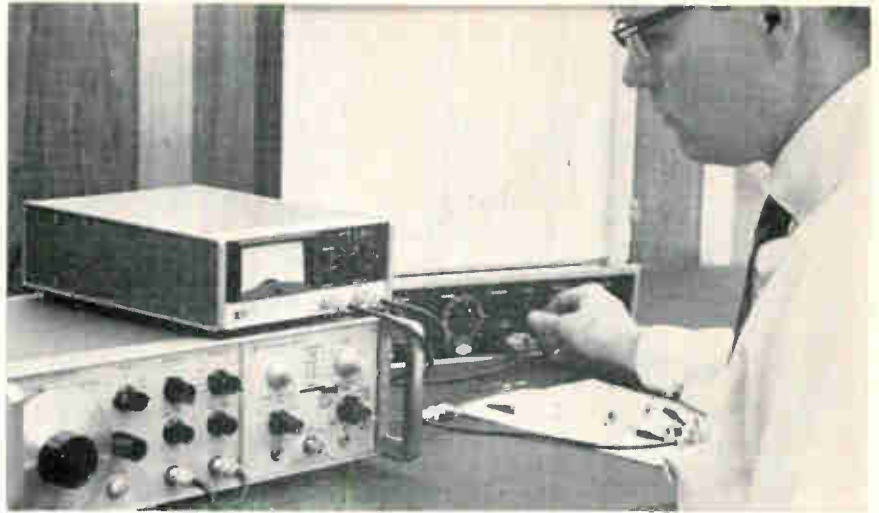

Teaming up. H-P's sweep plug-in provides logarithmic frequency control over more than four decades to simplify testing such devices as a Butterworth bandpass filter. Bode plot is obtained on x-y recorder directly by using Moseley division's new logarithmic converter.

remote triggered single-sweep, and normal 3300A main frame operation without the need to remove or change plug-ins.

Ramp control. The sweep control is a ramp generated by a Miller integrator, a current source, and two voltage comparators to sense the peak-to-peak levels.

The ramp is applied to the stop-frequency potentiometer, to the start potentiometer through an inverter, and to the sweep-output amplifier. The potentiometer outputs are summed to produce a ramp proportional to the difference of the start and stop frequency settings. To produce log-arithmetic plots directly, the ramp is shaped into an exponential curve using a piece-wise linear technique. Sixteen segments are needed to produce the desired two-decade exponential. This operation is performed by a log shaper which synthesizes the exponential curve with biased diodes. Excellent stability at low voltage levels is achieved by H-P's integrated circuit diodes designed especially to reject wide ambient temperature changes.

Two for one. A voltage comparator causes the shaper's output to go through two excursions for a single ramp excursion. At the beginning of the second shaper excursion, the 3300A's integrating capacitor is switched to a value 100 times smaller than before. Thus, two decades are swept, the capacitor is changed and two additional decades are swept. By changing two

frequency-determining elements in combination, the ability to sweep four decades of frequency is achieved with improved accuracy and stability. Phase continuity is preserved with capacitors.

In the worst case, the switching time required is two orders of magnitude shorter than one period of signal. The overlapping ranges permit narrow-band systems with a critical point at the switch frequency to be swept without losing data.

The shaper output is fed to two

Specifications

Frequency range	0.1 hz to 100 khz in 3 overlapping ranges. Limits adjustable 0 to 4 decades in any of three 4-decade bands; 0.1 hz to 1 khz, 1 hz to 10 khz, 10 hz to 100 khz.
Sweep width	
Start-stop dial accuracy	±5% of setting, 0.1 hz to 20 khz; ±7% of setting, 20 khz to 100 khz.
Sweep modes	
Automatic	Repetitive logarithmic sweep between start and stop frequency settings. Vernier adjustments of frequency between start and stop frequency settings.
Manual	
Trigger	Sweep between start and stop frequency settings and retrace with application of external trigger voltage or by depressing front-panel trigger button.
External frequency control	
Sensitivity	6v/decade (referenced to start setting), ±24 v max.
V-to-f conversion accuracy	For each 6 v change in programming voltage, frequency changes 1 decade ±5% of final frequency
Input impedance	400 k
Price	\$975

HOW CAN YOU USE THIS NEW WRINKLE IN PLASTIC TUBING?

FLEXITE SHRINKDOWN TUBING is fast becoming an "indispensable" to design engineers. It shrinks 50% in diameter, upon application of moderate heat, to form a tough, tight-fitting sheath of plastic around objects of irregular shape. Primarily intended for insulation, it is also being used in many other ingenious ways. Like binding things together — adding strength and rigidity — protecting against abrasion, wear, breakage — resisting corrosion, heat, moisture — preventing vibration and noise — etc. How can you use it? We'll be glad to send you our "Hot Idea" experimental sample kit of all 3 types of Markel Shrinkdown. Just write for it. No cost or obligation.

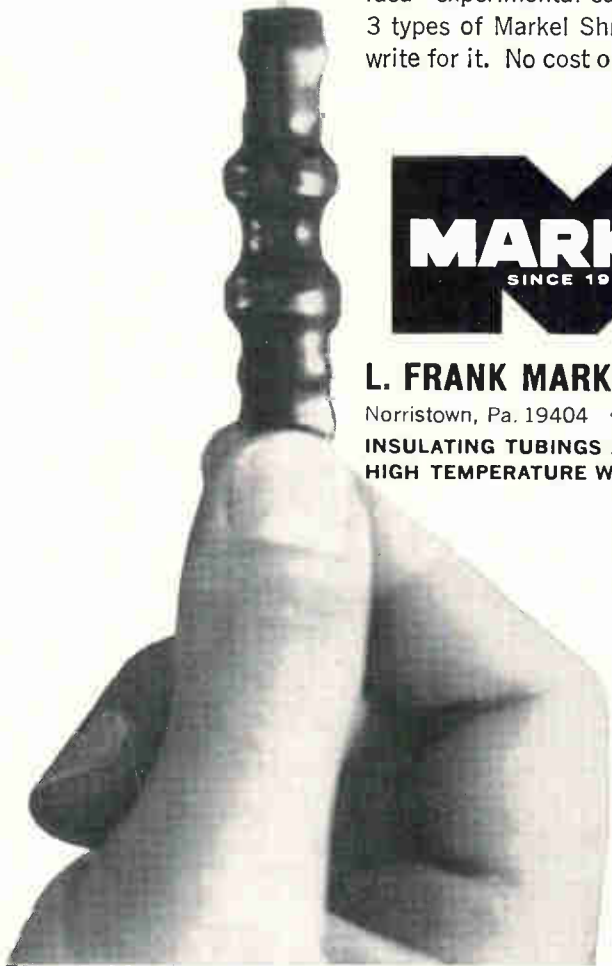

L. FRANK MARKEL & SONS
Norristown, Pa. 19404 • 215-272-8960
**INSULATING TUBINGS AND SLEEVINGS
HIGH TEMPERATURE WIRE AND CABLE**

voltage-to-current converters which supply the currents necessary to sweep the main oscillator—the 3300A. Precision converters insure less than a 1% symmetry error for the full range of frequencies and environmental temperatures from 0° to +55°C.

At the end of the sweep a multivibrator is triggered, blanking the main-frame's sine and triangle outputs. When the sweep output is reset to zero, blanking is removed and the 3300A begins to oscillate at the start frequency. After a short delay, the multivibrator again changes state, and the frequency is swept again. This delay provides for system recovery between sweeps.

Hewlett-Packard Co., Loveland Division,
Loveland, Colo. [377]

New instruments

Materials sensor measures heat flow

No-contact device operates
on convection principle
instead of measuring infrared

No-contact temperature sensing of materials, once the exclusive domain of infrared equipment, is now being accomplished by measuring heat flow instead of thermal radiation.

Called Nontact, the technique avoids some problems of infrared systems, such as having to compensate for different colors which radiate different amounts of energy, or looking through the material and picking up radiation from some other material behind it.

Nontact was developed by David Hornbaker and Dieter Rall, consulting engineers specializing in heat transfer and temperature measurement. They established a new company, Trans-Met Engineering, to produce the system.

Balances heat. The equipment consists of a sensing head and a temperature readout and control unit. It operates on a null-heat-balance principle employing convective heat exchange between the



The Electronic Countermeasures System, a valuable penetration and survival tool for B-52's, posed a tough isolator problem which was successfully solved by Sperry.

What was so tough about the isolator spec? Among other things were power handling capability (400W CW, 4kW peak); isolation VSWR limited to 1.18:1; insertion loss (only 1 db permitted), and RFI shielding to prevent interference with other aircraft systems. All parameters had to be met at altitudes up to 60,000 feet and over the temperature range of -55°C to $+55^{\circ}\text{C}$ without cooling.

Sperry met the challenge with Model No. D-44S9, a specially engineered isolator that helps assure the reliability of B-52 ECM.

Is there a particularly difficult isolator problem Sperry can solve for you? There's a broad line of standard items, plus plenty of engineering talent if you need it. For full details, contact your Cain & Co. man or write Sperry Microwave Electronics Division, Sperry Rand Corporation, Box 4648, Clearwater, Florida 33518.



SPERRY

MICROWAVE ELECTRONICS AND
ELECTRONIC TUBE DIVISIONS
SPERRY RAND CORPORATION
CLEARWATER AND GAINESVILLE, FLORIDA

When B-52's count on ECM, they count on isolators from Sperry . . . the first name in microwaves.

SPACELESS AGE RELAYS

DUNCO

LOW PROFILE

REEDS FIT WHEN

THE SQUEEZE IS ON



4-Pole



2-Pole



1-Pole

- Only 0.350" thin
- 1, 2, & 4 pole types
- For low level to 10 VA loads
- Internally shielded
- Printed circuit mounting
- Encapsulated into rigid homogenous structures.

For detailed specifications, write for Data Bulletin 3124.



STRUTHERS-DUNN, INC.

PITMAN, NEW JERSEY 08071

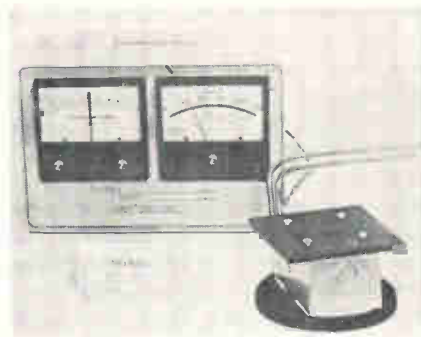

Standoffish. Sensor measures heat flow without touching surface of material.

sensing head and the material being studied.

The system can be used either to monitor temperature or to control the temperature of the material being processed, such as a hot plastic strip. In monitoring, the sensor head detects the heat flow from the hot strip. If the material is hotter than the head, a servo signal triggers an electric heater in the head assembly which heats the sensor assembly until its temperature is the same as that of the material. At this point there is no heat flow between the head and the material, the system is in null balance, and there is no output signal.

If the head is hotter than the material, output signals trigger a water- or air-cooling system and the coolant is circulated through passages in the sensor assembly until its temperature is the same as that of the material.

The sensor head measures about $2 \times 2\frac{1}{2}$ inches and is embedded in the center of a flat aluminum plate measuring about 6 inches in diameter. The sensor is a solid, potted assembly and is covered with a special reflective coating to cut out all radiant energy.

Sink plus sensor. Rall says the sensor assembly is basically a heat sink or heat reservoir, with a heat-flow sensor in the face to detect whether heat is flowing in or out. Included in the assembly are a potted electric heater and passages for air or water coolant. A thermocouple in the head monitors the temperature, which is read out on a meter.

When heat flows into the sensor, a positive d-c signal proportional to the rate of heat flow is generated for the control unit. When heat is flowing out, the voltage is negative.

In simple temperature tracking,

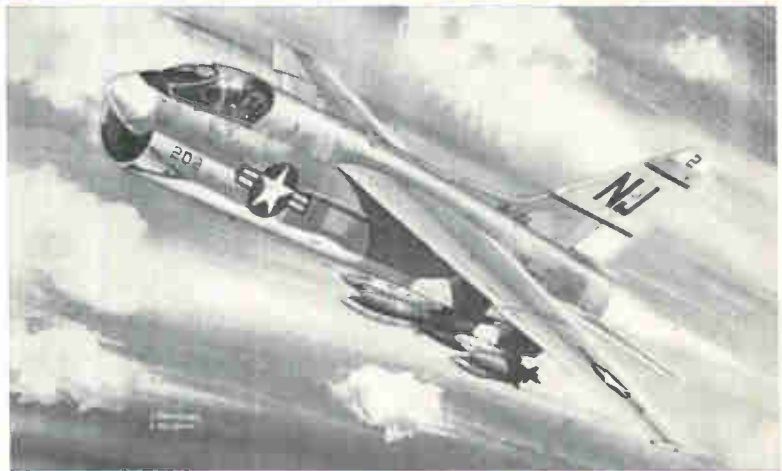

Sperry Rand Corporation has solved a unique oscillator application problem for multi-mode radars on the RF-4C and the A-7A. Texas Instruments Incorporated, prime contractor for both radar systems, needed a dual function tube — one which could serve as local oscillator in the radar, and would also work in the test and check-out circuit.

Sperry suggested the SRU-2161, and tests proved they were right. Today every AN/APQ-99 (for the RF-4C) and AN/APQ-116 (for the A-7A) system carries two of these Sperry reflex klystron oscillators.

The SRU-2161 delivers 50 mW at Ku band, while operating from a 300 V power supply. Since the oscillator has Sperry's unique adjustable reflector voltage, both tubes in the system can be driven from a single power supply. Mode shapes can be controlled to comply with the exacting tolerances of both systems.

If you need unusual performance from klystron oscillators, Sperry is the place to look. Contact your Cain & Co. representative, or write Sperry Electronic Tube Division, Sperry Rand Corporation, Gainesville, Florida 32601.

SPEERY
MICROWAVE ELECTRONICS AND
ELECTRONIC TUBE DIVISIONS
CLEARWATER AND GAINESVILLE, FLORIDA



Why multi-mode radars for RF-4C and A-7A depend on dual-purpose oscillators from Sperry... the first name in microwaves.

Order Compack Controllers from Stock / Save Space, Time, Money

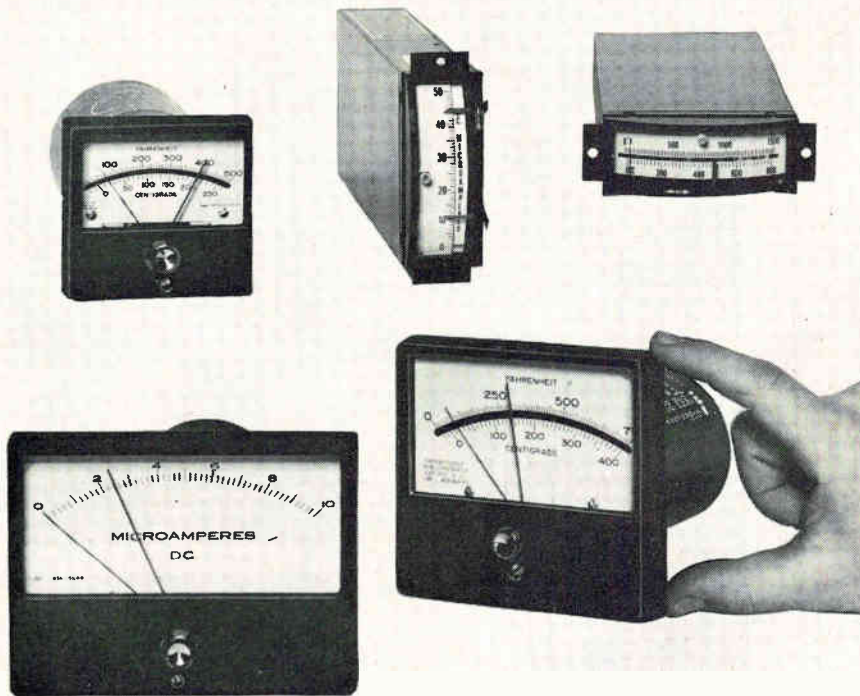

Everything about API Compacks is easy. They're space-saving controllers that simplify your design. You connect them quickly to any unamplified signal—AC, DC or temperature. You can get them from our stock without delay. Prices are painless.

In-stock Compacks come in the following general ranges:

NON-TEMPERATURE—0-10 to 0-100 microamperes DC, 0-1 to 0-50 milliamperes DC and AC, 0-10 and 0-50 millivolts DC. Special motor control range of 0-5 amperes AC. Single or double set point. On/Off, Cycling or Limit.

PYROMETERS—0-300°F to 0-2500°F. Single or double set point. On/Off, Time proportioning or SCR Driver output.

Select upright-type Compack I or edge-reading Compack II, whichever suits you better. Both contain reliable solid-state circuitry, rugged taut-band meter movement and other outstanding features that add up to the easiest approach to controlling any common variable.

Ask for: Bulletin 48 (non-temperature)
Bulletin 49 (pyrometer models)

api INSTRUMENTS CO.
CHESTERLAND, OHIO 44026 (CLEVELAND-216) 729-1611 • TWX: 810-427-9230

... output signals control process ...

the voltage—approximately 0.5 millivolt per degree F—goes to the solid state control unit where it is used to turn on either the heater or coolant to drive the sensor back to the null condition, equal to the temperature of the material being monitored. The sensor tracks at a rate of up to 10°F per minute, according to Trans-Met.

When the system is being used to control the temperature of material being processed, it is preset at the desired temperature and, as the temperature varies, the output signals are used to switch on controls to heat or cool the material.

In this mode, an indicator on the galvanometer is set at the required temperature. If the material is not at the right temperature, signals from the sensor head operate through a 5-amp relay to switch on controls to heat or cool the material.

When the galvanometer's temperature readout needle reaches the correct temperature, the needle vane shuts off light which has been passing through the set point indicator to a photoelectric cell inside the unit. This imbalances a bridge circuit, cutting off power.

Container application. A prototype unit is in operation at a plastics company in the Los Angeles area, where it monitors the temperature of styrene plastic sheet and controls a bank of heaters in an oven to keep the sheet at the right temperature. This is done just before the sheet enters a thermoforming press, where it is made into containers for cottage cheese. The plastic will not form properly if it is not at the right temperature.

Trans-Met is marketing two versions of the NCT 4,000 series system, one with a range from 75 to 300°F and one with a 75-400°F range. Accuracy is $\pm 2\%$ of full scale.

Price is \$1,875, including sensor head and mounting bracket with positioning mechanism, controller, readout system, and 10 feet of cabling. Rall says a comparable infrared system would cost \$2,000 to \$2,500.

Trans-Met Engineering, P.O. Box 56, Whittier, Calif. 90608. [378]



First full-range*
DC Voltage Calibrator
with .01% accuracy for under \$1000 —



Cohu's new Model 324A!

- *Output voltage ranges: 10-V Range: 0 to 11.11110 volts (10 μ V steps)
 100-V Range: 0 to 111.1110 volts (100 μ V steps)
 1000-V Range: 0 to 1111.110 volts (1mV steps)
- Output current capability: 0 to 25 milliamperes nominal at any voltage setting.
- Accuracy: 0.01% of setting.
- Stability: Within 30 PPM for 24 hours, 50 PPM for 30 days.
- Visual display: In-line readout, automatic decimal point positioning.
- Dimensions: Cabinet: 10 $\frac{1}{2}$ " W x 5 $\frac{1}{4}$ " H x 15 $\frac{1}{2}$ " D.
 Rackmount: 19" W x 5 $\frac{1}{4}$ " H x 15 $\frac{1}{2}$ " D.
- Price: Cabinet (324A): \$995. Rackmount (324AR): \$1050.
 F.O.B. San Diego. Additional export charge.
- Delivery: Immediate, from stock.

For full details, contact your Cohu engineering representative.

For illustrated brochure on how this instrument is applied in the auto repair industry, write for Bulletin E 5-29.



Box 623
 San Diego, California 92112
 Phone: 714-277-6700

New Subassemblies Review



Stepping commutator type 1724 Digicom is designed for multichannel telemetry. It provides up to 30 break-before-make signal channels with as many as two separate differential input sets of poles. Stepping rates as high as 200 samples/sec are reliably achieved. Production quantities sell for about \$1,100 each. General Devices Inc., P.O. Box 253, Princeton, N.J. 08540. [381]

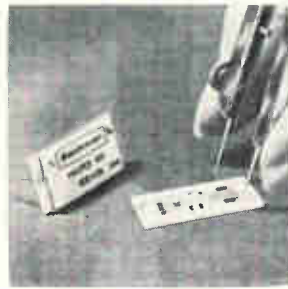

D-c voltage regulators series 803 permit $\pm 0.05\%$ regulation for line and load variations. Standard models offer fixed outputs of 24, 28 or 32 v. They supply up to 7.6 w to load at $+25^\circ\text{C}$ in free air, or 16 w with a heat sink. Operating temperature range is -55° to $+125^\circ\text{C}$. Units measure 0.990 x 0.490 x 0.170 in. Beckman Instruments Inc., 2500 Harbor Blvd., Fullerton, Calif. 92634. [382]

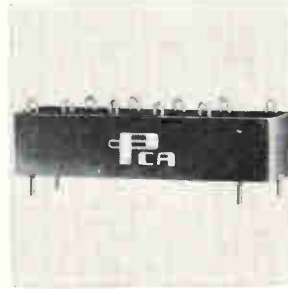

A delay line providing 16 combinations of nsec delays in 10-nsec steps is for installation in telemetry code and de-code circuits, computers and automation equipment, as well as on p-c boards. It has a maximum attenuation of 1 db, 510-ohm impedance, and a maximum 55-nsec output rise time. PCA Electronics Inc., 16799 Schoenborn St., Sepulveda, Calif. 91343. [383]

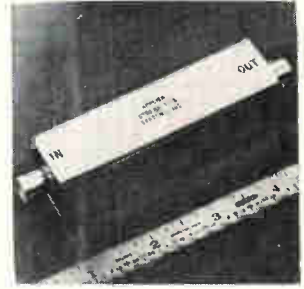

Instrumentation preamplifiers offer continuous operation for over a year from internal mercury cells. They are for use in upgrading the sensitivity and input impedance of scopes, counters, and vtvm's. Specs include input impedances up to 1,000 megohms, gains up to 40 db, and noise levels of $3\ \mu\text{v}$ broadband. Applied Cybernetics Systems Inc., 880 Bonfant St., Silver Spring, Md. 20900. [384]

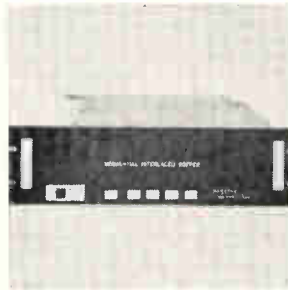

Keyboard communications buffers series 608E-1000 are adaptable to fill almost any buffer memory requirement for asynchronous input or output character rates of up to 500 khz or for synchronous rates up to 4 Mhz. The basic system provides storage of 4,096 8-bit characters and can be expanded to 131,072 characters. Digital Devices Inc., 200 Michael Dr., Syosset, N.Y. 11791. [385]



Digital tape transport GTM-14 generates computer-compatible data and features tape speeds up to 105 in./sec. It is designed for land-mobile and shipboard use in such applications as geophysical data gathering, oceanography, and reconnaissance. The unit is 14 x 25 x 12 in., weighs 90 lbs. Price ranges from \$16,000 to \$22,000. Ampex Corp., 401 Broadway, Redwood City, Calif. 94063. [386]



Core memory ICM-500 uses IC's in all electronic functions, including sensing and direct drive of selection lines. Full-cycle time is 600 nsec; access time, under 300 nsec. Capacities are from 4,096 to 32,768 words. Mean time between failure is over 25,000 hours for an 8,192-word, 28-bit-per-word memory at 35°C . Honeywell Inc., Old Connecticut Path, Framingham, Mass. 01701. [387]

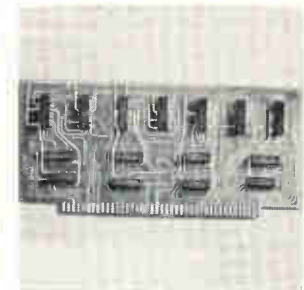

Decimal-to-binary converter card Z-253 is for use in transforming decade thumbwheel switch outputs to straight binary. It accepts 3 BCD digits on 12 lines and delivers a 10-bit output. Conversion is accomplished by a parallel decoder matrix providing continuous output information. Price is \$226. Metric Systems Corp., 736 N. Beal St., Ft. Walton Beach, Fla. 32548. [388]

New subassemblies

Making sure of dotted i's and crossed t's

Magnetic deflection amplifier gives fast, undistorted readout for computer displays, electronic typesetting

When a ransom note or a love letter appears blurry on the television screen, you can usually guess the contents from the context of the story.

This is not good enough in computer-driven alphanumeric displays, nor in electronic typesetting.

If letters and figures become rounded at the corners and plotted points become smears, computer speed must be sacrificed to improve resolution or the equipment loses its usefulness.

For fast, undistorted readout in any cathode ray tube or storage

tube display using magnetic deflection, the speed of the deflection amplifiers is crucial. A new line of amplifiers introduced by Beta Instrument Corp. provides very high speed deflection performance. The all-silicon solid state modular packages are d-c coupled operational-type difference amplifiers designed for any magnetic deflection system.

"The market is not a big one, about \$250,000 a year, but due for a quick rise when electronic typesetting gets off and running," says Norman Fine, president of Beta.

Fine says the new Beta line, available in three models, offers a 1-megahertz small-signal band-

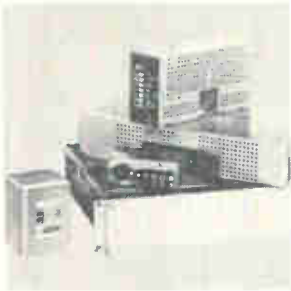

Modular and rack power supplies in the D and H series operate all types of IC's. Response to overvoltage is less than 10 μ sec and maximum voltage overshoot is 0.5 v above the overvoltage set point. Supplies have fixed overvoltage protection and output resolution as low as 1 mv. Prices start at \$130 each with quantity discounts. Dynage Inc., 1331 Blue Hills Ave., Bloomfield, Conn. 06002. [389]



Data entry keyboard KN-10 is supplied assembled and wired to a single p-c edge for a mating connector or for hard wiring to external circuitry. Keypushers are spaced on $\frac{5}{8}$ -in. centers, having momentary contact, with single or double output from a single common. The unit measures 3 x 4 x 1 $\frac{1}{4}$ in. Price is \$1.75 per button in quantity. Nutronics, Box 72, Paramus, N.J. 07652. [390]

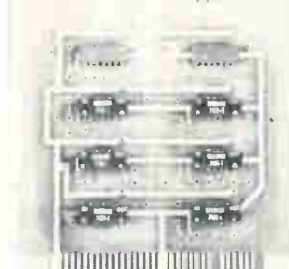

Dual in-line filters come in 2 series (7127, -8, -9 and 7130, -31, -32), each consisting of low-pass, high-pass and bandpass units in 10 Mhz and 30 Mhz frequencies. Miniature packaging conforms with IC configurations. Interconnection pins are located on 0.100-in. centers with 0.300 in. between pin contact rows. Cambridge Thermionic Corp., 445 Concord Ave., Cambridge, Mass. 02138. [391]

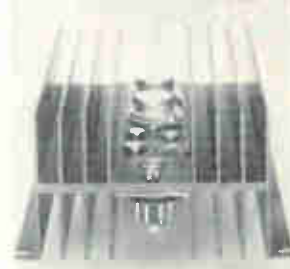

Differential d-c operational amplifier model 440 is intended for use as a servo motor or d-c through audio power amplifier. It may be used in audio applications with either a single polarity or bipolar power supply. Output capability is 60 w rms. Size is 4 $\frac{3}{4}$ x 5 $\frac{1}{2}$ x 2 $\frac{5}{8}$ in. Price for 1 to 99 is \$60 each. 100 to 999, \$55. Opanip Labs, 172 So. Alta Vista Blvd., Los Angeles 90036. [392]



Totalizing counter series 710830 Digi-Con contains from 3 to 7 Veeder Decade single wheel counters with necessary input, drive and reset circuitry. BCD or decimal output is standard. The unit has a speed of 2400 counts per minute and a minimum reset time of 300 msec. Reset is by panel push button, or remote connection if desired. Veeder-Root, Danvers, Mass. 01923. [393]

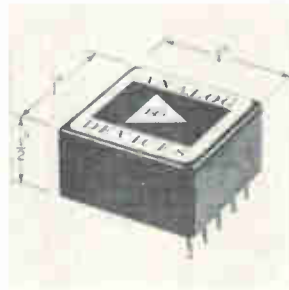

FET operational amplifier model 141A features maximum initial bias current of 50 pa and 75 μ v/ $^{\circ}$ C voltage drift. Models 141B and 141C feature reduced bias current of 25 pa maximum, and voltage drifts of 40 μ v/ $^{\circ}$ C and 25 μ v/ $^{\circ}$ C respectively. Prices of the 141A/B/C are \$25, \$30, and \$35 each in lots of 1 to 9. Analog Devices Inc., 221 Fifth St., Cambridge, Mass. 02142. [394]

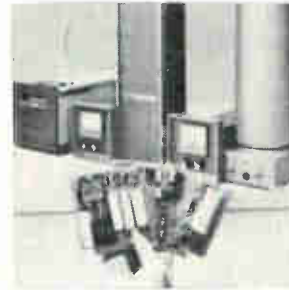

Nondispersive infrared analyzers models 215A, 315A, and 415A are for use in the process industries. All use a transistorized amplifier that converts millivolt output to current signals that are compatible with all miniature electronic recorders, controllers and data acquisition systems. Process Instruments Div., Beckman Instruments Inc., 2500 Harbor Blvd., Fullerton, Calif. 92634. [395]



Hermetically sealed style M overspeed monitor conforms to MIL-T-16049 specs. As an rpm monitor, it can be used in overspeed measurements and in warning/shutdown applications for alarm switching. It is a single set-point device adjustable over a $\pm 5\%$ span. Connectors for power, pickup, and output leads are on the unit's face. Airpax Electronics, Box 8488, Ft. Lauderdale, Fla. 33310. [396]

width, compared to 250-500 kilohertz generally available. This bandwidth is proportional to writing speed in small deflection operations, such as point plotting or character generation. With one of the new amplifiers retrofitted to an electronic typesetter, says Fine, the equipment might be able to work at two to four times its previous rate.

Settling time. The high-speed capability of the Beta amplifiers is also defined in terms of settling time—the time it takes an amplifier to reach a given percentage of a desired final voltage. "If you want a spot in the middle of a crt screen,"



Clear steer. Amplifier provides fast, precise deflection for alphanumeric readout.

says Fine, "it will take so many microseconds for the amplifier to reach the proper deflection voltage to within 1%, and then to within

0.1%. The 1% figure has been used to specify such amplifiers. But now, with higher-resolution displays needed for typesetting and computer systems, the settling time from one per cent to a tenth of a per cent is a more useful measure. Also, settling time to 1% is controlled more by constants of the crt deflection yoke and associated circuitry than by the speed of the deflection amplifier."

Beta's amplifiers settle from one to one-tenth of a per cent in 1 to 2 microseconds, says Fine. This is up to 1 $\frac{1}{2}$ times as fast as competing units, he asserts.

Symmetrical. Fine says the fast

Lapp Gas-filled Capacitors



Specially designed for a broad range of high voltage operating conditions.

High voltages, as well as high current and capacitance applications, are easily handled by Lapp Gas Filled Capacitors. For this type of service Lapp Capacitors offer small size and low cost.

Lapp precision-builds these capacitors to give years and years of accurate trouble-free operation. They are made in either fixed or variable models. All are equipped with external safety gap to protect against internal flashover.

Current ratings are available up to 400 amps at 1 mc., capacitance to 30,000 mmf, and safety gap settings to 85 kv peak. These characteristics fill a broad range of needs. May we send you more information? Ask for Bulletin 302. Lapp Insulator Co., Inc., LeRoy, N.Y. 14482.



... device symmetry adds bandwidth ...

settling time and broadbandness are achieved by means of the transistor output arrangement in the amplifier. This complementary symmetry output (npn-pnp) keeps the output impedance constant in both sweep directions, and therefore the settling time is equal in both directions.

In some deflection amplifiers, the yoke sees a different impedance depending on deflection direction. Thus settling occurs at a different rate in each direction. This type uses dual npn transistors and can be coupled through the emitter in only one sweep direction. When the output is from the collectors, impedance is higher than it is when the emitters are emitting. The circuit in the Beta amplifiers gives low-impedance emitter output in both directions, and this is a major reason for achievement of the 1-megahertz small-signal bandwidth and high speed.

The three models—priced from \$1,000 to \$2,000—can supply up to ± 2 , ± 4 , or ± 6 amperes of deflection current respectively to each axis of a directly-coupled deflection yoke. They offer maximum performance in bandwidth and settling time when operated from ± 35 volt power supplies.

Most deflection amplifiers use a potentiometer across the yoke to adjusting damping. But this costs power. The Beta devices incorporate the pot—adjustable by screwdriver—in the feedback loop. In this way, gain can be optimized for a given yoke without power loss due to a paralleled resistance across the yoke.

Specifications (Model DA 225)

Inputs	
a-c power (for fan)	115 v 60hz
d-c power (for full output)	± 35 v, 14 amp
signal	
amplitude*	± 5 v
impedance	1 kohm
Output	
deflection coil current (each axis)	± 6 amp
Linearity (deviation from best straight line)	
class AB	± 0.04 % max
class A	± 0.02 % max

* Input signal may be d-c, sawtooth, random positioning, sine, square, pulse, resolved sweeps, and/or complex waveforms.

Beta Instrument Corp., 377 Elliot St., Newton Upper Falls, Mass. 02164 [397]

ARNOLD IS



IRON POWDER CORES

From 5" dia. to Subminiature Toroids

Arnold has total capability across all design configurations—toroids, insert cores, threaded cores, plain cores, bobbin cores, sleeve and hollow cores, cup cores and subminiature toroids. All the necessary raw materials are carried in stock to provide optimum performance over the specified frequency spectrum. Our facilities include the most modern powder processing, pressing, quality control and final test equipment available in the industry.

Call us, write us, TWX us, we can handle any problem.

Arnold is also ■ Permanent Magnets ■ Tape Wound Cores ■ MPP Cores
■ Magnetic Shielding ■ Electrical Alloy Transformer Laminations ■ Trans-
former Cans and Hardware ■ Silectron Cores ■ Special Magnetic Materials.

 **ARNOLD**
SPECIALISTS in MAGNETIC MATERIALS

THE ARNOLD ENGINEERING COMPANY, Main Office MARENGO, ILL
BRANCH OFFICES and REPRESENTATIVES in PRINCIPAL CITIES

RMC DISCAPS

the complete Ceramic Disc line

Over the years Radio Materials Company has maintained its leadership in the production of ceramic disc capacitors. A complete line offering outstanding quality has been the key to continuing growth.

STANDARD

Type C, B, BA, JF, JL and JE

SUBMINIATURE

Type SM, BT, TA and Magnacaps

GREENCAPS

Type CG, JG, and BG

SPECIAL

U.L. Listed Discaps, T.C. High Voltage, High K High Voltage and Dual Section By-Pass

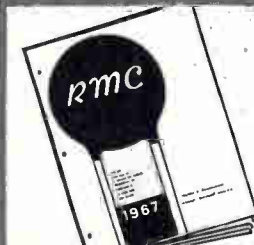

*Send for
Your
Catalog Today!*

Write on your letterhead for a copy of the RMC catalog that lists the complete line of RMC DISCAPS.

DISCAP
CERAMIC
CAPACITORS



RADIO MATERIALS COMPANY

A DIVISION OF P. R. MALLORY & CO., INC.
GENERAL OFFICE: 4242 W. Bryn Mawr Ave., Chicago 46, Ill.
Two RMC Plants Devoted Exclusively to Ceramic Capacitors
FACTORIES AT CHICAGO, ILL. AND ATTICA, IND.

New subassemblies

Color tv camera sells for \$9,850

Simplified optics

lower cost of unit

for schools, hospitals

The insides of the color television camera introduced this month at the National Association of Educational Broadcasters convention in Denver are so bare that the trick of producing a good picture is seemingly done with mirrors.

And it is. The International Video Corp. says the biggest single factor in getting the cost of its camera below \$10,000 was a radically redesigned optics system. The camera will sell for \$9,850.

Closed-circuit television in color has been a big-ticket item mainly because of camera cost. A broadcast-quality model can easily run \$75,000, and even the stripped-down model introduced by Cohu Electronics, Inc., last spring sells for about \$30,000. CBS Laboratories has built a \$10,000 camera using field-sequential techniques [Electronics, June 12, p. 33], but it does not produce a National Television Standards Committee signal and thus requires a special monitor.

International Video, founded two years ago by two graduates of Ampex Corp. and Memorex Corp., is marketing a complete CCTV system—camera, color tape recorder, and standard monitor—for \$15,000. President Donald F. Eldridge stresses that the camera does not produce a broadcast-quality signal. Its principal market, he believes, will be in hospital and educational CCTV systems.

Called the IVC 100, the camera has a self-contained encoder and a sync generator with integrated circuits. It is intended for use with the IVC 800 color recorder, introduced last spring.

One obvious difference between the IVC 100 and broadcast cameras is that the signal in the closed-circuit camera has a resolution of only 400 lines; broadcasters specify 525. Yet a broadcast signal is degraded,

When ordinary methods of observing and recording don't deliver

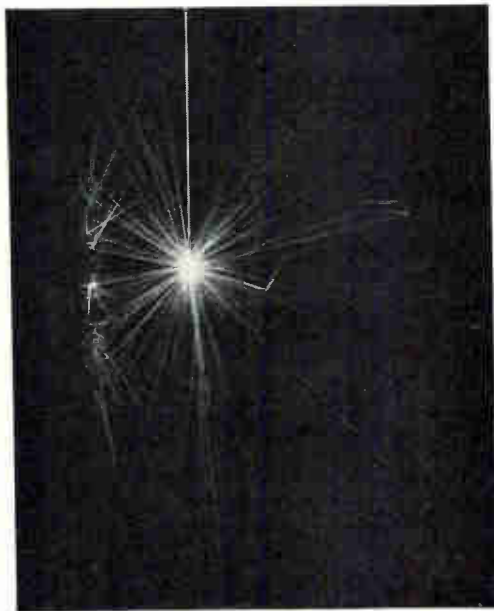

call Kodak

We have a very large staff of photographic engineers qualified to provide photographic solutions to previously unsolvable problems. Together, you and they can probably work out solutions. A few challenges presented to us recently . . .

A research team needed a way to study the combustion of metal droplets. Kodak was able to provide a film just right for high-speed cameras to record exactly what happens at 4000°C . . . and in what sequence (see picture above).

Another group, concerned with impact testing, faced the problem of oscillograph traces which intermixed

hopelessly at the point showing impact. They called Kodak. And found that we had a paper that, when exposed through appropriate filters, would provide multicolored traces. These could be interpreted even with large amplitude variations on narrow paper.

A third group had the problem of projecting computer output on a screen in color. Particularly troublesome was the fact that these data had to be updated and changed every few seconds. They called Kodak. Our engineers answered their problem with an embossed lenticular film originally intended for color kinescope recording. This film not only developed in 20

seconds to stay within their time requirements, but, with appropriate shooting and projecting techniques, produced the necessary color images.

Right now, you may be facing a data-collection problem that seems to defy solution. It may be quite different from those we mentioned. Your best bet could be a conversation with one of our photographic experts. Call Kodak.

Dial (716) 325-2000, Ext. 3257.

**Or write: Instrumentation Sales,
Eastman Kodak Company,
Rochester, N. Y.
14650.**

Kodak

How versatile is your leak detector



Can the complete instrument fit into spaces as small as 8 cu. ft.?

Does it have as many as 35 standard accessories available?

Is it available in models that sense for hydrogen, argon and neon, as well as helium?

CEC offers all of this and much more.

The following advantages explain why the 24-120B Leak Detector has become *the* instrument for virtually every aspect of commercial use, as well as for critical government programs. (*Federal stock number 6635-698-8086.*)

Compact size plus complete mobility assures access to difficult-to-reach locations.

Building block construction allows you to make substantial savings by buying *only* what is essential to the operation... then to add to it, if or when the need is called for, from the most complete line of accessories available.

Special models. Although the basic 24-120B is a helium detector, special models are available for monitoring argon, neon and hydrogen.

CEC backs you up with the most efficient sales, service and training organization in the field today.

For complete information, call your nearest CEC Field Office, or write Consolidated Electro-dynamics, Pasadena, Calif. 91109. A subsidiary of Bell & Howell. Bulletin 24120B-X18.

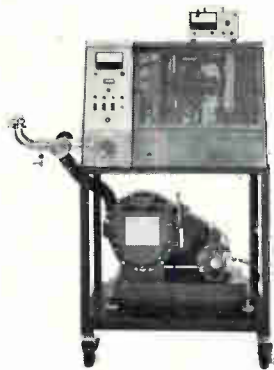

And be sure to ask for the free booklet:
LEAK DETECTION HINTS

CEC
ANALYTICAL INSTRUMENTS

 **BELL & HOWELL**

**... only 4 mirrors
in optics system ...**

in some cases down to 300 lines, by the time it reaches a home set; and Eldridge says that the IVC 100 picture appears to be equal in resolution and hue to one on a home receiver.

Zoom lens. Merely relaxing specs did not bring about the big cost reduction. The company developed a simplified optics system, consisting of a Nikon 50- to 300-millimeter zoom taking lens, relay lenses, and a system of plate beam-splitters. The relay lenses are necessary in order to shorten the back plane focal length of the taking lens.

The light from the relay lens passes first through a red-reflector dichroic mirror that reflects the long-wavelength portion of the spectrum to one side; another mirror redirects the reflected beam so that it is parallel to the main optical axis and imaged on the red vidicon. The main beam then passes through a blue-reflector dichroic surface that reflects to one side the short-wavelength portion of the spectrum. This beam is then redirected and imaged on the blue pickup tube. What is left of the main beam goes onto the green vidicon.

Doubling trouble. Plate beam-splitters are cheaper than solid glass block beam-splitters, but they can produce a double image—one from the front of the plate and one from the back. Skipworth Athey, a consultant to ivc and a director of the corporation, who designed the optics, says that the blue channel is most bothered by this double vision, because blue is low in luminosity. The blue channel thus has special circuitry to trim out the undesired reflection. Also, the backs of both dichroic mirrors have a coating the thickness of which is computer-calculated to suppress the undesired reflection.

The entire optics system thus requires only four fixed mirrors. These mirrors and the relay lenses are mounted in a subassembly sealed in a plastic case and mounted on the camera chassis. It never needs adjustment, according to ivc.

Thus, the camera consists of optics, three vidicons, deflection circuits, an integrated circuit sync

Show us your designs for thin metal parts... chances are we can show you cost-saving ideas.

We're specialists in making precision electronic parts in volume. And doing it economically. Integrated circuit frames and anything else you need.

Let us evaluate your designs and make cost-saving suggestions on materials and production methods. The end result will be parts that meet your specifications, and at the right price.

We make our own dies and can form almost any intricate shape to extremely close tolerances. In a wide variety of dimensions, finishes and tempers

in many different kinds of materials.

And our range of fabrication is not limited to metal parts. We have plants for wire products, plastic parts, and complete component assemblies.

Contact your nearest Sylvania Parts Division sales office or write to us here at Warren. You may find your parts cost will be a good deal less than if you produced the parts yourself.

Sylvania Electric Products Inc., Parts Division,
Warren, Pennsylvania 16365.

SYLVANIA
SUBSIDIARY OF
GENERAL TELEPHONE & ELECTRONICS **GTE**

2

ALIGNMENT OSCILLATORS DESIGNED TO MAKE SERVICING EASIER BOTH NEW FROM INTERNATIONAL

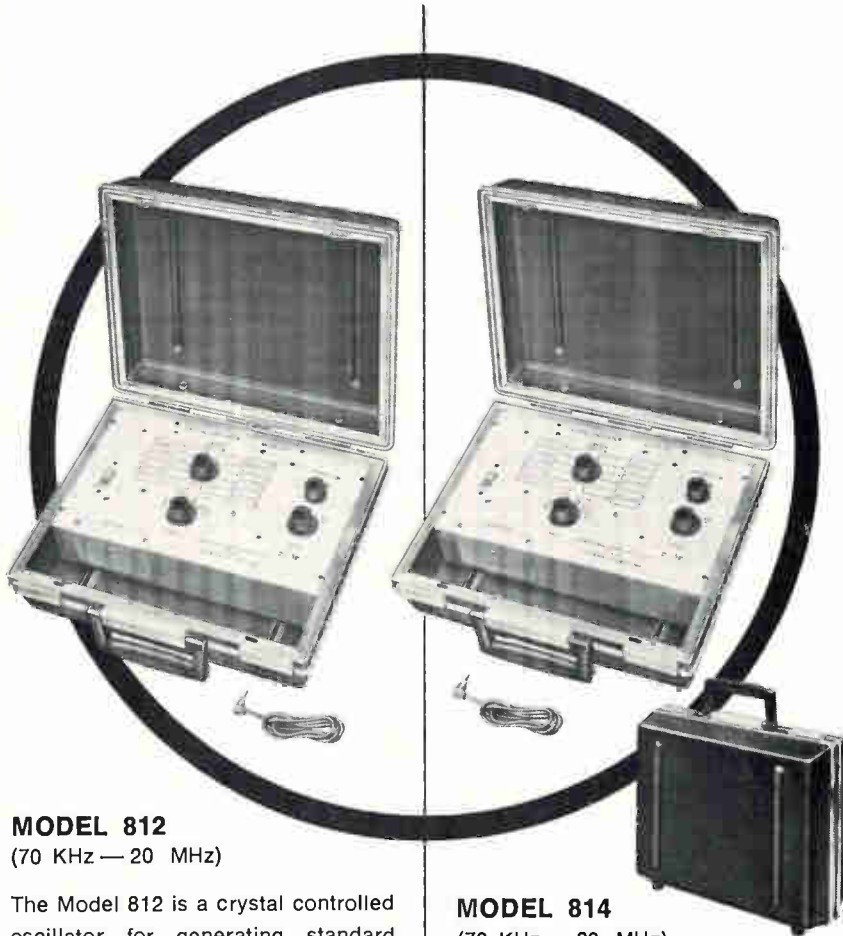

MODEL 812 (70 KHz — 20 MHz)

The Model 812 is a crystal controlled oscillator for generating standard signals in the alignment of IF and RF circuits. The portable design is ideal for servicing two-way radios, TV color sets, etc. This model can be zeroed and certified for frequency comparison on special order. Individual trimmers are provided for each crystal. Tolerance .001%. Output attenuators provided. Battery operated. Bench mount available.

Complete (less crystals) \$125.00

MODEL 814 (70 KHz — 20 MHz)

The Model 814 is identical in size to the 812. It does not have individual trimmers for crystals. Tolerance is .01%. Battery operated. Bench mount available.

Complete (less crystals) \$95.00

Both the Model 812 and Model 814 have positions for 12 crystals and the entire frequency range is covered in four steps.

Write for catalog



CRYSTAL MFG. CO., INC.
10 NO. LEE • OKLA. CITY, OKLA. 73102

generator, and an NTSC encoder. There are no external racks of equipment. The encoder is on a single printed circuit board about 8 by 10 inches.

To obtain registration of the three signals, IVC says it uses "considerable feedback" in the deflection circuits. The company asserts that component stability is such that the camera will operate for eight hours without adjustment.

Athey says that color tv is usually encoded by a method in which two different bandwidths are used. The color subcarrier is modulated in quadrature with the narrow-band Q-channel, corresponding to colors along the orange-blue axis, and the wideband I-channel, corresponding to colors along the red-green channel. But decoding is on the R-minus-Y and B-minus-Y axes (Y being luminance), which are in quadrature. The IVC camera uses R-Y and B-Y encoding as well, which Athey says is much simpler and requires fewer components.

The sync generator is simplified. It does not lock the color signal to the horizontal sync. No one would know it by looking at the picture, says IVC.

Ronald Freid, IVC marketing manager, says he already has a \$500,000 backlog from "two of the largest electronic manufacturers in the CCTV area." One is interested in audio-visual training, and the other in computer-aided education. International Video Corp., Mountain View, Calif. [398]

New subassemblies

2-minute detector of water pollution

Carbon analyzer system
operates on-line for
process control uses

Water pollution, according to recent government reports, is killing fish and spoiling recreation areas at an alarming rate.

Present systems for detecting organic pollution require hours or even days to determine the exact

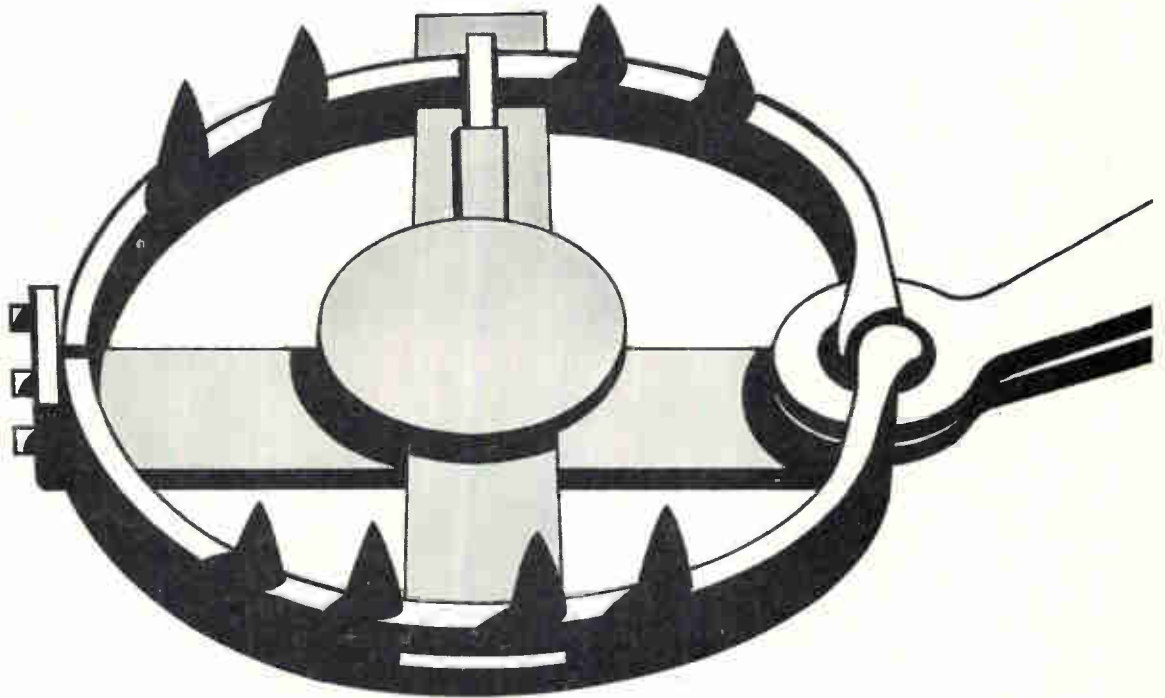

Sure way to trap IC parameters

(without losing your hide)

Again, Beckman EiD has come up with the answer.

Because the Model 999 Integrated Circuit Tester is utterly ruthless where dc parameters are concerned. It checks them all – easily, quickly. It eliminates expensive, complicated programming. *And* – the usual wear and tear on the budget. How does \$495 grab you?

Furthermore, anyone with just a basic IC familiarity can operate it.

Is it any wonder that the Model 999 IC Tester has become the choice of so many laboratory, quality control, manufacturing and educational facilities?



EiD more than
measures up.

You can bait your local EiD Sales Representative for all the facts...or just call our nearest office.

Beckman®

INSTRUMENTS, INC.

ELECTRONIC INSTRUMENTS DIVISION

INTERNATIONAL SUBSIDIARIES: GENEVA; MUNICH; GLENROTHES, SCOTLAND; TOKYO; PARIS; CAPETOWN; LONDON; MEXICO CITY

Baltimore	(301) 252-4810
Boston	(617) 245-6800
Chicago	(312) 583-1020
Cincinnati	(513) 761-9560
Cleveland	(216) 886-3020
Dallas	(214) 637-1640
Detroit	(313) 353-7900
Houston	(713) 781-0810
Huntsville, Ala.	(205) 881-2383
Kansas City, Mo.	(816) 444-0559
Los Angeles	(213) 691-0841
Minneapolis	(612) 920-3232
New York	(201) 232-7600
Orlando, Fla.	(305) 841-1372
Palo Alto, Calif.	(415) 326-1970
Philadelphia	(215) 839-3844
Pittsburgh	(412) 921-1530
St. Louis	(314) 371-5900
San Francisco	(415) 526-7730
Seattle	(206) 454-9528

EFFICIENCY EXPERTS

BARNES CARRIERS AND CONTACTORS FOR FLAT-PACK HANDLING AND TESTING



Trying to increase flat-pack production rates or speed-up testing and board mounting? Then keep up with competition by using Barnes flat-pack Carriers for high-speed automatic handling, test and P.C. board insertion. Barnes Contactors accept $\frac{1}{8}'' \times \frac{1}{4}''$ to $\frac{3}{8}'' \times \frac{3}{8}''$ flat-packs with up to 14 leads, and facilitate quick and easy test and breadboarding. Write today for full information and ask for a free Carrier sample.

barnes
DEVELOPMENT COMPANY

Lansdowne, Pa. 19050 • 215/MA2-1525

barnes / THE FIRST WORD IN CARRIERS, CONTACTORS AND SOCKETS FOR I.C.'S

Circle 504 readers service card

You name the meter.

BRAND Ideal has it.

(or we'll make it for you)

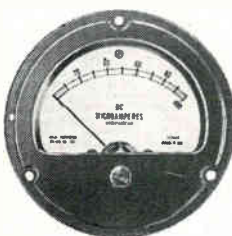
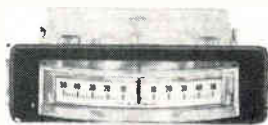
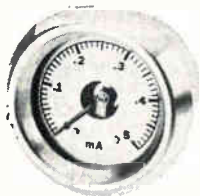
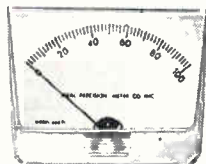
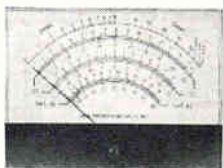

If one concentrates long and hard enough on panel meter development and engineering, one becomes expert.

IDEAL meters are used by all the Military and by leaders in defense and industry. For everything in meters—ruggedized or commercial, custom and stock, $\frac{1}{2}''$ to $7''$ —you can count on IDEAL, the proven leader.

Write for free 32-pg. catalog. Ideal Precision Meter Co., Inc., 218 Franklin St., Brooklyn, N.Y. 11222. (212) EVergreen 3-6904.

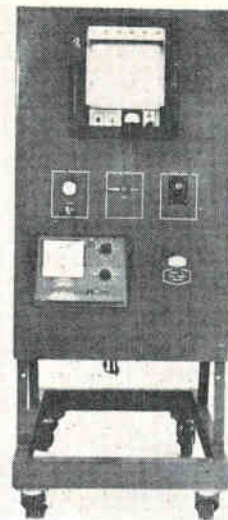

Sampler. System measures carbon content for pollution detection or process control.

carbon content—and hence organic content—of a sample. This is just too slow. In most cases, if the pollution is detected fast enough, it can be stopped.

A carbon analyzer built by Union Carbide Corp. completes the pollution check in two minutes. Designated the model 1212, the unit can detect organic pollution as small as a few parts per million.

Its rapid response also suits it for process control applications. In the treatment of chemical waste, continuous monitoring of both influent and effluent streams accurately measures efficiency of the process and permits regulation of operations to avoid upsets. Continuous monitoring of sewers or cooling water detects spills and leaks within moments. Circuitry can be added to sound an alarm when the quantity of organic matter rises above a preset level.

The analyzer consists of two sections: the preparation equipment and the analyzing equipment. A 40-microliter sample is introduced in the test chamber in either a batch or continuous process. Through a hot-wire catalytic system, the organic sample is changed to carbon dioxide which is carried to an infrared analyzer by a nitrogen gas stream. By measuring the amount of infrared energy absorbed by the CO_2 , the carbon content of the sample is determined.

Two readout devices, a panel meter and a strip-chart recorder, are provided in full scale ranges from 0 to 100 through 0 to 3,000 parts per

VSMF is a product supermarket

John Manning, Missiles Systems Division, Raytheon Company, Bedford, Mass., has installed 4 VSMF Files: Defense Design, Documentation, Mil Specs and Mil Standards.

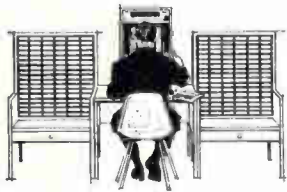

look into it!

Design engineers have been telling us for years that VSMF is much like a product supermarket. That's because Visual Search Microfilm Files contain more than 1,000,000 products from over 15,000 manufacturers—all arranged with design engineers in mind.

Of course, VSMF isn't exactly a supermarket. At Information Handling Services, we've collected 1¼ million pages of product data, indexed them, microfilmed them, put them in compact consoles, and combined them with the most modern microfilm retrieval equipment. VSMF has all the advantages of a product supermarket... complete, easy-to-use and up-to-date.

We know that when you design a product you want to use the best components and materials. And, to do this, you need to compare all that is available. VSMF can help you in this comparison because VSMF supplies the data on *all* products. You supply the judgment.

Manufacturers who place their data in VSMF know this and invite comparison. The constantly changing "state of the art" is reflected in the pages of VSMF.

More than 125,000 engineers in 500 great corporations now shop in the VSMF supermarket. If you have VSMF in your company, look into it. If you don't, you might look into that, too. Write for "Looking into VSMF."



Information

HANDLING SERVICES, INC.

Dept. E-529

Denver Technological Center
Englewood, Colo. 80110

Circle 245 on reader service card

Giant pulses easily obtained with revolutionary new PLASTIC LASER Q-SWITCH

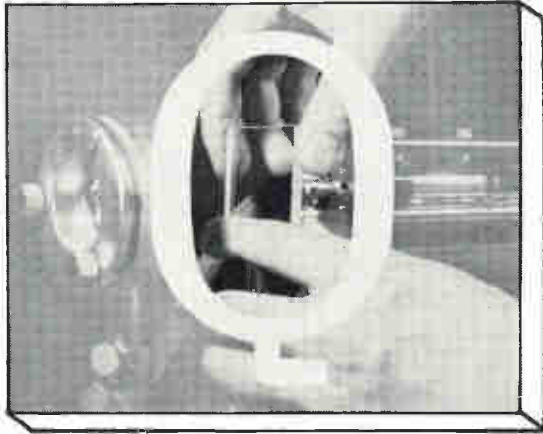

The Mitsubishi plastic Q-Switch is a plastic version of the reversible, bleachable-dye Q-switch. When placed on the laser resonator, it automatically controls the Q of the resonator, offering a simple and repeatable means of obtaining ruby laser giant pulses of 1~3MW. The device is a flat, transparent plastic plate in which bleachable-dye molecules are suspended.

Using closely coupled lamp reflector with a diffused reflecting surface, the device has successfully generated more than a hundred giant pulses with a peak power of a few megawatts. It can produce any desired contour and is stable for UV radiations. Since it can be used repeatedly, maintenance is minimal, and it saves space and weight in laser design.



Specifications:

Wavelength	6,943 Å (for ruby lasers)
Absorption	30~50% at 6,943 Å
Active dimensions	1½ x 1½ x ½ inches (thickness governs absorption)
Alignment	No precise alignment required

For full technical information, write to:
Mitsubishi International Corporation
277 Park Avenue, New York, N.Y. 10017
Phone: 922-3700



MITSUBISHI ELECTRIC CORPORATION

Head Office: Mitsubishi Denki Bldg., Marunouchi, Tokyo. Cable Address: MELCO TOKYO

Circle 246 on reader service card

Our little black book has over 100,000 phone numbers.

You never had a black book like it. Over 1,500 pages. And those phone numbers! More than 100,000 telling you who to call/where to go, for the over 4,000 different product categories listed and advertised in the yellow pages of the Electronics Buyers' Guide.

There's never been a buyer's directory like it. The new '68 edition will be coming your way in October.

Look for the book in the black box.

EBG for '68... bigger, better and more useful than ever before.

Electronics Buyers' Guide

A McGraw-Hill Market Directed Publication,
330 West 42nd Street, New York, N.Y. 10036

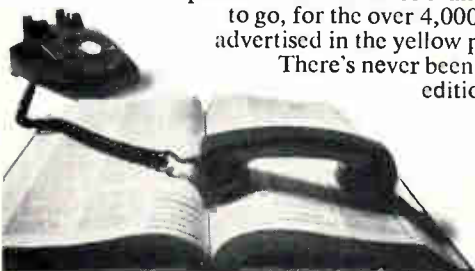

million. Both units have a repeatability to within $\pm 2\%$. The tester, priced at \$8,600, operates at ambient temperatures from 32° to 120°F. In process stream installations, it requires a sample flow rate of 5 gallons an hour.

Union Carbide Corp., Electronics Div.,
5 New St., White Plains, N.Y. [399]

New subassemblies

The price is right -- even with cores

Japanese firm produces \$900 desk calculator with new techniques

In the U.S., it's considered uneconomical to use magnetic core memory registers in electronic desk calculators. Acoustic delay lines are employed instead. Cores are rarely designed into data processing systems which store less than about 10,000 bits.

Not so in Japan. Casio Computer Co. of Tokyo adds to the growing list of electronic calculators with an entry which will sell for \$900 in Japan. Like the Hayakawa Electric Co. unit [Electronics, Aug. 21, p. 189] all its internal registers are made of magnetic cores.

Masakatsu Ara, Casio's submanager for new product development, says the low price is possible partly because of the magnetic core registers.

The limiting factor in core memories lies in the electronic circuitry which decodes addresses, drives current through the wires in the memory, and senses the output signals. Casio has used several techniques to help keep these costs down and make the use of cores economically feasible.

Noise dies. For one thing, the memory is designed to operate at very low speeds; at these speeds the pulse signals have relatively slow rise and fall times, and therefore generate little noise. In fact, capacitively-coupled crosstalk is virtually nonexistent. There is also plenty of time for the noise that is

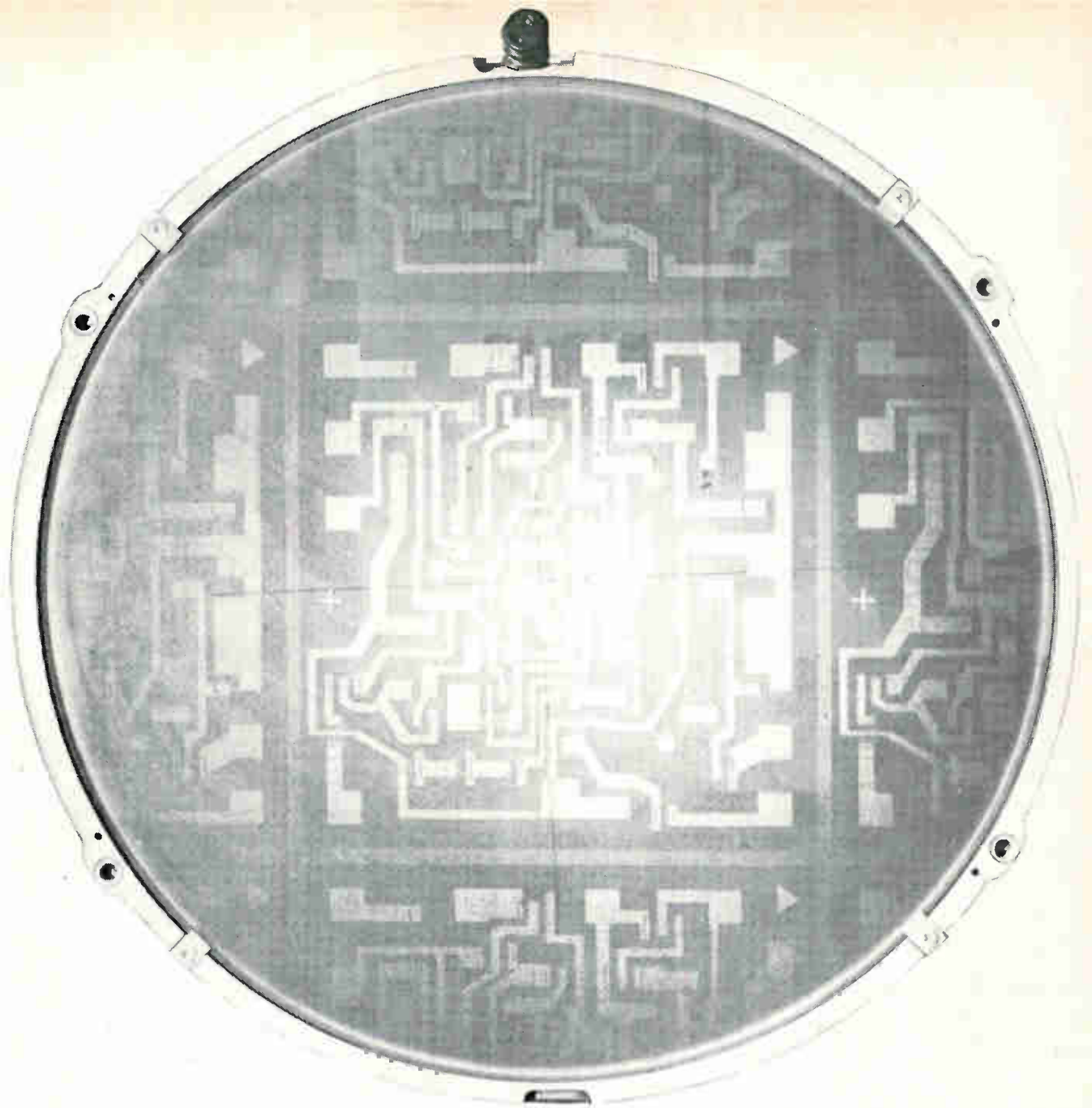

Challenge In Microelectronics

You'll find it at Delco Radio in a variety of research/development and manufacturing programs. Rapid expansion of microelectronics and silicon device projects has created new career opportunities for the B.S., M.S., Ph.D. in Chemistry, Electrical Engineering, Mechanical Engineering, Metallurgy, Physics, Physical Chemistry, and related fields.

Research and Development Programs in:

Linear and digital circuitry, embracing monolithic . . . thick film . . . thin film . . . and hybrid microcircuits

Silicon transistors from low power 10 milliampere through 25 ampere; voltages to 1200

High frequency transistors to 1GHz

Thyristors from 50 millampere through 500 ampere, 2000 volts

Silicon rectifiers from milliampere through 250 ampere, 3000 volts

Process Engineering Positions:

Unlimited opportunities in this area to develop and create new processes for manufacturing germanium and silicon semiconductor devices, integrated circuits, and automobile radios. Includes development of automatic and semiautomatic fabrication equipment, pilot line operation and general cost savings investigations pertinent to semiconductor manufacturing.

Call us collect for an interview or more information. Area Code 317/459-2808. Ask for C. D. Longshore. Or send your resume to Mr.

Longshore, Supervisor, Salaried Employment, Dept. 105, Delco Radio Division of General Motors, Kokomo, Indiana.

DELCO RADIO

DIVISION OF GENERAL MOTORS • KOKOMO, INDIANA

An equal opportunity employer



MARK OF EXCELLENCE

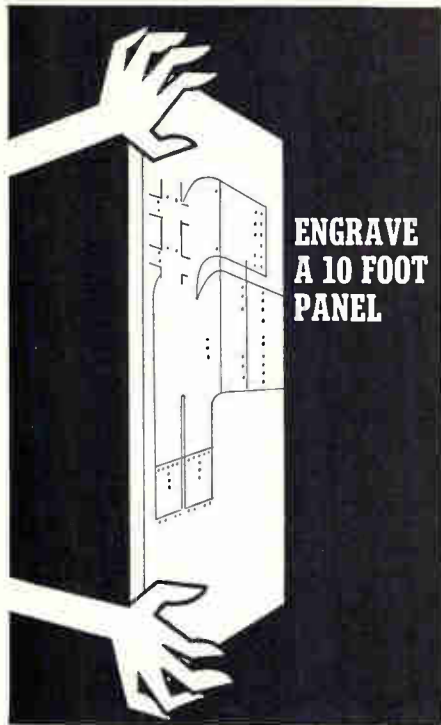

**ENGRAVE
A 10 FOOT
PANEL**

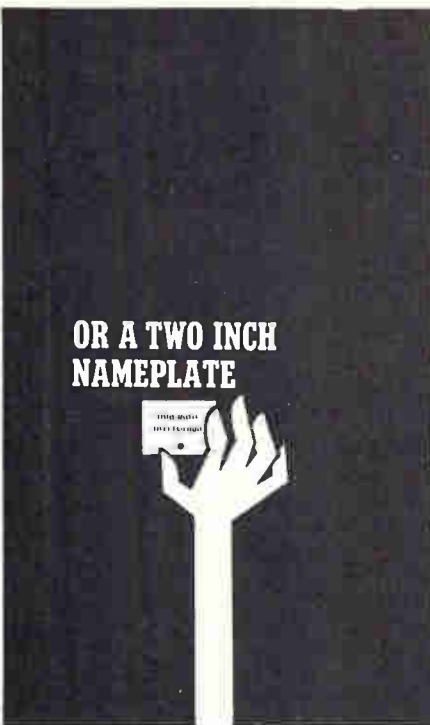

**OR A TWO INCH
NAMEPLATE**



The New Hermes Engravograph is a highly versatile pantographic engraving machine. Anyone in your plant can operate it—with big savings. Write for 24 page catalog to Dept. 156.



new hermes engraving machine corp.

20 Cooper Square, New York, N. Y. 10003 • Chicago, Atlanta, Los Angeles, Dallas, Montreal, Toronto, Mexico City
Circle 505 on reader service card



Teamed. Programed mode permits semiautomatic coupling to typewriter.

generated to die away; the sensing circuits need not have a high noise-rejection capability. Thus the circuits themselves can be simpler and can be built with wide-tolerance components.

Another important design feature is the serial loading and unloading of registers, one digit, or four bits, at a time. The memory has only four sense amplifiers and four write drivers, compared to the dozen or two of each found even in small computer memories.

Up to 14 digits. Using these techniques for a small core-memory unit, the Casio machine works with numbers of up to 14 digits. It stores them in four 14-digit registers, and two 7-digit registers. It also has a 30-digit program register, each digit corresponding to a single instruction.

The machine has a 14-instruction repertoire, any of which can be stored in a single digit position; ten decimal digits require four bits for a binary-code representation, and the four bits can represent up to 16 different symbols—the 10 digits and six others. The machine's output is through indicator tubes; its input is from its keyboard or from a typewriter.

The operator enters a program of up to 30 steps. He then enters data into the various registers and the program makes its calculations on this data; results appear in the indicator tubes above the keyboard. A semiautomatic mode, using a typewriter, is also available.

Specifications

Instruction repertoire	Add, subtract, multiply, divide Clear memory, clear keyboard Set memory registers 1, 2, 3, 4 Set minus sign Square root Program stop, program restart
Size	17½ x 15 x 9 in.
Weight	5 lbs
Power	30 w

Casio Computer Co., Tokyo [400]

NEW! smallest axial shielded inductor available the "NANO-RED"

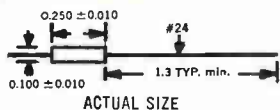

Range: 0.10 μ h to 1,000 μ h in 49 stock values

Size: 1/10 dia. by 1/4 lg.

Inductance Tolerance: $\pm 10\%$

This new "NANO-RED" offers the highest inductance to size ratio available in an axial shielded inductor. Exceptional "Q" and self-resonance characteristics. Max. coupling 2% units side by side. Non-flammable envelope. Designed to MIL-C-15305C. Operating temperature -55°C to 125°C .

Other Lenox-Fugle Subminiature Shielded Inductors:

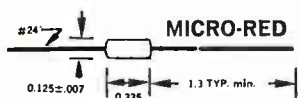

The "Micro-Red" is a shielded inductor that offers the largest inductance range in its size: 0.10 μ h to 10,000 μ h. "Q" to "L" ratio unsurpassed, with excellent distributed capacity. Inductance tolerance $\pm 10\%$. Designed to MIL-C-15305C. Stocked in 61 predesigned values.



The "Mini-Red" offers the highest "Q" to "L" ratio available over inductance range 0.10 μ h to 100,000 μ h in its size. Inductance tolerance $\pm 10\%$ measured per MIL-C-15305C. Stocked in 73 predesigned values.

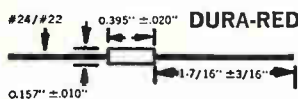

The "Dura-Red" is designed to MS-90537 with inductance range 0.10 μ h to 100,000 μ h with tolerance $\pm 10\%$. Stocked in 73 predesigned values.



Data Sheets: write or phone

LENOX-FUGLE ELECTRONICS, INC.

475 Watchung Avenue, Watchung, N. J. 07060

Telephone: Code 201, 756-1164-1165



DUPLEX
Spiral

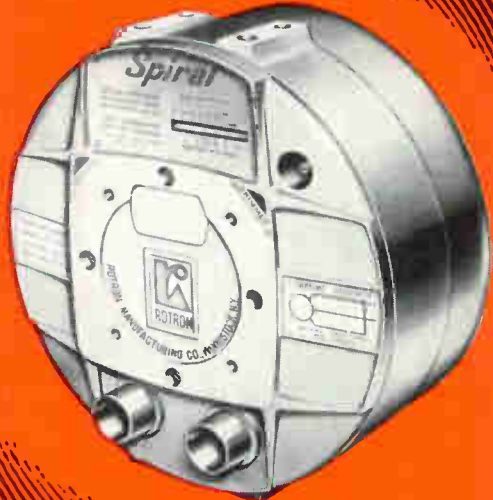

SIMPLEX
Spiral

HIGH PRESSURE / VACUUM AIR MOVERS

SIMPLEX SPIRAL • Compact — 10" diameter by 5 $\frac{7}{8}$ " axial depth • High pressures / vacuums—30 CFM @ 15" static pressure, 54 CFM @ free delivery, 27" static pressure. @ 0 CFM

DUPLEX SPIRAL • 10" diameter by 9 $\frac{1}{4}$ " axial depth • Two independent air sources from one package; Two jobs for the price of one or extended performance — Pressures — Vacuums to 2 PSIG or Airflow Delivery up to 94 CFM @ free delivery

- Oil free Air Flow — no possible contamination • Quiet —
- Economically priced.

Rotron Spirals are revolutionary air movers that have become standards in the process control and computer industries as: vacuum source for tape slack control . . . pressure source for tape air bearings . . . vacuum/pressure source for card handling and paper sorting equipments. Spirals are the choice—their brushless motor design offers unparalleled reliability, unusually long-life and eliminates costly equipment down-time.



ROTRON mfg. co., inc.

WOODSTOCK, NEW YORK • 914-679-2401
West Coast: Rotron / Pacific, Burbank, Calif.
Canada: Aerovox Canada Ltd., Hamilton, Ont.
Rotron Europa N.V. Breda, The Netherlands

Our digital voltmeter costs \$349, and measures Ohms free.



The Fairchild 7050 DVM is a digital rebuttal to analog meters. It measures volts or ohms with a resolution of 1mV or 1 ohm, and with an accuracy of 0.1%. Integrated circuits, dual slope integration, automatic polarity, floating input and display storage are all included as standard. The 7050 weighs less than four pounds and costs \$349. The tilt stand doubles as a handle and costs \$16 extra. Our data sheet is free. Circle Reader Service Number 72.

FAIRCHILD
INSTRUMENTATION

New Microwave Review



Microwave sweep oscillator model 221 features remote symmetrical sweep control, remote power level control, manual sweep mode, and a time delay at the beginning of each sweep to stabilize r-f power. Frequency coverage of the sweeper, utilizing various available oscillator plug-ins is 200 Mhz to 40 Ghz. Micro-Power Inc., 25-14 Broadway, Long Island City, N.Y. 11106. [401]



Backward-wave oscillator SE-218, covering 18 to 26.5 Ghz, has applications as a local oscillator in radar receivers, as a master oscillator in frequency diversity transmitters and in electronic counter-measure equipment. It features permanent-magnet focusing. The unit is 2½ x 2½ x 5 in. over-all, and weighs 4 lbs. Watkins-Johnson Co., 3333 Hillview Ave., Palo Alto, Calif. 94304. [402]



Type 4673-35 OSM Hybrid re-reflectometer has a residual swr under 1.055 over the range of 7.0 to 12.4 Ghz. No special storage oscilloscope or X-Y recorder is required since the entire swr vs frequency characteristic of the device under test can be determined in a single sweep cycle of the r-f source. Price is from \$470 to \$570. Alford Mfg. Co., 120 Cross St., Winchester, Mass. 01890. [403]



TR/limiter cell type BS808 is for X-band radars. It consists of a gas discharge TR cell and a solid state limiter fitted together. The limiter is self biasing, unlike p-i-n diodes, and thus requires no power supply. Frequency range is 9 to 10 Ghz. Peak operating power is 200 kw, and insertion loss is less than 0.8 db. Calvert Electronics Inc., 220 E. 23rd St., New York. 10010. [404]



Log periodic antenna AN112, covering the 1-12.5 Ghz range, is for use with wideband, electronically scanned microwave receivers. It is suited for rfi/emc surveillance. The assembly can withstand the continued flexing of a heavy coaxial cable attached to it such as RG-8. Dimensions are 8 x 6¼ x 6½ in. Price is \$195. Electro/Data Inc., 3121 Benton St., Garland, Texas. 75040. [405]



C-w tetrode cavity 11019 for radar system applications is rated at 1.0 kw output. Operation is Class B, linear. Frequency range is 400 to 800 Mhz with manual tuning. The unit has a bandwidth of 6 Mhz, a gain of 13 db, and is rated at 50% efficiency. Power input is 50 w; maximum input vswr, 2:1. Microwave Cavity Laboratories Inc., 10 N. Beach Ave., LaGrange, In. 60525. [406]



Four-section, gang-tuned coaxial filter G450T has direct frequency readout. It features a compact tape drive coupled to a low-torque precision geartrain. Tuning range is 4.4 to 5.0 Ghz. Insertion loss is 0.85 db max. Calibration accuracy is ±2 Mhz. Direct tape readout available on all standard models (1-12 Ghz) upon request. Gombos Microwave Inc., Webro Rd., Clifton, N.J. 07012. [407]



Directional detector model 3142 is an integrated package that combines a maximally flat directional coupler with a matched high sensitivity crystal detector. Frequency sensitivity is limited to ±0.2 db from 0.950 to 2.11 Ghz with a minimum directivity of 25 db. Total ±2 db flatness is guaranteed. Narda Microwave Corp., Engineers Hill, Plainview, L.I., N.Y. 11803. [408]

New microwave

Ultrafast switching--it's a snap

Uhf stripline device switches in 0.8 nsec, twice as fast as mathematics says it should

A mathematical oddity, that's what Microwave Associates Inc. has come up with in a diode switch that turns on or off twice as fast as it should.

In building its 800-megahertz single-pole, single-throw switch, the company found the device

turns on or off in only 0.5 to 0.8 nanosecond. This wasn't possible—according to an impressive technical paper presented last year in which the mathematics proved switching time cannot be less than 1.24 divided by the operating frequency. Based on that paper's

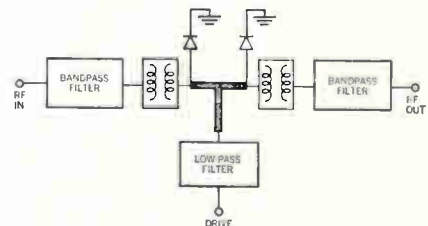

Speeder. Impulse from driver turns on diodes that conduct microwave energy to ground.

equation, the stripline device should turn on or off in about 1.8 nsec.

Paul Bascon, who headed the company's design effort, can demonstrate the mysterious speed on

... frequency multiplication features may account for switching speed ...

the test bench, but can't explain it mathematically.

With a snap. The device uses two of the company's snap varactor diodes to do the switching. Bandpass filters at input and output keep both switching transients and drive power out of the microwave transmission line. They seem to do their job—drive-signal attenuation reaches 50 decibels just below about 150 Mhz and keeps increasing as frequency decreases. Attenuation above the passband is almost as steep.

A third filter stands between the driver terminals and the transmission line as added interference protection for the microwave signal. This filter presented a knotty tradeoff problem. To keep the microwave energy from entering the driver circuitry and thus keep insertion loss low, the filter's impedance had to be high. That meant a low cutoff frequency.

But to get a fast-risetime switching pulse through the filter to the diodes, a high cutoff frequency was necessary—about 700-Mhz bandwidth was needed to get the required pulse and the bulk of its Fourier components to the diodes.

The compromise was a seven-element Chebyshev stopband filter with 40-db attenuation between 600 and 900 Mhz; above and below

the stopband, attenuation drops off rapidly.

The compromise seems to have worked. Across a 200-Mhz bandwidth centered at 800 Mhz, there is less than 1.5-db insertion loss when the switch is turned on; isolation exceeds 40 db when the switch is off. Input and output voltage standing-wave ratio is a maximum of 1.67.

Bootstrapping hinted. Bascon believes the varactor diodes' frequency-multiplication characteristic may account for the speed. Perhaps the diodes are multiplying the Fourier components of the switching pulse to even higher frequencies, thus bootstrapping their way to ultrafast switching speeds. On oscilloscope traces, the switching signal was found to have frequency components well above 1,000 Mhz after it had passed through the diodes.

But Bascon also found that the diodes changed between the on and off states long before the switching pulse had completed even a small part of its 2-nsec rise to peak amplitude. It may be that the diodes need little power to switch and are being overdriven to high speed performance.

Preliminary applications are in military and research programs. The switch, designated the MA-8306-ILIN, was built for the Hughes Aircraft Co. for use in a classified system. Bell Telephone Laboratories, interested in switches that can stop a radio-frequency signal in mid-cycle, seeks a 300-Mhz switch with 2-nsec speed—another impossible combination of speed and frequency. And the Air Force wants an ultrahigh speed switch for an S-band application.

Specifications

Switching speed	0.5-0.8 nsec
Bandwidth to 1.5-db attenuation points	700-900 Mhz
Bandwidth to 3-db attenuation points	650-950 Mhz
Drive voltage	+1, -2 v
Drive-pulse risetime	2 nsec
Drive-pulse falltime	1.5 nsec
Power capability	more than 700 mw continuous

Microwave Associates Inc., Burlington, Mass. 01803 [409]

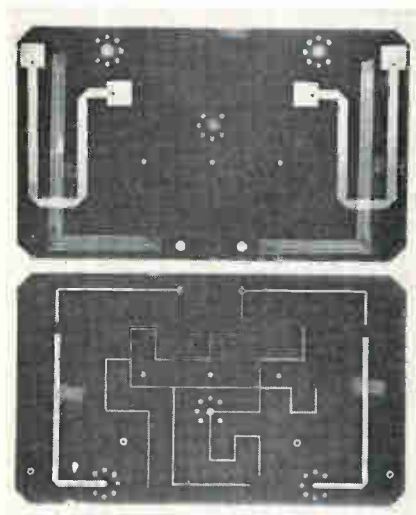

Stripped down. Both faces of stripline circuit boards are shown with filter stubs and interconnections.

Some other **ENGELHARD** products

PRECISION-DRAWN TAPE is supplied to specification in bimetals or solid precious metals. ECON-O-TAPE is available in any thickness, length or width (from .0095"). Shaped or rectangular sections. Excellent material for electrical contacts subject to corrosion.

E-70 BRIGHT GOLD PROCESS produces mirror bright electroplates from flash deposits to 500 microinches in thickness. This highly efficient, neutral bath produces hard, wear resistant finishes suitable for the complete range of decorative applications.

CLAD CONTACT PARTS provide a precious metal layer essentially pore free and durable, with an extremely strong bond to the base metal. These parts are supplied usually in the form of blades and spring assemblies.

ACID GOLD PLATING PROCESS provides high purity gold electrodeposits (24 Karat) that are smooth, lustrous, free from porosity, highly ductile, relatively hard. Excellent deposits up to several mils in either still or barrel plating. Highly stable and simple to handle over long periods. Adaptable to plating wide variety of electronic components.

SEMICONDUCTOR MATERIALS are supplied in a wide range of precious and base metals and their alloys. These include solid sheet, wire, tape, base tab materials and clad products, fine gold wire, and ribbon. New materials are constantly under development. Technical assistance is available.

PRECIOUS METAL CONTACTS in pure or alloyed forms of silver, platinum, palladium and gold provide unmatched resistance to atmospheric corrosion and electrical pitting. Engelhard will manufacture to specifications or provide material in wire, rod or sheet form.

THIN WIRE AND FOIL are produced by Engelhard Industries to meet rigid electronic design requirements. Both extruded and Taylor Process thin wire are available in diameters as small as .001". Thin-gauge foil is supplied in sheets up to 8" to 18".

MILL PRODUCTS include sheet, thin foils, wire, seamless tubing, gauze, platinum clad and fabricated items. All are precision made using skills resulting from over seventy-five years experience in the working, drawing, machining, spinning, forging, and weaving of basic forms of platinum metals and alloys.

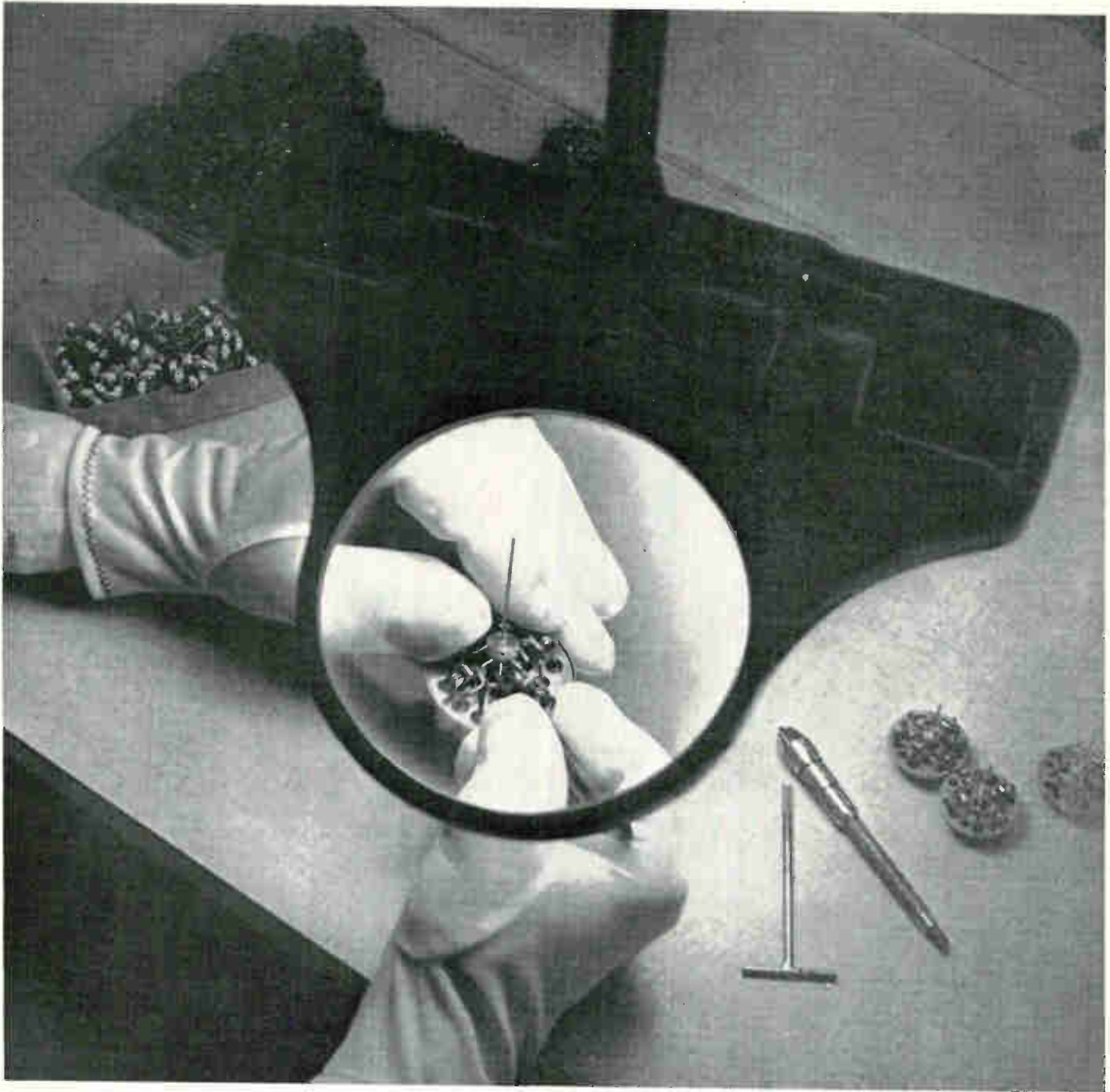

ENGELHARD gold and silver on relay contacts assure only one miss in ten million cycles!

Electro-Tec Corp. faced one of its toughest problems—develop electromechanical relays to meet the extraordinary reliability requirements of missiles, manned aircraft and space craft, and computers. The solution: new Wedge-Action relays using Engelhard 24K gold and fine silver for contacts.

These remarkable relays have the highest confidence level ever achieved in any electromechanical relay—only one miss in 10 million cycles. Engelhard impurity-free gold and silver, electrodeposited to both moving and stationary switching contacts, helped do the trick. Contact resistance is an extremely low 0.012 ohms to

0.015 ohms. And remains constant to within 15 milliohms for more than 100,000 operations.

This is just one more example of the problem-solving capabilities of Engelhard precious metals—capabilities that result from our constant search and development of the precious metals. When you have a precious metals problem, call on Engelhard Industries, *working wonders with wonder-working metals!*

ENGELHARD
INDUSTRIES
113 Astor Street, Newark, New Jersey 07114

A DIVISION OF ENGELHARD MINERALS & CHEMICALS CORPORATION

6508

it costs you nothing to call on experience:

Reeves-Hoffman design and manufacture
is 100% custom . . .
let us quote your needs!

★ quartz crystals

★ crystal filters

★ oscillators

★ discriminators

★ standards

★ ovens



REEVES- HOFFMAN

DIVISION OF **DCA**

400 W. NORTH ST., CARLISLE, PA. 17013
TELEPHONE • AREA CODE 717 • 243-5929



Md., O.C., Va., W.Va., N.C.
Valley Electronics, Inc.
Baltimore, Maryland
(301)668-4900; (202)659-1760

New England
Howard Jappe Company
Wakefield, Mass.
(617)245-9359

Pa. (not western), Del., So.N.J.
Eastern Components, Inc.
Philadelphia, Pa.
(215)927-6262

New York (except N.Y.C.)
Midstate Research Sales Co.
Syracuse, New York
(315)478-8314; (315)478-0715

New York City, No.N.J.
G. M. Moch Company
Ridgefield, New Jersey
(201)945-0080; (212)279-6758

So. California
Ash M. Wood Company
Arcadia, California
(213)283-1201; (213)287-0449

No. California
L & M Engineering
Santa Clara, Cal.
(408)243-6661

Ill., Ind., Wisc., Minn.
PGM Sales, Inc.
Chicago, Illinois
(312)622-8183

Ohio, W.Pa., Mich., Ky.
Tri-State Marketing, Inc.
Cincinnati, Ohio
(513)631-5060

Texas, Okla., Ark.
Carter Associates, Inc.
Garland, Texas
(214)276-7151

Ariz., N.M., Las Vegas
Carter Associates, Inc.
Scottsdale, Arizona
(602)947-4355

Circle 507 on reader service card

New microwave

Coaxial connector for fast crimping

Uniform contacts assured
by mechanical process
including cable preparation

There was a time when the installation of solder-type coaxial connectors, with their many loose parts, was difficult and time-consuming. Stray braid strands were a common cause of trouble. This situation was somewhat alleviated by crimp-type connectors but the process still took too much time—especially when it came to stripping subminiature cable.

To eliminate these problems, AMP Incorporated has developed a system—including connectors and installation equipment—that does the job in 20 seconds. The contact exhibits a voltage standing wave ratio of less than 1.5:1 at 500 megahertz.

Designed for high-density, multiple-circuit connector applications, the subminiature, 0.11-inch contact fits into any AMP connector housing that accepts size 16 pin-and-socket contacts. Either pin-and-socket or coaxial contacts will fit into any of the 14 to 156 positions of the 19 connector styles available.

The contact body is stamped from strip brass conforming to MIL-B-50. A polypropylene dielectric surrounds and supports the inner contact for accurate mating alignment, and a tin-plated copper retention spring attached to the outer contact surface secures the crimped contact from axial pullout.

Application tooling for the stripped connector includes two electrically operated bench machines—an applicator and a crimping press—that complete the assembly in 20 seconds.

Collared. Operation of the applicator tool is simple. A piece of cable is inserted through a funnel-like opening, a button pushed, and the stripped cable removed with a crimping collar put in place. Inside the machine, a vibratory hop-

**A NEW
CONCEPT IN
ENERGY
CONVERSION**

A basic discovery that transfers
transient-free energy without
the use of mutual inductance.

WANLASS
ELECTRIC CO.

A Subsidiary of American Bosch Arma Company
2175 South Grand Avenue/Santa Ana, California 92705

ECONOMICAL Thin Film!

Resistor-Module and Discrete Resistor Plate-ohm
have been developed by SUSUMU's unique thin-film
techniques. The Ideal resistor for your purposes!

HIGH RELIABILITY and LOW NOISE CHARACTERISTICS from
SUSUMU's evaporation techniques.

LESS EXPENSIVE as carbon resistor due to SUSUMU's fine
engineering.

ADVANTAGEOUS for your printed circuit wiring, with high-
density assembling.

EXCELLENT T.C.R.: applicable in range of $-100 \text{ ppm}/^{\circ}\text{C} \sim +$
 $100 \text{ ppm}/^{\circ}\text{C}$.

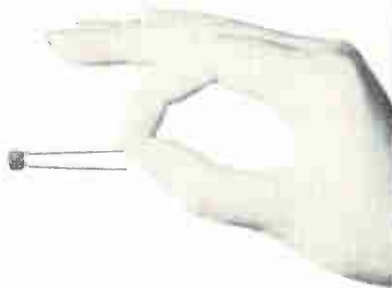

Specialists in Vacuum Evaporation:

SUSUMU INDUSTRIAL CO., LTD.

HEAD OFFICE AND EXPORT DEPT.:
6 Shonouchi, Chudoji, Shimogyo-ku, Kyoto, Japan
Phone: Kyoto 075 (311) 4459 Cable address: SUSUMU KYOTO
FACTORIES: KYOTO, NAGASHINO
TELEX NO. 5422-359



**Don't try to sell her
on the challenging career
Hughes has offered you.**

Just mention . . .

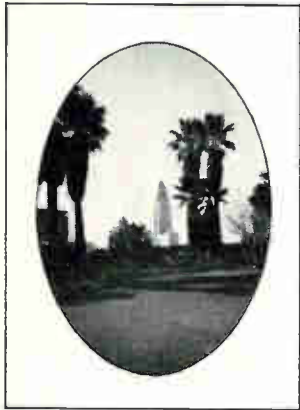

The climate. Often it's compared with the Riviera's. In truth, Southern California's is better. Dryer in summer: no mosquitos, little mugginess. Balmy in winter: seven hours of sunshine a day. You'll save on galoshes!



Family fun. You literally can ski and sunbathe the same day here. Swimming pools and ski runs are an hour apart. The kids will love mountain climbing, surfing, sailing, desert rockhounding. Every weekend's a vacation.

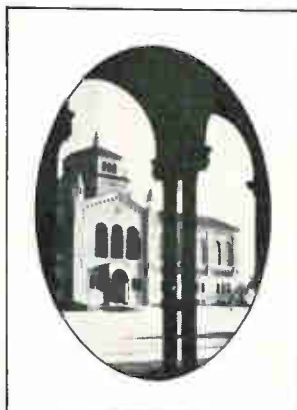

Great schools. Some of America's most respected school systems are in the Los Angeles area. Also, many fine city colleges; three branches of California State; U.C.L.A., U.S.C., Caltech, Occidental, Loyola, and *more*.

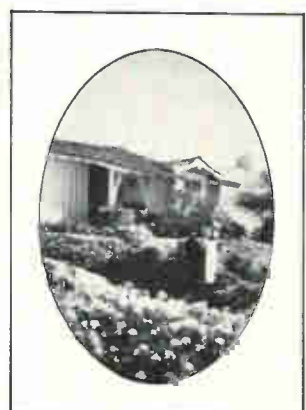

The good life. You can find it in communities like Westchester, Redondo, Playa del Rey. Or Sherman Oaks, Canoga Park or Pasadena. We have literally scores of beautiful residential areas within easy reach of Hughes plants.

About that challenging career . . . The Hughes Aerospace Divisions have over 200 openings now for graduate engineers. Opportunities exist on advanced projects and programs like ATS, VATE, TOW, PHOENIX, Communications Satellites, and many others. Please send resume to:

**Mr. Robert A. Martin
Head of Employment, Dept. 16
Hughes Aerospace Divisions
11940 W. Jefferson Blvd.
Culver City, California 90230**



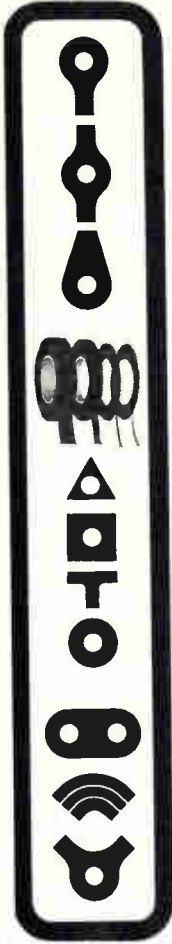

No Engineer or Draftsman
should be without the **BY-BUK**
handy **CROSS REFERENCE**
GUIDE to better
printed circuit
drafting

which include standard sizes
as specified in MS 16912,
(NORD) conforming to MIL-P-
55110A... & its **FREE**



The booklet features over 3000 sizes of tapes, pads
and shapes for **FASTER MORE ACCURATE DISTOR-**
TION-FREE PRINTED CIRCUIT MASTER DRAWINGS.

Write today for **FREE** handy cross-reference guide, price list and
FREE samples from the most complete supplier of Printed Cir-
cuit Drafting and Masking Aids.

BY-BUK COMPANY

4326 West Pico Blvd., Los Angeles, Calif. 90019 • Phone (213) 937-3511

Circle 508 readers service card

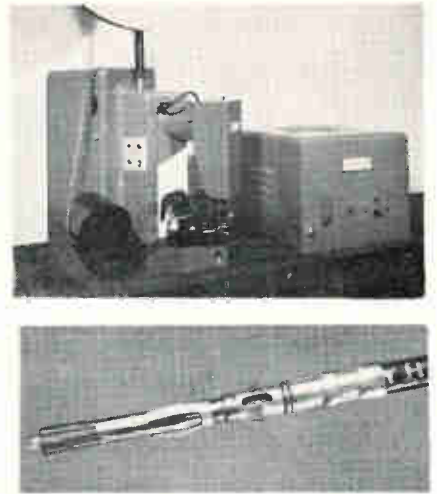

Strip fed. Connectors are automatically
supplied to crimping tool from spool.

per orients the crimping collar so
that when the cable is inserted the
collar slides on.

When the button is pushed, a
series of shear blades close to trim
the outer jacket, braid, dielectric,
and center conductor to the proper
length. The shear blades then
move axially away from the cable,
stripping each layer of the cable
to its trimmed length. Oscillation
of the center conductor and dielec-
tric flares the braid to a mechan-
ically fixed limit and the jaws open,
permitting the operator to with-
draw the prepared cable.

The crimping is done in one of
AMP's newer electric bench presses
fitted with a set of dies designed
specifically for this new contact.
The operator positions the cable,
locates the collar, and depresses a
foot pedal. Closing of the crimping
die simultaneously crimps the outer
jacket, braid, and center conduc-
tor, then releases the installed con-
tact.

The collar is crimped over the
outer jacket to provide rigidity and
to prevent cable damage due to
flexing at this point. The cable
braid is crimped between the col-
lar and the rear of the contact out-
er body. Peripheral V-groove serr-
ations on the body grip the braid
and help secure the cable against
a maximum axial pullout force of
25 pounds. Two slender protrus-
ions on the die extend through
ports in the outer portion of the
contact to crimp the center con-
ductor.

AMP Incorporated, Harrisburg, Pa.
17105 [410]

Circle 257 readers service card →

High Reliability Instruments

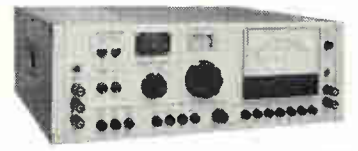

MAK-659

Dist. meter
— for AUDIO LABS and PRODUCTION —

MEASUREMENT RANGES

■ **Distortion**
Range: 0.1 to 30%, 5 steps; frequency: 20Hz-200kHz;
input impedance: 600, 10k, 20k ohms; automatic con-
trol range: 40dBm or 100X in voltage; fundamental sup-
pression: over 60dB.

■ **Level**
Range: -70 to +40dBm, 600 ohms, and -70 to
+20dB (0.3mV-10V), 10k and 20k ohms; frequency:
20Hz to 600kHz.

■ **S/N (signal/noise)**

Range	Input
0 to 70dB	-22 to 0dBm
0 to 90dB	0 to +38dBm

frequency: 20Hz to 60kHz.

• Catalog sheet on request

MEGURO DENPA SOKKI K.K.
(Meguro Electric Instrument Co., Ltd.)
No. 5, 1-2-chome, Chuo-cho, Meguro-ku, Tokyo, Japan
TEL: 711-7191 ~ 7 Cables: MEGURO DENPA TOKYO



256 Circle 256 on reader service card

FOR
Electronic Components



Solve all component
procurement problems
quickly and
economically...
simply specify GC!

Choose from a wide
variety of binding
posts, alligator clips,
phone tips and jacks,
banana plugs, and the
exclusive GC "Klipzon"
products to speed
production on every
electronic assembly.

Write today on your
Company letterhead
for the big **FREE GC**
Electronic Components

FREE! Catalog —
FR-66-1, and ready-
reference
Wall Chart —
FR-029-E...
your GC keys to
greater profits.

GC Electronics
400 South Wyman Street
Rockford, Ill. 61101

A Division of
GC - Hydrometals, Inc.
Shipping warehouses in:
Hicksville, L.I., N.Y.
Los Angeles, California



Circle 509 readers service card

POUF....**THAT'S ALL IT TAKES
TO ACTUATE THIS
NEW SWITCH.**



SKEPTICAL? TRY IT.

(we'll send you a free sample)



Just a gentle whisper of force ($1\frac{1}{4}$ grams) actuates this new Cherry E22 miniature switch. As easy as blowing fluff off a dandelion. It's so sensitive, we had to make the actuator of aluminum (to permit re-setting of the switch). Dependability? This 3 amp., 125 VAC switch features Cherry's exclusive long-life coil-spring mechanism that insures positive snap action...proven in over 100 million product applications.

But, see for yourself. Send for a free sample and complete specifications.

CHERRY 

Cherry Electrical Products Corporation • 1656 Old Deerfield Road • Highland Park, Illinois 60035

Only new Lambda LP Series lab power supplies provide all these big system features in a small, low-cost package.

Starting at only \$114.

- High power output—up to 28 watts.
- Wide voltage range versatility—0-10 VDC up to 0-250 VDC.
- Bench or rack use—without adapters.
- Unusually wide automatic current limiting—from 1% (or 5 MA) to 105% of rated output current.
- Two meters for voltage and current.
- Both coarse and fine adjustment of voltage and current.
- Over-temperature protection by thermal relay—prevents overheating.
- Convection cooled—no blower failures.

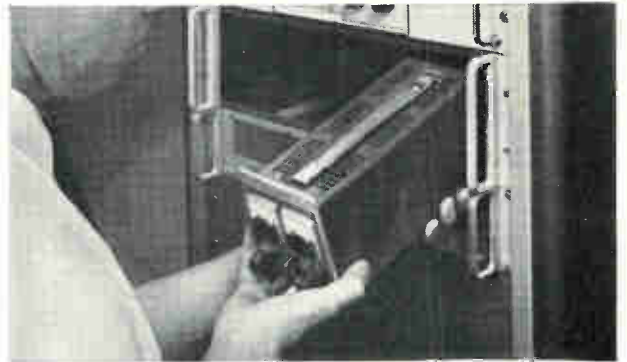

You can mount up to 4 units in a standard LRA-1 or LRA-2 rack adapter.

Other features

- Regulation (line or load): .01% + 1 MV.
- Ripple: 500 μ V RMS. 1.5 MV p-p
- Temperature coefficient: .015% + .5 MV/ $^{\circ}$ C.
- CV/CC with automatic crossover.
- A-C input: 105-132 VAC 45-440 Hz (ratings based on 57-63 Hz operation).
- All Lambda power supplies are guaranteed for 5 years.

Select from six models

Model	Voltage Range	MAX. CURRENT AT AMBIENT OF:				Price ¹
		30 $^{\circ}$ C	40 $^{\circ}$ C	50 $^{\circ}$ C	60 $^{\circ}$ C	
LP 410	0-10 VDC ²	2A	1.8A	1.6A	1.4A	\$129
LP 411	0-20 VDC ²	1.2A	1.1A	1.0A	0.8A	119
LP 412	0-40 VDC ²	0.70A	0.65A	0.60A	0.50A	114
LP 413	0-60 VDC ²	0.45A	0.41A	0.37A	0.33A	129
LP 414	0-120 VDC	0.20A	0.18A	0.16A	0.12A	149
LP 415	0-250 VDC	80MA	72MA	65MA	60MA	164

*Overvoltage Protection available as an accessory—\$40.00 each.

¹Prices are for non-metered models. For metered models, add suffix (FM) and add \$10.00 to price.

SEND FOR COMPLETE LAMBDA CATALOG

LAMBDA
ELECTRONICS CORP.
515 BROADHOLLOW ROAD · MELVILLE, L.I., NEW YORK 11746 · (516) 894-4200

A  SUBSIDIARY

VEECO HIGH VACUUM EQUIPMENT/LAMBDA POWER SUPPLIES



New Production Equipment Review



Weld head model 820-IWW is designed for welding insulated wire to terminals, without prestripping. Equipped with water-cooled electrodes, the head will operate for hours at high production rates. It has a force range of 8 oz to 20 lbs and a digital force readout. Throat depth is 2 5/8 in. Price is \$495. Wells Electronics Inc., 1701 S. Main St., South Bend, Ind. 46623. [421]

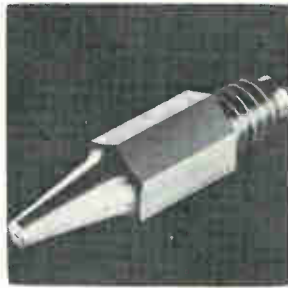

Long-life sapphire capillaries are for the precision flameoff of bonding wire used in the manufacture of IC's. Bore sizes are 0.002, 0.003, and 0.004 in. Bores are accurate to 0.0005 in., assuring accurate reproducibility of flame levels from capillary to capillary with little if any pressure compensation. Specialty Glass Products Inc., 147 Terwood Rd., Willow Grove, Pa. 19090. [422]

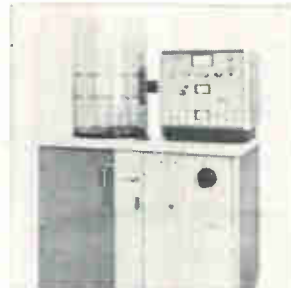

Vacuum evaporator VE-30 is automatic and has built-in fail-safe features. Working vacuum is in the 10^{-9} torr range, with 7-minute pumpdown to 10^{-6} torr. Features include an 18 x 30 in. work area; 1,440 liter per sec diffusion pump; and 2 kva filament power supply. Uses include thin film deposition work and r-f sputtering. Varian Associates, N.W. Science Park Dr., Portland, Ore. 97229. [423]



Model 300 Autopulse soldering system places all critical aspects of hand soldering under fully automatic programed control. It generates temperatures higher than 1,000°F in as little as 100 msec, and permits soldering of insulated wires smaller than 0.001 in. The system is suited for IC production. Browne Engineering Co., 2003 State St., Santa Barbara, Calif. 93105. [424]



Ultrasonic scrubber 020 cleans semiconductor wafers in the process steps leading to making epitaxial slices. It includes a 150-w, 6- x 10- x 4-in. tank system. Its transducers are lead titanate. The power supply driving them is oversized by 300%, giving long life and eliminating need for a fan. Pittsburgh Materials & Chemicals Corp., 3400 Old Wm. Penn H'way, Murrysville, Pa. 15668. [425]



Wafer dicing machine 3312 offers yields of 99% plus. It uses fine diameter steel wires combined with an abrasive slurry to saw through materials such as glass, silicon and germanium. Wafers with center-to-center spacing as little as 0.010 in. can be cut at rates of 1 1/2 minutes each including wafer loading and unloading. Micro Tech Mfg. Inc., 703 Plantation St., Worcester, Mass. 01605. [426]

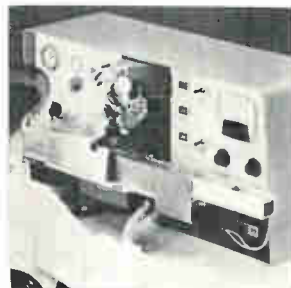

Die bonder model 1212 accommodates dual-in-line (DIL) IC's. Its carrier holds 4 tiers of 1 5/8-in-wide indexing belts and each belt holds 16 lineal inches of DIL strips. A bonding needle is contained in an air bearing. Vacuum creates the bonding force. A horizontal movement of the needle provides scrubbing motion. Sola Basic Industries, 2450 W. Hubbard St., Chicago. 60612. [427]



A conveyor furnace offers precise process control and high production yields for thick-film firing of semiconductors. It can be adapted for soldering, alloying, brazing, and sintering. Solid state controls hold set temperatures of up to 1,000° within $\pm 2^\circ\text{C}$. The belt drive provides accurate speeds from 1 to 10 in./minute. Sola Basic Industries, 2450 W. Hubbard St., Chicago. 60612. [428]

New production equipment

Controlled overloading tunes up resistors

Applying excessive current to thin-film devices produces an adjustment tolerance of 0.02%

Overloading a resistor can blow or degrade a circuit.

But controlled overloading is the heart of a new technique for adjusting thin-film resistors to tolerances as tight as $\pm 0.02\%$. A precision resistor adjustment machine designed at the Bunker-Ramo Corp.

is said to be the first commercially available machine of its kind which works on an electrical-thermal principle. Most use mechanical or chemical means to adjust thin-film resistors.

The new equipment, which is being offered for lease, emerged from



Settable. Operator selects the desired resistance and attaches the probes. The rest of the operation is automatic.

WHICH DEFLECTION YOKE FOR YOUR DISPLAY ?



Consult **SYNTRONIC**

YOKE SPECIALISTS

Syntronic's team of experts knows more about yoke design, engineering and quality control than anyone else. A solid 10-year record of leadership—acknowledged throughout the industry. Benefit from it.

syntronic **INSTRUMENTS, INC.**
100 Industrial Road, Addison, Illinois
Phone: Kingswood 3-6444

Circle 510 on reader service card

For
Production
Efficiency



CRM FINE WIRE
for **ULTRASONIC BONDING —**
ALUMINUM & ALUMINUM ALLOYS
featuring
Cleanliness • Strength • Uniformity

Contact CRM engineers for recommendations
for your application.

Write for latest catalog.



CONSOLIDATED REACTIVE METALS, inc.
115 Hoyt Avenue — Mamaroneck, N. Y. — OWens 8-2300 — TWX 914-835-3380

... process slow,
so no hot spots ...

a program to develop equipment for in-house use by Bunker-Ramo, a major supplier of custom-designed hybrid thin-film circuits. The machine is used with a digital voltmeter, which reads out resistance values.

No hot spots. According to Jack W. Ireland, director of the company's microelectronics and advanced technology operations, the controlled, relatively slow nature of the new process eliminates the hot spots and noise that are characteristic of chemical and mechanical adjustment techniques.

The new technique alters the temperature coefficient of resistance (TCR) of resistors. This is not true of mechanical adjustment techniques such as scribing or the use of shorting bars. "When you adjust with our equipment," Ireland says, "you get a TCR change at a predictable rate with respect to the change in resistance. This TCR change can be advantageous for tracking purposes—where you have two adjacent resistors that have to remain identical in resistance over a wide temperature range. For every degree of heat, you add maybe 10 to 50 parts per million, depending on the TCR factor of the material."

Balancing the bridge. The equipment consists of a Wheatstone bridge, power supplies and associated circuitry to selectively energize and de-energize the bridge arrangement. The bridge has four arms, two of which have the resistors to be adjusted—and standard wire-wound resistors against which they'll be checked—sequentially switched into them. The resistors and the standards are so arranged that when a switch positions the resistor to be adjusted into the Wheatstone bridge, the standard resistor is placed in the adjacent arm of the bridge. A current from a secondary winding of a transformer in the circuitry flows through the bridge arrangement, including both the resistor and the standard. Current flowing through the resistor to be adjusted is controlled by the setting of an autotransformer in the circuitry, and a reading of the current is provided by a milliam-

eter in series with the autotransformer.

When the resistance value of the resistor to be adjusted equals that of the standard, a detector functions to de-energize the circuit. A stepping switch can then be advanced to the next position, bringing another resistor and its standard reference into the bridge arrangement. The standard resistors are much larger than the resistors that must be adjusted. They easily dissipate the heat and their values remain unchanged.

The resistance tolerance of the equipment is adjustable, "but there's a practical value beyond which you don't need to go," says Ireland. "A good practical limit for repeatable production rates is $\pm 0.01\%$." A typical production rate at this accuracy, Ireland says, is 10 resistors per hour, using single probes and depending on the accuracy of the DVM used.

Up or down. Some typical resistance changes accomplished with the equipment in an oxidizing atmosphere show that the resistance of uncoated chromium resistors was boosted from 1,927 ohms to 2,156 ohms in 13 seconds at 570 watts per square inch; coated chromel-C resistance was lowered from 1,950 ohms to 1,879 ohms in two seconds with 565 watts per square inch.

Ireland says the advent of hybrid circuits has created the market for precision resistor adjustment equipment. "This equipment should assist major users of hybrid microcircuits on make or buy decisions at a minimum outlay," he says. "The major aerospace companies are going the hybrid route with their own research and development efforts. Our equipment comes into play in this subsystems work."

A typical customer, Ireland believes, might be a large-volume user of analog circuits such as a manufacturer of analog computers. Such a customer could use the equipment for prototype work, then let out production specifications for resistors to a volume vendor.

The company has identified an initial market potential of about 100 units, and will lease the equipment for \$300 a month plus one cent per pulse.

Bunker-Ramo Corp., Western Technical Center, 8433 Fallbrook Ave., Canoga Park, Calif. 91304 [429]

You're a year behind the times if you think our RF1 vacuum relay is just for the communications industry.

Sure our RF1 vacuum relay is ideal for such typical communications uses as antenna switching and band switching. But in the year since it was introduced this remarkable little relay has proven itself in a multitude of markets and in applications where vacuum relays had never been considered.

Once for ounce, the RF1 controls more power for more applications than any other relay in the world. It's replacing mercury wetted contacts for switching in capacitor circuits for protection on arc lamps. It's used for circuit control aboard railway locomotives and in automated remote control systems for controlling locomotives. It's also controlling power supplies in laser range finders and making millisecond tuning possible in digitally tuned transmitters, logic circuit all-electronic tuning and

binarily tuned HF radio transceivers.

We could go on and on about the merits of these $\frac{3}{4}$ -ounce relays with their superclean contacts. They cost no more than other relays of their power level, but look at their performance: 4 kv peak 60 cycle test voltage • 2 kv peak operate voltage at 16 mc • 4 amps rms at 16 mc • Interrupt 1 kw dc power; interrupt inductive loads • .020 ohms maximum contact resistance at 32 mc remains permanently low • 10 g to 2000 cps vibration resistance • Impervious to environmental conditions • Rapid operation (10 ms maximum).

For complete information on the RF1 and a copy of our new vacuum relay catalog, write to ITT Jennings, a division of International Telephone and Telegraph Corporation, 970 McLaughlin Avenue, San Jose, California 95108



Shown actual size

JENNINGS **ITT**

need a
front-yard
market?

IOWA has
that, too!

Chicago, Detroit, Milwaukee, Minneapolis, Kansas City and St. Louis are all in Iowa's front yard. That's one reason Iowa's last 4 record years of industrial growth have seen 438 new industries invest \$205,000,000 in Iowa and 626 industries spend \$346,000,000 for expansion.

Some other important reasons: *Labor Force* . . . talented, trainable men and women from 32 colleges and universities and many vocational schools. *Water* . . . from the Mississippi, Missouri and many other Iowa rivers. *Transportation* . . . two navigable rivers, plus roads, rails and an airline network to every conceivable point. *Management Time* . . . Iowa executives just naturally have more. They don't waste hours commuting daily.

There's more. Fill out the handy coupon . . . we'll send all the facts. Fast!

(Confidential Reply Coupon)
IOWA DEVELOPMENT COMMISSION
Dept. 5117, 250 Jewett Building
Des Moines, Iowa 50309



Name _____

Firm _____

Address _____

City _____

State _____

Zip _____

New production equipment

Welding fasteners quick as a flash

High-speed stud welding unit
numerically controlled
for parts production

Numerical control, used extensively to run drilling machines, boring mills and punch presses, has been coupled to stud welding techniques for mass-production of parts for the electronics industry.

Stud welding is the joining of metal fasteners of various dimensions. The use of a tape-fed numerical control machine means that intricate welding patterns can be accomplished on items ranging from electronic housings to appliance panels without the need for auxiliary tooling or multiple welding heads, according to KSM division of Omark Industries Inc.

The company coupled its production welding unit to a numerical control system and positioning table made by Hughes Aircraft Co. The resulting system permits about 30 welds per minute, in virtually any pattern and within 0.001 inch of the desired location. The company sees primary applications in electronic parts production, where precisely-positioned fasteners are often needed in a small area to secure components.

Studs of up to one-quarter inch in diameter can be attached by the welding unit, which can be stocked with more than 15,000 fasteners. A weld is completed in a few milliseconds, so quickly that there is no burning on the reverse side of the thinnest-gauge materials, KSM says. The capacitor-discharge method of welding is used. A steel stud with a small, protruding tip is placed on the workpiece. Electrical energy stored in the capacitors is then released, instantly melting the projection and the surface of the material, and permanently joining the stud and the piece. The process can be used on a variety of metals, including aluminum.

Omark Industries, Inc., KSM Division,
Moorestown, N.J. 08057 [430]

Mold-A-Terms cut terminal insulating costs to 50%!

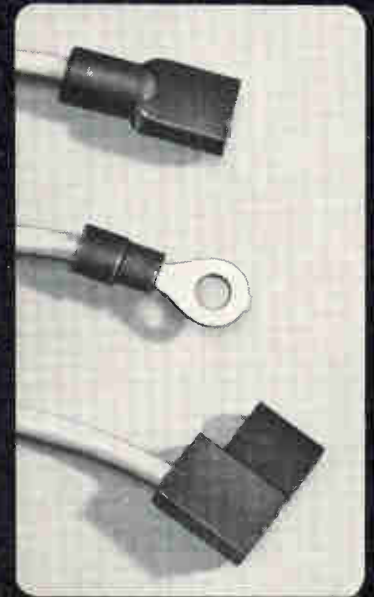

This technique consists of encapsulating any desired portion of the standard open barrel terminals after they are crimped onto wire leads. PVC and various other thermoplastic materials have been found equally adaptable.

Beman refined "MOLD-A-TERMS" to overcome price inequities found in comparable cost studies with pre-insulated and post-insulating methods.

ADVANTAGES OF "MOLD-A-TERMS"

Freedom of Design...Smaller size...
Protection against Moisture and
Natural Contaminants.

Applied singly or in multiples...
Write for further details on "MOLD-
A-TERMS."

BEMAN MFG., INC.

P. O. Box 370 New Cumberland, Pa., 17070
Phone: (717) 774-0210

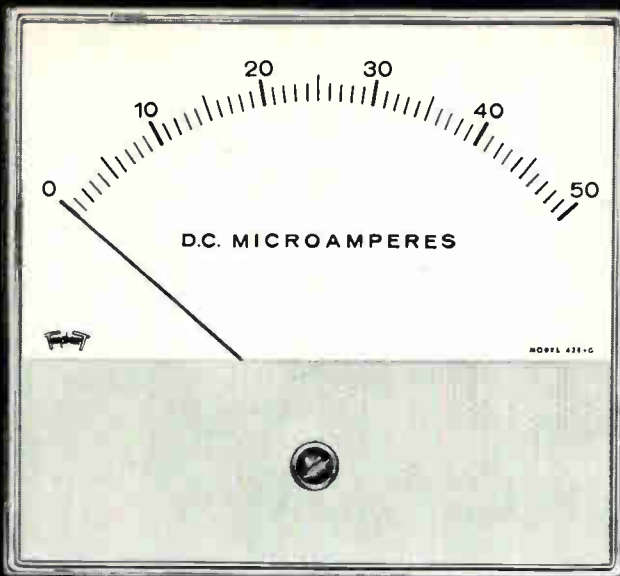

now you see it

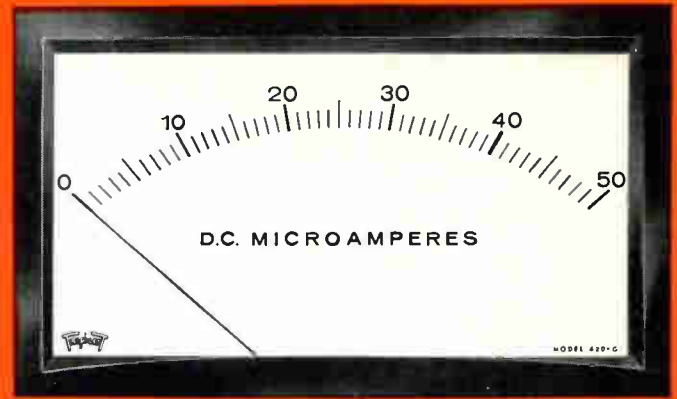
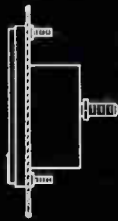

now you don't



THE PANEL INSTRUMENT WITH BUILT-IN FLEXIBILITY

TWO NEW SIZES!
5½" and 1½" (Miniature)

TRIPLET

New Triplet G-Series Panel Instruments offer a modern design that features a greater degree of flexibility and interchangeability.

1 Two types of mounting are available—conventional flush type or behind-the-panel with a bezel for modern picture window appearance. **2** The insert shield on the front of the meter can be custom painted or printed to meet customer's requirements.

3 Triplet's famous self-shielded Bar-Ring magnet, with one-piece die-cast frame, in all DC and DC suspension type instruments.

In five popular sizes: 5½" DC and AC; 4½" DC and AC; 3½" DC and AC; 2½" DC and AC; 1½" (conventional flush mounting only) DC and AC rectifier type.

Circle 263 on reader service card

NOW IN FIVE POPULAR SIZES:
1½" (Miniature); 2½"; 3½";
4½"; & 5½".

NEW

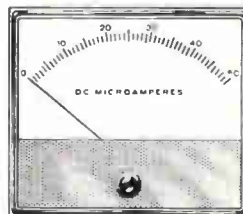
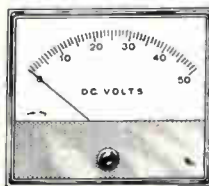

TRIPLET ELECTRICAL INSTRUMENT COMPANY, BLUFFTON, OHIO



**Last
Tuesday
morning
a lot of people
on Pleasant
Avenue were
glum.**

But not "Smiling" Sam Price. He's one of the Twelve Cranks on Pleasant Avenue. And last Tuesday he found a lousy connection in a Trygon Liberator Power Supply that was coming off the line! It made his day!

The point is, of course, that loused-up Liberators never leave Trygon. Not with Sam Price and his un-merry men around. Their job is finding problems for us; so you don't get any problems from us.

Sam's pet, the Liberator, gives you the ultimate in IC and transistor system power in minimum size at lowest possible cost. Wide slot adjustment ranges with voltages up to 160v. Output current levels up to 40 Amp (3½") and 70 Amp (5¼"). .005% regulation/.5 mv ripple/3mv P-P noise/.01% stability/extremely low output impedance/MIL Spec. performance / integral slide mounting/automatic load share paralleling/overvoltage protection.

And you can be sure of this. Every Trygon Liberator Power Supply comes off the line under Sam's baleful eye. Order one and see.

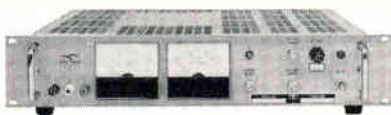

Trygon Power Supplies

111 Pleasant Avenue, Roosevelt, L.I., N.Y. 11575
Trygon GmbH 8 Munchen 60, Haidelweg 20, Germany

New Books

Less guesswork

Handbook of filter synthesis
Anatol I. Zverev
John Wiley and Sons, Inc.,
576 pp. \$19.95

Today a systems engineer can specify almost any type of filter response as a subsystem on a block diagram and be reasonably sure that it can be approximated and built into an operating electronic filter. This handbook makes it easier for filter designers to satisfy such specifications. It combines the best features of a theoretical text with those of a practical filter design manual.

Performance and design data for all possible filter types—inductance/capacitance, crystal, and coupled resonators—are given in both the time and frequency domains. Designed primarily as a guide to solving filter problems, the book also covers basic network synthesis.

Zverev starts with the underlying theory, concepts, and techniques of selective networks and then moves to the responses that are provided by passive, linear, bilateral filtering structures. These are illustrated by specialized networks such as crystal and helical filters.

Other sections cover polynomial filters with monotonic attenuation curves, design tables for lowpass element values, normalized coupling coefficients, quality factors, and network-transformation techniques.

Although the author does an excellent, comprehensive job of describing passive filters, the reader will not find an extensive treatment of active networks and microwave structures.

A for effort

Introduction to Quantum Mechanics
for Electrical Engineers
P.A. Linsay
McGraw-Hill Book Co., 240 pp., \$9.50

Few books have been aimed at making quantum mechanics palatable to electrical engineers. Any that try to are like coeds at Princeton—on the basis of rarity alone they demand attention. This book

tries and partially succeeds.

The importance of quantum mechanics to today's inventive electrical engineer is summed up by Rudolf Kompfner of Bell Telephone Laboratories in his introduction: "I expect to see a reversal of a trend . . . that the major inventions in the recent past in the sciences of communications and electronics have been made by physicists." Presumably, notes Kompfner, the physicists studied quantum mechanics at school.

In a discussion of waves Lindsay glosses over the first experiments that suggested the wave properties of matter and omits illustrations that might be helpful. He assumes the reader is familiar with wave equations, and points out the similarities between Heisenberg's uncertainty principle and the time-frequency domain correspondence. Liberal use is made of transmission line theory throughout to support the author's presentations.

The book concludes with a discussion of the concept of energy bands in crystals. Most readers would expect, and profit by, a discussion of the relationship between this concept and semiconductor physics—but it is lacking. Instead the reader must refer to texts on solid state physics, for which Lindsay's book is an excellent introduction.

For those who are seriously interested in the subject, he includes problems at the close of each chapter. Some instruct the reader to "discuss" specific areas. One wonders with whom the solitary student will discuss such problems; wives, for example, are notoriously poor conversationalists when it comes to quantum mechanics.

Two in one

Tunnel Diodes
M.A. Lee, B. Easter, H.A. Bell,
Chapman and Hall Ltd.,
Distributed in the U.S. by Barnes &
Noble Inc., 196 pp., \$6.25

As one of a series of brief, inexpensive monographs on selected topics in electronics, it's easy to see why this book has been published. The

How to keep relay contact forces balanced at 30 G's.

Picking a relay for an extreme shock/vibration environment is a tough problem for many a circuit designer. Few relays are designed to meet the problem head on. There is now one notable exception—a 4PDT, 10 ampere relay in a one-inch cube.

Using a new design principle—balanced-force—this relay withstands severe shock, vibration or acceleration while maintaining high contact and overload capabilities. It will take more than 30 G's to 3000 Hz vibration, a shock of 100 G's and has a minimum life of 100,000 cycles. This one-inch cube is all welded, weighs 2.5 ounces, and is rated at 2.9 watts coil power.

EFFICIENT MAGNETIC CIRCUIT

In the conventional relay motor, forces for open and closed contacts are unequal. Energized coil power causes the armature to close the normally open contacts. But, when the coil power is removed and the contacts return to the normally closed position, only the spring forces of the contacts and the return spring provide the force. These combined spring forces are usually low, allowing the contacts to bounce. In addition, the low spring force allows the armature to rebound off the armature stop, again knocking the contacts open—sometimes, for as long as several milliseconds after they have initially closed.

Force-Stroke Curve of Typical Relay and Balanced-Force Relay.

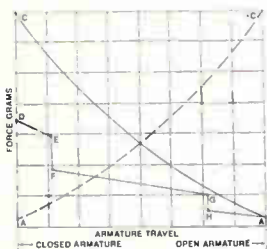

Curve CA—Balanced-Force Relay normally closed contacts.
Curve A'C'—Balanced-Force Relay normally open contacts.
Curve DEFGH—Typical Relay.

An obvious method of getting rid of a bounce condition is to balance the armature forces exactly. This is achieved in the

Leach Balanced Force Relay by use of an extremely efficient magnetic design. It has to be to

keep the forces balanced while ignoring 30 G's. Basically it is a controlled application of magnet and coil flux. In the de-energized position, a permanent magnet flux flows between the armature and the tip of the adjacent pole piece, resulting in a high holding force. The motor is, therefore, relatively immune to shock and vibration. When coil power is applied, the flux from the permanent magnet is nullified by the coil flux flowing in an opposite direction. The armature closes with a rapid build-up of magnetic force driving it against the contact overtravel forces and into a sealed position.

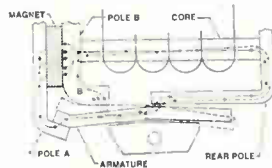

Balanced-Force Motor De-Energized

When coil power is removed and the armature returns, the

restoring force of the permanent magnet builds up quickly. The armature is then driven against the overtravel forces of the normally closed contacts and into its de-energized sealed position. With this type of force-displacement, the armature isn't about to rebound.



New Leach Model K employs balanced-force concept.

BUFFERED CONTACTS

The moving contacts are mounted to an armature, which is held firmly at the end of each stroke by high magnetic forces. Since the armature can't move during shock

or vibration, undesirable contact opening is eliminated.

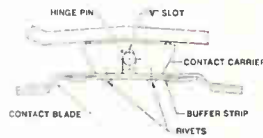

Moving Contact System

Reinforcing the moving contact is a buffer strip which assumes a

variety of chores. It has a bow in the center to act as a spring load while serving as a rivet plate. It works as a heat sink. It will break the contact strip free from a weld if one occurs because of excessive overload. It makes contact with the moving blade which results in excellent low contact drop. It serves as an electrical contact between the moving blade system and the header. And, as the name implies, it buffers the contact blade against extreme shocks and vibrations.

WELDED ASSEMBLY

In assembling the relay all detail parts are welded. No part is solder assembled. There is no possibility of contamination from solder flux. The unit is then pressed into a can and electron-beam sealed, leaving only an evacuation hole. After a high temperature bake, the relay is filled with a dried inert gas, and the hole is welded shut. Here, ready for shipment, is a relay with a magnetic circuit designed so the force without coil power applied is equal to the force with coil power applied, but in exactly the opposite direction. And you can rest assured those forces stay balanced no matter how you shake them.

Complete Motor and Contact Assembly

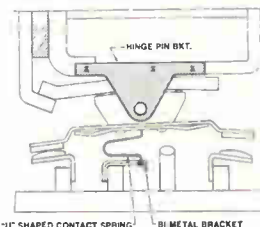

U-SHAPED CONTACT SPRING BI-METAL BRACKET

Write for your copy "Tomorrow's Relay Today", a technical paper presented at the

National Relay Conference. Leach Corporation, Relay Division, 5915 Avalon Boulevard, Los Angeles, California 90003
LEACH (213) 232-8221.

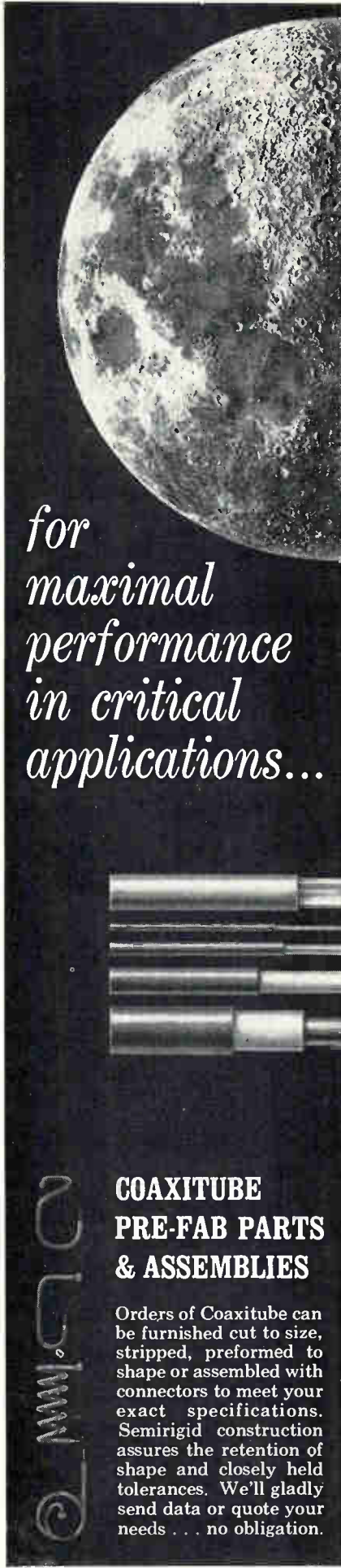

*for
maximal
performance
in critical
applications...*



COAXITUBE PRE-FAB PARTS & ASSEMBLIES

Orders of Coaxitube can be furnished cut to size, stripped, preformed to shape or assembled with connectors to meet your exact specifications. Semirigid construction assures the retention of shape and closely held tolerances. We'll gladly send data or quote your needs . . . no obligation.

© 1974

New Books

topic of tunnel diodes is narrow and lends itself to coverage in less than 200 pages.

Tunnel diodes, today, are useful in only two applications: microwave amplifiers and high-speed logic circuits. This book covers both areas. But a reader interested in logic circuits would care little about microwave amplifiers, and vice versa. Thus, either reader, if he buys the book, is also paying for information that will probably be useless to him in his work.

One wonders, in fact, why two books were not prepared for the series, one on each major application area. This would have allowed deeper coverage of each type circuit and made each one more useful to a particular reader.

The best section in the book is the first one, on physical aspects of tunnel diodes. This is a well-written discussion of the tunneling phenomenon and the construction and metallurgy of the devices.

Bright hope

The Physics of
Electroluminescent Devices
P.R. Thornton
E&F.N. Spon Ltd., 382 pp., \$14.50

After candidly indicating the breadth of topics needed to cover the subject in his very first sentence—"The study of electroluminescent devices is not one for faint hearts"—the author goes on to deliver one of the best books yet published on the subject. It is complete, well written, and will be useful for a long time as this embryonic segment of electronics grows to major importance.

It highlights the changing nature of electronics engineering. With the advent of new devices, today's engineer must be part metallurgist, part thermodynamicist, part optics specialist, and still be all engineer.

As a primer for the understanding of the basic mechanisms of electroluminescence, the first two chapters are devoted to excitation and recombination processes. The author then moves on to avalanche breakdown and reverse-bias light emission, and then zeroes in on



PRECISION Semi-rigid COAXITUBE



These high performance solid-jacketed cables offer broad frequency response, low attenuation, zero radiation and lowest possible VSWR. The splined, air-articulated types provide

minimum attenuation and highest cutoff frequencies, eliminate periodicity phenomena, and insure phase stability in the order of 20 PPM/°C from 10°C to 40°C, and 35 PPM/°C from -40°C to +125°C. They also provide excellent external RF shielding. For critical applications in severe environments, your best decision is Precision.



PRECISION TUBE COMPANY, INC.
SPECIAL PRODUCTS DIVISION
North Wales, Pennsylvania 19454
Phone 215-699-4806 TWX 510-661-8427

Even if it weren't the lowest-cost digital translator-display the new Sigma 7 would be a bargain.

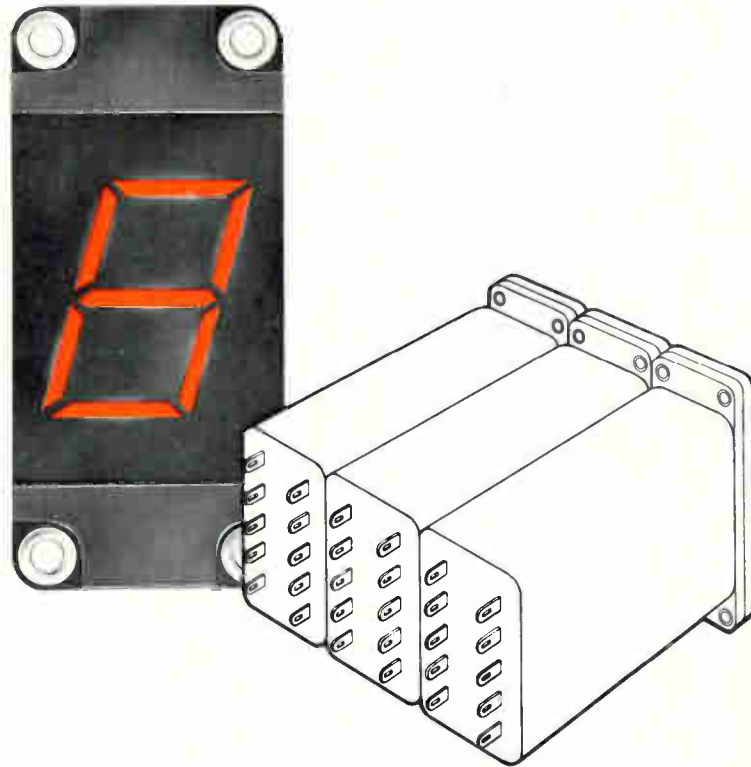

The new Sigma 7 is available in quantity at under \$15 with all of these advantages:

Combines code translation and numerical display in a compact opto-electronic module.

Eliminates need for high voltage switching transistors and separate high-voltage supply.

Accepts binary-coded decimal input at low voltage levels of either polarity.

Inputs interface directly with integrated circuit or transistor levels of 6, 12, or 24 VDC or 115 VAC.

Generates decimal output, 0 through 9, on an integral 7-bar neon display that lights directly from 115 VAC, 60 Hz.

Modules may be grouped for high visibility, single plane, multidigit display.

Translator utilizes Sigma's unique solid-state Datacel[®], the opto-electronic switching device that provides input-output isolation and rugged long life.

Drive module available separately. Memory optional.

Sigma 7 is applicable in automatic test equipment, computers and peripheral equipment, digital process control indicators, laboratory instruments and read-out display boards.

Want more information—or a sample Sigma 7? Contact us or your Sigma representative today.



SIGMA INSTRUMENTS INC
Assured Reliability With Advanced Design / Braintree, Mass. 02185
Sigma Instruments (Canada) Ltd., P.O. Box 43, Toronto 18

3 integrated bridge rectifiers with 3 mounting options

Each of these Varo Integrated Bridge Rectifiers is a controlled avalanche, full-wave bridge, and is electrically insulated for direct chassis mounting. Each offers three mounting options: Press mount. Single stud. TO-3 mounting adapter.

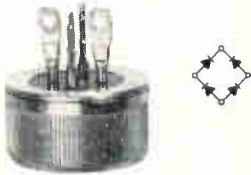

10 amp fast recovery IBR. Recovery time: 200 nanoseconds. 100V, 200V, and 400V ratings.

only \$4.75 *



10 amp IBR. 200V, 400V, and 600V ratings.

only \$2.35 *



25 amp IBR. 200V, 400V, and 600V ratings.

only \$3.05 *

* In 200V rating and quantity of 1,000 (press mount).

Write for complete information on Varo rectifier products.



SPECIAL PRODUCTS DIVISION
2203 WALNUT STREET, GARLAND TEXAS 75040
(214) 272-3561

New Books

electroluminescent behavior in zinc sulfide, cadmium sulfide, gallium arsenide, and gallium phosphide. He winds up with a discussion of injection lasers and points out in detail the many applications for electroluminescent devices.

In his section on applications, the author has looked far enough ahead to areas that are only theoretical today. Since the most likely applications for injection lasers will be in room temperature devices—where cryogenic cooling will not be required—the author discusses the thermal effects in detail. To minimize the contact resistance and provide better heat sinking, he points up the need to improve laser materials. Applications of noncoherent electroluminescent devices in optical coupling, x-y displays, and electrical scanning are also discussed.

The book concludes with the physics of failure. The author cites the built-in effects, such as mechanical defects, variations in doping levels, and surface contamination, and the operational effects, such as ionic movement, and thermal effects.

Why bother?

Servomechanisms
L.J. Bulliet
Addison-Wesley Publishing Co., 276 pp., \$9.95

A major technical advance during World War II occurred in servomechanisms and, shortly thereafter, several basic books appeared on the subject. Two notable texts were by Brown and Campbell, and by Lauer, Lesnik, and Matson. The first treated servomechanisms on an analytical basis, the second described servo components and system design.

This duo was in the vanguard of a variety of works by others in the field of servos. For years, industry has not suffered from a lack of servomechanism textbooks. And, except for treating very specialized aspects, most authors have had the good grace not to produce additional readings.

But here is another book on servos. It would not warrant re-

Need custom sub-miniature oscillators fast?



For logic clock applications?

Call Varo.

Model 7003 crystal oscillator is just $\frac{7}{8}$ " x $\frac{7}{8}$ " x $\frac{3}{8}$ ". Weighs only $\frac{1}{2}$ ounce. Extremely accurate for its size. Stability vs. time at any constant temperature is one part in 10 million per 24 hours. Frequency range: 3 MHz to 100 MHz. Stability $\pm .005\%$ from -55°C to $+125^{\circ}\text{C}$.

Varo answers fast.

Because our business is oscillators. Not oscillators and ovens and crystals, etc., but oscillators. Period. Tell us what you need. We'll tell you how and when. Like we've done for McDonnell-Douglas, Martin, Honeywell, R.C.A., Aerojet-General and others. Try us for speed.



TIME & FREQUENCY PRODUCTS
402 GUTIERREZ ST. SANTA BARBARA, CALIF.
TELEPHONE (805) 963-2055 TWX 805 4497200

Don't sit there
wishing your
 support people
 knew more
 electronics...

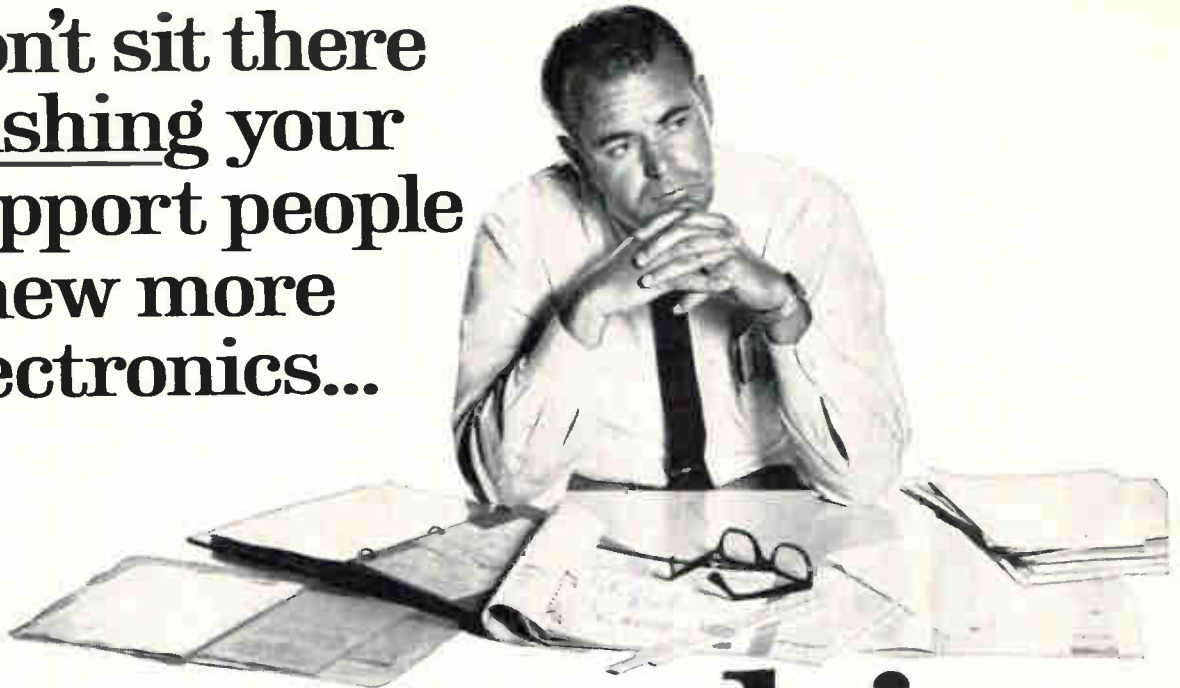

do something

Look over your men. Pick out a few who are intelligent enough to profit from more education in electronics, ambitious enough to work hard to get it. Send us their names and addresses. We'll send them complete information about CREI Home Study Programs in Electronics, tell them how these programs have helped thousands of young men increase their value to their employers. We'll explain how they can study at home, at their own pace, on their own schedule

without traveling to classes. We'll give them the names of the more than 80 leading scientists and engineers who help us develop and update programs related directly to the needs of industry.

Yes, we'll do all that. If you're lucky some of your men may enroll. Why not give it a try? Fill out the coupon and get it in the mail today.



CREI Programs cover these specialized areas of advanced electronics:

- Communications Engineering •
- Aeronautical and Navigational Engineering •
- Television Engineering •
- Computers • Nuclear Instrumentation and Control •
- Automatic Control Engineering •
- Missile and Spacecraft Guidance •
- Radar and Sonar Engineering •
- Nuclear Engineering Technology •
- Industrial Electronics for Automation •
- Computer Systems Technology.

CREI
THE CAPITOL RADIO ENGINEERING INSTITUTE
 A Division of McGraw-Hill, Inc.
 Dept. 1846-E, 3224 Sixteenth Street, N.W.
 Washington, D.C. 20010

Gentlemen: The men listed at right are high school graduates working in some phase of electronics. Please send them your FREE book, "How to Prepare Today for Tomorrow's Jobs" and complete information about CREI Home Study Programs.

And please send me the free brochure which tells how we can use CREI Home Study Programs to supplement our educational program for electronics personnel.

Name _____
 Title _____
 Company _____
 Address _____
 City _____ State _____ Zip Code _____

Name _____
 Address _____
 City _____ State _____ Zip Code _____

Name _____
 Address _____
 City _____ State _____ Zip Code _____

Name _____
 Address _____
 City _____ State _____ Zip Code _____

Name _____
 Address _____
 City _____ State _____ Zip Code _____

Name _____
 Address _____
 City _____ State _____ Zip Code _____

(Not enough room? Attach sheet of paper with additional names and addresses)



KEPCO OPERATIONAL POWER

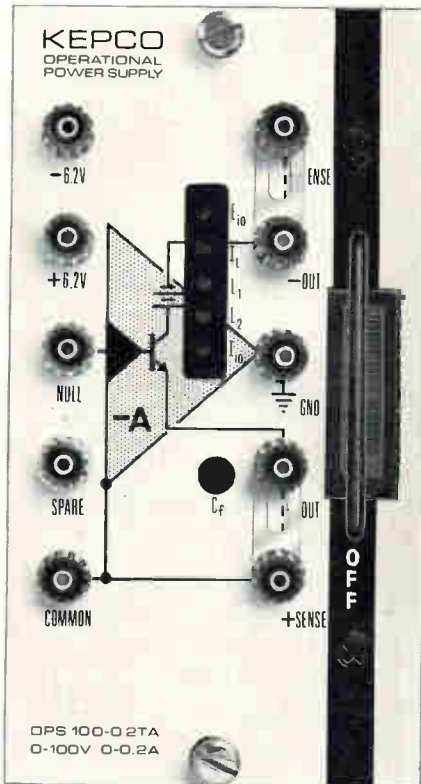

Model OPS 100-0.2TA Panel

PATCHBOARD ACCESSIBILITY

Now you can order operational power supplies (amplifiers) with a convenient patch board access. Not only are both references, the null, output and common terminal made readily available, but all operating controls are brought to the front in a convenient recessed slot. They include offset voltage nulling (E_{io}), offset current nulling (I_{io}), the current limit adjustment (10% - 110% range) and two AC stabilizing adjustments.

Amplifier characteristics include: 500,000 V/sec slewing speed, 80db open loop gain. Six models from 0-7V at 2A to 0-100V at 0.2A.

FOR COMPLETE SPECIFICATIONS AND APPLICATIONS NOTES, WRITE DEPT. 0-14



131-38 SANFORD AVE. • FLUSHING, N.Y. 11352
(212) 461-7000 • TWX # 710-582-2631

New Books

view except for one thing—the author's admirable intention is to educate technicians among others. To accomplish this he "avoids the deeper theoretical subtleties which can be appreciated only through the use of higher mathematics."

Such a statement cannot acquit, in advance, the failure of a book to come to grips with its subject at the required level. Technicians are better educated than the author implies. Were they not, the book would be of little use to technician-readers, for the author doesn't spare the mathematics anyway. He just avoids mathematics to give a real insight into servomechanism principles.

For example, Bulliet overlooks a fundamental servomechanism concept—that of stability—and his insistence on eschewing mathematics is probably the reason. Any technician who thinks he can understand servomechanisms from this book will be in for a mighty big surprise when the real servomechanism on which he's working with a development engineer suddenly starts oscillating. Unfortunately, he won't have time to read another book on servos to discover why that's happening.

Perhaps to compensate for leaving out thorough treatment of stability, the author dwells at great length on ideas like saturation, isolation, and time constant. After defining time constant in a complex paragraph, Bulliet uses the term vaguely—parenthetically stating that the time constant is the "time to settle down." Settling time does relate to time constant, but the two are not the same.

Recently Published

Handbook of Numerical Methods and Applications, Louis G. Kelley, Addison-Wesley Publishing Company, 354 pp., \$14.50

Designed mainly as a handbook, this volume is also a reference for engineers and scientists who program their own problems. The author discusses numerical analysis, curve fitting and data smoothing, nonlinear algebraic equations, Eigenvectors, and the Gram-Schmidt orthogonalization procedure.

Modern Transistor Electronics Analysis and Design, Fred K. Manasse, John A. Ekiss, and Charles R. Gray, Prentice-Hall, Inc., 555 pp., \$12.95

Primarily for the electronics design engineer, this book focuses on development and analysis of semiconductors. Included are several

Why MARYLAND?

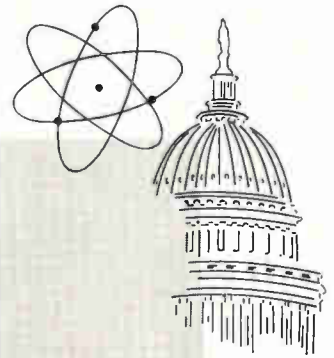

Proximity to federal agencies in Washington, D.C. affords the unique advantage of constant personal contact with government officials working with science-oriented industry. Such contact is an increasingly important locational criterion.

No other state is as convenient to as many Federal agencies as Maryland. For example, Maryland's major government scientific installations include NASA, AEC, NIH, the National Bureau of Standards, plus some 20 others.

Are there other reasons why R&D activities and science-oriented industries should consider locating in MARYLAND?

Yes... emphatically!

The availability of personnel, particularly engineers and scientists, is recognized as a chief criterion governing the location of any science-oriented industry.

There are almost 30,000 scientists and over 25,000 engineers living and working in Maryland and the District of Columbia.

There are 39 four-year colleges and universities in Maryland and the District of Columbia. Graduate and post-doctoral programs considered most significant to research and science industry are available.

Shouldn't you locate in MARYLAND?

Get All The Facts.

MARYLAND DEPARTMENT OF ECONOMIC DEVELOPMENT DIVISION E

State Office Bldg. • Annapolis, Md. 21404

Write, Wire Or Phone Collect

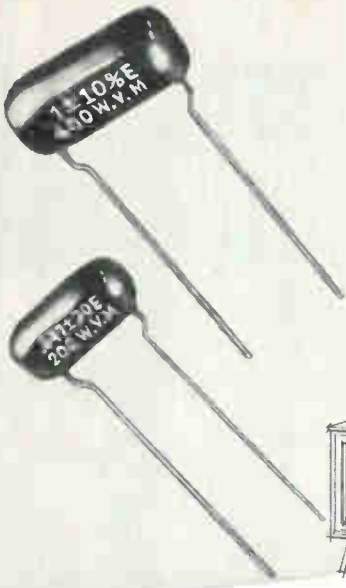

Proof Positive of High Reliability of EL-MENCO *MYLAR-PAPER DIPPED Capacitors

OVER 330,000,000 OF THESE HIGH QUALITY UNITS USED IN TV SETS SINCE 1959!

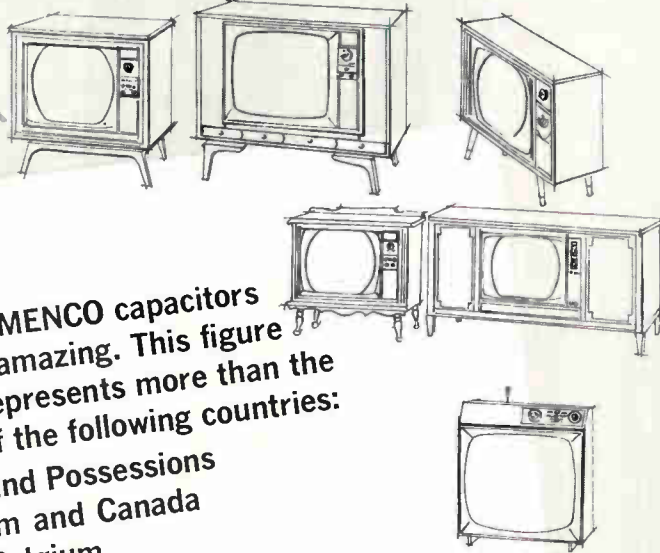

Imagine! Over 330 million EL-MENCO Mylar* Paper Dipped Capacitors have been used in black and white and in color TV sets since 1959! These capacitors of the highest quality and reliability help bring programs to millions of people who have invested in TV sets . . . and 330 million is just a drop in the bucket! For the demand for EL-MENCO capacitors still far exceeds the supply!

The number of EL-MENCO capacitors in TV sets is truly amazing. This figure of 330,000,000 represents more than the total population of the following countries:

- United States and Possessions
- United Kingdom and Canada
- Argentina
- Denmark
- Belgium
- Ecuador
- Chile

299,813,929 people (1960 Census)

Even with this tremendous mass production the quality of EL-MENCO capacitors has not suffered. Here's a fine tribute of the high reliability of EL-MENCO capacitors from a leading TV manufacturer:

"... I am certain that you are aware of the enthusiasm our Engineering and Quality people have displayed for this unit, for to us it represents the virtual elimination of capacitor field problems in the future ..."



Write dept. AE for descriptive bulletin #MPD

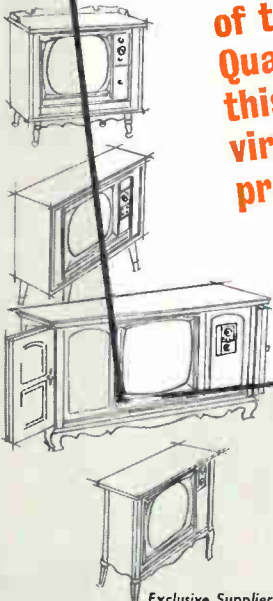

EL-Menco
Capacitors

THE ELECTRO MOTIVE MFG. CO., INC.
WILLIMANTIC, CONNECTICUT

DIPPED MICA
MOLDED MICA
SILVERED MICA FILMS
MICA TRIMMERS & PADDERS
MYLAR* PAPER DIPPED
PAPER DIPPED
MYLAR* DIPPED
TUBULAR PAPER

*Registered Trade Mark of DuPont Co.

Exclusive Supplier to Jobbers and Distributors in the U. S. and Canada

ARCO ELECTRONICS, INC., COMMUNITY DRIVE,
GREAT NECK, L. I. NEW YORK

West Coast Manufacturers Contact:

COLLINS & HYDE CO., 1020 CORPORATION WAY, PALO ALTO, CALIFORNIA
5380 WHITTIER BOULEVARD, LOS ANGELES, CALIFORNIA



VERSATILE POWER

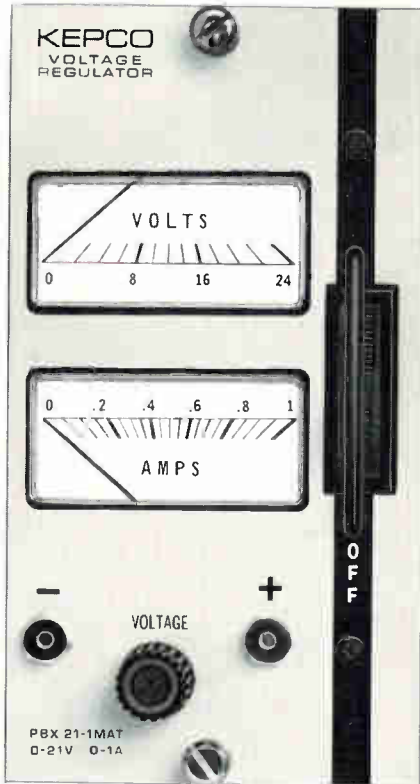

Model PBX 21-1MAT Panel

KEPCO'S PLUG-IN POWER MODULES

Six voltage regulated models from 0-7 volts to 0-100 volts (up to 20 watts) in single, double, triple and six-unit plug-in enclosures. Create your own custom d-c power systems. Mix 'em or match 'em.

Kepco's new line of versatile PBX-MAT plug-in laboratory modules are covered in the big new Kepco Catalog B-678. Write for your copy today.

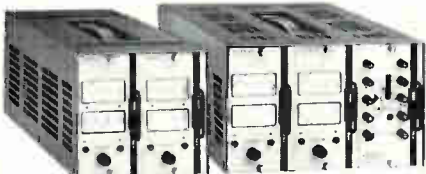

Dual slot housing Model CA-4 Triple slot housing Model CA-5

FOR COMPLETE SPECIFICATIONS AND APPLICATIONS NOTES, WRITE DEPT. U-14



131-38 SANFORD AVE. • FLUSHING, N.Y. 11352
(212) 461-7000 • TWX # 710-582-2631

New Books

new areas of development—integrated circuits, avalanching and Gunn-effect diodes, charge-control models, and choppers.

Reusable Protective Packaging, Steven E. Mautner, Kayar Publishing Co., 101 pp., \$8.50

Protecting electronic equipment during shipment and storage has become a problem that the electronic designer has to face. This book attempts to lead him through the maze of military specifications for shock, vibration, and hostile environments.

Magnetism and Magnetic Materials 1967 Digest, Edited by W.D. Doyle and A.B. Harris, Academic Press, 278 pp., \$11

A concise review of papers on magnetism and magnetic materials published in 1966, designed as a reference for the graduate student or the practicing engineer.

Electric Power Systems, B.M. Weedy, John Wiley and Sons, 302 pp., \$8.50

This introductory text provides students with the basic essentials of power system operation and analysis. Equivalent circuits, d-c transmission, and the limitations of transmittable power are discussed.

Handbook of Analog Computation, Maxwell C. Gilliland, Systron-Donner Corp., 40 pp., \$5

Provides students as well as experienced computer users with up-to-date analog computer software. Basic fundamentals and advanced programming techniques are presented.

Marks' Mechanical Engineers Handbook, Seventh Edition, Edited by Theodore Baumeister, McGraw-Hill Book Co., \$29.50

Latest edition of a standard work, most useful for electrical engineers in the areas of cryogenics, ultrasonics, optics, and thermal properties of materials.

Basic Analog Computation, Gerald R. Peterson, The Macmillan Co., 124 pp., \$3.95

How an analog computer functions and what makes it function are covered in this undergraduate text. Simple linear, high-order linear, and nonlinear and time-varying systems programming are included.

Digital Logic and Computer Operations, Robert C. Baron and Albert T. Piccirilli, McGraw-Hill Book Co., 321 pp., \$13.50

Beginning with a general introduction to the computer field, this textbook covers Boolean algebra, computer logic, storage, input and output functions, and control elements. Time-sharing, and multiaccess systems are also included.

High Frequency Communications, J.A. Betts, American Elsevier Publishing Co., 98 pp., \$5

The application of error detection and correction is explained, showing the difference between systems used on one-way and two-way circuits. Also included are methods of ionospheric forecasting.

Electric Circuit Problems With Solutions, F.A. Benson, Barnes and Noble, 257 pp., \$4.95

Aimed at the laboratory technician, this book contains a wide variety of problems in a-c, d-c, and polyphase circuits provides the reader with detailed solutions.

Characteristics and Operation of MOS Field Effect Devices, Paul Richman, McGraw-Hill Book Co., 146 pp., \$10

The book covers the electrical characteristics of MOS transistors, MOS technology, fabrication techniques, and linear and digital MOS circuit applications. Included are recent developments in the fabrication of low power MOS complementary integrated circuits.

WHICH INSULATING TECHNIQUE WOULD YOU HAVE PICKED?

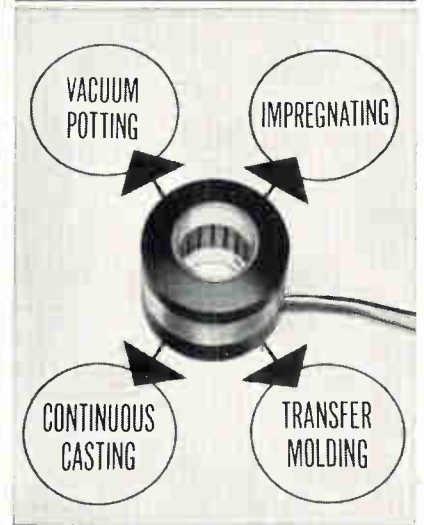

(HULL provides equipment for all of them)

Hull recommended vacuum potting. For this servo motor, cost, quantity and application requirements pointed to that choice.

Your unit may call for extremely high potentials. Or wide thermal shock resistance. It may encounter vibration, corrosive atmospheres, high ambient temperatures.

One of the four insulating techniques—or a combination will meet the end-use requirements. And keep your cost/quantity/quality ratios in line. Hull's application engineers will recommend and provide the ideal equipment.

You'll get guidance in resin selection. We'll furnish your work-holding fixtures and molds. Your complete production or pilot plant if you say go.

Hull's the only company we know of that can provide you all this. We'd like to work with you. Simply write or phone us: HULL CORPORATION, 7037 Davisville Road, Hatboro, Pa. 19040. Phone: (215) 672-7800



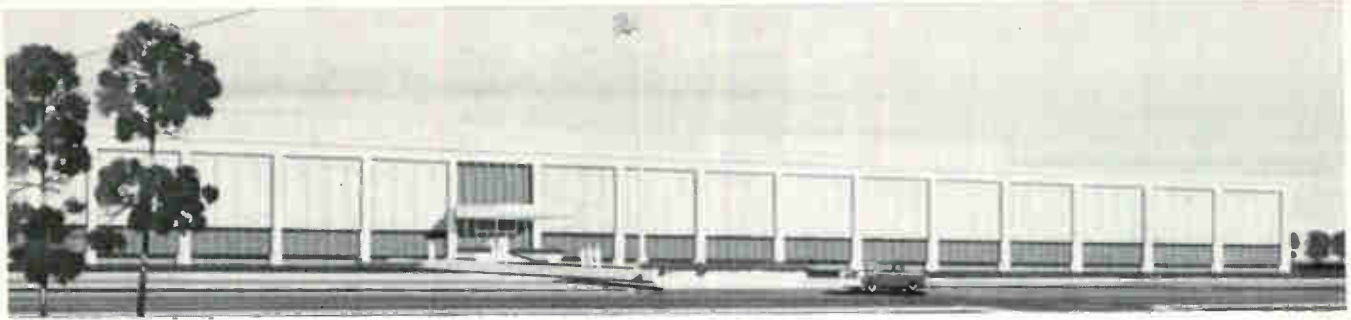

THE PLANT IN PERSPECTIVE

The Fort Worth Division of General Dynamics plant, located in the northwest quadrant of the Greater Fort Worth area, is one of the largest and best equipped facilities in the country. The 600 acre site contains well over 100 buildings. More than 100 acres of floor area are enclosed; 75 acres are under the roof of the main building. Of primary interest in the Fort Worth Division's current \$37 million facility expansion program is the new \$8 million Engineering and Office Building, encompassing 581,400 square feet and covering 12 acres.

Numerous laboratories are provided for performing tests and experiments in a wide range of disciplines. In addition to the well equipped Engineering Test Laboratories, there are several other major laboratories:

- Advanced Mechanics Lab
- Analog Computer Lab
- Antenna Range
- Biological Lab
- Cryogenic Lab
- Design Aids Lab
- Digital Computer Lab with an IBM 360 System (Model 65/40 ASP) assigned to Engineering
- Extensive Electronics Labs
- Infrared Visual Ultraviolet Lab
- Instrumentation Lab
- Nuclear Science Labs
- Radar Scattering Range

Production facilities are continually being updated in order to capitalize on new techniques, materials, manufacturing processes, and services. The emphasis on staying abreast of the state of the art provides an ever increasing capability for the manufacture of high performance aerospace vehicles.

Situated in an area where employees have a choice of urban, suburban, rural, or lakeside living, the air conditioned plant can be rapidly reached from all parts of Fort Worth.

Find room for thought and career potential . . . and room for better living in smog-free Fort Worth, where the cost of living is low, and where metropolitan advantages exist alongside year-around outdoor recreational areas in a temperate climate.

Call Collect — 817-732-4811, Extension 3551; or send a resume of your education and experience to Mr. J. B. Ellis, Industrial Relations Administrator-Engineering, General Dynamics, Fort Worth Division, P. O. Box 748E, Fort Worth, Texas 76101. An equal opportunity employer. U. S. Citizenship required.

GENERAL DYNAMICS
Fort Worth Division



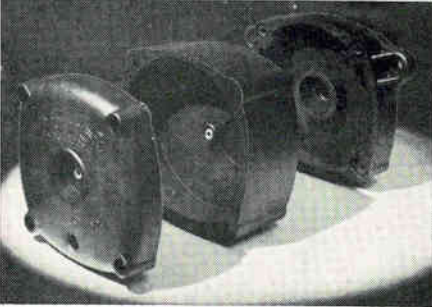
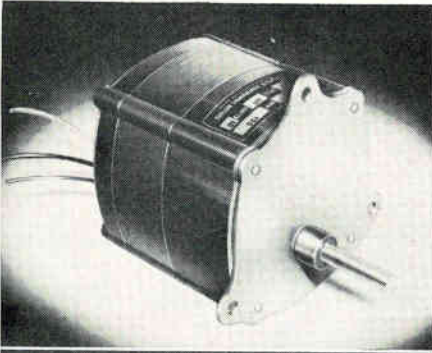

Polycarbafil Instrument Motor Housing molded for Hurst by Lenco, Inc., Jackson, Mo.

A better motor housing at lower cost with Polycarbafil®

Hurst Mfg. Corp., Princeton, Indiana chose fiberglass reinforced polycarbonate.

For the new Model GA 600 inch-ounce, Synchronous Hysteresis Instrument Motor, Hurst chose Polycarbafil (fiberglass reinforced polycarbonate). Hurst research and tests proved that the FRTP adds performance characteristics for the user. It has lighter weight, reduced noise level, high impact strength, dimensional stability and heat resistance. Flexural and Tensile strength of Polycarbafil is higher than many common aluminum alloys. The company found that they gained a cost advantage because the Polycarbafil housing needs no finishing and painting, as aluminum housings would:

Compare Physical Properties

Property	Unit	Unreinforced Polycarbonate	Polycarbafil G-50/20
Tensile Strength @ 73°F.	PSI	8,000	18,500
Flexural Strength @ 73°F.	PSI	13,500	25,000
Coef. Linear Thermal Expansion	°F./in./in.	3.75 x 10 ⁻⁵	1.07 x 10 ⁻⁵
Heat Distortion Temp. @ 66 PSI	°F.	285	308
Water Absorption 24 Hrs.	%	0.15	0.4

Polycarbafil is just one of several fiberglass reinforced thermoplastics pioneered and patented by Fiberfil. Only Fiberfil can give you complete technical data, practical experience and a full line of reinforced materials. Send for your free copy of the FRTP engineering manual. Fiberfil Div., Rexall Chemical Co. Evansville, Indiana 47717



Fiberglass Reinforced Thermoplastics ©

Technical Abstracts

Large repertoire

An LSI variable function register
Robert J. Lesniewski
Goddard Space Flight Center
Greenbelt, Md.

Although large-scale integrated circuits are usually designed for just one purpose, the true value of LSI may be in more versatile arrays—such as those that can be electrically programmed to perform many different functions.

Such circuit versatility will soon be almost mandatory in sophisticated spacecraft with on-board data processing. As an example, a variable function register capable of four different operations has been built using metal oxide semiconductor technology, and 500 active devices on a chip.

A second-generation register, capable of parallel processing with 18 different operations using 1,300 active devices, also has been designed, but not yet built. The complementary MOS technology makes such design possible by reducing power dissipation and element count.

The variable-function repertoire includes seven basic operations—parallel loading and outputting, rotating data, shifting data to the right and left, and complementing the register's contents. The shifting and rotating operations can be electrically programmed by setting MOS switches between the shift-register stages.

The register chips also can be cascaded to form large registers. With a bypass switch, information can be shifted past a register while it continues to operate.

Presented at Eastcon, Washington, Oct. 16-18.

Two-way etch

Anisotropic etching for forming isolation slots
H.A. Waggner, R.C. Kragness, and A.L. Tyler,
Beli Telephone Laboratories,
Allentown, Pa.

A technique that etches downward into a silicon wafer much more rapidly than it etches sideways gives narrow, precisely defined isolation slots. As a result, more beam-leaded integrated circuits can be

fabricated in a silicon slice than is possible with standard etching techniques. The new method requires a unique orientation of the etching mask on a specific lattice plane of the silicon crystal, and an etchant that attacks one plane more than the others. Etchants now being investigated for silicon consist of strong alkaline solutions, such as a mixture of potassium hydroxide, propanol, and water.

To fully exploit the difference in etch rates, two conditions are required: the face of the silicon disk to be etched is made parallel to the lattice planes having a high etch rate; and the edges of masked areas are aligned parallel to a second lattice plane with a negligible etch rate. Under these conditions, slots are formed with slanted sides, in the shape of flat-bottomed wedges. Each slot steadily becomes narrower as the etching progresses, and thus the slot's depth and width are precisely defined by the etching mask and etching rate. Etching terminates when the two sloping sides of the deepening slot meet, or when it etches through the slide, whichever occurs first.

During the fabrication of beam-leaded integrated circuits, slots are etched out of the semiconductor slice to separate the many individual circuits and/or to isolate components within each integrated circuit. Standard (nonpreferential) etchants result in fewer integrated circuits because variations in the thickness of silicon slices cannot be reduced economically to less than a few tenths of a mil. To insure complete penetration at the thickest parts of the slice, considerable over-etching must be tolerated at the thinner portions. Since the isotropic, nonpreferential solutions etch as fast sideways as downward, the active devices on the opposite side of the slice must be spaced three to four times farther apart than the average slice thickness to protect them against over-etching during separation.

With preferential etching, the masking operation is done after the desired devices have been fabricated on one side of the slice. A silicon dioxide mask then is applied

you get a choice,

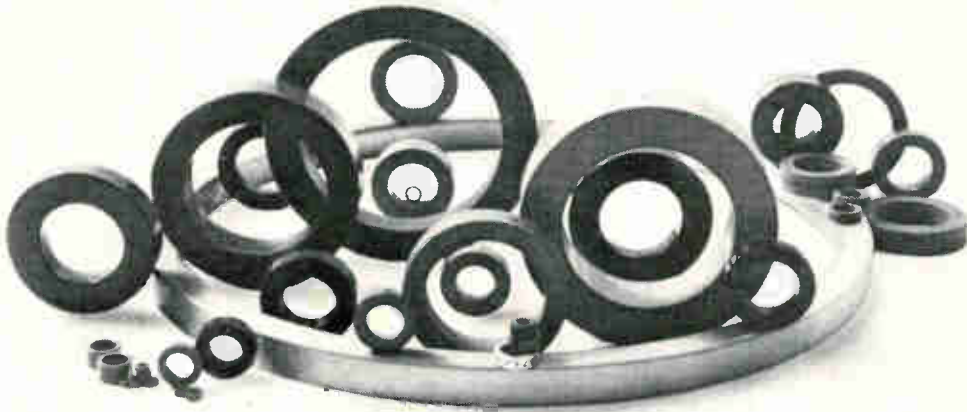

not a challenge



Most complete line of high quality tape wound cores available from any manufacturer

Magnetics' selection of tape wound cores encompasses eight material types, in a range of sizes from 0.050" to 12" inside diameter. For frequencies from DC through 500 kc, materials are produced in thicknesses ranging from 1/8 mil through 14 mils. All core sizes are available boxed in phenolic or plastic, aluminum or GVB- coated

aluminum. Magnesil[®], less sensitive to external stresses, is also available unboxed or epoxy encapsulated.

In addition to offering this broad range of tape wound cores, Magnetics has improved its production of raw materials, using the most advanced testing devices to control quality in metals, winding, annealing, potting compounds, boxing processes and the application of encapsulating

materials. This across-the-board control assures you of getting what you pay for in performance.

If you have an application for tape wound cores, why settle for an approximation of your specifications? With Magnetics, you don't have to "make do"—you get a choice, not a challenge. For further information on our complete line of tape wound cores, write for Catalog TWC-300, Magnetics Inc., Butler, Pennsylvania 16001

MAGNETICS inc.

Power supplies

portable high-voltage DC power supplies

Widely used for powering electronic equipment and for routine breakdown and insulation testing. Output voltage is well filtered DC which is adjustable with convenient front panel control. Input is 115 VAC, 60 CPS. Larger 6" precision 1% mirror scale movement available on order. Regulated models provide closely stabilized output voltage regardless of line or load changes.



heavy-duty power supplies

Employing husky components selected for power handling capacity these industrial type power supplies are built for service and efficiency. Output is continuously variable from 0 to full rated values. Standard ripple is 5% or less. Ripple of 0.01% to 1%, and regulated supplies available on special order. All units feature automatic overload cutout control circuits.



3φ heavy-duty power supplies

For use in applications where high voltages at extra high currents are required. Fixed or fully variable types available. Automatic circuits protect against over-current conditions. Widely used in plasma research, electron beam furnaces, plate power and condenser charging applications. Voltage or current regulated types available.



constant-current power supplies

Designed for applications where output current must remain constant regardless of loading resistance changes. Used for magnet fields, plating applications, gaseous lamps. Magnetic current stabilizer has no moving parts, no tubes, no transistors to replace. No balancing or adjustment needed, simply set current to desired level. Standard hum level 5%, lower hum levels available on order.



Beckman INSTRUMENTS, INC.

CEDAR GROVE OPERATIONS
89 Commerce Road
Cedar Grove, New Jersey 07009

INTERNATIONAL SUBSIDIARIES:
Geneva; Munich; Glenrothes, Scotland;
Tokyo; Paris; Capetown; London; Mexico City.

Technical Abstracts

to the opposite side to delineate the slots for etching. Because the sides of the slots are stationary, only relatively simple etching controls are required.

An important feature of the improved etching technique is that the mask shape is altered to compensate for undercutting at the outside corners of the mask, where the third main lattice plane of silicon is exposed. The etch rate of this third plane can be made much slower than that of the primary etching plane, but it is still significant. Therefore, enlarged corner areas of calculated size and shape are added to the etch mask to compensate for the undercutting at these corners.

Presented at the International Electron Devices Meeting, Washington, Oct. 18-20.

Featherweights

A digitally implemented microelectronic i-f decoder

Richard S. Ocheret

General Instrument Corp., Radio Receptor Division, Brooklyn, N.Y.

Metal oxide semiconductor technology may slash the size and price of delay lines. Beaconry and interrogation-friend-or-foe (IFF) systems use delay lines for passive decoding of a pulse train to see if it agrees with a preselected code. The new digital equivalent for the IFF passive decoder—a shift register—is built on a single silicon chip with MOS technology that is easy to design and simple to make.

With the MOS device, transconductance can be determined by geometry so that all chip devices can be simultaneously diffused in a single step. Since both drain and source are reverse-biased with respect to the substrate, no isolation is required between devices, and, because the input impedance of each device is high, increased fan-out is possible.

The single chip holds a 43-bit shift register, decoding logic, and input circuitry. The circuitry can operate down to d-c but if this is not needed, four-phase logic can be used. With the four-phase scheme, power is dissipated only during switching.

The shift register is continuously

NEW

-100°F. TO +400°F.



BLUE M

VERSA-RANGE TEST CHAMBERS

with

POWER-O-MATIC-60
PATENTED

Saturable Reactor Proportioning Control and FLO-KOLD Mechanical Refrigeration

New chambers designed especially for critical high and low temperature research/military testing and processing.

POWER-O-MATIC 60 Control — stepless, switchless, fully automatic—provides infinitely proportional control, true straight-line performance. Free of moving parts, arcing components, and failure-prone auxiliary devices, it provides unequalled reliability—will outlast the chamber it controls!

Exclusive FLO-KOLD cascade mechanical refrigeration system lowers chamber temperature to -100°F. in 60 minutes or less. Non-cycling, operates continuously.

Refrigeration system and reactor control carefully matched for maximum efficiency and operating economy in chambers of 3, 8, 12, 27 and 64 cubic feet. Easily the most reliable and dependable units of their kind ever built!

NEW -40°F. TO +200°F. CHAMBERS

Similar to broader range units in construction and performance for applications where extremes of temperature are not needed. Features single-stage refrigeration system and POWER-O-MATIC 60 Control.

NEW COMPACT TOP-LOADING CHAMBER



-100°F. to +200°F. Same control, refrigeration, and construction as larger chambers. Work chamber measures 18" W. x 16" H. x 16" D. Efficiently loads and unloads from top. Companion Full Range Constant Temperature/Humidity Chamber also available.

SEND FOR FULL INFORMATION

BLUE M

BLUE M Engineering Company

A DIVISION OF BLUE M ELECTRIC COMPANY

Corporate Headquarters:
BLUE ISLAND, ILLINOIS 60406
Offices strategically located to serve you.

WHO'LL
make the
next
breakthrough
in EDP
design?

Could be YOU: with
Mosaic's
Fiber
Optics!

EDP systems design engineers are only beginning to tap the potential of fiber optics. Yet, after a brief acquaintance with this broad, new technology, they have made breakthroughs already . . . obsolescing "standard" EDP design solutions. Advances like greater speeds. Design freedom. New capabilities. Reliability and lower costs.

Do you know the story on Mosaic's Fiber Optic systems? In new EDP readers, printers, punched tape and card verifiers . . . in keypunch and teletype equipment, they're more dependable, less complicated, less costly and over 4 times faster than heat, wear and friction-prone mechanical systems!

Mosaic's fiber optics can help you make breakthroughs to advance the EDP state-of-the-art, too. Give those specific design problems of yours a hard look now. Then get going with the solution.



Start by contacting Mosaic Fabrications, the people who know fiber optics inside-out . . . the largest single source of fiber optics technology, capability and productivity on earth!

Call or write Mosaic Fabrications, Inc., Galileo Park, Sturbridge, Mass. 01518, (617) 347-9191 for descriptive literature today!

Bendix Electronics

TOTALLY ENCLOSED ROTARY SWITCHES. TEMPERATURE to 125°C. MULTI-POLE. 30°, 36°, 45°, 60° and 90° ANGLE of THROW. 100,000 OPERATIONS.

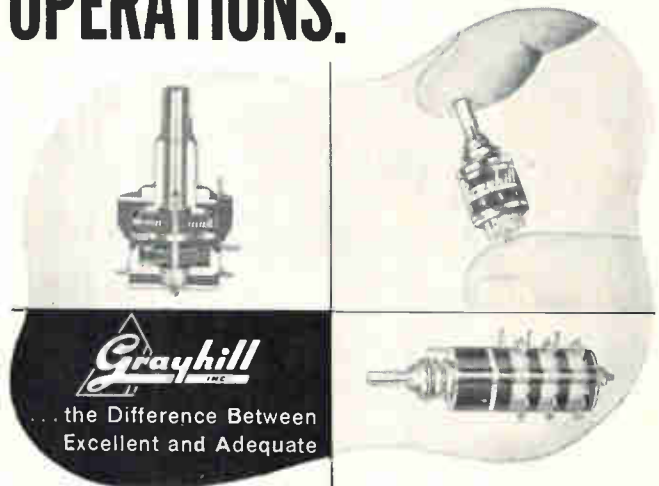

Select Materials:

- Contacts: Silver Alloy, Silver Plated Brass, Gold Plated when needed
- Terminals: Silver Alloy or Brass—Plated with Gold, Silver or Lead-Tin
- Molded Parts: Thermosetting Plastic to MIL-M-14
- Detent Spring: Tinned Music Wire
- All other Metal Parts: Stainless Steel or Cadmium Plated Brass

Typical Specifications:

- Explosion Proof
- Contact Resistance 10 Milliohms
- Make or Break ¼ Amp. to 15 Amps., 115 VAC Resistive
- 1 to 6 Poles per Deck
- 2 to 12 Positions per Pole
- 1 to 12 Decks

Send for
Engineering Catalog
G304



Grayhill
INC

523 Hillgrove Avenue
LaGrange, Illinois 60525
Area Code 312, Phone 354-1040

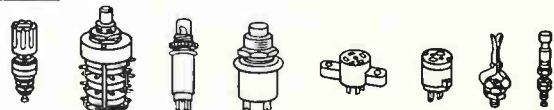

"PIONEERS IN MINIATURIZATION"

FOR SALE:

Linde

**HELIUM
NEON
ARGON
KRYPTON
XENON**

(and other ultra-high purity gases in glass bulbs and a variety of high pressure cylinder sizes)

Linde

GAS MIXTURES

Mixtures of any number of gases and volatile liquids in high pressure cylinders—available in these three grades:

- **LINDE Primary Standard Grade**—prepared by weight to the highest possible accuracy then calculated to mole percent.
- **LINDE Analyzed Grade**—mixed and analyzed to high laboratory standards.
- **LINDE Utility Grade**—prepared with a mixing tolerance of $\pm 10\%$ and an analysis accuracy of $\pm 5\%$ of the minor component. Available with or without analysis.

Call (201) 925-8990—the direct line to your LINDE lab gas specialist. Union Carbide Corporation, Linde Division, 2365 East Linden Avenue, Linden, N.J. 07036.

LINDE is a registered trademark of Union Carbide Corporation



GAS PRODUCTS

Technical Abstracts

clocked at 2.069 megahertz with three bits provided for every pulse interval in the IFF reply train. The decoding logic on the chip compares incoming trains with a code selected by external switches.

The input video signal is fed to a strobe circuit, which clocks the signal into the shift register. The outputs of every third stage are fed to logic circuits, NAND and NOR gates, and compared with the coded input.

Presented at Eastcon, Washington, Oct. 16-18.

Sound design

Monolithic limiter and balanced discriminator for f-m and tv receivers
A. Bilotti and R.S. Pepper
Sprague Electric Co.,
North Adams, Mass.

Quadrature detectors have found widespread use in f-m receivers and tv audio sections because they are simple to design and provide excellent performance. Less costly than other types such as ratio detectors and discriminators, they require inexpensive single-tuned coils rather than costlier double-tuned transformers. A design, based on the quadrature approach, for a monolithic limiter and balanced discriminator for f-m and tv receivers using full-wave coincidence gates offers even lower cost to manufacturers of television sets.

Basically, f-m detectors fall into three broad categories—slope, phase shift, and pulse averaging.

In the slope detector, the frequency deviation is transformed into a variable amplitude voltage by a reactive circuit's amplitude versus frequency slope. In the phase-shift detector, a reactive circuit's phase versus frequency characteristic transforms the instantaneous frequency deviation into a relative phase deviation, which is then detected by either a vector addition- or coincidence-type phase detector. In the pulse-averaging detector, single-polarity pulses are generated at each zero crossing of the signal. The resulting pulses of constant area are integrated and demodulated.

Of the three, a strong case can be made for an LC-type phase-

Now Available...

**Power Supply Manual
From
Transformer Electronics
Company**



Imaginative engineering, a proven record of reliability and dependability, plus a dedication to customer service have given T.E.C. an international reputation in the design and manufacture of miniature regulated DC to DC converters and associated solid state products for aerospace, military and commercial systems. Now, for the first time in one easy-to-use catalog... the details, the specifications, the technical data and the prices, all packaged for your convenience. For your copy, write or call...



**TRANSFORMER
ELECTRONICS
COMPANY**

**BOULDER INDUSTRIAL PARK
BOULDER, COLORADO
T.W.X. 910-940-3246 PHONE (303) 442-3837**

**POWER SUPPLIES • INVERTERS
CONVERTERS • TRANSFORMERS**

Now—save vital space with 30-gauge hook-up wire



General Electric saved space and weight in wiring the back panels of its GE-PAC® Process Computers by using 30-gauge hook-up wire insulated with Kynar.

... Made with
tough, durable
Kynar®

Thirty gauge wire is nothing new . . . but what is new is wire insulated with Kynar, the fluoroplastic that's tough. It has twice the cut-through resistance of other fluoroplastics, cuts and strips smoothly, takes 180° bends without splitting, stands up to the punishment of automatic wiring machines or semi-automatic hand tools.

What's more, Kynar resists cleaning solvents, won't degrade with age, and operates at temperatures from -80° to 300°F.

For samples of 30-gauge wire insulated with Kynar plus information on how you can save space, reduce weight, write Plastics Department, Pennsalt Chemicals Corporation, 3 Penn Center, Philadelphia, Pa. 19102.

Kynar...the fluoroplastic that's tough!



the
big

3

for
precision
high speed
circuit
board
production



1/8" shank
SOLID
CARBIDE
DRILLS

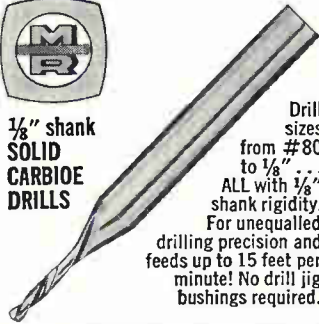

Drill
sizes
from #80
to 1/8" . . .
ALL with 1/8"
shank rigidity.
For unequalled
drilling precision and
feeds up to 15 feet per
minute! No drill jig
bushings required.

PCB-1
AIR
BEARING
SPINDLES



UP TO
150,000 RPM
SPINDLE SPEED

Absolutely vibration free . . .
spindle shaft literally "floats" on air
film . . . no ball bearings, no metal-
to-metal contact. Eliminates all har-
monics. Creates the truest running
drill spindle ever made. Air turbine or
electric high frequency driven.

SOLID CARBIDE
DIAMOND CUT
ROUTERS



For the
smoothest finish
in routing . . . any
material or plastic-
metal laminate.
Choice of end styles
including drill point.

Take the proved solid carbide advan-
tages of rigidity and wear resistance
. . . add the proved advantages of Metal
Removal tool design and precision . . .
to give you problem-free production in
circuit board drilling and routing.

Write for Catalogs.

THE METAL REMOVAL COMPANY
1859 W. Columbia Ave., Chicago 60626
Plants in Chicago • Los Angeles • San Juan

MASTER TOOL AND WHEEL
MAKERS FOR THE WORLD

Technical Abstracts

shift network used in conjunction with a quadrature detector. Phase shifts can be transformed into amplitude variations without regard to the amplitude characteristics of the reactive circuit in which it is used. Complete linearity between the phase-shift deviation and the resulting output signal is also exhibited.

To enhance performance, a wide-band limiter precedes the detector circuit.

F-m and tv applications require a high a-m rejection. Since wide-band limiters tend to convert a-m signals to pulse-width asymmetries, rejection of these signals can be seriously degraded by the amplifier. This, however, is overcome by a full-wave quadrature circuit. This type of circuit has an added advantage: it can be used as either a high-performance synchronous demodulator or a double-balanced mixer.

Presented at the International Electronic
Devices Meeting, Washington, D. C.,
Oct. 18-20.

A new image

Electron-beam-accessed silicon diode
arrays for image-sensing applications
M. H. Crowell and E. F. Labuda,
Bell Telephone Labs,
Murray Hill, N.J.

Semiconductor diodes outshine thin-film photoconductive targets in vidicon applications. And a planar array of reverse-biased silicon p-n diodes can afford advantages over evaporated photoconductors as image-sensing elements in television camera tubes. Among these advantages:

- photoconductive lag problems don't arise;
- spectral response is broader;
- sensitivity is higher;
- there are no associated optical and electron-beam "burn-in" effects;
- higher temperatures can be tolerated during vacuum processing.

A 1-centimeter-square matrix containing a 660-by-660 diode pattern constitutes the array; the diodes are fabricated by photolithographic techniques. An optical image is focused on the laterally homogeneous n-type substrate,

*The sky is no limit
for design engineers
and designers
at Lockheed*



You can choose your environment at Lockheed: air, land, sea, or space. Important and exciting long-term projects are now under way involving Poseidon, advanced Polaris, unique land vehicles, Deep Quest, deep submergence rescue vehicles and Agena. □ There is no limit on individual achievement and recognition at Lockheed. An engineer's responsibility for a design package continues from initial concept through manufacturing and successful operation. Nothing is static. Demand for rapid response to changing requirements continually creates new challenges, opens new avenues of opportunity for advancement. □ At present, design openings include development of hydraulic and pneumatic components, mechanical/structural design of missiles and aircraft, mechanisms and antennas, ground support equipment, reentry vehicles, automotive design, conceptual design, missile basic and secondary structures, material-handling equipment and analysis of material usage and producibility. □ If you are looking for new horizons of opportunity in the field of design, look into Lockheed. Write: R. C. Birdsall, Professional Placement Manager, P.O. Box 504, Sunnyvale, California. An equal opportunity employer.

LOCKHEED
MISSILES & SPACE COMPANY
A GROUP DIVISION OF LOCKHEED AIRCRAFT CORPORATION

DALIC

PLATING PROCESS

SHAVES

COSTS

DOWN TO

SIZE!



Plating is expensive, but necessary. But smart metal men realize that Dalic plating is today's only answer to quality plating repair at minimum cost! Because Sifco's Dalic portable plating unit takes the process to the job. No expensive disassembly of equipment; no expensive shipping. No waste of time or money. Dalic plating goes to the job and produces quality repairs equal to any other process available today. Don't continue to waste time. Write today for complete technical data on your Dalic plating process equipment and supplies. Start shaving costs on your next plating job.

DALIC'S WIDE RANGE PLATING PROCESS

Complete line of PREPARATORY AND STRIPPING SOLUTIONS. NON-PRECIOUS METAL PLATING SOLUTIONS: Antimony, Bismuth, Cadmium, Chromium, Cobalt, Copper, Iron, Lead, Nickel, Tin and Zinc. PRECIOUS METAL PLATING SOLUTIONS: Gallium, Gold, Indium, Palladium, Platinum, Rhenium, Rhodium and Silver. ALLOY PLATING SOLUTIONS: Brass, Nickel-Cobalt, Tin-Indium and Gold-Antimony. SPECIAL COATINGS.



Dalic Plating Goes to the Job
SIFCO METACHEMICAL

Division of Steel Improvement & Forge Co.
935 EAST 63rd ST., CLEVELAND, OHIO 44103

SMALL COMPANY

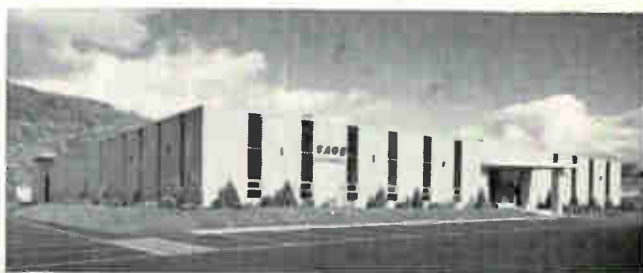

BIG PERFORMANCE



Why knock yourself out when your customer keeps scoring your performance at zero? It makes sense at Sage Electronics, especially when that score is another Zero Defects citation, as evidenced by the examples above.

We are specialists in MINIATURE POWER RESISTOR products. Accordingly SAGE pursues active programs second to none in respect to:

1. Zero Defects
2. High Reliability
3. MIL spec production and test
4. High volume commercial production

Look us over, first by exploring SAGE Catalog R-66. A phone or letter request will promptly bring your copy.



SAGE



SAGE ELECTRONICS CORP.

BOX 3926 ROCHESTER, N. Y. 14610

Phone: (716) 586-8010

**WHY SETTLE FOR LESS?
GET TOP
PERFORMANCE
WITH
DELTA'S FABULOUS
MARK® TEN**

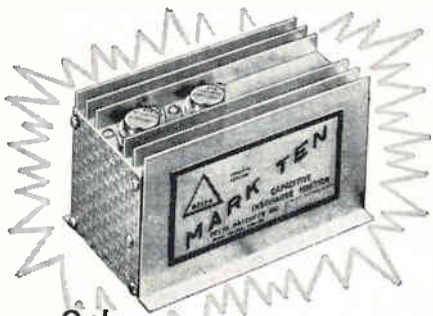

Only
\$44.95 CAPACITIVE
ppd. DISCHARGE
IGNITION SYSTEM

Deltakit - Only
\$29.95 ppd.

You read about the Mark Ten in the April issue of Popular Mechanics!

Now discover why even Detroit has finally come around. In 4 years of proven performance and reliability, the Mark Ten has set new records of ignition benefits. No wiring. And works on literally any type of gasoline engine. Buy the original, the genuine, the real McCoy — Mark Ten. From Delta. The true electronic solution to a major problem of engine operation.

READY FOR THESE BENEFITS?

- ▲ Dramatic Increase in Performance and in Fast Acceleration
- ▲ Promotes more Complete Combustion
- ▲ Points and Plugs last 3 to 10 Times Longer
- ▲ Up to 20% Mileage Increase (saves gas)

LITERATURE SENT BY RETURN MAIL
BETTER YET — ORDER TODAY!

DP 7-8

DELTA PRODUCTS, INC.

P.O. Box 1147 E • Grand Junction, Colo. 81501

Enclosed is \$_____. Ship prepaid.
Please send: Ship C.O.D.

Mark Tens (Delta Kit) @ \$29.95
(12 Volt Positive or Negative Ground Only)

Mark Tens (Assembled) @ \$44.95

6 Volt: Negative Ground only.
 12 Volt: Specify Positive Ground
 Negative Ground

Car Year _____ Make _____
Name _____
Address _____
City/State _____ Zip _____

Technical Abstracts

which is typically 1 mil thick.

The diode side of the array serves as a p-type target and is scanned by an electron beam. Resolution capability and spectral sensitivity are functions of the minority carrier lifetime in the substrate and of recombination velocity of the light-incident surface.

Collection efficiencies—the ratio of holes collected at the diode depletion regions to the photons absorbed in the substrate—have topped 50%, better than twice the level achieved by conventional means. Useful spectral range is 4,500 to 9,500 angstroms, and dark currents are kept below 10 nano-amperes.

Presented at the International Electronic Devices Meeting, Washington, D. C., Oct. 18-20.

Noisy light

Pulse interval modulation laser communications
Monte Ross
McDonnell Douglas Corp.,
St. Louis, Mo.

Darkened somewhat by the problem of interfering quantum noise—from stray photons at light frequencies—the prospect of laser communications now appears brighter. A proposed pulse-interval modulation (pim) system takes into account the probability of stray photons ending up at the receiver by sending short, high peak power laser pulses in one of several possible coded time intervals.

Because the system's detector must only sample transmitted pulses for a short time period, there is less chance of its also seeing stray photons. Such a system would pack a lot of power into each pulse, making it possible to raise the detector's threshold so that it could easily distinguish between signals and quantum noise.

The number of bits one pulse could carry would depend on the number of possible time intervals in each time slot, because the number of time intervals determine the number of combinations of binary ones and zeros.

Pim laser systems might find application in space communications where it's particularly important to send the most information per watt

**Say "Good Bye"
to hand loading
of charts**

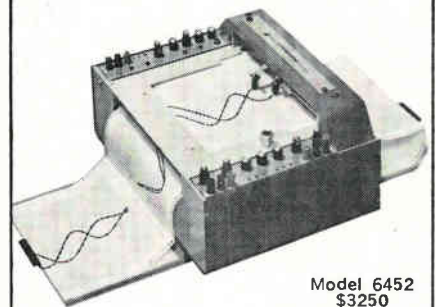

Model 6452
\$3250

New Concept in

**X-Y-Y'
Recording**

- Continuous supply of Z-fold paper charts
- 11" x 17" Recording Surface
- Bi-directional chart control
- Notebook size charts—8 1/2" x 11" or 11" x 17"
- Local or remote control of recording mechanism and pen lift
- English/Metric scaling
- 15 in./sec. slewing speed
- 18 calibrated voltage ranges for each axis, continuously variable in between
- ± .2% Accuracy
- ± .1% Repeatability

Ask about our single pen versions also

houston instrument | DIVISION OF BAUSCH & LOMB

4950 TERMINAL AVENUE, BELLAIRE, TEXAS 77401
17131 867 7403 CABLE HOINGCO

Laminated plastic tubing

at its very best



all shapes and sizes



instant stock



fabricated

We're so well equipped that you can get practically any diameter, shape or wall thickness you want—in every commercial grade of Synthane laminated plastic tubing.

And we stock so many finished tubes we can often fill your order from our inventory. This saves you time if you do your own machining, gives us a flying start if we fabricate for you.

Ask for Synthane tubing by name. Write for information.

36 River Road, Oaks, Pa. 19456

SYNTHANE

CORPORATION S OAKS, PA. 19456

Laminated Plastic Sheets, Rods, Tubes and Fabricated Parts

Circle 122 on reader service card

DC~5MHz 20mV/cm

MODEL

557A

5" OSCILLOSCOPE



VERTICAL AXIS

Deflection Sensitivity 20mV/cm AC & DC
Frequency Response

AC: 2Hz~5MHz within -3dB
DC: 0~5MHz within -3dB

Input Impedance 1MΩ, shunted by 30pF

TIME AXIS

Sweep Frequency TV·H. 10Hz~

100KHz (4 ranges) & Line Sweep

HORIZONTAL AXIS

Deflection Sensitivity 300mV/cm
Frequency Response

2Hz~500KHz, within -3dB

Calibration Voltage 0.05V, 0.5V,

5Vp-p Square Wave

CRT: 5UPIF

Dimensions 200W×300H×445Dmm

Net Weight 10 kg approx.



kikusui

KIKUSUI ELECTRONICS CORP.

3-1175, SHINMARUKO-HIGASHI, KAWASAKI-CITY,
KANAGAWA-PREF., JAPAN.

CABLE ADDRESS "KIKUSUIDE" KAWASAKI

Circle 123 on reader service card

today's...

MICRO-MINIATURE TUNED-CIRCUIT PACKAGE

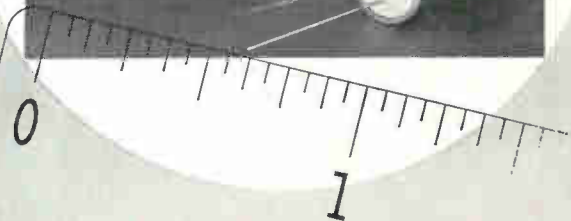
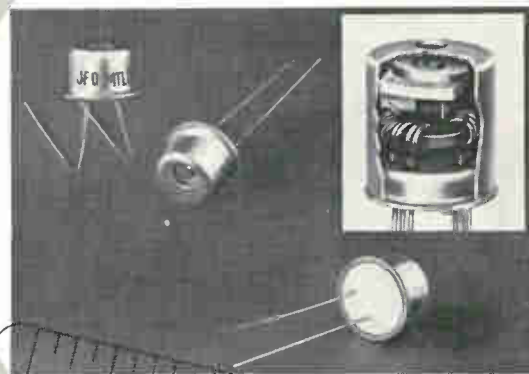

JFD TO-5 Enclosed MTLC Tuners

JFD MTLC TUNERS enable circuit designers to shrink various LC circuits into TO-5 configurations completely compatible with today's miniaturized or hybrid circuitry. The tuning element is a subminiature variable ceramic capacitor measuring: .2 x .28 x .12 in. thick. These variable ceramic capacitors offer high capacitance plus a choice of wide Δ Cs in extra small, ultra stable units.

JFD builds these miniature circuits with high quality ferrite and iron inductor toroidal cores, providing maximum Q for any given frequency. Where necessary, special JFD Unicoram fixed capacitors are used with Modutrim units to yield lower center frequencies or to satisfy special circuit requirements.

Ten standard tunable LC networks are available for a wide range of applications. Variations of these standard units, or special designs, will satisfy most other requirements.

Write for bulletin MTLC-67-A.

JFD

"TODAY'S COMPONENTS BUILT FOR TOMORROW'S CHALLENGES"

JFD ELECTRONICS CO. / COMPONENTS DIVISION 15th Avenue at 62nd Street
Brooklyn, New York 11219 / Phone 212-331-1000
Offices and subsidiaries in principal cities, world-wide.

Circle 275 on reader service card

283



Cramped for space?

Use Couch 1/7-size Relays

Space/weight problem? The new Couch 2X 1/7-size crystal can relay gives you tremendous savings in space and weight. 0.1" grid — plus many outstanding specs — all in micro-miniature. Thoroughly field-proven in electronics and space applications.

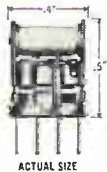

	2X (DPDT)	1X (SPDT)
Size	0.2" x 0.4" x 0.5"	same
Contacts	0.5 amp @ 30 VDC	same
Coil Operating Power	100 mw 150 mw	70 mw 100 mw
Coil Resistance	60 to 4000 ohms	125 to 4000 ohms
Temperature	-65°C to 125°C	same
Vibration	20 G	same
Shock	75 G	same

Broad choice of terminals, coil resistances, mounting styles. Write for detailed data sheets.

RUGGED ROTARY RELAYS  Dynamically and Statically Balanced

COUCH ORDNANCE INC.

3 Arlington St., North Quincy, Mass. 02171, Area Code 617, CYPRESS 8-4147 • A subsidiary of S. H. COUCH COMPANY, INC.

Technical Abstracts

of power. For example, assume a data link between Mars and the Earth. A pim system with a 150 watt input would require a four inch focusing lens and a 40 foot receiving antenna to send 1,000,000 bits per second using 1-nanosecond pulses. In contrast, an r-f system operating under the same power would require an eight foot transmitting antenna and a 210 foot receiving antenna and would only send 10,000 bits per second.

Presented at Eastcon, Washington, Oct. 16-18.

Semiconductor tube

A germanium space-charge-limited triode,
A. Shumka,
Jet Propulsion Laboratory
Pasadena, Calif.

A solid state triode that behaves like a vacuum-tube triode offers a low level of sensitivity to thermal change, high input impedance, and tube-like transfer characteristics. The first of these features is new to semiconductor devices; the latter two are more pronounced in the triode than in field effect transistors. until now considered the semiconductors most similar to tubes.

The new device, fabricated from germanium, has an electrode that controls and modulates the flow of space-charge-limited electron currents and is analogous to the vacuum tube's grid. The p^+ stripes forming this grid electrode are inserted in an $n^+ - \pi n^{\dagger} =$ type diode structure. The closely spaced stripes are capacitively coupled to the diode's terminals to establish emitter and collector regions analogous to a plate and anode.

Currents follow the three-halves power law when an electric field is impressed between the control electrode and the emitter. Over-all current-voltage characteristics show high transconductance, a large amplification factor, and an input impedance exceeding 1 megaohm.

Noise figures are a few decibels lower than those of conventional bipolar semiconductors, and susceptibility to temperature change is at least an order of magnitude less.

Presented at International Electron Devices Meeting, Washington, D. C., Oct. 18-20.

\$1,000,000 INVENTORY OF ELECTRONIC TEST EQUIPMENT



Name brand test equipment fully calibrated with certificate of traceability if desired. Maintenance provided and all equipment is insured against fire, theft and damage in shipment. Short term rentals our specialty but yearly rental available. Fast delivery. Wide variety and depth. If you need equipment NOW, call Jim Powers or Frank Cassidy at (301) 424-2333. If you want a copy of our rental list or more information write:

RENTAL ELECTRONICS, INC.

16203 FREDERICK ROAD
ROCKVILLE, MARYLAND 20850

'BESTSELLER'



Recently published, this magnetic shielding manual has already become the leading reference book in the industry. It is a complete Stocking Guide for Netic and Co-Netic sheet stock and foil alloys. It also contains detailed specifications and general fabrication information assembled for the first time. It is a clear and concise selection of "what's available," "how to specify it" and "how to use it." In actual fact it isn't a "Bestseller" . . . but only because we don't sell it, it's free. For your copy of catalog No. SG-1 write:

MAGNETIC SHIELD DIVISION

Perfection Mica Company
1322 N. Elston Ave., Chicago, Illinois 60622

Also available: a complete line of magnetic shield product data sheets and catalogs on fabricated shields, tape preserver containers, and foil. They're yours for the asking.

Circle 108 on reader service card

Pick a switch—any switch—

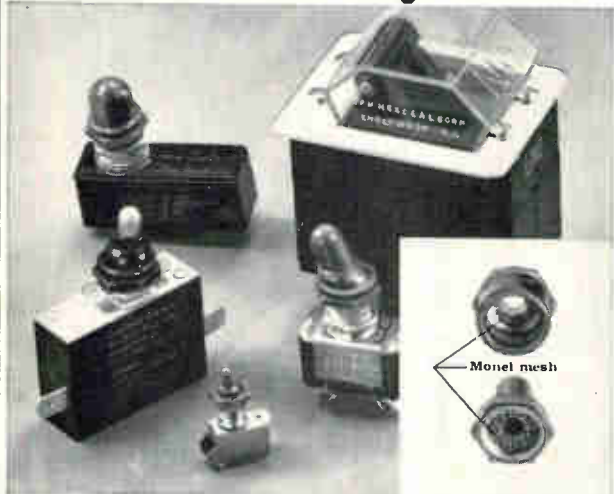

a Hexseal environmental boot will shield it from RFI.

A unique knitted Monel metal wire molded or "stuffed" into our Hexseal boots effectively eliminates RFI. Used on standard pushbutton, toggle or rotary switches, these Hexseals save sensitive equipment from harmful interference, whether received or radiated. Keep out air, gases and liquids as well.

Just replace the mounting nut with a Hexseal, and you have a sealed, RFI-shielded switch that works longer, and more reliably. (Available as a sealing boot alone, if shielding is not needed.)

Hexseals meet all applicable military applications. Send for more data and prices right away. Write:

APM-HEXSEAL
41 Honeck St., Englewood, N.J.

Circle 109 on reader service card

DIALIGHT READOUTS

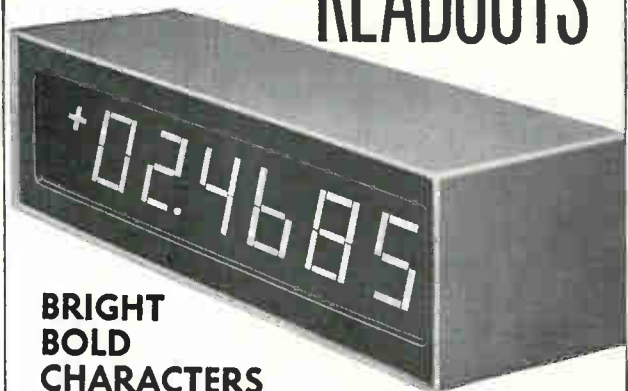

**BRIGHT
BOLD
CHARACTERS
WITH
MAXIMUM
RELIABILITY**

Need more data? Ask
for Catalog L-181.

As low as

\$3.99

per digit (less lamps)
in 1000 lot quantities

DIALCO

Foremost Manufacturer of Indicator Lights

DIALIGHT CORPORATION

60 STEWART AVE., BROOKLYN, N.Y. 11237 Area Code 212 497-7600

Circle 285 on reader service card

285

FOR PRECIOUS METAL POWDERS COME TO MATTHEY BISHOP

Here's Why

- Matthey Bishop offers variety in metals and their characteristics
- Matthey Bishop is willing to "tailor" to your specs and our prices are amazingly low

Matthey Bishop's wide variety of powders differ in particle size, surface area, bulk density, shape (powder or flake) to meet exacting requirements. No matter how you use powders—for fuel cells, metalizing preparations, resistors, printed circuits, circuit decals, capacitors, or in other ways, you will find Matthey Bishop has, or will make, precious metal powders to meet your particular specifications. By all means, contact us when you need a precious metal powder for making inks or pastes or for your own special application.

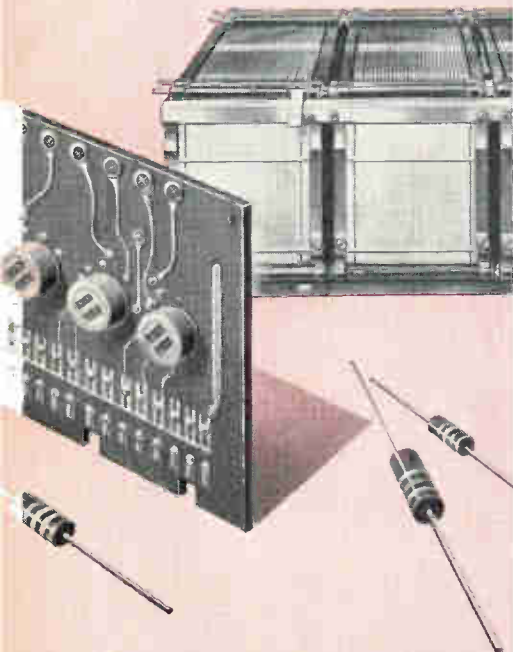

MATTHEY BISHOP, INC.

Chemicals Division / Chemical Products
MALVERN, PENNSYLVANIA 19355

Phone: (215) 644-3100

A Johnson Matthey Affiliate

In Canada: Johnson Matthey & Mallory Limited

New Literature

Microwave glossary. Alfred Electronics, 3176 Porter Drive, Palo Alto, Calif., has published a four-page application note entitled "Glossary of Microwave Terms" that lists 115 microwave definitions. Circle 446 on reader service card.

R-f test instruments. Kay Electric Co., Maple Ave., Pine Brook, N.J. 07058, has released a 32-page brochure illustrating and describing a line of r-f test instruments. [447]

Capacitance probes. Wayne Kerr Corp., 22 Frink St., Montclair, N.J. 07042. A two-page, illustrated bulletin describes the company's capacitance probes. [448]

Slip ring capsules. Collectron Corp., 304 E. 45th St., New York 10017, offers a brochure describing a simplified method in designing a completely functional and highly reliable miniature and subminiature slip ring capsule. [449]

Tape reel drive motors. General Electric Co., Schenectady, N.Y. 12305. Technical data sheet GEC-1795 describes direct-current, fractional h-p motors for use as computer tape transport drives. [450]

Ultrasonic cleaning equipment. Delta Sonics Inc., 12918 Cerise Ave., Hawthorne, Calif. 90250, has released a 12-page brochure on ultrasonic cleaning equipment. Detailed specifications for tank sizes from 3- to 90-gallon capacity and 300 to 4,000 w are listed. [451]

Avalanche diode oscillator. Sylvania Electric Products Inc., 1100 Main St., Buffalo, N.Y. 14209, offers a brochure describing the SYA-3200, an X-band avalanche diode oscillator that simplifies construction of parametric amplifiers. [452]

Instrument motors. Amphenol Controls Division, Amphenol Corp., 120 S. Main St., Janesville, Wis. 53545. An eight-page catalog covers servocontrol, induction, reluctance and hysteresis synchronous motors. [453]

Vacuum coaxial switching. ITT Jennings Division, ITT Corp., P.O. Box 1278, San Jose, Calif. 95108. Brochure 108 describes the characteristics, construction, and application of vacuum coaxial switching systems. [454]

Emi/rfi shielding. Technical Wire Products Inc., 129D Dermody St., Cranford, N.J. 07016, has published an eight-page booklet containing information on its emi/rfi shielding products and services. [455]

Random data generator. Datapulse Inc., 10150 W. Jefferson Blvd., Culver City, Calif. 90230, offers a technical bul-



APT-1; 1 cu. in., 3.15 oz. (actual size)

More torque, Less weight in moving coil mechanism

Highly stable, linear and accurate mechanism for indicating, control or recording systems. 18-0-18° linearity is 1%. Coil design with over 75% of winding "working" in high energy, uniform field air gap assures greater accuracy. Coil system weighs 0.85 gm, develops 26.4 mmg of torque; 31:1 T/W. Mechanism offers negligible vibration pivots and jewels — custom damping — wide range of sensitivities.

AMMON

AMMON INSTRUMENTS, INC.
345 Kelley St., Manchester, N.H. 03105

Circle 110 on reader service card



Eight fact-packed pages tell how we've combined up-to-the-minute production facilities with the kind of meticulous New England craftsmanship you probably didn't realize still existed. Read how the combination benefits you, whenever you need quality.

PRINTED CIRCUITS ASSEMBLIES PROTOTYPES



ELECTRO-SONICS, INC.

210 Main St., Spofford, N. H. 03462

Tel. 603/363-4701

← Circle 286 on reader service card

Circle 111 on reader service card

Smallest 3-Phase Electronic Frequency Converters Ever Made!



Now, from CML, comes a series of the smallest 3-phase Electronic Frequency Converters ever made... featuring fixed or adjustable plug-in oscillators at frequencies ranging from 45 to 6,000 cycles. Write today for details on Models T500A through T2500A!

Model	3 ϕ Output VA	Dimensions (For standard 19" relay rack mounting)
T500A	500	8 $\frac{3}{4}$ " h x 21" d
T750A	750	14" h x 21" d
T1200A	1200	14" h x 21" d
T1750A	1750	14" h x 21" d
T2500A	2500	14" h x 21" d



CML, Inc.
A Subsidiary of Tenney Engineering, Inc.
350 Leland Avenue • Plainfield, New Jersey
Telephone (201) 754-5502 • TWX: 201-756-2064

Circle 112 on reader service card

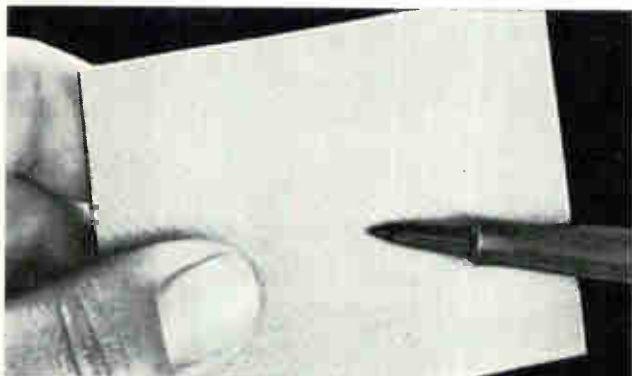

Porcupine Metalastic™

... best RF characteristics of any flat material

Hundreds of tiny contact points per square inch give Porcupine Metalastic exceptional RF shielding characteristics. Consisting of distorted solid Monel sheeting in silicone rubber, Porcupine is ideal in vacuum, atmosphere or moisture seal

applications. For high temperatures, it's available without silicone rubber. Standard widths: 8" & 10". Thickness: .020" and .030". Other sizes, too. About 6¢ per sq. in. Write for free samples, prices and literature.

METEX Corporation
970 New Durham Road, Edison, N.J. 08817
(201) 287-0800 • TWX 710-998-0578
West Coast: Cal-Metex Corp., 509 Hindry Ave., Inglewood, Calif. 90304

Circle 113 on reader service card

If You're Still Using A V.T.V.M. It's Time To Change ... Go Solid-State!



A Kit IM-16
\$44.95
Wired IMW-16
\$64.95



B Kit IM-25
\$80.00
Wired IMW-25
\$115.00

These New Heathkit® Solid-State Meters Feature State-Of-The-Art Performance At Prices You Can Afford

- Modern, stable, long-life solid-state circuitry
- New low-voltage ranges to accurately analyze modern transistor circuits
- Full capability to go "out on the job" ... instant selection of internal battery power or 120/240 v. 50-60 Hz AC operation
- Exceptional accuracy ... 3% on DC volts, plus a large, easy-to-read 6" meter face
- High impedance F.E.T. input for minimum circuit loading

A **New! Deluxe Solid-State Volt-Ohm Meter**
Features 8 DC and 8 AC voltage ranges from 0.5 v to 1500 v full scale; 7 ohmmeter ranges (10 ohms center scale) x1, x10, x100, x1k, x10k, x100k, & x1 megohm; 11 megohm input on DC ranges; 1 megohm on AC ranges; internal battery or 120/240 v 50-60 Hz AC power for portable or "in shop" use; large readable-across-the-bench 6" meter; separate switches for individual functions; single test probe for all measurements; modern, stable solid-state circuit-board construction.

Kit IM-16, 10 lbs. \$44.95; Wired IMW-16, 10 lbs. \$64.95

B **New! Deluxe Solid-State Volt-Ohm-Milliammeter**
All silicon transistors plus FET's. Features 9 AC and 9 DC voltage ranges from 150 mV to 1500 volts full scale; 7 ohmmeter ranges (10 ohms center scale) x1, x10, x100, x1k, x10k, x100k, & x1 megohm; 11 current ranges from 15 uA to 1.5 Amperes full scale; 11 megohm input on DC voltage ranges; 10 megohm input on AC voltage ranges; internal battery power or 120/240 v 50-60 Hz AC power for maximum versatility; easily readable 6" meter face; $\pm 3\%$ accuracy on DC volts; $\pm 4\%$ on DC current; $\pm 5\%$ accuracy on AC voltage and current; separate range switches "human engineered" for efficiency in actual use; modern circuit board construction; all solid-state components; easy to assemble.

Kit IM-25, 10 lbs. \$80.00
Wired IMW-25, 10 lbs. \$115.00

HEATH COMPANY,
Benton Harbor, Mich. 49022 Dept. 520-28
In Canada, Daystrom Ltd.

Please send my FREE 1968 Heathkit Catalog.

Enclosed is \$ _____, plus postage.

Please send model(s) _____

Name _____

Address _____

City _____ State _____ Zip _____

Prices & Specifications subject to change without notice.

TE-165R

Circle 287 on reader service card

287

Supplies for Transmitter



Model 220

Budget Price!

\$540* buys this completely self-gaussmeter (*plus probe). Measures flux density from 0.2 gauss to 20,000 gauss; permanent magnet, DC and AC fields up to 50 kHz, allowing measurement of fields with a time base down to the microsecond region. Better than $\pm 3\%$ accuracy with self-calibrating feature which requires no reference magnets. Accuracy capabilities to $\pm 1\%$. Wide application in production, engineering, research and QC.



For detailed data and free Magnetic Application Booklet, write or call Herb Brumbach.

RFL Industries, Inc.

FORMERLY RADIO FREQUENCY LABORATORIES, INC.

Instrumentation Div. • Boonton, N. J. 07005
Tel: 201-334-3100 / TWX: 710-987-8352 / CABLE: RADARCO, N.J.

New Literature

letin on the model 213 random data generator for data error analysis and pattern sensitivity detection in transmission-medium systems and storage elements. [456]

Parametric amplifier systems. TRG Division, Control Data Corp., 535 Broad Hollow Road, Melville, N.Y. 11746, has issued brochures describing models 4-500 and 7-120 parametric amplifier systems. [457]

Motors. A.W. Haydon Co., 232 North Elm St., Waterbury, Conn. 06720. A four-page bulletin contains information on 16 types of d-c motors, synchronous motors, stepper motors and drives, and gearheads for timing, driving and positioning applications. [458]

Diode reliability. Unirode Corp., 580 Pleasant St., Watertown, Mass. 02172, has available reliability report TR-129 covering rectifiers, zeners, and assemblies. [459]

Metal-to-ceramic components. Advac Division, GTI Corp., Stamford, Conn., offers a metal-to-ceramic components and assemblies folder. [460]

Dynamic bridge amplifier. Redcor Corp., 7800 Deering Ave., Canoga Park, Calif. 91304, has issued a booklet containing numerous applications for a dynamic bridge amplifier module designed for use in low level data acquisition and instrumentation systems. [461]

Pressure actuated switch. Electro Marine Corp., 4 Robbins Road, Falmouth, Mass. 02540. Bulletin 800 describes a pressure actuated switch for oceanographic instrumentation applications. [462]

Laser components. Oriel Optics Corp., 1 Market St., Stamford, Conn. 06902, has published a data sheet on carbon-dioxide-laser end reflectors made from germanium and silicon with high efficiency multilayer dielectric coatings. [463]

Card reader. Scientific Data Systems, 1649 Seventeenth St., Santa Monica, Calif. 90404. Model 7140 card reader, a high-speed peripheral device that reads punched cards at a rate of 1,500 cards per minute, is described in data sheet 64-24-16A. [464]

Synchro converters. Natel Engineering Co., 7129 Gerald Ave., Van Nuys, Calif. 91406, has issued catalog 101 on a family of synchro converters including synchro-to-sine/cosine converters, synchro-to-linear d-c converters, synchro-to-digital converters, and angle position indicators. [465]

Time-sharing computers. Scientific Data Systems, 1649 Seventeenth St., Santa Monica, Calif. 90404. The SDS940

MICO

NEW MODEL 885 SEVEN RATIO WIDE-RANGE ENGRAVER

NO. 885

FOR LONG AND
MULTI-LINE WORK

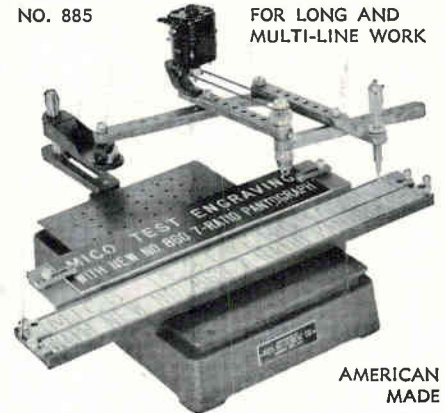

AMERICAN
MADE

- A time-saver for large plate work
- Engraves 3" x 19" area in one set-up.
- Seven pantograph ratios—from 1:5:1 to 6:1.
- Choice of 3-ball-bearing spindle assemblies for 1/8", 3/16" or taper-shank cutters.
- HSS, COBALT and Solid Carbide Cutters.
- Single and multi-line copy carriers for holding, blanks 3/4" to 3 1/2" high.
- Accommodates Mico standard accessories.

Send for bulletins and prices

MICO INSTRUMENT CO.

77 Trowbridge St. Cambridge, Mass. 02138
Circle 114 on reader service card



Capacity problem with high frequency transistors?

IERC's efficient Therma-link heat dissipators/retainers with their .060" beryllium oxide washers reduce normal mounting capacitance by 1/2 to 2/3 between transistor case and chassis or heat sink. Washer has same excellent thermal conductivity as aluminum metal and is electrically insulative. Various models; may be soldered down or mounted with screw or stud. Send for data sheet 141. IERC, 135 W. Magnolia Blvd., Burbank, Calif. 91502.



A corporate div. of Dynamics Corp. of America

FREE

**NEW 1968
ALLIED
INDUSTRIAL
ELECTRONICS
CATALOG**
600
VALUE-PACKED PAGES

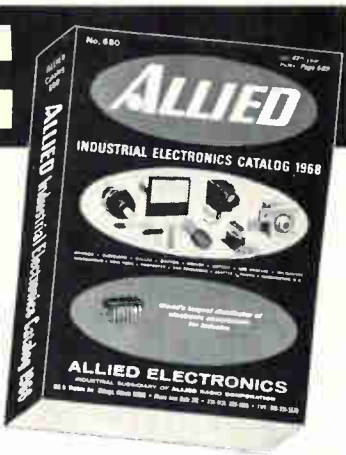

P & B RELAYS

SEE THE 1968
ALLIED CATALOG

Allied stocks Potter & Brumfield Relays in depth: General purpose, special purpose, power, high performance, mercury wetted contact, telephone types.

World's Largest Selection
of Electronic Components
for Industry

- Scores of new products
- Factory OEM prices
- Same-day shipment
- All merchandise stocked in depth

Write for Your Copy Today
Write to: Dept. 82-L

ALLIED ELECTRONICS

A Subsidiary of Allied Radio Corp.

Our 47th Year
100 N. Western Ave.
Chicago, Ill. 60680

Circle 116 on reader service card

GLOBE

Some blowers just
blow and blow and
blow and blow and
blow and blow and
blow and blow and
blow.



Globe's VAX-3-BR d.c. brushless blower will still be on the job long after you've retired other d.c. blowers plagued by brush caused problems—bearing wear, arcing, brush changing, etc. This compact 17 oz. unit delivers 50 cfm at .8" H₂O for more than 3,000 hours. The VAX-3-BR packs a proven a.c. brushless design in a reliable d.c. unit. It's one of many long-life a.c. and d.c. Globe blowers available in production quantities at production prices. Write for Bulletin BR.

GLOBE INDUSTRIES
DIVISION OF TRW INC.

2275 Stanley Ave., Dayton, Ohio 45404, Tel: 513 222-3741

Circle 117 on reader service card

Still using LC's? This might change your mind:



Clevite's ceramic ladder filters deliver 80 db rejection in 0.1 cu.in.!

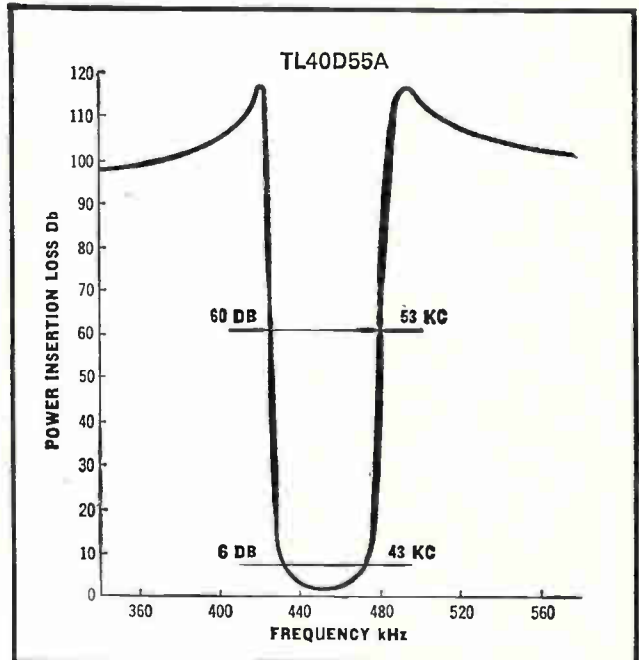

Here's a fixed-tuned filter that offers more selectivity for its size than any conventional i-f filter on the market! Clevite's non-magnetic, non-microphonic, 17-disc ceramic ladder filter is ideal for i-f stages of high quality superheterodyne radio receivers used in airborne or ground AM and FM communications equipment. Stop band rejection: 60 or 80 db. Center frequency tolerance: ± 1 kHz for 20 kHz B/W and below; ± 2 kHz for 30 kHz B/W and above. Stability: within +0.2% for 5 years; within 0.2% from -40°C to $+85^{\circ}\text{C}$. Impedance (in and out) 2500 ohms for 12 kHz bandwidth and below; 1500 ohms for 13 kHz to 29 kHz B/W; 1200 ohms for 30 kHz bandwidth and above.

Following models standard at 455 kHz (A) or 500 kHz (C) (custom models on special order):

Model Number	B/W		Model Number	B/W	
	Min. @ 6db	Max. @ 60db		Min. @ 6db	Max. @ 60db
TL-2D5 (A)	2 kHz	5 kHz	TL-20D32 (A)	20 kHz	32 kHz
TL-4D8 (A)	4 kHz	8 kHz	TL-30D45 (A)	30 kHz	45 kHz
TL-6D11 (A)	6 kHz	11 kHz	TL-40D55 (A)	40 kHz	55 kHz
TL-8D14 (A)	8 kHz	14 kHz	TL-45D65 (A)	45 kHz	65 kHz
TL-10D16 (A)	10 kHz	16 kHz	TL-50D75 (C)	50 kHz	75 kHz
TL-16D25 (A)	16 kHz	25 kHz			

PRICES: 1 — \$52.50; 25 — \$42.00 ea; 100 — \$36.75 ea; 500 — \$31.50 ea; 2000 — \$26.00 ea.

(Prices subject to change without notice.)

Send order or request for Bulletin 94017 to: Clevite Corporation, Piezoelectric Div., 232 Forbes Rd., Bedford, Ohio 44014, U.S.A. Or: Brush Clevite Company, Limited, Southampton, England.

CLEVITE

Circle 289 on reader service card

289

*So
you think
our team of
plant site
engineers
couldn't
possibly
furnish all
the specific
answers
you need?*

Try us

Our engineers have numerous files full of detailed relocation data. They also have contact with authoritative sources of information. All correspondence or facts about your business will be handled in strictest confidence. Let us open a comprehensive plant site research file for your company soon.

The upper Texas-Louisiana Gulf Coast area served by Gulf States encompasses 28,000 square miles, including several highly industrialized metropolitan areas and many resource-rich smaller communities. Already, over 65 "blue chip" industries have established in our service area.

Send me your area development brochure, "Upper Texas-Louisiana Gulf Coast-Land, Labor Resources", and more information about the growth and profit opportunities in your service region.



NAME _____
TITLE _____
COMPANY _____
ADDRESS _____
CITY _____ STATE _____ ZIP _____

Mail to:
L. V. Dugas, Vice President
GULF STATES UTILITIES COMPANY
Department E-4
Lock Drawer 2951
Beaumont, Texas 77704

**GULF STATES
UTILITIES COMPANY**

New Literature

time-sharing computer system is the subject of brochure 64-03-29A. [466]

Audio interference suppressor. Narda Microwave Corp., Plainview, L.I., N.Y. 11803, has available a technical bulletin on the model 562 audio interference suppressor. [467]

Biased amplifier. Hamner Electronics Co., Box 531, Princeton, N.J. 08540, offers a technical bulletin covering the NA-18 biased amplifier that permits a section of the spectrum to be spread over a larger number of channels of a multichannel analyzer. [468]

Semiconductor products. Westinghouse Semiconductor Division, Youngwood, Pa., 15697. Condensed catalog B-9418 describes a wide variety of semiconductor devices ranging from a 250-amp transistor to a full line of low-cost plastic-case rectifiers. [469]

Computers on campus. Scientific Data Systems, 1649 Seventeenth St., Santa Monica, Calif. 90404. Interface 12, the latest issue of the company's quarterly magazine, contains a feature article describing the use of SDS computers in some 40 colleges and universities. [470]

Vacuum systems. Consolidated Vacuum Corp., 1775 Mt. Read Blvd., Rochester, N.Y. 14603. Two bulletins describe new vacuum systems that feature AutoMate control. [471]

Interchangeable thermistors. Victory Engineering Corp., 128 Springfield Ave., Springfield, N.J. 07081. Product bulletin MTM141 describes Isotherm interchangeable thermistors and contains a comprehensive resistance vs temperature table. [472]

Wire marking. W.H. Brady Co., 727 W. Glendale Ave., Milwaukee, Wis. 53209. A 20-page catalog lists over 5,000 different self-sticking wire markers and several dispensing methods to speed wire identification. [473]

Operational amplifier. National Semiconductor Corp., 2950 San Ysidro Way, Santa Clara, Calif. 95051. Bulletin SC-103 describes and illustrates the LM101 general-purpose operational amplifier. [474]

Thermal relays. G-V Controls Inc., Okner Parkway, Livingston, N.J. 07039, has available a file folder including information on two series of commercial thermal relays. [475]

Trimming potentiometers. Conelco Components, 465 W. Fifth St., San Bernardino, Calif. 92401. A four-page brochure details the Midgi-Trim line of precision wirewound/slidewire trimming potentiometers. [476]

R-3000

SOLID STATE AC VOLTAGE REGULATORS

Write
today
for new
Brochure



Designed Especially for OEM Application.
Two Lines Available.

SPECIFICATIONS

	R-3100	R-3200
Type of Voltage Regulation	True RMS	Peak
Regulation Technique	Peak Clipping	Peak Clipping
Type of Reference	RMS Sensor	Zener Diode
Input	100-130 VAC	100-130 VAC
	47-63 Hz	47-63 Hz
Output	115 VAC	115 VAC (RMS)
Line Regulation ($\pm 10\%$ line variation)	$\pm 0.5\%$	$\pm 1.0\%$
Load Regulation (10% to Full Load)	$\pm 0.5\%$	$\pm 1.0\%$
Frequency Regulation (47-63 Hz)	$\pm 0.5\%$	$\pm 1.0\%$
Power Factor Regulation (+0.7 to -0.7)	$\pm 0.5\%$	$\pm 1.0\%$
Phase Shift	None	None
Response Time	10-50 μ sec.	10-50 μ sec.
Models Available	15-1000 va	15-1000 va

**WANLASS
ELECTRIC CO.**



A Subsidiary of American Bosch Arma Corporation
2175 South Grand Avenue/Santa Ana, California 92705
Circle 118 on reader service card

Cartoon by Whitney Darrow, Jr.



Be a buddy!

One gift works many wonders
THE UNITED WAY



Standard and Special NATIONAL® Readout Tubes

Wide variety of symbols μA to K Hz

- Side view tubes ■ End view tubes
- Inverted side view tubes

Also: TTL IC Drivers, Sockets and Bezels

REQUEST BULLETIN

NATIONAL

ELECTRONICS, INC.
a varian subsidiary

PHONE: (312) 232-4300 • GENEVA, ILLINOIS 60134

Circle 119 on reader service card

**High intensity,
infrared...**



spot heater

NO CONTAMINATION

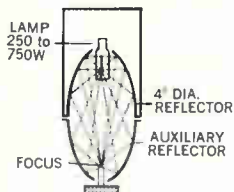

Heat from lamp at one ellipsoid focus is concentrated at the other focus. (Auxiliary reflector may be removed or cut away to accommodate the heated item.)

Here's clean, quick, precisely controllable heat for small parts. A high-intensity, iodine-cycle lamp with 5400° F tungsten filament provides energy that is concentrated by an elliptical reflector on one very small spot. Heating rate and maximum temperature depend on absorptivity of the part heated. Reflector has provisions for air cooling.

APPLICATIONS: Soldering, glass-metal sealing, stress relieving, igniting, decoating.



Research, Inc.

R-I CONTROLS DIVISION
BOX 6164H MINNEAPOLIS, MINN. 55424

Circle 120 on reader service card

IS THERE A SINGLE INSTRUMENT THAT WILL:

- identify frequency
- test crystal devices
- determine bandpass filter response
- equalize transmission lines
- check dynamic impedance
- align wide or narrow band amplifiers
- determine signal purity?

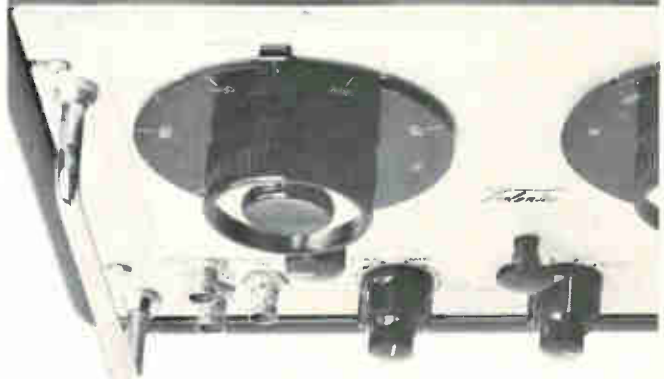

Try the TELONIC SM-2000 Sweep Generator

It covers DC to 3000 MHz, sweep or CW, has variable rate, and uses convenient plug-in oscillators for range selection. A complete description of the instrument and those applications listed above may be found in Catalog 70-A. Yours on request.

Telonic INSTRUMENTS A Division of
Telonic Industries, Inc.
60 North First Avenue Beach Grove, Indiana 46107
Tel.: (317) 787-3231 TWX.: 810-341-3202

Representatives throughout the U.S., Canada and Overseas. Branch offices in Maidenhead, England, Frankfurt, Germany, and Milan, Italy.

Circle 291 on reader service card

291

Outstanding Technical Books

from McGRAW-HILL

1 MOSFET IN CIRCUIT DESIGN: Metal-Oxide Semiconductor Field-Effect Transistors for Discrete and Integrated-Circuit Technology.
By ROBERT H. CRAWFORD.

This sixth book in the Texas Instruments Electronics Series gives circuit designers the basic principles necessary in MOSFET device and circuit engineering, and includes a description of an actual MOSFET complex integrated circuit. **144 pp., \$10.00.**

2 COMMUNICATION SYSTEM ENGINEERING HANDBOOK.
By DONALD H. HAMSHER.

This practical compendium of basic data and the combined experience of 33 specialists gives you an informed overview of the entire field and shows you how to apply the systems approach to communication engineering. Includes data and material not published elsewhere. **600 pp., \$28.50.**

3 ANALYSIS AND DESIGN OF INTEGRATED CIRCUITS.

By the Engineering Staff, Motorola Inc. Semiconductor Products Division.

This book establishes analytical and experimental techniques to bring about the balance between system, circuit, and device research and development required in integrated circuits. **500 pp., \$16.50.**

4 DIGITAL LOGIC AND COMPUTER OPERATIONS.

By ROBERT C. BARON and ALBERT T. PICCIRILLI.

For anyone with some basic math training, this book stresses matter applicable to all computers, and shows how to use various methods to solve a given problem. It is the ideal preparation for anyone intending to use a computer for the first time. **352 pp., \$13.50.**

5 CHARACTERISTICS AND OPERATION OF MOS FIELD-EFFECT DEVICES.

By PAUL RICHMAN.

Beginning with fundamentals, this book provides a concise, straightforward introduction to the theory, characteristics, and operation of metaloxide semiconductor field effect transistors (MOSFET) and related devices. **200 pp., \$10.00.**

At your bookstore or
send coupon for:

10 DAYS FREE EXAMINATION

McGRAW-HILL BOOK CO., Dept. 23-L-1111
330 West 42nd Street, New York, N.Y. 10036

Send me the book(s) circled below for 10 days on approval. In 10 days I will remit for book(s) I keep, plus a few cents delivery costs, and return others postpaid.

1 13475-9 2 25960-6 3 43526-3
4 03760-6 5 52340-7

Name (print) _____

Address _____

City _____

State _____

Zip Code _____

For prices and terms outside U.S.
write McGraw-Hill Int'l. NYC

23-L-1111

New Literature

Temperature-humidity chambers. Tenney Engineering Inc., 1090 Springfield Road, Union, N.J. 07083, offers bulletin 106 describing an advanced version of its temperature and temperature-humidity chambers. [477]

RC networks. Electro Cube Inc., 1710 S. DelMar Ave., San Gabriel, Calif. 91776, has published a brochure on precision RC networks for contact protection and noise suppression. [478]

Vibration meter. Wayne Kerr Corp., 22 Frink St., Montclair, N.J. Three-color literature describes the B731B vibration meter that features linear output characteristics. [479]

Solderless terminals. Hollingsworth Solderless Terminal Co., Nutt & French Creek Roads, Phoenixville, Pa. 19460. A complete line of solderless terminals, splices and tools is described and illustrated in a 30-page catalog. [480]

Versatile digital instrument. Technology/Versatronics Inc., 506 S. High St., Yellow Springs, Ohio 45387. Three instruments in one—digital voltmeter, electronic counter, and electronic integrator—are provided by the model DM5000 Versa/meter described in bulletin 701-B. [481]

Plastic-encapsulated transistors. Motorola Semiconductor Products Inc., Box 955, Phoenix, Ariz. 85001. A 12-page brochure presents a reliability report on small-signal, plastic-encapsulated transistors. [482]

Casting system. Hysol Corp., Franklin St., Olean, N.Y. 14760. Bulletin E3-225 describes water white hardener H-3840, a room-temperature-cure casting system for electrical and electronic applications. [483]

Wirewound resistors. RCL Electronics Inc., 700 So. 21st St., Irvington, N.J. 07111. Engineering catalog 678 lists hundreds of types of wirewound resistors, together with complete engineering information. [484]

Ceramic capacitors. Gulton Industries Inc., 212 Durham Ave., Metuchen, N.J. 08840. High capacitance subminiature ceramic capacitors are described in bulletin H29. [485]

Electronic timers. Brooks Instrument Division, Emerson Electric Co., Hatfield, Pa. 19440. Digital-readout electronic timers that maintain accuracy regardless of power line frequency variations are discussed in technical bulletin DS-4580. [486]

High-vacuum system. Ultek Division, Perkin-Elmer Corp., P.O. Box 10920, Palo Alto, Calif. 94303. A bakeable, tabletop high-vacuum system is the subject of a six-page bulletin. [487]

MATSUO

Highly Reliable Capacitors

POLYESTER FILM CAPACITORS.

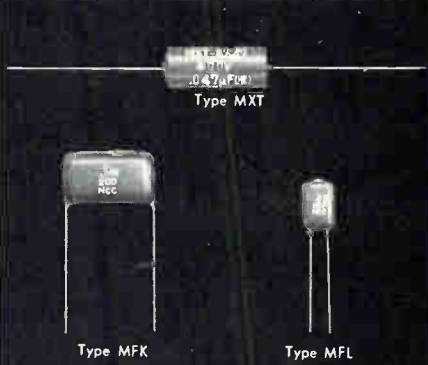

Type MXT
In plastic tube.
Capacitance Range: .001 MFD to .22 MFD.
Voltages: 100v, 200v, 400v, 600v DC.

Type MFK
Dipped flat shape non-inductive construction.
capacitance Range: .01 MFD to .47 MFD.
Voltages: 100v, 200v, 400v, 600v DC.

Type MFL
Dipped flat shape.
Capacitance Range: .001 MFD to .22 MFD.
Voltages: 50v, 100v, 200v DC.

METALLIZED POLYESTER FILM CAPACITORS.



Type FNX-H
Mylar wrapped semi-wrapped with epoxy end seal.
Capacitance Range: 1 MFD to 10 MFD
Voltages: 100v, 200v, 400v, 600v DC.

SOLID TANTALUM CAPACITORS.

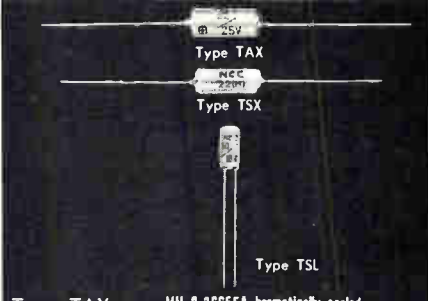

Type TAX
MIL-C-26655A hermetically sealed.

Type TSX-TSL
Sealed with epoxy resin.
Capacitance Range: 22MFD to 330 MFD.
Voltages: 3v, 6v, 10v, 15v, 20v, 25v, 35v, 50v DC.

for full details, contact :

**MATSUO
ELECTRIC CO., LTD.**

3-chome, Sennari cho, Toyonaka-shi, Osaka, Japan
Cable Address "NCC MATSUO" OSAKA

PROGRESS REPORT



The lines on this part are about one-seventh the diameter of the usual paper staple

3 mil lines on 5 mil centers

APPROXIMATELY ACTUAL SIZE

ENLARGED 5 TIMES TO SHOW DETAIL



PRECISION METALLIZING ON Substrates

New precision of metallized patterns is now practical on Substrates produced to the customer's blue print. Definition is sharper, tighter pattern tolerances are now possible, line widths have been materially reduced, and line conductivity has been increased.

The basic ALSiBase substrate is usually an ALSiMag high-alumina ceramic, which has excellent heat dissipation. Where heat conduction is especially important, ALSiMag beryllia ceramics may be specified.

The size and complexity of design control the metallizing capabilities to some extent. This new precision metallizing offers several advantages to the designer:

- Circuit space is saved.
- Pattern sizes up to 3" square are practical.

- Line widths of 7 mils on 14 mil centers are readily handled.
- 4 mil lines on 8 mil centers can converge about a chip area.
- In some instances, even smaller line widths and closer centers are feasible. Specific inquiry is suggested.
- Line resistance down to 10 milliohms per square or better is often possible.
- The metallized areas can be supplied with plating to facilitate chip attachment, wire bonding and hermetic sealing.

Designers are invited to explore with our Engineers the possibilities of these newest capabilities in precision. All production processes of metallizing and plating are concentrated in one specially designed climate controlled area. Prototypes are available at reasonable cost.

Circle 293 on reader service card

CODE IDENT. NO. 70311

PHONE 615 265-3411, CHATTANOOGA, TENN. 37405

American Lava Corporation **3M**
A SUBSIDIARY OF COMPANY

For service, contact American Lava representatives in Offices of Minnesota Mining and Manufacturing Company in these cities (see your local telephone directory): Boston, Needham Heights, Massachusetts • Chicago, Glen Ellyn, Illinois • Cleveland, Ohio • Dallas, Texas • Laurens, S.C. • Los Angeles, Calif. • Metropolitan New York: Ridgfield, N.J. • Up State New York and Canada: Baldwinsville, N.Y. • Orange, Conn. • Philadelphia, Penna. • Roanoke, Virginia • St. Louis, Lee's Summit, Missouri • San Francisco, Cal. • Troy, Mich. • 3M International, c/o American Lava Corp., Chattanooga, Tenn. 37405 U.S.A. 615/265-3411

66th
YEAR
OF
CERAMIC
LEADERSHIP



If you don't see 'Charley' in this night scene, join the group of Scientists and Engineers who have enough vision to to make this a reality.

New positions in advanced research and development projects are open at a unique laboratory with mission to accomplish applied research development and engineering of materials, methods and techniques; procurement of services; and design testing and test evaluation of night vision systems for the Army.

AT

NIGHT VISION LABORATORY

OF THE ARMY ELECTRONICS COMMAND

—IF YOU ARE A U.S. CITIZEN, HAVE A DEGREE AND AN INTEREST IN ANY OF THE FOLLOWING FIELDS . . .

OPTICS

PULSED CIRCUITRY
PHOTOEMISSION
VACUUM TECHNIQUES
LASER RESEARCH
LIGHT SOURCE RESEARCH
TRANSISTORIZED ELECTRONICS
AUTOMATIC PATTERN . .
RECOGNITION

VISUAL PERCEPTION

ATMOSPHERIC OPTICS
VISIONICS
IMAGE INTENSIFICATION . .
COMPONENTS & SYSTEMS
FAR INFRARED COMPONENTS
& SYSTEMS
ILLUMINATION SYSTEMS
TV SYSTEMS

SEND RESUME OR SF 57 TO . .

CIVILIAN PERSONNEL OFFICE
Building T-2323, Room No. 1
Fort Belvoir, Virginia 22060

FORT BELVOIR IS LOCATED APPROXIMATELY 15 MILES SOUTH OF WASHINGTON, D.C. STARTING SALARIES RANGE FROM \$6,387 TO \$20,000 PER ANNUM. RELOCATION EXPENSE PAID. THESE ARE CAREER CIVIL SERVICE POSITIONS.

AN EQUAL OPPORTUNITY EMPLOYER

CIRCLE 951 ON READER SERVICE CARD

GOODYEAR AEROSPACE

Combine outstanding technical opportunity with ideal living in Phoenix and the Valley of the Sun.

Radar Sensors, Satellite Radar, Electronic/Optical Data Processors, E.C.M. and Advanced Studies represent some of the current efforts in our Arizona Electronics Division.

Current openings for degreed engineering personnel include:

CIRCUIT DESIGN

Senior Engineers with extensive backgrounds in the areas of IF-Video circuits; CRT sweeps; servo circuits; pulse and analog circuits; digital circuits; and power supplies.

MICROWAVES

Senior engineers for microwave systems design with experience in radar microwave engineering.

OPTICS

Senior optics engineers with extensive experience in the design of optical systems such as correlators, recorders and displays.

SERVOMECHANISMS

Senior engineers with experience in the design of precision digital servomechanisms.

Send resume and salary requirement to:

M. J. McColgan,

Engineering Personnel,

**GOODYEAR AEROSPACE
CORP.**

Litchfield Park, Arizona 85340

An Equal Opportunity Employer

CIRCLE 952 ON READER SERVICE CARD

We have been placing B.S., M.S., & Ph.D.

ELECTRONIC ENGINEERS

in FEE PAID positions throughout the U.S. since 1959 through our PERSONALIZED SERVICE.



Over 1000 client companies rely on us to provide carefully screened, technical referrals. We are staffed by experienced graduate engineers **WORKING FULL TIME FOR YOU!**

SEND RESUME TODAY

If none, send this ad with your name and address for confidential application.

ATOMIC PERSONNEL, INC.

Suite L, 1518 Walnut St., Phila., Pa. 19102

AN EMPLOYMENT AGENCY FOR ALL TECHNICAL FIELDS

CIRCLE 953 ON READER SERVICE CARD

ADDRESS BOX NO. REPLIES TO: Box No.

Classified Adv. Div. of this publication.

Send to office nearest you.

NEW YORK, N. Y. 10036: P. O. Box 12

CHICAGO, Ill. 60611: 645 N. Michigan Ave.

SAN FRANCISCO, Cal. 94111: 255 California St.

POSITION VACANT

Operations Manager for New Radiation processing company. Must have extensive Linear Accelerator experience, 5 to 7 Mev. New \$200,000 building. East coast. P-4189, Electronics.

—PROFESSIONAL SERVICES—

Donald C. Harder, Inc.

Magnetic Component Engineers

Reactors—Transformers—Filters

Serving the Research Laboratory

2580 K Street, San Diego, Calif. 92102

Phone (714) 239-8021

ENGINEERS!!!

Looking for the perfect place to work???

There ain't hardly any such animal!!!

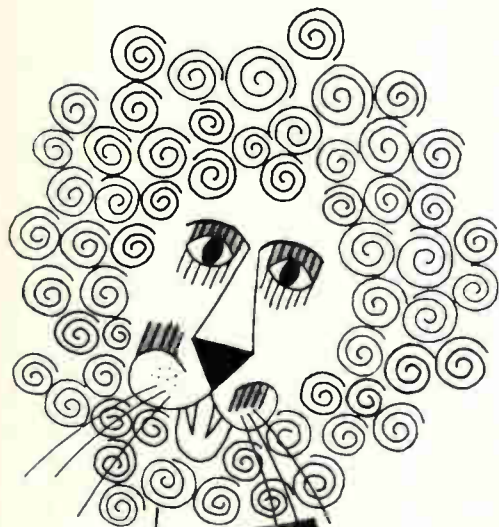

UNLIMITED SICK LEAVE

THREE HOUR LUNCHES

20-HOUR WORK WEEK

NO INCOME TAX

SIX-MONTH VACATIONS

RAISES ONCE A MONTH

No, the perfect job or place to work . . . is as elusive as the Fountain of Youth. This multiple hybrid, patchwork creature simply does not exist. Yet, we are convinced the Naval Ship Missile Systems Engineering Station has much to interest you in that direction. For example, we offer an excellent, smog-free, year-around climate, (thirty miles from Santa Barbara) generous vacation and sick leave plans; opportunities for earning educational degrees up to the PhD level, as well as project responsibility and personal achievement recognition. Rapid career growth / salary increases are provided through our career development program.

As an expanding organization, engaged in equipment and systems engineering both ashore and at sea with the Navy's surface missile system ships . . . we offer a variety of stimulating assignments. They include such areas as systems equipment engineering • computer/data processing • weapons performance evaluation • missile launching, handling and stowage . . . to name but a few.

So, if you have at least a BS degree and you're an electronic, mechanical, electro-mechanical, electrical or general engineer, looking for a place to grow . . . consider the Missile Engineering Station. We're not exactly perfect, but we have much in our favor. At least, we'd like the chance to convince you. Fair enough? If you agree, let us know by writing or calling (collect):

W. S. (Bud) Dundore Dept. 121-B

NAVAL SHIP MISSILE SYSTEMS ENGINEERING STATION

Port Hueneme, California 93041, Area Code 805

Phone 982-4324 or 982-5124

An Equal Opportunity Employer / U.S. CITIZENSHIP REQUIRED

STIMULATING ASSIGNMENTS

PHD'S FOR THE ASKING

ALWAYS YOUR OWN BOSS

RAPID CAREER GROWTH

BEST CLIMATE IN THE WORLD

YOUR NAME ON EVERY PROJECT

CIRCLE 954 ON READER SERVICE CARD

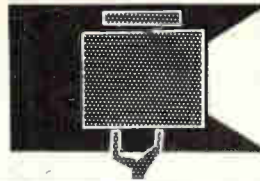

SEARCHLIGHT SECTION

• CLASSIFIED ADVERTISING • BUSINESS OPPORTUNITIES
• USED OR SURPLUS EQUIPMENT

AUTOTRACK ANTENNA MOUNT



360 degree azimuth, 210 degree elevation sweep with better than 1 mil. accuracy. Missile velocity acceleration and slewing rates. Amplitude and servo control. Will handle up to 20 ft. dish. Supplied complete with control chassis. In stock—Immediate delivery. Used world over by NASA, USAF, MP-61-B, Type SCR-584, Nike Ajax mounts also in stock.

PULSE MODULATORS

MIT MODEL 9 PULSER 1 MW—HARD TUBE

Output 25kr 40 amp. Duty cycle .002. pulse lengths .25 to 2 microsec. Also .5 to 5 microsec. and 1 to .5 microsec. Uses 6C21. Input 115v 60 cycle AC. Mfg. GE. Complete with driver and high voltage power supply. Ref: MIT Rad. Lab. Series, Vol. 5, p. 152.

2 MEGAWATT PULSER

Output 30 kr at 70 amp. Duty cycle .001. Rep rates 1 microsec 600 pps. 1 or 2 msec 300 pps. Uses 5948 hydrogen thyratron. Input 120/208 VAC 60 cycle. Mfr. GE. Complete with high voltage power supply.

250 KW HARD TUBE PULSER

Output 16 kv 16 amp. Duty cycle .002. Pulses can be coded. Uses 5D21, 715C or 4PK60A. Input 115 v 60 cy. AC \$1200 ea.

18 MEGAWATT PULSER

Output 150KV at 120 amps. Rep rate: 50-500 PPS. Pulse length: 5 msec. 15KV 120 amp. into pulse transformer. Rise time 1.5 msec. Filament supply 5V 80 amp. Incl. 17.5KV 1.5 amp DC power supply. Input: 220V 60 cy AC.

VARIAN KLYSTRONS

V-45: 15W output CW 9 to 10 KMC
VA-800: 10 KW output CW 1.7 to 2.4 KMC
VA-806H: 1KW output CW 7.5 to 8.5 KMC

IBM 704 IBM 650

These computers in stock for immediate delivery

SCR 584 AUTOTRACK RADARS

Our 584s in like new condition, ready to go, and in stock for immediate delivery. Ideal for telemetry research and development, missile tracking, satellite tracking. Fully Desc. MIT Rad. Lab. Series, Vol. 1, pps. 207, 210, 228, 284-286. Comp. Inst. Bk available \$25 00 each.

MICROWAVE SYSTEMS

L BAND RF PKG.

20 KW peak 990 to 1040 MC. Pulse width .7 to 1.2 micro sec. Rep. rate 180 to 420 pps. Input 115 vac incl. Receiver \$1200

200-225 mc RADAR SYSTEM

1 Megawatt output. 200 nautical mile range for long range detection of medium and high altitude jet aircraft as well as general search. AN/TPS-28.

10 KW CW S-BAND

Complete 1700-2400 MCS RF system using VA-800 Klystron. New.

SURVEILLANCE DRONE RADAR SYSTEM

X-Band tracking system with plotting boards. Type AN/MPQ-29. Drone also in stock.

5 MEGAWATT C-BAND

Klystron RF package delivering nominal 5 megawatt pulse RF. Complete with pulser and power supply.

500 KW L BAND RADAR

500 kw 1220-1359 msc. 160 nautical mile search range P.P.I. and A scopes. MTI, thyratron mod 5J26 magnetron. Complete system.

100 KW X BAND RADAR

Complete 100 kw output airborne system with AMTI. 5C22 thyr. mod. 4J52 magnetron. PPI, 360 deg as sweep, 60 deg. elev. sweep, gyro stabilizer, hi-gain revr. Complete with all plugs and cables.

AN/GPG-1 SKY-SWEEP TRACKER

3 cm. automatic tracking radar system. Complete package with indicator system. Full target acquisition and automatic tracking. Input 115 volts 60 cycle New. In stock for immediate delivery. Entire System 6' long, 3' wide, 10" high. Ideal for Infrared Tracker, Drone Tracker, Missile Tracker, R & D.



500KW S BAND RADAR

250 miles search 115V 60 cy AC. Mfg. G.E.

RADAR AUTO-TRACK & TELEMETRY ANTENNA PEDESTALS 3 & 10 CM. SCR 584 AUTOTRACK RADARS. M-33 RADAR TPS-ID SEARCH. APS-45 TPS-100 HT. FINDERS. WX RADARS. FPN-32GCA. APS-10 APS-15B APS-27 (AMTI) SEARCH. APN-102 DOPPLER. DOZENS MORE. CARCINOTRONS. PPN'S. 25-5-1-2-3-6 MEGAWATT PULSE MODULATORS. CAVITIES. PULSE TRANSFORMERS. IF STRIPS. WAVEGUIDE BENDS 200 MC. 1 KMC. 3 KMC. 6 KMC. 9 KMC. 24 KMC. RF PKGS.

RADIO RESEARCH INSTRUMENT CO.

550 5TH AVE., NEW YORK 36, N. Y. JU 6-4691

CIRCLE 967 ON READER SERVICE CARD

BIG CATALOG

World's "BEST BUYS" in GOVT. SURPLUS Electronic Equipment

FULL OF TOP QUALITY ITEMS—Transmitters, Receivers, Power Supplies, Inverters, Microphones, Filters, Meters, Cable, Keyers, Phones, Antennas, Chokes, Dynamotors, Blowers, Switches, Test Equipment, Headsets, Amplifiers, etc. SEND 25¢ (stamps or coin) for CATALOG and receive 50¢ CREDIT on your order. Address Dept. E-7.

FAIR RADIO SALES

P.O. Box 1105 · LIMA, OHIO · 45802

MINI-FLUID DISPENSER

AIR OPERATED

for miniature potting and encapsulating

Available in 3 sizes
6cc - 12cc - 30cc

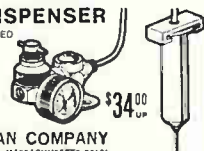

\$34.00 UP

PHILIP FISHMAN COMPANY
7 CAMDEN ST., WELLESLEY, MASSACHUSETTS 02181

CIRCLE 968 ON READER SERVICE CARD

ELECTRON TUBES

KLYSTRONS • ATR & TR • MAGNETRONS
SUBMINIATURES • C.F.T. • T.W.T. • 5000-6000 SERIES

• SEND FOR NEW CATALOG A2 •

A & A ELECTRONICS CORP.
1063 PERRY ANNEX
WHITTIER, CALIF.
896-7544

CIRCLE 969 ON READER SERVICE CARD

In electronics it's Electronics magazine to sell used equipment!

Your advertisement will produce Results in Electronics. Engineers turn to Electronics magazine for the latest technical developments — and for the latest buying information. You can reach them inexpensively in Electronics Searchlight Section.

For information:
Searchlight Section
Classified Advertising Division
Post Office Box 12
New York 10036



CIRCLE 297 ON READER SERVICE CARD →

Johnson gives you the most moves in capacitor selection



MORE THAN 11 BASIC SERIES AVAILABLE IN A WIDE SELECTION OF SINGLE SECTION, DUAL SECTION, BUTTERFLY AND DIFFERENTIAL TYPES. FOR MORE DETAILS, TURN THE PAGE.



Now from a new, expanded air variable capacitor line, you can satisfy your capacitor needs in more ways at low cost. From the Johnson line, offering capacitance values up to 1700 pf. and peak voltage ratings from 650 to 13,000 volts, you can specify air variables and be assured your design will yield a product that's competitively priced. Johnson air variable capacitors range from sub-miniature types to large units suitable for heavy duty applications. Whatever the use, they provide excellent stability, high Q, uniform capacitance, and exhibit low "hock" in applications involving a square wave form.

For complete capacitor information write on company letterhead for free, detailed Johnson components catalog No. 700.



E. F. JOHNSON COMPANY
W A S E C A, M I N N E S O T A 5 6 0 9 3

CAPACITORS

MACHINED PLATE TRIMMER AND TUNER TYPES – U, UA, UB, U-LC, V, AND W – Available in both printed circuit and chassis mounting types. U types available in differential and butterfly printed circuit mounting types in addition to single section types. V and W capacitors available in single section type only. Maximum capacities of up to 54 pf. Tuners consist of a machined plate trimmer and high Q air wound silver plated inductor, in resonant frequencies of 100 to 750 Mc.

SOLDER PLATE TYPES – Type M: Capacity values to 30 pf. Voltage ratings to 1250 volts peak. Available in single section, differential and butterfly types.

Type S: Capacity values to 100 pf. Voltage ratings to 3000 volts peak. Available in single section, differential and butterfly types.

Type K: Capacity values to 150 pf. Voltage ratings to 3800 volts peak. Available only in single section types. May be furnished in production quantities in full compliance to MIL-C-92A.

Type R: Capacity values to 340 pf. Voltage ratings to 4400 volts peak. Available only in single section type.

Type L: Capacity values to 200 pf. Voltage ratings to 3500 volts peak. Available in single section differential, butterfly and dual section types.

SPACER TYPES – Type C: Capacity values to 1500 pf. Voltage ratings to 13,000 volts peak. Available in single section and dual section types.

Type D: Capacity values to 1700 pf. Voltage ratings to 9000 volts peak. Available in single section and dual section types.

STAKED PLATE TYPES – Type E: Capacity values to 1000 pf. Voltage ratings to 4500 volts peak. Available in single section and dual section types.

Type F: Capacity values to 400 pf. Voltage ratings to 3000 volts peak. Available in single section and dual section types.

CONNECTORS

SUB-MINIATURE INSULATED TYPES – Designed for printed circuit applications. Operating voltages to 1500 volts RMS . . . 5 amperes current carrying capacity . . . contact resistance less than 2 milliohms. Capacitance between two adjacent jacks less than one pf at 1 Mc. 10 colors available. Test-Point Strip/Handle – rapid-mounting polyamide body contains 12 test points each rated at 5 amps., maximum current capacity. Operating voltage 1500 volts RMS at sea level, 350 volts RMS at 50,000 feet. Contact resistance less than 2 milliohms.

STANDARD INSULATED CONNECTORS – A complete line of connectors molded of tough, low-loss, shock-proof polyamide in 10

colors meeting Fed. Std. 595. Tip, Banana and Dual Banana Plugs; Tip and Banana Jacks; Metal-Clad Tip Jack, Military; Jack and Sleeve; Binding Posts.

RIB-LOC TERMINALS – A new line of miniature, one-piece, insulated terminals with a unique serrated conical design, which resists loosening and turning. Provides an inexpensive approach to convenient press-in type terminals. Six colors conforming to Federal Color Standard No. 595. Terminal styles include single and double turret feed-thrus and stand-offs, .040" dia. tip plug and mating jack for .040 plug.

Tube Sockets, Insulators, Pilot Lights, and Hardware

ULTRA HIGH FREQUENCY SOCKETS – Continuous heat resistance to 500°F. with low loss, glass filled silicone base and heat treated beryllium copper contacts. Low inductance screen bypass capacitor available for VHF and UHF operation.

KEL-F SERIES – Molded of low dielectric loss-factor Kel-F plastic – designed for use with a wide selection of high power transmitting tubes.

STEATITE WAFER TYPES – Available in 4, 5, 6, 7, and 8-pin standard socket types, as well as Super Jumbo 4-pin types. Also giant 5 pin, and 7 pin Septar and VHF Septar Sockets.

SPECIAL PURPOSE TYPES – Includes sockets for special purpose tubes.

Note: For detailed specifications, request Socket Standardization Booklet 536 on your company letterhead.

INSULATORS – Low loss, high-voltage breakdown in either steatite or porcelain. Complete line includes Thru-panel Bushings and Insulators, Antenna Strain and Feeder Types, Cone and Stand-off Insulators, Lead-in Bushings and Feed-Thru Bowl Assemblies.

PILOT LIGHTS – Over 47 separate assemblies. Continuous indication neon types, models for high and low voltage incandescent bulbs, standard or wide angle glass, and lucite jewels. Specials, including types meeting military specifications, also available in production quantities.

PANEL BEARINGS – For use on ¼" shafts and panels up to ¾" thick. **CRYSTAL SOCKETS** – For low capacity, high voltage and high temperature operation. Glazed steatite, Grade L-423 or better. DC-200 impregnated. **RF CHOKES** – High quality construction. For 1.7 to 30 Mc range.

CHECK Johnson for all your component requirements

Johnson also offers a complete line of heavy-duty RF components for broadcast transmitting, RF heating, antenna phasing and other commercial applications.

Equipment in this line includes fixed and variable inductors, antenna phase sampling loops, isolation filter inductors, feed-thru bowl insulators, static drain chokes, RF contactors and heavy-duty make-before-break switches.



E. F. JOHNSON COMPANY
W A S E C A, M I N N E S O T A 5 6 0 9 3

Newsletter from Abroad

November 13, 1967

British government funds CAD project

Britain's Ministry of Technology believes the country's electronics industry needs computer aid in designing circuits, and is backing this conviction with money.

Over the next three years, the ministry will pick up half the tab for a CAD project started two years ago by Racal Electronics, a leading British producer of high-frequency communications equipment and electronic instruments. Cost of the project next year is estimated at \$365,000 and subsequent rises are expected. In return for the ministry's help, Racal will offer CAD services to the electronics industry at commercial rates.

Racal already has developed CAD programs for relatively simple circuits such as gated carrier amplifiers. Along with circuit parameters, the programs develop information on cost, life, and reliability. With the government money, Racal will tackle more complicated devices, particularly integrated circuits.

Color-tv spurs mergers in France

A wave of mergers among small set makers in France seems inevitable. Few of the 100-plus companies now producing radio and tv receivers have the financial strength to go into color-tv production alone or to weather the expected drop in black-and-white set sales now that color-tv has arrived.

A big merger already is in sight. Compagnie Generale d'Electricite, France's largest electrical-electronics firm, and two smaller companies are well along in negotiations for lumping the consumer electronics operations of all three together. CGE would combine its subsidiary, Continental Edison, with Compagnie Centrale d'Electronique et d'Appareils de Mesure. Cocelam is jointly owned by Lebon et Cie. and the Societe Lyonnaise des Eaux et de l'Eclairage.

Consumer electronics sales of Continental Edison and Cocelam this year will run about \$60 million. Merged, they'd rank as the third largest set maker in France behind Compagnie Francaise Thomson Houston-Hotchkiss Brandt and La Radiotechnique, an affiliate of Philips' Gloeilampenfabrieken of the Netherlands.

Taiwan may get big tube plant

The Westinghouse Electric Corp. says it's negotiating a deal to supply the Industrial Development Corp. of Boston with more than \$1 million worth of equipment for the manufacture of receiving tubes. The Boston firm apparently wants to use the equipment to produce replacement tubes in Taiwan in conjunction with Taipei interests.

Westinghouse insists the sale would not affect production capacity at its plant at Elmira, N.Y. Officials say the equipment is surplus and has been in storage for some time.

Telefunken bolsters its computer effort

AEG-Telefunken has readied a new family of small computers in a bid to get a better foothold in the German data processing market. Although Telefunken is Germany's number two electronics producer, its share of the computer market is less than 1% and there has been speculation that the company was on its way out as a contender in computers.

Telefunken is expected to announce the new family of computers—the TR 8 series—before the end of the year. Price tag for the basic commercial machine will run about \$87,000. It will have nine input-output

Newsletter from Abroad

channels, a core memory with a capacity of 64,000 words of 24 bits, and a cycle time of 900 nanoseconds.

The TR 8 series will also include a computer for military applications. This version will be smaller and have fewer channels than the commercial machine.

Tide of IC imports is rising in Japan

Japan is braced for a surge of integrated-circuit imports during the next few months. Such imports—all but a handful from the U.S.—totaled 270,000 packages in September but are expected to climb to about 500,000 this month and hold at that level through the rest of the year.

The industry guess is that Nippon Electric, Fujitsu, and Hitachi are gobbling up more than half the IC's coming into the country. Both Nippon Electric and Fujitsu are major producers of IC logic but their production schedules will keep them heavy importers of computer circuits for some time to come. Hitachi, which has put initial in-house emphasis on IC packages for calculators and consumer electronics, imports logic circuits for the RCA Spectra 70 computer it produces under license.

So sharp is the projected import rise that the flood of foreign IC's may temporarily top domestic production. But by early next year, Japanese producers figure to dominate their home market even though there's little prospect of a drop in imports.

Nippon Electric, currently the top Japanese IC producer, turned out 250,000 packages in September and expects a 600,000 monthly output rate by March. Mitsubishi production is close to 200,000 circuits a month; but the other two major producers, Fujitsu and Tokyo Shibaura Electric, are still below the 100,000-a-month mark.

AEI resists takeover bid

Defensive maneuvers by Associated Electrical Industries have so far blocked efforts by Britain's General Electric Co. to take over the firm.

Since its first bid of \$330 million last month [Electronics, Oct. 16, p. 225], GEC has upped the ante twice. Arnold Weinstock, head of GEC (not connected with General Electric in the U.S.), describes the present offer of \$450 million—rejected by AEI's management—as "final." But there's speculation he may go higher since the latest bid is still some \$80 million shy of AEI's total assets.

Meanwhile, AEI has acquired a new chairman and come up with a plan to put its telecommunications equipment business into a joint venture with Standard Telephones and Cables, an ITT subsidiary. These moves have helped AEI hold the fort, but insiders say the battle could still go either way.

Kremlin programs tv production boost

New emphasis on consumer goods in Soviet economic plans will push television-set production to record levels next year. The target is 5.7 million sets, up nearly 20% from this year's estimated output of 4.8 million.

Most of the sets will be black and white. Although nationwide colorcasts started last week with a live showing of the Red Square festivities marking the 50th anniversary of the Bolshevik revolution, volume production of color sets won't come until 1970.

The stepped-up tv-set production apparently won't be at the expense of other electronic sectors. Despite the secrecy surrounding sophisticated technology, there are indications that the Soviets have plotted a solid boost in automatic controls and computers over the next three years.



Why do so many people come to us when there's GE, Westinghouse and Tung-Sol?

Hudson designs and makes a full line of great miniature, sub-miniature and micro-miniature lamps—millions of them. But we're not giant-killers for that alone. Our product is lamps. Our business is service.

We climb beanstalks for our customers. If you need lamps—a box of ten or a carload—there's nothing more important to us than getting them to you on time,

in quantity. And if you need a bulb that's off the beaten path, we'll supply it without fuss or bother. At the right price. Soonest.

Next time you get a giant pain in your bulb supplier, ask for Hudson. (We get more new customers that way!) Hudson Lamp Company, 528 Elm Street, Kearny, New Jersey 07032. Telephone: (201) 997-1850.



LAMP COMPANY
Hudson

Free: a new Hudson Catalog (The Giant-Killer)

Circle 301 on reader service card

IBM Circuit Design and Packaging Topics

- packaging cost reductions
- high-speed switching
- reed switch application data

packaging cost reductions

Performance Measurements Co., Detroit, Michigan, reports significant savings in packaging their new electronic recording system. The packaging method previously employed required two gates to mount the components in the main console. Now, with IBM's modular packaging as pictured below, only one gate is needed. That's because the IBM technique makes the most efficient use of console space with compactly mounted and connected circuit boards, relays and hardware.

Mounting time has been saved too. Pluggable components, low-cost card receptacles and interlocking card guides have so simplified the packaging job, that Performance Measurements now saves 70% on the cost of mounting hardware. Fewer and shorter wires are needed in the compact console — eliminating three feet of 1½-inch cable and shortening a second cable by eight inches. The modular chassis gave designers freedom to experiment freely with various mounting configurations. It also permits easy access for servicing and diagnostic analysis.

The same design freedom, plus significant hardware and labor savings are available in many applications.

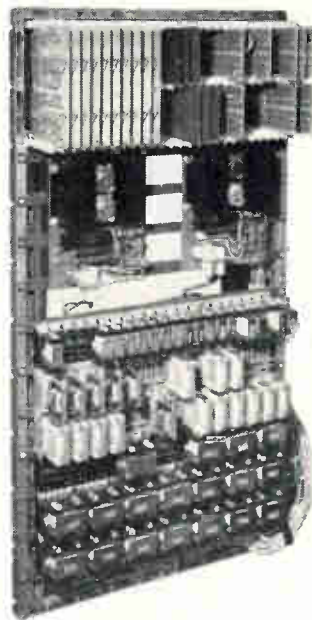

IBM components and packaging can help you in timing control, digital logic testing, telemetering, process or numerical control.

high-speed switching

IBM wire contact relays were originally designed for data processing use. Now they are being used extensively in machine tool and assembly applications. One of these assembly applications is a numerically-controlled component insertion machine. It sequentially inserts random combinations of up to 24 different types of axial lead resistors and diodes into printed circuit boards. Such machines have been widely used, often on a round-the-clock, three-shift basis, in IBM's electronic assembly operations.

Insertion rates range from 3,000 to 4,500 components per hour, depending upon the type of components being inserted.

Instructions from an 8-channel punched paper tape provide the logic input to the relay gate. The gate employs three rows of 6- and 12-pole IBM wire contact relays. These relays control the movement of each printed circuit

board through the X and Y axis positioning of the board for each component insertion. They also control the component feed, component insert, and cut-and-clinch cycles for each insertion operation.

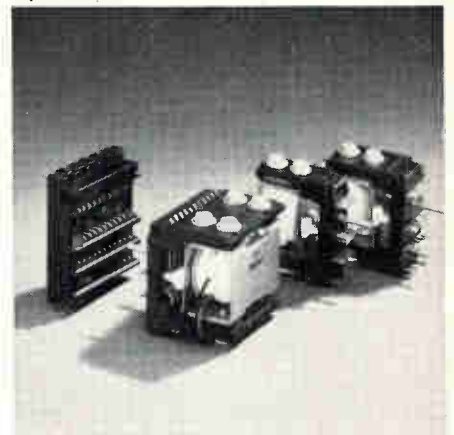

IBM wire contact relays can perform in excess of 200 million operations with an operate speed as fast as 4.5 ms, a release time of 5 ms maximum. The product line includes 4-, 6-, and 12-pole Form C relays, 4- and 6-pole latch models, all with compact, solderless, pluggable mountings—with coil-voltages up to 100 VDC.

reed switch application data

Data on the magnetic switching characteristics of miniature dry reed switches is available to design engineers on request. The data was compiled from ex-

tensive tests conducted by IBM to help the design engineer use these switches most effectively. It can also help him determine the motion and position of the magnet required.

Simply described, a miniature dry reed switch operates under the influence of a permanent magnet. When the magnet is adjacent to the reed switch,

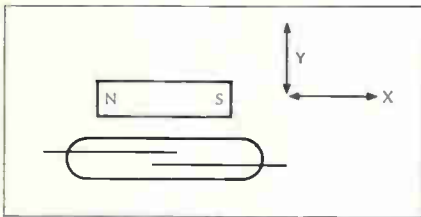

the flux of the magnet flows through the cantilever beams, as illustrated. While this magnetic flux is being carried by the beams, a polarity exists across the beams. Look at the overlap area of the beams. The north pole of one beam and south pole of the other beam are in proximity. Since unlike poles of a magnet attract each other, when the magnetic force becomes great enough to overcome the physical mass of the beams, they "snap" together, thus switching.

On the graph the X axis represents the displacement (in degrees for rotary motion, inches for lateral motion) of a magnet's center with reference to the center of the reed switch. The Y axis represents displacement (in inches) of the magnet from the outer edge of the

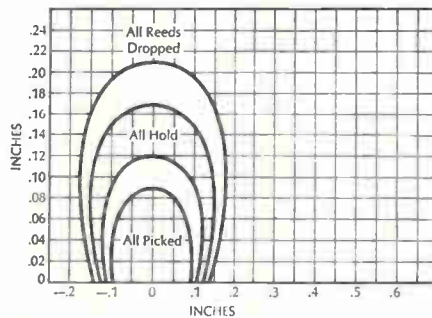

dry reed switch glass envelope. Dimensions shown along both axes represent displacement from the center of the magnet in alignment with the center of the reed switch.

There are some "gray areas" where performance varies due to minor differ-

ences in the characteristics of each switch. In these areas the status of each switch is not completely predictable.

Assume the zero point on the X axis is the magnetic center of an IBM reed switch. The magnet is positioned with its center at +.5 on the X axis, and .04 inches above the glass envelope. If the magnet is set in motion along the X axis toward the center of the switch, some reeds will pick when the center of the magnet reaches the point +.12 on the X axis. (The magnet has then reached the "gray area"). If motion is continued toward the center of the switch, all reeds will pick when the center of the magnet reaches the point +.09 on the X axis.

IBM Industrial Products Marketing Dept. T1
1000 Westchester Avenue
White Plains, New York 10604

- packaging cost reductions
- high-speed switching
- reed switch application data

name _____

position _____

company _____

address _____

city _____ state _____ zip _____

IBM[®]
 INDUSTRIAL
 PRODUCTS



Servo is microwaves

Want to generate a signal in the Ka band, test electronic gear on an aircraft, or check out the guidance system of a missile? Servo designs and manufactures instruments for these applications. And many others.

Our engineers are expert in producing microwave pulse-swept systems, microwave signal generators, microwave amplifiers and high voltage power supplies. Take the unit pictured above, for example. It's the first 20-watt TWT amplifier available...and industry's most compact, too. Servo's amplifiers have many unusual features, and are

supplied in models for operation from 1 to 18 GHz in octave bandwidths.

Our Servodynamics Division also supplies special synchro-to-digital and digital-to-synchro conversion equipment and servo analyzers, digitally programmable function generators, and phase meters.

Other Servo divisions design systems and products which serve safety through science: the Railroad Products Division, the Infrared & Electro-Optics Division, and the Communications & Navigation Division.

servo corporation of america

111 new south road
hicksville, l.i., new york 11802
516 938-9700

Circle 304 on reader service card

Servo

Soviet Union

Red glow in space

The packet of sophisticated hardware put into orbit by the Soviet Union in recent weeks added up to a stunning celestial celebration of the 50th anniversary of the Bolshevik revolution. And with their November space spectacular, the Soviets demonstrated dramatically that electronic controls is no longer a soft spot in their space effort.

Most space specialists rate the automatic docking of the Cosmos 186 and Cosmos 188 spacecraft as an achievement the U.S. would be hard put to match. Although American Gemini spacecraft scored nine dockings before the Russian feat, in each case an astronaut was at the controls for the final, delicate maneuvers.

In the Soviet view, expressed by Georgi Petrov, director of the Space Exploration Institute of the Soviet Academy of Sciences, "automatic linkup will always be more economical" than manual docking.

Radio and radar. The Russians used a combination of ground commands through a radio link and radar on the spacecraft to bring the Cosmos together under computer control. During the docking maneuver, the Cosmos 186, which was launched first, worked as the active partner with Cosmos 188 as the target. Both were Soyuz spacecraft, the latest Soviet capsules designed to carry cosmonauts.

The target vehicle went into orbit a scant 15 miles from Cosmos 186, which caught up with it and locked on before it had made its first orbit. Just before the docking, Cosmos 186 sent a signal to the target that caused it to point its docking socket toward the approaching craft.

The docking, say the Soviets, was shockless. The two spacecraft remained linked, with their elec-

trical circuits connected for 3½ hours. On ground command, the two separated and Cosmos 188 came down to a soft landing.

The race. The successful landing indicates the Russians have corrected the fault that caused a Soyuz to tumble and crash last summer, killing cosmonaut Vladimir Komarov. And the automatic docking proves the Russians can assemble heavy packages in an earth orbit with existing rockets. Such a heavy space station could then continue on to the moon.

Like the U.S. with its Saturn 5, the Soviet Union is apparently ready to test a rocket that could put a heavy lunar spacecraft into earth orbit. On balance, then, the USSR seems to be running neck-and-neck with the U.S. in the race to put a man on the moon.

Nationwide. Space also figured in the pomp and ceremony last week that marked the anniversary celebration. The military parade through Moscow's Red Square was televised live for the first time to the farthest reaches of the country by the Soviet satellite communications network, Orbita.

For the network, the Soviets have built 20 ground stations, stretching from Moscow to Siberia and on to the Pacific regions. Antenna dishes of the stations measure 39 feet in diameter. The receivers operate at liquid nitrogen temperature and have a maximum noise temperature of 30°K.

Up there. The stations work with second-generation versions of the Soviet communications satellite called Molnya 1 [Electronics, Nov. 1, 1965, p. 158]. Although the Russians refer to the satellite in the singular, Western space specialists think that four second-generation Molnya-1's have been launched and that two still are operating. These satellites have 12-hour orbits. The more-sophisticated U.S. communications satellites have stationary 24-hour orbits.

The Netherlands

Filling the blanks

There's so little room to spare in the broadcast frequency spectrum these days that anyone who wants to put a new service like facsimile transmission on the air has to snatch at snippets. One snippet still up for grabs is the 1.3-millisecond blanking interval between successive fields in television transmission.

Since there are 50 or 60 blanking intervals per second, depending on whether you're using the European or U.S. standard, considerable information can be slipped in without disturbing the tv picture that regular viewers see.

In the U.S., the Radio Corp. of America last summer reported it had developed an experimental system to transmit printed material over regular television broadcasts. RCA since has been running on-the-



Still life. Pickup unit of Philips' system that transmits still photos, drawings and the like during the vertical blanking periods of regular tv broadcasts.

air tests during the early-morning hours when there are no programs and will report the results to the Federal Communications Commission early next year.

Market bound. N.V. Philips' Gloeilampenfabrieken, too, has developed a system that fills in the blanks between tv scanning fields and hopes to start marketing the equipment perhaps late next year. But where RCA's receiver reproduces the transmitted graphic material with an electrostatic printer, Philips' receiver photographs the image that appears on a cathode-ray-tube.

With the European tv broadcasting setup of 625 lines per frame and 25 frames per second (there are two fields in a frame), it takes as little as 2.5 seconds to transmit graphic material—a photo, for example, or a printed text. Because of the time it takes for the scan, only still material can be handled.

Philips thinks the Dutch police will be among the first to use the system. They may use the equipment to broadcast pictures of wanted criminals and missing persons to stations throughout the country.

The lineup. The vertical blanking period lasts long enough to transmit between 20 and 28 lines, but because of the time it takes to switch the auxiliary circuit in and out—and to provide a safety margin—Philips designed its equipment to transmit a maximum of 5 lines per interval. Any number of lines from 1 to 5 can be chosen.

The pickup equipment, which has its own camera, is tied into the regular tv video path by means of a relay. It switches on when the operator pushes a start button, and it develops a pulse that initiates transmission of the still material.

Vertical synchronization pulses of the normal tv signal are used to trigger a pulse generator that gates out lines scanned by the auxiliary camera. The camera's horizontal deflection circuits get normal drive pulses, also from a special pulse generator.

Vertical deflection circuits, though, are set up so the scan for a field is reduced from the normal 312.5 lines to 310 lines or 312 lines.

That way, the reduced scanning pattern shifts gradually down, compared with the normal scan pattern, as each group of 1 to 5 lines is transmitted during the vertical blanking period. The reduced number of lines for the auxiliary camera's scan is obtained by slightly increasing the frequency of vertical deflection pulses by means of a frequency divider.

Receiver. Vidco information inserted into the vertical blanking interval is picked up on a receiver whose front end is identical to a normal receiver except that there's no sound channel.

Deflection circuits for the cathode ray tube are set up to match the horizontal and vertical pulse trains in the pickup equipment. The camera that photographs the crt display has its shutter opened and closed automatically.

Great Britain

New beat

Thus far, consumer radio set designers have played it conservative with integrated circuits. To be sure, there's many a set with ic's on the market. All, however, merely use ic's as a new kind of hardware to build an old circuit—the superheterodyne with an envelope detector.

This state of affairs won't last much longer, thinks R.C.V. Marcario of the University of Wales. Marcario maintains it's high time that designers revive a couple of circuit concepts that have been around for some time but weren't practical for domestic sets before low-cost ic's came along.

The concepts Marcario has in mind are homodyne reception and the single-span receiver. In the homodyne technique, a suppressed carrier is reconstituted in the receiver and added to the broadcast signal at the detecting diode. In the single-span receiver, the intermediate frequency is set higher than the highest carrier frequency to be received. Thus both the long-wave and medium-wave bands used in

Europe for popular broadcasting can be covered by tuning the local oscillator with one variable condenser.

Off-the-shelf. Marcario already has breadboarded a homodyne circuit using standard linear ic's produced by Fairchild Semiconductor for the crucial circuits. He currently is putting together a single-span receiver whose kingpin component is a dual-gate field effect transistor.

And since the single-span receiver needs a broadband antenna, Marcario has designed one that can be tucked into the cabinet of a line-operated table set. A few feet of plain wire would serve the purpose equally as well, but Marcario is convinced that few consumers would buy a set that needed a living-room aerial.

This trio of developments, Marcario says, together add up to a receiver that would outperform conventional a-m superhets, especially for long-distance reception. Fading would no longer plague, as it now does, a Londoner listening to a station in Rome. That's because the coherent detection used in the homodyne concept adds the signals—but not the noise—in the two sidebands. This improves the signal-to-noise ratio by 3 decibels, a big advantage when the signal deteriorates during a fade.

Zeroed in. For homodyne reception, one obvious way to supply the demodulating frequency is to lock a local oscillator in phase onto the signal carrier. But unless the set were tuned more carefully than most consumers are in the habit of doing, the oscillator would tend to jump out of lock on a fade. Automatic frequency correction to prevent jump-out would cost too much for a consumer set.

Marcario's homodyne develops a demodulating frequency precisely matched to the carrier frequency by tying a Schmitt trigger circuit to a zero-crossing detector. The basis of the arrangement is that if a station can be picked up at all, the carrier will appear at the detector and will change polarity regularly at twice the carrier frequency. Because the zero-crossing detector drives the Schmitt trigger, then, its square-wave output stays locked to

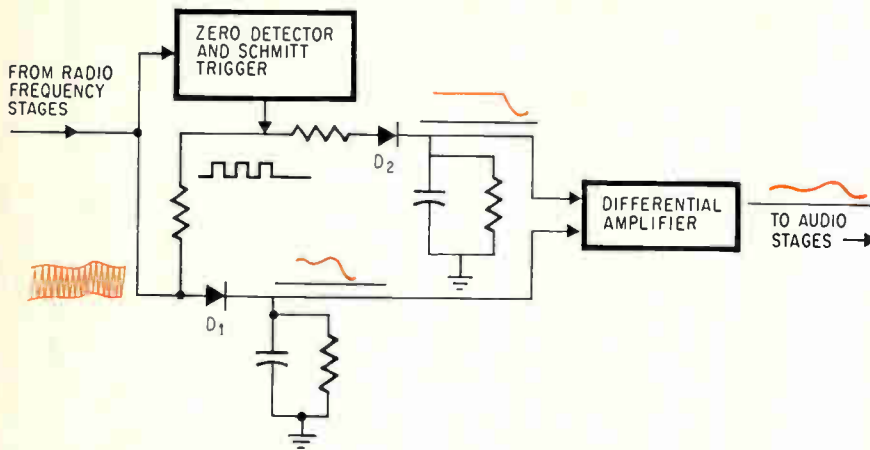

Coherent. Adding square-wave signal from Schmitt trigger to input from r-f stages turns diode D_1 into a coherent detector.

the carrier frequency.

For the crossing detector, Marcaro uses a Fairchild μA 702 wide-band linear ic amplifier; the Schmitt trigger is a μL 914 package.

The square-wave output signal is applied, along with the amplified radio-frequency signal, to a detecting diode (D_1). The square-wave also is applied to a second diode (D_2) which in effect measures the enhanced carrier. The outputs from both diodes pass through a differential amplifier and then go to conventional audio filtering and amplifying stages. The second detecting diode and the differential amplifier prevent an audible step waveform from developing when the Schmitt trigger switches off, as it would during a very deep fade.

Up and down. In Marcaro's scheme of things, the homodyne detection system would have upstream of it an r-f front end that could cover the long-wave and medium-wave broadcast bands with no band-switching. For practical purposes, this means a pair of local oscillators, one working well above 1,600 kilohertz and a second to bring the i-f down to an easily handled frequency not in the antenna band, something like 100 khz. The problem here is spurious heterodyning between the two oscillators. Marcaro believes balanced mixing with the dual gate field effect transistor should bring an economic answer.

The other major design problem for a single-span receiver—an ape-

riodic antenna that can be packaged into the set—has been solved. The antenna consists of a pair of parallel unetched copper printed circuit boards, one at the top of the set and the other at the bottom.

Each board has an area of 50 square inches and the two lie about 4 inches apart.

France

Foresight

For the Jaguar jet that will be the mainstay trainer of the French and British air arms in the early 1970's, the French air force divided the contracts for the fire control equipment in what it considered a logical fashion.

To CSF-Compagnie Générale de Télégraphie sans Fil, France's top avionics producer, went the job of developing the fire-control computer and the target-sighting gear. And to the Compagnie Générale d'Electricité, the country's front-runner in laser research, went the contract for building an airborne laser rangefinder for precision bombing.

CSF's top brass, though, figured it would be logical for the company to develop a laser rangefinder on its own. That way, CSF could offer complete fire-control systems to potential buyers of Jaguars other than the French air force.

The edge. CSF, in fact, managed

to get its laser telemetry hardware ready before CCE. The French air force already has completed tests on CSF's laser and is currently checking out CCE's.

Although there's only an outside chance that the air force will adopt the CSF laser, the company thinks it can win out in export deals for Jaguars because of its edge in technology. Instead of a rotating prism and complicated synchronizing circuitry to Q-switch the ruby laser so that it builds up giant pulses for ranging, CSF uses a fixed slab of dark red glass. At an energy level of about 100 millijoules, the glass becomes transparent and releases the pent-up laser energy.

Relatively rapid. The Mitsubishi Electric Corp. put a laser rangefinder with similar passive Q-switching on the market 15 months ago [Electronics, Aug. 8, 1966, p. 300], but CSF apparently is one of the first to adapt the technique for airborne fire control, where the repetition rate of the laser pulses has to be high.

The CSF laser can put out bursts of 5 ranging pulses at a rate of 1 per second or 10 pulses at a rate of one every 2 seconds. But after a burst, it then needs 40 seconds to recoup. Alternatively, the unit can pulse without recovery intervals at a rate of 12 pulses per minute. The pulse length is about 30 nanoseconds.

Maximum range of the laser is 10,000 meters and accuracy within 5 meters. The pilot aims the beam of the nose-mounted laser through a sight incorporated in the head-up display of the fire-control system. Range to the target is measured by a quartz-oscillator clock circuit operating at 30 megahertz. The clocking is started by a fast photodiode that picks up part of the outgoing pulse and continues until the reflected beam hits a photomultiplier.

The receiver optics have a 10-angstrom passband and limit the field of reception to an angle of 3 milliradians. The divergence of the outgoing beam is 1 milliradian.

Even faster. Although the laser pulses are fast enough for air-to-ground bombing or strafing runs, CSF now is trying to develop a ver-

We just took a great step backwards



(with three new, forward-looking unitized DVMs)

Trymetrics' new 4243 Digital Multimeter with AC, DC and OHM readings—auto polarity—full four digit—.01% (\$850) ... a tremendous step backwards. And so are the 4240 DVM (\$695) and 4230 DVM (\$595).

We started with our Model 4100: stored display—precision .01%, four-digit DVM and its full range of plug-ins for the price of an ordinary 3-digit job—just \$740 with the ± 9.999 v DC head; \$1045 with a complete multimeter head; and eight other plug-ins to choose from. For an encore, the only way to go was down.

Down \$195 to \$850 for the versatile 4243 Digital Multimeter: DC-AC-OHMS .01% — auto polarity ± 999.9 mv to ± 999.9 v. Same 4-digit stored display—no plug-ins. Sorry—unless you don't need plug-ins.

Down again, \$155, to \$695, for the 4240 DVM. Same high accuracy, same stored display, same ± 999.9 mv DC to ± 999.9 v DC 4-digit measurements. But, no AC or OHMS—unless, of course you don't need AC or OHMS.

Once more, down, to \$595 for the Trymetrics 4230 DVM. Still the same precise 4-digit unit with readings ± 9.999 v DC to ± 999.9 v DC. Don't buy this one if you need to measure in the low millivolts.

You don't need true 4-digit readout with .01% accuracy at a 3-digit, .05% price? Sorry—but we can't keep backtracking forever. May we send you our new catalog that shows ALL our models, all our plug-in versatility, all our reasons for going backwards?

PRICES SLIGHTLY HIGHER IN EQUIPEL.

TRYMETRICS
Corporation
A SUBSIDIARY OF TRYCON ELECTRONICS, INC.
204 Babylon Tpke., Roosevelt, L.I., N.Y.
Phone 516-378-2800 11575

Electronics Abroad

sion suitable for air-to-air weapons. "What we need," says the engineer who headed the Jaguar fire-control project, "is a laser with a much-higher firing rate."

West Germany

New geometry

In long-distance broadcasting, radical improvements in antenna design are rare happenings now.

A few years ago, American antenna designers bettered transmission characteristics significantly by rigging a log-periodic half-rhombic array of dipole elements vertically between supporting masts. Another step forward, says AEG-Telefunken, is the full-rhombic vertical array its designers came up with for an antenna field now going up at Usingen, near Frankfurt.

The full rhombus arrangement keeps the elevation angle of the radiation pattern down low and thus well-suited for long-distance transmission. Further, the pattern is independent of frequency and can be highly directional. A frequency range of 6:1 can be handled without any tuning.

Five by five. The Usingen field, scheduled to go into full service by early 1968, will air intercontinental broadcasts at frequencies from 3 to 30 megahertz. All told, Usingen will have five arrays, each made up of five dipole curtains extending out from a center mast. One array, designed for transmission in the 3 to 18 Mhz range, will have a center mast 230 feet high. The other four arrays, for 5 to 30 Mhz broadcasting, will have center masts 130 feet high.

A typical antenna curtain has a vertical radiation pattern whose main lobe lies between 4° and 12° in elevation. This relatively low angle makes for optimum transmission characteristics at distances

from 900 to 1,200 miles. The elevation angle isn't changed appreciably for greater distances. They are covered by "skips" between the earth's surface and the ionosphere.

Curtain time. Since the horizontal radiation pattern of each dipole curtain is about 72° at the half-power width, five curtains are required to get omnidirectional transmission characteristics for an array. Any of the curtains can be switched by remote control onto the transmitter to select the one best matched to the propagation conditions.

Each curtain is made up of 19 vertically rigged and vertically polarized rhombic half-wave dipole elements. At the top, the elements hang from an isolator attached to a guy wire; at the bottom the dipoles are joined to an isolator tied to a weight. The arrangement lets the rhombic elements "give" under high wind loads.

Energy feed to the array is by a two-conductor cable that runs through the center of each dipole. The dipoles are alternately connected to the conductors so that the energy in adjacent dipoles is 180° out of phase. Excitation, by means of a wire running parallel to the energy cable, starts with the



Weighted antenna. Lower ends of rhombic dipole elements in West German antenna are held down by weights that can move up and down.

shortest dipole and progresses along the array toward the center mast.

Reflections. Much as in a Yagi antenna, the larger dipoles immediately behind the one that's radiating act as a reflector. And the smaller dipoles next in front act as a director. As seen from the excitation feed-in point at the smallest dipole, the dipole elements before the one that's radiating present a reactive load to the energy cable.

The voltage standing wave ratio, at a 60-ohm input impedance, is less than 2. Gain of the individual dipole curtain depends somewhat on frequency. But compared to a $\lambda/2$ radiator in free space, gain is approximately 12 decibels. Transmitting power is 20 kilowatts.

Where away?

Specialists in wave propagation don't have any particular trouble checking total atmospheric noise in the very-low-frequency band. Finding out where the noise is coming from, though, is another matter. The usual methods of measurement can't sort out the individual contributions from various directions.

But at a radio-frequency propagation conference held by the Institution of Electrical Engineers in London last week, a trio of West German scientists reported on a method of plotting both the direction and spectral amplitude of incoming atmospheric noise. The work was done jointly by Guenter Heydt and Joachim Frisius of the Heinrich Hertz Radio Frequency Institute in West Berlin and Hans Volland of the Radioastronomy Institute of Bonn University.

Pinpointed. The system picks up atmospheric noise on a vertical rod antenna and a pair of cross-loop antennas. Each incident atmospheric pulse thus induces three voltage pulses, and these are processed in a narrowband direction-finding circuit to obtain a direct-current pulse whose amplitude indicates the azimuth angle from which the noise came. This pulse drives the vertical amplifier of an oscilloscope.

Input for the horizontal amplifier

control/alarm cost-cut

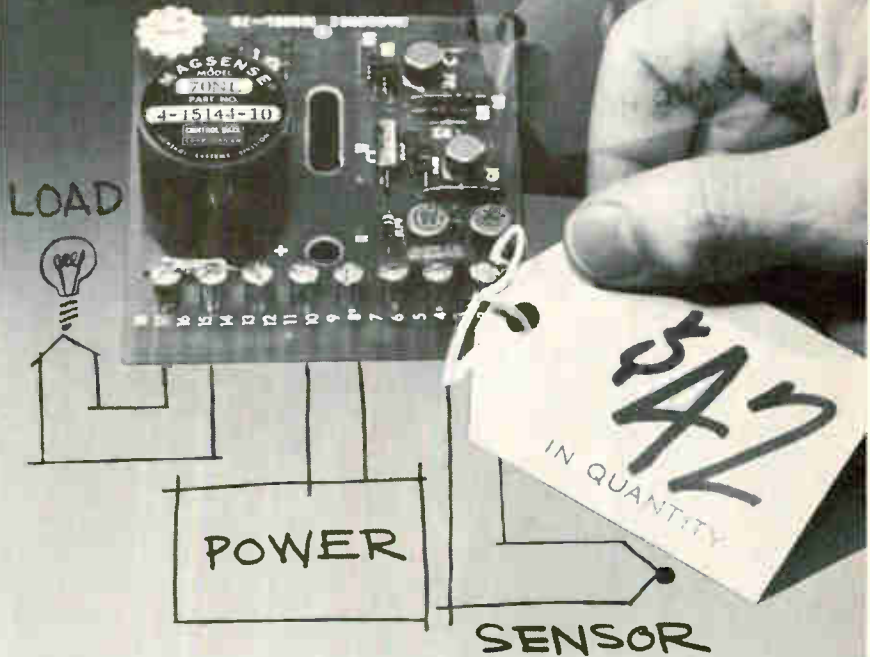

MAGSENSE

control/alarm for temperature, pressure, speed, flow

Here's the low-cost way to solve your control/alarm problem. Hook up sensor, load and power source to a MAGSENSE® control/alarm module and adjust the setpoint. That's it. No time wasted designing and debugging a circuit. And while you're saving time you'll be saving money, getting *proven-in-service* performance.

Capabilities? All MAGSENSE modules offer 100-billion power gain, accept inputs as low as 10 microvolts or 1 microamp *directly* without preamplification. Completely isolated inputs are unaffected by common mode voltages as high as 110vac, 60Hz, or overloads as large as 1000-times full scale input. Typical accuracy is $\pm 0.5\%$ full scale. And they all

operate from a *single* DC power source (either 28v or 12v).

Options? The list includes remote and dual setpoints, adjustable hysteresis, choice of output action, transducer excitation voltage and cold junction and copper compensation on thermocouple models. There's a MAGSENSE model for your application.

Price? Get the MAGSENSE control/alarm module shown for as little as \$42 in quantity, others as low as \$35. Compare that with the cost of developing and building your own circuit.

More information? Write or call, or circle the reader service number and we'll send you complete specifications and prices.

CONTROL DATA

CORPORATION

4455 Eastgate Mall, La Jolla, Calif.

MAGSENSE Sales, Dept. 220
Analog-Digital Systems Division
Control Data Corporation
4455 Eastgate Mall
La Jolla, Calif. 92037
Phone 714/453-2500

VACTEC

announces a new line of

VACTROL Lamp-Cell Controls

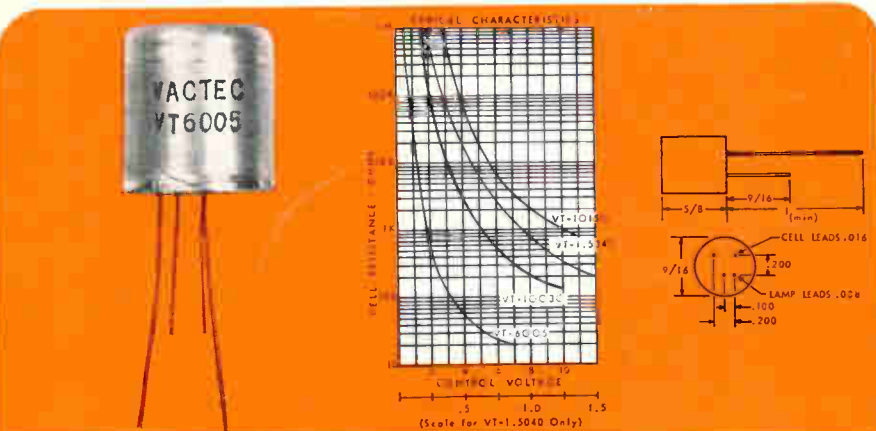

Now 1.5v, 6v, and two 10-volt Vactrols are available for electronic amplifier applications. Combines a dependable Vactec photocell with the proper long-life incandescent lamp in a complete low-cost module. Provides noiseless, trouble-free volume and

tone control for TV, radio, guitars, organs, and other musical instruments. Unit is protected by an epoxy sealed metal enclosure. Leads are spaced on .100" centers for circuit board mounting. Special characteristic designs available for unique applications. Write for Vactrol Bulletin PDC-4C 1.



VACTEC, INC.

2423 Northline Ind. Blvd. • Maryland Hts., Mo. 63042 • AC 314, 432-4200

See Vactec's listing in EBG under "Semi-Conductors," and in EEM, Sec. 3700.

Circle 124 on reader service card

Electronics Abroad

of the oscilloscope comes from a narrowband amplifier linked only to the vertical rod antenna. The amplifier, whose resonant frequency can be set from 5 to 50 kilohertz, measures the spectral amplitude of the atmospheric. Its output is also fed to a differentiating network that derives a short, high-amplitude pulse that controls the oscilloscope's electron gun.

The screen is photographed with a long exposure. The result is a pattern of light spots distributed according to the direction and amplitude of incoming atmospheric noise.

Variations. The scientists have also come up with equipment modifications that make it possible to spot different noise sources lying on the same azimuth. In one variation, the pulse outputs of two narrowband amplifiers set at different frequencies are compared. In another, a combination of narrowband circuits develops a pulse proportional to the difference in the group delay times of the noise spectrum at two different frequencies in the range from 4 to 10 khz.

Japan

Tuned IC

Cost-conscious radio and television-set makers are always on the lookout for ways to do away with tuned transformers in intermediate-frequency amplifiers. Aligning i-f strips after a set is built adds a significant chunk to its labor cost.

Murata Manufacturing Co. thinks it has a way—hybrid integrated circuits incorporating ceramic filters. Although the company says the hybrids are still under development, it already has them available in sample quantities.

Murata's lead-zirconate-titanate piezoelectric filters have been used previously by the Sony Corp. as discrete components in a 455-kilohertz i-f amplifier for portable radios [Electronics, Nov. 14, 1966, p. 160]. As could be expected, a 455-khz i-f amplifier turns up in Murata's hybrid line. But the com-





Write for
bulletin
describing

New

CDS type 6C

Photochopper

Cells

- High Efficiency
- Low Temperature Coefficient
- Resistance Tolerance ±50%
- Internal Electrostatic Shielding
- Dumet Leads

CLAIREX ELECTRONICS, INC. ■ 1239 BROADWAY, NEW YORK, N. Y. 10001

pany feels its eventual best sellers will be 4.5-megahertz i-f amplifier modules for tv-sound channels and 10.7-Mhz units for f-m receivers.

The trap. When its first discrete 455-khz filter was under development several years ago, Murata felt it had gone about as far as it could in standard i-f frequencies. At 4.5 and 10.7 Mhz, the filters showed intolerable spurious responses because of coupling between the several modes of vibration that can exist simultaneously in ceramic wafers.

Then William Shockley, best known as one of the inventors of

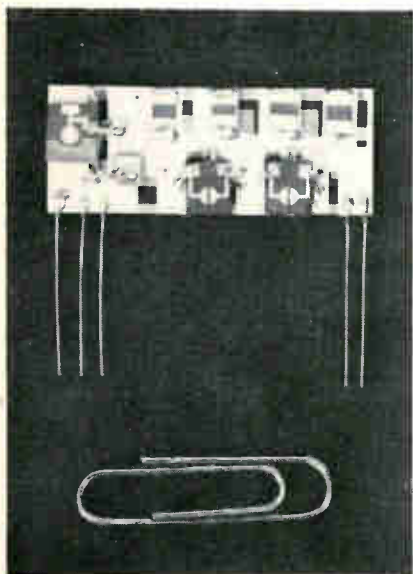

Hybrid. I-f amplifier module for tv-sound channel substitutes three energy-trap ceramic filters (large dark rectangles) for the transformers used to tune conventional i-f strips.

the transistor, discovered the energy-trap mode. In this mode, the frequency band is set by the thickness of the wafer and its electrodes. Only the energy trapped between the electrodes is effective; energy at other frequencies escapes so that spurious response cannot occur.

In the U.S., the Clevite Corp. produces high-quality crystal filters based on the energy-trap mode, largely for military equipment. Murata, however, claims to be the first to develop low-cost ceramic versions for consumer sets.

In the package. For its 4.5-Mhz module, Murata uses two energy-trap filters in the amplifier and one

Can your executives and their wives find happiness in "the sticks" ? (impossible!)



Robert J. Greenebaum, president of Inland Steel Products Co., and Mrs. Greenebaum view a new acquisition at the Milwaukee Art Center.

Move your plant to Milwaukee ...Cosmopolitan, Cultural, Congestion-free

Before you move your plant to a nice, airy, nowhere . . . think! What will it do to that savvy staff of executives? Stick them away in an unstimulating wilderness and you'll soon wind up with a lackluster command team.

Instead . . . set 'em free in Milwaukee, the midwest's heritage city where the best of all the arts is not more than a relaxed 20-minute drive away. Milwaukee offers an exciting *smorgasbord* of things to do and see . . . Saarinen-designed art center, a variety of top theater including an outstanding repertory company, concerts, art galleries, continuing education, a new museum, the world's finest new zoo and our unique year-round tri-domed horticultural conservatory. Our \$10,000,000 Center for the Performing Arts is almost up. A new planetarium is imminent. There's much, much more, including elegant shops, international restaurants and the most comprehensive park/recreation system in the country. It's all here . . . in a city whose heartbeat is manufacturing geared to profitable production.

Come to Milwaukee . . . where your executives (and all your work force) will like the living . . . cosmopolitan, cultural, congestion-free!

Division of Economic Development
Dept. E-11, Office of the Mayor / Room 201, City Hall / Milwaukee, Wisconsin 53202

Gentlemen: Please send free copy of "there's MORE in Milwaukee". Inquiries handled in strict confidence.

NAME _____

ADDRESS _____

CITY _____

STATE _____

ZIP _____

MILWAUKEE . . . GREAT FOR BUSINESS, GREAT FOR LIVING, and growing greater

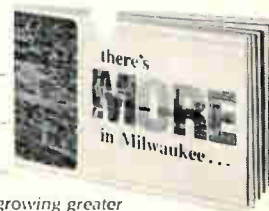

COMPUTER TALK

by W. Henry du Pont, President

SCI-TEK

COMPUTER CENTER, INC.



WHAT SHOULD A SCIENTIFIC COMPUTER CENTER DO?

In our business we get paid for solving technical and scientific problems using the most powerful computer in the country. When we've done that, we've earned our money as computer men.

But we try to do something more, too. We think it's our job to make electronic data processing as prudent an investment as you can make.

This means—among other things—that we must understand your problems and opportunities from an engineering point of view first and from a computer man's view second.

We must be doing a good job because we have just opened up a satellite computer center at the Franklin Institute Research Laboratories building in Philadelphia to serve their R & D needs.

Our charges for these services? Nothing but the standard fee you pay when you actually use our 1107 computer.

Send for our helpful brochures describing SCI-TEK. They're yours without obligation.

SCI-TEK
COMPUTER CENTER, INC.
1707 GILPIN AVENUE
WILMINGTON, DELAWARE 19806
Phone: (302) 652-3967

Electronics Abroad

for the discriminator. On the substrate with the filters are three transistor chips, a pair of diodes, a dozen resistors and five capacitors. The diodes are used with the third filter in the discriminator circuit. Gain ranges between 40 and 46 decibels.

The 10.7-Mhz unit is similar to the 4.5-Mhz module, but does not include a discriminator circuit. Murata, however, is developing a filter that can be used as a discriminator at 10.7 Mhz.

Inside job

With much fanfare, Matsushita Electrical Industrial Co. and N.V. Philips' Gloeilampenfabrieken last month signed a pact extending for another 10 years their long-standing joint venture in Japan—the Matsushita Electronics Corp.

In view of such close cooperation, observers wondered why Matsushita Electric has quietly set up a semiconductor group in its central research laboratory to develop integrated circuits. Until now, the job has been handled by the joint venture.

Competing. Matsushita vice-president Tetsujiro Nakao says there's nothing sinister in the development, even though the new group is led by the former director of research at Matsushita Electronics.

Under the joint agreement, Nakao points out, Philips has access to any Matsushita Electric semiconductor developments. And he adds that there's no plan to set up separate semiconductor production facilities in which Philips won't share. Nakao insists the move was made mainly because the Japanese company likes some internal competition among its researchers and development groups.

Outsiders, though, feel there's another reason behind the new IC research group: a freer hand for Matsushita Electric. Apparently Matsushita has had trouble selling its partner on some research projects that look promising from a Japanese standpoint but nonetheless seem unattractive to Philips, whose prime market is Europe.

Feedback AGC
using the . . .

VCR* FET

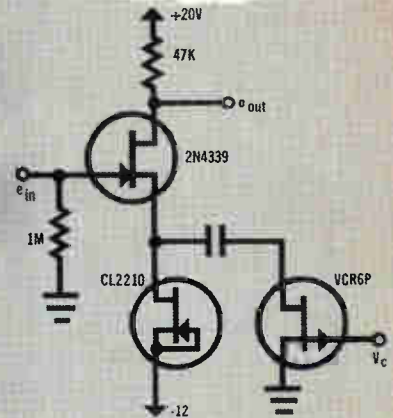

Siliconix assumes no responsibility for the circuit shown, nor do they represent or warrant that it does not infringe any patents.

Here's a common-source FET amplifier, with a current-limiter diode as a source resistor and a VCR FET gain control. With $V_C = 0$, the gain is 32 dB. Gain decreases as V_C approaches pinch-off for the VCR. Maximum gain depends on r_{ds} at $V_{GS} = 0$ for the VCR6P. Gain with full AGC ($V_C = V_P$) is controlled by the current limiter. Variations in maximum gain are due to variations in r_{ds} .

If you'd like to investigate this and other VCR FET designs, order your VCR FET Designer's Kit from a Siliconix distributor. For just \$19.50 you'll get 6 different VCRs (worth \$30) plus data. More information? Just write us.

* VCR - Voltage Controlled Resistor - a FET bilateral resistance whose value is voltage controlled from one high-impedance terminal.



Siliconix incorporated

1140 W. Evelyn Ave. • Sunnyvale, CA 94086
Phone (408) 245-1000 • TWX: 910-339-9216

Electronics advertisers

November 13, 1967

Ideal Precision Meter Co., Inc. Zam & Kirshner, Inc.	244	Markem Machine Co. Culver Advertising, Inc.	184	Research, Inc. Gordon Rosholt & Co.	291
Image Instruments, Div. of DASA Corp. L.K. Frank Co., Inc.	58	Maryland Dept. of Economic Development The Robert Goodman Agcy., Inc.	270	RFL Industries, Inc., Instrumentation Div. Josephson, Cuffari & Co.	288
Indiana General Corp., Ferrites Div. Griswold & Eshleman	24	Matsuo Electric Co., Ltd. Daiyusha, Inc.	292	Rochar Electronique, Div. of Schlumberger Promotion Vente Publicite	OAS 9
Information Handling Services Martz & Associates	245	Matthey Bishop Inc. Richardson, Thomas & Bushman, Inc.	286	Rohde & Schwarz Walker & Gessell, Inc.	6
International Crystal Mfg. Co. Robert V. Freeland & Assoc.	242	Meguro Electronic Instrument General Advertising Agency, Inc.	256	Rotron Manufacturing Co. Lescarboura Adv., Inc.	249
International Electronic Research Corp. Van Der Boom, McCarron, Inc., Adv.	288	Metal Removal Co., The Advertising Producers Assoc.	280	Sage Electronics Corp. Mathison Adv., Inc.	281
International Rectifier Corp. Botsford, Constantine & McCarty, Inc.	151	Metex Corp. Keyes, Martin & Co.	287	Scintillonics, Inc. Mosher & Assoc., Inc.	52
Intercontinental Instruments, Inc. J.S. Lanza & Assoc.	223	Mico Instrument Co.	288	Sci-Tek Computing Center, Inc. Stanley, Richard & Frederick, Inc.	312
Iowa Development Commission L.W. Ramsey Advertising	262	Microdot, Inc.	15	Sel-Rex Corp. Gaynor & Ducas, Inc.	74
I R C, Inc. Gray & Rogers, Inc.	199	Gumpertz, Bentley & Dolan Adv.	15	Semcor Div. Components, Inc. Marketing & Corporate Communications, Inc.	63
ITT Electron Tube Div. West, Weir & Bartel, Inc.	149	Micro Science Associates of Mountain View, California Stadler/Cowman Adv.	71	Semi-Elements, Inc. Sub. of Riker Video Ind., Inc. Cavanaugh Morris Adv.	315
ITT Jennings Mfg. Co. West, Weir & Bartel, Inc.	261	Milgray Electronics Bliss/Gruenwald, Inc.	197	Semtech Corp. Burruss Advertising	64
ITT Jennings Mfg. Co. West, Weir & Bartel, Inc.	OAS 18	Milo International, Div. of Milo Electronics Corp. Industrial Marketing Assoc., Div. of J.M. Schrier, Inc.	OAS 6	Servo Corporation of America Basford, Inc.	304
ITT Semiconductors Div. Neals & Hickok, Inc.	162, 316	Milwaukee, City of, Div. of Economic Development Grablin-Shaw Adv., Inc.	311	Sifco Metachemical, Div. of Steel Improvement & Forge Co. Creative/3	281
ITT Standard Brockie Haslam & Co.	OAS 15	Mitsubishi Electric Corp. Hakuhodo, Inc.	246	Sigma Instruments, Inc. Marschalk Co., Inc.	267
James Electronics, Inc. George Bond & Associates	208	Mosaic Fabrications, Inc., Sub. of Bendix Corp. Van Christo Assoc., Inc.	277	Signetics Corp., Sub. Corning Glass Works Cunningham & Walsh, Inc.	90
J F D Electronics Co., Components Div. Delphi Advertising, Inc.	283	Motorola Communications & Electronics, Inc. K & A, Inc.	154	Siliconix, Inc. Graphics West	312
Johnson Co., E. F. Midland Associates	297, 298	Motorola Semiconductor Products, Inc. Lane & Bird Adv., Inc.	81, 137	Singer Co., Metrics Div. Hepler & Gibney, Inc.	181
Kepeco, Inc. Weiss Advertising	270, 272	National Capacitors, Inc. Haselmire Pearson Adv., Inc.	213	Soliton Devices, Inc., Transistor Div. Haselmire Pearson Adv., Inc.	43
Keystone Carbon Co. Downing Industrial Adv., Inc.	192	National Electronics, Inc. Connor-Sager Assoc.	291	S. P. Elettronica Publicitas SPA	OAS 12
Kikusui Electronics Corp. Kyodo Adv. Co., Ltd.	283	National Semiconductor Corp. Jay Chiat & Assoc.	12, 13	Spectral Electronics Corp. Jones, Maher, Roberts, Inc.	157
Krohn-Hite Corp. L.K. Frank Co., Inc.	176	Natvar Corp. Sanger-Funnell, Inc.	202	Sperry Rand Corp., Microwave Components Neals & Hickok, Inc.	229, 231
Lambda Electronics Corp. Michel Cather, Inc.	258	New Hermes Engraving Machine Corp. Lester Harrison Adv., Inc.	248	Sperry Rand Research Center Reach, McClinton & Co.	209
Lapp Insulator Co. Wolff Associates	236	North Atlantic Industries, Inc. Murray Heyert Assoc.	8	Sprague Electric Co., The Harry P. Bridge Co.	5, 10
Leach Corporation Jay Chiat & Associates	265	Pamotor, Inc. Harry P. Bridge Co.	175	Stackpole Carbon Co., Electronic Components Div. Meek & Thomas, Inc.	155
Ledex, Inc., Bramco Controls Div. Yeck & Yeck, Inc.	212	Pennsalt Chemicals Corp. Aitkin-Kynett Co., Inc.	279	Struthers-Dunn, Inc. Harry P. Bridge Co.	230
Lenox-Fugle Electronics, Inc. Keyes, Martin & Co.	248	Philips Eindhoven, N.V. T.A.G. De La Mar	OAS 1, OAS 5	Susumu Industry Co., Ltd. Dentsu Advertising	254
Litton Industries, Inc., Winchester Electronics Div. West, Weir & Bartel, Inc.	226, 227	Plastic Capacitors, Inc. Sander Rodkin Adv. Agcy., Ltd.	182	Sweet's Industrial Information System Wank, Williams & Neylan, Inc.	189
Lockheed Electronics Co. McCann-Erickson, Inc.	185, 194	Precision Tube Co., George Moll Adv., Inc.	266	Sylvania Electric Products, Inc., Electronic Tube Div. Doyle, Dane, Bernbach, Inc.	39
Lockheed Missiles & Space Co. McCann-Erickson, Inc.	280	Princeton Applied Research Corp. Mort Barish Assoc., Inc.	44	Sylvania Electric Products, Inc. Parts Div. Doyle, Dane, Bernbach, Inc.	241
L T T Promotion Vente Publicite	OAS 20	Radio Cores, Inc. Sander Rodkin Adv. Agcy., Ltd.	180	Syntron Co. De Sales Advertising, Inc.	87
McGraw Hill Book Co.	292	Radio Corporation of America Al Paul Lefton Co.	4th Cover, 20, 21, 57, 207	Synthane Corp. Arndt, Preston, Chapin, Lamb & Keen, Inc.	283
Machlett Laboratories, Raytheon Co., Div. Fuller & Smith & Ross, Inc.	11	Radio Materials Co., Div. of P.R. Mallory & Co. Gallay Adv., Inc.	238	Syntronic Instruments, Inc. Burton Browne Advertising	260
Magnecraft Electric Co. Allbright Associates	62	Rally Dumesnil Publicite	OAS 19	Systron-Donner Corp. Bonfield Assoc., Inc.	214
Magnetic Shield Div. Perfection Mica Co. Burton Browne Adv.	285	Raytheon Co., Components Div. Fuller & Smith & Ross, Inc.	186	Systron-Donner International Bonfield Assoc., Inc.	OAS 11
Magnetics, Inc. Lando Adv. Agcy., Inc.	275	Raytheon Semiconductor Botsford, Constantine & McCarty, Inc.	65	Taylor Corp. Gray & Rogers, Inc.	168
Mallory Battery Co., Div. of P.R. Mallory & Co., Inc. Needham, Harper & Steers, Inc.	82	RCL Electronics, Inc. Morvay Adv. Agcy.	14	Tektronix, Inc. Hugh Dwight Adv., Inc.	51
Marconi Company, Ltd. Hampshire House, Ltd.	OAS 8	Redcor Corp. Smith-Klitten, Inc.	188	Teledyne Relays Co. S. Michelson Advertising	66
Markel & Sons, L. Frank George Moll Adv., Inc.	228	Reeves Hoffman, Div. of Dynamics Corp. of America Adams Associates, Inc.	254	Telonic Instruments Jansen Assoc., Inc.	291
		Rental Electronics, Inc. Raymond E. Finn Adv.	284		



Advertising sales staff

Tempress Research Co., Inc. Hal Lawrence, Inc.	159	Frank E. LeBeau [212] 971-6464 Advertising sales manager Wallis Clarke [212] 971-2187 Assistant to sales manager Donald J. Austermann [212] 971-3139 Promotion Manager Atlanta, Ga. 30309: Michael H. Miller, 1375 Peachtree St., N.E. [404] TR 5-0523
■ Texas Instruments Incorporated Components Group Don L. Baxter, Division of Albert Frank- Guenther Law Incorporated	27 to 32	Boston, Mass. 02116: William S. Hodgkinson McGraw-Hill Building, Copley Square [617] CO 2-1160
■ Transformer Electronics Co. Dacey, Wolff & Weir	278	Chicago, Ill. 60611: Robert M. Denmead, J. Bradley MacKimm, Ralph Hanning, 645 North Michigan Avenue, [312] MO 4-5800
Triplet Electrical Instrument Co. Burton Browne Advertising	263	Cleveland, Ohio 44113: William J. Boyle, 55 Public Square, [216] SU 1-7000
TRW Electronics, Capacitors Div. Fuller & Smith & Ross, Inc.	49	Dallas, Texas 75201: Richard P. Poole, 1800 Republic National Bank Tower, [214] RI 7-9721
■ Trygon Electronics, Inc. Kameny Associates, Inc.	264	Denver, Colo. 80202: Joseph C. Page, David M. Watson, Tower Bldg., 1700 Broadway, [303] 255-5484
Trymetrics Corp. Kameny Associates, Inc.	308	Detroit, Michigan 48226: Ralph Hanning 856 Penobscot Building [313] 962-1793
■ Tung Sol Div, Wagner Electric Corp E. M. Freystadt Assoc.	148	Houston, Texas 77002: Kenneth George, 2270 Humble Bldg., [713] CA 4-8381
Ulano & Co., J. Byrde, Richard & Pound, Inc.	203	Los Angeles, Calif. 90017: Ian C. Hill, John G. Zisch, 1125 W. 6th St., [213] HU 2-5450
Union Carbide Corp., Electronics Div J. M. Mathes, Inc.	161	Minneapolis, Minn. 55402: J. Bradley MacKimm, 1104 Northstar Center [612] 332-7425
Union Carbide Corp., Group I— Chemicals & Plastics Div. J. M. Mathes, Inc.	86	New York, N.Y. 10036 500 Fifth Avenue Donald R. Furth [212] 971-3615 James R. Pierce [212] 971-3616 Jeffrey M. Preston [212] 971-3617
Union Carbide Corp., Linde Div. J. M. Mathes, Inc.	278	Philadelphia, Pa. 19103: Warren H. Gardner, Jeffrey M. Preston, 6 Penn Center Plaza, [215] LO 8-6161
■ United Transformer Co., Div of TRW Inc. Philip Stogel Co.	2nd Cover	Pittsburgh, Pa. 15222: Warren H. Gardner, 4 Gateway Center, [412] 391-1314
■ Unitrode Corp. Silton Brothers, Inc.	55	Portland, Ore. 97204: James T. Hauptli, 218 Mohawk Building, 222 S.W. Morrison Street, Phone [503] 223-5118
■ Vactec, Inc. Coleman & Assoc. Adv.	310	Rochester, N.Y. 14534: William J. Boyle, 9 Greylock Ridge, Pittsford, N.Y. [716] 586-5040
■ Varo, Inc. Tracy-Locke Co., Inc.	268	St. Louis, Mo. 63105: Robert M. Denmead The Clayton Tower, 7751 Carondelet Ave. [314] PA 5-7285
Vidar Corp. Hal Lawrence, Inc.	147	San Francisco, Calif. 94111: James T. Hauptli, 255 California Street, [415] DO 2-4600
Vishay Instruments, Inc. Alpern Communications	169	London W1: Edwin S. Murphy Jr., 34 Dover Street, Hyde Park 1451
Wanlass Electric Co. Leland Oliver Co., Inc.	254, 290	Paris: Pierre Braude, European Director Iena Commercial Bldg., 33 rue Galilee Phone: 553-47-79
Wavetek Michetti Advertising	193	Milan: Robert Saidel 1 via Baracchini Phone: 86-90-656
Westinghouse Electric Corp., Electronic Tube Div. McCann/ITSM	67	Frankfurt/Main: Dieter Rothenback Elsa Brandstroem Str. 2 Phone: 72 01 81
Westinghouse Semiconductor Div. McCann/ITSM	178	Geneva: Mike Zeynel 1, rue du Temple Phone: 31 95 60
■ Weston Instruments, Inc., Newark Div. Arndt, Preston, Chapin, Lamb & Keen, Inc.	88	Tokyo: Nobuyuki Sato, 1, Kotohiracho Shiba, Minato-Ku [502] 0656

Classified Advertising

F. J. Eberle, Manager	
PROFESSIONAL SERVICES	294
EMPLOYMENT OPPORTUNITIES	294-295
EQUIPMENT (Used or Surplus New) For Sale	296
ADVERTISERS INDEX	
A & A Electronics Corp.	296
Atomic Personnel Inc.	294
Fair Radio Sales	296
Fishman Co., Phillip	296
Goodyear Aerospace Corp.	294
Naval Ship Missile Systems Engineering Station	295
Night Vision Laboratory of the Army Electronics Command	294
Radio Research Corp.	296

■ For more information on complete product line see advertisement in the latest Electronics Buyers' Guide

□ Advertising in Overseas Section following Newsletter from Abroad

Business Department

Wallace C. Carmichael, Manager [212] 971-3191
Stephen R. Weiss, Production Manager [212] 971-2044
Thomas M. Egan, Assistant Production Manager [212] 971-3140
Dorothy Carmesin, Contracts and Billings [212] 971-2908

Circulation and Research

Milton Drake, Manager [212] 971-3485
Isaaca Siegel, Assistant Circulation Manager [212] 971-6057
David Strassler, Assistant Research Manager [212] 971-6058
Chloe D. Glover, Research Associate [212] 971-6057

Electronics Buyers' Guide

George F. Werner, General Manager [212] 971-2310
Ray Smith, Eastern Regional Manager [212] 971-6538
Regina Hera, Directory Manager [212] 971-2544
Thomas M. Egan, Production Manager [212] 971-3140

SINGLE CRYSTALS OF HIGH PURITY METALS

For Laser Applications, Gamma Ray Spectrometry Plates and Bending Blocks, Neutron Spectrometry Plates and Accessories, Thin Film and Acoustic Studies, Solid State Research.

Semi-Elements offers the largest variety of single crystals of high purity metals commercially available from any source. These single crystals are of extremely high purity, and are available in many as grown sizes and shapes.

- Rhenium • Cadmium
- Titanium • Indium
- Vanadium • Tin
- Cobalt • Gold
- Iron • Platinum
- Copper • Thallium
- Zirconium • Bismuth
- Silver • Antimony
- Metal Single Crystal Alloys

Metal single crystals can be grown, cut, oriented and polished to your specifications. We will be pleased to quote to your specific requirements.

Write or call for literature.



semi-elements, inc.

Saxonburg Blvd., Saxonburg, Pa., 16056

Phone: 412-352-1548

The Predictables.



When ITT people ship your Series 930 DTL order you get on-time delivery.

More than 97% of your Series 930 DTL orders get delivered on time. How's that for predictability? We offer the same 15 circuit functions in the same packages as those people you've been having delivery problems with. Doesn't that justify a change?

To see how little trouble DTL buying can be, try the ITT "Predictables." Order off the shelf from your distributor or direct from your factory representative. Our shipping people may have to work late, but your receiving people won't.

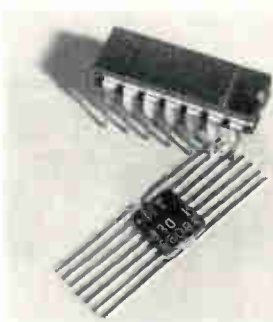

Integrated circuits **ITT**

FACTORIES IN WEST PALM BEACH, FLORIDA; PALO ALTO, CALIFORNIA; LAWRENCE, MASSACHUSETTS; HARLOW AND FOOTSCRAY, ENGLAND; FREIBURG AND NURENBERG, GERMANY

Electronics reader service

Warning: The Post Office now requires your ZIP CODE on all mail. Please include your ZIP CODE number when filling out your reply card.

Use these handy post cards for more detailed information on: products advertised, new products, new literature.

Circle the number on the Reader Service post card that corresponds to the number at the bottom of the advertisement, new product item, or new literature in which you are interested.

Please print clearly. All written information must be legible to be efficiently processed.

If someone has beaten you to the post cards, you may obtain the needed information by writing directly to the manufacturer, or by sending your name and address, plus the Reader Service number, to Electronics Reader Service department.

All inquiries from outside the U.S. that cannot reach Electronics before the expiration dates noted on the Reader Service post card, must be mailed directly to the manufacturer. The manufacturer assumes all responsibilities for responding to inquiries. Electronics merely provides and clears requests for information from inquirer to manufacturer.

Correct amount of postage must be affixed for all mailings from outside the U.S.

To subscribe to or to renew Electronics

Fill in the "For Subscriptions" area on the card if you desire to subscribe to or renew your present subscription to Electronics. Send no money. Electronics will bill you at the address indicated on the Reader Service post card.

Multi-product advertisements

For information on specific items in multi-product advertisements which do not have a specific Reader Service number indicated write directly to manufacturer for information on precise product in which you are interested.

23 Please Print Clearly *For employment inquires fill in home address. 14

Name _____ title _____ November 13, 1967

Company* _____ Card Expires

Address _____ January 13, 1968

City _____ State _____ Zip Code _____

1	20	39	58	77	96	115	134	153	172	191	210	229	248	267	286	305	324	343	362	381	400	419	438	457	476	495	514	962
2	21	40	59	78	97	116	135	154	173	192	211	230	249	268	287	306	325	344	363	382	401	420	439	458	477	496	515	963
3	22	41	60	79	98	117	136	155	174	193	212	231	250	269	288	307	326	345	364	383	402	421	440	459	478	497	516	964
4	23	42	61	80	99	118	137	156	175	194	213	232	251	270	289	308	327	346	365	384	403	422	441	460	479	498	517	965
5	24	43	62	81	100	119	138	157	176	195	214	233	252	271	290	309	328	347	366	385	404	423	442	461	480	499	518	966
6	25	44	63	82	101	120	139	158	177	196	215	234	253	272	291	310	329	348	367	386	405	424	443	462	481	500	967	
7	26	45	64	83	102	121	140	159	178	197	216	235	254	273	292	311	330	349	368	387	406	425	444	463	482	501	968	
8	27	46	65	84	103	122	141	160	179	198	217	236	255	274	293	312	331	350	369	388	407	426	445	464	483	502	969	
9	28	47	66	85	104	123	142	161	180	199	218	237	256	275	294	313	332	351	370	389	408	427	446	465	484	503	970	
10	29	48	67	86	105	124	143	162	181	200	219	238	257	276	295	314	333	352	371	390	409	428	447	466	485	504	971	
11	30	49	68	87	106	125	144	163	182	201	220	239	258	277	296	315	334	353	372	391	410	429	448	467	486	505	972	
12	31	50	69	88	107	126	145	164	183	202	221	240	259	278	297	316	335	354	373	392	411	430	449	468	487	506	973	
13	32	51	70	89	108	127	146	165	184	203	222	241	260	279	298	317	336	355	374	393	412	431	450	469	488	507	974	
14	33	52	71	90	109	128	147	166	185	204	223	242	261	280	299	318	337	356	375	394	413	432	451	470	489	508	975	
15	34	53	72	91	110	129	148	167	186	205	224	243	262	281	300	319	338	357	376	395	414	433	452	471	490	509	976	
16	35	54	73	92	111	130	149	168	187	206	225	244	263	282	301	320	339	358	377	396	415	434	453	472	491	510	977	
17	36	55	74	93	112	131	150	169	188	207	226	245	264	283	302	321	340	359	378	397	416	435	454	473	492	511	978	
18	37	56	75	94	113	132	151	170	189	208	227	246	265	284	303	322	341	360	379	398	417	436	455	474	493	512	960	979
19	38	57	76	95	114	133	152	171	190	209	228	247	266	285	304	323	342	361	380	399	418	437	456	475	494	513	961	980

23 Please Print Clearly *For employment inquires fill in home address. 14

Name _____ title _____ November 13, 1967

Company* _____ Card Expires

Address _____ January 13, 1968

City _____ State _____ Zip Code _____

1	20	39	58	77	96	115	134	153	172	191	210	229	248	267	286	305	324	343	362	381	400	419	438	457	476	495	514	962
2	21	40	59	78	97	116	135	154	173	192	211	230	249	268	287	306	325	344	363	382	401	420	439	458	477	496	515	963
3	22	41	60	79	98	117	136	155	174	193	212	231	250	269	288	307	326	345	364	383	402	421	440	459	478	497	516	964
4	23	42	61	80	99	118	137	156	175	194	213	232	251	270	289	308	327	346	365	384	403	422	441	460	479	498	517	965
5	24	43	62	81	100	119	138	157	176	195	214	233	252	271	290	309	328	347	366	385	404	423	442	461	480	499	518	966
6	25	44	63	82	101	120	139	158	177	196	215	234	253	272	291	310	329	348	367	386	405	424	443	462	481	500	967	
7	26	45	64	83	102	121	140	159	178	197	216	235	254	273	292	311	330	349	368	387	406	425	444	463	482	501	968	
8	27	46	65	84	103	122	141	160	179	198	217	236	255	274	293	312	331	350	369	388	407	426	445	464	483	502	969	
9	28	47	66	85	104	123	142	161	180	199	218	237	256	275	294	313	332	351	370	389	408	427	446	465	484	503	970	
10	29	48	67	86	105	124	143	162	181	200	219	238	257	276	295	314	333	352	371	390	409	428	447	466	485	504	971	
11	30	49	68	87	106	125	144	163	182	201	220	239	258	277	296	315	334	353	372	391	410	429	448	467	486	505	972	
12	31	50	69	88	107	126	145	164	183	202	221	240	259	278	297	316	335	354	373	392	411	430	449	468	487	506	973	
13	32	51	70	89	108	127	146	165	184	203	222	241	260	279	298	317	336	355	374	393	412	431	450	469	488	507	974	
14	33	52	71	90	109	128	147	166	185	204	223	242	261	280	299	318	337	356	375	394	413	432	451	470	489	508	975	
15	34	53	72	91	110	129	148	167	186	205	224	243	262	281	300	319	338	357	376	395	414	433	452	471	490	509	976	
16	35	54	73	92	111	130	149	168	187	206	225	244	263	282	301	320	339	358	377	396	415	434	453	472	491	510	977	
17	36	55	74	93	112	131	150	169	188	207	226	245	264	283	302	321	340	359	378	397	416	435	454	473	492	511	978	
18	37	56	75	94	113	132	151	170	189	208	227	246	265	284	303	322	341	360	379	398	417	436	455	474	493	512	960	979
19	38	57	76	95	114	133	152	171	190	209	228	247	266	285	304	323	342	361	380	399	418	437	456	475	494	513	961	980

Electronics New subscription application

Please start my three year subscription for only \$16 — I save \$8!

1 Year \$8 Bill Me Bill Company Payment Enclosed

Subscription Includes 1,200 Page Annual Buyers' Guide Issue

Name _____ Title _____

Company _____ Please Fill in All Spaces

Company address _____

City _____ State _____ Zip code

Product manufactured _____ or Service performed _____

Are you involved in the specification of electronic or allied products? Yes No

Please check your department or function:

Research Design, development Production, operation, maintenance

Other (please describe) _____

Above rates apply only to those professionally engaged in electronics technology. All others, \$25 per year.

L.
M.

Reprint service

All Electronics editorial matter available in reprint form:

For reprints of special reports and feature articles see list on right side of this page. Send your order to Electronics Reprint Department at the address indicated. To expedite mailing of your order for single reprints please send cash, check or money order with your order. Allow 3-4 weeks for delivery.

Bulk reprints of editorial matter can be ordered from current or past issues. The minimum quantity is 100 copies. Prices quoted on request: call 212-971-2274, or write to address below.

Warning: The Post Office now requires your ZIP CODE on all mail. Please include your ZIP CODE number when filling out your reply card.

3

Business reply mail
No postage stamp necessary if mailed in the United States

Postage will be paid by

Electronics
Reader service department
Box 444
Hightstown, N. J. 08520

First class
Permit no. 42
Hightstown, N. J.



2

Business reply mail
No postage stamp necessary if mailed in the United States

Postage will be paid by

Electronics
Reader service department
Box 444
Hightstown, N.J. 08520

First class
Permit no. 42
Hightstown, N. J.



1

Business reply mail
No postage stamp necessary if mailed in the United States

Postage will be paid by

Electronics
P. O. Box 514
Hightstown, N. J. 08520

Subscription department

First class
Permit no. 42
Hightstown, N. J.



To order reprints or for further information, please write to: **Electronics Reprint Department, 330 West 42nd Street, New York, N.Y. 10036.**

You may order any of the below listed reprints by key number. Discounts on quantities over 10.

- Key no. R-01 **Computer-aided Design: Part I, The Man-machine Merger.** 16 pages. \$1.25.
- Key no. R-02 **Vietnam Communications Network Growing Into Southeast Asia's Best.** 3 pages. 25¢.
- Key no. R-03 **Sense Amplifier Fits Any Product.** 6 pages. 25¢
- Key no. R-04 **Multilayer Circuit Boards: Sharpening An Imperfect Art.** 7 pages. 50¢.
- Key no. R-05 **Topology Cuts Design Drudgery.** 12 pages. 50¢.
- Key no. R-06 **Report on Japanese Technology: Sony.** 20 pages. 50¢.
- Key no. R-07 **European Electronics Markets 1967.** 22 page forecast report with 4 page foldout chart. \$1.00.
- Key no. R-08 **U.S. Electronics Markets 1967.** 26 page forecast report with 6 page foldout. \$1.00.
- Key no. R-09 **1966 Electronics Index to Technical Articles and Authors Free.**
- Key no. R-010 **Special Report on Large Scale Integration.** 54 pages. \$1.50.
- Key no. R-011 **Medical Electronics (1967).** 8 part series, 44 pages. \$1.25.
- Key no. R-87a **The Packaging Revolution in Microelectronics, Parts I through VI.** 64 pages. \$2.00.
- Key no. R-86a **Computer Time Sharing, Parts I and II.** 32 pages. \$1.00.
- Key no. R-79 **MOS Integrated Circuits.** 12 pages. 50¢.
- Key no. R-78 **The Overlay Transistor.** 15 pages. 50¢.
- Key no. R-75 **Biotelemetry.** 2 part series, 16 pages. 50¢.
- Key no. R-74 **Unijunction Transistors.** 24 pages. 50¢.
- Key no. R-64 **Field Effect Transistors, Parts I, II, and III.** 64 pages. \$1.00.
- Key no. R-60 **Transistor Heat Dissipators.** 32 pages. 50¢.
- Key no. R-31 **Electromagnetic Spectrum Chart.** (22" x 30" foldout chart). \$1.00.



DALE

**stacks up
better in
industrial
wirewounds!**

*Dale CW Resistors chosen for North Electric's
advanced NX Crossbar Switching System*

For more than seven years, Dale CW Wirewounds have been an integral part of the high efficiency NX Crossbar Switching Systems produced by North Electric Company, Galion, Ohio. Found in Independent telephone exchanges nationwide, North's NX Crossbar uses proven components, such as the CW, to provide decades of continuous, trouble-free service.

Chances are your industrial applications are similar — requiring long-term assurance of stable performance and uninterrupted delivery. Here are three solid reasons why Dale CW Resistors provide the best all-around value:

FOR COMPLETE INFORMATION OR A QUICK QUOTE PHONE 402-564-3131

Circle No. 181 for Dale's complete Resistor Catalog A

1. HIGHER STABILITY is provided by silicone coating and wirewinding methods patterned after Dale's precision RS Series. Meets MIL-R-26C, RW-57, 58, 59.

2. HIGH POWER TO SIZE RATIO. Eight standard models provide up to 13 watts (Char. V) in 1.781" x .375" size.

3. VERSATILE. Pre-engineered to meet hundreds of special applications.

DALE ELECTRONICS, INC.

1300 28th Avenue Columbus, Nebraska
In Canada: Dale Electronics Canada, Ltd.



Explore the "Undiscovered"

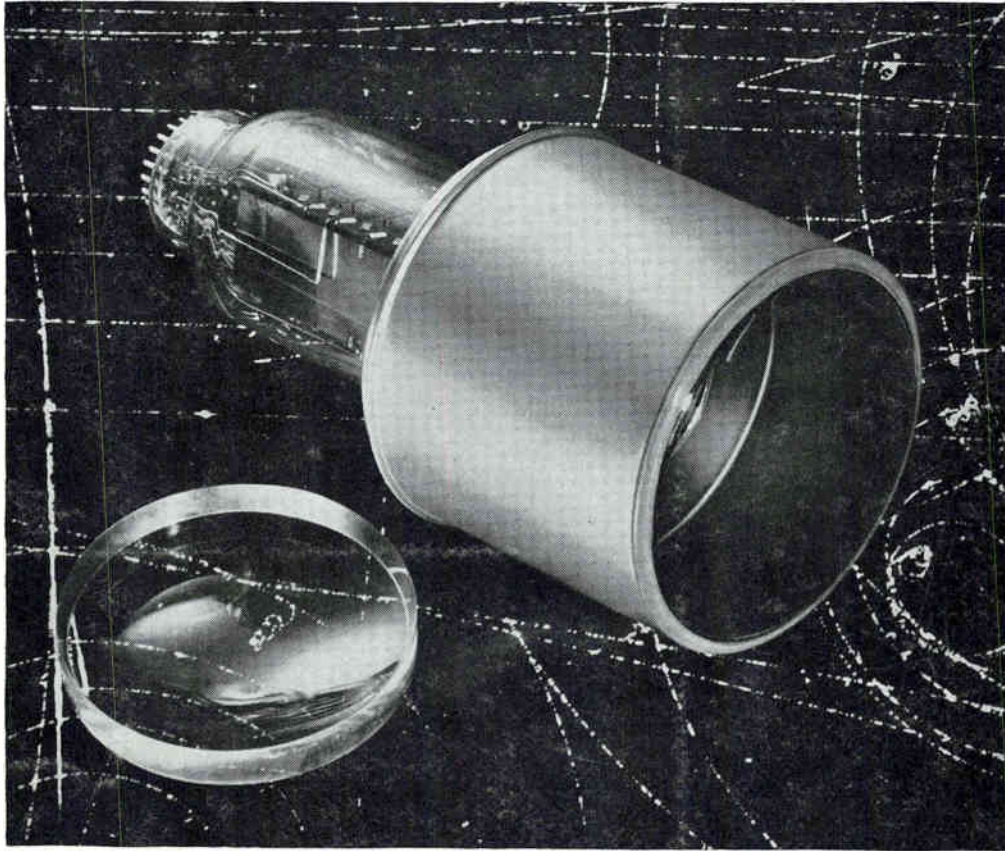

RCA-4522, 5" Photomultiplier and accessory Light Guide provide a full 4.5 inches of useful diameter of the faceplate. Socket adapters available, too.

with RCA-4522 at the forefront of physics

RCA announces a highly desirable complement of characteristics in its new 5-inch photomultiplier, RCA-4522, for heretofore undreamed of measurements in high-energy physics. With a minimum irradiation area of 15.9 square inches, this high-speed photomultiplier has the RCA Bialkali Photocathode to beef up performance levels with clearly superior quantum efficiency and low noise.

This 5" photomultiplier has a pulse rise time of 3.5×10^{-9} sec. Its noise characteristic has been measured as low as 1 electron/ $\text{sec}^{-1}/\text{cm}^{-2}$ from the photocathode at 25°C . Typical QE is 28% and dark current values are as much as three orders of magnitude better than S-11 types.

Designed primarily for use in scintillation-counting systems, RCA-4522 can be equipped with a high-quality light guide to provide a 4.5-inch diameter flat entrance window faceplate.

At the same time, through the use of available sockets, such as DP2118 and AJ2143, this tube becomes an ideal tool for scientists studying exotic phenomena.

For more information on RCA-4522, its accessories, and other RCA Photomultipliers, see your RCA Representative. For technical bulletins on specific types or a wall chart covering the RCA Photomultiplier line, contact your RCA Industrial Tube Distributor or write: RCA Commercial Engineering, Section K-19Q, Harrison, N.J. 07029.

ALSO AVAILABLE FROM YOUR RCA INDUSTRIAL TUBE DISTRIBUTOR



RCA Electronic Components and Devices

The Most Trusted Name in Electronics