

Electronics[®]

Product planning at IEEE: page 116

Computer aid for nonlinear design: page 140

Understanding logic in integrated circuits: page 149

March 6, 1967

\$1.00

A McGraw-Hill Publication

Below: Tapered Gunn device
is voltage tunable, page 134

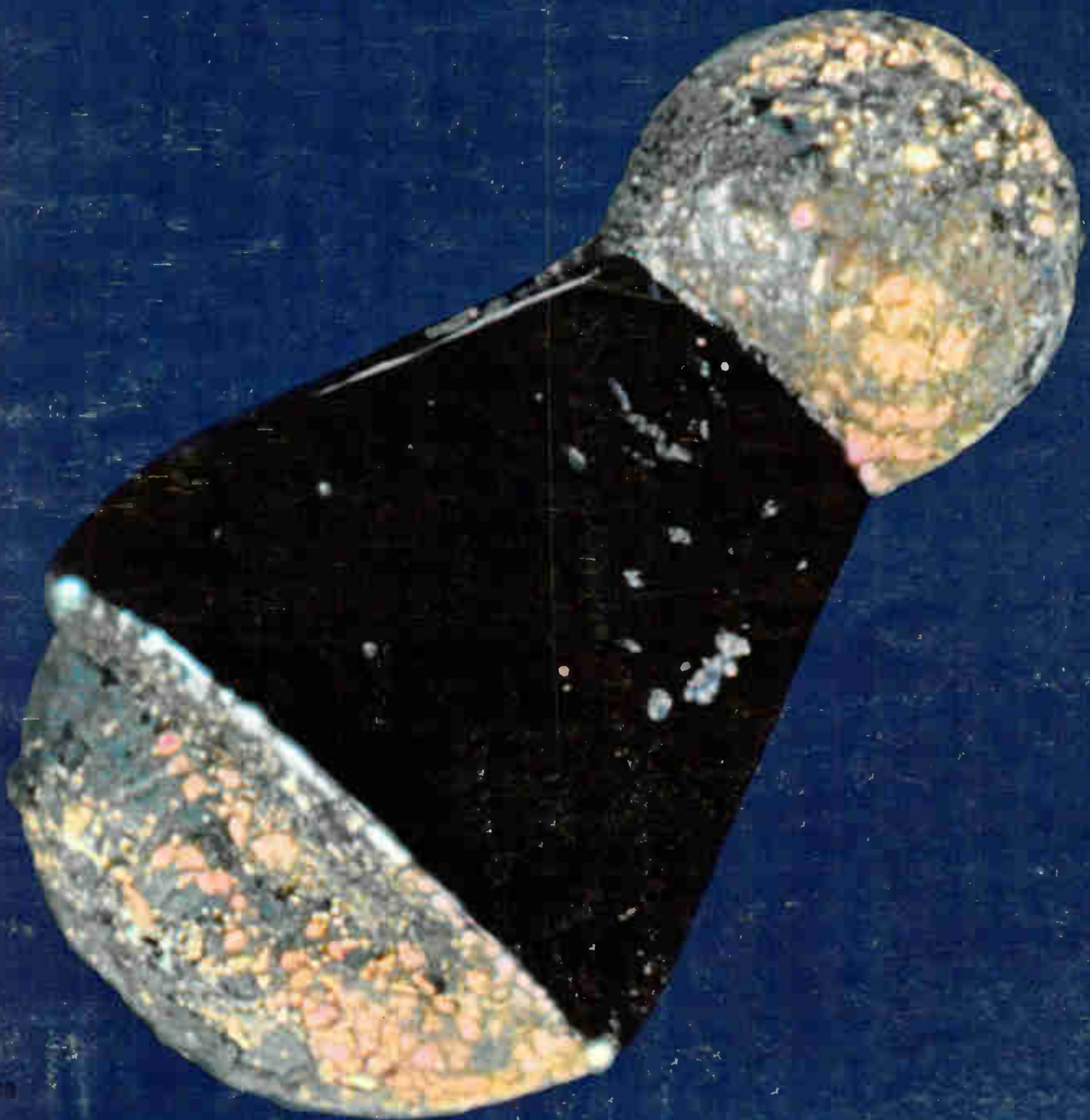



**PIONEERS IN
MINIATURIZATION**

"SPECIAL" CUSTOM BUILT FILTERS

TO YOUR SPECIFICATIONS

**ILLUSTRATED ARE
TYPICAL SPECIAL FILTERS**

RANGE OF FREQUENCIES ON SPECIAL UNITS
IS FROM 0.1 CYCLE TO 400 MC.

Over thirty years of experience in the design and production of special filters have resulted in UTC being a first source for difficult units. Present designs both military and commercial incorporate a wide variety of core structures, winding methods, and capacitors to provide maximum performance, stability, and reliability. Fully experienced, top engineering talent backed by complete environmental testing and life testing facilities assure the highest standard in the industry. Full analysis and evaluation of materials are conducted in UTC's Material and Chemical Laboratories. Rigid quality control measures coordinated with exhaustive statistical findings and latest production procedures results in the industry's highest degree of reliability.

**MILITARY AND COMMERCIAL TYPES FOR
EVERY PHASE OF THE ELECTRONICS ART**

POWER TRANSFORMERS • AUDIO TRANSFORMERS • INDUCTORS • PULSE TRANSFORMERS • ELECTRIC WAVE FILTERS • LUMPED CONSTANT DELAY LINES • HIGH Q COILS • MAGNETIC AMPLIFIERS • SATURABLE REACTORS • REFERENCE UNITS

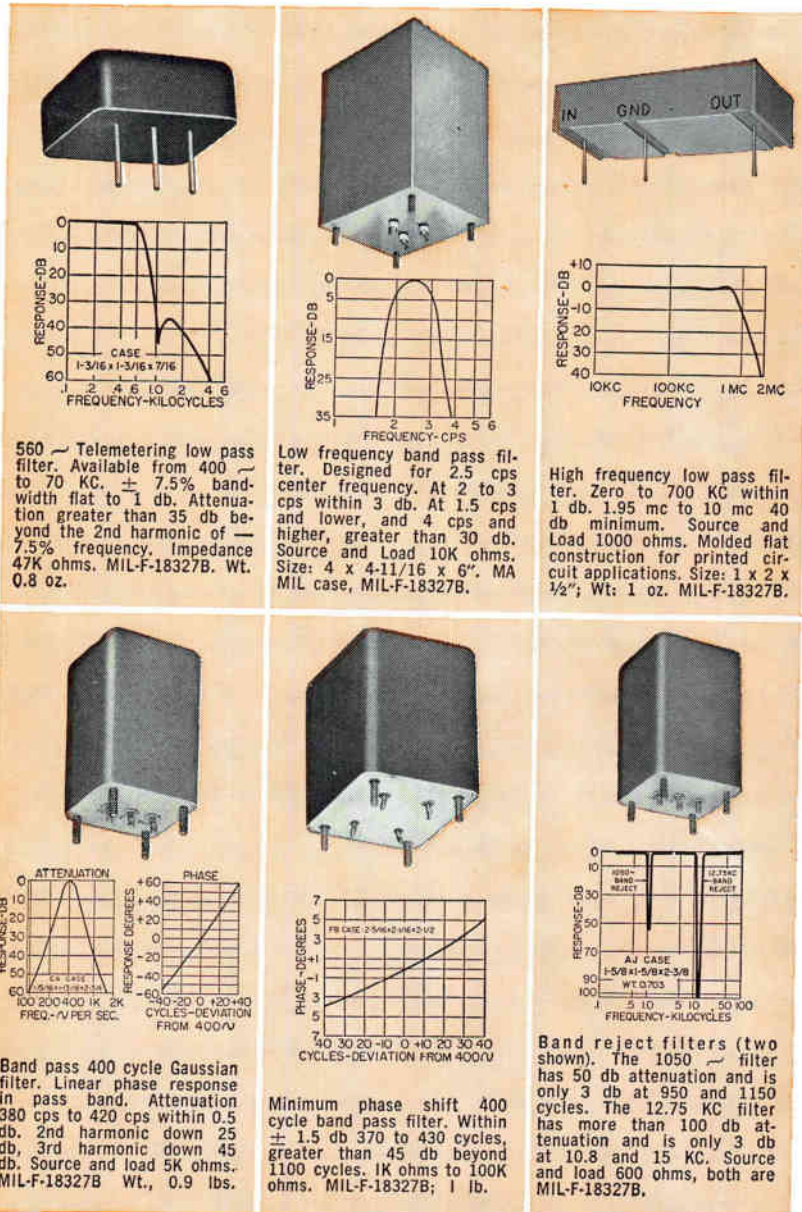

Write for catalog of over
1,300 UTC TOP QUALITY
STOCK ITEMS
IMMEDIATELY AVAILABLE
from your local distributor.



UNITED® TRANSFORMER CO.

DIVISION OF TRW INC. • 150 VARICK STREET, NEW YORK, N. Y. 10013

Circle 900 on reader service card

Introducing 'the strong, silent one.'

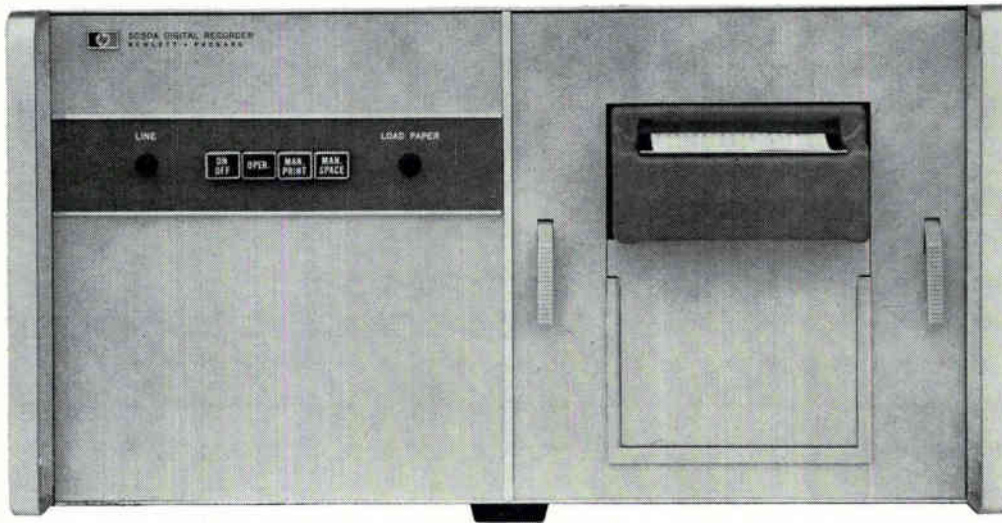

The HP 5050A Digital Recorder is no quitter. New mechanical techniques make this 20-line-per-second printer rugged, quiet, economical and simple. For example, there are no rotating electrical contacts for decoding, and no start-stop operation of printwheel and ink ribbon. Instead, photo-electric decoding is used, and the print drum rotates continually against an ink-impregnated roller. Fewer parts lead to increased reliability potential, which is necessary in printers with the 5050A's speed. Zero suppression is available.

The 5050A is quiet, too... measured noise is less than an electric typewriter, less than other printers in its speed class. It accepts 4-line BCD data from one or two sources, which can be in different BCD codes. For extra versatility, formats and codes are easily and economically changed by mechanical means without buying new circuitry for driving the printer.

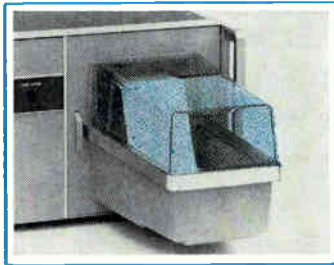

The 5050A can print up to 18 columns at rates to 20 lines per second... and without making a lot of noise about it.

Notice the unusual transparent hood. It muffles the sound. It lets you hear yourself think. It keeps your printed records in a neatly folded stack, instead of streaming over equipment, bench and floor. And it stores completely within the recorder when you're not using it.

The 5050A is, of course, fully compatible with other HP solid-state equipment. Price is favorable, too: \$1750 without the driving electronics (which are an additional \$35 per column).

For more information call your local Hewlett-Packard field engineer or write Hewlett-Packard, 1501 Page Mill Rd., Palo Alto, Calif. 94304; Europe: 54 Route des Acacias, Geneva.

Brief Specifications

Print Cycle Time: 50 msec, asynchronous.
Maximum Capacity: 18 columns, 16 characters each.
Data Input: Parallel entry, BCD (1-2-2-4, 1-2-4-8 or 1-2-4-2); "1" must differ from "0" by 4.5 V min. to 75 V max.
Reference Voltage: ± 150 V max.; both "0" and "1" states are required.

Input Impedance: Approximately two megohms.
Hold-off Signals: Both polarities diode coupled, simultaneously available; 10 mA load max.
+15 V open circuit from 1 K source
-15 V open circuit from 1 K source
Print Command: + or - pulse, 6 to 20 V amplitude, 1 V/ μ sec min. rise time, 20 μ sec or greater in width, AC coupled.

HEWLETT  PACKARD

See new Hewlett-Packard instrumentation
at IEEE Show New York Coliseum March 20-23

Circle 1 on reader service card

2561

1

VARIABLE
BANDWIDTH
MARKERS
PINPOINT THE
FREQUENCY



Sweep Oscillator gives top performance in the 100 kHz to 110 MHz range

All solid-state Hewlett-Packard 3211A Sweep Oscillators with RF and marker plug-ins meet virtually all of your swept frequency testing requirements. Variable bandwidth markers permit accurate, well defined marking under a variety of test conditions.

The main frame of the 3211A contains everything you could hope to find in a sweeper. RF plug-ins operate at fundamental frequencies with good linearity and spurious mixing products are eliminated. Plug-in markers offer not only variable bandwidth, but also Z-axis or pulse-type marking. An accurate 59-db attenuator makes the unit a valuable tool for testing both high- and low-gain circuits.

Circle 2 on reader service card

The 3211A is ideal for general testing in the video to VHF range where flat, linear output and an accurate marking system is required. Typical applications are: alignment, calibration and design of FM tuners and receivers and testing filters, amplifiers, transformers, resonant circuits and IF sections of TV receivers, radar and communications systems. For complete specifications, contact your local Hewlett-Packard field engineer or write Hewlett-Packard, Green Pond Road, Rockaway, N.J. 07866.

HEWLETT  **PACKARD**
measuring instruments
for science and industry

News Features

Probing the News

- 211 **Electronic engineers are fair game**
- 217 **Friden looks for pot of gold**
- 221 **Time-sharing inquiry shakes industry**
- 227 **Easing of tube shortage in Japan opens color tv markets for set makers**
- 231 **Uncalculated risks keep calculator on the shelf**

Electronics Review

- 45 **Companies:** Follow the leader
- 45 **Computers:** Soft hardware
- 46 **Communications:** Phone-a-train
- 47 **Manufacturing:** Testing on the run; Hot tips on IC's
- 48 **Meetings:** By invitation only
- 48 **Medical electronics:** Magnified X rays
- 49 **Employment:** Raiding the Pentagon
- 50 **Military electronics:** Know your enemy; . . . do you read me?
- 52 **Advanced technology:** Standard volt; Single frequency; Cold-cathode emitters
- 56 **For the record**

Electronics Abroad

- 357 **Switzerland:** IC time
- 357 **Great Britain:** Dishing it up; Brighter color
- 359 **Japan:** Light touch
- 359 **France:** Millimeter waveguide; In the whirl
- 360 **West Germany:** Solar storm clouds; Finding faults
- 363 **Around the world**

Departments

- 4 **Readers Comment**
- 8 **People**
- 14 **Meetings**
- 16 **Meetings Preview**
- 23 **Editorial**
- 25 **Electronics Newsletter**
- 67 **Washington Newsletter**
- 251 **New Products**
- 252 **New Products Index**
- 325 **New Books**
- 330 **Technical Abstracts**
- 336 **New Literature**
- 351 **Newsletter from Abroad**

Title R registered U.S. Patent Office; © copyright 1967 by McGraw-Hill, Inc. All rights reserved, including the right to reproduce the contents of this publication, in whole or in part.

Technical Articles

I. Design

- Product development** 116 **The year of the integrated circuit**
At the IEEE show, IC's will be showing up routinely in products
- Circuit design** 130 **Designer's casebook**
 - Gain-multiplied capacitance generates ramp waveform
 - IC amplifier serves as stable current source
 - Constant relay on-time for any input pulse
- Advanced technology** 134 **A worldwide look at the Gunn effect (cover)**
While the Gunn effect seems confined to laboratories, other solid-state microwave phenomena may replace it
Stephen E. Scrupski, senior associate editor
- Design theory** 140 **Computer-aided design: part 7**
Performing nonlinear d-c analysis
Nonlinear devices such as transistors and zener diodes require a different approach and program than linear devices
M.J. Goldberg and J.W. Achard, Norden Division, United Aircraft Corp.
- Integrated electronics** 149 **Integrated circuits in action: part 5**
In search of the ideal logic scheme
A survey of the kinds of integrated-circuit logic illustrates the advantages of each
Donald Christiansen, senior editor
- 158 **Understanding integrated-circuit logic**
The engineer has to know how logic works because the specifications are often sketchy
Robert Sanford, Babcock Electronics Corp.
- 162 **Logic IC's don't live alone**
The ultimate system determines the final performance of the logic scheme
W.T. Rhoades, Hughes Aircraft Co.
- Computers** 171 **II. Application**
The airborne 4 pi computer:
IBM aims at aerospace guidance
A low-cost mass-produced computer may replace special-purpose machines
W.N. Carroll and F.F. Jenny, IBM
- Space electronics** 180 **TV show of the century:**
A travelogue with no atmosphere
Apollo astronauts will use an unusual tv camera to send back pictures of their trip
S. Lebar and C.P. Hoffman, Westinghouse Electric Corp.

Electronics

Editor-in-Chief: Lewis H. Young

Associate managing editors

Design: Samuel Weber
Application: George Sideris
News: Robert Henkel
Copy: Sally Powell

Senior editor

Special projects: Donald Christiansen

Senior associate editors

John F. Mason, Joseph Mittleman, Stephen E. Scrupski

Department editors

Advanced technology: Stephen E. Scrupski
Avionics: W.J. Evanzia
Communications: Leonard Weller
Computers: Wallace B. Riley
Design theory: Joseph Mittleman
Industrial electronics: Alfred Rosenblatt
Instrumentation: Carl Moskowitz
Military electronics: John Mason
New products: William P. O'Brien
Staff writers: Paul Dickson, Jan Rahm

Section editors

Electronics abroad: Arthur Erikson
Electronics review: Stanley Zarowin
Probing the news: Eric Aiken

Regional bureaus

Domestic

Boston: Thomas Maguire, manager; Robin Carlson
Los Angeles: Lawrence Curran, manager; June Ranill
San Francisco: Walter Barney, manager; Mary Jo Jadin
Washington: William D. Hickman, Patricia C. Hoehling, correspondents

Foreign

Bonn: John Gosch
London: Michael Payne
Tokyo: Charles Cohen

Copy editors

Albert Tannenbaum, James Chang, Frederick Corey

Graphic design

Art director: Saul Sussman
Assistant art directors: Ann Mella, Valerie Betz
Production editor: Arthur C. Miller

Editorial secretaries: Marlene Angrist, Claire Benell, Lynn Emery, Lorraine Fabry, Kay Fontana, Patricia Gardner, Lorraine Longo

McGraw-Hill News Service

Director: John Wilhelm; **Atlanta:** Fran Ridgway; **Chicago:** James Rubenstein;
Cleveland: Arthur Zimmerman; **Dallas:** Marvin Reid;
Detroit: N. Hunter; **Houston:** Robert E. Lee; **Los Angeles:** Michael Murphy, Gerald Parkinson
Pittsburgh: Louis Gomolak
San Francisco: Margaret Drossel
Seattle: Ray Bloomberg; **Washington:** Arthur L. Moore, Charles Gardner,
Herbert W. Cheshire, Seth Payne, Warren Burkett

McGraw-Hill World News Service

Bonn: John Johnsrud; **London:** John Shinn;
Mexico City: Bruce Cross; **Milan:** Ronald Taggiasco;
Moscow: Howard Rausch; **Paris:** Peter Kilborn;
Rio de Janeiro: Wes Perry; **Tokyo:** Marvin Petal

Reprints: Susan Nugent

Publisher: Gordon Jones

Electronics: March 6, 1967, Vol. 40, No. 5

Published every other Monday by McGraw-Hill, Inc. Founder: James H. McGraw 1860-1958.
Printed at 99 North Broadway, Albany, N.Y. 12207; second class postage paid at Albany, N.Y.

Executive, editorial, circulation and advertising addresses: McGraw-Hill Building, 330 W. 42nd Street, New York, N.Y. 10036. Telephone (212) 971-3333. Teletype TWX N.Y. 212-640-4646. Cable address: MCGRAWHILL N.Y.

Subscriptions are solicited only from those actively engaged in the field of the publication. Position and company connection must be indicated on orders. Subscription prices: United States and possessions and Canada, \$8.00 one year, \$12.00 two years, \$16.00 three years; all other countries, \$25.00 one year. Single copies: United States and possessions and Canada, \$1.00; all other countries, \$1.75.

Officers of McGraw-Hill Publications: Joseph H. Allen, President; Bayard E. Sawyer, Executive Vice President; Vice Presidents: J. Elton Tuohig, Operations; John R. Callahan, Editorial; Donald C. McGraw, Jr., Marketing; John M. Holden, Marketing Services; Huber M. Gemmill, Circulation; Angelo R. Venezian, Production; Robert M. Wilhelmy, Controller.

Officers of the Corporation: Donald C. McGraw, Chairman of the Board; Shelton Fisher, President; L. Keith Goodrich, Hugh J. Kelly and Robert E. Slaughter, Executive Vice Presidents; John J. Cooke, Vice President and Secretary; John L. McGraw, Treasurer.

Title © registered in U.S. Patent Office; © Copyright 1967 by McGraw-Hill, Inc. All rights reserved. The contents of this publication may not be reproduced either in whole or in part without the consent of copyright owner.

Subscribers: The publisher, upon written request to our New York office from any subscriber, agrees to refund that part of the subscription price applying to copies not yet mailed. Please send change of address notices or complaints to Fulfillment Manager; subscription orders to Circulation Manager, Electronics at address below. Change of address notices should provide old as well as new address, including postal zip code number. If possible, attach address label from recent issue. Allow one month for change to become effective.

Postmaster: Please send form 3579 to Fulfillment Manager, Electronics, P.O. Box 430, Hightstown, New Jersey 08520

Readers Comment

Nothing new under the sun

To the Editor:

In the article "Tv cameras are slimmed down to follow action on sports field" [Feb. 6, p. 103], your Tokyo regional editor described a simplified color television pickup system, made and used by NHK. One essential part of this highly and deservedly praised development effort is a lenticular plate used before the pickup television camera and preceded by a primary color strip filter or dichroic mirror.

It may be of interest that a system using a lenticular plate with a tricolor filter on the pickup side for the purpose of producing color television was published by me in August 1937, in *Television and Shortwave World*, in a paper entitled:

"A Novel Scheme for Television in Colours."

Victor A. Babits
Vice President of Research
Marshall Laboratories
Torrance, Calif.

Ancient lore

To the Editor:

At the 1967 International Solid State Circuit Conference, after having heard the problems users had with integrated circuits and large-scale integration, I recalled an ancient form of circuitry, now in disrepute, known as DCC.

In this, the user has the following building block characteristics:

Transistors

Types: PNP and NPN
Max. voltage: 300 volts
Max. current: 5 amperes

Capacitors

Range: picofarads to microfarads
Max. voltage: kilovolts

Resistors

Initial tolerance: below .1%
Range: fraction of an ohm to hundreds of megohms
Temp. coeff.: 5 ppm
Note: Resistors are linear and symmetrical

This ancient form requires a minimum investment by the user. All that is required is a workbench and a few hand tools available at the local hardware store. The building

Only from Sprague!

D to A

DIGITAL-TO-ANALOG

HYBRID D to A CIRCUITS

with precision components not found in monolithic integrated microcircuits

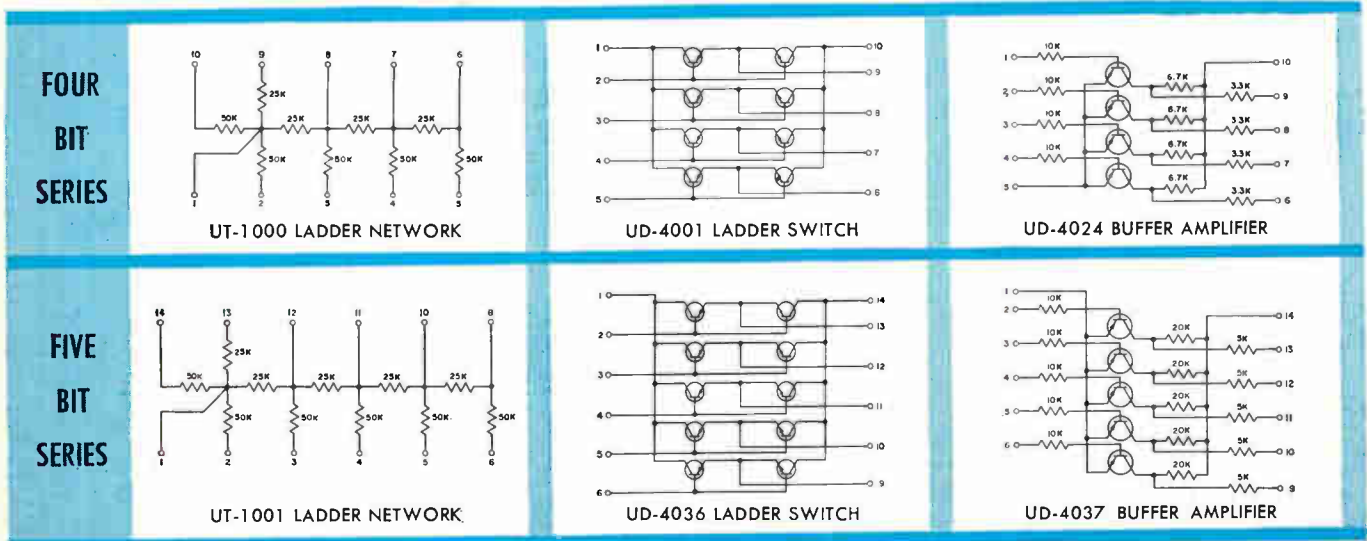

Up to 12 bits with less than 1/2 bit error!

- Silicon-base hybrid microcircuits in hermetically-sealed flat packs.
- 3 to 1 size reduction over conventional converters using discrete components.
- Improved tracking over temperature range of -55 C to +125 C.
- Reduced handling of components... fewer external connections... lower assembly costs.
- 4-bit series expandable to 8 or 12 bits... 5-bit series expandable to 10 bits.

- Combination of precision thin-film tantalum nitride resistors, nickel-chromium resistors, and active devices of planar construction.
- Packaged for compatibility with monolithic circuits.



For complete technical data on D-to-A microcircuits, write to Technical Literature Service, Sprague Electric Company, 35 Marshall Street, North Adams, Massachusetts 01247.

SPRAGUE COMPONENTS

THIN-FILM MICROCIRCUITS
INTEGRATED CIRCUITS
TRANSISTORS
CAPACITORS
RESISTORS

PULSE TRANSFORMERS
INTERFERENCE FILTERS
PULSE-FORMING NETWORKS
TOROIDAL INDUCTORS
ELECTRIC WAVE FILTERS

CERAMIC-BASE PRINTED NETWORKS
PACKAGED COMPONENT ASSEMBLIES
BOBBIN and TAPE WOUND MAGNETIC CORES
SILICON RECTIFIER GATE CONTROLS
FUNCTIONAL DIGITAL CIRCUITS



*Sprague' and '®' are registered trademarks of the Sprague Electric Co.



Introducing GR's new...

Standard-Signal Generator with a 9.5- to 500-MHz frequency range and 10-V, cw output behind 50 Ω ; or 5 V, modulated, behind 50 Ω . It has automatic output leveling *in all modes of operation* and true single-dial tuning (no trimmer adjustment needed). The generator frequency can be phase-locked to an external standard frequency. Modulation distortion is less than 3% at 80% AM. Type 1026-A Standard Signal Generator . . . \$6500.

Sweep and Marker Generator for use with GR Synthesizers. It has nine sweep speeds, from 0.02 to 60 seconds, and sweep excursion is adjustable from $\pm .001$ Hz to ± 1 MHz. Generates scope markers for quick calibration of the swept output. The synthesized center-frequency marker and side markers are accurate, stable, and precisely settable. Type 1160-P2 Sweep and Marker Generator . . . \$495.

General-Purpose Laboratory Oscillator with its full 10-Hz to 50-kHz range covered by one turn of the dial. No range switch to wear out! This also means no range-switching transients and no ambiguous dial multipliers. Generates both sine and square waves, and can be synchronized to an external signal or can supply a sync signal. Has a calibrated 60-dB step attenuator and a 20-dB continuously adjustable attenuator. Type 1313-A Oscillator . . . \$325.

Scanner System to connect up to 100 capacitors sequentially to GR's 1680-A automatic capacitance bridge. Also useful for other scanning applications. Modular construction offers great versatility in the number of input channels, number of lines switched per channel, and line termination. Preserves the three-terminal, guarded connection between bridge and unknown. Digital readout and BCD output of channel identification. Automatic, manual, or externally programmed operating modes. Type 1770 Scanner System . . . \$3500 for a typical 50-channel guarded system.

Precision Decade Transformer with 0.2 PPM linearity and easily repeatable settings to 1×10^{-9} . Lever switches for easy, in-line readout plus infinite-resolution slide wire (that can be switched out of circuit for calibration). Type 1493 Precision Decade Transformer . . . \$1100.

Other new products include the Type 1406 Coaxial Capacitance Standards and several additions to the GR874 and GR900 lines of coaxial equipment. You can see these and many other new GR instruments at the New York IEEE Show, Booth No. 2E26-2E36.

For complete information, write General Radio Company, W. Concord, Massachusetts 01781; telephone (617) 369-4400; TWX 710 347-1051.

blocks can be obtained from a wide number of interchangeable, competing sources and are so cheap that they can be stocked by the user. It gives the manufacturer a much larger value added than integrated circuits or large-scale integration and he can use his own proprietary circuit.

The designer can use DCC blocks in a wide variety of digital logic configurations. The same elements can be used for analog as well as digital applications.

The parts can be readily repaired or changed as all parts are readily accessible.

The design turnaround time can be measured in minutes rather than months.

In case the reader has not guessed it by now, DCC is discrete component circuitry.

Philip D. Goodman
Narberth, Pa.

What's the time?

To the Editor:

It seems to me there's something missing from your report on the Harris-Intertype photographic typesetter [Feb. 6, p. 34], namely: the time required to transfer the text to the magnetic tape, the time required for the computer to justify lines, and the time to convert the crt display to a metal plate.

Surely you would not have us believe that all these steps are completed in 30 seconds.

Clarence W. Metcalf
Engineered Advertising
Stoughton, Mass.

▪ The telephone company supplies its subscriber information to the printer on magnetic tape that serves as an input to the computer typesetter. In 30 seconds, the ma-

chine sets each line, justifies it, and produces a complete page on film. Making the printing plate takes a few minutes more. Formerly, the telephone company supplied subscriber names on punched paper tape that ran an automatic linotype machine. Setting a page this way took an hour and a half.

The numbers game

To the Editor:

In the article "Light touch" [Dec. 26, 1966, p. 168], you included some misinformation.

Although you are, of course, at the mercy of manufacturers' exaggerated claims about their sales, this statement of 200 cameras sold with 80% to North American manufacturers is unusual. The general consensus around this country is that Marconi has delivered about 16 cameras and there are firm orders for about 34 more. With 50 cameras ordered in the U.S., this would mean 110 cameras in Canada and since the Canadian Broadcasting Corporation has ordered none of its color yet, this seems very unrealistic.

Generally our information indicates that Norelco and RCA are about equal in color camera sales at around 300 (excluding the earlier 3-tube image orthicon cameras which are no longer being built), GE is somewhere around half this number, and Marconi sales are well below that.

Charles E. Spicer
Vice President-Engineering
Visual Electronics Corp.
New York, N.Y.

▪ Executives at Marconi Co. in London insist they have received orders for 160 Mark Seven color tv cameras from the U.S. and Canada.

**"9 years ago
we had a great
idea that put us
in the high-rel
relay business.**



**It's still a great
idea, and now
we've put it
in a one-inch
package!"**

Wedge-action* was the great idea. By combining long precious-metal contact wipe with high contact force, it gives Electro-Tec relays the highest dry-circuit confidence level ever reached. (90%, based on a failure rate of only .001% in 10,000 operations.)



Packing wedge-action into a one-inch envelope wasn't easy. But it was worth it. It gives you maximum reliability in minimum space. And it's available for both 6PDT and 4PDT operations, in relays that exceed all requirements of MIL-R-5757/1 and /7.

The one-inch relay is just one of our family of wedge-action relays, which cover almost every dry-circuit to 2 amp application. When you need a high-rel relay that really works, remember our great idea, and put it to work for you.

*U.S. Patent No. 2,866,048 and others pending.



Electro-Tec Corp.

SLIP RINGS • RELAYS • SWITCHES • OPTICS

P. O. Box 667 • Ormond Beach, Florida
(904) 677-1771 • TWX 810-857-0305

Manufacturing Facilities:
Ormond Beach, Fla. • Blacksburg, Va.

SUBSCRIPTION SERVICE

Please include an Electronics Magazine address label to insure prompt service whenever you write us about your subscription.

Mail to: Fulfillment Manager
Electronics
P.O. Box 430
Hightstown, N.J. 08520

To subscribe mail this form with your payment and check new subscription renew my present subscription

Subscription rates: in the U.S.: 1 year \$8; two years, \$12; three years, \$16. Subscription rates for foreign countries available on request

CHANGE OF ADDRESS

ATTACH
LABEL
HERE

If you are moving, please let us know five weeks before changing your address. Place magazine address label here, print your new address below.

name

address

city

state

zip code

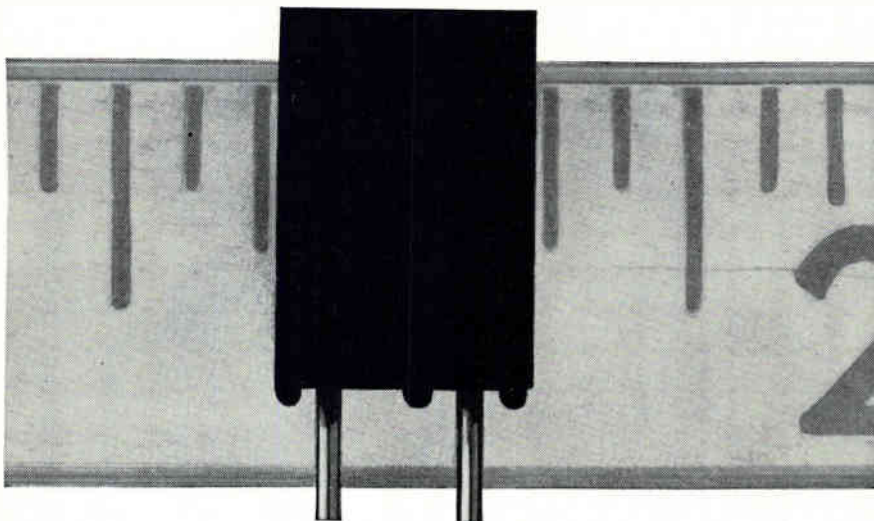

New solid tantalum capacitor for printed circuits

actual size

TIM miniatures are fully molded in a rectangular epoxy case that makes maximum use of space on printed circuit boards. Parallel leads, spaced .125". Ideal for automatic insertion.

Exceptionally stable electrical characteristics, proved by 5000-hour life test at 85°C . . . long shelf life.

Excellent performance in severe environments . . . values stay well within spec limits after 5000-hour humidity test.

One case size: .345" by .288" by .105" thick. Values from 12 mfd, 3 volts to .68 mfd, 50 volts. Temperature rating -55°C to +85°C at full voltage, +125°C at 2/3 nominal voltage.

Write for Bulletin 4-82, and for quotation. Mallory Capacitor Company, a division of P. R. Mallory & Co. Inc., Indianapolis, Indiana 46206.

See our full line of molded electrolytic capacitors at the I.E.E.E. Booth 3C11-3C17.

MALLORY

People

Northrop Corp.'s Nortronics division means to expand and intensify its efforts in inertial guidance work. It has just named **Helmut Schlitt**, an expert in the field, to the new post of director of advanced development.



Helmut Schlitt

Nortronics already has a capability in airborne digital computers, inertial platforms and gyroscopes. The division's biggest effort at the moment is for the C-5A systems.

Schlitt's plans for Nortronics go beyond the general type of work the division has been doing. "We want to become more systems oriented," he says.

Well rounded. While declining to be specific about his plans, he said they include tactical systems such as low-cost, precision navigation systems, target-location systems, and radars and doppler systems. He added that these are not necessarily all for aircraft.

Schlitt, a native of Germany, comes to Nortronics from Litton Industries Inc. He was vice president of new product technology at Litton's Guidance and Control Systems division, Woodland Hills, Calif., and was also in charge of its space science laboratory in Beverly Hills, Calif., where he directed work on plasma engines and space suits.

He holds many patents in the field of inertial guidance and is credited with development of the case-rotation concept for gyros.

In his new job, Schlitt is in charge of Nortronics' advanced avionics laboratory, the inertial systems applications group (marketing), and the commercial navigation systems group.

Although some electronic equipment makers do produce their own integrated circuits—or at least maintain an in-house capability—most still buy on the open market. But in the view of **William J. Mac-**



Here's an engineer's magazine even your wife will love

It's the *portable* chart paper magazine from our new Mark 250 Strip Chart Recorder. Now you can take the record home with you, or any place for that matter! Manual turning knobs let you roll the chart forward and back. Later, you can re-record on the same chart for side-by-side comparison. Chart take-up is automatic. And you can reload the magazine in seconds. (Many users get an extra magazine . . . study one while the other is in the recorder.)

But the world's slickest chart magazine is just one of the Mark 250's great new features. Step response over the full 4½-inch span (10% to 90%) is 40 milliseconds . . . records up to 100 cps . . . flat to 10 cps full scale! Choice of 21 interchangeable preamps. Pushbutton selection of 12 chart speeds. Crisp, clear, recitilinear presentation. Patented,

pressurized inking system. Owners say there's no other strip chart recorder in the same league.

Words just don't do it. You have to see a Mark 250 to understand why it's called "the first strip chart recorder for the perfectionists of the world." A call to your local Brush Sales Engineer brings a Mark 250 right to your office or lab. Go ahead. Even *our* wives will love you for *that*. Clevite Corporation, Brush Instruments Division, 37th & Perkins, Cleveland, Ohio 44114.



brush **CLEVITE**
INSTRUMENTS DIVISION

Did You Know Sprague Makes 32 Types of Foil Tantalum Capacitors?

125 C TUBULAR TANTALEX® CAPACITORS



- Type 120D polarized plain-foil
- Type 121D non-polarized plain-foil
- Type 122D polarized etched-foil
- Type 123D non-polarized etched-foil

ASK FOR BULLETIN 3602C

Circle 332 on readers
service card

85 C TUBULAR TANTALEX® CAPACITORS



- Type 110D polarized plain-foil
- Type 111D non-polarized plain-foil
- Type 112D polarized etched-foil
- Type 113D non-polarized etched-foil

ASK FOR BULLETIN 3601C

Circle 333 on readers
service card

RECTANGULAR TANTALEX® CAPACITORS



- Type 300D polarized plain-foil
- Type 301D non-polarized plain-foil
- Type 302D polarized etched-foil
- Type 303D non-polarized etched-foil

ASK FOR BULLETIN 3650

Circle 334 on readers
service card

TUBULAR TANTALUM CAPACITORS TO MIL-C-3965C



- CL20, CL21 125 C polarized etched-foil
- CL22, CL23 125 C non-polarized etched-foil
- CL24, CL25 85 C polarized etched-foil
- CL26, CL27 85 C non-polarized etched-foil
- CL30, CL31 125 C polarized plain-foil
- CL32, CL33 125 C non-polarized plain-foil
- CL34, CL35 85 C polarized plain-foil
- CL36, CL37 85 C non-polarized plain-foil

Circle 335 on readers
service card

RECTANGULAR TANTALUM CAPACITORS TO MIL-C-3965C



- CL51 polarized plain-foil
- CL52 non-polarized plain-foil
- CL53 polarized etched-foil
- CL54 non-polarized etched-foil

Circle 336 on readers
service card

For comprehensive engineering bulletins on the capacitor types in which you are interested, write to:

Technical Literature Service
Sprague Electric Company
35 Marshall Street
North Adams, Mass. 01248

480-5161 81

SPRAGUE
THE MARK OF RELIABILITY

Sprague and *®* are registered trademarks of the Sprague Electric Co.

People

Donald, the new president of a small Burlington, Mass., company, Film Microelectronics Inc., the number of companies with an in-house IC capability will soon rise sharply. Film Microelectronics is counting on this trend; it specializes in selling or leasing do-it-yourself hybrid IC production facilities.



W. J. MacDonald

"The threat to equipment makers without an in-house capability is that they will be contributing less and less to their own equipment as time goes on," says MacDonald, a 41-year-old engineer.

Subtractive process. The do-it-yourself approach employs printed-circuit board techniques and etching to produce a passive network of resistors and conductors. It is a subtractive process. Starting with a resistor-conductor board that has already been coated with layers of metallic material, the circuit maker selectively etches to remove the unwanted portions, leaving the desired pattern of resistors, capacitors and interconnections.

"If a device maker needs 20,000 circuits a year, or fewer, he should be using hybrids," MacDonald claims. "Development costs vary from \$100 to \$10,000 for a hybrid circuit, but it costs at least \$50,000 to develop a monolithic IC."

He sees an increasing market in commercial applications, including television and hearing aids. The company recently bid on a new device proposed for installation on the wheels of automobiles to sense motion and trigger antiskid equipment.

MacDonald got where he is because the company did not grow faster. Film Microelectronics was founded in 1964 as Mallory-Xerox Corp., a joint venture of P.R. Mallory & Co. and the Xerox Corp. Xerox quickly bought out Mallory's interest and operated the company as Electronic Films Inc. until December 1966, when it offered to sell the business to MacDonald, then chief engineer.

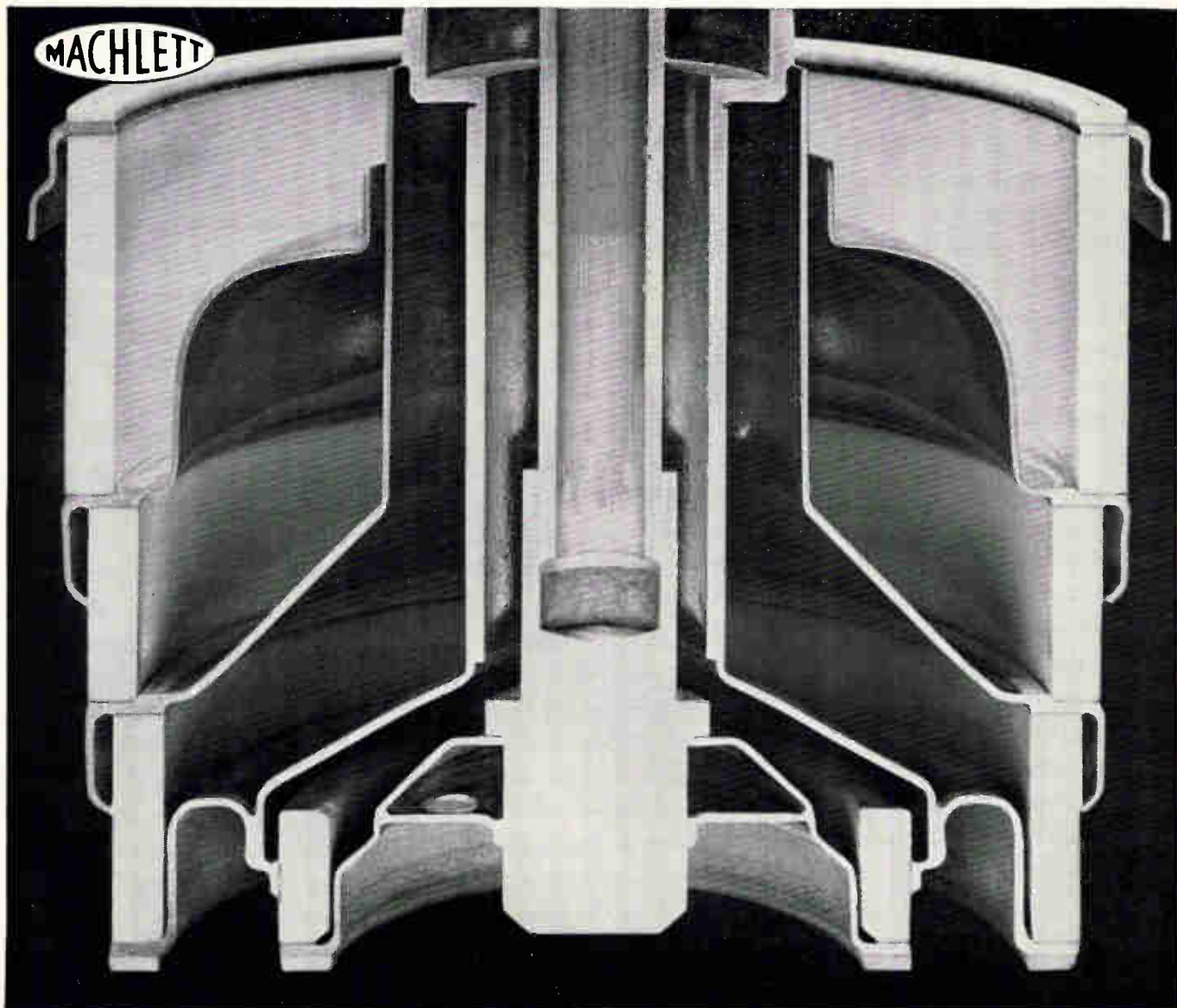

Continuous cone electrode geometry: designed into all these tetrodes only by Machlett

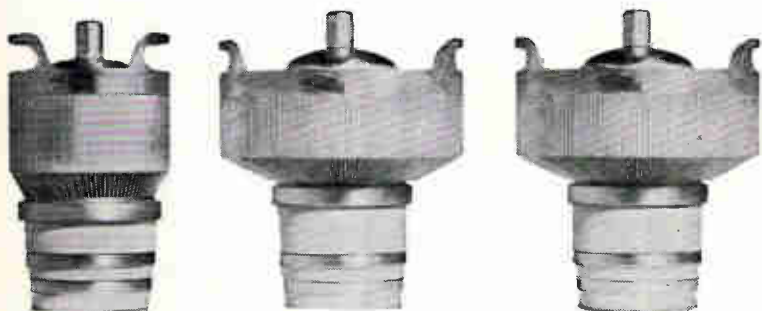

ML-8170/
4CX5000A

ML-8171/
4CX10000D

ML-8281/
4CX15000A

The result: uniform internal r.f. energy distribution and high performance stability.

Write for complete details: The Machlett Laboratories, Inc., Springdale (Stamford), Conn. 06879.

Engineers' resumes invited



THE MACHLETT LABORATORIES, INC.

A SUBSIDIARY OF RAYTHEON COMPANY



PATENT NO. 3117260: THE DIFFUSION ISOLATION TECHNIQUE

**A hundred insulated
components living
on a silicon speck.
Diffusion isolation.
Invented here.**

FAIRCHILD

SILICON DEVICES

THE HULL STORY...
ENCAPSULATION
BY TRANSFER MOLDING

**For components
like these...**



**Why do the world's
leading manufacturers*
depend on Hull
packaged systems?**

Here's why:

**RECOMMENDATIONS BASED UPON
OVER 500 INSTALLATIONS**—Since
1956, Hull has accumulated a wealth
of encapsulation know-how to guide
selection of the *right* production
equipment.

UNDIVIDED SYSTEM RESPONSIBILITY
—The Hull "package" includes
press, molds, loading frames, and
auxiliary handling equipment . . .
assuring smooth, economical flow of
production parts.

INTO PRODUCTION, FASTER, SURER
—Hull can help steer system design
for optimum encapsulation while
product is at "bread-board" stage . . .
minimizing lost motion and delays.

**LOW-COST, QUALITY PRODUCT AS-
SURED**—Hull encapsulation systems
offer a *proven* method for rapid, pre-
cise, and economical packaging of
electronic components and circuits,
large or small.

FOR MORE OF THE HULL STORY on
encapsulation by transfer molding,
write for a copy of Bulletin P963.
HULL CORPORATION, 7032 Davis-
ville Road, Hatboro, Pa. 19040.
Telephone: (215) 675-5000. Export:
1505 Race St., Phila., Pa. 19102.

*Texas Instruments, General Electric, IBM,
Motorola, Philips, Fairchild Semiconductor,
Siemens & Halske—to name a few.

Visit us at I.E.E.E. Show, Booths 1H02-1H04.



H-38

Meetings

**Symposium on the Effects of Radiation
in Semiconductor Components**, Faculte
de Sciences of the University of
Toulouse; Toulouse, France,
March 7-10.

**International Symposium on Residual
Gases in Electron Tubes and Sorption-
Desorption Phenomena in High
Vacuum**, Italian Society of Physics;
Rome, March 14-17.

National Convention, Air Force
Association; Hilton and St. Francis
Hotels, San Francisco, March 14-17.

**Temperature Measurements Society
Conference and Exhibit**, Temperature
Measurements Society; Hawthorne
Memorial Center, Los Angeles,
March 14-15.

International Convention, IEEE; New
York Hilton Hotel and Coliseum,
March 20-24.

Symposium on Modern Optics,
Polytechnic Institute of Brooklyn;
Waldorf-Astoria Hotel, New
York, March 22-24.*

Lectures on Glass in Electronics, New
York State Science of Technology
Foundation; Polytechnic Institute, Troy,
New York, March 28-29.

Photovoltaic Specialists Conference,
IEEE; Sheraton Cape Colony Inn, Cocoa
Beach, Fla., March 28-30.

**Advancing Technology & Purchasing
Management Workshop**, Institute of
Science & Technology; University of
Michigan, Ann Arbor, Mich.,
March 29-30.

**Structures, Structural Dynamics &
Materials Meetings**, American Institute
of Aeronautics and Astronautics; Palm
Springs, Calif., March 29-31.

Symposium on Microwave Power,
International Microwave Power Institute;
Stanford University, Stanford, Calif.,
March 29-31.

**Conference on the Transport Properties
of Semiconductors**, Solid State Physics
Committee of Institute of Physics;
Canterbury, Kent, England,
March 30-31.

**Rubber & Plastics Industries Technical
Conference**, IEEE; Sheraton-Mayflower
Hotel, Akron, Ohio, April 3-4.

Call for papers

**Union Radio Scientific International
Meeting**, IEEE; Ottawa, Canada, 1967,
22-25. **March 15** is deadline for sub-
mission of abstracts to George
clair, department of electrical en-
gineering, University of Toronto,
Toronto 5, Canada.

Electrochemical Society, Lumin-
cence Session; Dallas, Texas, May
12. **March 31** is deadline for sub-
mission of abstracts to Paul Gold-
General Telephone & Electronics La-
boratories Inc., 208-20 Willets Pt.
Blvd., Bayside, N.Y. 11361.

Symposium on Adaptive Processes,
IEEE; Chicago, Oct. 23-25. **April 15**
is deadline for submission of abstracts
to Lloyd Benningfield, Sixth Sympo-
sium on Adaptive Processes, Uni-
versity of Missouri-Columbia, Colum-
bia, Mo.

Symposium on Microelectronics,
IEEE; the Colony Motor Hotel,
Louis, Mo., June 19-21. **April 15**
is deadline for submission of papers;
Dr. Remo Pellin, Inorganic Chemistry
Division, the Monsanto Co., 300
North Lindberg Blvd., St. Louis, Mo.
63166.

Computer Conference, IEEE; Chi-
cago, Sept. 6-8. **April 10** is dead-
line for submission of abstracts to S.
Yau, Department of Electrical En-
gineering, Technological Institute
Northwestern University, Evanston,
Ill., 60201.

Winter Meeting, American Society
Mechanical Engineers; Penn-Sherat-
on Hotel, Pittsburgh, Pa., Nov. 12-14.
April 15 is deadline for submission
of abstracts to T.V. Sheehan, program
representative, Brookhaven National
Laboratory, 81 Cornell Ave., Upton,
N.Y. 11973.

Fall Joint Computer Conference,
American Federation of Information
Processing Societies; Convention Cen-
ter, Anaheim, Calif., Nov. 14-16.
April 17 is deadline for submission
of papers to Mr. Larson, 1967 Fall Joint
Computer Conference, P.O. Box 44,
Costa Mesa, Calif. 92627.

**Conference on High-Frequency Gen-
eration and Amplification**, Cornell Uni-
versity, Aug. 29-31. **May 1** is dead-
line for submission of abstracts to
Conference Committee, School of
Electrical Engineering, Cornell Uni-
versity, Ithaca, N.Y.

* Meeting preview on page 16

the connector thing

A periodical periodical designed, quite frankly, to further the sales of Microdot Inc. connectors and cables. Published entirely in the interest of profit.

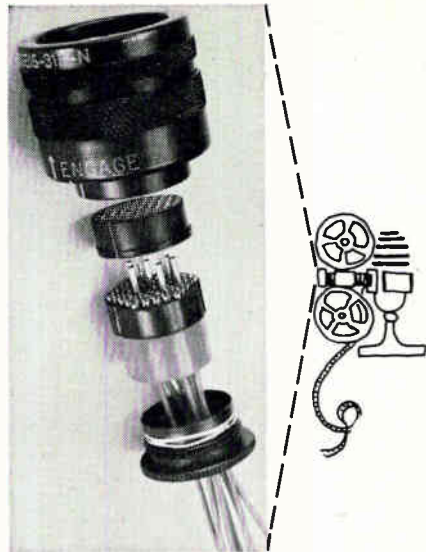
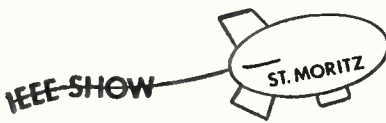

MARC 53 is the world's smallest, high-performance circular connector with as many as 61 crimp contacts in a tiny $\frac{1}{16}$ inch receptacle shell. "Posi-lock" push-pull coupling mates easily with no danger of damage and eliminates accidental disconnect. "Posiseal" guarantees an interfacial seal. The new rear-insertable version of the MARC 53 is a revolution—field assembly without special insertion or extraction tools. We will have a sound color film at the St. Moritz during IEEE which explains all about the MARC 53.

WIN

THE BROOKLYN BRIDGE!

Every March, rumblings of wanderlust begin to stir within the breast of every true electronic engineer. It is time for the IEEE convention. It is time once more to bend one's lance against the Visigoths of New York: waiters, cab drivers, mods on Bleeker Street, the maitre d' at 21, bilious brokers of theater tickets, the subway and just plain people who use words like "chic," "fabulous" and "devastating."

Really



EVERYBODY WINS

In honor of all those beautiful people, simple of soul, broad of brow, and intrepid of heart, who stem from the provinces, Microdot is offering a genuine, invalid DEED OF TRUST TO THE BROOKLYN BRIDGE printed on equally invalid parchment. Or, if you prefer, Microdot will send you a handsome, invaluable booklet entitled NEW YORK DIETARY LAWS or How to Eat Dinner at the King Henry IV Without Floating a Loan from Chase Manhattan. Nothing to do.

You only get one of these, so choose carefully. There is a way you can get both. Patient reading will tell you how.

THE BEST CONNECTIONS IN NEW YORK! (PL. 5-5800)

Microdot makes connectors, as a matter of fact, the best microminiature coax connectors in the industry. Whether you're talking about the some 6000 standard off-the-shelf items or the high density, multi-pin MARC 53, Microdot has some rather surprising answers to connector problems. Of course, some of you will not have the advantage of exposing yourselves to the invectives of the hotel clerk in the St. Moritz for the IEEE show. Don't be sad. This is what you would have seen.

LEPRA/CON is Microdot's newest ultraminiature series of coax connectors. The screw-on has an OD of only $\frac{1}{8}$ inch with a mated length of only one inch. Packaging can be reduced by as much as 50%. New versions of the LEPRA/CON include the slip-on, multi-pin and rack and panel based on the TWIST/CON concept. See below.

TWIST/CON is a concept as much as a product...the most economical microminiature pin and socket in the history of electronics. TWIST/CON permits high density packaging of contacts on .050" centers, up to 420 contacts per square inch.

There are also the Microcrimp, Golden Crimp, Mini-Noise coaxial cable and those 6000 standards we were talking about.

SEE US AT THE ST. MORITZ!

Microdot will not have a booth at the IEEE show. Instead it has set up a Bessarabian Harem at the St. Moritz, one of the finest combined inns and watering holes in the world. Here, any of you making the trek to Gotham can get all the hot Microdot news first hand. And while you are there you can pick up (free!!!!) at the St. Moritz BOTH your Brooklyn Bridge Deed and your copy of the New York Dietary Laws. By the way, we did say it was a watering hole.



MICRODOT INC.

Microdot Inc., 220 Pasadena Avenue, South Pasadena, California 91030

Dear Mr. Microdot:

- Please send me my personal Deed of Trust to the Brooklyn Bridge. I can understand people leaving Brooklyn to come to New York. But going to Brooklyn?
- Although I am a personal friend of David Rockefeller and could get a Chase Manhattan loan easily, I still want my free copy of the New York Dietary Laws.

NOTE: Only one of the above is available per person unless you visit the Microdot Pasha's suite at the St. Moritz in New York. Both will be sent only to those people who state in 25 words or less (1) why they are a hardship case and (2) why Microdot makes the best connectors in the world.

- Send me information on all those things like MARC 53 and TWIST/CON, etc. I am going to New York, but I have better things to do.

Name _____

Title _____

Firm _____

Address _____

City _____

State _____ Zip _____

MARC 53, Posi-lock, Posiseal, TWIST/CON, LEPRA/CON, Microcrimp, Golden Crimp and Mini-Noise are registered trademarks of Microdot Inc.

INTRODUCING LEMO CONNECTORS



Swiss-made LEMO connectors are precision machined like fine watches. A complete line offers you total connector capabilities in sizes from $\frac{1}{4}$ to $1\frac{1}{2}$ inches in diameter for critical applications requiring contacts up to 104 pins with multi-coaxial and power pin combinations to function under severe environmental conditions. The patented LEMO snap-latch, self-locking device—with its positive locking and easy disconnect features—is what you've been looking for. The clean functional design and competitive pricing will please you. If you use cylindrical connectors you will want engineering facts on LEMO . . . now available in the United States exclusively from Frazar & Hansen. For information, write or call for Data File H317.

 **LEMO** INC.

DIVISION OF

 **Frazar & Hansen**

150 California St., San Francisco, Calif. 94111 • (415) 981-5262

Meeting preview

Optics topics

An optical recorder that may compete with magnetic tape in certain applications, real-time holographic techniques, and a single-frequency argon laser are among the advances to be discussed at the three-day Symposium on Modern Optics to be held at the Waldorf-Astoria Hotel in New York City beginning March 22. The session is sponsored by Brooklyn Polytechnic Institute, the IEEE and the military.

The recorder is a multichannel electro-optical device for pulsed signals being developed by Columbia University's electronic research laboratory for the Defense Department. Far smaller than conventional signal-processing equipment, the recorder is designed to save hours of computing time by processing signals optically. The recorder—currently working with 24 channels—is the first to convert multichannel parallel electric signals into optical signals that can be recorded on film. Moses Arm, the Columbia lab's supervisor, says that this recording technique will be used in telemetry, communications, and medical electronics systems. The recorder will be installed in existing radar systems in early 1969.

Real-time 3-D. Techniques for producing both magnified and real-time holograms that can be viewed continuously without requiring the development of a photographic plate will also be discussed. Theoretically, the combination of the magnification and holographic techniques will produce a "holoscope"—a real-time hologram that magnifies the subject. Such a system would permit the viewing of an entire volume of material rather than just the single plane upon which the conventional microscope can focus.

Among the laser work to be discussed will be an argon laser developed for NASA by Donald Caddes of Sylvania Electronic Systems, Mountain View, Calif. It's slated for installation in an optical radar system for tracking launch vehicles. The laser employs supermode control to convert output to a single frequency; it radiates in the blue-green portion of the spectrum.



new disciplines in DC



take the **COOL** slot supplies

No need to put 'em on ice • no need for added heat sinks

All Silicon • Fully Serviceable • No Encapsulated Components

HP's new SLOT Series of DC Regulated Power Supplies have a constant voltage output, screwdriver adjustable $\pm 10\%$. Using four nuts imbedded in end plate, modules can be mounted inside instrument or on standard 19" rack panels available from hp. Barrier strip has terminals for AC input, DC output, and remote sensing.

Design insures operation to 50°C without derating or added heat sinks. Internal construction employs no cables, hand-soldered connections, or component encapsulation — units are fully serviceable. Stock models, available on a short-delivery basis, are listed below. The area below each curve at the right indicates limits of ratings available on special order.

STOCK MODELS					DIMENSIONS		
Voltage	Output Current	Package Size	Model Number	Price Qty. 1-9	Module Size	Mounting Surface	Length
6V $\pm 10\%$	0-3A	5	60065A	\$100.	2	3 $\frac{3}{8}$ " x 4 $\frac{1}{8}$ "	4 $\frac{1}{8}$ "
12V $\pm 10\%$	0-1A	3	60123A	79.	3	3 $\frac{3}{8}$ " x 4 $\frac{1}{8}$ "	6"
12V $\pm 10\%$	0-2.2A	5	60125A	100.	4	3 $\frac{3}{8}$ " x 5 $\frac{1}{8}$ "	6"
24V $\pm 10\%$	0-1A	4	60244A	88.	5	3 $\frac{3}{8}$ " x 5 $\frac{1}{8}$ "	7 $\frac{3}{8}$ "
28V $\pm 10\%$	0-1.5A	5	60285A	100.	6	4 $\frac{1}{4}$ " x 5 $\frac{1}{8}$ "	11"

Load Regulation, 0.05%; Line Regulation, 0.05%; Ripple, less than 0.006% or 1 MV RMS, whichever is greater • Transient Recovery Time, less than 25 μsec to within 10 MV • Short-Circuit-Proof, Current-Limited Output • No Overshoot on Turn-On, Turn-Off, or AC Power Removal • Operating Temperature, 0°C to 50°C ; Storage — 40°C to $+85^{\circ}\text{C}$

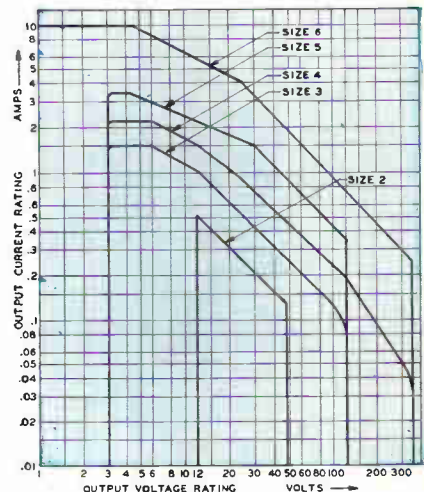

Contact your nearest Hewlett-Packard Sales Office for full specifications.

**HEWLETT
PACKARD**  **HARRISON
DIVISION**

100 Locust Ave., Berkeley Heights, New Jersey 07922 • Telephone 201-464-1234 TWX 710-984-7972

NEW



SOLID STATE TIMER

CA100

YOUR GREATEST CHOICE

NEW



ELECTROMECHANICAL DUAL-FUNCTION TIMER

HG100

The Man from E.A.G.L.E.* presents two samples that show the range in his bag of timing tricks. The CA100 solid state timer provides split-second control of continuous, high-speed, "on-off" cycles from 3 to 2000 times a minute. Housed in Eagle's famous Cycl-Flex case, the CA100 can be plugged in and taken out in seconds. Solid state circuitry eliminates moving parts, makes this timer great for dusty, dirty locations. At the other extreme the HG100 electromechanical dual-function timer does the job of two ordinary timers. With a single, easily-set dial it provides adjustable "on" and "off" time periods for cycles ranging from 30 seconds to 60 hours. It gives you unmatched ease of adjustment without setting cams or changing gears.

For detailed descriptions of one or both of these timers, get our CA Series Bulletin 322 and our HG Series Bulletin 320. Write Eagle Signal Division, E. W. Bliss Company, 736 Federal Street, Davenport, Iowa 52808; or call (319) 324-1361.

BLISS  **EAGLE SIGNAL**

A DIVISION OF THE E. W. BLISS COMPANY

*E.A.G.L.E.—Engineering Assistance Given Locally—Effectively.

Visit With the Man From E.A.G.L.E. at March IEEE Show, Booth 4G36-4G38

For information on CA100 Timer circle reader service number 18.

For information on HG100 Timer circle reader service number 19.

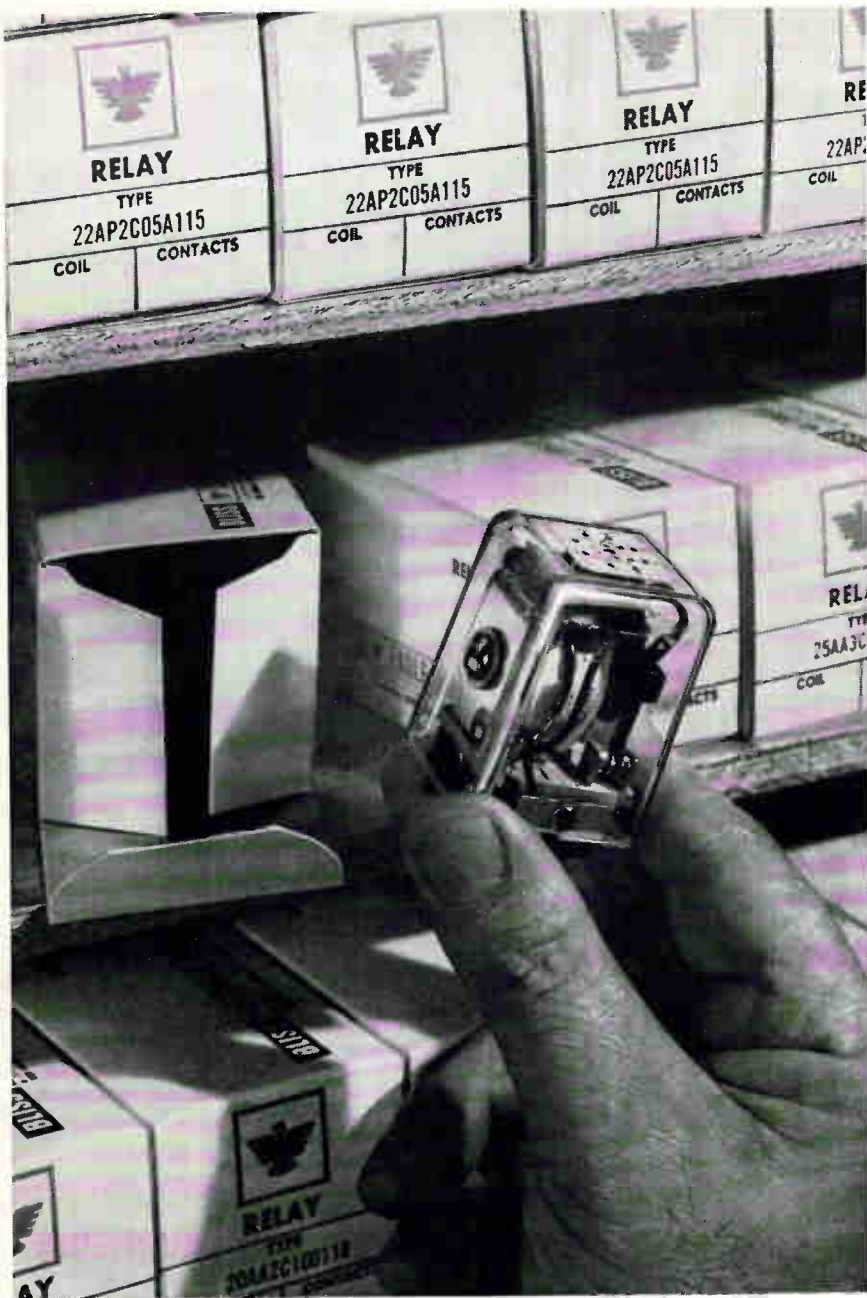

INSTANT EAGLE RELAYS

***Test Them Immediately...
Get Production Quantities in Two Weeks!***

That's right . . . Eagle challenges you to compare them with any relay on the market. NOW you can get immediate delivery on these general-purpose or medium-power relays. Test results prove they're the finest of their kind in the world. Eliminate your relay delivery problems. Call your "Man from E.A.G.L.E.". . . listed at the right. You'll find he has full details and specifications on Eagle relays.

BLISS  **EAGLE SIGNAL**

A DIVISION OF THE E. W. BLISS COMPANY
736 Federal Street, Davenport, Iowa

Visit With the Man From E.A.G.L.E. at March IEEE Show, Booth 4G36-4G38

YOUR "MAN FROM E.A.G.L.E."

Distributors

Burlingame, California
415-697-6244
Glendale, California
213-245-1172
Englewood, Colorado
303-781-0912
Hamden, Connecticut
203-288-9276
Orlando, Florida
305-855-3964
Baltimore, Maryland
301-484-5400
Newton Highlands, Massachusetts
617-969-7140
Minneapolis, Minnesota
612-922-7011
Clifton, New Jersey
201-471-6090
Haddonfield, New Jersey
609-429-1526
Albuquerque, New Mexico
505-265-1020
Albany, New York
518-436-8536
Depew, New York
716-684-5731
Endwell, New York
607-723-8743
Fairborn, Ohio
513-878-2631
Fairview Park, Ohio
216-333-4120
Dallas, Texas
214-363-1526
Houston, Texas
713-649-5756
Seattle, Washington
206-725-7800

Representatives

Scottsdale, Arizona
602-947-4336
Pasadena, California
213-681-4421
Jacksonville, Florida
305-388-7656
Orlando, Florida
305-422-4295
Roswell, Georgia
404-993-6498
Chicago, Illinois
312-775-5300
Chicago Illinois
312-784-7314
Baltimore, Maryland
301-276-1505
Norwood, Massachusetts
617-769-3600
Minneapolis, Minnesota
612-922-0243
St. Louis, Missouri
314-428-5313
Hackensack, New Jersey
201-342-2602
Latham, New York
518-785-5032
Rochester, New York
716-436-4410
Skaneateles, New York
315-685-6172
Fairfield, Ohio
216-333-4120
Havertown, Pennsylvania
215-528-6640
Dallas, Texas
214-748-7788
Houston, Texas
713-224-9715
Bellevue, Washington
206-454-5200
Charleston, West Virginia
304-342-2211



Five new complex-function ICs . . .

Cut costs, simplify designs and improve reliability . . . use these new Texas Instruments Series 74 TTL integrated circuits in your digital electronic systems.

Cut costs two ways. First, you pay less per circuit function than when buying conventional ICs. Second, you save on connectors, circuit boards, inventory, and assembly costs . . . since fewer packages and less area is required. Net result . . . you can often realize over-all savings in excess of 50 percent!

You simplify designs because TI has already done a lot of the work for you. These devices, which are fully compatible with

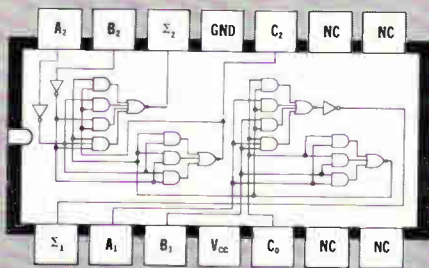

SN7482N DUAL ADDER

- Cost savings of 26% over two single IC adders.
 - 15 nsec serial carry through both additions.
 - Provides the Σ₁ of A₁ and B₁, and the Σ₂ of A₂ and B₂, including appropriate carry manipulations.
- Circle 497 on Reader Service card for data sheet.

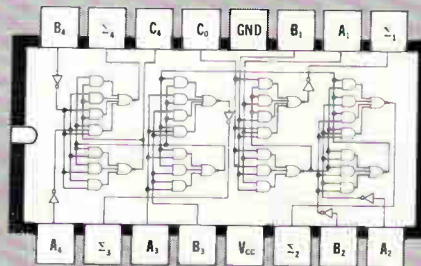

SN7483N QUAD ADDER

- Saves 41% over four single IC adders.
 - 30 nsec serial carry through four additions
 - Provides the Σ₁ of A₁ and B₁, the Σ₂ of A₂ and B₂, the Σ₃ of A₃ and B₃, and the Σ₄ of A₄ and B₄, including appropriate carry manipulations
- Circle 498 on Reader Service card for data sheet.

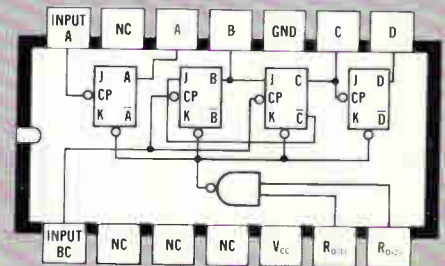

SN7492N DIVIDE-BY-12 COUNTER

- Saves 19% over four separate IC flip-flops and gating.
 - Operates at 15 MHz.
 - Frequency divides by twelve, six, three, or two.
 - Simultaneous independent operation of divide-by-six and divide-by-two sections.
- Circle 499 on Reader Service card for data sheet.

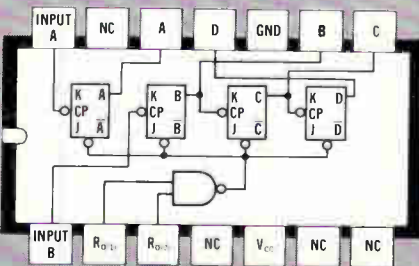

SN7493N FOUR BIT BINARY COUNTER

- Saves 16% over four separate IC flip-flops.
 - Operates at 15 MHz.
 - Ripple through operation provides frequency division by sixteen, eight, four, or two.
 - Simultaneous independent operation of divide-by-eight and divide-by-two sections.
- Circle 500 on Reader Service card for data sheet.

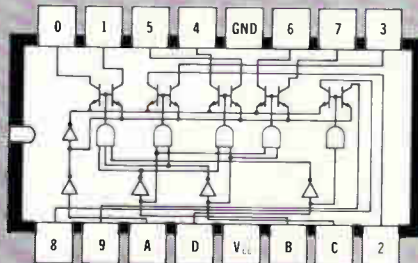

SN7441N BCD-TO-DECIMAL DECODER/DRIVER

- Saves 23% over separate IC decoding circuits and driver transistors.
 - High-voltage output (65 volt guarantee) transistors directly drive gas-filled readout tubes.
 - BCD inputs provided for use with SN7490N decade counter.
- Circle 501 on Reader Service card for data sheet.

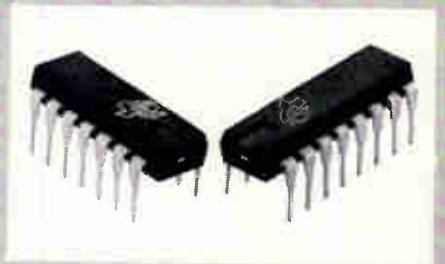

MOLDED PLUG-IN PACKAGES

All Series 74 TTL integrated circuits—including these five new complex functions—are available in TI's popular molded plug-in package. A new 16-pin configuration (right) is provided for circuits requiring more than 14 pins. Both packages have pins located on standard 100-mil centers. These packages provide highest reliability and greatest ease of handling at lowest possible cost.



Find out how TTL complex-function integrated circuits from Texas Instruments can fit into your programs. Ask your local TI Sales Engineer, or write us at P.O. Box 5012, Dallas, Texas 75222

here's how they can work for you!

all other Series 74 integrated circuits, will enable you to develop new systems faster, at reduced expense.

You also improve system reliability — because the increased circuit complexity per package means fewer soldered joints and plug-in connectors.

How can these new TI complex-function ICs work for you? For illustration, we have designed the frequency-measuring subsystem shown below, and compared it with a similar subsystem using conventional ICs. The savings realized here will give some idea of what you may expect.

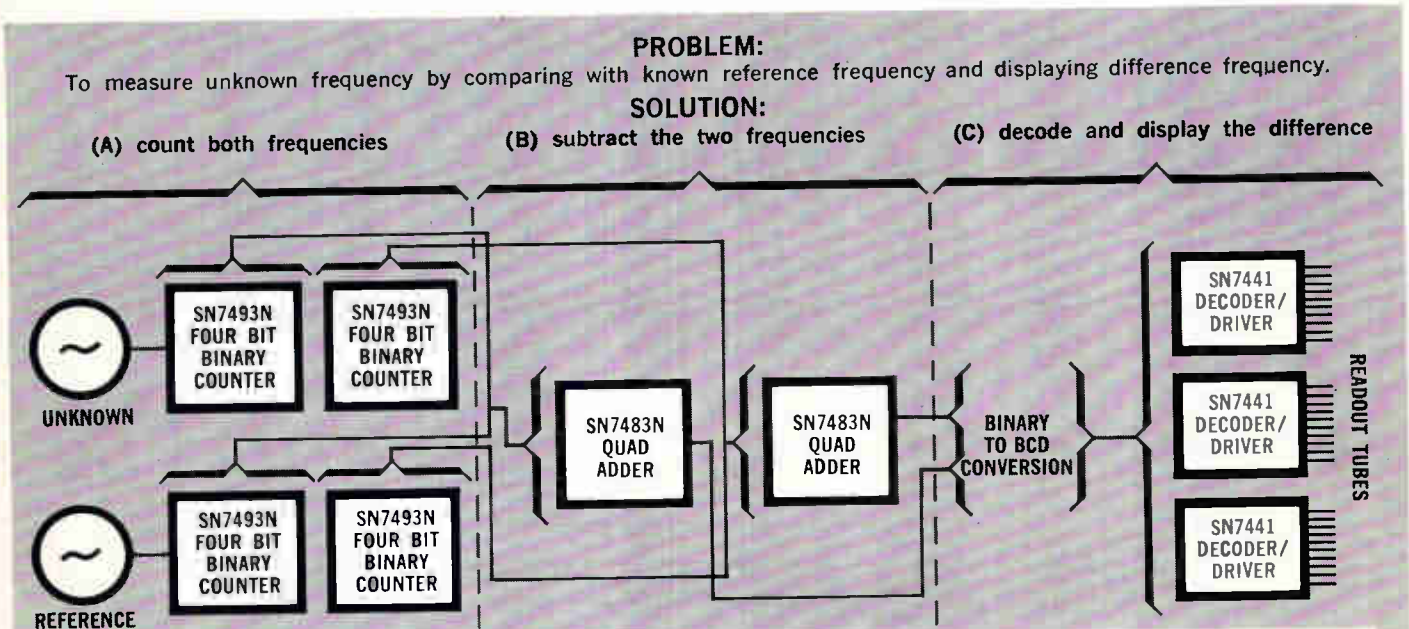

With new TI complex-function integrated circuits:		
<p>YOU SAVE...</p> <ul style="list-style-type: none"> 16% in IC costs 75% in number of packages 168 soldered connections 	<p>YOU SAVE...</p> <ul style="list-style-type: none"> 19% in IC costs 87% in number of packages 178 soldered connections 	<p>YOU SAVE...</p> <ul style="list-style-type: none"> 23% in IC and transistor costs 93% in number of packages 196 soldered connections
HERE'S HOW...		
With new TI complex-function integrated circuits, you require:		
<ul style="list-style-type: none"> Four SN7493N four bit binary counters 56 pins are to be soldered 	<ul style="list-style-type: none"> Two SN7483N quad adders connected to subtract 32 pins to be soldered 	<ul style="list-style-type: none"> Three SN7441N BCD-to-decimal decoder drivers 48 pins to be soldered
With conventional integrated circuits you would require:		
<ul style="list-style-type: none"> 16 single flip-flops 224 pins to be soldered 	<ul style="list-style-type: none"> 12 quad two-input gates 2$\frac{2}{3}$ triple three-input gates 210 pins to be soldered 	<ul style="list-style-type: none"> Three dual four-input gates Six triple three-input gates 1$\frac{1}{2}$ quad two-input gates 30 driver transistors 244 pins to be soldered

TEXAS INSTRUMENTS

INCORPORATED



From RCA "overlay" first high-reliability RF-power transistors available off-the-shelf

RATINGS FOR RF SERVICE				
	40305	40306	40307	Units
V _{CB0} (max)	65	65	65	Volts
V _{CEV} (max)	65	65	65	Volts
V _{CEO} (max)	40	40	40	Volts
I _c (max)	1.0	1.5	3.0	Amperes
P _{OUT} (min)	2.5W @ 175 MHz	7.5W @ 100 MHz	13.5W @ 175 MHz	

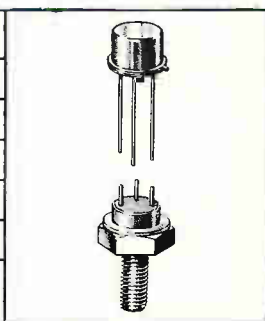

RCA, originator of the revolutionary "overlay" technique, introduces another new concept in rf-power transistors... high-reliability units *available off-the-shelf*. Designed primarily for critical aerospace and military high-frequency applications, RCA 40305, 40306, and 40307 transistors go beyond the high standard of reliability established by RCA "overlay" to assure a new level of confidence... confidence for those designs where device failure cannot be tolerated.

Available now, these three "overlay" transistors drastically reduce the time and effort normally demanded by hi-rel specs... response time is kept to minimum with no delivery problems. And because they are part of a formal RCA high-reliability program, the high cost of "customizing" is eliminated.

Electrically similar to RCA types 2N3553, 2N3375, and 2N3632, these hi-rel devices are designed to

meet MIL-S-19500. (Hi-rel selections of "overlay" types 2N3733, 2N4012, and 2N4440 are also available.) Each transistor is subjected to strictly controlled pre-conditioning tests including:

- Fine Leak, 1×10^{-8} cc/sec/max.
- Gross Leak, 70 psig, 16 hours min.
- Acceleration Test (2006 of MIL-STD-750, 10,000 G, Y₁ axis)
- Temperature Cycling (MIL-STD-202)
- Power Age (168 hours)
- X-ray Inspection, RCA Spec 1750326

For more information on RCA's "overlay" high-reliability capability, consult your RCA Representative. For technical data on 40305, 40306, and 40307, write: RCA Commercial Engineering, Section IN3-1, Harrison, N.J. 07029.

ALSO AVAILABLE FROM YOUR RCA DISTRIBUTOR

RCA Electronic Components and Devices



The Most Trusted Name in Electronics

Circle 22 on reader service card

Editorial

Credibility gap in hiring

There are more job openings for electronics engineers than there are engineers available and seeking to fill them. That's the conclusion of Electronics' annual survey of employment which begins on page 211. To hear the recruiters tell it, a good engineer with the right specialization can pick a top notch spot anywhere in the country.

But the survey produced one alarming note: fewer and fewer engineers believe what companies tell them about their jobs and their futures. In spite of—or maybe because of—the tantalizing descriptions in advertisements that would have applicants believe that the job is the way to wealth, power, prestige, and paradise, a credibility gap has opened. One executive of a personnel agency reported that some of his engineer applicants were insisting that companies guarantee the jobs will still exist in a year.

The disenchantment with what recruiters promise is part of a bigger picture of business's sagging reputation. Not too long ago, a study at Harvard University concluded that the brightest undergraduates don't want to work in private industry. The students associate industry with some distinctly distasteful characteristics, mainly exaggerated advertising whose claims are overstated or overdramatized, products that are delivered new but in unworkable condition, and unfulfilled promises of services. So, instead, they seek jobs at nonprofit foundations or in government agencies. An IBM executive complains that his company can't hire the cream of a college graduating class because the top students prefer nonindustrial work.

Fear of being drafted has caused some young engineers to go to work in industry when they preferred other work, but clearly their motivation is the poorest possible.

Unhappily, a lot of companies have earned this distrust. They have hired willy-nilly for a short-term project, completed the work, and promptly laid off the engineers. Then they've gone out and hired a batch of new technical men for a new project. Or a few companies have stockpiled engineers on the chance that they would receive a big contract. When the project went to another

company, they promptly dumped the engineers they had so recently hired. Practically none of these defense-business-oriented companies were interested in cultivating long-time engineering employees, training engineers to keep pace with technology, or planning growth to build a solid enterprise.

Too often, a company has jumped on a technical fad, hired a lot of engineers to pursue it, then discovered the company had no management or marketing ability in this area so the executives closed down the entire new operation, throwing the engineers onto the street without warning.

At too many companies engineers have become expendable, like paper clips, staples, and typewriter ribbons. Now management is beginning to pay for this sloppy attitude and haphazard hiring practice.

Not enough companies can boast, as Hewlett-Packard Inc. did in an advertisement last month, that it has never had a layoff. Steady employment has not come easy to this progressive and profitable instrument company. It takes careful planning, painful patience, intimate knowledge of technical trends, aggressive product planning, and superb management. The company may have missed participating in one or two technical areas because its management couldn't be sure the developments wouldn't be just passing fancies, but it is represented in most of the important product lines.

The credibility gap makes hiring more difficult, but there is even a more important aspect that should concern the industry. If an engineer doesn't trust a company enough to go to work for it, will he trust its products in a critical application that could cost him his job? The answer clearly is no.

Thus electronics companies have several urgent reasons to improve their reputations—and quickly. The best method is not with a public relations campaign to improve the image, a favorite ploy in the 60's. What's needed are realistic hiring practices, a business-like approach to planning the company's future, a willingness to train the company's technical people so they can keep pace with technological advances, and a determination to tell the truth about job prospects, product performance, and the company's future.

Some electronics companies have already reached the point where they cannot hire good engineers because their reputations are so bad and they have trouble selling their products. Unchecked, the credibility gap can sink a company.

They've just been approved as Automatic Direction Finding antennas on the new supersonic jets where high skin temperatures demand an antenna with a high Curie point coupled with low loss characteristics at high frequencies.

They are used on submarines where low frequency signals demand high permeability, low loss, and the ability to operate over a wide range of temperatures.

Both these ultra-sophisticated antennas are made from the same Indiana General

ferrite material. Our Ferramic® O-5.

This versatile material is the preferred antenna material in practically every type of application. It exhibits high permeability, a high Curie point, low loss and maintains these characteristics over a frequency range up to 400 KHz. It can be fabricated in practically any antenna configuration from the smallest rods to plates a foot or more in length. This is one more example of the newest uses of ferrites in an ever-widening range of industries.

Our engineering department is perhaps the most knowledgeable in the industry in the application of ferrite materials to antenna designs. Their experience is available to you. So is literature on our O-5 ferrite and a complete set of ferrite information sheets. Just write Mr. K. S. Talbot, Manager of Sales, Indiana General Corporation, Electronics Division/Ferrites, Keasbey, N.J.

INDIANA GENERAL 

**Our new ferrite antennas can follow
faint radio signals just about anywhere.**



Electronics Newsletter

March 6, 1967

Litton plans two computers with MOS arrays

Litton Industries is designing two experimental computers based on large-scale arrays of metal oxide semiconductor integrated circuits. Both are in the early stages of development; the more advanced design has recently received financial support from the Air Force.

One machine is essentially a complex of digital differential analyzers that can perform such limited tasks as solving for trigonometric functions. Designed for aircraft navigation, it could be applied to automatic tool control. The other machine, planned as either a backup or replacement for the differential-analyzer unit, uses MOS arrays to perform logic and memory functions. Its design, more advanced and more along the lines of a general-purpose computer, could be expanded to handle target recognition or fire control.

Both designs depend heavily on the development of highly reliable, easily reproducible MOS arrays. Litton has asked Philco-Ford and General Instrument to prepare experimental circuits.

The two circuit makers are acting as consultants to Litton. Both received specifications for the production of a limited quantity of test arrays designed to be quickly tested with a single probe. Litton's plan is to determine quickly the expected yield (the number of usable functions on an array) that will result from the still-infant MOS technology.

For the more advanced machine, called a block-oriented computer, Litton engineers haven't decided whether to use single or two-layer metalization to interconnect the circuits within the wafers.

The major reason for turning to the MOS arrays is reduction in cost, size, and power needs. It's estimated that the price of a production-model MOS computer would be about a tenth the cost of a computer using bipolar devices; the size would be reduced by a factor of 5 to 10 and the power needs would be cut by a factor of from 100 to 1,000.

Scr's power rises but prices hold

The power-handling capability of low-cost silicon controlled rectifiers is continuing to rise, making them more attractive for use in consumer appliance. Motorola Semiconductor Products has just introduced an 8-ampere, 600-volt scr—one of a series of four plastic-encapsulated types. The scr's, 2N4441 through 2N4444, are rated at 8 amperes root-mean-square forward current and have blocking voltages ranging from 50 to 600 volts. Typical gate current is 10 milliamps. In quantities over 100, they cost from 80 cents to \$3. General Electric's C106 series of plastic-encapsulated scr's cost about the same. However, the highest power unit in GE's line, which has probably had the giant share of the consumer scr market, is rated at 2 amperes, 300 volts.

Patent reform hits a snag in court

Just as the Administration's patent reform bill was being sent to Congress late last month, a Federal court handed down a ruling that threatens to stir up a new controversy over patent jurisdiction.

The bill, containing sweeping proposals to end the long and costly court battles, calls for ultimate jurisdiction by a regional court. But the U.S. Court of Claims, ruling in behalf of Technograph Printed Electronics, said a patent judged invalid in one court case can be brought up in another case.

Technograph, whose main business is to exploit its patents and licenses,

Electronics Newsletter

had lost its battle for back royalties on printed circuits from Bendix [Electronics, Nov. 2, 1964, p. 23]. Now the firm has been given the green light to sue the Government, as purchaser of circuits, and others over the same patents as in the Bendix case. Outlook: the controversy is likely to embroil the Supreme Court as well as Congress.

Peak laser pulses top billion watts

Peak powers greater than a billion watts have been achieved with an experimental two-stage Raman-effect laser that uses reverse pumping. The work, done at Gaithersburg, Md., by the International Business Machines' Federal Systems division, has produced pulses as short as $\frac{1}{2}$ nanosecond. Although the in-house effort is a long way from application, IBM believes an optical system based on the development could enable precise tracking of orbiting spacecraft.

FAA will test "inexpensive" anticollision unit

A new proximity-warning system, designed by the National Co. of Melrose, Mass., will be flight-tested this spring by the Federal Aviation Administration. The system is being considered for use by planes flying the North Atlantic routes.

National's design is hardly a full-fledged collision-avoidance system, but it can warn a pilot if another aircraft comes within 60 nautical miles in any horizontal direction and within 1,500 feet in either vertical direction. It'll cost considerably less than the estimated \$50,000 unit price of a collision-avoidance system, which would use either cooperating ground stations or highly accurate time-frequency techniques.

With an expected accuracy of within 1 mile, the National system is adequate to maintain safe separation between planes flying over the ocean. For the dense overland routes, better accuracy is needed.

Production woes beset Philco-Ford

Though it is not yet out of trouble with its integrated-circuit calculator (see story on p. 31), the Santa Clara, Calif., operation of the Philco-Ford Corp.'s Microelectronics division has a new worry with one of its major programs in bipolar integrated circuits. Because of production difficulties, the plant has been temporarily suspended as a qualified source on the National Security Agency's classified R-13 program. Santa Clara was making milliwatt resistor-transistor logic for the project. According to insiders, unless the suspension is lifted, the plant will have to lay off a large percentage of its 1,200 employees. Although Philco-Ford executives have admitted having a problem, they say no layoff is now planned. Nearly 60% of Santa Clara's output is in bipolar IC's.

The troubles are in the deposition of aluminum metalization. If the suspension on the Santa Clara plant continues, Philco-Ford will shift all its bipolar production to a sister plant in Lansdale, Pa., which currently is also producing circuits for the security agency project. Ironically, Philco had wanted to switch bipolar production there a year ago, but the agency opposed the idea.

Transit bids

The Westinghouse Electric Co. was the apparent low bidder for the train control and communications portion of the San Francisco area's rapid-transit system. The bid, for \$26.2 million, must now be studied to make sure it meets specifications. Official word is expected March 23.

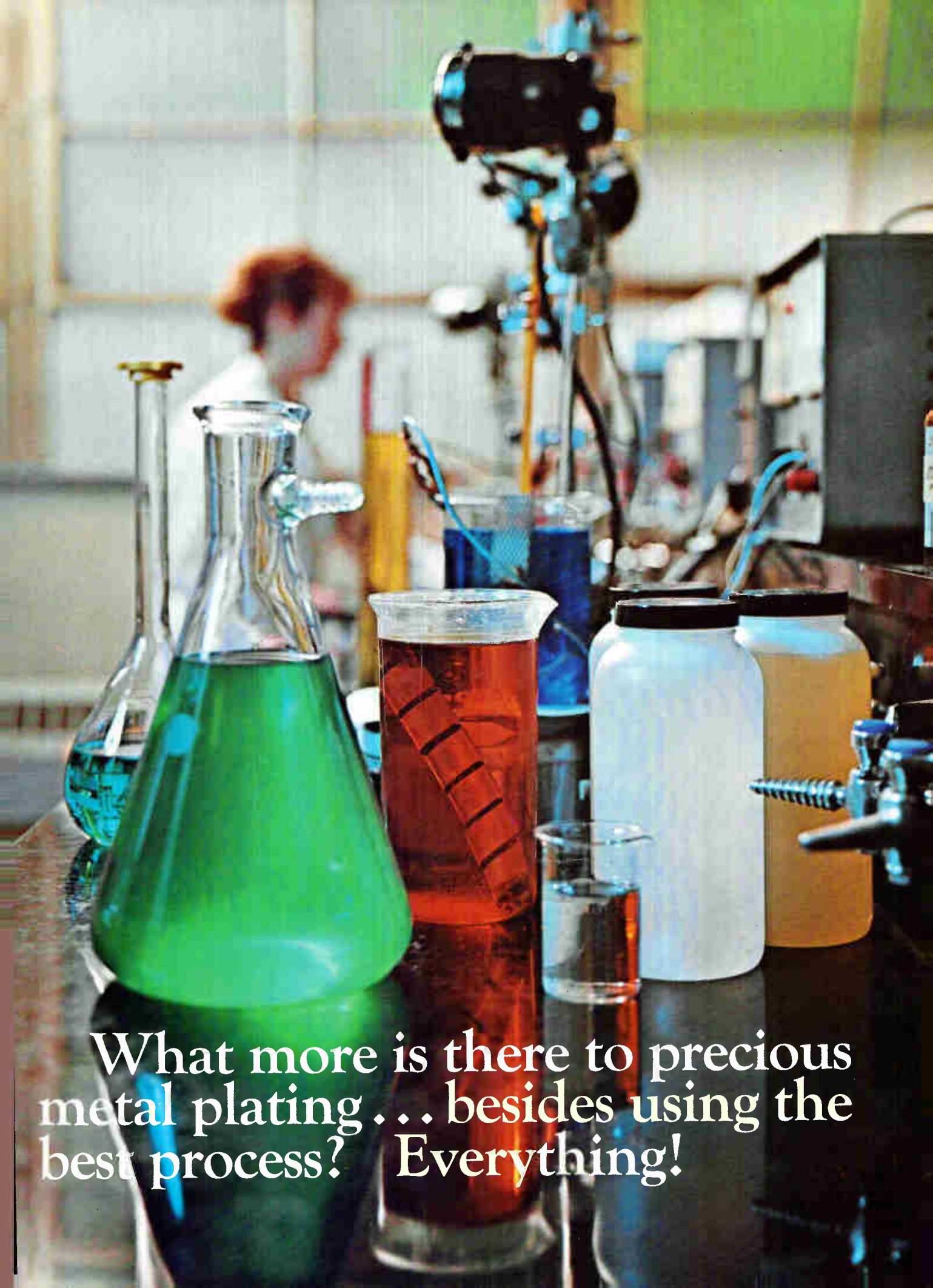

What more is there to precious metal plating... besides using the best process? Everything!

“We don't disappear once we sell you the process.”

If precious metal electroplating could be learned from a set of textbook rules, half the need for service would vanish.

But since electroplating is a dynamic, living thing, a blend of skill and science, optimum results depend on more than just a process.

That's why Sel-Rex offers a “total approach”. One that guarantees consistent reliability. Maximum production.

Such an approach *starts out with* the best process for your product. (Sel-Rex probably has the best process for you because Sel-Rex has the greatest number of precious metal electroplating processes.)

And if we don't have a process that's just right for you, we'll develop one.

You'd expect that from the company that developed the first bright gold, the first acid gold, and the first non-cyanide gold processes for industry.

Prototype Plating Service

Bring us your product, and we'll conduct process studies for you aimed at satisfying your specifications. (Last year we were involved in evaluating *over 5000* high-reliability electroplating applications.)

Whether you have an in-plant plating operation or a job shop, we'll help you select a process and we'll run a sufficient number of samples to prove out the process.

We'll recommend the proper type of plating equipment, supply it if you need

it, provide information on plating procedure and process control, and offer technical information on the maintenance of the bath.

If you've re-designed a product and it's not going through the cycle properly, our prototype plating service will check it out for you.

Or if your product can't be plated with standard equipment, we'll help design new equipment for you—just as we designed the special type of plating barrel that made transistor plating a routine operation.

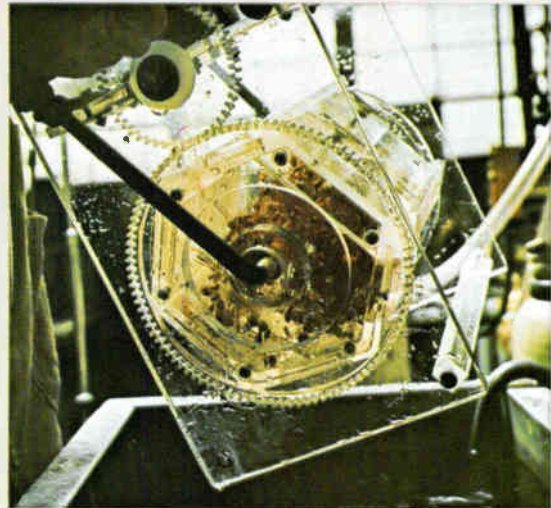

Matter of fact, the Meaker Company (a Sel-Rex subsidiary), is responsible for many widely-accepted advances in rectifier and control circuitry, and in manual and automatic equipment design. A number of these are still exclusive with us.



Preventive Maintenance

Once you're set up and running, we'll help you continue running properly—with preventive maintenance.

We'll backstop your control procedures in our analytical labs.

Every month we'll double-check samples from your plating baths with our direct emission spectrograph *and* our X-ray spectrograph. (In about 2½ minutes we obtain analyses of 22 elements in your sample.) We also check for non-metallic constituents, efficiency and other physical values.

Within 48 hours of receipt of your sample, we'll put our analysis in the mail to you. If the sample reveals less than optimum conditions, we'll offer recommendations for improving the bath's plating performance.



Research for your needs

While all this is going on, we'll also serve you indirectly through continuing research; and we'll make available to you the results of our new knowledge.

Our research spans the full spectrum from extremely high purity gold deposits to the relatively unexplored areas of low karat gold.

For example, we've developed several low karat gold alloy processes that perform the same functions, at lower cost, in certain applications, as high-karat deposits.

And though we're best known for our work in gold, we've made and continue to make significant contributions in rhodium, silver, platinum and palladium plating.

The final step

One other thing. If you use precious metal, you are bound to generate scrap. When we handle your scrap salvage, you can be sure of a complete refinery service with full technical facilities. Including, under one roof, a fire assay laboratory, instrumentation laboratory, and laboratory facilities for wet chemical analysis and electrolytic methods of analysis.



Fact is, when it comes to research and technical service, Sel-Rex has more people involved than anyone else in the field.

Any questions?



Sel-Rex specialists share their knowledge with you.

If you run into a particularly unusual or difficult situation, you can turn to the staff at Sel-Rex's central headquarters—the greatest concentration of know-how in the precious metals plating field.

This staff represents a totality of diverse experience that ranges from the purely theoretical to the highly practical.

They've provided answers to just about every question that's ever been asked...so they probably know the answer to most any question you might ask.

But quite often you need a plating specialist close at hand. Therefore, in order to make service more convenient, we've divided the U. S. into major areas, and have placed a man in each of them, close to your plant.

These specialists back up our field men, who are excellent technicians themselves and represent our first line of service.

Which means that wherever you are, there's someone within hailing distance who can supply technical advice. Immediately.

If your product involves precious metal electroplating, find out what Sel-Rex service can mean to you. Write to us about your specific requirements. We can be of help. Address: Sel-Rex Corporation, Nutley, New Jersey 07110.



We keep some powerful experiments quiet.



Fuel cells don't have to be noisy.

We developed one for the Army that you can't hear only 100 feet away. This 300-watt cell should produce 28 VDC for more than 1000 hours without special attention.

Yet, complete with cell stack, blower, pump, starter and voltage regulator, it weighs only 30 lbs.

Fuel cells are the lightest, most effective, non-mechanical devices yet discovered for generating electric power.

We make them in all sizes.

But fuel cells are only one of the activities that keep Union Carbide up front, on the frontiers of electronics. For instance, among other things, we're leaders in research, development and production of single crystals and crystal products; solid tantalum and foil-film capacitors; laser systems and accessories; solid state devices.

These are among the reasons to think of Union Carbide for help before your projects get beyond the talking stage.



ELECTRONICS

Union Carbide Corporation, Electronics Division, 270 Park Avenue, New York 10017.

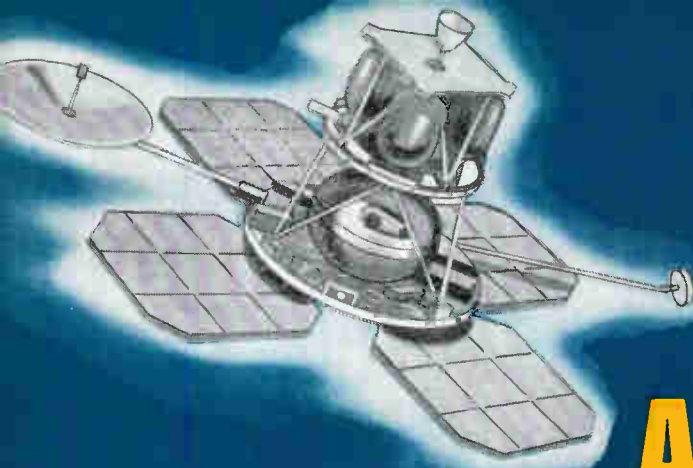

G/M COMPONENTS have proven to be superior in function and reliability of operation in thousands of military, space and commercial applications, including aircraft automatic flight control, guidance, weapon systems, fire control, missile and space vehicle flight and stabilization control, pressure volume-temperature control of gases and liquids. They conform to MIL T 27 and MIL E 5400 specifications, and provide a ready solution to problems involving solid state—integrated or micro circuit— analog computer design. Call or write for Bulletins.

Analog Computing

Magnetic Division Modules

ACCURACY OF 1% OR BETTER!



FEATURES:

- Micro-miniature Size
- Completely Solid State
- Low Power Consumption
- Wide Numerator and Denominator Ranges

REQUEST BULLETIN MM 110

These Analog Division Modules employ a concept which eliminates high gain operational amplifiers and logarithmic circuitry used in electronic dividers. The result is fewer components, excellent stability, micro-miniature size, lower cost. The combination of magnetic and semiconductor circuitry results in analog division accuracy of 1% or better.

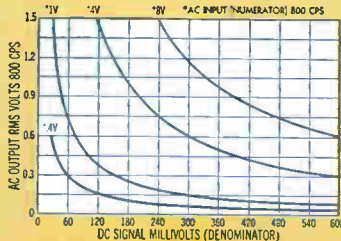

NANO AMP LEVEL

Current Sensing Magnetic Modulator

ULTRA LOW LEVEL—HIGH STABILITY!



This G/M extremely low level signal current magnetic modulator operates from 0 to $\pm 1 \mu$ a DC full scale with a frequency response of 0 to 100 cps minimum for a carrier excitation of 400 cycles. Excellent zero point, amplitude and phase angle stability with respect to line voltage, frequency and temperature range.

- Wide Frequency Response (over 100 cps)
- 0 to 1μ a DC Full Scale Input
- Drift: Less than 10 Nanoamps referred to Input Terminal
- Input Resistance 1 Megohm
- Complete Solid State Magnetic
- Rugged, Unlimited Life

FEATURES:

Magnetic Demodulators

HIGH RELIABILITY—SMALL SIZE!



The new G/M Magnetic Demodulator is a solid state circuit for converting phase reversing AC signal voltages into phase detected polarity reversing DC voltages. The amplitude and polarity of the DC output are directly proportional to the phase and amplitude of the AC signal. High reference impedance results in very small reference power requirements.

FEATURES:

- Output as High as ± 10 v. DC in Present Units
- Very Low DC Offset Null Voltages (As low as 0.1% of full scale)
- Operation Over Wide Environmental Conditions
- Completely Solid State — No Moving Parts

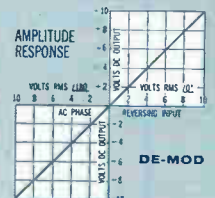

REQUEST BULLETIN MM 108



$$E_o = V \sin^2 \theta$$

EQUATION SOLUTION
ACCURACY—2% fs

A micro magnetic multiplier and squaring block assembled with appropriate semiconductor-transfer gain to solve the indicated expression. Micro miniature, solid state microblock design features high accuracy, extremely stable operation through the application of micro magnetic stages in cascade circuitry.

FEATURES:

- Operates over Wide Environmental Ranges
- Unlimited Life, Low Milliwatt Power Level
- Wide Frequency Range
- Wide Dynamic Computing Range

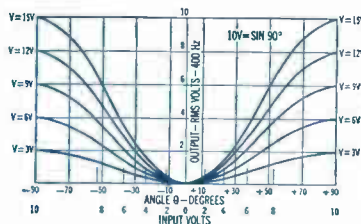

REQUEST DESCRIPTIVE LITERATURE

THERE IS NO SUBSTITUTE FOR RELIABILITY



Circuit and Fundamental Principles of Magnetic Modulators are covered by U. S. Pat. No. 2758162

$$E_o = x^2 + y^2$$

The algebraic sum of two magnetic squaring blocks feeding a switching Demodulator, delivers the indicated DC analog output. Input and output data may be either AC or DC, depending on system requirements.

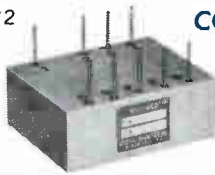

COMPLETELY SOLID STATE

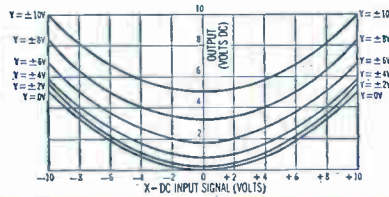

Extremely Broad Range of Voltage, Current Impedance Levels may be handled
 Computing Accuracy to 3% f.s. over temperature range of -55°C to $+85^{\circ}\text{C}$
 Completely Solid State
 Low Milliwatt Power Requirements

with Magnetic Microblocks

Micro "Mag Mods"®

SINE WAVE OUTPUT, NO TUNED FILTERS!



"MAG MODS"® provide four quadrant operation, extreme stability with negligible change of phase, gain and zero position over a wide temperature range. Design is simple, featherweight and rugged—with no vacuum tubes, semiconductors or moving parts to limit life. These Modulators are available in micro, miniaturized and standard sizes depending on requirements, and feature an essentially drift-free, wide-band width circuit with superior phase and gain stability.

Greatest Reliability, Unlimited Life
 Repeatable Data over Years of Continuous, Unattended Operation
 High Shock and Vibration Proof
 Low Milliwatt Power Consumption
 Wide Band Width
 Clean Sine Wave Output without Resonant Filtering

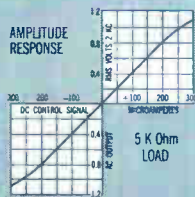

REQUEST BULLETIN MM 101X

$$E_o = \frac{x^2}{y}$$

EQUATION SOLUTION ACCURACY—2% fs

The micro magnetic squaring block and division module are assembled with semi-conductor operational amplifier for the solution of the indicated equation. Completely magnetic, solid state microblocks constitute the most reliable, space-saving analog voltage computing circuits available.

Equation solution accuracy—2% fs
 Low Milliwatt Power Consumption
 Completely Solid State Magnetics
 Wide Dynamic Range

REQUEST DESCRIPTIVE LITERATURE

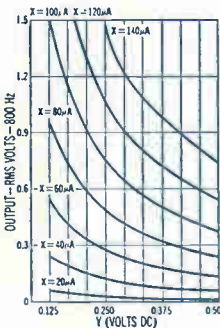

Analog Voltage Multiplier

WORLD'S SMALLEST; MOST RELIABLE!



Available as small as 0.1 cubic inch and weighing as little as 0.1 ounce, Micro Magnetic Multipliers feature extreme stability with negligible change of product over wide temperature range, high shock and vibration proof. Band-width may be extended into the kilocycle range. Low milliwatt power consumption; four quadrant operation.

FEATURES:

- Four Quadrant Multiplication or Squaring Monolithic Micro Circuit Block for Analog Voltage Multiplying of DC/AC Voltages
- Addition, Subtraction, Multiplication, Division and Extracting a Root of Many Voltage Variables may be Handled by one G/M Magnetic Microblock
- Product Accuracy of up to 0.5% of Full Scale, with very slight Derating over a Wide Temperature Range

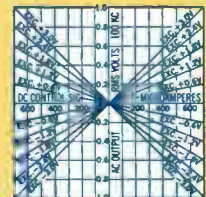

REQUEST BULLETIN MM 109

General Magnetics • Inc

135 BLOOMFIELD AVENUE
 BLOOMFIELD, NEW JERSEY 07003

Telephone: (201) 743 2700

THE
NEW

IN
ELECTRONICS

IS MUCH

MORE THAN

PRODUCT

IDEA

It's the right electronic component plus a trained and experienced marketing man working on your team

Straight talk! The new idea in electronics starts with a man—a man with a unique orientation to the special needs of your business.

He's more than a salesman. He's an expert oriented to your markets and to your business problems. He's not just looking for ways to replace the old with a new component; his responsibility is to find new ways electronically to do things for your business. He's business oriented. He's new idea oriented. He's new product oriented. He's customer oriented.

He's backed by General Electric's total electronic capability—in-depth technical backup assistance and the biggest (by far) product market basket in the world. You name it, and it's available through this one man. To mention just a few of the component types he offers:

compactrons
film and paper-oil capacitors
epoxy transistors
general purpose motors
full-line receiving tubes
aluminum electrolytic capacitors
silicon, selenium, germanium rectifiers
and stacks
Volt-Pac* variable transformers
microwave ceramic tubes

foil and wet slug tantalum capacitors
integrated circuits
sealed relays
five-star military tubes
signal diodes
Alnico and Lodex* magnets
carbon brushes
general purpose and reed relays—
contactors
current transformers

*Reg. Trademark of General Electric Co.

He's your Electronic Components Sales Operation District Sales Manager—your single source for almost any electronic component requirement. He's located in every major market area.

Give him a call. Put the new idea in electronics to work for you. 285-19

ELECTRONIC COMPONENTS SALES OPERATION

GENERAL  **ELECTRIC**

THE

YOU BUY

Service beyond the call of duty

Those red and yellow ones at the left. They're for action, beyond the call of duty on a computer application. The little round one in the middle. Fighting at close quarters on a panel. The next two rows were on machine tools, office machines, guidance control and a few other items. We put the whole Licon® lighted switch story in a book. **It looks like this.**



Request your copy

**Join forces with LICON...
fastest growing full-line switch supplier**

i t LICON
DIVISION ILLINOIS TOOL WORKS INC.
6615 WEST IRVING PARK ROAD - CHICAGO, ILLINOIS 60634

**Remember, you're never more than a few feet away from a product of ITW* ©*



NEW! A commercial relay this  small with 2-ampere dpdt contacts. Printed circuit or socket terminals.  Has Lexan dust cover. This design bonus from our aero/space program is ideal for tape recorders, desk-top computers,  copying machines, television cameras, alarm systems, etc., etc., etc., etc., etc.

High density relay packaging becomes a reality with the low profile HP Series. Only one-fifth of a cubic inch is required for each relay. Seated height in socket or printed circuit board is 0.49". Mechanical life is placed at 10 million operations.

The DPDT contacts are rated from low level to 2 amperes at 30V DC resistive or 0.5 ampere maximum at 120V AC. Coil voltages range from 6V to 48V DC . . . with 12- and 24-volt models available from authorized electronic parts distributors.

These microminiature relays are direct descendants of our military, aero/space designs and have been engineered to perform with singular reliability in modern commercial equipment.

HP SPECIFICATIONS

GENERAL:

Temperature Range: -45°C to +70°C.

Dimensions: 0.49" x 0.88" x 0.48" max.

CONTACTS:

Arrangement: DPDT, 2 Form C.

Rating: Low level to 2 amps @ 30V DC, resistive;
0.5 amps max. @120V AC.

Contact Resistance: 50 milliohms before life
measured at maximum rated load.

COILS:

Power: Approximately .662 watts nominal @ 25°C.
1.0 watts max. @ 25°C.

Duty: Continuous.

Pick-up: 75% of nominal @ 25°C.

Operate Time: 5 milliseconds max. at nominal coil
voltage and 25°C.

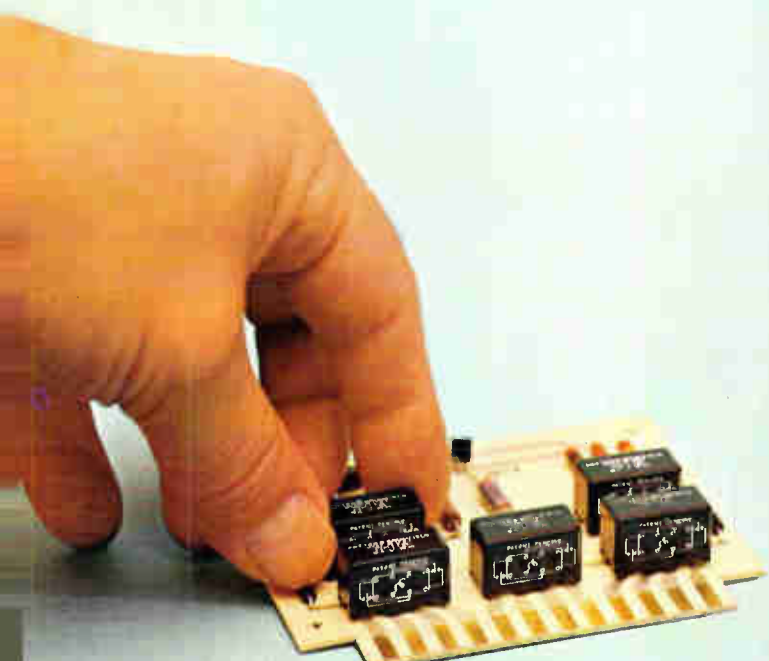

Call your electronic parts distributor



POTTER & BRUMFIELD

Division of American Machine & Foundry Co., Princeton, Ind. 47570
Export: AMF International, 261 Madison Ave., New York, N.Y. 10016

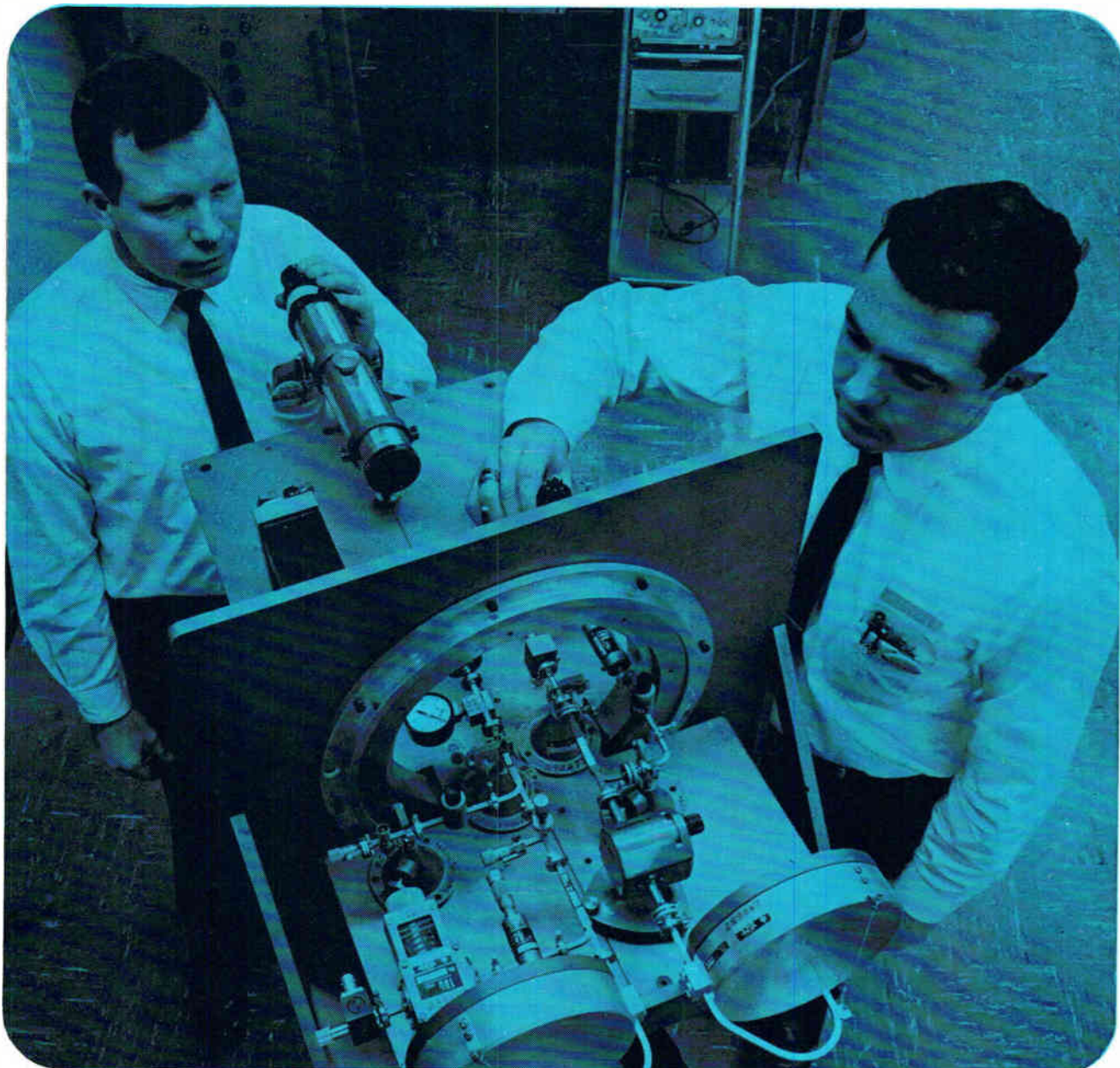

3.2-mm 10-Kw Pulsed Radar System For Target Analysis Studies

Photo courtesy of North American Aviation, Inc., Columbus Division

For designing millimeter wave antenna systems, no one can match the capability and experience of TRG, the country's largest supplier of millimeter wave components.



There is no other source for millimeter wave antenna systems that has had the engineering and design experience of TRG. These systems have included: prime focus, four horn monopulse, conical scan, cassegrain, linear and circular polarized . . . to name a few. If millimeter wave antenna systems figure in your future, it's a sure bet you save yourself a lot of headaches by contacting your TRG representative or writing to: TRG, 400 Border St., East Boston, Mass. 02128. Phone (617) 569-2110.

TRG | A Division of Control Data Corporation

Please
be
seated...





Specimen: Austenite (6% manganese, 1% carbon, 93% iron).
Rolled, quenched in brine from 2000°F. Etched with Vilella's reagent.
Original magnification: 100X.

Specimen prepared by and photographed on the new Research II
Metallograph by Prof. Joseph R. Vilella, Department of Metallurgical
Engineering, School of Mines, University of Pittsburgh.

...and create

outstanding photomicrographs like this on the

NEW BAUSCH & LOMB RESEARCH II METALLOGRAPH

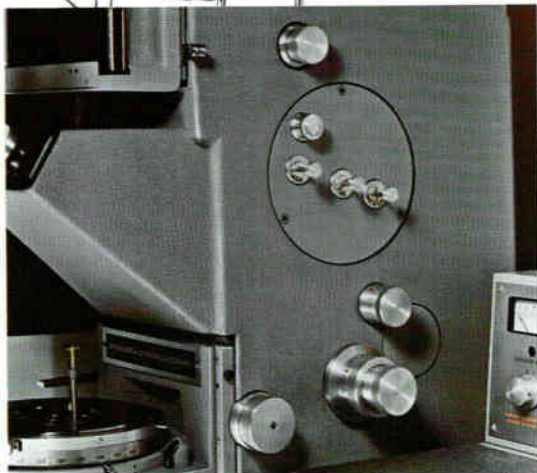

All features you want are built-in, at your fingertips. They can be used while you're comfortably seated. Conveniently reached control zone. Focusable stage. $.5 \times -3 \times$ zooming variable magnification. Exclusive high-power stereo viewing. Visual observation, projection or photomicrography. Built-in shutter controls. Selector for transposable camera and viewing screen.



Close at hand... the quickly-interchangeable combination xenon-tungsten light source. Highest-intensity, long-life xenon, best for bright field, dark field, stereo, polarized light, sensitive tint and projection. Tungsten ideal for visual and photomicrographic work.



Everything is faster, easier, handier to use. Low-positioned inverted stage is at correct, table-top level. Operation of interchangeable stage plates and traversing controls is simple and effortless.

New flat field objectives for bright field, dark field, polarized light and phase contrast; give highest quality results. Individually-centered, parfocalized objectives selected by turning quintuple nosepiece. No handling of objectives—eliminates danger of dropping—smearing. Focus is automatic. Focus and resolution are uniform across entire field.



The exclusive Bausch & Lomb Foster Calcite Prism... your assurance of the finest results in polarized light... also provides vertical illumination for built-in bright field, sensitive tint, phase contrast and high power stereo viewing. A second prism produces an optimum level of dark field illumination.



An integral exposure meter removes guesswork—lets you turn every film into a properly exposed photomicrograph with optimum contrast, high resolution. Within arm's reach is the built-in desiccator cabinet—a moisture-free area for safe storage of normal size and most frequently used specimens.

every-
thing's
right
at your
finger-
tips...

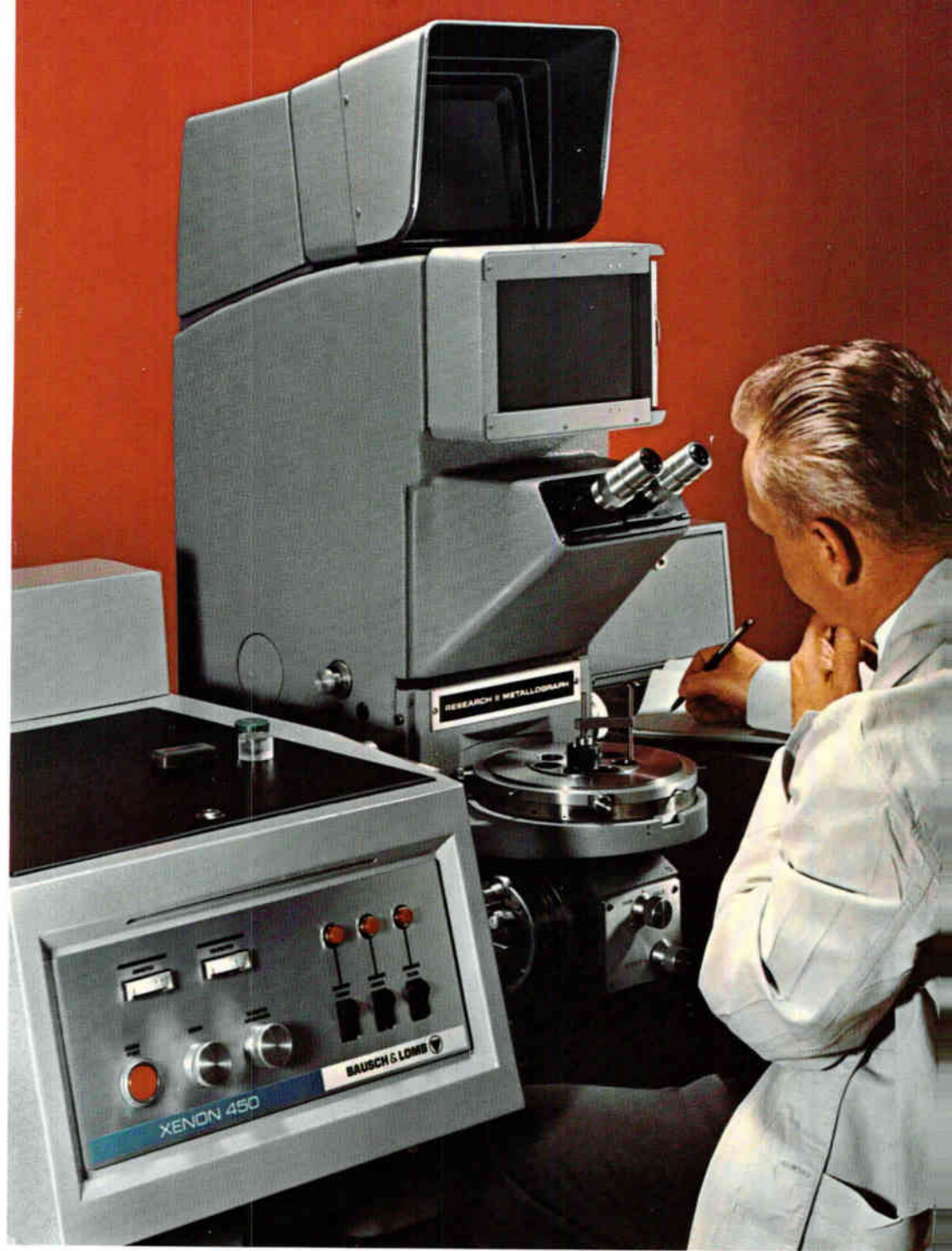

with the **NEW RESEARCH II METALLOGRAPH**

Just imagine a materials study center loaded with every feature you could ever want. It includes a never-before available high power stereo viewing system to enable you to see areas in three-dimensional clarity. An exclusive .5X-3X zoom system permits a total magnification range of from 25X to 3000X. A design so modern, user-oriented and engineered, that everything you want is readily-at-hand. From your comfortable seat you're in complete command of every operational feature. Only Bausch & Lomb, the traditional leader in metallograph manufacture, could have produced this outstanding instrument. Convince yourself with a demonstration. Write Bausch & Lomb, 61403 Bausch Street, Rochester, New York 14602. Our fully-detailed Catalog 42-2154, which also describes the equally revolutionary Routine model, the new Balphot II, is available for the asking.

BAUSCH & LOMB 

AUTOMATIC SCANNING FOR EMI MEASUREMENTS

from 20-15,000 Hz
WITH THE APPROVED ONE

EMPIRE^{*} Noise and Field Intensity Meter



ON DISPLAY AT IEEE
BOOTHS 2B25-2B30

Solid-State, Compact and Lightweight Model NF-315A is preferred by military and civilian government agencies, and major aerospace contractors for rapid and precise EMI measurements. Here's why:

- Three scanning modes: manual, sector, and single sweep over the complete frequency range
- Three separate calibrated scales — peak, average and RMS
- 180 db signal range
- 0.005 μ v sensitivity
- 7 or 70 Hz bandwidth selection
- Reliable scanning at maximum sensitivity
- >70 db spurious response rejection
- Internal frequency and amplitude calibrators for on-the-spot checking without disconnecting signal input leads
- Highly stable circuits eliminate recalibration when tuning to new frequencies
- Excellent shock, vibration and temperature characteristics
- Six hours of continuous operation with built-in rechargeable batteries

Write for complete technical data; better yet, call for a demonstration.



THE TRADEMARK OF THE SINGER COMPANY

EMC • GERTSCH • PANORAMIC • SENSITIVE RESEARCH

SINGER
INSTRUMENTATION

THE SINGER COMPANY, METRICS DIVISION • 915 Pembroke St., Bridgeport, Conn. 06608, U. S. A. • PHONE (203) 366-3201

E-67-1



MODEL 121

New PAR Lock-In Amplifiers Recover Low-Level Signals from Noise



MODEL 120

Model 120 is a fixed frequency unit which allows the benefits of phase sensitive detection to be achieved at an economical price. Representative specifications are:

FREQUENCY RANGE: 5 Hz to 150 kHz. Frequency is determined by two plug-in circuit boards, each of which contains two or four (depending upon frequency) resistors and two capacitors. Plug-in frequency determining boards for any particular frequency in the above range can be ordered from PAR or the user can change frequency by changing the resistors and capacitors on the two plug-in circuit boards. A front panel vernier adjustment functions as a fine frequency control.

SIGNAL INPUT CHARACTERISTICS: Single-ended input of 10 Megohms shunted by 30 pF. Selectivity characteristic is that of a parallel resonant circuit with a Q of approximately 10.

SENSITIVITY: 100 μ V to 50 mV rms full scale in a 1, 2, 5 sequence. Output x10 monitor position increases meter sensitivity by factor of 10 on any range.

FILTER TIME CONSTANT: 1 mS to 30 seconds in a 1, 3, 10 sequence and EXT position. 6 dB/octave roll-off rate.

OUTPUT: \pm 10 volts full scale, single-ended with respect to ground.

PRICE: \$765.00.

Export Prices approximately 5% higher, (except Canada).

Model 121 is continuously tunable throughout its entire operating frequency range. It provides the versatility required for use in many sophisticated research applications. Illustrative specifications are:

FREQUENCY RANGE: Continuously tunable from 1.5 Hz to 150 kHz in 5 ranges.

SIGNAL INPUT CHARACTERISTICS: Single-ended input of 10 Megohms, shunted by 20 pF. Adjustable Q from 5 to 25 over the entire frequency range.

SENSITIVITY: 10 μ V to 500 mV in 1, 2, 5 sequence. Output x10 monitor position increases meter sensitivity by factor of ten on any range.

FILTER TIME CONSTANTS: 1 mS to 100 sec. in 1, 3, 10 sequence and EXT. position. 6 or 12 dB per octave roll-off.

OUTPUT: \pm 10 volts full scale, single-ended with respect to ground.

VOLTMETER MODE: Internal demodulator reference signal derived from signal to be measured. Unit operates as average responding AC voltmeter with overall sensitivity unchanged.

PRICE: \$1,600.00.

Export Prices approximately 5% higher, (except Canada).

For additional information write to Princeton Applied Research Corporation, Dept. D, P.O. Box 565, Princeton, New Jersey 08540. Telephone: (609) 924-6835.



PRINCETON APPLIED RESEARCH CORP.

Companies

Follow the leader

Even in a business as used to management raids as the semiconductor industry, the grabbing of five top executives of giant Fairchild Semiconductor by little National Semiconductor Corp. is startling.

In fact, National's chairman, Peter Sprague, seemed a bit overwhelmed after hiring Charles E. Sporck, former general manager of the Fairchild Camera & Instrument Corp., division, and naming him president. As an added windfall, four of Sporck's cohorts at Fairchild followed him to National. They are: Pierre Lamond, integrated circuit manager; Fred Bialek, director of international operations; Roger Smullen, IC manufacturing manager; and Floyd Kvamme, marketing product manager for IC's.

Fairchild wasted no time in trying to repair the damage, appointing Tom Bay, its Instrumentation division manager, to head the Semiconductor division.

Described by Sprague as the latest in a series of moves to strengthen and expand the Danbury, Conn., semiconductor firm, he said the addition of the Fairchild group is expected to have a negative effect on company earnings initially, but is part of a four-to-five-year growth plan. "Right now, we have a lot of chiefs and only a few Indians," Sprague commented.

Asked if the five Fairchild executives were hired as a group, Sprague noted that Sporck "is pretty much of a leader and when it became known that he was leaving, the others asked to come with him." He called their arrival late last month "somewhat of a surprise."

As to definite plans regarding the group, Sprague said they had

not been accurately worked out as yet. But the additions do mean that National will expand its hybrid-integrated-circuit operations in Danbury and monolithic-IC work in Santa Clara much faster. After it firms up plans, National will seek new financing, Sprague said.

Other recent additions are Ken Davis, West Coast sales manager for Texas Instruments Incorporated; Ken Moyle, leader of an integrated circuit development group at the Hewlett-Packard Co.; and John F. Hughes, a financial vice president at the Perkin-Elmer Corp. Davis will become marketing manager of National, and Hughes will become chief financial vice president.

All of this talent, except for Hughes, is currently clustered at National's Santa Clara, Calif., operation at what used to be called Molecro, Corp., before National bought it year and a half ago. Molecro employs about 50 persons.

National's main business is in discrete components, although it recently introduced a line of its own linear IC's. The company holds licenses from Fairchild. "Our plans are not completed in terms of what circuits we will make," Sporck said. "Planning is our first step."

Jack F. Hegarty, National's president for the past six months, will take over Danbury operations and product marketing, according to Sprague.

Both Fairchild and Sporck said that the parting of the ways was friendly. "The reason we left," Sporck said, "was that the attraction of working with a small company was just too great."

Fairchild group vice president Robert N. Noyce says the loss of five top men won't hurt Fairchild's operations. "You ask me how I am and it's a little like 'aside from that, how did you like the play, Mrs. Lincoln,'" he grinned. "And

to be honest, last week I did feel a little low. But Fairchild is not just a few people; we're not scraping the bottom of the barrel for talent."

Computers

Soft hardware

For years the Stanford Research Institute has been studying ways of organizing integrated circuits in standardized arrays that could be used as computer building blocks. Theory may soon become practice with a plan to program the functions of IC arrays by external electrical signals.

The institute is now seeking funds to fabricate experimental computers with arrays. A 64-cell model array was designed by Sven Wahlstrom of the institute's computer techniques lab. Each cell will have a working structure, or "base," of 13 logic gates, plus 13 flip-flops that will be switched on or off by programming signals to control data flow through the arrays and processing by the logic circuitry.

One cell, for example, might be set up as a NAND gate with any number of inputs up to seven. Several cells would then be combined to form a subsystem, such as an adder. The flip-flop could later be switched by a new program to form another type of logic function, or the other functions could be programmed into duplicate arrays.

In the past, the institute's scientists have concentrated on cellular arrays organized by cutting or adding wiring, an approach that resembles the methods IC manufacturers are now using to make large-scale arrays. The institute has also studied such techniques for altering arrays as shining light through a mask onto photoconductive switches in the array. But the new design is the most flexible yet

—the array's function can be controlled through only two leads.

MOS for more cells. Wahlstrom and an associate, Bruce Clark, have decided to use metal-oxide-semiconductor circuitry. Layout is simple, Clark explains, and the small size of MOS devices allows large arrays—probably larger than 64 cells per chip in the future. Several semiconductor companies near the Menlo Park, Calif., lab have checked the design and found it feasible for production, Wahlstrom says. Clock cycle will be 2 megahertz, slower than most logic circuitry but fast enough for good computers.

Single-chip arrays are needed to fit the building-block concept. If mass-produced, the blocks would be far less expensive than custom arrays made with fixed wiring, Wahlstrom notes; custom arrays can cost as much as \$30,000, depending on the number of computers made. Wahlstrom thinks the standardized arrays might cost as little as 5% as much as custom arrays, though over-all systems savings wouldn't be that great. If fewer than 500 computers were built in a production run, the savings would be significant, he says.

Programs for chips. Programing the building blocks would add little to system design costs, Wahlstrom believes. As the computer is designed, the logic designers would list cell logic functions and record them in code on magnetic tape. When the computer is turned on, the tape would be the initial input to the computer, setting up the functions.

Because logic IC's require power to retain switch positions, the program tape would have to be rerun each time the computer is turned off and on, or standby power would have to be provided by a battery during the time the computer is turned off.

The control circuits would operate like an X-Y switching matrix, using one set of input signals for X and another for Y. These signals would enter the array as serial bit streams and would be passed on to the cells by a cluster of input circuits at one corner of the chip.

They initially go to the cell in the

corner of the chip farthest from the input. That cell decodes the signals that set its switches, and this decoding and switching process then works back, cell by cell, to the input. Clear paths for re-programing signals can be left in the array.

Communications

Phone-a-train

Before the year is out, rail travelers will be able to make telephone calls while zipping along at speeds of up to 160 miles an hour from New York City to Washington, D.C. Telephone booths are being installed on Budd Co.-built cars to be put into service by the Pennsylvania Railroad in the first test of advanced data links planned for rapid-transit systems [Electronics, Jan. 23, p. 59].

Expected to start in October, the test will be one in a year-long series of Northeast Corridor demonstrations sponsored by the Office of High-Speed Ground Transportation (soon to become part of the newly formed Department of Transportation). The Northeast Corridor is the high-traffic-density sector from Boston to Washington, where improved rail service is sought.

The Pennsy, prime contractor for the New York-to-Washington test run, will use 30 electric-powered parlor and snack-bar cars equipped

for phone service — actually, a radio-telephone setup.

No cross talk. The American Telephone & Telegraph Co. will provide the radio-telephone service. Sixteen Government frequencies—8 mobile and 8 wayside—in the 400-megahertz band will be used. Each channel will be 100 kilohertz wide, and a 1-Mhz separation between transmit and receive bands will prevent cross-talk.

Fifty-watt transmitters and receivers will be included on the telephone-equipped cars. There will be nine wayside stations, each with a 300-watt transmitter, a receiver and an antenna. These stations will be from 35 to 40 miles apart and will link the mobile equipment with a central operator in Philadelphia.

Down the tracks. As a train nears the range limit of the wayside transmitter carrying a signal, a wayside coil—essentially a magnetic triggering device—will automatically shift the signal at the same frequency to the next wayside station.

The General Electric Co. is providing the mobile equipment and Motorola Inc. is making the wayside station gear, both as AT&T subcontractors. Bell Telephone Laboratories, an AT&T subsidiary, is to supply the amplifiers and waveguides to carry signals through the two tunnels near the Baltimore terminal.

A "leaky" waveguide consisting of two parallel wires is expected to overcome the problem of signal attenuation in the Baltimore tun-

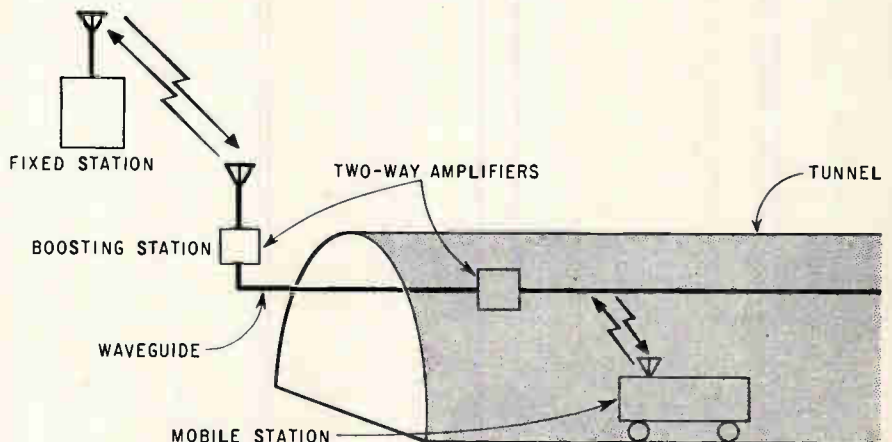

Passengers will make phone calls from trains—even while under a tunnel.

nels. Two-way amplifiers may be placed along the waveguide as needed, and a two-way amplifier at the tunnel portals will boost the signal for relay either to the train or a wayside station.

A communications consultant estimates the cost of the mobile and wayside hardware at between \$1 million and \$1.5 million.

Routing. To make a call, a passenger deposits a coin in the pay phone to reach a Philadelphia operator who can connect him with any phone system in the country. Incoming calls will also be routed through the Philadelphia system.

Amplitude-modulated voice signals generated at the telephone handset are converted into frequency-modulated, single-sideband signals before reaching the train transmitter. The transmitter relays the signals to a wayside station; from there they go by land line to Philadelphia and are converted back to a-m at the switchboard. Similarly, incoming signals are converted to f-m at Philadelphia and sent by wire to a wayside station that beams them to a train. They are converted to a-m after reception.

Manufacturing

Testing on the run

Sylvania Electric Products Inc. is betting a half-million dollars that production volume of monolithic integrated circuits has reached a point where automatic in-line testing and sorting will pay off in reliability and orders.

Sylvania, a subsidiary of the General Telephone & Electronics Corp., has put the \$500,000 into a computer-controlled system now undergoing final tests at its semiconductor division headquarters in Woburn, Mass. Two more systems are in the works—one is to be installed in May.

Called Mr. Atomic, for multiple rapid automatic test of monolithic integrated circuits, the Sylvania system is the industry's first automatic in-line tester-sorter. It will be

used on Sylvania's entire circuit production output. Within the next month, the division will also install a commercially produced automatic probe for testing dice prior to assembly.

The market push. These are part of a quadrupling of Sylvania's IC facilities since August 1964, when Alvin B. Phillips left Motorola Inc. to become the general manager of the integrated circuit operation at Sylvania.

Phillips is setting his sights on third or fourth place in IC production within the next year. Presently, the company ranks about fifth or sixth. Phillips' optimism is based on the 100% testing of d-c parameters at four temperatures, plus a-c switching tests at room temperature. "This would be close to impossible without Mr. Atomic," he says.

Mr. Atomic's four temperature-controlled d-c test chambers and one switching test station are designed in-line with an automatic mechanical feed and regulated by a digital computer. An operator leads the circuits into plastic pallets, which take either TO-5's, flat packs or dual in-line plug-in packages. The dispensing rack presents a new circuit to the tester every 2.2 seconds. It takes a circuit 25 minutes to go through the entire system. During that time, 60 d-c characteristics are probed in each of the temperature chambers and 20 a-c tests are made at room temperature, for a total of 260 tests.

Circuit warmer. As each circuit enters the first chamber, with a 75° C ambient temperature, it is automatically inserted into a wheel-type holding device, designed in such a way that the circuit travels 180° to the test position. The time required to reach this point insures that the chip, case, and junction will have stabilized at the test temperature. Two probes contact each of the 14 leads on the package, one is the test probe and the other a sensor to signal the system that electrical contact has been established. A circuit that fails this contact-sensing test is automatically sorted into a bin for future reinsertion.

The circuits move on to other

chambers of 125°C and -55°C. The computer memory stores the results obtained at each temperature.

After completion of d-c tests, the IC is moved to the fifth test station for the switching tests. Here, as in d-c testing, the circuit is "worse case" tested. Rise time, fall time, turn-on delay, and turn-off delay are all verified to each circuit's specification.

After the switching test, the circuit's performance is reviewed by the computer and a decision is made on its limits. The circuit then goes into one of 20 sorting bins where it is stored until removed by the machine operator.

Because the system can't handle all the a-c tests, some tests are made off-line. This is particularly true for J-K flip-flops, where from 30 to 35 a-c tests are required. According to John C. Blackie, engineer in charge of test equipment, as much as 25% of all a-c testing is done off-line.

In the system, 700 circuits at a time are run through the machine and each is allocated a slot in the computer memory. To reduce the amount of information the computer has to retain, the test limits are divided into performance bands. The memory keeps track of the bands and sorts the circuits accordingly into groups of devices that are suited for specific applications.

Computer control. "The bands are adequate for sorting," says Blackie, "but the computer keeps other quality-control types of information that can be read out."

The second Mr. Atomic will be a copy of the first. But No. 3 is being designed with a different concept: to test functions instead of circuit parameters. "It will ripple through a truth table in maybe 100 microseconds," says Blackie, "moving through all possible logic combinations."

Parameter testing, he points out, is limited. But a simple gate can have as many as 250 possible logic combinations. "We'll hit the circuit with most all of them, and any leakage is bound to show up," says Blackie.

Functional tests will require

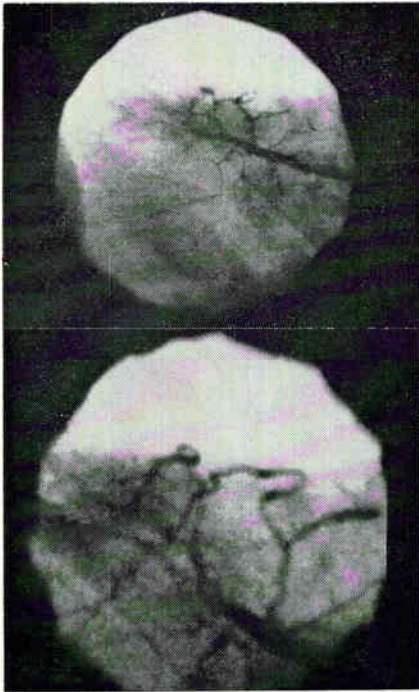

Researchers study X-ray motion picture taken with new Picker equipment. Image, of main trunk of a coronary artery, is magnified three times (photo on left). Top photo shows same section enlarged only 1½ times, the best that could be achieved previously.

ing on and off the primary or secondary power but Picker uses a grid effect. A grid control turns the electron stream on and off with square-wave pulses, resulting in a higher-energy X ray leading to shorter exposure times. In fact, says Valhjan, the exposure time can be as low as 0.5 millisecond.

The X-ray's square-wave control is pulse-width modulated. To operate, the set is adjusted for the density required on the film. The amount of tissue to be penetrated by the X-rays determines the exposure time and therefore the total energy of the beam. This closed-loop control provides a uniform density on the film independent of the patient or his position.

The next step, says Dr. Zimmerman, will be to perfect the equipment so surgeons will be able to take X-rays as they operate and get an almost instantaneous view of their work.

Employment

Raiding the Pentagon

Back in the 1950's, the Defense Department and the high-paying "think factories" it employed raided

college campuses for gifted professors. The lure was money. But in recent years the pendulum has swung the other way. Using the same bait—money—the nation's colleges have been busy raiding the Pentagon and its "think tanks."

Faculty pay scales have risen sharply in the past few years and, as an added incentive, lucrative consultant positions for moonlighting professors have been on the upswing. The result: a professor earning \$25,000 a year—which is on a par with a top-rated think-tank researcher—is almost sure to be able to pick up another \$15,000 to \$20,000 as a consultant.

Eye for an eye. Among the first to feel the squeeze are the same defense agencies and semi-independent research groups which raided the campuses a decade ago. And those most difficult to keep are the personnel trained in systems analysis and computer technology.

Although the greatest competition is coming from colleges, industry and other Government agencies—where the systems approach is becoming increasingly fashionable—also are grabbing their share of scientists whom the Pentagon once had merely for the asking.

Examples of what has been happening:

- The deputy directorship of the

Pentagon's Advanced Research Projects Agency—hardly a sinecure or a dead-end to a scientific career—went unfilled for six months before the Pentagon latched on to Peter Franken, a laser expert, last month.

- The Institute for Defense Analyses reports that top scientists and engineers are rejecting its job offers 30% to 40% more often than was the case a year ago.

Says Gordon MacDonald, the institute's vice president for research: "We're finding an increased reluctance on the part of first-rate people to commit themselves to defense problems, at a time when we very badly need their help on major systems decisions being made."

Among the institute's projects are antiballistic missile defense and the new generation of intercontinental ballistic missiles.

MacDonald and Lawrence J. Henderson Jr., vice president in charge of the Rand Corp.'s Washington office, cheer the keen competition from universities even though it poses problems. They feel those returning to the campuses from defense and the think tanks will show the schools the need to train more systems men, thus eventually raising the supply to meet the demand.

Moral stand. Do their objections

TRW ANNOUNCES NEW MILITARY MYLARS



Up to 72% smaller than MIL-C-25C paper capacitors!

MIL-C-19978B/2 reduces capacitor size drastically—down to .125" diameter by 1/2" long. At the same time electrical characteristics are upgraded sharply.

MIL-C-19978B/2 hermetically sealed mylar* capacitors are available now from TRW with immediate delivery in production quantities.

- REDUCED SIZE—35% to 72% smaller than MIL-C-25C.
- VOLTAGE CHOICE—30V, 50V, 100V, 200V, 600V, 1000V.
- CAPACITANCE CHOICE—.001 mfd through 10.0 mfd.
- TOLERANCE CHOICE—±10%, ±5%, ±2%, ±1%.

For full information contact: TRW Capacitors, 112 W. First St., Ogallala, Nebraska. Phone: 308-284-3611 • TWX: 910-620-0321

These capacitors—when designated TRW Type 693—are available to high reliability specifications, and in custom capacitances and tolerances beyond the range of MIL-C-19978B/2.

*Du Pont registered trademark

TRW CAPACITORS

program your Tektronix Type 561A or 564 oscilloscope for DC-to-15 MHz applications



Here's new convenience for many Type 561A or 564 applications.

You can program the Tektronix oscilloscope for 6 measurement setups—using the new Type 263 Programmer and the Types 3A5 and 3B5 Automatic/Programmable Plug-In Units.

PUSHBUTTON PROGRAMMING

In this mode, both plug-ins can be programmed using the Type 263 Programmer, which accepts up to 6 plug-in type program cards. Each program card, after initial set-up, establishes the plug-in control functions required for a particular test or measurement . . . with actual measurements made conveniently from the CRT display, as usual. Any number of programmers can be cascaded for applications requiring pushbutton control of more than six measurement set-ups. In REMOTE PROGRAMMING mode, the deflection factor is 10 mV/div to 50 V/div and sweep range is 5 s/div to 10 ns/div.

Programmable Functions: **from Type 3A5**—V/div, 10X probe indication, and AC, AC Trace Stabilized, or DC coupling, by program card jumper connection . . . vertical positioning by program card potentiometer setting; **from Type 3B5**—Time/div, X10 or X100 magnifier, trigger mode with coupling, and trigger slope, by program card jumper connection . . . horizontal positioning, trigger level, and magnifier delay, by program card potentiometer setting.

AUTOMATIC SEEKING

In this mode upon SEEK command from the probe or the plug-ins, the oscilloscope automatically presents an optimum display. The SEEK command to the plug-in units automatically adjusts the time and amplitude settings and automatically checks the trigger logic—switching to auto trigger mode, if not correctly triggered, to present a stable display whenever possible. Indicators on the plug-ins light automatically to show the time and amplitude settings. Measurements can then be made quickly and accurately from the CRT display. In AUTOMATIC SEEKING mode, the deflection factor is 10 mV/div to 50 V/div and sweep range is 5 s/div to 0.1 μ s/div.

MANUAL OPERATION

In this mode, both plug-ins are controlled conventionally. Indicators on the plug-ins show the time and amplitude settings. In MANUAL OPERATION mode, deflection factor is 1 mV/div to 50 V/div (5 MHz bandwidth at 1, 2 or 5 mV/div and 15 MHz at 10 mV/div to 50V/div) and sweep range is 5 s/div to 10 ns/div.

Type 263 Programmer (complete with 6 program cards)	\$.325
Type 3A5 Automatic/Programmable Amplifier Unit	\$.760
Type 3B5 Automatic/Programmable Time-Base Unit	\$.890

Oscilloscopes which accept both Automatic/Programmable Plug-Ins:	
Type 561A Oscilloscope	\$.500
Type RM561A Oscilloscope	\$.550
Type 564 Storage Oscilloscope	\$.875
Type RM564 Storage Oscilloscope	\$.960

U.S. Sales Prices f.o.b. Beaverton, Oregon

Tektronix, Inc.



For complete information, contact your nearby Tektronix field engineer or write: Tektronix, Inc., P.O. Box 500, Beaverton, Oregon 97005

SEE THE LATEST TEKTRONIX INSTRUMENTS AT IEEE—BOOTH 2C03-2C13

If your blip is a blooper, you'll know it in 10 seconds.

Once you start using Polaroid Land film, you'll wonder how you and your oscilloscope ever got along without it.

In 10 seconds, you get an on-the-spot record. You can study it, attach it to a report, send it as a test record along with a product shipment, or file it for future reference.

You have a choice of 5 films for oscilloscope recording.

The standard film has an A.S.A. equivalent rating of 3000. You can get it both in pack film [Type 107] and roll film [Type 47]. They both give you 8 pictures $3\frac{1}{4} \times 4\frac{1}{4}$ inches. This emulsion is also available in 4×5 sheets [Type 57].

And for extremely high-speed oscilloscope recording, there's Polaroid PolaScope Land film [a roll film, Type 410].

It has an A.S.A. equivalent rating of 10,000. It can discover traces too

fleeting for the human eye: such as a scintillation pulse with a rise time of less than 3 nanoseconds.

Because these films are so sensitive, you can use small camera apertures and low-intensity settings. Every shot is a sharp, high-contrast image that's easy to read.

To put these films to work on your scope, you need a camera equipped with a Polaroid Land Camera Back.

Most oscilloscope camera manufacturers have one.

For instance: Analab, BNK Associates, Coleman Engineering, EG&G, Fairchild, General Atronics, Hewlett-Packard and Tektronix.

You can get the full story by writing to Polaroid Corporation, Technical Sales Department, Cambridge, Massachusetts 02139 [or directly to the manufacturers mentioned above].

About the only thing we can't tell you is how to keep your blips from being bloopers.

"Polaroid" and "PolaScope"®

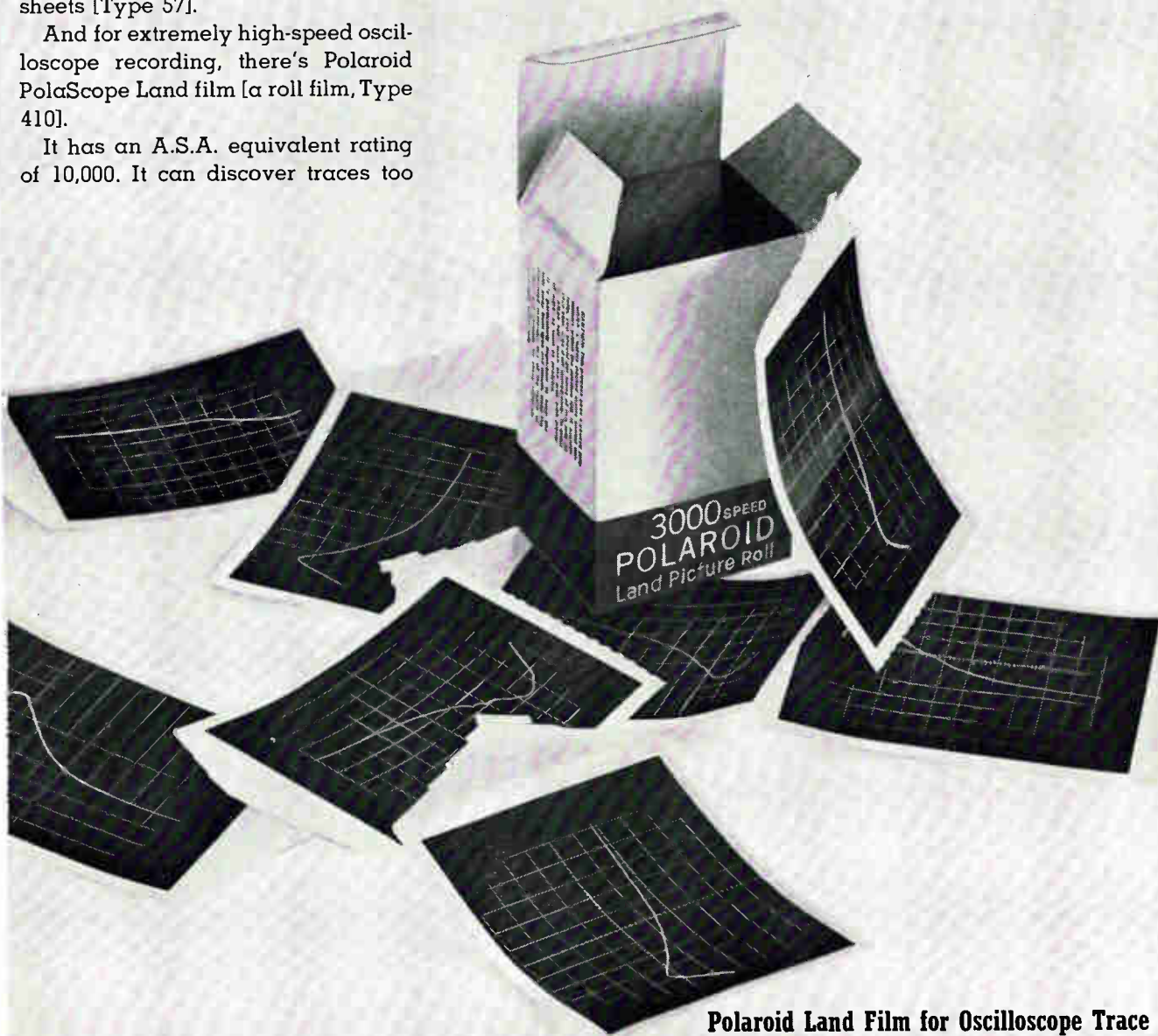

Polaroid Land Film for Oscilloscope Trace Recording.

Tony DeBerardis likes green eyes, freckles and buck teeth...but he just can't stand crooked knees.

Tony will be the first to admit that not everybody likes buck teeth.

Freckles, yes. Green eyes? O.K. . . .

But buck teeth . . . ?

When it comes to knees, though, Tony likes them the same way you do. Because, when you're Product Assurance Manager at Unitrode you *know*: Either your diodes have sharp, crisp knees, or you simply don't have the ability that's built into every Unitrode to handle avalanche current, whether surge or continuous.

So Tony's got to be fussy. He knows controlled

avalanche is just one of the qualities he's responsible for assuring. And when you're testing diodes that are designed to deliver an entirely new level of performance and reliability, you've got some "assuring" to do.

Of course, *entirely new* is the key phrase there.

And it's easy enough to say. But when we say it, we mean just that.

Because the Unitrode diode was developed from the ground up. With entirely new design. With entirely new methods of construction. The metallurgical bond that joins the silicon between the two terminal pins is stronger than the silicon itself, so the silicon will break before the bond does. The entire unit is fused in hard glass at over 800°C. It's voidless, so all contaminants are excluded.

Because the pins are bonded over the full face of the silicon die, heat due to surge is carried away quickly from the silicon into the terminal pins. So even the smallest Unitrode diode can take a surge of 600 amps for one microsecond, and the big ones can take 4000 amps.

Nevertheless, we try not to ever forget that people like Tony DeBerardis are more important than any process. After all, they're the reason we can virtually guarantee: Unitrodes don't fail. Ever.

Maybe the work your company is doing could profit from diodes with this kind of reliability. It doesn't cost anything to find out.

We'll be glad to send you complete information and samples. We're at 580 Pleasant St., Watertown, Mass. 02172. Telephone (617) 926-0404. TWX (710) 327-1296.

UNITRODE®



See us at the IEEE Show, Booth 4K19

When it comes to custom assemblies, we can solve millions of problems.

Like taking millions of plastic and/or metal parts made to the most exacting tolerances, fitting them into an assembly, sub-assembly or finished product, wrapping them, sealing them and shipping them.

Complex components like computer circuit boards, telephone switching equipment, memory core frames, computer control connectors, switches, contacts for plug assemblies, practically anything you specify, we can make and put together.

That means your designers need not be inhibited by

the limitations of your own facilities and machinery.

We're the one single source you need deal with. We'll take care of it all—from initial fabrication of the parts to the finished assembly. And we'll do it all, probably at a lower cost than if you did it yourself.

Let us put our men, machines and plants to work for you. Give us your specifications, we'll do the rest. We've done it for a lot of others.

Sylvania Electric Products Inc., Parts Division,
Warren, Pennsylvania 16365.

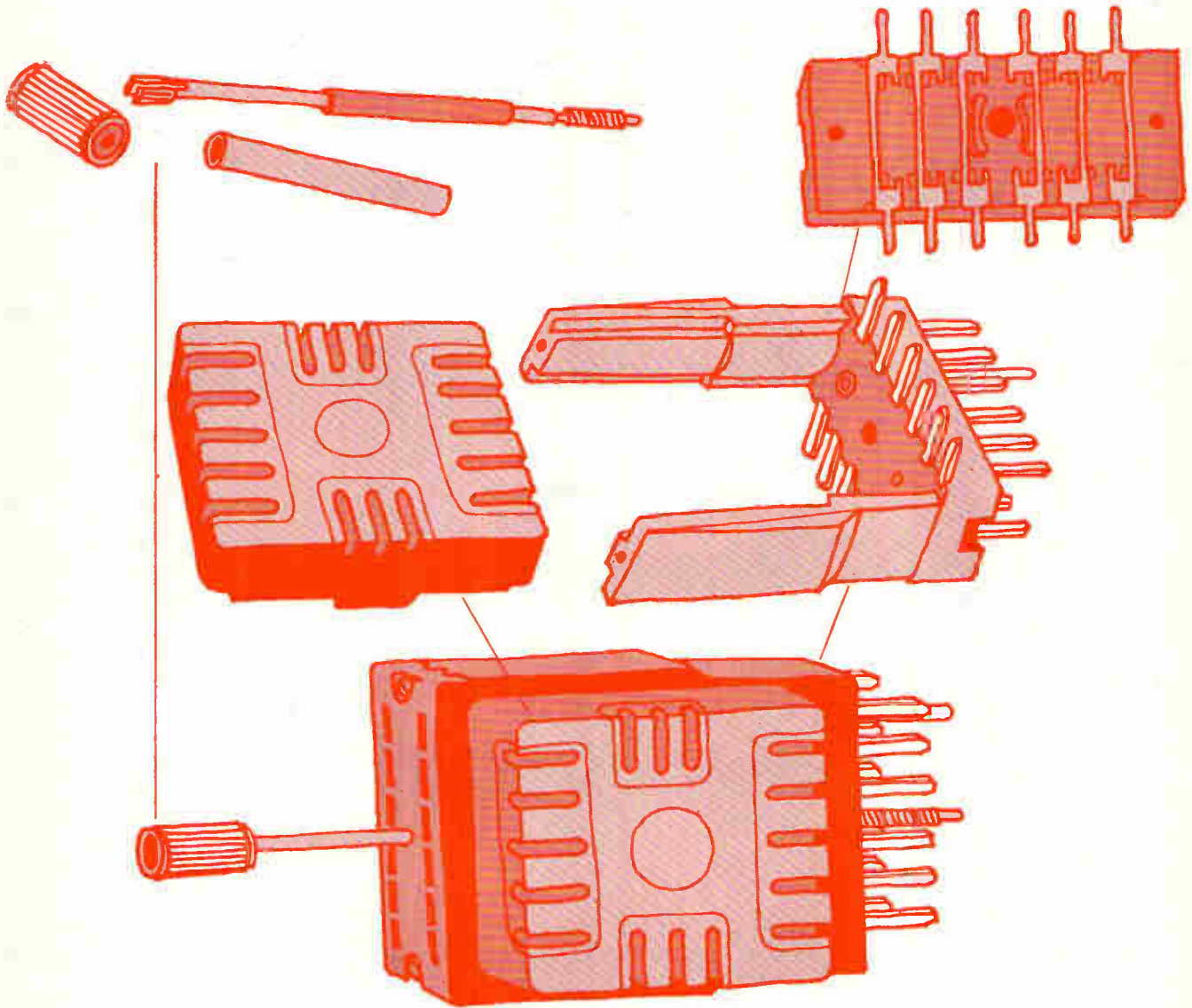

SYLVANIA
SUBSIDIARY OF
GENERAL TELEPHONE & ELECTRONICS **GTE**

No trace of overload problems



withstand -100 V to +4 V signal surges

withstand 2:1 power supply surges

withstand -100 V to +100 V momentary signal transients

When you use RCA nuvistors

If you find it necessary to include overload protection in your solid-state circuit designs, look to RCA nuvistors. Nuvistors can withstand severe signal and power surges without catastrophic failure.

Nuvistors eliminate many other problems, too, through the benefits of their unique construction: demonstrated reliability of 99.901% per 1,000 hours out to 30,000 hours of operation; temperature stability, $\Delta g_m \cong 4 \mu\text{mho}$ per degree C over the range -55°C to $+250^\circ\text{C}$; dependable performance in the presence of both pulse and steady state nuclear radiation; low RF and sub-audio noise; 1,000 g shock rating, and exceptional uniformity of electrical characteristics from tube to tube and throughout life.

For complete data on the entire RCA line of nuvistors for industrial and military applications, call your nearest RCA District Office or write RCA Commercial Engineering, Section 219DE-1, Harrison, N.J. 07029.

RCA DISTRICT OFFICES—OEM SALES: EAST, 2075 Millburn Ave., Maplewood, N.J. 07040, (201) 485-3900 • MID-ATLANTIC: 605 Marlton Pike, Haddonfield, N.J. 08034, (609) 428-4802 • MID-CENTRAL: 1600 Keith Bldg., 1621 Euclid Ave., Cleveland, Ohio 44115, (216) 241-3450; 2511 East 46th St., Bldg. Q2, Atkinson Sq., Indianapolis, Ind. 46205, (317) 546-4001 • CENTRAL: 446 East Howard Ave., Des Plaines, Illinois 60018, (312) 827-0033 • WEST: 6363 Sunset Blvd., Hollywood, Cal. 90028, (213) 461-9171 • INTERNATIONAL OPERATIONS, RCA International Division: Central and Terminal Aves., Clark, N.J. 07066, (201) 485-3900 • 118 Rue du Rhone, Geneva, Switzerland, 35 75 00

RCA Electronic Components and Devices, Harrison, N.J. 07029



The Most Trusted Name in Electronics

Circle 61 on reader service card

State of the design art

The flexibility of Radiation IC Operational Amplifiers is illustrated by the circuit below. Here, the RA-240 is used in the design of a highly stable, uncompensated Wien bridge

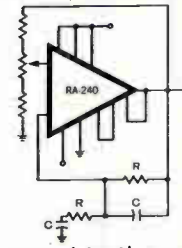

oscillator which is virtually unaffected by temperature variations. Using the RA-240, engineers may select a wide range of RC combinations without regard to the active element of the circuit. Frequency of oscillation (up to 500 kHz) is defined by:

$$f_o = \frac{1}{2\pi RC}$$

Stability and versatility of our Radiation Operational Amplifiers is made possible through advanced dielectric isolation and thin film over oxide technology. Further information will appear in our ELECTRONIC DESIGN advertisement of March 15.

Radiation's line of IC operational amplifiers opens the door for integration of systems requiring high-performance analog circuitry. These amplifiers provide the ideal 6 dB per octave high frequency roll-off required for unconditional stability in operational feedback connections *without* use of external compensation . . . even in the critical unity gain configuration.

Three types are immediately available in T0-84 flat packages: general-purpose, broadband, and high-gain amplifiers.

Write for data sheets. *Worst-case limits* are included, as well as all necessary design information. We'll also be glad to send you our new manual, Operational Amplifier Technical Information and Applications, ROA-T01/A01. Contact our Melbourne, Florida office for your copy.

Radiation's popular dielectrically isolated matrices provide an unusual degree of flexibility. (1) RM-30 Matrices contain 48 active devices per chip. (2) A fusible link in series with each diode permits unlimited matrix patterns to be formed. And (3), circuits can be combined to produce an almost infinite variety of size configurations.

In addition to flexibility, Radiation 6 x 8 Matrices offer the increased reliability of monolithic construction. Size and weight requirements are slashed through reduced package count. Further, cost of matching, testing and assembly of discrete diodes is eliminated.

Production has been expanded to guarantee fast shipment of ma-

trices "customized" to your exact requirements. In fact, most orders are shipped on a 24-hour basis.

A new low-cost RM-134 design in a ceramic dual in-line package is available in volume at a unit price of less than \$5.00—and can be supplied to any code configuration requested.

Write for data sheets on the entire line of Radiation Monolithic Diode Matrices. *Worst-case limits* are included, as well as all information required by design engineers. We'll also be glad to supply our new manual, Monolithic Diode Matrix Technical Information and Applications. For your copy, request publication number RDM-T01/A01 from our Melbourne, Florida office.

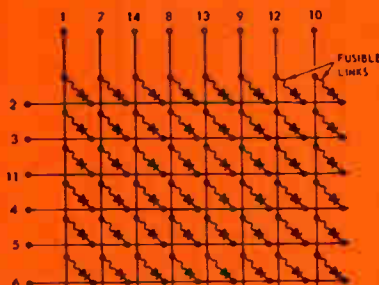

BEFORE "CUSTOMIZING"



Radiation 6 x 8 Monolithic Diode Matrices* (typical limits)

Characteristic	Symbol	RM-30	RM-31	RM-34 RM-134†	Unit	Test conditions (T _A = +25°C)
Forward drop	V _F	1.0 0.7	1.3 0.75	1.0 0.7	V	I _F = 20 mA I _R = 1 mA
Reverse breakdown	BV _R	60	60	50	V	I _R = 100 μA
Reverse current	I _R	7	25	70	nA	V _R = 25 V
Reverse recovery	t _{rr}	7	11	30	ns	I _F = 10 mA to I _R = 10 mA
Crosspoint capacitance	C _{cp}	1.9	1.9	2.0	pF	V _R = 5 V; f = 1 MHz
Coupling coefficient	I _{CL}	20	20	20	μA	See data sheet

*Supplied in T0-84 packages. †Supplied in ceramic dual in-line package.

All Radiation integrated circuits are dielectrically isolated.

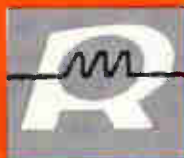

RADIATION INCORPORATED

MICROELECTRONICS DIVISION

Sales offices: Suite 622, 650 North Sepulveda Blvd., El Segundo, Calif. (213) 772-6371—Suite 232, 600 Old Country Road, Garden City, N. Y. (516) 747-3730—Suite 201, 1725 Eye Street, N. W., Washington, D.C. (202) 337-4514—P.O. Box 37, Dept. EL 03, Melbourne, Florida (305) 723-1311, ext. 534

Circle 62 on reader service card



Circle 63 on reader service card

"DIBBLE"

Perhaps the manpower and mindpower of Panasonic can do the "incredible" for you. Why not find out?

For more information about us, write: Panasonic Electronic Components & Devices, Matsushita Electric Corp. of America, P.O. Box 3980, Pan Am Bldg., 200 Park Ave., New York, N.Y. 10017.

5 "Incredible"—until Panasonic created it: New condenser microphone with exclusive back-electrode design provides high sensitivity despite small size (only 1/4" diameter) and low polarization voltage. Plus high signal-to-noise ratio.

6 "Incredible"—until Panasonic created them: New "PCM" Ceramics have the unique combination of superior mechanical properties, a high dielectric constant, a planar coupling coefficient over 40% and uniform quality over a wide temperature range.

Panasonic invites you to a special exhibit in Booths 3A45 and 3A46, IEEE Show, New York Coliseum, March 20-23, 1967.

PANASONIC®

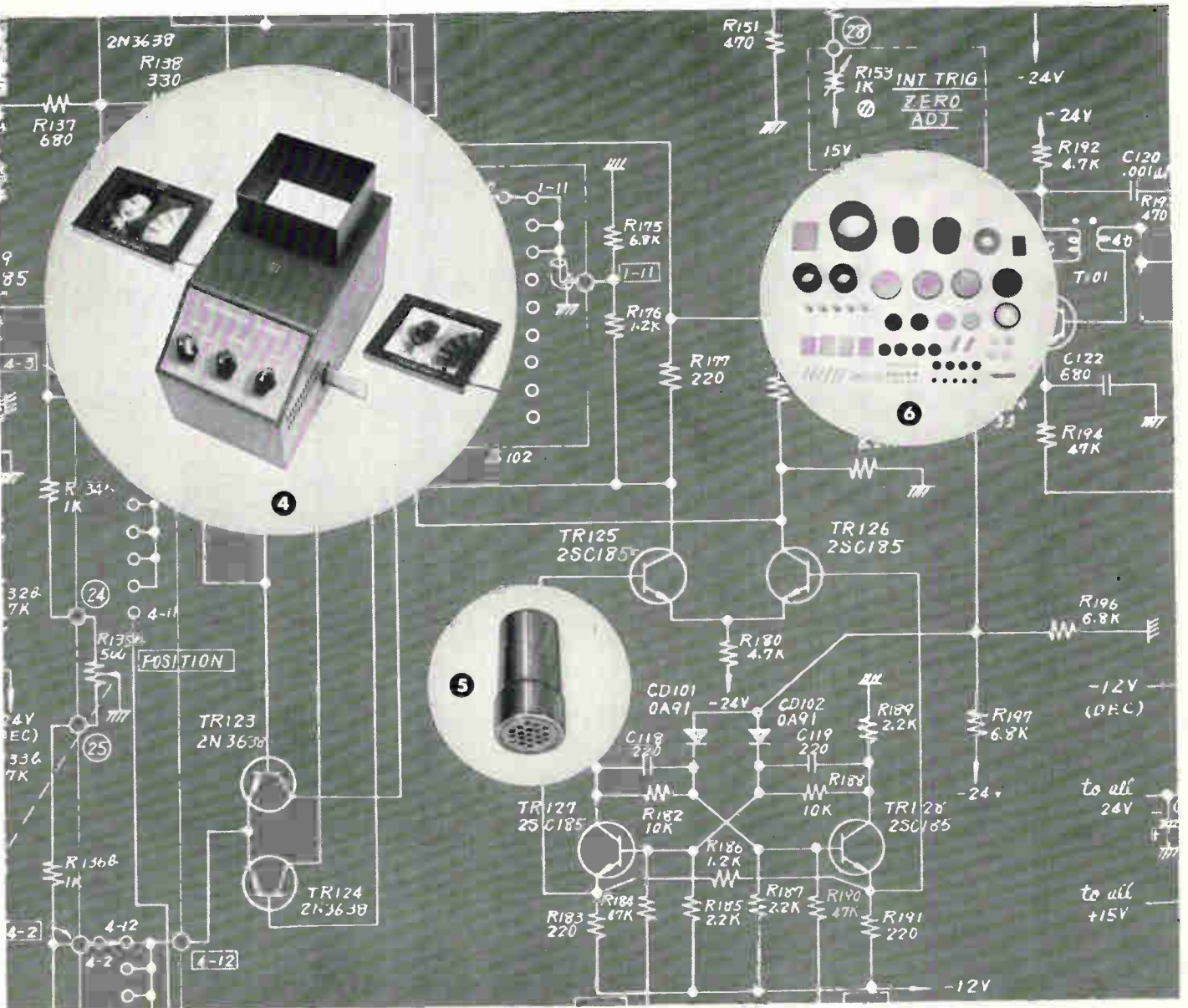

Washington Newsletter

March 6, 1967

GE wins contract to develop a radar for Nike-X system

A contract to develop one of the five Nike-X antiballistic missile system radars has been won by the General Electric Co. The award will be announced after price negotiations are completed between GE and the prime contractor, Western Electric Co., the manufacturing arm of AT&T. GE will develop the phased-array perimeter-acquisition radar that will be used for long-range area defense if the antimissile system is deployed. The company already has a contract for the beam-forming subsystem of the Nike-X multifunction array radar.

GE edged out Bendix Corp.'s Radio division in the competition for the latest order, although Bendix was the only bidder to have built a prototype—the AN/FPS-85 at Eglin Air Force Base [Electronics, June 27, 1966, p. 133]. Bendix opted for the FPS-85 frequency in its bid, though Western Electric had asked for a different frequency. However, after GE was selected, Western Electric is said to have changed the perimeter-acquisition radar frequency to conform with the Bendix FPS-85.

Burroughs submits low bid for FAA's digitizer subsystem

Burroughs Corp. is the apparent winner of a contract to develop and build the common-digitizer portion of the Federal Aviation Administration's National Airspace System. The company was low bidder for the radar and beacon processing subsystem for the semiautomated traffic control program, a contract that will total either \$16 million or \$22 million, depending on the number of units initially ordered. The award, to be announced shortly by the FAA, will cover production of either 111 or 177 digitizers.

FCC will test use of tv frequencies by radio operators

The Federal Communications Commission will begin tests next month to see if it can assign commercial television frequencies to mobile-radio operators. The FCC is confident the feasibility trials will show that these new users can take over unused tv channels in the vhf area.

In the test, transmitters at various locations around Washington, D.C., will send 25-kilohertz-bandwidth signals over unused Channel 6 (82 to 88 megahertz). If the test transmissions don't interfere with tv reception on Channels 5 and 7, the FCC will be able to allocate the frequencies to mobile-radio users in Washington. In order to make similar assignments in other cities, however, the agency would have to hold new tests to gauge local conditions.

Television broadcasters oppose such sharing, maintaining that they were given exclusive use of the spectrum they were allocated.

IBM aims to make space-tv lasers of gallium arsenide

Researchers at IBM's Federal Systems division are working to develop arrays of gallium-arsenide injection lasers for a system to transmit real-time tv pictures from a spacecraft to earth at interplanetary distances. Other work on a laser link for NASA has incorporated such gas devices as the Hughes Aircraft Co.'s ionized argon laser and Sylvania Electric Products Inc.'s carbon-dioxide laser [Electronics, Feb. 20, 1967, p. 25].

IBM's quantum electronics department at Yorktown Heights, N.Y., has been studying ways to phase a number of gallium arsenide lasers to yield a 10-watt data link able to transmit a million bits per second. Researchers have succeeded in phasing the lasers—just how many IBM won't say—

**What increased
chemical cleaning
production 20%
and cut solvent
costs in half?**

**ITT says:
FREON® solvents
and Branson
Ultrasonics.**

At ITT's Electron Tube Plant in Easton, Pa., components are now cleaned in a Branson ultrasonic system using FREON TF solvent. Standard degreasing just couldn't do the job as efficiently. Time and money were lost through recleaning.

Now, FREON leaves components microscopically clean—the first time through. With its low surface tension it reaches into the smallest pores and crevices. With its high density, FREON carries off all traces of dirt, cutting oils and other contaminants. It dries quickly, leaving no residue.

The result: chemical cleaning production up 20% . . . solvent costs down 52% from \$100 to \$48 per week.

And, because FREON is nonexplosive and relatively nontoxic, no special exhaust system is needed. Its high stability permits recovery and reuse after simple distillation.

FREON solvents could be the answer to your cleaning problems. For more information, write Du Pont Co., Room 4975, Wilmington, Delaware 19898. (In Europe, write: Du Pont de Nemours International S.A., "FREON" Products Div., 81 Route de l'Aire, CH 1211 Geneva 24, Switzerland.)



Better Things for Better Living
... through Chemistry

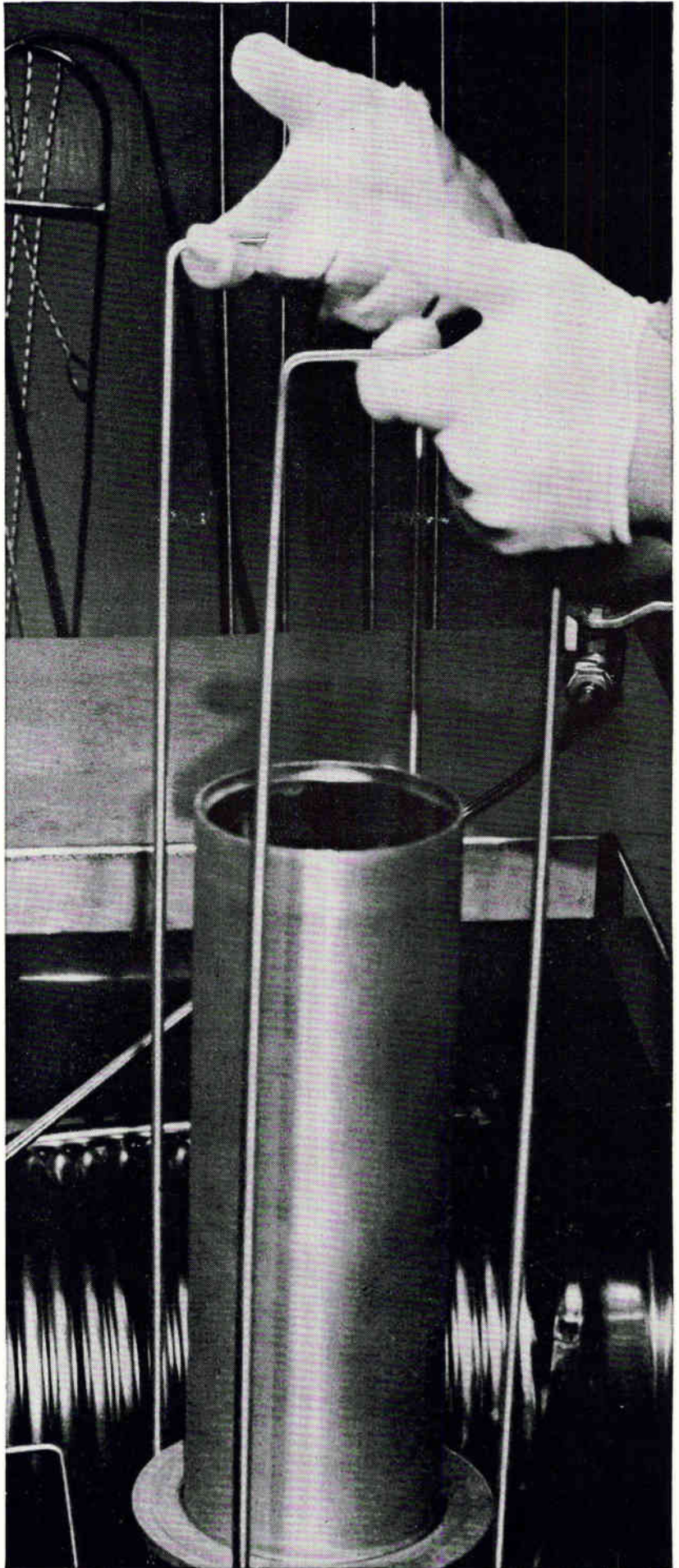



COMPONENT CAPSULES

New economy breakthrough for UHF TV oscillators

Just specify GE D16G6 silicon planar transistors—priced now at less than 25¢ in volume quantities. The D16G6 comes in GE's familiar T098 economy package and features an injection current of 0.5 ma at 940 MHz and low output capacitance of typically 1.2 pf. Circle Number 90 for more details.

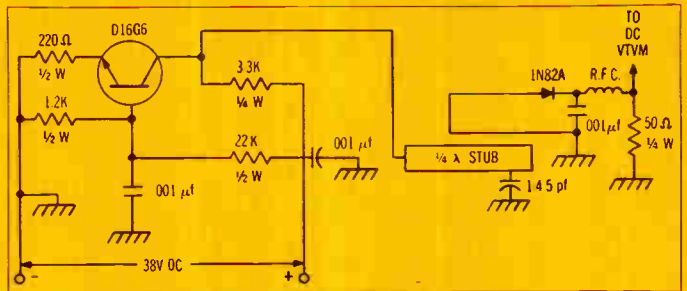

Test circuit—940 MHz oscillator

Out front . . . meeting more of your tube requirements



Look to the leader. General Electric is your number one supplier and number one innovator of tubes for entertainment-type products such as radio and TV. GE developed more than twice as many new tube types in 1966 as any other manufacturer. GE now offers over 125 different compactrons you can apply to reduce assembly time and related costs. Circle Number 91 for more information on GE compactrons and other tube innovations.



Typical GE compactron

Automatic de-gaussing for color TV sets

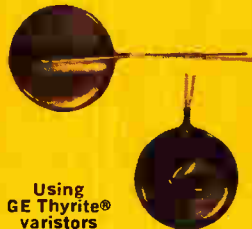

Using GE Thyrite® varistors

Used in conjunction with a thermistor, GE disk-type Thyrite varistors will develop, automatically, an ideal de-gaussing waveform in your color television receivers. Many have hailed this as one of the most important circuit developments in the TV industry, since it can eliminate so many costly service calls. Contact General Electric for these and all other varistor and thermistor requirements. Circle Number 92 on the Reader's Service Card.

Rechargeable nickel cadmium batteries last so much longer

Available types—suitable for many commercial applications—include sealed, pressure relieved, and vented cells nominally rated from 0.5 amp-hours to 160 amp-hours at the one hour rate. Shock-resistant GE nickel cadmium batteries operate over a wide temperature range and have a high discharge rate capability with constant voltage output. Custom designs are also available. Circle Number 93 for more facts.



Can last hundreds of times longer

New 2-transistor Darlington amplifier costs as low as 35¢*



Actual size

Use GE's new D16P NPN device (in monolithic structure) to simplify your audio amplifier circuits in pre-amps for phonographs and tape recorders. One D16P actually costs less than its discrete counterpart in these applications—two 2N3394's. D16P's provide single stage input impedance over 2 megohms with a 6-to-1 voltage gain at negligible distortion (less than 0.1%). For more information, Circle Number 94.

*In lots of 1,000 and up

WE MAY NOT OFFER EVERYTHING YOU WANT FROM ONE COMPONENTS SUPPLIER. BUT WE DO COME A LITTLE CLOSER THAN ANYONE ELSE.

GENERAL  ELECTRIC

SCIENCE/SCOPE

Commercial communications service to the Far East was inaugurated January 26 over COMSAT's Intelsat IIB. New satellite, launched January 11 and put into synchronous orbit over the Pacific, is relaying telephone, TV, Teletype, and data between the U.S. and Hawaii, Japan, and Australia on a round-the-clock basis, and will also be used by NASA in support of the Apollo program. It has three times more transmitter power, five times greater bandwidth, substantially greater antenna-beam coverage than COMSAT's Early Bird, also built by Hughes. COMSAT operates it for the International Telecommunications Consortium.

Contract for a vast NATO air defense system has been awarded to a six-company European consortium led by Hughes. Known as the NADGE (for NATO Air Defense Ground Environment) system, it's the largest military electronics project ever undertaken in Europe. NADGE will identify all aircraft crossing NATO borders, decide if they're unfriendly, warn the military within seconds, and advise them what interceptors and missiles are available and which should be dispatched.

Instant moon shelters from ordinary gelatin have been developed by Hughes research chemists under an Air Force study contract. Shelters would be prefabricated of fiber glass cloth, impregnated with gelatin, sealed in airtight containers. Opened and unfolded on the moon, they'd harden into rigid, light-weight shelters as the water evaporated from the gelatin in the vacuum of space.

Rapid expansion of several advanced programs at Hughes has created important and immediate assignments for electro-optical, microcircuit, space systems, information processing, circuit design, and communication/radar systems engineers. If you have an accredited engineering or scientific degree, have at least two years of applicable experience, and are a U.S. citizen, please send your resume to: Mr. J. C. Cox, Hughes Aircraft Company, Culver City, California. Hughes is an equal opportunity employer.

The Army's new Missile Mentors, computer systems developed by Hughes to coordinate the firing of Nike Hercules and Hawk missiles, now provide major U.S. cities with air defense umbrellas. Systems detect and track all aircraft in the defense areas, give commanders more data for split-second battle decisions than ever before. Missile Mentors, with solid-state circuitry, cost about 1/10 as much as the tube-circuitry systems they replace, can be operated and maintained by 50 men compared with 200. Basic systems are carried in two mobile vans, which operate as a single command post. A third van, designated RRIS, can be added to collect remote radar inputs.

A color camera for NASA's ATS-C satellite, scheduled for launch in December, is being developed by Santa Barbara Research Center (a Hughes subsidiary). ATS-C will be spin-stabilized in a synchronous orbit over the Atlantic. New camera's data will consist of simultaneous blue, green, and red video channels, from which full-color photos can be processed. SBRC also built the spin-scan camera that has been sending back high-resolution black-and-white photos of the earth's cloud cover from ATS-1, now in geostationary orbit over the Pacific.

Creating a new world with electronics



When even the Best Carbon or Wirewound Pots won't do...

CTS Cermet Pots Offer a Solution

6 WEEKS DELIVERY...NEW LOWER PRICES...

due to CTS automated production techniques and the industry's biggest output.

Consider these CTS Cermet Pot characteristics:

1. 20 Ω to 5 megohms resistance range.
2. Greater power/size ratio. (See captions.)
3. The environmental stability & higher wattage rating of wirewound.
4. The wide resistance range & infinite resolution of carbon.
5. Extremely high temperature capabilities.
6. Stability under extreme humidity.
7. No catastrophic failures.
8. Low noise. Long life.
9. Exceed MIL-R-23285 (Navy) metal film; far exceed MIL-R-94B.

Specify from the broadest line of thick film controls available.

New low prices begin at \$1.35 each in large quantities.



Series 400
1-3/64" dia.
3 watts @85°C



Series 500
3/4" dia.
1-1/2 watts @85°C



Series 600
1/2" dia.
3/4 watt @85°C



Series 550
3/4" dia.
2 watts @70°C



Series 2-500
3/4" dia.
1-1/2 watts @85°C
Tandem Series 500



Series 385
11/32" dia.
1/8 watt @125°C
For P.C. applications



Series 600PC
1/2" dia.
3/4 watt @85°C
For P.C. applications



Series 660
3/8" dia.
1/4 watt @125°C



Series 630
1/2" dia.
1/2 watt @85°C

Request Cermet Catalog.



Founded 1896

CTS OF BERNE, INC.
BERNE, INDIANA

Subsidiary of CTS Corporation, Elkhart, Indiana



TEST BOARD BEFORE...



AND AFTER SOLUTEC PROCESSING

New Solutec system cleans PCB's faster, more economically than ultrasonics or vapor degreasing

You can improve your productivity, cut your investment in cleaning equipment and get more uniform results by switching to the Solutec method of printed circuit board cleaning. It's a simple process, requiring only one cleaning solution and generating no fumes, films or toxicity problems.

If it takes you more than three minutes to clean a board — whether you use ultrasonic, vapor degreasing or manual methods — you need more information about the Solutec "hydrogen scrubbing" system! It removes tenacious contaminants by generating hydrogen bubbles on or near the surfaces of parts being cleaned. In the presence of

"Hydrochemex," a proprietary activated alkaline detergent, the bubbles actually scrub surfaces clean.

How clean? Clean enough to accept electroless copper plating after less than three minutes of processing. The Solutec system also gives you excellent wetting action for subsequent soldering operations.

In addition to the scrubber and its detergent solution, Solutec offers a complete line of board processing chemicals — deoxidizers, strippers and electroless copper solutions. Start cutting your board cleaning time and cost today: send this coupon for more information.



THE SOLUTEC Model 900 is a bench-type hydrogen scrubber. The device is also available in larger capacities for production line use.



SOLUTEC

SOLUTEC CORPORATION
5903 Seminole Boulevard
Largo, Florida 33540 • Phone 813/392-4268

- Please send me more information about the Solutec PCB cleaning system.
- Please have your representative call me to arrange a demonstration.

NAME _____ TITLE _____

COMPANY _____

ADDRESS _____

CITY _____ STATE _____ ZIP _____



New Raytheon Projectoray* Tube produces more than double the light output of standard projection-type cathode ray tubes. The tube's light output is 30,000 foot lamberts, which results in a light level of 15-foot lamberts on a 3' x 4' lenticular screen.

The tube's expected minimum operating life is 500 hours—20 times the life of a standard projection tube.

The Projectoray's high light output and long life are due to its novel design. The design incorporates liquid cooling of the phosphor backplate. This allows the phosphor to be energized with a very intense electron beam. At high beam levels, very high peak light output is obtained. The light image is projected through a 5" optical window in the face of the tube. The electron gun is set at an angle to the phosphor and the deflection system compensates for keystone effects.

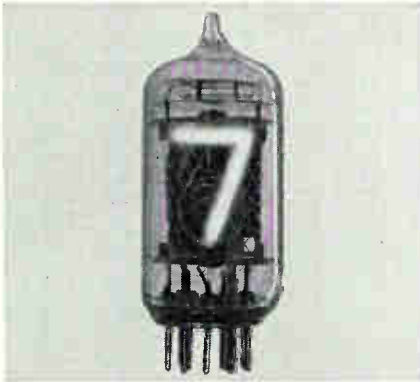

Datavue* Side-View Tubes. New Type CK8650, with numerals close to the front, permits wide-angle viewing. These side-view, in-line visual readout tubes display single numerals 0 through 9 or preselected symbols such as + and - signs. Their 3/8"-high characters are easily read from a distance of 30 feet. Less than \$5 each in 500 lots, they also cost less to use because the bezel and filter assembly can be eliminated and because their mating sockets are inexpensive.



Recording Storage Tubes. The miniature tubes shown here are Raytheon's single-gun (CK1516) and dual-gun (CK1519). They provide high resolution, long storage, and fast erase capability.

Raytheon electronic input-output storage devices feature the above capabilities and immediate readout. Information can be written and stored by sequential techniques or by random-access writing. Complete, gradual or selective erasure is possible.

Raytheon storage tubes are readily available for applications in radar scan conversion, slow-down video, signal processing, signal enhancement, time delay, and stop motion.

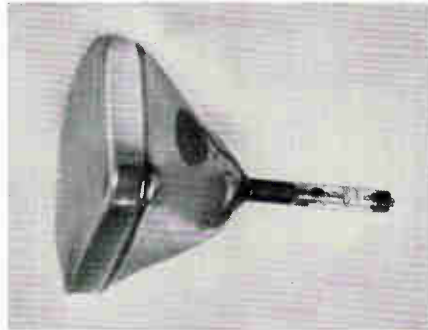

Dataray* Cathode Ray Tubes. Raytheon makes a wide range of industrial CRTs—including special types—in screen sizes from 7" to 24". Electrostatic, magnetic, and combination deflection types are available for writing alphanumeric characters while raster scanning. All standard phosphors are available and specific design requirements can be met. Combination deflection or "diddle plate" types include CK1395P (24" rectangular tube), CK1400P (21" rectangular), and CK1406P (17" rectangular).

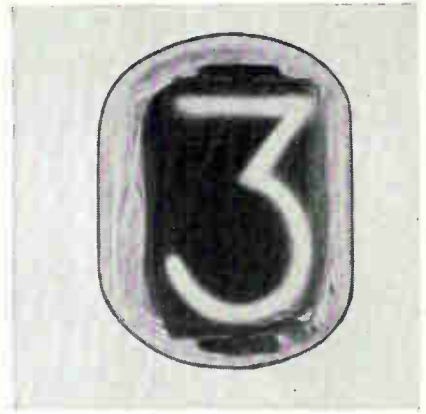

Datavue* End-View Tubes. These tubes are easily read in high ambient light—do not wash out like other displays. Erroneous readings due to segment failure do not occur because the characters are fully formed. Raytheon Datavue End-View Tubes fit existing sockets and conform to EIA ratings. Models include round (CK8421) and rectangular (CK8422). Ultra-long-life types are designed for 200,000 hours or more of dynamic operation.



Send Reader Service Card for literature on the:

Symbolray CRT	491
Projectoray CRT	492
Datavue Indicator Tubes	493
Recording Storage Tubes	494
Dataray CRTs	495

Or call your Raytheon regional sales office. Or write to *Raytheon Company, Components Division, Quincy, Mass 02169.*

*Trademark of Raytheon Company

Visit Raytheon Booth 3D02—3D18 at IEEE.



Industrial Components Operation—A single source for Circuit Modules/Control Knobs/Display Devices/Filters/Hybrid Thick-Film Circuits/Industrial Tubes/Optoelectronic Devices/Panel Hardware

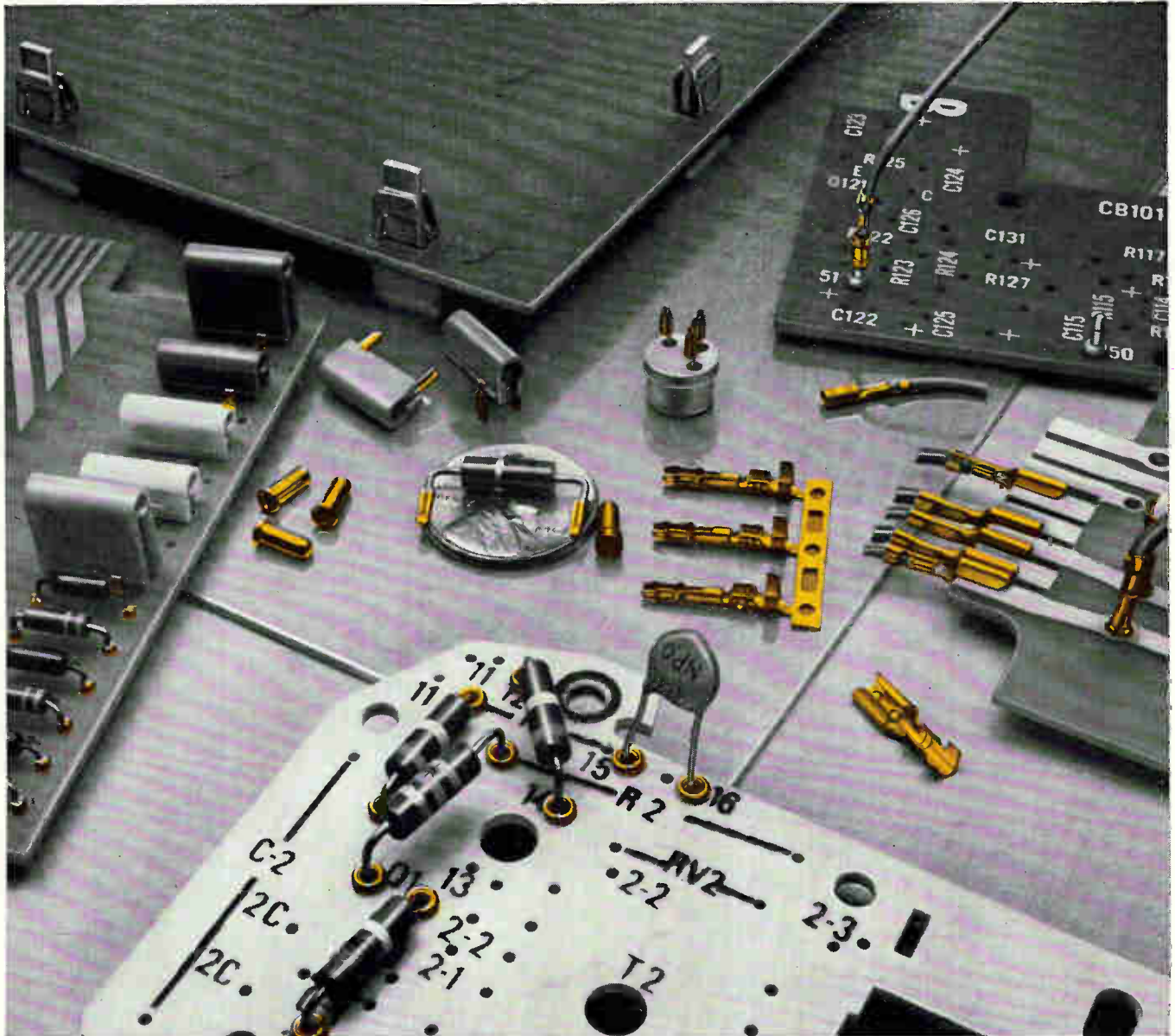

Small size. Small price. Big printed circuit convenience.

These little time-savers can help simplify, economize, and automate your printed circuit board production. Specifically designed for users of printed circuit boards, they each incorporate AMP's quarter century of development and experience in precision solderless techniques. One or more can benefit you if you use printed circuit boards.

For example, AMP-IN* Printed Circuit Pins (A) may be attached at rates up to 4,000 an hour; snap-in design holds leads in position for easy solder dipping. With AMP's handy Test Probe Receptacles (B), test points may be provided anywhere on printed circuit boards. Color coded for quick location; double-ended probe entry. The AMP-EDGE* Single Circuit Edge Connector (C) is a quick disconnect contact that fits an edge slot in printed circuit boards from .040" to .093" thick. Its wiping action pre-cleans board contacts. AMP's Printed Circuit Board Disconnect (D) comprises a staked pin and a receptacle which is crimped to the lead. This enables you to bring a variety of wires to a printed circuit board and to disconnect them at will.

Components are held in place during assembly with CIRCUITIP* Terminals (E), which also pro-

mote uniform solder fillets; machine-applied at rates of 7,200 an hour. The many ways to use AMP's Reusable Component Test Receptacles (F) include testing, breadboarding, and modular connector design. One size accepts leads from .018" to .040" in diameter; eliminates soldering. The newest product for printed circuit boards is AMP's Printed Circuit Board Fastener (G), which speeds up the process of assembling a printed circuit board to a chassis and greatly aids servicing. Includes types which facilitate component mounting and power input connections radio, TV, Hi-Fi, vending, and commercial control products. Write today for full information about any of these useful printed circuit board aids. Or, let us help solve your special printed circuit problem.

*Trademark of AMP INCORPORATED

AMP
INCORPORATED
 Harrisburg, Pennsylvania

AMP* products and engineering assistance are available through subsidiary companies in: Australia • Canada • England • France • Holland • Italy • Japan • Mexico • Spain • West Germany

Here's A PNP Silicon RF Transistor That's Going To Change The Polarity of A Lot of Present Designs!



TO-72

3.0 dB max. Noise Figure } @ 450 MHz
17 dB min. Power Gain }
1200 MHz min f_T

An easy modification of the bias arrangement of your NPN circuit — by simply reversing dc polarity, or grounding the emitter circuit instead of collector circuit (or vice versa) — and you're ready to plug in the far superior performance of the new Motorola silicon PNP 2N4957-9 VHF/UHF transistors.

Take the 2N4957 — for true state of the art. Even at 1 GHz, the N.F. is only 5.0 dB and with a power gain of 13 dB! Other key advantages: breakdown voltage for the 2N4957-9 series is a relatively high 30 V, plus you benefit from low collector-base capacitance and resultant low feedback ($C_{cb} = 0.4$ pF typ).

What's more, with these PNP devices you can have

silicon noise figures that are comparable to low-noise PNP germanium at prices as low as \$4.50 (100-up lots)! (Incidentally, Motorola also can supply NPN devices 2N2857 and 2N3839 if that's what you're presently using!)

These "state-of-the-art" devices are available at low prices, too:

Type	100-up
2N4957	\$13.50
2N4958	6.90
2N4959	4.50

For evaluation units and application information, see your Motorola sales representative. For detailed data sheets, write Motorola Semiconductor Products Inc., Box 955, Phoenix, Arizona 85001.

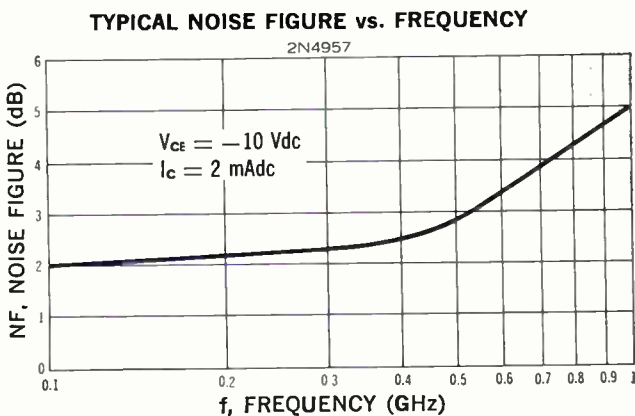

CHANGING DC CIRCUITRY TO PNP POLARITY:

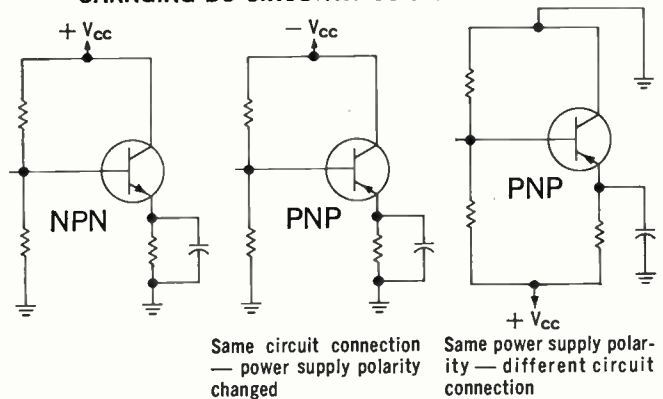

- where the priceless ingredient is care!



MOTOROLA
Semiconductors



Sierra brings to light...

You'll spot them all with lightning speed on Sierra's Model 360A Spectrum Display Unit: Overload, noise, crosstalk, carrier leak. The communications disrupters!

Tracking automatically across the tuning range of a companion frequency selective voltmeter (shown above, Sierra's Model 128A), Model 360A presents an expanded view of selected frequency segments on a high-resolution, swept-band CRT display. Sweepwidths of 120 kHz or 12 kHz display thirty- or three-channel segments of the multiplex baseband. A 3.6-kHz sweep position narrows the view to one voice channel, resolving approximately 30 Hz at 3 db down from a carrier peak and 60 Hz at 40 db down. The voltmeter indicates precisely the frequency and amplitude of any displayed signals.

Price of the Model 360A is \$2,450. The bulletin sheds further light on the matter. Write Sierra, 3885 Bohannon Drive, Menlo Park, California 94025.

Circle 85 on reader service card

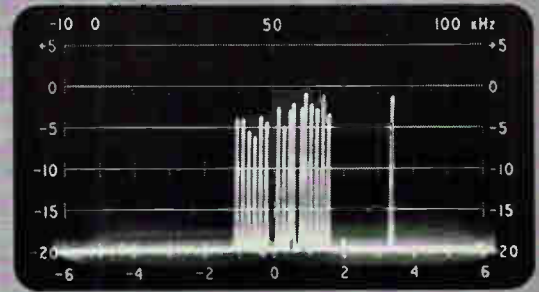

Three L-3 carrier channels shown in 12-kHz sweep width mode. teletype signals on center channel, 2500-Hz "on hook" tone on right channel, left channel idle.

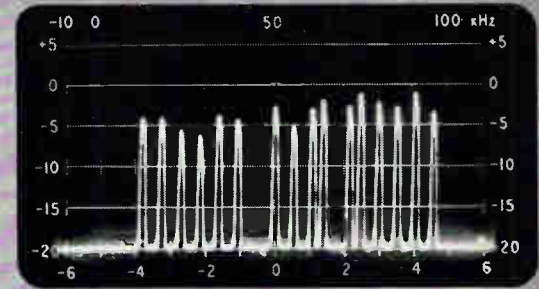

Center channel above expanded to 3.6 kHz sweep width mode. 17 teletype carriers, 1 missing, 2 showing "mark space" information.

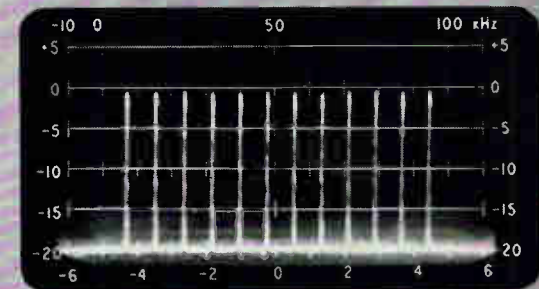

Complete N-1 carrier system shown in 120-kHz sweep width mode. Slope is 0 db; all carriers present, channels 2-13, high group.

dark deeds in the under-world of high-density carrier systems

PHILCO



PHILCO-FORD CORPORATION
Sierra Electronic Operation
Menlo Park, California • 94025



Fluorine is such an active element that, until 1886, it had never been successfully separated from its compounds. When isolated, it combines immediately with water, many metals and even glass. Finally Henri Moissan, a French chemist, fabricated containers of a platinum-iridium alloy, the most inert metals known. By cooling his equipment to slow down fluorine's activity, he managed to capture some free fluorine. In 1906, he received the Nobel prize in chemistry for his achievement.

INNOVATION IS THE PULSE OF PROGRESS

In 1957 Raychem pioneered a series of innovations in the field of radiation chemistry. Among the first was heat shrinkable tubing which has since become an accepted device throughout the aerospace, communication and commercial equipment industries. Today Raychem continues to be the world leader in the development of commercially irradiated products.

THERMOFIT NT is one development of Raychem's experience in the field of radiation chemistry and heat-shrinkable materials. It is a flexible, abrasion resistant insulating tubing, manufactured from a specially formulated Neoprene which has been cross-linked by irradiation, resulting in a unique combination of properties, including elastic memory. Thermofit NT is primarily used as a jacketing material for cables and harnesses. It is a genuine improvement over conventional jacketing methods.



RAYCLAD TUBES INCORPORATED
A SUBSIDIARY OF
RAYCHEM CORPORATION

300 Constitution Drive • Menlo Park, California

Adlake Mercury Wetted Relay — Application Data

Measurement of "Dynamic Contact Noise" for Low Level Signal Applications

Adlake AWCS 26000 Series Relay — 2 Switch Form C



In small signal applications, such as computers, telemetric systems, strain gauges, etc. generated emf. within the system's relays must be taken into account.

Dynamic Contact Noise is a "coined" phrase used to indicate an undesired generated emf. upon contact closure. It is the result of mechanical oscillation of the armature—caused by the impact of the armature on the stationary contacts — sweeping the coil flux.

Typical illustrations of this noise are shown in the oscillograms, with the relay being driven at nominal voltage in the test circuit shown below. The frequency and amplitude are integral functions of system bandwidth and coil drive conditions.

The slight ripple seen at the end of each trace is not noise, but due to resolution of test equipment and test circuit.

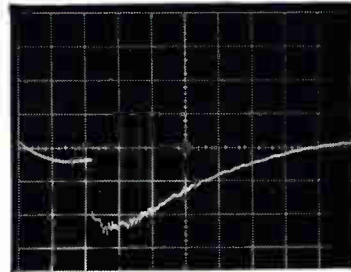

FIGURE 1

Horizontal Deflection 1.0 ms/cm
Vertical Deflection 20 μ V/cm
Systems Bandwidth .06–60 Hz.

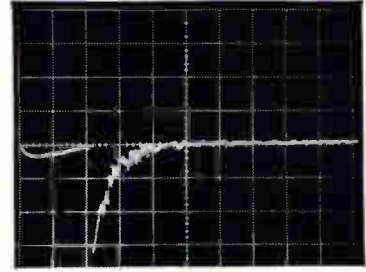

FIGURE 2

Horizontal Deflection 1.0 ms/cm
Vertical Deflection 100 μ V/cm
Systems Bandwidth .06–600 Hz.

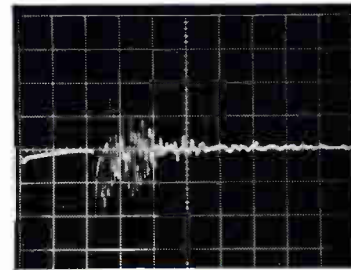

FIGURE 3

Horizontal Deflection 1.0 ms/cm
Vertical Deflection 200 μ V/cm
Systems Bandwidth .06–6K Hz.

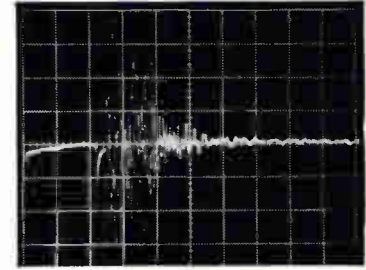

FIGURE 4

Horizontal Deflection 1.0 ms/cm
Vertical Deflection 200 μ V/cm
Systems Bandwidth .06–60K Hz.

TEST CIRCUIT

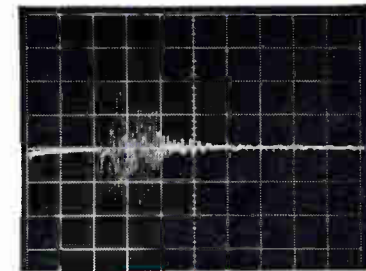
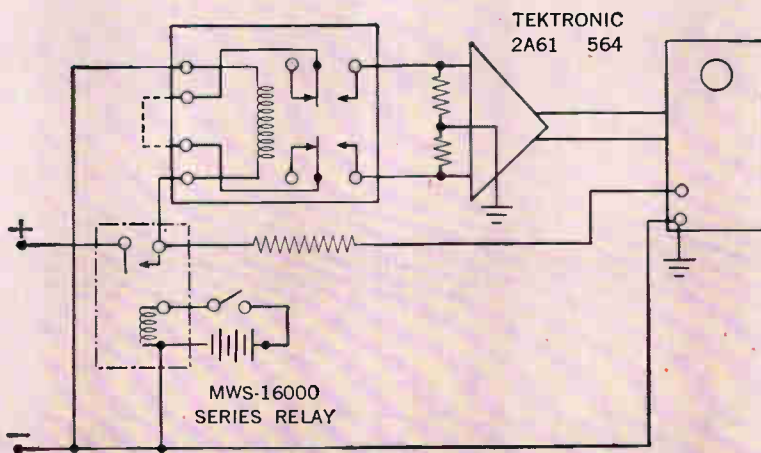

FIGURE 5

Horizontal Deflection 1.0 ms/cm
Vertical Deflection 500 μ V/cm
Systems Bandwidth .06–100K Hz.

* If you have a problem regarding relay applications to a particular system our engineering staff is ready to help you. Contact Mr. Le Roy Carlson, Chief Project Engineer.

Backed by sound research and disciplined engineering, Adlake applies the industry's broadest line of mercury displacement and mercury wetted relays to the creative solution of design circuit problems. However unique or special your application, Adlake can assist you in

developing it. For prompt, personal and knowledgeable attention to your relay needs, contact the one source that is the complete source in the mercury relay field. Contact Adlake today for catalog and further information.



THE ADAMS & WESTLAKE COMPANY

Dept. 2037, Elkhart, Indiana, U.S.A. 46514 • (AC 219) 264-1141

TRANSPORTATION EQUIPMENT • ARCHITECTURAL PRODUCTS • MERCURY RELAYS • DOORS AND ENTRANCES • CONTRACT MANUFACTURING

NEW!

**IMMEDIATE DELIVERY
FROM STOCK
\$7,705**

470-1000 MHz

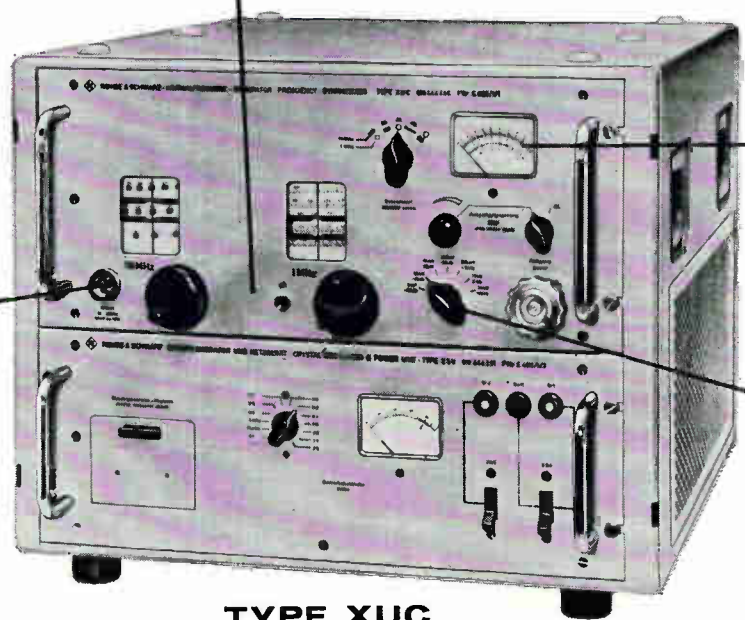

**PROVISION FOR
CRYSTAL STEP
VERNIER**

3V (MAX.) OUTPUT

70 dB ATTENUATOR

TYPE XUC

UHF FREQUENCY SYNTHESIZER

FEATURES:

- High Resolution:
470-1000 MHz Xtal steps, and continuously variable
0-10 MHz interpolation oscillator, 10 kHz/Div.
- Built-in 5 MHz crystal has proportional oven and 2×10^{-9} stability
- Spurious frequency suppression greater than 80 dB
- Fixed frequency outputs:
100 kHz, 1 MHz, 10 MHz
- Solid State Design

TYPICAL SYNCHRONIZING SYSTEM

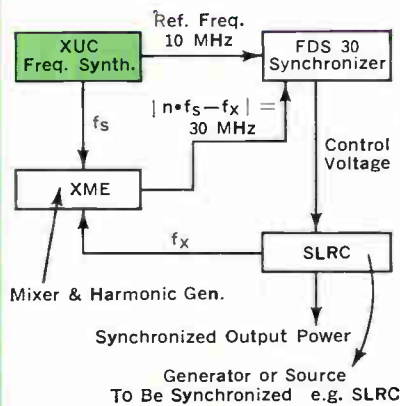

The Type XUC is the only true UHF-Synthesizer. It is the only single instrument to provide output frequencies to 1 GHz with 3V and 80 dB suppression of spurious. Generation of ultra-stable microwave frequencies is simplified and can be accomplished in two ways:

a) Multiplication: Lower multiplication factors result in better S/N, for instance 60 dB at 10 GHz.

b) Synchronization: XUC permits continuous tuning. Synchronizes to any frequency up to 80 GHz. Positive synchronization without ambiguity and with better stability obtained by use of higher fundamental frequencies, larger output and improved S/N.

Resolution of Type XUC is 5 kHz and can be extended to 1.0 Hz using R/S Type ND 30 M Frequency Synthesizer as a vernier.

Applications include checking selective 2 and 4 terminal networks, frequency measurements, microwave spectroscopy, nuclear magnetic resonance, synchronization of microwave generators and tubes, etc.



Get The Extra Capability,
Greater Reliability, and
Longer Useful Life Of . . .

ROHDE & SCHWARZ

111 LEXINGTON AVENUE, PASSAIC, N. J. 07055 • (201) 773-8010

Inquiries outside the U.S.A. should be directed to Rohde & Schwarz, Muehlhofstrasse 15, Munchen 8, West Germany

Words about wines

It has occurred to us that a good product — like a good wine — gains far more renown from what its users say about it than from what its makers say about it. Therefore, in this column we eschew the temptation to discuss that over which we labor in our own vineyard, and instead bring you each month some random thoughts on the science of making wines and the art of enjoying them.

* First, a comforting thought for the wine lover who is aware of the value of the grape as a gentle tranquilizer, but who worries lest its nourishing effect on his psychical well-being is offset by any threat to his physical welfare. Rest easy. There is sound medical evidence that—among wine's many salutary effects—it may be useful in prevention or treatment of coronary problems. (But if it increases your appetite and you over-eat, that's another problem.)

* Wine-making is as old as history. You'll find more than 150 references to it in the Bible (including a number counseling its temperate use). The more recent history of wine still has a religious flavor. *Vitis vinifera*, the Old World grape, was first introduced in California—where 80% of U. S. wine is made—by the Spanish missionaries in 1769. Much wine is still produced today in monastic surroundings.

* The spirit of inquiry leads many Americans to make their own wine at home, under a law that lets heads of households make 200 gallons for personal use. It is an official tribute to wine's unique status as a food. Most of the results are so unusual they are quietly trickled down the drain after a few months. Write to us for a how-to bulletin if you have hopes of doing better.



ELECTRONICS

SEMICONDUCTOR PRODUCTS

365 Middlefield Road • Mountain View, California

During IEEE 1967
UNION CARBIDE SEMICONDUCTOR
Cordially invites you
to attend an authentic

Wine Tasting

**TUESDAY, MARCH 21,
5:30 PM TO 7:30 PM
West Ballroom
New York Hilton Hotel**

You will taste samples from fifteen different wineries. To obtain your free pass and program for this delightful event, contact your Union Carbide Semiconductor distributor, representative, or factory sales engineer, or stop by the Union Carbide exhibit (Booth 3J06-3J16) at the IEEE show.

Note of Interest: Whether or not you can join us for the wine tasting in New York, you are also invited to join the intellectually curious who will be following our current series of advertisements appearing each month in *Scientific American*. The first in this series is reprinted at left. (Use reader service card to request the wine bulletin offered in the advertisement.)



ELECTRONICS

365 Middlefield Road, Mountain View, California 94040 (415) 961-3300

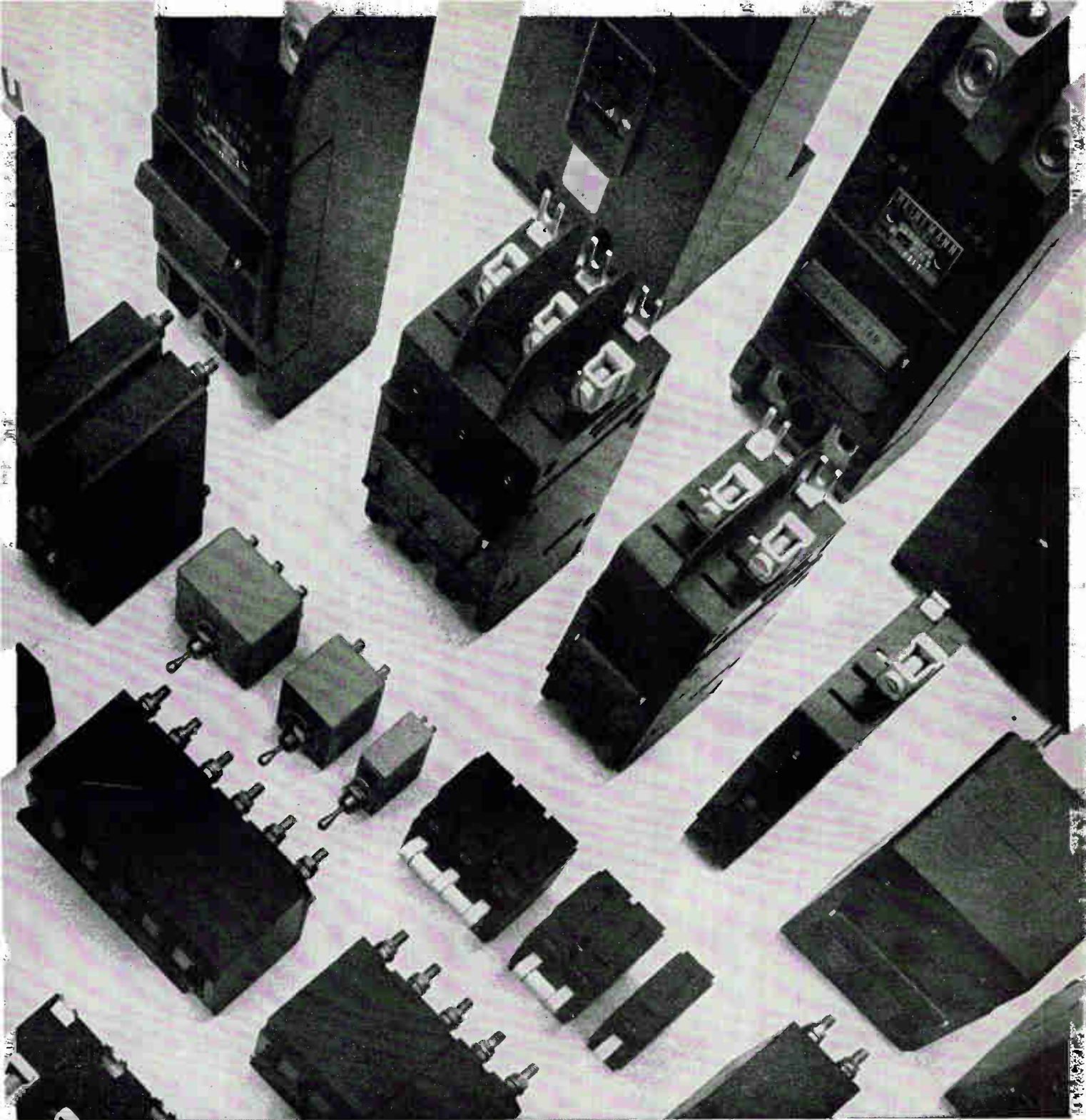

Over 60% of all Heinemann hydraulic-magnetic circuit breakers produced each year are rather odd in one way or another.

By the usual standards, at any rate. But for us the far-out is all in a day's work. We're tooled up to manufacture the out-of-the-ordinary as a matter of routine.

The fact is, we have an extensive roster of options for you to work with when you want really tight overload protection. Current ratings in any integral or fractional value, from 0.010 to 225 amps. A choice of several time-delay characteristics or instantaneous trip. A selection of special-function internal circuits—relay-trip, shunt-trip, etc. A broad array of models, from one to six poles, from subminiature on up.

The cost of a job-matched Heinemann breaker will probably be a good bit less than you would expect. The reason is simple enough. 'Specials' are our specialty—60% every year.

If you've got a knotty protection requirement, get in touch with us. For a starter, try our Bulletin 302; it covers our entire line of breakers. We'll put a copy in the mail as soon as we hear from you. Heinemann Electric Company, 2626 Brunswick Pike, Trenton, N.J. 08602.

 **HEINEMANN**
Circle 95 on reader service card

A family of insulating products...

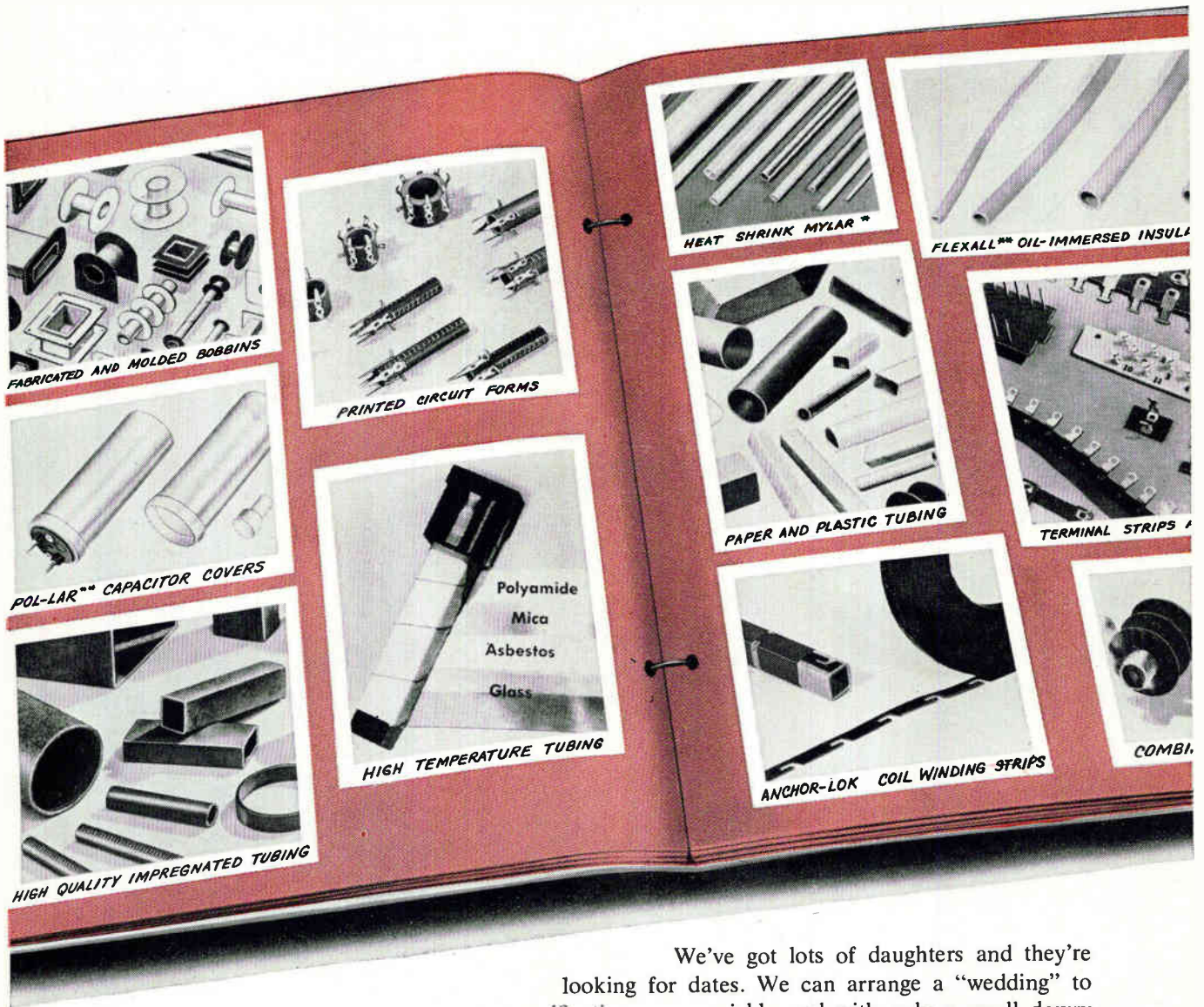

We've got lots of daughters and they're looking for dates. We can arrange a "wedding" to your specifications . . . quickly and with only a small dowry on your part. If you see a member of our family you'd like to know better . . . drop us a line or phone us at our "home" in Wheeling (Ill.). Let us know which one interests you the most and we'll send you full particulars.

*Registered trademark—DuPont Co.

**Registered trademark—Precision Paper Tube Co.



Precision

Paper Tube Company

Divisions: Resinite • Buckeye Bobbin • Automation Devices
 1033 S. Noel Ave., Wheeling, Ill. Phones: Chicago: 631-1445 • Long Distance: 312-537-4250

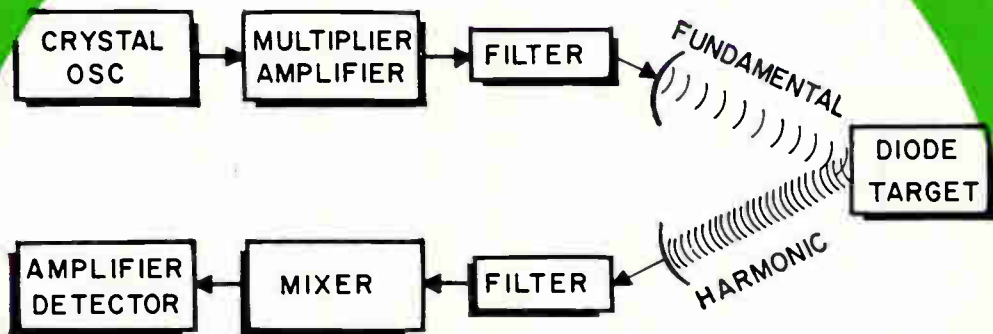

Can a diode in free space generate harmonics?

YES—and it's the basis of a new communications & navigation system from Microlab/FXR!

Everyone knows that diodes generate harmonics—in a circuit! But perhaps you didn't know that diodes can be made to do this in free space—without any attached circuitry or power source.

Microlab/FXR has applied this principle to a new Diode Interrogation, Communication and Navigation System*. This is a harmonic radar system, consisting of a Diode Exciter/Receiver plus a passive diode antenna—or a self-focusing phased array where increased range is required—either modulated or unmodulated.

This new Microlab/FXR system can thus detect and communicate with any object (or person) to which the diode is attached. Perhaps even more important, it can positively

single out and identify any particular target from all others. Microlab/FXR's new system can well be the answer to heretofore unyielding problems connected with air/sea navigation, flight traffic control, rescue and recovery operations, IFF systems, etc. In other areas, the system can be used for everything from automobile traffic control to aircraft blind landing systems; from bird and animal migratory studies to human medical diagnostics.

Maybe these applications whet your appetite — maybe they fit in neatly with a project you're working on— maybe they give you a new idea for something we haven't thought of. If so, you'll want more information. Just circle the Reader Service Card. Better still, write us directly, at Dept. E-61.



MICROLAB/FXR

*patents pending

Livingston, New Jersey 07039 Phones: (201) 992-7700; (212) 721-9000

©1967

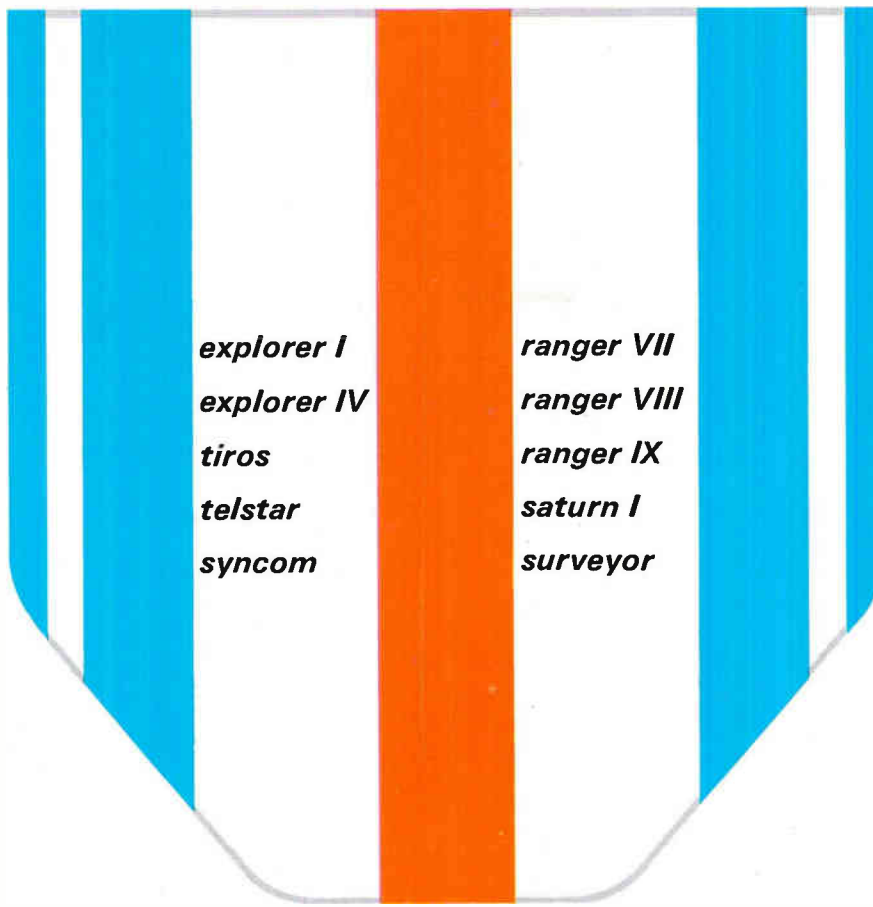

explorer I
explorer IV
tiros
telstar
syncom

ranger VII
ranger VIII
ranger IX
saturn I
surveyor



the most honored resistor in the Space Program

■ Allen-Bradley hot molded resistors were chosen to participate in these many history-making space projects for only one vital reason—a history of proven performance that dates back for more than a quarter of a century! A record more conclusive than any testing program could possibly provide!

The superiority of Allen-Bradley resistors is found in the exclusive hot molding process. Through the use of completely automatic machines—developed and used *only* by Allen-Bradley—there is obtained such uniformity of characteristics from resistor to resistor, year after year, that the resistors' long term performance can be accurately predicted. Furthermore, no Allen-Bradley hot molded resistor has ever been found to have failed catastrophically.

The widespread use of the Allen-Bradley hot molded resistors in these space programs should convince you that to include this plus value in the equipment which you produce gives it the mark of "extra quality." Let us tell

you more about the complete line of Allen-Bradley electronic components. Please write for Publication 6024. Allen-Bradley Co., 222 W. Greenfield Ave., Milwaukee, Wis. 53204. In Canada: Allen-Bradley Canada Limited. Export Office: 630 Third Ave., N. Y., N. Y. U.S.A. 10017.



HOT MOLDED FIXED RESISTORS are available in all standard resistance values and tolerances, plus values above and below standard limits. Shown actual size.



ALLEN-BRADLEY

QUALITY ELECTRONIC COMPONENTS



Soliton announces

A MAJOR BREAKTHROUGH in Silicon Power Transistors:

ISOLTAXIALTM

NPN SILICON TRANSISTORS

PAT. PENDING

Featuring

- ✓ low leakage currents
- ✓ freedom from secondary breakdown
- ✓ flat gain curve
- ✓ 15 amp capabilities
- ✓ 145 Watts @ 25°C
- ✓ low output admittance
- ✓ low saturation voltages
- ✓ high reliability

Now — for the first time — a transistor has been developed with the characteristics of low-leakage planar units, combined with resistance to secondary breakdown offered by homogenous devices. The results are Soliton's ISOLTAXIAL NPN Silicon Power Transistors! The ISOLTAXIAL transistors have special construction innovations and processing techniques, and were developed with the high reliability standards associated with Soliton. A few of their many applications include power supplies, audio amplifiers, inverters, converters, relay drivers and series regulators. ISOLTAXIAL transistors are low-cost and packaged in TO-3 and T-61 cases.



Type Number	Pkg. Size	Type Number	Pkg. Size	DESIGN LIMITS			PERFORMANCE SPECS.	
				BV _{CBO}	V _{CEO} (SUS)	BV _{EBO}	i _{CEX} @ V _{CE} (V _{EB} = 1.5V)	
				Volts	Volts	Volts	μA (Max.)	Volts
SDT9801	TO-3	SDT9901	TO-61	60	40	12	100	40
SDT9802	TO-3	SDT9902	TO-61	80	60	12	100	60
SDT9803	TO-3	SDT9903	TO-61	100	80	12	100	80
SDT9804	TO-3	SDT9904	TO-61	120	100	12	100	100

ALL TYPES INCLUDE THE FOLLOWING SPECIFICATIONS:
Gain 20-60 @ 5 A
V_{CE} (sat) 0.5 V Max. @ 5 A
V_{BE} (sat) 1.2 V Max. @ 5 A
ft 1.0 MHz Min.

CONTACT US TODAY FOR COMPLETE INFORMATION AND SEE THESE DEVICES IN OUR DISPLAY AT THE IEEE SHOW

TRANSISTOR DIVISION

Soliton DEVICES, INC.

1177 BLUE HERON BLVD. / RIVIERA BEACH, FLORIDA / (305) 848-4311 / TWX: (510) 952-6676

Leader in Germanium and Silicon Power Transistors, Cryogenic Thermometers, High Voltage Rectifiers, Hot Carrier Diodes, Temperature Compensated Zeners, Voltage Variable Capacitors, Random/White Noise Components, Microelectronic Circuits, and Power-Sink Interconnection Systems.

VALUE

BIG:
11" x 17"
X-Y RECORDER



SMALL:

\$1195

Now in a bigger chart size—a value-priced Moseley X-Y recorder offering solid-state reliability and the same performance you get from the Model 7035A 8½"x11" X-Y Recorder (\$895).

The Moseley 7005A lets you record on an 11"x17" chart for increased resolution. Five calibrated ranges each axis, 1 m V/in. to 10 V/in. High input impedance, floating and guarded input, 0.2% accuracy at full scale. Adjustable zero set each axis. Autogrip care-free electric paper holddown. Electric pen lift. Bench and rack mount model in one. Metric Model 7005AM is also available.

You get all these features for your recording applications for just \$1195. For complete information just call your

Hewlett-Packard field engineer or write Hewlett-Packard, Palo Alto, California 94304, Tel. (415) 326-7000; Europe: 54 Route des Acacias, Geneva.

BRIEF SPECIFICATIONS

Input Ranges: 7005A 1, 10, 100 mV/in.; 1, 10 V/in.

7005AM 0.4, 4, 40, 400 mV/cm; 4 V/cm

Input Resistance: Potentiometric—1 mV/in. range; 100K—10 mV/in.;
1 Megohm—0.1, 1, 10 V/in.

Accuracy: ± 0.2% at full scale; linearity: ± 0.1% of full scale;
dead band: ± 0.1% of full scale.

Model 17108A External Time Base provides 5 sweep speeds either axis 0.5 to 50 sec/in. (\$175).

**HEWLETT
PACKARD**  **MOSELEY
DIVISION**

CONSUMER

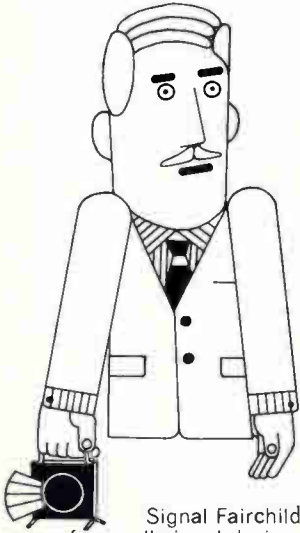

Signal Fairchild
for small signal devices
PRODUCT SELECTOR

FAIRCHILD
SEMICONDUCTOR

Please send me

- Military small-signal device selection guide
(Military computers, radar, etc.)
- Industrial small-signal device selection guide
(Instruments, test equipment, etc.)
- Consumer small-signal device selection guide
(AM, FM, TV, etc.)
- Commercial computer small-signal device selection guide
(Core drivers, logic switches, lamp drivers, etc.)

Name _____

Company _____

Title _____

Address _____

City _____ State _____ Zip _____

Four new, Fairchild selection guides for small-signal transistors and diodes. The easiest way to choose the optimum device for your new design.

Free.

Fairchild Semiconductor ■ A Division of Fairchild Camera and Instrument Corporation ■ 313 Fairchild Drive, Mountain View, California 94040 (415) 962-5011 ■ TWX: 910-379-6435

Linear RF Sweeper

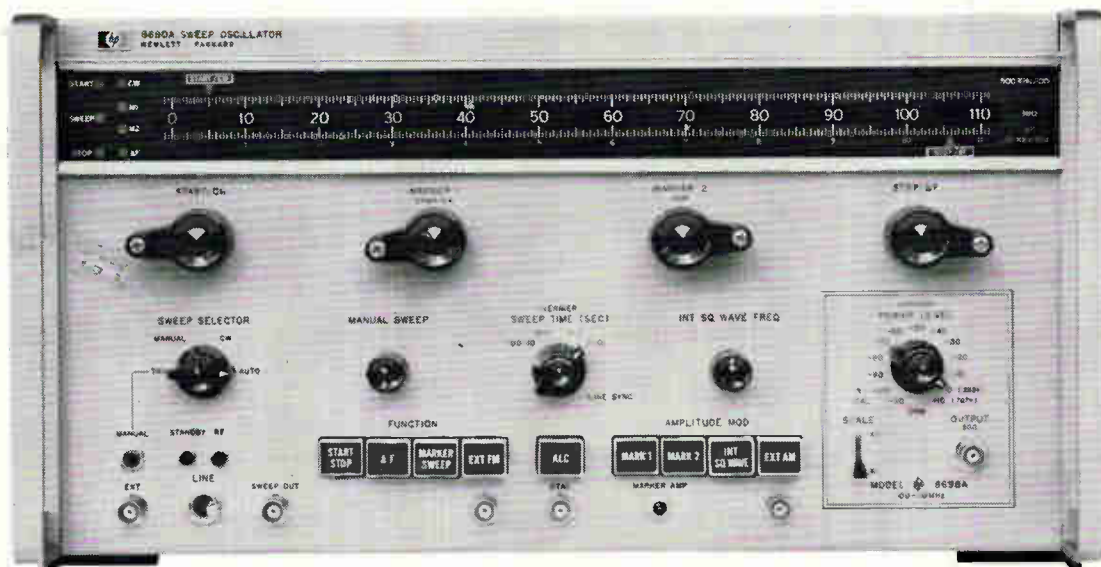

Residual FM:

0.1 to 11 MHz <150 Hz peak, 1 to 110 MHz <500 Hz peak.

Frequency Stability:

With temperature: 0.1 to 11 MHz, $\pm 0.01\%$ / $^{\circ}\text{C}$ or ± 200 Hz/ $^{\circ}\text{C}$, whichever is greater; 1 to 110 MHz, $\pm 0.01\%$ / $^{\circ}\text{C}$ or ± 2 kHz/ $^{\circ}\text{C}$, whichever is greater.

With 10% line voltage change: 0.1 to 11 MHz, ± 5 kHz; 1 to 110 MHz, ± 50 kHz.

Spurious Signals:

Non-harmonics at least 40 dB below CW output. Harmonics at least 35 dB below +10 dBm CW output.

POWER SPECIFICATIONS

Power Output:

At least +20 dBm max. (2.23 VRMS into 50 ohms). Calibrated power output adjustable in 10 dB steps from +10 dBm to -110 dBm; 10 dB vernier permits continuous adjustment between steps. Source impedance is 50 ohms.

Power Accuracy:

± 1 dB + attenuator accuracy (vernier in CAL position).

Attenuator Accuracy:

± 1 dB to 70 dB attenuation; ± 2 dB to 120 dB attenuation.

Output Flatness:

± 0.25 dB (± 0.1 dB over any 10 MHz bandwidth).

Price: Model 8698A RF Sweeper Generator, \$950.
(Model 8690A Sweep Oscillator, \$1550.)

For more information contact your local HP field engineer or write Hewlett-Packard, 1501 Page Mill Road, Palo Alto, California 94304, Tel: (415) 326-7000; Europe: 54 Route des Acacias, Geneva.

HEWLETT  PACKARD

IC	VCEO	hFE	VCE(sat)	PT	SWITCHING TIME			
					t _{on} ns	t _{off} ns	@ I _C A	@ ± I _B mA
3A	40 to 60V	25 min @ 2A, 10V	0.5V max @ 1A, 0.1A	5W	35	75	1.5	150
5A	40 to 80V	120 min @ 3A, 10V	0.75V max @ 3A, 0.3A		40	300	3.0	300
10A		40 min @ 5A, 10V	1V max @ 5A, 0.5A	25W to 50W	225	600	10	1000
15A	60 to 100V	15 min @ 10A, 5V	1.5V max @ 15A, 3A					
20A		20 min @ 10A, 5V	1.5V max @ 20A, 4A					

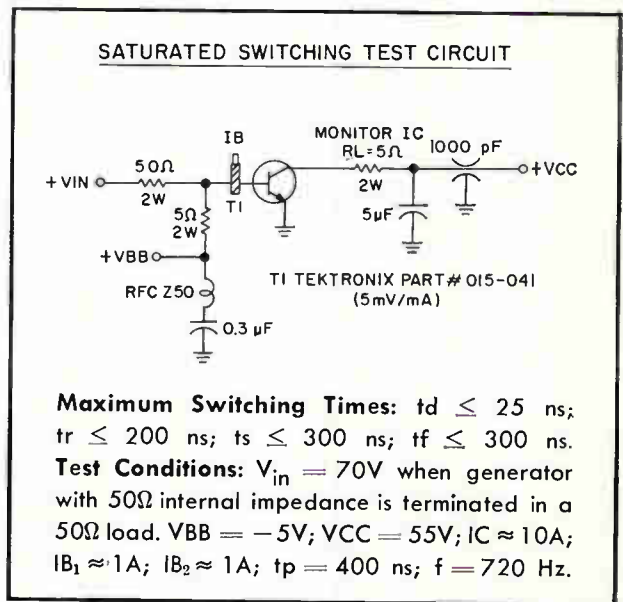
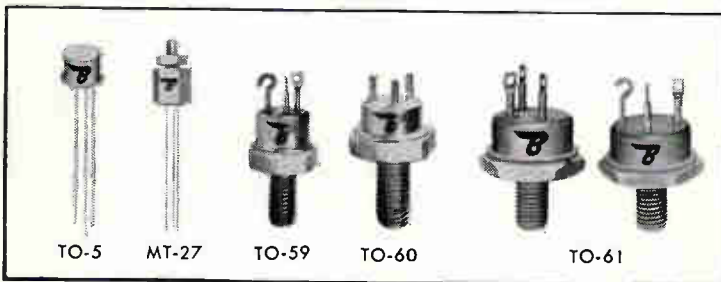

You'll find over 100 types to choose from. With IC's of 3, 5, 10, 15 and 20 amps, and VCEO from 40 to 100 volts. Low saturation at high current, and low thermal resistance provides more useable power. There's sure to be one suited for your high current switching or amplifier application. Bendix silicon planar power NPN transistors come in six different package configurations, too.

You'll also find the top performance you're looking for—operating reliability from quality workmanship

Stop at Bendix IEEE Booth 4C04

in construction. There's another big benefit, too. **SOAR**. Clearly defined Safe Operating Areas for every transistor application. Second breakdown just doesn't occur when you operate within the SOAR specs. And SOAR saves design engineering time—lets you pick the right transistor for the right job.

So wind up your planar power needs the easy way. Just call our nearest office. We're all wound up to deliver. Bendix Semiconductor Division, Holmdel, New Jersey 07733.

Bendix Electronics

Atlanta—Grady Duckett Sales Co., (404) 451-3529; Baltimore (Towson), Md.—(301) 828-6877; Chicago—(312) 637-6929; Dallas—(214) 357-1972; Detroit—(313) 548-2120; Greenwich, Conn.—(203) 869-7797; Holmdel, N. J.—(201) 946-9400; Los Angeles—(213) 776-4100; Minneapolis—(612) 926-4633; Los Altos, Calif.—W. W. Posey Co., (415) 948-7771; Seattle—Ray Johnston Co., Inc. (206) LA 4-5170; Syracuse, N. Y.—(315) 474-7531; Waltham, Mass.—(617) 899-0770; Export—Cable: "Bendixint," 605 Third Avenue, New York, (212) 973-2121; Ottawa, Ont.—Computing Devices of Canada, P.O. Box 508—(613) TA1bot 8-2711.

Satellite communications transmitters can now operate broad band using MEC's high power, high efficiency TWT, the M4444. This tube delivers more than 12 kilowatts of c.w. power from 7.7 to 8.4 GHz at efficiencies greater than 35%. For the first time, a TWT matches klystron efficiency while providing 14 times their instantaneous bandwidth!

The metal-ceramic construction of the M4444 permits high temperature processing, and its integral ion pump and low cathode current density assure stable, long lived dependability.

A single stage depressed collector minimizes power supply complexity, and broad band operation is obtained at constant beam voltage.

Complete gain, phase shift, intermodulation, power and electrical characteristics are available for the asking. Our technical staff will be pleased to fill in the details on the M4444 or its counterparts in other frequency ranges.

The M4444 is one more example of MEC being first with the best in high power TWTs.



A new dimension in satellite communications



MICROWAVE ELECTRONICS

A TELEDYNE COMPANY

3165 Porter Drive • Palo Alto, California 94304

Visit us at the Essex House during IEEE

Technical Articles

Product planning at IEEE
page 116

This year will see integrated circuits move into a variety of new equipment. In this examination of some significant products to be introduced at the annual show of the Institute of Electrical and Electronic Engineers, the emphasis is on integrated circuits and instruments to test them. The trend in new products shows industry has a continuing interest in reducing production costs.

Worldwide look at the Gunn effect
page 134



The Gunn effect is the best known of the new phenomena that are exciting semiconductor engineers and microwave experts. Except for some production in Europe, however, the Gunn effect is confined to research laboratories. Some newer effects like limited space-charge accumulation now hold greater promise. On the cover is a many-times magnification of a voltage tunable oscillator, built at Bell Telephone Laboratories, that is tapered to allow control of the Gunn effect. The oscillator is about 30 mils long.

Earlier in this important series, there were extensive descriptions of how a computer can help in design when linear elements like resistors and capacitors are involved. These components require simple models. But nonlinear devices like the transistor and zener diodes require more complex models and procedures. A computer program has been prepared to solve nonlinear d-c problems and statistical, worst-case, and stress analysis.

Computer-aided design, part 7: Performing nonlinear d-c analysis
page 140

Earlier in this important series, there were extensive descriptions of how a computer can help in design when linear elements like resistors and capacitors are involved. These components require simple models. But nonlinear devices like the transistor and zener diodes require more complex models and procedures. A computer program has been prepared to solve nonlinear d-c problems and statistical, worst-case, and stress analysis.

Integrated circuits in action, part 5: In search of the ideal logic scheme
page 149

In the brief history of integrated electronics, many different logic schemes have been proposed. The engineer who has to choose one ought to understand the weaknesses and strengths of each.

1. Dilemmas galore—a survey of types of integrated logic
2. Understanding integrated-circuit logic—the engineer has to know how the logic works because specifications are often sketchy
3. Logic ic's don't live alone—the system affects the choice of circuit logic too

Coming
March 20

- How the computer handles transient analysis
- Measuring the transconductance of field effect transistors
- Computers for research satellites
- Glass isolation at work



Price of meter drops near predicted level

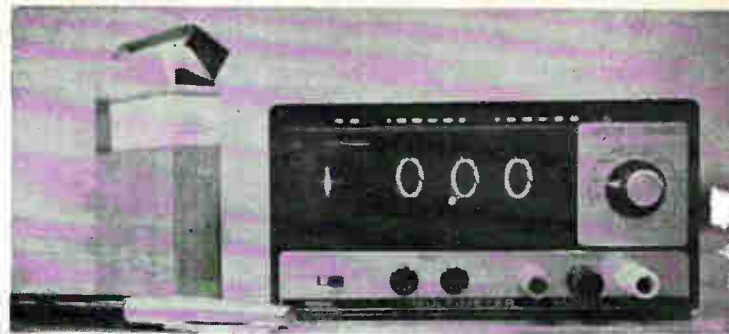

Some scoffed at the prediction four months ago that mass-produced integrated circuits would make possible a \$100 digital instrument for measuring voltage and resistance [Electronics, Nov. 28, 1966, p. 88]. Well, it hasn't been done yet, but the Instrumentation division of Fairchild Camera & Instrument Corp. has brought the price of a multimeter down to \$249, and claims this is one-fourth the cost of a comparable unit with conventional circuitry.

The company says the meter's size and price make it ideal for production-line use, systems testing and calibration, quality assurance, field service and educational applications.

Like the \$100 prototype predicted, the Fairchild multimeter uses a dual-slope (up-down) integrating technique for making measurements, but with fewer components. Besides combining the noise-rejection capability of integration with the accuracy and stability provided by automatic comparison to an internal standard, the dual-slope integrating method is better suited to IC's than are

other digital voltmeter techniques.

Fairchild's model 7050 uses off-the-shelf IC's for a pair of linear amplifiers and a number of logic elements.

According to the company, the model 7050 can replace not only analog meters and panel indicators but digital voltmeters costing much more. Measured values are displayed on Nixie tubes and are easy to read, even from a distance and at wide angles. The three-digit readout is said to be accurate to within 0.1% of reading. With analog instruments, on the other hand, operator and parallax errors, meter movement wear and aging often reduce their nominal accuracies—1% to 3%, typically. The model 7050 can withstand input voltages up to 1,000 volts d-c on any of its ranges without being damaged, according to Fairchild.

The meter measures d-c voltages from 1.5 to 1,000 v full scale and resistance from 1.5 kilohms full scale to 15 megohms full scale. For voltage measurements, the input is connected directly to the dual-amplifier range selection circuit (below).

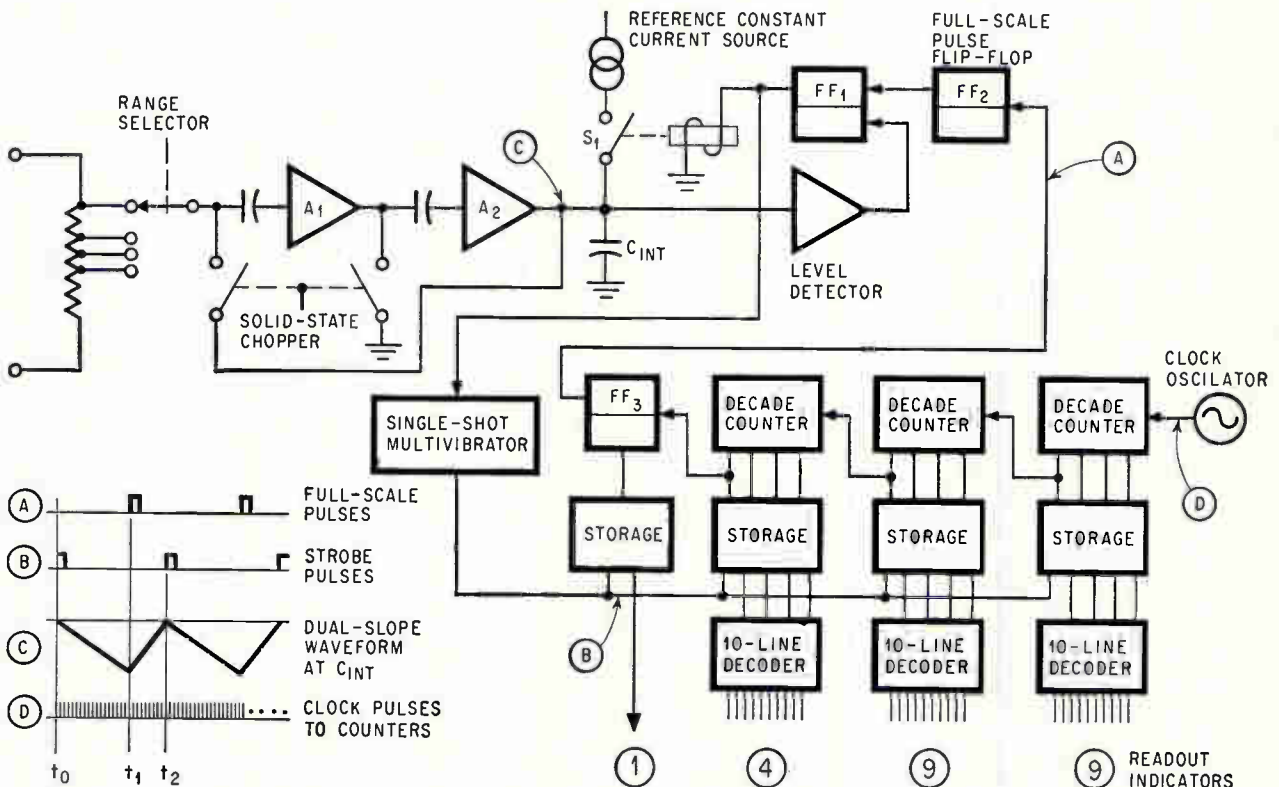

To measure voltage, multimeter measures the time required for the constant-current reference to discharge the integrating capacitor to zero volts after it has been charged to an initial value by an input voltage. The level detector senses the moment when C_{INT} reaches zero volts and generates a strobe pulse to transfer the count from the counters to the readout and restart the measurement cycle.

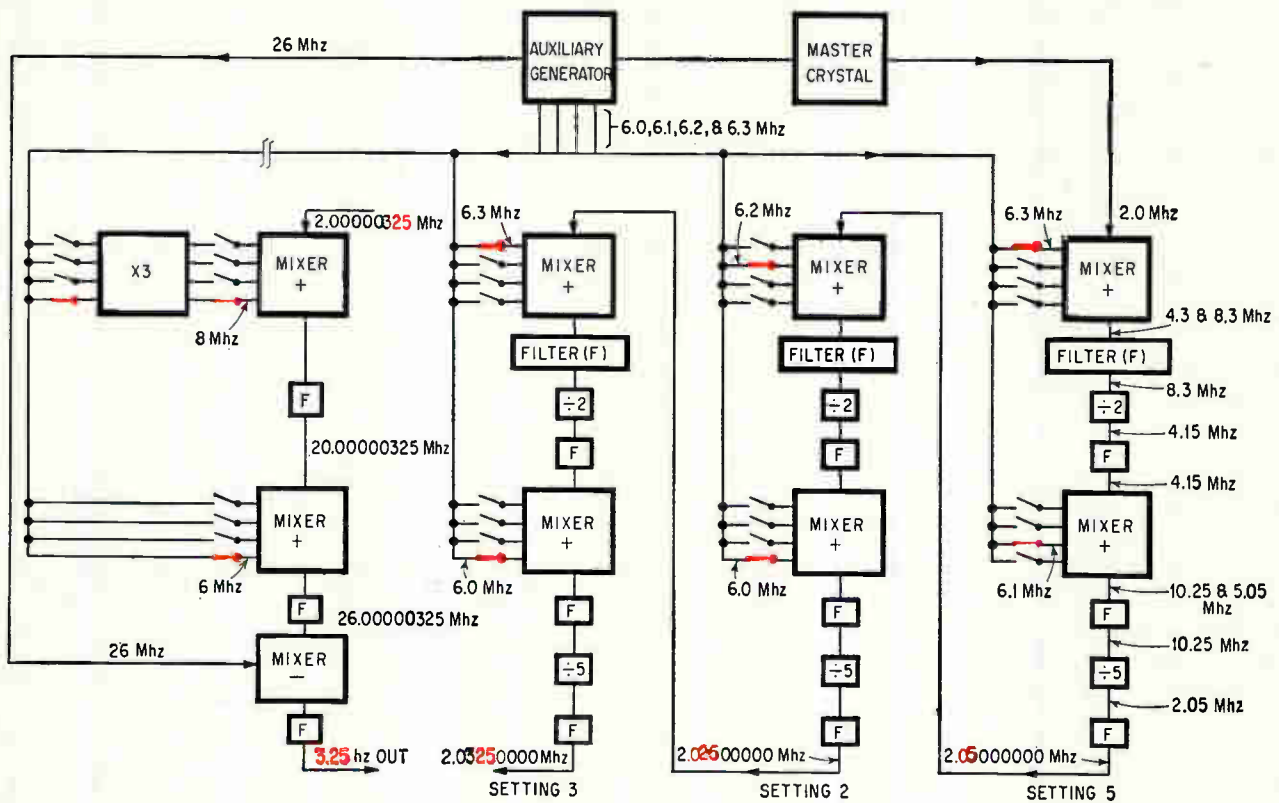

Decade modules mix signals produced by crystal oscillator to produce desired output—3.25 hertz in this example. Selecting the desired frequency closes various switch-contacts to feed the proper slave frequencies into mixer. Decimal portion (in color) of each decade's output is shifted one digit to the right as it progresses.

ample, the unit can sweep from 1 Mhz to 1.001 Mhz or from 1 kilohertz to 1.3 khz. The two fixed sweep rates are either 1 hz for monitoring on a recorder or 50 hz for viewing on the scope. As in other synthesizers, an external source can control the vco to frequency modulate the output or to provide other sweep rates. This instrument also makes it possible to amplitude modulate the output frequency derived from either the vco or the crystal. A d-c offset feature permits placing the output signal on a d-c bias level, variable between ± 2 volts—useful for testing solid state circuits. An attenuator can vary the output amplitude in 10 decibel steps from -70 db above a milliwatt to 20 dbm.

The instrument can be remotely programmed for testing frequency-sensitive devices like narrow band filters, delay lines and amplifiers. In this mode, the synthesizer can derive its output from

the crystal source or the vco or a combination of both. Frequencies can be selected in any desired pattern.

The unique doubly-balanced mixer circuits in this unit aid in reducing spurious outputs. Using only diodes, transistor and resistors, they suppress input frequencies about 60 db below the sideband. Eventually, Monsanto expects to fabricate these mixers in a special-purpose integrated circuit.

Specifications

Output frequency	0.01 hz to 1.3 Mhz in 0.01 hz steps
Stability	1×10^{-9} per day
Output voltage	2 v across 50 ohms
Spurious signals	80 db below desired output
Harmonic signals	50 db below desired output
Modulation	Amplitude or frequency
Size	5 1/4 in. high, mountable in 19-in. rack
Weight	Approx. 35 pounds
Price	Approx. \$4,000
Monsanto Co., 620 Passaic Ave., West Caldwell, N.J. 07006	



'Unusual marriage': Constancy, variation

"It took an unusual marriage to do it," says an official of the Weston-Rotek division of Weston Instruments Inc. The comment by Peter Richman, a vice president of the division, refers to the devel-

opment of an oscillator that provides both a continuously variable frequency capability and a constant output voltage.

Until now, engineers measuring frequency response have had to choose between these two properties. An instrument with a constant output was tunable in discrete steps only, so that if one continuous tuning was required, one had to learn to live with sizable amplitude changes in the output.

In designing its new oscillator, Richman says,

output dividers to provide flexibility when using the instrument in both one-and two-phase applications.

Specifications	
Frequency range	9.6 hz to 104 khz
Voltage output	12 v rms
frequency response (flatness)	±0.01% to 50 khz ±0.02% to 100 khz
Total harmonic distortion	0.01% above 20 hz
Frequency stability	0.01% per hour above 100 hz 0.02% per hour from 10 to 100 hz
Price	about \$900
Weston-Rotek division of Weston Instruments Inc., 17 Hartwell Ave., Lexington, Mass.	

Plug-in modules for blue-collar job



Setting its sights on a new market—bench and production-line instrumentation—Electronic Associates Inc. is offering a low-cost, flexible digital measuring system. The modular instrumentation concept was first exploited by oscilloscope makers.

EAI, which previously had limited itself to costly laboratory-type precision-accuracy units, has developed an instrument built around a universal main frame and a plug-in approach—the main frame for display of the measured variable, the plug-ins to adapt the system for measurements such as voltages, frequency and resistance.

“The modular approach,” says Andy Anderson, the EAI Instrument division’s marketing manager, “affords maximum flexibility at low cost by enabling the user to mix or match modules according to his particular needs. Previously, if an engineer wanted to measure voltage and frequency, he would buy a voltmeter and a counter—a fairly expensive procedure. This no longer has to be the case.” The company’s basic display unit, the model 6200, will sell for about \$525, including a d-c plug-in. “Other measurement capabilities can be added for as little as \$185,” says Anderson. The unit contains power supplies, high-speed counting circuits, a display-time generator and numerical readout indicators. Drawer space is provided with wired receptacles for up to two plug-in modules, and a switch that permits the output of either module to be read out eliminates changing modules when more than one measurement is made.

The readout is displayed on Nixie tubes. There are four digits—three full range plus the fourth digit 1 for overranging. An illuminated decimal point is automatically positioned according to the range selected. Display time is variable, from 0.2 second to six seconds; it can also be held. Readout reset is both automatic and manual, and can be done from the front panel. The main frame can be supplied with a data output consisting of binary-coded decimal (1-2-4-8) logic. The unit’s

dimensions are a compact 7 x 8½ x 11 inches.

The model 6201 voltmeter module provides the system with a means of measuring d-c voltage from 100 millivolts to 1,000 volts full scale in five ranges. The module has automatic polarity selection and pushbutton ranging for fast operation.

EAI’s voltmeter module operates on the integrating principle, thereby reducing the system’s susceptibility to superimposed noise and hum. The module includes a high-speed solid state chopper to eliminate amplifier drift and reduce circuit time constants. This permits fast response to full-scale input step functions. A built-in calibrating system allows the operator to check the instrument’s accuracy—±0.1% ± 1 digit. The voltmeter module’s 10-megohm input impedance is constant over the measuring range.

When the a-c converter module is used with the voltmeter module, the system can measure a-c voltages from 20 hertz to 200 kilohertz. The unit, the model 6204, converts an a-c input to a d-c output voltage proportional to the root-mean-square value of the input sine wave. The module allows the measurement of voltages from 1 volt rms to 300 volts rms full scale.

Specifications	
Display readout	4 digits in-line (40% overranging)
Display time	Continuously variable from 0.2 sec to 6 sec
Signal input	0 to 10 Mhz from compatible plug-in module
Voltmeter	
Full-scale ranges	100.0 mv (100 μv resolution) 1.000 v 10.00 v 100.0 v 1000.0 v
Overrange capability	40% on all except 1,000=v range
A-c rejection	80 db at 60 hz 90 db at 120 hz
Conversion time	100 msec
Response time	700 msec to reach 99.9% of value for full-scale step input
A-c converter	
Frequency range	20 to 200,000 hz
Full-scale voltage ranges	1, 10, 100, 300 v rms
Accuracy	± 0.02% to 10 khz, ± 0.3% for 10 to 100 khz, 0.4% for 100 to 200 khz
Input impedance	1 megohm shunted by 30 pf.
Floating input	Enables a-c measurement of signals having ± 500 volts d-c with respect to line ground
Electronic Associates Inc., West Long Branch, N. J.	

Integrated circuits



TI backs bet on TTL with two new series

The wave of the future—that’s the way Texas Instruments Incorporated views the place of transistor-transistor logic (TTL) in the integrated circuit business.

TI has been backing this conviction with a \$5

Series 54 TTL "family" of eight gates and a flip-flop, with 13 nsec propagation delay and 10 new power dissipation.

Prior to this, Litton Industries Inc. had developed the "Phoenix gate" TTL for the Phoenix missile. It contained a multiple-emitter transistor, a device nonexistent in discrete-component circuitry and a key element in TTL work. The logic family, originally called TCL for transistor-coupled logic, was first developed by Pacific Semiconductor Inc.,

now TRW Semiconductor, Inc.

Tr's TTL's are diffused-planar, double-layer epitaxial structures. Circuit construction is similar to DTL layouts, but the input diode gate of the DTL is replaced with the multiple-emitter transistor.

"The diffusion techniques and other manufacturing steps are much simpler for TTL's," Fowler declares. "They actually have fewer component elements than earlier DTL types but they perform more functions."

Specifications

	Series 54H (High speed)	Series 54 (Standard)	Series 54L (Low power)
Propagation delay.....	6 nsec	13 nsec	35 nsec
Power dissipation.....	25 mw	10mw	1mw
Fanout.....	10	10	10
Power supply voltage.....	4.5 to 5.5 v	4.5 to 5.5 v	4.5 to 5.5 v
Temperature range.....	Military and industrial ranges on all three		
Packages.....	Flatpack and plastic	Flatpack and plastic	Flatpack
D-c noise margin.....	1 v	1 v	1 v

Norden is putting zip in tailored IC service

Telephoning an order one day and getting the integrated circuit a day or so later is normal service when buying off-the-shelf IC's. But the Norden divi-

sion of United Aircraft Corp. offers the same service for custom-made, dielectrically isolated circuits.

Norden can prepare either digital or linear IC's by stitch bonding wires between component elements on chips. Although breadboard chips have been sold by Norden and other semiconductor manufacturers for several years, these, Norden claims, are the first with dielectric isolation.

The isolated elements speed the design work

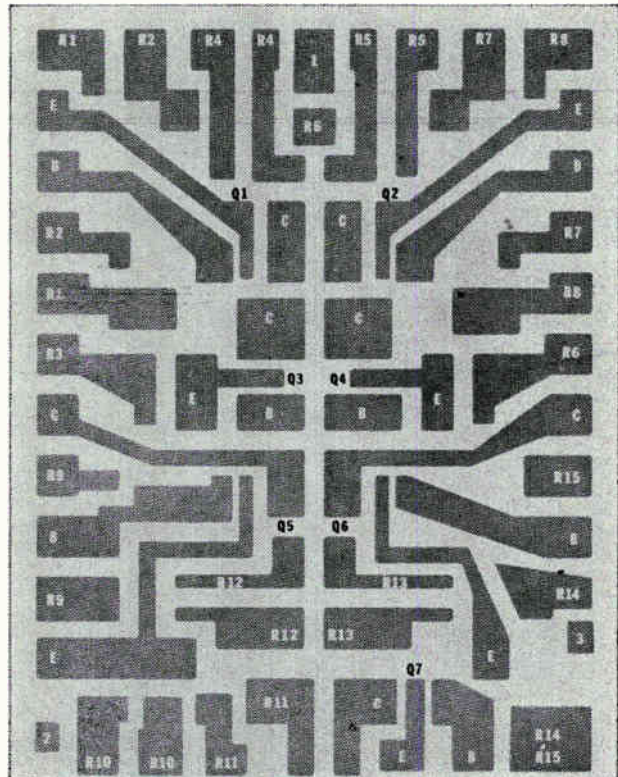
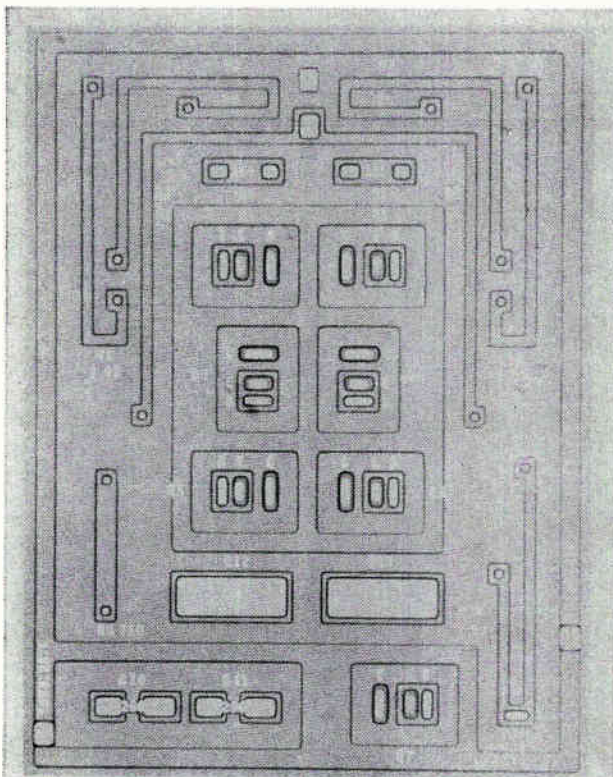

Master dice breadboard has six transistors and 33 resistors varying in value from 75 ohms to 10,000 ohms. Aluminum bonding pads shown in photo at right are connected to each resistor and to the emitter, base, and collector of each transistor.

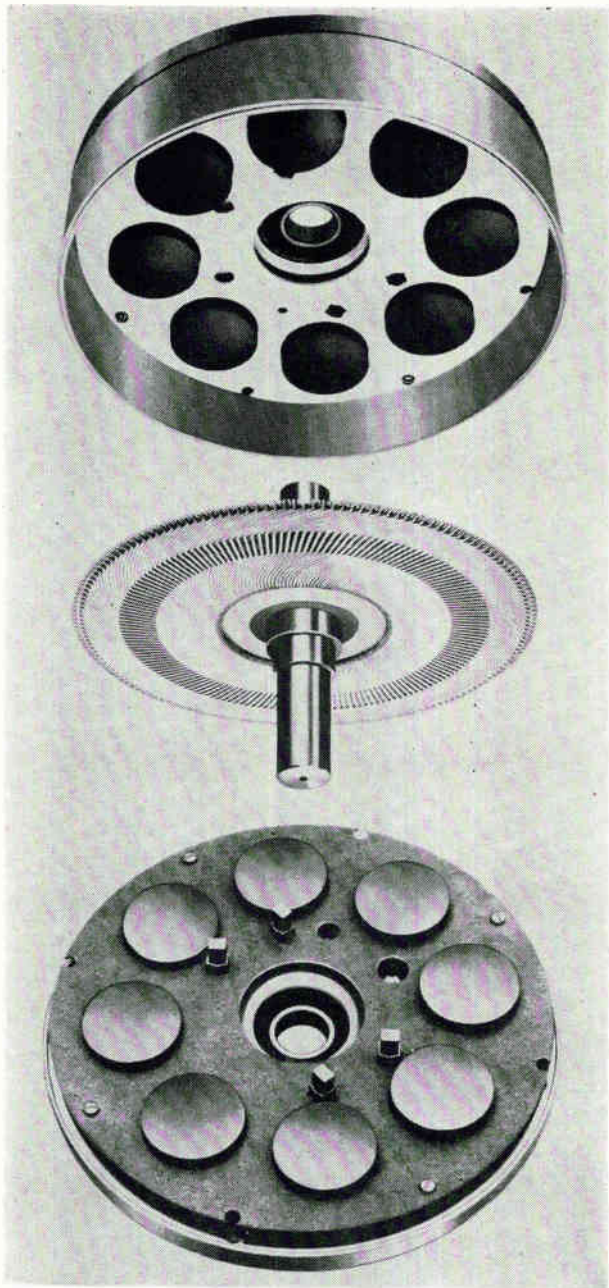

Armature for new line of precision motors is stamped from sheet of copper. Flat armature is shown between two sets of Alnico field magnets.

company, Societe Electronique et Automatisme, which holds the basic flat-armature patent. This is the same firm that licenses Printed Motors' parent concern.

Instead of printed circuit techniques, Yaskawa uses mechanically stamped-out armatures for its line of inexpensive d-c motors. These have been sold in large volume for about \$5 to \$6 each to the automotive industry; precision printed-circuit motors have been selling for 15 to 20 times these prices.

The mechanical armature has one distinct advantage over the printed-circuit design: its basic fabrication approach allows four layers of continuous conductors to be placed on a single arma-

ture. The printed circuit approach permits only two layers, one on each side of the insulating copper-clad laminate on which the conductors are etched.

With twice the conductors, each armature should have twice the torque sensitivity. Based on this and the fact that production costs could be lowered, Printed Motors decided to upgrade the mechanical approach for the manufacture of a precision servo motor.

Conductor patterns in the new armatures are stamped from copper sheets by a notching press that can make 700 notches per minute. Two sheets of conductors are laminated and welded at their inner diameters, and two sets of these double-conductor sheets are then laminated together and their outer diameters are welded.

The result: a sturdy structure that doesn't require the support ring for the less rigid armature.

In addition, the stamped armatures don't have the thickness variations of the printed circuit armatures, variations due to control problems in the electro-plating process.

Printed Motors has also improved on the low-cost motor design by using:

- Higher flux density Alnico magnets, instead of ferrite magnets.
- Four brushes instead of two, reducing the current density per brush and allowing higher currents in the motor.
- Ball bearings rather than a sleeve bearing, so that the armature turns with considerably less wobble and more concentricity.
- Epoxy-glass insulating materials that can withstand higher temperatures than the copper-clad laminates used in the printed circuit motors.

Specifications

	U9M4	U12M4	U16M4
Power (horsepower)	1/12	1/3	1/2
Torque constant (Kt-ounce-in./amp)	7.0	16.0	31.2
Mechanical time constant (seconds)	.013	.010	.011
Terminal resistance (Rt-ohms)	.8	.75	.79
Inertia (J-ounce-in./sec ²)	.0055	.023	.099
Weight (pounds)	4-1/2	8	16-1/2
Diameter (inches)	4-3/8	5-1/2	7-3/8
Length (inches)	1-27/32	2-7/64	2-9/16
Cost per motor (in quantities of 100)	\$77	\$94	\$140

Printed Motors Inc., 31 Seacliff Ave., Glen Cove, N.Y.

Sputtered oxides form thin-film thermistor



A new low-energy sputtering technique, combined with a multiple-oxide target material, adds a thin-film thermistor to the circuit designer's bag of tricks.

The A-Thinistor, the first deposited-film thermistor, can be attached at a critical area in a circuit to trigger a signal when a predetermined



Test display uses IR missile scanner

Adapted from a Sidewinder missile technique, an infrared scanner will compete in the fast-developing market for thermal sensing and display devices.

The Sierra Electronic division of the Philco-Ford Corp. sees a broad market, ranging from tests of printed circuit boards to diagnosis of muscle inflammations, for its 710B scanner, which incorporates both direct-viewing and picture-taking capabilities.

Sierra's system uses the output of the Sidewinder device, an indium antimonide cell, to provide two types of oscilloscope display:

- A video display of the subject's infrared radiation, with 10 black-to-white ranges covering temperatures from 2 degrees to 1,200 degrees centigrade.
- A scope tracing that shows i-r energy as a curve derived from the video signal, with the amount of energy determining vertical deflection.

Both types of display, known respectively as C-scan and B-scan, can be shown on one cathode ray tube, but the Sierra console has two scopes because the light levels best for the human eye are less than optimum for cameras. Either scope will provide both types of display.

The Boeing Co. was the catalyst in the development of the 710B, a follow-on to an earlier scanner-plus-scope system that was more suited to laboratory than production-line use. Boeing wanted to test the bonding process in which plastic skin is mated to the aluminum honeycomb used in helicopter rotor blades. The company had been leaning toward ultrasonic testing, but Sierra pointed out that if a heat source were placed behind the blade, bonding flaws would show up as cool spots on the front.

That test is passive, but the system is equally valuable for active testing of components on a printed-circuit board. As diodes heat up, for example, their picture becomes brighter and brighter on the cathode-ray tube. Poor welds are also shown by irregular heat transfer.

In the single-scope system, the operator had to swing the camera away in order to see the crt picture. Not only was this procedure awkward, but the light settings that were best for direct viewing were too bright for picture-taking and they washed out detail. The persistence of the scope that was necessary for a raster scan took five seconds from top to bottom, and did not have enough grey scale for good pictures.

In the 710B, the top scope is coated with P7 phosphor for good persistence, and the bottom with

Infrared scanner developed for the Sidewinder's guidance system nondestructively test solid state components. The output signal . . .



P4 phosphor, which has short persistence but a good grey scale. Both scopes are modified by their builder, Tektronix Inc., Beaverton, Ore.

The raster is produced by a mirror that is mechanically rotated at 30 revolutions per second. It is tilted up and down so that a complete 150-line picture is produced every five seconds.

Sierra also offers a "quantizer" that puts thermal contours, analogous to the isometric lines on a weather map, on the scope. The analog traces are digitized into six discrete temperature levels.

The company sees applications in reliability testing and in medical electronics. In solar cell tests, a malfunctioning cell would show up as a cold spot. Subcontractors to the Lockheed-Georgia Co., a subsidiary of the Lockheed Aircraft Corp., are now required to take thermal pictures of circuit boards for reliability testing. The University of Washington medical school will use a Sierra system to study muscle inflammation. The company says that the

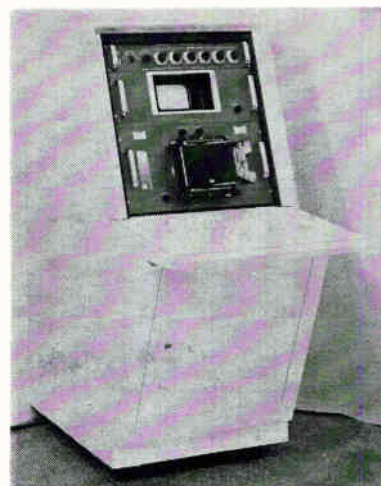

. . . from an indium antimonide cell paints a picture with 10 black-to-white ranges on the monitor console's oscilloscope. A built-in Polaroid camera makes a permanent record of the scope's traces.



Fast, low-cost testing with limit comparator

"It looked like an instrument we'd be able to use on our own production lines. If we could use it, probably other people could too. So we went ahead and built it."

That, according to one of the design engineers, is the uncomplicated reasoning behind the Hewlett-Packard Co.'s first instrument aimed at the production line—a high-go-low limit comparator for automated testing of electronic components, including integrated circuits. The new production tool marks a departure for Hewlett-Packard from laboratory-type instrumentation.

The high-speed, multifunction model 3434A has a basic price of \$1,575 and can be used in sorting, batching and matching components, testing printed circuit boards and cables, and calibrating.

The comparator can handle four types of limit measurements—a-c voltage, d-c voltage, direct current and resistance—against the single d-c voltage measurement available with most analog comparators. Limits can be selected automatically or manually. As many as 12 different sets of limits can be preprogrammed and quickly selected by a 12-position rotary switch as test conditions change.

Its versatility and cost make the comparator attractive for automated testing on low-volume production runs of from 50 to 100 pieces. But it is fast enough—at 15 decisions per second—to be used on high-volume lines as well.

The comparator can accept the plug-in function modules Hewlett-Packard has designed for its line of digital voltmeters, as the comparator circuitry uses the same ramp-comparison techniques.

The plug-ins range in price from \$40 for the 3441A voltage range selector with 10-, 100- and 1,000-volt ranges, to \$575 for the 3444A d-c multifunction unit with voltage, current and resistance functions.

High and low limits can be set separately on the comparator by:

- Dialing thumbwheel switches on the front panel during routine testing.
- Plugging in a preprogrammed board on which 12 different pairs of limits are set.
- External binary-coded decimal limits driven by a computer or other programming source.
- Remote analog voltage inputs.

When the comparator is used to test integrated circuits, both the 3444A d-c multifunction plug-in and the preset limit board are needed. The built-in rotary switch brings in bias and signal voltages to the ic test jig, selects the appropriate input and output pins and programs the comparator's 12 sets of test limits. A complete test set



Limit comparator can be used with external test jig for integrated circuits.

(without the jig) would cost \$2,375. This includes \$225 for the limit program board.

If ic's are to be tested semiautomatically at high speeds, an external scanning switch is needed.

Except for the external analog signals, the limit voltages are produced in digital form and converted to analog form before they're applied to the comparator circuit.

The comparator circuit takes the two input analog voltages and compares them with a +12- to -12-volt ramp. Output pulses appear when the ramp voltage is coincident with the analog voltage, and are applied to the decoding and logic circuits. The time sequence of the pulses yields the proper decision—high, go or low.

Each decision is flashed by colored lights on the front panel. The indication is held until the next limit condition occurs. The decision circuits can also drive floating contact closures, which can be used, in turn, to activate such production-line accessories as parts counters and materials-handling equipment, or a printer. A switchable input filter allows the comparator to operate in a noisy environment.

Specifications

Functions (plug-ins required)

- HP 3441A range selector (d-c voltage)
- HP 3442A automatic range selector (d-c voltage)
- HP 3443A high gain/auto range unit (d-c voltage)
- HP 3444A d-c multifunction unit (d-c voltage, d-c current resistance)
- HP 3445A a-c/d-c range unit
- HP 3446A a-c/d-c remote unit

Accuracy (10-, 100-, 1000-volt ranges)
External analog: $\pm 0.02\%$ full scale
Other modes: $\pm 0.04\%$ full scale
Other accuracies depend on plug-ins

Decision rate

- Normal: fixed at 15 decisions/sec
- Manual: front panel control
- Remote: variable to 15 decisions/sec

Power: 115 and 230 volts $\pm 10\%$ 50-1,000 hertz
Approximately 30 watts

Dimensions: $16\frac{3}{4} \times 5\frac{7}{32} \times 18\frac{3}{8}$ in. deep

Weight: 18 lbs.
\$1,575 with thumbwheel limit set

Price: \$225 for limit programmer

Hewlett-Packard Co., Loveland Div., P.O. Box 301, Loveland, Colo. 80537

If Q_1 is kept off, the charge on C_1 is maintained until an incoming pulse triggers the circuit and starts the ramp.

Transistor Q_1 is kept off by the conduction to ground through D_1 and Q_5 , which back-biases D_2 and prevents base current from reaching Q_1 . Transistor Q_5 is held on by Q_3 ; Q_3 conducts because its base potential is slightly more positive than Q_4 's due to the action of R_4 , P_2 and R_5 together with R_6 and D_4 .

The ramp is started when a positive triggering pulse at the base of Q_5 turns Q_5 off, dropping this transistor's collector voltage to -20 volts and back-biasing D_4 . With D_4 off, the base of Q_3 goes more negative than the base of Q_4 because of the action of R_4 , R_5 and P_2 ; thus Q_3 cuts off (holding Q_5 off) and Q_4 turns on.

The turnoff of Q_5 also back biases D_1 , so D_2 turns on, starting the Miller effect ramp generator. With D_2 conducting, Q_1 turns on, turning on D_3 . Constant current is then provided by Q_1 to linearly discharge C_1 , and the output ramp is generated.

When the combinations of currents through R_4 , R_5 and P_2 bring the potential at the base of Q_3 to -15.9 volts (or slightly more positive than the base of Q_4), Q_3 turns on, turning Q_4 off and Q_5 on. With Q_5 on, diode D_1 again conducts, back-biasing D_2 and cutting off Q_1 . Now that Q_1 is off, diode D_3 is back-biased and Q_2 turns on, rapidly charging C_1 to -16 volts. The cycle is now complete and the circuit is ready to accept the next input pulse.

The slope of the ramp is controlled by P_1 and R_1 , which can vary it through a range of 50 to 1 by changing the amount of constant current through C_1 .

Ramp height is controlled by P_2 and R_5 . The output voltage for the ramp is given by

$$V = V_{out} = \frac{-V_{cc}R_4}{P_2 + R_5} + \frac{V'_{B4}R_4}{R_{equiv}} \quad (1)$$

$$\text{if } R_{equiv} = \frac{(P_2 + R_5)R_4}{P_2 + R_5 + R_4}$$

where V_{cc} is the -20 volt supply and V'_{B4} is the voltage at the base of Q_4 . This equation shows the ramp amplitude to be inversely proportional to P_2 and R_5 .

The ramp reaches its maximum amplitude at ground when the combination of P_2 and R_5 is 3 kilohms. With P_2 almost an open circuit, the ramp amplitude is zero volts.

$$\text{The timing equation is: } T = \frac{\Delta V \cdot C}{\Delta I} \quad (2)$$

where ΔV is the increment of voltage across C_1 and I is the increment of current.

$$\Delta I = \frac{V_{cc}}{P_1 + R_1} \quad (3)$$

Substituting equations 1 and 3 into 2 yields

$$T = \frac{R_4(V_{cc} - V_{B4})(P_1 + R_1) \cdot C_1}{(P_2 + R_5)V_{cc}} \quad (4)$$

where

$$V_{B4} = \frac{V'_{BA}(R_1 + P_2 + R_5)}{R_4}$$

Setting $R_2' = (P_2 + R_5)$ and $R_1' = (P_1 + R_1)$ yields:

$$T = \frac{R_4(V_{cc} - V_{B4})(R_1')(C_1)}{(R_2')(V_{cc})} \quad (5)$$

Equation 5 indicates that the duration of the ramp may be varied by slope control R_1' or amplitude control R_2' .

Pulse-width modulation can be achieved with the circuit by fixing $(P_2 + R_6)$ and connecting the top of potentiometer P_2 to a control voltage V_c . The new timing equation then becomes:

$$T = \frac{R_4(V_c - V_{B4})(R_1')(C_1)}{(R_2')(V_{cc})} \quad (6)$$

Equation 6 indicates that T is directly proportional to control voltage V_c .

If R_1 is made large enough the circuit will oscillate:

$$f = \frac{(R_2')(V_{cc})}{(R_4)(V_c - V_{B4})(R_1')(C_1)} \quad (7)$$

and if P_1 goes to a control voltage V_c , then

$$f = \frac{(R_2')(V_c)}{(R_4)(V_{cc} - V_{B4})(R_1')(C_1)}$$

The operating frequency may then be controlled by the same voltage V_c . The resulting output is a train of negative-going pulses and a positive-going sawtooth wave.

IC amplifier serves as stable current source

By Clement S. Pepper

Marine Physical Laboratory
Scripps Institution of Oceanography, San Diego

For less than \$40, a stable 185-milliamper current source can be built with an integrated amplifier and a feedback circuit. The circuit has excellent regulation and serves as a laboratory standard for

Constant relay on-time for any input pulse

By Ken Wahl

Photo Bell Co., New York City

A monostable relay driver can be made independent of the input pulse's amplitude or duration by feeding back a negative pulse generated by the output circuit. The pulse holds the input transistor off for a predetermined time. The circuit shown below was designed to drive a 4-watt relay momentarily. Since the circuit holds the output transistor in conduction for 25 milliseconds regardless of the input pulse duration, the power to drive the relay is generated without the additional transistor stage normally required for pulse stretching. Thus the circuit's cost is reduced by 25%.

In the conventional high-gain pulse amplifier at the right transistor Q'_1 is normally on, Q'_2 is off and the relay is not energized. When an incoming negative pulse turns Q'_1 off, Q'_2 turns on and the relay energizes. The time Q'_1 is off depends on the pulse duration, pulse amplitude, and the time constant $R'_2C'_1$.

With the modified circuit the relay's on-time is independent of input pulse characteristics. Diode D_3 is normally off and capacitor C_2 is charged to +10 volts.

When a negative input pulse turns Q_1 off, Q_2 turns on and its collector voltage drops to ground. Since the charge on C_1 cannot change instantaneously, the voltage at point A will drop to -12 v which turns on diode D_3 , enabling C_1 to charge toward the +12-v supply with time constant R_1C_2 .

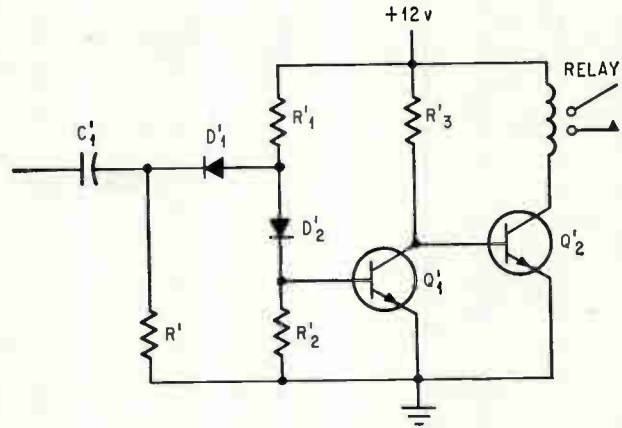

Conventional high-gain pulse amplifier generates output pulses whose duration is determined by the time and amplitude of input pulses together with time constant $R'_2C'_1$.

When the voltage at point A nears +0.6 v, the base of Q_1 turns on, terminating the output pulse and causing the relay to drop out.

The output pulse duration of 25 milliseconds is approximately 0.7 of the time constant R_1C_2 , since C_1 stops charging when point A becomes slightly positive, far below the charging potential of +12 v. Resistors R_3 and R_1 are large with respect to R_2 so their contribution to the charging (and hence to the timing) is negligible; they are in the circuit to provide back bias for D_3 when the circuit is in its stable state. The relay's on-time can be adjusted by replacing R_2 with a potentiometer.

A desirable feature of this circuit is that the turn-on time of the relay is very sharp. However, the turn-off time is slightly exponential. The exponential condition does not cause any problems during normal operation of the circuit for any of the intended applications of the relay.

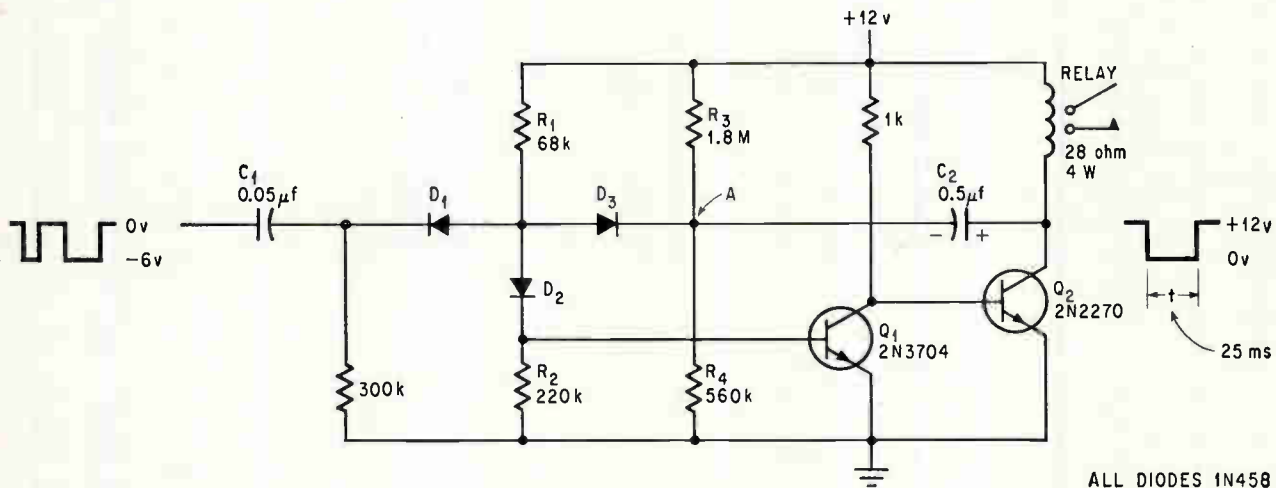

ALL DIODES 1N458

Modified circuit generates a fixed output pulse of 25 milliseconds for each input pulse.

Army's Electronics Command, Ft. Monmouth, N.J., if he were to design a low-power local oscillator today, he says he would choose the avalanche diode over the Gunn device. "The major reasons are better reliability, better yield and better [lower] cost," says Brand. For a higher power pulsed radar, however, Brand says he would look more closely at the Gunn and LSA mode devices.

The LSA device, since it is not a transit-time device, can be made thick enough to take high voltages and thus deliver high power. The conventional Gunn unit, as a transit-time device, must be kept thin for high microwave frequencies, which limits its power capabilities.

The limited space-charge accumulation device suppresses the Gunn mode and operates as a bulk negative resistance which, when properly biased and driven, provides power at a frequency determined by the external resonant circuit and not by the device itself. Rudolf Engelbrecht, head of Bell's microwave integrated device department, compares it, in a gross sense, to a giant tunnel diode, in that its volt-ampere characteristic is similar to the tunnel diode's, biased on the negative-resistance portion of the curve to allow oscillations in the circuit. The LSA device, however, doesn't have a junction whose width limits the available power from tunnel diodes. The only limitation of the LSA device is that the voltage must swing back over the current hump during each cycle to quench the space charge that would build up to force the device to operate in the Gunn mode.

If he were questioned six months ago, says Brand, he would probably have said that the first bulk gallium-arsenide devices in general use would be the original Gunn type. Now, however, he believes the LSA mode could conceivably leapfrog its predecessor and be used first because of its high peak power, reasonable efficiency, and the possibility of easy tuning.

The new devices will affect varactor multipliers in cases where frequencies near X-band are needed. At this frequency, where several stages of varactors are needed, Gunn devices can operate directly. Present efficiencies of the two systems, though, still are comparable.

Much more can be done with Gunn-effect devices beyond supplying microwave power. Since an electric field controls the operation of the device, researchers are studying methods of shaping the electric field by means of device geometry. A variable voltage to modulate or sweep the frequency of the device is a likelihood. The high-resolution mask-making capability of semiconductor manufacturers suggests that a high level of dimensional control of the devices is possible.

But the immediate problem is to design devices to perform predictably. To reach this point, more research on the materials and contacts is needed.

Better materials technology needed

While gallium arsenide has been used in many semiconductor devices, the effort expended on de-

Growing the layers . . .

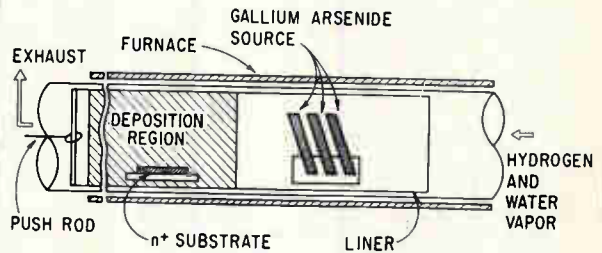

Hydrogen-water vapor process has been successfully used at Bell Telephone Laboratories to epitaxially grow an intermediate-resistivity active layer on a low-resistivity n^+ substrate. The gallium-arsenide source is maintained at $1,050^\circ\text{C}$ and the substrate at $1,000^\circ\text{C}$. A mixture of hydrogen and water vapor enters one end of the tube and flows over the GaAs, forming gases of gallium sub-oxide and arsenic. When these gases flow into the lower temperature region containing the substrate, they reform into GaAs and water vapor. The water vapor exhausts from the tube while the GaAs deposits onto the substrate.

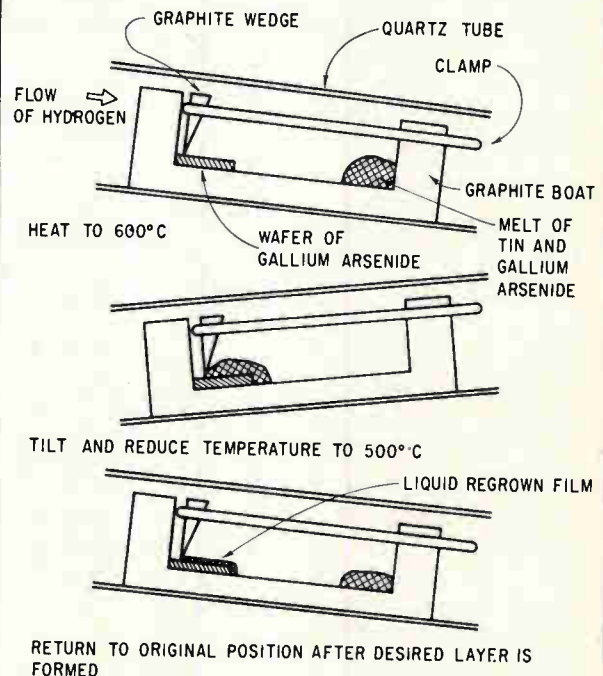

Liquid-regrowth process is used at Bell Labs to grow the low-resistivity n^{++} layer on the active layer which was grown in the hydrogen water-vapor process. A graphite wedge holds the n -type gallium arsenide in place at one end of the boat and a melted solution of tin and GaAs is placed at the other end. Hydrogen is admitted into the reaction tube to prevent formation of gallium oxide. The boat is first tilted while the temperature is increased to 600°C and then is tilted back to allow the melt to run onto and cover the wafer. The boat then is cooled to 500°C and as it cools, the gallium arsenide precipitates from the melt and deposits on the wafer to form the n^{++} layer.

Simulating the Gunn Effect

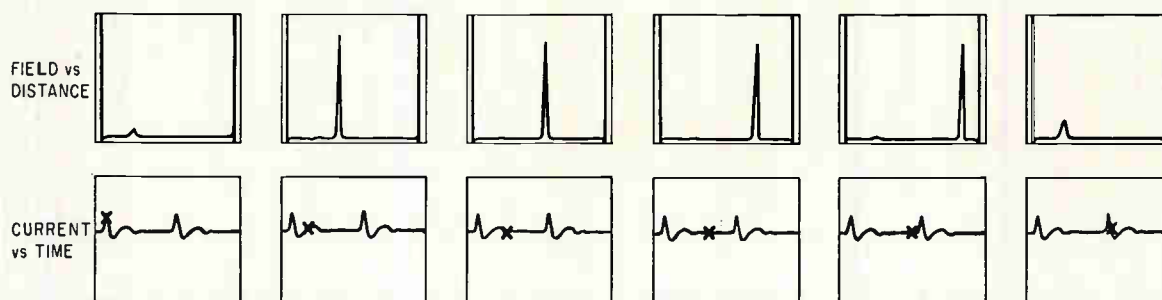

Several frames of computer-produced motion picture show how the dipole layer propagates through the sample after being nucleated at a point where the doping is 10% lower than the doping throughout the rest of the sample. The X's on the current curve show the current at the instant which is pictured in the field distribution plot. The time between frames is about 0.6 nanosecond. The repetition frequency is 680 megahertz.

Some of the most important research on Gunn effect is being done at the computer console, not the lab bench. Engineers are gaining a wealth of knowledge from computer simulations by Dean E. McCumber and others at Bell Telephone Laboratories. The new limited space-charge accumulation mode, for example, was identified by Bell's John Copeland while working on a computer simulation of the Gunn effect.

The basic, observed facts of the Gunn effect are: when the d-c voltage impressed across a small sample of gallium arsenide is slowly increased, the current rises at first according to the material's normal positive bulk resistance, but at a particular critical voltage, the sample suddenly begins to produce a high-frequency current oscillation. Capacitive probe measurements made by J.B. Gunn at IBM showed that a dipole layer was moving through the sample at a velocity of about 10^7 centimeters/second, and that the time needed for one passage through the device corresponded to the period of the oscillations. For example, a 0.01 cm-long device oscillated at 10^9 hertz, or 1 gigahertz.

The Gunn effect is seen only in semiconductors having two electron conduction bands separated by an energy gap. The normal conduction band is at the lower energy level. In the higher conduction band, electrons have a lower mobility, but in normal operation this state is unfilled. A high electric field can excite electrons to the higher-energy, lower mobility band. As the electric field is increased from zero, the current increases at

first as the normal conduction band electrons are accelerated. But as the field is increased further, more electrons are excited to the lower-mobility band where they move more slowly. The net effect: overall current tends to decrease with increasing voltage and the material is said to have a negative resistance.

Repeats itself. This kind of situation is unstable. Any deviation in charge concentration will cause the building up of a charge accumulation layer and a depletion layer. For example, at a point where the electron density suddenly decreases due to, say, nonuniform doping, the field will increase and the electrons will move more slowly. (On the negative resistance portion of the characteristic, increased field produces decreased current.) Thus, at the edge of the depletion layer nearer the negative electrode, electrons traveling toward the positive electrode tend to accumulate and the accumulation layer grows; at the edge nearer the positive electrode, electrons tend to move away from the depletion layer faster than they move into the layer, so the depletion layer grows. The layers move across the sample at the average electron drift velocity until they reach the positive electrode, where they disappear. Then a new accumulation-depletion layer appears and the process repeats itself.

Working from the basic field and charge-continuity equations and the doping and energy band structure of the material, McCumber programmed the computer to produce the internal field pattern and oscillating current waveforms on

a cathode-ray tube. These clearly show the dipole layer moving through the device.

The crt display of the computed field distribution at each instant can be photographed and the photos sequenced to produce a motion picture of the field's movement through the device. Bell researchers used a Stromberg-Carlson microfilm recorder to photograph the output display from an IBM 7094 computer and produced movies of the device's operation. The film has been shown at technical meetings.

Transactions award. The computer studies show that the moving dipole layer originates, or nucleates, at a point where the doping level of the sample deviates from the average doping level. Although measurements on the first samples showed an approximate relationship between frequency and sample length, the computer studies show how the frequency depends on the length of the dipole path. If the dipole layer is nucleated at one end, then the period would be equal to the transit time from one end of the device to the other. However, if the dipole nucleates at a point inside the sample, then the path length will be less and the frequency higher.

A flip-page sequence of the film's individual frames was published in the January 1966 issue of the IEEE Transactions on Electron Devices. For their paper accompanying it, McCumber and A.G. Chyonweth—also of Bell—will receive the W.R.C. Baker Prize at the IEEE convention this month for the year's outstanding Transactions paper.

■ 140 mw continuous wave at 6 Ghz at TI, Dallas, where devices are reported to have been subjected to 3,500 hours of test operation.

■ 10 mw c-w at 10 Ghz with efficiency of 0.5% at Mullard, London. Carrying out the work in conjunction with the Royal Radar Establishment in Malvern, the Gunn-effect oscillators have been used as local oscillators in radar systems and as pumps for parametric amplifiers.

■ 100 mw c-w at 8 to 12 Ghz and 5 to 10 mw at 24 Ghz with 2 to 3% efficiency at Japan's Nippon Electric Co. The life of these epitaxial devices appears to be good, with the company reporting continuous operation in excess of 700 hours with 10 mw output. Nippon engineers say the resistivity of the undoped epitaxial material increases with increasing temperature, which decreases the input current and thus prevents thermal runaway.

■ 120 mw c-w in S band with 18% efficiency at the Westinghouse Electric Corp.'s Aerospace division in Baltimore, Md., where a Read avalanche diode oscillator also has been operated in X band, delivering 240 mw c-w with 3.8% efficiency.

■ 60 mw c-w at 13.5 Ghz at Raytheon. Pucell calls conventional packages unsatisfactory for Gunn devices—"We'd like to expand the holder in a way that does not forfeit high-frequency performance." Two methods are being tried: mounting the chip on a waveguide wall and making a package resonant to the desired frequency and coupling it to the cavity structure. Neither method will sacrifice high-frequency performance, says Pucell. But for c-w operation, the most serious problem is appropriate heat-sinking. "We need an ingenious way of getting heat out of the top and the bottom of the device," says Pucell.

■ 1 kw peak at 1 Ghz at NASA's Electronics Research Center, Cambridge, Mass. "We don't know if this is a single frequency pulse or not," says Harold Roth, head of advanced research. "When it runs that high, it's difficult to see separate frequencies." Roth suspects that this diode was operating in the LSA mode, but the results were obtained before the LSA mode was identified. "Now we're looking specifically for LSA operation," adds Roth. A Gunn transmitter using pulse rate modulation has been tested. The device was driven by a pulse circuit triggered by a modulated, voltage-controlled oscillator.

■ 15 w peak in the 4 to 7 Ghz range, with efficiency about 2.5% at Standard Telecommunications Laboratories, Harlow, Essex, England. Frequency stability with time and temperature was found to be largely determined by the cavity. The shape and the construction of the cavity, it is reported, also affects the noise.

■ 2 w peak at 10 Ghz with 0.5 microsecond pulses and an efficiency of 9% at Lincoln Laboratory. "It's a question of power dissipation," says Foyt. "You can't get rid of more than a few watts." But in the LSA mode, Foyt adds, it may be possible to get away from dimensional problems and thereby get more heat out.

■ 1.5 w peak at X band at Motorola Inc.'s aerospace center at Scottsdale, Ariz. "It is not a transit-mode type of operation," says Tony Kallas, Gunn-effect project leader, noting that the 45 to 50-volt input was well above the transit-time voltage. "By going to a higher voltage, you can get a higher power output, but efficiency is only about 1%," he says. "Reproducibility is now very, very poor." Motorola's preliminary objective is to reproduce a 10-watt output and then extend this to 400 watts by paralleling several chips. It feels it has solved the heat sinking problem on peak powers up to 100 watts by thermally bonding the chip to a heat sink on its lower side. The upper contact is a low-inductance bellows contact. "Before we developed this system, we were burning contacts out one after the other," Kallas says.

Motorola also is investigating the use of a Gunn-effect device in the construction of microcircuit modules in an active phased array configuration to drive a phased-array antenna. The goal is 1- to 5-watt output in X band. "We think we will have circuits for prototype demonstration by the end of the year, particularly in phased arrays," says Kallas. He expects Gunn-effect devices will be in general use in the field in 18 to 24 months.

Comparing Gunn-effect devices with avalanche type devices, Kallas sees greater power potential in Gunn devices because of the greater area available compared with the small active area of the junction devices. However, at present, the results with junction devices are much easier to reproduce because the technology is more advanced.

Says Kallas: "Once they [Gunn devices] are in production, costs will be considerably less than conventional devices, such as ceramic triodes."

But regardless of the promise shown by Gunn devices, NASA's Carol Veronda, head of microwave circuits research, says the Electronics Research Center will continue working on tubes and other solid-state sources. He points out that "if people had given up triodes when the traveling-wave tube was invented, we would have missed out on the higher frequency, better performing triodes that came along."

Bibliography

Complete issue, IEEE Transactions on Electron Devices, January 1966.

John A. Copeland, "A New Mode of Operation for Bulk Negative Resistance Oscillators," IEEE Proceedings, October 1966, p. 1479.

D.P. Brady, S. Knight, K.L. Lawley and M. Uenohara, "Recent Results With Epitaxial GaAs Gunn Effect Oscillators," IEEE Proceedings, October 1966, p. 1497.

M. Shoji, "A Voltage Tunable Gunn-Effect Oscillator," IEEE Proceedings, January 1967, p. 130.

For a history of the Gunn effect see:

R. Bowers, "A Solid-State Source of Microwaves," Scientific American, August 1966, p. 22.

Contributions to this report were made by the following Electronics regional editors: Thomas Maguire, Boston; Walter Barney, San Francisco; John Gosch, Bonn; Michael Payne, London; and Charles Cohen, Tokyo. Contributions were also received from the following McGraw-Hill News Service reporters: James Rubenstein, Chicago; Marvin Reid, Dallas; Gerald Parkinson, Los Angeles; and Peter Kilborn, Paris.

Active circuit models

TRANSISTOR MODEL

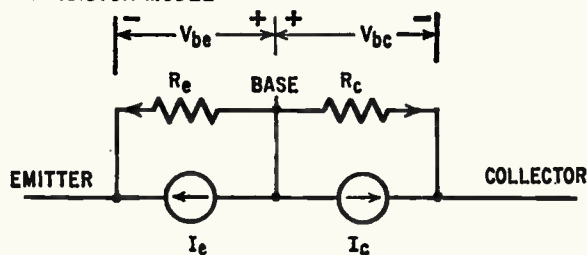

Transistor equations:

$$I_e = I_{es} (e^{\frac{qV_{be}}{M_e k T}} - 1) - \frac{\beta_R}{\beta_R + 1} I_{cs} (e^{\frac{qV_{bc}}{M_c k T}} - 1)$$

$$I_c = I_{cs} (e^{\frac{qV_{bc}}{M_c k T}} - 1) - \frac{\beta_F}{\beta_F + 1} I_{es} (e^{\frac{qV_{be}}{M_e k T}} - 1)$$

Definition of terms:

- I_{es}, I_{cs} = Saturation currents
- q = Electronic charge
- k = Boltzmann constant
- T = Absolute junction temperature
- β_F = Forward beta gain
- β_R = Reverse beta gain
- M_e, M_c = Constants determined empirically

DIODE MODEL

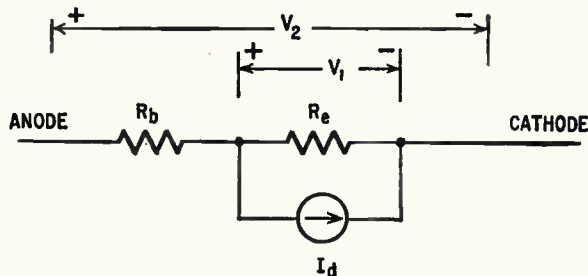

Diode Equations:

$$I_d = I_s \left(e^{\frac{qV_1}{M k T N}} - 1 \right)$$

$$V_2 \approx M \frac{k T N}{q} \log \left(\frac{I_d + I_s}{I_s} \right) + N I_d R_b$$

Definition of terms:

- N = Number of diodes in series
- R_b = Bulk resistance
- R_e = Leakage resistance
- I_s = Saturation current
- M = A constant determined empirically
- k = Boltzmann constant

Model for the transistor and the diode are used for d-c analysis. Equations represent current-source relations.

gram is based, each branch can have a voltage source, a dependent current source, an independent current source and a passive element (written as an impedance, or an admittance). Nonlinearities of the circuit branches are included in the dependent current source and solved by iterative procedure.

The equivalent circuit for the transistor model consists of two diodes, one each for the base-emitter junction and collector-base junction. It is a nonlinear version of the Ebers-Moll model and is similar to the model used in NET-1; however, it contains far fewer parameters. Capacitors have been removed since they are not pertinent to d-c analysis. To reduce computational complexity and the number of model elements that the operator must specify, the following parameters are omitted: the emitter-bulk resistance, base-spreading resistance and collector-bulk resistance. The dependency of the current gains β_F and β_R on junction voltages is also neglected.

All four regions of operation are covered by the model: cutoff, active normal, active inverted and saturation. The nonlinear equations for the dependent current sources appear on the diagram. These equations are combined with linear network equations and solved iteratively for the operating points of the transistors.

The equivalent circuit for the zener diode or a conventional diode model is represented by the same model. The zener diode operates in three distinct regions with each region described by an appropriate equation. The term N in the equations represents the number of series diodes.

When strings of series diodes are examined, it is usually the voltage drop across the entire chain that is of interest. Therefore, the equations were modified to account for the number of diodes in a series string. Thus, the desired effect was obtained without the addition of extraneous nodes that occur when each diode is examined individually.

Field effect transistors and other less conventional devices require different models than the program provides. Because of this, the program has been extended to allow the inclusion of linear equivalent circuit models with appropriate input data. However, these models must be constructed from the basic circuit branch. An equivalent circuit model for a transconductance, G_m , can also be inserted between branches. The transconductance sets up a dependent current source in one branch related to the voltage drop across the resistance in another. The equation is expressed by $I_d = G_m V$.

A nonlinear d-c analysis

The capabilities of the program are best illustrated with a sample problem. In the problem circuit all nodes and branches are arbitrarily numbered. Additional nodes and branches are automatically inserted by the program where required for the equivalent models of the transistors and diodes.

The operator enters both control and general information—which describe the circuit—on the first

Nonlinear d-c analysis example

The sample circuit at the right contains nonlinear transistors and diodes. To begin the nonlinear d-c analysis of the circuit the operator arbitrarily numbers all the node points and branches—circled numbers for the nodes, boxed numbers for the branches. Then a description of all the branch-node connection data is entered in the three input cards that are shown below in abridged form.

Also entered on the cards are the values for the node voltages, transistor emitter saturation currents and diode currents, emitter and collector resistances, diode saturation currents, diode currents, bulk resistances, and diode leakage resistances.

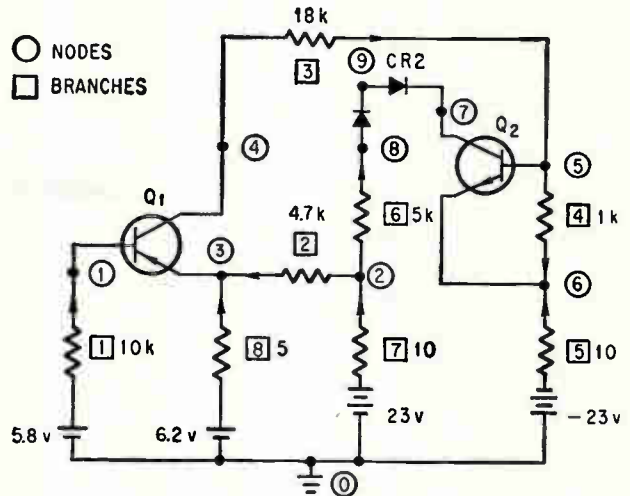

RESISTOR	FROM	NODES TO	RESISTANCE -OHMS	± % R	VOLTAGE -VOLTS	± % E	CURRENT -AMPS
R 1	1	0 1	10. E + 03		5.8		
R 2	2	3	4700.	5.			
R 3	4	5	18. E + 03	5.			
R 4	5	6	1000.	5.			
R 5	0	6	10.				
R 6	2	8	5000.	1.			
R 7	0	2	10.		-23.		
R 8	0	3	5.				

Branch-node resistor connection data for input card.

TRANS-ISTOR	NODES E B C	TYPE	BETA FORWARD				BETA REVERSE	EMITTER 1. SAT. CURRENT	EMITTER 2. DIODE CURRENT	COLLECTOR 2. DIODE CURRENT	EMITTER LEAKAGE RESIS.	COLLECTOR LEAKAGE RESIS.
			NOM.	LOW	HIGH							
Q1	3 1 4	P	60.	30.	90.	.8	5. E - 09	.001		1. E + 06	2. E + 06	
Q2	6 5 7	N	60.	30.	90.	.8	1. E - 08	.005		1. E + 06	2. E + 06	

Transistor connection and parameter data for input card.

DIODES	NODES ANODE CATHODE		SATURATION CURRENT		CURRENT	BULK RESISTANCE	LEAKAGE RESISTANCE		NO
CR 1	8	9	1. E - 12		.005	10.	1. E + 06		1.
CR 2	9	7	1. E - 12		.005	10.	1. E - 06		1.
CR 1 + 2	8	7	1. E - 12		.005	10.	1. E + 06		2.

ALTERNATE METHOD OF CODING, FORMING A STRING OF DIODES AND ELIMINATING NODE 9

Diode connection and parameter data for input card.

BREAKDOWN OF VARIANCE (PERCENT)										
PARAMETER	MODE 1	MODE 2	MODE 3	MODE 4	MODE 5	MODE 6	MODE 7	MODE 8	MODE 9	MODE 10
R 1	0.00E-99	0.00E-99	0.00E-99	0.00E-99	0.00E-99	0.00E-99	0.00E-99	0.00E-99	0.00E-99	0.00E-99
R 2	8.29E-01	8.01E+01	2.97E+01	1.27E-02	9.73E-03	9.17E-03	1.18E-02	1.26E-02	1.23E-02	1.23E-02
R 3	3.01E-01	5.34E-05	2.13E-01	1.42E+00	2.81E-01	2.75E-01	2.60E-01	2.44E-01	2.34E-01	2.34E-01
R 4	2.82E+09	9.20E-05	1.15E-09	1.41E+08	4.23E-02	4.37E-05	5.64E-01	5.29E-01	5.50E-01	5.50E-01
R 5	0.00E-99	0.00E-99	0.00E-99	0.00E-99	0.00E-99	0.00E-99	0.00E-99	0.00E-99	0.00E-99	0.00E-99
R 6	5.87E-08	1.97E+01	2.64E-05	2.07E-06	7.22E+00	9.54E+00	9.01E-01	7.07E+00	3.32E+00	3.32E+00
R 7	0.00E-99	0.00E-99	0.00E-99	0.00E-99	0.00E-99	0.00E-99	0.00E-99	0.00E-99	0.00E-99	0.00E-99
R 8	0.00E-99	0.00E-99	0.00E-99	0.00E-99	0.00E-99	0.00E-99	0.00E-99	0.00E-99	0.00E-99	0.00E-99
E 1	0.00E-99	0.00E-99	0.00E-99	0.00E-99	0.00E-99	0.00E-99	0.00E-99	0.00E-99	0.00E-99	0.00E-99
E 5	0.00E-99	0.00E-99	0.00E-99	0.00E-99	0.00E-99	0.00E-99	0.00E-99	0.00E-99	0.00E-99	0.00E-99
E 7	0.00E-99	0.00E-99	0.00E-99	0.00E-99	0.00E-99	0.00E-99	0.00E-99	0.00E-99	0.00E-99	0.00E-99
E 8	0.00E-99	0.00E-99	0.00E-99	0.00E-99	0.00E-99	0.00E-99	0.00E-99	0.00E-99	0.00E-99	0.00E-99
RF 1	9.88E+01	1.75E-02	7.00E+01	9.85E+01	9.22E+01	9.01E+01	8.54E+01	8.01E+01	8.33E+01	8.33E+01
BF 2	1.09E-08	2.08E-03	1.34E-09	5.96E-08	1.79E-01	1.00E-03	1.28E+01	1.20E+01	1.24E+01	1.24E+01

MANEX WORST-CASE ANALYSIS, NODE 5 HIGH

NO. OF ITERATIONS = 2

NODE VOLTAGES ARE

1= 5.894E+00, 2= 2.287E+01, 3= 6.212E+00, 4=-2.194E+00, 5=-2.254E+01,
6=-2.289E+01, 7=-2.282E+01, 8=-2.146E+01, 9=-2.214E+01.

STRESS ANALYSIS

BRANCH	CURRENT	VOLT-BRANCH	VOLT-COIL	POWER-DISSIPATED	POWER-BRANCH
1	-9.444E-06	-5.894E+00	-9.444E-02	8.919E-07	5.586E-05
2	3.731E-03	1.666E+01	1.666E+01	6.216E-02	6.216E-02
3	1.189E-03	2.034E+01	2.034E+01	2.823E-02	2.823E-02
4	3.389E-04	3.558E-01	3.558E-01	1.206E-04	1.206E-04
5	-1.014E-02	2.289E+01	-1.014E-01	1.029E-03	-2.323E-01
6	8.957E-03	4.434E+01	4.434E+01	3.972E-01	3.972E-01
7	1.268E-02	-2.287E+01	1.268E-01	1.610E-03	-2.292E-01
8	-2.531E-03	-6.212E+00	-1.268E-02	3.205E-05	1.572E-02

SUMMATION OF BRANCH POWERS =-2.311E-02 WATTS

TRANSISTOR ANALYSIS

NO.	STATE	VBE	VBC	VCE	IE	IB	POWER
1	-ACT-NOR	-3.182E-01	8.088E+00	-8.407E+00	-1.199E-03	-9.444E-06	1.000E-02
2	-SAT	3.558E-01	2.832E-01	7.261E-02	9.808E-03	8.510E-04	9.533E-04

DIODE ANALYSIS

NO.	STATE	VOLTAGE	CURRENT	POWER
1	-ON	6.786E-01	8.957E-03	6.079E-03
2	-ON	6.783E-01	8.957E-03	6.076E-03

TOTAL POWER DISSIPATED IN CIRCUIT= 5.095E-01 WATTS

MANEX WORST-CASE ANALYSIS, NODE 5 LOW

NO. OF ITERATIONS = 3

NODE VOLTAGES ARE

1= 5.913E+00, 2= 2.289E+01, 3= 6.213E+00, 4=-1.129E+01, 5=-2.257E+01,
6=-2.292E+01, 7=-1.416E+01, 8=-1.285E+01, 9=-1.351E+01.

STRESS ANALYSIS

BRANCH	CURRENT	VOLT-BRANCH	VOLT-COIL	POWER-DISSIPATED	POWER-BRANCH
1	-1.130E-05	-5.913E+00	-1.130E-01	1.278E-06	6.686E-05
2	3.380E-03	1.668E+01	1.668E+01	5.638E-02	5.638E-02
3	5.970E-04	1.128E+01	1.128E+01	6.738E-03	6.738E-03
4	3.651E-04	3.448E-01	3.448E-01	1.266E-04	1.266E-04
5	-7.677E-03	2.292E+01	-7.677E-02	5.894E-04	-1.759E-01
6	7.080E-03	3.575E+01	3.575E+01	2.531E-01	2.531E-01
7	1.046E-02	-2.289E+01	1.046E-01	1.094E-03	-2.394E-01
8	-2.771E-03	-6.213E+00	-1.385E-02	3.841E-05	1.722E-02

SUMMATION OF BRANCH POWERS =-8.179E-02 WATTS

TRANSISTOR ANALYSIS

NO.	STATE	VBE	VBC	VCE	IE	IB	POWER
1	-ACT-NOR	-3.007E-01	1.720E+01	-1.750E+01	-6.084E-04	-1.130E-05	1.045E-02
2	-ACT-NOR	3.468E-01	-8.410E+00	8.757E+00	7.312E-03	2.319E-04	6.208E-02

DIODE ANALYSIS

NO.	STATE	VOLTAGE	CURRENT	POWER
1	-ON	6.534E-01	7.080E-03	4.626E-03
2	-ON	6.535E-01	7.080E-03	4.627E-03

TOTAL POWER DISSIPATED IN CIRCUIT= 3.999E-01 WATTS

MANEX ANALYSIS COMPLETED

standard deviation for node voltage v . The term $\partial v / \partial P_i$ is the partial derivative of the node voltage with respect to the i -th parameter and σP_i is the standard deviation of the i -th parameter. The formula is valid only for small excursions about the nominal values of the node voltages, but requires less input information on parameter distributions and far less computing time than a more sophisticated Monte-Carlo analysis. The outputs of this analysis are the standard deviation, variance and the 1-sigma and 3-sigma limits for each node voltage. The 1-sigma limit is obtained by adding the standard deviation to the nominal value of the node voltage, with the corresponding operation for the 3-sigma limits.

Examination of the outputs indicates whether circuit voltage excursions due to parameter variations will remain within specified limits. The "break-down of variance" printout lists the percent contribution of each parameter to the variance of the node voltage and shows which parameter tolerances are most critical. These are obtained by dividing each parameter in the propagation of variance formula by the total variance, σ_v^2 . By scanning the printout for a particular node, the designer can find the parameters that cause most of the variance.

Conversely, it is possible to determine the parameter tolerance that yields a desired value of variance for a particular node voltage. With this information the circuit is easily optimized with respect to design centers and parameter tolerances. This reduces the amount of overdesign that often occurs when only sketchy information is available for parameter tolerances on circuit performance.

The last optional routine in the sample problem is the "Mandex worst-case analysis." This analysis is helpful where large tolerance extremes are encountered. The approximate solution obtains worst-case limits by summing the contribution of each parameter tolerance to the worst-case limit. The formulas are

$$\Delta v = \sum_{i=1}^N \frac{\partial v}{\partial P_i} \Delta P$$

$$V_{wc} \approx V_{nom} \pm \Delta V$$

where V_{wc} is the worst-case limit, and ΔP is the parameter tolerance expressed as the tolerance extreme minus the nominal value of the parameter. The solution breaks down for nonlinear circuits with large parameter variations because the partial derivative is not constant throughout the range of the variation.

The Mandex analysis obtains a new nominal solution with all parameters set to their tolerance extremes. It requires more computer time to obtain the worst-case limits but gives more accurate results.

A Mandex analysis was run for node 5 in the sample problem and the results are tabulated. The analysis is made first for node 5 at its high (maxi-

imum) value and then for the low (minimum) value. The values for all the node voltages are given along with the stress, transistor and diode analyses. This additional information may show overstressed components even for the node voltage that is within worst-case tolerance limits.

A comparison of the approximate worst-case minimum and maximum values with the Mandex high and low values for node 5 is:

	Mandex	Node 5	Approximate
High	-22.54		-22.54 Maximum
Low	-22.57		-22.55 Minimum

The small tolerances on the circuit's parameters caused the node voltage is almost identical for both analyses. This would not be the case, however, if the tolerances had been large, i.e. 10-20%.

It should also be noted that the Mandex analysis for the low value on node 5 shows that transistor 2 has changed state, whereas no indication of this was given in the approximate analysis.

Communication—still a stumbling block

One of the biggest bottlenecks to the efficient use of circuit analysis is man-machine communication. Normally several computer runs are required per circuit to correct input errors and to investigate the effects of design modifications. With each computer run the user must contend with delays associated with the mechanics of getting a job run. Also, it is difficult for him to gain insight into a circuit's operation by looking at printouts.

Norden is planning to add on-line graphics to its circuit analysis programs. This will enable the user to correct input errors and make modifications directly with a light pen on a cathode-ray-tube display console. Thus, as fast as the modifications can be made they will appear as program outputs displayed directly on the crt. With the display console time-shared with the central processor, the computer can be doing other jobs while the user is observing outputs on the crt and deciding what to do next. Time sharing will make on-line operation economically feasible.

An experimental version of ECAP with on-line graphics has already been developed at IBM. Thus, the trend to graphics combined with circuit analysis programs is already started.

Reference

1. F.H. Branin Jr., "Machine Analysis of Networks and Its Applications," International Business Machines Corp. Data Systems Division, Poughkeepsie, N.Y., TR00.855, March 30, 1962.

Bibliography

- "Development of On-Line System for Computer-Aided Design of Integral Circuits," Interim Engineering Progress Report IR-9-521 (III), September 1—November 30, 1966, prepared under Contract AF 33 (615)—3544 for the Air Force Materials Laboratory, Wright-Patterson Air Force Base, Ohio.

Integrated circuits in action: part 5

In search of the ideal logic scheme

Dilemmas galore confront the uninitiated designer trying to pick the logic form that is best for his application

By Donald Christiansen

Senior editor

The history of the integrated circuit is a short one but already many logic schemes have been proposed and a score of them have been fabricated. Trying to make sense of the mishmash has caused sleepless nights for the prospective user of IC's.

Circuit experts, on the other hand, maintain things are a good deal simpler than they appear. For example, if consideration is restricted to bipolar gate topologies, they note, there are just three basic forms of IC logic schemes. They are: collector-coupled, input-coupled inverter, and emitter-coupled logic. The types are also known as current sourcing, current sinking, and current mode, respectively.

Sourcing and sinking

In those types of logic classified as collector-coupled or current-sourcing, current flows from the output of a circuit and is forced into the input of a similar circuit to activate the circuit which it drives.

Input-coupled or current-sinking logic types on the other hand, require that current flow out of the input of a circuit and back into the output of the preceding stage, which serves as a current sink instead of a source.

Finally, current-mode logic circuits can be either sink or source types. The salient point is that such circuits switch logic levels by assuming one of two active current modes. The circuits have common-emitter inputs and emitter-follower outputs.

Easy way in

When IC designers first began building logic devices, they took the path of least resistance, converting directly from well-known and widely used discrete component logic schemes. One of the earliest formats was direct-coupled transistor logic

(DCTL), shown in the schematic on page 150, a basic form of collector-coupled logic. An advantage of this logic is that power dissipation is low, but current hogging by one of several transistors which it is attempting to drive limits its usefulness. To overcome this shortcoming, the logic was modified by adding either resistor or resistor-capacitor coupling networks. The resulting circuits were resistor-transistor logic (RTL) and resistor-capacitor-transistor logic (RCTL), shown in the schematics on page 150. RTL was popularized by Fairchild Semiconductor, a division of Fairchild Camera & Instrument Corp. in its Micrologic lines. Texas Instruments Incorporated made its debut into the IC field with its Series 51 RCTL line. RCTL differs from RTL chiefly in the use of small speedup capacitors across the input resistors. The resistors in commercial RTL circuits are significantly smaller than those in RCTL circuits, and the signal swing for RTL is about a volt compared to 6 volts for RCTL. As a result, the problem of noise rejection is more serious in RTL, though it can be improved at the expense of fan-out.

Less noise

Attempts to improve noise margin resulted in the development by the Signetics Corp., a subsidiary of the Corning Glass Works, of the first input coupled logic scheme, diode-transistor logic (DTL), whose basic schematic is shown on page 150. In this circuit, R_3 and C form a dynamic battery whose purpose is to set the input threshold level of the gate.

Usually R_3 and C are replaced by one or more diodes. What is sought is a fast turnoff of Q_1 . Therefore, the coupling diodes should be charge-storage diodes (unlike the input diodes). Since the two types of diodes are hard to achieve in a mono-

Flip-flops: designer's mainstay

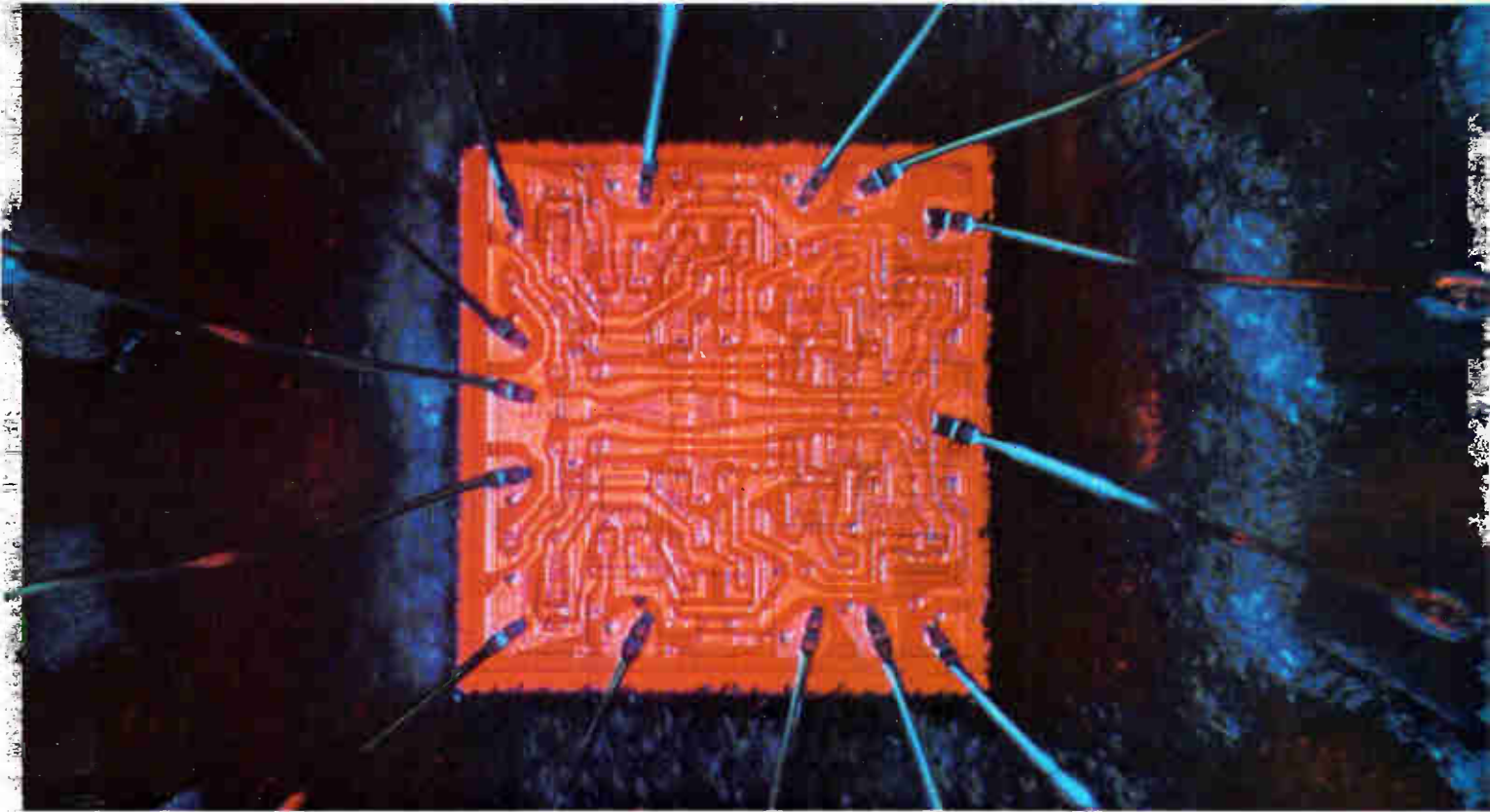

Dual J-K flip-flop contains 28 transistors, 38 resistors. The RTL device is a complete general-purpose storage element designed by Fairchild Semiconductor for industrial shift registers and binary counters.

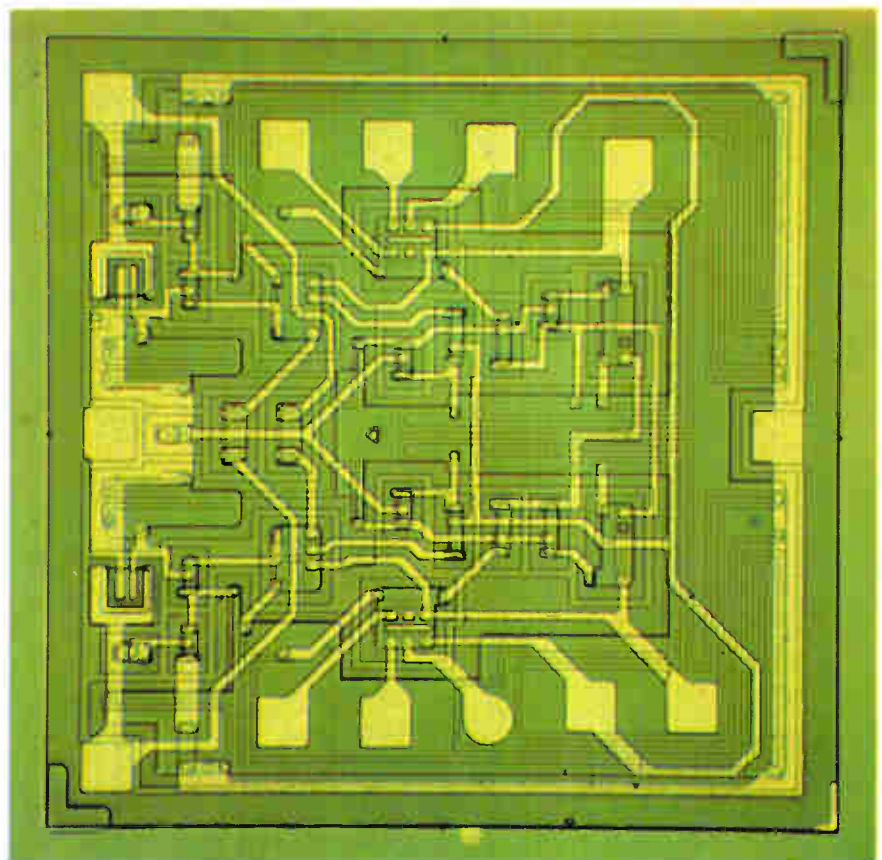

Master-slave flip-flop in new low-power TTL line, series 54L, will be introduced by Texas Instruments at the IEEE show and convention.

Cracking the consumer and industrial markets

New ceramic dual in-line package containing DTL IC's will be exhibited by Fairchild at the IEEE show and convention. Circuit is contained on circular ceramic "button," bonded face down to join with fired-on lead pattern on underside of rectangular ceramic body. The package may help IC vendors reach avowed goal of supplying military-grade IC's at industrial and consumer price levels.

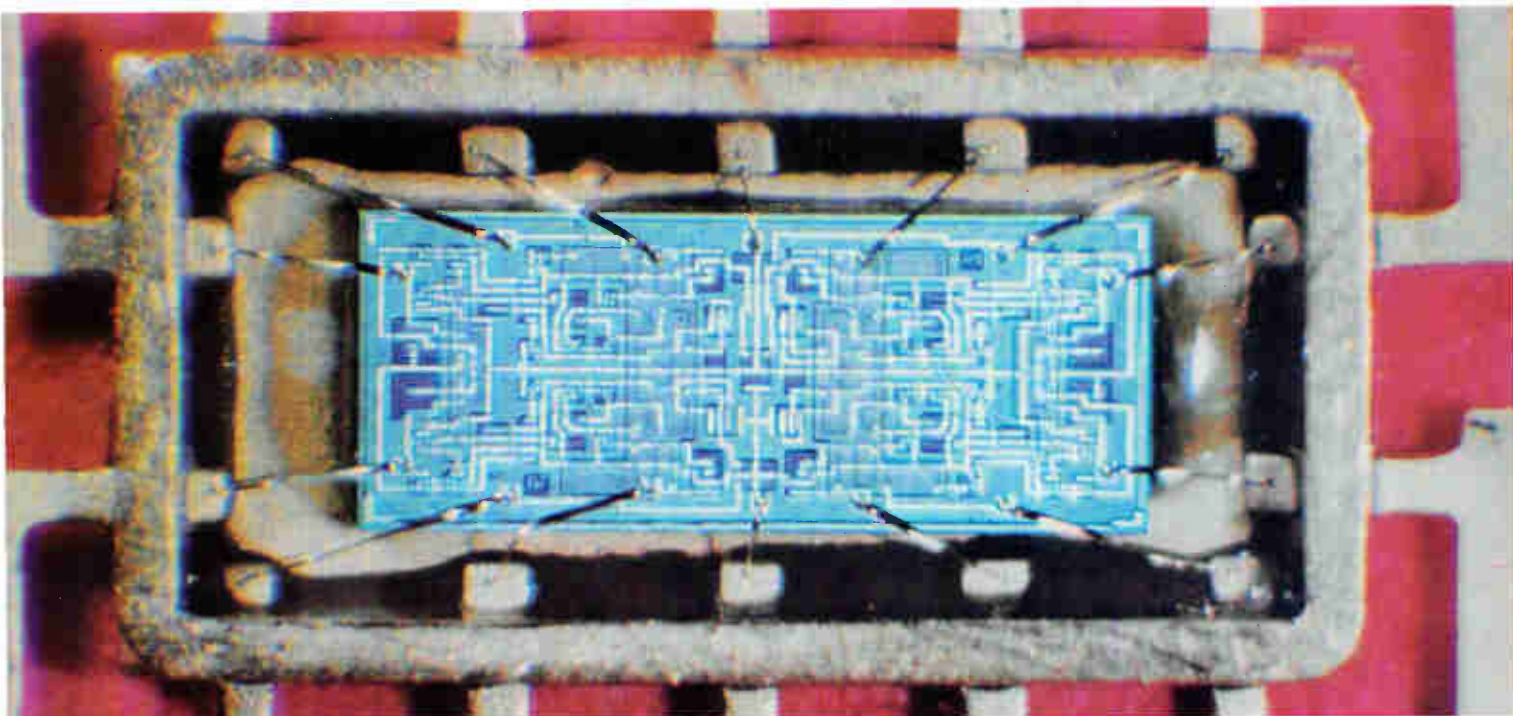
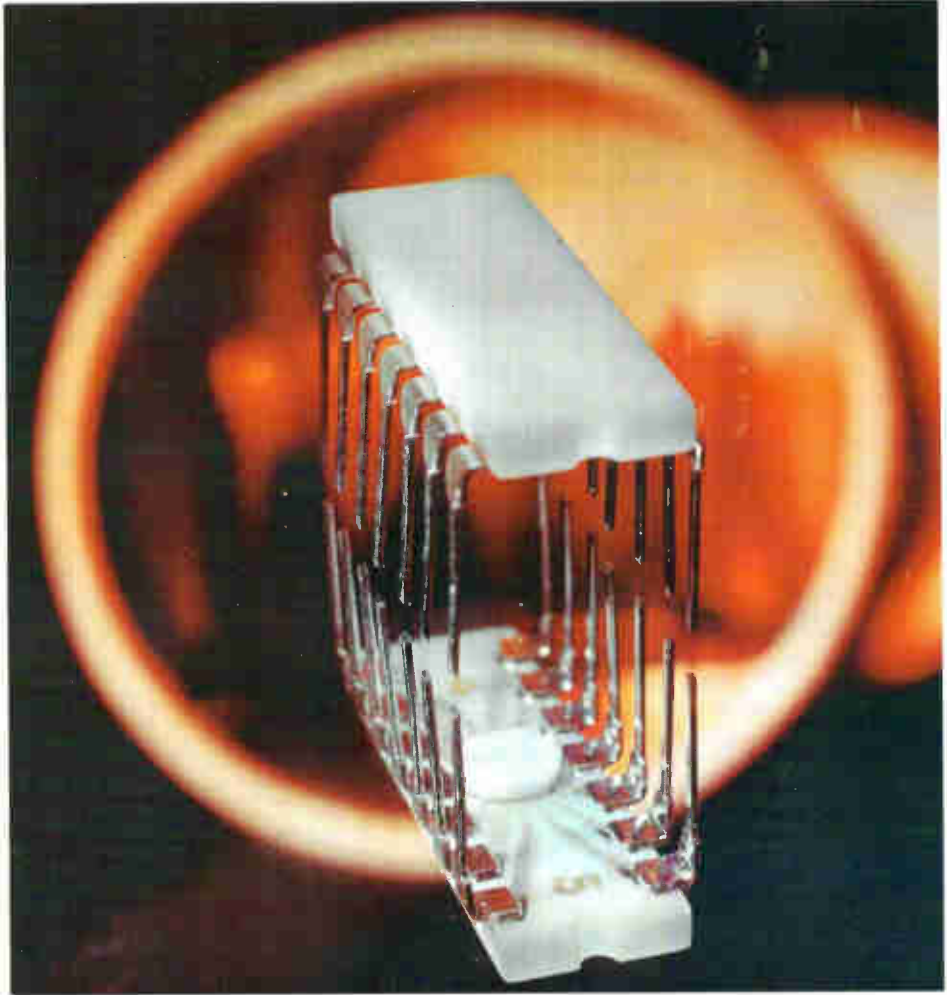

One of modified-DTL devices used in Cincinnati Milling Machine numerical control system is this dual J-K flip-flop, part of TI's series 73. Silicon slice contains total of 80 transistors, resistors, and capacitors.

label it, belatedly, complementary-transistor logic (CTL). The fan-out of the driving circuit is boosted by the pnp transistors. Q_3 is driven by Q_2 operating as a collector follower, and Q_1 provides extra gain. Driving the succeeding stages through R_3 and permitting resistor tolerances up to 30%.

Low- or ZERO-level DTL output voltage is determined by the saturation voltage of the output transistor, and high- or ONE-level voltage is equal to supply voltage V_{CC} . Thus the voltage swing is basically large, leading to good noise immunity.

Of those logic types mentioned so far, DTL is unquestionably the most widely used.

TTL a comer

The logic type destined to become the work-horse of the industry, however, appears to be transistor-transistor logic (TTL), a direct descendant of DTL.

A shortcoming of DTL is that it is not fast enough for some applications. The input diode network and the first coupling diode of a DTL gate can be replaced by a multiple-emitter npn, top right. This decreases capacitance loading and as a result boosts speed. The resulting circuit is TTL (when first developed it was called transistor-coupled logic).

One of the early TTL circuits, dubbed the Phoenix gate because of its use by Litton Industries Inc. in the Phoenix missile, is shown at middle, right. In TTL, a low impedance path is developed through which Q_1 is discharged; after Q_1 is turned off,

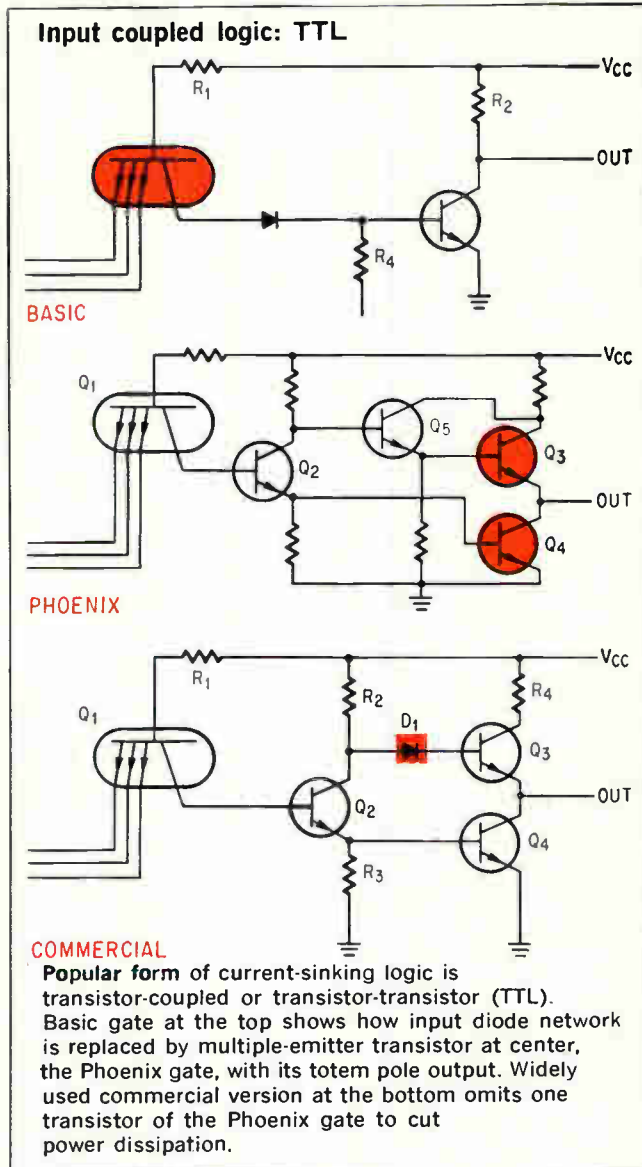

the collector of the multiple-emitter transistor effectively opens.

It is possible that high leakage of the multiple-emitter transistor may load a circuit excessively. To offset this, and to provide a charging current during both ON and OFF transient conditions under capacitive loading, the totem pole output stage is used. Totem pole refers to stacking Q_3 and Q_4 ; the output is thus driven through an active device during both rise- and fall-time, (through Q_3 and Q_4 , respectively). Commercial versions of TTL are called high-level TTL because they provide a voltage swing of about 3 volts. Among them are the version produced by TI, Series 54, and the almost identical version shown above, made by the Sylvania Electronic Components Group, a division of the General Telephone & Electronics Corp., and the Transistron Electronic Corp. Note that the Darlington amplifier of the Phoenix gate has been omitted in favor of the single transistor Q_1 . By avoiding the extra transistor and by altering the values of resistors, the manufacturers have reduced power dissipation

DTL variations cut noise

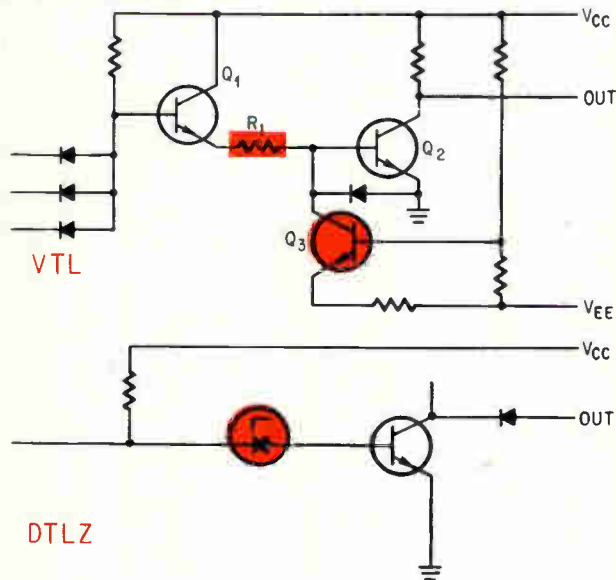

Variable-threshold logic, at the top, in which supply voltages are set at high or low values to provide high or low noise rejection. R_1 replaces level-setting diodes of DTL, and Q_3 acts as constant-current source. Zener diode in the DTLZ circuit, below, replaces conventional diodes to boost noise threshold to about 6 v, but power and propagation delay zooms.

Hybrid method

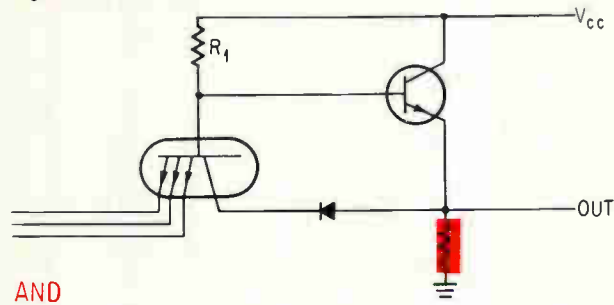

AND

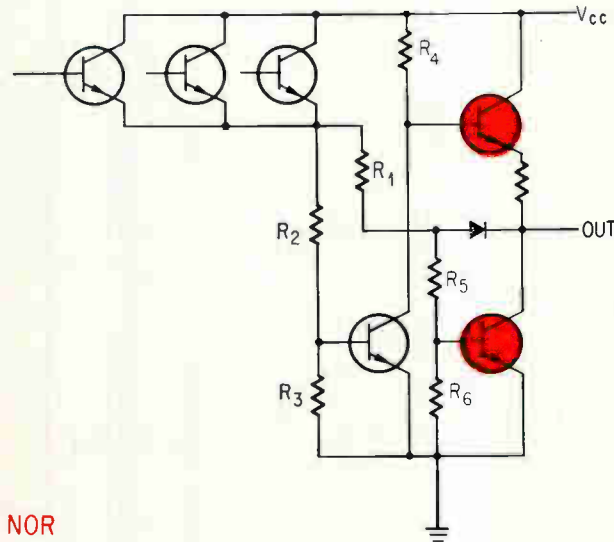

NOR

AND gate, at the top, in "Utilogic" has noninverted emitter-follower output. NOR gate, at the bottom, has totem pole output, all npn transistors.

rent to R_1 and the output goes low.

Several transistors can be paralleled with transistor Q_1 , forming an emitter-coupled npn gate at the input. The output will be the logic OR of the inputs or, if a resistor is placed in the common-collector circuit of the input and an emitter-follower stage added, as in the commercial version, illustrated on the opposite page, an inverted output (NOR) is provided.

CML is finding application in very high speed general-purpose computers. However its critics cite the need for multiple reference and power supply voltages and its relatively high power dissipation, particularly in lower speed applications.

Another deterrent to widespread use of CML is its incompatibility with all saturating types of logic.

One variation of CML is called current-mode complementary transistor logic (CMCTL). Its developers, Compagnie Europeene d'Automatisme et d'Electronique of France, claim very high speed, low package count and power consumption. The basic gate, opposite page, uses coupled emitters and a current-mode amplifier. The output is transmitted through emitter followers and the voltage level is restored by a current-mode amplifier. The circuit provides a logic swing of 1.1 volts and gives complementary logic outputs. Only one supply voltage

is needed, and its tolerance need be no better than 10%.

Fairchild's complementary-transistor logic line (CTL or CT μ L) can be classed as a current-mode type. Fairchild notes it was designed for use in simple circuit board or open transmission line systems. The inputs in the circuit, opposite page, require low voltage, a current sink to drive the output to its low level value, and a current source to drive it to its high level value. The pnp transistors, the company notes, have a low f_T of only about 30 Mhz, which helps avoid instability.

A problem encountered in some current-mode circuits, including CTL, is shifts in level due to a voltage gain of slightly less than unity. The result is an output voltage not quite equal to the input voltage, and after propagation of a signal through several stages, the logic level must be restored.

Hybrids

Not all designers believe that using a single logic scheme will necessarily provide the optimum system. The important thing, they point out, is to match logic levels, get the needed speed and keep power dissipation low.

Fortunately, there is good compatibility among saturating logic schemes. Fairchild Semiconductor has exploited this compatibility to pick and choose in order to come up with a line it calls compatible current-sinking logic (CCSL). The new line combines three families: TTL, DTL and low-power DTL. All are classed as current-sinking circuits, meaning circuits that accept current into their outputs from the circuits they drive. Each CCSL gate can drive or be driven by every other CCSL gate.

Signetics several years ago introduced a line of digital IC's called Utilogic.

Utilogic is a line built around a basic AND and a basic NOR circuit, displayed at top left. The AND has multiple-emitter inputs while the NOR has emitter-follower inputs. Output for the AND is an emitter-follower and, for the NOR, a totem pole arrangement. In the NOR circuit, the threshold levels are determined by the ratios of R_2/R_3 and R_5/R_6 . The NOR gate will drive capacitive loads efficiently. Notice the similarity of the NOR gate to the TI Series 53 "modified DTL" line. Some engineers label it a variation of Series 53—one that does not require complementary transistors. Since the emitter-coupled input gate is npn, it performs the OR function for positive logic. Hence this is a DTL modification that performs NOR logic instead of the usual NAND logic.

Bibliography

- J.N. Harris, P.E. Gray and C.L. Searle, "Digital Transistor Circuits," John Wiley & Sons, N.Y., 1966.
- "Microelectronics in Space Research," Technology Utilization Division, National Aeronautics and Space Administration, Washington, August, 1965.
- D. Christiansen, "Microelectronics '65," EEE, November 1965, pp. 65-70.
- J.W. Martin, "The evolution of saturated digital design," Proceedings of the 1965 Western Electronic Show and Convention. C.F. O'Donnell (Editor), "Applied Microelectronics," America House, Division of American Aviation Publications Inc., Washington, 1966.

When monolithic diode-transistor logic (DTL) was introduced it copied discrete NAND circuitry, and began the present emphasis on NAND devices.

Easier than it looks

Any system can be built up from OR and NOT (NOR) circuits or from AND and NOT (NAND) circuits. A case in point is the Apollo program, which used NOR gates throughout in its first and second generation spaceborne guidance computers. Either scheme (NOR or NAND) uses inversion (NOT) in each gate. The inverter (a common-emitter amplifier circuit) provides power gain, which permits it to drive a number of other similar circuits. Thus it provides fan-out capability, or what is sometimes called logical gain. Furthermore, it serves as a logic-level restorer since its output is accurately determined by either its cutoff or saturation mode of operation, even though its input may range over wide values.

An ABC approach

Should the designer want to avoid a long, involved Boolean transformation, he may duplicate any natural AND-OR logic system using NAND circuits and inverters. NAND inputs are tied together or unused inputs are bussed to the positive supply or left open when an inverter is desired. An AND gate, for example, is made from a NAND followed by an inverter, above right. An OR is a NAND with an inverter ahead of each input, while an AND-OR combination is made from NAND's into another NAND. An OR-AND combination is more complex, requiring inverters working into NAND's, then into a NAND followed by another inverter. Fortunately, this combination rarely occurs in logic systems.

The AND-NOR function is available directly in several devices. A number of IC vendors provide such a device, page 160, with two 2-input AND gates into a NOR and call it an exclusive-OR gate.

A true exclusive OR provides a ONE output when one or the other but not both of its inputs is ONE. When the inputs are not of the same value a ONE output appears; similar inputs provide a ZERO. The AND-NOR device in question, on the other hand, provides the inverse; dissimilar inputs cause the ZERO output. Thus a better label would be "exclusive NOR." Furthermore, the device works only as an exclusive-OR if both inputs provide both regular and complementary signals, as in the diagram on page 160. If complementary signals are not available, two additional input inverters are required.

Fun with flip-flops

A flip-flop is essentially a pair of cross-coupled inverters in which a high output of one holds the output of the other low, and vice versa. A flip-flop remains in a stable state until externally triggered. Alone it is useless; its value is determined solely by its input gating. The simple flip-flop, page 160, is made from two NOR gates. The Q output is low and the \bar{Q} output is high in the normal or ZERO state. The leading edge of a momentary positive pulse applied to either the S or P input turns

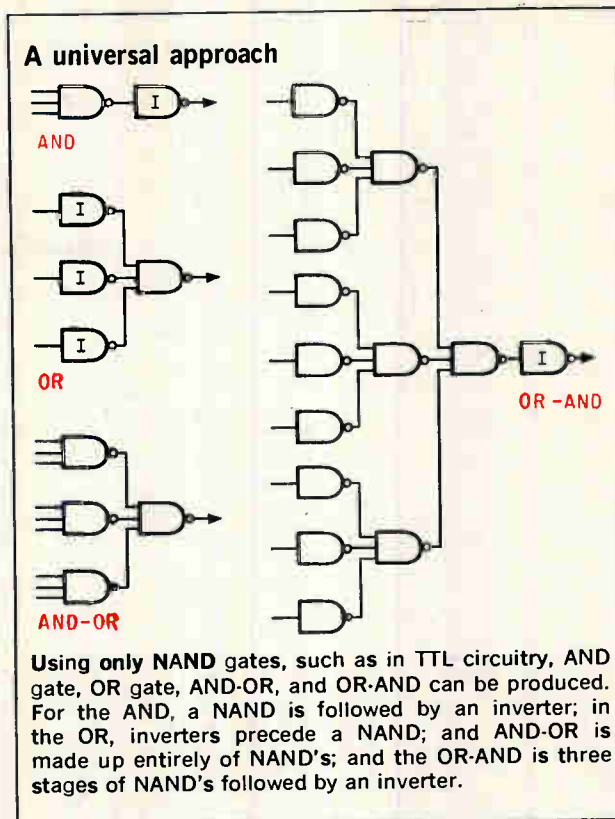

the OFF side to ON, reversing the flip-flop. In this new state (the ONE state), Q is high and \bar{Q} is low. A simple change in d-c level cannot be used as a trigger because it locks up the flip-flop against further changes; a pulse is a must. Reset to the ZERO state results from a pulse on the R or C lines.

While discrete-component flip-flops are a-c gated, IC flip-flops are normally d-c gated. A delay flip-flop is produced by adding a gating scheme like the one shown at the bottom of page 160. The basic flip-flop is shown as a simple rectangle. Complementary control levels are applied to the D inputs and the clock is normally low. A pulse on the clock line passes through the gate to which the higher control level is applied and changes the state of the flip-flop accordingly. If the flip-flop was already in that state, nothing happens. The d-c conditions applied to the control inputs appear at the outputs one clock pulse later, hence the name delay flip-flop.

If the clock line in the delay flip-flop is high or missing, the circuit reverts to the simple SET-RESET type. If the clock is present but the D inputs are both high or missing, the flip-flop is useless because it has an indeterminate state for each clock pulse. This is the outstanding disadvantage of a SET-RESET flip-flop when both inputs are applied simultaneously. The flip-flop does not toggle.

Shortcomings

The simple SET-RESET flip-flop can be used in storage registers and in some control functions, but it is otherwise not very useful. Indeed, some SR flip-flops on the market are worse than useless, because they have an indeterminate stage for both

which the a-c flip-flop can be SET and then RESET is limited by twice the transition time—the time required for a change of state—and by the width of the trigger pulses. Moreover, if both pulses are applied simultaneously, the flip-flop can't decide which state to assume. With the gates, however, the pulse width is not important because it is only the transition times of the trailing edges that count. If both signals are applied at the same time—either through coincident trailing edges or equal-width pulses—the flip-flop assumes the opposite state; it complements or toggles.

Universal circuit

If the flip-flop is modified by tying the J-K inputs to form a clock input, and additional control inputs are added, opposite page, an a-c "universal" flip-flop is formed. While similar in some respects to the D flip-flop, it has two differences. If the clock is high or missing, the D inputs become true J-K inputs that SET and RESET the flip-flop. If the D inputs are high or missing, the flip-flop toggles from a clock input. When additional inputs are added to the gates, this configuration is truly universal in application.

Unfortunately, not one single available d-c J-K integrated circuit flip-flop will perform the functions of the a-c universal circuit. They are, however,

designed to perform the D logic function. And they will toggle if the D inputs are high or missing. They do not, however, perform the true unclocked J-K function. The essence of this is that "J" and "K" inputs of available d-c integrated circuit flip-flops are really only D and \bar{D} inputs as far as functions go. The devices do have the additional capability of toggling but this is only one special use of the J-K function.

NAND not NOR

Most IC flip-flops are made from two cross-connected NAND gates rather than the NOR gates of the basic flip-flop, opposite page. The positive AND direct inputs are OR inputs for negative logic so most IC flip-flops SET and RESET on negative (toward ground) pulses from a normally high level. A few leading-edge flip-flops SET and RESET on positive pulses, however. Several devices can be used for other than their stated purposes. For example, one device labeled "two-phase SR clocked flip-flop" provides the D function, triggering on the leading edge of positive clock pulses. A second set of inputs provides SET and RESET functions for negative pulses. The device does not toggle.

Regardless of whether the direct SET (PRESET) and RESET (CLEAR) inputs require positive or negative pulses, the vast majority of IC firms offer so-

Using IC's: Trials and tribulations

While integrated-circuit manufacturers promote lines that are designed to eliminate all woes of the digital equipment designer, users express skepticism. Robert Sanford, author of the article, "Understanding IC logic," beginning on page 158, experiences frustration each time he begins work on a new logic system and finds that available IC's are woefully inadequate. Sanford, a senior digital engineer working on ECM systems for the Babcock Electronics Corp's Aerospace division, finds that unclocked asynchronous systems for the military don't always fit gracefully into the "computer scheme of things," where IC's are concerned.

No one series provides all the functions needed, he says, so most systems combine IC's from two or more lines. That's when the fun begins, Sanford reports, citing differences in logic levels, power supply requirements, fan-out, and input loading.

A pet peeve of Sanford's is the flip-flop. Most control flip-flops, he notes, are SET and RESET as opposed to toggle types—and this requires one-shots for pulse generators. A typical one-shot used by Sanford will set and reset a flip-flop made by another manufacturer, but it requires an additional inverter for use with flip-flops of its own line.

Frequently special logic schemes must be fabricated to circumvent the shortcomings of existing IC's. Designs could be simplified, Sanford notes, if the flip-flops were true J-K's that would respond to changes in level, instead of requiring trigger pulses.

William Rhoades, who wrote the article "Logic IC's don't live alone," starting on page 162, emphasizes that the IC must be considered as part of the over-all system. Equipment performance often rests

more upon the interconnections than in the IC's themselves, reports Rhoades, who is a senior staff engineer in advanced techniques for the engineering division of the Hughes Aircraft Co. Rhoades is now evaluating high-speed IC logic circuits for general-purpose computer programs. Problems faced by digital system designers, Rhoades says, are turn-around time, cost of spares, and the time and complexity of field testing. If a true sequential test of a computer system were to be undertaken, one would not live long enough to see the end of the test, Rhoades points out. Furthermore, the test equipment in the field could be more complex than the system being tested.

How noise affects a system is another big problem. Both Sanford and Rhoades criticize the conventional ways that vendors characterize IC's for noise. Both deride the fictitious "switching point." Semiconductor junctions do not switch on and off like a light switch, Sanford points out. In a TTL gate, for example, any input voltage greater than 0.5 to 1.0 volt will cause partial conduction and a reduction of the output voltage from its ONE level. Usually the output transistor in a gate will be at the ZERO level when the input is above about 1.4 to 1.7 volts. Any input voltage between these limits will produce an indeterminate output voltage.

The real troublemaker is a-c noise—primarily switching spikes. But, Sanford says, the IC vendor is careful to avoid specifying a-c noise immunity. About all one can do, he says, is use large power busses—particularly for ground, clean up the power lines and use LC filters in the positive lead on each board—and hope.

noise immunity under 20% require shielded structures such as coaxial or strip lines. Noise immunity for typical gates, operating without a hysteresis effect, is about 20% to 30%.

Spurious signals

In a transmission network designed to connect digital IC's together in a logic system, coupling between nearby signal paths can raise havoc. For example, a signal passed through one transmission line can produce spurious signals at the terminations of adjacent lines. The spurious signals, called crosstalk, can be classified in terms of the ways in which coupling occurs: common impedance, electrostatic, and electromagnetic.

Factors that combine to make analysis of crosstalk difficult are:

- Interaction is usually not just between two but among many circuits of a transmission complex.
- The distributed, rather than lumped, nature of the inductances and capacitances of the circuits involved.

Nevertheless, there are precautions that can be taken to reduce crosstalk. For example, where two or more loads share a common line impedance such as in power distribution, a solution is to run separate lines to each load, or reduce the impedance common to both.²

When a line connecting two IC's is cut by magnetic lines of force generated by a nearby current-carrying conductor, an unwanted voltage will be induced.

Below 10 kilohertz, shielding, to be effective, must be done with ferromagnetic materials. Decreasing the length of the coupled lines is usually the most effective way to reduce crosstalk. Finally, changing the circuit parameters—such as increasing the signal-source impedance, decreasing the signal-load impedance, and decreasing the magnitude and frequency of the currents generating the field—may reduce coupling.

Electrostatic coupling

When two lines differ in potential, capacitive coupling can exist. The coupling current will result in a voltage drop in the signal load. An electrically conductive shield reduces the stray coupling, by-passing it to ground.

Unfortunately, the capacitances of the shield to ground are across the load and may be significant. If the shield is ungrounded and its potential is varied with the signal voltage, part of the capacitance is eliminated but the shielding effect is reduced.

Other ways to reduce capacitive coupling are standard: increase the distance between lines, decrease the dielectric constant between lines, and decrease the diameter and length of the conductors. The best choice is usually to reduce length, since the relationship of capacitance to spacing and diameter is logarithmic, and the dielectric constant is low to begin with. Helpful circuit changes include reducing voltage differences between close wires,

Crosstalk circuits

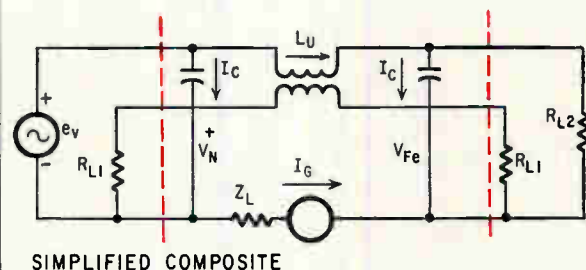
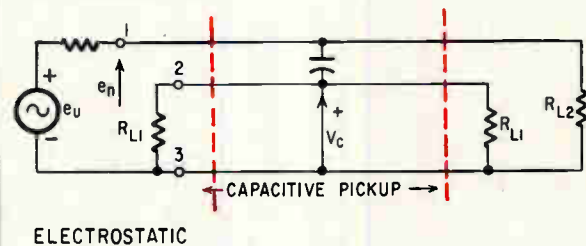
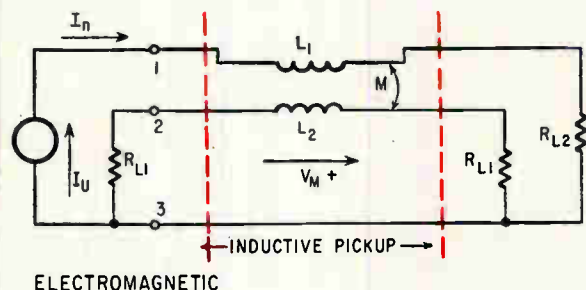
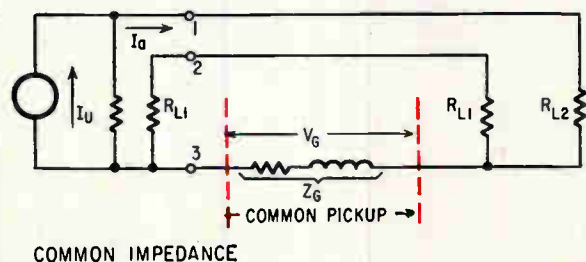
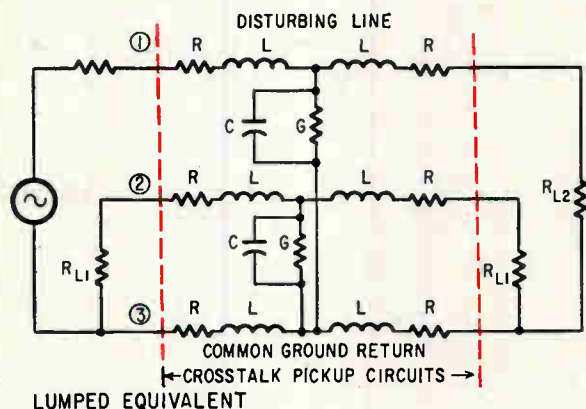

Equivalent circuit for a multiconductor system, top, accounts for common impedance, capacitive and inductive crosstalk. Next three diagrams show separate equivalent circuits for the three crosstalk sources, and the bottom circuit represents the simplified composite equivalent.

lowering frequency and signal-source impedance and signal-load impedance.

Multiconductor systems can be studied through the equivalent circuit on page 163 representing two lines sharing a common ground return.³ In that circuit, R, L, C, and G are distributed parameters per unit length.

The common impedance, capacitive, and magnetic crosstalk sources for multiconductor systems can be represented separately, as in the three diagrams on page 163. The composite equivalent circuit at the bottom shows how the crosstalk pickup voltages differ at the near and far ends of the circuit. The dominant crosstalk mode can be found by either measuring the polarity of the voltage on the coupled line or through calculation. If $M_P/C_P \gg R_{L1} R_{L2}$, the inductive mode predominates, whereas if $M_P/C_P \ll R_{L1} R_{L2}$, the capacitive mode is dominant, and the appropriate equivalent circuit can be used. In the above expressions, M_P is mutual inductance and C_P is capacitive coupling.

More noise

Ground noise margin is the voltage that may be applied at the ground connection without causing the circuit to malfunction. It is usually measured by increasing the static ground voltage on a single gate until the logic fails to operate properly. By sweeping the ground both positive and negative while the input voltage, V_{in} , is set at the operating logic levels, the change in the output voltage can be observed as a function of ground noise.

A more accurate method of testing ground noise also makes use of a pair of gates. V_{in} is set at the worst-case logic levels, and ground voltage is increased on both gates—in the worst-case direction—until the output changes state.

With ground noise margin known, one must determine how much ground noise will be developed. Ground noise is the sum of the voltage developed due to series inductance in the ground paths and the d-c drops. The latter voltages are often negligible, although they cannot be overlooked in high current circuits such as CML or in large-scale integration. Thermal effects also plague very high speed systems.⁴

A-c voltages developed in the ground path can be determined from the rate of change of current in the ground path and its inductance. The former, a function of the t_c , is called the inductance factor. It is high in HL-TTL gates because of the totem-pole output and modifications of HL-TTL are sought to reduce it.

One can compare the permissible inductance dictated by noise margin of the circuit itself with that which would result from the use of specific transmission line formats. The table on the next page can be used to compute the latter.

Propagation delay

Two important sources of delay in a logic system are circuit delay, t_c , and delay caused by the media used to interconnect the circuits, t_i . Circuit delay,

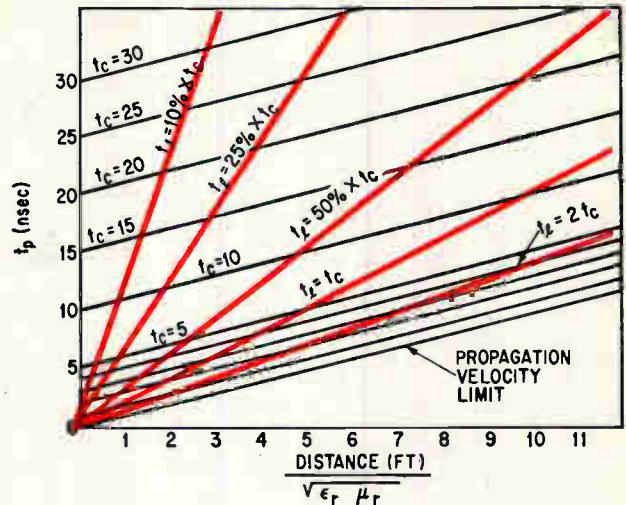

Trade off between system logic delay, t_p , and interconnection lengths between IC's. Delay resulting from IC is t_c , while delay caused by the interconnecting media is t_i . The line lengths are normalized for relative permittivity and permeability of unity.

meaning propagation delay due to the IC alone, is usually expressed on IC data sheets as t_p , but we reserve t_p for the propagation delay (per logic decision) resulting from the circuit and its interconnections in a system; we call this "system logic delay." The trade off between the system logic delay and the interconnection lengths can be determined with the aid of the universal chart directly above. The chart is applicable to a matched signal transmission system. Its abscissa is the allowable line length normalized for relative permittivity and permeability of unity, so that allowable line lengths are reduced for media having constants greater than unity. The graph is general in that dividing or multiplying the abscissa by a scale factor divides or multiplies the ordinate and lines of constant t_c by the same factor.

It is important to recognize that t_c is not only constrained by t_p and t_i but it is also a function of the circuit design and loading. It is useful to introduce the concept of propagation power, P_p , and examine the thermal problems related to it. Propagation power is the absolute minimum rate of energy dissipation required to propagate logical information at the slowest permissible rate throughout a system. An ideal logic element would draw no power when it is not switching, and only propagation power when it is switching. Standby power is considered wasted, although it may be required to make the logic element work properly.

Consider a case in which the load R_L , and source impedance R_s are very large compared to the line impedance, Z_0 . Propagation power can be found experimentally by measuring t_c as a function of load capacitance, C_L . Due to fixed propagation power available from the logic circuit, t_c increases as a function of some power of C_L (i.e., $C_L^{1/n}$ with $n > 0$, where larger values of n indicate greater propagation power capacity). In our example

$$P_p = (\Delta e)^2 C_L / 2t_p$$

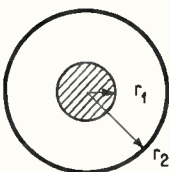
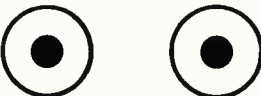
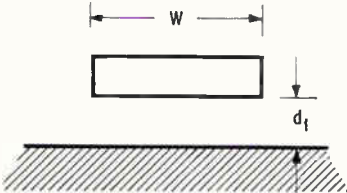
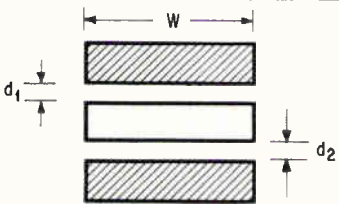
CROSS SECTION	INDUCTANCE L IN NANOHENRIES/ FOOT (ALL DIMENSIONS IN INCHES)	COMMENT
	$140 \text{ LOG}_{10} \frac{r_2}{r_1}$	FOR 10 AWG, AT 0.005 INCH SPACING L = 2.8 nh/FT
TWISTED PAIR 	SAME FORM AS THE COAXIAL LINE, BUT THE VALUES FOR THE ARGUMENT OF THE LOG FACTOR IS A FUNCTION OF TWISTS/FOOT	FOR 24 AWG, 19 STRAND TEFLON INSULATED, EE, 60 TWISTS/FT, L = 140 nh/FT
	$385 \frac{d_1}{w}$	FOR 0.75 INCH BY 0.002 INCH SPACING L = 1.02 nh/FT
	$\frac{385}{w} \frac{d_1 d_2}{d_1 + d_2}$	FOR 0.75 INCH BY 0.002 INCH SPACING L = 0.51 nh/FT

is permitted for the line. The table at the right gives typical capacitance values per unit length of various types of unmatched lines, which are used to calculate allowable line lengths.

High-speed rules

For high-speed systems in which the effective delay must equal the line delay, fan-out methods can be a problem. For one thing, good matching is a must. Two popular techniques are the radial method, on the next page, and the tapped method, below it. In the radial approach, all inputs to the logic circuits must be matched to the transmission line. Also, the driver must drive an impedance of Z_0/n , where n is the fan-out. Such an impedance can be undesirably low if n is large. Then too, a separate line is used for each load. This method is recommended only for n equal to one.

The tapped method requires very high impedance loads to prevent undue line loading.

A third method, the tree method, is recommended when $1 < n < 5$ since it provides matching at every point in the line. It also drives loads located in

different directions (like the radial method). Yet it requires a smaller number of lines than the radial method and, for reasonable fan-outs, the driver output impedance need not be unusually low. If there are just two tree members, the driving gate may be placed anywhere along the line.

The radial method is superior in the case of ex-

Capacitance for various transmission lines

Type of line	Typical capacitance per inch (pf)
Microcoaxial	2.5
Microstrip	1.0
Strip line	1.79
Multilaminate	1.20
Flat flexible wiring	0.6
Twisted pair	1.10
Point-to-point	0.4
Conventional etch	0.5

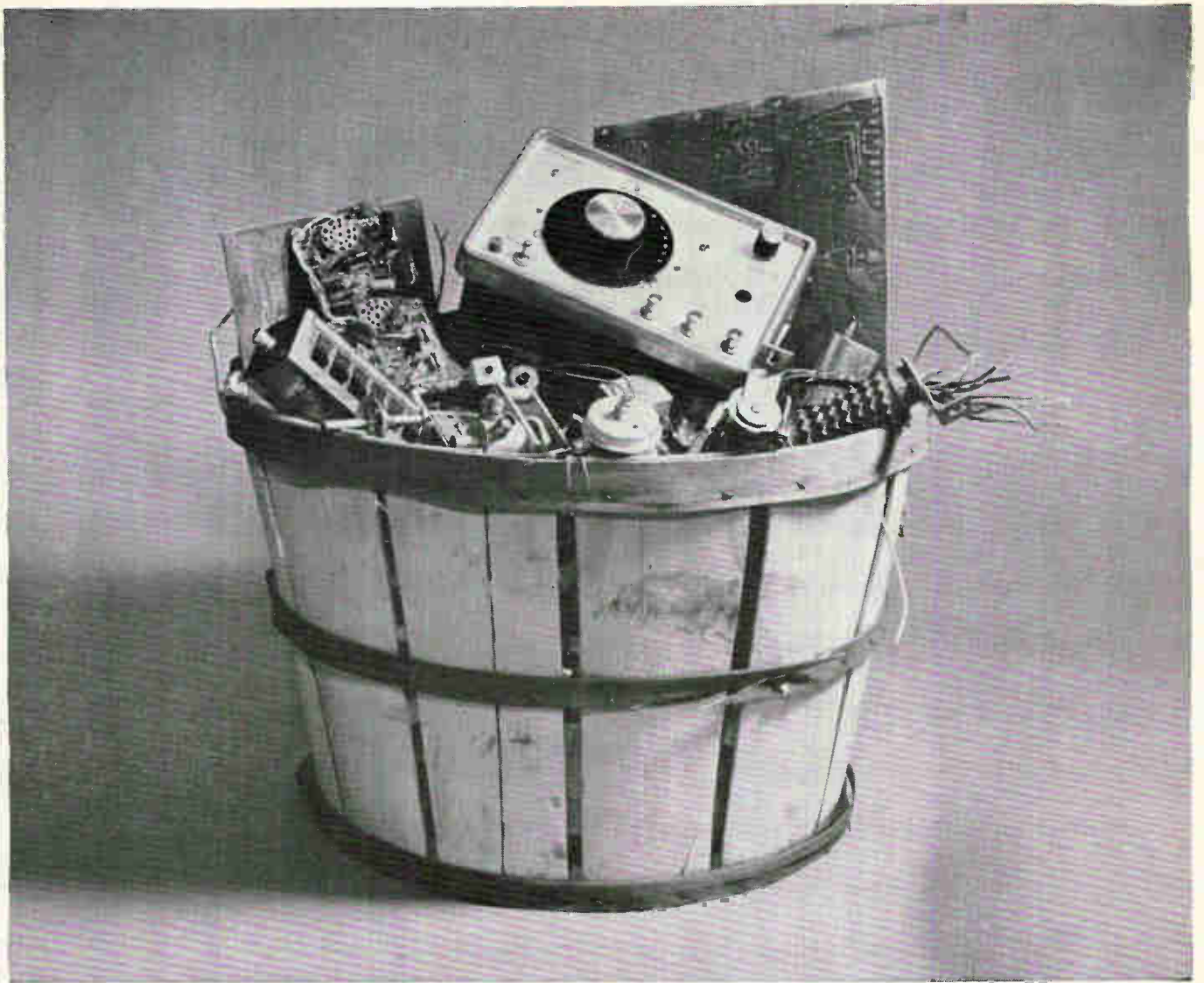

You order it. We'll build it.

Let's face it. No two jobs are alike. Then why should one instrument be expected to fill the needs of all electronic engineers? Knowing this, we design and engineer all our equipment with utmost flexibility.

Our new VS-80 sweep signal generator is a good example.

Proven equipment design has produced an extremely stable oscillator, which provides an exceptionally accurate CW output as well as wide sweep capabilities.

So far we've described a good, solid state sweep signal generator.

But what raises it above the ordinary is the range of options available.

At your request we can add a switchable, 1 KHZ, 100%, amplitude modulation function, or an additional 0 to 10 db in 1 db step attenuator, or the sweep rate can be changed to 0.1 HZ to 10 HZ. And we've just started. Maybe you need markers to modulate the RF output or external amplitude modulation, or increased RF output.

Remember, we'll build the instrument you need . . . even if your name is Rube Goldberg.

FREQUENCY RANGE

1 MHZ to 1200 MHZ

SWEEP WIDTH

50 KHZ to 400 MHZ

FLATNESS

±0.25 low band,
±0.50 high band

OUTPUT

0.5v rms

SWEEP RATES

Manual, 60 cycle, ex-

ternal, variable

ATTENUATION

0-70 db in 10 db steps,

0-10 db vernier

PRICE

\$1495.00



Specialists In Electronic Instrumentation

Texscan
CORPORATION

51 Koweba Lane • Indianapolis, Indiana 46207 • Ph. (317) 632-7351

TURRET ATTENUATORS • TERMINATIONS • IMPEDANCE MATCHING PADS • REFLECTION COEFFICIENT BRIDGES

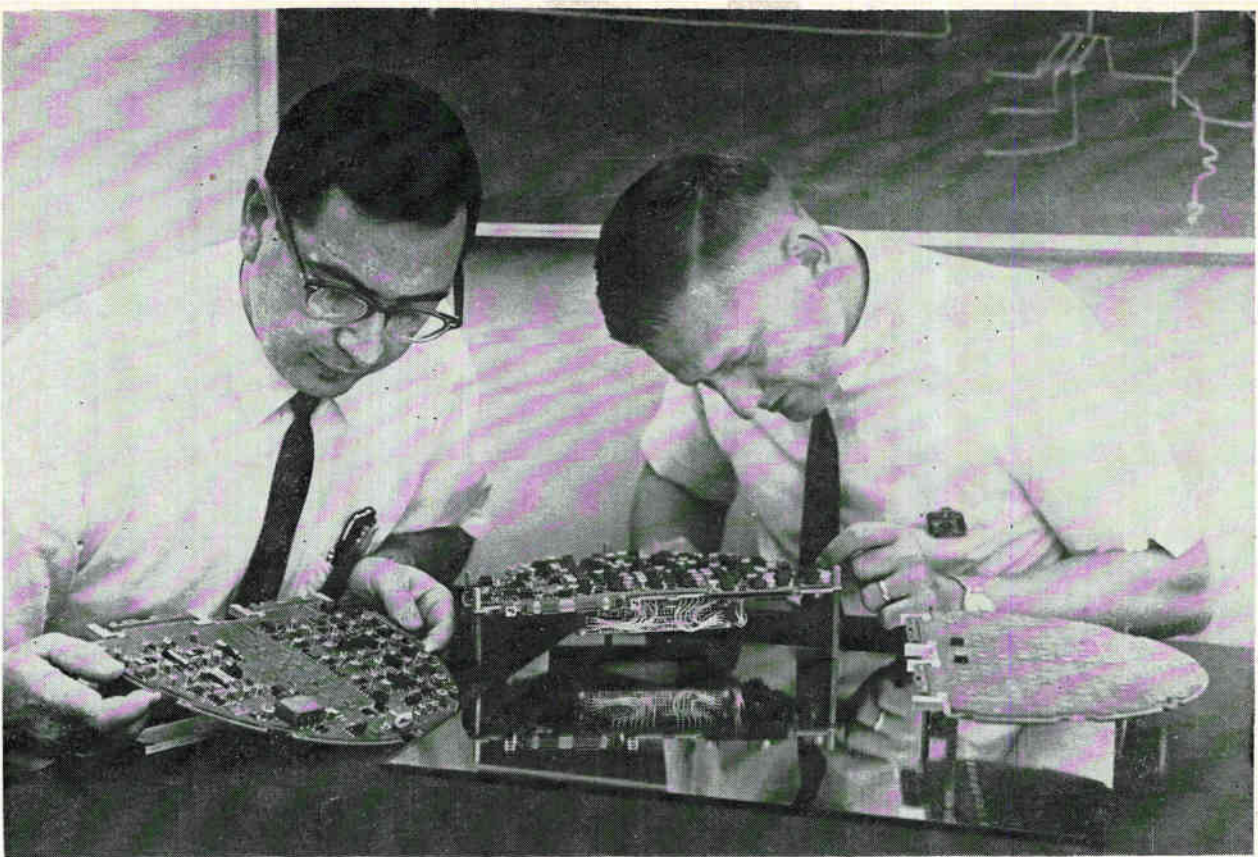

Three subassemblies constitute IBM's new mass production computer for varied aerospace applications.

Computers

The airborne 4 Pi computer: IBM aims at aerospace guidance

A low-cost computer now being mass-produced promises to replace traditional computers in guided missiles. Intriguing organization and the use of IC's contribute to its attractiveness

By William N. Carroll and Frederick F. Jenny

International Business Machines Corp., Owego, N.Y.

General-purpose digital computers have heretofore been too expensive and too large for use in expendable aerospace applications such as in the guidance system of a missile. But now they can compete with the special-purpose machines that have traditionally been used in such vehicles. The widespread availability of varied monolithic integrated circuits, new packaging techniques and high-speed core

memories makes the competition possible. Mass production of logic circuits has cut the cost of such a general-purpose computer and the inclusion of IC's has reduced the size of the machine sharply.

Although special-purpose analog, hybrid analog and digital, and incremental computers have all been used in aerospace vehicles, the military would prefer a general-purpose machine instead because

wired, the read-only portion stores programs and subroutines that have been completely debugged. Instructions in the read-only memory aren't changed by temporary malfunctions or unusual conditions that arise during missile storage, testing or flight. In space vehicles particularly, the read-only memory is useful because it occupies little space and is highly reliable. In the larger models of the 4 Pi series [Electronics, Oct. 31, 1966, p. 42], and in general-purpose computers like IBM's System 360, the read-only memory controls the execution of programs but does not itself contain program instructions; the programmer is not concerned with the read-only memory.

The set contains only eight instructions, each consisting of an operation code and a single address. All instructions have the same execution time except the multiply and shift instructions. Two of the eight instructions can be coded to perform different operations: the process input-output can initiate 31 different operations, and the transfer can cause either conditional or unconditional transfers (execution out of normal sequence) or a change in the memory sector being addressed.

Memory design

The core array is a single plane automatically fabricated and tested, containing 1,024 eight-bit words, expandable to 2,048 words. Additional planes can be stacked to build larger memories, up to 16,384 words. The larger memories, however, will not fit on a single page. Drive and sense electronics consist of monolithic and discrete components. The memory system cycle is 2.5 microseconds, but each active cycle is followed by a 1.5- μ sec idle period to reduce power consumption; the total cycle is therefore 4 μ sec.

The read-only memory is identical to a normal memory except that cores are removed from those locations which contain zeros. This arrangement has several advantages. The memory construction is essentially similar to a conventional system and can be fabricated on existing automatic equipment. Data can be written into as well as read from the memory during development, thereby allowing flexibility in the programming design. The memory with appropriate cores missing is truly unalterable, and cannot be affected by electrical transients or erroneous addressing. The same drive and sense circuitry can be used as with the normal memory; the memory addressing is also the same.

A memory of this type presents certain difficulties. For example, cores with hysteresis loops that are not square could generate unwanted outputs caused by noise from the slanting top of the square. To reduce this hazard the timing of the memory drivers is staggered and extra cores on the drive lines compensate for the noise.

Sensing and controlling

The input-output section of the guidance computer performs important functions:

- It decodes, buffers and amplifies control outputs

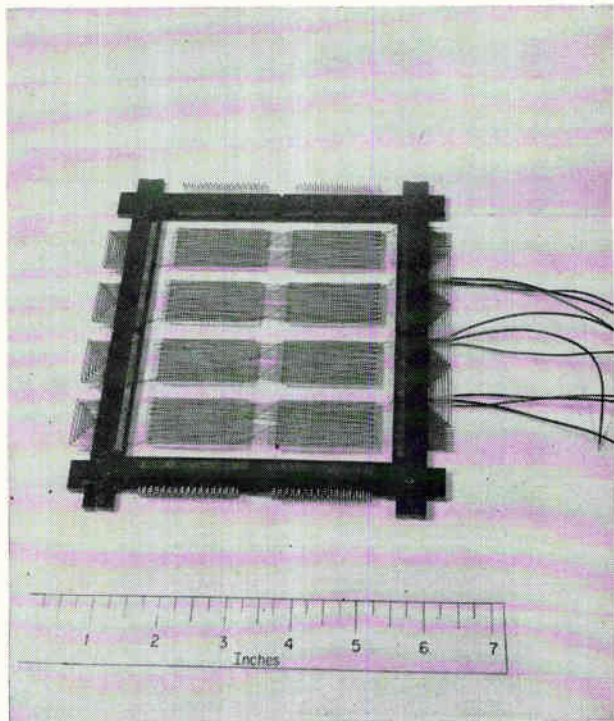

Memory array used in the tactical-missile computer is a single core plane that can hold 1,024 eight-bit words.

and decodes and gates control inputs.

- It monitors the guidance processor, signals the occurrence of any program or power malfunctions and keeps track of real time.
- It accumulates input signals from the accelerometers for later processing, and works with external equipment during initialization and retargeting procedures.
- It assists in the alignment and torquing of the inertial platform and other control functions.
- It controls the sequence of power on-off to various subassemblies.

The specialized nature of these tasks require a mixture of digital and analog circuits using both discrete components and IC's in flatpacks. However, all circuits are mounted on a single multilayer board, as shown in the bottom table, p. 175.

All digital transmission line circuitry, all control circuitry, and most digital-analog conversion circuits are IC's packaged in 14-lead flatpacks. In most cases, analog IC's proved too costly to use.

A major consideration with the multilayer boards

How fast the 4 π works

Instruction set	Time (μ sec)
Clear and add.....	12
Add.....	12
Subtract.....	12
Multiply.....	140
Store.....	12
Shift (left or right up to 16 places).....	20
Process input-output (31 codes).....	12
Transfer (6 codes).....	12

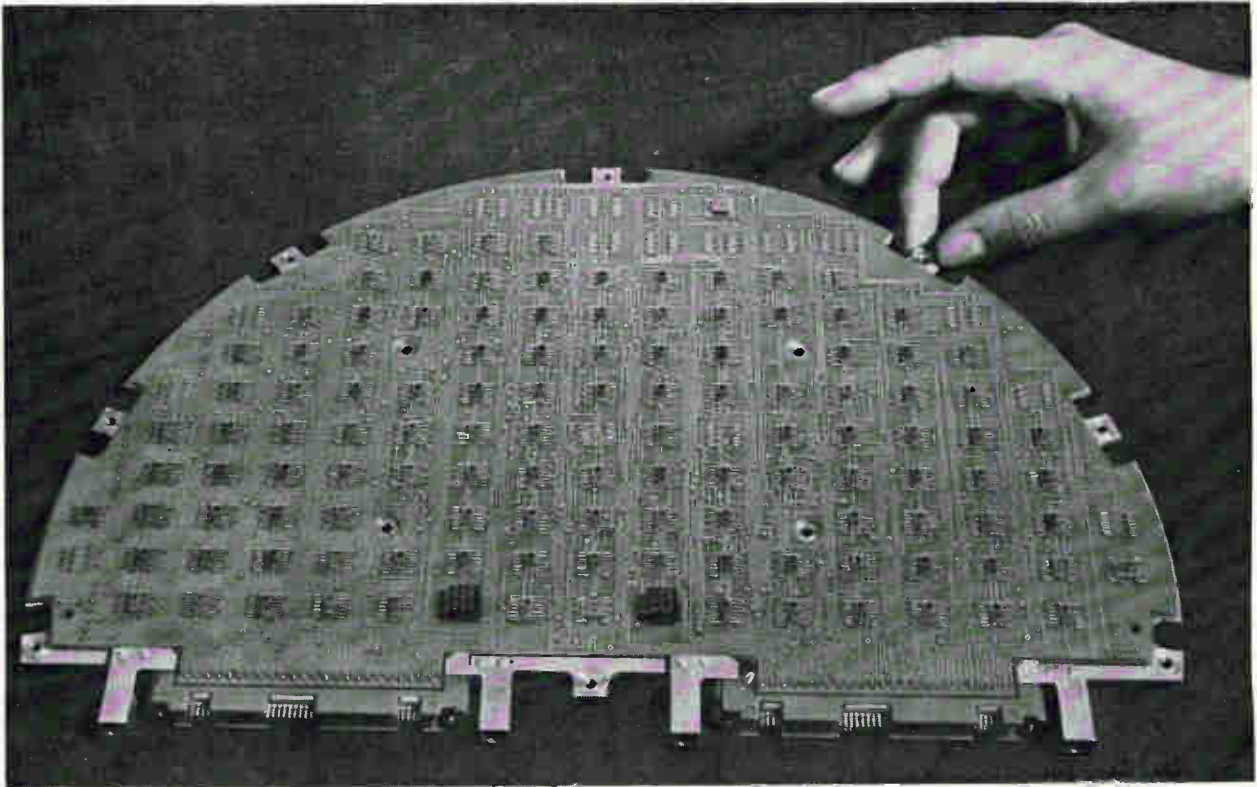

Flatpack mounting and wiring details are visible in this view of the arithmetic and control subassembly.

placed next to the memory with either one in the middle. The entire unit is sealed with a O-ring gasket to keep out excessive humidity and dirt.

Heart of the computer

The central processor subassembly is a general-purpose unit that performs the basic arithmetic and control functions. The two multilayer boards making up this subassembly contain 243 standard 14-lead flatpacks. The basic structure of the board avoids signal crosstalk and provides some power supply decoupling; additional discrete decoupling capacitors are mounted around the page assembly. Connections between boards are provided by 100 feed-through pins along the edge of the boards. Two 98-pin connectors are mounted on the flat edge of the subassembly for connections to the memory, input-output pages, and external guidance equipment.

The computer is built with seven types of transistor-transistor logic (TTL) circuits. One consideration in the choice of an IC family was its applica-

T²L circuit characteristics

Circuit delay (maximum).....	25 nanoseconds
Power consumption (average)...	10 milliwatts per gate
Power supply.....	5 volts ± 10%
Fan-in.....	8
Fan-out.....	10
Signal levels, nominal.....	0 and +5 V
Noise margins (minimum).....	400 millivolts
Temperature range.....	0 to 70° C

bility to other programs, since purchase in large volume saves money.

The logic requirements of the computer suggested a few additions to the standard TTL line, the most significant of which was two flip-flops on one flatpack. Sixty-three of these dual flip-flops are used in the design as registers, shifters and counters.

What lies ahead

The logic circuits now used are nonfunctionally

Counting the components

	Processor	Memory	Input-Output	Total
Integrated circuit flatpacks.....	243	56	34	333
Discrete semiconductor flatpacks.....	80	...	80
Transistors.....	76	59	135
Diodes.....	109	39	148
Resistors.....	288	98	386
Capacitors.....	12	79	33	124
Miscellaneous.....	68	1	69

ANALOG MONOLOGUE

On Means for Modelling, Measuring, Manipulating, & Much Else

Volume 1, No. 4

A SHORTER PATH TO PRACTICAL ELECTRONIC MEASUREMENTS

One requirement is common to all scientific research . . . threads through all development engineering . . . marks every empirical exercise — *the need to measure*. Our interest in this arises from the fact that electronic circuits (often with transducers) are generally the most practical means for measuring and recording parameters. Moreover, an increasing number of practical and economical electronic measuring circuits employ Operational Amplifiers — our specialty in analog computing devices since before 1946, and as a circuit component since their introduction as such in 1952.

During the past twenty years, we have been privileged to work closely with specialists in many disciplines, helping them to design and build literally thousands of different kinds of circuits — instruments, signal “conditioners”, and data “processors” and others ad infinitum. We have learned that our “opposite numbers” in Chemistry, Metallurgy, Aerodynamics, Hydraulics, Mathematics, Stress Analysis, Physics, Thermodynamics, etc., are generally enthusiastic about what Analog Operational circuits *can do*, but almost totally disinterested in *how* they can be made to do it . . . and that is pretty much as it should be. To each his own.

We have observed that a major deterrent to more widespread use of the powerful Analog Way (of sensitive, accurate measurement and data processing) has been the time, effort, and considerable skill required to convert the circuit diagram into a complete, functioning instrument. Now we have found a way to speed and simplify that process. We call it the *Universal Operational Module* (U.O.M.): One such module, the Q3-A1P, is shown here.

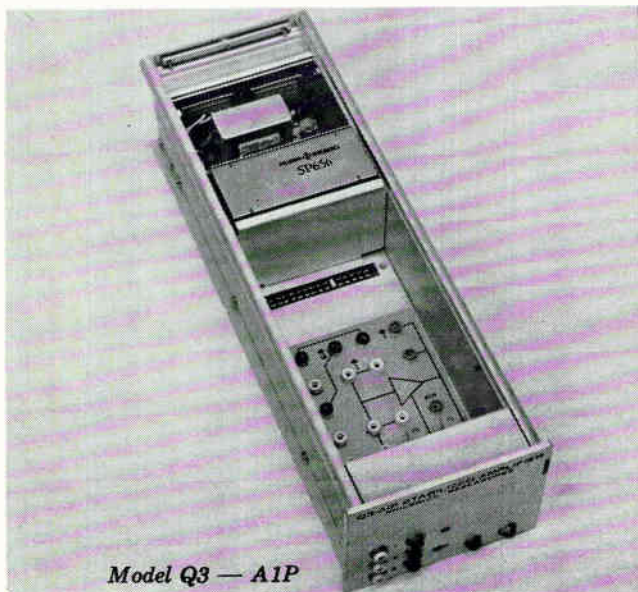

The Q3-A1P consists of a unique mechanical structure, in which are mounted a high-performance, chopper-stabilized Operational Amplifier, a compatible power supply, and an “Operating Deck”, on which is located a cluster of conveniently-disposed, clearly-labeled jacks, for interconnecting input and feedback components with the amplifier and its supply. The structure also provides connectors and space for auxiliary networks, for input and output cables, and a front panel with duplicate input/output terminations. With a Q3-A1P and a few simple pluggable components (i.e., resistors, capacitors, etc.) any one of literally thousands of useful circuits — complete and ready to use — may be realized . . . *minutes after it is conceived*, without punching a hole, or soldering a wire.

Best of all, the physical organization of the Q3-A1P has been carefully planned to anticipate and prevent or circumvent most of the tiresome and unproductive “debugging” and “tweaking” that plagues almost any original design. Shielding, guarding, wire-routing; “strays”, “sneaks”, “parasitics” — you may forget them all, in almost every instance.

The Q3-modular packaging system which includes a variety of universal operational modules, some of which are listed in Table 1, permits concentration on the *important* things — What and Why, instead of How.

TABLE 1

Q3-A1P Compact, self-powered, chopper-stabilized amplifier complete with patch panel and accessory socket.
Q3-A2P As above, but using a low noise, low current-offset, differential amplifier.
Q3-J1P A switch-programmable, self-powered integrator-differentiator.
Q3-M1P A switch-programmable, self-powered unit capable of performing non-linear functions such as multiplying, dividing, squaring and rooting.
Q3-M2P As above, less switches, programmable via a patch panel.

These universal operational modules (U.O.M.'s) consist of a standard Q3 series package, equipped with a carefully optimized interface facility to permit the combination of amplifiers, networks, components, and power supplies into highly-flexible, universal analog devices.

If you have been thinking of adding staff, perhaps to accelerate important programs, consider this alternate possibility: reducing the instrumentation burden on your present staff, with Philbrick Q3 U.O.M.'s and Philbrick Applications Engineering assistance — both distinguished by their versatility, integrity and reliability.

Write today for MBA Package #4 which contains a short form catalog. Philbrick Researches, Inc., 22-H Allied Drive at Route 128, Dedham, Massachusetts 02026. Phone (617) 329-1600.



PHILBRICK

Visit us at IEEE March 20-23 Booth No. 3k 51-52



Speeds to mach 2.5. Altitudes to 65,000 ft. Trans-sonic shock, moisture and temperatures to -65°F . Tough duty, but applications like the F-111 demand reliability.

500 Amphenol connectors fly with the F-111 avionics package. Proof of Amphenol connector reliability.

Build the same confidence into your next project.

Choose standard or special circular power connectors, printed circuit or rack and panel, commercial plugs and sockets, even cable assemblies and harnesses, or a full line of microminiature connectors.

Call your local distributor or Sales Engineer. Or write **Amphenol Connector Division**, 1830 S. 54th Ave., Chicago, Illinois 60650.



AMPHENOL

Specify Amphenol . . . the leading name in cable, connectors, assemblies, RF switches, potentiometers, motors, microelectronics

Circle 179 on reader service card



Apollo television camera with telephoto lens attached is held by Westinghouse engineer. Handle also serves as an electrical connector that can be engaged and disengaged without the contacts welding in the moon's vacuum environment. Cable in handle carries d-c voltages to camera and video output to transmitter in the spacecraft. All the electronics are mounted on the top plate. Bottom pan is an enclosure. Thick casing is for protection from meteors.

also connect the camera's video output with the module's S-band transmitter. After selecting a lens appropriate to the light conditions and the scene to be viewed, an astronaut will switch to the desired scan mode. He will use the edges of the camera as an aiming sight.

The heart of the Apollo camera is a sensitive image tube that combines a variable-gain light intensifier with a secondary electron conduction (SEC) target.^{1,2} This target produces gain and stores the image that is subsequently scanned by the tube's electron beam gun. Although the tube is slightly less sensitive than an image orthicon, the electronics for reading out the stored image are as simple as those of a vidicon tube. With fast response, the SEC tube's video output signal at low light level reproduces objects in motion without smearing—unlike the video output of vidicon and image orthicon tubes. At the same time, the SEC target can store and integrate signal information over a relatively long time period, a factor that contributes to the tube's slow-scan capability and sensitivity.

Optical system

The Apollo camera, built by the Westinghouse Electric Corp.'s Defense and Space Center, is provided with four interchangeable lenses of fixed focal length. A wide-angle lens will be used primarily for pictures inside the command module, while a telephoto lens will be used to view the earth and moon during the trip back and forth. Two general-purpose lenses will be used on the moon's surface,

one during the lunar day and the other during periods of darkness.

The lenses focus light onto the electrostatic diode image intensifier's photocathode, which emits electrons in proportion to the incident light level. A faster lens—one with a larger aperture—collects more light and thus increases the number of emitted electrons. S-20 photocathode material is used in this tube because its quantum efficiency is relatively high and uniform over visible wave lengths.

The potential difference between the photocathode and the SEC target accelerates the emitted electrons and the intensifier's electronic optics focus the image onto the SEC target.

Depending on the incident light level, an automatic control circuit varies the accelerating potential so that electrons hitting the target have energies ranging from 2,000 to 8,000 electron volts, with the higher energy level corresponding to low light levels. In this way, the tube is able to accommodate a wide range of illumination while maintaining a relatively constant signal output.

The SEC target releases secondary electrons in proportion to the number and energy of the impinging electrons. These secondary electrons are collected by a thin aluminum plate that is at a higher potential than the target material. As a result, each point on the face of the target becomes positively charged in proportion to the incident light level.

The operation of reading the stored image out of the SEC target is similar to that in a vidicon tube. When the electron gun scans across the target, it

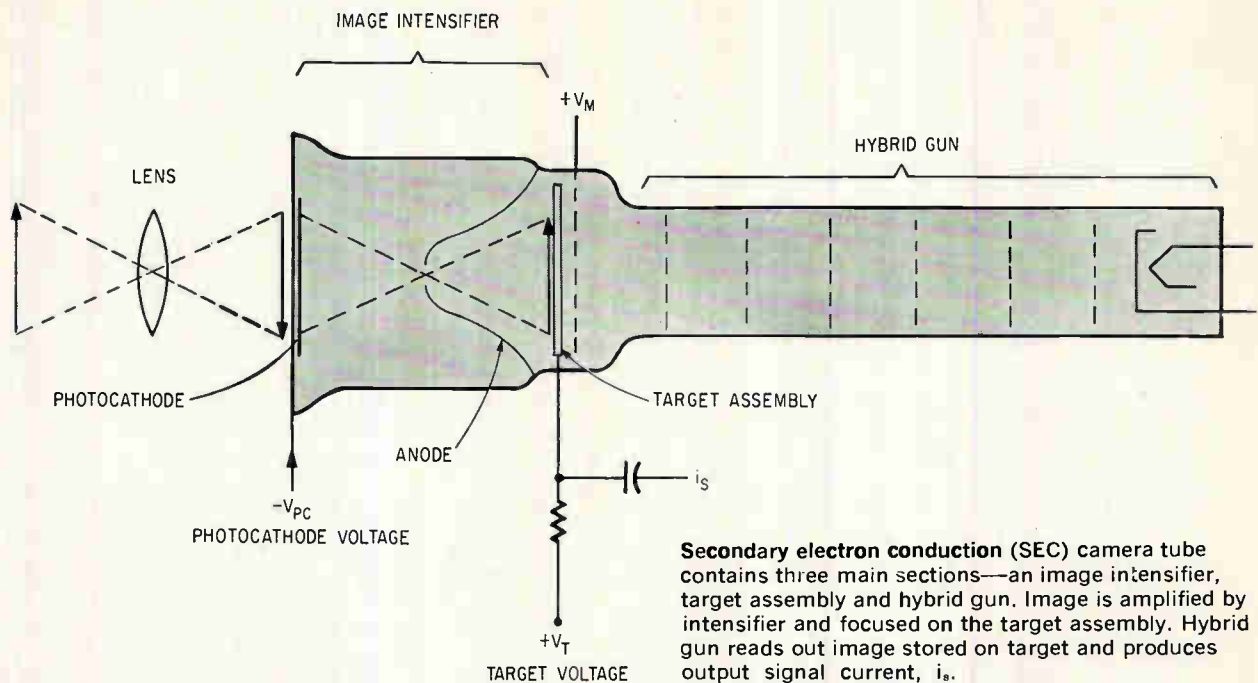

Secondary electron conduction (SEC) camera tube contains three main sections—an image intensifier, target assembly and hybrid gun. Image is amplified by intensifier and focused on the target assembly. Hybrid gun reads out image stored on target and produces output signal current, i_s .

circuit. Hybrid circuits were used in the mixer, sweeps and power supply.

Whether made by Westinghouse or purchased from outside vendors, the circuits have had to meet specifications far in excess of the environmental stresses they are liable to encounter.

Design constraints

For transmission of pictures back to earth, the camera's video output frequency-modulates the S-band transmitter. The signals will be transmitted in analog form because NASA studies have shown that such a system requires only one fourth the bandwidth of a digital transmission scheme. Since power is limited, the bandwidth has to be restricted to 500 kilohertz.

To prevent excessive deviation of transmitter frequency, the video signal must be less than 2.1 volts when working into 100 ohms. The sync burst format used puts both the sync amplitude and the video signal above a reference black level. In this way, both the sync and picture information can have a full 2-volt swing and thus deviate the transmitter the full 500 khz. In comparison, the amplitude-modulated format of commercial tv would prevent full deviation because video information is on one side of a fixed black level and the sync information is on the other.

As in commercial tv, the vertical sync pulses in the Apollo system are serrated at the horizontal line frequency to maintain horizontal sync in the receiver during the vertical sync pulses.

Scan modes

The 10-frames-per-second, 320-line scan format—the primary mode in the Apollo camera—affords good vertical resolution and adequate display of motion. In telecasting fast actions—a man quickly

raising his arm, for instance—there is breakup or smear at frame rates below 15 frames per second, and this breakup is quite pronounced at 10 frames per second. However, because the astronauts will move slowly in the spacecraft and on the lunar surface, the rendition of motion at the slower rate is acceptable.

The resolution is actually lower than the number of lines. A 500-khz transmitter bandwidth would theoretically limit the maximum resolution to 210 lines, but because the filter in the video amplifier section has a frequency response that rolls off gradually, the resolution is equivalent to that of a 250-line system.

The high resolution offered by the slower scan mode— $\frac{5}{8}$ frame per second with 1,280 vertical lines—is limited by the camera's aperture response.

Signal controls

The combined control of the photocathode and video gain by the ALC-AGC circuit compensates for a 65-db change in light level in about 2 seconds. Over this wide dynamic range, the signal-to-noise ratio will change only about 20 db. Not shown in the schematic diagram on page 185 are transistors that electronically switch the input level, detector time constants and threshold levels when changing operation modes.

The first step in controlling the signals is to produce a d-c signal proportional to the video signal. This conversion starts in detector Z_1 . D_1 and C_1 will clamp to a fraction of a positive voltage (black level) that is generated by the blanking pulse at the end of each sweep. In this camera, R_1 is usually set so that the clamping level is about 1.5 volts. This fixes the minimum peak-to-peak video signal that must appear before D_2 begins to conduct. The video output (white signal) is a negative-polarity

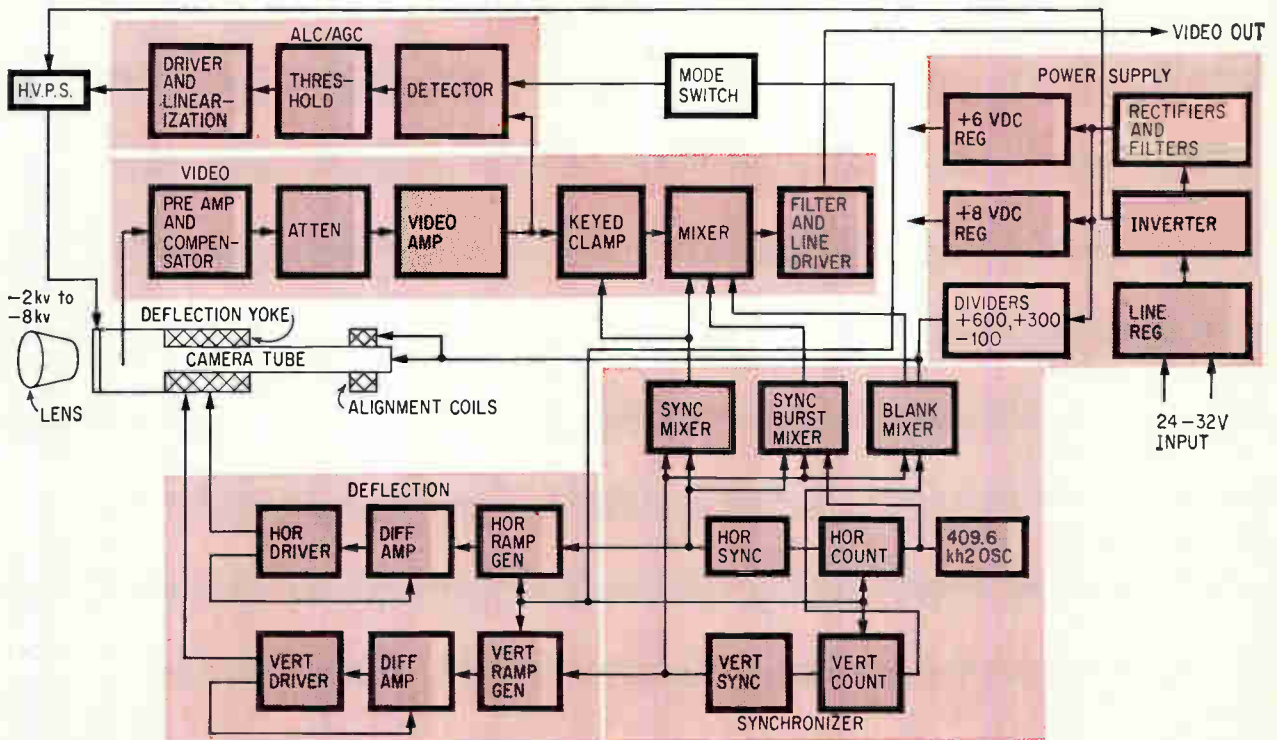

Camera's five major sections are shown in color in the block diagram above. Shaded portions indicate the percentage of integrated circuitry. Deflection circuits generate the waveforms to scan the tube. Camera's signal is controlled by the automatic light control and automatic gain control (ALC/AGC) circuit. Video signal is fed to S-band transmitter after amplification and mixing with synchronizing and blanking signals.

The 2-hz limitation is fixed by the amount of "droop" allowed in the slow scan mode. Droop is a change in amplitude caused by the loss of low-frequency components in the brightness signal; when viewing a uniform white scene, droop will cause the picture to have varying shades of gray. The 2-hz limitation is a compromise between acceptable droop and the increased size of the coupling capacitors that the amplifiers would otherwise

require to improve the low-frequency response.

Three basically similar monolithic integrated circuits are used for the preamplifiers and post-amplifiers. The preamplifier is designed to compensate for the reduced frequency response that would be caused by the capacitance in the camera's target. The sec camera tube has no detectable dark current, so low-noise performance is improved by reducing the noise in the preamplifier. A discrete

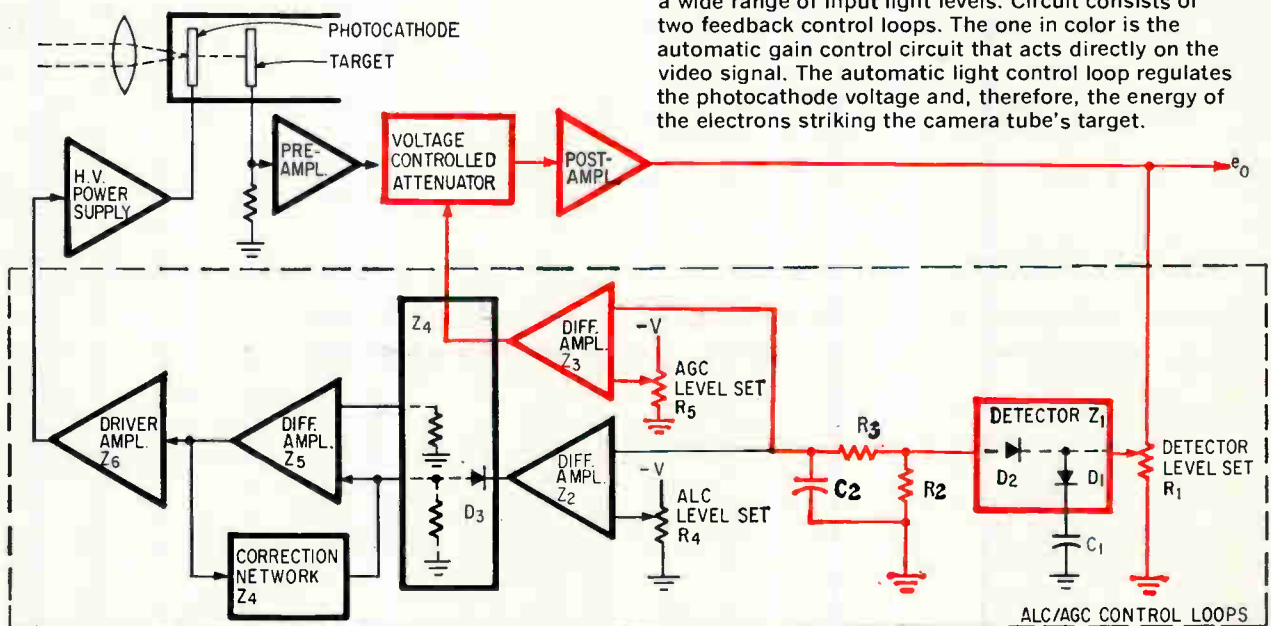

ALC/AGC control circuit holds video output constant over a wide range of input light levels. Circuit consists of two feedback control loops. The one in color is the automatic gain control circuit that acts directly on the video signal. The automatic light control loop regulates the photocathode voltage and, therefore, the energy of the electrons striking the camera tube's target.

"Worst Case" Noise Immunity is our best case

AMELCO HNIL

Logic guarantees 3.3-volt noise immunity,
now packaged and priced for industrial users!



GENERAL SPECIFICATIONS

V _{cc}	12 volts
Logical "1"	11 volts
Logical "0"	1.2 volts
Fan Out	5 (min.)
Noise Immunity	4.2 volts (typ.) 3.3 volts (min.)
Propagation Delay	60 nsec

Amelco's new High Noise Immunity Logic family was made for nasty, noisy industrial applications. Available for the first time in a low-cost 16-lead dual in-line epoxy package, the nine-function HNIL Series guarantees a worst case noise immunity of 3.3 volts—from 0 to 70°C, in both the Logic "1" and Logic "0" states. HNIL circuits can be used in the noisiest industrial control applications, without fear of spurious operation. Compare the prices and write for full details today. HNIL may be the logical answer for your next process control or data monitoring system. Amelco HNIL is available in the following nine logic elements*

301 Dual 5-Input Buffer with Expanders (\$2.90)
311 J-K Flip-Flop (\$4.20)
321 Quad 2-Input Gate with Expanders (\$2.75)
322 Dual 5-Input Gate with Expanders (\$2.75)
331 Dual 5-Input Expander (\$2.75)
341 Dual Exclusive OR with Expanders (\$2.90)
342 Dual One-Shot (\$5.30)
361 Input Interface Circuit (\$4.20)
362 Output Interface Circuit (\$4.20)

*Prices shown are for quantities of 1000 or more.

AMELCO SEMICONDUCTOR

DIVISION OF TELEDYNE, INC. • 1300 TERRA BELLA AVENUE • MOUNTAIN VIEW, CALIFORNIA • Mail Address: P.O. Box 1030, Mountain View, California • Phone: (415) 968-9241 / TWX: (415) 969-9112 / Telex: 34-8416 • REGIONAL OFFICES: Southwest—Suite 213, 8621 Bellanca Ave., Los Angeles, California 90045, (213) 678-3146 • Northwest—1300 Terra Bella Ave., Mountain View, California, (415) 968-9241 East—P. O. Box 2091, Paterson, New Jersey, (201) 696-4747 • Southeast—711 Magnolia Avenue, Orlando, Florida 32803, (305) 423-5833 • Northeast—805 High Street, Westwood, Massachusetts 02090, (617) 326-6600; 60 Broad Hollow Rd., Melville, L. I., N. Y. 11749, (516) 692-4070 • Midwest—650 West Algonquin Road, Des Plaines, Illinois, (312) 439-3250 • Canada—Deskin Sales, Montreal, Quebec, (514) 384-1420.



King Radio needed: capacitors that stay reliable even with extreme cold, humidity and vibration. So King Radio chose: capacitors of MYLAR.

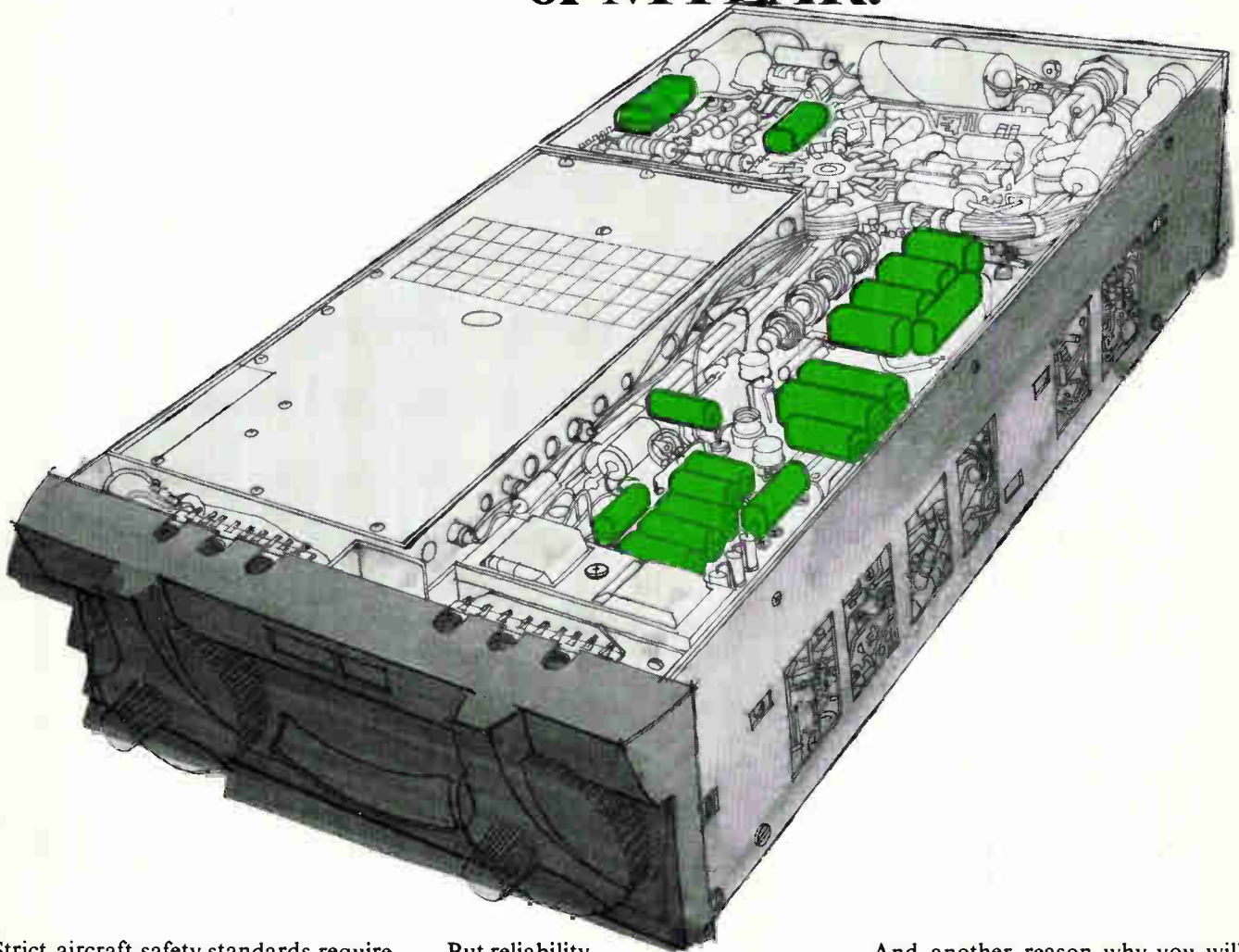

Strict aircraft safety standards require the most reliable navigation equipment available. That's why King Radio Corporation uses capacitors of MYLAR* for their Distance Measuring Equipment. MYLAR can take temperature extremes from -60° to $+150^{\circ}\text{C}$; MYLAR remains constantly stable under humid conditions.

But reliability isn't the only reason King Radio chose MYLAR. The extremely high dielectric strength of MYLAR permits its use in thinner film, thus helping King Radio to build the lightest and most compact distance measuring unit on the market. MYLAR is available in films as thin as 15 gauge.

And another reason why you will want to investigate using capacitors of MYLAR: they usually cost no more than others. Write for complete technical data to DuPont Company, Room 4960A, Wilmington, Delaware 19898. (In Canada, for information write Du Pont of Canada Ltd., Post Office Box 660, Montreal, Quebec.)

 **MYLAR[®]**

*DU PONT'S REGISTERED TRADEMARK FOR ITS POLYESTER FILM.

PROGRESS REPORT

ALSiMAG

**SMALL
PRECISION CERAMICS
"AS FIRED"**

Five years ago we made guarded statements about meeting certain precision requirements with "as fired" ceramics in some configurations. Volume production of small alumina ceramics to close tolerances was the key to many electronic advances. There has been continual pressure for ever-smaller ceramics to still closer tolerances.

About once a year we have reported and illustrated our current abilities in this field. Each year progress has been made. It is based on hard won experience, employee training programs, specialized equipment and ability to control more variables.

Throughout most of this period our fast growing deliveries have not been satisfactory to us or to our customers. Now we feel that our staff of specially trained people plus our greatly enlarged production areas in both our Chattanooga and Laurens plants enable us to handle new volume requirements in agreed production time.

DELIVERIES

We will be glad to discuss your requirements and show you the current state of the art in precision alumina, steatite, Forsterite and beryllia ceramics.

PROGRESS IN BERYLLIA

It is often said that close tolerances on beryllia ceramics are difficult if not impossible. Small precision beryllia components are being processed regularly and in volume by American Lava. The favorable characteristics of beryllia, including its remarkable heat conduction, are thus available for a whole new range of applications.

Parts illustrated approximately actual size.

ALUMINA

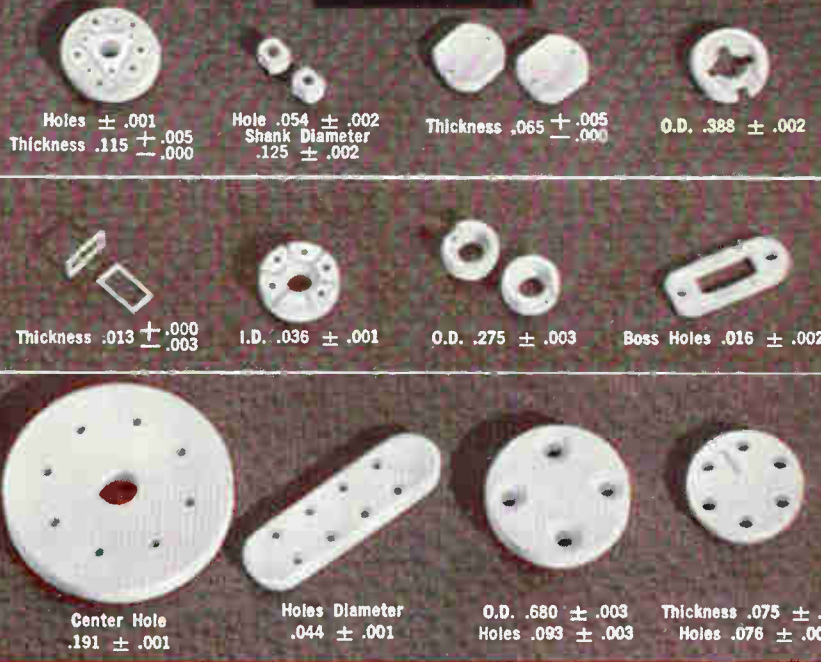

BERYLLIA

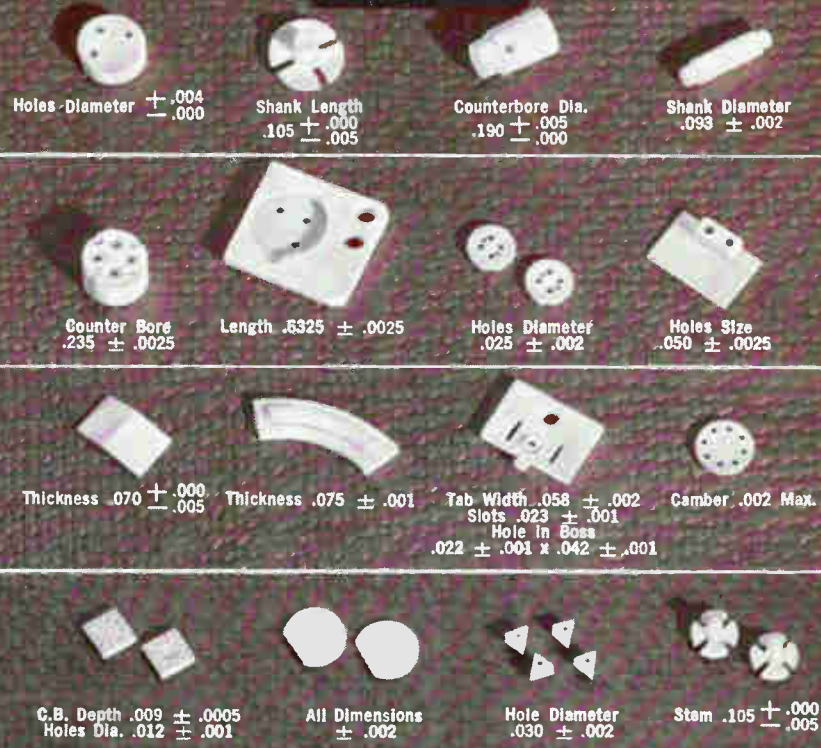

STEATITE & FORSTERITE

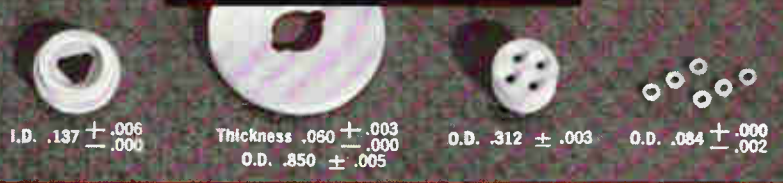

CODE IDENT. NO. 70371

PHONE 615 265-3411 • CHATTANOOGA, TENNESSEE 37405, U.S.A.

American Lava Corporation **3M**
A SUBSIDIARY OF COMPANY

For service, contact American Lava representatives in Offices of Minnesota Mining and Manufacturing Company in these cities (see your local telephone directory): Atlanta, Ga. • Boston: Needham Heights, Mass. • Chicago: Bedford Park, Ill. • Cleveland, Ohio • Dallas, Texas • Laurens, S. C. • Los Angeles, Calif. • Metropolitan New York: Ridgefield, N. J. • Up-State New York and Canada: Baldwinsville, N. Y. • Orange, Conn. • Philadelphia, Penn. • Roanoke, Va. • St. Louis: Lee's Summit, Mo. • South San Francisco, Cal. • Troy, Mich. • 3M International: c/o American Lava Corporation, Chattanooga, Tenn. 37405, U.S.A., 615/265-3411

65th
YEAR
OF
CERAMIC
LEADERSHIP

ZENERS



IRC can fill all your MIL and industrial needs

Now, IRC offers one of the industry's largest selections of MIL and industrial zener diodes. And, with the addition of new production facilities, they are immediately available from stock to meet all your application, environment and price requirements.

- 229 MIL devices—power ratings range from 250mW up to 10 watts
- All popular industrial-type devices—power ratings up to 50 watts
- The industry's only 1-watt zener in a DO-7 package

- New high-strength Poly-Sil zeners—up to 30% smaller and up to 2½ times more wattage dissipation than glass packages. Over 400 JEDEC types
- Complete selection of package styles and mechanical configurations

If you specify or buy zener diodes, you should know about the money-saving advantages of IRC's complete zener diode line. Write for new catalog, prices and samples to: IRC, Inc., Semiconductor Division (formerly North American Electronics), 71 Linden Street, West Lynn, Massachusetts 01905.



RECTIFIERS

Complete choice, including sub-miniature, fast recovery and high-power types. All popular configurations.



AXIAL LEAD RECTIFIERS

AR16—AR24 replaces 363 JEDEC devices for 50 to 1000 V/.25 to 1A needs. Cost less than stud types.



SCR'S

MIL and industrial devices, including fast-switching types. Choice of ratings and package shapes.



SPECIAL ASSEMBLIES

Rectifier stacks, potted bridges, epoxy resin encapsulations and high voltage assemblies.



Rewarding engineering opportunities are immediately available.

Discovering



QUARTZ, LUCALOX® AND ELECTRONIC GLASS . . . SELECTED BY THE ELECTRONICS INDUSTRY TO MEET THE UNCOMMON CHALLENGE

It's so hot it's freezing. This statement comes close to reality at Hughes Aircraft's Santa Barbara Research Center. They use G-E Type 204 fused quartz prepared for application in infrared detectors. In the process, a quartz tube is partially filled with semiconductor materials and evacuated. It is then torch-sealed at 1800°C

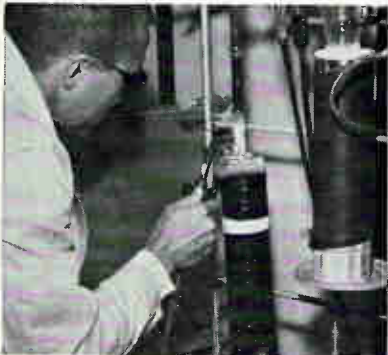

while one half inch away the same quartz tube is cooled by liquid nitrogen to -196°C. In half an inch, G-E fused quartz accepts a temperature gradient of 1994°C. Remember this fantastic capability of G-E quartz as you, in your own field, seek solutions to the uncommon challenge.

Circle 575 on reader service card

Ceramic-to-metal seals posed no problems for RCA when G-E Lucalox® ceramic was selected as the faceplate material in its multiplier phototube. This Lucalox application, a unique development in scintillation counters, not only simplifies nuclear detection systems but also makes scintillation counting more accurate. Why? The answer is in the high purity of Lucalox; its freedom from radioactive elements. Elimination of conventional graded seals results in sturdier construction which in turn reduces tube failures. Perhaps this evidence of Lucalox's ability to meet demanding ceramic-to-metal seal requirements will point the way to solving one of your problems in your industry. Translucent Lucalox®, 99% alpha alumina, has unique

transmission characteristics for numerous applications.

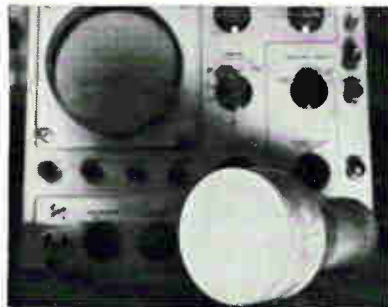

Circle 576 on reader service card

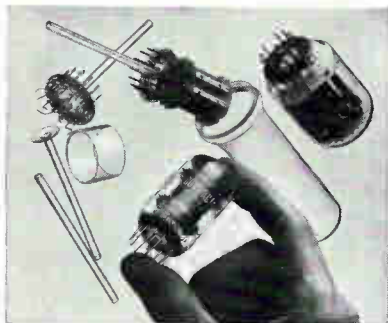

Over 100,000,000 have been made, so there must be something special about the G-E Compactron tube. There is. One Compactron, as produced by the G. E. Tube Dept., can do the work of up to three conventional vacuum tubes. But right here, we at the Lamp Glass Dept. think the Compactron can be used to illustrate our own capability in selecting specific glass types for specific applications. We provided three types for the Compactron: Type 008 lime glass, best for close tolerance forming of bulbs; Type 012 lead glass, best for preventing glass electrolysis in stems; Type 001 glass, best for close tolerance cutting of tubulations, in this case ± 0.5 mm. If you want electronic glass to do something for you, call us. We have the types and we know when to use which one.

Circle 577 on reader service card

Drawing .010 inch tube from one-inch lead glass stock is the artistry performed by Hanibal Glass in Santa Ana. Hanibal produces about 100,000,000 assorted tubes monthly, used as seals for electronic circuitry components. Seals of G-E Type 012 lead glass are virtually

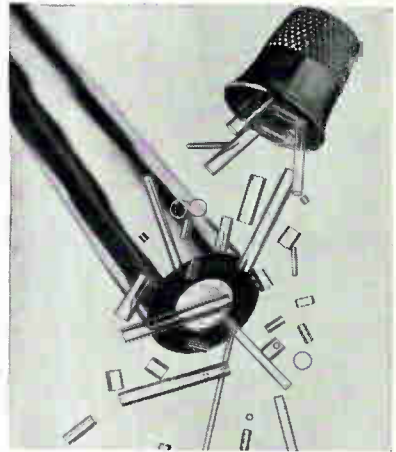

inert, durable, stand up to heat and humidity and have excellent dielectric properties. Why does Hanibal use General Electric glass? Because tubing won't draw to .010 acceptably unless the one-inch raw stock has uniformity in wall thickness and weight. Quality control, as delivered by the Lamp Glass Dept., turns out to be the key to this advanced application of a versatile material you might give more thought to. Electronic glass.

Circle 578 on reader service card

WORLDWIDE SERVICE. For sales and application assistance, contact your nearest regional office:

CALIFORNIA, Los Angeles	213 723-2541
ILLINOIS, Chicago	312 332-4712
MASSACHUSETTS, Boston	617 332-6200
NEW JERSEY, Newark	201 824-5200
OHIO, Cleveland	216 266-4001
CANADA, Toronto	416 537-4481
INTERNATIONAL, International General Electric Co., Export Division, 159 Madison Avenue, New York, N. Y. Telephone	212 751-1311

See us at Booths 3E-15 and 3E-17
at the IEEE Show.

Write for illustrated technical literature

LAMP GLASS DEPARTMENT

GENERAL ELECTRIC

24400 Highland Road • Cleveland, Ohio 44121
MANUFACTURERS OF LUCALOX® CERAMIC — ELECTRONIC GLASSWARE —
FUSED QUARTZ PRODUCTS—JET-TEMP® AND JET-B.O.P. THERMOCOUPLES.

Discovering



QUARTZ, LUCALOX® AND ELECTRONIC GLASS . . . SELECTED BY THE ELECTRONICS INDUSTRY TO MEET THE UNCOMMON CHALLENGE

It's so hot it's freezing. This statement comes close to reality at Hughes Aircraft's Santa Barbara Research Center. They use G-E Type 204 fused quartz prepared for application in infrared detectors. In the process, a quartz tube is partially filled with semiconductor materials and evacuated. It is then torch-sealed at 1800°C



while one half inch away the same quartz tube is cooled by liquid nitrogen to -196°C. In half an inch, G-E fused quartz accepts a temperature gradient of 1994°C. Remember this fantastic capability of G-E quartz as you, in your own field, seek solutions to the uncommon challenge.

Circle 575 on reader service card

Ceramic-to-metal seals posed no problems for RCA when G-E Lucalox® ceramic was selected as the faceplate material in its multiplier phototube. This Lucalox application, a unique development in scintillation counters, not only simplifies nuclear detection systems but also makes scintillation counting more accurate. Why? The answer is in the high purity of Lucalox; its freedom from radioactive elements. Elimination of conventional graded seals results in sturdier construction which in turn reduces tube failures. Perhaps this evidence of Lucalox's ability to meet demanding ceramic-to-metal seal requirements will point the way to solving one of your problems in your industry. Translucent Lucalox®, 99% alpha alumina, has unique

transmission characteristics for numerous applications.

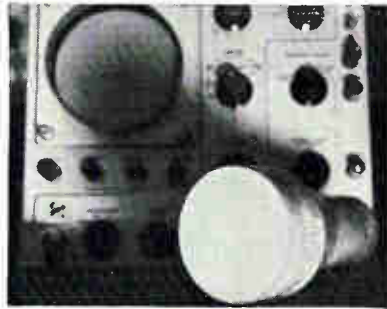

Circle 576 on reader service card

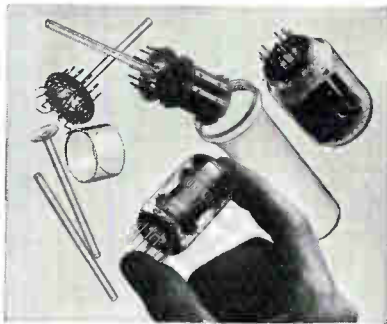

Over 100,000,000 have been made, so there must be something special about the G-E Compactron tube. There is. One Compactron, as produced by the G. E. Tube Dept., can do the work of up to three conventional vacuum tubes. But right here, we at the Lamp Glass Dept. think the Compactron can be used to illustrate our own capability in selecting specific glass types for specific applications. We provided three types for the Compactron: Type 008 lime glass, best for close tolerance forming of bulbs; Type 012 lead glass, best for preventing glass electrolysis in stems; Type 001 glass, best for close tolerance cutting of tubulations, in this case ± 0.5 mm. If you want electronic glass to do something for you, call us. We have the types and we know when to use which one.

Circle 577 on reader service card

Drawing .010 inch tube from one-inch lead glass stock is the artistry performed by Hanibal Glass in Santa Ana. Hanibal produces about 100,000,000 assorted tubes monthly, used as seals for electronic circuitry components. Seals of G-E Type 012 lead glass are virtually

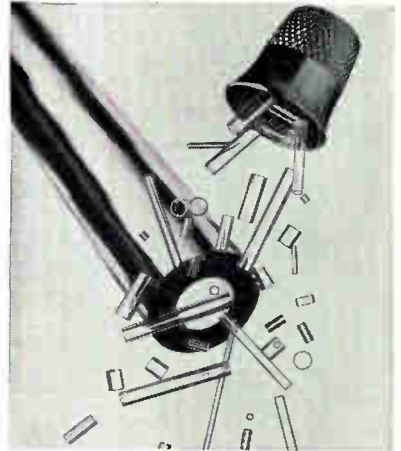

inert, durable, stand up to heat and humidity and have excellent dielectric properties. Why does Hanibal use General Electric glass? Because tubing won't draw to .010 acceptably unless the one-inch raw stock has uniformity in wall thickness and weight. Quality control, as delivered by the Lamp Glass Dept., turns out to be the key to this advanced application of a versatile material you might give more thought to. Electronic glass.

Circle 578 on reader service card

WORLDWIDE SERVICE. For sales and application assistance, contact your nearest regional office:

CALIFORNIA, Los Angeles	213 723-2541
ILLINOIS, Chicago	312 332-4712
MASSACHUSETTS, Boston	617 332-6200
NEW JERSEY, Newark	201 824-5200
OHIO, Cleveland	216 266-4001
CANADA, Toronto	416 537-4481
INTERNATIONAL, International General Electric Co., Export Division, 159 Madison Avenue, New York, N. Y. Telephone	212 751-1311

See us at Booths 3E-15 and 3E-17
at the IEEE Show.

Write for illustrated technical literature

LAMP GLASS DEPARTMENT

GENERAL ELECTRIC

24400 Highland Road • Cleveland, Ohio 44121
MANUFACTURERS OF LUCALOX® CERAMIC — ELECTRONIC GLASSWARE —
FUSED QUARTZ PRODUCTS—JET-TEMP® AND JET-B.O.P. THERMOCOUPLES.



Happiness is an Acopian power supply . . . because it's shipped in only 3 days.

Whether your application is op amps, ICs, logic circuits, relays, lamps or electronic measuring equipment, look to Acopian to meet your needs for AC to DC plug-in power supplies. Acopian's new catalog lists over 62,000 different supplies . . . all available for shipment within 3 days. Get your 16 pages of happiness by writing or calling Acopian Corp., Easton, Pennsylvania (215) 258-5441.



Circle 197 on reader service card

ARNOLD IS

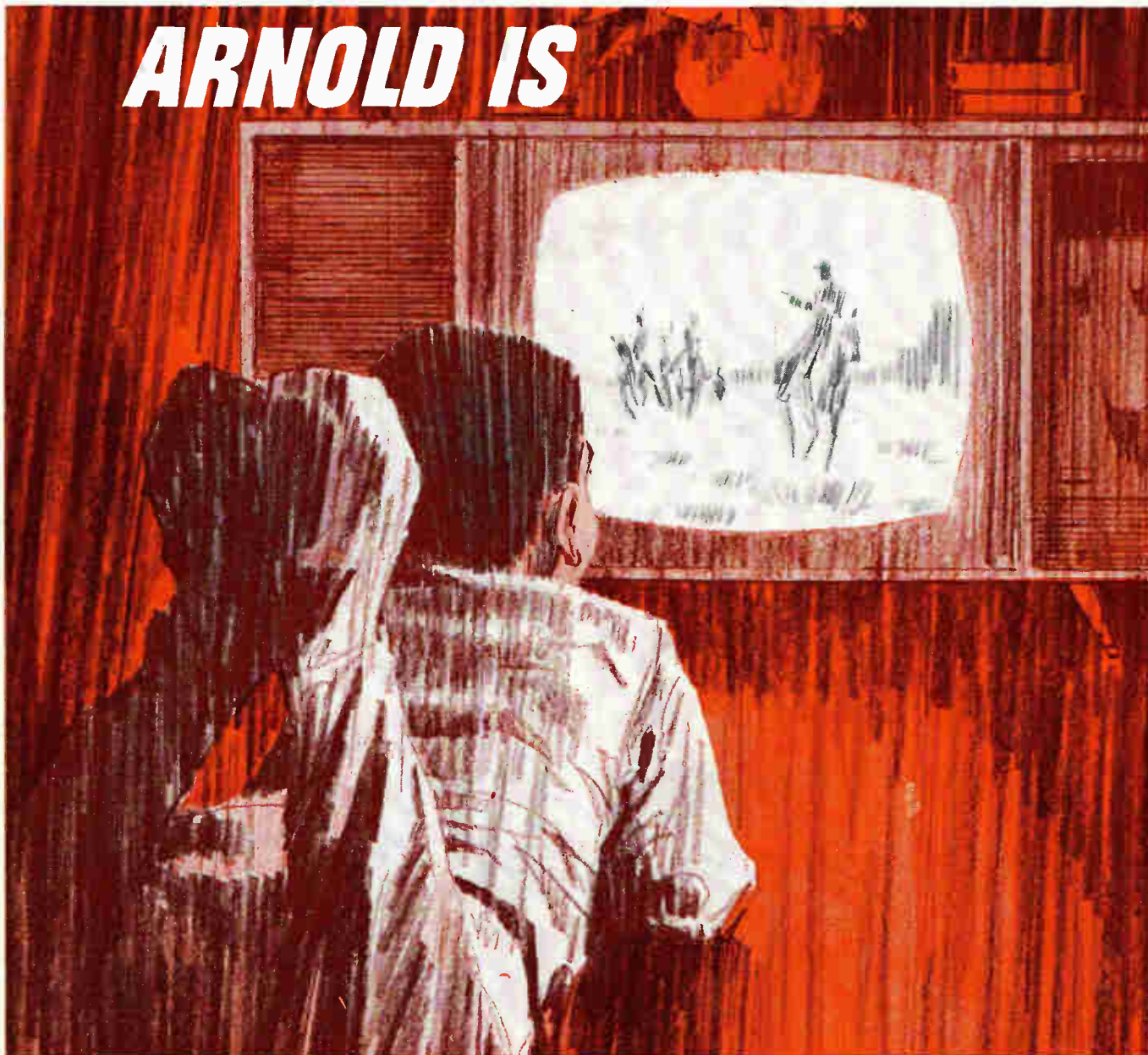

IRON POWDER CORES

From 5" dia. to Subminiature Toroids

Arnold has total capability across all design configurations—toroids, insert cores, threaded cores, plain cores, bobbin cores, sleeve and hollow cores, cup cores and subminiature toroids. All the necessary raw materials are carried in stock to provide optimum performance over the specified frequency spectrum. Our facilities include the most modern powder processing, pressing, quality control and final test equipment available in the industry.

Call us, write us, TWX us, we can handle any problem.

Arnold is also ■ Permanent Magnets ■ Tape Wound Cores ■ MPP Cores
■ Magnetic Shielding ■ Electrical Alloy Transformer Laminations ■ Trans-
former Cans and Hardware ■ Silectron Cores ■ Special Magnetic Materials.

 **ARNOLD**
SPECIALISTS in MAGNETIC MATERIALS

THE ARNOLD ENGINEERING COMPANY, Main Office: MARENGO, ILL.
BRANCH OFFICES and REPRESENTATIVES in PRINCIPAL CITIES

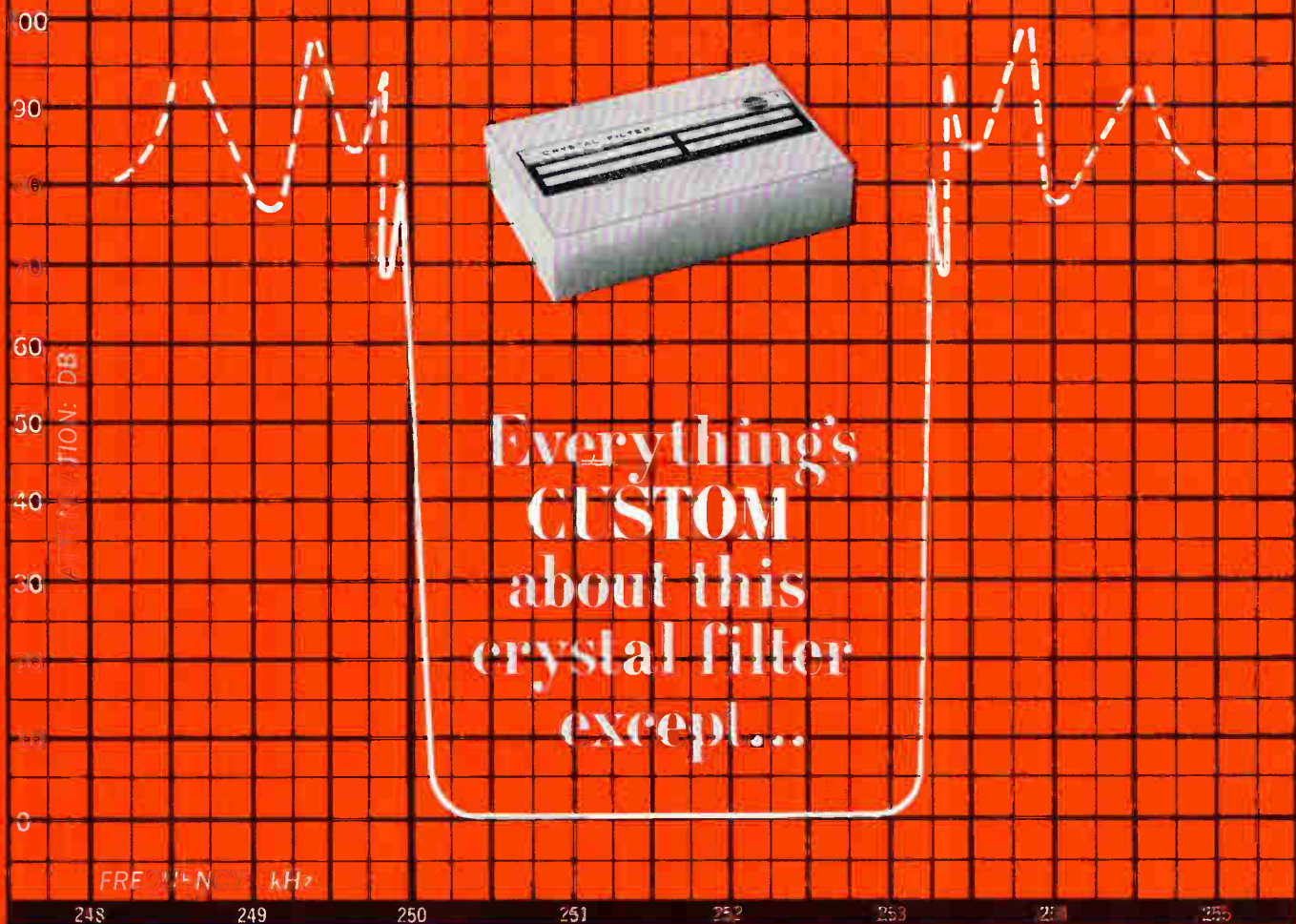

production, price, and delivery—they're **STANDARD**

Collins' prototype crystal filters with the response illustrated above are now available in the 100-kHz to 500-kHz region both in upper and lower sideband designs and to the following specifications:

Bandwidth at 1 db:	2780 Hz.
Bandwidth at 60 db:	3300 Hz.
Carrier rejection:	60 db min.
Passband ripple:	1/2 db max.
Differential delay:	500 μ sec. max. over 70% of passband.
Operating temperature range:	-20° C to +70° C.
Typical case size:	1.9" X 2.8" X 0.7" max.

Collins' crystal filters meet most narrow band needs (from 5 kHz to 20 MHz) in designs such as Butterworth, Tchebycheff, and Linear Phase. Prototypes to your specifications are

generally available in four to six weeks. Collins' crystal filter capability is expanding rapidly. Send your specifications for design analysis. As one of the largest suppliers, Collins satisfies delivery requirements for all major programs.

Collins' entire filter product line covers the practical spectrum from 1 kHz to 100 MHz, offering LC and mechanical filters for applications where crystal filters are not suitable. If an advantage can be obtained in performance, price, or delivery through LC or mechanical filters, Collins is in a position to recommend these filters rather than crystal filters.

Send or call your performance requirements to Components Division, Collins Radio Company, Newport Beach, California 92663 Phone: (714) 833-0600.

COMMUNICATION / COMPUTATION / CONTROL

Visit Collins' IEEE Booth 3B24, in New York, March 20-23.



COLLINS RADIO COMPANY / DALLAS, TEXAS • CEDAR RAPIDS, IOWA • NEWPORT BEACH, CALIFORNIA • TORONTO ONTARIO
Bangkok • Beirut • Frankfurt • Hong Kong • Kuala Lumpur • Los Angeles • London • Melbourne • Mexico City • New York • Paris • Rome • Washington • Wellington

Circle 201 on reader service card

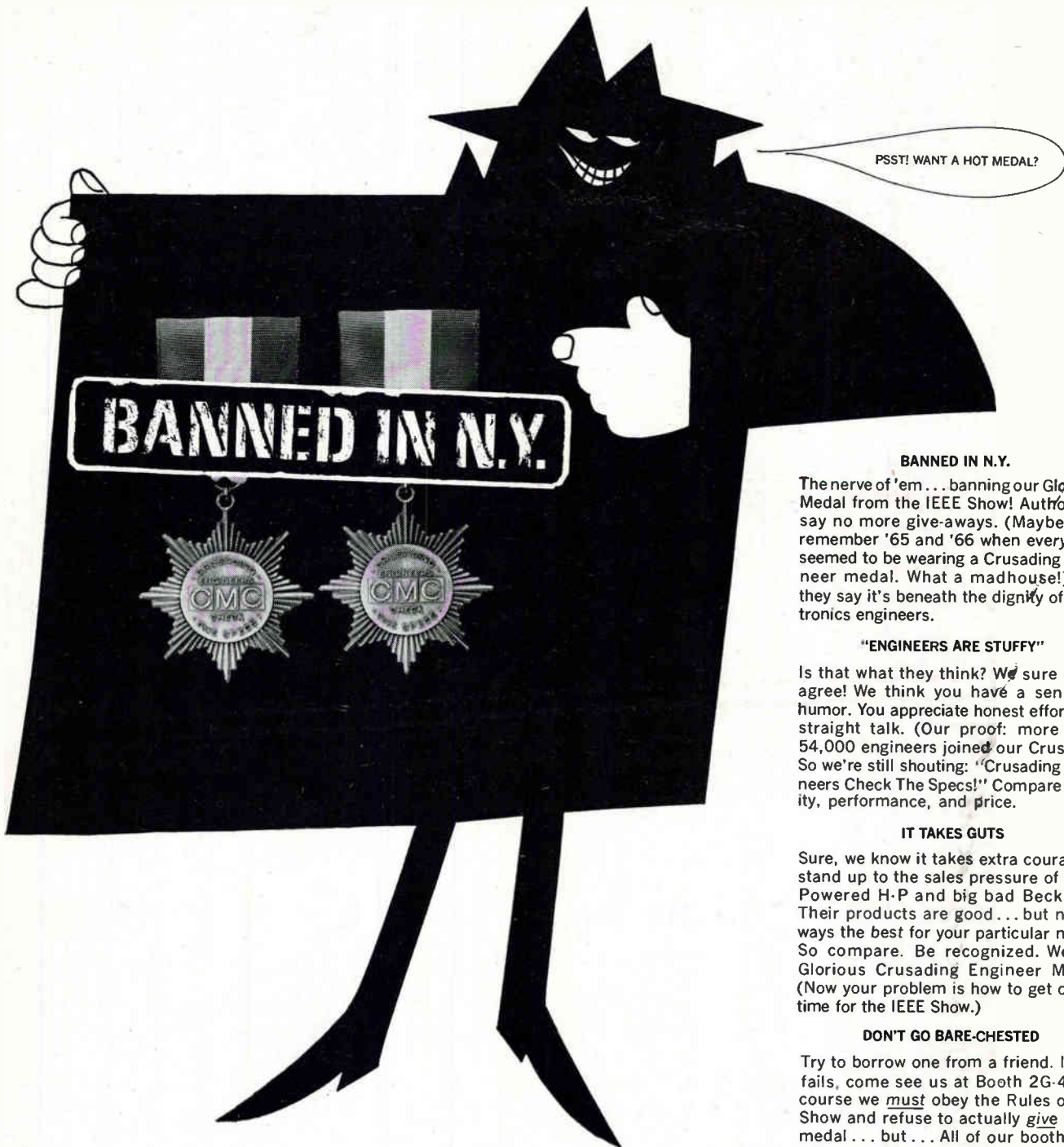

PSST! WANT A HOT MEDAL?

BANNED IN N.Y.

The nerve of 'em... banning our Glorious Medal from the IEEE Show! Authorities say no more give-aways. (Maybe they remember '65 and '66 when everybody seemed to be wearing a Crusading Engineer medal. What a madhouse!) But they say it's beneath the dignity of electronics engineers.

"ENGINEERS ARE STUFFY"

Is that what they think? We sure don't agree! We think you have a sense of humor. You appreciate honest effort and straight talk. (Our proof: more than 54,000 engineers joined our Crusade.) So we're still shouting: "Crusading Engineers Check The Specs!" Compare quality, performance, and price.

IT TAKES GUTS

Sure, we know it takes extra courage to stand up to the sales pressure of High-Powered H-P and big bad Beckman. Their products are good... but not always the best for your particular needs. So compare. Be recognized. Wear a Glorious Crusading Engineer Medal. (Now your problem is how to get one in time for the IEEE Show.)

DON'T GO BARE-CHESTED

Try to borrow one from a friend. If that fails, come see us at Booth 2G-40. Of course we must obey the Rules of The Show and refuse to actually give you a medal... but... All of our booth staff will be wearing their own medals (loosely pinned). So if you snatch one, we won't exactly chase you down the aisles.

NO-SHOW?

Can't fly to New York this time? You still can get a medal. Just write us. We'll mail you a medal, and a new condensed catalog so you can earn your medal by checking specs.

Then, next time you talk to an H-P or Beckman salesman, wear your medal. You'll see grown men cry.

12981 Bradley/San Fernando, California
Ph. (213) 367-2161/TWX 910-496-1487

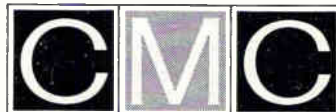

VISIT BOOTH 2G-40: See counters, timers, printers, systems, Rutherford pulse and time delay generators, target simulators, surprises.
COMPUTER MEASUREMENTS COMPANY IS A LEADING DESIGNER AND MANUFACTURER OF ELECTRONIC INSTRUMENTATION TO COUNT, MEASURE, AND CONTROL.

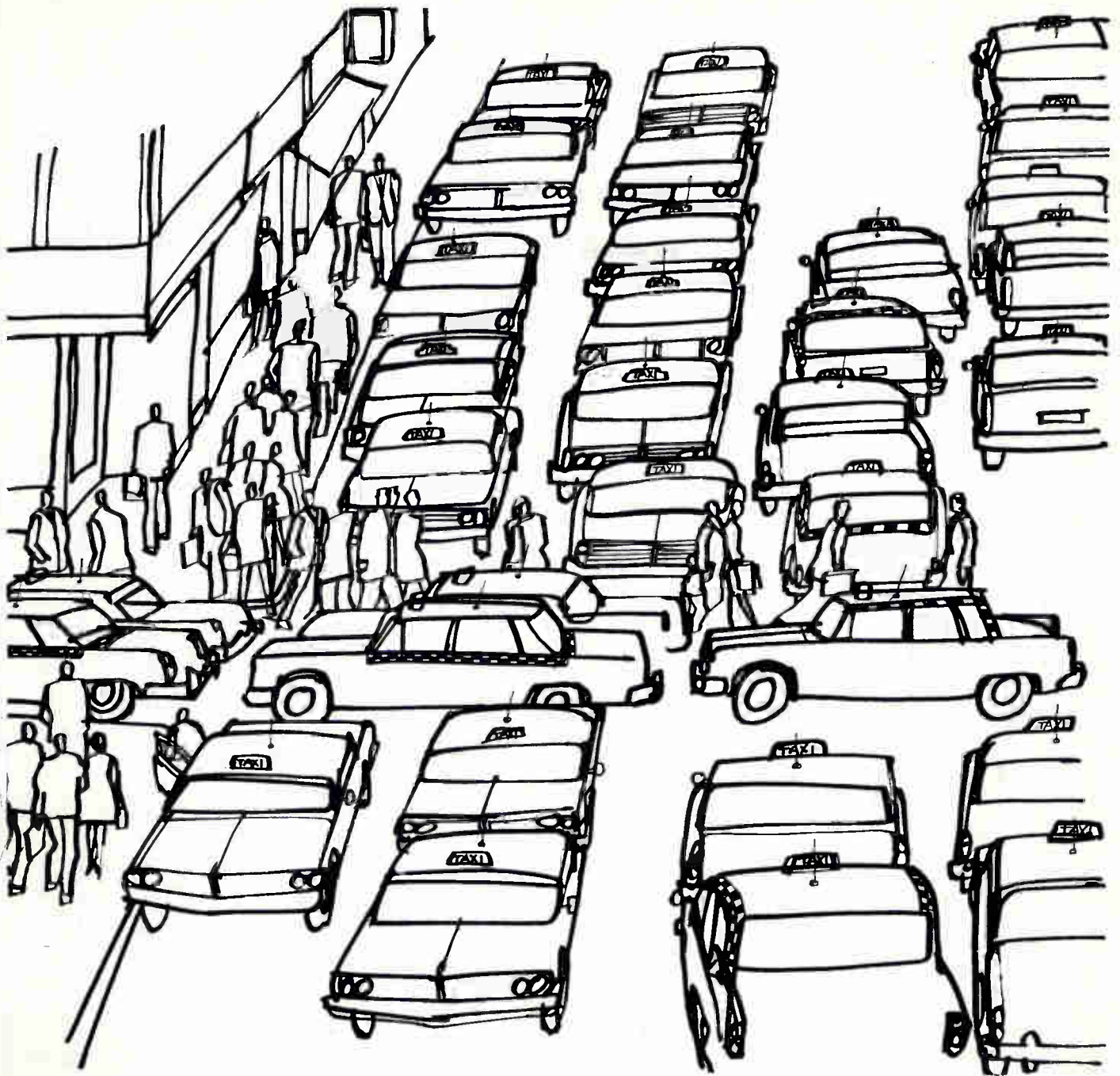

153,472 radio-dispatched taxicabs and only one tetrode rated for PTTS*

The cab driver is rarely on the air with his dispatcher for as long as 60 seconds and he drives at least 5 minutes between calls. The same goes for most radio-dispatched vehicles.

PTTS* (Push-To-Talk-Service), with its duty cycle of ONE MINUTE ON and FOUR MINUTES OFF has been shown to be the most realistic, economical and practical rating system for vehicular communications systems.

For this reason, Amperex developed the 8637, the only twin tetrode ever designed and rated for PTTS. Featuring high thermal inertia anodes and

incorporating a wealth of twin-tetrode manufacturing experience, the 8637 offers the designer a new approach in creating a better vehicular radio. Fewer, and less costly components may be used. Some typical operating conditions which bear this out are shown on the chart at right . . . lower plate voltage, lower drive and higher efficiency at the VHF frequencies.

The 8637 is a 'small tube', (only 3 1/4" seated height), perfectly suited for today's low-profile designs. Its cost is lower than ICAS and CCS rated tube types of the same power.

For data, applications reports and engineering assistance, write: Amperex Electronic Corporation, Tube Division, Hicksville, L. I., N. Y. 11802.

ALL THIS—and AMPEREX QUALITY, TOO!			
ONE 8637—PUSH-PULL			
Internally Neutralized Throughout Entire Freq. Range			
50 MHz	PLATE	OUTPUT	DRIVE
CCS	375v.	25w.	0.67w.
ICAS	450v.	34w.	0.82w.
PTTS	600v.	84w.	0.86w.
175 MHz			
CCS	300v.	18w.	1.4w.
ICAS	350v.	26w.	1.6w.
PTTS	560v.	63w.	2.2w.



Amperex®
TOMORROW'S THINKING IN TODAY'S PRODUCTS

Circle 205 on reader service card

Because RCA's New 40466 Silicon Power Transistor was developed specifically for Hi-Fi Amplifiers...

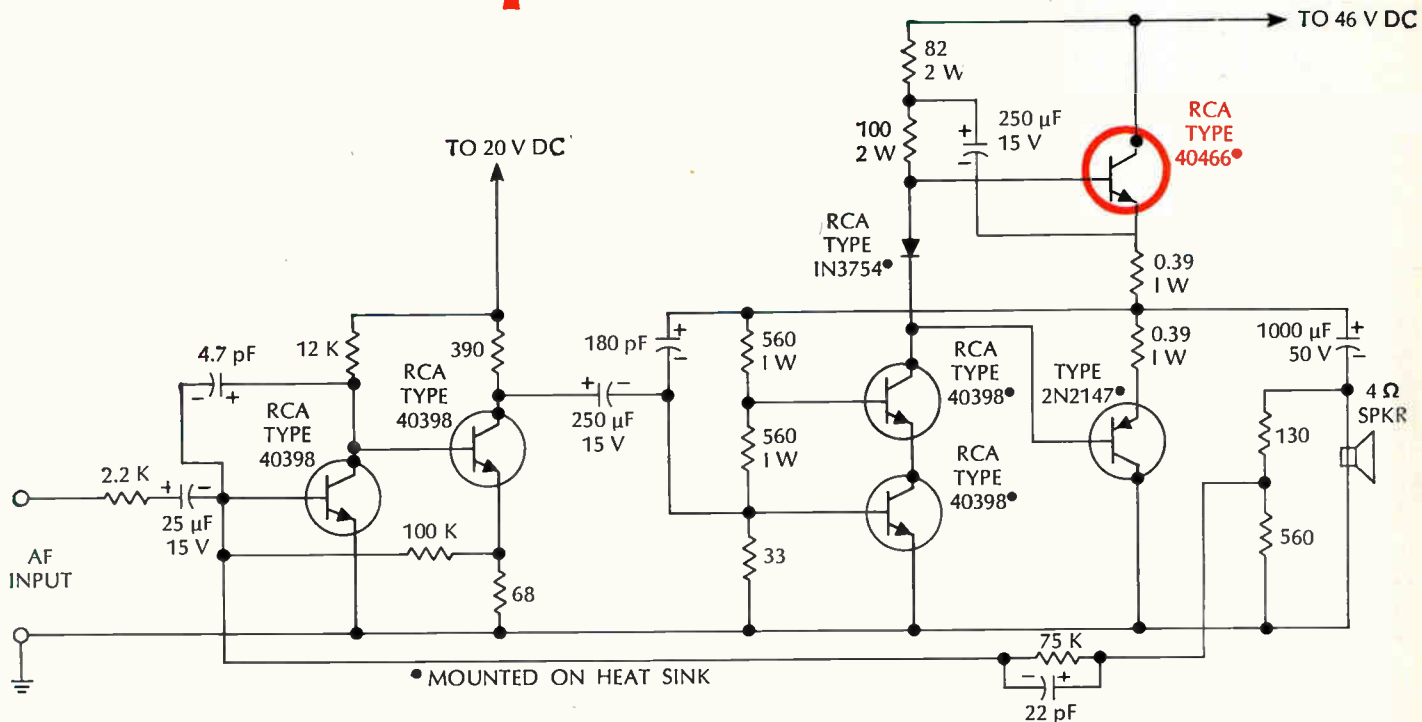

you can now design economical complementary-symmetry audio power amplifiers with extended high frequency response...simple driver requirements...and low distortion!



Hermetically sealed in a TO-3 low profile metal case

RCA's new 40466 silicon n-p-n power output transistor lets you combine real high fidelity performance with superior electrical ruggedness and the economy of *transformerless design*.

You can get 50 watts music power per channel in the circuit shown when the 40466 is complemented with the high-performing RCA 2N2147 germanium drift-field power transistor. Together they make a low cost output pair.

Response is flat from 10 Hz to 80 KHz...total harmonic distortion at 20 watts with a 1 KHz signal is 0.13%... 0.05% at 1 watt.

Because of its epitaxial base construction, the 40466

also provides virtual freedom from second breakdown. And its high minimum beta of 50 at 2 amperes simplifies driver stage requirements.

RCA's new 40464 and 40465 silicon transistors are also available for lower power hi-fi stereo circuits. Your RCA Field Representative can tell you the whole story of how these new audio power devices can improve the performance of stereo phonographs, receivers, and tape recorders. He can also give you price and delivery. For a technical data sheet on the RCA 40464, 40465, 40466, write RCA Commercial Engineering, Sec.EN3-1, Harrison, N.J. 07029. ALSO AVAILABLE THROUGH YOUR RCA DISTRIBUTOR



RCA Electronic Components and Devices

The Most Trusted Name in Electronics

Circle 207 on reader service card



This multiple pair, Beldfoil shielded cable is typical of the types of Belden cable used in recording critical measurements on the Goldstone tracking antenna.

BELDFOIL* SHIELDED CABLE

SOLVED

CRITICAL NASA INSTRUMENTATION PROBLEM!

The unique insulating properties of Belden's exclusive Beldfoil shielding provides 100% protection against "cross-talk" and spurious signal impulses in highly sensitive circuit applications. That's why NASA used Beldfoil cable for its Goldstone Tracking Station. ■ In this massive 210 foot diameter antenna, built to track lunar and planetary probes, Belden Beldfoil shielded cables carry instrumentation signals from sensitive structural detectors to an instrumentation facility nearby.

Every measurement of critical structure deflection, angular position, structure temperatures, and bearing pressures are recorded and analyzed prior to tracking operations.

■ Get the same precision analyzation in your critical instrumentation. Specify Belden Beldfoil shielded cable —the only cable providing 100% Isolation.

*Belden Trademark Reg. U.S. Pat. Off.

Belden

FOR COMPLETE INFORMATION
CONTACT YOUR BELDEN
DISTRIBUTOR.



BELDEN MANUFACTURING COMPANY • P.O. Box 5070A • Chicago, Illinois 60680

8-1-6

Probing the News

Manpower

Electronics engineers are fair game

With graduates becoming choosier and experienced specialists warier, the scramble for talent is becoming more intense and wide ranging

"If 300 of the right electronics engineers walked in this door right now, I could find a job for them." The open door is at Lockheed Missiles & Space Co. in Sunnyvale, Calif., and the speaker is Lloyd Leoma, supervisor of employment. Over-all, the division of Lockheed Aircraft Corp. is beating the bushes for 1,000 electronics engineers.

Up the coast in San Francisco, an employment agency manager, John M. Harris, says: "We're down 40% in the number of qualified applicants from a year ago, and up 25% or more in job requests from electronics firms. There just aren't as many men available."

In Boston, the Raytheon Co. is urgently seeking 935 engineers for four New England divisions.

In New York City, Careers Inc., a recruiting organization, has booked 200 hotel rooms for interviews during the four-day International convention of the Institute of Electrical and Electronics Engineers, which opens March 20. Last year the firm represented 40 companies at the convention and attracted over 1,300 job-seeking engineers. This year it is back representing even more firms.

Paradox. This contest for electronics engineers, however, is being staged against a strange backdrop. While recruiters point despairingly to the problem of finding enough warm bodies, the threat of layoffs hangs over the semiconductor and consumer-oriented sectors of the industry. At some companies, one division will be hiring while another is laying off engineers.

Companies that have had to furlough engineers recently include the National Video Corp., Motorola Inc., and the appliance division of

Where the jobs are

	types of engineers	openings
East		
General Precision, Aerospace Group	circuit, systems	150
Lockheed Electronics	radar, antenna, circuit	175-200
Grumman Aircraft Engineering	systems	200
General Electric		
Missile and Space division	design	200
Sperry Gyroscope	design, systems, inertial	200
Westinghouse Electric		
Defense and Space Center	radar	300
Southeast		
Lockheed-Georgia	design, systems	100
Pan American World Airways	radar, communications	100
Radiation	systems, computer	150
Douglas Aircraft,		
Missile and Space division	computer	75-100
Southwest		
Collins Radio, Dallas	systems	200
Texas Instruments	circuit design, semiconductor	600
General Dynamics, Ft. Worth	systems, electromagnetics	200
Ling-Temco-Vought	digital, electro-optics	200
Midwest		
Control Data (nationwide)	circuit design, logic	200-250
Automatic Electric	solid state, packaging	175
Conduction	computer, radar	200
AC Electronics	circuit design, systems	50
New England		
Raytheon	circuit design	935
Microwave Associates	microwave, solid state	50
Mitre	communications, data processing	70-80
Honeywell, Electronic		
Data Processing division	computer development	100
West Coast		
Ampex	circuit design, audio	100
Lockheed Missiles and Space	communications, circuit	1,700
Fairchild Semiconductor	circuit, product	150
Varian Associates	instrumentation, circuit design	150
Litton Industries, Guidance and		
Controls Systems division	computer design, control systems	50-100
Hughes Aircraft	circuit design, radar	525
Autonetics	systems, circuit	800
TRW Systems	guidance and control, communications	1,450



indicate the shortage of professional electronics engineers; recruiters to staff design facilities and research laboratories.

and aggressiveness. They get out to the campus early to secure the names of the students so they can send letters of invitation. Many send telegrams to remind students of scheduled interviews. Some even phone the students' homes or give prospects a dollar just to fill out a questionnaire.

Despite these efforts, many interviews are cancelled. The reason, says Dale Barbee, director of student placement at Case, is that the number of companies in search of employees is increasing while the number of students is holding fairly steady.

Jerry Hall, employment manager at Sylvania Electric Products Inc., a General Telephone subsidiary in Mountain View, Calif., agrees. He says his company is attracting fewer graduates than usual because the number of companies re-

cruiting on campuses has more than doubled since last year. And Frank McCarter, employment manager at Litton Industries Inc.'s Guidance and Controls group, says: "We would like to fill about 25% of our engineering needs from college, but we only talk to the top one-third and they're hard to get." Litton usually ends up filling 15% of its new job openings with recent college graduates, according to McCarter.

III. Playing hard-to-get

With an increasing number of graduates, many of them concerned about the draft, going on to work on advanced degrees, the available talent is getting choosier about the sort of job offers it will consider. Many students, taking the big pay packet for granted, are more interested in the level at which they

would enter a company and their prospects for promotion, possible graduate work, and membership in prestigious professional societies.

With all of the attention being paid to the student, however, it isn't surprising to find that he's also asking for more money. "It's not unusual for the college student to be offered \$9,450 a year," says Barbee of Case. Hall of Sylvania finds that new graduates with masters' degrees are asking \$10,000 and up right off the bat. What's more, they're getting it. Larry Dooley, manager of personnel for the Bendix Corp.'s Launch Support division at Merritt Island, Fla., says a brand-new electrical engineer can expect \$7,500 and up, depending on his background, his class standing, and the reputation of his college.

Like his younger colleague, the experienced engineer making a move is asking for, and getting, more money, but there is some disagreement as to how much the increase comes to.

For instance, most recruiters in the Southeast report a leveling off in the rate of salary rises at about 5%. But on the West Coast, the home of so many aerospace concerns, recruiters see no such leveling off. John Doolittle, personnel manager at Ampex, says engineers moving to new jobs can expect a 10% to 15% pay increase. James Pietrowsky, at the Autonetics division of North American Aviation, Inc., Anaheim, Calif., concurs. "Engineers won't move for less than a 10% salary hike, and they'll often ask for 15% without batting an eye," he says.

However, a fellow Californian

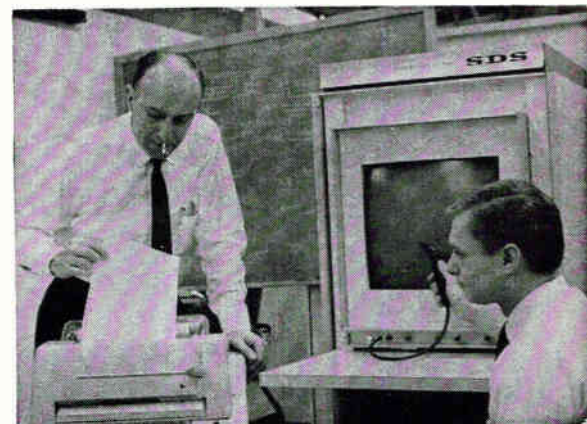

Brand new Case graduate learns the ropes at Goodyear Aerospace.

Q:

What are 400-Volt Silicon Power Transistors like you doing in a place like this?

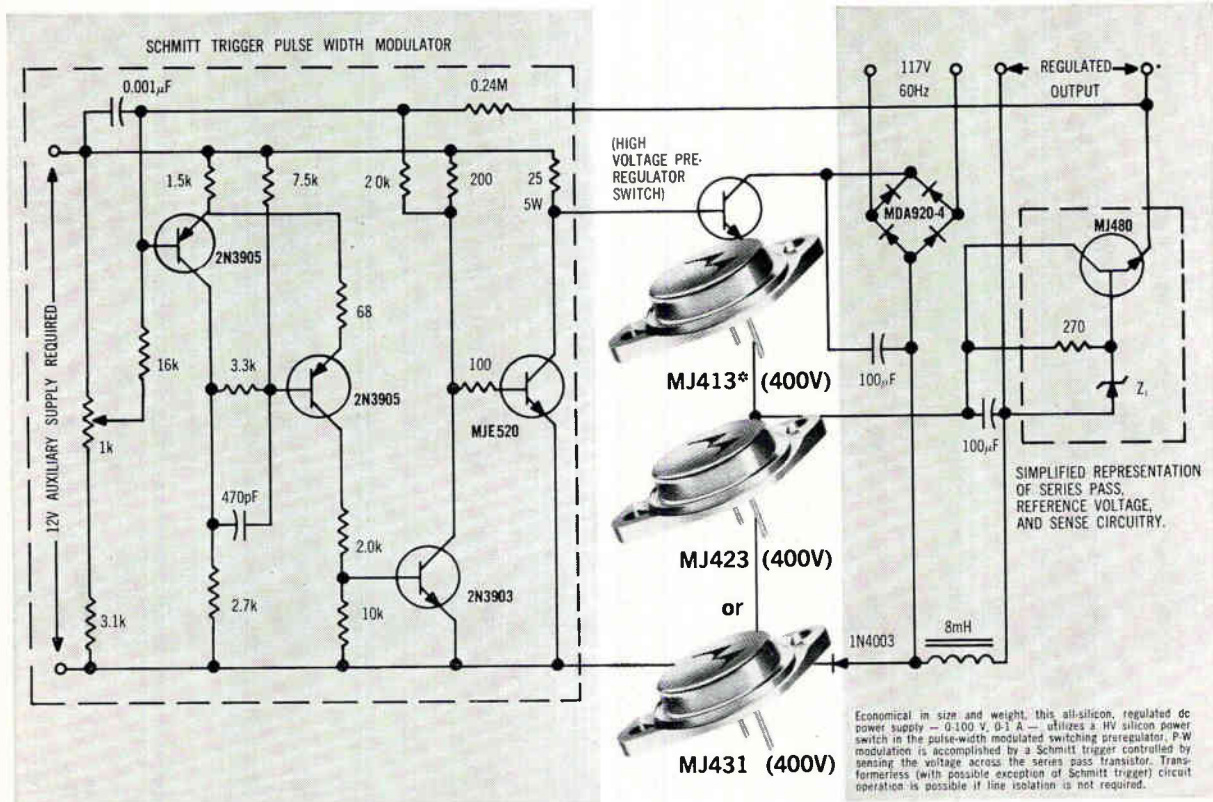

A: Lowering costs and simplifying circuitry.

Right now you can use these three new Motorola 400-volt silicon power units in virtually all the right places: in line-operated audio and servo amplifiers, inverters, choppers, switching and series pass regulators and horizontal and vertical TV outputs!

Advantages? Many. You can reduce the size, cost and complexity of input, output and filtering components. Plus, reduce current and keep your circuitry more compact, lighter and easier to cool. They can also replace similar, limited-source devices at no increase in cost.

And there's no "punch-through" (secondary breakdown) with any of them because Motorola's triple diffusion process allows device acceptance of very high voltages even in the most demanding designs.

We've prepared an informative package of technical data on the broadest line of 200 to 400V silicon power transistors in the industry — 14 NPN units that let you optimize your application with a wider choice of packages, current capabilities, voltage/gain characteristics . . . and availability. You'll also receive an enlightening article on the significant advantages and uses of HV silicon power in modern, high energy circuitry. Send for it today! Box 955, Phoenix, Arizona 85008.

Evaluation units from your franchised Motorola distributor.

NOW — Select from the Broadest HV Silicon Power Line Available!

TYPE	V _{CEO}	V _{CEO} (Sus)	I _C (Max)	h _{FE}	f _r	CASE
MJ400	325	325	200 mA	30 min (@ 50 mA, 10V)	15 MHz min	TO-66
MJ420 MJ421	250 325	250 325	100 mA	25 min (@ 30 mA, 20V)	30 MHz min	TO-5
MJ3201 MJ3202	225 300	225 300	100 mA	30 min (@ 50 mA, 10V)	15 MHz min	TO-66
MJ2251 MJ2252	225 300	225 300	500 mA	25 min (@ 50 mA, 10V)	10 MHz min	TO-66
2N3738 2N3739	225 300	225 300	3 A	40 min (@ 100 mA, 10V)	10 MHz min	TO-66
MJ3010 MJ3011	200 325	200 325	3.5 A	20 min (@ 0.5 A, 5V) 10 min (@ 2 A, 5V)	4 MHz min	TO-3
MJ413 MJ423 MJ431	400 400 400	325 325 325	5 A	15 min (@ 1 A, 5V) 10 min (@ 2.5 A, 5V) 10 min (@ 3.5 A, 5V)	6 MHz min 5 MHz min 4 MHz min	TO-3

*For output currents to 300 mA.

— where the priceless ingredient is care!



MOTOROLA
Semiconductors

Friden looks for pot of gold at end of electronics rainbow

Five-year program to put electronics in its business machines is set to pay off as company introduces a billing and accounting unit with integrated circuits

By William Arnold

San Francisco Bureau

When the Friden Co. realized that electronics would eventually obsolete its entire product line of electromechanical business machines, it turned to advanced technology in general and integrated circuits in particular. Friden's effort to break into advanced electronics took almost five years to pay off. But late last month the company introduced its first homegrown product with ic's—a desk-sized billing and accounting machine, called the model 5610 Computyper, that employs transistor-transistor-logic circuits for all logic functions. These devices were supplied by Texas Instruments Incorporated and 85% were made to Friden's specifications.

"We are a big company now and we're beginning to think and act like one," says Martin H. Dubilier, 40, who wears two hats as executive vice president and executive

vice president for operations. "Five years ago, we had two product lines in a stable business. Today, we have five product lines in a rapidly changing business," he asserts. Dubilier estimates that this year Friden will buy more commercial integrated circuits than any company outside of the computer business. Its demand will rise to over three million circuits this year and more than six million in 1968.

Winds of change. Since the Computyper represents Friden's ic debut, the huge increase in ic purchases suggests that the company is ready to make extensive changes in its products. "We can't rely on anything in the sales line being there five years from now," Dubilier says.

Electronic products, with life expectancies of five years or less, clearly require development times faster than those of Friden's con-

ventional products, which once lasted from 10 to 15 years. "You can't waste six months on a product with a life cycle of four years," Dubilier reports.

Friden, which was acquired by the Singer Co. in 1963, took its first tentative step into electronics that year by bringing out the model 6010 computer—essentially a sophisticated billing machine. A year later the company introduced its solid-state model 130 calculator, a desk-top unit for those with big desks. It followed up with the model 132—a 130 dressed up with a square-root key.

In 1966, Alan W. Drew took over as president and started action programs, increasing the number of employees in market research, and converting some field sales personnel to product management. He also redefined the product manager's role by making him a busi-

Custom-built IC's are mounted on board for Computyper—Friden's first advanced electronics business machine.



ness manager for his line. To speed the planning process he tightened liaison between product planning, the product line manager, and the engineers.

During this period, Friden expanded its small stakes in graphic arts, mailing-room devices, and such original equipment as the photoelectric keyboard into full product lines to match its original lines of adding machines, calculators, and data processing wares. Concurrently, it began pumping more money into research and development. Friden had created the base for this diversification program during the 1950's when it acquired plants in Rochester, N.Y., Lewiston, Pa., Nijmegen, the Netherlands, and Mechelen, Belgium. In 1963 it acquired the Physical Sciences Corp. of Arcadia, Calif.

I. Double Time

In 1964, the company invested 2% of its sales dollar in research and development. Now it allocates 3%—a level that Dubilier expects to maintain. On an estimated \$170 million in sales last year, that amounts to over \$5 million. With sales growing at an annual rate of 20%, the company will spend another \$1 million on R&D in 1967.

Two groups share research funds. One, the Friden Research division, is an autonomous entity set up to do Singer-wide research, though 99% of its work is now done for Friden. Its chief, Leland P. Robinson, stresses that his bailiwick is mainly a computer lab for applied research.

"Part of our mission for the next few years is to help in every way to accelerate the industrial design of integrated circuit technology," he says. By improving wiring, minimizing interconnections, and reducing the number of components, Robinson's group hopes to lower production costs on Friden's equipment. The group has two main approaches: incorporating IC's in Friden products, and introducing computer-aided design to the engineering process.

Friden's other R&D operation is headquartered in a \$1.25-million, 40,000-square-foot building that houses 180 employees. Three years ago, it had only 80. This facility is set up to compress research time, according to George E. Comstock,

vice president for research and development. Essentially, he explains, Friden wants to use engineering as "a working tool for the marketing man to evaluate new products from a marketing point of view." Thus Friden can be in a better position to consider the economic tradeoffs in its custom-designed circuits.

Pathway. So far, and for some time to come, Comstock indicates, Friden sees those tradeoffs favoring double-diffused integrated circuits. "In today's technology," he says, "double-diffused technology is economical. It's basic, the art is well understood, and the yields are agreed upon." Comstock calls metal-oxide semiconductor technology "glamorous but impractical," and does not expect it to be really useful for five years.

II. Hardware and soft

First fruit of Friden's fling with advanced technology is the 5610, which makes use of about 220 custom-built circuits containing six inverters, acting as three flip-flops per chip. The chip has been dubbed the Hex (Greek for six) and costs about \$2 per unit. Friden chose the transistor-transistor-logic chip some 18 months ago on the advice of Texas Instruments which said that it would be cheaper for custom design.

Friden claims it achieves flexibility by using the same chip throughout the machine. With external diodes the chip functions as a diode-transistor-logic input, since TTL devices can't operate with diodes. As a TTL output, the circuits afford speed and high fan-out. The 5610 contains 3,000 diodes in high-voltage delay lines and in the interface with Friden's model 2205 Flexowriter, one of the 5610's input-output paths.

The machine stores 60 programs on punched tape and comes with a simple software package called Swift—for software implemented Friden translation. With Swift, an operator can type out simple commands in English or any other language, and not worry about adhering strictly to computerese.

One program gives the 5610 troubleshooting capability, which Friden says is unique in a small-scale data processor. If the machine malfunctions, a diagnostic program

can be fed in and the fault will be isolated and typed out.

III. Taking it easy

The glamor of IC's has not blinded Friden to its bread-and-butter business. The company now produces four times as many conventional calculators as electronic machines, and expects the change-over to all-electronic units to be gradual. It will be some time, Dubilier believes, before electronic calculators can match rotary machines in price. One conventional machine costs \$1,195, while its speedier electronic counterpart has a price tag of \$1,950.

But the company is now in the third year of an ambitious sales drive which it hopes will more than double volume and profits by 1970. At the same time Friden wants to keep its production force at the 13,000 level that now prevails around the world. "We're right on target, so far," Dubilier says. The business-machine industry, with a growth rate more than five times that of the economy as a whole, provides a nice foundation for Friden's ambitions.

A possible check on those ambitions is the need for trained personnel. Comstock admits to some difficulties in recruiting because "we're cloistered and not well-known in electronics." He feels, however, these drawbacks are offset by Friden's aggressiveness, growth, potential, and high salary scales. Still, San Leandro is across San Francisco Bay and removed from the electronics enclave in Santa Clara County. Robinson's research division, now located near Oakland International Airport, is currently negotiating for land in the Stanford University Industrial Park in Palo Alto in an attempt to bridge that distance. Friden is also trying to set up with the University of California at Berkeley the same kind of working agreements that many Peninsula companies enjoy with Stanford.

Change is not easy. Friden, which considers itself number one in calculators and adding machines, was once in danger of being leapfrogged by the electronics industry. But with electronics capability, says Dubilier, "... you keep up the momentum, and competitors can't catch up."

Time-sharing inquiry shakes industry

The FCC probe into computers' impact on communications will bring to a boil the controversies now simmering among common carriers, computer makers, users, service bureaus, and specialty companies

When the FCC decided to probe the impact of computers on communications last November, the language of its notice startled a lot of attorneys used to working with regulatory agencies. Instead of requesting comments on carefully defined issues, the Federal Communications Commission asked business firms to suggest areas for the inquiry. Said one attorney, "From reading this notice, I'd say the commission doesn't even know where to begin."

Now the commission has filed a supplementary notice of inquiry and everybody can see where the probe is going. It will delve into every aspect of time-sharing from the pricing of computers to the policing of computer connections. Its scope could reshape the computer industry. At the International Business Machines Corp., an excited executive who studied the announcement exclaimed, "There's a large chunk of our future in here."

Nearly 35 companies responded to the FCC's November call for suggestions and the replies fell into two broad camps: one wants the commission to regulate time-sharing of computers completely, the other wants as little regulation as possible. In general, the common carriers familiar with the FCC and its procedures want regulation; industrial companies want regulations restricted to tariffs for communication lines.

The current investigation started when the FCC found difficulty untangling cases involving time-shared computers, machines in which many users have simultaneous access to a single computer from a distant site. Ostensibly the commission's interests were threefold:

- Are there any aspects of data processing that the commission should regulate?

- Is the privacy of subscribers to time-shared computers being adequately safeguarded?

Now industrial companies, to whom any regulation is anathema, believe the probe is going much deeper. What is at stake, they feel, is who will profit from the exploding market for data transmission. In fact, almost every company that has a computer may have something to gain or lose from the outcome of the inquiry. Soon there will be hardly a single computer that is not connected by telephone lines to a data bank, other computers, branch offices, or departments within a company.

I. Behind the probe

At the FCC over the past 18 months, the men assigned to watch communication common carrier companies, facilities, and services have become preoccupied with computer matters. The first major impasse, which most people claim prompted the FCC's inquiry, cropped up in 1965 when the Bunker-Ramo Corp. complained unofficially that the American Telephone and Telegraph Co. would not make telephone lines available for a specialized computer service to connect brokerage houses around the country with stock exchanges. The telephone company claimed that 5% of the traffic the new service would carry was the kind that ought to go over ordinary telephone or telegraph lines.

In the new service, which was to be called Telequote IV, a broker in any branch office anywhere in the United States could send a buy or sell order for a stock or commodity to any security or commodity exchange through a central computer which would assign the order

to the firm's floor man at the proper security exchange, and send an acknowledgment of the completed transaction back to the proper office as well as do all the necessary computation and paperwork. Using the system, the branch office could also send and receive such ordinary messages as requests for hotel reservations, inquiries about the weather, or personal communications. Bunker-Ramo saw the system as an extension of the stock market pricing service it now offers brokerage firms. But the telephone company considered the move a definite encroachment upon its common carrier business.

Basics. Since both the service company and the telephone company recognized that a fundamental principle was involved, they agreed to go to the FCC unofficially. Since the experts at the commission did not have enough background information to make a precedent-setting ruling they persuaded the two companies to compromise. Bunker-Ramo would eliminate the features the telephone company found objectionable and the utility would supply lines for the remaining service. The company's modified service, now called Telecenter omniprocessing system will begin in about two months.

Then, Western Union International, a carrier regulated by the commission, disclosed plans for leasing data processing time on the same computers it was installing to switch Telex lines [Electronics, Nov. 28, 1966, p. 128], thereby adding an activity the commission could not regulate.

To cap the commission's worries, a professor at the Massachusetts Institute of Technology warned that computers were generating so much data for transmission over telephone lines the lines were in danger of being clogged, and the tele-

Some other **ENGELHARD** products

PRECISION-DRAWN TAPE is supplied to specification in bimetals or solid precious metals. **ECON-O-TAPE** is available in any thickness, length or width (from .0095"). Shaped or rectangular sections. Excellent material for electrical contacts subject to corrosion.

E-70 BRIGHT GOLD PROCESS produces mirror bright electroplates from flash deposits to 500 microinches in thickness. This highly efficient, neutral bath produces hard, wear resistant finishes suitable for the complete range of decorative applications.

CLAD CONTACT PARTS provide a precious metal layer essentially pore free and durable, with an extremely strong bond to the base metal. These parts are supplied usually in the form of blades and spring assemblies.

ACID GOLD PLATING PROCESS provides high purity gold electrodeposits (24 Karat) that are smooth, lustrous, free from porosity, highly ductile, relatively hard. Excellent deposits up to several mils in either still or barrel plating. Highly stable and simple to handle over long periods. Adaptable to plating wide variety of electronic components.

SEMICONDUCTOR MATERIALS are supplied in a wide range of precious and base metals and their alloys. These include solid sheet, wire, tape, base tab materials and clad products, fine gold wire, and ribbon. New materials are constantly under development. Technical assistance is available.

PRECIOUS METAL CONTACTS in pure or alloyed forms of silver, platinum, palladium and gold provide unmatched resistance to atmospheric corrosion and electrical pitting. Engelhard will manufacture to specifications or provide material in wire, rod or sheet form.

THIN WIRE AND FOIL are produced by Engelhard's Baker Platinum Division to meet rigid electronic design requirements. Both extruded and Taylor Process thin wire are available in diameters as small as .001". Thinnest gauge foil is supplied in sheets up to 8" x 18".



... common carriers want to diversify into data processing services ...

phone system faced ruin.

In the replies to the commission's first notice of inquiry, storm signals were apparent from the number of companies that responded and their conflicting interests. Among them were: common carriers, including the two biggest, AT&T and Western Union; computer companies like IBM, Honeywell Inc., and the General Electric Co.; service bureaus operations like CEIR and McDonnell Computer Service; leasing companies such as Randolph Computer Co.; trade associations, the National Association of Manufacturers, the National Association of Broadcasters, the Business Equipment Manufacturers Association, and the American Petroleum Institute; manufacturing companies with an interest in electronics, for example, the Xerox Corp. and the Collins Radio Co.; and companies that want to sell specialized computer services like Bunker-Ramo.

Specific battle lines have been clearly drawn:

- The common carriers will fight to keep any computer-oriented company from performing a service which could be done by conventional telephone or telegraph lines. At the same time, the carriers want to diversify into data processing.

- Service bureaus and computer users want lower charges for the use of telephone and telegraph lines carrying data. They claim that the lines in use today are not as efficient as they should be because they were designed to carry voice communication primarily, not data.

- Computer manufacturers want a relaxation of restrictions that ban their hardware from being connected directly to telephone and telegraph lines. They fear that carriers could set arbitrary rules that would make some forms of data transmission uneconomic. AT&T has enjoyed a marketing advantage because it is the only data input gear a Bell System company will allow on a dial telephone line. Late last year, Bunker-Ramo Corp. went to the FCC and forced a reduction in rental of Dataphone sets, charging that AT&T's prices were far too high. The commission agreed and

cut rentals from \$40 per month to \$30.

- Specialty companies want the common communication carriers to provide all the lines they need even if some ordinary message traffic is carried by the specialized service. For example, Bunker-Ramo expected to use the same telephone lines that already supplied buy and sell prices for its proposed Telexquote IV brokerage service and its stock market quotation service. So far AT&T has forced the company to use separate lines—a procedure which runs up a customer's cost considerably.

II. The computer utility

In addition, Western Union, which is diversifying into a data processing service bureau operation, would like the commission to regulate prices of computers, a proposal that makes computer manufacturers furious.

Western Union's plans to build a so-called computer utility that will provide all kinds of data processing services has given the FCC still another kind of problem. The telegraph company has already installed big computers to switch Telex lines automatically, a function clearly under the FCC's jurisdiction. Later this year, the company will start leasing time for data processing to outside customers on these same machines, an activity the commission currently does not regulate. The big dilemma is how Western Union should divide the cost of the computers between regulated and nonregulated services when they are operating at the same time.

Which route? A question that worries nearly everybody is what the giant AT&T will do about data processing. So far, the telephone company has shown no inclination to follow Western Union down the computer utility route. But computer manufacturers and service bureaus are nervous because Bell System companies are installing electronic switching systems that are really special-purpose computers. Although AT&T engineers say considerable hardware and software modifications would be

build a
\$125,000
machine

Our skills and services are available to you. For Cinch creative problem solving assistance, contact Cinch Manufacturing Company, 1026 South Homan Avenue, Chicago, Illinois 60624.

See us at Booth No. 3B01 at
the IEEE Show

required to enable these machines to perform ordinary data processing, they admit it is technically feasible.

Some people have felt that a consent decree in which AT&T entered with the Justice Department in 1956 would bar the company's diversification into the data processing business or service bureau operation. But some experts say no and the company agrees with that view. In the consent decree, the phone company agreed to engage only in activities regulated by the FCC. Testifying before a Congressional committee last year, AT&T executives offered the opinion that if the company filed and the FCC accepted a tariff for a computer service, the strictures of the consent decree would not apply.

Thus if, as a result of the current probe, the FCC should ask for and receive legislation to control data processing activities that cross state lines, AT&T might well launch a large-scale invasion of the data processing service bureau business.

Government's role. The great concern over, and interest in, computer utilities is shown by the calling of two major meetings later this month. The American Management Association has scheduled a three-day session from March 8 to 10 entitled "The computer utility—management's stake in shared-time and shared-information systems." Later in the month, March 20 to 22, the College of Engineering at the University of California at Los Angeles will host a meeting called: "Computers and communications; toward a computer utility." At both meetings a discussion of the role of Government in the computer utility occupies an important place on the program.

Nobody expects the FCC to reach a fast conclusion from its probe into computers and communications. Most experts are predicting the inquiry will take three or four years. But the betting is that the commission will decide to ask Congress for additional legislation so it can regulate time-sharing. Explained one attorney who has specialized in presenting cases before Government agencies, "I never heard of a regulatory agency that didn't try to expand its operations. The main question is where the FCC will stop with time-sharing."

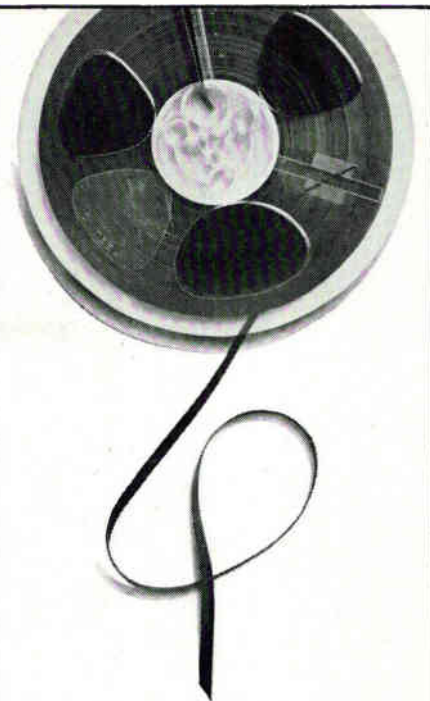

GREATER TAPE SENSITIVITY

with Pfizer
magnetic iron oxides

Whenever there's a need for a more sensitive magnetic tape of any kind, chances are Pfizer has the magnetic oxide for you to produce it. Significant advances in magnetic tape technology have coincided with Pfizer's continuing development of high quality oxides. Available are IRN® magnetic oxides of high density which facilitate more magnetic action in a given volume, providing greater sensitivity in a wide variety of uses:

- Audio, video, computer and instrumentation tapes;
- Memory drums and discs;
- Cinema film stripings;
- Magnetic inks;
- Transfer tapes;
- Ribbons.

Pfizer's continuing research & technical service programs are ready to help you on any specific problem you may have in this growing field. Complete technical data on request.

Pioneering in Physical Chemicals

Pfizer

**MINERALS
PIGMENTS
& METALS
DIVISION**

Dept., 75, 235 East 42nd Street
New York, New York 10017

Easing of tube shortage in Japan opens color tv markets for set makers

With prices coming down and outlets available both at home and in the U.S., the industry gears for volume production

By the Lunar calendar, this is the year of the sheep in Japan. But for the country's color television manufacturers, 1967 could be more aptly named.

For the color tv industry in Japan has moved into a phase where none can afford docility. The color tube shortage that long held the pack at bay ended last summer. Unleashed, the dozen or so Japanese receiver makers scurried to get into big-volume production. Now that the production lines are pouring out sets, the scramble to sell them has started.

Geared up to turn out upwards of a million color tv sets this year, the Japanese will toil like beavers to keep their prodigious output from piling up in warehouses. Color tv makers figure to be tigerish in their marketing techniques. Indeed, any set maker who outwardly appears attuned to the celestial conjunction of the ancient calendar most likely is a wolf masquerading in sheep's clothing.

Poised to climb. Luckily, the two major outlets for Japanese color tv makers should expand sharply this year. An early-year flurry of new models priced at below \$500 shows signs of triggering a color boom in the domestic market. And in the United States, where the outlook is for total sales of some 6 million sets, Japanese producers expect to sell at least 500,000 units, double their 1966 business.

Export prospects, in fact, may become even brighter before year's end. So far, Japanese producers have made the 19-inch set their bread-and-butter model. Most, though, will add 15-inch sets to their lines before the year is out. Traditionally, Japanese consumer electronics producers have fared best in the U.S. market with small,

low-cost receivers.

For the long term, Japanese producers seem to be in a good position to snare a substantial share of the U.S. small-screen color tv market. Both the Sony Corp. and the General Corp. (formerly the Yaoun Electric Co.) have in the works post-deflection focus tubes—without shadow masks—that are admirably suited for the forthcoming generation of small solid-state sets.

I. Full swing

More than anything else, what makes 1967 anything but the year of the sheep for Japanese color tv makers is a burgeoning shadow-mask tube output in the country. In mid-1966, the Asahi Glass Co. boosted its bulb capacity substantially. The company, which exports heavily but at the same time supplies more than half of the bulbs used in Japanese color sets, will

probably turn out two million this year, as against 800,000 last year.

Smaller tube makers have followed suit. Tokyo Shibaura Electric Co. (Toshiba), for example, recently doubled its monthly capacity to 60,000 bulbs. Hitachi Ltd. is going from 13,000 to 30,000 units and the Matsushita Electrical Industrial Co. from 15,000 to 25,000. The New Nippon Electric Co. will soon begin its own tube production at a rate of 20,000 units a month.

Shadow-mask makers are keeping pace. By mid-1967, the three major Japanese producers will have doubled their output. By then, the industry leader, the Dai Nippon Micro Co., a subsidiary of the Dai Nippon Printing Co., will hit 100,000 monthly. The other two will put out 70,000 between them.

With tubes no longer a problem, Japanese color set production most likely will run about 1.3 million



Toshiba, one of a dozen Japanese tv makers cashing in on the color boom, at home and overseas, will be producing at a rate of 30,000 sets in March.

Easing of tube shortage in Japan opens color tv markets for set makers

With prices coming down and outlets available both at home and in the U.S., the industry gears for volume production

By the Lunar calendar, this is the year of the sheep in Japan. But for the country's color television manufacturers, 1967 could be more aptly named.

For the color tv industry in Japan has moved into a phase where none can afford docility. The color tube shortage that long held the pack at bay ended last summer. Unleashed, the dozen or so Japanese receiver makers scurried to get into big-volume production. Now that the production lines are pouring out sets, the scramble to sell them has started.

Geared up to turn out upwards of a million color tv sets this year, the Japanese will toil like beavers to keep their prodigious output from piling up in warehouses. Color tv makers figure to be tigerish in their marketing techniques. Indeed, any set maker who outwardly appears attuned to the celestial conjunction of the ancient calendar most likely is a wolf masquerading in sheep's clothing.

Poised to climb. Luckily, the two major outlets for Japanese color tv makers should expand sharply this year. An early-year flurry of new models priced at below \$500 shows signs of triggering a color boom in the domestic market. And in the United States, where the outlook is for total sales of some 6 million sets, Japanese producers expect to sell at least 500,000 units, double their 1966 business.

Export prospects, in fact, may become even brighter before year's end. So far, Japanese producers have made the 19-inch set their bread-and-butter model. Most, though, will add 15-inch sets to their lines before the year is out. Traditionally, Japanese consumer electronics producers have fared best in the U.S. market with small,

low-cost receivers.

For the long term, Japanese producers seem to be in a good position to snare a substantial share of the U.S. small-screen color tv market. Both the Sony Corp. and the General Corp. (formerly the Yaoun Electric Co.) have in the works post-deflection focus tubes—without shadow masks—that are admirably suited for the forthcoming generation of small solid-state sets.

I. Full swing

More than anything else, what makes 1967 anything but the year of the sheep for Japanese color tv makers is a burgeoning shadow-mask tube output in the country. In mid-1966, the Asahi Glass Co. boosted its bulb capacity substantially. The company, which exports heavily but at the same time supplies more than half of the bulbs used in Japanese color sets, will

probably turn out two million this year, as against 800,000 last year.

Smaller tube makers have followed suit. Tokyo Shibaura Electric Co. (Toshiba), for example, recently doubled its monthly capacity to 60,000 bulbs. Hitachi Ltd. is going from 13,000 to 30,000 units and the Matsushita Electrical Industrial Co. from 15,000 to 25,000. The New Nippon Electric Co. will soon begin its own tube production at a rate of 20,000 units a month.

Shadow-mask makers are keeping pace. By mid-1967, the three major Japanese producers will have doubled their output. By then, the industry leader, the Dai Nippon Micro Co., a subsidiary of the Dai Nippon Printing Co., will hit 100,000 monthly. The other two will put out 70,000 between them.

With tubes no longer a problem, Japanese color set production most likely will run about 1.3 million



Toshiba, one of a dozen Japanese tv makers cashing in on the color boom, at home and overseas, will be producing at a rate of 30,000 sets in March.

0 ← **SCAN** → 25 MHz

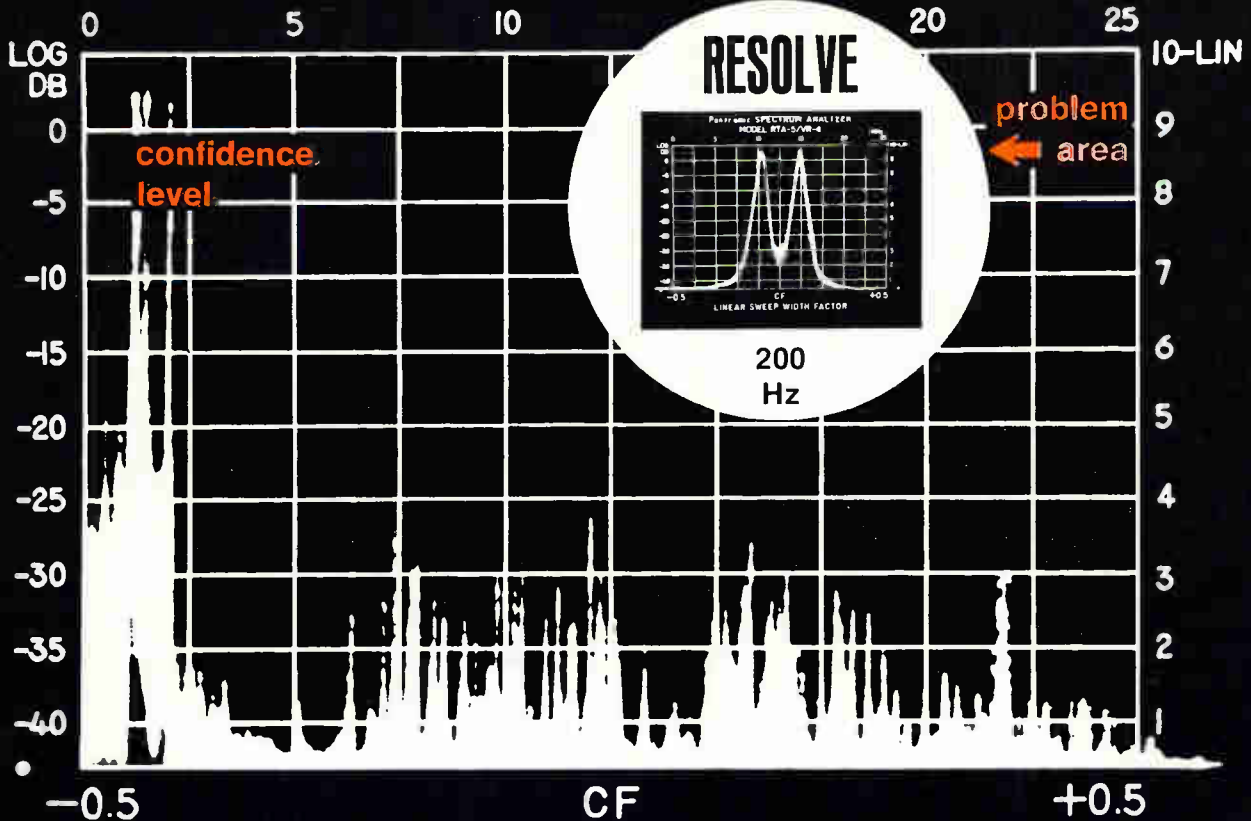

MONITOR

COMMUNICATIONS
SECURITY
TELEPHONY
TELEVISION

DIAGNOSE

only with the **Panoramic* VR-4/RTA-5 modular[†] spectrum analyzer**



ON DISPLAY AT IEEE
BOOTHS 2B25-2B30

SPECIFICATION HIGHLIGHTS

- Frequency range:** 1 kHz-27.5 MHz digital readout
- Scan widths:** 50 kHz-5 MHz, or 500 Hz-50 kHz phase locked, digital readout; preset 0-25 MHz full dispersion
- Resolution:** 200 Hz
- Sensitivity:** 30 μ v linear full scale
- Log display:** 40 db calibrated
- Display flatness:** ± 1 db
- Frequency calibration:** $\pm 0.02\%$ internal crystal markers
- Main frames:** rack-mount or portable

[†] Currently-available interchangeable modules: sonic (AR-1), log-scan sonic (AL-2), ultrasonic (UR-3), and video (VR-4).



* A Trademark of THE SINGER COMPANY

EMPIRE • EMC • GERTSCH • SENSITIVE RESEARCH

SINGER
INSTRUMENTATION

THE SINGER COMPANY, METRICS DIVISION • 915 Pembroke St., Bridgeport, Conn. 06608, U. S. A. • PHONE (203) 366-3201

P-67-1

Uncalculated risks keep calculator on the shelf

Trying to take too big a step from the lab to production of an IC-equipped calculator, General Micro-electronics stumbled over a number of technical obstacles

By Lewis H. Young

Editor-in-chief

Sixteen months ago, at the annual show of the Business Equipment Manufacturers Association, the Victor Comptometer Corp. introduced a radically new electronic calculator that set some startling precedents. For one thing, 29 metal oxide semiconductor chips were to replace nearly 21,000 conventional discrete components. For another, the entire calculator, the Victor 3900, was to be fabricated and assembled by a semiconductor company, General Micro-electronics Inc. of Santa Clara, Calif. After the show, however, the Victor 3900 disappeared.

Last month, executives at Victor and the Philco-Ford Corp., which purchased General Micro-electronics last summer, shamefacedly explained the disappearance. The semiconductor company hasn't been able to manufacture the Victor 3900.

Philip Ferguson, president of Philco-Ford Micro-electronics, conceded that serious production problems have delayed the calculator's debut.

Items:

- Nearly half of the 29 integrated circuits had to be redesigned.
- Cost reduction efforts were too stringent and resulted in the use of components that couldn't perform satisfactorily.
- Engineers who designed the IC's underestimated the difficulty of shifting from hand manufacture in a research laboratory to commercial production.

But Ferguson had some good news, too. Redesign of the calculator has now been completed and mass production will start this summer. The new circuits are cur-

rently being evaluated and a few calculators are being assembled for testing.

Prototype on schedule. The initial design and construction of a prototype moved right on schedule after the project was begun in September 1964. By October 1965, every circuit worked and the assembled machine performed well. An over-confident Victor signed a fixed price contract with General Micro-electronics for a large number of machines at this point, but big troubles cropped up when the design went into production.

Because General Micro-electronics was running a pilot-line operation in 1965, the switch to mass production became a nightmare. Employment was more than tripled, and floor space was increased from 30,000 square feet to 100,000. The

company, which was to deliver the calculators at a price low enough to make them competitive with conventional machines, found itself anteing up money at a rate it couldn't sustain. On some circuits, the yield was, in Ferguson's words, "substantially less than 1%." On one or two, yields were zero; they simply couldn't be mass produced.

Pound foolish. To keep costs down, the company cut corners and suffered the consequences. For example, it bought a cheaper transformer for the power supply only to find that the component couldn't perform satisfactorily. By the spring of 1966, Ferguson realized the worst; a major redesign was necessary if the calculator was ever to be mass produced.

The chief difficulty, according to Ferguson, was that the engineers who designed the circuits were overoptimistic about what they could do. "Mos was in research and development when the project started," he said, "so both systems designers and circuit people were going to school on the calculator, learning the technology."

I. A matter of microns

Probably the most important thing the engineers learned was that while design rules produced theoretically satisfactory integrated circuits when the devices were carefully made in the laboratory, the same rules weren't practical for commercial production. The big problem turned out to be a matter of microns.

One big advantage of MOS technology is that a transistor takes up an area only 5% the size of that required by a similar device made



Problems. "Most large steps forward take longer than you think," says Philco-Ford's J. Philip Ferguson.

ponent density. Fewer components per chip would have meant more chips and raised costs sharply. As Ferguson explains it, "We think the true potential of mos technology is in very complex circuits. The attractiveness of mos drops rapidly as complexity falls." Even with revised design rules and loosened geometrical restrictions, Philco-Ford engineers have put 400 to 600 components on each of the machine's 23 different circuits (seven of the machine's total of 29 circuits are 96-bit shift registers). "We took exactly the right design route," Ferguson asserts.

Rumor: The electronic calculator was a poor product in which to try integrated circuits.

Experts at competitors debunk this charge. At Texas Instruments Incorporated, for example, Jack Kilby, often regarded as the father of ic's, agrees that the calculator is an excellent subject for mos technology. His company is one of several conducting research aimed at producing mos circuitry for a calculator.

Rumor: The work on mos integrated circuits has gone so badly that Philco-Ford has built calculators with discrete transistors in mos ic cans to replace ic's that didn't work.

"Ridiculous," scoffs Philco-Ford's Ferguson. Another executive declared that the high cost of such discrete devices would preclude their use in this design.

Rumor: Victor is so upset about missed deliveries it is ready to sue Philco-Ford.

At Victor, Albert C. Beuler Jr., executive vice president, admits he would like to have had the machines in time for the planned January 1966 marketing debut, but says he understands the delay caused by the pioneering nature of the development. Victor has kept close watch on the difficulties at Santa Clara, so the schedule slippage was no surprise. Beuler says the relationship between the two companies is as good as ever.

Rumor: Philco-Ford will never build the Victor 3900.

Ferguson says prototype production has started again and deliveries should begin by summer. Beuler, at Victor, expects to start receiving machines by mid-1967. Normally, the business-machines company

Only Norden

can give you
custom-made IC's
with Glastrate isolation.

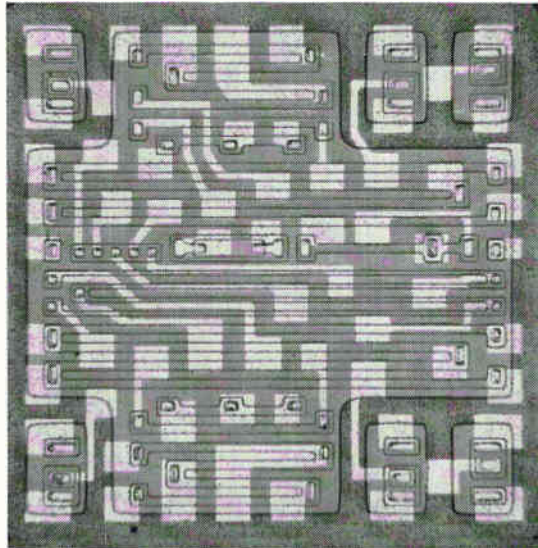

The shortest route to a new IC is Norden's Master Dice Breadboard technique. Each Master Dice contains all the elements, in monolithic integrated form, to perform a variety of analog and digital functions. All you do is tell us your circuit requirements, and we ship you an IC stitched to your specifications. *Glastrate* dielectric isolation of active elements is built in, insuring high performance.

Or interconnect your own Master Dice — and try out a new monolithic circuit at about the cost of a production chip. Either way, you save both time and money.

Many of Norden's breadboard designs have been converted to production circuits for some of the nation's leading programs... Minuteman, Apollo, Saturn, IHAS and C-5A. Need we say more about proven performance?

For more information about this fast, low-cost approach to IC's, write to the Microcircuits Department, Norden Division, United Aircraft Corp. Norwalk, Conn. 06856, or call (203) 838-4471.

Because of its growing role in the microcircuitry field, Norden has many openings for qualified solid state engineers. Send your resume to Personnel Department, Norden, an equal opportunity employer.

Norden DIVISION OF UNITED AIRCRAFT CORPORATION
NORWALK, CONNECTICUT

U
A

See our Master Dice technique demonstrated
at the IEEE Show, Booths 4G25-4G33.

Six ratings from 1 to 3 amps...

1.0 amps, VT1

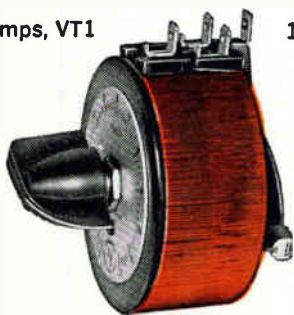

1.2 amps, VT1N

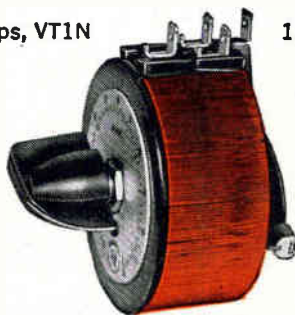

1.75 amps, VT02

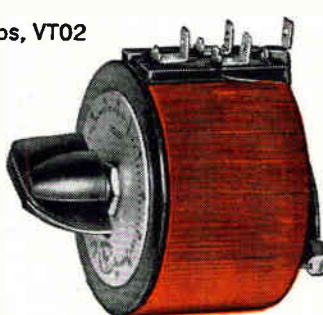

2.0 amps, VT02N

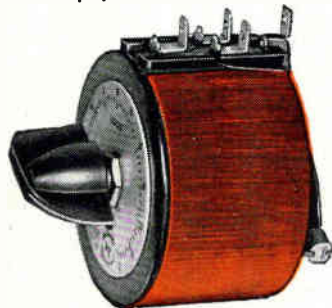

2.6 amps, VT3

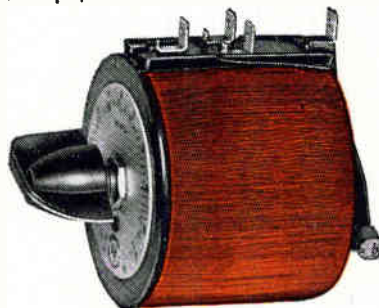

3.0 amps, VT3N

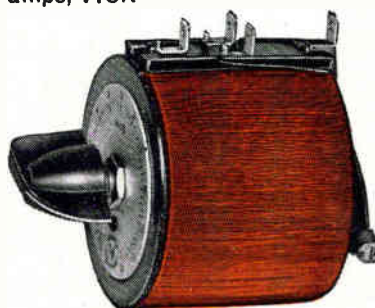

CUT COSTS by SPECIFYING CLOSER to YOUR NEEDS

with OHMITRAN *v.t.*® Low Power, Variable Transformers

You don't have to be satisfied any longer with a few meager ratings in low power variable transformers. Make your selection from 1.0, 1.2, 1.75, 2.0, 2.6, and 3.0-amp Ohmitran *v.t.*® ratings. No other manufacturer offers this extensive selection, or the exclusive series VT1 and VT3 units.

By specifying closer to actual needs, you normally can cut component cost and make your equipment more competitive.

Ohmitran units offer some unique engineering features, too:

Adjustable shaft (extends from either end) for mounting convenience or for operating auxiliary controls.

Multi-purpose terminals for soldering, quick connectors or screws.

Replaceable brushes with rapid, snap-in design and husky heat sink.

Same silhouette and mounting arrangement for all six ratings allowing standardization of panel treatment.

Model variations include fixed and portable enclosures, ganged assemblies, and motor-driven assemblies.

The Industry's Fastest Growing Line of Variable Transformers . . . 1 to 25 Amps, Hundreds of Stock and Made-To-Order Models. Write for Catalog 500.

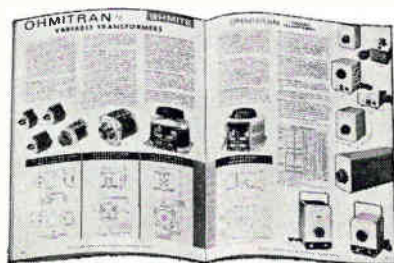

OHMITE



Resistors



Rheostats



Variable Transformers



Relays



Tap Switches



Tantalum Capacitors



Semiconductor Diodes



R.F. Chokes

OHMITE

MANUFACTURING COMPANY

3610 Howard Street • Skokie, Illinois 60076

Phone: (312) ORchard 5-2600

Introducing... RCA Solid-State GaAs Optical Devices



TA2930 50-W Laser

TA2628 1-W Laser

TA7008 IR Diode

- Injection Lasers with 1- to 50-W outputs at *room temperature* and threshold currents *below 15A*
- Miniature IR Diode Emitter with focused light output

	TA2628 laser	TA2930 laser	TA7008 IR diode
Peak Power Output (min) @ 27°C	1 W @ 30 A	50 W @ 30 A	0.6 mW @-0.1 A
Threshold Current	15 A	15 A	100 mA
Output Wavelength	9050 Å ±50	9050 Å ±50	9100 Å ±300
Line Width	5-10 Å	60-100 Å	600 Å ±50
Operating Temp.	-196 to 50°C	-196 to 50°C	-73 to 50°C
Pulse Width/ Repetition Rate	0.2 μs/1000 pps	0.2 μs/1000 pps	CW

RCA's wealth of semiconductor experience introduces a new dimension of practicality to solid-state lasers and light diodes. Available now in sampling quantities, each of these optical devices represents an important new tool for the field of electro-optics.

Check these performance benefits of RCA's TA2628 and TA2930* laser diodes:

Practical Power Outputs—conservative peak power rating from 1 to 50 W at room temperature.

Practical Pulse Current—lasing action begins with threshold currents below 15 A.

Practical Circuit Usage—Inexpensive semiconductor pulse circuits can be used without cryogenic hardware.

Practical Size—hermetically sealed in modified TO-5 and TO-46 packages.

RCA's new laser diodes are ready now for your evaluation in applications such as secure communications, intrusion alarms, traffic control, instrumentation, ranging and field illumination.

And RCA's new TA7008 IR emitter is equally exciting. Featuring a miniature but highly efficient parabolic reflection system, this tiny device provides a new source of focused light for applications such as card-reading.

Call your RCA representative today for more information on RCA's new family of developmental optical devices. For data sheets and application note on laser power supplies, write RCA Commercial Engineering, Section IN3-1, Harrison, N. J.

*The availability of the TA2930 laser array is presently limited to qualified defense contractors.

RCA Electronic Components and Devices



The Most Trusted Name in Electronics

Circle 237 on reader service card

Introducing... RCA Solid-State GaAs Optical Devices



TA2930 50-W Laser

TA2628 1-W Laser

TA7008 IR Diode

- Injection Lasers with 1- to 50-W outputs at *room temperature* and threshold currents *below 15A*
- Miniature IR Diode Emitter with focused light output

	TA2628 laser	TA2930 laser	TA7008 IR diode
Peak Power Output (min) @ 27°C	1 W @ 30 A	50 W @ 30 A	0.6 mW @ 0.1 A
Threshold Current	15 A	15 A	100 mA
Output Wavelength	9050 Å ±50	9050 Å ±50	9100 Å ±300
Line Width	5—10 Å	60—100 Å	600 Å ±50
Operating Temp.	-196 to 50°C	-196 to 50°C	-73 to 50°C
Pulse Width/ Repetition Rate	0.2 μs/1000 pps	0.2 μs/1000 pps	CW

RCA's wealth of semiconductor experience introduces a new dimension of practicality to solid-state lasers and light diodes. Available now in sampling quantities, each of these optical devices represents an important new tool for the field of electro-optics.

Check these performance benefits of RCA's TA2628 and TA2930* laser diodes:

Practical Power Outputs—conservative peak power rating from 1 to 50 W at room temperature.

Practical Pulse Current—lasing action begins with threshold currents below 15 A.

Practical Circuit Usage—Inexpensive semiconductor pulse circuits can be used without cryogenic hardware.

Practical Size—hermetically sealed in modified TO-5 and TO-46 packages.

RCA's new laser diodes are ready now for your evaluation in applications such as secure communications, intrusion alarms, traffic control, instrumentation, ranging and field illumination.

And RCA's new TA7008 IR emitter is equally exciting. Featuring a miniature but highly efficient parabolic reflection system, this tiny device provides a new source of focused light for applications such as card-reading.

Call your RCA representative today for more information on RCA's new family of developmental optical devices. For data sheets and application note on laser power supplies, write RCA Commercial Engineering, Section IN3-1, Harrison, N. J.

*The availability of the TA2930 laser array is presently limited to qualified defense contractors.

RCA Electronic Components and Devices



The Most Trusted Name in Electronics

Circle 237 on reader service card

Booths 3G13-3G15 IEEE

Bayonet Globar® heating elements offer complete design freedom. Introduce them—through roof, walls, or floor.

Three advanced grades of Combat boron nitride. For fixtures, jigs, and boats.

New oxide refractories extend the range of high purity, physical and thermal strengths. Check Mate system makes selection easy.

Fiberfrax® ceramic-fiber insulation holds K factors down in the one-figure range all the way up to 2300°F. Precisely. In 40 forms.



Precise physical properties and precise electrical characteristics start with our control over the electric-furnaced raw materials.

Then we work to hold that precision. The goal is to give you components and ceramic materials whose characteristics are those of their fire-born grain. Precisely. Meticulous technologies help us meet that goal.

Once we're satisfied with the precision of a given product, we get even more meticulous. We nail down every production step to assure you of automated precision that's uniform in part after part after part.

You're invited to talk with us at the Coliseum about our components for temperature or voltage compensation and about production uses of our ceramic products.

Precisely yours...

CARBORUNDUM



Circle 239 on reader service card

Broadest line of all-silicon equipment and laboratory use.

For Rack or Bench Use—From 1/2 amp to 35 amps,
0-10, 0-20, 0-40, 0-60, 0-120 VDC—with full five year
guarantee on materials and labor

Features and Data

- Convection Cooled
- Remotely Programable
- Remote Sensing
- Regulation—.015% or 1 MV (Line or Load)
- Temp. Coef. .015%/°C
- Transformer—designed to MIL-T-27 Grade 6
- Completely Protected—Short Circuit Proof—Continuously Adjustable Automatic Current Limiting
- Constant I./Constant V by automatic crossover

- Series/Parallel Operation
- No Voltage Spikes or Overshoot on "turn on", "turn off" or power failure
- Meet Mil. Environment Specs.
Vibration; MIL-T-4807A
Shock: MIL-E-4970A
- Proc. 1 & 2
Humidity: MIL-STD-810
- Meth. 507
Temp. Shock: MIL-E-5272C
- (ASG) Proc. 1
Altitude: MIL-E-4970A
- (ASG) Proc. 1
Marking: MIL-STD-130
Quality: MIL-Q-9858

- Ripple—
LK models—500 μ V RMS
LH models—250 μ V RMS,
1 MV P-P
- Wide Input Voltage and Frequency Range—
LK models—105-132 VAC,
47-63 cps
LH models—105-135 VAC,
45-480 cps.
- LH models meet RFI Spec.—Mil-I-16910
- Rack Adapters
LRA-1—5 1/4" Height x 16 1/2" Depth (For use with chassis slides) Price \$60.00
LRA-2—5 1/4" Height
Price \$25.00

3 full-rack LK models—Size 5 1/4" x 19" x 16 1/2"

Model ²	Voltage Range	CURRENT RANGE AT AMBIENT OF: ¹				Price ²
		40°C	50°C	60°C	71°C	
LK 350	0-20VDC	0-35A	0-31A	0-26A	0-20A	\$675
LK 351	0-36VDC	0-25A	0-23A	0-20A	0-15A	640
LK 352	0-60VDC	0-15A	0-14A	0-12.5A	0-10A	650

6 half-rack LK models—Size 5 3/16" x 8 3/8" x 16 1/2"

Model ²	Voltage Range	CURRENT RANGE AT AMBIENT OF: ¹				Price ²
		40°C	50°C	60°C	71°C	
LK 340	0-20VDC	0- 8.0A	0- 7.0A	0- 6.1A	0-4.9A	\$330
LK 341	0-20VDC	0-13.5A	0-11.0A	0-10.0A	0-7.7A	385
LK 342	0-36VDC	0- 5.2A	0- 5.0A	0- 4.5A	0-3.7A	335
LK 343	0-36VDC	0- 9.0A	0- 8.5A	0- 7.6A	0-6.1A	395
LK 344	0-60VDC	0- 4.0A	0- 3.5A	0- 3.0A	0-2.5A	340
LK 345	0-60VDC	0- 6.0A	0- 5.2A	0- 4.5A	0-4.0A	395

¹ Current rating applies over entire voltage range.

² Prices are for non-metered models. For metered models add suffix (FM) to model number and add \$30.00 to price.

³ Overvoltage Protection: Add suffix (OV) to model number and add \$70.00 to the price for half-rack models; \$90.00 for full-rack models.

⁴ Chassis Slides: Add suffix (CS) to model number and add \$60.00 to the price.

5 quarter-rack LH models—Size 5 1/16" x 4 3/16" x 15 1/2"

Model ²	Voltage Range	CURRENT RANGE AT AMBIENT OF: ¹				Price ²
		30°C	50°C	60°C	71°C	
LH 118	0-10VDC	0-4.0A	0-3.5A	0-2.9A	0-2.3A	\$175
LH 121	0-20VDC	0-2.4A	0-2.2A	0-1.8A	0-1.5A	159
LH 124	0-40VDC	0-1.3A	0-1.1A	0-0.9A	0-0.7A	154
LH 127	0-60VDC	0-0.9A	0-0.7A	0-0.6A	0-0.5A	184
LH 130	0-120VDC	0-0.50A	0-0.40A	0-0.35A	0-0.25A	225

5 half-rack LH models—Size 5 3/16" x 8 3/8" x 15 1/2"

Model ²	Voltage Range	CURRENT RANGE AT AMBIENT OF: ¹				Price ²
		30°C	50°C	60°C	71°C	
LH 119	0-10VDC	0-9.0A	0-8.0A	0-6.9A	0-5.8A	\$289
LH 122	0-20VDC	0-5.7A	0-4.7A	0-4.0A	0-3.3A	260
LH 125	0-40VDC	0-3.0A	0-2.7A	0-2.3A	0-1.9A	269
LH 128	0-60VDC	0-2.4A	0-2.1A	0-1.8A	0-1.5A	315
LH 131	0-120VDC	0-1.2A	0-0.9A	0-0.8A	0-0.6A	320

¹ Current rating applies over entire voltage range.

² Prices are for non-metered models. For metered models add suffix (FM) to model number and add \$25.00 to price. For non-metered chassis mounting models, add suffix (S) to model number and subtract \$5.00 from non-metered price.

³ Overvoltage Protection: Add suffix (OV) to model number and add \$60.00 to the price.

SEND FOR NEW
LAMBDA CATALOG



LAMBDA ELECTRONICS CORP.

515 BROAD HOLLOW ROAD • MELVILLE, L. I., NEW YORK • 516 MYRTLE 4-4200

A  SUBSIDIARY

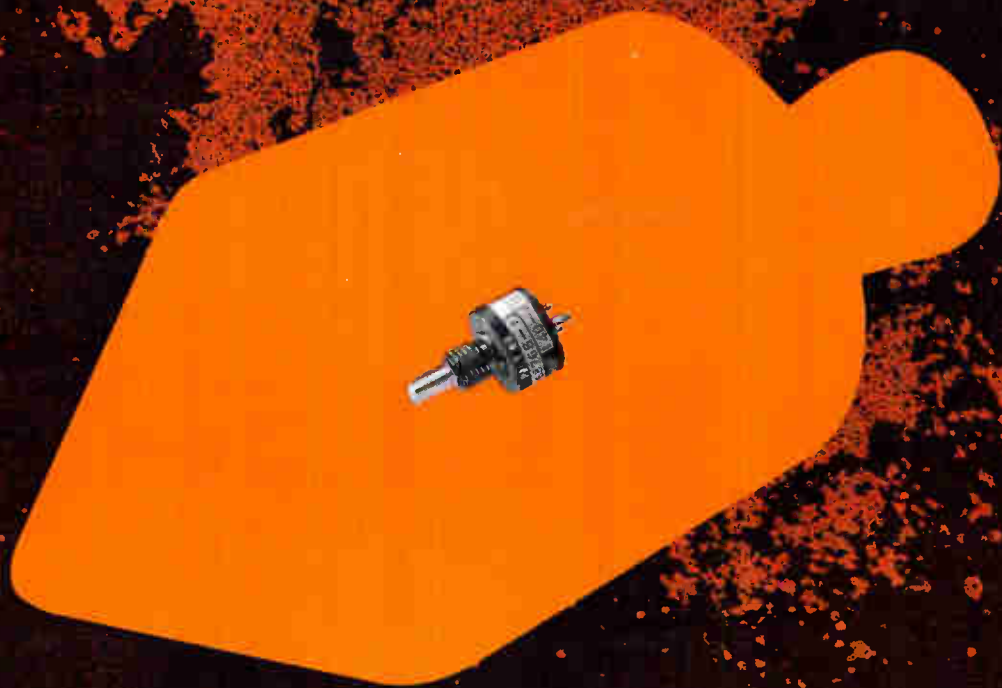

Big systems "go" only when small components do!

That's why for projects like Apollo, NASA hand-picks its primes. That's why each prime hand-picks its subs. And that's why each sub hand-picks the components that go into its NASA equipment. And, in this manned space venture, every link in the "High Reliability" chain must be as strong as modern technology can make it. And that's why "standard" components are usually considered "substandard."

But not so with the "standard" Spectrol Model 140, single-turn, precision potentiometer. Here's a standard component that qualified for Apollo simply "by having its hair combed and its face washed."

True! The only difference between a standard Spectrol Model 140 potentiometer and the high-rel component that Spectrol provides for the Apollo Command Module is a tighter starting

torque band. The rest of the story is told by the rigorous "Quality Assurance Program" established by Spectrol to the stringent Apollo specifications. If you would like an outline of this comprehensive program, write for your copy of the "Spectrol High-Rel Potentiometer Program for Project Apollo." Our experience is our greatest asset—we'd like to share it with you.

Better Components for Better Systems

SPECTROL ELECTRONICS CORPORATION

17070 E. GALE AVENUE, CITY OF INDUSTRY, CALIFORNIA 91745



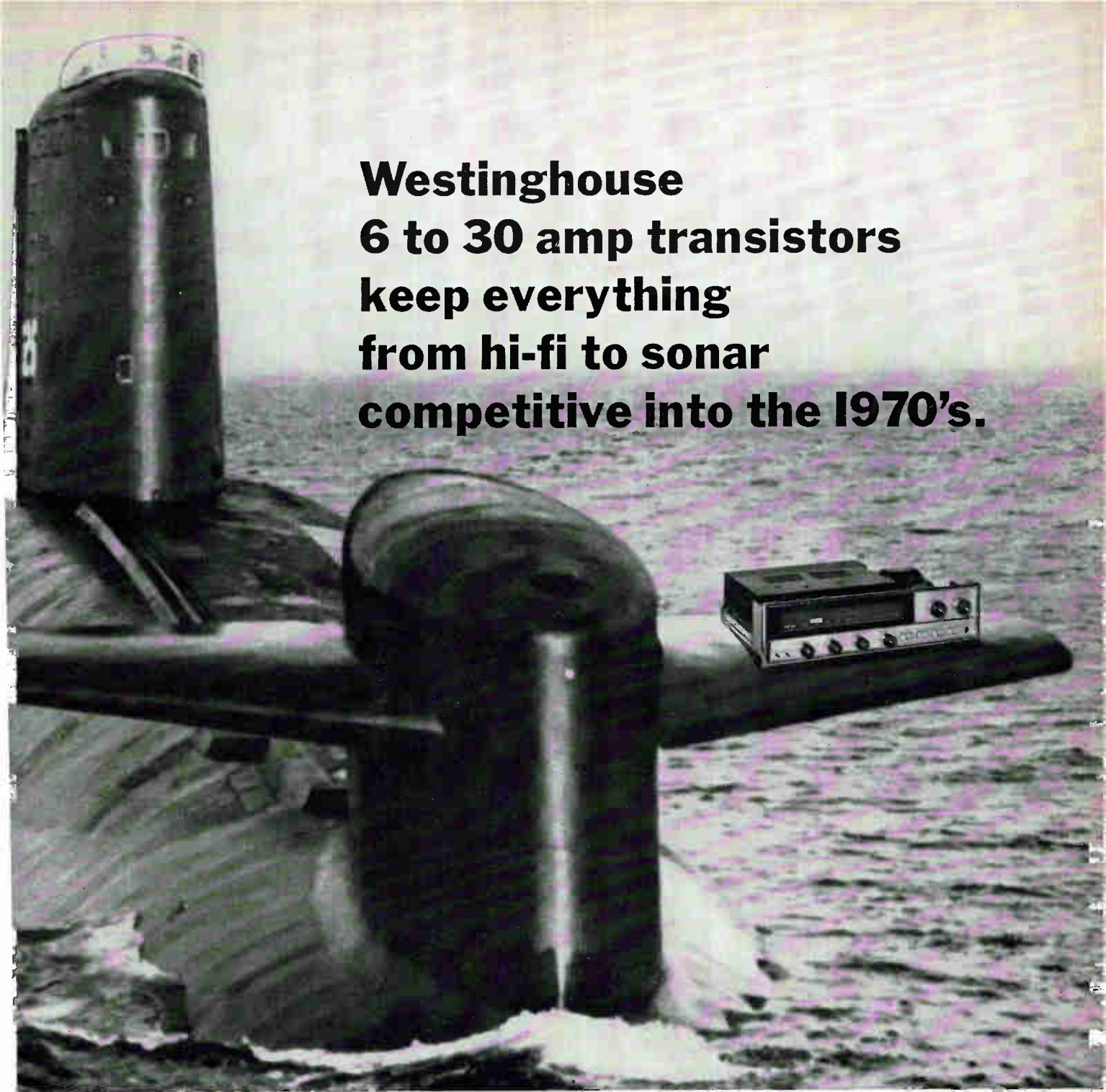

Westinghouse 6 to 30 amp transistors keep everything from hi-fi to sonar competitive into the 1970's.

Look beyond the JEDEC number. Test transistors competitively. Like many of our customers, you'll find that Westinghouse transistors deliver performance bonuses...and at competitive prices.

Peak Power Handling. For example, a manufacturer of hi-fi amplifiers needed transistors that could take the peak power pulses generated by a carelessly-dropped pickup arm. He tested plenty of 2N3055's and chose the Westinghouse product. It solved his problem best. It also offered the exclusive Westinghouse Lifetime Guarantee.

Westinghouse 2N3055 Series transistors feature DC power dissipation ratings to 117 W., V_{CE} from 55 to 140 V., gain from 18 at 3 A. to 20 at 4 A.

Cool-Running Reliability. A sonar manufacturer needed kilowatts of power output with tight Navy performance and

reliability specifications. His solution: Westinghouse's 2N2757 Series Lifetime Guaranteed transistors.

Their low saturation voltage (typical 0.4 V. @ 10 A.), and low thermal impedance (0.5° C. per W.), insure cool running.

This, plus demonstrated freedom from second breakdown, makes them ideal for repetitive switching into inductive loads. Perfect for inverters and regulators as well as sonar amplifiers.

Westinghouse 2N2757 Series transistors feature 250 watt power dissipation capability, V_{CE} from 50 to 250 V., gain from 10 at 10 A. to 10 at 25A.

Broad Line. Between these extremes, Westinghouse has a complete transistor line ranging from military types to plastic-case types. And most have the unique Westinghouse Lifetime Guarantee identified by this symbol ♣ on the case.

Send for our Semiconductor Condensed Catalog now. Meet the transistors, rectifiers, and thyristors for now and 1970. Call your Westinghouse distributor. Or write Westinghouse Semiconductor Division, Youngwood, Pa. 15697.

♣ Westinghouse warrants to the original purchaser that it will correct any defects in workmanship, by repair or replacement f.o.b. factory, for any silicon power semiconductor bearing this symbol ♣ during the life of the equipment in which it is originally installed, provided said device is used within manufacturer's published ratings and applied in accordance with good engineering practice. The foregoing warranty is exclusive and in lieu of all other warranties of quality whether written, oral, or implied (including any warranty of merchantability or fitness for purpose).

You can be sure
if it's Westinghouse



SC 2086



The World's Most Complete Line of...

PRECISION TRIMMER CAPACITORS

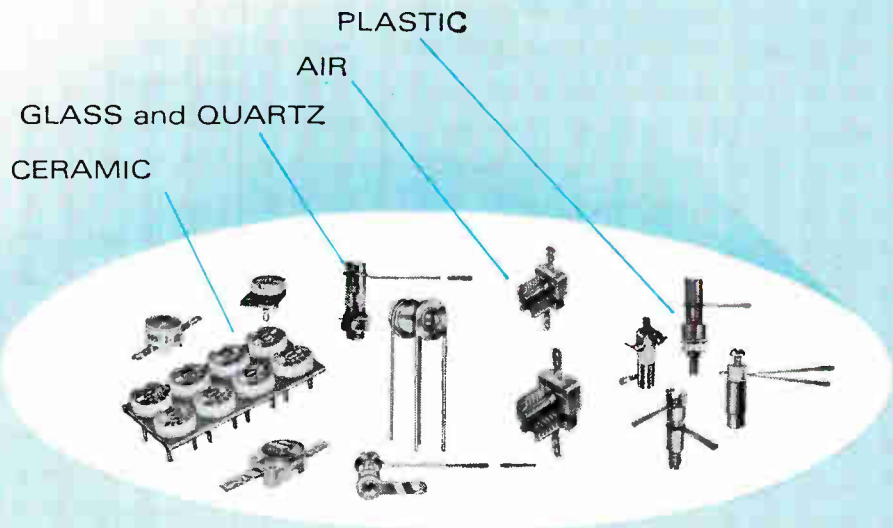

MINIATURIZED ERIE TRIMMER CAPACITORS FOR PRINTED CIRCUIT BOARD... OR PANEL MOUNT APPLICATIONS—MILITARY OR COMMERCIAL TYPES

When knowledgeable engineers discuss quality Precision Trimmer Capacitors... ERIE is the name most often mentioned as the best single-source in the industry.

Today, miniaturized ERIE Trimmer Capacitors are available in a wide selection of dielectrics for virtually any circuit application... Ceramic, Glass, Quartz, Air and Plastic.

For more than 20 years ERIE has earned an enviable reputation for quality components. Quality, however, is a by-product of experience and advanced engineering capability. At ERIE, Precision Trimmer Capacitors are smaller than ever with better than ever quality.

If you have a specific Trimmer Capacitor problem... we suggest ERIE as your one-stop source. One of our standard units will probably fulfill your requirements. If not, our Trimmer Engineering Department will welcome the opportunity to discuss your circuit needs.

Write TODAY for new Precision Trimmer Capacitor catalog.

Another Series of Components in Erie's Project "ACTIVE"
Advanced Components Through Increased Volumetric Efficiency

ERIE

TECHNOLOGICAL

PRODUCTS, INC.



Formerly
Erie Resistor
Corporation

Erie, Pennsylvania

100 μ v resolution auto polarity-display storage overrange digit



[\$595]

The new Hewlett-Packard 3430A Digital Voltmeter is a high-performance utility instrument ideal for production line work, repair or inspection stations, in the lab or for quality control. It offers the highest value available today in terms of price and performance.

- 100 μ v sensitivity for low-level measurements
- Auto polarity
- Non-blinking display, ideal for faster, easier, less vulnerable measurements
- 60% overrange with an extra digit
- Floating measurement with 10 Meg input impedance
- Fast (half second) response
- Analog dc output from amplifier, useful as a 100:1 voltage amplifier
- RATIO measurement option

Nowhere else can you get these extra "luxury" features at such a low cost. High-speed measurement, 100 mv-1000 v, accuracy 0.1% of full scale ± 1 digit, plus the 4th digit for over-ranging. Measure to ± 500 v dc with respect to ground. No worry about circuit loading with the high input impedance. High stability with the voltage accuracy guaranteed to 3 months, one-year warranty on the instrument. The only DVM of its type available with ratio measurement capability, at an accuracy of $\pm 0.15\% \pm 1$ digit. With the ratio option 01 (\$80), you can normalize transducer dc outputs without taking time for recalculation. It offers all polarity combinations. The bonus amplifier output, $\pm 0.1\%$ accuracy, increases testing flexibility.

Call your Hewlett-Packard field engineer for a demonstration or write for complete specifications: Hewlett-Packard, Palo Alto, California 94304, Tel. (415) 326-7000; Europe: 54 Route des Acacias, Geneva.

Data subject to change without notice. Price f.o.b. factory.

HEWLETT  **PACKARD**
An extra measure of quality

1648

Microwave switch is integrated by microstrip

Interconnections printed on a ceramic base and elimination of diode packages improves isolation and raises speed of S-band device

High isolation, fast switching speed and low insertion loss have been achieved by putting an S-band switch and its driver circuit onto ceramic substrates and interconnect components with a microstrip transmission line. Because the assembly is a hybrid integrated circuit, it's also small—about one-sixteenth the size of its predecessor, also made by Microwave Associates, Inc. The company claims it's the first commercially made IC that operates at microwave frequencies.

It has always been difficult to get high isolation and speed with low insertion loss in solid-state microwave switches. With discrete components, parasitic capacitance from the diodes' packages increased the over-all capacitance. The capacitance could be reduced by using several series-connected diodes. But the more numerous the diodes, the higher the insertion loss and the longer the time required to remove the injected charge.

The company solved this circular problem by getting rid of the diode packaging and by using only two diodes, specially made p-i-n chips, mounted directly onto the microstrip transmission line. The resulting circuit switches in 20 nanoseconds, with 50-decibel isolation and 1.75-db insertion loss.

The driver circuit's bipolar signal quickly removes the injected charge in the diodes during turn-off. The importance of the driver's

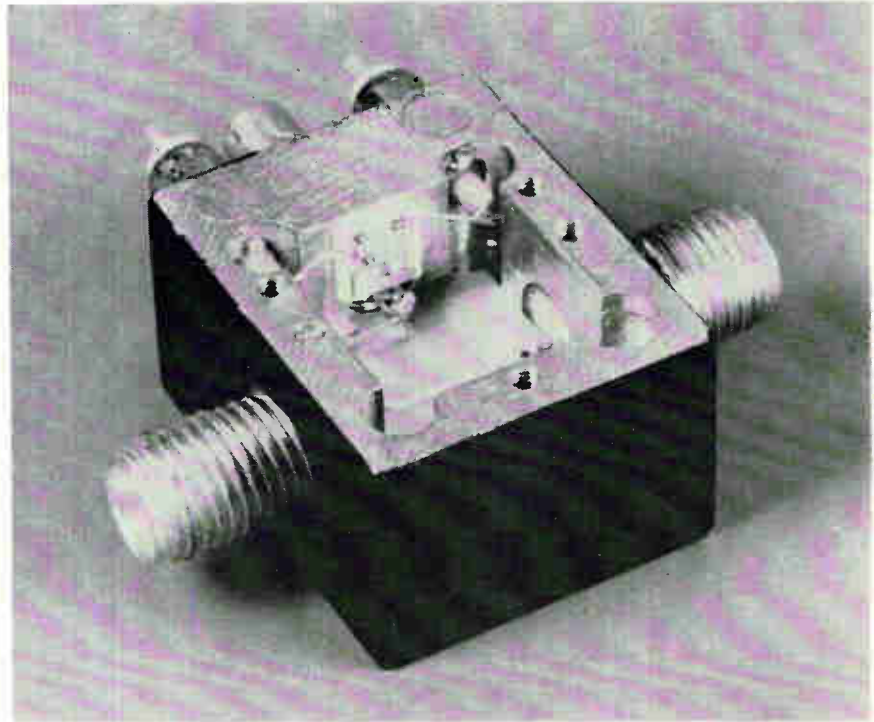

closeness to the diodes is shown by comparison tests. Using the internal driver, the switching speed is nominally 20 nanoseconds (in experimental models, the time has been halved). When the same switch was actuated by an external driver connected by a 10-inch coaxial lead, the best speed possible was 30 to 35 nsec.

One major factor in reducing size stems from the high dielectric constant of the ceramic substrate. Alumina—which has a dielectric constant of close to 9—was chosen.

Specifications

Frequency	S band
Bandwidth	1 Ghz
VSWR	1.5 max.
Isolation	50 db
Insertion loss	1.75 db max.
Switching speed	20 nsec
Power handling	
continuous wave	0.5 watt
peak	25 watts
Size	0.875 x 0.675 x 0.55 in.
Weight	0.5 oz
Price	
with driver	\$375
without driver	\$295
Delivery	60 days

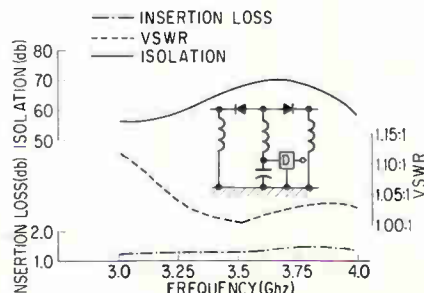
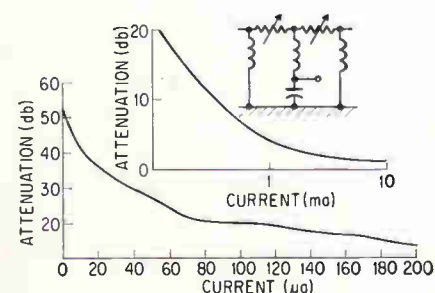

Since wavelength is proportional to the square root of the dielectric constant, the microstrip was trimmed to about one-third the size of one with a conventional dielectric.

The microstrip is formed on the alumina board by depositing a silver circuit pattern and ground plane. When the structure is fired at high temperatures, the resulting bond forms a strong base for soldering and welding the components and leads. Since the microstrip can

In Making Masks for
Electronic Components...
...there's no
Margin for Error!

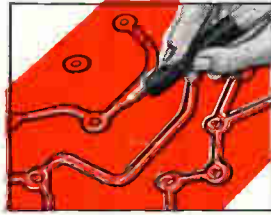

With sharp blade, outline the areas to be masked. Do not cut through the backing sheet. The Ulano Swivel Knife does the job quickly, easily.

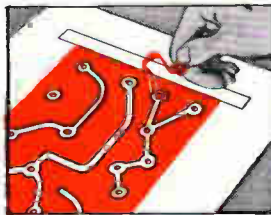

Now carefully peel off the film as outlined leaving a completed photo mask, positive or negative, that corresponds exactly to the desired pattern.

**THAT'S WHY EXPERIENCED DESIGNERS
AND ENGINEERS ALWAYS INSIST ON...**



RUBYLITHTM

HAND-CUT MASKING FILM FOR THE GRAPHIC ARTS

**THE KNIFE-CUT, LIGHT-SAFE MASKING FILM
LAMINATED TO A STABLE POLYESTER BASE**

The most versatile line of hand-cut masking films, including

.0075—RUBYLITH 75 DR* .005 RUBYLITH 5 DR
.005 AMBERLITH 5 DA

These new, thick Ulano films provide the positive answers where exact register assumes a critical importance.

**Available in sheets only, cut to your specifications.*

by

UlanoTM

ulanoTM

610 DEAN STREET, BROOKLYN, N. Y. 11238

NEW YORK • CALIFORNIA • CHICAGO • ZURICH

In Europe: ULANO A. G., Untere Heslibachstrasse 22, Kusnacht 8700, Switzerland

Write on your letterhead for special electronic test kit (no charge) No. 4148

Reel fast delivery of ceramic capacitors . . . the result of Mepeco's automated production techniques

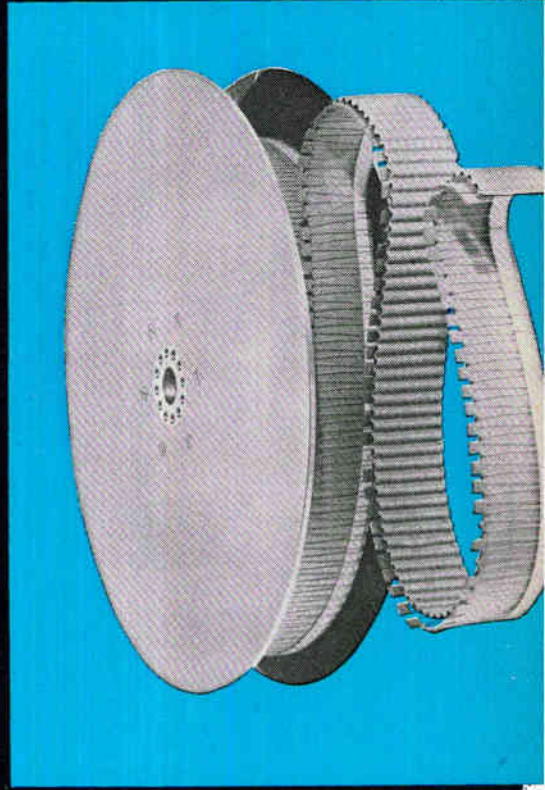
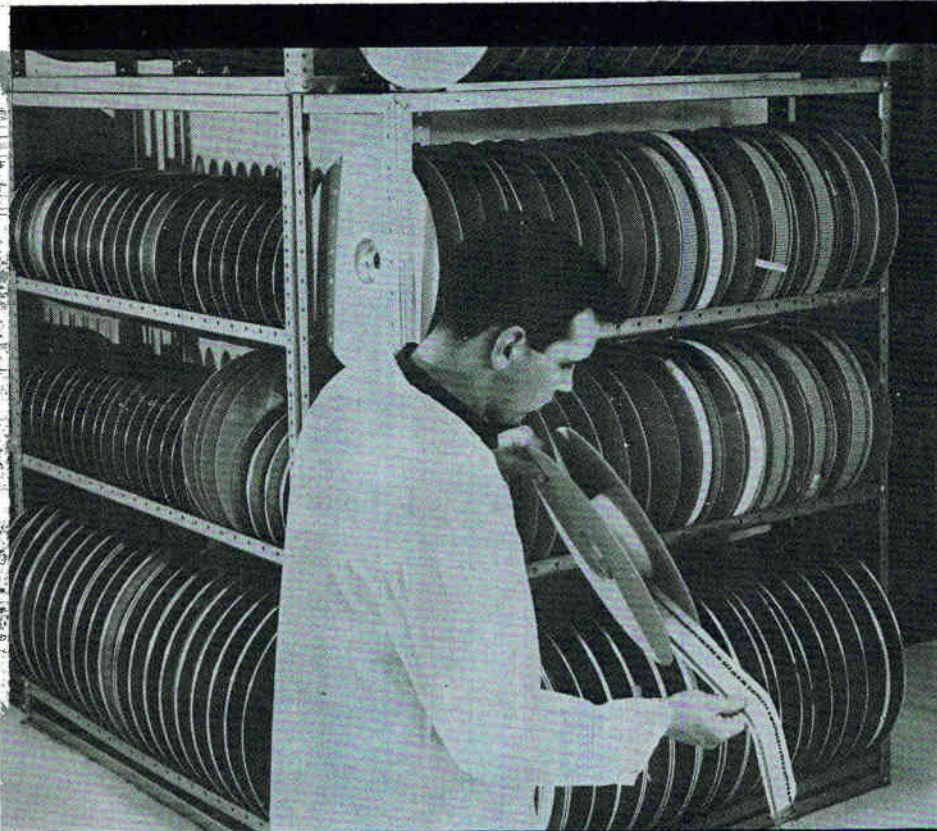

Mepeco's subminiature Ceramic Capacitors meet the standards of military specifications, yet are designed and priced for high-volume industrial-commercial programs.

- Conformal epoxy enclosure offers excellent environmental protection and unusually high body insulation.
- Mepeco's unique, non-migratory electrode system eliminates a major cause of ceramic capacitor failure.
- Delivery weeks ahead of usual industry standards.
- Dimensions as small as .100" x .100".
- Capacity ranges from 2.2 pF to 10,000 pF.

For complete details, call or write today
Mepeco, Inc., Morristown, New Jersey 07960
(201) 539-2000 TWX: 201-538-6709

O.E.M. Sales Offices from Coast to Coast

MEPCO



MANUFACTURERS OF **PRECISION
ELECTRONIC DEVICES**

A Heritage of Reliability



Available from your

NSC
distributor

WESTERN DISTRIBUTORS:

Fortune Electronics
695 Veterans Blvd.
Redwood City, California 94063
(415) 365-4000

Kierulff Electronics
3969 East Bayshore Road
Palo Alto, California 94303
(415) 968-6292

Arco Pacific
Bohamon Drive
Menlo Park, Calif. 94025
(415) 324-1356

Liberty Electronics Corp.
339 South Isis Avenue
Inglewood, California
(213) 678-8111

Spectronics
131 Garnet
Ridgecrest, California 93555
(714) 378-2831

Western Electronic Components
4301 Birch St.
Newport Beach, California
(714) 540-1322
(213) 631-6119

Newark-Denver Electronics Supply
P. O. Box 22045
Denver, Colorado
(303) 757-3351

Pacific Electronics
1336-4 Dillingham Blvd.
Honolulu, Hawaii 96817
817-118

Sterling Electronics, Inc.
1712 Lomas Blvd., N.E.
Albuquerque, New Mexico
(505) 247-2486

Kierulff Electronics
2585 Commerce Way
Los Angeles, California 90022
(213) 685-5511

Ballard Supply Company
3109 Washington Blvd.
Ogden, Utah 84400
(801) 394-5541

Ballard Supply Company
44 East 6th Street, South
Salt Lake City, Utah 84100
(801) 364-6541

Kierulff Electronics
6133 Maynard Ave., S.
Seattle, Wash. 98108
(206) PA 5-1550

Kierulff Electronics
8137 Engineer Road
San Diego, California
(714) 278-2112

New Components

ings in both ends of the shield, and an aluminum bar stock attached to the outer wall perimeters provides the spacing between shields. To simplify tube installation, all lower shield cylinders are cemented in position with epoxies and remaining components are detachable. Shielding qualities are not affected by ordinary shock.

After proper heat treatment of magnetic components, the Netic shield sections are cadmium plated to minimize rusting with no periodic annealing required. The outer shield has a baked wrinkle enamel finish.

Prices, beginning at \$350, depend on complexity and size. Delivery is four to six weeks depending on structural modifications required.

To be exhibited at the IEEE show. Magnetic Shield Division, Perfection Mica Co., 1322 North Elston Ave., Chicago, Ill., 60622. [352]

Vacuum dielectric gives long life to relay



Interrupting resistive power, carrying high r-f currents and withstanding high voltage, are features of the RF1D vacuum relay.

The relay interrupts 1,000 watts of d-c power for over 100,000 operations at a maximum of 1 amp or 2 kv. It also withstands 4 kv peak test voltage and carries r-f currents of 4 amps rms at 16 Mhz. This is

PERMACOR®
powdered iron cores
...unequalled for
design and prompt
delivery!



Illustrated: **TOROIDAL IRON CORES**
available from 1/8" to 2" O.D.

As the largest maker of iron cores in the world, we offer unequalled production and design facilities for any core design problem. AND, we stock a full line of standard cores at all times.

Need the best in cores . . . Plain, Hollow, Threaded, Insert, Tuning, Cup, and Toroidal Iron Cores, Iron Coil Forms, Sleeves, Flexible Magnetic Shielding, Bobbins and special shapes . . . write and find out why we are unequalled.

PERMACOR®

A Division of Radio Cores, Inc.

9540 Tully Ave., Oak Lawn, Ill. 60454
Phone: 312-422-3353

TWO ENGINEERS WITH THE SAME PROGRAMMING PROBLEM

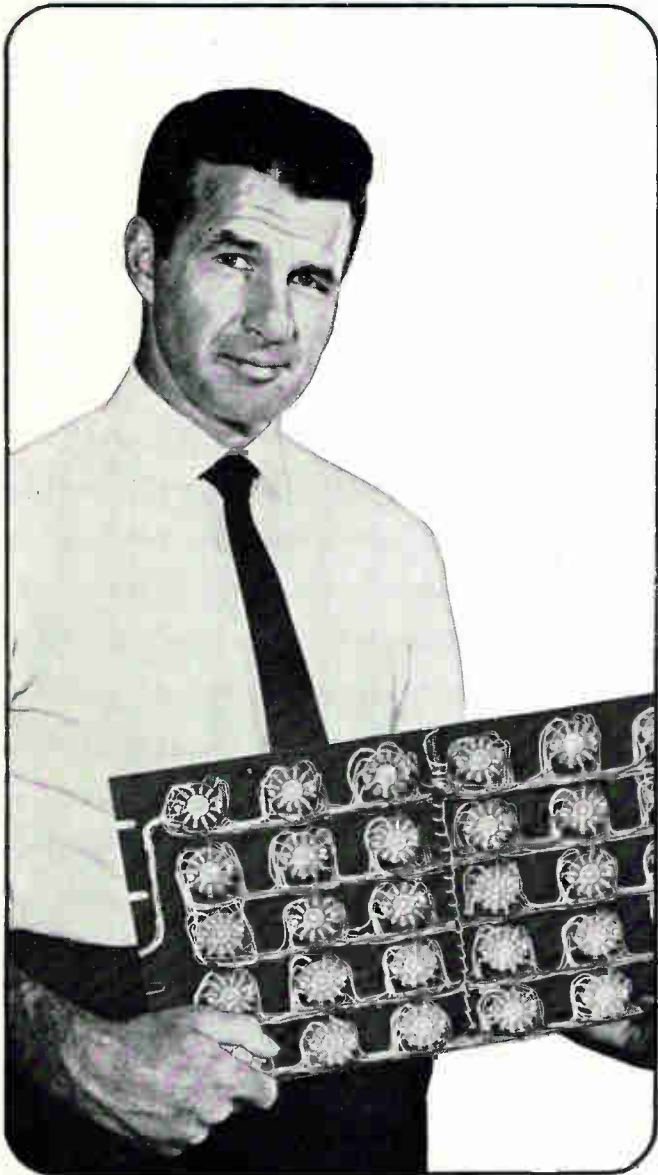

USING ROTARY SWITCHES requires 330 soldered joints . . . over 8 hours of labor . . . occupies 293 square inches of panel space . . . costs \$88.00 installed.
(That's \$0.29 per switching point.)

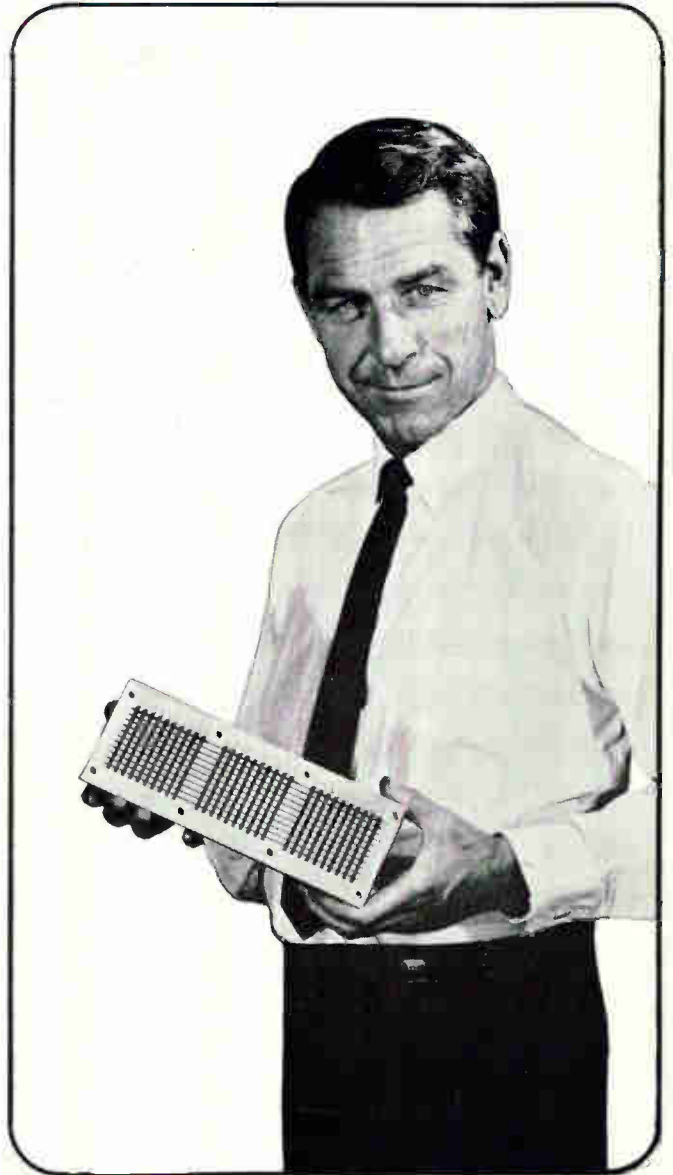

USING CHERRY SELECTOR SWITCH requires no soldering . . . less than 5 minutes of labor . . . occupies 41 square inches of panel space . . . costs \$32.95 installed.
(That's \$0.11 per switching point.)

WHICH ONE WOULD YOU LIKE TO CHECK FOR A MISTAKE IN WIRING?

WRITE TODAY for full details on the totally new Cherry Selector Switch. It may change all your old ideas about programming devices.



CHERRY ELECTRICAL PRODUCTS CORP.

1656 Old Deerfield Road • Highland Park, Illinois 60035

Does AE make the world's prettiest dry-reed switches?

Some of our customers think so. They go for the chic look of our PC Correeds on a printed circuit board.

Our designers are flattered. But they point out that the beauty of a PC Correed is more than skin-deep.

Take the contact leads. We keep them separate from the terminals—to eliminate strain. The terminals themselves have "I-beam" strength. They are longitudinally ribbed for extra rigidity—for easy insertion in PC boards.

The contact terminals are *welded*, not soldered. This makes a better electrical connection.

We filled the plastic bobbins with glass, to prevent moisture absorption. And to boost structural

strength. You can pack these smart-looking switches as densely as you like. Because of their low profiles, magnetic shielding, and standard PC terminal spacing (multiples of 0.200").

PC Correeds are available with 1, 2, 3 and 5 reedcapsules, in contact forms A, B, C and magnetic latching. You can get many of these modules right from stock. So it's easy to put a little beauty in your life.

Want some helpful new design information? Ask your nearest AE representative for Circular 1070-B. Or drop a line to the Director, Electronic Control Equipment Sales, Automatic Electric Company, Northlake, Illinois 60164.



AUTOMATIC ELECTRIC
SUBSIDIARY OF
GENERAL TELEPHONE & ELECTRONICS **GT&E**



How the leading, one-source supplier of Mil-Spec synchros will solve your design problems: by the numbers.

Bendix® Mil-Spec synchros total 107 different synchro models—cover 11 major military specifications—and include nine primary sizes, ranging from the dwarf Size 08 (our most recent addition) to Size 37 (see chart for both).

What the numbers mean to you is simple: you now have a single source of supply for virtually every Mil-Spec synchro you'll ever need—and nearly all the others, just in case.

What the numbers mean to us is simple, too: Bendix Mil-S-20708 synchros are consistently chosen for

use on ground support equipment and navy ships. That's a record we intend to keep.

There's more: a valuable asset

Size	Max. Diameter (In.)	Typical Weight (Oz.)	No. of Models
BuWeps 08	0.750	1.6	3
BuWeps 11	1.062	4.4	10
BuWeps 15	1.437	9	19
BuWeps 18	1.750	17	16
Ordnance 23*	2.250	21	20
BuWeps 23	2.250	31	20
BuWeps 30	2.962	99	2
BuWeps 31	3.100	65	10
BuWeps 37	3.625	124	7

*MIL-S-12472, 16892, 20708, 2335; MS-51080, 51081, 51082, 51083.

called experience. Ours began in the 1920's with the original synchro concept. Since then we've helped develop nearly every major military spec in use. Today, we'll provide everything from Mil-Spec to our famous Autosyn® line to special, custom-made synchros for the unique problem.

What it all boils down to is this: when you need a Mil-Spec synchro (or any other kind), call the leader in synchros at (717) 278-1161. Or write for our 42-pg. catalog. Flight & Engine Instruments Division, Montrose, Pa.

Bendix **Aerospace Products**

1967 Catalog

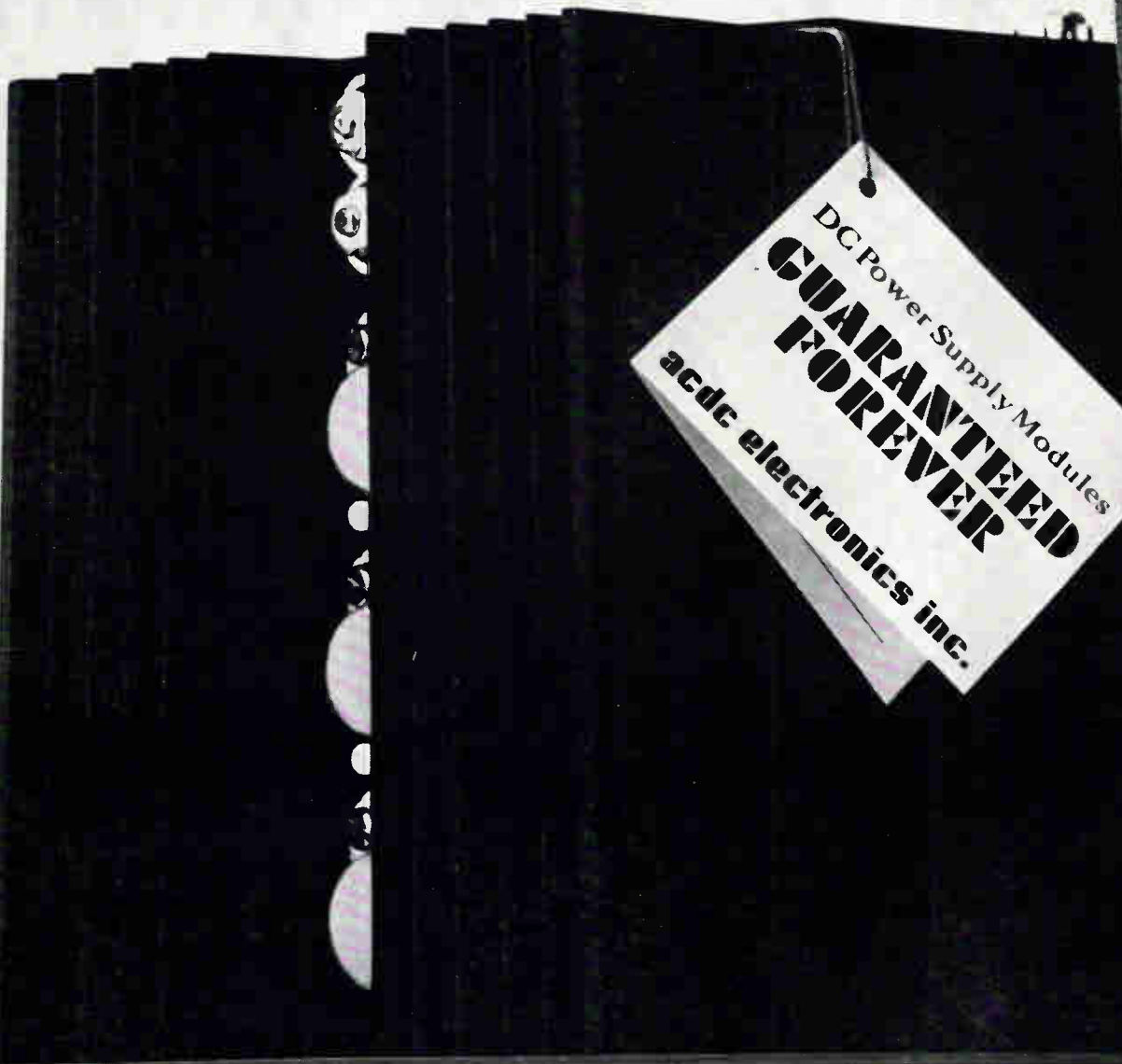

If you'll circle Reader Service #25,
we'll send you one by return mail.



We've got a chip on our shoulder!

Not enough of you know that we are one of the industry's leading manufacturers of high-quality 930 DTL digital integrated circuits. Well, we are.

Who has a larger more modern facility devoted exclusively to the manufacture of these kinds of microcircuits? (We don't dilute our efforts with the manufacture of a thousand other semiconductor components.)

Who has better yields in this DTL line? (Our manufacturing capability is unsur-

passed, and we invite you to inspect it for yourself.)

Who can give you better delivery on these products? (It's pretty hard to beat our immediate delivery!)

Who can offer you better prices? (Try us on a quantity bid.)

Who has a more substantial name behind them than the "Stewart-Warner" name—a name associated with the manufacture of quality products for more than 85 years? (We'll be around to keep you supplied with

microcircuits for years to come.)

Why have we got a chip on our shoulder? Not enough of you have tried our 930 DTL monolithic circuits, and that's too bad. We know you'd like our product, available in all the standard packages. So why not help us take the "chip" off our shoulder and put it in your equipment. Send for our 20-page "Composite Data Book" for the industry's best coverage of the 930 DTL series.

STEWART  WARNER
MICROCIRCUITS, INC.
SUBSIDIARY OF STEWART-WARNER CORPORATION

New Components

or conversely, feeding one signal channel to a large number of outputs.

The switch consists of from one to ten 2-pole wafers with 64 ways per wafer. Information can be accurately fed to computers and data logging instruments, display oscilloscopes or trip level controls at 640 points per second, per wafer. Action is break before make. Scanning speed is 30 to 120 rpm at 50 hz.

Switching contacts and brushes are 0.015 in. 24-K electrodeposited gold to reduce self-generated noise to less than 3 μ v. Disk flatness is controlled to a 4-micron finish and the insulating medium has no effect on contact performance. Each switch wafer is fitted with four printed-circuit edge connectors for input cables. Solder terminals are provided for output cables.

Normal method of connection is by printed socket, but the unit can be modified to meet customer requirements. Synchronization of any number of scanners and random access can be achieved by incorporating a 64-bit binary coded disk and logic module. A mounted 45 v single-phase synchronous motor drive is also available.

Suggested applications include scanning, multiplexing, distributing, sampling, programing, testing, process control, data logging, transducers, thermocouples, strain gauges and telemetering. Electro-Tec Corp., Box 667, Ormond Beach, Fla., 32704. [360]

Metal-ceramic triodes operate at 250 Mhz

The demand for high frequencies and high power in today's dielectric and induction heating equipment has led to the development of a line of metal-ceramic industrial triodes. These units extend the equipment capability to frequencies greater than 160 Mhz without derating; 250 Mhz with derated operation.

Two families of tubes are available: the series 8731, 8732 and 8733 with 5-kw dissipation and the se-

plug-in control / alarm

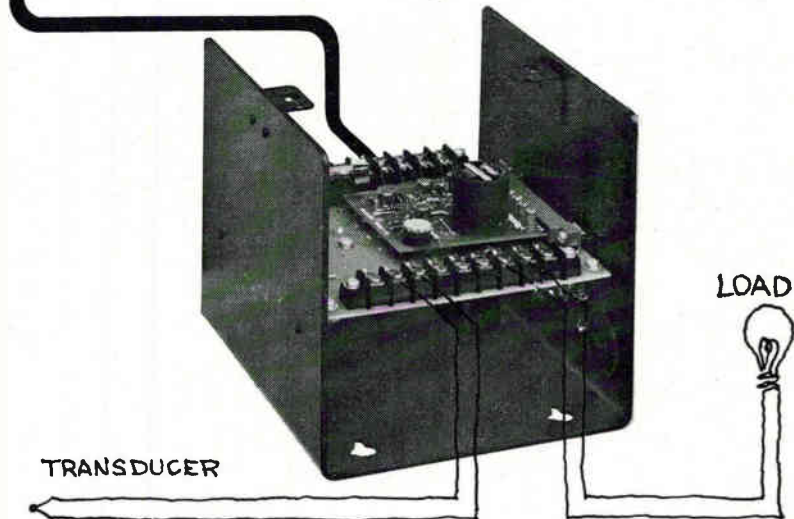

MAGSENSE®

control / alarm for temperature, pressure, speed, flow

Just connect sensor and load to a MAGSENSE Model 101 or 102 and plug the line cord into the nearest AC outlet. That's all there is to accurate, reliable control/alarm of temperature, pressure, speed, position or flow.

Models 101 and 102 are completely assembled control modules with self-contained power supplies and output relays. Each can be used with any of a variety of MAGSENSE comparator boards depending on the type of transducer, load and control/alarm action desired.

MAGSENSE Model 101 provides single point control/alarm, while Model 102 is a dual setpoint and output unit. Set point and hysteresis are easily adjusted internally or remotely. You can specify latching, non-latching or SCR control/alarm action. Non-latching and SCR units have adjustable differential gap and proportional band capabilities.

Solid-state MAGSENSE units have 100-billion power gain permitting actuation *directly* from inputs as low as 1 microamp or 10 microvolts without preamplification.

Continuous overload capability is 1,000 times nominal full-scale input without damage. Trip point is unaffected by common mode voltages as high as 110 VAC, 60 Hz because input is full floating with respect to the output circuit. Models 101 and 102 measure 7 inches long, 6 1/4 inches wide and 6 inches high. Priced from \$136, they're available from stock, of course.

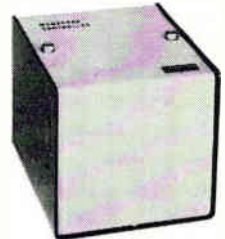

For data sheets or a quote, contact MAGSENSE Sales, Dept. 106, La Jolla Division, Control Data Corporation, 4455 Eastgate Mall, La Jolla, Calif. 92037. For immediate action, phone (714) 453-2500.

LA JOLLA DIVISION

CONTROL DATA

CORPORATION

4455 Eastgate Mall, La Jolla, Calif

advantage of the mesh design is the increase in contact area from the grid to its external connection which results in excellent heat transfer and insures high thermal conductivity. This construction technique limits the possibility of deformation of the grid or cathode during life, thus minimizing the possibility of grid-to-cathode shorts.

Electrode connections with large contact area achieve low thermal resistance between connectors and the tube. This reduces r-f losses and heat at the connection.

Amperex Electronic Corp., Hicksville, L.I., N.Y., 11802. [361]

Phase detector in a square can

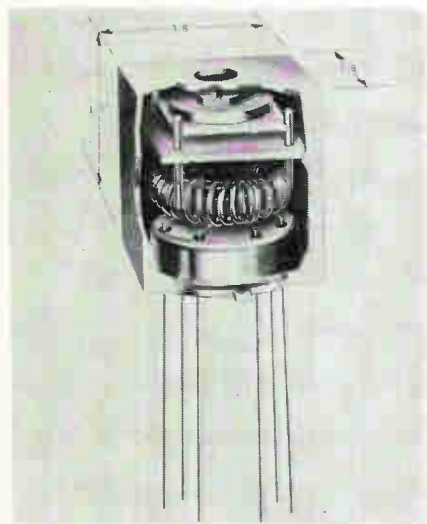

Typical of a line of miniature LC circuits is this phase detector packaged in a square can— $\frac{3}{8}$ in. square and $\frac{1}{2}$ in. high—mounted on a standard 6-pin, TO-5 glass-to-metal-sealed header. A recent application has been in a mono-pulse radar system for weapons control, in which it detects the output phase difference between two 60-Mhz input signals emitted from an i-f amplifier.

Model MTLCJ013 includes a trifilar wound toroidal inductor and a MT320 Modutrim ceramic variable capacitor which is adjustable from the top. The capacitor uses a proprietary ceramic and patented monolithic rotor for extremely high stability (capacitance drift is 0.75% of nominal maximum capacitance). Operating frequency of the

TEMPERATURE HUMIDITY CHAMBERS?

Get proved reliability,
lower prices,
stock delivery—
from Associated



- Temperature range from -100°F to $+350^{\circ}\text{F}$, $\pm 2^{\circ}\text{F}$ control accuracy.
- Humidity range from 20% to 95% RH, $\pm 5\%$ RH.
- Two-pen, two-cam programming and recording controller.
- Stainless steel heliarc welded interior.
- Integral demineralizer with replaceable cartridge.

Here is a complete line of temperature-humidity chambers for testing everything from resistors to rocket motors!

Choose from two basic systems: one offers a two-stage cascade refrigeration system permitting mechanical pull-down to -100°F . The other provides single-stage mechanical refrigeration to 0°F , plus a liquid CO_2 system for pull-down to -100°F .

Both types of units offer dependable, proved-in-use performance. They're the same units used in Associated's own testing laboratories. What's more, they're available for immediate delivery from stock!

Prices start at \$3395. Write today for our complete catalog showing full specifications. Address: Dept. E-3.



**ASSOCIATED TESTING
LABORATORIES, INC.**

200 Route 46, Wayne, New Jersey
(201) 256-2800

Northwest Industrial Park,
Burlington, Mass. • (617) 272-9050

Control Switch announces

First and only pushbutton switches certifiable to MIL-S-8805

All 110 Versions of MIL-S-8805/3 – MS25089

● 7 mounting styles

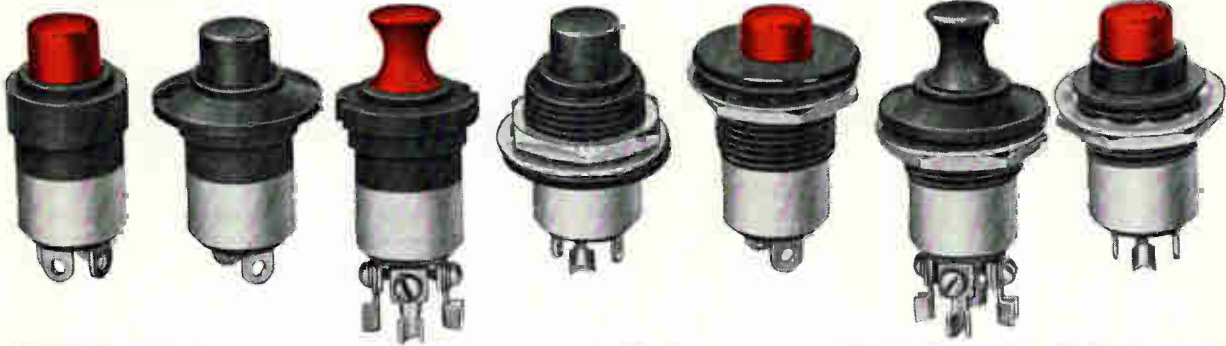

● 5 circuit arrangements

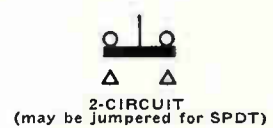
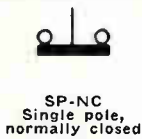

- 2 button colors.
- 2 button styles.
- Momentary or push-pull actions.
- Temperature range: -55°C to 85°C .
- Life: 25,000 operations minimum at rated load.
- Shock: High Impact, momentary types. 50G, all types.
- Vibration: 10 to 500 cps.

This new Series may include the pushbutton switch you need right now for extreme dependability in military or other equipment. Or the switch that breaks a design block, or sparks a new design idea. The specifications speak for themselves!

Series W190 pushbutton switches are another in a spectacular series of firsts from Control

Switch . . . source of the widest selection of high-reliability switches and indicator lights available anywhere. More firsts are coming. Soon! Order Series W190 from your Control Switch distributor, or direct from us.

DETAILED BULLETIN I

Check Number on Reader Service Card corresponding to number at left below for our Bulletin on new Series W190 pushbutton switches. While you're at it, get all the items listed below:

- #483 MIL-S-8805 Bulletin 64
- #484 Condensed Switch Catalog 100
- #485 Basic Snap-Action Switch Catalog 110
- #486 Toggle Catalog 180
- #487 Indicator Light Catalog 120
- #488 Hermetic Switch Catalog 130
- #489 Switchlite Catalog 220
- #490 Pushbutton Catalog 190

**CONTROLS
COMPANY**
OF AMERICA
CONTROL SWITCH DIVISION
1420 Delmar Drive, Folcroft, Pennsylvania 19032
A Subsidiary of
 General Precision Equipment Corp.

Control Switch announces

First and only pushbutton switches certifiable to MIL-S-8805

All 110 Versions of MIL-S-8805/3 - MS25089

● 7 mounting styles

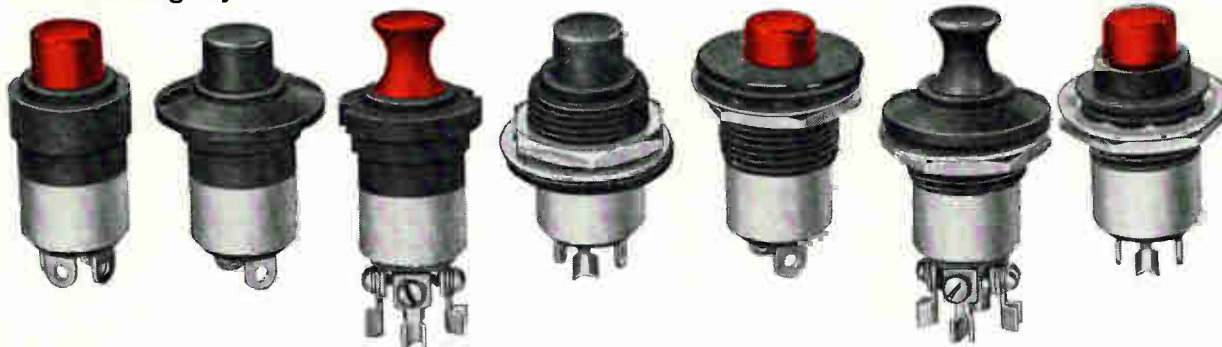

● 5 circuit arrangements



SP-NO
Single pole,
normally open



SP-NC
Single pole,
normally closed



SP-NO 3 Terminal
Single pole, normally open,
three terminal



SP-NC 3 Terminal
Single pole, normally closed,
three terminal



2-CIRCUIT
(may be jumpered for SPDT)

- 2 button colors.
- 2 button styles.
- Momentary or push-pull actions.
- Temperature range: -55°C to 85°C .
- Life: 25,000 operations minimum at rated load.
- Shock: High Impact, momentary types. 50G, all types.
- Vibration: 10 to 500 cps.

This new Series may include the pushbutton switch you need right now for extreme dependability in military or other equipment. Or the switch that breaks a design block, or sparks a new design idea. The specifications speak for themselves!

Series W190 pushbutton switches are another in a spectacular series of firsts from Control

Switch . . . source of the widest selection of high-reliability switches and indicator lights available anywhere. More firsts are coming. Soon! Order Series W190 from your Control Switch distributor, or direct from us.

DETAILED BULLETIN I

Check Number on Reader Service Card corresponding to number at left below for our Bulletin on new Series W190 pushbutton switches. While you're at it, get all the items listed below:

- #483 MIL-S-8805 Bulletin 64
- #484 Condensed Switch Catalog 100
- #485 Basic Snap-Action Switch Catalog 110
- #486 Toggle Catalog 180
- #487 Indicator Light Catalog 120
- #488 Hermetic Switch Catalog 130
- #489 Switchlite Catalog 220
- #490 Pushbutton Catalog 190

 **CONTROLS
COMPANY**
OF AMERICA
CONTROL SWITCH DIVISION
1420 Delmar Drive, Folcroft, Pennsylvania 19032
A Subsidiary of
 General Precision Equipment Corp.

NEW

semi-automatic integrated circuit analyzer

MICA-150

IEEE DEMONSTRATION

During the IEEE Show,
you are cordially invited
to a demonstration of
the MICA-150 IC Analyzer

St. Moritz Hotel
50 Central Park South
Mar. 20-23 From 12 Noon

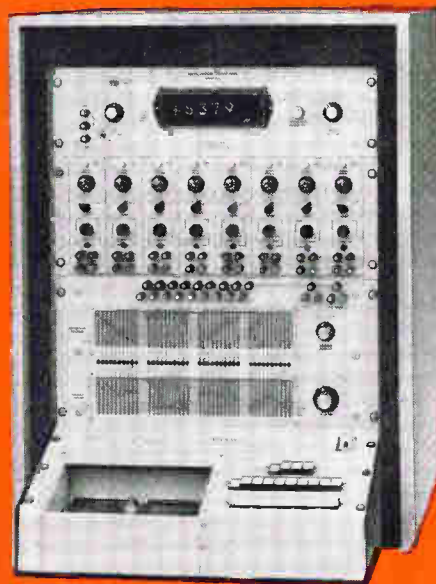

COMPUTER TEST
CORPORATION

Now the integrated circuit user can get all the flexibility and performance of an expensive, large scale IC test system in an accurate and reliable DC bench top analyzer.

The new MICA-150 Modular Integrated Circuit Analyzer tests all IC configurations of up to 40 pins with unique programming, fast pushbutton sequencing and built-in DVM readout.

Fast, Versatile Programming Two independent 10x40 crossbar switches and rapid pushbutton sequencing provide up to 40 tests on a single device without re-programming. For example, it's now quick and easy to check a 10 pin device using four completely different test programs without resetting any switches to advance the test from pin-to-pin or program-to-program. Additional flexibility allows the built-in DVM to measure current on one pin of the device and voltage on another—all pre-programmed.

Universal Test Adapters Through use of universal test adapters, the MICA-150 is designed to check ICs according to the number of pins of a particular package, not device or circuit type. Adapters are available for diode, transistor, TO-5, flat-pack, dual in-line and other package configurations, and can also be provided for Kelvin connections.

Accurate Digital Readout Specifically designed for the MICA-150 analyzer, the built-in Digital Volt/Ammeter has a conservatively rated readout accuracy of 0.1% with a four digit display. Other features include automatic ranging and polarity selection, self-calibration, automatic voltage or current readout selection. Measures currents as low as 1 nanoamp, voltages to 1 mv.

Modular Design Modular construction allows users to select an economical, customized tester without obsolescence problems. Maximum capacity of eight function generators permits later expansion, including modules for AC and pulse testing, without additional modifications.

Variable Soak Time Marginal device operation can be easily detected through use of an adjustable test time control which provides a period for thermal stabilization prior to measurement. A continuous position on the control allows parameters to be varied while observing results.

Precision, Wide Range Power Supplies Highly precise supplies utilize multi-turn calibrated potentiometer controls with high resolution and repeatability. Constant current supplies are continuously variable from 0-100 ma with voltage compliance adjustable to 100v. Constant voltage supplies are variable from 0-100v with automatic current limiting to 100 ma to provide device protection.

QUICK ACTION REPLY

Detailed technical literature on the MICA-150 will be mailed immediately upon receipt of this request.

Attn.: A. Norman Into, Marketing Manager
Computer Test Corporation, Three Computer Drive
Cherry Hill, N.J. 08034 - Phone: (609) 424-2400

Name _____

Company _____

Address _____

City _____ State _____ Zip _____

Circle 275 on reader service card



**People who counteract
countermeasures
count on us.**

A traveling wave tube for a missile to enable it to home on a target despite the most sophisticated countermeasures. That's what the OEM design engineer on the phone needed. His frequency, power output, and gain requirements were way out. Like nothing we had, or anyone else had. And his time schedule was tight.

In two days we'd visited his plant. Reviewed the performance criteria. Committed ourselves. Another seven days and we'd submitted complete tube specifications. And ninety days

later we delivered the first tube. On time and bug-free.

That's how we do business with everyone. We react fast and we know you can't afford false starts. We'll review your technical requirements and if we can't meet them, we'll say so—on the spot. Or we'll take on your job, and stick with it until our tube is working in your system.

If that's how you like to do business, call us. Or write for complete data on our standard TWT's and other types of high-performance tubes: Dept. EL, ITT Electron Tube Division, International Telephone and Telegraph Corporation, P.O. Box 100, Easton, Pennsylvania.

electron tube division

ITT



SEMICONDUCTORS

NEW IDEAS IN APPLICATION AND DESIGN

PROVEN PERFORMER FOR HIGH POWER SWITCHING: GE C500X1 WATER-COOLED SWITCH

Even welding locomotives doesn't tax the high power capability of these SCR's.

For seven months one GE C500X1 water-cooled switch has been in use at a large locomotive plant. It operates at 900 amperes RMS and 480 volts, with an on-time of 1.5 seconds and a 25% duty cycle for resistance welding.

The same plant has been using a second C500X1 for five months and expects to install more of them in the future.

C500X1's are also now in use for automotive welding. Other possible applications include particle accelerator power supplies, primary transformer control, static switching, and control of large lighting loads. (Three C500X1's could theoretically control all the lighting in a 60,000-seat stadium.) The C500X1 is rated at 1200 amps

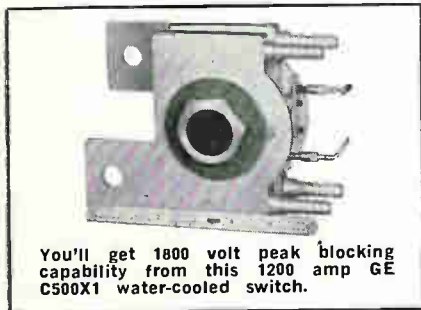

You'll get 1800 volt peak blocking capability from this 1200 amp GE C500X1 water-cooled switch.

RMS with peak blocking capability to 1800 volts in both directions. Surge ratings are 4000 amperes peak for ten cycles and 7000 amperes for one cycle. The device can be used directly in 440 or 550 volt a-c service. Circle number 811.

These are just a few examples of General Electric's total electronic capability. For more information on all GE semiconductor products, call your GE engineer/salesman or distributor. Or write to Section 220-53, General Electric Company, Schenectady, New York. In Canada: Canadian General Electric, 189 Dufferin St., Toronto, Ont. Export: Electronic Components Sales, IGE Export Division, 159 Madison Ave., New York, N.Y., USA.

Lots of new application ideas at GE's IEEE seminars

New application ideas for both standard and exotic semiconductors—ideas that can enhance your solid-state circuitry—will be presented at GE's Semiconductor Products Department IEEE seminars on March 21 at the Barbizon-Plaza Hotel Theater, New York City.

The morning session, titled "Innovations for Industrial Semiconductor Circuits," starts at 9 a.m. and features these subjects and speakers:

The complementary unijunction . . .

Bob Muth discusses new IC fabrication techniques and characteristics of this ultra-stable threshold for timers and oscillators.

Tunnel Diodes revisited . . .

Rick Spofford introduces the first truly low-cost planar tunnel diode.

Opto-electronics . . .

Dick Stasior examines the principles and applications of lasers, light emitting diodes, detectors, light-activated SCR's, and SCS's.

Sophisticated functions using GE's newest plastic semiconductors . . .

Joe Byerly presents some of the new, low-cost circuit approaches now possible with advanced plastic encapsulated semiconductors.

The afternoon seminar (1:30), "Semiconductor Control and Power Conversion Applications," features:

The widening world of the fast recovery rectifier diode . . .

John Hey discusses the unique advantages of fast recovery diodes for both low and high frequency power conversion equipment.

Design/application assistance case histories . . .

Tom Penkalski uses actual cases to illustrate symptoms, analysis, and solutions of semiconductor application problems.

Increased current ratings from PRESS PAK semiconductors . . .

Bernie Jalbert shows how new mounting methods increase power handling capability without increasing pellet size.

Primary phase control of transformer coupled loads . . .

Forest Golden examines trigger circuit and transformer requirements in three phase applications.

Economy control circuits and modules for light industrial and consumer applications . . .

Andy Adem discusses a variety of low-cost reliable motor and temperature controls, and power switching circuit modules.

Low-cost precision power control module using zero-voltage switching . . .

Jim Galloway presents a compact control with 3600 watt capability for a variety of open and closed loop control systems.

You'll also be interested in GE's computer time sharing demonstration. Just feed simple design or specification problems into one of the four consoles at the exhibit and the pre-programmed computer will recommend a solution.

All this and more is waiting for you from GE's Semiconductor Products Department at the IEEE show.

GENERAL  ELECTRIC

The Predictables.

ARIZONA

Phoenix (602) 264-2778

CALIFORNIA

Burlingame (415) 692-2777

El Segundo (714) 772-1437

COLORADO

R. G. Bowen Company, Inc.
Denver (303) 722-4641

FLORIDA

J. F. Griffin & Company
North Palm Beach (305) 848-4617

J. F. Griffin & Company
Sanford (305) 322-2094

ILLINOIS

Chicago (312) 282-4777

MARYLAND

Towson (301) 828-4616

MASSACHUSETTS

Wakefield (617) 245-8350

MINNESOTA

Minneapolis (612) 920-2943

E. C. Electronics
Minneapolis (612) 869-1144

NEW YORK

James Semple Associates
Rochester (716) 342-1413

NEW JERSEY

Clifton (201) 284-2770
South Orange (201) 763-5010

PENNSYLVANIA

Bala Cynwyd (215) 667-4596

OHIO

Electro Com
Cleveland (216) 886-2404

Electro Com
Dayton (513) 278-4797

TEXAS

Dallas (214) 369-3882

UTAH

R. G. Bowen Company, Inc.
Salt Lake City (801) 364-4632

WASHINGTON

Seattle (206) 282-9150

CANADA

Elpro Electronic Sales
Montreal, Quebec (514) 381-8331

Elpro Electronic Sales
Scarborough, Ont. (416) 223-3160

diodes **ITT**

New Semiconductors

are packaged in hermetically sealed metal cases and come in three sizes: TO-46, TO-18 and TO-5. Specifications are essentially identical, except as package size increases, so do average current and power ratings.

The silicon planar passivated construction employed provides long-term parameter stability and inherent reliability. The units are available in anode voltage ratings from 30 to 200 v and feature peak forward currents to 40 amps, maximum trigger currents of 200 μ a, 8- μ sec recovery times, and 0.2- μ sec turn-on times.

The scr's are suited for solenoid or lamp driving, sensing, timing, programing, motor control, and other related high-gain, high-out-put functions.

All are available from stock and are designated as follows: B150 series—TO-46, BA150 series—TO-18, and CD1040 series—TO-5. They are priced at under \$1 in 100-lot quantities.

To be exhibited at the IEEE show. Solid State Products Inc., One Pingree St., Salem, Mass. [367]

High voltage rectifier stacks

Avalanche silicon rectifier stacks can supply 350 ma at voltage ratings varying from 3,000 to 30,000 volts. Type 35-ST stacks have built-in reverse avalanche voltage characteristic at a minimum of 20% or 2,000 v above the rated peak inverse voltage. All rectifier stacks have a built-in short circuit surge capacity of 15 amps for a maximum of 8 msec.

These high-current stacks are made up of hermetically sealed glass diodes encased in Hysol epoxy which has a dielectric strength of 900 v/mil and electrical insulation resistance of 4.3×10^{14} ohms at 30°C.

Prices start at \$2 each for the 3,000-v units in quantities of 100 and run up to \$12.50 each for the 30,000-v units.

Atlantic Semiconductor Inc., a division of Aerological Research Inc., 905 Mattison Ave., Asbury Park, N.J. [368]

The advertisement is a vertical rectangular panel. At the top, there is a large, stylized graphic of a bundle of wires. The word "Simplify" is written in a large, white, cursive font across the wires. Below it, the words "WIRE ASSEMBLY" are printed in a bold, white, sans-serif font. Underneath that, the text "with a" is in a smaller font, followed by "KINGSLEY Wire and Tube Marking Machine" in a large, bold, white, sans-serif font. Below the text is a photograph of the marking machine, which is a complex mechanical device with various rollers and a cutting mechanism. The machine is shown in a dark setting, highlighting its metallic components. Below the photograph, there is a white rectangular box containing text. The text describes the machine's capabilities and provides contact information for Kingsley Machines. At the bottom of the advertisement, the company name "KINGSLEY MACHINES" is printed in a large, bold, white, sans-serif font, followed by the address "850 Cahuenga • Hollywood 38, Calif." and the website "See us at Booth 1G25—IEEE Exhibition".

with a
KINGSLEY
Wire and Tube
Marking Machine

Now you can mark each wire or piece of plastic tubing with its own circuit number... quickly...economically, right in your own plant.

You reduce wire inventories because you need only one color of wire for as many circuits as necessary.

Simplify your assembly methods and speed production with the same machine that has proven so successful in the aircraft and missile field. Write for details.

KINGSLEY MACHINES
850 Cahuenga • Hollywood 38, Calif.

See us at Booth 1G25—IEEE Exhibition

Find your way to Winchester Electronics for the best selection of quality rack and panel connectors.

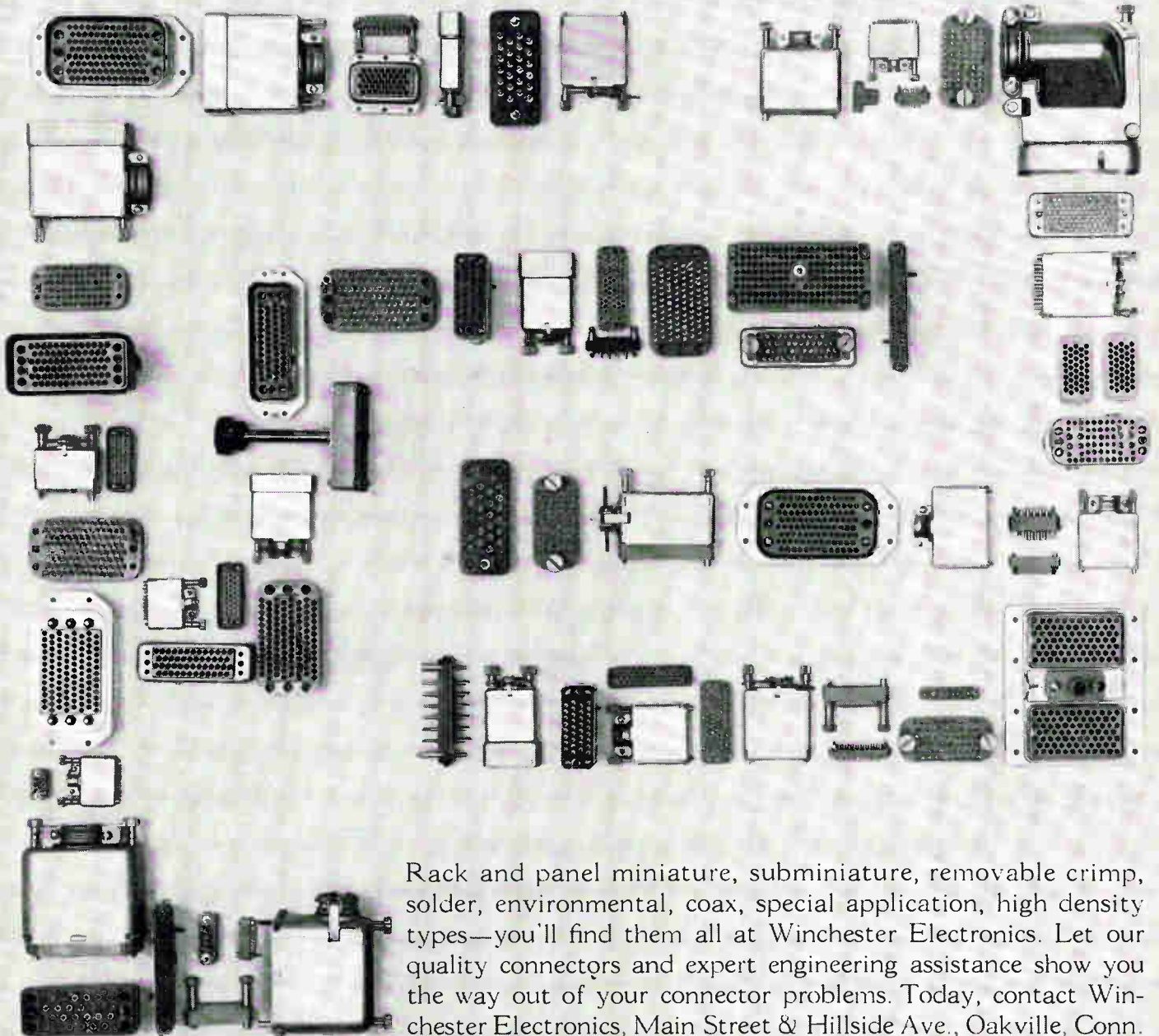

Rack and panel miniature, subminiature, removable crimp, solder, environmental, coax, special application, high density types—you'll find them all at Winchester Electronics. Let our quality connectors and expert engineering assistance show you the way out of your connector problems. Today, contact Winchester Electronics, Main Street & Hillside Ave., Oakville, Conn.

Signal conditioning is a push-in with these input couplers

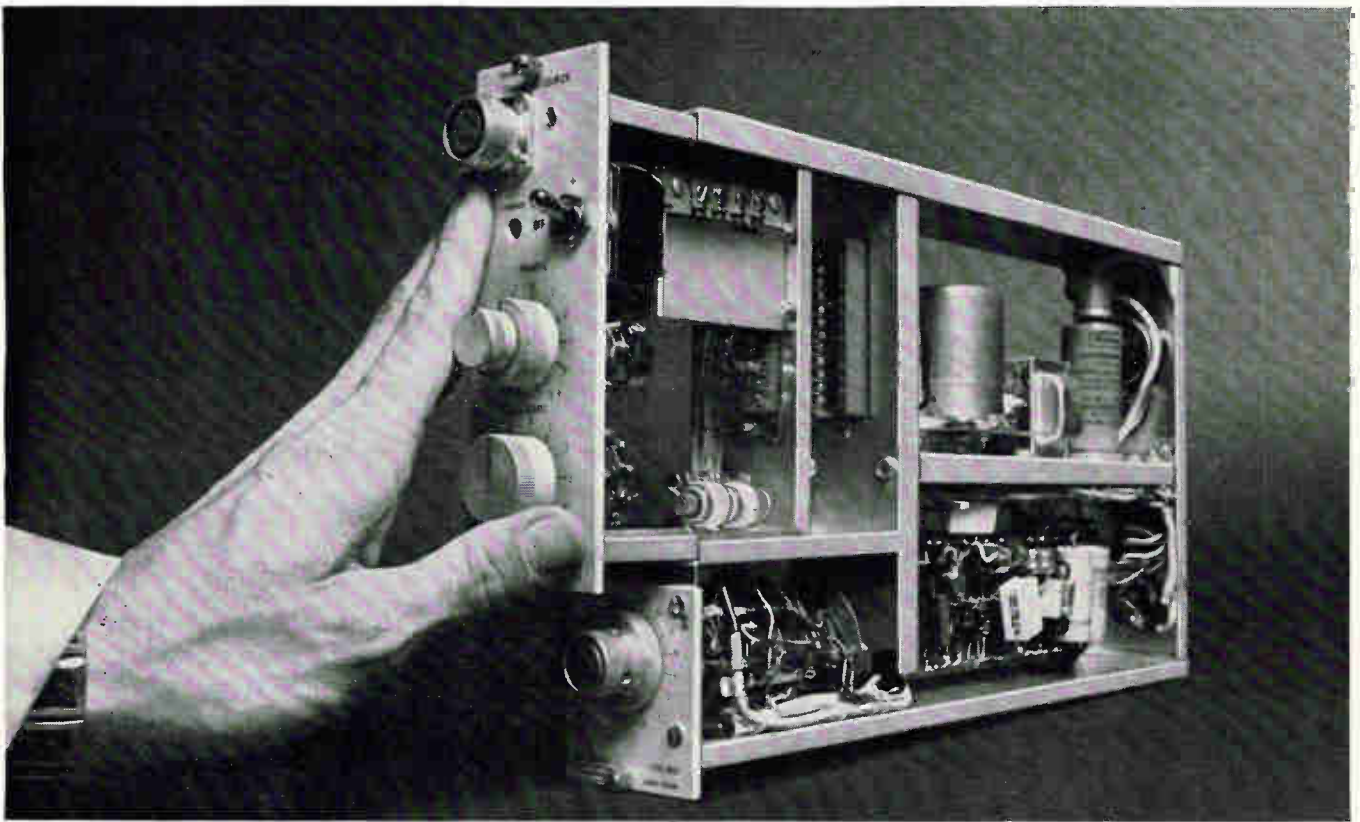
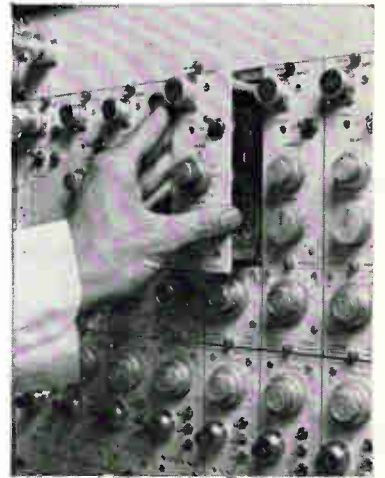

Record directly . . . strain . . . pressure . . . displacement . . . temperature . . . or any other phenomena that can be transduced into an electrical signal. The Beckman 9800 Series Input Couplers (over 30 of them) plug directly into the preamplifier in the Dynograph® Recorder, averting heavy expenditures for specialized amplifier systems when your application needs change.

Low-cost versatility . . . a simple change of couplers adapts the recorder to your particular requirement. They provide all the signal conditioning required for recording, including computation, demodulation, rectification, etc. Additionally, they supply the excitation and calibration signals necessary for many types of transducers . . . such as strain gage and reluctance gage.

Your Dynograph Recorder, with no complicated and expensive amplifier system changes, can readily meet your recording requirements today . . . and tomorrow.

For further information, including application, price and delivery, contact your local Beckman Sales Engineering Representative . . . or write direct.

The Electronic Instruments Division manufactures electronic counters, oscillographic recorders, and systems components.

Beckman®

INSTRUMENTS, INC.

ELECTRONIC INSTRUMENTS DIVISION
SCHILLER PARK, ILLINOIS • 60176

INTERNATIONAL SUBSIDIARIES:
GENEVA; MUNICH; GLENROTHES, SCOTLAND; TOKYO; PARIS; CAPE TOWN; LONDON; MEXICO CITY

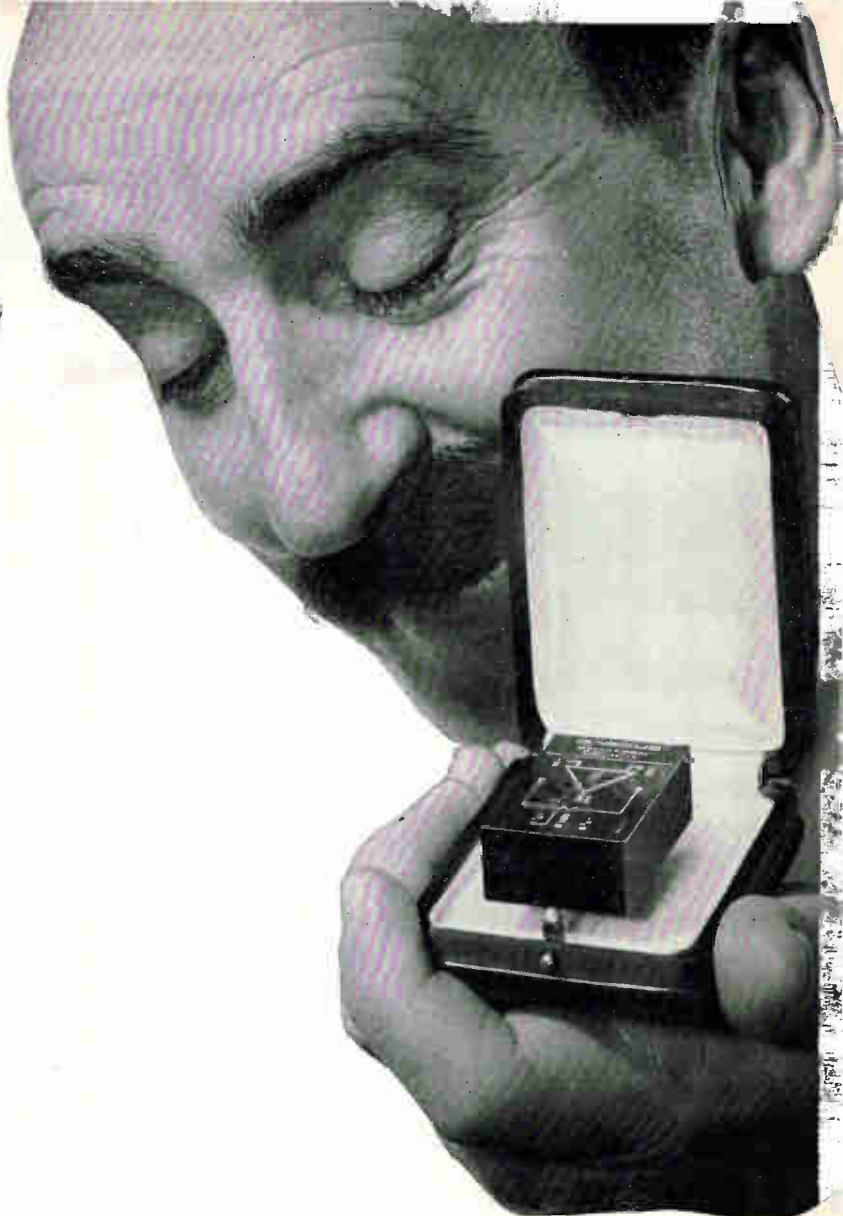

Others make promises...

Why is it that NEXUS can usually deliver operational amplifiers, even when others can't? Mainly because we are set up — from teletype machine to shipping dock — to handle the extra-big orders . . . the special orders . . . the rush orders . . . the extra-small orders . . . as well as routine business. Here's how we do it —



Computerized order processing — An IBM system eliminates paperwork bottlenecks, slow-downs, and human error. Your order is normally processed and

in the works within minutes after we receive it.



Automated production — A completely automated line permits fast, error-free assembly of large production orders — fast change-over for special orders.



Large stocks of standards — Complete

Nexus delivers

inventories of standard Nexus models are maintained on the shelf for immediate shipment.

Customer-first policy — Small orders handled promptly . . . partial shipments made when you request it . . . air shipments routine . . .



We stand on our heads to get you what you need, when you need it. Send today for Nexus new short form catalog



NEXUS
RESEARCH LABORATORY, INC.
480 NEPONSET STREET, CANTON, MASS 02021
TEL 16171 828-9000 TWX 16171 828-1022

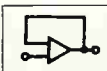

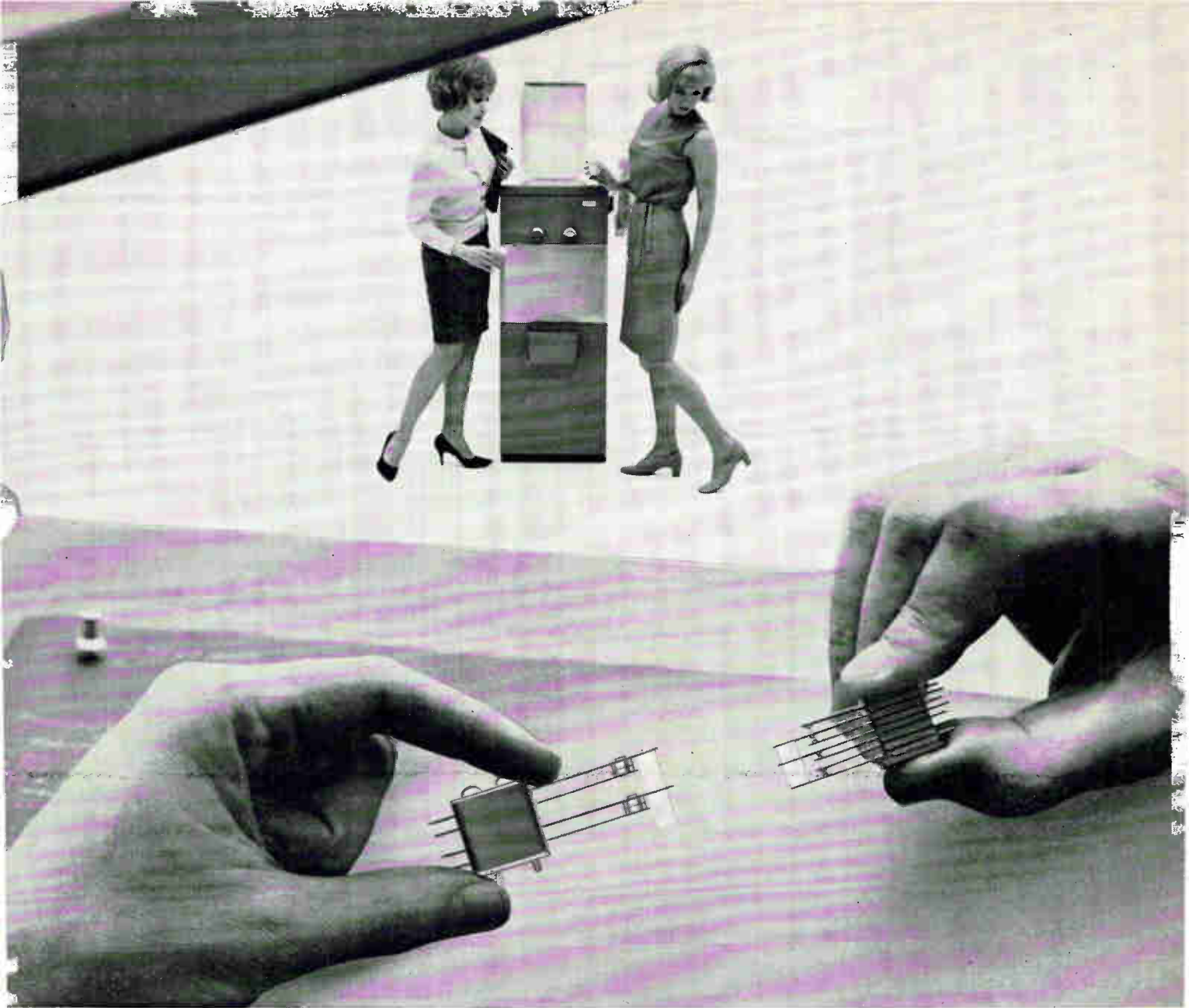

It's time you learned the difference between MOLDED and STACKED

On the one hand, there's the molded switch. And on the other, the stack switch. Both extremely able performers. The stack switch, which is probably more familiar to most people, does the job it was designed to do—and does it well. Perhaps that's why it's always been (and still is) so popular.

Then, about a year ago, something new was added . . . the molded switch—which does everything the stack switch does, and because of its solid, one-piece design, is easier to handle. The molded switch not only saves time on your production line—cutting labor costs and speeding delivery—but it's so well put together that its alignment never wavers. No wonder the molded switch gained enthusiastic acceptance throughout

the industry as soon as it was introduced.

We recently increased our molded switch line so that we now have models available to cover most requests for this type of switch. These switches can be used anywhere conventional-type switches with $\frac{1}{4}$ " or $\frac{3}{8}$ " mounting are now being specified. Models range in amperage from $1\frac{1}{2}$ to $12\frac{1}{2}$, and lifters from $\frac{1}{16}$ " to $\frac{1}{2}$ " can be supplied. A snap-on lifter is available for special applications.

We'd like you to see the difference in molded switches for yourself. Drop us a line, and we'll send you a free sample plus our new catalog, which gives a complete breakdown of all the contact combinations we currently have available.

After all, seeing is believing.

Be Seeing You at the IEEE

Show, Booth 4E04 and 4E06

GUARDIAN



ELECTRIC

Manufacturing Company • 1550 W. Carroll Avenue, Chicago, Illinois 60607

Circle 289 on reader service card

New Instruments

nas. It is also useful for reflectivity measurements and for gauging phase delay, impedance and insertion loss of microwave components.

In measuring phase with the series 1750, a comparison is made between the phase of a heterodyned 1-khz test signal and the phase of a second 1-khz signal derived from a reference r-f signal at the other input. The 1-khz phase reference can be delayed in steps of 0.1° .

Phase differences are converted to d-c voltages that are then displayed on the meter or are available at the recorder-output terminal. This d-c signal is linearly proportional to the phase delay between the two input signals.

Except for an oscilloscope monitor and a triode cavity local oscil-

lator, all the circuitry in this receiver is transistorized. The new system weighs only 90 pounds, compared with the 500 pounds of Scientific-Atlanta's earlier 1650 series. Except for external mixer circuits to heterodyne to 45 Mhz, the receiver includes all circuits for measuring over the entire band.

To be exhibited at the IEEE show.

Specifications

Frequency range	100 Mhz to 40 Ghz
Typical sensitivity	120 db below a milliwatt at 2 Ghz
Phase resolution	0.1°
Dynamic range	60 decibels
Size	15 x 20 x 22 inches
Weight	Approx. 90 pounds
Cost	Less than \$20,000

Scientific-Atlanta Inc., Box 13654, Atlanta, Ga. 30324 [371]

Sensing envelope delay over extended range

An instrument to measure delay distortion over the entire 30-Khz to 5-Mhz range has heretofore been

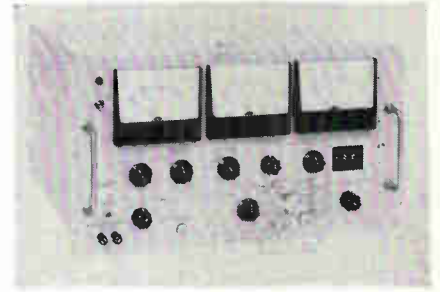

unavailable. Instruments manufactured in Germany cover only portions of the range. Now, a device developed by the Wiltron Co., employs crystal controlled frequency and counter techniques to obtain very stable and accurate time delay measurements. The instrument is specifically designed for delay distortion application.

The unit has crystal controlled reference delays in $10\text{-}\mu\text{sec}$ steps up to $200\ \mu\text{sec}$ for use in offsetting the time delay. This permits precision measurement on a sensitive scale. The most sensitive scale is

Fuseholders of Unquestioned High Quality

TRON SUB-MINIATURE PIGTAIL FUSES

BODY SIZE ONLY
.145 x .300 INCHES

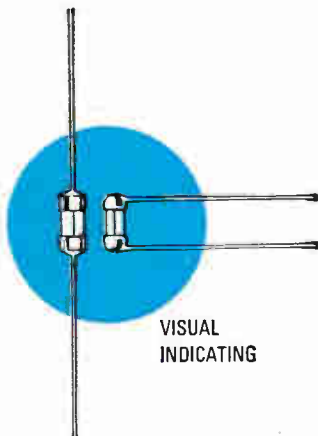

For use on miniaturized devices, or on gigantic space tight multi-circuit electronic devices.

Glass tube construction permits visual inspection of element.

Smallest fuses available with wide ampere range. Twenty-three ampere sizes from 1/100 thru 15 amps.

Hermetically sealed for potting without danger of sealing material affecting operation. Extremely high resistance to shock or vibration. Operate without exterior venting.

Tell us what you need or . . .

Write for Buss Bulletin SFB

INSIST ON **BUSS**
QUALITY

BUSSMANN MFG. DIVISION McGraw-Edison Co., St. Louis, Mo. 63107

Circle 290 on reader service card

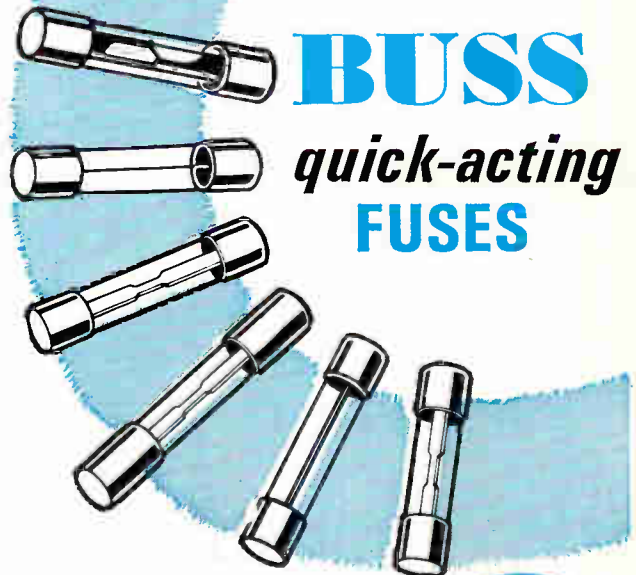

BUSS quick-acting FUSES

"Quick-Acting" fuses for protection of sensitive instruments or delicate apparatus;—or normal acting fuses for protection where circuit is not subject to current transients or surges.

Write for
BUSS
Bulletin SFB

INSIST ON **BUSS**
QUALITY

BUSSMANN MFG. DIVISION, McGraw-Edison Co., ST. LOUIS, MO. 63107

Circle 290 on reader service card

New Instruments

form and \$11.35 for the stainless. Substantial quantity discounts apply. Delivery is from stock.

To be exhibited at the IEEE show. Harrel Inc., 16 Fitch St., E. Norwalk, Conn., 06855. [373]

Relay characteristics measured automatically

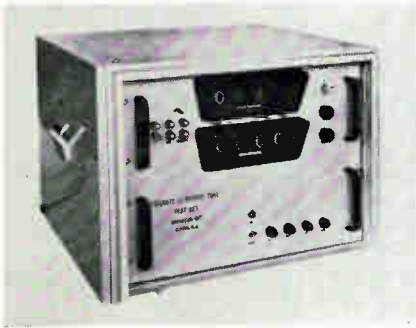

An automatic test set makes possible accurate measurement and visual readout of transfer time and bounce time of electromechanical relays. The equipment offers a clearly visible, in-line decimal readout in milliseconds of operate time (or release time) and bounce on two separate displays.

Operate time is the interval between the application of voltage to the relay coil and the first contact closures; bounce time is the interval from initial contact closure until the final contact closure. Operate times and bounce times from 00.01 msec to 99.99 are measured simultaneously, in one relay cycle. A $\times 10$ multiplier switch increases the maximum time for both measured times by a factor of ten.

The unit's circuitry is all solid state, including power supply, and is housed in a desk-top cabinet. It operates on 115 v a-c power. Panel dimensions are 8 $\frac{3}{4}$ by 19 by 17 in.

To be exhibited at the IEEE show. Datascan Inc., 1111 Paulison Ave., Clifton, N.J., 07013 [374]

Audio oscillator spans wide range

Band switching is not required in an audio oscillator that covers from 10 hz to 50 khz in one turn

Ballantine Announces a New Solid State DC Digital Voltmeter



Model 353

Gives you fast, accurate readings to 0.02% \pm 0.01% f.s. and at a low cost of just \$490

Ballantine's new Model 353 enables you to speed up dc measurements materially over those made on multi-knob differential voltmeters. And with laboratory accuracy from 0 to 1000 volts dc.

It requires just two steps: (1) Set knob to NORMAL mode and read voltage; (2) dial in the first digit in EXPAND mode and read voltage to four places with over-range to five; and, in addition, interpolate to another digit.

Step 1.
NORMAL
Mode
8.342 V



Step 2.
EXPAND
Mode
8.3420 V



The NORMAL mode error becomes submerged by more than ten to one, and the operation is fast and accurate to 0.02% of reading \pm 0.01% f.s. If the input signal is varying, the last digit may be followed visually, thus providing the advantage of analog display.

Example of
"Overrange"
presentation
108.340 V



Note these other interesting features of the new 353: a left-to-right digital readout; an automatic display of "mV" or "V"; proper placement of the decimal point; 10 megohms input resistance; an automatic disabling of the motor during the "expand" dialing; a red light to indicate overrange or wrong polarity; and provision for a foot-operated switch for a "read" or "hold" function.

Write for brochure giving many more details



— Since 1932 —

BALLANTINE LABORATORIES INC.

Boonton, New Jersey

CHECK WITH BALLANTINE FIRST FOR DC AND AC ELECTRONIC VOLTMETERS/AMMETERS/DHMMETERS, REGARDLESS OF YOUR REQUIREMENTS. WE HAVE A LARGE LINE, WITH ADDITIONS EACH YEAR. ALSO AC/DC LINEAR CONVERTERS, AC/DC CALIBRATORS, WIDE BAND AMPLIFIERS, DIRECT-READING CAPACITANCE METERS, AND A LINE OF LABORATORY VOLTAGE STANDARDS FOR 0 TO 1,000 MHZ.

MAGNETIC SHIELDING

**TAILOR MADE...
QUICKLY...BY YOU...**

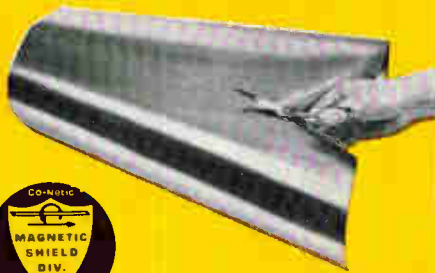

Ideal for initial experimental evaluation. Also for production applications. Eliminate interference in your display or system by wrapping permanently effective Netic Co-Netic Magnetic Shielding Foils around offending components. Presto! No more interference. Easily shaped with ordinary scissors to your outline.

Co-Netic and Netic foils are not significantly affected by dropping, vibration or shock and do not require periodic annealing. High attenuation to weight ratio performance. Available in any required length in thickness from .004" in rolls 4", 15", and 19 3/8" wide.



Foil Performance Evaluation



Spiral Counter
Spiral Cable
Shielding



Adhesive
backed Foil



MAGNETIC SHIELD DIVISION

Perfection Mica Company

1322 N. ELSTON AVENUE, CHICAGO, ILLINOIS 60622

ORIGINATORS OF PERMANENTLY EFFECTIVE NETIC CO-NETIC MAGNETIC SHIELDING

Circle 295 on reader service card

FREE TECHNICAL MICA MANUAL K-6

*gives electrical and physical
data on all types of mica*

No tooling cost on numerous fabricated parts of natural and built-up mica.

Pre-punched insulating wafers to electrically isolate transistors, diodes, etc. from heat sinks.

Corrugated mica to reduce handling and fabrication costs for thermal elements.

All grades of mica offered.

Immediate delivery from stock on many items.

PERFECTION MICA CO.

1322 No. Elston Ave.

Chicago, Illinois 60622

Phone: 312, EV 4-2122

Circle 512 on reader service card

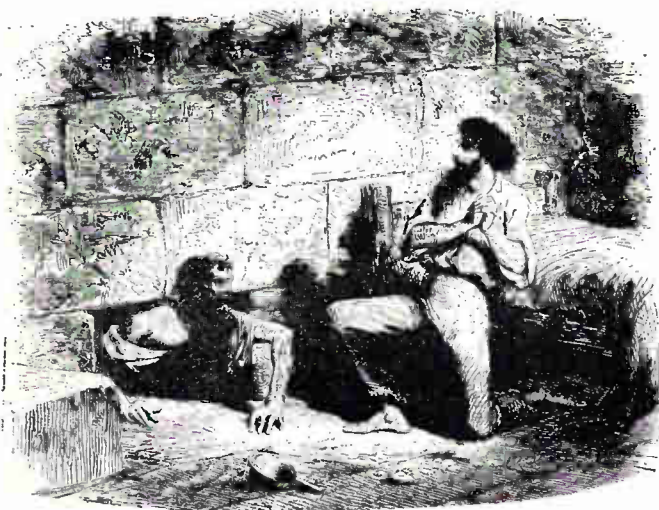

**NO MATTER WHERE
YOU'RE LOCATED . . .
FEDERATED
DELIVERS!**

**MOST COMPLETE ACROSS THE
BOARD INVENTORY OF 
TUBES, SEMICONDUCTORS &
TEST EQUIPMENT!**



FEDERATED PURCHASER INC.

Your broadline distributor for whatever you need . . . whenever you need it! There's a Federated warehouse close to you.

SPRINGFIELD, NEW JERSEY.....	155 U.S. Route 22 (201) 376-8900
SHREWSBURY, NEW JERSEY.....	483 Broad Street (201) 741-8811
ALLENTOWN, PENNSYLVANIA.....	936 Union Boulevard (215) 437-4481
SILVER SPRING, MARYLAND.....	1310 Apple Avenue (301) 588-6830
LOS ANGELES, CALIFORNIA	11820 W. Olympic Blvd. (213) 477-8274 (213) 272-8771

ELECTRICAL DISTRIBUTOR: JOSEPH KURZON, INC. 112 West 31st St., New York, N. Y. 10001

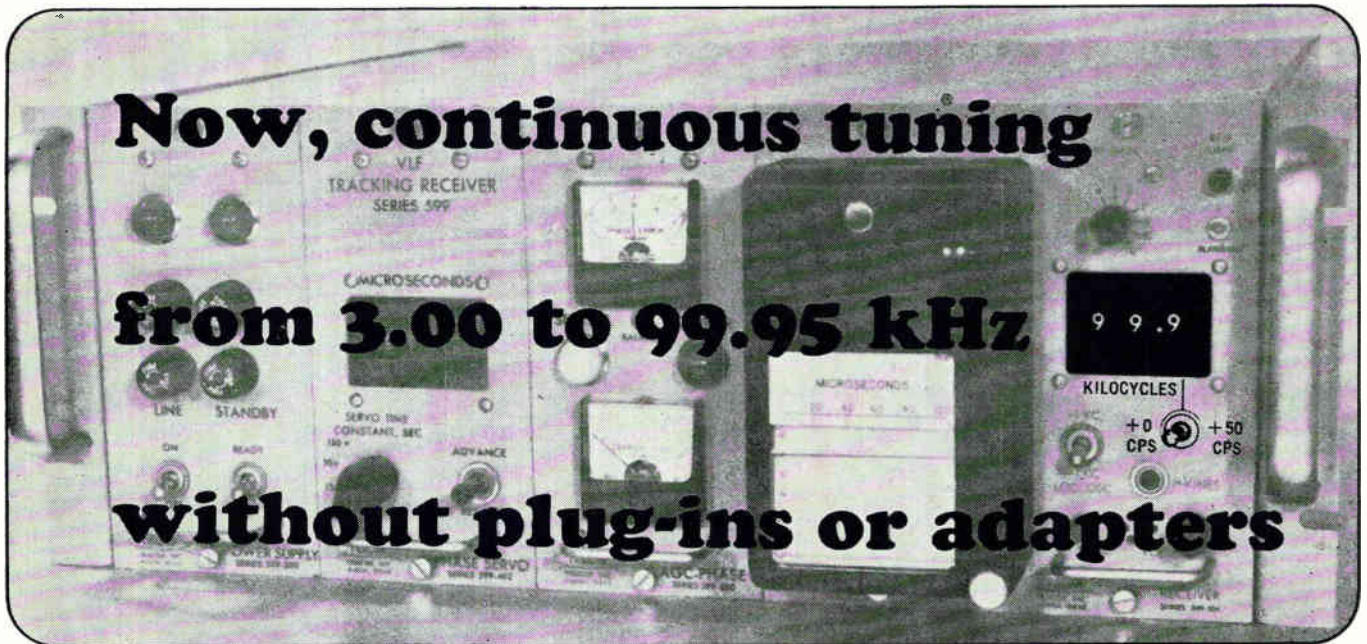

TFA 366A

IN THE NEW TRACOR MODEL 599-J
FULL-FREQUENCY-RANGE
VLF RECEIVER

you'll find these unique features: High image rejection over full tuning range . . . 60 db 3-30 kHz, 50 db 30-99.95 kHz. □ Tuning in 50 Hz increments. □ Tracks even with signal 50 db down in noise in 1kHz band width. □ Standard features include all-electronic servo with non-granular response, easy access via modular construction, and 10 nanovolt sensitivity. □

Full details from: Tracor, Inc.
6500 Tracor Lane □ Austin, Texas
78721 □ AC 512 926-2800

DCF-77
77.5 kHz
Mainflingen,
Germany

JG2AS
40.0 kHz
Kemigawa,
Japan

OMA
50.0 kHz
Podezady,
Czech.

MSF
60.0 kHz
Rugby,
England

WWVB
60.0 kHz
Fort Collins,
Colorado

HBG
75.0 kHz
Prangins,
Switzerland

CYZ-40
80.0 kHz
Ottawa,
Canada

FTA-91
91.15 kHz
St. Andre of
Corcy, France

NOW TRACK WITH ONE RECEIVER THE FULL VLF RANGE

Time & Frequency Instruments by **TRACOR**

REPRESENTATIVES IN PRINCIPAL CITIES

Lockheed's 417.



Lockheed makes the portable portable. At 28 pounds, including its self-contained batteries, the 417 recorder comes in at 50 pounds less than any comparable recorder. And the 417 measures up in more ways than weight. □ It starts off with a price tag as low as \$7000. It operates on 110/220 volts AC/DC, with a power consumption that goes down to 10 watts. It has an exclusive, rugged low-mass differential capstan drive for precision operation under

vibration in any position. It has ph lock servomotor control; a simplified maintenance-free transport mechanism; a frequency response of 100 kc direct to 10 kc FM; and, scaling in at only 14" x 6", it can even fit under an airplane seat. □ We believe the 417 is the most portable recorder on the market. But check it out for yourself. □ Just ask for the Lightweight, one of a family of recorders for undersea, land, air and space applications.

The lightweight.

LOCKHEED ELECTRONICS COMPANY
A Division of Lockheed Aircraft Corporation, Edison, New Jersey

New Subassemblies and Systems

Tape reader-spooler is compact and fast

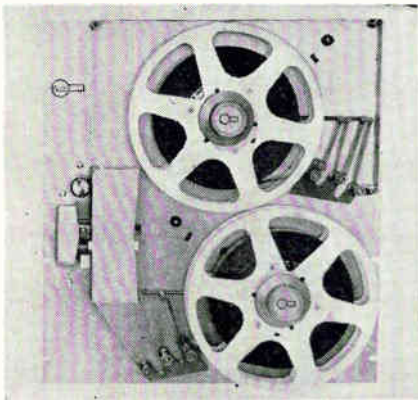

A compact, punched-tape reader and spooler reads 500 characters per second optically, and winds the tape on 10½-inch reels at 50 inches per second. The unit is only 21 inches high.

The all solid state electronics portion is in a common chassis with a choice of output signals available. The reader-spooler operates continuously at 500 characters per second or at any slower speed asynchronously. It is available in both unidirectional and bidirectional configurations and can read tape loops if required.

The spooler portion rewinds in either direction independently at high speed, and has a soft take-up feature that precludes the possibility of breaking the most fragile of paper tapes.

The RRS-502-10½ is priced at \$3,435 in low quantities with substantial discounts available for higher quantities. Deliveries are 10 weeks after receipt of order.

To be exhibited at the IEEE show. Remex Electronics, a unit of Ex-Cell-O Corp., 5250 W. El Segundo Blvd., Hawthorne, Calif., 90250. [378]

Operational amplifier sells for under \$10

Suitable for many noncritical industrial applications, a new general-purpose operational amplifier offers the peak performance among units in its price range. The SD-5

will sell for \$9.75 in quantities of 10 to 99.

This encapsulated unit avoids the need for external components. It is fully protected for input overdrive and indefinite short circuit to ground. Stability with a variety of feedback elements is insured by internal compensation for a controlled -6 db/octave gain bandwidth roll-off.

Typical performance of the SD-5 (at 25°C) includes a supply voltage of ± 15 v; output, ± 10 v at 2.2 ma; open loop d-c gain, 10,000; offset voltage change, $30 \mu\text{v}/^\circ\text{C}$; offset current change, $1.5 \text{ na}/^\circ\text{C}$; input offset current, 200 na; frequency limit for full output, 20 khz; unity gain crossover frequency, 1.5 Mhz; common mode input im-

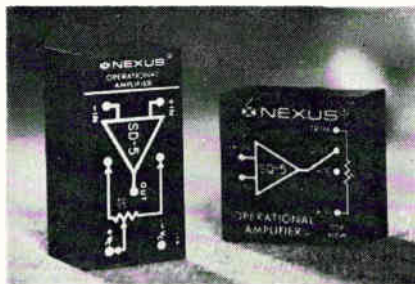

pedance, 20 megohms; differential input impedance, 200 kilohms. The unit measures 1.55 in. long, 0.78 in. wide and 0.60 in. high.

To be exhibited at the IEEE show. Nexon Research Laboratory Inc., 480 Neponset St., Canton, Mass., 02021. [379]

Tiny circuit breaker protects power supply

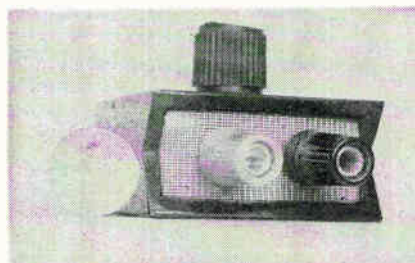

A solid state circuit breaker smaller than a pack of cigarettes provides high speed overload protection for

digital systems

opportunities at NCR electronics division in los angeles

- PROJECT ENGINEERS
 - Computing Systems
 - Peripheral Equipment
 - Discs & Controllers
 - Packaging
- CIRCUIT DESIGN ENGINEERS
- ELECTRICAL & MECHANICAL LIAISON ENGINEERS
- PACKAGING ENGINEERS (ALL LEVELS)
- MECHANICAL DEVELOPMENT ENGINEER
- RELIABILITY ENGINEERS
- QUALITY CONTROL ENGINEERS
- PROCESS ENGINEER—ELECTRONIC
- LOGIC DESIGN ENGINEERS
- MEMORY DESIGN—RESEARCH
- MECHANISMS SPECIALIST—Ph.D.
- MECHANICAL/OPTICS DESIGN ENGINEER
- SYSTEMS FORMULATION & ANALYSIS ENGINEERS

For assignments in commercial on-line computer applications with emphasis on communications interface. Extensive experience required in hardware specifications and advanced systems, including multiprogramming and list processing. Requires B.S. in engineering, business or related field.

- SOFTWARE PROGRAMMER
- DIAGNOSTIC PROGRAMMER

FOR A CONFIDENTIAL INTERVIEW...

For an interview at the IEEE Convention in New York, the SJCC in Atlantic City, or in your area, fill out and send in the postage-paid card at the left. If card has been removed, send a resume to Bill Holloway, Technical Placement, at the address below or call him during the IEEE Convention in New York at the convention headquarters hotel, 765-9158.

The National Cash Register Company



ELECTRONICS DIVISION
2816 W. El Segundo Blvd., Hawthorne,
Calif. 90250 ☐ Phone (213) 777-7346
An equal-opportunity employer

open-loop gain of 140,000.

The ADO-29 economy version (\$45) of the hybrid amplifiers has 25 $\mu\text{V}/^\circ\text{C}$ drift, a gain of 140,000, and the 10^{12} -ohm input impedance.

Price of the ADO-26 is \$98; and the ADO-27 is \$70 in quantities of 1 to 9.

To be exhibited at the IEEE show. Fairchild Instrumentation, a division of Fairchild Camera & Instrument Corp., 475 Ellis St., Mountain View, Calif., 94040. [381]

Programmable attenuator is light & dependable



Intended for incorporation into sophisticated test and communications assemblies, a programmable attenuator weighs only 12 lbs and measures 7 $\frac{3}{4}$ x 5 $\frac{1}{2}$ x 10 $\frac{1}{2}$ in.

Model 2163/1M2 covers d-c to 1 Ghz, accepts 1-2-4-8 binary coded decimals, and has a range of 139 db in 1-db steps. Accuracy at 1 khz is $\pm 0.5\%$, ± 0.1 db to 120 db; at 1 Ghz it is $\pm 1\%$, ± 0.2 db to 100 db.

Setting speed is less than 100 msec and at no time during switching is the attenuation less than the initial or final programmed value. High reliability is achieved since the only moving parts are a number of solenoid-microswitch assemblies having a maximum displacement of 0.015 in.

To be exhibited at the IEEE show. Marconi Instruments, 111 Cedar Lane, Englewood, N.J., 07631. [382]

Operational amplifier in minute package

The incorporation of thin-film hybrid circuitry has resulted in a



PORTABLE



RACK MOUNT — HORIZONTAL OR VERTICAL

\$3200⁰⁰ EACH



COMPLETE!

DIGITAL STEPPING RECORDER

STORE

DATA AT ANY RATE — A CHOICE OF 0-200 CPS OR OPTIONAL TO 1500 CPS

READ

ON ANY IBM COMPATIBLE TRANSPORT

GENERATES FULLY COMPATIBLE IBM TAPE AUTOMATICALLY!

- Choice of 200 or optional 556 bits per inch
- Standard IBM type 10 $\frac{1}{2}$ " reels, $\frac{1}{2}$ " tape
- 7 track standard spacing
- $\frac{3}{4}$ " inter record gap with longitudinal check character
- Lateral parity selectable — odd or even
- Binary Zero to BCD 10 Converter

DDC DIGITAL STEPPING RECORDERS
DIGITAL DATA HANDLING EQUIPMENT

DIGI-DATA CORPORATION

Main Office: 4315 Baltimore Ave. • Bladensburg, Md. 20710 • (301) 277-9378

Circle 514 on reader service card

ACHIEVEMENT

Monday through Thursday
MARCH 20-23 1967
In Electrical Electronics Engineering

IEEE '67 CONVENTION & EXHIBITION

EXHIBITS
NEW YORK COLISEUM
TECHNICAL SESSIONS
NEW YORK HILTON

74 Technical Sessions at the New York Hilton. Hours: Mon. 9:30-12:00 a.m.; 2:00-4:30 p.m. — other days 9:00-11:30 a.m.; 2:00-4:30 p.m.

FOUR COMPLETE FLOORS OF EXHIBITS at the New York Coliseum including over 700 firms. Hours: 10 a.m.-8 p.m. 4 Days.

Gala Annual Banquet — Wednesday 7:15 p.m. New York Hilton Grand Ballroom — \$15.00

Free shuttle busses between the Hilton and the Coliseum — every few minutes.

Registration — IEEE Members \$2.00 Non-members \$5.00 Ladies \$1.00 High School Students \$2.00 if accompanied by an adult. One student per adult Monday through Wednesday. Thursday only — limit of 3 students per adult. Good for all days — Technical Sessions and exhibits. In and out privileges.

Look for the world's premier of the Murata's remarkable new high frequency ceramic filters for use in IC TVs at IEEE Show, Booth 3B31.

Murata will display the new ceramic filters for IC TV use for the first time in the history. Murata's chief engineers from Tokyo will be in person at the Booth to help you design IC TV circuitry with ceramic filters that replace the conventional IFTs.

Don't forget to visit Booth 3B31 when you are at IEEE Show. It's worth a visit.

Other Murata ceramic filters available today for radio use are:

- **Ladder type** ceramic filter CF-455 and CF-455P (popular type) are ideal for IF stages of high quality super-heterodyne radio receivers.

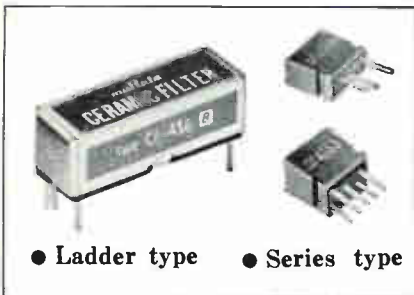

● Ladder type ● Series type

- **Series type** (model SF-455) is a standard type of 455KC filter. It replaces the transistor radio's IFT or makes a intermediate frequency amplifier in combination with IFT.
- **Model BF-455A** improves the selectivity of transistor radios when used as an emitter by-pass in transistor I-F stages.
- **Model SF-262.5** is ideal for car radios.

Request today for the latest technical bulletins for complete specifications and selectivity curves for each stock model.



Murata Manufacturing Company
Nagaokacho, Kyoto, Japan.
Cable: MURATA KYOTO
In the United States:
Murata Corp. of America,
440 Park Avenue South, New York, N.Y. 10016.
Phone: (Area 212) 686-2510.

velope regulation, margin-checking, turn-on and turn-off sequencing, and remote sensing. Also provided are automatic current limiting, interlocks, and high pulse load capabilities.

All control components are mounted on two printed wiring boards that are removable through the rear panel. Designed for 19-in. rack mounting, the compact supply has a panel height of 7¼ in. and is 7½ in. deep.

Total power output is 312 watts, and the supply uses system air flow for cooling.

Advanced Development Corp., 2014 W. 139th St., Gardena, Calif., 90249. [384]

Amplifier-demodulator for control systems



A miniature, solid state a-c amplifier-demodulator performs in extreme operational environments with the accuracy of laboratory-type instruments. It weighs less than 6 oz and occupies only 2.5 cu in. The unit operates either as an a-c to d-c converter or as a phase-sensitive synchronous detector for gyros, synchros, and linear variable differential transformers.

Providing a high input impedance and low output impedance, with input, output, and power supply isolated, the unit converts phase-sensitive, suppressed-carrier a-c input signals into a linearly proportional bipolar d-c output signal.

Typically incorporated in control and instrumentation system applications, the unit can operate f-m subcarrier oscillators, meters, or recorders. The unit, D6076, also can serve as a linear differential d-c current drive for an integrating

**knot
it
twist
it
bend
it**

**HYGRADE[®]
VF
Fiberglass Sleeving**

can take it! It's a tough and extremely flexible insulating material. This Class B insulation combines the advantages of an inorganic fiberglass base with a heat resistant, tough, flexible plastic insulation. It provides excellent electrical characteristics, chemical resistance, heat stability, abrasion and cut-through resistance. Hygrade VF is recommended for continuous operation at temperatures up to 130°C. Write for samples, data and prices.



L. FRANK MARKEL & SONS
Norristown, Pennsylvania 19404
INSULATING TUBINGS AND SLEEVINGS
HIGH TEMPERATURE WIRE AND CABLE

injection of precise calibration signals. Available modifications include controlled high- and low-frequency rolloffs; remote switching of gain and low-frequency rolloff and power output stages for driving very long lines.

Ithaco Inc., 413 Taughanock Blvd., Ithaca, N.Y., 14850. [386]

Operational amplifier develops low voltage

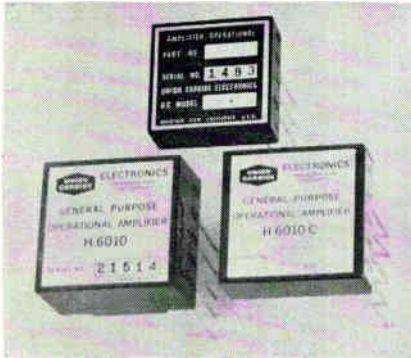

Low voltage and low current drift are offered in a general purpose operational amplifier. Type H6020 develops less than $5 \mu\text{V}/^\circ\text{C}$ and $0.5 \text{ na}/^\circ\text{C}$ of voltage and current drift respectively.

Bandwidth is greater than 5 Mhz; common mode rejection ratio, greater than 80 db; and input wideband noise, less than $5 \mu\text{V}$ rms. The output is $\pm 10 \text{ v}$ at $\pm 2 \text{ ma}$.

The amplifier is available in three modular packages, the smallest measuring $1 \times 1 \times 2/5$ in. Price, in quantities of 1 to 4, is \$45.

Union Carbide Electronics, 365 Middlefield Road, Mountain View, Calif., 94040. [387]

Block tape readers improve programing

Photoblock punched tape readers can now be supplied with silicon latching output circuits. Block tape readers sense up to 40 eight-bit lines in each frame. This large frame capacity—up to 320 bits—provides an economical method of programing automatic test equipment and process control and is urgent when more information is required than can be obtained from a single-line punched tape reader.

The new latching output cir-

storable tubular satellite antenna cold rolled to $\pm 0.00015''$ tolerance

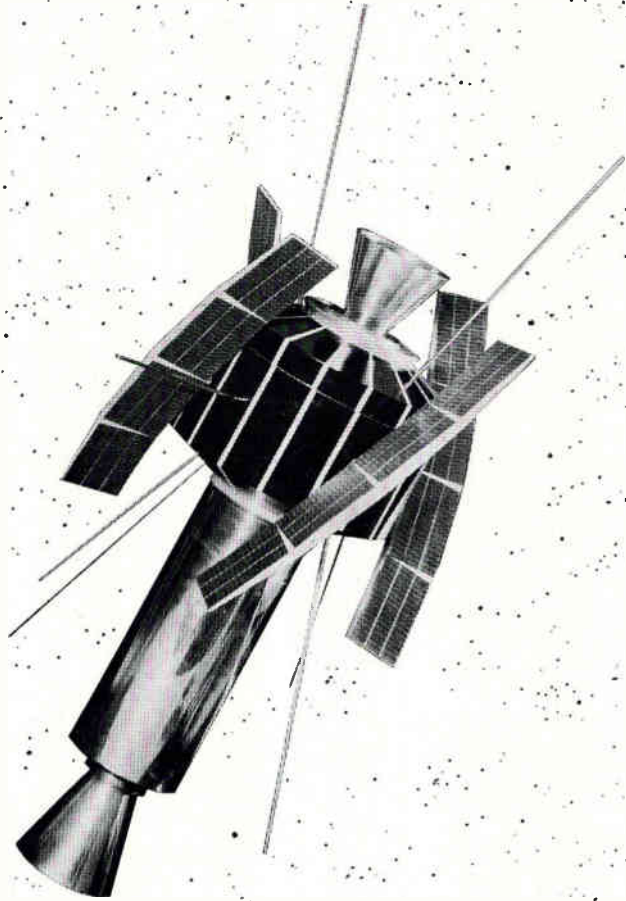

The Radio Astronomy Explorer (RAE) satellite is designed to give NASA an electronic map of the galaxy. Four reel-stored antennae of the RAE satellite consist of 2-in.-wide beryllium-copper strips over a tenth of a mile long. These antennae are made with furled metal strip produced by Hamilton Precision Metals, rolled to a thickness of $0.002''$ and held to a tolerance of $\pm 0.00015''$.

Hamilton Precision Metals is your prime source for ultra-precision-rolled metals in mass production quantities. 7 proprietary metals, 12 pure metals and 112 commercial alloys are available from Precision Metals. Write today for new 48-page data book.

HAMILTON PRECISION METALS

division of Hamilton Watch Company, Lancaster, Pa. 17604

°C drift, 50 na initial offset at 25°C. The differential and common-mode input impedance is 1 megohm and 100 megohms and the output is ± 1.5 v, 2.5 ma.

Besides conventional instrumentation uses, model 150 has a wide range of applications in upgrading or retrofitting existing instruments and systems. The inputs are floating with respect to ground (with the battery pack). The device can make measurements of high voltage cables; increase range, sensitivity and input impedance of d'Arsonval meters; turn d-c meters into wideband a-c instruments; raise input impedance of chart recorders and other apparatus; and operate remotely from sun-powered photovoltaic cells.

Analog Devices, 221 Fifth St., Cambridge, Mass., 02142. [389]

Low-noise amplifiers aid geophysical work

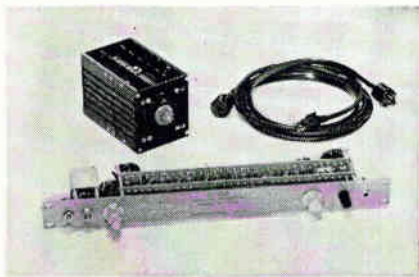

Nine high-gain solid state amplifiers can be used with acoustical instrument systems in the geophysical field and other applications. Series 505 amplifiers feature a wide dynamic range of 60 db which allows reception of greatly attenuated signals. The units can also handle large signals (200% overload) without blocking.

Typical amplifier gain is 10^6 ; response, 1 hz to 100 khz; noise, 0.1 v per 5,000 ohms output impedance. The input impedance on most models is adjustable from 50 to 1,000 ohms. Required power is 22.5 v d-c, 30 ma. With the company's 506 power supply the amplifiers can be operated on standard a-c current.

The amplifiers fit a standard 19-in. rack panel. They are $1\frac{3}{4}$ in. high and $4\frac{1}{2}$ in. in over-all depth.

Prices range from \$385 to \$455. Alpine Geophysical Associates, Inc., Oak St., Norwood, N.J. 07648. [390]

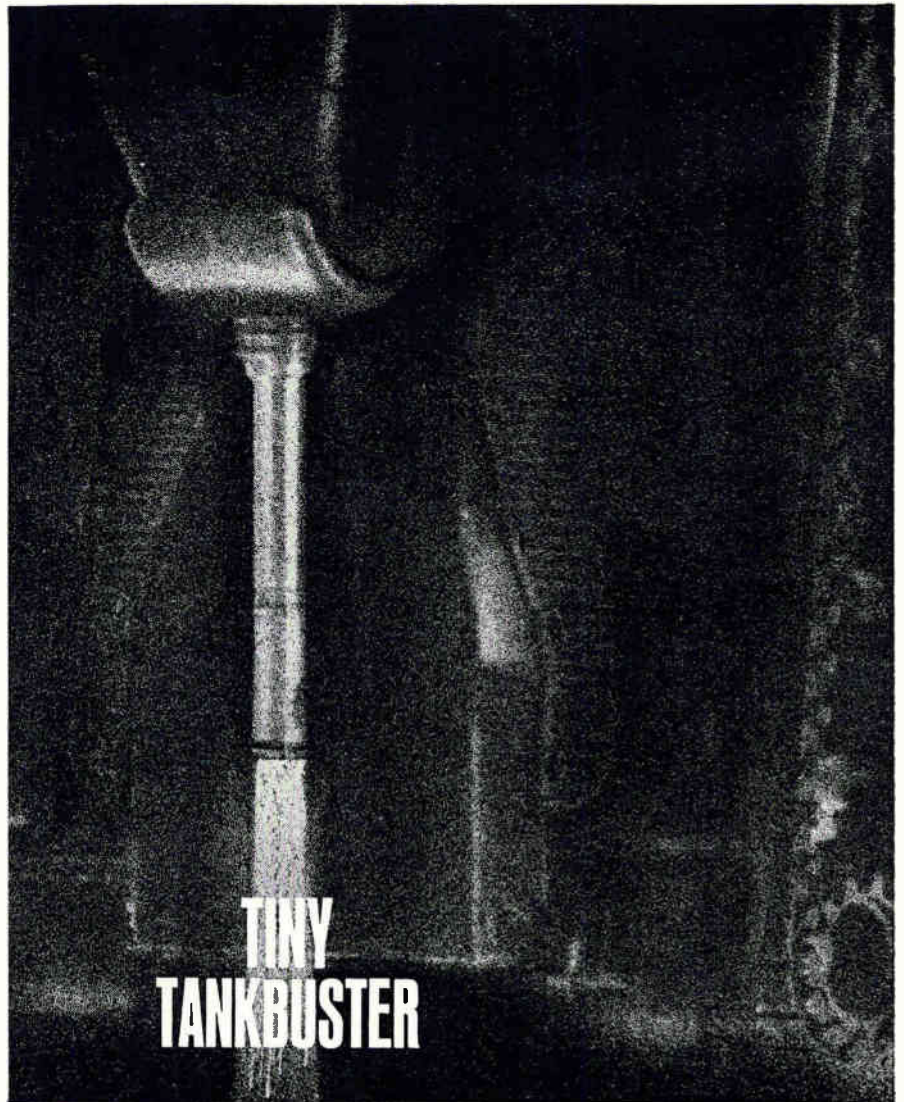

ACTUAL SIZE

The U.S. Army's new optically aimed, surface-to-surface Shillelagh missile is designed to kill tough armored targets. Produced by Philco-Ford Corporation's Aeronutronic Division, the Shillelagh is usually launched from the turret of a tank. Lodged in its inner recesses is the Gamewell precision resistance element shown above. This precise, half-inch, half-moon-shaped component contains 187 turns of precious metal alloy wire only .0007 inches in diameter. Linearity of output within this limited area is held to $\pm 0.7\%$. Termed a "gyro pick off," the element's wiper moves through a 50° arc to supply the desired resistance, helping establish the Shillelagh missile's attitude during its flight. The element's dielectric base and the face of the mounted coil are held to within .0002" total indicated radius.

Precision elements such as these are also used in accelerometers, strain gauges, differential transformers and the like. Both wire-wound and conductive plastics styles are available from Gamewell, as is a complete line of custom-built precision potentiometers in single and multi-turn or translatory types. No matter what your pot requirements, they take a turn for the better when you contact Gamewell Division, E. W. Bliss Company, 1304 Chestnut Street, Newton, Massachusetts 02164.



FIRST...WHEN PRECISION COUNTS



A DIVISION OF THE E. W. BLISS COMPANY

"Visit with us at Booth 4K-22, IEEE Show."

and nonstandard telemetry and communications signals. The receiver is capable of receiving frequency, phase, and amplitude modulated r-f carrier signals.

The modular construction affords modifications for a wide variety of special-purpose applications at minimum cost.

Defense Electronics Inc., Rockville, Md. [393]

X-band antennas designed for aircraft



Beacon antennas—both stub and dipole—that operate from 8.5 to 9.6 Ghz are specifically designed for high performance aircraft.

The stub type has a pattern similar to a quarter-wave monopole. The dipole's pattern is similar to a half-wave dipole over a ground plane and provides excellent horizon coverage. Units weigh less than 0.4 lb each and are vertically polarized. Maximum vswr is 1.5:1. Transco Products Inc., 4241 Glencoe Ave., Venice, Calif., 90291. [394]

High power capability in 4-port circulator



High peak and average power capability are features of a 4-port, liquid-cooled circulator. Model 336180 can handle 20 Mw of peak power and 20 kw of average power while maintaining a low insertion loss of 0.5 db maximum.

The unit can also be used as an isolator by terminating the appropriate ports. Operating in the fre-



financeability

(low, low interest rates)



In WESTern PENNSylvania, you can obtain 100% financing of industrial plant space at average interest rates as low as 4%. This can result in savings of as much as \$106,828 on a 62,000-square-foot industrial plant. In addition, financing of industrial machinery and equipment and loans for working capital are readily available. This complete financeability . . . plus a fair tax climate . . . pre-production training of a work force, usually at no cost to you . . . four-season livability . . . gives WESTern PENNSylvania a top combination of plant-location values.

West Penn Power

Part of the Allegheny Power System 

Area Development Department, Room 761
WEST PENN POWER—Greensburg, Pa. 15601

Phone: 412-837-3000

In strict confidence, I'd like to know more about WESTern PENNSylvania's:

- | | |
|---|--|
| <input type="checkbox"/> Financing Plans | <input type="checkbox"/> Fair Tax Climate |
| <input type="checkbox"/> Pre-Production Training | <input type="checkbox"/> Industrial Properties and Shell Buildings |
| <input type="checkbox"/> Please have your Plant Location Specialist call. | |

Name _____ Title _____

Company _____

Address _____

City _____ State _____ Zip Code _____ Phone _____

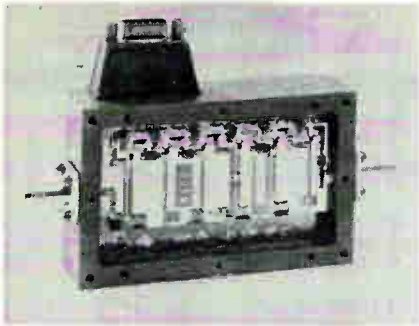

and frequency coverage from 0.5 to 2.4 Ghz.

The amplifiers are small, reliable, have low power drain and are unaffected by temperature and other environmental conditions. Using microminiature silicon transistors and what are claimed to be unique stripline and printed circuit techniques, mean-times-between-failures of over 10 years are achieved. All units are packaged in rugged machined aluminum housings.

Prices start at \$695. Delivery takes 4 to 6 weeks.

RHG Electronics Laboratory, Inc., 94 Milbar Blvd., Farmingdale, N.Y., 11735. [397]

Microwave transistor intended for S band

Development of a microwave transistor that offers a maximum frequency of oscillation (f_{max}) of 4.5 Ghz is announced. An f_{max} specification rather than f_t is used because it is more indicative of power capability at any frequency. Maximum power dissipation at 25°C case temperature is 300 mw.

Model MT1062 is intended for use in preamplifier and local oscillator applications through S band. It can deliver a calculated maximum available gain of 7 db at 2 Ghz and 3.5 db at 3 Ghz. This is achieved by the manufacturer's ability to photomask very narrow base-widths of about 2 microns (in production quantities) which reduce collector-to-base time constants, yielding higher f_{max} values.

Guaranteed over the full military temperature range of -55° to +125°C, the MT1062 in the TO-51 stripline package is priced at \$42.50 each in lots of 10 to 99.

Fairchild Semiconductor, a division of Fairchild Camera and Instrument Corp., 313 Fairchild Drive, Mountain View, Calif. [398]

RMC

DISCAPS

*the complete
Ceramic Disc
line*

Over the years Radio Materials Company has maintained its leadership in the production of ceramic disc capacitors. A complete line offering outstanding quality has been the key to continuing growth.

STANDARD

Type C, B, BA, JF, JL and JE

SUBMINIATURE

Type SM, BT, TA and Magnacaps

GREENCAPS

Type CG, JG, and BG

SPECIAL

U.L. Listed Discaps, T.C. High Voltage, High K High Voltage and Dual Section By-Pass



SEE
RMC
at the
IEEE

Booth 3C11 thru 3C17

DISCAP
CERAMIC
CAPACITORS

RMC

RADIO MATERIALS COMPANY

A DIVISION OF P. R. MALLORY & CO., INC.
GENERAL OFFICE: 4242 W. Bryn Mawr Ave., Chicago 46, Ill.
Two RMC Plants Devoted Exclusively to Ceramic Capacitors
FACTORIES AT CHICAGO, ILL. AND ATTICA, IND.

The Material of Unlimited Uses...

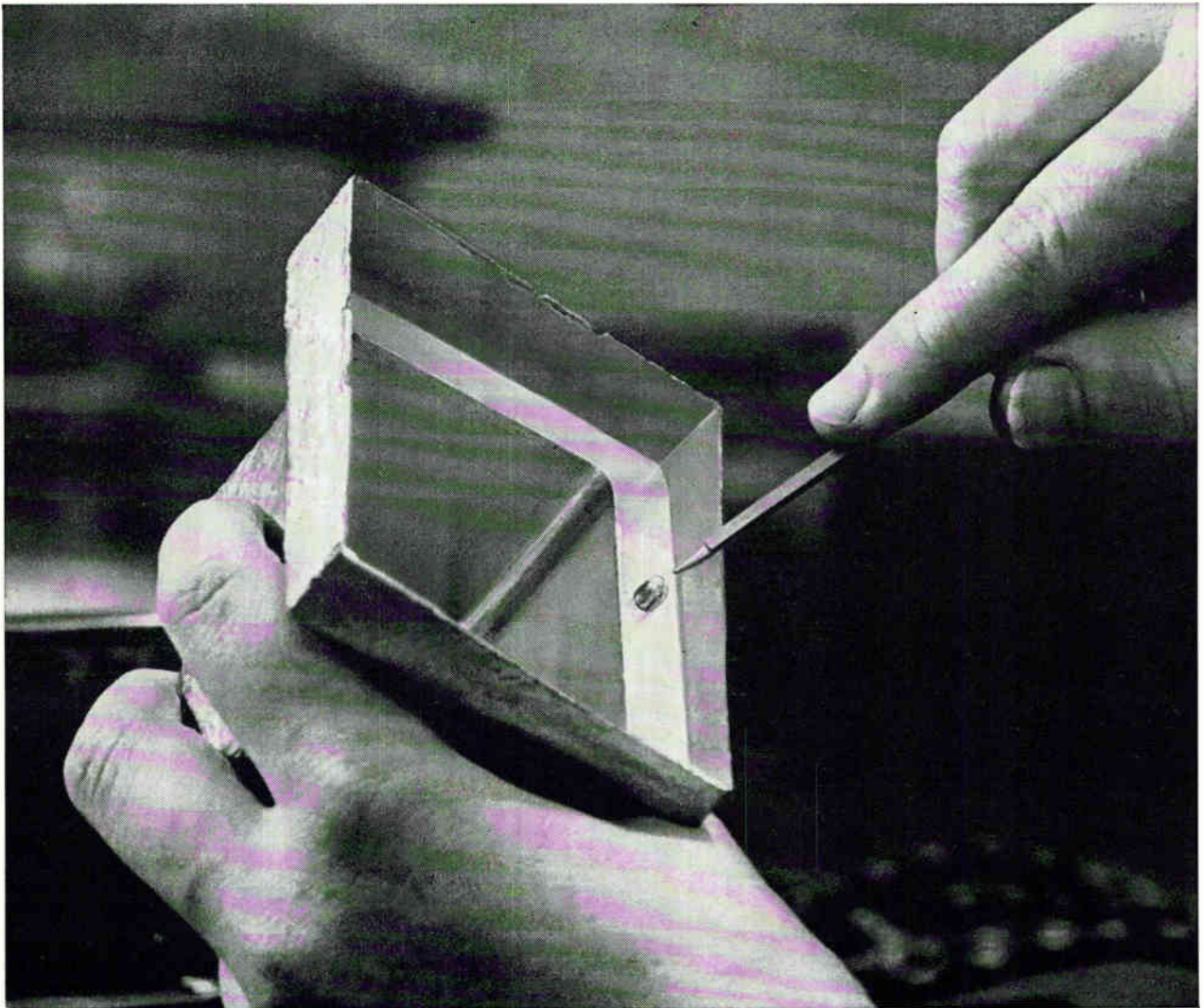

INSTANT DIP-A- MOLD

In seconds, you can make perfect molds, like this one, for potting any encapsulation, *and* make them economically, with low-melting CERRO® Alloys. Just dip the master in molten alloy. A thin coating of alloy clings to the pattern. Withdraw the pattern, and you have a perfect high fidelity mold. When the encapsulating plastic cures, simply remove the CERRO Alloy. Use it over and over again, almost without limit.

This particular alloy — CERROTRU® — does not shrink, slips easily from the pattern without parting or contaminating compounds or coatings. Because of its low melting point, it is safe and easy to handle.

You can reproduce such unusual details as positioning lugs for transformer cases, as shown above, without the use of cores, inserts or secondary operations.

Instant molding is just one of the many uses for CERRO Alloys. To find out more, contact Cerro Sales Corporation, 300 Park Ave., N. Y., N. Y. 10022 . . . R. Darnell (203) 327-0550.

CERRO®

to high volume production of printed circuits using flatpacks or other miniature multiple-lead components.

The model 950, SRM/FPR contains an a-c power supply, a programmer-controller for actuating the head, a dual reflow solder head that will handle all 14 leads of a flatpack at one time, a holding and locating fixture for the board, a swing-away component loading device, cooling equipment, and a console-type work table.

The operator manually positions a flatpack in the loader and moves it under the reflow head. The machine is actuated for automatic pickup of the component, positioning, and reflow soldering at a predetermined location on the board. The entire cycle, including loading, takes from 10 to 15 seconds, depending upon the dexterity of the operator. The basic machine will accommodate a printed circuit board up to 5 x 7 in. in size, although it may easily be modified to hold a much larger board.

A special feature of the model 950 allows the machine to be reversed in cycle so that it can be used to remove multiple-lead components for repairs.

Price is \$6,360; delivery, six to eight weeks. The manufacturer also offers a free course in microjoining processes for purchasers of the machine.

To be exhibited at the IEEE show. Weltek, a division of Wells Electronics Inc., 1701 S. Main St., South Bend, Ind., 46623. [402]

Rapid testing, sorting of diodes in production



Testing and classifying diodes and rectifiers on production lines and at incoming inspection stations is done with a family of instruments. Designed for application with fast

Looking for a fast & precise way to...

- test crystal devices?**
- identify frequency?**
- determine signal purity?**
- check dynamic impedance?**
- find band-pass filter response?**
- equalize transmission lines?**
- align a color TV tuner?**

Those assignments, plus a few thousand others, are routine for a Telonic Sweep Generator. You'll find the above applications and many more described in detail in Catalog 70. Also included are specifications for all Telonic Sweep Generators and Accessories, data on sweep generator operation, and frequency marking techniques. Send for a copy.

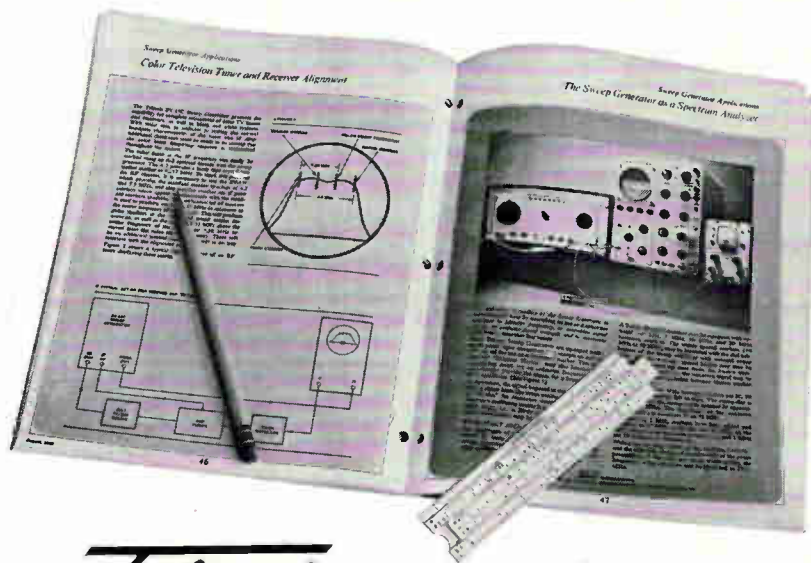

Telonic INSTRUMENTS

A DIVISION OF TELONIC INDUSTRIES, INC.
60 No. First Ave., Beech Grove, Indiana 46107. TEL: (317) 787-3231 TWX - 810 - 341-3202

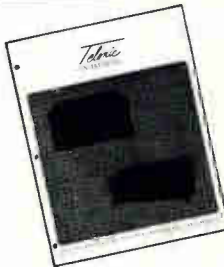

Telonic INSTRUMENTS
60 No. First Ave., Beech Grove, Indiana 46107
TEL: (317) 787-3231 TWX - 810 - 341-3202

Yes, send a copy of Catalog 70, Sweep Generators and their Application, to

Name _____

Firm _____

Address _____

City _____ State _____ Zip _____

See Telonic at IEEE, Booths 2G02-2G10

has an extremely narrow "C" type head for easy accessibility and unlimited visibility. Quick change, positive-locking, color-coded dies cannot be installed incorrectly. In addition, the tool is designed for both automatic and manual operations.

Featured with the Y40LH Hy-press is a line of termination rings for the cable shields called Hying. The rings come in 22 sizes and are capable of terminating conductor bundles ranging from 0.430 in. to 2.905 in. in diameter. The Hying line is color-coded with an ink that will not chip, flake, or peel after crimping, or in any way interfere with the conductivity of the crimped assembly.

Burndy Corp., Norwalk, Conn. [404]

Automatic, high-speed thin-film evaporator

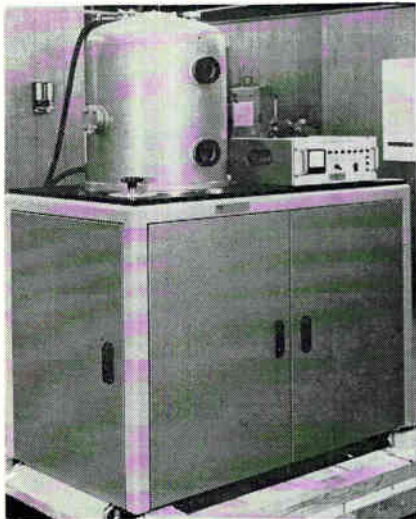

A fully automatic high-vacuum evaporator for producing thin film components can reach to pressures of less than 5×10^{-8} torr in a 20-inch diameter bell jar. Fast cycling time is achieved with liquid nitrogen and a 1900-liters-per-second oil diffusion pumping system. The pumping system is made fail-safe with an interlocked automatic valve control.

The model BA-510A's many accessories include single or multiple electron sources, an 8-position mask-substrate changer, optical and conductance thin-film monitors, rotary cage motor and planetary gear drive. Bendix-Balzers Vacuum, Inc., 1645 St. Paul St., Rochester, N.Y. [405]

fearless distributor on the moon needs a tube to get back...

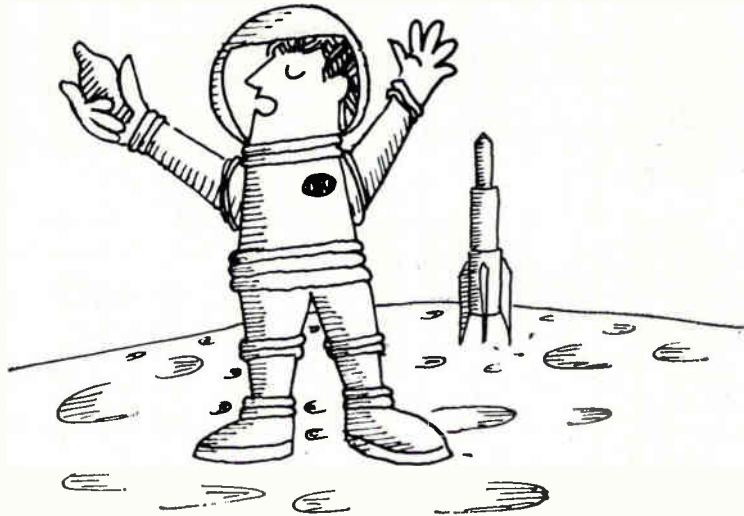

get on the hot-line (212) 533-5580

Get out of the "no-bid" habit and get with the action. Join the profit-making distributors who have found Transitube the reliable source for current, original boxed industrial electron tubes and semiconductors from every major manufacturer in the industry—all at below distributor cost. We are the distributor's supplier (not his competitor) A phone call lets you enter a competitive bid on any quotation.

Tubes and semiconductors can be supplied to meet commercial or military specifications. Immediate delivery is assured from our comprehensive stock, housed within our modern 30,000 sq. foot warehouse.

Get on the "hot-line"—we're waiting for your call.

Transitube Inc., 300 Park Ave. South, New York 10010, phone: (212) 533-5580, cable address: Transitube, New York.



Circle 321 on reader service card

To order reprints: Fill in, cut out coupon below, insert in envelope and mail to: **Electronics Reprint Dept., 330 W. 42nd Street, New York, N.Y. 10036**

Reprint order form

For listing of reprints available see the Reader Service Card.

Communications Satellites. Parts I and II.

Send me reprints of Key no. R-90a at \$1.25 each.

For reprints of previous special reports fill in below:

Send me reprints of Key No.(s) @¢ each.
(For prices, see Reader Service Card)

Name

Number of street

City, State, Zip Code

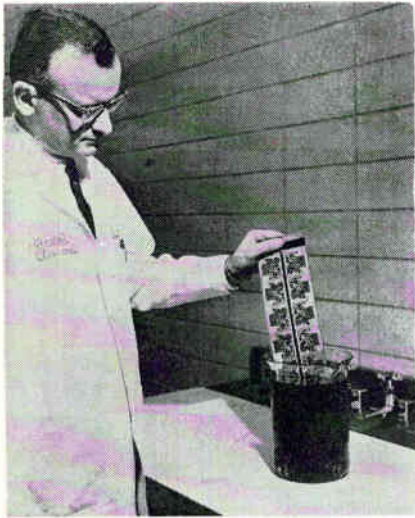

mixtures of high-purity organic solvents and activating ingredients. The nonflammable liquids remove resist films quickly and completely without causing damage to delicate surfaces.

Solution CB-1 was especially formulated to strip Kodak Photo Resist and other photosensitive resists of this family from p-c boards. Solution A-20 was developed to strip Kodak Metal-Etch Resist and Kodak Thin Film Resist from silicon, silicon oxide, aluminum and other metals commonly used in manufacturing both discrete semiconductor components and integrated circuits.

While CB-1 is used full strength at room temperatures, A-20 is most effective when used full strength at 90° to 100° C. The latter solution, however, may be used at a lower temperature if the characteristics of the polymerized resist film permit. With both solutions, the product to be stripped is immersed in the solution for several minutes, then washed in a direct stream of ordinary tap water. Mechanical scrubbing is not necessary for complete cleaning of the p-c boards. Allied Chemical Corp., Industrial Chemicals Division, P.O. Box 353, Morristown, N.J., 07960. [408]

Zinc oxide crystals show high resistivity

Large single crystals of zinc oxide have been grown by the hydrothermal method which allows a doping agent to be added during the growth process to control con-

From the Problem Solvers at Ucinite...

A redesigned test-probe receptacle that cuts costs 25%

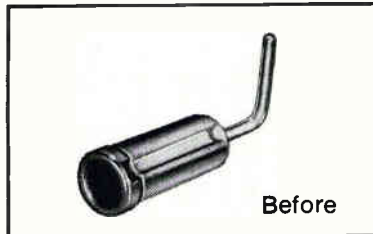
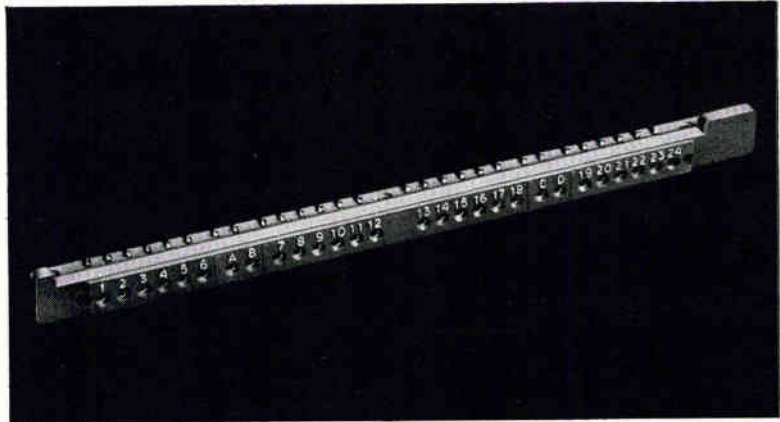

A prominent electronic equipment manufacturer asked Ucinite for help in reducing production costs of this 28-contact test-probe receptacle for printed circuit boards. The original design of this molded plastic receptacle had used screw-machined contacts and required the three threaded mounting inserts to be molded in. Putting their cost-cutting ingenuity to work, Ucinite engineers first replaced the 28 costly machined contacts with economical stamped closed-entry contacts of simple one-piece design. They cut costs still further by replacing the three expensive molded-in inserts with economical self-tapping inserts. Result: a 25% saving with no sacrifice in reliability or electrical characteristics.

This is just one example of the money-saving design innovations you can expect from Ucinite. Learn more about how Ucinite's design and manufacturing capabilities can help you get *better* electromechanical parts for *less*. Just write or call: The Ucinite Company, Division of United-Carr Incorporated, Newtonville, Mass. 02160 • 617-527-8400.

UCINITE
DIVISION OF UNITED-CARR

New Books

Semantic arbiter

Electronics and Nucleonics Dictionary, third edition
John Markus
McGraw-Hill Book Co., 743 pp., \$16.50

Language changes, warns an ad for Merriam-Webster's newest desk dictionary, adding that your dictionary should change too. As every electronicer knows, this warning is even more pertinent for that segment of the language describing electronic phenomena and devices than it is for the language as a whole. And now, Cooke and Markus' excellent dictionary, first published in 1945 and revised and expanded to include nucleonic terms in 1960, has been revised again, this time by Markus alone.

It is regrettable that books are not published with more speed. Markus continues to use "cycles per second" instead of "hertz." He is, however, fighting a battle that has already been decided. Although the dictionary received, in late December, a 1966 copyright date from the Library of Congress, the book reflects usage common in early 1966. That's why the old definition of hertz still stands. It is also the reason why the book doesn't differentiate between "integrated electronics" and "microelectronics" as recommended by the Institute of Electrical and Electronics Engineers last fall. Fortunately, we have grown up expecting hysteresis in hard cover books and are accustomed to relying on periodical publications for news of changes in approved terminology.

The book's type is easy to read, and items being defined are printed in bold letters. The drawings are clear, and the paper used is heavy enough to minimize printthrough from the other side. Markus' spelling and hyphenation of terms, while not necessarily that employed by a particular magazine or company, has the decided virtue of consistency. He also clearly marks commonly used words which are trademarks, to avoid, as he says in the preface, "unpleasant correspondence with lawyers representing the owner of the trademark."

The following comments are

quibbles—nitpicking, so to speak—and are prompted only by a hope for an impossible perfection. Why is a phonograph record a "disk," when Webster, the New York Times and this magazine (to name just three authorities) distinguish it from other types of thin, circular objects by calling it a "disc"? Why does the definition of "umbilical cord" mention only the type used to test a missile and not include the lifeline that connects an astronaut to an orbiting spacecraft?

There is an error in the definition of picosecond; it is called one-millionth of a second, instead of one-millionth of a microsecond. The prefix "nano-" is curiously defined as "one-thousandth of a millionth," instead of the simpler "one-billionth."

The dictionary, Markus states in his preface, is meant for technical writers and advertising copy writers as well as for engineers and technicians. Hence, one questions the omission of "trade off"—a term which engineers know, but one which is not in the latest Webster's dictionary. The definitions of "electrical" and "electronic" are adequate for the engineer, but a paragraph elaborating the difference would greatly aid a new man in a public relations department.

The electronics engineer who wants to find out about some nucleonics terms may be similarly confused. For example, the definition of a "quark" as "a postulated but as yet undiscovered heavy triplet" makes sense to a high-energy physicist who knows that a heavy triplet is one of three nuclear particles, each of which is heavier than a proton. But "triplet" is defined only as "three radio navigation stations operated as a group"; "heavy triplet" is not defined.

Markus also falls into the trap of too narrowly defining some terms. For instance, after a clear explanation of how the Gunn effect works, he adds the gratuitous comment that "frequencies range from 500 to 7,000 Mc, depending on the thickness of the block." Recently one company built a Gunn-effect device which oscillates at 30 gigahertz [Electronics, Jan. 23, p. 26] and

EDGE GARD HOOD by BAKER



NEW CONCEPT

Our engineers have developed a radically new horizontal laminar flow work space which eliminates the two major faults found in conventional laminar flow work spaces . . . Turbulence and backwash.

Our new super clean work space, called Edgard* Hood, features a series of perforations along the leading edges which reclaim better than half of the air flowing across the work surface. This action creates a secondary air curtain which prevents foreign matter from entering the work area during operation.

Unlike conventional laminar flow work spaces, Edgard* Hoods maintain minimum particle counts continuously throughout the work cycle.

TEST DATA

Upon request, we will forward to you, the results of a comparison study between a conventional laminar flow work space and an EDGE GARD* HOOD, showing the degree of cleanliness of each unit under actual operating conditions.

Edgard* Hoods meet or exceed requirements of Mil Specs. FS-209 Class 100.

The Baker Company, Inc., the world's leader in the development of clean air equipment, also manufactures dry boxes, vacuum ovens, vertical flow units, clean room components and completely integrated clean air work systems.

FOR COMPLETE INFORMATION, SEND TODAY FOR YOUR COPY OF BAKER'S PURCHASING GUIDE OF CLEAN AIR EQUIPMENT.

®TRADE MARK

THE **BAKER** CO., INC.

BIDDEFORD, MAINE 04005

207-284-5951

creating the world's most immaculate atmospheres

the new 
 model PAR 1612A
 S-Band

Avalanche Diode Pumped Parametric Amplifier



it's a major
 breakthrough
 in size, cost and
 reliability...

compared with all existing conventional parametric amplifiers

The avalanche diode-pump makes possible an all-solid state design, at low cost and eliminates the need for a pump klystron with its bulky power supplies. For the first time, parametric amplifier noise figures can be achieved in a package comparable to tunnel diode amplifiers. Check these features...

- Noise figure: 2.5 db, maximum
- Size: Param—5 $\frac{5}{8}$ " x 4" x 1 $\frac{1}{4}$ "
 Power Supply—3 $\frac{1}{4}$ " x 3 $\frac{1}{4}$ " x 5"
- Weight: 3 pounds including Paramp and Power Supply
- Price: \$4,595. standard model
- Delivery: 90 to 120 days

Write for complete details.



American **E**lectronic
Laboratories, Inc.

P. O. Box 552, LANSDALE, PA. 19446 • (215) 822-2929

**PROVEN RELIABILITY—
 SOLID-STATE POWER INVERTERS,**
 over 260,000 logged operational hours—
 voltage-regulated, frequency-controlled,
 for missile, telemeter, ground support,
 135°C all-silicon units available now—

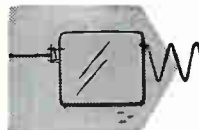
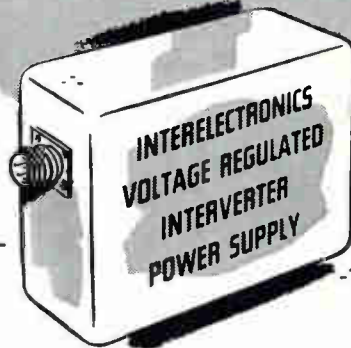

Interelectronics all-silicon thyatron-like gating elements and cubic-grain toroidal magnetic components convert DC to any desired number of AC or DC outputs from 1 to 10,000 watts.

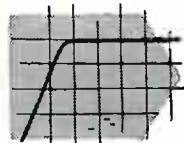

Ultra-reliable in operation (over 260,000 logged hours), no moving parts, unharmed by shorting output or reversing input polarity. High conversion efficiency (to 92%, including voltage regulation by Interelectronics patented reflex high-efficiency magnetic amplifier circuitry.)

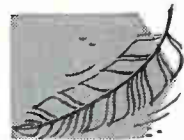

Light weight (to 6 watts/oz.), compact (to 8 watts/cu. in.), low ripple (to 0.01 mv. p-p), excellent voltage regulation (to 0.1%), precise frequency control (to 0.2% with Interelectronics extreme environment magnetostrictive standards or to 0.0001% with fork or piezoelectric standards.)

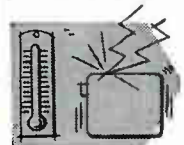

Complies with MIL specs. for shock (100G 11 mlsc.), acceleration (100G 15 min.), vibration (100G 5 to 5,000 cps.), temperature (to 150 degrees C), RF noise (I-26600).



AC single and polyphase units supply sine waveform output (to 2% harmonics), will deliver up to ten times rated line current into a short circuit or actuate MIL type magnetic circuit breakers or fuses, will start gyros and motors with starting current surges up to ten times normal operating line current.

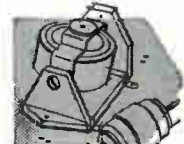

Now in use in major missiles, powering telemeter transmitters, radar beacons, electronic equipment. Single and polyphase units now power airborne and marine missile gyros, synchros, servos, magnetic amplifiers.

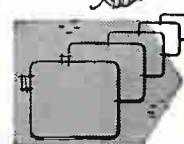

Interelectronics—first and most experienced in the solid-state power supply field produces its own all-silicon solid-state gating elements, all high flux density magnetic components, high temperature ultra-reliable film capacitors and components, has complete facilities and know how—has designed and delivered more working KVA than any other firm!

For complete engineering data, write Inter-electronics today, or call 914 Elmwood 8-8000.

INTERELECTRONICS CORP.

700 U. S. Route 303 Congers, New York 10920



microbial
contamination
product spoilage,
downtime,
need for excessive
additives

for use in DEIONIZED WATER SYSTEMS

Steroline's Aquafine Ultraviolet purification systems are designed to produce unlimited quantities of 99+% of safe, pure water and other liquids.

Skilled Steroline specialists will design the most economical purification system for you...reducing bacterial build-up...eliminating downtime...ending product spoilage...reducing maintenance costs. And, Steroline purification systems are available with special warning device and/or automatic shut off. Whether you select a portable or permanent system, you'll find that your over-all savings quickly exceed your capital investment.

Get the facts on liquid purification. Write:

Steroline Systems Corporation

11809 (J) East Slauson Avenue
Santa Fe Springs, California 90670
Telephone: (213) 698-8157 Cable: Sterline

DISTRIBUTORS! Valuable territories open. Write for full information.
Circle 528 on reader service card

**Leadership is
no accident!**

in sports
or in
industry

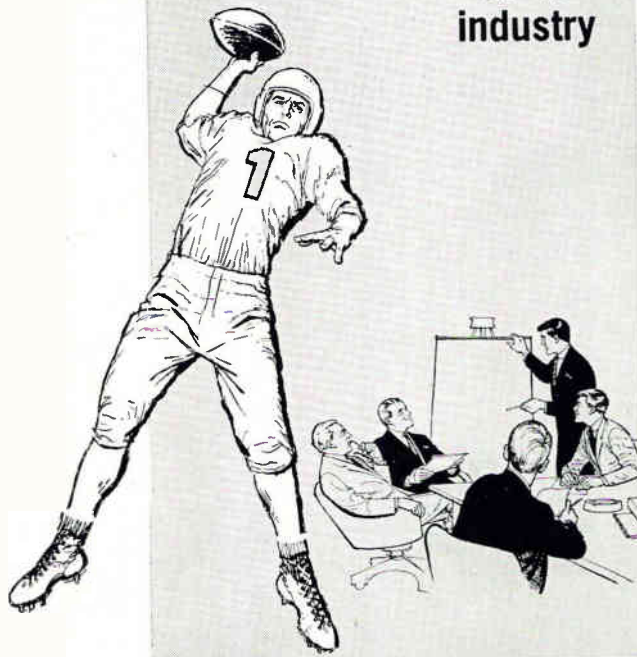

**YOU THE CUSTOMER
are the main
reason for ALPHA'S
LEADERSHIP**

We don't kid ourselves at Alpha. Building a better mousetrap is not enough. Leadership demands a close interplay with customers so that products meet their needs. The many Alpha Soldering Firsts are due to your faith in our R & D activities, in our customer service program, and in our integrity. To our customers goes a major share of the credit for Alpha's acknowledged Soldering Leadership. Other reasons include the most complete quality line available anywhere; authoritative Soldering Technology Seminars; an outstanding Research and Development Department geared to problem solving; prompt, reliable service; and unequalled know-how and experience in the development and production of solders, soldering chemicals, preforms and ultra-high purity metal fabrications for the semi-conductor industry.

BULLETIN A103 TELLS THE ALPHA STORY.
WRITE FOR YOUR FREE COPY TODAY.

alpha® **alpha metals, inc.**

56 WATER STREET, JERSEY CITY, N. J. 07304 201-434-6778

Los Angeles, Calif. • Alpha Alloy Corp. (Div.), Chicago, Ill.
Alpha Metals, Inc. (U.K.) Ltd., Hounslow, Middlesex, Eng.

J-6829

Pick a switch—any switch—

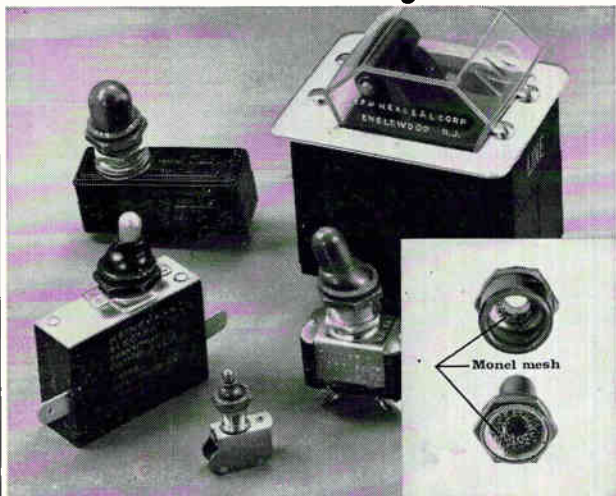

**a Hexseal environmental
boot will shield it from RFI.**

A unique knitted Monel metal wire molded or "stuffed" into our Hexseal boots effectively eliminates RFI. Used on standard pushbutton, toggle or rotary switches, these Hexseals save sensitive equipment from harmful interference, whether received or radiated. Keep out air, gases and liquids as well.

Just replace the mounting nut with a Hexseal, and you have a sealed, RFI-shielded switch that works longer, and more reliably. (Available as a sealing boot alone, if shielding is not needed.)

Hexseals meet all applicable military applications. Send for more data and prices right away. Write:



APM-HEXSEAL

41 Honeck St., Englewood, N. J.

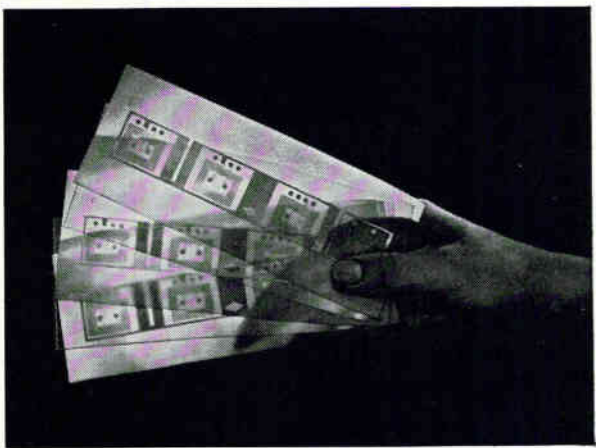

Highest-quality copper-clad laminates for multi-layer printed circuits

Laminated plastics for multi-layer printed circuits have to be a special breed—very thin, made to exacting tolerances, uniform, free of voids and pinholes, suitable for etching and all soldering operations.

Synthane Thin Laminated grades G-10 and FR-4 are highest-quality fabric epoxy laminates. All produced under exacting clean room conditions. Write for leaflet. Synthane Corporation 36 River Road, 666-5011 (Area Code 215).

SYNTHANE
CORPORATION

OAKS, PA. 19456

Laminated Plastic Sheets, Rods, Tubes and Fabricated Parts

Circle 570 on reader service card



NEW lower-cost, epoxy flame-retardant copper-clad laminate

In response to the demand for a more economical epoxy grade of laminated plastic, Synthane now offers new grade FR-16.

FR-16 is reinforced with a random-oriented glass fiber mat which, because it can be produced on a modified paper machine, costs less than fabric reinforcements used in other flame-retardant grades.

FR-16 is excellent for printed circuits. It is mechanically strong, moisture-resistant, has a low dielectric loss and a high dielectric breakdown. Write Synthane Corporation, 36 River Road for the FR-16 Engineering Data Bulletin.

SYNTHANE
CORPORATION

OAKS, PA. 19456

Laminated Plastic Sheets, Rods, Tubes and Fabricated Parts

Circle 530 on reader service card

Just right for two-way radio!

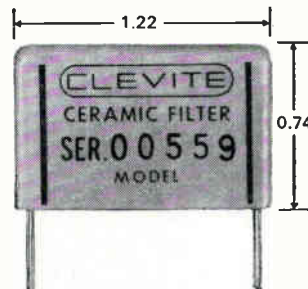

Clevite's computer-designed TCF ceramic filter.

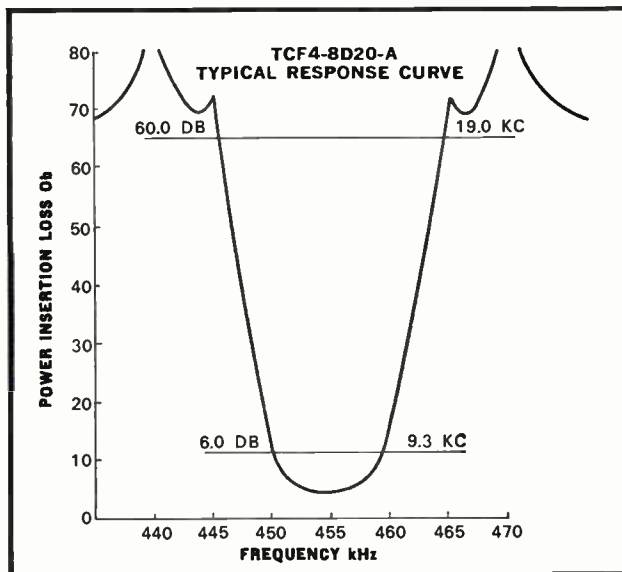

TCF — a hybrid combination of a tuned transformer and ceramic resonators . . . in less than 0.6 cu. in!

The TCF is made specifically for CB, mobile, aircraft and marine radios; combines the input advantages of a tuned transformer with the stability and high performance of a ceramic filter. Result: manufacturers of quality AM receiving equipment get greater selectivity at a lower cost. TCF filters are completely free of unwanted responses, and input impedances are suitable for both transistor and vacuum tube circuits. (A selection of other bandwidths and characteristics to cover a range of applications from FM to CW is available on request.)

TCF4-8D20A	B/W	Insertion Loss	Impedance
Center Freq: 455± 1kHz	@6db	6db max.	In 40K ohms
Temp. Stability: less than 800 Hz variation	8kHz min.	@60db	Out 1.5K ohms
-20 to +60°C	20kHz max.		

PRICES: 1 — \$15 ea; 25 — \$10 ea; 100 — \$8.50 ea; 500 — \$6.75 ea; 1000 — \$6.00 ea; 2500 — \$5.45 ea.

(Prices subject to change without notice.)

Send order or request for Bulletin 94024 to: Clevite Corporation, Piezoelectric Div., 232 Forbes Rd., Bedford, Ohio 44014, U.S.A. Or: Brush Clevite Company, Ltd., Southampton, England.

CLEVITE

Circle 331 on reader service card

331



Low cost, benchtop humidity test chamber 24" W x 26" D

Tenney Humidity Jr. is a compact, self-contained, full range benchtop chamber for low-cost humidity simulation. Plug into 115 V outlet for lab work, product development, Mil-spec testing, quality control testing, incubation, etc.—*maintenance-free.*

- Humidity Range: 20-95%
- Humidity Tolerance: $\pm 1\%$
- Temperature Range: $+20^\circ$ F to $+200^\circ$ F
- Control Tolerance: $\pm 1/2^\circ$ F
- Interior Dimensions: 20" W x 12" D x 15" H (2 cu. ft.)
- Off the shelf delivery.

Write or call today for complete details.



Tenney

ENGINEERING, INC.

1090 Springfield Rd., Union, N.J. 07083 • (201) 686-7870
Western Division: 15700 S. Garfield Ave., Paramount, Calif. 90723 446

Circle 531 on reader service card

Smallest 3-Phase Electronic Frequency Converters Ever Made!



Now, from CML, comes a series of the smallest 3-phase Electronic Frequency Converters ever made... featuring fixed or adjustable plug-in oscillators at frequencies ranging from 45 to 6,000 cycles. Write today for details on Models T500A through T2500A!

Model	3 ϕ Output VA	Dimensions (For standard 19" relay rack mounting)
T500A	500	8 $\frac{3}{4}$ " h x 21" d
T750A	750	14" h x 21" d
T1200A	1200	14" h x 21" d
T1750A	1750	14" h x 21" d
T2500A	2500	14" h x 21" d



CML, Inc.
A Subsidiary of Tenney Engineering, Inc.
350 Leland Avenue • Plainfield, New Jersey
Telephone (201) 754-5502 • TWX: 201-756-2064

Circle 532 on reader service card

What's New With HEATH At IEEE

Preview of New Heathkit®/ Thomas "Theatre" Organ

All solid-state; 19 voices; 2 amplifiers; 200 watts peak power; instant-play "Color-Glo"; horseshoe console; flip-type tabs; chimes; rotating Leslie plus main speaker systems; preassembled cabinet & bench.
Kit TO-67 \$995



Preview of New Heathkit Solid-State High Impedance Volt-Ohm-Milliammeter

Full scale ranges down to 150 mV & 15 μ a; all-silicon plus FET's; AC and DC powered; 6" meter; new unitized construction.
Kit IM-25 \$80
Assembled IMW-25 \$115

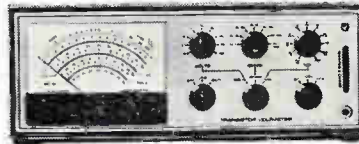

NEW Heathkit "180" Color TV

180 sq. in. viewing area; exclusive built-in self-servicing facilities so you can converge & maintain best color pictures; exclusive 3-way installation; rare earth phosphors; automatic degaussing; 25-hr. assembly.
Kit GR-180 (less cab.) \$379.95



Preview of New Heathkit AR-15

Solid-State 150-Watt AM/FM Stereo Receiver

Two integrated circuits and crystal filters in the IF section; preassembled FET FM tuner; positive circuit protection; 2 calibrated tuning meters; "black magic" panel lighting; All-silicon transistor circuitry.
Kit AR-15 (less cabinet) \$329.95



New Heathkit 60-Watt Transistor Guitar Amplifier

Cool, solid-state circuit; two 12" heavy-duty speakers; two channels & 4 inputs; tremolo & reverb; foot switches; line bypass reversing switch for hum reduction; preassembled cabinet.
Kit TA-16 \$129.95

New Heathkit Deluxe

80-10 Meter SSB Transceiver

Front panel switch-selection of standard USB/LSB 2.1 kHz SSB filter or optional 400 kHz CW filter; 180 watts P.E.P. — 170 watts CW on 5 bands; operates PTT or VOX.
Kit SB-101 \$360



See 'em All At Japan Room & Booths 2C47, 2C48, 2C49 & 2C50.



HEATH COMPANY, Dept. 520-28
Benton Harbor, Michigan 49022

Please send FREE Heathkit Catalog

Name _____

Address _____

City _____ State _____ Zip _____

Prices & specifications subject to change without notice. CL-287

Circle 537 on reader service card

333

yes,

CCTV Cameras work best



with COSMICAR[®] LENSES

Superior cameras deserve superior lenses. COSMICAR's proven precision performance is the combined result of advanced optical engineering and exquisite workmanship.

Now widely used, COSMICAR LENSES come in 23 models for focal lengths ranging from 12.5 mm to 500 mm, and in 3 zoom models including a remote control zoom.

Your CCTV camera and COSMICAR LENSES will make an unbeatable team. For technical data and other particulars, please write.

ICHIZUKA OPTICAL CO., LTD.

568, Shimoochiai, 2-chome, Shinjuku-ku, Tokyo
CABLE ADDRESS: "MOVIEKINO TOKYO"

Circle 533 on reader service card

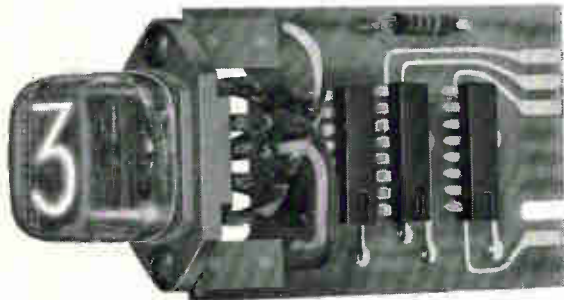

TTL IC Drivers for NATIONAL[®] Readout Tubes

From stock: Decoder/Driver, Decimal Counter/Driver and Decimal Counter/Driver with Latching Memory.

■ 15 MHz Counting Rate ■ For all side and end view National readout tubes.

IEEE
BOOTHS
3F01-3F18

NATIONAL

REQUEST
BULLETIN

ELECTRONICS, INC.

a varian subsidiary

PHONE: (312) 232-4300 - GENEVA, ILLINOIS, U.S.A.

Weld, Solder and Bond with this Versatile Machine!

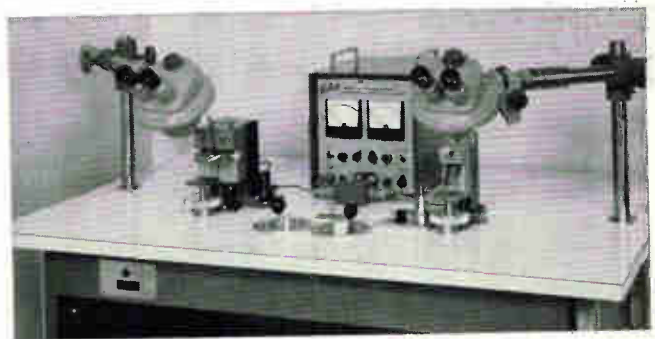

Weltek's new Model 750 can be set up in minutes to do micro-miniature welding, controlled soldering or "nail head" bonding. With this one piece of equipment you can solder or weld flat packs to p.c. boards, do module welding, point-to-point microsoldering or bond a wire to a transistor chip! The possibilities are unlimited. The 750 can do *all* of your miniature joining work... in the lab or in production. And it is reasonably priced.

FREE SAMPLING SERVICE!

Send us your miniature joining problems... we sample quickly. No obligation.

Weltek

Precision Bonders

by WELLS ELECTRONICS, INC.

1701 S. Main Street, South Bend, Indiana, U.S.A.

Circle 534 on reader service card

Circle 539 on reader service card

335

E-Z-HOOK
Box 105 Covington
Ky. 41012

Phone 606-261-1495

E-Z-HOOK®

TEST AND PRODUCTION CONNECTORS

• CLIPS • ADAPTERS • TEST LEADS • PROBES

Pat. No. 2702892

SAVE TIME
E-Z-HOOK's
SAVE TROUBLE

® E-Z-HOOK is a Reg. T.M.

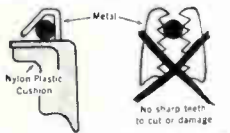

Reduces rejects repairs & salvage... protects Quality
The Gentle Connector



E-Z-Mini-HOOK X-100
Hold between the thumb and two fingers. Slide a hypodermic needle. Press on Q-Ball with thumb until hook is exposed. Release pressure, to close.

Easy To Use

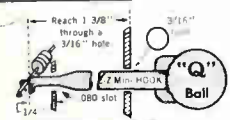

Reach 1 3/8" through a 3/16" hole.
Reach 1/4" through a .080 slot.
Makes connections in places never before possible

Hard-To-Get-To Places



Not A Short In The Dozen

Designed for Your Pleasure and Profit

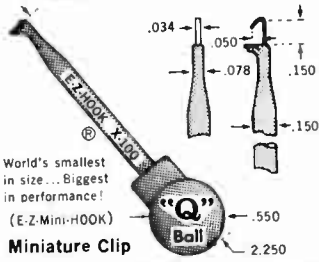

World's smallest in size... Biggest in performance!
(E-Z-Mini-HOOK)
Miniature Clip

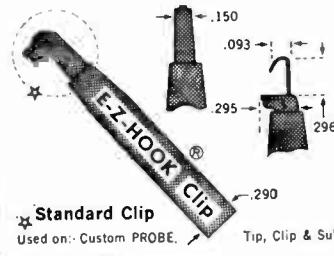

Standard Clip
Used on: Custom PROBE. Tip, Clip & Sub.

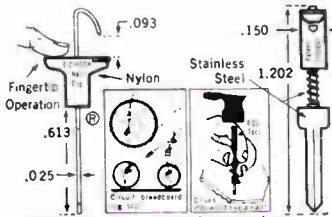

No holes to drill, or washers & nuts to place
Harness Cable Board Clip

Harness Cable Board Clips

Use E-Z-HOOK "Nail" Clips to improve quality, to reduce rejects and scrap, to increase production and profits. Write for the Reprint which tells how one Company estimated saving over \$20,000, annually by switching to them.

Catalogue In V.S.M.F. - ascam

Satisfaction Guaranteed

eem - Radio Master

Order E-Z-HOOKs from your Parts Distributor or direct from Factory



Automatic short protection spring keeps Nylon Insulator over any unshod clip metal. Provides constant protection against accidental shorts.

Won't Short... Can't Pull Off



Easy To Use

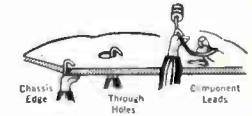

A new freedom of action in connecting
Connects Anywhere



Made of finest materials in an efficient hook design that provides good, reliable performance

Durably Constructed

Circle 541 on reader service card

ANOTHER WORLD'S SMALLEST Soshin's Dipped Mica Capacitors/DM05

Developed by SOSHIN ELECTRIC, the only mica capacitor maker in Japan with MIL-C-5C qualifications. This newest and its bigger brothers will meet all your requirements. Volume orders accepted.

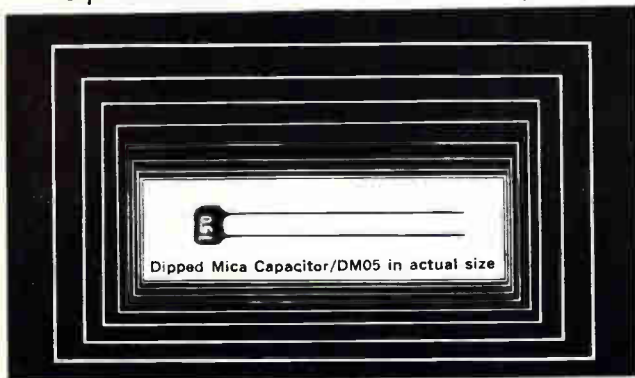

Types	Max Allowable Capacitance (pf)			Dimension (mm)								
	100 WV	300 WV	500 WV	100 WV			300 WV			500 WV		
Standard				L Max	W Max	T Max	L Max	W Max	T Max	L Max	W Max	T Max
DM05	200	130	-	7.0	5.0	3.5	7.0	5.0	3.5	-	-	-
DM10	440	300	330	8.5	5.5	3.5	8.5	5.5	3.5	8.5	5.5	3.5
DM15 C.M05	2000	1200	510	13.0	11.0	6.5	12.5	10.5	6.0	12.0	10.0	5.5
DM19 C.M05	10000	6800	5100	18.0	15.0	8.5	18.0	15.0	8.0	17.5	15.0	7.5

For further information, write to

SOSHIN SOSHINELECTRIC CO., LTD.
18-18, Nakamagome 1-chome, Ohta-ku, Tokyo, Japan
Cables: SOSHINCAPACITOR TOKYO

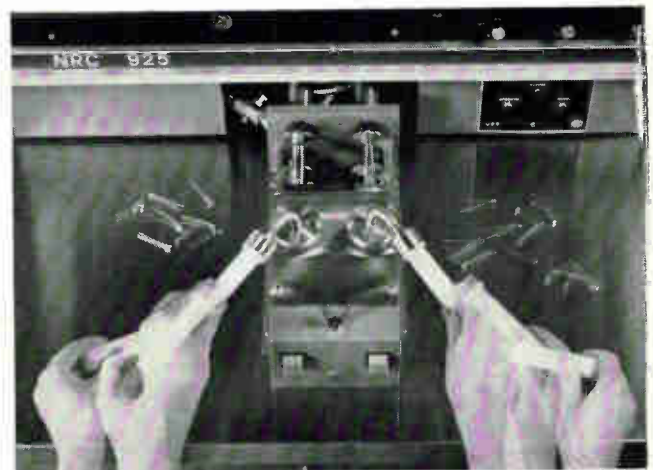

**an individual leak test every 3 seconds
... again ... again ... and again**

... up to 1200 per hour. NRC's dual-port 925 VFT enables one operator to test as many small electronic components per hour as two operators using conventional multi-port methods. No wonder more and more companies are adopting this new, proven approach to production mass spectrometer leak testing. Write for the whole story.

NRC EQUIPMENT DIVISION
NATIONAL RESEARCH CORPORATION
A SUBSIDIARY OF NORTON COMPANY
160 Charlemont Street, Newton, Massachusetts 02161

Circle 543 on reader service card

Circle 337 on reader service card

337

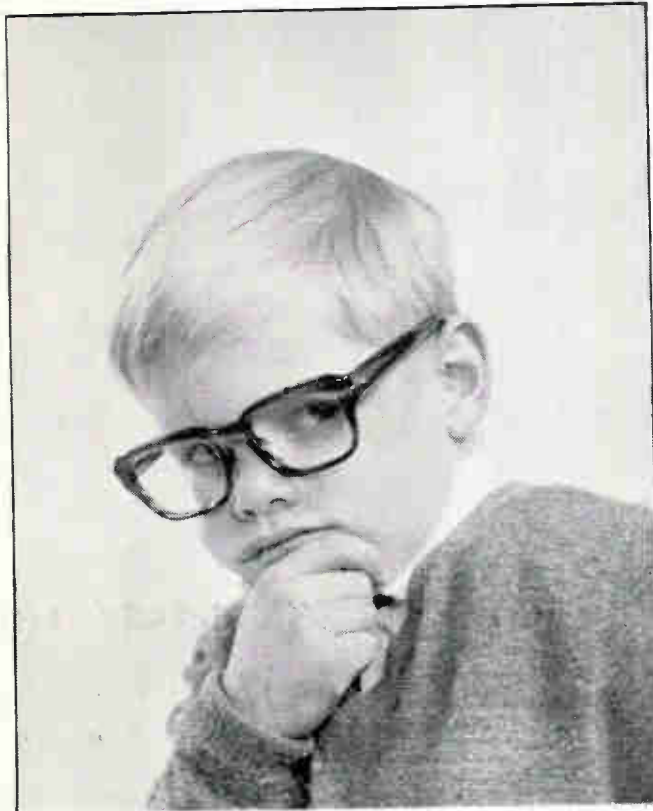

Are you a chronic skeptic?

You've read about Compet 20A! We have told you that it has no moving parts, so its operation is silent.

You've heard that it automatically indicates plus, minus, and decimals; that it calculates 14 digits instantly.

We've said misuse can't hurt it, plug-in circuits simplify maintenance, and a special mechanism prevents pressing 2 keys at once.

But some people have to see for themselves. A Sharp Compet will be on exhibit at the IEEE Show, Booth 4J24.

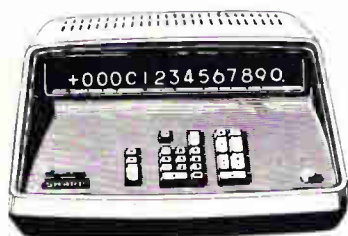

COMPET Model CS-20A

SHARP

HAYAKAWA ELECTRIC CO., LTD.
Osaka, Japan

U.S. Subsidiary: SHARP ELECTRONICS CORP. 178 Commerce Road, Carlstadt, New Jersey

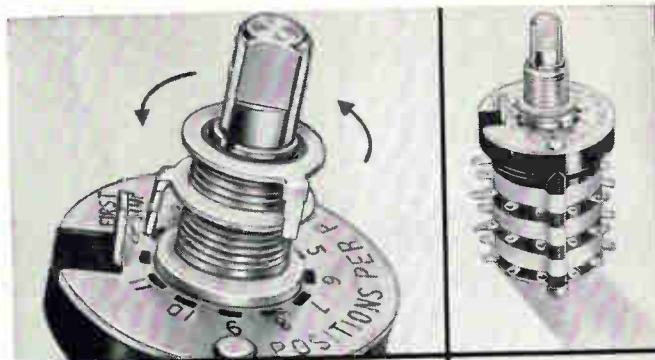

Grayhill[®]

Miniature Adjustable Stop Rotary Switches...

... the Difference Between Excellent and Adequate ...

Select your own circuitry.
Ideal for prototype and small production runs.

Select Materials:

- Contacts: Silver Alloy
- Terminals: Brass, Lead-Tin Plated and Fused
- Common Plate: Brass, Silver Plated

Typical Specifications:

- Explosion Proof
- Stop strength: 12 Pound-Inches Minimum
- 1 to 12 Decks
- 1 to 4 Poles per Deck
- 2 to 12 Positions per Pole
- Life Expectancy; 100,000 Operations

... in
**Design
Materials
Construction**

Send for
Engineering
Data
Book

Grayhill
INC

523 Hillgrove Avenue
LaGrange, Illinois 60526
Area Code 312, Phone 354-1040

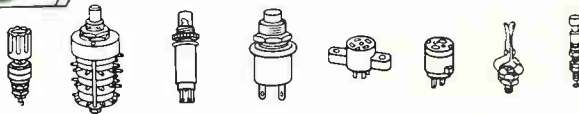

See us in Booth 4E03-IEEE

NOW

illuminated panel switch

- UL LISTED
2 amps 115 V a-c
- Combination Light
and Switch
- Low Cost per unit

Designed for functional beauty—with unlimited button and trim ring color combinations. Unique snap-in mounting available for panel installations from 1/32" to 7/16" thickness. Diffused lens. Legend identification on button available. Switch is available in push-on-push-off and momentary contact units. 115 V a-c (neon) 6 thru 28 V (incandescent). Specials up to 8.5 amp. rating.

For complete details . . . write to

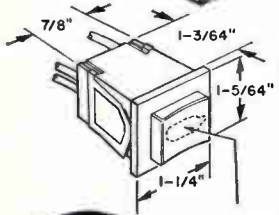

NEON BULB



MOLEX® PRODUCTS CO.

5222 Katrine Ave., (312) 969-4550
Downers Grove, Ill. 60515 TWX 910 695-3533

Circle 547 on reader service card

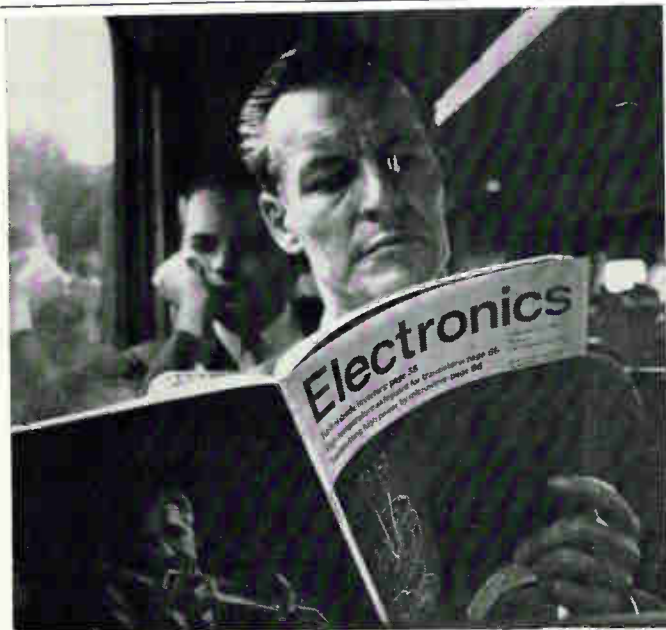

Great editorial is
something he takes to work
(What a climate for selling!)

Electronics

A McGraw-Hill Market-Directed Publication
230 West 42nd Street, New York, N.Y. 10036



WHEN YOUR PRODUCT IS AT STAKE

DON'T
DISREGARD
EXPERIENCE

Ney has been in the highly specialized field of precious metals for over 150 years—in the ELECTRICAL CONTACT business for over 20 years. This adds up to the kind of EXPERIENCE that guarantees greater RELIABILITY when your product includes contacts made from Paliney and Neyoro alloys.

No contact assembly can be more reliable than the precious metals that go into it, and Ney has always developed and manufactured its own proprietary precious metal alloys from the raw metal up. Obviously, this insures optimum control of the critical physical properties of the alloys you find in Ney parts or assemblies.

Ney has also contributed to advances in precious metal technology with such innovations as the Neyetch process. Neyetch commutators give you a pattern of SOLID PRECIOUS METAL ALLOY, Neyoro G, bonded to a rigid insulator. This means added product reliability and greatly reduces costly maintenance. Wear is longer and such common plating defects as porosity, flaking, peeling, pits and inclusions are eliminated. This is a perfect example of what we mean when we say Ney experience brings you greater product reliability. Get all the facts in our 48-page Catalog R-65.



48-PAGE ELECTRICAL CONTACT CATALOG ON REQUEST

THE J.M. NEY COMPANY
Maplewood Ave., Bloomfield, Conn.

NEY



*Our pulse
is running faster
these days*

The pulse of Electronics Division is found in a broad spectrum of equipment these days. Exciting, sophisticated equipment like the F-111 AGE, AUTODIN, unusual K-band ECM, and Polaris/Nike-Zeus/Atlas checkout systems.

Our pulse can be found in many environments: guiding an aircraft via TACAN, or radar-mapping terrain; on the ground, in a mobile communications central; on the ocean, in a NASA Apollo instrumentation ship; and beneath, in a high-power ASW acoustic system.

The scope and depth of our interests can carry you into any one of a multitude of pursuits. Your objective will be excellence; sustained excellence that generates new business, and, not incidentally,

**(has it been a while
since yours did?)**

a chance to work on the really meaty problems skilled engineers thrive on.

Meeting this objective will demand a lot of new ideas. Ideas in research, design, engineering, design assurance, production and quality control. Ideas in product and process engineering, manufacturing, and a host of other areas.

We've created an environment where new ideas flourish. A thoroughly professional environment, as a matter of fact, in Rochester, New York, the city with more professionals per capita than any other its size. Why not consider joining us? We can promise you a chance to test your engineering mettle to its fullest. Send your resume, in confidence, to Mr. L. A. Corwin, Dept. 193.

GENERAL DYNAMICS

Electronics Division

1400 N. Goodman St., Rochester, New York 14601

An Equal Opportunity Employer (M&F)



A new approach to engineering

At Hewlett-Packard you can take your engineering training to market.

There's little point to designing and manufacturing an electronic measuring instrument unless it's going to be useful to someone. That's why, at Hewlett-Packard, many engineers make a career of marketing.

All engineers at Hewlett-Packard are marketing oriented, but a defined and trained group is assigned the engineering task of helping customers. These engineers work at our headquarters, at operating divisions and in the field, helping customers select, apply and get the best use out of their instrumentation.

With our concept that every new instrument must make a contribution to the science of measurement, our instruments and marketing engineers create new markets, and the sales engineer finds his stimulation...and success...in defining and exploring these markets and in helping to solve the measurement problems found there. And at Hewlett-Packard you can start as a design engineer and later move into marketing.

If, as an engineer, this type of dynamic work interests you, we'd be interested in talking to you. At Hewlett-Packard marketing is a career, and our sales success—over \$200 million this year—is an ever growing challenge to our marketing engineers. Would you like to join them?

Write Ray Wilbur, Vice President, 1501 Page Mill Road, Palo Alto, California 94304. An equal opportunity employer.

HEWLETT  PACKARD



A new approach to engineering

At Hewlett-Packard you can take your engineering training to market.

There's little point to designing and manufacturing an electronic measuring instrument unless it's going to be useful to someone. That's why, at Hewlett-Packard, many engineers make a career of marketing.

All engineers at Hewlett-Packard are marketing oriented, but a defined and trained group is assigned the engineering task of helping customers. These engineers work at our headquarters, at operating divisions and in the field, helping customers select, apply and get the best use out of their instrumentation.

With our concept that every new instrument must make a contribution to the science of measurement, our instruments and marketing engineers create new markets, and the sales engineer finds his stimulation... and success... in defining and exploring these markets and in helping to solve the measurement problems found there. And at Hewlett-Packard you can start as a design engineer and later move into marketing.

If, as an engineer, this type of dynamic work interests you, we'd be interested in talking to you. At Hewlett-Packard marketing is a career, and our sales success—over \$200 million this year—is an ever growing challenge to our marketing engineers. Would you like to join them?

Write Ray Wilbur, Vice President, 1501 Page Mill Road, Palo Alto, California 94304. An equal opportunity employer.



CIRCLE 707 ON READER SERVICE CARD

FOR SALE



When you have used electronics equipment to sell, advertise in Electronics Searchlight Section for fastest results.

For information:
Searchlight Section
Classified Advertising Division
Post Office Box 12
New York 10036

CIRCLE 707 ON READER SERVICE CARD

BIG CATALOG

World's "BEST BUYS" in GOV'T. SURPLUS Electronic Equipment

FULL OF TOP QUALITY ITEMS—Transmitters, Receivers, Power Supplies, Inverters, Microphones, Filters, Meters, Cable, Keyers, Phones, Antennas, Chokes, Dynamotors, Blowers, Switches, Test Equipment, Headsets, Amplifiers, etc., etc. SEND 25¢ (stamps or coin) for CATALOG and receive 50¢ CREDIT on your order. Address Dept. E-7.

FAIR RADIO SALES
P.O. Box 1105 · LIMA, OHIO · 45802

ELECTRON TUBES

KLYSTRONS • ATR & TR • MAGNETRONS
SUBMINIATURES • C.R.T. • T.W.T. • 5000-6000 SERIES
• SEND FOR NEW CATALOG A2 •
A & A ELECTRONICS CORP.
1063 PERRY ANNEX
WHITTIER, CALIF.
696-7544

CIRCLE 968 ON READER SERVICE CARD

In electronics it's Electronics magazine to sell used equipment!

Your advertisement will produce Results in Electronics. Engineers turn to Electronics magazine for the latest technical developments — and for the latest buying information. You can reach them inexpensively in Electronics Searchlight Section.

For information:
Searchlight Section
Classified Advertising Division
Post Office Box 12
New York 10036

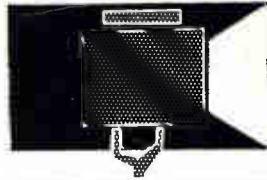

SEARCHLIGHT SECTION

• CLASSIFIED ADVERTISING • BUSINESS OPPORTUNITIES
• USED OR SURPLUS EQUIPMENT

AUTOTRACK ANTENNA MOUNT

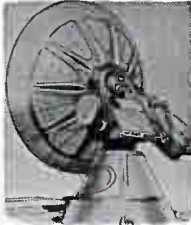

360 degree azimuth, 210 degree elevation sweep with better than 1 mil. accuracy. Missile velocity acceleration and slewing rates. Amplidyne and servo control. Will handle up to 20 ft. dish. Supplied complete with control chassis. In stock—immediate delivery. Used world over by NASA. USAF, MP-61-B. Type SCR-584. Nike Ajax mounts also in stock.

PULSE MODULATORS

MIT MODEL 9 PULSER 1 MW—HARD TUBE
Output 25kv 40 amp. Duty cycle .002. pulse lengths .25 to 2 microsec. Also .5 to 5 microsec. and 1 to .5 microsec. Uses 6C21. Input 115v 60 cycle AC. Mfr. GE. Complete with driver and high voltage power supply. Ref: MIT Rad. Lab. Series, Vol. 5, p. 152.

2 MEGAWATT PULSER
Output 30 kv at 70 amp. Duty cycle .001. Rep rates. 1 microsec 600 pps. 1 or 2 msec 300 pps. Uses 5948 hydrogen thyratron. Input 120/208 VAC 60 cycle. Mfr. GE. Complete with high voltage power supply.

250 KW HARD TUBE PULSER
Output 16 kv 16 amp. Duty cycle .002. Pulses can be coded. Uses 5D21, 715C or 4PR60A. Input 115 v 60 cy. AC \$1200 ea.

VARIAN KLYSTRONS

V-45: 15W output CW 9 to 10 KMC
VA-800: 10 KW output CW 1.7 to 2.4 KMC
VA-806H: 1KW output CW 7.5 to 8.5 KMC
T.W.T.
VA-137C: 5KW Peak, 350 W avg. .87 to 1.0 KMC
RCA-1154: 10 MW output 1.5 to 4.5 KMC
RCA-1181: 1 Watt output 1.9 to 4.1 KMC

PLAN POSITION INDICATOR CONSOLE

Complete PPI console operating from 115 volt 60 cycle AC. 10" CRT range 4 to 250 miles. Digital height readout. Complete AN/UPA-25. Price \$1200.

SCR 584 AUTOTRACK RADARS

Our 584s in like new condition, ready to go, and in stock for immediate delivery. Ideal for telemetry research and development, missile tracking, satellite tracking. Fully Desc. MIT Rad. Lab. Series, Vol. 1, pps. 207-210, 228, 284-286. Comp. Inst. Bk available \$25.00 each.

MICROWAVE SYSTEMS

L BAND RF PKG.

20 KW peak 890 to 1040 MC. Pulse width .7 to 1.2 micro sec. Rep. rate 180 to 420 pps. Input 115 vac incl. Receiver \$1200

200-225 mc RADAR SYSTEM

1 Megawatt output. 200 nautical mile range for long range detection of medium and high altitude jet aircraft as well as general search. Complete system in stock. Input 120/208 V. 60 cy. Type TFS-28.

C-BAND RADAR

250 KW output. C-band. PPI indicator. 5C22 thyratron modulator. Antenna hi gain parabolic section. Input 115 volts 60 cycle AC, complete \$2750.00

200 TO 2400 MC RF PKG.

200 to 2400 MC CW. Tuneable. Transmitter 10 to 80 Watts. Output. As new \$475.

500 KW L BAND RADAR

500 kw 1220-1359 msc. 160 nautical mile search range P.P.I. and A scopes. MTI. Thyratron mod 5J26 magnetron. Complete system.

100 KW X BAND RADAR

Complete 100 kw output airborne system with AMTI. 5C22 thyr. mod. 4J52 magnetron. PPI, 360 deg as sweep, 60 deg. elev. sweep, gyro stabilizer, hi-gain revr. Complete with all plugs and cables.

AN/GPG-1 SKY-SWEEP TRACKER

3 cm. automatic tracking radar system. Complete package with indicator system. Full target acquisition and automatic tracking. Input 115 volts 60 cycle Now in stock for immediate delivery. Entire System 6' long, 3' wide, 10" high. Ideal for Infrared Tracker. Drone Tracker, Missile Tracker, R. & D.



500KW S BAND RADAR

250 miles search 115V 60 cy AC. Mfg. G.E.

RADAR AUTO-TRACK & TELEMETRY ANTENNA PEDESTALS 3 & 10 CM. SCR 584 AUTOTRACK RADARS. M-33 RADAR TPS-10 SEARCH. APS-45 TPS-10D HT. FINDERS. WX RADARS. FPN-320CA. APS-10 APS-15B APS-27 (AMTI) SEARCH. ■ ■ ■ APN-102. DOPPLER. DOZENS MORE. CARCINOTRONS. PPN'S. 25-.5-1-2-3-6 MEGAWATT PULSE MODULATORS. CAVITIES. PULSE TRANSFORMERS. IF STRIPS. WAVEGUIDE. BENDS 200 MC. 1 KMC. 3 KMC. 6 KMC. 9 KMC. 24 KMC. RF PKGS.

RADIO RESEARCH INSTRUMENT CO.
550 5TH AVE., NEW YORK 36, N. Y. JU 6-4691

CIRCLE 966 ON READER SERVICE CARD

MINI-FLUID DISPENSER

AIR OPERATED

for miniature potting and encapsulating

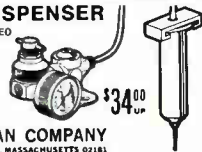

Available in 3 sizes
6cc - 12cc - 30cc

PHILIP FISHMAN COMPANY
7 CARMON ST., WELLESLEY, MASSACHUSETTS 02151

CIRCLE 969 ON READER SERVICE CARD

FOR SALE

When you have used electronics equipment to sell, advertise in Electronics Searchlight Section for fastest results.

For information:
Searchlight Section
Classified Advertising Division
Post Office Box 12
New York 10036

TEST EQUIPMENT

For over 20 years specializing in top brands only. Write for our latest listing. We buy complete inventories.



ELECTRONIC SALES

1413 Howard Street, Chicago, Illinois 60626
Telephone ROgers Park 4-0600

CIRCLE 967 ON READER SERVICE CARD

BIG CATALOG

World's "BEST BUYS" in GOV'T. SURPLUS Electronic Equipment

FULL OF TOP QUALITY ITEMS—Transmitters, Receivers, Power Supplies, Inverters, Microphones, Filters, Meters, Cable, Keys, Phones, Antennas, Chokes, Dynamotors, Blowers, Switches, Test Equipment, Headsets, Amplifiers, etc. SEND 25¢ (stamps or coin) for CATALOG and receive 50¢ CREDIT on your order. Address Dept. E-7.

FAIR RADIO SALES
P.O. Box 1105 • LIMA, OHIO • 45802

ELECTRON TUBES

KLYSTRONS • ATR & TR • MAGNETRONS
SUBMINIATURES • C.R.T. • T.W.T. • 5000-6000 SERIES
• SEND FOR NEW CATALOG A2 •
A & A ELECTRONICS CORP.
1063 PERRY ANNEX
WHITTIER, CALIF.
696-7544

CIRCLE 968 ON READER SERVICE CARD

Newsletter from Abroad

March 6, 1967

Five nations plan '69 communications satellite launch

There's a good chance that the first all-European telecommunications satellite will be in service before 1970. The Scandinavian countries, together with Italy and Belgium, expect to nail down an agreement next month with the European Launcher Development Organization for a mid-1969 launching of an experimental satellite the five nations plan to build.

The booster would put the satellite—dubbed F-9 because it will be the ninth ELDO launch—into a polar orbit with an apogee of 2,500 miles and a perigee of 250 miles. Because of the varying altitude, the capacity of the satellite would range between 60 and 240 channels.

Instead of the traveling-wave tubes used so far for satellite transmitters, the F-9 will have a solid state transmitter built by Sweden's L.M. Ericsson Co. The associated receiver will come from the Danish government's microwave laboratory, and the microwave beacon from the Bell Telephone Mfg. Co., a Belgian subsidiary of the International Telephone and Telegraph Corp. The Italians will build the satellite airframe and a second transponder unit. The Norwegians will supply the telemetering facilities.

Defense R&D cuts hurt West German avionics producers

Most West German electronics companies expect their avionics business to plummet this year. Some anticipate a drop of as much as 60% in their sales to the aircraft industry, and several are shifting emphasis to the production of tank equipment.

The dismal outlook stems from a decision by the Kiesinger government to cut back sharply on development of military aircraft. This year's budget earmarks only \$75 million for R&D in this field, compared to \$89 million last year. And \$45 million of the 1967 allotment will cover work done last year. Because the remaining \$30 million can't support the aircraft industry's current research effort, the government urged aerospace firms to trim their work forces by 15%. As a result, some 1,200 scientists and engineers will be laid off by the end of this month. Another wave of layoffs may follow in June.

Rental returns worry Japanese computer makers

A rise in turnbacks of rented machines in recent years has Japanese computer makers uneasy. For the fiscal year that ends this month, returned data-processing equipment will total about \$12 million, compared with an estimated \$80 million of new machines leased. The percentage of returns—15% this year—has been increasing steadily since the first turnback of a rented machine in 1961.

To ease the sting, Japanese computer firms are plumping for a faster writeoff of rented units. The government-sponsored Japan Electronic Computer Co., which buys computers from the six native computer makers and leases them, currently depreciates new equipment at a rate of 15% over the first six years and 10% for the seventh year. The computer makers are pressing for a five-year writeoff. At the same time, they have asked the Ministry of Finance for a tax writeoff on returned computers they carry in stock or resell at a loss. Japan Electronic Computer has the right to unload a returned computer—at its depreciated value—on its manufacturer.

The six Japanese computer makers last fall moved to forestall future

Just push a button to select one of five different functions and make measurements in a total of 23 ranges.

Measure (1) dc voltage in 3 ranges from 0.0000 to ± 999.99 volts with automatic and manual ranging. Accuracy: $.005\% \pm 1$ digit. Sensitivity: 100 microvolts. Measure dc millivolts in 2 ranges from 00.000 to 100.00 millivolts. Accuracy: $.02\% \pm 1$ digit. Sensitivity: 1 microvolt. Stability: 30 days with 10°C temperature variation. Push a button for (2) DC/DC ratios in 3 ranges from .00000:1 to $\pm 99.999:1$. Standard feature: automatic polarity selection. Push a button to measure (3) ac in 3 ranges from 00.000 to 1000.0 volts rms; (4) dc current in 6 ranges from 0.0000 microamperes to ± 100.00 milliamperes; (5) resistance in 6 ranges from 0.0000 kilohms to 100.00 megohms.



Each button lights up for positive identification. And this versatile instrument takes up just $5\frac{1}{4}$ inches in a 19-inch rack. Model 533-4810, rackmount: \$2,750.

Also available: our new 530 Series DC DVM/Ratiometer, which measures dc voltage in 3 ranges from 0.0000 to ± 999.99 volts and DC/DC ratios in 3 ranges from .00000:1 to $\pm 99.999:1$. Accuracy: $.005\% \pm 1$ digit. Automatic ranging and pushbutton function selection are included in both cabinet (half-rack) Model 531-1000 and rackmounting Model 531-3000 at \$1,495.

Prices FOB San Diego. Additional export charge. Better get full details now from your nearest Cohu engineering representative. Or contact Ken Walker, Manager, Instruments and Systems. Phone 714-227-6700, or write Box 623, San Diego, California 92112.

NOW
FIVE
FUNCTIONS
AT
YOUR
FINGERTIPS
WITH
THE
FIRST
TRUE
PUSHBUTTON
MULTIMETER—

COHU'S NEW 530 SERIES



See us at IEEE, Booth 2D13



**Delegate
your
communication
system
message integrity
problem
to us.**

If we haven't already solved it, we will. That goes for your size/weight, compatibility and dependability problems too.



ELECTRONIC COMMUNICATIONS, INC.
ST. PETERSBURG DIVISION

To investigate career opportunities in communications, call or write Mr. Chuck Kelly, Professional Placement Office, Electronic Communications Inc., P.O. Box 12248, St. Petersburg, Florida 33733. Telephone (813) 347-1121. (Equal opportunity employer, M & F.)

Circle 550 on reader service card

New ECI satellite ground terminal at St. Petersburg will enable our space communications specialists to conduct real-time experiments with advanced satellites.

Switzerland

IC time

New timekeeping techniques, now in the research stage, will depend heavily on integrated circuits for extremely low-power logic.

At the Neuchâtel Horological Electronics Center, the research and development arm of the Swiss watchmaking industry, engineers are working on a timepiece based on a small quartz-crystal oscillator. It will make obsolete "electronic" tuning fork wristwatches like the Accutron of the Bulova Watch Co. and the Horological Center's own improved versions of the Accutron which the Swiss will show next month at Expo 67, the Montreal World Fair.

The Swiss versions use integrated circuits and have tuning forks with a circular or H-shape rather than the U-shape of the Accutron's fork. For its part, Bulova sees no particular advantage in an IC for a tuning-fork watch. William O. Bennett, the company's vice president for research, points out that the circuit has only three components: a transistor, a capacitor, and a resistor. He maintains IC's have an edge only for circuits with many components. Bulova incidentally, owns a Swiss watch company and thus indirectly has a hand in the Neuchâtel work.

Divide and conquer. The all-electronic watch the Swiss have as their goal will use an 8.2-kilo-hertz quartz oscillator as the basic timekeeping element. The crystal output will be counted down to one hertz by binary dividers.

"This is the classical way of dividing down," says project engineer Fred Leuenberger, "but the power consumption goal is quite unique." The aim is to do the whole thing with 10 microwatts. "We are now high by a factor of two," says Leuenberger, "because we have not

yet optimized the circuits."

The next-generation timepiece will use integrated circuits fabricated by quartz isolation techniques adapted from the "epic" technique of Motorola Inc. [Electronics, April 6, 1964, p. 29]. The Swiss use a single crystal material on a polycrystalline substrate and the two are insulated by a thermally grown silicon dioxide layer.

The crystal now being developed is three-quarters of an inch long, suitable for use in a man's watch but too big for a woman's. A 1.3-volt battery provides power.

Hands off. At present, says Leuenberger, there are no short-term plans for "display" beyond the conventional hands. The quartz oscillator divides down to the low frequency, and this triggers a step motor that moves the hands.

But eventually, says Leuenberger, the all-electronic watch will have no moving parts. Techniques for converting electricity into light require too much power, so other possibilities are under study.

These include such electro-optic techniques as using crystals to control the incidence of ambient light and change angles of diffraction in such a way that the pattern will give a readout of time. Also under study is an electro-capillary technique, using a liquid such as mercury in a shaped capillary tube. By application of an electromagnetic field, the liquid metal can be made to appear in small windows to indicate minutes and hours.

"The principle is not new, but this sort of thing is a long way off as far as power requirements are concerned," says Leuenberger of the capillary readout. The IC logic available to control it requires too much power. One low-power avenue the Swiss are trying is complementary metal oxide semiconductor circuits, using a pulsed power mode and therefore essentially zero standby power.

Great Britain

Dishing it up

An inordinate bustle is in store for the Marconi Co. over the next 13 months. Marconi in mid-February landed a \$4 million contract to add a new terminal with a 90-foot antenna to Britain's satellite communications station at Goonhilly Downs in Cornwall. Marconi has to turn over the station—ready to work—to the government-run telephone system by April 1968.

Although the job involves the biggest antenna dish ever built in Britain, Marconi executives are con-

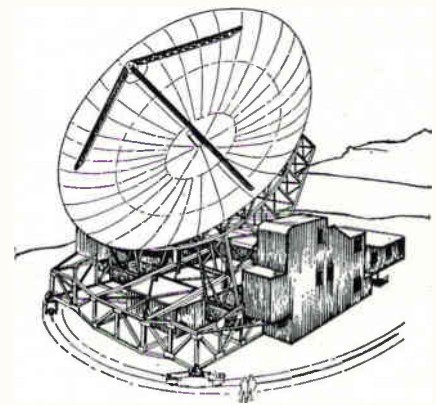

British dish. To tie into the Intelsat 3 satellite system, Goonhilly Downs ground station in Cornwall next year will have a new terminal with a 90-foot diameter stainless steel antenna.

fidant they can make the deadline with a crash production program. Marconi, one of the companies in the English Electric group, previously rushed through four satellite communications terminals with 40-foot dishes in less than a year.

Underlying reason for the tight deadline is Britain's fast-growing overseas telephone traffic. Post Office officials who run the phone system estimate they'll need about

black-and-white standard in from 10 to 15 years. Both BBC-1 and ITV will have to broadcast in black-and-white on 405-lines the same programs they air in color for perhaps another decade. But after that, the government plans to phase out the 405-line standard.

Japan

Light touch

Even though it cranks out radios, television sets and desk calculators by the thousands, the Hayakawa Electric Co. has become something of a specialist in photoelectric components. At this month's Institute of Electrical and Electronics Engineers convention in New York, Hayakawa will be out to make U.S. equipment makers see the light its way.

The company is introducing a silicon solar cell with a response that peaks in the visible part of the spectrum rather than in the infrared region as conventional units do. Another new Hayakawa device that will bow at the show is a tiny phototransistor that develops an output signal strong enough to drive a relay directly. And Haya-

kawa will display building blocks that have been used to make up some of the largest earthbound solar batteries yet.

Blue cell. Hayakawa put a twist on a widely used passivation technique to get a "blue" silicon solar cell that has its peak response to light at a wavelength of 0.56 micron, in the visible region. Peak outputs of ordinary silicon solar cells occur at wavelengths between 0.80 and 0.90 micron.

With its fast response to visible light—the rise time is less than 10 microseconds—the blue cell may find wide use in electronic shutters. Other potential applications are exposure meters, flame detectors and spectrum analyzers.

To make the cell, Hayakawa starts with p-type silicon and grows a thermal silicon-dioxide layer atop it—the usual passivation layer. In the process, an n-type inversion layer 0.3 micron thick forms directly beneath the passivation layer. The n-p junction thus lies much closer to the surface than does the junction in an ordinary solar cell, and this results in less attenuation of shorter wavelengths.

To further improve the cell's response to light in the visible spectrum, Hayakawa deposits by vacuum over the thermally grown silicon dioxide layer a second sili-

con dioxide layer and finishes off the cell with a proprietary epoxy coating. The coating is designed to pass visible light and block out most of the infrared. Optical interference between the three layers gives the cells their blue color.

Miniscule. Hayakawa also has an apparent winner in its minute phototransistor, a chip 650-microns square packaged in a pin-head-size mount. There are many photodiodes as small, but this transistor has a big plus: for many applications, its output needs no amplification. With an illumination of 5,000 lux, for example, the transistor's output current is at least 3 milliamperes, enough to operate a small relay.

Although the device will make its public debut at the IEEE convention, it's already been adopted by one Japanese manufacturer for a card reader. And it seems a likely component for infrared communications gear, control equipment, and pattern-recognition units.

King size. In contrast to the tiny phototransistors, the solar-cell battery packages are king size, each made up of 20 semicircular silicon wafers of 23-millimeter diameter. The package is shatter-resistant plastic, sealed to make it weather-tight. Power output is better than 360 milliwatts. From these packages Hayakawa has built panels with outputs as high as 225 watts to power unattended lighthouses off the Japanese coast.

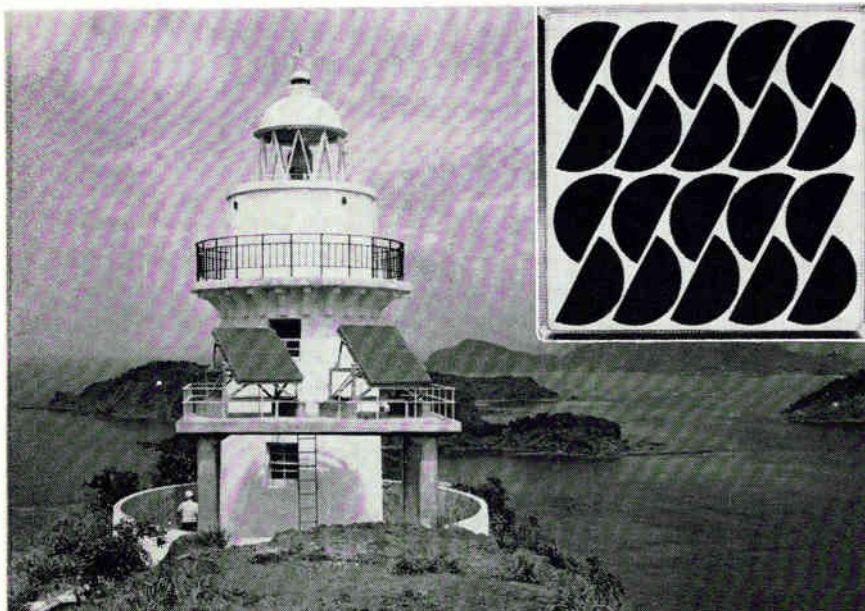

Alone under the sun. Unattended lighthouse off Japanese coast is powered by solar panels that generate 225 watts. Panels are built up of 20-cell packages shown in inset.

France

Millimeter waveguide

Blue-sky thinkers already foresee a time when city dwellers will need transmission lines with megacycles of bandwidth to handle the flow of data for computer-run electronic households. The household hardware still is a long way off, but a likely candidate for the transmission line is in sight.

In a project that's been kept largely under wraps so far, the Centre National d'Études des Télécommunications (CNET) is install-

Planck Institute for Radio Astronomy near Bonn is now using a radio telescope that "takes the sun's temperature" at points across the solar surface. With a 33-foot-diameter antenna dish, the telescope picks up signal strength caused by the different levels of light intensity. These readings are then plotted. From the plottings, maps are drawn showing the contours of the sun's hot and cold zones. Daily shifts of these contours—sometimes called coronal condensations—may indicate impending proton shower activity. The telescope is atop Stockert Mountain, about 20 miles southwest of Bonn.

Round the clock. Similar work is being done in the U.S. Under an Air Force sponsored program, the Prospect Hill Radio Observatory at Waltham, Mass., has plotted a number of sun temperature readings using a radio telescope operating on an 8.6-millimeter wavelength and having a 29-foot-diameter antenna dish. By coordinating solar research with observatories around the world, it is possible to provide round-the-clock forecasts as the sun moves across the sky, says Otto H. Nachenberg, the Bonn institute's technical director. But so far the Waltham and Stockert installations are the only ones built for this purpose.

The West German telescope has an aluminum antenna dish whose shape varies by no more than 0.5 mm from that of an ideal parabola. The antenna is equatorially mounted—one axis in the north-south direction and the other perpendicular to it. The telescope has a beamwidth of 3.5 minutes of arc.

As the sun moves across the sky, the antenna automatically follows it. The feedhorn scans the sun in discrete steps of 2.5 minutes of arc from top to bottom in columns from right to left. In this raster-type motion, 80 regions are scanned. It takes about three minutes to cover the solar surface. The antenna movement is controlled by a synchomotor-driven quartz clock, supplied by West Germany's Rhode and Schwarz AG.

Clearer picture. The receiver—designed by the institute—has a 10 decibel noise level and a band-

NEW! ONLY FROM INDUSTRO

HIGH VOLTAGE

SILICON TRANSISTORS

PNP
200-500V

NPN
200-1000V



TO-5
5 WATTS



MD-14
15 WATTS

Design Your Complementary Circuits with INDUSTRO High Voltage Transistors

PNP		NPN	
V_{CEO} @ $I_C = 10mA$	200-500V	V_{CEO} @ $I_C = 25mA$	200-600V
V_{CER} @ $I_C = 200\mu A$	200-500V	V_{CER} @ $I_C = 200\mu A$	200-1000V
H_{FE} @ $V_{CE} = 10V$ $I_C = 20mA$	30 min.	H_{FE} @ $V_{CE} = 4V$ to 475V: $I_C = 50mA$ from 500V: $I_C = 25mA$	30 min.
GBW @ $V_{CE} = 20V$ $I_C = 10mA$	30 MHz	GBW @ $V_{CE} = 10V$ $I_C = 50mA$	60 MHz

Write today for complete specifications.

watch...



INDUSTRO TRANSISTOR CORPORATION

35-10 36th AVENUE / LONG ISLAND CITY, NEW YORK 11106 / (212) EX 2-8000

Visit us at The Plaza (Fifth Ave. at 59th St.) during the IEEE Show

Glen Cove, N.Y., and Electronic Associates of Canada Ltd. are also manufacturing paper-monitoring devices.

Around the world

Sweden. Saab AB has developed a television tracker to guide missiles and aircraft. With the system, an operator views target sectors on a tv screen and sets a contrast control to select targets. The system then locks onto the target automatically.

Italy. The first satellite launching from Italy's San Marco Texas-tower platform off the coast of Kenya is scheduled for late April. The Italian-built 250-pound satellite—San Marco 2—will be put into an orbit of 155 to 185 miles by a NASA Scout rocket. San Marco 1 was launched in the U.S. in December, 1964, by an Italian crew.

Great Britain. The General Electric Co. (not connected with its U.S. namesake) has found the computer business too rough. The company last month sold its computer-making subsidiary to Elliott-Automation Ltd. for approximately the value of the contracts it had in progress—some \$5.5 million.

France. The first phase of France's space program ended last month with two launches and mixed success. The first satellite sent up, D-1C, went into a lower orbit than planned and the French had trouble tracking it with laser stations set up in France, Algeria, and Greece. The second satellite, D-1D, went into an orbit with a 1,900-kilometer apogee. This was not as high as planned but high enough for laser tracking from the three stations. The next all-French satellite launching is expected in the spring of 1969 from the new space center in French Guiana.

Japan. The Keihanshin Kyuko Railway Co. will soon have an unmanned station on one of its commuter lines. The station will have five ticket-vending machines, a bill changer, 10 automatic ticket checkers, and an automatic commutation ticket puncher.

WHICH DEFLECTION YOKE ? FOR YOUR DISPLAY ?



Consult **SYNTRONIC**

YOKE SPECIALISTS

Syntronic's team of experts knows more about yoke design, engineering and quality control than anyone else. A solid 10-year record of leadership—acknowledged throughout the industry. Benefit from it.

syntronic **INSTRUMENTS, INC.**
100 Industrial Road, Addison, Illinois
Phone: Kingswood 3-6444

Circle 553 on reader service card

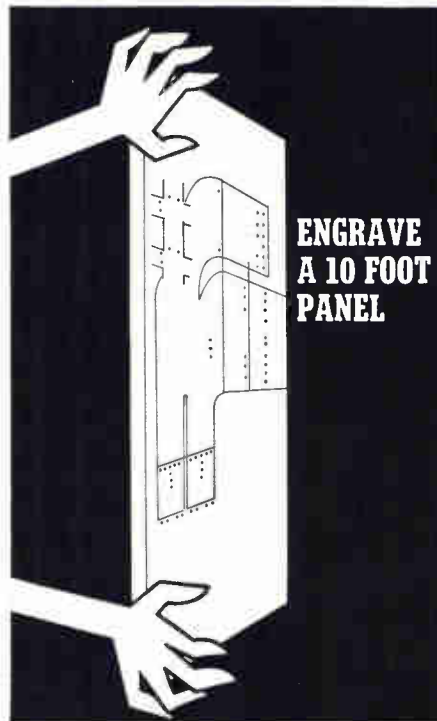

ENGRAVE
A 10 FOOT
PANEL

OR A TWO INCH
NAMEPLATE



The New Hermes Engravograph is a highly versatile pantographic engraving machine. Anyone in your plant can operate it—with big savings. Write for 24 page catalog to Dept. 156.



new hermes engraving machine corp.

20 Cooper Square, New York, N. Y. 10003 • Chicago, Atlanta, Los Angeles, Dallas, Montreal, Toronto, Mexico City

AMP Incorporated Garceau, Hargrave & McCullough Incorporated	81	Burroughs Corporation, Electronic Components Division Conti Advertising Agency, Incorporated	114	Engineered Electronics Jansen Associates	292
APM-HEXSEAL Corporation Mohr & Company, Incorporated	329	■ Busmann Mfg., Division of McGraw- Edison Company	290, 291	Erie Technological Products Co. Inc. Altman-Hall Associates	247
ACDC Faust/Day Incorporated	265	Henderson Advertising Company		■ E-Z Hook Test Products	337
■ Acme Electric Corporation Scheel Advertising Agency Incorporated	284	By-Buk Company Albert Frank, Guenther Law Advertising Incorporated	318	Fairchild Semiconductor Incorporated	12 & 13 106 & 107
■ Acopian Corporation Mohr & Company, Incorporated	197	■ CML, Division of Tenney Engineering Company Keyes, Martin & Company	333	■ Federated Purchaser Incorporated Marech Advertising Incorporated	295
Adams & Westlake Company F.H. Brown Advertising Agency	89	■ CTS Corporation Burton Browne Advertising	75	Field Emission Corporation Ken Webber Advertising	264
Adret Electronique P. V. P.	356	Carborundum Company Rumrill-Hoyt, Incorporated	238, 239	Frazar & Hansen, Limited Hixson & Jorgensen, Incorporated	16
Aero Jet Corporation, Division of General Tire & Rubber Corporation D'Arcy Advertising Company	112	Cerro Sales Corporation Feeley Advertising Agency, Incorporated	317	■ Fujitsu, Limited Shinwa Incorporated	76
Airpax Electronics Incorporated Welch, Mirabile & Company	250	Cherry Electrical Products Corporation K & A Incorporated	259	General Dynamics, Fort Worth Division Glenn Advertising Incorporated	208
■ Air Products & Chemicals Incorporated Arthur Falconer Associates	312	■ Cinch Manufacturing Company Stral Advertising Company	224, 225	■ General Electric Company George R. Nelson Incorporated	56
Allen-Bradley Company Fensholt Advertising Agency	101, 102	■ Clairex Corporation Michel-Cather Incorporated	170	General Electric Company, Electronic Components Sales Operation	34, 35
Alpha Metals Incorporated Black-Russell-Morris Advertising	329	Clarest Manufacturing Company Lescarboura Advertising Incorporated	264	General Electric Company, Component Capsules Division George R. Nelson Incorporated	71
Alpha Wire Corporation, Sub. of Lorai Electronics Corporation Campbell-Ewald Company	268	■ Clevite Corporation, Piezoelectric Division Carr Liggett Advertising Incorporated	331	General Electric Company, Lamp Glass Department Dix & Eaton Incorporated	195
■ Amelco Semiconductor, Division of Teledyne Incorporated Sturges & Associates	187	Cohu Electronics Erwin Wasey, Incorporated	353	General Electric Company, Semiconductor Products Division George R. Nelson Incorporated	279
American Coldset Corporation Apteryx Ltd.	218	■ Coil Winding Equipment Company J.J. Coppo Company Incorporated	198	General Magnetics Incorporated George Homer Martin Associates	32, 33
■ American Electronics Laboratories Greenfield-Ullman, Incorporated	327	Collins Radio Company John G. Barnett Advertising Agency	201	General Microwave Corporation Industrial Marketing Associates	236
■ American Lava Corporation Designers Incorporated	191	Computer Test Corporation James Lees Advertising	275	General Radio Company Horton, Church & Goff	6
■ Ammon Instruments Incorporated Culver Advertising Agency	338	Computer Measurements Company Charles Bowes Advertising Incorporated	203	Globe Industries Incorporated Odiorne Industrial Advertising	290
■ Amperex Electronics Corporation Sam Graden Incorporated	205	Control Data Corporation, AD-Comp Division Barner-Champ Advertising	269	■ Grayhill Incorporated Merchandising Advertising	339
Amperite Company H. J. Gold Company	282	Control Switch Division of Control Co. of America Harry P. Bridge Company	273	Gries Reproducer Company Harold Marshall Advertising	338
Amphenol Corporation, Connector Division Marsteller Incorporated	178, 179	Coto Coil Company Incorporated Williams Company	320	■ Guardian Electric Manufacturing Company K. & A. Advertising	289
Arnold Engineering Company Burton Browne Advertising	199	Damon Engineering Incorporated L.K. Frank Company, Incorporated	286	■ Gudebrod Brothers Silk Company Ramsdell-Buckley & Company	88
Associated Testing Laboratories, Incorporated Frank Best & Company, Incorporated	270, 271	Di-Acro Corporation Charles E. Brown Advertising	272	Hamilton Standard Company, Division of United Aircraft Corporation Cunningham & Walsh	92
■ Astrosystems Incorporated Edward W. Robotham Company	316	Digi-Data Corporation Product Promotions Agency	305	Hamilton Watch Company Beaumont, Heller & Sperling Incorporated	309
Automatic Electric Company Tatham-Laird & Kudner, Incorporated	261	Dormeyer Industries Symonds, Drimilla & Company	314	Hayakawa Electronics Company, Limited Dai-Ichi International	339
■ Bausch & Lomb Incorporated Wolff Associates Incorporated	39 to 42	■ Dorne & Margolin Incorporated Snow & Depew Advertising	234	■ Heath Company Advance Advertising	333
The Baker Company, Incorporated Northern Advertising, Incorporated	325	Duncan Electronics Incorporated Bonfield Associates	288	Heinemann Electric Company Thomas R. Sundheim	95
Ballantine Laboratories Lang-Lawrence Advertising	293	■ DuPont de Nemours & Company, Freon Division Batten, Barton, Durstine & Osborn Incorporated	69	Hewlett-Packard, Harrison Division Healy Advertising Agency	17
■ Barnstead Still & Sterilizer Company Creamer Trowbridge & Case Incorporated	258	■ DuPont de Nemours & Company, Mylar Division Batten, Barton, Durstine & Osborn Incorporated	189	Hewlett-Packard, Frequency & Time Division Lennen & Newell Incorporated	1
Beckman Instrument Incorporated, Offner Division Hixson & Jorgensen Incorporated	285	Durant Manufacturing Company Franklin Mautner Advertising	190	Hewlett-Packard, Loveland Division Tallant/Yates	249
■ Belden Manufacturing Company Fensholt Advertising, Incorporated	209	E G & G Incorporated Culver Advertising Incorporated	334	Hewlett-Packard, Microwave Division Lennen & Newell Incorporated	108, 109
Bell Telephone Laboratories N.W. Ayer & Son Incorporated	210	■ Eagle Signal Division of Gamewell, Sub. of E.W. Bliss Company Feeley Advertising Agency	18, 19	■ Hewlett-Packard, F.L. Mosley Company Division Lennen & Newell Incorporated	105
Bendix Corporation, Flight & Engine Instruments Division MacManus, John & Adams Incorporated	263	Electro Scientific Industries Nadler & Larimer, Incorporated	80	Hewlett-Packard, Rockaway Division Culver Advertising Incorporated	2
Bendix Corporation, Semiconductor Products Division MacManus, John & Adams Incorporated	110, 111	Electro Tec Corporation McClellan Associates	7	■ Houston Omnigraphic Corporation Ray Cooley & Associates	330
Bliss Gamewell Division of E. W. Bliss Company Feeley Advertising Agency	311	Electronic Communications Incorporated Neals & Hickok Incorporated	354, 355	Hughes Aircraft Company 73, 332, 334, 338 Foote, Cone & Belding Incorporated	338
Borden Chemical Company, Mystik Tape Industrial Division Conahay & Lyon, Incorporated	242	Eigenco Incorporated Wesco Advertising	326	■ Hull Corporation Michener Company Advertising	14
Bourns Incorporated, Trimpot Division Lester Company	220	Emerson & Cuming Incorporated Edwin F. Hall	324	Hysol Corporation Barber & Drullard Incorporated	276
Brush Instruments, Division of Clevite Corporation Carr Liggett Advertising Incorporated	9	Engelhard Industries Incorporated Keyes, Martin & Company	222, 223	IEEE (Institute of Electrical & Electronic Engineers) Alpaugh Advertising	305



■ Stackpole Carbon Company, Electronic Components Division Meek & Thomas Incorporated Steroline Systems Corporation	70 329
Clinton E. Frank Incorporated	
Stewart Warner Micro Circuits Incorporated	267
Jones, Mahar, Roberts Advertising	
Sylvania Electric Products Incorporated (Parts Division) Tatham-Laird & Kudner Incorporated Advertising	59
Sylvania Electric Products Incorporated, General Telephone and Electronics	3rd Cover
Tatham-Laird & Kudner, Incorporated	
Synthane Corporation	331
Arndt, Preston, Chapin, Lamb & Keen, Incorporated	
Syntronic Instruments, Incorporated	363
Burton Browne Advertising	
TRG, Incorporation (Division of Control Data Corporation Culver Advertising Incorporation	38
TRW Capacitors	51
Fuller & Smith & Ross Incorporated	
TRW, Equipment Operations	304
Ritchie & Sattler, Incorporation	
TRW Instruments	336
Fuller & Smith & Ross Incorporated	
TRW (Systems) & Semiconductors	206
Fuller & Smith & Ross Incorporated	
■ Tektronix, Incorporated	53
Hugh Dwight Advertising Incorporated	
Tel-Com Instruments Incorporated	94
Gross Advertising Services	
Telonic Engineering Company	192
Jansen Associates Incorporated	
Telonic Instruments	319
Jansen Associates Incorporated	
Tenney Engineering, Incorporated	333
Keyes, Martin & Company	
Texas Instruments Incorporated	20, 21
Don L. Baxter Incorporated	
■ Tung Sol Division, Wagner Electric Corporation	196
E M Freystadt Association	
Texscan Corporation	169
Burton Browne Advertising	
Tokyo Print Industrial Company Limited	332
General Advertising Agency	
■ Tonegen Electric Company Limited	320
Japan Business Services Limited	
■ Tracor, Incorporated	297
Weekley & Valenti Incorporated	
Transformer Electronics Company	304
Dacey, Wolff, & Weir	
■ Transitube Incorporated	321
Herbert Arthur Morris Advertising	
Trygon Electronics	274
Solow/Weston Company, Incorporated	
The Ucinite Company	323
Sulver Advertising Incorporated	
Ulano & Company, J.	253
Byrde, Richard & Pound Incorporated	
■ Uniform Tubes Incorporated	266
The Michener Company Advertising	
Union Carbide Corporation (Electronics Division)	31
J.M. Mathes Incorporation	
Union Carbide Electronics Semiconductor Products	93
Hal Lawrence Incorporated	
United Mineral & Chemical Corporation	60
Benauf Associates	
■ United Transformer Company	2nd Cover
Philip Stogel Company	

■ Unirode Corporation	57
Silton, Huffman Incorporated	
The Victoreen Instrument Company	296
Palm & Peterson Incorporated	
■ Vitro Corporation of America, Vitro Electronics	294
Buchen Advertising Incorporated	
Volkert Stampings	228
Fred Wittner Company	
Wang Laboratories	342
Larcom Randall Advertising Incorporated	
Wavetek	82
Chapman, McQuiston, Suzuki & Wright Advertising	
Wayne Kerr Corporation	214
Josephson, Cuffari Company	
Wells Electronics Incorporated	335
Weco Advertising	
Westinghouse Semiconductor Division	245
ITSM Division of McCann-Erickson	
Allegheny Power System, West Penn Power Company, Area Development Department	313
Fuller & Smith & Ross Incorporated	
■ Weston Instruments Incorporated	74
Electronics	
Arndt, Preston Chapin, Lamb, Keen Incorporated	
S.S. White Company	104
Resistor Trimmer Division	
W.L. Towne Company Incorporated	

Classified Advertising

F.J. Eberle, Business Mgr.

PROFESSIONAL SERVICES 346

EMPLOYMENT OPPORTUNITIES 343-348

EQUIPMENT (Used or Surplus New) For Sale 349

ADVERTISERS INDEX

A & A Electronics Corp.	349
Amphenol, RF Div	344
Atomic Personnel, Inc.	346
Conductron-Missouri	348
Corcoran, Joseph P. Personnel Consultants	344
Fair Radio Sales	349
Fishman Co., Philip	349
General Dynamics, Electronics Div	343
General Precision, Inc.	344
Hewlett Packard	345
International Business Machines Corp.	347
Loral Electronic Systems	346
NYS, Dept. of Civil Service	346
Norman Electronic Sales	349
Radio Research Instrument Co.	349

■ For more information on complete product line see advertisement in the latest Electronics Buyers' Guide

Advertising sales staff

Frank E. LeBeau [212] 971-6464

Advertising sales manager

Wallis Clarke [212] 971-2187

Assistant to sales manager

Donald J. Austermann [212] 971-3139

Promotion Manager

Atlanta, Ga. 30309: Michael H. Miller, 1375

Peachtree St., N.E.

[404] TR 5-0523

Boston, Mass. 02116: William S. Hodgkinson

McGraw-Hill Building, Copley Square

[617] CO 2-1160

Chicago, Ill. 60611: Robert M. Denmead,

J. Bradley MacKimm, Ralph Hanning,

645 North Michigan Avenue,

[312] MO 4-5800

Cleveland, Ohio 44113: William J. Boyle, 55

Public Square, [216] SU 1-7000

Dallas, Texas 75201: Richard P. Poole, 1800

Republic National Bank Tower,

[214] RI 7-9721

Denver, Colo. 80202: Joseph C. Page, David

M. Watson, Tower Bldg., 1700 Broadway,

[303] 255-5484

Detroit, Michigan 48226: Ralph Hanning

856 Penobscot Building

[313] 962-1793

Houston, Texas 77002: Kenneth George,

2270 Humble Bldg., [713] CA 4-8381

Los Angeles, Calif. 90017: Ian C. Hill,

John G. Zisch, 1125 W. 6th St.,

[213] HU 2-5450

Minneapolis, Minn. 55402: J. Bradley

MacKimm, 1104 Northstar Center

[612] 332-7425

New York, N.Y. 10036

500 Fifth Avenue

Donald R. Furth [212] 971-3615

James R. Pierce [212] 971-3616

Stanley J. Kail, Jr. [212] 971-3617

Philadelphia, Pa. 19103:

Warren H. Gardner, Jeffrey M. Preston,

6 Penn Center Plaza,

[215] LO 8-6161

Pittsburgh, Pa. 15222: Warren H. Gardner,

4 Gateway Center, [412] 391-1314

Portland, Ore. 97204: James T. Hauptli,

218 Mohawk Building, 222 S.W. Morrison

Street, Phone [503] 223-5118

Rochester, N.Y. 14534: William J. Boyle,

9 Greylock Ridge, Pittsford, N.Y.

[716] 586-5040

St. Louis, Mo. 63105: Robert M. Denmead

The Clayton Tower, 7751 Carondelet Ave.

[314] PA 5-7285

San Francisco, Calif. 94111:

James T. Hauptli, 255 California Street,

[415] DO 2-4600

London W1: John W. Patten, Edwin S.

Murphy Jr., 34 Dover Street,

Hyde Park 1451

Milan: Robert M. Saidel

1 via Baracchini Phone: 86-90-656

Frankfurt/Main: Gerd Hinske, Dieter

Rothenbach, Elsa-Brandstroem Str. 2

Phone: 72 01 81

Geneva: Michael R. Zeynel,

1, rue du Temple Phone: 31 95 60

Paris VIII: Denis Jacob, Kenneth Davey,

17 Avenue Matignon Phone: 359 6637

Tokyo: Nobuyuki Sato, 1, Kotohiracho

Shiba, Minato-Ku [502] 0656

Osaka: Ryoji Kobayashi 163, Umegae-cho

Kita-ku [362] 8771

Business department

Wallace C. Carmichael, Manager

[212] 971-3191

Stephen R. Weiss, Production Manager

[212] 971-2044

Thomas M. Egan,

Assistant Production Manager [212] 971-3140

Dorothy Carmesin, Contracts and Billings

[212] 971-2908

Circulation and research

Milton Drake, Manager [212] 971-3485

Isaaca Siegel, Assistant Circulation Manager

[212] 971-6057

David Strassler, Assistant Research Manager

[212] 971-6058

Chloe D. Glover, Research Associate

[212] 971-6057

Electronics buyers' guide

George F. Werner, General Manager

[212] 971-2310

Regina Hera, Directory Manager

[212] 971-2544

Thomas M. Egan, Production Manager

[212] 971-3140

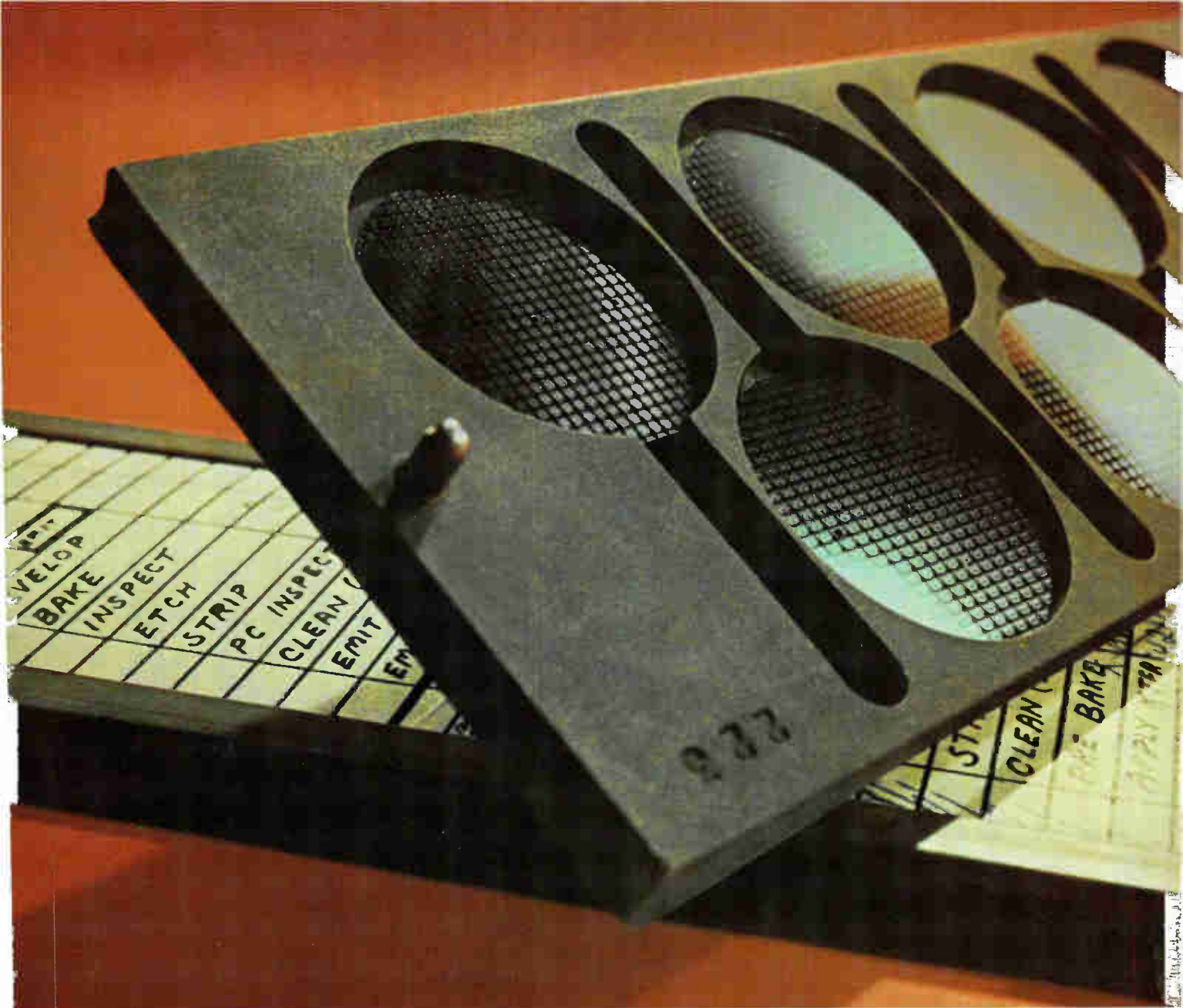

Even the biggest IC order you give us is made in small pedigreed batches.

Mistakes don't get far at Sylvania. By making ICs in small batches and logging their performance on charts that follow them through every step of production, we spot trends and make corrections early. You get reliable ICs, on time.

To assure reliability, vendors' materials must pass stringent tests. Parts made within Sylvania must pass the same tests.

For reliability, processing areas are designed to eliminate contamination. Ceilings, floors and furnishings are impervious to dirt. Temperature,

humidity and air are precisely-controlled.

We've virtually eliminated damage to chip substrates, metallizations and bond wires with mechanized handling equipment. And to make certain we achieve reliability, every IC must survive 100% testing in 12 steps during production. And 100% testing again at the very end.

Sylvania Semiconductor Division, Electronic Components Group, Woburn, Massachusetts 01801. Sylvania achieves reliability; *Sylvania really delivers ICs.*

SYLVANIA
SUBSIDIARY OF
GENERAL TELEPHONE & ELECTRONICS **GTE**

Circ. 901 on reader service card